



Technical Education Series

# BASIC ELECTRICAL ENGINEERING

With Numerical Problems

VOLUME I

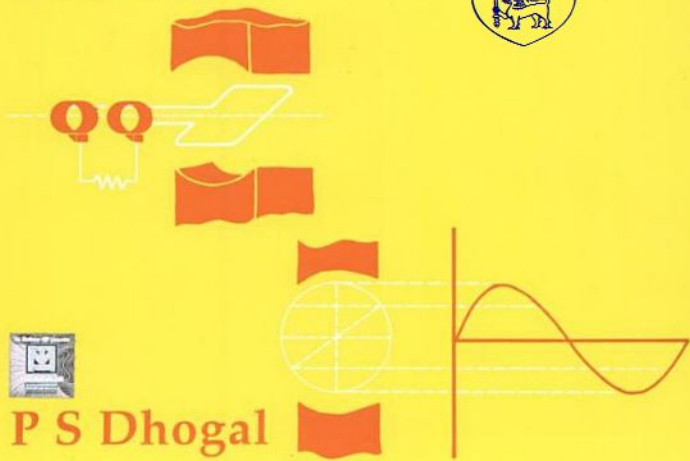

P S Dhogal

This book has been recommended by the Directorate General of Employment and Training (DGE&T), New Delhi, vide their circular No. DGET-14(2)/86-CD, dated April 1, 1986.

Volume II has been recommended by the Directorate General of Employment and Training (DGE&T), New Delhi, vide their circular No. DGET-10(6)/88-CD, dated November 22, 1988.



**Tata McGraw-Hill**

© 1985. Tata McGraw-Hill Publishing Company Limited

30<sup>th</sup> reprint 2006

**RADLRDRKRLBQQ**

No part of this publication can be reproduced in any form or by any means without the prior written permission of the publishers

This edition can be exported from India only by the publishers, Tata McGraw-Hill Publishing Company Limited

**ISBN 0-07-451586-1**

Published by Tata McGraw-Hill Publishing Company Limited, 7 West Patel Nagar, New Delhi 110, and printed at Ram Book Binding House, New Delhi 110 020.

*Tata McGraw-Hill*

# Contents

<i>Foreword</i>	<i>vii</i>
<i>Preface</i>	<i>ix</i>
<i>First-Year Syllabus for the Trade Theory—Electrician</i>	<i>xii</i>
<b>1. Introduction</b>	<b>1</b>
<b>2. Wires, Cables and General Electrical Accessories</b>	<b>22</b>
<b>3. Nature of Electricity and its Fundamental Laws</b>	<b>41</b>
<b>4. Work, Power and Energy</b>	<b>60</b>
<b>5. Chemical and Heating Effects of Electric Current</b>	<b>71</b>
<b>6. Magnetism, Electromagnetism and Electromagnetic Induction</b>	<b>87</b>
<b>7. DC Generators</b>	<b>107</b>
<b>8. DC Motors</b>	<b>137</b>
<b>9. Cells and Batteries</b>	<b>162</b>
<b>10. Wiring System</b>	<b>192</b>
<b>11. Single-Phase AC Circuits</b>	<b>210</b>
<b>12. Poly-Phase System</b>	<b>241</b>

# First-Year Syllabus for the Trade Theory—Electrician

The following syllabus is for the first 52 weeks consisting of:

Induction Training	1 week	Main Trade Training	42 weeks
Allied Trade Training		Test	1 week
Fitting	3 weeks		
Carpentry	3 weeks		
Sheet Metal Work	2 weeks		<hr/> 52 weeks
	(Knowledge of Making Panel Board)		

**Week 1.** Introduction to the trade, scope for training in the trade. Safety precautions, elementary first aid, resuscitation and treatment for electric shock, burns etc.

**Week 2.** Description, specification & general care and maintenance of common hand tools, identification and measurements of bolt, nuts & screws. Electron theory, miniature solar system elements, atom and free electron. Fundamental terms, definitions, units, etc., effects of electric current.

**Week 3.** Qualities of good electrical conductors, common conductors, their shape, size and use of wire—gauge, etc. Insulated conductors in general use. Their kinds as regards insulation & voltage. Grades, low, medium and high voltage.

**Week 4.** Soldering—its purpose, different percentage of solder used, use of flux. Different fluxes for different purposes or metals, use of resin and core solder. Description of soldering equipment. Care & maintenance of the blow lamp.

**Week 5.** Common electrical accessories, specification & common insulating materials used. Ohm's law and its application. Series connection of appliances or resistances, characteristics and uses. Use of voltmeter and ammeter.  
(IS: 3202—1965/4, 5)

**Week 6.** Different types of resistances, parallel circuit, its characteristics and application. Use of protective devices like fuses, earthing, etc. Precautions in using Aluminium conductor cable.

(IS: 732—1963/ App-D)

**Week 7.** Work, power and energy, their inter-relation, calculation of power & energy in electrical circuits. Ohm's law. Simple problems.

**Week 8.** Chemical effect of electrical current, principle of electrolysis, Faraday's law of electrolysis. Electrochemical equivalent. Values of E.C.E. for different electrolytes. Explanation of anode, cathode, etc.

## Allied Trades

**Week 9.** Introduction of fitting trade, safety precautions to be observed. Descriptions of files, hammers, chisels, hacksaw frames, blades, their specification and grades. Care and maintenance of steel rules, try-square and files.

**Week 10.** Marking tools, description and use. Types of drills, description of drilling machines, proper use, care and maintenance.

**Week 11.** Description of taps and dies, types of rivets and rivetted joints, Use of thread gauge.

## Carpentry

**Week 12.** Description of carpenter's common hand tools, such as saws, planes, chisels, mallet, claw hammer, marking and dividing and holding tools, their care & maintenance.

**Week 13.** Timber, its description, seasoning process and their use for different purposes.

**Week 14.** Finishing and polishing materials. Sand papers—their grades and proper selection. Preparation of spirit polish and polishing process.

## Sheet Metal

- Week 15.** Description of marking and cutting tools, such as snips, shears and punches, etc. used by sheet metal workers. Types of soldering irons—their proper use, description and proper use of different bench tools used by sheet metal workers.
- Week 16.** Description of M.S. tinned and galvanised sheets and their advantages. Soldering materials, fluxes and process of soldering methods of jointing and soldering.
- Week 17.** Magnetism—terms used, types and shapes of magnets, properties of magnets. General care and maintenance, methods of magnetising. Magnetic materials.
- Week 18.** Electromagnet, advantages and uses. Principle of electromagnetism, cork screw rule and right hand thumb rule, magnetic field of current carrying conductor and loop. Earth magnetism, solenoid, its polarity, palm rule, etc. Magnetic terms and equations.
- Week 19.** Principle of electromagnetic induction, Faraday's law, Lenz's law—resistance variation of resistance with temperature, material, cross section & length.
- Week 20.** Principle of dc generator—Fleming's right hand rule. Use of slip rings and split rings and the function of commutator. Ohm's law and its application.
- Week 21.** Parts and functions of dc generator, emf equation, self and separately excited generators, their application in practical field. Use of megger.
- Week 22.** Types and characteristics of dc generators such as series, shunt and compound, their application. Simple problems on electric circuit. Making a circuit diagram.
- Week 23.** Armature-reaction, use of interpoles and their polarity, connection of interpoles, commutation.
- Week 24.** Electromagnetic drag, Fleming's left hand rule. Principle of dc motor.
- Week 25.** Terms used in dc motor such as torque, speed, back emf, etc. their relation and practical application.
- Week 26.** Types and characteristics of dc motor. Industrial application of dc motor. Starting methods.
- Week 27.** Types of dc motor starters, 3 point and 4 points. Protective devices used.
- Week 28.** Methods of controlling speed of dc motor—their advantages and disadvantages and industrial application.
- Week 29.** Types, grades, sizes of insulated wires and cables such as rubber insulated, CTS, weather proof, PVC, multicoated, armoured cables, etc.—their selection as per standards laid down.
- Week 30.** Principles and description of voltaic cell defects and remedies. Leclanche cell and dry cell description, voltages, advantages, use, care and maintenance. Grouping of cells for different voltage and current.
- Week 31.** Lead acid cell, description of parts. Methods of charging—precautions to be taken and testing equipment.
- Week 32.** General defects and remedies of lead acid cells. General maintenance and up-keep of lead acid cells and nickel-alkaline cells. General idea of growing importance of alternating current system with suitable examples.
- Week 33.** Kirchhoff's laws and its application, Wheatstone bridge and its application.
- Week 34.** Alternating current related terms viz., frequency, rms value, etc. with simple problems. General idea of standard sizes of casing and capping. (IS: 732-1963/table-1)
- Week 35.** Resistance of capacitance and inductance. Simple definitions. Simple problems proving the effect of varying frequency. Phase relationship, power and power factor. Identification of ac and dc meters. Use of watt meters and energy meters.
- Week 36.** Resistance, capacitance and inductance. Simple definitions. Simple problems proving the effect of varying frequency. Phase relationship, power and power factor. Identification of ac and dc meters. Use of watt meters and energy meters.
- Week 37.** Ac circuit. Simple problems on ac circuits containing R & XI, R and L and XC. Calculating current, voltage drop across each and impedance of circuit. General idea of conduits and its accessories. IE rules pertaining to conduit pipe wiring.
- Week 38.** —do—
- Week 39.** Poly-phase circuits, star-delta connection. Relation between line and phase voltage, and simple problems based on it. I.E. rules. Use of reference book and tables.
- Week 40.** Alternators, parts, emf equation, regulation, Phase sequence. Transformers—construction, work-

ing principle, cooling method. Conduit capacities and IE rules pertaining to conduit pipe installations. (IS : 3156-Part 1/1965 APP. C. and E)

**Week 41.** Alternators, parts, emf equation, regulation. Phase sequence. Transformers—construction, working principle, Cooling method. Conduit capacities and IE rules pertaining to conduit pipe. Installations.

**Week 42.** Working principle of induction motor. Construction and characteristic of squirrel cage and slip ring induction motor.

**Week 43.** Single-phase motors. Split phase, capacitor. Repulsion and series motor—working principle, parts and characteristics. Starters—types and characteristics.

**Week 44.** Single-phase motor. Split phase, capacitor. Repulsion and series motors—working principle, parts and characteristics. Starters—types and characteristics.

**Week 45.** Electric instruments: Classifications as regards force employed, etc., constructional details of MC and MI type meters. Dynamometer and hot wire instrument. Constructional details of energy-

meter and megger. Use of shunt and multiplier. Principle and use of CT and PT.

**Week 46.** Ac Winding terms: ac armature winding terms—coil side, coil end, coil lead, coil group and connections. Adjacent pole connected armature winding, and alternate pole connected armature winding, lap and wave connected.

**Week 47.** Coil wound armature according to their shapes and arrangement—single and multi-coils.

**Week 48.** Dc winding terms: Introduction, winding terms such as lap winding, wave winding pole pitch, coil pitch or back pitch, front pitch, resultant pitch, progressive and retrogressive winding.

**Week 49.** Mercury vapour and sodium vapour lamp—Construction, characteristic and wattage available. Fluorescent tube—construction, characteristic, size and wattage available. Types of lighting.

**Week 50.** —REVISION—

**Week 51.** —REVISION—

**Week 52.** —TEST—

# 1

## Introduction

### 1.1 SAFETY PRECAUTIONS

We know electricity is invisible. Therefore, while working in electrical installations one should always first take care of one's own safety. A little carelessness can result in an accident, which many times can be fatal. Therefore, electricity needs certain precautions of handling it to avoid danger. The following "Do Nots" (precautions) should always be observed before starting work on electrical equipment and apparatus :

- (i) Do not forget that electric shocks are generally received by the worker and can be avoided. Be careful.
- (ii) Do not forget to put off the main switch (if near it) in the case of a person still in contact with a live conductor or apparatus
- (iii) Do not attempt to disengage a person in contact with a live apparatus which you cannot switch off immediately. Insulate yourself from the earth by standing on a rubber mat or dry board of wood before attempting to get him clear. Even then do not touch his body; push him clear with a piece of dry wood.
- (iv) Do not forget to put off the main switch and take away the fuse carrier along while working on an installation. Also, then put a caution notice on or near the main switch inscribing "Danger, Men at Work".
- (v) Do not have a false feeling of security by believing that resuscitation can always bring a person back to life after an electric shock. First of all, call the doctor at once and apply artificial respiration quickly.
- (vi) Do not discontinue artificial respiration until recovery or death is certified by the doctor.
- (vii) Do not forget to put on your safety belt before starting work on a pole. If a ladder is used, it must be held by another man to avoid slipping.
- (viii) Do not have any sharp tool protruding from the pocket when working on a high voltage overhead line. Always keep one hand in the pocket.
- (ix) Do not secure a position where the head is likely to become a conductor in overhead lines.
- (x) Do not forget to discharge the overhead lines by earthing or by other suitable means.
- (xi) Do not forget to earth all metallic coverings of the electrical wiring installation.
- (xii) Do not forget to connect a switch on a live conductor.
- (xiii) Do not use wires and tools having poor insulation.
- (xiv) Do not open or close a switch slowly or hesitatingly. Do it quickly.
- (xv) Do not disconnect a plug point by pulling a flexible cable.
- (xvi) Do not work on energised circuits without taking all precautions, such as the use of a rubber mat, shoes and gloves, etc.
- (xvii) Do not tamper with an electrical equipment or a conductor, unless you are sure that it is dead and earthed.
- (xviii) Do not renew a blown fuse until you are satisfied as to its cause and have rectified the fault.
- (xix) Do not close any switch unless you are familiar with the circuit which it controls and know the reason for it being open.
- (xx) Do not allow unauthorised persons to touch or handle electrical apparatus or come within the danger zone of high voltage apparatus.
- (xxi) Do not add water to acid while preparing an electrolyte. Always add acid to water.

- (xxii) Do not bring a naked flame near an accumulator. Also, keep the room where the accumulator is housed well-ventilated.
- (xxiii) Do not throw water on a live conductor or equipment in the case of a fire.
- (xxiv) Do not use a fire extinguisher on electrical equipment unless it is clearly marked for that purpose. Use only carbon tetrachloride or liquid carbon dioxide extinguishers or dry sand. It is advisable to switch off the main switch before attempting to put off an electric fire.
- (xxv) Do not forget that safety depends upon good earthing; so always keep the earth connections in a good condition.

### 1.2 METHODS FOR RESCUING AN UNCONSCIOUS PERSON SUFFERING FROM AN ELECTRIC SHOCK

If a person receives a shock, it is the utmost duty of the observer to disconnect him immediately from the live supply mains by either switching off the main switch. The body should be pushed away with a dry stick or rope. If a stick is not available, then insulate yourself by standing on a dry wooden board, thick cardboard or rubber (or coconut) matting before trying to get him clear, and even then do not touch his body. Pull him with his loose clothes like his shirt or coat. Then extinguish the spark if there is any smouldering on the clothes of the victim. If the heart of the victim stops beating it means death is certain. However, if the victim becomes unconscious and stops breathing, but his heart still beats, he should be immediately given artificial respiration because a slight delay may cause death. Artificial respiration should be continued till the patient regains his natural breathing or as the doctor advises after his arrival.

A slight regaining of natural breathing is not an indication for stopping the artificial respiration because the victim may stop breathing again. Therefore, the patient should be carefully watched and if the natural breathing stops again, the artificial respiration should be followed at once. Before starting the first aid for resuscitation, the clothes around the throat, chest and waist should be loosened. If there are any false teeth or any foreign body in the mouth, they should be removed. The doctor should be sent for and till the

doctor arrives, artificial respiration should be continued.

There are many methods of artificial respiration and any one of them can be followed depending upon the necessity and requirement. Some of these methods are given below.

**First Method** It is the best method of artificial respiration and can be followed as explained below :

1. Lay the victim on the ground as illustrated in Fig. 1.1.



Fig. 1.1 Inspiration

2. Pull his arms forward and put his head on one side resting on an arm so that he can breath easily.
3. Kneel over the victim, placing your hand flat on his back near the lowest rib in such a manner that the thumbs touch each other and are parallel to the spine. Now spread the fingers on each side over his lower ribs.
4. Lean forward gently over the patient, exerting a downward pressure for two seconds. Similarly, release the pressure slowly by moving backward, keeping the hands in the same position for two seconds as shown in Fig. 1.2. This expands and contracts the patient's lungs so as to imitate the breathing.



Fig. 1.2 Expiration

5. When the victim starts breathing, it is better if the rescuer synchronizes his own breathing with him so that the victim can arrive at the natural rate of breathing.

This process should be repeated 12 to 15 times per minute and should be followed continuously with great patience because it can take hours to bring the respiration back.

**Second Method** This method is adopted only when a victim's body has some burns on the chest or anywhere on the front side of the body. The patient must be laid on the floor as shown in Fig. 1.3 with a pillow or rolled coat under his shoulder. Then the following procedure should be followed.

1. The operator should kneel in the position shown in Fig. 1.3.

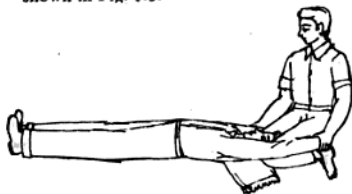

Fig. 1.3 Inspiration

2. Tilt the head a little back. It keeps the tongue out of the throat, thus giving passage to the air.
3. Hold the victim just below the elbow and draw his hand over his head until they are horizontal. Keep them in that state for about two seconds.
4. Now bring the victim's arms down on each side of his chest, pressing inward on his arms so as to compress his chest as in Fig. 1.4.

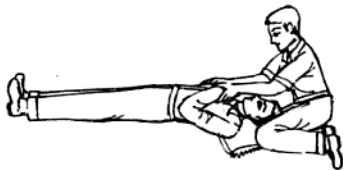

Fig. 1.4 Expiration

5. After two seconds, repeat the process again. It should be done 12 to 15 times a minute till the patient resumes breathing.

In this procedure two persons are necessary for performing the artificial respiration because it is required to draw the tongue of the patient out during each inhalation attempt and release it during each expiration stroke. For this reason this method is a little bit difficult and inconvenient to perform.

**Third Method (Artificial Respiator Method)** It is the easiest and most hygienic method of artificial respiration, if the apparatus is available. When the victim has suffered an electric shock and is unconscious, and it is required to bring his respiration back, an artificial respirator is used. It consists of a rubber-bulb mask and an air filter along with a transparent celluloid valve arrangement. The air enters through the holes of rubber bulb and goes out through the outlet valve. The mask is placed on the mouth and nose of the patient as shown in Fig. 1.5 and the rubber bulb is pressed at the rate of 12 to 15 times per minute to bring his respiration back. This process should be continued regularly till the doctor advises to stop. The operation of the respirator is explained below.



Fig. 1.5 Artificial respirator

The rubber mask is fitted on the mouth and nose of the victim. When the rubber bulb is pressed the air of the bulb passes through the air filter which lifts the inlet valve and closes the outlet valve. Now this filtered air enters the lungs of the patient through the mask and nose. When the pressure on the bulb is released, the inlet valve closes and the outlet valve is opened which now gives path to the used air to go out. The detailed diagram of the resuscitator is shown in Fig. 1.6.

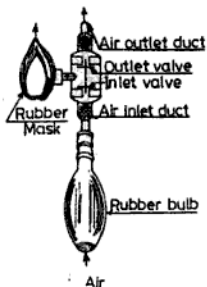

Fig. 1.6 Resuscitator

*Special Instructions*

1. Never give any drink to the unconscious man.
2. Violent operation of the process must be avoided because an internal injury in the affected organ may be harmed due to quick and excessive pressure.
3. If there is a burn on the body, it should be properly dressed after the recovery of the patient.
4. The patient should be kept warm.
5. No medicine should be given without the consent of the doctor.
6. An owner of the factory must provide and fix a chart explaining the methods of artificial respiration and carrying the name of the nearest doctor, telephone number, and hospital and residential address so that he may be contacted immediately in time of need.

### 1.3 COMMON HAND TOOLS, THEIR USES, CARE AND MAINTENANCE

For easy performance and good quality of work, it is always preferred to have standard tools. Most accidents occur due to the use of cheap and blunt tools. It is, therefore, always necessary to take proper care and maintenance of tools (Table 1.1).

### 1.4 IDENTIFICATION OF BOLTS, NUTS AND SCREWS

**Bolt** It is a locking device which is used with the combination of nuts. It is specified with its diameter and length. It is generally not fully threaded. (See Fig. 1.7).



Fig. 1.7 Bolt

**Screw** It is also a type of bolt but its threads are from the head to the bottom. The size of the screw is also measured according to its threaded length and diameter, as shown in Fig. 1.8



Fig. 1.8 Screw

**Nut** It is generally used on screws and bolts for locking purposes. Its size is specified by its internal diameter, as shown in Fig. 1.9



Fig. 1.9 Nut

TABLE 1.1 COMMON HAND TOOLS, THEIR USES, CARE AND MAINTENANCE





S. No.	Name of tool	Size	Figure	Description and Use	Care and Maintenance
1	Combination plier	150 mm, 200 mm (6", 8")		<p>It is made of steel and its size is given according to its length. It has a cutter for cutting the wires. It is so named because it is used for multi-purposes, such as cutting, twisting of wires and holding round and flat jobs. They are either insulated or uninsulated. An insulated combination plier is specially used to work on live conductors where it prevents the current from leaking to the human body.</p>	<ol style="list-style-type: none"> <li>1. Do not use a plier as a hammer.</li> <li>2. Never cut hard substances like steel wires with it.</li> <li>3. Do not grip hot substances with it.</li> <li>4. Never try to spoil the insulation of an insulated plier.</li> <li>5. Keep the plier safe from rust.</li> <li>6. Lubricate only its moving part after sometime.</li> </ol>
2	Nose plier	100 mm, 150 mm, 200 mm (4", 6", 8")		<p>Flat and round nose pliers (long or short) are used for holding work. Flat nose pliers are used for holding flat objects like hexagonal nuts, etc. at places where other pliers are unable to reach. Round nose pliers are used for making hooks and loops of thin wires. Long nose pliers are used for connecting and disconnecting small wires in narrow spaces. They are also used for tightening and loosening small nuts in narrow places like long holes. They have also a cutter on one side for cutting the thin wires.</p>	
3	Side cutting plier	150 mm, 200 mm (6", 8")		<p>The side cutting plier has a cutter on its side and is used for cutting wires and nipping the insulation from them; It is generally used in armature windings, instrument works, radio assembling, etc.</p>	(contd.)

Table I.1. (contd.)

1	2	3	4	5	6
4.	Screw driver 75, 100, 150, 200, 250, 300 mm (2', 4', 6', 8', 10', 12')		It has three parts, namely the handle, blade and working edge. The handle is either made of wood, plastic or celluloid and the blade is made of hard steel. Its working edge is tempered. Its size is measured from the length of its blade. It is used for tightening and loosening the screw. A screw driver having a 75 mm long working blade is called a terminal screw driver or connector screw driver and is used for working at small screws of wiring accessories, such as switches, holders, wall sockets etc.	1. A screw driver with a loose handle should not be used. 2. The working edge of the blade must correctly fit in the slot of the screw heads. 3. Do not hammer the wooden handle of the screw driver. 4. Never try to use it as (firmer) chisel.	
5.	Electrician's knife 50 mm (2')		It is a tool used for removing the insulation from the wires. It has two folding blades, one for removing the insulation and the other for cleaning the wires. Its size is measured by the length of the cutting blade.	1. Do not use it for cutting wires. 2. Keep it well sharpened. 3. Keep it safe from rust.	
6.	Test lamp		A testing holder with a lamp is called a test lamp. It is used for testing the supply.	1. Give a knot of wires under the cap of the holder. 2. Handle it with great care, otherwise the lamp can get damaged.	
7.	Hand Saw 250 mm, 300 mm (10', 12')		It has a thin steel blade having 5 to 8 teeth per 25.4 mm (per inch). Its teeth are tapered towards the handle. It has greater width near the handle than at the point end. It is used for cutting thick wood. The sizes of the saws are determined by the total length of the blade.	1. Protect it from rust. 2. Do not use a saw with a loose handle. 3. Keep the teeth well sharpened. 4. Always use it straight. 5. Apply grease when out of use. 6. It should not be used	

where nails are driven.  
7. Saw with even strokes.

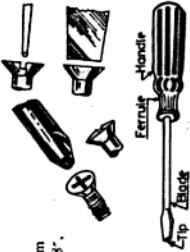
It has 8 to 12 teeth per 25.4 mm (per inch) and the width of the blade is 10 cm (4"). It is used for cutting thin pieces of wood, casing capping, teak wood batten, wooden boards and blocks.

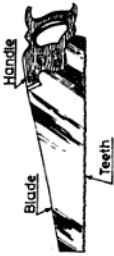
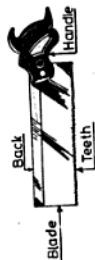

8. Tennon Saw  
250 mm,  
300 mm,  
(10", 12")

1. The blade should be tight enough.

2. Use a coolant while cutting.

3. The teeth of the blade should point away from the handle.

4. It should be used straight during cutting, otherwise the blade can get damaged.

5. Put sufficient pressure on the forward stroke to enable the teeth to cut.

6. Lift the saw slightly on the return stroke.

7. Do not attempt to saw too fast.

It is used for cutting conduit pipes, G.I. pipes and small pieces of iron. Hacksaws are of two types:

(i) fixed hacksaw and (ii) adjustable hacksaw. In the adjustable hacksaw different length of blades can be fixed. Its main parts are the frame, blade, handle and fly-nut. As the blade is designed to cut on the forward stroke, it should be fixed on the frame with its teeth pointing away from the handle.

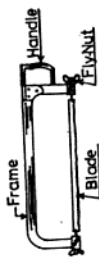

9. Hack saw  
200 mm,  
250 mm,  
300 mm,  
adjust-  
able

It has a wooden handle and a blade. The blade is made of cast steel of 15 cm (6") length and is sharp at the working edge. Its size is measured according to its width which varies from 0.5 to 5 cm (1" to 2"). It is used for chipping and scraping unwanted wood.



10. Firmer chisel  
6 mm,  
12 mm,  
18 mm,  
25 mm  
(1", 1/2", 3/4", 1")

1. Do not use it as screw driver.

2. Always strike the firmer chisel with a mallet.

3. Grind on a water stone and sharpen on an oil stone.

4. Do not use it without a handle.

5. Never use it at places where nails are driven.



It is specially used for making deep holes in wood.



11. Mortise chisel  
6 mm,  
12 mm,  
18 mm,  
25 mm

(contd.)

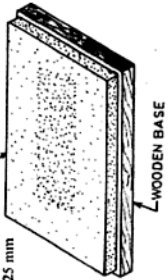
Table 1.1 (contd.)

1	2	3	4	5	6
12.	Flat cold chisel	18 mm x 200 mm, 25 mm x 200 mm	 <p>Diagram of a flat cold chisel. It shows a long, narrow tool with a flat cutting edge and a head at one end. The body is octagonal in shape. Labels include 'Cutting edge', 'Head', and 'Octagonal shape body'.</p>	<p>It is made of high carbon steel and its cutting angle varies from 30° to 45°. The cutting edge is hardened and tempered. In the electrical trade it is used for making holes in walls or ceilings to fix wooden plugs (gutters) for wiring purposes. For better gripping, its body is made in octagonal shape.</p> <p>It is 15, 20 cm (6", 8") long and its size is measured according to its width as 12, 18 and 25 mm. Its length can vary according to the nature of job. Note that if its length is one metre and has a little bend at its face side, then it is known as a crowbar, used as a lever for shifting machines.</p> <p>It is used to sharpen the firmer chisel, knife, etc.</p>	<ol style="list-style-type: none"> <li>1. Grind the cold chisel to the proper angle.</li> <li>2. Grind mushrooms, if any.</li> <li>3. While in use, apply oil as a coolant to the cutting edge frequently.</li> <li>4. The working edge must be properly maintained.</li> <li>5. There should be no trace of grease or oil on the head of the chisel.</li> </ol>
13.	Water stone	150 mm x 50 mm x 25 mm	 <p>Diagram of a water stone. It shows a rectangular block of stone with a porous texture, resting on a wooden base. Labels include 'STONE' and 'WOODEN BASE'.</p>	<p>It is used to sharpen the firmer chisel, knife, etc.</p>	<ol style="list-style-type: none"> <li>1. Do not throw it.</li> <li>2. Apply water frequently when in use.</li> </ol>
14.	Hand drill machine	6 mm capacity (1')	 <p>Diagram of a hand drill machine. It shows a hand-operated drill with a handle, gear, chuck, crank, and jaw. Labels include 'HANDLE', 'GEAR', 'CHUCK', 'CRANK', and 'JAW'.</p>	<p>A hand drill machine is a tool used for making holes in metal or wood. Twist drill bits are fitted in it for making holes and have a capacity of holding drill bit up to 6 mm.</p>	<ol style="list-style-type: none"> <li>1. Lubricate all the moving parts of the machine.</li> <li>2. The drill bit should be correctly and firmly fixed in the jaws.</li> <li>3. Before drilling, mark the job with a centre punch.</li> <li>4. If a large hole is to be</li> </ol>

made, first make a pilot hole of small size and then a big hole with a correct size drill bit.

5. Keep the drill perpendicular to the job.
6. The handle should be moved in the reverse direction while taking out the drill bit after drilling.
7. Do not use too much pressure on small drill bits.
8. Avoid any vibrations and jerks.
9. In the case of an electric drill machine, it must not be earthed and the cable insulation should be sound.

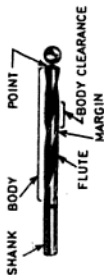

It is specially used for making holes in wood work at narrow places like corners. It can also be used for loosening and tightening the screws by using a screw bit.

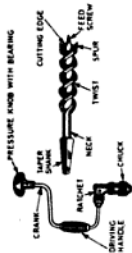

6 mm ( $\frac{1}{4}$ "),  
capacity

15. Ratchet brace machine with bit

1. Keep it in a well-sharpened condition.

2. Never use it on metals for marking guide holes.

It is long sharp tool used for making pilot holes in wood before fixing and tightening of wood screws.

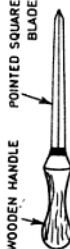

150 mm x  
6 mm

16. Bradawl square pointed (or pocker)

1. Do not use it as a hammer, the wood. Its size is measured from its overall length.





100 mm,  
150 mm,  
200 mm  
(4", 6", 8")

17. Pincer

(contd.)

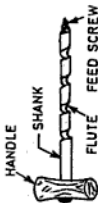
Table 1.1 (contd).

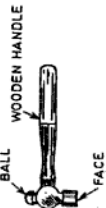
1	2	3	4	5	6
18.	Gimlet	3 to 10 mm	 <p>HANDLE SHANK FLUTE FEED SCREW</p>	<p>It is used for boring small holes in wood. It has a wooden handle and a boring screwed edge. The size of it depends upon its diameter.</p>	<ol style="list-style-type: none"> <li>Do not use it without a handle.</li> <li>The handle should be tight.</li> <li>Do not use it on nails.</li> <li>Keep it straight while making holes, otherwise the screwed portion can get damaged.</li> </ol>
19.	Auger	12 mm, 15 mm, 18 mm, 25 mm	 <p>EYE HANDLE BODY SPUR CUTTING EDGE TWIST FEED SCREW</p>	<p>The auger is a kind of gimlet of big size and is used for boring deep holes in wooden beams. These are always self-driven.</p>	<ol style="list-style-type: none"> <li>Give a slight rotation after each hammering when making holes in walls or ceilings.</li> <li>Do not use on metal.</li> <li>Do not throw it on the ground.</li> </ol>
20.	Rebel plug tool and bit	8, 10, 12, 14 Nos.	 <p>TOOL HOLDER TOOL BIT</p>	<p>It has two parts, namely the tool bit and tool holder. The tool bit is made of carbon steel and the holder is made of mild steel. It is used for making holes in bricks and concrete walls or ceilings. Wooden or fibre plugs are inserted in them to fix the wooden casing, capping or teak wood batten. For fixing it, screws are driven in the plugs which cause them to expand and thus grip the walls. Its size depends upon the number; as the number increases, the thickness of the bit as well as the plug also increases.</p>	<ol style="list-style-type: none"> <li>The handle must be properly tight.</li> <li>Never use it with a loose handle.</li> <li>There should be no traces of oil or grease on the face of the hammer.</li> <li>Do not strike hard steel with the hammer as its face can get damaged.</li> </ol>
21.	Ball peen hammer	0.12 kg, 0.25 kg, 0.50 kg, 0.75 kg, 1.00 kg.	 <p>WOODEN HANDLE BALL FACE</p>	<p>There are many kinds of hammers used for different purposes. The ball peen hammer is generally used in electrical trades, whereas the cross peen hammer is best suited for rivetting purposes in sheet metal works. The size of the hammer is usually indicated by its weight.</p>	

22. Cross peen hammer  
0.50 kg

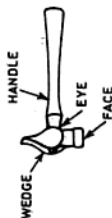

The cross peen hammer is best suited for clipping on teak wood battens and for rivetting purposes in sheet metal works.

23. Mallet  
75 mm x  
150 mm  
0.50 kg,  
1.00 kg

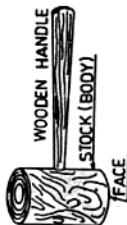

It is made of wood or celluloid. It is used while assembling side covers of electric motors, driving the firm chisel while working and straightening and bending of thin metallic sheets.

24. Ordinary copper bit soldering iron  
0.250 kg



It consists of a copper pointed bit fitted on an iron rod which is fixed to a wooden handle. The bit is first heated in the furnace and then used for soldering the joints.

25. Electric soldering iron  
65, 125,  
250 W;  
230-250 V



It is used for soldering wires to commutator segments and small joints with solder. It consists of pointed oval copper bit fixed to an iron rod which is heated by an electric element only.

26. Wooden foot rule four-fold  
600 mm  
(24")



It is used for measuring dimensions. It is made of wood having four folds. It is 60 cm (2 feet) long. On one side it is graduated in inches, while on the other side it is marked in centimetres.

27. Melting pot and ladle  
200 mm x  
150 mm

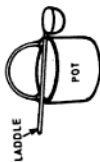

It is used for soldering big joints by heating the solder in the pot and then pouring it over the joints by ladle.

1. Never use it on hard metal other than copper, aluminium or tin.
2. Never use it on nails for flaring them.

1. Before attempting to solder a joint, first clean and tin its bit.
2. Do not overheat the soldering iron.

1. Iron must be properly connected to earth.



2. Flexible wire should be used

1. Do not throw it with other tools in the tool box.

2. Keep it safe from dust, dirt, grease and oil.

Clean the surface of the object with sandpaper. Apply flux and then put the melted solder on the joint.  
(contd.)

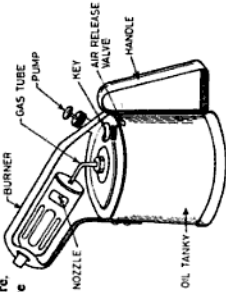
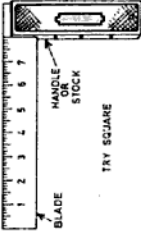
Table I.1. (contd.)

1	2	3	4	5	6
28.	Blow lamp	0.5 litre, 1 litre		<p>It is used for soldering cable joints. Kerosene oil is used for producing flames at very high temperatures, which melts the solder and thus the joints are soldered.</p>	<ol style="list-style-type: none"> <li>1. While starting for burning, its nozzle should not be kept towards any body.</li> <li>2. Do not give too much air pressure to it during working.</li> </ol>
29.	Try square	150 mm, 200 mm (6", 8")		<p>It is used to check whether the object is plane and perpendicular. It consists of two straight blades set at right angles to each other. The steel blade is riveted to the stock, which is of cast iron. Generally, the stock is thicker than the blade so that it can set against the edge of the job.</p>	<ol style="list-style-type: none"> <li>1. Never use it as a hammer.</li> <li>2. Its blade should not be loose in the stock.</li> <li>3. The blade must be at right angles to the stock.</li> </ol>
30.	Spanner set—double ended, set of six keys	1. 10×11 mm 2. 12-13 mm 3. 14-15 mm 4. 16-17 mm 5. 18-19 mm 6. 20-22 mm		<p>Spanner sets are used for loosening and tightening nuts and bolts. It is made of cast steel. The size of the spanner is indicated so as to fit on the nuts. They are available in many sizes and shapes. They are either single-ended or double-ended. The adjustable spanner is also known as the monkey wrench and saves time while working. Ring and box spanners are also used at places where nut and bolts are in narrow and deep places.</p>	<ol style="list-style-type: none"> <li>1. It should not be loose on the nut and bolt.</li> <li>2. It should not be used as a hammer.</li> <li>3. Never strike the spanner with a hammer, while loosening or tightening the nut and bolt.</li> <li>4. The width of the face should be parallel throughout.</li> <li>5. Care should be taken to have no trace of grease on its jaws.</li> </ol>
					

31.

Pair of  
scissors  
(straight  
edge)

150 mm,  
200 mm  
(6", 8")



It is used for cutting the insulation of the armature winding. Its size is determined from its overall length.

- Do not use it as a hammer.
- Do not cut tin sheets and wires with it.
- Keep it always sharp.

32.

Snip straight  
or bent

150 mm,  
200 mm,  
250 mm  
(6", 8",  
10")



It is used for cutting thin sheets of iron, copper and brass. It is also used for cutting the armature winding of a damaged machine.

- Keep it well sharpened.

33.

Measuring  
tape

20 m

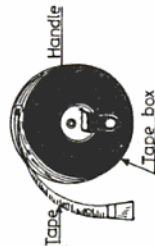

Use it with great care as a little carelessness can spoil the tape.

It is used for measuring the dimension of the wiring installation. The measuring tape is either made of cloth or a thin steel blade, bearing dimensions on it.

34.

Smoothing  
plane

300 mm ×  
50 mm

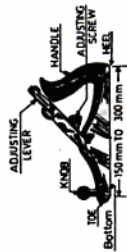

It is mainly used for making wooden surfaces smooth. It is either made of wood or iron and the size is measured according to length and width of its blade.

- Do not use it at places where a nail is driven in the wood.
- Keep it always well sharpened.

35.

File

150 mm,  
200 mm,  
250 mm,  
300 mm  
(6", 8",  
10", 12")





Files are cutting tools. The body of the files are made of cast steel, hardened except for the tang, and have different number of teeth (according to the nature of jobs) which remove fine chips of material. Files are designed to cut only in the forward stroke. They are available in different lengths.

- Do not use the file as a hammer.
- Never use a file without a handle.
- Do not throw a file with other tools as its teeth can get spoiled.

(Contd.)

Table 1.1 (Contd.)

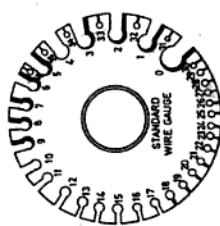
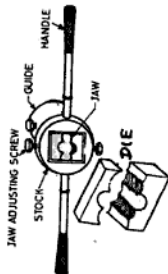
1	2	3	4	5	6
				sections (namely flat, half round, round, square, triangular), grades and cuts.	
					
					
36.	Standard wire gauge	Standard size			It is a thin circular steel plate having a number of slots on its circumference. Different numbers are allotted to different slots according to their diameter. It is used to find the gauge of winding wires.
37.	Stock-and-die (conduit pipe)	12 mm, 18 mm, 25 mm, and 30 mm ( $\frac{1}{2}$ , $\frac{3}{4}$ , 1" to 2")			<p>Stock-and-dies are of two types: (i) fixed and (ii) adjustable. These are used for making external threads on pipes and have four main parts: (i) stock, (ii) die, (iii) guide and (iv) handle.</p> <p>Stock: It is made of cast iron. Dies are held in it.</p> <p>Die: It is the part which makes threads on conduit pipes and is made of carbon steel. They are known by their diameter as 12, 18, 25, 32, 38 and 50 mm (<math>\frac{1}{2}</math>, <math>\frac{3}{4}</math>, 1", 1<math>\frac{1}{4}</math>, 1<math>\frac{1}{2}</math> &amp; 2") dies. The threads of dies are slightly tapered at one side to help the starting of threads.</p>

Guide : Guides are also made of cast iron and their size is known by their diameter. They are used to keep the die straight on the conduit pipe.

Handle : Handles are screwed and fixed in the stock and helps to rotate it easily.

It consists of a glass tube containing neon gas and two electrodes sealed in it. A high value of resistance is connected in series with one of the electrode for limiting the current. One end of these electrodes is connected to the upper end (clip) of the pencil, whereas the second end is connected to the lower brass pointed end. It is used for testing the presence of supply in the terminal of switches, sockets, etc. If it glows on touching the terminal, it indicates the presence of supply.

38. Neon tester  
pencil bit  
type



39. Pulley  
puller

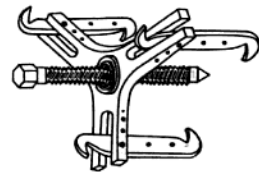

1. Lubricate the screw and screwed plate after some interval.

It consists of three adjusting legs, a tightening screw and a screwed plate. It is made of mild steel and is used for removing the pulley from the shaft of a machine.

1.5 GENERAL SYMBOLS USED IN ELECTRICAL CIRCUIT

The list of general symbols is given in Table 1.2.



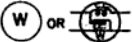



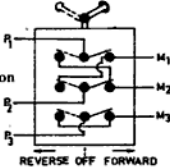









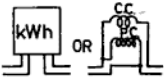

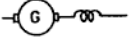

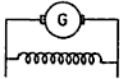

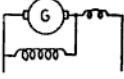
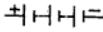



TABLE 1.2 GENERAL SYMBOLS

Particulars		Symbol
1	2	3
1.	Direct current	
2.	Positive	
3.	Negative	
4.	Alternating current	
5.	Single phase	$1\phi$ OR $1\sim$
6.	Three phase	$3\phi$ OR $3\sim$
7.	Phase sequence	R Y B
8.	Neutral	$\perp$ OR N OR O
9.	Crossed wires	
10.	Connected wires	
11.	Earth	
12.	Fuse (rewirable)	
13.	Cartridge fuse	
14.	Porcelain connector single way	
15.	Neutral link	
16.	Single pole switch	
17.	Two-way switch	
18.	Push button switch	
19.	Intermediate switch	
20.	Lamp	
21.	Lamp in series	
22.	Lamp in parallel or lamp load	

- 23. Fan
- 24. Fan regulator
- 25. Two-pin wall socket
- 26. Three-pin wall socket
- 27. Two-plate ceiling rose
- 28. Three-plate ceiling rose
- 29. Electric bell
- 30. Electric buzzer
- 31. Double-pole switch
- 32. Triple-pole switch
- 33. Knife blade, double-pole, double-throw switch
- 34. Knife blade triple-pole, double-throw switch
- 35. Double-pole, iron clad main switch with fuses
- 36. Triple-pole, iron clad main switch with fuses









(contd.)

Table 1.2.(contd.)

37. Oil immersed single-pole switch		52. Volt meter (i) ac, (ii) dc, (iii) ac/dc	
38. Oil immersed double-pole switch		53. Watt meter	
39. Oil immersed triple-pole switch		54. Ohm meter	
40. Reversing switch (Double pole)		55. Multi-meter	
41. Reversing switch iron clad (Triple pole)		56. Phase indicator meter	
42. Fixed resistance		57. Power factor meter	
43. Variable resistance		58. Frequency meter	
44. Coil (inductive coil or reactor)		59. Galvanometer	
45. Variable inductive coil		60. Synchroscope	
46. Choke coil		61. Single-phase energy meter	
47. Fixed condenser		62. Series generator (or motor)	
48. Variable condenser		63. Shunt generator (or motor)	
49. Cell		64. Compound generator (or motor)	
50. Battery		65. Single-phase alternator	
51. Ampere meter (i) ac (ii) dc, (iii) ac/dc		66. Three-phase alternator	
		67. Single-phase motor	

(contd.)

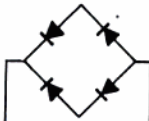
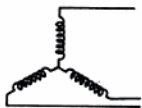

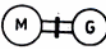









Table 1.2 (contd.)

68.	Three-phase sq. cage induction motor	
69.	Three-phase slipping motor	
70.	Transformer	
71.	Auto-transformer	
72.	Potential transformer	
73.	Current transformer	
74.	Half-wave metal rectifier	
75.		
76.	Star connection	
77.	Delta connection	
78.	Rotary convertor	
79.	Motor generator set—mechanically coupled	























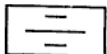



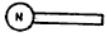





## 1.6 I.S.I. CONVENTIONAL SYMBOLS FOR ELECTRICAL INSTALLATION.

The I.S.I. electrical symbols are given in Table 1.3.

TABLE 1.3 I.S.I. ELECTRICAL SYMBOLS

































Particulars	Symbol
1. Main fuse board without switches and lighting	
2. Main fuse board with switch and lighting	
3. Main fuse board without switches (power)	
4. Main fuse board with switches (power)	
5. Distribution fuse board without switches (lighting)	
6. Distribution fuse board with switches (lighting)	
7. Distribution fuse board without switches (power)	
8. Distribution fuse board with switches (power)	
9. Main switch (light)	
10. Main switch (power)	
11. Changeover switch	
12. Meter	

(contd.)

13. Pendant light single		30. Socket outlet, 2 pin, 15 A	
14. Pendant light counter weight		31. Socket outlet switch combined, 2 pin, 15 A	
15. Pendant rod		32. Socket outlet switch combined, 3 pin, 5 A	
16. Chain Pendant		33. Socket outlet switch combined 3 pin, 5 A	
17. Light bracket		34. Socket outlet, 3 pin, 15 A	
18. Batten lamp holder		35. Socket outlet switch combined, 3 pin, 15 A	
19. Watertight fitting		36. Convection heater	
20. Bulk-head fitting		37. Electric heater unit	
21. Light outlet connection to an emergency system		38. Tubular heater	
22. Switch (general symbol)		39. Immersion heater	
23. One-way switch		40. Thermostat	
24. Two-way switch		41. Immersion heater with thermostat	
25. Intermediate switch		42. Self-contained electric water heater	
26. Pendant switch		43. Fan	
27. Pull switch		44. Bracket fan	
28. Socket outlet, 2 pin, 5 A		45. Exhaust fan	
29. Socket outlet switch combined, 2 pin, 5 A		46. Fan regulator	

(contd.)

Table 1.3 (contd).

47. Bell push		64. Master clock outlet	
48. Bell		65. Bell connected to fire alarm	
49. Buzzer		66. Fire alarm indicator ( <i>N</i> = No. of ways)	
50. Indicator		67. Amplifier	
51. Relay		68. Control board	
52. Bell system relay		69. Microphone	
53. Indicator and bell		70. Loudspeaker	
54. Power factor capacitor		71. Receiver point	
55. Choke		72. Aerial	
56. DC		73. Earth	
57. AC		74. Earth plate	
58. Positive		75. Earth test point	
59. Negative		76. Surge diverter	
60. Neutral		77. Pilot or corridor lamp	
61. Phase		78. Siren	
62. Clock outlet—synchronous		79. Horn or hooter	
63. Master clock			

## REVIEW QUESTIONS

- 1.1 What safety precautions would you observe to avoid electrical accidents ?
- 1.2 How will you remove a person who has received an electric shock from an electric appliance?  
(NCVT 1966 Elect.)
- 1.3 Name and explain the use of five important hand tools used by an electrician giving their sizes, care and maintenance.
- 1.4 Draw any 15 general symbols used in electrical circuit from the following:  
1. Alternating current; 2. Neutral; 3. Three phase; 4. Earth; 5. Intermediate switch; 6. Variable resistance; 7. Coil; 8. Fixed condenser; 9. Cell; 10. Battery; 11. Energy meter—single phase; 12. Compound motor; 13. Single-phase alternator; 14. Three-phase slipring motor; 15. Transformer; 16. Metal plate rectifier (full-wave); 17. Star connection; 18. Rotary converter.
- 1.5 Draw any 15 symbols according to I.S.I. from the following:  
1. Main fuse board with switches (light); 2. Distribution fuse board with switches (power); 3. Main switch (light); 4. Meter; 5. Light bracket; 6. Bulk-head fitting; 7. Pull switch; 8. Socket outlet switch combined, 3 pin, 15A; 9. Electric heater unit; 10. Immersion heater with thermostat; 11. Exhaust fan; 12. Fan regulator; 13. Bell push; 14. Bell connected to fire alarm; 15. Relay; 16. Earth plate; 17. Pilot lamp; 18. Siren.
- 1.6 (a) Explain in brief the action you will take in restoring a person who has suffered from an electric shock and is unconscious.  
(b) Make out a list of safety equipments that should be available with an electrician/wireman working on a line electrical installation.  
(NCVT 1984 W/man)
- 1.7 What type of fire extinguisher will you use to extinguish fire due to (i) Electric short circuit (ii) High temperature in an oil reservoir.

(All India Skill Competition 1985)

## 2

# Wires, Cables and General Electrical Accessories

### 2.1 CONDUCTOR

A substance which offers low resistance to the flow of electric current is called a conductor. Almost all pure metals are good conductors of electricity. Some important conductors in the order of their conducting ability are: silver, copper, aluminium, brass, zinc, nickel, iron, tin, lead, german silver, manganese, eureka, nichrome, tungsten and mercury.

### 2.2 PROPERTIES OF A GOOD CONDUCTOR

The following are the properties of a good conductor:

- (i) It should be of low cost.
- (ii) It should be easily available in the market.
- (iii) It should have sufficient tensile strength.
- (iv) Its joint should easily be made and soldered.
- (v) It should have sufficient mechanical strength.
- (vi) It should not be much affected by changing atmospheric conditions.
- (vii) It should have high conductivity and low specific resistance to keep the electrical losses as low as possible.
- (viii) It should have flexibility.

### 2.3 CLASSIFICATION OF CONDUCTORS

Conductors can be classified as under:

- (i) Bare conductors, and
- (ii) Insulated conductors.

**Bare Conductors** Conductors which are not covered with insulation are known as bare conductors. They are used in overhead lines for transmission and distribution.

**Insulated Conductors** Conductors which are covered with insulation are called insulated

conductors. They are used for indoor wiring installations and underground distribution systems.

### 2.4 COMMON CONDUCTORS—THEIR PROPERTIES AND USES

The following are the best conductors of electricity.

(i) **Silver** Silver is the best conductor and has very low specific resistance. This metal is very costly and its general use in industry is limited. However, it is still used in electrical instruments, relays and contact points of high-current starters. Its conductivity is approximately 98%.

(ii) **Copper** Copper is the next best conductor. It is mostly used for all commercial purposes. Its resistivity is a little higher than silver. Its conductivity is approximately 90% of that of silver. It has all the properties of a good conductor and can be exposed to any weather.

It is generally used in electrical industries as in overhead lines, cables, armature winding, earthing electrodes, contact points of starters, busbars, etc. Nowadays, its use is limited because of its shortage in India and its high cost.

Bare copper conductors are of two types:

- (i) Hard drawn copper conductor, and
- (ii) annealed copper conductor.

**Hard-drawn Copper Conductor** It is used in earthing and overhead lines. Its size varies from 7/0 to 1 to 20 S.W.G.

**Annealed Copper Conductor** The hard-drawn copper conductor is made soft by heating it at a high temperature and then cooling it

slowly. The annealing of copper conductor also depends upon the purity of copper.

Annealed round copper conductors are manufactured from 6 to 50 S.W.G. It is used as winding wires in electrical apparatuses, machines and transformers.

Strips and bars of insulated copper wires are used for winding heavy-duty machines and transformers, for earthing purposes, etc.

(iii) **Aluminium** It has 60% electrical conductivity as compared to that of copper and is light in weight. It is affected by the surrounding atmosphere. Its soldering is somewhat difficult. It can also be made into wires, but they are not as strong as copper wires. To make it strong, a steel wire is used in the centre of the stranded aluminium conductors; the conductor is then known as aluminium cored steel reinforced (A.C.S.R.) conductor. These conductors are used in overhead lines, cables, etc. where its lightness is an advantage in reducing the cost of transmission.

Nowadays aluminium conductors are also used in winding chokes of fluorescent tubes and in the rotor cage winding of a squirrel cage induction motor. It is specially preferred to copper for transmission lines because there is no shortage of it in India. Its sizes are available from 1.5 to 625 mm.

(iv) **Brass** It is a harder alloy of copper and zinc and is used for making terminals of more or less all types of electrical accessories, such as terminals of holders, switches, wall sockets, etc. It is resistant to corrosion. Its conductivity is about 48% as compared to silver.

(v) **Iron and Steel** It has approximately eight times higher resistance than that of copper of the same length and area. It can easily be made into small wires and is used in automobile chassis and electric traction steel rails as a return conductor.

(vi) **G.I. Wire** Iron oxidises easily. To make it resistant to corrosion it is coated with zinc, which is then called galvanised iron (G.I.) wire. It is used for telephone lines and overhead lines as guard wires, stay wires, earth wires, etc.

(vii) **Tungsten** It is a good conductor of electricity and has a high melting point. It is

also made into small wires and is used for making filaments of electric lamps, fluorescent tubes, radio valves, etc.

(viii) **Tin** It has low melting point and is not affected by oxidation. Owing to its low melting point it is used in fuse wires and solder wire in different percentages.

(ix) **Zinc** It is also a good conductor and is used for making containers for dry cells and for galvanizing iron.

(x) **Lead** Its melting point is higher than that of tin and is not affected by the surrounding atmosphere. It is used as a sheathing in lead-covered wires and cables.

(xi) **Mercury** It is a liquid conductor which on heating, evaporates. It is used in mercury vapour lamps, mercury floating switches, mercury arc rectifiers and ferranti-ampere hour meters.

(xii) **Electrolyte** It is also a liquid conductor. Water containing some acid is called an electrolyte. Thus all electrolytes are liquid conductors. Their resistances decrease with a rise in temperature. They are used in primary cells, secondary cells and in vats (i.e. tanks) of electroplating.

(xiii) **Gaseous** There are certain gases which allow current through them, such as helium, argon, neon, etc. At low temperatures, they have high resistance and at comparatively very high temperatures they have less resistance.

## 2.5 SEMI-CONDUCTORS

Semi-conductors are special resistance alloys which offer fairly high resistance to the flow of current. Alloys and carbon have high resistances and they fall in this category. They are very valuable for making standard resistances. The important ones are given below.

(i) **Eureka or Constantan** It is an alloy of 40% nickel and 60% copper. It has very high resistivity and can be easily made into thin wires. It is used for making resistances of fan regulator, starters, etc.

(ii) **German Silver** It is also an alloy of 60% copper, 15% nickel and 25% zinc.

(iii) **Manganin** This material is an alloy of 84% copper, 12% manganese and 4% nickel.

(iv) **Platinoid** Platinoid is an alloy of 64% copper, 15% nickel, 20% zinc and 1% tungsten.

**NOTE** : All these above wires are very costly and have high resistivity. Therefore they are used as standard resistances in some costly instruments.

(v) **Nichrome** It is an alloy of 80% nickel and 20% chromium. Its specific resistance is high. It is made into wires. It is also used for making elements of heating appliances, such as the electric press, heater, electric kettle, furnace, toaster, etc.

(vi) **Kanthal** It is also an alloy of chromium, nickel, iron, etc. It is prepared in different percentages of combination for different purposes. These heating alloys are specially used for heating coils of furnaces, etc.

(vii) **Carbon** It has high specific resistance. Its resistance increases with decrease in temperature and vice versa. It is used for making carbon resistances, brushes of electrical machines, etc.

## 2.6 DIFFERENCE BETWEEN A WIRE AND A CABLE

Any conductor which is composed of a conducting material, and is uniform in diameter and circular in cross-section is called a *wire*. A length of a single insulated conductor (solid or stranded) or two or more such conductors, each provided with its own insulation which are laid up together is called a *cable*. The insulated conductor or conductors may or may not be provided with an overall mechanical, protective covering. In short, any conductor which is provided with insulation is called a cable.

## 2.7 PARTS OF A CABLE

A cable consists of the following three main parts :

- (i) Conductor,
- (ii) insulation covering, and
- (iii) protective covering.

**Conductor** Any pure metal which offers low resistance to the passage of electric current is called a conductor. The current is taken from one place to the other by means of a conductor. Copper is used as a conductor in overhead lines, cables, armature windings, etc. However, due to shortage and nonavailability of copper at low cost, aluminium is also widely used as a conductor in electrical industries.

**Insulation Covering** It is the covering which bounds the current to flow in a definite path. The insulation of the cable must be strong enough because a leakage current will start giving electrical shocks and can cause fire.

The strength of insulation of the insulated cable depends upon dampness, heat and voltage. Damp and heat will reduce the insulation. Also, if the electrical pressure is increased to more than the normal working voltage of the insulated cable, it reduces the strength of the insulation.

**Protective Covering** It protects the insulation covering against any mechanical injury.

## 2.8 CURRENT RATING AND FUSING CURRENT OF CABLE

When a current is passed through a conductor some heat is produced in it. If more and more current is passed, more heat will be produced. This results in melting the conductor of the cable or damaging its insulation. The rise of temperature can be controlled by only controlling the current as the resistance is constant (because heat  $\propto I^2Rt$ ). The maximum value of the current that a conductor can pass safely (without damaging it) at ambient temperature (i.e. room temperature) is called the current rating or current carrying capacity of the conductor. The minimum current at which the conductor melts is known as the fusing current of the conductor. For increasing the life of the conductor and for safe operation, the value of the current passing through the conductor should never be more than its current carrying capacity.

## 2.9 STRANDED CABLE

Electrical energy is supplied from the generating station to the consumer by means of overhead lines or underground cables. The conductor of the cable is of two types :

- (i) Solid conductor, and
- (ii) stranded conductor.

In a solid conductor cable, there is only one conductor. But in a stranded conductor cable, it is made of a number of strands of wires of circular cross-section so that it can become flexible.

The number of strands used in a cable are 3, 7, 19, 37, 61, 91, 127 or 169. These numbers are specifically chosen because they give a circular shape to the conductor of a cable. In a three-strand cable, two strands are twisted around the third strand. Similarly, in the case of seven or more strands the arrangements of the conductor is as given below.

- 7 Strands: Six strands are twisted around a central strand.
- 19 Strands: Seven strands are twisted as above and the rest of the 12 strands in a direction opposite to that of the previous layer.
- 37 Strands: Nineteen strands as above and the remaining 18 strands for the opposite direction.

## 2.10 NECESSITY OF STRANDING CABLES

Cables are stranded to increase the current carrying capacity of the cable. A stranded cable has a larger current carrying capacity as compared to a solid conductor because it has larger heat-radiating and conducting surfaces and therefore allows a higher current for the same temperature.

**Advantages of Stranding Cables** The following are the advantages of stranding cables :

- (i) As there are many conductors in a stranded cable, thin wires can be used which increase the flexibility of the cable.
- (ii) It provides ease in handling during installation and erection work.
- (iii) It facilitates making of joints.
- (iv) If a conductor breaks, there are other conductors to which the current can pass and thus there is no complete break down.
- (v) It provides ease in soldering joints.

## 2.11 CORE OF A CABLE

The core of a cable is single conductor of a cable with its insulation but not including any mechanical protective covering.

**Core Colour** For identification of multi-

core cables having wires of different polarities, the cores are allotted different core colours.

In a three-phase, four-wire system, the three phases 1, 2 and 3 are given the core colours red, yellow and blue respectively. For a neutral wire, the colour of the core insulation is black, while it is green in the case of an earth wire. These core colours should always be kept in mind while connecting conductors of the same colour in multi-core cables.

## 2.12 MEASUREMENT OF SIZE OF CABLE

The size of a cable depends on the size of the conductor. The following are the methods by which the size of a cable or conductor is determined :

- (i) With a standard wire gauge,
- (ii) according to the diameter of the conductor, and
- (iii) according to the cross-sectional area of the conductor.

## 2.13 STANDARD WIRE GAUGE

The standard wire gauge (S.W.G.) is an instrument which is used for determining the size of a cable. The wire gauge commonly used in India is the British standard wire gauge. It consists of a thin circular plate of steel with a number of slots on its circumference as shown in Fig. 2.1. Each slot is marked with different numbers. Holes are provided at the end of each slot for removing the wires easily.

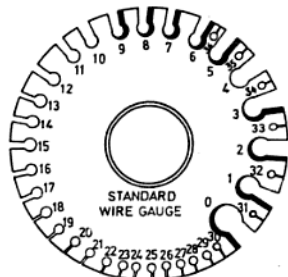

Fig. 2.1 Standard wire gauge (S.W.G.)

For determining the gauge of a wire, a particular slot is found by trial. The slot in which the wire just slides is the slot of the gauge and the number marked opposite to the slot is the required gauge of the wire in S.W.G. Now suppose a wire just slides in slot No. 22 and does not slide in slot No. 23. Then the gauge of the wire is said to be 22 S.W.G. The smallest gauge number is 40 with a diameter of 0.0048" and the largest is 0,000,000 (known as seven-zero) and written as 7/0 with a diameter of 0.5".

It should be kept in mind that as the number of S.W.G. increases, the diameter of the wire decreases.

The conductor used in a cable is either of copper or aluminium. The size of a copper conductor is found by any one of the above three mentioned methods. However, the size of a conductor of an aluminium cable is not measured in S.W.G. It is either measured according to the cross-sectional area in  $\text{mm}^2$  or by the number and diameter of wires.

If a stranded cable is of 3/22, it means that the conductor is made of copper and there are three strands in a cable each of 22 S.W.G. Similarly, if a conductor of aluminium cable has a cross-sectional area of  $25 \text{ mm}^2$ , it can have a 7/2.24 stranded conductor. This shows that there are seven strands in a cable and each strand has a cross-sectional area of  $4 \text{ mm}^2$ .

#### 2.14 TYPES OF CABLES

The following cables are used for different types of wiring installation :

- (i) V.I.R. (vulcanized insulation rubber) cable,
- (ii) C.T.S. (cab tyre sheathed) cable,
- (iii) P.V.C. (polyvinyl chloride) cable,
- (iv) lead-sheathed cable,
- (v) weather-proof cable,
- (vi) tropodure cable, and
- (vii) flexible cable.

**Vulcanized Insulation Rubber (V.I.R) Cable**  
This cable is also known as V.R.I. cable (vulcanised rubber insulation cable). In this cable tinned copper or aluminium conductors are used. The conductor is insulated with vulcanized rubber. It is then covered with cotton tape and finally finished with compounded braiding. This cable is available in single core only. It is used in casing capping,

ing, conduits and temporary light wirings. The sizes available in copper conductors are 1/18, 3/22, 3/20, 7/22, 7/20, 7/18, 7/17, 7/16, 19/18, 19/17, 19/16, etc. Similarly, in aluminium conductors its sizes are given in  $\text{mm}^2$  as 1/1.40 ( $1.5 \text{ mm}^2$ ), 1/1.80 ( $2.5 \text{ mm}^2$ ), 1/2.24 ( $4 \text{ mm}^2$ ), 1/2.80 ( $6 \text{ mm}^2$ ), 1/3.55 ( $10 \text{ mm}^2$ ), 7/1.70 ( $16 \text{ mm}^2$ ), 7/2.24 ( $25 \text{ mm}^2$ ), 7/2.50 ( $35 \text{ mm}^2$ ), 7/3.00 ( $50 \text{ mm}^2$ ), etc.

**Cab Tyre Sheathed (C.T.S.) Cable** This cable is also known as T.R.S. (tough rubber sheathed) cable. The conductors are insulated with vulcanized rubber insulation but the protective covering used on the cable is a sheath of tough rubber compound. The cables are resistant to moisture and are used at damp places. These cables are available in 1, 2, 3 and 2 core with earth continuity conductors. These cables are available in the same sizes as those of V.I.R. cables.

**Poly Vinyl Chloride (P.V.C.) Cable** The conductor of this cable is covered with polyvinyl chloride insulation and serves both the purposes of insulation covering and mechanical protective covering. It is a very hard and tough synthetic chemical substance and resists the action of acid alkali and atmospheric variations in temperature. Its use is restricted where there is a possibility of the temperature being very high as it softens (being thermoplastic) and at low temperatures where it becomes brittle. This cable has now replaced the C.T.S. cable.

In this cable aluminium or copper conductors (without tinning) are used because the P.V.C. insulation itself is very hard. Therefore, there is no need of adding sulphur to it for making it hard. It is used for indoor wiring and panel wiring and is available in the same sizes as the V.I.R. cable.

**Lead Sheathed Cable** These cables are also insulated with vulcanized rubber insulation. However, the protective covering employed on these cables is the metallic lead sheathing. These cables are manufactured in 1, 2, 3 and 2 core with earth continuity conductors. As these cables are very costly, they are not used for house wiring. However, they are used in open places for short-distance overhead lines, service lines and also for indoor wiring in chemical plants. Its sizes are the same as that of V.I.R. cables.

**Weather-proof Cable** The conductors of weather-proof cables are also insulated with vulcanised rubber which is covered with empire tape to make it non-absorptive of moisture. It is then again covered with a braiding of cotton thread. To make the cable insulation more effective against the atmospheric moisture, this braiding is dipped in a waterproof compound. All the above mentioned cables are available in rolls of hundred metres or yards. They are also available in the same sizes as those of V.I.R. cables.

**Tropodure Cable** Tropodure is the trade mark for thermoplastic compounds on a polyvinyl chloride basis. This insulation is harder than the P.V.C. insulation. It is employed on conductors both as an insulation and as a sheathing. These cables are suitable for lighting, power installation as well as railway signalling. They can also be laid in water and used as submarine cables or buried directly in the ground. They are also available in aluminium and copper conductors of 1, 2, 3, 3½ and 4 cores.

**Flexible Cord** These flexible cords consists of two separately insulated flexible stranded conductors of a thin copper conductor of 36 S.W.G. The insulation used on these wires is also vulcanized rubber but the protective covering used is either silk or cotton. These cords are used for domestic, portable appliances, such as table fans, table lamps, electric

irons, heaters, refrigerators, etc. They must be durable and very flexible. Flexibility is required because of the handling of portable equipment and to prevent the wires from breaking. The following are different types of flexible cords :

- (i) P.V.C. flexible cord,
- (ii) cotton or silk-covered flexible cord, and
- (iii) workshop flexible cord.

The first two cords are used for light-duty and the third one for heavy-duty work. These cords are available in two and three cores. The sizes and current rating of copper conductor flexible cords are given in Table 2.1.

### 2.15 NECESSITY OF TINNING

There is an insulation covering of rubber on copper conductors. However, rubber in the pure form is not tough. Therefore, to make it tough and hard, 5% sulphur is added in the rubber. This sulphur in the rubber reacts with the untinned copper, thus forming copper sulphate which destroys the conductor. Tinning on the copper conductor prevents the conductor from reacting with the sulphur. It also prevents the rubber to stick to the conductor.

### 2.16 VOLTAGE GRADE OF CABLE

By grading means the working voltage of the cable. The thickness of the rubber insulation covering of the cable depends upon the voltage at which a cable is to work. Therefore, cables are manufactured in two different

TABLE 2.1 SIZES AND CURRENT RATING OF COPPER CONDUCTOR FLEXIBLE CORDS

Nominal area	Size of Conductor		Current rating	
		Number and diameter of wire		Twin, 3 core, 4 core (subject to voltage drop)
in. <sup>2</sup>	mm <sup>2</sup>	in.	mm	A
0.0006	—	14/0.0076	14/0.193	3
—	0.5	16/0.00787	16/0.200	3
0.001	—	23/0.0076	23/0.193	6
—	0.75	24/0.00787	24/0.200	6
—	1.00	32/0.00787	32/0.200	10
0.0017	—	40/0.00787	40/0.193	13
—	1.5	48/0.0076	48/0.200	15
0.003	—	70/0.0076	70/0.193	18
—	2.5	80/0.00787	80/0.200	20
0.0048	—	110/0.0076	110/0.193	24
—	4.0	128/0.00787	128/0.200	25
0.007	—	162/0.0076	162/0.200	31

grades, namely 230/400 V and 650/1100 V grades. The 230/400 V grade cables are used for domestic, power wiring installation and 650/1100 V grade cables are used for industrial power wiring. The insulation on the wire of grade 650/1100 V is comparatively thicker than the 230/400 V grade cable (as the working voltage is higher in the former).

### 2.17 SELECTION OF CABLE FOR WIRING INSTALLATION

The following points should be considered while selecting a cable for a wiring installation:

(i) **Effect of Atmosphere** The insulation of cable should not be affected by the surrounding atmosphere condition. For example, a weather-proof cable is used for open places, a Tropodure cable is used for oil mills and a

lead-covered cable is used in chemical plants as the acid fumes can destroy the insulation of other cables.

(ii) **Maximum Voltage of the Circuit** The grading of the cable should be equal to the maximum working voltage of the circuit.

(iii) **Full Load Current of the Circuit** The current rating of the cable must be at least such that it can pass the full load current of the circuit. Table 2.2 gives the current carrying capacity of V.I.R and P.V.C insulated cables.

### 2.18 INSULATION AND PROTECTIVE COVERING OF DIFFERENT CABLES ALONG WITH THEIR USES

Table 2.3 gives a summary chart of insulation and protective covering of different cables along with their uses.

TABLE 2.2 CURRENT CARRYING CAPACITY OF V.I.R AND P.V.C. INSULATED CABLES

Sl. No.	Stranded copper conductor		Stranded aluminium conductor		Current rating of two single core cable in amperes
	Strand (in)	Area (in <sup>2</sup> )	Strand (mm)	Area (mm <sup>2</sup> )	
1	2	3	4	5	6
1.	1/0.044 (1/18)	0.0015	—	—	5
2.	3/0.029 (3/22)	0.002	1/1.40	1.5	10
3.	3/0.036 (3/20)	0.023	1/1.80	2.5	15
4.	7/0.029 (7/22)	0.0045	—	—	20
5.	—	—	1/2.24	4	20
6.	—	—	1/2.80	6	27
7.	7/0.036 (7/20)	0.007	—	—	28
8.	—	—	1/3.55	10	34
9.	7/0.044 (7/18)	0.01	—	—	36
10.	7/0.052 (7/17)	0.0145	7/1.70	16	43
11.	7/0.064 (7/16)	0.0225	—	—	53
12.	—	—	7/2.24	25	59
13.	19/0.044 (19/18)	0.03	—	—	62
14.	—	—	7/2.50	35	69
15.	19/0.052 (19/17)	0.04	—	—	74
16.	—	—	7/3.00 or 19/1.80	50	91
17.	19/0.064 (19/16)	0.06	—	—	97
18.	19/0.072 (19/15)	0.075	—	—	123
19.	—	—	19/2.24	70	134
20.	—	—	19/2.50	95	153
21.	19/0.083 (19/14)	0.1	—	—	160
22.	37/0.064 (37/16)	0.12	—	—	177
23.	—	—	37/2.06	120	184
24.	37/0.072 (37/15)	0.15	—	—	205
25.	—	—	37/2.24	150	210

(contd.)

Table .2.(Contd.)

1	2	3	4	5	6
26.	—	—	37/2.50	185	246
27.	37/0.083	0.2	—	—	250
28.	—	—	37/2.80	225	290
29.	37/0.093	0.25	—	—	295
30.	37/0.103	0.3	—	—	335
31.	—	—	61/2.50	300	354
32.	61/0.093	0.4	—	—	425
33.	—	—	61/3.00	400	435
34.	61/0.103	0.5	91/2.65	500	480
35.	—	—	91/3.00	625	565
36.	91/0.103	0.75	—	—	610
37.	127/0.103	1.0	—	—	740

TABLE 2.3 INSULATION AND PROTECTIVE COVERING OF DIFFERENT CABLES

Sl. No.	Types of cable	Insulation covering	Protective covering	Uses
1.	V.I.R. cable	Vulcanized insulation rubber (i.e. V.I.R)	Compounded cotton braiding	Used for general electrification casing capping, conduit and cleat wiring.
2.	C.T.S. cable	Vulcanised insulation rubber	Cab tyre Sheath	Does not absorb moisture; used in teak wood batten wiring, etc.
3.	P.V.C. cable	P.V.C.	Nil	Suitable for general wiring and teak wood batten wiring.
4.	Lead-covered cable	Vulcanized insulation rubber	Lead sheathing	Used at open places for short distances, like service lines, indoor wiring of chemical plants, etc.
5.	Weather-proof cable	V.I.R.	Water-proof coverings of empire tape, cotton braiding compounded with moisture-resistant insulating material	Used at damp places and for short-distance service lines.
6.	P.V.C. flexible cord	V.I.R.	Nil	Used with domestic portable appliances like table lamp, table fan etc.
7.	Cotton covered flexible cable	V.I.R.	Cotton braiding	Suitable for electric press, heater, soldering iron, refrigerator, etc.
8.	Workshop flexible cord	V.I.R.	Tough rubber	Used with heavy duty portable electrical machines like drill machine, portable grinder, etc.

(Contd.)

Sl. No.	Types of cable	Insulation covering	Protective covering	Uses
9.	Tropodure cable	P.V.C	Tropodure thermo-plastic compound	Suitable for lighting power, railway signalling and can be buried directly in ground. Special cable of this type can also be used for submarine purposes.
10.	Armoured cable	Impregnated cable	Lead sheath, galvanized steel, tape and jute coated with tar and chattered compound	Used in under-ground systems for distribution purposes, etc.

### 2.19 SOLDERING

Soldering is the act of uniting two pieces of similar or dissimilar metals by an alloy called *solder*, the melting point of which is lower than that of the metal to be united. When two surfaces of the metal are soldered together, the solder penetrates the pores of the metal and thus makes a firm grip with permanent electrical continuity and strength.

### 2.20 SOLDER

In electrical engineering, solder is an alloy of tin and lead in different proportions for different purposes. Sometimes, other metals are also added to lower the melting point. There are two classes of solder: soft solder and hard solder. However, for electrical jobs only soft solder is generally used and the compositions of this solder for different purposes are given in Table 2.4.

### 2.20 NECESSITY OF SOLDERING

In order to make the joint 95% mechanically strong and 100% electrically continuous, it is necessary to solder a joint.

### 2.21 FLUX

When a metal is heated in free air, it is immediately affected by oxygen. A layer of oxide is formed over the surface which is a hindrance during soldering. This layer of oxygen can be removed with chemical compounds called fluxes. They are deoxidizing agents and are used to keep the surface clean from oxide, increase the fluidity of the solder and help the joint to adhere perfectly. The melting temperature of the flux is always less than that of the solder used. The flux must not contain any corrosive substances which react on the metal. Resin is the safest for electrical jobs such as soldering on a commutator, etc. Flux is also available in the form

TABLE 2.4 COMPOSITION OF SOLDER FOR VARIOUS PURPOSES

Types of soft solder	Tin	Lead	Antimony	Melting point	Nature of work
1	2	3	4	5	6
Fine solder	60%	40%	—	190°C	Suitable for radio, T.V and electronics.
Soft solder	50%	50%	—	205°C	Suitable for electrical purposes.
Cheap solder	40%	60%	—	230°C	Suitable for general purposes such as sheet metal works.
(Hard Solder	33%	66%	1%	243°C	For plumber's purposes.

TABLE 2.5 VARIOUS TYPES OF FLUXES

Sl. No.	Metal	Type of flux	Corrosive or noncorrosive
1.	Electrical goods	Resin or fluxite	Noncorrosive
2.	Copper and its alloys	Resin or tallow	Noncorrosive
3.	Aluminium	Aluminium flux, Eyre No. 7	Noncorrosive
4.	Mild Iron sheet	Zinc chloride	Corrosive
5.	G.I. Sheet	Dilute hydrochloric acid	Corrosive

of a paste which is also quite safe to use for electrical jobs. A single flux is not suitable for all metals and hence different kinds of fluxes are used for different purposes as given in Table 2.5.

### 2.22 GENERAL ELECTRICAL ACCESSORIES

These electrical accessories are used in wiring installation. They are of many types according to their function, such as controlling accessories (e.g. switches), safety accessories (e.g. fuses), supply distribution accessories and general accessories. Each electrical accessory is composed of conducting and insulating materials.

**Conducting Material** It is the part of the accessory through which the current passes. It is usually made of copper or brass. Its current rating depends on the maximum current that can flow through it without producing any harm. For example, if a switch is designed for 15 A, it means that we can easily pass 15 A through its conducting material, but on passing higher current than specified, say 15 A, it will be overheated and may burn due to sparking, etc. Thus, the use of a particular accessory is limited only for the current rating specified.

**Insulating Material** It is the substance which binds the current to flow in a definite direction, or in other words, the substance which does not allow the leakage current to flow through. Their rating is considered according to the maximum safe working voltage at which no leakage of current can take place through the insulation. If the rating of the switch is 250 V, it means the insulation can withstand 250 V and there will be no leakage current, but at a higher value of voltage, the current could leak through the insulation. The insulating material that is used

for electrical accessories is either Bakelite or porcelain.

**Main Switches** Double-pole iron-clad (D.P.I.C) main switches with the fuses fitted in iron covers are used for lighting and power wiring installation for a working voltage of 250/500 V. For ac three-phase, four-wire supply systems, triple-pole iron-clad (T.P.I.C) main switches with fuses are used. The working voltage of these main switches is 400/440 V. The current ratings of all the above mentioned switches are 15, 30, 60, 100, 200 and 300 A.

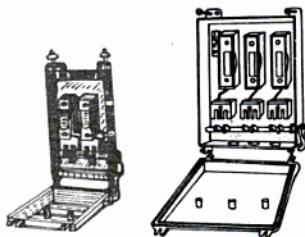

Fig. 2.2 main switches

A double-pole iron-clad switch is so named because it controls two different polarities of supply mains, whereas a triple pole main switch has three different polarities of mains and controls.

**Distribution Busbar Chamber** A busbar chamber consists of heavy thick copper strips insulated from each other and from the enclosed metallic covering chamber (Fig. 2.3). Cable lugs of different distribution fuse boards

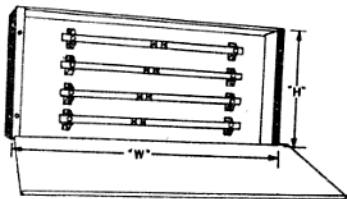

Fig. 2.3 Distribution busbar chamber

are screwed to these busbars. The supply from the main switch is fed direct to these busbars, from where the supply mains are taken to the distribution fuse board.

**Distribution Fuse Board** It consists of a rectangular iron box with a number of carrier-type fuses fitted in it (Fig. 2.4). The number

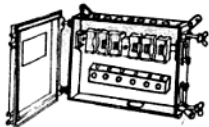

Fig. 2.4 Distribution fuse board

of fuses in it depends upon the number of circuits (or ways) of the wiring to which it is to be installed. The supply from the main switch is given direct to the distribution fuse board in the case of a small distribution of supply, and from there the supply mains are taken independently for each circuit. If there is any fault in any one of the circuits, the other circuit will not be affected. These are available in 2, 4, 6, 8, 10 and 12 ways and are designed for carrying 15, 30, 60, 100, 200 and 300 A.

**Single-Pole (S.P.) One-way Tumbler Switch, 5 A, 250 V** The S.P. one-way switch is made



Fig. 2.5 Single-pole one-way tumbler switch

of Bakelite and in some durable switches its base is made of porcelain (Fig. 2.5). It is used in domestic wiring for controlling the circuit. The single-pole switch is so named because it only controls a single polarity of wire, i.e. phase (live) wire. They are also known by their appearance and shape, i.e. tumbler shape, oblong shape, etc.

**Single-Pole (S.P.) One-way Tumbler Switch 15 A, 250 V** It is bigger in size than the S.P. one-way switch of 5 A, 250 V as it has to pass 15 A of current in the circuit. Its base is made of porcelain and its cover is of Bakelite. It is used to control the current of water heaters, refrigerators, etc. in domestic power wiring.

**Single-pole (S.P.) Two-way Switch 5 A, 250V** It is made of Bakelite and controls a single polarity of the mains but gives two paths for the current to flow. It is generally used in the staircase wiring circuit where a lamp has to be controlled from two different locations.

**Intermediate Switch 5 A, 250 V** It is used in staircase wiring where a bulb is to be controlled from more than two locations. It is made of Bakelite but it is available with a porcelain base and a brass metallic cover.

**Two-Pin Wall Socket 5 A, 250 V** Its cover and base are also made of Bakelite. Two hollow pins of equal size are used in it for providing supply to the table lamp, fan, etc. (Fig. 2.6). It is not generally used nowadays as it has no provision for earth connection. Every socket is controlled by a switch.

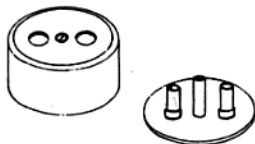

Fig. 2.6 Two-pin wall socket, 5 A, 250 V

**Three-Pin Wall Socket 5 A, 250 V** All portable appliances, such as table fans, radios, etc. are connected to the supply mains by these wall sockets made of Bakelite (Fig. 2.7).

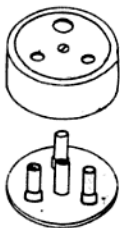

Fig. 2.7 Three-pin wall socket 5 A, 250 V

Sometimes its base is also made of porcelain. It is used in domestic lighting wiring. There are three hollow pins in it. Two pins are of equal size and the third one is longer and thicker than the other two. The two equal pins are connected to the live and neutral wire of the circuit and the third pin is meant for connecting the earth wire.

**Three-Pin Wall Socket 15 A, 250 V** It is bigger in size and similar in construction than the three-pin wall socket of 5 A because it is to pass a higher value of current (say 15 A). It is also called the three-pin power socket. It is used in domestic power circuits for providing supply for heaters, refrigerators, room coolers, etc.

For neat and attractive appearance, all single pole switches and wall sockets are manufactured in flush type also (Fig. 2.8). They are available as given below:

- (i) S.P. one-way flush mounting switch 5 or 15 A, 250 V, and

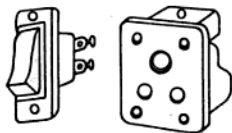

Fig. 2.8 Flush-type switch and wall socket.

- (ii) S.P. two-way flush mounting switch 5 A, 250 V.

They are also known as piano switches or tinned switches. Two or three-pin flush mount-

ing wall socket 5 A, 250 V and three-pin wall socket flush type 15 A, 250 V are also available.

**Push Button Switch** It is also known as the bell push and is used for switching on the electric bell, (Fig. 2.9). It is made of plastic or Bakelite.

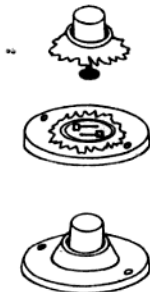

Fig. 2.9 Bell push

**Bed Switch** It is either made of Bakelite or plastic and is used for switching ON and OFF the bed lamp (Fig. 2.10).



Fig. 2.10 Bed switch

**Table Lamp Switch** It is also a type of push button switch which is used to operate the table lamp. It is made of Bakelite.

**Plug Tops** These are made of Bakelite and are used to supply current to various appliances (Fig. 2.11)

The following types are available:

Two-pin plug top      Both these are used  
5 A, 250 V              for feeding supply to

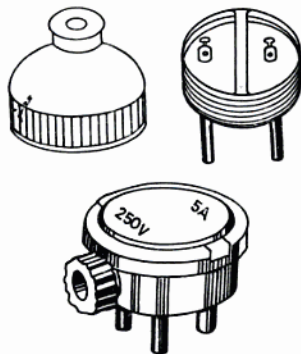

Fig. 2.11 Two- and three-pin plug top

Three-pin plug top 5 A, 250 V the appliances from two- and three-pin lighting wall sockets respectively.

Three-pin plug top 15 A, 250 V It is only meant for the power wall socket.

There are three solid pins in it. Two pins are of equal size and third pin is longer and thicker than the other two. The third pin is connected to the earth wire and the other two are connected to the phase and neutral wire in the socket outlet. While fixing a three pin plug top with a three-core flexible cord, always connect the red wire to the live terminal, black with the neutral and green with the earth terminal. In case there is leakage from the element to the metallic body of the appliance, a heavy current will start to flow through the earth pin. The following are the advantages of keeping the third (earth) pin thicker and longer:

- (i) It does not allow incorrect plugging in the three-pin sockets.
- (ii) It provide sufficient contact area with the hollow pin of the socket which reduces the contact resistance of the earth wire.
- (iii) While inserting in the socket, the longer pin makes contact much earlier

than the other pins. Thus the metallic body of the appliance makes contact with the earth wire before energizing. Similarly, when disconnecting it from the socket, it loses contact last.

**Lamp Holder** It is used to hold the lamp. Earlier brass holders were most commonly used but nowadays these have been replaced by Bakelite-insulated holders. These holders have solid or hollow spring contact terminals. Two types of lamp holders are available :

- (i) Bayonet cap lamp holder, and
- (ii) Edison screw-type cap-lamp holder.

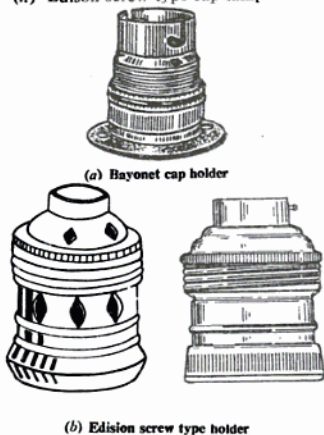

Fig. 2.12 Bayonet cap and screw-type holder

In the bayonet cap lamp holder, the bulb is fitted into the slots provided in the skirt and is held in position by means of two pins in the lamp cap. These lamp holders have two solid or hollow spring contact terminals. The supply mains through the switch are connected to these contacts.

In the Edison screw-type lamp holder, the cap is provided with screw threads and the lamp used also has a screw-type cap. It has a centre contact which is connected to the live wire and the screwed cap is connected to the

neutral wire. These holders are used with those lamps whose wattage exceeds 150 W.

The following types of bayonet lamp holders are available (Fig. 2.13).

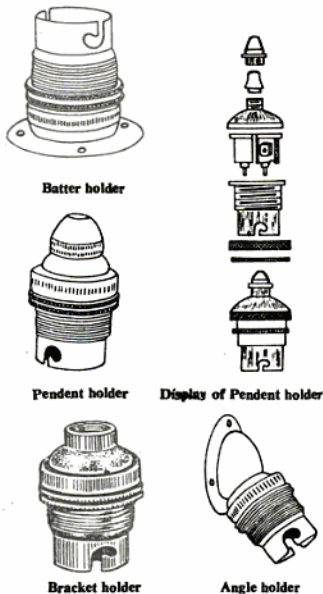

Fig. 2.13 Different types of lamp holders

- (i) batten holder,
- (ii) pendant holder,
- (iii) angle batten holder, and
- (iv) bracket holder.

Bayonet cap lamp holders are used for lamps of wattages below 200 W. For lamps with wattages above 200 W and not exceeding 300 W, Edison screw-type holders are used. Goliath screw-type lamp holders are used in lamps with wattages above 300 W.

**Wall Bracket** There are many types of wall brackets in use and the use of a particular one

depends upon the nature of light required. If a light point is required to be installed at an angle, then an angle-type wall bracket is used (Fig. 2.14). Similarly, if light outlets are to be installed projecting from the wall at angles of  $90^\circ$ , then L-type wall brackets are used. Fancy brackets are used for interior decoration.



Fig. 2.14 Angle wall bracket

**NOTE :** According to Indian Electricity Rules, the height of a lamp from the ground level should not be less than 2.5 m.

**Ceiling Rose** Ceiling roses are used as tapping points from the wiring for supplying power to fans, pendant holders, tube lights, etc. by means of flexibility wires. Their use is restricted to those circuits whose voltage

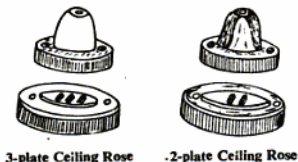

Fig. 2.15 Two- and three-plate ceiling rose

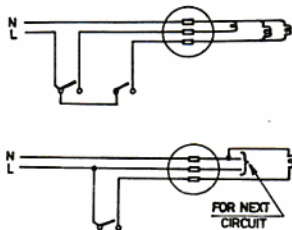

Fig. 2.15 (a): Uses of Ceiling Rose

exceeds 250 V. These are also made of Bakelite. Two types of ceiling roses are in use, namely two-plate and three-plate ceiling roses. The two-plate ceiling rose is used for a single light point, whereas a three-plate ceiling rose is used for a bunch of lights. Its uses are illustrated in Fig. 2.15(a).

**NOTE :** Ceiling fans should be installed at a height not less than 2.75 m from the floor level according to I. E. Rules.

**Porcelain Connectors** These are made of porcelain clay and are of single, two and three ways. These serve as tapping points from electrical installations for supplying power to the circuit and are available in different current carrying capacities: 15, 30, 60 and 100 A.

**Adapter Lamp Holder** It is used for taking supply for small portable appliances from the lamp holder (Fig. 2.16). Its use is generally



Fig. 2.16 Adapter lamp holder

not recommended. It should never be used in damp places such as bathrooms, etc.

**Iron Connectors or Press Connectors** These are used as female connectors to supply current to electric kettles, presses, heaters,



Fig. 2.17 Iron connectors

etc. These connectors are provided with two-pin sockets and an earth connection strip (Fig. 2.17). They are available in flat or round shape with top or side entry for the cable.

**Reflectors and Shades** The main idea of using these shades or reflectors is to give even illumination and prevent direct glare from the filament. Different types of reflectors are available to suit the different types of lamps and illumination required (Fig. 2.18).

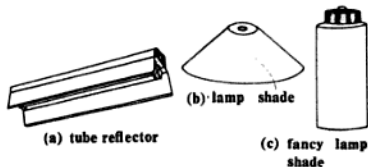

Fig. 2.18 Types of shades and reflectors.

**Lamp Holder of Fluorescent Tube** The fluorescent tube lamp holder are of two types :

- (i) Two-pin, and
- (ii) bayonet cap type.



Fig. 2.19 Fluorescent tube holder

Pin-type holders are generally used with 20 and 40 W tubes; for 80 W tubes, bayonet cap type holders are used as their caps also generally of this type.

**Fuses** A fuse is a safety device which is connected in series to the circuit and protects the appliance or apparatus from possible damage when abnormal current flows through it (Fig. 2.20).

A kit-kat fuse is commonly used in domestic installation for this purpose. It consists of a porcelain base having fixed contacts to which

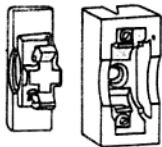

Fig. 2.20 Fuse kit-kat

are connected the incoming and outgoing cables of the live wire. The carrier is also made of porcelain and carries the fuse element. The following are the main advantages of this design.

- (i) It facilitates easy renewal of the fuse wire and does not involve any danger of coming in contact with it.
- (ii) It is very cheap to replace the fuse wire.
- (iii) It does not involve any possibilities of coming in contact with the metallic covering.

It, however, suffers from unreliable operation owing to the use of an incorrect size of the fuse wire and owing to oxidation. These fuses are meant for low rupturing capacity and are not employed for the power circuit.

**Iron-Clad Cut-out** The general practice is not to use semi-enclosed fuse holders unless they are provided with an iron cover. These fuse holders are known as iron-clad cut-outs (Fig. 2.21).

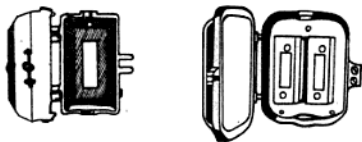

Fig. 2.21 Iron-clad cut-out

## 2.23 INSULATOR

A substance which (at a particular voltage) does not allow the flow of electrons (current) through them is called an *insulator*. For example, some of the good insulators are mica, porcelain, glass, rubber, Bakelite, etc.

In insulators the electrons are closely and strongly bound to the nucleus. There are

very few free electrons in them and the interchange between atoms is little. Therefore, insulators do not conduct any electric current or conduct very little if a very high potential difference is applied across them.

## 2.24 QUALITIES OF INSULATING MATERIALS

The following are the main qualities of good insulating materials which should be considered while selecting a particular one for use :

- (i) It should be flexible.
- (ii) It should have good mechanical strength.
- (iii) It should be nonabsorptive of moisture.
- (iv) It should be easily moulded to any shape.
- (v) It should be noninflammable.
- (vi) It should not be affected by acids or alkalis.
- (vii) It should have high specific resistance to reduce the possibilities of leakage current. It should be capable of working at high temperature because insulators lose their insulating properties as the temperature increases.
- (viii) It should have high dielectric strength, i.e. the value of the voltage at which the breakdown takes place in a plate of insulator 1 mm thick should be high. Dielectric strength of an insulator is measured in kilovolts per millimetre thickness.

The majority of insulating materials available for use in the construction of electrical machines and apparatus have only a few of the above mentioned properties. It is, therefore, the work of the designer to select a particular insulation for the purpose for which it is required.

## 2.25 COMMON INSULATING MATERIALS—THEIR PROPERTIES AND USES

The following are the common insulators which are extensively used in electrical and electronic industries.

**Mica** It is a very good insulator and is widely used as an insulating material in electrical and electronic industries. It has very high specific resistance and dielectric strength. It is fireproof and does not absorb moisture.

Mica is obtained from mines in big solid sheets. Thin sheets can be obtained of thick-

ness 0.0005 in. On account of it being available in thin sheets, it can be rolled and used where the space is limited. Mica starts softening at 1200°C. However, at 600°C it is very stable. Therefore, it can be used as an insulating material where the temperature is not to increase beyond 600°C. In between 600° and 1200°C mica starts disassociating. Therefore, it cannot be used at an insulator beyond 600°C. For temperatures above 600°C it is mixed with shellac or a resin adhesive known as micanite, which can withstand higher temperature. A mixture of mica and adhesive pasted on paper or cloth is known as micanite paper or micanite cloth. Micanite can be bent into any shape when it is heated. Mica is used as an insulator in electric irons, between commutator segments, slot linings for high voltage machines, condensers and for many other electrical and electronics work.

**Rubber** Rubber in the pure form is very soft and to make it tough and hard, 5% sulphur and other mineral materials, such as zinc oxide, red lead and some colour are added to it. It is then known as vulcanized rubber. It does not absorb moisture up to a certain limit and serves as a good insulation and protective covering for conductors for low and medium voltages. It melts easily and can be moulded into any shape. It is flexible, resistant to abrasion, chemicals and the affects of oxygen. It is inflammable but has low conductivity. Therefore, it is used as an insulating material in various electrical appliances, insulation on wires, rubber gloves, hard rubber battery containers, etc.

**Polyvinyl Chloride (P.V.C.)** It is a synthetic chemical substance which is used as a sheathing on insulated cables or flexible cords to form an outer protective covering. This protective covering makes the cable reasonably resistant to decay, mechanical abrasion, acid alkalis and other corrosive materials. It has very good insulating properties and has now superseded the cab-type insulation of the cable. It can be moulded into any shape. It is available in many colours. It does not absorb moisture and is unaffected by oil, grease and acid. P.V.C. has very good insulating properties and nowadays it is replacing rubber for cable insulation.

**Tropodure** It is a hard, tough and excellent insulation like P.V.C. and is not affected by the atmosphere. It does not easily get damaged by mechanical injury. It is used on cables which are subjected to work at damp places, chemical plants and oil factories. Tropodure is the trade mark for the thermoplastic compound on a polyvinyl chloride. This insulation is also employed on submarine cables.

**Ebonite or Vulcanite** It is a good insulator and can be moulded into any shape. It is manufactured by mixing 30 to 50% sulphur with vulcanized rubber and then heating it 3 to 4 h at about 150°C. It is a hard substance and becomes soft at 70°C. It is used for making covers for resistance boxes, containers of lead acid batteries, panel frames, etc.

**Bakelite** It is a synthetic material of brown colour. It can be moulded to make rods, tubes, sheets and to any shape to suit a particular purpose. Its working temperature is higher than ebonite and is not affected by moisture, oil and acid. It is a very good insulating material and is used for making electrical accessories, such as switches, wall sockets, ceiling roses, holders, etc.

**Asbestos** It is a white fibrous material and is incombustible. It is a good conductor of heat. It is manufactured into ropes, tapes, sheets and sleeves. It is used in the form of sheets for lining in ovens, electric irons, kettles, arc shields in circuit breakers, etc.

**Glass** It is a transparent insulator and is not affected by chemical fumes. It can also be moulded into any shape and is brittle. It is nonhygroscopic and can withstand high temperatures. It is used in making the glass bulb of electric lamps, tubes, mercury arc rectifiers, overhead line insulators, etc. It is also used in making glass tapes, sleeves for armature winding, etc.

**Porcelain** It is made from china clay and quartz stone and can be moulded into any shape. It is white or brown in colour and is not as brittle as glass. It is not affected by chemical fumes and the atmosphere. Porcelain is glazed to make it nonabsorptive of moisture. It is used for making low, medium-

and high-tension insulators of overhead lines, bases of switches, kit-kat fuses, holders, transformer bushings, etc.

**Paper** It is hygroscopic, but when treated with insulating oil or wax, it becomes a good insulator. It is cheaper than rubber and has replaced rubber insulation in oil-filled power cables. It is used as a dielectric in condensers and insulating strands of cables.

**Leatheroid or Film Leatheroid** It is a type of tough grey paper, chemically prepared from cotton rags in the form of sheets. It is not influenced by oil and grease. When leatheroid is pasted with an insulating film, it is called a film leatheroid. They are mainly used for insulating slots, bobbins, etc.

**Polyester Milky Film** It is also known as *millinex film*. It is a synthetic product and is used in the armature rewinding of electrical machines. Its sizes are 5, 7, and 10 mils and is available in kilogram rolls.

**Cotton and Silk** They serve as good insulators when varnished. They are used on conductors required for low voltage instrument wires and motor windings.

**Enamelled Insulation** It is an insulation prepared chemically to insulate winding wires. It is cheaper than cotton and silk but is liable to crack with rough handling.

**Insulating Varnish** It is a very good insulator. It is a solution of resinous substances (resin, bitumen, drying oil, etc.) in a solvent. On drying, the solvent evaporates, leaving the "base" which hardens and becomes a varnish film.

**Dry Air** Dry air is also a good insulator but wet air is not. The dry air in between the conductors of overhead lines acts as an insulator.

**Water** It should be noted that water is neither a good conductor nor a good insula-

TABLE 2.6 CLASSIFICATION OF INSULATORS (AS PER IS : 1271-1958)

Sl. No. (1)	Class (2)	Max. safe temp. (3)	Description of insulation (4)
1	V (Formerly 0)	90°C	The insulation of this class consists of materials such as cotton, silk, paper without impregnation, etc.
2	A	105°C	Class A insulation consists of materials such as cotton, silk, paper immersed with oil, etc.
3	E	120°C	The insulation of this class consists of materials of better quality than Class A materials such as leatheroid, paper, empire cloth, fibre, etc.
4	B	130°C	Class B insulation consists of materials such as mica, glass fibre, asbestos, etc.
5	F	155°C	The insulation of this class consists of materials of better quality than Class B insulation, such as glass fibre, mica, asbestos, etc.
6	H	180°C	The insulation of this group consists of materials such as silicone elastomer, and combinations of materials such as mica, glass fibre, asbestos, etc.
7	C	Above 180°C	Class C consists of materials, such as mica, porcelain, glass, quartz, etc.

tor. Water when pure (i.e. free from impurities) is a very poor conductor of electricity. However, when slight impurities are added to water, it becomes a partial conductor. When an acid or salt is added to water, it becomes a good conductor of electricity.

**Gutta Percha** It is a chemical substance and has properties similar to rubber. It becomes soft at about 65°C. It does not absorb moisture even if dipped in water. Therefore, it is used as an insulation for submarine cables and for telegraphic and telephone purposes.

**Shellac** It is a very good insulator. It is a natural product obtained from some varieties of trees in India. It is a main constituent of many insulating varnishes and is dissolved in spirit or alcohol to form shellac varnish.

**Mineral Oil** Mineral oils are excellent insulators when free from moisture. It is a liquid insulator and is incombustible. It reduces sparking. It is used for filling transformer tanks, cable boxes, circuit breakers, starters and in oil-filled paper insulated cables.

**Marble and Slate** They are also nonflammable mineral insulators and do not absorb moisture. They are going out of use nowadays due to the possibility of metallic veins in them.

**Empire Cloth** Empire cloth is an insulating cloth and is used in slot linings, machines, coils, etc. It is resistant to moisture. Tape made from empire cloth is called empire tape and is used on the conductors of the cables that are subjected to work at damp places.

**Wood** Dry wood is an insulator. However, it absorbs moisture and becomes a conductor. Wood when treated with oil or varnish serves as a good insulator for low and medium voltages. Therefore, it is used as wooden poles for overhead lines as cross-arm separators in lead acid batteries, for wiring boards, etc.

## 2.27 CLASSIFICATION OF INSULATING MATERIALS

Insulation may be grouped into recognized classes as given in Table 2.6.

## REVIEW QUESTIONS

- 2.1 Name three types of conductors used in overhead lines and briefly compare them, regarding their use for medium pressure, H.T. and E.H.T. lines.  
(NCVT 1974 W/Man)
- 2.2 What is the difference between a wire and a cable?
- 2.3 What are the conducting materials used in cables for internal house wiring? Briefly explain any five conductors in the order of their conductivity.
- 2.4 Explain any five insulating substances that are extensively used in the electrical industry.
- 2.5 What are the essential properties that an insulator must have which is used in the manufacture of a cable?
- 2.6 Give the difference between conductors and insulators, naming a few common materials used. Explain the use of a few different types of insulators that are commonly used.
- 2.7 (a) Why are cables stranded?  
(b) Describe the use of the following types of wire :  
(i) Vulcanised insulation rubber cables  
(ii) eureka wire,  
(iii) nichrome wire,  
(iv) hard-drawn copper conductor, and  
(v) aluminium conductor.
- 2.8 What is a standard wire gauge? Why is it used? Explain in brief.
- 2.9 What is the term used for comparing the insulation properties of insulating substances. Give the names of six insulating materials that are used in electrical machines. Put them in the order of good to bad insulation strengths.  
(NCVT 1962 Elec 1984 W/man)

# 3

## Nature of Electricity and its Fundamental Laws

### 3.1 NATURE OF ELECTRICITY

Just like heat and light, electricity is also a kind of energy which is not visible but whose presence can be determined from its effects.

### 3.2 TYPES OF ELECTRICITY

Electricity is of two kinds:

- (i) Static electricity, and
- (ii) dynamic electricity.

**Static Electricity** This type of electricity is produced by friction and cannot be taken from one place to another. This kind of electricity cannot be produced in bulk quantities.

The Greek philosopher Thales (about 600 B.C.) observed that when amber (a yellow-brown resin) is rubbed with a piece of silk cloth, it attained the property of attracting small pieces of paper, pith ball, etc. In Greek, amber is known as "elektron". Therefore the agency which produces such a property in amber was first called electricity by Dr. Gilbert in A.D. 1600 and the substances possessing this property were known as electrified substances or charged with electricity. He showed that this property was not peculiar to amber alone; many other substances could also be electrified.

**Dynamic Electricity** Dynamic electricity is also known as current electricity and can easily be taken from the generating station to far-off places by means of wires and cables. This type of electricity is generated in power houses in bulk quantities at high voltages and can be produced by the following methods :

(i) **Electromagnetic Induction** The magnetic effect of electric current is used in generating dynamic electricity in all types of dc and ac generators.

(ii) **Chemical Effect** Current electricity is also generated by means of cells and batteries but cannot be produced in huge quantities.

(iii) **Heating Effect** In a thermocouple (junction of two dissimilar metals) electricity is also produced by heating the junction of it but its value is also very small.

(iv) **Lighting Effect** In solar cells and photo cells, light rays are used for developing current electricity. Now we know that all bodies can be electrified if proper precautions are taken. Substances in their normal state are called neutral substances.

Benjamin Franklin called the charge acquired by the glass rod rubbed with silk as positive and the charge attained by the amber rod rubbed with flannel as negative. Benjamin Franklin also advanced a fluid theory of electricity which stated that the current flowed from the positive to negative terminal of a current source. Unfortunately, he made a wrong assumption regarding the direction of current flow. Franklin's mistake was not discovered until the modern electron theory had been developed and by then it had become a convention to say that current flows from positive to negative.

### 3.3 ELECTRONIC THEORY

The modern electron theory is also called the electronic theory. For understanding this theory let us consider that the complete universe is made of matter and energy. Matter may be defined as any substance which occupies space, possesses weight and can be in any of the three forms : solid, liquid or gaseous. Matter consists of small particles called molecules which still retain the property of that substance. A further sub-division of the molecule results in particles of matter known

as atoms. An atom may be again further sub-divided into its constituents (i.e. electron, proton, etc), arranged in a particular fashion known as atomic structure. The fundamental particles of matter are given below.

**Electrons** These particles possess negative charge and are of negligible weight. The mass of an electron is about  $1/1837$  times that of the mass of a hydrogen atom.

**Protons** These particles have positive charge which is equal to the negative charge of the electron. The mass of the proton is about 1837 times greater than that of the electron.

**Neutrons** These particles are neutral and have no charge.

**Structure of an Atom** An atom consists of a central portion called the nucleus which contains protons and neutrons.

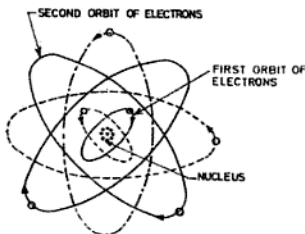

Fig. 3.1 Electrons revolving in orbits

Around this nucleus there are a number of electrons revolving in orbits (Fig. 3.1). The number of electrons present in an atom vary with the atoms of different substances. For example, if the structure of aluminium is examined, it will be found to have a certain specified number of electrons and protons arranged in a definite manner, and if the structure of iron is examined, it will also be found to have electrons and protons but their number will be different and also arranged in a different manner. Under normal conditions, the number of electrons are equal to the number of protons and the atom as a whole is electrically uncharged, i.e. it is neutral.

These revolving electrons rotate on their own axis. They are held to the nucleus by an attractive force between the electrons and the nucleus. Thus the atomic structure of an atom resembles the solar system with the planets revolving on their own axis.

If the atomic structure of an hydrogen atom is examined (Fig. 3.2), it will be found that there is one proton in the nucleus around which a single electron revolves. The nucleus of helium gas consists of two protons and two neutrons around which two electrons revolve. Similarly, if the structure of copper is studied, it will be observed that there are 29 protons and 35 neutrons in the nucleus, and 29 orbital electrons. Therefore, all matter according to this theory is basically the same. Thus all metals, such as silver, aluminium, copper, iron, etc. have electrons and protons but arranged in a different manner. The electrons in the outermost orbits of all pure metals are not strongly bound to the nucleus and are called free electrons. The electrons in the outermost orbits are farther away from the nucleus, and hence the attraction between electrons and protons is less.

The free electrons of an atom can be easily removed by applying a suitable amount of energy. This is what exactly happens when a glass rod is rubbed with a piece of silk cloth. The electrons are passed from the glass rod to the silk due to friction (i.e. heat energy). Thus the glass rod is left with a deficit of electrons and becomes positively charged and the silk which gains electrons becomes negatively charged.

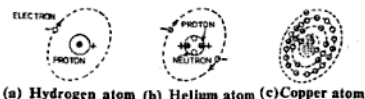

Fig. 3.2

### 3.4 FLOW OF ELECTRIC CURRENT

As discussed earlier in Sec. 3.3, as the electrons in the outermost orbit of all pure metals are not strongly bound to the nucleus; they are called free electrons. These free electrons of metals (conductors) move in a haphazard manner from atom to atom as shown in Fig. 3.3.

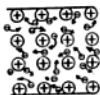

Fig. 3.3 Haphazard movement of electrons in conductor

When a suitable force, i.e. potential difference (P.D.) is applied between the ends *A* and *B* of a conductor, end *A* at positive potential and end *B* at negative potential, as shown in Fig. 3.4, the haphazard movement of electrons assumes steady flow along the conductor. This flow of electrons in one direction in a conductor is called *electric current*.

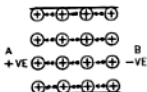

Fig. 3.4 Movement of electrons from -ve to +ve when potential difference is applied

The flow of electrons is from end *B* to end *A* because electrons have negative charge and are attracted by the positive end *A*. The drift of electrons is from negative to positive, i.e. opposite to the conventional direction of current (assumed before the modern electron theory was advanced) which always flows from positive to negative direction (Fig. 3.5).

### 3.5 ELECTRON DRIFT

The steady flow of free electrons under the application of potential difference is known as *electron drift*. The followings are the differ-

ent ways by which free electrons can be made to drift in a circuit.

(i) **By Friction** The free electrons of an atom can be made to drift by means of friction. When a glass rod is rubbed with a piece of silk cloth, the electrons are passed from the glass rod to silk due to friction. Thus the glass rod is left with a deficit of electrons and becomes positively charged and the silk which gains electrons becomes negatively charged.

(ii) **By Heating** If the junction of two dissimilar metals is heated, and a galvanometer is connected in between the two free ends, the needle of the meter deflects. This indicates that the electrons are flowing in the circuit.

(iii) **By Magnetism** If a conductor is moved in a magnetic field, an electric current starts flowing in it. This method is used for producing electricity from dc and ac generators.

(iv) **By Chemical Effect** If copper and zinc plates are immersed in dilute  $H_2SO_4$ , an emf (electromotive force) is induced. On connecting a lamp at the terminals of copper and zinc plates, it will start glowing due to the flow of electrons. This type of electricity is produced from cells and batteries.

### 3.6 ELECTRICAL CIRCUIT

The path taken by electric current to flow through a consuming device shown in Fig. 3.6 is called an *electrical circuit*. It comprises the following parts :

- Sources of supply, such as generators, cells, etc.;
- conducting devices, such as wires, cables etc.;

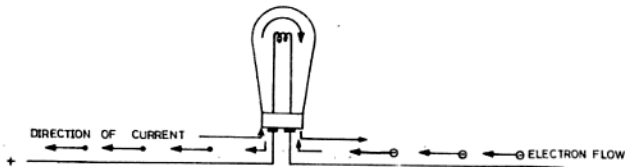

Fig. 3.5 Electron flow and conventional direction of current

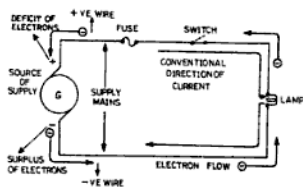

Fig. 3.6 Electrical circuit

- (iii) safety devices, such as fuses etc ;
- (iv) controlling devices, such as switches etc.; and
- (v) consuming devices, such as lamps, heaters, fans, etc.

### 3.7 PATH OF ELECTRIC CURRENT

Figure 3.6 shows the path of current from the source of supply to an electric bulb. From the figure it is clear that the current starts from the dynamo (source of supply), flows to the bulb, and after flowing through the bulb it returns back to the supply source. The wire or conductor through which the current starts from the dynamo to the bulb is called the positive wire, main wire or live wire (in ac it is called the phase wire) and the wire through which the current returns back to the source of supply after passing through the bulb is called the negative wire or return wire (in ac it is called the neutral wire). The two conductors through which the current is taken from the supply source and returns back are known as supply mains. Here we have considered the conventional direction of flow of current but in reality the electronic current always flows from negative to positive (reverse of the conventional current) as discussed earlier in this chapter.

### 3.8 TYPES OF ELECTRIC CIRCUITS

An electric circuit can be divided into four classes as given below.

- (i) Closed circuit,
- (ii) open circuit,
- (iii) short circuit, and
- (iv) earth or leakage circuit.

(i) **Closed Circuit** The complete path for the flow of electric current through the load is called a closed circuit, such as the glowing of

a lamp, heating of a press, etc.

(ii) **Open Circuit** If any one of the supply wires is disconnected or the fuse burns out, then the current will not flow through the bulb. The circuit is then called an open circuit.

(iii) **Short Circuit** If the supply mains are connected directly by a piece of wire without any load, it is called a short circuit. Since in this circuit the value of the current is much greater than in the closed circuit, the fuse gets blown off.

(iv) **Earth or Leakage Circuit** If any wire of supply mains touches the body of an appliance, then it is called earth circuit or leakage circuit.

### 3.9 ANALOGY BETWEEN FLOW OF WATER AND ELECTRIC CURRENT

The flow of electric current is similar to the flow of water. If there are two tanks *A* and *B* containing water, no water will flow from tank *A* to tank *B* unless they are connected through a pipe. Moreover, no water will flow till there is a difference of level between the surfaces of water in the two tanks.

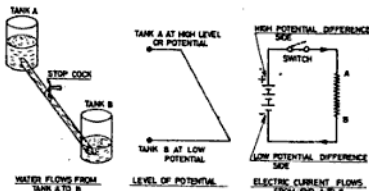

Fig. 3.7 Similarity in flow of water and electric current

In Fig 3.7 two tanks *A* and *B* containing water are shown connected by a pipe. Water will flow from tank *A* containing water at the higher level to tank *B* which is at the lower level. Water flows from tank *A* to tank *B* because the level or pressure at *A* is greater than at *B*. If we want to increase the rate of flow of water from tank *A* to tank *B*, it is necessary to reduce the frictional resistance offered to the flow of water. This can be done

by increasing the diameter of the pipe. A pipe of small length gives less resistance than a pipe of larger length of the same diameter.

The manner in which water flows under these conditions is similar to what occurs in the case of an electric circuit.

Consider an electrical conductor which is nothing but a metal wire by which current is taken from one place to another place just like water is taken through pipes. For electric current to flow from one end of the conductor, say *A* to the other end of conductor *B*, the electrical pressure at *A* must be greater than *B*. The conductor offers some resistance to the flow of current and the difference in pressure between *A* and *B* causes the current to flow against resistance. The bigger the conductor in diameter, the less is the resistance offered to the electric current. The longer the conductor, the greater is the resistance.

### 3.10 DEFINITIONS OF ELECTRICAL TERMS

**Electrical Resistance** The property of a conductor which opposes the flow of electric current through it is known as *resistance*. Its symbol is *R* and its unit of measurement is ohm represented by  $\Omega$  (omega). The instrument that measures resistance is known as an *ohmmeter*. Good conductors have small resistances and insulators have large resistances.

**Conductance** The property of a conductor which conducts the flow of current through it is called *conductance*. In other words, conductance is the reciprocal of resistance. Its symbol is *G* ( $G=1/R$ ) and its unit is mho represented by  $\mathfrak{U}$ . Good conductors have large conductances and insulators have small conductances. Thus if a wire has a resistance of *R*  $\Omega$ , its conductance will be  $1/R \mathfrak{U}$ .

**Electric Current** The flow of (electricity) electrons in one direction along any path or around any circuit is called *electric current*. Its symbol is *I* and its unit is ampere (A). The instrument by which the current is measured is called an ampere meter which is always connected in series with the circuit.

**Electro Motive Force (emf)** The force which causes current to flow in the circuit is called emf. Its symbol is *E* and is measured in

volts (V). It can be calculated as :

$$\text{emf} = \text{voltage at the terminal of source of supply} + \text{voltage drop in the source of supply}$$

$$\text{or emf} = V_r + IR$$

**Electrical Potential Difference (P.D.)** It is the difference of electrical potential (i.e. pressure) between the two points in an electric circuit. It is always less than the emf. Its symbol is *V* and the unit of measurement is volts. The instrument that measures the potential difference is called a voltmeter. It is always connected in parallel with the circuit whose voltage is to be measured.

**Voltage** It is the electrical potential (i.e. pressure) between any two live wires or between one live wire and earth. Its symbol is *V* and the unit of measurement is volts. It is also measured by a voltmeter.

**Voltage Drop** It is the voltage developed across a component or conductor by the flow of current through the resistance (or impedance) of that component or conductors. Its unit is the volt and is measured by a voltmeter.

**Terminal Voltage** It is the voltage available at the terminal of the source of supply. Its symbol is  $V_r$ . Its unit is also the volt and is also measured by a voltmeter. It is given by the emf minus the voltage drop in the source of supply, i.e.

$$V_r = \text{emf} - IR$$

where *I* is the current and *R* the resistance.

### 3.11 CLASSIFICATION OF VOLTAGE

Voltage is classified in the following manners.

- (i) Low voltage: Normally not exceeding 250 V, i.e. from 0 to 250 V
- (ii) Medium voltage: Exceeding 250 V but not exceeding 650 V; i.e. from 250 to 650 V
- (iii) High voltage: Exceeding 650 V but not exceeding 33,000 V
- (iv) Extra high voltage : All voltages above 33,000 V comes under this category.

### 3.12 DIRECT CURRENT

It is the current which always flows in one direction. It is also known as continuous current or unidirectional current. It is denoted

by "dc". This type of current is obtained from a cell, battery, dc generator, dc rectifier, etc. It is used for battery charging, electroplating work, etc.

### 3.13 ALTERNATING CURRENT

Alternating current is that current which alters both in value and direction periodically. It is denoted by "ac". This current increases from zero to the maximum value and then decreases to zero in one direction and again increases from zero to the maximum value and then decreases to zero in the opposite direction.

### 3.14 OHM'S LAW

G.S. Ohm established this law which gives the relation between current, voltage and resistance in a closed electric circuit.

Ohm's law states that in a closed circuit the strength of the current flowing through a solid conductor at constant temperature is directly proportional to the voltage across the conductor and inversely proportional to its resistance.

It is expressed in the form of an equation as:

$$I \propto V \quad (i)$$

$$I \propto \frac{1}{R} \quad (ii)$$

where  $V$  = electrical potential difference in V,  
 $R$  = resistance of the conductor in ohms ( $\Omega$ ).

$I$  = electric current in A.

From Eqs. (i) and (ii), we have

$$I \propto \frac{V}{R}$$

$$\text{or} \quad I = \frac{V}{R} \times K$$

where  $K$  is a constant.

We thus have from ohm's law,

$$I = \frac{V}{R} \text{ A} \quad (3.1)$$

From the above equation, if any two quantities are known, the third can be found:

$$R = \frac{V}{I} \Omega \quad (3.2)$$

$$\text{and} \quad V = IR \text{ V} \quad (3.3)$$

For example, if the voltage applied to a heater coil of  $25 \Omega$  resistance is 250 V, then the current flowing in the coil is given by

$$I = \frac{V}{R} = \frac{250}{25} = 10 \text{ A}$$

Again, to send a current of 10 A through a coil of  $25 \Omega$  resistance, the voltage required is given by

$$V = IR = 10 \times 25 = 250 \text{ V}$$

Once again, if a current of 10 A passes through the coil when the potential difference across the coil is 250 V, then the resistance of coil is given by

$$R = \frac{V}{I} = \frac{250}{10} = 25 \Omega$$

### 3.15 DEFINITIONS OF OHM, AMPERE, AND VOLT WITH THEIR INTERNATIONAL STANDARD DEFINITIONS

**Ohm** It is the unit of resistance. It is defined as that resistance offered by a conductor which will allow one ampere of current to flow if one volt is applied across its terminals.

**International Ohm** It is defined as that resistance offered to an unvarying current (dc) by a column of mercury at the temperature of melting ice (i.e.  $0^\circ\text{C}$ ), 14.4521 g in mass, of constant cross-sectional area (1 sq. mm) and 106.3 cm in length.

**Ampere** It is the unit of current and is defined as that current which is produced by a pressure of one volt in a circuit having a resistance of one ohm.

**International Ampere** One international ampere may be defined as that unvarying current (dc) which when passed through a solution of silver nitrate in water, deposits silver at the rate of 1.118mg per second at the cathode.

**Volt** One volt is that electromotive force (emf) or electrical pressure which produces a current of one ampere in a conductor having a resistance of one ohm.

**International Volt** It is defined as that potential difference which when applied to a conductor whose resistance is one international ohm produces a current of one international ampere. Its value is equal to 1.00049 V.

### Multiples and Submultiples of Volt

1. 1 megavolt (MV) = 1000000 =  $10^6$  V

2. 1 kilovolt (kV) = 1000 =  $10^3$  V  
 3. 1 millivolt (mV) = 1/1000 =  $1/10^3$   
 =  $10^{-3}$  V  
 4. 1 microvolt ( $\mu$ V) = 1/1000000  
 =  $1/10^6$  =  $10^{-6}$  V  
 5. 1 picovolt ( $\mu\mu$ V) = 1/10<sup>12</sup> =  $10^{-12}$  V

### 3.16 QUANTITY OF ELECTRICITY

As the current is measured in terms of the rate of flow of electricity, another unit is necessary to denote the quantity of electricity ( $Q$ ) passing through any part of the circuit in a certain time. This unit is called the coulomb (C). It is denoted by the letter  $Q$ . Thus

$$\text{Quantity of electricity} = \frac{\text{current in amperes} \times \text{time in seconds}}{Q = I \times T C}$$

**Coulomb** It is the quantity of electricity transferred by a current of one ampere in one second. Another name for the above unit is the *ampere-second*. A larger unit of the quantity of electricity is the ampere-hour (A.h) and is obtained when the time unit is in hours:

$$1 \text{ A.h} = 3600 \text{ A.s or } 3600 \text{ C}$$

### 3.17 DIFFERENCE BETWEEN RESISTOR, RHEOSTAT, AND POTENTIAL DIVIDER

**Resistor** A fixed resistance connected permanently in the circuit for limiting the current to a definite value is called a *resistor*. It should be capable of withstanding the temperature developed in it.

**Rheostat** A variable resistance by sliding contact on it is called a *rheostat*. The current flowing through the circuit is controlled by inserting and varying this resistance with the help of a sliding contact.

**Potential Divider** When a resistance is used to develop a voltage drop, it is called a *potential divider*.

**EXAMPLE 3.1** An electric heater takes 10 A when connected across a supply mains of 230 V. Find the resistance of the heating element.

**Solution :** Voltage = 230 V  
 Current = 10 A

$$\text{We know } I = \frac{V}{R}$$

$$\therefore \text{Resistance of element, } R = \frac{V}{I}$$

$$= \frac{230}{10} = 23 \Omega$$

**EXAMPLE 3.2** The maximum resistance of a rheostat is 20  $\Omega$  and minimum value of it is 0.5  $\Omega$ . Find for each conditions the voltage across the rheostat when the current passing through it is 1.2 A.

**Solution :** Minimum value of resistance of rheostat

$$= 0.5 \Omega$$

Maximum value of resistance = 20  $\Omega$

Current passing = 1.2 A

Voltage drop in first case when resistance is minimum,

$$V = I \times R = 1.2 \times 0.5 = 0.6 \text{ V Ans.}$$

Similarly, voltage drop in second case when resistance is maximum,

$$V = I \times R = 1.2 \times 20 = 24 \text{ V Ans.}$$

### 3.18 LAWS OF RESISTANCE

As already discussed in Sec. 3.9, longer the length of the conductor, greater will be the resistance of the conductor, and greater the diameter of the conductor, lower will be the resistance to the flow of electrons and vice versa. It may be also mentioned here that the resistance of each metal is different owing to the difference in atomic structure.

The above facts can be well-summarized to form the laws of resistance as under:

- The resistance of a conductor is directly proportional to the length of the conductor, i.e.  $R \propto L$ . Thus if a 10 S.W.G copper conductor of length 300 m has 1  $\Omega$  resistance, the resistance of the same size of wire 600 m long will be 2  $\Omega$ .
- The resistance of a conductor is inversely proportional to the area of cross-section ( $a$ ), i.e.  $R \propto 1/a$ . If a copper wire of 0.25 cm<sup>2</sup> cross-section and given length, has a resistance of 10  $\Omega$ , the resistance of copper wire of 0.125 cm<sup>2</sup> cross-section and of the same length will be 20  $\Omega$ . In usual round wires it is inversely proportional to the square of the diameter, i.e.  $1/d^2$ .
- The resistance of a conductor depends upon the material. Thus a nichrome wire has about sixty-six times more resistance than a copper wire of the same dimensions.

- (iv) The resistance of a conductor depends upon the temperature. In a pure metal conductor, when the temperature increases the resistance also increases.

From the above, we have

$$R \propto \frac{L}{a}$$

$$\text{or } R = \frac{\rho L}{a} \quad (3.4)$$

where  $\rho$  is constant and is called the specific resistance of the conductor, it depends upon the third law which states that the resistance depends upon the nature of material

$L$  is the length of the conductor in m

$a$  is the area of cross-section in  $\text{cm}^2$

$R$  is the resistance of the conductor in  $\Omega$ .

### 3.19 SPECIFIC RESISTANCE OF A CONDUCTOR

The specific resistance of a material may be defined as the resistance offered to a current if passed between the opposite faces of the unit cube of the material (Fig. 3.8). It is also known as the resistivity of the material.

Specific resistance or resistivity is therefore measured in ohm-centimetre or usually micro-ohm-centimetre. ( $\mu\Omega\text{-cm}$ ). It should be noted that if the specific resistance is in ( $\mu\Omega\text{-cm}$ ) the rest of the units must be changed to cm while solving the problems.

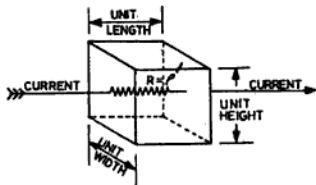

Fig. 3.8 Specific resistance

**EXAMPLE 3.3** If  $10\text{m}$  of Eureka wire  $0.14\text{ cm}$  in diameter has the resistance of  $2.5\ \Omega$ . Find the specific resistance of the material.

**Solution:** Length of wire,  $L = 10\text{ m} = 10 \times 100 = 1000\text{ cm}$   
 Diameter of wire,  $d = 0.14\text{ cm}$   
 Resistance,  $R = 2.5\ \Omega = 2.5 \times 10^6\ \mu\Omega$

Cross-sectional area,

$$a = \pi r^2 = \frac{\pi d^2}{4} = \frac{22 \times (0.14)^2}{7 \times 4}\text{ cm}^2$$

We know,  $R = \frac{\rho L}{a}$

$\therefore$  Specific resistance,

$$\begin{aligned} \rho &= \frac{R \times a}{L} = \frac{2.5 \times 22 \times (0.14)^2}{10 \times 100 \times 7 \times 4}\ \Omega\text{-cm} \\ &= \frac{2.5 \times 22 \times (0.14)^2 \times 10^6}{1000 \times 7 \times 4}\ \mu\ \Omega\text{-cm} \\ &= 38.5\ \mu\Omega\text{-cm}\ \text{Ans.} \end{aligned}$$

### 3.20 VARIATION IN RESISTANCE OF METAL-ALLOY, ELECTROLYTE AND GASES WITH VARIATION IN TEMPERATURE

(i) **Metals** The resistance of all pure metals, such as iron, brass, copper, tungsten, etc. increases with a rise in temperature.

(ii) **Alloys** Alloys are mixtures of metals. Most alloys increase very slightly in resistance with a rise in temperature. Some alloys possess practically constant resistance at all temperatures, such as German silver, eureka (an alloy of 60% copper and 40% nickel) and Manganin (an alloy of 65% copper, 30% ferro-manganese and 5% nickel). They are very valuable for making standard resistances and hence are used extensively with instruments for multipliers and shunts.

(iii) **Electrolyte** The value of resistance of carbon, electrolytes and insulators decreases as temperature increases. Their insulating properties are not as good at high temperatures as at low temperatures, i.e. at high temperatures they become extremely bad insulators.

(iv) **Gases** The gases which are used in some vacuum/tubes or in discharge lamps, such as argon, neon, helium, etc. decrease in resistance with a rise in temperature.

### 3.21 TEMPERATURE COEFFICIENT OF RESISTANCE

In Sec. 3.10 it has been seen that the resistance of a conductor increases with an increase in temperature. However, the resistance does not increase haphazardly but increases according to a linear law.

Suppose a conductor has a resistance of  $R_0\ \Omega$  at  $0^\circ\text{C}$ . Let this resistance be increased by  $R_0\alpha$  per degree celsius rise in temperature.

- ∴ Resistance at  $0^\circ\text{C} = R_0 \Omega$   
 Increase in resistance at  $1^\circ\text{C} = R_0 \alpha \Omega$   
 Total increase in resistance  
 at  $1^\circ\text{C} = \text{resistance at } 0^\circ\text{C} + \text{increase}$   
 at  $1^\circ\text{C} = R_0 + R_0 \alpha \Omega$
- ∴ Total resistance at  $t^\circ\text{C} = R_0 + R_0 \alpha t \Omega$   
 $= R_0(1 + \alpha t)$  (3.5)
- Ratio of increase in resistance per  $^\circ\text{C}$  to the  
 resistance at  $0^\circ\text{C} = \frac{R_0 \alpha}{R_0}$   
 $= \alpha$

where  $\alpha$  is known as the temperature coefficient of the resistance of the material. It can be defined as the ratio of change in resistance of a material per ohm when its temperature is increased per degree celsius from  $0^\circ\text{C}$  to its actual resistance at  $0^\circ\text{C}$ . It can also be simply defined as the change in  $1\Omega$  resistance of a material when its temperature is increased to  $1^\circ\text{C}$  from  $0^\circ\text{C}$ .

The temperature coefficient of resistance is positive for all those substances whose resistances increase with a rise in temperature and negative for substances whose resistances decrease with a rise in temperature.

In most practical cases, the initial temperature of the conductor will not be  $0^\circ\text{C}$ . It will have the same temperature as its surrounding. However, when it is heated owing to the passage of current, its final temperature will be greater. Let  $R_{t_1}$  be the cold resistance at temperature  $t_1^\circ\text{C}$  and  $R_{t_2}$  be the hot resistance at temperature  $t_2^\circ\text{C}$ .

Then, we have

$$R_{t_1} = R_0(1 + \alpha t_1) \quad (i)$$

$$R_{t_2} = R_0(1 + \alpha t_2) \quad (ii)$$

Dividing the above Eq. (ii) by Eq. (i), we have

$$\frac{R_{t_2}}{R_{t_1}} = \frac{R_0(1 + \alpha t_2)}{R_0(1 + \alpha t_1)}$$

$$\frac{R_{t_2}}{R_{t_1}} = \frac{(1 + \alpha t_2)}{(1 + \alpha t_1)}$$

$$\therefore R_{t_2} = \frac{R_{t_1}(1 + \alpha t_2)}{(1 + \alpha t_1)} \quad (3.6)$$

**EXAMPLE 3.4** A copper choke coil has a resistance of  $54.3 \Omega$  at  $20^\circ\text{C}$ . What will be its resistance at  $40^\circ\text{C}$ . The resistance temperature coefficient of copper is  $0.0043$  per  $^\circ\text{C}$  at  $0^\circ\text{C}$ .

**Solution:**  $R_t = R_0(1 + \alpha t)$

$$\therefore \text{At temperature } t_1, R_{t_1} = R_0(1 + \alpha t_1) \quad (i)$$

$$\text{Similarly at temperature } t_2, R_{t_2} = R_0(1 + \alpha t_2) \quad (ii)$$

Dividing Eq. (ii) by Eq. (i), we have

$$\frac{R_{t_2}}{R_{t_1}} = \frac{R_0(1 + \alpha t_2)}{R_0(1 + \alpha t_1)}$$

$$\therefore R_{t_2} = \frac{R_{t_1}(1 + \alpha t_2)}{(1 + \alpha t_1)} = \frac{54.3(1 + 0.0043 \times 40)}{(1 + 0.0043 \times 20)}$$

$$\therefore R_{t_2} = \frac{54.3 \times 1.172}{1.086} = 58.6 \Omega \text{ Ans.}$$

### COMBINATION OF RESISTANCES

Resistances can be connected in three ways as follows:

- Series combination,
- parallel combination, and
- series parallel combination.

**Series Combination of Resistance** If two or more resistances are connected in such a way that there is only one path for the current to flow, it is known as the series combination of resistances. In a series combination, resistances are connected end-to-end, and the beginning of the first and the end of the last are taken as two supply terminals as shown in Fig. 3.9.

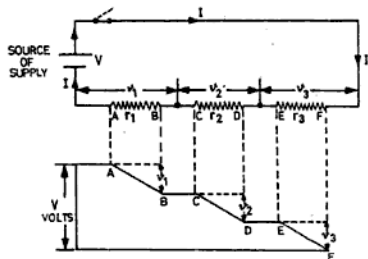

Fig. 3.9 Fall in potential across each resistance

**Current** The current passing through each resistance in a series circuit remains the same as there is only one path for the current to flow.

**Voltage** When current passes through a series circuit there is a drop of voltage in each

sistance. The voltage drops across the resistances are proportional to their individual resistances as the current passing through each of them is the same and is equal to the total current of the circuit. Therefore, the supply voltage is equal to the sum of all the voltage drops across the resistances. Therefore,

$$\text{Voltage drop across resistance, } r_1 = v_1 = Ir_1$$

$$\text{Voltage drop across resistance, } r_2 = v_2 = Ir_2$$

$$\text{Voltage drop across resistance, } r_3 = v_3 = Ir_3$$

where  $I$  is the current flowing in the series circuit.

**Calculation of Total Resistance in Series Combination** Consider the three resistances,  $r_1, r_2, r_3$  connected in series shown in Fig. 3.9. Let the potential difference across all of them be  $V$  which causes the same current  $I$  amperes to flow in each resistance. Now the potential difference across each of them will be different. Let the voltage drops across each resistance be  $v_1, v_2,$  and  $v_3$  V respectively, so that the applied potential difference will be the sum of all the voltage drops, i.e.

$$V = v_1 + v_2 + v_3 \quad (i)$$

By applying ohm's law, we have

$$v_1 = Ir_1$$

$$v_2 = Ir_2$$

$$v_3 = Ir_3$$

Putting these values of  $v_1, v_2$  and  $v_3$  in Eq. (i)

$$V = Ir_1 + Ir_2 + Ir_3 \quad (ii)$$

If  $R$  is the total resistance of the series circuit, then

$$V = IR$$

Putting this value in Eq. (ii), we have

$$IR = Ir_1 + Ir_2 + Ir_3$$

or  $R = r_1 + r_2 + r_3$  ( $I$  being common) (3.7)

Therefore, the total resistance in a series circuit is equal to the sum of the individual resistances.

**Uses of Series Combination** We know that in a series circuit there is only one path for the current to flow, but in an open circuit no current will flow through the circuit. Therefore, series connections are not generally used for house wiring. These connections are used as given below:

- (i) Where a variable voltage is to be given to the load, a variable resistance is connected in series with the load, e.g.

a fan regulator is connected in series with the fan.

- (ii) Where many lamps of low voltage are to be operated on the main supply, they are all connected in series with each other.
- (iii) Where a load of low voltage is to be operated on a higher supply voltage, a fixed value of resistance is connected in series with the load.

**EXAMPLE 3.5** Three resistors 30, 35 and 45  $\Omega$  are connected in series across 220 V mains (Fig. E.3.5). Calculate (i) total resistance of the circuit (ii) current flowing through the circuit.

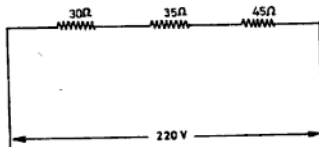

Fig. E.3.5

**Solution:** Total resistance =  $r_1 + r_2 + r_3$   
 $= 30 + 35 + 45$   
 $= 110 \Omega$  Ans.

We know PD across the circuit = 220 V

$\therefore$  Current flowing through circuit,

$$I = \frac{V}{R} = \frac{220}{110} = 2 \text{ A Ans.}$$

As it is a series circuit, the current of 2 A will flow through each resistance.

**EXAMPLE 3.6** A generator supplies 75 A at 220 V through a pair of feeders each having a resistance of 0.15  $\Omega$  (Fig. E.3.6). What is the voltage at the generating station?

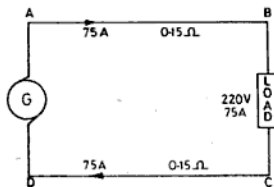

Fig. E.3.6

**Solution:** There is also some voltage drop due to the resistance of the feeder.

By Ohm's Law:  $V = IR$

∴ Voltage drop of feeder in section  $AB$   
 $= 75 \times 0.15 = 11.25 \text{ V}$

Similarly,

Voltage drop of the feeder in section  $CD$   
 $= 75 \times 0.15 = 11.25 \text{ V}$

Total voltage drop in the lead and return feeder  
 $= 11.25 + 11.25 = 22.5 \text{ V}$

∴ Voltage at the generating station  
 $= 220 + 22.5 = 242.5 \text{ V}$  Ans.

**Parallel Combination of Resistances** If two or more than two resistances are connected in such a way that all the entry ends are joined together at one junction and all the exit ends are connected together at another junction and these two junctions are taken as terminals for supply as shown in Fig. 3.10, then such an arrangement is called a parallel combination of resistance.

In a parallel combination there are more than one paths for the current to flow.

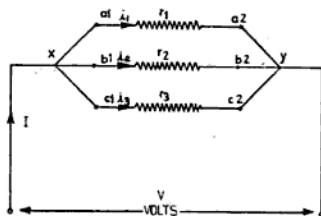

Fig. 3.10 Parallel combination of resistance

**Voltage** In a parallel circuit the voltage across each resistance is the same as each resistance is connected across the supply mains.

**Current** The current flowing through each resistance in a circuit is inversely proportional to the value of individual resistances as the voltage applied at each resistance is same. Hence the greater the resistance, the less will be the current flowing through it.

Current in resistance,  $r_1 = i_1 = \frac{V}{r_1}$

Current in resistance,  $r_2 = i_2 = \frac{V}{r_2}$

Current in resistance,  $r_3 = i_3 = \frac{V}{r_3}$

The line current will be equal to the sum of the current flowing through each resistance, i.e.

$$I = i_1 + i_2 + i_3$$

If equal values of resistances are connected in parallel, equal currents will flow through each resistance and the total current will be the sum of all currents flowing through the circuit.

**Calculation of Total Resistances in Parallel Combination Circuit** Now consider three resistances  $r_1$ ,  $r_2$  and  $r_3$  connected in parallel as shown in Fig. 3.10. Let the potential difference of  $V$  be applied across the two junctions  $x$  and  $y$  so that the potential is the same across each resistance. Let the supply current be  $IA$  and the current flowing through the individual resistance be  $i_1$ ,  $i_2$  and  $i_3$ , i.e.

$$I = i_1 + i_2 + i_3 \quad (i)$$

Applying Ohm's law, we have

$$i_1 = \frac{V}{r_1}$$

$$i_2 = \frac{V}{r_2}$$

$$i_3 = \frac{V}{r_3}$$

Putting these values  $i_1$ ,  $i_2$  and  $i_3$  in Eq. (i),

$$I = \frac{V}{r_1} + \frac{V}{r_2} + \frac{V}{r_3} \quad (ii)$$

If  $R$  is total resistance of the parallel combination circuit, then

$$\text{Total current, } I = \frac{V}{R}$$

Putting the value of  $I$  in Eq. (ii), we have

$$\frac{V}{R} = \frac{V}{r_1} + \frac{V}{r_2} + \frac{V}{r_3}$$

$$\therefore \frac{1}{R} = \frac{1}{r_1} + \frac{1}{r_2} + \frac{1}{r_3}$$

$$(V \text{ being common}) \quad (3.8)$$

The reciprocal resistance  $1/R$  is also known as conductance represented by  $G$  and is measured in mhos ( $\Omega^{-1}$ ).

Therefore, in a parallel circuit, the reciprocal of the total resistance is equal to the reciprocal of the sum of the individual resistances.

**Use of Parallel Connection** Parallel connections are used in all types of house and power wiring because in this connection the working voltage of the load is equal to the supply voltage.

**Equal Resistances in Parallel** If three resistances each equal to  $r \Omega$  are connected in parallel, then

$$\frac{1}{R} = \frac{1}{r} + \frac{1}{r} + \frac{1}{r}$$

$$= \frac{1+1+1}{r} = \frac{3}{r} \text{ } \Omega$$

$$\therefore R = \frac{r}{3}$$

$$= \frac{\text{Value of one resistance}}{\text{No. of resistances connected in parallel}} \quad (3.9)$$

It means that the total resistance will be one-third the resistance of one of them. Hence if  $n$  number of equal resistances are connected in parallel, then

$$\text{Total resistance} = \frac{1}{n} \times \text{resistance of one of them.}$$

**Unequal Resistances in Parallel** If there are only two resistances connected in parallel, then

$$\frac{1}{R} = \frac{1}{r_1} + \frac{1}{r_2}$$

$$= \frac{r_2 + r_1}{r_1 r_2}$$

$$\therefore R = \frac{r_1 r_2}{r_1 + r_2} \quad (3.10)$$

Total resistance =  $\frac{\text{product of two resistances}}{\text{sum of the two resistances}}$

When there are three resistances connected in parallel, then

$$\frac{1}{R} = \frac{1}{r_1} + \frac{1}{r_2} + \frac{1}{r_3}$$

$$= \frac{r_2 r_3 + r_3 r_1 + r_1 r_2}{r_1 r_2 r_3}$$

$$\therefore R = \frac{r_1 r_2 r_3}{r_2 r_3 + r_3 r_1 + r_1 r_2} \quad (3.11)$$

**EXAMPLE 3.7** Three resistances of 6, 10 and 15  $\Omega$  are connected in parallel. Find out the total resistance of the circuit.

**Solution:** We know,

$$\frac{1}{R} = \frac{1}{r_1} + \frac{1}{r_2} + \frac{1}{r_3}$$

$$\frac{1}{R} = \frac{1}{6} + \frac{1}{10} + \frac{1}{15}$$

$$= \frac{5+3+2}{30} = \frac{10}{30} \text{ } \Omega$$

$\therefore$  Equivalent resistance,

$$R = \frac{30}{10} = 3.0 \Omega \text{ Ans.}$$

### Series-Parallel Combination of Resistances

Figure 3.11 shows the arrangement of series-parallel combinations of resistances. In this circuit the current divides itself into two branches as shown in Fig. 3.11.

More complicated circuits of series-parallel combinations are also called *network circuits*. The current and voltage drops of various branches can be more easily calculated with the help of Kirchhoff's laws which are explained in Chapter 9.

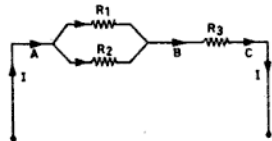

Fig. 3.11 Series parallel combination of resistance

### 3.23 AMMETER

An ammeter is required to measure the current. Therefore, it must be connected in series to the load of which the current is to be measured. As it is connected in series, it must have low resistance, otherwise the resistance of the

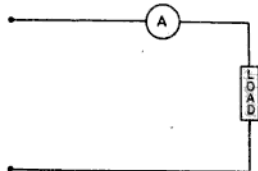

Fig. 3.12 Ammeter in series

instrument will appreciably change the current through the load. For connecting it in series with the load, open the circuit at one place and connect the meter in the circuit as shown in Fig. 3.12.

**NOTE:** An ammeter should never be connected in parallel with the load otherwise it can get damaged.

### 3.24 VOLTMETER

A voltmeter is used to measure the potential difference. Therefore it must be connected in parallel to the circuit of which the potential difference is to be measured. A voltmeter must have high resistance otherwise it will take heavy current. When a voltmeter is connected in series, it measures the voltage drop across its own terminals. For connecting the voltmeter in parallel to the circuit, the meter should be connected across the load resistance as shown in Fig. 3.13.

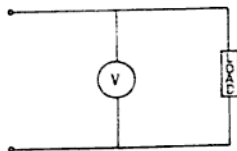

Fig. 3.13 Voltmeter in parallel

**EXAMPLE 3.8** Find the equivalent resistance of the circuit shown in Fig. E3.8. If the current passing through the circuit is 5 A, find the voltage of supply.

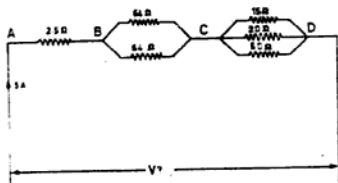

Fig. E 3.8

**Solution:** Equivalent resistance of section BC  

$$= \frac{\text{value of one resistance}}{\text{no. of resistances in parallel}}$$

$$= \frac{6\Omega}{2} = 3\Omega$$

Equivalent resistance of section CD

$$= \frac{r_1 r_2 r_3}{r_1 r_2 + r_2 r_3 + r_1 r_3}$$

$$= \frac{15 \times 20 \times 60}{(15 \times 20) + (20 \times 60) + (60 \times 15)}$$

$$= \frac{15 \times 20 \times 60}{300 + 1200 + 900} = \frac{18000}{2400} = \frac{15}{2} = 7.5\Omega$$

Equivalent resistance of section AD

$$= 2.5 + 3 + 7.5 = 13\Omega$$

∴ Voltage across the circuit = IR

$$= 5 \times 13 = 65\text{ V Ans.}$$

**EXAMPLE 3.9** Calculate the effective resistance of the circuit shown in Fig. E 3.9 and the voltage drops of each resistance when a potential difference of 240 V is applied between AB. Also calculate the current flowing through 2 and 3 Ω resistances connected in parallel in combination.

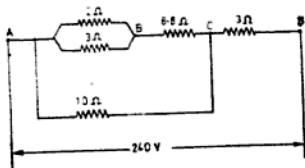

Fig. E 3.9

**Solution:** Equivalent resistance of parallel branch

$$\frac{1}{R} = \frac{1}{r_1} + \frac{1}{r_2} = \frac{1}{2} + \frac{1}{3}$$

$$= \frac{3+2}{6} = \frac{5}{6} \text{ } \square$$

$$\therefore R = \frac{6}{5} = 1.2\Omega$$

Equivalent resistance of section ABC = 1.2 + 8.8 = 10 Ω

$$\frac{1}{R} = \frac{1}{r_1} + \frac{1}{r_2}$$

$$= \frac{1}{10} + \frac{1}{10}$$

$$= \frac{1}{10} + \frac{1}{10} = \frac{2}{10} = \frac{1}{5} \text{ } \square$$

$$\therefore R = 5\Omega$$

Total resistance of section AD = 5 + 3 = 8 Ω Ans.

Total current of the circuit,

$$I = \frac{V}{R} = \frac{240}{8} = 30 \text{ A}$$

Voltage drop across  $3\Omega$  resistance

$$= I \times R = 30 \times 3 = 90 \text{ V Ans.}$$

Voltage drop across section ABC

$$= 240 - 90 = 150 \text{ V Ans.}$$

Current flowing through  $10\Omega$  resistance,

$$I = \frac{V}{R} = 150/10 = 15 \text{ A}$$

Current in  $8.8\Omega$  resistance =  $30 - 15 = 15 \text{ A}$

Voltage drop across  $8.8\Omega$  resistance, Section ABC

$$= I \times R = 15 \times 8.8 = 132 \text{ V Ans.}$$

Voltage drop between section AB =  $150 - 132$

$$= 18 \text{ V Ans.}$$

Current flowing through  $2\Omega$  resistance,

$$I = \frac{V}{R} = \frac{18}{2} = 9 \text{ A Ans.}$$

Similarly current flowing through  $3\Omega$  resistance,

$$I = \frac{V}{R} = \frac{18}{3} = 6 \text{ A Ans.}$$

**EXAMPLE 3.10** Three resistors of  $6, 12$  and  $18\Omega$  are joined in parallel. If the total current taken by the circuit is  $44 \text{ A}$ , find the current through each resistance.

**Solution:** 1st Method In a parallel circuit the current passing through each resistance is different. Greater the resistance, lesser the current flowing through it and the total current is given by

$$I = i_1 + i_2 + i_3$$

The current is shared in the ratio

$$\frac{1}{6} : \frac{1}{12} : \frac{1}{18} = 6 : 3 : 2$$

Total number of shares = 11

Current flowing through  $6\Omega$  resistance

$$= \frac{6 \times 44}{11} = 24 \text{ A Ans.}$$

Current flowing through  $12\Omega$  resistance

$$= \frac{3 \times 44}{11} = 12 \text{ A Ans.}$$

Current in  $18\Omega$  resistance

$$= \frac{2 \times 44}{11} = 8 \text{ A Ans.}$$

2nd Method First find the equivalent resistance of the complete circuit.

$$\therefore \frac{1}{R} = \frac{1}{6} + \frac{1}{12} + \frac{1}{18} = \frac{6 + 3 + 2}{36} = \frac{11}{36} \text{ } \Omega$$

$$\therefore R = \frac{36}{11} \Omega$$

Potential difference across the parallel circuit

$$= I \times R = \frac{36 \times 44}{11} = 144 \text{ V}$$

Applying Ohm's law to each circuit, we have

Current in  $6\Omega$  resistance

$$= \frac{V}{R} = \frac{144}{6} = 24 \text{ A}$$

Current in  $12\Omega$  resistance

$$= \frac{V}{R} = \frac{144}{12} = 12 \text{ A}$$

Current in  $18\Omega$  resistance

$$= \frac{V}{R} = \frac{144}{18} = 8 \text{ A}$$

**EXAMPLE 3.11** In the parallel circuit shown in Fig. E 3.11, the current through the resistor  $x$  is  $2 \text{ A}$  and the total current taken from the supply mains is  $15 \text{ A}$ . Find (i) the value of the unknown resistance  $x$ , (ii) the PD across the circuit, (iii) the current in each resistance, and (iv) the total resistance of the circuit.

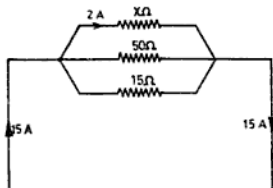

Fig. E 3.11

**Solution:** Let the potential difference across the circuit be  $V$  when the current through  $x\Omega$  resistance is  $2 \text{ A}$ , then:

Voltage acting across the circuit  $V = IR = 2x \text{ V}$

Current through the  $50\Omega$  resistance,

$$i_2 = \frac{2x}{50} = \frac{x}{25} \text{ A}$$

Current in  $15\Omega$  resistance,

$$i_3 = \frac{V}{R} = \frac{2x}{15} \text{ A}$$

Total current of the circuit =  $i_1 + i_2 + i_3$

$$2 + \frac{x}{25} + \frac{2x}{15} = 15$$

$$\frac{x}{25} + \frac{2x}{15} = 15 - 2$$

$$\frac{x}{25} + \frac{2x}{15} = 13$$

$$\frac{3x + 10x}{75} = 975,$$

$$13x = 975$$

$\therefore$  Value of unknown resistance,

$$x = \frac{975}{13} = 75 \Omega \text{ Ans.}$$

∴ P.D. of the circuit,

$$V = 2x = 2 \times 75 = 150 \text{ V Ans.}$$

Current through 50  $\Omega$  resistance,

$$i_2 = \frac{V}{R} = \frac{150}{50} = 3 \text{ A Ans.}$$

Current through 15  $\Omega$  resistance,  $i_3 = \frac{V}{R_3}$

$$= \frac{150}{15} = 10 \text{ A Ans.}$$

For total resistance of the circuit,

$$\frac{1}{R} = \frac{1}{r_1} + \frac{1}{r_2} + \frac{1}{r_3}$$

$$= \frac{1}{75} + \frac{1}{50} + \frac{1}{15}$$

$$= \frac{2 + 3 + 10}{150} = \frac{15}{150}$$

$$\therefore \text{Total resistance, } R_T = \frac{150}{15} = 10 \Omega \text{ Ans.}$$

### 3.25 COMPARISON OF SERIES AND PARALLEL CIRCUITS

A comparison of the two circuits is given in Table 3.1

TABLE 3.1 COMPARISON OF SERIES AND PARALLEL CIRCUITS

S.No.	Series Circuit	Parallel Circuit
1.	There is only one path for the current to flow.	There is more than one path for the current to flow.
2.	Total resistance is equal to the sum of its individual resistances i.e. $R = r_1 + r_2 + r_3 + \dots$	The reciprocal of the total resistance is equal to the reciprocal of the sum of individual resistances, i.e. $\frac{1}{R} = \frac{1}{r_1} + \frac{1}{r_2} + \frac{1}{r_3} + \dots$
3.	The current passing through all the resistances will be the same and equal to the main current.	The current passing through each resistance is different (if not equal). Greater the resistance, lesser the current flowing through it.
4.	The voltage in a series circuit is divided across each resistance according to the value of resistance. Greater the value of resistance, greater will be the voltage drop across it.	The voltage across each resistance is the same.
5.	The total voltage applied is equal to the sum of the voltage drops in individual resistances, i.e. $V = v_1 + v_2 + v_3 + \dots$	The total current of the circuit is equal to the sum of all the currents flowing through various resistances connected in parallel, i.e. $I = i_1 + i_2 + i_3 + \dots$
6.	The total resistance is greater than the greatest resistance connected in the series circuit.	The total resistance is less than the least resistance connected in the parallel circuit.

### NUMERICAL EXERCISES

- The resistance of a 220 V incandescent lamp is 250  $\Omega$ . Calculate the current taken by the lamp. (Ans. 0.88 A)
- The resistance of the motor is 220  $\Omega$  and the maximum current that it can take is 2 A. Find the main supply voltage on which it works effectively. (Ans. 440 V)
- A 670 m long eureka wire has a resistance of 250  $\Omega$ . What length of the same wire will have a resistance of 110  $\Omega$ ? (Ans. 294.8 m)
- A 500 m long wire has a resistance of 20  $\Omega$ . How much must be cut off to reduce its resistance to 12  $\Omega$ ? (Ans. 200 m)
- A cable has a resistance of 10.5  $\Omega$ . What will be the resistance of another cable of the same material twice as long and half the cross-sectional area? (Ans. 42  $\Omega$ )
- A piece of underground cable 100 m long has insulation resistance 500 M $\Omega$ . What is its insulation resistance per km? (Hint : Insulation resistance is inversely proportional to the length of the cable) (Ans. 50 M $\Omega$ )
- A platinum wire 40 m long, 0.04 cm in diameter has a resistance of 35  $\Omega$ . Find the specific resistance of the material. (Ans. 11  $\mu\Omega\text{-cm}$ )

- 3.8 If a piece of a certain wire 35 m long, 0.07 cm in radius has a resistance of 14  $\Omega$ . Find the specific resistance of the material. (Ans. 61.6  $\mu\Omega$ -cm)
- 3.9 Find the resistance of a 450 m long tungsten wire 0.05 cm in diameter. The specific resistance of tungsten is 5.5  $\mu\Omega$ -cm. (Ans. 126  $\Omega$ )
- 3.10 Find the resistance of copper wire 1100 m long and 0.1 cm in diameter. The specific resistance of copper is 1.7  $\mu\Omega$ -cm. (Ans. 23.8  $\Omega$ )
- 3.11 Find the length of a piece of nichrome wire 0.5 mm in diameter which has resistance of 30.52  $\Omega$ . The specific resistance of nichrome wire is 109  $\mu\Omega$ -cm. (Ans. 5.5 m)
- 3.12 The specific resistance of manganin wire is 44.5  $\mu\Omega$ -cm. What is the diameter of manganin wire 154 m long which has a resistance of 44.5  $\Omega$ ? (Ans. 0.14 cm)
- 3.13 The field winding of a motor has a resistance of 30  $\Omega$  at 0°C. What is the resistance at 40°C? The temperature coefficient of resistance of winding wire is 0.0043 per °C at 0°C. (Ans. 35.16  $\Omega$ )
- 3.14 A copper coil has a resistance of 2.43  $\Omega$  at 50°C. Find its resistance at 60°C. The resistance temperature coefficient of copper is 0.0043 per °C at 0°C. (Ans. 2.516  $\Omega$ )
- 3.15 A shunt field coil has a resistance of 21.29  $\Omega$  at 15°C. What will be its resistance at 40°C? The temperature coefficient of copper is 0.0043 per °C at 0°C. (Ans. 23.44  $\Omega$ )
- 3.16 Three resistances 10, 15 and 25  $\Omega$  are connected in series and the potential difference across them is 250 V. Find (i) the total resistance of the circuit, (ii) the main current of the circuit, and (iii) the voltage drop across each resistance. (Ans. (i) 50  $\Omega$ ; (ii) 5 A; (iii) 50 V, 75 V, 125 V)
- 3.17 Calculate the total resistance in each case of the following:
- Resistances 8 and 12  $\Omega$  are joined in parallel. (Ans. 4  $\Omega$ )
  - Resistances 4, 6 and 36  $\Omega$  are joined in parallel. (Ans. 2.25  $\Omega$ )
  - Resistances 4, 6, 8 and 12  $\Omega$  are joined in parallel. (Ans. 1.6  $\Omega$ )
  - Resistances 1.2, 2.4, 4.8 and 9.6  $\Omega$  are joined in parallel. (Ans. 0.64  $\Omega$ )
- 3.18 Find the equivalent resistance in individual cases of the following:
- Resistances 2.5 and 10  $\Omega$  are joined in parallel. (Ans. 2  $\Omega$ )
  - Resistances 3, 9 and 18  $\Omega$  are connected in parallel. (Ans. 2  $\Omega$ )
  - Resistances 8, 12, 16 and 24  $\Omega$  are joined in parallel. (Ans. 3.2  $\Omega$ )
  - Resistances 0.05, 0.25 and 1  $\Omega$  are connected in parallel. (Ans. 0.04  $\Omega$ )
  - Resistances 2.1, 4.2, 12.6 and 25.2  $\Omega$  are connected in parallel. (Ans. 1.2  $\Omega$ )
- 3.19 What resistance must be connected in parallel with one of 8.5  $\Omega$  to give an equivalent resistance of 5.1  $\Omega$ ? (Ans. 12.75  $\Omega$ )
- 3.20 Three resistances connected in parallel have an equivalent resistance of 2.5  $\Omega$ . The value of the first resistance is 15  $\Omega$  and the second 18  $\Omega$ . Calculate the value of the third resistance. (Ans. 3.6  $\Omega$ )
- 3.21 A resistance of 8.55  $\Omega$  is connected in series with another resistance of 12.9  $\Omega$ . What resistance must be placed in parallel to 12.9  $\Omega$  resistance so that the total resistance of the circuit becomes 15  $\Omega$ . (Ans. 12.9  $\Omega$ )
- 3.22 Calculate the equivalent resistance of the circuit shown in Fig. NE 3.22. (Ans. 3  $\Omega$ )

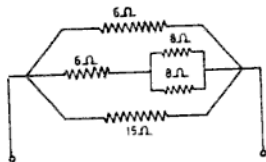

Fig. NE 3.22

- 3.23 Find the total resistance of the circuit shown in Fig. NE 3.23. (Ans.  $5.2 \Omega$ )

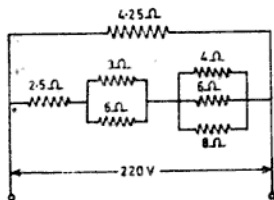

Fig. NE 3.23

- 3.24 Calculate the total resistance of the circuit shown in Fig. NE 3.24. Also find the current taken by the circuit if the applied voltage is 220 V.

(Ans.  $5.5 \Omega$ , 40 A)

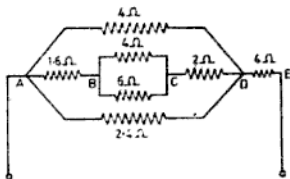

Fig. NE 3.24

- 3.25 Find the equivalent resistance of the circuit shown in Fig. NE 3.25.

(Ans.  $30 \Omega$ )

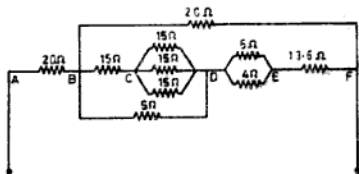

Fig. NE 3.25

- 3.26 Three resistances of 8, 12 and  $24 \Omega$  are connected in parallel. If the total current taken by the circuit is 12 A, find the current through each resistance.

(Ans. 6 A, 4 A, 2 A)

- 3.27 Three resistances 6, 9 and  $18 \Omega$  are connected in parallel and takes a total current of 15 A. Find (i) voltage drop across each resistance and (ii) the current in each resistance.

(Ans. (i) 45 V, (ii) 7.5 A, 5 A, 2.5 A)

- 3.28 Four resistances 2.4, 4.8, 9.6 and 19.2  $\Omega$  are connected in parallel and takes 22.5 A current. Find (i) the voltage drop across each resistance, and (ii) the current passing through each resistance.  
(Ans. (i) 28.8 V, (ii) 12 A, 6 A, 3 A, 1.5 A)
- 3.29 Three resistances 4, 8 and 12  $\Omega$  are connected in parallel. The current flowing through the 12  $\Omega$  resistance is 20 A. Find the current through other resistances and also the total current of the circuit.  
(Ans. 60 A, 30 A, 110 A)
- 3.30 Two resistances of 4 and 16  $\Omega$  are connected in parallel. The group is connected in series with a 19.8  $\Omega$  resistance. Find (i) the total resistance of the circuit, (ii) the total current if the applied voltage of the whole circuit is 230 V, (iii) the current in the parallel branch, and (iv) the voltage across 19.8  $\Omega$  resistance.  
(Ans. 23  $\Omega$ , 10 A, 8 A, 2 A, 198 V)
- 3.31 A factory is supplied by a pair of feeders each 100 m long and 3.54  $\text{cm}^2$  in cross-section and takes 200 A at 440 V. What voltage must be maintained at the sub-station if the specific resistance of the copper feeder is 1.77  $\mu\Omega/\text{cm}$ .  
(Ans. 442 V)
- 3.32 A certain load takes 100 A at 220 V. This load is supplied by a pair of feeders each 625 m long and 1.25  $\text{cm}^2$  in cross-section. Find the voltage at the end of the feeders if the specific resistance of the aluminium feeder is 2.83  $\mu\Omega$ .  
(Ans. 248.3 V)
- 3.33 A certain factory has a miscellaneous parallel load of resistances 4, 8, 10 and 40  $\Omega$  connected across 500 V supply. Find the current taken by the load. If this load is supplied by a pair of feeders each 78 m long having a cross-sectional area of 1.3  $\text{cm}^2$  and specific resistance 1.7  $\mu\Omega/\text{cm}$ , find the voltage at the sending end.  
(Ans. 250 A, 505.1 V)

### REVIEW QUESTIONS

- 3.1 What is an electrical circuit? Explain the essential parts of an electrical circuit along with their functions.
- 3.2 Define "resistance" in an electrical circuit. On what factors does the resistance of a substance depend.  
(NCVT 1966)
- 3.3 State Ohm's law along with the equations derived from it, indicating what each of the symbols used in the equations mean. Give an example showing the use of each of these equations.
- 3.4 Explain the terms "electromotive force", "potential difference" and "voltage drop" in a circuit.
- 3.5 How does the resistance of the following vary with temperature: (a) copper wire, (b) eureka wire, (c) internal resistance of a secondary cell, and (d) carbon.
- 3.6 In a store there are 200 lamps of 2 V each. It is desired that they be operated on 220 V mains. How would you arrange them so that they can give full light? Also, state the number of lamps required for the arrangement.
- 3.7 Three resistances  $r_1$ ,  $r_2$  and  $r_3$  are connected in parallel across a circuit between the terminals of which a potential difference of  $V$  Volts is applied. Deduce an equation giving the value of resistance  $R$  in terms of  $r_1$ ,  $r_2$  and  $r_3$ , which if placed in the circuit would allow the same total current  $I$  ampere to flow.
- 3.8 Distinguish between the following: (a) Series and parallel circuits; (b) resistor and rheostat; (c) electric current and electronic current; (d) voltage and terminal voltage; (e) 1 M $\Omega$  and 1  $\mu\Omega$ ; and (f) alternating current and direct current.
- 3.9 Define and give the units of the following: Current, conductance, specific resistance, temperature, coefficient of resistance and quantity of electricity.

- 3.10 Two resistances  $8 \Omega$  each are connected in parallel and the group is connected in series with a  $21 \Omega$  resistance.
- What will be the total resistance of the circuit?
  - What will be total current of the circuit, if the applied voltage of the whole group is  $100 \text{ V}$ ?
  - What will be the current in each parallel circuit?
  - What will be the voltage as measured across a  $21 \Omega$  resistance? (NCVT 1962 Elect) (Ans. (i)  $25 \Omega$  (ii)  $4 \text{ A}$  (iii)  $2 \text{ A}$  each (iv)  $84 \text{ V}$ )
- 3.11 Calculate the effective resistance of the following combinations of resistances and the voltage drops of each resistance when a potential difference of  $100 \text{ V}$  is applied between  $A$  and  $B$ .
- Total resistance =  $13.3 \Omega$   
 Voltage drop across  $10 \Omega$  resistance =  $75.1 \text{ V}$   
 Voltage drop across  $5 \Omega$  resistance =  $24.9 \text{ V}$   
 Voltage drop across  $7 \Omega$  resistance =  $17.71 \text{ V}$   
 Voltage drop across  $4 \Omega$  resistance =  $7.19 \text{ V}$   
 Voltage drop across  $9 \Omega$  resistance =  $7.19 \text{ V}$

(NCVT 1965 Elect)

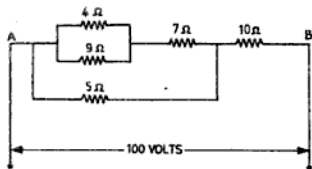

Fig. RQ 3.11

- 3.12 (a) What is the effect of a rise in temperature upon the resistance of a metal?
- (b) What rise in temperature would be necessary to increase the resistance of a conductor from  $50$  to  $51 \Omega$  if the temperature coefficient of resistance of the conductor material is  $0.00268$  per  $^{\circ}\text{C}$  at initial temperature.  
 (NCVT 1972 Elect) (Ans.  $7.46^{\circ}\text{C}$ )
- 3.13 (a) Find the resistance of a copper conductor  $1.5 \text{ km}$  in length and  $6 \text{ mm}$  in diameter. The specific resistance of copper may be taken as  $1.7 \mu\Omega/\text{m}$ .
- (b) If a feeder having two conductors of this length and diameter is used to transmit  $100 \text{ A}$ , what is the voltage drop in the feeder?  
 (NCVT W Cal Elect. 1982) (Ans.  $0.9 \Omega$ ,  $180 \text{ V}$ )
- 3.14 A  $6 \Omega$  resistor and a resistor of unknown value are connected in series to a  $12 \text{ V}$  supply. The P.D. across the  $6 \Omega$  resistor is measured as  $9 \text{ V}$ . What is the value of the unknown resistor?  
 (NCVT Theory W/man Prelim. 1982) (Ans.  $2 \Omega$ )

# 4

## Work, Power and Energy

### 4.1 WORK

Work is said to be done by force  $F$  when the point of its application moves through a distance  $S$ . Mathematically,

$$\begin{aligned}\text{Work} &= \text{force} \times \text{distance} \\ &= F \times S\end{aligned}$$

The unit force in the mks system is newton (N). It is defined as the force acting on one kilogram mass of a body for one second which gives an acceleration of one metre per second.

If in the above equation, force = 1 N and time = 1 m, then

$$\text{Work done} = 1 \text{ N}\cdot\text{m or joule (J)}$$

In the mks system of units, work done is given in joules. It is defined as the work done by a force of one newton when the point of its application moves through a distance of one metre in the direction of the force. Therefore,

$$1 \text{ J} = 1 \text{ N}\cdot\text{m}$$

### 4.2 POWER

Power may be defined as the rate of doing work. In other words, we can say that it is the work done per second. Mathematically,

$$\text{Power} = \frac{\text{work done}}{\text{time}}$$

NOTE: Work done or energy expanded = power  $\times$  time.

If in time  $t$  s a quantity of electricity  $Q$  C is transferred between the ends of a conductor when a potential difference is  $V$  V, then

$$\text{Work done per second} = \frac{VQ}{t} \quad (i)$$

$$\begin{aligned}\text{But} \quad Q &= I \times t \\ \frac{Q}{t} &= I\end{aligned}$$

Substituting the value of  $Q/t$  in Eq. (i), we have

$$\text{Power} = V \times I$$

In the mks system, the unit of power is the watt. It is denoted by the letter W. In electrical engineering one watt is equal to one joule

per second or one newton-metre per second.

$$\begin{aligned}1 \text{ W} &= 1 \text{ J/s} \\ &= 1 \text{ N}\cdot\text{m/s}.\end{aligned}$$

**Watt** It is a unit of electrical power. A watt is equal to the energy expanded per second by an unvarying current of one ampere under the pressure of one volt. It is denoted by the letter W and is measured by an instrument known as wattmeter.

The electrical power or wattage of a machine can be obtained by multiplying the current in amperes by the pressure across the terminals in volts.

$$\begin{aligned}\therefore \text{Wattage} &= \text{voltage} \times \text{current} \\ \text{or} \quad W &= V \times I \quad (4.1)\end{aligned}$$

(Since  $V = I \times R$  by Ohm's law)

Substituting the value of  $V$  in Eq. (4.1), we have

$$W = IR \times I$$

$$\therefore W = I^2 R \quad (4.2)$$

Again, by Ohm's law,

$$I = \frac{V}{R}$$

Therefore, by substituting the value of  $I$  in Eq. (4.1),

$$W = V \times \frac{V}{R}$$

$$\therefore W = \frac{V^2}{R} \quad (4.3)$$

In practice, the watt is a very small unit of power. A bigger unit is the kilowatt kW. The power of electric machines is generally given in this unit.

$$1 \text{ kW} = 1000 \text{ W}$$

Even a bigger unit of power is the megawatt (MW).

$$1 \text{ MW} = 10^6 \text{ W}$$

Also,  $746 \text{ W} = 1$  mechanical horse-power (standard unit of horsepower)

or  $1000 \text{ W} = 1.341 \text{ hp}$

However, the horsepower reading obtained by electrical means is known as the ihp (indicated horsepower) or 'ehp' (electrical horsepower). This is measured in watts.

$$1 \text{ ihp} = 746 \text{ W}$$

The horsepower obtained by mechanical means is called bhp (brake horsepower) measured in ft. lb/min in the British system and is equal to 33000 ft. lb/min (or 550 ft lb/sec).

However the metric unit of horsepower is equal to 4500 kg-m/min (or 75 kg-m/s).

Therefore,

$$1 \text{ metric horsepower} = 75 \text{ kg-m/s} = 75 \times 9.81 = 735.5 \text{ J/s}$$

$$\text{or } 1 \text{ hp (metric)} = 735.5 \text{ W (approx.)}$$

$$\begin{aligned} \text{Again, } 746 \text{ W} &= 1 \text{ mechanical horsepower} \\ &= 33000 \text{ ft. lb/min (or } 550 \text{ ft. lb/sec in the British system)} \\ &= 4500 \text{ kg-m/min (or } 75 \text{ kg-m/s in the mks system)} \end{aligned}$$

**EXAMPLE 4.1** A carbon arc lamp takes 11 A at 55 V.

(i) Find the value of the resistance to be connected in series so that the lamp may give full light across a 220 V supply.

(ii) Calculate the power lost in the resistance. Refer Fig. E 4.1.

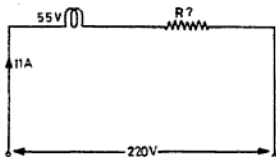

**Solution :**

Voltage drop by resistance connected in series

$$= 220 - 55 = 165 \text{ V}$$

$$\text{Value of resistance, } R = \frac{V}{I} = \frac{165}{11} = 15 \Omega \text{ Ans.}$$

Power lost due to the

$$\text{resistance} = I^2 R$$

$$= (11)^2 \times 15 = 1815 \text{ W Ans.}$$

**EXAMPLE 4.2** Two coils connected in parallel take 6 A from a 300 V supply. The power lost in one coil is

360 W. Find the resistance of each coil. Refer Fig. E 4.2.

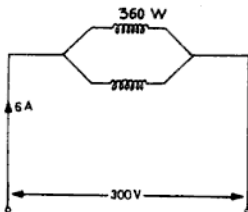

**Solution:** Total resistance of the circuit,

$$\begin{aligned} R &= \frac{V}{I} \\ &= \frac{300}{6} = 50 \Omega \end{aligned}$$

We know,

$$W = \frac{V^2}{R}$$

$$\therefore \text{Resistance of } 360 \text{ W coil, } R = \frac{V^2}{W} = \frac{300 \times 300}{360} = 250 \Omega \text{ Ans}$$

$$\text{In parallel circuit, } \frac{1}{R} = \frac{1}{r_1} + \frac{1}{r_2}$$

$$\begin{aligned} \text{then } \frac{1}{r_2} &= \frac{1}{50} - \frac{1}{250} \\ &= \frac{5-1}{4} = \frac{4}{250} \end{aligned}$$

$$\text{The resistance of second coil, } r_2 = \frac{250}{4} = 62.5 \Omega \text{ Ans.}$$

**EXAMPLE 4.3** A 100 W, 110 V lamp is connected in series with another lamp of 60 W, 110 V across 220 V supply mains. Calculate the value of resistance to be connected in parallel to a 60 W lamp so that the two can take their rating power (Fig. E 4.3).

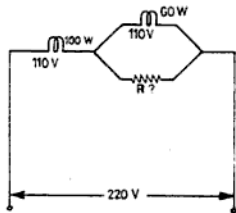

**Solution:** Current taken by 100 W lamp,

$$I = \frac{W}{E}$$

$$= \frac{100}{110} = \frac{10}{11} \text{ A}$$

Similarly, current taken by 60 W lamp,

$$I = \frac{60}{110} = \frac{6}{11} \text{ A}$$

Value of current which will flow through the shunt

$$= \frac{10}{11} - \frac{6}{11}$$

$$= \frac{10 - 6}{11} = \frac{4}{11} \text{ A}$$

$$\therefore \text{Value of shunt, } R = \frac{V}{I} = \frac{110}{4/11} = \frac{110 \times 11}{4}$$

$$= 302.5 \Omega \text{ Ans.}$$

**EXAMPLE 4.4** Two lamps of 100 W each are connected (i) in parallel and (ii) in series to a 220 V supply main. Calculate the power taken in each case.

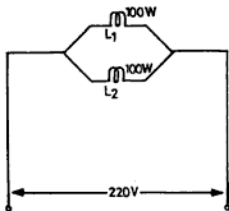

**Solution:** (i) When lamps are connected in parallel Refer Fig. E 4.4 (a).

$$\text{We know, } W = \frac{V^2}{R}, \text{ or } R = \frac{V^2}{W}$$

Resistance of the individual lamp,

$$R = \frac{V^2}{W} = \frac{220 \times 220}{100}$$

$$= 484 \Omega$$

Total resistance of the circuit,

$$R = \frac{\text{value of one resistance}}{\text{no. of resistance in parallel}}$$

$$= \frac{484}{2} = 242 \Omega$$

Current flowing through the circuit,

$$I = \frac{V}{R} = \frac{220}{242} = \frac{10}{11} \text{ A}$$

Total power when lamps connected in parallel,

$$W = I^2 R = \left(\frac{10}{11}\right)^2 \times 242$$

$$= 200 \text{ W Ans.}$$

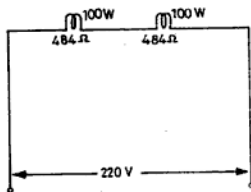

(ii) When lamps are connected in series

Refer Fig E 4.4 (b).

We know resistance of each lamp = 484 Ω

$\therefore$  Total resistance when lamps are connected in series,

$$R = r_1 + r_2$$

$$= 484 + 484 = 968 \Omega$$

Total current flowing in the series circuit,

$$I = \frac{V}{R} = \frac{220}{968} = \frac{55}{242} \text{ A}$$

$\therefore$  Power consumed in series circuit,

$$W = I^2 R = \left(\frac{55}{242}\right)^2 \times 968$$

$$= \frac{55 \times 55 \times 968}{242 \times 242}$$

$$= 50 \text{ W Ans.}$$

**NOTE:** From the above we see that the wattage is always added in the case of a parallel circuit and in this case it is only 100 + 100 = 200 W. However, in the case of a series circuit the wattage remains only one-fourth of that in the parallel circuit. This is because the current and voltage remain only half of that in the parallel circuit. Therefore, while calculating power,  $W (= I^2 R = (I)^2 \times R)$  will be one-fourth as that in the case of the parallel circuit and in this case it will only be 50 W.

Therefore, in the parallel circuit the total power is equal to the sum of individual powers of the circuit, i.e.

$$W_1 = V \times i_1, W_2 = V \times i_2$$

But  $V$  is constant and  $I = i_1 + i_2$

$$\text{Again, } V \times I = W_T$$

$$\therefore W_T = W_1 + W_2$$

**EXAMPLE 4.5** A building is being supplied with power at 220 V. The load consist of 300 lamps of 60 W each and 100 fans of 40 W each. Find: (i) the total load in kilowatts and (ii) the current taken by the load.

**Solution;** Wattage required for 300 lamps, 60 W each =  $300 \times 60 = 18000 \text{ W} = 18 \text{ kW}$   
 Wattage required for 100 fans, 40 W each  
 =  $100 \times 40 = 4000 \text{ W} = 4 \text{ kW}$   
 $\therefore$  Total load in kilowatts =  $18 + 4 = 22 \text{ kW}$ , Ans.  
 Current taken by the load,

$$I = \frac{W}{V} = \frac{22 \times 1000}{220} = 100 \text{ A. Ans.}$$

### 4.3 ENERGY

Joule is the smaller unit of energy. It is the energy used in a circuit when one watt has been absorbed for one second. One joule is therefore equal to one watt second.  
 Watt second or joule = watt  $\times$  time in seconds

$$= \frac{\text{watt-second}}{60 \times 60} \text{ Wh}$$

Again, 1000 Wh = 1 kWh or one unit.

The kilowatt hour (kWh) is a commercial unit of energy. This is the standard unit on which charges for electric energy are made. This practical unit is called the Board of Trade (BOT) unit.

The BOT unit is measured by an energy meter or kilowatt-hour meter. Therefore,  
 1 B.O.T unit = 1 kWh = 1000 Wh  
 = 3,600,000 W/s or J

**EXAMPLE 4.6** The electrical installation in a house is used in the following manner:

- lamps 100 W each, 12 Nos., 6 h a day,
- fan 60 W each, 6 Nos., 5 h day,
- electric cooker 1.5 kW, 2 Nos., 4 h a day, and
- electric geyser 1 kW each, 2 Nos., 3 h a day.

Calculate the total cost of electric energy for 30 days, at the rate of 40 paise per unit for light and fans and 35 paise per unit for the cooker and geyser. Also find the total charges of the bill

**Solution:** Wattage of 12 lamps, 100 W each  
 =  $100 \times 12 = 1200 \times 6 = 7200 \text{ Wh}$

Wattage of 6 fans, 60 W each  
 =  $60 \times 6 = 360 \times 5 = 1800 \text{ Wh}$

Total wattage of lamps and fans  
 =  $7200 + 1800 = 9000 \text{ Wh}$   
 = 9 kWh

Similarly,

Wattage of 2 electric cookers, 1.5 kW each  
 =  $1.5 \times 2 \times 4 = 12 \text{ kWh}$

Wattage of 2 electric geysers, 1 kWh each  
 =  $1 \times 2 \times 3 = 6 \text{ kWh}$

Total kilowatt-hours of cooker and geyser  
 =  $12 + 6 = 18 \text{ kWh}$

Energy charges of lighting load @ 40 paise per unit  
 =  $\frac{9 \times 40 \times 30}{100} = \text{Rs. } 108.00$

Energy charges of power load (i.e., geyser and cooker @ 35 paise unit)

$$= \frac{18 \times 35 \times 30}{100} = \text{Rs. } 189.00$$

Total charges for light and power  
 = Rs. 108.00 + Rs. 189.00  
 = Rs. 297.00 Ans.

**EXAMPLE 4.7** The total resistance of a pair of feeders through which a factory is being supplied power at 250 V is 0.03. The load of the factory is as follows:

- lighting 400 lamps, 100 W each, 200 wall sockets of 60 W each and 100 fans, 40 W each,
- miscellaneous load taking 20 A,
- heating 50 kW furnaces,
- Motors — 50  $\times$  Bhp which run at 80% of full load.

Assume that the lighting load works for a period of 5 h per day, and heating load for 4 h per day, motors 8 h a day miscellaneous load for 2 h per day. Calculate: (i) the total consumption of the factory in kilowatts, (ii) total current taken, (iii) voltage at the sending end of the feeders, (iv) power wasted in the feeders, (v) weekly cost of energy when working six days in a week at the rate of 30 paise per unit for lighting load and 35 paise per unit for power load. The meter rent for lighting load is Rs. 2.00 per metre and for power load it is Rs. 50.00 per metre whereas the electricity tax is 2 paise per unit for lighting load and 3 paise per unit for power load, (vi) Also find the grand total of the bills.

**Solution:**

Lighting load:	Power consumed by loads
(a) Lamps = $400 \times 100 = 40,000 = 40 \text{ kW}$	
Wall sockets = $200 \times 60 = 12,000 = 12 \text{ kW}$	
Fan points = $100 \times 40 = 4,000 = 4 \text{ kW}$	

Total lighting load in kilowatts = 56 kW

(b) Miscellaneous load  

$$\frac{V \times I}{1000} = \frac{250 \times 20}{1000} = 5 \text{ kW}$$

(c) Heating load = 50 kW

(d) Output of the motors at 80% full load  

$$= \frac{50 \times 80 \times 746}{100 \times 1000} = 29.84 \text{ kW}$$

Total load in kilowatt

$$= 56 + 50 + 29.84 + 5 \\ = 140.84 \text{ kW Ans.} \quad (i)$$

Total current taken by factory,

$$I = \frac{W}{V} = \frac{140.84 \times 1000}{250}$$

$$= \frac{14084}{25} = 563.36 \text{ A Ans.} \quad (ii)$$

Voltage drop in the cable  $V = I \times R = 563.36 + 0.03$   
 $= 16.9 \text{ V}$

$\therefore$  Voltage at the sending end of the cable  
 $=$  receiving end voltage + voltage drop in  
 feeders

$$= 250 + 16.9 = 266.9 \text{ V Ans.} \quad (iii)$$

Power wasted in the feeders,

$$W = I^2 R = (563.36)^2 \times 0.03 \\ = 19.52 \text{ kW Ans.} \quad (iv)$$

Energy consumed per day by the lighting load is as

follows:

(i) Lighting load  $= 56 \text{ kW} \times 5 \text{ h} = 280 \text{ kWh}$

(b) Miscellaneous

load  $= 5 \times 2 \text{ h} = 10 \text{ kWh}$

Total energy consumed per day

$$280 + 10 = 290 \text{ kWh}$$

Energy consumed in 6 days

$$= 290 \times 6$$

$$= 1740 \text{ units}$$

Energy charges @ 30 paise per unit

$$= \frac{1740 \times 30}{100} = \text{Rs } 522.00$$

Total lighting load charges including meter rent and  
 electricity tax @ 2 paise per unit

$$= \text{Rs } 522.00 + \text{Rs } 2.00 + \text{Rs } 34.80$$

$$= \text{Rs } 558.80 \text{ Ans.} \quad (iv)$$

Energy consumed per day by Power load

(c) Heating load  $= 50 \text{ kW} \times 4 \text{ h}$

$$= 200 \text{ kWh}$$

(d) Motor load  $= 29.84 \text{ kW} \times 8 \text{ h}$

$$= 238.72 \text{ kWh}$$

Total energy per day

$$= 200 + 238.72 = 438.72 \text{ kWh}$$

Energy consumed in 6 days

$$= 438.72 \times 6 = 2632.32 \text{ units}$$

Energy charges @ 35 paise per unit

$$= \frac{2632.32 \times 35}{100} = \text{Rs } 921.31$$

Total power load charges including meter rent and  
 electricity tax @ 3 paise per unit

$$= \text{Rs } 921.31 + \text{Rs } 50.00$$

$$+ \text{Rs } 78.96$$

$$= \text{Rs } 1,050.27 \text{ Ans.} \quad (v)$$

Grand total of bills  $= \text{Rs } 558.80 + \text{Rs } 1050.27$

$$= 1609.07 \text{ Ans.} \quad (vi)$$

#### 4.4 EFFICIENCY OF CONVERSION

The efficiency of conversion of energy is the ratio of the energy developed in a machine by the energy consumed in driving it and is represented by the Greek letter eta ( $\eta$ ).

Efficiency,  $\eta = \frac{\text{energy developed in a machine}}{\text{energy consumed in a machine}}$

$$\text{or} \quad \eta = \frac{\text{output}}{\text{input}} \quad (4.4)$$

In the case of a motor, the efficiency will be

$$\eta = \frac{\text{Bhp}}{\text{ihp}}$$

$$\eta \% = \frac{\text{Bhp} \times 100}{\text{ihp}} \% \quad (4.5)$$

$$\therefore \text{ihp} = \frac{\text{Bhp} \times 100 \times 746 \text{ W}}{\eta \%}$$

In the case of a generator, the efficiency will be

$$\eta = \frac{\text{ihp}}{\text{Bhp}}$$

$$\text{Then} \quad \eta \% = \frac{\text{ihp} \times 100\%}{\text{Bhp}} \quad (4.6)$$

$\therefore$  Bhp of a dynamo

$$= \frac{\text{ihp} \times 100}{\eta \% \times 4500} \text{ hp in mks system}$$

$$\text{or} \quad = \frac{\text{ihp} \times 100}{\eta \% \times 33000} \text{ hp in British system}$$

**EXAMPLE 4.8** The potential difference at the terminals of 5 hp motor is 250 V. Find the current taken by it when the efficiency of the motor is 80%.

**Solution:** Output of the motor at full load

$$= 5 \times 746 \text{ W}$$

Efficiency of the motor

$$= 80\%$$

$$\text{We know,} \quad \eta \% = \frac{\text{output} \times 100}{\text{input}} \%$$

$$\therefore \text{Input of the motor} = \frac{\text{output} \times 100}{\eta \%}$$

$$= \frac{5 \times 746 \times 100 \text{ W}}{80}$$

$\therefore$  Current taken by the motor,

$$I = \frac{W}{V} = \frac{5 \times 746 \times 100}{80 \times 250} \\ = 18.65 \text{ A Ans.}$$

**EXAMPLE 4.9** A consumer with 30 hp motors is charged at Rs. 24.00 per kWh for the demand load per month plus the energy charged at 35 paise per unit. What will be the amount of his bill in a month when

motors run at 80% of full load for 8 h a day for 25 days in a month. The efficiency of the motor is 96%.

**Solution:** Output of the motors at 80% of full load

$$= \frac{80 \times 30}{100} = 24 \text{ hp}$$

$$\begin{aligned} \text{Input of motor} &= \frac{\text{output} \times 100}{\eta\%} \\ &= \frac{24 \times 100 \times 746}{96 \times 1000} \\ &= 18.65 \text{ kW} \end{aligned}$$

Energy consumed in a month of 25 days, 8 h a day  
 $= 18.65 \times 8 \times 25 \text{ kWh}$

$$\begin{aligned} \text{Energy charges @ 35 paise unit} &= \frac{18.65 \times 8 \times 25 \times 35}{100} \\ &= \text{Rs. } 1305.50 \end{aligned}$$

$$\begin{aligned} \text{Input of motor at demanded (i.e. connected) load} &= \frac{30 \times 100 \times 746}{96 \times 1000} \text{ kW} \end{aligned}$$

$$\begin{aligned} \text{Energy charges at demanded load @ Rs. 24.00 per kWh} &= \frac{30 \times 100 \times 746 \times 24}{96 \times 1000} \\ &= \text{Rs. } 559.50 \\ \therefore \text{Total bill} &= \text{Rs. } 1305.50 + \text{Rs. } 559.50 \\ &= \text{Rs. } 1865.00 \text{ Ans.} \end{aligned}$$

**EXAMPLE 4.10** A house has to be wired up with conduit pipe wiring system for three phase 400 V (50 cycle) ac supply system with the following points:

- light points—50 Nos. of 60 W each,
- fan points—20 Nos. of 100 W each,
- wall plug points—10 Nos. of 60 W each,
- bell points—5 Nos. of 40 W each, and
- power plug points—8 Nos. of 500 W each.

Calculate the following:

- The total load of lights and fans.
- The total load of the power connection.
- The standard size of the main switch required for light and fan connections.
- The standard size of main switch required for power connection.
- Number of circuits proposed to be provided for light and fan connections.
- Number of circuits proposed to be provided for power connection.
- Size of the circuit wire and the main line connecting the distribution board with the main supply meter for light and fan connections. Similarly, for the power connection. (NCVT 1965)

**Solution:**

- Wattage of 50 lamps, 60 W each  $= 50 \times 60 = 3000 \text{ W}$
- Wattage of 20 fans, 100 W each  $= 20 \times 100 = 2000 \text{ W}$

- Wattage of 10 plug points, 60 W each  $= 10 \times 60 = 600 \text{ W}$

- Wattage of 5 bell points, 40 W each  $= 5 \times 40 = 200 \text{ W}$

$$\begin{aligned} \text{Total wattage of lighting load} &= 3000 + 2000 + 600 + 200 = 5800 \text{ W} \end{aligned}$$

$$\text{Wattage of power plug point} = 8 \times 500 = 4000 \text{ W}$$

$$\text{Total wattage of complete circuit} = 5800 + 4000 = 9800 \text{ W}$$

$$\begin{aligned} \text{Current flowing through lighting load,} \quad I &= \frac{W}{E} = \frac{5800}{400} = 14.5 \text{ A} \end{aligned}$$

Current flowing through power load,

$$I = \frac{W}{V} = \frac{4000}{400} = 10 \text{ A}$$

$$\begin{aligned} \text{Total load current,} \quad I &= \frac{W}{V} = \frac{9800}{400} \\ &= 24.5 \text{ A or say } 25 \text{ A} \end{aligned}$$

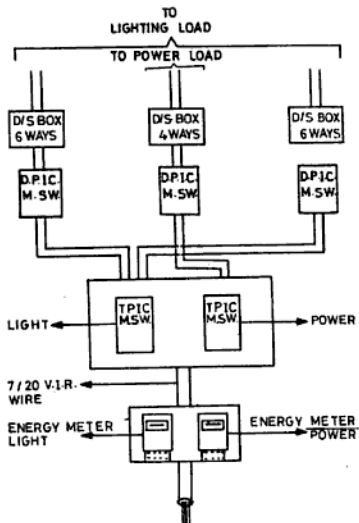

Refer Fig E 4.10

The load current of 25 A will be supplied by a three-phase supply system. Therefore, to pass a current of 25 A in the circuit, the size of the main circuit wire from the energy meter to the distribution box will be  $7/20$  (or  $6 \text{ mm}^2$  of the aluminium conductor) V.I.R. wire.

A T.P.I.C. main switch of 30 A, 400/440 V with a neutral link will be used for controlling the main circuit of the lighting load and a D.P.I.C. main switch of 15 A, 250 V is required for the power circuit. Three separate D.P.I.C. main switches of 15 A, 250 V will be required.

As the total number of light points are 85 and power points 8, therefore, according to I.E. rules there should be 0.25 kW load on each lighting circuit and thus a circuit should have 8 points. Similarly, there should be 1 kW load on each power circuit and as one point of power circuit is of 500 W, in a power circuit there should be at least two points in it. Thus the total number of circuits to be proposed for the lighting is 11 or 12 and for the power circuit 4.

Separate distribution boxes for the lighting load and power load will be used. Two distribution boxes of 15 A, 6 ways each (as the total number of circuits are 12) will be required for the lighting load and one for the power circuit also of 15 A, 4 ways.

For further distribution of supply from distribution boxes to the load, the size of the wire required for the lighting load is  $3/22$  (or  $1.5 \text{ mm}^2$ ) and for power circuit it will be  $3/20$  (or  $2.5 \text{ mm}^2$ ).

**EXAMPLE 4.11** Water is required to be raised out of a tube well 30 m deep at the rate of 243 t of water per hour. If the efficiency of the pump is 90%, find the horsepower of the motor. Assume that 10% of the height is lost in friction. One tonne of water weighs 1000 kg.

Friction loss = 10%

$$\therefore \text{Head lost} = \frac{10 \times 30}{100} = 3 \text{ m}$$

$$\text{Total height} = 30 + 3 = 33 \text{ m}$$

Work done by the pump = force  $\times$  distance

$\therefore$  Work done by pump in raising 243 t of water per hour

$$= \frac{243 \times 1000 \times 33 \text{ kg-m/h}}{60} = \frac{243 \times 1000 \times 33}{60} \text{ kg-m/min}$$

Output of pump

$$= \frac{243 \times 1000 \times 33}{60 \times 4500} \text{ hp}$$

Input of pump

$$= \frac{\text{output} \times 100}{\% \text{ efficiency}} = \frac{243 \times 1000 \times 33 \times 100}{60 \times 4500 \times 90} = 33 \text{ hp}$$

But Input of pump = output of motor

$\therefore$  Output of motor = 33 hp Ans.

**EXAMPLE 4.12** An electric lift raises a load of 7.5 t to a height of 135 m. The cage weight is 0.5 t. The balance weight is 3 t and the time taken by an either upward or downward journey is 90 s. Calculate (i) the Bhp of the motor and (ii) the cost of energy when lift makes 10 double journeys per hour at the rate of 40 paise per unit. The efficiency of the motor is 80%.

$$\left[ \begin{aligned} 1 \text{ t} &= 1000 \text{ kg} \\ 1 \text{ hp} &= 746 \text{ W} \end{aligned} \right]$$

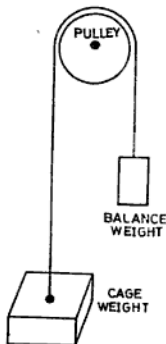

**Solution :** Refer Fig. E 4.12.

Weight lifted during upward journey

$$= 7.5 + 0.5 - 3 = 5 \text{ t}$$

Weight during downward journey

$$= 3.0 - 0.5 = 2.5 \text{ t}$$

Work done by the lift per minute during upward journey

$$= \frac{5 \times 1000 \times 135}{90} \text{ kg-m/min}$$

Output of the motor

$$= \frac{5 \times 1000 \times 135 \times 60}{90 \times 4500} = 100 \text{ hp Ans.}$$

Input of the motor

$$= \frac{\text{output} \times 100}{\eta\%} = \frac{100 \times 746 \times 100}{80 \times 1000}$$

$$= \frac{373}{4} = 93.25 \text{ kW}$$

Work done by the lift during downward journey

$$= \frac{2.5 \times 1000 \times 135}{90} \text{ kg-m/min}$$

Output of the motor

$$= \frac{2.5 \times 1000 \times 135 \times 60}{90 \times 4500} = 50 \text{ hp Ans.}$$

Input of the motor

$$= \frac{50 \times 746 \times 100}{80 \times 1000} = \frac{373}{8} = 46.625 \text{ kW}$$

Total consumption of power for one double journey

$$= 93.25 + 46.625 = 139.875 \text{ kW}$$

Energy consumption per hour

$$= 139.875 \times 10 = 1398.75 \text{ kW}$$

Cost of energy

$$= 1398.75 \times \frac{40}{100} = \text{Rs. } 559.50 \text{ Ans.}$$

### NUMERICAL EXERCISES

- 4.1 A 250 V lamp has its hot resistance of 625  $\Omega$ . Find (i) the current taken by the lamp and (ii) the power rating of lamp. (Ans. 0.4 A, 100W)
- 4.2 A dynamo supplies 59.68 A at 250 V. What is its power output in kilowatts. Also express it in horsepower. (Ans. 14.92 kW, 20 hp)
- 4.3 Two lamps 500 W each are connected (i) in parallel and (ii) in series across 250 V supply. Calculate (i) the total power absorbed in each case and (ii) total current taken in each. (Ans. (i) 1000 W, 4 A, (ii) 250 W, 1 A)
- 4.4 Two lamps of 200 W each are connected (i) in parallel and (ii) in series across 250 V supply. Calculate (i) the total current in each case and (ii) the power absorbed in both cases. (Ans. (i) 1.64 A, 400 W, (ii) 0.4 A, 100 W)
- 4.5 Calculate the voltage required to pass a current of 30 A through a resistance of 8  $\Omega$ . If a resistance of 4  $\Omega$  is connected in series to reduce the current, find (i) the voltage drop across the original resistance and (ii) the power lost in the added resistance. (Ans. 240 V, 160 V, 1600 W)
- 4.6 A 250 V generator supplies through a pair of feeders to a load consisting of 200 lamps of 200 W each, 50 lamps of 100 W each and 25 lamps of 40 W each at a distance of 200 m. The potential difference across the lamps is 230 V. Find the cross-sectional area of the wire, if the specific resistance of the wire is 1.77  $\mu\Omega\text{-cm}$ . (Ans. 0.708  $\text{cm}^2$ )
- 4.7 A pair of feeders each half kilometre long has to deliver 100 kW at 500 V. What cross-section must they have so that the loss in them does not exceed 5% of the power delivered. The specific resistance of the feeder is 1.7  $\mu\Omega\text{-cm}$ . (Ans. 1.36  $\text{cm}^2$ )
- 4.8 A 1210 W, 220 V heater is connected in series with a 100 W, 100 V lamp. If this system is connected to a 210 V supply, what would be the voltage drop across each and the power consumed by the heater. (Ans. 60 V, 150 V, 90 W)
- 4.9 Find the horsepower of a motor to run a generator supplying 18.65 A at 300 V, the efficiency being 75%. (Ans. 10 hp)
- 4.10 An electric installation consists of the following load :—  
 (a) 20 lamps 100 W each, working 6 h/day  
 (b) 1500 W heater, working 8 h/day  
 (c) A 6 hp (metric) motor efficiency 88.26% , working 4 h/day.  
 Calculate the total number of units consumed during one month of 30 days if all these operate as given above on each day. (Ans. 1320 units)
- 4.11 A heater of 1000 W is required to work for 4 h a day. Find the monthly cost of energy for 30 days at the rate of 35 paise per unit. (Ans. Rs. 42.00)
- 4.12 The potential difference of a motor is 500 V. On full load the motor takes 22.38 A. What is the input of the motor in horsepower and what is the cost

of energy for a week when the motor runs 8 h a day at the rate of 30 paise per kWh. (Ans. 15 hp, Rs 187.99)

- 4.13 A factory is supplied at 250 V through a pair of feeders having a  $0.25 \Omega$  resistance. The factory load is as follows :

- (i) lighting load—250 lamps of 200 W each,  
200 lamps of 100 W each, and  
150 lamps of 60 W each working 6 h/day  
(ii) heating load—130 kW furnaces and ovens working 5 h/day  
(iii) motors—60 hp motors working at 50% of full load, working 4 h/day  
(iv) miscellaneous load—taking 50 A for 3 h/day.

Calculate : (i) The total consumption of the factory in kilowatts, (ii) the total current taken by the factory, (iii) the voltage at the sending end, (iv) power wasted in the feeders, and (v) monthly cost of energy at the rate of 35 paise per kWh

for lighting load, and 40 paise per unit for power load. The meter rent is Rs. 2.00 per month for lighting load and for power load it is Rs. 50.00 per month, whereas the electricity tax is 2 paise per unit for lighting load and 3 paise per unit for power load. Heaters and motors are connected on the power circuit. (Ans. (i) 143.88 kW ; (ii) 575.52 A ; (iii) 392.28 V ;

(iv) 82.8 kW ; (v) Rs. 8, 819.45

- 4.14 Calculate the power and current supplied to a 250 V dc motor coupled to a pump which delivers 100 tone of water per hour to a tank at a height of 17.9 m. The head lost in friction is 1 m. Take efficiencies of the pump and motor as 70% and 73.55% respectively. (1 hp = 735.5 W) (Ans. 10 kW, 40 A)

- 4.15 An electric hoist lifts a load of 3 t to a height of 45 m. The cage weight is 0.5 t and the balance weight is 2 t. The time taken for each upward or downward journey is one minute. Calculate : (i) hp of the motor. (ii) find the cost of energy for 180 double journeys per day @ 40 paise per kWh. The efficiency of the hoist is 75% and that of the motor is 80% (one tonne = 1000 kg). 1 tone = 1000 kg. (Ans. (i) 20 hp, (ii) Rs 44.13)

- 4.16 An electric lift raises a load of 9 t to a height of 80 m. The cage weight is 1 t, the balance weight 5.5 t and the time taken by an either up journey or down journey is 80 s. Calculate : (i) hp of the motor and (ii) the current taken by a 500 V motor. (iii) Also, find the cost of energy when the lift makes 15 double journeys per hour at the rate of 30 paise per kWh. The efficiency of the lift and motor are 60 and 73.55%. (One tonne = 1000 kg ; 1 hp = 735.5 W) (Ans. 100 hp, 2000 A, Rs. 900.00)

- 4.17 An electric elevator makes 20 double journeys per hour. A load of 3.75 t is lifted by it to a height of 90 m in 75 s and it returns empty in 50 s. The weight of the cage is 0.25 t and the balance weight is 1.5 t. Calculate : (i) the horsepower of the motor and (ii) hourly cost of energy @ 30 paise per unit. The efficiency of the motor is 73.55 1 hp = 735.5W (Ans. 40 hp, Rs 420.00)

- 4.18 A pair of dc feeders 500 m long supplies a load of 50 hp at 500 V. If the voltage drop in the line is not to exceed 5% of the receiving end voltage, find the size of the copper conductor used. Take specific resistance  $1.7 \mu\Omega\text{-cm}$ .

(Ans.  $507.28 \times 10^{-3} \text{ cm}^2$ )

- 4.19 A dc load of 54 hp is to be supplied through a pair of feeders 600 m long from a sub-station maintaining a voltage of 462 V. The declared voltage of the supply is 450 V but a variation of 4% is permitted to the supply company. Calculate the size of the conductor if the specific resistance is  $1.7 \mu\Omega\text{-cm}$ .

(Ans.  $0.6314 \text{ cm}^2$ )

## REVIEW QUESTIONS

- 4.1 Define power and energy in an electrical circuit. State the units in which they are measured.  
(NCVT 1963)
- 4.2 Define the BOT unit and explain its importance in daily life.
- 4.3 What do you understand by the efficiency of conversion of machine.
- 4.4 What is the difference between the terms "power" and "energy"? What are the names of instruments used for the measurement of each in electrical terms and the units used for each?  
(NCVT 1980/W/man)
- 4.5 Find the voltage across each lamp and current through each of them in the given circuit Fig. RQ 4.5.

(NCVT 1967 W/man)

Ans. Current in upper branch = 0.303 A.  
Current in lower branch = 0.2727 A  
Voltage drop in 100 W lamp = 146.67 V  
Voltage drop in 200 W lamp = 73.33 V  
Voltage drop in 60 W lamp = 220 V

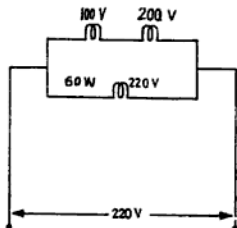

- 4.6 What is the voltage required to pass a current of 35 A through a resistance of 5.7  $\Omega$ . If further a 4.3  $\Omega$  resistance be put in series to reduce the current, find the power lost in the added resistance and the voltage across the original resistance.  
(NCVT 1972 Elect)
- Ans. First case : 199.5 V  
Second case : 1711.4 W, 113.7 V
- 4.7 The lamps A and B when connected in series across a dc mains of 250 V dissipate a total power of 1.5 kW. The resistance of A is twice that of B. Find what total current will they take when connected across the same supply in parallel.  
(NCVT 1976 W/cal)
- Ans. 27 A
- 4.8 A small office building is to be wired up in a conduit wiring system for 3-phase, 400 V supply with the following points.
- light points—30 Nos. of 60 W each,
  - fan points—10 Nos. of 100 W each,
  - wall plug points—5 Nos. of 60 watts each.

- (d) bell points—2 Nos. of 40 W each, and
- (e) power plug points—8 Nos. of 1000 W each.

Calculate the following :

- (i) total load of light and fan connections,
- (ii) total load of power connections,
- (iii) standard size of main switches for lights and fans,
- (iv) standard size of the main switch for power, and
- (v) size of the wire connecting the distribution board with supply for power connection only.

(NCVT 1966)

- 4.9 An electrical installation consists of 15 light points of 60 W each, 8 light points of 40 W lamp, 4 fans of 60 W capacity and a pump motor of 0.5 hp. Assume that 50% of lights and fans are used for 4 h/day and the water pump works for 3 h daily. Find out the monthly consumption and cost of the electric bill, based on tariff of 35 paise per unit.

(NCVT 1981 W/man)

(Ans. Rs 39.98)

# 5

## Chemical and Heating Effects of Electric Current

### 5.1 EFFECTS OF ELECTRIC CURRENT

When an electric current flows through a circuit, its presence is judged by its effects, which are given below.

(i) **Chemical Effect** When an electric current is passed through a conducting liquid (i.e. acidulated water) called an electrolyte, it is decomposed into its constituents due to chemical action. The practical application of this effect is utilized in electroplating, block-making, battery charging, metal refinery, etc.

(ii) **Heating Effect** When an electric potential is applied to a conductor, the flow of electrons is opposed by the resistance of the conductor and thus some heat is produced. The heat produced may be greater or lesser according to the circumstances, but some heat is always produced. The application of this effect is in the use of electric presses, heaters, electric lamps, etc.

(iii) **Magnetic Effect** When a magnetic compass is placed under a current carrying wire, it is deflected. It shows that there is some relation between the current and magnetism. The wire carrying current does not become magnet but produces a magnetic field in the space. If this wire is wound on an iron core (i.e. bar), it becomes an electro-magnet. This effect of electric current is applied in electric bells, motors, fans, electric instruments, etc.

(iv) **Gas Ionization Effect** When electrons pass through a certain gas sealed in a glass tube, it becomes ionised and starts emitting light rays, such as in fluorescent tubes, mercury vapour lamps, sodium vapour lamps, neon lamps, etc.

(v) **Special Rays Effect** Special rays like X-rays and laser rays can also be developed by means of an electric current.

(vi) **Shock Effect** The flow of current through the human body may cause a severe shock or even death in many cases. If this current is controlled to a specific value, this effect of current can be used to give light shocks to the brain for the treatment of mental patients.

### 5.2 ELECTROLYSIS

The process of decomposing a liquid by the passage of electric current (dc only) through it is called electrolysis or electric analysis.

The vessel containing the liquid is known as the vat or electrolytic cell. The liquid to be decomposed is known as an electrolyte and the metal plates immersed in the electrolyte are called electrodes. The plate through which the current enters the electrolytic cell is called the anode or positive electrode and through which it leaves the vat is called the cathode or negative electrode (Fig. 5.1).

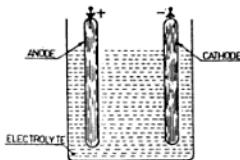

Fig. 5.1 Electrolytic cell

When direct current is passed through an electrolyte, it splits up into its components (in the case of water it decomposes into

hydrogen and oxygen). The atom which loses or gains an electron and thus possesses some electric charge is called an ion. The ion which gains an electron, has an excess of electrons and is therefore negatively charged and called electro-negative. Similarly, the ion which loses an electron has a deficit of electrons and is therefore positively charged and called electro-positive. The negative ions go to the anode and are called anions. The positive ions move to the negative electrode and are known as cations.

Now suppose the anode is made of copper and the cathode is of iron and are immersed in an electrolyte of copper sulphate. On passing the current through the electrolyte the following changes take place: The copper sulphate solution is split up into copper ions ( $\text{Cu}^{++}$ ) and sulphate ions ( $\text{SO}_4^{--}$ ). The copper ions possessing positive charge move to the cathode and deposit as metallic copper on it. The sulphate ions possessing negative charge ( $\text{SO}_4^{--}$ ) travel to the anode and attack the copper to form copper sulphate ( $\text{CuSO}_4$ ). This results in the transfer of copper from the anode to the cathode and thus the strength of the copper sulphate solution remains constant.

Now again suppose that the anode is of platinum and by the passage of electric current the electrolyte splits up into copper and sulphate ions. The sulphate ions will then take hydrogen from the water and the reaction will be as follows:

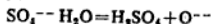

The oxygen will be given off at the anode. The copper ions which are deposited on the

cathode in the form of metallic copper will not be replaced by the solution at the anode. Thus the concentration of the copper sulphate solution will gradually decrease. From the above it is clear that the electrolyte will be converted into sulphuric acid.

### 5.3 ELECTRO-CHEMICAL EQUIVALENT

*It is the mass of an element in grams which is deposited on the cathode by the passage of one ampere steady current for one second (i.e., one coulomb). For example, if a steady current (i.e. dc) of one ampere is flowing in a solution of silver nitrate and silver deposits at the rate of 1.118 milligrams per coulomb on the cathode, then we will say the E.C.E. of silver is 1.118 mg/per coulomb.*

### 5.4 CHEMICAL EQUIVALENT

*It is the mass of an element which in chemical action will combine with or replace one gram of hydrogen. Its value is given by atomic weight divided by valency. Therefore, the chemical equivalent of copper is  $63.57/2 = 31.78$ , for chlorine 35.46 and for silver it is 107.88 (see Table 5.1).*

Table 5.1 gives the values of E.C.E., valencies and atomic weight of some elements.

### 5.5 VALENCY

*It is the combining power of an atom with the number of hydrogen atoms. In other words, it is the number of hydrogen atoms which combine with or displace one atom of an element. For example, one atom of nitrogen (N) combines with three atoms of hydrogen ( $\text{H}_3$ ) for*

TABLE 5.1 VALUES OF E.C.E., VALENCY AND ATOMIC WEIGHT

Name of element	E.C.E. in Milligrams per Coulomb	Valency	Atomic Weight
Hydrogen	0.01044	1	1
Oxygen	0.08293	2	16
Sodium	0.2394	1	23
Chlorine	0.3676	1	35.46
Nickle	0.3041	2	58.68
Copper	0.3296	1 or 2	63.57
Zinc	0.3387	2	65.37
Bromine	0.8284	1	79.92
Silver	1.118	1	107.88

making ammonia ( $\text{NH}_3$ ). Here the valency of nitrogen (N) is equal to 3. Similarly, in the case of water ( $\text{H}_2\text{O}$ ), the valency of oxygen (O) is 2.

### 5.6 FARADAY'S LAWS OF ELECTROLYSIS

The following two laws of electrolysis were established by Faraday.

**First Law** *The mass of any substance liberated during electrolysis is proportional to the quantity of electricity which has passed through the electrolyte.* The quantity of electricity is also known as the charge ( $Q$ ) and its unit is the coulomb (C). The coulomb is the product of current in amperes and time in seconds. Hence,

$$\text{Mass} \propto \text{charge}$$

$$M \propto Q$$

$$M \propto It \text{ g}$$

where

$$I = \text{current in amperes}$$

$$t = \text{time in seconds}$$

$$M = \text{mass deposited in grams.}$$

**Second Law** *The masses of different substances liberated by the same quantity of electricity during electrolysis are proportional to the electro-chemical equivalents of the substance.*

$$\text{Mass} \propto \text{E.C.E.}$$

or

$$M \propto Z$$

where

$$Z = \text{electro-chemical equivalent}$$

These two laws may be expressed in the form of an equation as follows :

$$M \propto Q$$

$$\propto It$$

$$M = ZIt \quad (5.1)$$

When once the electro-chemical equivalent of the substance is known (from Table 5.1), we can find the total mass of the substance liberated or deposited by a given quantity of electricity.

### 5.7 ELECTROPLATING

The process of depositing a metal on the surface of another metal by electrolysis is known as electroplating. Electroplating is widely used in giving an attractive appearance and finish to all types of industrial products. In this process inferior metals are coated with costly metals (such as silver, chromium, etc.)

to give an attractive shiny appearance and rust-proof surface.

### 5.8 CONDITION FOR ELECTROPLATING

The following conditions must be fulfilled before electroplating an article:

- (i) The article to be electroplated must have a chemically cleaned surface, i.e., it must not have any sort of dirt, rust and greasy surface.
- (ii) The article to be plated should form a cathode.
- (iii) The anode must be of the metal to be deposited for maintaining the concentration of the solution constant during electrolysis.
- (iv) The metal to be coated has to be in the solution of an electrolyte.

The electrolyte is contained in a wooden reinforced cement concrete tank which is known as a "vat". The anode as well as the article to be plated are hung from conducting wires so as to dip in the solution. The value of the current is adjusted according to the metal deposited on the surface area of the article. The time required for electroplating can be calculated if we know the mass of the metal deposited and E.C.E. with the formula

$$M = ZIt$$

$$\text{Therefore, Time } t = \frac{M}{IZ}$$

Some Formulae : (1) We know  $M = ZIt$

$$I = \frac{M}{Zt} \text{ and } Z = \frac{M}{It} \text{ m. gm./Coulomb}$$

(2) We know  $\text{Volume} = \text{Area} \times \text{Thickness}$

$$\text{Area} = \frac{\text{Volume}}{\text{Thickness}} \text{ and}$$

$$\text{Thickness} = \frac{\text{Volume}}{\text{Area}}$$

(3)  $\text{Mass} = \text{Volume} \times \text{Density}$

$$\text{Volume} = \frac{\text{Mass}}{\text{Density}} \text{ c.c. and}$$

$$\text{Density} = \frac{\text{Mass}}{\text{Volume}} \text{ gm./c.c.}$$

**EXAMPLE 5.1** If 111.83 mg of silver is deposited on the cathode in 3 min 20 s, by a dc current of 0.5 A, calculate the E.C.E. of silver.

**Solution :**

$$t = 3 \text{ min } 20 \text{ s} = 200 \text{ s}$$

$$M = 111.83 \text{ mg}$$

From Faraday's law,

$$M = ZIt$$

$$Z = \frac{M}{It} = \frac{111.83}{0.5 \times 200 \times 1000}$$

$$= 0.0011183 \text{ g/C}$$

$$= 1.1183 \text{ mg/C Ans.}$$

**EXAMPLE 5.2** It is required to deposit copper on the both surfaces of an iron plate 200 cm<sup>2</sup> in area. What thickness of copper will be deposited if one ampere of current is passed through the solution for 1½ hours. The density of copper is equal to 8.9 g/cc and E.C.E. of copper is 0.329 mg/C.

**Solution :**

$$Z = 0.329 \text{ mg/C} = \frac{0.329}{10^3} = 0.329 \times 10^{-3} \text{ g/C}$$

$$I = 1 \text{ A}$$

$$t = 90 \times 60 = 5400 \text{ s}$$

From Faraday's law,

$$M = ZIt$$

$$= \frac{0.329 \times 10^{-3} \times 1 \times 5400}{103} = 1.7766 \text{ g (i)}$$

Suppose the thickness of copper deposited – x cm

$$A, \text{ea} = 200 \text{ cm}^2$$

$$\text{Density} = 8.9 \text{ g/cc}$$

Volume of copper deposited

$$= 2 \times \text{area} \times \text{thickness}$$

$$= 2 \times 200 \times x \text{ cc}$$

Mass of copper deposited

$$= \text{volume} \times \text{density}$$

$$= 400 \times x \times 8.9 \quad (ii)$$

Equating (i) and (ii);

$$400 \times 8.9 \times x = 1.776$$

$$\text{or } x = \frac{1.7766}{400 \times 8.9} = 0.000499 \text{ cm Ans.}$$

## 5.9 APPLICATIONS OF ELECTROLYSIS

Some practical applications of electrolysis are described below :

**Silver Plating** The solution of silver potassium cyanide is used as an electrolyte. The job to be plated is thoroughly cleaned with sandpaper and then dipped in caustic soda solution to remove grease. The silver plate is used as an anode and the job to be plated is

made the cathode. Now current is allowed to flow till the required thickness of metal to be deposited is obtained. After this the plated article is washed and polished to give a shining finish.

**Nickle Plating** The solution contains nickle ammonium sulphate. The process of plating is similar to the description given above for silver plating.

**Chromium Plating** The electrolyte contains chromic acid and sulphuric acid. For example, if an iron plate is to be plated with chromium, it is first cleaned and then plated in a solution of copper sulphate. After this a layer of nickle is added and then chromium plating is done to give a hard and brilliant finish.

**Electro-Refining of Metals** If an impure copper ingot is to be refined, it is made as an anode and a thin pure copper plate is used as a cathode dipped in a solution of copper sulphate. During electrolysis copper migrates into the solution from the anode and deposits on the cathode as pure copper. Thus copper is purified and impurities are precipitated in the bottom of the anode. Similarly, many other metals can also be refined by the electrolysis of their compounds.

**Determining the Polarity of dc Supply** Due to electrolysis in acidulated water, it is possible to identify the positive and negative terminals of dc supply. Take two supply mains through a lamp and dip them in the electrolyte. As electrolysis starts, the hydrogen ion will move to the cathode and oxygen ion will go to the anode. Therefore more bubble will appear on the negative terminal and less on the positive terminal.

**Electrotyping** Ordinary printing letters are made of lead, which is soft and breaks damages very soon. Therefore hard printing electrotype plates are manufactured. In this process first a block of a letter is prepared and its negative impression is taken on a block of wax. After this the surface of wax is dusted with a powder of graphite to make it a conductor. Then it is electroplated in copper solution to the required thickness. After this, it is removed from the wax and then its back is

strengthened with another metal. This electrolyte is then used for printing. Similar methods are used for making replica of medals, etc.

### 5.10 CURRENT REQUIRED FOR PLATING

Low pressure direct current (dc) supply is always used for electroplating purposes. The pressure used varies from 1 to 16 V depending upon the rate of plating and the nature of the electrolyte.

### 5.11 DYNAMO FOR ELECTROPLATING

The shunt dynamo is generally used for electroplating. It delivers large current at low pressure and this requires a large commutator and brush gear. Such types of dynamos are run by either an ac or a dc motor or by some other means, such as the petrol engine, etc. and the current required for plating is controlled by the current regulator. The generated voltage of the dynamo is controlled by the voltage regulator.

Figure 5.2 shows the essential connections of a dynamo connected with a vat for plating.

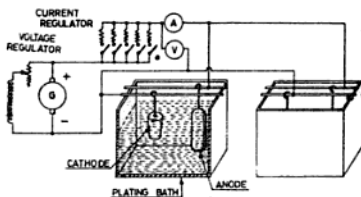

Fig. 5.2 Panel layout of electroplating generator with plating bath

### 5.12 HEATING EFFECT OF ELECTRIC CURRENT

When an electric current flows through a conductor, some energy is consumed. This electrical energy is converted into heat energy as a result of the electrons colliding with the molecules of the atom during their flow. Moreover, there is considerable friction between electrons and molecules of the conductor (Fig. 5.3). Thus some heat is produced. This transformation of electrical energy into heat energy is the heating effect of electric current.

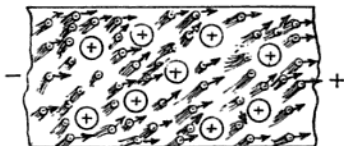

Fig. 5.3 Collision of electrons with molecules of the atom

### 5.13 KILOCALORIE

The kilocalorie (kcal) is the unit of heat in the mks system. It is defined as the amount of heat required to increase the temperature of one kg of water through  $1^{\circ}\text{C}$ . It has been experimentally proved that if 4187 J of electrical energy is completely converted to heat, produces one kilocalorie of heat energy, i.e., 1 kilocalorie = 4187 J.

### 5.14 JOULE'S LAW OF HEAT

This law states that the heat generated in a conductor by the flow of an electric current is proportional to the square of the current value, the resistance of the conductor and the time for which the current flows.

The above law can be expressed in the form of an equation as follows :

$$H \propto I^2 R t$$

where  $I$  = current in the conductor in amperes  
 $R$  = resistance of the conductor in ohms  
 $t$  = time for which the current flows in seconds  
 $H$  = quantity of heat developed in calories

It may be noted that if the current is reduced to half, the heating effect is reduced to one quarter.

Again, if a current of  $I$  A flows for  $t$  s through a resistance of  $R$   $\Omega$ , then the electrical energy consumed ( $I^2 R t$  J) is converted into heat so that we have

$$H \propto I^2 R t J$$

$$\text{or } H = \frac{I^2 R t}{J}$$

where  $J$  is Joule's constant and equals 4187 J/kcal. Thus,

$$H = \frac{I^2 R t}{4187} \text{ kcal} \quad (5.2)$$

$$\text{or } H = \frac{V I t}{4187} \text{ kcal} \quad (5.3)$$

$$\text{or } H = \frac{V^2 t}{R 4187} \text{ kcal} \quad (5.4)$$

$$\text{or } H = \frac{W t}{4187} \text{ kcal} \quad (5.5)$$

where  $W$  is the power in watts.

### 5.15 THERMAL EFFICIENCY

It is the efficiency of an electrical appliance and is defined as the ratio of the heat actually used for heating water to the total heat developed for this purpose.

$$\begin{aligned} \text{Thermal efficiency } (\eta_{th}) &= \frac{\text{useful heat}}{\text{heat generated}} \\ &= \frac{\text{total heat-loses}}{\text{total heat}} \end{aligned}$$

**EXAMPLE 5.3** It is required to heat 15 kg of water from 15° to 100°C in 25 min. when the heater takes 10 A. Calculate the resistance of the heater element. Assume that the efficiency of the heater is 85%.

**Solution :**

Output heat required

$$\begin{aligned} &= \text{weight in kilograms} \times \text{temperature rise} \\ &= 15(100 - 15) \text{ kcal} \\ &= 15 \times 85 \text{ kcal} \end{aligned} \quad (i)$$

Heat generated (input heat)

$$= \frac{I^2 R t}{4187} = \frac{(10)^2 \times R \times 25 \times 60}{4187} \text{ kcal}$$

Useful heat at 85% efficiency

$$\begin{aligned} &= \frac{\text{input} \times \eta}{100} \\ &= \frac{(10)^2 \times R \times 25 \times 60 \times 85}{4187 \times 100} \end{aligned} \quad (ii)$$

Useful heat = heat required

Equating Eqs (i) and (ii), we have

$$\frac{(10)^2 \times R \times 25 \times 60 \times 85}{4187 \times 100} = 15 \times 85$$

Resistance of element,

$$R = \frac{15 \times 85 \times 4187 \times 100}{10 \times 10 \times 25 \times 60 \times 85} = 41.87 \Omega \text{ Ans.}$$

**EXAMPLE 5.4** An electric heater takes 4 A to increase the temperature of 20 kg water from 10°C to 90°C in 2 h, 19 min, 34 s. Calculate the potential difference across the heater when the efficiency of the heater is 80%.

**Solution :**

Time required to raise the temperature of water

$$\begin{aligned} &= 2 \text{ h, } 19 \text{ min, } 34 \text{ s} \\ &= 8374 \text{ s} \end{aligned}$$

Output heat required

$$\begin{aligned} &= 20(90 - 10) \\ &= 20 \times 80 = 1600 \text{ kcal} \end{aligned} \quad (i)$$

Heat generated

$$\begin{aligned} &= \frac{V I t}{4187} \\ &= \frac{V \times 4 \times 8374}{4187} \text{ kcal} \end{aligned}$$

$$\text{Useful heat} = \frac{V \times 4 \times 8374 \times 80}{4187 \times 100} \quad (ii)$$

We know,

$$\begin{aligned} \text{Useful heat} &= \text{heat required} \\ \therefore \frac{V \times 4 \times 8374 \times 80}{4187 \times 100} &= 1600 \end{aligned}$$

or Voltage across the heater

$$= \frac{1600 \times 4187 \times 100}{4 \times 8374 \times 80} = 250 \text{ V Ans.}$$

### 5.16 HEATING UNIT

A resistor when employed for producing heat is called a heating unit or heating element. It is generally made in three forms :

- (i) Round wires,
- (ii) ribbon wires, and
- (iii) strips.

Round and ribbon wires are used in small heating units, such as electric stoves, room heaters, soldering irons, heat convectors, electric kettles, electric irons, hot plates, water heaters and other electric heating appliances. The round or ribbon wire is first wound over some insulating material such as mica or asbestos and then pressed between the surfaces to be heated.

Strips are generally employed in big furnaces where the quantity of heat required is very high.

### 5.17 MATERIALS FOR HEATING ELEMENTS

The material required for making heating element is either Kanthal or nichrome wire.

**Kanthal** It is an alloy of chromium, nickel, iron, etc., prepared in different percentages of combination for different purposes. Its maximum working temperature is 1280°C (2336°F). Its specific resistance is 135  $\mu\Omega$ -cm at 20°C. Its melting point is approximately 1510°C (2750°F). It is specially used in big furnaces for annealing stainless steel and various types of pottery works.

**Nichrome Wire** It is an alloy of 80% nickel and 20% chromium. The maximum temperature at which it can work safely is 1150°C (2102°F). Its specific resistance is  $110 \mu\Omega\text{-cm}$  at 20°C. It is generally used for making elements of heating appliances for domestic purposes.

#### 5.18 APPLICATIONS OF HEATING EFFECT

This principle of electricity is widely used in the operation of many electrical devices, such as electric lamps, fuses, arc welding, spot welding, domestic power appliances, etc. Some of its various and important applications are discussed below.

**Incandescent Lamp** The heating effect of electric current is used in the artificial production of light by an incandescent lamp. When electric current is passed through the filament of the lamp, heat is produced and the filament emits light rays. Carbon arc lamps and searchlights are also examples where the heating effect of electric current is utilized. For further details refer to Chapter 20. The working voltage of these lamps is 220 or 230 V and the power consumption of different lamps is 15, 25, 40, 60, 100, 200, 300 and 500 W.

**Arc Welding** In arc welding the arc is produced by the flow of electric current between the job to be welded and an electrode held in the welding holder. The current is supplied by means of a motor generator set having its output voltage in the range of 40 to 60 V dc. One wire of the generator is connected to the job to be welded and other to the electrode holder. When welding, the electrode is first touched with the job for a moment and then drawn slightly away to develop the arc. The developed arc produces a temperature of 3300°C to 3593°C. As heat is produced at the arc, it melts the electrode with which it comes in contact. Thus two metals are fused together forming a pool of molten metal, which on cooling becomes a mechanical strong joint.

**Electric Heaters** A large variety of domestic appliances, such as the electric stove, room heater, soldering iron, electric irons, hot air circular, hair drier, electric kettle, toaster, hot plate and water heater are examples of electric heaters.

All these appliances have heating elements made of nichrome wire which has high specific resistance. This wire can be heated to high temperature in air without oxidizing. The elements are wound on mica or fire clay which is electrically insulated and can stand prolonged heating. Each device is designed for different power ratings and voltages. So before using them it is necessary to see the rating of the appliances for their satisfactory operation.

For purposes of safety a three-core flexible cable should always be used with all the appliances. Two wires are used as the main lead and the third one is the earth continuity conductor. One end of it is connected to the metal body of the appliance and the other end to the earth pin of a three-pin plug top. The maximum operating voltage of all domestic appliances is 230 or 250 V and the power ratings are 750, 1000 and 1500 W. Fig. 5.4 shows an electric stove.

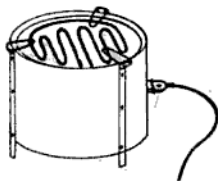

Fig. 5.4 Heater

**Room Heater** In these heaters, the heat produced is radiated by means of a well-polished reflector.

These heaters are of two types:

- (i) Bowl-type room heater, and
- (ii) rod-type room heater.

A room heater consists of an element, a reflector and a base plate. The element of the bowl-type room heater is wound over a cone-shaped or tubular-shaped porcelain insulator with two-pin bases as shown in Fig. 5.5.

The element of the rod-type room heater is wound over the china clay insulating rod. These heating rods may be either plug-in type or screw-in type as shown in Fig. 5.6.

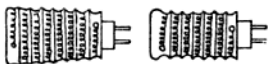
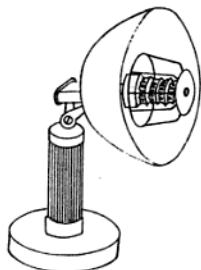

Fig. 5.5 Bowl-type room heater

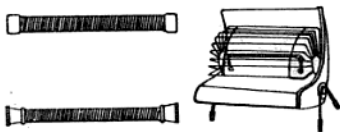

Fig. 5.6 Rod-type room heater

**Soldering Iron** It consists of a copper bit, wooden handle and an element embedded in the copper bit (Fig. 5.7). This element heats up the copper bit of the soldering iron and for its easy handling a wooden handle is provided. The soldering irons are generally of 65, 125 and 250 W, 230 volts and are used for soldering wire joints, commutator segments, etc.

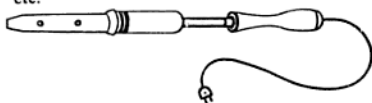

Fig. 5.7 Soldering iron

**Air Circulator** It consists of a fan motor of 1/60 hp, 2400 rpm, two elements of 1000 W each and a special rotary switch which can make contact with all the terminals of the switch at a time when required.

The fan circulates the cool air into the room when the switch makes contact at first position

tion. At second position the fan delivers low heat and similarly at the third position maximum heat. The essential parts and connection are shown in Fig. 5.8. It is only suitable for operating on 230 V ac and takes either 1000 or 2000 W.

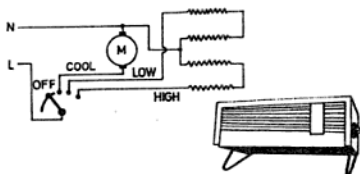

Fig. 5.8 Air circulator

**Electric Kettle** The electric kettle consists of a container, handle and an element. The element is made of a long, flat nichrome wire arranged in a zig-zag manner and fitted between the two sheets of mica. The element is properly fitted under the base of the kettle and is covered with a metal plate (which acts as a pressure plate) fitted with nuts.

In some cases the heating element is embedded in a brass chromium plated tube and insulated from it with some insulating material. Such a type of element is known as an immersion element and the kettle in which it is used is known as an immersion-type electric kettle, as shown in Fig. 5.9 This type of kettle is

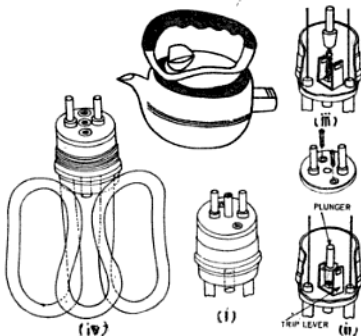

Fig. 5.9 Electric kettle and function of its thermal plunger

more efficient because the whole length of the immersion heater is dipped in the water and thus the heat loss is minimum. In this kettle a thermal plunger is also provided in the socket. When the kettle boils dry, the plunger is released by the trip lever. Due to excessive heat on this the plunger in the socket of the kettle pushes back the female connector socket and thus disengages the connector socket from the element. This lever does not permit the making of contact again. The contact of the female connector socket can only be made again by pushing the plunger inward to its original position when the element of the kettle has cooled down again.

The power taken by the electric kettle (heater type) is 450 W at 230 V and for the immersion-type electric kettle, it is 600 to 1500 W.

**Electric Iron** The main purpose of the electric iron is to press the clothes. Electric irons can be classified into two types as given below :

- (i) Ordinary electric iron, and
- (ii) automatic electric iron.

(i) **Ordinary Electric Iron** It consists of chromium-plated base plate, an electric heating element of nichrome wire fitted between the two sheets of mica, a cast iron pressure plate, a chromium plated cover with insulated terminals and a handle. For heating it is connected with the supply by means of a female connector having flexible cord and a three-pin plug top. Figure 5.10 shows the parts of an electric iron.

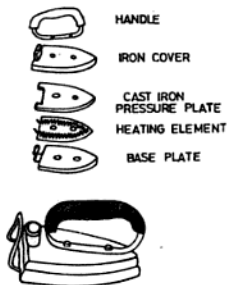

Fig. 5.10 Electric iron

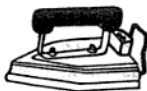

Fig. 5.11 Laundry iron

The power consumption of domestic electric iron is 450 W while laundry irons (bigger in size, shown in Fig. 5.11) are of 750, 1000 and 1500 W.

(ii) **Automatic Electric Iron** In addition to the above mentioned parts, the automatic electric iron has a thermostat which is connected in series with the element. This thermostat controls the temperature, prevents overheating of the iron and thus avoids damage to the heating element. The necessity of the thermostat is due to the fact that some clothes like cotton and linen require high temperature for pressing while terylene and silk require low temperature. The required temperature can be obtained with the help of thermostat. The essential parts of an automatic iron are shown in Fig. 5.12.

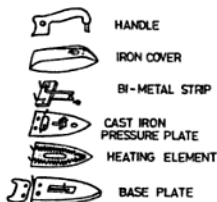

Fig. 5.12 Automatic electric iron

**Thermostat** The thermostat is a switch which operates automatically due to the variation of heat produced around it. It functions on the principle that different metals have different rates of expansion when heated. For example,

brass has a greater coefficient of expansion than iron. If a strip is made of bimetal (i.e., say brass and iron) and heated beyond a certain temperature, it will bend downwards.

The above principle is used in operating the thermostat (thermal switch). The thermostat has two contact points, namely, the fixed contact point and moveable contact point. The moveable contact of thermostat consists of a bimetal strip which is normally in contact with another strip of metal having fixed contact. The thermostat is connected in series with the heating element as shown in the Fig. 5.13 and is fitted inside the cover of the iron above the pressure plate.

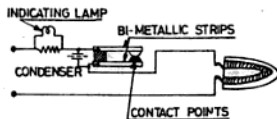

Fig. 5.13 Thermostatic control of an electric iron

After switching on the iron, the current starts to flow through this contact point and thus the temperature rises. When the temperature reaches beyond a certain adjusted temperature, the contact point of the bimetal strip opens which now stops the flow of current through the heating element. Thus the circuit of the heating element is opened. The circuit cannot be closed again till the base plate of the iron cools down again. After cooling the iron, the bimetal strip regains its original normal position and thus the circuit is again completed. By means of an insulated knob on the contact point, the distance between the contact points is adjusted. This regulates the temperature of iron for different types of clothes. It should always be kept in mind that the setting of the bimetal strip should not be disturbed because the rate of linear expansion is known to the manufacturer only. If once its setting is disturbed, it will stop functioning properly.

A condenser is connected across the contact point of the bimetal strip. Its function is to minimize the sparking at the contact point and thus increase the life of the contact point. A short-circuited condenser decreases the life of the element because it will always give path to the current, and the iron even after it

has become hot cannot then be operated through the contact point.

An indicator lamp of 2.8 V is also fitted in the handle of the iron and is connected across a small resistance which is connected in series with the element. When the lamp lights up, it indicates that current is passing through the heating element and when it goes off, it shows that iron has attained the required temperature and the current has stopped flowing. Automatic irons are of 750 W only.

**Hot Plate** Hot plates are used for cooking food stuffs. These are of two types, namely, the single hot plate and double hot plate (Fig. 5.14 and 5.15).



Fig. 5.14 Single hot plate



Fig. 5.15 Double hot plate

The heating element of the hot plate consists of a single or double spirally wound heating element which is embedded in between an insulating cemented material like plaster of paris or fire clay and then baked hard. The fire clay is then covered with a steel plate and the foodstuff boils over this plate. In simple design, the heating element is divided into two parts of equal heating capacity, as shown in Fig. 5.16. Each element is independently controlled by a separate switch. When either switch is in the ON position it gives half of the full heat and when both switches are on the full heat is available.

In other cases, heat is controlled by a separate special rotary switch which has four positions, giving full heat, medium heat, low heat and OFF. The heating element is divided into two parts. When the switch is in the full position, the two elements are connected in parallel and the element takes its full



Fig. 5.16 Connection diagram of two ranges of heat

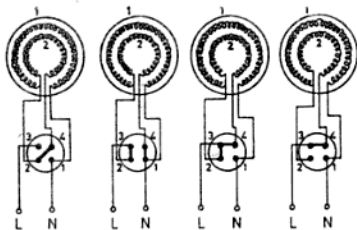

Fig. 5.17 Connection diagram of multi range of heat

rated current. When the switch is in the medium position, one part of the element is connected to the supply and it takes half of its rated current. Similarly, the low position of the switch connects element 1 and 2 in series and the current is reduced to one quarter of its full value. Figure 5.17 shows the connection of such types of hot plate.

The power consumption of a single hot plate is 1000 and 1500 W, whereas it is 1000 and 2000 watts in the case of a double plate.

NOTE: For getting maximum variation of heat, two elements of different wattage can be used.

**Water Heater** Water heaters are of two types:

- (i) Immersion water heater, and
- (ii) self-contained water heater.

**Immersion Water Heater** As is apparent from the name, it is dipped in the vessel containing water for heating. There is a heating element in the brass chromium plated water-tight tube and insulated from it with an insulating material like plaster of paris. There is no wastage of heat in it, so its efficiency is greater than other type of heaters. It is a portable water heater, as shown in Fig. 5.18. The immersion heaters are manufactured in 250, 1000 and 1500 W ranges. The 250 W immersion heater is used for heating water for shaving purposes only.

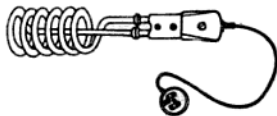

Fig. 5.18 Immersion heater

**Storage Water Heater** It consists of a double-walled reservoir known as the cistern, a heating element and a thermostat. It is not a portable water heater and is fixed on the wall where it is to be used (Fig. 5.19). It can be further divided into two classes:

- (i) Non-pressure type, and
- (ii) pressure type.



Fig. 5.19 Storage water heater

**Non-pressure Type Water Heater** Figure 5.20 shows a non-pressure type water heater. It is used at places where hot water is required at one service point only.

It has only one outlet for water without a stop cock. The water is controlled only from inlet side by a valve as shown in Fig. 5.20. It consists of a double-walled chamber. The space between the two chambers is filled with a heat insulating material like glass wool or cork. The heating chamber generally consists of tinned copper and the outer cover-

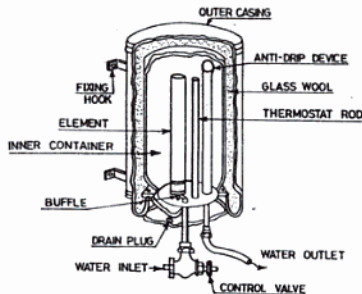

Fig. 5.20 Non-pressure type water heater

ing of lead coated steel. This outer coating is given a final coat of white enamel paint. The inner chamber has a drip device, a thermostat for controlling the temperature of the water and a heating element erected vertically. The anti-drip device is connected to the outlet pipe which helps in having a quick cut-off of hot water.

When the inlet valve is opened, it allows an equal quantity of hot water into the outlet pipe. The pressure inside the chamber does not develop because the outlet valve is always opened.

It should be always remembered to earth all the metal coverings of the water heater.

**Pressure-type Water Heater** When the hot water is needed at more than one service

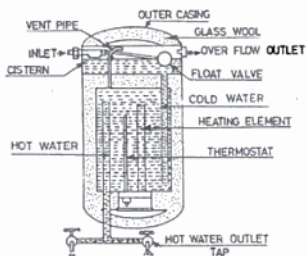

Fig. 5.21 Pressure type water heater

point and only one heater is to be used, then this type of water heater is used only. This kind of water heater gets water supply through the cistern (i.e., reservoir) which is connected to the water mains through a controlling float valve.

The power consumption of a 25-litre bathroom geyser is either 1000 or 1500 W.

Figure 5.21 shows the essential parts of this type of water heater. The heater cistern is always full of water. The cold water comes through the cistern and replaces the drained off hot water in the tank in equal volumes. The level of the water in the cistern always remains constant as it is controlled by a floating-ball valve. During the heating process, the water expands and a vent pipe is also provided for its expansion.

The main disadvantage in this water heater is that cold water mixes with hot water and thus reduces the temperature of the water at the service point. This type of water heater is also known as a constant volume pressure type water heater.

### 5.19 FUSE

A fuse is a safety device connected in series to the circuit which protects the electrical apparatus from possible damage when abnormal current flows through it. In other words, it is a short element or conducting material of low melting point connected in series to the load. When normal current flows, the fuse serves as a conductor, but when the current flows above the pre-determined value through a circuit due to a short circuit, failure of insulation or overload, enough heat is produced to melt the fuse wire, thus breaking the circuit to protect the equipment from damage due to excessive current.

Fuse wires are bare wires made of easily melting materials having high specific resistance. Usually standard alloy (63% tin and 37% lead) fuse wires are used for small currents, say up to 5 A and tinned copper for large value of currents.

The size of the fuse wire is such that the maximum current (fusing current) will produce sufficient heat due to  $I^2Rt$  to melt the fuse wire. So far higher current fuse wires of large diameters are used. Fuse wires are always passed through asbestos or fire resisting tube and fixed in a fire proof material like glazed porcelain, etc.

## 5.20 CLASSIFICATION OF FUSES

Fuses may be classified into two groups :

- (i) Those designed to protect the circuit both from overload and short circuits, and
- (ii) those designed to protect the circuit from short circuits only.

In the first condition fuse element breaks the circuit above 25% overload, and in the second case the fuse wire melts at a current which is several times greater than the normal current.

If a fuse wire does not melt on excessive current, it may damage the motor winding, wiring installation and the instrument connected in the circuit because each has its own rated current, and an abnormal current through them will spoil them.

## 5.21 PARTS OF A FUSE

The following are the main parts of a fuse:

**Fuse Wire** It is that part of a fuse which melts when abnormal current flows through the circuit and thus disconnects the apparatus or circuit from the supply mains.

**Fuse Carriers** The part to which the fuse wire is fitted is called fuse carrier and is made of porcelain having two contact strips. It is a removable part of a fuse (i.e., kit-kat fuse).

**Fuse Carrier Contacts** These are the contact strips which engage or disengage the fixed contacts of the fuse base and have a fuse wire attached to them.

**Fuse Base** It is the fixed part of a fuse and is made of porcelain. It is the part of a fuse which has fixed contacts. The circuit is broken in this part of the fuse and the ends of the circuit cables are connected in its fixed contacts.

**Fixed Contacts** These contacts are provided in the porcelain base of the fuse and engage with the fuse carrier contacts.

The fuses (including fuse boards and main switches) should be installed at an easily accessible position of fuse, the factors given in Sec. 5.24 must be kept in mind.

## 5.22 MINIMUM FUSING CURRENT AND CURRENT RATING OF FUSE ELEMENT

**Minimum Fusing Current** Minimum fusing current is that least value of current at which the fuse wire melts.

**Current Rating of Fuse Element** The current rating of a fuse element or wire is the current which it can carry without melting. Its value is always less than the minimum value of the fusing current.

The ratio of the minimum fusing current and the current rating of the fuse element is called the *fusing factor* and is always more than unity.

## 5.23 TYPES OF FUSES

Generally, two types of fuses are used in practice :

- (i) Rewirable fuse, and
- (ii) cartridge fuse.

**Rewirable Fuse** These fuses are also known as semi-enclosed fuses or kit-kat fuses and are used in domestic installation. In these types of fuses, the fuse wire is neither totally enclosed nor is it kept in free air. Figure 5.22 (a) shows a semi-enclosed fuse. In these types of

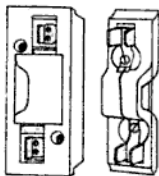

Fig. 5.22 Re-wirable fuses

fuses the fusing current of a copper conductor is nearly double the rated current and has a low rupturing capacity.

**Cartridge Fuse** The cartridge fuse is an enclosed type of fuse. It is of two types:

- (i) D-type cartridge fuse [Fig. 5.22 (b)], and
- (ii) link-type cartridge fuse. Fig. 5.23

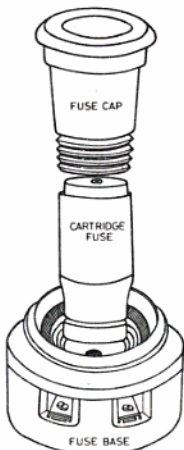

Fig. 5.23 (b) D-type cartridge fuse

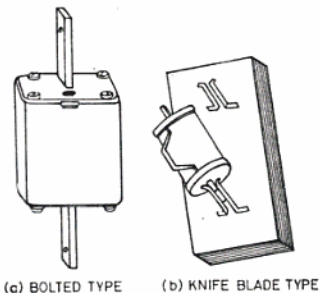

Fig. 5.23 (b) Link-type cartridge Fuse

The link-type cartridge fuse can be further grouped as: (i) Knife blade-type H.R.C. cartridge fuse link, and (ii) bolted-type H.R.C. cartridge fuse link. The fuse wire consists of a non-deteriorating solid silver wire without a joint (i.e., the number of silver wires are run in parallel to reduce the section in the centre)

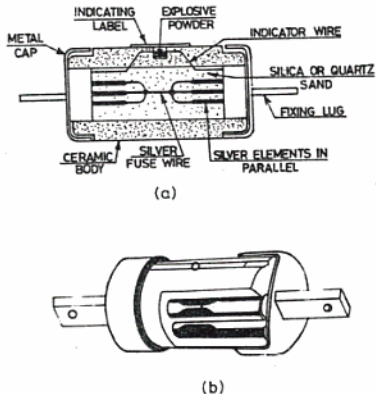

Fig. 5.24 Details of HRC cartridge fuse

and is enclosed in a ceramic tube having caps and connecting lugs which are fitted under pressure at both ends of the tube. No cement is used in securing the caps and even then the tube is kept air-tight. The ceramic tube is filled with powder of silica or quartz which quenches the arc.

In some cartridge fuses, as shown in Fig. 5.24, a fine indicating wire is run in parallel to the main fuse through an indicator in the form of a bead having a small quantity of mild explosive underneath. The bead is ejected when the fuse blows off and thus explosive material burns the indicating label. Figure 5.24 (b) shows the detailed diagram of such a fuse. These fuses are also known as high rupturing capacity (H.R.C.) fuses and can pass overload or a short circuit current for a known period. If the fault current is reduced during this period, then it does not blow off, otherwise it will melt and thus open the circuit. For the protection of electric motors, H.R.C. fuses are employed. These fuses can operate with high current even up to 46 kA. These fuses cannot be used again if once damaged and have to be replaced.

Cartridge fuses are installed in the fuse base along with other accessories like adaptor screws and screw caps.

**5.24 PRECAUTIONS FOR RENEWING A FUSE**

The precautions to be followed for renewing a fuse are given below.

- (i) Open the main switch of the wiring installation before withdrawing the fuse carrier from the circuit.
- (ii) Then ascertain the fault and remove it before replacing a blown fuse.
- (iii) A fuse carrier should always be wired with a fuse wire having the same fusing current as that which has blown. If it is wired with a thicker wire, it may be

dangerous when a short circuit or over-load occurs. This may cause fire as a renewed fuse may not operate even when the safe maximum current is passing through it.

- (iv) The fuse wire provided in a circuit should not be rated to exceed the current rating of the smallest cable used in it.

**NOTE:** If the cable of the motor circuit is rated to carry the full load current of the motor, the fuses should be rated to carry twice the full load current of the circuit.

**EXERCISES**

- 5.1 How much silver would be deposited in 8 min 20 s when a current of 2 A flows through the solution?  
The E.C.E. of silver is 1.118 mg/coulomb. (Ans. 5.59 g)
- 5.2 Find the mass deposited of chromium if a current of 100 A flows for 16 min 40 s.  
The E.C.E. of chromium is 0.1797 mg/coulomb. (Ans. 17.97 g)
- 5.3 Calculate the strength of the current which will deposit 9.87 g of copper in 20 min. The E.C.E. of copper is 0.329 mg/coulomb. (Ans. 25 A)
- 5.4 Calculate the value of the current required to deposit 3.24 g of chromium in 2 h if the E.C.E. of chromium is 0.18 mg/coulomb. (Ans. 2.5 A)
- 5.5 Calculate the current required to deposit 0.987 g of copper in 25 min if the E.C.E. of copper is 0.329 mg/coulomb. (Ans. 2 A)
- 5.6 A current of 1.5 A is flowing in a copper electrolytic cell for 40 min and the mass of the copper deposited is 1184.4 mg. Find the E.C.E. of copper.  
(Ans. 0.329 mg/coulomb)
- 5.7 How long will it take a current of 6 A to put a layer of copper 0.987 cm thick on both sides of a brass rectangular piece 1.5 cm × 3 cm. Density of copper = 8.9 g/cc and the E.C.E. of it is equal to 0.329 mg/coulomb.  
(Ans. 11 hr. 7 min. 30 s)
- 5.8 An iron plate of total surface area 658 sq. cm is to be electroplated with copper. How long will it take to deposit copper 0.18 cm thick, if a current of 44.5 A is passed. The E.C.E. of copper is 0.329 mg/coulomb and density of copper is 8.9 g/cc. (Ans. 20 h)
- 5.9 A metal plate having a total surface area of 200 sq. cm is to be silver plated. What thickness of silver will be deposited by a current of 21 A in half an hour? Density of silver is 10.5 g/cc and E.C.E. is 1.2 mg/coulomb.  
(Ans.  $216 \times 10^{-4}$  cm)
- 5.10 Calculate the amount of heat generated when a current of 3 A flows for 5 min through a circuit having 83.74Ω resistance. (Ans. 54 kcal)
- 5.11 An electric heater raises the temperature of 2.5 kg of water from 20°C to boiling point in 20 min. Calculate the resistance of the heating element if it is connected with a 250 V supply and its efficiency is 83.74%. (Ans. 75 Ω)
- 5.12 Find the current taken by 24 kg of water required to raise its temperature from 16°C to 100°C in 10 min. The thermal efficiency of the kettle is 84% and the potential difference across it is 400 V. (Ans. 41.87 A)
- 5.13 An electric water heater of 2.5 kW contains 80 kg of water at 30°C. Consider the heater losses to be 20% of the input. Calculate the temperature of the water after the heater has been switched on for 2 h 19 min 34 s. (Ans. 80°C)
- 5.14 A heater connected to a 230 V supply is used for heating 5 kg of water from

- 20°C to 100°C in 1 h 9 min 47 s. Calculate the resistance of the heating element. (Ans. 132.25  $\Omega$ )
- 5.15 An electric heater takes 4 A to raise the temperature of 10 kg water from 19°C to 100°C in 8 min 20 s. Calculate the potential difference across the heater when the efficiency of the heater is 80%. (Ans. 209.35 V)
- 5.16 Calculate the time required to boil 6 kg of water by a water heater of 0.2 kW. The heater efficiency is 90% and the initial temperature of water is 10°C. (Ans. 3 h 29 min 21 s)
- 5.17 An electric water heater contains 8 kg of water at 28°C. It takes 10 min to boil the water. Consider the losses of the water heater to be 24 kcal. Calculate the power rating of the heater. (Ans. 4.187 kW)
- 5.18 An electric kettle has 15 kg of water at 12°C. It takes 8374 s to raise the temperature to 94°C. Assume the heat losses due to radiation and heating the kettle to be 20 kcal. Calculate the current taken by the kettle if the potential difference across it is 250 V. (Ans. 2.5 A)
- 5.19 The resistance of the heating element of a kettle is 46  $\Omega$ . It is seen that it takes 2 h 19 min 34 s when connected across 230 V mains to raise the temperature of 23 kg of water from 30°C to 100°C. What is the thermal efficiency of the kettle? (Ans. 70%)

#### REVIEW QUESTIONS

- 5.1 (a) Describe Faraday's laws of electrolysis.  
 (b) The electro-chemical equivalent of copper is 0.00033 g-coulomb. What is the current required to deposit 6 g of copper on an article in one hour. (N.C.T.V.T. 1978 Elect) (Ans. 5.05 A)
- 5.2 Explain briefly the process of electroplating.
- 5.3 What are the effects of an electric current. Write a short note on it.
- 5.4 (a) Define mechanical equivalent of heat.  
 (b) An electric kettle is marked for 500 W, 230 V. It is found to take 15 min to bring 1 kg of water at 15°C to boiling point. Determine the efficiency of the kettle. (N.C.V.T. 1979 Elect) (Ans. 79.08 %)
- 5.5 Assume that you are supplied with two heating elements each rated at 500 W, 240 V. Give diagrams showing how these would be connected to a 240 V supply to give high, medium and low heat. Calculate the wattage of the consumption in each case. (All India Skill Competition, 1969 Elect)
- 5.6 A rectangular disc 15 cm long and 10 cm wide is to be nickel plated on both sides with a coating of 0.1 mm thick. If a steady current of 6 amps is passed through the electrolyte how long must the disc remain immersed. Density of nickel is 8.8 g per c.c. electro-chemical equivalent is 0.000304 gm per coulomb. (N.C.V.T. W/celect Elect 1982) (Ans. 4h 1 min 13s)

# 6

## Magnetism, Electromagnetism and Electromagnetic Induction

### 6.1 MAGNET

Magnet is a piece of ferromagnetic or ferri-magnetic material substance which has the property of attracting iron, nickle and cobalt.

### 6.2 CLASSIFICATION OF MAGNETS

The main classes of magnets are as follows:

- (i) Natural magnet, and
- (ii) artificial magnet.

**Natural Magnet** The term "lodestone" was first applied to a hard black mineral stone found in Magnesia, a province in Asia. Lodestone possesses the property of attracting small pieces of iron and points along the north-south direction when hung freely by a thread. Later, this stone began to be known as magnetite and due to its property of attracting iron, it is now more popular by the name of "magnet."

If a lodestone is dipped into iron fillings, the latter clings to the two opposite regions of the lodestone as shown in Fig. 6.1. These regions are known as "poles" and the line joining the poles is known as the "magnetic axis". If the lodestone is suspended freely, it

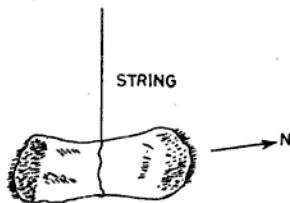

Fig. 6.1 Natural magnet

will so adjust itself that the magnetic axis almost coincides with the geographical meridian. The poles which point north and south are respectively called north-seeking and south-seeking poles. In short, the north-seeking pole is known as the north pole and the south-seeking pole as the south pole.

A substance which possesses these two properties, namely of attracting iron fillings and pointing in the direction of north and south when freely suspended is called a magnet. The lodestone is an example of a natural magnet.

**Artificial Magnet** The lodestone is now seldom in use as its degree of magnetization is less than a piece of steel which have been magnetised by artificial method and is known as *artificial magnet*.

### 6.3 CLASSES AND SHAPES OF ARTIFICIAL MAGNET

The artificial magnets can be divided into two classes as:

- (i) Permanent magnet
- (ii) Temporary magnet.

**Permanent Magnet** Permanent magnets are made of steel and retain magnetism (i.e., the property of attracting iron) for a long time. They are generally made as bar magnets, horse-shoe magnets, U-shaped magnets and cylindrical magnets, as shown in Fig. 6.2. The material used for making permanent magnets is either cobalt, steel or tungsten steel.

*Uses of Permanent Magnet* Bar magnets are used in laboratories for making small magnets while horse-shoe and U-shaped magnets are employed in the moving coil instrument for producing deflecting torque. They are also provided in an energy meter as a braking

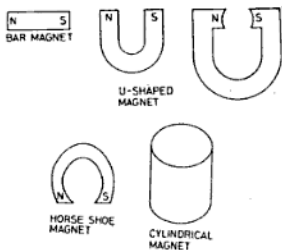

Fig. 6.2 Types of artificial magnet

magnet. Cylindrical magnets are used in the manufacture of loud-speakers, moving coil instruments, microphones, ear phones magnetic needles, etc. They are also used for navigation purposes.

**Temporary Magnets** All electromagnets are temporary magnets. These are made by sending a current through a wire wound around a piece of iron and remain magnetic

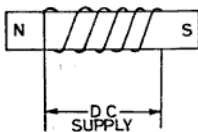

Fig. 6.3 Temporary magnet (electromagnet)

till the current flows through them. The material used for making temporary magnets is soft iron or silicon steel.

**Applications of Electromagnets** Electromagnets are employed in the electric bell, electric fan, bell indicator, etc. and all types of electrical machines.

#### 6.4 TEST OF MAGNETISM

If a piece of iron or steel is brought near either of the poles of a magnet, it is attracted. If a north pole of a magnet is brought near the south pole of another freely suspended magnet, there is again an attraction between

them. But if two south poles are brought near each other, they repel. The same happens in the case of two north poles. This means that (i) like poles repel each other and (ii) unlike poles attract each other.

From the above it is clear that a magnet attracts pieces of iron or steel but repels only magnets. Therefore repulsion is a sure test of magnetism.

#### 6.5 METHODS OF MAGNETIZATION

There are three principle methods of magnetizing a steel bar as given below:

- (i) Touch method,
- (ii) by means of electric current, and
- (iii) induction method.

(i) **Touch method** This method can be further divided as:

- (a) Single touch method,
- (b) double touch method, and
- (c) divided touch method.

(a) **Single Touch Method** In the single touch method, the steel bar to be magnetized is rubbed with either of the poles of a magnet, keeping the other pole away from it. Rubbing

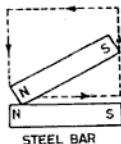

Fig. 6.4 Single-touch method

is only done in one direction as shown in Fig. 6.4. The process should be repeated many times for magnetization of the bar.

(b) **Double Touch Method** In this method the steel bar to be magnetized is placed over the two opposite pole ends of a magnet and the rubbing magnets are placed together over the centre of the bar with a small wooden piece in between, as shown in Fig. 6.5. They are never lifted off the surface of the steel bar, but rubbed again and again from end to end, and finally ending at the centre where the rubbing was started.

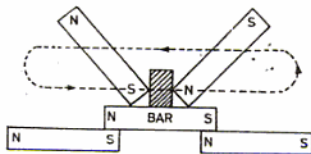

Fig. 6.5 Double-touch method

(c) **Divided Touch Method** Here the two different poles of rubbing magnets are placed as in the previous case. They are then separated along the surface of the steel bar to the opposite ends. The rubbing magnets are then

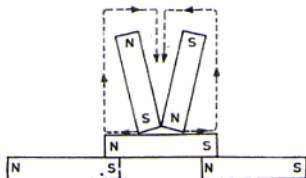

Fig. 6.6 Divided-touch method

lifted off the surface of the steel bar and placed back in the centre of the bar. This whole process is repeated again and again as shown in Fig. 6.6.

The steel bar thus magnetized becomes a permanent magnet but the degree of magnetization is very low.

(ii) **By Electric Current** The bar to be magnetized is wound with an insulated copper wire and then a strong electric current (dc) from a battery is passed through the wire for sometime. The steel bar then becomes highly magnetized. If the bar is of soft iron, the magnetism remains as long as the current continues but almost completely disappears as soon as the current ceases. The magnet made by such an arrangement is called an electromagnet and is generally used in laboratories.

(iii) **Induction Method** This is a commercial method of making permanent magnets. In

this method a pole charger is used which has a coil of many turns and an iron core inside it as shown in Fig. 6.7. The direct current supply is fed to the coil through a push button switch.

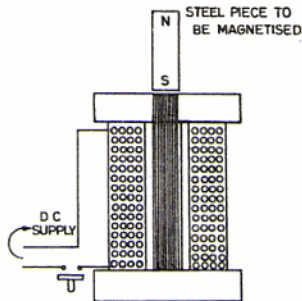

Fig. 6.7 Sectional view of a pole charger

The steel piece to be magnetized is placed on the iron core kept inside the coil and the direct current is passed through the coil. The iron core now becomes a powerful magnet and thus the steel piece placed on it also becomes a magnet by induction. The magnetized piece of steel is then lifted up after switching off the current.

**Advantages:** The following are the advantages:

- (i) In this method small pieces of steel can easily be magnetized.
- (ii) It takes very less time to make a magnet.
- (iii) Steel pieces of any shape can be magnetized easily.

**Uses** This is a commercial process for making permanent magnets for speakers, telephones, microphones, earphones, electrical instruments, magnetos, etc.

## 6.6 MOLECULAR THEORY OF MAGNETISM

This theory tells us that each molecule of a magnetic substance is a complete magnet having both north and south poles. Prior to magnetizing a substance, the molecules are arranged in a haphazard way, in different directions and groups. The result of magne-

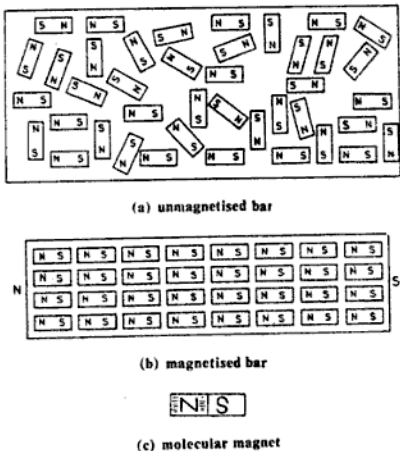

Fig. 6.8 Arrangement of molecular magnet in a substance

tisation is to arrange the each molecules in such a way that their similar poles point in one direction

In the unmagnetized condition, the molecular magnets are grouped in all directions as shown in Fig. 6.8(a). Due to magnetic attraction between unlike poles, they form close groups because the north pole of one molecular magnet comes near the south pole of another molecules. Hence none of the poles can produce any magnetic force outside.

When an iron bar is rubbed with the north pole of a permanent magnet, then all the south poles of molecular magnets are attracted toward it. If one continues to rub again and again with the permanent magnet, each molecule is forced to break up their groups and arrange themselves with their north poles on one side and south poles on the other side as in Fig. 6.8 (b). In this way one end of the bar becomes the north pole and other end the south pole. Hence magnetism is nothing which is given or taken to a substance, but is

simply a change in the condition of its molecules.

## 6.7 FUNDAMENTAL MAGNETIC TERMS

**Magnetic Poles** These are the ends of a magnet from where the magnetic lines appear to emit or enter and are identified as north and south pole.

**Magnetic Lines of Force** These are the imaginary magnetic lines which start travelling from the south pole to north pole inside the magnet and from the north pole to south pole outside the magnet (as shown in Fig. No. 6.9).

The lines of force are more intense near the poles of a magnet and as the distance from the magnet is increased, they become weaker. The unit of measurement of lines of force is maxwell and its bigger unit is weber which is equal to  $10^8$  maxwell.

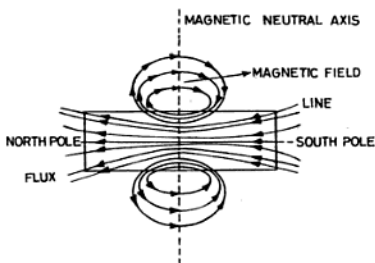

Fig. 6.9 Field produced by a magnet

**Magnetic Circuit** The complete path of magnetic lines of force from north to south and externally and from south to north internally is called the magnetic circuit.

**Magnetic Field** The space occupied by the lines of force around a magnet is called the magnetic field.

**Magnetic Flux** The total number of lines of force existing in a magnetic field is called the magnetic flux. Its symbol is  $\phi$  (phi) and the unit of measurement is weber ( $1 \text{ weber} = 10^8 \text{ maxwells}$ )

**Magnetic Axis** The imaginary line joining the two poles of a magnet is called the magnetic axis. It is also known as the magnetic equator.

**Magnetic Neutral Axis** The imaginary line which is perpendicular to the magnetic axis and passes through the centre of the magnet is called the magnetic neutral axis.

**Magnetic Saturation** When a piece of steel or iron fails to acquire a higher degree of magnetization however much the magnetizing power is increased is known to be magnetically saturated. According to the molecular theory of magnetization, this would happen only when every molecule in the magnetic substance is lined up in the magnetic position.

**Magnetic Induction** It is the action by which a magnetic substance acquires a magnetic property by the presence of a magnet without

actual contact. For example, if a short thin bar of iron is placed with its one end near the iron dust (Fig. 6.10) and a magnet is brought

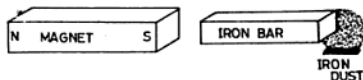

Fig. 6.10 Magnetic induction

near the other end of the bar, magnetism will be induced in it by simply the presence of the magnet and thus the iron dust will be attracted at its first end. It will be found that the magnetized iron bar has two poles. The end of the bar nearer the magnet will be of opposite polarity and the farther end will be of the same polarity as that of the magnet. This effect of magnetism due to the influence of a magnet is called magnetic induction.

**Magnetic Screening** Magnetic lines can pass through any media because there is no known insulation for them. Whenever it is required to protect any instrument or device from the magnetic effect, they are magnetically screened or shielded. A space is said to be magnetically screened when the magnetic force at that point is destroyed. This can be done by placing an iron ring in the magnetic field.

Figure 6.11 shows the influence of a circular

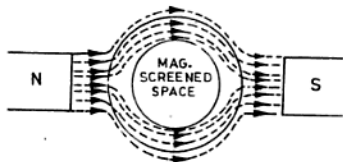

Fig. 6.11 Magnetic screening

ring on the distribution of magnetic lines of force between the two opposite poles. The lines of force will pass through the iron ring rather than air, and there will be no lines of force inside the ring. The space which is not effected by the magnetic lines of force is known as a magnetically screened space.

**Residual Magnetism** When current is passed through a coil wound on a soft iron rod, the

rod become magnetized, and when current is switched off, the iron rod loses its magnetism. But practically there is still some magnetism left in the rod when the current is reduced to zero. The magnetism which remains in the iron rod when the current is reduced to zero in an electromagnet is called residual magnetism. In other words, it is the magnetism left in a magnetic substance after the magnetizing force has been removed.

**Retentivity** It is the property of retaining magnetism by a magnetic substance after the magnetizing force has been reduced to zero.

If two pieces, one of steel and the other of soft iron of the same dimension are aimed at the same magnetizing force, it will be observed that when the magnetizing force is removed, the two pieces do not retain the same value of magnetism. The soft iron has lesser magnetism than the piece of steel. Hence their power of retaining magnetism, or say retentivity, is different.

**Susceptibility** It is the property of an unmagnetized body of acquiring induced polarity when under the influence of a magnetic field. The susceptibility of iron is much greater than that of hard steel.

#### 6.8 PROPERTIES OF MAGNETIC LINES OF FORCE

The properties of magnetic lines of force are given below:

- (i) The lines of force always travel from north to south pole outside the magnet and from south to north pole inside the magnet.
- (ii) All the magnetic lines of force complete their circuit.
- (iii) The magnetic lines do not cross each other.
- (iv) The lines of force travelling in one direction have a repulsive force between them and therefore do not cross.
- (v) The magnetic lines prefer to pass and complete their circuit through a magnetic material.
- (vi) So far there is no insulator for the lines of force which can bound them to pass in a definite direction.
- (vii) These lines magnetize the magnetic substance on their way.
- (viii) They behave like an elastic band.

#### 6.9 PROPERTIES OF A MAGNET

The following are the properties of magnets.

- (i) **Attractive Property** A magnet has the property of attracting magnetic substance (such as iron, nickel and cobalt) and its power of attraction is greatest at its poles.
- (ii) **Directive Property** If a magnet is freely suspended, its poles will always tend to set themselves in the direction of north and south.
- (iii) **Induction Property** A magnet has the property of producing magnetism in a nearby magnetic substance by induction.
- (iv) **Poles Existing Property** A single pole can never exist in a magnet if it is broken into its molecules.
- (v) **Demagnetising Property** If a magnet is handled roughly (such as heating, hammering, etc.), it will lose its magnetism.
- (vi) **Property of Strength** The two poles of a magnet have equal pole strength.
- (vii) **Saturation Property** If a magnet of higher strength is further subjected to magnetization, it will never acquire more magnetization due to its being already saturated.

(viii) **Property of Attraction and repulsion** Unlike poles (i.e., north and south) attract each other, while like poles (north and north) repel each other.

#### 6.10 PROPERTIES OF MAGNETIC FIELD

The space around the magnetic field has the following properties:

- (i) If a soft iron bar is kept in a magnetic field, it is magnetized due to magnetic induction.
- (ii) If another magnet is brought in the magnetic field, it experiences a force of attraction or repulsion.
- (iii) If a current carrying conductor is kept in such a field, it develops a mechanical force; this basic phenomenon is utilized for the operation of electric motors.
- (iv) If a coil having a closed circuit is moved across a magnetic field, an emf is generated in it; this is the basic principle of an electric generator.

### 6.11 CATEGORIZATION OF MAGNETIC SUBSTANCES

Magnetic materials can be categorized into three groups as follows :

(i) **Ferromagnetic Substances** Those substances which are strongly attracted by a magnet are known as ferromagnetic substances, such as iron, nickel, cobalt, steel and their alloys.

(ii) **Paramagnetic Substances** Those substances which are slightly attracted by a magnet of common strength are called Paramagnetic Substances. Their attraction can easily be observed with a powerful magnet. In short, paramagnetic substances are similar in behaviour to ferromagnetic materials. Examples are : aluminium, manganese, platinum, copper etc.

(iii) **Diamagnetic Substances** Those substances which are slightly repelled by a magnet of powerful strength only diamagnetic substances, e.g. bismuth, sulphur, graphite, glass, paper, wood, etc. Bismuth is the strongest diamagnetic substance.

**NOTE :** There is no substance which can be properly called nonmagnetic. It may also be noted that water is diamagnetic material and air is a paramagnetic substance.

### 6.12 CARE AND MAINTENANCE OF PERMANENT MAGNETS

These are as follows:

- (i) Do not throw them. Permanent magnets should not be thrown about.
- (ii) They should not be hammered.
- (iii) They should not be heated.
- (iv) Bar magnets should be placed side by side with their ends facing opposite polarity.
- (v) Keepers should be used for the magnets.
- (vi) As far as possible the magnets poles north and south should be kept in the direction of south and north of the earth.

### 6.13 ELECTROMAGNETISM

On passing a current through a coil of wire, a magnetic field is set up around the coil. If a soft iron bar is placed in the coil of wire carrying the current, the iron bar becomes magnetized. This complete process is known

as "electromagnetism". The soft iron bar remains as a magnet as long as the current is flowing in the coil and loses its magnetism when the current is switched off from the coil.

The polarity of this electromagnet depends upon the direction of the current flowing through it. If the direction of the current is altered, the polarity of the magnetic field will also be changed as shown in Fig. 6.12.

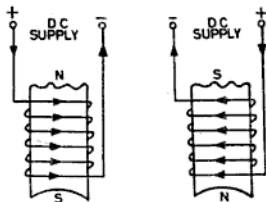

Fig. 6.12 Polarity of a pole changes with change of current in the coil

**Advantages of Electromagnetism** The followings are the main advantages of an electromagnet:

- (i) Electromagnets can be magnetized easily by sending a current through them.
- (ii) The polarity of the poles can simply be changed by changing the direction of the current flowing through the coil.
- (iii) Magnetic power (i.e. strength) can be controlled by controlling the value of the current only.
- (iv) Electromagnets can be made in any shape depending on the requirement.
- (v) The magnetic strength remains constant as long as the value of the magnetizing current is not changed.

### 6.14 PRACTICAL APPLICATIONS OF ELECTROMAGNETS

Electromagnets are used in the manufacture of all types of electrical machines, such as motors, generators, transformers, converters, some electrical measuring instruments, protective relays, for medical purposes (like removing iron pieces from eyes) and in many other electrical devices. The detailed description of them is given later in the respective chapters.

## 6.15 MAGNETIC TERMS

The important magnetic terms are defined below.

(i) **Magnetomotive Force (mmf)** The force which drives the magnetic flux through a magnetic circuit is called the magnetomotive force (mmf). It corresponds to the electromotive force (emf) in an electric circuit. Its unit in the mks system is ampere-turns and is determined by

$$\text{mmf} = IN \text{ ampere-turns} \quad (6.1)$$

where  $I$  = value of the current in amperes

$N$  = number of turns in the coil

mmf = magnetomotive force in ampere-turns.

(ii) **Ampere-turns AT** It is the unit of magnetomotive force (mmf) and is the product of the number of turns of magnetic circuit (i.e., coil) and the current passing through it in amperes. A coil of wire having 100 turns will have 100 ampere-turns if 1 A current is flowing through it.

(iii) **Reluctance** It is the property of a magnetic material (i.e. circuit) which opposes the establishment of magnetic flux in it. It corresponds to resistance in an electric circuit. It is represented by the letter  $S$  and its unit of measurement is ampere-turns per weber. (AT)/wb.

(iv) **Permeability** If a piece of soft iron is placed between two magnets, it will be seen that lines of force prefer to pass through the piece of iron than through air. In fact, iron is a better conductor of lines of force than air. The same idea can be expressed by saying that iron has greater permeability. Harder magnetic substances have less permeability than softer ones.

Therefore, the permeability of a substance may be defined as the conducting power for lines of force of magnetic materials as compared with air. Its symbol is ( $\mu$ ). In other words, it can also be defined that it is the ratio of flux density ( $\mu$ ) and magnetizing force ( $H$ ), i.e.

$$\text{Permeability } \mu = \frac{\text{flux density } (\beta)}{\text{magnetizing force } (H)}$$

(v) **Permeance** It is the reciprocal of reluctance and is the property of magnetic circuit

which helps to develop magnetic flux easily. It is similar to conductance in an electric circuit. It is measured in terms of Wb/ampere-turns GHenry and is denoted by  $1/S$ .

(vi) **Reluctivity** It is the specific reluctance of a magnetic circuit and corresponds to resistivity in an electric circuit.

(vii) **Coil** A coil has concentric circular turns with only one layer.

(viii) **Helix** It is also a type of coil having circular turns with more than one layer and its diameter more than its length.

(ix) **Solenoid** It is also a type of coil having circular turns with more than one layer and its length greater than its diameter.

(x) **Toroid** It is also just like a solenoid bent into the form of a closed ring as shown in Fig. 6.12.

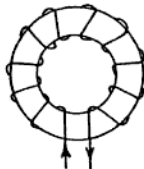

Fig. 6.13 Toroid

(xi) **Unit Pole** A unit pole may be defined as that pole which when placed one metre apart from an equal and similar pole repels it with a force of 10 N.

Suppose two like poles of  $m_1$  and  $m_2$  units are placed  $d$  m apart in air. Then the force of repulsion between the poles is directly proportional to the strength of the poles and inversely proportional to the square of the distance, i.e.

$$F \propto \frac{m_1 \times m_2}{d^2}$$

$$\text{or} \quad F = \frac{m_1 \times m_2}{4\pi\mu_0 d^2} \quad (6.2)$$

where  $m_1$  and  $m_2$  = poles strength in webers  
 $d$  = distance in metres

$\mu_0$  = permeability of the medium  
(for air it is one)

$\frac{1}{4\pi}$  = constant in mks system

$F$  = Force in newtons

(xii) **Magnetic Field Strength** This is sometimes also known as field intensity, magnetic intensity or magnetic field and is represented by the letter  $H$ . Its unit is ampere-turns per metre.

Consider a coil having  $N$  number of turns wound on a hollow cylindrical nonmagnetic material of length  $L$  and a current  $I$  passing through it. Then the magnetizing force is given by

$$H = \frac{\text{mmf}}{\text{Length of coil (in metres)}} \quad (6.3)$$

$$= \frac{IN \text{ (ampere-turns)}}{\text{Length (in metres)}} \text{ ampere-turns/m or N/Wb}$$

Therefore the magnetizing force can be defined as the quantity of mmf per metre length of the magnetic circuit. It can also be defined as that force experienced by a north pole of 1 Wb placed at point  $A$  from another pole of  $m$  Wb when the distance between them is  $d$  m. The force experienced by the pole is

$$F = \frac{m \times 1}{4\pi\mu_0 d^2}$$

$$\therefore H = \frac{m}{4\pi\mu_0 d^2} \text{ ampere-turns/m or N/Wb}$$

It should be noted that ampere-turns per metre is equivalent to N/Wb.

(xiii) **Flux Density (B)** The total number of lines of force per square metre of cross section area of magnetic core is called flux density and is represented by the symbol  $B$ . Its unit in the mks system is tesla (weber per metre square).

$$\text{Flux density (B)} = \frac{\phi \text{ total flux}}{\text{area of the core (A)}} \quad (6.4)$$

where  $\phi$  = total flux in webers  
 $A$  = area of the core in square metres  
 $B$  = flux density in weber/metre square

## 6.16 OERSTED'S EXPERIMENT

Oersted, a Danish scientist discovered in 1819 while giving a demonstration lecture that there is a close relationship between electricity and magnetism. He observed that when a magnetic needle is placed under and parallel to a conductor and then the current is switched on, the needle tends to deflect at right angles to the wire.

Suppose a wire in which the current is to be passed is arranged in a direction north to south by placing the needle above the wire as in Fig. 6.14 (a). Then the north pole of the needle will be deflected to the west, nearly perpendicular to the wire. If now the needle is placed below the wire, the deflection will be to the east, as in Fig. 6.14 (b). When the

direction of the flow of current is reversed, the deflections of the needle will be in opposite direction as shown in Fig. 6.14 (c) and (d).

In these cases the deflection of the needle shows that the lines of force are produced around the current carrying conductor as shown in Fig. 6.15 (a) and (b)

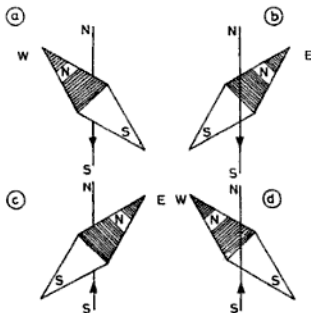

Fig. 6.14 Deflection of magnetic needle by an electric current

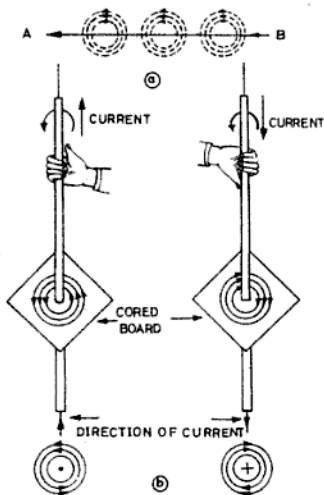

Fig. 6.15 Lines of force surrounding a current carrying conductor

### 6.17 OERSTED'S LAW AND ITS RESULTS

Oersted's law states that whenever a current is passed through a conductor, a flux is set up around the conductor in the shape of a concentric circle. Oersted arrived at the following results:

- (i) A current carrying conductor is always encircled by magnetic lines of force.
- (ii) The magnetic flux of the current carrying conductor will be coaxial and concentric.
- (iii) The plane of the magnetic lines of force will always be perpendicular to the plane of the conductor.
- (iv) The strength of the magnetic lines of force will decrease as the distance of the lines of force increases from the centre of the conductor.
- (v) The area of the magnetic field is directly proportional to the magnitude of the current flowing.

### 6.18 DETERMINING DIRECTION OF LINES OF FORCE

From Oersted's experiment (Sec. 6.16), the following rules may be deduced with which we can determine the direction of flow of current in any conductor :

- (i) **Right Hand Palm Rule** Place the palm of the right hand facing the compass needle in such a way that the tips of the fingers will indicate the direction of the current in the conductor thumb should point in the direction of the North pole of the needle as shown in Fig. 6.16.

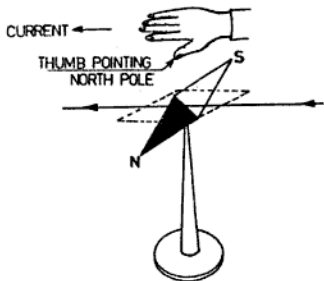

Fig. 6.16 Right hand palm rule

### 6.19 DETERMINATION OF DIRECTION OF MAGNETIC FIELD AROUND A CURRENT CARRYING CONDUCTOR

The direction of the magnetic field around a current carrying conductor can be found from either of the following two rules:

- (i) Cork screw rule, and
- (ii) right hand thumb rule.

**Cork Screw Rule** Imagine a right-handed cork screw being screwed along the wire in the direction of current as shown in Fig. 6.17. Then the direction of rotation of the cork

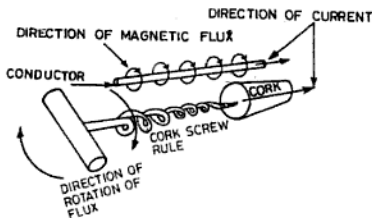

Fig. 6.17 Cork screw rule

screw or the thumb represents the direction of magnetic lines of force around the conductor.

**Right Hand Thumb Rule** Imagine a current carrying conductor held in the right hand with the thumb pointing in the direction of flow of current as shown in Fig. 6.18. Then the finger tips represent the direction of the magnetic field.



Fig. 6.18 Right hand thumb rule

### 6.20 MAGNETIC FIELD DUE TO SINGLE CIRCULAR LOOP

Suppose a straight conductor is bent so as to form a circular loop and it carries current in the direction as shown by the arrow in Fig. 6.19. The magnetic lines of force will be found to be around the loop entering one side and leaving the other side, thus forming a north pole on one side and south pole on the other.

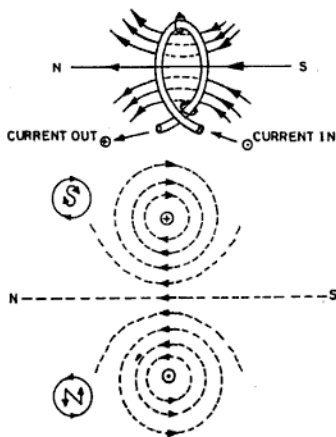

Fig. 6.19 Magnetic field about a circular loop

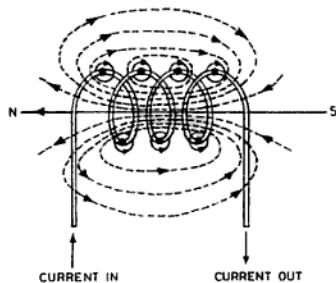

Fig. 6.20 Magnetic field around a solenoid

### 6.21 MAGNETIC FIELD DUE TO SOLENOID

When an electric current passes through a solenoid, it operates as a magnet having the polarity of north pole at one end and south pole at the other end. The strength of the solenoid can be increased by inserting a soft iron core inside it Fig. 6.20.

### 6.22 POLARITY OF A SOLENOID

The following are the rules by which the polarity of a solenoid can be determined.

- (i) **Clock Rule** Look at one end of the coil. If the current flows in the clockwise direction (at the viewer end) then that end will be

south pole and if it is anti-clockwise then it is north pole as in Fig. 6.21.

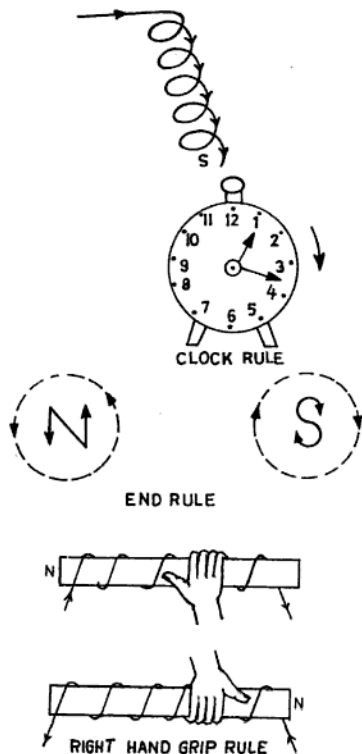

Fig. 6.21 Determining the polarity of a solenoid

(ii) **End Rule** If the direction of the current at the end of the solenoid is the same as indicated by the arrow end of S, then it is the south pole, and if it is same as indicated by the arrow end of N, it is the north pole.

In other words, if the direction of flow of current in the solenoid is towards the observer end, then it is the south pole and if it is away from the observer, it is North pole.

(iii) **Right Hand Grip Rule** Hold the solenoid in the right hand with the fingers in the direction of the current. Then the extended thumb will indicate the north pole of the solenoid.

### 6.23 FIELD STRENGTH PRODUCED BY A SOLENOID

The strength of magnetic field produced by a straight solenoid of length  $l$  m is directly proportional to the strength of current passing through it and the number of turns on it. If  $I$  be the current strength in a solenoid which

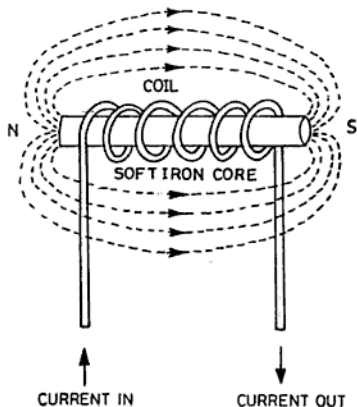

Fig. 6.22 Effect of iron core in a solenoid

has  $N$  number of turns and if the magnetic field strength produced by it is  $H$ , then

$$H \propto IN$$

The field strength produced inside the solenoid is given by

$$H = \frac{IN}{L} \text{ ampere-turns/m}$$

where  $I$  = current flowing through the solenoid in amperes

$N$  = number of turns in the solenoid  
 $L$  = length of the solenoid in metres  
 $H$  = field strength or field intensity measured in ampere turns per metre or newton per weber

If in the above solenoid a piece of magnetic substance is inserted, then the number of lines per square metre is increased to a very high value.

This means that the number of lines of force per square metre cross-section area of a solenoid having a magnetic core is increased to a very high value in comparison with the number of lines of force produced per square metre of the air core coil. The increase in lines of force due to the magnetic core depends upon the nature of the magnetic material used.

If for a given substance, the number of lines increased per square metre be  $\beta$  for every value of the magnetizing force of  $H$ , then

$$B/H = \mu \quad (6.5)$$

where  $\mu$  is known as permeability (or magnetic conductivity).

**EXAMPLE 6.1** What is the field strength at the centre of a solenoid having 50 turns, if length of the coil is 0.25m and it takes a current of 1.5 A.

**Solution:** We know that the field strength

$$H = \frac{IN}{L} \text{ ampere-turns/m}$$

$$H = \frac{1.5 \times 50}{0.25} = 300 \text{ ampere-turns/m Ans.}$$

#### 6.24 RESULTANT MAGNETIC FIELD DUE TO CURRENTS IN TWO PARALLEL CONDUCTORS

If two straight long current carrying conductors are placed side by side parallel to each other, they experience a mechanical force due to the magnetic field around them.

When two conductors carry current in the same direction, then the flux surrounding them is as shown in Fig. 6.23 (a). It means that they experience a force of attraction between them. When the currents flow in the conductor in opposite directions, they experience a force of repulsion as shown in Fig. 6.23 (b).

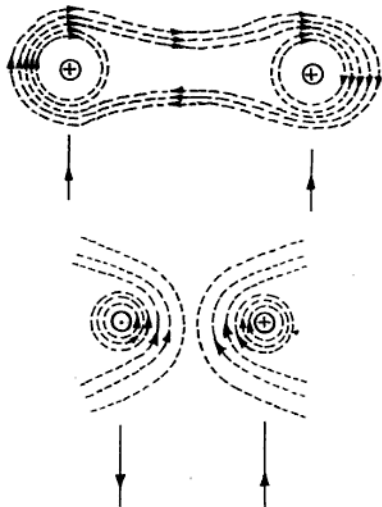

Fig. 6.23 Force acting between current carrying conductors:

- current flowing in the same direction fluxes help each other causes attraction.
- current flowing in the opposite direction fluxes oppose each other causes repulsion

**NOTE :** The symbol  $\oplus$  means current flowing into the wire i.e. away from the observer and symbol  $\odot$  means current coming out of the conductor, i.e. towards the observer.

#### 6.25 FORCE EXPERIENCED BY A CURRENT CARRYING CONDUCTOR IN A MAGNETIC FIELD

Suppose a straight conductor carrying current  $I$  A is kept in a magnetic field having a flux of  $B$  W/m<sup>2</sup> with the whole of its length  $L$  metres perpendicular to the flux, it experiences a mechanical force  $F$  which is given by

$$F = BILN \quad (6.6)$$

where  $B$  = flux density in Weber/metre<sup>2</sup>.

$I$  = Current flowing in amperes  
 $L$  = Length of the conductor in metres  
 $F$  = Force developed on the conductor in newtons

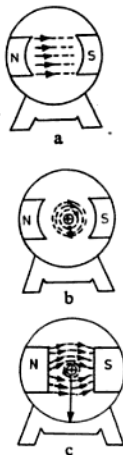

- (a) flux due to field poles only;  
 (b) flux due to current in the conductor only;  
 (c) force developed as flux tends to travel in straight line

Fig. 6.24 Force acting on a current carrying conductor kept in a magnetic field:

Figure 6.24 shows the magnetic flux due to the field, the current carrying conductor, the resultant flux and the force developed in the conductor,

**EXAMPLE 6.2** A conductor carrying current of 70 A is kept perpendicular to the magnetic field of flux density  $0.4 \text{ Wb/m}^2$ . Calculate the force developed in the conductor in newtons when the length of the conductor is 1m.

*Solution :*

$$\begin{aligned} \text{Force} &= BILN \\ &= 0.4 \times 70 \times 1 \\ &= 28 \text{ N Ans.} \end{aligned}$$

## 6.26 MAGNETIC LEAKAGE

The total flux developed in an iron ring does not pass through the air gap but some of it takes the leakage path (as shown in Fig. 6.25) because there is no insulating material for the magnetic circuit.

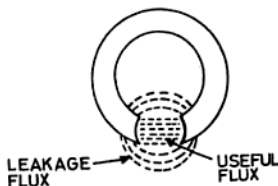

Fig. 6.25 Magnetic leakage

The ratio of the total flux developed and the flux passing through the air gap is called the leakage factor.

$$\text{Leakage factor} = \frac{\text{total flux}}{\text{useful flux}} \quad (6.7)$$

It is found that 15 to 20% of the total flux leaks away without doing useful work and is not desired in motors and generators because it lowers the efficiency of the machine. Leakage can be reduced by keeping the field coils as near the air gap as possible.

## 6.27 B/H CURVE

The permeability of a magnetic substance does not remain constant at all values of flux den-

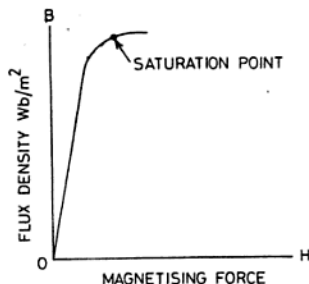

Fig. 6.26  $B/H$  Curve

sity i.e. the ratio of  $B/H = \mu$  (permeability) is not constant. In other words, the flux density ( $B$ ) does not vary in the same ratio as the magnetizing force at all values of  $H$ .

If for a piece of iron initially unmagnetized, the different values of the magnetizing force ( $H$ ) and the different values of the flux density ( $B$ ) are obtained by practical observation and a graph is drawn, it will be seen that for every value of  $H$ ,  $B$  is also small. When  $H$  is gradually increased,  $B$  increases very rapidly up to a certain value, and after that the increase in  $B$  is either very small or ceases for any further rise in  $H$ .

The point at which the increase in the flux density  $B$  ceases is called the saturation point. The value of permeability ( $\mu$ ) at this point is maximum and this is the value of permeability ( $\mu$ ) which is considered for all practical purposes.

The graph thus drawn is known as the  $B/H$  curve as shown in Fig. 6.26 and is very useful for finding the permeability of a magnetic substance at any desired flux density.

## 6.28 HYSTERESIS

Take a sample of ferromagnetic material that was originally completely demagnetized and now magnetize it to saturation point along curve  $oa$  as shown in the Fig. 6.27.

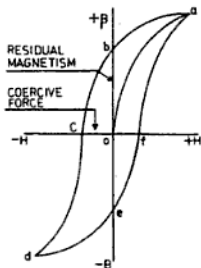

Fig. 6.27 Hysteresis loop of a typical ferromagnetic substance

It should be noted that this portion of the curve is identical with the magnetization curve (i.e.,  $B/H$  curve). If now the magnetizing force ( $H$ ) is reduced gradually, it will be noted that the flux density ( $B$ ) does not fall in the same

manner as it is increased, but has higher values at each step. Even when the magnetizing force ( $H$ ) becomes zero, an appreciable value of the flux density ( $B$ ) is retained by the magnetic substance. In the figure shown  $oa$  represents the rising curve and  $ab$  the falling curve. From the curve it is clear that the flux density ( $B$ ) has a value equal to  $ob$  when the magnetizing force ( $H$ ) is zero. The amount of flux density (i.e.,  $ob$ ) remaining when the magnetizing force has been reduced to zero is known as residual magnetism or remanence. For demagnetizing the sample, if the magnetizing force is reversed and then gradually increased, the flux density will continue to fall along the curve  $bc$  until it reaches a certain negative value of the magnetizing force ( $H$ ) equal to  $oc$ , after which the flux density ( $B$ ) will reach zero. The value of the negative magnetizing force required to demagnetize the sample completely (i.e.  $oc$ ) is known as the *coercive force*.

Again, if the magnetizing force ( $H$ ) in the reverse direction is increased above  $oc$ , the flux density ( $B$ ) will also be reversed and will start rising once it reaches to the reversed saturation point  $d$ . From there, if the magnetizing force ( $H$ ) is again gradually reduced to zero and then increased in the previous positive direction, the flux density will trace the curve  $defa$ . In the curve we find that the magnetism does not go in steps with the magnetizing force, but always remains behind the magnetizing force. The property of *lagging magnetism* behind the magnetizing force is called *hysteresis* and the curve formed ( $abcdefa$ ) is known as the *hysteresis loop*. If now the magnetizing force is again carried through another cycle of magnetization, the hysteresis loop will continue to follow the curve  $abcdefa$  and original magnetization curve (i.e.,  $B/H$  curve) ( $oa$ ) is never repeated.

The cause of the hysteresis is the friction between the molecules of the magnetic substance which requires expenditure of energy to change their position. The molecules change their position in the process of magnetization as well as demagnetization, and the energy thus expended in the process is converted into heat. The harder the material, the larger will be the area of the loop and therefore the greater will be the hysteresis loss. In other words, the hysteresis loss will be greater if the coercive force is greater. The area of the hysteresis loop depends upon the nature of

the soft iron or steel. In case of steel which is subjected to repeated reversals of magnetism (e.g. in the transformer core) it is essential that the area of the loop is very small. For this purpose steel alloyed with 4% silicon is used, which has a very narrow hysteresis loop. While using silicon, the material becomes brittle and reduces the efficiency. More silicon is added to reduce the hysteresis coefficient of the core material of the transformer; for the armature core, less silicon is added as there is a risk of it being broken due to the rotating part of the machine. Moreover, silicon increases the electrical resistivity and thereby also reduces the eddy current loss which will be discussed later.

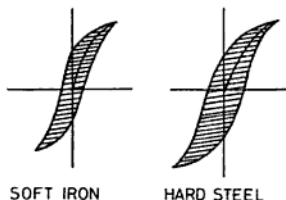

Fig. 6.28 Hysteresis loop for hard and soft ferromagnetic substances

Figure 6.28 shows the hysteresis loops for steel and soft iron. As may be seen from the figure, steel has a larger hysteresis loss than soft iron. Hence, for all armature cores of dynamo, motors, alternators, etc., soft iron is used.

The energy required for one cubic metre sample of iron for one complete cycle (or loop) is determined by

$$\text{Hysteresis loss per cycle} = \eta \beta_m^{1.6} \text{ J/m}^2/\text{cycle}$$

$$\text{Hysteresis loss per second} = \eta f \beta_m^{1.6} \text{ J/m}^2 \text{ (6'8)}$$

$$\text{Power loss in magnetic core} = \eta \beta_m^{1.6} f v \text{ W/m}^2$$

where  $\beta_m$  = Maximum flux density in a cycle

$f$  = Frequency (i.e. number of complete cycle per second).

$V$  = Volume of magnetic material in cubic metres

$\eta$  = Constant of hysteresis co-efficient

#### 6.29 MAGNETIC MATERIALS FOR PERMANENT MAGNET

For the manufacturing of magnetic materials

for permanent magnets, the following materials can be alloyed with iron or steel.

- (i) Nickel,
- (ii) manganese,
- (iii) aluminium,
- (iv) silicon, and
- (v) cobalt.

If the presence of nickel in the steel is less than 20%, it causes an increase in the coercive force, but if its presence is more than 20%, the coercive force is decreased.

The presence of aluminium in a small quantity increases the permeability, but the addition of silicon in a low quantity decreases the permeability and thus increases the coercive force. However, if the quantity of silicon is more than 2.5%, the permeability of the magnetic material increases and the coercive force decreases. Similarly, the addition of manganese reduces the permeability to a great extent, and its presence up to 15.2% causes iron to be nonmagnetic.

It has also been observed that alloy of nonmagnetic materials has shown magnetic properties, i.e., an alloy of 14.6% aluminium, 26.5% manganese and 58.9% copper has a permeability of 37%. This alloy is known as *henster*.

#### 6.30 MAGNETIC MATERIAL FOR TEMPORARY MAGNET

Temporary magnets can easily be made by sending current through them and their magnetic strength can also be increased or decreased easily. It is for this reason that they are considered more useful than permanent magnets.

Earlier the soft iron was used for making temporary magnets but later, silicon steel was used which has 2-4% silicon. Now a days some more metals have also been developed for making temporary magnet as permalloy, mumetal, etc.

**Permalloy** It is an alloy containing 78.5% nickel and 21.5% iron. It can be magnetized in a very weak magnetic field and is useful for telephones.

**Mumetal** It is also an alloy of 75% nickel, 5% copper, 2-4% chromium and 16-18% iron. It has very high permeability and high resistivity, so the eddy current loss is

small. This metal is useful for making core of the instrument transformers and for screening the magnetic field.

### 6.31 ELECTROMAGNETIC INDUCTION

The tendency of electric current to flow in a conductor when it is moved in a magnetic field is known as *electromagnetic induction*. This phenomenon of electromagnetic induction was discovered by Faraday.

### 6.32 FARADAY'S LAWS OF ELECTRO-MAGNETIC INDUCTION

**First Law** This law can be stated as follows: When a changing flux is linked with the circuit, an emf is induced in the circuit. This emf will last only during the interval of change of the number of lines of force linked with the circuit.

Alternatively, it can be stated as: Whenever a conductor (circuit) cuts across the magnetic lines of force, an emf is induced in it.

**Second Law** The value of the emf produced is directly proportional to the rate of change (or cutting) of flux linked with the conductor.

### 6.33 FARADAY'S PRINCIPLE

When a conductor is moved in a magnetic field so as to change the number of lines of force passing through it or when the strength of the magnetic field is varied so as to either increase or decrease the number of lines of force passing through it, an emf is induced in the conductor as long as the number of lines of force are being changed.

The emf thus produced in the conductor is known as induced emf and that part of the conductor which cuts the lines of force is

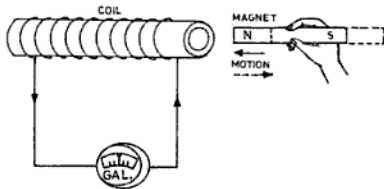

Fig. 6.29 Field moved and conductor kept stationary

known as an *inductor*. The change in the number of lines of force linked with the conductor is obtained by the relative motion between the conductor and the magnetic field, i.e., (i) either the field is moved and the conductor is kept stationary (Fig. 6.29) or the field is kept stationary and the conductor is moved (Fig. 6.31). This method is known as the dynamic method of producing emf and is employed in the case of generators, or (ii) both the field and the conductor are kept stationary and the number of lines of force of the magnetic field is varied as shown in Fig. 6.30. This method of producing emf is called statically induced emf and is utilized in the case of transformers only.

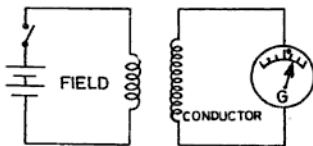

Fig. 6.30 Both conductor and field stationary but flux varied

According to Faraday's second law, the emf induced in a conductor is also proportional to the rate of change of flux linked with the conductor. Therefore, when a straight conductor cuts flux at the rate of  $1\text{Wb}$  ( $10^8$  maxwells) per second, an emf of  $1\text{V}$  is generated in it, and if it forms a closed circuit, a current will flow through the galvanometer as shown in Fig. 6.31.

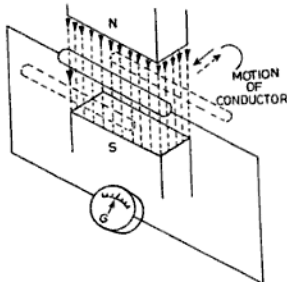

Fig. 6.31 Conductor cuts stationary flux

emf induced = flux cut per second  
 if  $\beta$  = flux density in  $\text{Wb/m}^2$   
 $L$  = active length of the conductor cutting the flux in metres  
 $V$  = velocity in metres per second  
 then  $\text{emf} = \beta L V$

In the above relation it is assumed that the conductor cuts perpendicularly across the field, but if the conductor makes an angle  $\theta$  with the lines of force, then  
 $\text{emf induced} = \beta L V \sin \theta$  (6.9)

### 6.34 FLEMING'S RIGHT HAND RULE

The direction of the induced emf in the conductor of the generator can be determined by Fleming's right hand rule as in Fig. 6.32.

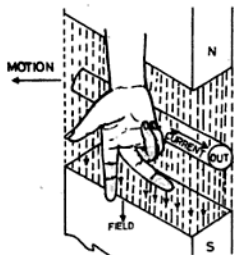

Fig. 6.32 Fleming's right hand rule

This law states that if one extends the thumb, forefinger and middle finger of the right hand at right angles to each other in such a way that the thumb points in the direction of motion of the conductor, the forefinger in the direction of flux (from north to south), then the middle finger will indicate the direction of the induced emf in the conductor.

**EXAMPLE 6.3** If a straight conductor, 6m long is moved at a speed of 0.75 metre per second perpendicular to a uniform magnetic field of  $2 \text{ Wb/m}^2$ . Calculate the emf induced in the conductor.

**Solution :** –

$$\begin{aligned} \text{emf induced} &= \beta L V \sin \theta \text{ V} \\ &= 2 \times 6 \times 0.75 \times \sin 90 \\ &= 2 \times 6 \times 0.75 \times 1 = 9\text{V} \text{ Ans.} \end{aligned}$$

### 6.35 LENZ'S LAW

Lenz's law states that the induced emf in the coil is developed in such a direction that it always opposes the cause due to which it is induced.

To understand the above fact, let us suppose that the north pole of a bar magnet is brought near the coil as shown in Fig. 6.33 and

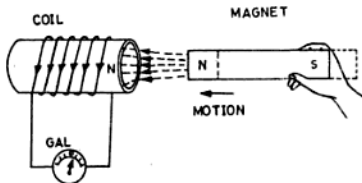

Fig. 6.33 North pole of bar magnet repelled back by induced north pole of coil

induces an emf in it which circulates the current in the coil. This induced current flows in the coil in anticlockwise direction and produces north pole in the coil (viewing from the north pole of the magnet) which now tends to push back the magnet.

Again, when the magnet is taken away from the coil as shown in Fig. 6.34, the induced current in the coil flows in clockwise direction and thus produces the south pole. In this case the north pole of the bar magnet is attracted by the south pole of the coil. Therefore, we come to know that the cause (i.e., relative motion) which produces induced current in the coil is opposed by the magnetic effect of the induced current. It means that the induced current always tends to flow in such a direction as to oppose the cause which produces it.

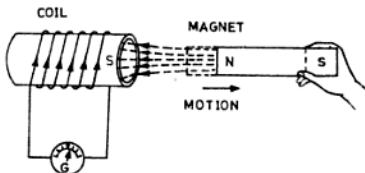

Fig. 6.34 North pole of the magnet attracted by induced south pole on the coil

## EXERCISES

- 6.1 A solenoid of 3m length has 90 turns and takes 3.5 A. Find the field intensity of the solenoid at its centre. (Ans. 105 ampere-turns/m)
- 6.2 The length of the solenoid is 50 cm and has 77 turns. It takes 4.5 A when connected to 220 V supply mains. Determine the intensity of the magnetic field. (Ans. 630 ampere-turns/m)
- 6.3 A solenoid 65 cm long has 78 turns and its resistance is 44  $\Omega$ . Calculate the magnetic intensity of solenoid when connected across 220 V supply. (Ans. 600 ampere-turns/m)
- 6.4 A solenoid of 40 turns of wire has a length of 32 cm. What will be the value of the current to set up a field strength of 2500 ampere-turns/m inside the solenoid? (Ans. 20 A)
- 6.5 A solenoid 200 cm long is wound with 400 turns of wire. What will be the current required to set up a field strength of 5000 ampere-turns/m inside the solenoid? (Ans. 25 A)
- 6.6 A solenoid of 800 turns is 750 cm long. What current will be required to set up a field strength of 6000 ampere-turns/m? (Ans. 56.25 A)
- 6.7 A conductor carrying current of 50 A is kept perpendicular to the magnetic field of flux density 0.25 Wb/m<sup>2</sup>. Find the force acting on the conductor in newtons when the length of the conductor is 2250 cm. (Ans. 562.5 N)
- 6.8 A conductor lying perpendicular to a magnetic field of flux density 0.55 Wb/m<sup>2</sup> is carrying a current of 0.75 A. Calculate the force acting on the conductor if the length of the conductor is 1.2 m. (Ans. 0.495 N)
- 6.9 A coil is wound with 50 turns of wire. The flux density in the air gap is 0.45 Wb/m<sup>2</sup> and the effective length of the coil sides in the gap is 5 cm. Find the force in newtons acting on the coil sides when carrying a current of 80 mA. (Ans. 0.09 N)
- 6.10 If a straight conductor 1.5 m long is moved at a speed of 55 cm/s at right angles to a uniform magnetic field of 1 Wb/m<sup>2</sup>. Find the induced emf in the conductor. (Ans. 0.825 V)
- 6.11 How much emf will be induced in a conductor of 4 m long if it is rotated at 0.75 m/s at an angle of 30° to a uniform magnetic field of 2 Wb/m<sup>2</sup> (Ans. 3 V)

## REVIEW QUESTIONS

- 6.1 (a) What is the difference between natural and artificial magnets?  
(b) Explain the main differences between permanent magnets and electro-magnets.
- 6.2 What is the difference between ferromagnetic, paramagnetic and diamagnetic substances?
- 6.3 What do you understand by a magnetic line of force and a magnetic field? Also, mention the properties of a magnet and magnetic lines of force.
- 6.4 Describe the molecular theory of magnetism and explain how an iron bar is magnetized according to this theory.
- 6.5 What material is used for a permanent magnet? How will you magnetize a horse-shoe magnet which has lost most of its magnetism. (N.C. V.T. 1962 Elect.)
- 6.6 (a) What is electromagnetism? Give some examples of uses of electromagnets.  
(b) What are the advantages of electromagnets over permanent magnets. (N.C. V.T. 1967 Elect.)
- 6.7 What is meant by the term magnetic hysteresis. Explain it.

- 6.8 What do you understand by electromagnetic induction? Explain Faraday's laws of electromagnetic induction.
- 6.9 (a) Define induced emf and induced current. Describe Faraday's principle of electromagnetism.  
(b) Describe with a diagram Fleming's rule for determining the direction of induced current in a magnetic field. (NCVT 1966 Elect.)
- 6.10 (a) State Faraday's laws of electromagnetic induction.  
(b) What do you understand by Fleming's right and left hand rules for dc degenerators and motors. (NCVT 1980 W/man)
- 6.11 Explain the following:
- (i) Fleming's left hand rule,
  - (ii) Faraday's laws of electromagnetic induction
  - (iii) Lenz's law,
  - (iv) solenoid,
  - (v) cork screw rule,
  - (vi) ampere's rule,
  - (vii) coercive force,
  - (viii) remanance,
  - (ix) magnetizing force, and
  - (x) magnetic saturation.

# 7

## DC Generators

### 7.1 DC GENERATOR

A generator is a machine which takes mechanical energy and converts it into electricity. A generator does not produce electricity by magic, it simply converts mechanical energy given to it into electrical energy. This mechanical energy rotates the armature of a generator and thus electrical energy is produced in the armature conductors. For producing electricity from a generator, the following three requirements are essential:

- (i) Conductors,
- (ii) magnetic field, and
- (iii) mechanical energy.

(i) **Conductor** Insulated conductors are placed in armature slots.

(ii) **Magnetic Field** The magnetic field is obtained by the use of either a permanent magnet or an electromagnet. However, in all generators the electromagnet is widely used. The reason is that the magnetic field can be easily controlled. These field poles are provided on the pole shoe of the generator.

(iii) **Mechanical Energy** For the rotation of the conductor, mechanical energy is obtained from the primemover. The mechanical energy given to the generator rotates the armature conductors which cuts the magnetic lines of force, and emf is induced.

### 7.2 WORKING PRINCIPLE OF DC GENERATOR

A generator works on the principle of Faraday's law of electromagnetic induction which says that *whenever a conductor is moved in the magnetic field, an emf is generated in the conductors and the magnitude of the induced emf is directly proportional to the rate of the cutting flux.*

The emf generated in the conductor is of alternating nature and the generator which

gives out electrical energy in the form of alternating current is called an alternator and will be discussed in Chapter 13.

The generator which gives out electrical energy in the form of direct current is called a dc generator or dynamo. The essential difference between the alternator and the dynamo is that in an alternator slip rings are used to collect the supply (in a rotating-type armature), while in the dynamo, the commutator is used for this purpose. This commutator also converts the alternating current induced in the conductors into direct current for the external circuit.

### 7.3 CONVERSION OF AC INTO DC BY COMMUTATOR

The way the commutator converts ac into dc is explained below with the help of Fig. 7.1.

In Fig. 7.1a, two coil sides  $AB$  and  $CD$  rotate anticlockwise under the poles north and south. The end of the conductor  $AB$  is connected with segment  $S_1$  which is a half of a ring and is a part of a commutator consisting of two segments, say  $S_1$  and  $S_2$ . The end of the coil side  $CD$  is connected with the segment  $S_2$ . These segments rotate along with the armature. To collect the supply from these segments, two brushes  $B_1$  and  $B_2$  are provided. The two brushes are stationary and supply a current to the external load  $LM$ . The nature of the current flowing through the load resistance will be considered when the coil rotates.

In Fig. 7.1 (a), since the coil sides are midway between the poles, no emf is induced in the conductors, and also, there is no current through  $LM$ .

In Fig. 7.1 (b), the conductors have moved one-fourth of a revolution and now the coil side  $CD$  is under the north pole while the coil side  $AB$  is under the south pole. The current induced in  $CD$  is outward and in  $AB$  inward. The coil side  $CD$  is connected to the segment  $S_2$  which is in contact with

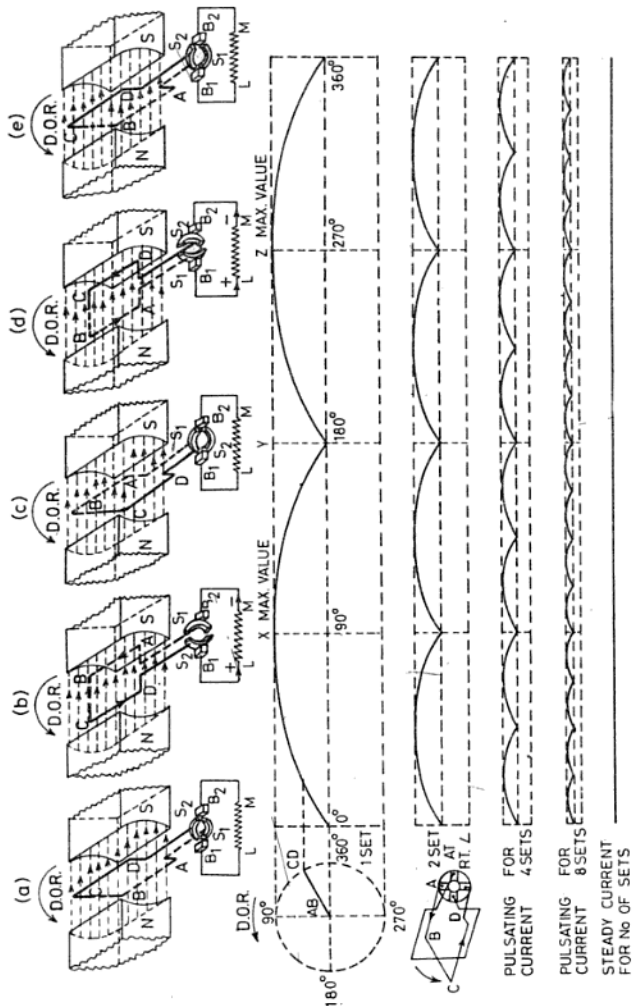

Fig. 7.1 DC generator

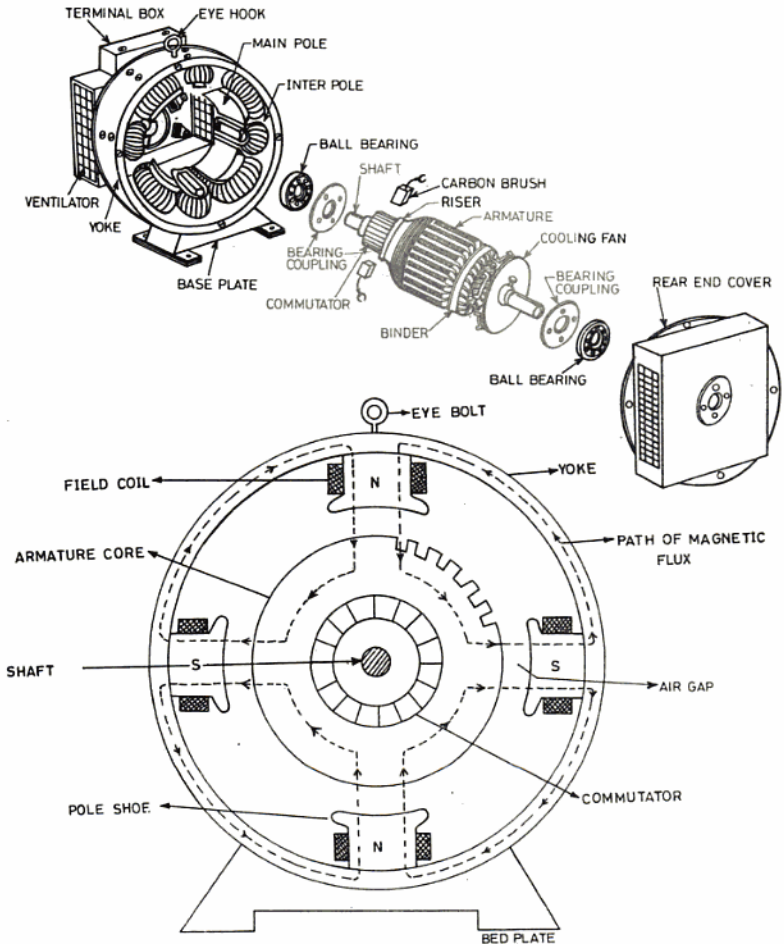

Fig. 7.2 Parts of generator

brush  $B_1$ . Therefore, a current flows through the external load resistance  $LM$  in the direction from  $L$  to  $M$ . The brush  $B_1$  now becomes positive. The position of the current (voltage) at this instant is shown in the graph at  $X$ .

In Fig. 7.1 (c) the conductors have again rotated through another one-fourth of a revolution and again there is no emf induced in them in this position. It means that the emf has decreased to zero from its maximum value and the graph of the current is shown at  $Y$ .

When the conductors further rotate, an emf is again induced in them but now the current in the coil side  $CD$  is inward while in the coil side  $AB$  it is outward. In this position segment  $S_1$  is touching the brush  $B_1$  which again receives a positive current and therefore again the current in the resistance  $LM$  is in the same direction,  $L$  to  $M$ . The position of the current at this instant is shown in the graph at  $Z$ .

When the coil sides further rotate, the emf decreases till the coil sides are midway between the pole. Therefore, the current through the load resistance  $LM$  is zero at this instant as shown in Fig. 7.1 (e) and in the graph.

From Figs 7.1 (b) and (d), it is also clear that in one complete revolution of the coil, the brush  $B_1$  always receives a positive current. In other words, the current from the brush  $B_1$  always flows in one direction. This current is pulsating in nature, but for many purposes steady current is more desirable than a pulsating one. The pulsations are reduced by using many conductors on the armature. The resultant emf for two sets of coils which are  $90^\circ$  apart are shown in the graph. The resultant emf is very nearly steady. In a commercial machine the armature consists of several coils wound on it. Turbines are used to drive the armature.

#### 7.4 PARTS OF DC GENERATOR

The essential parts of a dc generator (or motor) are discussed below (Fig 7.2).

**Yoke** The yoke is also known as the body of the machine. The field poles are screwed to the yoke. It offers easy path to the magnetic lines produced by the field poles. The yoke carries only half of the flux carried by the main pole, so that the cross sectional

area of the yoke frame can be kept half of the area of the main pole. The function of the yoke is to provide support to the armature and field windings.

The yoke is made of a magnetic material such as cast iron or Silicon steel, which has great strength and permeability. In small machines, where cost is the main consideration and the weight of the machine does not matter, cast iron is mainly used. In big machines where weight and efficiency are main considerations cast steel is used. Undoubtedly, cast iron is cheaper, having half the permeability as that of cast steel.

**Field Pole** In small dc machines the poles are cast with the body or the yoke, but in big machines the pole shoes are screwed with the yoke. They are made of cast steel or cast iron as it offers low reluctance to the magnetic lines. Wound coils are slipped over the pole shoes. All the field coils (four or six as the case may be) are connected in series in such a way as to produce opposite polarities at the adjacent poles. The ends of the field coils are brought out to the terminal box of the machine. In Fig. 7.2, the arrangement of a four-pole system and the path of the magnetic lines are shown. The function of these poles is to support the field coils and to produce magnetic field in the machine.

The field poles are always electromagnet except occasionally in very small generators (known as magneto-generators or magnetos) where a permanent magnet is used. The narrow space between the pole shoe and the armature core is called the air gap.

**Armature Core and Winding** The armature is a cylindrical drum consisting of thin circular stampings of silicon steel (to reduce the hysteresis losses) and winding as shown in Fig 7.3.



Fig. 7.3 Armature without winding

The core provides low reluctance to the magnetic lines of force. The discs or stamping are insulated from each other by a shellac varnish, thin paper or oxide film coating. The thickness of the stampings varies from 0.35 to 0.5 mm in order to reduce the heat produced due to eddy currents. The armature is provided with slots on its circumference in which the conductors are housed. These stampings are mounted on the shaft and are held firmly by a key. The armature is free to rotate between the magnetic poles. A commutator is fixed on one side of the shaft and on the other side, a fan is fitted to increase the circulation of air.

The armature performs three main functions. Firstly, it supports the conductor, secondly, it causes the conductor to rotate between the magnetic field, and thirdly, it provides low reluctance. There are two types of armature in use :

- (i) ring-type armature, and
- (ii) drum-type armature. Mostly, the drum-type armature is used nowadays. The slots are made on the circumference of the armature and are of three types

as follows : (a) open-type slot, (b) semi-enclosed type slot, and (c) enclosed-type slot.

**Commutator** It is an electrical device which automatically reverses the direction of the coil. It is cylindrical in shape and consists of a number of copper segments of high conductivity, hard-drawn copper, insulated from each other as well as from the shaft by mica (Fig. 7.4).

The commutator is fixed at one end of the shaft, usually on the opposite side to which the pulley is fixed. Raised extensions are provided to each commutator segment. They are called risers. Armature coil ends are soldered to these risers.

**Brushes** In small machines the current collecting brushes are made of carbon and of copper-carbon alloy or copper in heavy-current, big machines. Each brush is placed in hollow brass bars known as brush holders so that it can slide in them. They rest on the commutator against the spring tension. The tension of the spring varies from 0.1 to 0.25 kg/cm<sup>2</sup> of the brush surface area. Its

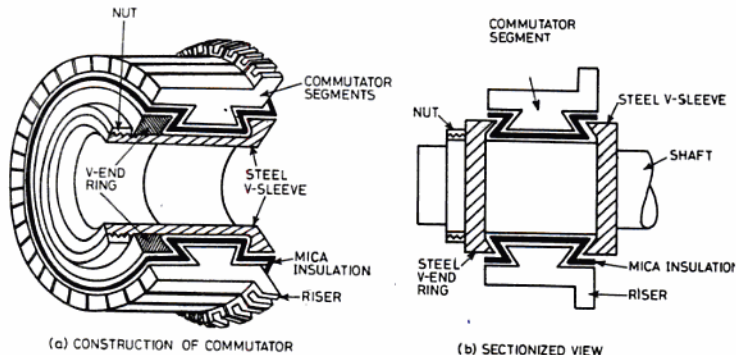

Fig. 7.4 Construction of commutator

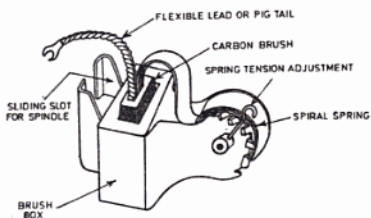

Fig. 7.5 Carbon brush and brush-holder

tension is adjusted by means of a lever provided with it. They collect the current from the armature and deliver the same to the external circuit.

**Brush Lead** The brush lead is also sometimes known as the pig tail. It is a piece of wire connected to the carbon. It is made of a copper conductor and its purpose is to make a connection between the brush and a point outside the circuit.

**Brush Rocker** It is also known as a brush gear. It consists of a circular ring fixed by studs to the front end plate. The stud holes are slotted so that the brush rocker can be moved either way and the brushes can thus be placed at the desired position on the commutator. The brush holders are insulated in the rocker and fixed to it.

**Front End Cover** The front end cover is also sometimes known as the commutator end Plate. It is fitted with bush bearings, ball bearings or roller bearings. The front end cover carries the brush gear. However, in the case of the motor, the cover on the pulley side is called the front end cover. It is made of cast iron and is screwed with the yoke.

**Rear End Cover** It is also made of cast iron and is screwed with the body. It is also fitted with the bearing. Both the end covers are provided with ventilation slots or holes for cooling purposes.

**Cooling Fan** A cooling fan made of cast iron is also fitted on the opposite side of the commutator shaft. As the armature starts rotating, it also rotates and gives fresh air for cooling the armature.

**Bearing** It is a device which gives free and smooth rotation to the armature. It is fitted inside the side cover and between them the armature revolves. The following types of bearings are in use:

- (i) Bush bearing,
- (ii) ball bearing, and
- (iii) roller bearing.

**Shaft and Pulley** It is made of mild steel and rests on the two bearings provided in the side covers. The armature and commutator are also fitted on the shaft.

The pulley is made of cast iron and is fixed on the shaft by a key or stud.

**Eye Bolt** The eye-bolt is provided with the body generally on the top for lifting the machine.

**Bed Plate** The bed plate is also known as the base of the machine. The machine is fitted on the foundation and is bolted at the bed plate.

**Coupling** It is the mechanical connection between the shaft of the generator and that of the steam engine or any other primemover which drives the generator.

**Terminal Box** This is an insulated box which carries the brass nuts and bolts to which wires from the brushes and field poles are brought out for connection with the external circuit.

## 7.5 EDDY CURRENTS

If the armature is made of solid iron (i.e., it has low resistance) and is rotated in between the poles of a magnet, emf is induced in the armature core as it is generated in the coils placed in the armature. This emf which causes the current to flow in the core are known as eddy currents.

Since the resistance of the armature is low, heavy currents will flow resulting in heavy power loss ( $I^2R$ ), which is converted into heat. This heat is directly proportional to the square of eddy currents, resistance of the core and the time for which the currents flows. Due to this heat the winding on the armature core is also heated. This, in turn, increases the temperature of the core and weakens the

insulation of the winding, and hence reduces the efficiency of the machine.

These eddy currents can be minimized by increasing the resistance of the armature core (Fig. 7.6). The resistance of the core is

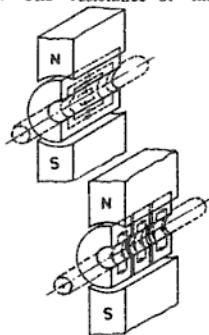

Fig. 7.6 How eddy currents are minimized

increased by making the core of thin sheets (0.35 to 0.5mm) lightly insulated from each other. By this the cross-section of the core is reduced and the length remains the same. This results in an increase of resistance of the individual core, thereby decreasing the eddy currents which are bound to their respective core. This type of core is called a laminated core and the sheet from which it is made is called lamination.

#### 7.6 TYPES OF WINDINGS ON THE ARMATURE

There are two main types of windings done on the armature:

- (i) Lap winding, and
- (ii) wave winding.

The difference between two exist merely in the end connection of the armature coils on the commutator.

**Lap Winding** In lap-wound armatures there are as many paths in parallel as the machine has poles and the total current divides equally among them. The number of brushes is equal to the number of poles in the machine. This winding is also known as

parallel paths or multiple circuit winding. The generators of a larger current and low voltage output (and Large variable speed motors) have this type of armature winding.

**Wave Winding** In wave-wound armatures there are two paths in parallel irrespective of poles in the machine and each path passes half the total current. Two sets of carbon brushes are fitted for the collection of current, but it is usual to install as many sets of carbon brushes as the machine has poles. The generators of low current and high voltage have wave-wound armatures.

#### 7.7 EMF EQUATION OF GENERATOR

The emf induced in a conductor when rotated in a magnetic field is directly proportional to the rate of change of magnetic lines of force.

It is found that when a conductor cuts or varies one weber ( $10^8$  maxwells) magnetic lines of force per second, one volt is induced in the conductor. Let, in a machine

$P$  = number of poles

$\phi$  = flux per pole in Wb

$N$  = speed of armature in revolution/min

$Z$  = total number of conductors on armature

$a$  = number of parallel paths in armature

$E$  = emf produced by one of the parallel paths in volts

emf generated by armature = flux cut per second in volts

Flux varied by one conductor during one revolution =  $P\phi$  Wb/m<sup>2</sup>

Flux varied by one conductor per second

$$= \frac{P\phi N}{60}$$

emf induced in one conductor

$$= \frac{P\phi N}{60} \text{ V}$$

No. of conductors in one path of the arma-

ture =  $\frac{Z}{a}$  where  $a$  = Parallel paths in armature

$$\begin{aligned} \therefore \text{ emf induced/path} &= \frac{P\phi N}{60} \times \frac{Z}{a} \text{ V} \\ \text{ emf} &= \frac{\phi Z N}{60} \times \frac{P}{a} \end{aligned} \quad (7.1)$$

(Here  $P$ ,  $a$  and  $Z$  are constant)

NOTE: This means that emf induced depends upon the flux and speed.

EXAMPLE 7.1 An eight pole lap-wound armature has 800 conductors and a flux of 15 mWb per pole. Find the emf induced in an armature when running at a speed of 500 rpm. Also, calculate the emf generated if the armature is wave-wound.

Solution:

Given  $P = 8$  poles

$$\phi \text{ per pole} = 15 \text{ mWb} = \frac{15}{10^3} = 15 \times 10^{-3} \text{ wb.}$$

$$N = 500 \text{ rev/min}$$

$$Z = 800 \text{ conductors}$$

(i) When the armature is lap-wound

We know, emf induced

$$= \frac{\phi Z N}{60} \times \frac{P}{a}$$

$\therefore$  emf induced in lap-wound armature

$$= \frac{15 \times 10^{-3} \times 800 \times 500}{60} \times \frac{8}{8}$$

(in lap winding  $a = P = 8$ )

$$= 100 \text{ V Ans.}$$

(ii) When the armature is wave-wound

emf induced in wave-wound armature

$$= \frac{\phi Z N}{60} \times \frac{P}{a} \text{ (in wave-winding } a = 2)$$

$$= \frac{15 \times 10^{-3} \times 800 \times 500}{60} \times \frac{8}{2}$$

$$= 400 \text{ V Ans.}$$

## 7.8 CHARACTERISTICS OF DC GENERATOR

The characteristic curves of a dc generator

are discussed below:

(i) **Open Circuit Characteristic Curve (OCC)**  
Sometimes, it is also called no load or magnetic characteristic curve. This curve gives the relation between the emf generated ( $E$ ) in the armature and the field current ( $I_f$ ) at the rated speed.

(ii) **Internal Characteristic Curve (ICC)**  
This curve is also known as the total characteristic curve and gives the relation between the emf generated ( $E$ ) and the armature current ( $I_a$ ) of the generator.

(iii) **External Characteristic Curve (ECC)**  
This curve gives the relation between the load current ( $I_L$ ) and the terminal voltage ( $V_t$ ).

**Methods of Magnetization of Field For Generator**  
There are three principle methods of magnetization of a field for generators as discussed below:

(i) **Permanent Magnetic Fields Method**  
In this method permanent magnets are used for producing a magnetic field and the generator is then known as a permanent magnet generator or "magneto".

(ii) **Separately Excited Fields Method**  
In this method electromagnetic field poles are excited by a current supplied from a separate independent source such as a battery. The generator is then said to be a separately excited generator.

(iii) **Self-Excited Fields Method**  
In this method electromagnetic fields are magnetized by a current obtained from the generator itself. In this case the generator is said to be a self-excited generator.

## 7.9 CLASSIFICATION OF DC GENERATORS

The classification is given below:

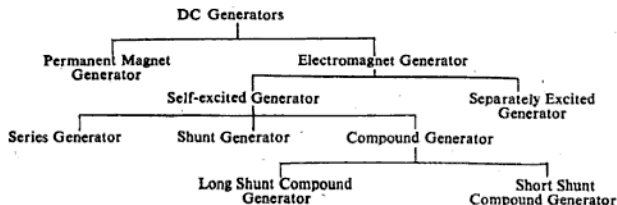

### 7.10 PERMANENT MAGNET GENERATOR

This type of generator is also known as a magneto-generator or simply magneto (Fig. 7.7). As it is clear from its name, the field

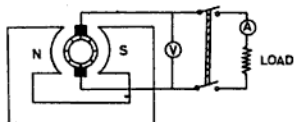

Fig. 7.7 Magneto generator

flux in this type of generator is produced by permanent magnets. We know that the field strength of a permanent magnet remains constant, so that emf induced in the armature of such type of generator remains constant. Thus the emf induced in the armature of a magneto is directly proportional to the speed and for a given speed the emf generated is constant.

**Characteristics of Magneto Generator** The characteristics of a magneto generator are shown in Fig. 7.8. Curve 1 is the OCC curve which gives the relation between the induced emf and the load current (in this case there is no field current and therefore,  $I_L = I_f$ ). As the induced emf is independent of the load current, the curve is a straight line parallel to the x-axis.

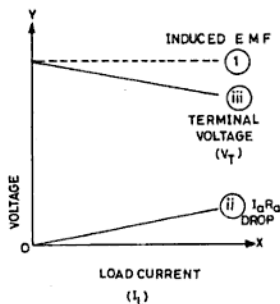

Fig. 7.8 Characteristics of magneto generator

Curve 2 is for voltage drop in the armature and as the voltage drop increases with the load current, this curve also starts from zero and increases in a straight line.

Curve 3 represents the terminal voltage ( $V_T$ ) of the generator which is the difference of emf induced and voltage drop in the armature (i.e.  $V_T = \text{emf} - I_a R_a$ ). Curve 3 drops a little with an increase in current because the voltage drop in the armature increases with the increase of load current.

Magneto generators are not much used in practice and are only used in instruments, such as megger and cycle, motor cycle dynamo.

**Disadvantages of Magneto** The main disadvantages of the magneto are :

- (i) Its voltage cannot be changed.
- (ii) It is difficult to have very strong permanent magnets.
- (iii) The magnetic power of the permanent magnet changes, though slightly, with time.

### 7.11 ELECTROMAGNET GENERATOR

In this type of generator the field flux is produced by passing the current through the coils wound on the pole shoe. The electromagnet generator may be a separately excited generator or a self-excited generator.

### 7.12 SEPARATELY EXCITED GENERATOR

In this type of generator, the field flux is produced by winding coils on the pole pieces through which dc is passed from the external source which may be a battery or another dynamo. The connections of such a generator are shown in the Fig. 7.9. The field windings

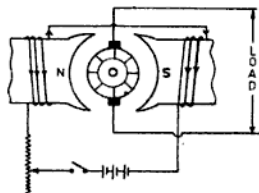

Fig. 7.9 Separately excited generator

are connected in series and are supplied from a battery through a variable resistance which can vary the current in the field coils to which the flux is directly proportional.

#### Characteristic of Separately Excited Generator

The characteristic curves of separately excited generators are shown in Figs. 7.10 and 7.11. The curve in Fig. 7.10 is the OCC curve and gives the relation between the current through the field windings and the emf induced in the armature. The curve starts from zero (0), increases rapidly and then becomes approximately parallel to the  $x$ -axis. The reason for its becoming parallel to the  $x$ -axis is the magnetic saturation of the field poles. The curves in Fig. 7.11 gives the relation between load current induced emf, drop in the armature and terminal voltage. These curves are similar to the magneto.

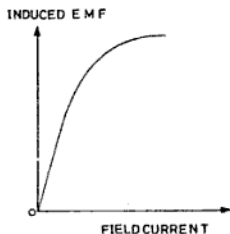

Fig. 7.10 OCC curve of generator

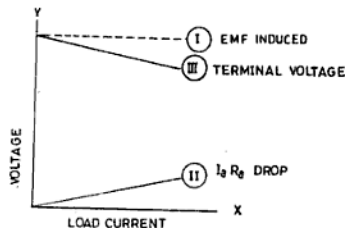

Fig. 7.11 ICC-cum-ECC curve of separately excited generator

As a separate dc source is required for field excitation, these generators are not generally used but can be used where large variation in voltage is required.

#### 7.13 SELF-EXCITED GENERATOR

In addition to the field winding on the poles, in such generators some residual magnetism is also provided in the poles. When the armature rotates under the poles, due to the residual magnetism, the some emf is induced in the armature windings (though very small). This emf is applied across the field winding and the current flows in such a way that it increases the magnetic power of the field poles, i.e. increases the flux. This increase in flux increases more emf in the armature conductors which further increases the flux and in this way the armature produces full voltage after a short time. Thus in a self-excited generator, no external source is needed and the emf induced in the armature itself is used to excite the field poles.

There are three types of self-excited generators as given below :

- (i) Series generator,
- (ii) shunt generator, and
- (iii) compound generator.

#### 7.14 SERIES GENERATOR

The series wound generator is so named because the armature and field windings are connected in series as shown in Fig. 7.12. The wire used for the armature and series field winding is comparatively thick and has only few turns with the result that the resistance within the generator is small.

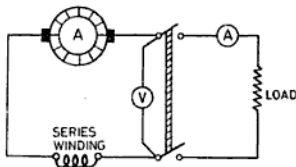

Fig. 7.12 Series generator

This type of generator is run at full speed and the load switch is put on. Due to residual magnetism a small emf is produced

which causes a current to flow in the armature, field winding and load. The current through the field winding produces more flux which further increase the induced emf. In this way the generator builds up its full voltage.

In an open circuit there is no flow of current through the generator as the field winding is in series with the armature. This kind of generator is always started after installing the constant load on it. If some load is increased, the exciting current is also increased. Thus the armature will cut more flux. Therefore in this way the generator will produce higher voltage than before and the outer circuit will be disrupted. Therefore, this kind of generator is always started on load, specially on constant load.

To regulate the emf induced, the current of the series field is controlled (or diverted) by a diverter. The diverter is installed in parallel to the series field so as to divert some of the current as shown in the Fig. 7.13. The current in a series generator is given by

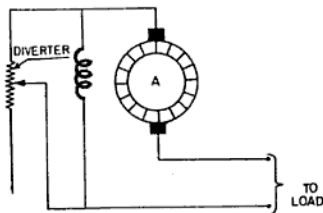

Fig. 7.13 Series generator with diverter

$$I = \frac{E}{R_a + R_f + R_L}$$

where  $E$  = emf induced in the armature in volts

$R_a$  = Resistance of the armature in ohms

$R_f$  = Resistance of series field in ohms

$R_L$  = Resistance of the load in ohms

Voltage drop across the load is given by

$$I_L \times R_L = E - I(R_a + R_f) \text{ V}$$

$$\text{or } V_T = E - I(R_a + R_f) \text{ V} \quad (7.2)$$

$$\text{or } E = V_T + I(R_a + R_f) \text{ V} \quad (7.3)$$

Series generators are generally not used because their terminal voltage varies with variation in the load. These are only used as a booster generator in dc long transmission line to boost or inject the line voltage drop.

**Characteristic Curve of dc Series Generator** A curve between the field current (which is also the load current ( $I_L$ ) or armature current ( $I_a$ )) and the emf induced in the armature conductor is shown in Fig. 7.14. The curve starts a little above zero because when the field current is zero, even then some induced emf is due to residual magnetism. The curve increases rapidly in a straight line with the increase of current and then it becomes flat due to magnetic saturation of the field poles.

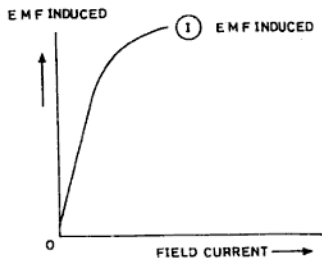

Fig. 7.14 OCC curve of dc series generator

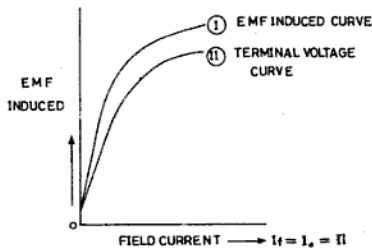

Fig. 7.15 ICC-cum-ECC characteristic curve of dc series generator

In Fig. 7.15 two curves are shown. Curve I is the induced emf curve and curve II is the terminal voltage curve. Curve II of the terminal voltage is similar to curve I but it is a little below curve I. The reason for this is the voltage drop in the armature and the field winding. In the beginning the difference between curves I and II is less, but it increases as the terminal voltage of the generator decreases.

### 7.15 SHUNT GENERATOR

In a shunt generator the field winding is in parallel to the armature (Fig. 7.16) and thus the full voltage induced in the armature is applied to the shunt field winding. That is why the field winding consists of a thin wire of many turns so as to drop the full voltage across it.

The generator is started at its normal speed by the primemover with the load and field switches open. A small emf is generated which is due to residual magnetism. If now the field switch is closed, this small emf will send a current through the field winding which increases the field flux. This increase in the flux causes more emf to be induced in the armature and this goes on till the generator attains its full voltage. The load switch is kept open at the time of starting because the emf induced at that time is very small. If at the time of starting full load is connected in parallel to the field winding and armature, the current starts to flow in the load and not in the shunt field winding. This is because the resistance of the load is lower and current always flows through the easiest path. Thus there will not be sufficient current in the shunt field winding and the generator will not build up its voltage. Therefore, the shunt generator should not be started with the load, instead the external load should be connected after the generator has built up its full voltage.

After normal running, if the load is increased heavily, the external resistance of the load will reach its critical point and the voltage will fall to zero. Therefore, a heavy load should not be put on the shunt generator.

In a shunt generator the armature current has two parallel paths, one through the load and the other through the shunt field winding. Thus the armature current is equal to the sum of the load current and field current.

$$I_a = I_L + I_f$$

The terminal voltage is given by

$$V_T = I_L \times R_L$$

$$\text{or } V_T = E - I_a R_a$$

where  $E$  is the emf induced and  $I_a R_a$  is the armature drop.

The voltage of the shunt generator can be increased or decreased by adjusting a variable resistance connected in series with the field winding as shown in Fig. 7.16.

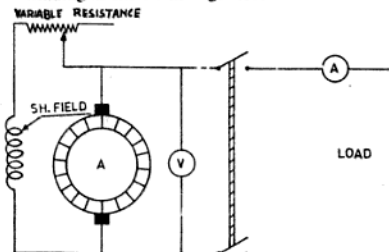

Fig. 7.16 Dc shunt generator

A shunt generator is always started without a load and is used where there is no great fluctuation of load (i.e., the load is approximately constant). Shunt generators are used for battery charging, electroplating, welding sets and as a balancer set.

### 7.16 CHARACTERISTIC OF SHUNT GENERATOR

In Fig. 7.17 a curve is shown between the induced emf and the field current. This curve

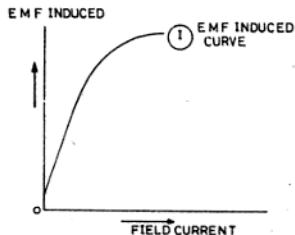

Fig. 7.17 OCC curve of shunt generator

is similar to the induced emf curve of the series generator.

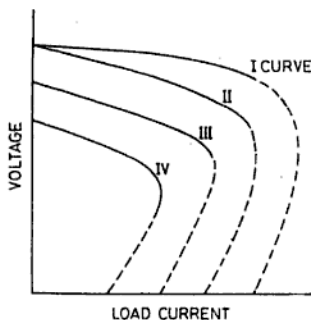

Fig. 7.18 ECC curve of dc shunt generator

Curve I in Fig. 7.18 represents the induced emf against the armature current, (but  $I_a = I_L$  at no load). The curve is more or less a straight line, but drooping a little at higher current values. The fall in the curve is due to a decrease in the emf across the field winding with an increase in the load due to a greater  $I_a R_a$  drop in the armature.

Curve II is a plot of the terminal voltage against the load current. The curve is a drooping straight line from its starting portion and after a certain point it bends and decreases to zero. A drop in the starting portion of the curve is due to a voltage drop in the armature.

In the beginning the fall in the curve is not excessively great, provided the generator is normally excited. However, when the load increases beyond a certain limit (much higher than the full load) the load resistance becomes very small and there is no appreciable current in the field winding to maintain its voltage and it finally falls to zero as shown in curves III and IV.

**EXAMPLE 7.2** A four-pole, lap-wound shunt generator has field and armature resistance of 100 and 0.1  $\Omega$  respectively, supplies 200 V to 60 lamps of 40 W each. Calculate: (i) the total armature current, (ii) current per armature path and (iii) the emf generated. Allow the brush contact drop to be 1 V per pair.

**Solution:**

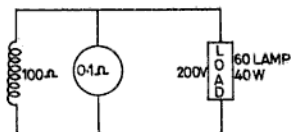

Fig. ES 7.2

Terminal voltage,	$V_T = 200 \text{ V}$
Shunt field resistance,	$R_{sh} = 100 \Omega$
Armature resistance,	$R_a = 0.1 \Omega$
Total load across the dynamo	$= 60 \times 40$ $= 2400 \text{ W}$
$\therefore$ Load current,	$I_L = \frac{W}{V} = \frac{2400}{200} = 12 \text{ A}$
Shunt field current,	$I_{sh} = \frac{V}{R_{sh}} = \frac{200}{100} = 2 \text{ A}$
$\therefore$ Armature current,	$I_a = I_L + I_{sh} = 12 + 2 = 14 \text{ A}$ <span style="float: right;">Ans.</span>

We know, number of poles in a lap wound dynamo = 4

$\therefore$ Number of parallel paths =	Number of poles = 4
Current per path in an armature =	$\frac{14}{4} = 3.5 \text{ A}$ Ans.
Armature voltage drop, $I_a R_a =$	$14 \times 0.1 = 1.4 \text{ V}$
Brush contact drop for 2 pair of poles	$= 1 + 1 = 2 \text{ V}$
$\therefore$ emf generated, $E = V_T + I_a R_a + V_b$ (brush drop)	$= 200 + 1.4 + 2 = 203.4 \text{ V}$ Ans.

**EXAMPLE 7.3** A shunt generator supplies a load of 10 kW at 250 V through a pair of feeders of total resistance 0.07  $\Omega$ . The resistance of the armature and field windings are 0.05 and 63.2  $\Omega$  respectively. Find:

- (i) the terminal voltage and (ii) the emf generated in the armature. Assume brush contact drops of 2 V on the load.

**Solution:**

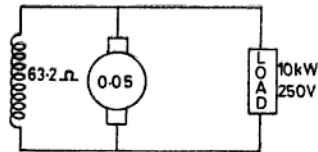

Fig. ES 7.3

Output of the generator = 10 kW  
 Load current,  $I_L = \frac{W}{V} = \frac{10 \times 1000}{250} = 40 \text{ A}$   
 Voltage drop in Feeders =  $40 \times 0.07 = 2.8 \text{ V}$   
 Terminal voltage of the generator  
 =  $250 + 2.8 = 252.8 \text{ V}$  Ans.  
 Shunt field current,  $I_{sh} = \frac{V_T}{R_{sh}} = \frac{252.8}{63.2} = 4 \text{ A}$   
 Armature current,  $I_a = I_L + I_f = 40 + 4 = 44 \text{ A}$   
 Voltage drop in the armature,  
 $I_a R_a = 44 \times 0.05 = 2.2 \text{ V}$   
 emf generated,  
 $E = V_T + I_a R_a + V_b$   
 =  $252.8 + 2.2 + 2$   
 =  $257 \text{ V}$  Ans.

### 7.17 COMPOUND GENERATOR

A generator consists of an armature, a series field and a shunt field and has the properties of both series and shunt generators. Connections of the compound generator are shown in Fig. 7.19. The field winding of a compound generator consists of two electrically insulated coils wound on the same pole pieces. One of the two windings is called the shunt winding and is connected in parallel to the armature. As the shunt winding has to drop the full terminal voltage, it is made of thin wire of many turns. The other series field winding is of thick wire of few turns and is connected in series with the armature.

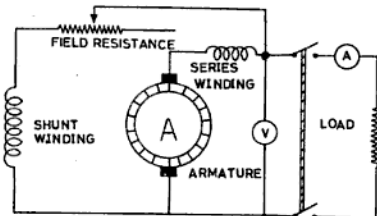

Fig. 7.19 DC compound generator

The emf characteristics (i.e., OCC) of the compound generator is similar to that of the shunt generator when started without the load as shown in Fig. 7.20.

The terminal voltage of a compound generator depends upon the field winding. If with an increase of load the terminal voltage of the generator increases a little as shown in

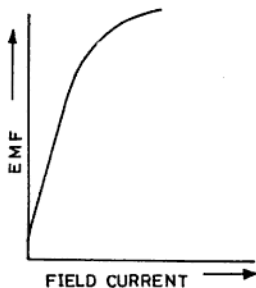

Fig. 7.20 OCC curve of DC compound generator

Fig. 7.21, then the generator is called an overcompound generator. In an overcompound generator the total flux increases with an increase of load. This means that the decrease of flux with the increase of load in the shunt winding is less than the increase of flux in the series winding.

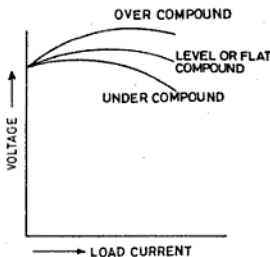

Fig. 7.21 ECC curve of dc compound generator

When the terminal voltage remains approximately constant with the rise of load, the generator is called a level or flat-compound generator. In a level compound generator the increase of flux in the series winding is equal to the decrease of flux in the shunt winding due to the increase of load.

If the terminal voltage of a generator decreases with an increase of load, the genera-

tor is called an undercompound generator. In an undercompound generator the effect of the shunt field winding is greater than that of series winding, i.e. the decrease in flux of the shunt winding is greater than the increase in flux in the series winding with an increase in the load.

A compound generator can build up voltage both on no load as well as on full load. This type of generator is best-suited for supplying power to far-off places where the voltage in the cable needs to be compensated.

### 7.18 CLASSIFICATION OF COMPOUND GENERATORS

DC compound generators can be classified as :

- (i) Short-shunt compound generators, and
  - (ii) long-shunt compound generators.
- (i) **Short-Shunt Compound Generators** If the shunt winding is connected in parallel to the armature and the series winding is connected in series with the combination, as shown in the Fig. 7.22 it is called a short compound generator.

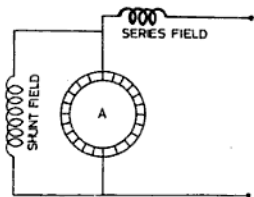

Fig. 7.22 Short-Shunt Compound generator

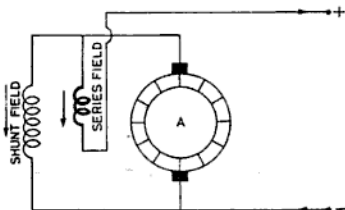

Fig. 7.23 Short-shunt commutative compound generator

If the series field helps the shunt field or the effect of the two is additive, it is called a short-shunt commutative compound generator as shown in Fig. 7.23.

If the series field connections are now reversed, then the series field flux opposes the shunt field flux as shown in Fig. 7.24. In this case it is called a short-shunt differential compound generator.

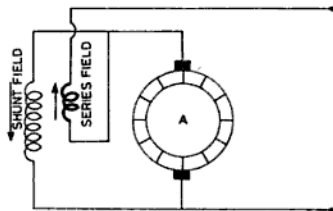

Fig. 7.24 Short-shunt differential compound generator

- (ii) **Long Shunt Compound Generator** If the series winding is connected in series with the armature and then the shunt winding is put in parallel to the combination, as shown in Fig. 7.25 it is called a long shunt compound generator. In this case also, if the effect of both the field is additive, as shown in Fig. 7.26, it is called a long shunt commutative compound generator.

If the series field connections are interchanged so that the series field is in opposition to the shunt field as in Fig. 7.27, it is called a long shunt differential compound generator. The voltage of a compound generator can be regulated in the same

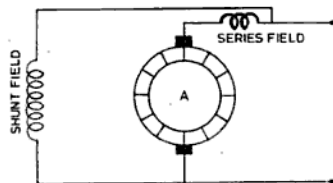

Fig. 7.25 Long-shunt compound generator

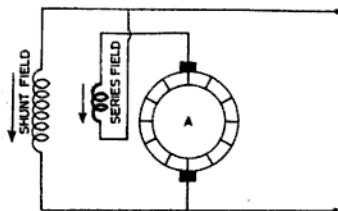

Fig. 7.26 Long-shunt commulative compound generator

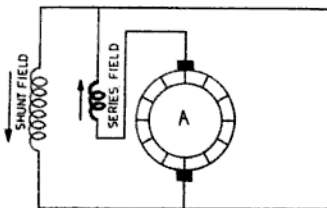

Fig. 7.27 Long-shunt differential compound generator

manner as in the shunt generator by connecting a variable resistance in series to the field winding as shown earlier in Fig. 7.19.

### 7.19 DIFFERENTIAL COMPOUND GENERATOR

The differential compound generator has an external characteristic similar to that of a shunt generator with a large demagnetizing armature reaction. It is used in arc welding where a large voltage drop is required when the current increases.

### 7.20 COMMULATIVE COMPOUND GENERATOR

This type of generators is widely used. Its external characteristic is usually adjusted to compensate for the voltage drop in the line resistance. The commulative compound generator is used for motor drives which require a dc supply at constant voltage, for supplying current to incandescent lamps, for heavy power lines, such as electric railways, etc.

### 7.21 CONDITIONS FOR SELF-EXCITATION

The following are the essential conditions for building up voltage in a self-excited generator:

- (i) There must be residual magnetism on the pole shoes of a self-excited generator so as to induce enough emf in the armature to cause a current to flow through the field winding.
- (ii) The field must be connected in such a way as to strengthen the residual magnetism when current due to induced emf flows through them.
- (iii) In the case of a series generator there must be some load on the generator, while in the other case no load or a small load is required on the generator.

### 7.22 ARMATURE REACTION

It is the effect of the armature flux produced by the armature current which distorts and weakens the main magnetic flux produced by the field poles. This results in sparking at the brushes and low voltage at the terminals.

#### General Terms used in Armature Reaction

**Geometrical Neutral Axis (GNA)** The geometrical neutral axis is an axis midway between the opposite adjacent field poles and right angles to the centre lines of poles.

**Magnetic Neutral Axis (MNA)** The magnetic neutral axis is perpendicular to the lines of force between the two opposite adjacent poles. This is the axis at which the brushes are placed, i.e., the brushes make direct contact with the conductors which lie on this axis.

**Leading Pole Tip (LPT)** It is the end of the pole which first comes in contact with the armature in the direction of rotation when it rotates.

**Trailing Pole Tip (TPT)** It is the end of the pole which comes in contact later with the armature when it rotates.

To study the effect of the armature flux on the field flux, let us consider Figs. 7.28 to 7.30 of a bipolar machine, running in the clockwise direction. In Fig. 7.28 only the flux due to the field pole is shown and there is no flux due to the armature. As it is working without load the flux is uniform in the air gap and the

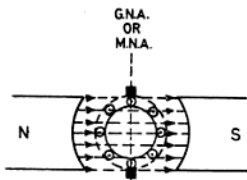

Fig. 7.28 Flux due to field alone

GNA coincides with the MNA. The flux at the leading pole tip is equal to the flux at the trailing pole tip.

The flux due to the armature current is shown in Fig. 7.29 and there is no flux due to the field poles.

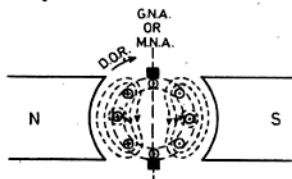

Fig. 7.29 Flux due to armature

When the machine is under operation, both the fluxes due to the armature and field poles act in the air gap and the resultant flux is the resultant of these two fluxes. The resultant flux is shown in Fig. 7.30. From the figure, it is clear that the flux at the LPT has decreased while at the TPT has increased. However,

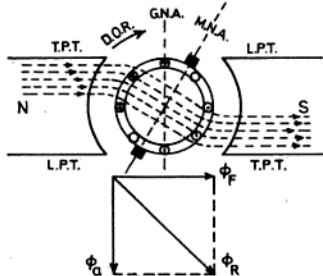

Fig. 7.30 Resultant flux

as the field poles work near their saturation point and the decrease of the flux at the leading pole tip is much more than the increase of flux at the TPT, there is a net decrease in the total flux and the emf induced also decreases. Due to the strengthening of the TPT and weakening of the LPT, the MNA is advanced from the GNA in the direction of rotation. This effect goes on increasing as the armature current increases with the increase of load. If the brushes are not shifted to this new position of the MNA, heavy sparking can take place at the brushes.

From the above, it may be concluded that the armature flux produces the following effects on the machine :

- (i) It distorts the uniformity of the main flux.
- (ii) It produces a demagnetizing effect on the main poles.
- (iii) It reduces the emf induced.
- (iv) It decreases the efficiency of the machine.
- (v) It produces sparking at the brushes due to shifting of the MNA.
- (vi) When self-excited generators are subjected to heavy short circuit, it can fail to self-excite again. The reason is that the heavy current due to short circuit creates heavy armature reaction and it demagnetizes the pole cores. The result is that the residual magnetism is completely lost and thus it cannot self-excite again.

### 7.23 REMEDIES FOR ARMATURE REACTION

The following are the remedies for armature reaction:

- (i) Brushes must be shifted to the new position of the MNA in the direction of rotation of the armature by shifting the rocker's position (Fig. 7.31). This is done by rocker arm as shown in Fig. 7.31.
- (ii) As the demagnetizing effect of the armature reaction weakens the main flux, extra turns are necessary in the field winding to neutralize it.
- (iii) It should be noted that the armature reaction takes place in the core tips. Therefore, in order to drive the main flux from the tips to the centre of the

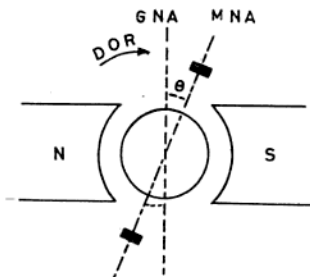

Fig. 7.31 Remedy of armature reaction

pole core, slots are made on the tips to increase the reluctance as shown in Fig. 7.32.

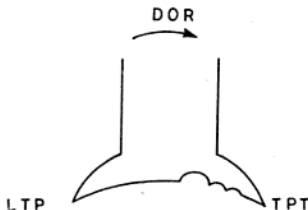
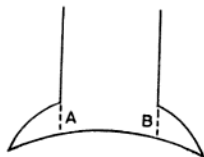

Fig. 7.32 Remedy of arm reaction

ELEVATION VIEW



PLAN VIEW

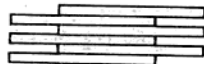

Fig. 7.33 Remedy of arm reaction

(iv) In order to drive the main flux from the tips to the centre of the core, the laminated cores of the shoe are staggered as shown in Fig. 7.33. By staggering the tip, the width is reduced to half of the main core. Therefore, saturation takes place much earlier in the pole tips and the flux thus drives to the centre.

(v) In big machines where there is great fluctuation of load, a compensating winding is provided on the pole shoes as shown in Figs. 7.34 and 7.35. The

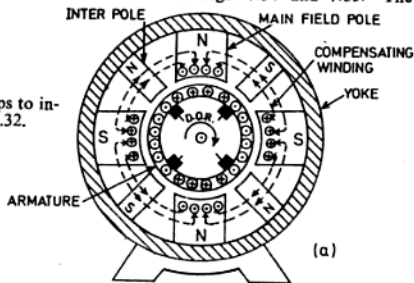

Fig. 7.34 Current in compensating winding is flowing in opposite direction to the armature current

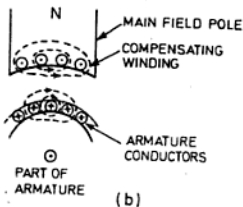

Fig. 7.35 Flux of compensating winding cancels armature flux

compensating winding produces a flux which just opposes the armature mmf flux automatically.

NOTE: The current in the compensating winding has an opposite direction to the armature current.

## 7.23 COMMUTATION

Whenever a brush contacts two or more commutator segments, the coils connected to those segments are short circuited. After the period of short circuiting the current on these coils change their direction. The changes that take place in the coil after the period of short circuiting of the coil is called commutation. When the change is gradual, it is known as smooth commutation and when the change is sudden, it is known as rough commutation. Owing to rough commutation, sparking occurs in the brush contacts. To understand the effect of commutation, let us consider the following description :

In Fig. 7.36, a portion of the winding is shown and only the changes in coil  $B$  will be considered. For easy understanding the coil connected to the segments are shown with a single turn. However, in actual practice the coils can have a number of turns.

**Before Short Circuit** In Fig. 7.36, the brush is only in contact with segment  $S_2$ . The brush collects a current of  $I$  A from the left-hand side

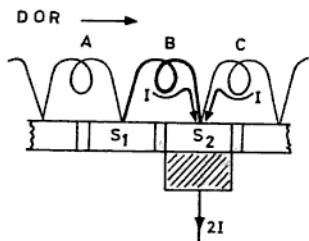

Fig. 7.36 Commutation before short circuit

winding and  $I$  A from the right-hand side winding. Therefore, the brush collects  $2 I$  A for the external circuit through segment  $S_2$ . It may be noted that coil  $B$  carries current from left to right, or say in the clockwise direction.

**On Short Circuit** In Fig. 7.37 the brush is shown touching both the segments  $S_1$  and  $S_2$  and coil  $B$  is short-circuited. Therefore,  $I$  A of the left-hand side winding reaches the brush through coil  $A$  and segment  $S_1$  without

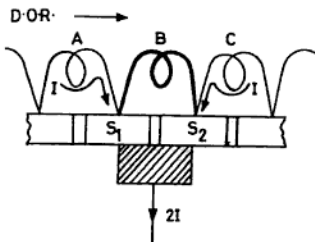

Fig. 7.37 On short circuit

passing through coil  $B$ . Similarly,  $I$  A of the right-hand side winding reaches the brush through coil  $C$  and segment  $S_2$  without passing through coil  $B$ . It may be noted that coil  $B$  carries no current through it.

**After Short Circuit** In Fig. 7.38, the brush contacts segment  $S_1$  alone. Therefore,  $I$  A

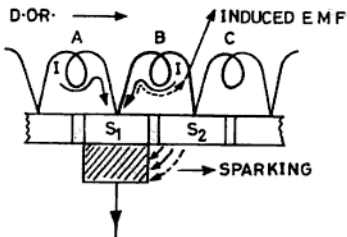

Fig. 7.38 After short circuit

of the left side winding reaches the brush through coil  $A$  and segment  $S_1$  without passing through coil  $B$ . The current  $I$  A of the right side winding reaches the brush through coil  $B$  and segment  $S_1$ . It should be again noted that coil  $B$  passes the current in anti-clockwise direction. This is just opposite the first position as shown in Fig. 7.36.

Owing to this sudden reversal of current in coil  $B$  from clockwise to anticlockwise direction, a self induced emf is produced in coil  $B$ . This does not allow the total current of right side winding to pass through coil  $B$ . A fraction of the current passes

through coil  $B$  and the rest jumps from segment  $S_2$  to the brush in the form of a spark. This spark can spoil the brush and commutator, and can heat up the machine. Therefore, this sparking has to be minimized for improving the efficiency of the machine.

**Effects of Sparking** The effects of sparking are as follows :

- If the sparking is not reduced, the commutator surface may be carbonized and will short circuit all the coils of the armature.
- Sparking can damage the surface of the commutator. Thus brushes can jump from time to time, resulting in more sparking.
- Sparking can result in excess heating of the surface of the commutator, thus melting the solder of the armature segments.

#### 7.24 METHODS OF REMOVING COMMUTATION

To change rough commutation into smooth commutation, the following two methods are adopted :

- Resistance commutation, and
- emf commutation.

**(i) Resistance Commutation Method** In the resistance commutation method the current in the short-circuited coil is made to change gradually by using high resistance carbon brushes. Carbon has about 4000 times higher resistance than that of copper for the given dimensions. To understand this let us consider the following : In Fig. 7.39, the brush touches segment

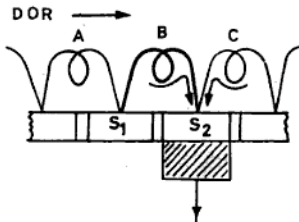

Fig. 7.39 Remedy of commutation by resistance commutation method

$S_2$  and the current in coil  $C$  is anticlockwise (i.e. right to left) and in coil  $B$  clockwise (from left to right). As the commutator moves in the direction of rotation marked in the figure, the brush will touch two commutator segments  $S_1$  and  $S_2$  together, as shown in Fig. 7.40 and coil  $B$  will come under commutation.

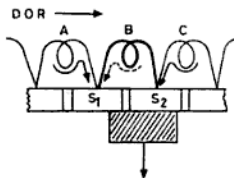

Fig. 7.40 Remedy of commutation by resistance commutation method

If the brushes are of low resistance, then there will be no current in coil  $B$  and it will be short circuited by the brush. However, as the brushes have high resistance, then the current from the right side will have two parallel paths. One path will be from coil  $C$  to commutator segment  $S_2$  to the brush and the other from coil  $C$  to  $B$  through commutator segment  $S_1$  as shown in Fig. 7.40. But the contact area of brush  $S_2$  is more and of brush  $S_1$  less. We know that the resistance of a conductor is inversely proportional to the area of cross-section. Therefore, segment  $S_2$  has lesser resistance than segment  $S_1$ . Hence a major portion of current in the winding passes easily through segment  $S_2$  and a lesser portion of the current passes through segment  $S_1$ . However, gradually the area of contact of the brush on segment  $S_1$  increases and on  $S_2$  decreases, which decreases the resistance of segment  $S_1$  and increases the resistance of segment  $S_2$ . This allows more current to pass through segment  $S_1$  and less current to pass through segment  $S_2$ .

Thus the change of current in the coil  $B$  will not be sudden and in this case it is gradual and hence less reactance emf will be induced. In the meantime when the brush moves from commutator segment  $S_2$  to  $S_1$ , it is possible that the current in coil  $B$  will increase to its full value. Thus by the use of high resistance carbon brushes the change is made gradual and sparking is reduced.

(ii) **EMF Commutation Method.** In this method the induced voltage in the armature is neutralized by producing equal and opposite voltages in the short-circuited coil and thus sparking is minimized.

From Fig. 7.41 it is clear that the winding on the left side is under the effect of the north pole and the winding on right side is under the influence of the south pole. If we provide a small south pole before the main south pole, the former south pole will produce a voltage in the short circuited coil to produce the reactance voltage. This small pole is known as the interpole, commutating pole or auxiliary pole.

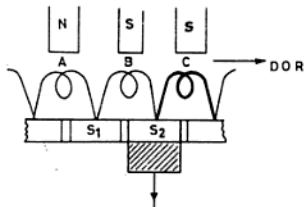

Fig. 7.41 Remedy of commutation by EMF commutation method

The polarity of the interpole should be the same as that of the next main pole ahead in the direction of rotation for the generator, as shown in Fig. 7.42. For motors, the polarity of the interpole should be the same as the next main pole behind in the direction of rotation as illustrated in Fig. 7.43.

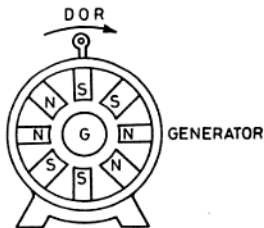

Fig. 7.42 Polarity of pole in case of generator

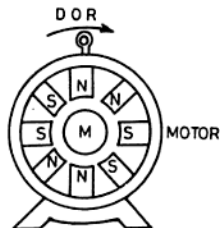

Fig. 7.43 Polarity of pole in case of motor

Interpoles are equal in number to the main poles. The winding on the interpole is joined in series with the armature as the commutation depends upon the armature current. By connecting the interpole winding in series with the armature, the commutating voltage is kept the same as the reactance voltage. In this way the automatic opposition for the reactance voltage is developed which reduces the sparking on the commutator.

Armature reaction also takes place in the interpole. However, the interpole's trailing pole tips are nearer the weakened leading pole tips of the main pole so that it strengthens that side. Thus to some extent it reduces the armature reaction. But the interpoles in the machine are only provided for smooth commutation. A machine fitted with interpoles have 25% more capacity than a non-interpole machine.

#### 7.25 LOSSES IN DC GENERATORS

A generator converts mechanical energy into electrical energy and in doing so it also consumes some energy which is converted into heat energy. Thus the input that a generator takes is always greater than the output it gives. The difference between the input and the output are the "losses". The losses in a generator can be divided into :

- (i) Copper losses (sometimes known as electrical losses; the losses are variables), and
- (ii) stray losses (sometimes known as rotational losses ; the losses are constant).

(i) **Copper Losses** These are the losses that occurs in the winding of the machine. As the armature and field windings are made of

## 7.27 EFFICIENCY OF DC GENERATOR

The efficiency of a generator is determined by the ratio of electrical output developed by it to the mechanical power taken by it. It is generally expressed as a percentage.

$$\therefore \text{Efficiency } (\eta) = \frac{\text{output}}{\text{input}} = \frac{\text{output}}{\text{output} + \text{losses}}$$

$$\text{Efficiency percentage } (\eta\%) = \frac{\text{output} \times 100}{\text{input}} \% \quad (7.6)$$

Efficiency can be classified as follows:

- Mechanical efficiency,
- electrical efficiency, and
- overall efficiency or commercial efficiency.

Mechanical efficiency ( $\eta_m$ )

$$\frac{\text{electrical power developed by generator in watts}}{\text{generator input (mechanical) in watts}}$$

$$= \frac{\text{emf} \times I_a}{\text{Bhp} \times 746} \quad (7.7)$$

Electrical efficiency

$$\frac{\text{electrical output of generator in watts}}{\text{electrical power developed by generator in watts}}$$

$$= \frac{V_L \times I_L}{\text{emf} \times I_a} \quad (7.8)$$

Commercial efficiency ( $\eta_c$ )

$$\frac{\text{electrical output}}{\text{mechanical output}}$$

$$= \frac{\text{electrical output of generator in watts}}{\text{generator input (mechanical) in watts}}$$

$$= \frac{V_L \times I_L}{\text{Bhp} \times 746}$$

NOTE: Iron and friction losses

$$= \text{Bhp} \times 746 - \text{emf} \times I_a$$

$$\text{Copper losses} = \text{emf} \times I_a - V_L \times I_L$$

**EXAMPLE 7.4** A short-shunt compound generator supplies a load of 20 kW at 200 V through a pair of feeders of total resistance 0.08  $\Omega$ . The shunt field resistance is 42  $\Omega$ , armature resistance 0.04  $\Omega$  and series field resistance 0.02  $\Omega$ . If the iron and friction losses are 309.5 W, find: (i) Terminal voltage of generator, (ii) emf generated, (iii) copper losses,

(iv) Bhp metric of the primemover and (v) commercial efficiency.

Solution:

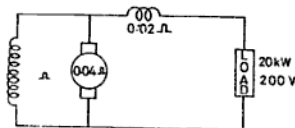

Fig. ES 7.4

$$\text{Load current, } I_L = \frac{W}{V} = \frac{20 \times 1000}{200} = 100 \text{ A}$$

$$\text{Voltage drop in feeders} = I \times R = 100 \times 0.08 = 8 \text{ V}$$

$$\text{Voltage drop in series field} = 100 \times 0.02 = 2 \text{ V}$$

$$\text{Voltage drops of feeders and series field} = 8 + 2 = 10 \text{ V}$$

$$\text{Voltage at the terminal of the generator, } V_G = 200 + 10 = 210 \text{ V Ans.}$$

$$\text{Shunt field current, } (I_{sh}) = \frac{V_G}{R_{sh}} = \frac{210}{42} = 5 \text{ A}$$

$$\text{Armature current, } I_a = I_L + I_f = 100 + 5 = 105 \text{ A}$$

$$\text{Voltage drop in armature, } I_a R_a = 105 \times 0.04 = 4.2 \text{ V}$$

$$\text{emf generated, } = V_G + I_a R_a = 210 + 4.2 = 214.2 \text{ V}$$

Ans.

$$\text{Electrical power output} = 20 \text{ kW}$$

$$\text{Electrical power developed in the armature} = \text{emf} \times I_a = 214.2 \times 105 = 22491 \text{ W}$$

$$\text{Copper losses} = \text{electrical power developed} - \text{electrical power output} = 22491 - 20000 = 2491 \text{ W Ans.}$$

$$\text{Mechanical power input} = \text{output} + \text{copper losses} + \text{iron and friction losses} = 20,000 + 2491 + 309.5 = 22,800.5 \text{ W}$$

Bhp (metric)

$$= \frac{\text{mechanical power input}}{735.5}$$

$$= \frac{22,800.5}{735} = 31 \text{ Ans.}$$

Efficiency,  $\eta_{com}\%$

$$= \frac{\text{electrical power output}}{\text{mechanical power input}}$$

$$= \frac{20,000 \times 100}{22,800.5} = 87.7\% \text{ Ans.}$$

**EXAMPLE 7.5** A four-pole lap wound shunt generator supplies a load of three motors each taking 30 A at 440 V. The armature resistance is 0.08  $\Omega$  and the shunt field resistance is 44  $\Omega$ . The Bhp of the driving

engine is 65 hp. Calculate: (i) Total armature current, (ii) current in each path (iii) emf generated, (iv) Power developed in the armature, (v) copper losses, (vi) stray losses, and (vii) efficiencies: (a) electrical, (b) commercial and (c) mechanical.

**Solution :**

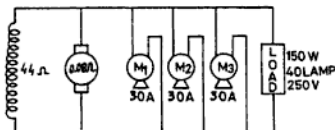

Fig. ES 7.5

Current taken by three motors,

$$I = 30 \times 3 = 90 \text{ A}$$

Shunt field current,

$$I_{sh} = \frac{V}{R_{sh}} = \frac{440}{44} = 10 \text{ A}$$

(i)  $\therefore$  Total armature current,

$$I_a = I_L + I_f = 90 + 10 = 100 \text{ A Ans.}$$

(ii) Current in each path

$$\begin{aligned} &= \frac{\text{total armature current}}{\text{No. of parallel path in winding}} \\ &= \frac{100}{4} = 25 \text{ A Ans.} \end{aligned}$$

Armature drop,

$$V_a = I_a R_a = 100 \times 0.08 = 8 \text{ V}$$

We know,

$$\text{Brush contact drops} = 2 \text{ V}$$

(iii)  $\therefore$  emf generated,

$$450 \text{ E} = V_T + I_a R_a + V_b = 440 + 8 + 2 \\ = 281.8 \text{ V Ans.}$$

(iv) Electrical power developed in the armature

$$= \text{emf} \times I_a$$

Output of the generator,

$$W = V_T \times I_L = 440 \times 90 = 39,600 \text{ W}$$

Mechanical power input

$$= \text{Bhp} \times 746 \quad (\text{assume Bhp} = 746 \text{ W as it is not mentioned in the metric system})$$

$$= 65 \times 746 = 48,490 \text{ W}$$

(v)  $\therefore$  Copper losses

$$\begin{aligned} &= \text{electrical power developed} - \text{elect. power output} \\ &= 45,000 - 39,600 = 5400 \text{ W} \end{aligned}$$

(vi) Stray losses

$$\begin{aligned} &= \text{mechanical power input} - \text{electrical power developed in armature} \\ &= 48,490 - 45,000 = 3490 \text{ W Ans.} \end{aligned}$$

(vii) (a) Electrical efficiency ( $\eta_e$ )

$$\begin{aligned} &= \frac{\text{Electrical power output}}{\text{power developed in armature}} \times 100\% \\ &= \frac{39,600}{45,000} \times 100\% = 88\% \end{aligned}$$

(b) Commercial efficiency ( $\eta_c$ )

$$\begin{aligned} &= \frac{\text{electrical power output}}{\text{mechanical power input}} \times 100\% \\ &= \frac{39,600}{48,490} \times 100\% = 81.67\% \end{aligned}$$

(c) Mechanical efficiency ( $\eta_m$ )

$$\begin{aligned} &= \frac{\text{power developed in armature}}{\text{mechanical power input}} \times 100\% \\ &= \frac{45,000}{48,490} \times 100\% = 92.8\% \end{aligned}$$

## 7.28 RATING OF A GENERATOR

The rating of generators are generally given in terms of voltage, current, speed and output. All these particulars are provided on the name plate of the generator. Suppose the following details are given on a name plate :

Voltage—220 V  
Current—10 A  
Output—2.2 kW  
Speed—2800 rpm  
Type—dc Shunt

It means that the generator generates a voltage of 220 V at 2800 rpm and is capable of giving a current of 10 A at an output of 2.2 kW.

## 7.29 TROUBLE SHOOTING OF DC GENERATOR

The general defects and remedies of dc generators are given in Table 7.1

TABLE 7.1 TROUBLE-SHOOTING CHART OF DC GENERATOR

S. No.	Reason	Remedy	S. No.	Reason	Remedy
(a) <i>Generator fails to build up voltage:</i>		(b) <i>Generator badly sparking.</i>			
1.	The direction of rotation must have been reversed in which case residual magnetism will be opposed	The direction of rotation will be changed	1.	Brushes loose contact	Adjust spring tension
2.	Speed too low	Generator should be rotated at its constant speed	2.	Improper contact surface of the brush	Brush face should be ground properly on sand paper
3.	Brushes not resting on the commutator or in the wrong position	Brushes to be set or shifted to the correct position of MNA	3.	Brushes not on magnetic neutral axis	Brushes to be shifted in the direction of rotation
4.	Residual magnetism is completely lost	A. generator should give a reading up to 5% of its full voltage when it is run without excitation. If it does not fulfil the above condition, then run the generator as dc motor for few seconds. If dc supply is not available, a battery of emf 10% of the generator voltage must be used for sending current to re-establish the residual magnetism. This is called flashing of the field	4.	Brush holders not properly insulated	Insulate the brush holder properly
5.	Short circuit in the armature	Remove the short circuit which may lie in the generator itself, the switch board or the external circuit. If the short circuit is in the external circuit, the generator will excite when it is disconnected from the load	5.	Over-loaded generator	Decrease the load on the generator
6.	Short circuit in the field circuit	Test and remove short circuit which may be on the terminals or within the coil. Faulty coil will show much less resistance than the perfect coil	6.	Grooves on the commutator surface	Commutator to be turned on the lathe machine
7.	Open circuit in the armature	Test and repair for open circuit if possible	7.	Incorrect direction of rotation	Change the direction of rotation
			8.	Dirty, dust, oil and carbon fillings on the commutator	Dip and wash the commutator in petrol and then clean it with sandpaper
			9.	Mica above the commutator segments	Under cutting of mica is done in the commutator segments
			10.	Over-loaded dynamo	Reduce the load on the generator.
			11.	Open or earth or short circuit in the armature circuit	Test and remove the open earth or short circuit
			12.	Cross in the armature circuit	Disconnect the crossed coils and reconnect them properly.
			13.	Short circuit or break in the field winding	Test and remove the faults
			14.	Wrong polarity of the interpoles	Reconnect the interpole coils as the polarity is required.
			15.	Wrong grade of brushes	Replace proper grade of brushes
			16.	Brush sticking in the holder box	Slightly grind the brush

- 7.15 A short-shunt compound generator delivers 80 A at a terminal voltage of 210 V through a pair of feeders of total resistance  $0.2\Omega$ . The armature resistance is  $0.05\Omega$ , series field resistance  $0.06\Omega$  and shunt field resistance  $57.7\Omega$ . Find (i) terminal voltage of the generator and (ii) the emf generated.  
(Ans. 230.8 V; 235 V)
- 7.16 A long-shunt compound generator supplies a load of 11 kW at a terminal voltage of 220 V. The armature resistance is  $0.04\Omega$ , series field resistance  $0.06\Omega$ , and shunt field resistance  $110\Omega$ . Find (i) the armature current and (ii) the emf generated.  
(Ans. (i) 52 A; (ii) 225.2 V)
- 7.17 A long-shunt compound generator supplies a load at 110 V through a pair of feeders of total resistance  $0.04\Omega$ . The load consist of lighting load of 110 lamps of 150 W each and two motors each taking 15 A. The shunt field resistance is  $29.3\Omega$ , series field resistance  $0.025\Omega$  and armature resistance  $0.05\Omega$ . Find (i) the load current, (ii) the armature current and (iii) the emf generated.  
(Ans. 180 A; 184 A; 131 V)
- 7.18 A 500 V shunt generator has a full load current of 78 A. The stray losses are 548 W. Calculate the Bhp (metric) of the primemover at full load if the armature and field resistances are  $0.1\Omega$  and  $250\Omega$  respectively.  
(Ans. 56 Bhp)
- 7.19 A shunt generator supplies to a load of 145 A at 250 V. The shunt field resistance is  $50\Omega$  and armature resistance is  $0.04\Omega$ . If the iron and friction losses amount to 392 W, find (i) the emf generated, (ii) copper losses, (iii) Bhp of the driving engine, (iv) electrical efficiency and (v) mechanical efficiency.  
(Ans. 256 V 2150 W, 524 b 94.4%, 98.98%)
- 7.20 A petrol engine of 26 Bhp is mechanically coupled with a shunt generator which supplies a load of 75 A at 220 V. If the shunt field resistance is  $44\Omega$  and armature resistance  $0.2\Omega$ , find (i) copper losses, (ii) iron and friction losses and (iii) overall efficiency of the machine.  
(Ans. 2380 W; 516 W, 685.06 )
- 7.21 The output of the shunt generator is 37.3 A at 270 V. The shunt field resistance is  $100\Omega$  and armature resistance  $0.05\Omega$ . If the total efficiency at this load is 90%, find (i) copper losses, (ii) stray losses and (iii) Bhp of the primemover.  
(Ans. 809 W; 310 W; 15 Bhp)
- 7.22 A short-shunt compound generator supplies 90 A at 110 V. The shunt field resistance is  $64\Omega$ , series field resistance  $0.2\Omega$  and armature resistance  $0.25\Omega$ . Iron and friction losses are 250 W. Find (i) the emf generated; (ii) copper losses in (a) shunt field, (b) series field (c) armature, and (d) total copper losses; and (iii) total efficiency of the machine.  
(Ans. (i) 151 V; (ii) 256 W, 1620 W, 2116 W, 3992 W; (iii) 70%)
- 7.23 A short-shunt compound generator supplies a load of 11 kW at 220 V through a pair of feeders of total resistance  $0.2\Omega$ , series field resistance  $0.15\Omega$  armature resistance  $0.02\Omega$  and shunt field resistance  $47\Omega$ . Stray losses are 305 W. Find : (i) thermal voltage, (ii) the emf generated, (iii) copper losses, (iv) Bhp of the driving engine and (v) commercial and electrical efficiencies.  
(Ans. (i) 237.5 V ; (ii) 238.6 V ; (iii) 2123 W ; (iv) 18 Bhp ; (v) 81.9%, 83.8%)
- 7.24 A long-shunt compound generator supplies to a load of 80 A at a terminal voltage of 240 V. The resistance of the shunt field winding, series field winding and armature are  $80\Omega$ ,  $0.04\Omega$  and  $0.03\Omega$  respectively. The driving engine develops 30 Bhp. Find : (i) armature copper loss, (ii) shunt field copper loss (iii) series field copper loss, (iv) total copper loss and (v) stray losses.  
(Ans. (i) 206.67 W ; (ii) 720 W (iii) 275.56 W ; (iv) 1202.23 W (v) 1977.77 W)

- 7.25 A long-shunt compound generator supplies a full load current of 190 A at a terminal voltage of 250 V. The resistance of armature, shunt field and series field windings are respectively  $0.04\Omega$ ,  $50\Omega$  and  $0.02\Omega$ . Iron and friction losses are 4% of the full load output. Calculate: (i) the emf generated, (ii) copper losses and (iii) overall efficiency.  
(Ans. (i) 261.7 V; (ii) 3531.5 W (iii) 89.7%)
- 7.26 A four pole, lap-connected shunt generator supplies to a load of four motors each taking 30 A and a lighting load of 46 lamps, 100 W each at 230 V. Armature and shunt field resistances are respectively  $0.25\Omega$  and  $46\Omega$ . If stray losses are 1.14 kW, find: (i) total armature current, (ii) current in each path, (iii) the emf generated, (iv) power developed in the armature, (v) copper losses and (vi) electrical, commercial and mechanical efficiencies.  
(Ans. 145 A; 36.25 A; 268 V; 38.86 kW; 6.66 kW; 82.86%; 80.5%; 97.15%)
- 7.27 A four-pole, wave-connected, long-shunt generator supplies to a load of five motors, each taking 20 A and a lighting load of 50 lamps, 200 W each at 500 V. Armature, series field and shunt field resistances are respectively 0.2, 0.3 and  $0.50\Omega$ . If stray losses are 350 W, find: (i) total armature current, (ii) current in each path, (iii) the emf generated, (iv) power developed in the armature, (v) copper losses and (vi) electrical, commercial and mechanical efficiencies. Assume brush contact drop of 2 V.  
(Ans. (i) 130 A; (ii) 65 A; (iii) 567 V (iv) 73710 W; (v) 13710 W; (vi) 81.4%, 81.01%, 99.5%)

#### REVIEW QUESTIONS

- 7.1 What is electromagnetic induction? Describe the construction and working of a dc dynamo.
- 7.2 (a) Draw neat sketches of the principle parts of a dc generator and briefly state the function of each part.  
(b) Draw the field connections of the three types of a self excited generator with a field regulator.
- 7.3 (a) Explain the difference between a shunt and a series generator.  
(b) In a long-shunt compound generator, the potential difference at the terminal is 240 V, the shunt field resistance is  $120\Omega$ , series field resistance  $0.04\Omega$ , armature resistance  $0.035\Omega$  and load current 56 A. Calculate:  
(i) output of the generator, (ii) the emf generated and (iii) total copper losses. (State Competition, Aug. 1971 ELECT.)  
(Ans. (i) 13.44 kW (ii) 244.35 V (iii) 732.3 W)
- 7.4 Compare the working of a dc series and shunt generator and explain their characteristics. (NCVT 1973).
- 7.5 Write brief notes on any three of the following: (i) series dynamo, (ii) compound dynamo, (iii) shunt dynamo and (iv) sparking at the brushes of a dynamo. (Inter I.T.I. Competition, Delhi 1966).
- 7.6 (a) Describe in detail the function of a commutator in a dc generator.  
(b) What are the possible causes and their remedies for excessive sparking in the commutator? (State Competition, Aug. '71)
- 7.7 (a) Explain briefly with the aid of diagrams the difference between series, shunt and compound dc generator.  
(b) A dc shunt generator delivers a current of 96 A at 240 V. The armature resistance is  $0.15\Omega$  and the field winding has a resistance of  $60\Omega$ . Assuming

a brush contact drop of 2 V, calculate: (i) the current in the armature and (ii) the generated emf.

(Ans. 100 A, 257 V)

(All India Skill Competition 1969 Elect.)

- 7.8 A shunt-wound generator delivers a load of 40 A at 440 V. If the resistance of the armature is  $0.8\Omega$  and that of the shunt field  $220\Omega$ , calculate: (i) The current in the armature, (ii) the emf generated, and (iii) copper losses in the generator. Illustrate with neat diagrams.

(Ans. (i) 42 A (ii) 473.6 V (iii) 2291.2 W)

(NCVT 1970)

- 7.9 What are the various losses that occurs in a dc generator.

7.10 How are dc generators classified. Show by simple diagrams the various types and briefly state their characteristics.

(NCVT 1980 W/man)

- 7.11 (a) Explain why the generator magnetisation curve is not a straight line.  
(b) What is interpole? What is its purpose? How its winding is connected.  
(c) A certain generator may be connected for either separate or self excitation. Which of the two connections should be used to obtain better voltage regulation.

(All India Skill Competition 1985)

hand in such a way that the thumb, first finger and middle finger are at right angles to each other as shown in Fig. 8.2 such that the first finger points in the direction of flux (from north to south) and the middle finger in the direction of current in the conductor, then the thumb will indicate the direction in which the force will act on the conductor.

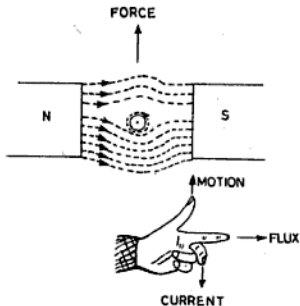

Fig. 8.2 Fleming's left-hand rule

The magnitude of the force exerted is given by the equation:

$$F = \beta IL$$

where  $\beta$  = flux density in weber/metre<sup>2</sup>

$I$  = current in amperes

$L$  = active length of the conductor in metres

$F$  = force developed on the conductor in newtons

### 8.3 DIFFERENCE BETWEEN CONSTRUCTION OF DC MOTOR AND GENERATOR

There is no essential difference in the construction between a dc motor and a dc generator. The same machine may be used as a motor or generator. The dc generators are generally of the open type for better cooling while dc motors are usually partial or completely enclosed as they are required to operate on rough work such as flour mills, saw mills, etc.

### 8.4 WORKING PRINCIPLE OF DC MOTOR

The working of a dc Motor depends upon the principle that *when a current-carrying conductor is kept in a magnetic field, a force acts on*

*the conductor which tends to rotate it.* How this force acts and produces a continuous motion is explained below:

In Fig. 8.3, a sectional view of a loop of wire is shown under north and south poles. The current in conductor  $A$  is shown inward while in conductor  $B$  it is outward. A force will act on both conductors  $A$  and  $B$  which

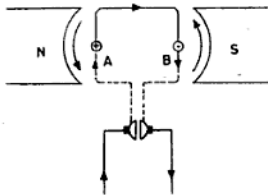

Fig. 8.3 Force acting on a current carrying conductor

will tend to rotate the loop in the anticlockwise direction as given by the Fleming's left hand rule. This force will act till the conductors are in the magnetic field. Therefore to obtain a continuous motion, many conductors are placed such that if one leaves the magnetic field, another enters it.

When loop  $AB$  starts rotating, after a very short time, conductor  $B$  will come under the north pole and conductor  $A$  under the south pole. Now the current in conductor  $B$  is inward, while in conductor  $A$  it is outward as it is automatically changed with the help of the commutator as explained in the previous chapter. Again an anticlockwise force will act on the loop of wire and thus a continuous motion in the anticlockwise direction will be obtained in this case.

### 8.5 TERMS USED IN DC MOTORS

**Back Emf or Counter Emf** When the armature of a motor (carrying a conductor) rotates in a magnetic field, an emf is generated in its conductor according to Faraday's laws of electromagnetic induction. This emf generated in the conductor acts in opposition to the applied voltage ( $V$ ) and is therefore called the back emf or counter emf represented by  $E_b$ . Its value is always less than the applied voltage.

Consider an armature having a conductor under the north pole as shown in Fig. 8.4 (a). If the conductor is carrying current inward, then a force will act on the conductor in the anticlockwise direction. Now if the same conductor is moving under the north pole in the anticlockwise, an emf will be generated in the conductor which will act in the outward direction according to Fleming's right hand rule as shown in Fig. 8.4 (b). From the above it is clear that the applied voltage is inward and the induced emf is outward.

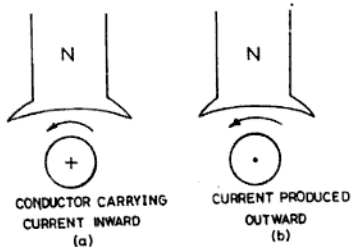

Fig. 8.4 Back emf

The back emf is induced due to the motion of the conductors in the magnetic field, and therefore its value is determined by the emf equation of generator as:

$$E_b = \frac{P\phi N}{60} \times \frac{Z}{a} \text{ V}$$

This back emf ( $E_b$ ) is always less than the applied voltage ( $V$ ) because if it becomes equal to it, no current will flow through the armature and thus the motor action will stop. The current through the armature is due to the net emf acting on the armature. Therefore

$$I_a = \frac{V - E_b}{R_a} \quad (8.1)$$

$$\text{or } I_a R_a = V - E_b$$

$$\text{or } E_b = V - I_a R_a \quad (8.2)$$

$$\text{Similarly, } V = E_b + I_a R_a \quad (8.3)$$

where  $E_b$  = back emf

$I_a R_a$  = armature drop

$V$  = applied voltage

Multiplying both sides of Eq. (8.3) by  $I_a$ , we have

$$V I_a = E_b I_a + I_a^2 R_a \quad (8.4)$$

where  $V I_a$  = power input to the armature

$E_b I_a$  = power converted into mechanical energy

$I_a^2 R_a$  = armature copper losses

Equation (8.4) is called the power equation of the motor.

**Torque** Torque may be defined as the turning or twisting moment of force about an axis. It is measured by the product of force and radius at which the force acts. Therefore,

$$\text{Torque, } T = F \times r$$

where  $F$  = force acting in newtons

$r$  = radius in metres

$T$  = torque developed in newton metres

Let  $F$  be the force acting on a pulley of radius  $r$  m which revolves at a speed of  $N$  revolution per minute (Fig. 8.5). Then the work done in revolving the pulley through one revolution is given by

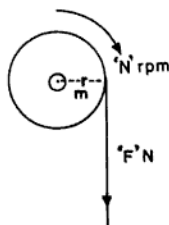

Fig. 8.5 Torque acting on pulley

Work done = force  $\times$  distance

$$W = F \times 2\pi r$$

$$\text{or } W = 2\pi T \quad (\because T = F \times r)$$

$$\therefore \text{Work done by the force in 1 s} = 2\pi T \frac{N}{60} \text{ J/s or W}$$

$$\therefore \text{Horsepower developed} = \frac{2\pi TN}{60 \times 746} \quad (8.5)$$

One horsepower is equal to 746 W in the British system and 735.5 W in the metric system. In this case the British horsepower is taken to be the international standard.

**Armature Torque** Every armature conductor of a dc motor lying under a pole produces a torque, which tends to rotate the motor. The sum of all these torque is called the armature torque or gross torque.

Let  $T_a$  be the armature torque of a motor running at a speed of  $N$  rpm, then the power developed in the armature is

$$\begin{aligned} \text{Bhp} &= \frac{2\pi T_a N}{60 \times 746} \\ &= \frac{2\pi T_a N \times 746}{60 \times 746} \text{ W} \\ &= \frac{2\pi T_a N}{60} \text{ W} \end{aligned}$$

However power developed in the armature is also  $E_b I_a$

$$\begin{aligned} \therefore E_b I_a &= \frac{2\pi T_a N}{60} \\ \text{or } T_a &= \frac{E_b I_a \times 60}{2\pi N} \\ &= \frac{9.55 E_b I_a}{N} \text{ N-m} \quad (8.6) \end{aligned}$$

**Shaft Torque** The shaft torque  $T_{sh}$  is the net torque available at the pulley for doing useful work while the armature torque is the total torque developed in the motor. The shaft torque is a little less than the armature torque because some power is used in overcoming the stray losses (i.e. iron and friction losses). The horsepower available at the shaft of the motor is known as brake horsepower (bhp). The difference between  $T_a$  and  $T_{sh}$  is called *lost torque*.

Let  $T_{sh}$  be the shaft torque of a motor developing a power when running at a speed of  $N$  rpm. Then

$$\begin{aligned} \text{bhp} &= \frac{2\pi T_{sh} N}{60 \times 746} \\ \therefore T_{sh} &= \frac{\text{bhp} \times 60 \times 746}{2\pi N} \text{ N-m} \quad (8.7) \end{aligned}$$

We know that  $E_b I_a$

$$= \frac{2\pi T_a N}{60} \text{ W} \quad (i)$$

$$\text{But } E_b = \frac{P\phi N \times Z}{60 \times a}$$

Substituting the value of  $E_b$  in Eq. (i), we get

$$\frac{P\phi N Z \times I_a}{60 \times a} = \frac{2\pi T_a N}{60}$$

$$\text{or } 2\pi T_a N \times 60 \times a = P\phi N Z I_a \times 60$$

$$\therefore T_a = \frac{P\phi N Z I_a \times 60}{2\pi N \times 60 \times a}$$

$$T_a = K I_a \phi \quad (\text{where } K = \text{const})$$

$$\therefore T_a \propto I_a \phi \quad (8.8)$$

where  $I_a$  = current flowing through the armature

$\phi$  = field flux per pole

$T_a$  = Armature torque produced in newton-metre

**EXAMPLE 8.1** The power developed at the shaft of the motor is 22 hp. Calculate the speed if the torque is 210 N-m.

**Solution :** We know that

$$\text{Shaft torque, } T_{sh} = \frac{\text{bhp} \times 60 \times 746}{2\pi N}$$

$$\begin{aligned} \therefore \text{Speed, } N &= \frac{\text{bhp} \times 60 \times 746}{2\pi T_{sh}} \\ &= \frac{22 \times 60 \times 746}{2 \times 22 \times 210} = 746 \text{ rpm Ans.} \end{aligned}$$

**Torque of dc Motor** We know that

$$T \propto I_a \phi$$

This means that the torque of a dc motor is directly proportional to the armature current and field flux. Heavier the load on a motor, greater will be the torque exerted by the armature conductors, and stronger the field flux of the motor, more will be the torque developed.

**Speed of dc Motor** The back emf is given by

$$E_b = \frac{P\phi N Z}{60 \times a}$$

However for a given motor  $\frac{PZ}{60 \times a}$  is constant.

Let it be equal to  $K$ . Therefore

$$K\phi N = E_b$$

$$KN = \frac{E_b}{\phi}$$

$$\text{or } N \propto \frac{E_b}{\phi} \quad (8.9)$$

This means that if  $E_b$  increases, the speed will increase, and if it decreases, the speed will decrease. Similarly, if  $\phi$  (flux) increases, the speed will decrease and if  $\phi$  decreases, the speed will increase.

Let  $N_1$ ,  $\phi_1$  and  $E_{b1}$  be the speed, flux per pole and back emf when the motor is on no

load. Also, Let  $N_2$ ,  $\phi_2$  and  $E_{b_2}$  be the speed, flux per pole and back emf when the machine is loaded. Then

$$N_1 = \frac{KE_{b_1}}{\phi_1} \quad (i)$$

$$\text{and } N_2 = \frac{KE_{b_2}}{\phi_2} \quad (ii)$$

Dividing Eq. (i) by Eq. (ii), we have

$$\frac{N_1}{N_2} = \frac{E_{b_1}}{\phi_1} \times \frac{\phi_2}{E_{b_2}}$$

$$\text{or } \frac{N_1}{N_2} = \frac{E_{b_1} \phi_2}{E_{b_2} \phi_1} \quad (8.10)$$

$$\text{Similarly, } \frac{T_{a_1}}{T_{a_2}} = \frac{I_{a_1} \phi_1}{I_{a_2} \phi_2} \quad (8.11)$$

### 8.6 CHARACTERISTICS OF DC MOTORS

The characteristic curves of a motor are the curves which show the relation between armature current, speed and torque. The following are the characteristic curves of a motor:

(i) **Torque and Armature Current Characteristic ( $T/I_a$  Characteristic)** This characteristic is also known as the electrical characteristic and shows the relation between torque developed and the armature current of the motor.

(ii) **Speed and Armature Current Characteristic ( $N/I_a$  Characteristic)** This curve shows the relation between the speed and armature current.

(iii) **Speed and Torque Characteristic ( $N/T$  Characteristic)** This characteristic is also known as the mechanical characteristic and

shows the relation between the speed and torque developed of a motor.

### 8.7 POWER STAGES OF DC MOTOR

The losses which occur during the transformation of electrical energy into mechanical energy can be shown diagrammatically as in Fig. 8.6.

### 8.8 EFFICIENCY OF DC MOTOR

The efficiency of a motor is equal to the output developed by the motor divided by the electrical input of the motor, i.e. input minus the losses divided by the input. The efficiency can be calculated in the same way as for the dc generator. It is usually expressed in percentage.

$$\text{Efficiency} = \frac{\text{output}}{\text{input}} = \frac{\text{input} - \text{losses}}{\text{input}}$$

$$\text{Percentage efficiency} = \frac{\text{output}}{\text{input}} \times 100\%$$

Efficiency in the case of motors can also be classified as in the case of generators as follows:

- (i) Mechanical efficiency
- (ii) electrical efficiency, and
- (iii) commercial efficiency.

Mechanical efficiency

$$(\eta_m) = \frac{V}{III} = \frac{\text{motor output}}{\text{mechanical power developed}}$$

$$= \frac{\text{bhp} \times 746}{E_b \times I_a} \quad (8.12)$$

Electrical efficiency

$$(\eta_e) = \frac{III}{I} = \frac{\text{mechanical power developed}}{\text{electrical power input}}$$

$$= \frac{E_b \times I_a}{V_L \times I_L} \quad (8.13)$$

Commercial efficiency

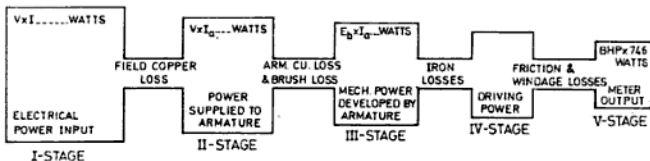

Fig. 8.6 Different power stages of dc motor

$$\begin{aligned} \eta &= \frac{V}{I} = \frac{\text{motor bhp}}{\text{electrical power input}} \\ &= \frac{\text{bhp} \times 746}{V_L \times I_L} \end{aligned} \quad (8.14)$$

NOTE: Iron and friction losses  
 $= III - V = E_b \times I_a - \text{bhp}$

Copper losses  $= I - III = V_L \times I_L - E_b \times I_a$

### 8.9 RATING OF DC MOTORS

The rating of a motor is usually mentioned on the name plate of the machine as in the example given below:

Horsepower — 5 hp  
 Voltage — 220 V  
 Current — 21 A  
 Speed — 2600 rpm  
 Type — dc shunt

This means that when a dc shunt motor is supplied with a voltage of 220 V, it runs at a speed of 2600 rpm and is capable of delivering 5 hp when it takes a current of 21 A.

### 8.10 CLASSIFICATION OF DC MOTORS

The classification of dc motors is shown below.

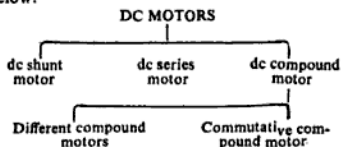

### 8.11 DC SHUNT MOTOR

In a dc shunt motor the field winding is connected in parallel to the armature (8.7) and

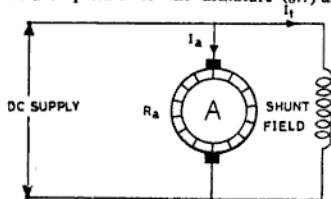

Fig. 8.7 DC Shunt motor

hence the full line voltage is applied across it. So the shunt field winding consists of thin wire of many turns.

The shunt field current is given by

$$I_{sh} = \frac{V}{R_{sh}}$$

where  $V$  = voltage applied across the shunt field winding

$R_{sh}$  = resistance of the field winding

$I_{sh}$  = current of the field winding

As  $V$  and  $R_{sh}$  are constant, the shunt field current  $I_{sh}$  is constant and hence the field flux  $\phi$  is constant and independent of the load current. Therefore, the speed of the shunt motor will be constant. The current taken by the armature is  $I_a = I_L - I_{sh}$ .

### 8.12 CHARACTERISTIC OF DC SHUNT MOTOR

It is important to note that while considering and discussing the characteristics of dc shunt motors, the following relation should always be kept in mind:

$$I \propto I_a \phi$$

and

$$N \propto \frac{E_b}{\phi}$$

$T/I_a$  Characteristic We know that

$$T \propto I_a \phi$$

But  $\phi$  is constant in shunt motors and hence

$$T \propto I_a$$

This means that if  $I_a$  (or load current) decreases, the torque decreases and if  $I_a$  increases, the torque increases. Shunt motors

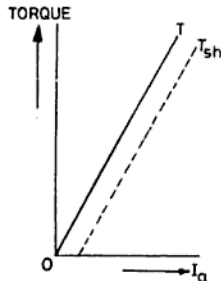

Fig. 8.8  $T/I_a$  characteristic

are never used at heavy load because a heavy load will require a heavy starting current which may effect the voltage regulation of the supply and the connected installation.

This characteristic is shown in Fig. 8.8.

**$N/I_a$  Characteristic** For dc motors the speed

$$N \propto \frac{E_b}{\phi}$$

But  $E_b = V - I_a R_a$

Since  $R_a$  is very small, the  $I_a R_a$  drop does not change very much with the load and hence  $E_b$  is approximately constant. The field flux of a shunt motor is also approximately constant and hence the speed of a dc shunt motor is approximately constant. Therefore, this motor is used for constant loads, such as in water pumps, saw mills, blowers, lathes, wood-working machines, etc.

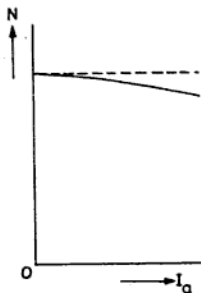

Fig. 8.9  $N/I_a$  characteristic

Strictly speaking, both  $E_b$  and  $\phi$  decrease with the load. However  $E_b$  decreases a little more than  $\phi$  and hence the speed  $N$  of the motor decreases a little with an increase of load. There is no danger of attaining the motor a high speed at little load because the speed does not vary much with load (see Fig. 8.9 for  $N/I_a$  characteristic).

**$N/T$  Characteristic** This characteristic is shown in Fig. 8.10 and can be found from curves 1 and 2 as shown in the two curves of the dc shunt motor. The  $N/T$  characteristic falls a little due to the fact that when the load is increased, the motor tends to slow

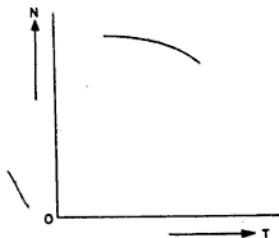

Fig. 8.10  $N/T$  characteristic

down. The decrease of speed reduces the back emf and more current flows through the armature which increases the torque within the capacity of the motor. Again, if the load is suddenly thrown off, the motor will not speed up since the field strength is constant and will accelerate at constant speed.

**EXAMPLE 8.2** A shunt motor takes 72 A at 230 V and runs at 955 rpm. The resistance of the armature is 0.5  $\Omega$  and of the shunt field is 115  $\Omega$ . If the iron and friction losses are 968 W, find: (i) bhp, (ii) copper losses, (iii) armature torque, (iv) shaft torque, (v) lost torque and (vi) commercial efficiency.

**Solution:** Input of the motor,

$$W = V \times I = 230 \times 72 = 16560 \text{ W}$$

Shunt field current,

$$I_{sh} = \frac{V}{R_{sh}} = \frac{230}{115} = 2 \text{ A}$$

Armature current,

$$I_a = I_L - I_f = 72 - 2 = 70 \text{ A}$$

Back emf,  $E_b = V - I_a R_a$

$$= 230 - 70 \times 0.5$$

$$= 230 - 35 = 195 \text{ V}$$

Driving power developed  $= E_b \times I_a$

$$= 195 \times 70 = 13650 \text{ W}$$

Mechanical power output of motor = driving power -

$$\text{stray losses} = 13650 - 968 = 12682 \text{ W}$$

$$(i) \quad \text{bhp} = \frac{\text{output}}{746} = \frac{12682}{746} = 17 \text{ Ans.}$$

$$(ii) \quad \text{Copper losses} = \text{input} - \text{driving power} = 16560 - 13650 = 2910 \text{ W Ans.}$$

(iii) We know

Armature torque,

$$T_a = \frac{9.55 \times E_b I_a}{N}$$

$$= \frac{9.55 \times 195 \times 70}{955}$$

$$= 136.5 \text{ N-m Ans.}$$

(iv) Shaft torque,

$$T_{sh} = \frac{\text{bhp} \times 60 \times 746}{2N} \text{ N-m}$$

$$= \frac{17 \times 60 \times 746}{2 \times \frac{22}{7} \times 955}$$

$$= \frac{17 \times 60 \times 746 \times 7}{44 \times 955} = 126.75 \text{ N-m Ans.}$$

(v) Lost torque =  $T_a - T_{sh} = 136.5 - 126.75$ 

$$= 9.75 \text{ N-m Ans.}$$

(vi) Commercial efficiency,

$$\eta_c = \frac{\text{output}}{\text{input}} \times 100\%$$

$$= \frac{12682 \times 100}{16560} = 76.58\% \text{ Ans.}$$

**EXAMPLE 8.3** A shunt motor of 230 V takes 5 A on no load and runs at 914 rpm. The resistance of armature is 0.5  $\Omega$  and of the shunt field 115  $\Omega$ . Find the speed when it is loaded taking current of 30 A. Assume that the armature reaction weakens the field by 10% when loaded.

**Solution:** Shunt field current,

$$I_{sh} = \frac{V}{R_{sh}} = \frac{230}{115} = 2 \text{ A}$$

Armature current at no load,  $I_a = I_L - I_f = 5 - 2 = 3 \text{ A}$

Armature current when loaded,  $I_a = I_L - I_a$

$$= 30 - 2 = 28 \text{ A}$$

Back emf,  $E_{b1}$  at no load =  $V - I_a R_a$

$$= 230 - 3 \times 0.5$$

$$= 228.5 \text{ V}$$

Back emf,  $E_{b2}$  at load =  $230 - 28 \times 0.5$

$$= 230 - 14 = 216 \text{ V}$$

$$\phi_1 = 100$$

$$\phi_2 = 100 - 10 = 90$$

We know,

$$\frac{N_1}{N_2} = \frac{E_{b1} \phi_2}{E_{b2} \phi_1}$$

$\therefore$  Speed when loaded,

$$N_2 = \frac{N_1 E_{b2} \phi_1}{E_{b1} \phi_2}$$

$$= \frac{914 \times 216 \times 100}{228.5 \times 90}$$

$$= 960 \text{ rpm Ans.}$$

**EXAMPLE 8.4** A 110 V shunt motor takes a current of 5 A at light load (i.e. running without load). If the armature resistance is 0.5  $\Omega$  and of shunt field is 110  $\Omega$ , calculate (i) stray losses, (ii) horsepower

and (iii) efficiency of the motor when it is working on full load and takes a current of 83 A.

**Solution:** Shunt field current,

$$I_{sh} = \frac{V}{R_{sh}} = \frac{110}{110} = 1 \text{ A}$$

Armature current at no load,  $I_a = I_L - I_f = 5 - 1 = 4 \text{ A}$

Armature current when loaded,  $I_a = I_L - I_f = 83 - 1$

$$= 82 \text{ A}$$

Back emf at no load,  $E_{b1} = V - I_a R_a = 110 - 4 \times 0.5$

$$= 110 - 2$$

$$= 108 \text{ V}$$

Back emf at load,  $E_{b2} = V - I_a R_a = 110 - 82 \times 0.5$

$$= 110 - 41 = 69 \text{ V}$$

Driving power at no load, i.e. stray losses

$$= E_{b1} I_a = 108 \times 4 = 432 \text{ W Ans.}$$

Driving power at load =  $E_{b2} \times I_a = 69 \times 82 = 5658 \text{ W}$

Output of the motor = driving power ( $E_{b2} \times I_a$ ) - stray losses

$$= 5658 - 432 = 5226 \text{ W}$$

$$\text{bhp} = \frac{\text{output}}{746}$$

$$= \frac{5226}{746} = 7.0 \text{ A Ans.}$$

Input of the motor,  $W = V \times I = 110 \times 83 = 9130 \text{ W}$

Efficiency,  $\eta\% = \frac{5226 \times 100}{9130} = 56.13\% \text{ Ans.}$

### 8.13 DC SERIES MOTOR

In the dc series motor the field winding is connected in series to the armature as shown in Fig. 8.11. As the field winding is connected

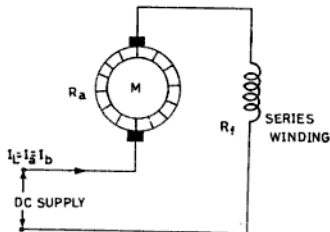

Fig. 8.11 DC series motor

in series to the armature, it carries full load current and has to be of thick wire of few turns. The line current taken by the motor is equal to the armature current or field current, i.e.

$$I_L = I_a = I_f$$

where  $I_L$  = load current or line current  
 $I_a$  = armature current  
 $I_f$  = series field current

Also, the applied voltage is given by

$$V = E_b + I_a R_a + I_f R_f$$

where  $E_b$  = back emf induced

$I_a R_a$  = voltage drop in the armature

and  $I_f R_f$  = voltage drop in the series field winding.

#### 8.14 CHARACTERISTICS OF DC SERIES MOTOR

$T/I_a$  Characteristic We know that

$$T \propto I_a \phi$$

It means the torque of the dc motor is directly proportional to the armature current and field flux per pole. But the field flux is proportional to  $I_f$  or  $I_a$  as it is a series motor (till saturation takes place). Therefore

$$T \propto I_a \times I_a$$

or  $T \propto I_a^2$ .

After saturation, flux ( $\phi$ ) is almost independent of  $I_a$  and therefore after saturation  $T \propto I_a$  only. The  $T/I_a$  curve is shown in Fig. 8.12. As  $T \propto I_a^2$  (before magnetic saturation),

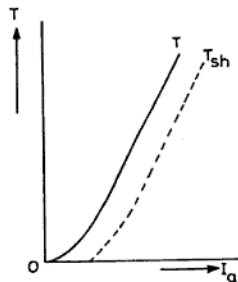

Fig. 8.12  $T/I_a$  characteristic

series motors have high starting torque on heavy loads and are therefore used for electric cranes, electric trains, hoists, etc.

$N/I_a$  Characteristic We know that

$$N \propto \frac{E_b}{\phi}$$

But  $E_b = V - I_a R_a$

However the  $I_a R_a$  armature drop does not change much with variation of load ( $R_a$  being very small). Therefore,  $E_b$  is approximately constant for different loads. Hence  $N \propto \frac{1}{\phi}$

But in a series motor,  $\phi$  is proportional to  $I_f$  or  $I_a$ . Therefore

$$N \propto \frac{1}{I_a}$$

It is clear that if load increases, the speed will decrease and if load decreases, the speed will increase. This means that when the load is heavy,  $I_a$  is large and hence the speed is low and the torque is high. However when the load is completely removed, the armature current falls to a small value and thus the speed becomes dangerously high. Hence series motors are never started without load and are only used where there is no possibility of load being removed from the motor just as a belt coupling or rope coupling because a sudden removal of the load would cause the motor to attain a dangerously high speed. Small motors may be used without a belt because their large frictional resistance represents appreciable load on it which limits the motor to reach dangerous speeds. The speed/armature current curve is shown in Fig. 8.13.

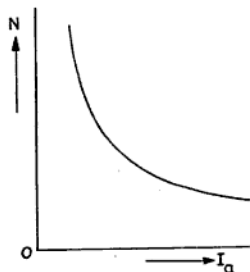

Fig. 8.13  $N/I_a$  characteristic

From the above description, it is clear that a series motor is a variable speed motor which adjust its speed according to load.

$N/T$  Characteristic The output of the motor is given by

$$\text{bhp} = \frac{2\pi TN}{60 \times 746}$$

$$\text{or } T = \frac{\text{bhp} \times 60 \times 746}{2\pi N}$$

But  $\frac{\text{bhp} \times 60 \times 746}{2\pi}$  is constant for a given load.

$$\therefore T = K \frac{1}{N} \quad (K = \text{const})$$

$$\text{or } T \propto \frac{1}{N}$$

For constant load, if the speed is increased, the torque decreases and if the speed decreases, the torque is increased. The speed/torque curve is shown in Fig. 8.14.

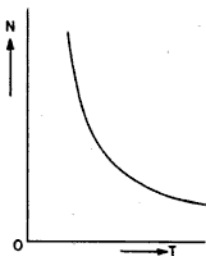

Fig. 8.14  $N/T$  characteristic

**EXAMPLE 8.5.** A series motor takes 60 A at 230 V and runs at 955 rpm. The armature resistance is 0.2  $\Omega$  and the series field resistance is 0.15  $\Omega$ . If the stray losses are equal to 604 W, calculate (i) the back emf (ii) copper losses, (iii) bhp, (iv) total torque, (v) shaft torque, (vi) lost torque, and (vii) commercial efficiency.

**Solution:**

Total resistance of the motor,  $R_m = 0.2 + 0.15 = 0.35 \Omega$

$$\begin{aligned} \text{Back emf, } E_b &= V - I_a R_a \\ &= 230 - 60 \times 0.35 = 209 \text{ V Ans.} \end{aligned}$$

$$\begin{aligned} \text{Input of the motor } W &= V \times I \\ &= 230 \times 60 = 13800 \text{ W} \end{aligned}$$

$$\begin{aligned} \text{Driving power} &= E_b \times I_a = 209 \times 60 = 12540 \text{ W} \\ \text{Copper losses} &= \text{input} - \text{driving power} \\ &= 13800 - 12540 = 1260 \text{ W Ans.} \end{aligned}$$

$$\begin{aligned} \text{Output of the motor} &= \text{Driving power} - \text{stray losses} \\ &= 12540 - 604 = 11936 \text{ W} \end{aligned}$$

$$\text{bhp of the motor} = \frac{\text{output}}{746} = \frac{11936}{746} = 16 \text{ Ans.}$$

$$\begin{aligned} \text{Total torque, } T_a &= \frac{9.55 \times E_b \times I_a}{N} \\ &= \frac{9.55 \times 209 \times 60}{955} \end{aligned}$$

$$\begin{aligned} &= 125.4 \text{ N-m Ans.} \\ \text{Shaft torque, } T_{sh} &= \frac{\text{bhp} \times 60 \times 746}{2\pi N} \end{aligned}$$

$$\begin{aligned} &= \frac{16 \times 60 \times 746 \times 7}{2 \times 22 \times 955} \\ &= 119.3 \text{ N-m Ans.} \end{aligned}$$

$$\begin{aligned} \text{Lost torque} &= T_a - T_{sh} \\ &= 125.4 - 119.3 = 6.1 \text{ N-m Ans.} \end{aligned}$$

$$\begin{aligned} \text{Commercial efficiency, } \eta_c &= \frac{\text{output} \times 100\%}{\text{input}} \\ &= \frac{11936 \times 100\%}{13800} \\ &= 86.35\% \text{ Ans.} \end{aligned}$$

**EXAMPLE 8.6** Calculate the current taken by a series motor which runs at 728 rpm, when then potential difference across its terminals is 220 V. The shaft torque is 150 N-m and the efficiency at this load is 80%.

**Solution:**

Let the current taken by the motor = I A

$$\therefore \text{Input of the motor, } W = V \times I = 220 \times I \text{ W}$$

$$\text{We know efficiency, } \% = \frac{\text{output} \times 100\%}{\text{input}}$$

$$\begin{aligned} \therefore \text{Output (i.e. bhp)} &= \frac{\text{input} \times \eta\%}{100} \\ &= \frac{220 \times I \times 80}{100} \text{ W} \quad \text{(i)} \end{aligned}$$

But

$$\begin{aligned} \text{Shaft torque, } T_{sh} &= \frac{\text{bhp} \times 60 \times 746 \times 7}{2 \times 22 \times 728} \\ 150 &= \frac{\text{bhp} \times 60 \times 746 \times 7}{2 \times 22 \times 728} \end{aligned}$$

$$\therefore \text{bhp} = \frac{150 \times 2 \times 22 \times 728 \times 746}{60 \times 746 \times 7} \text{ W} \quad \text{(ii)}$$

From Eqs. (i) and (ii), we have

$$0.80 \times 220 \times I = \frac{150 \times 2 \times 22 \times 728 \times 746}{60 \times 746 \times 7}$$

$\therefore$  Current taken by motor,

$$\begin{aligned} I &= \frac{150 \times 2 \times 22 \times 728 \times 746}{60 \times 746 \times 7 \times 0.80 \times 220} \\ &= 65 \text{ A Ans.} \end{aligned}$$

## 8.15 COMPOUND MOTORS

Compound motors are a combination of series and shunt motors. A compound motor has two field windings, one is a series field winding and is connected in series with the armature winding, and which is therefore made of thick wire of few turns. The second winding is called the shunt field winding and is joined in parallel with the armature and is

flux is produced by the shunt field winding. Therefore, the motor has approximately constant speed at different loads within the capacity of the motor. All compound motors are usually commulative connected.

This type of motor is used where a heavy load is suddenly thrown ON and OFF, such as in rolling mills, heavy tool machines, big presses, printing machines, punches, shears, elevators, heavy planners, conveyors, etc. Owing to the sudden change of load, the motor will tend to change its speed (having a characteristic of the series motor). Therefore, in case of large output motors, the change of speed is protected by providing a fly wheel on the shaft of the motor which serves as a constant load in the case of a sudden fall of load on the motor.

### 8.18 CHARACTERISTIC OF DC COMPOUND MOTOR

Motors of this type are usually commulative-connected and therefore while discussing its characteristic, we will consider only the commulative compound motor. As discussed earlier, in these motors, the series field flux

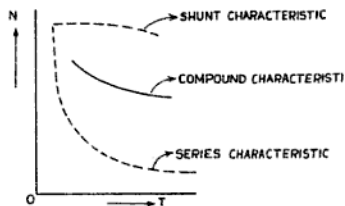

Fig. 8.18  $N/T$  characteristic of commulative compound motor

helps the shunt field flux. Therefore the speed/torque characteristic of this motor lies in between the characteristics of the series and shunt motor as shown in Fig. 8.18.

### 8.19 APPLICATIONS OF DC MOTORS

A summary of the applications of dc motors are given in Table 8.1.

TABLE 8.1

<i>Types of motor</i>	<i>Working characteristic</i>	<i>Applications</i>
DC Series Motor	<p>(i) It is a variable speed motor having high starting torque under heavy load</p> <p>(ii) Started on load but load should be constant within the capacity of the motor</p>	Series motors are used where high starting torque is required, such as in electric trains, trams, cranes, lifts, conveyors, etc.
DC Shunt Motor	<p>(i) It is a constant speed motor from no load to full load. Its starting torque is low but running torque is good.</p> <p>(ii) Started without load and constant load is put on it.</p>	Shunt motors are used where constant speed is required at low starting torque, such as in wood working machines, water pumps, blowers, lathes, etc.
DC Commulative Compound Motor	It is a variable speed motor and is used for intermittent high starting torque.	This motor is used where intermittent high starting torque is required as rolling mills, heavy tool machines, big presses, printing machines, punches, shears, heavy planners, elevators, conveyors, etc.

### 8.20 NECESSITY OF STARTERS

When a motor is connected to the supply, heavy current will flow through the armature as the armature resistance is very low. Moreover there is no back emf in it at the time of starting. Therefore to reduce this high starting current, resistance is connected in series to the armature at the time of starting the motor. This resistance is gradually cut off as the armature gains speed because the armature develops back emf and hence the current falls. Therefore, to start a motor, a starter having variable resistance is required.

### 8.21 TYPES OF STARTERS

The dc shunt or Compound Motor is started by the following two types of starters:

- (i) The dc three-point starter, and
- (ii) the dc four-point starter.

### 8.22 DC THREE-POINT STARTER

The dc shunt motor is started by a three-point starter consisting of the resistance, handle, studs, no-volt coil and overload release as shown in Fig. 8.19.

When a motor is connected to the supply, the current to the armature goes through the starting resistance and the field winding is connected directly to the mains through the no-volt coil. When the motor attains speed, some back emf is induced in the armature. The starting resistance is gradually cut off and thus the starting current is reduced to a low value.

**No-volt Release Coil** No-volt and overload release coils are the safety devices provided in the starter. The no-volt coil consists of a thin wire of many turns and is connected in series with the field winding of the motor. This coil is magnetised when the current flows through the shunt field winding. Its function is to attract the handle of the starter and keep it in the ON position. It releases the handle and goes to the OFF position by the spring tension due to the failure of supply and in this way disconnects the motor from the supply.

**Overload Release Coil** Its function is to demagnetize the no-volt release coil in the case of fault or overload of the machine. It consists of a few turns of thick wire and is

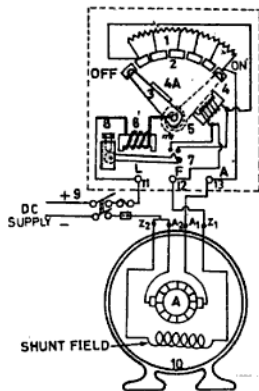

Fig. 8.19 Shunt motor with three-point starter

1. Starting resistance
2. Brass studs
3. Starting handle
4. No-volt release coil
5. Spring
6. Overload release
7. Tripping lever with contact point
8. Current adjustment
9. DPIC main switch
10. DC motor
11. Live terminal
12. Shunt field terminal
13. Armature terminal

connected in series to the armature. This coil will only be sufficiently magnetised when excessive current flows through the armature due to overload or some fault. Now the coil attracts the tripping plunger which short circuits the terminal of the no-volt coil. The no-volt release coil will be demagnetised and release the starting handle which will come to the OFF position at once due to the spring tension. Thus the motor stops.

### 8.23 STARTING OF DC COMPOUND MOTOR

The use of the dc three-point starter with the compound motor is shown in Fig. 8.20. Its use is the same as in the case of the dc shunt motor except that the series field winding is connected in series with the armature.

This starter is used at places where much speed regulation is required. For maximum variation of speed a high resistance in series is put with the shunt field winding. If instead of a four-point starter, a three-point starter is used, this high resistance will reduce the current of the shunt field winding. However, the no-volt release coil is connected in series with the shunt field winding and thus the current passing through the no-volt coil is also decreased. Thus the no-volt release coil will be unable to produce sufficient magnetic power and therefore releases the gripping handle to the OFF position.

In the dc four-point starter the no-volt coil is connected across the supply mains. Therefore, the current passing through it is independent of the shunt field current and thus higher speed can be obtained by putting a higher value of resistance without the interruption of the handle. This method of speed control is employed where a much higher speed than its rated speed is required.

### 8.25 STARTING OF DC SERIES MOTOR

A dc series motor is started by the two-point dc series motor starter.

### 8.26 TWO-POINT STARTER

Series motors are started by the two point dc series motor starter in which there is a starting resistance of low value and of high current carrying capacity. This resistance is

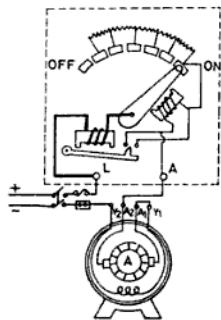

Fig. 8.22 Two-point series motor starter

completely inserted in the motor circuit at the time of starting the motor and is gradually cut off when the motor attains normal speed. This resistance is inserted in the circuit because the motor takes heavy current at starting as the resistance of the motor is very small and moreover there is no back emf in it. This resistance can also be used as a speed regulator if it is designed for continuous rating.

In this starter various protective devices such as the no-volt release coil and overload release coils are also provided for the protection of the motor and their function is the same as discussed earlier. The connection diagram of such type of starters are shown in Fig. 8.22.

### 8.27 CHANGING DIRECTION OF ROTATION

The direction of rotation (DOR) of a dc motor can be reversed by either reversing the direction of current in the field winding or in the armature winding.

Consider a conductor of armature carrying current inward placed under the influence of the north pole as shown in Fig. 8.23. By applying

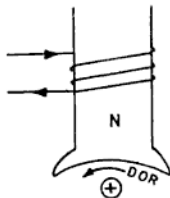

Fig. 8.23 DOR changes with the changes of either armature current or field current

Fleming's Left hand rule, it will be seen that a force will act on the conductor which will move it in the anticlockwise direction. If now the current in the armature conductor is changed from inward to outward, the direction of rotation will also be changed and now it will be clockwise as shown in Fig. 8.24. Hence the direction of rotation of the motor can be changed by changing the armature current.

Again suppose that a conductor carrying

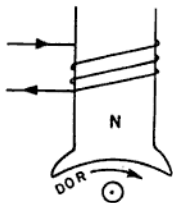

Fig. 8.24

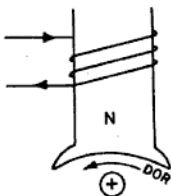
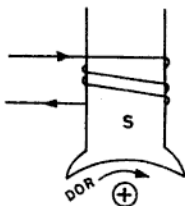

Fig. 8.25

current inward is placed under the north pole as shown in Fig. 8.25. Therefore, a force will act on the conductor which will move it in anticlockwise direction. On changing the current through the field winding, the polarity of the pole will be changed from north to south and the same current carrying conductor will again experience a force acting in the clockwise direction as shown in Fig. 8.26.



DC SUPPLY

Fig. 8.26

**NOTE :** For the reversal of direction of rotation of dc motors, either the current through the field winding or in the armature is changed, if the direction of current in both is changed, the direction of rotation will not change.

The direction of rotation of series, shunt and compound motors are changed by changing the armature current and field current as shown in Figs. 8.27, 8.28 and 8.29.

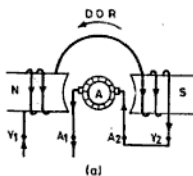

(a)

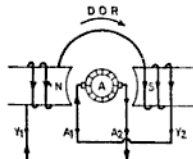

(b)

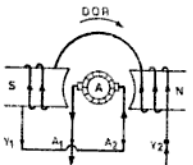

(c)

Fig. 8.27 (a) Original connection  
(b) Armature current changed  
(c) Field current changed

The motor generator set always runs at constant speed in one direction and the speed of the main motor can be changed by changing the direction of the field current of the generator. Therefore a reversing switch is provided in the field winding of the generator which reverses the direction of the field current. Thus the polarity of the emf generated is changed and hence the direction of the main motor is reversed.

The disadvantage of this system is that its initial cost is very high and the efficiency is less. This method of speed control is used where very sensitive variations of speed is required as in reversing mills, elevators, mines, hoists, etc.

**Speed control of dc Compound Motor** The speed regulation of dc compound motors is obtained by the same manner as in the case of the dc shunt motor.

### 8.32 ARMATURE REACTION

Just as in dc generators, in dc motors also the flux produced by the armature also effects the main magnetic flux produced by the field winding. In the motor the MNA is shifted from the GNA to the opposite side of the direction of rotation (i.e. opposite to the

generator), so the flux increases at the leading pole tip and decreases at the trailing pole tip. As the MNA lags behind the GNA, for sparkless operation it is necessary to shift the brushes opposite to the direction of rotation.

### 8.33 COMMUTATION

Commutation in the case of dc motors is exactly similar to what happens in the case of dc generators. It should also be noted that the method of decreasing the armature reaction and commutation are the same as discussed in dc generators.

**NOTE :** The polarity of interpoles in the case of dc motors is kept similar to that of the main pole behind in the direction of rotation of the motor.

### 8.34 LOSSES IN DC MOTORS

Losses in dc motors are the same as in the generators, namely (i) copper losses and (ii) stray losses. These losses have already been discussed in Chapter 7.

### 8.35 COMMON DEFECTS AND THEIR REMEDIES IN DC MOTORS

The common defects and their remedies are given in Table 8.2.

TABLE 8.2 TROUBLE-SHOOTING CHART

Motor fails to start	Incorrect speed	Motor badly sparking	Fuse blowing off at starting	Excessive over heating of machine	Noise in the machine
(a) Motor does not start: 1. Main supply off—Test close the main switch if supply is there. 2. Fuses not in contact in main switch—Replace fuses. 3. Open circuit in the wiring—Check continuity of wiring from main switch to motor. 4. Brush not resting on the commutator—Brushes to be set or replaced. 5. Open circuit in armature—Test the armature and remove the fault. 6. Open, loose or bad contact in starting gear—Examine each contact of the starting gear for fault.	(a) Motor runs at terrible speed at starting: 1. Rheostat is completely in the shunt field—Adjust the rheostat to cut off all the resistance from shunt winding. 2. Loose or open connection in the shunt field or no-volt coil circuit—Test for continuity. 3. Series motor running without load—Put load on motor before starting. 4. Compound motor may be differential—Reverse direction of current in series field. 5. Motor is badly jammed—Overhaul the motor and lubricate the bearings.	1. Brushes loose contact—Adjust spring tension. 2. Brushes not in MNA—Adjust brush position. 3. Overload on the motor—Reduce some load on the motor. 4. Commutator not having smooth surface—Turn commutator on lathe. 5. Dirty commutator surface—Dip and wash in petrol and then clean it with sand paper. 6. Open or earth or short circuit in armature and commutator circuit—Test and remove the fault. 7. Open circuit in the armature coil or loose connection at the commutator—Test for continuity 8. Reverse inter-pole polarity—Test polarity compass 9. Wrong speed—Change direction of rotation.	1. Bad starting i.e. moving the handle quickly—Move the handle slowly. 2. Open circuit in the field or no-volt coil—Test for continuity. 3. A short circuit either in the armature or in the starter resistance—Locate the fault. 4. Fuses too small for load—Replace proper size of fuse. 5. Due to overload—Adjust the load. 6. Earth fault in the machine—Trace the earth and insulate it properly if possible. Fuse will only blow if the motor is fully earthed. 7. Test and remove the fault and connect it to a good earth connection. 8. Excessive current in the shunt field winding—Increase the field resistance by putting field rheostat in series with the shunt field winding. 9. Excessive load on the series motor—Adjust the load. 10. Eddy current—Faulty lamination core will cause the pole shoe to be more hot than	(a) Excessive heating due to armature: 1. Overload of the machine i.e. armature—Adjust the load. 2. Short circuit or ground in the armature or commutator—Test for short circuit with milli-volt meter or with growler and remove the fault. 3. Moisture in the coil—Dry out the armature by very small heat; it may be done by sending a very small current through the armature. 4. Excessive current in the shunt field winding—Increase the field resistance by putting field rheostat in series with the shunt field winding. 5. Excessive load on the series motor—Adjust the load. 6. Eddy current—Faulty lamination core will cause the pole shoe to be more hot than	1. Loose fan or pulley—Tighten them properly. 2. Loose bolts of side covers—Check and screw them lightly. 3. Armature strikes poles pieces—Loose bearing may be the cause. 4. Commutator rib strikes brush holder—Insert washer on shaft towards commutator side.

(Contd.)

<i>Motor fails to start</i>	<i>Incorrect speed</i>	<i>Motor badly sparking</i>	<i>Fuse blowing off at starting</i>	<i>Excessive over heating of machine</i>
<p>them properly.</p> <p>10. <i>Mica above the commutator segment</i>—Turn the commutator and cut down the mica a little below the commutator with a fine saw.</p>	<p>11. <i>Cross in the armature circuit</i>—Disconnect the crossed coil and reconnect</p> <p>12. <i>Wrong grade of brushes</i>—Replace proper grade of brushes.</p>	<p>13. <i>Brush sticking in the holder</i>—Slightly grind the brush.</p>	<p>the field coil after short run. Re-insulate the field core.</p> <p>7. <i>Worn-out bearings</i>—Replace bearings.</p> <p>8. <i>Too much grease in bearing-housing</i>—Reduce extra grease.</p> <p>9. <i>Dirt or dust in the bearing</i>—Wash it thoroughly.</p> <p>10. <i>Belt too tight</i>—Loose the belt a little.</p> <p>11. <i>Overload on the machine</i>—Decrease the load.</p> <p>12. <i>Brush pressure too high</i>—Reduce the pressure.</p>	<p>(b) <i>Excessive heat due to sparking at the commutator.</i></p>
<p>(b) <i>Motor starts but does not take load due to the following reasons:</i></p> <p>1. <i>Excessive overload</i>—Remove complete or some load and then start.</p> <p>2. <i>Low setting of the current adjuster</i>—Set it at proper current rating of motor.</p> <p>3. <i>Incorrect setting of the overload strips</i>—Bring adjusting knob to zero. If contact point is not touching, set overload strips and contact point both at zero overload—</p>	<p>(b) <i>Motor runs at low speed due to the following reasons:</i></p> <p>1. <i>Worn-out bearings</i>—Replace the bearing.</p> <p>2. <i>Excessive load on the motor</i>—Remove some load.</p> <p>3. <i>Low supply voltage</i>—Check the supply voltage.</p> <p>4. <i>Wrong polarity of the main poles</i>—Check polarity of main pole with compass needle and connect them alternatively north and south if required.</p>	<p>(b) <i>Motor gives shock if the body of the motor is not properly earthed, then it will give shock—</i></p>	<p>(b) <i>Motor gives shock if the body of the motor is not properly earthed, then it will give shock—</i></p>	<p>(b) <i>Motor gives shock if the body of the motor is not properly earthed, then it will give shock—</i></p>

- 8.13 A shunt motor of 110 V takes 4 A at no load and runs at 1919 rpm. The resistance of the armature is  $0.5 \Omega$  and that of the shunt field is  $50 \Omega$ . Find the speed when it is loaded and taking a current of 60 A. Assume that the armature reaction weakens the field by 5%. (Ans. 1622 rpm)
- 8.14 A 110 V shunt motor takes a current of 4 A without load. If the armature resistance is  $0.2 \Omega$  and the shunt field resistance  $55 \Omega$ , calculate:  
 (i) Stray losses (i.e. iron and friction losses)  
 (ii) hp metric, and  
 (iii) efficiency of the motor when taking a current of 66 A on full load. (Ans. (i) 219.2 W  
 (ii) 8.04 hp  
 (iii) 82.68%)
- 8.15 A series motor takes 50 A at 110 V. The armature resistance is  $0.1 \Omega$  and series field resistance is  $0.06 \Omega$ . If the stray losses are equal to copper losses at this load, find:  
 (i) Back emf (Ans. (i) 102 V  
 (ii) bhp, and (ii) 6.3 hp  
 (iii) commercial efficiency (iii) 85.45%)
- 8.16 A 210 V series motor takes a current of 40 A and runs at 840 rpm. The resistance of the armature is  $0.5 \Omega$  and that of the series field is  $0.3 \Omega$ . If the stray losses are 4% lesser than electrical losses at this load, find:  
 (i) hp metric, and (Ans. (i) 8 hp  
 (ii) commercial efficiency. (ii) 70.14%)
- 8.17 A series motor takes 50 A at 230 V. The resistance of the armature is  $0.4 \Omega$  and that of the series field is  $0.2 \Omega$ . Find:  
 (i) Voltage at the brushes  
 (ii) back emf  
 (iii) power loss in the armature winding  
 (iv) power loss in the series field winding, and  
 (v) driving power.  
 (Ans. (i) 220 V, (ii) 200 V, (iii) 1000 W, (iv) 500 W, (v) 10 kW)
- 8.18 Find the current taken by a series motor which runs at 350 rpm, when a potential difference across its terminals is 110 V. The shaft torque is 120 N-m and the efficiency at this load is 80%. (Ans. 50 A)
- 8.19 A 500 V shunt motor having a shunt field resistance  $250 \Omega$  and armature resistance  $0.4 \Omega$ , and running at a speed of 2454 rpm, takes a current of 25 A from the supply. Calculate the speed if a resistance of  $9.6 \Omega$  is connected in the armature circuit when the current remains the same in the armature and field circuit. (Ans. 1350 rpm/min)
- 8.20 A 250 V shunt motor has an armature resistance of  $0.35 \Omega$  and a shunt field resistance of  $250 \Omega$  takes a current of 22 A from the supply when it runs at 2250 rpm. Find the speed at which the motor will run if a  $200 \Omega$  resistance is connected in series with the shunt field if the current remains the same in the armature. (Ans. 3600 rpm)
- 8.21 A 500 V shunt motor runs at its normal speed of 1923 rpm when the armature current is 150 A. The armature resistance is  $0.16 \Omega$ . Find the speed when a resistance is inserted in the field circuit reducing the shunt field current to 15% of the normal value and the armature current is 75 A. (Ans. 2440 rpm)

#### REVIEW QUESTIONS

- 8.1 Explain the working principle of a dc motor. Is there any difference in construction between a motor and a generator?

- 8.2 Explain why the torque developed by a dc series motor is proportional to the square of the armature current.
- 8.3 Explain back emf. What is its relation to the applied voltage ?
- 8.4 Explain the working principle of a dc series motor and its uses in various industries. Why it is always started with a load on its shaft. Graphically show the speed load characteristic of a series motor.  
(NCVT 1966 & 1972 Elect.)
- 8.5 What are characteristics of a shunt wound motor ? State the purpose for which they can be utilized. Draw a wiring diagram showing the necessary equipment required for its operation.  
(NCVT 1965 Elect.)
- 8.6 (a) Sketch a dc shunt motor starter and show how the speed is controlled.  
(b) Explain briefly the function of a no-volt coil and overload coil in the above starter.  
(All India Skill Compet. 1969, NCVT 1962 Elect.)
- 8.7 (a) A dc shunt motor fails to start. What may be the probable faults and how would you locate the trouble ?  
(b) Draw the internal connection diagram of a four-point starter and state how it differs from a three-point starter.  
(NCVT 1967 Elect.)
- 8.8 Sketch the shapes of the speed-torque characteristics of shunt and series dc motors. Explain the shapes of the curves. State the uses of each type of these motors in industry.  
(NCVT 1962, 64, 72, 79 Elect.)
- 8.9 Give the classification of dc motors. Draw connection diagrams and explain principles of working of any one motor. State the factors on which the speed of a dc motor depends.  
(NCVT 1982 Elect.)
- 8.10 (a) A four-pole dc shunt motor runs at a speed of 850 rpm when taking a line current of 120 A from 440 V supply mains. The armature is wave-wound with 47 slots having six conductors. Determine the value of the useful flux per pole given that the resistance of the armature is  $0.12 \Omega$  and that of the shunt field  $200 \Omega$ .  
(Ans.  $0.053 \text{ Wb}$ )  
(b) If the above motor has iron and mechanical losses totalling 3 kW, determine the efficiency of the motor and the bhp developed.  
(Inter ITIUT Compet. 1969 Elect.)  
(Ans. 94.3%, 66.7 hp)
- 8.11 Describe the methods of speed control of dc motors with their advantages and disadvantages.  
(NCVT 1976 Elect.)
- 8.12 Derive the formula for the speed of dc motors. Discuss the various methods of changing the speed of dc series and shunt motors explaining their advantages and disadvantages.  
(NCVT 1978 Elect.)
- 8.13 What is meant by :  
(a) copper losses  
(b) iron losses, and  
(c) stray losses. In dc motors, which of these three losses are variable and which constant ?
- 8.14 What safety devices are used in a dc three-point starter? Explain the function of each.
- 8.15 The bhp of a dc shunt motor is 10 and the efficiency is 90%. Find the current if the supply voltage is 250 V dc. Find also the losses.  
(NCVT 1981 Elect.)  
(Ans. 29.84 A, 828.88 W)

# 9

## Cells and Batteries

### 9.1 PRODUCTION OF EMF BY CHEMICAL ACTION

In this method two dissimilar metal plates (known as electrodes or elements) are immersed in a fluid called an electrolyte. When these electrodes are externally connected by means of wires, chemical action takes place inside the electrolyte. Thus a potential difference is created between the two electrodes which causes a flow of current in the external circuit through the connecting wires. This device is called the *cell* and the combination of two or more cells is known as the *battery*. The plate through which the current leaves the cell to the external circuit is called the *positive plate* and the plate from which the current enters the cell is known as the *negative plate*.

If the plates are of like material, say two sheets of either zinc or copper, there is no emf produced. If the plates are of different materials, then we find that an emf is produced, and the value of which depends upon the pair of metal chosen.

### 9.2 CLASSIFICATION OF CELLS

The cells may be classified into two general classes:

- (i) Primary cells, and
- (ii) secondary cells.

### 9.3 PRIMARY CELLS

Primary cells are those cells in which we put some chemical substances to produce emf by chemical action. After the cell is used, the substances used in it become useless. This means that the life of the cell depends upon the material used in it. Also if once the substance becomes useless, new materials are required to get it again ready for use.

The primary cells in common use are given below.

- (i) Simple voltaic cell—one-fluid cell,

- (ii) Daniel cell—two fluid cell,
- (iii) Leclanche cell—two-fluid cell, and
- (iv) Dry cell—fluid in paste form.

### 9.4 SECONDARY CELLS

Secondary cells are those cells that are first charged from the external source, storing up electrical energy in the form of chemical energy, and which later on gives out electric current in the opposite direction of the charging current. Thus the chemical energy stored is converted into electric energy. When the cell becomes discharged, electrical energy is again supplied to get it ready again.

### 9.5 VOLTAIC CELL

It consists of a glass container in which copper and zinc plates are immersed in dilute sulphuric acid (i.e.  $\text{H}_2\text{SO}_4 + \text{H}_2\text{O}$ ) as shown in Fig. 9.1. The zinc plate acts as the negative electrode while the copper plate acts as the positive electrode. When a voltmeter is connected across these two electrodes, it indicates the presence of emf.

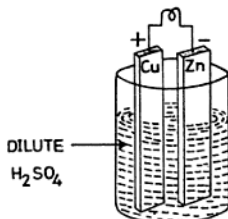
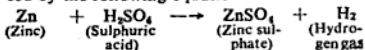

Fig. 9.1 Simple voltaic cell

If now these electrodes are connected by a wire in series with the resistance and an ammeter, the chemical action takes place on the zinc plate first because the zinc is more

active than copper in dilute sulphuric acid and current starts to flow through the electrolyte. The molecules of the sulphuric acid split up into hydrogen ( $H^+$ ) and sulphate ( $SO_4^{--}$ ) ions. The hydrogen ions ( $H^+$ ) travel in the direction of the flow of current and cling to the surface of the copper electrode in form of bubbles, whereas sulphate ions ( $SO_4^{--}$ ) go to the zinc electrode and form zinc sulphate ( $ZnSO_4$ ). The chemical action can be expressed by the following equation:



The flow of current from zinc to copper is inside the cell and from copper to zinc outside the cell. Thus the copper and zinc electrodes become respectively positive and negative terminals of the cell. The emf of the cell is 1.1 V.

This cell suffers from two defects, namely polarization and local action.

**Polarization** When current is taken from the cell, hydrogen gas is given off in the form of small bubbles of gas from the copper plate. However, it is the tendency of the gas to adhere to the surface of the electrode in the solution. Thus a thin film of hydrogen is formed which acts as a resistance. This increases the internal resistance of the cell. This reduces the emf of the cell and hence the cell soon becomes inactive. This effect is known as polarization and is prevented by

rubbing the copper plate with a wire brush. However in the other type of primary cells, a chemical substance is used in the cell which gives up oxygen to mix with the hydrogen during chemical reaction and thus water is formed. This chemical substance is known as the depolarizer.

**Local Action** This defect is due to the impurities in the zinc electrode. Commercial zinc usually contains particles of iron, copper, tin, etc. When a commercial zinc electrode is used in the cell, small cells are formed between these impurities and zinc, and thus local currents are circulated between them inside the cell. This effect is what is known as local action. Due to this effect the terminal voltage of the cell is reduced. To avoid the cell from such action, the zinc electrode is generally coated with mercury amalgam. This process is known as amalgamation.

#### 9.6 DANIELL CELL

The Daniell cell is a two-fluid cell and is a modification of the simple voltaic cell because it is similar in chemical action. It was the first cell in which a depolarizer was used to avoid polarization and amalgamated zinc rod for preventing local action.

This cell consists of an outer copper vessel (Fig. 9.2) which serves as a positive electrode of the cell. This vessel contains a concentrated solution of copper sulphate ( $CuSO_4$ ) which acts as the depolarizer. Inside this

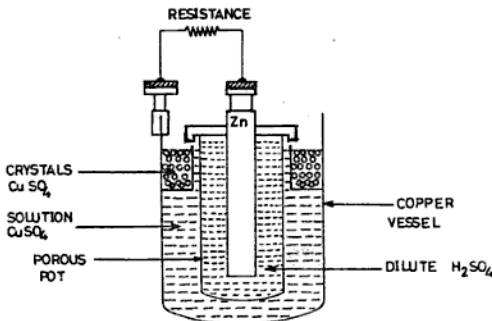
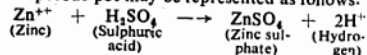

Fig. 9.2 Daniellcell

vessel is a porous pot containing dilute sulphuric acid ( $H_2SO_4$ ) and an amalgamated zinc rod. This zinc rod acts as the negative electrode of the cell. The copper sulphate solution is kept saturated by placing crystals of copper sulphate in the solution.

When the terminals of the cells are joined to form a closed circuit, the zinc electrode in the porous pot begins to dissolve in the dilute sulphuric acid ( $H_2SO_4$ ) and thus hydrogen ions ( $H^+$ ) are liberated. These hydrogen ions pass through the porous pot, thus entering the copper sulphate solution ( $CuSO_4$ ) and forming  $H_2SO_4$  and copper ions ( $Cu^{++}$ ). These copper ions are deposited over the copper vessel. The chemical reaction inside the porous pot may be represented as follows:



The chemical reaction outside the porous pot is:

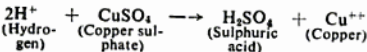

In this manner polarization is prevented. When the cell is not in use, it must be dismantled. This is because the copper sulphate solution passes through the porous pot and is replaced by the zinc with the result that the copper is deposited on the zinc electrode causing local action.

The emf of the cell is about 1.12 V and its internal resistance varies from 2 to 6  $\Omega$ . It is cheap and gives constant voltage and is therefore, still used in laboratories for experiments.

### 9.7 LECLANCHÉ CELL

This cell consists of a glass jar which contains a solution of ammonium chloride ( $NH_4Cl$ ) and a zinc rod amalgamated with mercury immersed in it (Fig. 9.3). The figure also shows a porous pot containing a carbon rod. The pot is tightly packed with manganese dioxide and powdered carbon particles. The zinc rod works as the negative electrode, the carbon rod as the positive electrode, ammonium chloride as the electrolyte and manganese dioxide as the depolarizer. The carbon particles along with manganese dioxide serves as a conductor. A hole is provided on the top of the porous pot for the gases to escape during the chemical reaction.

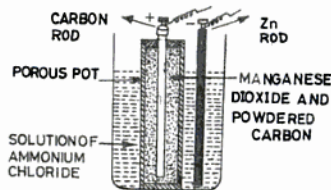
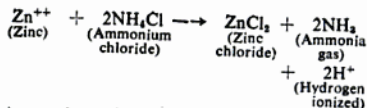

Fig. 9.3 Leclanché cell

When the cell is working, ammonium chloride reacts with the zinc forming zinc chloride and thus liberates ammonia and hydrogen ions ( $H^+$ ). The chemical reaction outside the porous pot is as follows:



Ammonia gas is soluble in water. When the water becomes saturated with ammonia, the gas is given off and can be detected by its smell. The hydrogen which passes through the porous pot reacts with the manganese dioxide ( $MnO_2$ ) and is converted into water ( $H_2O$ ) taking oxygen from  $MnO_2$ .

The chemical reaction inside the porous pot is:

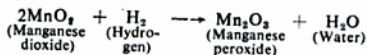

In this cell polarization has been removed but not completely because the hydrogen is liberated at a quicker rate than the action of the depolarizer. Therefore, some hydrogen gas gets accumulated around the carbon rod. If a little rest is given to the cell, it becomes depolarized and the cell return to its normal condition. Therefore, the cell is useful for intermittent currents as required in electric bells, telephones, etc.

The emf of this cell is 1.45 V and its internal resistance varies from 1 to 5  $\Omega$  depending upon the size of the cell.

**Advantages** The advantages of the Leclanché cell are given below:

- It is very cheap as only ammonium chloride is to be changed occasionally.

- (ii) There is only one kind of solution and hence no diffusion takes place.

**Disadvantages** The disadvantages of the cell are:

- (i) It is not portable.  
(ii) It cannot be used for constant long service.

### 9.8 DRY CELL

The dry cell is a modification of the Leclanché cell. It is portable. In a dry cell the electrolyte is in the form of a paste which prevents spilling.

Figure 9.4 shows the parts of a dry cell. It consists of a zinc container which forms the negative plate of the cell. The positive electrode is a carbon rod kept in the centre of the zinc container. The carbon rod is surrounded with a mixture of manganese dioxide and ground carbon which is enclosed

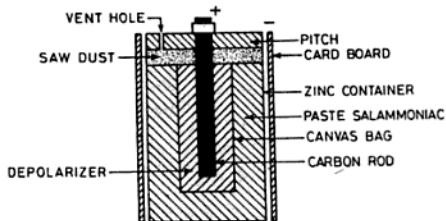

Fig. 9.4 Dry cell

in a canvas bag. This canvas bag works as a porous pot. The space outside the canvas bag is filled with a paste of plaster of paris, flour, sal ammoniac, zinc chloride and water. This paste serves the function of an electrolyte in the cell. The zinc chloride is added in the paste as it has a tendency to absorb moisture from the atmosphere and thus help to keep the paste damp. The top of the cell is covered with saw dust and sealed with a pitch compound leaving a vent hole for the gases to escape due to chemical action.

The chemical action is exactly the same as in the Leclanché cell. The emf of the cell is about 1.5 V but the internal resistance is 0.1 to 0.5  $\Omega$ , which is much lower than the Leclanché cell due to the large surface area of the zinc container. These cells are generally used in radio sets, portable transis-

tors, torch lights, electric bells, horns, telegraph, etc.

### 9.9 CHARACTERISTICS OF A GOOD CELL

A good cell should have the following characteristics:

- (i) High and constant emf,
- (ii) very small internal resistance,
- (iii) completely inactive when the circuit is opened,
- (iv) able to give constant current for a long time,
- (v) free from polarization,
- (vi) no emission of corrosive fumes during chemical action, and
- (vii) cheap and of durable materials.

### 9.10 CARE AND MAINTENANCE OF PRIMARY CELL

To get best service results from primary cells,

they should be given regular attention and should be maintained in the following conditions:

- (i) The terminals and electrodes of the cell should be kept thoroughly cleaned to avoid corrosion and to reduce contact resistance to a low value.
- (ii) The zinc plate should be amalgamated with mercury to prevent local action.
- (iii) The strength of the depolarizer should be maintained.
- (iv) The porous pot should be kept outside the cell when it is not in use after washing it in clean water.
- (v) The positive and negative plates of the cell should not touch each other in the electrolyte. They should be kept apart by at least a distance of 15 mm.

## 9.11 DIFFERENCE BETWEEN EMF AND PD OF A CELL

**EMF of a Cell** As seen in Chapter 3, the force which causes current to flow in the circuit is called emf. It is the PD between the terminals of a cell on open circuit, i.e. when the cell is not delivering any current. If a voltmeter is connected across the two terminals of a cell which is not delivering any current to the external load, the voltage indicated by the voltmeter is called the emf as the current drawn by the voltmeter is very small (because the voltmeter has high resistance). Therefore, the voltage drop in the internal resistance of the cell is also very small and hence the voltage indicated by the voltmeter is called emf.

**Potential Difference (PD)** It is the difference of electrical potential between the two points in an electric circuit. If a cell is delivering current to the external load and a voltmeter is connected across its terminals, the voltage indicated by the voltmeter is now known as the potential difference and is always less than the emf of the cell due to the voltage drop in the internal resistance of the cell. Internal resistance is the resistance within the cell offered by the positive plate, negative plate and the electrolyte.

$$\text{emf} = V_T + Ir \quad (9.1)$$

where  $I$  = current of the cell in amperes  
 $r$  = internal resistance of the cell in ohms  
 $V_T$  = voltage drop across the terminal of external resistance.

## 9.12 GROUPING OF CELLS

Cells may be grouped in three ways:

- Series combination,
- parallel combination, and
- series-parallel combination.

**Series Combination** When it is required to have a higher voltage than that given by one cell, many cells are connected in series. In that case the positive terminal of one cell is connected to the negative terminal of the other, and so on as shown in Fig. 9.5.

If  $n$  number of cells are joined in series each having an emf of  $E$  V, an internal resistance of  $r$   $\Omega$  and if a load of  $R$   $\Omega$  resistance is connected across them, then

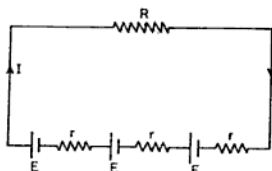

Fig. 9.5 Cells in series

Internal resistance of the battery =  $nr$   $\Omega$   
 Load resistance =  $R$   $\Omega$   
 Total resistance =  $R + nr$   $\Omega$   
 Total emf =  $nE$  V

$$\therefore \text{Current in load} = \frac{nE}{R + nr} \text{ A} \quad (9.2)$$

**EXAMPLE 9.1** Twenty dry cells of emf 1.5 V and internal resistance 0.5  $\Omega$  each are joined in series. If a 5  $\Omega$  external resistance is connected across the group, find the value of the current flowing.

**Solution :**

We know that

$$I = \frac{nE}{R + nr}$$

$$\therefore \text{Current flowing} = \frac{20 \times 1.5}{5 + (20 \times 0.5)} = \frac{30}{15} = 2 \text{ A. Ans.}$$

**Parallel Combination** If it is required to have a high current output given by the cells, several cells are joined in parallel as shown in Fig. 9.6. In the parallel connection of cells, all the positive terminals of the cells are connected together at one junction. Similarly the negative terminals of the cells are joined together at the other junction.

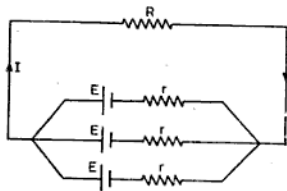

Fig. 9.6 Cells in parallel

If  $n$  number of cells are joined in parallel each having an emf of  $E$  V, internal resistance  $r$   $\Omega$  and connected to a load of  $R$   $\Omega$ , then :

$$\text{Internal resistance of the battery} = \frac{r}{n} \Omega$$

$$\text{Load resistance} = R \Omega$$

$$\text{Total resistance} = R + \frac{r}{n} \Omega$$

$$\text{emf of the battery} = nE$$

$\therefore$  Current in load

$$= \frac{nE}{R + \frac{r}{n}} = \frac{nE}{nR + r} \text{ A} \quad (9.3)$$

**EXAMPLE 9.2** Ten dry cells each of emf 1.5 V and internal resistance 1  $\Omega$  are joined in parallel. If 4.9  $\Omega$  resistance is connected across the group, find the value of the current passing through it.

**Solution :**

We know that

$$I = \frac{nE}{nR + r}$$

$$I = \frac{10 \times 1.5}{10 \times 4.9 + 1} = \frac{10 \times 1.5}{49 + 1}$$

$$= \frac{10 \times 1.5}{50} = 0.3 \text{ A Ans.}$$

**Series-Parallel Combination** A group of same number of cells connected in series may be joined in parallel, thus making a series-parallel combination of cells as shown in Fig. 9.7. The total emf of such a combination is equal to the total emf of one of the series group.

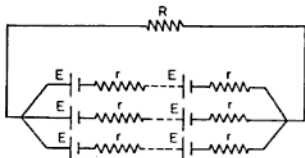

Fig. 9.7 Cells in series and parallel

If there are  $m$  sets of cells in series-parallel combination, each set having  $n$  cells in series and joined to a load of resistance  $R$   $\Omega$ , then :

$$\text{Internal resistance of each series group} = nr \Omega$$

Internal resistance of  $m$  set of battery

$$= \frac{nr}{m} \Omega$$

Load resistance

$$= R \Omega$$

Total resistance of the battery

$$= \frac{R + nr}{m} \Omega$$

emf of the series-parallel combination

$$= nE$$

$\therefore$  Current in the load

$$= \frac{nE}{\frac{R + nr}{m}} = \frac{mnE}{mR + nr} \text{ A} \quad (9.4)$$

The current in such an arrangement will be maximum when the total internal resistance of the battery is equal to the load resistance.

**EXAMPLE 9.3** Thirty cells each having an emf 1.5 V and internal resistance 0.5  $\Omega$  are connected ten in series per row, three rows in parallel. If a 2.5  $\Omega$  resistance is connected across the battery, find the value of the current passing through the external load.

**Solution :**

We know that

$$I = \frac{mnE}{mR + nr} = \frac{3 \times 10 \times 1.5}{3 \times 2.5 + 10 \times 0.5}$$

$$= \frac{3 \times 15}{7.5 + 5} = \frac{45}{12.5} = 3.6 \text{ A Ans}$$

### 9.13 SECONDARY CELL

The construction of the secondary cell and its working principle is explained below.

If two lead plates are dipped in dilute sulphuric acid as shown in Fig. 9.8 and connected to the dc supply mains, the current flowing through the electrolyte splits it up into hydrogen and sulphate ions. The hydrogen ion travels towards the negative plate as it has positive charge where gives up its charge and liberates. Thus the negative plate remains as pure spongy lead which is metallic grey in colour. The negatively charged sulphate ion goes to the positive plate where it gives up its charge and reacts with the water of the electrolyte to form sulphuric acid. The chemical action is as given below:

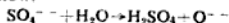

The liberated oxygen attacks the positive lead

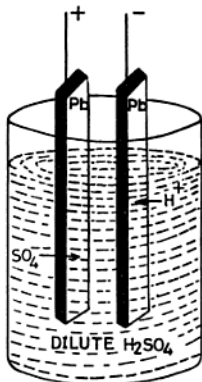
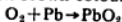

Fig. 9.8 Secondary cell

plate and changes it into lead peroxide giving the plate a dark-brown colour:



After the flow of this charging current, an elementary accumulator is developed. When the two plates are connected to an external load with an ammeter in the circuit, a discharging of electricity is observed due to the chemical reaction in the cell. During discharging, the electrodes are converted into lead sulphate. Such type of cells are called secondary cells.

In a lead acid cell, the cell is only capable of supplying electrical energy to the external load due to its secondary action. The primary action of the cell is to store electrical energy in the form of chemical energy. During the secondary action, cell converts the chemical energy stored into electrical energy.

The following two types of secondary cells are in use nowadays:

- (i) Lead acid cell, and
- (ii) nickel-iron alkaline cell.

**Advantages** The advantages of secondary cell over primary cell are as:

- (i) A secondary cell gives a strong current as its internal resistance is very low.
- (ii) It gives a constant current.

- (iii) Its efficiency is very high i.e. it gives back the most of the energy used in charging it.

**Characteristics of a Good Secondary Cell** A good secondary cell has the following characteristics:

- (i) Low internal resistance,
- (ii) high efficiency,
- (iii) fairly constant emf,
- (iv) durable,
- (v) cheap,
- (vi) good mechanical strength, and
- (vii) large storage capacity.

#### 9.14 DIFFERENTIATION BETWEEN CELL AND BATTERY

A cell is a single unit of source of supply, whereas a battery is a combination of two or more than two cells joined in series, in parallel or in series-parallel combination so as to supply together.

#### 9.15 CONSTRUCTION OF LEAD ACID BATTERY

A lead acid battery consists of three cells, six cells or 12 cells in series giving 6 V, 12 V and 24 V respectively. Positive and negative plates are immersed in dilute sulphuric acid and kept apart by separators in each of its cells. Figure 9.9 shows the parts of a lead acid cell.

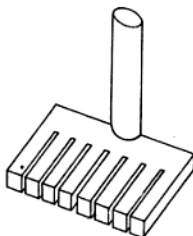

PLATE CONNECTOR

(a)

different cells so that their electrolyte may not mix together. Each cell is provided with a lid known as a *cell cover* fitted with a vent plug. Holes are provided in the vent plug cover for the gases to escape. The cell covers are sealed with a sealing compound or pitch.

**Plate Connector** It is made of pure lead. All the positive and negative plates are assembled and welded separately with it forming positive and negative groups.

**Post Terminal** A small pole extended upward from each group of welded plates from the plate connector forms the post terminal. This terminal passes through the cell cover and helps to connect the individual cells in series to form a battery.

**Cell Connectors** These are the thick drilled bars made of pure lead. The cells are connected and welded in series to form a battery with their help.

**Electrolyte** It is a mixture of sulphuric acid having specific gravity of 1.850 diluted with distilled water in the ratio of 1:3 (approximately), thereby making the specific gravity of the electrolyte 1.280.

**NOTE:** Specific gravity is the ratio between the weight of an equal volume of any substance and the weight of an equal volume of water at the same temperature.

### 9.16 PREPARATION OF ELECTROLYTE

The electrolyte for a cell can be prepared by adding sulphuric acid to distilled water drop by drop and not vice versa. A glass rod should be used for stirring the electrolyte. It should be noted that while preparing the electrolyte the specific gravity decreases as the temperature increases. Therefore the electrolyte should be allowed to cool to room temperature before filling it in the battery. Electrolytes of specific gravity 1.200 to 1.300 are generally used in the lead acid battery because the resistance of the electrolyte at this value is minimum and thus the internal resistance of the cell is kept minimum.

### 9.17 DETERMINATION OF SPECIFIC GRAVITY OF AN ELECTROLYTE

The specific gravity of an electrolyte can be determined with the help of an instrument known as a hydrometer.

A hydrometer consists of a long glass tube. One end of it is provided with a rubber nozzle and the other end is fitted with a rubber bulb as shown in Fig. 9.10. By compressing and releasing the rubber bulb, the liquid can be pushed out or sucked in. A glass float is provided inside the glass tube whose bottom is filled with lead shots. In the upper part of the glass float is a paper scale which indicates the specific gravity of the electrolyte. The lead shots are put in the float to enable the float to stand vertically when floating in the liquid.

The glass tube of the float is calibrated for different specific gravities from 1.100 to 1.300. If the float is high in the electrolyte or liquid, the specific gravity is high and if it is low in the liquid, the specific gravity is low, as shown in the figure.

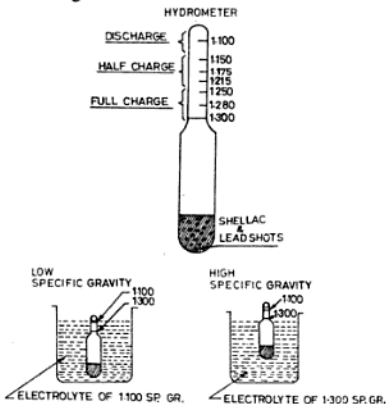

Fig. 9.10 Hydrometer

### 9.18 DISCHARGING OF BATTERY

When a battery is connected to a load, it supplies electrical energy which it had stored in the chemical form. Thus during discharging chemical energy is converted to electrical energy.

When the cell is fully charged, its positive plate is of lead peroxide ( $\text{PbO}_2$ ) which is dark-brown in colour. The negative plate is of spongy lead ( $\text{Pb}$ ), the colour of which is slate-grey. The electrolyte is dilute sulphuric acid ( $\text{Dil. H}_2\text{SO}_4$ ) of specific gravity 1.280. The plates are immersed in this electrolyte. If a resistance,  $R \Omega$  is connected between the plates (Fig. 9.11), the cell supplies current to the external load, then the sulphuric acid ( $\text{H}_2\text{SO}_4$ ) is split up into hydrogen ions ( $\text{H}^+$ ) and sulphate ions ( $\text{SO}_4^{--}$ ). The sulphate ions  $\text{SO}_4^{--}$  have negative charge and therefore they move towards the cathode. There they react with the active material of negative plate and form lead sulphate ( $\text{PbSO}_4$ ). The chemical reaction is as given below :

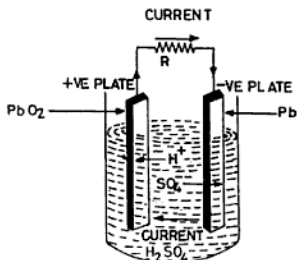
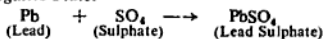

Fig. 9.11 Discharging of secondary cell

At Negative Plate:



At Positive Plate:

The hydrogen ions ( $\text{H}^+$ ) move towards the anode and there they react with the active material to form lead sulphate ( $\text{PbSO}_4$ ) and water ( $\text{H}_2\text{O}$ ) as under:

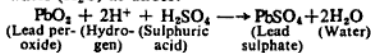

As discharging goes on, a layer of  $\text{PbSO}_4$  is formed on both the plates which gets thicker and gradually the voltage of the cell falls down.

The specific gravity of the electrolyte also decreases due to the formation of  $\text{H}_2\text{O}$ . The

cell is discharged till its voltage falls to 1.3 V 'at no load' and the specific gravity of electrolyte decreases to 1.180. If the cell is further discharged beyond this limit, then the layer of  $\text{PbSO}_4$  becomes so thick and hard that it cannot be reconverted to  $\text{Pb}$  or  $\text{PbO}_2$ . The changes during discharging can be summed up as follows:

- (i) The positive plate is covered with a layer of  $\text{PbSO}_4$  which is white in colour.
- (ii) The negative plate is also covered with a layer of  $\text{PbSO}_4$  and changes the plate from slate grey colour to white.
- (iii) Due to formation of water, the specific gravity of electrolyte decreases from 1.280 to 1.180.
- (iv) The voltage of the cell falls from 2.2 to 1.8 volts (at no load).
- (v) Chemical energy stored in the cell changes into electrical energy.

### 9.19 CHARGING OF BATTERY

For charging a battery, a dc supply of voltage little higher than the battery voltage is applied across the battery, taking care that the positive terminal of the supply is connected to the positive terminal of the battery and the negative terminal of the supply to the negative of the battery as shown in Fig. 9.12. The current passes from the positive plate to the negative plate inside the cell and splits up the sulphuric acid ( $\text{H}_2\text{SO}_4$ ) in the electrolyte into  $\text{SO}_4^{--}$  and  $\text{H}^+$  ions. The  $\text{SO}_4^{--}$  ions travel towards the anode and  $\text{H}^+$  ions towards cathode where they react with  $\text{SO}_4^{--}$  ions to form lead peroxide and spongy lead respectively. The chemical reaction is as follows:

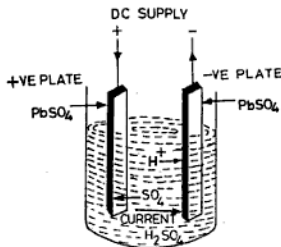
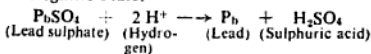
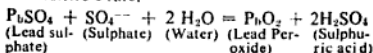

Fig. 9.12 Charging of secondary cell

**At Negative Plate:****At Positive Plate:**

The charges which occur during charging can be summed up as follows:

- The positive plate changes to lead peroxide ( $\text{PbO}_2$ ) which is dark chocolate brown in colour.
- The negative plate changes to spongy lead which is slate-grey in colour.
- The voltage per cell increases from 1.8 to 2.2 V (without load).
- The specific gravity of each cell rises from 1.180 to 1.280.
- The cell stores electrical energy in the form of chemical energy.

**9.20 INDICATIONS OF FULLY CHARGED CELL**

The following can help indicate a fully charged cell:

- colour of plates,
- specific gravity,
- gassing,
- voltage per cell, and
- high rate discharge cell tester.

**Colour of plates** The colour of the positive and negative plates change into dark brown and slate-grey colour respectively. The colour changes are visible in the case of a transparent container only.

**Specific Gravity** In the case of fully-charged cell, the specific gravity of the electrolyte increases from 1.180 to 1.280.

**Gassing** When a cell has been fully charged, gassing will occur on both the plates of each cell. This indicates that the current through the cell produces no chemical action on the plates, but it simply splits up the water ( $\text{H}_2\text{O}$ ) in the electrolyte, liberating  $\text{H}_2$  and  $\text{O}_2$  gases in the form of bubbles.

**Voltage Per Cell** The per cell voltage of a fully-charged cell rises from 1.8 to 2.2 V at no load.

**High Rate Discharge Cell Tester** The voltage of a fully-charged cell may be tested on load with the help of a high rate discharge cell tester. The specific gravity can also be increased by adding concentrated sulphuric acid to the electrolyte and the voltage should be 2 V per cell.

**9.21 EMF OF SECONDARY CELL**

The emf of the secondary cell depends upon the following factors:

- chemical composition of the plates (i.e. active material),
- area of the plates and their assembly (i.e. the number of positive plates), and
- temperature and specific gravity of the electrolyte.

**9.22 INTERNAL RESISTANCE OF LEAD ACID CELL**

The internal resistance is the resistance within the cell offered by the positive plates, negative plates and the electrolyte. Due to this internal resistance, there is always some power loss inside the cell which is converted into heat and reduces the terminal voltage of the cell. Therefore to overcome the above loss and to reduce the temperature (because at high temperatures the plates and cell may get damaged), the internal resistance of the cell is kept as low as possible. This internal resistance can be calculated as explained below. In Sec. 9.11, we have seen that

$$\text{emf} = V_T + Ir$$

The emf ( $E$ ) of a given cell is constant but the terminal voltage ( $V_T$ ) depends upon the value of the load current which further depends on the load resistance. If the voltmeter readings are recorded (i) when there is no load on the cell (i.e.  $E$ ) and (ii) when it is delivering the load current (i.e.  $V_T$ ), then the internal resistance can be calculated as:

$$\text{Internal resistance, } r = \frac{E - V_T}{I}$$

$$\text{But } I = \frac{V}{R}$$

$$\therefore r = \left( \frac{E - V_T}{V} \right) R \quad (9.5)$$

**EXAMPLE 9.4** Ten similar cells are connected in series to a load resistance of 4  $\Omega$ . On connecting a high resistance voltmeter across the battery, it shows

## 9.24 TYPES OF EFFICIENCY OF SECONDARY CELL

There are two types of efficiency :

- (i) quantity efficiency or ampere-hour efficiency, and
- (ii) energy efficiency.

(i) **Quantity Efficiency** The quantity efficiency is the ratio between the quantity of electricity during discharge and the quantity of electricity during charging. However, the quantity of electricity is the product of current in amperes and time in hours. Therefore, the quantity efficiency is also known as the ampere-hour efficiency.

∴ Ampere-hour efficiency,  $\eta_{A-H}\%$

$$= \frac{\text{Ampere-hours on discharging}}{\text{Ampere-hours on charging}} \times 100\%$$

(ii) **Energy Efficiency** It is the ratio between the energy which a cell gives out during discharging and the energy which it requires to regain the original condition during charging.

Energy efficiency in percentage

$$\begin{aligned} \eta_E \% &= \frac{\text{Energy during discharging}}{\text{Energy during charging}} \times 100\% \\ &= \frac{\text{Watt-hours on discharging}}{\text{Watt-hours on charging}} \times 100\% \end{aligned}$$

As the energy efficiency is the ratio of watt-hours, it is also known as the watt-hour efficiency.

As the voltage on discharge is always less than the voltage on charge, the watt-hour efficiency is always less than the quantity efficiency (or  $\eta_{LA-H}$ .)

For a normal lead acid cell, the quantity efficiency varies between 90 to 95% whereas the watt-hour efficiency varies 80 to 85%.

**EXAMPLE 9.7** Calculate the (i) ampere-hour efficiency and (ii) watt-hour efficiency of a secondary cell which is discharged at a uniform rate of 30 A for 6 h at an average terminal voltage of 2 V. It is then charged at the uniform rate of 40 A for 5 h to restore it to its original condition. The terminal voltage during charging is 2.5 V.

**Solution :**

Ampere-hour output =  $30 \times 6 = 180$

Ampere-hour input =  $40 \times 5 = 200$

Percentage ampere-hour efficiency

$$(\eta_{A-H}) = \frac{\text{Ampere-hours on discharging}}{\text{Ampere-hours on charging}} \times 100\%$$

$$= \frac{180}{200} \times 100\% = 90\% \text{ Ans.}$$

Terminal voltage during charging = 2.5 V

Watt-hour output = voltage  $\times$  current  $\times$  time in hours  
=  $2 \times 30 \times 6$

Watt-hour input =  $2.5 \times 40 \times 5$

∴ Watt-hour efficiency in percentage

$$\begin{aligned} &= \frac{\text{watt-hours on discharging}}{\text{Watt hours on charging}} \times 100\% \\ &= \frac{2 \times 30 \times 6}{2.5 \times 40 \times 5} \times 100\% = 72\% \text{ Ans.} \end{aligned}$$

## 9.25 PRECAUTIONS FOR BATTERY CHARGING

The current required for charging a battery is direct current (dc). If the available supply is alternating current (ac), then it should be converted into dc either by a motor-generator set or by a rectifier. The undermentioned precautions should be observed before putting a battery on charge.

(i) **Topping Up** If the level of the electrolyte on the surface of the plate is less than 10 to 15 mm, then some distilled water should be added in the cell. This process is known as 'topping up'. It should be remembered that for topping up, sulphuric acid or prepared electrolyte should never be poured into the cell.

(ii) **DC Voltage** For charging a battery, dc voltage 10% higher than the full charged battery voltage is required.

(iii) **Connection** The positive terminal of the dc supply should be connected to the positive terminal of the battery, and similarly, the negative terminal of the supply to the negative terminal of the battery.

(iv) **Ventilation** The room where batteries are to be charged should be well ventilated as the gases liberated during charging are of flammable and explosive nature. Therefore, burning flame should not be brought near charging batteries.

(v) **Charging Rate** The safe rate of current at which the battery is to be charged is called the charging rate. It is always better to charge a battery at the rate specified by the manufacturer. In case it is not known, it should be charged at a low rate, say 0.75 A per positive plate (or 5% of the capacity of the battery).

### 9.26 CHARGING A BATTERY

The following three systems of charging batteries are in practice:

- (i) constant current charging system,
- (ii) constant potential charging system, and
- (iii) trickle charging system.

**(i) Constant Current Charging System** In this system, the charging current is controlled by inserting either carbon filament lamps or resistance rheostat in series with the battery and thus varying the supply voltage to overcome the increased back emf of the batteries. In this system many batteries connected in series can be charged considering that the total voltage of the battery should not increase the main applied voltage otherwise the batteries would discharge.

Charging current,

$$I = \frac{V - E_b}{R + r} \text{ A} \quad (9.6)$$

where

$V$  = charging applied voltage in volts

$E_b$  = total counter emf of the battery in volts

$R$  = external resistance of the lamp or rheostat in ohms

$r$  = internal resistance of the battery in ohms

$I$  = charging current in amperes.

The value of the charging current is varied by varying the number of lamps by switching ON and OFF the lamps in the battery circuit taking care that the temperature of the battery does not exceed  $43^\circ\text{C}$ . An ammeter shown in

series with the circuit indicates the charging current. The connection diagram of a lamp charging board is shown in Fig. 9.13.

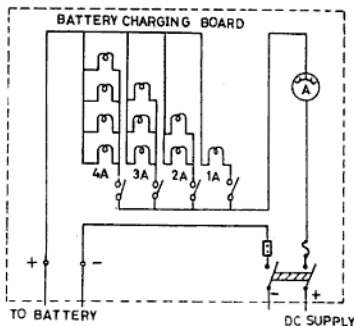

Fig. 9.13 Lamp-charging board for constant-current method

**Advantage** This system of charging the battery increases the life of the battery.

**Disadvantage** It takes longer time to charge a battery and needs constant observation for checking the charging current.

**(ii) Constant Potential Charging System** To charge a battery with the help of a motor-generator set (or metal rectifier which will be discussed later on) is based on this system. Figure 9.14 shows the connection of this

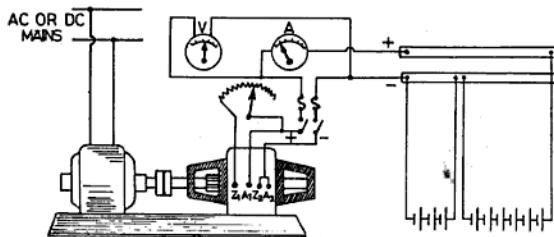

Fig. 9.14 Constant potential method of battery charging

system. The generated voltage is kept constant at 10% higher than the full charged voltage of the battery. The charging current in this system is either varied by controlling the field regulator of the dynamo or by the speed of the primemover. In the beginning the value of the charging current will be very high as the counter emf of the battery is very low. But after some time, the charging current decreases to a very small value as the back emf of the battery increases on being charged.

**Advantage** In this system, the time required for charging is less than that in the constant current system but this reduces the efficiency.

**Disadvantage** This system of charging reduces the life of the battery up to some extent.

(iii) **Trickle-Charging System** The continuous charging of a battery at a low rate for keeping the battery ready in good working condition is called trickle charging. This value of charging current is approximately 2% of the full charging current of the battery.

### 9.27 LAMP FOR CHARGING

The best type of lamp for charging a battery is a carbon filament lamp and is preferred because it allows greater amount of current to the given size (i.e. 3.5 W/candle power). Moreover, there is no brightness in the light as compared to other types of lamps.

**EXAMPLE 9.8** A battery of 50 cells connected in series is to be charged from 250 V dc supply mains. The battery has been discharged to 1.8 V per cell and in the final charged condition its value is 2.2 V per cell. The internal resistance of each cell is 0.01  $\Omega$ , connecting leads has a resistance of 0.1  $\Omega$  and there is an external resistance of 19.4  $\Omega$  connected in the circuit. Find the (i) initial charging current and (ii) final charging current.

**Solution:**

(i) Internal resistance of battery =  $0.01 \times 50 = 0.5 \Omega$

Resistance of connecting leads = 0.1  $\Omega$

Total resistance of battery and leads =  $0.5 + 0.1 = 0.6 \Omega$

emf of the battery ( $E_b$ ) =  $1.8 \times 50 = 90 \text{ V}$

We know that

$$I = \frac{E - E_b}{R + r}$$

$\therefore$  Initial charging current,

$$I = \frac{250 - 90}{19.4 + 0.6} = \frac{160}{20} = 8 \text{ A} \quad \text{Ans.}$$

(ii) emf of the battery at the end of charge

$$= 2.2 \times 50 = 110 \text{ V}$$

$\therefore$  Final charging current,

$$I = \frac{250 - 110}{19.4 + 0.6} = \frac{140}{20} = 7 \text{ A} \quad \text{Ans.}$$

### 9.28 TESTING OF BATTERY

The condition of the battery can be examined either by checking the specific gravity of the electrolyte or by the per cell voltage. The voltage does not change much from the discharged condition to the fully charged condition of the battery. Therefore to find the condition of the battery, the specific gravity is checked with the help of a hydrometer as discussed earlier.

The specific gravity value alone cannot give the internal condition of a lead cell because it can also be increased by putting concentrated sulphuric acid in the electrolyte of the cell. Therefore to find the condition of the cell, its voltage when supplying high current is measured. The instrument which is used for this purpose is known as the high rate discharge cell tester.

### 9.29 HIGH RATE DISCHARGE CELL TESTER

It consists of a wooden handle having two pointed metal strips parallel to each other (Fig. 9.15). Between them is provided a load

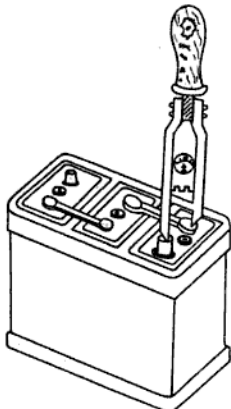

Fig. 9.15. Voltage test with cell tester

of low resistance across which is fixed a voltmeter of zero centered is fixed.

When pointed strips of the tester are pressed on each of the terminals of the battery, this resistance takes a current of 150 to 300 A. The tester should not be applied for more than 10 s on each cell and the voltmeter readings are recorded in each case. The voltage of a fully-charged cell of a battery should not be less than 1.8 V when delivering high current. If it falls rapidly, this indicates that either the cell (or battery) is not fully charged or the plates are sulphated or the active material from the plates has fallen down.

### 9.30 PREVENTIVE MAINTENANCE OF BATTERY

The following steps should be adopted for the preventive maintenance of a lead acid battery.

- (i) Before putting a battery on charge, always maintain the level of the electrolyte 15 mm above the plates. For this distilled water should always be added in the cell. Prepared electrolyte or  $H_2SO_4$  should never be added for this purpose.
- (ii) The positive terminal of the battery should always be connected to the positive terminal of the supply and the negative terminal of the battery to the negative terminal of the supply while charging a battery.
- (iii) The vent plug should be kept loose for the liberation of gases during charging.
- (iv) The battery terminals should be kept clean. A thin layer of vaseline or petroleum jelly should be applied over them to prevent corrosion.
- (v) A battery should not be charged and discharged at a higher rate continuously. It should be charged and discharged only according to the manufacturer's instructions.
- (vi) The battery should be overcharged once after four months so that the traces of lead sulphate formed during this period can be finished. If the lead sulphate is not removed, it will change into an insoluble whitish salt which increases the internal resistance of the battery.
- (vii) The battery should never be discharged beyond 1.8 V (without load) otherwise the traces of lead sulphate changes into an insoluble salt.

- (viii) The battery should be recharged as soon as possible after discharge.
- (ix) The room where the batteries are charged should be well-ventilated because the gases liberated during charging are of flammable and explosive nature. Therefore, it is advisable not to bring a burning flame near charging batteries.
- (x) A discharge battery should not be tested with a high rate discharge cell tester. It should be applied to a charged cell for not more than 10 s.
- (xi) The specific gravity of the electrolyte should be checked before and after a battery is put on charge.
- (xii) When preparing the electrolyte, the acid should always be added drop by drop into the water and not vice versa.
- (xiii) If the battery is not being used for long period, then it should be put on trickle charge.

### 9.31 APPLICATIONS OF LEAD ACID BATTERY

The following are the most important applications of the lead acid battery.

- (i) These batteries are used in hospitals, cinema houses and generating stations for local lighting in the case of failure of supply.
- (ii) These are used in sub-stations for maintaining the feeder drops during peak-load hours.
- (iii) For ignition and starting of heavy petrol automobiles.
- (iv) As a source of supply for railway trains, mines, small trolleys, telephone exchanges, etc.
- (v) For automatic operation of high tension switch gears.

### 9.32 TYPES OF ALKALINE CELLS

Alkaline Cells are of two types:

- (i) Nickel iron cell also known as the Edison cell, and
- (ii) nickel cadmium cell also called the Junger cell.

In construction there is no difference between the two cells except that the negative plate of the nickel iron cell is made of iron and in the nickel cadmium cell it is of Cadmium.

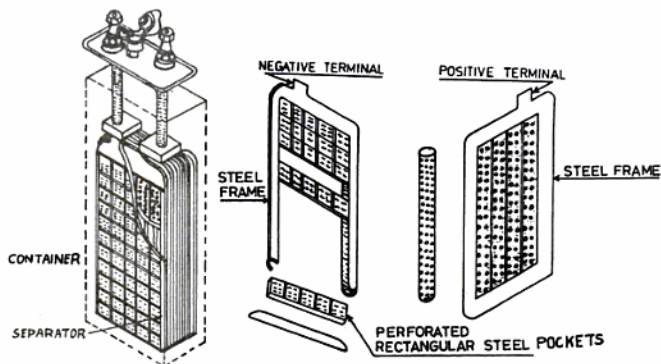

Fig. 9.16 Nickel-iron alkaline cell

### 9.33 NICKEL-IRON CELL

Figure 9.16 shows the construction of the alkaline cell which consists of :

- (i) positive plate,
- (ii) negative plate,
- (iii) electrolyte,
- (iv) container, and
- (v) separator.

**Positive Plate** It consists of many perforated steel tubes which contain active material of nickel hydroxide ( $\text{Ni}(\text{OH})_2$ ). Nickel hydroxide is a poor conductor of electricity. Therefore to increase the electrical conductivity of the cell, pure nickel flakes are alternatively added to the active material in the steel tubes. A steel tube about 15 mm in diameter and 100 mm in length contains nearly 300 such layers. These tubes are then compressed in a nickel plated steel frame which serves as a positive plate. Many plates are used in a cell to form one positive group of plates.

**Negative Plate** The negative plate is similar in construction to the positive plate but is always one more in number than the positive plate. It also consists of many rectangular perforated steel pockets into which powdered iron, oxide is filled. This oxide is also a poor conductor of electricity and therefore its conductivity is increased by adding a small

quantity of mercury in the pocket. These pockets are clamped in a steel grid which forms a negative plate. To form one negative group of plates, a number of plates are grouped.

**Electrolyte** It is an alkaline solution of 21% potassium hydroxide ( $\text{KOH}$ ) of specific gravity 1.220 which remains constant during discharging and charging. The hydroxide if kept open to atmosphere combines with the carbon dioxide present in it. Thus it forms potassium carbonate which decreases the capacity of the cell. To avoid this, the cell is sealed. For increasing the capacity of the cell, a little quantity of lithium hydroxide ( $\text{LiOH}$ ) is added to the electrolyte.

**Container** The container consists of a steel box. The inside and top of the cell cover is given a thick layer of insulating compound to avoid short circuiting as it is made of steel. The container is made air-tight and a small hole is provided in the vent plug which allows the gases to escape out from the cell during discharging and charging.

**Separator** These are placed in between the plates to avoid short circuiting and are made of perforated hard rubber.

### 9.34 DISCHARGING OF BATTERY

When a cell is fully charged, the positive plate is of nickle hydroxide ( $\text{Ni(OH)}_2$ ) and the negative plate is of iron ( $\text{Fe}$ ). When a cell is discharged (Fig. 9.17), a current flows from the positive plate to the negative plate outside the cell and from the negative plate to the positive plate inside the cell. The current through the electrolyte breaks it into potassium ions ( $\text{K}^+$ ) and hydroxide ions ( $\text{OH}^-$ ). The  $\text{K}^+$  ions move towards the anode ( $\text{Ni(OH)}_2$ ) and  $\text{OH}^-$  ions move towards the cathode ( $\text{Fe}$ ). The reaction of the two plates are given below:

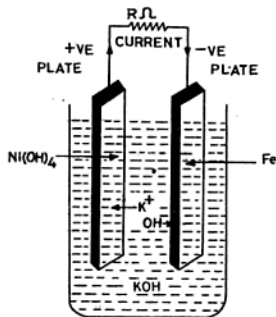
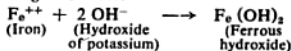
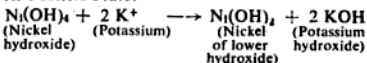

Fig. 9.17 Discharging of nickel-iron cell

*At Negative Plate:*



*At Positive Plate:*



From the above reaction we find that the undermentioned changes occur during the discharging of a battery.

- (i) The negative plate turns into ferrous hydroxide.
- (ii) The positive plate turns into the lower hydroxide of nickel.
- (iii) The strength of the electrolyte remains constant because the  $\text{KOH}$  which breaks due to the flow of current is also again

formed.

- (iv) The per cell voltage falls from 1.4 to 1.15 V (on load).
- (v) The energy stored in the cell changes from chemical to electrical.

### 9.35 CHARGING OF BATTERY

In the nickel iron battery also the current supplied for charging is of direct current of voltage 1.7 V/cell, which is a little higher voltage than the battery voltage. As in the lead acid battery, in the nickle iron battery also the positive and negative terminals are reconnected to the positive and negative terminals of the supply respectively as shown in Fig. 9.18.

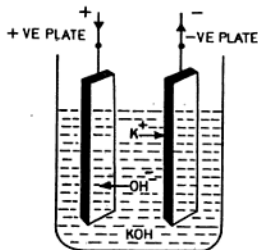
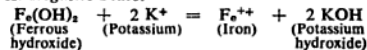

Fig. 9.18 Charging of nickle-iron cell

During charging the current flows through the electrolyte in the direction from the positive plate to the negative plate. This current splits up the electrolyte into potassium ions ( $\text{K}^+$ ) and hydroxide ions ( $\text{OH}^-$ ). The  $\text{K}^+$  ions move towards the negative plate and the  $\text{OH}^-$  ions to the positive plate. During charging the reaction is as follows:

*At Negative Plate:*



*At Positive Plate:*

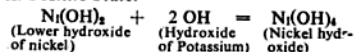

Again the following changes occur during the charging of a discharged battery:

- (i) The negative plate turns into iron ( $\text{Fe}$ ).
- (ii) The positive plate turns into nickel hydroxide.

- (iii) The specific gravity of the electrolyte remains constant.
- (iv) The per cell voltage on the load increases from 1.15 to 1.4 V.
- (v) Electrical energy is stored in the form of chemical energy.

**Application of Nickel Iron Cell** This cell is used in aeroplanes, industrial trucks, etc.

### 9.36 CHARACTERISTICS OF NICKEL IRON CELL

The characteristics of the nickel iron cell are given below:

- (i) This type of cell is light in weight.
- (ii) When fully charged, the voltage per cell is 1.4 V and is discharged till its voltage falls to 1.15 V. It can be discharged further without any damage but the efficiency below this value is very low due to an increase in the internal resistance of the cell.
- (iii) The average charging voltage of a cell is 1.7 V.
- (iv) The internal resistance of the cell is high (i.e. four to five times that of the lead acid cell). Therefore, the efficiency of the cell is low. The ampere-hours efficiency of the cell is about 75 to 85% and the watt-hours efficiency is 60 to 65%.
- (v) This cell has good mechanical strength as its plates are made of steel.

- (vi) Unlike the lead acid cell, this cell can be charged and discharged at a high rate without any damage. That is why it is also used for rough work.
- (vii) Nickel iron cell is light in weight, and therefore is also used in aeroplanes, etc.
- (viii) The cell can be left in the discharge condition for long time without any harm.
- (ix) With increase of temperature of the cell the capacity increases.
- (x) The cost of the nickel iron cell is about twice that of the lead acid cell for the same capacity.
- (xi) The life of the cell is much greater than the lead acid cell and is at least five years.

### 9.37 BOOST CHARGE

The charging of a cell at high rate is called boost charge. For boost charge, the cell is given twice the charging current than its normal charging rate. It should be kept in mind that during charging, the temperature of any cell should not be more than 40°C to 45°C.

The charging requirements are the same as in the case of a lead acid battery. It is better to overcharge the nickel iron cell.

### 9.38 TROUBLE SHOOTING OF LEAD ACID BATTERY

Table 9.1 gives some important defects and remedies of lead acid battery:

TABLE 9.1 TROUBLE-SHOOTING CHART FOR LEAD ACID BATTERY

Sl. No.	Troubles	Reasons	Remedies
1	2	3	4
1.	Buckling of plates	Continuously charging and discharging battery at high rate.	(a) Battery should be charged and discharged as specified by the manufacturer (b) Straighten the buckled plates by holding in vice and then applying little pressure
2.	Sulphation	(a) Keeping discharged battery in discharge condition for long time. (b) Low or too strong acid electrolyte (c) Overdischarging battery continuously at high rate	(a) If not in use for long time, put it on trickle charge (b) Use electrolyte of specific gravity as instructed by the manufacturer
3.	Short circuit (Due to sediment or failure)	(a) Short-circuited cell will show low voltage on no load	Thoroughly wash the cell with distilled water or reassemble

(contd.)

ected across it. The pressure on the positive side of the resistance will be high and on the negative side it will be low. This high pressure will uniformly fall in the resistance and will be zero on the other side of the resistance. In other words, the voltage applied to the circuit is equal to the voltage drop in the circuit.

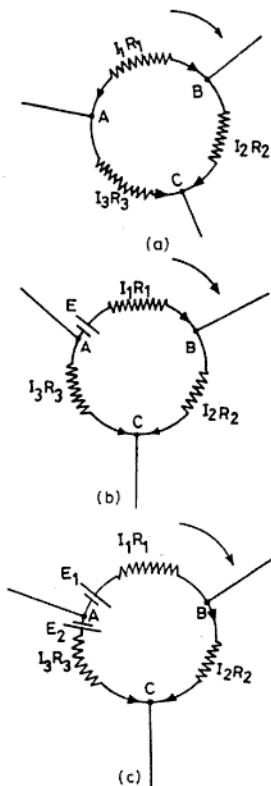

Fig. 9.21

Now considering and going around the circle  $ABCA$  as shown in Fig. 9.21 (a), we have the voltage drops as

$$I_1 r_1 + I_2 r_2 - I_3 r_3 = 0$$

(emf acting is zero)

It may be noted that Clockwise currents are taken as positive. Again in Fig. 9.21 (b) the voltage drops in the circuit is equal to the emf acting in the circuit. Therefore

$$I_1 r_1 + I_2 r_2 - I_3 r_3 = E$$

Similarly, in Fig. 9.21(c)

$$I_1 r_1 + I_2 r_2 - I_3 r_3 = E_1 - E_2$$

In this case  $E_2$  is considered to be negative because its positive terminal is in opposite directions to the supposed positive direction.

**EXAMPLE 9.9** Two batteries  $A$  and  $B$  are connected to  $230\text{ V}$  dc supply for charging as shown in Fig. 9.9. Battery  $A$  of emf  $122\text{ V}$  and internal resistance  $0.4\ \Omega$  is connected in parallel with another battery  $B$  of emf  $130\text{ V}$  and internal resistance  $0.5\ \Omega$ . Find the (i) value and direction of current in each battery, (ii) total current supplied, and (iii) power dissipated in  $6\ \Omega$  resistance.

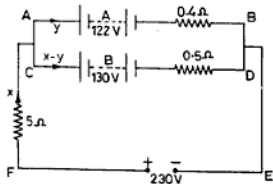

Fig. S.E. 9.9

**Solution :**

Using Kirchhoff's first law, let

Total current taken by both batteries =  $x\text{ A}$

Current taken by battery  $A$  =  $y\text{ A}$

Current taken by battery  $B$  =  $(x - y)\text{ A}$

By Kirchhoff's second law the voltage drop in mesh  $ABEF$  is

$$5x + 0.4y = 230 - 122$$

$$5x + 0.4y = 180 \quad (i)$$

In going round mesh  $CDEF$ ,

$$5x + 0.5(x - y) = 230 - 130$$

$$5x + 0.5x - 0.5y = 100$$

$$5.5x + 0.5y = 100 \quad (ii)$$

Multiplying Eq. (i) by 5 and Eq. (ii) by 4, we have

$$25x + 2y = 540$$

$$22x - 2y = 400$$

By adding,  $47x = 940$   
 Total current  $x = 940 / 47 = 20$  A (Charging)  
 Substituting the value of  $x$  in Eq. (i)  
 $5 \times 20 - 0.4 y = 108$   
 $100 - 0.4 y = 108$   
 $0.4 y = 108 - 100 = 8$   
 Current in battery A  $y = \frac{8}{0.4} = 20$  A (Discharging)  
 Current in battery B  $= (x - y) = (20 - 20) = 0$   
 Power dissipated in  $5\Omega$  resistance  $= I^2 R$   
 $= (20)^2 \times 5 = 400 \times 5 = 2000$  W  
 Ans.

#### 9.40 WHEATSTONE BRIDGE

The Wheatstone bridge is a network of resistances and is used to measure the value of unknown resistances. Its principle of working is based on the fall of potential along two conductors connected in parallel.

Figure 9.22 shows the internal connection of a Wheatstone bridge in which there are four resistances,  $P$ ,  $Q$ ,  $R$  and  $X$  (unknown) arranged in the form of a network. A battery is connected to junctions  $A$  and  $C$  through a switch and a galvanometer ( $G$ ) is connected to junctions  $B$  and  $D$ .

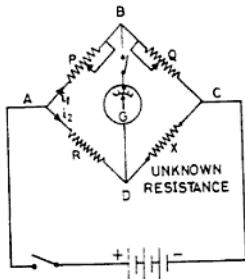

Fig. 9.22 Wheatstone bridge

When the switch is put on, the current from the battery starts to flow and divides into two parts. Current  $i_1$  flows through the branch  $ABC$  and current  $i_2$  through  $ADC$ . Current  $i_1$  through  $AB$  is equal to the current through  $BC$  and current  $i_2$  through  $AD$  is equal to the current through  $DC$ . Now the

switch of the galvanometer is closed. The ratio between  $P$  and  $Q$  is adjusted for any value of  $R$  and  $X$  so that there is no deflection in the galvanometer, i.e. there is no current flowing through it. Then at that time the potential difference between  $B$  and  $D$  will be zero. This means that both the points are at equipotential. Then

$$PD \text{ between } AB = PD \text{ between } AD$$

$$\text{or } i_1 P = i_2 R \quad (i)$$

$$\text{Similarly } PD \text{ between } BC = PD \text{ between } DC$$

$$\text{or } i_1 Q = i_2 X \quad (ii)$$

Dividing Eq. (i) by Eq. (ii), we have

$$\frac{i_1 P}{i_1 Q} = \frac{i_2 R}{i_2 X}$$

$$\frac{P}{Q} = \frac{R}{X}$$

By cross-multiplying, we have

$$XP = RQ$$

$$\text{or } X \text{ (unknown resistance)} = \frac{RQ}{P} \quad (9.7)$$

This means that for any value of  $P$ ,  $Q$  and  $R$ , we can find the value of an unknown resistance  $X$ .

**EXAMPLE 9.10** In the Wheatstone bridge network shown in Fig. SE 9.10, find the direction of current passing through each resistance and the total resistance between  $A$  and  $C$ .

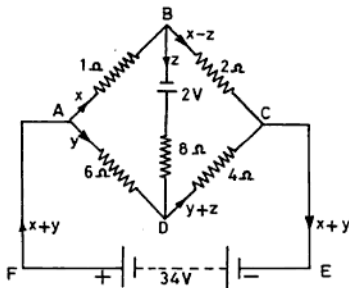

Fig. SE 9.10

**Solution:**

By Kirchhoff's first law, let currents flow in the direction indicated by the arrows. In the figure the resistance in  $AB=x$ ,  $AC=y$ ,  $BD=z$ ,  $BC=x-z$ , and in  $DC=y+z$ .

By Kirchhoff's second law, in mesh  $ABD$

$$x+8z-6y=2$$

$$\text{or } x-6y+8z=2 \quad (i)$$

In mesh  $BCD$ , we get

$$2(x-z)-4(y+z)-8z=-2$$

$$\text{or } 2x-2z-4y-4z-8z=-2$$

$$\text{or } 2x-4y-14z=-2 \quad (ii)$$

In mesh  $ADCEF$ , we get drops

$$6y+4(y+z)=34$$

$$\text{or } 6y+4y+4z=34$$

$$10y+4z=34 \quad (iii)$$

Multiplying Eq. (i) by 2 and subtracting Eq. (ii), we get

$$2x-12y+16z=4$$

$$2x-4y-14z=-2 \quad (iv)$$

By subtracting,  $-8y+30z=6$

Now multiplying (iii) by 4 and Eq. (iv), by 5 we have drops,

$$40y+16z=136$$

$$40y+150z=30$$

$$\text{By adding, } 166z=166$$

$$\text{or } z=\frac{166}{166}$$

$$=1A \text{ (from } B \text{ to } D \text{ in } 8\Omega \text{ resistance)}$$

Putting the value of  $z$  in Eq. (iii), we get

$$10y+4 \times 1=34$$

$$10y=34-4=30$$

$$y=\frac{30}{10}=3A \text{ (from } A \text{ to } D \text{ in } 6\Omega \text{ resistance)}$$

Putting the value of  $y$  and  $z$  in Eq. (i), we have

$$x-6 \times 3+8 \times 1=2$$

$$\text{or } x-18+8=2$$

$$\text{or } x=2+18-8$$

$$=12A \text{ (from } A \text{ to } B \text{ in } 1 \text{ resistance)}$$

Current in  $2 \Omega$  resistance  $=x-z$

$$=12-1=11A \text{ (from } B \text{ to } C)$$

Current in  $4 \Omega$  resistance  $=y+z$

$$=3+1=4A \text{ (from } D \text{ to } C)$$

Total resistance between  $A$  and  $C$

$$= \frac{\text{total PD between } A \text{ and } C}{\text{total current } (x+y)}$$

$$= \frac{6y+4(y+z)}{x+y}$$

$$= \frac{6 \times 3+4(3+1)}{12+3} = \frac{18+16}{15}$$

$$= \frac{34}{15} = 2.27 \Omega \text{ Ans.}$$

**EXERCISES**

- An external resistance of  $15 \Omega$  is connected to the terminals of a battery having 15 cells each of 1.5 V and internal resistance  $0.5 \Omega$  connected in series. Find the value of the current flowing through the circuit. (Ans. 1.1 A)
- A battery of 12 cells each of 2 V and internal resistance of  $0.25 \Omega$  connected in series. Find the value of the external resistance if it sends a current of 4 A through it. (Ans. 3  $\Omega$ )
- A dry cell of emf 1.5 V supplies a current of 0.5 A to an external resistance of  $2.5 \Omega$ . Find the value of the internal resistance of the cell. (Ans.  $0.5 \Omega$ )
- Find the strength of current flowing in the circuit, if five cells each of emf 1.5 V and internal resistance  $0.5 \Omega$  are connected in parallel and joined to an external resistance of  $4.9 \Omega$ . (Ans.  $0.3 A$ )
- Find the value of current flowing in the circuit, if 12 cells each of emf 1.45 V and internal resistance of  $0.6 \Omega$  are joined in parallel and supply current to an external resistance of  $2.85 \Omega$ . (Ans.  $0.5 A$ )
- An external resistance of  $1.95 \Omega$  is joined across the terminals of a battery consisting of six cells, each of emf 1.5 V connected in parallel. Find the internal resistance of each cell, if current is  $0.75 A$ . (Ans.  $0.3 \Omega$ )
- Thirty similar cells when connected in parallel send a current of  $2.25 A$  through an external resistance of  $0.55 \Omega$ . Find the emf of individual cell if internal resistance is  $3.5 \Omega$ . (Ans.  $1.5 V$ )
- Sixteen Leclanche' cells, each of emf 1.45 V and internal resistance  $0.125 \Omega$  are connected, four cells in series per row, four rows in parallel. Find the current through the external resistance of  $3.5 \Omega$ . (Ans.  $1.6 A$ )

- 9.9 Thirty-two cells, each of 1.5 V and internal resistance  $0.1 \Omega$ , are connected, four in series per row, eight rows in parallel. Find the current through the external resistance of  $3.95 \Omega$ . (Ans. 1.5 A)
- 9.10 A battery consisting of 12 cells, each having an emf of 1.5 V and internal resistance  $0.25 \Omega$  are connected in series and deliver current to an external resistance of  $6 \Omega$ . If six cells are reversed, find (i) the current through the external circuit, and (ii) the reduction in the current. (Ans. 2A, 1A)
- 9.11 Six cells are joined in series together with an external resistance of  $12 \Omega$ . The emf of each cell is 2.4 V and internal resistance of  $0.4 \Omega$ . Find :  
 (i) current through each cell and external resistance,  
 (ii) voltage drop inside the cells, and  
 (iii) terminal voltage of the battery.  
 (Ans. (i) 1 A (ii) 2.4 V (iii) 12 V)
- 9.12 Eight cells connected in parallel are connected to an external load resistance of  $12.4 \Omega$ . If the total emf of each cell is 1.5 V and the internal resistance per cell is  $0.8 \Omega$  calculate :  
 (i) current passing in external resistance and each cell,  
 (ii) voltage drop in each cell, and  
 (iii) terminal voltage of the battery.  
 (Ans. (i) 0.12A, 0.015A (ii) 0.012V (iii) 488 V)
- 9.13 The emf of a cell falls from 2.34 V to 1.95 V when an external resistance of  $5 \Omega$  is connected across its terminals. Find (i) the internal resistance, and (ii) the current passing through the external resistance. (Ans. 1  $\Omega$  0.39A, )
- 9.14 A battery is formed of eight cells connected in series. When the external resistance of  $4 \Omega$  is connected, the current is 5 A and when it  $10 \Omega$ , the current falls to 2.5 A. Find the internal resistance and emf of each cell. (Ans.  $0.25 \Omega$ , 3.75 V)
- 9.15 In the circuit shown the potential difference across the  $4 \Omega$  resistance is 15 V. On short-circuiting the  $5 \Omega$  resistance, the potential difference across the  $4 \Omega$  resistance rises to 27.5 V. Find (i) the internal resistance and (ii) emf of the battery. (Ans.  $2 \Omega$ , 41.25 V)

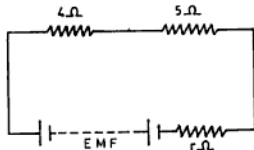

Fig. S.E. 9.15

- 9.16 A battery has been put on charge for 8h at a discharge rate of 40 A at an average terminal voltage of 2.7 V. The battery was discharged in 9 h when supplying 32 A at an average discharge voltage of 2.4 V. Determine :  
 (i) ampere-hour efficiency, and  
 (ii) watt-hour efficiency. (Ans. (i) 90%, (ii) 80%)
- 9.17 A 24 V, 200 A-h lead acid battery is to be charged from 250 V dc mains using 250 W, 250 V lamps at 10 A. Find the total number of lamps required for charging the battery. (Ans. 10 Lamps)
- 9.18 A battery of emf 30 V and internal resistance  $2 \Omega$  is charged on 100 V dc mains. Calculate the value of the resistance to be added in series to the circuit so that the charging current is equal to 5 A. If the cost of the energy is 40 paise per unit, what will it cost to charge the battery for 10 h. (Ans. 12  $\Omega$ , Rs. 2.00)

- 9.19 The emf of a six-cell storage battery is 13.6 V and the internal resistance is  $0.086 \Omega$ . If the battery is to be (a) charged at the rate of 15 A, and (b) discharged at 10 A, find :
- terminal voltage,
  - power loss in the battery, and
  - energy stored per second.
- (Hint  $\text{emf} = V_T \pm I_r$  (Plus sign for charging. Minus sign for discharging))  
 Energy stored =  $E \times I \times L$  Joules. (Ans: (a) 12.31 V (b) 14.46 V  
 (a) 19.35 W (b) 8.6 W  
 (a) 204 w/s, (b) 136 w/s)
- 9.20 A battery of 30 cells connected in series is to be charged at 20 A from 100 V dc supply mains. The emf of each cell at the time of charging is 1.8 V per cell and at the end of charge it is 2.4 V per cell. Each cell has an internal resistance of  $0.02 \Omega$  and the leads connecting the batteries has a resistance of  $0.01 \Omega$ . Find the series resistance required at the time of (i) switching ON and (ii) end of charge. (Ans. 1.69  $\Omega$ , 0.79  $\Omega$ )
- 9.21 A shunt dynamo is used to charge a battery of 60 cells in series. On completion of the charge each cell has a terminal potential difference of 2.4 V and internal resistance  $0.002 \Omega$ . Find the emf to be generated to give a charging current of 10 A at the end of the charge. Assume that the armature and field resistances are respectively 0.25 and  $74.6 \Omega$  and the cable connecting the dynamo to the battery has a resistance of  $0.4 \Omega$ . (Ans. 152.2 V)
- 9.22 A battery is made of 10 cells connected in series. If an external resistance of  $8 \Omega$  is connected across the battery, the current in the circuit is 5 A and when it is  $15 \Omega$ , the currents fall to 3 A. Find the internal resistance of each cell. (Ans. 0.25  $\Omega$ )
- 9.23 A battery of emf 236 V and internal resistance  $0.4 \Omega$  is connected in parallel with another battery which has an emf of 232 V and internal resistance of  $0.3 \Omega$  supply to an external load of  $R \Omega$ . Find :
- current in each battery,
  - potential difference across the terminals of batteries if the total current supplied to the external load is 80 A, and
  - the value of external resistance
- (Ans. (i) 40 A, each battery  
 (ii) 220 V, each battery  
 (iii) 2.75  $\Omega$ )

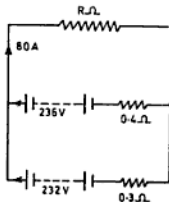

Fig. NE 9.23

- 9.24 A battery of emf 26 V and internal resistance  $0.5 \Omega$  supplies current to the network shown in Fig NE 9.24. Calculate the current in each branch and the total current supplied by the battery. (Ans. Upper branch 1 A  
 Lower branch 3 A  
 Total current 4 A)

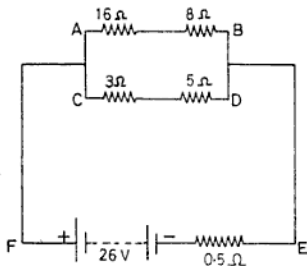

Fig. NE 9.24

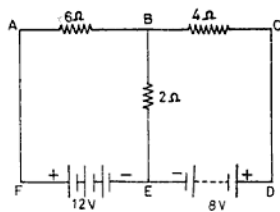

Fig. NE 9.25

- 9.25 Find the value and direction of current in each resistance of the circuit shown in Fig. NE 9.25. Assume the internal resistance of the batteries to be negligible.  
(Ans. Current in  $6\ \Omega$  resistor = 2 A from A to B  
Current in  $2\ \Omega$  resistor = 0 A)
- 9.26 Find the value and direction of current in each resistance of the circuit shown in Fig. NE 9.26. Assume the internal resistance of the batteries to be negligible.  
(Ans. Current in  $2\ \Omega$  resistor = 3 A from A to B  
Current in  $4\ \Omega$  resistor = 1 A from D to E in reverse direction.  
Current in  $6\ \Omega$  resistance = 2 A from C to F)

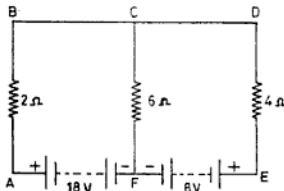

Fig. NE 9.26

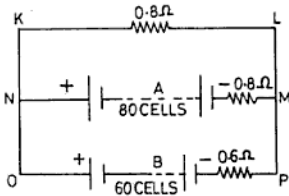

Fig. NE 9.27

- 9.27 Two batteries A and B are connected in parallel and supply to the circuit shown in Fig. NE 9.27. Battery A consist of 80 cells and battery B of 60 cells connected in series. The emf and internal resistance per cell is 2.5 V and 0.01  $\Omega$  respectively. Find the value and direction of current flowing in each battery and in the  $6.8\ \Omega$  resistance.  
(Ans. Battery A : 100 A, Discharge  
Battery B : 50 A, Discharge  
Current in  $0.8\ \Omega$  resistance = 150 A)
- 9.28 Two batteries A and B are connected in parallel and supply to the circuit shown in Fig. NE 9.28. Battery A consists of 40 cells and battery B of 20 cells connected in series. The emf and internal resistance per cell is 2 V and 0.05  $\Omega$  respectively. Find the value and direction of current flowing in each battery and the  $6\ \Omega$  resistance.  
(Ans. Battery A : 16 A discharging  
Battery B : 8 A charging  
Current in  $6\ \Omega$  resistance : 8 A)

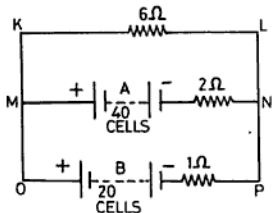

Fig. NE 9.28

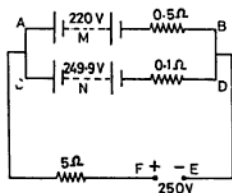

Fig. NE 9.29

- 9.29 Two batteries  $M$  and  $N$  are connected to a 250 V dc supply for charging through the  $5\ \Omega$  resistance as shown in Fig NE 9.29. Battery  $M$  is of emf 220 V and internal resistance  $0.5\ \Omega$  and battery  $N$  of emf 249.7 V and internal resistance  $0.1\ \Omega$ . Find (i) the value and direction of current in each battery and (ii) the total current taken from the supply.
- (Ans. Battery  $M$  50 A charging  
Battery  $N$  49 A discharging  
Total current 1 A)
- 9.30 Two batteries  $M$  and  $N$  are connected to a 250 V dc supply for charging through a  $12\ \Omega$  resistance as shown in Fig. NE 9.30. Battery  $M$  is of emf 120 V and internal resistance  $0.2\ \Omega$  and battery  $N$  of emf 150 V and internal resistance  $0.5\ \Omega$ . Find :
- The value and direction of current in each battery,
  - total current, and
  - the power dissipated in  $12\ \Omega$  resistance.

(Ans. Battery  $M$ , 50 A charging.  
Battery  $N$ , 40 A discharging.  
Total current 10 A  
Power dissipated 1200 W)

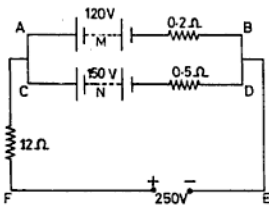

Fig. NE 9.30

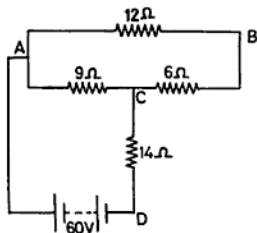

Fig. NE 9.31

- 9.31 In the circuit shown, find the value and direction of current in  $14\ \Omega$  resistance if the internal resistance of the battery is negligible.
- (Ans. Current in  $14\ \Omega$  resistor = 3A from C to D)
- 9.32 Find the value of current in the  $50\ \Omega$  resistance in the circuit shown in Fig NE 9.32.
- (Ans. Current in  $50\ \Omega$  resistance = 0.8 A)

- (Ans. Current in  $5\ \Omega$  resistor = 2 A from B to C  
 Current in  $4\ \Omega$  resistor = 5 A from A to C  
 Current in  $1\ \Omega$  resistor = 15 A from A to B  
 Current in  $2\ \Omega$  resistor = 13 A from B to D  
 Current in  $3\ \Omega$  resistor = 7 A from C to D  
 Resistance between A and D =  $2.05\ \Omega$ )

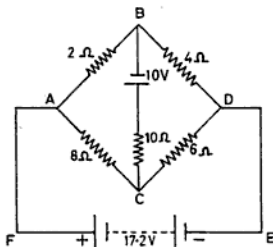

Fig. NE 9.36

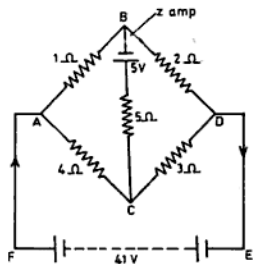

Fig. NE 9.37

## REVIEW QUESTIONS

- 9.1 What do you understand by local action and polarisation in the electric cell? How can they be removed in the Leclanche' cell.
- 9.2 Describe the construction of the Daniel cell and explain its action.
- 9.3 Explain the terms primary cell, local action and polarisation. Describe the construction, working, chemical action and application of the Leclanche' cell.  
 (NCVT, 1978, 67 W/ma n1964, Elect.)
- 9.4 (a) What is the difference between a primary and secondary cell?  
 (b) Why it is preferred to connect the cells (a) in series, (b) in parallel and (c) in combination of series and parallel? Also, derive an expression for current in a load resistance  $R\ \Omega$  for each case.
- 9.5 What are the different methods of forming the plates of the lead acid battery?
- 9.6 Describe the parts and working of the lead acid cell. What precautions will you take for its maintenance? (NCVT 1968, 1972, Elect., All India Compt. 1968)
- 9.7 (a) Describe with a neat sketch the construction of the lead acid cell and give the chemical equations on charging and discharging.  
 (b) What precautions should be taken if a battery is to be kept unused for a long period?  
 (c) State the value of the cell emf and the specific gravity of the acid at charge and discharge. (NCVT 1970, 72, 79 Elect.; Inter ITI U.T. Compet. 1971)
- 9.8 A lead acid battery comprises of 50 cells in series each of open circuit emf 2 V and internal resistance  $0.02\ \Omega$ . Calculate the terminal voltage (a) when supplying a load current of 10 A and (b) when being charged at 10 A.  
 (All India Compet. 1969) (Ans. 90 V, 110 V)
- 9.9 What are the two methods of expressing the efficiency of a battery? Why is the watt-hour efficiency of a cell less than its ampere-hour efficiency.
- 9.10 (a) Explain how a lead acid storage cell functions.  
 (b) A 12-V lead acid battery of 90 A-h capacity is to be recharged. What test would you make on the battery and how would you arrange to charge it from a rectifier? How many hours should the battery remain on charge and what test would you take to determine if it is fully charged.

(NCVT, 1965 67 Elect.)

- 9.11 What do you understand by :
- ampere-hour capacity of a cell,
  - trickle charging of batteries, and
  - high rate discharge tester.

(NCVT 1979 Elect.)

- 9.12 What do you understand by secondary cells? Explain different types of secondary cells and their applications. What are the important properties that a secondary cell should possess?

(NCVT 1965 Elect.)

- 9.13 Describe the chemical reactions that take place during charging and discharging of an Edison cell.

- 9.14 What are the advantages and disadvantages of the lead acid cell over the nickel iron cell?

- 9.15 State Kirchhoff's laws.

A battery of 10 V and internal resistance  $0.5 \Omega$  is connected in parallel with another battery of 12 V and internal resistance  $0.8 \Omega$ . The terminals are connected by an external resistance of  $20 \Omega$ . Find the current in each battery and the external resistance.

(Ans. 1.212 A charging, 1.742 A discharging, current in  $20 \Omega = 0.531$  A)

- 9.16 The emf of a three-cell storage battery is 5.80 V and the internal resistance is  $0.072 \Omega$ . If the battery is being charged at the rate of 12 A, determine :

- Terminal voltage,
- power loss in heating of battery and
- energy stored per second.

(Ans. 4.736 V, 10.368 W, 69.6 J)

- 9.17 (a) A battery of secondary cell having an emf of 150 volts and internal resistance  $2.2 \Omega$  is to be charged from 220 volts dc mains. What series resistance will be necessary to adjust the initial charging current to 4.5 A.

- How should the resistance be varied to keep the charging current same till the end of the charge when the emf of the battery rises to 175 V.

(NCVT/WJCal Elect 1982)

(Ans. 13.35  $\Omega$ , 5.55  $\Omega$ )

- R. 9.19. Explain the working principle of a wheatstone bridge. In a wheatstone Bridge experiment for determining the resistance of a wire balance point was obtained when  $R = 30 \Omega$ ,  $P = Q = 10 \Omega$ . Find the resistance of the wire. If the length of the wire was found to be 110 cm and its diameter be 0.014 cm, find the specific resistance of the material of the wire.

(NCVT 1984 Elect)

(Ans. 40. cm)

# 10

## Wiring System

### 10.1 SYSTEM OF SUPPLY

There are two systems of tapping off supply from the mains for the different branches as follows :

- (i) tree system, and
- (ii) distribution system.

**Tree System** In this system sub-circuits are tapped off from the main circuit at some convenient place. Nowadays this system is out of practice as there are many joints for sub-circuits. Moreover it is very difficult to find faults. Figure 10.1 shows the connection of such a system.

**Advantages** The length of cables required for the installation of the wiring is less and therefore the initial cost is also very less.

**Disadvantages** The disadvantages of the tree system are :

- (i) fuses in the installation are scattered, and
- (ii) location of faults is not easy.

(iii) The voltage available at different points of load will vary.

(iv) Appearance of the system is not so good.

**Distribution System** This system is most commonly used nowadays. In this system the main distribution circuit is brought to one or more distribution boxes from where it is further distributed to different branch circuits as shown in Fig. 10.2. This system requires no joints, but each circuit is tapped off from the distribution box without interfering with the other circuit. Moreover, each circuit is independently tested for finding the faults.

**Advantages** The advantages of this system are :

- (i) fault finding is very easy,
- (ii) the voltage available at different points of the circuit will be the same, and
- (iii) renewal or extension of the circuit is easy.

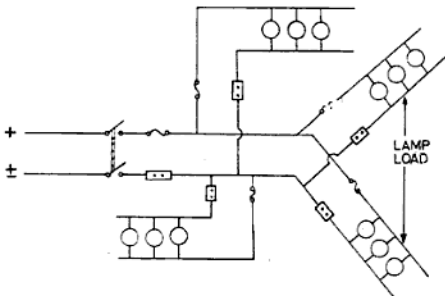

Fig. 10.1 Arrangement of tree system

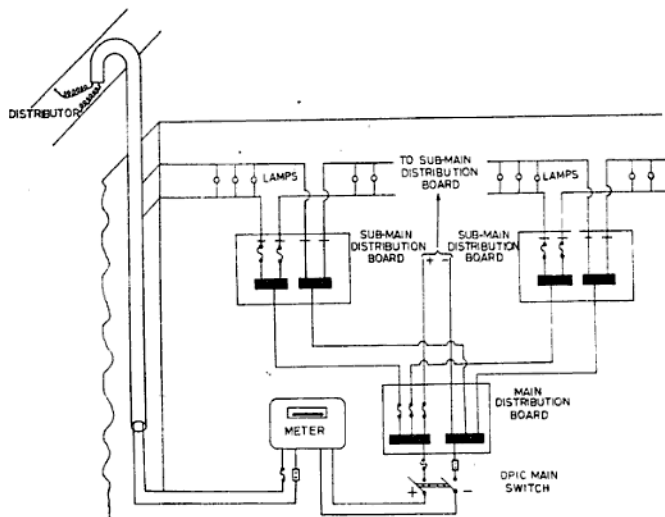

Fig. 10.2 Distribution system

**Disadvantage** In this system the length of the cable required for the installation of the wiring is more. Therefore, the initial cost of erection is also more.

## 10.2 SELECTION OF WIRING

Wiring systems are of many types and have different advantages and disadvantages. The selection of an individual system depends upon many factors. The following main points must be considered while selecting a particular type of wiring:

- (i) **Initial Cost** The initial cost of the wiring system adopted must be economical to suit the consumer.
- (ii) **Durability** The cable used in the installation of the wiring must be sufficiently sound so as to bear the changing atmosphere of the surrounding. It should also be in a position to pass the full-load current of the circuit.
- (iii) **Mechanical Protection** The system chosen must provide good mechanical protection to the cables used in the installation of the wiring.
- (iv) **Safety from Fire** This is an important factor and must be considered while selecting an individual system. The system adopted should be free from risk of fire as far as possible.
- (v) **Appearance** After completion of the job, the wiring should appear attractive. From this point of view concealed conduit wiring is best, but its initial cost is very high. However, C.T.S. wiring also looks attractive and has low cost of installation.
- (vi) **Accessibility** It should be easy to extend or repair the wiring.
- (vii) **Life** The system adopted should have good life.

### 10.3 RULES FOR WIRING

Before the erection of wiring, the following general rules should be kept in view :

- (i) According to ISI, the total lighting load in a sub-circuit should not be more than 800 W or ten points, whichever is less. For estimating the load, the following values should be considered for individual points.
  - (a) Fluorescent tube—40 W each
  - (b) socket outlet, ceiling fan, lamp—60 W each, and
  - (c) mercury vapour lamp—80 W each.
- (ii) According to ISI, the maximum power load in a sub-circuit should not be more than 2000 W or two points, whichever is less.
- (iii) The current rating of the main switch and distribution box should be calculated according to the load on the circuit.
- (iv) The cable used in the installation should be kept free from dampness, fire, chemical fumes and leakage. Therefore, all metal coverings provided for the protection of cables must be earthed, so that there is no damage due to the leakage of the installation.
- (v) In domestic wiring, the wall socket used must have an earth point connected with the earth continuity conductor.
- (vi) All the metal covering (as the cover of the main switches, pipes, brackets, fans, etc. including the earth point of the wall socket) in an installation should be earthed.
- (vii) No switch or fuse should be installed in the earth continuity conductor.
- (viii) A live wire must be protected by a fuse of current rating depending on the requirement of the load. Further it should be controlled through the switch.
- (ix) The height of the controlling board in an installation should be 1.5 m (5 feet) from the ground level and should be installed on the left side of the entrance.
- (x) The height of the fan and light points should be 2.75 m (9 feet) and 2.5 m (8 feet) respectively from the ground level.
- (xi) Round blocks should be fixed with two screws on diametrical ends.
- (xii) Every sub-circuit must have a separate distribution fuse board.
- (xiii) The light and power wiring circuits should be installed independently.
- (xiv) The switches and starters of the motor should be easily accessible to the operator.
- (xv) In an ac three-phase, four-wire system, the distribution of the load should be kept balanced on each phase as far as possible. The three phases should be indicated by red, yellow and blue colour and the neutral with black. In dc distribution, the positive and negative wire should be represented with the red and blue colour respectively and the neutral with black.
- (xvi) When the installation has been completed, it should be tested with a megger before connecting it to supply. The leakage current in this case should not exceed 1/5000th part of the maximum current of the load.
- (xvii) Double earthing should be provided with all machines that work on medium and high voltages.
- (xviii) If the operating voltage of the circuit exceeds more than 250 V, a CAUTION notice should be fixed to motors, generators, transformers, etc. If several apparatus are installed in one enclosure, one notice will serve the purpose.

### 10.4 SYSTEM OF WIRING

The following are the various systems of domestic and industrial wiring:

- (i) cleat wiring system,
- (ii) wooden casing and capping wiring system,
- (iii) lead sheathed wiring system,
- (iv) C.T.S./T.R.S. wiring system, and
- (v) conduit pipe wiring.

**(i) Cleat Wiring System** This is a very simple system and also the cheapest method of running wires (shown in Fig. 10.3) and is used for temporary lighting at dry places. The wiring is run in the visible condition except in places where they are likely to be protected from mechanical damage and less than 1.5 m above the ground level. Single-core V.I.R. cables or P.V.C. insulated cables are used in this system.

These cables are run in the grooves of glazed porcelain cleats which are fastened in wooden wall plugs ("gutties" by means of wood

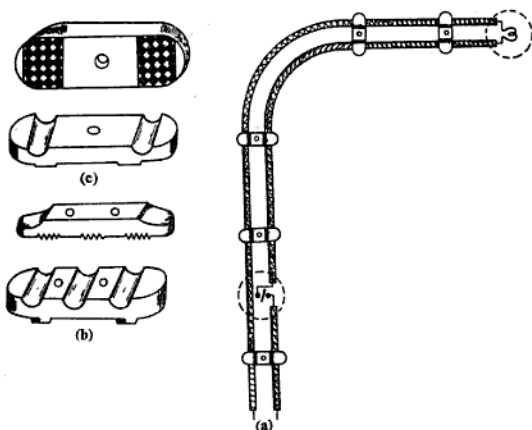

Fig. 10.3 (a) Cleat wiring  
(b) Three-way cleat  
(c) Two-way cleat

screws. The grooves of the porcelain cleat should neither compress the insulation nor be loose fitting. The cleat should be provided every 60 cm to avoid sag in the cables. Sharp bends should be avoided in the wiring and the spacing between the cleats should be reduced to prevent the touching of wall and sagging. The distance between the cables should be 2.5 cm in the case of branch circuits and 4 cm apart in the case of sub-mains. The cables are prevented to avoid coming in contact with other conductors, earthed metal, gas or water mains: cross-cleated cables should be separated by an insulating bridge piece which should at least maintain a distance of 1.3 cm between the cables. When the wires are to pass through walls or ceilings, they must be taken through conduit pipes.

In this wiring system, where joints are to be made for connecting bifurcating wires, wooden or other insulating material junction boxes with porcelain connectors inside should be used.

The life of this wiring system is approximately five years. The system is not used on damp walls, ceilings etc.

**NOTE:** For temporary power connection for marriages, etc., wooden cleats of three, four and five ways are also used as per the need.

**Advantage** In this wiring faults can easily be located.

**Disadvantages** The disadvantages are:

- (i) It collects dust over the wire, and
- (ii) there is no protection from mechanical injury, fire, gas or water pipes.

(ii) **Wooden Casing and Capping Wiring System** This system of wiring is shown in Fig. 10.4. It is suitable for low voltage domestic installations where vulcanised rubber-insulated cables or plastic-insulated cables are used. This wiring system is not used in damp places such as hilly areas as it absorbs moisture.

The casing should be of well-seasoned teak wood, free from knots, damp and other defects. Before the installation of the casing capping, it should be well-varnished from all sides with pure shellac varnish.

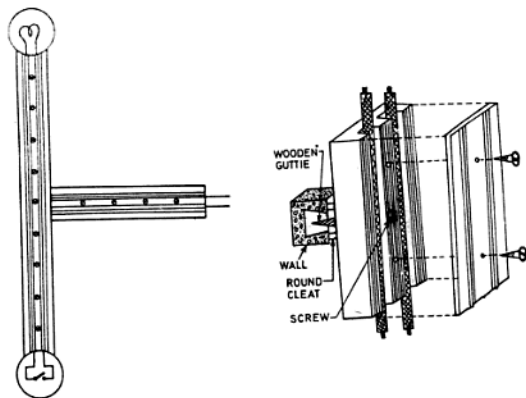

Fig. 10.4 Casing capping wiring

The casing is first installed by means of flathead, countersunk wood screws to the wooden plugs ("gutties") on dry walls or ceilings at an interval of not exceeding 90 cm for sizes up to 64 mm and not exceeding 60 cm for sizes above 64 mm casing. The casing should not be fixed near or under the gas, steam or water line. It should be separated from the wall or ceiling by porcelain round cleats not less than 6.5 mm thick, thus avoiding the effect of moisture if it is in the wall. While laying out the casing, try to avoid corners and crossing of cables as far as possible. If this cannot be avoided, then use wooden corners or bridge pieces. Casing capping joints should be cut diagonally and made to fit properly. The joints in the casing should not be overlapped by the joint of the capping. Moreover, the casing capping should never be buried in the plaster work, to cross the wall, floor or ceiling, it should be passed through the conduit pipe.

After fixing the casing, cables of opposite polarity or of different phases are run in different grooves. There should be no joint in the groove and for this purpose a separate joint cut-out is used. After running the wires in the grooves, the casing is then covered with capping by means of round-head brass

screws at a distance not exceeding 15 cm (6") cross-wise (i.e. 30 cm (12") between two successive screws on each side) for all sizes up to 64 mm ( $2\frac{1}{2}$ ") casing capping. For sizes above 64 mm ( $2\frac{1}{2}$ ") casing capping, the screws are fixed at an interval of 22.5 cm (9") cross-wise (i.e. 45 cm (18") between two screws on each side) on the capping. It should be kept in mind that while fixing the screws on the capping, the side fillets (i.e. walls) do not spoil as it may damage the insulation of the cable used. After the completion of the installation, it should be varnished again.

The cost of labour required in this system is comparatively high. This system of wiring is suitable for dry places only and the life is about 20 years. This system of wiring has now been superseded by the C.T.S. wiring system.

**Advantages** There is sufficient mechanical protection to the cable used.

**Disadvantages** The following are the disadvantages of the system :

- (i) There is a great risk of fire in this system.
- (ii) It is difficult to find faults.

- (iii) It is not damp proof. Although it is painted with shellac varnish, yet it absorbs moisture easily.
- (iv) Its erection is not very simple and therefore requires more time and skilled labour.

**Dimensions** The sizes of casing and capping for various sizes of 250 V grade insulated cable in a groove should be in accordance with those mentioned in Table 10.1.

TABLE 10.1 SIZES OF WOOD CASING AND CAPPING (AS PER IS 732-1963)

S. No.	Particulars	Sizes of casing or capping in mm						
		3						
1.	Width of casing or capping	38	44	51	64	76	89	102
2.	No. of grooves	2	2	2	2	2	2	2
3.	Width of grooves	6	6	9	13	16	16	19
4.	Width of dividing fillet (wall)	12	12	13	18	24	35	82
5.	Thickness of outer wall	7	10	10	10	10	11	13
6.	Thickness of casing	16	16	18	19	25	32	32
7.	Thickness of capping	6	6	10	10	10	13	13
8.	Thickness at the black under the grooves	6	6	6	10	10	10	13
9.	Length	2.5 to 3.0 m						

TABLE 10.2 MAXIMUM PERMISSIBLE NUMBER OF 250-V GRADE SINGLE-CORE CABLES THAT CAN BE DRAWN INTO RIGID STEEL CONDUITS (AS PER IS 732-1963)

Nominal cross sectional area mm <sup>2</sup>	Number and diameter in mm of wires	Size of conduit (mm)																											
		16				20				25				32				40				50				63			
		S		B		S		B		S		B		S		B		S		B		S		B		S		B	
1.0	1/1.12*	5	4	7	5	13	10	20	14	—	—	—	—	—	—	—	—	—	—	—	—	—	—	—	—	—	—	—	—
1.5	1/1.40	4	3	7	5	12	10	20	14	—	—	—	—	—	—	—	—	—	—	—	—	—	—	—	—	—	—	—	—
2.5	{ 1/1.80 } { 3/1.06* }	3	2	6	5	10	8	18	12	—	—	—	—	—	—	—	—	—	—	—	—	—	—	—	—	—	—	—	—
4	{ 1/2.24 } { 7/0.85* }	3	2	4	3	7	6	12	10	—	—	—	—	—	—	—	—	—	—	—	—	—	—	—	—	—	—	—	—
6	{ 1/2.80 } { 7/1.06* }	2	—	3	2	6	5	10	8	—	—	—	—	—	—	—	—	—	—	—	—	—	—	—	—	—	—	—	—
10	{ 1/3.55† } { 7/1.40* }	—	—	2	—	5	4	8	7	—	—	—	—	—	—	—	—	—	—	—	—	—	—	—	—	—	—	—	—
16	7/1.70	—	—	—	—	2	—	4	3	7	6	—	—	—	—	—	—	—	—	—	—	—	—	—	—	—	—	—	—
25	7/2.24	—	—	—	—	—	—	3	2	5	4	8	6	9	7	—	—	—	—	—	—	—	—	—	—	—	—	—	

Table 10.2 (contd).

35	7/2.50	—	—	—	—	2	—	4	3	7	5	8	6
50	{ 7/3.00† 19/1.80	—	—	—	—	—	—	2	—	5	4	6	5
		—	—	—	—	—	—	2	—	5	4	6	5

NOTE 1—The table shows the maximum capacity of conduits for the simultaneous drawing-in of cables. The table applies to 250-volt grade cables. The columns headed 'S' apply to runs of conduit which have distance not exceeding 4.25 m between draw-in boxes, and which do not deflect from the straight by an angle of more than 15°. The columns headed 'B' apply to runs of conduit which deflect from the straight by an angle of more than 15°.

NOTE 2—In case an inspection type draw-in box has been provided and if the cable is first drawn through one straight conduit, then through the draw-in box, and then through the second straight conduit, such systems may be considered as that of a straight conduit even if the conduit deflects through the straight by more than 15°.

\*For copper conductors only.

†For aluminium conductors only.

TABLE 10.3 MAXIMUM PERMISSIBLE NUMBER OF 250-VOLTS GRADE SINGLE-CORE CABLES THAT MAY BE DRAWN INTO RIGID NON-METALLIC CONDUITS (AS PER IS 732-1963)

Size of cable		Size of conduit (mm)					
Nominal cross-sectional area mm <sup>2</sup>	Number and diameter in mm of wires	16	20	25	32	40	50
		(Number of cables, max)					
1.0	1/1.12*	5	7	13	20	—	—
1.5	1/1.40	4	6	10	14	—	—
2.5	{ 1/1.80 3/1.06*	3	5	10	14	—	—
4	{ 1/2.24 7/0.85*	2	3	6	10	14	—
6	{ 1/2.80 7/1.06*	—	2	5	8	11	—
10	{ 1/3.55† 7/1.40*	—	—	4	7	9	—
16	7/1.70	—	—	2	4	5	12
25	7/2.24	—	—	—	2	2	6
35	7/2.50	—	—	—	—	2	5
50	{ 7/3.00† 19/1.80	—	—	—	—	2	3

\*For copper conductors only.

†For aluminium conductors only.

(iii) **Lead-sheathed Wiring System** This type of wiring is used for low voltage installation and is not suitable where acids or alkalis are likely to be present. In this wiring system, single, two- and three-core lead covered V.I.R. cables are used in places exposed to the sun and rain, provided no joint is there in the installation.

In lead-sheathed wiring the cables are fixed to the wooden batten by means of nails and joint clips or link clips. These clips are fixed at an interval of 10 cm in the case of horizontal distances and 15 cm in the case of vertical distances. After this these wooden battens are then fixed by means of wooden screws to the wooden plugs which are fixed

in the walls at the distance not less than 60 cm (2') or 75 cm (2.5') maximum (shown in Fig. 10.5).

In such a system of wiring extra care should be taken to prevent any heavy mechanical strain over lead-covered cables while installing them. The cable should be run in conduit pipes when crossing the wall or ceiling. If the cable is passing through the floor, it should be protected by the conduit pipe and brought to the wall up to a maximum height of 1.5 m. The sharp bending of the cable should be avoided. This system requires good earthing. Hence electrical continuity should be formed over the whole length of lead and should therefore be earthed. The joints of lead-covered cables are made in the well-enclosed metal joint boxes by means of a porcelain connector. The metal sheathing of all the jointed cables should be bound through these boxes. In any installation the total resistance of the metal sheathing from any point in it to the earth electrode should not exceed  $1 \Omega$ . This wiring gives a neat appearance and requires superior workmanship.

This wiring system is very costly and is generally used in large buildings, hospitals and for short distance service mains in domestic wiring. The life of such a wiring system is 30 years or more.

**Advantages** The advantages of this system are :

- (i) There is sufficient mechanical protection to the cable due to lead sheathing on the cable.
- (ii) Protection from fire is also good in this system of wiring.
- (iii) This system provides good protection from dampness if the ends of the cables are properly sealed.

**Disadvantages** The disadvantages of the system are as follows:

- (i) This system of wiring is expensive.
- (ii) Insulation of the cable can be damaged due to the bad workmanship.
- (iii) This type of wiring is not suitable where fumes of acid are present.
- (iv) **C.T.S. T.R.S. Wiring System** In this wiring system, single, twin or three-core, tough rubber-sheathed cables are used for low-voltage wiring installation. It should not

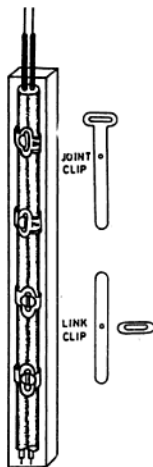

Fig. 10.5 C.T.S. wiring

be exposed to the sun and rain. However, PVC sheathed cables are also suitable for medium-voltage installations and they may be installed under exposed conditions of the sun, rain or damp places and where fumes of acid or alkalis are present.

T.R.S. cables are fixed on well-seasoned, perfectly straight and well-varnished wooden battens by means of joint clips as explained in lead sheathed wiring system, not less than 10 mm in thickness (10 to 19 mm usually) and the width of which is such as to fit the total width of the cables laid on the batten (10 to 50 mm) as shown in Fig 10.5. Wooden plugs used for fixing the batten should be fixed at a minimum interval of 60 cm (2') apart or 75 cm (2½') apart maximum. The wiring should not be given any right-angle bend. For this purpose, it should be rounded off at the corner to a radius not less than six times than the overall diameter of the cable. It is preferred to pass the wire through the conduit pipe when passing through the walls, ceiling or floor. For this purpose wooden or porcelain bushes should be provided on both sides of the conduit. In no condition the

T.R.S. cables should be buried directly under the plaster. After the completion of the wiring installation, it should be varnished again to suit the surrounding atmosphere.

This system of wiring has taken the place of lead-sheathed wiring because in this system the sheathing of the cable does not require earthing and moreover it can safely be used in situations where neither conduit nor lead-covered wiring would serve the purpose. This wiring can be erected very easily and quickly, and hence there is much saving in labour. The wiring has a neat and attractive appearance. This wiring is free from chemical action and is waterproof within limits.

The life of such a wiring system is about 30 years and is used in large buildings, hospitals and at places where chemical fumes and moisture are present.

**Advantages** The advantages of the system are as follows:

- (i) In this system, protection from dampness is excellent.
- (ii) This system requires semi-skilled labour for erection and therefore is less costly.
- (iii) Its life is very long.
- (iv) This system provides good mechanical protection to the cable used in the installation.
- (v) Its general appearance is very good.

(v) **Conduit Wiring System** This system of wiring can be divided into two further systems as follows:

- (i) surface conduit wiring, and
- (ii) concealed conduit wiring.

**Surface Conduit Wiring** This system is suitable for low and medium voltage wiring installations. V.I.R. or P.V.C. cables are run in metal pipes known as conduits which provide good mechanical protection to the insulation of the cable and reduce the risk of fire.

The cables are drawn through the conduit pipe by means of a steel wire known as fish wire. Conduit pipes are available in various sizes which vary from 12 mm (1/2") to 75 mm (3"). The size of the conduit to be selected for the wiring depends upon the diameter and the number of cables to be carried through the conduit.

In this wiring system threaded conduits (thread should be between 11 to 27 mm) are

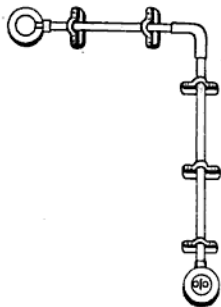

Fig. 10.6 Surface conduit wiring

fixed on the surface of the walls by means of a saddle, screwed to the wooden plugs, provided at an interval of not more than 1 m as shown in Fig. 10.6. The distance of the wooden plugs on either side of the junction box or other conduit accessories should not be more than 30 cm (1') from the centre of the fittings. In long running of pipes, the junction boxes are provided at a sufficient distance to facilitate the drawing in of wires, etc. Burrs are formed inside the conduit pipe, while cutting it. If these burrs are not removed, that can damage the insulation of the cables. Wooden or plastic bushes are inserted inside the conduit pipes where the wires enter or leave the conduit. All outlets (switches, holders, etc.) are fitted on the metal boxes installed either surface mounted or flush mounted.

**Concealed Conduit Wiring** This wiring is also known as recessed conduit wiring and comply with all the requirements of surface conduit wiring.

In this system small channels are formed in the walls, ceiling, etc. when the building is under construction. The conduit pipes are erected in these channels by staples or saddles not more than 60 cm (2') apart. Inspection-type conduit accessories like inspection-tee, elbow or junction boxes are fitted flush mounted on the walls at a sufficient distance during the installation of the conduit to facilitate the drawing in or removal of wires. After the erection of the conduit pipes in the

TABLE 10.4 COMPARISON OF DIFFERENT SYSTEMS OF WIRING

S. No.	Particulars	Chase Wiring	Casing and Capping Wiring	Lead sheathed Wiring	C.T./I.T./R.S Wiring	Conduit pipe Wiring
1	2	3	4	5	6	7
1.	Protection from mechanical damage	None	Fair	Fair	Good	Very good
2.	Protection from fire	No protection	Bad	Good	Fair resistance	Very good
3.	Protection from dampness	No protection	Little	Good	Excellent	Fair
4.	Cost	Cheap	Fairly expensive	Expensive	Cheap	Very expensive
5.	Life	Short	Fairly long	Long	Long	Very long if erected carefully
6.	Types of labour required	Skilled	Very superior	Superior	Semi-skilled	Superior
7.	Appearance	Bad	Fair	Good	Good	Very good
8.	Nature of application	Temporary	Domestic	Service mains	Domestic, office buildings	Workshops
9.	Repair, extensions or renewals	Easy	Difficult	Difficult	Very easy	Very difficult
10.	Time required for erection	Short	Fairly long	Fairly long	Very short	Long
11.	General reliability	Poor	Good	Fair	Very good	Very good

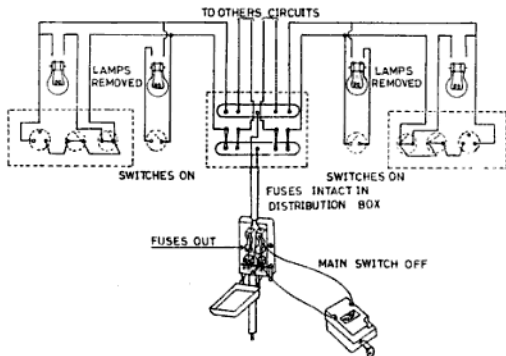

Fig. 10.8 Insulation test between conductors

and can be judged with this test. Figure 10.9 shows the essential connection.

In this test the main switch is opened and one end of the meggar is joined to one end of the conduit or lead sheathing of the wiring installation and the other end to the earth (i.e. water mains) and then the resistance is measured. If the meggar shows zero reading, it means that the conduit is properly earthed. If the reading is high, it shows that the conduit has not been properly earthed.

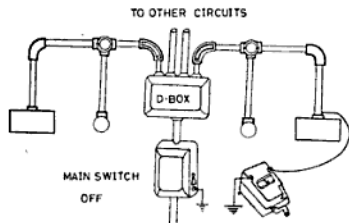

Fig. 10.9 Earth continuity test of conduit wiring

**Polarity Test of Switches** The test is applied to know, whether the switches are correctly installed on live terminals of the supply to

make the lamp holders quite dead when the switch is in the OFF position. If the holder is wrongly connected in the live wire directly, the operator may get a severe shock in case of its repair.

This test is only performed if the wiring is found satisfactory in the above three tests. In this test, the main switch should be put ON only when all the fuses should be intact, all the switches are ON and the lamps are OFF. The test is made with a testing lamp. One end of the testing lamp is earthed and the other end of the lamp is connected to the switch as shown in Fig. 10.10. If the lamp lights, the switch is correctly installed on the live wire. If it does not light, it means that the switch has not been correctly installed.

The range and testing voltage of the meggar is given in Table 10.5.

TABLE 10.5 RANGE AND TESTING VOLTAGE OF MEGGAR

S. No.	Working voltage of line, V	Testing voltage of Meggar, V	Range, M $\Omega$
1	250	500	0-20
2	500	1000	0-2000
3	11000	254000	10 000

## 10.8 NECESSITY OF EARTHING

By earthing we mean a metallic connection of the body to the general mass of the earth

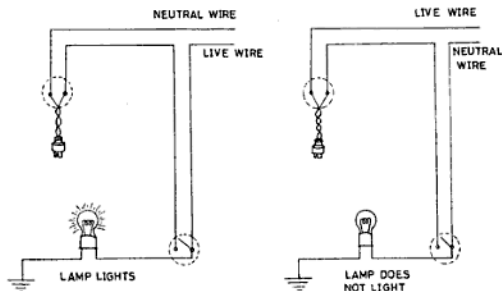

Fig. 10.10 Polarity test of switches

(considered to be at zero potential) for the safety of the human body from shocks.

All metallic covers of machines, starter or sheathing of wiring, etc. are generally dead but can become alive due to failure of insulation or bad workmanship. When a person touches such parts of machine or installation, gets a serious shock. To avoid from such severe shocks, all the metallic covers and frames of machines are earthed. A good earthing should have very low resistance and easily allow the leakage current through it.

#### 10.9 FACTORS GOVERNING RESISTANCE OF EARTH ELECTRODE

The resistance of an earth electrode depends upon the depth of the electrode, nature of soil and area of the earth plate.

#### 10.10 SYSTEMS OF EARTHING

There are two systems of earthing as :

- (i) pipe earthing, and
- (ii) plate earthing.

**Pipe Earthing** In this method a galvanised iron (G.I.) pipe of 38 mm ( $1\frac{1}{2}$ " diameter, 2 m ( $6\frac{1}{2}$ ' length (for ordinary earthing) having 12 mm ( $\frac{1}{2}$ " diameter holes on its surface is buried vertically in the wet earth to work as an earth electrode. If the soil is dry, then the length of the pipe varies to 2.75 m (9'). The lower end of the pipe is made tapered (Fig. 10.11) to make driving easy.

The depth to which the G.I. pipe should be embedded depends upon the moisture in the

soil. It should normally be 4.75 m (15'), but this is not a hard and fast rule. Another pipe of 19 mm ( $\frac{3}{4}$ " diameter and of sufficient length (depending upon the moisture in the soil) is connected to the earth electrode of 38 mm diameter pipe through a reducing socket (38 mm  $\times$  19 mm size). A funnel having a wire mesh is provided at the top of 19 mm diameter pipe. During the summer season water is poured in the funnel for maintaining the earth connection in good condition. The funnel is enclosed in a concrete box with a cover fitted with a hinge.

The earth electrode pipe is surrounded by 15 cm (6") thick alternate layers of salt and charcoal powder. The reason for adding the salt is that it attracts moisture from the soil. Charcoal retains the moisture near the earth electrode which decreases the earth resistance.

The G.I. earth wire (i.e. earth continuity conductor) of suitable size to carry the fault current safely is connected to a 19 mm diameter pipe below the funnel and is carried through a 12 mm dia G.I. pipe at a depth of 60 cm (2') below the ground level. Further, the earth continuity conductor is brought to the main switch, distribution box and individual machine for earthing.

**Plate Earthing** In this system of earthing a pit is dug in the ground until sufficient moisture is available in the soil (3 m approximately). Then a G.I. or copper plate is connected to the earth continuity conductor with nuts and bolts as shown in Fig. 10.12.

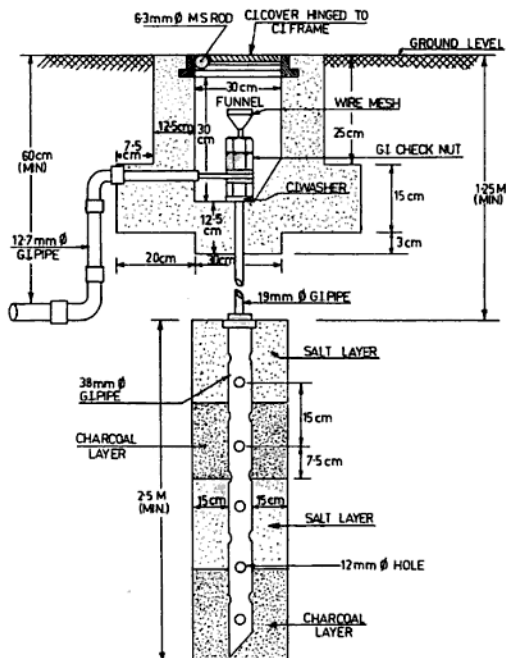

Fig. 10.11 Pipe earthing (as per IS: 3043-1966)

When a G.I. plate is used, it should be of size  $60\text{ cm} \times 60\text{ cm} \times 6.35\text{ mm}$  ( $2' \times 2' \times \frac{1}{4}''$ ) and for copper plate the dimension may be  $50\text{ cm} \times 60\text{ cm} \times 3.18\text{ mm}$  ( $2' \times 2' \times \frac{1}{8}''$ ). It should also be noted that nut and bolts must be of G.I. for the G.I. plate and should be of copper for the copper plate.

After this the plate is placed at the bottom of the pit and is covered with 15 cm (6") thick alternate layers of salt and powdered charcoal. Then the bolted earth wire is drawn through the G.I. pipe of diameter 12.7 mm to some convenient point of the commencement of supply. Another G.I. pipe of 19

mm dia. with a funnel and wire mesh at the top is provided to pour water in the pit of the earth electrode. The funnel is enclosed in a concrete box having an iron cover and hinge to protect it from dust as in the case of pipe earthing.

#### 10.11 RULES FOR EARTHING

The following are the general rules for earthing :

- (i) In the case of the lead and conduit house wiring, the earthing must be continuous by a single solid conductor of 14 S.W.G.

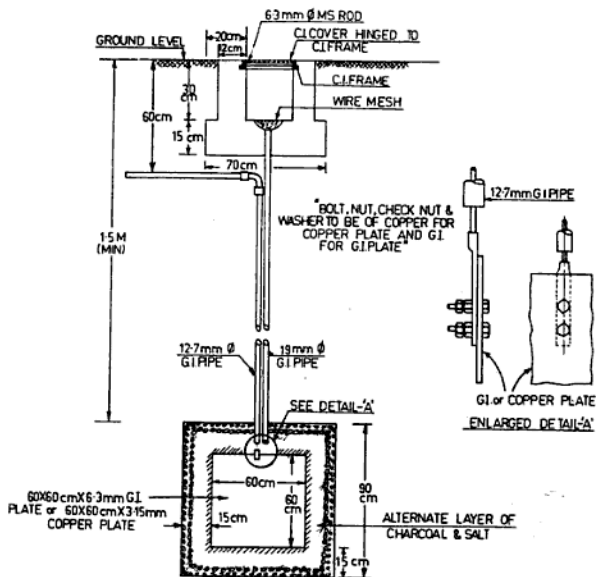

Fig. 10.12 Plate earthing

- (ii) All the metallic covering of the main switch, distribution box, ceiling fans, brackets, etc. along with the earth point of the wall socket should be earthed.
- (iii) The metallic cover of all medium-voltage machines should be earthed by two separate earth connections. This means that double earthing is done in the case of medium-voltage machines.
- (iv) In any case the resistance of the earth continuity conductor should not be greater than  $1 \Omega$  throughout the system.
- (v) In the case of ordinary soil the earth resistance of the electrode should not be more than  $3 \Omega$  and  $8 \Omega$  in rocky soil.

do the purpose. This means that the double earthing provides extra safety.

The second reason is that it offers minimum resistance (as in parallel) to the flow of leakage current.

The distance between the two earth electrodes should be 5 m (15') approximately. If these electrode are buried near the wall of the building, then the minimum distance from the wall should be 1.5 m.

#### 10.13 METHODS OF IMPROVING THE EARTH RESISTANCE

The following are the methods of improving the earth resistance of an electrode :

- (i) **Soldering Nuts and Bolts** The earth resistance can be increased by soldering the nuts and bolts of the earth electrode instead of simply tightening.

#### 10.12 DOUBLE EARTHING

The reason for using double earthing is that if one earth fails, then the second earth will

(ii) **Increase in Plate Area** By increasing the area of the plate, the resistance will decrease but the decrease in resistance is extremely small. Therefore this method is not practicable.

(iii) **By Powder Charcoal and Salt** Salt and charcoal is mixed in the ratio of 1:5 respectively and added around the earth electrode. This reduces the contact area of the plate as well as provides moisture around the electrode, thereby reducing the earth resistance.

(iv) **Depth of Plate** If the same plate is buried deep in the earth, it reduces the resistance of the earthing system up to a certain limit. No doubt this value is also very small but it helps to a great extent.

(v) **Installation of Parallel Electrode** The installation of a number of earth electrodes in parallel for the same depth decrease the earth resistance to a great extent. This system requires greater area of soil and therefore it is suitable where sufficient open soil is available for earthing. In this system all the earth plates are connected in parallel for reducing the overall earth resistance. This method is adopted for all big power houses and sub-stations where the earth resistance has to be reduced to a great extent.

(vi) **By Pouring Water** In the summer season the dampness around the earth electrode considerably decreases which increases the resistance of the earth electrode. For increasing the moisture three to four buckets of water mixed with salt are poured down in the funnel every few days to keep the soil moist around the electrode.

#### 10.14 RESISTANCE OF EARTH ELECTRODE

The main purpose of keeping the earth resistance to a very low value is to give easy path to the flow of leakage or fault current as soon as it occurs. The resistance of the earth electrode is kept according to load and inversely proportional to it. Table 10.6 gives the value of resistance of the earth system.

TABLE 10.6

S. No.	Types of installation	Resistance of earth electrode in ohms
1.	Big power station	0.5
2.	Main sub-station	1.0
3.	Small sub-station	2.0
4.	Others	8.00

**NOTE:** The resistance of the earth continuity conductor from the earth electrode to any other point in the installation should not be more than  $1 \Omega$  in any case.

#### 10.15 SIZE OF EARTH CONTINUITY CONDUCTOR

According to the recommendation of I.S.I. the size of the earth continuity conductor (not contained in the cables) should be correlated with the size of the current carrying conductor. It should not be less than half the largest current carrying conductor in the system, provided that the minimum size is not less than  $1.5 \text{ mm}^2$  for copper and  $2.5 \text{ mm}^2$  for aluminium and not greater than  $70 \text{ mm}^2$  for copper and  $120 \text{ mm}^2$  for aluminium. In the case when all galvanised iron (G.I.) wire is used as the earth continuity conductor, its size may be equal to the size of the current carrying conductors with which they are employed.

TABLE 10.7 RESISTANCE TO EARTH AND SIZE OF EARTH CONTINUITY CONDUCTOR FOR ELECTRICAL APPARATUS

S. No.	Sizes bhp or kVA	Max. resistance of earth in ohms	Size of earth continuity conductor in S.W.G.	
			Copper wire	G.I. wire
1	2	3	4	5
1	10	6.0	8	8
2	12	5.0	8	8
3	15	4.0	8	8 (contd.)

1	2	3	4	5
4	20	3.0	8	5
5	25	2.5	8	4
6	30	2.0	8	3
7	40	1.6	8	3
8	60	1.4	8	1
9	75	1.1	6	For apparatus of
10	100	0.8	5	higher size, copper
11	125	0.6	3	conductor should
12	150	0.5	1	be used
13	175	0.45	0	
14	200	0.4	3/0	
15	250	0.3	5/0	

### REVIEW QUESTIONS

- 10.1 (a) Describe the various tests necessary before a new domestic installation can be connected to the supply.  
 (b) What do you understand by earthing an electrical installation? Explain briefly a method for providing a good 'earth'.  
*(NCVT 1980 Elect.)*
- 10.2 What are the different systems of wiring used for domestic installations? What are the tests to be performed under the Indian electricity rules before energising a domestic installation?  
*(NCVT 1964, 66, 68, 70)*
- 10.3 Describe with a neat sketch how a domestic installation is connected with the service line of the supplier. Show clearly the position of the meter board and other apparatus and fixtures. Mention the provision of sealing of cut-outs in the I.E. Rules.  
*(NCVT 1970 W/man.)*
- 10.4 Describe the procedure for laying concealed conduit wiring in a building. Describe the method(s) of draining cables through a conduit. Explain why a conduit is earthed.  
*(NCVT 1970 W/man.)*
- 10.5 Describe and compare the different systems of wiring used for domestic installations.
- 10.6 (a) What is the necessity of earthing?  
 (b) What is the size and material of the earth wire usually used for domestic wiring?  
 (c) Sketch a simple earth-pit complete as per I.E. Rules.  
*(NCVT 1976 Elect.)*
- 10.7 Describe with a sketch, a method of providing a good earth for an electric sub-station. What method would you adopt to improve the value of the earth, if it is not found satisfactory.  
*(NCVT 1974 Elect.)*
- 10.8 Why should electric equipment be earthed? What is the minimum size of the earth wire recommended for a 10 hp motor? Give a complete list of materials required for earthing the above motor assuming a distance of 10 m between the motor and earth electrode. Explain the procedure to be followed.  
*(Inter ITI U.T. 1969)*

# 11 Single-Phase AC Circuits

## 11.1 ALTERNATING CURRENT

An *alternating current* is that current whose magnitude and direction change periodically. It is denoted by 'ac'.

## 11.2 MAGNITUDE OF ALTERNATING EMF OR CURRENT

For understanding the production of ac and determining the magnitude of alternating quantities (i.e. emf or current), let us consider a coil side  $OA$  of coil  $AOB$  revolving in bipolar machine [Fig. 11.1 (a)] with a uniform angular speed of  $\omega$ . In  $OA$  side of the coil, an alternating emf will be induced which will be minimum when the coil is midway between the poles and the emf is maximum when  $OA$  is directly under the poles. Such a quantity can be represented by a line equal to its maximum value, rotating with a uniform angular velocity about a fixed point. The value of the induced emf at any instant is given by its projection on the vertical line through the point about it is revolving.

In Fig. 11.1 (b)  $oa$  is the original position of the  $OA$  side and the length of  $oa$  represents the maximum value of the induced emf. If  $OA$  is rotated anticlockwise with a uniform angular velocity  $\omega$ , then after a time interval  $t$ ,  $OA$  will have moved through an angle  $\omega t$  or  $\theta^\circ$ , say to the position shown by  $Ob$ . The instantaneous value of  $Ob$  is its projection on the vertical line, shown by  $OP$ .

By trigonometry  $\frac{OP}{Ob} = \sin \theta$

or  $OP = Ob \sin \theta$

But  $Ob$  is the maximum value ( $E_{\max}$ ) of the induced emf and  $OP$  is the instantaneous value  $e$  of the emf.

$\therefore$  Instantaneous emf,

$$e = E_{\max} \times \sin \theta \quad (11.1)$$

Similarly, the instantaneous value of the induced current is given by:

Instantaneous current,

$$i = I_{\max} \times \sin \theta \quad (11.2)$$

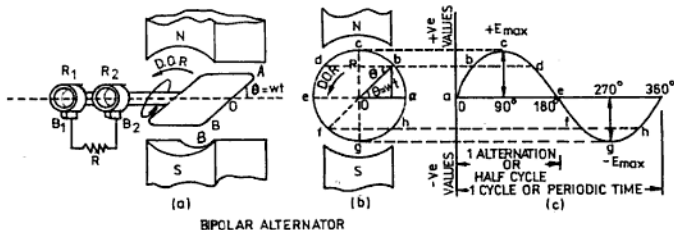

Fig. 11.1: Development of alternating current sine wave

It is also clear from Fig. 11.1 that the induced emf varies as the sine function of angle  $\omega t$ . When the induced emf is plotted against time, a curve as shown in the Fig 11.1 (c) is obtained. Such a curve is known as a *sine curve* and the emf as a *sinusoidal emf*.

**EXAMPLE 11.1** The maximum value of an alternating induced emf is 500 V. Find its instantaneous value at  $30^\circ$ .

**Solution:** We know that the instantaneous emf,

$$\begin{aligned} e &= E_{\max} \times \sin \theta \\ &= 500 \times \sin 30^\circ \\ &= 500 \times 0.5 = 250 \text{ V Ans.} \end{aligned}$$

### 11.3 POPULARITY OF AC

The generation of ac is preferred over dc because of the reasons given in Table 11.1.

### 11.4 DEFINITION

**Alternating Current (AC)** It is the current in which the magnitude and direction vary periodically. The characteristic of ac is that the current first rises from its minimum to a maximum value and then falls back to the minimum only to repeat the process in the opposite direction.

**Cycle** One complete set of change in value and direction of alternating quantities emf or current is called a *cycle*.

**Periodic Time** *Periodic time* is the time taken to complete one cycle. For example, a 50 Hz alternating current has a periodic time of  $1/50$  s. Its symbol is  $T$ .

**Frequency** The number of cycles completed per second (hertz or Hz) is known as the *frequency* of the alternating current. It is represented by letter  $f$ .

The standard frequency in most countries, including India, is 50 Hz. Below this frequency incandescent lamps flicker noticeably. According to the I.E. Rules, the frequency of an ac supply can vary only by  $\pm 3\%$  of the declared frequency.

**Instantaneous Value** The value of an alternating quantity (current or emf) at a particular instant in a cycle is called its *instantaneous value*.

**Peak Value or Amplitude** The maximum value of an alternating current or voltage during a cycle is known as its amplitude (Fig. 11.2).

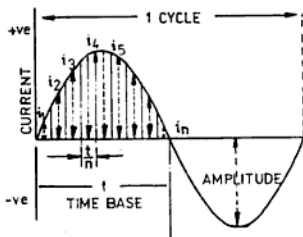

Fig. 11.2: Average value over half cycle

**Average Value** The average value of ac is given by that direct current (dc) which transfers across any circuit in a given time the same charge as transferred by the ac in the same circuit.

In the case of ac, there are two half-cycles which are exactly opposite to each other. Therefore, the average value over a complete cycle is zero. The average value over a half-cycle is obtained as in Fig. 11.2.

$$I_{av} = \frac{i_1 + i_2 + i_3 + \dots + i_n}{n}$$

$$I_{av} = I_{\max} \times 0.637 \quad (11.3)$$

Similarly,  $E_{av} = E_{\max} \times 0.637 \quad (11.4)$

**Root Mean Square (rms) Value** The rms value of an alternating current (or emf) is expressed by that direct current which when applied to a circuit for a given time, produces the same amount of heat energy as when the alternating current (or emf) is applied to the same circuit for the same time. It is also known as the *effective* or *virtual value*.

For determining the rms value of an alternating current (or emf), its instantaneous values are taken at several points of time during a cycle. These values are then squared, added, and then averaged. The square root of this average value gives the rms value of the alternating current (or emf).

In short; rms value,

$$I_{rms} = \sqrt{\frac{i_1^2 + i_2^2 + i_3^2 + \dots + i_n^2}{n}}$$

or rms value,

$$I_{rms} = I_{max} \times 0.707 \quad (15.5)$$

Similarly, rms value,

$$E_{rms} = E_{max} \times 0.707 \quad (11.6)$$

It should be remembered that the scales of deflecting instruments do not indicate the maximum value of an alternating current (or emf) but measure the rms values.

**EXAMPLE 11.2** Find the rms value of an alternating current which has a maximum value of 1.414 A.

**Solution:** We know that

$$\begin{aligned} I_{rms} &= I_{max} \times 0.707 \\ &= 1.414 \times 0.707 \\ &= 0.999698 \approx 1 \text{ A} \quad \text{Ans.} \end{aligned}$$

**Form Factor** The ratio of the rms value to the average value is called the *form factor*.

For a sinusoidal alternating current,

Form factor

$$\begin{aligned} \frac{I_{rms} \text{ value}}{\text{Average value}} &= \frac{I_{max} \times 0.707}{I_{max} \times 0.637} \\ &= 1.11 \quad (11.7 \text{ a}) \end{aligned}$$

For a sinusoidal alternating voltage,

Form factor

$$\begin{aligned} \frac{I_{rms} \text{ value}}{\text{Average value}} &= \frac{E_{max} \times 0.707}{E_{max} \times 0.637} \\ &= 1.11 \quad (11.7 \text{ b}) \end{aligned}$$

A knowledge of the form factor helps one to calculate the rms value from the average value and vice-versa.

**Crest Factor** The ratio of the maximum value to the rms value is known as the *crest factor* or the *amplitude factor*.

For a sinusoidal current,

Crest factor

$$\begin{aligned} \frac{I_{\text{maximum value}}}{E_{rms} \text{ value}} &= \frac{I_{max}}{I_{max} \times 0.707} \\ &= 1.414 \quad (11.8 \text{ a}) \end{aligned}$$

For a sinusoidal voltage,

Crest factor

$$\begin{aligned} \frac{E_{\text{maximum value}}}{E_{rms} \text{ value}} &= \frac{E_{max}}{E_{max} \times 0.707} \\ &= 1.414 \quad (11.8 \text{ b}) \end{aligned}$$

**Scalar Quantity** A *scalar quantity* is that which has only magnitude but no direction.

**Vector Quantity** A *vector quantity* has both direction as well as magnitude. An example of a vector is force. When the effect of a force is under consideration, its magnitude as well as direction must be considered. When it is required to add two forces, they should not be added algebraically but must be combined in a way so to take into consideration their magnitudes as well as directions.

**Phase** During a complete cycle, an alternating current goes through various stages or phases of development at a given instant. Starting from zero, it reaches its maximum value (positive half) and then fall down to zero. It then again rises in the reverse direction (negative half) and finally falls down zero thus completing a cycle. The development of an ac quantity through different stages is known as *phase*.

**In-phases** When two alternating quantities (current and voltage) attain their maximum and minimum value simultaneously, then these quantities are said to be in-phase as shown in Fig. 11.3.

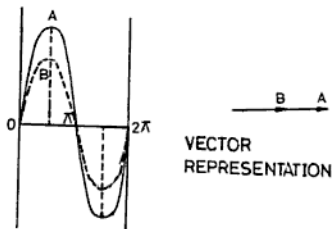

Fig. 11.3: Quantities in-phase

**Out of Phase (or Phase Difference)** When two alternating quantities do not reach their maximum and minimum values simultaneously, then they are *out of phase* (Fig. 11.4). Phase difference is measured in electrical degrees or radians.

**Phase Angle** It is an angular displacement between two alternating quantities as shown in Fig. 11.4. Phase angle is measured in electrical degrees or radians.

**Quadrature Quantities** When the phase difference between two alternating quantities is  $90^\circ$  electrical they are said to be *quadrature quantities* as shown in Fig. 11.5.

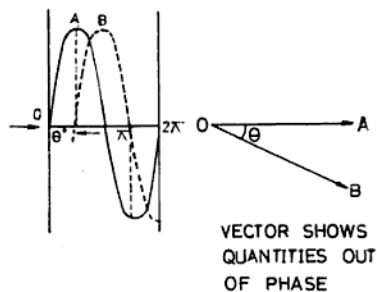

Fig. 11.4: Quantities out of phase

**Anti-Phase Quantities** When two quantities are out of phase by  $180^\circ$  electrical, they are said to be *anti-phase quantities* as shown in Fig. 11.6.

**Leading Quantity** The alternating quantity that reaches its maximum value earlier than the other quantity is known as the *leading quantity*. For example in Fig. 11.4 quantity *A* leads *B* by an angle  $\theta$ .

**Lagging Quantity** The alternating quantity that attains its maximum value later than the other quantity is called the *lagging quantity*. For example in Fig. 11.4 quantity *B* lags behind *A* by an angle  $\theta$ .

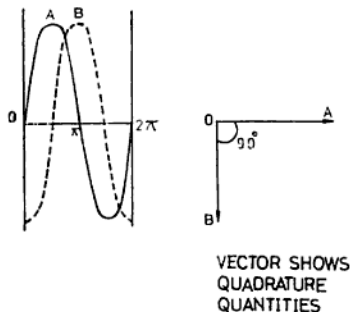

Fig. 11.5: Quadrature quantities

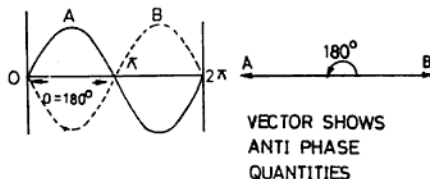

Fig. 11.6: Antiphase quantities

TABLE 11.1 COMPARISON OF AC TO DC GENERATION

S. No.	Alternating Current (ac)	Direct Current (dc)
	2	3
1.	Alternators (ac generators) do not have any commutators and this enables the generating unit to be operated at high speeds.	Due to commutation, dc generators cannot run at high speeds.
2.	It is easy to insulate the slip rings for high voltage and hence the generation of high voltage is possible. In India, the maximum induced voltage that can be obtained directly from an alternator is 11,000 V while in the U.S.A. it is 13,800 V.	In dc machines, it is very difficult to give extra ordinary insulation to the commutator. Therefore, the generation of high dc voltage is not possible.
3.	ac voltage can be stepped up for the transmission of power and stepped down for the distribution of power by transformers.	dc voltages cannot be stepped up or down.
4.	The transmission of power at high ac voltages is economical. For this reason ac is preferred to dc.	As the dc voltage cannot be stepped up or down, the question of transmission of power at high voltages does not arise.
5.	Alternators can produce high voltage at high current ratings. In India, the maximum output of an alternator is 220 M W.	Owing to commutation difficulties, dc generators cannot be designed for large outputs. The maximum induced voltage and current ratings of a Jc generator is 1500 V and 8000 A respectively.
6.	For the same speed ac motors are cheaper, require less maintenance and, hence, are more efficient than dc motors.	dc motors are expensive and require more maintenance.

### 11.5 AC AS COMPARED TO DC OF SAME VOLTAGE

The reason the human body receives a more severe shock by ac than dc of the same voltage is as follows: We know the rms value of an ac voltage is equal to the value of dc voltage. However, ac attains its maximum value twice in a cycle (i.e. 100 times in a second), which causes a severe shock to the human body as it is much higher in magnitude as compared to the rms value of the ac voltage (or dc voltage). For example an ac supply of 230 V (rms) has its maximum value:

$$E_{rms} = E_{max} \times 0.707$$

$$\text{or } 230 = E_{max} \times 0.707$$

$$\therefore E_{max} = 230/0.707 = 325.3 \text{ V}$$

From the above it is clear that the maximum value of ac voltage is 95.3 V (41.4%) higher than the dc equivalent. Hence the man does not get a shock of 230 V ac but actually gets a shock of 325.3 V which is much higher than dc voltage of 230 V.

### 11.6 SELF INDUCTION AND MUTUAL INDUCTION

It was seen in Chap. 7 that the emf induced in a conductor may be (i) a dynamically induced emf or (ii) a statically induced emf. In a dynamically induced emf, the variation of flux is produced (i) either by the motion of the conductor or (ii) by the motion of the magnetic field.

In a statically induced emf, the change of flux due to which emf is induced in the coil is brought about by a change in current, either in the neighbouring coil or in the coil itself. In the former case, the emf is known as mutually induced emf and in the latter case it is called self induced emf.

**Mutual Induction** Consider two coils *A* and *B*, placed side by side. A galvanometer is connected in the circuit of coil *B* and a battery, along with a switch is connected in the circuit of coil *A* as shown in Fig. 11.7.

When the switch is closed, a sudden deflection is noticed in the needle of the galvanometer, which comes back to the zero position of the scale of the galvanometer soon after.

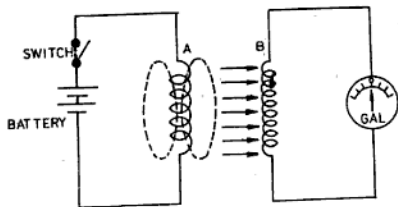

Fig. 11.7: Self and mutual induction

The deflection in the needle of galvanometer indicates that an emf is induced in coil *B*. When the switch is turned off, again a deflection in the galvanometer's needle is seen which is now in the opposite direction. It shows that again there is an emf induced but in the opposite direction. In short, when two coils are placed near each other and a varying current is passed through one coil, it causes a variation of flux which links with the other coil and induces emf in it, which is called mutually induced emf and the process is known as *mutual induction*.

**Self-induction** When a varying current is passed through a coil, a variation of flux is developed in it which links the coil itself and induces emf in it which is called *self-induced*

*emf* and the process is known as *self-induction*. Now consider coil *A* (Fig. 11.7) which is connected to the battery through a switch and assume that coil *B* is not placed near it. The moment the switch is closed, a changing current will start flowing in the coil, which produces a changing flux linked with the coil itself and thereby inducing an emf in it. This induced emf is the self-induced emf or reactance emf (opposes the main supply voltage) and the whole phenomena is *self-induction*. The reactance emf is represented by  $L$  and is known as *self-inductance* of the coil. Its unit of measurement is henry (H).

### 11.7 INDUCTANCE

It is that property of a coil due to which a varying current passing through it produces a variation in the flux linked with it and thereby inducing an emf in the coil. This induced emf opposes any change of current through the coil. Such a coil is called an *inductance* having unit henry (H) denoted by ' $L$ '.

**Note:** The inductance of a circuit depends upon the shape and path of the circuit. For example, a bent wire is a non-inductive circuit (Fig. 11.8 (a)). The magnetic field produced by the current flowing in one direction is opposed by the current flowing in the opposite direction. A straight wire is an example of a slightly inductive circuit, while an air-core coil is an inductive circuit. Similarly a coil wound on a magnetic core is an example of a highly inductive circuit.

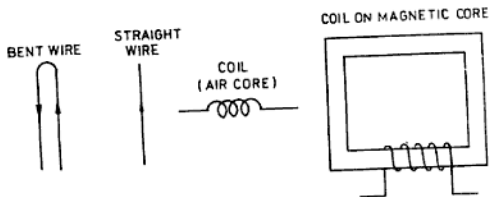

Fig. 11.8: Inductive and non-inductive circuits

**Henry** A coil is said to have an inductance of one henry if an emf of one volt is induced in the coil when current changes at the rate of one ampere per second (i.e. one coulomb).

$$\therefore 1 \text{ henry (L)} = \frac{1 \text{ volt}}{1 \text{ ampere/second (1 coulomb)}}$$

**Inductive Reactance** The opposition due to inductance of the coil in ohms is called the *inductive reactance*, represented by  $X_L$ .

If  $L$  is the inductance of a coil, then its inductive reactance will be:

$$X_L = 2\pi fL \quad (11.9)$$

where  $f$  = the frequency of the supply in cycles per second (Hz)

$L$  = inductance of the coil in henries

$X_L$  = inductive reactance in ohms

From the above formula,

$$L \text{ (inductance)} = \frac{X_L}{2\pi f} \quad (11.10)$$

### 11.8 CAPACITOR

A device capable of storing electric charge in it, when it is connected across the supply, is known as a *condenser* or *capacitor*.

A system consisting of two metal plates (i.e. aluminium, brass or tin, etc.) which may or may not be separated by an insulator (known as *dielectric*) forms a condenser.

### 11.9 CAPACITANCE

The property of a condenser to store electric charge in it when connected across a supply is called *capacitance*. Its unit is farad (F) and is denoted by the letter  $C$ .

Farad is too big a unit for practical purposes. So its smaller and practicable unit microfarad, written as  $\mu\text{F}$ , is used.

$$1 \text{ F} = 10^6 \mu\text{F}$$

$$1 \mu\text{F} = 1/10^6 \text{ F or } 10^{-6} \text{ F}$$

**Farad** A capacitor has a capacitance of one farad when a charge of one coulomb (one ampere  $\times$  one second) produces a potential difference of one volt between the plates.

$$1 \text{ F} = \frac{1 \text{ coulomb}}{1 \text{ V}}$$

$$C = \frac{Q}{V} \quad (11.11)$$

**Capacitive Reactance** The opposition due to the capacitance of a condenser is called *capacitive reactance* and is denoted by  $X_C$ .

If  $C$  is the capacitance of a condenser, then its capacitive reactance will be

$$X_C = \frac{1}{2\pi fc}$$

where  $f$  = frequency of the supply

$C$  = capacity of the condenser in farads

$X_C$  = capacitive reactance in ohms

From the above formula,

$$C = \frac{1}{2\pi fX_C} \quad (11.12)$$

### 11.10 IMPEDANCE

The vector sum of resistances and reactances (i.e. the total opposition) connected in an ac circuit is called *impedance*. Its unit is ohm and is indicated by the letter  $Z$ .

$$\therefore Z = \sqrt{R^2 + X^2} \quad (11.13)$$

$$= \sqrt{R^2 + (X_L - X_C)^2}$$

$$= \sqrt{R^2 + \left(2\pi fL - \frac{1}{2\pi fc}\right)^2}$$

**Impedance Triangle** The impedance, resistance and reactance can also be denoted by the sides of a right angled triangle, whose two sides enclose an angle  $\theta^\circ$ . With  $Z$  as the hypotenuse  $R$  by the adjacent side and the reactance  $X$  by the side opposite to the angle  $\theta$ , as shown in Fig. 11.9.

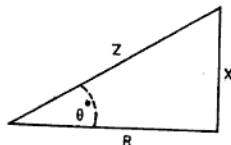

Fig. 11.9: Impedance triangle

$$Z = \sqrt{R^2 + X^2} \quad (11.14)$$

$$X = \sqrt{Z^2 - R^2} \quad (11.15)$$

$$R = \sqrt{Z^2 - X^2} \quad (11.16)$$

But

$$\cos \theta = \frac{R}{Z} \quad (11.17)$$

$$\sin \theta = \frac{X}{Z} \quad (11.18)$$

$$X = ZX \sin \theta \quad (11.19)$$

$$R = ZX \cos \theta \quad (11.20)$$

$$Z = R/\cos \theta \quad (11.21)$$

$$\text{and } Z = X/\sin \theta \quad (11.22)$$

But  $\cos \theta$  is known as the power factor.

### 11.11 POWER FACTOR

The power factor may be defined in any of the following ways:

1. It is the cosine of the angle between voltage and current in a circuit.
2. From the impedance triangle,  $\cos \theta = R/Z$ . Therefore, power factor is the ratio of the resistance and impedance of the circuit.
3. It is the ratio between the real and apparent power. It is denoted by ' $\cos \theta$ '.

$\therefore$  Power factor,

$$\cos \theta = \frac{\text{Real power}}{\text{Apparent power}} \quad (11.23)$$

$$\text{or } \cos \theta = \frac{V \times I \times \cos \theta}{V \times I}$$

The product  $VI \cos \theta$  is the real power (or true power) and is measured in watts or some times in kilowatts (kW). Similarly the product  $VI$  is known as the apparent power measured in volt-amperes or sometimes in kilo-volt-ampere written as kVA.

The following are the different conditions of the power factor in different circuits.

**Unity Power Factor** A circuit with a *unit power factor* will have equal real and apparent power, so that the current remains in phase with the voltage and hence some useful work can be done.

**Leading Power Factor** A circuit will have a leading power factor if the current leads

voltage by an angle of  $\theta$  electrical and the true power will be less than the apparent power.

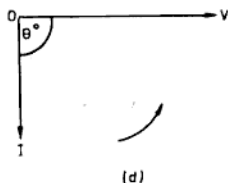
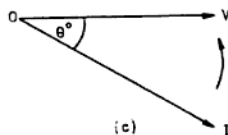
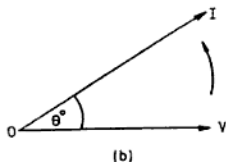
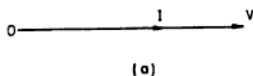

Fig. 11.10: Different conditions of power factor  
 (a) Vector diagram of unity power factor  
 (b) Vector diagram of leading power factor  
 (c) Vector diagram of lagging power factor  
 (d) Vector diagram of zero power factor lagging

**Lagging Power Factor** In such a circuit the true power is also less than the apparent power and current lags behind the voltage by an angle, say  $\theta^\circ$  electrical.

**Zero Power Factor** When there is a phase difference of  $90^\circ$  between the current and voltage, the circuit will have zero power factor and no useful work can be done.

**NOTE:** The power factor can be one or less than one but can never be greater than one.

### 11.12 AC CIRCUIT CONTAINING PURE RESISTANCE ONLY

A pure resistive circuit is that which has no inductance and capacitance but only resistance as shown in Fig. 11.11. When an ac voltage  $V$  is applied across such a circuit, a current will flow through it. The value of the current is given by ohm's law, as applied in the case of a dc circuit.

$$I = \frac{V}{Z} \quad (11.24)$$

where  $Z$  is the total opposition of the circuit.

But  $Z = R$  (Since the circuit is purely resistive)

$$\therefore I = \frac{V}{R} \quad (11.25)$$

where  $R$  = the resistance of the circuit in ohms

$V$  = rms value of the electrical pressure in volts

$I$  = rms value of the current in amperes

In a pure resistive circuit, the current remains in phase with the voltage as shown graphically in Fig. 11.11 (b) and vectorially in Fig. 11.11 (c).

Power in such a circuit can be obtained as shown in Fig. 11.11(d).

When the current is rising in the positive half, power is given by

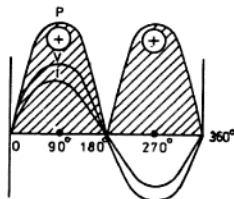
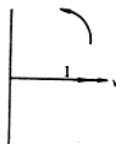
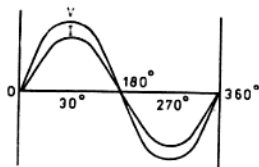
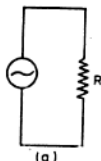

**Fig. 11.11:** Circuit containing resistance only  
 (a) Resistance connected across ac supply  
 (b) Graphs shows the voltage and current are in-phase  
 (c) Vector diagram shows the voltage and the current are in phase  
 (d) Power in a pure resistive circuit

$$W = I^2 R$$

$$= I \times I \times R = \frac{V}{Z} \times I \times R$$

$$\left( \because I = \frac{V}{Z} \right)$$

$$= V \times I \times \left( \frac{R}{Z} \right)$$

$$= V \times I \times \cos \theta$$

(By the impedance triangle,  $\cos \theta = \frac{R}{Z}$ )

$$\therefore W = VI \cos \theta \quad (11.26)$$

Power when the current is falling in the negative half,

$$W = (-I)^2 R = I^2 R$$

In this case also the power is positive, so it is shown in the upper half of the cycle. This is true only for resistive circuits.

$$\therefore W = I^2 R \quad (11.27)$$

$$\cos \theta = \frac{R}{Z}$$

But  $Z = R$

$$\therefore \cos \theta = \frac{R}{R} = 1$$

Now  $\cos \theta$  for the resistive circuit is one, and therefore its phase angle is zero.

Therefore, the power developed in such a circuit is the product of rms values of the voltage and current.

$$W = V \times I \quad (11.28)$$

The power developed is real and is dissipated in the form of heat.

**Combination of Resistances** In ac, the combination of resistances in series and parallel follows the same rule as in the case of dc circuits, i.e. the total resistance in series.

$$R = r_1 + r_2 + r_3 + \dots$$

The total resistance in parallel

$$\frac{1}{R} = \frac{1}{r_1} + \frac{1}{r_2} + \frac{1}{r_3} + \dots$$

### 11.13 AC CIRCUIT CONTAINING PURE INDUCTANCE

A pure inductive circuit is one which has no resistance and capacitance but only inductances as shown in Fig. 11.12.

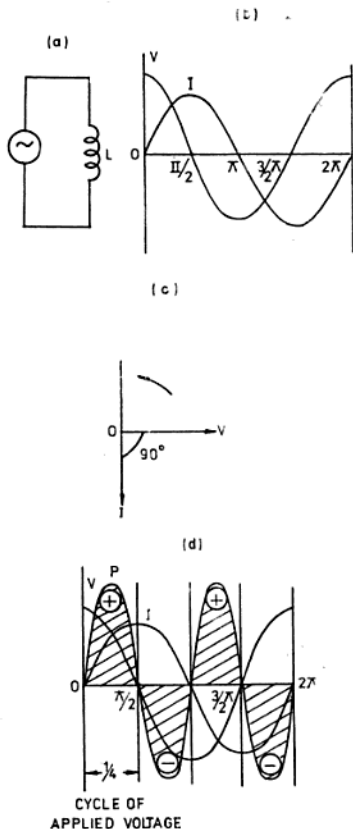

Fig. 11.12: Circuit containing pure inductance only  
 (a) Inductance connected across ac supply  
 (b) Graph shows the current lags behind the voltage by  $90^\circ$   
 (c) Vector diagram shows the current and voltage are in quadrature  
 (d) power in a pure inductive circuit

It is not possible to have a pure inductive circuit in practice because a coil always has a finite resistance. But an approximation to a pure inductance is a coil wound on a laminated iron core with a few turns of thick wire. If an ac voltage  $V$  is applied across such a circuit, a current will flow through it. The magnitude of the current is given by:

$$I = \frac{V}{Z}$$

But in this case  $Z = X_L$

$$\therefore I = \frac{V}{X_L} \quad (11.29)$$

But  $X_L = 2\pi fL$

where

$X_L$  = inductive reactance of the circuit in ohms

$V$  = rms value of the potential difference in volts

$I$  = rms value of the current in amperes.

It is seen that in a pure inductive circuit, the current is not in phase with the voltage but lags behind the voltage by  $90^\circ$  electrical. The current and voltage are shown graphically in Fig. 11.12 (b) and vectorially in Fig. 11.12 (c).

Again we see

$$W = V \times I \times \cos \theta$$

But  $\cos \theta = R/Z$

But  $R = 0$ ,

$$\therefore \cos \theta = \frac{0}{Z} = 0$$

$$\text{Hence } W = V \times I \times 0 \\ W = 0$$

In a pure inductive circuit, as the value of the resistance is zero, there is no resistive potential drop in the circuit and hence the power developed in it is zero.

In Fig. 11.12 (d), the power graph is shown which is a product of the instantaneous voltage and current. It should be noted that the power is positive when the current is increasing and negative when it is decreasing. During the first quarter cycle of the applied voltage the power is positive (because both value of  $V$  and  $I$  are positive) when the current and flux are increasing. During the next quarter of the cycle, the current is

decreasing to zero and the voltage has reversed, and the power dissipated is therefore zero. These two operations are repeated in the third and fourth quarter of the cycle. Hence the power over a complete cycle is zero.

**Combination of Inductances** When two or more inductive coils are connected in series, the total inductance will be equal to the sum of their individual inductances, i.e.

$$L = L_1 + L_2 + L_3 \dots \dots \quad (11.30)$$

If two or more inductances are joined in parallel, then the reciprocal of the total inductance is equal to the sum of the reciprocal of the individual inductances, i.e.

$$\frac{1}{L} = \frac{1}{L_1} + \frac{1}{L_2} + \frac{1}{L_3} + \dots \quad (11.31)$$

**NOTE:** The values calculated from Eqs. (11.30) and (11.31) are correct only if the coils are placed sufficiently apart from each other so that no coil is influenced by the field of any other coil.

**Application of Inductance** Inductive coils are used in all types of electrical machines, such as motors, generators, transformers, electromagnets, chokes, etc.

#### 11.14 CHOKE COIL

As discussed earlier, the inductance of a straight conductor is very small as compared to that of a coil having an air core. If in such a coil, an iron bar is introduced, its inductance will increase to a very high value. Such a coil, with a low resistance insulated wire wound over an iron core, is known as a choke coil.

The choke is generally used in ac circuits in order to limit the current. A part of the applied voltage drops across the choke due to the reactance emf (the back emf) but the power loss across it is apparent and zero.

**EXAMPLE 11.3** An inductance of  $0.2 \text{ H}$  is connected to a  $220 \text{ V } 50 \text{ Hz}$  supply. Find the current drawn.

**Solution:** We know that the inductive reactance,

$$X_L = 2\pi fL$$

$$\therefore X_L = 2 \times \frac{22}{7} \times 50 \times 0.2 \\ = \frac{20 \times 22}{7} \Omega$$

$$\therefore \cos \theta = \frac{0}{Z} = 0 \quad (\text{as } R=0)$$

$$\text{Hence } W = V \times I \times 0$$

$$\therefore W = 0$$

In this circuit, no current flows through the dielectric of the condenser, but it flows back and forth from plate to plate and the circuit appears to be closed. Hence the current is said to be flowing through the capacitive circuit. However this is not actually true. It only appears so. Hence the resistance offered by the pure capacitive circuit to the flow of current, though infinite, is taken to be zero if the resistance of the plates and connecting leads, etc. is neglected.

In Fig. 11.13 (d), the graph of power is shown. This is obtained by the product of instantaneous voltage and current. It is clear from the graph that during the first quarter, the power is positive when the voltage is increasing from zero to its maximum. The capacitor takes a charging current and thus the energy is stored in it. During the next quarter, when the voltage is decreasing from the maximum to zero, the power being negative, the capacitor discharges. This releases the stored energy to the supply. Therefore, during the complete cycle the total amount of energy received by the capacitor from the supply is zero.

**Combination of Capacitors** The resultant capacitance of capacitors connected in series is given by

$$\frac{1}{C} = \frac{1}{C_1} + \frac{1}{C_2} + \frac{1}{C_3} + \dots \quad (11.33)$$

When connected in parallel, the total capacitance

$$C = C_1 + C_2 + C_3 + \dots \quad (11.34)$$

**Application of Capacitors** Capacitors are used for improving the power factor of a circuit in substations, power stations and in large industries and for neutralizing the effect of inductances of motors, alternators, transformers, choke coils, etc. The condenser is also used for starting the single-phase motors, reducing sparking at movable contact points, etc.

**EXAMPLE 11.4** A pure capacitor of  $100 \mu\text{F}$  is connected across a  $210 \text{ V } 50 \text{ Hz}$  supply. Calculate the current flowing.

**Solution:** We know that the capacitive reactance,

$$X_C = \frac{1}{2\pi fC}$$

$$X_C = \frac{1}{2 \times \frac{22}{7} \times 50 \times \frac{100}{10^6}}$$

$$= \frac{1 \times 7 \times 10^4}{2 \times 22 \times 50 \times 100} = \frac{350}{11} \Omega$$

We know that current is given by

$$I = \frac{V}{Z}$$

But

$$Z = X_C$$

$\therefore$  Current

$$I = \frac{V}{X_C} = \frac{210}{350/11} = \frac{210 \times 11}{350}$$

$$= \frac{33}{5} = 6.6 \text{ A} \quad \text{Ans.}$$

**EXAMPLE 11.5** An electric pressure of  $220 \text{ V } 50 \text{ Hz}$  is applied to a coil of negligible resistance and  $0.4 \text{ H}$  inductance. Find the current flowing. Also find the current that will flow through the coil if frequency is (i) halved and (ii) doubled.

**Solution:** Inductive reactance at  $50 \text{ Hz}$ ,

$$X_L = 2\pi fL$$

$$= \frac{2 \times 22 \times 50 \times 0.4}{7}$$

$$= \frac{40 \times 22}{7} = 125.7 \Omega$$

$\therefore$  Current flowing,

$$I = \frac{V}{X_L}$$

$$= \frac{220}{40 \times 22 / 7} = \frac{220 \times 7}{40 \times 22}$$

$$= \frac{7}{4} = 1.75 \text{ A} \quad \text{Ans.}$$

When frequency is halved (i.e.  $25 \text{ Hz}$ ), inductive reactance,

$$X_L = 2\pi fL = \frac{2 \times 22 \times 25 \times 0.4}{7}$$

$$= \frac{20 \times 22}{7} = 62.85 \Omega$$

$\therefore$  Current flowing at  $25 \text{ Hz}$

$$I = \frac{V}{X_L}$$

$$= \frac{220}{20 \times 22 / 7} = \frac{220 \times 7}{20 \times 22}$$

$$= \frac{7}{2} = 3.5 \text{ A} \quad \text{Ans.}$$

When the frequency is doubled ( $100 \text{ Hz}$ ), Inductive reactance,

$$X_L = 2\pi fL$$

$$= \frac{2 \times 22 \times 100 \times 0.4}{7}$$

$$= \frac{80 \times 22}{7} = 251.4 \Omega$$

∴ Current flowing at 100 Hz,

$$I = \frac{V}{X_L}$$

$$= \frac{220}{\frac{80 \times 22}{7}} = \frac{220 \times 7}{80 \times 22}$$

$$= \frac{7}{8} = 0.875 \text{ A Ans.}$$

**EXAMPLE 11.6** Calculate the current taken by a capacitor of  $28 \mu\text{F}$  when connected to a  $250 \text{ V}$ ,  $50 \text{ Hz}$  supply. Also calculate the current that will flow through the capacitor if the frequency is (i) halved and (ii) doubled.

**Solution:** We know capacitive reactance,

$$X_c = \frac{1}{2\pi fC}$$

or 
$$X_c = \frac{1}{2 \times \frac{22}{7} \times 50 \times \frac{28}{100}}$$

$$= \frac{7 \times 10^4}{2 \times 22 \times 50 \times 28}$$

$$= \frac{10^4}{2 \times 4} = \frac{2500}{22} \Omega$$

∴ Current when frequency is  $50 \text{ Hz}$ ,

$$I = \frac{V}{X_c}$$

$$= \frac{250}{\frac{2500}{22}} = \frac{250 \times 22}{2500} = 2.2 \text{ A Ans.}$$

If frequency is halved (i.e.  $25 \text{ Hz}$ ),

Capacitive reactance,

$$X_c = \frac{1}{2\pi fC}$$

$$= \frac{1}{2 \times \frac{22}{7} \times 25 \times \frac{28}{100}}$$

$$= \frac{1 \times 7 \times 10^4}{2 \times 22 \times 25 \times 28}$$

$$= \frac{2500}{11} \Omega$$

∴ Current at  $25 \text{ Hz}$  frequency,

$$I = \frac{V}{X_c}$$

$$= \frac{250}{\frac{2500}{11}} = \frac{250 \times 11}{2500} = 1.1 \text{ A Ans.}$$

If frequency is doubled (i.e.  $100 \text{ Hz}$ ),

Capacitive reactance,

$$X_c = \frac{1}{2\pi fC}$$

$$= \frac{1}{2 \times \frac{22}{7} \times 100 \times \frac{28}{100}}$$

$$= \frac{1 \times 7 \times 10^4}{2 \times 22 \times 100 \times 28}$$

$$= \frac{625}{11} \Omega$$

∴ Current at  $100 \text{ Hz}$  frequency,

$$I = \frac{V}{X_c}$$

$$= \frac{250}{\frac{625}{11}} = \frac{250 \times 11}{625} = \frac{22}{5}$$

$$I = 4.4 \text{ A Ans.}$$

#### 11.16 EFFECT OF VARIATION OF FREQUENCY ON INDUCTIVE AND CAPACITIVE CIRCUITS

**Effect of variation frequency on Inductive circuit.** We have already discussed that the inductive reactance of a coil is equal to  $2\pi fL$ , i.e.

$$X_L = 2\pi fL$$

If the inductance ( $L$ ) of the circuit is kept constant, the inductive reactance is directly proportional to the frequency (i.e.  $X_L \propto f$ ) of the supply. It means if frequency of the supply is increased, it will increase the inductive reactance ( $X_L$ ) of the circuit thereby reducing the current taken by the circuit. On reducing the frequency, the inductive reactance is also reduced and in this case the total current in the circuit increases. In both the cases we have seen that it will affect the performance of the circuit.

**Effect of variation of frequency on a capacitive circuit.** Similarly in case of a capacitive circuit, the capacitive reactance is given by

$$X_c = 1/2\pi fC$$

It will be seen that if the capacitance is kept constant and the frequency increased, the capacitive reactance,  $X_c$ , of the circuit will be reduced since it is inversely proportional to the frequency. On reducing the frequency the capacitive reactance increases. It is clear from the above that if the frequency

increase the current drawn by the capacitor will increase and if the frequency is reduced, the condenser will draw less current from the same supply. Thus the working of the whole circuit will be affected. It is for this reason that the frequency of the supply is kept constant.

### 11.17 AC CIRCUIT CONTAINING RESISTANCE AND INDUCTANCE IN SERIES

So far we have studied the case of purely reactive circuits.

In Fig. 11.14 (a), a series circuit having resistance  $R$  and inductance  $L$  is shown connected across an ac supply of voltage  $V$  and frequency  $f$ . In a pure resistive circuit, the current remains in phase with the voltage and in a pure inductive circuit, the current lags behind the voltage by  $90^\circ$ .

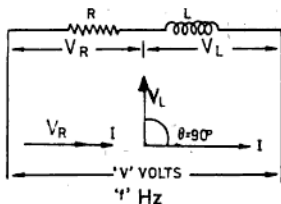

Fig. 11.14: R and L in series

In the vector diagram, Fig. 11.14 (b),

$V_R$  = voltage drop across resistance  
(i.e.  $IR$ )

$V_L$  = voltage drop across inductance  
(i.e.  $IX_L$ )

$V$  = applied voltage to the circuit  
(i.e.  $IZ$ ) and is the vector sum of  $V_R$  and  $V_L$

From the vector diagram in Fig. 11.14 (b), the applied voltage is

$$V^2 = V_R^2 + V_L^2$$

$$V = \sqrt{V_R^2 + V_L^2}$$

$$= \sqrt{(IR)^2 + (IX_L)^2}$$

$$\therefore V = I \sqrt{R^2 + X_L^2}$$

$$\text{or } \frac{V}{I} = \sqrt{R^2 + X_L^2}$$

$V/I$  is the total impedance of the circuit to the flow of current. It is the vector, sum of the resistance and reactance, and is denoted by  $Z$ .

$$\therefore Z = \sqrt{R^2 + X_L^2} \quad (11.35)$$

$$\text{But } X_L = 2\pi fL$$

The current taken by the circuit is given by

$$I = V/Z$$

Voltage drop across resistance  $R = IR$

Voltage drop across inductance  $L$  having reactance  $X_L = IX_L$

Similarly, voltage drop across impedance,  
 $Z = IZ$

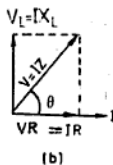

Power in such a circuit,

$$W = VI \cos \theta \quad (11.36)$$

where  $\cos \theta = R/Z$

**EXAMPLE 11.7** A coil having a resistance of  $40\Omega$  and an inductance of  $0.07\text{ H}$  is connected across a  $223\text{ V}$   $50\text{ Hz}$  supply. Calculate (i) inductive reactance, (ii) impedance, (iii) current and (iv) angle of phase difference.

**Solution:** Inductive reactance,

$$X_L = 2\pi fL = 2 \times \frac{22}{7} \times 50 \times 0.07$$

$$= 22\ \Omega \quad \text{Ans.}$$

Impedance  $Z = \sqrt{R^2 + X_L^2}$

$$= \sqrt{(40)^2 + (22)^2}$$

$$= \sqrt{1600 + 484}$$

$$= \sqrt{2084} = 45.65 \Omega \text{ Ans.}$$

∴ Current taken by the circuit,

$$I = \frac{V}{Z} = \frac{223}{45.65} = 4.8 \text{ A Ans.}$$

Power factor,  $\cos \theta = R/Z$

$$= \frac{40}{45.65} = 0.8762 \text{ lagging}$$

∴ Angle of phase difference,  
 $\theta = \cos^{-1} 0.8762 = 28^\circ 49' \text{ Ans.}$

### 11.18 AC CIRCUIT CONTAINING RESISTANCE AND CAPACITANCE IN SERIES

In Fig. 11.15 (a), a series circuit having resistance  $R$  and capacitance  $C$  is shown connected across an ac supply of voltage  $V$  and frequency  $f$ . In a pure resistive circuit, the current is in phase with the voltage, and in a purely capacitive circuit it leads the voltage by  $90^\circ$  electrical. The applied voltage  $V$  of the circuit is the vector sum of the voltage across the resistance ( $V_R$ ) and capacitance ( $V_C$ ).

From the vector diagram in Fig. 11.15 (b), the applied voltage is

$$V^2 = \sqrt{V_R^2 + V_C^2}$$

$$V = \sqrt{V_R^2 + V_C^2}$$

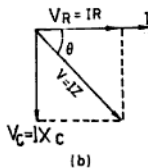
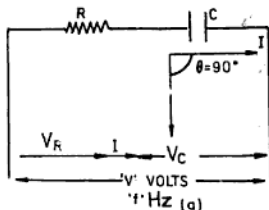

Fig. 11.15: R and C in series

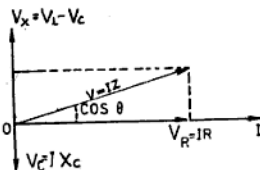
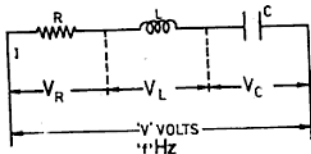

Fig. 11.16: Circuit containing R, L and C in series

$$V = \sqrt{(IR)^2 + (IX_C)^2}$$

$$V = I \sqrt{R^2 + X_C^2}$$

$$\text{or } V/I = \sqrt{R^2 + X_C^2}$$

$$\text{or } Z = \sqrt{R^2 + X_C^2} \quad (11.37)$$

$$\text{But } X_C = \frac{1}{2\pi fC}$$

The current taken by the circuit is given by

$$I = V/Z$$

Voltage drop across resistance,  $R = IR$   
 Similarly,

Voltage drop across capacitance  $C$  having reactance  $X_C = IX_C$

Power in capacitive circuit,

$$W = VI \cos \theta$$

where  $\cos \theta = R/Z$  (11.38)

### 11.19 AC CIRCUIT CONSISTING OF RESISTANCE INDUCTANCE AND CAPACITANCE IN SERIES

Let a resistance  $R$ ,  $L$  Henry be connected in series with a choke coil  $L$  and a capacitor  $C$  farad or across a supply of voltage  $V$  and frequency  $f$  as shown in Fig. 11.16.

In such a circuit, the inductance and capacitance are first converted into inductive reactance ( $X_L$ ) and capacitive reactance ( $X_C$ ) as under:

$$\text{Inductive reactance, } X_L = 2\pi fL$$

$$\text{Capacitive reactance, } X_C = 1/2\pi fC$$

The total reactance is found by taking the difference of inductive and capacitive reactances.

$$\text{Total reactance, } X_T = X_L - X_C$$

The total opposition of circuit is known as impedance,  $Z$ , and is given by

$$Z = \sqrt{(R)^2 + (X_L - X_C)^2} \quad (11.39)$$

The current taken by the circuit is given by

$$I = V/Z = \frac{V}{\sqrt{(R)^2 + (X_L - X_C)^2}}$$

Voltage drop across resistance,

$$R = I \times R$$

Voltage drop across inductance,  $L$  having reactance  $X_L = I \times X_L$

Similarly,

Voltage drop across capacitance,  $C$  having reactance  $X_C = I \times X_C$

Power consumed in the circuit

$$W = VI \cos \theta \quad (11.40)$$

where  $\cos \theta = R/Z$  and is called the power factor of the circuit. If the inductive reactance is greater than the capacitive reactance ( $X_L > X_C$ ), the current in the circuit lags behind the voltage by some angle ' $\theta$ ' electrical and if the capacitive reactance is greater than the inductive reactance ( $X_C > X_L$ ), then the current leads the voltage by some ' $\theta$ ' electrical.

#### 11.20 MEASUREMENT OF POWER IN A SINGLE PHASE AC CIRCUIT

The power in a single-phase ac circuit is measured by an instrument known as the wattmeter. A wattmeter consists of two coils, namely current coil (CC) which is connected in series with the line voltage and the pressure coil (PC) which is connected across the line. The connections of the wattmeter are shown in Fig. 11.17.

A wattmeter measures the true power of a circuit in watts (W). Moreover this method gives an accurate measurement of power.

$$\text{Power, } W = V \times I \cos \theta \quad (11.41)$$

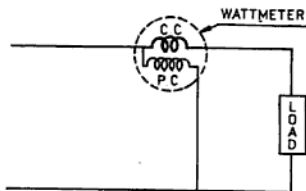

Fig. 11.17: Connections of wattmeter

**NOTE:** For further information on the measurement of power in an ac system, refer to Chapter 12 on polyphase circuits.

**EXAMPLE 11.8** A set of 200 V lamps takes 2.5 A. Find the inductance of the choke coil to be connected in series with them so that they may operate on 250 V 50 Hz supply. What will be the phase angle between the voltage and current.

**Solution:** Resistance of lamps,

$$R = \frac{V}{I} = \frac{200}{2.5} = 80 \Omega$$

Impedance,

$$Z = \frac{V}{I} = \frac{250}{2.5} = 100 \Omega$$

$\therefore$  Inductive reactance,

$$\begin{aligned} X_L &= \sqrt{Z^2 - R^2} = \sqrt{100^2 - 80^2} \\ &= \sqrt{10000 - 6400} \\ &= \sqrt{3600} = 60 \Omega \end{aligned}$$

We know,

$$X_L = 2\pi fL$$

$\therefore$  Inductance,

$$\begin{aligned} L &= \frac{X_L}{2\pi f} = \frac{60}{2 \times \frac{22}{7} \times 50} \\ &= \frac{60 \times 7}{2 \times 22 \times 50} = 0.1909 \text{ H Ans.} \end{aligned}$$

Power factor,  $\cos \theta$

$$= R/Z = \frac{80}{100} = 0.8$$

$\therefore$  Phase angle,

$$\theta = 36^\circ.52' \text{ Ans.}$$

**EXAMPLE 11.9** Find the capacitance that must be connected in series with a 100 W, 110 V lamps, so that the lamp may take its normal current when the circuit is connected to a 220 V, 50 Hz supply.

### 11.22 POWER FACTOR AND ITS IMPORTANCE

The power factor can be defined in any of the three ways as already explained in Sec. 11.11.

The vectorial and sinusoidal relations involved in the power factor can be explained by the power triangle (also known as the kVA triangle) shown in Fig. 11.19.

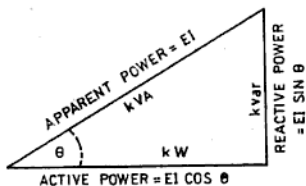

Fig. 11.19: kVA triangle

From the triangle, we have

$$\begin{aligned}\cos \theta &= \frac{\text{adjacent side}}{\text{hypotenuse}} \\ &= \frac{\text{active power}}{\text{apparent power}}\end{aligned}\quad (i)$$

The cosine of angle  $\theta$  is defined as the power factor and can never be greater than one, irrespective of whether the circuit is inductive or capacitive.

Similarly,

$$\begin{aligned}\sin \theta &= \frac{\text{opposite side}}{\text{hypotenuse}} \\ &= \frac{\text{reactive power}}{\text{apparent power}}\end{aligned}\quad (ii)$$

From Eq. (i), we have

$$\begin{aligned}\text{Active power} &= \text{apparent power} \times \cos \theta \\ &= VI \times \cos \theta\end{aligned}$$

This component of the apparent power (actual power) is known as the wattful component which is measured in watts or kilowatts and does, useful work in the circuit.

From Eq. (ii), we have

$$\begin{aligned}\text{Reactive power} &= \text{apparent power} \times \sin \theta \\ &= VI \times \sin \theta\end{aligned}$$

This component of apparent power (or reactive power) is known as kilovolt amperes reactive (kVar).

Again from Eq. (i), we have

$$\text{Apparent power} = \frac{\text{Active power}}{\text{Power factor} (\cos \theta)}$$

This apparent power is measured in kilovoltamperes written as kVA. Truly speaking, the active power or wattful power supplies the power losses in line and load resistances and does the actual work in the system. The instrument which measures this power is called a wattmeter.

**Effect of Reactive Power** The wattless or reactive power does no real work in a system but on the other hand it increases the current taken by the load and reduces the power factor of the circuit.

To understand it let us consider a single-phase ac generator (alternator), delivering a maximum current of 1000 A at 250 V.

$$\begin{aligned}\text{Rating of alternator,} &= \frac{V \times I}{1000} \text{ kVA} \\ &= \frac{1000 \times 250}{1000} \\ &= 250 \text{ kVA}\end{aligned}$$

Let the alternator be working at a unity power factor.

$$\begin{aligned}\therefore \text{Power supplied} &= \text{kVA} \times \cos \theta \\ &= 250 \times 1 = 250 \text{ kW}\end{aligned}$$

Now if the power factor of the alternator is reduced to 0.5,

$$\begin{aligned}\text{Power supplied} &= \text{kVA} \times \cos \theta \\ &= 250 \times 0.5 = 125 \text{ kW}\end{aligned}$$

Undoubtedly the alternator is fully loaded but due to the low power factor, it is supplying only 50% of its full load (125 kW). In order to supply the full load of 250 kW at 0.5 power factor, the alternator must be overloaded and the cable connecting the alternator to the load must be made of a much larger cross-sectional area to carry the increased current.

From the above, it is clear that the wattless component is responsible for the increase in current which further decreases the ratio between the real and apparent power and hence the power factor is low.

According to IE rules the consumers are stressed to keep their power factor at 0.8.

$$= \frac{1 \times 7 \times 10^6}{2 \times 22 \times 50 \times 100}$$

$$\begin{aligned} \therefore Z_2 &= \frac{31.81 \Omega}{\sqrt{(R)^2 + (X_C)^2}} \\ &= \frac{31.81}{\sqrt{(15)^2 + (31.81)^2}} \\ &= \frac{31.81}{\sqrt{225 + 1011.87}} \\ &= \frac{31.81}{\sqrt{1236.87}} \\ &= 35.16 \Omega \end{aligned}$$

Current,

$$I_2 = \frac{V}{Z_2} = \frac{200}{35.16} = 5.68 \text{ A}$$

$$\cos \theta_2 = \frac{R}{Z_2} = \frac{15}{35.16} = 0.4266$$

Phase angle,

$$\theta_2 = 64^\circ 45', \sin \theta_2 = 0.9037$$

Energy component of current in branch 3

$$= I_2 \cos \theta_2$$

$$= 5.68 \times 0.4266 = 2.423 \text{ A}$$

Idle component of current in branch 3

$$= I_2 \sin \theta_2 = 5.68 \times 0.9037$$

$$= 5.133 \text{ A}$$

Sum of energy component of current

$$= 20 + 5.469 + 2.423$$

$$= 27.89 \text{ A}$$

Sum of idle component of current

$$= 0 + 13.74 - 5.133$$

$$= 8.607 \text{ A}$$

(Minus sign occurs since phases of inductive and capacitive currents are opposite to each other.)

∴ Total current,

$$I = \sqrt{(\text{energy component of } I)^2 + (\text{idle component of } I)^2}$$

$$= \sqrt{(27.89)^2 + (8.607)^2}$$

$$= \sqrt{777.85 + 74.08}$$

$$= \sqrt{851.93}$$

$$= 29.18 \text{ A}$$

Power factor of the complete circuit

$$\cos \theta = \frac{\text{energy component of current}}{\text{total current}}$$

$$= \frac{27.89}{29.18}$$

$$= 0.95 \text{ lagging Ans.}$$

Phase angle,

$$\theta = 18^\circ 12', \text{ Ans. } (\sin \theta = 0.3123)$$

Impedance of the circuit,

$$Z = \frac{V}{I} = \frac{200}{29.18} = 6.8 \Omega$$

∴ Equivalent series resistance,

$$R = Z \times \cos \theta$$

$$= 6.8 \times 0.95 = 6.46 \Omega \text{ Ans.}$$

Similarly equivalent series reactance,

$$X = Z \sin \theta = 6.8 \times 0.3123$$

$$= 2.123 \Omega \text{ Ans.}$$

**11.26 DIFFERENCES BETWEEN AC AND DC**

The differences between ac and dc are listed in Table 11.2.

TABLE 11.2 DIFFERENCES BETWEEN AC AND DC

Sl. No.	Alternating Current	Direct Current
1.	Its polarity is constantly changing.	Its polarity remains constant.
2.	The current can flow through a condenser.	The current cannot flow through a condenser.
3.	Current flowing through the circuit is given by.	Current passing through the circuit is given by
	$I = \frac{V}{Z} = \frac{V}{\sqrt{R^2 + (X_L - X_C)^2}}$	$I = \frac{V}{R}$
4.	Power depends upon the power factor of the circuit and is given by	Power in dc circuit is given by
	$W = V \times I \times \cos \theta$	$W = V \times I$
5.	ac machines are cheap and require lesser maintenance.	dc machines are costly and require more maintenance.
6.	The speed control of an ac motor is more difficult as well as costlier.	The speed control of a dc motor is easier and more economical.
7.	ac can easily and economically be changed into dc.	Conversion of dc to ac is not so easy.
8.	The voltage can easily be stepped up or down by transformers and hence its transmission and distribution is more economical.	dc voltage cannot be varied so easily.

## NUMERICAL EXERCISES

- 11.1 The maximum voltage of an alternating induced emf is 450 V. Find its instantaneous value at  $30^\circ$ ,  $180^\circ$ ,  $270^\circ$  and  $330^\circ$ .  
(Ans. 225 V, 0 V, -450 V and -225 V)
- 11.2 Calculate the current that will flow through a coil of negligible resistance and 0.05 H inductance, when connected to a 220 V 50 Hz supply. (Ans. 14 A)
- 11.3 Find the current that will flow through a pure capacitance of 140  $\mu\text{F}$ , when connected to a 250 V, 50 Hz supply. (Ans. 11 A)
- 11.4 Find the current that will flow through a coil of negligible resistance and 0.2 H inductance, when connected across a 220 V, 50 Hz supply. Calculate the value of the current flowing through the coil if the frequency is: (i) halved and (ii) doubled.  
(Ans. 3.5; (i) current will be doubled, 7 A;  
(ii) current will be halved, 1.75 A)
- 11.5 An electrical pressure of 210 V, 50 Hz is applied to a 20  $\mu\text{F}$  capacitor. Find the current flowing through the capacitor. Also calculate the change in the value of current that will flow through the capacitor if the frequency is: (i) halved and (ii) doubled.  
(Ans. 1.32 A; (i) 0.66 A; (ii) 2.64 A)
- 11.6 A condenser takes a current of 4.4 A from a 280 V, 50 Hz supply. Find the capacitance of the condenser. (Ans. 50  $\mu\text{F}$ )
- 11.7 A condenser, when connected across a 110 V, 40 Hz supply, takes a current of 2.5 A. Calculate the value of current if the capacitance and frequency are both doubled. (Ans. 10 A)
- 11.8 Two similar condensers, connected in parallel, take a current of 3.3 A when connected across a 105 V, 50 Hz supply. Find the value of each condenser. Find also the current taken if these condensers are joined in series across the same supply. (Ans. 50  $\mu\text{F}$ , 0.825 A)
- 11.9 An inductive coil with a resistance of 50  $\Omega$  and an inductance of 0.35 H is connected to a 283 V, 60 Hz supply. Find:  
(i) The inductive reactance of the circuit. (Ans. 132  $\Omega$ )  
(ii) The impedance of the circuit. (Ans. 141.1  $\Omega$ )  
(iii) The current flowing in the circuit. (Ans. 2.00 A)  
(iv) The angle of lag. (Ans.  $69^\circ.15'$ )
- 11.10 A resistance of 14  $\Omega$  is connected in series with an inductive coil of 0.28 H. If the circuit is connected to a 270 V, 50 Hz supply, calculate the current drawn and power absorbed. (Ans. 3.03 A, 128.5 W)
- 11.11 A 350  $\mu\text{F}$  condenser is connected in series with a resistance of 8  $\Omega$  and fed by a 240 V, 50 Hz supply. Calculate the current drawn and power absorbed by the circuit. (Ans. 26.4 A, 5576 W)
- 11.12 A current of 14 A flows through a coil of 0.035 H inductance when connected to a 210 V dc supply. If the circuit is reconnected to a 210 V, 50 Hz ac supply, find:  
(i) The current drawn. (Ans. 11.29 A)  
(ii) The power absorbed. (Ans. 1911.9 W)  
(iii) The power factor of the circuit. (Ans. 0.8061)
- 11.13 A 250 W, 100 V lamp is to be supplied from a 125 V, 50 Hz supply through a pure inductive coil. Find:  
(ii) The inductance of the coil. (Ans. 0.095 H)  
(iii) The phase angle. (Ans.  $36^\circ.52'$ )
- 11.14 A non-inductive resistor takes 5 A at 119 V. Calculate the inductance of a choke coil of negligible resistance which when connected in series with the resistor, may be supplied the same current from a 250 V, 50 Hz supply. What will be the phase angle between the voltage and current?  
(Ans. 0.14 H,  $61^\circ.34'$ )
- 11.15 A choke coil of negligible resistance draws a current of 2.5 A, when connected across a 180 V, 50 Hz supply. Find: (i) the inductance and (ii) the current taken, if the frequency is decreased to 25 Hz. (Ans. (i) 0.229 H; (ii) 5 A)

- 11.27 A coil with an effective resistance of  $11 \Omega$  is connected to reduce the supply voltage of a  $4 \Omega$  pure resistor. The pure resistor requires a current of  $10 \text{ A}$ . The magnitude of the supply voltage is  $250 \text{ V}$  and its frequency is  $50 \text{ Hz}$ . Find:
- The inductance of the coil. (Ans.  $0.063 \text{ H}$ )
  - The voltage across the pure resistance. (Ans.  $40 \text{ V}$ )
  - The voltage across the coil. (Ans.  $228.2 \text{ V}$ )
  - The power factor. (Ans.  $0.6$ )
- 11.28 A choking coil of  $20 \Omega$  resistance having a power factor of  $0.2$  is connected in series with a  $35 \mu\text{F}$  capacitor and across a  $212 \text{ V}$ ,  $50 \text{ Hz}$  supply. Find:
- The resultant power factor. (Ans.  $0.9424$ )
  - The potential drop across the reactor. (Ans.  $1000 \text{ V}$ )
  - The potential drop across the capacitor. (Ans.  $909 \text{ V}$ )
- 11.29 The circuit shown in Fig. NE 11.29 is connected to a  $110 \text{ V}$ ,  $60 \text{ Hz}$  supply. Calculate:
- The total impedance. (Ans.  $11 \Omega$ )
  - The current taken. (Ans.  $10 \text{ A}$ )
  - The phase angle of the circuit. (Ans.  $0$ )
  - The potential differences  $V_1$  and  $V_2$ . (Ans.  $V_1=600 \text{ V}$ ,  $V_2=598 \text{ V}$ )

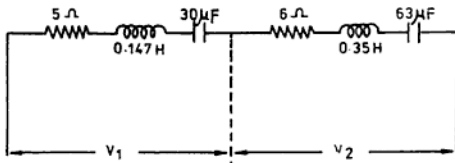

Fig. NE 11.29

- 11.30 A coil with a resistance of  $4 \Omega$  and a reactance of  $3 \Omega$  is connected in parallel with a  $70 \mu\text{F}$  capacitor and across a  $250 \text{ V}$ ,  $50 \text{ Hz}$  supply. Find the total current drawn. (Ans.  $46.9 \text{ A}$ )
- 11.31 A coil of resistance  $4 \Omega$  and inductance  $0.07 \text{ H}$  is connected in parallel with a non-inductive resistor of  $10 \Omega$  and across a  $223.6 \text{ V}$ ,  $50 \text{ Hz}$  supply. Calculate:
- The current in each branch. (Ans.  $10 \text{ A}$ ,  $22.36 \text{ A}$ )
  - The total current supplied. (Ans.  $26.07 \text{ A}$ )
  - The power factor of the circuit. (Ans.  $0.9262$  lagging)
- 11.32 A choke coil has a resistance of  $2 \Omega$  and an inductance of  $0.035 \text{ H}$ . It is connected in parallel with a  $350 \mu\text{F}$  capacitor which is in series with a resistance of  $20 \Omega$ . Find:
- the total current taken and
  - the power factor of the circuit, when the whole combination is connected across a  $200 \text{ V}$ ,  $50 \text{ Hz}$  supply. Also draw the vector diagram of the circuit. (Ans.  $18.1 \text{ A}$ ,  $0.6342$  lagging)
- 11.33 Two coils as shown in the circuit (Fig. NE 11.33) are connected in parallel and take currents  $2 \text{ A}$  and  $5 \text{ A}$  at power factors  $0.866$  and  $0.5$  respectively. If the whole combination is connected across a  $220 \text{ V}$ ,  $50 \text{ Hz}$  supply, calculate:
- The total current taken. (Ans.  $6.8 \text{ A}$ )
  - The power factor of the circuit. (Ans.  $0.6223$  lagging)

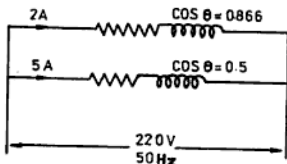

Fig. NE 11.33

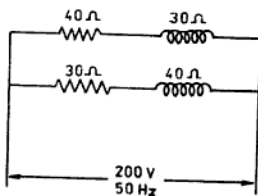

Fig. NE 11.34

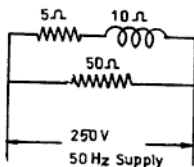

Fig. NE 11.36

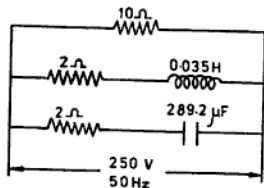

Fig. NE 11.37

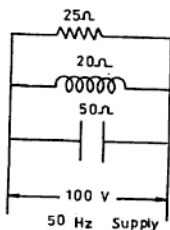

Fig. NE 11.38

- 11.34 The circuit shown in Fig. NE 11.34 is connected across a 200 V, 50 Hz supply. Calculate:
- The current taken by each coil. (Ans. 4 A each)
  - The total current. (Ans. 7.92 A)
- 11.35 A coil with a resistance of  $10\ \Omega$  and an inductive reactance of  $5\ \Omega$  is connected in parallel with a capacitance of  $319\ \mu\text{F}$  and connected across a 250 V, 50 Hz supply. Calculate the values of the resistance and reactance in an equivalent series arrangement of the circuit. (Ans.  $R = 8\ \Omega$ ,  $X_L = 6\ \Omega$ )
- 11.36 The circuit shown in Fig. NE 11.36 is connected across a 200 V, 50 Hz supply. Calculate:
- The total current taken. (Ans. 25 A)
  - The resistance and reactance of the single coil which will take the same current and power as taken by the original circuit. (Ans.  $R = 6\ \Omega$ ,  $X_L = 8\ \Omega$ )
- 11.37 In the circuit shown in Fig. NE 11.37, find:
- The total current flowing. (Ans. 33 A)

- (ii) The values of resistance and reactance in an equivalent series arrangement of the circuit. (Ans.  $R = 7.575 \Omega$ ,  $X = 0 \Omega$ )
- 11.38 A resistance of  $25 \Omega$ , and inductive reactance of  $20 \Omega$  and a capacitive reactance of  $50 \Omega$  are connected in parallel to each other and across a  $100 \text{ V}$ ,  $50 \text{ Hz}$  supply as shown in Fig NE 11.38. Calculate:
- (i) The total current taken. (Ans.  $5 \text{ A}$ )  
 (ii) The power factor of the circuit. (Ans.  $0.8$ )  
 (iii) The angle of the phase difference between voltage and current. (Ans.  $36^\circ.52'$ )

## REVIEW QUESTIONS

- 11.1 In the case of an ac supply, explain the terms: amplitude, phase, period, frequency, average value of current, rms value of current and maximum value of current. Give the relation between the last three terms. (NCVT 1978 W/man)
- 11.2 (a) State the relation between voltage and current in an ac circuit and define the terms used.  
 (b) An inductive coil with a resistance of  $10 \Omega$  and an inductance of  $0.05 \text{ H}$  is connected across a  $230 \text{ V}$ ,  $50 \text{ Hz}$  ac mains. Calculate:  
 (i) The current taken by the coil. (Ans.  $12.35 \text{ A}$ )  
 (ii) The power factor of the circuit. (Ans.  $0.937$ )  
 (iii) The power consumed. (Ans.  $1525.23 \text{ W}$ ) (NCVT 1980 Electr.)
- 11.3 Explain the terms self-induction and mutual induction. Also define the unit of inductance.
- 11.4 Explain what do you understand by the term impedance of a circuit. Calculate the current taken, power input and angle of lag for the circuit in Fig. RQ 11.4. (NCVT 1970 W/man) (Ans.  $26.13 \text{ A}$ ,  $2731 \text{ W}$ ,  $62.58^\circ$ )

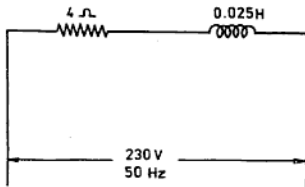

Fig. RQ 11.4

- 11.5 (a) In an ac-fed industrial area, why is the power factor generally low? What are the disadvantages of a low power factor?  
 (b) Why is ac becoming more popular than dc nowadays?
- 11.6 What is power factor? Why is power factor improvement necessary in an industrial installation? How can it be improved in an ac circuit?
- 11.7 What do you mean by the following: (a) inductance, (b) inductive reactance, (c) capacitive reactance, (d) impedance, (e) frequency, (f) in phase and (g) lagging and leading of current.
- 11.8 A coil has a resistance of  $4 \Omega$  and an inductive reactance of  $6 \Omega$ . Find:  
 (i) The current and power factor of the coil when it is connected to a  $250 \text{ V}$ ,  $50 \text{ Hz}$  supply. (Ans.  $34.67 \text{ A}$ ,  $0.554$ )  
 (ii) The power consumed and the kVA of the circuit. (All India Skill Competition 1969) (Ans.  $4.8 \text{ kW}$ ,  $8.67 \text{ kVA}$ )
- 11.9 An inductive circuit has a resistance of  $2 \Omega$  in series with an inductance of

0.015 H. Find the current and power factor when connected across a 200 V, 50 Hz supply.

(NCVT 1981 W/man)

(Ans. 39.06 A; 0.3906)

- 11.10 An ac circuit takes a current of 15 A when connected to a 240 V, single phase ac supply. If the power factor is 0.9 lagging, find: (i) the power consumed, (ii) the resistance of the circuit and (iii) the angle of lag.

(NCVT W/cal Elect. 1982)

(Ans. 3240 W, 14.4  $\Omega$ , 25°-50°)

- 11.11 Define the power factor. Explain the effects of low power factor in (i) distribution system (ii) domestic appliances. NCVT 1982

- 11.12 (a) In an inductive circuit does the inductance have any effect on the flow of steady current.  
(b) Give the three ways in which the flux that mutually links two circuits may be varied. Which of these methods are used in (i) proforma (ii) ignition wire.  
(c) A series AC circuit has a capacitive reactance of 40  $\Omega$  and a resistance of 20  $\Omega$ . What is a powers factor.  
(d) If the capacitance of the above circuit is doubled, will the power factor increases or decreases. All India Skill Competition 1985

# 12 POLYPHASE System

## 12.1 POLYPHASE

We have already studied about the generation and application of a single-phase system in different ac circuits. It is also possible to generate two-phase and three-phase supplies and from them we can have four, six, nine and twelve phases. A system with two or more than two phases is known as a *poly-phase system*

## 12.2 DIFFERENT SYSTEMS OF GENERATION OF AC SUPPLY

In a *single-phase system* there is only one coil which rotates in the magnetic field and the voltage generated in the coil is of an alternating nature. If instead of one coil, two or more than two coils are placed on the armature, voltage will be induced in all the coils and a load can be connected across each coil. When in the machine two electrically insulated windings are used which are  $90^\circ$  electrical

out of phase, the machine is called a two-phase machine and the supply system is known as a *two-phase system*. If in the machine three coils are placed which are  $120^\circ$  electrical apart, the machine is known as a three-phase machine and the supply system is called a *three-phase system*.

**Two-Phase System** In this system, two electrically insulated windings (or coils) are used in the armature which are  $90^\circ$  electrical apart and their ends are brought to the slip rings. If the windings are rotated with a constant angular velocity in a uniform magnetic field, the emf's generated in the windings will have a phase difference of  $90^\circ$ . This is shown graphically and vectorially in Fig. 12.1 (b), (c) respectively. As the two windings or coils are wound on the same armature and have the same number of turns, the emf generated in the two coils have the same maximum value, frequency and wavelength.

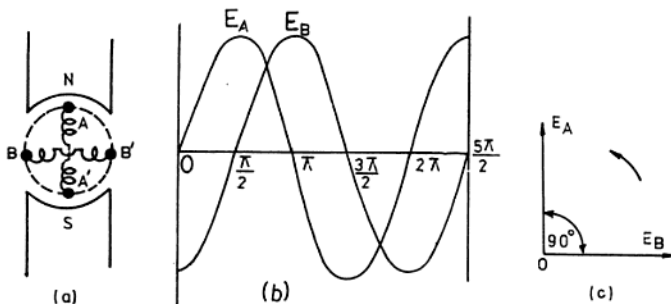

Fig. 12.1: Generation of two-phase supply  
(a) Two-phase generation of supply  
(b) Emf generation graphically  
(c) Emf generation vectorially

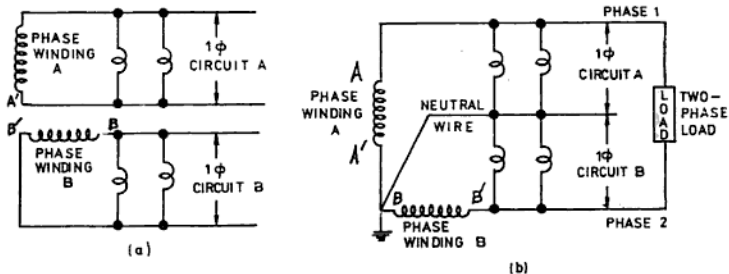

Fig. 12.2: Two-phase system of supply  
(a) Two-phase four-wire system  
(b) Two-phase three-wire system

This arrangement gives a simple form of a two-phase ac generator (alternator) and such a supply is called a two-phase supply.

From a two-phase supply either two single-phase circuit or a two-phase circuit can be supplied. In the latter case, any one of the two terminals of each coil is connected together to form a common or neutral terminal. The two terminals left are called phase terminals and the connections are shown in Fig. 12.2 (b). The voltage between any phase terminal and the common terminal is termed as the *phase voltage* and the voltage between the two phases is known as the *line voltage*.

**Relation between Line Voltage ( $V_L$ ) and Phase Voltage ( $V_{ph}$ )** As discussed before, the voltage induced in each winding is of the same maximum value and the two are  $90^\circ$  apart. The voltage between the two phases is the vector sum of the voltages generated in the two windings.

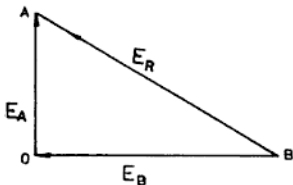

Fig. 12.3: Resultant voltage of two phases

In Fig. 12.3,  $OA$  represents  $E_A$ —the voltage generated in coil  $A$ .  $OB$  represents  $E_B$ —the voltage produced in coil  $B$ . The resultant line voltage  $E_R$  is given by the closing side of triangle  $AOB$  which is  $AB$ . From triangle  $AOB$ , we have

$$AB^2 = OA^2 + OB^2$$

$$\text{or } E_R^2 = E_A^2 + E_B^2$$

But  $E_A$  and  $E_B$  are phase voltages and are equal. Therefore

$$E_R^2 = E^2 + E^2$$

$$\text{or } E_R^2 = 2E^2$$

$$\text{Line voltage, } E_R = \sqrt{2} E$$

This means that the line voltage in a two-phase system is  $\sqrt{2}$  times the phase voltage.

**Three-Phase System** In a three-phase system, three electrically insulated windings (coils) are wound on the armature and a phase difference of  $120^\circ$  electrical is kept between the coils. The three starting ends of each coil are brought to the slip rings and the three remaining ends are connected together at a point in the winding. The three coils, with the same number of turns, are wound on the armature and all of them revolve with

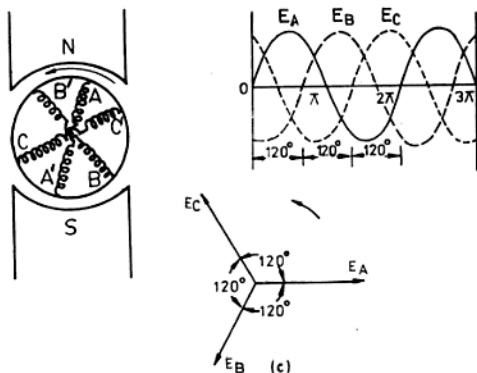

Fig. 12.4: Generation of three phase system  
 (a) Three-phase generation of supply  
 (b) Emf generation graphically  
 (c) Emf generation vectorially

the same speed in the magnetic field. Hence the emf's generated have the same maximum value, frequency and wavelength. The induced emf's in these three coils (Fig. 12.4 (a)) have a phase difference of  $120^\circ$  electrical. The emf's induced in the three coils are represented graphically and vectorially in Fig. 12.4 (b) and Fig. 12.4 (c) respectively.

A three-phase system can either supply three single-phase circuits (Fig. 12.5(a) or a single three-phase circuit (Fig. 12.5 (b)).

The current in different phases depends upon the nature of the load and the phase angle between the current and voltage. If a load is such that the same current flows through each of the three phases and the angle of phase difference between each current and voltage is also same, this load is said to be a balanced load. If three equal resistances are connected across the three phases, the current in each of the three phases will be in phase with the respective voltage as shown vectorially in Fig. 12.6(a).

If the load is balanced but reactive, the

currents will be lagging behind the voltages by an angle  $\theta$  as shown in Fig. 12.6 (b). If the magnitudes or phase angles of the currents are different, the circuit is called an unbalanced circuit as shown in Fig. 12.6 (c).

### 12.3 PHASE SEQUENCES

Figure 12.7 shows the instantaneous values of emf's in each phase. The emf of phase A has attained its maximum value at the instant shown. If this phase is rotated in the anticlockwise direction through an angle of  $120^\circ$  electrical, phase B will attain the position of phase A with the induced emf at its maximum value. If phase A is further rotated by  $240^\circ$  electrical, phase C will reach the position of maximum induced emf. Therefore, the sequence of attaining the maximum value of the induced emf is ABC. This is also represented by 123, RYB, etc. where R, Y, B stand for Red, Yellow, Blue respectively.

In short the sequence of attaining the maximum value of induced emf in a three-phase system is known as *phase sequence*.

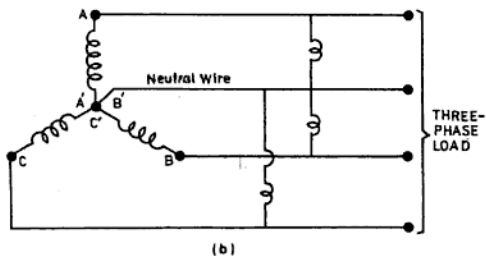
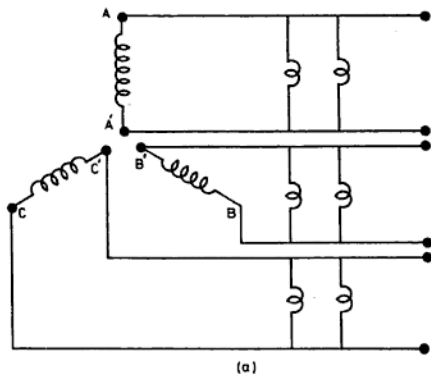

Fig. 12.5: System of supply in a three phase generation

- (a) Three phase system supplies 3 separate single phase circuits
- (b) Three-phase system supplies a three-phase circuit and 3 single-phase circuits

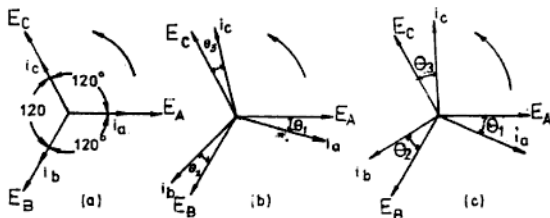

Fig. 12.6: Current in different phases  
 (a) Currents and voltages are in-phase  
 (b) Currents lag behind voltages by an angle  $\theta$   
 (c) Unbalanced current

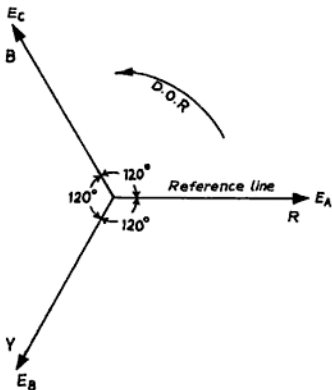

Fig. 12.7: The phase sequence

## 12.4 DEFINITIONS OF FUNDAMENTAL TERMS

**Phase Voltage** The voltage between one of the phases and the neutral terminal is known as phase voltage and is represented by  $V_{ph}$ .

**Phase Current** The current flowing through any of the phase windings is called phase current and is denoted by  $I_{ph}$ .

**Line Voltage** The voltage between any two phases of the supply system is called line voltage and is denoted by  $V_L$ .

**Line Current** The current flowing between any two phases of the windings is termed as line current and is denoted by  $I_L$ .

**Balanced Load** If in a three-phase system, the power factors and the phase (or line) currents of the three phases are equal, then that load is called balanced load.

**Unbalanced Load** If the three phases have different power factors and the phase (or line) current, then the load is an unbalanced load.

**Phase Power** The power measured between a phase and the neutral terminal is known as phase power.

**Total Power** In a three-phase system, the total power measured between the three phases is called total power.

## 12.5 METHODS OF CONNECTING THREE PHASE WINDINGS

There are two ways of connecting three-phase windings:

1. Star or wye ( $Y$ ) connection
2. Delta or mesh ( $\Delta$ ) connection

**Star Connection** Three coils of 3 phase windings can be connected in star. In this system,

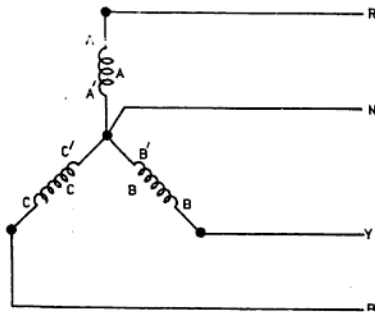

Fig. 12.8: Three-phase star connection

the three ends of the three windings are connected together to form a common or neutral point. In Fig. 12.8,  $AA$  is the first winding,  $BB$  the second winding and  $CC$  the third winding.  $A$ ,  $B$  and  $C$  are connected together to form the neutral terminal and the remaining three terminals  $A$ ,  $B$  and  $C$  are the three phases which are marked in Fig. 12.8 as  $R$ ,  $Y$  and  $B$ . This system is also known as a three-phase, four-wire system.

**Relation between Phase Current and Line Current and between Phase Voltage and Line Voltage in Star Connection** From Fig 12.8 it is clear that the current flowing through the phase windings will be the same as that flowing through the respective phase wires (i.e. line current).

Line current ( $I_L$ ) = Phase current ( $I_{ph}$ )

In Fig. 12.9, the voltage generated in each phase is the phase voltage. They are represented by  $OE_A$ ,  $OE_B$  and  $OE_C$  which are  $120^\circ$  electrical apart from each other. The vector difference between  $OE_A$  and  $OE_B$  yields line voltage. For obtaining this,  $OE_B'$  is produced in a direction reverse to  $OE_B$  but equal in length to it. Next, a parallelogram, as shown in Fig. 12.9, is drawn. Its diagonal gives the line voltage  $EA_B$  according to the parallelogram law of vectors.

$$E_{AB}^2 = E_A^2 + E_B^2 + 2E_A E_B \cos 60^\circ$$

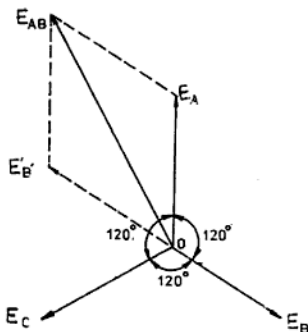

Fig. 12.9: Resultant voltage in star

$$(\because \cos 60^\circ = \frac{1}{2})$$

$$E_{AB}^2 = E_A^2 + E_B^2 + E_A E_B$$

Let  $E_A = E_B = E$  (phase voltage)

$$\therefore E_{AB}^2 = E^2 + E^2 + E^2$$

$$= 3 E^2$$

Line voltage,  $E_{AB} = \sqrt{3} E$

It means the line voltage in star connection is  $\sqrt{3}$  times the phase voltage, i.e.

$$V_L = \sqrt{3} V_{ph}$$

**Application of Star Connection** The application of star connection enables to supply a lighting load of 230 V which can be connected between any of the phases and the neutral wire if connected between the three phases. It also supplies a three-phase load of 400 V. So star connections are made in the case of ac generators (i.e. alternators) and transformers, especially in the secondary windings of distribution transformers. This connection is also done in the case of small three-phase induction motors.

**Delta Connection** Three coils of three-phase windings can also be connected in delta as

**Application of Delta Connection** Three phase motors may be connected either in star or in delta but large output motors are initially started in star connection. This reduces the starting current to  $\sqrt{3}$  times the line voltage and after this the motor winding is connected in delta connection for the running position so that the full voltage is applied to develop the required torque. Moreover, the primary winding of the distribution transformer is usually connected in delta because it works more efficiently.

### 12.6 POWER IN A THREE-PHASE SYSTEM

Let  $V_L$ ,  $I_L$ ,  $V_{ph}$  and  $I_{ph}$  be the line voltage, line current, phase voltage and phase current respectively. If  $\theta$  be the angle of phase difference between  $V_{ph}$  and  $I_{ph}$ , then the power consumed in that phase will be

$$W = V_{ph} \times I_{ph} \times \cos \theta$$

(But since there are three phases, the total power consumed

$$\begin{aligned} W &= 3 \times \text{single-phase power} \\ &= 3 \times V_{ph} \times I_{ph} \cos \theta \quad (i) \end{aligned}$$

In star connection, we know

$$I_{ph} = I_L \quad \text{and} \quad V_{ph} = V_L / \sqrt{3}$$

Substituting the values of  $I_{ph}$  and  $V_{ph}$  in Eq. (i) we get the power in star connection

$$\begin{aligned} W &= \frac{3 \times V_L \times I_L \times \cos \theta}{\sqrt{3} \times \sqrt{3}} \\ &= \frac{\sqrt{3} \times \sqrt{3} \times V_L \times I_L \times \cos \theta}{\sqrt{3}} \end{aligned}$$

$$\therefore \text{Total power, } W = \sqrt{3} \times V_L \times I_L \times \cos \theta \quad (12.5 a)$$

In delta connection

$$V_{ph} = V_L$$

$$I_{ph} = \frac{I_L}{\sqrt{3}}$$

Again by putting the values of  $V_{ph}$  and  $I_{ph}$  in Eq. (i), we get the power in delta

$$W = 3 \times V_L \times \frac{I_L}{\sqrt{3}} \times \cos \theta$$

Total power,  $W = \sqrt{3} \times V_L \times I_L \times \cos \theta$   
So the power in a three-phase system, whether star or delta connected, is the same and is equal to

$$W = \sqrt{3} V_L \times I_L \times \cos \theta \quad (12.5 b)$$

where  $V_L$  = Line voltage  
 $I_L$  = Line current

$\cos \theta$  = cosine of the phase angle between phase voltage and phase current (and not between line voltage and line current)

$W$  = Total power consumed in the three-phase system

$$\text{Power factor, } \cos \theta = \frac{W}{\sqrt{3} V_L \times I_L} \quad (12.6)$$

The above equation can be used for finding the power factor of an unbalanced circuit provided the imbalance is not appreciable.

**EXAMPLE 12.1** A three-phase system supplies a load of 30 kW at a pf of 0.8. The line voltage is 250V. If the load is connected in (i) star and (ii) delta find:

- (i) The line current  
(ii) The phase current

**Solution:** (a) Power in a three-phase star connected system is:

$$W = \sqrt{3} \times V_L \times I_L \times \cos \theta$$

$$30 \times 1000 = \sqrt{3} \times 250 \times I_L \times 0.8$$

$$\therefore \text{Line current, } I_L = \frac{30000}{\sqrt{3} \times 250 \times 0.8} = 86.6 \text{ A}$$

But in star connection,

$$I_{ph} = I_L$$

$$\therefore I_{ph} = 86.6 \text{ A}$$

Ans.

(b) Line current in delta connection,  $I_L = 86.6 \text{ A}$

But  $\sqrt{3}$  Phase current = Line current

$$\therefore \text{Phase current, } I_{ph} = \frac{I_L}{\sqrt{3}} = \frac{86.6}{1.732} = 50 \text{ A Ans.}$$

**EXAMPLE 12.2** Three coils each with a resistance of 11.88  $\Omega$  and an inductance of 0.07 H are connected in star to a three-phase 433 V, 50 Hz supply. Find (i) the line current and the total power absorbed. (ii) If these three coils are connected in delta to the same supply, calculate the line current and the total power absorbed.

**Solution:** In star connection,

$$\sqrt{3} \text{ Phase voltage } (V_{ph}) = \text{Line voltage } (V_L)$$

$\therefore$  Potential difference across each phase winding

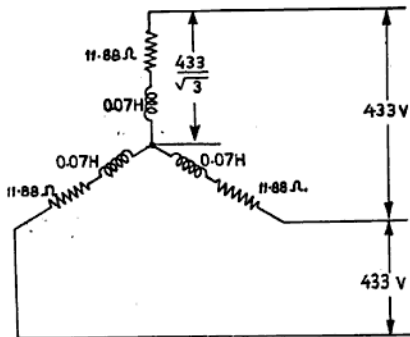

Fig. SE 12.2a

$$V_{ph} = \frac{V_L}{\sqrt{3}}$$

$$= \frac{433}{1.73} = 250 \text{ V}$$

Inductive reactance of the coil,

$$X_L = 2 \times \pi \times f \times L$$

$$= 2 \times \frac{22}{7} \times 50 \times 0.07 = 22 \Omega$$

Impedance of each phase,  $Z_{ph} = \sqrt{R^2 + X_L^2}$

$$= \sqrt{(11.88)^2 + (22)^2}$$

$$= \sqrt{141.1 + 484} = \sqrt{625.1}$$

$$= 25 \Omega$$

$$\therefore \text{Current in each phase winding} = \frac{V_{ph}}{Z_{ph}}$$

$$= \frac{250}{25} = 10 \text{ A Ans.}$$

But in star connection

$$I_{ph} = I_L$$

$$\therefore \text{Line current due to star connection} = 10 \text{ A Ans.}$$

$$\therefore \text{Power factor, } \cos \theta = \frac{R}{Z} = \frac{12}{25} = 0.48$$

$\therefore$  Power taken in star connection,

$$W = \sqrt{3} V_L \times I_L \times \cos \theta$$

$$= \frac{1.732 \times 433 \times 10 \times 0.48}{1000}$$

$$= 3.6 \text{ kW Ans.}$$

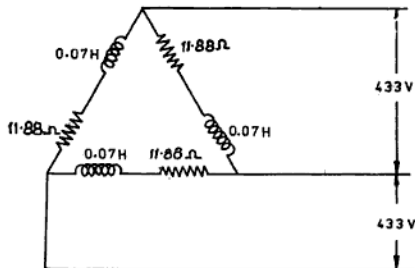

Fig. SE 12.7B

(b) In delta connection

$$\text{Phase voltage } (V_{ph}) = \text{Line voltage } (V_L) = 433 \text{ V}$$

$$\therefore \text{Current in each phase } I_{ph} = \frac{V_{ph}}{Z_{ph}} = \frac{433}{25}$$

$$= 17.32 \text{ A}$$

But

$$\text{Line current } (I_L) = \sqrt{3} \text{ Phase current } (I_{ph})$$

$$\therefore \text{Line current due to delta connection}$$

$$= \sqrt{3} \times 17.32 = 30 \text{ A Ans.}$$

Power taken in delta connection,

$$\begin{aligned}
 W &= \sqrt{3} \times V_L \times I_L \times \cos \theta \\
 &= \frac{1.732 \times 433 \times 30 \times 0.48}{1000} \\
 &= 10.8 \text{ kW Ans.}
 \end{aligned}$$

**EXAMPLE 12.3** A 99 hp (metric) mesh-connected induction motor is supplied by a three-phase, 1100 V, star-connected ac generator. If the efficiency of the motor is 75% and the power factor is 0.8, calculate the current in each phase of the (i) motor and (ii) generator.

Also find the active and reactive component of the currents in each case. Assume the power factor of the motor and generator to be the same (neglecting the line impedance).

**Solution:** Output of the motor = 99 × 735.5

$$\text{Efficiency (\%)} = \frac{\text{Output} \times 100}{\text{Input}} \%$$

$$\begin{aligned}
 \therefore \text{Input of the motor} &= \frac{\text{Output} \times 100}{\text{Efficiency}} \\
 &= \frac{99 \times 735.5 \times 100}{75} \text{ W}
 \end{aligned}$$

Power in a three-phase system,

$$\begin{aligned}
 W &= \sqrt{3} V_L \times I_L \times \cos \theta \\
 \therefore \text{or } I_L &= \frac{99 \times 735.5 \times 100}{\sqrt{3} \times 1100 \times 0.8}
 \end{aligned}$$

$$\begin{aligned}
 \therefore \text{Line current, } I_L &= \frac{99 \times 735.5 \times 100}{75 \times \sqrt{3} \times 1100 \times 0.8} \\
 &= 63.69 \text{ A}
 \end{aligned}$$

In delta,

$$\sqrt{3} I_{ph} = I_L$$

Phase current of the delta-connected motor,

$$\begin{aligned}
 I_{ph} &= \frac{I_L}{\sqrt{3}} \\
 &= \frac{63.69}{\sqrt{3}} = 36.78 \text{ A Ans.}
 \end{aligned}$$

Phase current of the generator = 63.69 A Ans,

$$(\therefore I_{ph} = I_L \text{ in star})$$

Active component of phase current in the motor

$$\begin{aligned}
 &= I \times \cos \theta \\
 &= 36.78 \times 0.8 \\
 &= 29.424 \text{ A Ans.}
 \end{aligned}$$

Reactive component of phase current in the motor

$$\begin{aligned}
 &= I \times \sin \theta \\
 &= 36.78 \times 0.6 \\
 &= 22.068 \text{ A Ans.}
 \end{aligned}$$

Active component of phase current in the generator

$$\begin{aligned}
 &= I \times \cos \theta \\
 &= 63.69 \times 0.8 \\
 &= 50.952 \text{ A Ans.}
 \end{aligned}$$

Reactive component of phase current in the generator

$$\begin{aligned}
 &= I \times \sin \theta \\
 &= 63.69 \times 0.6 \\
 &= 38.214 \text{ A Ans.}
 \end{aligned}$$

## 12.7 MEASUREMENT OF POWER IN THREE-PHASE CIRCUITS

The power in three-phase circuits can be measured by the following three methods.

1. Single-wattmeter method
2. Three-wattmeter method
3. Two-wattmeter method

**Single-Wattmeter Method for Balanced Load**  
This method is applicable only to a balanced load and when a neutral wire is available. The

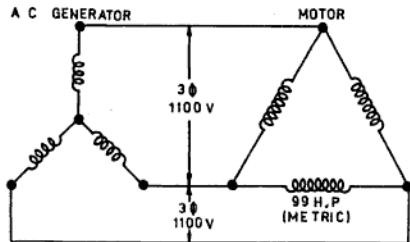

Fig. SE 12.3

power consumed in the three-phase circuit is three times the reading of the wattmeter which is connected to a single phase as shown in Fig. 12.12 (a).

$$\therefore \text{Total power} = 3 \times W_1 \quad (12.7)$$

If in the system a neutral wire is not available, an artificial neutral point can be made by connecting the pressure coil of the wattmeter with two resistances each with a value equal

to the resistance of the pressure coil of the wattmeter as shown in Fig. 12.12 (b).

**Three-Wattmeter Method (for Unbalanced Load)** In this system three wattmeters  $W_1$ ,  $W_2$  and  $W_3$  are connected as illustrated in Fig. 12.13. Each wattmeter measures the power of the phase to which it is connected. So the total power consumed in a three-phase circuit is the sum of the three-wattmeter readings.

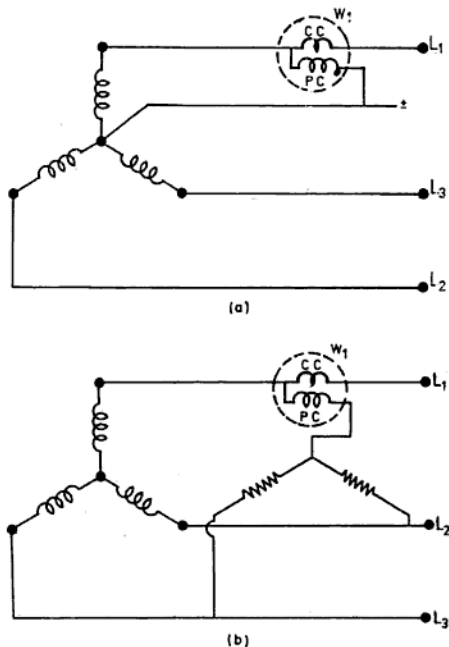

Fig. 12.12: Methods of measuring power  
 (a) Power measurement by single wattmeter if neutral wire is available  
 (b) Power measurement by a wattmeter if neutral wire is not available

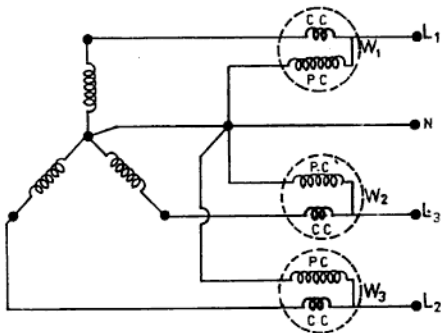

Fig. 12.13: Power measurement by three wattmeter method

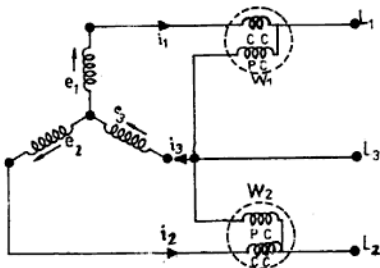

Fig. 12.14: Power measurement by two wattmeter method

∴ Total power,

$$W = W_1 + W_2 + W_3 \quad (12.8)$$

**Two-Wattmeter Method (for Balanced or Unbalanced Load)** In a three-phase, three-wire system, two wattmeter  $W_1$  and  $W_2$  are connected across the two phases as shown in Fig. 12.14 for measuring the total power of

the circuit, irrespective of whether the load is balanced or unbalanced. The current coil of the wattmeter must have sufficient rating to carry the load current, while the rating of the pressure coil should correspond to the voltage across the line. The connection for a star-connected load is drawn and can also be drawn for a delta-connected load.

$$= \frac{\sqrt{3}(4.5 - (-3))}{4.5 + (-3)} = \frac{\sqrt{3}(7.5)}{1.5}$$

$$= 1.732 \times 5 = 8.66$$

∴ Phase angle,  $\theta = \tan^{-1} 8.66 = 83^\circ 27'$

∴ Power factor,  $\cos \theta = 0.1140$  Ans.

## 12.9 COMPARISON BETWEEN POLY PHASE AND SINGLE-PHASE SYSTEMS

The advantages of the polyphase system over a single-phase system are given in Table 12.2.

TABLE 12.1 CONDITIONS OF TOTAL POWER BY TWO-WATTMETER METHOD

S.No.	Power factor (pf)	Phase angle	Reading of wattmeters	Total power of load
1.	1	0°	In this case both the wattmeter readings will be equal and positive.	$W_1 + W_2$
2.	<1 but >0.5	0-59°	Both the wattmeter readings will be positive and different.	$W_1 + W_2$
3.	0.5	60°	In this condition the reading of the first wattmeter will be zero and the total power consumed in the circuit will be indicated by the second wattmeter.	$W_2$
4.	<0.5 and >0	60-89°	In this case the needle of one of the wattmeters will kick back. In order to find the total power, the connections of either the current coil or the pressure coil (usually it is the current coil) of the wattmeter, which will deflect in the reverse direction, need to be interchanged. This means that the reading of this wattmeter will be subtracted from the other.	$W_1 - W_2$
5.	0	90°	In this position also the needle of one of the wattmeters will deflect back. Again, the connections of the current coil of the wattmeter which will kick back need to be interchanged. However, in this case the two wattmeters will have the same reading, but since their signs are opposite, the total power is zero.	$W_1 - W_2 = 0$

TABLE 12.2 COMPARISON BETWEEN POLYPHASE AND SINGLE-PHASE SYSTEMS

S. No.	Polyphase system	Single-phase System
1.	For the same size of an ac generator, the output of a three-phase generator is double that of a single-phase generator.	For the same size, the output of a single-phase generator is 50% less than a three-phase generator.
2.	In a polyphase system (three-phase, four-wire system) a low voltage for the lighting load and a medium voltage for the power load may be taken from the same system.	In a single-phase system, it is not possible to have two different voltages.
3.	Due to the rotating magnetic field, polyphase motors are self-starting.	Single-phase motors are not self-starting.
4.	Polyphase motors have uniform torque.	Single-phase motors have a pulsating torque.
5.	Polyphase motors have better torque and hence good efficiency.	Due to the low power factor the efficiency of the single-phase motor is poor.
6.	Fault-location in the case of a polyphase motor is easier.	Fault location is not so easy.

S. No.	Polyphase system	Single-phase System
7.	Polyphase motors with large outputs (i.e. in hp) can be manufactured.	Single-phase motors with large outputs cannot be manufactured. They are usually fractional horsepower motors.
8.	For an equal size motor, the output of a three-phase motor is high.	The output of a single-phase motor of the same size is always low.
9.	To transmit a given amount of power over a given distance, less copper and other material is required.	More copper and material is required for the transmission of power in this system.
10.	Polyphase generators (alternator) can easily be synchronized for parallel running.	Synchronizing in this system is difficult.

### NUMERICAL EXERCISES

- 12.1 A three-phase, delta-connected induction motor has a full output load of 10 hp, the power factor is 0.8335 and the efficiency is 80%. If the line voltage is 373 V, calculate :
- The line current 17.32 A (Ans. 17.32A)
  - The phase current 10 A
- 12.2 A three-phase system supplies a load of 30 kW with a power factor of 0.5 when the line voltage is 200 V. Find (i) line current and (ii) the phase current, if the load is connected :
- In star (Ans. (i) 173.2 A, (ii) 173.2 A)
  - In delta (Ans. (i)  $I_L = 173.2$  A, (ii)  $I_{ph} = 100$  A)
- 12.3 A three-phase system supplies a load of 52.8 kW at 0.8 power factor, when the line voltage is 220 V. Find the (i) line current and (ii) the phase current if the load is connected:
- In star (Ans. (i) 173.2 A, (ii) 173.2 A)
  - In delta (Ans. (i) 173.2 A, (ii) 100 A)
- 12.4 The full-load efficiency of a 90 hp (metric) three-phase, 400 V mesh-connected induction motor is 90% at a power factor of 0.8. Calculate (i) the line and phase current of the motor. (ii) Also find the active and reactive component of the line and phase current. (Ans. (i)  $I_L = 132.7$  A,  $I_{ph} = 76.63$  A)
- $I_L$  Active component = 106.16 A,  $I_L$  Reactive component = 79.62 A
- (ii)  $I_{ph}$  Active component = 61.304 A,  $I_{ph}$  Reactive component = 45.978 A
- 12.5 Three resistances, each of 250  $\Omega$  are connected in star to a three-phase 433 V supply. Calculate the line current and power taken. If these resistances are then connected in delta to the same supply, find the line current and the total power absorbed. (Ans. In star : 1 A, 750 W, In delta : 3 A, 2250 W)
- 12.6 Three equal 60  $\Omega$  resistances are connected in (i) star and (ii) delta across a three-phase, 519.6 V supply. Calculate for each case the line current and the total power absorbed. (Ans. In star : 5 A, 4.5 kW  
In delta : 15 A, 13.5 kW)
- 12.7 Three coils, each with a resistance of 62.5  $\Omega$  and inductance 0.0007 H are connected in star to a three-phase, 433 V, 50 Hz supply. Find the line current and the total power absorbed. If these three coils are next connected in delta to the same supply, what is the line current and the total power absorbed. (Ans. In star : 4 A, 3 kW, In delta : 12 A, 9 kW)

factor of 0.8 lagging and with an efficiency of 73.55%. Find the readings on each of the two wattmeters connected to measure the input.

(Ans. 71.65 kW, 28.35 kW)

- 12.19 A three-phase, 400 V motor has an output of 60 hp at a pf of 0.8 lagging with an efficiency of 74.6%. Find the readings on each of the two wattmeters.

(Ans.  $W_1 = 42.99$  kW,  $W_2 = 17.01$  kW)

- 12.20 Two wattmeters connected to measure the power input to a balanced three-phase load indicate 25 and 5 kW respectively. Find the power factor of the circuit when (i) both the readings are positive and (ii) the latter reading is obtained after reversing the connections of the current coil of the wattmeter.

(Ans. 0.6547, 0.3592)

### REVIEW QUESTIONS

- 12.1 What is meant by the term 'polyphase system'. Give the advantages of star connection in this system.
- 12.2 What are the advantages of a polyphase system over a single-phase system in the distribution of electricity. Show the relationship of the line to the phase current and the line to the phase voltage in star and delta connection.  
(NCVT 1974 *Elect.* 76 W/Man)
- 12.3 Explain with the help of calculations and a diagram how the three-phase power can be measured by the two-wattmeter method.  
(NCVT 1964, 76 W/Man)
- 12.4 (a) Draw a circuit diagram for measuring the power of a three-phase, delta-connected motor by the two-wattmeter method.  
(b) What is power factor? What are the disadvantages of a low power factor?  
(NCVT 1980 *Elect.*)
- 12.5 A three-phase circuit takes a current of 15 A at a pf of 0.8 when connected to a 400 V supply. Calculate the power and energy consumed for a duration of two hours.  
(8313.6 W, 16.627 kW h)  
(NCVT 1980 *Elect.*)
- 12.6 What method can be used to measure power in a three phase circuit. Describe the two Wattmeter method used for the purpose. With the help of diagram and calculation show that the sum of the two Wattmeter reading represents, the power consumed on all the three phases. (NCVT 1984 *Elect.*)
- 12.7 (a) Enumerate the difference between the single phase and three-phase supply system.  
(b) What is form factor and what is its value? (NCVT 1984 *Elect.*)

## BASIC ELECTRICAL ENGINEERING

With Numerical Problems

### Volume I

The book has been written according to the syllabus prescribed by the Directorate General of Employment and Training for the Craftsman Training Scheme and the Apprenticeship Training Scheme for the Electrical Trades (Electrician, Wireman and Lineman).

The first volume covers what should be taught in the first year. The language is very simple and the concepts are explained with the help of clear illustrations. The theory is supported by practical applications of the concepts. A number of solved examples have been provided. At each chapter end is a set of unsolved numerical problems and review questions. Answers to these have been provided. These review questions are taken from the examination papers of the National Council for Vocational trades and from the All India Skill Competitions. This book will help trainees and apprentices prepare themselves for the final examination and for job interviews.

**P S Dhogal** has been an Instructor-Electrical Trades, in the Directorate of Training and Technical Education, New Delhi, for 32 years. Prior to this assignment he was with Delhi College of Engineering, Delhi. He holds a diploma from ITC Delhi Polytechnic and CTI Electrician trade certificate from Ludhiana.

#### *Other Related Books from TMH*

Dhogal : *Basic Electrical Engineering-Vol. II*

Ghosh : *Electrical Trade Theory-for Electrician, Lineman and Wireman*

Gulati : *Social Studies & Entrepreneurship*

(Also available in Hindi & Marathi)

Sharma : *Basic Radio and Television*

TMH : *Radio & TV-in Questions and Answers*



*The McGraw-Hill Companies*



**Tata McGraw-Hill**  
**Publishing Company Limited**  
7 West Patel Nagar, New Delhi 110 008

Visit our website at : [www.tatamcgrawhill.com](http://www.tatamcgrawhill.com)

ISBN-13: 978-0-07-451586-0

ISBN-10: 0-07-451586-1



9 780074 515860