

JOHN BIRD

**Electrical
AND
Electronic
Principles
AND
Technology**

Second edition



TLFeBOOK

Electrical and Electronic Principles and Technology

To Sue

Electrical and Electronic Principles and Technology

Second edition

JOHN BIRD, BSc(Hons) CEng CMath MIEE FIMA FIIE(ELEC) FCollP



Newnes

OXFORD AMSTERDAM BOSTON LONDON NEW YORK PARIS
SAN DIEGO SAN FRANCISCO SINGAPORE SYDNEY TOKYO

Newnes

An imprint of Elsevier Science

Linacre House, Jordan Hill, Oxford OX2 8DP

200 Wheeler Rd, Burlington MA 01803

Previously published as *Electrical Principles and Technology for Engineering*

Reprinted 2001

Second edition 2003

Copyright © 2000, 2003, John Bird. All rights reserved

The right of John Bird to be identified as the author of this work has been asserted in accordance with the Copyright, Designs and Patents Act 1988

No part of this publication may be reproduced in any material form (including photocopying or storing in any medium by electronic means and whether or not transiently or incidentally to some other use of this publication) without the written permission of the copyright holder except in accordance with the provisions of the Copyright, Designs and Patents Act 1988 or under the terms of a licence issued by the Copyright Licensing Agency Ltd, 90 Tottenham Court Road, London, England W1T 4LP. Applications for the copyright holder's written permission to reproduce any part of this publication should be addressed to the publisher

British Library Cataloguing in Publication Data

A catalogue record for this book is available from the British Library

ISBN 0 7506 5778 2

For information on all Newnes publications visit our website at www.newnespress.com

Typeset by Laserwords Private Limited, Chennai, India
Printed and bound in Great Britain

Contents

Preface ix

SECTION 1 Basic Electrical and Electronic Engineering Principles 1

1 Units associated with basic electrical quantities 3

- 1.1 SI units 3
- 1.2 Charge 3
- 1.3 Force 4
- 1.4 Work 4
- 1.5 Power 4
- 1.6 Electrical potential and e.m.f. 5
- 1.7 Resistance and conductance 5
- 1.8 Electrical power and energy 6
- 1.9 Summary of terms, units and their symbols 7

2 An introduction to electric circuits 9

- 2.1 Electrical/electronic system block diagrams 9
- 2.2 Standard symbols for electrical components 10
- 2.3 Electric current and quantity of electricity 10
- 2.4 Potential difference and resistance 12
- 2.5 Basic electrical measuring instruments 12
- 2.6 Linear and non-linear devices 12
- 2.7 Ohm's law 13
- 2.8 Multiples and sub-multiples 13
- 2.9 Conductors and insulators 14
- 2.10 Electrical power and energy 15
- 2.11 Main effects of electric current 17
- 2.12 Fuses 18

3 Resistance variation 20

- 3.1 Resistance and resistivity 20
- 3.2 Temperature coefficient of resistance 22
- 3.3 Resistor colour coding and ohmic values 25

4 Chemical effects of electricity 29

- 4.1 Introduction 29
- 4.2 Electrolysis 29
- 4.3 Electroplating 30
- 4.4 The simple cell 30
- 4.5 Corrosion 31
- 4.6 E.m.f. and internal resistance of a cell 31
- 4.7 Primary cells 34
- 4.8 Secondary cells 34
- 4.9 Cell capacity 35

Assignment 1 38

5 Series and parallel networks 39

- 5.1 Series circuits 39
- 5.2 Potential divider 40
- 5.3 Parallel networks 42
- 5.4 Current division 45
- 5.5 Wiring lamps in series and in parallel 49

6 Capacitors and capacitance 52

- 6.1 Electrostatic field 52
- 6.2 Electric field strength 53
- 6.3 Capacitance 54
- 6.4 Capacitors 54
- 6.5 Electric flux density 55
- 6.6 Permittivity 55
- 6.7 The parallel plate capacitor 57
- 6.8 Capacitors connected in parallel and series 59
- 6.9 Dielectric strength 62
- 6.10 Energy stored in capacitors 63
- 6.11 Practical types of capacitor 64
- 6.12 Discharging capacitors 66

7 Magnetic circuits 68

- 7.1 Magnetic fields 68
- 7.2 Magnetic flux and flux density 69
- 7.3 Magnetomotive force and magnetic field strength 70
- 7.4 Permeability and B-H curves 70
- 7.5 Reluctance 73

- 7.6 Composite series magnetic circuits 74
- 7.7 Comparison between electrical and magnetic quantities 77
- 7.8 Hysteresis and hysteresis loss 77

Assignment 2 81

8 Electromagnetism 82

- 8.1 Magnetic field due to an electric current 82
- 8.2 Electromagnets 84
- 8.3 Force on a current-carrying conductor 85
- 8.4 Principle of operation of a simple d.c. motor 89
- 8.5 Principle of operation of a moving-coil instrument 89
- 8.6 Force on a charge 90

9 Electromagnetic induction 93

- 9.1 Introduction to electromagnetic induction 93
- 9.2 Laws of electromagnetic induction 94
- 9.3 Inductance 97
- 9.4 Inductors 98
- 9.5 Energy stored 99
- 9.6 Inductance of a coil 99
- 9.7 Mutual inductance 101

10 Electrical measuring instruments and measurements 104

- 10.1 Introduction 104
- 10.2 Analogue instruments 105
- 10.3 Moving-iron instrument 105
- 10.4 The moving-coil rectifier instrument 105
- 10.5 Comparison of moving-coil, moving-iron and moving-coil rectifier instruments 106
- 10.6 Shunts and multipliers 106
- 10.7 Electronic instruments 108
- 10.8 The ohmmeter 108
- 10.9 Multimeters 109
- 10.10 Wattmeters 109
- 10.11 Instrument 'loading' effect 109
- 10.12 The cathode ray oscilloscope 111
- 10.13 Waveform harmonics 114
- 10.14 Logarithmic ratios 115
- 10.15 Null method of measurement 118
- 10.16 Wheatstone bridge 118

- 10.17 D.C. potentiometer 119
- 10.18 A.C. bridges 120
- 10.19 Q-meter 121
- 10.20 Measurement errors 122

11 Semiconductor diodes 127

- 11.1 Types of materials 127
- 11.2 Silicon and germanium 127
- 11.3 n-type and p-type materials 128
- 11.4 The p-n junction 129
- 11.5 Forward and reverse bias 129
- 11.6 Semiconductor diodes 130
- 11.7 Rectification 132

12 Transistors 136

- 12.1 The bipolar junction transistor 136
- 12.2 Transistor action 137
- 12.3 Transistor symbols 139
- 12.4 Transistor connections 139
- 12.5 Transistor characteristics 140
- 12.6 The transistor as an amplifier 142
- 12.7 The load line 144
- 12.8 Current and voltage gains 145
- 12.9 Thermal runaway 147

Assignment 3 152

Formulae for basic electrical and electronic engineering principles 153

SECTION 2 Further Electrical and Electronic Principles 155

13 D.C. circuit theory 157

- 13.1 Introduction 157
- 13.2 Kirchhoff's laws 157
- 13.3 The superposition theorem 161
- 13.4 General d.c. circuit theory 164
- 13.5 Thévenin's theorem 166
- 13.6 Constant-current source 171
- 13.7 Norton's theorem 172
- 13.8 Thévenin and Norton equivalent networks 175
- 13.9 Maximum power transfer theorem 179

14 Alternating voltages and currents 183

- 14.1 Introduction 183
- 14.2 The a.c. generator 183
- 14.3 Waveforms 184
- 14.4 A.C. values 185

- 14.5 The equation of a sinusoidal waveform 189
- 14.6 Combination of waveforms 191
- 14.7 Rectification 194

Assignment 4 197

15 Single-phase series a.c. circuits 198

- 15.1 Purely resistive a.c. circuit 198
- 15.2 Purely inductive a.c. circuit 198
- 15.3 Purely capacitive a.c. circuit 199
- 15.4 $R-L$ series a.c. circuit 201
- 15.5 $R-C$ series a.c. circuit 204
- 15.6 $R-L-C$ series a.c. circuit 206
- 15.7 Series resonance 209
- 15.8 Q-factor 210
- 15.9 Bandwidth and selectivity 212
- 15.10 Power in a.c. circuits 213
- 15.11 Power triangle and power factor 214

16 Single-phase parallel a.c. circuits 219

- 16.1 Introduction 219
- 16.2 $R-L$ parallel a.c. circuit 219
- 16.3 $R-C$ parallel a.c. circuit 220
- 16.4 $L-C$ parallel a.c. circuit 222
- 16.5 $LR-C$ parallel a.c. circuit 223
- 16.6 Parallel resonance and Q-factor 226
- 16.7 Power factor improvement 230

17 Filter networks 236

- 17.1 Introduction 236
- 17.2 Two-port networks and characteristic impedance 236
- 17.3 Low-pass filters 237
- 17.4 High-pass filters 240
- 17.5 Band-pass filters 244
- 17.6 Band-stop filters 245

18 D.C. transients 248

- 18.1 Introduction 248
- 18.2 Charging a capacitor 248
- 18.3 Time constant for a $C-R$ circuit 249
- 18.4 Transient curves for a $C-R$ circuit 250
- 18.5 Discharging a capacitor 253
- 18.6 Current growth in an $L-R$ circuit 255
- 18.7 Time constant for an $L-R$ circuit 256
- 18.8 Transient curves for an $L-R$ circuit 256

- 18.9 Current decay in an $L-R$ circuit 257
- 18.10 Switching inductive circuits 260
- 18.11 The effects of time constant on a rectangular waveform 260

19 Operational amplifiers 264

- 19.1 Introduction to operational amplifiers 264
- 19.2 Some op amp parameters 266
- 19.3 Op amp inverting amplifier 267
- 19.4 Op amp non-inverting amplifier 269
- 19.5 Op amp voltage-follower 270
- 19.6 Op amp summing amplifier 271
- 19.7 Op amp voltage comparator 272
- 19.8 Op amp integrator 272
- 19.9 Op amp differential amplifier 274
- 19.10 Digital to analogue (D/A) conversion 276
- 19.11 Analogue to digital (A/D) conversion 276

Assignment 5 281

Formulae for further electrical and electronic engineering principles 283

SECTION 3 Electrical Power Technology 285

20 Three-phase systems 287

- 20.1 Introduction 287
- 20.2 Three-phase supply 287
- 20.3 Star connection 288
- 20.4 Delta connection 291
- 20.5 Power in three-phase systems 293
- 20.6 Measurement of power in three-phase systems 295
- 20.7 Comparison of star and delta connections 300
- 20.8 Advantages of three-phase systems 300

21 Transformers 303

- 21.1 Introduction 303
- 21.2 Transformer principle of operation 304
- 21.3 Transformer no-load phasor diagram 306
- 21.4 E.m.f. equation of a transformer 308

- 21.5 Transformer on-load phasor diagram 310
- 21.6 Transformer construction 311
- 21.7 Equivalent circuit of a transformer 312
- 21.8 Regulation of a transformer 313
- 21.9 Transformer losses and efficiency 314
- 21.10 Resistance matching 317
- 21.11 Auto transformers 319
- 21.12 Isolating transformers 321
- 21.13 Three-phase transformers 321
- 21.14 Current transformers 323
- 21.15 Voltage transformers 324

Assignment 6 327

22 D.C. machines 328

- 22.1 Introduction 328
- 22.2 The action of a commutator 329
- 22.3 D.C. machine construction 329
- 22.4 Shunt, series and compound windings 330
- 22.5 E.m.f. generated in an armature winding 330
- 22.6 D.C. generators 332
- 22.7 Types of d.c. generator and their characteristics 333
- 22.8 D.C. machine losses 337
- 22.9 Efficiency of a d.c. generator 337
- 22.10 D.C. motors 338
- 22.11 Torque of a d.c. motor 339
- 22.12 Types of d.c. motor and their characteristics 341
- 22.13 The efficiency of a d.c. motor 344
- 22.14 D.C. motor starter 347
- 22.15 Speed control of d.c. motors 347
- 22.16 Motor cooling 350

23 Three-phase induction motors 354

- 23.1 Introduction 354
- 23.2 Production of a rotating magnetic field 354
- 23.3 Synchronous speed 356
- 23.4 Construction of a three-phase induction motor 357
- 23.5 Principle of operation of a three-phase induction motor 358
- 23.6 Slip 358
- 23.7 Rotor e.m.f. and frequency 359
- 23.8 Rotor impedance and current 360
- 23.9 Rotor copper loss 361
- 22.10 Induction motor losses and efficiency 361
- 23.11 Torque equation for an induction motor 363
- 23.12 Induction motor torque-speed characteristics 366
- 23.13 Starting methods for induction motors 367
- 23.14 Advantages of squirrel-cage induction motors 367
- 23.15 Advantages of wound rotor induction motors 368
- 23.16 Double cage induction motor 369
- 23.17 Uses of three-phase induction motors 369

Assignment 7 372

Formulae for electrical power technology 373

Answers to multi-choice questions 375

Index 377

Preface

Electrical and Electronic Principles and Technology, 2nd edition introduces the principles which describe the operation of d.c. and a.c. circuits, covering both steady and transient states, and applies these principles to filter networks (which is new for this edition), operational amplifiers, three-phase supplies, transformers, d.c. machines and three-phase induction motors.

This second edition of the textbook provides coverage of the following:

- (i) 'Electrical and Electronic Principles (National Certificate and National Diploma unit 6)
- (ii) 'Further Electrical and Electronic Principles' (National Certificate and National Diploma unit 17)
- (iii) 'Electrical and Electronic Principles' (Advanced GNVQ unit 7)
- (iv) 'Further Electrical and Electronic Principles' (Advanced GNVQ unit 13)
- (v) 'Electrical Power Technology' (Advanced GNVQ unit 27)
- (vi) Electricity content of 'Applied Science and Mathematics for Engineering' (Intermediate GNVQ unit 4)
- (vii) The theory within 'Electrical Principles and Applications' (Intermediate GNVQ unit 6)
- (viii) 'Telecommunication Principles' (City & Guilds Technician Diploma in Telecommunications and Electronics Engineering)
- (ix) Any introductory/Access/Foundation course involving Electrical and Electronic Engineering

The **text** is set out in three main sections:

Part 1, comprising chapters 1 to 12, involves essential **Basic Electrical and Electronic Engineering Principles**, with chapters on electrical units and quantities, introduction to electric circuits, resistance variation, chemical effects of electricity, series and parallel networks, capacitors and capacitance, magnetic circuits, electromagnetism, electromagnetic induction, electrical measuring instruments

and measurements, semiconductors diodes and transistors.

Part 2, comprising chapters 13 to 19, involves **Further Electrical and Electronic Principles**, with chapters on d.c. circuit theorems, alternating voltages and currents, single-phase series and parallel networks, filter networks, d.c. transients and operational amplifiers.

Part 3, comprising chapters 20 to 23, involves **Electrical Power Technology**, with chapters on three-phase systems, transformers, d.c. machines and three-phase induction motors.

Each topic considered in the text is presented in a way that assumes in the reader little previous knowledge of that topic. Theory is introduced in each chapter by a reasonably brief outline of essential information, definitions, formulae, procedures, etc. The theory is kept to a minimum, for problem solving is extensively used to establish and exemplify the theory. It is intended that readers will gain real understanding through seeing problems solved and then through solving similar problems themselves.

'Electrical and Electronic Principles and Technology' contains over **400 worked problems**, together with **340 multi-choice questions** (with answers at the back of the book). Also included are over **420 short answer questions**, the answers for which can be determined from the preceding material in that particular chapter, and some **560 further questions**, arranged in **142 Exercises**, all with answers, in brackets, immediately following each question; the Exercises appear at regular intervals - every 3 or 4 pages - throughout the text. **500 line diagrams** further enhance the understanding of the theory. All of the problems - multi-choice, short answer and further questions - mirror practical situations found in electrical and electronic engineering.

At regular intervals throughout the text are seven **Assignments** to check understanding. For example, Assignment 1 covers material contained in chapters 1 to 4, Assignment 2 covers the material contained in chapters 5 to 7, and so on. These Assignments do not have answers given since it is envisaged that lecturers could set the Assignments for students to

attempt as part of their course structure. Lecturers' may obtain a complimentary set of solutions of the Assignments in an **Instructor's Manual** available from the publishers via the internet – see below.

A list of relevant **formulae** are included at the end of each of the three sections of the book.

'**Learning by Example**' is at the heart of *Electrical and Electronic Principles and Technology, 2nd edition*.

John Bird
University of Portsmouth

Instructor's Manual

Full worked solutions and mark scheme for all the Assignments are contained in this Manual, which is available to lecturers only. To obtain a password please e-mail J.Blackford@Elsevier.com with the following details: course title, number of students, your job title and work postal address.

To download the Instructor's Manual visit <http://www.newnepress.com> and enter the book title in the search box, or use the following direct URL: <http://www.bh.com/manuals/0750657782/>

Electrical and Electronic Principles and Technology

Section 1

Basic Electrical and Electronic Engineering Principles

Units associated with basic electrical quantities

At the end of this chapter you should be able to:

- state the basic SI units
- recognize derived SI units
- understand prefixes denoting multiplication and division
- state the units of charge, force, work and power and perform simple calculations involving these units
- state the units of electrical potential, e.m.f., resistance, conductance, power and energy and perform simple calculations involving these units

1.1 SI units

The system of units used in engineering and science is the *Système Internationale d'Unités* (International system of units), usually abbreviated to SI units, and is based on the metric system. This was introduced in 1960 and is now adopted by the majority of countries as the official system of measurement.

The basic units in the SI system are listed below with their symbols:

Quantity	Unit
length	metre, m
mass	kilogram, kg
time	second, s
electric current	ampere, A
thermodynamic temperature	kelvin, K
luminous intensity	candela, cd
amount of substance	mole, mol

Derived SI units use combinations of basic units and there are many of them. Two examples are:

Velocity – metres per second (m/s)

Acceleration – metres per second squared (m/s²)

SI units may be made larger or smaller by using prefixes which denote multiplication or division by a particular amount. The six most common multiples, with their meaning, are listed below:

Prefix	Name	Meaning
M	mega	multiply by 1 000 000 (i.e. $\times 10^6$)
k	kilo	multiply by 1000 (i.e. $\times 10^3$)
m	milli	divide by 1000 (i.e. $\times 10^{-3}$)
μ	micro	divide by 1 000 000 (i.e. $\times 10^{-6}$)
n	nano	divide by 1 000 000 000 (i.e. $\times 10^{-9}$)
p	pico	divide by 1 000 000 000 000 (i.e. $\times 10^{-12}$)

1.2 Charge

The **unit of charge** is the coulomb (C) where one coulomb is one ampere second. (1 coulomb =

6.24×10^{18} electrons). The coulomb is defined as the quantity of electricity which flows past a given point in an electric circuit when a current of one ampere is maintained for one second. Thus,

$$\text{charge, in coulombs} \quad \boxed{Q = It}$$

where I is the current in amperes and t is the time in seconds.

Problem 1. If a current of 5 A flows for 2 minutes, find the quantity of electricity transferred.

Quantity of electricity $Q = It$ coulombs

$$I = 5 \text{ A}, t = 2 \times 60 = 120 \text{ s}$$

Hence $Q = 5 \times 120 = \mathbf{600 \text{ C}}$

1.3 Force

The **unit of force** is the **newton (N)** where one newton is one kilogram metre per second squared. The newton is defined as the force which, when applied to a mass of one kilogram, gives it an acceleration of one metre per second squared. Thus,

$$\text{force, in newtons} \quad \boxed{F = ma}$$

where m is the mass in kilograms and a is the acceleration in metres per second squared. Gravitational force, or weight, is mg , where $g = 9.81 \text{ m/s}^2$

Problem 2. A mass of 5000 g is accelerated at 2 m/s^2 by a force. Determine the force needed.

$$\begin{aligned} \text{Force} &= \text{mass} \times \text{acceleration} \\ &= 5 \text{ kg} \times 2 \text{ m/s}^2 = 10 \text{ kg m/s}^2 = \mathbf{10 \text{ N}} \end{aligned}$$

Problem 3. Find the force acting vertically downwards on a mass of 200 g attached to a wire.

Mass = 200 g = 0.2 kg and acceleration due to gravity, $g = 9.81 \text{ m/s}^2$

$$\begin{aligned} \left. \begin{array}{l} \text{Force acting} \\ \text{downwards} \end{array} \right\} &= \text{weight} \\ &= \text{mass} \times \text{acceleration} \\ &= 0.2 \text{ kg} \times 9.81 \text{ m/s}^2 \\ &= \mathbf{1.962 \text{ N}} \end{aligned}$$

1.4 Work

The **unit of work or energy** is the **joule (J)** where one joule is one newton metre. The joule is defined as the work done or energy transferred when a force of one newton is exerted through a distance of one metre in the direction of the force. Thus

$$\text{work done on a body, in joules,} \quad \boxed{W = Fs}$$

where F is the force in newtons and s is the distance in metres moved by the body in the direction of the force. Energy is the capacity for doing work.

1.5 Power

The **unit of power** is the **watt (W)** where one watt is one joule per second. Power is defined as the rate of doing work or transferring energy. Thus,

$$\text{power, in watts,} \quad \boxed{P = \frac{W}{t}}$$

where W is the work done or energy transferred, in joules, and t is the time, in seconds. Thus,

$$\text{energy, in joules,} \quad \boxed{W = Pt}$$

Problem 4. A portable machine requires a force of 200 N to move it. How much work is done if the machine is moved 20 m and what average power is utilized if the movement takes 25 s?

$$\begin{aligned} \text{Work done} &= \text{force} \times \text{distance} \\ &= 200 \text{ N} \times 20 \text{ m} \\ &= \mathbf{4000 \text{ Nm or 4 kJ}} \end{aligned}$$

$$\begin{aligned} \text{Power} &= \frac{\text{work done}}{\text{time taken}} \\ &= \frac{4000 \text{ J}}{25 \text{ s}} = \mathbf{160 \text{ J/s} = 160 \text{ W}} \end{aligned}$$

Problem 5. A mass of 1000 kg is raised through a height of 10 m in 20 s. What is (a) the work done and (b) the power developed?

- (a) Work done = force \times distance
and force = mass \times acceleration
Hence, work done = $(1000 \text{ kg} \times 9.81 \text{ m/s}^2) \times (10 \text{ m})$
= 98 100 Nm
= **98.1 kNm or 98.1 kJ**
- (b) Power = $\frac{\text{work done}}{\text{time taken}} = \frac{98100 \text{ J}}{20 \text{ s}}$
= 4905 J/s = **4905 W or 4.905 kW**

Now try the following exercise

Exercise 1 Further problems on charge, force, work and power

(Take $g = 9.81 \text{ m/s}^2$ where appropriate)

- 1 What quantity of electricity is carried by 6.24×10^{21} electrons? [1000 C]
- 2 In what time would a current of 1 A transfer a charge of 30 C? [30 s]
- 3 A current of 3 A flows for 5 minutes. What charge is transferred? [900 C]
- 4 How long must a current of 0.1 A flow so as to transfer a charge of 30 C? [5 minutes]
- 5 What force is required to give a mass of 20 kg an acceleration of 30 m/s^2 ? [600 N]
- 6 Find the accelerating force when a car having a mass of 1.7 Mg increases its speed with a constant acceleration of 3 m/s^2 [5.1 kN]
- 7 A force of 40 N accelerates a mass at 5 m/s^2 . Determine the mass. [8 kg]

- 8 Determine the force acting downwards on a mass of 1500 g suspended on a string. [14.72 N]
- 9 A force of 4 N moves an object 200 cm in the direction of the force. What amount of work is done? [8 J]
- 10 A force of 2.5 kN is required to lift a load. How much work is done if the load is lifted through 500 cm? [12.5 kJ]
- 11 An electromagnet exerts a force of 12 N and moves a soft iron armature through a distance of 1.5 cm in 40 ms. Find the power consumed. [4.5 W]
- 12 A mass of 500 kg is raised to a height of 6 m in 30 s. Find (a) the work done and (b) the power developed. [(a) 29.43 kNm (b) 981 W]

1.6 Electrical potential and e.m.f.

The **unit of electric potential** is the volt (V), where one volt is one joule per coulomb. One volt is defined as the difference in potential between two points in a conductor which, when carrying a current of one ampere, dissipates a power of one watt, i.e.

$$\begin{aligned} \text{volts} &= \frac{\text{watts}}{\text{amperes}} = \frac{\text{joules/second}}{\text{amperes}} \\ &= \frac{\text{joules}}{\text{ampere seconds}} = \frac{\text{joules}}{\text{coulombs}} \end{aligned}$$

A change in electric potential between two points in an electric circuit is called a **potential difference**. The **electromotive force (e.m.f.)** provided by a source of energy such as a battery or a generator is measured in volts.

1.7 Resistance and conductance

The **unit of electric resistance** is the **ohm (Ω)**, where one ohm is one volt per ampere. It is defined as the resistance between two points in a conductor when a constant electric potential of one volt applied

at the two points produces a current flow of one ampere in the conductor. Thus,

$$\text{resistance, in ohms} \quad R = \frac{V}{I}$$

where V is the potential difference across the two points, in volts, and I is the current flowing between the two points, in amperes.

The reciprocal of resistance is called **conductance** and is measured in siemens (S). Thus

$$\text{conductance, in siemens} \quad G = \frac{1}{R}$$

where R is the resistance in ohms.

Problem 6. Find the conductance of a conductor of resistance: (a) 10Ω (b) $5 \text{ k}\Omega$ (c) $100 \text{ m}\Omega$.

$$(a) \text{ Conductance } G = \frac{1}{R} = \frac{1}{10} \text{ siemen} = \mathbf{0.1 \text{ S}}$$

$$(b) G = \frac{1}{R} = \frac{1}{5 \times 10^3} \text{ S} = 0.2 \times 10^{-3} \text{ S} = \mathbf{0.2 \text{ mS}}$$

$$(c) G = \frac{1}{R} = \frac{1}{100 \times 10^{-3}} \text{ S} = \frac{10^3}{100} \text{ S} = \mathbf{10 \text{ S}}$$

1.8 Electrical power and energy

When a direct current of I amperes is flowing in an electric circuit and the voltage across the circuit is V volts, then

$$\text{power, in watts} \quad P = VI$$

$$\begin{aligned} \text{Electrical energy} &= \text{Power} \times \text{time} \\ &= VI t \text{ joules} \end{aligned}$$

Although the unit of energy is the joule, when dealing with large amounts of energy, the unit used is the **kilowatt hour (kWh)** where

$$\begin{aligned} 1 \text{ kWh} &= 1000 \text{ watt hour} \\ &= 1000 \times 3600 \text{ watt seconds or joules} \\ &= 3\,600\,000 \text{ J} \end{aligned}$$

Problem 7. A source e.m.f. of 5 V supplies a current of 3 A for 10 minutes. How much energy is provided in this time?

Energy = power \times time, and power = voltage \times current. Hence

$$\begin{aligned} \text{Energy} &= VI t = 5 \times 3 \times (10 \times 60) \\ &= 9000 \text{ Ws or J} = \mathbf{9 \text{ kJ}} \end{aligned}$$

Problem 8. An electric heater consumes 1.8 MJ when connected to a 250 V supply for 30 minutes. Find the power rating of the heater and the current taken from the supply.

$$\begin{aligned} \text{Power} &= \frac{\text{energy}}{\text{time}} = \frac{1.8 \times 10^6 \text{ J}}{30 \times 60 \text{ s}} \\ &= 1000 \text{ J/s} = 1000 \text{ W} \end{aligned}$$

i.e. **power rating of heater = 1 kW**

$$\text{Power } P = VI, \text{ thus } I = \frac{P}{V} = \frac{1000}{250} = 4 \text{ A}$$

Hence the current taken from the supply is 4 A.

Now try the following exercise

Exercise 2 Further problems on e.m.f., resistance, conductance, power and energy

- Find the conductance of a resistor of resistance (a) 10Ω (b) $2 \text{ k}\Omega$ (c) $2 \text{ m}\Omega$
[(a) 0.1 S (b) 0.5 mS (c) 500 S]
- A conductor has a conductance of $50 \mu\text{S}$. What is its resistance? [20 k Ω]
- An e.m.f. of 250 V is connected across a resistance and the current flowing through the resistance is 4 A . What is the power developed? [1 kW]
- 450 J of energy are converted into heat in 1 minute. What power is dissipated? [7.5 W]
- A current of 10 A flows through a conductor and 10 W is dissipated. What p.d. exists across the ends of the conductor? [1 V]

6 A battery of e.m.f. 12 V supplies a current of 5 A for 2 minutes. How much energy is supplied in this time? [7.2 kJ]

7 A d.c. electric motor consumes 36 MJ when connected to a 250 V supply for 1 hour. Find the power rating of the motor and the current taken from the supply. [10 kW, 40 A]

1.9 Summary of terms, units and their symbols

Quantity	Quantity Symbol	Unit	Unit Symbol
Length	l	metre	m
Mass	m	kilogram	kg
Time	t	second	s
Velocity	v	metres per second	m/s or m s^{-1}
Acceleration	a	metres per second squared	m/s^2 or m s^{-2}
Force	F	newton	N
Electrical charge or quantity	Q	coulomb	C
Electric current	I	ampere	A
Resistance	R	ohm	Ω
Conductance	G	siemen	S
Electromotive force	E	volt	V
Potential difference	V	volt	V
Work	W	joule	J
Energy	E (or W)	joule	J
Power	P	watt	W

Now try the following exercises

Exercise 3 Short answer questions on units associated with basic electrical quantities

- 1 What does 'SI units' mean?
- 2 Complete the following:
Force = \times
- 3 What do you understand by the term 'potential difference'?

4 Define electric current in terms of charge and time

5 Name the units used to measure:
(a) the quantity of electricity
(b) resistance
(c) conductance

6 Define the coulomb

7 Define electrical energy and state its unit

8 Define electrical power and state its unit

9 What is electromotive force?

10 Write down a formula for calculating the power in a d.c. circuit

11 Write down the symbols for the following quantities:

- (a) electric charge (b) work
(c) e.m.f. (d) p.d.

12 State which units the following abbreviations refer to:

- (a) A (b) C (c) J (d) N (e) m

Exercise 4 Multi-choice questions on units associated with basic electrical quantities (Answers on page 375)

- 1 A resistance of 50 k Ω has a conductance of:
(a) 20 S (b) 0.02 S
(c) 0.02 mS (d) 20 kS
- 2 Which of the following statements is incorrect?
(a) 1 N = 1 kg m/s² (b) 1 V = 1 J/C
(c) 30 mA = 0.03 A (d) 1 J = 1 N/m
- 3 The power dissipated by a resistor of 10 Ω when a current of 2 A passes through it is:
(a) 0.4 W (b) 20 W (c) 40 W (d) 200 W
- 4 A mass of 1200 g is accelerated at 200 cm/s² by a force. The value of the force required is:
(a) 2.4 N (b) 2400 N
(c) 240 kN (d) 0.24 N
- 5 A charge of 240 C is transferred in 2 minutes. The current flowing is:
(a) 120 A (b) 480 A (c) 2 A (d) 8 A
- 6 A current of 2 A flows for 10 h through a 100 Ω resistor. The energy consumed by the resistor is:

- | | | | |
|---|--------------|------------------------------------|----------------|
| (a) 0.5 kWh | (b) 4 kWh | (c) energy | |
| (c) 2 kWh | (d) 0.02 kWh | (d) quantity of electricity | |
| 7 The unit of quantity of electricity is the: | | 10 In order that work may be done: | |
| (a) volt | (b) coulomb | (a) a supply of energy is required | |
| (c) ohm | (d) joule | (b) the circuit must have a switch | |
| 8 Electromotive force is provided by: | | (c) coal must be burnt | |
| (a) resistance's | | (d) two wires are necessary | |
| (b) a conducting path | | 11 The ohm is the unit of: | |
| (c) an electric current | | (a) charge | (b) resistance |
| (d) an electrical supply source | | (c) power | (d) current |
| 9 The coulomb is a unit of: | | 12 The unit of current is the: | |
| (a) power | | (a) volt | (b) coulomb |
| (b) voltage | | (c) joule | (d) ampere |

An introduction to electric circuits

At the end of this chapter you should be able to:

- appreciate that engineering systems may be represented by block diagrams
- recognize common electrical circuit diagram symbols
- understand that electric current is the rate of movement of charge and is measured in amperes
- appreciate that the unit of charge is the coulomb
- calculate charge or quantity of electricity Q from $Q = It$
- understand that a potential difference between two points in a circuit is required for current to flow
- appreciate that the unit of p.d. is the volt
- understand that resistance opposes current flow and is measured in ohms
- appreciate what an ammeter, a voltmeter, an ohmmeter, a multimeter and a C.R.O. measure
- distinguish between linear and non-linear devices
- state Ohm's law as $V = IR$ or $I = V/R$ or $R = V/I$
- use Ohm's law in calculations, including multiples and sub-multiples of units
- describe a conductor and an insulator, giving examples of each
- appreciate that electrical power P is given by $P = VI = I^2R = V^2/R$ watts
- calculate electrical power
- define electrical energy and state its unit
- calculate electrical energy
- state the three main effects of an electric current, giving practical examples of each
- explain the importance of fuses in electrical circuits

2.1 Electrical/electronic system block diagrams

An electrical/electronic **system** is a group of components connected together to perform a desired function. Figure 2.1 shows a simple public address

system, where a microphone is used to collect acoustic energy in the form of sound pressure waves and converts this to electrical energy in the form of small voltages and currents; the signal from the microphone is then amplified by means of an electronic circuit containing transistors/integrated circuits before it is applied to the loudspeaker.

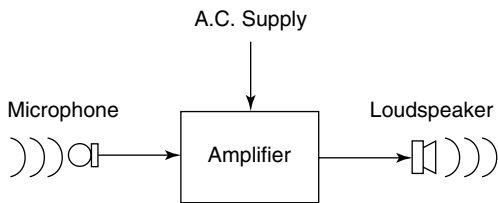

Figure 2.1

A **sub-system** is a part of a system which performs an identified function within the whole system; the amplifier in Fig. 2.1 is an example of a sub-system

A **component** or **element** is usually the simplest part of a system which has a specific and well-defined function – for example, the microphone in Fig. 2.1

The illustration in Fig. 2.1 is called a block diagram and electrical/electronic systems, which can often be quite complicated, can be better understood when broken down in this way. It is not always necessary to know precisely what is inside each sub-system in order to know how the whole system functions.

As another example of an engineering system, Fig. 2.2 illustrates a temperature control system containing a heat source (such as a gas boiler), a fuel controller (such as an electrical solenoid valve), a thermostat and a source of electrical energy. The system of Fig. 2.2 can be shown in block diagram form as in Fig. 2.3; the thermostat compares the

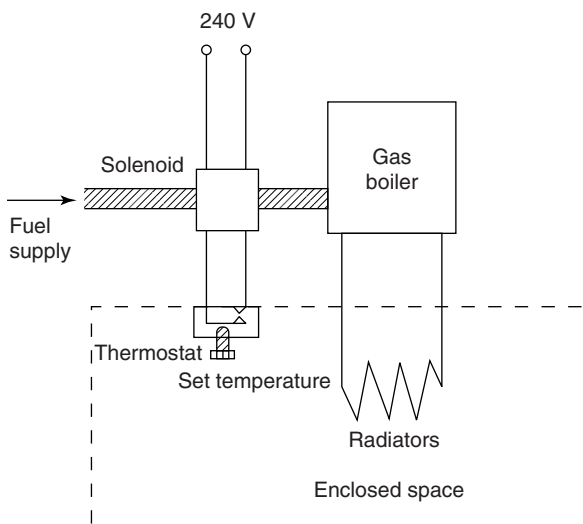

Figure 2.2

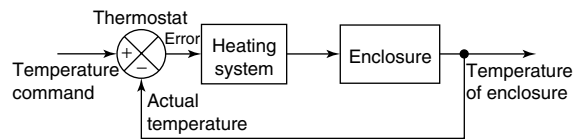

Figure 2.3

actual room temperature with the desired temperature and switches the heating on or off.

There are many types of engineering systems. A **communications system** is an example, where a local area network could comprise a file server, coaxial cable, network adapters, several computers and a laser printer; an **electromechanical system** is another example, where a car electrical system could comprise a battery, a starter motor, an ignition coil, a contact breaker and a distributor. All such systems as these may be represented by block diagrams.

2.2 Standard symbols for electrical components

Symbols are used for components in electrical circuit diagrams and some of the more common ones are shown in Fig. 2.4

2.3 Electric current and quantity of electricity

All **atoms** consist of **protons**, **neutrons** and **electrons**. The protons, which have positive electrical charges, and the neutrons, which have no electrical charge, are contained within the **nucleus**. Removed from the nucleus are minute negatively charged particles called electrons. Atoms of different materials differ from one another by having different numbers of protons, neutrons and electrons. An equal number of protons and electrons exist within an atom and it is said to be electrically balanced, as the positive and negative charges cancel each other out. When there are more than two electrons in an atom the electrons are arranged into **shells** at various distances from the nucleus.

All atoms are bound together by powerful forces of attraction existing between the nucleus and its electrons. Electrons in the outer shell of an atom, however, are attracted to their nucleus less powerfully than are electrons whose shells are nearer the nucleus.

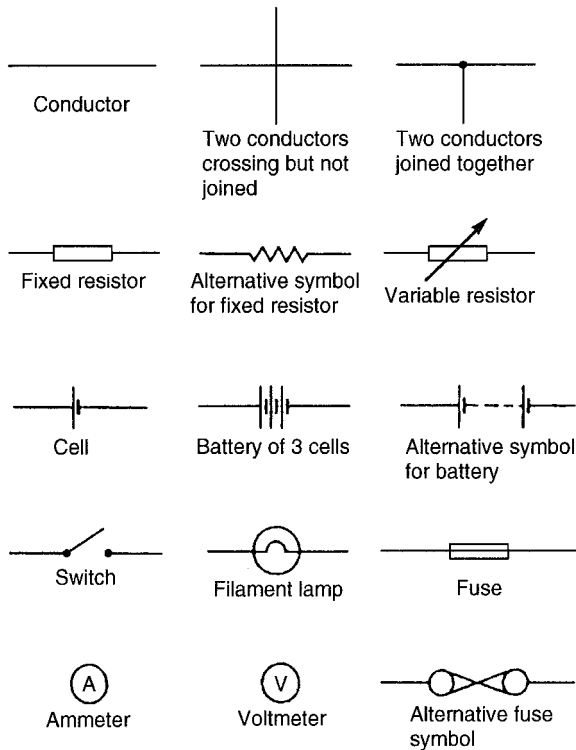

Figure 2.4

It is possible for an atom to lose an electron; the atom, which is now called an **ion**, is not now electrically balanced, but is positively charged and is thus able to attract an electron to itself from another atom. Electrons that move from one atom to another are called free electrons and such random motion can continue indefinitely. However, if an electric pressure or **voltage** is applied across any material there is a tendency for electrons to move in a particular direction. This movement of free electrons, known as **drift**, constitutes an electric current flow. **Thus current is the rate of movement of charge.**

Conductors are materials that contain electrons that are loosely connected to the nucleus and can easily move through the material from one atom to another.

Insulators are materials whose electrons are held firmly to their nucleus.

The unit used to measure the **quantity of electrical charge Q** is called the **coulomb C** (where 1 coulomb = 6.24×10^{18} electrons)

If the drift of electrons in a conductor takes place at the rate of one coulomb per second the resulting

current is said to be a current of one ampere.

Thus 1 ampere = 1 coulomb per second or

$$1 \text{ A} = 1 \text{ C/s}$$

Hence 1 coulomb = 1 ampere second or

$$1 \text{ C} = 1 \text{ As}$$

Generally, if I is the current in amperes and t the time in seconds during which the current flows, then $I \times t$ represents the quantity of electrical charge in coulombs, i.e. quantity of electrical charge transferred,

$$Q = I \times t \text{ coulombs}$$

Problem 1. What current must flow if 0.24 coulombs is to be transferred in 15 ms?

Since the quantity of electricity, $Q = It$, then

$$\begin{aligned} I &= \frac{Q}{t} = \frac{0.24}{15 \times 10^{-3}} = \frac{0.24 \times 10^3}{15} \\ &= \frac{240}{15} = \mathbf{16 \text{ A}} \end{aligned}$$

Problem 2. If a current of 10 A flows for four minutes, find the quantity of electricity transferred.

Quantity of electricity, $Q = It$ coulombs. $I = 10 \text{ A}$ and $t = 4 \times 60 = 240 \text{ s}$. Hence

$$Q = 10 \times 240 = \mathbf{2400 \text{ C}}$$

Now try the following exercise

Exercise 5 Further problems on charge

- 1 In what time would a current of 10 A transfer a charge of 50 C ? [5 s]
- 2 A current of 6 A flows for 10 minutes. What charge is transferred ? [3600 C]
- 3 How long must a current of 100 mA flow so as to transfer a charge of 80 C? [13 min 20 s]

2.4 Potential difference and resistance

For a continuous current to flow between two points in a circuit a **potential difference (p.d.)** or **voltage, V**, is required between them; a complete conducting path is necessary to and from the source of electrical energy. The unit of p.d. is the **volt, V**.

Figure 2.5 shows a cell connected across a filament lamp. Current flow, by convention, is considered as flowing from the positive terminal of the cell, around the circuit to the negative terminal.

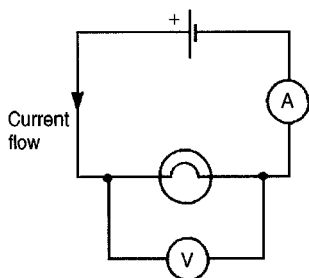

Figure 2.5

The flow of electric current is subject to friction. This friction, or opposition, is called **resistance R** and is the property of a conductor that limits current. The unit of resistance is the **ohm**; 1 ohm is defined as the resistance which will have a current of 1 ampere flowing through it when 1 volt is connected across it,

i.e.
$$\text{resistance } R = \frac{\text{Potential difference}}{\text{current}}$$

2.5 Basic electrical measuring instruments

An **ammeter** is an instrument used to measure current and must be connected **in series** with the circuit. Figure 2.5 shows an ammeter connected in series with the lamp to measure the current flowing through it. Since all the current in the circuit passes through the ammeter it must have a very **low resistance**.

A **voltmeter** is an instrument used to measure p.d. and must be connected **in parallel** with the part of the circuit whose p.d. is required. In Fig. 2.5, a voltmeter is connected in parallel with the lamp to measure the p.d. across it. To avoid a significant

current flowing through it a voltmeter must have a very **high resistance**.

An **ohmmeter** is an instrument for measuring resistance.

A **multimeter**, or universal instrument, may be used to measure voltage, current and resistance. An 'Avometer' is a typical example.

The **cathode ray oscilloscope (CRO)** may be used to observe waveforms and to measure voltages and currents. The display of a CRO involves a spot of light moving across a screen. The amount by which the spot is deflected from its initial position depends on the p.d. applied to the terminals of the CRO and the range selected. The displacement is calibrated in 'volts per cm'. For example, if the spot is deflected 3 cm and the volts/cm switch is on 10 V/cm then the magnitude of the p.d. is $3 \text{ cm} \times 10 \text{ V/cm}$, i.e. 30 V.

(See Chapter 10 for more detail about electrical measuring instruments and measurements.)

2.6 Linear and non-linear devices

Figure 2.6 shows a circuit in which current I can be varied by the variable resistor R_2 . For various settings of R_2 , the current flowing in resistor R_1 , displayed on the ammeter, and the p.d. across R_1 , displayed on the voltmeter, are noted and a graph is plotted of p.d. against current. The result is shown in Fig. 2.7(a) where the straight line graph passing through the origin indicates that current is directly proportional to the p.d. Since the gradient, i.e. (p.d.)/(current) is constant, resistance R_1 is constant. A resistor is thus an example of a **linear device**.

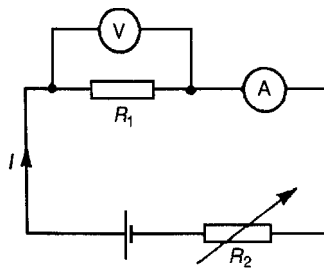

Figure 2.6

If the resistor R_1 in Fig. 2.6 is replaced by a component such as a lamp then the graph shown in Fig. 2.7(b) results when values of p.d. are noted for various current readings. Since the gradient is

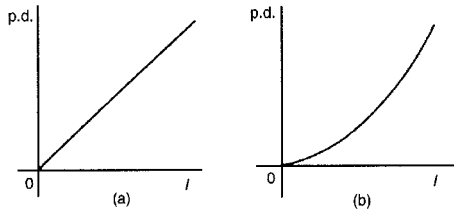

Figure 2.7

changing, the lamp is an example of a **non-linear device**.

2.7 Ohm's law

Ohm's law states that the current I flowing in a circuit is directly proportional to the applied voltage V and inversely proportional to the resistance R , provided the temperature remains constant. Thus,

$$I = \frac{V}{R} \text{ or } V = IR \text{ or } R = \frac{V}{I}$$

Problem 3. The current flowing through a resistor is 0.8 A when a p.d. of 20 V is applied. Determine the value of the resistance.

From Ohm's law,

$$\text{resistance } R = \frac{V}{I} = \frac{20}{0.8} = \frac{200}{8} = \mathbf{25 \Omega}$$

2.8 Multiples and sub-multiples

Currents, voltages and resistances can often be very large or very small. Thus multiples and sub-multiples of units are often used, as stated in chapter 1. The most common ones, with an example of each, are listed in Table 2.1

Problem 4. Determine the p.d. which must be applied to a 2 kΩ resistor in order that a current of 10 mA may flow.

$$\text{Resistance } R = 2 \text{ k}\Omega = 2 \times 10^3 = 2000 \Omega$$

$$\begin{aligned} \text{Current } I &= 10 \text{ mA} = 10 \times 10^{-3} \text{ A} \\ &\text{or } \frac{10}{10^3} \text{ A or } \frac{10}{1000} \text{ A} = 0.01 \text{ A} \end{aligned}$$

From Ohm's law, potential difference,

$$V = IR = (0.01)(2000) = \mathbf{20 \text{ V}}$$

Problem 5. A coil has a current of 50 mA flowing through it when the applied voltage is 12 V. What is the resistance of the coil?

$$\begin{aligned} \text{Resistance, } R &= \frac{V}{I} = \frac{12}{50 \times 10^{-3}} \\ &= \frac{12 \times 10^3}{50} = \frac{12000}{50} = \mathbf{240 \Omega} \end{aligned}$$

Table 2.1

Prefix	Name	Meaning	Example
M	mega	multiply by 1 000 000 (i.e. $\times 10^6$)	2 MΩ = 2 000 000 ohms
k	kilo	multiply by 1000 (i.e. $\times 10^3$)	10 kV = 10 000 volts
m	milli	divide by 1000 (i.e. $\times 10^{-3}$)	25 mA = $\frac{25}{1000}$ A = 0.025 amperes
μ	micro	divide by 1 000 000 (i.e. $\times 10^{-6}$)	50 μV = $\frac{50}{1\,000\,000}$ V = 0.000 05 volts

Problem 6. A 100 V battery is connected across a resistor and causes a current of 5 mA to flow. Determine the resistance of the resistor. If the voltage is now reduced to 25 V, what will be the new value of the current flowing?

$$\begin{aligned} \text{Resistance } R &= \frac{V}{I} = \frac{100}{5 \times 10^{-3}} = \frac{100 \times 10^3}{5} \\ &= 20 \times 10^3 = \mathbf{20 \text{ k}\Omega} \end{aligned}$$

Current when voltage is reduced to 25 V,

$$I = \frac{V}{R} = \frac{25}{20 \times 10^3} = \frac{25}{20} \times 10^{-3} = \mathbf{1.25 \text{ mA}}$$

Problem 7. What is the resistance of a coil which draws a current of (a) 50 mA and (b) 200 μA from a 120 V supply?

$$\begin{aligned} \text{(a) Resistance } R &= \frac{V}{I} = \frac{120}{50 \times 10^{-3}} \\ &= \frac{120}{0.05} = \frac{12000}{5} \\ &= \mathbf{2400 \Omega \text{ or } 2.4 \text{ k}\Omega} \end{aligned}$$

$$\begin{aligned} \text{(b) Resistance } R &= \frac{120}{200 \times 10^{-6}} = \frac{120}{0.0002} \\ &= \frac{1200000}{2} = \mathbf{600000 \Omega} \\ &\text{or } \mathbf{600 \text{ k}\Omega \text{ or } 0.6 \text{ M}\Omega} \end{aligned}$$

Problem 8. The current/voltage relationship for two resistors A and B is as shown in Fig. 2.8 Determine the value of the resistance of each resistor.

For resistor A,

$$\begin{aligned} R &= \frac{V}{I} = \frac{20 \text{ V}}{20 \text{ mA}} = \frac{20}{0.02} = \frac{2000}{2} \\ &= \mathbf{1000 \Omega \text{ or } 1 \text{ k}\Omega} \end{aligned}$$

For resistor B,

$$\begin{aligned} R &= \frac{V}{I} = \frac{16 \text{ V}}{5 \text{ mA}} = \frac{16}{0.005} = \frac{16000}{5} \\ &= \mathbf{3200 \Omega \text{ or } 3.2 \text{ k}\Omega} \end{aligned}$$

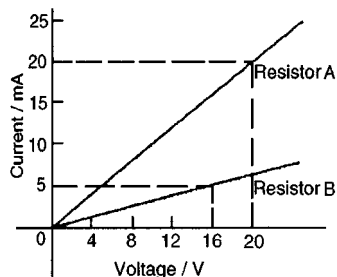

Figure 2.8

Now try the following exercise

Exercise 6 Further problems on Ohm's law

- The current flowing through a heating element is 5 A when a p.d. of 35 V is applied across it. Find the resistance of the element. [7 Ω]
- A 60 W electric light bulb is connected to a 240 V supply. Determine (a) the current flowing in the bulb and (b) the resistance of the bulb. [(a) 0.25 A (b) 960 Ω]
- Graphs of current against voltage for two resistors P and Q are shown in Fig. 2.9 Determine the value of each resistor. [2 m Ω , 5 m Ω]

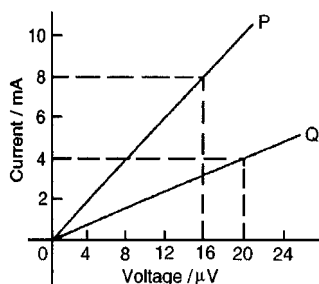

Figure 2.9

- Determine the p.d. which must be applied to a 5 k Ω resistor such that a current of 6 mA may flow. [30 V]

2.9 Conductors and insulators

A **conductor** is a material having a low resistance which allows electric current to flow in it. All metals

are conductors and some examples include copper, aluminium, brass, platinum, silver, gold and carbon.

An **insulator** is a material having a high resistance which does not allow electric current to flow in it. Some examples of insulators include plastic, rubber, glass, porcelain, air, paper, cork, mica, ceramics and certain oils.

2.10 Electrical power and energy

Electrical power

Power P in an electrical circuit is given by the product of potential difference V and current I , as stated in Chapter 1. The unit of power is the **watt, W** .

Hence

$$\boxed{P = V \times I \text{ watts}} \quad (1)$$

From Ohm's law, $V = IR$. Substituting for V in equation (1) gives:

$$P = (IR) \times I$$

i.e.

$$\boxed{P = I^2 R \text{ watts}}$$

Also, from Ohm's law, $I = V/R$. Substituting for I in equation (1) gives:

$$P = V \times \frac{V}{R}$$

i.e.

$$\boxed{P = \frac{V^2}{R} \text{ watts}}$$

There are thus three possible formulae which may be used for calculating power.

Problem 9. A 100 W electric light bulb is connected to a 250 V supply. Determine
(a) the current flowing in the bulb, and
(b) the resistance of the bulb.

Power $P = V \times I$, from which, current $I = \frac{P}{V}$

$$(a) \text{ Current } I = \frac{100}{250} = \frac{10}{25} = \frac{2}{5} = \mathbf{0.4 \text{ A}}$$

$$(b) \text{ Resistance } R = \frac{V}{I} = \frac{250}{0.4} = \frac{2500}{4} = \mathbf{625 \Omega}$$

Problem 10. Calculate the power dissipated when a current of 4 mA flows through a resistance of 5 k Ω .

$$\begin{aligned} \text{Power } P &= I^2 R = (4 \times 10^{-3})^2 (5 \times 10^3) \\ &= 16 \times 10^{-6} \times 5 \times 10^3 \\ &= 80 \times 10^{-3} \\ &= \mathbf{0.08 \text{ W}} \text{ or } \mathbf{80 \text{ mW}} \end{aligned}$$

Alternatively, since $I = 4 \times 10^{-3}$ and $R = 5 \times 10^3$ then from Ohm's law, voltage

$$V = IR = 4 \times 10^{-3} \times 5 \times 10^3 = 20 \text{ V}$$

Hence,

$$\begin{aligned} \text{power } P &= V \times I = 20 \times 4 \times 10^{-3} \\ &= \mathbf{80 \text{ mW}} \end{aligned}$$

Problem 11. An electric kettle has a resistance of 30 Ω . What current will flow when it is connected to a 240 V supply? Find also the power rating of the kettle.

$$\text{Current, } I = \frac{V}{R} = \frac{240}{30} = \mathbf{8 \text{ A}}$$

$$\begin{aligned} \text{Power, } P &= VI = 240 \times 8 = 1920 \text{ W} \\ &= \mathbf{1.92 \text{ kW}} = \text{power rating of kettle} \end{aligned}$$

Problem 12. A current of 5 A flows in the winding of an electric motor, the resistance of the winding being 100 Ω . Determine
(a) the p.d. across the winding, and (b) the power dissipated by the coil.

(a) Potential difference across winding,

$$V = IR = 5 \times 100 = \mathbf{500 \text{ V}}$$

(b) Power dissipated by coil,

$$\begin{aligned} P &= I^2 R = 5^2 \times 100 \\ &= \mathbf{2500 \text{ W}} \text{ or } \mathbf{2.5 \text{ kW}} \end{aligned}$$

$$\begin{aligned} (\text{Alternatively, } P &= V \times I = 500 \times 5 \\ &= \mathbf{2500 \text{ W}} \text{ or } \mathbf{2.5 \text{ kW}}) \end{aligned}$$

Problem 13. The hot resistance of a 240 V filament lamp is $960\ \Omega$. Find the current taken by the lamp and its power rating.

From Ohm's law,

$$\begin{aligned}\text{current } I &= \frac{V}{R} = \frac{240}{960} \\ &= \frac{24}{96} = \frac{1}{4}\text{ A or } \mathbf{0.25\text{ A}}\end{aligned}$$

$$\text{Power rating } P = VI = (240)\left(\frac{1}{4}\right) = \mathbf{60\text{ W}}$$

Electrical energy

$$\mathbf{\text{Electrical energy} = \text{power} \times \text{time}}$$

If the power is measured in watts and the time in seconds then the unit of energy is watt-seconds or **joules**. If the power is measured in kilowatts and the time in hours then the unit of energy is **kilowatt-hours**, often called the '**unit of electricity**'. The 'electricity meter' in the home records the number of kilowatt-hours used and is thus an energy meter.

Problem 14. A 12 V battery is connected across a load having a resistance of $40\ \Omega$. Determine the current flowing in the load, the power consumed and the energy dissipated in 2 minutes.

$$\text{Current } I = \frac{V}{R} = \frac{12}{40} = \mathbf{0.3\text{ A}}$$

$$\text{Power consumed, } P = VI = (12)(0.3) = \mathbf{3.6\text{ W.}}$$

$$\begin{aligned}\text{Energy dissipated} &= \text{power} \times \text{time} \\ &= (3.6\text{ W})(2 \times 60\text{ s}) \\ &= \mathbf{432\text{ J}} \text{ (since } 1\text{ J} = 1\text{ Ws)}\end{aligned}$$

Problem 15. A source of e.m.f. of 15 V supplies a current of 2 A for 6 minutes. How much energy is provided in this time?

Energy = power \times time, and power = voltage \times current. Hence

$$\begin{aligned}\text{energy} &= VIt = 15 \times 2 \times (6 \times 60) \\ &= 10\,800\text{ Ws or J} = \mathbf{10.8\text{ kJ}}\end{aligned}$$

Problem 16. Electrical equipment in an office takes a current of 13 A from a 240 V supply. Estimate the cost per week of electricity if the equipment is used for 30 hours each week and 1 kWh of energy costs 6p.

$$\begin{aligned}\text{Power} &= VI \text{ watts} = 240 \times 13 \\ &= 3120\text{ W} = \mathbf{3.12\text{ kW}}\end{aligned}$$

$$\begin{aligned}\text{Energy used per week} &= \text{power} \times \text{time} \\ &= (3.12\text{ kW}) \times (30\text{ h}) \\ &= \mathbf{93.6\text{ kWh}}\end{aligned}$$

Cost at 6p per kWh = $93.6 \times 6 = 561.6\text{p}$. Hence **weekly cost of electricity = £5.62**

Problem 17. An electric heater consumes 3.6 MJ when connected to a 250 V supply for 40 minutes. Find the power rating of the heater and the current taken from the supply.

$$\text{Power} = \frac{\text{energy}}{\text{time}} = \frac{3.6 \times 10^6\text{ J}}{40 \times 60\text{ s}} \text{ (or W)} = 1500\text{ W}$$

i.e. Power rating of heater = **1.5 kW**.

$$\begin{aligned}\text{Power } P &= VI, \\ \text{thus } I &= \frac{P}{V} = \frac{1500}{250} = \mathbf{6\text{ A}}\end{aligned}$$

Hence the current taken from the supply is **6 A**.

Problem 18. Determine the power dissipated by the element of an electric fire of resistance $20\ \Omega$ when a current of 10 A flows through it. If the fire is on for 6 hours determine the energy used and the cost if 1 unit of electricity costs 6.5p.

$$\begin{aligned}\text{Power } P &= I^2R = 10^2 \times 20 \\ &= 100 \times 20 = \mathbf{2000\text{ W or } 2\text{ kW.}}\end{aligned}$$

(Alternatively, from Ohm's law,

$$V = IR = 10 \times 20 = 200\text{ V},$$

hence power

$$P = V \times I = 200 \times 10 = 2000\text{ W} = 2\text{ kW}.)$$

Energy used in 6 hours = power \times time = $2 \text{ kW} \times 6 \text{ h} = \mathbf{12 \text{ kWh}}$.

1 unit of electricity = 1 kWh; hence the number of units used is 12. Cost of energy = $12 \times 6.5 = \mathbf{78p}$

Problem 19. A business uses two 3 kW fires for an average of 20 hours each per week, and six 150 W lights for 30 hours each per week. If the cost of electricity is 6.4p per unit, determine the weekly cost of electricity to the business.

Energy = power \times time.

Energy used by one 3 kW fire in 20 hours = $3 \text{ kW} \times 20 \text{ h} = 60 \text{ kWh}$.

Hence weekly energy used by two 3 kW fires = $2 \times 60 = 120 \text{ kWh}$.

Energy used by one 150 W light for 30 hours = $150 \text{ W} \times 30 \text{ h} = 4500 \text{ Wh} = 4.5 \text{ kWh}$.

Hence weekly energy used by six 150 W lamps = $6 \times 4.5 = 27 \text{ kWh}$.

Total energy used per week = $120 + 27 = 147 \text{ kWh}$.

1 unit of electricity = 1 kWh of energy. Thus weekly cost of energy at 6.4p per kWh = $6.4 \times 147 = 940.8p = \mathbf{\pounds 9.41}$.

Now try the following exercise

Exercise 7 Further problems on power and energy

- The hot resistance of a 250 V filament lamp is 625Ω . Determine the current taken by the lamp and its power rating. [0.4 A, 100 W]
- Determine the resistance of a coil connected to a 150 V supply when a current of (a) 75 mA (b) $300 \mu\text{A}$ flows through it. [(a) $2 \text{ k}\Omega$ (b) $0.5 \text{ M}\Omega$]
- Determine the resistance of an electric fire which takes a current of 12 A from a 240 V supply. Find also the power rating of the fire and the energy used in 20 h. [20Ω , 2.88 kW, 57.6 kWh]
- Determine the power dissipated when a current of 10 mA flows through an appliance having a resistance of $8 \text{ k}\Omega$. [0.8 W]
- 85.5 J of energy are converted into heat in 9 s. What power is dissipated? [9.5 W]

- A current of 4 A flows through a conductor and 10 W is dissipated. What p.d. exists across the ends of the conductor? [2.5 V]
- Find the power dissipated when:
 - a current of 5 mA flows through a resistance of $20 \text{ k}\Omega$
 - a voltage of 400 V is applied across a $120 \text{ k}\Omega$ resistor
 - a voltage applied to a resistor is 10 kV and the current flow is 4 mA
[(a) 0.5 W (b) 1.33 W (c) 40 W]
- A battery of e.m.f. 15 V supplies a current of 2 A for 5 min. How much energy is supplied in this time? [9 kJ]
- A d.c. electric motor consumes 72 MJ when connected to 400 V supply for 2 h 30 min. Find the power rating of the motor and the current taken from the supply. [8 kW, 20 A]
- A p.d. of 500 V is applied across the winding of an electric motor and the resistance of the winding is 50Ω . Determine the power dissipated by the coil. [5 kW]
- In a household during a particular week three 2 kW fires are used on average 25 h each and eight 100 W light bulbs are used on average 35 h each. Determine the cost of electricity for the week if 1 unit of electricity costs 7p. [£12.46]
- Calculate the power dissipated by the element of an electric fire of resistance 30Ω when a current of 10 A flows in it. If the fire is on for 30 hours in a week determine the energy used. Determine also the weekly cost of energy if electricity costs 6.5p per unit. [3 kW, 90 kWh, £5.85]

2.11 Main effects of electric current

The three main effects of an electric current are:

- magnetic effect
- chemical effect
- heating effect

Some practical applications of the effects of an electric current include:

Magnetic effect: bells, relays, motors, generators, transformers, telephones, car-ignition and lifting magnets (see Chapter 8)

Chemical effect: primary and secondary cells and electroplating (see Chapter 4)

Heating effect: cookers, water heaters, electric fires, irons, furnaces, kettles and soldering irons

2.12 Fuses

A **fuse** is used to prevent overloading of electrical circuits. The fuse, which is made of material having a low melting point, utilizes the heating effect of an electric current. A fuse is placed in an electrical circuit and if the current becomes too large the fuse wire melts and so breaks the circuit. A circuit diagram symbol for a fuse is shown in Fig. 2.1, on page 11.

Problem 20. If 5 A, 10 A and 13 A fuses are available, state which is most appropriate for the following appliances which are both connected to a 240 V supply: (a) Electric toaster having a power rating of 1 kW
(b) Electric fire having a power rating of 3 kW.

Power $P = VI$, from which, current $I = \frac{P}{V}$

(a) For the toaster,

$$\text{current } I = \frac{P}{V} = \frac{1000}{240} = \frac{100}{24} = 4.17 \text{ A}$$

Hence a **5 A fuse** is most appropriate

(b) For the fire,

$$\text{current } I = \frac{P}{V} = \frac{3000}{240} = \frac{300}{24} = 12.5 \text{ A}$$

Hence a **13 A fuse** is most appropriate

Now try the following exercises

Exercise 8 Further problem on fuses

- 1 A television set having a power rating of 120 W and electric lawnmower of power rating 1 kW are both connected to a 250 V supply. If 3 A, 5 A and 10 A fuses are available state which is the most appropriate for each appliance. [3 A, 5 A]

Exercise 9 Short answer questions on the introduction to electric circuits

- Draw the preferred symbols for the following components used when drawing electrical circuit diagrams:

(a) fixed resistor	(b) cell
(c) filament lamp	(d) fuse
(e) voltmeter	
- State the unit of
 - current
 - potential difference
 - resistance
- State an instrument used to measure
 - current
 - potential difference
 - resistance
- What is a multimeter?
- State Ohm's law
- Give one example of
 - a linear device
 - a non-linear device
- State the meaning of the following abbreviations of prefixes used with electrical units:

(a) k	(b) μ	(c) m	(d) M
-------	-----------	-------	-------
- What is a conductor? Give four examples
- What is an insulator? Give four examples
- Complete the following statement: 'An ammeter has a ... resistance and must be connected ... with the load'
- Complete the following statement: 'A voltmeter has a ... resistance and must be connected ... with the load'
- State the unit of electrical power. State three formulae used to calculate power

- 13 State two units used for electrical energy
- 14 State the three main effects of an electric current and give two examples of each
- 15 What is the function of a fuse in an electrical circuit?

Exercise 10 Multi-choice problems on the introduction to electric circuits (Answers on page 375)

- 1 $60\ \mu\text{s}$ is equivalent to:
 - (a) 0.06 s
 - (b) 0.00006 s
 - (c) 1000 minutes
 - (d) 0.6 s
- 2 The current which flows when 0.1 coulomb is transferred in 10 ms is:
 - (a) 1 A
 - (b) 10 A
 - (c) 10 mA
 - (d) 100 mA
- 3 The p.d. applied to a $1\ \text{k}\Omega$ resistance in order that a current of $100\ \mu\text{A}$ may flow is:
 - (a) 1 V
 - (b) 100 V
 - (c) 0.1 V
 - (d) 10 V
- 4 Which of the following formulae for electrical power is incorrect?
 - (a) VI
 - (b) $\frac{V}{I}$
 - (c) I^2R
 - (d) $\frac{V^2}{R}$
- 5 The power dissipated by a resistor of $4\ \Omega$ when a current of 5 A passes through it is:
 - (a) 6.25 W
 - (b) 20 W
 - (c) 80 W
 - (d) 100 W
- 6 Which of the following statements is true?
 - (a) Electric current is measured in volts
 - (b) $200\ \text{k}\Omega$ resistance is equivalent to $2\ \text{M}\Omega$
 - (c) An ammeter has a low resistance and must be connected in parallel with a circuit
 - (d) An electrical insulator has a high resistance
- 7 A current of 3 A flows for 50 h through a $6\ \Omega$ resistor. The energy consumed by the resistor is:
 - (a) 0.9 kWh
 - (b) 2.7 kWh
 - (c) 9 kWh
 - (d) 27 kWh
- 8 What must be known in order to calculate the energy used by an electrical appliance?
 - (a) voltage and current
 - (b) current and time of operation
 - (c) power and time of operation
 - (d) current and resistance
- 9 Voltage drop is the:
 - (a) maximum potential
 - (b) difference in potential between two points
 - (c) voltage produced by a source
 - (d) voltage at the end of a circuit
- 10 A 240 V, 60 W lamp has a working resistance of:
 - (a) 1400 ohm
 - (b) 60 ohm
 - (c) 960 ohm
 - (d) 325 ohm
- 11 The largest number of 100 W electric light bulbs which can be operated from a 240 V supply fitted with a 13 A fuse is:
 - (a) 2
 - (b) 7
 - (c) 31
 - (d) 18
- 12 The energy used by a 1.5 kW heater in 5 minutes is:
 - (a) 5 J
 - (b) 450 J
 - (c) 7500 J
 - (d) 450 000 J
- 13 When an atom loses an electron, the atom:
 - (a) becomes positively charged
 - (b) disintegrates
 - (c) experiences no effect at all
 - (d) becomes negatively charged

Resistance variation

At the end of this chapter you should be able to:

- appreciate that electrical resistance depends on four factors
- appreciate that resistance $R = \rho l/a$, where ρ is the resistivity
- recognize typical values of resistivity and its unit
- perform calculations using $R = \rho l/a$
- define the temperature coefficient of resistance, α
- recognize typical values for α
- perform calculations using $R_\theta = R_0(1 + \alpha\theta)$
- determine the resistance and tolerance of a fixed resistor from its colour code
- determine the resistance and tolerance of a fixed resistor from its letter and digit code

3.1 Resistance and resistivity

The resistance of an electrical conductor depends on four factors, these being: (a) the length of the conductor, (b) the cross-sectional area of the conductor, (c) the type of material and (d) the temperature of the material. Resistance, R , is directly proportional to length, l , of a conductor, i.e. $R \propto l$. Thus, for example, if the length of a piece of wire is doubled, then the resistance is doubled.

Resistance, R , is inversely proportional to cross-sectional area, a , of a conductor, i.e. $R \propto 1/a$. Thus, for example, if the cross-sectional area of a piece of wire is doubled then the resistance is halved.

Since $R \propto l$ and $R \propto 1/a$ then $R \propto l/a$. By inserting a constant of proportionality into this relationship the type of material used may be taken into account. The constant of proportionality is known as the **resistivity** of the material and is given the

symbol ρ (Greek rho). Thus,

$$\text{resistance} \quad R = \frac{\rho l}{a} \text{ ohms}$$

ρ is measured in ohm metres ($\Omega \text{ m}$). The value of the resistivity is that resistance of a unit cube of the material measured between opposite faces of the cube.

Resistivity varies with temperature and some typical values of resistivities measured at about room temperature are given below:

Copper $1.7 \times 10^{-8} \Omega \text{ m}$ (or $0.017 \mu\Omega \text{ m}$)

Aluminium $2.6 \times 10^{-8} \Omega \text{ m}$ (or $0.026 \mu\Omega \text{ m}$)

Carbon (graphite) $10 \times 10^{-8} \Omega \text{ m}$ ($0.10 \mu\Omega \text{ m}$)

Glass $1 \times 10^{10} \Omega \text{ m}$ (or $10^4 \mu\Omega \text{ m}$)

Mica $1 \times 10^{13} \Omega \text{ m}$ (or $10^7 \mu\Omega \text{ m}$)

Note that good conductors of electricity have a low value of resistivity and good insulators have a high value of resistivity.

Problem 1. The resistance of a 5 m length of wire is 600Ω . Determine (a) the resistance of an 8 m length of the same wire, and (b) the length of the same wire when the resistance is 420Ω .

- (a) Resistance, R , is directly proportional to length, l , i.e. $R \propto l$. Hence, $600 \Omega \propto 5 \text{ m}$ or $600 = (k)(5)$, where k is the coefficient of proportionality.

$$\text{Hence, } k = \frac{600}{5} = 120$$

When the length l is 8 m, then resistance $R = kl = (120)(8) = \mathbf{960 \Omega}$

- (b) When the resistance is 420Ω , $420 = kl$, from which,

$$\text{length } l = \frac{420}{k} = \frac{420}{120} = \mathbf{3.5 \text{ m}}$$

Problem 2. A piece of wire of cross-sectional area 2 mm^2 has a resistance of 300Ω . Find (a) the resistance of a wire of the same length and material if the cross-sectional area is 5 mm^2 , (b) the cross-sectional area of a wire of the same length and material of resistance 750Ω .

Resistance R is inversely proportional to cross-sectional area, a , i.e. $R \propto 1/a$

$$\text{Hence } 300 \Omega \propto \frac{1}{2} \text{ mm}^2 \text{ or } 300 = (k)\left(\frac{1}{2}\right),$$

from which, the coefficient of proportionality, $k = 300 \times 2 = 600$

- (a) When the cross-sectional area $a = 5 \text{ mm}^2$ then

$$\begin{aligned} R &= (k)\left(\frac{1}{5}\right) \\ &= (600)\left(\frac{1}{5}\right) = \mathbf{120 \Omega} \end{aligned}$$

(Note that resistance has decreased as the cross-sectional area is increased.)

- (b) When the resistance is 750Ω then

$$750 = (k)\left(\frac{1}{a}\right)$$

from which

$$\begin{aligned} \text{cross-sectional area, } a &= \frac{k}{750} = \frac{600}{750} \\ &= \mathbf{0.8 \text{ mm}^2} \end{aligned}$$

Problem 3. A wire of length 8 m and cross-sectional area 3 mm^2 has a resistance of 0.16Ω . If the wire is drawn out until its cross-sectional area is 1 mm^2 , determine the resistance of the wire.

Resistance R is directly proportional to length l , and inversely proportional to the cross-sectional area, a , i.e.

$R \propto l/a$ or $R = k(l/a)$, where k is the coefficient of proportionality.

Since $R = 0.16$, $l = 8$ and $a = 3$, then $0.16 = (k)(8/3)$, from which $k = 0.16 \times 3/8 = 0.06$

If the cross-sectional area is reduced to $1/3$ of its original area then the length must be tripled to 3×8 , i.e. 24 m

$$\begin{aligned} \text{New resistance } R &= k\left(\frac{l}{a}\right) = 0.06\left(\frac{24}{1}\right) \\ &= \mathbf{1.44 \Omega} \end{aligned}$$

Problem 4. Calculate the resistance of a 2 km length of aluminium overhead power cable if the cross-sectional area of the cable is 100 mm^2 . Take the resistivity of aluminium to be $0.03 \times 10^{-6} \Omega \text{ m}$.

Length $l = 2 \text{ km} = 2000 \text{ m}$, area $a = 100 \text{ mm}^2 = 100 \times 10^{-6} \text{ m}^2$ and resistivity $\rho = 0.03 \times 10^{-6} \Omega \text{ m}$.

$$\begin{aligned} \text{Resistance } R &= \frac{\rho l}{a} \\ &= \frac{(0.03 \times 10^{-6} \Omega \text{ m})(2000 \text{ m})}{(100 \times 10^{-6} \text{ m}^2)} \\ &= \frac{0.03 \times 2000}{100} \Omega = \mathbf{0.6 \Omega} \end{aligned}$$

Problem 5. Calculate the cross-sectional area, in mm^2 , of a piece of copper wire, 40 m in length and having a resistance of 0.25Ω . Take the resistivity of copper as $0.02 \times 10^{-6} \Omega \text{ m}$.

Resistance $R = \rho l/a$ hence cross-sectional area

$$\begin{aligned} a &= \frac{\rho l}{R} = \frac{(0.02 \times 10^{-6} \Omega \text{ m})(40 \text{ m})}{0.25 \Omega} \\ &= 3.2 \times 10^{-6} \text{ m}^2 \\ &= (3.2 \times 10^{-6}) \times 10^6 \text{ mm}^2 = \mathbf{3.2 \text{ mm}^2} \end{aligned}$$

Problem 6. The resistance of 1.5 km of wire of cross-sectional area 0.17 mm^2 is 150Ω . Determine the resistivity of the wire.

Resistance, $R = \rho l/a$ hence

$$\begin{aligned} \text{resistivity } \rho &= \frac{Ra}{l} \\ &= \frac{(150 \Omega)(0.17 \times 10^{-6} \text{ m}^2)}{(1500 \text{ m})} \\ &= \mathbf{0.017 \times 10^{-6} \Omega \text{ m}} \\ &\text{ or } \mathbf{0.017 \mu\Omega \text{ m}} \end{aligned}$$

Problem 7. Determine the resistance of 1200 m of copper cable having a diameter of 12 mm if the resistivity of copper is $1.7 \times 10^{-8} \Omega \text{ m}$.

Cross-sectional area of cable,

$$\begin{aligned} a &= \pi r^2 = \pi \left(\frac{12}{2}\right)^2 \\ &= 36\pi \text{ mm}^2 = 36\pi \times 10^{-6} \text{ m}^2 \end{aligned}$$

$$\begin{aligned} \text{Resistance } R &= \frac{\rho l}{a} \\ &= \frac{(1.7 \times 10^{-8} \Omega \text{ m})(1200 \text{ m})}{(36\pi \times 10^{-6} \text{ m}^2)} \\ &= \frac{1.7 \times 1200 \times 10^6}{10^8 \times 36\pi} \Omega \\ &= \frac{1.7 \times 12}{36\pi} \Omega = \mathbf{0.180 \Omega} \end{aligned}$$

Now try the following exercise

Exercise 11 Further problems on resistance and resistivity

- The resistance of a 2 m length of cable is 2.5Ω . Determine (a) the resistance of a 7 m length of the same cable and (b) the length of the same wire when the resistance is 6.25Ω .
[(a) 8.75Ω (b) 5 m]
- Some wire of cross-sectional area 1 mm^2 has a resistance of 20Ω . Determine (a) the resistance of a wire of the same length and material if the cross-sectional area is 4 mm^2 , and (b) the cross-sectional area of a wire of the same length and material if the resistance is 32Ω .
[(a) 5Ω (b) 0.625 mm^2]
- Some wire of length 5 m and cross-sectional area 2 mm^2 has a resistance of 0.08Ω . If the wire is drawn out until its cross-sectional area is 1 mm^2 , determine the resistance of the wire.
[0.32Ω]
- Find the resistance of 800 m of copper cable of cross-sectional area 20 mm^2 . Take the resistivity of copper as $0.02 \mu\Omega \text{ m}$.
[0.8Ω]
- Calculate the cross-sectional area, in mm^2 , of a piece of aluminium wire 100 m long and having a resistance of 2Ω . Take the resistivity of aluminium as $0.03 \times 10^{-6} \Omega \text{ m}$.
[1.5 mm^2]
- The resistance of 500 m of wire of cross-sectional area 2.6 mm^2 is 5Ω . Determine the resistivity of the wire in $\mu\Omega \text{ m}$.
[$0.026 \mu\Omega \text{ m}$]
- Find the resistance of 1 km of copper cable having a diameter of 10 mm if the resistivity of copper is $0.017 \times 10^{-6} \Omega \text{ m}$.
[0.216Ω]

3.2 Temperature coefficient of resistance

In general, as the temperature of a material increases, most conductors increase in resistance, insulators decrease in resistance, whilst the resistance of some special alloys remain almost constant.

The **temperature coefficient of resistance** of a material is the increase in the resistance of a 1Ω

resistor of that material when it is subjected to a rise of temperature of 1°C . The symbol used for the temperature coefficient of resistance is α (Greek alpha). Thus, if some copper wire of resistance $1\ \Omega$ is heated through 1°C and its resistance is then measured as $1.0043\ \Omega$ then $\alpha = 0.0043\ \Omega/\Omega^\circ\text{C}$ for copper. The units are usually expressed only as 'per $^\circ\text{C}$ ', i.e. $\alpha = 0.0043/^\circ\text{C}$ for copper. If the $1\ \Omega$ resistor of copper is heated through 100°C then the resistance at 100°C would be $1 + 100 \times 0.0043 = 1.43\ \Omega$. Some typical values of temperature coefficient of resistance measured at 0°C are given below:

Copper	$0.0043/^\circ\text{C}$
Nickel	$0.0062/^\circ\text{C}$
Constantan	0
Aluminium	$0.0038/^\circ\text{C}$
Carbon	$-0.00048/^\circ\text{C}$
Eureka	$0.00001/^\circ\text{C}$

(Note that the negative sign for carbon indicates that its resistance falls with increase of temperature.)

If the resistance of a material at 0°C is known the resistance at any other temperature can be determined from:

$$R_\theta = R_0(1 + \alpha_0\theta)$$

where $R_0 =$ resistance at 0°C

$R_\theta =$ resistance at temperature $\theta^\circ\text{C}$

$\alpha_0 =$ temperature coefficient of resistance at 0°C

Problem 8. A coil of copper wire has a resistance of $100\ \Omega$ when its temperature is 0°C . Determine its resistance at 70°C if the temperature coefficient of resistance of copper at 0°C is $0.0043/^\circ\text{C}$.

Resistance $R_\theta = R_0(1 + \alpha_0\theta)$. Hence resistance at 100°C ,

$$\begin{aligned} R_{100} &= 100[1 + (0.0043)(70)] \\ &= 100[1 + 0.301] \\ &= 100(1.301) = \mathbf{130.1\ \Omega} \end{aligned}$$

Problem 9. An aluminium cable has a resistance of $27\ \Omega$ at a temperature of 35°C . Determine its resistance at 0°C . Take the temperature coefficient of resistance at 0°C to be $0.0038/^\circ\text{C}$.

Resistance at $\theta^\circ\text{C}$, $R_\theta = R_0(1 + \alpha_0\theta)$. Hence resistance at 0°C ,

$$\begin{aligned} R_0 &= \frac{R_\theta}{(1 + \alpha_0\theta)} = \frac{27}{[1 + (0.0038)(35)]} \\ &= \frac{27}{1 + 0.133} \\ &= \frac{27}{1.133} = \mathbf{23.83\ \Omega} \end{aligned}$$

Problem 10. A carbon resistor has a resistance of $1\ \text{k}\Omega$ at 0°C . Determine its resistance at 80°C . Assume that the temperature coefficient of resistance for carbon at 0°C is $-0.0005/^\circ\text{C}$.

Resistance at temperature $\theta^\circ\text{C}$,

$$R_\theta = R_0(1 + \alpha_0\theta)$$

i.e.

$$\begin{aligned} R_\theta &= 1000[1 + (-0.0005)(80)] \\ &= 1000[1 - 0.040] = 1000(0.96) = \mathbf{960\ \Omega} \end{aligned}$$

If the resistance of a material at room temperature (approximately 20°C), R_{20} , and the temperature coefficient of resistance at 20°C , α_{20} , are known then the resistance R_θ at temperature $\theta^\circ\text{C}$ is given by:

$$R_\theta = R_{20}[1 + \alpha_{20}(\theta - 20)]$$

Problem 11. A coil of copper wire has a resistance of $10\ \Omega$ at 20°C . If the temperature coefficient of resistance of copper at 20°C is $0.004/^\circ\text{C}$ determine the resistance of the coil when the temperature rises to 100°C .

Resistance at $\theta^\circ\text{C}$,

$$R_\theta = R_{20}[1 + \alpha_{20}(\theta - 20)]$$

Hence resistance at 100°C ,

$$\begin{aligned} R_{100} &= 10[1 + (0.004)(100 - 20)] \\ &= 10[1 + (0.004)(80)] \\ &= 10[1 + 0.32] \\ &= 10(1.32) = \mathbf{13.2\ \Omega} \end{aligned}$$

Problem 12. The resistance of a coil of aluminium wire at 18°C is $200\ \Omega$. The temperature of the wire is increased and the resistance rises to $240\ \Omega$. If the temperature coefficient of resistance of aluminium is $0.0039/^{\circ}\text{C}$ at 18°C determine the temperature to which the coil has risen.

Let the temperature rise to $\theta^{\circ}\text{C}$. Resistance at $\theta^{\circ}\text{C}$,

$$R_{\theta} = R_{18}[1 + \alpha_{18}(\theta - 18)]$$

i.e.

$$240 = 200[1 + (0.0039)(\theta - 18)]$$

$$240 = 200 + (200)(0.0039)(\theta - 18)$$

$$240 - 200 = 0.78(\theta - 18)$$

$$40 = 0.78(\theta - 18)$$

$$\frac{40}{0.78} = \theta - 18$$

$$51.28 = \theta - 18, \text{ from which,}$$

$$\theta = 51.28 + 18 = 69.28^{\circ}\text{C}$$

Hence the temperature of the coil increases to 69.28°C

If the resistance at 0°C is not known, but is known at some other temperature θ_1 , then the resistance at any temperature can be found as follows:

$$R_1 = R_0(1 + \alpha_0\theta_1)$$

and

$$R_2 = R_0(1 + \alpha_0\theta_2)$$

Dividing one equation by the other gives:

$$\frac{R_1}{R_2} = \frac{1 + \alpha_0\theta_1}{1 + \alpha_0\theta_2}$$

where $R_2 =$ resistance at temperature θ_2

Problem 13. Some copper wire has a resistance of $200\ \Omega$ at 20°C . A current is passed through the wire and the temperature rises to 90°C . Determine the resistance of the wire at 90°C , correct to the nearest ohm, assuming that the temperature coefficient of resistance is $0.004/^{\circ}\text{C}$ at 0°C .

$$R_{20} = 200\ \Omega, \alpha_0 = 0.004/^{\circ}\text{C}$$

$$\text{and } \frac{R_{20}}{R_{90}} = \frac{[1 + \alpha_0(20)]}{[1 + \alpha_0(90)]}$$

Hence

$$\begin{aligned} R_{90} &= \frac{R_{20}[1 + 90\alpha_0]}{[1 + 20\alpha_0]} \\ &= \frac{200[1 + 90(0.004)]}{[1 + 20(0.004)]} \\ &= \frac{200[1 + 0.36]}{[1 + 0.08]} \\ &= \frac{200(1.36)}{(1.08)} = \mathbf{251.85\ \Omega} \end{aligned}$$

i.e. the resistance of the wire at 90°C is $252\ \Omega$, correct to the nearest ohm

Now try the following exercises

Exercise 12 Further problems on the temperature coefficient of resistance

- 1 A coil of aluminium wire has a resistance of $50\ \Omega$ when its temperature is 0°C . Determine its resistance at 100°C if the temperature coefficient of resistance of aluminium at 0°C is $0.0038/^{\circ}\text{C}$ [69 Ω]
- 2 A copper cable has a resistance of $30\ \Omega$ at a temperature of 50°C . Determine its resistance at 0°C . Take the temperature coefficient of resistance of copper at 0°C as $0.0043/^{\circ}\text{C}$ [24.69 Ω]
- 3 The temperature coefficient of resistance for carbon at 0°C is $-0.00048/^{\circ}\text{C}$. What is the significance of the minus sign? A carbon resistor has a resistance of $500\ \Omega$ at 0°C . Determine its resistance at 50°C . [488 Ω]

- 4 A coil of copper wire has a resistance of $20\ \Omega$ at 18°C . If the temperature coefficient of resistance of copper at 18°C is $0.004/^\circ\text{C}$, determine the resistance of the coil when the temperature rises to 98°C [26.4 Ω]
- 5 The resistance of a coil of nickel wire at 20°C is $100\ \Omega$. The temperature of the wire is increased and the resistance rises to $130\ \Omega$. If the temperature coefficient of resistance of nickel is $0.006/^\circ\text{C}$ at 20°C , determine the temperature to which the coil has risen. [70 $^\circ\text{C}$]
- 6 Some aluminium wire has a resistance of $50\ \Omega$ at 20°C . The wire is heated to a temperature of 100°C . Determine the resistance of the wire at 100°C , assuming that the temperature coefficient of resistance at 0°C is $0.004/^\circ\text{C}$ [64.8 Ω]
- 7 A copper cable is 1.2 km long and has a cross-sectional area of $5\ \text{mm}^2$. Find its resistance at 80°C if at 20°C the resistivity of copper is $0.02 \times 10^{-6}\ \Omega\ \text{m}$ and its temperature coefficient of resistance is $0.004/^\circ\text{C}$ [5.95 Ω]

3.3 Resistor colour coding and ohmic values

(a) Colour code for fixed resistors

The colour code for fixed resistors is given in Table 3.1

- (i) For a **four-band fixed resistor** (i.e. resistance values with two significant figures): yellow-violet-orange-red indicates $47\ \text{k}\ \Omega$ with a tolerance of $\pm 2\%$
(Note that the first band is the one nearest the end of the resistor)
- (ii) For a **five-band fixed resistor** (i.e. resistance values with three significant figures): red-yellow-white-orange-brown indicates $249\ \text{k}\ \Omega$ with a tolerance of $\pm 1\%$
(Note that the fifth band is 1.5 to 2 times wider than the other bands)

Table 3.1

Colour	Significant Figures	Multiplier	Tolerance
Silver	–	10^{-2}	$\pm 10\%$
Gold	–	10^{-1}	$\pm 5\%$
Black	0	1	–
Brown	1	10	$\pm 1\%$
Red	2	10^2	$\pm 2\%$
Orange	3	10^3	–
Yellow	4	10^4	–
Green	5	10^5	$\pm 0.5\%$
Blue	6	10^6	$\pm 0.25\%$
Violet	7	10^7	$\pm 0.1\%$
Grey	8	10^8	–
White	9	10^9	–
None	–	–	$\pm 20\%$

Problem 14. Determine the value and tolerance of a resistor having a colour coding of: orange-orange-silver-brown.

The first two bands, i.e. orange-orange, give 33 from Table 3.1

The third band, silver, indicates a multiplier of 10^2 from Table 3.1, which means that the value of the resistor is $33 \times 10^{-2} = 0.33\ \Omega$

The fourth band, i.e. brown, indicates a tolerance of $\pm 1\%$ from Table 3.1 Hence a colour coding of orange-orange-silver-brown represents a resistor of value **$0.33\ \Omega$ with a tolerance of $\pm 1\%$**

Problem 15. Determine the value and tolerance of a resistor having a colour coding of: brown-black-brown.

The first two bands, i.e. brown-black, give 10 from Table 3.1

The third band, brown, indicates a multiplier of 10 from Table 3.1, which means that the value of the resistor is $10 \times 10 = 100\ \Omega$

There is no fourth band colour in this case; hence, from Table 3.1, the tolerance is $\pm 20\%$ Hence a colour coding of brown-black-brown represents a resistor of value **$100\ \Omega$ with a tolerance of $\pm 20\%$**

Problem 16. Between what two values should a resistor with colour coding brown-black-brown-silver lie?

From Table 3.1, brown-black-brown-silver indicates 10×10 , i.e. 100Ω , with a tolerance of $\pm 10\%$. This means that the value could lie between

$$(100 - 10\% \text{ of } 100) \Omega$$

and $(100 + 10\% \text{ of } 100) \Omega$

i.e. brown-black-brown-silver indicates any value **between 90Ω and 110Ω**

Problem 17. Determine the colour coding for a $47 \text{ k} \Omega$ having a tolerance of $\pm 5\%$.

From Table 3.1, $47 \text{ k} \Omega = 47 \times 10^3$ has a colour coding of yellow-violet-orange. With a tolerance of $\pm 5\%$, the fourth band will be gold. Hence $47 \text{ k} \Omega \pm 5\%$ has a colour coding of: **yellow-violet-orange-gold**.

Problem 18. Determine the value and tolerance of a resistor having a colour coding of: orange-green-red-yellow-brown.

orange-green-red-yellow-brown is a five-band fixed resistor and from Table 3.1, indicates: $352 \times 10^4 \Omega$ with a tolerance of $\pm 1\%$
 $352 \times 10^4 \Omega = 3.52 \times 10^6 \Omega$, i.e. $3.52 \text{ M} \Omega$

Hence orange-green-red-yellow-brown indicates **$3.52 \text{ M} \Omega \pm 1\%$**

(b) Letter and digit code for resistors

Another way of indicating the value of resistors is the letter and digit code shown in Table 3.2

Table 3.2

Resistance Value	Marked as:
0.47Ω	R47
1Ω	1R0
4.7Ω	4R7
47Ω	47R
100Ω	100R
$1 \text{ k} \Omega$	1K0
$10 \text{ k} \Omega$	10K
$10 \text{ M} \Omega$	10M

Tolerance is indicated as follows: $F = \pm 1\%$, $G = \pm 2\%$, $J = \pm 5\%$, $K = \pm 10\%$ and $M = \pm 20\%$. Thus, for example,

$$\text{R}33\text{M} = 0.33 \Omega \pm 20\%$$

$$4\text{R}7\text{K} = 4.7 \Omega \pm 10\%$$

$$390\text{RJ} = 390 \Omega \pm 5\%$$

Problem 19. Determine the value of a resistor marked as 6K8F.

From Table 3.2, 6K8F is equivalent to: **$6.8 \text{ k} \Omega \pm 1\%$**

Problem 20. Determine the value of a resistor marked as 4M7M.

From Table 3.2, 4M7M is equivalent to: **$4.7 \text{ M} \Omega \pm 20\%$**

Problem 21. Determine the letter and digit code for a resistor having a value of $68 \text{ k} \Omega \pm 10\%$.

From Table 3.2, $68 \text{ k} \Omega \pm 10\%$ has a letter and digit code of: **68 KK**

Now try the following exercises

Exercise 13 Further problems on resistor colour coding and ohmic values

- Determine the value and tolerance of a resistor having a colour coding of: blue-grey-orange-red [$68 \text{ k} \Omega \pm 2\%$]
- Determine the value and tolerance of a resistor having a colour coding of: yellow-violet-gold [$4.7 \Omega \pm 20\%$]
- Determine the value and tolerance of a resistor having a colour coding of: blue-white-black-black-gold [$690 \Omega \pm 5\%$]
- Determine the colour coding for a $51 \text{ k} \Omega$ resistor having a tolerance of $\pm 2\%$ [green-brown-orange-red]

- 5 Determine the colour coding for a $1\text{ M}\Omega$ resistor having a tolerance of $\pm 10\%$
[brown-black-green-silver]
- 6 Determine the range of values expected for a resistor with colour coding: red-black-green-silver
[$1.8\text{ M}\Omega$ to $2.2\text{ M}\Omega$]
- 7 Determine the range of values expected for a resistor with colour coding: yellow-black-orange-brown
[$39.6\text{ k}\Omega$ to $40.4\text{ k}\Omega$]
- 8 Determine the value of a resistor marked as (a) R22G (b) 4K7F
[(a) $0.22\Omega \pm 2\%$ (b) $4.7\text{ k}\Omega \pm 1\%$]
- 9 Determine the letter and digit code for a resistor having a value of $100\text{ k}\Omega \pm 5\%$
[100 KJ]
- 10 Determine the letter and digit code for a resistor having a value of $6.8\text{ M}\Omega \pm 20\%$
[6M8 M]

Exercise 14 Short answer questions on resistance variation

- 1 Name four factors which can effect the resistance of a conductor
- 2 If the length of a piece of wire of constant cross-sectional area is halved, the resistance of the wire is
- 3 If the cross-sectional area of a certain length of cable is trebled, the resistance of the cable is
- 4 What is resistivity? State its unit and the symbol used.
- 5 Complete the following:
Good conductors of electricity have a value of resistivity and good insulators have a value of resistivity
- 6 What is meant by the 'temperature coefficient of resistance'? State its units and the symbols used.
- 7 If the resistance of a metal at 0°C is R_0 , R_θ is the resistance at $\theta^\circ\text{C}$ and α_0 is the temperature coefficient of resistance at 0°C then: $R_\theta = \dots\dots$

- 8 Explain briefly the colour coding on resistors
- 9 Explain briefly the letter and digit code for resistors

Exercise 15 Multi-choice questions on resistance variation (Answers on page 375)

- 1 The unit of resistivity is:
 - (a) ohms
 - (b) ohm millimetre
 - (c) ohm metre
 - (d) ohm/metre
- 2 The length of a certain conductor of resistance 100Ω is doubled and its cross-sectional area is halved. Its new resistance is:
 - (a) 100Ω
 - (b) 200Ω
 - (c) 50Ω
 - (d) 400Ω
- 3 The resistance of a 2 km length of cable of cross-sectional area 2 mm^2 and resistivity of $2 \times 10^{-8}\Omega\text{m}$ is:
 - (a) 0.02Ω
 - (b) 20Ω
 - (c) $0.02\text{ m}\Omega$
 - (d) 200Ω
- 4 A piece of graphite has a cross-sectional area of 10 mm^2 . If its resistance is 0.1Ω and its resistivity $10 \times 10^8\Omega\text{m}$, its length is:
 - (a) 10 km
 - (b) 10 cm
 - (c) 10 mm
 - (d) 10 m
- 5 The symbol for the unit of temperature coefficient of resistance is:
 - (a) $\Omega/^\circ\text{C}$
 - (b) Ω
 - (c) $^\circ\text{C}$
 - (d) $\Omega/\Omega^\circ\text{C}$
- 6 A coil of wire has a resistance of 10Ω at 0°C . If the temperature coefficient of resistance for the wire is $0.004/^\circ\text{C}$, its resistance at 100°C is:
 - (a) 0.4Ω
 - (b) 1.4Ω
 - (c) 14Ω
 - (d) 10Ω
- 7 A nickel coil has a resistance of 13Ω at 50°C . If the temperature coefficient of resistance at 0°C is $0.006/^\circ\text{C}$, the resistance at 0°C is:
 - (a) 16.9Ω
 - (b) 10Ω
 - (c) 43.3Ω
 - (d) 0.1Ω

8 A colour coding of red-violet-black on a resistor indicates a value of:

- (a) $27\ \Omega \pm 20\%$ (b) $270\ \Omega$
(c) $270\ \Omega \pm 20\%$ (d) $27\ \Omega \pm 10\%$

9 A resistor marked as 4K7G indicates a value of:

- (a) $47\ \Omega \pm 20\%$ (b) $4.7\ \text{k}\ \Omega \pm 20\%$
(c) $0.47\ \Omega \pm 10\%$ (d) $4.7\ \text{k}\ \Omega \pm 2\%$

Chemical effects of electricity

At the end of this chapter you should be able to:

- understand electrolysis and its applications, including electroplating
- appreciate the purpose and construction of a simple cell
- explain polarisation and local action
- explain corrosion and its effects
- define the terms e.m.f., E , and internal resistance, r , of a cell
- perform calculations using $V = E - Ir$
- determine the total e.m.f. and total internal resistance for cells connected in series and in parallel
- distinguish between primary and secondary cells
- explain the construction and practical applications of the Leclanché, mercury, lead–acid and alkaline cells
- list the advantages and disadvantages of alkaline cells over lead–acid cells
- understand the term ‘cell capacity’ and state its unit

4.1 Introduction

A material must contain **charged particles** to be able to conduct electric current. In **solids**, the current is carried by **electrons**. Copper, lead, aluminium, iron and carbon are some examples of solid conductors. In **liquids and gases**, the current is carried by the part of a molecule which has acquired an electric charge, called **ions**. These can possess a positive or negative charge, and examples include hydrogen ion H^+ , copper ion Cu^{++} and hydroxyl ion OH^- . Distilled water contains no ions and is a poor conductor of electricity, whereas salt water contains ions and is a fairly good conductor of electricity.

4.2 Electrolysis

Electrolysis is the decomposition of a liquid compound by the passage of electric current through it. Practical applications of electrolysis include the electroplating of metals (see Section 4.3), the refining of copper and the extraction of aluminium from its ore.

An **electrolyte** is a compound which will undergo electrolysis. Examples include salt water, copper sulphate and sulphuric acid.

The **electrodes** are the two conductors carrying current to the electrolyte. The positive-connected electrode is called the **anode** and the negative-connected electrode the **cathode**.

When two copper wires connected to a battery are placed in a beaker containing a salt water solution, current will flow through the solution. Air bubbles appear around the wires as the water is changed into hydrogen and oxygen by electrolysis.

4.3 Electroplating

Electroplating uses the principle of electrolysis to apply a thin coat of one metal to another metal. Some practical applications include the tin-plating of steel, silver-plating of nickel alloys and chromium-plating of steel. If two copper electrodes connected to a battery are placed in a beaker containing copper sulphate as the electrolyte it is found that the cathode (i.e. the electrode connected to the negative terminal of the battery) gains copper whilst the anode loses copper.

4.4 The simple cell

The purpose of an **electric cell** is to convert chemical energy into electrical energy.

A **simple cell** comprises two dissimilar conductors (electrodes) in an electrolyte. Such a cell is shown in Fig. 4.1, comprising copper and zinc electrodes. An electric current is found to flow between the electrodes. Other possible electrode pairs exist, including zinc–lead and zinc–iron. The electrode potential (i.e. the p.d. measured between the electrodes) varies for each pair of metals. By knowing the e.m.f. of each metal with respect to some standard electrode, the e.m.f. of any pair of metals may be determined. The standard used is the hydrogen electrode. The **electrochemical series** is a way of listing elements in order of electrical potential, and Table 4.1 shows a number of elements in such a series.

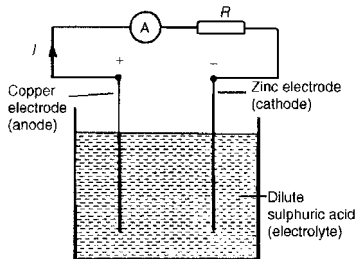

Figure 4.1

Table 4.1 Part of the electrochemical series

Potassium
sodium
aluminium
zinc
iron
lead
hydrogen
copper
silver
carbon

In a simple cell two faults exist – those due to **polarisation** and **local action**.

Polarisation

If the simple cell shown in Fig. 4.1 is left connected for some time, the current I decreases fairly rapidly. This is because of the formation of a film of hydrogen bubbles on the copper anode. This effect is known as the polarisation of the cell. The hydrogen prevents full contact between the copper electrode and the electrolyte and this increases the internal resistance of the cell. The effect can be overcome by using a chemical depolarising agent or depolariser, such as potassium dichromate which removes the hydrogen bubbles as they form. This allows the cell to deliver a steady current.

Local action

When commercial zinc is placed in dilute sulphuric acid, hydrogen gas is liberated from it and the zinc dissolves. The reason for this is that impurities, such as traces of iron, are present in the zinc which set up small primary cells with the zinc. These small cells are short-circuited by the electrolyte, with the result that localised currents flow causing corrosion. This action is known as local action of the cell. This may be prevented by rubbing a small amount of mercury on the zinc surface, which forms a protective layer on the surface of the electrode.

When two metals are used in a simple cell the electrochemical series may be used to predict the behaviour of the cell:

- (i) The metal that is higher in the series acts as the negative electrode, and vice-versa. For example, the zinc electrode in the cell shown in Fig. 4.1 is negative and the copper electrode is positive.

- (ii) The greater the separation in the series between the two metals the greater is the e.m.f. produced by the cell.

The electrochemical series is representative of the order of reactivity of the metals and their compounds:

- (i) The higher metals in the series react more readily with oxygen and vice-versa.
- (ii) When two metal electrodes are used in a simple cell the one that is higher in the series tends to dissolve in the electrolyte.

4.5 Corrosion

Corrosion is the gradual destruction of a metal in a damp atmosphere by means of simple cell action. In addition to the presence of moisture and air required for rusting, an electrolyte, an anode and a cathode are required for corrosion. Thus, if metals widely spaced in the electrochemical series, are used in contact with each other in the presence of an electrolyte, corrosion will occur. For example, if a brass valve is fitted to a heating system made of steel, corrosion will occur.

The **effects of corrosion** include the weakening of structures, the reduction of the life of components and materials, the wastage of materials and the expense of replacement.

Corrosion may be **prevented** by coating with paint, grease, plastic coatings and enamels, or by plating with tin or chromium. Also, iron may be galvanised, i.e., plated with zinc, the layer of zinc helping to prevent the iron from corroding.

4.6 E.m.f. and internal resistance of a cell

The **electromotive force (e.m.f.)**, E , of a cell is the p.d. between its terminals when it is not connected to a load (i.e. the cell is on 'no load').

The e.m.f. of a cell is measured by using a **high resistance voltmeter** connected in parallel with the cell. The voltmeter must have a high resistance otherwise it will pass current and the cell will not be on 'no-load'. For example, if the resistance of a cell is $1\ \Omega$ and that of a voltmeter $1\ \text{M}\Omega$ then the equivalent resistance of the circuit is $1\ \text{M}\Omega + 1\ \Omega$,

i.e. approximately $1\ \text{M}\Omega$, hence no current flows and the cell is not loaded.

The voltage available at the terminals of a cell falls when a load is connected. This is caused by the **internal resistance** of the cell which is the opposition of the material of the cell to the flow of current. The internal resistance acts in series with other resistances in the circuit. Figure 4.2 shows a cell of e.m.f. E volts and internal resistance, r , and XY represents the terminals of the cell.

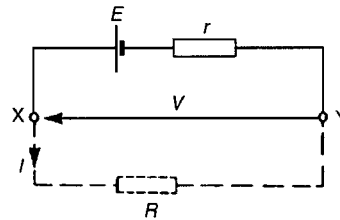

Figure 4.2

When a load (shown as resistance R) is not connected, no current flows and the terminal p.d., $V = E$. When R is connected a current I flows which causes a voltage drop in the cell, given by Ir . The p.d. available at the cell terminals is less than the e.m.f. of the cell and is given by:

$$V = E - Ir$$

Thus if a battery of e.m.f. 12 volts and internal resistance $0.01\ \Omega$ delivers a current of 100 A, the terminal p.d.,

$$\begin{aligned} V &= 12 - (100)(0.01) \\ &= 12 - 1 = 11\ \text{V} \end{aligned}$$

When different values of potential difference V across a cell or power supply are measured for different values of current I , a graph may be plotted as shown in Fig. 4.3 Since the e.m.f. E of the cell or power supply is the p.d. across its terminals on no load (i.e. when $I = 0$), then E is as shown by the broken line.

Since $V = E - Ir$ then the internal resistance may be calculated from

$$r = \frac{E - V}{I}$$

When a current is flowing in the direction shown in Fig. 4.2 the cell is said to be **discharging** ($E > V$).

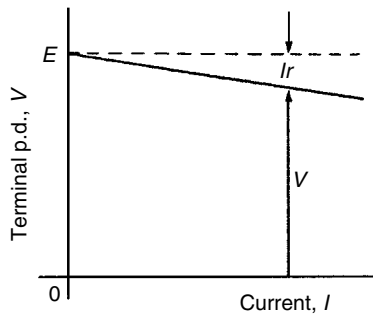

Figure 4.3

When a current flows in the opposite direction to that shown in Fig. 4.2 the cell is said to be **charging** ($V > E$).

A **battery** is a combination of more than one cell. The cells in a battery may be connected in series or in parallel.

(i) **For cells connected in series:**

Total e.m.f. = sum of cell's e.m.f.s
Total internal resistance = sum of cell's internal resistances

(ii) **For cells connected in parallel:**

If each cell has the same e.m.f. and internal resistance:

Total e.m.f. = e.m.f. of one cell
Total internal resistance of n cells

$$= \frac{1}{n} \times \text{internal resistance of one cell}$$

Problem 1. Eight cells, each with an internal resistance of 0.2Ω and an e.m.f. of 2.2 V are connected (a) in series, (b) in parallel. Determine the e.m.f. and the internal resistance of the batteries so formed.

(a) When connected in series, total e.m.f.

$$\begin{aligned} &= \text{sum of cell's e.m.f.} \\ &= 2.2 \times 8 = \mathbf{17.6 \text{ V}} \end{aligned}$$

Total internal resistance

$$\begin{aligned} &= \text{sum of cell's internal resistance} \\ &= 0.2 \times 8 = \mathbf{1.6 \Omega} \end{aligned}$$

(b) When connected in parallel, total e.m.f.

$$\begin{aligned} &= \text{e.m.f. of one cell} \\ &= \mathbf{2.2 \text{ V}} \end{aligned}$$

Total internal resistance of 8 cells

$$\begin{aligned} &= \frac{1}{8} \times \text{internal resistance of one cell} \\ &= \frac{1}{8} \times 0.2 = \mathbf{0.025 \Omega} \end{aligned}$$

Problem 2. A cell has an internal resistance of 0.02Ω and an e.m.f. of 2.0 V . Calculate its terminal p.d. if it delivers (a) 5 A (b) 50 A .

(a) Terminal p.d. $V = E - Ir$ where $E =$ e.m.f. of cell, $I =$ current flowing and $r =$ internal resistance of cell

$$E = 2.0 \text{ V}, I = 5 \text{ A and } r = 0.02 \Omega$$

Hence **terminal p.d.**

$$V = 2.0 - (5)(0.02) = 2.0 - 0.1 = \mathbf{1.9 \text{ V}}$$

(b) When the current is 50 A , terminal p.d.,

$$V = E - Ir = 2.0 - 50(0.02)$$

$$\text{i.e. } V = 2.0 - 1.0 = \mathbf{1.0 \text{ V}}$$

Thus the terminal p.d. decreases as the current drawn increases.

Problem 3. The p.d. at the terminals of a battery is 25 V when no load is connected and 24 V when a load taking 10 A is connected. Determine the internal resistance of the battery.

When no load is connected the e.m.f. of the battery, E , is equal to the terminal p.d., V , i.e. $E = 25 \text{ V}$

When current $I = 10 \text{ A}$ and terminal p.d.

$$V = 24 \text{ V}, \text{ then } V = E - Ir$$

$$\text{i.e. } 24 = 25 - (10)r$$

Hence, rearranging, gives

$$10r = 25 - 24 = 1$$

and the internal resistance,

$$r = \frac{1}{10} = \mathbf{0.1 \Omega}$$

Problem 4. Ten 1.5 V cells, each having an internal resistance of 0.2 Ω, are connected in series to a load of 58 Ω. Determine (a) the current flowing in the circuit and (b) the p.d. at the battery terminals.

- (a) For ten cells, battery e.m.f., $E = 10 \times 1.5 = 15 \text{ V}$, and the total internal resistance, $r = 10 \times 0.2 = 2 \text{ } \Omega$. When connected to a 58 Ω load the circuit is as shown in Fig. 4.4

$$\begin{aligned} \text{Current } I &= \frac{\text{e.m.f.}}{\text{total resistance}} \\ &= \frac{15}{58 + 2} \\ &= \frac{15}{60} = \mathbf{0.25 \text{ A}} \end{aligned}$$

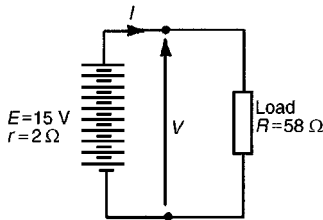

Figure 4.4

- (b) P.d. at battery terminals, $V = E - Ir$
 i.e. $V = 15 - (0.25)(2) = \mathbf{14.5 \text{ V}}$

Now try the following exercise

Exercise 16 Further problems on e.m.f. and internal resistance of a cell

- Twelve cells, each with an internal resistance of 0.24 Ω and an e.m.f. of 1.5 V are connected (a) in series, (b) in parallel. Determine the e.m.f. and internal resistance of the batteries so formed.
 [(a) 18 V, 2.88 Ω (b) 1.5 V, 0.02 Ω]
- A cell has an internal resistance of 0.03 Ω and an e.m.f. of 2.2 V. Calculate its terminal p.d. if it delivers
 (a) 1 A, (b) 20 A, (c) 50 A
 [(a) 2.17 V (b) 1.6 V (c) 0.7 V]

- The p.d. at the terminals of a battery is 16 V when no load is connected and 14 V when a load taking 8 A is connected. Determine the internal resistance of the battery. [0.25 Ω]
- A battery of e.m.f. 20 V and internal resistance 0.2 Ω supplies a load taking 10 A. Determine the p.d. at the battery terminals and the resistance of the load. [18 V, 1.8 Ω]
- Ten 2.2 V cells, each having an internal resistance of 0.1 Ω are connected in series to a load of 21 Ω. Determine (a) the current flowing in the circuit, and (b) the p.d. at the battery terminals [(a) 1 A (b) 21 V]
- For the circuits shown in Fig. 4.5 the resistors represent the internal resistance of the batteries. Find, in each case:
 (i) the total e.m.f. across PQ
 (ii) the total equivalent internal resistances of the batteries.
 [(i) (a) 6 V (b) 2 V (ii) (a) 4 Ω (b) 0.25 Ω]

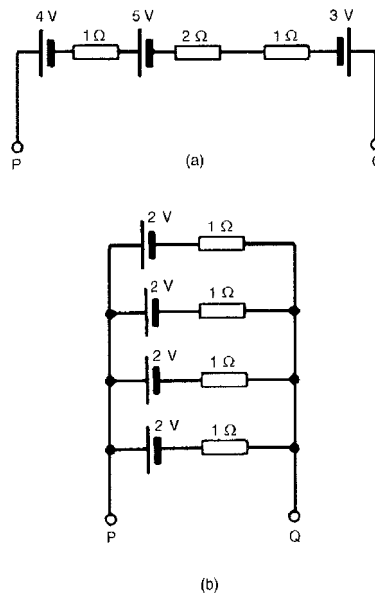

Figure 4.5

- The voltage at the terminals of a battery is 52 V when no load is connected and 48.8 V when a load taking 80 A is connected. Find the internal resistance of the battery. What would be the terminal voltage when a load taking 20 A is connected? [0.04 Ω, 51.2 V]

4.7 Primary cells

Primary cells cannot be recharged, that is, the conversion of chemical energy to electrical energy is irreversible and the cell cannot be used once the chemicals are exhausted. Examples of primary cells include the Leclanché cell and the mercury cell.

Leclanché cell

A typical dry Leclanché cell is shown in Fig. 4.6 Such a cell has an e.m.f. of about 1.5 V when new, but this falls rapidly if in continuous use due to polarisation. The hydrogen film on the carbon electrode forms faster than can be dissipated by the depolariser. The Leclanché cell is suitable only for intermittent use, applications including torches, transistor radios, bells, indicator circuits, gas lighters, controlling switch-gear, and so on. The cell is the most commonly used of primary cells, is cheap, requires little maintenance and has a shelf life of about 2 years.

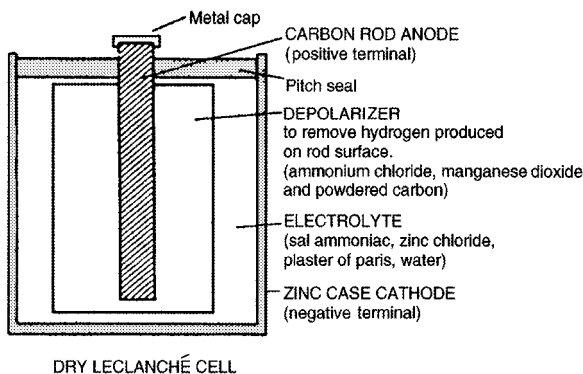

Figure 4.6

Mercury cell

A typical mercury cell is shown in Fig. 4.7 Such a cell has an e.m.f. of about 1.3 V which remains

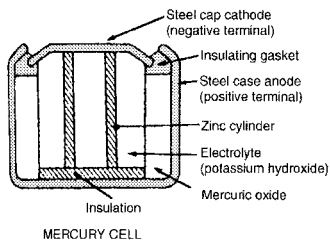

Figure 4.7

constant for a relatively long time. Its main advantages over the Leclanché cell is its smaller size and its long shelf life. Typical practical applications include hearing aids, medical electronics, cameras and for guided missiles.

4.8 Secondary cells

Secondary cells can be recharged after use, that is, the conversion of chemical energy to electrical energy is reversible and the cell may be used many times. Examples of secondary cells include the lead–acid cell and the alkaline cell. Practical applications of such cells include car batteries, telephone circuits and for traction purposes – such as milk delivery vans and fork lift trucks.

Lead–acid cell

A typical lead–acid cell is constructed of:

- (i) A container made of glass, ebonite or plastic.
 - (ii) **Lead plates**
 - (a) the negative plate (cathode) consists of spongy lead
 - (b) the positive plate (anode) is formed by pressing lead peroxide into the lead grid.
- The plates are interleaved as shown in the plan view of Fig. 4.8 to increase their effective cross-sectional area and to minimize internal resistance.

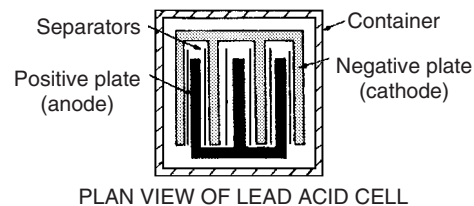

Figure 4.8

- (iii) **Separators** made of glass, celluloid or wood.
- (iv) An **electrolyte** which is a mixture of sulphuric acid and distilled water.

The relative density (or specific gravity) of a lead–acid cell, which may be measured using a hydrometer, varies between about 1.26 when the cell is fully charged to about 1.19 when discharged. The terminal p.d. of a lead–acid cell is about 2 V.

When a cell supplies current to a load it is said to be **discharging**. During discharge:

- (i) the lead peroxide (positive plate) and the spongy lead (negative plate) are converted into lead sulphate, and
- (ii) the oxygen in the lead peroxide combines with hydrogen in the electrolyte to form water. The electrolyte is therefore weakened and the relative density falls.

The terminal p.d. of a lead–acid cell when fully discharged is about 1.8 V. A cell is **charged** by connecting a d.c. supply to its terminals, the positive terminal of the cell being connected to the positive terminal of the supply. The charging current flows in the reverse direction to the discharge current and the chemical action is reversed. During charging:

- (i) the lead sulphate on the positive and negative plates is converted back to lead peroxide and lead respectively, and
- (ii) the water content of the electrolyte decreases as the oxygen released from the electrolyte combines with the lead of the positive plate. The relative density of the electrolyte thus increases.

The colour of the positive plate when fully charged is dark brown and when discharged is light brown. The colour of the negative plate when fully charged is grey and when discharged is light grey.

Alkaline cell

There are two main types of alkaline cell – the nickel–iron cell and the nickel–cadmium cell. In both types the positive plate is made of nickel hydroxide enclosed in finely perforated steel tubes, the resistance being reduced by the addition of pure nickel or graphite. The tubes are assembled into nickel–steel plates.

In the nickel–iron cell, (sometimes called the **Edison cell** or **nife cell**), the negative plate is made of iron oxide, with the resistance being reduced by a little mercuric oxide, the whole being enclosed in perforated steel tubes and assembled in steel plates. In the nickel–cadmium cell the negative plate is made of cadmium. The electrolyte in each type of cell is a solution of potassium hydroxide which does not undergo any chemical change and thus the quantity can be reduced to a minimum. The plates

are separated by insulating rods and assembled in steel containers which are then enclosed in a non-metallic crate to insulate the cells from one another. The average discharge p.d. of an alkaline cell is about 1.2 V.

Advantages of an alkaline cell (for example, a nickel–cadmium cell or a nickel–iron cell) over a lead–acid cell include:

- (i) More robust construction
- (ii) Capable of withstanding heavy charging and discharging currents without damage
- (iii) Has a longer life
- (iv) For a given capacity is lighter in weight
- (v) Can be left indefinitely in any state of charge or discharge without damage
- (vi) Is not self-discharging

Disadvantages of an alkaline cell over a lead–acid cell include:

- (i) Is relatively more expensive
- (ii) Requires more cells for a given e.m.f.
- (iii) Has a higher internal resistance
- (iv) Must be kept sealed
- (v) Has a lower efficiency

Alkaline cells may be used in extremes of temperature, in conditions where vibration is experienced or where duties require long idle periods or heavy discharge currents. Practical examples include traction and marine work, lighting in railway carriages, military portable radios and for starting diesel and petrol engines.

However, the lead–acid cell is the most common one in practical use.

4.9 Cell capacity

The **capacity** of a cell is measured in ampere-hours (Ah). A fully charged 50 Ah battery rated for 10 h discharge can be discharged at a steady current of 5 A for 10 h, but if the load current is increased to 10 A then the battery is discharged in 3–4 h, since the higher the discharge current, the lower is the effective capacity of the battery. Typical discharge characteristics for a lead–acid cell are shown in Fig. 4.9

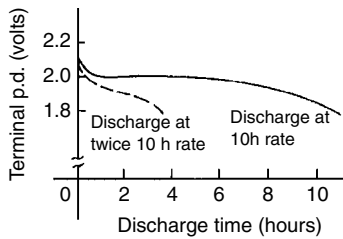

Figure 4.9

Now try the following exercises

Exercise 17 Short answer questions on the chemical effects of electricity

- 1 What is electrolysis?
- 2 What is an electrolyte?
- 3 Conduction in electrolytes is due to
- 4 A positive-connected electrode is called the and the negative-connected electrode the
- 5 State two practical applications of electrolysis
- 6 The purpose of an electric cell is to convert to
- 7 Make a labelled sketch of a simple cell
- 8 What is the electrochemical series?
- 9 With reference to a simple cell, explain briefly what is meant by (a) polarisation (b) local action
- 10 What is corrosion? Name two effects of corrosion and state how they may be prevented
- 11 What is meant by the e.m.f. of a cell? How may the e.m.f. of a cell be measured?
- 12 Define internal resistance
- 13 If a cell has an e.m.f. of E volts, an internal resistance of r ohms and supplies a current I amperes to a load, the terminal p.d. V volts is given by: $V = \dots\dots$
- 14 Name the two main types of cells
- 15 Explain briefly the difference between primary and secondary cells
- 16 Name two types of primary cells
- 17 Name two types of secondary cells

- 18 State three typical applications of primary cells
- 19 State three typical applications of secondary cells
- 20 In what unit is the capacity of a cell measured?

Exercise 18 Multi-choice questions on the chemical effects of electricity (Answers on page 375)

- 1 A battery consists of:
 - (a) a cell
 - (b) a circuit
 - (c) a generator
 - (d) a number of cells
- 2 The terminal p.d. of a cell of e.m.f. 2 V and internal resistance 0.1Ω when supplying a current of 5 A will be:
 - (a) 1.5 V
 - (b) 2 V
 - (c) 1.9 V
 - (d) 2.5 V
- 3 Five cells, each with an e.m.f. of 2 V and internal resistance 0.5Ω are connected in series. The resulting battery will have:
 - (a) an e.m.f. of 2 V and an internal resistance of 0.5Ω
 - (b) an e.m.f. of 10 V and an internal resistance of 2.5Ω
 - (c) an e.m.f. of 2 V and an internal resistance of 0.1Ω
 - (d) an e.m.f. of 10 V and an internal resistance of 0.1Ω
- 4 If the five cells of question 2 are connected in parallel the resulting battery will have:
 - (a) an e.m.f. of 2 V and an internal resistance of 0.5Ω
 - (b) an e.m.f. of 10 V and an internal resistance of 2.5Ω
 - (c) an e.m.f. of 2 V and an internal resistance of 0.1Ω
 - (d) an e.m.f. of 10 V and an internal resistance of 0.1Ω
- 5 Which of the following statements is false?
 - (a) A Leclanché cell is suitable for use in torches
 - (b) A nickel–cadmium cell is an example of a primary cell
 - (c) When a cell is being charged its terminal p.d. exceeds the cell e.m.f.
 - (d) A secondary cell may be recharged after use

- 6 Which of the following statements is false?
When two metal electrodes are used in a simple cell, the one that is higher in the electrochemical series:
- (a) tends to dissolve in the electrolyte
 - (b) is always the negative electrode
 - (c) reacts most readily with oxygen
 - (d) acts as an anode
- 7 Five 2 V cells, each having an internal resistance of 0.2Ω are connected in series to a load of resistance 14Ω . The current flowing in the circuit is:
- (a) 10 A
 - (b) 1.4 A
 - (c) 1.5 A
 - (d) $\frac{2}{3}$ A
- 8 For the circuit of question 7, the p.d. at the battery terminals is:
- (a) 10 V
 - (b) $9\frac{1}{3}$ V
 - (c) 0 V
 - (d) $10\frac{2}{3}$ V
- 9 Which of the following statements is true?
- (a) The capacity of a cell is measured in volts
 - (b) A primary cell converts electrical energy into chemical energy
 - (c) Galvanising iron helps to prevent corrosion
 - (d) A positive electrode is termed the cathode
- 10 The greater the internal resistance of a cell:
- (a) the greater the terminal p.d.
 - (b) the less the e.m.f.
 - (c) the greater the e.m.f.
 - (d) the less the terminal p.d.
- 11 The negative pole of a dry cell is made of:
- (a) carbon
 - (b) copper
 - (c) zinc
 - (d) mercury
- 12 The energy of a secondary cell is usually renewed:
- (a) by passing a current through it
 - (b) it cannot be renewed at all
 - (c) by renewing its chemicals
 - (d) by heating it

Assignment 1

This assignment covers the material contained in Chapters 1 to 4.

The marks for each question are shown in brackets at the end of each question.

- 1 An electromagnet exerts a force of 15 N and moves a soft iron armature through a distance of 12 mm in 50 ms. Determine the power consumed. (5)
- 2 A d.c. motor consumes 47.25 MJ when connected to a 250 V supply for 1 hour 45 minutes. Determine the power rating of the motor and the current taken from the supply. (5)
- 3 A 100 W electric light bulb is connected to a 200 V supply. Calculate (a) the current flowing in the bulb, and (b) the resistance of the bulb. (4)
- 4 Determine the charge transferred when a current of 5 mA flows for 10 minutes. (4)
- 5 A current of 12 A flows in the element of an electric fire of resistance 10 Ω . Determine the power dissipated by the element. If the fire is on for 5 hours every day, calculate for a one week period (a) the energy used, and (b) cost of using the fire if electricity cost 7p per unit. (6)
- 6 Calculate the resistance of 1200 m of copper cable of cross-sectional area 15 mm². Take the resistivity of copper as 0.02 $\mu\Omega$ m (5)
- 7 At a temperature of 40°C, an aluminium cable has a resistance of 25 Ω . If the temperature coefficient of resistance at 0°C is 0.0038/°C, calculate its resistance at 0°C (5)
- 8 (a) Determine the values of the resistors with the following colour coding:
 - (i) red-red-orange-silver
 - (ii) orange-orange-black-blue-green(b) What is the value of a resistor marked as 47 KK? (6)
- 9 Four cells, each with an internal resistance of 0.40 Ω and an e.m.f. of 2.5 V are connected in series to a load of 38.4 Ω . (a) Determine the current flowing in the circuit and the p.d. at the battery terminals. (b) If the cells are connected in parallel instead of in series, determine the current flowing and the p.d. at the battery terminals. (10)

Series and parallel networks

At the end of this chapter you should be able to:

- calculate unknown voltages, current and resistances in a series circuit
- understand voltage division in a series circuit
- calculate unknown voltages, currents and resistances in a parallel network
- calculate unknown voltages, currents and resistances in series-parallel networks
- understand current division in a two-branch parallel network
- describe the advantages and disadvantages of series and parallel connection of lamps

5.1 Series circuits

Figure 5.1 shows three resistors R_1 , R_2 and R_3 connected end to end, i.e. in series, with a battery source of V volts. Since the circuit is closed a current I will flow and the p.d. across each resistor may be determined from the voltmeter readings V_1 , V_2 and V_3 .

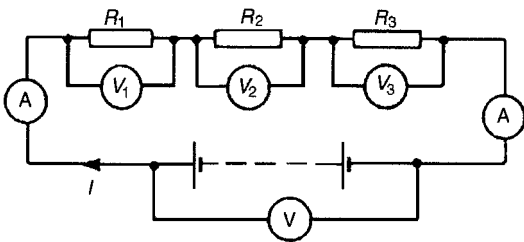

Figure 5.1

In a series circuit

- the current I is the same in all parts of the circuit and hence the same reading is found on each of the ammeters shown, and
- the sum of the voltages V_1 , V_2 and V_3 is equal to the total applied voltage, V ,

i.e.
$$V = V_1 + V_2 + V_3$$

From Ohm's law: $V_1 = IR_1$, $V_2 = IR_2$, $V_3 = IR_3$ and $V = IR$ where R is the total circuit resistance. Since $V = V_1 + V_2 + V_3$ then $IR = IR_1 + IR_2 + IR_3$. Dividing throughout by I gives

$$R = R_1 + R_2 + R_3$$

Thus for a series circuit, the total resistance is obtained by adding together the values of the separate resistances.

Problem 1. For the circuit shown in Fig. 5.2, determine (a) the battery voltage V , (b) the total resistance of the circuit, and (c) the values of resistors R_1 , R_2 and R_3 , given that the p.d.'s across R_1 , R_2 and R_3 are 5 V, 2 V and 6 V respectively.

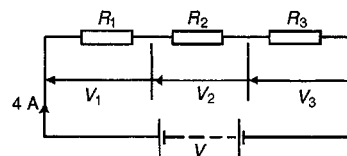

Figure 5.2

- Battery voltage $V = V_1 + V_2 + V_3$

$$= 5 + 2 + 6 = 13 \text{ V}$$

(b) Total circuit resistance $R = \frac{V}{I} = \frac{13}{4} = 3.25 \Omega$

(c) Resistance $R_1 = \frac{V_1}{I} = \frac{5}{4} = 1.25 \Omega$

Resistance $R_2 = \frac{V_2}{I} = \frac{2}{4} = 0.5 \Omega$

Resistance $R_3 = \frac{V_3}{I} = \frac{6}{4} = 1.5 \Omega$

(Check: $R_1 + R_2 + R_3 = 1.25 + 0.5 + 1.5 = 3.25 \Omega = R$)

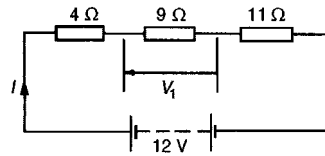

Figure 5.4

which is the current in the 9 Ω resistor.
P.d. across the 9 Ω resistor,

$$V_1 = I \times 9 = 0.5 \times 9 = 4.5 \text{ V}$$

Power dissipated in the 11 Ω resistor,

$$P = I^2 R = (0.5)^2 (11) = (0.25)(11) = 2.75 \text{ W}$$

Problem 2. For the circuit shown in Fig. 5.3, determine the p.d. across resistor R_3 . If the total resistance of the circuit is 100Ω , determine the current flowing through resistor R_1 . Find also the value of resistor R_2 .

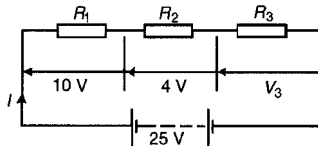

Figure 5.3

P.d. across R_3 , $V_3 = 25 - 10 - 4 = 11 \text{ V}$

$$\text{Current } I = \frac{V}{R} = \frac{25}{100} = 0.25 \text{ A,}$$

which is the current flowing in each resistor

$$\text{Resistance } R_2 = \frac{V_2}{I} = \frac{4}{0.25} = 16 \Omega$$

Problem 3. A 12 V battery is connected in a circuit having three series-connected resistors having resistance's of 4Ω , 9Ω and 11Ω . Determine the current flowing through, and the p.d. across the 9Ω resistor. Find also the power dissipated in the 11Ω resistor.

The circuit diagram is shown in Fig. 5.4

Total resistance $R = 4 + 9 + 11 = 24 \Omega$

$$\text{Current } I = \frac{V}{R} = \frac{12}{24} = 0.5 \text{ A,}$$

5.2 Potential divider

The voltage distribution for the circuit shown in Fig. 5.5(a) is given by:

$$V_1 = \left(\frac{R_1}{R_1 + R_2} \right) V \text{ and } V_2 = \left(\frac{R_2}{R_1 + R_2} \right) V$$

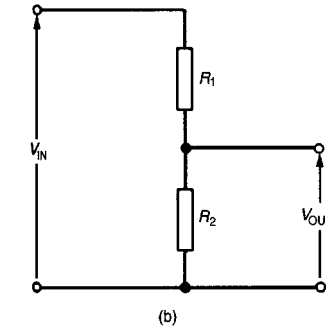
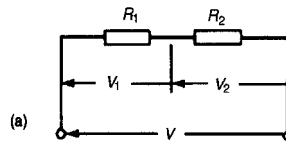

Figure 5.5

The circuit shown in Fig. 5.5(b) is often referred to as a **potential divider** circuit. Such a circuit can consist of a number of similar elements in series connected across a voltage source, voltages

being taken from connections between the elements. Frequently the divider consists of two resistors as shown in Fig. 5.5(b), where

$$V_{\text{OUT}} = \left(\frac{R_2}{R_1 + R_2} \right) V_{\text{IN}}$$

Problem 4. Determine the value of voltage V shown in Fig. 5.6

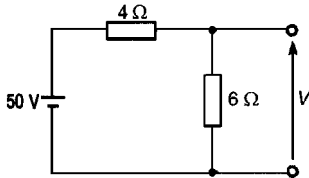

Figure 5.6

Figure 5.6 may be redrawn as shown in Fig. 5.7, and

$$\text{voltage } V = \left(\frac{6}{6 + 4} \right) (50) = 30 \text{ V}$$

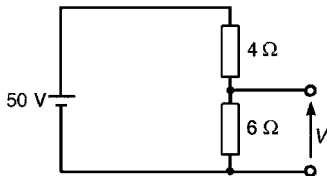

Figure 5.7

Problem 5. Two resistors are connected in series across a 24 V supply and a current of 3 A flows in the circuit. If one of the resistors has a resistance of 2 Ω determine (a) the value of the other resistor, and (b) the p.d. across the 2 Ω resistor. If the circuit is connected for 50 hours, how much energy is used?

The circuit diagram is shown in Fig. 5.8

(a) Total circuit resistance

$$R = \frac{V}{I} = \frac{24}{3} = 8 \Omega$$

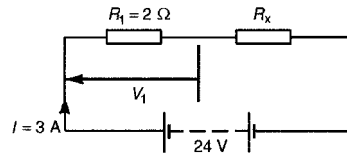

Figure 5.8

Value of unknown resistance,

$$R_x = 8 - 2 = 6 \Omega$$

(b) P.d. across 2 Ω resistor,

$$V_1 = IR_1 = 3 \times 2 = 6 \text{ V}$$

Alternatively, from above,

$$\begin{aligned} V_1 &= \left(\frac{R_1}{R_1 + R_x} \right) V \\ &= \left(\frac{2}{2 + 6} \right) (24) = 6 \text{ V} \end{aligned}$$

Energy used = power × time

$$\begin{aligned} &= (V \times I) \times t \\ &= (24 \times 3 \text{ W})(50 \text{ h}) \\ &= 3600 \text{ Wh} = 3.6 \text{ kWh} \end{aligned}$$

Now try the following exercise

Exercise 19 Further problems on series circuits

- The p.d.'s measured across three resistors connected in series are 5 V, 7 V and 10 V, and the supply current is 2 A. Determine (a) the supply voltage, (b) the total circuit resistance and (c) the values of the three resistors.
[(a) 22 V (b) 11 Ω (c) 2.5 Ω, 3.5 Ω, 5 Ω]
- For the circuit shown in Fig. 5.9, determine the value of V_1 . If the total circuit resistance is 36 Ω determine the supply current and the value of resistors R_1 , R_2 and R_3
[10 V, 0.5 A, 20 Ω, 10 Ω, 6 Ω]
- When the switch in the circuit in Fig. 5.10 is closed the reading on voltmeter 1 is 30 V

and that on voltmeter 2 is 10 V. Determine the reading on the ammeter and the value of resistor R_x [4 A, 2.5 Ω]

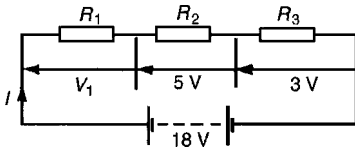

Figure 5.9

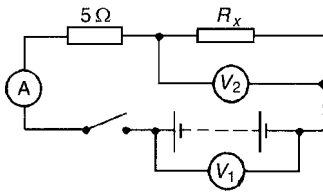

Figure 5.10

4 Calculate the value of voltage V in Fig. 5.11 [45 V]

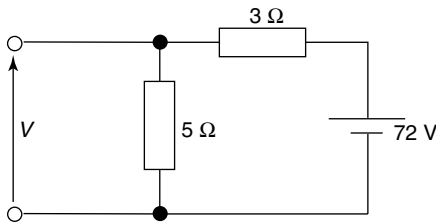

Figure 5.11

5 Two resistors are connected in series across an 18 V supply and a current of 5 A flows. If one of the resistors has a value of 2.4 Ω determine (a) the value of the other resistor and (b) the p.d. across the 2.4 Ω resistor. [(a) 1.2 Ω (b) 12 V]

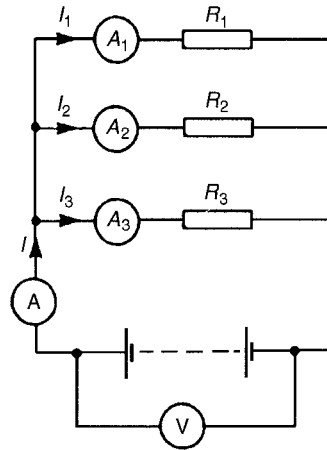

Figure 5.12

In a parallel circuit:

(a) the sum of the currents I_1 , I_2 and I_3 is equal to the total circuit current, I ,

i.e.
$$I = I_1 + I_2 + I_3$$
 and

(b) the source p.d., V volts, is the same across each of the resistors.

From Ohm's law:

$$I_1 = \frac{V}{R_1}, I_2 = \frac{V}{R_2}, I_3 = \frac{V}{R_3} \text{ and } I = \frac{V}{R}$$

where R is the total circuit resistance. Since

$$I = I_1 + I_2 + I_3 \text{ then } \frac{V}{R} = \frac{V}{R_1} + \frac{V}{R_2} + \frac{V}{R_3}$$

Dividing throughout by V gives:

$$\frac{1}{R} = \frac{1}{R_1} + \frac{1}{R_2} + \frac{1}{R_3}$$

This equation must be used when finding the total resistance R of a parallel circuit. For the special case of **two resistors in parallel**

$$\frac{1}{R} = \frac{1}{R_1} + \frac{1}{R_2} = \frac{R_2 + R_1}{R_1 R_2}$$

Hence
$$R = \frac{R_1 R_2}{R_1 + R_2}$$
 (i.e. $\frac{\text{product}}{\text{sum}}$)

5.3 Parallel networks

Figure 5.12 shows three resistors, R_1 , R_2 and R_3 connected across each other, i.e. in parallel, across a battery source of V volts.

Problem 9. Given four $1\ \Omega$ resistors, state how they must be connected to give an overall resistance of (a) $\frac{1}{4}\ \Omega$ (b) $1\ \Omega$ (c) $1\frac{1}{3}\ \Omega$ (d) $2\frac{1}{2}\ \Omega$, all four resistors being connected in each case.

(a) **All four in parallel** (see Fig. 5.16), since

$$\frac{1}{R} = \frac{1}{1} + \frac{1}{1} + \frac{1}{1} + \frac{1}{1} = \frac{4}{1} \text{ i.e. } R = \frac{1}{4}\ \Omega$$

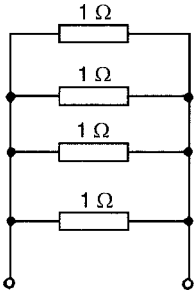

Figure 5.16

(b) **Two in series, in parallel with another two in series** (see Fig. 5.17), since $1\ \Omega$ and $1\ \Omega$ in series gives $2\ \Omega$, and $2\ \Omega$ in parallel with $2\ \Omega$ gives

$$\frac{2 \times 2}{2 + 2} = \frac{4}{4} = 1\ \Omega$$

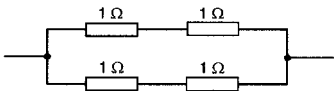

Figure 5.17

(c) **Three in parallel, in series with one** (see Fig. 5.18), since for the three in parallel,

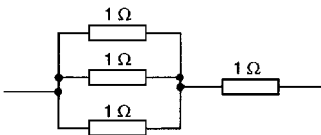

Figure 5.18

$$\frac{1}{R} = \frac{1}{1} + \frac{1}{1} + \frac{1}{1} = \frac{3}{1},$$

i.e. $R = \frac{1}{3}\ \Omega$ and $\frac{1}{3}\ \Omega$ in series with $1\ \Omega$ gives $1\ \Omega$

(d) **Two in parallel, in series with two in series** (see Fig. 5.19), since for the two in parallel

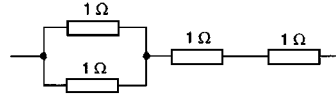

Figure 5.19

$$R = \frac{1 \times 1}{1 + 1} = \frac{1}{2}\ \Omega,$$

and $\frac{1}{2}\ \Omega$, $1\ \Omega$ and $1\ \Omega$ in series gives $2\frac{1}{2}\ \Omega$

Problem 10. Find the equivalent resistance for the circuit shown in Fig. 5.20

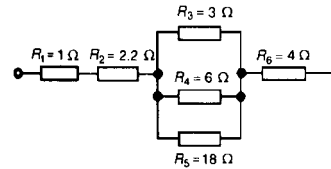

Figure 5.20

R_3 , R_4 and R_5 are connected in parallel and their equivalent resistance R is given by

$$\frac{1}{R} = \frac{1}{3} + \frac{1}{6} + \frac{1}{18} = \frac{6 + 3 + 1}{18} = \frac{10}{18}$$

hence $R = (18/10) = 1.8\ \Omega$. The circuit is now equivalent to four resistors in series and the **equivalent circuit resistance** = $1 + 2.2 + 1.8 + 4 = 9\ \Omega$

Problem 11. Resistances of $10\ \Omega$, $20\ \Omega$ and $30\ \Omega$ are connected (a) in series and (b) in parallel to a $240\ \text{V}$ supply. Calculate the supply current in each case.

(a) The series circuit is shown in Fig. 5.21

The equivalent resistance

$$R_T = 10\ \Omega + 20\ \Omega + 30\ \Omega = 60\ \Omega$$

$$\text{Supply current } I = \frac{V}{R_T} = \frac{240}{60} = 4\ \text{A}$$

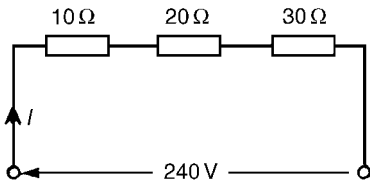

Figure 5.21

- (b) The parallel circuit is shown in Fig. 5.22. The equivalent resistance R_T of $10\ \Omega$, $20\ \Omega$ and $30\ \Omega$ resistance's connected in parallel is given by:

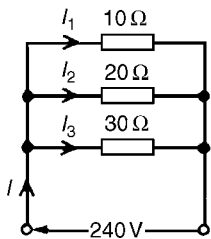

Figure 5.22

$$\frac{1}{R_T} = \frac{1}{10} + \frac{1}{20} + \frac{1}{30} = \frac{6+3+2}{60} = \frac{11}{60}$$

$$\text{hence } R_T = \frac{60}{11}\ \Omega$$

Supply current

$$I = \frac{V}{R_T} = \frac{240}{\frac{60}{11}} = \frac{240 \times 11}{60} = \mathbf{44\ A}$$

(Check:

$$I_1 = \frac{V}{R_1} = \frac{240}{10} = 24\ \text{A},$$

$$I_2 = \frac{V}{R_2} = \frac{240}{20} = 12\ \text{A}$$

$$\text{and } I_3 = \frac{V}{R_3} = \frac{240}{30} = \mathbf{8\ A}$$

For a parallel circuit $I = I_1 + I_2 + I_3 = 24 + 12 + 8 = \mathbf{44\ A}$, as above)

5.4 Current division

For the circuit shown in Fig. 5.23, the total circuit resistance, R_T is given by

$$R_T = \frac{R_1 R_2}{R_1 + R_2}$$

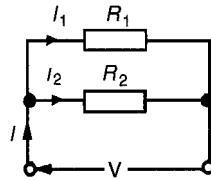

Figure 5.23

$$\text{and } V = IR_T = I \left(\frac{R_1 R_2}{R_1 + R_2} \right)$$

$$\begin{aligned} \text{Current } I_1 &= \frac{V}{R_1} = \frac{I}{R_1} \left(\frac{R_1 R_2}{R_1 + R_2} \right) \\ &= \left(\frac{R_2}{R_1 + R_2} \right) (I) \end{aligned}$$

Similarly,

$$\begin{aligned} \text{current } I_2 &= \frac{V}{R_2} = \frac{I}{R_2} \left(\frac{R_1 R_2}{R_1 + R_2} \right) \\ &= \left(\frac{R_1}{R_1 + R_2} \right) (I) \end{aligned}$$

Summarising, with reference to Fig. 5.23

$$I_1 = \left(\frac{R_2}{R_1 + R_2} \right) (I)$$

and

$$I_2 = \left(\frac{R_1}{R_1 + R_2} \right) (I)$$

Problem 12. For the series-parallel arrangement shown in Fig. 5.24, find (a) the supply current, (b) the current flowing through each resistor and (c) the p.d. across each resistor.

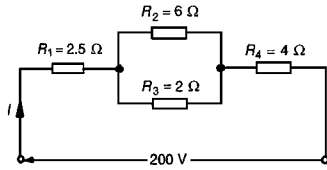

Figure 5.24

- (a) The equivalent resistance R_x of R_2 and R_3 in parallel is:

$$R_x = \frac{6 \times 2}{6 + 2} = 1.5 \Omega$$

The equivalent resistance R_T of R_1 , R_x and R_4 in series is:

$$R_T = 2.5 + 1.5 + 4 = 8 \Omega$$

Supply current

$$I = \frac{V}{R_T} = \frac{200}{8} = 25 \text{ A}$$

- (b) The current flowing through R_1 and R_4 is 25 A. The current flowing through

$$R_2 = \left(\frac{R_3}{R_2 + R_3} \right) I = \left(\frac{2}{6 + 2} \right) 25 = 6.25 \text{ A}$$

The current flowing through

$$R_3 = \left(\frac{R_2}{R_2 + R_3} \right) I = \left(\frac{6}{6 + 2} \right) 25 = 18.75 \text{ A}$$

(Note that the currents flowing through R_2 and R_3 must add up to the total current flowing into the parallel arrangement, i.e. 25 A)

- (c) The equivalent circuit of Fig. 5.24 is shown in Fig. 5.25

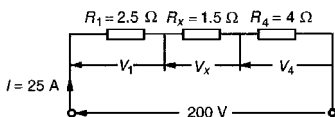

Figure 5.25

p.d. across R_1 , i.e.

$$V_1 = IR_1 = (25)(2.5) = 62.5 \text{ V}$$

p.d. across R_x , i.e.

$$V_x = IR_x = (25)(1.5) = 37.5 \text{ V}$$

p.d. across R_4 , i.e.

$$V_4 = IR_4 = (25)(4) = 100 \text{ V}$$

Hence the p.d. across R_2

$$= \text{p.d. across } R_3 = 37.5 \text{ V}$$

Problem 13. For the circuit shown in Fig. 5.26 calculate (a) the value of resistor R_x such that the total power dissipated in the circuit is 2.5 kW, (b) the current flowing in each of the four resistors.

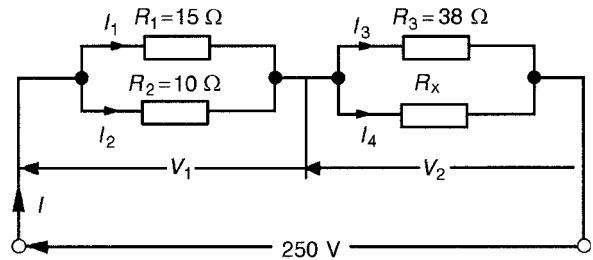

Figure 5.26

- (a) Power dissipated $P = VI$ watts, hence $2500 = (250)(I)$

$$\text{i.e. } I = \frac{2500}{250} = 10 \text{ A}$$

From Ohm's law,

$$R_T = \frac{V}{I} = \frac{250}{10} = 25 \Omega,$$

where R_T is the equivalent circuit resistance. The equivalent resistance of R_1 and R_2 in parallel is

$$\frac{15 \times 10}{15 + 10} = \frac{150}{25} = 6 \Omega$$

The equivalent resistance of resistors R_3 and R_x in parallel is equal to $25 \Omega - 6 \Omega$, i.e. 19Ω .

There are three methods whereby R_x can be determined.

Method 1

The voltage $V_1 = IR$, where R is $6\ \Omega$, from above, i.e. $V_1 = (10)(6) = 60\text{ V}$. Hence

$$\begin{aligned} V_2 &= 250\text{ V} - 60\text{ V} = 190\text{ V} \\ &= \text{p.d. across } R_3 \\ &= \text{p.d. across } R_x \\ I_3 &= \frac{V_2}{R_3} = \frac{190}{38} = 5\text{ A.} \end{aligned}$$

Thus $I_4 = 5\text{ A}$ also, since $I = 10\text{ A}$. Thus

$$R_x = \frac{V_2}{I_4} = \frac{190}{5} = 38\ \Omega$$

Method 2

Since the equivalent resistance of R_3 and R_x in parallel is $19\ \Omega$,

$$19 = \frac{38R_x}{38 + R_x} \quad \left(\text{i.e. } \frac{\text{product}}{\text{sum}}\right)$$

Hence

$$\begin{aligned} 19(38 + R_x) &= 38R_x \\ 722 + 19R_x &= 38R_x \\ 722 &= 38R_x - 19R_x = 19R_x \end{aligned}$$

$$\text{Thus } R_x = \frac{722}{19} = 38\ \Omega$$

Method 3

When two resistors having the same value are connected in parallel the equivalent resistance is always half the value of one of the resistors. Thus, in this case, since $R_T = 19\ \Omega$ and $R_3 = 38\ \Omega$, then $R_x = 38\ \Omega$ could have been deduced on sight.

$$\begin{aligned} \text{(b) Current } I_1 &= \left(\frac{R_2}{R_1 + R_2}\right) I \\ &= \left(\frac{10}{15 + 10}\right) (10) \\ &= \left(\frac{2}{5}\right) (10) = 4\text{ A} \end{aligned}$$

$$\begin{aligned} \text{Current } I_2 &= \left(\frac{R_1}{R_1 + R_2}\right) I = \left(\frac{15}{15 + 10}\right) (10) \\ &= \left(\frac{3}{5}\right) (10) = 6\text{ A} \end{aligned}$$

From part (a), method 1, $I_3 = I_4 = 5\text{ A}$

Problem 14. For the arrangement shown in Fig. 5.27, find the current I_x .

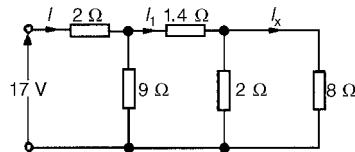

Figure 5.27

Commencing at the right-hand side of the arrangement shown in Fig. 5.27, the circuit is gradually reduced in stages as shown in Fig. 5.28(a)–(d).

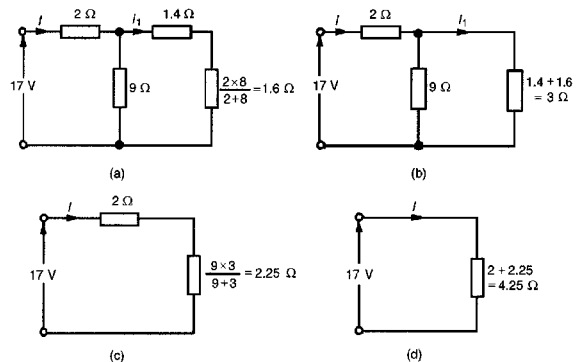

Figure 5.28

From Fig. 5.28(d),

$$I = \frac{17}{4.25} = 4\text{ A}$$

From Fig. 5.28(b),

$$I_1 = \left(\frac{9}{9 + 3}\right) (I) = \left(\frac{9}{12}\right) (4) = 3\text{ A}$$

From Fig. 5.27

$$I_x = \left(\frac{2}{2 + 8}\right) (I_1) = \left(\frac{2}{10}\right) (3) = 0.6\text{ A}$$

Now try the following exercise

Exercise 20 Further problems on parallel networks

1 Resistances of $4\ \Omega$ and $12\ \Omega$ are connected in parallel across a 9 V battery. Determine (a) the equivalent circuit resistance, (b) the supply current, and (c) the current in each resistor.

[(a) $3\ \Omega$ (b) 3 A (c) 2.25 A , 0.75 A]

2 For the circuit shown in Fig. 5.29 determine (a) the reading on the ammeter, and (b) the value of resistor R

[2.5 A , $2.5\ \Omega$]

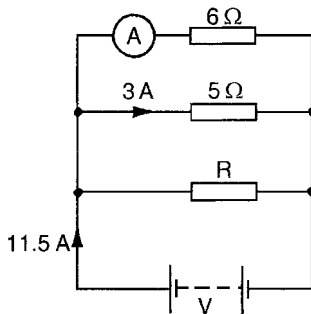

Figure 5.29

3 Find the equivalent resistance when the following resistances are connected (a) in series (b) in parallel (i) $3\ \Omega$ and $2\ \Omega$ (ii) $20\text{ k}\Omega$ and $40\text{ k}\Omega$ (iii) $4\ \Omega$, $8\ \Omega$ and $16\ \Omega$ (iv) $800\ \Omega$, $4\text{ k}\Omega$ and $1500\ \Omega$

(a) (i) $5\ \Omega$ (ii) $60\text{ k}\Omega$
(iii) $28\ \Omega$ (iv) $6.3\text{ k}\Omega$

(b) (i) $1.2\ \Omega$ (ii) $13.33\text{ k}\Omega$
(iii) $2.29\ \Omega$ (iv) $461.54\text{ k}\Omega$

4 Find the total resistance between terminals A and B of the circuit shown in Fig. 5.30(a)

[$8\ \Omega$]

5 Find the equivalent resistance between terminals C and D of the circuit shown in Fig. 5.30(b)

[$27.5\ \Omega$]

6 Resistors of $20\ \Omega$, $20\ \Omega$ and $30\ \Omega$ are connected in parallel. What resistance must be added in series with the combination to obtain a total resistance of $10\ \Omega$. If the com-

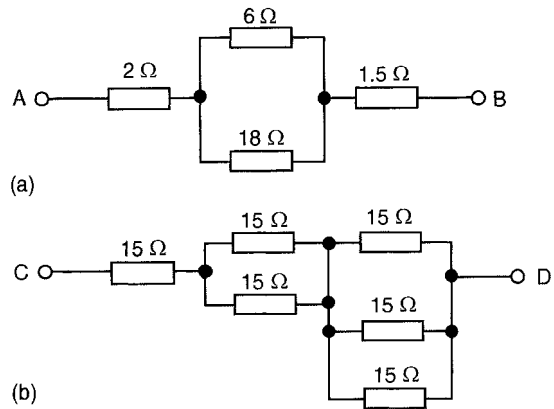

Figure 5.30

plete circuit expends a power of 0.36 kW , find the total current flowing.

[$2.5\ \Omega$, 6 A]

7 (a) Calculate the current flowing in the $30\ \Omega$ resistor shown in Fig. 5.31 (b) What additional value of resistance would have to be placed in parallel with the $20\ \Omega$ and $30\ \Omega$ resistors to change the supply current to 8 A , the supply voltage remaining constant.

[(a) 1.6 A (b) $6\ \Omega$]

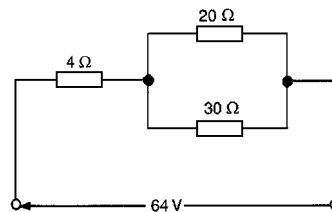

Figure 5.31

8 For the circuit shown in Fig. 5.32, find (a) V_1 , (b) V_2 , without calculating the current flowing.

[(a) 30 V (b) 42 V]

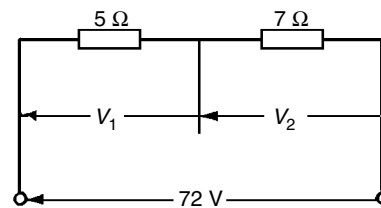

Figure 5.32

9 Determine the currents and voltages indicated in the circuit shown in Fig. 5.33

$$[I_1 = 5 \text{ A}, I_2 = 2.5 \text{ A}, I_3 = 1\frac{2}{3} \text{ A}, I_4 = \frac{5}{6} \text{ A}, I_5 = 3 \text{ A}, I_6 = 2 \text{ A}, V_1 = 20 \text{ V}, V_2 = 5 \text{ V}, V_3 = 6 \text{ V}]$$

10 Find the current I in Fig. 5.34 [1.8 A]

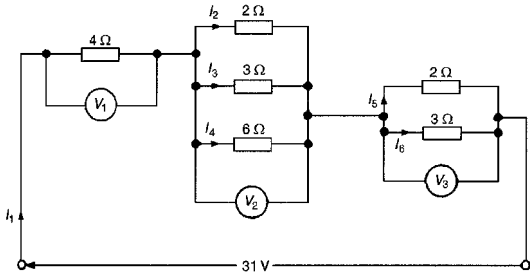

Figure 5.33

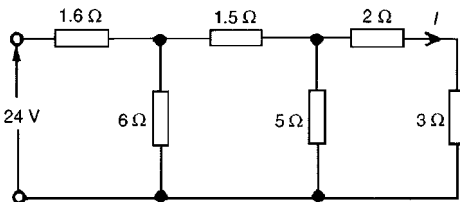

Figure 5.34

now has $(240/4) \text{ V}$, i.e. 60 V across it and each now glows even more dimly.

- (iii) If a lamp is removed from the circuit or if a lamp develops a fault (i.e. an open circuit) or if the switch is opened, then the circuit is broken, no current flows, and the remaining lamps will not light up.
- (iv) Less cable is required for a series connection than for a parallel one.

The series connection of lamps is usually limited to decorative lighting such as for Christmas tree lights.

Parallel connection

Figure 5.36 shows three similar lamps, each rated at 240 V , connected in parallel across a 240 V supply.

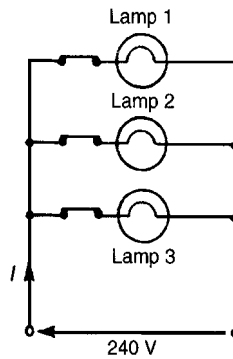

Figure 5.36

- (i) Each lamp has 240 V across it and thus each will glow brilliantly at their rated voltage.
- (ii) If any lamp is removed from the circuit or develops a fault (open circuit) or a switch is opened, the remaining lamps are unaffected.
- (iii) The addition of further similar lamps in parallel does not affect the brightness of the other lamps.
- (iv) More cable is required for parallel connection than for a series one.

The parallel connection of lamps is the most widely used in electrical installations.

5.5 Wiring lamps in series and in parallel

Series connection

Figure 5.35 shows three lamps, each rated at 240 V , connected in series across a 240 V supply.

- (i) Each lamp has only $(240/3) \text{ V}$, i.e. 80 V across it and thus each lamp glows dimly.
- (ii) If another lamp of similar rating is added in series with the other three lamps then each lamp

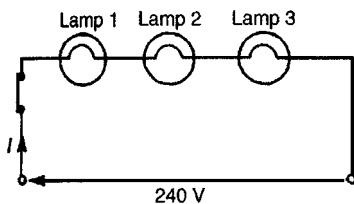

Figure 5.35

Problem 15. If three identical lamps are connected in parallel and the combined resistance is 150Ω , find the resistance of one lamp.

Let the resistance of one lamp be R , then

$$\frac{1}{150} = \frac{1}{R} + \frac{1}{R} + \frac{1}{R} = \frac{3}{R},$$

from which, $R = 3 \times 150 = 450 \Omega$

Problem 16. Three identical lamps A, B and C are connected in series across a 150 V supply. State (a) the voltage across each lamp, and (b) the effect of lamp C failing.

- (a) Since each lamp is identical and they are connected in series there is $150/3 \text{ V}$, i.e. **50 V** across each.
- (b) If lamp C fails, i.e. open circuits, no current will flow and **lamps A and B will not operate.**

Now try the following exercises

Exercise 21 Further problems on wiring lamps in series and in parallel

- If four identical lamps are connected in parallel and the combined resistance is 100Ω , find the resistance of one lamp. [400 Ω]
- Three identical filament lamps are connected (a) in series, (b) in parallel across a 210 V supply. State for each connection the p.d. across each lamp. [(a) 70 V (b) 210 V]

Exercise 22 Short answer questions on series and parallel networks

- Name three characteristics of a series circuit
- Show that for three resistors R_1 , R_2 and R_3 connected in series the equivalent resistance R is given by $R = R_1 + R_2 + R_3$
- Name three characteristics of a parallel network
- Show that for three resistors R_1 , R_2 and R_3 connected in parallel the equivalent resistance R is given by

$$\frac{1}{R} = \frac{1}{R_1} + \frac{1}{R_2} + \frac{1}{R_3}$$

- Explain the potential divider circuit
- Compare the merits of wiring lamps in (a) series (b) parallel

Exercise 23 Multi-choice questions on series and parallel networks (Answers on page 375)

- If two 4Ω resistors are connected in series the effective resistance of the circuit is: (a) 8Ω (b) 4Ω (c) 2Ω (d) 1Ω
- If two 4Ω resistors are connected in parallel the effective resistance of the circuit is: (a) 8Ω (b) 4Ω (c) 2Ω (d) 1Ω
- With the switch in Fig. 5.37 closed, the ammeter reading will indicate: (a) 1 A (b) 75 A (c) $\frac{1}{3} \text{ A}$ (d) 3 A

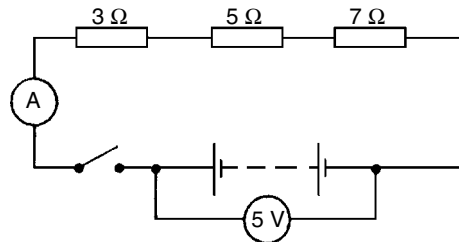

Figure 5.37

- The effect of connecting an additional parallel load to an electrical supply source is to increase the (a) resistance of the load (b) voltage of the source (c) current taken from the source (d) p.d. across the load
- The equivalent resistance when a resistor of $\frac{1}{3} \Omega$ is connected in parallel with a $\frac{1}{4} \Omega$ resistance is: (a) $\frac{1}{7} \Omega$ (b) 7Ω (c) $\frac{1}{12} \Omega$ (d) $\frac{3}{4} \Omega$
- With the switch in Fig. 5.38 closed the ammeter reading will indicate: (a) 108 A (b) $\frac{1}{3} \text{ A}$ (c) 3 A (d) $4\frac{3}{4} \text{ A}$
- A 6Ω resistor is connected in parallel with the three resistors of Fig. 5.38. With the

switch closed the ammeter reading will indicate:

- (a) $\frac{3}{4}$ A (b) 4 A (c) $\frac{1}{4}$ A (d) $1\frac{1}{3}$ A

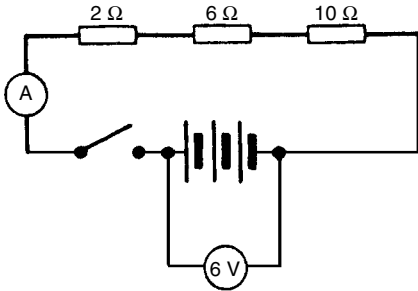

Figure 5.38

8 A $10\ \Omega$ resistor is connected in parallel with a $15\ \Omega$ resistor and the combination in series with a $12\ \Omega$ resistor. The equivalent resistance of the circuit is:

- (a) $37\ \Omega$ (b) $18\ \Omega$ (c) $27\ \Omega$ (d) $4\ \Omega$

9 When three $3\ \Omega$ resistors are connected in parallel, the total resistance is:

- (a) $3\ \Omega$ (b) $9\ \Omega$
 (c) $1\ \Omega$ (d) $0.333\ \Omega$

10 The total resistance of two resistors R_1 and R_2 when connected in parallel is given by:

- (a) $R_1 + R_2$ (b) $\frac{1}{R_1} + \frac{1}{R_2}$
 (c) $\frac{R_1 + R_2}{R_1 R_2}$ (d) $\frac{R_1 R_2}{R_1 + R_2}$

11 If in the circuit shown in Fig. 5.39, the reading on the voltmeter is $5\ \text{V}$ and the reading on the ammeter is $25\ \text{mA}$, the resistance of resistor R is:

- (a) $0.005\ \Omega$ (b) $5\ \Omega$
 (c) $125\ \Omega$ (d) $200\ \Omega$

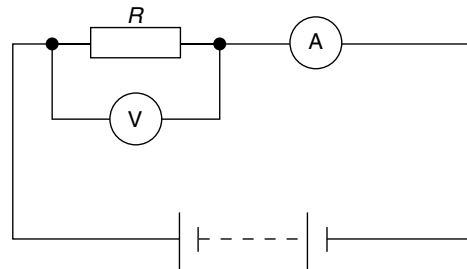

Figure 5.39

Capacitors and capacitance

At the end of this chapter you should be able to:

- describe an electrostatic field
- appreciate Coulomb's law
- define electric field strength E and state its unit
- define capacitance and state its unit
- describe a capacitor and draw the circuit diagram symbol
- perform simple calculations involving $C = Q/V$ and $Q = It$
- define electric flux density D and state its unit
- define permittivity, distinguishing between ϵ_0 , ϵ_r and ϵ
- perform simple calculations involving

$$D = \frac{Q}{A}, E = \frac{V}{d} \text{ and } \frac{D}{E} = \epsilon_0 \epsilon_r$$

- understand that for a parallel plate capacitor,

$$C = \frac{\epsilon_0 \epsilon_r A (n - 1)}{d}$$

- perform calculations involving capacitors connected in parallel and in series
- define dielectric strength and state its unit
- state that the energy stored in a capacitor is given by $W = \frac{1}{2} CV^2$ joules
- describe practical types of capacitor
- understand the precautions needed when discharging capacitors

6.1 Electrostatic field

Figure 6.1 represents two parallel metal plates, A and B , charged to different potentials. If an electron that has a negative charge is placed between the plates, a force will act on the electron tending to push it away from the negative plate B towards the positive plate, A . Similarly, a positive charge would be acted on by a force tending to move it toward

the negative plate. Any region such as that shown between the plates in Fig. 6.1, in which an electric charge experiences a force, is called an **electrostatic field**. The direction of the field is defined as that of the force acting on a positive charge placed in the field. In Fig. 6.1, the direction of the force is from the positive plate to the negative plate. Such a field may be represented in magnitude and direction by **lines of electric force** drawn between the charged surfaces. The closeness of the lines is

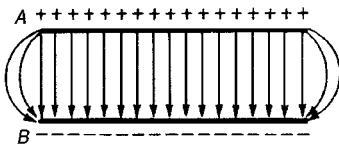

Figure 6.1

an indication of the field strength. Whenever a p.d. is established between two points, an electric field will always exist.

Figure 6.2(a) shows a typical field pattern for an isolated point charge, and Fig. 6.2(b) shows the field pattern for adjacent charges of opposite polarity. Electric lines of force (often called electric flux lines) are continuous and start and finish on point charges; also, the lines cannot cross each other. When a charged body is placed close to an uncharged body, an induced charge of opposite sign appears on the surface of the uncharged body. This is because lines of force from the charged body terminate on its surface.

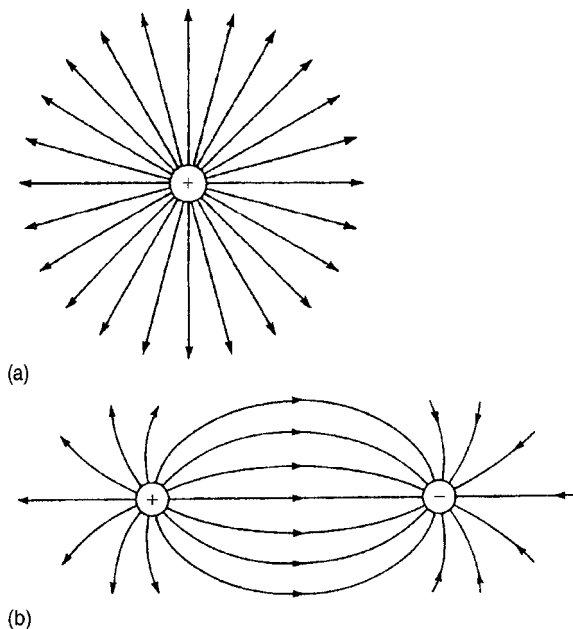

Figure 6.2

The concept of field lines or lines of force is used to illustrate the properties of an electric field. However, it should be remembered that they are only aids to the imagination.

The **force of attraction or repulsion** between two electrically charged bodies is proportional to

the magnitude of their charges and inversely proportional to the square of the distance separating them, i.e.

$$\text{force} \propto \frac{q_1 q_2}{d^2}$$

or

$$\text{force} = k \frac{q_1 q_2}{d^2}$$

where constant $k \approx 9 \times 10^9$. This is known as **Coulomb's law**.

Hence the force between two charged spheres in air with their centres 16 mm apart and each carrying a charge of $+1.6 \mu\text{C}$ is given by:

$$\begin{aligned} \text{force} &= k \frac{q_1 q_2}{d^2} \approx (9 \times 10^9) \frac{(1.6 \times 10^{-6})^2}{(16 \times 10^{-3})^2} \\ &= 90 \text{ newtons} \end{aligned}$$

6.2 Electric field strength

Figure 6.3 shows two parallel conducting plates separated from each other by air. They are connected to opposite terminals of a battery of voltage V volts. There is therefore an electric field in the space between the plates. If the plates are close together, the electric lines of force will be straight and parallel and equally spaced, except near the edge where fringing will occur (see Fig. 6.1). Over the area in which there is negligible fringing,

$$\text{Electric field strength, } E = \frac{V}{d} \text{ volts/metre}$$

where d is the distance between the plates. Electric field strength is also called **potential gradient**.

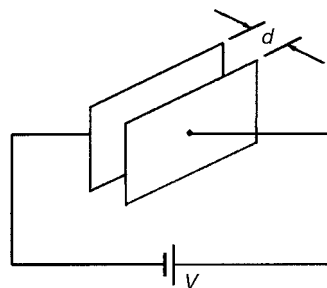

Figure 6.3

6.3 Capacitance

Static electric fields arise from electric charges, electric field lines beginning and ending on electric charges. Thus the presence of the field indicates the presence of equal positive and negative electric charges on the two plates of Fig. 6.3. Let the charge be $+Q$ coulombs on one plate and $-Q$ coulombs on the other. The property of this pair of plates which determines how much charge corresponds to a given p.d. between the plates is called their capacitance:

$$\text{capacitance } C = \frac{Q}{V}$$

The **unit of capacitance** is the **farad F** (or more usually $\mu F = 10^{-6} F$ or $pF = 10^{-12} F$), which is defined as the capacitance when a p.d. of one volt appears across the plates when charged with one coulomb.

6.4 Capacitors

Every system of electrical conductors possesses capacitance. For example, there is capacitance between the conductors of overhead transmission lines and also between the wires of a telephone cable. In these examples the capacitance is undesirable but has to be accepted, minimized or compensated for. There are other situations where capacitance is a desirable property.

Devices specially constructed to possess capacitance are called **capacitors** (or condensers, as they used to be called). In its simplest form a capacitor consists of two plates which are separated by an insulating material known as a **dielectric**. A capacitor has the ability to store a quantity of static electricity.

The symbols for a fixed capacitor and a variable capacitor used in electrical circuit diagrams are shown in Fig. 6.4

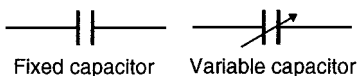

Figure 6.4

The **charge Q** stored in a capacitor is given by:

$$Q = I \times t \text{ coulombs}$$

where I is the current in amperes and t the time in seconds.

Problem 1. (a) Determine the p.d. across a $4 \mu F$ capacitor when charged with 5 mC
(b) Find the charge on a 50 pF capacitor when the voltage applied to it is 2 kV .

- (a) $C = 4 \mu F = 4 \times 10^{-6} F$ and
 $Q = 5 \text{ mC} = 5 \times 10^{-3} C$.

$$\begin{aligned} \text{Since } C = \frac{Q}{V} \text{ then } V &= \frac{Q}{C} = \frac{5 \times 10^{-3}}{4 \times 10^{-6}} \\ &= \frac{5 \times 10^6}{4 \times 10^3} = \frac{5000}{4} \end{aligned}$$

Hence p.d. $V = 1250 \text{ V}$ or 1.25 kV

- (b) $C = 50 \text{ pF} = 50 \times 10^{-12} F$ and
 $V = 2 \text{ kV} = 2000 \text{ V}$

$$\begin{aligned} Q = CV &= 50 \times 10^{-12} \times 2000 \\ &= \frac{5 \times 2}{10^8} = 0.1 \times 10^{-6} \end{aligned}$$

Hence, charge $Q = 0.1 \mu C$

Problem 2. A direct current of 4 A flows into a previously uncharged $20 \mu F$ capacitor for 3 ms . Determine the p.d. between the plates.

$I = 4 \text{ A}$, $C = 20 \mu F = 20 \times 10^{-6} F$ and $t = 3 \text{ ms} = 3 \times 10^{-3} \text{ s}$. $Q = It = 4 \times 3 \times 10^{-3} C$.

$$\begin{aligned} V &= \frac{Q}{C} = \frac{4 \times 3 \times 10^{-3}}{20 \times 10^{-6}} \\ &= \frac{12 \times 10^6}{20 \times 10^3} = 0.6 \times 10^3 = 600 \text{ V} \end{aligned}$$

Hence, the p.d. between the plates is 600 V

Problem 3. A $5 \mu F$ capacitor is charged so that the p.d. between its plates is 800 V . Calculate how long the capacitor can provide an average discharge current of 2 mA .

$C = 5 \mu F = 5 \times 10^{-6} F$, $V = 800 \text{ V}$ and
 $I = 2 \text{ mA} = 2 \times 10^{-3} \text{ A}$.
 $Q = CV = 5 \times 10^{-6} \times 800 = 4 \times 10^{-3} C$

Also, $Q = It$. Thus,

$$t = \frac{Q}{I} = \frac{4 \times 10^{-3}}{2 \times 10^{-3}} = 2 \text{ s}$$

Hence, the capacitor can provide an average discharge current of 2 mA for 2 s.

Now try the following exercise

Exercise 24 Further problems on capacitors and capacitance

- 1 Find the charge on a $10 \mu\text{F}$ capacitor when the applied voltage is 250 V [2.5 mC]
- 2 Determine the voltage across a 1000 pF capacitor to charge it with $2 \mu\text{C}$ [2 kV]
- 3 The charge on the plates of a capacitor is 6 mC when the potential between them is 2.4 kV. Determine the capacitance of the capacitor. [2.5 μF]
- 4 For how long must a charging current of 2 A be fed to a $5 \mu\text{F}$ capacitor to raise the p.d. between its plates by 500 V. [1.25 ms]
- 5 A direct current of 10 A flows into a previously uncharged $5 \mu\text{F}$ capacitor for 1 ms. Determine the p.d. between the plates. [2 kV]
- 6 A $16 \mu\text{F}$ capacitor is charged at a constant current of $4 \mu\text{A}$ for 2 min. Calculate the final p.d. across the capacitor and the corresponding charge in coulombs. [30 V, 480 μC]
- 7 A steady current of 10 A flows into a previously uncharged capacitor for 1.5 ms when the p.d. between the plates is 2 kV. Find the capacitance of the capacitor. [7.5 μF]

6.5 Electric flux density

Unit flux is defined as emanating from a positive charge of 1 coulomb. Thus electric flux ψ is measured in coulombs, and for a charge of Q coulombs, the flux $\psi = Q$ coulombs.

Electric flux density D is the amount of flux passing through a defined area A that is perpendicular to the direction of the flux:

$$\text{electric flux density, } D = \frac{Q}{A} \text{ coulombs/metre}^2$$

Electric flux density is also called **charge density**, σ .

6.6 Permittivity

At any point in an electric field, the electric field strength E maintains the electric flux and produces a particular value of electric flux density D at that point. For a field established in **vacuum** (or for practical purposes in air), the ratio D/E is a constant ϵ_0 , i.e.

$$\frac{D}{E} = \epsilon_0$$

where ϵ_0 is called the **permittivity of free space** or the free space constant. The value of ϵ_0 is $8.85 \times 10^{-12} \text{ F/m}$.

When an insulating medium, such as mica, paper, plastic or ceramic, is introduced into the region of an electric field the ratio of D/E is modified:

$$\frac{D}{E} = \epsilon_0 \epsilon_r$$

where ϵ_r , the **relative permittivity** of the insulating material, indicates its insulating power compared with that of vacuum:

relative permittivity,

$$\epsilon_r = \frac{\text{flux density in material}}{\text{flux density in vacuum}}$$

ϵ_r has no unit. Typical values of ϵ_r include air, 1.00; polythene, 2.3; mica, 3–7; glass, 5–10; water, 80; ceramics, 6–1000.

The product $\epsilon_0 \epsilon_r$ is called the **absolute permittivity**, ϵ , i.e.

$$\epsilon = \epsilon_0 \epsilon_r$$

The insulating medium separating charged surfaces is called a **dielectric**. Compared with conductors, dielectric materials have very high resistivities. They are therefore used to separate conductors at different potentials, such as capacitor plates or electric power lines.

Problem 4. Two parallel rectangular plates measuring 20 cm by 40 cm carry an electric charge of $0.2 \mu\text{C}$. Calculate the electric flux density. If the plates are spaced 5 mm apart and the voltage between them is 0.25 kV determine the electric field strength.

Area = $20 \text{ cm} \times 40 \text{ cm} = 800 \text{ cm}^2 = 800 \times 10^{-4} \text{ m}^2$
and charge $Q = 0.2 \mu\text{C} = 0.2 \times 10^{-6} \text{ C}$,

Electric flux density

$$D = \frac{Q}{A} = \frac{0.2 \times 10^{-6}}{800 \times 10^{-4}} = \frac{0.2 \times 10^4}{800 \times 10^6}$$

$$= \frac{2000}{800} \times 10^{-6} = \mathbf{2.5 \mu\text{C/m}^2}$$

Voltage $V = 0.25 \text{ kV} = 250 \text{ V}$ and plate spacing,
 $d = 5 \text{ mm} = 5 \times 10^{-3} \text{ m}$.

Electric field strength

$$E = \frac{V}{d} = \frac{250}{5 \times 10^{-3}} = \mathbf{50 \text{ kV/m}}$$

Problem 5. The flux density between two plates separated by mica of relative permittivity 5 is $2 \mu\text{C/m}^2$. Find the voltage gradient between the plates.

Flux density $D = 2 \mu\text{C/m}^2 = 2 \times 10^{-6} \text{ C/m}^2$,
 $\epsilon_0 = 8.85 \times 10^{-12} \text{ F/m}$ and $\epsilon_r = 5$.

$D/E = \epsilon_0 \epsilon_r$, hence **voltage gradient**,

$$E = \frac{D}{\epsilon_0 \epsilon_r} = \frac{2 \times 10^{-6}}{8.85 \times 10^{-12} \times 5} \text{ V/m}$$

$$= \mathbf{45.2 \text{ kV/m}}$$

Problem 6. Two parallel plates having a p.d. of 200 V between them are spaced 0.8 mm apart. What is the electric field strength? Find also the electric flux density when the dielectric between the plates is (a) air, and (b) polythene of relative permittivity 2.3

Electric field strength

$$E = \frac{V}{d} = \frac{200}{0.8 \times 10^{-3}} = \mathbf{250 \text{ kV/m}}$$

(a) For air: $\epsilon_r = 1$ and $\frac{D}{E} = \epsilon_0 \epsilon_r$

Hence **electric flux density**

$$D = E \epsilon_0 \epsilon_r$$

$$= (250 \times 10^3 \times 8.85 \times 10^{-12} \times 1) \text{ C/m}^2$$

$$= \mathbf{2.213 \mu\text{C/m}^2}$$

(b) For polythene, $\epsilon_r = 2.3$

Electric flux density

$$D = E \epsilon_0 \epsilon_r$$

$$= (250 \times 10^3 \times 8.85 \times 10^{-12} \times 2.3) \text{ C/m}^2$$

$$= \mathbf{5.089 \mu\text{C/m}^2}$$

Now try the following exercise

Exercise 25 Further problems on electric field strength, electric flux density and permittivity

(Where appropriate take ϵ_0 as $8.85 \times 10^{-12} \text{ F/m}$)

- 1 A capacitor uses a dielectric 0.04 mm thick and operates at 30 V. What is the electric field strength across the dielectric at this voltage?
[750 kV/m]
- 2 A two-plate capacitor has a charge of 25 C. If the effective area of each plate is 5 cm^2 find the electric flux density of the electric field.
[50 kC/m²]
- 3 A charge of $1.5 \mu\text{C}$ is carried on two parallel rectangular plates each measuring 60 mm by 80 mm. Calculate the electric flux density. If the plates are spaced 10 mm apart and the voltage between them is 0.5 kV determine the electric field strength.
[312.5 $\mu\text{C/m}^2$, 50 kV/m]
- 4 Two parallel plates are separated by a dielectric and charged with $10 \mu\text{C}$. Given that the

area of each plate is 50 cm^2 , calculate the electric flux density in the dielectric separating the plates. [2 mC/m²]

5 The electric flux density between two plates separated by polystyrene of relative permittivity 2.5 is $5 \mu\text{C/m}^2$. Find the voltage gradient between the plates. [226 kV/m]

6 Two parallel plates having a p.d. of 250 V between them are spaced 1 mm apart. Determine the electric field strength. Find also the electric flux density when the dielectric between the plates is (a) air and (b) mica of relative permittivity 5 [250 kV/m (a) $2.213 \mu\text{C/m}^2$ (b) $11.063 \mu\text{C/m}^2$]

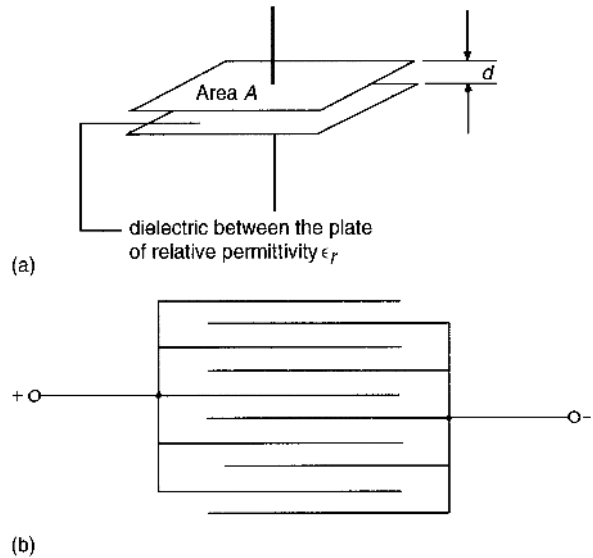

Figure 6.5

6.7 The parallel plate capacitor

For a parallel-plate capacitor, as shown in Fig. 6.5(a), experiments show that capacitance C is proportional to the area A of a plate, inversely proportional to the plate spacing d (i.e. the dielectric thickness) and depends on the nature of the dielectric:

$$\text{Capacitance, } C = \frac{\epsilon_0 \epsilon_r A}{d} \text{ farads}$$

where $\epsilon_0 = 8.85 \times 10^{-12} \text{ F/m}$ (constant)

ϵ_r = relative permittivity

A = area of one of the plates, in m^2 , and

d = thickness of dielectric in m

Another method used to increase the capacitance is to interleave several plates as shown in Fig. 6.5(b). Ten plates are shown, forming nine capacitors with a capacitance nine times that of one pair of plates.

If such an arrangement has n plates then capacitance $C \propto (n - 1)$. Thus capacitance

$$C = \frac{\epsilon_0 \epsilon_r A (n - 1)}{d} \text{ farads}$$

Problem 7. (a) A ceramic capacitor has an effective plate area of 4 cm^2 separated by 0.1 mm of ceramic of relative permittivity 100. Calculate the capacitance of the capacitor in picofarads. (b) If the capacitor in part (a) is given a charge of $1.2 \mu\text{C}$ what will be the p.d. between the plates?

(a) Area $A = 4 \text{ cm}^2 = 4 \times 10^{-4} \text{ m}^2$,
 $d = 0.1 \text{ mm} = 0.1 \times 10^{-3} \text{ m}$,

$\epsilon_0 = 8.85 \times 10^{-12} \text{ F/m}$ and $\epsilon_r = 100$

Capacitance,

$$\begin{aligned} C &= \frac{\epsilon_0 \epsilon_r A}{d} \text{ farads} \\ &= \frac{8.85 \times 10^{-12} \times 100 \times 4 \times 10^{-4}}{0.1 \times 10^{-3}} \text{ F} \\ &= \frac{8.85 \times 4}{10^{10}} \text{ F} \\ &= \frac{8.85 \times 4 \times 10^{12}}{10^{10}} \text{ pF} = \mathbf{3540 \text{ pF}} \end{aligned}$$

(b) $Q = CV$ thus

$$V = \frac{Q}{C} = \frac{1.2 \times 10^{-6}}{3540 \times 10^{-12}} \text{ V} = \mathbf{339 \text{ V}}$$

Problem 8. A waxed paper capacitor has two parallel plates, each of effective area 800 cm^2 . If the capacitance of the capacitor is 4425 pF determine the effective thickness of the paper if its relative permittivity is 2.5

$A = 800 \text{ cm}^2 = 800 \times 10^{-4} \text{ m}^2 = 0.08 \text{ m}^2$, $C = 4425 \text{ pF} = 4425 \times 10^{-12} \text{ F}$, $\epsilon_0 = 8.85 \times 10^{-12} \text{ F/m}$ and $\epsilon_r = 2.5$. Since

$$\begin{aligned} C &= \frac{\epsilon_0 \epsilon_r A}{d} \text{ then } d = \frac{\epsilon_0 \epsilon_r A}{C} \\ &= \frac{8.85 \times 10^{-12} \times 2.5 \times 0.08}{4425 \times 10^{-12}} \\ &= 0.0004 \text{ m} \end{aligned}$$

Hence, the thickness of the paper is 0.4 mm.

Problem 9. A parallel plate capacitor has nineteen interleaved plates each 75 mm by 75 mm separated by mica sheets 0.2 mm thick. Assuming the relative permittivity of the mica is 5, calculate the capacitance of the capacitor.

$n = 19$ thus $n - 1 = 18$, $A = 75 \times 75 = 5625 \text{ mm}^2 = 5625 \times 10^{-6} \text{ m}^2$, $\epsilon_r = 5$, $\epsilon_0 = 8.85 \times 10^{-12} \text{ F/m}$ and $d = 0.2 \text{ mm} = 0.2 \times 10^{-3} \text{ m}$. Capacitance,

$$\begin{aligned} C &= \frac{\epsilon_0 \epsilon_r A (n - 1)}{d} \\ &= \frac{8.85 \times 10^{-12} \times 5 \times 5625 \times 10^{-6} \times 18}{0.2 \times 10^{-3}} \text{ F} \\ &= \mathbf{0.0224 \mu\text{F} \text{ or } 22.4 \text{ nF}} \end{aligned}$$

Now try the following exercise

Exercise 26 Further problems on parallel plate capacitors

(Where appropriate take ϵ_0 as $8.85 \times 10^{-12} \text{ F/m}$)

1 A capacitor consists of two parallel plates each of area 0.01 m^2 , spaced 0.1 mm in air. Calculate the capacitance in picofarads. [885 pF]

2 A waxed paper capacitor has two parallel plates, each of effective area 0.2 m^2 . If the capacitance is 4000 pF determine the effective thickness of the paper if its relative permittivity is 2 [0.885 mm]

3 Calculate the capacitance of a parallel plate capacitor having 5 plates, each 30 mm by 20 mm and separated by a dielectric 0.75 mm thick having a relative permittivity of 2.3 [65.14 pF]

4 How many plates has a parallel plate capacitor having a capacitance of 5 nF , if each plate is 40 mm by 40 mm and each dielectric is 0.102 mm thick with a relative permittivity of 6. [7]

5 A parallel plate capacitor is made from 25 plates, each 70 mm by 120 mm interleaved with mica of relative permittivity 5. If the capacitance of the capacitor is 3000 pF determine the thickness of the mica sheet. [2.97 mm]

6 A capacitor is constructed with parallel plates and has a value of 50 pF . What would be the capacitance of the capacitor if the plate area is doubled and the plate spacing is halved? [200 pF]

7 The capacitance of a parallel plate capacitor is 1000 pF . It has 19 plates, each 50 mm by 30 mm separated by a dielectric of thickness 0.40 mm . Determine the relative permittivity of the dielectric. [1.67]

8 The charge on the square plates of a multiplate capacitor is $80 \mu\text{C}$ when the potential between them is 5 kV . If the capacitor has twenty-five plates separated by a dielectric of thickness 0.102 mm and relative permittivity 4.8, determine the width of a plate. [40 mm]

9 A capacitor is to be constructed so that its capacitance is 4250 pF and to operate at a p.d. of 100 V across its terminals. The dielectric is to be polythene ($\epsilon_r = 2.3$) which, after allowing a safety factor, has a dielectric strength of 20 MV/m . Find (a) the thickness of the polythene needed, and (b) the area of a plate. [(a) 0.005 mm (b) 10.44 cm^2]

6.8 Capacitors connected in parallel and series

(a) Capacitors connected in parallel

Figure 6.6 shows three capacitors, C_1 , C_2 and C_3 , connected in parallel with a supply voltage V applied across the arrangement.

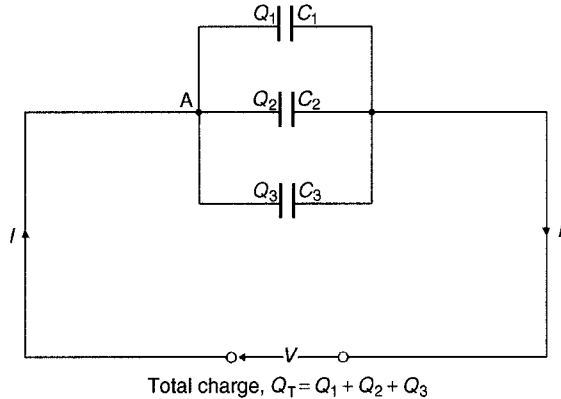

Figure 6.6

When the charging current I reaches point A it divides, some flowing into C_1 , some flowing into C_2 and some into C_3 . Hence the total charge $Q_T (= I \times t)$ is divided between the three capacitors. The capacitors each store a charge and these are shown as Q_1 , Q_2 and Q_3 respectively. Hence

$$Q_T = Q_1 + Q_2 + Q_3$$

But $Q_T = CV$, $Q_1 = C_1V$, $Q_2 = C_2V$ and $Q_3 = C_3V$. Therefore $CV = C_1V + C_2V + C_3V$ where C is the total equivalent circuit capacitance, i.e.

$$C = C_1 + C_2 + C_3$$

It follows that for n parallel-connected capacitors,

$$C = C_1 + C_2 + C_3 + \dots + C_n$$

i.e. the equivalent capacitance of a group of parallel-connected capacitors is the sum of the capacitances of the individual capacitors. (Note that this formula is similar to that used for **resistors** connected in **series**).

(b) Capacitors connected in series

Figure 6.7 shows three capacitors, C_1 , C_2 and C_3 , connected in series across a supply voltage V . Let

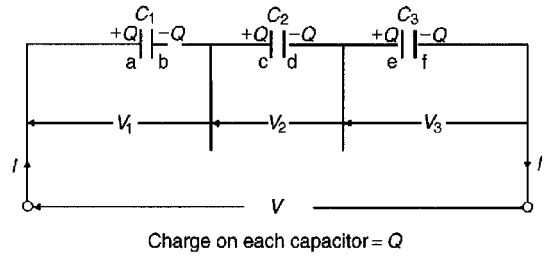

Figure 6.7

the p.d. across the individual capacitors be V_1 , V_2 and V_3 respectively as shown.

Let the charge on plate ‘ a ’ of capacitor C_1 be $+Q$ coulombs. This induces an equal but opposite charge of $-Q$ coulombs on plate ‘ b ’. The conductor between plates ‘ b ’ and ‘ c ’ is electrically isolated from the rest of the circuit so that an equal but opposite charge of $+Q$ coulombs must appear on plate ‘ c ’, which, in turn, induces an equal and opposite charge of $-Q$ coulombs on plate ‘ d ’, and so on.

Hence when capacitors are connected in series the charge on each is the same. In a series circuit:

$$V = V_1 + V_2 + V_3$$

$$\text{Since } V = \frac{Q}{C} \text{ then } \frac{Q}{C} = \frac{Q}{C_1} + \frac{Q}{C_2} + \frac{Q}{C_3}$$

where C is the total equivalent circuit capacitance, i.e.

$$\frac{1}{C} = \frac{1}{C_1} + \frac{1}{C_2} + \frac{1}{C_3}$$

It follows that for n series-connected capacitors:

$$\frac{1}{C} = \frac{1}{C_1} + \frac{1}{C_2} + \frac{1}{C_3} + \dots + \frac{1}{C_n}$$

i.e. for series-connected capacitors, the reciprocal of the equivalent capacitance is equal to the sum of the reciprocals of the individual capacitances. (Note that this formula is similar to that used for **resistors** connected in **parallel**).

For the special case of **two capacitors in series**:

$$\frac{1}{C} = \frac{1}{C_1} + \frac{1}{C_2} = \frac{C_2 + C_1}{C_1 C_2}$$

Hence

$$C = \frac{C_1 C_2}{C_1 + C_2} \quad \left(\text{i.e. } \frac{\text{product}}{\text{sum}} \right)$$

Problem 10. Calculate the equivalent capacitance of two capacitors of $6\mu\text{F}$ and $4\mu\text{F}$ connected (a) in parallel and (b) in series.

- (a) In parallel, equivalent capacitance,
 $C = C_1 + C_2 = 6\mu\text{F} + 4\mu\text{F} = \mathbf{10\mu\text{F}}$
- (b) In series, equivalent capacitance C is given by:

$$C = \frac{C_1 C_2}{C_1 + C_2}$$

This formula is used for the special case of **two** capacitors in series. Thus

$$C = \frac{6 \times 4}{6 + 4} = \frac{24}{10} = \mathbf{2.4\mu\text{F}}$$

Problem 11. What capacitance must be connected in series with a $30\mu\text{F}$ capacitor for the equivalent capacitance to be $12\mu\text{F}$?

Let $C = 12\mu\text{F}$ (the equivalent capacitance),
 $C_1 = 30\mu\text{F}$ and C_2 be the unknown capacitance.
 For two capacitors in series

$$\frac{1}{C} = \frac{1}{C_1} + \frac{1}{C_2}$$

Hence

$$\frac{1}{C_2} = \frac{1}{C} - \frac{1}{C_1} = \frac{C_1 - C}{CC_1}$$

and

$$C_2 = \frac{CC_1}{C_1 - C} = \frac{12 \times 30}{30 - 12} = \frac{360}{18} = \mathbf{20\mu\text{F}}$$

Problem 12. Capacitance's of $1\mu\text{F}$, $3\mu\text{F}$, $5\mu\text{F}$ and $6\mu\text{F}$ are connected in parallel to a direct voltage supply of 100V . Determine (a) the equivalent circuit capacitance, (b) the total charge and (c) the charge on each capacitor.

- (a) The equivalent capacitance C for four capacitors in parallel is given by:

$$C = C_1 + C_2 + C_3 + C_4$$

$$\text{i.e. } C = 1 + 3 + 5 + 6 = \mathbf{15\mu\text{F}}$$

- (b) Total charge $Q_T = CV$ where C is the equivalent circuit capacitance i.e.

$$Q_T = 15 \times 10^{-6} \times 100 = 1.5 \times 10^{-3} C \\ = \mathbf{1.5\text{mC}}$$

- (c) The charge on the $1\mu\text{F}$ capacitor

$$Q_1 = C_1 V = 1 \times 10^{-6} \times 100 = \mathbf{0.1\text{mC}}$$

The charge on the $3\mu\text{F}$ capacitor

$$Q_2 = C_2 V = 3 \times 10^{-6} \times 100 = \mathbf{0.3\text{mC}}$$

The charge on the $5\mu\text{F}$ capacitor

$$Q_3 = C_3 V = 5 \times 10^{-6} \times 100 = \mathbf{0.5\text{mC}}$$

The charge on the $6\mu\text{F}$ capacitor

$$Q_4 = C_4 V = 6 \times 10^{-6} \times 100 = \mathbf{0.6\text{mC}}$$

[Check: In a parallel circuit

$$Q_T = Q_1 + Q_2 + Q_3 + Q_4.$$

$$Q_1 + Q_2 + Q_3 + Q_4 = 0.1 + 0.3 + 0.5 + 0.6 \\ = 1.5\text{mC} = Q_T]$$

Problem 13. Capacitance's of $3\mu\text{F}$, $6\mu\text{F}$ and $12\mu\text{F}$ are connected in series across a 350V supply. Calculate (a) the equivalent circuit capacitance, (b) the charge on each capacitor, and (c) the p.d. across each capacitor.

The circuit diagram is shown in Fig. 6.8.

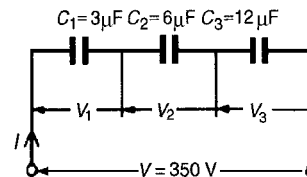

Figure 6.8

- (a) The equivalent circuit capacitance C for three capacitors in series is given by:

$$\frac{1}{C} = \frac{1}{C_1} + \frac{1}{C_2} + \frac{1}{C_3}$$

$$\text{i.e. } \frac{1}{C} = \frac{1}{3} + \frac{1}{6} + \frac{1}{12} = \frac{4 + 2 + 1}{12} = \frac{7}{12}$$

Hence the equivalent circuit capacitance

$$C = \frac{12}{7} = 1\frac{5}{7} \mu\text{F} \text{ or } 1.714 \mu\text{F}$$

(b) Total charge $Q_T = CV$, hence

$$\begin{aligned} Q_T &= \frac{12}{7} \times 10^{-6} \times 350 \\ &= 600 \mu\text{C} \text{ or } 0.6 \text{ mC} \end{aligned}$$

Since the capacitors are connected in series **0.6 mC is the charge on each of them.**

(c) The voltage across the $3 \mu\text{F}$ capacitor,

$$\begin{aligned} V_1 &= \frac{Q}{C_1} \\ &= \frac{0.6 \times 10^{-3}}{3 \times 10^{-6}} = \mathbf{200 \text{ V}} \end{aligned}$$

The voltage across the $6 \mu\text{F}$ capacitor,

$$\begin{aligned} V_2 &= \frac{Q}{C_2} \\ &= \frac{0.6 \times 10^{-3}}{6 \times 10^{-6}} = \mathbf{100 \text{ V}} \end{aligned}$$

The voltage across the $12 \mu\text{F}$ capacitor,

$$\begin{aligned} V_3 &= \frac{Q}{C_3} \\ &= \frac{0.6 \times 10^{-3}}{12 \times 10^{-6}} = \mathbf{50 \text{ V}} \end{aligned}$$

[Check: In a series circuit $V = V_1 + V_2 + V_3$.
 $V_1 + V_2 + V_3 = 200 + 100 + 50 = 350 \text{ V} =$
 supply voltage]

In practice, capacitors are rarely connected in series unless they are of the same capacitance. The reason for this can be seen from the above problem where the lowest valued capacitor (i.e. $3 \mu\text{F}$) has the highest p.d. across it (i.e. 200 V) which means that if all the capacitors have an identical construction they must all be rated at the highest voltage.

Problem 14. For the arrangement shown in Fig. 6.9 find (a) the equivalent capacitance of the circuit, (b) the voltage across QR , and (c) the charge on each capacitor.

(a) $2 \mu\text{F}$ in parallel with $3 \mu\text{F}$ gives an equivalent capacitance of $2 \mu\text{F} + 3 \mu\text{F} = 5 \mu\text{F}$. The circuit is now as shown in Fig. 6.10.

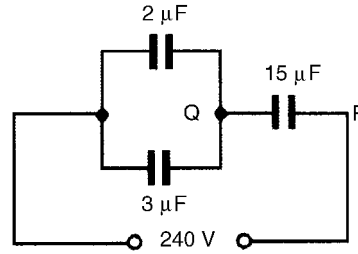

Figure 6.9

The **equivalent capacitance** of $5 \mu\text{F}$ in series with $15 \mu\text{F}$ is given by

$$\frac{5 \times 15}{5 + 15} \mu\text{F} = \frac{75}{20} \mu\text{F} = \mathbf{3.75 \mu\text{F}}$$

(b) The charge on each of the capacitors shown in Fig. 6.10 will be the same since they are connected in series. Let this charge be Q coulombs.

$$\text{Then} \quad Q = C_1 V_1 = C_2 V_2$$

$$\text{i.e.} \quad 5V_1 = 15V_2$$

$$V_1 = 3V_2 \quad (1)$$

$$\text{Also} \quad V_1 + V_2 = 240 \text{ V}$$

Hence $3V_2 + V_2 = 240 \text{ V}$ from equation (1)

$$\text{Thus} \quad V_2 = 60 \text{ V} \text{ and } V_1 = 180 \text{ V}$$

Hence the voltage across QR is **60 V**

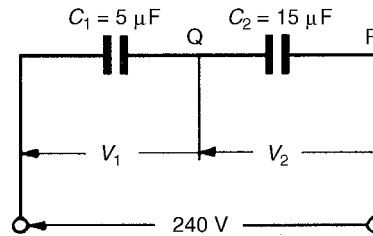

Figure 6.10

(c) The charge on the $15 \mu\text{F}$ capacitor is

$$C_2 V_2 = 15 \times 10^{-6} \times 60 = \mathbf{0.9 \text{ mC}}$$

The charge on the $2 \mu\text{F}$ capacitor is

$$2 \times 10^{-6} \times 180 = \mathbf{0.36 \text{ mC}}$$

The charge on the $3 \mu\text{F}$ capacitor is

$$3 \times 10^{-6} \times 180 = \mathbf{0.54 \text{ mC}}$$

Now try the following exercise

Exercise 27 Further problems on capacitors in parallel and series

- Capacitors of $2\ \mu\text{F}$ and $6\ \mu\text{F}$ are connected (a) in parallel and (b) in series. Determine the equivalent capacitance in each case.
[(a) $8\ \mu\text{F}$ (b) $1.5\ \mu\text{F}$]
- Find the capacitance to be connected in series with a $10\ \mu\text{F}$ capacitor for the equivalent capacitance to be $6\ \mu\text{F}$ [15 μF]
- What value of capacitance would be obtained if capacitors of $0.15\ \mu\text{F}$ and $0.10\ \mu\text{F}$ are connected (a) in series and (b) in parallel
[(a) $0.06\ \mu\text{F}$ (b) $0.25\ \mu\text{F}$]
- Two $6\ \mu\text{F}$ capacitors are connected in series with one having a capacitance of $12\ \mu\text{F}$. Find the total equivalent circuit capacitance. What capacitance must be added in series to obtain a capacitance of $1.2\ \mu\text{F}$? [2.4 μF , 2.4 μF]
- Determine the equivalent capacitance when the following capacitors are connected (a) in parallel and (b) in series:
 - $2\ \mu\text{F}$, $4\ \mu\text{F}$ and $8\ \mu\text{F}$
 - $0.02\ \mu\text{F}$, $0.05\ \mu\text{F}$ and $0.10\ \mu\text{F}$
 - $50\ \text{pF}$ and $450\ \text{pF}$
 - $0.01\ \mu\text{F}$ and $200\ \text{pF}$

[(a) (i) $14\ \mu\text{F}$ (ii) $0.17\ \mu\text{F}$
(iii) $500\ \text{pF}$ (iv) $0.0102\ \mu\text{F}$
(b) (i) $1.143\ \mu\text{F}$ (ii) $0.0125\ \mu\text{F}$
(iii) $45\ \text{pF}$ (iv) $196.1\ \text{pF}$]
- For the arrangement shown in Fig. 6.11 find (a) the equivalent circuit capacitance and (b) the voltage across a $4.5\ \mu\text{F}$ capacitor.
[(a) $1.2\ \mu\text{F}$ (b) $100\ \text{V}$]

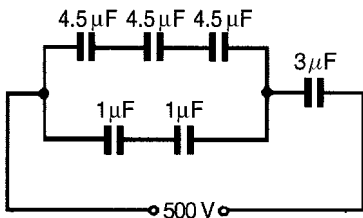

Figure 6.11

- Three $12\ \mu\text{F}$ capacitors are connected in series across a $750\ \text{V}$ supply. Calculate (a) the equivalent capacitance, (b) the

charge on each capacitor and (c) the p.d. across each capacitor.

[(a) $4\ \mu\text{F}$ (b) $3\ \text{mC}$ (c) $250\ \text{V}$]

- If two capacitors having capacitances of $3\ \mu\text{F}$ and $5\ \mu\text{F}$ respectively are connected in series across a $240\ \text{V}$ supply, determine (a) the p.d. across each capacitor and (b) the charge on each capacitor.
[(a) $150\ \text{V}$, $90\ \text{V}$ (b) $0.45\ \text{mC}$ on each]
- In Fig. 6.12 capacitors P , Q and R are identical and the total equivalent capacitance of the circuit is $3\ \mu\text{F}$. Determine the values of P , Q and R [$4.2\ \mu\text{F}$ each]

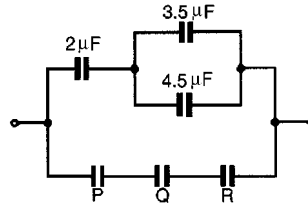

Figure 6.12

- Capacitors of $4\ \mu\text{F}$, $8\ \mu\text{F}$ and $16\ \mu\text{F}$ are connected in parallel across a $200\ \text{V}$ supply. Determine (a) the equivalent capacitance, (b) the total charge and (c) the charge on each capacitor.
[(a) $28\ \mu\text{F}$ (b) $5.6\ \text{mC}$
(c) $0.8\ \text{mC}$, $1.6\ \text{mC}$, $3.2\ \text{mC}$]
- A circuit consists of two capacitors P and Q in parallel, connected in series with another capacitor R . The capacitances of P , Q and R are $4\ \mu\text{F}$, $12\ \mu\text{F}$ and $8\ \mu\text{F}$ respectively. When the circuit is connected across a $300\ \text{V}$ d.c. supply find (a) the total capacitance of the circuit, (b) the p.d. across each capacitor and (c) the charge on each capacitor.
[(a) $5.33\ \mu\text{F}$ (b) $100\ \text{V}$ across P , $100\ \text{V}$ across Q , $200\ \text{V}$ across R (c) $0.4\ \text{mC}$ on P , $1.2\ \text{mC}$ on Q , $1.6\ \text{mC}$ on R]

6.9 Dielectric strength

The maximum amount of field strength that a dielectric can withstand is called the dielectric strength of the material. Dielectric strength,

$$E_m = \frac{V_m}{d}$$

Problem 15. A capacitor is to be constructed so that its capacitance is $0.2\ \mu\text{F}$ and to take a p.d. of $1.25\ \text{kV}$ across its terminals. The dielectric is to be mica which, after allowing a safety factor of 2, has a dielectric strength of $50\ \text{MV/m}$. Find (a) the thickness of the mica needed, and (b) the area of a plate assuming a two-plate construction. (Assume ϵ_r for mica to be 6).

(a) Dielectric strength,

$$E = \frac{V}{d}$$

$$\text{i.e. } d = \frac{V}{E} = \frac{1.25 \times 10^3}{50 \times 10^6} \text{ m} \\ = \mathbf{0.025 \text{ mm}}$$

(b) Capacitance,

$$C = \frac{\epsilon_0 \epsilon_r A}{d}$$

hence

$$\text{area } A = \frac{Cd}{\epsilon_0 \epsilon_r} = \frac{0.2 \times 10^{-6} \times 0.025 \times 10^{-3}}{8.85 \times 10^{-12} \times 6} \text{ m}^2 \\ = 0.09416 \text{ m}^2 = \mathbf{941.6 \text{ cm}^2}$$

6.10 Energy stored in capacitors

The energy, W , stored by a capacitor is given by

$$W = \frac{1}{2} CV^2 \text{ joules}$$

Problem 16. (a) Determine the energy stored in a $3\ \mu\text{F}$ capacitor when charged to $400\ \text{V}$ (b) Find also the average power developed if this energy is dissipated in a time of $10\ \mu\text{s}$.

(a) **Energy stored**

$$W = \frac{1}{2} CV^2 \text{ joules} = \frac{1}{2} \times 3 \times 10^{-6} \times 400^2 \\ = \frac{3}{2} \times 16 \times 10^{-2} = \mathbf{0.24 \text{ J}}$$

$$\text{(b) Power} = \frac{\text{energy}}{\text{time}} = \frac{0.24}{10 \times 10^{-6}} W = \mathbf{24 \text{ kW}}$$

Problem 17. A $12\ \mu\text{F}$ capacitor is required to store $4\ \text{J}$ of energy. Find the p.d. to which the capacitor must be charged.

Energy stored

$$W = \frac{1}{2} CV^2$$

$$\text{hence } V^2 = \frac{2W}{C}$$

$$\text{and p.d. } V = \sqrt{\frac{2W}{C}} = \sqrt{\frac{2 \times 4}{12 \times 10^{-6}}} \\ = \sqrt{\frac{2 \times 10^6}{3}} = \mathbf{816.5 \text{ V}}$$

Problem 18. A capacitor is charged with $10\ \text{mC}$. If the energy stored is $1.2\ \text{J}$ find (a) the voltage and (b) the capacitance.

Energy stored $W = \frac{1}{2} CV^2$ and $C = Q/V$. Hence

$$W = \frac{1}{2} \left(\frac{Q}{V} \right) V^2$$

$$= \frac{1}{2} QV \text{ from which}$$

$$V = \frac{2W}{Q}$$

$$Q = 10\ \text{mC} = 10 \times 10^{-3}\ \text{C}$$

and $W = 1.2\ \text{J}$

(a) Voltage

$$V = \frac{2W}{Q} = \frac{2 \times 1.2}{10 \times 10^{-3}} = \mathbf{0.24 \text{ kV} \text{ or } 240 \text{ V}}$$

(b) Capacitance

$$C = \frac{Q}{V} = \frac{10 \times 10^{-3}}{240}\ \text{F} = \frac{10 \times 10^6}{240 \times 10^3}\ \mu\text{F} \\ = \mathbf{41.67 \mu\text{F}}$$

Now try the following exercise

Exercise 28 Further problems on energy stored in capacitors

(Assume $\epsilon_0 = 8.85 \times 10^{-12}$ F/m)

- When a capacitor is connected across a 200 V supply the charge is $4 \mu\text{C}$. Find (a) the capacitance and (b) the energy stored
[(a) $0.02 \mu\text{F}$ (b) 0.4 mJ]
- Find the energy stored in a $10 \mu\text{F}$ capacitor when charged to 2 kV [20 J]
- A 3300 pF capacitor is required to store 0.5 mJ of energy. Find the p.d. to which the capacitor must be charged. [550 V]
- A capacitor is charged with 8 mC . If the energy stored is 0.4 J find (a) the voltage and (b) the capacitance. [(a) 100 V (b) $80 \mu\text{F}$]
- A capacitor, consisting of two metal plates each of area 50 cm^2 and spaced 0.2 mm apart in air, is connected across a 120 V supply. Calculate (a) the energy stored, (b) the electric flux density and (c) the potential gradient
[(a) $1.593 \mu\text{J}$ (b) $5.31 \mu\text{C}/\text{m}^2$ (c) $600 \text{ kV}/\text{m}$]
- A bakelite capacitor is to be constructed to have a capacitance of $0.04 \mu\text{F}$ and to have a steady working potential of 1 kV maximum. Allowing a safe value of field stress of $25 \text{ MV}/\text{m}$ find (a) the thickness of bakelite required, (b) the area of plate required if the relative permittivity of bakelite is 5, (c) the maximum energy stored by the capacitor and (d) the average power developed if this energy is dissipated in a time of $20 \mu\text{s}$.
[(a) 0.04 mm (b) 361.6 cm^2
(c) 0.02 J (d) 1 kW]

plates rotate on a spindle as shown by the end view of Fig. 6.13.

As the moving plates are rotated through half a revolution, the meshing, and therefore the capacitance, varies from a minimum to a maximum value. Variable air capacitors are used in radio and electronic circuits where very low losses are required, or where a variable capacitance is needed. The maximum value of such capacitors is between 500 pF and 1000 pF .

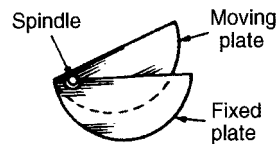

Figure 6.13

- Mica capacitors.** A typical older type construction is shown in Fig. 6.14.

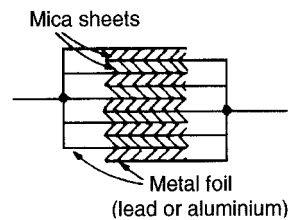

Figure 6.14

Usually the whole capacitor is impregnated with wax and placed in a bakelite case. Mica is easily obtained in thin sheets and is a good insulator.

However, mica is expensive and is not used in capacitors above about $0.2 \mu\text{F}$. A modified form of mica capacitor is the silvered mica type. The mica is coated on both sides with a thin layer of silver which forms the plates. Capacitance is stable and less likely to change with age. Such capacitors have a constant capacitance with change of temperature, a high working voltage rating and a long service life and are used in high frequency circuits with fixed values of capacitance up to about 1000 pF .

- Paper capacitors.** A typical paper capacitor is shown in Fig. 6.15 where the length of the roll corresponds to the capacitance required. The whole is usually impregnated with oil or wax to exclude moisture, and then placed in a plastic or aluminium container for protection.

6.11 Practical types of capacitor

Practical types of capacitor are characterized by the material used for their dielectric. The main types include: variable air, mica, paper, ceramic, plastic, titanium oxide and electrolytic.

- Variable air capacitors.** These usually consist of two sets of metal plates (such as aluminium), one fixed, the other variable. The set of moving

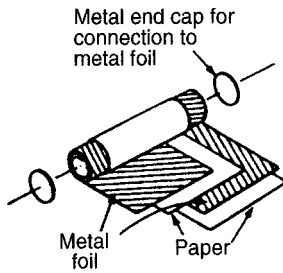

Figure 6.15

Paper capacitors are made in various working voltages up to about 150 kV and are used where loss is not very important. The maximum value of this type of capacitor is between 500 pF and 10 μ F. Disadvantages of paper capacitors include variation in capacitance with temperature change and a shorter service life than most other types of capacitor.

4. Ceramic capacitors. These are made in various forms, each type of construction depending on the value of capacitance required. For high values, a tube of ceramic material is used as shown in the cross section of Fig. 6.16. For smaller values the cup construction is used as shown in Fig. 6.17, and for still smaller values the disc construction shown in Fig. 6.18 is used. Certain ceramic materials have a very high permittivity and this enables capacitors of high capacitance to be made which are of small physical size with a high working voltage rating. Ceramic capacitors are available in the range 1 pF to 0.1 μ F and may be used in high frequency electronic circuits subject to a wide range of temperatures.

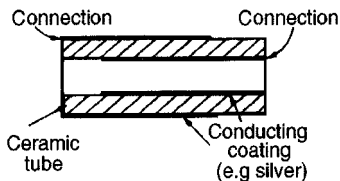

Figure 6.16

5. Plastic capacitors. Some plastic materials such as polystyrene and Teflon can be used as dielectrics. Construction is similar to the paper capacitor but using a plastic film instead of paper. Plastic capacitors operate well under conditions of high temperature, provide a precise value of

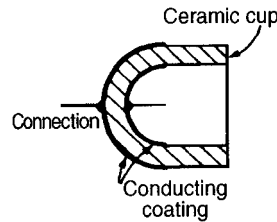

Figure 6.17

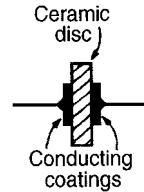

Figure 6.18

capacitance, a very long service life and high reliability.

6. Titanium oxide capacitors have a very high capacitance with a small physical size when used at a low temperature.

7 Electrolytic capacitors. Construction is similar to the paper capacitor with aluminium foil used for the plates and with a thick absorbent material, such as paper, impregnated with an electrolyte (ammonium borate), separating the plates. The finished capacitor is usually assembled in an aluminium container and hermetically sealed. Its operation depends on the formation of a thin aluminium oxide layer on the positive plate by electrolytic action when a suitable direct potential is maintained between the plates. This oxide layer is very thin and forms the dielectric. (The absorbent paper between the plates is a conductor and does not act as a dielectric.) Such capacitors **must always be used on d.c.** and must be connected with the correct polarity; if this is not done the capacitor will be destroyed since the oxide layer will be destroyed. Electrolytic capacitors are manufactured with working voltage from 6 V to 600 V, although accuracy is generally not very high. These capacitors possess a much larger capacitance than other types of capacitors of similar dimensions due to the oxide film being only a few microns thick. The fact that they can be used only on d.c. supplies limit their usefulness.

6.12 Discharging capacitors

When a capacitor has been disconnected from the supply it may still be charged and it may retain this charge for some considerable time. Thus precautions must be taken to ensure that the capacitor is automatically discharged after the supply is switched off. This is done by connecting a high value resistor across the capacitor terminals.

Now try the following exercises

Exercise 29 Short answer questions on capacitors and capacitance

- 1 Explain the term 'electrostatics'
- 2 Complete the statements:
Like charges ; unlike charges
- 3 How can an 'electric field' be established between two parallel metal plates?
- 4 What is capacitance?
- 5 State the unit of capacitance
- 6 Complete the statement:
Capacitance = $\frac{\dots\dots}{\dots\dots}$
- 7 Complete the statements:
(a) $1\ \mu\text{F} = \dots\ \text{F}$ (b) $1\ \text{pF} = \dots\ \text{F}$
- 8 Complete the statement:
Electric field strength $E = \frac{\dots\dots}{\dots\dots}$
- 9 Complete the statement:
Electric flux density $D = \frac{\dots\dots}{\dots\dots}$
- 10 Draw the electrical circuit diagram symbol for a capacitor
- 11 Name two practical examples where capacitance is present, although undesirable
- 12 The insulating material separating the plates of a capacitor is called the
- 13 10 volts applied to a capacitor results in a charge of 5 coulombs. What is the capacitance of the capacitor?
- 14 Three $3\ \mu\text{F}$ capacitors are connected in parallel. The equivalent capacitance is. . .

- 15 Three $3\ \mu\text{F}$ capacitors are connected in series. The equivalent capacitance is. . .
- 16 State a disadvantage of series-connected capacitors
- 17 Name three factors upon which capacitance depends
- 18 What does 'relative permittivity' mean?
- 19 Define 'permittivity of free space'
- 20 What is meant by the 'dielectric strength' of a material?
- 21 State the formula used to determine the energy stored by a capacitor
- 22 Name five types of capacitor commonly used
- 23 Sketch a typical rolled paper capacitor
- 24 Explain briefly the construction of a variable air capacitor
- 25 State three advantages and one disadvantage of mica capacitors
- 26 Name two disadvantages of paper capacitors
- 27 Between what values of capacitance are ceramic capacitors normally available
- 28 What main advantages do plastic capacitors possess?
- 29 Explain briefly the construction of an electrolytic capacitor
- 30 What is the main disadvantage of electrolytic capacitors?
- 31 Name an important advantage of electrolytic capacitors
- 32 What safety precautions should be taken when a capacitor is disconnected from a supply?

Exercise 30 Multi-choice questions on capacitors and capacitance (Answers on page 375)

- 1 Electrostatics is a branch of electricity concerned with
 - (a) energy flowing across a gap between conductors
 - (b) charges at rest
 - (c) charges in motion
 - (d) energy in the form of charges

- 2 The capacitance of a capacitor is the ratio
 (a) charge to p.d. between plates
 (b) p.d. between plates to plate spacing
 (c) p.d. between plates to thickness of dielectric
 (d) p.d. between plates to charge
- 3 The p.d. across a $10\ \mu\text{F}$ capacitor to charge it with $10\ \text{mC}$ is
 (a) $10\ \text{V}$ (b) $1\ \text{kV}$
 (c) $1\ \text{V}$ (d) $10\ \text{V}$
- 4 The charge on a $10\ \text{pF}$ capacitor when the voltage applied to it is $10\ \text{kV}$ is
 (a) $100\ \mu\text{C}$ (b) $0.1\ \text{C}$
 (c) $0.1\ \mu\text{C}$ (d) $0.01\ \mu\text{C}$
- 5 Four $2\ \mu\text{F}$ capacitors are connected in parallel. The equivalent capacitance is
 (a) $8\ \mu\text{F}$ (b) $0.5\ \mu\text{F}$
 (c) $2\ \mu\text{F}$ (d) $6\ \mu\text{F}$
- 6 Four $2\ \mu\text{F}$ capacitors are connected in series. The equivalent capacitance is
 (a) $8\ \mu\text{F}$ (b) $0.5\ \mu\text{F}$
 (c) $2\ \mu\text{F}$ (d) $6\ \mu\text{F}$
- 7 State which of the following is false. The capacitance of a capacitor
 (a) is proportional to the cross-sectional area of the plates
 (b) is proportional to the distance between the plates
 (c) depends on the number of plates
 (d) is proportional to the relative permittivity of the dielectric
- 8 Which of the following statement is false?
 (a) An air capacitor is normally a variable type
 (b) A paper capacitor generally has a shorter service life than most other types of capacitor
 (c) An electrolytic capacitor must be used only on a.c. supplies
 (d) Plastic capacitors generally operate satisfactorily under conditions of high temperature
- 9 The energy stored in a $10\ \mu\text{F}$ capacitor when charged to $500\ \text{V}$ is
 (a) $1.25\ \text{mJ}$ (b) $0.025\ \mu\text{J}$
 (c) $1.25\ \text{J}$ (d) $1.25\ \text{C}$
- 10 The capacitance of a variable air capacitor is at maximum when
 (a) the movable plates half overlap the fixed plates
 (b) the movable plates are most widely separated from the fixed plates
 (c) both sets of plates are exactly meshed
 (d) the movable plates are closer to one side of the fixed plate than to the other
- 11 When a voltage of $1\ \text{kV}$ is applied to a capacitor, the charge on the capacitor is $500\ \text{nC}$. The capacitance of the capacitor is:
 (a) $2 \times 10^9\ \text{F}$ (b) $0.5\ \text{pF}$
 (c) $0.5\ \text{mF}$ (d) $0.5\ \text{nF}$

Magnetic circuits

At the end of this chapter you should be able to:

- describe the magnetic field around a permanent magnet
- state the laws of magnetic attraction and repulsion for two magnets in close proximity
- define magnetic flux, Φ , and magnetic flux density, B , and state their units
- perform simple calculations involving $B = \Phi/A$
- define magnetomotive force, F_m , and magnetic field strength, H , and state their units
- perform simple calculations involving $F_m = NI$ and $H = NI/l$
- define permeability, distinguishing between μ_0 , μ_r and μ
- understand the B–H curves for different magnetic materials
- appreciate typical values of μ_r
- perform calculations involving $B = \mu_0\mu_rH$
- define reluctance, S , and state its units
- perform calculations involving

$$S = \frac{\text{m.m.f.}}{\Phi} = \frac{l}{\mu_0\mu_rA}$$

- perform calculations on composite series magnetic circuits
- compare electrical and magnetic quantities
- appreciate how a hysteresis loop is obtained and that hysteresis loss is proportional to its area

7.1 Magnetic fields

A **permanent magnet** is a piece of ferromagnetic material (such as iron, nickel or cobalt) which has properties of attracting other pieces of these materials. A permanent magnet will position itself in a north and south direction when freely suspended. The north-seeking end of the magnet is called the **north pole**, N, and the south-seeking end the **south pole**, S.

The area around a magnet is called the **magnetic field** and it is in this area that the effects of the

magnetic force produced by the magnet can be detected. A magnetic field cannot be seen, felt, smelt or heard and therefore is difficult to represent. Michael Faraday suggested that the magnetic field could be represented pictorially, by imagining the field to consist of **lines of magnetic flux**, which enables investigation of the distribution and density of the field to be carried out.

The distribution of a magnetic field can be investigated by using some iron filings. A bar magnet is placed on a flat surface covered by, say, cardboard, upon which is sprinkled some iron filings. If the

cardboard is gently tapped the filings will assume a pattern similar to that shown in Fig. 7.1. If a number of magnets of different strength are used, it is found that the stronger the field the closer are the lines of magnetic flux and vice versa. Thus a magnetic field has the property of exerting a force, demonstrated in this case by causing the iron filings to move into the pattern shown. The strength of the magnetic field decreases as we move away from the magnet. It should be realized, of course, that the magnetic field is three dimensional in its effect, and not acting in one plane as appears to be the case in this experiment.

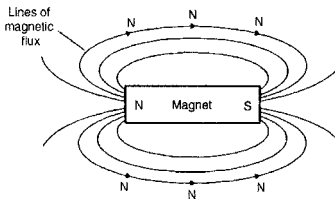

Figure 7.1

If a compass is placed in the magnetic field in various positions, the direction of the lines of flux may be determined by noting the direction of the compass pointer. The direction of a magnetic field at any point is taken as that in which the north-seeking pole of a compass needle points when suspended in the field. The direction of a line of flux is from the north pole to the south pole on the outside of the magnet and is then assumed to continue through the magnet back to the point at which it emerged at the north pole. Thus such lines of flux always form complete closed loops or paths, they never intersect and always have a definite direction.

The laws of magnetic attraction and repulsion can be demonstrated by using two bar magnets. In Fig. 7.2(a), **with unlike poles adjacent, attraction takes place**. Lines of flux are imagined to contract and the magnets try to pull together. The magnetic field is strongest in between the two magnets, shown by the lines of flux being close together. In Fig. 7.2(b), **with similar poles adjacent (i.e. two north poles), repulsion occurs**, i.e. the two north poles try to push each other apart, since magnetic flux lines running side by side in the same direction repel.

7.2 Magnetic flux and flux density

Magnetic flux is the amount of magnetic field (or the number of lines of force) produced by a

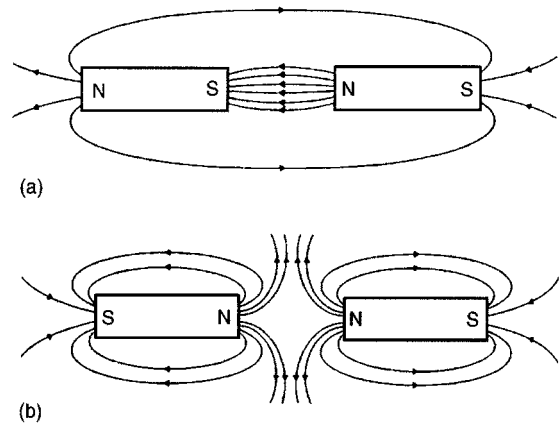

Figure 7.2

magnetic source. The symbol for magnetic flux is Φ (Greek letter 'phi'). The unit of magnetic flux is the **weber, Wb**

Magnetic flux density is the amount of flux passing through a defined area that is perpendicular to the direction of the flux:

$$\text{Magnetic flux density} = \frac{\text{magnetic flux}}{\text{area}}$$

The symbol for magnetic flux density is B . The unit of magnetic flux density is the tesla, T , where $1 T = 1 \text{ Wb/m}^2$. Hence

$$B = \frac{\Phi}{A} \text{ tesla}$$

where $A(m^2)$ is the area

Problem 1. A magnetic pole face has a rectangular section having dimensions 200 mm by 100 mm. If the total flux emerging from the pole is $150 \mu\text{Wb}$, calculate the flux density.

Flux $\Phi = 150 \mu\text{Wb} = 150 \times 10^{-6} \text{ Wb}$
 Cross sectional area $A = 200 \times 100 = 20\,000 \text{ mm}^2 = 20\,000 \times 10^{-6} \text{ m}^2$.

$$\begin{aligned} \text{Flux density, } B &= \frac{\Phi}{A} = \frac{150 \times 10^{-6}}{20\,000 \times 10^{-6}} \\ &= \mathbf{0.0075 \text{ T or } 7.5 \text{ mT}} \end{aligned}$$

Problem 2. The maximum working flux density of a lifting electromagnet is 1.8 T and the effective area of a pole face is circular in cross-section. If the total magnetic flux produced is 353 mWb, determine the radius of the pole face.

Flux density $B = 1.8$ T and flux $\Phi = 353$ mWb = 353×10^{-3} Wb.

Since $B = \Phi/A$, cross-sectional area $A = \Phi/B$

$$= \frac{353 \times 10^{-3}}{1.8} \text{ m}^2 = 0.1961 \text{ m}^2$$

The pole face is circular, hence area = πr^2 , where r is the radius. Hence $\pi r^2 = 0.1961$ from which, $r^2 = 0.1961/\pi$ and radius $r = \sqrt{(0.1961/\pi)} = 0.250$ m i.e. **the radius of the pole face is 250 mm.**

7.3 Magnetomotive force and magnetic field strength

Magnetomotive force (m.m.f.) is the cause of the existence of a magnetic flux in a magnetic circuit,

$$\text{m.m.f. } F_m = NI \text{ amperes}$$

where N is the number of conductors (or turns) and I is the current in amperes. The unit of mmf is sometimes expressed as ‘ampere-turns’. However since ‘turns’ have no dimensions, the S.I. unit of m.m.f. is the ampere.

Magnetic field strength (or **magnetising force**),

$$H = \frac{NI}{l} \text{ ampere per metre}$$

where l is the mean length of the flux path in metres. Thus

$$\text{m.m.f.} = NI = Hl \text{ amperes}$$

Problem 3. A magnetising force of 8000 A/m is applied to a circular magnetic circuit of mean diameter 30 cm by passing a current through a coil wound on the circuit. If the coil is uniformly wound around the circuit and has 750 turns, find the current in the coil.

$H = 8000$ A/m, $l = \pi d = \pi \times 30 \times 10^{-2}$ m and $N = 750$ turns. Since $H = NI/l$, then

$$I = \frac{Hl}{N} = \frac{8000 \times \pi \times 30 \times 10^{-2}}{750}$$

Thus, **current $I = 10.05$ A**

Now try the following exercise

Exercise 31 Further problems on magnetic circuits

- 1 What is the flux density in a magnetic field of cross-sectional area 20 cm² having a flux of 3 mWb? [1.5 T]
- 2 Determine the total flux emerging from a magnetic pole face having dimensions 5 cm by 6 cm, if the flux density is 0.9 T [2.7 mWb]
- 3 The maximum working flux density of a lifting electromagnet is 1.9 T and the effective area of a pole face is circular in cross-section. If the total magnetic flux produced is 611 mWb determine the radius of the pole face. [32 cm]
- 4 An electromagnet of square cross-section produces a flux density of 0.45 T. If the magnetic flux is 720 μ Wb find the dimensions of the electromagnet cross-section. [4 cm by 4 cm]
- 5 Find the magnetic field strength applied to a magnetic circuit of mean length 50 cm when a coil of 400 turns is applied to it carrying a current of 1.2 A [960 A/m]
- 6 A solenoid 20 cm long is wound with 500 turns of wire. Find the current required to establish a magnetising force of 2500 A/m inside the solenoid. [1 A]
- 7 A magnetic field strength of 5000 A/m is applied to a circular magnetic circuit of mean diameter 250 mm. If the coil has 500 turns find the current in the coil. [7.85 A]

7.4 Permeability and B–H curves

For air, or any non-magnetic medium, the ratio of magnetic flux density to magnetising force is a constant, i.e. $B/H = \text{a constant}$. This constant is

μ_0 , the **permeability of free space** (or the magnetic space constant) and is equal to $4\pi \times 10^{-7}$ H/m, i.e. **for air, or any non-magnetic medium**, the ratio

$$\frac{B}{H} = \mu_0$$

(Although all non-magnetic materials, including air, exhibit slight magnetic properties, these can effectively be neglected.)

For all media other than free space,

$$\frac{B}{H} = \mu_0 \mu_r$$

where μ_r is the relative permeability, and is defined as

$$\mu_r = \frac{\text{flux density in material}}{\text{flux density in a vacuum}}$$

μ_r varies with the type of magnetic material and, since it is a ratio of flux densities, it has no unit. From its definition, μ_r for a vacuum is 1.

$\mu_0 \mu_r = \mu$, called the **absolute permeability**

By plotting measured values of flux density B against magnetic field strength H , a **magnetisation curve** (or **B–H curve**) is produced. For non-magnetic materials this is a straight line. Typical curves for four magnetic materials are shown in Fig. 7.3

The **relative permeability** of a ferromagnetic material is proportional to the slope of the B–H curve and thus varies with the magnetic field strength. The approximate range of values of relative permeability μ_r for some common magnetic materials are:

Cast iron	$\mu_r = 100\text{--}250$
Mild steel	$\mu_r = 200\text{--}800$
Silicon iron	$\mu_r = 1000\text{--}5000$
Cast steel	$\mu_r = 300\text{--}900$
Mumetal	$\mu_r = 200\text{--}5000$
Stalloy	$\mu_r = 500\text{--}6000$

Problem 4. A flux density of 1.2 T is produced in a piece of cast steel by a magnetising force of 1250 A/m. Find the relative permeability of the steel under these conditions.

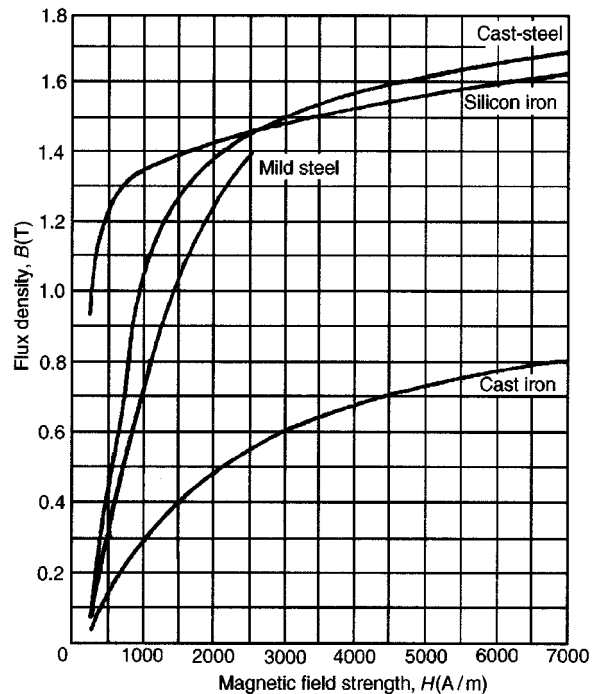

Figure 7.3

For a magnetic material: $B = \mu_0 \mu_r H$

$$\text{i.e. } \mu_r = \frac{B}{\mu_0 H} = \frac{1.2}{(4\pi \times 10^{-7})(1250)} = 764$$

Problem 5. Determine the magnetic field strength and the m.m.f. required to produce a flux density of 0.25 T in an air gap of length 12 mm.

For air: $B = \mu_0 H$ (since $\mu_r = 1$)

Magnetic field strength,

$$H = \frac{B}{\mu_0} = \frac{0.25}{4\pi \times 10^{-7}} = 198\,940 \text{ A/m}$$

$$\text{m.m.f.} = Hl = 198\,940 \times 12 \times 10^{-3} = 2387 \text{ A}$$

Problem 6. A coil of 300 turns is wound uniformly on a ring of non-magnetic material. The ring has a mean circumference of 40 cm and a uniform cross-sectional area of 4 cm^2 . If the current in the coil is 5 A, calculate (a) the magnetic field strength, (b) the flux density and (c) the total magnetic flux in the ring.

(a) Magnetic field strength

$$H = \frac{NI}{l} = \frac{300 \times 5}{40 \times 10^{-2}} = 3750 \text{ A/m}$$

(b) For a non-magnetic material $\mu_r = 1$, thus flux density $B = \mu_0 H$

$$\text{i.e. } B = 4\pi \times 10^{-7} \times 3750 = 4.712 \text{ mT}$$

(c) Flux $\Phi = BA = (4.712 \times 10^{-3})(4 \times 10^{-4}) = 1.885 \mu\text{Wb}$

Problem 7. An iron ring of mean diameter 10 cm is uniformly wound with 2000 turns of wire. When a current of 0.25 A is passed through the coil a flux density of 0.4 T is set up in the iron. Find (a) the magnetising force and (b) the relative permeability of the iron under these conditions.

$l = \pi d = \pi \times 10 \text{ cm} = \pi \times 10 \times 10^{-2} \text{ m}$,
 $N = 2000$ turns, $I = 0.25 \text{ A}$ and $B = 0.4 \text{ T}$

$$\text{(a) } H = \frac{NI}{l} = \frac{2000 \times 0.25}{\pi \times 10 \times 10^{-2}} = 1592 \text{ A/m}$$

$$\text{(b) } B = \mu_0 \mu_r H, \text{ hence } \mu_r = \frac{B}{\mu_0 H} = \frac{0.4}{(4\pi \times 10^{-7})(1592)} = 200$$

Problem 8. A uniform ring of cast iron has a cross-sectional area of 10 cm^2 and a mean circumference of 20 cm. Determine the m.m.f. necessary to produce a flux of 0.3 mWb in the ring. The magnetisation curve for cast iron is shown on page 71.

$A = 10 \text{ cm}^2 = 10 \times 10^{-4} \text{ m}^2$, $l = 20 \text{ cm} = 0.2 \text{ m}$ and $\Phi = 0.3 \times 10^{-3} \text{ Wb}$.

$$\text{Flux density } B = \frac{\Phi}{A} = \frac{0.3 \times 10^{-3}}{10 \times 10^{-4}} = 0.3 \text{ T}$$

From the magnetisation curve for cast iron on page 71, when $B = 0.3 \text{ T}$, $H = 1000 \text{ A/m}$, hence **m.m.f.** $= Hl = 1000 \times 0.2 = 200 \text{ A}$

A tabular method could have been used in this problem. Such a solution is shown below in Table 1.

Problem 9. From the magnetisation curve for cast iron, shown on page 71, derive the curve of μ_r against H .

$B = \mu_0 \mu_r H$, hence

$$\mu_r = \frac{B}{\mu_0 H} = \frac{1}{\mu_0} \times \frac{B}{H} = \frac{10^7}{4\pi} \times \frac{B}{H}$$

A number of co-ordinates are selected from the B–H curve and μ_r is calculated for each as shown in Table 2.

Table 1

Part of circuit	Material	Φ (Wb)	A (m^2)	$B = \frac{\Phi}{A}$ (T)	H from graph	l (m)	m.m.f. = Hl (A)
Ring	Cast iron	0.3×10^{-3}	10×10^{-4}	0.3	1000	0.2	200

Table 2

B (T)	0.04	0.13	0.17	0.30	0.41	0.49	0.60	0.68	0.73	0.76	0.79
H (A/m)	200	400	500	1000	1500	2000	3000	4000	5000	6000	7000
$\mu_r = \frac{10^7}{4\pi} \times \frac{B}{H}$	159	259	271	239	218	195	159	135	116	101	90

μ_r is plotted against H as shown in Fig. 7.4. The curve demonstrates the change that occurs in the relative permeability as the magnetising force increases.

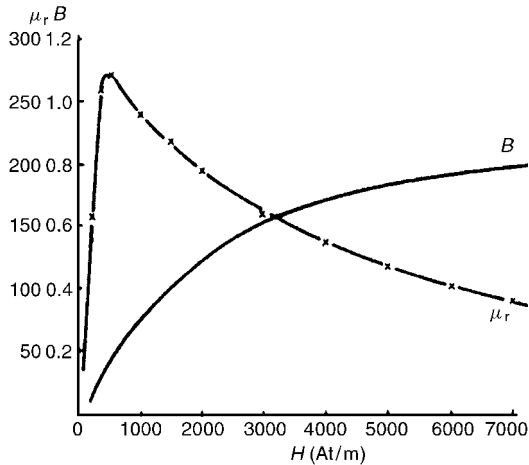

Figure 7.4

Now try the following exercise

Exercise 32 Further problems on magnetic circuits

(Where appropriate, assume $\mu_0 = 4\pi \times 10^{-7}$ H/m)

- Find the magnetic field strength and the magnetomotive force needed to produce a flux density of 0.33 T in an air-gap of length 15 mm.
[(a) 262 600 A/m (b) 3939 A]
- An air-gap between two pole pieces is 20 mm in length and the area of the flux path across the gap is 5 cm². If the flux required in the air-gap is 0.75 mWb find the m.m.f. necessary.
[23 870 A]
- (a) Determine the flux density produced in an air-cored solenoid due to a uniform magnetic field strength of 8000 A/m (b) Iron having a relative permeability of 150 at 8000 A/m is inserted into the solenoid of part (a). Find the flux density now in the solenoid.
[(a) 10.05 mT (b) 1.508 T]
- Find the relative permeability of a material if the absolute permeability is 4.084×10^{-4} H/m.
[325]

- Find the relative permeability of a piece of silicon iron if a flux density of 1.3 T is produced by a magnetic field strength of 700 A/m
[1478]
- A steel ring of mean diameter 120 mm is uniformly wound with 1500 turns of wire. When a current of 0.30 A is passed through the coil a flux density of 1.5 T is set up in the steel. Find the relative permeability of the steel under these conditions.
[1000]
- A uniform ring of cast steel has a cross-sectional area of 5 cm² and a mean circumference of 15 cm. Find the current required in a coil of 1200 turns wound on the ring to produce a flux of 0.8 mWb. (Use the magnetisation curve for cast steel shown on page 71)
[0.60 A]
- (a) A uniform mild steel ring has a diameter of 50 mm and a cross-sectional area of 1 cm². Determine the m.m.f. necessary to produce a flux of 50 μ Wb in the ring. (Use the B–H curve for mild steel shown on page 71) (b) If a coil of 440 turns is wound uniformly around the ring in Part (a) what current would be required to produce the flux?
[(a) 110 A (b) 0.25 A]
- From the magnetisation curve for mild steel shown on page 71, derive the curve of relative permeability against magnetic field strength. From your graph determine (a) the value of μ_r when the magnetic field strength is 1200 A/m, and (b) the value of the magnetic field strength when μ_r is 500
[(a) 590–600 (b) 2000]

7.5 Reluctance

Reluctance S (or R_M) is the ‘magnetic resistance’ of a magnetic circuit to the presence of magnetic flux.
Reluctance,

$$S = \frac{F_M}{\Phi} = \frac{NI}{\Phi} = \frac{Hl}{BA} = \frac{l}{(B/H)A} = \frac{l}{\mu_0 \mu_r A}$$

The unit of reluctance is 1/H (or H^{-1}) or A/Wb.

Ferromagnetic materials have a low reluctance and can be used as **magnetic screens** to prevent magnetic fields affecting materials within the screen.

Problem 10. Determine the reluctance of a piece of mumetal of length 150 mm and cross-sectional area 1800 mm² when the relative permeability is 4000. Find also the absolute permeability of the mumetal.

Reluctance,

$$S = \frac{l}{\mu_0 \mu_r A}$$

$$= \frac{150 \times 10^{-3}}{(4\pi \times 10^{-7})(4000)(1800 \times 10^{-6})}$$

$$= \mathbf{16\,580/H}$$

Absolute permeability,

$$\mu = \mu_0 \mu_r = (4\pi \times 10^{-7})(4000)$$

$$= \mathbf{5.027 \times 10^{-3} \text{ H/m}}$$

Problem 11. A mild steel ring has a radius of 50 mm and a cross-sectional area of 400 mm². A current of 0.5 A flows in a coil wound uniformly around the ring and the flux produced is 0.1 mWb. If the relative permeability at this value of current is 200 find (a) the reluctance of the mild steel and (b) the number of turns on the coil.

$$l = 2\pi r = 2 \times \pi \times 50 \times 10^{-3} \text{ m}, A = 400 \times 10^{-6} \text{ m}^2,$$

$$I = 0.5 \text{ A}, \Phi = 0.1 \times 10^{-3} \text{ Wb and } \mu_r = 200$$

(a) **Reluctance,**

$$S = \frac{l}{\mu_0 \mu_r A}$$

$$= \frac{2 \times \pi \times 50 \times 10^{-3}}{(4\pi \times 10^{-7})(200)(400 \times 10^{-6})}$$

$$= \mathbf{3.125 \times 10^6/H}$$

(b) $S = \frac{\text{m.m.f.}}{\Phi}$ from which m.m.f.

$$= S\Phi \quad \text{i.e.} \quad NI = S\Phi$$

Hence, number of terms

$$N = \frac{S\Phi}{I} = \frac{3.125 \times 10^6 \times 0.1 \times 10^{-3}}{0.5}$$

$$= \mathbf{625 \text{ turns}}$$

Now try the following exercise

Exercise 33 Further problems on magnetic circuits

(Where appropriate, assume $\mu_0 = \pi \times 10^{-7} \text{ H/m}$)

- Part of a magnetic circuit is made from steel of length 120 mm, cross sectional area 15 cm² and relative permeability 800. Calculate (a) the reluctance and (b) the absolute permeability of the steel. [(a) 79 580/H (b) 1 mH/m]
- A mild steel closed magnetic circuit has a mean length of 75 mm and a cross-sectional area of 320.2 mm². A current of 0.40 A flows in a coil wound uniformly around the circuit and the flux produced is 200 μWb . If the relative permeability of the steel at this value of current is 400 find (a) the reluctance of the material and (b) the number of turns of the coil. [(a) 466 000/H (b) 233]

7.6 Composite series magnetic circuits

For a series magnetic circuit having n parts, the **total reluctance** S is given by: $S = S_1 + S_2 + \dots + S_n$ (This is similar to resistors connected in series in an electrical circuit)

Problem 12. A closed magnetic circuit of cast steel contains a 6 cm long path of cross-sectional area 1 cm² and a 2 cm path of cross-sectional area 0.5 cm². A coil of 200 turns is wound around the 6 cm length of the circuit and a current of 0.4 A flows. Determine the flux density in the 2 cm path, if the relative permeability of the cast steel is 750.

For the 6 cm long path:

$$\text{Reluctance } S_1 = \frac{l_1}{\mu_0 \mu_r A_1}$$

$$= \frac{6 \times 10^{-2}}{(4\pi \times 10^{-7})(750)(1 \times 10^{-4})}$$

$$= \mathbf{6.366 \times 10^5/H}$$

For the 2 cm long path:

$$\begin{aligned} \text{Reluctance } S_2 &= \frac{l_2}{\mu_0 \mu_r A_2} \\ &= \frac{2 \times 10^{-2}}{(4\pi \times 10^{-7})(750)(0.5 \times 10^{-4})} \\ &= 4.244 \times 10^5 / H \end{aligned}$$

Total circuit reluctance $S = S_1 + S_2$
 $= (6.366 + 4.244) \times 10^5 = 10.61 \times 10^5 / H$

$$\begin{aligned} S &= \frac{\text{m.m.f.}}{\Phi} \text{ i.e. } \Phi = \frac{\text{m.m.f.}}{S} = \frac{NI}{S} \\ &= \frac{200 \times 0.4}{10.61 \times 10^5} = 7.54 \times 10^{-5} \text{ Wb} \end{aligned}$$

Flux density in the 2 cm path,

$$B = \frac{\Phi}{A} = \frac{7.54 \times 10^{-5}}{0.5 \times 10^{-4}} = 1.51 \text{ T}$$

Problem 13. A silicon iron ring of cross-sectional area 5 cm^2 has a radial air gap of 2 mm cut into it. If the mean length of the silicon iron path is 40 cm calculate the magnetomotive force to produce a flux of 0.7 mWb. The magnetisation curve for silicon is shown on page 71.

There are two parts to the circuit – the silicon iron and the air gap. The total m.m.f. will be the sum of the m.m.f.'s of each part.

For the silicon iron:

$$B = \frac{\Phi}{A} = \frac{0.7 \times 10^{-3}}{5 \times 10^{-4}} = 1.4 \text{ T}$$

From the B–H curve for silicon iron on page 71, when $B = 1.4 \text{ T}$, $H = 1650 \text{ At/m}$ Hence the m.m.f. for the iron path $= Hl = 1650 \times 0.4 = 660 \text{ A}$

For the air gap:

The flux density will be the same in the air gap as in the iron, i.e. 1.4 T (This assumes no leakage or fringing occurring). For air,

$$H = \frac{B}{\mu_0} = \frac{1.4}{4\pi \times 10^{-7}} = 1\,114\,000 \text{ A/m}$$

Hence the m.m.f. for the air gap $= Hl = 1\,114\,000 \times 2 \times 10^{-3} = 2228 \text{ A}$.

Total m.m.f. to produce a flux of 0.6 mWb = 660 + 2228 = 2888 A.

A tabular method could have been used as shown at the bottom of the page.

Problem 14. Figure 7.5 shows a ring formed with two different materials – cast steel and mild steel. The dimensions are:

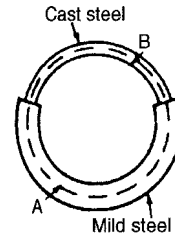

Figure 7.5

	mean length	cross-sectional area
Mild steel	400 mm	500 mm^2
Cast steel	300 mm	312.5 mm^2

Find the total m.m.f. required to cause a flux of $500 \mu\text{Wb}$ in the magnetic circuit. Determine also the total circuit reluctance.

Part of circuit	Material	$\Phi(\text{Wb})$	$A(\text{m}^2)$	$B(\text{T})$	$H(\text{A/m})$	$l(\text{m})$	$\Sigma \text{m.m.f.} = \Sigma Hl(\text{A})$
Ring	Silicon iron	0.7×10^{-3}	5×10^{-4}	1.4	1650 (from graph)	0.4	660
Air-gap	Air	0.7×10^{-3}	5×10^{-4}	1.4	$\frac{1.4}{4\pi \times 10^{-7}}$ $= 1\,114\,000$	2×10^{-3}	2228
Total:							2888 A

Part of circuit	Material	Φ (Wb)	A (m ²)	B (T) (= Φ/A)	H (A/m) (from graphs page 71)	l (m)	m.m.f. = HI (A)
A	Mild steel	500×10^{-6}	500×10^{-6}	1.0	1400	400×10^{-3}	560
B	Cast steel	500×10^{-6}	312.5×10^{-6}	1.6	4800	300×10^{-3}	1440
Total:							2000 A

A tabular solution is shown above.

$$\left. \begin{array}{l} \text{Total circuit} \\ \text{reluctance} \end{array} \right\} S = \frac{\text{m.m.f.}}{\Phi}$$

$$= \frac{2000}{500 \times 10^{-6}} = 4 \times 10^6/\text{H}$$

Problem 15. A section through a magnetic circuit of uniform cross-sectional area 2 cm^2 is shown in Fig. 7.6. The cast steel core has a mean length of 25 cm. The air gap is 1 mm wide and the coil has 5000 turns. The B - H curve for cast steel is shown on page 71. Determine the current in the coil to produce a flux density of 0.80 T in the air gap, assuming that all the flux passes through both parts of the magnetic circuit.

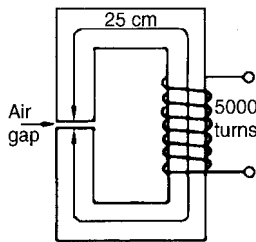

Figure 7.6

For the cast steel core, when $B = 0.80 \text{ T}$, $H = 750 \text{ A/m}$ (from page 71).

$$\text{Reluctance of core } S_1 = \frac{l_1}{\mu_0 \mu_r A_1} \text{ and}$$

$$\text{since } B = \mu_0 \mu_r H, \text{ then } \mu_r = \frac{B}{\mu_0 H}.$$

$$S_1 = \frac{l_1}{\mu_0 \left(\frac{B}{\mu_0 H} \right) A_1} = \frac{l_1 H}{BA_1}$$

$$= \frac{(25 \times 10^{-2})(750)}{(0.8)(2 \times 10^{-4})} = 1\,172\,000/\text{H}$$

For the air gap:

$$\text{Reluctance, } S_2 = \frac{l_2}{\mu_0 \mu_r A_2}$$

$$= \frac{l_2}{\mu_0 A_2} \text{ (since } \mu_r = 1 \text{ for air)}$$

$$= \frac{1 \times 10^{-3}}{(4\pi \times 10^{-7})(2 \times 10^{-4})}$$

$$= 3\,979\,000/\text{H}$$

Total circuit reluctance

$$S = S_1 + S_2 = 1\,172\,000 + 3\,979\,000$$

$$= 5\,151\,000/\text{H}$$

$$\text{Flux } \Phi = BA = 0.80 \times 2 \times 10^{-4} = 1.6 \times 10^{-4} \text{ Wb}$$

$$S = \frac{\text{m.m.f.}}{\Phi},$$

thus

$$\text{m.m.f.} = S\Phi \text{ hence } NI = S\Phi$$

and

$$\text{current } I = \frac{S\Phi}{N} = \frac{(5\,151\,000)(1.6 \times 10^{-4})}{5000}$$

$$= 0.165 \text{ A}$$

Now try the following exercise

Exercise 34 Further problems on composite series magnetic circuits

1 A magnetic circuit of cross-sectional area 0.4 cm^2 consists of one part 3 cm long, of material having relative permeability 1200, and a second part 2 cm long of material having relative permeability 750. With a 100 turn coil

carrying 2 A, find the value of flux existing in the circuit. [0.195 mWb]

- 2 (a) A cast steel ring has a cross-sectional area of 600 mm^2 and a radius of 25 mm. Determine the mmf necessary to establish a flux of 0.8 mWb in the ring. Use the B–H curve for cast steel shown on page 71. (b) If a radial air gap 1.5 mm wide is cut in the ring of part (a) find the m.m.f. now necessary to maintain the same flux in the ring. [(a) 270 A (b) 1860 A]
- 3 A closed magnetic circuit made of silicon iron consists of a 40 mm long path of cross-sectional area 90 mm^2 and a 15 mm long path of cross-sectional area 70 mm^2 . A coil of 50 turns is wound around the 40 mm length of the circuit and a current of 0.39 A flows. Find the flux density in the 15 mm length path if the relative permeability of the silicon iron at this value of magnetising force is 3000. [1.59 T]
- 4 For the magnetic circuit shown in Fig. 7.7 find the current I in the coil needed to produce a flux of 0.45 mWb in the air-gap. The silicon iron magnetic circuit has a uniform cross-sectional area of 3 cm^2 and its magnetisation curve is as shown on page 71. [0.83 A]

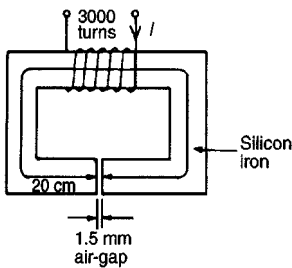

Figure 7.7

- 5 A ring forming a magnetic circuit is made from two materials; one part is mild steel of mean length 25 cm and cross-sectional area 4 cm^2 , and the remainder is cast iron of mean length 20 cm and cross-sectional area 7.5 cm^2 . Use a tabular approach to determine the total m.m.f. required to cause a flux of 0.30 mWb in the magnetic circuit. Find also the total reluctance of the circuit. Use the magnetisation curves shown on page 71. [550 A, $18.3 \times 10^5 / \text{H}$]

- 6 Figure 7.8 shows the magnetic circuit of a relay. When each of the air gaps are 1.5 mm wide find the mmf required to produce a flux density of 0.75 T in the air gaps. Use the B–H curves shown on page 71. [2970 A]

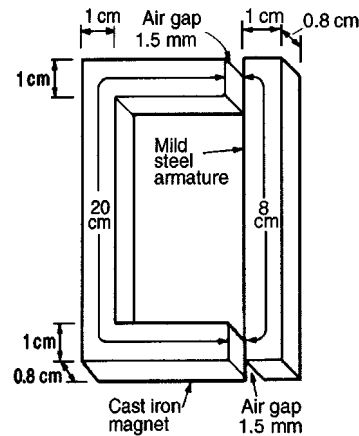

Figure 7.8

7.7 Comparison between electrical and magnetic quantities

Electrical circuit	Magnetic circuit
e.m.f. E (V)	m.m.f. F_m (A)
current I (A)	flux Φ (Wb)
resistance R (Ω)	reluctance S (H^{-1})
$I = \frac{E}{R}$	$\Phi = \frac{\text{m.m.f.}}{S}$
$R = \frac{\rho l}{A}$	$S = \frac{l}{\mu_0 \mu_r A}$

7.8 Hysteresis and hysteresis loss

Hysteresis loop

Let a ferromagnetic material which is completely demagnetised, i.e. one in which $B = H = 0$ be subjected to increasing values of magnetic field strength H and the corresponding flux density B measured. The resulting relationship between B and H is shown by the curve Oab in Fig. 7.9. At a

particular value of H , shown as Oy , it becomes difficult to increase the flux density any further. The material is said to be saturated. Thus by is the **saturation flux density**.

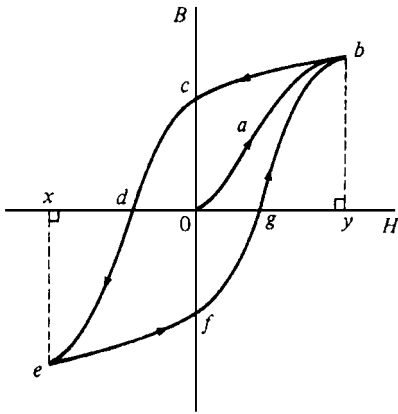

Figure 7.9

If the value of H is now reduced it is found that the flux density follows curve bc . When H is reduced to zero, flux remains in the iron. This **remanent flux density** or **remanence** is shown as Oc in Fig. 7.9. When H is increased in the opposite direction, the flux density decreases until, at a value shown as Od , the flux density has been reduced to zero. The magnetic field strength Od required to remove the residual magnetism, i.e. reduce B to zero, is called the **coercive force**.

Further increase of H in the reverse direction causes the flux density to increase in the reverse direction until saturation is reached, as shown by curve de . If H is varied backwards from Ox to Oy , the flux density follows the curve $efgb$, similar to curve $bcde$.

It is seen from Fig. 7.9 that the flux density changes lag behind the changes in the magnetic field strength. This effect is called **hysteresis**. The closed figure $bcdefgb$ is called the **hysteresis loop** (or the B/H loop).

Hysteresis loss

A disturbance in the alignment of the domains (i.e. groups of atoms) of a ferromagnetic material causes energy to be expended in taking it through a cycle of magnetisation. This energy appears as heat in the specimen and is called the **hysteresis loss**.

The energy loss associated with hysteresis is proportional to the area of the hysteresis loop.

The area of a hysteresis loop varies with the type of material. The area, and thus the energy loss, is much greater for hard materials than for soft materials.

Figure 7.10 shows typical hysteresis loops for:

- hard material**, which has a high remanence Oc and a large coercivity Od
- soft steel**, which has a large remanence and small coercivity
- ferrite**, this being a ceramic-like magnetic substance made from oxides of iron, nickel, cobalt, magnesium, aluminium and manganese; the hysteresis of ferrite is very small.

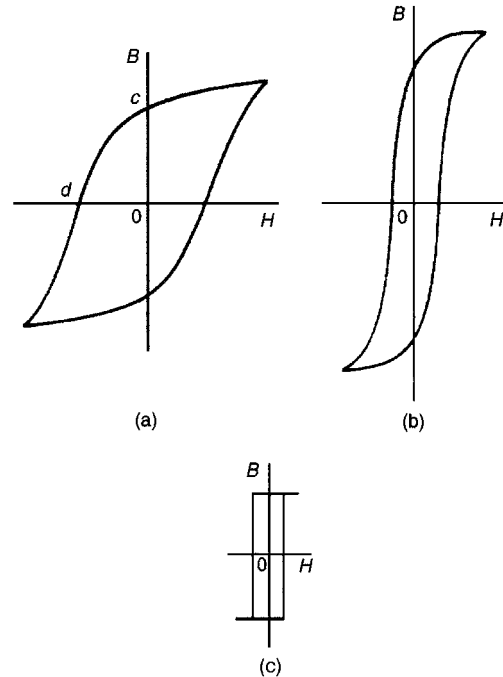

Figure 7.10

For a.c.-excited devices the hysteresis loop is repeated every cycle of alternating current. Thus a hysteresis loop with a large area (as with hard steel) is often unsuitable since the energy loss would be considerable. Silicon steel has a narrow hysteresis loop, and thus small hysteresis loss, and is suitable for transformer cores and rotating machine armatures.

Now try the following exercises

Exercise 35 Short answer questions on magnetic circuits

- 1 What is a permanent magnet?
- 2 Sketch the pattern of the magnetic field associated with a bar magnet. Mark the direction of the field.
- 3 Define magnetic flux
- 4 The symbol for magnetic flux is ... and the unit of flux is the ...
- 5 Define magnetic flux density
- 6 The symbol for magnetic flux density is ... and the unit of flux density is ...
- 7 The symbol for m.m.f. is ... and the unit of m.m.f. is the ...
- 8 Another name for the magnetising force is ; its symbol is ... and its unit is ...
- 9 Complete the statement:

$$\frac{\text{flux density}}{\text{magnetic field strength}} = \dots$$
- 10 What is absolute permeability?
- 11 The value of the permeability of free space is ...
- 12 What is a magnetisation curve?
- 13 The symbol for reluctance is ... and the unit of reluctance is ...
- 14 Make a comparison between magnetic and electrical quantities
- 15 What is hysteresis?
- 16 Draw a typical hysteresis loop and on it identify:
 - (a) saturation flux density
 - (b) remanence
 - (c) coercive force
- 17 State the units of (a) remanence (b) coercive force
- 18 How is magnetic screening achieved?
- 19 Complete the statement: magnetic materials have a ... reluctance; non-magnetic materials have a ... reluctance
- 20 What loss is associated with hysteresis?

Exercise 36 Multi-choice questions on magnetic circuits (Answers on page 375)

- 1 The unit of magnetic flux density is the:
 - (a) weber
 - (b) weber per metre
 - (c) ampere per metre
 - (d) tesla
- 2 The total flux in the core of an electrical machine is 20 mWb and its flux density is 1 T. The cross-sectional area of the core is:
 - (a) 0.05 m²
 - (b) 0.02 m²
 - (c) 20 m²
 - (d) 50 m²
- 3 If the total flux in a magnetic circuit is 2 mWb and the cross-sectional area of the circuit is 10 cm², the flux density is:
 - (a) 0.2 T
 - (b) 2 T
 - (c) 20 T
 - (d) 20 mT

Questions 4 to 8 refer to the following data: A coil of 100 turns is wound uniformly on a wooden ring. The ring has a mean circumference of 1 m and a uniform cross-sectional area of 10 cm². The current in the coil is 1 A.

- 4 The magnetomotive force is:
 - (a) 1 A
 - (b) 10 A
 - (c) 100 A
 - (d) 1000 A
- 5 The magnetic field strength is:
 - (a) 1 A/m
 - (b) 10 A/m
 - (c) 100 A/m
 - (d) 1000 A/m
- 6 The magnetic flux density is:
 - (a) 800 T
 - (b) 8.85×10^{-10} T
 - (c) $4\pi \times 10^{-7}$ T
 - (d) $40\pi \mu\text{T}$
- 7 The magnetic flux is:
 - (a) $0.04\pi \mu\text{Wb}$
 - (b) 0.01 Wb
 - (c) $8.85 \mu\text{Wb}$
 - (d) $4\pi \mu\text{Wb}$
- 8 The reluctance is:
 - (a) $\frac{10^8}{4\pi} \text{H}^{-1}$
 - (b) 1000H^{-1}
 - (c) $\frac{2.5}{\pi} \times 10^9 \text{H}^{-1}$
 - (d) $\frac{10^8}{8.85} \text{H}^{-1}$
- 9 Which of the following statements is false?
 - (a) For non-magnetic materials reluctance is high
 - (b) Energy loss due to hysteresis is greater for harder magnetic materials than for softer magnetic materials
 - (c) The remanence of a ferrous material is measured in ampere/metre

Assignment 2

This assignment covers the material contained in Chapters 5 to 7.

The marks for each question are shown in brackets at the end of each question.

- Resistances of $5\ \Omega$, $7\ \Omega$, and $8\ \Omega$ are connected in series. If a $10\ \text{V}$ supply voltage is connected across the arrangement determine the current flowing through and the p.d. across the $7\ \Omega$ resistor. Calculate also the power dissipated in the $8\ \Omega$ resistor. (6)
- For the series-parallel network shown in Fig. A2.1, find (a) the supply current, (b) the current flowing through each resistor, (c) the p.d. across each resistor, (d) the total power dissipated in the circuit, (e) the cost of energy if the circuit is connected for 80 hours. Assume electrical energy costs 7.2p per unit. (15)
- The charge on the plates of a capacitor is $8\ \text{mC}$ when the potential between them is $4\ \text{kV}$. Determine the capacitance of the capacitor. (2)
- Two parallel rectangular plates measuring $80\ \text{mm}$ by $120\ \text{mm}$ are separated by $4\ \text{mm}$ of mica and carry an electric charge of $0.48\ \mu\text{C}$. The voltage between the plates is $500\ \text{V}$. Calculate (a) the electric flux density (b) the electric field strength, and (c) the capacitance of the capacitor, in picofarads, if the relative permittivity of mica is 5. (7)
- A $4\ \mu\text{F}$ capacitor is connected in parallel with a $6\ \mu\text{F}$ capacitor. This arrangement is then connected in series with a $10\ \mu\text{F}$ capacitor. A supply p.d. of $250\ \text{V}$ is connected across the circuit. Find (a) the equivalent capacitance of the circuit, (b) the voltage across the $10\ \mu\text{F}$ capacitor, and (c) the charge on each capacitor. (7)
- A coil of 600 turns is wound uniformly on a ring of non-magnetic material. The ring has a uniform cross-sectional area of $200\ \text{mm}^2$ and a mean circumference of $500\ \text{mm}$. If the current in the coil is $4\ \text{A}$, determine (a) the magnetic field strength, (b) the flux density, and (c) the total magnetic flux in the ring. (5)
- A mild steel ring of cross-sectional area $4\ \text{cm}^2$ has a radial air-gap of $3\ \text{mm}$ cut into it. If the mean length of the mild steel path is $300\ \text{mm}$, calculate the magnetomotive force to produce a flux of $0.48\ \text{mWb}$. (Use the B–H curve on page 71) (8)

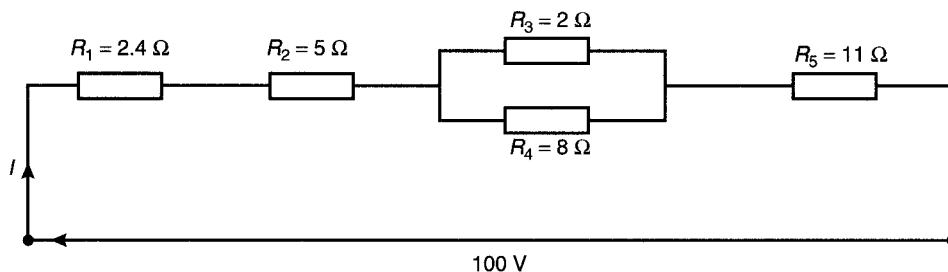

Figure A2.1

Electromagnetism

At the end of this chapter you should be able to:

- understand that magnetic fields are produced by electric currents
- apply the screw rule to determine direction of magnetic field
- recognize that the magnetic field around a solenoid is similar to a magnet
- apply the screw rule or grip rule to a solenoid to determine magnetic field direction
- recognize and describe practical applications of an electromagnet, i.e. electric bell, relay, lifting magnet, telephone receiver
- appreciate factors upon which the force F on a current-carrying conductor depends
- perform calculations using $F = BIl$ and $F = BIl \sin \theta$
- recognize that a loudspeaker is a practical application of force F
- use Fleming's left-hand rule to pre-determine direction of force in a current carrying conductor
- describe the principle of operation of a simple d.c. motor
- describe the principle of operation and construction of a moving coil instrument
- appreciate that force F on a charge in a magnetic field is given by $F = QvB$
- perform calculations using $F = QvB$

8.1 Magnetic field due to an electric current

Magnetic fields can be set up not only by permanent magnets, as shown in Chapter 7, but also by electric currents.

Let a piece of wire be arranged to pass vertically through a horizontal sheet of cardboard on which is placed some iron filings, as shown in Fig. 8.1(a). If a current is now passed through the wire, then the iron filings will form a definite circular field pattern with the wire at the centre, when the cardboard is gently tapped. By placing a compass in different positions the lines of flux are seen to have a definite direction as shown in Fig. 8.1(b).

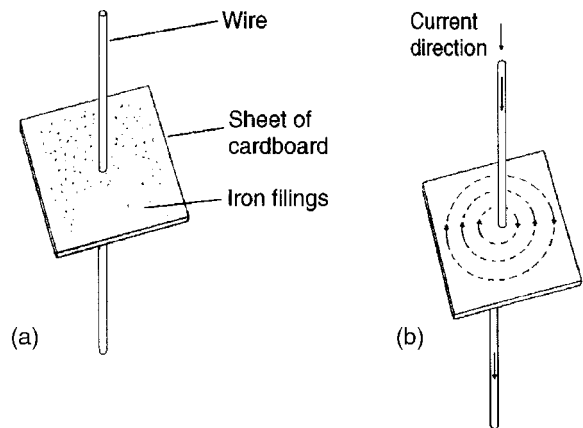

Figure 8.1

If the current direction is reversed, the direction of the lines of flux is also reversed. The effect on both the iron filings and the compass needle disappears when the current is switched off. The magnetic field is thus produced by the electric current. The magnetic flux produced has the same properties as the flux produced by a permanent magnet. If the current is increased the strength of the field increases and, as for the permanent magnet, the field strength decreases as we move away from the current-carrying conductor.

In Fig. 8.1, the effect of only a small part of the magnetic field is shown. If the whole length of the conductor is similarly investigated it is found that the magnetic field round a straight conductor is in the form of concentric cylinders as shown in Fig. 8.2, the field direction depending on the direction of the current flow.

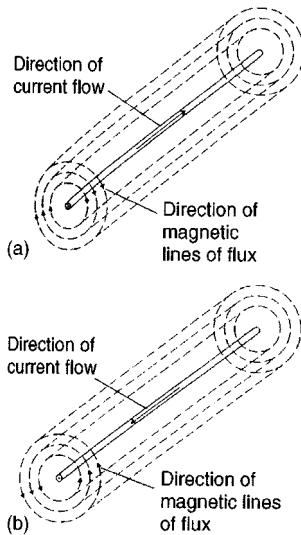

Figure 8.2



Figure 8.4

When dealing with magnetic fields formed by electric current it is usual to portray the effect as shown in Fig. 8.3. The convention adopted is:

- (i) Current flowing away from the viewer, i.e. into the paper, is indicated by \oplus . This may be thought of as the feathered end of the shaft of an arrow. See Fig. 8.3(a).
- (ii) Current flowing towards the viewer, i.e. out of the paper, is indicated by \ominus . This may be thought of as the point of an arrow. See Fig. 8.3(b).

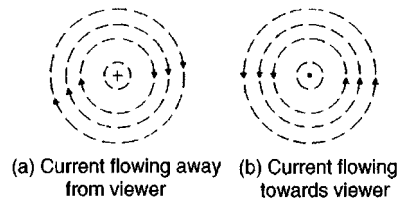

Figure 8.3

The direction of the magnetic lines of flux is best remembered by the **screw rule** which states that:

If a normal right-hand thread screw is screwed along the conductor in the direction of the current, the direction of rotation of the screw is in the direction of the magnetic field.

For example, with current flowing away from the viewer (Fig. 8.3(a)) a right-hand thread screw driven into the paper has to be rotated clockwise. Hence the direction of the magnetic field is clockwise.

A magnetic field set up by a long coil, or **solenoid**, is shown in Fig. 8.4(a) and is seen to be similar to that of a bar magnet. If the solenoid is wound on an iron bar, as shown in Fig. 8.4(b), an even stronger magnetic field is produced, the iron

becoming magnetised and behaving like a permanent magnet. The direction of the magnetic field produced by the current I in the solenoid may be found by either of two methods, i.e. the screw rule or the grip rule.

- (a) **The screw rule** states that if a normal right-hand thread screw is placed along the axis of the solenoid and is screwed in the direction of the current it moves in the direction of the magnetic field **inside** the solenoid. The direction of the magnetic field **inside** the solenoid is from south to north. Thus in Figures 4(a) and (b) the north pole is to the right.
- (b) **The grip rule** states that if the coil is gripped with the **right** hand, with the fingers pointing in the direction of the current, then the thumb, outstretched parallel to the axis of the solenoid, points in the direction of the magnetic field **inside** the solenoid.

Problem 1. Figure 8.5 shows a coil of wire wound on an iron core connected to a battery. Sketch the magnetic field pattern associated with the current carrying coil and determine the polarity of the field.

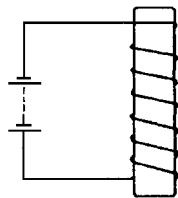

Figure 8.5

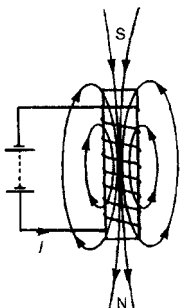

Figure 8.6

The magnetic field associated with the solenoid in Fig. 8.5 is similar to the field associated with a bar magnet and is as shown in Fig. 8.6 The polarity of the field is determined either by the screw rule or by the grip rule. Thus the north pole is at the bottom and the south pole at the top.

8.2 Electromagnets

The solenoid is very important in electromagnetic theory since the magnetic field inside the solenoid is practically uniform for a particular current, and is also versatile, inasmuch that a variation of the current can alter the strength of the magnetic field. An electromagnet, based on the solenoid, provides the basis of many items of electrical equipment, examples of which include electric bells, relays, lifting magnets and telephone receivers.

(i) Electric bell

There are various types of electric bell, including the single-stroke bell, the trembler bell, the buzzer and a continuously ringing bell, but all depend on the attraction exerted by an electromagnet on a soft iron armature. A typical single stroke bell circuit is shown in Fig. 8.7 When the push button is operated a current passes through the coil. Since the iron-cored coil is energised the soft iron armature is attracted to the electromagnet. The armature also carries a striker which hits the gong. When the circuit is broken the coil becomes demagnetised and the spring steel strip pulls the armature back to its original position. The striker will only operate when the push button is operated.

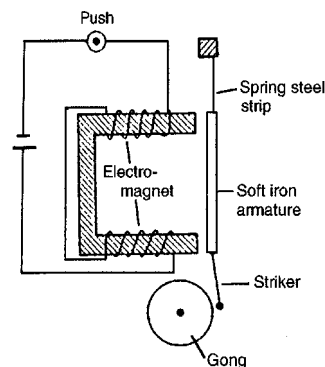
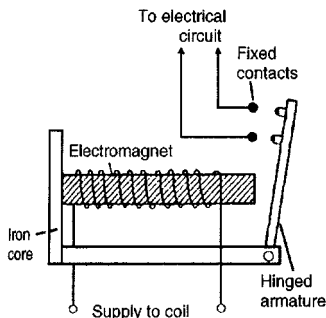

Figure 8.7

(ii) Relay

A relay is similar to an electric bell except that contacts are opened or closed by operation instead of a gong being struck. A typical simple relay is shown in Fig. 8.8, which consists of a coil wound on a soft iron core. When the coil is energised the hinged soft iron armature is attracted to the electromagnet and pushes against two fixed contacts so that they are connected together, thus closing some other electrical circuit.

**Figure 8.8****(iii) Lifting magnet**

Lifting magnets, incorporating large electromagnets, are used in iron and steel works for lifting scrap metal. A typical robust lifting magnet, capable of exerting large attractive forces, is shown in the elevation and plan view of Fig. 8.9 where a coil, C, is wound round a central core, P, of the iron casting. Over the face of the electromagnet is placed

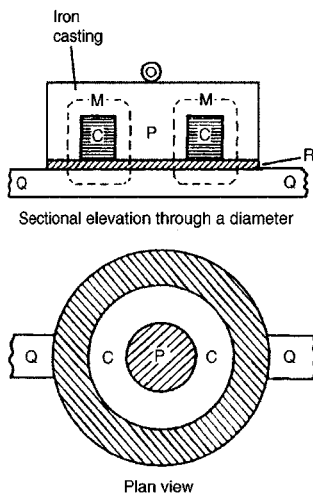
**Figure 8.9**

a protective non-magnetic sheet of material, R. The load, Q, which must be of magnetic material is lifted when the coils are energised, the magnetic flux paths, M, being shown by the broken lines.

(iv) Telephone receiver

Whereas a transmitter or microphone changes sound waves into corresponding electrical signals, a telephone receiver converts the electrical waves back into sound waves. A typical telephone receiver is shown in Fig. 8.10 and consists of a permanent magnet with coils wound on its poles. A thin, flexible diaphragm of magnetic material is held in position near to the magnetic poles but not touching them. Variation in current from the transmitter varies the magnetic field and the diaphragm consequently vibrates. The vibration produces sound variations corresponding to those transmitted.

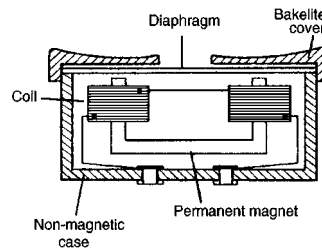
**Figure 8.10****8.3 Force on a current-carrying conductor**

If a current-carrying conductor is placed in a magnetic field produced by permanent magnets, then the fields due to the current-carrying conductor and the permanent magnets interact and cause a force to be exerted on the conductor. The force on the current-carrying conductor in a magnetic field depends upon:

- the flux density of the field, B teslas
- the strength of the current, I amperes,
- the length of the conductor perpendicular to the magnetic field, l metres, and
- the directions of the field and the current.

When the magnetic field, the current and the conductor are mutually at right angles then:

$$\text{Force } F = BIl \text{ newtons}$$

When the conductor and the field are at an angle θ° to each other then:

$$\text{Force } F = BIl \sin \theta \text{ newtons}$$

Since when the magnetic field, current and conductor are mutually at right angles, $F = BIl$, the magnetic flux density B may be defined by $B = (F)/(Il)$, i.e. the flux density is 1 T if the force exerted on 1 m of a conductor when the conductor carries a current of 1 A is 1 N.

Loudspeaker

A simple application of the above force is the moving coil loudspeaker. The loudspeaker is used to convert electrical signals into sound waves.

Figure 8.11 shows a typical loudspeaker having a magnetic circuit comprising a permanent magnet and soft iron pole pieces so that a strong magnetic field is available in the short cylindrical airgap. A moving coil, called the voice or speech coil, is suspended from the end of a paper or plastic cone so that it lies in the gap. When an electric current flows through the coil it produces a force which tends to move the cone backwards and forwards according to the direction of the current. The cone acts as a piston, transferring this force to the air, and producing the required sound waves.

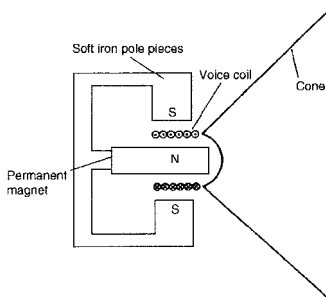

Figure 8.11

Problem 2. A conductor carries a current of 20 A and is at right-angles to a magnetic field having a flux density of 0.9 T. If the length of the conductor in the field is 30 cm, calculate the force acting on the conductor. Determine also the value of the force if the conductor is inclined at an angle of 30° to the direction of the field.

$B = 0.9 \text{ T}$, $I = 20 \text{ A}$ and $l = 30 \text{ cm} = 0.30 \text{ m}$
 Force $F = BIl = (0.9)(20)(0.30)$ newtons when the conductor is at right-angles to the field, as shown in Fig. 8.12(a), i.e. $F = 5.4 \text{ N}$.

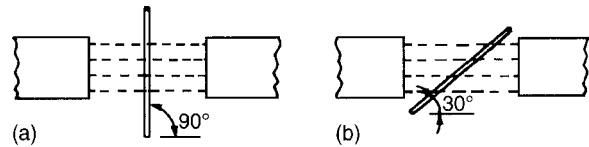

Figure 8.12

When the conductor is inclined at 30° to the field, as shown in Fig. 8.12(b), then

$$\begin{aligned} \text{Force } F &= BIl \sin \theta \\ &= (0.9)(20)(0.30) \sin 30^\circ \\ \text{i.e. } F &= 2.7 \text{ N} \end{aligned}$$

If the current-carrying conductor shown in Fig. 8.3 (a) is placed in the magnetic field shown in Fig. 8.13(a), then the two fields interact and cause a force to be exerted on the conductor as shown in Fig. 8.13(b). The field is strengthened above the conductor and weakened below, thus tending to move the conductor downwards. This is the basic principle of operation of the electric motor (see Section 8.4) and the moving-coil instrument (see Section 8.5)

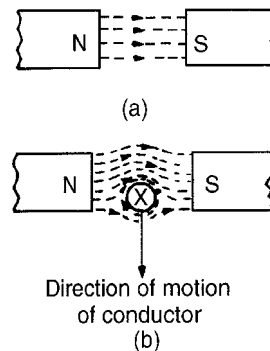

Figure 8.13

The direction of the force exerted on a conductor can be pre-determined by using **Fleming's left-hand rule** (often called the motor rule) which states:

Let the thumb, first finger and second finger of the left hand be extended such that they are all at right-angles to each other, (as shown in Fig. 8.14) If the first finger points in the direction of the magnetic

field, the second finger points in the direction of the current, then the thumb will point in the direction of the motion of the conductor.

Summarising:

First finger - Field

SeCond finger - Current

ThuMb - Motion

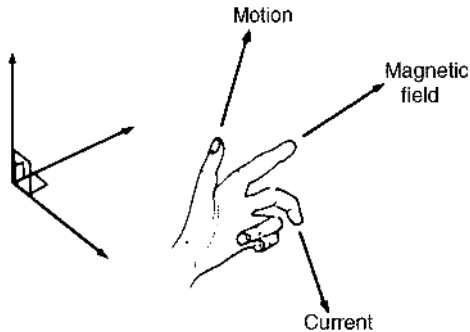

Figure 8.14

Problem 3. Determine the current required in a 400 mm length of conductor of an electric motor, when the conductor is situated at right-angles to a magnetic field of flux density 1.2 T, if a force of 1.92 N is to be exerted on the conductor. If the conductor is vertical, the current flowing downwards and the direction of the magnetic field is from left to right, what is the direction of the force?

Force = 1.92 N, $l = 400 \text{ mm} = 0.40 \text{ m}$ and $B = 1.2 \text{ T}$. Since $F = BIl$, then $I = F/Bl$ hence

$$\text{current } I = \frac{1.92}{(1.2)(0.4)} = 4 \text{ A}$$

If the current flows downwards, the direction of its magnetic field due to the current alone will be clockwise when viewed from above. The lines of flux will reinforce (i.e. strengthen) the main magnetic field at the back of the conductor and will be in opposition in the front (i.e. weaken the field). **Hence the force on the conductor will be from back to front (i.e. toward the viewer).** This direction may also have been deduced using Fleming's left-hand rule.

Problem 4. A conductor 350 mm long carries a current of 10 A and is at right-angles to a magnetic field lying between two circular pole faces each of radius 60 mm. If the total flux between the pole faces is 0.5 mWb, calculate the magnitude of the force exerted on the conductor.

$l = 350 \text{ mm} = 0.35 \text{ m}$, $I = 10 \text{ A}$, area of pole face $A = \pi r^2 = \pi(0.06)^2 \text{ m}^2$ and $\Phi = 0.5 \text{ mWb} = 0.5 \times 10^{-3} \text{ Wb}$

Force $F = BIl$, and $B = \frac{\Phi}{A}$ hence

$$\begin{aligned} \text{force } F &= \frac{\Phi}{A} Il \\ &= \frac{(0.5 \times 10^{-3})}{\pi(0.06)^2} (10)(0.35) \text{ newtons} \end{aligned}$$

i.e. force = 0.155 N

Problem 5. With reference to Fig. 8.15 determine (a) the direction of the force on the conductor in Fig. 8.15(a), (b) the direction of the force on the conductor in Fig. 8.15(b), (c) the direction of the current in Fig. 8.15(c), (d) the polarity of the magnetic system in Fig. 8.15(d).

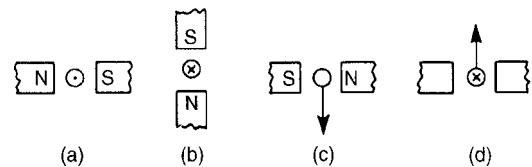

Figure 8.15

- (a) The direction of the main magnetic field is from north to south, i.e. left to right. The current is flowing towards the viewer, and using the screw rule, the direction of the field is anticlockwise. Hence either by Fleming's left-hand rule, or by sketching the interacting magnetic field as shown in Fig. 8.16(a), the direction of the force on the conductor is seen to be upward.
- (b) Using a similar method to part (a) it is seen that the force on the conductor is to the right – see Fig. 8.16(b).

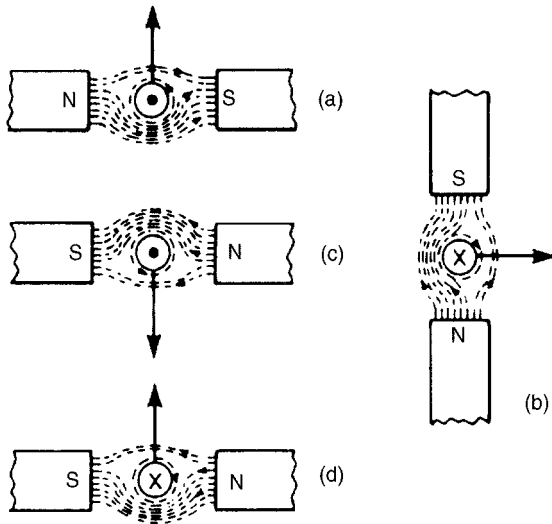

Figure 8.16

- (c) Using Fleming's left-hand rule, or by sketching as in Fig. 8.16(c), it is seen that the current is toward the viewer, i.e. out of the paper.
- (d) Similar to part (c), the polarity of the magnetic system is as shown in Fig. 8.16(d).

Problem 6. A coil is wound on a rectangular former of width 24 mm and length 30 mm. The former is pivoted about an axis passing through the middle of the two shorter sides and is placed in a uniform magnetic field of flux density 0.8 T, the axis being perpendicular to the field. If the coil carries a current of 50 mA, determine the force on each coil side (a) for a single-turn coil, (b) for a coil wound with 300 turns.

- (a) Flux density $B = 0.8$ T, length of conductor lying at right-angles to field $l = 30 \text{ mm} = 30 \times 10^{-3} \text{ m}$ and current $I = 50 \text{ mA} = 50 \times 10^{-3} \text{ A}$
For a single-turn coil, force on each coil side

$$F = BIl = 0.8 \times 50 \times 10^{-3} \times 30 \times 10^{-3} \\ = 1.2 \times 10^{-3} \text{ N, or } 0.0012 \text{ N}$$

- (b) When there are 300 turns on the coil there are effectively 300 parallel conductors each carrying a current of 50 mA. Thus the total force produced by the current is 300 times that for

a single-turn coil. Hence force on coil side,
 $F = 300 BIl = 300 \times 0.0012 = 0.36 \text{ N}$

Now try the following exercise

Exercise 37 Further problems on the force on a current-carrying conductor

- A conductor carries a current of 70 A at right-angles to a magnetic field having a flux density of 1.5 T. If the length of the conductor in the field is 200 mm calculate the force acting on the conductor. What is the force when the conductor and field are at an angle of 45° ?
[21.0 N, 14.8 N]
- Calculate the current required in a 240 mm length of conductor of a d.c. motor when the conductor is situated at right-angles to the magnetic field of flux density 1.25 T, if a force of 1.20 N is to be exerted on the conductor.
[4.0 A]
- A conductor 30 cm long is situated at right-angles to a magnetic field. Calculate the strength of the magnetic field if a current of 15 A in the conductor produces a force on it of 3.6 N.
[0.80 T]
- A conductor 300 mm long carries a current of 13 A and is at right-angles to a magnetic field between two circular pole faces, each of diameter 80 mm. If the total flux between the pole faces is 0.75 mWb calculate the force exerted on the conductor.
[0.582 N]
- (a) A 400 mm length of conductor carrying a current of 25 A is situated at right-angles to a magnetic field between two poles of an electric motor. The poles have a circular cross-section. If the force exerted on the conductor is 80 N and the total flux between the pole faces is 1.27 mWb, determine the diameter of a pole face.
(b) If the conductor in part (a) is vertical, the current flowing downwards and the direction of the magnetic field is from left to right, what is the direction of the 80 N force?
[(a) 14.2 mm (b) towards the viewer]
- A coil is wound uniformly on a former having a width of 18 mm and a length of 25 mm. The former is pivoted about an axis passing through the middle of the two shorter sides and is placed in a uniform magnetic field of

flux density 0.75 T, the axis being perpendicular to the field. If the coil carries a current of 120 mA, determine the force exerted on each coil side, (a) for a single-turn coil, (b) for a coil wound with 400 turns.

[(a) 2.25×10^{-3} N (b) 0.9 N]

8.4 Principle of operation of a simple d.c. motor

A rectangular coil which is free to rotate about a fixed axis is shown placed inside a magnetic field produced by permanent magnets in Fig. 8.17. A direct current is fed into the coil via carbon brushes bearing on a commutator, which consists of a metal ring split into two halves separated by insulation. When current flows in the coil a magnetic field is set up around the coil which interacts with the magnetic field produced by the magnets. This causes a force F to be exerted on the current-carrying conductor which, by Fleming's left-hand rule, is downwards between points A and B and upward between C and D for the current direction shown. This causes a torque and the coil rotates anticlockwise. When the coil has turned through 90° from the position shown in Fig. 8.17 the brushes connected to the positive and negative terminals of the supply make contact with different halves of the commutator ring, thus reversing the direction of the current flow in the conductor. If the current is not

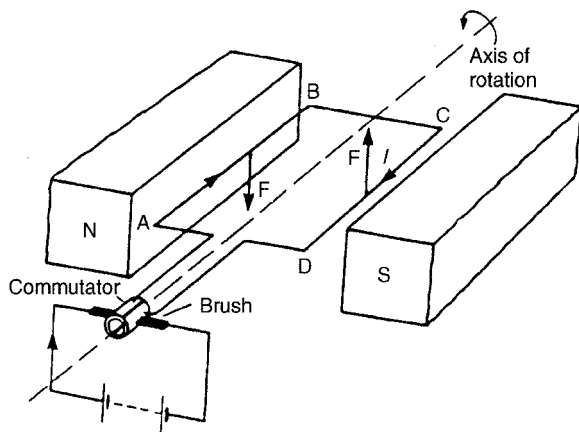

Figure 8.17

reversed and the coil rotates past this position the forces acting on it change direction and it rotates in the opposite direction thus never making more than half a revolution. The current direction is reversed every time the coil swings through the vertical position and thus the coil rotates anti-clockwise for as long as the current flows. This is the principle of operation of a d.c. motor which is thus a device that takes in electrical energy and converts it into mechanical energy.

8.5 Principle of operation of a moving-coil instrument

A moving-coil instrument operates on the motor principle. When a conductor carrying current is placed in a magnetic field, a force F is exerted on the conductor, given by $F = BIl$. If the flux density B is made constant (by using permanent magnets) and the conductor is a fixed length (say, a coil) then the force will depend only on the current flowing in the conductor.

In a moving-coil instrument a coil is placed centrally in the gap between shaped pole pieces as shown by the front elevation in Fig. 8.18(a). (The air-gap is kept as small as possible, although for clarity it is shown exaggerated in Fig. 8.18) The coil is supported by steel pivots, resting in jewel bearings, on a cylindrical iron core. Current is led into and out of the coil by two phosphor bronze spiral hairsprings which are wound in opposite directions to minimize the effect of temperature change and to limit the coil swing (i.e. to **control** the movement) and return the movement to zero position when no current flows. Current flowing in the coil produces forces as shown in Fig. 8.18(b), the directions being obtained by Fleming's left-hand rule. The two forces, F_A and F_B , produce a torque which will move the coil in a clockwise direction, i.e. move the pointer from left to right. Since force is proportional to current the scale is linear.

When the aluminium frame, on which the coil is wound, is rotated between the poles of the magnet, small currents (called eddy currents) are induced into the frame, and this provides automatically the necessary **damping** of the system due to the reluctance of the former to move within the magnetic field. The moving-coil instrument will measure only direct current or voltage and the terminals are marked positive and negative to ensure that the current passes through the coil in the correct direction to deflect the pointer 'up the scale'.

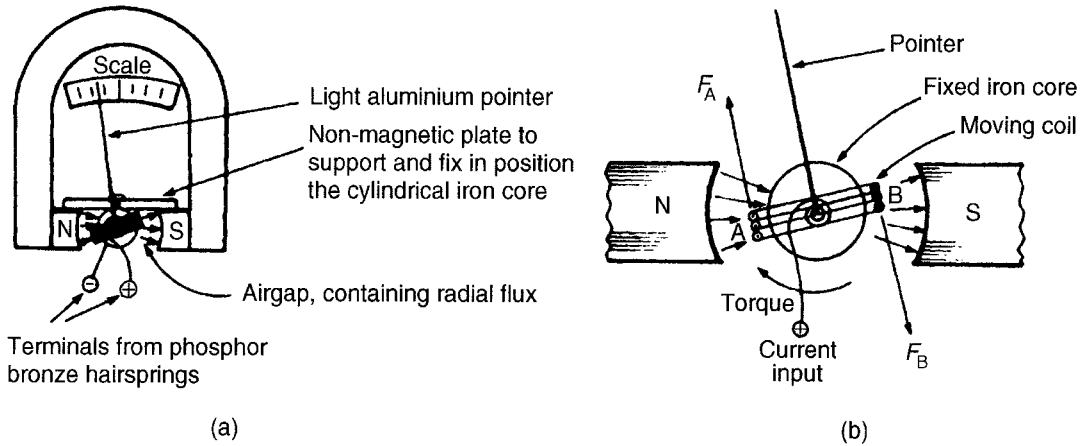

Figure 8.18

The range of this sensitive instrument is extended by using shunts and multipliers (see Chapter 10)

8.6 Force on a charge

When a charge of Q coulombs is moving at a velocity of v m/s in a magnetic field of flux density B teslas, the charge moving perpendicular to the field, then the magnitude of the force F exerted on the charge is given by:

$$F = QvB \text{ newtons}$$

Problem 7. An electron in a television tube has a charge of 1.6×10^{-19} coulombs and travels at 3×10^7 m/s perpendicular to a field of flux density $18.5 \mu\text{T}$. Determine the force exerted on the electron in the field.

From above, force $F = QvB$ newtons, where Q = charge in coulombs = 1.6×10^{-19} C, v = velocity of charge = 3×10^7 m/s, and B = flux density = 18.5×10^{-6} T. Hence force on electron,

$$\begin{aligned} F &= 1.6 \times 10^{-19} \times 3 \times 10^7 \times 18.5 \times 10^{-6} \\ &= 1.6 \times 3 \times 18.5 \times 10^{-18} \\ &= 88.8 \times 10^{-18} = \mathbf{8.88 \times 10^{-17} \text{ N}} \end{aligned}$$

Now try the following exercises

Exercise 38 Further problems on the force on a charge

- 1 Calculate the force exerted on a charge of 2×10^{-18} C travelling at 2×10^6 m/s perpendicular to a field of density 2×10^{-7} T
[8×10^{-19} N]
- 2 Determine the speed of a 10^{-19} C charge travelling perpendicular to a field of flux density 10^{-7} T, if the force on the charge is 10^{-20} N
[10^6 m/s]

Exercise 39 Short answer questions on electromagnetism

- 1 The direction of the magnetic field around a current-carrying conductor may be remembered using the rule.
- 2 Sketch the magnetic field pattern associated with a solenoid connected to a battery and wound on an iron bar. Show the direction of the field.
- 3 Name three applications of electromagnetism.
- 4 State what happens when a current-carrying conductor is placed in a magnetic field between two magnets.
- 5 The force on a current-carrying conductor in a magnetic field depends on four factors. Name them.

- 6 The direction of the force on a conductor in a magnetic field may be predetermined using Fleming's rule.
- 7 State three applications of the force on a current-carrying conductor.
- 8 Figure 8.19 shows a simplified diagram of a section through the coil of a moving-coil instrument. For the direction of current flow shown in the coil determine the direction that the pointer will move.

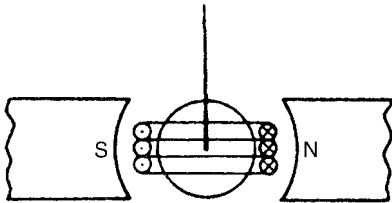

Figure 8.19

- 9 Explain, with the aid of a sketch, the action of a simplified d.c. motor.
- 10 Sketch and label the movement of a moving-coil instrument. Briefly explain the principle of operation of such an instrument.

Exercise 40 Multi-choice questions on electromagnetism (Answers on page 375)

- 1 A conductor carries a current of 10 A at right-angles to a magnetic field having a flux density of 500 mT. If the length of the conductor in the field is 20 cm, the force on the conductor is:
(a) 100 kN (b) 1 kN (c) 100 N (d) 1 N
- 2 If a conductor is horizontal, the current flowing from left to right and the direction of the surrounding magnetic field is from above to below, the force exerted on the conductor is:
(a) from left to right
(b) from below to above
(c) away from the viewer
(d) towards the viewer
- 3 For the current-carrying conductor lying in the magnetic field shown in Fig. 8.20(a), the direction of the force on the conductor is:
(a) to the left (b) upwards
(c) to the right (d) downwards

- 4 For the current-carrying conductor lying in the magnetic field shown in Fig. 8.20(b), the direction of the current in the conductor is:
(a) towards the viewer
(b) away from the viewer

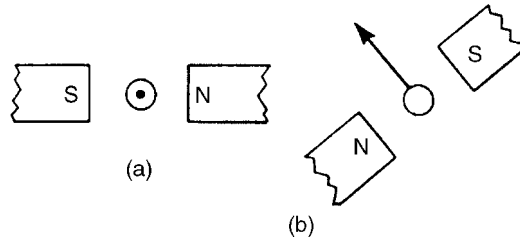

Figure 8.20

- 5 Figure 8.21 shows a rectangular coil of wire placed in a magnetic field and free to rotate about axis AB. If the current flows into the coil at C, the coil will:
(a) commence to rotate anti-clockwise
(b) commence to rotate clockwise
(c) remain in the vertical position
(d) experience a force towards the north pole

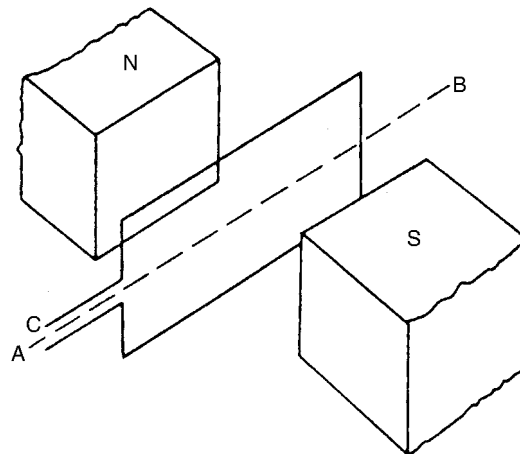

Figure 8.21

- 6 The force on an electron travelling at 10^7 m/s in a magnetic field of density $10 \mu\text{T}$ is 1.6×10^{-17} N. The electron has a charge of:
(a) 1.6×10^{-28} C (b) 1.6×10^{-15} C
(c) 1.6×10^{-19} C (d) 1.6×10^{-25} C

7 An electric bell depends for its action on:

- (a) a permanent magnet
- (b) reversal of current
- (c) a hammer and a gong
- (d) an electromagnet

8 A relay can be used to:

- (a) decrease the current in a circuit
- (b) control a circuit more readily
- (c) increase the current in a circuit
- (d) control a circuit from a distance

9 There is a force of attraction between two current-carrying conductors when the current

in them is:

- (a) in opposite directions
- (b) in the same direction
- (c) of different magnitude
- (d) of the same magnitude

10 The magnetic field due to a current-carrying conductor takes the form of:

- (a) rectangles
- (b) concentric circles
- (c) wavy lines
- (d) straight lines radiating outwards

Electromagnetic induction

At the end of this chapter you should be able to:

- understand how an e.m.f. may be induced in a conductor
- state Faraday's laws of electromagnetic induction
- state Lenz's law
- use Fleming's right-hand rule for relative directions
- appreciate that the induced e.m.f., $E = Blv$ or $E = Blv \sin \theta$
- calculate induced e.m.f. given B , l , v and θ and determine relative directions
- define inductance L and state its unit
- define mutual inductance
- appreciate that emf

$$E = -N \frac{d\Phi}{dt} = -L \frac{dI}{dt}$$

- calculate induced e.m.f. given N , t , L , change of flux or change of current
- appreciate factors which affect the inductance of an inductor
- draw the circuit diagram symbols for inductors
- calculate the energy stored in an inductor using $W = \frac{1}{2}LI^2$ joules
- calculate inductance L of a coil, given $L = N\Phi/I$
- calculate mutual inductance using $E_2 = -M(dI_1/dt)$

9.1 Introduction to electromagnetic induction

When a conductor is moved across a magnetic field so as to cut through the lines of force (or flux), an electromotive force (e.m.f.) is produced in the conductor. If the conductor forms part of a closed circuit then the e.m.f. produced causes an electric current to flow round the circuit. Hence an e.m.f. (and thus current) is 'induced' in the conductor as a result of its movement across the magnetic

field. This effect is known as '**electromagnetic induction**'.

Figure 9.1 (a) shows a coil of wire connected to a centre-zero galvanometer, which is a sensitive ammeter with the zero-current position in the centre of the scale.

- (a) When the magnet is moved at constant speed towards the coil (Fig. 9.1(a)), a deflection is noted on the galvanometer showing that a current has been produced in the coil.

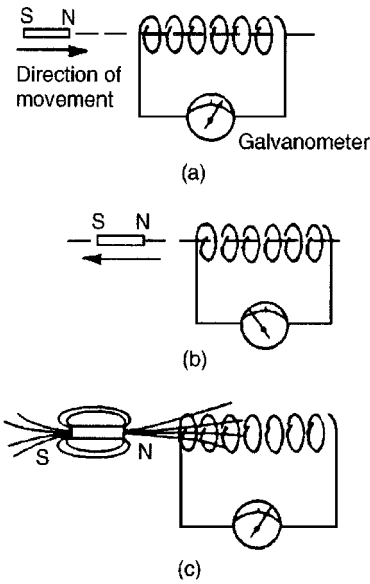

Figure 9.1

- (b) When the magnet is moved at the same speed as in (a) but away from the coil the same deflection is noted but is in the opposite direction (see Fig. 9.1(b))
- (c) When the magnet is held stationary, even within the coil, no deflection is recorded.
- (d) When the coil is moved at the same speed as in (a) and the magnet held stationary the same galvanometer deflection is noted.
- (e) When the relative speed is, say, doubled, the galvanometer deflection is doubled.
- (f) When a stronger magnet is used, a greater galvanometer deflection is noted.
- (g) When the number of turns of wire of the coil is increased, a greater galvanometer deflection is noted.

Figure 9.1(c) shows the magnetic field associated with the magnet. As the magnet is moved towards the coil, the magnetic flux of the magnet moves across, or cuts, the coil. **It is the relative movement of the magnetic flux and the coil that causes an e.m.f. and thus current, to be induced in the coil.** This effect is known as electromagnetic induction. The laws of electromagnetic induction stated in section 9.2 evolved from experiments such as those described above.

9.2 Laws of electromagnetic induction

Faraday's laws of electromagnetic induction state:

- (i) An induced e.m.f. is set up whenever the magnetic field linking that circuit changes.
- (ii) The magnitude of the induced e.m.f. in any circuit is proportional to the rate of change of the magnetic flux linking the circuit.

Lenz's law states:

The direction of an induced e.m.f. is always such that it tends to set up a current opposing the motion or the change of flux responsible for inducing that e.m.f.

An alternative method to Lenz's law of determining relative directions is given by **Fleming's Right-hand rule** (often called the generator rule) which states:

Let the thumb, first finger and second finger of the right hand be extended such that they are all at right angles to each other (as shown in Fig. 9.2). If the first finger points in the direction of the magnetic field and the thumb points in the direction of motion of the conductor relative to the magnetic field, then the second finger will point in the direction of the induced e.m.f.

Summarising:

First finger - Field

ThuMb - Motion

SEcond finger - E.m.f.

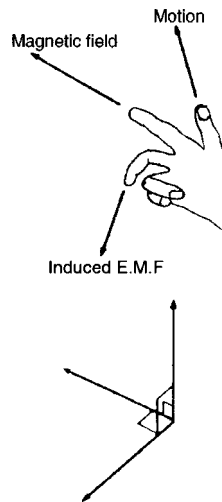

Figure 9.2

In a generator, conductors forming an electric circuit are made to move through a magnetic field. By Faraday's law an e.m.f. is induced in the conductors and thus a source of e.m.f. is created. A generator converts mechanical energy into electrical energy. (The action of a simple a.c. generator is described in Chapter 14).

The induced e.m.f. E set up between the ends of the conductor shown in Fig. 9.3 is given by:

$$E = Blv \text{ volts}$$

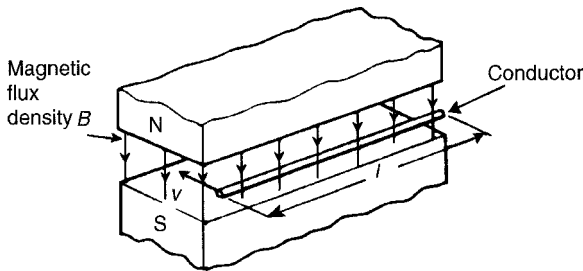

Figure 9.3

where B , the flux density, is measured in teslas, l , the length of conductor in the magnetic field, is measured in metres, and v , the conductor velocity, is measured in metres per second.

If the conductor moves at an angle θ° to the magnetic field (instead of at 90° as assumed above) then

$$E = Blv \sin \theta \text{ volts}$$

Problem 1. A conductor 300 mm long moves at a uniform speed of 4 m/s at right-angles to a uniform magnetic field of flux density 1.25 T. Determine the current flowing in the conductor when (a) its ends are open-circuited, (b) its ends are connected to a load of 20Ω resistance.

When a conductor moves in a magnetic field it will have an e.m.f. induced in it but this e.m.f. can only produce a current if there is a closed circuit. Induced e.m.f.

$$E = Blv = (1.25) \left(\frac{300}{1000} \right) (4) = 1.5 \text{ V}$$

(a) If the ends of the conductor are open circuited **no current will flow** even though 1.5 V has been induced.

(b) From Ohm's law,

$$I = \frac{E}{R} = \frac{1.5}{20} = \mathbf{0.075 \text{ A} \text{ or } 75 \text{ mA}}$$

Problem 2. At what velocity must a conductor 75 mm long cut a magnetic field of flux density 0.6 T if an e.m.f. of 9 V is to be induced in it? Assume the conductor, the field and the direction of motion are mutually perpendicular.

Induced e.m.f. $E = Blv$, hence velocity $v = E/Bl$
Thus

$$\begin{aligned} v &= \frac{9}{(0.6)(75 \times 10^{-3})} \\ &= \frac{9 \times 10^3}{0.6 \times 75} \\ &= \mathbf{200 \text{ m/s}} \end{aligned}$$

Problem 3. A conductor moves with a velocity of 15 m/s at an angle of (a) 90° (b) 60° and (c) 30° to a magnetic field produced between two square-faced poles of side length 2 cm. If the flux leaving a pole face is $5 \mu\text{Wb}$, find the magnitude of the induced e.m.f. in each case.

$v = 15 \text{ m/s}$, length of conductor in magnetic field, $l = 2 \text{ cm} = 0.02 \text{ m}$, $A = 2 \times 2 \text{ cm}^2 = 4 \times 10^{-4} \text{ m}^2$ and $\Phi = 5 \times 10^{-6} \text{ Wb}$

(a) $E_{90} = Blv \sin 90^\circ$

$$\begin{aligned} &= \left(\frac{\Phi}{A} \right) lv \sin 90^\circ \\ &= \left(\frac{5 \times 10^{-6}}{4 \times 10^{-4}} \right) (0.02) (15) (1) \\ &= \mathbf{3.75 \text{ mV}} \end{aligned}$$

(b) $E_{60} = Blv \sin 60^\circ = E_{90} \sin 60^\circ$

$$= 3.75 \sin 60^\circ = \mathbf{3.25 \text{ mV}}$$

(c) $E_{30} = Blv \sin 30^\circ = E_{90} \sin 30^\circ$

$$= 3.75 \sin 30^\circ = \mathbf{1.875 \text{ mV}}$$

Problem 4. The wing span of a metal aeroplane is 36 m. If the aeroplane is flying at 400 km/h, determine the e.m.f. induced between its wing tips. Assume the vertical component of the earth's magnetic field is $40 \mu\text{T}$.

Induced e.m.f. across wing tips, $E = Blv$
 $B = 40 \mu\text{T} = 40 \times 10^{-6} \text{ T}$, $l = 36 \text{ m}$ and

$$v = 400 \frac{\text{km}}{\text{h}} \times 1000 \frac{\text{m}}{\text{km}} \times \frac{1 \text{ h}}{60 \times 60 \text{ s}}$$

$$= \frac{(400)(1000)}{3600}$$

$$= \frac{4000}{36} \text{ m/s}$$

Hence

$$E = Blv = (40 \times 10^{-6})(36) \left(\frac{4000}{36} \right)$$

$$= \mathbf{0.16 \text{ V}}$$

Problem 5. The diagrams shown in Fig. 9.4 represents the generation of e.m.f's. Determine (i) the direction in which the conductor has to be moved in Fig. 9.4(a), (ii) the direction of the induced e.m.f. in Fig. 9.4(b), (iii) the polarity of the magnetic system in Fig. 9.4(c)

Figure 9.4

The direction of the e.m.f., and thus the current due to the e.m.f. may be obtained by either Lenz's law or Fleming's Right-hand rule (i.e. GeneRator rule).

(i) Using Lenz's law: The field due to the magnet and the field due to the current-carrying conductor are shown in Fig. 9.5(a) and are

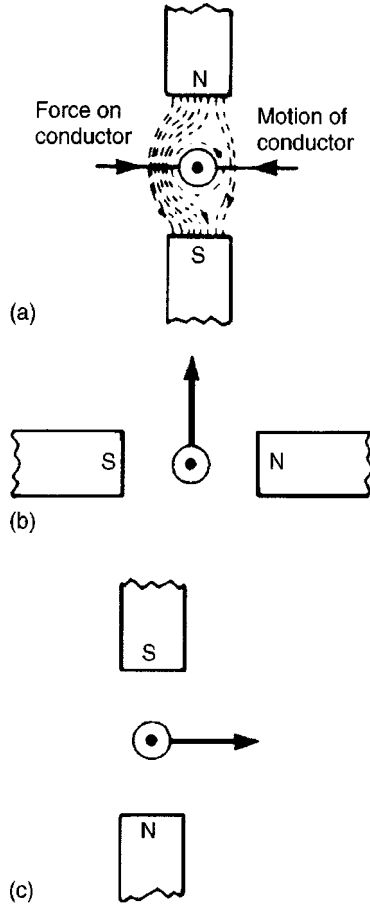

Figure 9.5

seen to reinforce to the left of the conductor. Hence the force on the conductor is to the right. However Lenz's law states that the direction of the induced e.m.f. is always such as to oppose the effect producing it. **Thus the conductor will have to be moved to the left.**

(ii) Using Fleming's right-hand rule:

First finger - Field,

i.e. $N \rightarrow S$, or right to left;

ThMb - Motion, i.e. upwards;

SEcond finger - E.m.f.

i.e. **towards the viewer or out of the paper**, as shown in Fig. 9.5(b)

(iii) The polarity of the magnetic system of Fig. 9.4(c) is shown in Fig. 9.5(c) and is obtained using Fleming's right-hand rule.

Now try the following exercise

Exercise 41 Further problems on induced e.m.f.

- 1 A conductor of length 15 cm is moved at 750 mm/s at right-angles to a uniform flux density of 1.2 T. Determine the e.m.f. induced in the conductor. [0.135 V]
- 2 Find the speed that a conductor of length 120 mm must be moved at right angles to a magnetic field of flux density 0.6 T to induce in it an e.m.f. of 1.8 V [25 m/s]
- 3 A 25 cm long conductor moves at a uniform speed of 8 m/s through a uniform magnetic field of flux density 1.2 T. Determine the current flowing in the conductor when (a) its ends are open-circuited, (b) its ends are connected to a load of 15 ohms resistance. [(a) 0 (b) 0.16 A]
- 4 A straight conductor 500 mm long is moved with constant velocity at right angles both to its length and to a uniform magnetic field. Given that the e.m.f. induced in the conductor is 2.5 V and the velocity is 5 m/s, calculate the flux density of the magnetic field. If the conductor forms part of a closed circuit of total resistance 5 ohms, calculate the force on the conductor. [1 T, 0.25 N]
- 5 A car is travelling at 80 km/h. Assuming the back axle of the car is 1.76 m in length and the vertical component of the earth's magnetic field is 40 μ T, find the e.m.f. generated in the axle due to motion. [1.56 mV]
- 6 A conductor moves with a velocity of 20 m/s at an angle of (a) 90° (b) 45° (c) 30°, to a magnetic field produced between two square-faced poles of side length 2.5 cm. If the flux on the pole face is 60 mWb, find the magnitude of the induced e.m.f. in each case. [(a) 48 V (b) 33.9 V (c) 24 V]

9.3 Inductance

Inductance is the name given to the property of a circuit whereby there is an e.m.f. induced into the circuit by the change of flux linkages produced by a current change.

When the e.m.f. is induced in the same circuit as that in which the current is changing, the property is

called **self inductance, L**. When the e.m.f. is induced in a circuit by a change of flux due to current changing in an adjacent circuit, the property is called **mutual inductance, M**. The unit of inductance is the **henry, H**.

A circuit has an inductance of one henry when an e.m.f. of one volt is induced in it by a current changing at the rate of one ampere per second. Induced e.m.f. in a coil of N turns,

$$E = -N \frac{d\Phi}{dt} \text{ volts}$$

where $d\Phi$ is the change in flux in Webers, and dt is the time taken for the flux to change in seconds (i.e. $\frac{d\Phi}{dt}$ is the rate of change of flux).

Induced e.m.f. in a coil of inductance L henrys,

$$E = -L \frac{dI}{dt} \text{ volts}$$

where dI is the change in current in amperes and dt is the time taken for the current to change in seconds (i.e. $\frac{dI}{dt}$ is the rate of change of current). The minus sign in each of the above two equations remind us of its direction (given by Lenz's law)

Problem 6. Determine the e.m.f. induced in a coil of 200 turns when there is a change of flux of 25 mWb linking with it in 50 ms.

$$\begin{aligned} \text{Induced e.m.f. } E &= -N \frac{d\Phi}{dt} \\ &= -(200) \left(\frac{25 \times 10^{-3}}{50 \times 10^{-3}} \right) \\ &= -100 \text{ volts} \end{aligned}$$

Problem 7. A flux of 400 μ Wb passing through a 150-turn coil is reversed in 40 ms. Find the average e.m.f. induced.

Since the flux reverses, the flux changes from +400 μ Wb to -400 μ Wb, a total change of flux of 800 μ Wb.

$$\text{Induced e.m.f. } E = -N \frac{d\Phi}{dt}$$

$$\begin{aligned}
 &= -(150) \left(\frac{800 \times 10^{-6}}{40 \times 10^{-3}} \right) \\
 &= -\frac{150 \times 800 \times 10^3}{40 \times 10^6}
 \end{aligned}$$

Hence, the average e.m.f. induced, $E = -3$ volts

Problem 8. Calculate the e.m.f. induced in a coil of inductance 12 H by a current changing at the rate of 4 A/s.

$$\begin{aligned}
 \text{Induced e.m.f. } E &= -L \frac{dI}{dt} = -(12)(4) \\
 &= -48 \text{ volts}
 \end{aligned}$$

Problem 9. An e.m.f. of 1.5 kV is induced in a coil when a current of 4 A collapses uniformly to zero in 8 ms. Determine the inductance of the coil.

Change in current, $dI = (4 - 0) = 4$ A,
 $dt = 8$ ms $= 8 \times 10^{-3}$ s,

$$\begin{aligned}
 \frac{dI}{dt} &= \frac{4}{8 \times 10^{-3}} = \frac{4000}{8} \\
 &= 500 \text{ A/s}
 \end{aligned}$$

and $E = 1.5$ kV $= 1500$ V

Since $|E| = L \frac{dI}{dt}$,

$$\text{inductance, } L = \frac{|E|}{(dI/dt)} = \frac{1500}{500} = 3 \text{ H}$$

(Note that $|E|$ means the 'magnitude of E ' which disregards the minus sign)

Problem 10. An average e.m.f. of 40 V is induced in a coil of inductance 150 mH when a current of 6 A is reversed. Calculate the time taken for the current to reverse.

$|E| = 40$ V, $L = 150$ mH $= 0.15$ H and change in current, $dI = 6 - (-6) = 12$ A (since the current is reversed).

$$\text{Since } |E| = \frac{dI}{dt},$$

$$\begin{aligned}
 \text{time } dt &= \frac{LdI}{|E|} = \frac{(0.15)(12)}{40} \\
 &= 0.045 \text{ s or } 45 \text{ ms}
 \end{aligned}$$

Now try the following exercise

Exercise 42 Further problems on inductance

- Find the e.m.f. induced in a coil of 200 turns when there is a change of flux of 30 mWb linking with it in 40 ms. [−150 V]
- An e.m.f. of 25 V is induced in a coil of 300 turns when the flux linking with it changes by 12 mWb. Find the time, in milliseconds, in which the flux makes the change. [144 ms]
- An ignition coil having 10 000 turns has an e.m.f. of 8 kV induced in it. What rate of change of flux is required for this to happen? [0.8 Wb/s]
- A flux of 0.35 mWb passing through a 125-turn coil is reversed in 25 ms. Find the magnitude of the average e.m.f. induced. [3.5 V]
- Calculate the e.m.f. induced in a coil of inductance 6 H by a current changing at a rate of 15 A/s [−90 V]

9.4 Inductors

A component called an inductor is used when the property of inductance is required in a circuit. The basic form of an inductor is simply a coil of wire. Factors which affect the inductance of an inductor include:

- the number of turns of wire – the more turns the higher the inductance
- the cross-sectional area of the coil of wire – the greater the cross-sectional area the higher the inductance
- the presence of a magnetic core – when the coil is wound on an iron core the same current sets up a more concentrated magnetic field and the inductance is increased
- the way the turns are arranged – a short thick coil of wire has a higher inductance than a long thin one.

Two examples of practical inductors are shown in Fig. 9.6, and the standard electrical circuit diagram symbols for air-cored and iron-cored inductors are shown in Fig. 9.7

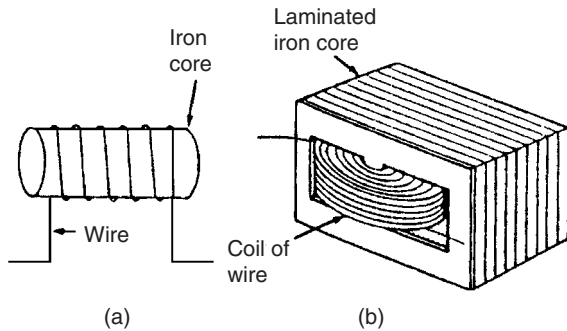

Figure 9.6

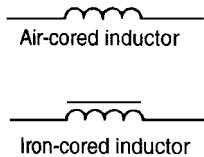

Figure 9.7

An iron-cored inductor is often called a **choke** since, when used in a.c. circuits, it has a choking effect, limiting the current flowing through it.

Inductance is often undesirable in a circuit. To reduce inductance to a minimum the wire may be bent back on itself, as shown in Fig. 9.8, so that the magnetising effect of one conductor is neutralised by that of the adjacent conductor. The wire may be coiled around an insulator, as shown, without increasing the inductance. Standard resistors may be non-inductively wound in this manner.

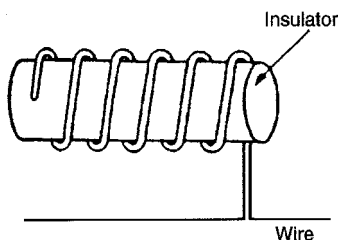

Figure 9.8

9.5 Energy stored

An inductor possesses an ability to store energy. The energy stored, W , in the magnetic field of an inductor is given by:

$$W = \frac{1}{2}LI^2 \text{ joules}$$

Problem 11. An 8 H inductor has a current of 3 A flowing through it. How much energy is stored in the magnetic field of the inductor?

Energy stored,

$$W = \frac{1}{2}LI^2 = \frac{1}{2}(8)(3)^2 = 36 \text{ joules}$$

Now try the following exercise

Exercise 43 Further problems on energy stored

- 1 An inductor of 20 H has a current of 2.5 A flowing in it. Find the energy stored in the magnetic field of the inductor. [62.5 J]
- 2 Calculate the value of the energy stored when a current of 30 mA is flowing in a coil of inductance 400 mH [0.18 mJ]
- 3 The energy stored in the magnetic field of an inductor is 80 J when the current flowing in the inductor is 2 A. Calculate the inductance of the coil. [40 H]

9.6 Inductance of a coil

If a current changing from 0 to I amperes, produces a flux change from 0 to Φ webers, then $dI = I$ and $d\Phi = \Phi$. Then, from section 9.3,

$$\text{induced e.m.f. } E = \frac{N\Phi}{t} = \frac{LI}{t}$$

from which, **inductance of coil,**

$$L = \frac{N\Phi}{I} \text{ henrys}$$

Problem 12. Calculate the coil inductance when a current of 4 A in a coil of 800 turns produces a flux of 5 mWb linking with the coil.

For a coil, inductance

$$L = \frac{N\Phi}{I} = \frac{(800)(5 \times 10^{-3})}{4} = \mathbf{1 \text{ H}}$$

Problem 13. A flux of 25 mWb links with a 1500 turn coil when a current of 3 A passes through the coil. Calculate (a) the inductance of the coil, (b) the energy stored in the magnetic field, and (c) the average e.m.f. induced if the current falls to zero in 150 ms.

(a) **Inductance,**

$$L = \frac{N\Phi}{I} = \frac{(1500)(25 \times 10^{-3})}{3} = \mathbf{12.5 \text{ H}}$$

(b) **Energy stored,**

$$W = \frac{1}{2}LI^2 = \frac{1}{2}(12.5)(3)^2 = \mathbf{56.25 \text{ J}}$$

(c) **Induced emf,**

$$E = -L \frac{dI}{dt} = -(12.5) \left(\frac{3 - 0}{150 \times 10^{-3}} \right) \\ = \mathbf{-250 \text{ V}}$$

(Alternatively,

$$E = -N \frac{d\Phi}{dt} \\ = -(1500) \left(\frac{25 \times 10^{-3}}{150 \times 10^{-3}} \right) \\ = \mathbf{-250 \text{ V}}$$

since if the current falls to zero so does the flux)

Problem 14. When a current of 1.5 A flows in a coil the flux linking with the coil is 90 μ Wb. If the coil inductance is 0.60 H, calculate the number of turns of the coil.

For a coil, $L = \frac{N\Phi}{I}$. Thus

$$N = \frac{LI}{\Phi} = \frac{(0.6)(1.5)}{90 \times 10^{-6}} = \mathbf{10\,000 \text{ turns}}$$

Problem 15. A 750 turn coil of inductance 3 H carries a current of 2 A. Calculate the flux linking the coil and the e.m.f. induced in the coil when the current collapses to zero in 20 ms.

Coil inductance, $L = \frac{N\Phi}{I}$ from which, flux

$$\Phi = \frac{LI}{N} = \frac{(3)(2)}{750} = 8 \times 10^{-3} = \mathbf{8 \text{ mWb}}$$

Induced e.m.f.

$$E = -L \frac{dI}{dt} = -(3) \left(\frac{2 - 0}{20 \times 10^{-3}} \right) \\ = \mathbf{-300 \text{ V}}$$

(Alternatively,

$$E = -N \frac{d\Phi}{dt} = -(750) \left(\frac{8 \times 10^{-3}}{20 \times 10^{-3}} \right) \\ = \mathbf{-300 \text{ V}}$$

Now try the following exercise

Exercise 44 Further problems on the inductance of a coil

- 1 A flux of 30 mWb links with a 1200 turn coil when a current of 5 A is passing through the coil. Calculate (a) the inductance of the coil, (b) the energy stored in the magnetic field, and (c) the average e.m.f. induced if the current is reduced to zero in 0.20 s
[(a) 7.2 H (b) 90 J (c) 180 V]
- 2 An e.m.f. of 2 kV is induced in a coil when a current of 5 A collapses uniformly to zero in 10 ms. Determine the inductance of the coil.
[4 H]
- 3 An average e.m.f. of 60 V is induced in a coil of inductance 160 mH when a current of 7.5 A is reversed. Calculate the time taken for the current to reverse.
[40 ms]
- 4 A coil of 2500 turns has a flux of 10 mWb linking with it when carrying a current of 2 A. Calculate the coil inductance and the e.m.f. induced in the coil when the current collapses to zero in 20 ms.
[12.5 H, 1.25 kV]

- 5 Calculate the coil inductance when a current of 5 A in a coil of 1000 turns produces a flux of 8 mWb linking with the coil. [1.6 H]
- 6 A coil is wound with 600 turns and has a self inductance of 2.5 H. What current must flow to set up a flux of 20 mWb? [4.8 A]
- 7 When a current of 2 A flows in a coil, the flux linking with the coil is $80 \mu\text{Wb}$. If the coil inductance is 0.5 H, calculate the number of turns of the coil. [12 500]
- 8 A coil of 1200 turns has a flux of 15 mWb linking with it when carrying a current of 4 A. Calculate the coil inductance and the e.m.f. induced in the coil when the current collapses to zero in 25 ms [4.5 H, 720 V]
- 9 A coil has 300 turns and an inductance of 4.5 mH. How many turns would be needed to produce a 0.72 mH coil assuming the same core is used? [48 turns]
- 10 A steady current of 5 A when flowing in a coil of 1000 turns produces a magnetic flux of $500 \mu\text{Wb}$. Calculate the inductance of the coil. The current of 5 A is then reversed in 12.5 ms. Calculate the e.m.f. induced in the coil. [0.1 H, 80 V]

9.7 Mutual inductance

Mutually induced e.m.f. in the second coil,

$$E_2 = -M \frac{dI_1}{dt} \text{ volts}$$

where M is the **mutual inductance** between two coils, in henrys, and (dI_1/dt) is the rate of change of current in the first coil.

The phenomenon of mutual inductance is used in **transformers** (see chapter 21, page 303)

Problem 16. Calculate the mutual inductance between two coils when a current changing at 200 A/s in one coil induces an e.m.f. of 1.5 V in the other.

Induced e.m.f. $|E_2| = M dI_1/dt$, i.e. $1.5 = M(200)$. Thus **mutual inductance**,

$$M = \frac{1.5}{200} = \mathbf{0.0075 \text{ H or } 7.5 \text{ mH}}$$

Problem 17. The mutual inductance between two coils is 18 mH. Calculate the steady rate of change of current in one coil to induce an e.m.f. of 0.72 V in the other.

Induced e.m.f. $|E_2| = M \frac{dI_1}{dt}$
Hence rate of change of current,

$$\frac{dI_1}{dt} = \frac{|E_2|}{M} = \frac{0.72}{0.018} = \mathbf{40 \text{ A/s}}$$

Problem 18. Two coils have a mutual inductance of 0.2 H. If the current in one coil is changed from 10 A to 4 A in 10 ms, calculate (a) the average induced e.m.f. in the second coil, (b) the change of flux linked with the second coil if it is wound with 500 turns.

(a) Induced e.m.f.

$$\begin{aligned} |E_2| &= -M \frac{dI_1}{dt} \\ &= -(0.2) \left(\frac{10 - 4}{10 \times 10^{-3}} \right) = \mathbf{-120 \text{ V}} \end{aligned}$$

(b) Induced e.m.f.

$$|E_2| = N \frac{d\Phi}{dt}, \text{ hence } d\Phi = \frac{|E_2| dt}{N}$$

Thus the change of flux,

$$d\Phi = \frac{(120)(10 \times 10^{-3})}{500} = \mathbf{2.4 \text{ mWb}}$$

Now try the following exercises

Exercise 45 Further problems on mutual inductance

- 1 The mutual inductance between two coils is 150 mH. Find the magnitude of the e.m.f.

induced in one coil when the current in the other is increasing at a rate of 30 A/s.

[4.5 V]

2 Determine the mutual inductance between two coils when a current changing at 50 A/s in one coil induces an e.m.f. of 80 mV in the other.

[1.6 mH]

3 Two coils have a mutual inductance of 0.75 H. Calculate the magnitude of the e.m.f. induced in one coil when a current of 2.5 A in the other coil is reversed in 15 ms

[250 V]

4 The mutual inductance between two coils is 240 mH. If the current in one coil changes from 15 A to 6 A in 12 ms, calculate (a) the average e.m.f. induced in the other coil, (b) the change of flux linked with the other coil if it is wound with 400 turns.

[(a) -180 V (b) 5.4 mWb]

5 A mutual inductance of 0.06 H exists between two coils. If a current of 6 A in one coil is reversed in 0.8 s calculate (a) the average e.m.f. induced in the other coil, (b) the number of turns on the other coil if the flux change linking with the other coil is 5 mWb

[(a) -0.9 V (b) 144]

Exercise 46 Short answer questions on electromagnetic induction

- 1 What is electromagnetic induction?
- 2 State Faraday's laws of electromagnetic induction
- 3 State Lenz's law
- 4 Explain briefly the principle of the generator
- 5 The direction of an induced e.m.f. in a generator may be determined using Fleming's rule
- 6 The e.m.f. E induced in a moving conductor may be calculated using the formula $E = Blv$. Name the quantities represented and their units
- 7 What is self-inductance? State its symbol
- 8 State and define the unit of inductance
- 9 When a circuit has an inductance L and the current changes at a rate of (di/dt) then the induced e.m.f. E is given by $E = \dots\dots$ volts

10 If a current of I amperes flowing in a coil of N turns produces a flux of Φ webers, the coil inductance L is given by $L = \dots\dots$ henrys

11 The energy W stored by an inductor is given by $W = \dots\dots$ joules

12 What is mutual inductance? State its symbol

13 The mutual inductance between two coils is M . The e.m.f. E_2 induced in one coil by the current changing at (dI_1/dt) in the other is given by $E_2 = \dots\dots$ volts

Exercise 47 Multi-choice questions on electromagnetic induction (Answers on page 375)

- 1 A current changing at a rate of 5 A/s in a coil of inductance 5 H induces an e.m.f. of:
 - (a) 25 V in the same direction as the applied voltage
 - (b) 1 V in the same direction as the applied voltage
 - (c) 25 V in the opposite direction to the applied voltage
 - (d) 1 V in the opposite direction to the applied voltage
- 2 A bar magnet is moved at a steady speed of 1.0 m/s towards a coil of wire which is connected to a centre-zero galvanometer. The magnet is now withdrawn along the same path at 0.5 m/s. The deflection of the galvanometer is in the:
 - (a) same direction as previously, with the magnitude of the deflection doubled
 - (b) opposite direction as previously, with the magnitude of the deflection halved
 - (c) same direction as previously, with the magnitude of the deflection halved
 - (d) opposite direction as previously, with the magnitude of the deflection doubled
- 3 When a magnetic flux of 10 Wb links with a circuit of 20 turns in 2 s, the induced e.m.f. is:
 - (a) 1 V
 - (b) 4 V
 - (c) 100 V
 - (d) 400 V
- 4 A current of 10 A in a coil of 1000 turns produces a flux of 10 mWb linking with the coil. The coil inductance is:
 - (a) 10^6 H
 - (b) 1 H
 - (c) 1 μ H
 - (d) 1 mH
- 5 An e.m.f. of 1 V is induced in a conductor moving at 10 cm/s in a magnetic field of

0.5 T. The effective length of the conductor in the magnetic field is:

- (a) 20 cm
- (b) 5 m
- (c) 20 m
- (d) 50 m

6 Which of the following is false ?

- (a) Fleming's left-hand rule or Lenz's law may be used to determine the direction of an induced e.m.f.
- (b) An induced e.m.f. is set up whenever the magnetic field linking that circuit changes
- (c) The direction of an induced e.m.f. is always such as to oppose the effect producing it
- (d) The induced e.m.f. in any circuit is proportional to the rate of change of the magnetic flux linking the circuit

7 The effect of inductance occurs in an electrical circuit when:

- (a) the resistance is changing
- (b) the flux is changing
- (c) the current is changing

8 Which of the following statements is false? The inductance of an inductor increases:

- (a) with a short, thick coil
- (b) when wound on an iron core

- (c) as the number of turns increases
- (d) as the cross-sectional area of the coil decreases

9 The mutual inductance between two coils, when a current changing at 20 A/s in one coil induces an e.m.f. of 10 mV in the other, is:

- (a) 0.5 H
- (b) 200 mH
- (c) 0.5 mH
- (d) 2 H

10 A strong permanent magnet is plunged into a coil and left in the coil. What is the effect produced on the coil after a short time?

- (a) There is no effect
- (b) The insulation of the coil burns out
- (c) A high voltage is induced
- (d) The coil winding becomes hot

11 Self-inductance occurs when:

- (a) the current is changing
- (b) the circuit is changing
- (c) the flux is changing
- (d) the resistance is changing

12 Faraday's laws of electromagnetic induction are related to:

- (a) the e.m.f. of a chemical cell
- (b) the e.m.f. of a generator
- (c) the current flowing in a conductor
- (d) the strength of a magnetic field

Electrical measuring instruments and measurements

At the end of this chapter you should be able to:

- recognize the importance of testing and measurements in electric circuits
- appreciate the essential devices comprising an analogue instrument
- explain the operation of an attraction and a repulsion type of moving-iron instrument
- explain the operation of a moving-coil rectifier instrument
- compare moving-coil, moving-iron and moving coil rectifier instruments
- calculate values of shunts for ammeters and multipliers for voltmeters
- understand the advantages of electronic instruments
- understand the operation of an ohmmeter/megger
- appreciate the operation of multimeters/Avometers
- understand the operation of a wattmeter
- appreciate instrument 'loading' effect
- understand the operation of a C.R.O. for d.c. and a.c. measurements
- calculate periodic time, frequency, peak to peak values from waveforms on a C.R.O.
- recognize harmonics present in complex waveforms
- determine ratios of powers, currents and voltages in decibels
- understand null methods of measurement for a Wheatstone bridge and d.c. potentiometer
- understand the operation of a.c. bridges
- understand the operation of a Q-meter
- appreciate the most likely source of errors in measurements
- appreciate calibration accuracy of instruments

10.1 Introduction

Tests and measurements are important in designing, evaluating, maintaining and servicing electrical circuits and equipment. In order to detect electrical

quantities such as current, voltage, resistance or power, it is necessary to transform an electrical quantity or condition into a visible indication. This is done with the aid of instruments (or meters) that indicate the magnitude of quantities either by the

position of a pointer moving over a graduated scale (called an analogue instrument) or in the form of a decimal number (called a digital instrument).

10.2 Analogue instruments

All analogue electrical indicating instruments require three essential devices:

- A deflecting or operating device.** A mechanical force is produced by the current or voltage which causes the pointer to deflect from its zero position.
- A controlling device.** The controlling force acts in opposition to the deflecting force and ensures that the deflection shown on the meter is always the same for a given measured quantity. It also prevents the pointer always going to the maximum deflection. There are two main types of controlling device – spring control and gravity control.
- A damping device.** The damping force ensures that the pointer comes to rest in its final position quickly and without undue oscillation. There are three main types of damping used – eddy-current damping, air-friction damping and fluid-friction damping.

There are basically **two types of scale** – linear and non-linear. A **linear scale** is shown in Fig. 10.1(a), where the divisions or graduations are evenly spaced. The voltmeter shown has a range 0–100 V, i.e. a full-scale deflection (f.s.d.) of 100 V. A **non-linear scale** is shown in Fig. 10.1(b) where the scale is cramped at the beginning and the graduations are uneven throughout the range. The ammeter shown has a f.s.d. of 10 A.

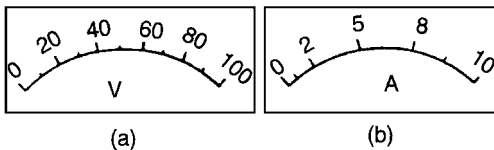

Figure 10.1

10.3 Moving-iron instrument

- An **attraction type** of moving-iron instrument is shown diagrammatically in Fig. 10.2(a). When

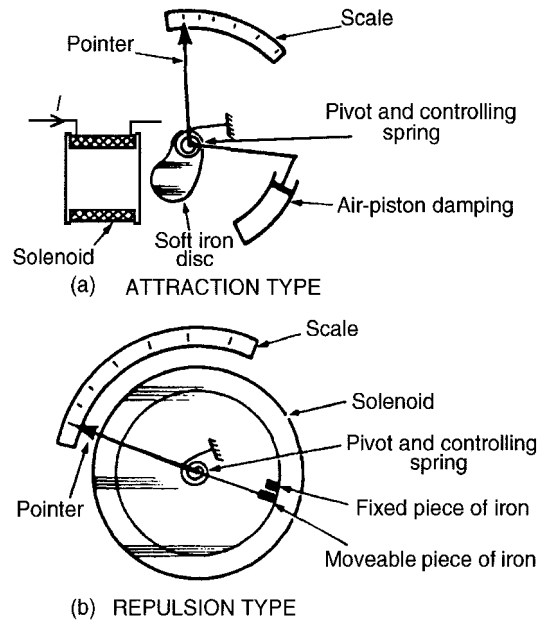

Figure 10.2

current flows in the solenoid, a pivoted soft-iron disc is attracted towards the solenoid and the movement causes a pointer to move across a scale.

- In the **repulsion type** moving-iron instrument shown diagrammatically in Fig. 10.2(b), two pieces of iron are placed inside the solenoid, one being fixed, and the other attached to the spindle carrying the pointer. When current passes through the solenoid, the two pieces of iron are magnetized in the same direction and therefore repel each other. The pointer thus moves across the scale. The force moving the pointer is, in each type, proportional to I^2 and because of this the direction of current does not matter. The moving-iron instrument can be used on d.c. or a.c.; the scale, however, is non-linear.

10.4 The moving-coil rectifier instrument

A moving-coil instrument, which measures only d.c., may be used in conjunction with a bridge rectifier circuit as shown in Fig. 10.3 to provide an indication of alternating currents and voltages (see Chapter 14). The average value of the full wave rectified current is $0.637 I_m$. However, a meter being used to measure a.c. is usually calibrated in r.m.s.

Type of instrument	Moving-coil	Moving-iron	Moving-coil rectifier
Suitable for measuring	Direct current and voltage	Direct and alternating currents and voltage (reading in rms value)	Alternating current and voltage (reads average value but scale is adjusted to give rms value for sinusoidal waveforms)
Scale	Linear	Non-linear	Linear
Method of control	Hairsprings	Hairsprings	Hairsprings
Method of damping	Eddy current	Air	Eddy current
Frequency limits	—	20–200 Hz	20–100 kHz
Advantages	<ol style="list-style-type: none"> 1 Linear scale 2 High sensitivity 3 Well shielded from stray magnetic fields 4 Low power consumption 	<ol style="list-style-type: none"> 1 Robust construction 2 Relatively cheap 3 Measures dc and ac 4 In frequency range 20–100 Hz reads rms correctly regardless of supply wave-form 	<ol style="list-style-type: none"> 1 Linear scale 2 High sensitivity 3 Well shielded from stray magnetic fields 4 Lower power consumption 5 Good frequency range
Disadvantages	<ol style="list-style-type: none"> 1 Only suitable for dc 2 More expensive than moving iron type 3 Easily damaged 	<ol style="list-style-type: none"> 1 Non-linear scale 2 Affected by stray magnetic fields 3 Hysteresis errors in dc circuits 4 Liable to temperature errors 5 Due to the inductance of the solenoid, readings can be affected by variation of frequency 	<ol style="list-style-type: none"> 1 More expensive than moving iron type 2 Errors caused when supply is non-sinusoidal

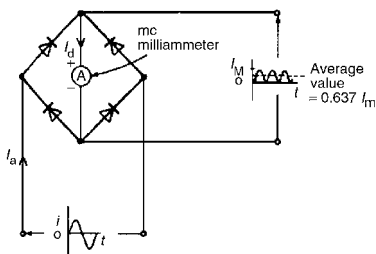

Figure 10.3

values. For sinusoidal quantities the indication is $(0.707I_m)/(0.637I_m)$ i.e. 1.11 times the mean value. Rectifier instruments have scales calibrated in r.m.s. quantities and it is assumed by the manufacturer that the a.c. is sinusoidal.

10.5 Comparison of moving-coil, moving-iron and moving-coil rectifier instruments

See Table above. (For the principle of operation of a moving-coil instrument, see Chapter 8, page 89).

10.6 Shunts and multipliers

An **ammeter**, which measures current, has a low resistance (ideally zero) and must be connected in series with the circuit.

A **voltmeter**, which measures p.d., has a high resistance (ideally infinite) and must be connected in parallel with the part of the circuit whose p.d. is required.

There is no difference between the basic instrument used to measure current and voltage since both use a milliammeter as their basic part. This is a sensitive instrument which gives f.s.d. for currents of only a few milliamperes. When an ammeter is required to measure currents of larger magnitude, a proportion of the current is diverted through a low-value resistance connected in parallel with the meter. Such a diverting resistor is called a **shunt**.

From Fig. 10.4(a), $V_{PQ} = V_{RS}$.

Hence $I_a r_a = I_s R_s$. Thus the value of the shunt,

$$R_s = \frac{I_a r_a}{I_s} \text{ ohms}$$

The milliammeter is converted into a voltmeter by connecting a high value resistance (called a **multiplier**) in series with it as shown in Fig. 10.4(b). From Fig. 10.4(b),

$$V = V_a + V_M = I r_a + I R_M$$

Thus the value of the multiplier,

$$R_M = \frac{V - I r_a}{I} \text{ ohms}$$

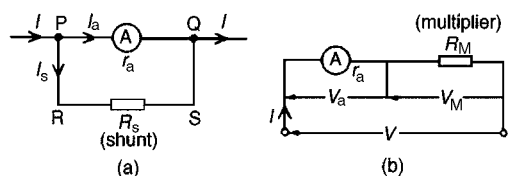

Figure 10.4

Problem 1. A moving-coil instrument gives a f.s.d. when the current is 40 mA and its resistance is 25 Ω . Calculate the value of the shunt to be connected in parallel with the meter to enable it to be used as an ammeter for measuring currents up to 50 A

The circuit diagram is shown in Fig. 10.5, where r_a = resistance of instrument = 25 Ω , R_s = resistance of shunt, I_a = maximum permissible

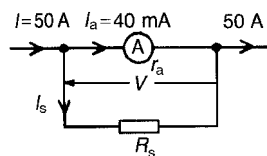

Figure 10.5

current flowing in instrument = 40 mA = 0.04 A, I_s = current flowing in shunt and I = total circuit current required to give f.s.d. = 50 A.

$$\begin{aligned} \text{Since } I &= I_a + I_s \text{ then } I_s = I - I_a \\ &= 50 - 0.04 = 49.96 \text{ A.} \end{aligned}$$

$V = I_a r_a = I_s R_s$, hence

$$\begin{aligned} R_s &= \frac{I_a r_a}{I_s} = \frac{(0.04)(25)}{49.96} = 0.02002 \Omega \\ &= \mathbf{20.02 \text{ m}\Omega} \end{aligned}$$

Thus for the moving-coil instrument to be used as an ammeter with a range 0–50 A, a resistance of value 20.02 m Ω needs to be connected in parallel with the instrument.

Problem 2. A moving-coil instrument having a resistance of 10 Ω , gives a f.s.d. when the current is 8 mA. Calculate the value of the multiplier to be connected in series with the instrument so that it can be used as a voltmeter for measuring p.d.s. up to 100 V

The circuit diagram is shown in Fig. 10.6, where r_a = resistance of instrument = 10 Ω , R_M = resistance of multiplier I = total permissible instrument current = 8 mA = 0.008 A, V = total p.d. required to give f.s.d. = 100 V

$$V = V_a + V_M = I r_a + I R_M$$

i.e. $100 = (0.008)(10) + (0.008)R_M$
or $100 - 0.08 = 0.008 R_M$, thus

$$R_M = \frac{99.92}{0.008} = 12490 \Omega = \mathbf{12.49 \text{ k}\Omega}$$

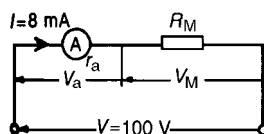

Figure 10.6

Hence for the moving-coil instrument to be used as a voltmeter with a range 0–100 V, a resistance of value 12.49 k Ω needs to be connected in series with the instrument.

Now try the following exercise

Exercise 48 Further problems on shunts and multipliers

- 1 A moving-coil instrument gives f.s.d. for a current of 10 mA. Neglecting the resistance of the instrument, calculate the approximate value of series resistance needed to enable the instrument to measure up to (a) 20 V (b) 100 V (c) 250 V [(a) 2 k Ω (b) 10 k Ω (c) 25 k Ω]
- 2 A meter of resistance 50 Ω has a f.s.d. of 4 mA. Determine the value of shunt resistance required in order that f.s.d. should be (a) 15 mA (b) 20 A (c) 100 A [(a) 18.18 Ω (b) 10.00 m Ω (c) 2.00 m Ω]
- 3 A moving-coil instrument having a resistance of 20 Ω , gives a f.s.d. when the current is 5 mA. Calculate the value of the multiplier to be connected in series with the instrument so that it can be used as a voltmeter for measuring p.d.'s up to 200 V [39.98 k Ω]
- 4 A moving-coil instrument has a f.s.d. of 20 mA and a resistance of 25 Ω . Calculate the values of resistance required to enable the instrument to be used (a) as a 0–10 A ammeter, and (b) as a 0–100 V voltmeter. State the mode of resistance connection in each case. [(a) 50.10 m Ω in parallel (b) 4.975 k Ω in series]
- 5 A meter has a resistance of 40 Ω and registers a maximum deflection when a current of 15 mA flows. Calculate the value of resistance that converts the movement into (a) an ammeter with a maximum deflection of 50 A (b) a voltmeter with a range 0–250 V [(a) 12.00 m Ω in parallel (b) 16.63 k Ω in series]

10.7 Electronic instruments

Electronic measuring instruments have advantages over instruments such as the moving-iron or moving-coil meters, in that they have a much higher

input resistance (some as high as 1000 M Ω) and can handle a much wider range of frequency (from d.c. up to MHz).

The digital voltmeter (DVM) is one which provides a digital display of the voltage being measured. Advantages of a DVM over analogue instruments include higher accuracy and resolution, no observational or parallax errors (see section 10.20) and a very high input resistance, constant on all ranges.

A digital multimeter is a DVM with additional circuitry which makes it capable of measuring a.c. voltage, d.c. and a.c. current and resistance.

Instruments for a.c. measurements are generally calibrated with a sinusoidal alternating waveform to indicate r.m.s. values when a sinusoidal signal is applied to the instrument. Some instruments, such as the moving-iron and electro-dynamic instruments, give a true r.m.s. indication. With other instruments the indication is either scaled up from the mean value (such as with the rectified moving-coil instrument) or scaled down from the peak value.

Sometimes quantities to be measured have complex waveforms (see section 10.13), and whenever a quantity is non-sinusoidal, errors in instrument readings can occur if the instrument has been calibrated for sine waves only. Such waveform errors can be largely eliminated by using electronic instruments.

10.8 The ohmmeter

An **ohmmeter** is an instrument for measuring electrical resistance. A simple ohmmeter circuit is shown in Fig. 10.7(a). Unlike the ammeter or voltmeter, the ohmmeter circuit does not receive the energy necessary for its operation from the circuit under test. In the ohmmeter this energy is supplied by a self-contained source of voltage, such as a battery. Initially, terminals XX are short-circuited

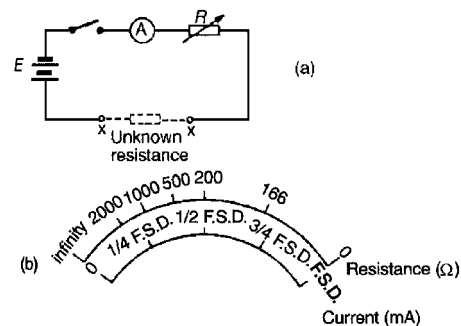

Figure 10.7

and R adjusted to give f.s.d. on the milliammeter. If current I is at a maximum value and voltage E is constant, then resistance $R = E/I$ is at a minimum value. Thus f.s.d. on the milliammeter is made zero on the resistance scale. When terminals XX are open circuited no current flows and $R (= E/O)$ is infinity, ∞ .

The milliammeter can thus be calibrated directly in ohms. A cramped (non-linear) scale results and is 'back to front', as shown in Fig. 10.7(b). When calibrated, an unknown resistance is placed between terminals XX and its value determined from the position of the pointer on the scale. An ohmmeter designed for measuring low values of resistance is called a **continuity tester**. An ohmmeter designed for measuring high values of resistance (i.e. megohms) is called an **insulation resistance tester** (e.g. 'Megger').

10.9 Multimeters

Instruments are manufactured that combine a moving-coil meter with a number of shunts and series multipliers, to provide a range of readings on a single scale graduated to read current and voltage. If a battery is incorporated then resistance can also be measured. Such instruments are called **multimeters** or **universal instruments** or **multirange instruments**. An 'Avometer' is a typical example. A particular range may be selected either by the use of separate terminals or by a selector switch. Only one measurement can be performed at a time. Often such instruments can be used in a.c. as well as d.c. circuits when a rectifier is incorporated in the instrument.

10.10 Wattmeters

A **wattmeter** is an instrument for measuring electrical power in a circuit. Fig. 10.8 shows typical connections of a wattmeter used for measuring power

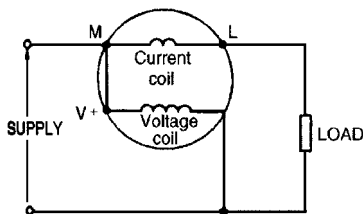

Figure 10.8

supplied to a load. The instrument has two coils:

- (i) a current coil, which is connected in series with the load, like an ammeter, and
- (ii) a voltage coil, which is connected in parallel with the load, like a voltmeter.

10.11 Instrument 'loading' effect

Some measuring instruments depend for their operation on power taken from the circuit in which measurements are being made. Depending on the 'loading' effect of the instrument (i.e. the current taken to enable it to operate), the prevailing circuit conditions may change.

The resistance of voltmeters may be calculated since each have a stated sensitivity (or 'figure of merit'), often stated in 'k Ω per volt' of f.s.d. A voltmeter should have as high a resistance as possible (– ideally infinite). In a.c. circuits the impedance of the instrument varies with frequency and thus the loading effect of the instrument can change.

Problem 3. Calculate the power dissipated by the voltmeter and by resistor R in Fig. 10.9 when (a) $R = 250 \Omega$ (b) $R = 2 \text{ M}\Omega$. Assume that the voltmeter sensitivity (sometimes called figure of merit) is $10 \text{ k}\Omega/\text{V}$

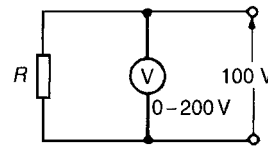

Figure 10.9

- (a) Resistance of voltmeter, $R_v = \text{sensitivity} \times \text{f.s.d.}$ Hence, $R_v = (10 \text{ k}\Omega/\text{V}) \times (200 \text{ V}) = 2000 \text{ k}\Omega = 2 \text{ M}\Omega$. Current flowing in voltmeter,

$$I_v = \frac{V}{R_v} = \frac{100}{2 \times 10^6} = 50 \times 10^{-6} \text{ A}$$

Power dissipated by voltmeter

$$= VI_v = (100)(50 \times 10^{-6}) = \mathbf{5 \text{ mW.}}$$

When $R = 250 \Omega$, current in resistor,

$$I_R = \frac{V}{R} = \frac{100}{250} = \mathbf{0.4 \text{ A}}$$

Power dissipated in load resistor $R = VI_R = (100)(0.4) = \mathbf{40\text{ W}}$. Thus the power dissipated in the voltmeter is insignificant in comparison with the power dissipated in the load.

(b) When $R = 2\text{ M}\Omega$, current in resistor,

$$I_R = \frac{V}{R} = \frac{100}{2 \times 10^6} = 50 \times 10^{-6}\text{ A}$$

Power dissipated in load resistor $R = VI_R = 100 \times 50 \times 10^{-6} = \mathbf{5\text{ mW}}$. In this case the higher load resistance reduced the power dissipated such that the voltmeter is using as much power as the load.

Problem 4. An ammeter has a f.s.d. of 100 mA and a resistance of $50\ \Omega$. The ammeter is used to measure the current in a load of resistance $500\ \Omega$ when the supply voltage is 10 V. Calculate (a) the ammeter reading expected (neglecting its resistance), (b) the actual current in the circuit, (c) the power dissipated in the ammeter, and (d) the power dissipated in the load.

From Fig. 10.10,

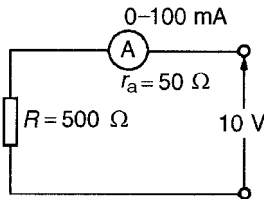

Figure 10.10

- (a) expected ammeter reading $= V/R = 10/500 = \mathbf{20\text{ mA}}$.
- (b) Actual ammeter reading $= V/(R + r_a) = 10/(500 + 50) = \mathbf{18.18\text{ mA}}$. Thus the ammeter itself has caused the circuit conditions to change from 20 mA to 18.18 mA.
- (c) Power dissipated in the ammeter $= I^2 r_a = (18.18 \times 10^{-3})^2(50) = \mathbf{16.53\text{ mW}}$.
- (d) Power dissipated in the load resistor $= I^2 R = (18.18 \times 10^{-3})^2(500) = \mathbf{165.3\text{ mW}}$.

Problem 5. A voltmeter having a f.s.d. of 100 V and a sensitivity of $1.6\text{ k}\Omega/\text{V}$ is used to measure voltage V_1 in the circuit of Fig. 10.11 Determine (a) the value of voltage V_1 with the voltmeter not connected, and (b) the voltage indicated by the voltmeter when connected between A and B

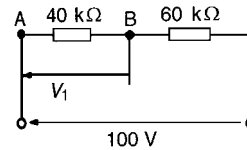

Figure 10.11

(a) By voltage division,

$$V_1 = \left(\frac{40}{40 + 60} \right) 100 = \mathbf{40\text{ V}}$$

(b) The resistance of a voltmeter having a 100 V f.s.d. and sensitivity $1.6\text{ k}\Omega/\text{V}$ is $100\text{ V} \times 1.6\text{ k}\Omega/\text{V} = 160\text{ k}\Omega$. When the voltmeter is connected across the $40\text{ k}\Omega$ resistor the circuit is as shown in Fig. 10.12(a) and the equivalent resistance of the parallel network is given by

$$\left(\frac{40 \times 160}{40 + 160} \right) \text{ k}\Omega \text{ i.e.}$$

$$\left(\frac{40 \times 160}{200} \right) \text{ k}\Omega = 32\text{ k}\Omega$$

The circuit is now effectively as shown in Fig. 10.12(b). Thus the voltage indicated on the voltmeter is

$$\left(\frac{32}{32 + 60} \right) 100\text{ V} = \mathbf{34.78\text{ V}}$$

A considerable error is thus caused by the loading effect of the voltmeter on the circuit. The error is reduced by using a voltmeter with a higher sensitivity.

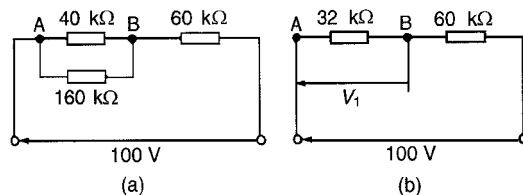

Figure 10.12

Problem 6. (a) A current of 20 A flows through a load having a resistance of $2\ \Omega$. Determine the power dissipated in the load. (b) A wattmeter, whose current coil has a resistance of $0.01\ \Omega$ is connected as shown in Fig. 10.13 Determine the wattmeter reading.

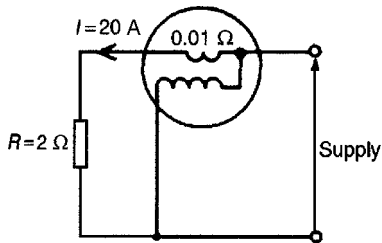

Figure 10.13

- (a) Power dissipated in the load, $P = I^2 R = (20)^2(2) = 800\ \text{W}$
- (b) With the wattmeter connected in the circuit the total resistance R_T is $2 + 0.01 = 2.01\ \Omega$. The wattmeter reading is thus $I^2 R_T = (20)^2(2.01) = 804\ \text{W}$

Now try the following exercise

Exercise 49 Further problems on instrument 'loading' effects

1 A 0–1 A ammeter having a resistance of $50\ \Omega$ is used to measure the current flowing in a $1\ \text{k}\Omega$ resistor when the supply voltage is 250 V. Calculate: (a) the approximate value of current (neglecting the ammeter resistance), (b) the actual current in the circuit, (c) the power dissipated in the ammeter, (d) the power dissipated in the $1\ \text{k}\Omega$ resistor.

- [(a) 0.250 A (b) 0.238 A
(c) 2.83 W (d) 56.64 W]

2 (a) A current of 15 A flows through a load having a resistance of $4\ \Omega$. Determine the power dissipated in the load. (b) A wattmeter, whose current coil has a resistance of $0.02\ \Omega$ is connected (as shown in Fig. 10.13) to measure the power in the load. Determine the wattmeter reading assuming the current in the load is still 15 A.

- [(a) 900 W (b) 904.5 W]

- 3 A voltage of 240 V is applied to a circuit consisting of an $800\ \Omega$ resistor in series with a $1.6\ \text{k}\Omega$ resistor. What is the voltage across the $1.6\ \text{k}\Omega$ resistor? The p.d. across the $1.6\ \text{k}\Omega$ resistor is measured by a voltmeter of f.s.d. 250 V and sensitivity $100\ \Omega/\text{V}$. Determine the voltage indicated. [160 V; 156.7 V]

10.12 The cathode ray oscilloscope

The **cathode ray oscilloscope** (c.r.o.) may be used in the observation of waveforms and for the measurement of voltage, current, frequency, phase and periodic time. For examining periodic waveforms the electron beam is deflected horizontally (i.e. in the X direction) by a sawtooth generator acting as a timebase. The signal to be examined is applied to the vertical deflection system (Y direction) usually after amplification.

Oscilloscopes normally have a transparent grid of 10 mm by 10 mm squares in front of the screen, called a graticule. Among the timebase controls is a 'variable' switch which gives the sweep speed as time per centimetre. This may be in s/cm, ms/cm or $\mu\text{s}/\text{cm}$, a large number of switch positions being available. Also on the front panel of a c.r.o. is a Y amplifier switch marked in volts per centimetre, with a large number of available switch positions.

- (i) With **direct voltage measurements**, only the Y amplifier 'volts/cm' switch on the c.r.o. is used. With no voltage applied to the Y plates the position of the spot trace on the screen is noted. When a direct voltage is applied to the Y plates the new position of the spot trace is an indication of the magnitude of the voltage. For example, in Fig. 10.14(a), with no voltage applied to the Y plates, the spot trace is in the centre of the screen (initial position) and then the spot trace moves 2.5 cm to the final position shown, on application of a d.c. voltage. With the 'volts/cm' switch on 10 volts/cm the magnitude of the direct voltage is $2.5\ \text{cm} \times 10\ \text{volts/cm}$, i.e. 25 volts.
- (ii) With **alternating voltage measurements**, let a sinusoidal waveform be displayed on a c.r.o. screen as shown in Fig. 10.14(b). If the time/cm switch is on, say, 5 ms/cm then the **periodic time T** of the sinewave is $5\ \text{ms/cm} \times 4\ \text{cm}$, i.e. **20 ms** or **0.02 s**. Since frequency

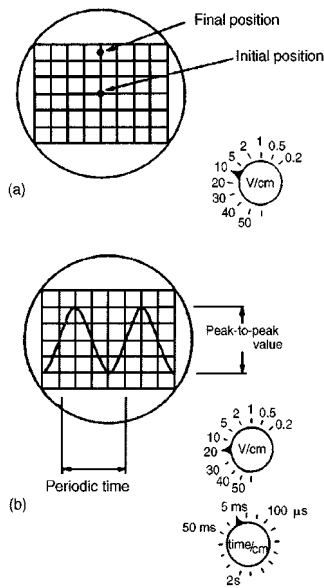

Figure 10.14

$$f = \frac{1}{T}, \text{ frequency} = \frac{1}{0.02} = 50 \text{ Hz}$$

If the 'volts/cm' switch is on, say, 20 volts/cm then the **amplitude** or **peak value** of the sinewave shown is 20 volts/cm \times 2 cm, i.e. 40 V. Since

$$\text{r.m.s. voltage} = \frac{\text{peak voltage}}{\sqrt{2}}, \text{ (see Chapter 14),}$$

$$\text{r.m.s. voltage} = \frac{40}{\sqrt{2}} = 28.28 \text{ volts}$$

Double beam oscilloscopes are useful whenever two signals are to be compared simultaneously. The c.r.o. demands reasonable skill in adjustment and use. However its greatest advantage is in observing the shape of a waveform – a feature not possessed by other measuring instruments.

Problem 7. Describe how a simple c.r.o. is adjusted to give (a) a spot trace, (b) a continuous horizontal trace on the screen, explaining the functions of the various controls.

- (a) To obtain a spot trace on a typical c.r.o. screen:
- (i) Switch on the c.r.o.
 - (ii) Switch the timebase control to off. This control is calibrated in time per centimetres – for example, 5 ms/cm or 100 μ s/cm.

Turning it to zero ensures no signal is applied to the X-plates. The Y-plate input is left open-circuited.

- (iii) Set the intensity, X-shift and Y-shift controls to about the mid-range positions.
 - (iv) A spot trace should now be observed on the screen. If not, adjust either or both of the X and Y-shift controls. The X-shift control varies the position of the spot trace in a horizontal direction whilst the Y-shift control varies its vertical position.
 - (v) Use the X and Y-shift controls to bring the spot to the centre of the screen and use the focus control to focus the electron beam into a small circular spot.
- (b) To obtain a continuous horizontal trace on the screen the same procedure as in (a) is initially adopted. Then the timebase control is switched to a suitable position, initially the millisecond timebase range, to ensure that the repetition rate of the sawtooth is sufficient for the persistence of the vision time of the screen phosphor to hold a given trace.

Problem 8. For the c.r.o. square voltage waveform shown in Fig. 10.15 determine (a) the periodic time, (b) the frequency and (c) the peak-to-peak voltage. The 'time/cm' (or timebase control) switch is on 100 μ s/cm and the 'volts/cm' (or signal amplitude control) switch is on 20 V/cm

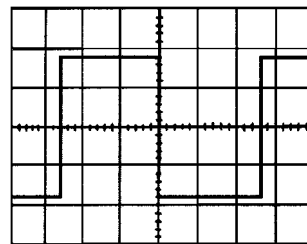

Figure 10.15

(In Figures 10.15 to 10.18 assume that the squares shown are 1 cm by 1 cm)

- (a) The width of one complete cycle is 5.2 cm. Hence the periodic time,
 $T = 5.2 \text{ cm} \times 100 \times 10^{-6} \text{ s/cm} = 0.52 \text{ ms}.$
- (b) Frequency, $f = \frac{1}{T} = \frac{1}{0.52 \times 10^{-3}} = 1.92 \text{ kHz}.$

- (c) The peak-to-peak height of the display is 3.6 cm, hence the peak-to-peak voltage

$$= 3.6 \text{ cm} \times 20 \text{ V/cm} = \mathbf{72 \text{ V}}$$

Problem 9. For the c.r.o. display of a pulse waveform shown in Fig. 10.16 the 'time/cm' switch is on 50 ms/cm and the 'volts/cm' switch is on 0.2 V/cm. Determine (a) the periodic time, (b) the frequency, (c) the magnitude of the pulse voltage.

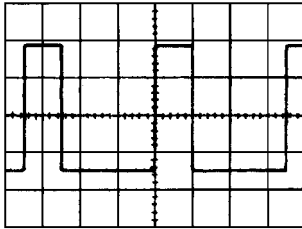

Figure 10.16

- (a) The width of one complete cycle is 3.5 cm. Hence the periodic time, $T = 3.5 \text{ cm} \times 50 \text{ ms/cm} = \mathbf{175 \text{ ms}}$.
- (b) Frequency, $f = \frac{1}{T} = \frac{1}{0.52 \times 10^{-3}} = \mathbf{5.71 \text{ Hz}}$.
- (c) The height of a pulse is 3.4 cm hence the magnitude of the pulse voltage = $3.4 \text{ cm} \times 0.2 \text{ V/cm} = \mathbf{0.68 \text{ V}}$.

Problem 10. A sinusoidal voltage trace displayed by a c.r.o. is shown in Fig. 10.17 If the 'time/cm' switch is on 500 $\mu\text{s/cm}$ and the 'volts/cm' switch is on 5 V/cm, find, for the waveform, (a) the frequency, (b) the peak-to-peak voltage, (c) the amplitude, (d) the r.m.s. value.

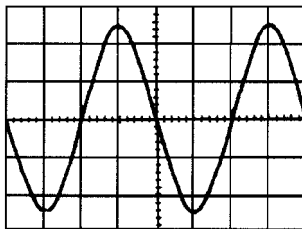

Figure 10.17

- (a) The width of one complete cycle is 4 cm. Hence the periodic time, T is $4 \text{ cm} \times 500 \mu\text{s/cm}$, i.e. 2 ms.

$$\text{Frequency, } f = \frac{1}{T} = \frac{1}{2 \times 10^{-3}} = \mathbf{500 \text{ Hz}}$$

- (b) The peak-to-peak height of the waveform is 5 cm. Hence the peak-to-peak voltage = $5 \text{ cm} \times 5 \text{ V/cm} = \mathbf{25 \text{ V}}$.
- (c) Amplitude = $\frac{1}{2} \times 25 \text{ V} = \mathbf{12.5 \text{ V}}$
- (d) The peak value of voltage is the amplitude, i.e. 12.5 V, and r.m.s.

$$\text{voltage} = \frac{\text{peak voltage}}{\sqrt{2}} = \frac{12.5}{\sqrt{2}} = \mathbf{8.84 \text{ V}}$$

Problem 11. For the double-beam oscilloscope displays shown in Fig. 10.18 determine (a) their frequency, (b) their r.m.s. values, (c) their phase difference. The 'time/cm' switch is on 100 $\mu\text{s/cm}$ and the 'volts/cm' switch on 2 V/cm.

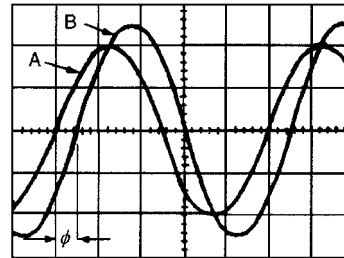

Figure 10.18

- (a) The width of each complete cycle is 5 cm for both waveforms. Hence the periodic time, T , of each waveform is $5 \text{ cm} \times 100 \mu\text{s/cm}$, i.e. 0.5 ms. Frequency of each waveform,

$$f = \frac{1}{T} = \frac{1}{0.5 \times 10^{-3}} = \mathbf{2 \text{ kHz}}$$

- (b) The peak value of waveform A is $2 \text{ cm} \times 2 \text{ V/cm} = \mathbf{4 \text{ V}}$, hence the r.m.s. value of waveform A

$$= 4/(\sqrt{2}) = \mathbf{2.83 \text{ V}}$$

The peak value of waveform B is $2.5 \text{ cm} \times 2 \text{ V/cm} = 5 \text{ V}$, hence the r.m.s. value of waveform B

$$= 5/(\sqrt{2}) = \mathbf{3.54 \text{ V}}$$

- (c) Since 5 cm represents 1 cycle, then 5 cm represents 360° , i.e. 1 cm represents $360/5 = 72^\circ$.
 The phase angle $\phi = 0.5 \text{ cm} = 0.5 \text{ cm} \times 72^\circ/\text{cm} = 36^\circ$.

Hence waveform A leads waveform B by 36°

Now try the following exercise

Exercise 50 Further problems on the cathode ray oscilloscope

- 1 For the square voltage waveform displayed on a c.r.o. shown in Fig. 10.19, find (a) its frequency, (b) its peak-to-peak voltage
 [(a) 41.7 Hz (b) 176 V]

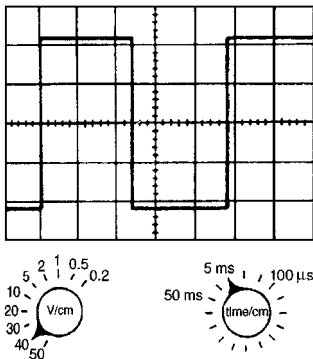

Figure 10.19

- 2 For the pulse waveform shown in Fig. 10.20, find (a) its frequency, (b) the magnitude of the pulse voltage
 [(a) 0.56 Hz (b) 8.4 V]

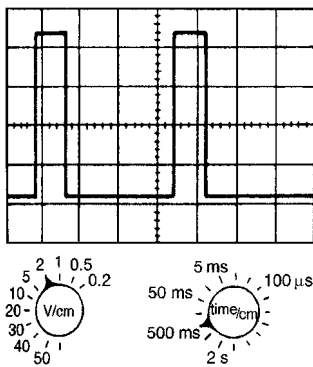

Figure 10.20

- 3 For the sinusoidal waveform shown in Fig. 10.21, determine (a) its frequency, (b) the peak-to-peak voltage, (c) the r.m.s. voltage
 [(a) 7.14 Hz (b) 220 V (c) 77.78 V]

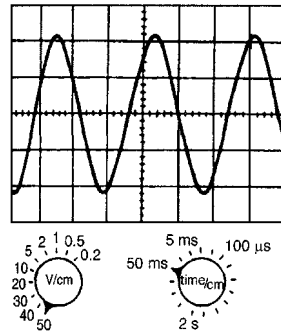

Figure 10.21

10.13 Waveform harmonics

- (i) Let an instantaneous voltage v be represented by $v = V_m \sin 2\pi ft$ volts. This is a waveform which varies sinusoidally with time t , has a frequency f , and a maximum value V_m . Alternating voltages are usually assumed to have wave-shapes which are sinusoidal where only one frequency is present. If the waveform is not sinusoidal it is called a **complex wave**, and, whatever its shape, it may be split up mathematically into components called the **fundamental** and a number of **harmonics**. This process is called harmonic analysis. The fundamental (or first harmonic) is sinusoidal and has the supply frequency, f ; the other harmonics are also sine waves having frequencies which are integer multiples of f . Thus, if the supply frequency is 50 Hz, then the third harmonic frequency is 150 Hz, the fifth 250 Hz, and so on.
- (ii) A complex waveform comprising the sum of the fundamental and a third harmonic of about half the amplitude of the fundamental is shown in Fig. 10.22(a), both waveforms being initially in phase with each other. If further odd harmonic waveforms of the appropriate amplitudes are added, a good approximation to a square wave results. In Fig. 10.22(b), the third harmonic is shown having an initial phase displacement from the fundamental. The positive

and negative half cycles of each of the complex waveforms shown in Figures 10.22(a) and (b) are identical in shape, and this is a feature of waveforms containing the fundamental and only odd harmonics.

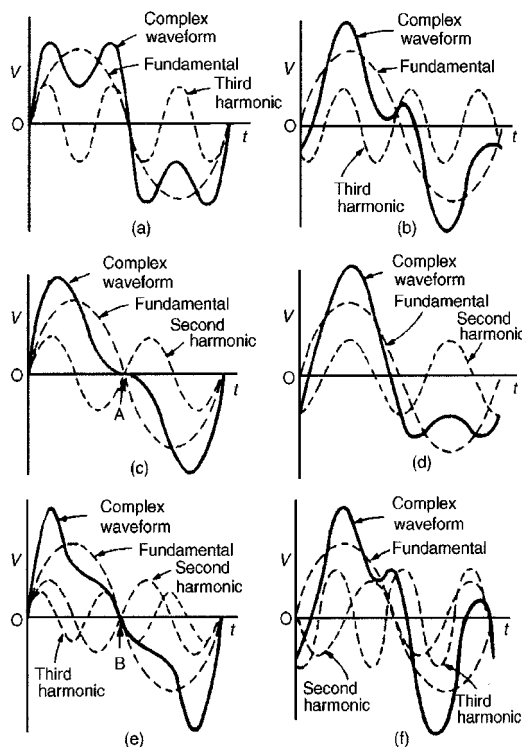

Figure 10.22

- (iii) A complex waveform comprising the sum of the fundamental and a second harmonic of about half the amplitude of the fundamental is shown in Fig. 10.22(c), each waveform being initially in phase with each other. If further even harmonics of appropriate amplitudes are added a good approximation to a triangular wave results. In Fig. 10.22(c), the negative cycle, if reversed, appears as a mirror image of the positive cycle about point A. In Fig. 10.22(d) the second harmonic is shown with an initial phase displacement from the fundamental and the positive and negative half cycles are dissimilar.
- (iv) A complex waveform comprising the sum of the fundamental, a second harmonic and a third harmonic is shown in Fig. 10.22(e), each waveform being initially 'in-phase'. The negative half cycle, if reversed, appears as

a mirror image of the positive cycle about point B. In Fig. 10.22(f), a complex waveform comprising the sum of the fundamental, a second harmonic and a third harmonic are shown with initial phase displacement. The positive and negative half cycles are seen to be dissimilar.

The features mentioned relative to Figures 10.22 (a) to (f) make it possible to recognize the harmonics present in a complex waveform displayed on a CRO.

10.14 Logarithmic ratios

In electronic systems, the ratio of two similar quantities measured at different points in the system, are often expressed in logarithmic units. By definition, if the ratio of two powers P_1 and P_2 is to be expressed in **decibel (dB) units** then the number of decibels, X , is given by:

$$X = 10 \lg \left(\frac{P_2}{P_1} \right) \text{ dB} \quad (1)$$

Thus, when the power ratio, $P_2/P_1 = 1$ then the decibel power ratio = $10 \lg 1 = 0$, when the power ratio, $P_2/P_1 = 100$ then the decibel power ratio = $10 \lg 100 = +20$ (i.e. a power gain), and when the power ratio, $P_2/P_1 = 1/100$ then the decibel power ratio = $10 \lg 1/100 = -20$ (i.e. a power loss or attenuation).

Logarithmic units may also be used for voltage and current ratios. Power, P , is given by $P = I^2 R$ or $P = V^2/R$. Substituting in equation (1) gives:

$$X = 10 \lg \left(\frac{I_2^2 R_2}{I_1^2 R_1} \right) \text{ dB}$$

$$\text{or} \quad X = 10 \lg \left(\frac{V_2^2 / R_2}{V_1^2 / R_1} \right) \text{ dB}$$

If $R_1 = R_2$,

$$\text{then} \quad X = 10 \lg \left(\frac{I_2^2}{I_1^2} \right) \text{ dB or}$$

$$X = 10 \lg \left(\frac{V_2^2}{V_1^2} \right) \text{ dB}$$

i.e.
$$X = 20 \lg \left(\frac{I_2}{I_1} \right) \text{ dB}$$

or
$$X = 20 \lg \left(\frac{V_2}{V_1} \right) \text{ dB}$$

(from the laws of logarithms).

From equation (1), X decibels is a logarithmic ratio of two similar quantities and is not an absolute unit of measurement. It is therefore necessary to state a **reference level** to measure a number of decibels above or below that reference. The most widely used reference level for power is 1 mW, and when power levels are expressed in decibels, above or below the 1 mW reference level, the unit given to the new power level is dBm.

A voltmeter can be re-scaled to indicate the power level directly in decibels. The scale is generally calibrated by taking a reference level of 0 dB when a power of 1 mW is dissipated in a 600 Ω resistor (this being the natural impedance of a simple transmission line). The reference voltage V is then obtained from

$$P = \frac{V^2}{R},$$

i.e.
$$1 \times 10^{-3} = \frac{V^2}{600}$$

from which, $V = 0.775$ volts. In general, the number of dBm,

$$X = 20 \lg \left(\frac{V}{0.775} \right)$$

Thus $V = 0.20$ V corresponds to $20 \lg \left(\frac{0.2}{0.775} \right)$

$$= -11.77 \text{ dBm and}$$

$$V = 0.90 \text{ V corresponds to } 20 \lg \left(\frac{0.90}{0.775} \right)$$

$$= +1.3 \text{ dBm, and so on.}$$

A typical **decibelmeter**, or **dB meter**, scale is shown in Fig. 10.23. Errors are introduced with dB meters when the circuit impedance is not 600 Ω .

Problem 12. The ratio of two powers is (a) 3 (b) 20 (c) 4 (d) 1/20. Determine the decibel power ratio in each case.

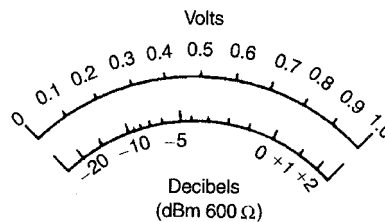

Figure 10.23

From above, the power ratio in decibels, X , is given by: $X = 10 \lg (P_2/P_1)$

(a) When $\frac{P_2}{P_1} = 3$,

$$X = 10 \lg (3) = 10(0.477) \\ = \mathbf{4.77 \text{ dB}}$$

(b) When $\frac{P_2}{P_1} = 20$,

$$X = 10 \lg (20) = 10(1.30) \\ = \mathbf{13.0 \text{ dB}}$$

(c) When $\frac{P_2}{P_1} = 400$,

$$X = 10 \lg (400) = 10(2.60) \\ = \mathbf{26.0 \text{ dB}}$$

(d) When $\frac{P_2}{P_1} = \frac{1}{20} = 0.05$,

$$X = 10 \lg (0.05) = 10(-1.30) \\ = \mathbf{-13.0 \text{ dB}}$$

(a), (b) and (c) represent power gains and (d) represents a power loss or attenuation.

Problem 13. The current input to a system is 5 mA and the current output is 20 mA. Find the decibel current ratio assuming the input and load resistances of the system are equal.

From above, the decibel current ratio is

$$20 \lg \left(\frac{I_2}{I_1} \right) = 20 \lg \left(\frac{20}{5} \right) \\ = 20 \lg 4 = 20(0.60) \\ = \mathbf{12 \text{ dB gain}}$$

Problem 14. 6% of the power supplied to a cable appears at the output terminals. Determine the power loss in decibels.

If P_1 = input power and P_2 = output power then

$$\frac{P_2}{P_1} = \frac{6}{100} = 0.06$$

$$\begin{aligned} \text{Decibel power ratio} &= 10 \lg \left(\frac{P_2}{P_1} \right) = 10 \lg (0.06) \\ &= 10(-1.222) = -12.22 \text{ dB} \end{aligned}$$

Hence the decibel power loss, or attenuation, is 12.22 dB.

Problem 15. An amplifier has a gain of 14 dB and its input power is 8 mW. Find its output power.

Decibel power ratio = $10 \lg (P_2/P_1)$ where P_1 = input power = 8 mW, and P_2 = output power. Hence

$$14 = 10 \lg \left(\frac{P_2}{P_1} \right)$$

from which

$$1.4 = \lg \left(\frac{P_2}{P_1} \right)$$

and $10^{1.4} = \frac{P_2}{P_1}$ from the definition of a logarithm

$$\text{i.e. } 25.12 = \frac{P_2}{P_1}$$

Output power, $P_2 = 25.12 P_1 = (25.12)(8) = \mathbf{201 \text{ mW}}$ or $\mathbf{0.201 \text{ W}}$

Problem 16. Determine, in decibels, the ratio of output power to input power of a 3 stage communications system, the stages having gains of 12 dB, 15 dB and -8 dB. Find also the overall power gain.

The decibel ratio may be used to find the overall power ratio of a chain simply by adding the decibel power ratios together. Hence the overall decibel

power ratio = $12 + 15 - 8 = \mathbf{19 \text{ dB gain}}$.

$$\text{Thus } 19 = 10 \lg \left(\frac{P_2}{P_1} \right)$$

$$\text{from which } 1.9 = \lg \left(\frac{P_2}{P_1} \right)$$

$$\text{and } 10^{1.9} = \frac{P_2}{P_1} = 79.4$$

Thus the overall power gain, $\frac{P_2}{P_1} = 79.4$

[For the first stage,

$$12 = 10 \lg \left(\frac{P_2}{P_1} \right)$$

from which

$$\frac{P_2}{P_1} = 10^{1.2} = 15.85$$

Similarly for the second stage,

$$\frac{P_2}{P_1} = 31.62$$

and for the third stage,

$$\frac{P_2}{P_1} = 0.1585$$

The overall power ratio is thus $15.85 \times 31.62 \times 0.1585 = \mathbf{79.4}$

Problem 17. The output voltage from an amplifier is 4 V. If the voltage gain is 27 dB, calculate the value of the input voltage assuming that the amplifier input resistance and load resistance are equal.

Voltage gain in decibels = $27 = 20 \lg (V_2/V_1) = 20 \lg (4/V_1)$. Hence

$$\frac{27}{20} = \lg \left(\frac{4}{V_1} \right)$$

$$\text{i.e. } 1.35 = \lg \left(\frac{4}{V_1} \right)$$

$$\text{Thus } 10^{1.35} = \frac{4}{V_1}$$

from which
$$V_1 = \frac{4}{10^{1.35}}$$

$$= \frac{4}{22.39}$$

$$= 0.179 \text{ V}$$

Hence the input voltage V_1 is **0.179 V**.

Now try the following exercise

Exercise 51 Further problems on logarithmic ratios

- The ratio of two powers is (a) 3 (b) 10 (c) 20 (d) 10 000. Determine the decibel power ratio for each.
[(a) 4.77 dB (b) 10 dB (c) 13 dB (d) 40 dB]
- The ratio of two powers is (a) $\frac{1}{10}$ (b) $\frac{1}{3}$ (c) $\frac{1}{40}$ (d) $\frac{1}{100}$. Determine the decibel power ratio for each.
[(a) -10 dB (b) -4.77 dB
(c) -16.02 dB (d) -20 dB]
- The input and output currents of a system are 2 mA and 10 mA respectively. Determine the decibel current ratio of output to input current assuming input and output resistances of the system are equal. [13.98 dB]
- 5% of the power supplied to a cable appears at the output terminals. Determine the power loss in decibels. [13 dB]
- An amplifier has a gain of 24 dB and its input power is 10 mW. Find its output power. [2.51 W]
- Determine, in decibels, the ratio of the output power to input power of a four stage system, the stages having gains of 10 dB, 8 dB, -5 dB and 7 dB. Find also the overall power gain. [20 dB, 100]
- The output voltage from an amplifier is 7 mV. If the voltage gain is 25 dB calculate the value of the input voltage assuming that the amplifier input resistance and load resistance are equal. [0.39 mV]
- The voltage gain of a number of cascaded amplifiers are 23 dB, -5.8 dB, -12.5 dB and

3.8 dB. Calculate the overall gain in decibels assuming that input and load resistances for each stage are equal. If a voltage of 15 mV is applied to the input of the system, determine the value of the output voltage.

[8.5 dB, 39.91 mV]

- The scale of a voltmeter has a decibel scale added to it, which is calibrated by taking a reference level of 0 dB when a power of 1 mW is dissipated in a 600 Ω resistor. Determine the voltage at (a) 0 dB (b) 1.5 dB (c) -15 dB (d) What decibel reading corresponds to 0.5 V?

[(a) 0.775 V (b) 0.921 V
(c) 0.138 V (d) -3.807 dB]

10.15 Null method of measurement

A **null method of measurement** is a simple, accurate and widely used method which depends on an instrument reading being adjusted to read zero current only. The method assumes:

- if there is any deflection at all, then some current is flowing;
- if there is no deflection, then no current flows (i.e. a null condition).

Hence it is unnecessary for a meter sensing current flow to be calibrated when used in this way. A sensitive milliammeter or microammeter with centre zero position setting is called a **galvanometer**. Examples where the method is used are in the Wheatstone bridge (see section 10.16), in the d.c. potentiometer (see section 10.17) and with a.c. bridges (see section 10.18)

10.16 Wheatstone bridge

Figure 10.24 shows a **Wheatstone bridge** circuit which compares an unknown resistance R_x with others of known values, i.e. R_1 and R_2 , which have fixed values, and R_3 , which is variable. R_3 is varied until zero deflection is obtained on the galvanometer G. No current then flows through the meter, $V_A = V_B$, and the bridge is said to be 'balanced'. At

balance,

$$R_1 R_x = R_2 R_3 \text{ i.e. } R_x = \frac{R_2 R_3}{R_1} \text{ ohms}$$

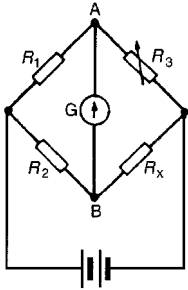

Figure 10.24

Problem 18. In a Wheatstone bridge ABCD, a galvanometer is connected between A and C, and a battery between B and D. A resistor of unknown value is connected between A and B. When the bridge is balanced, the resistance between B and C is 100 Ω, that between C and D is 10 Ω and that between D and A is 400 Ω. Calculate the value of the unknown resistance.

The Wheatstone bridge is shown in Fig. 10.25 where R_x is the unknown resistance. At balance, equating the products of opposite ratio arms, gives:

$$(R_x)(10) = (100)(400)$$

and
$$R_x = \frac{(100)(400)}{10} = 4000 \Omega$$

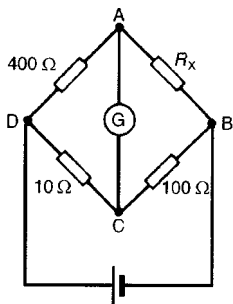

Figure 10.25

Hence, the unknown resistance, $R_x = 4 \text{ k}\Omega$.

10.17 D.C. potentiometer

The **d.c. potentiometer** is a null-balance instrument used for determining values of e.m.f.'s and p.d.s. by comparison with a known e.m.f. or p.d. In Fig. 10.26(a), using a standard cell of known e.m.f. E_1 , the slider S is moved along the slide wire until balance is obtained (i.e. the galvanometer deflection is zero), shown as length l_1 .

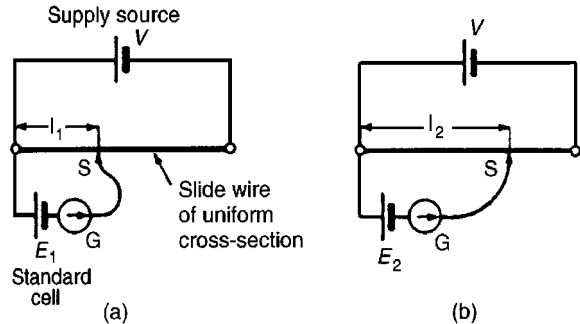

Figure 10.26

The standard cell is now replaced by a cell of unknown e.m.f. E_2 (see Fig. 10.26(b)) and again balance is obtained (shown as l_2). Since $E_1 \propto l_1$ and $E_2 \propto l_2$ then

$$\frac{E_1}{E_2} = \frac{l_1}{l_2}$$

and

$$E_2 = E_1 \left(\frac{l_2}{l_1} \right) \text{ volts}$$

A potentiometer may be arranged as a resistive two-element potential divider in which the division ratio is adjustable to give a simple variable d.c. supply. Such devices may be constructed in the form of a resistive element carrying a sliding contact which is adjusted by a rotary or linear movement of the control knob.

Problem 19. In a d.c. potentiometer, balance is obtained at a length of 400 mm when using a standard cell of 1.0186 volts. Determine the e.m.f. of a dry cell if balance is obtained with a length of 650 mm

$$E_1 = 1.0186 \text{ V}, l_1 = 400 \text{ mm and } l_2 = 650 \text{ mm}$$

With reference to Fig. 10.26,

$$\frac{E_1}{E_2} = \frac{l_1}{l_2}$$

from which,

$$E_2 = E_1 \left(\frac{l_2}{l_1} \right) = (1.0186) \left(\frac{650}{400} \right) \\ = \mathbf{1.655 \text{ volts}}$$

Now try the following exercise

Exercise 52 Further problems on the Wheatstone bridge and d.c. potentiometer

- In a Wheatstone bridge PQRS, a galvanometer is connected between Q and S and a voltage source between P and R. An unknown resistor R_x is connected between P and Q. When the bridge is balanced, the resistance between Q and R is 200Ω , that between R and S is 10Ω and that between S and P is 150Ω . Calculate the value of R_x [3 k Ω]
- Balance is obtained in a d.c. potentiometer at a length of 31.2 cm when using a standard cell of 1.0186 volts. Calculate the e.m.f. of a dry cell if balance is obtained with a length of 46.7 cm [1.525 V]

10.18 A.C. bridges

A Wheatstone bridge type circuit, shown in Fig. 10.27, may be used in a.c. circuits to determine unknown values of inductance and capacitance, as well as resistance.

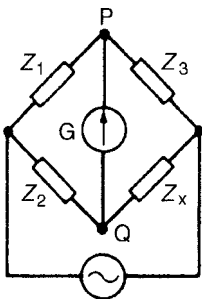

Figure 10.27

When the potential differences across Z_3 and Z_x (or across Z_1 and Z_2) are equal in magnitude and phase, then the current flowing through the galvanometer, G , is zero. At balance, $Z_1 Z_x = Z_2 Z_3$ from which

$$Z_x = \frac{Z_2 Z_3}{Z_1} \Omega$$

There are many forms of a.c. bridge, and these include: the Maxwell, Hay, Owen and Heaviside bridges for measuring inductance, and the De Sauty, Schering and Wien bridges for measuring capacitance. A **commercial or universal bridge** is one which can be used to measure resistance, inductance or capacitance. A.c. bridges require a knowledge of complex numbers (i.e. j notation, where $j = \sqrt{-1}$).

A Maxwell-Wien bridge for measuring the inductance L and resistance r of an inductor is shown in Fig. 10.28

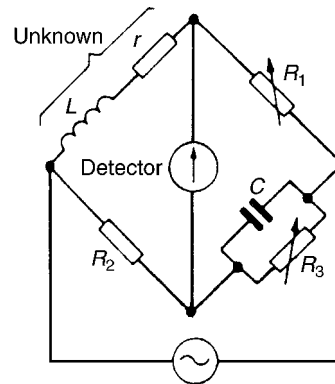

Figure 10.28

At balance the products of diagonally opposite impedances are equal. Thus

$$Z_1 Z_2 = Z_3 Z_4$$

Using complex quantities, $Z_1 = R_1$, $Z_2 = R_2$,

$$Z_3 = \frac{R_3(-jX_C)}{R_3 - jX_C} \left(\text{i.e. } \frac{\text{product}}{\text{sum}} \right)$$

and $Z_4 = r + jX_L$. Hence

$$R_1 R_2 = \frac{R_3(-jX_C)}{R_3 - jX_C} (r + jX_L)$$

i.e. $R_1 R_2 (R_3 - jX_C) = (-jR_3 X_C)(r + jX_L)$

$$R_1 R_2 R_3 - jR_1 R_2 X_C = -j r R_3 X_C - j^2 R_3 X_C X_L$$

$$\text{i.e. } R_1 R_2 R_3 - j R_1 R_2 X_C = -j r R_3 X_C + R_3 X_C X_L$$

(since $j^2 = -1$).

Equating the real parts gives:

$$R_1 R_2 R_3 = R_3 X_C X_L$$

$$\text{from which, } X_L = \frac{R_1 R_2}{X_C}$$

$$\text{i.e. } 2\pi f L = \frac{R_1 R_2}{\frac{1}{2\pi f C}} = R_1 R_2 (2\pi f C)$$

Hence inductance,

$$L = R_1 R_2 C \text{ henry} \quad (2)$$

Equating the imaginary parts gives:

$$-R_1 R_2 X_C = -r R_3 X_C$$

from which, resistance,

$$r = \frac{R_1 R_2}{R_3} \text{ ohms} \quad (3)$$

Problem 20. For the a.c. bridge shown in Fig. 10.28 determine the values of the inductance and resistance of the coil when $R_1 = R_2 = 400 \Omega$, $R_3 = 5 \text{ k}\Omega$ and $C = 7.5 \mu\text{F}$

From equation (2) above, inductance

$$L = R_1 R_2 C = (400)(400)(7.5 \times 10^{-6}) \\ = \mathbf{1.2 \text{ H}}$$

From equation (3) above, resistance,

$$r = \frac{R_1 R_2}{R_3} = \frac{(400)(400)}{5000} = \mathbf{32 \Omega}$$

From equation (2),

$$R_2 = \frac{L}{R_1 C}$$

and from equation (3),

$$R_3 = \frac{R_1}{r} R_2$$

$$\text{Hence } R_3 = \frac{R_1}{r} \frac{L}{R_1 C} = \frac{L}{Cr}$$

If the frequency is constant then $R_3 \propto L/r \propto \omega L/r \propto Q$ -factor (see Chapters 15 and 16). Thus the bridge can be adjusted to give a direct indication of Q-factor. A Q-meter is described in section 10.19 following.

Now try the following exercise

Exercise 53 Further problem on a.c. bridges

1 A Maxwell bridge circuit ABCD has the following arm impedances: AB, 250Ω resistance; BC, $15 \mu\text{F}$ capacitor in parallel with a $10 \text{ k}\Omega$ resistor; CD, 400Ω resistor; DA, unknown inductor having inductance L and resistance R . Determine the values of L and R assuming the bridge is balanced. [1.5 H, 10Ω]

10.19 Q-meter

(3) The **Q-factor** for a series L–C–R circuit is the voltage magnification at resonance, i.e.

$$\text{Q-factor} = \frac{\text{voltage across capacitor}}{\text{supply voltage}} \\ = \frac{V_c}{V} \text{ (see Chapter 15).}$$

The simplified circuit of a **Q-meter**, used for measuring Q-factor, is shown in Fig. 10.29. Current from a variable frequency oscillator flowing through a very low resistance r develops a variable frequency voltage, V_r , which is applied to a series L–R–C circuit. The frequency is then varied until resonance causes voltage V_c to reach a maximum value. At resonance V_r and V_c are noted. Then

$$\text{Q-factor} = \frac{V_c}{V_r} = \frac{V_c}{I r}$$

In a practical Q-meter, V_r is maintained constant and the electronic voltmeter can be calibrated to indicate the Q-factor directly. If a variable capacitor C is used and the oscillator is set to a given frequency, then C can be adjusted to give resonance. In this way inductance L may be calculated using

$$f_r = \frac{1}{2\pi\sqrt{LC}}$$

$$\text{Since } Q = \frac{2\pi f L}{R},$$

then R may be calculated.

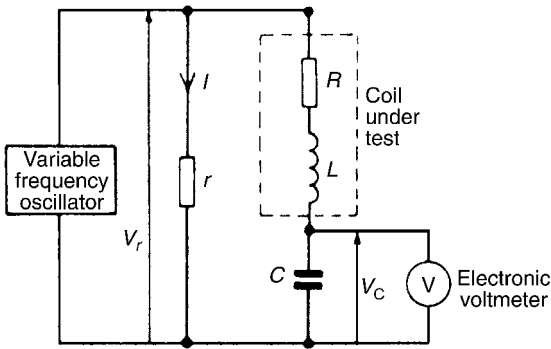

Figure 10.29

Q-meters operate at various frequencies and instruments exist with frequency ranges from 1 kHz to 50 MHz. Errors in measurement can exist with Q-meters since the coil has an effective parallel self capacitance due to capacitance between turns. The accuracy of a Q-meter is approximately $\pm 5\%$.

Problem 21. When connected to a Q-meter an inductor is made to resonate at 400 kHz. The Q-factor of the circuit is found to be 100 and the capacitance of the Q-meter capacitor is set to 400 pF. Determine (a) the inductance, and (b) the resistance of the inductor.

Resonant frequency, $f_r = 400 \text{ kHz} = 400 \times 10^3 \text{ Hz}$,
 Q-factor = 100 and capacitance, $C = 400 \text{ pF} = 400 \times 10^{-12} \text{ F}$. The circuit diagram of a Q-meter is shown in Fig. 10.29

(a) At resonance,

$$f_r = \frac{1}{2\pi\sqrt{LC}}$$

for a series L-C-R circuit. Hence

$$2\pi f_r = \frac{1}{\sqrt{LC}}$$

from which

$$(2\pi f_r)^2 = \frac{1}{LC}$$

and **inductance**,

$$\begin{aligned} L &= \frac{1}{(2\pi f_r)^2 C} \\ &= \frac{1}{(2\pi \times 400 \times 10^3)^2 (400 \times 10^{-12})} \text{ H} \\ &= \mathbf{396 \mu\text{H} \text{ or } 0.396 \text{ mH}} \end{aligned}$$

(b) Q-factor at resonance = $2\pi f_r L/R$ from which resistance

$$\begin{aligned} R &= \frac{2\pi f_r L}{Q} \\ &= \frac{2\pi(400 \times 10^3)(0.396 \times 10^{-3})}{100} \\ &= \mathbf{9.95 \Omega} \end{aligned}$$

Now try the following exercise

Exercise 54 Further problem on the Q-meter

- 1 A Q-meter measures the Q-factor of a series L-C-R circuit to be 200 at a resonant frequency of 250 kHz. If the capacitance of the Q-meter capacitor is set to 300 pF determine (a) the inductance L , and (b) the resistance R of the inductor. [(a) 1.351 mH (b) 10.61 Ω]

10.20 Measurement errors

Errors are always introduced when using instruments to measure electrical quantities. The errors most likely to occur in measurements are those due to:

- (i) the limitations of the instrument;
- (ii) the operator;
- (iii) the instrument disturbing the circuit.

(i) Errors in the limitations of the instrument

The **calibration accuracy** of an instrument depends on the precision with which it is constructed. Every instrument has a margin of error which is expressed as a percentage of the instruments full scale deflection. For example, industrial grade instruments have an accuracy of $\pm 2\%$ of f.s.d. Thus if a voltmeter has a f.s.d. of 100 V and it indicates 40 V say, then the actual voltage may be anywhere between $40 \pm (2\% \text{ of } 100)$, or 40 ± 2 , i.e. between 38 V and 42 V.

When an instrument is calibrated, it is compared against a standard instrument and a graph is drawn of 'error' against 'meter deflection'. A typical graph is shown in Fig. 10.30 where it is seen that the accuracy varies over the scale length. Thus a meter

with a $\pm 2\%$ f.s.d. accuracy would tend to have an accuracy which is much better than $\pm 2\%$ f.s.d. over much of the range.

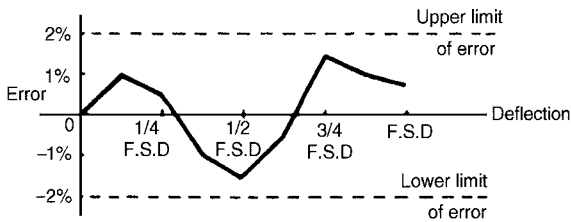

Figure 10.30

(ii) Errors by the operator

It is easy for an operator to misread an instrument. With linear scales the values of the sub-divisions are reasonably easy to determine; non-linear scale graduations are more difficult to estimate. Also, scales differ from instrument to instrument and some meters have more than one scale (as with multimeters) and mistakes in reading indications are easily made. When reading a meter scale it should be viewed from an angle perpendicular to the surface of the scale at the location of the pointer; a meter scale should not be viewed 'at an angle'.

(iii) Errors due to the instrument disturbing the circuit

Any instrument connected into a circuit will affect that circuit to some extent. Meters require some power to operate, but provided this power is small compared with the power in the measured circuit, then little error will result. Incorrect positioning of instruments in a circuit can be a source of errors. For example, let a resistance be measured by the voltmeter-ammeter method as shown in Fig. 10.31. Assuming 'perfect' instruments, the resistance should be given by the voltmeter reading divided by the ammeter reading (i.e. $R = V/I$). However, in Fig. 10.31(a), $V/I = R + r_a$ and in Fig. 10.31(b) the current through the ammeter is that through the resistor plus that through the voltmeter. Hence the voltmeter reading divided by the ammeter reading will not give the true value of the resistance R for either method of connection.

Problem 22. The current flowing through a resistor of $5\text{ k}\Omega \pm 0.4\%$ is measured as 2.5 mA with an accuracy of measurement of $\pm 0.5\%$. Determine the nominal value of the voltage across the resistor and its accuracy.

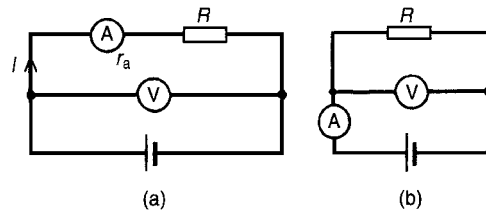

Figure 10.31

Voltage, $V = IR = (2.5 \times 10^{-3})(5 \times 10^3) = 12.5\text{ V}$.
The maximum possible error is
 $0.4\% + 0.5\% = 0.9\%$.

Hence the voltage, $V = 12.5\text{ V} \pm 0.9\%$ of 12.5 V
 0.9% of $12.5 = 0.9/100 \times 12.5 = 0.1125\text{ V} = 0.11\text{ V}$ correct to 2 significant figures.

Hence the voltage V may also be expressed as $12.5 \pm 0.11\text{ volts}$ (i.e. a voltage lying between 12.39 V and 12.61 V).

Problem 23. The current I flowing in a resistor R is measured by a $0\text{--}10\text{ A}$ ammeter which gives an indication of 6.25 A . The voltage V across the resistor is measured by a $0\text{--}50\text{ V}$ voltmeter, which gives an indication of 36.5 V . Determine the resistance of the resistor, and its accuracy of measurement if both instruments have a limit of error of 2% of f.s.d. Neglect any loading effects of the instruments.

Resistance,

$$R = \frac{V}{I} = \frac{36.5}{6.25} = 5.84\ \Omega$$

Voltage error is $\pm 2\%$ of $50\text{ V} = \pm 1.0\text{ V}$ and expressed as a percentage of the voltmeter reading gives

$$\frac{\pm 1}{36.5} \times 100\% = \pm 2.74\%$$

Current error is $\pm 2\%$ of $10\text{ A} = \pm 0.2\text{ A}$ and expressed as a percentage of the ammeter reading gives

$$\frac{\pm 0.2}{6.25} \times 100\% = \pm 3.2\%$$

Maximum relative error = sum of errors = $2.74\% + 3.2\% = \pm 5.94\%$. 5.94% of $5.84\ \Omega = 0.347\ \Omega$. Hence the resistance of the resistor may be expressed as:

$$5.84\ \Omega \pm 5.94\% \text{ or } 5.84 \pm 0.35\ \Omega$$

(rounding off)

Problem 24. The arms of a Wheatstone bridge ABCD have the following resistances: AB: $R_1 = 1000 \Omega \pm 1.0\%$; BC: $R_2 = 100 \Omega \pm 0.5\%$; CD: unknown resistance R_x ; DA: $R_3 = 432.5 \Omega \pm 0.2\%$. Determine the value of the unknown resistance and its accuracy of measurement.

The Wheatstone bridge network is shown in Fig. 10.32 and at balance:

$$R_1 R_x = R_2 R_3,$$

$$\text{i.e. } R_x = \frac{R_2 R_3}{R_1} = \frac{(100)(432.5)}{1000} = 43.25 \Omega$$

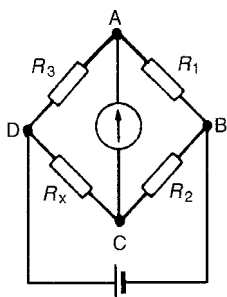

Figure 10.32

The maximum relative error of R_x is given by the sum of the three individual errors, i.e. $1.0\% + 0.5\% + 0.2\% = 1.7\%$. **Hence**

$$R_x = 43.25 \Omega \pm 1.7\%$$

1.7% of $43.25 \Omega = 0.74 \Omega$ (rounding off). Thus R_x may also be expressed as

$$R_x = 43.25 \pm 0.74 \Omega$$

Now try the following exercises

Exercise 55 Further problems on measurement errors

- 1 The p.d. across a resistor is measured as 37.5 V with an accuracy of $\pm 0.5\%$. The value of the resistor is $6 \text{ k}\Omega \pm 0.8\%$. Determine the current

flowing in the resistor and its accuracy of measurement.

$$[6.25 \text{ mA} \pm 1.3\% \text{ or } 6.25 \pm 0.08 \text{ mA}]$$

- 2 The voltage across a resistor is measured by a 75 V f.s.d. voltmeter which gives an indication of 52 V . The current flowing in the resistor is measured by a 20 A f.s.d. ammeter which gives an indication of 12.5 A . Determine the resistance of the resistor and its accuracy if both instruments have an accuracy of $\pm 2\%$ of f.s.d. $[4.16 \Omega \pm 6.08\% \text{ or } 4.16 \pm 0.25 \Omega]$
- 3 A 240 V supply is connected across a load resistance R . Also connected across R is a voltmeter having a f.s.d. of 300 V and a figure of merit (i.e. sensitivity) of $8 \text{ k}\Omega/\text{V}$. Calculate the power dissipated by the voltmeter and by the load resistance if (a) $R = 100 \Omega$ (b) $R = 1 \text{ M}\Omega$. Comment on the results obtained. $[(a) 24 \text{ mW}, 576 \text{ W} \text{ (b) } 24 \text{ mW}, 57.6 \text{ mW}]$
- 4 A Wheatstone bridge PQRS has the following arm resistances: PQ, $1 \text{ k}\Omega \pm 2\%$; QR, $100 \Omega \pm 0.5\%$; RS, unknown resistance; SP, $273.6 \Omega \pm 0.1\%$. Determine the value of the unknown resistance, and its accuracy of measurement. $[27.36 \Omega \pm 2.6\% \text{ or } 27.36 \Omega \pm 0.71 \Omega]$

Exercise 56 Short answer questions on electrical measuring instruments and measurements

- 1 What is the main difference between an analogue and a digital type of measuring instrument?
- 2 Name the three essential devices for all analogue electrical indicating instruments
- 3 Complete the following statements:
 - (a) An ammeter has a resistance and is connected with the circuit
 - (b) A voltmeter has a resistance and is connected with the circuit
- 4 State two advantages and two disadvantages of a moving coil instrument
- 5 What effect does the connection of (a) a shunt (b) a multiplier have on a milliammeter?
- 6 State two advantages and two disadvantages of a moving coil instrument

- 7 Name two advantages of electronic measuring instruments compared with moving coil or moving iron instruments
- 8 Briefly explain the principle of operation of an ohmmeter
- 9 Name a type of ohmmeter used for measuring (a) low resistance values (b) high resistance values
- 10 What is a multimeter?
- 11 When may a rectifier instrument be used in preference to either a moving coil or moving iron instrument?
- 12 Name five quantities that a c.r.o. is capable of measuring
- 13 What is harmonic analysis?
- 14 What is a feature of waveforms containing the fundamental and odd harmonics?
- 15 Express the ratio of two powers P_1 and P_2 in decibel units
- 16 What does a power level unit of dBm indicate?
- 17 What is meant by a null method of measurement?
- 18 Sketch a Wheatstone bridge circuit used for measuring an unknown resistance in a d.c. circuit and state the balance condition
- 19 How may a d.c. potentiometer be used to measure p.d.'s
- 20 Name five types of a.c. bridge used for measuring unknown inductance, capacitance or resistance
- 21 What is a universal bridge?
- 22 State the name of an a.c. bridge used for measuring inductance
- 23 Briefly describe how the measurement of Q-factor may be achieved
- 24 Why do instrument errors occur when measuring complex waveforms?
- 25 Define 'calibration accuracy' as applied to a measuring instrument
- 26 State three main areas where errors are most likely to occur in measurements

Exercise 57 Multi-choice questions on electrical measuring instruments and measurements (Answers on page 375)

- 1 Which of the following would apply to a moving coil instrument?
 - (a) An uneven scale, measuring d.c.
 - (b) An even scale, measuring a.c.
 - (c) An uneven scale, measuring a.c.
 - (d) An even scale, measuring d.c.
- 2 In question 1, which would refer to a moving iron instrument?
- 3 In question 1, which would refer to a moving coil rectifier instrument?
- 4 Which of the following is needed to extend the range of a milliammeter to read voltages of the order of 100 V?
 - (a) a parallel high-value resistance
 - (b) a series high-value resistance
 - (c) a parallel low-value resistance
 - (d) a series low-value resistance
- 5 Fig. 10.33 shows a scale of a multi-range ammeter. What is the current indicated when switched to a 25 A scale?
 - (a) 84 A
 - (b) 5.6 A
 - (c) 14 A
 - (d) 8.4 A

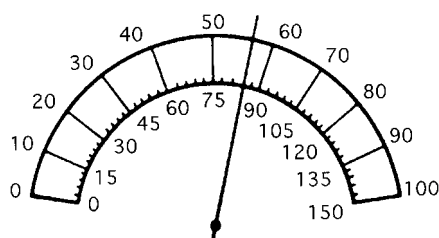

Figure 10.33

A sinusoidal waveform is displayed on a c.r.o. screen. The peak-to-peak distance is 5 cm and the distance between cycles is 4 cm. The 'variable' switch is on 100 $\mu\text{s}/\text{cm}$ and the 'volts/cm' switch is on 10 V/cm. In questions 6 to 10, select the correct answer from the following:

- | | | |
|------------|-----------|-------------|
| (a) 25 V | (b) 5 V | (c) 0.4 ms |
| (d) 35.4 V | (e) 4 ms | (f) 50 V |
| (g) 250 Hz | (h) 2.5 V | (i) 2.5 kHz |
| (j) 17.7 V | | |
- 6 Determine the peak-to-peak voltage
 - 7 Determine the periodic time of the waveform

- 8 Determine the maximum value of the voltage
 9 Determine the frequency of the waveform
 10 Determine the r.m.s. value of the waveform

Fig. 10.34 shows double-beam c.r.o. waveform traces. For the quantities stated in questions 11 to 17, select the correct answer from the following:

- (a) 30 V (b) 0.2 s (c) 50 V
 (d) $\frac{15}{\sqrt{2}}$ (e) 54° leading (f) $\frac{250}{\sqrt{2}}$ V
 (g) 15 V (h) 100 μ s (i) $\frac{50}{\sqrt{2}}$ V
 (j) 250 V (k) 10 kHz (l) 75 V
 (m) 40 μ s (n) $\frac{3\pi}{10}$ rads lagging
 (o) $\frac{25}{\sqrt{2}}$ V (p) 5 Hz (q) $\frac{30}{\sqrt{2}}$ V
 (r) 25 kHz (s) $\frac{75}{\sqrt{2}}$ V
 (t) $\frac{3\pi}{10}$ rads leading

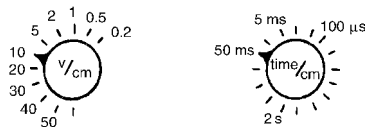
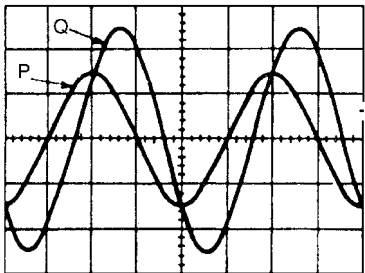

Figure 10.34

- 11 Amplitude of waveform P
 12 Peak-to-peak value of waveform Q
 13 Periodic time of both waveforms
 14 Frequency of both waveforms

- 15 R.m.s. value of waveform P
 16 R.m.s. value of waveform Q
 17 Phase displacement of waveform Q relative to waveform P
 18 The input and output powers of a system are 2 mW and 18 mW respectively. The decibel power ratio of output power to input power is:
 (a) 9 (b) 9.54 (c) 1.9 (d) 19.08
 19 The input and output voltages of a system are 500 μ V and 500 mV respectively. The decibel voltage ratio of output to input voltage (assuming input resistance equals load resistance) is:
 (a) 1000 (b) 30 (c) 0 (d) 60
 20 The input and output currents of a system are 3 mA and 18 mA respectively. The decibel ratio of output to input current (assuming the input and load resistances are equal) is:
 (a) 15.56 (b) 6 (c) 1.6 (d) 7.78
 21 Which of the following statements is false?
 (a) The Schering bridge is normally used for measuring unknown capacitances
 (b) A.C. electronic measuring instruments can handle a much wider range of frequency than the moving coil instrument
 (c) A complex waveform is one which is non-sinusoidal
 (d) A square wave normally contains the fundamental and even harmonics
 22 A voltmeter has a f.s.d. of 100 V, a sensitivity of 1 k Ω /V and an accuracy of $\pm 2\%$ of f.s.d. When the voltmeter is connected into a circuit it indicates 50 V. Which of the following statements is false?
 (a) Voltage reading is 50 ± 2 V
 (b) Voltmeter resistance is 100 k Ω
 (c) Voltage reading is $50 \text{ V} \pm 2\%$
 (d) Voltage reading is $50 \text{ V} \pm 4\%$
 23 A potentiometer is used to:
 (a) compare voltages
 (b) measure power factor
 (c) compare currents
 (d) measure phase sequence

Semiconductor diodes

At the end of this chapter you should be able to:

- classify materials as conductors, semiconductors or insulators
- appreciate the importance of silicon and germanium
- understand n-type and p-type materials
- understand the p-n junction
- appreciate forward and reverse bias of p-n junctions
- draw the circuit diagram symbol for a semiconductor diode
- understand how half wave and full wave rectification is obtained

11.1 Types of materials

Materials may be classified as **conductors**, **semiconductors** or **insulators**. The classification depends on the value of resistivity of the material. Good conductors are usually metals and have resistivities in the order of 10^{-7} to $10^{-8} \Omega \text{ m}$. Semiconductors have resistivities in the order of 10^{-3} to $3 \times 10^3 \Omega \text{ m}$. The resistivities of insulators are in the order of 10^4 to $10^{14} \Omega \text{ m}$. Some typical approximate values at normal room temperatures are:

Conductors:

Aluminium	$2.7 \times 10^{-8} \Omega \text{ m}$
Brass (70 Cu/30 Zn)	$8 \times 10^{-8} \Omega \text{ m}$
Copper (pure annealed)	$1.7 \times 10^{-8} \Omega \text{ m}$
Steel (mild)	$15 \times 10^{-8} \Omega \text{ m}$

Semiconductors:

Silicon	$2.3 \times 10^3 \Omega \text{ m}$	} at 27°C
Germanium	$0.45 \Omega \text{ m}$	

Insulators:

Glass	$\geq 10^{10} \Omega \text{ m}$
Mica	$\geq 10^{11} \Omega \text{ m}$
PVC	$\geq 10^{13} \Omega \text{ m}$
Rubber (pure)	10^{12} to $10^{14} \Omega \text{ m}$

In general, over a limited range of temperatures, the resistance of a conductor increases with temperature increase. The resistance of insulators remains approximately constant with variation of temperature. The resistance of semiconductor materials decreases as the temperature increases. For a specimen of each of these materials, having the same resistance (and thus completely different dimensions), at say, 15°C , the variation for a small increase in temperature to $t^\circ \text{C}$ is as shown in Fig. 11.1

11.2 Silicon and germanium

The most important semiconductors used in the electronics industry are silicon and germanium. As the temperature of these materials is raised above room temperature, the resistivity is reduced and ultimately a point is reached where they effectively become

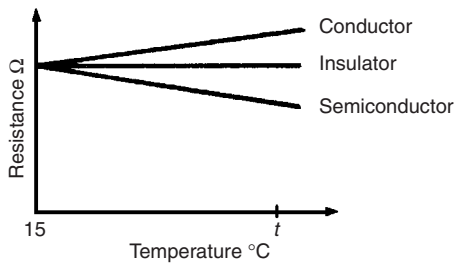

Figure 11.1

conductors. For this reason, silicon should not operate at a working temperature in excess of 150°C to 200°C , depending on its purity, and germanium should not operate at a working temperature in excess of 75°C to 90°C , depending on its purity. As the temperature of a semiconductor is reduced below normal room temperature, the resistivity increases until, at very low temperatures the semiconductor becomes an insulator.

11.3 n-type and p-type materials

Adding extremely small amounts of impurities to pure semiconductors in a controlled manner is called **doping**. Antimony, arsenic and phosphorus are called n-type impurities and form an **n-type material** when any of these impurities are added to silicon or germanium. The amount of impurity added usually varies from 1 part impurity in 10^5 parts semiconductor material to 1 part impurity to 10^8 parts semiconductor material, depending on the resistivity required. Indium, aluminium and boron are called p-type impurities and form a **p-type material** when any of these impurities are added to a semiconductor.

In semiconductor materials, there are very few charge carriers per unit volume free to conduct. This is because the 'four electron structure' in the outer shell of the atoms (called valency electrons), form strong covalent bonds with neighbouring atoms, resulting in a tetrahedral structure with the electrons held fairly rigidly in place. A two-dimensional diagram depicting this is shown for germanium in Fig. 11.2

Arsenic, antimony and phosphorus have five valency electrons and when a semiconductor is doped with one of these substances, some impurity atoms are incorporated in the tetrahedral structure. The 'fifth' valency electron is not rigidly bonded and is free to conduct, the impurity atom donating a charge carrier. A two-dimensional diagram depicting this is shown in Fig. 11.3, in which a phosphorus

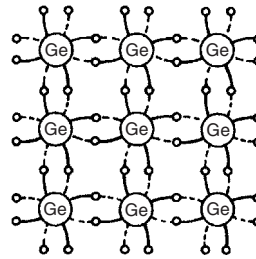

Figure 11.2

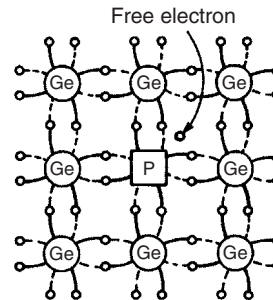

Figure 11.3

atom has replaced one of the germanium atoms. The resulting material is called n-type material, and contains free electrons.

Indium, aluminium and boron have three valency electrons and when a semiconductor is doped with one of these substances some of the semiconductor atoms are replaced by impurity atoms. One of the four bonds associated with the semiconductor material is deficient by one electron and this deficiency is called a **hole**.

Holes give rise to conduction when a potential difference exists across the semiconductor material due to movement of electrons from one hole to another, as shown in Fig. 11.4. In this figure, an

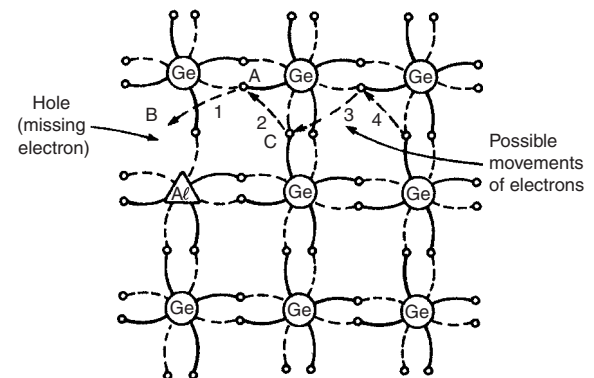

Figure 11.4

electron moves from A to B, giving the appearance that the hole moves from B to A. Then electron C moves to A, giving the appearance that the hole moves to C, and so on. The resulting material is p-type material containing holes.

11.4 The p-n junction

A **p-n junction** is a piece of semiconductor material in which part of the material is p-type and part is n-type. In order to examine the charge situation, assume that separate blocks of p-type and n-type materials are pushed together. Also assume that a hole is a positive charge carrier and that an electron is a negative charge carrier.

At the junction, the donated electrons in the n-type material, called **majority carriers**, diffuse into the p-type material (diffusion is from an area of high density to an area of lower density) and the acceptor holes in the p-type material diffuse into the n-type material as shown by the arrows in Fig. 11.5

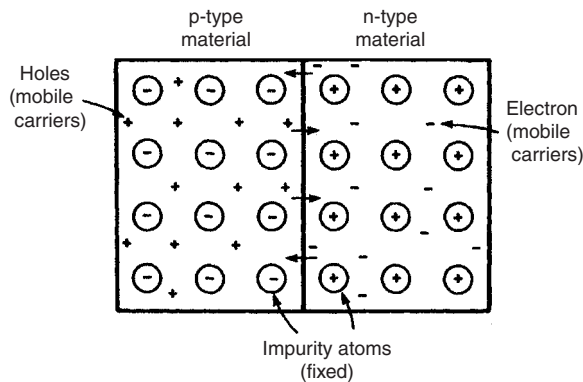

Figure 11.5

Because the n-type material has lost electrons, it acquires a positive potential with respect to the p-type material and thus tends to prevent further movement of electrons. The p-type material has gained electrons and becomes negatively charged with respect to the n-type material and hence tends to retain holes. Thus after a short while, the movement of electrons and holes stops due to the potential difference across the junction, called the **contact potential**. The area in the region of the junction becomes depleted of holes and electrons due to electron-hole recombinations, and is called a **depletion layer**, as shown in Fig. 11.6

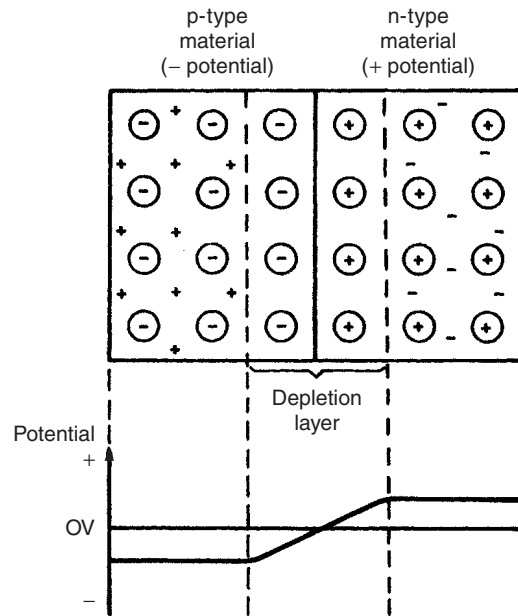

Figure 11.6

11.5 Forward and reverse bias

When, an external voltage is applied to a p-n junction making the p-type material positive with respect to the n-type material, as shown in Fig. 11.7, the p-n junction is **forward biased**. The applied voltage opposes the contact potential, and, in effect, closes

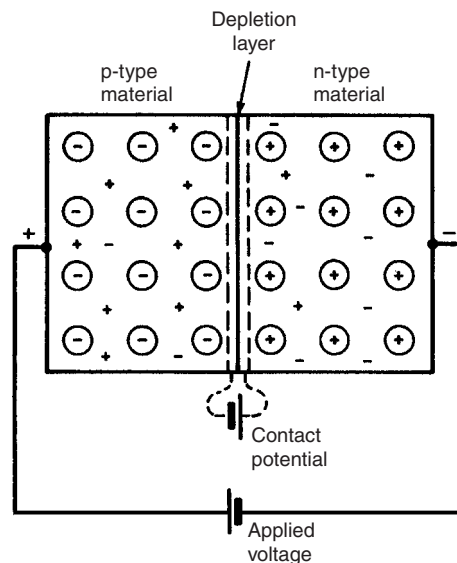

Figure 11.7

the depletion layer. Holes and electrons can now cross the junction and a current flows.

An increase in the applied voltage above that required to narrow the depletion layer (about 0.2 V for germanium and 0.6 V for silicon), results in a rapid rise in the current flow. Graphs depicting the current-voltage relationship for forward biased p-n junctions, for both germanium and silicon, called the **forward characteristics**, are shown in Fig. 11.8

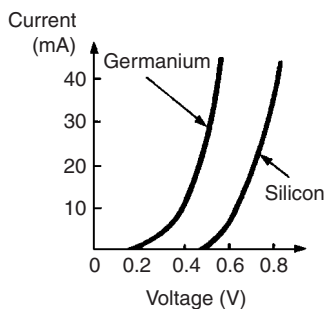

Figure 11.8

When an external voltage is applied to a p-n junction making the p-type material negative with respect to the n-type material as in shown in Fig. 11.9, the p-n junction is **reverse biased**. The

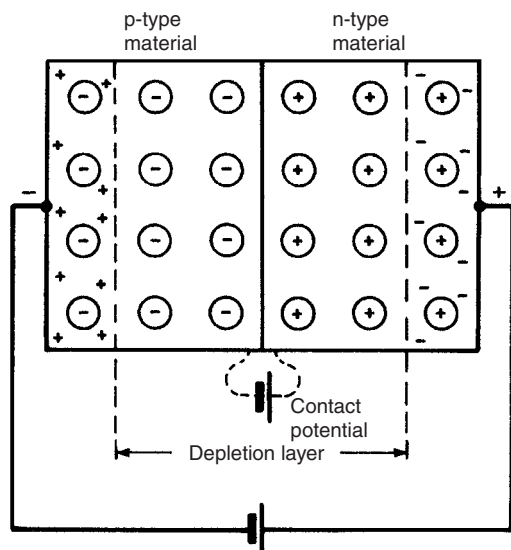

Figure 11.9

applied voltage is now in the same sense as the contact potential and opposes the movement of holes and electrons due to opening up the depletion layer. Thus, in theory, no current flows. However

at normal room temperature certain electrons in the covalent bond lattice acquire sufficient energy from the heat available to leave the lattice, generating mobile electrons and holes. This process is called electron-hole generation by thermal excitation.

The electrons in the p-type material and holes in the n-type material caused by thermal excitation, are called **minority carriers** and these will be attracted by the applied voltage. Thus, in practice, a small current of a few microamperes for germanium and less than one microampere for silicon, at normal room temperature, flows under reverse bias conditions. Typical **reverse characteristics** are shown in Fig. 11.10 for both germanium and silicon.

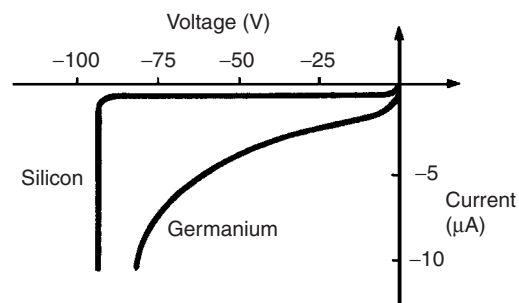

Figure 11.10

11.6 Semiconductor diodes

A semiconductor diode is a device having a p-n junction mounted in a container, suitable for conducting and dissipating the heat generated in operation and having connecting leads. Its operating characteristics are as shown in Figs. 11.8 and 11.10. Two circuit diagram symbols for semiconductor diodes are in common use and are as shown in Fig. 11.11. Sometimes the symbols are encircled as in Fig. 11.13 on page 132.

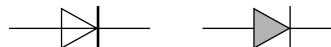

Figure 11.11

Problem 1. Explain briefly the terms given below when they are associated with a p-n junction: (a) conduction in intrinsic semiconductors (b) majority and minority carriers, and (c) diffusion

- (a) Silicon or germanium with no doping atoms added are called intrinsic semiconductors. At room temperature, some of the electrons acquire sufficient energy for them to break the covalent bond between atoms and become free mobile electrons. This is called thermal generation of electron-hole pairs. Electrons generated thermally create a gap in the crystal structure called a hole, the atom associated with the hole being positively charged, since it has lost an electron. This positive charge may attract another electron released from another atom, creating a hole elsewhere.

When a potential is applied across the semiconductor material, holes drift towards the negative terminal (unlike charges attract), and electrons towards the positive terminal, and hence a small current flows.

- (b) When additional mobile electrons are introduced by doping a semiconductor material with pentavalent atoms (atoms having five valency electrons), these mobile electrons are called majority carriers. The relatively few holes in the n-type material produced by intrinsic action are called minority carriers.

For p-type materials, the additional holes are introduced by doping with trivalent atoms (atoms having three valency electrons). The holes are positive mobile charges and are majority carriers in the p-type material. The relatively few mobile electrons in the p-type material produced by intrinsic action are called minority carriers.

- (c) Mobile holes and electrons wander freely within the crystal lattice of a semiconductor material. There are more free electrons in n-type material than holes and more holes in p-type material than electrons. Thus, in their random wanderings, on average, holes pass into the n-type material and electrons into the p-type material. This process is called diffusion.

Problem 2. Explain briefly why a junction between p-type and n-type materials creates a contact potential.

Intrinsic semiconductors have resistive properties, in that when an applied voltage across the material is reversed in polarity, a current of the same magnitude flows in the opposite direction. When a p-n junction is formed, the resistive property is replaced by

a rectifying property, that is, current passes more easily in one direction than the other.

An n-type material can be considered to be a stationary crystal matrix of fixed positive charges together with a number of mobile negative charge carriers (electrons). The total number of positive and negative charges are equal. A p-type material can be considered to be a number of stationary negative charges together with mobile positive charge carriers (holes). Again, the total number of positive and negative charges are equal and the material is neither positively nor negatively charged. When the materials are brought together, some of the mobile electrons in the n-type material diffuse into the p-type material. Also, some of the mobile holes in the p-type material diffuse into the n-type material.

Many of the majority carriers in the region of the junction combine with the opposite carriers to complete covalent bonds and create a region on either side of the junction with very few carriers. This region, called the depletion layer, acts as an insulator and is in the order of $0.5\ \mu\text{m}$ thick. Since the n-type material has lost electrons, it becomes positively charged. Also, the p-type material has lost holes and becomes negatively charged, creating a potential across the junction, called the barrier or contact potential.

Problem 3. Sketch the forward and reverse characteristics of a silicon p-n junction diode and describe the shapes of the characteristics drawn.

A typical characteristic for a silicon p-n junction having a forward bias is shown in Fig. 11.8 and having a reverse bias in Fig. 11.10. When the positive terminal of the battery is connected to the p-type material and the negative terminal to the n-type material, the diode is forward biased. Due to like charges repelling, the holes in the p-type material drift towards the junction. Similarly the electrons in the n-type material are repelled by the negative bias voltage and also drift towards the junction. The width of the depletion layer and size of the contact potential are reduced. For applied voltages from 0 to about 0.6 V, very little current flows. At about 0.6 V, majority carriers begin to cross the junction in large numbers and current starts to flow. As the applied voltage is raised above 0.6 V, the current increases exponentially (see Fig. 11.8) When the negative terminal of the battery is connected to the p-type material and the positive terminal to the n-type material the diode is reverse biased. The holes in the

p-type material are attracted towards the negative terminal and the electrons in the n-type material are attracted towards the positive terminal (unlike charges attract). This drift increases the magnitude of both the contact potential and the thickness of the depletion layer, so that only very few majority carriers have sufficient energy to surmount the junction.

The thermally excited minority carriers, however, can cross the junction since it is, in effect, forward biased for these carriers. The movement of minority carriers results in a small constant current flowing. As the magnitude of the reverse voltage is increased a point will be reached where a large current suddenly starts to flow. The voltage at which this occurs is called the breakdown voltage. This current is due to two effects:

- (i) the **zener effect**, resulting from the applied voltage being sufficient to break some of the covalent bonds, and
- (ii) the **avalanche effect**, resulting from the charge carriers moving at sufficient speed to break covalent bonds by collision.

A **zener diode** is used for voltage reference purposes or for voltage stabilisation. Two common circuit diagram symbols for a zener diode are shown in Fig. 11.12



Figure 11.12

11.7 Rectification

The process of obtaining unidirectional currents and voltages from alternating currents and voltages is called **rectification**. Automatic switching in circuits is carried out by diodes.

Using a single diode, as shown in Fig. 11.13, **half-wave rectification** is obtained. When P is sufficiently positive with respect to Q , diode D

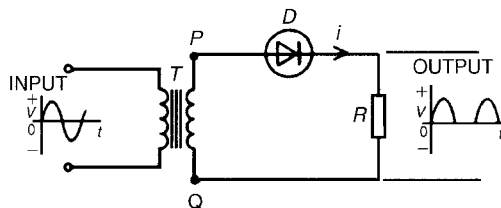

Figure 11.13

is switched on and current i flows. When P is negative with respect to Q , diode D is switched off. Transformer T isolates the equipment from direct connection with the mains supply and enables the mains voltage to be changed. Two diodes may be used as shown in Fig. 11.14 to obtain **full wave rectification**. A centre-tapped transformer T is used. When P is sufficiently positive with respect to Q , diode D_1 conducts and current flows (shown by the broken line in Fig. 11.14). When S is positive with respect to Q , diode D_2 conducts and current flows (shown by the continuous line in Fig. 11.14). The current flowing in R is in the same direction for both half cycles of the input. The output waveform is thus as shown in Fig. 11.14

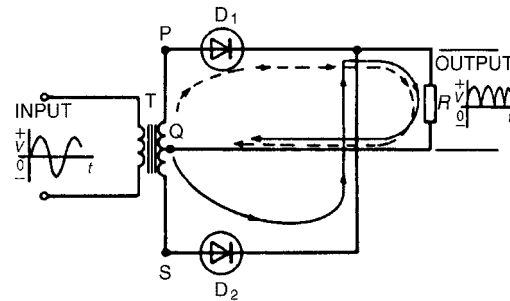

Figure 11.14

Four diodes may be used in a **bridge rectifier** circuit, as shown in Fig. 11.15 to obtain **full wave rectification**. As for the rectifier shown in Fig. 11.14, the current flowing in R is in the same direction for both half cycles of the input giving the output waveform shown.

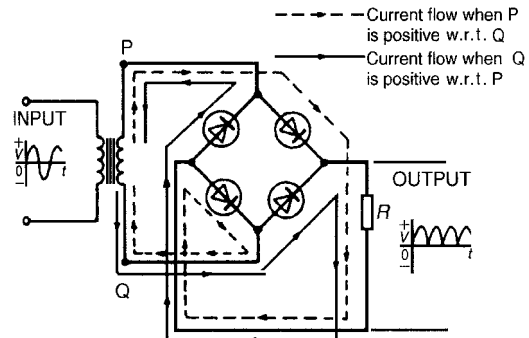

Figure 11.15

To smooth the output of the rectifiers described above, capacitors having a large capacitance may be connected across the load resistor R . The effect of this is shown on the output in Fig. 11.16

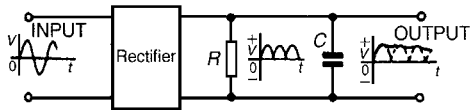

Figure 11.16

Now try the following exercises

Exercise 58 Further problems on semiconductor diodes

- 1 Explain what you understand by the term intrinsic semiconductor and how an intrinsic semiconductor is turned into either a p-type or an n-type material.
- 2 Explain what is meant by minority and majority carriers in an n-type material and state whether the numbers of each of these carriers are affected by temperature.
- 3 A piece of pure silicon is doped with (a) pentavalent impurity and (b) trivalent impurity. Explain the effect these impurities have on the form of conduction in silicon.
- 4 With the aid of simple sketches, explain how pure germanium can be treated in such a way that conduction is predominantly due to (a) electrons and (b) holes.
- 5 Explain the terms given below when used in semiconductor terminology:
 - (a) covalent bond
 - (b) trivalent impurity
 - (c) pentavalent impurity
 - (d) electron-hole pair generation.
- 6 Explain briefly why although both p-type and n-type materials have resistive properties when separate, they have rectifying properties when a junction between them exists.
- 7 The application of an external voltage to a junction diode can influence the drift of holes and electrons. With the aid of diagrams explain this statement and also how the direction and magnitude of the applied voltage affects the depletion layer.
- 8 State briefly what you understand by the terms:
 - (a) reverse bias
 - (b) forward bias
 - (c) contact potential

- (d) diffusion
- (e) minority carrier conduction.

- 9 Explain briefly the action of a p-n junction diode: (a) on open-circuit, (b) when provided with a forward bias, and (c) when provided with a reverse bias. Sketch the characteristic curves for both forward and reverse bias conditions.
- 10 Draw a diagram illustrating the charge situation for an unbiased p-n junction. Explain the change in the charge situation when compared with that in isolated p-type and n-type materials. Mark on the diagram the depletion layer and the majority carriers in each region.
- 11 Give an explanation of the principle of operation of a p-n junction as a rectifier. Sketch the current-voltage characteristics showing the approximate values of current and voltage for a silicon junction diode.

Exercise 59 Short answer problems on semiconductor diodes

- 1 A good conductor has a resistivity in the order of to Ω m
- 2 A semiconductor has a resistivity in the order of to Ω m
- 3 An insulator has a resistivity in the order of to Ω m
- 4 Over a limited range, the resistance of an insulator with increase in temperature.
- 5 Over a limited range, the resistance of a semiconductor with increase in temperature.
- 6 Over a limited range, the resistance of a conductor with increase in temperature.
- 7 Name two semiconductor materials used in the electronics industry.
- 8 Name two insulators used in the electronics industry.
- 9 Name two good conductors used in the electronics industry.

- 10 The working temperature of germanium should not exceed° C to° C, depending on its
- 11 The working temperature of silicon should not exceed° C to° C, depending on its
- 12 Antimony is called impurity.
- 13 Arsenic has valency electrons.
- 14 When phosphorus is introduced into a semiconductor material, mobile result.
- 15 Boron is called a impurity.
- 16 Indium has valency electrons.
- 17 When aluminium is introduced into a semiconductor material, mobile result
- 18 When a p-n junction is formed, the n-type material acquires a charge due to losing
- 19 When a p-n junction is formed, the p-type material acquires a charge due to losing
- 20 To forward bias a p-n junction, the terminal of the battery is connected to the p-type material
- 21 To reverse bias a p-n junction, the positive terminal of the battery is connected to the material
- 22 When a germanium p-n junction is forward biased, approximately mV must be applied before an appreciable current starts to flow.
- 23 When a silicon p-n junction is forward biased, approximately mV must be applied before an appreciable current starts to flow.
- 24 When a p-n junction is reversed biased, the thickness or width of the depletion layer
- 25 If the thickness or width of a depletion layer decreases, then the p-n junction is biased.
- 26 Draw an appropriate circuit diagram suitable for half-wave rectification
- 27 How may full-wave rectification be achieved?

- 28 What is a simple method of smoothing the output of a rectifier?

Exercise 60 Multi-choice questions on semiconductor diodes (Answers on page 375)

In questions 1 to 5, select which statements are true.

- 1 In pure silicon:
 - (a) the holes are the majority carriers
 - (b) the electrons are the majority carriers
 - (c) the holes and electrons exist in equal numbers
 - (d) conduction is due to there being more electrons than holes
- 2 Intrinsic semiconductor materials have:
 - (a) covalent bonds forming a tetrahedral structure
 - (b) pentavalent atoms added
 - (c) conduction by means of doping
 - (d) a resistance which increases with increase of temperature
- 3 Pentavalent impurities:
 - (a) have three valency electrons
 - (b) introduce holes when added to a semiconductor material
 - (c) are introduced by adding aluminium atoms to a semiconductor material
 - (d) increase the conduction of a semiconductor material
- 4 Free electrons in a p-type material:
 - (a) are majority carriers
 - (b) take no part in conduction
 - (c) are minority carriers
 - (d) exist in the same numbers as holes
- 5 When an unbiased p-n junction is formed:
 - (a) the p-side is positive with respect to the n-side
 - (b) a contact potential exists
 - (c) electrons diffuse from the p-type material to the n-type material
 - (d) conduction is by means of majority carriers

In questions 6 to 10, select which statements are false.

- 6 (a) The resistance of an insulator remains approximately constant with increase of temperature
(b) The resistivity of a good conductor is about 10^7 to 10^8 ohm metres
(c) The resistivity of a conductor increases with increase of temperature
(d) The resistance of a semiconductor decreases with increase of temperature
- 7 Trivalent impurities:
(a) have three valency electrons
(b) introduce holes when added to a semiconductor material
(c) can be introduced to a semiconductor material by adding antimony atoms to it
(d) increase the conductivity of a semiconductor material when added to it
- 8 Free electrons in an n-type material:
(a) are majority carriers
(b) diffuse into the p-type material when a p-n junction is formed
(c) as a result of the diffusion process leave the n-type material positively charged
(d) exist in the same numbers as the holes in the n-type material
- 9 When a germanium p-n junction diode is forward biased:
(a) current starts to flow in an appreciable amount when the applied voltage is about 600 mV
(b) the thickness or width of the depletion layer is reduced
(c) the curve representing the current flow is exponential
(d) the positive terminal of the battery is connected to the p-type material
- 10 When a silicon p-n junction diode is reverse biased:
(a) a constant current flows over a large range of voltages
(b) current flow is due to electrons in the n-type material
(c) current type is due to minority carriers
(d) the magnitude of the reverse current flow is usually less than $1 \mu\text{A}$
- 11 A rectifier conducts:
(a) direct currents in one direction
(b) alternating currents in both directions
(c) direct currents in both directions
(d) alternating currents in one direction

Transistors

At the end of this chapter you should be able to:

- understand the structure of a bipolar junction transistor
- understand transistor action for p-n-p and n-p-n types
- draw the circuit diagram symbols for p-n-p and n-p-n transistors
- appreciate common-base, common-emitter and common-collector transistor connections
- interpret transistor characteristics
- appreciate how the transistor is used as an amplifier
- determine the load line on transistor characteristics
- estimate current, voltage and power gains from transistor characteristics
- understand thermal runaway in a transistor

12.1 The bipolar junction transistor

The bipolar junction transistor consists of three regions of semiconductor material. One type is called a p-n-p transistor, in which two regions of p-type material sandwich a very thin layer of n-type material. A second type is called an n-p-n transistor, in which two regions of n-type material sandwich a very thin layer of p-type material. Both of these types of transistors consist of two p-n junctions placed very close to one another in a back-to-back arrangement on a single piece of semiconductor material. Diagrams depicting these two types of transistors are shown in Fig. 12.1

The two p-type material regions of the p-n-p transistor are called the **emitter** and **collector** and the n-type material is called the **base**. Similarly, the two n-type material regions of the n-p-n transistor are called the emitter and collector and the p-type material region is called the base, as shown in Fig. 12.1

Transistors have three connecting leads and in operation an electrical input to one pair of connections, say the emitter and base connections can control the output from another pair, say the collector and emitter connections. This type of

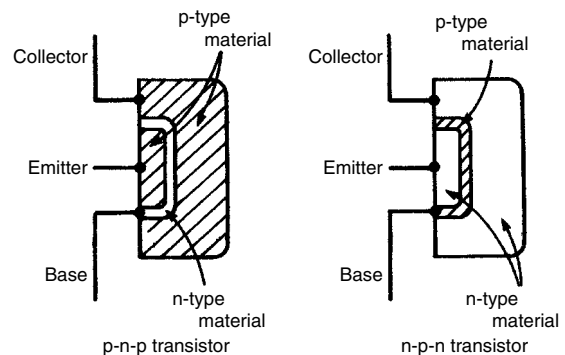

Figure 12.1

operation is achieved by appropriately biasing the two internal p-n junctions. When batteries and resistors are connected to a p-n-p transistor, as shown in Fig. 12.2(a) the base-emitter junction is **forward biased** and the base-collector junction is **reverse biased**.

Similarly, an n-p-n transistor has its base-emitter junction forward biased and its base-collector junction reverse biased when the batteries are connected as shown in Fig. 12.2(b).

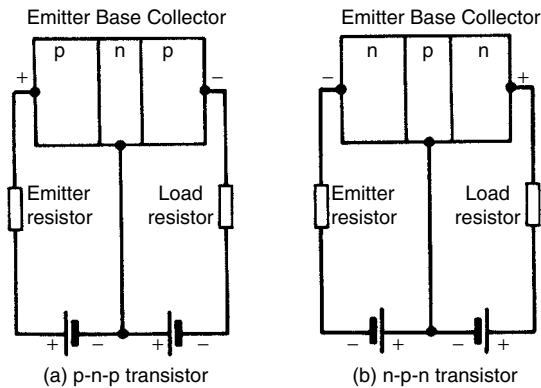

Figure 12.2

For a silicon p-n-p transistor, biased as shown in Fig. 12.2(a), if the base-emitter junction is considered on its own, it is forward biased and a current flows. This is depicted in Fig. 12.3(a). For example, if R_E is $1000\ \Omega$, the battery is $4.5\ \text{V}$ and the voltage drop across the junction is taken as $0.7\ \text{V}$, the current flowing is given by $(4.5 - 0.7)/1000 = 3.8\ \text{mA}$. When the base-collector junction is considered on its own, as shown in Fig. 12.3(b), it is reverse biased and the collector current is something less than $1\ \mu\text{A}$.

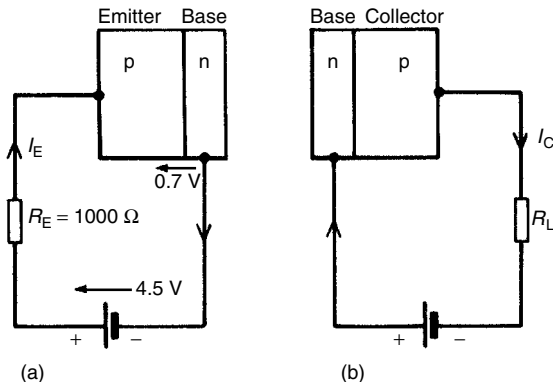

Figure 12.3

However, when both external circuits are connected to the transistor, most of the $3.8\ \text{mA}$ of current flowing in the emitter, which previously flowed from the base connection, now flows out through the collector connection due to transistor action.

12.2 Transistor action

In a **p-n-p** transistor, connected as shown in Fig. 12.2(a), transistor action is accounted for as follows:

- The majority carriers in the emitter p-type material are holes
- The base-emitter junction is forward biased to the majority carriers and the holes cross the junction and appear in the base region
- The base region is very thin and is only lightly doped with electrons so although some electron-hole pairs are formed, many holes are left in the base region
- The base-collector junction is reverse biased to electrons in the base region and holes in the collector region, but forward biased to holes in the base region; these holes are attracted by the negative potential at the collector terminal
- A large proportion of the holes in the base region cross the base-collector junction into the collector region, creating a collector current; conventional current flow is in the direction of hole movement

The transistor action is shown diagrammatically in Fig. 12.4. For transistors having very thin base regions, up to 99.5 per cent of the holes leaving the emitter cross the base collector junction.

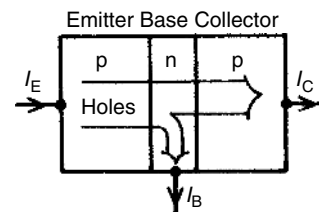

Figure 12.4

In an **n-p-n** transistor, connected as shown in Fig. 12.2(b), transistor action is accounted for as follows:

- The majority carriers in the n-type emitter material are electrons
- The base-emitter junction is forward biased to these majority carriers and electrons cross the junction and appear in the base region
- The base region is very thin and only lightly doped with holes, so some recombination with holes occurs but many electrons are left in the base region
- The base-collector junction is reverse biased to holes in the base region and electrons in

the collector region, but is forward biased to electrons in the base region; these electrons are attracted by the positive potential at the collector terminal

- (e) A large proportion of the electrons in the base region cross the base-collector junction into the collector region, creating a collector current

The transistor action is shown diagrammatically in Fig. 12.5 As stated in Section 12.1, conventional current flow is taken to be in the direction of hole flow, that is, in the opposite direction to electron flow, hence the directions of the conventional current flow are as shown in Fig. 12.5

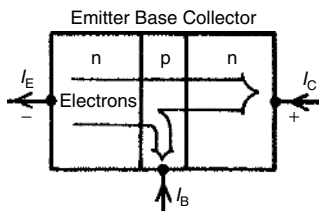

Figure 12.5

For a p-n-p transistor, the base-collector junction is reverse biased for majority carriers. However, a small leakage current, I_{CBO} flows from the base to the collector due to thermally generated minority carriers (electrons in the collector and holes in the base), being present.

The base-collector junction is forward biased to these minority carriers. If a proportion, α , (having a value of up to 0.995 in modern transistors), of the holes passing into the base from the emitter, pass through the base-collector junction, then the various currents flowing in a p-n-p transistor are as shown in Fig. 12.6(a).

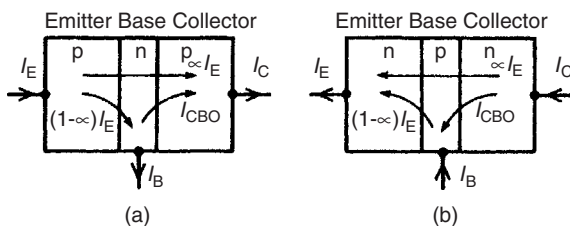

Figure 12.6

Similarly, for an n-p-n transistor, the base-collector junction is reversed biased for majority

carriers, but a small leakage current, I_{CBO} flows from the collector to the base due to thermally generated minority carriers (holes in the collector and electrons in the base), being present. The base-collector junction is forward biased to these minority carriers. If a proportion, α , of the electrons passing through the base-emitter junction also pass through the base-collector junction then the currents flowing in an n-p-n transistor are as shown in Fig. 12.6(b).

Problem 1. With reference to a p-n-p transistor, explain briefly what is meant by the term transistor action and why a bipolar junction transistor is so named.

For the transistor as depicted in Fig. 12.4, the emitter is relatively heavily doped with acceptor atoms (holes). When the emitter terminal is made sufficiently positive with respect to the base, the base-emitter junction is forward biased to the majority carriers. The majority carriers are holes in the emitter and these drift from the emitter to the base. The base region is relatively lightly doped with donor atoms (electrons) and although some electron-hole recombination's take place, perhaps 0.5 per cent, most of the holes entering the base, do not combine with electrons.

The base-collector junction is reverse biased to electrons in the base region, but forward biased to holes in the base region. Since the base is very thin and now is packed with holes, these holes pass the base-emitter junction towards the negative potential of the collector terminal. The control of current from emitter to collector is largely independent of the collector-base voltage and almost wholly governed by the emitter-base voltage. The essence of transistor action is this current control by means of the base-emitter voltage.

In a p-n-p transistor, holes in the emitter and collector regions are majority carriers, but are minority carriers when in the base region. Also, thermally generated electrons in the emitter and collector regions are minority carriers as are holes in the base region. However, both majority and minority carriers contribute towards the total current flow (see Fig. 12.6(a)). It is because a transistor makes use of both types of charge carriers (holes and electrons) that they are called bipolar. The transistor also comprises two p-n junctions and for this reason it is a junction transistor. Hence the name bipolar junction transistor.

12.3 Transistor symbols

Symbols are used to represent p-n-p and n-p-n transistors in circuit diagrams and are as shown in Fig. 12.7. The arrow head drawn on the emitter of the symbol is in the direction of conventional emitter current (hole flow). The potentials marked at the collector, base and emitter are typical values for a silicon transistor having a potential difference of 6 V between its collector and its emitter.

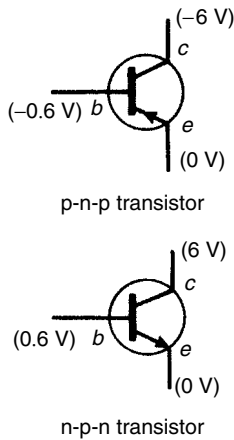

Figure 12.7

The voltage of 0.6 V across the base and emitter is that required to reduce the potential barrier and if it is raised slightly to, say, 0.62 V, it is likely that the collector current will double to about 2 mA. Thus a small change of voltage between the emitter and the base can give a relatively large change of current in the emitter circuit; because of this, transistors can be used as amplifiers (see Section 12.6).

12.4 Transistor connections

There are three ways of connecting a transistor, depending on the use to which it is being put. The ways are classified by the electrode which is common to both the input and the output. They are called:

- (a) common-base configuration, shown in Fig. 12.8(a)
- (b) common-emitter configuration, shown in Fig. 12.8(b)

- (c) common-collector configuration, shown in Fig. 12.8(c)

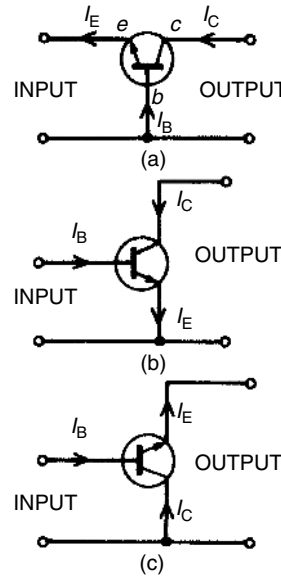

Figure 12.8

These configurations are for an n-p-n transistor. The current flows shown are all reversed for a p-n-p transistor.

Problem 2. The basic construction of an n-p-n transistor makes it appear that the emitter and collector can be interchanged. Explain why this is not usually done.

In principle, a bipolar junction transistor will work equally well with either the emitter or collector acting as the emitter. However, the conventional emitter current largely flows from the collector through the base to the emitter, hence the emitter region is far more heavily doped with donor atoms (electrons) than the base is with acceptor atoms (holes). Also, the base-collector junction is normally reverse biased and in general, doping density increases the electric field in the junction and so lowers the breakdown voltage. Thus, to achieve a high breakdown voltage, the collector region is relatively lightly doped.

In addition, in most transistors, the method of production is to diffuse acceptor and donor atoms onto the n-type semiconductor material, one after the other, so that one overrides the other. When this

is done, the doping density in the base region is not uniform but decreases from emitter to collector. This results in increasing the effectiveness of the transistor. Thus, because of the doping densities in the three regions and the non-uniform density in the base, the collector and emitter terminals of a transistor should not be interchanged when making transistor connections.

12.5 Transistor characteristics

The effect of changing one or more of the various voltages and currents associated with a transistor circuit can be shown graphically and these graphs are called the **characteristics** of the transistor. As there are five variables (collector, base and emitter currents, and voltages across the collector and base and emitter and base) and also three configurations, many characteristics are possible. Some of the possible characteristics are given below.

(a) Common-base configuration

(i) **Input characteristic.** With reference to Fig. 12.8(a), the input to a common-base transistor is the emitter current, I_E , and can be varied by altering the base emitter voltage V_{EB} . The base-emitter junction is essentially a forward biased junction diode, so as V_{EB} is varied, the current flowing is similar to that for a junction diode, as shown in Fig. 12.9 for a silicon transistor. Figure 12.9 is called the input characteristic for an n-p-n transistor having common-base configuration. The variation of the collector-base voltage V_{CB}

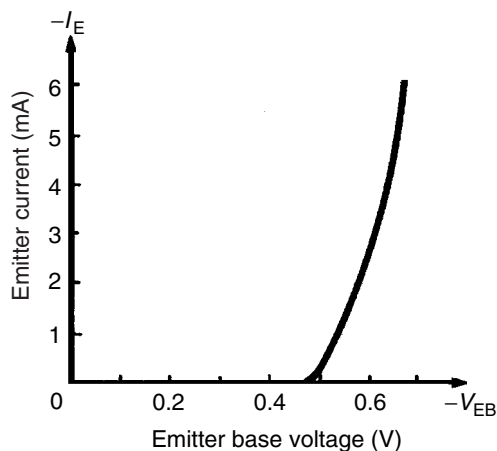

Figure 12.9

has little effect on the characteristic. A similar characteristic can be obtained for a p-n-p transistor, these having reversed polarities.

(ii) **Output characteristics.** The value of the collector current I_C is very largely determined by the emitter current, I_E . For a given value of I_E the collector-base voltage, V_{CB} , can be varied and has little effect on the value of I_C . If V_{CB} is made slightly negative, the collector no longer attracts the majority carriers leaving the emitter and I_C falls rapidly to zero. A family of curves for various values of I_E are possible and some of these are shown in Fig. 12.10. Figure 12.10 is called the output characteristics for an n-p-n transistor having common-base configuration. Similar characteristics can be obtained for a p-n-p transistor, these having reversed polarities.

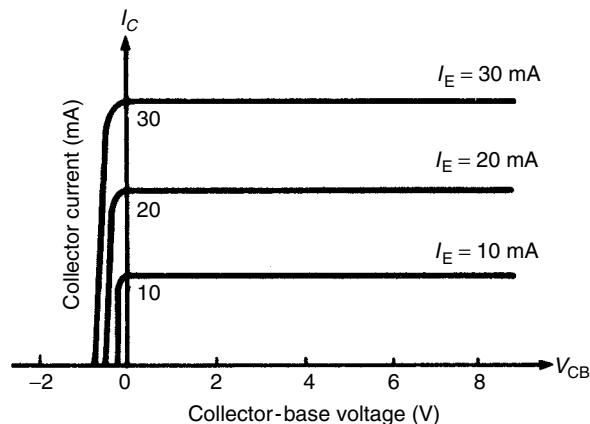

Figure 12.10

(b) Common-emitter configuration

(i) **Input characteristic.** In a common-emitter configuration (see Fig. 12.8(b)), the base current is now the input current. As V_{EB} is varied, the characteristic obtained is similar in shape to the input characteristic for a common-base configuration shown in Fig. 12.9, but the values of current are far less. With reference to Fig. 12.6(a), as long as the junctions are biased as described, the three currents I_E , I_C and I_B keep the ratio $1:\alpha:(1-\alpha)$, whichever configuration is adopted. Thus the base current changes are much smaller than the corresponding emitter current changes and the input characteristic for an n-p-n transistor is as shown in Fig. 12.11. A similar characteristic can be obtained for a p-n-p transistor, these having reversed polarities.

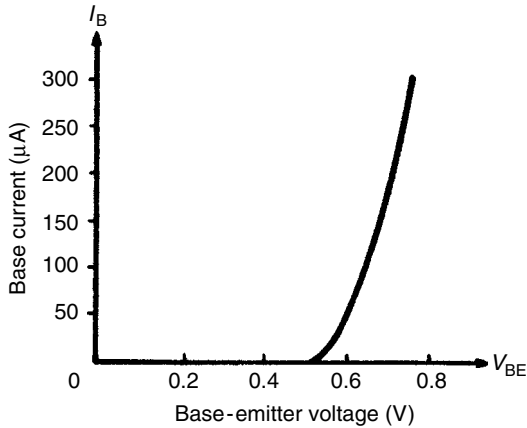

Figure 12.11

(ii) **Output characteristics.** A family of curves can be obtained, depending on the value of base current I_B and some of these for an n-p-n transistor are shown in Fig. 12.12. A similar set of characteristics can be obtained for a p-n-p transistor, these having reversed polarities. These characteristics differ from the common base output characteristics in two ways: the collector current reduces to zero without having to reverse the collector voltage, and the characteristics slope upwards indicating a lower output resistance (usually kilohms for a common-emitter configuration compared with megohms for a common-base configuration).

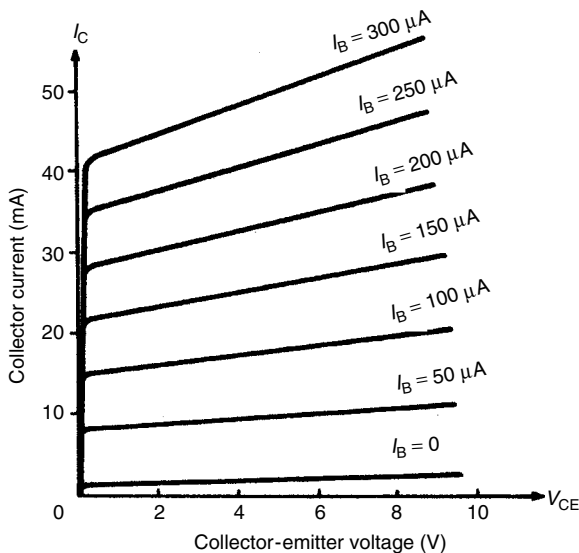

Figure 12.12

Problem 3. With the aid of a circuit diagram, explain how the input and output characteristics of an n-p-n transistor having a common-base configuration can be obtained.

A circuit diagram for obtaining the input and output characteristics for an n-p-n transistor connected in common-base configuration is shown in Fig. 12.13. The input characteristic can be obtained by varying R_1 , which varies V_{EB} , and noting the corresponding values of I_E . This is repeated for various values of V_{CB} . It will be found that the input characteristic is almost independent of V_{CB} and it is usual to give only one characteristic, as shown in Fig. 12.9

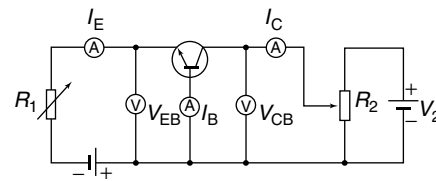

Figure 12.13

To obtain the output characteristics, as shown in Fig. 12.10, I_E is set to a suitable value by adjusting R_1 . For various values of V_{CB} , set by adjusting R_2 , I_C is noted. This procedure is repeated for various values of I_E . To obtain the full characteristics, the polarity of battery V_2 has to be reversed to reduce I_C to zero. This must be done very carefully or else values of I_C will rapidly increase in the reverse direction and burn out the transistor.

Now try the following exercise

Exercise 61 Further problems on transistors

- 1 Explain with the aid of sketches, the operation of an n-p-n transistor and also explain why the collector current is very nearly equal to the emitter current.
- 2 Explain what is meant by the term ‘transistor action’.
- 3 Describe the basic principle of operation of a bipolar junction transistor including why majority carriers crossing into the base from the emitter pass to the collector and why the

collector current is almost unaffected by the collector potential.

- 4 For a transistor connected in common-emitter configuration, sketch the output characteristics relating collector current and the collector-emitter voltage, for various values of base current. Explain the shape of the characteristics.
- 5 Sketch the input characteristic relating emitter current and the emitter-base voltage for a transistor connected in common-base configuration, and explain its shape.
- 6 With the aid of a circuit diagram, explain how the output characteristics of an n-p-n transistor having common-base configuration may be obtained and any special precautions which should be taken.
- 7 Draw sketches to show the direction of the flow of leakage current in both n-p-n and p-n-p transistors. Explain the effect of leakage current on a transistor connected in common-base configuration.
- 8 Using the circuit symbols for transistors show how (a) common-base, and (b) common-emitter configuration can be achieved. Mark on the symbols the inputs, the outputs, polarities under normal operating conditions to give correct biasing and current directions.
- 9 Draw a diagram showing how a transistor can be used in common emitter configuration. Mark on the sketch the input, output, polarities under normal operating conditions and current directions.
- 10 Sketch the circuit symbols for (a) a p-n-p and (b) an n-p-n transistor. Mark on the emitter electrodes the direction of conventional current flow and explain why the current flows in the direction indicated.

12.6 The transistor as an amplifier

The amplifying properties of a transistor depend upon the fact that current flowing in a low-resistance circuit is transferred to a high-resistance circuit with negligible change in magnitude. If the current

then flows through a load resistance, a voltage is developed. This voltage can be many times greater than the input voltage which caused the original current flow.

(a) Common-base amplifier

The basic circuit for a transistor is shown in Fig. 12.14 where an n-p-n transistor is biased with batteries b_1 and b_2 . A sinusoidal alternating input signal, v_e , is placed in series with the input bias voltage, and a load resistor, R_L , is placed in series with the collector bias voltage. The input signal is therefore the sinusoidal current i_e resulting from the application of the sinusoidal voltage v_e **superimposed** on the direct current I_E established by the base-emitter voltage V_{BE} .

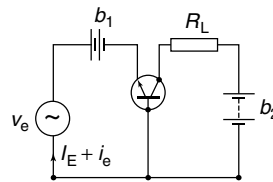

Figure 12.14

Let the signal voltage v_e be 100 mV and the base-emitter circuit resistance be 50Ω . Then the emitter signal current will be $100/50 = 2$ mA. Let the load resistance $R_L = 2.5 \text{ k}\Omega$. About 0.99 of the emitter current will flow in R_L . Hence the collector signal current will be about $0.99 \times 2 = 1.98$ mA and the signal voltage across the load will be $2500 \times 1.98 \times 10^{-3} = 4.95$ V. Thus a signal voltage of 100 mV at the emitter has produced a voltage of 4950 mV across the load. The voltage amplification or gain is therefore $4950/100 = 49.5$ times. This example illustrates the action of a common-base amplifier where the input signal is applied between emitter and base and the output is taken from between collector and base.

(b) Common-emitter amplifier

The basic circuit arrangement of a common-emitter amplifier is shown in Fig. 12.15. Although two batteries are shown, it is more usual to employ only one to supply all the necessary bias. The input signal is applied between base and emitter, and the load resistor R_L is connected between collector and emitter. Let the base bias battery provide a voltage which causes a base current I_B of 0.1 mA to flow. This value of base current determines the mean d.c.

level upon which the a.c. input signal will be superimposed. This is the **d.c. base current operating point**.

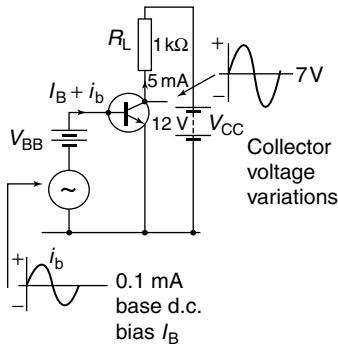

Figure 12.15

Let the static current gain of the transistor, α_E , be 50. Since 0.1 mA is the steady base current, the collector current I_C will be $\alpha_E \times I_B = 50 \times 0.1 = 5 \text{ mA}$. This current will flow through the load resistor $R_L (= 1 \text{ k}\Omega)$, and there will be a steady voltage drop across R_L given by $I_C R_L = 5 \times 10^{-3} \times 1000 = 5 \text{ V}$. The voltage at the collector, V_{CE} , will therefore be $V_{CC} - I_C R_L = 12 - 5 = 7 \text{ V}$. This value of V_{CE} is the mean (or quiescent) level about which the output signal voltage will swing alternately positive and negative. This is the **collector voltage d.c. operating point**. Both of these d.c. operating points can be pin-pointed on the input and output characteristics of the transistor. Figure 12.16 shows the I_B/V_{BE} characteristic with the operating point X positioned at $I_B = 0.1 \text{ mA}$, $V_{BE} = 0.75 \text{ V}$, say.

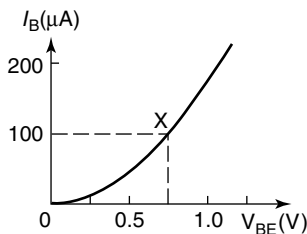

Figure 12.16

Figure 12.17 shows the I_C/V_{CE} characteristics, with the operating point Y positioned at $I_C = 5 \text{ mA}$, $V_{CE} = 7 \text{ V}$. It is usual to choose the operating point Y somewhere near the centre of the graph.

It is possible to remove the bias battery V_{BB} and obtain base bias from the collector supply battery

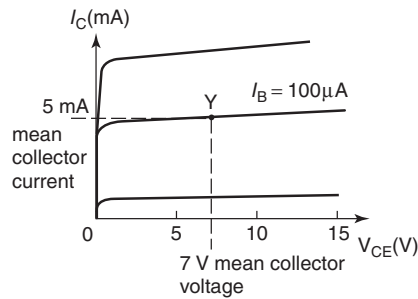

Figure 12.17

V_{CC} instead. The simplest way to do this is to connect a bias resistor R_B between the positive terminal of the V_{CC} supply and the base as shown in Fig. 12.18 The resistor must be of such a value that it allows 0.1 mA to flow in the base-emitter diode.

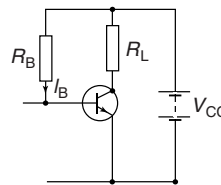

Figure 12.18

For a silicon transistor, the voltage drop across the junction for forward bias conditions is about 0.6 V. The voltage across R_B must then be $12 - 0.6 = 11.4 \text{ V}$. Hence, the value of R_B must be such that $I_B \times R_B = 11.4 \text{ V}$, i.e.

$$R_B = 11.4 / I_B = 11.4 / (0.1 \times 10^{-3}) = 114 \text{ k}\Omega.$$

With the inclusion of the $1 \text{ k}\Omega$ load resistor, R_L , a steady 5 mA collector current, and a collector-emitter voltage of 7 V, the d.c. conditions are established.

An alternating input signal (v_i) can now be applied. In order not to disturb the bias condition established at the base, the input must be fed to the base by way of a capacitor C_1 . This will permit the alternating signal to pass to the base but will prevent the passage of direct current. The reactance of this capacitor must be such that it is very small compared with the input resistance of the transistor. The circuit of the amplifier is now as shown in Fig. 12.19 The a.c. conditions can now be determined.

When an alternating signal voltage v_1 is applied to the base via capacitor C_1 the base current i_b varies. When the input signal swings positive, the base current increases; when the signal swings negative, the base current decreases. The base current consists of two components: I_B , the static base bias established

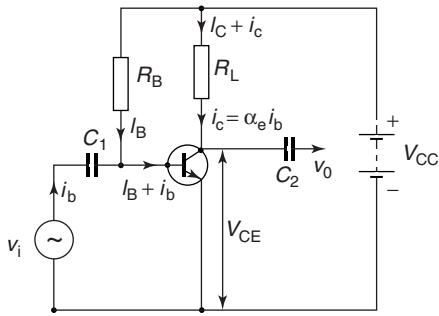

Figure 12.19

by R_B , and i_b , the signal current. The current variation i_b will in turn vary the collector current, i_c . The relationship between i_c and i_b is given by $i_c = \alpha_e i_b$, where α_e is the **dynamic current gain** of the transistor and is not quite the same as the static current gain α_e ; the difference is usually small enough to be insignificant.

The current through the load resistor R_L also consists of two components: I_C , the static collector current, and i_c , the signal current. As i_b increases, so does i_c and so does the voltage drop across R_L . Hence, from the circuit:

$$V_{CE} = V_{CC} - (I_C + i_c)R_L$$

The d.c. components of this equation, though necessary for the amplifier to operate at all, need not be considered when the a.c. signal conditions are being examined. Hence, the signal voltage variation relationship is:

$$V_{CE} = -\alpha_e \times i_b \times R_L = i_c R_L$$

the negative sign being added because V_{CE} decreases when i_b increases and vice versa. The signal output and input voltages are of opposite polarity i.e. a phase shift of 180° has occurred. So that the collector d.c. potential is not passed on to the following stage, a second capacitor, C_2 , is added as shown in Fig. 12.19. This removes the direct component but permits the signal voltage $v_o = i_c R_L$ to pass to the output terminals.

12.7 The load line

The relationship between the collector-emitter voltage (V_{CE}) and collector current (I_C) is given by the equation: $V_{CE} = V_{CC} - I_C R_L$ in terms of the **d.c. conditions**. Since V_{CC} and R_L are constant in any given circuit, this represents the equation of a

straight line which can be written in the $y = mx + c$ form. Transposing $V_{CE} = V_{CC} - I_C R_L$ for I_C gives:

$$I_C = \frac{V_{CC} - V_{CE}}{R_L} = \frac{V_{CC}}{R_L} - \frac{V_{CE}}{R_L}$$

$$= -\left(\frac{1}{R_L}\right) V_{CE} + \frac{V_{CC}}{R_L}$$

i.e.
$$I_C = -\left(\frac{1}{R_L}\right) V_{CE} + \frac{V_{CC}}{R_L}$$

which is of the straight line form $y = mx + c$; hence if I_C is plotted vertically and V_{CE} horizontally, then the gradient is given by $-(1/R_L)$ and the vertical axis intercept is V_{CC}/R_L .

A family of collector static characteristics drawn on such axes is shown in Fig. 12.12 on page 141, and so the line may be superimposed on these as shown in Fig. 12.20

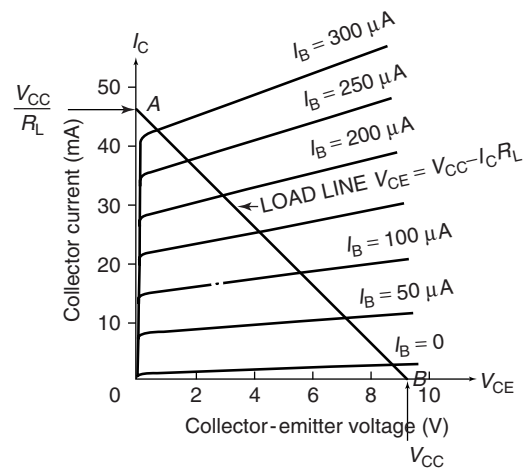

Figure 12.20

The reason why this line is necessary is because the static curves relate I_C to V_{CE} for a series of fixed values of I_B . When a signal is applied to the base of the transistor, the base current varies and can instantaneously take any of the values between the extremes shown. Only two points are necessary to draw the line and these can be found conveniently by considering extreme conditions. From the equation:

$$V_{CE} = V_{CC} - I_C R_L$$

(i) when $I_C = 0$, $V_{CE} = V_{CC}$

(ii) when $V_{CE} = 0$, $I_C = \frac{V_{CC}}{R_L}$

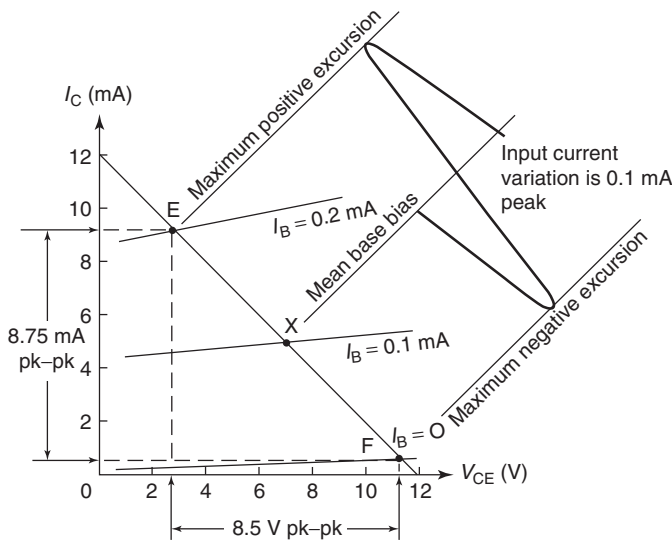

Figure 12.21

Thus the points *A* and *B* respectively are located on the axes of the I_C/V_{CE} characteristics. This line is called the **load line** and it is dependent for its position upon the value of V_{CC} and for its gradient upon R_L . As the gradient is given by $-(1/R_L)$, the slope of the line is negative.

For every value assigned to R_L in a particular circuit there will be a corresponding (and different) load line. If V_{CC} is maintained constant, all the possible lines will start at the same point (*B*) but will cut the I_C axis at different points *A*. Increasing R_L will reduce the gradient of the line and vice-versa. Quite clearly the collector voltage can never exceed V_{CC} (point *B*) and equally the collector current can never be greater than that value which would make V_{CE} zero (point *A*).

Using the circuit example of Fig. 12.15, we have

$$V_{CE} = V_{CC} = 12 \text{ V, when } I_C = 0$$

$$I_C = \frac{V_{CC}}{R_L}$$

$$= \frac{12}{1000} = 12 \text{ mA, when } V_{CE} = 0$$

The load line is drawn on the characteristics shown in Fig. 12.21 which we assume are characteristics for the transistor used in the circuit of Fig. 12.15 earlier. Notice that the load line passes through the operating point *X* as it should, since every position on the line represents a relationship between V_{CE} and I_C for the particular values of V_{CC} and R_L given. Suppose that the base current is caused to

vary ± 0.1 mA about the d.c. base bias of 0.1 mA. The result is I_B changes from 0 mA to 0.2 mA and back again to 0 mA during the course of each input cycle. Hence the operating point moves up and down the load line in phase with the input current and hence the input voltage. A sinusoidal input cycle is shown on Fig. 12.21

12.8 Current and voltage gains

The output signal voltage (V_{CE}) and current (i_C) can be obtained by projecting vertically from the load line on to V_{CE} and I_C axes respectively. When the input current i_b varies sinusoidally as shown in Fig. 12.21, then V_{CE} varies sinusoidally if the points *E* and *F* at the extremities of the input variations are equally spaced on either side of *X*.

The peak-to-peak output voltage is seen to be 8.5 V, giving an r.m.s. value of 3 V (i.e. $0.707 \times 8.5/2$). The peak-to-peak output current is 8.75 mA, giving an r.m.s. value of 3.1 mA. From these figures the voltage and current amplifications can be obtained.

The **dynamic current gain** $A_i (= \alpha_e)$ as opposed to the static gain α_E , is given by:

$$A_i = \frac{\text{change in collector current}}{\text{change in base current}}$$

This always leads to a different figure from that obtained by the direct division of I_C/I_B which

assumes that the collector load resistor is zero. From Fig. 12.21 the peak input current is 0.1 mA and the peak output current is 4.375 mA. Hence

$$A_i = \frac{4.375 \times 10^{-3}}{0.1 \times 10^{-3}} = 43.75$$

The **voltage gain** A_v is given by:

$$A_v = \frac{\text{change in collector voltage}}{\text{change in base voltage}}$$

This cannot be calculated from the data available, but if we assume that the base current flows in the input resistance, then the base voltage can be determined. The input resistance can be determined from an input characteristic such as was shown earlier.

$$\text{Then } R_i = \frac{\text{change in } V_{BC}}{\text{change in } I_B}$$

$$\text{and } v_i = i_b R_C \text{ and } v_o = i_C R_L$$

$$\text{and } A_v = \frac{i_C R_L}{I_b R_i} = \alpha_e \frac{R_L}{R_i}$$

For a resistive load, power gain, A_p , is given by

$$A_p = A_v \times A_i$$

Problem 4. An n-p-n transistor has the following characteristics which may be assumed to be linear between the values of collector voltage stated.

Base current (μA)	Collector current (mA) for collector voltages of	
	1 V	5 V
30	1.4	1.6
50	3.0	3.5
70	4.6	5.2

The transistor is used as a common-emitter amplifier with load resistor $R_L = 1.2 \text{ k}\Omega$ and a collector supply of 7 V. The signal input resistance is $1 \text{ k}\Omega$. Estimate the voltage gain A_v , the current gain A_i and the power gain A_p when an input current of $20 \mu\text{A}$ peak varies sinusoidally about a mean bias of $50 \mu\text{A}$.

The characteristics are drawn in Fig. 12.22. The load line equation is $V_{CC} = V_{CE} + I_C R_L$ which enables the extreme points of the line to be calculated.

$$\text{When } I_C = 0, V_{CE} = V_C = 7.0 \text{ V}$$

$$\text{and when } V_{CE} = 0, I_C = \frac{V_{CC}}{R_L} = \frac{7}{1200} = 5.83 \text{ mA}$$

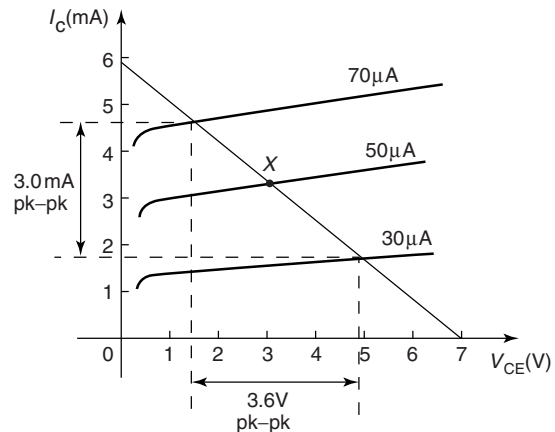

Figure 12.22

The load line is shown superimposed on the characteristic curves with the operating point marked X at the intersection of the line and the $50 \mu\text{A}$ characteristic.

From the diagram, the output voltage swing is 3.6 V peak-to-peak. The input voltage swing is $i_b R_i$ where i_b is the base current swing and R_i is the input resistance.

Therefore $v_i = 40 \times 10^{-6} \times 1 \times 10^3 = 40 \text{ mV}$ peak-to-peak. Hence, **voltage gain**,

$$A_v = \frac{\text{output volts}}{\text{input volts}} = \frac{3.6}{40 \times 10^{-3}} = 90$$

Note that peak-to-peak values are taken at both input and output. There is no need to convert to r.m.s. as only ratios are involved.

From the diagram, the output current swing is 3.0 mA peak-to-peak. The input base current swing is $40 \mu\text{A}$ peak-to-peak. Hence, **current gain**,

$$A_i = \frac{\text{output current}}{\text{input current}} = \frac{3 \times 10^{-3}}{40 \times 10^{-6}} = 75$$

For a resistance load R_L the **power gain**, A_p is given by:

$$A_p = \text{voltage gain} \times \text{current gain}$$

$$= A_v \times A_i = 90 \times 75 = \mathbf{6750}$$

12.9 Thermal runaway

When a transistor is used as an amplifier it is necessary to ensure that it does not overheat. Overheating can arise from causes outside of the transistor itself, such as the proximity of radiators or hot resistors, or within the transistor as the result of dissipation by the passage of current through it. Power dissipated within the transistor which is given approximately by the product $I_C V_{CE}$ is wasted power; it contributes nothing to the signal output power and merely raises the temperature of the transistor. Such overheating can lead to very undesirable results.

The increase in the temperature of a transistor will give rise to the production of hole electron pairs, hence an increase in leakage current represented by the additional minority carriers. In turn, this leakage current leads to an increase in collector current and this increases the product $I_C V_{CE}$. The whole effect thus becomes self-perpetuating and results in **thermal runaway**. This rapidly leads to the destruction of the transistor.

Problem 5. Explain how thermal runaway might be prevented in a transistor

Two basic methods are available and either or both may be used in a particular application.

Method 1

One approach is in the circuit design itself. The use of a single biasing resistor R_B as shown earlier in Fig. 12.18 is not particularly good practice. If the temperature of the transistor increases, the leakage current also increases. The collector current, collector voltage and base current are thereby changed, the base current decreasing as I_C increases. An alternative is shown in Fig. 12.23. Here the resistor R_B is returned, not to the V_{CC} line, but to the collector itself.

If the collector current increases for any reason, the collector voltage V_{CE} will fall. Therefore, the d.c. base current I_B will fall, since $I_B = V_{CE}/R_B$.

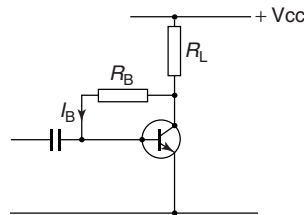

Figure 12.23

Hence the collector current $I_C = \alpha_E I_B$ will also fall and compensate for the original increase.

A commonly used bias arrangement is shown in Fig. 12.24. If the total resistance value of resistors R_1 and R_2 is such that the current flowing through the divider is large compared with the d.c. bias current I_B , then the base voltage V_{BE} will remain substantially constant regardless of variations in collector current. The emitter resistor R_E in turn determines the value of emitter current which flows for a given base voltage at the junction of R_1 and R_2 . Any increase in I_C produces an increase in I_E and a corresponding increase in the voltage drop across R_E . This reduces the forward bias voltage V_{BE} and leads to a compensating reduction in I_C .

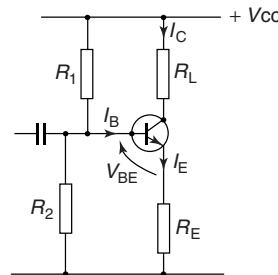

Figure 12.24

Method 2

A second method concerns some means of keeping the transistor temperature down by external cooling. For this purpose, a heat sink is employed, as shown in Fig. 12.25. If the transistor is clipped or bolted to

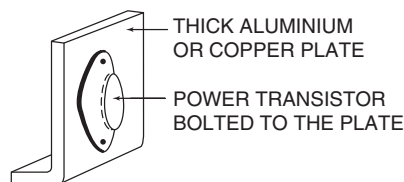

Figure 12.25

a large conducting area of aluminium or copper plate (which may have cooling fins), cooling is achieved by convection and radiation.

Heat sinks are usually blackened to assist radiation and are normally used where large power dissipation's are involved. With small transistors, heat sinks are unnecessary. Silicon transistors particularly have such small leakage currents that thermal problems rarely arise.

Now try the following exercises

Exercise 62 Further problems on the transistor as an amplifier

- State whether the following statements are true or false:
 - The purpose of a transistor amplifier is to increase the frequency of an input signal
 - The gain of an amplifier is the ratio of the output signal amplitude to the input signal amplitude
 - The output characteristics of a transistor relate the collector current to the base voltage.
 - The equation of the load line is $V_{CE} = V_{CC} - I_C R_L$
 - If the load resistor value is increased the load line gradient is reduced
 - In a common-emitter amplifier, the output voltage is shifted through 180° with reference to the input voltage
 - In a common-emitter amplifier, the input and output currents are in phase
 - If the temperature of a transistor increases, V_{BE} , I_C and α_E all increase
 - A heat sink operates by artificially increasing the surface area of a transistor
 - The dynamic current gain of a transistor is always greater than the static current
 - false
 - true
 - false
 - true
 - true
 - true
 - true
 - false (V_{BE} decreases)
 - true
 - true
- An amplifier has $A_i = 40$ and $A_v = 30$. What is the power gain? [1200]
- What will be the gradient of a load line for a load resistor of value $4\text{ k}\Omega$? What unit is the gradient measured in? [-1/4000 siemen]

- A transistor amplifier, supplied from a 9 V battery, requires a d.c. bias current of $100\text{ }\mu\text{A}$. What value of bias resistor would be connected from base to the V_{CC} line (a) if V_{CE} is ignored (b) if V_{CE} is 0.6 V ?
[(a) $90\text{ k}\Omega$ (b) $84\text{ k}\Omega$]

- The output characteristics of a transistor in common-emitter configuration can be regarded as straight lines connecting the following points

	$I_B = 20\text{ }\mu\text{A}$		$50\text{ }\mu\text{A}$		$80\text{ }\mu\text{A}$	
V_{CE} (V)	1.0	8.0	1.0	8.0	1.0	8.0
I_C (mA)	1.2	1.4	3.4	4.2	6.1	8.1

Plot the characteristics and superimpose the load line for a $1\text{ k}\Omega$ load, given that the supply voltage is 9 V and the d.c. base bias is $50\text{ }\mu\text{A}$. The signal input resistance is $800\text{ }\Omega$. When a peak input current of $30\text{ }\mu\text{A}$ varies sinusoidally about a mean bias of $50\text{ }\mu\text{A}$, determine (a) the quiescent collector current (b) the current gain (c) the voltage gain (d) the power gain
[(a) 4 mA (b) 104 (c) 83 (d) 8632]

Exercise 63 Short answer questions on transistors

- In a p-n-p transistor the p-type material regions are called the and, and the n-type material region is called the
- In an n-p-n transistor, the p-type material region is called the and the n-type material regions are called the and the
- In a p-n-p transistor, the base-emitter junction is biased and the base-collector junction is biased.
- In an n-p-n transistor, the base-collector junction is biased and the base-emitter junction is biased.
- Majority charge carriers in the emitter of a transistor pass into the base region. Most of them do not recombine because the base is doped.

- 6 Majority carriers in the emitter region of a transistor pass the base-collector junction because for these carriers it is biased.
- 7 Conventional current flow is in the direction of flow.
- 8 Leakage current flows from to in an n-p-n transistor.
- 9 The input characteristic of I_E against V_{EB} for a transistor in common-base configuration is similar in shape to that of a
- 10 The output resistance of a transistor connected in common-emitter configuration is than that of a transistor connected in common-base configuration.
- 11 Complete the following statements that refer to a transistor amplifier:
 - (a) An increase in base current causes collector current to
 - (b) When base current increases, the voltage drop across the load resistor
 - (c) Under no-signal conditions the power supplied by the battery to an amplifier equals the power dissipated in the load plus the power dissipated in the
 - (d) The load line has a gradient
 - (e) The gradient of the load line depends upon the value of
 - (f) The position of the load line depends upon
 - (g) The current gain of a common-emitter amplifier is always greater than
 - (h) The operating point is generally positioned at the of the load line
- 12 Draw a circuit diagram showing how a transistor can be used as a common-emitter amplifier. Explain briefly the purpose of all the components you show in your diagram.
- 13 Explain briefly what is meant by 'thermal runaway'.

Exercise 64 Multi-choice problems on transistors (Answers on page 375)

In Problems 1 to 10 select the correct answer from those given.

- 1 In normal operation, the junctions of a p-n-p transistor are:
 - (a) both forward biased
 - (b) base-emitter forward biased and base-collector reverse biased
 - (c) both reverse biased
 - (d) base-collector forward biased and base-emitter reverse biased.
- 2 In normal operation, the junctions of an n-p-n transistor are:
 - (a) both forward biased
 - (b) base-emitter forward biased and base-collector reverse biased
 - (c) both reverse biased
 - (d) base-collector forward biased and base-emitter reverse biased
- 3 The current flow across the base-emitter junction of a p-n-p transistor consists of
 - (a) mainly electrons
 - (b) equal numbers of holes and electrons
 - (c) mainly holes
 - (d) the leakage current
- 4 The current flow across the base-emitter junction of an n-p-n transistor consists of
 - (a) mainly electrons
 - (b) equal numbers of holes and electrons
 - (c) mainly holes
 - (d) the leakage current
- 5 In normal operation an n-p-n transistor connected in common-base configuration has
 - (a) the emitter at a lower potential than the base
 - (b) the collector at a lower potential than the base
 - (c) the base at a lower potential than the emitter
 - (d) the collector at a lower potential than the emitter
- 6 In normal operation, a p-n-p transistor connected in common-base configuration has
 - (a) the emitter at a lower potential than the base
 - (b) the collector at a higher potential than the base
 - (c) the base at a higher potential than the emitter
 - (d) the collector at a lower potential than the emitter.
- 7 If the per unit value of electrons which leave the emitter and pass to the collector, α , is 0.9

in an n-p-n transistor and the emitter current is 4 mA, then

- the base current is approximately 4.4 mA
- the collector current is approximately 3.6 mA
- the collector current is approximately 4.4 mA
- the base current is approximately 3.6 mA

8 The base region of a p-n-p transistor is

- very thin and heavily doped with holes
- very thin and heavily doped with electrons
- very thin and lightly doped with holes
- very thin and lightly doped with electrons

9 The voltage drop across the base-emitter junction of a p-n-p silicon transistor in normal operation is about

- 200 mV
- 600 mV
- zero
- 4.4 V

10 For a p-n-p transistor,

- the number of majority carriers crossing the base-emitter junction largely depends on the collector voltage
- in common-base configuration, the collector current is proportional to the collector-base voltage
- in common-emitter configuration, the base current is less than the base current in common-base configuration
- the collector current flow is independent of the emitter current flow for a given value of collector-base voltage.

In questions 11 to 15, which refer to the amplifier shown in Fig. 12.26, select the correct answer from those given

11 If R_L short-circuited:

- the amplifier signal output would fall to zero
- the collector current would fall to zero
- the transistor would overload

12 If R_2 open-circuited:

- the amplifier signal output would fall to zero
- the operating point would be affected and the signal would distort
- the input signal would not be applied to the base

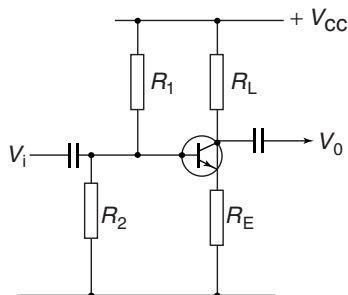

Figure 12.26

13 A voltmeter connected across R_E reads zero. Most probably

- the transistor base-emitter junction has short-circuited
- R_L has open-circuited
- R_2 has short-circuited

14 A voltmeter connected across R_L reads zero. Most probably

- the V_{CC} supply battery is flat
- the base collector junction of the transistor has gone open circuit
- R_L has open-circuited

15 If R_E short-circuited:

- the load line would be unaffected
- the load line would be affected

In questions 16 to 20, which refer to the output characteristics shown in Fig. 12.27, select the correct answer from those given

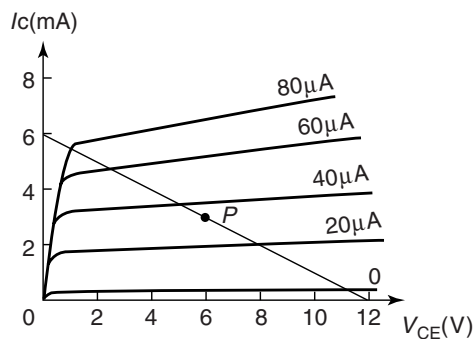

Figure 12.27

16 The load line represents a load resistor of

- 1 k Ω
- 2 k Ω
- 3 k Ω
- 0.5 k Ω

17 The no-signal collector dissipation for the operating point marked P is

- (a) 12 mW (b) 15 mW
(c) 18 mW (d) 21 mW

18 The greatest permissible peak input current would be about

- (a) 30 μA (b) 35 μA
(c) 60 μA (d) 80 μA

19 The greatest possible peak output voltage would then be about

- (a) 5.2 V (b) 6.5 V
(c) 8.8 V (d) 13 V

20 The power dissipated in the load resistor under no-signal conditions is:

- (a) 16 mW (b) 18 mW
(c) 20 mW (d) 22 mW

Assignment 3

This assignment covers the material contained in Chapters 8 to 12.

The marks for each question are shown in brackets at the end of each question.

- 1 A conductor, 25 cm long is situated at right angles to a magnetic field. Determine the strength of the magnetic field if a current of 12 A in the conductor produces a force on it of 4.5 N. (3)
- 2 An electron in a television tube has a charge of 1.5×10^{-19} C and travels at 3×10^7 m/s perpendicular to a field of flux density $20 \mu\text{T}$. Calculate the force exerted on the electron in the field. (3)
- 3 A lorry is travelling at 100 km/h. Assuming the vertical component of the earth's magnetic field is $40 \mu\text{T}$ and the back axle of the lorry is 1.98 m, find the e.m.f. generated in the axle due to motion. (5)
- 4 An e.m.f. of 2.5 kV is induced in a coil when a current of 2 A collapses to zero in 5 ms. Calculate the inductance of the coil. (4)
- 5 Two coils, *P* and *Q*, have a mutual inductance of 100 mH. If a current of 3 A in coil *P* is reversed in 20 ms, determine (a) the average e.m.f. induced in coil *Q*, and (b) the flux change linked with coil *Q* if it wound with 200 turns. (5)
- 6 A moving coil instrument gives a f.s.d. when the current is 50 mA and has a resistance of 40Ω . Determine the value of resistance required to enable the instrument to be used (a) as a 0–5 A ammeter, and (b) as a 0–200 V voltmeter. State the mode of connection in each case. (6)
- 7 An amplifier has a gain of 20 dB. Its input power is 5 mW. Calculate its output power. (3)
- 8 A sinusoidal voltage trace displayed on a c.r.o. is shown in Figure A3.1; the 'time/cm' switch is

on 50 ms and the 'volts/cm' switch is on 2 V/cm. Determine for the waveform (a) the frequency (b) the peak-to-peak voltage (c) the amplitude (d) the r.m.s. value. (7)

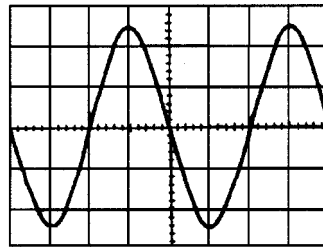

Figure A3.1

- 9 Explain, with a diagram, how semiconductor diodes may be used to give full wave rectification. (5)
- 10 The output characteristics of a common-emitter transistor amplifier are given below. Assume that the characteristics are linear between the values of collector voltage stated.

	$I_B = 10 \mu\text{A}$		$40 \mu\text{A}$		$70 \mu\text{A}$	
$V_{CE}(\text{V})$	1.0	7.0	1.0	7.0	1.0	7.0
$I_C(\text{mA})$	0.6	0.7	2.5	2.9	4.6	5.35

Plot the characteristics and superimpose the load line for a $1.5 \text{ k}\Omega$ load resistor and collector supply voltage of 8 V. The signal input resistance is $1.2 \text{ k}\Omega$. Determine (a) the voltage gain (b) the current gain (c) the power gain when an input current of $30 \mu\text{A}$ peak varies sinusoidally about a mean bias of $40 \mu\text{A}$. (9)

Formulae for basic electrical and electronic engineering principles

GENERAL:

Charge $Q = It$ Force $F = ma$

Work $W = Fs$ Power $P = \frac{W}{t}$

Energy $W = Pt$

Ohm's law $V = IR$ or $I = \frac{V}{R}$ or $R = \frac{V}{I}$

Conductance $G = \frac{1}{R}$ Resistance $R = \frac{\rho l}{a}$

Power $P = VI = I^2R = \frac{V^2}{R}$

Resistance at $\theta^\circ\text{C}$, $R_\theta = R_0(1 + \alpha_0\theta)$

Terminal p.d. of source, $V = E - Ir$

Series circuit $R = R_1 + R_2 + R_3 + \dots$

Parallel network $\frac{1}{R} = \frac{1}{R_1} + \frac{1}{R_2} + \frac{1}{R_3} + \dots$

CAPACITORS AND CAPACITANCE:

$E = \frac{V}{d}$ $C = \frac{Q}{V}$ $Q = It$ $D = \frac{Q}{A}$

$\frac{D}{E} = \epsilon_0\epsilon_r$ $C = \frac{\epsilon_0\epsilon_r A(n-1)}{d}$ $W = \frac{1}{2}CV^2$

Capacitors in parallel $C = C_1 + C_2 + C_3 + \dots$

Capacitors in series $\frac{1}{C} = \frac{1}{C_1} + \frac{1}{C_2} + \frac{1}{C_3} + \dots$

MAGNETIC CIRCUITS:

$B = \frac{\Phi}{A}$ $F_m = NI$ $H = \frac{NI}{l}$ $\frac{B}{H} = \mu_0\mu_r$

$S = \frac{mmf}{\Phi} = \frac{l}{\mu_0\mu_r A}$

ELECTROMAGNETISM:

$F = Bil \sin \theta$ $F = QvB$

ELECTROMAGNETIC INDUCTION:

$E = Blv \sin \theta$ $E = -N \frac{d\Phi}{dt} = -L \frac{dI}{dt}$

$W = \frac{1}{2}LI^2$ $L = \frac{N\Phi}{I}$ $E_2 = -M \frac{dI_1}{dt}$

MEASUREMENTS:

Shunt $R_s = \frac{I_a r_a}{I_s}$ Multiplier $R_M = \frac{V - Ir_a}{I}$

$$\begin{aligned}\text{Power in decibels} &= 10 \log \frac{P_2}{P_1} \\ &= 20 \log \frac{I_2}{I_1} \\ &= 20 \log \frac{V_2}{V_1}\end{aligned}$$

$$\text{Wheatstone bridge } R_X = \frac{R_2 R_3}{R_1}$$

$$\text{Potentiometer } E_2 = E_1 \left(\frac{l_2}{l_1} \right)$$

Section 2

Further Electrical and Electronic Principles

D.C. circuit theory

At the end of this chapter you should be able to:

- state and use Kirchhoff's laws to determine unknown currents and voltages in d.c. circuits
- understand the superposition theorem and apply it to find currents in d.c. circuits
- understand general d.c. circuit theory
- understand Thévenin's theorem and apply a procedure to determine unknown currents in d.c. circuits
- recognize the circuit diagram symbols for ideal voltage and current sources
- understand Norton's theorem and apply a procedure to determine unknown currents in d.c. circuits
- appreciate and use the equivalence of the Thévenin and Norton equivalent networks
- state the maximum power transfer theorem and use it to determine maximum power in a d.c. circuit

13.1 Introduction

The laws which determine the currents and voltage drops in d.c. networks are: (a) Ohm's law (see Chapter 2), (b) the laws for resistors in series and in parallel (see Chapter 5), and (c) Kirchhoff's laws (see Section 13.2 following). In addition, there are a number of circuit theorems which have been developed for solving problems in electrical networks. These include:

- the superposition theorem (see Section 13.3),
- Thévenin's theorem (see Section 13.5),
- Norton's theorem (see Section 13.7), and
- the maximum power transfer theorem (see Section 13.8)

13.2 Kirchhoff's laws

Kirchhoff's laws state:

- Current Law.** *At any junction in an electric circuit the total current flowing towards that*

junction is equal to the total current flowing away from the junction, i.e. $\Sigma I = 0$

Thus, referring to Fig. 13.1:

$$I_1 + I_2 = I_3 + I_4 + I_5$$

or
$$I_1 + I_2 - I_3 - I_4 - I_5 = 0$$

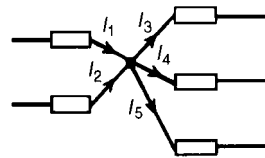

Figure 13.1

- Voltage Law.** *In any closed loop in a network, the algebraic sum of the voltage drops (i.e. products of current and resistance) taken around the loop is equal to the resultant e.m.f. acting in that loop.*

Thus, referring to Fig. 13.2:

$$E_1 - E_2 = IR_1 + IR_2 + IR_3$$

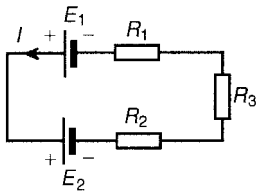

Figure 13.2

(Note that if current flows away from the positive terminal of a source, that source is considered by convention to be positive. Thus moving anticlockwise around the loop of Fig. 13.2, E_1 is positive and E_2 is negative)

(b) Applying Kirchhoff's voltage law and moving clockwise around the loop of Fig. 13.3(b) starting at point A:

$$3 + 6 + E - 4 = (I)(2) + (I)(2.5) + (I)(1.5) + (I)(1) = I(2 + 2.5 + 1.5 + 1)$$

i.e. $5 + E = 2(7)$, since $I = 2\text{ A}$

Hence $E = 14 - 5 = 9\text{ V}$

Problem 1. (a) Find the unknown currents marked in Fig. 13.3(a) (b) Determine the value of e.m.f. E in Fig. 13.3(b).

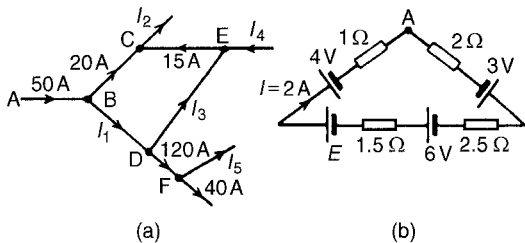

Figure 13.3

Problem 2. Use Kirchhoff's laws to determine the currents flowing in each branch of the network shown in Fig. 13.4

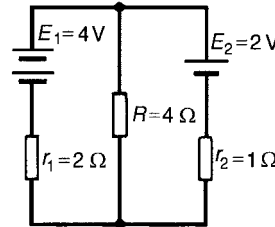

Figure 13.4

Procedure

1 Use Kirchhoff's current law and label current directions on the original circuit diagram. The directions chosen are arbitrary, but it is usual, as a starting point, to assume that current flows from the positive terminals of the batteries. This is shown in Fig. 13.5 where the three branch currents are expressed in terms of I_1 and I_2 only, since the current through R is $(I_1 + I_2)$

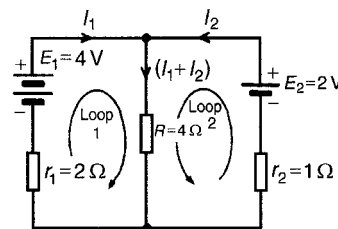

Figure 13.5

2 Divide the circuit into two loops and apply Kirchhoff's voltage law to each. From loop 1 of Fig. 13.5, and moving in a clockwise direction as

(a) Applying Kirchhoff's current law:

For junction B: $50 = 20 + I_1$.

Hence $I_1 = 30\text{ A}$

For junction C: $20 + 15 = I_2$.

Hence $I_2 = 35\text{ A}$

For junction D: $I_1 = I_3 + 120$

i.e. $30 = I_3 + 120$.

Hence $I_3 = -90\text{ A}$

(i.e. in the opposite direction to that shown in Fig. 13.3(a))

For junction E: $I_4 + I_3 = 15$

i.e. $I_4 = 15 - (-90)$.

Hence $I_4 = 105\text{ A}$

For junction F: $120 = I_5 + 40$.

Hence $I_5 = 80\text{ A}$

indicated (the direction chosen does not matter), gives

$$E_1 = I_1 r_1 + (I_1 + I_2)R$$

i.e. $4 = 2I_1 + 4(I_1 + I_2),$

i.e. $6I_1 + 4I_2 = 4$ (1)

From loop 2 of Fig. 13.5, and moving in an anticlockwise direction as indicated (once again, the choice of direction does not matter; it does not have to be in the same direction as that chosen for the first loop), gives:

$$E_2 = I_2 r_2 + (I_1 + I_2)R$$

i.e. $2 = I_2 + 4(I_1 + I_2)$

i.e. $4I_1 + 5I_2 = 2$ (2)

3 Solve Equations (1) and (2) for I_1 and I_2

$2 \times (1)$ gives: $12I_1 + 8I_2 = 8$ (3)

$3 \times (2)$ gives: $12I_1 + 15I_2 = 6$ (4)

$(3) - (4)$ gives: $-7I_2 = 2$

hence $I_2 = -2/7 = -0.286 \text{ A}$

(i.e. I_2 is flowing in the opposite direction to that shown in Fig. 13.5)

From (1) $6I_1 + 4(-0.286) = 4$

$$6I_1 = 4 + 1.144$$

Hence $I_1 = \frac{5.144}{6} = 0.857 \text{ A}$

Current flowing through resistance R is

$$(I_1 + I_2) = 0.857 + (-0.286) = 0.571 \text{ A}$$

Note that a third loop is possible, as shown in Fig. 13.6, giving a third equation which can be used as a check:

$$E_1 - E_2 = I_1 r_1 - I_2 r_2$$

$$4 - 2 = 2I_1 - I_2$$

$$2 = 2I_1 - I_2$$

[Check: $2I_1 - I_2 = 2(0.857) - (-0.286) = 2]$

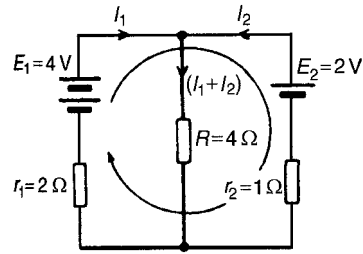

Figure 13.6

Problem 3. Determine, using Kirchhoff's laws, each branch current for the network shown in Fig. 13.7

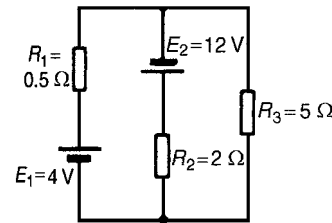

Figure 13.7

1 Currents, and their directions are shown labelled in Fig. 13.8 following Kirchhoff's current law. It is usual, although not essential, to follow conventional current flow with current flowing from the positive terminal of the source

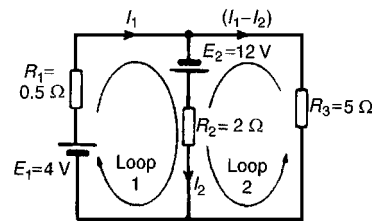

Figure 13.8

2 The network is divided into two loops as shown in Fig. 13.8. Applying Kirchhoff's voltage law gives:

For loop 1:

$$E_1 + E_2 = I_1 R_1 + I_2 R_2$$

i.e. $16 = 0.5I_1 + 2I_2$ (1)

For loop 2:

$$E_2 = I_2 R_2 - (I_1 - I_2) R_3$$

Note that since loop 2 is in the opposite direction to current $(I_1 - I_2)$, the volt drop across R_3 (i.e. $(I_1 - I_2)(R_3)$) is by convention negative.

Thus $12 = 2I_2 - 5(I_1 - I_2)$

i.e. $12 = -5I_1 + 7I_2$ (2)

3 Solving Equations (1) and (2) to find I_1 and I_2 :

$10 \times (1)$ gives: $160 = 5I_1 + 20I_2$ (3)

$(2) + (3)$ gives: $172 = 27I_2$

hence $I_2 = \frac{172}{27} = 6.37 \text{ A}$

From (1): $16 = 0.5I_1 + 2(6.37)$

$$I_1 = \frac{16 - 2(6.37)}{0.5} = 6.52 \text{ A}$$

Current flowing in $R_3 = (I_1 - I_2)$
 $= 6.52 - 6.37 = 0.15 \text{ A}$

Problem 4. For the bridge network shown in Fig. 13.9 determine the currents in each of the resistors.

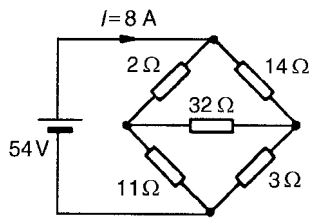

Figure 13.9

Let the current in the 2Ω resistor be I_1 , then by Kirchhoff's current law, the current in the 14Ω resistor is $(I - I_1)$. Let the current in the 32Ω resistor be I_2 as shown in Fig. 13.10. Then the current in the 11Ω resistor is $(I_1 - I_2)$ and that in the 3Ω resistor is $(I - I_1 + I_2)$. Applying Kirchhoff's voltage law to loop 1 and moving in a clockwise direction as shown in Fig. 13.10 gives:

$$54 = 2I_1 + 11(I_1 - I_2)$$

i.e. $13I_1 - 11I_2 = 54$ (1)

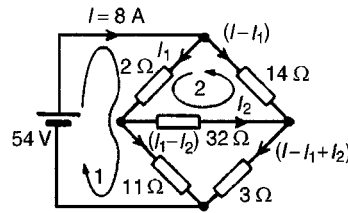

Figure 13.10

Applying Kirchhoff's voltage law to loop 2 and moving in a anticlockwise direction as shown in Fig. 13.10 gives:

$$0 = 2I_1 + 32I_2 - 14(I - I_1)$$

However $I = 8 \text{ A}$

Hence $0 = 2I_1 + 32I_2 - 14(8 - I_1)$

i.e. $16I_1 + 32I_2 = 112$ (2)

Equations (1) and (2) are simultaneous equations with two unknowns, I_1 and I_2 .

$16 \times (1)$ gives: $208I_1 - 176I_2 = 864$ (3)

$13 \times (2)$ gives: $208I_1 + 416I_2 = 1456$ (4)

$(4) - (3)$ gives: $592I_2 = 592$

$$I_2 = 1 \text{ A}$$

Substituting for I_2 in (1) gives:

$$13I_1 - 11 = 54$$

$$I_1 = \frac{65}{13} = 5 \text{ A}$$

Hence, the current flowing in the 2Ω resistor

$$= I_1 = 5 \text{ A}$$

the current flowing in the 14Ω resistor

$$= (I - I_1) = 8 - 5 = 3 \text{ A}$$

the current flowing in the 32Ω resistor

$$= I_2 = 1 \text{ A}$$

the current flowing in the 11Ω resistor

$$= (I_1 - I_2) = 5 - 1 = 4 \text{ A}$$

and the current flowing in the 3Ω resistor

$$= I - I_1 + I_2 = 8 - 5 + 1 = 4 \text{ A}$$

Now try the following exercise

Exercise 65 Further problems on Kirchhoff's laws

- 1 Find currents I_3, I_4 and I_6 in Fig. 13.11
 [$I_3 = 2\text{ A}, I_4 = -1\text{ A}, I_6 = 3\text{ A}$]

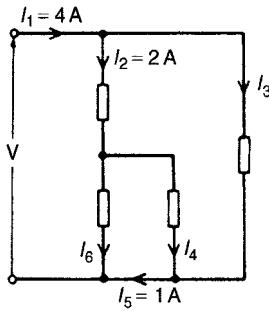

Figure 13.11

- 2 For the networks shown in Fig. 13.12, find the values of the currents marked.
 (a) $I_1 = 4\text{ A}, I_2 = -1\text{ A}, I_3 = 13\text{ A}$
 (b) $I_1 = 40\text{ A}, I_2 = 60\text{ A}, I_3 = 120\text{ A}$
 $I_4 = 100\text{ A}, I_5 = -80\text{ A}$

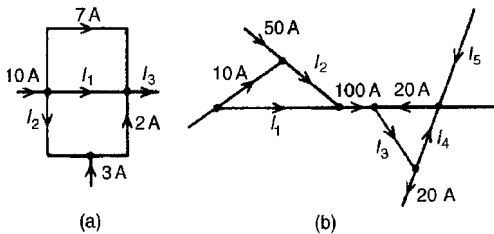

Figure 13.12

- 3 Use Kirchhoff's laws to find the current flowing in the $6\ \Omega$ resistor of Fig. 13.13 and the power dissipated in the $4\ \Omega$ resistor.
 [$2.162\text{ A}, 42.07\text{ W}$]

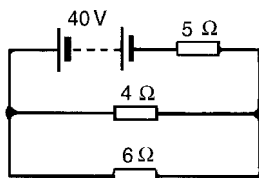

Figure 13.13

- 4 Find the current flowing in the $3\ \Omega$ resistor for the network shown in Fig. 13.14(a). Find also the p.d. across the $10\ \Omega$ and $2\ \Omega$ resistors.
 [$2.715\text{ A}, 7.410\text{ V}, 3.948\text{ V}$]

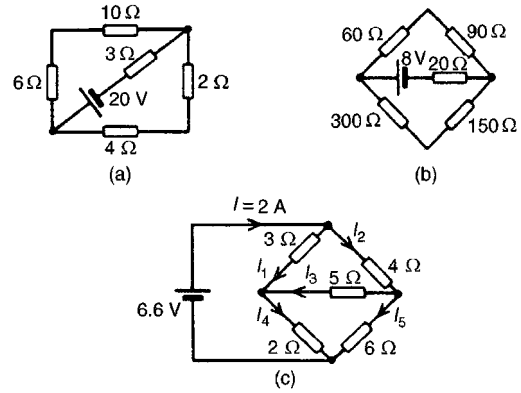

Figure 13.14

- 5 For the network shown in Fig. 13.14(b) find:
 (a) the current in the battery, (b) the current in the $300\ \Omega$ resistor, (c) the current in the $90\ \Omega$ resistor, and (d) the power dissipated in the $150\ \Omega$ resistor.
 [(a) 60.38 mA (b) 15.10 mA
 (c) 45.28 mA (d) 34.20 mW]
- 6 For the bridge network shown in Fig. 13.14(c), find the currents I_1 to I_5
 [$I_1 = 1.26\text{ A}, I_2 = 0.74\text{ A}, I_3 = 0.16\text{ A}, I_4 = 1.42\text{ A}, I_5 = 0.59\text{ A}$]

13.3 The superposition theorem

The superposition theorem states:

In any network made up of linear resistances and containing more than one source of e.m.f., the resultant current flowing in any branch is the algebraic sum of the currents that would flow in that branch if each source was considered separately, all other sources being replaced at that time by their respective internal resistances.

The superposition theorem is demonstrated in the following worked problems

Problem 5. Figure 13.15 shows a circuit containing two sources of e.m.f., each with their internal resistance. Determine the current in each branch of the network by using the superposition theorem.

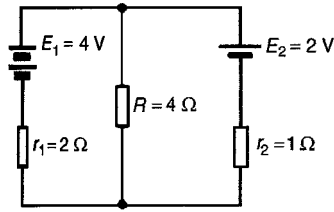

Figure 13.15

Procedure:

- 1 Redraw the original circuit with source E_2 removed, being replaced by r_2 only, as shown in Fig. 13.16(a)

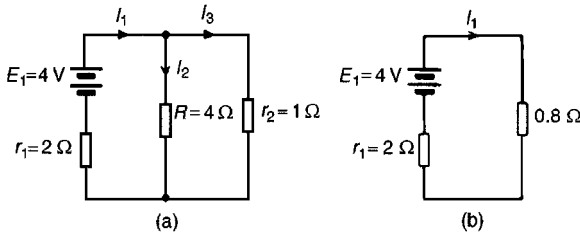

Figure 13.16

- 2 Label the currents in each branch and their directions as shown in Fig. 13.16(a) and determine their values. (Note that the choice of current directions depends on the battery polarity, which, by convention is taken as flowing from the positive battery terminal as shown)
 R in parallel with r_2 gives an equivalent resistance of $(4 \times 1)/(4 + 1) = 0.8 \Omega$
 From the equivalent circuit of Fig. 13.16(b),

$$I_1 = \frac{E_1}{r_1 + 0.8} = \frac{4}{2 + 0.8} = 1.429 \text{ A}$$

From Fig. 11.16(a),

$$I_2 = \left(\frac{1}{4 + 1} \right) I_1 = \frac{1}{5}(1.429) = 0.286 \text{ A}$$

$$\text{and } I_3 = \left(\frac{4}{4 + 1} \right) I_1 = \frac{4}{5}(1.429) = 1.143 \text{ A}$$

by current division

- 3 Redraw the original circuit with source E_1 removed, being replaced by r_1 only, as shown in Fig. 13.17(a)

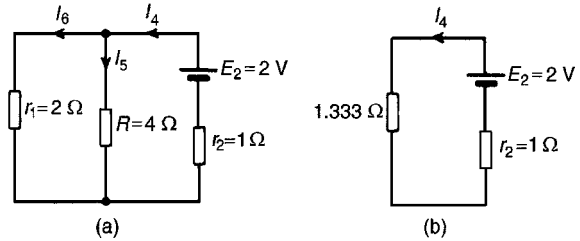

Figure 13.17

- 4 Label the currents in each branch and their directions as shown in Fig. 13.17(a) and determine their values.
 r_1 in parallel with R gives an equivalent resistance of $(2 \times 4)/(2 + 4) = 8/6 = 1.333 \Omega$
 From the equivalent circuit of Fig. 13.17(b)

$$I_4 = \frac{E_2}{1.333 + r_2} = \frac{2}{1.333 + 1} = 0.857 \text{ A}$$

From Fig. 13.17(a),

$$I_5 = \left(\frac{2}{2 + 4} \right) I_4 = \frac{2}{6}(0.857) = 0.286 \text{ A}$$

$$I_6 = \left(\frac{4}{2 + 4} \right) I_4 = \frac{4}{6}(0.857) = 0.571 \text{ A}$$

- 5 Superimpose Fig. 13.17(a) on to Fig. 13.16(a) as shown in Fig. 13.18

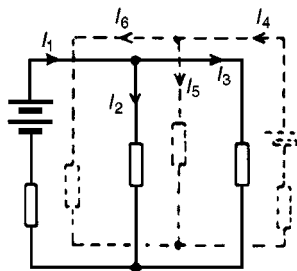

Figure 13.18

- 6 Determine the algebraic sum of the currents flowing in each branch.

Resultant current flowing through source 1, i.e.

$$I_1 - I_6 = 1.429 - 0.571$$

$$= \mathbf{0.858 \text{ A (discharging)}}$$

Resultant current flowing through source 2, i.e.

$$I_4 - I_3 = 0.857 - 1.143$$

$$= \mathbf{-0.286 \text{ A (charging)}}$$

Resultant current flowing through resistor R , i.e.

$$I_2 + I_5 = 0.286 + 0.286$$

$$= \mathbf{0.572 \text{ A}}$$

The resultant currents with their directions are shown in Fig. 13.19

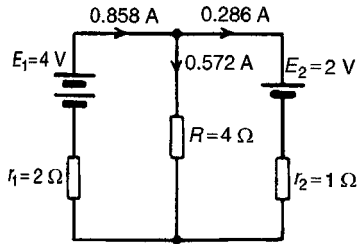

Figure 13.19

Problem 6. For the circuit shown in Fig. 13.20, find, using the superposition theorem, (a) the current flowing in and the p.d. across the 18Ω resistor, (b) the current in the 8 V battery and (c) the current in the 3 V battery.

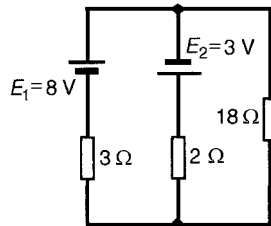

Figure 13.20

1 Removing source E_2 gives the circuit of Fig. 13.21(a)

2 The current directions are labelled as shown in Fig. 13.21(a), I_1 flowing from the positive terminal of E_1
From Fig 13.21(b),

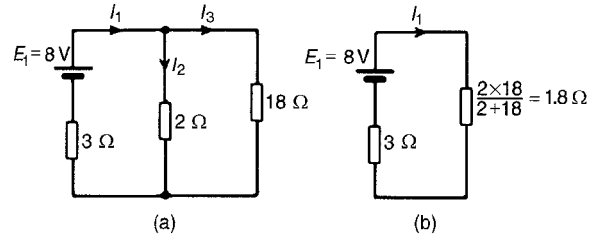

Figure 13.21

$$I_1 = \frac{E_1}{3 + 1.8} = \frac{8}{4.8} = 1.667 \text{ A}$$

From Fig 13.21(a),

$$I_2 = \left(\frac{18}{2 + 18} \right) I_1 = \frac{18}{20}(1.667) = 1.500 \text{ A}$$

and $I_3 = \left(\frac{2}{2 + 18} \right) I_1 = \frac{2}{20}(1.667) = 0.167 \text{ A}$

3 Removing source E_1 gives the circuit of Fig. 13.22(a) (which is the same as Fig. 13.22(b))

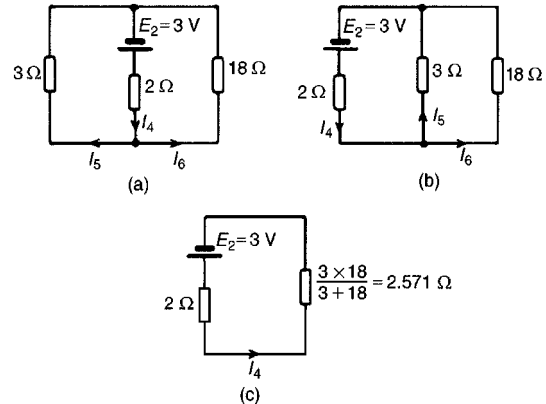

Figure 13.22

4 The current directions are labelled as shown in Figures 13.22(a) and 13.22(b), I_4 flowing from the positive terminal of E_2

From Fig. 13.22(c),

$$I_4 = \frac{E_2}{2 + 2.571} = \frac{3}{4.571} = 0.656 \text{ A}$$

From Fig. 13.22(b),

$$I_5 = \left(\frac{18}{3 + 18} \right) I_4 = \frac{18}{21}(0.656) = 0.562 \text{ A}$$

$$I_6 = \left(\frac{3}{3 + 18} \right) I_4 = \frac{3}{21} (0.656) = 0.094 \text{ A}$$

5 Superimposing Fig. 13.22(a) on to Fig. 13.21(a) gives the circuit in Fig. 13.23

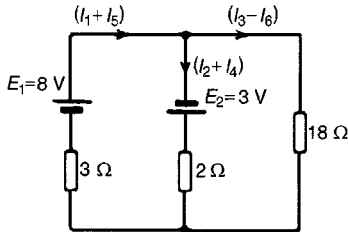

Figure 13.23

6 (a) Resultant current in the 18 Ω resistor

$$= I_3 - I_6$$

$$= 0.167 - 0.094 = \mathbf{0.073 \text{ A}}$$

P.d. across the 18 Ω resistor

$$= 0.073 \times 18 = \mathbf{1.314 \text{ V}}$$

(b) Resultant current in the 8 V battery

$$= I_1 + I_5 = 1.667 + 0.562$$

$$= \mathbf{2.229 \text{ A (discharging)}}$$

(c) Resultant current in the 3 V battery

$$= I_2 + I_4 = 1.500 + 0.656$$

$$= \mathbf{2.156 \text{ A (discharging)}}$$

Now try the following exercise

Exercise 66 Further problems on the superposition theorem

1 Use the superposition theorem to find currents I_1 , I_2 and I_3 of Fig. 13.24

$$[I_1 = 2 \text{ A}, I_2 = 3 \text{ A}, I_3 = 5 \text{ A}]$$

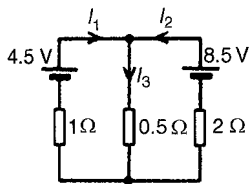

Figure 13.24

2 Use the superposition theorem to find the current in the 8 Ω resistor of Fig. 13.25
[0.385 A]

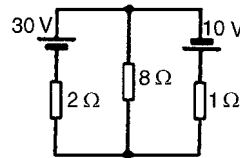

Figure 13.25

3 Use the superposition theorem to find the current in each branch of the network shown in Fig. 13.26

$$[10 \text{ V battery discharges at } 1.429 \text{ A}$$

$$4 \text{ V battery charges at } 0.857 \text{ A}$$

$$\text{Current through } 10 \Omega \text{ resistor is } 0.572 \text{ A}]$$

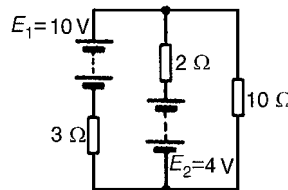

Figure 13.26

4 Use the superposition theorem to determine the current in each branch of the arrangement shown in Fig. 13.27

$$[24 \text{ V battery charges at } 1.664 \text{ A}$$

$$52 \text{ V battery discharges at } 3.280 \text{ A}$$

$$\text{Current in } 20 \Omega \text{ resistor is } 1.616 \text{ A}]$$

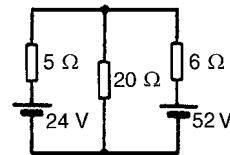

Figure 13.27

13.4 General d.c. circuit theory

The following points involving d.c. circuit analysis need to be appreciated before proceeding with problems using Thévenin's and Norton's theorems:

- (i) The open-circuit voltage, E , across terminals AB in Fig. 13.28 is equal to 10 V, since no current flows through the $2\ \Omega$ resistor and hence no voltage drop occurs.

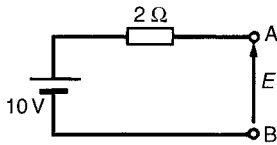

Figure 13.28

- (ii) The open-circuit voltage, E , across terminals AB in Fig. 13.29(a) is the same as the voltage across the $6\ \Omega$ resistor. The circuit may be redrawn as shown in Fig. 13.29(b)

$$E = \left(\frac{6}{6 + 4} \right) (50)$$

by voltage division in a series circuit, i.e. $E = 30\ \text{V}$

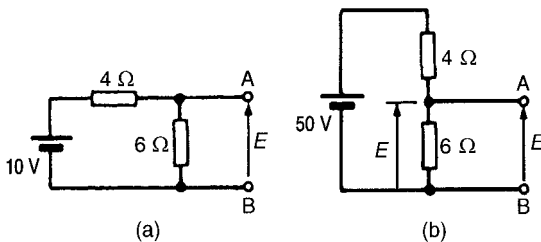

Figure 13.29

- (iii) For the circuit shown in Fig. 13.30(a) representing a practical source supplying energy, $V = E - Ir$, where E is the battery e.m.f., V is the battery terminal voltage and r is the internal resistance of the battery (as shown in Section 4.6). For the circuit shown in Fig. 13.30(b),

$$V = E - (-I)r, \text{ i.e. } V = E + Ir$$

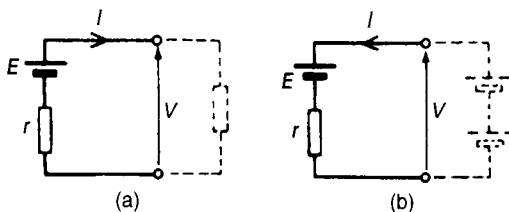

Figure 13.30

- (iv) The resistance ‘looking-in’ at terminals AB in Fig. 13.31(a) is obtained by reducing the circuit in stages as shown in Figures 13.31(b) to (d). Hence the equivalent resistance across AB is $7\ \Omega$.

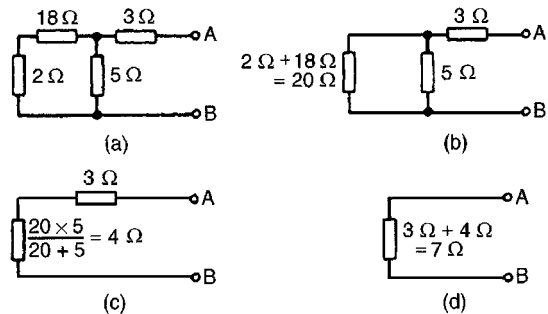

Figure 13.31

- (v) For the circuit shown in Fig. 13.32(a), the $3\ \Omega$ resistor carries no current and the p.d. across the $20\ \Omega$ resistor is 10 V. Redrawing the circuit gives Fig. 13.32(b), from which

$$E = \left(\frac{4}{4 + 6} \right) \times 10 = 4\ \text{V}$$

- (vi) If the 10 V battery in Fig. 13.32(a) is removed and replaced by a short-circuit, as shown in Fig. 13.32(c), then the $20\ \Omega$ resistor may be removed. The reason for this is that a short-circuit has zero resistance, and $20\ \Omega$ in parallel with zero ohms gives an equivalent resistance of $(20 \times 0)/(20 + 0)$ i.e. $0\ \Omega$. The circuit

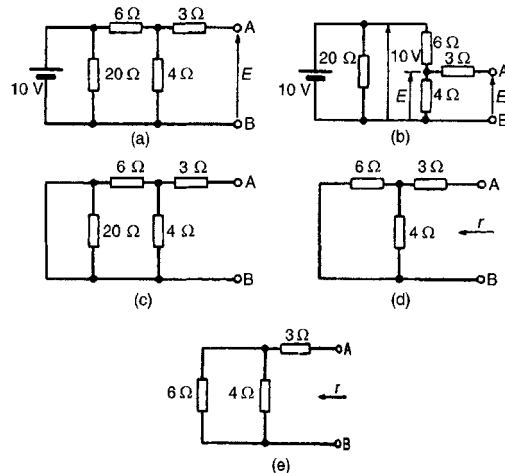

Figure 13.32

is then as shown in Fig. 13.32(d), which is redrawn in Fig. 13.32(e). From Fig. 13.32(e), the equivalent resistance across AB,

$$r = \frac{6 \times 4}{6 + 4} + 3 = 2.4 + 3 = \mathbf{5.4 \Omega}$$

- (vii) To find the voltage across AB in Fig. 13.33: Since the 20 V supply is across the 5 Ω and 15 Ω resistors in series then, by voltage division, the voltage drop across AC,

$$V_{AC} = \left(\frac{5}{5 + 15} \right) (20) = 5 \text{ V}$$

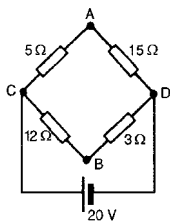

Figure 13.33

Similarly,

$$V_{CB} = \left(\frac{12}{12 + 3} \right) (20) = 16 \text{ V.}$$

V_C is at a potential of +20 V.

$$V_A = V_C - V_{AC} = +20 - 5 = 15 \text{ V}$$

$$\text{and } V_B = V_C - V_{BC} = +20 - 16 = 4 \text{ V.}$$

Hence the voltage between AB is $V_A - V_B = 15 - 4 = 11 \text{ V}$ and current would flow from A to B since A has a higher potential than B.

- (viii) In Fig. 13.34(a), to find the equivalent resistance across AB the circuit may be redrawn as in Figs. 13.34(b) and (c). From Fig. 13.26(c), the equivalent resistance across

$$\begin{aligned} AB &= \frac{5 \times 15}{5 + 15} + \frac{12 \times 3}{12 + 3} \\ &= 3.75 + 2.4 = \mathbf{6.15 \Omega} \end{aligned}$$

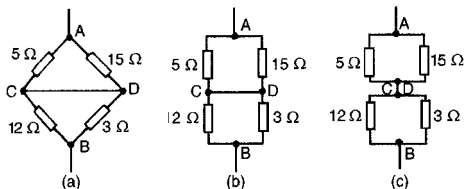

Figure 13.34

- (ix) In the worked problems in Sections 13.5 and 13.7 following, it may be considered that Thévenin's and Norton's theorems have no obvious advantages compared with, say, Kirchhoff's laws. However, these theorems can be used to analyse part of a circuit and in much more complicated networks the principle of replacing the supply by a constant voltage source in series with a resistance (or impedance) is very useful.

13.5 Thévenin's theorem

Thévenin's theorem states:

The current in any branch of a network is that which would result if an e.m.f. equal to the p.d. across a break made in the branch, were introduced into the branch, all other e.m.f.'s being removed and represented by the internal resistances of the sources.

The procedure adopted when using Thévenin's theorem is summarized below. To determine the current in any branch of an active network (i.e. one containing a source of e.m.f.):

- (i) remove the resistance R from that branch,
- (ii) determine the open-circuit voltage, E , across the break,
- (iii) remove each source of e.m.f. and replace them by their internal resistances and then determine the resistance, r , 'looking-in' at the break,
- (iv) determine the value of the current from the equivalent circuit shown in Fig. 13.35, i.e.

$$I = \frac{E}{R + r}$$

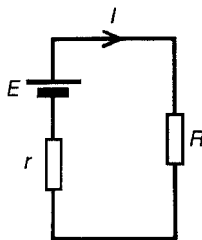

Figure 13.35

Problem 7. Use Thévenin's theorem to find the current flowing in the $10\ \Omega$ resistor for the circuit shown in Fig 13.36

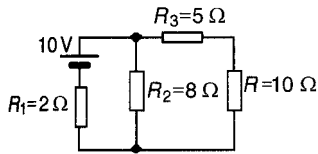

Figure 13.36

Following the above procedure:

- (i) The $10\ \Omega$ resistance is removed from the circuit as shown in Fig. 13.37(a)

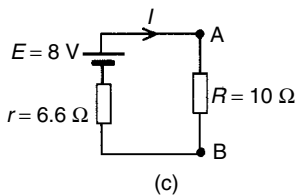
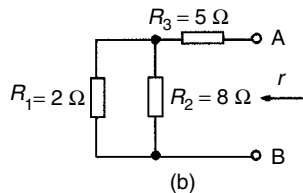
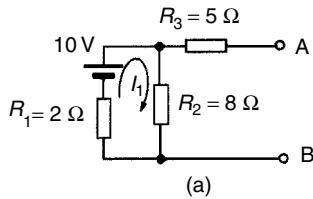

Figure 13.37

- (ii) There is no current flowing in the $5\ \Omega$ resistor and current I_1 is given by

$$I_1 = \frac{10}{R_1 + R_2} = \frac{10}{2 + 8} = 1\ \text{A}$$

P.d. across $R_2 = I_1 R_2 = 1 \times 8 = 8\ \text{V}$. Hence p.d. across AB, i.e. the open-circuit voltage across the break, $E = 8\ \text{V}$

- (iii) Removing the source of e.m.f. gives the circuit of Fig. 13.37(b) Resistance,

$$r = R_3 + \frac{R_1 R_2}{R_1 + R_2} = 5 + \frac{2 \times 8}{2 + 8} = 5 + 1.6 = 6.6\ \Omega$$

- (iv) The equivalent Thévenin's circuit is shown in Fig. 13.37(c)

$$\text{Current } I = \frac{E}{R + r} = \frac{8}{10 + 6.6} = \frac{8}{16.6} = 0.482\ \text{A}$$

Hence the current flowing in the $10\ \Omega$ resistor of Fig. 13.36 is **0.482 A**.

Problem 8. For the network shown in Fig. 13.38 determine the current in the $0.8\ \Omega$ resistor using Thévenin's theorem.

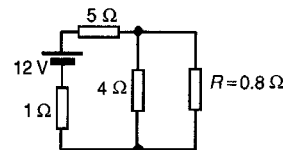

Figure 13.38

Following the procedure:

- (i) The $0.8\ \Omega$ resistor is removed from the circuit as shown in Fig. 13.39(a).

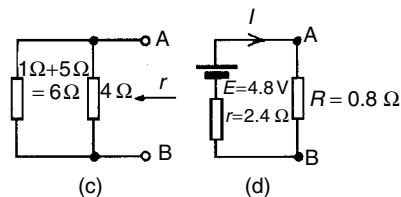
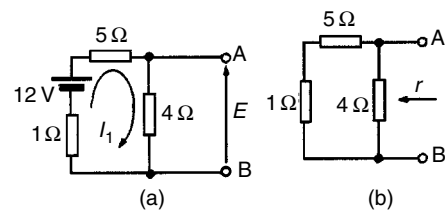

Figure 13.39

$$(ii) \text{ Current } I_1 = \frac{12}{1 + 5 + 4} = \frac{12}{10} = 1.2 \text{ A}$$

P.d. across 4Ω resistor = $4I_1 = (4)(1.2) = 4.8 \text{ V}$. Hence p.d. across AB, i.e. the open-circuit voltage across AB, $E = 4.8 \text{ V}$

- (iii) Removing the source of e.m.f. gives the circuit shown in Fig. 13.39(b). The equivalent circuit of Fig. 13.39(b) is shown in Fig. 13.39(c), from which, resistance

$$r = \frac{4 \times 6}{4 + 6} = \frac{24}{10} = 2.4 \Omega$$

- (iv) The equivalent Thévenin's circuit is shown in Fig. 13.39(d), from which, current

$$I = \frac{E}{r + R} = \frac{4.8}{2.4 + 0.8} = \frac{4.8}{3.2} = 1.5 \text{ A} = \text{current in the } 0.8 \Omega \text{ resistor}$$

Problem 9. Use Thévenin's theorem to determine the current I flowing in the 4Ω resistor shown in Fig. 13.40. Find also the power dissipated in the 4Ω resistor.

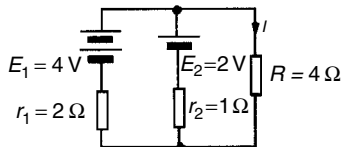

Figure 13.40

Following the procedure:

- (i) The 4Ω resistor is removed from the circuit as shown in Fig. 13.41(a)

$$(ii) \text{ Current } I_1 = \frac{E_1 - E_2}{r_1 + r_2} = \frac{4 - 2}{2 + 1} = \frac{2}{3} \text{ A}$$

P.d. across AB,

$$E = E_1 - I_1 r_1 = 4 - \frac{2}{3}(2) = 2\frac{2}{3} \text{ V}$$

(see Section 13.4(iii)). (Alternatively, p.d. across AB, $E = E_2 + I_1 r_2 = 2 + \frac{2}{3}(1) = 2\frac{2}{3} \text{ V}$)

- (iii) Removing the sources of e.m.f. gives the circuit shown in Fig. 13.41(b), from which, resistance

$$r = \frac{2 \times 1}{2 + 1} = \frac{2}{3} \Omega$$

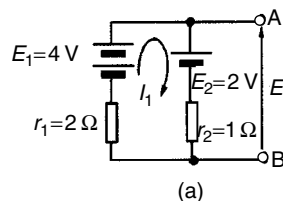

(a)

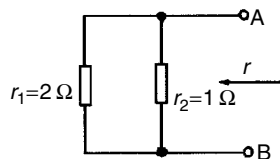

(b)

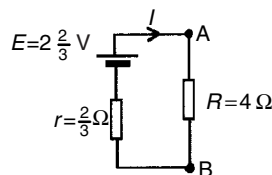

(c)

Figure 13.41

- (iv) The equivalent Thévenin's circuit is shown in Fig. 13.41(c), from which, current,

$$I = \frac{E}{r + R} = \frac{2\frac{2}{3}}{\frac{2}{3} + 4} = \frac{8/3}{14/3} = \frac{8}{14} = 0.571 \text{ A} = \text{current in the } 4 \Omega \text{ resistor}$$

Power dissipated in the 4Ω resistor,

$$P = I^2 R = (0.571)^2 (4) = 1.304 \text{ W}$$

Problem 10. Determine the current in the 5Ω resistance of the network shown in Fig. 13.42 using Thévenin's theorem. Hence find the currents flowing in the other two branches.

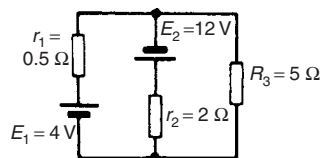

Figure 13.42

Following the procedure:

- (i) The 5 Ω resistance is removed from the circuit as shown in Fig. 13.43(a)

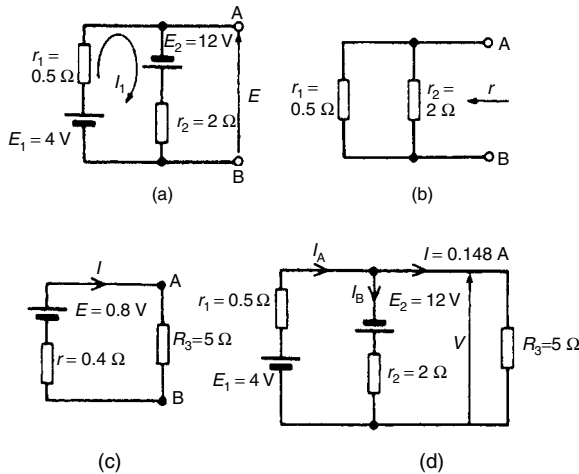

Figure 13.43

- (ii) Current $I_1 = \frac{12 + 4}{0.5 + 2} = \frac{16}{2.5} = 6.4 \text{ A}$

P.d. across AB,

$$E = E_1 - I_1 r_1 = 4 - (6.4)(0.5) = 0.8 \text{ V}$$

(see Section 13.4(iii)). (Alternatively, $E = -E_2 + I_1 r_1 = -12 + (6.4)(2) = 0.8 \text{ V}$)

- (iii) Removing the sources of e.m.f. gives the circuit shown in Fig. 13.43(b), from which resistance

$$r = \frac{0.5 \times 2}{0.5 + 2} = \frac{1}{2.5} = 0.4 \Omega$$

- (iv) The equivalent Thévenin's circuit is shown in Fig. 13.43(c), from which, current

$$I = \frac{E}{r + R} = \frac{0.8}{0.4 + 5} = \frac{0.8}{5.4} = \mathbf{0.148 \text{ A}}$$

= current in the 5 Ω resistor

From Fig. 13.43(d),

$$\text{voltage } V = IR_3 = (0.148)(5) = 0.74 \text{ V}$$

From Section 13.4(iii),

$$V = E_1 - I_A r_1$$

i.e. $0.74 = 4 - (I_A)(0.5)$

Hence current, $I_A = \frac{4 - 0.74}{0.5} = \frac{3.26}{0.5} = \mathbf{6.52 \text{ A}}$

Also from Fig. 13.43(d),

$$V = -E_2 + I_B r_2$$

i.e. $0.74 = -12 + (I_B)(2)$

Hence current $I_B = \frac{12 + 0.74}{2} = \frac{12.74}{2} = \mathbf{6.37 \text{ A}}$

[Check, from Fig. 13.43(d), $I_A = I_B + I$, correct to 2 significant figures by Kirchoff's current law]

Problem 11. Use Thévenin's theorem to determine the current flowing in the 3 Ω resistance of the network shown in Fig. 13.44. The voltage source has negligible internal resistance.

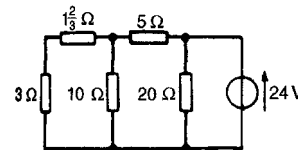

Figure 13.44

(Note the symbol for an ideal voltage source in Fig. 13.44 which may be used as an alternative to the battery symbol.)

Following the procedure

- (i) The 3 Ω resistance is removed from the circuit as shown in Fig. 13.45(a).

- (ii) The $1\frac{2}{3} \Omega$ resistance now carries no current.

P.d. across 10 Ω resistor

$$= \left(\frac{10}{10 + 5} \right) (24) = \mathbf{16 \text{ V}}$$

(see Section 13.4(v)). Hence p.d. across AB, $E = 16 \text{ V}$.

- (iii) Removing the source of e.m.f. and replacing it by its internal resistance means that the 20 Ω resistance is short-circuited as shown in Fig. 13.45(b) since its internal resistance is zero. The 20 Ω resistance may thus be removed as shown in Fig. 13.45(c) (see Section 13.4 (vi)).

From Fig. 13.45(c), resistance,

$$r = 1\frac{2}{3} + \frac{10 \times 5}{10 + 5} = 1\frac{2}{3} + \frac{50}{15} = 5 \Omega$$

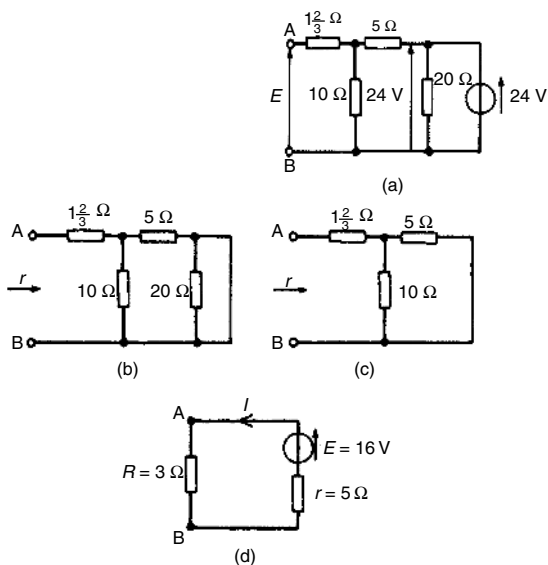

Figure 13.45

(iv) The equivalent Thévenin's circuit is shown in Fig. 13.45(d), from which, current,

$$I = \frac{E}{r + R} = \frac{16}{3 + 5} = \frac{16}{8} = 2 \text{ A}$$

= current in the 3 Ω resistance

Problem 12. A Wheatstone Bridge network is shown in Fig. 13.46. Calculate the current flowing in the 32 Ω resistor, and its direction, using Thévenin's theorem. Assume the source of e.m.f. to have negligible resistance.

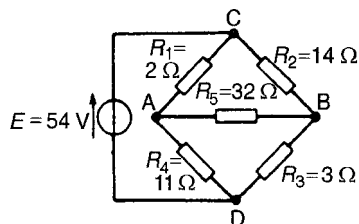

Figure 13.46

Following the procedure:

- (i) The 32 Ω resistor is removed from the circuit as shown in Fig. 13.47(a)
- (ii) The p.d. between A and C,

$$V_{AC} = \left(\frac{R_1}{R_1 + R_4} \right) (E) = \left(\frac{2}{2 + 11} \right) (54)$$

$$= 8.31 \text{ V}$$

The p.d. between B and C,

$$V_{BC} = \left(\frac{R_2}{R_2 + R_3} \right) (E) = \left(\frac{14}{14 + 3} \right) (54)$$

$$= 44.47 \text{ V}$$

Hence the p.d. between A and B = 44.47 – 8.31 = 36.16 V

Point C is at a potential of +54 V. Between C and A is a voltage drop of 8.31 V. Hence the voltage at point A is 54 – 8.31 = 45.69 V. Between C and B is a voltage drop of 44.47 V. Hence the voltage at point B is 54 – 44.47 = 9.53 V. Since the voltage at A is greater than

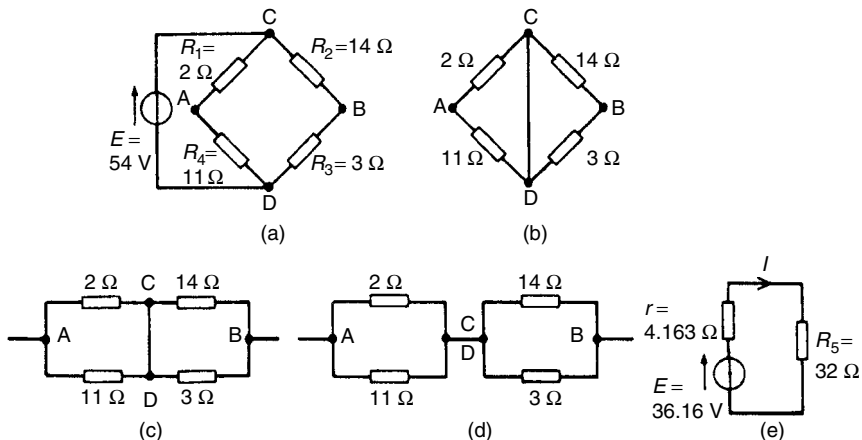

Figure 13.47

at B, current must flow in the direction A to B. (See Section 13.4 (vii))

- (iii) Replacing the source of e.m.f. with a short-circuit (i.e. zero internal resistance) gives the circuit shown in Fig. 13.47(b). The circuit is redrawn and simplified as shown in Fig. 13.47(c) and (d), from which the resistance between terminals A and B,

$$r = \frac{2 \times 11}{2 + 11} + \frac{14 \times 3}{14 + 3}$$

$$= \frac{22}{13} + \frac{42}{17}$$

$$= 1.692 + 2.471$$

$$= 4.163 \Omega$$

- (iv) The equivalent Thévenin's circuit is shown in Fig. 13.47(e), from which, current

$$I = \frac{E}{r + R_5}$$

$$= \frac{36.16}{4.163 + 32} = 1 \text{ A}$$

Hence the current in the 32Ω resistor of Fig. 13.46 is 1 A, flowing from A to B

Now try the following exercise

Exercise 67 Further problems on Thévenin's theorem

- 1 Use Thévenin's theorem to find the current flowing in the 14Ω resistor of the network shown in Fig. 13.48. Find also the power dissipated in the 14Ω resistor.

[0.434 A, 2.64 W]

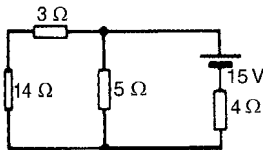

Figure 13.48

- 2 Use Thévenin's theorem to find the current flowing in the 6Ω resistor shown in Fig. 13.49 and the power dissipated in the 4Ω resistor.

[2.162 A, 42.07 W]

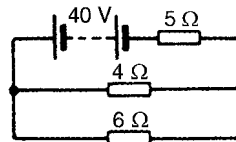

Figure 13.49

- 3 Repeat problems 1 to 4 of Exercise 66, page 164, using Thévenin's theorem.

- 4 In the network shown in Fig. 13.50, the battery has negligible internal resistance. Find, using Thévenin's theorem, the current flowing in the 4Ω resistor. [0.918 A]

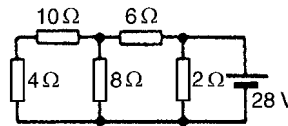

Figure 13.50

- 5 For the bridge network shown in Fig. 13.51, find the current in the 5Ω resistor, and its direction, by using Thévenin's theorem. [0.153 A from B to A]

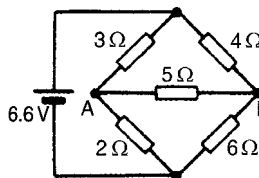

Figure 13.51

13.6 Constant-current source

A source of electrical energy can be represented by a source of e.m.f. in series with a resistance. In Section 13.5, the Thévenin constant-voltage source consisted of a constant e.m.f. E in series with an internal resistance r . However this is not the only form of representation. A source of electrical energy can also be represented by a constant-current source in parallel with a resistance. It may be shown that the two forms are equivalent. An **ideal constant-voltage generator** is one with zero internal resistance so that it supplies the same voltage to all

loads. An **ideal constant-current generator** is one with infinite internal resistance so that it supplies the same current to all loads.

Note the symbol for an ideal current source (BS 3939, 1985), shown in Fig. 13.52

13.7 Norton's theorem

Norton's theorem states:

The current that flows in any branch of a network is the same as that which would flow in the branch if it were connected across a source of electrical energy, the short-circuit current of which is equal to the current that would flow in a short-circuit across the branch, and the internal resistance of which is equal to the resistance which appears across the open-circuited branch terminals.

The procedure adopted when using Norton's theorem is summarized below. To determine the current flowing in a resistance R of a branch AB of an active network:

- (i) short-circuit branch AB
- (ii) determine the short-circuit current I_{SC} flowing in the branch
- (iii) remove all sources of e.m.f. and replace them by their internal resistance (or, if a current source exists, replace with an open-circuit), then determine the resistance r , 'looking-in' at a break made between A and B
- (iv) determine the current I flowing in resistance R from the Norton equivalent network shown in Fig. 13.52, i.e.

$$I = \left(\frac{r}{r + R} \right) I_{SC}$$

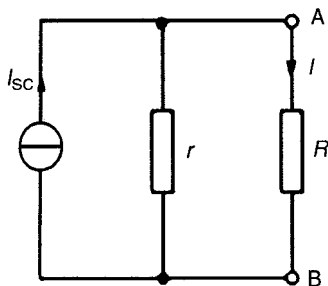

Figure 13.52

Problem 13. Use Norton's theorem to determine the current flowing in the $10\ \Omega$ resistance for the circuit shown in Fig. 13.53

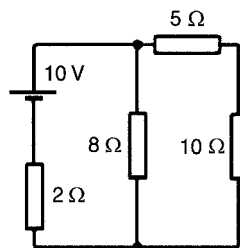

Figure 13.53

Following the above procedure:

- (i) The branch containing the $10\ \Omega$ resistance is short-circuited as shown in Fig. 13.54(a)

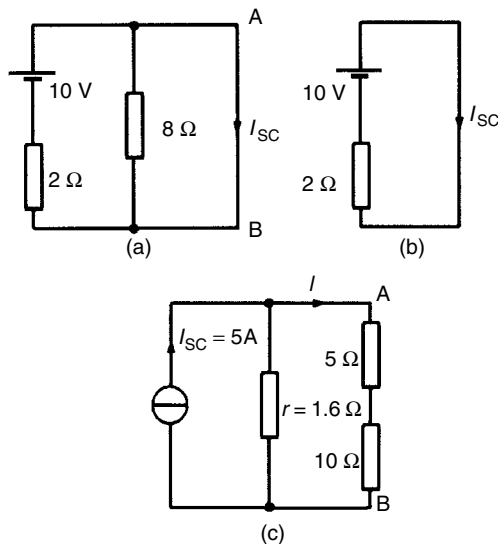

Figure 13.54

- (ii) Fig. 13.54(b) is equivalent to Fig. 13.54(a).

$$\text{Hence } I_{SC} = \frac{10}{2} = 5\ \text{A}$$

- (iii) If the $10\ \text{V}$ source of e.m.f. is removed from Fig. 13.54(a) the resistance 'looking-in' at a break made between A and B is given by:

$$r = \frac{2 \times 8}{2 + 8} = 1.6\ \Omega$$

- (iv) From the Norton equivalent network shown in Fig. 13.54(c) the current in the $10\ \Omega$ resistance, by current division, is given by:

$$I = \left(\frac{1.6}{1.6 + 5 + 10} \right) (5) = \mathbf{0.482\ A}$$

as obtained previously in Problem 7 using Thévenin's theorem.

Problem 14. Use Norton's theorem to determine the current I flowing in the $4\ \Omega$ resistance shown in Fig. 13.55

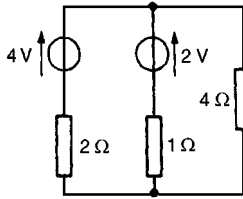

Figure 13.55

Following the procedure:

- (i) The $4\ \Omega$ branch is short-circuited as shown in Fig. 13.56(a)

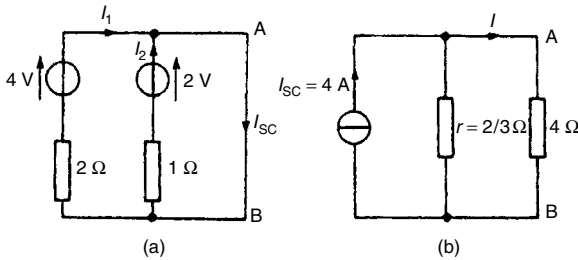

Figure 13.56

- (ii) From Fig. 13.56(a),

$$I_{SC} = I_1 + I_2 = \frac{4}{2} + \frac{2}{1} = 4\ \text{A}$$

- (iii) If the sources of e.m.f. are removed the resistance 'looking-in' at a break made between A and B is given by:

$$r = \frac{2 \times 1}{2 + 1} = \frac{2}{3}\ \Omega$$

- (iv) From the Norton equivalent network shown in Fig. 13.56(b) the current in the $4\ \Omega$ resistance is given by:

$$I = \left(\frac{\frac{2}{3}}{\frac{2}{3} + 4} \right) (4) = \mathbf{0.571\ A},$$

as obtained previously in problems 2, 5 and 9 using Kirchhoff's laws and the theorems of superposition and Thévenin

Problem 15. Determine the current in the $5\ \Omega$ resistance of the network shown in Fig. 13.57 using Norton's theorem. Hence find the currents flowing in the other two branches.

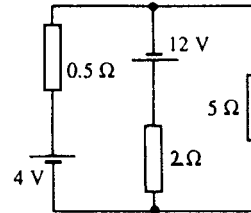

Figure 13.57

Following the procedure:

- (i) The $5\ \Omega$ branch is short-circuited as shown in Fig. 13.58(a)

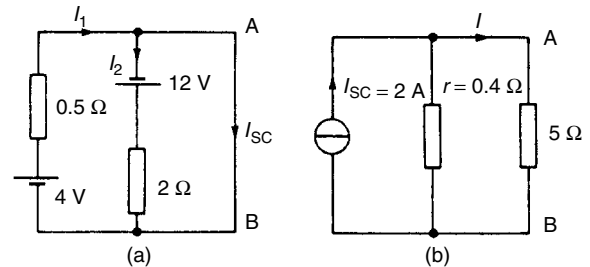

Figure 13.58

- (ii) From Fig. 13.58(a),

$$I_{SC} = I_1 - I_2 = \frac{4}{0.5} - \frac{12}{2} = 8 - 6 = 2\ \text{A}$$

- (iii) If each source of e.m.f. is removed the resistance 'looking-in' at a break made between A and B is given by:

$$r = \frac{0.5 \times 2}{0.5 + 2} = 0.4\ \Omega$$

- (iv) From the Norton equivalent network shown in Fig. 13.58(b) the current in the $5\ \Omega$ resistance is given by:

$$I = \left(\frac{0.4}{0.4 + 5} \right) (2) = \mathbf{0.148\ A},$$

as obtained previously in problem 10 using Thévenin's theorem.

The currents flowing in the other two branches are obtained in the same way as in Problem 10. Hence the current flowing from the $4\ \text{V}$ source is $\mathbf{6.52\ A}$ and the current flowing from the $12\ \text{V}$ source is $\mathbf{6.37\ A}$.

Problem 16. Use Norton's theorem to determine the current flowing in the $3\ \Omega$ resistance of the network shown in Fig. 13.59. The voltage source has negligible internal resistance.

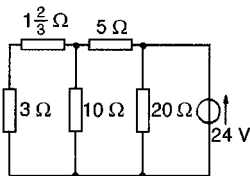

Figure 13.59

Following the procedure:

- (i) The branch containing the $3\ \Omega$ resistance is short-circuited as shown in Fig. 13.60(a)
- (ii) From the equivalent circuit shown in Fig. 13.60(b),

$$I_{SC} = \frac{24}{5} = 4.8\ \text{A}$$

- (iii) If the $24\ \text{V}$ source of e.m.f. is removed the resistance 'looking-in' at a break made between A and B is obtained from Fig. 13.60(c) and its equivalent circuit shown in Fig. 13.60(d) and is given by:

$$r = \frac{10 \times 5}{10 + 5} = \frac{50}{15} = 3\frac{1}{3}\ \Omega$$

- (iv) From the Norton equivalent network shown in Fig. 13.60(e) the current in the $3\ \Omega$ resistance is given by:

$$I = \left(\frac{3\frac{1}{3}}{3\frac{1}{3} + 1\frac{2}{3} + 3} \right) (4.8) = \mathbf{2\ A},$$

as obtained previously in Problem 11 using Thévenin's theorem.

Problem 17. Determine the current flowing in the $2\ \Omega$ resistance in the network shown in Fig. 13.61

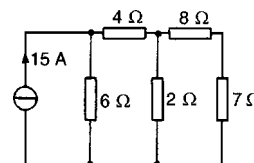

Figure 13.61

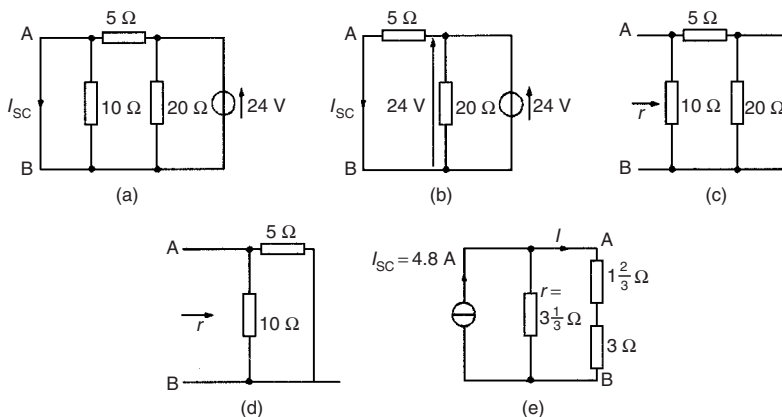

Figure 13.60

Following the procedure:

- (i) The 2 Ω resistance branch is short-circuited as shown in Fig. 13.62(a)
- (ii) Fig. 13.62(b) is equivalent to Fig. 13.62(a). Hence

$$I_{SC} = \frac{6}{6 + 4}(15) = 9 \text{ A by current division.}$$

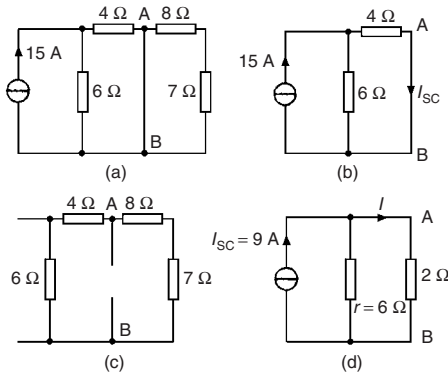

Figure 13.62

- (iii) If the 15 A current source is replaced by an open-circuit then from Fig. 13.62(c) the resistance ‘looking-in’ at a break made between A and B is given by (6 + 4) Ω in parallel with (8 + 7) Ω, i.e.

$$r = \frac{(10)(15)}{10 + 15} = \frac{150}{25} = 6 \Omega$$

- (iv) From the Norton equivalent network shown in Fig. 13.62(d) the current in the 2 Ω resistance is given by:

$$I = \left(\frac{6}{6 + 2} \right) (9) = 6.75 \text{ A}$$

Now try the following exercise

Exercise 68 Further problems on Norton’s theorem

- 1 Repeat Problems 1–4 of Exercise 66, page 164, by using Norton’s theorem
- 2 Repeat Problems 1, 2, 4 and 5 of Exercise 67, page 171, by using Norton’s theorem

- 3 Determine the current flowing in the 6 Ω resistance of the network shown in Fig. 13.63 by using Norton’s theorem. [2.5 mA]

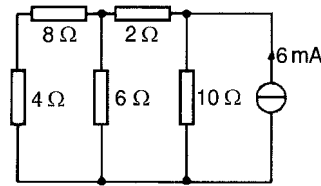

Figure 13.63

13.8 Thévenin and Norton equivalent networks

The Thévenin and Norton networks shown in Fig. 13.64 are equivalent to each other. The resistance ‘looking-in’ at terminals AB is the same in each of the networks, i.e. *r*

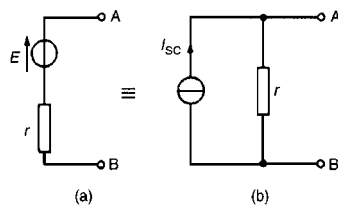

Figure 13.64

If terminals AB in Fig. 13.64(a) are short-circuited, the short-circuit current is given by E/r . If terminals AB in Fig. 13.64(b) are short-circuited, the short-circuit current is I_{SC} . For the circuit shown in Fig. 13.64(a) to be equivalent to the circuit in Fig. 13.64(b) the same short-circuit current must flow. Thus $I_{SC} = E/r$.

Figure 13.65 shows a source of e.m.f. E in series with a resistance r feeding a load resistance R
From Fig. 13.65,

$$I = \frac{E}{r + R} = \frac{E/r}{(r + R)/r} = \left(\frac{r}{r + R} \right) \frac{E}{r}$$

i.e. $I = \left(\frac{r}{r + R} \right) I_{SC}$

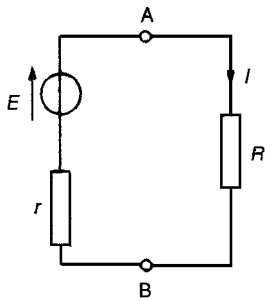

Figure 13.65

From Fig. 13.66 it can be seen that, when viewed from the load, the source appears as a source of current I_{SC} which is divided between r and R connected in parallel.

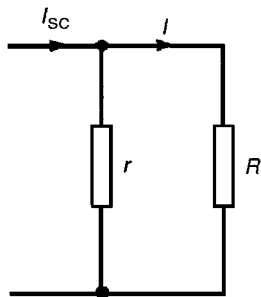

Figure 13.66

Thus the two representations shown in Fig. 13.64 are equivalent.

Problem 18. Convert the circuit shown in Fig. 13.67 to an equivalent Norton network.

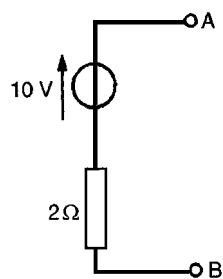

Figure 13.67

If terminals AB in Fig. 13.67 are short-circuited, the short-circuit current $I_{SC} = 10/2 = 5$ A

The resistance 'looking-in' at terminals AB is $2\ \Omega$. Hence the equivalent Norton network is as shown in Fig. 13.68

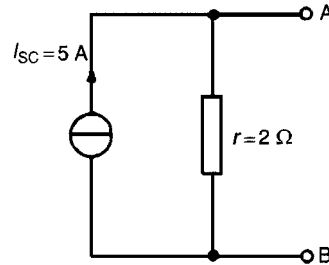

Figure 13.68

Problem 19. Convert the network shown in Fig. 13.69 to an equivalent Thévenin circuit.

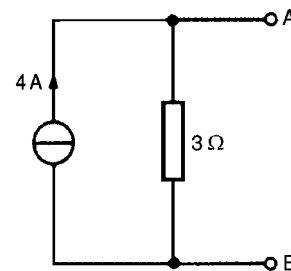

Figure 13.69

The open-circuit voltage E across terminals AB in Fig. 13.69 is given by:

$$E = (I_{SC})(r) = (4)(3) = 12\text{ V.}$$

The resistance 'looking-in' at terminals AB is $3\ \Omega$. Hence the equivalent Thévenin circuit is as shown in Fig. 13.70

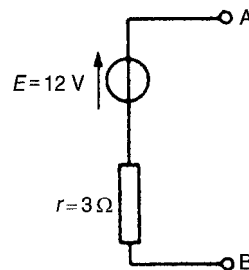

Figure 13.70

Problem 20. (a) Convert the circuit to the left of terminals AB in Fig. 13.71 to an equivalent Thévenin circuit by initially converting to a Norton equivalent circuit. (b) Determine the current flowing in the $1.8\ \Omega$ resistor.

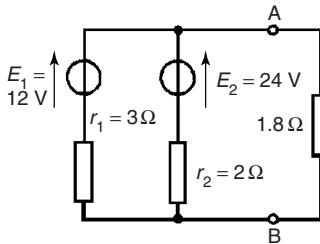
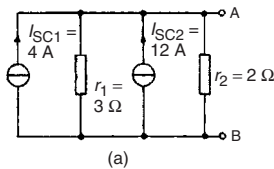
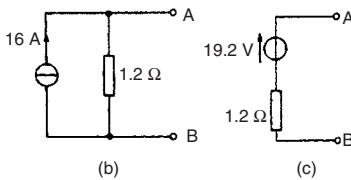

Figure 13.71

(a) For the branch containing the 12 V source, converting to a Norton equivalent circuit gives $I_{SC} = 12/3 = 4\text{ A}$ and $r_1 = 3\ \Omega$. For the branch containing the 24 V source, converting to a Norton equivalent circuit gives $I_{SC2} = 24/2 = 12\text{ A}$ and $r_2 = 2\ \Omega$. Thus Fig. 13.72(a) shows a network equivalent to Fig. 13.71



(a)



(b)

(c)

Figure 13.72

From Fig. 13.72(a) the total short-circuit current is $4 + 12 = 16\text{ A}$ and the total resistance is given by $(3 \times 2)/(3 + 2) = 1.2\ \Omega$. Thus Fig. 13.72(a) simplifies to Fig. 13.72(b). The open-circuit voltage across AB of Fig. 13.72(b), $E = (16)(1.2) = 19.2\text{ V}$, and the resistance 'looking-in' at AB is $1.2\ \Omega$. Hence the Thévenin equivalent circuit is as shown in Fig. 13.72(c).

(b) When the $1.8\ \Omega$ resistance is connected between terminals A and B of Fig. 13.72(c) the current

I flowing is given by

$$I = \left(\frac{19.2}{1.2 + 1.8} \right) = 6.4\text{ A}$$

Problem 21. Determine by successive conversions between Thévenin and Norton equivalent networks a Thévenin equivalent circuit for terminals AB of Fig. 13.73. Hence determine the current flowing in the $200\ \Omega$ resistance.

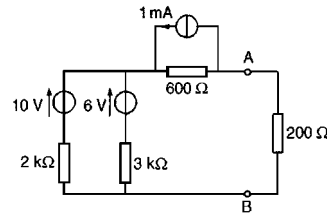

Figure 13.73

For the branch containing the 10 V source, converting to a Norton equivalent network gives $I_{SC} = 10/2000 = 5\text{ mA}$ and $r_1 = 2\text{ k}\Omega$

For the branch containing the 6 V source, converting to a Norton equivalent network gives $I_{SC} = 6/3000 = 2\text{ mA}$ and $r_2 = 3\text{ k}\Omega$

Thus the network of Fig. 13.73 converts to Fig. 13.74(a). Combining the 5 mA and 2 mA current sources gives the equivalent network of Fig. 13.74(b) where the short-circuit current for the original two branches considered is 7 mA and the resistance is $(2 \times 3)/(2 + 3) = 1.2\text{ k}\Omega$

Both of the Norton equivalent networks shown in Fig. 13.74(b) may be converted to Thévenin equivalent circuits. The open-circuit voltage across CD

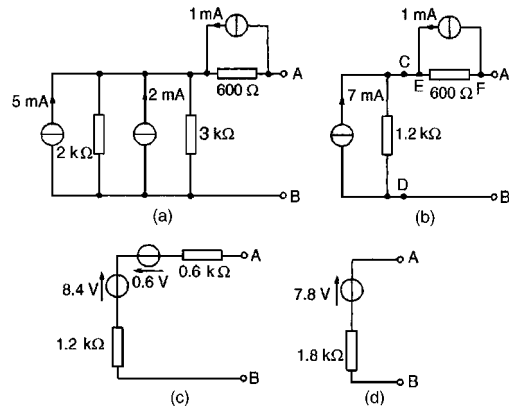

Figure 13.74

is $(7 \times 10^{-3})(1.2 \times 10^3) = 8.4 \text{ V}$ and the resistance 'looking-in' at CD is $1.2 \text{ k}\Omega$. The open-circuit voltage across EF is $(1 \times 10^{-3})(600) = 0.6 \text{ V}$ and the resistance 'looking-in' at EF is $0.6 \text{ k}\Omega$. Thus Fig. 13.74(b) converts to Fig. 13.74(c). Combining the two Thévenin circuits gives $E = 8.4 - 0.6 = 7.8 \text{ V}$ and the resistance $r = (1.2 + 0.6) \text{ k}\Omega = 1.8 \text{ k}\Omega$

Thus the Thévenin equivalent circuit for terminals AB of Fig. 13.73 is as shown in Fig. 13.74(d)

Hence the current I flowing in a 200Ω resistance connected between A and B is given by

$$I = \frac{7.8}{1800 + 200} = \frac{7.8}{2000} = 3.9 \text{ mA}$$

Now try the following exercise

Exercise 69 Further problems on Thévenin and Norton equivalent networks

1 Convert the circuits shown in Fig. 13.75 to Norton equivalent networks.

[(a) $I_{SC} = 25 \text{ A}$, $r = 2 \Omega$ (b) $I_{SC} = 2 \text{ mA}$, $r = 5 \Omega$]

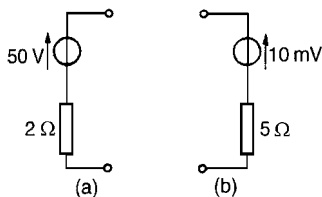

Figure 13.75

2 Convert the networks shown in Fig. 13.76 to Thévenin equivalent circuits

[(a) $E = 20 \text{ V}$, $r = 4 \Omega$ (b) $E = 12 \text{ mV}$, $r = 3 \Omega$]

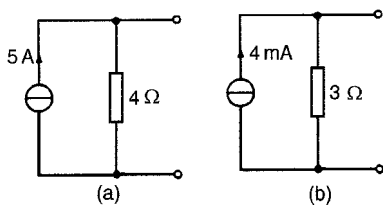

Figure 13.76

3 (a) Convert the network to the left of terminals AB in Fig. 13.77 to an equivalent Thévenin circuit by initially converting to a Norton equivalent network.

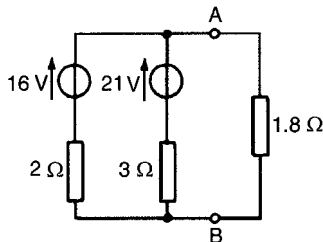

Figure 13.77

(b) Determine the current flowing in the 1.8Ω resistance connected between A and B in Fig. 13.77

[(a) $E = 18 \text{ V}$, $r = 1.2 \Omega$ (b) 6 A]

4 Determine, by successive conversions between Thévenin and Norton equivalent networks, a Thévenin equivalent circuit for terminals AB of Fig. 13.78. Hence determine the current flowing in a 6Ω resistor connected between A and B. [$E = 9\frac{1}{3} \text{ V}$, $r = 1 \Omega$, $1\frac{1}{3} \text{ A}$]

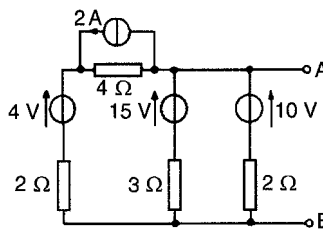

Figure 13.78

5 For the network shown in Fig. 13.79, convert each branch containing a voltage source to its Norton equivalent and hence determine the current flowing in the 5Ω resistance. [1.22 A]

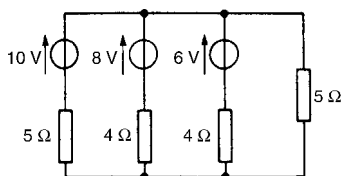

Figure 13.79

13.9 Maximum power transfer theorem

The maximum power transfer theorem states:

The power transferred from a supply source to a load is at its maximum when the resistance of the load is equal to the internal resistance of the source.

Hence, in Fig. 13.80, when $R = r$ the power transferred from the source to the load is a maximum.

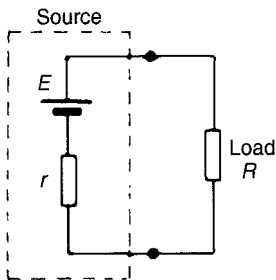

Figure 13.80

Problem 22. The circuit diagram of Fig. 13.81 shows dry cells of source e.m.f. 6 V, and internal resistance 2.5 Ω. If the load resistance R_L is varied from 0 to 5 Ω in 0.5 Ω steps, calculate the power dissipated by the load in each case. Plot a graph of R_L (horizontally) against power (vertically) and determine the maximum power dissipated.

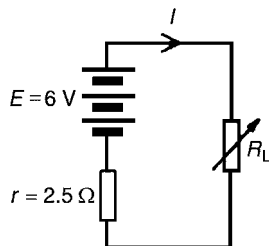

Figure 13.81

When $R_L = 0$, current $I = E/(r + R_L) = 6/2.5 = 2.4$ A and power dissipated in R_L , $P = I^2 R_L$ i.e. $P = (2.4)^2(0) = 0$ W.

When $R_L = 0.5$ Ω, current $I = E/(r + R_L) = 6/(2.5 + 0.5) = 2$ A and $P = I^2 R_L = (2)^2(0.5) = 2.00$ W.

When $R_L = 1.0$ Ω, current $I = 6/(2.5 + 1.0) = 1.714$ A and $P = (1.714)^2(1.0) = 2.94$ W.

With similar calculations the following table is produced:

$R_L(\Omega)$	0	0.5	1.0	1.5	2.0	2.5
$I = \frac{E}{r + R_L}$	2.4	2.0	1.714	1.5	1.333	1.2
$P = I^2 R_L$ (W)	0	2.00	2.94	3.38	3.56	3.60
$R_L(\Omega)$	3.0	3.5	4.0	4.5	5.0	
$I = \frac{E}{r + R_L}$	1.091	1.0	0.923	0.857	0.8	
$P = I^2 R_L$ (W)	3.57	3.50	3.41	3.31	3.20	

A graph of R_L against P is shown in Fig. 13.82. The maximum value of power is 3.60 W which occurs when R_L is 2.5 Ω, i.e. maximum power occurs when $R_L = r$, which is what the maximum power transfer theorem states.

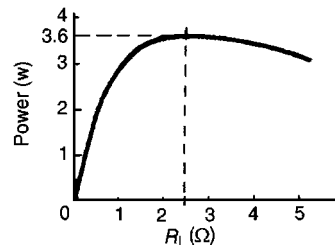

Figure 13.82

Problem 23. A d.c. source has an open-circuit voltage of 30 V and an internal resistance of 1.5 Ω. State the value of load resistance that gives maximum power dissipation and determine the value of this power.

The circuit diagram is shown in Fig. 13.83. From the maximum power transfer theorem, for maximum power dissipation, $R_L = r = 1.5$ Ω

From Fig. 13.83, current $I = E/(r + R_L) = 30/(1.5 + 1.5) = 10$ A

Power $P = I^2 R_L = (10)^2(1.5) = 150$ W = maximum power dissipated

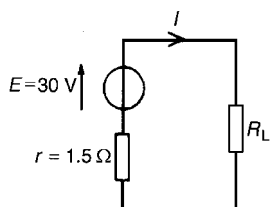

Figure 13.83

Problem 24. Find the value of the load resistor R_L shown in Fig. 13.84 that gives maximum power dissipation and determine the value of this power.

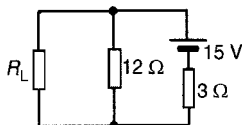

Figure 13.84

Using the procedure for Thévenin's theorem:

- (i) Resistance R_L is removed from the circuit as shown in Fig. 13.85(a)

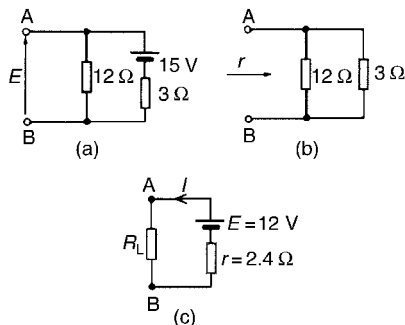

Figure 13.85

- (ii) The p.d. across AB is the same as the p.d. across the $12\ \Omega$ resistor. Hence

$$E = \left(\frac{12}{12 + 3} \right) (15) = 12\ \text{V}$$

- (iii) Removing the source of e.m.f. gives the circuit of Fig. 13.85(b), from which, resistance,

$$r = \frac{12 \times 3}{12 + 3} = \frac{36}{15} = 2.4\ \Omega$$

- (iv) The equivalent Thévenin's circuit supplying terminals AB is shown in Fig. 13.85(c), from which,

$$\text{current, } I = \frac{E}{r + R_L}$$

For maximum power, $R_L = r = 2.4\ \Omega$

$$\text{Thus current, } I = \frac{12}{2.4 + 2.4} = 2.5\ \text{A}$$

$$\text{Power, } P, \text{ dissipated in load } R_L, P = I^2 R_L = (2.5)^2 (2.4) = 15\ \text{W.}$$

Now try the following exercises

Exercise 70 Further problems on the maximum power transfer theorem

- 1 A d.c. source has an open-circuit voltage of 20 V and an internal resistance of 2 Ω. Determine the value of the load resistance that gives maximum power dissipation. Find the value of this power. [2 Ω, 50 W]
- 2 Determine the value of the load resistance R_L shown in Fig. 13.86 that gives maximum power dissipation and find the value of the power. [$R_L = 1.6\ \Omega$, $P = 57.6\ \text{W}$]

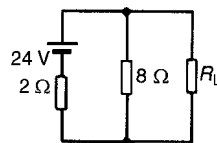

Figure 13.86

Exercise 71 Short answer questions on d.c. circuit theory

- 1 Name two laws and three theorems which may be used to find unknown currents and p.d.'s in electrical circuits
- 2 State Kirchhoff's current law
- 3 State Kirchhoff's voltage law
- 4 State, in your own words, the superposition theorem

- 5 State, in your own words, Thévenin's theorem
- 6 State, in your own words, Norton's theorem
- 7 State the maximum power transfer theorem for a d.c. circuit

Exercise 72 Multi-choice questions on d.c. circuit theory (Answers on page 375)

1 Which of the following statements is true:
For the junction in the network shown in Fig. 13.87:

- (a) $I_5 - I_4 = I_3 - I_2 + I_1$
- (b) $I_1 + I_2 + I_3 = I_4 + I_5$
- (c) $I_2 + I_3 + I_5 = I_1 + I_4$
- (d) $I_1 - I_2 - I_3 - I_4 + I_5 = 0$

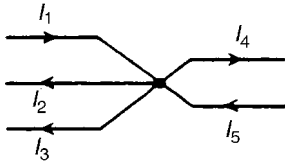

Figure 13.87

2 Which of the following statements is true?

- For the circuit shown in Fig. 13.88:
- (a) $E_1 + E_2 + E_3 = Ir_1 + Ir_2 + Ir_3$
 - (b) $E_2 + E_3 - E_1 - I(r_1 + r_2 + r_3) = 0$
 - (c) $I(r_1 + r_2 + r_3) = E_1 - E_2 - E_3$
 - (d) $E_2 + E_3 - E_1 = Ir_1 + Ir_2 + Ir_3$

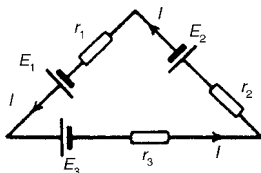

Figure 13.88

3 For the circuit shown in Fig. 13.89, the internal resistance r is given by:

- (a) $\frac{I}{V - E}$
- (b) $\frac{V - E}{I}$
- (c) $\frac{I}{E - V}$
- (d) $\frac{E - V}{I}$

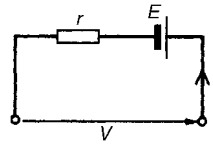

Figure 13.89

- 4 For the circuit shown in Fig. 13.90, voltage V is:
(a) 12 V (b) 2 V (c) 10 V (d) 0 V

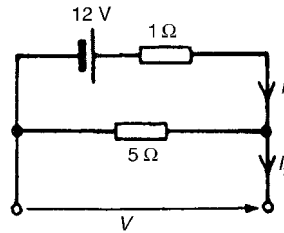

Figure 13.90

- 5 For the circuit shown in Fig. 13.90, current I_1 is:
(a) 2 A (b) 14.4 A
(c) 0.5 A (d) 0 A
- 6 For the circuit shown in Fig. 13.90, current I_2 is:
(a) 2 A (b) 14.4 A
(c) 0.5 A (d) 0 A
- 7 The equivalent resistance across terminals AB of Fig. 13.91 is:
(a) 9.31 Ω (b) 7.24 Ω
(c) 10.0 Ω (d) 6.75 Ω

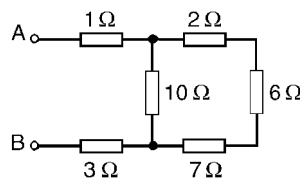

Figure 13.91

- 8 With reference to Fig. 13.92, which of the following statements is correct?
(a) $V_{PQ} = 2 V$
(b) $V_{PQ} = 15 V$

- (c) When a load is connected between P and Q, current would flow from Q to P
 (d) $V_{PQ} = 20\text{ V}$

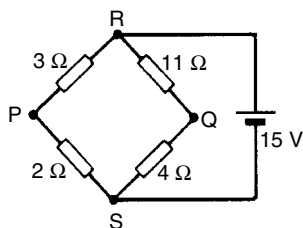

Figure 13.92

- 9 In Fig. 13.92, if the 15 V battery is replaced by a short-circuit, the equivalent resistance across terminals PQ is:
 (a) $20\ \Omega$ (b) $4.20\ \Omega$
 (c) $4.13\ \Omega$ (d) $4.29\ \Omega$
- 10 For the circuit shown in Fig. 13.93, maximum power transfer from the source is required. For this to be so, which of the following statements is true?
 (a) $R_2 = 10\ \Omega$ (b) $R_2 = 30\ \Omega$
 (c) $R_2 = 7.5\ \Omega$ (d) $R_2 = 15\ \Omega$

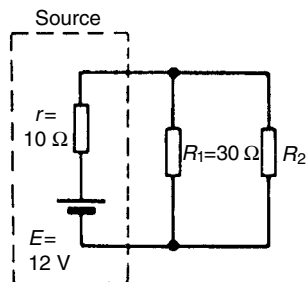

Figure 13.93

- 11 The open-circuit voltage E across terminals XY of Fig. 13.94 is:
 (a) 0 V (b) 20 V (c) 4 V (d) 16 V

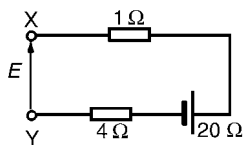

Figure 13.94

- 12 The maximum power transferred by the source in Fig. 13.95 is:
 (a) 5 W (b) 200 W
 (c) 40 W (d) 50 W

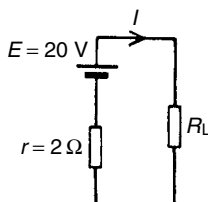

Figure 13.95

- 13 For the circuit shown in Fig. 13.96, voltage V is:
 (a) 0 V (b) 20 V
 (c) 4 V (d) 16 V

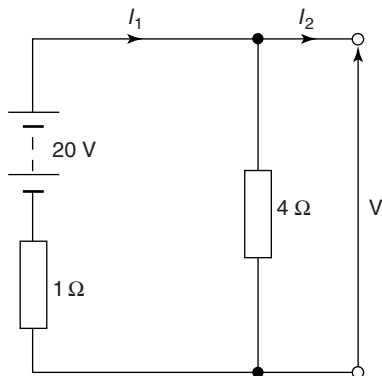

Figure 13.96

- 14 For the circuit shown in Fig. 13.96, current I_1 is:
 (a) 25 A (b) 4 A
 (c) 0 A (d) 20 A
- 15 For the circuit shown in Fig. 13.96, current I_2 is:
 (a) 25 A (b) 4 A
 (c) 0 A (d) 20 A
- 16 The current flowing in the branches of a d.c. circuit may be determined using:
 (a) Kirchhoff's laws
 (b) Lenz's law
 (c) Faraday's laws
 (d) Fleming's left-hand rule

Alternating voltages and currents

At the end of this chapter you should be able to:

- appreciate why a.c. is used in preference to d.c.
- describe the principle of operation of an a.c. generator
- distinguish between unidirectional and alternating waveforms
- define cycle, period or periodic time T and frequency f of a waveform
- perform calculations involving $T = 1/f$
- define instantaneous, peak, mean and r.m.s. values, and form and peak factors for a sine wave
- calculate mean and r.m.s. values and form and peak factors for given waveforms
- understand and perform calculations on the general sinusoidal equation
 $v = V_m \sin(\omega t \pm \phi)$
- understand lagging and leading angles
- combine two sinusoidal waveforms (a) by plotting graphically, (b) by drawing phasors to scale and (c) by calculation

14.1 Introduction

Electricity is produced by generators at power stations and then distributed by a vast network of transmission lines (called the National Grid system) to industry and for domestic use. It is easier and cheaper to generate alternating current (a.c.) than direct current (d.c.) and a.c. is more conveniently distributed than d.c. since its voltage can be readily altered using transformers. Whenever d.c. is needed in preference to a.c., devices called rectifiers are used for conversion (see Section 14.7).

14.2 The a.c. generator

Let a single turn coil be free to rotate at constant angular velocity symmetrically between the poles of a magnet system as shown in Fig. 14.1

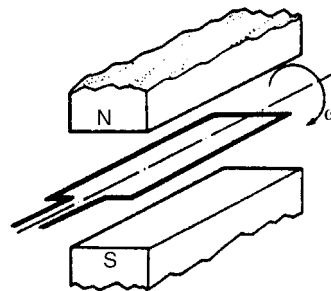

Figure 14.1

An e.m.f. is generated in the coil (from Faraday's laws) which varies in magnitude and reverses its direction at regular intervals. The reason for this is shown in Fig. 14.2 In positions (a), (e) and (i) the conductors of the loop are effectively moving along the magnetic field, no flux is cut and hence no e.m.f. is induced. In position (c) maximum flux is cut and

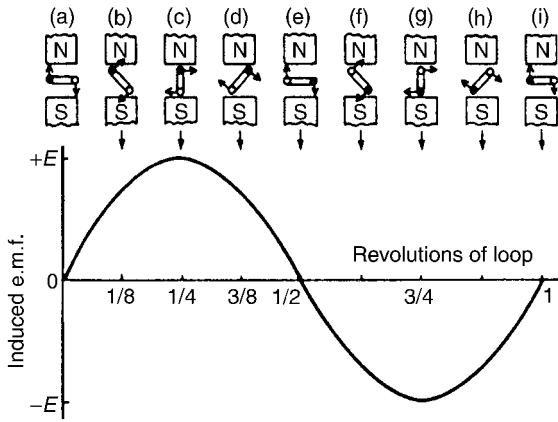

Figure 14.2

hence maximum e.m.f. is induced. In position (g), maximum flux is cut and hence maximum e.m.f. is again induced. However, using Fleming’s right-hand rule, the induced e.m.f. is in the opposite direction to that in position (c) and is thus shown as $-E$. In positions (b), (d), (f) and (h) some flux is cut and hence some e.m.f. is induced. If all such positions of the coil are considered, in one revolution of the coil, one cycle of alternating e.m.f. is produced as shown. This is the principle of operation of the a.c. generator (i.e. the alternator).

14.3 Waveforms

If values of quantities which vary with time t are plotted to a base of time, the resulting graph is called a **waveform**. Some typical waveforms are shown in Fig. 14.3. Waveforms (a) and (b) are **unidirectional waveforms**, for, although they vary considerably with time, they flow in one direction only (i.e. they do not cross the time axis and become negative). Waveforms (c) to (g) are called **alternating waveforms** since their quantities are continually changing in direction (i.e. alternately positive and negative).

A waveform of the type shown in Fig. 14.3(g) is called a **sine wave**. It is the shape of the waveform of e.m.f. produced by an alternator and thus the mains electricity supply is of ‘sinusoidal’ form.

One complete series of values is called a **cycle** (i.e. from O to P in Fig. 14.3(g)).

The time taken for an alternating quantity to complete one cycle is called the **period** or the **periodic time, T** , of the waveform.

The number of cycles completed in one second is called the **frequency, f** , of the supply and is

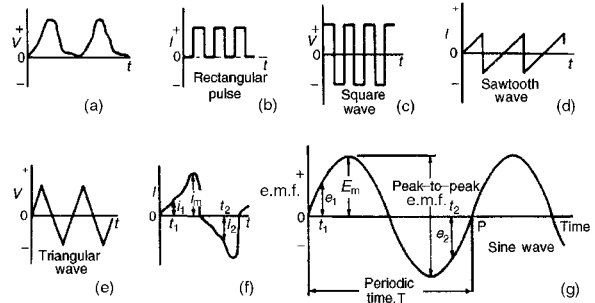

Figure 14.3

measured in **hertz, Hz**. The standard frequency of the electricity supply in Great Britain is 50 Hz

$$T = \frac{1}{f} \text{ or } f = \frac{1}{T}$$

Problem 1. Determine the periodic time for frequencies of (a) 50 Hz and (b) 20 kHz.

- (a) Periodic time $T = \frac{1}{f} = \frac{1}{50} = 0.02 \text{ s}$ or **20 ms**
- (b) Periodic time $T = \frac{1}{f} = \frac{1}{20\,000} = 0.00005 \text{ s}$ or **50 μs**

Problem 2. Determine the frequencies for periodic times of (a) 4 ms (b) 4 μs .

- (a) Frequency $f = \frac{1}{T} = \frac{1}{4 \times 10^{-3}} = \frac{1000}{4} = 250 \text{ Hz}$
- (b) Frequency $f = \frac{1}{T} = \frac{1}{4 \times 10^{-6}} = \frac{1\,000\,000}{4} = 250\,000 \text{ Hz}$
or **250 kHz** or **0.25 MHz**

Problem 3. An alternating current completes 5 cycles in 8 ms. What is its frequency?

Time for 1 cycle = $(8/5)$ ms = 1.6 ms = periodic time T .

$$\begin{aligned} \text{Frequency } f &= \frac{1}{T} = \frac{1}{1.6 \times 10^{-3}} = \frac{1000}{1.6} \\ &= \frac{10\,000}{16} = \mathbf{625 \text{ Hz}} \end{aligned}$$

Now try the following exercise

Exercise 73 Further problems on frequency and periodic time

- 1 Determine the periodic time for the following frequencies:
 (a) 2.5 Hz (b) 100 Hz (c) 40 kHz
 [(a) 0.4 s (b) 10 ms (c) 25 μ s]
- 2 Calculate the frequency for the following periodic times:
 (a) 5 ms (b) 50 μ s (c) 0.2 s
 [(a) 200 Hz (b) 20 kHz (c) 5 Hz]
- 3 An alternating current completes 4 cycles in 5 ms. What is its frequency? [800 Hz]

14.4 A.c. values

Instantaneous values are the values of the alternating quantities at any instant of time. They are represented by small letters, i , v , e , etc., (see Fig. 14.3(f) and (g)).

The largest value reached in a half cycle is called the **peak value** or the **maximum value** or the **crest value** or the **amplitude** of the waveform. Such values are represented by V_m , I_m , E_m , etc. (see Fig. 14.3(f) and (g)). A **peak-to-peak** value of e.m.f. is shown in Fig. 14.3(g) and is the difference between the maximum and minimum values in a cycle.

The **average** or **mean value** of a symmetrical alternating quantity, (such as a sine wave), is the average value measured over a half cycle, (since over a complete cycle the average value is zero).

$$\left. \begin{array}{l} \text{Average or} \\ \text{mean value} \end{array} \right\} = \frac{\text{area under the curve}}{\text{length of base}}$$

The area under the curve is found by approximate methods such as the trapezoidal rule, the mid-ordinate rule or Simpson's rule. Average values are represented by V_{AV} , I_{AV} , E_{AV} , etc.

For a sine wave:

$$\begin{aligned} \text{average value} &= \mathbf{0.637 \times \text{maximum value}} \\ &\text{(i.e. } 2/\pi \times \text{maximum value)} \end{aligned}$$

The **effective value** of an alternating current is that current which will produce the same heating effect as an equivalent direct current. The effective value is called the **root mean square (r.m.s.) value** and whenever an alternating quantity is given, it is assumed to be the rms value. For example, the domestic mains supply in Great Britain is 240 V and is assumed to mean '240 V rms'. The symbols used for r.m.s. values are I , V , E , etc. For a non-sinusoidal waveform as shown in Fig. 14.4 the r.m.s. value is given by:

$$I = \sqrt{\frac{i_1^2 + i_2^2 + \dots + i_n^2}{n}}$$

where n is the number of intervals used.

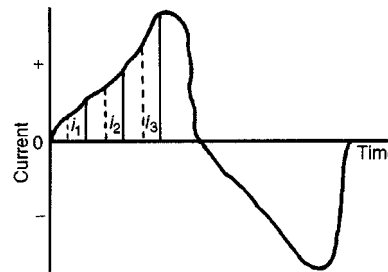

Figure 14.4

For a sine wave:

$$\begin{aligned} \text{rms value} &= \mathbf{0.707 \times \text{maximum value}} \\ &\text{(i.e. } 1/\sqrt{2} \times \text{maximum value)} \end{aligned}$$

$$\text{Form factor} = \frac{\text{r.m.s. value}}{\text{average value}}$$

For a sine wave, form factor = 1.11

$$\text{Peak factor} = \frac{\text{maximum value}}{\text{r.m.s. value}}$$

For a sine wave, peak factor = 1.41.

The values of form and peak factors give an indication of the shape of waveforms.

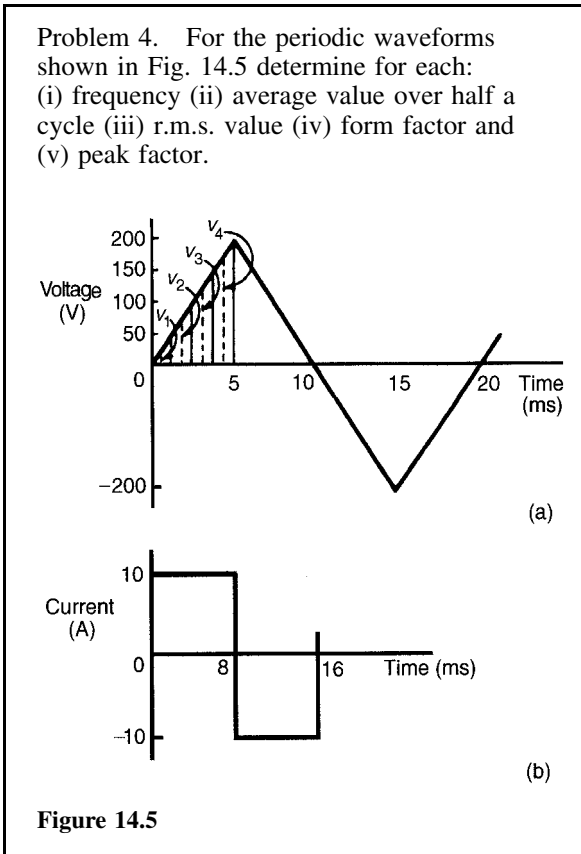

Figure 14.5

(a) **Triangular waveform** (Fig. 14.5(a)).

(i) Time for 1 complete cycle = 20 ms = periodic time, T . Hence

$$\begin{aligned} \text{frequency } f &= \frac{1}{T} = \frac{1}{20 \times 10^{-3}} \\ &= \frac{1000}{20} = \mathbf{50 \text{ Hz}} \end{aligned}$$

(ii) Area under the triangular waveform for a half-cycle = $\frac{1}{2} \times \text{base} \times \text{height}$
 = $\frac{1}{2} \times (10 \times 10^{-3}) \times 200 = 1 \text{ volt second}$

$$\left. \begin{array}{l} \text{Average value} \\ \text{of waveform} \end{array} \right\} = \frac{\text{area under curve}}{\text{length of base}}$$

$$\begin{aligned} &= \frac{1 \text{ volt second}}{10 \times 10^{-3} \text{ second}} \\ &= \frac{1000}{10} = \mathbf{100 \text{ V}} \end{aligned}$$

(iii) In Fig. 14.5(a), the first 1/4 cycle is divided into 4 intervals. Thus

$$\begin{aligned} \text{rms value} &= \sqrt{\frac{v_1^2 + v_2^2 + v_3^2 + v_4^2}{4}} \\ &= \sqrt{\frac{25^2 + 75^2 + 125^2 + 175^2}{4}} \\ &= \mathbf{114.6 \text{ V}} \end{aligned}$$

(Note that the greater the number of intervals chosen, the greater the accuracy of the result. For example, if twice the number of ordinates as that chosen above are used, the r.m.s. value is found to be 115.6 V)

(iv) Form factor = $\frac{\text{r.m.s. value}}{\text{average value}}$
 = $\frac{114.6}{100} = \mathbf{1.15}$

(v) Peak factor = $\frac{\text{maximum value}}{\text{r.m.s. value}}$
 = $\frac{200}{114.6} = \mathbf{1.75}$

(b) **Rectangular waveform** (Fig. 14.5(b)).

(i) Time for 1 complete cycle = 16 ms = periodic time, T . Hence

$$\begin{aligned} \text{frequency, } f &= \frac{1}{T} = \frac{1}{16 \times 10^{-3}} = \frac{1000}{16} \\ &= \mathbf{62.5 \text{ Hz}} \end{aligned}$$

(ii) $\left. \begin{array}{l} \text{Average value over} \\ \text{half a cycle} \end{array} \right\} = \frac{\text{area under curve}}{\text{length of base}}$
 = $\frac{10 \times (8 \times 10^{-3})}{8 \times 10^{-3}}$
 = $\mathbf{10 \text{ A}}$

(iii) The r.m.s. value = $\sqrt{\frac{i_1^2 + i_2^2 + i_3^2 + i_4^2}{4}}$
 = $\mathbf{10 \text{ A}}$, however many intervals are chosen, since the waveform is rectangular.

(iv) Form factor = $\frac{\text{r.m.s. value}}{\text{average value}} = \frac{10}{10} = 1$

(v) Peak factor = $\frac{\text{maximum value}}{\text{r.m.s. value}} = \frac{10}{10} = 1$

Problem 5. The following table gives the corresponding values of current and time for a half cycle of alternating current.

time t (ms)	0	0.5	1.0	1.5	2.0
current i (A)	0	7	14	23	40

time t (ms)	2.5	3.0	3.5	4.0	4.5	5.0
current i (A)	56	68	76	60	5	0

Assuming the negative half cycle is identical in shape to the positive half cycle, plot the waveform and find (a) the frequency of the supply, (b) the instantaneous values of current after 1.25 ms and 3.8 ms, (c) the peak or maximum value, (d) the mean or average value, and (e) the r.m.s. value of the waveform.

The half cycle of alternating current is shown plotted in Fig. 14.6

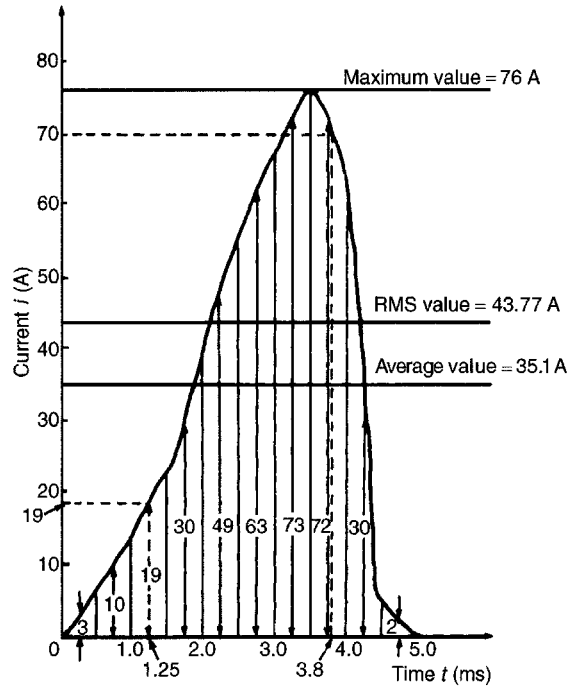

Figure 14.6

- (a) Time for a half cycle = 5 ms; hence the time for 1 cycle, i.e. the periodic time, $T = 10$ ms or 0.01 s
Frequency, $f = \frac{1}{T} = \frac{1}{0.01} = 100$ Hz
- (b) Instantaneous value of current after 1.25 ms is **19 A**, from Fig. 14.6. Instantaneous value of current after 3.8 ms is **70 A**, from Fig. 14.6
- (c) Peak or maximum value = **76 A**
- (d) Mean or average value = $\frac{\text{area under curve}}{\text{length of base}}$

Using the mid-ordinate rule with 10 intervals, each of width 0.5 ms gives:

$$\begin{aligned} \text{area under curve} \} &= (0.5 \times 10^{-3})[3 + 10 + 19 + 30 \\ &\quad + 49 + 63 + 73 + 72 + 30 + 2] \\ &\quad \text{(see Fig. 14.6)} \\ &= (0.5 \times 10^{-3})(351) \end{aligned}$$

$$\begin{aligned} \text{Hence mean or average value} \} &= \frac{(0.5 \times 10^{-3})(351)}{5 \times 10^{-3}} \\ &= 35.1 \text{ A} \end{aligned}$$

$$\begin{aligned} \text{(e) R.m.s value} &= \sqrt{\frac{3^2 + 10^2 + 19^2 + 30^2 + 49^2 + 63^2 + 73^2 + 72^2 + 30^2 + 2^2}{10}} \\ &= \sqrt{\frac{19157}{10}} = 43.8 \text{ A} \end{aligned}$$

Problem 6. Calculate the r.m.s. value of a sinusoidal current of maximum value 20 A.

For a sine wave,

$$\begin{aligned} \text{r.m.s. value} &= 0.707 \times \text{maximum value} \\ &= 0.707 \times 20 = 14.14 \text{ A} \end{aligned}$$

Problem 7. Determine the peak and mean values for a 240 V mains supply.

For a sine wave, r.m.s. value of voltage

$$V = 0.707 \times V_m.$$

A 240 V mains supply means that 240 V is the r.m.s. value, hence

$$V_m = \frac{V}{0.707} = \frac{240}{0.707} = \mathbf{339.5\text{ V}}$$

= peak value

Mean value

$$V_{AV} = 0.637 V_m = 0.637 \times 339.5 = \mathbf{216.3\text{ V}}$$

Problem 8. A supply voltage has a mean value of 150 V. Determine its maximum value and its r.m.s. value.

For a sine wave, mean value = 0.637 × maximum value. Hence

$$\mathbf{\text{maximum value}} = \frac{\text{mean value}}{0.637} = \frac{150}{0.637} = \mathbf{235.5\text{ V}}$$

$$\mathbf{\text{R.m.s. value}} = 0.707 \times \text{maximum value} = 0.707 \times 235.5 = \mathbf{166.5\text{ V}}$$

Now try the following exercise

Exercise 74 Further problems on a.c. values of waveforms

1 An alternating current varies with time over half a cycle as follows:

Current (A)	0	0.7	2.0	4.2	8.4
time (ms)	0	1	2	3	4

Current (A)	8.2	2.5	1.0	0.4	0.2	0
time (ms)	5	6	7	8	9	10

The negative half cycle is similar. Plot the curve and determine:

- (a) the frequency (b) the instantaneous values at 3.4 ms and 5.8 ms (c) its mean value and (d) its r.m.s. value

[(a) 50 Hz (b) 5.5 A, 3.4 A (c) 2.8 A (d) 4.0 A]

2 For the waveforms shown in Fig. 14.7 determine for each (i) the frequency (ii) the average value over half a cycle (iii) the r.m.s. value (iv) the form factor (v) the peak factor.

- [(a) (i) 100 Hz (ii) 2.50 A (iii) 2.88 A (iv) 1.15 (v) 1.74
 (b) (i) 250 Hz (ii) 20 V (iii) 20 V (iv) 1.0 (v) 1.0
 (c) (i) 125 Hz (ii) 18 A (iii) 19.56 A (iv) 1.09 (v) 1.23
 (d) (i) 250 Hz (ii) 25 V (iii) 50 V (iv) 2.0 (v) 2.0]

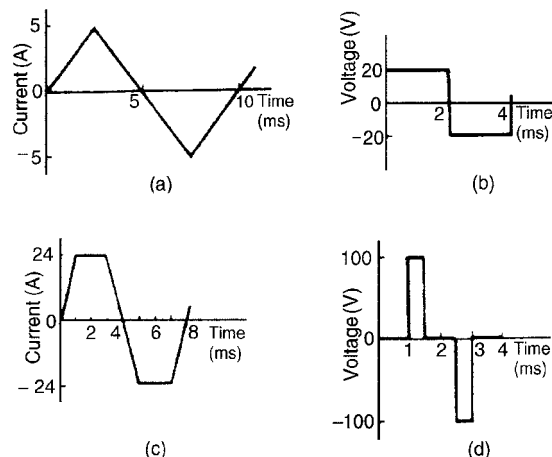

Figure 14.7

3 An alternating voltage is triangular in shape, rising at a constant rate to a maximum of 300 V in 8 ms and then falling to zero at a constant rate in 4 ms. The negative half cycle is identical in shape to the positive half cycle. Calculate (a) the mean voltage over half a cycle, and (b) the r.m.s. voltage

[(a) 150 V (b) 170 V]

4 An alternating e.m.f. varies with time over half a cycle as follows:

E.m.f. (V)	0	45	80	155
time (ms)	0	1.5	3.0	4.5

E.m.f. (V)	215	320	210	95
time (ms)	6.0	7.5	9.0	10.5

E.m.f. (V)	0
time (ms)	12.0

The negative half cycle is identical in shape to the positive half cycle. Plot the waveform and determine (a) the periodic time and frequency (b) the instantaneous value of voltage at 3.75 ms (c) the times when the voltage is 125 V (d) the mean value, and (e) the r.m.s. value

- [(a) 24 ms, 41.67 Hz (b) 115 V
(c) 4 ms and 10.1 ms (d) 142 V
(e) 171 V]

5 Calculate the r.m.s. value of a sinusoidal curve of maximum value 300 V [212.1 V]

6 Find the peak and mean values for a 200 V mains supply [282.9 V, 180.2 V]

7 Plot a sine wave of peak value 10.0 A. Show that the average value of the waveform is 6.37 A over half a cycle, and that the r.m.s. value is 7.07 A

8 A sinusoidal voltage has a maximum value of 120 V. Calculate its r.m.s. and average values. [84.8 V, 76.4 V]

9 A sinusoidal current has a mean value of 15.0 A. Determine its maximum and r.m.s. values. [23.55 A, 16.65 A]

If all such vertical components are projected on to a graph of y against angle ωt (in radians), a sine curve results of maximum value OA . Any quantity which varies sinusoidally can thus be represented as a phasor.

A sine curve may not always start at 0° . To show this a periodic function is represented by $y = \sin(\omega t \pm \phi)$, where ϕ is the phase (or angle) difference compared with $y = \sin \omega t$. In Fig. 14.9(a), $y_2 = \sin(\omega t + \phi)$ starts ϕ radians earlier than $y_1 = \sin \omega t$ and is thus said to **lead** y_1 by ϕ radians. Phasors y_1 and y_2 are shown in Fig. 14.9(b) at the time when $t = 0$.

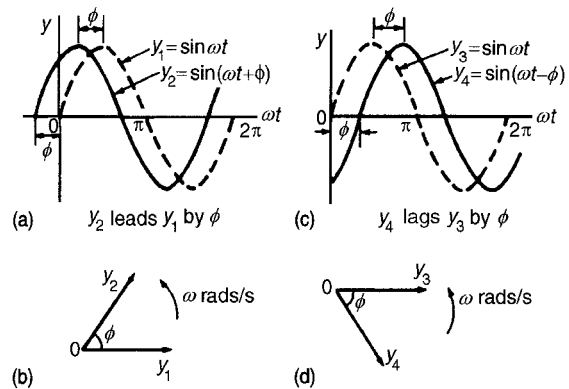

Figure 14.9

In Fig. 14.9(c), $y_4 = \sin(\omega t - \phi)$ starts ϕ radians later than $y_3 = \sin \omega t$ and is thus said to **lag** y_3 by ϕ radians. Phasors y_3 and y_4 are shown in Fig. 14.9(d) at the time when $t = 0$.

Given the general sinusoidal voltage, $v = V_m \sin(\omega t \pm \phi)$, then

- (i) Amplitude or maximum value = V_m
- (ii) Peak to peak value = $2V_m$
- (iii) Angular velocity = ω rad/s
- (iv) Periodic time, $T = 2\pi/\omega$ seconds
- (v) Frequency, $f = \omega/2\pi$ Hz (since $\omega = 2\pi f$)
- (vi) $\phi =$ angle of lag or lead (compared with $v = V_m \sin \omega t$)

Problem 9. An alternating voltage is given by $v = 282.8 \sin 314t$ volts. Find (a) the r.m.s. voltage, (b) the frequency and (c) the instantaneous value of voltage when $t = 4$ ms.

- (a) The general expression for an alternating voltage is $v = V_m \sin(\omega t \pm \phi)$. Comparing

14.5 The equation of a sinusoidal waveform

In Fig. 14.8, OA represents a vector that is free to rotate anticlockwise about O at an angular velocity of ω rad/s. A rotating vector is known as a **phasor**.

After time t seconds the vector OA has turned through an angle ωt . If the line BC is constructed perpendicular to OA as shown, then

$$\sin \omega t = \frac{BC}{OB} \quad \text{i.e. } BC = OB \sin \omega t$$

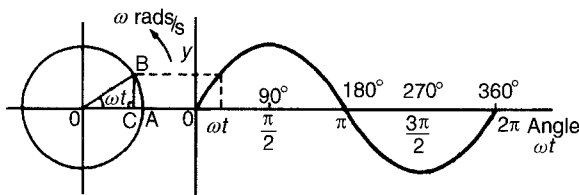

Figure 14.8

$v = 282.8 \sin 314 t$ with this general expression gives the peak voltage as 282.8 V. Hence the r.m.s. voltage = $0.707 \times$ maximum value = $0.707 \times 282.8 = \mathbf{200 \text{ V}}$

- (b) Angular velocity, $\omega = 314 \text{ rad/s}$, i.e. $2\pi f = 314$. Hence frequency,

$$f = \frac{314}{2\pi} = \mathbf{50 \text{ Hz}}$$

- (c) When $t = 4 \text{ ms}$,

$$\begin{aligned} v &= 282.8 \sin(314 \times 4 \times 10^{-3}) \\ &= 282.8 \sin(1.256) = \mathbf{268.9 \text{ V}} \end{aligned}$$

$$\begin{aligned} \text{Note that } 1.256 \text{ radians} &= \left[1.256 \times \frac{180^\circ}{\pi} \right] \\ &= 71.96^\circ \end{aligned}$$

Hence $v = 282.8 \sin 71.96^\circ = \mathbf{268.9 \text{ V}}$, as above.

Problem 10. An alternating voltage is given by $v = 75 \sin(200\pi t - 0.25)$ volts. Find

- (a) the amplitude, (b) the peak-to-peak value, (c) the r.m.s. value, (d) the periodic time, (e) the frequency, and (f) the phase angle (in degrees and minutes) relative to $75 \sin 200\pi t$.

Comparing $v = 75 \sin(200\pi t - 0.25)$ with the general expression $v = V_m \sin(\omega t \pm \phi)$ gives:

- (a) Amplitude, or peak value = $\mathbf{75 \text{ V}}$
 (b) Peak-to-peak value = $2 \times 75 = \mathbf{150 \text{ V}}$
 (c) The r.m.s. value = $0.707 \times$ maximum value = $0.707 \times 75 = \mathbf{53 \text{ V}}$

- (d) Angular velocity, $\omega = 200\pi \text{ rad/s}$. Hence periodic time,

$$T = \frac{2\pi}{\omega} = \frac{2\pi}{200\pi} = \frac{1}{100} = \mathbf{0.01 \text{ s or } 10 \text{ ms}}$$

- (e) Frequency, $f = \frac{1}{T} = \frac{1}{0.01} = \mathbf{100 \text{ Hz}}$

- (f) Phase angle, $\phi = 0.25$ radians lagging
 $75 \sin 200\pi t$

$$0.25 \text{ rads} = 0.25 \times \frac{180^\circ}{\pi} = 14.32^\circ$$

Hence phase angle = $\mathbf{14.32^\circ \text{ lagging}}$

Problem 11. An alternating voltage, v , has a periodic time of 0.01 s and a peak value of 40 V. When time t is zero, $v = -20 \text{ V}$. Express the instantaneous voltage in the form $v = V_m \sin(\omega t \pm \phi)$.

Amplitude, $V_m = 40 \text{ V}$.

Periodic time $T = \frac{2\pi}{\omega}$ hence angular velocity,
 $\omega = \frac{2\pi}{T} = \frac{2\pi}{0.01} = 200\pi \text{ rad/s}$.

$v = V_m \sin(\omega t + \phi)$ thus becomes

$$v = 40 \sin(200\pi t + \phi) \text{ volts.}$$

When time $t = 0$, $v = -20 \text{ V}$

i.e. $-20 = 40 \sin \phi$

so that $\sin \phi = -20/40 = -0.5$

Hence $\phi = \sin^{-1}(-0.5) = -30^\circ$

$$= \left(-30 \times \frac{\pi}{180} \right) \text{ rads} = -\frac{\pi}{6} \text{ rads}$$

Thus $v = \mathbf{40 \sin \left(200\pi t - \frac{\pi}{6} \right) \text{ V}}$

Problem 12. The current in an a.c. circuit at any time t seconds is given by:

$i = 120 \sin(100\pi t + 0.36)$ amperes. Find:

- (a) the peak value, the periodic time, the frequency and phase angle relative to $120 \sin 100\pi t$ (b) the value of the current when $t = 0$ (c) the value of the current when $t = 8 \text{ ms}$ (d) the time when the current first reaches 60 A, and (e) the time when the current is first a maximum.

- (a) Peak value = $\mathbf{120 \text{ A}}$

$$\begin{aligned} \text{Periodic time } T &= \frac{2\pi}{\omega} \\ &= \frac{2\pi}{100\pi} \text{ (since } \omega = 100\pi) \\ &= \frac{1}{50} = \mathbf{0.02 \text{ s or } 20 \text{ ms}} \end{aligned}$$

$$\text{Frequency, } f = \frac{1}{T} = \frac{1}{0.02} = \mathbf{50 \text{ Hz}}$$

Phase angle = 0.36 rads

$$= 0.36 \times \frac{180^\circ}{\pi} = \mathbf{20.63^\circ \text{ leading}}$$

(b) When $t = 0$,

$$i = 120 \sin(0 + 0.36) \\ = 120 \sin 20.63^\circ = \mathbf{42.3 \text{ A}}$$

(c) When $t = 8 \text{ ms}$,

$$i = 120 \sin \left[100\pi \left(\frac{8}{10^3} \right) + 0.36 \right] \\ = 120 \sin 2.8733 (= 120 \sin 164.63^\circ) \\ = \mathbf{31.8 \text{ A}}$$

(d) When $i = 60 \text{ A}$, $60 = 120 \sin(100\pi t + 0.36)$ thus $(60/120) = \sin(100\pi t + 0.36)$ so that $(100\pi t + 0.36) = \sin^{-1} 0.5 = 30^\circ = \pi/6 \text{ rads} = 0.5236 \text{ rads}$. Hence time,

$$t = \frac{0.5236 - 0.36}{100\pi} = \mathbf{0.521 \text{ ms}}$$

(e) When the current is a maximum, $i = 120 \text{ A}$.

$$\text{Thus } 120 = 120 \sin(100\pi t + 0.36) \\ 1 = \sin(100\pi t + 0.36) \\ (100\pi t + 0.36) = \sin^{-1} 1 = 90^\circ \\ = (\pi/2) \text{ rads} \\ = 1.5708 \text{ rads.} \\ \text{Hence time, } t = \frac{1.5708 - 0.36}{100\pi} = \mathbf{3.85 \text{ ms}}$$

Now try the following exercise

Exercise 75 Further problems on

$$v = V_m \sin(\omega t \pm \phi)$$

1 An alternating voltage is represented by $v = 20 \sin 157.1 t$ volts. Find (a) the maximum value (b) the frequency (c) the periodic time. (d) What is the angular velocity of the phasor representing this waveform?

- [(a) 20 V (b) 25 Hz
(c) 0.04 s (d) 157.1 rads/s]

2 Find the peak value, the r.m.s. value, the periodic time, the frequency and the phase angle

(in degrees) of the following alternating quantities:

- (a) $v = 90 \sin 400\pi t$ volts
[90 V, 63.63 V, 5 ms, 200 Hz, 0°]
(b) $i = 50 \sin(100\pi t + 0.30)$ amperes
[50 A, 35.35 A, 0.02 s, 50 Hz, 17.19° lead]
(c) $e = 200 \sin(628.4 t - 0.41)$ volts
[200 V, 141.4 V, 0.01 s, 100 Hz, 23.49° lag]

3 A sinusoidal current has a peak value of 30 A and a frequency of 60 Hz. At time $t = 0$, the current is zero. Express the instantaneous current i in the form $i = I_m \sin \omega t$

$$[i = 30 \sin 120\pi t]$$

4 An alternating voltage v has a periodic time of 20 ms and a maximum value of 200 V. When time $t = 0$, $v = -75$ volts. Deduce a sinusoidal expression for v and sketch one cycle of the voltage showing important points.

$$[v = 200 \sin(100\pi t - 0.384)]$$

5 The voltage in an alternating current circuit at any time t seconds is given by $v = 60 \sin 40t$ volts. Find the first time when the voltage is

- (a) 20 V (b) -30 V

$$[(a) 8.496 \text{ ms (b) } 91.63 \text{ ms}]$$

6 The instantaneous value of voltage in an a.c. circuit at any time t seconds is given by $v = 100 \sin(50\pi t - 0.523)$ V. Find:

- (a) the peak-to-peak voltage, the periodic time, the frequency and the phase angle
(b) the voltage when $t = 0$
(c) the voltage when $t = 8 \text{ ms}$
(d) the times in the first cycle when the voltage is 60 V
(e) the times in the first cycle when the voltage is -40 V
(f) the first time when the voltage is a maximum.

Sketch the curve for one cycle showing relevant points. [(a) 200 V, 0.04 s, 25 Hz, 29.97° lagging (b) -49.95 V (c) 66.96 V

- (d) 7.426 ms, 19.23 ms (e) 25.95 ms, 40.71 ms (f) 13.33 ms]

14.6 Combination of waveforms

The resultant of the addition (or subtraction) of two sinusoidal quantities may be determined either:

- (a) by plotting the periodic functions graphically (see worked Problems 13 and 16), or
- (b) by resolution of phasors by drawing or calculation (see worked Problems 14 and 15)

Problem 13. The instantaneous values of two alternating currents are given by $i_1 = 20 \sin \omega t$ amperes and $i_2 = 10 \sin(\omega t + \pi/3)$ amperes. By plotting i_1 and i_2 on the same axes, using the same scale, over one cycle, and adding ordinates at intervals, obtain a sinusoidal expression for $i_1 + i_2$.

$i_1 = 20 \sin \omega t$ and $i_2 = 10 \sin(\omega t + \pi/3)$ are shown plotted in Fig. 14.10. Ordinates of i_1 and i_2 are added at, say, 15° intervals (a pair of dividers are useful for this). For example,

- at 30° , $i_1 + i_2 = 10 + 10 = 20$ A
- at 60° , $i_1 + i_2 = 17.3 + 8.7 = 26$ A
- at 150° , $i_1 + i_2 = 10 + (-5) = 5$ A, and so on.

ωt (degrees)	0	30	60	90
$\sin \omega t$	0	0.5	0.866	1
$i_1 = 20 \sin \omega t$	0	10	17.32	20
$(\omega t + 60)$	60	90	120	150
$\sin(\omega t + \frac{\pi}{3})$	0.866	1	0.866	0.5
$i_2 = 10 \sin(\omega t + \frac{\pi}{3})$	8.66	10	8.66	5

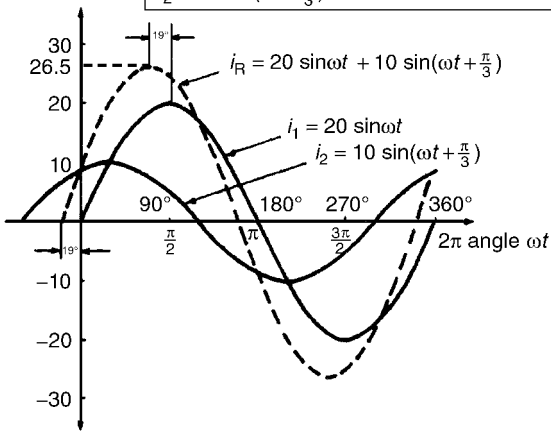

Figure 14.10

The resultant waveform for $i_1 + i_2$ is shown by the broken line in Fig. 14.10. It has the same period, and hence frequency, as i_1 and i_2 . The amplitude or peak value is 26.5 A

The resultant waveform leads the curve $i_1 = 20 \sin \omega t$ by 19° i.e. $(19 \times \pi/180)$ rads = 0.332 rads
 Hence the sinusoidal expression for the resultant $i_1 + i_2$ is given by:

$$i_R = i_1 + i_2 = 26.5 \sin(\omega t + 0.332) \text{ A}$$

Problem 14. Two alternating voltages are represented by $v_1 = 50 \sin \omega t$ volts and $v_2 = 100 \sin(\omega t - \pi/6)$ V. Draw the phasor diagram and find, by calculation, a sinusoidal expression to represent $v_1 + v_2$.

Phasors are usually drawn at the instant when time $t = 0$. Thus v_1 is drawn horizontally 50 units long and v_2 is drawn 100 units long lagging v_1 by $\pi/6$ rads, i.e. 30° . This is shown in Fig. 14.11(a) where 0 is the point of rotation of the phasors.

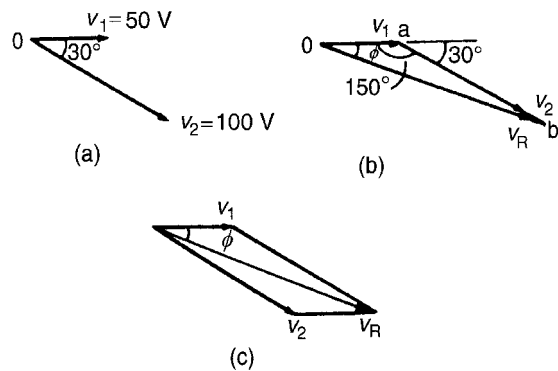

Figure 14.11

Procedure to draw phasor diagram to represent $v_1 + v_2$:

- (i) Draw v_1 horizontal 50 units long, i.e. oa of Fig. 14.11(b)
- (ii) Join v_2 to the end of v_1 at the appropriate angle, i.e. ab of Fig. 14.11(b)
- (iii) The resultant $v_R = v_1 + v_2$ is given by the length ob and its phase angle may be measured with respect to v_1

Alternatively, when two phasors are being added the resultant is always the diagonal of the parallelogram, as shown in Fig. 14.11(c).

From the drawing, by measurement, $v_R = 145$ V and angle $\phi = 20^\circ$ lagging v_1 .

A more accurate solution is obtained by calculation, using the cosine and sine rules. Using the cosine rule on triangle *Oab* of Fig. 14.11(b) gives:

$$\begin{aligned} v_R^2 &= v_1^2 + v_2^2 - 2v_1v_2 \cos 150^\circ \\ &= 50^2 + 100^2 - 2(50)(100) \cos 150^\circ \\ &= 2500 + 10000 - (-8660) \\ v_R &= \sqrt{21160} = 145.5 \text{ V} \end{aligned}$$

Using the sine rule,

$$\frac{100}{\sin \phi} = \frac{145.5}{\sin 150^\circ}$$

$$\begin{aligned} \text{from which } \sin \phi &= \frac{100 \sin 150^\circ}{145.5} \\ &= 0.3436 \end{aligned}$$

and $\phi = \sin^{-1} 0.3436 = 20.096^\circ = 0.35$ radians, and lags v_1 . Hence

$$v_R = v_1 + v_2 = 145.5 \sin(\omega t - 0.35) \text{ V}$$

Problem 15. Find a sinusoidal expression for $(i_1 + i_2)$ of Problem 13, (b) by drawing phasors, (b) by calculation.

- (a) The relative positions of i_1 and i_2 at time $t = 0$ are shown as phasors in Fig. 14.12(a). The phasor diagram in Fig. 14.12(b) shows the resultant i_R , and i_R is measured as 26 A and angle ϕ as 19° or 0.33 rads leading i_1 .

Hence, by drawing, $i_R = 26 \sin(\omega t + 0.33) \text{ A}$

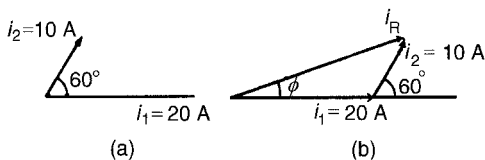

Figure 14.12

- (b) From Fig. 14.12(b), by the cosine rule:

$$i_R^2 = 20^2 + 10^2 - 2(20)(10)(\cos 120^\circ)$$

from which $i_R = 26.46 \text{ A}$

By the sine rule:

$$\frac{10}{\sin \phi} = \frac{26.46}{\sin 120^\circ}$$

from which $\phi = 19.10^\circ$ (i.e. 0.333 rads)

Hence, by calculation,

$$i_R = 26.46 \sin(\omega t + 0.333) \text{ A}$$

Problem 16. Two alternating voltages are given by $v_1 = 120 \sin \omega t$ volts and $v_2 = 200 \sin(\omega t - \pi/4)$ volts. Obtain sinusoidal expressions for $v_1 - v_2$ (a) by plotting waveforms, and (b) by resolution of phasors.

- (a) $v_1 = 120 \sin \omega t$ and $v_2 = 200 \sin(\omega t - \pi/4)$ are shown plotted in Fig. 14.13 Care must be taken when subtracting values of ordinates especially when at least one of the ordinates is negative. For example

at 30° , $v_1 - v_2 = 60 - (-52) = 112 \text{ V}$

at 60° , $v_1 - v_2 = 104 - 52 = 52 \text{ V}$

at 150° , $v_1 - v_2 = 60 - 193 = -133 \text{ V}$ and so on.

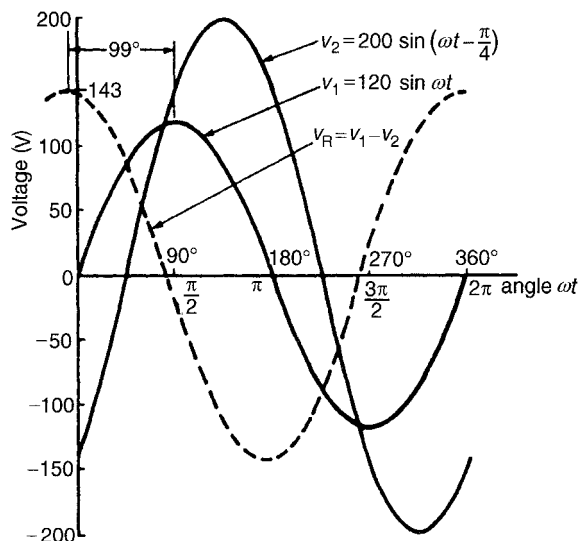

Figure 14.13

The resultant waveform, $v_R = v_1 - v_2$, is shown by the broken line in Fig. 14.13. The maximum value of v_R is 143 V and the waveform is seen to lead v_1 by 99° (i.e. 1.73 radians)

Hence, by drawing,

$$v_R = v_1 - v_2 = 143 \sin(\omega t + 1.73) \text{ volts}$$

- (b) The relative positions of v_1 and v_2 are shown at time $t = 0$ as phasors in Fig. 14.14(a). Since the resultant of $v_1 - v_2$ is required, $-v_2$ is drawn in the opposite direction to $+v_2$ and is shown by the broken line in Fig. 14.14(a). The phasor diagram with the resultant is shown in Fig. 14.14(b) where $-v_2$ is added phasorially to v_1 .

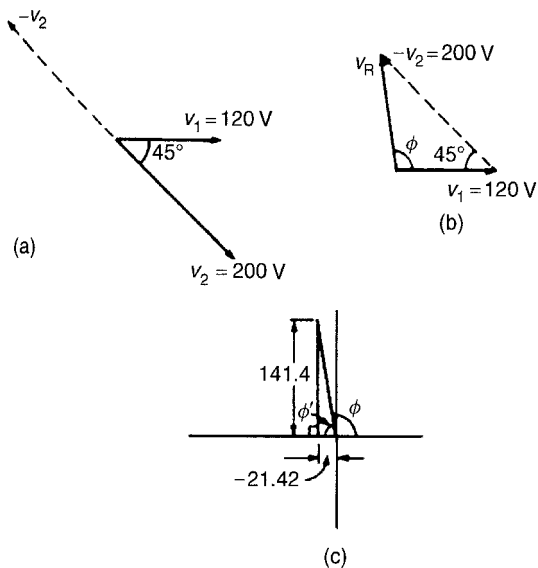

Figure 14.14

By resolution:

$$\text{Sum of horizontal components of } v_1 \text{ and } v_2 = 120 \cos 0^\circ - 200 \cos 45^\circ = -21.42$$

$$\text{Sum of vertical components of } v_1 \text{ and } v_2 = 120 \sin 0^\circ + 200 \sin 45^\circ = 141.4$$

From Fig. 14.14(c), resultant

$$v_R = \sqrt{(-21.42)^2 + (141.4)^2} = 143.0$$

$$\text{and } \tan \phi' = \frac{141.4}{21.42} = \tan 6.6013$$

$$\text{from which, } \phi' = \tan^{-1} 6.6013 = 81.39^\circ$$

$$\text{and } \phi = 98.61^\circ \text{ or } 1.721 \text{ radians}$$

Hence, by resolution of phasors,

$$v_R = v_1 - v_2 = 143.0 \sin(\omega t + 1.721) \text{ volts}$$

Now try the following exercise

Exercise 76 Further problems on the combination of periodic functions

- 1 The instantaneous values of two alternating voltages are given by $v_1 = 5 \sin \omega t$ and $v_2 = 8 \sin(\omega t - \pi/6)$. By plotting v_1 and v_2 on the same axes, using the same scale, over one cycle, obtain expressions for

(a) $v_1 + v_2$ and (b) $v_1 - v_2$

[(a) $v_1 + v_2 = 12.58 \sin(\omega t - 0.325) \text{ V}$

(b) $v_1 - v_2 = 4.44 \sin(\omega t + 2.02) \text{ V}$]

- 2 Repeat Problem 1 using resolution of phasors

- 3 Construct a phasor diagram to represent $i_1 + i_2$ where $i_1 = 12 \sin \omega t$ and $i_2 = 15 \sin(\omega t + \pi/3)$. By measurement, or by calculation, find a sinusoidal expression to represent $i_1 + i_2$

[$23.43 \sin(\omega t + 0.588)$]

Determine, either by plotting graphs and adding ordinates at intervals, or by calculation, the following periodic functions in the form $v = V_m \sin(\omega t \pm \phi)$

- 4 $10 \sin \omega t + 4 \sin(\omega t + \pi/4)$

[$13.14 \sin(\omega t + 0.217)$]

- 5 $80 \sin(\omega t + \pi/3) + 50 \sin(\omega t - \pi/6)$

[$94.34 \sin(\omega t + 0.489)$]

- 6 $100 \sin \omega t - 70 \sin(\omega t - \pi/3)$

[$88.88 \sin(\omega t + 0.751)$]

14.7 Rectification

The process of obtaining unidirectional currents and voltages from alternating currents and voltages is called **rectification**. Automatic switching in circuits is carried out by devices called diodes. Half and full-wave rectifiers are explained in Chapter 11, Section 11.7, page 132

Now try the following exercises

Exercise 77 Short answer questions on alternating voltages and currents

- Briefly explain the principle of operation of the simple alternator
- What is meant by (a) waveform (b) cycle
- What is the difference between an alternating and a unidirectional waveform?
- The time to complete one cycle of a waveform is called the
- What is frequency? Name its unit
- The mains supply voltage has a special shape of waveform called a
- Define peak value
- What is meant by the r.m.s. value?
- The domestic mains electricity voltage in Great Britain is
- What is the mean value of a sinusoidal alternating e.m.f. which has a maximum value of 100 V?
- The effective value of a sinusoidal waveform is \times maximum value
- What is a phasor quantity?
- Complete the statement:
Form factor = \div , and for a sine wave, form factor =
- Complete the statement:
Peak factor = \div , and for a sine wave, peak factor =
- A sinusoidal current is given by $i = I_m \sin(\omega t \pm \alpha)$. What do the symbols I_m , ω and α represent?
- How is switching obtained when converting a.c. to d.c.?

Exercise 78 Multi-choice questions on alternating voltages and currents (Answers on page 375)

- The value of an alternating current at any given instant is:

- a maximum value
- a peak value
- an instantaneous value
- an r.m.s. value

- An alternating current completes 100 cycles in 0.1 s. Its frequency is:
 - 20 Hz
 - 100 Hz
 - 0.002 Hz
 - 1 kHz
- In Fig. 14.15, at the instant shown, the generated e.m.f. will be:
 - zero
 - an r.m.s. value
 - an average value
 - a maximum value



Figure 14.15

- The supply of electrical energy for a consumer is usually by a.c. because:
 - transmission and distribution are more easily effected
 - it is most suitable for variable speed motors
 - the volt drop in cables is minimal
 - cable power losses are negligible
- Which of the following statements is false?
 - It is cheaper to use a.c. than d.c.
 - Distribution of a.c. is more convenient than with d.c. since voltages may be readily altered using transformers
 - An alternator is an a.c. generator
 - A rectifier changes d.c. to a.c.
- An alternating voltage of maximum value 100 V is applied to a lamp. Which of the following direct voltages, if applied to the lamp, would cause the lamp to light with the same brilliance?
 - 100 V
 - 63.7 V
 - 70.7 V
 - 141.4 V
- The value normally stated when referring to alternating currents and voltages is the:

- (a) instantaneous value
(b) r.m.s. value
(c) average value
(d) peak value
- 8 State which of the following is false. For a sine wave:
(a) the peak factor is 1.414
(b) the r.m.s. value is $0.707 \times$ peak value
(c) the average value is $0.637 \times$ r.m.s. value
(d) the form factor is 1.11
- 9 An a.c. supply is 70.7 V, 50 Hz. Which of the following statements is false?
(a) The periodic time is 20 ms
(b) The peak value of the voltage is 70.7 V
(c) The r.m.s. value of the voltage is 70.7 V
(d) The peak value of the voltage is 100 V
- 10 An alternating voltage is given by $v = 100 \sin(50\pi t - 0.30)$ V.
Which of the following statements is true?
(a) The r.m.s. voltage is 100 V
(b) The periodic time is 20 ms
(c) The frequency is 25 Hz
(d) The voltage is leading $v = 100 \sin 50\pi t$ by 0.30 radians
- 11 The number of complete cycles of an alternating current occurring in one second is known as:
(a) the maximum value of the alternating current
(b) the frequency of the alternating current
(c) the peak value of the alternating current
(d) the r.m.s. or effective value

Assignment 4

This assignment covers the material contained in chapters 13 and 14.

The marks for each question are shown in brackets at the end of each question.

- 1 Find the current flowing in the $5\ \Omega$ resistor of the circuit shown in Fig. A4.1 using (a) Kirchhoff's laws, (b) the Superposition theorem, (c) Thévenin's theorem, (d) Norton's theorem. Demonstrate that the same answer results from each method.

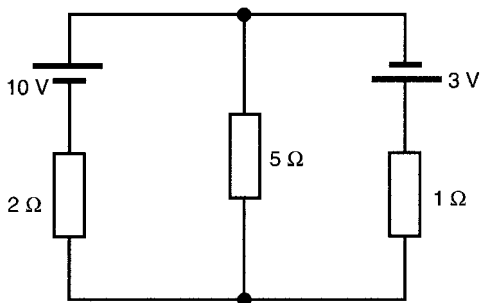

Figure A4.1

- Find also the current flowing in each of the other two branches of the circuit. (27)
- 2 A d.c. voltage source has an internal resistance of $2\ \Omega$ and an open circuit voltage of 24 V. State the value of load resistance that gives maximum power dissipation and determine the value of this power. (5)
- 3 A sinusoidal voltage has a mean value of 3.0 A. Determine its maximum and r.m.s. values. (4)
- 4 The instantaneous value of current in an a.c. circuit at any time t seconds is given by: $i = 50 \sin(100\pi t - 0.45)$ mA. Determine (a) the peak to peak current, the periodic time, the frequency and the phase angle (in degrees) (b) the current when $t = 0$ (c) the current when $t = 8$ ms (d) the first time when the voltage is a maximum. Sketch the current for one cycle showing relevant points. (14)

Single-phase series a.c. circuits

At the end of this chapter you should be able to:

- draw phasor diagrams and current and voltage waveforms for (a) purely resistive (b) purely inductive and (c) purely capacitive a.c. circuits
- perform calculations involving $X_L = 2\pi fL$ and $X_C = 1/(2\pi fC)$
- draw circuit diagrams, phasor diagrams and voltage and impedance triangles for $R-L$, $R-C$ and $R-L-C$ series a.c. circuits and perform calculations using Pythagoras' theorem, trigonometric ratios and $Z = V/I$
- understand resonance
- derive the formula for resonant frequency and use it in calculations
- understand Q-factor and perform calculations using

$$\frac{V_L(\text{or } V_C)}{V} \text{ or } \frac{\omega_r L}{R} \text{ or } \frac{1}{\omega_r C R} \text{ or } \frac{1}{R} \sqrt{\frac{L}{C}}$$

- understand bandwidth and half-power points
- perform calculations involving $(f_2 - f_1) = f_r/Q$
- understand selectivity and typical values of Q-factor
- appreciate that power P in an a.c. circuit is given by $P = VI \cos \phi$ or $I_R^2 R$ and perform calculations using these formulae
- understand true, apparent and reactive power and power factor and perform calculations involving these quantities

15.1 Purely resistive a.c. circuit

In a purely resistive a.c. circuit, the current I_R and applied voltage V_R are in phase. See Fig. 15.1

15.2 Purely inductive a.c. circuit

In a purely inductive a.c. circuit, the current I_L lags the applied voltage V_L by 90° (i.e. $\pi/2$ rads). See Fig. 15.2

In a purely inductive circuit the opposition to the flow of alternating current is called the **inductive reactance**, X_L

$$X_L = \frac{V_L}{I_L} = 2\pi fL \Omega$$

where f is the supply frequency, in hertz, and L is the inductance, in henry's. X_L is proportional to f as shown in Fig. 15.3

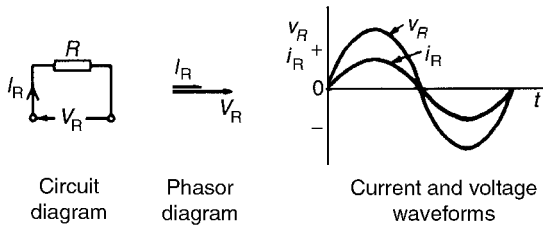

Figure 15.1

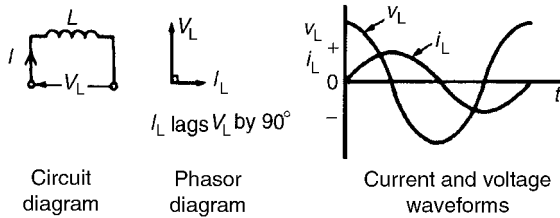

Figure 15.2

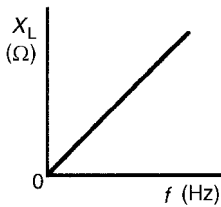

Figure 15.3

Problem 1. (a) Calculate the reactance of a coil of inductance 0.32 H when it is connected to a 50 Hz supply. (b) A coil has a reactance of 124 Ω in a circuit with a supply of frequency 5 kHz. Determine the inductance of the coil.

(a) Inductive reactance,

$$X_L = 2\pi fL = 2\pi(50)(0.32) = \mathbf{100.5 \Omega}$$

(b) Since $X_L = 2\pi fL$, inductance

$$L = \frac{X_L}{2\pi f} = \frac{124}{2\pi(5000)} \text{H} = \mathbf{3.95 \text{ mH}}$$

Problem 2. A coil has an inductance of 40 mH and negligible resistance. Calculate its inductive reactance and the resulting current if connected to (a) a 240 V, 50 Hz supply, and (b) a 100 V, 1 kHz supply.

(a) Inductive reactance,

$$X_L = 2\pi fL = 2\pi(50)(40 \times 10^{-3}) = \mathbf{12.57 \Omega}$$

$$\text{Current, } I = \frac{V}{X_L} = \frac{240}{12.57} = \mathbf{19.09 \text{ A}}$$

(b) Inductive reactance,

$$X_L = 2\pi(1000)(40 \times 10^{-3}) = \mathbf{251.3 \Omega}$$

$$\text{Current, } I = \frac{V}{X_L} = \frac{100}{251.3} = \mathbf{0.398 \text{ A}}$$

15.3 Purely capacitive a.c. circuit

In a purely capacitive a.c. circuit, the current I_C leads the applied voltage V_C by 90° (i.e. $\pi/2$ rads). See Fig. 15.4

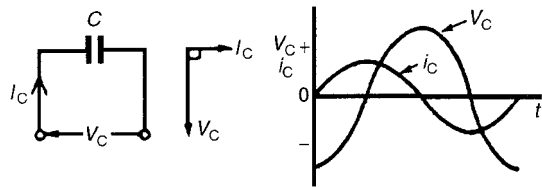

Figure 15.4

In a purely capacitive circuit the opposition to the flow of alternating current is called the **capacitive reactance**, X_C

$$X_C = \frac{V_C}{I_C} = \frac{1}{2\pi fC} \Omega$$

where C is the capacitance in farads.

X_C varies with frequency f as shown in Fig. 15.5

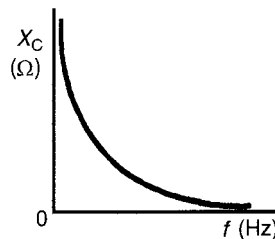

Figure 15.5

Problem 3. Determine the capacitive reactance of a capacitor of $10\ \mu\text{F}$ when connected to a circuit of frequency (a) 50 Hz (b) 20 kHz

(a) Capacitive reactance

$$\begin{aligned} X_C &= \frac{1}{2\pi f C} \\ &= \frac{1}{2\pi(50)(10 \times 10^{-6})} \\ &= \frac{10^6}{2\pi(50)(10)} = \mathbf{318.3\ \Omega} \end{aligned}$$

(b) $X_C = \frac{1}{2\pi f C}$

$$\begin{aligned} &= \frac{1}{2\pi(20 \times 10^3)(10 \times 10^{-6})} \\ &= \frac{10^6}{2\pi(20 \times 10^3)(10)} \\ &= \mathbf{0.796\ \Omega} \end{aligned}$$

Hence as the frequency is increased from 50 Hz to 20 kHz, X_C decreases from $318.3\ \Omega$ to $0.796\ \Omega$ (see Fig. 15.5)

Problem 4. A capacitor has a reactance of $40\ \Omega$ when operated on a 50 Hz supply. Determine the value of its capacitance.

Since

$$X_C = \frac{1}{2\pi f C},$$

capacitance

$$\begin{aligned} C &= \frac{1}{2\pi f X_C} \\ &= \frac{1}{2\pi(50)(40)}\ \text{F} \\ &= \frac{10^6}{2\pi(50)(40)}\ \mu\text{F} \\ &= \mathbf{79.58\ \mu\text{F}} \end{aligned}$$

Problem 5. Calculate the current taken by a $23\ \mu\text{F}$ capacitor when connected to a 240 V, 50 Hz supply.

Current $I = \frac{V}{X_C}$

$$\begin{aligned} &= \frac{V}{\left(\frac{1}{2\pi f C}\right)} \\ &= 2\pi f CV \\ &= 2\pi(50)(23 \times 10^{-6})(240) \\ &= \mathbf{1.73\ \text{A}} \end{aligned}$$

Now try the following exercise

Exercise 79 Further problems on purely inductive and capacitive a.c. circuits

- Calculate the reactance of a coil of inductance $0.2\ \text{H}$ when it is connected to (a) a 50 Hz, (b) a 600 Hz and (c) a 40 kHz supply. [(a) $62.83\ \Omega$ (b) $754\ \Omega$ (c) $50.27\ \text{k}\Omega$]
- A coil has a reactance of $120\ \Omega$ in a circuit with a supply frequency of 4 kHz. Calculate the inductance of the coil. [$4.77\ \text{mH}$]
- A supply of 240 V, 50 Hz is connected across a pure inductance and the resulting current is 1.2 A. Calculate the inductance of the coil. [$0.637\ \text{H}$]
- An e.m.f. of 200 V at a frequency of 2 kHz is applied to a coil of pure inductance 50 mH. Determine (a) the reactance of the coil, and (b) the current flowing in the coil. [(a) $628\ \Omega$ (b) $0.318\ \text{A}$]
- A 120 mH inductor has a 50 mA, 1 kHz alternating current flowing through it. Find the p.d. across the inductor. [$37.7\ \text{V}$]
- Calculate the capacitive reactance of a capacitor of $20\ \mu\text{F}$ when connected to an a.c. circuit of frequency (a) 20 Hz, (b) 500 Hz, (c) 4 kHz [(a) $397.9\ \Omega$ (b) $15.92\ \Omega$ (c) $1.989\ \Omega$]
- A capacitor has a reactance of $80\ \Omega$ when connected to a 50 Hz supply. Calculate the value of its capacitance. [$39.79\ \mu\text{F}$]
- Calculate the current taken by a $10\ \mu\text{F}$ capacitor when connected to a 200 V, 100 Hz supply. [$1.257\ \text{A}$]

9 A capacitor has a capacitive reactance of $400\ \Omega$ when connected to a $100\ \text{V}$, $25\ \text{Hz}$ supply. Determine its capacitance and the current taken from the supply.

[15.92 μF , 0.25 A]

10 Two similar capacitors are connected in parallel to a $200\ \text{V}$, $1\ \text{kHz}$ supply. Find the value of each capacitor if the circuit current is $0.628\ \text{A}$.

[0.25 μF]

15.4 R–L series a.c. circuit

In an a.c. circuit containing inductance L and resistance R , the applied voltage V is the phasor sum of V_R and V_L (see Fig. 15.6), and thus the current I lags the applied voltage V by an angle lying between 0° and 90° (depending on the values of V_R and V_L), shown as angle ϕ . In any a.c. series circuit the current is common to each component and is thus taken as the reference phasor.

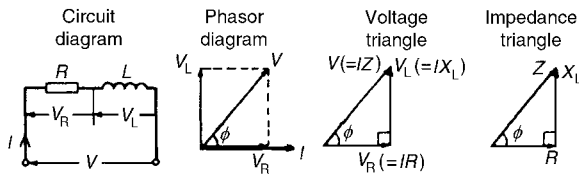

Figure 15.6

From the phasor diagram of Fig. 15.6, the ‘**voltage triangle**’ is derived.

For the R–L circuit:

$$V = \sqrt{V_R^2 + V_L^2} \quad (\text{by Pythagoras' theorem})$$

and

$$\tan \phi = \frac{V_L}{V_R} \quad (\text{by trigonometric ratios})$$

In an a.c. circuit, the ratio applied voltage V to current I is called the **impedance**, Z , i.e.

$$Z = \frac{V}{I} \Omega$$

If each side of the voltage triangle in Fig. 15.6 is divided by current I then the ‘**impedance triangle**’ is derived.

For the R–L circuit: $Z = \sqrt{R^2 + X_L^2}$

$$\tan \phi = \frac{X_L}{R},$$

$$\sin \phi = \frac{X_L}{Z}$$

and

$$\cos \phi = \frac{R}{Z}$$

Problem 6. In a series R–L circuit the p.d. across the resistance R is $12\ \text{V}$ and the p.d. across the inductance L is $5\ \text{V}$. Find the supply voltage and the phase angle between current and voltage.

From the voltage triangle of Fig. 15.6, supply voltage

$$V = \sqrt{12^2 + 5^2}$$

i.e.

$$V = 13\ \text{V}$$

(Note that in a.c. circuits, the supply voltage is **not** the arithmetic sum of the p.d.’s across components. It is, in fact, the **phasor sum**)

$$\tan \phi = \frac{V_L}{V_R} = \frac{5}{12},$$

from which, circuit phase angle

$$\phi = \tan^{-1} \left(\frac{5}{12} \right) = 22.62^\circ \text{ lagging}$$

(‘Lagging’ infers that the current is ‘behind’ the voltage, since phasors revolve anticlockwise)

Problem 7. A coil has a resistance of $4\ \Omega$ and an inductance of $9.55\ \text{mH}$. Calculate (a) the reactance, (b) the impedance, and (c) the current taken from a $240\ \text{V}$, $50\ \text{Hz}$ supply. Determine also the phase angle between the supply voltage and current.

$R = 4\ \Omega$, $L = 9.55\ \text{mH} = 9.55 \times 10^{-3}\ \text{H}$,
 $f = 50\ \text{Hz}$ and $V = 240\ \text{V}$

(a) Inductive reactance,

$$\begin{aligned} X_L &= 2\pi fL \\ &= 2\pi(50)(9.55 \times 10^{-3}) \\ &= 3\ \Omega \end{aligned}$$

(b) Impedance,

$$Z = \sqrt{R^2 + X_L^2} = \sqrt{4^2 + 3^2} = 5 \Omega$$

(c) Current,

$$I = \frac{V}{Z} = \frac{240}{5} = 48 \text{ A}$$

The circuit and phasor diagrams and the voltage and impedance triangles are as shown in Fig. 15.6

Since $\tan \phi = \frac{X_L}{R}$,

$$\phi = \tan^{-1} \frac{X_L}{R}$$

$$= \tan^{-1} \frac{3}{4}$$

$$= 36.87^\circ \text{ lagging}$$

Problem 8. A coil takes a current of 2 A from a 12 V d.c. supply. When connected to a 240 V, 50 Hz supply the current is 20 A. Calculate the resistance, impedance, inductive reactance and inductance of the coil.

Resistance

$$R = \frac{\text{d.c. voltage}}{\text{d.c. current}} = \frac{12}{2} = 6 \Omega$$

Impedance

$$Z = \frac{\text{a.c. voltage}}{\text{a.c. current}} = \frac{240}{20} = 12 \Omega$$

Since

$$Z = \sqrt{R^2 + X_L^2},$$

inductive reactance,

$$X_L = \sqrt{Z^2 - R^2} = \sqrt{12^2 - 6^2} = 10.39 \Omega$$

Since $X_L = 2\pi fL$, inductance,

$$L = \frac{X_L}{2\pi f} = \frac{10.39}{2\pi(50)} = 33.1 \text{ mH}$$

This problem indicates a simple method for finding the inductance of a coil, i.e. firstly to measure the current when the coil is connected to a d.c. supply of

known voltage, and then to repeat the process with an a.c. supply.

Problem 9. A coil of inductance 318.3 mH and negligible resistance is connected in series with a 200 Ω resistor to a 240 V, 50 Hz supply. Calculate (a) the inductive reactance of the coil, (b) the impedance of the circuit, (c) the current in the circuit, (d) the p.d. across each component, and (e) the circuit phase angle.

$$L = 318.3 \text{ mH} = 0.3183 \text{ H}, R = 200 \Omega,$$

$$V = 240 \text{ V and } f = 50 \text{ Hz.}$$

The circuit diagram is as shown in Fig. 15.6

(a) Inductive reactance

$$X_L = 2\pi fL = 2\pi(50)(0.3183) = 100 \Omega$$

(b) Impedance

$$Z = \sqrt{R^2 + X_L^2}$$

$$= \sqrt{200^2 + 100^2} = 223.6 \Omega$$

(c) Current

$$I = \frac{V}{Z} = \frac{240}{223.6} = 1.073 \text{ A}$$

(d) The p.d. across the coil,

$$V_L = IX_L = 1.073 \times 100 = 107.3 \text{ V}$$

The p.d. across the resistor,

$$V_R = IR = 1.073 \times 200 = 214.6 \text{ V}$$

$$[\text{Check: } \sqrt{V_R^2 + V_L^2} = \sqrt{214.6^2 + 107.3^2}$$

$$= 240 \text{ V, the supply voltage}]$$

(e) From the impedance triangle, angle

$$\phi = \tan^{-1} \frac{X_L}{R} = \tan^{-1} \left(\frac{100}{200} \right)$$

Hence the phase angle $\phi = 26.57^\circ$ lagging.

Problem 10. A coil consists of a resistance of 100 Ω and an inductance of 200 mH. If an alternating voltage, v , given by $v = 200 \sin 500t$ volts is applied across the coil, calculate (a) the circuit impedance, (b) the current flowing, (c) the p.d. across the resistance, (d) the p.d. across the inductance and (e) the phase angle between voltage and current.

Since $v = 200 \sin 500t$ volts then $V_m = 200$ V and $\omega = 2\pi f = 500$ rad/s

Hence r.m.s. voltage

$$V = 0.707 \times 200 = 141.4 \text{ V}$$

Inductive reactance,

$$\begin{aligned} X_L &= 2\pi fL \\ &= \omega L = 500 \times 200 \times 10^{-3} = 100 \Omega \end{aligned}$$

(a) Impedance

$$\begin{aligned} Z &= \sqrt{R^2 + X_L^2} \\ &= \sqrt{30^2 + 100^2} = \mathbf{104.2 \Omega} \end{aligned}$$

(b) Current

$$I = \frac{V}{Z} = \frac{141.4}{104.2} = \mathbf{1.357 \text{ A}}$$

(c) P.d. across the resistance

$$V_R = IR = 1.357 \times 30 = \mathbf{40.71 \text{ V}}$$

P.d. across the inductance

$$V_L = IX_L = 1.357 \times 100 = \mathbf{135.7 \text{ V}}$$

(d) Phase angle between voltage and current is given by:

$$\tan \phi = \frac{X_L}{R}$$

from which,

$$\phi = \tan^{-1} \left(\frac{100}{30} \right),$$

$$\text{hence } \phi = \mathbf{73.3^\circ} \text{ or } \mathbf{\frac{1.28 \text{ rads}}{4}}$$

Problem 11. A pure inductance of 1.273 mH is connected in series with a pure resistance of 30 Ω . If the frequency of the sinusoidal supply is 5 kHz and the p.d. across the 30 Ω resistor is 6 V, determine the value of the supply voltage and the voltage across the 1.273 mH inductance. Draw the phasor diagram.

The circuit is shown in Fig. 15.7(a)

Supply voltage, $V = IZ$

$$\text{Current } I = \frac{V_R}{R} = \frac{6}{30} = 0.20 \text{ A}$$

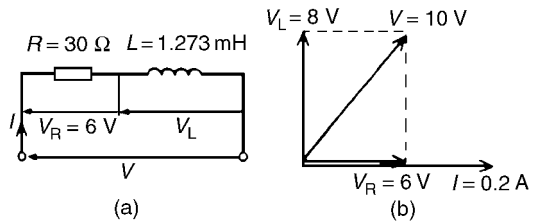

Figure 15.7

Inductive reactance

$$\begin{aligned} X_L &= 2\pi fL \\ &= 2\pi(5 \times 10^3)(1.273 \times 10^{-3}) \\ &= \mathbf{40 \Omega} \end{aligned}$$

Impedance,

$$Z = \sqrt{R^2 + X_L^2} = \sqrt{30^2 + 40^2} = \mathbf{50 \Omega}$$

Supply voltage

$$V = IZ = (0.20)(50) = \mathbf{10 \text{ V}}$$

Voltage across the 1.273 mH inductance,

$$V_L = IX_L = (0.2)(40) = \mathbf{8 \text{ V}}$$

The phasor diagram is shown in Fig. 15.7(b)

(Note that in a.c. circuits, the supply voltage is **not** the arithmetic sum of the p.d.'s across components but the **phasor sum**)

Problem 12. A coil of inductance 159.2 mH and resistance 20 Ω is connected in series with a 60 Ω resistor to a 240 V, 50 Hz supply. Determine (a) the impedance of the circuit, (b) the current in the circuit, (c) the circuit phase angle, (d) the p.d. across the 60 Ω resistor and (e) the p.d. across the coil. (f) Draw the circuit phasor diagram showing all voltages.

The circuit diagram is shown in Fig. 15.8(a). When impedances are connected in series the individual resistances may be added to give the total circuit resistance. The equivalent circuit is thus shown in Fig. 15.8(b).

Inductive reactance $X_L = 2\pi fL$

$$= 2\pi(50)(159.2 \times 10^{-3}) = \mathbf{50 \Omega}.$$

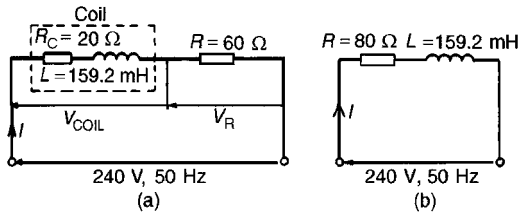

Figure 15.8

- (a) Circuit impedance, $Z = \sqrt{R^2 + X_L^2}$
 $= \sqrt{80^2 + 50^2} = \mathbf{94.34 \Omega}$
- (b) Circuit current, $I = \frac{V}{Z} = \frac{240}{94.34} = \mathbf{2.544 \text{ A}}$.
- (c) Circuit phase angle $\phi = \tan^{-1} X_L/R = \tan^{-1} (50/80) = \mathbf{32^\circ \text{ lagging}}$
 From Fig. 15.8(a):
- (d) $V_R = IR = (2.544)(60) = \mathbf{152.6 \text{ V}}$
- (e) $V_{\text{COIL}} = IZ_{\text{COIL}}$, where $Z_{\text{COIL}} = \sqrt{R_C^2 + X_L^2} = \sqrt{20^2 + 50^2} = 53.85 \Omega$.
 Hence $V_{\text{COIL}} = (2.544)(53.85) = \mathbf{137.0 \text{ V}}$
- (f) For the phasor diagram, shown in Fig. 15.9,
 $V_L = IX_L = (2.544)(50) = 127.2 \text{ V}$.
 $V_{R\text{COIL}} = IR_C = (2.544)(20) = 50.88 \text{ V}$

The 240 V supply voltage is the phasor sum of V_{COIL} and V_R as shown in the phasor diagram in Fig. 15.9

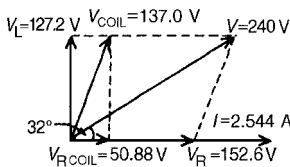

Figure 15.9

Now try the following exercise

Exercise 80 Further problems on R–L a.c. series circuits

- 1 Determine the impedance of a coil which has a resistance of 12Ω and a reactance of 16Ω [20 Ω]

- 2 A coil of inductance 80 mH and resistance 60Ω is connected to a 200 V , 100 Hz supply. Calculate the circuit impedance and the current taken from the supply. Find also the phase angle between the current and the supply voltage. [78.27 Ω , 2.555 A, 39.95° lagging]

- 3 An alternating voltage given by $v = 100 \sin 240t$ volts is applied across a coil of resistance 32Ω and inductance 100 mH . Determine (a) the circuit impedance, (b) the current flowing, (c) the p.d. across the resistance, and (d) the p.d. across the inductance. [(a) 40 Ω (b) 1.77 A (c) 56.64 V (d) 42.48 V]

- 4 A coil takes a current of 5 A from a 20 V d.c. supply. When connected to a 200 V, 50 Hz a.c. supply the current is 25 A. Calculate the (a) resistance, (b) impedance and (c) inductance of the coil. [(a) 4 Ω (b) 8 Ω (c) 22.05 mH]

- 5 A resistor and an inductor of negligible resistance are connected in series to an a.c. supply. The p.d. across the resistor is 18 V and the p.d. across the inductor is 24 V. Calculate the supply voltage and the phase angle between voltage and current. [30 V, 53.13° lagging]

- 6 A coil of inductance 636.6 mH and negligible resistance is connected in series with a 100Ω resistor to a 250 V , 50 Hz supply. Calculate (a) the inductive reactance of the coil, (b) the impedance of the circuit, (c) the current in the circuit, (d) the p.d. across each component, and (e) the circuit phase angle. [(a) 200 Ω (b) 223.6 Ω (c) 1.118 A (d) 223.6 V, 111.8 V (e) 63.43° lagging]

15.5 R–C series a.c. circuit

In an a.c. series circuit containing capacitance C and resistance R , the applied voltage V is the phasor sum of V_R and V_C (see Fig. 15.10) and thus the current I leads the applied voltage V by an angle lying between 0° and 90° (depending on the values of V_R and V_C), shown as angle α .

From the phasor diagram of Fig. 15.10, the ‘voltage triangle’ is derived.

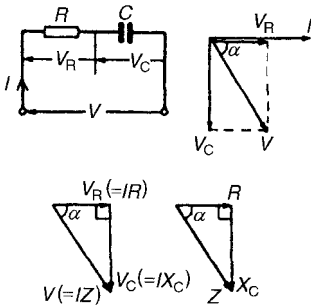

Figure 15.10

For the $R-C$ circuit:

$$V = \sqrt{V_R^2 + V_C^2} \quad (\text{by Pythagoras' theorem})$$

and

$$\tan \alpha = \frac{V_C}{V_R} \quad (\text{by trigonometric ratios})$$

As stated in Section 15.4, in an a.c. circuit, the ratio applied voltage V to current I is called the **impedance Z** , i.e. $Z = V/I \Omega$

If each side of the voltage triangle in Fig. 15.10 is divided by current I then the **'impedance triangle'** is derived.

$$\text{For the } R-C \text{ circuit: } Z = \sqrt{R^2 + X_C^2}$$

$$\tan \alpha = \frac{X_C}{R}, \sin \alpha = \frac{X_C}{Z} \text{ and } \cos \alpha = \frac{R}{Z}$$

Problem 13. A resistor of 25Ω is connected in series with a capacitor of $45 \mu\text{F}$. Calculate (a) the impedance, and (b) the current taken from a 240 V , 50 Hz supply. Find also the phase angle between the supply voltage and the current.

$R = 25 \Omega$, $C = 45 \mu\text{F} = 45 \times 10^{-6} \text{ F}$,
 $V = 240 \text{ V}$ and $f = 50 \text{ Hz}$. The circuit diagram is as shown in Fig. 15.10

Capacitive reactance,

$$X_C = \frac{1}{2\pi f C}$$

$$= \frac{1}{2\pi(50)(45 \times 10^{-6})} = 70.74 \Omega$$

(a) Impedance $Z = \sqrt{R^2 + X_C^2} = \sqrt{25^2 + 70.74^2}$
 $= 75.03 \Omega$

(b) Current $I = V/Z = 240/75.03 = 3.20 \text{ A}$

Phase angle between the supply voltage and current, $\alpha = \tan^{-1}(X_C/R)$ hence

$$\alpha = \tan^{-1}\left(\frac{70.74}{25}\right) = 70.54^\circ \text{ leading}$$

('Leading' infers that the current is 'ahead' of the voltage, since phasors revolve anticlockwise)

Problem 14. A capacitor C is connected in series with a 40Ω resistor across a supply of frequency 60 Hz . A current of 3 A flows and the circuit impedance is 50Ω . Calculate (a) the value of capacitance, C , (b) the supply voltage, (c) the phase angle between the supply voltage and current, (d) the p.d. across the resistor, and (e) the p.d. across the capacitor. Draw the phasor diagram.

(a) Impedance $Z = \sqrt{R^2 + X_C^2}$

Hence $X_C = \sqrt{Z^2 - R^2} = \sqrt{50^2 - 40^2} = 30 \Omega$

$X_C = \frac{1}{2\pi f C}$ hence,

$C = \frac{1}{2\pi f X_C} = \frac{1}{2\pi(60)(30)} \text{ F} = 88.42 \mu\text{F}$

(b) Since $Z = V/I$ then $V = IZ = (3)(50) = 150 \text{ V}$

(c) Phase angle, $\alpha = \tan^{-1} X_C/R = \tan^{-1}(30/40) = 36.87^\circ \text{ leading}$.

(d) P.d. across resistor, $V_R = IR = (3)(40) = 120 \text{ V}$

(e) P.d. across capacitor, $V_C = IX_C = (3)(30) = 90 \text{ V}$

The phasor diagram is shown in Fig. 15.11, where the supply voltage V is the phasor sum of V_R and V_C .

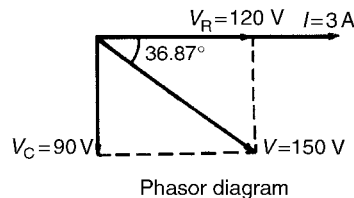

Figure 15.11

Now try the following exercise

Exercise 81 Further problems on R–C a.c. circuits

- 1 A voltage of 35 V is applied across a C–R series circuit. If the voltage across the resistor is 21 V, find the voltage across the capacitor. [28 V]
- 2 A resistance of 50 Ω is connected in series with a capacitance of 20 μF. If a supply of 200 V, 100 Hz is connected across the arrangement find (a) the circuit impedance, (b) the current flowing, and (c) the phase angle between voltage and current. [(a) 93.98 Ω (b) 2.128 A (c) 57.86° leading]
- 3 A 24.87 μF capacitor and a 30 Ω resistor are connected in series across a 150 V supply. If the current flowing is 3 A find (a) the frequency of the supply, (b) the p.d. across the resistor and (c) the p.d. across the capacitor. [(a) 160 Hz (b) 90 V (c) 120 V]
- 4 An alternating voltage $v = 250 \sin 800t$ volts is applied across a series circuit containing a 30 Ω resistor and 50 μF capacitor. Calculate (a) the circuit impedance, (b) the current flowing, (c) the p.d. across the resistor, (d) the p.d. across the capacitor, and (e) the phase angle between voltage and current [(a) 39.05 Ω (b) 4.527 A (c) 135.8 V (d) 113.2 V (e) 39.81°]
- 5 A 400 Ω resistor is connected in series with a 2358 pF capacitor across a 12 V a.c. supply. Determine the supply frequency if the current flowing in the circuit is 24 mA [225 kHz]

15.6 R–L–C series a.c. circuit

In an a.c. series circuit containing resistance R , inductance L and capacitance C , the applied voltage V is the phasor sum of V_R , V_L and V_C (see Fig. 15.12). V_L and V_C are anti-phase, i.e. displaced by 180°, and there are three phasor diagrams possible – each depending on the relative values of V_L and V_C .

When $X_L > X_C$ (Fig. 15.12(b)):

$$Z = \sqrt{R^2 + (X_L - X_C)^2}$$

and
$$\tan \phi = \frac{X_L - X_C}{R}$$

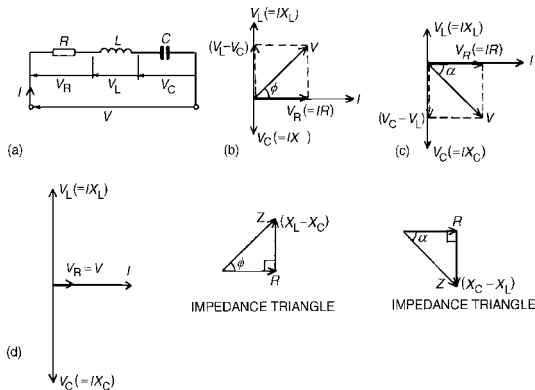

Figure 15.12

When $X_C > X_L$ (Fig. 15.12(c)):

$$Z = \sqrt{R^2 + (X_C - X_L)^2}$$

and
$$\tan \alpha = \frac{X_C - X_L}{R}$$

When $X_L = X_C$ (Fig. 15.12(d)), the applied voltage V and the current I are in phase. This effect is called **series resonance** (see Section 15.7).

Problem 15. A coil of resistance 5 Ω and inductance 120 mH in series with a 100 μF capacitor, is connected to a 300 V, 50 Hz supply. Calculate (a) the current flowing, (b) the phase difference between the supply voltage and current, (c) the voltage across the coil and (d) the voltage across the capacitor.

The circuit diagram is shown in Fig. 15.13

$$\begin{aligned} X_L &= 2\pi fL \\ &= 2\pi(50)(120 \times 10^{-3}) = \mathbf{37.70 \Omega} \end{aligned}$$

$$\begin{aligned} X_C &= \frac{1}{2\pi fC} \\ &= \frac{1}{2\pi(50)(100 \times 10^{-6})} = \mathbf{31.83 \Omega} \end{aligned}$$

Since X_L is greater than X_C the circuit is inductive.

$$X_L - X_C = 37.70 - 31.83 = 5.87 \Omega$$

Impedance

$$\begin{aligned} Z &= \sqrt{R^2 + (X_L - X_C)^2} \\ &= \sqrt{5^2 + 5.87^2} = 7.71 \Omega \end{aligned}$$

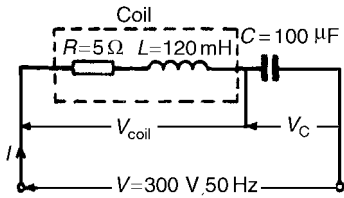

Figure 15.13

(a) Current $I = \frac{V}{Z} = \frac{300}{7.71} = 38.91 \text{ A}$

(b) Phase angle

$$\phi = \tan^{-1} \left(\frac{X_L - X_C}{R} \right)$$

$$= \tan^{-1} \left(\frac{5.87}{5} \right) = 49.58^\circ$$

(c) Impedance of coil

$$Z_{\text{COIL}} = \sqrt{R^2 + X_L^2}$$

$$= \sqrt{5^2 + 37.7^2} = 38.03 \Omega$$

Voltage across coil

$$V_{\text{COIL}} = IZ_{\text{COIL}}$$

$$= (38.91)(38.03) = 1480 \text{ V}$$

Phase angle of coil

$$= \tan^{-1} \frac{X_L}{R}$$

$$= \tan^{-1} \left(\frac{37.7}{5} \right) = 82.45^\circ \text{ lagging}$$

(d) Voltage across capacitor

$$V_C = IX_C = (38.91)(31.83) = 1239 \text{ V}$$

The phasor diagram is shown in Fig. 15.14. The supply voltage V is the phasor sum of V_{COIL} and V_C .

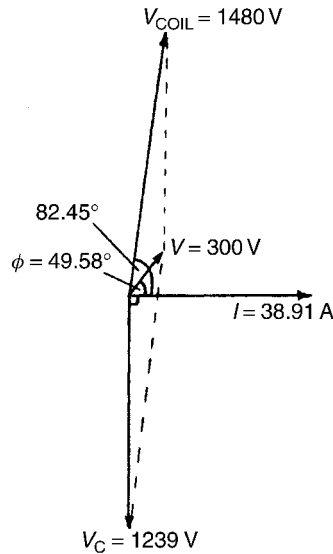

Figure 15.14

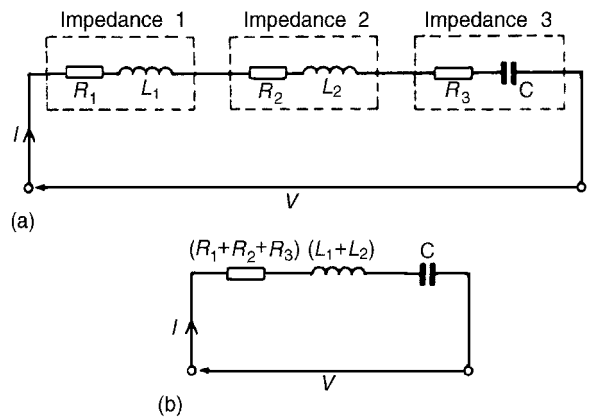

Figure 15.15

Series connected impedances

For series-connected impedances the total circuit impedance can be represented as a single $L-C-R$ circuit by combining all values of resistance together, all values of inductance together and all values of capacitance together, (remembering that for series connected capacitors

$$\frac{1}{C} = \frac{1}{C_1} + \frac{1}{C_2} + \dots)$$

For example, the circuit of Fig. 15.15(a) showing three impedances has an equivalent circuit of Fig. 15.15(b).

Problem 16. The following three impedances are connected in series across a 40 V, 20 kHz supply: (i) a resistance of 8 Ω, (ii) a coil of inductance 130 μH and 5 Ω resistance, and (iii) a 10 Ω resistor in series with a 0.25 μF capacitor. Calculate (a) the circuit current, (b) the circuit phase angle and (c) the voltage drop across each impedance.

The circuit diagram is shown in Fig. 15.16(a). Since the total circuit resistance is 8 + 5 + 10, i.e. 23 Ω, an equivalent circuit diagram may be drawn as shown in Fig. 15.16(b).

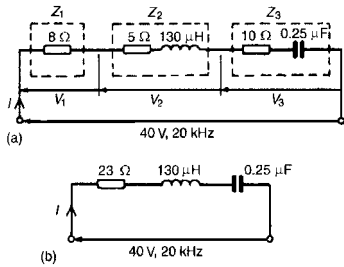
Figure 15.16

Inductive reactance,

$$\begin{aligned} X_L &= 2\pi fL \\ &= 2\pi(20 \times 10^3)(130 \times 10^{-6}) = 16.34 \Omega \end{aligned}$$

Capacitive reactance,

$$\begin{aligned} X_C &= \frac{1}{2\pi fC} = \frac{1}{2\pi(20 \times 10^3)(0.25 \times 10^{-6})} \\ &= 31.83 \Omega \end{aligned}$$

Since $X_C > X_L$, the circuit is capacitive (see phasor diagram in Fig. 15.12(c)).

$$X_C - X_L = 31.83 - 16.34 = 15.49 \Omega$$

$$\begin{aligned} \text{(a) Circuit impedance, } Z &= \sqrt{R^2 + (X_C - X_L)^2} = \\ &= \sqrt{23^2 + 15.49^2} = 27.73 \Omega \end{aligned}$$

$$\text{Circuit current, } I = V/Z = 40/27.73 = \mathbf{1.442 \text{ A}}$$

From Fig. 15.12(c), circuit phase angle

$$\phi = \tan^{-1} \left(\frac{X_C - X_L}{R} \right)$$

i.e.

$$\phi = \arctan^{-1} \left(\frac{15.49}{23} \right) = \mathbf{33.96^\circ \text{ leading}}$$

(b) From Fig. 15.16(a),

$$V_1 = IR_1 = (1.442)(8) = \mathbf{11.54 \text{ V}}$$

$$\begin{aligned} V_2 &= IZ_2 = I\sqrt{5^2 + 16.34^2} \\ &= (1.442)(17.09) = \mathbf{24.64 \text{ V}} \end{aligned}$$

$$\begin{aligned} V_3 &= IZ_3 = I\sqrt{10^2 + 31.83^2} \\ &= (1.442)(33.36) = \mathbf{48.11 \text{ V}} \end{aligned}$$

The 40 V supply voltage is the phasor sum of V_1 , V_2 and V_3

Problem 17. Determine the p.d.'s V_1 and V_2 for the circuit shown in Fig. 15.17 if the frequency of the supply is 5 kHz. Draw the phasor diagram and hence determine the supply voltage V and the circuit phase angle.

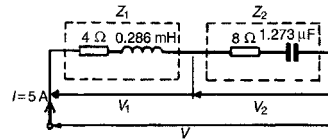
Figure 15.17

For impedance Z_1 : $R_1 = 4 \Omega$ and

$$\begin{aligned} X_L &= 2\pi fL \\ &= 2\pi(5 \times 10^3)(0.286 \times 10^{-3}) \\ &= 8.985 \Omega \end{aligned}$$

$$\begin{aligned} V_1 &= IZ_1 = I\sqrt{R^2 + X_L^2} \\ &= 5\sqrt{4^2 + 8.985^2} = 49.18 \text{ V} \end{aligned}$$

$$\begin{aligned} \text{Phase angle } \phi_1 &= \tan^{-1} \frac{X_L}{R} = \tan^{-1} \left(\frac{8.985}{4} \right) \\ &= \mathbf{66.0^\circ \text{ lagging}} \end{aligned}$$

For impedance Z_2 : $R_2 = 8 \Omega$ and

$$\begin{aligned} X_C &= \frac{1}{2\pi fC} = \frac{1}{2\pi(5 \times 10^3)(1.273 \times 10^{-6})} \\ &= 25.0 \Omega \end{aligned}$$

$$\begin{aligned} V_2 &= IZ_2 = I\sqrt{R^2 + X_C^2} = 5\sqrt{8^2 + 25.0^2} \\ &= 131.2 \text{ V.} \end{aligned}$$

$$\begin{aligned} \text{Phase angle } \phi_2 &= \tan^{-1} \frac{X_C}{R} \\ &= \tan^{-1} \left(\frac{25.0}{8} \right) \\ &= \mathbf{72.26^\circ \text{ leading}} \end{aligned}$$

The phasor diagram is shown in Fig. 15.18

The phasor sum of V_1 and V_2 gives the supply voltage V of 100 V at a phase angle of **53.13° leading**. These values may be determined by drawing or by calculation – either by resolving into horizontal and vertical components or by the cosine and sine rules.

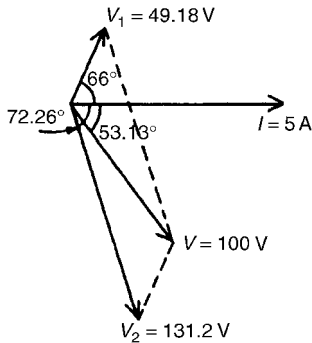

Figure 15.18

Now try the following exercise

Exercise 82 Further problems on R–L–C a.c. circuits

1 A $40\ \mu\text{F}$ capacitor in series with a coil of resistance $8\ \Omega$ and inductance $80\ \text{mH}$ is connected to a $200\ \text{V}$, $100\ \text{Hz}$ supply. Calculate (a) the circuit impedance, (b) the current flowing, (c) the phase angle between voltage and current, (d) the voltage across the coil, and (e) the voltage across the capacitor.

[(a) $13.18\ \Omega$ (b) $15.17\ \text{A}$ (c) 52.63°
(d) $772.1\ \text{V}$ (e) $603.6\ \text{V}$]

2 Three impedances are connected in series across a $100\ \text{V}$, $2\ \text{kHz}$ supply. The impedances comprise:

- an inductance of $0.45\ \text{mH}$ and $2\ \Omega$ resistance,
- an inductance of $570\ \mu\text{H}$ and $5\ \Omega$ resistance, and
- a capacitor of capacitance $10\ \mu\text{F}$ and resistance $3\ \Omega$

Assuming no mutual inductive effects between the two inductances calculate (a) the circuit impedance, (b) the circuit current, (c) the circuit phase angle and (d) the voltage across each impedance. Draw the phasor diagram.

[(a) $11.12\ \Omega$ (b) $8.99\ \text{A}$ (c) 25.92° lagging
(d) $53.92\ \text{V}$, $78.53\ \text{V}$, $76.46\ \text{V}$]

3 For the circuit shown in Fig. 15.19 determine the voltages V_1 and V_2 if the supply frequency is $1\ \text{kHz}$. Draw the phasor diagram and hence determine the supply voltage V and the circuit phase angle.

[$V_1 = 26.0\ \text{V}$, $V_2 = 67.05\ \text{V}$,
 $V = 50\ \text{V}$, 53.13° leading]

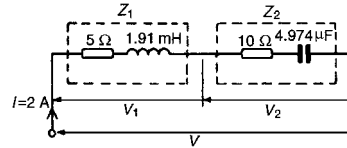

Figure 15.19

15.7 Series resonance

As stated in Section 15.6, for an R–L–C series circuit, when $X_L = X_C$ (Fig. 15.12(d)), the applied voltage V and the current I are in phase. This effect is called **series resonance**. At resonance:

- $V_L = V_C$
- $Z = R$ (i.e. the minimum circuit impedance possible in an L–C–R circuit)
- $I = V/R$ (i.e. the maximum current possible in an L–C–R circuit)
- Since $X_L = X_C$, then $2\pi f_r L = 1/2\pi f_r C$ from which,

$$f_r^2 = \frac{1}{(2\pi)^2 LC}$$

and

$$f_r = \frac{1}{2\pi\sqrt{LC}} \text{ Hz}$$

where f_r is the resonant frequency.

- The series resonant circuit is often described as an **acceptor circuit** since it has its minimum impedance, and thus maximum current, at the resonant frequency.
- Typical graphs of current I and impedance Z against frequency are shown in Fig. 15.20

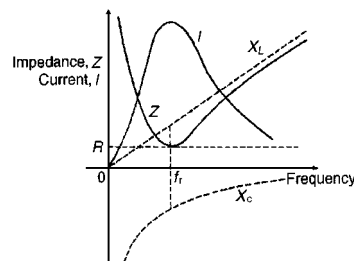

Figure 15.20

Problem 18. A coil having a resistance of $10\ \Omega$ and an inductance of $125\ \text{mH}$ is connected in series with a $60\ \mu\text{F}$ capacitor across a $120\ \text{V}$ supply. At what frequency does resonance occur? Find the current flowing at the resonant frequency.

Resonant frequency,

$$\begin{aligned} f_r &= \frac{1}{2\pi\sqrt{LC}} \text{ Hz} \\ &= \frac{1}{2\pi\sqrt{\left[\left(\frac{125}{10^3}\right)\left(\frac{60}{10^6}\right)\right]}} \\ &= \frac{1}{2\pi\sqrt{\left(\frac{125 \times 6}{10^8}\right)}} \\ &= \frac{1}{2\pi\left(\frac{\sqrt{(125)(6)}}{10^4}\right)} \\ &= \frac{10^4}{2\pi\sqrt{(125)(6)}} = \mathbf{58.12\ \text{Hz}} \end{aligned}$$

At resonance, $X_L = X_C$ and impedance $Z = R$. Hence current, $I = V/R = 120/10 = \mathbf{12\ \text{A}}$

Problem 19. The current at resonance in a series $L-C-R$ circuit is $100\ \mu\text{A}$. If the applied voltage is $2\ \text{mV}$ at a frequency of $200\ \text{kHz}$, and the circuit inductance is $50\ \mu\text{H}$, find (a) the circuit resistance, and (b) the circuit capacitance.

(a) $I = 100\ \mu\text{A} = 100 \times 10^{-6}\ \text{A}$ and $V = 2\ \text{mV} = 2 \times 10^{-3}\ \text{V}$. At resonance, impedance $Z =$ resistance R . Hence

$$R = \frac{V}{I} = \frac{2 \times 10^{-3}}{100 \times 10^{-6}} = \frac{2 \times 10^6}{100 \times 10^3} = \mathbf{20\ \Omega}$$

(b) At resonance $X_L = X_C$ i.e.

$$2\pi fL = \frac{1}{2\pi fC}$$

Hence capacitance

$$C = \frac{1}{(2\pi f)^2 L}$$

$$\begin{aligned} &= \frac{1}{(2\pi \times 200 \times 10^3)^2 (50 \times 10^{-6})} \text{ F} \\ &= \frac{(10^6)(10^6)}{(4\pi)^2 (10^{10})(50)} \mu\text{F} \\ &= \mathbf{0.0127\ \mu\text{F}} \text{ or } \mathbf{12.7\ \text{nF}} \end{aligned}$$

15.8 Q-factor

At resonance, if R is small compared with X_L and X_C , it is possible for V_L and V_C to have voltages many times greater than the supply voltage (see Fig. 15.12(d), page 206)

Voltage magnification at resonance

$$= \frac{\text{voltage across } L \text{ (or } C)}{\text{supply voltage } V}$$

This ratio is a measure of the quality of a circuit (as a resonator or tuning device) and is called the **Q-factor**. Hence

$$\begin{aligned} \text{Q-factor} &= \frac{V_L}{V} = \frac{IX_L}{IR} \\ &= \frac{X_L}{R} = \frac{2\pi f_r L}{R} \end{aligned}$$

Alternatively,

$$\begin{aligned} \text{Q-factor} &= \frac{V_C}{V} = \frac{IX_C}{IR} \\ &= \frac{X_C}{R} = \frac{1}{2\pi f_r CR} \end{aligned}$$

At resonance

$$f_r = \frac{1}{2\pi\sqrt{LC}}$$

i.e.
$$2\pi f_r = \frac{1}{\sqrt{LC}}$$

Hence

$$\text{Q-factor} = \frac{2\pi f_r L}{R} = \frac{1}{\sqrt{LC}} \left(\frac{L}{R}\right) = \frac{1}{R} \sqrt{\frac{L}{C}}$$

Problem 20. A coil of inductance 80 mH and negligible resistance is connected in series with a capacitance of 0.25 μF and a resistor of resistance 12.5 Ω across a 100 V, variable frequency supply. Determine (a) the resonant frequency, and (b) the current at resonance. How many times greater than the supply voltage is the voltage across the reactance's at resonance?

(a) Resonant frequency

$$\begin{aligned} f_r &= \frac{1}{2\pi\sqrt{\left(\frac{80}{10^3}\right)\left(\frac{0.25}{10^6}\right)}} \\ &= \frac{1}{2\pi\sqrt{\frac{(8)(0.25)}{10^8}}} = \frac{10^4}{2\pi\sqrt{2}} \\ &= \mathbf{1125.4 \text{ Hz}} \text{ or } \mathbf{1.1254 \text{ kHz}} \end{aligned}$$

(b) Current at resonance $I = V/R = 100/12.5 = \mathbf{8 \text{ A}}$

Voltage across inductance, at resonance,

$$\begin{aligned} V_L &= IX_L = (I)(2\pi fL) \\ &= (8)(2\pi)(1125.4)(80 \times 10^{-3}) \\ &= 4525.5 \text{ V} \end{aligned}$$

(Also, voltage across capacitor,

$$\begin{aligned} V_C &= IX_C = \frac{I}{2\pi fC} \\ &= \frac{8}{2\pi(1125.4)(0.25 \times 10^{-6})} \\ &= 4525.5 \text{ V} \end{aligned}$$

Voltage magnification at resonance = V_L/V or $V_C/V = 4525.5/100 = \mathbf{45.255}$ i.e. at resonance, the voltage across the reactance's are 45.255 times greater than the supply voltage. Hence **the Q-factor of the circuit is 45.255**

Problem 21. A series circuit comprises a coil of resistance 2 Ω and inductance 60 mH, and a 30 μF capacitor. Determine the Q-factor of the circuit at resonance.

At resonance,

$$\begin{aligned} \text{Q-factor} &= \frac{1}{R}\sqrt{\frac{L}{C}} = \frac{1}{2}\sqrt{\frac{60 \times 10^{-3}}{30 \times 10^{-6}}} \\ &= \frac{1}{2}\sqrt{\frac{60 \times 10^6}{30 \times 10^3}} \\ &= \frac{1}{2}\sqrt{2000} = \mathbf{22.36} \end{aligned}$$

Problem 22. A coil of negligible resistance and inductance 100 mH is connected in series with a capacitance of 2 μF and a resistance of 10 Ω across a 50 V, variable frequency supply. Determine (a) the resonant frequency, (b) the current at resonance, (c) the voltages across the coil and the capacitor at resonance, and (d) the Q-factor of the circuit.

(a) Resonant frequency,

$$\begin{aligned} f_r &= \frac{1}{2\pi\sqrt{LC}} = \frac{1}{2\pi\sqrt{\left(\frac{100}{10^3}\right)\left(\frac{2}{10^6}\right)}} \\ &= \frac{1}{2\pi\sqrt{\frac{20}{10^8}}} = \frac{1}{\frac{2\pi\sqrt{20}}{10^4}} \\ &= \frac{10^4}{2\pi\sqrt{20}} = \mathbf{355.9 \text{ Hz}} \end{aligned}$$

(b) Current at resonance $I = V/R = 50/10 = \mathbf{5 \text{ A}}$

(c) Voltage across coil at resonance,

$$\begin{aligned} V_L &= IX_L = I(2\pi f_r L) \\ &= (5)(2\pi \times 355.9 \times 100 \times 10^{-3}) = \mathbf{1118 \text{ V}} \end{aligned}$$

Voltage across capacitance at resonance,

$$\begin{aligned} V_C &= IX_C = \frac{I}{2\pi f_r C} \\ &= \frac{5}{2\pi(355.9)(2 \times 10^{-6})} = \mathbf{1118 \text{ V}} \end{aligned}$$

(d) Q-factor (i.e. voltage magnification at resonance)

$$\begin{aligned} &= \frac{V_L}{V} \text{ or } \frac{V_C}{V} \\ &= \frac{1118}{50} = \mathbf{22.36} \end{aligned}$$

Q-factor may also have been determined by

$$\frac{2\pi f_r L}{R} \text{ or } \frac{1}{2\pi f_r C R} \text{ or } \frac{1}{R} \sqrt{\frac{L}{C}}$$

Now try the following exercise

Exercise 83 Further problems on series resonance and Q-factor

- 1 Find the resonant frequency of a series a.c. circuit consisting of a coil of resistance $10\ \Omega$ and inductance $50\ \text{mH}$ and capacitance $0.05\ \mu\text{F}$. Find also the current flowing at resonance if the supply voltage is $100\ \text{V}$.
[3.183 kHz, 10 A]
- 2 The current at resonance in a series $L-C-R$ circuit is $0.2\ \text{mA}$. If the applied voltage is $250\ \text{mV}$ at a frequency of $100\ \text{kHz}$ and the circuit capacitance is $0.04\ \mu\text{F}$, find the circuit resistance and inductance.
[1.25 k Ω , 63.3 μH]
- 3 A coil of resistance $25\ \Omega$ and inductance $100\ \text{mH}$ is connected in series with a capacitance of $0.12\ \mu\text{F}$ across a $200\ \text{V}$, variable frequency supply. Calculate (a) the resonant frequency, (b) the current at resonance and (c) the factor by which the voltage across the reactance is greater than the supply voltage.
[(a) 1.453 kHz (b) 8 A (c) 36.52]
- 4 A coil of $0.5\ \text{H}$ inductance and $8\ \Omega$ resistance is connected in series with a capacitor across a $200\ \text{V}$, $50\ \text{Hz}$ supply. If the current is in phase with the supply voltage, determine the capacitance of the capacitor and the p.d. across its terminals.
[20.26 μF , 3.928 kV]
- 5 Calculate the inductance which must be connected in series with a $1000\ \text{pF}$ capacitor to give a resonant frequency of $400\ \text{kHz}$.
[0.158 mH]
- 6 A series circuit comprises a coil of resistance $20\ \Omega$ and inductance $2\ \text{mH}$ and a $500\ \text{pF}$ capacitor. Determine the Q-factor of the circuit at resonance. If the supply voltage is $1.5\ \text{V}$, what is the voltage across the capacitor?
[100, 150 V]

15.9 Bandwidth and selectivity

Fig. 15.21 shows how current I varies with frequency in an $R-L-C$ series circuit. At the resonant frequency f_r , current is a maximum value, shown as I_r . Also shown are the points A and B where the current is 0.707 of the maximum value at frequencies f_1 and f_2 . The power delivered to the circuit is $I^2 R$. At $I = 0.707 I_r$, the power is $(0.707 I_r)^2 R = 0.5 I_r^2 R$, i.e. half the power that occurs at frequency f_r . The points corresponding to f_1 and f_2 are called the **half-power points**. The distance between these points, i.e. $(f_2 - f_1)$, is called the **bandwidth**.

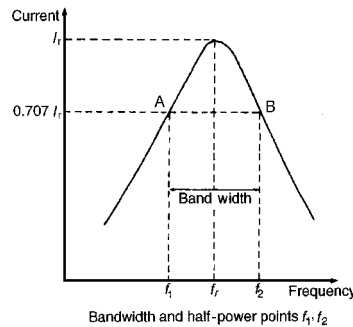

Figure 15.21

It may be shown that

$$Q = \frac{f_r}{(f_2 - f_1)}$$

or

$$(f_2 - f_1) = \frac{f_r}{Q}$$

Problem 23. A filter in the form of a series $L-R-C$ circuit is designed to operate at a resonant frequency of $5\ \text{kHz}$. Included within the filter is a $20\ \text{mH}$ inductance and $10\ \Omega$ resistance. Determine the bandwidth of the filter.

Q-factor at resonance is given by:

$$Q_r = \frac{\omega_r L}{R} = \frac{(2\pi \times 5000)(20 \times 10^{-3})}{10} = 62.83$$

Since $Q_r = f_r / (f_2 - f_1)$, **bandwidth**,

$$(f_2 - f_1) = \frac{f_r}{Q} = \frac{5000}{62.83} = 79.6 \text{ Hz}$$

Selectivity is the ability of a circuit to respond more readily to signals of a particular frequency to which it is tuned than to signals of other frequencies. The response becomes progressively weaker as the frequency departs from the resonant frequency. The higher the Q-factor, the narrower the bandwidth and the more selective is the circuit. Circuits having high Q-factors (say, in the order of 100 to 300) are therefore useful in communications engineering. A high Q-factor in a series power circuit has disadvantages in that it can lead to dangerously high voltages across the insulation and may result in electrical breakdown.

15.10 Power in a.c. circuits

In Figures 15.22(a)–(c), the value of power at any instant is given by the product of the voltage and current at that instant, i.e. the instantaneous power, $p = vi$, as shown by the broken lines.

- (a) For a purely resistive a.c. circuit, the average power dissipated, P , is given by: $P = VI = I^2R = V^2/R$ watts (V and I being rms values) See Fig. 15.22(a)
- (b) For a purely inductive a.c. circuit, the average power is zero. See Fig. 15.22(b)
- (c) For a purely capacitive a.c. circuit, the average power is zero. See Fig. 15.22(c)

Figure 15.23 shows current and voltage waveforms for an $R-L$ circuit where the current lags the voltage by angle ϕ . The waveform for power (where $p = vi$) is shown by the broken line, and its shape,

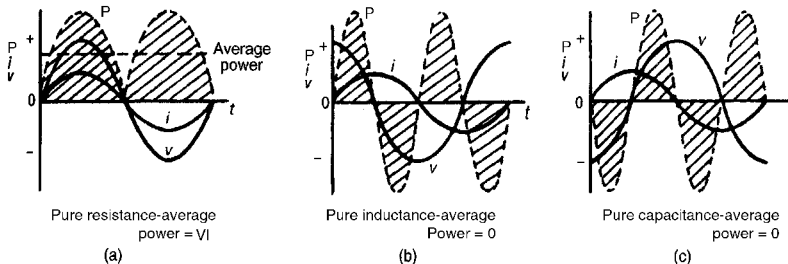

Figure 15.22

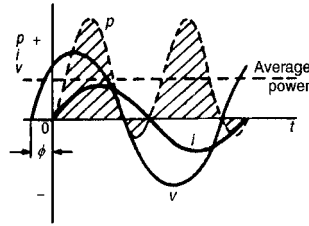

Figure 15.23

and hence average power, depends on the value of angle ϕ .

For an $R-L$, $R-C$ or $R-L-C$ series a.c. circuit, the average power P is given by:

$$P = VI \cos \phi \text{ watts}$$

or

$$P = I^2R \text{ watts}$$

(V and I being r.m.s. values)

Problem 24. An instantaneous current, $i = 250 \sin \omega t$ mA flows through a pure resistance of $5 \text{ k}\Omega$. Find the power dissipated in the resistor.

Power dissipated, $P = I^2R$ where I is the r.m.s. value of current. If $i = 250 \sin \omega t$ mA, then $I_m = 0.250$ A and r.m.s. current, $I = (0.707 \times 0.250)$ A. Hence **power $P = (0.707 \times 0.250)^2(5000) = 156.2$ watts.**

Problem 25. A series circuit of resistance 60Ω and inductance 75 mH is connected to a 110 V , 60 Hz supply. Calculate the power dissipated.

Inductive reactance, $X_L = 2\pi fL$
 $= 2\pi(60)(75 \times 10^{-3})$
 $= 28.27 \Omega$

Impedance, $Z = \sqrt{R^2 + X_L^2}$
 $= \sqrt{60^2 + 28.27^2}$
 $= 66.33 \Omega$

Current, $I = V/Z = 110/66.33 = 1.658 \text{ A}$.

To calculate power dissipation in an a.c. circuit two formulae may be used:

(i) $P = I^2R = (1.658)^2(60) = 165 \text{ W}$

or

(ii) $P = VI \cos \phi$ where $\cos \phi = \frac{R}{Z} = \frac{60}{66.33}$
 $= 0.9046$.

Hence $P = (110)(1.658)(0.9046) = 165 \text{ W}$

15.11 Power triangle and power factor

Figure 15.24(a) shows a phasor diagram in which the current I lags the applied voltage V by angle ϕ . The horizontal component of V is $V \cos \phi$ and the vertical component of V is $V \sin \phi$. If each of the voltage phasors is multiplied by I , Fig. 15.24(b) is obtained and is known as the 'power triangle'.

i.e. $\text{p.f.} = \cos \phi = \frac{R}{Z}$ (from Fig. 15.6)

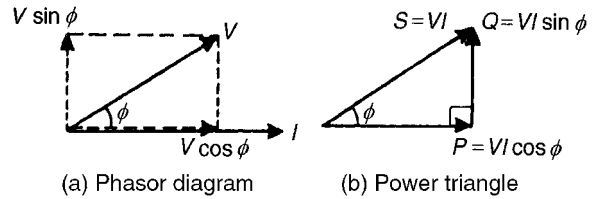

Figure 15.24

The relationships stated above are also true when current I leads voltage V .

Problem 26. A pure inductance is connected to a 150 V, 50 Hz supply, and the apparent power of the circuit is 300 VA. Find the value of the inductance.

Apparent power $S = VI$. Hence current $I = S/V = 300/150 = 2 \text{ A}$. Inductive reactance $X_L = V/I = 150/2 = 75 \Omega$. Since $X_L = 2\pi fL$,

$$\text{inductance } L = \frac{X_L}{2\pi f} = \frac{75}{2\pi(50)} = 0.239 \text{ H}$$

Apparent power,

$$S = VI \text{ voltamperes (VA)}$$

True or active power,

$$P = VI \cos \phi \text{ watts (W)}$$

Reactive power,

$$Q = VI \sin \phi \text{ reactive voltamperes (var)}$$

$$\text{Power factor} = \frac{\text{True power } P}{\text{Apparent power } S}$$

Problem 27. A transformer has a rated output of 200 kVA at a power factor of 0.8. Determine the rated power output and the corresponding reactive power.

$VI = 200 \text{ kVA} = 200 \times 10^3$ and $\text{p.f.} = 0.8 = \cos \phi$.
Power output, $P = VI \cos \phi = (200 \times 10^3)(0.8) = 160 \text{ kW}$.

Reactive power, $Q = VI \sin \phi$. If $\cos \phi = 0.8$, then $\phi = \cos^{-1} 0.8 = 36.87^\circ$. Hence $\sin \phi = \sin 36.87^\circ = 0.6$. Hence **reactive power, $Q = (200 \times 10^3)(0.6) = 120 \text{ kvar}$.**

Problem 28. A load takes 90 kW at a power factor of 0.5 lagging. Calculate the apparent power and the reactive power.

For sinusoidal voltages and currents,

$$\text{power factor} = \frac{P}{S} = \frac{VI \cos \phi}{VI}$$

True power $P = 90 \text{ kW} = VI \cos \phi$ and power factor $= 0.5 = \cos \phi$.

$$\text{Apparent power, } S = VI = \frac{P}{\cos \phi} = \frac{90}{0.5} = \mathbf{180 \text{ kVA}}$$

Angle $\phi = \cos^{-1} 0.5 = 60^\circ$ hence $\sin \phi = \sin 60^\circ = 0.866$.

Hence **reactive power, $Q = VI \sin \phi = 180 \times 10^3 \times 0.866 = 156 \text{ kvar}$** .

Problem 29. The power taken by an inductive circuit when connected to a 120 V, 50 Hz supply is 400 W and the current is 8 A. Calculate (a) the resistance, (b) the impedance, (c) the reactance, (d) the power factor, and (e) the phase angle between voltage and current.

(a) Power $P = I^2 R$ hence $R = \frac{P}{I^2} = \frac{400}{8^2} = \mathbf{6.25 \Omega}$.

(b) Impedance $Z = \frac{V}{I} = \frac{120}{8} = \mathbf{15 \Omega}$.

(c) Since $Z = \sqrt{R^2 + X_L^2}$, then $X_L = \sqrt{Z^2 - R^2} = \sqrt{15^2 - 6.25^2} = \mathbf{13.64 \Omega}$

(d) **Power factor** $= \frac{\text{true power}}{\text{apparent power}} = \frac{VI \cos \phi}{VI}$
 $= \frac{400}{(120)(8)} = \mathbf{0.4167}$

(e) p.f. $= \cos \phi = 0.4167$ hence phase angle, $\phi = \cos^{-1} 0.4167 = \mathbf{65.37^\circ \text{ lagging}}$

Problem 30. A circuit consisting of a resistor in series with a capacitor takes 100 watts at a power factor of 0.5 from a 100 V, 60 Hz supply. Find (a) the current flowing, (b) the phase angle, (c) the resistance, (d) the impedance, and (e) the capacitance.

(a) Power factor $= \frac{\text{true power}}{\text{apparent power}}$, i.e. $0.5 =$

$$\frac{100}{100 \times I} \text{ hence current,}$$

$$I = \frac{100}{(0.5)(100)} = \mathbf{2 \text{ A}}$$

(b) Power factor $= 0.5 = \cos \phi$ hence phase angle, $\phi = \cos^{-1} 0.5 = \mathbf{60^\circ \text{ leading}}$

(c) Power $P = I^2 R$ hence resistance,

$$R = \frac{P}{I^2} = \frac{100}{2^2} = \mathbf{25 \Omega}$$

(d) Impedance $Z = \frac{V}{I} = \frac{100}{2} = \mathbf{50 \Omega}$

(e) Capacitive reactance, $X_C = \sqrt{Z^2 - R^2} = \sqrt{50^2 - 25^2} = 43.30 \Omega$. $X_C = 1/2\pi f C$. Hence

$$\text{capacitance, } C = \frac{1}{2\pi f X_C} = \frac{1}{2\pi(60)(43.30)} \text{ F}$$

$$= \mathbf{61.26 \mu\text{F}}$$

Now try the following exercises

Exercise 84 Further problems on power in a.c. circuits

- 1 A voltage $v = 200 \sin \omega t$ volts is applied across a pure resistance of 1.5 k Ω . Find the power dissipated in the resistor. [13.33 W]
- 2 A 50 μF capacitor is connected to a 100 V, 200 Hz supply. Determine the true power and the apparent power. [0, 628.3 VA]
- 3 A motor takes a current of 10 A when supplied from a 250 V a.c. supply. Assuming a power factor of 0.75 lagging find the power consumed. Find also the cost of running the motor for 1 week continuously if 1 kWh of electricity costs 7.20 p [1875 W, £22.68]
- 4 A motor takes a current of 12 A when supplied from a 240 V a.c. supply. Assuming a power factor of 0.75 lagging, find the power consumed. [2.16 kW]
- 5 A transformer has a rated output of 100 kVA at a power factor of 0.6. Determine the rated power output and the corresponding reactive power. [60 kW, 80 kvar]
- 6 A substation is supplying 200 kVA and 150 kvar. Calculate the corresponding power and power factor. [132 kW, 0.66]
- 7 A load takes 50 kW at a power factor of 0.8 lagging. Calculate the apparent power and the reactive power. [62.5 kVA, 37.5 kvar]
- 8 A coil of resistance 400 Ω and inductance 0.20 H is connected to a 75 V, 400 Hz supply. Calculate the power dissipated in the coil. [5.452 W]

- 9 An $80\ \Omega$ resistor and a $6\ \mu\text{F}$ capacitor are connected in series across a $150\ \text{V}$, $200\ \text{Hz}$ supply. Calculate (a) the circuit impedance, (b) the current flowing and (c) the power dissipated in the circuit.
[(a) $154.9\ \Omega$ (b) $0.968\ \text{A}$ (c) $75\ \text{W}$]
- 10 The power taken by a series circuit containing resistance and inductance is $240\ \text{W}$ when connected to a $200\ \text{V}$, $50\ \text{Hz}$ supply. If the current flowing is $2\ \text{A}$ find the values of the resistance and inductance.
[$60\ \Omega$, $255\ \text{mH}$]
- 11 The power taken by a C - R series circuit, when connected to a $105\ \text{V}$, $2.5\ \text{kHz}$ supply, is $0.9\ \text{kW}$ and the current is $15\ \text{A}$. Calculate (a) the resistance, (b) the impedance, (c) the reactance, (d) the capacitance, (e) the power factor, and (f) the phase angle between voltage and current.
[(a) $4\ \Omega$ (b) $7\ \Omega$ (c) $5.745\ \Omega$ (d) $11.08\ \mu\text{F}$ (e) 0.571 (f) 55.18° leading]
- 12 A circuit consisting of a resistor in series with an inductance takes $210\ \text{W}$ at a power factor of 0.6 from a $50\ \text{V}$, $100\ \text{Hz}$ supply. Find (a) the current flowing, (b) the circuit phase angle, (c) the resistance, (d) the impedance and (e) the inductance.
[(a) $7\ \text{A}$ (b) 53.13° lagging (c) $4.286\ \Omega$ (d) $7.143\ \Omega$ (e) $9.095\ \text{mH}$]
- 13 A $200\ \text{V}$, $60\ \text{Hz}$ supply is applied to a capacitive circuit. The current flowing is $2\ \text{A}$ and the power dissipated is $150\ \text{W}$. Calculate the values of the resistance and capacitance.
[$37.5\ \Omega$, $28.61\ \mu\text{F}$]
- 2 Draw phasor diagrams to represent (a) a purely resistive a.c. circuit (b) a purely inductive a.c. circuit (c) a purely capacitive a.c. circuit
- 3 What is inductive reactance? State the symbol and formula for determining inductive reactance
- 4 What is capacitive reactance? State the symbol and formula for determining capacitive reactance
- 5 Draw phasor diagrams to represent (a) a coil (having both inductance and resistance), and (b) a series capacitive circuit containing resistance
- 6 What does 'impedance' mean when referring to an a.c. circuit ?
- 7 Draw an impedance triangle for an R - L circuit. Derive from the triangle an expression for (a) impedance, and (b) phase angle
- 8 Draw an impedance triangle for an R - C circuit. From the triangle derive an expression for (a) impedance, and (b) phase angle
- 9 What is series resonance ?
- 10 Derive a formula for resonant frequency f_r in terms of L and C
- 11 What does the Q-factor in a series circuit mean ?
- 12 State three formulae used to calculate the Q-factor of a series circuit at resonance
- 13 State an advantage of a high Q-factor in a series high-frequency circuit
- 14 State a disadvantage of a high Q-factor in a series power circuit
- 15 State two formulae which may be used to calculate power in an a.c. circuit
- 16 Show graphically that for a purely inductive or purely capacitive a.c. circuit the average power is zero
- 17 Define 'power factor'
- 18 Define (a) apparent power (b) reactive power
- 19 Define (a) bandwidth (b) selectivity

Exercise 85 Short answer questions on single-phase a.c. circuits

- 1 Complete the following statements:
- (a) In a purely resistive a.c. circuit the current is with the voltage
- (b) In a purely inductive a.c. circuit the current the voltage by degrees
- (c) In a purely capacitive a.c. circuit the current the voltage by degrees

Exercise 86 Multi-choice questions on single-phase a.c. circuits (Answers on page 376)

- 1 An inductance of 10 mH connected across a 100 V, 50 Hz supply has an inductive reactance of
 - (a) $10\pi\ \Omega$
 - (b) $1000\pi\ \Omega$
 - (c) $\pi\ \Omega$
 - (d) $\pi\ \text{H}$
- 2 When the frequency of an a.c. circuit containing resistance and inductance is increased, the current
 - (a) decreases
 - (b) increases
 - (c) stays the same
- 3 In question 2, the phase angle of the circuit
 - (a) decreases
 - (b) increases
 - (c) stays the same
- 4 When the frequency of an a.c. circuit containing resistance and capacitance is decreased, the current
 - (a) decreases
 - (b) increases
 - (c) stays the same
- 5 In question 4, the phase angle of the circuit
 - (a) decreases
 - (b) increases
 - (c) stays the same
- 6 A capacitor of $1\ \mu\text{F}$ is connected to a 50 Hz supply. The capacitive reactance is
 - (a) $50\ \text{M}\Omega$
 - (b) $\frac{10}{\pi}\ \text{k}\Omega$
 - (c) $\frac{\pi}{10^4}\ \Omega$
 - (d) $\frac{10}{\pi}\ \Omega$
- 7 In a series a.c. circuit the voltage across a pure inductance is 12 V and the voltage across a pure resistance is 5 V. The supply voltage is
 - (a) 13 V
 - (b) 17 V
 - (c) 7 V
 - (d) 2.4 V
- 8 Inductive reactance results in a current that
 - (a) leads the voltage by 90°
 - (b) is in phase with the voltage
 - (c) leads the voltage by π rad
 - (d) lags the voltage by $\pi/2$ rad
- 9 Which of the following statements is false ?
 - (a) Impedance is at a minimum at resonance in an a.c. circuit
 - (b) The product of r.m.s. current and voltage gives the apparent power in an a.c. circuit
 - (c) Current is at a maximum at resonance in an a.c. circuit
 - (d) $\frac{\text{Apparent power}}{\text{True power}}$ gives power factor
- 10 The impedance of a coil, which has a resistance of X ohms and an inductance of Y henrys, connected across a supply of frequency K Hz, is
 - (a) $2\pi KY$
 - (b) $X + Y$
 - (c) $\sqrt{X^2 + Y^2}$
 - (d) $\sqrt{X^2 + (2\pi KY)^2}$
- 11 In question 10, the phase angle between the current and the applied voltage is given by
 - (a) $\tan^{-1} \frac{Y}{X}$
 - (b) $\tan^{-1} \frac{2\pi KY}{X}$
 - (c) $\tan^{-1} \frac{X}{2\pi KY}$
 - (d) $\tan \left(\frac{2\pi KY}{X} \right)$
- 12 When a capacitor is connected to an a.c. supply the current
 - (a) leads the voltage by 180°
 - (b) is in phase with the voltage
 - (c) leads the voltage by $\pi/2$ rad
 - (d) lags the voltage by 90°
- 13 When the frequency of an a.c. circuit containing resistance and capacitance is increased the impedance
 - (a) increases
 - (b) decreases
 - (c) stays the same
- 14 In an $R-L-C$ series a.c. circuit a current of 5 A flows when the supply voltage is 100 V. The phase angle between current and voltage is 60° lagging. Which of the following statements is false?
 - (a) The circuit is effectively inductive
 - (b) The apparent power is 500 VA
 - (c) The equivalent circuit reactance is $20\ \Omega$
 - (d) The true power is 250 W
- 15 A series a.c. circuit comprising a coil of inductance 100 mH and resistance $1\ \Omega$ and a $10\ \mu\text{F}$ capacitor is connected across a 10 V supply. At resonance the p.d. across the capacitor is
 - (a) 10 kV
 - (b) 1 kV
 - (c) 100 V
 - (d) 10 V
- 16 The amplitude of the current I flowing in the circuit of Fig. 15.25 is:
 - (a) 21 A
 - (b) 16.8 A
 - (c) 28 A
 - (d) 12 A
- 17 If the supply frequency is increased at resonance in a series $R-L-C$ circuit and the values of L , C and R are constant, the circuit will become:

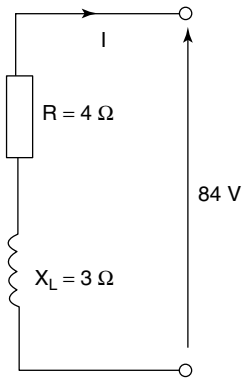

Figure 15.25

- (a) capacitive
- (b) resistive
- (c) inductive
- (d) resonant

18 For the circuit shown in Fig. 15.26, the value of Q-factor is:

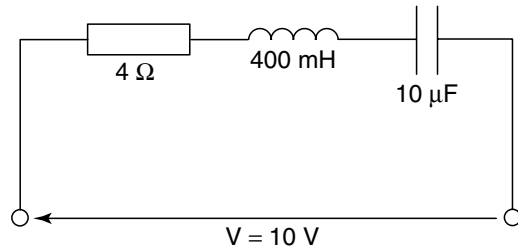

Figure 15.26

- (a) 50
- (b) 100
- (c) 5×10^{-4}
- (d) 40

19 A series $R-L-C$ circuit has a resistance of 8Ω , an inductance of 100 mH and a capacitance of $5 \mu\text{F}$. If the current flowing is 2 A , the impedance at resonance is:
 (a) 160Ω (b) 16Ω (c) $8 \text{ m}\Omega$ (d) 8Ω

Single-phase parallel a.c. circuits

At the end of this chapter you should be able to:

- calculate unknown currents, impedances and circuit phase angle from phasor diagrams for (a) $R-L$ (b) $R-C$ (c) $L-C$ (d) $LR-C$ parallel a.c. circuits
- state the condition for parallel resonance in an $LR-C$ circuit
- derive the resonant frequency equation for an $LR-C$ parallel a.c. circuit
- determine the current and dynamic resistance at resonance in an $LR-C$ parallel circuit
- understand and calculate Q -factor in an $LR-C$ parallel circuit
- understand how power factor may be improved

16.1 Introduction

In parallel circuits, such as those shown in Figs. 16.1 and 16.2, the voltage is common to each branch of the network and is thus taken as the reference phasor when drawing phasor diagrams.

For any parallel a.c. circuit:

True or active power, $P = VI \cos \phi$ watts (W)

or $P = I_R^2 R$ watts

Apparent power, $S = VI$ voltamperes (VA)

Reactive power, $Q = VI \sin \phi$ reactive
voltamperes (var)

$$\text{Power factor} = \frac{\text{true power}}{\text{apparent power}} = \frac{P}{S} = \cos \phi$$

(These formulae are the same as for series a.c. circuits as used in Chapter 15).

16.2 $R-L$ parallel a.c. circuit

In the two branch parallel circuit containing resistance R and inductance L shown in Fig. 16.1, the current flowing in the resistance, I_R , is in-phase with

the supply voltage V and the current flowing in the inductance, I_L , lags the supply voltage by 90° . The supply current I is the phasor sum of I_R and I_L and thus the current I lags the applied voltage V by an angle lying between 0° and 90° (depending on the values of I_R and I_L), shown as angle ϕ in the phasor diagram.

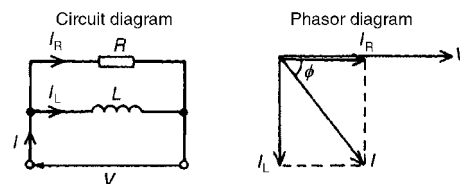

Figure 16.1

From the phasor diagram: $I = \sqrt{I_R^2 + I_L^2}$ (by Pythagoras' theorem) where

$$I_R = \frac{V}{R} \text{ and } I_L = \frac{V}{X_L}$$

$$\tan \phi = \frac{I_L}{I_R}, \sin \phi = \frac{I_L}{I} \text{ and } \cos \phi = \frac{I_R}{I}$$

(by trigonometric ratios)

$$\text{Circuit impedance, } Z = \frac{V}{I}$$

Problem 1. A $20\ \Omega$ resistor is connected in parallel with an inductance of $2.387\ \text{mH}$ across a $60\ \text{V}$, $1\ \text{kHz}$ supply. Calculate (a) the current in each branch, (b) the supply current, (c) the circuit phase angle, (d) the circuit impedance, and (e) the power consumed.

The circuit and phasor diagrams are as shown in Fig. 16.1

- (a) Current flowing in the resistor,

$$I_R = \frac{V}{R} = \frac{60}{20} = 3\ \text{A}$$

Current flowing in the inductance,

$$I_L = \frac{V}{X_L} = \frac{V}{2\pi fL}$$

$$= \frac{60}{2\pi(1000)(2.387 \times 10^{-3})} = 4\ \text{A}$$

- (b) From the phasor diagram, supply current,

$$I = \sqrt{I_R^2 + I_L^2} = \sqrt{3^2 + 4^2} = 5\ \text{A}$$

- (c) Circuit phase angle,

$$\phi = \tan^{-1} \frac{I_L}{I_R} = \tan^{-1} \frac{4}{3} = 53.13^\circ \text{ lagging}$$

- (d) Circuit impedance,

$$Z = \frac{V}{I} = \frac{60}{5} = 12\ \Omega$$

- (e) Power consumed

$$P = VI \cos \phi = (60)(5)(\cos 53.13^\circ)$$

$$= 180\ \text{W}$$

(Alternatively, power consumed, $P = I_R^2 R = (3)^2(20) = 180\ \text{W}$)

Now try the following exercise

Exercise 87 Further problems on R–L parallel a.c. circuits

1 A $30\ \Omega$ resistor is connected in parallel with a pure inductance of $3\ \text{mH}$ across a $110\ \text{V}$, $2\ \text{kHz}$ supply. Calculate (a) the current in each

branch, (b) the circuit current, (c) the circuit phase angle, (d) the circuit impedance, (e) the power consumed, and (f) the circuit power factor.

[(a) $I_R = 3.67\ \text{A}$, $I_L = 2.92\ \text{A}$ (b) $4.69\ \text{A}$
(c) 38.51° lagging (d) $23.45\ \Omega$
(e) $404\ \text{W}$ (f) 0.783 lagging]

- 2 A $40\ \Omega$ resistance is connected in parallel with a coil of inductance L and negligible resistance across a $200\ \text{V}$, $50\ \text{Hz}$ supply and the supply current is found to be $8\ \text{A}$. Draw a phasor diagram to scale and determine the inductance of the coil. [102 mH]

16.3 R–C parallel a.c. circuit

In the two branch parallel circuit containing resistance R and capacitance C shown in Fig. 16.2, I_R is in-phase with the supply voltage V and the current flowing in the capacitor, I_C , leads V by 90° . The supply current I is the phasor sum of I_R and I_C and thus the current I leads the applied voltage V by an angle lying between 0° and 90° (depending on the values of I_R and I_C), shown as angle α in the phasor diagram.

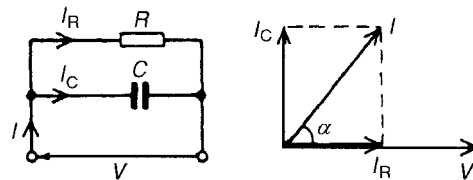

Figure 16.2

From the phasor diagram: $I = \sqrt{I_R^2 + I_C^2}$, (by Pythagoras' theorem) where

$$I_R = \frac{V}{R} \text{ and } I_C = \frac{V}{X_C}$$

$$\tan \alpha = \frac{I_C}{I_R}, \sin \alpha = \frac{I_C}{I} \text{ and } \cos \alpha = \frac{I_R}{I}$$

(by trigonometric ratios)

$$\text{Circuit impedance, } Z = \frac{V}{I}$$

Problem 2. A $30\ \mu\text{F}$ capacitor is connected in parallel with an $80\ \Omega$ resistor across a $240\ \text{V}$, $50\ \text{Hz}$ supply. Calculate (a) the current in each branch, (b) the supply current, (c) the circuit phase angle, (d) the circuit impedance, (e) the power dissipated, and (f) the apparent power

The circuit and phasor diagrams are as shown in Fig. 16.2

(a) Current in resistor,

$$I_R = \frac{V}{R} = \frac{240}{80} = 3\ \text{A}$$

Current in capacitor,

$$I_C = \frac{V}{X_C} = \frac{V}{\left(\frac{1}{2\pi f C}\right)} = 2\pi f C V$$

$$= 2\pi(50)(30 \times 10^6)(240) = 2.262\ \text{A}$$

(b) Supply current,

$$I = \sqrt{I_R^2 + I_C^2} = \sqrt{3^2 + 2.262^2}$$

$$= 3.757\ \text{A}$$

(c) Circuit phase angle,

$$\alpha = \tan^{-1} \frac{I_C}{I_R} = \tan^{-1} \frac{2.262}{3}$$

$$= 37.02^\circ \text{ leading}$$

(d) Circuit impedance,

$$Z = \frac{V}{I} = \frac{240}{3.757} = 63.88\ \Omega$$

(e) True or active power dissipated,

$$P = VI \cos \alpha = (240)(3.757) \cos 37.02^\circ$$

$$= 720\ \text{W}$$

(Alternatively, true power

$$P = I_R^2 R = (3)^2(80) = 720\ \text{W})$$

(f) Apparent power,

$$S = VI = (240)(3.757) = 901.7\ \text{VA}$$

Problem 3. A capacitor C is connected in parallel with a resistor R across a $120\ \text{V}$, $200\ \text{Hz}$ supply. The supply current is $2\ \text{A}$ at a power factor of 0.6 leading. Determine the values of C and R

The circuit diagram is shown in Fig. 16.3(a).

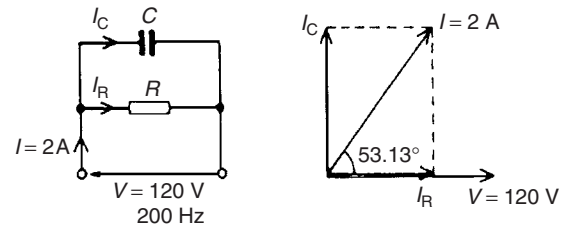

Figure 16.3

Power factor = $\cos \phi = 0.6$ leading, hence $\phi = \cos^{-1} 0.6 = 53.13^\circ$ leading.

From the phasor diagram shown in Fig. 16.3(b),

$$I_R = I \cos 53.13^\circ = (2)(0.6)$$

$$= 1.2\ \text{A}$$

and

$$I_C = I \sin 53.13^\circ = (2)(0.8)$$

$$= 1.6\ \text{A}$$

(Alternatively, I_R and I_C can be measured from the scaled phasor diagram).

From the circuit diagram,

$$I_R = \frac{V}{R} \text{ from which}$$

$$R = \frac{V}{I_R}$$

$$= \frac{120}{1.2} = 100\ \Omega$$

and

$$I_C = \frac{V}{X_C}$$

$$= 2\pi f C V \text{ from which}$$

$$C = \frac{I_C}{2\pi f V}$$

$$= \frac{1.6}{2\pi(200)(120)}$$

$$= 10.61\ \mu\text{F}$$

Now try the following exercise

Exercise 88 Further problems on R–C parallel a.c. circuits

1 A 1500 nF capacitor is connected in parallel with a 16 Ω resistor across a 10 V, 10 kHz supply. Calculate (a) the current in each branch, (b) the supply current, (c) the circuit phase angle, (d) the circuit impedance, (e) the power consumed, (f) the apparent power, and (g) the circuit power factor. Draw the phasor diagram.

[(a) $I_R = 0.625$ A, $I_C = 0.943$ A (b) 1.13 A (c) 56.46° leading (d) 8.85 Ω (e) 6.25 W (f) 11.3 VA (g) 0.55 leading]

2 A capacitor C is connected in parallel with a resistance R across a 60 V, 100 Hz supply. The supply current is 0.6 A at a power factor of 0.8 leading. Calculate the value of R and C
 $[R = 125$ Ω, $C = 9.55$ μF]

- (i) $I_L > I_C$ (giving a supply current, $I = I_L - I_C$ lagging V by 90°)
- (ii) $I_C > I_L$ (giving a supply current, $I = I_C - I_L$ leading V by 90°)
- (iii) $I_L = I_C$ (giving a supply current, $I = 0$).

The latter condition is not possible in practice due to circuit resistance inevitably being present (as in the circuit described in Section 16.5).

For the L – C parallel circuit,

$$I_L = \frac{V}{X_L}, I_C = \frac{V}{X_C},$$

I = phasor difference between I_L and I_C , and

$$Z = \frac{V}{I}$$

Problem 4. A pure inductance of 120 mH is connected in parallel with a 25 μF capacitor and the network is connected to a 100 V, 50 Hz supply. Determine (a) the branch currents, (b) the supply current and its phase angle, (c) the circuit impedance, and (d) the power consumed.

16.4 L–C parallel circuit

In the two branch parallel circuit containing inductance L and capacitance C shown in Fig. 16.4, I_L lags V by 90° and I_C leads V by 90°

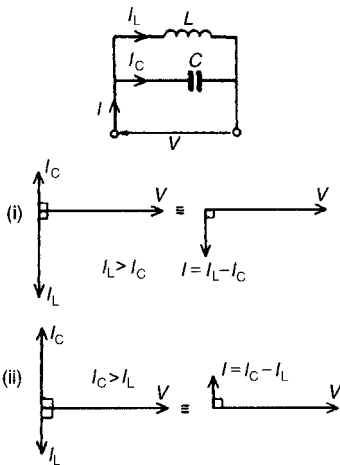

Figure 16.4

Theoretically there are three phasor diagrams possible – each depending on the relative values of I_L and I_C :

The circuit and phasor diagrams are as shown in Fig. 16.4

- (a) Inductive reactance,

$$X_L = 2\pi fL = 2\pi(50)(120 \times 10^{-3}) = 37.70 \Omega$$

Capacitive reactance,

$$X_C = \frac{1}{2\pi fC} = \frac{1}{2\pi(50)(25 \times 10^{-6})} = 127.3 \Omega$$

Current flowing in inductance,

$$I_L = \frac{V}{X_L} = \frac{100}{37.70} = 2.653 \text{ A}$$

Current flowing in capacitor,

$$I_C = \frac{V}{X_C} = \frac{100}{127.3} = 0.786 \text{ A}$$

- (b) I_L and I_C are anti-phase, hence supply current,

$$I = I_L - I_C = 2.653 - 0.786 = 1.867 \text{ A}$$

and the current lags the supply voltage V by 90° (see Fig. 16.4(i))

(c) Circuit impedance,

$$Z = \frac{V}{I} = \frac{100}{1.867} = 53.56 \Omega$$

(d) Power consumed,

$$P = VI \cos \phi = (100)(1.867) \cos 90^\circ = 0 \text{ W}$$

Problem 5. Repeat Problem 4 for the condition when the frequency is changed to 150 Hz

(a) Inductive reactance,

$$X_L = 2\pi(150)(120 \times 10^{-3}) = 113.1 \Omega$$

Capacitive reactance,

$$X_C = \frac{1}{2\pi(150)(25 \times 10^{-6})} = 42.44 \Omega$$

Current flowing in inductance,

$$I_L = \frac{V}{X_L} = \frac{100}{113.1} = 0.884 \text{ A}$$

Current flowing in capacitor,

$$I_C = \frac{V}{X_C} = \frac{100}{42.44} = 2.356 \text{ A}$$

(b) Supply current,

$$I = I_C - I_L = 2.356 - 0.884 = 1.472 \text{ A}$$

leading V by 90° (see Fig. 16.4(ii))

(c) Circuit impedance,

$$Z = \frac{V}{I} = \frac{100}{1.472} = 67.93 \Omega$$

(d) Power consumed,

$$P = VI \cos \phi = 0 \text{ W (since } \phi = 90^\circ)$$

From problems 4 and 5:

- (i) When $X_L < X_C$ then $I_L > I_C$ and I lags V by 90°
- (ii) When $X_L > X_C$ then $I_L < I_C$ and I leads V by 90°
- (iii) In a parallel circuit containing no resistance the power consumed is zero

Now try the following exercise

Exercise 89 Further problems on L–C parallel a.c. circuits

1 An inductance of 80 mH is connected in parallel with a capacitance of 10 μ F across a 60 V, 100 Hz supply. Determine (a) the branch currents, (b) the supply current, (c) the circuit phase angle, (d) the circuit impedance and (e) the power consumed

- [(a) $I_C = 0.377 \text{ A}$, $I_L = 1.194 \text{ A}$ (b) 0.817 A
(c) 90° lagging (d) 73.44 Ω (e) 0 W]

2 Repeat problem 5 for a supply frequency of 200 Hz

- [(a) $I_C = 0.754 \text{ A}$, $I_L = 0.597 \text{ A}$ (b) 0.157 A
(c) 90° leading (d) 382.2 Ω (e) 0 W]

16.5 LR–C parallel a.c. circuit

In the two branch circuit containing capacitance C in parallel with inductance L and resistance R in series (such as a coil) shown in Fig. 16.5(a), the phasor diagram for the LR branch alone is shown in Fig. 16.5(b) and the phasor diagram for the C branch is shown alone in Fig. 16.5(c). Rotating each and superimposing on one another gives the complete phasor diagram shown in Fig. 16.5(d)

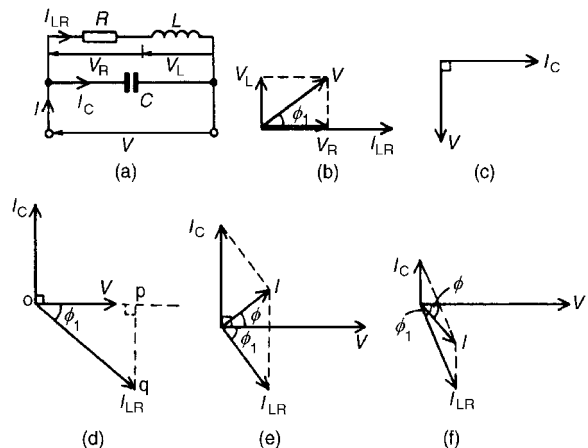

Figure 16.5

The current I_{LR} of Fig. 16.5(d) may be resolved into horizontal and vertical components. The horizontal component, shown as op is $I_{LR} \cos \phi_1$ and the vertical component, shown as pq is $I_{LR} \sin \phi_1$. There are three possible conditions for this circuit:

- (i) $I_C > I_{LR} \sin \phi_1$ (giving a supply current I leading V by angle ϕ —as shown in Fig. 16.5(e))
- (ii) $I_{LR} \sin \phi > I_C$ (giving I lagging V by angle ϕ —as shown in Fig. 16.5(f))
- (iii) $I_C = I_{LR} \sin \phi_1$ (this is called **parallel resonance**, see Section 16.6)

There are two methods of finding the phasor sum of currents I_{LR} and I_C in Fig. 16.5(e) and (f). These are: (i) by a scaled phasor diagram, or (ii) by resolving each current into their ‘in-phase’ (i.e. horizontal) and ‘quadrature’ (i.e. vertical) **components**, as demonstrated in problems 6 and 7. With reference to the phasor diagrams of Fig. 16.5:

Impedance of LR branch, $Z_{LR} = \sqrt{R^2 + X_L^2}$.

Current,

$$I_{LR} = \frac{V}{Z_{LR}} \text{ and } I_C = \frac{V}{X_C}$$

Supply current

$$\begin{aligned} I &= \text{phasor sum of } I_{LR} \text{ and } I_C \text{ (by drawing)} \\ &= \sqrt{(I_{LR} \cos \phi_1)^2 + (I_{LR} \sin \phi_1 \sim I_C)^2} \\ &\text{(by calculation)} \end{aligned}$$

where \sim means ‘the difference between’.

$$\text{Circuit impedance } Z = \frac{V}{I}$$

$$\tan \phi_1 = \frac{V_L}{V_R} = \frac{X_L}{R},$$

$$\sin \phi_1 = \frac{X_L}{Z_{LR}} \text{ and } \cos \phi_1 = \frac{R}{Z_{LR}}$$

$$\tan \phi = \frac{I_{LR} \sin \phi_1 \sim I_C}{I_{LR} \cos \phi_1} \text{ and } \cos \phi = \frac{I_{LR} \cos \phi_1}{I}$$

Problem 6. A coil of inductance 159.2 mH and resistance 40Ω is connected in parallel with a $30 \mu\text{F}$ capacitor across a 240 V, 50 Hz supply. Calculate (a) the current in the coil and its phase angle, (b) the current in the capacitor and its phase angle, (c) the supply current and its phase angle, (d) the circuit impedance, (e) the power consumed, (f) the apparent power, and (g) the reactive power. Draw the phasor diagram.

The circuit diagram is shown in Fig. 16.6(a).

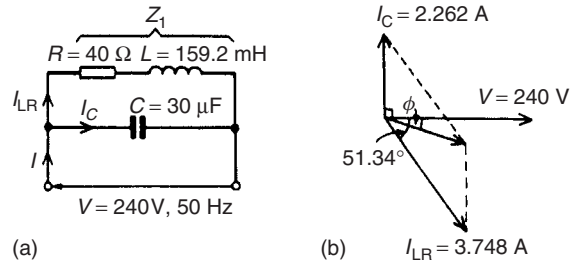

Figure 16.6

- (a) For the coil, inductive reactance $X_L = 2\pi fL = 2\pi(50)(159.2 \times 10^{-3}) = 50 \Omega$.

$$\begin{aligned} \text{Impedance } Z_1 &= \sqrt{R^2 + X_L^2} \\ &= \sqrt{40^2 + 50^2} \\ &= 64.03 \Omega \end{aligned}$$

Current in coil,

$$I_{LR} = \frac{V}{Z_1} = \frac{240}{64.03} = \mathbf{3.748 \text{ A}}$$

Branch phase angle

$$\begin{aligned} \phi_1 &= \tan^{-1} \frac{X_L}{R} = \tan^{-1} \frac{50}{40} \\ &= \tan^{-1} 1.25 = \mathbf{51.34^\circ \text{ lagging}} \end{aligned}$$

(see phasor diagram in Fig. 16.6(b))

- (b) Capacitive reactance,

$$\begin{aligned} X_C &= \frac{1}{2\pi fC} = \frac{1}{2\pi(50)(30 \times 10^{-6})} \\ &= 106.1 \Omega \end{aligned}$$

Current in capacitor,

$$\begin{aligned} I_C &= \frac{V}{X_C} = \frac{240}{106.1} \\ &= \mathbf{2.262 \text{ A leading the supply}} \end{aligned}$$

voltage by 90°

(see phasor diagram of Fig. 16.6(b)).

- (c) The supply current I is the phasor sum of I_{LR} and I_C . This may be obtained by drawing the phasor diagram to scale and measuring the current I and its phase angle relative to V . (Current I will always be the diagonal of the parallelogram formed as in Fig. 16.6(b)).

Alternatively the current I_{LR} and I_C may be resolved into their horizontal (or 'in-phase') and vertical (or 'quadrature') components. The horizontal component of I_{LR} is: $I_{LR} \cos 51.34^\circ = 3.748 \cos 51.34^\circ = 2.341$ A.

The horizontal component of I_C is

$$I_C \cos 90^\circ = 0$$

Thus the total horizontal component,

$$I_H = 2.341 \text{ A}$$

The vertical component of I_{LR}

$$\begin{aligned} &= -I_{LR} \sin 51.34^\circ = -3.748 \sin 51.34^\circ \\ &= -2.927 \text{ A} \end{aligned}$$

The vertical component of I_C

$$= I_C \sin 90^\circ = 2.262 \sin 90^\circ = 2.262 \text{ A}$$

Thus the total vertical component,

$$I_V = -2.927 + 2.262 = -0.665 \text{ A}$$

I_H and I_V are shown in Fig. 16.7, from which,

$$I = \sqrt{2.341^2 + (-0.665)^2} = 2.434 \text{ A}$$

$$\text{Angle } \phi = \tan^{-1} \frac{0.665}{2.341} = 15.86^\circ \text{ lagging}$$

Hence the supply current $I = 2.434$ A lagging V by 15.86°

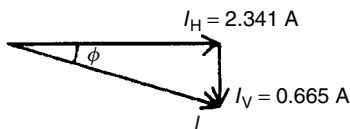

Figure 16.7

(d) Circuit impedance,

$$Z = \frac{V}{I} = \frac{240}{2.434} = 98.60 \Omega$$

(e) Power consumed,

$$\begin{aligned} P &= VI \cos \phi = (240)(2.434) \cos 15.86^\circ \\ &= 562 \text{ W} \end{aligned}$$

$$\begin{aligned} \text{(Alternatively, } P &= I_R^2 R = I_{LR}^2 R \text{ (in this case)} \\ &= (3.748)^2 (40) = 562 \text{ W)} \end{aligned}$$

(f) Apparent power,

$$S = VI = (240)(2.434) = 584.2 \text{ VA}$$

(g) Reactive power,

$$\begin{aligned} Q &= VI \sin \phi = (240)(2.434)(\sin 15.86^\circ) \\ &= 159.6 \text{ var} \end{aligned}$$

Problem 7. A coil of inductance 0.12 H and resistance 3 k Ω is connected in parallel with a 0.02 μ F capacitor and is supplied at 40 V at a frequency of 5 kHz. Determine (a) the current in the coil, and (b) the current in the capacitor. (c) Draw to scale the phasor diagram and measure the supply current and its phase angle; check the answer by calculation. Determine (d) the circuit impedance and (e) the power consumed.

The circuit diagram is shown in Fig. 16.8(a).

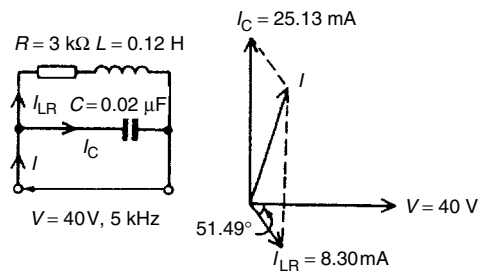

Figure 16.8

(a) Inductive reactance,

$$X_L = 2\pi fL = 2\pi(5000)(0.12) = 3770 \Omega$$

Impedance of coil,

$$\begin{aligned} Z_1 &= \sqrt{R^2 + X_L^2} = \sqrt{3000^2 + 3770^2} \\ &= 4818 \Omega \end{aligned}$$

Current in coil,

$$I_{LR} = \frac{V}{Z_1} = \frac{40}{4818} = 8.30 \text{ mA}$$

Branch phase angle

$$\begin{aligned} \phi &= \tan^{-1} \frac{X_L}{R} = \tan^{-1} \frac{3770}{3000} \\ &= 51.49^\circ \text{ lagging} \end{aligned}$$

(b) Capacitive reactance,

$$X_C = \frac{1}{2\pi f C} = \frac{1}{2\pi(5000)(0.02 \times 10^{-6})}$$

$$= 1592 \Omega$$

Capacitor current,

$$I_C = \frac{V}{X_C} = \frac{40}{1592}$$

$$= \mathbf{25.13 \text{ mA leading } V \text{ by } 90^\circ}$$

(c) Currents I_{LR} and I_C are shown in the phasor diagram of Fig. 16.8(b). The parallelogram is completed as shown and the supply current is given by the diagonal of the parallelogram. The current I is measured as **19.3 mA** leading voltage V by **74.5°**. By calculation,

$$I = \sqrt{(I_{LR} \cos 51.49^\circ)^2 + (I_C - I_{LR} \sin 51.49^\circ)^2}$$

$$= 19.34 \text{ mA}$$

and

$$\phi = \tan^{-1} \left(\frac{I_C - I_{LR} \sin 51.5^\circ}{I_{LR} \cos 51.5^\circ} \right) = 74.50^\circ$$

(d) Circuit impedance,

$$Z = \frac{V}{I} = \frac{40}{19.34 \times 10^{-3}} = \mathbf{2.068 \text{ k}\Omega}$$

(e) Power consumed,

$$P = VI \cos \phi$$

$$= (40)(19.34 \times 10^{-3}) \cos 74.50^\circ$$

$$= \mathbf{206.7 \text{ mW}}$$

$$\text{(Alternatively, } P = I_R^2 R$$

$$= I_{LR}^2 R$$

$$= (8.30 \times 10^{-3})^2 (3000)$$

$$= 206.7 \text{ mW})$$

Now try the following exercise

Exercise 90 Further problems on LR-C parallel a.c. circuit

1 A coil of resistance 60Ω and inductance 318.4 mH is connected in parallel with a

$15 \mu\text{F}$ capacitor across a 200 V , 50 Hz supply. Calculate (a) the current in the coil, (b) the current in the capacitor, (c) the supply current and its phase angle, (d) the circuit impedance, (e) the power consumed, (f) the apparent power and (g) the reactive power. Draw the phasor diagram.

[(a) 1.715 A (b) 0.943 A (c) 1.028 A at 30.90° lagging (d) 194.6Ω (e) 176.5 W (f) 205.6 VA (g) 105.6 var]

2. A 25 nF capacitor is connected in parallel with a coil of resistance $2 \text{ k}\Omega$ and inductance 0.20 H across a 100 V , 4 kHz supply. Determine (a) the current in the coil, (b) the current in the capacitor, (c) the supply current and its phase angle (by drawing a phasor diagram to scale, and also by calculation), (d) the circuit impedance, and (e) the power consumed

[(a) 18.48 mA (b) 62.83 mA (c) 46.17 mA at 81.48° leading (d) $2.166 \text{ k}\Omega$ (e) 0.683 W]

16.6 Parallel resonance and Q -factor

Parallel resonance

Resonance occurs in the two branch network containing capacitance C in parallel with inductance L and resistance R in series (see Fig. 16.5(a)) when the quadrature (i.e. vertical) component of current I_{LR} is equal to I_C . At this condition the supply current I is in-phase with the supply voltage V .

Resonant frequency

When the quadrature component of I_{LR} is equal to I_C then: $I_C = I_{LR} \sin \phi_1$ (see Fig. 16.9). Hence

$$\frac{V}{X_C} = \left(\frac{V}{Z_{LR}} \right) \left(\frac{X_L}{Z_{LR}} \right) \quad (\text{from Section 16.5})$$

from which,

$$Z_{LR}^2 = X_L X_C = (2\pi f_r L) \left(\frac{1}{2\pi f_r C} \right) = \frac{L}{C} \quad (1)$$

Hence

$$\left[\sqrt{R^2 + X_L^2} \right]^2 = \frac{L}{C} \quad \text{and} \quad R^2 + X_L^2 = \frac{L}{C}$$

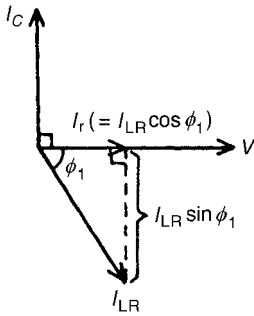

Figure 16.9

Thus $(2\pi f_r L)^2 = \frac{L}{C} - R^2$ and

$$2\pi f_r L = \sqrt{\frac{L}{C} - R^2}$$

and

$$f_r = \frac{1}{2\pi L} \sqrt{\frac{L}{C} - R^2}$$

$$= \frac{1}{2\pi} \sqrt{\frac{L}{L^2 C} - \frac{R^2}{L^2}}$$

i.e. parallel resonant frequency,

$$f_r = \frac{1}{2\pi} \sqrt{\frac{1}{LC} - \frac{R^2}{L^2}}$$

(When R is negligible, then $f_r = \frac{1}{2\pi\sqrt{LC}}$, which is the same as for series resonance)

Current at resonance

Current at resonance,

$$I_r = I_{LR} \cos \phi_1 \quad (\text{from Fig. 16.9})$$

$$= \left(\frac{V}{Z_{LR}} \right) \left(\frac{R}{Z_{LR}} \right) \quad (\text{from Section 16.5})$$

$$= \frac{VR}{Z_{LR}^2}$$

However, from equation (1), $Z_{LR}^2 = L/C$ hence

$$I_r = \frac{VR}{(L/C)} = \frac{VRC}{L} \quad (2)$$

The current is at a **minimum** at resonance.

Dynamic resistance

Since the current at resonance is in-phase with the voltage the impedance of the circuit acts as a resistance. This resistance is known as the **dynamic resistance**, R_D (or sometimes, the dynamic impedance).

From equation (2), impedance at resonance

$$= \frac{V}{I_r} = \frac{V}{\left(\frac{VRC}{L} \right)}$$

$$= \frac{L}{RC}$$

i.e. dynamic resistance,

$$R_D = \frac{L}{RC} \text{ ohms}$$

Rejector circuit

The parallel resonant circuit is often described as a **rejector** circuit since it presents its maximum impedance at the resonant frequency and the resultant current is a minimum.

Q-factor

Currents higher than the supply current can circulate within the parallel branches of a parallel resonant circuit, the current leaving the capacitor and establishing the magnetic field of the inductor, this then collapsing and recharging the capacitor, and so on. The **Q-factor** of a parallel resonant circuit is the ratio of the current circulating in the parallel branches of the circuit to the supply current, i.e. the current magnification.

Q-factor at resonance = current magnification

$$= \frac{\text{circulating current}}{\text{supply current}}$$

$$= \frac{I_C}{I_r} = \frac{I_{LR} \sin \phi_1}{I_r}$$

$$= \frac{I_{LR} \sin \phi_1}{I_{LR} \cos \phi_1}$$

$$= \frac{\sin \phi_1}{\cos \phi_1} = \tan \phi_1$$

$$= \frac{X_L}{R}$$

i.e.
$$Q\text{-factor at resonance} = \frac{2\pi f_r L}{R}$$

(which is the same as for a series circuit).

Note that in a **parallel** circuit the Q -factor is a measure of **current magnification**, whereas in a **series** circuit it is a measure of **voltage magnification**.

At mains frequencies the Q -factor of a parallel circuit is usually low, typically less than 10, but in radio-frequency circuits the Q -factor can be very high.

Problem 8. A pure inductance of 150 mH is connected in parallel with a 40 μ F capacitor across a 50 V, variable frequency supply. Determine (a) the resonant frequency of the circuit and (b) the current circulating in the capacitor and inductance at resonance.

The circuit diagram is shown in Fig. 16.10

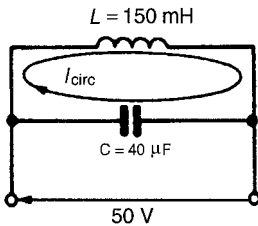

Figure 16.10

(a) Parallel resonant frequency,

$$f_r = \frac{1}{2\pi} \sqrt{\frac{1}{LC} - \frac{R^2}{L^2}}$$

However, resistance $R = 0$, hence,

$$\begin{aligned} f_r &= \frac{1}{2\pi} \sqrt{\frac{1}{LC}} \\ &= \frac{1}{2\pi} \sqrt{\frac{1}{(150 \times 10^{-3})(40 \times 10^{-6})}} \\ &= \frac{1}{2\pi} \sqrt{\frac{10^7}{(15)(4)}} = \frac{10^3}{2\pi} \sqrt{\frac{1}{6}} \\ &= \mathbf{64.97 \text{ Hz}} \end{aligned}$$

(b) Current circulating in L and C at resonance,

$$I_{\text{CIRC}} = \frac{V}{X_C} = \frac{V}{\left(\frac{1}{2\pi f_r C}\right)} = 2\pi f_r C V$$

Hence

$$\begin{aligned} I_{\text{CIRC}} &= 2\pi(64.97)(40 \times 10^{-6})(50) \\ &= \mathbf{0.816 \text{ A}} \end{aligned}$$

(Alternatively,

$$\begin{aligned} I_{\text{CIRC}} &= \frac{V}{X_L} = \frac{V}{2\pi f_r L} = \frac{50}{2\pi(64.97)(0.15)} \\ &= \mathbf{0.817 \text{ A}} \end{aligned}$$

Problem 9. A coil of inductance 0.20 H and resistance 60 Ω is connected in parallel with a 20 μ F capacitor across a 20 V, variable frequency supply. Calculate (a) the resonant frequency, (b) the dynamic resistance, (c) the current at resonance and (d) the circuit Q -factor at resonance.

(a) Parallel resonant frequency,

$$\begin{aligned} f_r &= \frac{1}{2\pi} \sqrt{\frac{1}{LC} - \frac{R^2}{L^2}} \\ &= \frac{1}{2\pi} \sqrt{\frac{1}{(0.20)(20 \times 10^{-6})} - \frac{(60)^2}{(0.20)^2}} \\ &= \frac{1}{2\pi} \sqrt{250000 - 90000} = \frac{1}{2\pi} \sqrt{160000} \\ &= \frac{1}{2\pi} (400) = \mathbf{63.66 \text{ Hz}} \end{aligned}$$

(b) Dynamic resistance,

$$R_D = \frac{L}{RC} = \frac{0.20}{(60)(20 \times 10^{-6})} = \mathbf{166.7 \Omega}$$

(c) Current at resonance,

$$I_r = \frac{V}{R_D} = \frac{20}{166.7} = \mathbf{0.12 \text{ A}}$$

(d) Circuit Q -factor at resonance

$$= \frac{2\pi f_r L}{R} = \frac{2\pi(63.66)(0.20)}{60} = \mathbf{1.33}$$

Alternatively, Q -factor at resonance

= current magnification (for a parallel circuit)

$$= \frac{I_C}{I_r}$$

$$I_C = \frac{V}{X_C} = \frac{V}{\left(\frac{1}{2\pi f_r C}\right)} = 2\pi f_r CV$$

$$= 2\pi(63.66)(20 \times 10^{-6})(20) = 0.16 \text{ A}$$

Hence Q -factor = $I_C/I_r = 0.16/0.12 = 1.33$, as obtained above.

Problem 10. A coil of inductance 100 mH and resistance 800Ω is connected in parallel with a variable capacitor across a 12 V, 5 kHz supply. Determine for the condition when the supply current is a minimum: (a) the capacitance of the capacitor, (b) the dynamic resistance, (c) the supply current, and (d) the Q -factor

- (a) The supply current is a minimum when the parallel circuit is at resonance and resonant frequency,

$$f_r = \frac{1}{2\pi} \sqrt{\frac{1}{LC} - \frac{R^2}{L^2}}$$

Transposing for C gives:

$$(2\pi f_r)^2 = \frac{1}{LC} - \frac{R^2}{L^2}$$

$$(2\pi f_r)^2 + \frac{R^2}{L^2} = \frac{1}{LC}$$

$$\text{and } C = \frac{1}{L \left\{ (2\pi f_r)^2 + \frac{R^2}{L^2} \right\}}$$

When $L = 100 \text{ mH}$, $R = 800 \Omega$ and $f_r = 5000 \text{ Hz}$,

$$C = \frac{1}{100 \times 10^{-3} \left\{ (2\pi(5000))^2 + \frac{800^2}{(100 \times 10^{-3})^2} \right\}}$$

$$= \frac{1}{0.1 \{ \pi^2 10^8 + (0.64)(10^8) \}} \text{ F}$$

$$= \frac{10^6}{0.1(10.51 \times 10^8)} \mu\text{F}$$

$$= \mathbf{0.009515 \mu\text{F}} \text{ or } \mathbf{9.515 \text{ nF}}$$

- (b) Dynamic resistance,

$$R_D = \frac{L}{CR} = \frac{100 \times 10^{-3}}{(9.515 \times 10^{-9})(800)}$$

$$= \mathbf{13.14 \text{ k}\Omega}$$

- (c) Supply current at resonance,

$$I_r = \frac{V}{R_D} = \frac{12}{13.14 \times 10^3} = \mathbf{0.913 \text{ mA}}$$

- (d) Q -factor at resonance

$$= \frac{2\pi f_r L}{R} = \frac{2\pi(5000)(100 \times 10^{-3})}{800} = \mathbf{3.93}$$

Alternatively, Q -factor at resonance

$$= \frac{I_C}{I_r} = \frac{(V/X_C)}{I_r} = \frac{2\pi f_r CV}{I_r}$$

$$= \frac{2\pi(5000)(9.515 \times 10^{-9})(12)}{0.913 \times 10^{-3}} = \mathbf{3.93}$$

Now try the following exercise

Exercise 91 Further problems on parallel resonance and Q -factor

- A $0.15 \mu\text{F}$ capacitor and a pure inductance of 0.01 H are connected in parallel across a 10 V , variable frequency supply. Determine (a) the resonant frequency of the circuit, and (b) the current circulating in the capacitor and inductance. [(a) 4.11 kHz (b) 38.73 mA]
- A $30 \mu\text{F}$ capacitor is connected in parallel with a coil of inductance 50 mH and unknown resistance R across a 120 V , 50 Hz supply. If the circuit has an overall power factor of 1 find (a) the value of R , (b) the current in the coil, and (c) the supply current. [(a) 37.7Ω (b) 2.94 A (c) 2.714 A]
- A coil of resistance 25Ω and inductance 150 mH is connected in parallel with a $10 \mu\text{F}$ capacitor across a 60 V , variable frequency

supply. Calculate (a) the resonant frequency, (b) the dynamic resistance, (c) the current at resonance and (d) the Q -factor at resonance.

[(a) 127.2 Hz (b) 600 Ω (c) 0.10 A (d) 4.80]

4 A coil having resistance R and inductance 80 mH is connected in parallel with a 5 nF capacitor across a 25 V, 3 kHz supply. Determine for the condition when the current is a minimum, (a) the resistance R of the coil, (b) the dynamic resistance, (c) the supply current, and (d) the Q -factor.

[(a) 3.705 k Ω (b) 4.318 k Ω (c) 5.79 mA (d) 0.41]

5 A coil of resistance 1.5 k Ω and 0.25 H inductance is connected in parallel with a variable capacitance across a 10 V, 8 kHz supply. Calculate (a) the capacitance of the capacitor when the supply current is a minimum, (b) the dynamic resistance, and (c) the supply current.

[(a) 1561 pF (b) 106.8 k Ω (c) 93.66 μ A]

16.7 Power factor improvement

For a particular power supplied, a high power factor reduces the current flowing in a supply system and therefore reduces the cost of cables, switch-gear, transformers and generators. Supply authorities use tariffs which encourage electricity consumers to operate at a reasonably high power factor. Industrial loads such as a.c. motors are essentially inductive ($R-L$) and may have a low power factor. One method of improving (or correcting) the power factor of an inductive load is to connect a static capacitor C in parallel with the load (see Fig. 16.11(a)). The supply current is reduced from I_{LR} to I , the phasor sum of I_{LR} and I_C , and the circuit power factor improves from $\cos \phi_1$ to $\cos \phi_2$ (see Fig. 16.11(b)).

Problem 11. A single-phase motor takes 50 A at a power factor of 0.6 lagging from a 240 V, 50 Hz supply. Determine (a) the current taken by a capacitor connected in parallel with the motor to correct the power factor to unity, and (b) the value of the supply current after power factor correction.

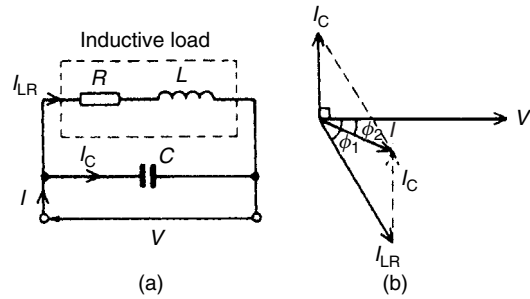

Figure 16.11

The circuit diagram is shown in Fig. 16.12(a).

(a) A power factor of 0.6 lagging means that $\cos \phi = 0.6$ i.e.

$$\phi = \cos^{-1} 0.6 = 53.13^\circ$$

Hence I_M lags V by 53.13° as shown in Fig. 16.12(b).

If the power factor is to be improved to unity then the phase difference between supply current I and voltage V needs to be 0° , i.e. I is in phase with V as shown in Fig. 16.12(c). For this to be so, I_C must equal the length ab , such that the phasor sum of I_M and I_C is I .

$$ab = I_M \sin 53.13^\circ = 50(0.8) = 40 \text{ A}$$

Hence the capacitor current I_c must be 40 A for the power factor to be unity.

(b) Supply current $I = I_M \cos 53.13^\circ = 50(0.6) = 30 \text{ A}$.

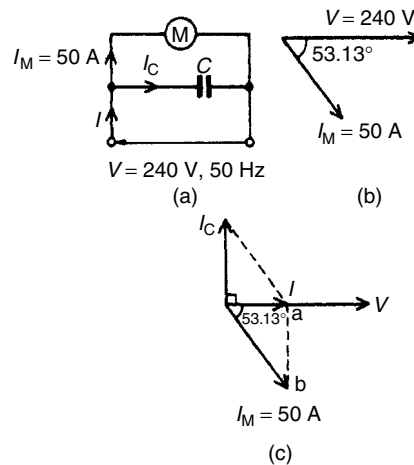

Figure 16.12

Problem 12. A 400 V alternator is supplying a load of 42 kW at a power factor of 0.7 lagging. Calculate (a) the kVA loading and (b) the current taken from the alternator. (c) If the power factor is now raised to unity find the new kVA loading.

(a) Power = $VI \cos \phi = (VI)$ (power factor)

$$\text{Hence } VI = \frac{\text{power}}{\text{p.f.}} = \frac{42 \times 10^3}{0.7} = \mathbf{60 \text{ kVA}}$$

(b) $VI = 60000 \text{ VA}$

$$\text{hence } I = \frac{60000}{V} = \frac{60000}{400} = \mathbf{150 \text{ A}}$$

(c) The kVA loading remains at **60 kVA** irrespective of changes in power factor.

Problem 13. A motor has an output of 4.8 kW, an efficiency of 80% and a power factor of 0.625 lagging when operated from a 240 V, 50 Hz supply. It is required to improve the power factor to 0.95 lagging by connecting a capacitor in parallel with the motor. Determine (a) the current taken by the motor, (b) the supply current after power factor correction, (c) the current taken by the capacitor, (d) the capacitance of the capacitor, and (e) the kvar rating of the capacitor.

(a) Efficiency = $\frac{\text{power output}}{\text{power input}}$

$$\text{hence } \frac{80}{100} = \frac{4800}{\text{power input}}$$

$$\text{and power input} = \frac{4800}{0.8} = 6000 \text{ W}$$

Hence, $6000 = VI_M \cos \phi = (240)(I_M)(0.625)$, since $\cos \phi = \text{p.f.} = 0.625$. Thus current taken by the motor,

$$I_M = \frac{6000}{(240)(0.625)} = \mathbf{40 \text{ A}}$$

The circuit diagram is shown in Fig. 16.13(a). The phase angle between I_M and V is given by: $\phi = \cos^{-1} 0.625 = 51.32^\circ$, hence the phasor diagram is as shown in Fig. 16.13(b).

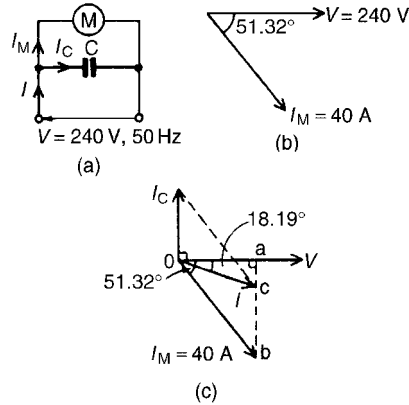

Figure 16.13

(b) When a capacitor C is connected in parallel with the motor a current I_C flows which leads V by 90° . The phasor sum of I_M and I_C gives the supply current I , and has to be such as to change the circuit power factor to 0.95 lagging, i.e. a phase angle of $\cos^{-1} 0.95$ or 18.19° lagging, as shown in Fig. 16.13(c). The horizontal component of I_M (shown as oa)

$$\begin{aligned} &= I_M \cos 51.32^\circ \\ &= 40 \cos 51.32^\circ = 25 \text{ A} \end{aligned}$$

The horizontal component of I (also given by oa)

$$\begin{aligned} &= I \cos 18.19^\circ \\ &= 0.95 I \end{aligned}$$

Equating the horizontal components gives: $25 = 0.95 I$. Hence the supply current after p.f. correction,

$$I = \frac{25}{0.95} = \mathbf{26.32 \text{ A}}$$

(c) The vertical component of I_M (shown as ab)

$$\begin{aligned} &= I_M \sin 51.32^\circ \\ &= 40 \sin 51.32^\circ = 31.22 \text{ A} \end{aligned}$$

The vertical component of I (shown as ac)

$$\begin{aligned} &= I \sin 18.19^\circ \\ &= 26.32 \sin 18.19^\circ = 8.22 \text{ A} \end{aligned}$$

The magnitude of the capacitor current I_C (shown as bc) is given by

$$ab - ac \quad \text{i.e.} \quad I_C = 31.22 - 8.22 = \mathbf{23 \text{ A}}$$

(d) Current $I_C = \frac{V}{X_C} = \frac{V}{\left(\frac{1}{2\pi f C}\right)} = 2\pi f CV$

from which

$$C = \frac{I_C}{2\pi f V} = \frac{23}{2\pi(50)(240)} F = \mathbf{305 \mu F}$$

(e) **kvar rating** of the capacitor

$$= \frac{VI_C}{1000} = \frac{(240)(23)}{1000} = \mathbf{5.52 \text{ kvar}}$$

In this problem the supply current has been reduced from 40 A to 26.32 A without altering the current or power taken by the motor. This means that the size of generating plant and the cross-sectional area of conductors supplying both the factory and the motor can be less – with an obvious saving in cost.

Problem 14. A 250 V, 50 Hz single-phase supply feeds the following loads
 (i) incandescent lamps taking a current of 10 A at unity power factor, (ii) fluorescent lamps taking 8 A at a power factor of 0.7 lagging, (iii) a 3 kVA motor operating at full load and at a power factor of 0.8 lagging and (iv) a static capacitor. Determine, for the lamps and motor, (a) the total current, (b) the overall power factor and (c) the total power. (d) Find the value of the static capacitor to improve the overall power factor to 0.975 lagging.

A phasor diagram is constructed as shown in Fig. 16.14(a), where 8 A is lagging voltage V by $\cos^{-1} 0.7$, i.e. 45.57° , and the motor current is $(3000/250)$, i.e. 12 A lagging V by $\cos^{-1} 0.8$, i.e. 36.87°

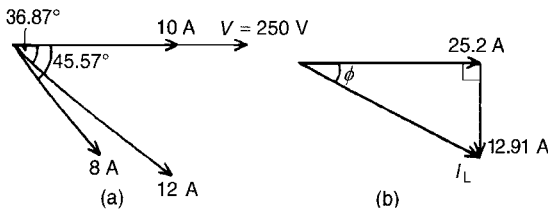

Figure 16.14

(a) The horizontal component of the currents

$$= 10 \cos 0^\circ + 12 \cos 36.87^\circ + 8 \cos 45.57^\circ$$

$$= 10 + 9.6 + 5.6 = 25.2 \text{ A}$$

The vertical component of the currents

$$= 10 \sin 0^\circ + 12 \sin 36.87^\circ + 8 \sin 45.57^\circ$$

$$= 0 + 7.2 + 5.713 = 12.91 \text{ A}$$

From Fig. 16.14(b), total current,

$$I_L = \sqrt{25.2^2 + 12.91^2} = \mathbf{28.31 \text{ A}}$$

at a phase angle of $\phi = \tan^{-1}(12.91/25.2)$ i.e. 27.13° lagging.

(b) Power factor

$$= \cos \phi = \cos 27.13^\circ = \mathbf{0.890 \text{ lagging}}$$

(c) Total power,

$$P = VI_L \cos \phi = (250)(28.31)(0.890)$$

$$= \mathbf{6.3 \text{ kW}}$$

(d) To improve the power factor, a capacitor is connected in parallel with the loads. The capacitor takes a current I_C such that the supply current falls from 28.31 A to I , lagging V by $\cos^{-1} 0.975$, i.e. 12.84° . The phasor diagram is shown in Fig. 16.15

$$oa = 28.31 \cos 27.13^\circ = I \cos 12.84^\circ$$

$$\text{hence } I = \frac{28.31 \cos 27.13^\circ}{\cos 12.84^\circ} = 25.84 \text{ A}$$

$$\text{Current } I_C = bc = (ab - ac)$$

$$= 28.31 \sin 27.13^\circ - 25.84 \sin 12.84^\circ$$

$$= 12.91 - 5.742 = 7.168 \text{ A}$$

$$I_C = \frac{V}{X_C} = \frac{V}{\left(\frac{1}{2\pi f C}\right)} = 2\pi f CV$$

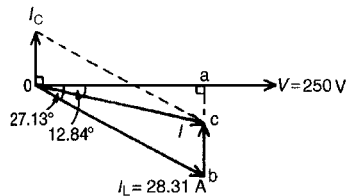

Figure 16.15

Hence capacitance

$$C = \frac{I_C}{2\pi f V} = \frac{7.168}{2\pi(50)(250)} F = \mathbf{91.27 \mu F}$$

Thus to improve the power factor from 0.890 to 0.975 lagging a $91.27 \mu F$ capacitor is connected in parallel with the loads.

Now try the following exercises

Exercise 92 Further problems on power factor improvement

1 A 415 V alternator is supplying a load of 55 kW at a power factor of 0.65 lagging. Calculate (a) the kVA loading and (b) the current taken from the alternator. (c) If the power factor is now raised to unity find the new kVA loading.

[(a) 84.6 kVA (b) 203.9 A (c) 84.6 kVA]

2 A single phase motor takes 30 A at a power factor of 0.65 lagging from a 240 V, 50 Hz supply. Determine (a) the current taken by the capacitor connected in parallel to correct the power factor to unity, and (b) the value of the supply current after power factor correction.

[(a) 22.80 A (b) 19.5 A]

3 A motor has an output of 6 kW, an efficiency of 75% and a power factor of 0.64 lagging when operated from a 250 V, 60 Hz supply. It is required to raise the power factor to 0.925 lagging by connecting a capacitor in parallel with the motor. Determine (a) the current taken by the motor, (b) the supply current after power factor correction, (c) the current taken by the capacitor, (d) the capacitance of the capacitor and (e) the kvar rating of the capacitor.

[(a) 50 A (b) 34.59 A (c) 25.28 A (d) 268.2 μ F (e) 6.32 kvar]

4 A supply of 250 V, 80 Hz is connected across an inductive load and the power consumed is 2 kW, when the supply current is 10 A. Determine the resistance and inductance of the circuit. What value of capacitance connected in parallel with the load is needed to improve the overall power factor to unity?

[$R = 20 \Omega$, $L = 29.84$ mH, $C = 47.75 \mu$ F]

5 A 200 V, 50 Hz single-phase supply feeds the following loads: (i) fluorescent lamps taking a current of 8 A at a power factor of 0.9 leading, (ii) incandescent lamps taking a current of 6 A at unity power factor, (iii) a motor taking a current of 12 A at a power factor of 0.65 lagging. Determine the total current taken from the supply and the overall power factor. Find also the value of a static capacitor connected

in parallel with the loads to improve the overall power factor to 0.98 lagging.

[21.74 A, 0.966 lagging, 21.68 μ F]

Exercise 93 Short answer questions on single-phase parallel a.c. circuits

1 Draw a phasor diagram for a two-branch parallel circuit containing capacitance C in one branch and resistance R in the other, connected across a supply voltage V

2 Draw a phasor diagram for a two-branch parallel circuit containing inductance L and resistance R in one branch and capacitance C in the other, connected across a supply voltage V

3 Draw a phasor diagram for a two-branch parallel circuit containing inductance L in one branch and capacitance C in the other for the condition in which inductive reactance is greater than capacitive reactance

4 State two methods of determining the phasor sum of two currents

5 State two formulae which may be used to calculate power in a parallel circuit

6 State the condition for resonance for a two-branch circuit containing capacitance C in parallel with a coil of inductance L and resistance R

7 Develop a formula for the resonant frequency in an $LR-C$ parallel circuit, in terms of resistance R , inductance L and capacitance C

8 What does Q -factor of a parallel circuit mean?

9 Develop a formula for the current at resonance in an $LR-C$ parallel circuit in terms of resistance R , inductance L , capacitance C and supply voltage V

10 What is dynamic resistance? State a formula for dynamic resistance

11 Explain a simple method of improving the power factor of an inductive circuit

12 Why is it advantageous to improve power factor?

Exercise 94 Multi-choice questions on single-phase parallel a.c. circuits (Answers on page 376)

A two-branch parallel circuit containing a $10\ \Omega$ resistance in one branch and a $100\ \mu\text{F}$ capacitor in the other, has a $120\ \text{V}$, $2/3\pi\ \text{kHz}$ supply connected across it. Determine the quantities stated in questions 1 to 8, selecting the correct answer from the following list:

- | | |
|-------------------------------------|-------------------------------------|
| (a) 24 A | (b) 6 Ω |
| (c) 7.5 k Ω | (d) 12 A |
| (e) $\tan^{-1} \frac{3}{4}$ leading | (f) 0.8 leading |
| (g) 7.5 Ω | (h) $\tan^{-1} \frac{4}{3}$ leading |
| (i) 16 A | (j) $\tan^{-1} \frac{5}{3}$ lagging |
| (k) 1.44 kW | (l) 0.6 leading |
| (m) 12.5 Ω | (n) 2.4 kW |
| (o) $\tan^{-1} \frac{4}{3}$ lagging | (p) 0.6 lagging |
| (q) 0.8 lagging | (r) 1.92 kW |
| (s) 20 A | |

- The current flowing in the resistance
 - The capacitive reactance of the capacitor
 - The current flowing in the capacitor
 - The supply current
 - The supply phase angle
 - The circuit impedance
 - The power consumed by the circuit
 - The power factor of the circuit
- 9 A two-branch parallel circuit consists of a $15\ \text{mH}$ inductance in one branch and a $50\ \mu\text{F}$ capacitor in the other across a $120\ \text{V}$, $1/\pi\ \text{kHz}$ supply. The supply current is:
- | |
|---|
| (a) 8 A leading by $\frac{\pi}{2}$ rad |
| (b) 16 A lagging by 90° |
| (c) 8 A lagging by 90° |
| (d) 16 A leading by $\frac{\pi}{2}$ rad |

- 10 The following statements, taken correct to 2 significant figures, refer to the circuit shown in Fig. 16.16. Which are false?

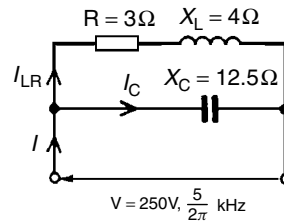

Figure 16.16

- | |
|--|
| (a) The impedance of the $R-L$ branch is 5 Ω |
| (b) $I_{LR} = 50\ \text{A}$ |
| (c) $I_C = 20\ \text{A}$ |
| (d) $L = 0.80\ \text{H}$ |
| (e) $C = 16\ \mu\text{F}$ |
| (f) The 'in-phase' component of the supply current is 30 A |
| (g) The 'quadrature' component of the supply current is 40 A |
| (h) $I = 36\ \text{A}$ |
| (i) Circuit phase angle = $33^\circ 41'$ leading |
| (j) Circuit impedance = 6.9 Ω |
| (k) Circuit power factor = 0.83 lagging |
| (l) Power consumed = 9.0 kW |
- 11 Which of the following statements is false?
- | |
|---|
| (a) The supply current is a minimum at resonance in a parallel circuit |
| (b) The Q -factor at resonance in a parallel circuit is the voltage magnification |
| (c) Improving power factor reduces the current flowing through a system |
| (d) The circuit impedance is a maximum at resonance in a parallel circuit |
- 12 An $LR-C$ parallel circuit has the following component values: $R = 10\ \Omega$, $L = 10\ \text{mH}$, $C = 10\ \mu\text{F}$ and $V = 100\ \text{V}$. Which of the following statements is false?
- | |
|---|
| (a) The resonant frequency f_r is $1.5/\pi\ \text{kHz}$ |
| (b) The current at resonance is 1 A |
| (c) The dynamic resistance is $100\ \Omega$ |
| (d) The circuit Q -factor at resonance is 30 |
- 13 The magnitude of the impedance of the circuit shown in Fig. 16.17 is:
- | | |
|------------------|-------------------|
| (a) 7 Ω | (b) 5 Ω |
| (c) 2.4 Ω | (d) 1.71 Ω |

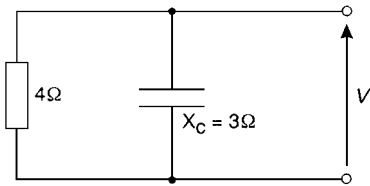

Figure 16.17

14 In the circuit shown in Fig. 16.18, the magnitude of the supply current I is:

- (a) 17 A (b) 7 A
 (c) 15 A (d) 23 A

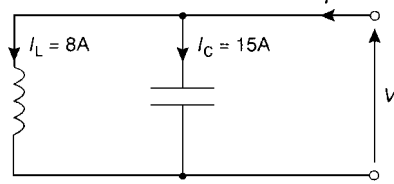

Figure 16.18

Filter networks

At the end of this chapter you should be able to:

- appreciate the purpose of a filter network
- understand basic types of filter sections, i.e. low-pass, high-pass, band-pass and band-stop filters
- define cut-off frequency, two-port networks and characteristic impedance
- design low- and high-pass filter sections given nominal impedance and cut-off frequency
- determine the values of components comprising a band-pass filter given cut-off frequencies
- appreciate the difference between ideal and practical filter characteristics

17.1 Introduction

Attenuation is a reduction or loss in the magnitude of a voltage or current due to its transmission over a line.

A **filter** is a network designed to pass signals having frequencies within certain bands (called **passbands**) with little attenuation, but greatly attenuates signals within other bands (called **attenuation bands** or **stopbands**).

A filter is frequency sensitive and is thus composed of reactive elements. Since certain frequencies are to be passed with minimal loss, ideally the inductors and capacitors need to be pure components since the presence of resistance results in some attenuation at all frequencies.

Between the pass band of a filter, where ideally the attenuation is zero, and the attenuation band, where ideally the attenuation is infinite, is the **cut-off frequency**, this being the frequency at which the attenuation changes from zero to some finite value.

A filter network containing no source of power is termed **passive**, and one containing one or more power sources is known as an **active** filter network.

Filters are used for a variety of purposes in nearly every type of electronic communications and

control equipment. The bandwidths of filters used in communications systems vary from a fraction of a hertz to many megahertz, depending on the application.

There are four basic types of filter sections:

- (a) low-pass
- (b) high-pass
- (c) band-pass
- (d) band-stop

17.2 Two-port networks and characteristic impedance

Networks in which electrical energy is fed in at one pair of terminals and taken out at a second pair of terminals are called **two-port networks**. The network between the input port and the output port is a transmission network for which a known relationship exists between the input and output currents and voltages.

Figure 17.1(a) shows a **T-network**, which is termed **symmetrical** if $Z_A = Z_B$, and Figure 17.1(b) shows a **π -network** which is symmetrical if $Z_E = Z_F$.

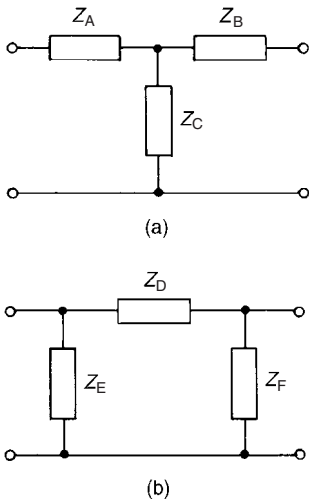

Figure 17.1

If $Z_A \neq Z_B$ in Figure 17.1(a) and $Z_E \neq Z_F$ in Figure 17.1(b), the sections are termed **asymmetrical**. Both networks shown have one common terminal, which may be earthed, and are therefore said to be **unbalanced**. The **balanced** form of the T-network is shown in Figure 17.2(a) and the balanced form of the π -network is shown in Figure 17.2(b).

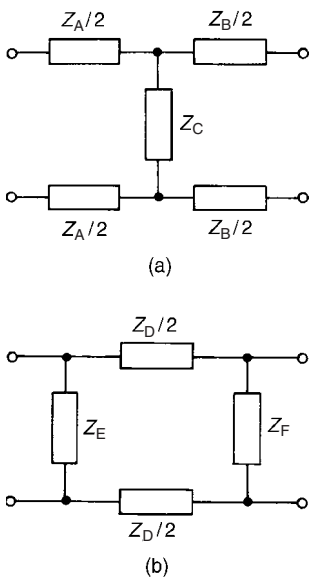

Figure 17.2

The input impedance of a network is the ratio of voltage to current at the input terminals. With a two-port network the input impedance often varies

according to the load impedance across the output terminals. For any passive two-port network it is found that a particular value of load impedance can always be found which will produce an input impedance having the same value as the load impedance. This is called the **iterative impedance** for an asymmetrical network and its value depends on which pair of terminals is taken to be the input and which the output (there are thus two values of iterative impedance, one for each direction).

For a symmetrical network there is only one value for the iterative impedance and this is called the **characteristic impedance** Z_0 of the symmetrical two-port network.

17.3 Low-pass filters

Figure 17.3 shows simple unbalanced T- and π -section filters using series inductors and shunt capacitors. If either section is connected into a network and a continuously increasing frequency is applied, each would have a frequency-attenuation characteristic as shown in Figure 17.4. This is an ideal characteristic and assumes pure reactive elements. All frequencies are seen to be passed from zero up to a certain value without attenuation, this value being shown as f_c , the cut-off frequency; all values of frequency above f_c are attenuated. It is for this reason that the networks shown in Figures 17.3(a) and (b) are known as **low-pass filters**.

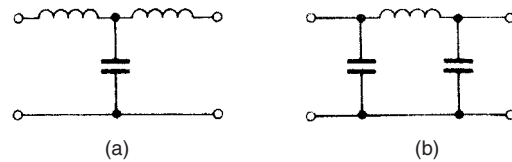

Figure 17.3

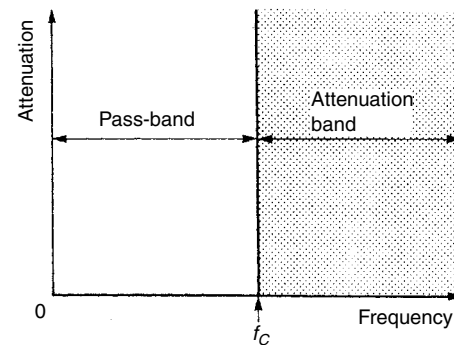

Figure 17.4

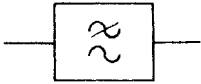

Figure 17.5

The electrical circuit diagram symbol for a low-pass filter is shown in Figure 17.5.

Summarising, a **low-pass filter is one designed to pass signals at frequencies below a specified cut-off frequency.**

In practise, the characteristic curve of a low-pass prototype filter section looks more like that shown in Figure 17.6. The characteristic may be improved somewhat closer to the ideal by connecting two or more identical sections in cascade. This produces a much sharper cut-off characteristic, although the attenuation in the pass band is increased a little.

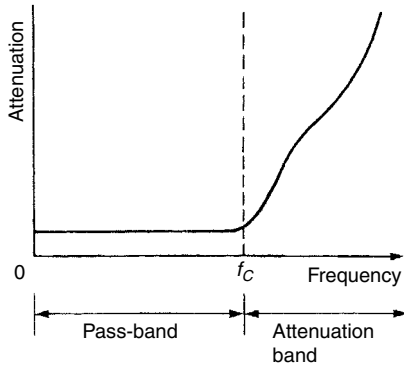

Figure 17.6

When rectifiers are used to produce the d.c. supplies of electronic systems, a large ripple introduces undesirable noise and may even mask the effect of the signal voltage. Low-pass filters are added to smooth the output voltage waveform, this being one of the most common applications of filters in electrical circuits.

Filters are employed to isolate various sections of a complete system and thus to prevent undesired interactions. For example, the insertion of low-pass decoupling filters between each of several amplifier stages and a common power supply reduces interaction due to the common power supply impedance.

Cut-off frequency and nominal impedance calculations

A low-pass symmetrical T-network and a low-pass symmetrical π -network are shown in Figure 17.7. It

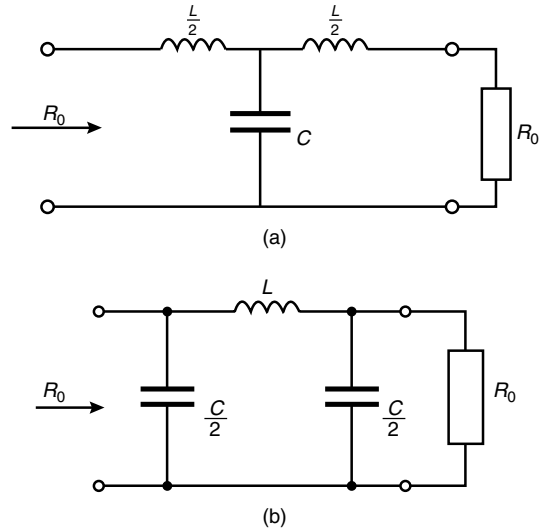

Figure 17.7

may be shown that the cut-off frequency, f_c , for each section is the same, and is given by:

$$f_c = \frac{1}{\pi\sqrt{LC}} \tag{1}$$

When the frequency is very low, the characteristic impedance is purely resistive. This value of characteristic impedance is known as the **design impedance** or the **nominal impedance** of the section and is often given the symbol R_0 , where

$$R_0 = \sqrt{\frac{L}{C}} \tag{2}$$

Problem 1. Determine the cut-off frequency and the nominal impedance for the low-pass T-connected section shown in Figure 17.8.

Figure 17.8

Comparing Figure 17.8 with the low-pass section of Figure 17.7(a), shows that:

$$\frac{L}{2} = 100 \text{ mH},$$

i.e. inductance, $L = 200 \text{ mH} = 0.2 \text{ H}$,
and capacitance $C = 0.2 \mu\text{F} = 0.2 \times 10^{-6} \text{ F}$.

From equation (1), **cut-off frequency**,

$$f_c = \frac{1}{\pi\sqrt{LC}} = \frac{1}{\pi\sqrt{(0.2 \times 0.2 \times 10^{-6})}} = \frac{10^3}{\pi(0.2)}$$

i.e. $f_c = 1592 \text{ Hz}$ or 1.592 kHz

From equation (2), **nominal impedance**,

$$R_0 = \sqrt{\frac{L}{C}} = \sqrt{\frac{0.2}{0.2 \times 10^{-6}}} = 1000 \Omega \text{ or } 1 \text{ k}\Omega$$

Problem 2. Determine the cut-off frequency and the nominal impedance for the low-pass π -connected section shown in Figure 17.9.

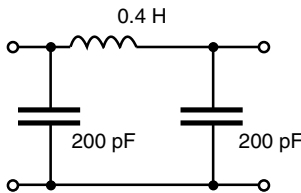

Figure 17.9

Comparing Figure 17.9 with the low-pass section of Figure 17.7(b), shows that:

$$\frac{C}{2} = 200 \text{ pF},$$

i.e. capacitance, $C = 400 \text{ pF} = 400 \times 10^{-12} \text{ F}$,
and inductance $L = 0.4 \text{ H}$.

From equation (1), **cut-off frequency**,

$$f_c = \frac{1}{\pi\sqrt{LC}} = \frac{1}{\pi\sqrt{(0.4 \times 400 \times 10^{-12})}} = \frac{10^6}{\pi\sqrt{160}}$$

i.e. $f_c = 25.16 \text{ kHz}$

From equation (2), **nominal impedance**,

$$R_0 = \sqrt{\frac{L}{C}} = \sqrt{\frac{0.4}{400 \times 10^{-12}}} = 31.62 \text{ k}\Omega$$

To determine values of L and C given R_0 and f_c

If the values of the nominal impedance R_0 and the cut-off frequency f_c are known for a low-pass T- or π -section, it is possible to determine the values of inductance and capacitance required to form the section. It may be shown that:

$$\text{capacitance } C = \frac{1}{\pi R_0 f_c} \quad (3)$$

and

$$\text{inductance } L = \frac{R_0}{\pi f_c} \quad (4)$$

Problem 3. A filter section is to have a characteristic impedance at zero frequency of 600Ω and a cut-off frequency of 5 MHz . Design (a) a low-pass T-section filter, and (b) a low-pass π -section filter to meet these requirements.

The characteristic impedance at zero frequency is the nominal impedance R_0 , i.e. $R_0 = 600 \Omega$; cut-off frequency $f_c = 5 \text{ MHz} = 5 \times 10^6 \text{ Hz}$.

From equation (3), capacitance,

$$C = \frac{1}{\pi R_0 f_c} = \frac{1}{\pi(600)(5 \times 10^6)} \text{ F} = 1.06 \times 10^{-10} \text{ F} = 106 \text{ pF}$$

From equation (4), inductance,

$$L = \frac{R_0}{\pi f_c} = \frac{600}{\pi(5 \times 10^6)} \text{ H} = 3.82 \times 10^{-5} = 38.2 \mu\text{H}$$

(a) A low-pass T-section filter is shown in Figure 17.10(a), where the series arm inductances are each $\frac{L}{2}$ (see Figure 17.7(a)), i.e. $\frac{38.2}{2} = 19.1 \mu\text{H}$

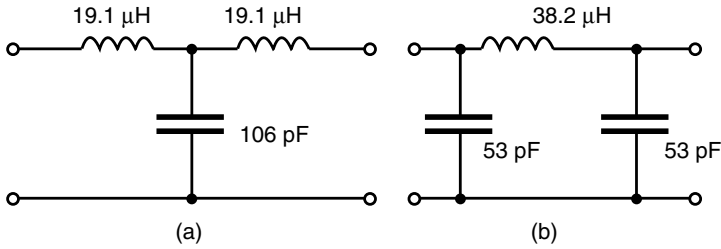

Figure 17.10

(b) A low-pass π -section filter is shown in Figure 17.10(b), where the shunt arm capacitances are each $\frac{C}{2}$ (see Figure 17.7(b)), i.e. $\frac{106}{2} = 53 \text{ pF}$

Now try the following exercise

Exercise 95 Further problems on low-pass filter sections

- Determine the cut-off frequency and the nominal impedance of each of the low-pass filter sections shown in Figure 17.11.
[(a) 1592 Hz; 5 k Ω (b) 9545 Hz; 600 Ω]

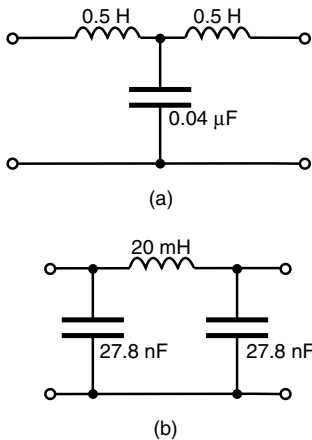

Figure 17.11

- A filter section is to have a characteristic impedance at zero frequency of 500 Ω and a cut-off frequency of 1 kHz. Design (a) a

low-pass T-section filter, and (b) a low-pass π -section filter to meet these requirements.

[(a) Each series arm 79.6 mH, shunt arm 0.637 μF

(b) Series arm 159 mH, each shunt arm 0.318 μF]

- Determine the value of capacitance required in the shunt arm of a low-pass T-section if the inductance in each of the series arms is 40 mH and the cut-off frequency of the filter is 2.5 kHz. [0.203 μF]
- The nominal impedance of a low-pass π -section filter is 600 Ω . If the capacitance in each of the shunt arms is 0.1 μF determine the inductance in the series arm. [72 mH]

17.4 High-pass filters

Figure 17.12 shows simple unbalanced T- and π -section filters using series capacitors and shunt inductors. If either section is connected into a network and a continuously increasing frequency is applied, each would have a frequency-attenuation characteristic as shown in Figure 17.13.

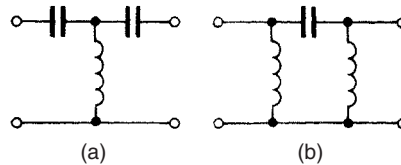

Figure 17.12

Once again this is an ideal characteristic assuming pure reactive elements. All frequencies below the cut-off frequency f_c are seen to be attenuated and all frequencies above f_c are passed without loss.

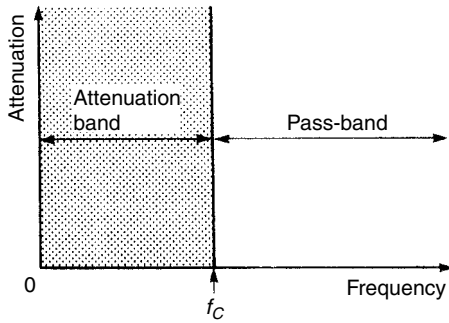

Figure 17.13

It is for this reason that the networks shown in Figures 17.12(a) and (b) are known as **high-pass filters**.

The electrical circuit diagram symbol for a high-pass filter is shown in Figure 17.14.

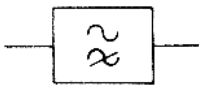

Figure 17.14

Summarising, a **high-pass filter is one designed to pass signals at frequencies above a specified cut-off frequency.**

The characteristic shown in Figures 17.13 is ideal in that it is assumed that there is no attenuation at all in the pass-bands and infinite attenuation in the attenuation band. Both of these conditions are impossible to achieve in practice. Due to resistance, mainly in the inductive elements the attenuation in the pass-band will not be zero, and in a practical filter section the attenuation in the attenuation band will have a finite value. In addition to the resistive loss there is often an added loss due to mismatching.

Ideally when a filter is inserted into a network it is matched to the impedance of that network. However the characteristic impedance of a filter section will vary with frequency and the termination of the section may be an impedance that does not vary with frequency in the same way.

Figure 17.13 showed an ideal high-pass filter section characteristic of attenuation against frequency. In practise, the characteristic curve of a high-pass prototype filter section would look more like that shown in Figure 17.15.

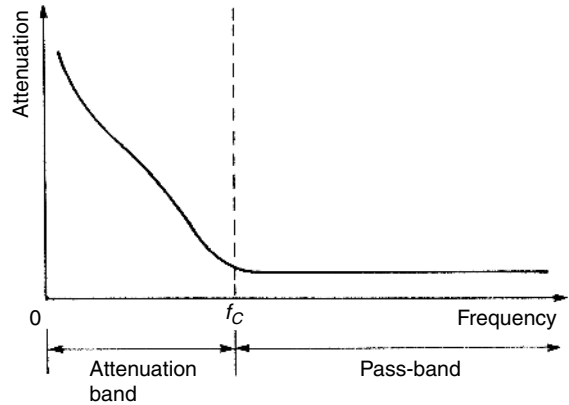

Figure 17.15

Cut-off frequency and nominal impedance calculations

A high-pass symmetrical T-network and a high-pass symmetrical π -network are shown in Figure 17.16. It may be shown that the cut-off frequency, f_c , for each section is the same, and is given by:

$$f_c = \frac{1}{4\pi\sqrt{LC}} \tag{5}$$

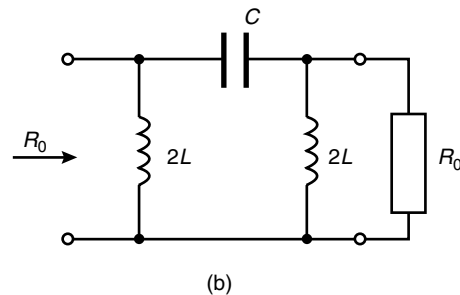
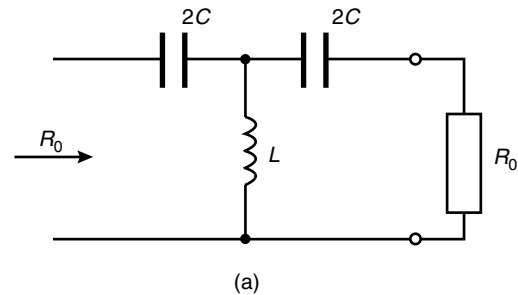

Figure 17.16

When the frequency is very high, the characteristic impedance is purely resistive. This value of characteristic impedance is then the **nominal impedance** of the section and is given by:

$$R_0 = \sqrt{\frac{L}{C}} \tag{6}$$

Problem 4. Determine the cut-off frequency and the nominal impedance for the high-pass T-connected section shown in Figure 17.17.

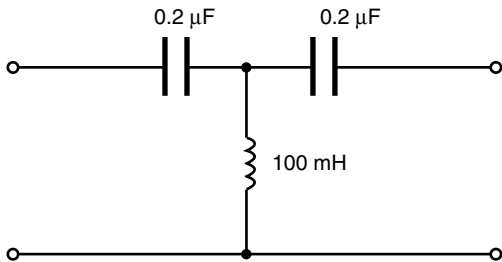

Figure 17.17

Comparing Figure 17.17 with the high-pass section of Figure 17.16(a), shows that:

$$2C = 0.2 \mu\text{F},$$

i.e. capacitance, $C = 0.1 \mu\text{F} = 0.1 \times 10^{-6}$,

and inductance, $L = 100 \text{ mH} = 0.1 \text{ H}$.

From equation (5), **cut-off frequency**,

$$f_c = \frac{1}{4\pi\sqrt{LC}} = \frac{1}{4\pi\sqrt{(0.1 \times 0.1 \times 10^{-6})}} = \frac{10^3}{4\pi(0.1)}$$

i.e. $f_c = 796 \text{ Hz}$

From equation (6), **nominal impedance**,

$$R_0 = \sqrt{\frac{L}{C}} = \sqrt{\frac{0.1}{0.1 \times 10^{-6}}} = 1000 \Omega \text{ or } 1 \text{ k}\Omega$$

Problem 5. Determine the cut-off frequency and the nominal impedance for the high-pass π -connected section shown in Figure 17.18.

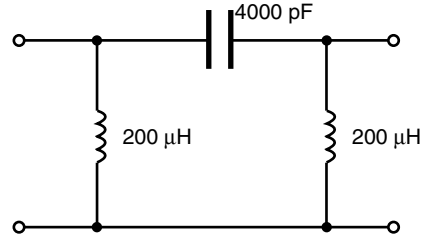

Figure 17.18

Comparing Figure 17.18 with the high-pass section of Figure 17.16(b), shows that:

$$2L = 200 \mu\text{H},$$

i.e. inductance, $L = 100 \mu\text{H} = 10^{-4} \text{ H}$,

and capacitance, $C = 4000 \text{ pF} = 4 \times 10^{-9} \text{ F}$.

From equation (5), **cut-off frequency**,

$$f_c = \frac{1}{4\pi\sqrt{LC}} = \frac{1}{4\pi\sqrt{(10^{-4} \times 4 \times 10^{-9})}} = 1.26 \times 10^5$$

i.e. $f_c = 126 \text{ kHz}$

From equation (6), **nominal impedance**,

$$R_0 = \sqrt{\frac{L}{C}} = \sqrt{\frac{10^{-4}}{4 \times 10^{-9}}} = \sqrt{\frac{10^5}{4}} = 158 \Omega$$

To determine values of L and C given R_0 and f_c

If the values of the nominal impedance R_0 and the cut-off frequency f_c are known for a high-pass T- or π -section, it is possible to determine the values of inductance and capacitance required to form the section. It may be shown that:

$$\text{capacitance } C = \frac{1}{4\pi R_0 f_c} \tag{7}$$

and

$$\text{inductance } L = \frac{R_0}{4\pi f_c} \quad (8)$$

Problem 6. A filter section is required to pass all frequencies above 25 kHz and to have a nominal impedance of 600 Ω. Design (a) a high-pass T-section filter, and (b) a high-pass π-section filter to meet these requirements.

Cut-off frequency $f_c = 25 \text{ kHz} = 25 \times 10^3 \text{ Hz}$, and nominal impedance, $R_0 = 600 \text{ }\Omega$.

From equation (7), capacitance,

$$\begin{aligned} C &= \frac{1}{4\pi R_0 f_c} = \frac{1}{4\pi(600)(25 \times 10^3)} \text{ F} \\ &= \frac{10^{12}}{4\pi(600)(25 \times 10^3)} \text{ pF} \\ &= 5305 \text{ pF or } 5.305 \text{ nF} \end{aligned}$$

From equation (8), inductance,

$$\begin{aligned} L &= \frac{R_0}{4\pi f_c} = \frac{600}{4\pi(25 \times 10^3)} \\ &= 0.00191 \text{ H} = 1.91 \text{ mH} \end{aligned}$$

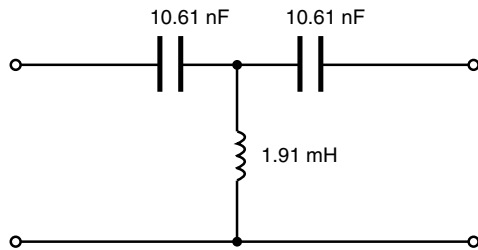

(a)

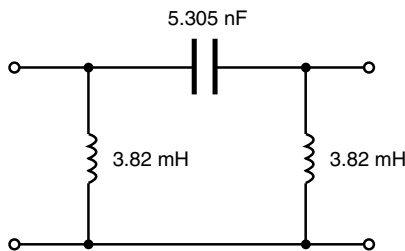

(b)

Figure 17.19

(a) A high-pass T-section filter is shown in Figure 17.19(a), where the series arm capacitances are each $2C$ (see Figure 17.16(a)), i.e. $2 \times 5.305 = 10.61 \text{ nF}$

(b) A high-pass π-section filter is shown in Figure 17.19(b), where the shunt arm inductances are each $2L$ (see Figure 17.6(b)), i.e. $2 \times 1.91 = 3.82 \text{ mH}$.

Now try the following exercise

Exercise 96 Further problems on high-pass filter sections

- Determine the cut-off frequency and the nominal impedance of each of the high-pass filter sections shown in Figure 17.20.
 [(a) 22.51 kHz; 14.14 kΩ
 (b) 281.3 Hz; 1414 Ω]

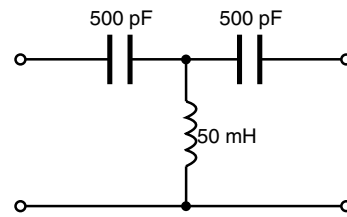

(a)

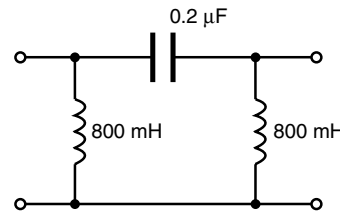

(b)

Figure 17.20

- A filter section is required to pass all frequencies above 4 kHz and to have a nominal impedance 750 Ω. Design (a) an appropriate high-pass T section filter, and (b) an appropriate high-pass π-section filter to meet these requirements.

- [(a) Each series arm = 53.1 nF, shunt arm = 14.92 mH
 (b) Series arm = 26.5 nF, each shunt arm = 29.84 mH]

3. The inductance in each of the shunt arms of a high-pass π -section filter is 50 mH. If the nominal impedance of the section is 600 Ω , determine the value of the capacitance in the series arm. [69.44 nF]
4. Determine the value of inductance required in the shunt arm of a high-pass T-section filter if in each series arm it contains a 0.5 μ F capacitor. The cut-off frequency of the filter section is 1500 Hz. [11.26 mH]

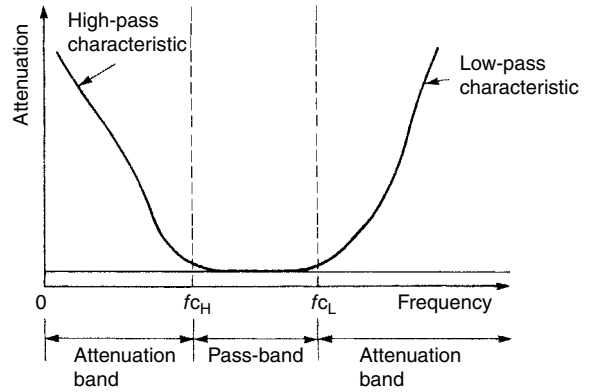

Figure 17.23

17.5 Band-pass filters

A band-pass filter is one designed to pass signals with frequencies between two specified cut-off frequencies. The characteristic of an ideal band-pass filter is shown in Figure 17.21.

where a precisely defined bandwidth must be maintained for good performance.

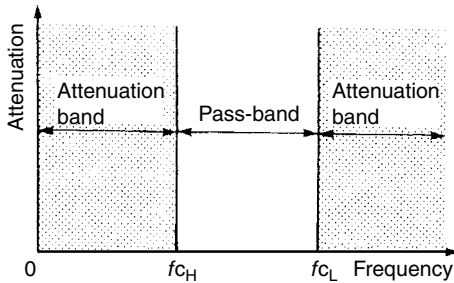

Figure 17.21

Such a filter may be formed by cascading a high-pass and a low-pass filter. f_{cH} is the cut-off frequency of the high-pass filter and f_{cL} is the cut-off frequency of the low-pass filter. As can be seen, for a band-pass filter $f_{cL} > f_{cH}$, the pass-band being given by the difference between these values.

Problem 7. A band-pass filter is comprised of a low-pass T-section filter having a cut-off frequency of 15 kHz, connected in series with a high-pass T-section filter having a cut-off frequency of 10 kHz. The terminating impedance of the filter is 600 Ω . Determine the values of the components comprising the composite filter.

The electrical circuit diagram symbol for a band-pass filter is shown in Figure 17.22.

For the low-pass T-section filter:

$$f_{cL} = 15\,000 \text{ Hz}$$

From equation (3), capacitance,

$$C = \frac{1}{\pi R_0 f_c} = \frac{1}{\pi(600)(15\,000)} = 35.4 \times 10^{-9} = 35.4 \text{ nF}$$

From equation (4), inductance,

$$L = \frac{R_0}{\pi f_c} = \frac{600}{\pi(15\,000)} = 0.01273 \text{ H} = 12.73 \text{ mH}$$

Thus, from Figure 17.7(a), the series arm inductances are each $\frac{L}{2}$, i.e.

$$\frac{12.73}{2} = 6.37 \text{ mH,}$$

and the shunt arm capacitance is 35.4 nF.

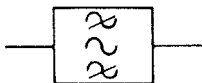

Figure 17.22

A typical practical characteristic for a band-pass filter is shown in Figure 17.23.

Crystal and ceramic devices are used extensively as band-pass filters. They are common in the intermediate-frequency amplifiers of v.h.f. radios

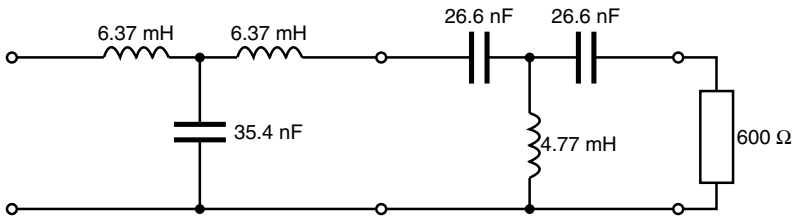

Figure 17.24

For the high-pass T-section filter:

$$f_{c_H} = 10\,000 \text{ Hz}$$

From equation (7), capacitance,

$$C = \frac{1}{4\pi R_0 f_c} = \frac{1}{4\pi(600)(10\,000)}$$

$$= 1.33 \times 10^{-8} = 13.3 \text{ nF}$$

From equation (8), inductance,

$$L = \frac{R_0}{4\pi f_c} = \frac{600}{4\pi(10\,000)}$$

$$= 4.77 \times 10^{-3} = 4.77 \text{ mH.}$$

Thus, from Figure 17.16(a), the series arm capacitances are each $2C$,

i.e. $2 \times 13.3 = 26.6 \text{ nF}$,

and the shunt arm inductance is 4.77 mH . The composite, band-pass filter is shown in Figure 17.24.

The attenuation against frequency characteristic will be similar to Figure 17.23 where $f_{c_H} = 10 \text{ kHz}$ and $f_{c_L} = 15 \text{ kHz}$.

Now try the following exercise

Exercise 97 Further problems on band-pass filters

1. A band-pass filter is comprised of a low-pass T-section filter having a cut-off frequency of 20 kHz , connected in series with a high-pass T-section filter having a cut-off frequency of 8 kHz . The terminating impedance of the filter is 600Ω . Determine the values of the components comprising the composite filter.

[Low-pass T-section: each series arm 4.77 mH , shunt arm 26.53 nF
High-pass T-section: each series arm 33.16 nF , shunt arm 5.97 mH]

2. A band-pass filter is comprised of a low-pass π -section filter having a cut-off frequency of 50 kHz , connected in series with a high-pass π -section filter having a cut-off frequency of 40 kHz . The terminating impedance of the filter is 620Ω . Determine the values of the components comprising the composite filter.

[Low-pass π -section: series arm 3.95 mH , each shunt arm 5.13 nF
High-pass π -section: series arm 3.21 nF , each shunt arm 2.47 mH]

17.6 Band-stop filters

A band-stop filter is one designed to pass signals with all frequencies except those between two specified cut-off frequencies. The characteristic of an ideal band-stop filter is shown in Figure 17.25.

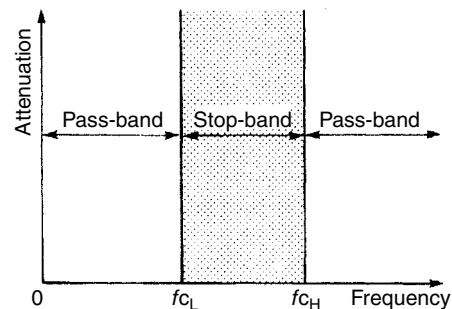

Figure 17.25

Such a filter may be formed by connecting a high-pass and a low-pass filter in parallel. As can be seen,

for a band-stop filter $f_{CH} > f_{CL}$, the stop-band being given by the difference between these values.

The electrical circuit diagram symbol for a band-stop filter is shown in Figure 17.26.

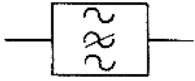

Figure 17.26

A typical practical characteristic for a band-stop filter is shown in Figure 17.27.

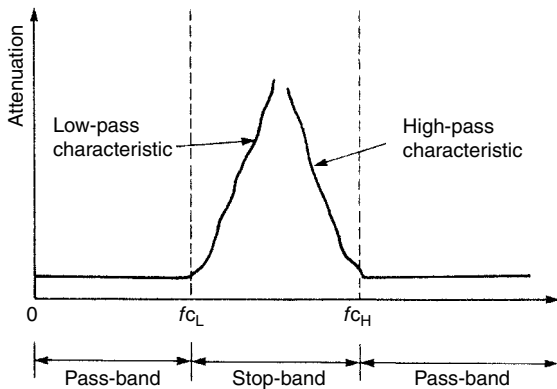

Figure 17.27

Sometimes, as in the case of interference from 50 Hz power lines in an audio system, the exact frequency of a spurious noise signal is known. Usually such interference is from an odd harmonic of 50 Hz, for example, 250 Hz. A sharply tuned band-stop filter, designed to attenuate the 250 Hz noise signal, is used to minimise the effect of the output. A high-pass filter with cut-off frequency greater than 250 Hz would also remove the interference, but some of the lower frequency components of the audio signal would be lost as well.

Filter design can be a complicated area. For more, see *Electrical Circuit Theory and Technology*.

Now try the following exercise

Exercise 98 Short answer questions on filters

1. Define a filter.
2. Define the cut-off frequency for a filter.
3. Define a two-port network.

4. Define characteristic impedance for a two-port network.
5. A network designed to pass signals at frequencies below a specified cut-off frequency is called a filter.
6. A network designed to pass signals with all frequencies except those between two specified cut-off frequencies is called a filter.
7. A network designed to pass signals with frequencies between two specified cut-off frequencies is called a filter.
8. A network designed to pass signals at frequencies above a specified cut-off frequency is called a filter.
9. State one application of a low-pass filter.
10. Sketch (a) an ideal, and (b) a practical attenuation/frequency characteristic for a low-pass filter.
11. Sketch (a) an ideal, and (b) a practical attenuation/frequency characteristic for a high-pass filter.
12. Sketch (a) an ideal, and (b) a practical attenuation/frequency characteristic for a band-pass filter.
14. State one application of a band-pass filter.
13. Sketch (a) an ideal, and (b) a practical attenuation/frequency characteristic for a band-stop filter.
15. State one application of a band-stop filter.

Exercise 99 Multi-choice questions on filters (Answers on page 376)

1. A network designed to pass signals with all frequencies except those between two specified cut-off frequencies is called a:
 - (a) low-pass filter
 - (b) high-pass filter
 - (c) band-pass filter
 - (d) band-stop filter
2. A network designed to pass signals at frequencies above a specified cut-off frequency is called a:
 - (a) low-pass filter
 - (b) high-pass filter
 - (c) band-pass filter
 - (d) band-stop filter
3. A network designed to pass signals at frequencies below a specified cut-off frequency is called a:
 - (a) low-pass filter
 - (b) high-pass filter
 - (c) band-pass filter
 - (d) band-stop filter

4. A network designed to pass signals with frequencies between two specified cut-off frequencies is called a:

- (a) low-pass filter (b) high-pass filter
(c) band-pass filter (d) band-stop filter

5. A low-pass T-connected symmetrical filter section has an inductance of 200 mH in each of its series arms and a capacitance of 0.5 μF in its shunt arm. The cut-off frequency of the filter is:

- (a) 1007 Hz (b) 251.6 Hz
(c) 711.8 Hz (d) 177.9 Hz

6. A low-pass π -connected symmetrical filter section has an inductance of 200 mH in its series arm and capacitances of 400 pF in each of its shunt arms. The cut-off frequency of the filter is:

- (a) 25.16 kHz (b) 6.29 kHz
(c) 17.79 kHz (d) 35.59 kHz

The following refers to questions 7 and 8.

A filter section is to have a nominal impedance of 620 Ω and a cut-off frequency of 2 MHz.

7. A low-pass T-connected symmetrical filter section is comprised of:

- (a) 98.68 μH in each series arm, 128.4 pF in shunt arm
(b) 49.34 μH in each series arm, 256.7 pF in shunt arm
(c) 98.68 μH in each series arm, 256.7 pF in shunt arm
(d) 49.34 μH in each series arm, 128.4 pF in shunt arm

8. A low-pass π -connected symmetrical filter section is comprised of:

- (a) 98.68 μH in each series arm, 128.4 pF in shunt arm
(b) 49.34 μH in each series arm, 256.7 pF in shunt arm
(c) 98.68 μH in each series arm, 256.7 pF in shunt arm

(d) 49.34 μH in each series arm, 128.4 pF in shunt arm

9. A high-pass T-connected symmetrical filter section has capacitances of 400 nF in each of its series arms and an inductance of 200 mH in its shunt arm. The cut-off frequency of the filter is:

- (a) 1592 Hz (b) 1125 Hz
(c) 281 Hz (d) 398 Hz

10. A high-pass π -connected symmetrical filter section has a capacitance of 5000 pF in its series arm and inductances of 500 μH in each of its shunt arms. The cut-off frequency of the filter is:

- (a) 201.3 kHz (b) 71.18 kHz
(c) 50.33 kHz (d) 284.7 kHz

The following refers to questions 11 and 12.

A filter section is required to pass all frequencies above 50 kHz and to have a nominal impedance of 650 Ω .

11. A high-pass T-connected symmetrical filter section is comprised of:

- (a) Each series arm 2.45 nF, shunt arm 1.03 mH
(b) Each series arm 4.90 nF, shunt arm 2.08 mH
(c) Each series arm 2.45 nF, shunt arm 2.08 mH
(d) Each series arm 4.90 nF, shunt arm 1.03 mH

12. A high-pass π -connected symmetrical filter section is comprised of:

- (a) Series arm 4.90 nF, and each shunt arm 1.04 mH
(b) Series arm 4.90 nF, and each shunt arm 2.07 mH
(c) Series arm 2.45 nF, and each shunt arm 2.07 mH
(d) Series arm 2.45 nF, and each shunt arm 1.04 mH

D.C. transients

At the end of this chapter you should be able to:

- understand the term ‘transient’
- describe the transient response of capacitor and resistor voltages, and current in a series C – R d.c. circuit
- define the term ‘time constant’
- calculate time constant in a C – R circuit
- draw transient growth and decay curves for a C – R circuit
- use equations $v_C = V(1 - e^{-t/\tau})$, $v_R = Ve^{-t/\tau}$ and $i = Ie^{-t/\tau}$ for a C – R circuit
- describe the transient response when discharging a capacitor
- describe the transient response of inductor and resistor voltages, and current in a series L – R d.c. circuit
- calculate time constant in an L – R circuit
- draw transient growth and decay curves for an L – R circuit
- use equations $v_L = Ve^{-t/\tau}$, $v_R = V(1 - e^{-t/\tau})$ and $i = I(1 - e^{-t/\tau})$
- describe the transient response for current decay in an L – R circuit
- understand the switching of inductive circuits
- describe the effects of time constant on a rectangular waveform via integrator and differentiator circuits

18.1 Introduction

When a d.c. voltage is applied to a capacitor C and resistor R connected in series, there is a short period of time immediately after the voltage is connected, during which the current flowing in the circuit and voltages across C and R are changing.

Similarly, when a d.c. voltage is connected to a circuit having inductance L connected in series with resistance R , there is a short period of time immediately after the voltage is connected, during which the current flowing in the circuit and the voltages across L and R are changing.

These changing values are called **transients**.

18.2 Charging a capacitor

- (a) The circuit diagram for a series connected C – R circuit is shown in Fig. 18.1 When switch S is closed then by Kirchhoff’s voltage law:

$$V = v_C + v_R \quad (1)$$

- (b) The battery voltage V is constant. The capacitor voltage v_C is given by q/C , where q is the charge on the capacitor. The voltage drop across R is given by iR , where i is the current flowing in the circuit. Hence at all times:

$$V = \frac{q}{C} + iR \quad (2)$$

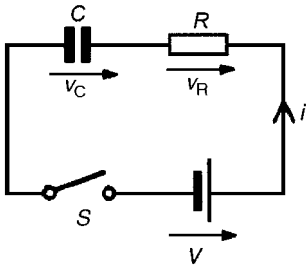

Figure 18.1

At the instant of closing S , (initial circuit condition), assuming there is no initial charge on the capacitor, q_0 is zero, hence v_{C0} is zero. Thus from Equation (1), $V = 0 + v_{R0}$, i.e. $v_{R0} = V$. This shows that the resistance to current is solely due to R , and the initial current flowing, $i_0 = I = V/R$

- (c) A short time later at time t_1 seconds after closing S , the capacitor is partly charged to, say, q_1 coulombs because current has been flowing. The voltage v_{C1} is now (q_1/C) volts. If the current flowing is i_1 amperes, then the voltage drop across R has fallen to i_1R volts. Thus, Equation (2) is now $V = (q_1/C) + i_1R$
- (d) A short time later still, say at time t_2 seconds after closing the switch, the charge has increased to q_2 coulombs and v_C has increased to (q_2/C) volts. Since $V = v_C + v_R$ and V is a constant, then v_R decreases to i_2R . Thus v_C is increasing and i and v_R are decreasing as time increases.
- (e) Ultimately, a few seconds after closing S , (i.e. at the final or **steady state** condition), the capacitor is fully charged to, say, Q coulombs, current no longer flows, i.e. $i = 0$, and hence $v_R = iR = 0$. It follows from Equation (1) that $v_C = V$.

- (f) Curves showing the changes in v_C , v_R and i with time are shown in Fig. 18.2

The curve showing the variation of v_C with time is called an **exponential growth curve** and the graph is called the ‘capacitor voltage/time’ characteristic. The curves showing the variation of v_R and i with time are called **exponential decay curves**, and the graphs are called ‘resistor voltage/time’ and ‘current/time’ characteristics respectively. (The name ‘exponential’ shows that the shape can be expressed mathematically by an exponential mathematical equation, as shown in Section 18.4).

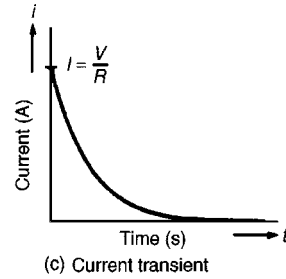
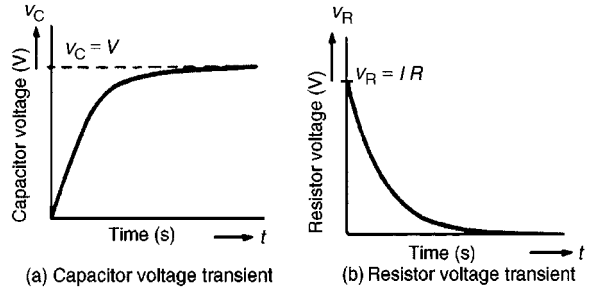

Figure 18.2

18.3 Time constant for a $C-R$ circuit

- (a) If a constant d.c. voltage is applied to a series connected $C-R$ circuit, a transient curve of capacitor voltage v_C is as shown in Fig. 18.2(a).
- (b) With reference to Fig. 18.3, let the constant voltage supply be replaced by a variable voltage supply at time t_1 seconds. Let the voltage be varied so that the **current** flowing in the circuit is **constant**.

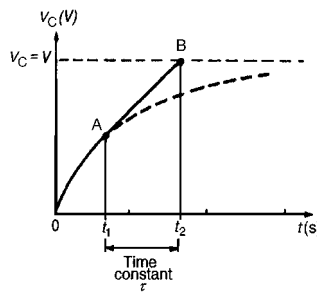

Figure 18.3

- (c) Since the current flowing is a constant, the curve will follow a tangent, AB , drawn to the curve at point A .
- (d) Let the capacitor voltage v_C reach its final value of V at time t_2 seconds.

- (e) The time corresponding to $(t_2 - t_1)$ seconds is called the **time constant** of the circuit, denoted by the Greek letter 'tau', τ . The value of the time constant is CR seconds, i.e. for a series connected $C-R$ circuit,

time constant $\tau = CR$ seconds

Since the variable voltage mentioned in paragraph (b) above can be applied at any instant during the transient change, it may be applied at $t = 0$, i.e. at the instant of connecting the circuit to the supply. If this is done, then the time constant of the circuit may be defined as: *'the time taken for a transient to reach its final state if the initial rate of change is maintained'*.

18.4 Transient curves for a $C-R$ circuit

There are two main methods of drawing transient curves graphically, these being:

- (a) the **tangent method** – this method is shown in Problem 1
- (b) the **initial slope and three point method**, which is shown in Problem 2, and is based on the following properties of a transient exponential curve:
 - (i) for a growth curve, the value of a transient at a time equal to one time constant is 0.632 of its steady state value (usually taken as 63 per cent of the steady state value), at a time equal to two and a half time constants is 0.918 of its steady state value (usually taken as 92 per cent of its steady state value) and at a time equal to five time constants is equal to its steady state value,
 - (ii) for a decay curve, the value of a transient at a time equal to one time constant is 0.368 of its initial value (usually taken as 37 per cent of its initial value), at a time equal to two and a half time constants is 0.082 of its initial value (usually taken as 8 per cent of its initial value) and at a time equal to five time constants is equal to zero.

The transient curves shown in Fig. 18.2 have mathematical equations, obtained by solving the differential equations representing the circuit. The equations of the curves are:

growth of capacitor voltage,

$$v_C = V(1 - e^{-t/CR}) = V(1 - e^{-t/\tau})$$

decay of resistor voltage,

$$v_R = V e^{-t/CR} = V e^{-t/\tau} \quad \text{and}$$

decay of resistor voltage,

$$i = I e^{-t/CR} = I e^{-t/\tau}$$

Problem 1. A $15 \mu\text{F}$ uncharged capacitor is connected in series with a $47 \text{ k}\Omega$ resistor across a 120 V , d.c. supply. Use the tangential graphical method to draw the capacitor voltage/time characteristic of the circuit. From the characteristic, determine the capacitor voltage at a time equal to one time constant after being connected to the supply, and also two seconds after being connected to the supply. Also, find the time for the capacitor voltage to reach one half of its steady state value.

To construct an exponential curve, the time constant of the circuit and steady state value need to be determined.

$$\begin{aligned} \text{Time constant} &= CR = 15 \mu\text{F} \times 47 \text{ k}\Omega \\ &= 15 \times 10^{-6} \times 47 \times 10^3 \\ &= 0.705 \text{ s} \end{aligned}$$

Steady state value of $v_C = V$, i.e. $v_C = 120 \text{ V}$.
 With reference to Fig. 18.4, the scale of the horizontal axis is drawn so that it spans at least five time constants, i.e. 5×0.705 or about 3.5 seconds. The scale of the vertical axis spans the change in

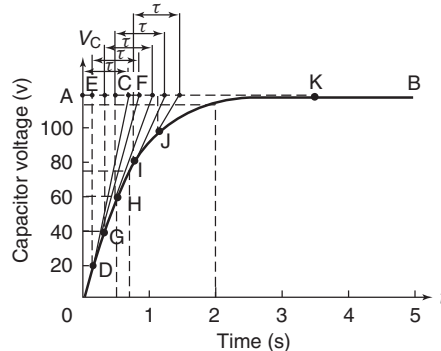

Figure 18.4

the capacitor voltage, that is, from 0 to 120 V. A broken line AB is drawn corresponding to the final value of v_C .

Point C is measured along AB so that AC is equal to 1τ , i.e. $AC = 0.705$ s. Straight line OC is drawn. Assuming that about five intermediate points are needed to draw the curve accurately, a point D is selected on OC corresponding to a v_C value of about 20 V. DE is drawn vertically. EF is made to correspond to 1τ , i.e. $EF = 0.705$ s. A straight line is drawn joining DF. This procedure of

- drawing a vertical line through point selected,
- at the steady-state value, drawing a horizontal line corresponding to 1τ , and
- joining the first and last points,

is repeated for v_C values of 40, 60, 80 and 100 V, giving points G, H, I and J.

The capacitor voltage effectively reaches its steady-state value of 120 V after a time equal to five time constants, shown as point K. Drawing a smooth curve through points O, D, G, H, I, J and K gives the exponential growth curve of capacitor voltage.

From the graph, the value of capacitor voltage at a time equal to the time constant is about **75 V**. It is a characteristic of all exponential growth curves, that after a time equal to one time constant, the value of the transient is 0.632 of its steady-state value. In this problem, $0.632 \times 120 = 75.84$ V. Also from the graph, when t is two seconds, v_C is about **115 Volts**. [This value may be checked using the equation $v_C = V(1 - e^{-t/\tau})$, where $V = 120$ V, $\tau = 0.705$ s and $t = 2$ s. This calculation gives $v_C = 112.97$ V].

The time for v_C to rise to one half of its final value, i.e. 60 V, can be determined from the graph and is about **0.5 s**. [This value may be checked using $v_C = V(1 - e^{-t/\tau})$ where $V = 120$ V, $v_C = 60$ V and $\tau = 0.705$ s, giving $t = 0.489$ s].

Problem 2. A $4\ \mu\text{F}$ capacitor is charged to 24 V and then discharged through a $220\ \text{k}\Omega$ resistor. Use the 'initial slope and three point' method to draw: (a) the capacitor voltage/time characteristic, (b) the resistor voltage/time characteristic and (c) the current/time characteristic, for the transients which occur. From the characteristics determine the value of capacitor voltage, resistor voltage and current 1.5 s after discharge has started.

To draw the transient curves, the time constant of the circuit and steady state values are needed.

$$\text{Time constant, } \tau = CR$$

$$= 4 \times 10^{-6} \times 220 \times 10^3$$

$$= 0.88 \text{ s}$$

Initially, capacitor voltage $v_C = v_R = 24$ V,

$$i = \frac{V}{R} = \frac{24}{220 \times 10^3}$$

$$= 0.109 \text{ mA}$$

Finally, $v_C = v_R = i = 0$.

- The exponential decay of capacitor voltage is from 24 V to 0 V in a time equal to five time constants, i.e. $5 \times 0.88 = 4.4$ s. With reference to Fig. 18.5, to construct the decay curve:

- the horizontal scale is made so that it spans at least five time constants, i.e. 4.4 s,
- the vertical scale is made to span the change in capacitor voltage, i.e. 0 to 24 V,
- point A corresponds to the initial capacitor voltage, i.e. 24 V,
- OB is made equal to one time constant and line AB is drawn; this gives the initial slope of the transient,
- the value of the transient after a time equal to one time constant is 0.368 of the initial

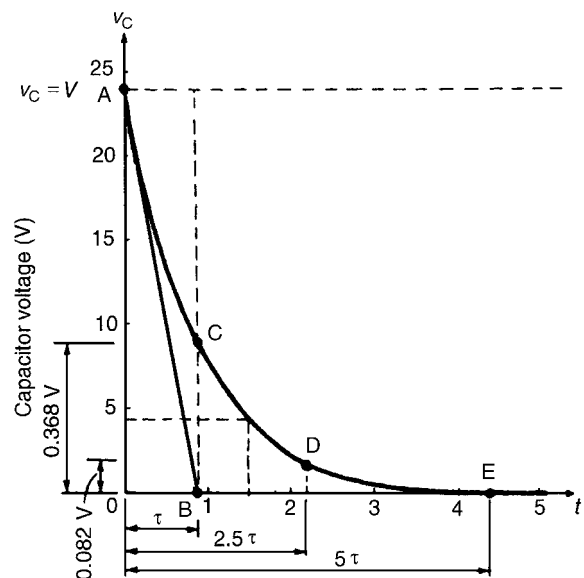

Figure 18.5

value, i.e. $0.368 \times 24 = 8.83 \text{ V}$; a vertical line is drawn through B and distance BC is made equal to 8.83 V ,

- (vi) the value of the transient after a time equal to two and a half time constants is 0.082 of the initial value, i.e. $0.082 \times 24 = 1.97 \text{ V}$, shown as point D in Fig. 18.5,
- (vii) the transient effectively dies away to zero after a time equal to five time constants, i.e. 4.4 s , giving point E.

The smooth curve drawn through points A, C, D and E represents the decay transient. At 1.5 s after decay has started, $v_C \approx 4.4 \text{ V}$.

[This may be checked using $v_C = Ve^{-t/\tau}$, where $V = 24$, $t = 1.5$ and $\tau = 0.88$, giving $v_C = 4.36 \text{ V}$]

- (b) The voltage drop across the resistor is equal to the capacitor voltage when a capacitor is discharging through a resistor, thus the resistor voltage/time characteristic is identical to that shown in Fig. 18.5 Since $v_R = v_C$, then at 1.5 seconds after decay has started, $v_R \approx 4.4 \text{ V}$ (see (vii) above).
- (c) The current/time characteristic is constructed in the same way as the capacitor voltage/time characteristic, shown in part (a), and is as shown in Fig. 18.6 The values are:

point A: initial value of current = 0.109 mA

point C: at 1τ , $i = 0.368 \times 0.109 = 0.040 \text{ mA}$

point D: at 2.5τ , $i = 0.082 \times 0.109 = 0.009 \text{ mA}$

point E: at 5τ , $i = 0$

Hence the current transient is as shown. At a time of 1.5 s , the value of current, from the characteristic is 0.02 mA

[This may be checked using $i = Ie^{(-t/\tau)}$ where $I = 0.109$, $t = 1.5$ and $\tau = 0.88$, giving $i = 0.0198 \text{ mA}$ or $19.8 \mu\text{A}$]

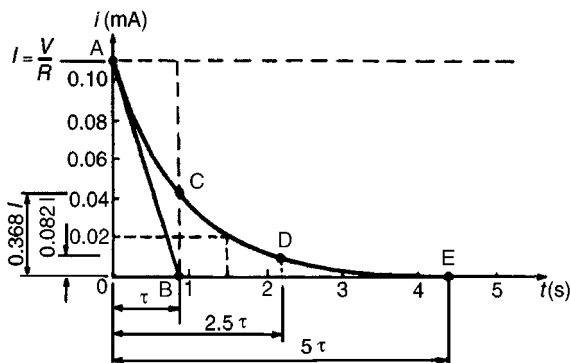

Figure 18.6

Problem 3. A $20 \mu\text{F}$ capacitor is connected in series with a $50 \text{ k}\Omega$ resistor and the circuit is connected to a 20 V , d.c. supply.

Determine: (a) the initial value of the current flowing, (b) the time constant of the circuit, (c) the value of the current one second after connection, (d) the value of the capacitor voltage two seconds after connection, and (e) the time after connection when the resistor voltage is 15 V .

Parts (c), (d) and (e) may be determined graphically, as shown in Problems 1 and 2 or by calculation as shown below.

$$V = 20 \text{ V}, C = 20 \mu\text{F} = 20 \times 10^{-6} \text{ F}, \\ R = 50 \text{ k}\Omega = 50 \times 10^3 \text{ }\Omega$$

- (a) The initial value of the current flowing is

$$I = \frac{V}{R} = \frac{20}{50 \times 10^3} = 0.4 \text{ mA}$$

- (b) From Section 18.3 the time constant,

$$\tau = CR = (20 \times 10^{-6})(50 \times 10^3) = 1 \text{ s}$$

- (c) Current, $i = Ie^{-t/\tau}$ and working in mA units,

$$i = 0.4e^{-1/1} = 0.4 \times 0.368 = 0.147 \text{ mA}$$

- (d) Capacitor voltage,

$$v_C = V(1 - e^{-t/\tau}) = 20(1 - e^{-2/1}) \\ = 20(1 - 0.135) = 20 \times 0.865 \\ = 17.3 \text{ V}$$

- (e) Resistor voltage, $v_R = Ve^{-t/\tau}$

Thus $15 = 20e^{-t/1}$, $15/20 = e^{-t}$ from which $e^t = 20/15 = 4/3$

Taking natural logarithms of each side of the equation gives

$$t = \ln \frac{4}{3} = \ln 1.3333 \text{ i.e. time, } t = 0.288 \text{ s}$$

Problem 4. A circuit consists of a resistor connected in series with a $0.5 \mu\text{F}$ capacitor and has a time constant of 12 ms . Determine: (a) the value of the resistor, and (b) the capacitor voltage, 7 ms after connecting the circuit to a 10 V supply.

(a) The time constant $\tau = CR$, hence

$$\begin{aligned}
 R &= \frac{\tau}{C} \\
 &= \frac{12 \times 10^{-3}}{0.5 \times 10^{-6}} \\
 &= 24 \times 10^3 = \mathbf{24 \text{ k}\Omega}
 \end{aligned}$$

(b) The equation for the growth of capacitor voltage is: $v_C = V(1 - e^{-t/\tau})$

Since $\tau = 12 \text{ ms} = 12 \times 10^{-3} \text{ s}$, $V = 10 \text{ V}$ and $t = 7 \text{ ms} = 7 \times 10^{-3} \text{ s}$, then

$$\begin{aligned}
 v_C &= 10(1 - e^{-7 \times 10^{-3} / 12 \times 10^{-3}}) \\
 &= 10(1 - e^{-0.583}) \\
 &= 10(1 - 0.558) = \mathbf{4.42 \text{ V}}
 \end{aligned}$$

Alternatively, the value of v_C when t is 7 ms may be determined using the growth characteristic as shown in Problem 1.

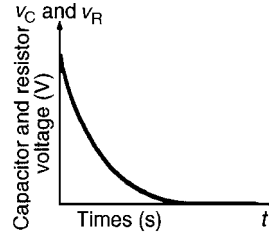

(a) Capacitor and resistor voltage transient

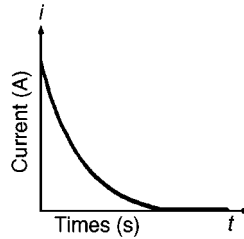

(b) Current transient

Figure 18.8

18.5 Discharging a capacitor

When a capacitor is charged (i.e. with the switch in position A in Fig. 18.7), and the switch is then moved to position B, the electrons stored in the capacitor keep the current flowing for a short time. Initially, at the instant of moving from A to B, the current flow is such that the capacitor voltage v_C is balanced by an equal and opposite voltage $v_R = iR$. Since initially $v_C = v_R = V$, then $i = I = V/R$. During the transient decay, by applying Kirchhoff's voltage law to Fig. 18.7, $v_C = v_R$.

Finally the transients decay exponentially to zero, i.e. $v_C = v_R = 0$. The transient curves representing the voltages and current are as shown in Fig. 18.8

The equations representing the transient curves during the discharge period of a series connected C-R circuit are:

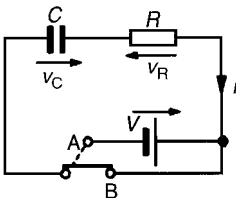

Figure 18.7

decay of voltage,

$$v_C = v_R = V e^{(-t/CR)} = V e^{(-t/\tau)}$$

decay of current, $i = I e^{(-t/CR)} = I e^{(-t/\tau)}$

When a capacitor has been disconnected from the supply it may still be charged and it may retain this charge for some considerable time. Thus precautions must be taken to ensure that the capacitor is automatically discharged after the supply is switched off. This is done by connecting a high value resistor across the capacitor terminals.

Problem 5. A capacitor is charged to 100 V and then discharged through a 50 kΩ resistor. If the time constant of the circuit is 0.8 s. Determine: (a) the value of the capacitor, (b) the time for the capacitor voltage to fall to 20 V, (c) the current flowing when the capacitor has been discharging for 0.5 s, and (d) the voltage drop across the resistor when the capacitor has been discharging for one second.

Parts (b), (c) and (d) of this problem may be solved graphically as shown in Problems 1 and 2 or by

calculation as shown below.

$$V = 100 \text{ V}, \tau = 0.8 \text{ s}, R = 50 \text{ k}\Omega = 50 \times 10^3 \Omega$$

(a) Since time constant, $\tau = CR$, capacitance,

$$C = \frac{\tau}{R} = \frac{0.8}{50 \times 10^3} = \mathbf{16 \mu\text{F}}$$

(b) Since $v_C = Ve^{-t/\tau}$ then $20 = 100e^{-t/0.8}$ from which $1/5 = e^{-t/0.8}$

Thus $e^{t/0.8} = 5$ and taking natural logarithms of each side, gives $t/0.8 = \ln 5$ and time, $t = 0.8 \ln 5 = \mathbf{1.29 \text{ s}}$.

(c) $i = Ie^{-t/\tau}$ where the initial current flowing,

$$I = \frac{V}{R} = \frac{100}{50 \times 10^3} = 2 \text{ mA}$$

Working in mA units,

$$\begin{aligned} i &= Ie^{-t/\tau} = 2e^{-(0.5/0.8)} \\ &= 2e^{-0.625} = 2 \times 0.535 = \mathbf{1.07 \text{ mA}} \end{aligned}$$

(d) $v_R = v_C = Ve^{-t/\tau} = 100e^{-1/0.8}$

$$= 100e^{-1.25} = 100 \times 0.287 = \mathbf{28.7 \text{ V}}$$

Problem 6. A $0.1 \mu\text{F}$ capacitor is charged to 200 V before being connected across a $4 \text{ k}\Omega$ resistor. Determine (a) the initial discharge current, (b) the time constant of the circuit, and (c) the minimum time required for the voltage across the capacitor to fall to less than 2 V .

(a) Initial discharge current,

$$i = \frac{V}{R} = \frac{200}{4 \times 10^3} = \mathbf{0.05 \text{ A} \text{ or } 50 \text{ mA}}$$

(b) Time constant $\tau = CR = 0.1 \times 10^{-6} \times 4 \times 10^3 = \mathbf{0.0004 \text{ s} \text{ or } 0.4 \text{ ms}}$

(c) The minimum time for the capacitor voltage to fall to less than 2 V , i.e. less than $2/200$ or 1 per cent of the initial value is given by 5τ . $5\tau = 5 \times 0.4 = \mathbf{2 \text{ ms}}$

In a d.c. circuit, a capacitor blocks the current except during the times that there are changes in the supply voltage.

Now try the following exercise

Exercise 100 Further problems on transients in series connected C–R circuits

- An uncharged capacitor of $0.2 \mu\text{F}$ is connected to a 100 V , d.c. supply through a resistor of $100 \text{ k}\Omega$. Determine, either graphically or by calculation the capacitor voltage 10 ms after the voltage has been applied [39.35 V]
- A circuit consists of an uncharged capacitor connected in series with a $50 \text{ k}\Omega$ resistor and has a time constant of 15 ms . Determine either graphically or by calculation (a) the capacitance of the capacitor and (b) the voltage drop across the resistor 5 ms after connecting the circuit to a 20 V , d.c. supply. [(a) $0.3 \mu\text{F}$ (b) 14.33 V]
- A $10 \mu\text{F}$ capacitor is charged to 120 V and then discharged through a $1.5 \text{ M}\Omega$ resistor. Determine either graphically or by calculation the capacitor voltage 2 s after discharging has commenced. Also find how long it takes for the voltage to fall to 25 V [105.0 V, 23.53 s]
- A capacitor is connected in series with a voltmeter of resistance $750 \text{ k}\Omega$ and a battery. When the voltmeter reading is steady the battery is replaced with a shorting link. If it takes 17 s for the voltmeter reading to fall to two-thirds of its original value, determine the capacitance of the capacitor. [55.9 μF]
- When a $3 \mu\text{F}$ charged capacitor is connected to a resistor, the voltage falls by 70 per cent in 3.9 s . Determine the value of the resistor. [1.08 $\text{M}\Omega$]
- A $50 \mu\text{F}$ uncharged capacitor is connected in series with a $1 \text{ k}\Omega$ resistor and the circuit is switched to a 100 V , d.c. supply. Determine: (a) the initial current flowing in the circuit, (b) the time constant, (c) the value of current when t is 50 ms and (d) the voltage across the resistor 60 ms after closing the switch. [(a) 0.1 A (b) 50 ms (c) 36.8 mA (d) 30.1 V]
- An uncharged $5 \mu\text{F}$ capacitor is connected in series with a $30 \text{ k}\Omega$ resistor across a 110 V , d.c. supply. Determine the time constant of the circuit and the initial charging current. Use a graphical method to draw the current/time

characteristic of the circuit and hence determine the current flowing 120 ms after connecting to the supply.

[150 ms, 3.67 mA, 1.65 mA]

8 An uncharged $80\ \mu\text{F}$ capacitor is connected in series with a $1\ \text{k}\Omega$ resistor and is switched across a $110\ \text{V}$ supply. Determine the time constant of the circuit and the initial value of current flowing. Derive graphically the current/time characteristic for the transient condition and hence determine the value of current flowing after (a) $40\ \text{ms}$ and (b) $80\ \text{ms}$

[80 ms, 0.11 A (a) 66.7 mA (b) 40.5 mA]

9 A resistor of $0.5\ \text{M}\Omega$ is connected in series with a $20\ \mu\text{F}$ capacitor and the capacitor is charged to $200\ \text{V}$. The battery is replaced instantaneously by a conducting link. Draw a graph showing the variation of capacitor voltage with time over a period of at least 6 time constants. Determine from the graph the approximate time for the capacitor voltage to fall to $75\ \text{V}$

[9.8 s]

$$V = L \frac{di}{dt} + iR \tag{4}$$

(c) At the instant of closing the switch, the rate of change of current is such that it induces an e.m.f. in the inductance which is equal and opposite to V , hence $V = v_L + 0$, i.e. $v_L = V$. From Equation (3), because $v_L = V$, then $v_R = 0$ and $i = 0$.

(d) A short time later at time t_1 seconds after closing S , current i_1 is flowing, since there is a rate of change of current initially, resulting in a voltage drop of i_1R across the resistor. Since V (which is constant) = $v_L + v_R$ the induced e.m.f. is reduced, and Equation (4) becomes:

$$V = L \frac{di_1}{dt_1} + i_1R$$

(e) A short time later still, say at time t_2 seconds after closing the switch, the current flowing is i_2 , and the voltage drop across the resistor increases to i_2R . Since v_R increases, v_L decreases.

(f) Ultimately, a few seconds after closing S , the current flow is entirely limited by R , the rate of change of current is zero and hence v_L is zero. Thus $V = iR$. Under these conditions, steady state current flows, usually signified by I . Thus, $I = V/R$, $v_R = IR$ and $v_L = 0$ at steady state conditions.

(g) Curves showing the changes in v_L , v_R and i with time are shown in Fig. 18.10 and indicate that

18.6 Current growth in an $L-R$ circuit

(a) The circuit diagram for a series connected $L-R$ circuit is shown in Fig. 18.9 When switch S is closed, then by Kirchhoff's voltage law:

$$V = v_L + v_R \tag{3}$$

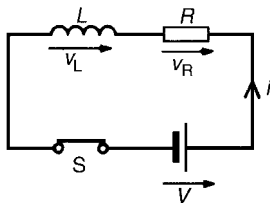
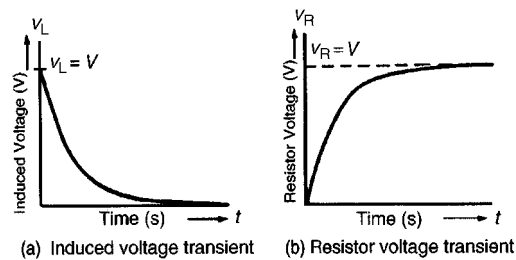

Figure 18.9

(b) The battery voltage V is constant. The voltage across the inductance is the induced voltage, i.e.

$$v_L = L \times \frac{\text{change of current}}{\text{change of time}} = L \frac{di}{dt}$$

The voltage drop across R , v_R is given by iR . Hence, at all times:



(a) Induced voltage transient (b) Resistor voltage transient

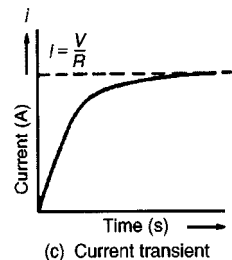

(c) Current transient

Figure 18.10

v_L is a maximum value initially (i.e. equal to V), decaying exponentially to zero, whereas v_R and i grow exponentially from zero to their steady state values of V and $I = V/R$ respectively.

18.7 Time constant for an $L-R$ circuit

With reference to Section 18.3, the time constant of a series connected $L-R$ circuit is defined in the same way as the time constant for a series connected $C-R$ circuit. Its value is given by:

time constant, $\tau = \frac{L}{R}$ seconds

18.8 Transient curves for an $L-R$ circuit

Transient curves representing the induced voltage/time, resistor voltage/time and current/time characteristics may be drawn graphically, as outlined in Section 18.4 A method of construction is shown in Problem 7.

Each of the transient curves shown in Fig. 18.10 have mathematical equations, and these are:

decay of induced voltage,

$$v_L = V e^{(-Rt/L)} = V e^{(-t/\tau)}$$

growth of resistor voltage,

$$v_R = V (1 - e^{-Rt/L}) = V (1 - e^{-t/\tau})$$

growth of current flow,

$$i = I (1 - e^{-Rt/L}) = I (1 - e^{-t/\tau})$$

The application of these equations is shown in Problem 9.

Problem 7. A relay has an inductance of 100 mH and a resistance of 20 Ω . It is connected to a 60 V, d.c. supply. Use the ‘initial slope and three point’ method to draw the current/time characteristic and hence determine the value of current flowing at a time equal to two time constants and the time for the current to grow to 1.5 A.

Before the current/time characteristic can be drawn, the time constant and steady-state value of the current have to be calculated.

Time constant,

$$\tau = \frac{L}{R} = \frac{10 \times 10^{-3}}{20} = 5 \text{ ms}$$

Final value of current,

$$I = \frac{V}{R} = \frac{60}{20} = 3 \text{ A}$$

The method used to construct the characteristic is the same as that used in Problem 2

- (a) The scales should span at least five time constants (horizontally), i.e. 25 ms, and 3 A (vertically)
- (b) With reference to Fig. 18.11, the initial slope is obtained by making AB equal to 1 time constant, (i.e. 5 ms), and joining OB.

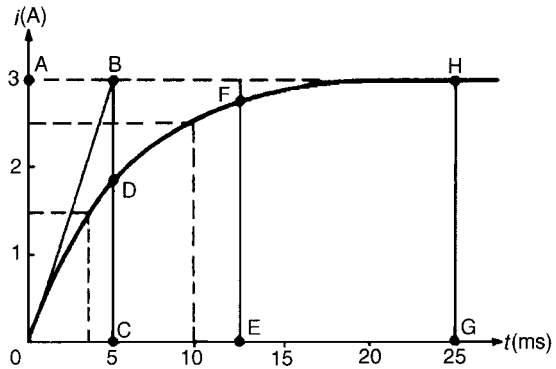

Figure 18.11

- (c) At a time of 1 time constant, CD is $0.632 \times I = 0.632 \times 3 = 1.896 \text{ A}$.
At a time of 2.5 time constants, EF is $0.918 \times I = 0.918 \times 3 = 2.754 \text{ A}$.
At a time of 5 time constants, GH is $I = 3 \text{ A}$.
- (d) A smooth curve is drawn through points 0, D, F and H and this curve is the current/time characteristic.

From the characteristic, when $t = 2\tau, i \approx 2.6 \text{ A}$. [This may be checked by calculation using $i = I(1 - e^{-t/\tau})$, where $I = 3$ and $t = 2\tau$, giving $i = 2.59 \text{ A}$]. Also, when the current is 1.5 A, the corresponding time is about **3.6 ms**. [Again, this may

be checked by calculation, using $i = I(1 - e^{-t/\tau})$ where $i = 1.5$, $I = 3$ and $\tau = 5$ ms, giving $t = 3.466$ ms].

Problem 8. A coil of inductance 0.04 H and resistance $10\ \Omega$ is connected to a 120 V, d.c. supply. Determine (a) the final value of current, (b) the time constant of the circuit, (c) the value of current after a time equal to the time constant from the instant the supply voltage is connected, (d) the expected time for the current to rise to within 1 per cent of its final value.

- (a) Final steady current, $I = \frac{V}{R} = \frac{120}{10} = \mathbf{12\ A}$
- (b) Time constant of the circuit,

$$\tau = \frac{L}{R} = \frac{0.004}{10} = \mathbf{0.004\ s\ or\ 4\ ms}$$
- (c) In the time τ s the current rises to 63.2 per cent of its final value of 12 A, i.e. in 4 ms the current rises to $0.632 \times 12 = \mathbf{7.58\ A}$.
- (d) The expected time for the current to rise to within 1 per cent of its final value is given by 5τ s, i.e. $5 \times 4 = \mathbf{20\ ms}$.

Problem 9. The winding of an electromagnet has an inductance of 3 H and a resistance of $15\ \Omega$. When it is connected to a 120 V, d.c. supply, calculate: (a) the steady state value of current flowing in the winding, (b) the time constant of the circuit, (c) the value of the induced e.m.f. after 0.1 s, (d) the time for the current to rise to 85 per cent of its final value, and (e) the value of the current after 0.3 s.

- (a) The steady state value of current,

$$I = \frac{V}{R} = \frac{120}{15} = \mathbf{8\ A}$$

- (b) The time constant of the circuit,

$$\tau = \frac{L}{R} = \frac{3}{15} = \mathbf{0.2\ s}$$

Parts (c), (d) and (e) of this problem may be determined by drawing the transients graphically, as shown in Problem 7 or by calculation as shown below.

- (c) The induced e.m.f., v_L is given by $v_L = Ve^{-t/\tau}$. The d.c. voltage V is 120 V, t is 0.1 s and τ is 0.2 s, hence

$$\begin{aligned} v_L &= 120e^{-0.1/0.2} = 120e^{-0.5} \\ &= 120 \times 0.6065 = \mathbf{72.78\ V} \end{aligned}$$

- (d) When the current is 85 per cent of its final value, $i = 0.85I$. Also, $i = I(1 - e^{-t/\tau})$, thus

$$0.85I = I(1 - e^{-t/\tau})$$

$$0.85 = 1 - e^{-t/\tau}$$

$\tau = 0.2$, hence

$$0.85 = 1 - e^{-t/0.2}$$

$$e^{-t/0.2} = 1 - 0.85 = 0.15$$

$$e^{t/0.2} = \frac{1}{0.15} = 6.\dot{6}$$

Taking natural logarithms of each side of this equation gives:

$$\ln e^{t/0.2} = \ln 6.\dot{6}$$

and by the laws of logarithms

$$\frac{t}{0.2} \ln e = \ln 6.\dot{6}$$

$\ln e = 1$, hence **time $t = 0.2 \ln 6.\dot{6} = 0.379$ s**

- (e) The current at any instant is given by $i = I(1 - e^{-t/\tau})$. When $I = 8$, $t = 0.3$ and $\tau = 0.2$, then

$$\begin{aligned} i &= 8(1 - e^{-0.3/0.2}) = 8(1 - e^{-1.5}) \\ &= 8(1 - 0.2231) = 8 \times 0.7769 = \mathbf{6.215\ A} \end{aligned}$$

18.9 Current decay in an L - R circuit

When a series connected L - R circuit is connected to a d.c. supply as shown with S in position A of

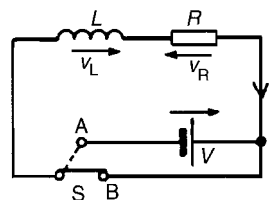

Figure 18.12

Fig. 18.12, a current $I = V/R$ flows after a short time, creating a magnetic field ($\Phi \propto I$) associated with the inductor. When S is moved to position B, the current value decreases, causing a decrease in the strength of the magnetic field. Flux linkages occur, generating a voltage v_L , equal to $L(di/dt)$. By Lenz's law, this voltage keeps current i flowing in the circuit, its value being limited by R . Thus $v_L = v_R$. The current decays exponentially to zero and since v_R is proportional to the current flowing, v_R decays exponentially to zero. Since $v_L = v_R$, v_L also decays exponentially to zero. The curves representing these transients are similar to those shown in Fig. 18.8

The equations representing the decay transient curves are:

decay of voltages,

$$v_L = v_R = V e^{(-Rt/L)} = V e^{(-t/\tau)}$$

decay of current, $i = I e^{(-Rt/L)} = I e^{(-t/\tau)}$

Problem 10. The field winding of a 110 V, d.c. motor has a resistance of 15Ω and a time constant of 2 s. Determine the inductance and use the tangential method to draw the current/time characteristic when the supply is removed and replaced by a shorting link. From the characteristic determine (a) the current flowing in the winding 3 s after being shorted-out and (b) the time for the current to decay to 5 A.

Since the time constant, $\tau = (L/R)$, $L = R\tau$ i.e. inductance $L = 15 \times 2 = 30 \text{ H}$

The current/time characteristic is constructed in a similar way to that used in Problem 1

- (i) The scales should span at least five time constants horizontally, i.e. 10 s, and $I = V/R = 110/15 = 7.3 \text{ A}$ vertically
- (ii) With reference to Fig. 18.13, the initial slope is obtained by making OB equal to 1 time constant, (i.e. 2 s), and joining AB
- (iii) At, say, $i = 6 \text{ A}$, let C be the point on AB corresponding to a current of 6 A. Make DE equal to 1 time constant, (i.e. 2 s), and join CE

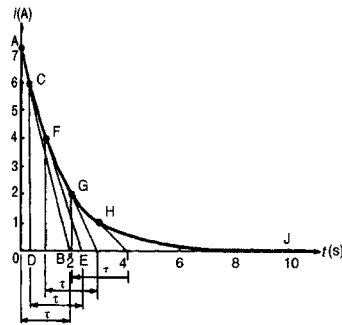

Figure 18.13

- (iv) Repeat the procedure given in (iii) for current values of, say, 4 A, 2 A and 1 A, giving points F, G and H
- (v) Point J is at five time constants, when the value of current is zero.
- (vi) Join points A, C, F, G, H and J with a smooth curve. This curve is the current/time characteristic.
 - (a) From the current/time characteristic, when $t = 3 \text{ s}$, $i = 1.3 \text{ A}$ [This may be checked by calculation using $i = I e^{-t/\tau}$, where $I = 7.3$, $t = 3$ and $\tau = 2$, giving $i = 1.64 \text{ A}$] The discrepancy between the two results is due to relatively few values, such as C, F, G and H, being taken.
 - (b) From the characteristic, when $i = 5 \text{ A}$, $t = 0.70 \text{ s}$ [This may be checked by calculation using $i = I e^{-t/\tau}$, where $i = 5$, $I = 7.3$, $\tau = 2$, giving $t = 0.766 \text{ s}$]. Again, the discrepancy between the graphical and calculated values is due to relatively few values such as C, F, G and H being taken.

Problem 11. A coil having an inductance of 6 H and a resistance of $R \Omega$ is connected in series with a resistor of 10Ω to a 120 V, d.c. supply. The time constant of the circuit is 300 ms. When steady-state conditions have been reached, the supply is replaced instantaneously by a short-circuit. Determine: (a) the resistance of the coil, (b) the current flowing in the circuit one second after the shorting link has been placed in the circuit, and (c) the time taken for the current to fall to 10 per cent of its initial value.

(a) The time constant,

$$\tau = \frac{\text{circuit inductance}}{\text{total circuit resistance}} = \frac{L}{R + 10}$$

$$\text{Thus } R = \frac{L}{\tau} - 10 = \frac{6}{0.3} - 10 = \mathbf{10 \Omega}$$

Parts (b) and (c) may be determined graphically as shown in Problems 7 and 10 or by calculation as shown below.

(b) The steady-state current,

$$I = \frac{V}{R} = \frac{120}{10 + 10} = 6 \text{ A}$$

The transient current after 1 second,

$$i = Ie^{-t/\tau} = 6e^{-1/0.3}$$

$$\text{Thus } i = 6e^{-3.3} = 6 \times 0.03567 \\ = \mathbf{0.214 \text{ A}}$$

(c) 10 per cent of the initial value of the current is $(10/100) \times 6$, i.e. 0.6 A Using the equation

$$i = Ie^{-t/\tau} \text{ gives}$$

$$0.6 = 6e^{-t/0.3}$$

$$\text{i.e. } \frac{0.6}{6} = e^{-t/0.3}$$

$$\text{or } e^{t/0.3} = \frac{6}{0.6} = 10$$

Taking natural logarithms of each side of this equation gives:

$$\frac{t}{0.3} = \ln 10$$

$$\text{from which, time, } t = \mathbf{0.3 \ln 10 = 0.691 \text{ s}}$$

Problem 12. An inductor has a negligible resistance and an inductance of 200 mH and is connected in series with a 1 k Ω resistor to a 24 V, d.c. supply. Determine the time constant of the circuit and the steady-state value of the current flowing in the circuit. Find (a) the current flowing in the circuit at a time equal to one time constant, (b) the voltage drop across the inductor at a time equal to two time constants and (c) the voltage drop across the resistor after a time equal to three time constants.

The time constant,

$$\tau = \frac{L}{R} = \frac{0.2}{1000} = \mathbf{0.2 \text{ ms}}$$

The steady-state current

$$I = \frac{V}{R} = \frac{24}{1000} = \mathbf{24 \text{ mA}}$$

(a) The transient current,

$$i = I(1 - e^{-t/\tau}) \text{ and } t = 1\tau.$$

Working in mA units gives,

$$i = 24(1 - e^{-(1\tau/\tau)}) = 24(1 - e^{-1}) \\ = 24(1 - 0.368) = \mathbf{15.17 \text{ mA}}$$

(b) The voltage drop across the inductor,

$$v_L = Ve^{-t/\tau}$$

$$\text{When } t = 2\tau, v_L = 24e^{-2\tau/\tau} = 24e^{-2} \\ = \mathbf{3.248 \text{ V}}$$

(c) The voltage drop across the resistor,

$$v_R = V(1 - e^{-t/\tau})$$

$$\text{When } t = 3\tau, v_R = 24(1 - e^{-3\tau/\tau}) \\ = 24(1 - e^{-3}) \\ = \mathbf{22.81 \text{ V}}$$

Now try the following exercise

Exercise 101 Further problems on transients in series L–R circuits

- 1 A coil has an inductance of 1.2 H and a resistance of 40 Ω and is connected to a 200 V, d.c. supply. Draw the current/time characteristic and hence determine the approximate value of the current flowing 60 ms after connecting the coil to the supply. [4.3 A]
- 2 A 25 V d.c. supply is connected to a coil of inductance 1 H and resistance 5 Ω . Use a graphical method to draw the exponential growth curve of current and hence determine the approximate value of the current flowing 100 ms after being connected to the supply. [2 A]

3 An inductor has a resistance of $20\ \Omega$ and an inductance of $4\ \text{H}$. It is connected to a $50\ \text{V}$ d.c. supply. By drawing the appropriate characteristic find (a) the approximate value of current flowing after $0.1\ \text{s}$ and (b) the time for the current to grow to $1.5\ \text{A}$

[(a) $1\ \text{A}$ (b) $0.18\ \text{s}$]

4 The field winding of a $200\ \text{V}$ d.c. machine has a resistance of $20\ \Omega$ and an inductance of $500\ \text{mH}$. Calculate:

- (a) the time constant of the field winding,
 (b) the value of current flow one time constant after being connected to the supply, and
 (c) the current flowing $50\ \text{ms}$ after the supply has been switched on

[(a) $25\ \text{ms}$ (b) $6.32\ \text{A}$ (c) $8.65\ \text{A}$]

18.10 Switching inductive circuits

Energy stored in the magnetic field of an inductor exists because a current provides the magnetic field. When the d.c. supply is switched off the current falls rapidly, the magnetic field collapses causing a large induced e.m.f. which will either cause an arc across the switch contacts or will break down the insulation between adjacent turns of the coil. The high induced e.m.f. acts in a direction which tends to keep the current flowing, i.e. in the same direction as the applied voltage. The energy from the magnetic field will thus be aided by the supply voltage in maintaining an arc, which could cause severe damage to the switch. To reduce the induced e.m.f. when the supply switch is opened, a discharge resistor R_D is connected in parallel with the inductor as shown in Fig. 18.14. The magnetic field energy is

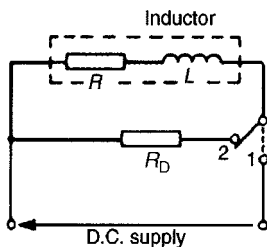

Figure 18.14

dissipated as heat in R_D and R and arcing at the switch contacts is avoided.

18.11 The effects of time constant on a rectangular waveform

Integrator circuit

By varying the value of either C or R in a series connected C - R circuit, the time constant ($\tau = CR$), of a circuit can be varied. If a rectangular waveform varying from $+E$ to $-E$ is applied to a C - R circuit as shown in Fig. 18.15, output waveforms of the capacitor voltage have various shapes, depending on the value of R . When R is small, $\tau = CR$ is small and an output waveform such as that shown in Fig. 18.16(a) is obtained. As the value of R is increased, the waveform changes to that shown in Fig. 18.16(b). When R is large, the waveform is as shown in Fig. 18.16(c), the circuit then being described as an **integrator circuit**.

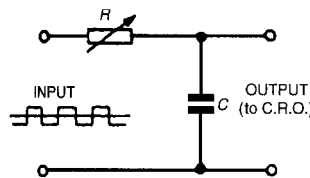

Figure 18.15

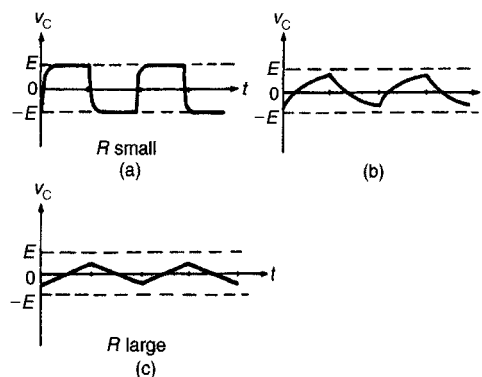

Figure 18.16

Differentiator circuit

If a rectangular waveform varying from $+E$ to $-E$ is applied to a series connected C - R circuit

Section 3

Electrical Power Technology

Three-phase systems

At the end of this chapter you should be able to:

- describe a single-phase supply
- describe a three-phase supply
- understand a star connection, and recognize that $I_L = I_p$ and $V_L = \sqrt{3}V_p$
- draw a complete phasor diagram for a balanced, star connected load
- understand a delta connection, and recognize that $V_L = V_p$ and $I_L = \sqrt{3}I_p$
- draw a phasor diagram for a balanced, delta connected load
- calculate power in three-phase systems using $P = \sqrt{3}V_L I_L \cos \phi$
- appreciate how power is measured in a three-phase system, by the one, two and three-wattmeter methods
- compare star and delta connections
- appreciate the advantages of three-phase systems

20.1 Introduction

Generation, transmission and distribution of electricity via the National Grid system is accomplished by three-phase alternating currents.

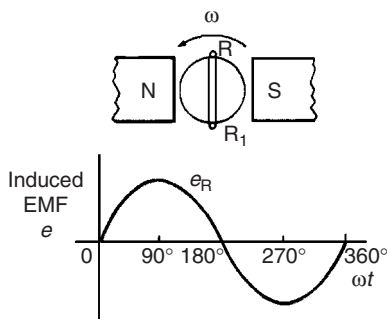

Figure 20.1

The voltage induced by a single coil when rotated in a uniform magnetic field is shown in Fig. 20.1 and is known as a **single-phase voltage**. Most consumers are fed by means of a single-phase a.c. supply. Two wires are used, one called the live conductor (usually coloured red) and the other is called the neutral conductor (usually coloured black). The neutral is usually connected via protective gear to earth, the earth wire being coloured green. The standard voltage for a single-phase a.c. supply is 240 V. The majority of single-phase supplies are obtained by connection to a three-phase supply (see Fig. 20.5, page 289).

20.2 Three-phase supply

A **three-phase supply** is generated when three coils are placed 120° apart and the whole rotated in a uniform magnetic field as shown in Fig. 20.2(a). The

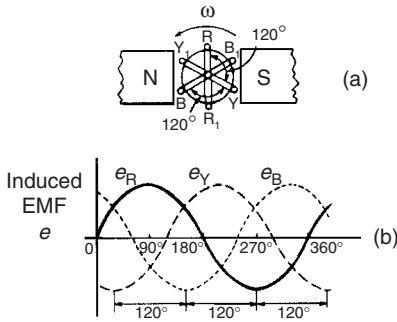

Figure 20.2

result is three independent supplies of equal voltages which are each displaced by 120° from each other as shown in Fig. 20.2(b).

- (i) The convention adopted to identify each of the phase voltages is: R-red, Y-yellow, and B-blue, as shown in Fig. 20.2
- (ii) The **phase-sequence** is given by the sequence in which the conductors pass the point initially taken by the red conductor. The national standard phase sequence is R, Y, B.

A three-phase a.c. supply is carried by three conductors, called ‘**lines**’ which are coloured red, yellow and blue. The currents in these conductors are known as line currents (I_L) and the p.d.’s between them are known as line voltages (V_L). A fourth conductor, called the **neutral** (coloured black, and connected through protective devices to earth) is often used with a three-phase supply.

If the three-phase windings shown in Fig. 20.2 are kept independent then six wires are needed to connect a supply source (such as a generator) to a load (such as motor). To reduce the number of wires it is usual to interconnect the three phases. There are two ways in which this can be done, these being:

- (a) a **star connection**, and (b) a **delta**, or **mesh**, connection. Sources of three-phase supplies, i.e. alternators, are usually connected in star, whereas three-phase transformer windings, motors and other loads may be connected either in star or delta.

20.3 Star connection

- (i) A **star-connected load** is shown in Fig. 20.3 where the three line conductors are each

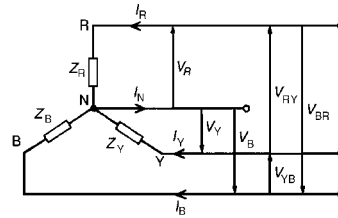

Figure 20.3

connected to a load and the outlets from the loads are joined together at N to form what is termed the **neutral point** or the **star point**.

- (ii) The voltages, V_R , V_Y and V_B are called **phase voltages** or line to neutral voltages. Phase voltages are generally denoted by V_p .
- (iii) The voltages, V_{RY} , V_{YB} and V_{BR} are called **line voltages**.
- (iv) From Fig. 20.3 it can be seen that the phase currents (generally denoted by I_p) are equal to their respective line currents I_R , I_Y and I_B , i.e. for a star connection:

$$I_L = I_p$$

- (v) For a balanced system:

$$I_R = I_Y = I_B, \quad V_R = V_Y = V_B$$

$$V_{RY} = V_{YB} = V_{BR}, \quad Z_R = Z_Y = Z_B$$

and the current in the neutral conductor, $I_N = 0$ When a star-connected system is balanced, then the neutral conductor is unnecessary and is often omitted.

- (vi) The line voltage, V_{RY} , shown in Fig. 20.4(a) is given by $V_{RY} = V_R - V_Y$ (V_Y is negative since it is in the opposite direction to V_{RY}). In the phasor diagram of Fig. 20.4(b),

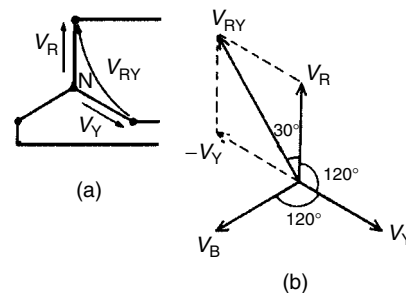

Figure 20.4

phasor V_Y is reversed (shown by the broken line) and then added phasorially to V_R (i.e. $V_{RY} = V_R + (-V_Y)$). By trigonometry, or by measurement, $V_{RY} = \sqrt{3} V_R$, i.e. for a balanced star connection:

$$V_L = \sqrt{3} V_p$$

(See Problem 3 following for a complete phasor diagram of a star-connected system).

- (vii) The star connection of the three phases of a supply, together with a neutral conductor, allows the use of two voltages – the phase voltage and the line voltage. A 4-wire system is also used when the load is not balanced. The standard electricity supply to consumers in Great Britain is 415/240 V, 50 Hz, 3-phase, 4-wire alternating current, and a diagram of connections is shown in Fig. 20.5

Problem 1. Three loads, each of resistance 30Ω , are connected in star to a 415 V, 3-phase supply. Determine (a) the system phase voltage, (b) the phase current and (c) the line current.

- (a) For a star connection, $V_L = \sqrt{3} V_p$. Hence phase voltage, $V_p = V_L/\sqrt{3} = 415/\sqrt{3} = 239.6 \text{ V}$ or **240 V**, correct to 3 significant figures.
- (b) Phase current, $I_p = V_p/R_p = 240/30 = 8 \text{ A}$
- (c) For a star connection, $I_p = I_L$ hence the line current, $I_L = 8 \text{ A}$

Problem 2. A star-connected load consists of three identical coils each of resistance 30Ω and inductance 127.3 mH . If the line current is 5.08 A , calculate the line voltage if the supply frequency is 50 Hz .

Inductive reactance

$$X_L = 2\pi fL = 2\pi(50)(127.3 \times 10^{-3}) = 40 \Omega$$

Impedance of each phase

$$Z_p = \sqrt{R^2 + X_L^2} = \sqrt{30^2 + 40^2} = 50 \Omega$$

For a star connection

$$I_L = I_p = \frac{V_p}{Z_p}$$

Hence phase voltage,

$$V_p = I_p Z_p = (5.08)(50) = 254 \text{ V}$$

Line voltage

$$V_L = \sqrt{3} V_p = \sqrt{3}(254) = 440 \text{ V}$$

A '415 V, 3-phase supply' means that 415 V is the line voltage, V_L

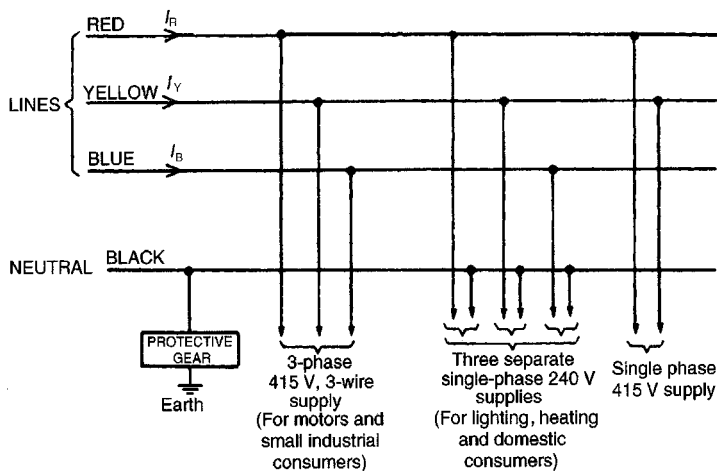

Figure 20.5

Problem 3. A balanced, three-wire, star-connected, 3-phase load has a phase voltage of 240 V, a line current of 5 A and a lagging power factor of 0.966. Draw the complete phasor diagram.

The phasor diagram is shown in Fig. 20.6.

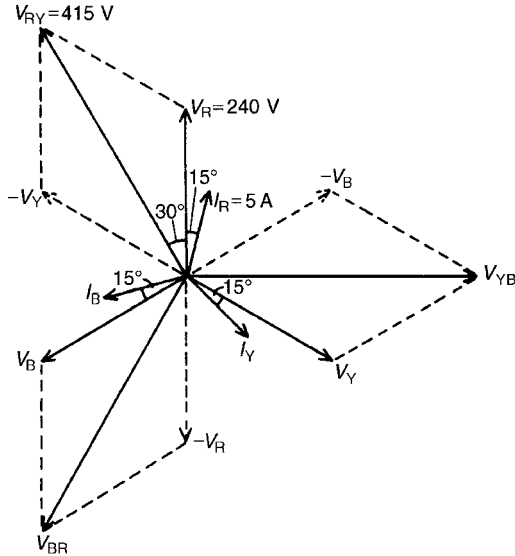

Figure 20.6

Procedure to construct the phasor diagram:

- (i) Draw $V_R = V_Y = V_B = 240\text{ V}$ and spaced 120° apart. (Note that V_R is shown vertically upwards – this however is immaterial for it may be drawn in any direction).
- (ii) Power factor = $\cos \phi = 0.966$ lagging. Hence the load phase angle is given by $\cos^{-1} 0.966$, i.e. 15° lagging. Hence $I_R = I_Y = I_B = 5\text{ A}$, lagging V_R, V_Y and V_B respectively by 15° .
- (iii) $V_{RY} = V_R - V_Y$ (phasorially). Hence V_Y is reversed and added phasorially to V_R . By measurement, $V_{RY} = 415\text{ V}$ (i.e. $\sqrt{3} \times 240$) and leads V_R by 30° . Similarly, $V_{YB} = V_Y - V_B$ and $V_{BR} = V_B - V_R$

Problem 4. A 415 V, 3-phase, 4 wire, star-connected system supplies three resistive loads as shown in Fig. 20.7 Determine (a) the current in each line and (b) the current in the neutral conductor.

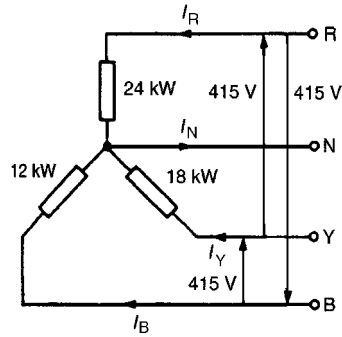

Figure 20.7

- (a) For a star-connected system $V_L = \sqrt{3} V_p$, hence

$$V_p = \frac{V_L}{\sqrt{3}} = \frac{415}{\sqrt{3}} = 240\text{ V}$$

Since current $I = \text{power } P / \text{voltage } V$ for a resistive load then

$$I_R = \frac{P_R}{V_R} = \frac{24\,000}{240} = 100\text{ A}$$

$$I_Y = \frac{P_Y}{V_Y} = \frac{18\,000}{240} = 75\text{ A}$$

and
$$I_B = \frac{P_B}{V_B} = \frac{12\,000}{240} = 50\text{ A}$$

- (b) The three line currents are shown in the phasor diagram of Fig. 20.8 Since each load is resistive the currents are in phase with the phase voltages and are hence mutually displaced by 120° . The current in the neutral conductor is given by $I_N = I_R + I_Y + I_B$ phasorially.

Figure 20.9 shows the three line currents added phasorially. oa represents I_R in magnitude and direction. From the nose of oa , ab is drawn representing I_Y in magnitude and direction. From the nose of ab ,

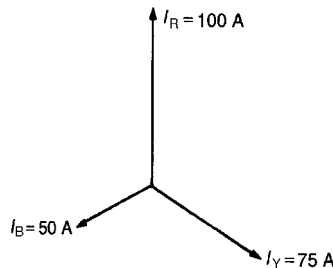

Figure 20.8

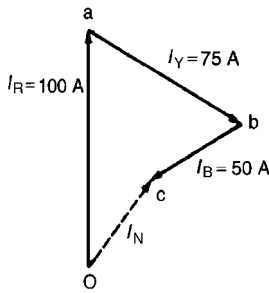

Figure 20.9

bc is drawn representing I_B in magnitude and direction. oc represents the resultant, I_N . By measurement, $I_N = 43 \text{ A}$.

Alternatively, by calculation, considering I_R at 90° , I_B at 210° and I_Y at 330° : Total horizontal component = $100 \cos 90^\circ + 75 \cos 330^\circ + 50 \cos 210^\circ = 21.65$. Total vertical component = $100 \sin 90^\circ + 75 \sin 330^\circ + 50 \sin 210^\circ = 37.50$. Hence magnitude of $I_N = \sqrt{21.65^2 + 37.50^2} = 43.3 \text{ A}$

Now try the following exercise

Exercise 108 Further problems on star connections

- 1 Three loads, each of resistance 50Ω are connected in star to a 400 V, 3-phase supply. Determine (a) the phase voltage, (b) the phase current and (c) the line current. [(a) 231 V (b) 4.62 A (c) 4.62 A]
- 2 A star-connected load consists of three identical coils, each of inductance 159.2 mH and resistance 50Ω . If the supply frequency is 50 Hz and the line current is 3 A determine (a) the phase voltage and (b) the line voltage. [(a) 212 V (b) 367 V]
- 3 Three identical capacitors are connected in star to a 400 V, 50 Hz 3-phase supply. If the line current is 12 A determine the capacitance of each of the capacitors. [165.4 μF]
- 4 Three coils each having resistance 6Ω and inductance L H are connected in star to a 415 V, 50 Hz, 3-phase supply. If the line current is 30 A, find the value of L. [16.78 mH]
- 5 A 400 V, 3-phase, 4 wire, star-connected system supplies three resistive loads of 15 kW,

20 kW and 25 kW in the red, yellow and blue phases respectively. Determine the current flowing in each of the four conductors.

$$[I_R = 64.95 \text{ A}, I_Y = 86.60 \text{ A}, I_B = 108.25 \text{ A}, I_N = 37.50 \text{ A}]$$

20.4 Delta connection

- (i) A **delta (or mesh) connected load** is shown in Fig. 20.10 where the end of one load is connected to the start of the next load.
- (ii) From Fig. 20.10, it can be seen that the line voltages V_{RY} , V_{YB} and V_{BR} are the respective phase voltages, i.e. for a delta connection:

$$V_L = V_p$$

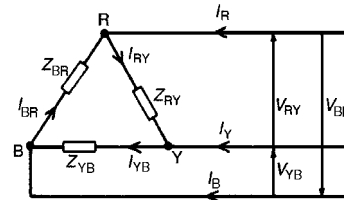

Figure 20.10

- (iii) Using Kirchhoff's current law in Fig. 20.10, $I_R = I_{RY} - I_{BR} = I_{RY} + (-I_{BR})$. From the phasor diagram shown in Fig. 20.11, by trigonometry or by measurement, $I_R = \sqrt{3} I_{RY}$, i.e. for a delta connection:

$$I_L = \sqrt{3} I_p$$

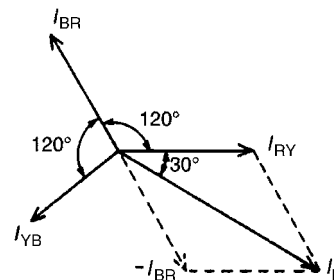

Figure 20.11

Problem 5. Three identical coils each of resistance $30\ \Omega$ and inductance $127.3\ \text{mH}$ are connected in delta to a $440\ \text{V}$, $50\ \text{Hz}$, 3-phase supply. Determine (a) the phase current, and (b) the line current.

Phase impedance, $Z_p = 50\ \Omega$ (from Problem 2) and for a delta connection, $V_p = V_L$.

(a) Phase current,

$$I_p = \frac{V_p}{Z_p} = \frac{V_L}{Z_p} = \frac{440}{50} = \mathbf{8.8\ \text{A}}$$

(b) For a delta connection,

$$I_L = \sqrt{3} I_p = \sqrt{3}(8.8) = \mathbf{15.24\ \text{A}}$$

Thus when the load is connected in delta, three times the line current is taken from the supply than is taken if connected in star.

Problem 6. Three identical capacitors are connected in delta to a $415\ \text{V}$, $50\ \text{Hz}$, 3-phase supply. If the line current is $15\ \text{A}$, determine the capacitance of each of the capacitors.

For a delta connection $I_L = \sqrt{3} I_p$. Hence phase current,

$$I_p = \frac{I_L}{\sqrt{3}} = \frac{15}{\sqrt{3}} = 8.66\ \text{A}$$

Capacitive reactance per phase,

$$X_C = \frac{V_p}{I_p} = \frac{V_L}{I_p}$$

(since for a delta connection $V_L = V_p$). Hence

$$X_C = \frac{415}{8.66} = 47.92\ \Omega$$

$X_C = 1/2\pi f C$, from which capacitance,

$$C = \frac{1}{2\pi f X_C} = \frac{2}{2\pi(50)(47.92)}\ \text{F} = \mathbf{66.43\ \mu\text{F}}$$

Problem 7. Three coils each having resistance $3\ \Omega$ and inductive reactance $4\ \Omega$ are connected (i) in star and (ii) in delta to a $415\ \text{V}$, 3-phase supply. Calculate for each connection (a) the line and phase voltages and (b) the phase and line currents.

(i) **For a star connection:** $I_L = I_p$ and $V_L = \sqrt{3} V_p$.

(a) A $415\ \text{V}$, 3-phase supply means that the line voltage, $V_L = \mathbf{415\ \text{V}}$

Phase voltage,

$$V_p = \frac{V_L}{\sqrt{3}} = \frac{415}{\sqrt{3}} = \mathbf{240\ \text{V}}$$

(b) Impedance per phase,

$$Z_p = \sqrt{R^2 + X_L^2} = \sqrt{3^2 + 4^2} = 5\ \Omega$$

Phase current,

$$I_p = V_p / Z_p = 240 / 5 = \mathbf{48\ \text{A}}$$

Line current,

$$I_L = I_p = \mathbf{48\ \text{A}}$$

(ii) **For a delta connection:** $V_L = V_p$ and

$$I_L = \sqrt{3} I_p.$$

(a) Line voltage, $V_L = 415\ \text{V}$

Phase voltage, $V_p = V_L = \mathbf{415\ \text{V}}$

(b) Phase current,

$$I_p = \frac{V_p}{Z_p} = \frac{415}{5} = \mathbf{83\ \text{A}}$$

Line current,

$$I_L = \sqrt{3} I_p = \sqrt{3}(83) = \mathbf{144\ \text{A}}$$

Now try the following exercise

Exercise 109 Further problems on delta connections

1 Three loads, each of resistance $50\ \Omega$ are connected in delta to a $400\ \text{V}$, 3-phase supply. Determine (a) the phase voltage, (b) the phase current and (c) the line current.

[(a) $400\ \text{V}$ (b) $8\ \text{A}$ (c) $13.86\ \text{A}$]

2 Three inductive loads each of resistance $75\ \Omega$ and inductance $318.4\ \text{mH}$ are connected in delta to a $415\ \text{V}$, $50\ \text{Hz}$, 3-phase supply. Determine (a) the phase voltage, (b) the phase current, and (c) the line current

[(a) $415\ \text{V}$ (b) $3.32\ \text{A}$ (c) $5.75\ \text{A}$]

- 3 Three identical capacitors are connected in delta to a 400 V, 50 Hz 3-phase supply. If the line current is 12 A determine the capacitance of each of the capacitors. [55.13 μ F]
- 4 Three coils each having resistance 6 Ω and inductance LH are connected in delta, to a 415 V, 50 Hz, 3-phase supply. If the line current is 30 A, find the value of L [73.84 mH]
- 5 A 3-phase, star-connected alternator delivers a line current of 65 A to a balanced delta-connected load at a line voltage of 380 V. Calculate (a) the phase voltage of the alternator, (b) the alternator phase current and (c) the load phase current. [(a) 219.4 V (b) 65 A (c) 37.53 A]
- 6 Three 24 μ F capacitors are connected in star across a 400 V, 50 Hz, 3-phase supply. What value of capacitance must be connected in delta in order to take the same line current? [8 μ F]

Hence for either a star or a delta balanced connection the total power P is given by:

$$P = \sqrt{3} V_L I_L \cos \phi \text{ watts}$$

$$\text{or } P = 3I_p^2 R_p \text{ watts}$$

Total volt-amperes

$$S = \sqrt{3} V_L I_L \text{ volt-amperes}$$

Problem 8. Three 12 Ω resistors are connected in star to a 415 V, 3-phase supply. Determine the total power dissipated by the resistors.

Power dissipated, $P = \sqrt{3} V_L I_L \cos \phi$ or $P = 3I_p^2 R_p$
Line voltage, $V_L = 415$ V and phase voltage

$$V_p = \frac{415}{\sqrt{3}} = 240 \text{ V}$$

(since the resistors are star-connected). Phase current,

$$I_p = \frac{V_p}{Z_p} = \frac{V_p}{R_p} = \frac{240}{12} = 20 \text{ A}$$

For a star connection

$$I_L = I_p = 20 \text{ A}$$

For a purely resistive load, the power

$$\text{factor} = \cos \phi = 1$$

Hence power

$$P = \sqrt{3} V_L I_L \cos \phi = \sqrt{3}(415)(20)(1)$$

$$= \mathbf{14.4 \text{ kW}}$$

or power

$$P = 3I_p^2 R_p = 3(20)^2(12) = \mathbf{14.4 \text{ kW}}$$

20.5 Power in three-phase systems

The power dissipated in a three-phase load is given by the sum of the power dissipated in each phase. If a load is balanced then the total power P is given by: $P = 3 \times$ power consumed by one phase.

The power consumed in one phase = $I_p^2 R_p$ or $V_p I_p \cos \phi$ (where ϕ is the phase angle between V_p and I_p).

For a star connection,

$$V_p = \frac{V_L}{\sqrt{3}} \text{ and } I_p = I_L$$

hence

$$P = 3 \frac{V_L}{\sqrt{3}} I_L \cos \phi = \sqrt{3} V_L I_L \cos \phi$$

For a delta connection,

$$V_p = V_L \text{ and } I_p = \frac{I_L}{\sqrt{3}}$$

hence

$$P = 3V_L \frac{I_L}{\sqrt{3}} \cos \phi = \sqrt{3} V_L I_L \cos \phi$$

Problem 9. The input power to a 3-phase a.c. motor is measured as 5 kW. If the voltage and current to the motor are 400 V and 8.6 A respectively, determine the power factor of the system.

Power $P = 5000 \text{ W}$,

line voltage $V_L = 400 \text{ V}$,

line current, $I_L = 8.6 \text{ A}$ and

power, $P = \sqrt{3} V_L I_L \cos \phi$

Hence

$$\begin{aligned} \text{power factor} = \cos \phi &= \frac{P}{\sqrt{3} V_L I_L} \\ &= \frac{5000}{\sqrt{3}(400)(8.6)} = \mathbf{0.839} \end{aligned}$$

Problem 10. Three identical coils, each of resistance 10Ω and inductance 42 mH are connected (a) in star and (b) in delta to a 415 V , 50 Hz , 3-phase supply. Determine the total power dissipated in each case.

(a) Star connection

Inductive reactance,

$$X_L = 2\pi fL = 2\pi(50)(42 \times 10^{-3}) = 13.19 \Omega.$$

Phase impedance,

$$Z_p = \sqrt{R^2 + X_L^2} = \sqrt{10^2 + 13.19^2} = 16.55 \Omega.$$

Line voltage,

$$V_L = 415 \text{ V}$$

and phase voltage,

$$V_p = V_L / \sqrt{3} = 415 / \sqrt{3} = 240 \text{ V}.$$

Phase current,

$$I_p = V_p / Z_p = 240 / 16.55 = 14.50 \text{ A}.$$

Line current,

$$I_L = I_p = 14.50 \text{ A}.$$

Power factor $= \cos \phi = R_p / Z_p = 10 / 16.55 = 0.6042$ lagging.

Power dissipated,

$$\begin{aligned} P &= \sqrt{3} V_L I_L \cos \phi = \sqrt{3}(415)(14.50)(0.6042) \\ &= \mathbf{6.3 \text{ kW}} \end{aligned}$$

(Alternatively,

$$P = 3I_p^2 R_p = 3(14.50)^2(10) = \mathbf{6.3 \text{ kW}})$$

(b) Delta connection

$V_L = V_p = 415 \text{ V}$,

$$Z_p = 16.55 \Omega, \cos \phi = 0.6042$$

lagging (from above).

Phase current,

$$I_p = V_p / Z_p = 415 / 16.55 = 25.08 \text{ A}.$$

Line current,

$$I_L = \sqrt{3} I_p = \sqrt{3}(25.08) = 43.44 \text{ A}.$$

Power dissipated,

$$P = \sqrt{3} V_L I_L \cos \phi$$

$$= \sqrt{3}(415)(43.44)(0.6042) = \mathbf{18.87 \text{ kW}}$$

(Alternatively,

$$P = 3I_p^2 R_p = 3(25.08)^2(10) = \mathbf{18.87 \text{ kW}})$$

Hence loads connected in delta dissipate three times the power than when connected in star, and also take a line current three times greater.

Problem 11. A 415 V , 3-phase a.c. motor has a power output of 12.75 kW and operates at a power factor of 0.77 lagging and with an efficiency of 85 per cent. If the motor is delta-connected, determine (a) the power input, (b) the line current and (c) the phase current.

(a) Efficiency = power output/power input. Hence $85/100 = 12750/\text{power input}$ from which,

$$\begin{aligned} \text{power input} &= \frac{12750 \times 100}{85} \\ &= \mathbf{15000 \text{ W or } 15 \text{ kW}} \end{aligned}$$

(b) Power, $P = \sqrt{3} V_L I_L \cos \phi$, hence **line current**,

$$\begin{aligned} I_L &= \frac{P}{\sqrt{3}(415)(0.77)} \\ &= \frac{15000}{\sqrt{3}(415)(0.77)} = \mathbf{27.10 \text{ A}} \end{aligned}$$

- (c) For a delta connection, $I_L = \sqrt{3}I_p$, hence **phase current**,

$$I_p = \frac{I_L}{\sqrt{3}} = \frac{27.10}{\sqrt{3}} = 15.65 \text{ A}$$

Now try the following exercise

Exercise 110 Further problems on power in three-phase systems

- Determine the total power dissipated by three 20Ω resistors when connected (a) in star and (b) in delta to a 440 V, 3-phase supply. [(a) 9.68 kW (b) 29.04 kW]
- Determine the power dissipated in the circuit of Problem 2, Exercise 103, page 279. [1.35 kW]
- A balanced delta-connected load has a line voltage of 400 V, a line current of 8 A and a lagging power factor of 0.94. Draw a complete phasor diagram of the load. What is the total power dissipated by the load? [5.21 kW]
- Three inductive loads, each of resistance 4Ω and reactance 9Ω are connected in delta. When connected to a 3-phase supply the loads consume 1.2 kW. Calculate (a) the power factor of the load, (b) the phase current, (c) the line current and (d) the supply voltage [(a) 0.406 (b) 10 A (c) 17.32 A (d) 98.49 V]
- The input voltage, current and power to a motor is measured as 415 V, 16.4 A and 6 kW respectively. Determine the power factor of the system. [0.509]
- A 440 V, 3-phase a.c. motor has a power output of 11.25 kW and operates at a power factor of 0.8 lagging and with an efficiency of 84 per cent. If the motor is delta connected determine (a) the power input, (b) the line current and (c) the phase current [(a) 13.39 kW (b) 21.96 A (c) 12.68 A]

- (i) **One-wattmeter method for a balanced load**
Wattmeter connections for both star and delta are shown in Fig. 20.12

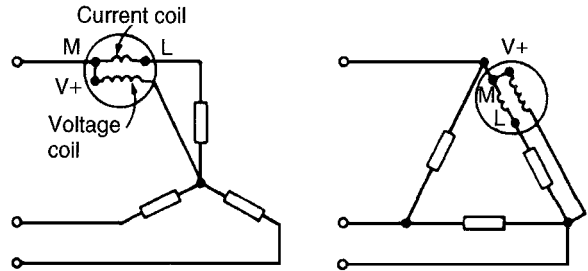

Figure 20.12

$$\text{Total power} = 3 \times \text{wattmeter reading}$$

- (ii) **Two-wattmeter method for balanced or unbalanced loads**

A connection diagram for this method is shown in Fig. 20.13 for a star-connected load. Similar connections are made for a delta-connected load.

$$\text{Total power} = \text{sum of wattmeter readings} = P_1 + P_2$$

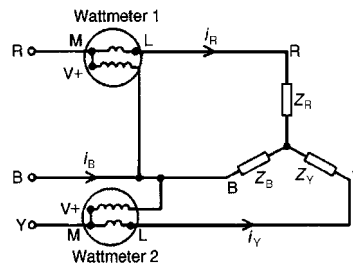

Figure 20.13

20.6 Measurement of power in three-phase systems

Power in three-phase loads may be measured by the following methods:

The power factor may be determined from:

$$\tan \phi = \sqrt{3} \left(\frac{P_1 - P_2}{P_1 + P_2} \right)$$

(see Problems 12 and 15 to 18).

It is possible, depending on the load power factor, for one wattmeter to have to be 'reversed' to obtain a reading. In this case it is taken as a negative reading (see Problem 17).

- (iii) **Three-wattmeter method for a three-phase, 4-wire system for balanced and unbalanced loads** (see Fig. 20.14).

$$\text{Total power} = P_1 + P_2 + P_3$$

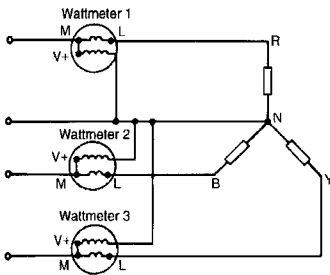

Figure 20.14

Problem 12. (a) Show that the total power in a 3-phase, 3-wire system using the two-wattmeter method of measurement is given by the sum of the wattmeter readings. Draw a connection diagram. (b) Draw a phasor diagram for the two-wattmeter method for a balanced load. (c) Use the phasor diagram of part (b) to derive a formula from which the power factor of a 3-phase system may be determined using only the wattmeter readings.

- (a) A connection diagram for the two-wattmeter method of a power measurement is shown in Fig. 20.15 for a star-connected load.

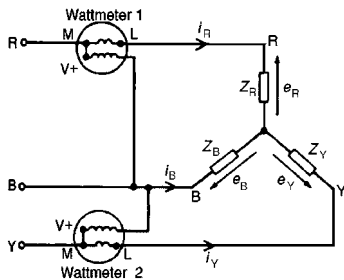

Figure 20.15

Total instantaneous power, $p = e_R i_R + e_Y i_Y + e_B i_B$ and in any 3-phase system $i_R + i_Y + i_B = 0$; hence $i_B = -i_R - i_Y$. Thus,

$$p = e_R i_R + e_Y i_Y + e_B (-i_R - i_Y)$$

$$= (e_R - e_B) i_R + (e_Y - e_B) i_Y$$

However, $(e_R - e_B)$ is the p.d. across wattmeter 1 in Fig. 20.15 and $(e_Y - e_B)$ is the p.d. across wattmeter 2. Hence total instantaneous power,

$$p = (\text{wattmeter 1 reading}) + (\text{wattmeter 2 reading})$$

$$= p_1 + p_2$$

The moving systems of the wattmeters are unable to follow the variations which take place at normal frequencies and they indicate the mean power taken over a cycle. Hence the total power, $P = P_1 + P_2$ for balanced or unbalanced loads.

- (b) The phasor diagram for the two-wattmeter method for a balanced load having a lagging current is shown in Fig. 20.16, where $V_{RB} = V_R - V_B$ and $V_{YB} = V_Y - V_B$ (phasorially).
- (c) Wattmeter 1 reads $V_{RB} I_R \cos(30^\circ - \phi) = P_1$.
Wattmeter 2 reads $V_{YB} I_Y \cos(30^\circ + \phi) = P_2$.

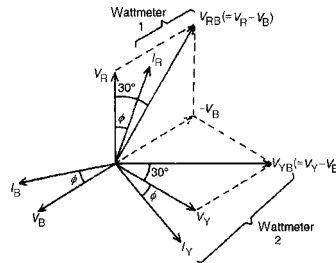

Figure 20.16

$$\frac{P_1}{P_2} = \frac{V_{RB} I_R \cos(30^\circ - \phi)}{V_{YB} I_Y \cos(30^\circ + \phi)} = \frac{\cos(30^\circ - \phi)}{\cos(30^\circ + \phi)}$$

since $I_R = I_Y$ and $V_{RB} = V_{YB}$ for a balanced load. Hence

$$\frac{P_1}{P_2} = \frac{\cos 30^\circ \cos \phi + \sin 30^\circ \sin \phi}{\cos 30^\circ \cos \phi - \sin 30^\circ \sin \phi}$$

(from compound angle formulae, see 'Engineering Mathematics').

Dividing throughout by $\cos 30^\circ \cos \phi$ gives:

$$\frac{P_1}{P_2} = \frac{1 + \tan 30^\circ \tan \phi}{1 - \tan 30^\circ \tan \phi}$$

$$= \frac{1 + \frac{1}{\sqrt{3}} \tan \phi}{1 - \frac{1}{\sqrt{3}} \tan \phi},$$

$$\left(\text{since } \frac{\sin \phi}{\cos \phi} = \tan \phi \right)$$

Cross-multiplying gives:

$$P_1 - \frac{P_1}{\sqrt{3}} \tan \phi = P_2 + \frac{P_2}{\sqrt{3}} \tan \phi$$

Hence

$$P_1 - P_2 = (P_1 + P_2) \frac{\tan \phi}{\sqrt{3}}$$

from which

$$\tan \phi = \sqrt{3} \left(\frac{P_1 - P_2}{P_1 + P_2} \right)$$

ϕ , $\cos \phi$ and thus power factor can be determined from this formula.

Problem 13. A 400 V, 3-phase star connected alternator supplies a delta-connected load, each phase of which has a resistance of 30Ω and inductive reactance 40Ω . Calculate (a) the current supplied by the alternator and (b) the output power and the kVA of the alternator, neglecting losses in the line between the alternator and load.

A circuit diagram of the alternator and load is shown in Fig. 20.17

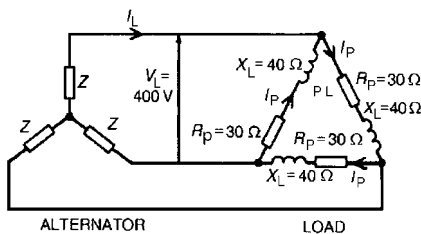

Figure 20.17

(a) Considering the load:

Phase current, $I_p = V_p/Z_p$.

$V_p = V_L$ for a delta connection,

hence $V_p = 400$ V.

Phase impedance,

$$Z_p = \sqrt{R_p^2 + X_L^2} = \sqrt{30^2 + 40^2} = 50 \Omega.$$

Hence $I_p = V_p/Z_p = 400/50 = 8$ A.

For a delta-connection, line current,

$$I_L = \sqrt{3} I_p = \sqrt{3}(8) = 13.86 \text{ A.}$$

Hence **13.86 A is the current supplied by the alternator.**

(b) Alternator output power is equal to the power dissipated by the load i.e.

$$P = \sqrt{3} V_L I_L \cos \phi,$$

where $\cos \phi = R_p/Z_p = 30/50 = 0.6$.

$$\text{Hence } P = \sqrt{3} (400)(13.86)(0.6)$$

$$= \mathbf{5.76 \text{ kW.}}$$

Alternator output kVA,

$$S = \sqrt{3} V_L I_L = \sqrt{3}(400)(13.86)$$

$$= \mathbf{9.60 \text{ kVA.}}$$

Problem 14. Each phase of a delta-connected load comprises a resistance of 30Ω and an $80 \mu\text{F}$ capacitor in series. The load is connected to a 400 V, 50 Hz, 3-phase supply. Calculate (a) the phase current, (b) the line current, (c) the total power dissipated and (d) the kVA rating of the load. Draw the complete phasor diagram for the load.

(a) Capacitive reactance,

$$X_C = \frac{1}{2\pi f C} = \frac{1}{2\pi(50)(80 \times 10^{-6})} = 39.79 \Omega$$

Phase impedance,

$$Z_p = \sqrt{R_p^2 + X_C^2} = \sqrt{30^2 + 39.79^2} = 49.83 \Omega.$$

Power factor = $\cos \phi = R_p/Z_p$

$$= 30/49.83 = 0.602$$

Hence $\phi = \cos^{-1} 0.602 = 52.99^\circ$ leading.

Phase current,

$$I_p = V_p/Z_p \text{ and } V_p = V_L$$

for a delta connection. Hence

$$I_p = 400/49.83 = \mathbf{8.027 \text{ A}}$$

- (b) Line current, $I_L = \sqrt{3} I_p$ for a delta-connection.
Hence $I_L = \sqrt{3}(8.027) = \mathbf{13.90 \text{ A}}$

- (c) Total power dissipated,

$$\begin{aligned} P &= \sqrt{3} V_L I_L \cos \phi \\ &= \sqrt{3}(400)(13.90)(0.602) = \mathbf{5.797 \text{ kW}} \end{aligned}$$

- (d) Total kVA,

$$S = \sqrt{3} V_L I_L = \sqrt{3}(400)(13.90) = \mathbf{9.630 \text{ kVA}}$$

The phasor diagram for the load is shown in Fig. 20.18

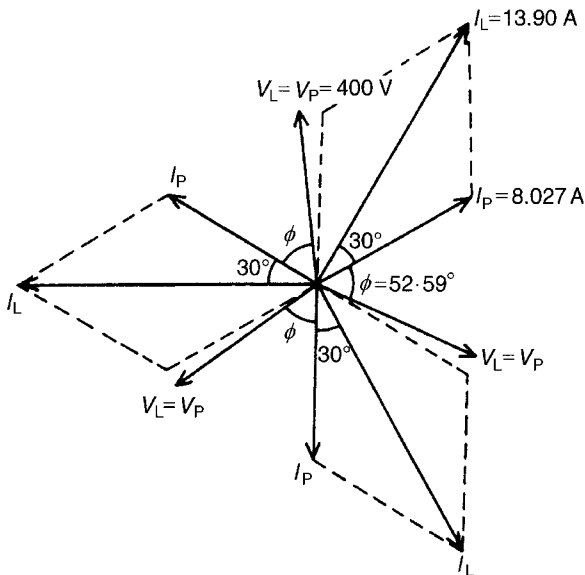

Figure 20.18

Problem 15. Two wattmeters are connected to measure the input power to a balanced 3-phase load by the two-wattmeter method. If the instrument readings are 8 kW and 4 kW, determine (a) the total power input and (b) the load power factor.

- (a) Total input power,

$$P = P_1 + P_2 = 8 + 4 = \mathbf{12 \text{ kW}}$$

- (b) $\tan \phi = \sqrt{3} \left(\frac{P_1 - P_2}{P_1 + P_2} \right) = \sqrt{3} \left(\frac{8 - 4}{8 + 4} \right)$
 $= \sqrt{3} \left(\frac{4}{12} \right) = \sqrt{3} \left(\frac{1}{3} \right) = \frac{1}{\sqrt{3}}$

$$\text{Hence } \phi = \tan^{-1} \frac{1}{\sqrt{3}} = 30^\circ$$

$$\text{Power factor} = \cos \phi = \cos 30^\circ = \mathbf{0.866}$$

Problem 16. Two wattmeters connected to a 3-phase motor indicate the total power input to be 12 kW. The power factor is 0.6. Determine the readings of each wattmeter.

If the two wattmeters indicate P_1 and P_2 respectively then

$$P_1 + P_2 = 12 \text{ kW} \quad (1)$$

$$\tan \phi = \sqrt{3} \left(\frac{P_1 - P_2}{P_1 + P_2} \right)$$

and power factor = 0.6 = $\cos \phi$. Angle $\phi = \cos^{-1} 0.6 = 53.13^\circ$ and $\tan 53.13^\circ = 1.3333$. Hence

$$1.3333 = \sqrt{3} \left(\frac{P_1 - P_2}{12} \right),$$

from which,

$$P_1 - P_2 = \frac{12(1.3333)}{\sqrt{3}}$$

$$\text{i.e. } P_1 - P_2 = 9.237 \text{ kW} \quad (2)$$

Adding Equations (1) and (2) gives:

$$2P_1 = 21.237$$

$$\text{i.e. } P_1 = \frac{21.237}{2}$$

$$= 10.62 \text{ kW}$$

Hence **wattmeter 1 reads 10.62 kW**

From Equation (1), **wattmeter 2 reads (12 - 10.62) = 1.38 kW**

Problem 17. Two wattmeters indicate 10 kW and 3 kW respectively when connected to measure the input power to a 3-phase balanced load, the reverse switch being operated on the meter indicating the 3 kW reading. Determine (a) the input power and (b) the load power factor.

Since the reversing switch on the wattmeter had to be operated the 3 kW reading is taken as -3 kW

(a) Total input power,

$$P = P_1 + P_2 = 10 + (-3) = 7 \text{ kW}$$

$$(b) \tan \phi = \sqrt{3} \left(\frac{P_1 - P_2}{P_1 + P_2} \right) = \sqrt{3} \left(\frac{10 - (-3)}{10 + (-3)} \right)$$

$$= \sqrt{3} \left(\frac{13}{7} \right) = 3.2167$$

$$\text{Angle } \phi = \tan^{-1} 3.2167 = 72.73^\circ$$

$$\text{Power factor} = \cos \phi = \cos 72.73^\circ = \mathbf{0.297}$$

Problem 18. Three similar coils, each having a resistance of 8Ω and an inductive reactance of 8Ω are connected (a) in star and (b) in delta, across a 415 V, 3-phase supply. Calculate for each connection the readings on each of two wattmeters connected to measure the power by the two-wattmeter method.

(a) **Star connection:** $V_L = \sqrt{3} V_p$ and $I_L = I_p$.

$$\text{Phase voltage, } V_p = \frac{V_L}{\sqrt{3}} = \frac{415}{\sqrt{3}}$$

and phase impedance,

$$Z_p = \sqrt{R_p^2 + X_L^2} = \sqrt{8^2 + 8^2} = 11.31 \Omega$$

Hence phase current,

$$I_p = \frac{V_p}{Z_p} = \frac{\frac{415}{\sqrt{3}}}{11.31} = 21.18 \text{ A}$$

Total power,

$$P = 3I_p^2 R_p = 3(21.18)^2(8) = 10\,766 \text{ W}$$

If wattmeter readings are P_1 and P_2 then:

$$P_1 + P_2 = 10\,766 \quad (1)$$

Since $R_p = 8 \Omega$ and $X_L = 8 \Omega$, then phase angle $\phi = 45^\circ$ (from impedance triangle).

$$\tan \phi = \sqrt{3} \left(\frac{P_1 - P_2}{P_1 + P_2} \right)$$

$$\text{hence } \tan 45^\circ = \frac{\sqrt{3}(P_1 - P_2)}{10\,766}$$

from which

$$P_1 - P_2 = \frac{(10\,766)(1)}{\sqrt{3}} = 6216 \text{ W} \quad (2)$$

Adding Equations (1) and (2) gives:

$$2P_1 = 10\,766 + 6216 = 16\,982 \text{ W}$$

$$\text{Hence } P_1 = 8491 \text{ W}$$

From Equation (1), $P_2 = 10\,766 - 8491 = 2275 \text{ W}$.

When the coils are star-connected the wattmeter readings are thus 8.491 kW and 2.275 kW

(b) **Delta connection:** $V_L = V_p$ and $I_L = \sqrt{3} I_p$.

$$\text{Phase current, } I_p = \frac{V_p}{Z_p} = \frac{415}{11.31} = 36.69 \text{ A.}$$

Total power,

$$P = 3I_p^2 R_p = 3(36.69)^2(8) = 32\,310 \text{ W}$$

$$\text{Hence } P_1 + P_2 = 32\,310 \text{ W} \quad (3)$$

$$\tan \phi = \sqrt{3} \left(\frac{P_1 - P_2}{P_1 + P_2} \right) \text{ thus } 1 = \frac{\sqrt{3}(P_1 - P_2)}{32\,310}$$

from which,

$$P_1 - P_2 = \frac{32\,310}{\sqrt{3}} = 18\,650 \text{ W} \quad (4)$$

Adding Equations (3) and (4) gives:

$$2P_1 = 50\,960 \text{ from which } P_1 = 25\,480 \text{ W.}$$

From Equation (3), $P_2 = 32\,310 - 25\,480 = 6830 \text{ W}$

When the coils are delta-connected the wattmeter readings are thus 25.48 kW and 6.83 kW

Now try the following exercise

Exercise 111 Further problems on the measurement of power in 3-phase circuits

1 Two wattmeters are connected to measure the input power to a balanced three-phase load. If the wattmeter readings are 9.3 kW and 5.4 kW determine (a) the total output power, and (b) the load power factor

[(a) 14.7 kW (b) 0.909]

2 8 kW is found by the two-wattmeter method to be the power input to a 3-phase motor. Determine the reading of each wattmeter if the power factor of the system is 0.85

[5.431 kW, 2.569 kW]

3 When the two-wattmeter method is used to measure the input power of a balanced load, the readings on the wattmeters are 7.5 kW and 2.5 kW, the connections to one of the coils on the meter reading 2.5 kW having to be reversed. Determine (a) the total input power, and (b) the load power factor

[(a) 5 kW (b) 0.277]

4 Three similar coils, each having a resistance of 4.0Ω and an inductive reactance of 3.46Ω are connected (a) in star and (b) in delta across a 400 V, 3-phase supply. Calculate for each connection the readings on each of two wattmeters connected to measure the power by the two-wattmeter method.

[(a) 17.15 kW, 5.73 kW
(b) 51.46 kW, 17.18 kW]

5 A 3-phase, star-connected alternator supplies a delta connected load, each phase of which has a resistance of 15Ω and inductive reactance 20Ω . If the line voltage is 400 V, calculate (a) the current supplied by the alternator and (b) the output power and kVA rating of the alternator, neglecting any losses in the line between the alternator and the load.

[(a) 27.71 A (b) 11.52 kW, 19.2 kVA]

6 Each phase of a delta-connected load comprises a resistance of 40Ω and a $40 \mu\text{F}$ capacitor in series. Determine, when connected to a 415 V, 50 Hz, 3-phase supply (a) the phase current, (b) the line current, (c) the total power dissipated, and (d) the kVA rating of the load

[(a) 4.66 A (b) 8.07 A
(c) 2.605 kW (d) 5.80 kVA]

20.7 Comparison of star and delta connections

- (i) Loads connected in delta dissipate three times more power than when connected in star to the same supply.
- (ii) For the same power, the phase currents must be the same for both delta and star connections

(since power = $3I_p^2R_p$), hence the line current in the delta-connected system is greater than the line current in the corresponding star-connected system. To achieve the same phase current in a star-connected system as in a delta-connected system, the line voltage in the star system is $\sqrt{3}$ times the line voltage in the delta system. Thus for a given power transfer, a delta system is associated with larger line currents (and thus larger conductor cross-sectional area) and a star system is associated with a larger line voltage (and thus greater insulation).

20.8 Advantages of three-phase systems

Advantages of three-phase systems over single-phase supplies include:

- (i) For a given amount of power transmitted through a system, the three-phase system requires conductors with a smaller cross-sectional area. This means a saving of copper (or aluminium) and thus the original installation costs are less.
- (ii) Two voltages are available (see Section 20.3 (vii))
- (iii) Three-phase motors are very robust, relatively cheap, generally smaller, have self-starting properties, provide a steadier output and require little maintenance compared with single-phase motors.

Now try the following exercises

Exercise 112 Short answer questions on three-phase systems

- 1 Explain briefly how a three-phase supply is generated
- 2 State the national standard phase sequence for a three-phase supply
- 3 State the two ways in which phases of a three-phase supply can be interconnected to reduce the number of conductors used compared with three single-phase systems

- 4 State the relationships between line and phase currents and line and phase voltages for a star-connected system
- 5 When may the neutral conductor of a star-connected system be omitted?
- 6 State the relationships between line and phase currents and line and phase voltages for a delta-connected system
- 7 What is the standard electricity supply to domestic consumers in Great Britain?
- 8 State two formulae for determining the power dissipated in the load of a three-phase balanced system
- 9 By what methods may power be measured in a three-phase system?
- 10 State a formula from which power factor may be determined for a balanced system when using the two-wattmeter method of power measurement
- 11 Loads connected in star dissipate the power dissipated when connected in delta and fed from the same supply
- 12 Name three advantages of three-phase systems over single-phase systems

Exercise 113 Multi-choice questions on three-phase systems (Answers on page 376)

Three loads, each of $10\ \Omega$ resistance, are connected in star to a 400 V, 3-phase supply. Determine the quantities stated in questions 1 to 5, selecting answers from the following list:

- | | | |
|-----------------------------|-----------------------|------------------------------|
| (a) $\frac{40}{\sqrt{3}}$ A | (b) $\sqrt{3}(16)$ kW | (c) $\frac{400}{\sqrt{3}}$ V |
| (d) $\sqrt{3}(40)$ A | (e) $\sqrt{3}(400)$ V | (f) 16 kW |
| (g) 400 V | (h) 48 kW | (i) 40 A |
- 1 Line voltage
 - 2 Phase voltage
 - 3 Phase current
 - 4 Line current
 - 5 Total power dissipated in the load
 - 6 Which of the following statements is false?

- (a) For the same power, loads connected in delta have a higher line voltage and a smaller line current than loads connected in star
- (b) When using the two-wattmeter method of power measurement the power factor is unity when the wattmeter readings are the same
- (c) A.c. may be distributed using a single-phase system with two wires, a three-phase system with three wires or a three-phase system with four wires
- (d) The national standard phase sequence for a three-phase supply is R, Y, B

Three loads, each of resistance $16\ \Omega$ and inductive reactance $12\ \Omega$ are connected in delta to a 400 V, 3-phase supply. Determine the quantities stated in questions 7 to 12, selecting the correct answer from the following list:

- | | | |
|------------------|-----------------------------|------------------------------|
| (a) $4\ \Omega$ | (b) $\sqrt{3}(400)$ V | (c) $\sqrt{3}(6.4)$ kW |
| (d) 20 A | (e) 6.4 kW | (f) $\sqrt{3}(20)$ A |
| (g) $20\ \Omega$ | (h) $\frac{20}{\sqrt{3}}$ V | (i) $\frac{400}{\sqrt{3}}$ V |
| (j) 19.2 kW | (k) 100 A | (l) 400 V |
| (m) $28\ \Omega$ | | |

7 Phase impedance

8 Line voltage

9 Phase voltage

10 Phase current

11 Line current

12 Total power dissipated in the load

13 The phase voltage of a delta-connected three-phase system with balanced loads is 240 V. The line voltage is:

- (a) 720 V (b) 440 V (c) 340 V (d) 240 V

14 A 4-wire three-phase star-connected system has a line current of 10 A. The phase current is:

- (a) 40 A (b) 10 A (c) 20 A (d) 30 A

15 The line voltage of a 4-wire three-phase star-connected system is 11 kV. The phase voltage is:

- (a) 19.05 kV (b) 11 kV
(c) 6.35 kV (d) 7.78 kV

16 In the two-wattmeter method of measurement power in a balanced three-phase system readings of P_1 and P_2 watts are obtained. The power factor may be determined from:

- (a) $\sqrt{3} \left(\frac{P_1 + P_2}{P_1 - P_2} \right)$ (b) $\sqrt{3} \left(\frac{P_1 - P_2}{P_1 + P_2} \right)$
(c) $\frac{(P_1 - P_2)}{\sqrt{3}(P_1 + P_2)}$ (d) $\frac{(P_1 + P_2)}{\sqrt{3}(P_1 - P_2)}$

17 The phase voltage of a 4-wire three-phase star-connected system is 110 V. The line voltage is:

- (a) 440 V
(b) 330 V
(c) 191 V
(d) 110 V

Transformers

At the end of this chapter you should be able to:

- understand the principle of operation of a transformer
- understand the term 'rating' of a transformer
- use $V_1/V_2 = N_1/N_2 = I_2/I_1$ in calculations on transformers
- construct a transformer no-load phasor diagram and calculate magnetising and core loss components of the no-load current
- state the e.m.f. equation for a transformer $E = 4.44 f \Phi_m N$ and use it in calculations
- construct a transformer on-load phasor diagram for an inductive circuit assuming the volt drop in the windings is negligible
- describe transformer construction
- derive the equivalent resistance, reactance and impedance referred to the primary of a transformer
- understand voltage regulation
- describe losses in transformers and calculate efficiency
- appreciate the concept of resistance matching and how it may be achieved
- perform calculations using $R_1 = (N_1/N_2)^2 R_L$
- describe an auto transformer, its advantages/disadvantages and uses
- describe an isolating transformer, stating uses
- describe a three-phase transformer
- describe current and voltage transformers

21.1 Introduction

A transformer is a device which uses the phenomenon of mutual induction (see Chapter 9) to change the values of alternating voltages and currents. In fact, one of the main advantages of a.c. transmission and distribution is the ease with which an alternating voltage can be increased or decreased by transformers.

Losses in transformers are generally low and thus efficiency is high. Being static they have a long life and are very stable.

Transformers range in size from the miniature units used in electronic applications to the large power transformers used in power stations; the principle of operation is the same for each.

A transformer is represented in Fig. 21.1(a) as consisting of two electrical circuits linked by a common ferromagnetic core. One coil is termed the

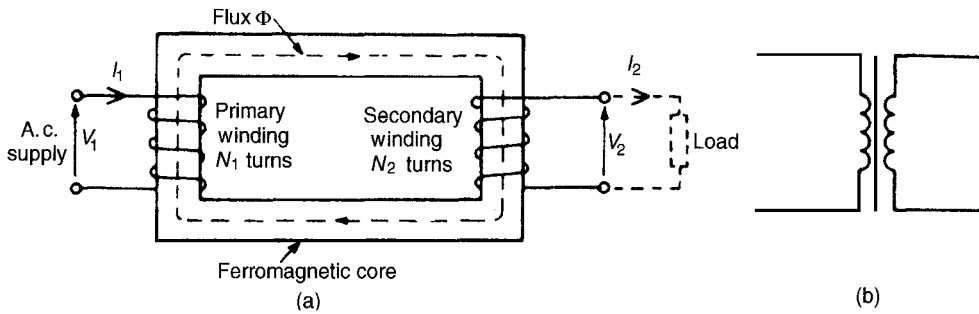

Figure 21.1

primary winding which is connected to the supply of electricity, and the other the **secondary winding**, which may be connected to a load. A circuit diagram symbol for a transformer is shown in Fig. 21.1(b)

transformer, the **primary and secondary ampere-turns are equal**

Thus
$$\frac{V_1}{V_2} = \frac{I_2}{I_1} \quad (2)$$

Combining equations (1) and (2) gives:

$$\boxed{\frac{V_1}{V_2} = \frac{N_1}{N_2} = \frac{I_2}{I_1}} \quad (3)$$

21.2 Transformer principle of operation

When the secondary is an open-circuit and an alternating voltage V_1 is applied to the primary winding, a small current – called the no-load current I_0 – flows, which sets up a magnetic flux in the core. This alternating flux links with both primary and secondary coils and induces in them e.m.f.'s of E_1 and E_2 respectively by mutual induction.

The induced e.m.f. E in a coil of N turns is given by $E = -N(d\Phi/dt)$ volts, where $\frac{d\Phi}{dt}$ is the rate of change of flux. In an ideal transformer, the rate of change of flux is the same for both primary and secondary and thus $E_1/N_1 = E_2/N_2$ i.e. **the induced e.m.f. per turn is constant.**

Assuming no losses, $E_1 = V_1$ and $E_2 = V_2$

Hence
$$\frac{V_1}{N_1} = \frac{V_2}{N_2} \text{ or } \frac{V_1}{V_2} = \frac{N_1}{N_2} \quad (1)$$

(V_1/V_2) is called the voltage ratio and (N_1/N_2) the turns ratio, or the '**transformation ratio**' of the transformer. If N_2 is less than N_1 then V_2 is less than V_1 and the device is termed a **step-down transformer**. If N_2 is greater than N_1 then V_2 is greater than V_1 and the device is termed a **step-up transformer**.

When a load is connected across the secondary winding, a current I_2 flows. In an ideal transformer losses are neglected and a transformer is considered to be 100 per cent efficient. Hence input power = output power, or $V_1I_1 = V_2I_2$ i.e. in an ideal

The **rating** of a transformer is stated in terms of the volt-amperes that it can transform without overheating. With reference to Fig. 21.1(a), the transformer rating is either V_1I_1 or V_2I_2 , where I_2 is the full-load secondary current.

Problem 1. A transformer has 500 primary turns and 3000 secondary turns. If the primary voltage is 240 V, determine the secondary voltage, assuming an ideal transformer.

For an ideal transformer, voltage ratio = turns ratio i.e.

$$\frac{V_1}{V_2} = \frac{N_1}{N_2} \text{ hence } \frac{240}{V_2} = \frac{500}{3000}$$

Thus secondary voltage

$$V_2 = \frac{(240)(3000)}{500} = 1440 \text{ V or } 1.44 \text{ kV}$$

Problem 2. An ideal transformer with a turns ratio of 2:7 is fed from a 240 V supply. Determine its output voltage.

A turns ratio of 2:7 means that the transformer has 2 turns on the primary for every 7 turns on the secondary (i.e. a step-up transformer); thus $(N_1/N_2) = (2/7)$.

For an ideal transformer, $(N_1/N_2) = (V_1/V_2)$ hence $(2/7) = (240/V_2)$ Thus the secondary voltage

$$V_2 = \frac{(240)(7)}{2} = \mathbf{840\text{ V}}$$

Problem 3. An ideal transformer has a turns ratio of 8:1 and the primary current is 3 A when it is supplied at 240 V. Calculate the secondary voltage and current.

A turns ratio of 8:1 means $(N_1/N_2) = (1/8)$ i.e. a step-down transformer.

$$\left(\frac{N_1}{N_2}\right) = \left(\frac{V_1}{V_2}\right) \text{ or secondary voltage}$$

$$V_2 = V_1 \left(\frac{N_1}{N_2}\right) = 240 \left(\frac{1}{8}\right) = \mathbf{30\text{ volts}}$$

Also, $\left(\frac{N_1}{N_2}\right) = \left(\frac{I_2}{I_1}\right)$ hence secondary current

$$I_2 = I_1 \left(\frac{N_1}{N_2}\right) = 3 \left(\frac{8}{1}\right) = \mathbf{24\text{ A}}$$

Problem 4. An ideal transformer, connected to a 240 V mains, supplies a 12 V, 150 W lamp. Calculate the transformer turns ratio and the current taken from the supply.

$V_1 = 240\text{ V}$, $V_2 = 12\text{ V}$, $I_2 = (P/V_2) = (150/12) = 12.5\text{ A}$.

$$\mathbf{\text{Turns ratio}} = \frac{N_1}{N_2} = \frac{V_1}{V_2} = \frac{240}{12} = \mathbf{20}$$

$\left(\frac{V_1}{V_2}\right) = \left(\frac{I_2}{I_1}\right)$, from which,

$$I_1 = I_2 \left(\frac{V_2}{V_1}\right) = 12.5 \left(\frac{12}{240}\right)$$

Hence current taken from the supply,

$$I_1 = \frac{12.5}{20} = \mathbf{0.625\text{ A}}$$

Problem 5. A $12\ \Omega$ resistor is connected across the secondary winding of an ideal transformer whose secondary voltage is 120 V. Determine the primary voltage if the supply current is 4 A.

Secondary current $I_2 = (V_2/R_2) = (120/12) = 10\text{ A}$.

$(V_1/V_2) = (I_2/I_1)$, from which the primary voltage

$$V_1 = V_2 \left(\frac{I_2}{I_1}\right) = 120 \left(\frac{10}{4}\right) = \mathbf{300\text{ volts}}$$

Problem 6. A 5 kVA single-phase transformer has a turns ratio of 10 : 1 and is fed from a 2.5 kV supply. Neglecting losses, determine (a) the full-load secondary current, (b) the minimum load resistance which can be connected across the secondary winding to give full load kVA, (c) the primary current at full load kVA.

(a) $N_1/N_2 = 10/1$ and $V_1 = 2.5\text{ kV} = 2500\text{ V}$.

Since $\left(\frac{N_1}{N_2}\right) = \left(\frac{V_1}{V_2}\right)$, secondary voltage

$$V_2 = V_1 \left(\frac{N_2}{N_1}\right) = 2500 \left(\frac{1}{10}\right) = 250\text{ V}$$

The transformer rating in volt-amperes = $V_2 I_2$ (at full load) i.e. $5000 = 250 I_2$

Hence full load secondary current $I_2 = (5000/250) = \mathbf{20\text{ A}}$.

(b) Minimum value of load resistance,

$$R_L = \left(\frac{V_2}{I_2}\right) = \left(\frac{250}{20}\right) = \mathbf{12.5\ \Omega}$$

(c) $\left(\frac{N_1}{N_2}\right) = \left(\frac{I_2}{I_1}\right)$ from which primary current

$$I_1 = I_2 \left(\frac{N_1}{N_2}\right) = 20 \left(\frac{10}{1}\right) = \mathbf{2\text{ A}}$$

Now try the following exercise

Exercise 114 Further problems on the transformer principle of operation

1 A transformer has 600 primary turns connected to a 1.5 kV supply. Determine the number of secondary turns for a 240 V output voltage, assuming no losses. [96]

- 2 An ideal transformer with a turns ratio of 2:9 is fed from a 220 V supply. Determine its output voltage. [990 V]
- 3 A transformer has 800 primary turns and 2000 secondary turns. If the primary voltage is 160 V, determine the secondary voltage assuming an ideal transformer. [400 V]
- 4 An ideal transformer with a turns ratio of 3:8 is fed from a 240 V supply. Determine its output voltage. [640 V]
- 5 An ideal transformer has a turns ratio of 12:1 and is supplied at 192 V. Calculate the secondary voltage. [16 V]
- 6 A transformer primary winding connected across a 415 V supply has 750 turns. Determine how many turns must be wound on the secondary side if an output of 1.66 kV is required. [3000 turns]
- 7 An ideal transformer has a turns ratio of 12:1 and is supplied at 180 V when the primary current is 4 A. Calculate the secondary voltage and current. [15 V, 48 A]
- 8 A step-down transformer having a turns ratio of 20:1 has a primary voltage of 4 kV and a load of 10 kW. Neglecting losses, calculate the value of the secondary current. [50 A]
- 9 A transformer has a primary to secondary turns ratio of 1:15. Calculate the primary voltage necessary to supply a 240 V load. If the load current is 3 A determine the primary current. Neglect any losses. [16 V, 45 A]
- 10 A 10 kVA, single-phase transformer has a turns ratio of 12:1 and is supplied from a 2.4 kV supply. Neglecting losses, determine (a) the full load secondary current, (b) the minimum value of load resistance which can be connected across the secondary winding without the kVA rating being exceeded, and (c) the primary current. [(a) 50 A (b) 4 Ω (c) 4.17 A]
- 11 A 20 Ω resistance is connected across the secondary winding of a single-phase power transformer whose secondary voltage is 150 V. Calculate the primary voltage and the turns ratio if the supply current is 5 A, neglecting losses. [225 V, 3:2]

21.3 Transformer no-load phasor diagram

The core flux is common to both primary and secondary windings in a transformer and is thus taken as the reference phasor in a phasor diagram. On no-load the primary winding takes a small no-load current I_0 and since, with losses neglected, the primary winding is a pure inductor, this current lags the applied voltage V_1 by 90° . In the phasor diagram assuming no losses, shown in Fig. 21.2(a), current I_0 produces the flux and is drawn in phase with the flux. The primary induced e.m.f. E_1 is in phase opposition to V_1 (by Lenz's law) and is shown 180° out of phase with V_1 and equal in magnitude. The secondary induced e.m.f. is shown for a 2:1 turns ratio transformer.

A no-load phasor diagram for a practical transformer is shown in Fig. 21.2(b). If current flows then losses will occur. When losses are considered then the no-load current I_0 is the phasor sum of two components – (i) I_M , **the magnetising component**, in phase with the flux, and (ii) I_C , **the core loss component** (supplying the hysteresis and eddy current losses). From Fig. 21.2(b):

$$\text{No-load current, } I_0 = \sqrt{I_M^2 + I_C^2} \text{ where}$$

$$I_M = I_0 \sin \phi_0 \text{ and } I_C = I_0 \cos \phi_0.$$

$$\text{Power factor on no-load} = \cos \phi_0 = (I_C/I_0).$$

$$\begin{aligned} \text{The total core losses (i.e. iron losses)} \\ = V_1 I_0 \cos \phi_0 \end{aligned}$$

Problem 7. A 2400 V/400 V single-phase transformer takes a no-load current of 0.5 A and the core loss is 400 W. Determine the values of the magnetising and core loss components of the no-load current. Draw to scale the no-load phasor diagram for the transformer.

$$V_1 = 2400\text{V}, V_2 = 400\text{V} \text{ and } I_0 = 0.5\text{ A} \text{ Core loss (i.e. iron loss)} = 400 = V_1 I_0 \cos \phi_0.$$

$$\text{i.e. } 400 = (2400)(0.5) \cos \phi_0$$

$$\text{Hence } \cos \phi_0 = \frac{400}{(2400)(0.5)} = 0.3333$$

$$\phi_0 = \cos^{-1} 0.3333 = 70.53^\circ$$

The no-load phasor diagram is shown in Fig. 21.3 Magnetising component,

$$I_M = I_0 \sin \phi_0 = 0.5 \sin 70.53^\circ = \mathbf{0.471\text{ A.}}$$

$$\begin{aligned} \text{Core loss component, } I_C = I_0 \cos \phi_0 = 0.5 \cos 70.53^\circ \\ = \mathbf{0.167\text{ A}} \end{aligned}$$

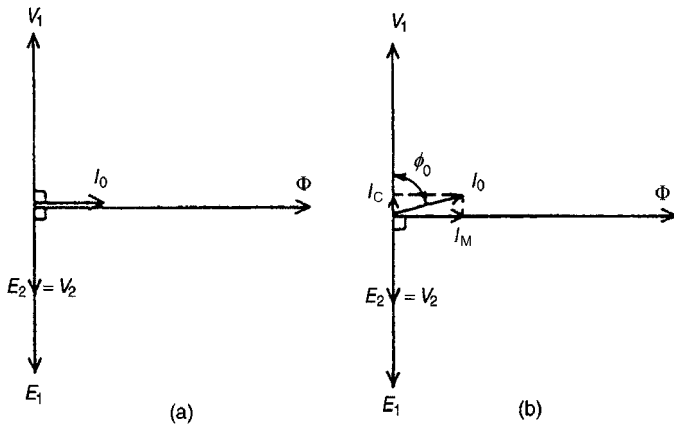

Figure 21.2

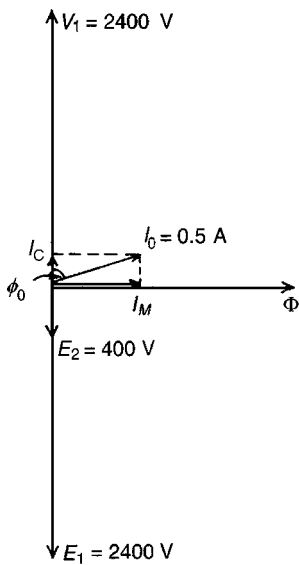

Figure 21.3

Problem 8. A transformer takes a current of 0.8 A when its primary is connected to a 240 volt, 50 Hz supply, the secondary being on open circuit. If the power absorbed is 72 watts, determine (a) the iron loss current, (b) the power factor on no-load, and (c) the magnetising current.

$I_0 = 0.8 \text{ A}$ and $V = 240 \text{ V}$

(a) Power absorbed = total core loss = 72 = $V_1 I_0 \cos \phi_0$. Hence $72 = 240 I_0 \cos \phi_0$ and iron loss current, $I_c = I_0 \cos \phi_0 = 72/240 = \mathbf{0.30 \text{ A}}$

(b) Power factor at no load,

$$\cos \phi_0 = \frac{I_c}{I_0} = \frac{0.3}{0.8} = \mathbf{0.375}$$

(c) From the right-angled triangle in Fig. 21.2(b) and using Pythagoras' theorem, $I_0^2 = I_c^2 + I_M^2$ from which, magnetising current,

$$I_M = \sqrt{I_0^2 - I_c^2} = \sqrt{0.8^2 - 0.3^2} = \mathbf{0.74 \text{ A}}$$

Now try the following exercise

Exercise 115 Further problems on the no-load phasor diagram

- 1 A 500 V/100 V, single-phase transformer takes a full load primary current of 4 A. Neglecting losses, determine (a) the full load secondary current, and (b) the rating of the transformer. [(a) 20 A (b) 2 kVA]
- 2 A 3300 V/440 V, single-phase transformer takes a no-load current of 0.8 A and the iron loss is 500 W. Draw the no-load phasor diagram and determine the values of the magnetising and core loss components of the no-load current. [0.786 A, 0.152 A]
- 3 A transformer takes a current of 1 A when its primary is connected to a 300 V, 50 Hz supply, the secondary being on open-circuit.

If the power absorbed is 120 watts, calculate
(a) the iron loss current, (b) the power factor
on no-load, and (c) the magnetising current.
[(a) 0.4 A (b) 0.4 (c) 0.92 A]

Problem 9. A 100 kVA, 4000 V/200 V,
50 Hz single-phase transformer has 100
secondary turns. Determine (a) the primary
and secondary current, (b) the number of
primary turns, and (c) the maximum value of
the flux.

21.4 E.m.f. equation of a transformer

The magnetic flux Φ set up in the core of a transformer when an alternating voltage is applied to its primary winding is also alternating and is sinusoidal.

Let Φ_m be the maximum value of the flux and f be the frequency of the supply. The time for 1 cycle of the alternating flux is the periodic time T , where $T = (1/f)$ seconds

The flux rises sinusoidally from zero to its maximum value in $(1/4)$ cycle, and the time for $(1/4)$ cycle is $(1/4f)$ seconds. Hence the average rate of change of flux $= (\Phi_m / (1/4f)) = 4f\Phi_m$ Wb/s, and since $1 \text{ Wb/s} = 1 \text{ volt}$, the average e.m.f. induced in each turn $= 4f\Phi_m$ volts. As the flux Φ varies sinusoidally, then a sinusoidal e.m.f. will be induced in each turn of both primary and secondary windings.

For a sine wave,

$$\begin{aligned} \text{form factor} &= \frac{\text{r.m.s. value}}{\text{average value}} \\ &= 1.11 \text{ (see Chapter 14)} \end{aligned}$$

Hence r.m.s. value $=$ form factor \times average value $= 1.11 \times$ average value Thus r.m.s. e.m.f. induced in each turn

$$\begin{aligned} &= 1.11 \times 4f\Phi_m \text{ volts} \\ &= 4.44f\Phi_m \text{ volts} \end{aligned}$$

Therefore, r.m.s. value of e.m.f. induced in primary,

$$E_1 = 4.44f\Phi_m N_1 \text{ volts} \quad (4)$$

and r.m.s. value of e.m.f. induced in secondary,

$$E_2 = 4.44f\Phi_m N_2 \text{ volts} \quad (5)$$

Dividing equation (4) by equation (5) gives:

$$\left(\frac{E_1}{E_2}\right) = \left(\frac{N_1}{N_2}\right),$$

as previously obtained in Section 21.2

$V_1 = 4000 \text{ V}$, $V_2 = 200 \text{ V}$, $f = 50 \text{ Hz}$, $N_2 = 100$ turns

(a) Transformer rating $= V_1 I_1 = V_2 I_2 = 100\,000 \text{ VA}$
Hence primary current,

$$I_1 = \frac{100\,000}{V_1} = \frac{100\,000}{4000} = 25 \text{ A}$$

and secondary current,

$$I_2 = \frac{100\,000}{V_2} = \frac{100\,000}{200} = 500 \text{ A}$$

(b) From equation (3), $\frac{V_1}{V_2} = \frac{N_1}{N_2}$ from which, primary turns,

$$N_1 = \left(\frac{V_1}{V_2}\right) (N_2) = \left(\frac{4000}{200}\right) (100) = 2000 \text{ turns}$$

(c) From equation (5), $E_2 = 4.44f\Phi_m N_2$ from which, maximum flux,

$$\begin{aligned} \Phi_m &= \frac{E}{4.44fN_2} \\ &= \frac{200}{(4.44)(50)(100)} \text{ (assuming } E_2 = V_2) \\ &= 9.01 \times 10^{-3} \text{ Wb or } 9.01 \text{ mWb} \end{aligned}$$

[Alternatively, equation (4) could have been used, where

$E_1 = 4.44f\Phi_m N_1$ from which,

$$\begin{aligned} \Phi_m &= \frac{4000}{(4.44)(50)(2000)} \text{ (assuming } E_1 = V_1) \\ &= 9.01 \text{ mWb as above] \end{aligned}$$

Problem 10. A single-phase, 50 Hz transformer has 25 primary turns and 300 secondary turns. The cross-sectional area of the core is 300 cm^2 . When the primary winding is connected to a 250 V supply, determine (a) the maximum value of the flux density in the core, and (b) the voltage induced in the secondary winding.

- (a) From equation (4),
e.m.f. $E_1 = 4.44 f \Phi_m N_1$ volts
i.e. $250 = 4.44(50)\Phi_m(25)$ from which, maximum flux density,

$$\Phi_m = \frac{250}{(4.44)(50)(25)} \text{ Wb} = 0.04505 \text{ Wb}$$

However, $\Phi_m = B_m \times A$, where B_m = maximum flux density in the core and A = cross-sectional area of the core (see Chapter 7). Hence $B_m \times 300 \times 10^{-4} = 0.04505$ from which,

$$\begin{aligned} \text{maximum flux density, } B_m &= \frac{0.04505}{300 \times 10^{-4}} \\ &= \mathbf{1.50 \text{ T}} \end{aligned}$$

- (b) $\frac{V_1}{V_2} = \frac{N_1}{N_2}$ from which, $V_2 = V_1 \left(\frac{N_2}{N_1} \right)$ i.e.
voltage induced in the secondary winding,

$$V_2 = (250) \left(\frac{300}{25} \right) = \mathbf{3000 \text{ V or } 3 \text{ kV}}$$

Problem 11. A single-phase 500 V/100 V, 50 Hz transformer has a maximum core flux density of 1.5 T and an effective core cross-sectional area of 50 cm^2 . Determine the number of primary and secondary turns.

The e.m.f. equation for a transformer is $E = 4.44 f \Phi_m N$ and maximum flux, $\Phi_m = B \times A = (1.5)(50 \times 10^{-4}) = 75 \times 10^{-4} \text{ Wb}$

Since $E_1 = 4.44 f \Phi_m N_1$ then primary turns,

$$\begin{aligned} N_1 &= \frac{E_1}{4.44 f \Phi_m} = \frac{500}{(4.44)(50)(75 \times 10^{-4})} \\ &= \mathbf{300 \text{ turns}} \end{aligned}$$

Since $E_2 = 4.4 f \Phi_m N_2$ then secondary turns,

$$\begin{aligned} N_2 &= \frac{E_2}{4.44 f \Phi_m} = \frac{100}{(4.44)(50)(75 \times 10^{-4})} \\ &= \mathbf{60 \text{ turns}} \end{aligned}$$

Problem 12. A 4500 V/225 V, 50 Hz single-phase transformer is to have an approximate e.m.f. per turn of 15 V and operate with a maximum flux of 1.4 T. Calculate (a) the number of primary and secondary turns and (b) the cross-sectional area of the core.

- (a) E.m.f. per turn = $\frac{E_1}{N_1} = \frac{E_2}{N_2} = 15$

$$\text{Hence primary turns, } N_1 = \frac{E_1}{15} = \frac{4500}{15} = \mathbf{300}$$

$$\text{and secondary turns, } N_2 = \frac{E_2}{15} = \frac{255}{15} = \mathbf{15}$$

- (b) E.m.f. $E_1 = 4.44 f \Phi_m N_1$ from which,

$$\Phi_m \frac{E_1}{4.44 f N_1} = \frac{4500}{(4.44)(50)(300)} = 0.0676 \text{ Wb}$$

Now flux, $\Phi_m = B_m \times A$, where A is the cross-sectional area of the core,

$$\begin{aligned} \text{hence area, } A &= \left(\frac{\Phi_m}{B_m} \right) = \left(\frac{0.0676}{1.4} \right) \\ &= \mathbf{0.0483 \text{ m}^2 \text{ or } 483 \text{ cm}^2} \end{aligned}$$

Now try the following exercise

Exercise 116 Further problems on the transformer e.m.f. equation

- A 60 kVA, 1600 V/100 V, 50 Hz, single-phase transformer has 50 secondary windings. Calculate (a) the primary and secondary current, (b) the number of primary turns, and (c) the maximum value of the flux
[(a) 37.5 A, 600 A (b) 800 (c) 9.0 mWb]
- A single-phase, 50 Hz transformer has 40 primary turns and 520 secondary turns. The cross-sectional area of the core is 270 cm^2 . When the primary winding is connected to a 300 volt supply, determine (a) the maximum value of flux density in the core, and (b) the voltage induced in the secondary winding
[(a) 1.25 T (b) 3.90 kV]

3 A single-phase 800 V/100 V, 50 Hz transformer has a maximum core flux density of 1.294 T and an effective cross-sectional area of 60 cm². Calculate the number of turns on the primary and secondary windings.

[464, 58]

4 A 3.3 kV/110 V, 50 Hz, single-phase transformer is to have an approximate e.m.f. per turn of 22 V and operate with a maximum flux of 1.25 T. Calculate (a) the number of primary and secondary turns, and (b) the cross-sectional area of the core

[(a) 150, 5 (b) 792.8 cm²]

However this does not happen since reduction of the core flux reduces E_1 , hence a reflected increase in primary current I'_1 occurs which provides a restoring m.m.f. Hence at all loads, primary and secondary m.m.f.'s are equal, but in opposition, and the core flux remains constant. I'_1 is sometimes called the 'balancing' current and is equal, but in the opposite direction, to current I_2 as shown in Fig. 21.4. I_0 , shown at a phase angle ϕ_0 to V_1 , is the no-load current of the transformer (see Section 21.3)

The phasor sum of I'_1 and I_0 gives the supply current I_1 and the phase angle between V_1 and I_1 is shown as ϕ_1

Problem 13. A single-phase transformer has 2000 turns on the primary and 800 turns on the secondary. Its no-load current is 5 A at a power factor of 0.20 lagging. Assuming the volt drop in the windings is negligible, determine the primary current and power factor when the secondary current is 100 A at a power factor of 0.85 lagging.

21.5 Transformer on-load phasor diagram

If the voltage drop in the windings of a transformer are assumed negligible, then the terminal voltage V_2 is the same as the induced e.m.f. E_2 in the secondary. Similarly, $V_1 = E_1$. Assuming an equal number of turns on primary and secondary windings, then $E_1 = E_2$, and let the load have a lagging phase angle ϕ_2

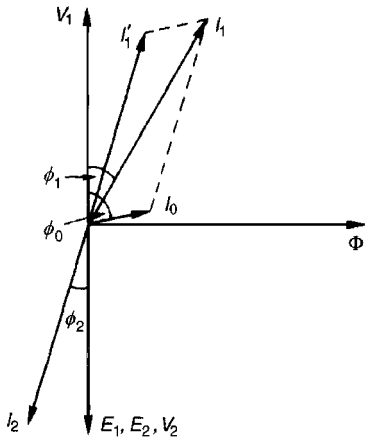

Figure 21.4

In the phasor diagram of Fig. 21.4, current I_2 lags V_2 by angle ϕ_2 . When a load is connected across the secondary winding a current I_2 flows in the secondary winding. The resulting secondary e.m.f. acts so as to tend to reduce the core flux.

Let I'_1 be the component of the primary current which provides the restoring m.m.f. Then

$$I'_1 N_1 = I_2 N_2$$

$$\text{i.e.} \quad I'_1 (2000) = (100)(800)$$

$$\begin{aligned} \text{from which,} \quad I'_1 &= \frac{(100)(800)}{2000} \\ &= 40 \text{ A} \end{aligned}$$

If the power factor of the secondary is 0.85, then $\cos \phi_2 = 0.85$, from which, $\phi_2 = \cos^{-1} 0.85 = 31.8^\circ$. If the power factor on no-load is 0.20, then $\cos \phi_0 = 0.2$ and $\phi_0 = \cos^{-1} 0.2 = 78.5^\circ$

In the phasor diagram shown in Fig. 21.5, $I_2 = 100$ A is shown at an angle of $\phi = 31.8^\circ$ to V_2 and $I'_1 = 40$ A is shown in anti-phase to I_2

The no-load current $I_0 = 5$ A is shown at an angle of $\phi_0 = 78.5^\circ$ to V_1 . Current I_1 is the phasor sum of I'_1 and I_0 , and by drawing to scale, $I_1 = 44$ A and angle $\phi_1 = 37^\circ$.

By calculation,

$$\begin{aligned} I_1 \cos \phi_1 &= 0a + 0b \\ &= I_0 \cos \phi_0 + I'_1 \cos \phi_2 \\ &= (5)(0.2) + (40)(0.85) \\ &= 35.0 \text{ A} \end{aligned}$$

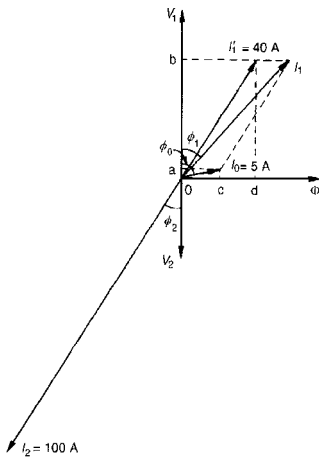

Figure 21.5

and $I_1 \sin \phi_1 = 0c + 0d$

$$\begin{aligned} &= I_0 \sin \phi_0 + I'_1 \sin \phi_2 \\ &= (5) \sin 78.5^\circ + (40) \sin 31.8^\circ \\ &= 25.98 \text{ A} \end{aligned}$$

Hence the magnitude of $I_1 = \sqrt{35.0^2 + 25.98^2} = 43.59 \text{ A}$ and $\tan \phi_1 = ((25.98/35.0))$ from which, $\phi_1 = \tan^{-1} ((25.98/35.0)) = 36.59^\circ$ Hence the power factor of the primary = $\cos \phi_1 = \cos 36.59^\circ = 0.80$

Now try the following exercise

Exercise 117 A further problem on the transformer on-load

- 1 A single-phase transformer has 2400 turns on the primary and 600 turns on the secondary. Its no-load current is 4 A at a power factor of 0.25 lagging. Assuming the volt drop in the windings is negligible, calculate the primary current and power factor when the secondary current is 80 A at a power factor of 0.8 lagging. [23.26 A, 0.73]

21.6 Transformer construction

- (i) There are broadly two types of single-phase double-wound transformer constructions – the **core type** and the **shell type**, as shown in

Fig. 21.6. The low and high voltage windings are wound as shown to reduce leakage flux.

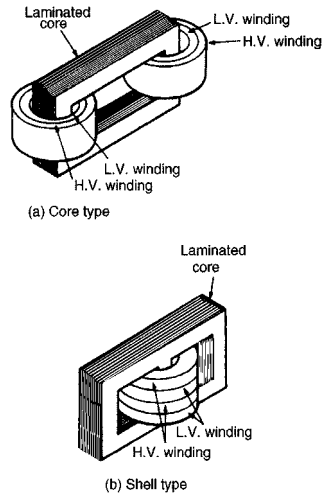

Figure 21.6

- (ii) For **power transformers**, rated possibly at several MVA and operating at a frequency of 50 Hz in Great Britain, the core material used is usually laminated silicon steel or stalloy, the laminations reducing eddy currents and the silicon steel keeping hysteresis loss to a minimum.

Large power transformers are used in the main distribution system and in industrial supply circuits. Small power transformers have many applications, examples including welding and rectifier supplies, domestic bell circuits, imported washing machines, and so on.

- (iii) For **audio frequency (a.f.) transformers**, rated from a few mVA to no more than 20 VA, and operating at frequencies up to about 15 kHz, the small core is also made of laminated silicon steel. A typical application of a.f. transformers is in an audio amplifier system.
- (iv) **Radio frequency (r.f.) transformers**, operating in the MHz frequency region have either an air core, a ferrite core or a dust core. Ferrite is a ceramic material having magnetic properties similar to silicon steel, but having a high resistivity. Dust cores consist of fine particles of carbonyl iron or permalloy (i.e. nickel and iron), each particle of which is insulated from its neighbour. Applications of r.f. transformers are found in radio and television receivers.

- (v) Transformer **windings** are usually of enamel-insulated copper or aluminium.
- (vi) **Cooling** is achieved by air in small transformers and oil in large transformers.

21.7 Equivalent circuit of a transformer

Figure 21.7 shows an equivalent circuit of a transformer. R_1 and R_2 represent the resistances of the primary and secondary windings and X_1 and X_2 represent the reactances of the primary and secondary windings, due to leakage flux.

The core losses due to hysteresis and eddy currents are allowed for by resistance R which takes a current I_C , the core loss component of the primary current. Reactance X takes the magnetising component I_m . In a simplified equivalent circuit shown in Fig. 21.8, R and X are omitted since the no-load current I_0 is normally only about 3–5 per cent of the full load primary current.

It is often convenient to assume that all of the resistance and reactance as being on one side of

the transformer. Resistance R_2 in Fig. 21.8 can be replaced by inserting an additional resistance R'_2 in the primary circuit such that the power absorbed in R'_2 when carrying the primary current is equal to that in R_2 due to the secondary current, i.e.

$$I_1^2 R'_2 = I_2^2 R_2$$

from which, $R'_2 = R_2 \left(\frac{I_2}{I_1}\right)^2 = R_2 \left(\frac{V_1}{V_2}\right)^2$

Then the total equivalent resistance in the primary circuit R_e is equal to the primary and secondary resistances of the actual transformer.

Hence $R_e = R_1 + R'_2$

i.e.

$$R_e = R_1 + R_2 \left(\frac{V_1}{V_2}\right)^2 \tag{6}$$

By similar reasoning, the equivalent reactance in the primary circuit is given by $X_e = X_1 + X'_2$

i.e.

$$X_e = X_1 + X_2 \left(\frac{V_1}{V_2}\right)^2 \tag{7}$$

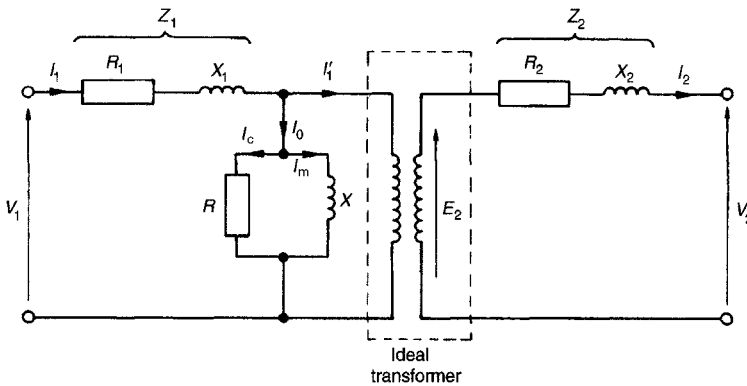

Figure 21.7

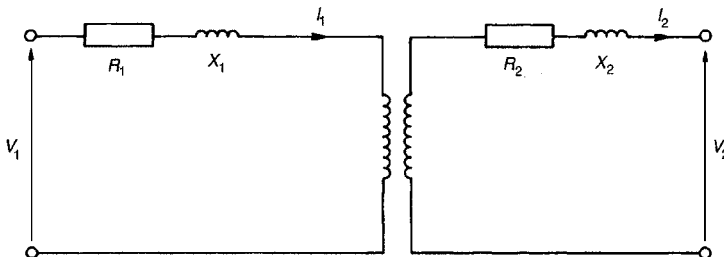

Figure 21.8

The equivalent impedance Z_e of the primary and secondary windings referred to the primary is given by

$$Z_e = \sqrt{R_e^2 + X_e^2} \quad (8)$$

If ϕ_e is the phase angle between I_1 and the volt drop $I_1 Z_e$ then

$$\cos \phi_e = \frac{R_e}{Z_e} \quad (9)$$

The simplified equivalent circuit of a transformer is shown in Fig. 21.9

Problem 14. A transformer has 600 primary turns and 150 secondary turns. The primary and secondary resistances are 0.25Ω and 0.01Ω respectively and the corresponding leakage reactances are 1.0Ω and 0.04Ω respectively. Determine (a) the equivalent resistance referred to the primary winding, (b) the equivalent reactance referred to the primary winding, (c) the equivalent impedance referred to the primary winding, and (d) the phase angle of the impedance.

(a) From equation (6), equivalent resistance

$$R_e = R_1 + R_2 \left(\frac{V_1}{V_2} \right)^2$$

$$\text{i.e. } R_e = 0.25 + 0.01 \left(\frac{600}{150} \right)^2$$

$$= 0.41 \Omega \text{ since } \frac{N_1}{N_2} = \frac{V_1}{V_2}$$

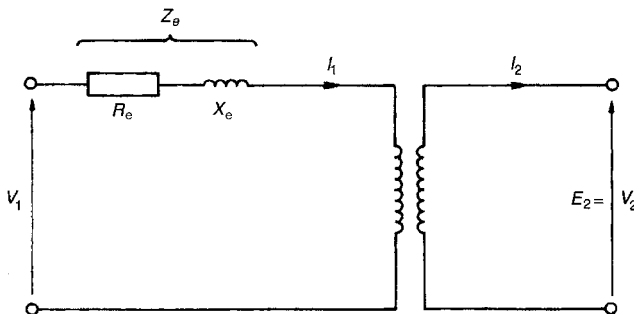

Figure 21.9

(b) From equation (7), equivalent reactance,

$$X_e = X_1 + X_2 \left(\frac{V_1}{V_2} \right)^2$$

$$\text{i.e. } X_e = 1.0 + 0.04 \left(\frac{600}{150} \right)^2 = 1.64 \Omega$$

(c) From equation (8), equivalent impedance,

$$Z_e = \sqrt{R_e^2 + X_e^2} = \sqrt{0.41^2 + 1.64^2} = 1.69 \Omega$$

(d) From equation (9),

$$\cos \phi_e = \frac{R_e}{Z_e} = \frac{0.41}{1.69}$$

$$\text{Hence } \phi_e = \cos^{-1} \frac{0.41}{1.69} = 75.96^\circ$$

Now try the following exercise

Exercise 118 A further problem on the equivalent circuit of a transformer

1 A transformer has 1200 primary turns and 200 secondary turns. The primary and secondary resistance's are 0.2Ω and 0.02Ω respectively and the corresponding leakage reactance's are 1.2Ω and 0.05Ω respectively. Calculate (a) the equivalent resistance, reactance and impedance referred to the primary winding, and (b) the phase angle of the impedance.

[(a) 0.92Ω , 3.0Ω , 3.14Ω (b) 72.95°]

21.8 Regulation of a transformer

When the secondary of a transformer is loaded, the secondary terminal voltage, V_2 , falls. As the

power factor decreases, this voltage drop increases. This is called the **regulation of the transformer** and it is usually expressed as a percentage of the secondary no-load voltage, E_2 . For full-load conditions:

$$\text{Regulation} = \left(\frac{E_2 - V_2}{E_2} \right) \times 100\% \quad (10)$$

The fall in voltage, $(E_2 - V_2)$, is caused by the resistance and reactance of the windings. Typical values of voltage regulation are about 3% in small transformers and about 1% in large transformers.

Problem 15. A 5 kVA, 200 V/400 V, single-phase transformer has a secondary terminal voltage of 387.6 volts when loaded. Determine the regulation of the transformer.

From equation (10):

$$\begin{aligned} \text{regulation} &= \left(\frac{\text{No load secondary voltage} - \text{terminal voltage on load}}{\text{no load secondary voltage}} \right) 100\% \\ &= \left(\frac{400 - 387.6}{400} \right) \times 100\% \\ &= \left(\frac{12.4}{400} \right) \times 100\% \\ &= 3.1\% \end{aligned}$$

Problem 16. The open circuit voltage of a transformer is 240 V. A tap changing device is set to operate when the percentage regulation drops below 2.5%. Determine the load voltage at which the mechanism operates.

$$\text{Regulation} = \left(\frac{\text{No load secondary voltage} - \text{terminal voltage on load}}{\text{no load secondary voltage}} \right) 100\%$$

$$\text{Hence} \quad 2.5 = \left(\frac{240 - V_2}{240} \right) \times 100\%$$

$$\therefore \frac{(2.5)(240)}{100} = 240 - V_2$$

$$\text{i.e.} \quad 6 = 240 - V_2$$

from which, **load voltage**, $V_2 = 240 - 6 = 234$ volts

Now try the following exercise

Exercise 119 Further problems on regulation

- 1 A 6 kVA, 100 V/500 V, single-phase transformer has a secondary terminal voltage of 487.5 volts when loaded. Determine the regulation of the transformer. [2.5%]
- 2 A transformer has an open circuit voltage of 110 volts. A tap-changing device operates when the regulation falls below 3%. Calculate the load voltage at which the tap-changer operates. [106.7 volts]

21.9 Transformer losses and efficiency

There are broadly two sources of **losses in transformers** on load, these being copper losses and iron losses.

- (a) **Copper losses** are variable and result in a heating of the conductors, due to the fact that they possess resistance. If R_1 and R_2 are the primary and secondary winding resistances then the total copper loss is $I_1^2 R_1 + I_2^2 R_2$
- (b) **Iron losses** are constant for a given value of frequency and flux density and are of two types – hysteresis loss and eddy current loss.
 - (i) **Hysteresis loss** is the heating of the core as a result of the internal molecular structure reversals which occur as the magnetic flux alternates. The loss is proportional to the area of the hysteresis loop and thus low loss nickel iron alloys are used for the core since their hysteresis loops have small areas. (See Chapters 7)
 - (ii) **Eddy current loss** is the heating of the core due to e.m.f.'s being induced not only in the transformer windings but also in the core. These induced e.m.f.'s set up circulating currents, called eddy currents. Owing to the low resistance of the core, eddy currents can be quite considerable and can cause a

large power loss and excessive heating of the core. Eddy current losses can be reduced by increasing the resistivity of the core material or, more usually, by laminating the core (i.e. splitting it into layers or leaves) when very thin layers of insulating material can be inserted between each pair of laminations. This increases the resistance of the eddy current path, and reduces the value of the eddy current.

Transformer efficiency,

$$\eta = \frac{\text{output power}}{\text{input power}} = \frac{\text{input power} - \text{losses}}{\text{input power}}$$

i.e.
$$\eta = 1 - \frac{\text{losses}}{\text{input power}} \quad (11)$$

and is usually expressed as a percentage. It is not uncommon for power transformers to have efficiencies of between 95% and 98%

$$\text{Output power} = V_2 I_2 \cos \phi_2.$$

$$\text{Total losses} = \text{copper loss} + \text{iron losses},$$

$$\text{and input power} = \text{output power} + \text{losses}$$

Problem 17. A 200 kVA rated transformer has a full-load copper loss of 1.5 kW and an iron loss of 1 kW. Determine the transformer efficiency at full load and 0.85 power factor.

$$\begin{aligned} \text{Efficiency, } \eta &= \frac{\text{output power}}{\text{input power}} \\ &= \frac{\text{input power} - \text{losses}}{\text{input power}} \\ &= 1 - \frac{\text{losses}}{\text{input power}} \end{aligned}$$

$$\text{Full-load output power} = VI \cos \phi = (200)(0.85) = 170 \text{ kW.}$$

$$\text{Total losses} = 1.5 + 1.0 = 2.5 \text{ kW}$$

$$\begin{aligned} \text{Input power} &= \text{output power} + \text{losses} \\ &= 170 + 2.5 = 172.5 \text{ kW.} \end{aligned}$$

$$\begin{aligned} \text{Hence efficiency} &= \left(1 - \frac{2.5}{172.5}\right) = 1 - 0.01449 \\ &= 0.9855 \text{ or } \mathbf{98.55\%} \end{aligned}$$

Problem 18. Determine the efficiency of the transformer in Problem 17 at half full-load and 0.85 power factor.

$$\begin{aligned} \text{Half full-load power output} &= (1/2)(200)(0.85) \\ &= 85 \text{ kW.} \end{aligned}$$

Copper loss (or I^2R loss) is proportional to current squared. Hence the copper loss at half full-load is: $(\frac{1}{2})^2(1500) = 375 \text{ W}$

$$\text{Iron loss} = 1000 \text{ W (constant)}$$

$$\text{Total losses} = 375 + 1000 = 1375 \text{ W or } 1.375 \text{ kW.}$$

$$\text{Input power at half full-load}$$

$$= \text{output power at half full-load} + \text{losses}$$

$$= 85 + 1.375 = 86.375 \text{ kW. Hence}$$

$$\begin{aligned} \text{efficiency} &= 1 - \frac{\text{losses}}{\text{input power}} \\ &= \left(1 - \frac{1.375}{86.375}\right) \\ &= 1 - 0.01592 \\ &= 0.9841 \text{ or } \mathbf{98.41\%} \end{aligned}$$

Problem 19. A 400 kVA transformer has a primary winding resistance of 0.5Ω and a secondary winding resistance of 0.001Ω . The iron loss is 2.5 kW and the primary and secondary voltages are 5 kV and 320 V respectively. If the power factor of the load is 0.85, determine the efficiency of the transformer (a) on full load, and (b) on half load.

(a) Rating = 400 kVA = $V_1 I_1 = V_2 I_2$. Hence primary current,

$$I_1 = \frac{400 \times 10^3}{V_1} = \frac{400 \times 10^3}{5000} = 80 \text{ A}$$

and secondary current,

$$I_2 = \frac{400 \times 10^3}{V_2} = \frac{400 \times 10^3}{320} = 1250 \text{ A}$$

$$\text{Total copper loss} = I_1^2 R_1 + I_2^2 R_2, \text{ (where } R_1 = 0.5 \Omega \text{ and } R_2 = 0.001 \Omega)$$

$$= (80)^2(0.5) + (1250)^2(0.001)$$

$$= 3200 + 1562.5 = 4762.5 \text{ watts}$$

On full load, total loss = copper loss + iron loss

$$= 4762.5 + 2500 = 7262.5 \text{ W} = 7.2625 \text{ kW}$$

Total output power on full load

$$= V_2 I_2 \cos \phi_2 = (400 \times 10^3)(0.85) = 340 \text{ kW}$$

$$\begin{aligned}\text{Input power} &= \text{output power} + \text{losses} \\ &= 340 \text{ kW} + 7.2625 \text{ kW} = 347.2625 \text{ kW}\end{aligned}$$

$$\begin{aligned}\text{Efficiency, } \eta &= \left(1 - \frac{\text{losses}}{\text{input power}}\right) \times 100\% \\ &= \left(1 - \frac{7.2625}{347.2625}\right) \times 100\% \\ &= \mathbf{97.91\%}\end{aligned}$$

- (b) Since the copper loss varies as the square of the current, then total copper loss on half load
 $= 4762.5 \times \left(\frac{1}{2}\right)^2 = 1190.625 \text{ W}$. Hence total loss on half load $= 1190.625 + 2500 = 3690.625 \text{ W}$ or 3.691 kW .
 Output power on half full load $= \left(\frac{1}{2}\right) (340) = 170 \text{ kW}$.
 Input power on half full load
 $= \text{output power} + \text{losses}$

$$\begin{aligned}&= 170 \text{ kW} + 3.691 \text{ kW} \\ &= 173.691 \text{ kW}\end{aligned}$$

Hence efficiency at half full load,

$$\begin{aligned}\eta &= \left(1 - \frac{\text{losses}}{\text{input power}}\right) \times 100\% \\ &= \left(1 - \frac{3.691}{173.691}\right) \times 100\% = \mathbf{97.87\%}\end{aligned}$$

Maximum efficiency

It may be shown that the efficiency of a transformer is a maximum when the variable copper loss (i.e. $I_1^2 R_1 + I_2^2 R_2$) is equal to the constant iron losses.

Problem 20. A 500 kVA transformer has a full load copper loss of 4 kW and an iron loss of 2.5 kW. Determine (a) the output kVA at which the efficiency of the transformer is a maximum, and (b) the maximum efficiency, assuming the power factor of the load is 0.75

- (a) Let x be the fraction of full load kVA at which the efficiency is a maximum. The corresponding total copper loss $= (4 \text{ kW})(x^2)$. At maximum efficiency, copper loss = iron loss. Hence $4x^2 = 2.5$ from which $x^2 = 2.5/4$ and $x = \sqrt{2.5/4} = 0.791$.
 Hence **the output kVA at maximum efficiency** $= 0.791 \times 500 = \mathbf{395.5 \text{ kVA}}$.

- (b) Total loss at maximum efficiency
 $= 2 \times 2.5 = 5 \text{ kW}$
 Output power $= 395.5 \text{ kVA} \times p.f.$
 $= 395.5 \times 0.75 = 296.625 \text{ kW}$
 Input power = output power + losses
 $= 296.625 + 5 = 301.625 \text{ kW}$

Maximum efficiency,

$$\begin{aligned}\eta &= \left(1 - \frac{\text{losses}}{\text{input power}}\right) \times 100\% \\ &= \left(1 - \frac{5}{301.625}\right) \times 100\% = \mathbf{98.34\%}\end{aligned}$$

Now try the following exercise

Exercise 120 Further problems on losses and efficiency

- A single-phase transformer has a voltage ratio of 6:1 and the h.v. winding is supplied at 540 V. The secondary winding provides a full load current of 30 A at a power factor of 0.8 lagging. Neglecting losses, find (a) the rating of the transformer, (b) the power supplied to the load, (c) the primary current
 [(a) 2.7 kVA (b) 2.16 kW (c) 5 A]
- A single-phase transformer is rated at 40 kVA. The transformer has full-load copper losses of 800 W and iron losses of 500 W. Determine the transformer efficiency at full load and 0.8 power factor [96.10%]
- Determine the efficiency of the transformer in problem 2 at half full-load and 0.8 power factor [95.81%]
- A 100 kVA, 2000 V/400 V, 50 Hz, single-phase transformer has an iron loss of 600 W and a full-load copper loss of 1600 W. Calculate its efficiency for a load of 60 kW at 0.8 power factor. [97.56%]
- Determine the efficiency of a 15 kVA transformer for the following conditions:
 - full-load, unity power factor
 - 0.8 full-load, unity power factor
 - half full-load, 0.8 power factor
 Assume that iron losses are 200 W and the full-load copper loss is 300 W
 [(a) 96.77% (ii) 96.84% (iii) 95.62%]

6 A 300 kVA transformer has a primary winding resistance of $0.4\ \Omega$ and a secondary winding resistance of $0.0015\ \Omega$. The iron loss is 2 kW and the primary and secondary voltages are 4 kV and 200 V respectively. If the power factor of the load is 0.78, determine the efficiency of the transformer (a) on full load, and (b) on half load.

[(a) 96.84% (b) 97.17%]

7 A 250 kVA transformer has a full load copper loss of 3 kW and an iron loss of 2 kW. Calculate (a) the output kVA at which the efficiency of the transformer is a maximum, and (b) the maximum efficiency, assuming the power factor of the load is 0.80

[(a) 204.1 kVA (b) 97.61%]

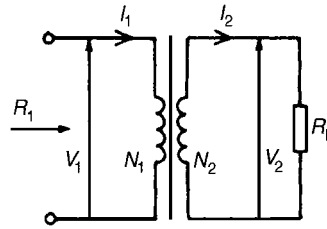

Figure 21.10

Thus the equivalent input resistance R_1 of the transformer is given by:

$$R_1 = \frac{V_1}{I_1} = \frac{\left(\frac{N_1}{N_2}\right) V_2}{\left(\frac{N_2}{N_1}\right) I_2} = \left(\frac{N_1}{N_2}\right)^2 \left(\frac{V_2}{I_2}\right) = \left(\frac{N_1}{N_2}\right)^2 R_L$$

i.e.

$$R_1 = \left(\frac{N_1}{N_2}\right)^2 R_L$$

Hence by varying the value of the turns ratio, the equivalent input resistance of a transformer can be ‘matched’ to the internal resistance of a load to achieve maximum power transfer.

Problem 21. A transformer having a turns ratio of 4:1 supplies a load of resistance $100\ \Omega$. Determine the equivalent input resistance of the transformer.

From above, the equivalent input resistance,

$$R_1 = \left(\frac{N_1}{N_2}\right)^2 R_L = \left(\frac{4}{1}\right)^2 (100) = \mathbf{1600\ \Omega}$$

Problem 22. The output stage of an amplifier has an output resistance of $112\ \Omega$. Calculate the optimum turns ratio of a transformer which would match a load resistance of $7\ \Omega$ to the output resistance of the amplifier.

21.10 Resistance matching

Varying a load resistance to be equal, or almost equal, to the source internal resistance is called **matching**. Examples where resistance matching is important include coupling an aerial to a transmitter or receiver, or in coupling a loudspeaker to an amplifier, where coupling transformers may be used to give maximum power transfer.

With d.c. generators or secondary cells, the internal resistance is usually very small. In such cases, if an attempt is made to make the load resistance as small as the source internal resistance, overloading of the source results.

A method of achieving maximum power transfer between a source and a load (see section 13.9, page 179), is to adjust the value of the load resistance to ‘match’ the source internal resistance. A transformer may be used as a **resistance matching device** by connecting it between the load and the source.

The reason why a transformer can be used for this is shown below. With reference to Fig. 21.10:

$$R_L = \frac{V_2}{I_2} \text{ and } R_1 = \frac{V_1}{I_1}$$

For an ideal transformer,

$$V_1 = \left(\frac{N_1}{N_2}\right) V_2$$

and

$$I_1 = \left(\frac{N_2}{N_1}\right) I_2$$

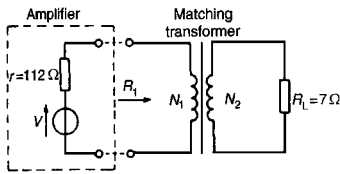

Figure 21.11

The circuit is shown in Fig. 21.11

The equivalent input resistance, R_1 of the transformer needs to be $112\ \Omega$ for maximum power transfer.

$$R_1 = \left(\frac{N_1}{N_2}\right)^2 R_L$$

$$\text{Hence } \left(\frac{N_1}{N_2}\right)^2 = \frac{R_1}{R_L} = \frac{112}{7} = 16$$

$$\text{i.e. } \frac{N_1}{N_2} = \sqrt{16} = 4$$

Hence the optimum turns ratio is 4:1

Problem 23. Determine the optimum value of load resistance for maximum power transfer if the load is connected to an amplifier of output resistance $150\ \Omega$ through a transformer with a turns ratio of 5:1

The equivalent input resistance R_1 of the transformer needs to be $150\ \Omega$ for maximum power transfer.

$$R_1 = \left(\frac{N_1}{N_2}\right)^2 R_L$$

$$\begin{aligned} \text{from which, } R_L &= R_1 \left(\frac{N_2}{N_1}\right)^2 \\ &= 150 \left(\frac{1}{5}\right)^2 = \mathbf{6\ \Omega} \end{aligned}$$

Problem 24. A single-phase, $220\ \text{V}/1760\ \text{V}$ ideal transformer is supplied from a $220\ \text{V}$ source through a cable of resistance $2\ \Omega$. If the load across the secondary winding is $1.28\ \text{k}\Omega$ determine (a) the primary current flowing and (b) the power dissipated in the load resistor.

The circuit diagram is shown in Fig. 21.12

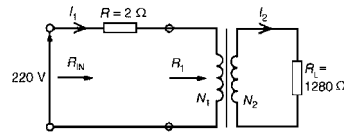

Figure 21.12

(a) Turns ratio

$$\left(\frac{N_1}{N_2}\right) = \left(\frac{V_1}{V_2}\right) = \left(\frac{220}{1760}\right) = \left(\frac{1}{8}\right)$$

Equivalent input resistance of the transformer.

$$R_1 = \left(\frac{N_1}{N_2}\right)^2 R_L = \left(\frac{1}{8}\right)^2 (1.28 \times 10^3) = 20\ \Omega$$

Total input resistance,

$$R_{\text{IN}} = R + R_1 = 2 + 20 = 22\ \Omega$$

Primary current,

$$I_1 = \frac{V_1}{R_{\text{IN}}} = \frac{220}{22} = \mathbf{10\ \text{A}}$$

(b) For an ideal transformer

$$\frac{V_1}{V_2} = \frac{I_2}{I_1}$$

from which,

$$I_2 = I_1 \left(\frac{V_1}{V_2}\right) = 10 \left(\frac{220}{1760}\right) = 1.25\ \text{A}$$

Power dissipated in load resistor R_L ,

$$\begin{aligned} P &= I_2^2 R_L = (1.25)^2 (1.28 \times 10^3) \\ &= \mathbf{2000\ \text{watts or } 2\ \text{kW}} \end{aligned}$$

Problem 25. An a.c. source of $24\ \text{V}$ and internal resistance $15\ \text{k}\Omega$ is matched to a load by a 25:1 ideal transformer. Determine (a) the value of the load resistance and (b) the power dissipated in the load.

The circuit diagram is shown in Fig. 21.13

(a) For maximum power transfer R_1 needs to be equal to $15\ \text{k}\Omega$.

$$R_1 = \left(\frac{N_1}{N_2}\right)^2 R_L$$

from which, load resistance,

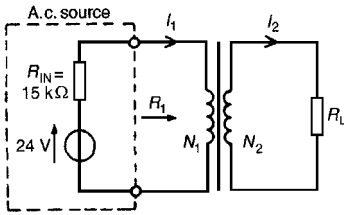

Figure 21.13

$$R_L = R_1 \left(\frac{N_2}{N_1} \right)^2 = (15\,000) \left(\frac{1}{25} \right)^2 = 24\ \Omega$$

- (b) The total input resistance when the source is connected to the matching transformer is $R_{IN} + R_1$ i.e. $15\text{ k}\Omega + 15\text{ k}\Omega = 30\text{ k}\Omega$.

Primary current,

$$I_1 = \frac{V}{30000} = \frac{24}{30000} = 0.8\text{ mA}$$

$$N_1/N_2 = I_2/I_1 \text{ from which, } I_2 = I_1(N_1/N_2) = (0.8 \times 10^{-3})(25/1) = 20 \times 10^{-3}\text{ A.}$$

Power dissipated in the load R_L ,

$$P = I_2^2 R_L = (20 \times 10^{-3})^2 (24) = 9600 \times 10^{-6}\text{ W} = 9.6\text{ mW}$$

Now try the following exercise

Exercise 121 Further problems on resistance matching

- 1 A transformer having a turns ratio of 8:1 supplies a load of resistance $50\ \Omega$. Determine the equivalent input resistance of the transformer. [3.2 k Ω]
- 2 What ratio of transformer is required to make a load of resistance $30\ \Omega$ appear to have a resistance of $270\ \Omega$? [3:1]
- 3 Determine the optimum value of load resistance for maximum power transfer if the load is connected to an amplifier of output resistance $147\ \Omega$ through a transformer with a turns ratio of 7:2 [12 Ω]
- 4 A single-phase, 240 V/2880 V ideal transformer is supplied from a 240 V source through a cable of resistance $3\ \Omega$. If the load across the secondary winding is $720\ \Omega$ determine (a) the primary current flowing and

- (b) the power dissipated in the load resistance. [(a) 30 A (b) 4.5 kW]

- 5 A load of resistance $768\ \Omega$ is to be matched to an amplifier which has an effective output resistance of $12\ \Omega$. Determine the turns ratio of the coupling transformer. [1:8]
- 6 An a.c. source of 20 V and internal resistance $20\text{ k}\Omega$ is matched to a load by a 16:1 single-phase transformer. Determine (a) the value of the load resistance and (b) the power dissipated in the load. [(a) 78.13 Ω (b) 5 mW]

21.11 Auto transformers

An auto transformer is a transformer which has part of its winding common to the primary and secondary circuits. Fig. 21.14(a) shows the circuit for a double-wound transformer and Fig. 21.14(b) that for an auto transformer. The latter shows that the secondary is actually part of the primary, the current in the secondary being $(I_2 - I_1)$. Since the current is less in this section, the cross-sectional area of the winding can be reduced, which reduces the amount of material necessary.

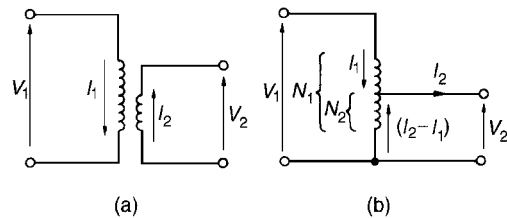

Figure 21.14

Figure 21.15 shows the circuit diagram symbol for an auto transformer.

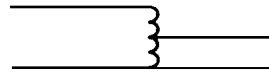

Figure 21.15

Problem 26. A single-phase auto transformer has a voltage ratio 320 V:250 V and supplies a load of 20 kVA at 250 V. Assuming an ideal transformer, determine the current in each section of the winding.

$$\text{Rating} = 20\text{ kVA} = V_1 I_1 = V_2 I_2.$$

Hence primary current,

$$I_1 = \frac{20 \times 10^3}{V_1} = \frac{20 \times 10^3}{320} = \mathbf{62.5 \text{ A}}$$

and secondary current,

$$I_2 = \frac{20 \times 10^3}{V_2} = \frac{20 \times 10^3}{250} = \mathbf{80 \text{ A}}$$

Hence current in common part of the winding = $80 - 62.5 = \mathbf{17.5 \text{ A}}$

The current flowing in each section of the transformer is shown in Fig. 21.16

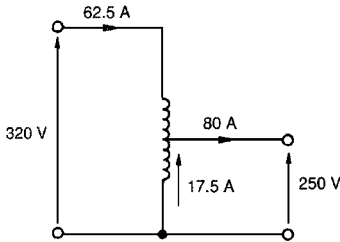

Figure 21.16

Saving of copper in an auto transformer

For the same output and voltage ratio, the auto transformer requires less copper than an ordinary double-wound transformer. This is explained below.

The volume, and hence weight, of copper required in a winding is proportional to the number of turns and to the cross-sectional area of the wire. In turn this is proportional to the current to be carried, i.e. volume of copper is proportional to NI .

Volume of copper in an auto transformer

$$\propto (N_1 - N_2)I_1 + N_2(I_2 - I_1)$$

see Fig. 21.14(b)

$$\propto N_1I_1 - N_2I_1 + N_2I_2 - N_2I_1$$

$$\propto N_1I_1 + N_2I_2 - 2N_2I_1$$

$$\propto 2N_1I_1 - 2N_2I_1 \quad (\text{since } N_2I_2 = N_1I_1)$$

Volume of copper in a double-wound transformer

$$\propto N_1I_1 + N_2I_2 \propto 2N_1I_1$$

(again, since $N_2I_2 = N_1I_1$). Hence

$$\frac{\text{volume of copper in an auto transformer}}{\text{volume of copper in a double-wound transformer}} = \frac{2N_1I_1 - 2N_2I_1}{2N_1I_1}$$

$$\begin{aligned} &= \frac{2N_1I_1}{2N_1I_1} - \frac{2N_2I_1}{2N_1I_1} \\ &= 1 - \frac{N_2}{N_1} \end{aligned}$$

If $(N_2/N_1) = x$ then

$$\begin{aligned} &(\text{volume of copper in an auto transformer}) \\ &= (1 - x) (\text{volume of copper in a double-wound transformer}) \quad (12) \end{aligned}$$

If, say, $x = (4/5)$ then (volume of copper in auto transformer)

$$= (1 - \frac{4}{5}) (\text{volume of copper in a double-wound transformer})$$

$$= \frac{1}{5} (\text{volume in double-wound transformer})$$

i.e. a saving of 80%.

Similarly, if $x = (1/4)$, the saving is 25 per cent, and so on. The closer N_2 is to N_1 , the greater the saving in copper.

Problem 27. Determine the saving in the volume of copper used in an auto transformer compared with a double-wound transformer for (a) a 200 V:150 V transformer, and (b) a 500 V:100 V transformer.

(a) For a 200 V:150 V transformer,

$$x = \frac{V_2}{V_1} = \frac{150}{200} = 0.75$$

Hence from equation (12), (volume of copper in auto transformer)

$$= (1 - 0.75) (\text{volume of copper in double-wound transformer})$$

$$= (0.25) (\text{volume of copper in double-wound transformer})$$

$$= 25\% (\text{of copper in a double-wound transformer})$$

Hence the saving is 75%

(b) For a 500 V:100 V transformer,

$$x = \frac{V_2}{V_1} = \frac{100}{500} = 0.2$$

Hence, (volume of copper in auto transformer)

$$= (1 - 0.2) \text{ (volume of copper in double-wound transformer)}$$

$$= (0.8) \text{ (volume in double-wound transformer)}$$

$$= 80\% \text{ of copper in a double-wound transformer}$$

Hence the saving is 20%.

Now try the following exercise

Exercise 122 Further problems on the auto-transformer

- 1 A single-phase auto transformer has a voltage ratio of 480 V:300 V and supplies a load of 30 kVA at 300 V. Assuming an ideal transformer, calculate the current in each section of the winding.
 $[I_1 = 62.5 \text{ A}, I_2 = 100 \text{ A}, (I_2 - I_1) = 37.5 \text{ A}]$
- 2 Calculate the saving in the volume of copper used in an auto transformer compared with a double-wound transformer for (a) a 300 V:240 V transformer, and (b) a 400 V:100 V transformer [(a) 80% (b) 25%]

Advantages of auto transformers

The advantages of auto transformers over double-wound transformers include:

- 1 a saving in cost since less copper is needed (see above)
- 2 less volume, hence less weight
- 3 a higher efficiency, resulting from lower I^2R losses
- 4 a continuously variable output voltage is achievable if a sliding contact is used
- 5 a smaller percentage voltage regulation.

Disadvantages of auto transformers

The primary and secondary windings are not electrically separate, hence if an open-circuit occurs in the secondary winding the full primary voltage appears across the secondary.

Uses of auto transformers

Auto transformers are used for reducing the voltage when starting induction motors (see Chapter 23) and

for interconnecting systems that are operating at approximately the same voltage.

21.12 Isolating transformers

Transformers not only enable current or voltage to be transformed to some different magnitude but provide a means of isolating electrically one part of a circuit from another when there is no electrical connection between primary and secondary windings. An **isolating transformer** is a 1:1 ratio transformer with several important applications, including bathroom shaver-sockets, portable electric tools, model railways, and so on.

21.13 Three-phase transformers

Three-phase double-wound transformers are mainly used in power transmission and are usually of the core type. They basically consist of three pairs of single-phase windings mounted on one core, as shown in Fig. 21.17, which gives a considerable saving in the amount of iron used. The primary and secondary windings in Fig. 21.17 are wound on top of each other in the form of concentric cylinders, similar to that shown in Fig. 21.6(a). The windings may be with the primary delta-connected and the secondary star-connected, or star-delta, star-star or delta-delta, depending on its use.

A delta-connection is shown in Fig. 21.18(a) and a star-connection in Fig. 21.18(b).

Problem 28. A three-phase transformer has 500 primary turns and 50 secondary turns. If the supply voltage is 2.4 kV find the secondary line voltage on no-load when the windings are connected (a) star-delta, (b) delta-star.

- (a) For a star-connection, $V_L = \sqrt{3} V_p$ (see Chapter 20). Primary phase voltage,

$$V_p = \frac{V_{L1}}{\sqrt{3}} = \frac{2400}{\sqrt{3}} = 1385.64 \text{ volts.}$$

For a delta-connection, $V_L = V_p \cdot N_1/N_2 = V_1/V_2$ from which, secondary phase voltage,

$$V_{p2} = V_{p1} \left(\frac{N_2}{N_1} \right) = (1385.64) \left(\frac{50}{500} \right)$$

$$= \mathbf{138.6 \text{ volts}}$$

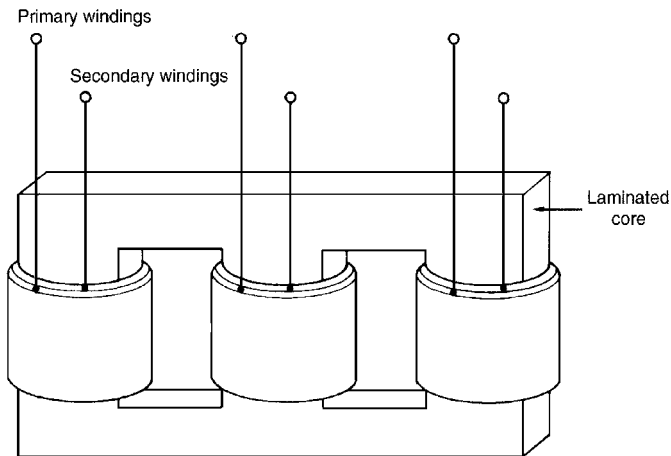

Figure 21.17

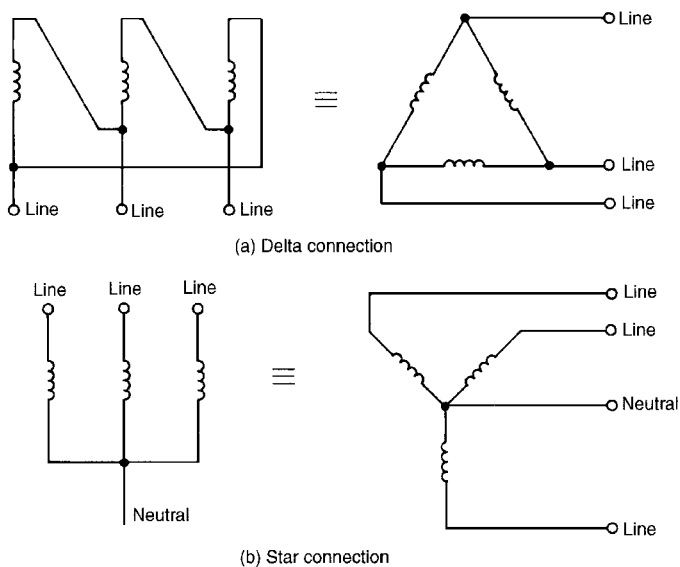

Figure 21.18

(b) For a delta-connection, $V_L = V_p$ hence, primary phase voltage $V_{p1} = 2.4 \text{ kV} = 2400 \text{ volts}$.
Secondary phase voltage,

$$V_{p2} = V_{p1} \left(\frac{N_2}{N_1} \right) = (2400) \left(\frac{50}{500} \right) = 240 \text{ volts}$$

For a star-connection, $V_L = \sqrt{3} V_p$ hence, the secondary line voltage, $V_{L2} = \sqrt{3}(240) = \mathbf{416 \text{ volts}}$.

Now try the following exercise

Exercise 123 A further problem on the three-phase transformer

1 A three-phase transformer has 600 primary turns and 150 secondary turns. If the supply voltage is 1.5 kV determine the secondary line voltage on no-load when the windings are connected (a) delta-star (b) star-delta

[(a) 649.5 V (b) 216.5 V]

21.14 Current transformers

For measuring currents in excess of about 100 A a current transformer is normally used. With a d.c. moving-coil ammeter the current required to give full scale deflection is very small – typically a few milliamperes. When larger currents are to be measured a shunt resistor is added to the circuit (see Chapter 10). However, even with shunt resistors added it is not possible to measure very large currents. When a.c. is being measured a shunt cannot be used since the proportion of the current which flows in the meter will depend on its impedance, which varies with frequency.

In a double-wound transformer:

$$\frac{I_1}{I_2} = \frac{N_2}{N_1}$$

from which,

$$\text{secondary current } I_2 = I_1 \left(\frac{N_1}{N_2} \right)$$

In current transformers the primary usually consists of one or two turns whilst the secondary can have several hundred turns. A typical arrangement is shown in Fig. 21.19

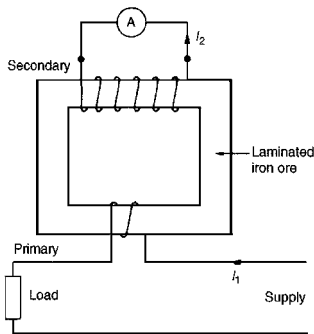

Figure 21.19

If, for example, the primary has 2 turns and the secondary 200 turns, then if the primary current is 500 A,

$$\begin{aligned} \text{secondary current, } I_2 &= I_1 \left(\frac{N_1}{N_2} \right) = (500) \left(\frac{2}{200} \right) \\ &= 5 \text{ A} \end{aligned}$$

Current transformers isolate the ammeter from the main circuit and allow the use of a standard range

of ammeters giving full-scale deflections of 1 A, 2 A or 5 A.

For very large currents the transformer core can be mounted around the conductor or bus-bar. Thus the primary then has just one turn.

It is very important to short-circuit the secondary winding before removing the ammeter. This is because if current is flowing in the primary, dangerously high voltages could be induced in the secondary should it be open-circuited.

Current transformer circuit diagram symbols are shown in Fig. 21.20

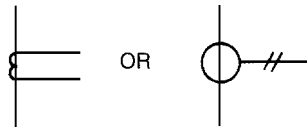

Figure 21.20

Problem 29. A current transformer has a single turn on the primary winding and a secondary winding of 60 turns. The secondary winding is connected to an ammeter with a resistance of 0.15 Ω. The resistance of the secondary winding is 0.25 Ω. If the current in the primary winding is 300 A, determine (a) the reading on the ammeter, (b) the potential difference across the ammeter and (c) the total load (in VA) on the secondary.

(a) Reading on the ammeter,

$$I_2 = I_1 \left(\frac{N_1}{N_2} \right) = 300 \left(\frac{1}{60} \right) = 5 \text{ A.}$$

(b) P.d. across the ammeter = $I_2 R_A$, (where R_A is the ammeter resistance) = $(5)(0.15) = 0.75 \text{ volts.}$

(c) Total resistance of secondary circuit = $0.15 + 0.25 = 0.40 \Omega.$

Induced e.m.f. in secondary = $(5)(0.40) = 2.0 \text{ V.}$

Total load on secondary = $(2.0)(5) = 10 \text{ VA.}$

Now try the following exercise

Exercise 124 A further problem on the current transformer

1 A current transformer has two turns on the primary winding and a secondary winding of

260 turns. The secondary winding is connected to an ammeter with a resistance of $0.2\ \Omega$. The resistance of the secondary winding is $0.3\ \Omega$. If the current in the primary winding is $650\ \text{A}$, determine (a) the reading on the ammeter, (b) the potential difference across the ammeter, and (c) the total load in VA on the secondary [(a) $5\ \text{A}$ (b) $1\ \text{V}$ (c) $7.5\ \text{VA}$]

21.15 Voltage transformers

For measuring voltages in excess of about $500\ \text{V}$ it is often safer to use a voltage transformer. These are normal double-wound transformers with a large number of turns on the primary, which is connected to a high voltage supply, and a small number of turns on the secondary. A typical arrangement is shown in Fig. 21.21

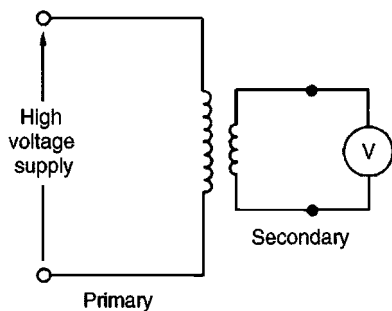

Figure 21.21

Since

$$\frac{V_1}{V_2} = \frac{N_1}{N_2}$$

the secondary voltage,

$$V_2 = \frac{V_1 N_2}{N_1}$$

Thus if the arrangement in Fig. 21.21 has 4000 primary turns and 20 secondary turns then for a voltage of $22\ \text{kV}$ on the primary, the voltage on the secondary,

$$V_2 = V_1 \left(\frac{N_2}{N_1} \right) = (22\ 000) \left(\frac{20}{4000} \right) = \mathbf{110\ \text{volts}}$$

Now try the following exercises

Exercise 125 Short answer questions on transformers

- 1 What is a transformer?
- 2 Explain briefly how a voltage is induced in the secondary winding of a transformer
- 3 Draw the circuit diagram symbol for a transformer
- 4 State the relationship between turns and voltage ratios for a transformer
- 5 How is a transformer rated?
- 6 Briefly describe the principle of operation of a transformer
- 7 Draw a phasor diagram for an ideal transformer on no-load
- 8 State the e.m.f. equation for a transformer
- 9 Draw an on-load phasor diagram for an ideal transformer with an inductive load
- 10 Name two types of transformer construction
- 11 What core material is normally used for power transformers
- 12 Name three core materials used in r.f. transformers
- 13 State a typical application for (a) a.f. transformers (b) r.f. transformers
- 14 How is cooling achieved in transformers?
- 15 State the expressions for equivalent resistance and reactance of a transformer, referred to the primary
- 16 Define regulation of a transformer
- 17 Name two sources of loss in a transformer
- 18 What is hysteresis loss? How is it minimised in a transformer?
- 19 What are eddy currents? How may they be reduced in transformers?
- 20 How is efficiency of a transformer calculated?
- 21 What is the condition for maximum efficiency of a transformer?
- 22 What does 'resistance matching' mean?

- 23 State a practical application where matching would be used
- 24 Derive a formula for the equivalent resistance of a transformer having a turns ratio of $N_1 : N_2$ and load resistance R_L
- 25 What is an auto transformer?
- 26 State three advantages and one disadvantage of an auto transformer compared with a double-wound transformer
- 27 In what applications are auto transformers used?
- 28 What is an isolating transformer? Give two applications
- 29 Describe briefly the construction of a three-phase transformer
- 30 For what reason are current transformers used?
- 31 Describe how a current transformer operates
- 32 For what reason are voltage transformers used?
- 33 Describe how a voltage transformer operates

Exercise 126 Multi-choice questions on transformers (Answers on page 376)

- 1 The e.m.f. equation of a transformer of secondary turns N_2 , magnetic flux density B_m , magnetic area of core a , and operating at frequency f is given by:
 - (a) $E_2 = 4.44N_2B_m a f$ volts
 - (b) $E_2 = 4.44 \frac{N_2 B_m f}{a}$ volts
 - (c) $E_2 = \frac{N_2 B_m f}{a}$ volts
 - (d) $E_2 = 1.11N_2 B_m a f$ volts
- 2 In the auto-transformer shown in Fig. 21.22, the current in section PQ is:
 - (a) 3.3 A (b) 1.7 A (c) 5 A (d) 1.6 A
- 3 A step-up transformer has a turns ratio of 10. If the output current is 5 A, the input current is:
 - (a) 50 A (b) 5 A (c) 2.5 A (d) 0.5 A

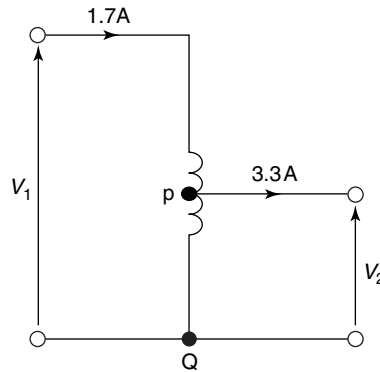

Figure 21.22

- 4 A 440 V/110 V transformer has 1000 turns on the primary winding. The number of turns on the secondary is:
 - (a) 550 (b) 250 (c) 4000 (d) 25
 - 5 An advantage of an auto-transformer is that:
 - (a) it gives a high step-up ratio
 - (b) iron losses are reduced
 - (c) copper loss is reduced
 - (d) it reduces capacitance between turns
 - 6 A 1 kV/250 V transformer has 500 turns on the secondary winding. The number of turns on the primary is:
 - (a) 2000 (b) 125 (c) 1000 (d) 250
 - 7 The core of a transformer is laminated to:
 - (a) limit hysteresis loss
 - (b) reduce the inductance of the windings
 - (c) reduce the effects of eddy current loss
 - (d) prevent eddy currents from occurring
 - 8 The power input to a mains transformer is 200 W. If the primary current is 2.5 A, the secondary voltage is 2 V and assuming no losses in the transformer, the turns ratio is:
 - (a) 40:1 step down (b) 40:1 step up
 - (c) 80:1 step down (d) 80:1 step up
 - 9 A transformer has 800 primary turns and 100 secondary turns. To obtain 40 V from the secondary winding the voltage applied to the primary winding must be:
 - (a) 5 V (b) 320 V
 - (c) 2.5 V (d) 20 V
- A 100 kVA, 250 V/10 kV, single-phase transformer has a full-load copper loss of 800 W and an iron loss of 500 W. The primary winding contains 120 turns. For the statements in

- questions 10 to 16, select the correct answer from the following list:
- (a) 81.3 kW (b) 800 W (c) 97.32%
(d) 80 kW (e) 3 (f) 4800
(g) 1.3 kW (h) 98.40% (i) 100 kW
(j) 98.28% (k) 200 W (l) 101.3 kW
(m) 96.38% (n) 400 W
- 10 The total full-load losses
- 11 The full-load output power at 0.8 power factor
- 12 The full-load input power at 0.8 power factor
- 13 The full-load efficiency at 0.8 power factor
- 14 The half full-load copper loss
- 15 The transformer efficiency at half full-load, 0.8 power factor
- 16 The number of secondary winding turns
- 17 Which of the following statements is false?
- (a) In an ideal transformer, the volts per turn are constant for a given value of primary voltage
- (b) In a single-phase transformer, the hysteresis loss is proportional to frequency
- (c) A transformer whose secondary current is greater than the primary current is a step-up transformer

- (d) In transformers, eddy current loss is reduced by laminating the core
- 18 An ideal transformer has a turns ratio of 1:5 and is supplied at 200 V when the primary current is 3 A. Which of the following statements is false?
- (a) The turns ratio indicates a step-up transformer
- (b) The secondary voltage is 40 V
- (c) The secondary current is 15 A
- (d) The transformer rating is 0.6 kVA
- (e) The secondary voltage is 1 kV
- (f) The secondary current is 0.6 A
- 19 Iron losses in a transformer are due to:
- (a) eddy currents only
- (b) flux leakage
- (c) both eddy current and hysteresis losses
- (d) the resistance of the primary and secondary windings
- 20 A load is to be matched to an amplifier having an effective internal resistance of $10\ \Omega$ via a coupling transformer having a turns ratio of 1:10. The value of the load resistance for maximum power transfer is:
- (a) $100\ \Omega$ (b) $1\ \text{k}\Omega$
(c) $100\ \text{m}\Omega$ (d) $1\ \text{m}\Omega$

Assignment 6

This assignment covers the material contained in Chapters 20 and 21.

The marks for each question are shown in brackets at the end of each question.

- 1 Three identical coils each of resistance $40\ \Omega$ and inductive reactance $30\ \Omega$ are connected (i) in star, and (ii) in delta to a $400\ \text{V}$, three-phase supply. Calculate for each connection (a) the line and phase voltages, (b) the phase and line currents, and (c) the total power dissipated. (12)
- 2 Two wattmeters are connected to measure the input power to a balanced three-phase load by the two-wattmeter method. If the instrument readings are $10\ \text{kW}$ and $6\ \text{kW}$, determine (a) the total power input, and (b) the load power factor. (5)
- 3 An ideal transformer connected to a $250\ \text{V}$ mains, supplies a $25\ \text{V}$, $200\ \text{W}$ lamp. Calculate the transformer turns ratio and the current taken from the supply. (5)
- 4 A $200\ \text{kVA}$, $8000\ \text{V}/320\ \text{V}$, $50\ \text{Hz}$ single phase transformer has 120 secondary turns. Determine (a) the primary and secondary currents, (b) the number of primary turns, and (c) the maximum value of flux. (9)
- 5 Determine the regulation of an $8\ \text{kVA}$, $100\ \text{V}/200\ \text{V}$, single phase transformer when its secondary terminal voltage is $194\ \text{V}$ when loaded. (3)
- 6 A $500\ \text{kVA}$ rated transformer has a full-load copper loss of $4\ \text{kW}$ and an iron loss of $3\ \text{kW}$. Determine the transformer efficiency (a) at full load and 0.80 power factor, and (b) at half full load and 0.80 power factor. (10)
- 7 Determine the optimum value of load resistance for maximum power transfer if the load is connected to an amplifier of output resistance $288\ \Omega$ through a transformer with a turns ratio $6:1$ (3)
- 8 A single-phase auto transformer has a voltage ratio of $250\ \text{V}:200\ \text{V}$ and supplies a load of $15\ \text{kVA}$ at $200\ \text{V}$. Assuming an ideal transformer, determine the current in each section of the winding. (3)

D.C. machines

At the end of this chapter you should be able to:

- distinguish between the function of a motor and a generator
- describe the action of a commutator
- describe the construction of a d.c. machine
- distinguish between wave and lap windings
- understand shunt, series and compound windings of d.c. machines
- understand armature reaction
- calculate generated e.m.f. in an armature winding using $E = 2p\Phi nZ/c$
- describe types of d.c. generator and their characteristics
- calculate generated e.m.f. for a generator using $E = V + I_a R_a$
- state typical applications of d.c. generators
- list d.c. machine losses and calculate efficiency
- calculate back e.m.f. for a d.c. motor using $E = V - I_a R_a$
- calculate the torque of a d.c. motor using $T = EI_a/2\pi n$ and $T = p\Phi ZI_a/\pi c$
- describe types of d.c. motor and their characteristics
- state typical applications of d.c. motors
- describe a d.c. motor starter
- describe methods of speed control of d.c. motors
- list types of enclosure for d.c. motors

22.1 Introduction

When the input to an electrical machine is electrical energy, (seen as applying a voltage to the electrical terminals of the machine), and the output is mechanical energy, (seen as a rotating shaft), the machine is called an electric **motor**. Thus an electric motor converts electrical energy into mechanical energy.

The principle of operation of a motor is explained in Section 8.4, page 89. When the input to an electrical machine is mechanical energy, (seen as, say, a diesel motor, coupled to the machine by a shaft), and the output is electrical energy, (seen as a voltage appearing at the electrical terminals of the machine), the machine is called a **generator**. Thus, a generator converts mechanical energy to electrical energy.

The principle of operation of a generator is explained in Section 9.2, page 94.

22.2 The action of a commutator

In an electric motor, conductors rotate in a uniform magnetic field. A single-loop conductor mounted between permanent magnets is shown in Fig. 22.1. A voltage is applied at points A and B in Fig. 22.1(a)

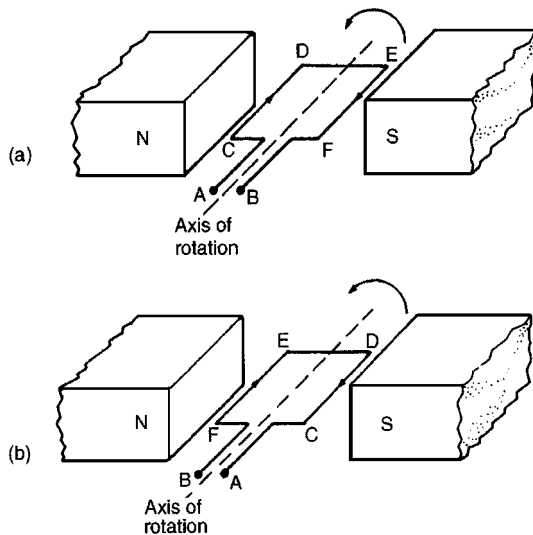

Figure 22.1

A force, F , acts on the loop due to the interaction of the magnetic field of the permanent magnets and the magnetic field created by the current flowing in the loop. This force is proportional to the flux density, B , the current flowing, I , and the effective length of the conductor, l , i.e. $F = BIl$. The force is made up of two parts, one acting vertically downwards due to the current flowing from C to D and

the other acting vertically upwards due to the current flowing from E to F (from Fleming's left hand rule). If the loop is free to rotate, then when it has rotated through 180° , the conductors are as shown in Fig. 22.1(b). For rotation to continue in the same direction, it is necessary for the current flow to be as shown in Fig. 22.1(b), i.e. from D to C and from F to E. This apparent reversal in the direction of current flow is achieved by a process called **commutation**. With reference to Fig. 22.2(a), when a direct voltage is applied at A and B, then as the single-loop conductor rotates, current flow will always be away from the commutator for the part of the conductor adjacent to the N-pole and towards the commutator for the part of the conductor adjacent to the S-pole. Thus the forces act to give continuous rotation in an anti-clockwise direction. The arrangement shown in Fig. 22.2(a) is called a 'two-segment' commutator and the voltage is applied to the rotating segments by stationary **brushes**, (usually carbon blocks), which slide on the commutator material, (usually copper), when rotation takes place.

In practice, there are many conductors on the rotating part of a d.c. machine and these are attached to many commutator segments. A schematic diagram of a multi-segment commutator is shown in Fig. 22.2(b)

Poor commutation results in sparking at the trailing edge of the brushes. This can be improved by using **interpoles** (situated between each pair of main poles), high resistance brushes, or using brushes spanning several commutator segments.

22.3 D.C. machine construction

The basic parts of any d.c. machine are shown in Fig. 22.3, and comprise:

- (a) a stationary part called the **stator** having,
 - (i) a steel ring called the **yoke**, to which are attached

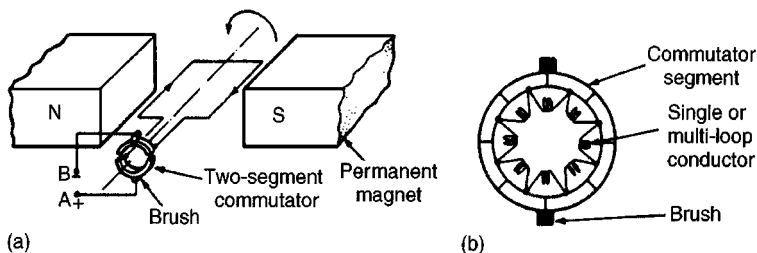

Figure 22.2

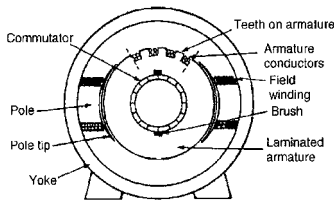

Figure 22.3

- (ii) the magnetic **poles**, around which are the
- (iii) **field windings**, i.e. many turns of a conductor wound round the pole core; current passing through this conductor creates an electromagnet, (rather than the permanent magnets shown in Fig. 22.1 and 22.2),
- (b) a rotating part called the **armature** mounted in bearings housed in the stator and having,
 - (iv) a laminated cylinder of iron or steel called the **core**, on which teeth are cut to house the
 - (v) **armature winding**, i.e. a single or multi-loop conductor system, and
 - (vi) the **commutator**, (see Section 22.2)

Armature windings can be divided into two groups, depending on how the wires are joined to the commutator. These are called **wave windings** and **lap windings**.

- (a) In **wave windings** there are two paths in parallel irrespective of the number of poles, each path supplying half the total current output. Wave wound generators produce high voltage, low current outputs.
- (b) In **lap windings** there are as many paths in parallel as the machine has poles. The total current output divides equally between them. Lap wound generators produce high current, low voltage output.

22.4 Shunt, series and compound windings

When the field winding of a d.c. machine is connected in parallel with the armature, as shown in Fig. 22.4(a), the machine is said to be **shunt** wound. If the field winding is connected in series with the armature, as shown in Fig. 22.4(b), then the machine is said to be **series** wound. A **compound** wound machine has a combination of series and shunt windings.

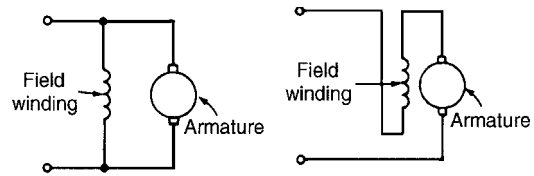

(a) Shunt-wound machine (b) Series-wound machine

Figure 22.4

Depending on whether the electrical machine is series wound, shunt wound or compound wound, it behaves differently when a load is applied. The behaviour of a d.c. machine under various conditions is shown by means of graphs, called characteristic curves or just **characteristics**. The characteristics shown in the following sections are theoretical, since they neglect the effects of armature reaction.

Armature reaction is the effect that the magnetic field produced by the armature current has on the magnetic field produced by the field system. In a generator, armature reaction results in a reduced output voltage, and in a motor, armature reaction results in increased speed.

A way of overcoming the effect of armature reaction is to fit compensating windings, located in slots in the pole face.

22.5 E.m.f. generated in an armature winding

- Let Z = number of armature conductors,
 Φ = useful flux per pole, in webers,
 p = number of **pairs** of poles
 and n = armature speed in rev/s

The e.m.f. generated by the armature is equal to the e.m.f. generated by one of the parallel paths. Each conductor passes $2p$ poles per revolution and thus cuts $2p\Phi$ webers of magnetic flux per revolution. Hence flux cut by one conductor per second = $2p\Phi n$ Wb and so the average e.m.f. E generated per conductor is given by:

$$E = 2p\Phi n \text{ volts}$$

(since 1 volt = 1 Weber per second)

- Let c = number of parallel paths
 through the winding between
 positive and negative brushes

$c = 2$ for a wave winding

$c = 2p$ for a lap winding

The number of conductors in series in each path = Z/c

The total e.m.f. between

$$\begin{aligned} \text{brushes} &= (\text{average e.m.f./conductor}) \\ &(\text{number of conductors in series} \\ &\text{per path}) \\ &= 2p\Phi nZ/c \end{aligned}$$

i.e. **generated e.m.f. $E = \frac{2p\Phi nZ}{c}$ volts** (1)

Since Z , p and c are constant for a given machine, then $E \propto \Phi n$. However $2\pi n$ is the angular velocity ω in radians per second, hence the generated e.m.f. is proportional to Φ and ω ,

i.e. **generated e.m.f. $E \propto \Phi \omega$** (2)

Problem 1. An 8-pole, wave-connected armature has 600 conductors and is driven at 625 rev/min. If the flux per pole is 20 mWb, determine the generated e.m.f.

$Z = 600$, $c = 2$ (for a wave winding), $p = 4$ pairs, $n = 625/60$ rev/s and $\Phi = 20 \times 10^{-3}$ Wb.

Generated e.m.f.

$$\begin{aligned} E &= \frac{2p\Phi nZ}{c} \\ &= \frac{2(4)(20 \times 10^{-3}) \left(\frac{625}{60}\right) (600)}{2} \\ &= \mathbf{500 \text{ volts}} \end{aligned}$$

Problem 2. A 4-pole generator has a lap-wound armature with 50 slots with 16 conductors per slot. The useful flux per pole is 30 mWb. Determine the speed at which the machine must be driven to generate an e.m.f. of 240 V.

$E = 240$ V, $c = 2p$ (for a lap winding), $Z = 50 \times 16 = 800$ and $\Phi = 30 \times 10^{-3}$ Wb.

Generated e.m.f.

$$E = \frac{2p\Phi nZ}{c} = \frac{2p\Phi nZ}{2p} = \Phi nZ$$

Rearranging gives, speed,

$$\begin{aligned} n &= \frac{E}{\Phi Z} = \frac{240}{(30 \times 10^{-3})(800)} \\ &= \mathbf{10 \text{ rev/s or } 600 \text{ rev/min}} \end{aligned}$$

Problem 3. An 8-pole, lap-wound armature has 1200 conductors and a flux per pole of 0.03 Wb. Determine the e.m.f. generated when running at 500 rev/min.

Generated e.m.f.,

$$\begin{aligned} E &= \frac{2p\Phi nZ}{c} \\ &= \frac{2p\Phi nZ}{2p} \text{ for a lap-wound machine,} \end{aligned}$$

i.e. $E = \Phi nZ$

$$\begin{aligned} &= (0.03) \left(\frac{500}{60}\right) (1200) \\ &= \mathbf{300 \text{ volts}} \end{aligned}$$

Problem 4. Determine the generated e.m.f. in Problem 3 if the armature is wave-wound.

Generated e.m.f.

$$\begin{aligned} E &= \frac{2p\Phi nZ}{c} \\ &= \frac{2p\Phi nZ}{2} \text{ (since } c = 2 \text{ for wave-wound)} \\ &= p\Phi nZ = (4)(\Phi nZ) \\ &= (4)(300) \text{ from Problem 3} \\ &= \mathbf{1200 \text{ volts}} \end{aligned}$$

Problem 5. A d.c. shunt-wound generator running at constant speed generates a voltage of 150 V at a certain value of field current. Determine the change in the generated voltage when the field current is reduced by 20 per cent, assuming the flux is proportional to the field current.

The generated e.m.f. E of a generator is proportional to $\Phi\omega$, i.e. is proportional to Φn , where Φ is the flux and n is the speed of rotation. It follows that $E = k\Phi n$, where k is a constant.

At speed n_1 and flux Φ_1 , $E_1 = k\Phi_1 n_1$

At speed n_2 and flux Φ_2 , $E_2 = k\Phi_2 n_2$

Thus, by division:

$$\frac{E_1}{E_2} = \frac{k\Phi_1 n_1}{k\Phi_2 n_2} = \frac{\Phi_1 n_1}{\Phi_2 n_2}$$

The initial conditions are $E_1 = 150 \text{ V}$, $\Phi = \Phi_1$ and $n = n_1$. When the flux is reduced by 20 per cent, the new value of flux is $80/100$ or 0.8 of the initial value, i.e. $\Phi_2 = 0.8\Phi_1$. Since the generator is running at constant speed, $n_2 = n_1$.

$$\text{Thus } \frac{E_1}{E_2} = \frac{\Phi_1 n_1}{\Phi_2 n_2} = \frac{\Phi_1 n_1}{0.8\Phi_1 n_2} = \frac{1}{0.8}$$

that is, $E_2 = 150 \times 0.8 = 120 \text{ V}$

Thus, a reduction of 20 per cent in the value of the flux **reduces the generated voltage to 120 V** at constant speed.

Problem 6. A d.c. generator running at 30 rev/s generates an e.m.f. of 200 V. Determine the percentage increase in the flux per pole required to generate 250 V at 20 rev/s.

From Equation (2), generated e.m.f., $E \propto \Phi\omega$ and since $\omega = 2\pi n$, $E \propto \Phi n$

Let $E_1 = 200 \text{ V}$, $n_1 = 30 \text{ rev/s}$

and flux per pole at this speed be Φ_1

Let $E_2 = 250 \text{ V}$, $n_2 = 20 \text{ rev/s}$

and flux per pole at this speed be Φ_2

Since $E \propto \Phi n$ then $\frac{E_1}{E_2} = \frac{\Phi_1 n_1}{\Phi_2 n_2}$

Hence $\frac{200}{250} = \frac{\Phi_1(30)}{\Phi_2(20)}$

from which, $\Phi_2 = \frac{\Phi_1(30)(250)}{(20)(200)}$
 $= 1.875\Phi_1$

Hence **the increase in flux per pole needs to be 87.5 per cent**

Now try the following exercise

Exercise 127 Further problems on generator e.m.f.

- 1 A 4-pole, wave-connected armature of a d.c. machine has 750 conductors and is driven at 720 rev/min. If the useful flux per pole is 15 mWb, determine the generated e.m.f. [270 volts]
- 2 A 6-pole generator has a lap-wound armature with 40 slots with 20 conductors per slot. The flux per pole is 25 mWb. Calculate the speed at which the machine must be driven to generate an e.m.f. of 300 V [15 rev/s or 900 rev/min]
- 3 A 4-pole armature of a d.c. machine has 1000 conductors and a flux per pole of 20 mWb. Determine the e.m.f. generated when running at 600 rev/min when the armature is (a) wave-wound (b) lap-wound. [(a) 400 volts (b) 200 volts]
- 4 A d.c. generator running at 25 rev/s generates an e.m.f. of 150 V. Determine the percentage increase in the flux per pole required to generate 180 V at 20 rev/s [50%]
- 5 Determine the terminal voltage of a generator which develops an e.m.f. of 240 V and has an armature current of 50 A on load. Assume the armature resistance is 40 m Ω [238 volts]

22.6 D.C. generators

D.C. generators are classified according to the method of their field excitation. These groupings are:

- (i) **Separately-excited generators**, where the field winding is connected to a source of supply other than the armature of its own machine.
- (ii) **Self-excited generators**, where the field winding receives its supply from the armature of its own machine, and which are sub-divided into (a) shunt, (b) series, and (c) compound wound generators.

22.7 Types of d.c. generator and their characteristics

(a) Separately-excited generator

A typical separately-excited generator circuit is shown in Fig. 22.5

When a load is connected across the armature terminals, a load current I_a will flow. The terminal voltage V will fall from its open-circuit e.m.f. E due to a volt drop caused by current flowing through the armature resistance, shown as R_a

i.e.

$$\text{terminal voltage, } V = E - I_a R_a$$

or

$$\text{generated e.m.f., } E = V + I_a R_a \quad (3)$$

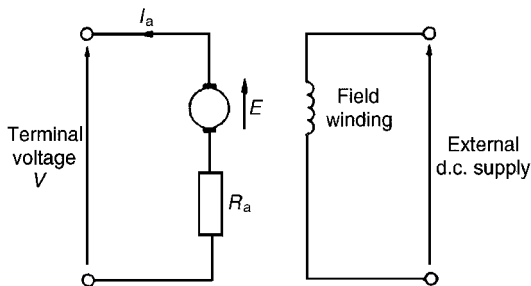

Figure 22.5

Problem 7. Determine the terminal voltage of a generator which develops an e.m.f. of 200 V and has an armature current of 30 A on load. Assume the armature resistance is 0.30 Ω .

With reference to Fig. 22.5, terminal voltage,

$$\begin{aligned} V &= E - I_a R_a \\ &= 200 - (30)(0.30) \\ &= 200 - 9 \\ &= \mathbf{191 \text{ volts}} \end{aligned}$$

Problem 8. A generator is connected to a 60 Ω load and a current of 8 A flows. If the armature resistance is 1 Ω determine (a) the terminal voltage, and (b) the generated e.m.f.

(a) Terminal voltage, $V = I_a R_L = (8)(60) = \mathbf{480 \text{ volts}}$

(b) Generated e.m.f.,

$$\begin{aligned} E &= V + I_a R_a \quad \text{from Equation (3)} \\ &= 480 + (8)(1) = 480 + 8 = \mathbf{488 \text{ volts}} \end{aligned}$$

Problem 9. A separately-excited generator develops a no-load e.m.f. of 150 V at an armature speed of 20 rev/s and a flux per pole of 0.10 Wb. Determine the generated e.m.f. when (a) the speed increases to 25 rev/s and the pole flux remains unchanged, (b) the speed remains at 20 rev/s and the pole flux is decreased to 0.08 Wb, and (c) the speed increases to 24 rev/s and the pole flux is decreased to 0.07 Wb.

(a) From Section 22.5, generated e.m.f. $E \propto \Phi n$

$$\text{from which, } \frac{E_1}{E_2} = \frac{\Phi_1 N_1}{\Phi_2 N_2}$$

$$\text{Hence } \frac{150}{E_2} = \frac{(0.10)(20)}{(0.1)(25)}$$

$$\begin{aligned} \text{from which, } E_2 &= \frac{(150)(0.10)(25)}{(0.10)(20)} \\ &= \mathbf{187.5 \text{ volts}} \end{aligned}$$

$$(b) \frac{150}{E_3} = \frac{(0.10)(20)}{(0.08)(20)}$$

$$\begin{aligned} \text{from which, e.m.f., } E_3 &= \frac{(150)(0.08)(20)}{(0.10)(20)} \\ &= \mathbf{120 \text{ volts}} \end{aligned}$$

$$(c) \frac{150}{E_4} = \frac{(0.10)(20)}{(0.07)(24)}$$

$$\begin{aligned} \text{from which, e.m.f., } E_4 &= \frac{(150)(0.07)(24)}{(0.10)(20)} \\ &= \mathbf{126 \text{ volts}} \end{aligned}$$

Characteristics

The two principal generator characteristics are the generated voltage/field current characteristics, called the **open-circuit characteristic** and the terminal voltage/load current characteristic, called the **load characteristic**. A typical separately-excited generator **open-circuit characteristic** is shown in Fig. 22.6(a) and a typical **load characteristic** is shown in Fig. 22.6(b)

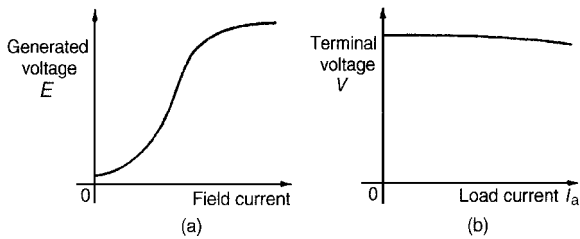

Figure 22.6

A separately-excited generator is used only in special cases, such as when a wide variation in terminal p.d. is required, or when exact control of the field current is necessary. Its disadvantage lies in requiring a separate source of direct current.

(b) Shunt wound generator

In a shunt wound generator the field winding is connected in parallel with the armature as shown in Fig. 22.7 The field winding has a relatively high resistance and therefore the current carried is only a fraction of the armature current.

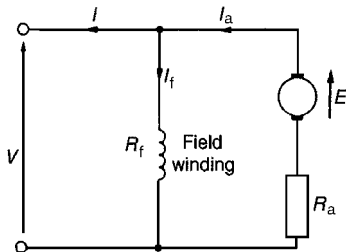

Figure 22.7

For the circuit shown in Fig. 22.7,

$$\text{terminal voltage, } V = E - I_a R_a$$

or generated e.m.f., $E = V + I_a R_a$

$I_a = I_f + I$ from Kirchhoff's current law, where $I_a =$ armature current, $I_f =$ field current ($= V/R_f$) and $I =$ load current

Problem 10. A shunt generator supplies a 20 kW load at 200 V through cables of resistance, $R = 100 \text{ m}\Omega$. If the field winding resistance, $R_f = 50 \text{ }\Omega$ and the armature resistance, $R_a = 40 \text{ m}\Omega$, determine (a) the terminal voltage, and (b) the e.m.f. generated in the armature.

(a) The circuit is as shown in Fig. 22.8

$$\text{Load current, } I = \frac{20\,000 \text{ watts}}{200 \text{ volts}} = 100 \text{ A}$$

Volt drop in the cables to the load $= IR = (100)(100 \times 10^{-3}) = 10 \text{ V}$. Hence **terminal voltage, $V = 200 + 10 = 210 \text{ volts}$** .

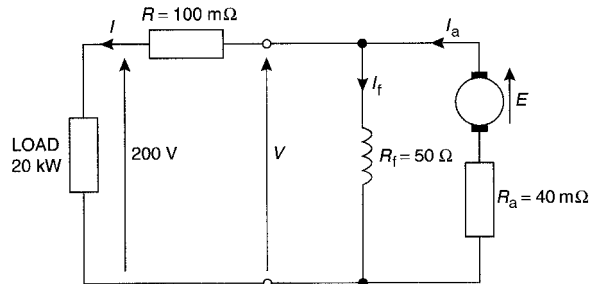

Figure 22.8

(b) Armature current $I_a = I_f + I$

$$\text{Field current, } I_f = \frac{V}{R_f} = \frac{210}{50} = 4.2 \text{ A}$$

$$\text{Hence } I_a = I_f + I = 4.2 + 100 = 104.2 \text{ A}$$

$$\begin{aligned} \text{Generated e.m.f. } E &= V + I_a R_a \\ &= 210 + (104.2)(40 \times 10^{-3}) \\ &= 210 + 4.168 \\ &= \mathbf{214.17 \text{ volts}} \end{aligned}$$

Characteristics

The generated e.m.f., E , is proportional to $\Phi\omega$, (see Section 22.5), hence at constant speed, since $\omega = 2\pi n$, $E \propto \Phi$. Also the flux Φ is proportional to field current I_f until magnetic saturation of the iron circuit of the generator occurs. Hence the open circuit characteristic is as shown in Fig. 22.9(a).

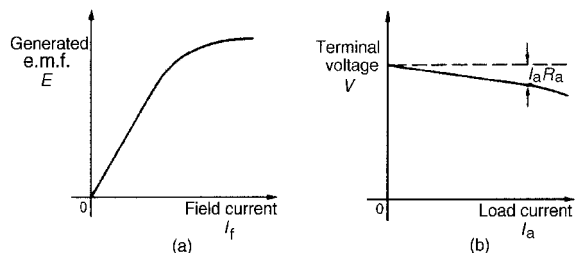

Figure 22.9

As the load current on a generator having constant field current and running at constant speed increases, the value of armature current increases, hence the armature volt drop, $I_a R_a$ increases. The generated voltage E is larger than the terminal voltage V and the voltage equation for the armature circuit is $V = E - I_a R_a$. Since E is constant, V decreases with increasing load. The load characteristic is as shown in Fig. 22.9(b). In practice, the fall in voltage is about 10 per cent between no-load and full-load for many d.c. shunt-wound generators.

The shunt-wound generator is the type most used in practice, but the load current must be limited to a value that is well below the maximum value. This then avoids excessive variation of the terminal voltage. Typical applications are with battery charging and motor car generators.

(c) Series-wound generator

In the series-wound generator the field winding is connected in series with the armature as shown in Fig. 22.10

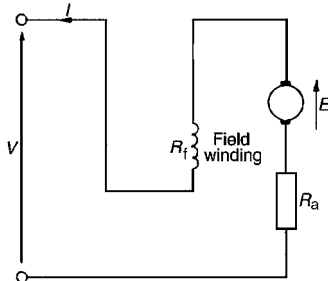

Figure 22.10

Characteristic

The load characteristic is the terminal voltage/current characteristic. The generated e.m.f. E , is proportional to $\Phi\omega$ and at constant speed $\omega (= 2\pi n)$ is a constant. Thus E is proportional to Φ . For values of current below magnetic saturation of the yoke, poles, air gaps and armature core, the flux Φ is proportional to the current, hence $E \propto I$. For values of current above those required for magnetic saturation, the generated e.m.f. is approximately constant. The values of field resistance and armature resistance in a series wound machine are small, hence the terminal voltage V is very nearly equal to E . A typical load characteristic for a series generator is shown in Fig. 22.11

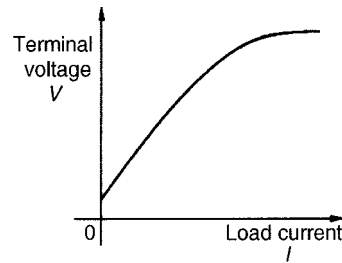

Figure 22.11

In a series-wound generator, the field winding is in series with the armature and it is not possible to have a value of field current when the terminals are open circuited, thus it is not possible to obtain an open-circuit characteristic.

Series-wound generators are rarely used in practise, but can be used as a 'booster' on d.c. transmission lines.

(d) Compound-wound generator

In the compound-wound generator two methods of connection are used, both having a mixture of shunt and series windings, designed to combine the advantages of each. Fig. 22.12(a) shows what is termed a **long-shunt** compound generator, and Fig. 22.12(b) shows a **short-shunt** compound generator. The latter is the most generally used form of d.c. generator.

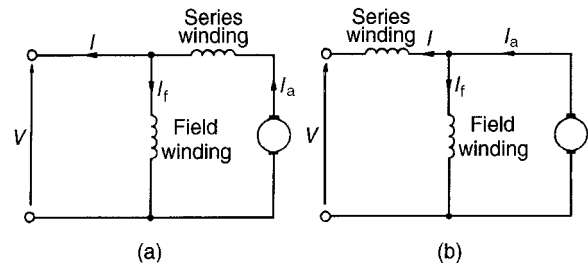

Figure 22.12

Problem 11. A short-shunt compound generator supplies 80 A at 200 V. If the field resistance, $R_f = 40 \Omega$, the series resistance, $R_{Se} = 0.02 \Omega$ and the armature resistance, $R_a = 0.04 \Omega$, determine the e.m.f. generated.

The circuit is shown in Fig. 22.13.

Volt drop in series winding = $IR_{Se} = (80)(0.02) = 1.6 \text{ V}$.

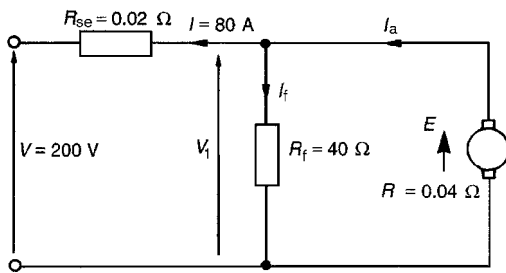

Figure 22.13

P.d. across the field winding = p.d. across armature = $V_1 = 200 + 1.6 = 201.6 \text{ V}$

$$\text{Field current } I_f = \frac{V_1}{R_f} = \frac{201.6}{40} = 5.04 \text{ A}$$

Armature current, $I_a = I + I_f = 80 + 5.04 = 85.04 \text{ A}$

$$\begin{aligned} \text{Generated e.m.f., } E &= V_1 + I_a R_a \\ &= 201.6 + (85.04)(0.04) \\ &= 201.6 + 3.4016 \\ &= \mathbf{205 \text{ volts}} \end{aligned}$$

Characteristics

In cumulative-compound machines the magnetic flux produced by the series and shunt fields are additive. Included in this group are **over-compounded**, **level-compounded** and **under-compounded machines** – the degree of compounding obtained depending on the number of turns of wire on the series winding.

A large number of series winding turns results in an over-compounded characteristic, as shown in Fig. 22.14, in which the full-load terminal voltage exceeds the no-load voltage. A level-compound machine gives a full-load terminal voltage which is equal to the no-load voltage, as shown in Fig. 22.14

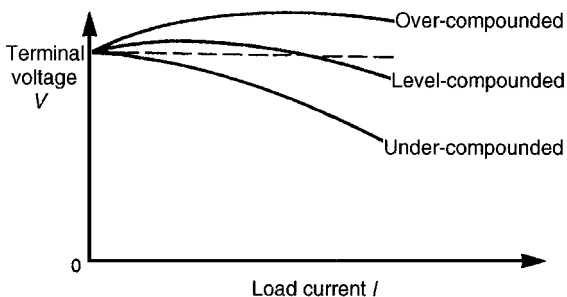

Figure 22.14

An under-compounded machine gives a full-load terminal voltage which is less than the no-load voltage, as shown in Fig. 22.14. However even this latter characteristic is a little better than that for a shunt generator alone. Compound-wound generators are used in electric arc welding, with lighting sets and with marine equipment.

Now try the following exercise

Exercise 128 Further problems on the d.c. generator

- A generator is connected to a 50Ω load and a current of 10 A flows. If the armature resistance is 0.5Ω , determine (a) the terminal voltage, and (b) the generated e.m.f.
[(a) 500 volts (b) 505 volts]
- A separately excited generator develops a no-load e.m.f. of 180 V at an armature speed of 15 rev/s and a flux per pole of 0.20 Wb . Calculate the generated e.m.f. when:
 - the speed increases to 20 rev/s and the flux per pole remains unchanged
 - the speed remains at 15 rev/s and the pole flux is decreased to 0.125 Wb
 - the speed increases to 25 rev/s and the pole flux is decreased to 0.18 Wb
 [(a) 240 volts (b) 112.5 volts (c) 270 volts]
- A shunt generator supplies a 50 kW load at 400 V through cables of resistance 0.2Ω . If the field winding resistance is 50Ω and the armature resistance is 0.05Ω , determine (a) the terminal voltage, (b) the e.m.f. generated in the armature
[(a) 425 volts (b) 431.68 volts]
- A short-shunt compound generator supplies 50 A at 300 V . If the field resistance is 30Ω , the series resistance 0.03Ω and the armature resistance 0.05Ω , determine the e.m.f. generated
[304.5 volts]
- A d.c. generator has a generated e.m.f. of 210 V when running at 700 rev/min and the flux per pole is 120 mWb . Determine the generated e.m.f.
 - at 1050 rev/min , assuming the flux remains constant,
 - if the flux is reduced by one-sixth at constant speed, and

(c) at a speed of 1155 rev/min and a flux of 132 mWb

[(a) 315 V (b) 175 V (c) 381.2 V]

6 A 250 V d.c. shunt-wound generator has an armature resistance of 0.1Ω . Determine the generated e.m.f. when the generator is supplying 50 kW, neglecting the field current of the generator. [270 V]

22.8 D.C. machine losses

As stated in Section 22.1, a generator is a machine for converting mechanical energy into electrical energy and a motor is a machine for converting electrical energy into mechanical energy. When such conversions take place, certain losses occur which are dissipated in the form of heat.

The principal losses of machines are:

- (i) **Copper loss**, due to I^2R heat losses in the armature and field windings.
- (ii) **Iron (or core) loss**, due to hysteresis and eddy-current losses in the armature. This loss can be reduced by constructing the armature of silicon steel laminations having a high resistivity and low hysteresis loss. At constant speed, the iron loss is assumed constant.
- (iii) **Friction and windage losses**, due to bearing and brush contact friction and losses due to air resistance against moving parts (called windage). At constant speed, these losses are assumed to be constant.
- (iv) **Brush contact loss** between the brushes and commutator. This loss is approximately proportional to the load current.

The total losses of a machine can be quite significant and operating efficiencies of between 80 per cent and 90 per cent are common.

22.9 Efficiency of a d.c. generator

The efficiency of an electrical machine is the ratio of the output power to the input power and is usually expressed as a percentage. The Greek letter, ' η ' (eta)

is used to signify efficiency and since the units are, power/power, then efficiency has no units. Thus

$$\text{efficiency, } \eta = \left(\frac{\text{output power}}{\text{input power}} \right) \times 100\%$$

If the total resistance of the armature circuit (including brush contact resistance) is R_a , then **the total loss in the armature circuit is $I_a^2R_a$**

If the terminal voltage is V and the current in the shunt circuit is I_f , then **the loss in the shunt circuit is I_fV**

If the sum of the iron, friction and windage losses is C then **the total losses is given by: $I_a^2R_a + I_fV + C$** ($I_a^2R_a + I_fV$ is, in fact, the 'copper loss').

If the output current is I , then **the output power is VI** . Total input power = $VI + I_a^2R_a + I_fV + C$. Hence

$$\text{efficiency, } \eta = \frac{\text{output}}{\text{input}}, \text{ i.e.}$$

$$\eta = \left(\frac{VI}{VI + I_a^2R_a + I_fV + C} \right) \times 100\% \quad (4)$$

The **efficiency of a generator is a maximum** when the load is such that:

$$I_a^2R_a = VI_f + C$$

i.e. when the variable loss = the constant loss

Problem 12. A 10 kW shunt generator having an armature circuit resistance of 0.75Ω and a field resistance of 125Ω , generates a terminal voltage of 250 V at full load. Determine the efficiency of the generator at full load, assuming the iron, friction and windage losses amount to 600 W.

The circuit is shown in Fig. 22.15

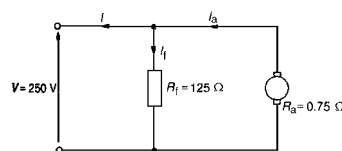

Figure 22.15

Output power = 10 000 W = VI from which, load current $I = 10\,000/V = 10\,000/250 = 40$ A.
Field current, $I_f = V/R_f = 250/125 = 2$ A.
Armature current, $I_a = I_f + I = 2 + 40 = 42$ A

$$\begin{aligned}\text{Efficiency, } \eta &= \left(\frac{VI}{VI + I_a^2 R + I_f V + C} \right) \times 100\% \\ &= \left(\frac{10\,000}{10\,000 + (42)^2(0.75) + (2)(250) + 600} \right) \times 100\% \\ &= \left(\frac{10\,000}{12\,423} \right) \times 100\% \\ &= \mathbf{80.50\%}\end{aligned}$$

Now try the following exercise

Exercise 129 A further problem on the efficiency of a d.c. generator

1 A 15 kW shunt generator having an armature circuit resistance of 0.4Ω and a field resistance of 100Ω , generates a terminal voltage of 240 V at full load. Determine the efficiency of the generator at full load, assuming the iron, friction and windage losses amount to 1 kW
[82.14%]

22.10 D.C. motors

The construction of a d.c. motor is the same as a d.c. generator. The only difference is that in a generator the generated e.m.f. is greater than the terminal voltage, whereas in a motor the generated e.m.f. is less than the terminal voltage.

D.C. motors are often used in power stations to drive emergency stand-by pump systems which come into operation to protect essential equipment and plant should the normal a.c. supplies or pumps fail.

Back e.m.f.

When a d.c. motor rotates, an e.m.f. is induced in the armature conductors. By Lenz's law this induced e.m.f. E opposes the supply voltage V and is called

a **back e.m.f.**, and the supply voltage, V is given by:

$$V = E + I_a R_a \quad \text{or} \quad E = V - I_a R_a \quad (5)$$

Problem 13. A d.c. motor operates from a 240 V supply. The armature resistance is 0.2Ω . Determine the back e.m.f. when the armature current is 50 A.

For a motor, $V = E + I_a R_a$ hence back e.m.f.,

$$\begin{aligned}E &= V - I_a R_a \\ &= 240 - (50)(0.2) \\ &= 240 - 10 = \mathbf{230 \text{ volts}}\end{aligned}$$

Problem 14. The armature of a d.c. machine has a resistance of 0.25Ω and is connected to a 300 V supply. Calculate the e.m.f. generated when it is running: (a) as a generator giving 100 A, and (b) as a motor taking 80 A.

(a) As a generator, generated e.m.f.,

$$\begin{aligned}E &= V + I_a R_a, \text{ from Equation (3),} \\ &= 300 + (100)(0.25) \\ &= 300 + 25 \\ &= \mathbf{325 \text{ volts}}\end{aligned}$$

(b) As a motor, generated e.m.f. (or back e.m.f.),

$$\begin{aligned}E &= V - I_a R_a, \text{ from Equation (5),} \\ &= 300 - (80)(0.25) \\ &= \mathbf{280 \text{ volts}}\end{aligned}$$

Now try the following exercise

Exercise 130 Further problems on back e.m.f.

1 A d.c. motor operates from a 350 V supply. If the armature resistance is 0.4Ω determine the back e.m.f. when the armature current is 60 A
[326 volts]

2 The armature of a d.c. machine has a resistance of $0.5\ \Omega$ and is connected to a 200 V supply. Calculate the e.m.f. generated when it is running (a) as a motor taking 50 A, and (b) as a generator giving 70 A

[(a) 175 volts (b) 235 volts]

3 Determine the generated e.m.f. of a d.c. machine if the armature resistance is $0.1\ \Omega$ and it (a) is running as a motor connected to a 230 V supply, the armature current being 60 A, and (b) is running as a generator with a terminal voltage of 230 V, the armature current being 80 A

[(a) 224 V (b) 238 V]

22.11 Torque of a d.c. motor

From Equation (5), for a d.c. motor, the supply voltage V is given by

$$V = E + I_a R_a$$

Multiplying each term by current I_a gives:

$$VI_a = EI_a + I_a^2 R_a$$

The term VI_a is the **total electrical power supplied to the armature**, the term $I_a^2 R_a$ is the **loss due to armature resistance**, and the term EI_a is the **mechanical power developed by the armature**. If T is the torque, in newton metres, then the mechanical power developed is given by $T\omega$ watts (see 'Science for Engineering')

Hence
$$T\omega = 2\pi nT = EI_a$$

from which,

$$\text{torque } T = \frac{EI_a}{2\pi n} \text{ newton metres} \quad (6)$$

From Section 22.5, Equation (1), the e.m.f. E generated is given by

$$E = \frac{2p\Phi nZ}{c}$$

Hence
$$2\pi nT = EI_a = \left(\frac{2p\Phi nZ}{c}\right) I_a$$

$$\text{Hence torque } T = \frac{\left(\frac{2p\Phi nZ}{c}\right) I_a}{2\pi n}$$

i.e.
$$T = \frac{p\Phi Z I_a}{\pi c} \text{ newton metres} \quad (7)$$

For a given machine, Z , c and p are fixed values

Hence
$$\text{torque, } T \propto \Phi I_a \quad (8)$$

Problem 15. An 8-pole d.c. motor has a wave-wound armature with 900 conductors. The useful flux per pole is 25 mWb. Determine the torque exerted when a current of 30 A flows in each armature conductor.

$p = 4$, $c = 2$ for a wave winding,
 $\Phi = 25 \times 10^{-3}$ Wb, $Z = 900$ and $I_a = 30$ A.
 From Equation (7),

$$\begin{aligned} \text{torque, } T &= \frac{p\Phi Z I_a}{\pi c} \\ &= \frac{(4)(25 \times 10^{-3})(900)(30)}{\pi(2)} \\ &= \mathbf{429.7 \text{ Nm}} \end{aligned}$$

Problem 16. Determine the torque developed by a 350 V d.c. motor having an armature resistance of $0.5\ \Omega$ and running at 15 rev/s. The armature current is 60 A.

$V = 350$ V, $R_a = 0.5\ \Omega$, $n = 15$ rev/s and $I_a = 60$ A
 Back e.m.f. $E = V - I_a R_a = 350 - (60)(0.5) = 320$ V.
 From Equation (6),

$$\text{torque, } T = \frac{EI_a}{2\pi n} = \frac{(320)(60)}{2\pi(15)} = \mathbf{203.7 \text{ Nm}}$$

Problem 17. A six-pole lap-wound motor is connected to a 250 V d.c. supply. The armature has 500 conductors and a resistance of $1\ \Omega$. The flux per pole is 20 mWb. Calculate (a) the speed and (b) the torque developed when the armature current is 40 A.

$V = 250$ V, $Z = 500$, $R_a = 1\ \Omega$, $\Phi = 20 \times 10^{-3}$ Wb,
 $I_a = 40$ A and $c = 2p$ for a lap winding

$$(a) \text{ Back e.m.f. } E = V - I_a R_a = 250 - (40)(1) \\ = 210 \text{ V}$$

$$\text{E.m.f. } E = \frac{2p\Phi nZ}{c}$$

$$\text{i.e. } 210 = \frac{2p(20 \times 10^{-3})n(500)}{2p} = 10n$$

$$\text{Hence speed } n = \frac{210}{10} = \mathbf{21 \text{ rev/s}} \text{ or } (21 \times 60) \\ = \mathbf{1260 \text{ rev/min}}$$

$$(b) \text{ Torque } T = \frac{EI_a}{2\pi n} = \frac{(210)(40)}{2\pi(21)} = \mathbf{63.66 \text{ Nm}}$$

Problem 18. The shaft torque of a diesel motor driving a 100 V d.c. shunt-wound generator is 25 Nm. The armature current of the generator is 16 A at this value of torque. If the shunt field regulator is adjusted so that the flux is reduced by 15 per cent, the torque increases to 35 Nm. Determine the armature current at this new value of torque.

From Equation (8), the shaft torque T of a generator is proportional to ΦI_a , where Φ is the flux and I_a is the armature current, or, $T = k\Phi I_a$, where k is a constant.

The torque at flux Φ_1 and armature current I_{a1} is $T_1 = k\Phi_1 I_{a1}$. Similarly, $T_2 = k\Phi_2 I_{a2}$

$$\text{By division } \frac{T_1}{T_2} = \frac{k\Phi_1 I_{a1}}{k\Phi_2 I_{a2}} = \frac{\Phi_1 I_{a1}}{\Phi_2 I_{a2}}$$

$$\text{Hence } \frac{25}{35} = \frac{\Phi_1 \times 16}{0.85\Phi_1 \times I_{a2}}$$

$$\text{i.e. } I_{a2} = \frac{16 \times 35}{0.85 \times 25} = \mathbf{26.35 \text{ A}}$$

That is, **the armature current at the new value of torque is 26.35 A**

Problem 19. A 100 V d.c. generator supplies a current of 15 A when running at 1500 rev/min. If the torque on the shaft driving the generator is 12 Nm, determine (a) the efficiency of the generator and (b) the power loss in the generator.

$$(a) \text{ From Section 22.9, the efficiency of a generator} \\ = \text{output power/input power} \times 100 \text{ per cent.}$$

The output power is the electrical output, i.e. VI watts. The input power to a generator is the mechanical power in the shaft driving the generator, i.e. $T\omega$ or $T(2\pi n)$ watts, where T is the torque in Nm and n is speed of rotation in rev/s. Hence, for a generator,

$$\text{efficiency, } \eta = \frac{VI}{T(2\pi n)} \times 100\% \\ = \frac{(100)(15)(100)}{(12)(2\pi) \left(\frac{1500}{60} \right)}$$

$$\text{i.e. efficiency} = \mathbf{79.6\%}$$

(b) The input power = output power + losses

$$\text{Hence, } T(2\pi n) = VI + \text{losses}$$

$$\text{i.e. losses} = T(2\pi n) - VI \\ = \left[(12)(2\pi) \left(\frac{1500}{60} \right) \right] \\ - [(100)(15)]$$

$$\text{i.e. power loss} = 1885 - 1500 = \mathbf{385 \text{ W}}$$

Now try the following exercise

Exercise 131 Further problems on losses, efficiency, and torque

- The shaft torque required to drive a d.c. generator is 18.7 Nm when it is running at 1250 rev/min. If its efficiency is 87 per cent under these conditions and the armature current is 17.3 A, determine the voltage at the terminals of the generator [123.1 V]
- A 220 V, d.c. generator supplies a load of 37.5 A and runs at 1550 rev/min. Determine the shaft torque of the diesel motor driving the generator, if the generator efficiency is 78 per cent [65.2 Nm]
- A 4-pole d.c. motor has a wave-wound armature with 800 conductors. The useful flux per pole is 20 mWb. Calculate the torque exerted when a current of 40 A flows in each armature conductor. [203.7 Nm]
- Calculate the torque developed by a 240 V d.c. motor whose armature current is 50 A,

armature resistance is $0.6\ \Omega$ and is running at 10 rev/s [167.1 Nm]

- 5 An 8-pole lap-wound d.c. motor has a 200 V supply. The armature has 800 conductors and a resistance of $0.8\ \Omega$. If the useful flux per pole is 40 mWb and the armature current is 30 A, calculate (a) the speed and (b) the torque developed

[(a) 5.5 rev/s or 330 rev/min (b) 152.8 Nm]

- 6 A 150 V d.c. generator supplies a current of 25 A when running at 1200 rev/min. If the torque on the shaft driving the generator is 35.8 Nm, determine (a) the efficiency of the generator, and (b) the power loss in the generator

[(a) 83.4 per cent (b) 748.8 W]

Problem 20. A 240 V shunt motor takes a total current of 30 A. If the field winding resistance $R_f = 150\ \Omega$ and the armature resistance $R_a = 0.4\ \Omega$ determine (a) the current in the armature, and (b) the back e.m.f.

$$(a) \text{ Field current } I_f = \frac{V}{R_f} = \frac{240}{150} = 1.6\ \text{A}$$

$$\text{Supply current } I = I_a + I_f$$

$$\text{Hence armature current, } I_a = I - I_f = 30 - 1.6 = \mathbf{28.4\ \text{A}}$$

- (b) Back e.m.f.

$$E = V - I_a R_a = 240 - (28.4)(0.4) = \mathbf{228.64\ \text{volts}}$$

22.12 Types of d.c. motor and their characteristics

(a) Shunt wound motor

In the shunt wound motor the field winding is in parallel with the armature across the supply as shown in Fig. 22.16

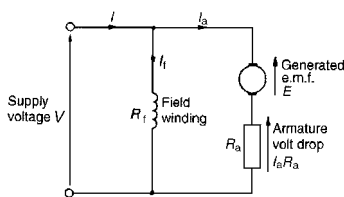

Figure 22.16

For the circuit shown in Fig. 22.16,

$$\text{Supply voltage, } V = E + I_a R_a$$

$$\text{or generated e.m.f., } E = V - I_a R_a$$

$$\text{Supply current, } I = I_a + I_f$$

from Kirchhoff's current law

Characteristics

The two principal characteristics are the torque/armature current and speed/armature current relationships. From these, the torque/speed relationship can be derived.

- (i) The theoretical torque/armature current characteristic can be derived from the expression $T \propto \Phi I_a$, (see Section 22.11). For a shunt-wound motor, the field winding is connected in parallel with the armature circuit and thus the applied voltage gives a constant field current, i.e. a shunt-wound motor is a constant flux machine. Since Φ is constant, it follows that $T \propto I_a$, and the characteristic is as shown in Fig. 22.17

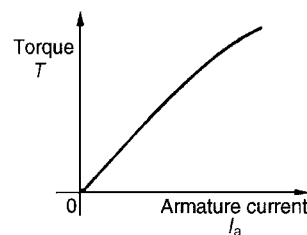

Figure 22.17

- (ii) The armature circuit of a d.c. motor has resistance due to the armature winding and brushes, R_a ohms, and when armature current I_a is flowing through it, there is a voltage drop of $I_a R_a$ volts. In Fig. 22.16 the armature resistance is

shown as a separate resistor in the armature circuit to help understanding. Also, even though the machine is a motor, because conductors are rotating in a magnetic field, a voltage, $E \propto \Phi\omega$, is generated by the armature conductors. From Equation (5), $V = E + I_a R_a$ or $E = V - I_a R_a$. However, from Section 22.5, $E \propto \Phi n$, hence $n \propto E/\Phi$ i.e.

$$\text{speed of rotation, } n \propto \frac{E}{\Phi} \propto \frac{V - I_a R_a}{\Phi} \quad (9)$$

For a shunt motor, V , Φ and R_a are constants, hence as armature current I_a increases, $I_a R_a$ increases and $V - I_a R_a$ decreases, and the speed is proportional to a quantity which is decreasing and is as shown in Fig. 22.18 As the load on the shaft of the motor increases, I_a increases and the speed drops slightly. In practice, the speed falls by about 10 per cent between no-load and full-load on many d.c. shunt-wound motors. Due to this relatively small drop in speed, the d.c. shunt-wound motor is taken as basically being a constant-speed machine and may be used for driving lathes, lines of shafts, fans, conveyor belts, pumps, compressors, drilling machines and so on.

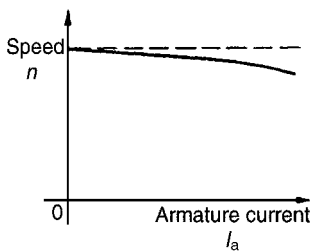

Figure 22.18

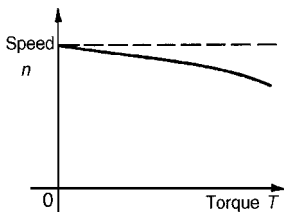

Figure 22.19

- (iii) Since torque is proportional to armature current, (see (i) above), the theoretical speed/torque characteristic is as shown in Fig. 22.19

Problem 21. A 200 V, d.c. shunt-wound motor has an armature resistance of 0.4Ω and at a certain load has an armature current of 30 A and runs at 1350 rev/min. If the load on the shaft of the motor is increased so that the armature current increases to 45 A, determine the speed of the motor, assuming the flux remains constant.

The relationship $E \propto \Phi n$ applies to both generators and motors. For a motor, $E = V - I_a R_a$, (see equation (5))

$$\text{Hence } E_1 = 200 - 30 \times 0.4 = 188 \text{ V}$$

$$\text{and } E_2 = 200 - 45 \times 0.4 = 182 \text{ V}$$

The relationship

$$\frac{E_1}{E_2} = \frac{\Phi_1 n_1}{\Phi_2 n_2}$$

applies to both generators and motors. Since the flux is constant, $\Phi_1 = \Phi_2$. Hence

$$\frac{188}{182} = \frac{\Phi_1 \times \left(\frac{1350}{60}\right)}{\Phi_1 \times n_2}$$

$$\text{i.e. } n_2 = \frac{22.5 \times 182}{188} = 21.78 \text{ rev/s}$$

Thus the speed of the motor when the armature current is 45 A is 21.78×60 rev/min i.e. **1307 rev/min.**

Problem 22. A 220 V, d.c. shunt-wound motor runs at 800 rev/min and the armature current is 30 A. The armature circuit resistance is 0.4Ω . Determine (a) the maximum value of armature current if the flux is suddenly reduced by 10 per cent and (b) the steady state value of the armature current at the new value of flux, assuming the shaft torque of the motor remains constant.

- (a) For a d.c. shunt-wound motor, $E = V - I_a R_a$. Hence initial generated e.m.f.,
 $E_1 = 220 - 30 \times 0.4 = 208 \text{ V}$. The generated e.m.f. is also such that $E \propto \Phi n$, so at the instant the flux is reduced, the speed has not had time to change, and $E = 208 \times 90/100 = 187.2 \text{ V}$. Hence, the voltage drop due to the armature resistance is $220 - 187.2$

i.e. 32.8 V. The **instantaneous value of the current** = $32.8/0.4 = 82 \text{ A}$. This increase in current is about three times the initial value and causes an increase in torque, ($T \propto \Phi I_a$). The motor accelerates because of the larger torque value until steady state conditions are reached.

- (b) $T \propto \Phi I_a$ and, since the torque is constant, $\Phi_1 I_{a1} = \Phi_2 I_{a2}$. The flux Φ is reduced by 10 per cent, hence $\Phi_2 = 0.9\Phi_1$. Thus, $\Phi_1 \times 30 = 0.9\Phi_1 \times I_{a2}$ i.e. the steady state value of armature current, $I_{a2} = 30/0.9 = 33.33 \text{ A}$

(b) Series-wound motor

In the series-wound motor the field winding is in series with the armature across the supply as shown in Fig. 22.20

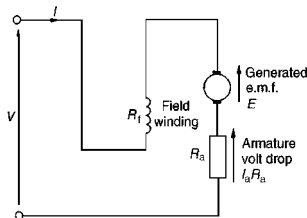

Figure 22.20

For the series motor shown in Fig. 22.20,

$$\text{Supply voltage } V = E + I(R_a + R_f)$$

$$\text{or generated e.m.f. } E = V - I(R_a + R_f)$$

Characteristics

In a series motor, the armature current flows in the field winding and is equal to the supply current, I .

(i) The torque/current characteristic

It is shown in Section 22.11 that torque $T \propto \Phi I_a$. Since the armature and field currents are the same current, I , in a series machine, then $T \propto \Phi I$ over a limited range, before magnetic saturation of the magnetic circuit of the motor is reached, (i.e. the linear portion of the B–H curve for the yoke, poles, air gap, brushes and armature in series). Thus $\Phi \propto I$ and $T \propto I^2$. After magnetic saturation, Φ almost becomes a constant and $T \propto I$. Thus the theoretical torque/current characteristic is as shown in Fig. 22.21

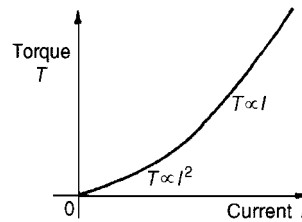

Figure 22.21

(ii) The speed/current characteristic

It is shown in equation (9) that

$$n \propto \frac{V - I_a R_a}{\Phi}$$

In a series motor, $I_a = I$ and below the magnetic saturation level, $\Phi \propto I$. Thus $n \propto (V - IR)/I$ where R is the combined resistance of the series field and armature circuit. Since IR is small compared with V , then an approximate relationship for the speed is $n \propto V/I \propto 1/I$ since V is constant. Hence the theoretical speed/current characteristic is as shown in Fig. 22.22. The high speed at small values of current indicate that this type of motor must not be run on very light loads and invariably, such motors are permanently coupled to their loads.

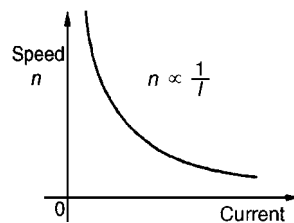

Figure 22.22

- (iii) The theoretical **speed/torque characteristic** may be derived from (i) and (ii) above by obtaining the torque and speed for various values of current and plotting the co-ordinates on the speed/torque characteristics. A typical speed/torque characteristic is shown in Fig. 22.23

A d.c. series motor takes a large current on starting and the characteristic shown in Fig. 22.21 shows that the series-wound motor has a large torque when the current is large. Hence these motors are used for traction (such as trains, milk delivery vehicles, etc.), driving fans and for cranes and hoists, where a large initial torque is required.

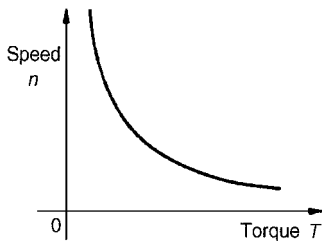

Figure 22.23

Problem 23. A series motor has an armature resistance of 0.2Ω and a series field resistance of 0.3Ω . It is connected to a 240 V supply and at a particular load runs at 24 rev/s when drawing 15 A from the supply. (a) Determine the generated e.m.f. at this load (b) Calculate the speed of the motor when the load is changed such that the current is increased to 30 A . Assume that this causes a doubling of the flux.

- (a) With reference to Fig. 22.20, generated e.m.f., E_1 at initial load, is given by

$$\begin{aligned} E_1 &= V - I_a(R_a + R_f) \\ &= 240 - (15)(0.2 + 0.3) \\ &= 240 - 7.5 = \mathbf{232.5 \text{ volts}} \end{aligned}$$

- (b) When the current is increased to 30 A , the generated e.m.f. is given by:

$$\begin{aligned} E_2 &= V - I_2(R_a + R_f) \\ &= 240 - (30)(0.2 + 0.3) \\ &= 240 - 15 = 225 \text{ volts} \end{aligned}$$

Now e.m.f. $E \propto \Phi n$ thus

$$\frac{E_1}{E_2} = \frac{\Phi_1 n_1}{\Phi_2 n_2}$$

$$\text{i.e. } \frac{232.5}{225} = \frac{\Phi_1(24)}{(2\Phi_1)n_2} \text{ since } \Phi_2 = 2\Phi_1$$

Hence

$$\text{speed of motor, } n_2 = \frac{(24)(225)}{(232.5)(2)} = \mathbf{11.6 \text{ rev/s}}$$

As the current has been increased from 15 A to 30 A , the speed has decreased from 24 rev/s to 11.6 rev/s . Its speed/current characteristic is similar to Fig. 22.22

(c) Compound wound motor

There are two types of compound wound motor:

- (i) **Cumulative compound**, in which the series winding is so connected that the field due to it assists that due to the shunt winding.
- (ii) **Differential compound**, in which the series winding is so connected that the field due to it opposes that due to the shunt winding.

Figure 22.24(a) shows a **long-shunt** compound motor and Fig. 22.24(b) a **short-shunt** compound motor.

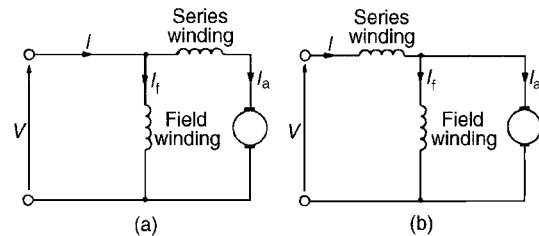

Figure 22.24

Characteristics

A compound-wound motor has both a series and a shunt field winding, (i.e. one winding in series and one in parallel with the armature), and is usually wound to have a characteristic similar in shape to a series wound motor (see Figures 22.21–22.23). A limited amount of shunt winding is present to restrict the no-load speed to a safe value. However, by varying the number of turns on the series and shunt windings and the directions of the magnetic fields produced by these windings (assisting or opposing), families of characteristics may be obtained to suit almost all applications. Generally, compound-wound motors are used for heavy duties, particularly in applications where sudden heavy load may occur such as for driving plunger pumps, presses, geared lifts, conveyors, hoists and so on.

Typical compound motor torque and speed characteristics are shown in Fig. 22.25

22.13 The efficiency of a d.c. motor

It was stated in Section 22.9, that the efficiency of a d.c. machine is given by:

$$\text{efficiency, } \eta = \frac{\text{output power}}{\text{input power}} \times 100\%$$

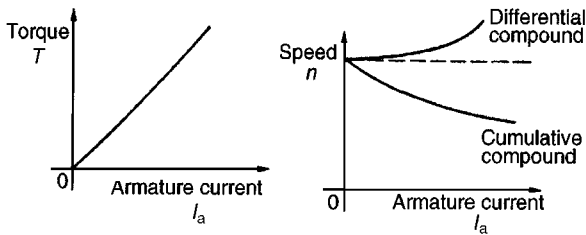

Figure 22.25

Also, the total losses = $I_a^2 R_a + I_f V + C$ (for a shunt motor) where C is the sum of the iron, friction and windage losses.

For a motor,

$$\text{the input power} = VI$$

$$\text{and the output power} = VI - \text{losses}$$

$$= VI - I_a^2 R_a - I_f V - C$$

Hence **efficiency**,

$$\eta = \left(\frac{VI - I_a^2 R_a - I_f V - C}{VI} \right) \times 100\% \quad (10)$$

The **efficiency of a motor is a maximum** when the load is such that:

$$I_a^2 R_a = I_f V + C$$

Problem 24. A 320 V shunt motor takes a total current of 80 A and runs at 1000 rev/min. If the iron, friction and windage losses amount to 1.5 kW, the shunt field resistance is 40 Ω and the armature resistance is 0.2 Ω, determine the overall efficiency of the motor.

The circuit is shown in Fig. 22.26. Field current, $I_f = V/R_f = 320/40 = 8$ A. Armature current $I_a = I - I_f = 80 - 8 = 72$ A. $C =$ iron, friction and windage losses = 1500 W. Efficiency,

$$\begin{aligned} \eta &= \left(\frac{VI - I_a^2 R_a - I_f V - C}{VI} \right) \times 100\% \\ &= \left(\frac{(320)(80) - (72)^2 (0.2) - (8)(320) - 1500}{(320)(80)} \right) \times 100\% \end{aligned}$$

$$\begin{aligned} &= \left(\frac{25600 - 1036.8 - 2560 - 1500}{25600} \right) \times 100\% \\ &= \left(\frac{20503.2}{25600} \right) \times 100\% \\ &= \mathbf{80.1\%} \end{aligned}$$

Problem 25. A 250 V series motor draws a current of 40 A. The armature resistance is 0.15 Ω and the field resistance is 0.05 Ω. Determine the maximum efficiency of the motor.

The circuit is as shown in Fig. 22.27 From equation (10), efficiency,

$$\eta = \left(\frac{VI - I_a^2 R_a - I_f V - C}{VI} \right) \times 100\%$$

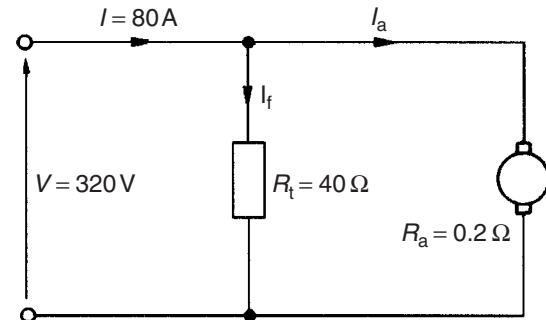

Figure 22.26

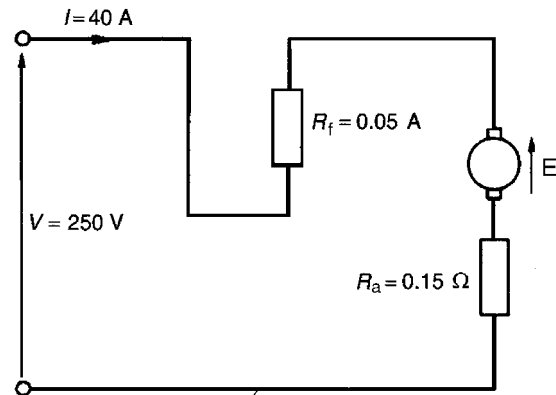

Figure 22.27

However for a series motor, $I_f = 0$ and the $I_a^2 R_a$ loss needs to be $I^2(R_a + R_f)$ Hence efficiency,

$$\eta = \left(\frac{VI - I^2(R_a + R_f) - C}{VI} \right) \times 100\%$$

For maximum efficiency $I^2(R_a + R_f) = C$ Hence efficiency,

$$\begin{aligned} \eta &= \left(\frac{VI - 2I^2(R_a + R_f)}{VI} \right) \times 100\% \\ &= \left(\frac{(250)(40) - 2(40)^2(0.15 + 0.05)}{(250)(40)} \right) \times 100\% \\ &= \left(\frac{10\,000 - 640}{10\,000} \right) \times 100\% \\ &= \left(\frac{9360}{10\,000} \right) \times 100\% = \mathbf{93.6\%} \end{aligned}$$

Problem 26. A 200 V d.c. motor develops a shaft torque of 15 Nm at 1200 rev/min. If the efficiency is 80 per cent, determine the current supplied to the motor.

The efficiency of a motor = output power/input power $\times 100\%$

The output power of a motor is the power available to do work at its shaft and is given by $T\omega$ or $T(2\pi n)$ watts, where T is the torque in Nm and n is the speed of rotation in rev/s. The input power is the electrical power in watts supplied to the motor, i.e. VI watts.

Thus for a motor,

$$\text{efficiency, } \eta = \frac{T(2\pi n)}{VI} \times 100\%$$

$$\text{i.e. } 80 = \left[\frac{(15)(2\pi n) \left(\frac{1200}{60} \right)}{(200)(I)} \right] \times 100$$

Thus the current supplied,

$$\begin{aligned} I &= \frac{(15)(2\pi)(20)(100)}{(200)(80)} \\ &= \mathbf{11.8 \text{ A}} \end{aligned}$$

Problem 27. A d.c. series motor drives a load at 30 rev/s and takes a current of 10 A when the supply voltage is 400 V. If the total resistance of the motor is 2Ω and the iron, friction and windage losses amount to 300 W, determine the efficiency of the motor.

Efficiency,

$$\begin{aligned} \eta &= \left(\frac{VI - I^2R - C}{VI} \right) \times 100\% \\ &= \left(\frac{(400)(10) - (10)^2(2) - 300}{(400)(10)} \right) \times 100\% \\ &= \left(\frac{4000 - 200 - 300}{4000} \right) \times 100\% \\ &= \left(\frac{3500}{4000} \right) \times 100\% = \mathbf{87.5\%} \end{aligned}$$

Now try the following exercise

Exercise 132 Further problems on d.c. motors

- 1 A 240 V shunt motor takes a total current of 80 A. If the field winding resistance is 120Ω and the armature resistance is 0.4Ω , determine (a) the current in the armature, and (b) the back e.m.f. [(a) 78 A (b) 208.8 V]
- 2 A d.c. motor has a speed of 900 rev/min when connected to a 460 V supply. Find the approximate value of the speed of the motor when connected to a 200 V supply, assuming the flux decreases by 30 per cent and neglecting the armature volt drop. [559 rev/min]
- 3 A series motor having a series field resistance of 0.25Ω and an armature resistance of 0.15Ω , is connected to a 220 V supply and at a particular load runs at 20 rev/s when drawing 20 A from the supply. Calculate the e.m.f. generated at this load. Determine also the speed of the motor when the load is changed such that the current increases to 25 A. Assume the flux increases by 25 per cent [212 V, 15.85 rev/s]

- 4 A 500 V shunt motor takes a total current of 100 A and runs at 1200 rev/min. If the shunt field resistance is $50\ \Omega$, the armature resistance is $0.25\ \Omega$ and the iron, friction and windage losses amount to 2 kW, determine the overall efficiency of the motor. [81.95 per cent]
- 5 A 250 V, series-wound motor is running at 500 rev/min and its shaft torque is 130 Nm. If its efficiency at this load is 88 per cent, find the current taken from the supply. [30.94 A]
- 6 In a test on a d.c. motor, the following data was obtained. Supply voltage: 500 V, current taken from the supply: 42.4 A, speed: 850 rev/min, shaft torque: 187 Nm. Determine the efficiency of the motor correct to the nearest 0.5 per cent [78.5 per cent]
- 7 A 300 V series motor draws a current of 50 A. The field resistance is $40\ \text{m}\Omega$ and the armature resistance is $0.2\ \Omega$. Determine the maximum efficiency of the motor. [92 per cent]
- 8 A series motor drives a load at 1500 rev/min and takes a current of 20 A when the supply voltage is 250 V. If the total resistance of the motor is $1.5\ \Omega$ and the iron, friction and windage losses amount to 400 W, determine the efficiency of the motor. [80 per cent]
- 9 A series-wound motor is connected to a d.c. supply and develops full-load torque when the current is 30 A and speed is 1000 rev/min. If the flux per pole is proportional to the current flowing, find the current and speed at half full-load torque, when connected to the same supply. [21.2 A, 1415 rev/min]

22.14 D.C. motor starter

If a d.c. motor whose armature is stationary is switched directly to its supply voltage, it is likely that the fuses protecting the motor will burn out. This is because the armature resistance is small, frequently being less than one ohm. Thus, additional resistance must be added to the armature circuit at the instant of closing the switch to start the motor.

As the speed of the motor increases, the armature conductors are cutting flux and a generated voltage, acting in opposition to the applied voltage, is produced, which limits the flow of armature current.

Thus the value of the additional armature resistance can then be reduced.

When at normal running speed, the generated e.m.f. is such that no additional resistance is required in the armature circuit. To achieve this varying resistance in the armature circuit on starting, a d.c. motor starter is used, as shown in Fig. 22.28

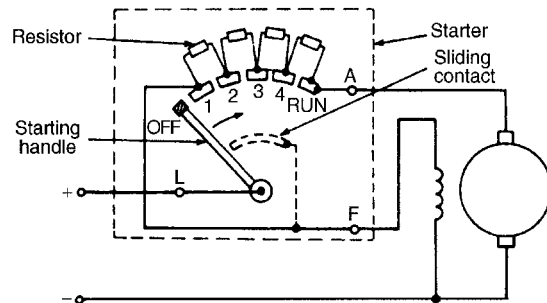

Figure 22.28

The starting handle is moved **slowly** in a clockwise direction to start the motor. For a shunt-wound motor, the field winding is connected to stud 1 or to *L* via a sliding contact on the starting handle, to give maximum field current, hence maximum flux, hence maximum torque on starting, since $T \propto \Phi I_a$. A similar arrangement without the field connection is used for series motors.

22.15 Speed control of d.c. motors

Shunt-wound motors

The speed of a shunt-wound d.c. motor, n , is proportional to

$$\frac{V - I_a R_a}{\Phi}$$

(see equation (9)). The speed is varied either by varying the value of flux, Φ , or by varying the value of R_a . The former is achieved by using a variable resistor in series with the field winding, as shown in Fig. 22.29(a) and such a resistor is called the **shunt field regulator**.

As the value of resistance of the shunt field regulator is increased, the value of the field current, I_f , is decreased. This results in a decrease in the value of flux, Φ , and hence an increase in the speed, since $n \propto 1/\Phi$. Thus only speeds **above** that given without a shunt field regulator can be obtained by this method. Speeds **below** those given by

$$\frac{V - I_a R_a}{\Phi}$$

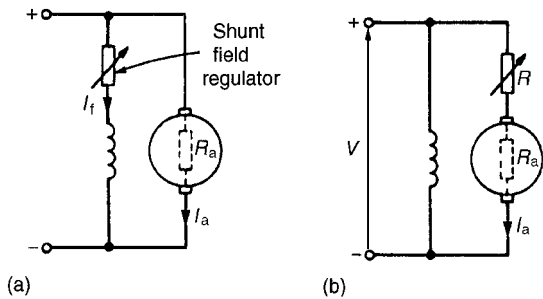

Figure 22.29

are obtained by increasing the resistance in the armature circuit, as shown in Fig. 22.29(b), where

$$n \propto \frac{V - I_a(R_a + R)}{\Phi}$$

Since resistor R is in series with the armature, it carries the full armature current and results in a large power loss in large motors where a considerable speed reduction is required for long periods.

These methods of speed control are demonstrated in the following worked problem.

Problem 28. A 500 V shunt motor runs at its normal speed of 10 rev/s when the armature current is 120 A. The armature resistance is 0.2Ω . (a) Determine the speed when the current is 60 A and a resistance of 0.5Ω is connected in series with the armature, the shunt field remaining constant (b) Determine the speed when the current is 60 A and the shunt field is reduced to 80 per cent of its normal value by increasing resistance in the field circuit.

(a) With reference to Fig. 22.29(b), back e.m.f. at 120 A, $E_1 = V - I_a R_a = 500 - (120)(0.2) = 500 - 24 = 476$ volts. When $I_a = 60$ A,

$$\begin{aligned} E_2 &= 500 - (60)(0.2 + 0.5) \\ &= 500 - (60)(0.7) \\ &= 500 - 42 = 458 \text{ volts} \end{aligned}$$

$$\text{Now } \frac{E_1}{E_2} = \frac{\Phi_1 n_1}{\Phi_2 n_2}$$

$$\text{i.e. } \frac{476}{458} = \frac{\Phi_1(10)}{\Phi_1 n_2} \text{ since } \Phi_2 = \Phi_1$$

from which,

$$\text{speed } n_2 = \frac{(10)(458)}{476} = 9.62 \text{ rev/s}$$

(b) Back e.m.f. when $I_a = 60$ A,

$$\begin{aligned} E_3 &= 500 - (60)(0.2) \\ &= 500 - 12 = 488 \text{ volts} \end{aligned}$$

$$\text{Now } \frac{E_1}{E_3} = \frac{\Phi_1 n_1}{\Phi_3 n_3}$$

$$\text{i.e. } \frac{476}{488} = \frac{\Phi_1(10)}{0.8\Phi_1 n_3} \text{ since } \Phi_3 = 0.8\Phi_1$$

from which,

$$\text{speed } n_3 = \frac{(10)(488)}{(0.8)(476)} = 12.82 \text{ rev/s}$$

Series-wound motors

The speed control of series-wound motors is achieved using either (a) field resistance, or (b) armature resistance techniques.

(a) The speed of a d.c. series-wound motor is given by:

$$n = k \left(\frac{V - IR}{\Phi} \right)$$

where k is a constant, V is the terminal voltage, R is the combined resistance of the armature and series field and Φ is the flux. Thus, a reduction in flux results in an increase in speed. This is achieved by putting a variable resistance in parallel with the field winding and reducing the field current, and hence flux, for a given value of supply current. A circuit diagram of this arrangement is shown in Fig. 22.30(a). A variable resistor connected in parallel with the series-wound field to control speed is called a **diverter**. Speeds above those given with no diverter are obtained by this method. Problem 29 below demonstrates this method.

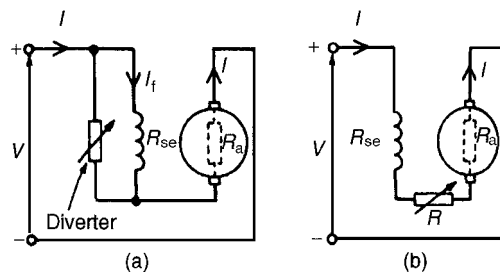

Figure 22.30

(b) Speeds below normal are obtained by connecting a variable resistor in series with the field winding and armature circuit, as shown in Fig. 22.30(b). This effectively increases the value of R in the equation

$$n = k \left(\frac{V - IR}{\Phi} \right)$$

and thus reduces the speed. Since the additional resistor carries the full supply current, a large power loss is associated with large motors in which a considerable speed reduction is required for long periods. This method is demonstrated in problem 30.

Problem 29. On full-load a 300 V series motor takes 90 A and runs at 15 rev/s. The armature resistance is 0.1Ω and the series winding resistance is $50 \text{ m}\Omega$. Determine the speed when developing full load torque but with a 0.2Ω diverter in parallel with the field winding. (Assume that the flux is proportional to the field current).

At 300 V, e.m.f.

$$\begin{aligned} E_1 &= V - IR = V - I(R_a + R_{se}) \\ &= 300 - (90)(0.1 + 0.05) \\ &= 300 - (90)(0.15) \\ &= 300 - 13.5 = 286.5 \text{ volts} \end{aligned}$$

With the 0.2Ω diverter in parallel with R_{se} (see Fig. 22.30(a)), the equivalent resistance,

$$R = \frac{(0.2)(0.05)}{0.2 + 0.05} = \frac{(0.2)(0.05)}{0.25} = 0.04 \Omega$$

By current division, current

$$I_1 \text{ (in Fig. 22.30(a))} = \left(\frac{0.2}{0.2 + 0.05} \right) I = 0.8 I$$

Torque, $T \propto I_a \Phi$ and for full load torque, $I_{a1} \Phi_1 = I_{a2} \Phi_2$

Since flux is proportional to field current $\Phi_1 \propto I_{a1}$ and $\Phi_2 \propto 0.8 I_{a2}$ then $(90)(90) = (I_{a2})(0.8 I_{a2})$

from which,
$$I_{a2}^2 = \frac{90^2}{0.8}$$

and
$$I_{a2} = \frac{90}{\sqrt{0.8}} = 100.62 \text{ A}$$

Hence e.m.f.
$$\begin{aligned} E_2 &= V - I_{a2}(R_a + R) \\ &= 300 - (100.62)(0.1 + 0.04) \end{aligned}$$

$$\begin{aligned} &= 300 - (100.62)(0.14) \\ &= 300 - 14.087 = 285.9 \text{ volts} \end{aligned}$$

Now e.m.f., $E \propto \Phi n$, from which,

$$\frac{E_1}{E_2} = \frac{\Phi_1 n_1}{\Phi_2 n_2} = \frac{I_{a1} n_1}{0.8 I_{a2} n_2}$$

Hence

$$\frac{286.5}{285.9} = \frac{(90)(15)}{(0.8)(100.62)n_2}$$

and **new speed, n_2** =
$$\frac{(285.9)(90)(15)}{(286.5)(0.8)(100.62)} = 16.74 \text{ rev/s}$$

Thus the speed of the motor has increased from 15 rev/s (i.e. 900 rev/min) to 16.74 rev/s (i.e. 1004 rev/min) by inserting a 0.2Ω diverter resistance in parallel with the series winding.

Problem 30. A series motor runs at 800 rev/min when the voltage is 400 V and the current is 25 A. The armature resistance is 0.4Ω and the series field resistance is 0.2Ω . Determine the resistance to be connected in series to reduce the speed to 600 rev/min with the same current.

With reference to Fig. 22.30(b), at 800 rev/min,

e.m.f.,
$$\begin{aligned} E_1 &= V - I(R_a + R_{se}) \\ &= 400 - (25)(0.4 + 0.2) \\ &= 400 - (25)(0.6) \\ &= 400 - 15 = 385 \text{ volts} \end{aligned}$$

At 600 rev/min, since the current is unchanged, the flux is unchanged.

Thus $E \propto \Phi n$ or $E \propto n$ and

$$\frac{E_1}{E_2} = \frac{n_1}{n_2}$$

Hence

$$\frac{385}{E_2} = \frac{800}{600}$$

from which,
$$E_2 = \frac{(385)(600)}{800} = 288.75 \text{ volts}$$

and
$$E_2 = V - I(R_a + R_{se} + R)$$

Hence
$$288.75 = 400 - 25(0.4 + 0.2 + R)$$

Rearranging gives:

$$0.6 + R = \frac{400 - 288.75}{25} = 4.45$$

from which, extra series resistance, $R = 4.45 - 0.6$ i.e. **$R = 3.85 \Omega$** .

Thus the addition of a series resistance of 3.85Ω has reduced the speed from 800 rev/min to 600 rev/min.

Now try the following exercise

Exercise 133 Further problems on the speed control of d.c. motors

- 1 A 350 V shunt motor runs at its normal speed of 12 rev/s when the armature current is 90 A. The resistance of the armature is 0.3Ω .
 - (a) Find the speed when the current is 45 A and a resistance of 0.4Ω is connected in series with the armature, the shunt field remaining constant
 - (b) Find the speed when the current is 45 A and the shunt field is reduced to 75 per cent of its normal value by increasing resistance in the field circuit.
[(a) 11.83 rev/s (b) 16.67 rev/s]
- 2 A series motor runs at 900 rev/min when the voltage is 420 V and the current is 40 A. The armature resistance is 0.3Ω and the series field resistance is 0.2Ω . Calculate the resistance to be connected in series to reduce the speed to 720 rev/min with the same current. [2 Ω]
- 3 A 320 V series motor takes 80 A and runs at 1080 rev/min at full load. The armature resistance is 0.2Ω and the series winding resistance is 0.05Ω . Assuming the flux is proportional to the field current, calculate the speed when developing full-load torque, but with a 0.15Ω diverter in parallel with the field winding. [1239 rev/min]

22.16 Motor cooling

Motors are often classified according to the type of enclosure used, the type depending on the conditions under which the motor is used and the degree of ventilation required.

The most common type of protection is the **screen-protected type**, where ventilation is achieved by fitting a fan internally, with the openings at the end of the motor fitted with wire mesh.

A **drip-proof type** is similar to the screen-protected type but has a cover over the screen to prevent drips of water entering the machine.

A **flame-proof type** is usually cooled by the conduction of heat through the motor casing.

With a **pipe-ventilated type**, air is piped into the motor from a dust-free area, and an internally fitted fan ensures the circulation of this cool air.

Now try the following exercises

Exercise 134 Short answer questions on d.c. machines

- 1 A converts mechanical energy into electrical energy
- 2 A converts electrical energy into mechanical energy
- 3 What does 'commutation' achieve?
- 4 Poor commutation may cause sparking. How can this be improved?
- 5 State any five basic parts of a d.c. machine
- 6 State the two groups armature windings can be divided into
- 7 What is armature reaction? How can it be overcome?
- 8 The e.m.f. generated in an armature winding is given by $E = 2p\Phi nZ/c$ volts. State what p , Φ , n , Z and c represent.
- 9 In a series-wound d.c. machine, the field winding is in with the armature circuit
- 10 In a d.c. generator, the relationship between the generated voltage, terminal voltage, current and armature resistance is given by $E =$
- 11 A d.c. machine has its field winding in parallel with the armatures circuit. It is called a wound machine
- 12 Sketch a typical open-circuit characteristic for (a) a separately excited generator (b) a shunt generator (c) a series generator
- 13 Sketch a typical load characteristic for (a) a separately excited generator (b) a shunt generator (c) a series generator
- 14 State one application for (a) a shunt generator (b) a series generator (c) a compound generator
- 15 State the principle losses in d.c. machines
- 16 The efficiency of a d.c. machine is given by the ratio (.) per cent

- 17 The equation relating the generated e.m.f., E , terminal voltage, armature current and armature resistance for a d.c. motor is $E = \dots\dots$
- 18 The torque T of a d.c. motor is given by $T = p\Phi ZI_a/\pi c$ newton metres. State what p , Φ , Z , I and c represent
- 19 Complete the following. In a d.c. machine
(a) generated e.m.f. $\propto \dots\dots \times \dots\dots$
(b) torque $\propto \dots\dots \times \dots\dots$
- 20 Sketch typical characteristics of torque/armature current for
(a) a shunt motor
(b) a series motor
(c) a compound motor
- 21 Sketch typical speed/torque characteristics for a shunt and series motor
- 22 State two applications for each of the following motors:
(a) shunt (b) series (c) compound
In questions 23 to 26, an electrical machine runs at n rev/s, has a shaft torque of T , and takes a current of I from a supply voltage V
- 23 The power input to a generator is $\dots\dots$ watts
- 24 The power input to a motor is $\dots\dots$ watts
- 25 The power output from a generator is $\dots\dots$ watts
- 26 The power output from a motor is $\dots\dots$ watts
- 27 The generated e.m.f. of a d.c. machine is proportional to $\dots\dots$ volts
- 28 The torque produced by a d.c. motor is proportional to $\dots\dots$ Nm
- 29 A starter is necessary for a d.c. motor because the generated e.m.f. is $\dots\dots$ at low speeds
- 30 The speed of a d.c. shunt-wound motor will $\dots\dots$ if the value of resistance of the shunt field regulator is increased
- 31 The speed of a d.c. motor will $\dots\dots$ if the value of resistance in the armature circuit is increased
- 32 The value of the speed of a d.c. shunt-wound motor $\dots\dots$ as the value of the armature current increases

- 33 At a large value of torque, the speed of a d.c. series-wound motor is $\dots\dots$
- 34 At a large value of field current, the generated e.m.f. of a d.c. shunt-wound generator is approximately $\dots\dots$
- 35 In a series-wound generator, the terminal voltage increases as the load current $\dots\dots$
- 36 One type of d.c. motor uses resistance in series with the field winding to obtain speed variations and another type uses resistance in parallel with the field winding for the same purpose. Explain briefly why these two distinct methods are used and why the field current plays a significant part in controlling the speed of a d.c. motor.
- 37 Name three types of motor enclosure

Exercise 135 Multi-choice questions on d.c. machines (Answers on page 376)

- 1 Which of the following statements is false?
(a) A d.c. motor converts electrical energy to mechanical energy
(b) The efficiency of a d.c. motor is the ratio input power to output power
(c) A d.c. generator converts mechanical power to electrical power
(d) The efficiency of a d.c. generator is the ratio output power to input power
- A shunt-wound d.c. machine is running at n rev/s and has a shaft torque of T Nm. The supply current is IA when connected to d.c. bus-bars of voltage V volts. The armature resistance of the machine is R_a ohms, the armature current is I_aA and the generated voltage is E volts. Use this data to find the formulae of the quantities stated in questions 2 to 9, selecting the correct answer from the following list:
- | | |
|------------------|------------------|
| (a) $V - I_aR_a$ | (b) $E + I_aR_a$ |
| (c) VI | (d) $E - I_aR_a$ |
| (e) $T(2\pi n)$ | (f) $V + I_aR_a$ |
- 2 The input power when running as a generator
- 3 The output power when running as a motor
- 4 The input power when running as a motor

- 5 The output power when running as a generator
- 6 The generated voltage when running as a motor
- 7 The terminal voltage when running as a generator
- 8 The generated voltage when running as a generator
- 9 The terminal voltage when running as a motor
- 10 Which of the following statements is false?
 - (a) A commutator is necessary as part of a d.c. motor to keep the armature rotating in the same direction
 - (b) A commutator is necessary as part of a d.c. generator to produce unidirectional voltage at the terminals of the generator
 - (c) The field winding of a d.c. machine is housed in slots on the armature
 - (d) The brushes of a d.c. machine are usually made of carbon and do not rotate with the armature
- 11 If the speed of a d.c. machine is doubled and the flux remains constant, the generated e.m.f. (a) remains the same (b) is doubled (c) is halved
- 12 If the flux per pole of a shunt-wound d.c. generator is increased, and all other variables are kept the same, the speed
 - (a) decreases (b) stays the same (c) increases
- 13 If the flux per pole of a shunt-wound d.c. generator is halved, the generated e.m.f. at constant speed (a) is doubled (b) is halved (c) remains the same
- 14 In a series-wound generator running at constant speed, as the load current increases, the terminal voltage
 - (a) increases (b) decreases (c) stays the same
- 15 Which of the following statements is false for a series-wound d.c. motor?
 - (a) The speed decreases with increase of resistance in the armature circuit
 - (b) The speed increases as the flux decreases
 - (c) The speed can be controlled by a diverter
 - (d) The speed can be controlled by a shunt field regulator
- 16 Which of the following statements is false?
 - (a) A series-wound motor has a large starting torque
 - (b) A shunt-wound motor must be permanently connected to its load
 - (c) The speed of a series-wound motor drops considerably when load is applied
 - (d) A shunt-wound motor is essentially a constant-speed machine
- 17 The speed of a d.c. motor may be increased by
 - (a) increasing the armature current
 - (b) decreasing the field current
 - (c) decreasing the applied voltage
 - (d) increasing the field current
- 18 The armature resistance of a d.c. motor is 0.5Ω , the supply voltage is 200 V and the back e.m.f. is 196 V at full speed. The armature current is:
 - (a) 4 A (b) 8 A (c) 400 A (d) 392 A
- 19 In d.c. generators iron losses are made up of:
 - (a) hysteresis and friction losses
 - (b) hysteresis, eddy current and brush contact losses
 - (c) hysteresis and eddy current losses
 - (d) hysteresis, eddy current and copper losses
- 20 The effect of inserting a resistance in series with the field winding of a shunt motor is to:
 - (a) increase the magnetic field
 - (b) increase the speed of the motor
 - (c) decrease the armature current
 - (d) reduce the speed of the motor
- 21 The supply voltage to a d.c. motor is 240 V. If the back e.m.f. is 230 V and the armature resistance is 0.25Ω , the armature current is:
 - (a) 10 A (b) 40 A (c) 960 A (d) 920 A
- 22 With a d.c. motor, the starter resistor:
 - (a) limits the armature current to a safe starting value
 - (b) controls the speed of the machine
 - (c) prevents the field current flowing through and damaging the armature
 - (d) limits the field current to a safe starting value
- 23 From Fig. 22.31, the expected characteristic for a shunt-wound d.c. generator is:
 - (a) P (b) Q (c) R (d) S

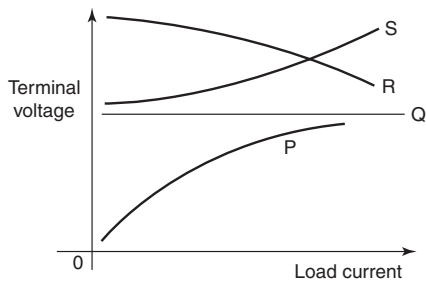

Figure 22.31

- 24 A commutator is a device fitted to a generator. Its function is:
- (a) to prevent sparking when the load changes
 - (b) to convert the a.c. generated into a d.c. output
 - (c) to convey the current to and from the windings
 - (d) to generate a direct current

Three-phase induction motors

At the end of this chapter you should be able to:

- appreciate the merits of three-phase induction motors
- understand how a rotating magnetic field is produced
- state the synchronous speed, $n_s = (f/p)$ and use in calculations
- describe the principle of operation of a three-phase induction motor
- distinguish between squirrel-cage and wound-rotor types of motor
- understand how a torque is produced causing rotor movement
- understand and calculate slip
- derive expressions for rotor e.m.f., frequency, resistance, reactance, impedance, current and copper loss, and use them in calculations
- state the losses in an induction motor and calculate efficiency
- derive the torque equation for an induction motor, state the condition for maximum torque, and use in calculations
- describe torque-speed and torque-slip characteristics for an induction motor
- state and describe methods of starting induction motors
- state advantages of cage rotor and wound rotor types of induction motor
- describe the double cage induction motor
- state typical applications of three-phase induction motors

23.1 Introduction

In d.c. motors, introduced in Chapter 22, conductors on a rotating armature pass through a stationary magnetic field. In a **three-phase induction motor**, the magnetic field rotates and this has the advantage that no external electrical connections to the rotor need be made. Its name is derived from the fact that the current in the rotor is **induced** by the magnetic field instead of being supplied through electrical connections to the supply. The result is a motor which: (i) is cheap and robust, (ii) is explosion proof, due to the absence of a commutator or slip-rings and brushes with their associated sparking,

(iii) requires little or no skilled maintenance, and (iv) has self-starting properties when switched to a supply with no additional expenditure on auxiliary equipment. The principal disadvantage of a three-phase induction motor is that its speed cannot be readily adjusted.

23.2 Production of a rotating magnetic field

When a three-phase supply is connected to symmetrical three-phase windings, the currents flowing in the windings produce a magnetic field.

This magnetic field is constant in magnitude and rotates at constant speed as shown below, and is called the **synchronous speed**.

With reference to Fig. 23.1, the windings are represented by three single-loop conductors, one for each phase, marked $R_S R_F$, $Y_S Y_F$ and $B_S B_F$, the S and F signifying start and finish. In practice, each phase winding comprises many turns and is distributed around the stator; the single-loop approach is for clarity only.

When the stator windings are connected to a three-phase supply, the current flowing in each winding varies with time and is as shown in

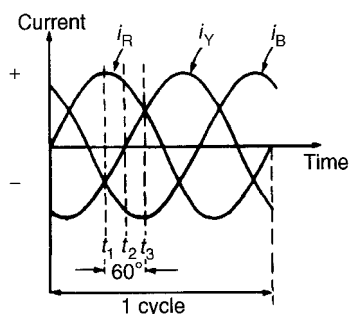

(a)

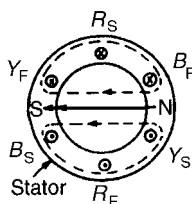

(b)

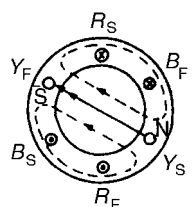

(c)

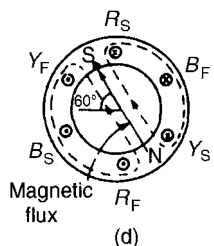

(d)

Figure 23.1

Fig. 23.1(a). If the value of current in a winding is positive, the assumption is made that it flows from start to finish of the winding, i.e. if it is the red phase, current flows from R_S to R_F , i.e. away from the viewer in R_S and towards the viewer in R_F . When the value of current is negative, the assumption is made that it flows from finish to start, i.e. towards the viewer in an 'S' winding and away from the viewer in an 'F' winding. At time, say t_1 , shown in Fig. 23.1(a), the current flowing in the red phase is a maximum positive value. At the same time t_1 , the currents flowing in the yellow and blue phases are both 0.5 times the maximum value and are negative.

The current distribution in the stator windings is therefore as shown in Fig. 23.1(b), in which current flows away from the viewer, (shown as \otimes) in R_S since it is positive, but towards the viewer (shown as \odot) in Y_S and B_S , since these are negative. The resulting magnetic field is as shown, due to the 'solenoid' action and application of the corkscrew rule.

A short time later at time t_2 , the current flowing in the red phase has fallen to about 0.87 times its maximum value and is positive, the current in the yellow phase is zero and the current in the blue phase is about 0.87 times its maximum value and is negative. Hence the currents and resultant magnetic field are as shown in Fig. 23.1(c). At time t_3 , the currents in the red and yellow phases are 0.5 of their maximum values and the current in the blue phase is a maximum negative value. The currents and resultant magnetic field are as shown in Fig. 23.1(d).

Similar diagrams to Fig. 23.1(b), (c) and (d) can be produced for all time values and these would show that the magnetic field travels through one revolution for each cycle of the supply voltage applied to the stator windings.

By considering the flux values rather than the current values, it is shown below that the rotating magnetic field has a constant value of flux. The three coils shown in Fig. 23.2(a), are connected in star to a three-phase supply. Let the positive directions of the fluxes produced by currents flowing in the coils, be ϕ_A , ϕ_B and ϕ_C respectively. The directions of ϕ_A , ϕ_B and ϕ_C do not alter, but their magnitudes are proportional to the currents flowing in the coils at any particular time. At time t_1 , shown in Fig. 23.2(b), the currents flowing in the coils are: i_B , a maximum positive value, i.e. the flux is towards point P; i_A and i_C , half the maximum value and negative, i.e. the flux is away from point P.

These currents give rise to the magnetic fluxes ϕ_A , ϕ_B and ϕ_C , whose magnitudes and directions are as shown in Fig. 23.2(c). The resultant flux is

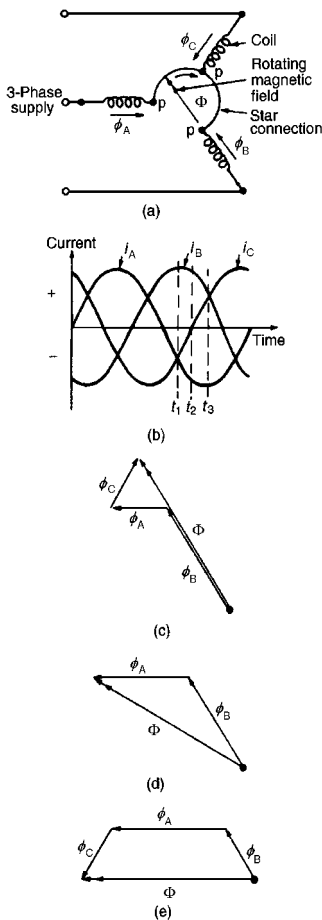

Figure 23.2

the phasor sum of ϕ_A , ϕ_B and ϕ_C , shown as Φ in Fig. 23.2(c). At time t_2 , the currents flowing are:

i_B , $0.866 \times$ maximum positive value, i_C , zero, and i_A , $0.866 \times$ maximum negative value.

The magnetic fluxes and the resultant magnetic flux are as shown in Fig. 23.2(d).

At time t_3 ,

i_B is $0.5 \times$ maximum value and is positive

i_A is a maximum negative value, and

i_C is $0.5 \times$ maximum value and is positive.

The magnetic fluxes and the resultant magnetic flux are as shown in Fig. 23.2(e)

Inspection of Fig. 23.2(c), (d) and (e) shows that the magnitude of the resultant magnetic flux, Φ , in each case is constant and is $1\frac{1}{2} \times$ the maximum value of ϕ_A , ϕ_B or ϕ_C , but that its direction is changing. The process of determining the resultant flux may

be repeated for all values of time and shows that the magnitude of the resultant flux is constant for all values of time and also that it rotates at constant speed, making one revolution for each cycle of the supply voltage.

23.3 Synchronous speed

The rotating magnetic field produced by three-phase windings could have been produced by rotating a permanent magnet's north and south pole at synchronous speed, (shown as N and S at the ends of the flux phasors in Fig. 23.1(b), (c) and (d)). For this reason, it is called a 2-pole system and an induction motor using three phase windings only is called a 2-pole induction motor. If six windings displaced from one another by 60° are used, as shown in Fig. 23.3(a), by drawing the current and resultant magnetic field diagrams at various time values, it may be shown that one cycle of the supply current to the stator windings causes the magnetic field to move through half a revolution. The current distribution in the stator windings are shown in Fig. 23.3(b), for the time t shown in Fig. 23.3(b).

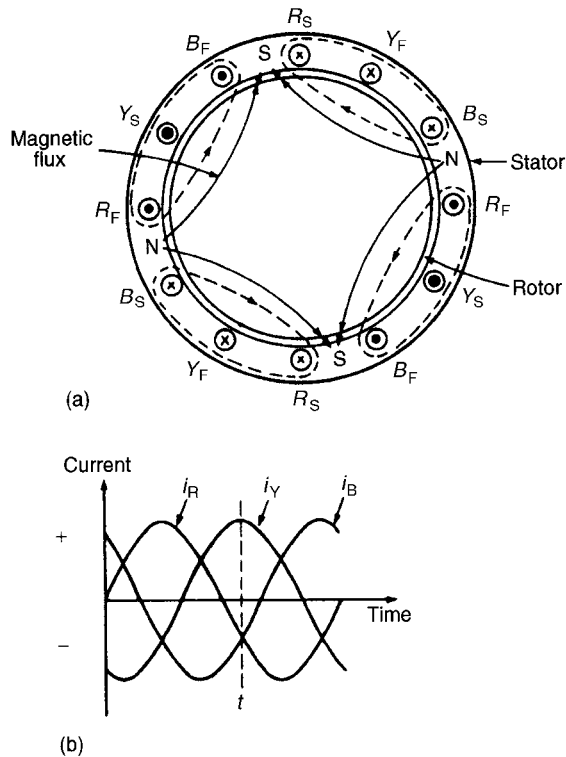

Figure 23.3

It can be seen that for six windings on the stator, the magnetic flux produced is the same as that produced by rotating two permanent magnet north poles and two permanent magnet south poles at synchronous speed. This is called a 4-pole system and an induction motor using six phase windings is called a 4-pole induction motor. By increasing the number of phase windings the number of poles can be increased to any even number.

In general, if f is the frequency of the currents in the stator windings and the stator is wound to be equivalent to p **pairs** of poles, the speed of revolution of the rotating magnetic field, i.e. the synchronous speed, n_s is given by:

$$n_s = \frac{f}{p} \text{ rev/s}$$

Problem 1. A three-phase two-pole induction motor is connected to a 50 Hz supply. Determine the synchronous speed of the motor in rev/min.

From above, $n_s = (f/p)$ rev/s, where n_s is the synchronous speed, f is the frequency in hertz of the supply to the stator and p is the number of **pairs** of poles. Since the motor is connected to a 50 hertz supply, $f = 50$.

The motor has a two-pole system, hence p , the number of pairs of poles, is 1. Thus, synchronous speed, $n_s = (50/1) = 50$ rev/s = 50×60 rev/min = **3000 rev/min**.

Problem 2. A stator winding supplied from a three-phase 60 Hz system is required to produce a magnetic flux rotating at 900 rev/min. Determine the number of poles.

Synchronous speed,

$$n_s = 900 \text{ rev/min} = \frac{900}{60} \text{ rev/s} = 15 \text{ rev/s}$$

Since

$$n_s = \left(\frac{f}{p}\right) \text{ then } p = \left(\frac{f}{n_s}\right) = \left(\frac{60}{15}\right) = 4$$

Hence **the number of pole pairs is 4** and thus **the number of poles is 8**

Problem 3. A three-phase 2-pole motor is to have a synchronous speed of 6000 rev/min. Calculate the frequency of the supply voltage.

Since $n_s = \left(\frac{f}{p}\right)$ then

$$\begin{aligned} \text{frequency, } f &= (n_s)(p) \\ &= \left(\frac{6000}{60}\right) \left(\frac{2}{2}\right) = \mathbf{100 \text{ Hz}} \end{aligned}$$

Now try the following exercise

Exercise 136 Further problems on synchronous speed

- The synchronous speed of a 3-phase, 4-pole induction motor is 60 rev/s. Determine the frequency of the supply to the stator windings. [120 Hz]
- The synchronous speed of a 3-phase induction motor is 25 rev/s and the frequency of the supply to the stator is 50 Hz. Calculate the equivalent number of pairs of poles of the motor. [2]
- A 6-pole, 3-phase induction motor is connected to a 300 Hz supply. Determine the speed of rotation of the magnetic field produced by the stator. [100 rev/s]

23.4 Construction of a three-phase induction motor

The stator of a three-phase induction motor is the stationary part corresponding to the yoke of a d.c. machine. It is wound to give a 2-pole, 4-pole, 6-pole, rotating magnetic field, depending on the rotor speed required. The rotor, corresponding to the armature of a d.c. machine, is built up of laminated iron, to reduce eddy currents.

In the type most widely used, known as a **squirrel-cage rotor**, copper or aluminium bars are placed in slots cut in the laminated iron, the ends of the bars being welded or brazed into a heavy conducting ring, (see Fig. 23.4(a)). A cross-sectional view of a three-phase induction motor is shown in Fig. 23.4(b).

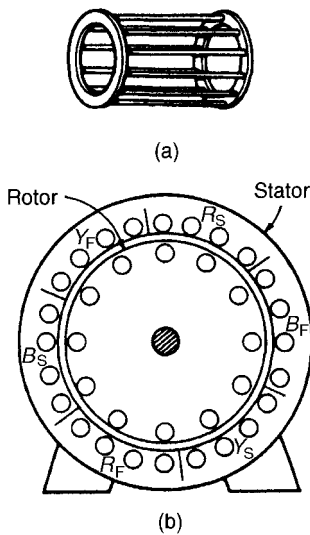

Figure 23.4

The conductors are placed in slots in the laminated iron rotor core. If the slots are skewed, better starting and quieter running is achieved. This type of rotor has no external connections which means that slip rings and brushes are not needed. The squirrel-cage motor is cheap, reliable and efficient. Another type of rotor is the **wound rotor**. With this type there are phase windings in slots, similar to those in the stator. The windings may be connected in star or delta and the connections made to three slip rings. The slip rings are used to add external resistance to the rotor circuit, particularly for starting (see Section 23.13), but for normal running the slip rings are short-circuited.

The principle of operation is the same for both the squirrel cage and the wound rotor machines.

23.5 Principle of operation of a three-phase induction motor

When a three-phase supply is connected to the stator windings, a rotating magnetic field is produced. As the magnetic flux cuts a bar on the rotor, an e.m.f. is induced in it and since it is joined, via the end conducting rings, to another bar one pole pitch away, a current flows in the bars. The magnetic field associated with this current flowing in the bars interacts with the rotating magnetic field and a force is produced, tending to turn the rotor in the same direction as the rotating magnetic field, (see Fig. 23.5). Similar forces are applied to all the

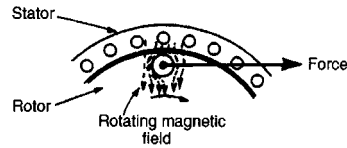

Figure 23.5

conductors on the rotor, so that a torque is produced causing the rotor to rotate.

23.6 Slip

The force exerted by the rotor bars causes the rotor to turn in the direction of the rotating magnetic field. As the rotor speed increases, the rate at which the rotating magnetic field cuts the rotor bars is less and the frequency of the induced e.m.f.'s in the rotor bars is less. If the rotor runs at the same speed as the rotating magnetic field, no e.m.f.'s are induced in the rotor, hence there is no force on them and no torque on the rotor. Thus the rotor slows down. For this reason the rotor can never run at synchronous speed.

When there is no load on the rotor, the resistive forces due to windage and bearing friction are small and the rotor runs very nearly at synchronous speed. As the rotor is loaded, the speed falls and this causes an increase in the frequency of the induced e.m.f.'s in the rotor bars and hence the rotor current, force and torque increase. The difference between the rotor speed, n_r , and the synchronous speed, n_s , is called the **slip speed**, i.e.

$$\text{slip speed} = n_s - n_r \text{ rev/s}$$

The ratio $(n_s - n_r)/n_s$ is called the **fractional slip** or just the **slip**, s , and is usually expressed as a percentage. Thus

$$\text{slip, } s = \left(\frac{n_s - n_r}{n_s} \right) \times 100\%$$

Typical values of slip between no load and full load are about 4 to 5 per cent for small motors and 1.5 to 2 per cent for large motors.

Problem 4. The stator of a 3-phase, 4-pole induction motor is connected to a 50 Hz supply. The rotor runs at 1455 rev/min at full load. Determine (a) the synchronous speed and (b) the slip at full load.

- (a) The number of pairs of poles, $p = (4/2) = 2$
The supply frequency $f = 50\text{ Hz}$ The **synchronous speed**, $n_s = (f/p) = (50/2) = 25\text{ rev/s}$.
- (b) The rotor speed, $n_r = (1455/60) = 24.25\text{ rev/s}$.

$$\begin{aligned}\text{Slip, } s &= \left(\frac{n_s - n_r}{n_s} \right) \times 100\% \\ &= \left(\frac{25 - 24.25}{25} \right) \times 100\% \\ &= 3\%\end{aligned}$$

Problem 5. A 3-phase, 60 Hz induction motor has 2 poles. If the slip is 2 per cent at a certain load, determine (a) the synchronous speed, (b) the speed of the rotor, and (c) the frequency of the induced e.m.f.'s in the rotor.

- (a) $f = 60\text{ Hz}$ and $p = (2/2) = 1$ Hence **synchronous speed**, $n_s = (f/p) = (60/1) = 60\text{ rev/s}$ or $60 \times 60 = 3600\text{ rev/min}$.
- (b) Since slip,

$$\begin{aligned}s &= \left(\frac{n_s - n_r}{n_s} \right) \times 100\% \\ 2 &= \left(\frac{60 - n_r}{60} \right) \times 100\end{aligned}$$

Hence

$$\frac{2 \times 60}{100} = 60 - n_r$$

i.e.

$$n_r = 60 - \frac{2 \times 60}{100} = 58.8\text{ rev/s}$$

i.e. the rotor runs at $58.8 \times 60 = 3528\text{ rev/min}$

- (c) Since the synchronous speed is 60 rev/s and that of the rotor is 58.8 rev/s, the rotating magnetic field cuts the rotor bars at $(60 - 58.8) = 1.2\text{ rev/s}$.

Thus the frequency of the e.m.f.'s induced in the rotor bars is 1.2 Hz.

Problem 6. A three-phase induction motor is supplied from a 50 Hz supply and runs at 1200 rev/min when the slip is 4 per cent. Determine the synchronous speed.

$$\text{Slip, } s = \left(\frac{n_s - n_r}{n_s} \right) \times 100\%$$

Rotor speed, $n_r = (1200/60) = 20\text{ rev/s}$ and $s = 4$. Hence

$$4 = \left(\frac{n_s - 20}{n_s} \right) \times 100\% \text{ or } 0.04 = \frac{n_s - 20}{n_s}$$

from which, $n_s(0.04) = n_s - 20$ and $20 = n_s - 0.04n_s = n_s(1 - 0.04)$. Hence **synchronous speed**,

$$\begin{aligned}n_s &= \frac{20}{1 - 0.04} = 20.83\text{ rev/s} \\ &= (20.83 \times 60)\text{ rev/min} \\ &= 1250\text{ rev/min}\end{aligned}$$

Now try the following exercise

Exercise 137 Further problems on slip

- A 6-pole, 3-phase induction motor runs at 970 rev/min at a certain load. If the stator is connected to a 50 Hz supply, find the percentage slip at this load. [3%]
- A 3-phase, 50 Hz induction motor has 8 poles. If the full load slip is 2.5 per cent, determine (a) the synchronous speed, (b) the rotor speed, and (c) the frequency of the rotor e.m.f.'s [(a) 750 rev/min (b) 731 rev/min (c) 1.25 Hz]
- A three-phase induction motor is supplied from a 60 Hz supply and runs at 1710 rev/min when the slip is 5 per cent. Determine the synchronous speed. [1800 rev/min]
- A 4-pole, 3-phase, 50 Hz induction motor runs at 1440 rev/min at full load. Calculate (a) the synchronous speed, (b) the slip and (c) the frequency of the rotor induced e.m.f.'s [(a) 1500 rev/min (b) 4% (c) 2 Hz]

23.7 Rotor e.m.f. and frequency

Rotor e.m.f.

When an induction motor is stationary, the stator and rotor windings form the equivalent of a transformer as shown in Fig. 23.6

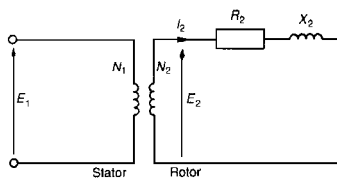

Figure 23.6

The rotor e.m.f. at standstill is given by

$$E_2 = \left(\frac{N_2}{N_1} \right) E_1 \quad (1)$$

where E_1 is the supply voltage per phase to the stator.

When an induction motor is running, the induced e.m.f. in the rotor is less since the relative movement between conductors and the rotating field is less. The induced e.m.f. is proportional to this movement, hence it must be proportional to the slip, s . Hence **when running**, rotor e.m.f. per phase = $E_r = sE_2$

$$\text{i.e. rotor e.m.f. per phase} = s \left(\frac{N_2}{N_1} \right) E_1 \quad (2)$$

Rotor frequency

The rotor e.m.f. is induced by an alternating flux and the rate at which the flux passes the conductors is the slip speed. Thus the frequency of the rotor e.m.f. is given by:

$$f_r = (n_s - n_r)p = \left(\frac{n_s - n_r}{n_s} \right) (n_s p)$$

However $(n_s - n_r)/n_s$ is the slip s and $(n_s p)$ is the supply frequency f , hence

$$f_r = sf \quad (3)$$

Problem 7. The frequency of the supply to the stator of an 8-pole induction motor is 50 Hz and the rotor frequency is 3 Hz. Determine: (a) the slip, and (b) the rotor speed.

(a) From Equation (3), $f_r = sf$. Hence $3 = (s)(50)$ from which,

$$\text{slip, } s = \frac{3}{50} = \mathbf{0.06 \text{ or } 6\%}$$

(b) Synchronous speed, $n_s = f/p = 50/4 = 12.5 \text{ rev/s}$ or $(12.5 \times 60) = 750 \text{ rev/min}$

$$\text{Slip, } s = \left(\frac{n_s - n_r}{n_s} \right)$$

$$\text{hence } 0.06 = \left(\frac{12.5 - n_r}{12.5} \right)$$

$$(0.06)(12.5) = 12.5 - n_r$$

and **rotor speed**,

$$n_r = 12.5 - (0.06)(12.5)$$

$$= \mathbf{11.75 \text{ rev/s or } 705 \text{ rev/min}}$$

Now try the following exercise

Exercise 138 Further problems on rotor frequency

- A 12-pole, 3-phase, 50 Hz induction motor runs at 475 rev/min. Determine
 - the slip speed,
 - the percentage slip and
 - the frequency of rotor currents
[(a) 25 rev/min (b) 5% (c) 2.5 Hz]
- The frequency of the supply to the stator of a 6-pole induction motor is 50 Hz and the rotor frequency is 2 Hz. Determine
 - the slip, and
 - the rotor speed, in rev/min
[(a) 0.04 or 4% (b) 960 rev/min]

23.8 Rotor impedance and current

Rotor resistance

The rotor resistance R_2 is unaffected by frequency or slip, and hence remains constant.

Rotor reactance

Rotor reactance varies with the frequency of the rotor current. At standstill, reactance per phase, $X_2 = 2\pi fL$. When running, reactance per phase,

$$\begin{aligned} X_r &= 2\pi f_r L \\ &= 2\pi (sf)L \quad \text{from equation (3)} \\ &= s(2\pi fL) \end{aligned}$$

$$\text{i.e. } X_r = sX_2 \quad (4)$$

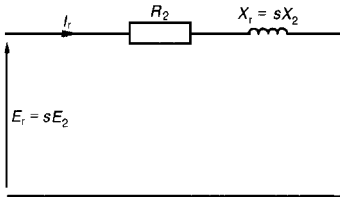

Figure 23.7

Figure 23.7 represents the rotor circuit when running.

Rotor impedance

Rotor impedance per phase,

$$Z_r = \sqrt{R_2^2 + (sX_2)^2} \tag{5}$$

At standstill, slip $s = 1$, then

$$Z_2 = \sqrt{R_2^2 + X_2^2} \tag{6}$$

Rotor current

From Fig. 23.6 and 23.7, at standstill, starting current,

$$I_2 = \frac{E_2}{Z_2} = \frac{\left(\frac{N_2}{N_1}\right) E_1}{\sqrt{R_2^2 + X_2^2}} \tag{7}$$

and when running, current,

$$I_r = \frac{E_r}{Z_r} = \frac{s \left(\frac{N_2}{N_1}\right) E_1}{\sqrt{R_2^2 + (sX_2)^2}} \tag{8}$$

23.9 Rotor copper loss

Power $P = 2\pi nT$, where T is the torque in newton metres, hence torque $T = (P/2\pi n)$. If P_2 is the power input to the rotor from the rotating field, and P_m is the mechanical power output (including friction losses)

then
$$T = \frac{P_2}{2\pi n_s} = \frac{P_m}{2\pi n_r}$$

from which,
$$\frac{P_2}{n_s} = \frac{P_m}{n_r} \text{ or } \frac{P_m}{P_2} = \frac{n_r}{n_s}$$

Hence
$$1 - \frac{P_m}{P_2} = 1 - \frac{n_r}{n_s}$$

$$\frac{P_2 - P_m}{P_2} = \frac{n_s - n_r}{n_s} = s$$

$P_2 - P_m$ is the electrical or copper loss in the rotor, i.e. $P_2 - P_m = I_r^2 R_2$. Hence

$$\text{slip, } s = \frac{\text{rotor copper loss}}{\text{rotor input}} = \frac{I_r^2 R_2}{P_2} \tag{9}$$

or power input to the rotor,

$$P_2 = \frac{I_r^2 R_2}{s} \tag{10}$$

23.10 Induction motor losses and efficiency

Figure 23.8 summarises losses in induction motors. Motor efficiency,

$$\eta = \frac{\text{output power}}{\text{input power}} = \frac{P_m}{P_1} \times 100\%$$

Problem 8. The power supplied to a three-phase induction motor is 32 kW and the stator losses are 1200 W. If the slip is 5 per cent, determine (a) the rotor copper loss, (b) the total mechanical power developed by the rotor, (c) the output power of the motor if friction and windage losses are 750 W, and (d) the efficiency of the motor, neglecting rotor iron loss.

(a) Input power to rotor = stator input power
 – stator losses
 = 32 kW – 1.2 kW
 = 30.8 kW

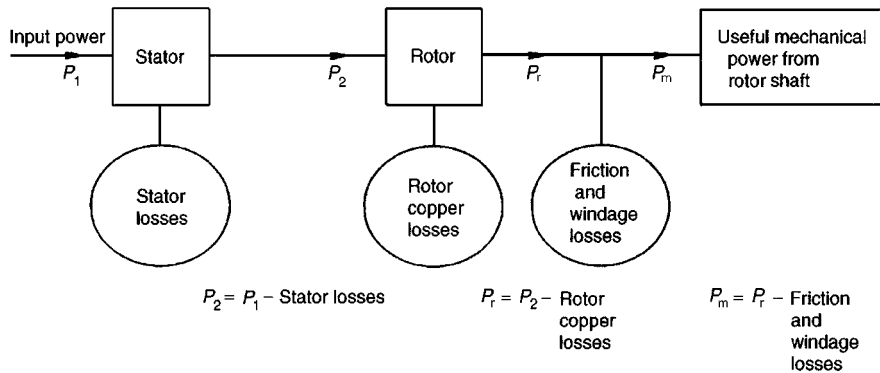

Figure 23.8

From Equation (9),

$$\text{slip} = \frac{\text{rotor copper loss}}{\text{rotor input}}$$

$$\text{i.e. } \frac{5}{100} = \frac{\text{rotor copper loss}}{30.8}$$

from which, **rotor copper loss** = $(0.05)(30.8)$
= **1.54 kW**

(b) Total mechanical power developed by the rotor

$$= \text{rotor input power} - \text{rotor losses}$$

$$= 30.8 - 1.54 = \mathbf{29.26 \text{ kW}}$$

(c) Output power of motor

$$= \text{power developed by the rotor}$$

$$- \text{friction and windage losses}$$

$$= 29.26 - 0.75 = \mathbf{28.51 \text{ kW}}$$

(d) Efficiency of induction motor,

$$\eta = \left(\frac{\text{output power}}{\text{input power}} \right) \times 100\%$$

$$= \left(\frac{28.51}{32} \right) \times 100\%$$

$$= \mathbf{89.10\%}$$

Problem 9. The speed of the induction motor of Problem 8 is reduced to 35 per cent of its synchronous speed by using external rotor resistance. If the torque and stator losses are unchanged, determine (a) the rotor copper loss, and (b) the efficiency of the motor.

$$(a) \text{ Slip, } s = \left(\frac{n_s - n_r}{n_s} \right) \times 100\%$$

$$= \left(\frac{n_s - 0.35n_s}{n_s} \right) \times 100\%$$

$$= (0.65)(100) = 65\%$$

Input power to rotor = 30.8 kW (from Problem 8)

$$\text{Since } s = \frac{\text{rotor copper loss}}{\text{rotor input}}$$

then **rotor copper loss** = $(s)(\text{rotor input})$

$$= \left(\frac{65}{100} \right) (30.8)$$

$$= \mathbf{20.02 \text{ kW}}$$

(b) Power developed by rotor

$$= \text{input power to rotor}$$

$$- \text{rotor copper loss}$$

$$= 30.8 - 20.02 = 10.78 \text{ kW}$$

Output power of motor

$$= \text{power developed by rotor}$$

$$- \text{friction and windage losses}$$

$$= 10.78 - 0.75 = 10.03 \text{ kW}$$

Efficiency,

$$\eta = \left(\frac{\text{output power}}{\text{input power}} \right) \times 100\%$$

$$= \left(\frac{10.03}{32} \right) \times 100\%$$

$$= \mathbf{31.34\%}$$

Now try the following exercise

Exercise 139 Further problems on losses and efficiency

- 1 The power supplied to a three-phase induction motor is 50 kW and the stator losses are 2 kW. If the slip is 4 per cent, determine
- the rotor copper loss,
 - the total mechanical power developed by the rotor,
 - the output power of the motor if friction and windage losses are 1 kW, and
 - the efficiency of the motor, neglecting rotor iron losses.
- [(a) 1.92 kW (b) 46.08 kW (c) 45.08 kW (d) 90.16%]
- 2 By using external rotor resistance, the speed of the induction motor in Problem 1 is reduced to 40 per cent of its synchronous speed. If the torque and stator losses are unchanged, calculate
- the rotor copper loss, and
 - the efficiency of the motor.
- [(a) 28.80 kW (b) 36.40%]

If there are m phases then torque,

$$T = \left(\frac{m}{2\pi n_s} \right) \left(\frac{s \left(\frac{N_2}{N_1} \right)^2 E_1^2 R_2}{R_2^2 + (sX_2)^2} \right)$$

i.e.

$$T = \left(\frac{m \left(\frac{N_2}{N_1} \right)^2}{2\pi n_s} \right) \left(\frac{sE_1^2 R_2}{R_2^2 + (sX_2)^2} \right) \quad (11)$$

$$= k \left(\frac{sE_1^2 R_2}{R_2^2 + (sX_2)^2} \right)$$

where k is a constant for a particular machine, i.e.

$$\text{torque, } T \propto \left(\frac{sE_1^2 R_2}{R_2^2 + (sX_2)^2} \right) \quad (12)$$

Under normal conditions, the supply voltage is usually constant, hence Equation (12) becomes:

$$T \propto \frac{sR_2}{R_2^2 + (sX_2)^2}$$

$$\propto \frac{R_2}{\frac{R_2^2}{s} + sX_2^2}$$

The torque will be a maximum when the denominator is a minimum and this occurs when

$$\frac{R_2^2}{s} = sX_2^2$$

i.e. when

$$s = \frac{R_2}{X_2} \quad \text{or} \quad R_2 = sX_2 = X_r$$

from Equation (4). Thus **maximum torque** occurs when rotor resistance and rotor reactance are equal, i.e. when $R_2 = X_r$

Problems 10 to 13 following illustrate some of the characteristics of three-phase induction motors.

23.11 Torque equation for an induction motor

Torque

$$T = \frac{P_2}{2\pi n_s} = \left(\frac{1}{2\pi n_s} \right) \left(\frac{I_r^2 R_2}{s} \right)$$

(from Equation (10))

$$\text{From Equation (8), } I_r = \frac{s \left(\frac{N_2}{N_1} \right) E_1}{\sqrt{R_2^2 + (sX_2)^2}}$$

Hence torque per phase,

$$T = \left(\frac{1}{2\pi n_s} \right) \left(\frac{s^2 \left(\frac{N_2}{N_1} \right)^2 E_1^2}{R_2^2 + (sX_2)^2} \right) \left(\frac{R_2}{s} \right)$$

i.e.

$$T = \left(\frac{1}{2\pi n_s} \right) \left(\frac{s \left(\frac{N_2}{N_1} \right)^2 E_1^2 R_2}{R_2^2 + (sX_2)^2} \right)$$

Problem 10. A 415 V, three-phase, 50 Hz, 4 pole, star-connected induction motor runs at 24 rev/s on full load. The rotor resistance and reactance per phase are 0.35Ω and 3.5Ω respectively, and the effective rotor-stator turns ratio is 0.85:1. Calculate (a) the synchronous speed, (b) the slip, (c) the full load torque, (d) the power output if mechanical losses amount to 770 W, (e) the maximum torque, (f) the speed at which maximum torque occurs, and (g) the starting torque.

(a) Synchronous speed, $n_s = (f/p) = (50/2) =$
25 rev/s or $(25 \times 60) =$ **1500 rev/min**

(b) Slip, $s = \left(\frac{n_s - n_r}{n_s}\right) = \frac{25 - 24}{25} =$ **0.04** or **4%**

(c) Phase voltage,

$$E_1 = \frac{415}{\sqrt{3}} = 239.6 \text{ volts}$$

Full load torque,

$$T = \left(\frac{m \left(\frac{N_2}{N_1}\right)^2}{2\pi n_s}\right) \left(\frac{sE_1^2 R_2}{R_2^2 + (sX_2)^2}\right)$$

from Equation (11)

$$= \left(\frac{3(0.85)^2}{2\pi(25)}\right) \left(\frac{(0.04)(239.6)^2(0.35)}{(0.35)^2 + (0.04 \times 3.5)^2}\right)$$

$$= (0.01380) \left(\frac{803.71}{0.1421}\right)$$

$$= \mathbf{78.05 \text{ Nm}}$$

(d) Output power, including friction losses,

$$\begin{aligned} P_m &= 2\pi n_r T \\ &= 2\pi(24)(78.05) \\ &= 11\,770 \text{ watts} \end{aligned}$$

Hence, **power output** = P_m – mechanical losses

$$= 11\,770 - 770$$

$$= 11\,000 \text{ W}$$

$$= \mathbf{11 \text{ kW}}$$

(e) Maximum torque occurs when

$$R_2 = X_r = 0.35 \Omega$$

$$\text{Slip, } s = \frac{R_2}{X_2} = \frac{0.35}{3.5} = 0.1$$

Hence **maximum torque**,

$$T_m = (0.01380) \left(\frac{sE_1^2 R_2}{R_2^2 + (sX_2)^2}\right) \text{ from part (c)}$$

$$= (0.01380) \left(\frac{0.1(239.6)^2(0.35)}{0.35^2 + 0.35^2}\right)$$

$$= (0.01380) \left(\frac{2009.29}{0.245}\right) = \mathbf{113.18 \text{ Nm}}$$

(f) For maximum torque, slip $s = 0.1$

$$\text{Slip, } s = \left(\frac{n_s - n_r}{n_s}\right) \text{ i.e.}$$

$$0.1 = \left(\frac{25 - n_r}{25}\right)$$

$$\text{Hence } (0.1)(25) = 25 - n_r \text{ and}$$

$$n_r = 25 - (0.1)(25)$$

Thus speed at which maximum torque occurs,

$$n_r = 25 - 2.5 = \mathbf{22.5 \text{ rev/s}} \text{ or } \mathbf{1350 \text{ rev/min}}$$

(g) At the start, i.e. at standstill, slip $s = 1$. Hence,

$$\text{starting torque} = \left(\frac{m \left(\frac{N_2}{N_1}\right)^2}{2\pi n_s}\right) \left(\frac{E_1^2 R_2}{R_2^2 + X_2^2}\right)$$

from Equation (11) with $s = 1$

$$= (0.01380) \left(\frac{(239.6)^2(0.35)}{0.35^2 + 3.5^2}\right)$$

$$= (0.01380) \left(\frac{20\,092.86}{12.3725}\right)$$

i.e. **starting torque** = **22.41 Nm**

(Note that the full load torque (from part (c)) is 78.05 Nm but the starting torque is only 22.41 Nm)

Problem 11. Determine for the induction motor in Problem 10 at full load, (a) the rotor current, (b) the rotor copper loss, and (c) the starting current.

- (a) From Equation (8),
- rotor current**
- ,

$$\begin{aligned}
 I_r &= \frac{s \left(\frac{N_2}{N_1} \right) E_1}{\sqrt{R_2^2 + (sX_2)^2}} \\
 &= \frac{(0.04)(0.85)(239.6)}{\sqrt{0.35^2 + (0.04 \times 3.5)^2}} \\
 &= \frac{8.1464}{0.37696} = \mathbf{21.61 \text{ A}}
 \end{aligned}$$

- (b) Rotor copper

$$\begin{aligned}
 \text{loss per phase} &= I_r^2 R_2 \\
 &= (21.61)^2 (0.35) \\
 &= 163.45 \text{ W}
 \end{aligned}$$

$$\begin{aligned}
 \text{Total copper loss (for 3 phases)} \\
 &= 3 \times 163.45 \\
 &= \mathbf{490.35 \text{ W}}
 \end{aligned}$$

- (c) From Equation (7), starting current,

$$\begin{aligned}
 I_2 &= \frac{\left(\frac{N_2}{N_1} \right) E_1}{\sqrt{R_2^2 + X_2^2}} = \frac{(0.85)(239.5)}{\sqrt{0.35^2 + 3.5^2}} \\
 &= \mathbf{57.90 \text{ A}}
 \end{aligned}$$

(Note that the starting current of 57.90 A is considerably higher than the full load current of 21.61 A)

Problem 12. For the induction motor in Problems 10 and 11, if the stator losses are 650 W, determine (a) the power input at full load, (b) the efficiency of the motor at full load and (c) the current taken from the supply at full load, if the motor runs at a power factor of 0.87 lagging.

- (a) Output power
- $P_m = 11.770 \text{ kW}$
- from part (d), Problem 10. Rotor copper loss = 490.35 W = 0.49035 kW from part (b), Problem 11.
- Stator input power**
- ,

$$\begin{aligned}
 P_1 &= P_m + \text{rotor copper loss} + \text{rotor stator loss} \\
 &= 11.770 + 0.49035 + 0.650 \\
 &= \mathbf{12.91 \text{ kW}}
 \end{aligned}$$

- (b) Net power output = 11 kW from part (d), Problem 10. Hence efficiency,

$$\begin{aligned}
 \eta &= \frac{\text{output}}{\text{input}} \times 100\% = \left(\frac{11}{12.91} \right) \times 100\% \\
 &= \mathbf{85.21\%}
 \end{aligned}$$

- (c) Power input,
- $P_1 = \sqrt{3} V_L I_L \cos \phi$
- (see Chapter 20) and
- $\cos \phi = \text{p.f.} = 0.87$
- hence,
- supply current**
- ,

$$I_L = \frac{P_1}{\sqrt{3} V_L \cos \phi} = \frac{12.91 \times 1000}{\sqrt{3}(415)0.87} = \mathbf{20.64 \text{ A}}$$

Problem 13. For the induction motor of Problems 10 to 12, determine the resistance of the rotor winding required for maximum starting torque.

From Equation (4), rotor reactance $X_r = sX_2$. At the moment of starting, slip, $s = 1$. Maximum torque occurs when rotor reactance equals rotor resistance hence for **maximum torque**, $R_2 = X_r = sX_2 = X_2 = \mathbf{3.5 \Omega}$.

Thus if the induction motor was a wound rotor type with slip rings then an external star-connected resistance of $(3.5 - 0.35) \Omega = 3.15 \Omega$ per phase could be added to the rotor resistance to give maximum torque at starting (see Section 23.13).

Now try the following exercise

Exercise 140 Further problems on the torque equation

- 1 A 400 V, three-phase, 50 Hz, 2-pole, star-connected induction motor runs at 48.5 rev/s on full load. The rotor resistance and reactance per phase are 0.4 Ω and 4.0 Ω respectively, and the effective rotor-stator turns ratio is 0.8:1. Calculate
- the synchronous speed,
 - the slip,
 - the full load torque,
 - the power output if mechanical losses amount to 500 W,
 - the maximum torque,
 - the speed at which maximum torque occurs, and
 - the starting torque.
- [(a) 50 rev/s or 3000 rev/min (b) 0.03 or 3% (c) 22.43 Nm (d) 6.34 kW (e) 40.74 Nm (f) 45 rev/s or 2700 rev/min (g) 8.07 Nm]

- 2 For the induction motor in Problem 1, calculate at full load
- the rotor current,
 - the rotor copper loss, and
 - the starting current.
- [(a) 10.62 A (b) 135.3 W (c) 45.96 A]
- 3 If the stator losses for the induction motor in Problem 1 are 525 W, calculate at full load
- the power input,
 - the efficiency of the motor and
 - the current taken from the supply if the motor runs at a power factor of 0.84
- [(a) 7.49 kW (b) 84.65% (c) 12.87 A]
- 4 For the induction motor in Problem 1, determine the resistance of the rotor winding required for maximum starting torque [4.0 Ω]

The rotor resistance of an induction motor is usually small compared with its reactance (for example, $R_2 = 0.35 \Omega$ and $X_2 = 3.5 \Omega$ in the above Problems), so that maximum torque occurs at a high speed, typically about 80 per cent of synchronous speed.

Curve P in Fig. 23.9 is a typical characteristic for an induction motor. The curve P cuts the full-load torque line at point X, showing that at full load the slip is about 4–5 per cent. The normal operating conditions are between 0 and X, thus it can be seen that for normal operation the speed variation with load is quite small – the induction motor is an almost constant-speed machine. Redrawing the speed-torque characteristic between 0 and X gives the characteristic shown in Fig. 23.10, which is similar to a d.c. shunt motor as shown in Chapter 22.

23.12 Induction motor torque-speed characteristics

From Problem 10, parts (c) and (g), it is seen that the normal starting torque may be less than the full load torque. Also, from Problem 10, parts (e) and (f), it is seen that the speed at which maximum torque occurs is determined by the value of the rotor resistance. At synchronous speed, slip $s = 0$ and torque is zero. From these observations, the torque-speed and torque-slip characteristics of an induction motor are as shown in Fig. 23.9

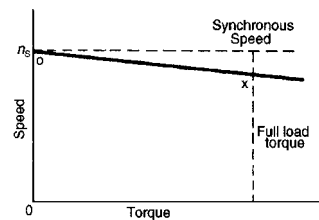

Figure 23.10

If maximum torque is required at starting then a high resistance rotor is necessary, which gives characteristic Q in Fig. 23.9. However, as can be seen, the motor has a full load slip of over 30 per cent, which results in a drop in efficiency. Also such a motor has a large speed variation with variations of

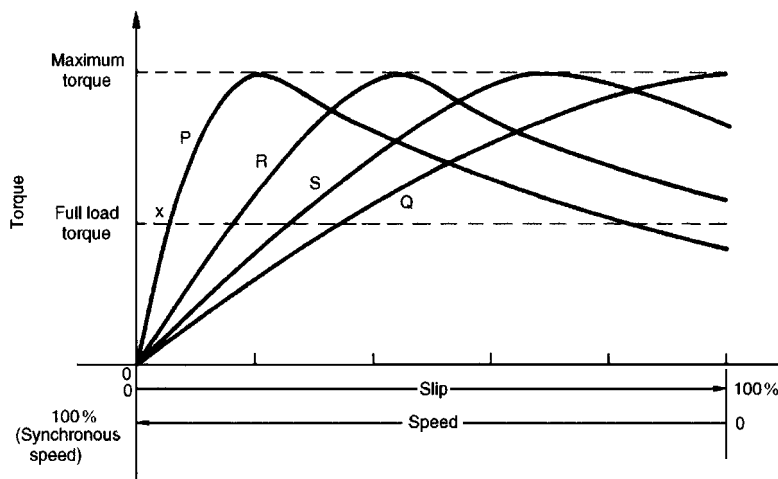

Figure 23.9

load. Curves R and S of Fig. 23.9 are characteristics for values of rotor resistance's between those of P and Q. Better starting torque than for curve P is obtained, but with lower efficiency and with speed variations under operating conditions.

A **squirrel-cage induction motor** would normally follow characteristic P. This type of machine is highly efficient and about constant-speed under normal running conditions. However it has a poor starting torque and must be started off-load or very lightly loaded (see Section 23.13 below). Also, on starting, the current can be four or five times the normal full load current, due to the motor acting like a transformer with secondary short circuited. In Problem 11, for example, the current at starting was nearly three times the full load current.

A **wound-rotor induction motor** would follow characteristic P when the slip-rings are short-circuited, which is the normal running condition. However, the slip-rings allow for the addition of resistance to the rotor circuit externally and, as a result, for starting, the motor can have a characteristic similar to curve Q in Fig. 23.9 and the high starting current experienced by the cage induction motor can be overcome.

In general, for three-phase induction motors, the power factor is usually between about 0.8 and 0.9 lagging, and the full load efficiency is usually about 80–90 per cent.

From Equation (12), it is seen that torque is proportional to the square of the supply voltage. Any voltage variations therefore would seriously affect the induction motor performance.

23.13 Starting methods for induction motors

Squirrel-cage rotor

(i) Direct-on-line starting

With this method, starting current is high and may cause interference with supplies to other consumers.

(ii) Auto transformer starting

With this method, an auto transformer is used to reduce the stator voltage, E_1 , and thus the starting current (see Equation (7)). However, the starting torque is seriously reduced (see Equation (12)), so the voltage is reduced only sufficiently to give the required reduction of the starting current. A typical arrangement is shown in Fig. 23.11. A double-throw switch

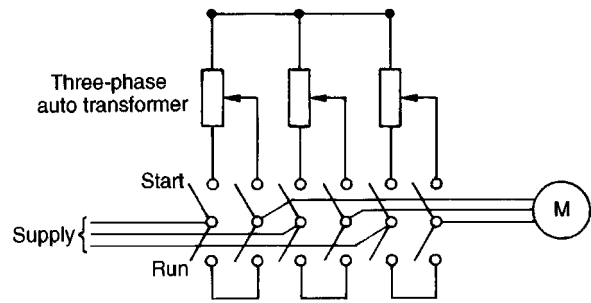

Figure 23.11

connects the auto transformer in circuit for starting, and when the motor is up to speed the switch is moved to the run position which connects the supply directly to the motor.

(iii) Star-delta starting

With this method, for starting, the connections to the stator phase winding are star-connected, so that the voltage across each phase winding is $(1/\sqrt{3})$ (i.e. 0.577) of the line voltage. For running, the windings are switched to delta-connection. A typical arrangement is shown in Fig. 23.12 This method of starting is less expensive than by auto transformer.

Wound rotor

When starting on load is necessary, a wound rotor induction motor must be used. This is because maximum torque at starting can be obtained by adding external resistance to the rotor circuit via slip rings, (see Problem 13). A face-plate type starter is used, and as the resistance is gradually reduced, the machine characteristics at each stage will be similar to Q, S, R and P of Fig. 23.13. At each resistance step, the motor operation will transfer from one characteristic to the next so that the overall starting characteristic will be as shown by the bold line in Fig. 23.13 For very large induction motors, very gradual and smooth starting is achieved by a liquid type resistance.

23.14 Advantages of squirrel-cage induction motors

The advantages of squirrel-cage motors compared with the wound rotor type are that they:

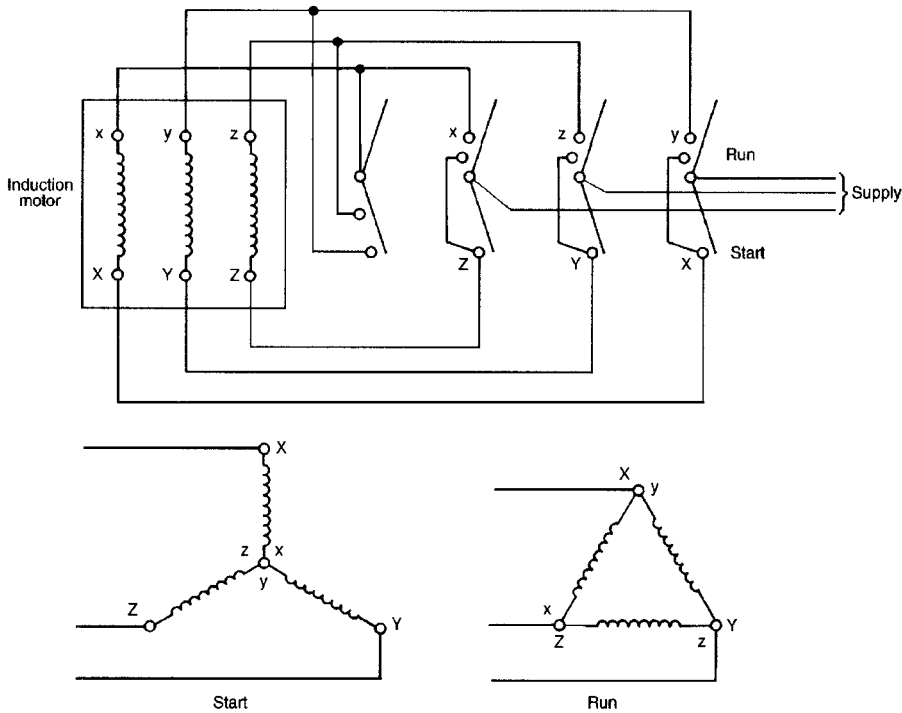

Figure 23.12

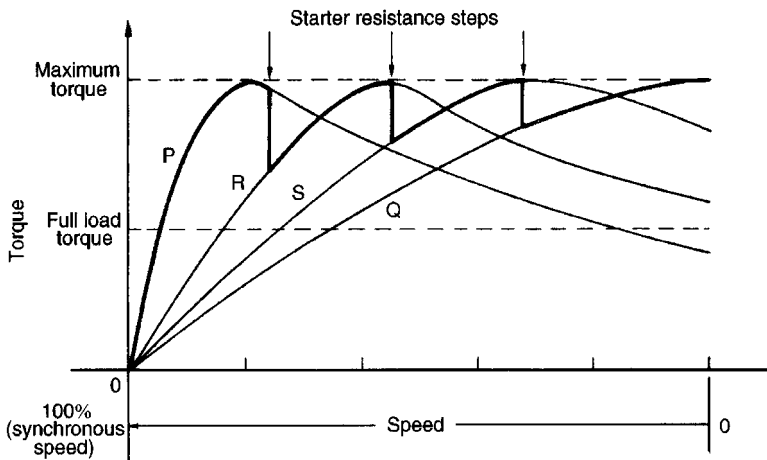

Figure 23.13

- (i) are cheaper and more robust
- (ii) have slightly higher efficiency and power factor
- (iii) are explosion-proof, since the risk of sparking is eliminated by the absence of slip rings and brushes.

23.15 Advantages of wound rotor induction motors

The advantages of the wound rotor motor compared with the cage type are that they:

- (i) have a much higher starting torque
- (ii) have a much lower starting current
- (iii) have a means of varying speed by use of external rotor resistance.

23.16 Double cage induction motor

The advantages of squirrel-cage and wound rotor induction motors are combined in the double cage induction motor. This type of induction motor is specially constructed with the rotor having two cages, one inside the other. The outer cage has high resistance conductors so that maximum torque is achieved at or near starting. The inner cage has normal low resistance copper conductors but high reactance since it is embedded deep in the iron core. The torque-speed characteristic of the inner cage is that of a normal induction motor, as shown in Fig. 23.14. At starting, the outer cage produces the torque, but when running the inner cage produces the torque. The combined characteristic of inner and outer cages is shown in Fig. 23.14 The double cage induction motor is highly efficient when running.

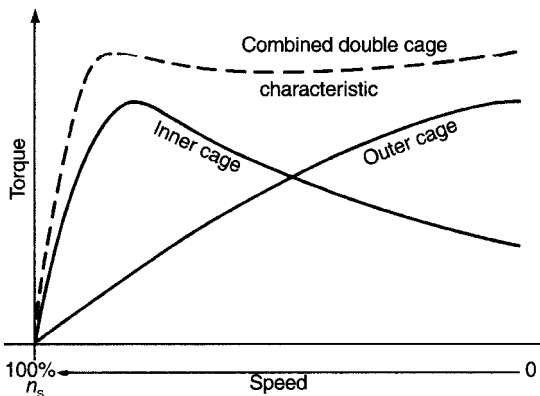

Figure 23.14

23.17 Uses of three-phase induction motors

Three-phase induction motors are widely used in industry and constitute almost all industrial drives where a nearly constant speed is required, from small workshops to the largest industrial enterprises.

Typical applications are with machine tools, pumps and mill motors. The squirrel cage rotor type is the most widely used of all a.c. motors.

Now try the following exercises

Exercise 141 Short answer questions on three-phase induction motors

- 1 Name three advantages that a three-phase induction motor has when compared with a d.c. motor
- 2 Name the principal disadvantage of a three-phase induction motor when compared with a d.c. motor
- 3 Explain briefly, with the aid of sketches, the principle of operation of a 3-phase induction motor.
- 4 Explain briefly how slip-frequency currents are set up in the rotor bars of a 3-phase induction motor and why this frequency varies with load.
- 5 Explain briefly why a 3-phase induction motor develops no torque when running at synchronous speed. Define the slip of an induction motor and explain why its value depends on the load on the rotor.
- 6 Write down the two properties of the magnetic field produced by the stator of a three-phase induction motor
- 7 The speed at which the magnetic field of a three-phase induction motor rotates is called the speed
- 8 The synchronous speed of a three-phase induction motor is proportional to supply frequency
- 9 The synchronous speed of a three-phase induction motor is proportional to the number of pairs of poles
- 10 The type of rotor most widely used in a three-phase induction motor is called a
- 11 The slip of a three-phase induction motor is given by: $s = \frac{\dots}{\dots} \times 100\%$
- 12 A typical value for the slip of a small three-phase induction motor is ... %
- 13 As the load on the rotor of a three-phase induction motor increases, the slip
- 14 $\frac{\text{Rotor copper loss}}{\text{Rotor input power}} = \dots$

- 15 State the losses in an induction motor
- 16 Maximum torque occurs when =
.....
- 17 Sketch a typical speed-torque characteristic for an induction motor
- 18 State two methods of starting squirrel-cage induction motors
- 19 Which type of induction motor is used when starting on-load is necessary?
- 20 Describe briefly a double cage induction motor
- 21 State two advantages of cage rotor machines compared with wound rotor machines
- 22 State two advantages of wound rotor machines compared with cage rotor machines
- 23 Name any three applications of three-phase induction motors

Exercise 142 Multi-choice questions on three-phase induction motors (Answers on page 376)

- 1 Which of the following statements about a three-phase squirrel-cage induction motor is false?
 - (a) It has no external electrical connections to its rotor
 - (b) A three-phase supply is connected to its stator
 - (c) A magnetic flux which alternates is produced
 - (d) It is cheap, robust and requires little or no skilled maintenance
- 2 Which of the following statements about a three-phase induction motor is false?
 - (a) The speed of rotation of the magnetic field is called the synchronous speed
 - (b) A three-phase supply connected to the rotor produces a rotating magnetic field
 - (c) The rotating magnetic field has a constant speed and constant magnitude
 - (d) It is essentially a constant speed type machine
- 3 Which of the following statements is false when referring to a three-phase induction motor?

- (a) The synchronous speed is half the supply frequency when it has four poles
 - (b) In a 2-pole machine, the synchronous speed is equal to the supply frequency
 - (c) If the number of poles is increased, the synchronous speed is reduced
 - (d) The synchronous speed is inversely proportional to the number of poles
- 4 A 4-pole three-phase induction motor has a synchronous speed of 25 rev/s. The frequency of the supply to the stator is:
- | | |
|-----------|-------------|
| (a) 50 Hz | (b) 100 Hz |
| (c) 25 Hz | (d) 12.5 Hz |

Questions 5 and 6 refer to a three-phase induction motor. Which statements are false?

- 5 (a) The slip speed is the synchronous speed minus the rotor speed
 - (b) As the rotor is loaded, the slip decreases
 - (c) The frequency of induced rotor e.m.f.'s increases with load on the rotor
 - (d) The torque on the rotor is due to the interaction of magnetic fields
- 6 (a) If the rotor is running at synchronous speed, there is no torque on the rotor
- (b) If the number of poles on the stator is doubled, the synchronous speed is halved
 - (c) At no-load, the rotor speed is very nearly equal to the synchronous speed
 - (d) The direction of rotation of the rotor is opposite to the direction of rotation of the magnetic field to give maximum current induced in the rotor bars

A three-phase, 4-pole, 50 Hz induction motor runs at 1440 rev/min. In questions 7 to 10, determine the correct answers for the quantities stated, selecting your answer from the list given below:

- | | | |
|----------------|--------------|-------------|
| (a) 12.5 rev/s | (b) 25 rev/s | (c) 1 rev/s |
| (d) 50 rev/s | (e) 1% | (f) 4% |
| (g) 50% | (h) 4 Hz | (i) 50 Hz |
| (j) 2 Hz | | |
- 7 The synchronous speed
 - 8 The slip speed
 - 9 The percentage slip
 - 10 The frequency of induced e.m.f.'s in the rotor
 - 11 The slip speed of an induction motor may be defined as the:

- (a) number of pairs of poles \div frequency
(b) rotor speed – synchronous speed
(c) rotor speed + synchronous speed
(d) synchronous speed – rotor speed
- 12 The slip speed of an induction motor depends upon:
(a) armature current (b) supply voltage
(c) mechanical load (d) eddy currents
- 13 The starting torque of a simple squirrel-cage motor is:
(a) low
(b) increases as rotor current rises
(c) decreases as rotor current rises
(d) high
- 14 The slip speed of an induction motor:
(a) is zero until the rotor moves and then rises slightly
(b) is 100 per cent until the rotor moves and then decreases slightly
(c) is 100 per cent until the rotor moves and then falls to a low value
(d) is zero until the rotor moves and then rises to 100 per cent
- 15 A four-pole induction motor when supplied from a 50 Hz supply experiences a 5 per cent slip. The rotor speed will be:
(a) 25 rev/s (b) 23.75 rev/s
(c) 26.25 rev/s (d) 11.875 rev/s
- 16 A stator winding of an induction motor supplied from a three-phase, 60 Hz system is required to produce a magnetic flux rotating at 900 rev/min. The number of poles is:
(a) 2 (b) 8 (c) 6 (d) 4
- 17 The stator of a three-phase, 2-pole induction motor is connected to a 50 Hz supply. The rotor runs at 2880 rev/min at full load. The slip is:
(a) 4.17% (b) 92%
(c) 4% (d) 96%
- 18 An 8-pole induction motor, when fed from a 60 Hz supply, experiences a 5 per cent slip. The rotor speed is:
(a) 427.5 rev/min (b) 855 rev/min
(c) 900 rev/min (d) 945 rev/min

Assignment 7

This assignment covers the material contained in Chapters 22 and 23.

The marks for each question are shown in brackets at the end of each question.

- 1 A 6-pole armature has 1000 conductors and a flux per pole of 40 mWb. Determine the e.m.f. generated when running at 600 rev/min when (a) lap wound (b) wave wound. (6)
- 2 The armature of a d.c. machine has a resistance of $0.3\ \Omega$ and is connected to a 200 V supply. Calculate the e.m.f. generated when it is running (a) as a generator giving 80 A (b) as a motor taking 80 A (4)
- 3 A 15 kW shunt generator having an armature circuit resistance of $1\ \Omega$ and a field resistance of $160\ \Omega$ generates a terminal voltage of 240 V at full-load. Determine the efficiency of the generator at full-load assuming the iron, friction and windage losses amount to 500 W. (6)
- 4 A 4-pole d.c. motor has a wave-wound armature with 1000 conductors. The useful flux per pole is 40 mWb. Calculate the torque exerted when a current of 25 A flows in each armature conductor. (4)
- 5 A 400 V shunt motor runs at its normal speed of 20 rev/s when the armature current is 100 A. The armature resistance is $0.25\ \Omega$. Calculate the speed, in rev/min when the current is 50 A and a resistance of $0.40\ \Omega$ is connected in series with the armature, the shunt field remaining constant. (7)
- 6 The stator of a three-phase, 6-pole induction motor is connected to a 60 Hz supply. The rotor runs at 1155 rev/min at full load. Determine (a) the synchronous speed, and (b) the slip at full load. (6)
- 7 The power supplied to a three-phase induction motor is 40 kW and the stator losses are 2 kW. If the slip is 4 per cent determine (a) the rotor copper loss, (b) the total mechanical power developed by the rotor, (c) the output power of the motor if frictional and windage losses are 1.48 kW, and (d) the efficiency of the motor, neglecting rotor iron loss. (9)
- 8 A 400 V, three-phase, 100 Hz, 8-pole induction motor runs at 24.25 rev/s on full load. The rotor resistance and reactance per phase are $0.2\ \Omega$ and $2\ \Omega$ respectively and the effective rotor-stator turns ratio is 0.80:1. Calculate (a) the synchronous speed, (b) the slip, and (c) the full load torque. (8)

Formulae for electrical power technology

THREE-PHASE SYSTEMS:

$$\text{Star } I_L = I_p \quad V_L = \sqrt{3} V_p$$

$$\text{Delta } V_L = V_p \quad I_L = \sqrt{3} I_p$$

$$P = \sqrt{3} V_L I_L \cos \phi \quad \text{or} \quad P = 3 I_p^2 R_p$$

Two-wattmeter method

$$P = P_1 + P_2 \quad \tan \phi = \sqrt{3} \frac{(P_1 - P_2)}{(P_1 + P_2)}$$

TRANSFORMERS:

$$\frac{V_1}{V_2} = \frac{N_1}{N_2} = \frac{I_2}{I_1} \quad I_0 = \sqrt{(I_M^2 + I_C^2)}$$

$$I_M = I_0 \sin \phi_0 \quad I_C = I_0 \cos \phi_0$$

$$E = 4.44 f \Phi_m N$$

$$\text{Regulation} = \left(\frac{E_2 - E_1}{E_2} \right) \times 100\%$$

$$\text{Equivalent circuit: } R_e = R_1 + R_2 \left(\frac{V_1}{V_2} \right)^2$$

$$X_e = X_1 + X_2 \left(\frac{V_1}{V_2} \right)^2 \quad Z_e = \sqrt{(R_e^2 + X_e^2)}$$

$$\text{Efficiency, } \eta = 1 - \frac{\text{losses}}{\text{input power}}$$

$$\text{Output power} = V_2 I_2 \cos \phi_2$$

$$\text{Total loss} = \text{copper loss} + \text{iron loss}$$

Input power = output power + losses

$$\text{Resistance matching: } R_1 = \left(\frac{N_1}{N_2} \right)^2 R_L$$

D.C. MACHINES:

$$\text{Generated e.m.f. } E = \frac{2p\Phi nZ}{c} \propto \Phi \omega$$

($c = 2$ for wave winding, $c = 2p$ for lap winding)

$$\text{Generator: } E = V + I_a R_a$$

$$\text{Efficiency, } \eta = \left(\frac{VI}{VI + I_a^2 R_a + I_f V + C} \right) \times 100\%$$

$$\text{Motor: } E = V - I_a R_a$$

$$\text{Efficiency, } \eta = \left(\frac{VI - I_a^2 R_a - I_f V - C}{VI} \right) \times 100\%$$

$$\text{Torque} = \frac{E I_a}{2\pi n} = \frac{p\Phi Z I_a}{\pi c} \propto I_a \Phi$$

THREE-PHASE INDUCTION MOTORS:

$$n_s = \frac{f}{p} \quad s = \left(\frac{n_s - n_r}{n_s} \right) \times 100$$

$$f_r = s f \quad X_r = s X_2$$

$$I_r = \frac{E_r}{Z_r} = \frac{s \left(\frac{N_2}{N_1} \right) E_1}{\sqrt{[R_2^2 + (sX_2)^2]}} \quad s = \frac{I_r^2 R_2}{P_2}$$

Efficiency,

$$\eta = \frac{P_m}{P_1} = \frac{\text{input} - \text{stator loss} - \text{rotor copper loss} - \text{friction \& windage loss}}{\text{input power}}$$

Torque,

$$T = \left(\frac{m \left(\frac{N_2}{N_1} \right)^2}{2\pi n_s} \right) \left(\frac{sE_1^2 R_2}{R_2^2 + (sX_2)^2} \right) \propto \frac{sE_1^2 R_2}{R_2^2 + (sX_2)^2}$$

Answers to multi-choice questions

CHAPTER 1. EXERCISE 4 (page 7)

1 (c) 2 (d) 3 (c) 4 (a) 5 (c)
6 (b) 7 (b) 8 (c) 9 (d) 10 (a)
11 (b) 12 (d)

CHAPTER 2. EXERCISE 10 (page 19)

1 (b) 2 (b) 3 (c) 4 (b) 5 (d)
6 (d) 7 (b) 8 (c) 9 (b) 10 (c)
11 (c) 12 (d) 13 (a)

CHAPTER 3. EXERCISE 15 (page 27)

1 (c) 2 (d) 3 (b) 4 (d) 5 (d)
6 (c) 7 (b) 8 (c) 9 (d)

CHAPTER 4. EXERCISE 18 (page 36)

1 (d) 2 (a) 3 (b) 4 (c) 5 (b)
6 (d) 7 (d) 8 (b) 9 (c) 10 (d)
11 (c) 12 (a)

CHAPTER 5. EXERCISE 23 (page 50)

1 (a) 2 (c) 3 (c) 4 (c) 5 (a)
6 (b) 7 (d) 8 (b) 9 (c) 10 (d)
11 (d)

CHAPTER 6. EXERCISE 30 (page 66)

1 (b) 2 (a) 3 (b) 4 (c) 5 (a)
6 (b) 7 (b) 8 (a) 9 (c) 10 (c)
11 (d)

CHAPTER 7. EXERCISE 36 (page 79)

1 (d) 2 (b) 3 (b) 4 (c) 5 (c)
6 (d) 7 (a) 8 (c) 9 (c) 10 (c)
11 (a) and (d), (b) and (f), (c) and (e) 12 (a)
13 (a)

CHAPTER 8. EXERCISE 40 (page 91)

1 (d) 2 (c) 3 (d) 4 (a) 5 (b)
6 (c) 7 (d) 8 (a) 9 (a) 10 (b)

CHAPTER 9. EXERCISE 47 (page 102)

1 (c) 2 (b) 3 (c) 4 (b) 5 (c)
6 (a) 7 (c) 8 (d) 9 (c) 10 (a)
11 (a) 12 (b)

CHAPTER 10. EXERCISE 57 (page 125)

1 (d) 2 (a) or (c) 3 (b) 4 (b)
5 (c) 6 (f) 7 (c) 8 (a)
9 (i) 10 (j) 11 (g) 12 (c)
13 (b) 14 (p) 15 (d) 16 (o)
17 (n) 18 (b) 19 (d) 20 (a)
21 (d) 22 (c) 23 (a)

CHAPTER 11. EXERCISE 60 (page 134)

1 (c) 2 (a) 3 (d) 4 (c) 5 (b)
6 (b) 7 (c) 8 (d) 9 (a) 10 (b)
11 (d)

CHAPTER 12. EXERCISE 64 (page 149)

1 (b) 2 (b) 3 (c) 4 (a) 5 (a)
6 (d) 7 (b) 8 (d) 9 (b) 10 (c)
11 (a) 12 (b) 13 (b) 14 (b) 15 (b)
16 (b) 17 (c) 18 (b) 19 (a) 20 (b)

CHAPTER 13. EXERCISE 72 (page 181)

1 (d) 2 (c) 3 (b) 4 (c) 5 (a)
6 (d) 7 (c) 8 (a) 9 (c) 10 (c)
11 (b) 12 (d) 13 (d) 14 (b) 15 (c)
16 (a)

CHAPTER 14. EXERCISE 78 (page 195)

1 (c) 2 (d) 3 (d) 4 (a) 5 (d)
6 (c) 7 (b) 8 (c) 9 (b) 10 (c)
11 (b)

CHAPTER 15. EXERCISE 86 (page 217)

- 1 (c) 2 (a) 3 (b) 4 (b) 5 (a)
6 (b) 7 (a) 8 (d) 9 (d) 10 (d)
11 (b) 12 (c) 13 (b) 14 (c) 15 (b)
16 (b) 17 (c) 18 (a) 19 (d)

CHAPTER 16. EXERCISE 94 (page 234)

- 1 (d) 2 (g) 3 (i) 4 (s)
5 (h) 6 (b) 7 (k) 8 (l)
9 (a) 10 (d), (g), (i) and (l) 11 (b)
12 (d) 13 (c) 14 (b)

CHAPTER 17. EXERCISE 99 (page 246)

- 1 (d) 2 (b) 3 (a) 4 (c)
5 (c) 6 (a) 7 (b) 8 (a)
9 (d) 10 (b) 11 (d) 12 (c)

CHAPTER 18. EXERCISE 103 (page 262)

- 1 (c) 2 (b) 3 (b) 4 (g) 5 (g)
6 (e) 7 (l) 8 (c) 9 (a) 10 (d)
11 (g) 12 (b) 13 (c) 14 (j) 15 (h)
16 (c) 17 (a) 18 (a)

CHAPTER 19. EXERCISE 107 (page 279)

- 1 (c) 2 (b) 3 (b) 4 (d) 5 (a)
6 (b) 7 (d) 8 (a) 9 (c) 10 (c)

CHAPTER 20. EXERCISE 113 (page 301)

- 1 (g) 2 (c) 3 (a) 4 (a) 5 (f)
6 (a) 7 (g) 8 (l) 9 (l) 10 (d)
11 (f) 12 (j) 13 (d) 14 (b) 15 (c)
16 (b) 17 (c)

CHAPTER 21. EXERCISE 126 (page 325)

- 1 (a) 2 (d) 3 (a) 4 (b) 5 (c)
6 (a) 7 (b) 8 (a) 9 (b) 10 (g)
11 (d) 12 (a) 13 (h) 14 (k) 15 (j)
16 (f) 17 (c) 18 (b) and (c) 19 (c)
20 (b)

CHAPTER 22. EXERCISE 135 (page 351)

- 1 (b) 2 (e) 3 (e) 4 (c) 5 (c)
6 (a) 7 (d) 8 (f) 9 (b) 10 (c)
11 (b) 12 (a) 13 (b) 14 (a) 15 (d)
16 (b) 17 (b) 18 (b) 19 (c) 20 (b)
21 (b) 22 (a) 23 (c) 24 (d)

CHAPTER 23. EXERCISE 142 (page 370)

- 1 (c) 2 (b) 3 (d) 4 (a) 5 (b)
6 (d) 7 (b) 8 (c) 9 (f) 10 (j)
11 (d) 12 (c) 13 (a) 14 (c) 15 (b)
16 (b) 17 (c) 18 (b)

Index

- Absolute permeability, 71
- Absolute permittivity, 55
- A.c. bridges, 120
 - generator, 183
 - values, 185
- Acceptor circuit, 209
- Active power, 214
- Advantages of:
 - squirrel cage induction motor, 367
 - three-phase systems, 300
 - wound rotor induction motor, 368
- Air capacitors, 64
- Alkaline cell, 35
- Alternating voltages and currents, 183
- Ammeter, 12, 106
- Amplifier gain, 267, 269
- Amplifier, transistor, 142
- Amplitude, 112, 185, 189
- Analogue instruments, 105
 - to digital conversion, 276
- Angular velocity, 189
- Anode, 29
- Apparent power, 214
- Armature, 330
 - reaction, 330
- Asymmetrical network, 236
- Atoms, 10
- Attenuation, 236
 - bands, 236
- Attraction-type m.i. instrument, 105
- Audio frequency transformer, 311
- Auto transformer, 319
- Avalanche effect, 132
- Average value, 185
- Avometer, 12, 109

- Back e.m.f., 338
- Balanced network, 236
- Band-pass filter, 236, 244
- Band-stop filter, 236, 245
- Bandwidth, 212, 265
- Base, 136
- Battery, 32
- B-H curves, 70, 71
- Bipolar junction transistor, 136
- Block diagram, electrical, 9, 10
- Bridge, a.c., 120
 - rectifier, 132
 - Wheatstone, 118

- Brush contact loss, 337
- Buffer amplifier, 270

- Calibration accuracy, 122
- Capacitance, 54
- Capacitive a.c. circuit, 199
 - reactance, 199
- Capacitors, 54
 - charging, 248
 - discharging, 66, 253
 - energy stored, 63
 - in parallel and series, 59
 - parallel plate, 57
 - practical types, 64
- Capacity of cell, 35
- Cathode, 29
- Cathode ray oscilloscope, 12, 111
 - double beam, 112
- Cell capacity, 35
 - primary, 34
 - secondary, 34
 - simple, 30
- Ceramic capacitor, 65
- Characteristic impedance, 236, 237
- Characteristics, transistor, 140
- Charge, 3, 54
 - density, 55
 - force on, 90
- Charging a capacitor, 248
 - of cell, 32
- Chemical effects of current, 17, 18, 29
- Circuit diagram symbols, 10, 11
- Closed-loop gain, 268
- Coercive force, 78
- Collector, 136
- Colour coding of resistors, 25
- Combination of waveforms, 191
- Common-mode rejection ratio, 266
- Commutation, 329
- Commutator, 329, 330
- Comparison between electrical and magnetic quantities, 77
- Complex wave, 114
- Composite series magnetic circuits, 74
- Compound winding, 330
- Compound wound generator, 335
 - motor, 344
- Conductance, 5, 6
- Conductors, 11, 14, 127

- Constant current source, 171
- Contact potential, 129
- Continuity tester, 109
- Control, 89
- Cooling of transformers, 312
- Copper loss, 314, 337
 - rotor, 361
- Core loss, 337
 - component, 306
- Core type transformer, 311
- Corrosion, 31
- Coulomb, 3, 11
- Coulomb's law, 53
- Crest value, 185
- Current, 10
 - decay in L–R circuit, 257
 - division, 45
 - gain, transistor, 145
 - growth, L–R circuit, 255
 - main effects, 17
 - transformer, 323
- Cut-off frequency, 236, 238
- Cycle, 184

- Damping, 89, 105
- D.C. circuit theory, 157, 164
 - generator, 332
 - characteristics, 333
 - efficiency, 337
- D.C. machine, 328
 - construction, 329
 - losses, 337
 - torque, 339
- D.C. motor, 89, 338
 - efficiency, 344
 - speed control, 347
 - starter, 347
 - types, 341
- D.C. potentiometer, 119
 - transients, 248
- Decibel, 115
 - meter, 116
- Delta connection, 291
- Delta/star comparison, 300
- Depletion layer, 129
- Design impedance, 238
- Dielectric, 54, 56
 - strength, 62
- Differential amplifier, 272, 274
- Differentiator circuit, 260
- Digital to analogue conversion, 276
 - voltmeter, 108
- Discharging capacitors, 66, 253
 - of cell, 31
- Diverter, 348
- Doping, 128
- Double beam c.r.o., 112
- Double cage induction motor, 369
- Drift, 11

- Dynamic current gain, 144
 - resistance, 227

- Edison cell, 35
- Eddy current loss, 314
- Effective value, 185
- Effect of time constant on rectangular wave, 260
- Effects of electric current, 17
- Efficiency of:
 - d.c. generator, 337
 - d.c. motor, 344
 - induction motor, 361
 - transformer, 314, 315
- Electrical:
 - energy, 16
 - measuring instruments, 12, 104
 - potential, 5
 - power, 15
- Electric:
 - bell, 84
 - cell, 30
 - field strength, 53
 - flux density, 55
- Electrochemical series, 30
- Electrodes, 29
- Electrolysis, 29
- Electrolyte, 29, 34
- Electrolytic capacitor, 65
- Electromagnetic induction, 93
 - laws of, 94
- Electromagnetism, 82
- Electromagnets, 84
- Electronic instruments, 108
- Electrons, 10, 29
- Electroplating, 30
- Electrostatic field, 52
- E.m.f., 5
 - equation of transformer, 308
 - in armature winding, 330
 - induced in conductors, 95
 - of a cell, 31
- Emitter, 136
- Energy, 4, 16
 - stored in:
 - capacitor, 63
 - inductor, 99
- Equivalent circuit of transformer, 312

- Farad, 54
- Faraday's laws, 94
- Ferrite, 78
- Filter, 236
- Fleming's left hand rule, 86
- Fleming's right hand rule, 94
- Force, 4
 - on a charge, 90
 - current-carrying conductor, 85

- Form factor, 185
 Formulae, lists of, 153, 283, 373
 Forward bias, 129, 136
 characteristics, 130
 Frequency, 184, 189
 Friction and windage losses, 337
 Full wave rectification, 132
 Fuses, 18
- Galvanometer, 118
 Generator:
 a.c., 183
 d.c., 328
 Germanium, 127
 Grip rule, 84
- Half-power points, 212
 Half-wave rectification, 132
 Harmonics, 114
 Heating effects of current, 17, 18
 Henry, 97
 Hertz, 184
 High-pass filter, 236, 240
 Hole, 128
 Hysteresis, 77
 loop, 77, 78
 loss, 78, 302
- Impedance, 201, 205
 triangle, 201, 205
 Induced e.m.f., 95
 Inductance, 97
 of a coil, 99
 Induction motor, 354
 construction, 357
 double cage, 369
 losses and efficiency, 361
 principle of operation, 358
 production of rotating field, 354
 starting methods, 367
 torque equation, 363
 -speed characteristic, 366
 uses of, 369
 Inductive a.c. circuit, 198
 switching, 260
 reactance, 198
 Inductors, 98
 Initial slope and three point method, 250
 Instantaneous values, 185
 Instrument loading effect, 109
 Insulation resistance tester, 109
 Insulators, 11, 15, 127
 Integrator circuit, 260
 op amp, 272
 Internal resistance of cell, 31
 Interpoles, 329
- Inverting amplifier op amp, 267
 Iron losses, 314, 337
 Isolating transformer, 321
 Iterative impedance, 237
- Joule, 4, 6, 16
- Kilowatt hour, 6, 16
 Kirchhoff's laws, 157
- Lamps in series and parallel, 49
 Lap winding, 330
 Laws of electromagnetic induction, 94
 L-C parallel circuit, 222
 Lead acid cell, 34
 Leclanche cell, 34
 Lenz's law, 9
 Lifting magnet, 85
 Linear device, 12
 Linear scale, 105
 Lines of electric force, 52
 Lines of magnetic flux, 68
 Load line, 144, 145
 Local action, 30
 Logarithmic ratios, 115
 Losses:
 d.c. machines, 337
 induction motors, 361
 transformers, 314
 Loudspeaker, 86
 Low-pass filter, 236, 237
 LR-C a.c. circuit, 223
- Magnetic:
 circuits, 68, 74
 effects of current, 17, 18
 field due to electric current, 82
 fields, 68
 field strength, 70
 flux, 69
 flux density, 69
 screens, 73
 Magnetisation curves, 71
 Magnetising component, 306
 Magnetising force, 70
 Magnetomotive force, 70
 Majority carriers, 129
 Matching, 317
 Maximum power transfer theorem, 179
 value, 185, 189
 Maxwell bridge, 120
 Mean value, 185
 Measurement errors, 122
 of power in 3 phase system, 183
 Megger, 109

- Mercury cell, 34
- Mesh connection, 291
- Mica capacitor, 64
- Minority carriers, 130
- Motor cooling, 350
 - d.c., 89, 328, 338
 - efficiency, 344
 - speed control, 347
 - starter, 347
 - types, 341
- Moving coil instrument, 89
- Moving coil rectifier instrument, 105
 - iron instrument, 105
- Multimeter, 12, 109
- Multiples of units, 13
- Multiplier, 107
- Mutual induction, 97, 101

- Negative feedback, 265
- Neutral conductor, 288
- Neutrons, 10
- Newton, 4
- Nife cell, 35
- Nominal impedance, 238
- Non-inverting amplifier, 270
- Non-linear device, 12, 13
- n-p-n transistor, 137
- Norton's theorem, 172
 - and Thévenin equivalent circuits, 175
- n-type material, 128
- Nucleus, 10
- Null method of measurement, 118

- Ohm, 5, 12
- Ohmmeter, 12, 108
- Ohm's law, 13
- Operational amplifiers, 264
 - differential amplifier, 274
 - integrator, 272
 - inverting amplifier, 267
 - non-inverting amplifier, 269
 - parameters, 266
 - summing amplifier, 271
 - transfer characteristics, 265
 - voltage comparator, 272
 - voltage follower, 270

- Paper capacitor, 64
- Parallel:
 - a.c. circuits, 219
 - connected capacitors, 59
 - lamps, 49
 - networks, 42
 - plate capacitor, 57
 - resonance, 224, 226
- Passbands, 236

- Peak factor, 186
- Peak value, 112, 185
- Peak-to-peak value, 185, 189
- Period, 184
- Periodic time, 111, 184, 189
- Permanent magnet, 68
- Permeability, 70
 - absolute, 71
 - of free space, 71
 - relative, 71
- Permittivity, 55
 - absolute, 55
 - of free space, 55
 - relative, 55
- Phasor, 189
- Plastic capacitor, 65
- Polarisation, 30
- Potential:
 - difference, 5, 12
 - divider, 40
 - gradient, 53
- Potential, electric, 5
- Potentiometer, d.c., 119
- Power, 4, 6, 15
 - active, 214
 - apparent, 214
 - factor, 214
 - improvement, 230
 - in a.c. circuits, 213
 - 3-phase systems, 293
 - measurement in 3-phase systems, 295
 - reactive, 214
 - transformers, 311
 - triangle, 214
- p-n junction, 129
- p-n-p transistor, 137
- p-type material, 128
- Practical types of capacitor, 64
- Prefixes of units, 3
- Primary cells, 34
- Principle of operation of:
 - moving-coil instrument, 89
 - d.c. motor, 89
 - 3-phase induction motor, 358
 - transformer, 304
- Protons, 10

- Q-factor, 121, 210, 227
- Q-meter, 121
- Quantity of electricity, 11

- Radio frequency transformer, 311
- Rating, 304
- R-C parallel a.c. circuit, 220
- R-C series a.c. circuit, 204
- Reactive power, 214
- Rectification, 132, 194

- Regulation of transformer, 313
- Relative permeability, 71
- Relative permittivity, 55
- Relay, 85
- Reluctance, 73
- Rejector circuit, 227
- Remanence, 78
- Repulsion type m.i. instrument, 105
- Resistance, 5, 12, 20
 - internal, 31
 - matching, 317
 - variation, 20
- Resistivity, 20
- Resistor colour coding, 25
- Resonance:
 - parallel, 224, 226
 - series, 206, 209
- Reverse bias, 130, 136
 - characteristics, 130
- R–L parallel a.c. circuit, 219
 - series a.c. circuit, 201
- R–L–C series a.c. circuit, 206
- R.m.s. value, 112, 185
- Rotor copper loss, 361

- Scale, 105
- Screw rule, 83, 84
- Secondary cells, 34
- Selectivity, 213
- Self-excited generators, 332, 333
- Self inductance, 97
- Semiconductor diodes, 127, 130
- Semiconductors, 127
- Separately-excited generators, 332, 333
- Series:
 - a.c. circuits, 198
 - circuit, 39
 - connected capacitors, 59
 - lamps, 49
 - resonance, 206, 209
 - winding, 330
 - wound generator, 335
 - motor, 343
- Shells, 10
- Shell type transformer, 311
- Shunt, 107
 - field regulator, 347
 - winding, 330
 - wound generator, 334
 - motor, 341
- Siemen, 6
- Silicon, 127
- Simple cell, 30
- Sine wave, 184, 185
- Single-phase:
 - parallel a.c. circuit, 219
 - series a.c. circuit, 198
 - voltage, 287
- Sinusoidal waveform equation, 189
- S.I. units, 3
- Slew rate, 267
- Slip, 358
- Solenoid, 83
- Speed control of d.c. motors, 347
- Squirrel-cage rotor induction motor, 357, 367
 - advantages of, 367
- Star connection, 288
- Star/delta comparison, 300
- Stator, 329
- Steady state, 249
- Stopbands, 236
- Sub-multiples of units, 13
- Sub-system, 10
- Summing amplifier, 271
- Superposition theorem, 161
- Switching inductive circuits, 260
- Symbols, electrical, 10, 11
- Symmetrical network, 236
- Synchronous speed, 355, 356
- System, electrical, 9

- T-network, 236
- Tangent method, 250
- Telephone receiver, 85
- Temperature coefficient of resistance, 22
- Thermal runaway, 147
- Thévenin's theorem, 166
 - and Norton equivalent circuits, 175
- Three-phase:
 - induction motor, 354
 - supply, 287
 - systems, 287
 - advantages of, 300
 - power, 293
 - transformers, 321
- Time constant:
 - CR circuit, 249, 250
 - LR circuit, 256
- Titanium oxide capacitor, 65
- Torque equation:
 - for induction motor, 363
 - of a d.c. machine, 339
 - speed characteristic of induction motor, 366
- Transformation ratio, 304
- Transformers, 303
 - auto, 319
 - construction, 311
 - current, 323
 - e.m.f. equation, 308
 - equivalent circuit, 312
 - isolating, 321
 - losses and efficiency, 314, 315
 - no-load phasor diagram, 306
 - on-load phasor diagram, 310
 - principle of operation, 304
 - regulation of, 313
 - three-phase, 321
 - voltage, 324

- Transient CR circuit, 250
- Transient LR circuit, 256
- Transistor:
 - action, 137
 - amplifier, 142
 - characteristics, 140
 - connections, 139
 - symbols, 139
- Transistors, 136
- True power, 214
- Two-port networks, 236

- Unbalanced network, 236
- Unit of electricity, 16
- Units, 3, 7

- Variable air capacitor, 64
- Virtual earth, 267
- Volt, 5, 12
- Voltage, 12
 - comparator, 272
 - follower amplifier, 270
 - gain, transistor, 146
 - transformer, 324
 - triangle, 201, 204
- Voltmeter, 12, 107

- Watt, 4, 15
- Wattmeter, 109
- Wave winding, 330
- Waveform harmonics, 114
- Waveforms, 184
 - combination of, 191
- Weber, 69
- Wheatstone bridge, 118, 170
- Work, 4
- Wound rotor induction motor, 358, 367
 - advantages of, 368

- Yoke, 329

- Zener diode, 132
- Zener effect, 132