

THE BACKYARD HOMESTEAD *Book of* BUILDING PROJECTS



76 Useful Things You Can Build To:

Create Customized Working Spaces and Storage Facilities

Equip the Garden • Store the Harvest

House Your Animals

Make Practical Outdoor Furniture

by Spike Carlsen

THE
BACKYARD HOMESTEAD
Book of
**BUILDING
PROJECTS**

For Peter Hasselquist — the original backyard homesteader and Kat — my partner in all things

*The mission of Storey Publishing is to serve our customers by
publishing practical information that encourages
personal independence in harmony with the environment.*

Edited by Philip Schmidt, Sarah Guare, and Carleen Madigan
Art direction and book design by Carolyn Eckert, based on a design by Dan O. Williams
Text production by Jennifer Jepson Smith

Cover illustration and part openers by © Michael Austin/Jing and Mike Company
Project illustrations by © Elayne Sears
Plan drawings by Bruce Kieffer
Photography by © Tom Thulen

Indexed by Christine R. Lindemer, Boston Road Communications

© 2014 by Spike Carlsen

Be sure to read all instructions thoroughly, and be sure that you know how to safely operate your machinery and tools, before beginning any of the projects in this book. Take appropriate safety precautions and remain alert when using potentially dangerous tools and equipment or undertaking potentially dangerous activities.

All rights reserved. No part of this book may be reproduced without written permission from the publisher, except by a reviewer who may quote brief passages or reproduce illustrations in a review with appropriate credits; nor may any part of this book be reproduced, stored in a retrieval system, or transmitted in any form or by any means — electronic, mechanical, photocopying, recording, or other — without written permission from the publisher.

The information in this book is true and complete to the best of our knowledge. All recommendations are made without guarantee on the part of the author or Storey Publishing. The author and publisher disclaim any liability in connection with the use of this information.

Storey books are available for special premium and promotional uses and for customized editions. For further information, please call 1-800-793-9396.

Storey Publishing

210 MASS MoCA Way
North Adams, MA 01247
www.storey.com

Printed in the United States by Courier

10 9 8 7 6 5 4 3 2 1

Library of Congress Cataloging-in-Publication Data

Carlsen, Spike, 1952-

The backyard homestead book of building projects / by Spike Carlsen.

pages cm

Includes index.

ISBN 978-1-61212-085-0 (pbk. : alk. paper)

ISBN 978-1-60342-846-0 1. Garden structures. 2. Gardening—Equipment and supplies. I. Title.

TH4961.C37 2014

690'.892--dc23

2013040121

Storey Publishing is committed to making environmentally responsible manufacturing decisions.

This book was printed on paper made from sustainably harvested fiber.

THE
BACKYARD HOMESTEAD

Book of

**BUILDING
PROJECTS**



Spike Carlsen



Storey Publishing

Contents

Foreword by Carleen Madigan vii
Introduction viii



CHAPTER 1

TOOLS, MATERIALS & SKILLS 9

- My Go-To Hand Tools 10
- Safety and Safety Equipment 12
- Lifting and Moving Heavy Stuff 14
- Woods and Plywoods 16
- Glues and Caulks 19
- Exterior Fasteners 20
- Drilling Holes and Driving Screws 22
- Tool Sharpening and Maintenance 24
- Digging Holes and Setting Posts 26
- Circular Saw Basics 28
- Measuring, Leveling, and Squaring 30
- Paints and Finishes 32

CHAPTER 2

FOR THE GARDEN 35

- Two-Wheel Garden Cart 36
- Cold Frame 40
- Compost Bin Trio 44
- Critter-Proof Fence 50
- Shadow Box Fence Panel 54
- Drip Irrigation Basics 57
- Simple Hose Guides 60
- Garden Marker/Stepping Stone 62
- Super-Simple Path 64
- Sitting and Kneeling Garden Stool 66
- Five Raised-Bed Gardens 69
- Five Simple Plant Supports 74
- Bent Rebar Pergola 77
- Golf Cart Garden Dolly 80
- Rain Barrel Basics 82
- Potting Bench 85
- Hoop Greenhouse 90
- Rustic Trellis 96

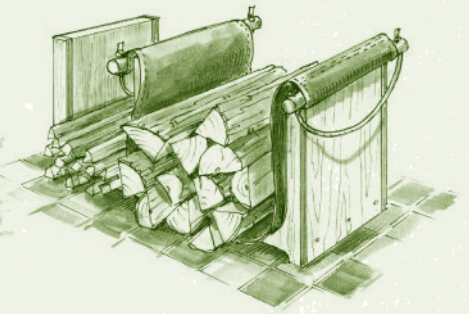
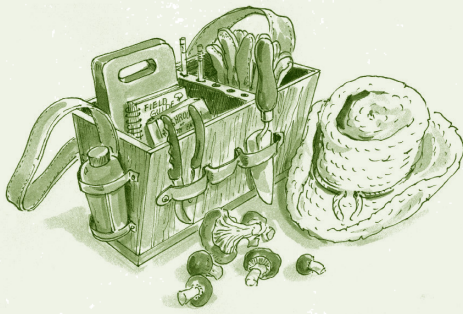

CHAPTER 3

HARVESTING & FOOD PREPARATION 101

Harvesting Tote 102
Foldaway Countertop Rack 104
Harvest Trug 107
Shoulder Bucket Yoke 110
Outdoor Workbench 112
Multipurpose Produce Rack 116

Fire Pit Grilling Station 121
Root Cellar 124
Root Cellar Storage System 129
Flowerpot Smoker 133

CHAPTER 4

STORAGE & WORKSPACES 137

Overhead Storage Cradles 138
Sawbuck Bench 140
Firewood Storage and Splitting Station 143
Knockdown Sawhorses 147
Stand-Up Tool Rack 150
Patio Storage Chest 152

Wall-Hung Tool Rack 156
Mini Tool Shed 158
Modular Shed 163
Homestead Emergency Cart 170
Ultimate Yard Shed 172
Hose Headquarters 179

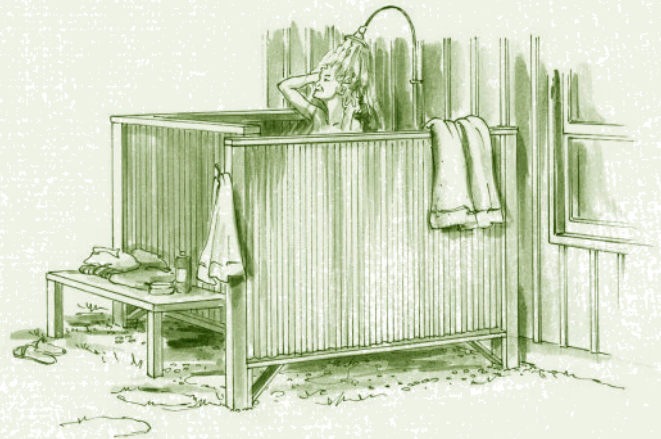

CHAPTER 5

ANIMAL SHELTERS & FEEDERS

181

Nesting Box Buckets 182

Rabbit Hutch 184

Bat House 189

Animal Shelter 192

Chicken Ark 198

Outdoor Outlets, Switches, and Lights 204

Run-In Shelter 206

Classy, Classic Chicken Coop 213

Coffee Can Bird Feeder 221

Top Bar Beehive 224

CHAPTER 6

FOR THE HOUSE & YARD

231

Boot Scraper and Jack 232

Leopold Bench 236

Firewood Cradle and Carrying Sling 239

Lawn Bag Stand 242

Backdoor Storage Locker 244

Punched Tin Jelly Cabinet 248

Clothes Pole Trellis 252

Spice Planter 255

Rustic Garden Table 258

Concrete Planter 262

Seedling Rack 265

Outdoor Shower 269

Pickin' and Grinnin' Chair 274

Solar Window Heater 276

Recommended Reading 282

Resources 283

Index 284

Foreword

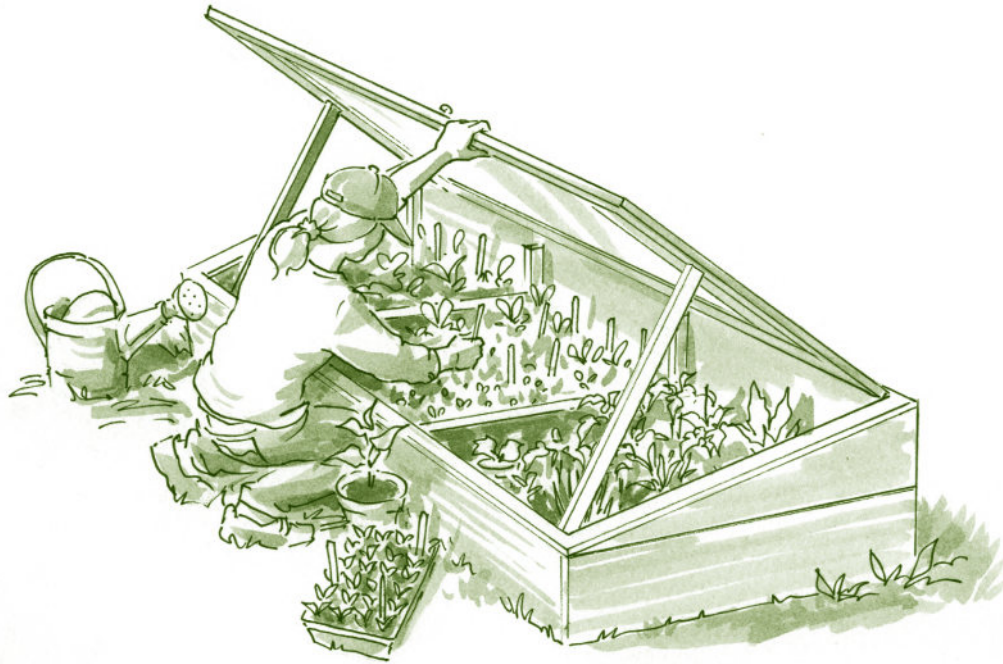

I often say that a “backyard homestead” is not just a place, but a place of the mind. It’s an approach to life that leads you to want to make something rather than buy it, no matter how much (or how little) land you have. After all, you can make yogurt or preserve fruit or sprout grains whether you live in an apartment or a house with 10 acres. Wherever you live, any skill you acquire is a step on the path to self-sufficiency.

At some point, though, the homestead becomes an actual physical place that requires some level of infrastructure — a few tools, some raised beds, maybe a chicken coop or a bee hive. It requires careful planning; when you’re ramping up to the point of keeping larger animals, especially, you need to think seriously about how you’ll house them. But sometimes little things can make all the difference on a homestead: a well-built place to store your root vegetables, an organized way to stash tools, a sturdy hoophouse that won’t collapse under a load of snow.

This is where the rubber meets the road, where the hoe meets the soil, where the dreamy “homesteader of the mind” must hunker down and learn some building skills. And this is where *The Backyard Homestead Book of Building Projects* comes in handy. First of all, Spike Carlsen is the ideal teacher. A master carpenter with more than 30 years’ experience and a true affinity for the homesteading life, Spike is superbly qualified to lead novice backyard builders through a variety of projects, from simple to complex.

With his background as a homesteader, he understands what one needs on the homestead and has selected projects with practicality, usefulness, and thrift in mind.

In my own garden, I’ve been lucky to have friends and neighbors show me the ropes. When I was building the fence around my garden, Ron Kujawski — co-author of *The Week-by-Week Vegetable Gardener’s Handbook* — and his wife, Pat, and my neighbors Brian and Diane came to offer guidance and several days of elbow grease. I’m not sure what I would have done without them. The days when I was working solo (or with another inexperienced helper) were full of snapped fence welds and smashed fingers. Also, the hoophouse in the garden would still be a pile of metal hoops and a roll of plastic in the garage if it weren’t for the Kujawskis and my friend Sarah Fournier-Scanlon, who spent a day in the garden with me, pounding stakes and sharing hilltown gossip.

As you read this book, think of Spike as your virtual neighbor — the homestead mentor you wish lived next door. Whether he’s teaching you the basics of using a circular saw or how to build a shed from the foundation up, he’ll give you the skills you need to take another step down the path to self-sufficiency.

Happy homesteading!

Carleen Madigan
Editor of *The Backyard Homestead*

Introduction

When my wife and I ran into our good friends Mike and Zanny the other day, we asked them what was new. They grinned at each other and said in unison, “Chickens.” A week earlier, in a state of what they called “irrational exuberance,” they’d purchased nine baby chicks. Unprepared for the new arrivals, they housed the chicks in their downstairs sauna for a few days while Mike converted their kids’ old playhouse into a chicken coop. What makes their story more interesting is that Mike, Zanny, and their three daughters don’t live on a farm or even in the suburbs — their backyard homestead is right smack-dab in the middle of town. Neither of them is all that handy, either; they simply loved the idea of becoming more self-sufficient. So they took the plunge.

Mike and Zanny are not alone. Backyard homesteaders are everywhere: country, suburbs, and city. The excavator who hauled gravel for our patio told me over half his work now is hauling dirt for “city folks” starting gardens. One of our daughters and her family live on a postage-stamp lot, and a good part of that postage stamp is now covered with raised-bed gardens. Within a stone’s throw of us, there’s a financial planner who’s a beekeeper, a patent lawyer who makes his own maple syrup, and a social worker who raises rabbits.

People tend toward a more self-sufficient lifestyle for a variety of reasons. Some people are born that way. It’s how they’re wired, and it’s as natural as breathing. Others move in that direction for economic reasons: every load of clothes dried on the clothesline or load of wood tossed in the woodstove is money in the pocket. Some people like self-sufficiency because it’s good for the environment;

others like it because it evokes a sense of community. Some treat it like a hobby; others treat it as a small business. Some like knowing they can provide the basics they need to survive come hell or high water. And for some it’s just good, clean (or dirty) fun. All reasons are good reasons.

This book is for those working toward (or dreaming toward) a more self-sufficient lifestyle. The beauty of creating a backyard homestead is that it can be done in bits and pieces. You start with a compost bin, add a few raised-bed gardens, and then move up to a hoop greenhouse. (And, hey, wouldn’t it be fun to have fresh eggs every morning?) You get to set the pace and extent of what you do.

This book is part of a larger series. Its first book, *The Backyard Homestead*, shows you how to do just what the title proclaims: “Produce all the food you need on just a quarter acre!” The second book, *The Backyard Homestead Guide to Raising Farm Animals*, focuses more on the meat than on the potatoes. This book helps round out the series by giving you the tools (and the places to store those tools) for crafting the coops, bins, benches, sheds, racks, and storage doodads you’ll need for making a self-sufficient life easier and better organized.

A few final words about the projects in this book: There’s more than one “right” way to build everything. Although most of the projects include dimensions and plans, you can modify the designs to meet your own needs and budget. Our caveat would be to err on the side of “overbuilding” and “overengineering,” rather than skimping, so your projects are safe and you have peace of mind.

So dig in, hammer away, and enjoy.

Spike Carlsen

THE PROJECTS



POTTING BENCH

(page 85)

Crafted from standard cedar boards and lumber, this potting bench has a large work surface for working with plants, and plenty of space above and below for storage. The side bins provide a convenient place to stow dirt, clippings, and other gardening materials as you work.



HOMESTEAD EMERGENCY CART

(page 170)



Spend two hours building this self-contained cart and you'll create year-round peace of mind. This portable cart provides a single convenient place to stow flashlights, radios, first aid kits, and other essential supplies you need in the event of a power outage or other emergency.



HARVESTING TOTE

(page 102)

This over-the-shoulder tote provides a hands-free way to haul hand tools into your garden or favorite blueberry patch, and a convenient way to haul your bounty out.



TOP BAR BEEHIVE

(page 224)

This unique beehive is the perfect project for those interested in entering the world of beekeeping. Better yet, the viewing window gives you an inside look at the fascinating world of bees and honey production.



TWO-WHEEL GARDEN CART

(page 36)

Haul twice the stuff with half the effort. This cart, crafted from a single sheet of plywood, allows you to easily transport bales of hay, bags of mulch, piles of brush, and more. Tipped down, it's a cinch to load, too.



FLOWERPOT SMOKER

(page 133)

You don't need piles of wood and expensive equipment to smoke your own meat. This flowerpot smoker — using a hot plate for heat and wood chips for smoke — can cook everything the "big boys" can (just on a smaller scale).



FIREWOOD STORAGE AND SPLITTING STATION

(page 143)

This weekend project provides a solid pad for splitting your wood and a handy rack for storing it. Add hooks for your maul and wheelbarrow, and you have everything stowed in one convenient place.



ROOT CELLAR STORAGE SYSTEM

(page 129)

Modular racks, slide-out bins, shelves, and drawers allow you to store tons of fresh and canned goods from your garden. It's easy to modify it for the produce and space you have.



HOOP GREENHOUSE

(page 90)



Add months to your growing season with this hoop greenhouse made of PVC pipe, plastic sheeting, and standard lumber. It is easy to erect and disassemble for off-season storage.



FOLDAWAY COUNTER-TOP RACK

(page 104)

Need a place to dry your spices, suspend your jelly strainer bag, or dry your noodles? Build this folding rack. You'll find dozens of other uses for it, too!

PUNCHED TIN JELLY CABINET

(page 248)

This attractive cabinet is made from inexpensive home center cabinets, readily available boards, and roof flashing "punched" with a 16-penny nail. The design is easily adapted for a variety of cabinet sizes and punched panel patterns.



CONCRETE PLANTER

(page 262)

A five-gallon bucket, a cardboard tube, and a bag of cement are all you need to form these inexpensive planters. Create the perfect home for those back stoop spices and herbs.

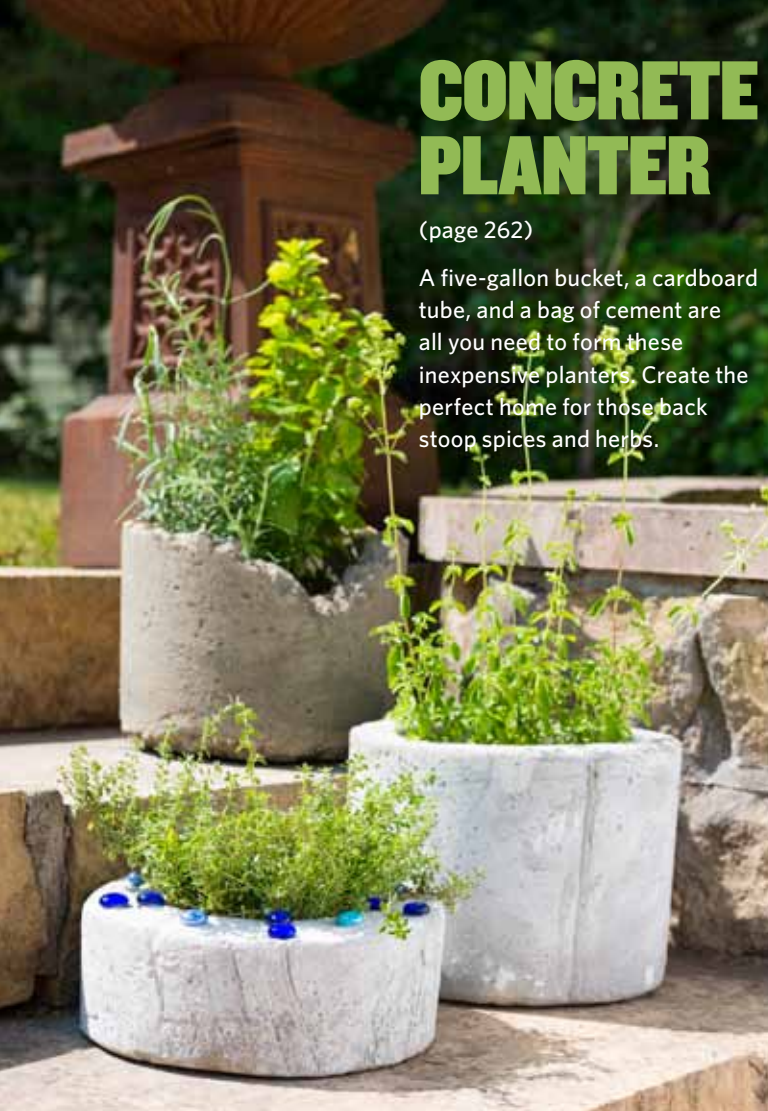

CHICKEN ARK

(page 198)

Build an excellent home for your eggs-cellent friends. The spacious coop and run provide plenty of wing room, and the built-in handles allow you — with the help of three friends — to move the coop around your yard or field.



MINI TOOL SHED

(page 158)

This 16" x 40" tool shed has a small footprint but stores tons of stuff. Perched against your house, garage, or fence, this shed keeps your shovels, hoses, rakes, and other often-used yard and garden equipment close at hand, dry, and safely stowed.



Tools, Materials, and Skills

You gotta have four things to tackle any project: (1) a plan, (2) tools, (3) materials, and (4) the skills to put the first three together. The bulk of this book contains projects and plans; this first chapter focuses on the other three things.

If you're new to building, I suggest easing into things with a simple project that requires only basic tools and materials. A raised-bed garden, a compost bin, or a simple storage rack are good starting points. If you're not comfortable with power tools, use their nonmotorized counterparts (see *No Fancy-Pants Tools*, page 11). It may take longer, but you'll still wind up with a fine finished project and that fine feeling of accomplishment. And your confidence will grow.

Experienced builders may be familiar with much of the information in this chapter, but it's still worth a browse. There may be new materials and tools you want to acquaint yourself with. And it's always a good idea to bone up on safety. Just about the time you begin feeling comfortable with a tool is the time you let your guard down and accidents happen. So roll up your sleeves and let's get started.

My Go-To Hand Tools

A dozen helpers for creating better projects

A few tools (e.g., a tape measure, a hammer, and a drill) are no-brainers when it comes to must-have tools. But in my 30 years as a carpenter I've found myself consistently reaching for a few

slightly out-of-the-ordinary tools; some I keep in my tool belt (in fact, one *is* my tool belt), others in a bucket close by (another must-have, slightly offbeat tool).

Tool belt. You can waste tons of time and create lots of frustration searching for misplaced tools and climbing ladders to fetch handfuls of nails because you're *over here* and they're *over there*. It doesn't matter if you prefer a light-weight canvas belt or a beefy leather one; just make sure you use a belt. At a minimum, your belt should have a handy place for stashing your hammer, your tape measure, and whatever fasteners you're using at the time. If wearing it for extended periods hurts your back, then buy tool belt suspenders; they'll help distribute the weight to your upper body.

5-gallon bucket organizer. I keep my most frequently used tools in a 5-gallon bucket organizer rather than a toolbox. This is a fabric organizer with pockets and compartments that fits over a standard 5-gallon plastic bucket. It's especially handy when I'm working outside or away from my workshop. With a bucket, I can see everything in a single glance. The dozens of pockets keep all the tools organized. And if I find an empty pocket at the end of a day, I know a tool is hiding someplace it shouldn't be. I can easily stash long tools like 2-foot levels, framing squares, and handsaws in a bucket. There also are a few small pockets for stashing little things I use (and lose) a lot, like driver bits and drill bits.

Speed Square. A Speed Square (a.k.a. triangle square or rafter angle square) makes it easy to mark boards at 90- and 45-degree angles. And with just a little know-how, you can use one to mark every other angle or roof pitch in this book. They're easy to slip in and out of the back pocket of your tool belt.

Wire cutters or end nippers. These are handy for cutting electrical and fence wire, pulling slivers, and holding dinky nails and screws as you drive them. I also use cutters or nippers for pulling small finish nails out through the backs of recycled boards, which minimizes splintering on the good face of the wood.

Sharp and beater chisels. I carry two $\frac{3}{4}$ " chisels: a sharp one for shaving wood, cleaning up edges, and cutting hardware recesses, and a dull one for prying, gouging,

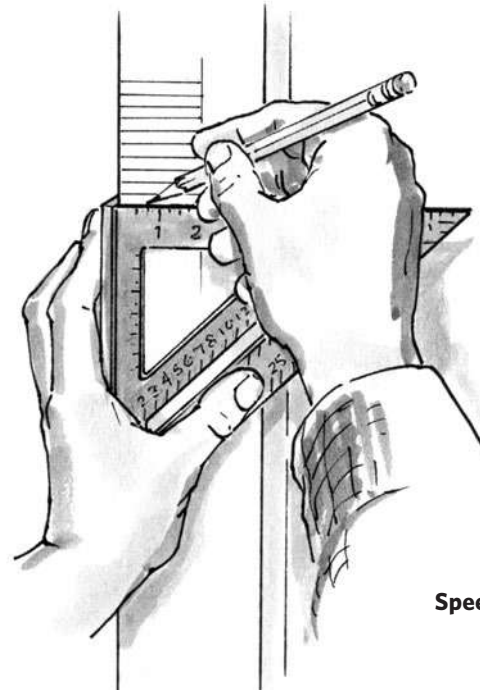

Speed Square

and hacking away. As your sharp chisel becomes war torn, demote it to the "beater chisel" role.

Multi-tip screwdriver. You can carry three or four separate screwdrivers or carry one multi-tip version. Buy a multi-tip tool with a magnetic shaft that will hold screws onto the screwdriver tip, making it easy to start them in awkward places. Tools with a ratcheting handle make life easier, too.

Japanese pull saw. These tools cut on the pull stroke, which allows for an ultra-thin blade. They cut quickly, and the blade (with most saws) can be turned upside down and flexed for cutting in hard-to-reach places. They'll cut PVC pipe, moldings, plywood, dowels, and even 2x4s in a pinch. They don't take up much room, and they stay sharp for years. It's not worth it to sharpen these saws, so be sure to stay clear of nails.

Double-ended cat's paw. These are great for digging out and pulling old nails or for yanking new nails that

didn't quite hit the mark. The curved claw offers superb leverage for pulling nails (especially in tight places), and the straight claw is good for prying, chiseling, and other dismantling tasks.

Chalk line. Chalk lines are great for marking long, straight lines on flat surfaces and materials like plywood, boards, roofs, and floors. They're good for other things, too: Most can be used as a plumb bob. Strung between stakes, they're handy for making sure holes and posts are aligned when building fences and decks. You can also slip a 2" line level on the string and use it as a semiaccurate tool for leveling over long distances.

TAKE NOTE Before filling your chalk box, unreel 10 or 15 feet of line, and then squeeze in the chalk and reel the line in. This will help distribute the chalk more evenly along your line and throughout the box.

Permanent marking pen. Carpenter pencils are perfect for marking and laying out boards, but sometimes you need something with a little more oomph. Permanent markers can mark concrete, metal, plastic, and nearly every other surface. They're also great for making impromptu KEEP OFF OR WET PAINT signs and for labeling tools.

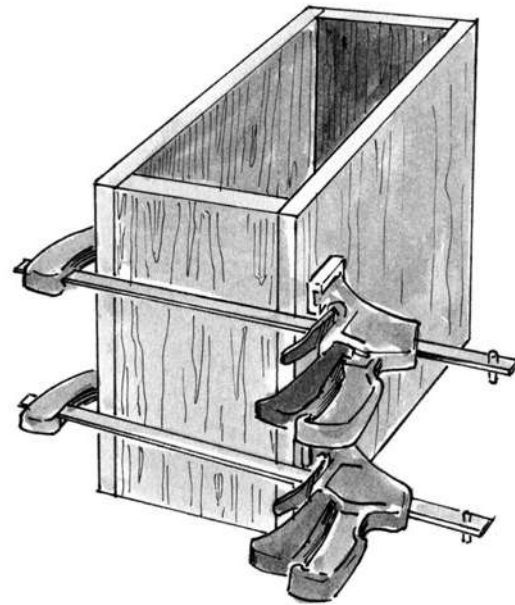

Squeeze clamps

Squeeze clamps. These ratcheting bar clamps that you can operate with one hand are indispensable and can be used for a lot more than holding boards together while the glue dries. You can clamp one to a ladder to hold the long end of a molding while you're cutting or installing it, or use one to squeeze and "coax" boards into position.

Masking tape. I always keep a little piece of masking tape stuck to my tape measure for writing down numbers and dimensions I need to remember; when it's full, I toss it and stick on a new strip. Masking tape can also be used to keep glue off areas when gluing up boards and as a mini-clamp. It's great for creating temporary labels and emergency bandages.

LESSONS FROM THE HOMESTEAD

No Fancy-Pants Tools

BY SPIKE CARLSEN

I'd just begun the day working alongside Isaak, a carpenter at a secondary school in rural, electricity-less Tanzania, when he explained our first mission was to rip the boards to width for the chairs we were building. I looked around for the table saw and generator, or at least a beefy handsaw, but no. He pulled out a machete and with six swift whacks of

the razor-sharp blade accomplished a task I'd never performed with anything other than a power tool. As the day progressed we cut all the parts to length with a handsaw, instead of a miter saw; crafted mortise-and-tenon joints with a hand drill and chisel, rather than a drill press and fancy jigs; and smoothed seats with a well-used hand plane instead of a power planer.

You might think working without power would slow the process down, but by the end of the day we had a fine set of four chairs. That day, I learned it was not the tools themselves that made the difference between a well-built project and a shabby one, but rather the attitude and experience of the person wielding them. Don't use the old excuse "I can't do it because I don't have a . . ." Just do it.

Safety and Safety Equipment

See no evil, hear no evil, inhale no evil — stay healthy while you work

Some people shy away from tackling projects because of safety issues. But the truth is, with the right protective gear and work habits, you can enjoy a lifetime of accident-free building. Here are some things to keep in mind (and in your toolbox).

Hearing Protection

You should wear hearing protection when sound levels exceed about 85 decibels (dB). As a point of reference, conversational speech is about 60 dB, shop vacuums emit about 85 dB, and most saws generate 90 dB or more.

There are dozens of different hearing protectors on the market. The most important thing is to find one that you'll actually wear: it has to be comfortable and suit the way you work. The two most common options are earplugs and earmuffs.

Earplugs are little foam “bullets” that you twist and insert directly into the ear. They're inexpensive and offer the greatest degree of hearing protection. On the downside, they're easy to misplace, they don't last long and must be replaced frequently, and may give you the unpleasant sensation of having something stuck in your ears.

Earmuffs are “headsets” that completely cover the ear. They cost more and are bulkier than earplugs, but many people find them more comfortable to wear than plugs. It's easy to perch them on top of your head, “Mickey Mouse” style, when not in use.

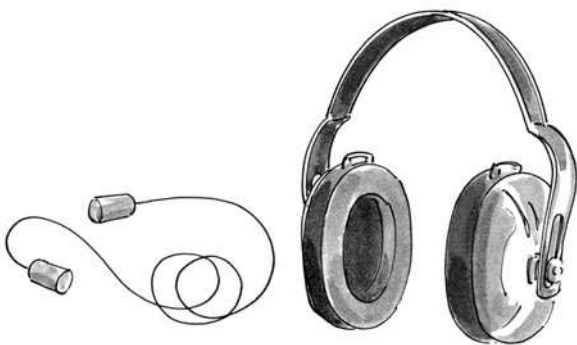

compressible foam earplugs

earmuffs

Sight Protection

Different types of sight protection are designed for different situations.

Safety glasses (with side shields) protect your eyes whenever small chips and debris are flying, or when you're driving nails. Prescription safety glasses with special lenses are available; to be effective they must have side shields.

Safety goggles should be worn whenever you are using chemicals or generating clouds of dust. **Direct vent** goggles offer superior airflow and ventilation for comfort but offer less protection against chemical splashes.

Indirect vent or **splashproof** goggles are designed so liquids can't enter through the vents. If you wear regular prescription glasses, goggles offer the best protection.

Face shields offer protection against large chips, sparks, and bigger types of airborne debris. People commonly wear these when working on a lathe or grinder, or when working with outdoor power equipment. Since shields are open on the bottom, for complete protection wear safety goggles or glasses beneath.

Welding helmets with specially designed lenses for the type of welding you're doing will protect your eyes and face from infrared and ultraviolet light, as well as sparks, particularly when you are arc welding.

Respiratory Protection

Since sawdust has been classified as a nasal carcinogen, you should wear respiratory protection anytime you pick up a saw. Cutting drywall, concrete, and fiberglass — or simply sweeping the floor — can also generate substantial amounts of airborne particles.

Dust masks have “N” ratings on the package that indicate the percentage of particles the mask will filter out; an N99 mask offers more protection than an N95 mask.

Cartridge-type respirators are required when you are using furniture strippers, spray paints, and other

chemicals. Some masks are “half-face,” while others are “full-face.” Read the warning label on the package or can to find out which type of mask and cartridge you should wear to secure full protection, and follow the directions.

Working Accident-Free

You can avoid most accidents by using common sense, maintaining your tools, and keeping your work area free of debris. A few other tips to keep you intact:

- Keep your hands and other body parts out of the projected path of utility knives, chisels, blades, and other sharp objects. Before making any cut, ask yourself, “What’s going to happen if that cutting tool slips?”
- Clamp down boards and other workpieces before boring large holes through them; a spinning workpiece is a dangerous workpiece.
- Keep your hands and body away from the projected kickback path of blades and boards when using power saws, particularly circular saws and table saws. Stand to the side, rather than directly behind, boards and blades during cuts.
- Beware of binding blades as you work. A pinched blade can propel the saw you’re working with, or the board it’s cutting, in unexpected directions.
- Use a starter block when cutting with a handsaw. It will keep your fingers away from sharp teeth and, as a bonus, help you establish a squarer cut.

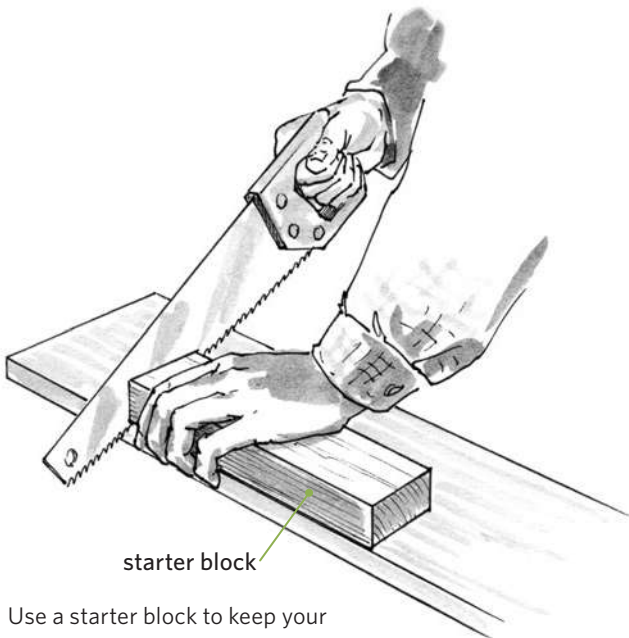

Use a starter block to keep your fingers away from the saw.

- Unplug tools whenever you change blades or bits or perform maintenance.
- Keep a first-aid kit nearby. At a minimum, the kit should contain adhesive and elastic bandages, gauze, antiseptic cream, scissors, tweezers, eyewash and cup, latex gloves, and an instant ice pack.

Ladders, Scaffolds, and Heights

Falls from extension ladders, stepladders, roofs, and scaffolds are responsible for nearly half a million injuries per year in the United States alone. Avoid becoming a statistic by setting up and using these helpers correctly:

- Set your extension ladder at the correct angle. Many ladders have a little L-shaped diagram on the side. Hold a torpedo level so it’s aligned with the long edge of this diagram, and position the base of the ladder so the level reads plumb. Otherwise, use this rule of thumb: Position the tips of your shoes or boots against the ladder feet; then stand upright with your arms extended directly in front of you. You have the correct angle if the palms of your hands just touch the ladder rung in front of you.
- Make sure your stepladder or extension ladder sit on a level base. You can quickly dig a trench under the high side using the claw of a hammer or pry bar. Avoid propping boards under one leg; they can slip.
- Confirm that the base of your extension ladder is secure. If you’re working on a deck, nail a 2x4 behind the feet to prevent slipping. On the ground, swivel the ladder feet on the bottom; then apply pressure until the spurs of the feet dig in.
- Stabilize the top of extension ladders with rope, blocks of wood, or a U-shaped ladder stabilizer.
- Always keep your belt buckle between the rungs. Load your tools into a tool belt so you can use both hands to grip the rails when climbing and descending the ladder.
- Before you extend or raise a ladder, check overhead to make certain there are no power lines in the vicinity.
- Make sure all four legs of a stepladder or scaffold make solid contact with the ground. One soft or low spot can create an unstable condition.
- When working on a scaffold, use a rope tied to a 5-gallon bucket to haul stuff up so you can use both hands while you climb.

Lifting and Moving Heavy Stuff

Use your brain and physics, rather than brawn and ibuprofen, to get the job done

Let's face it: While building around your homestead you're going to encounter heavy stuff. Let's face something else: Moving heavy stuff the wrong way can put you out of commission

for days, weeks, or longer. It's always better to use your brain and physics than to rely on brute strength when moving heavy materials. Here are some tips.

Let's roll. You can move everything from flagstone steps to yard sheds by placing them on sections of 4"-diameter PVC pipe and pushing them. Keep leapfrogging rollers to the front as you progress. This works best for objects with flat bottoms being moved on relatively flat ground.

Two wheely good ideas. A wheelbarrow can be your best friend for moving a heavy object, but often the trick is getting the object into the wheelbarrow to start with. If you're loading a large stone or other heavy material, lay the wheelbarrow on its side and roll or shove the material in. Then, with the help of a friend, push the wheelbarrow upright.

You'll also find a wheelbarrow easier to push and steer if you load the material closer to the front than the back. Your arms can do less lifting and more steering.

Hello, dolly. Dollies are great for moving furniture and appliances, but they can also be great for moving stones, building materials, potted trees, and other hefty landscaping materials. A dolly with air-filled tires will negotiate uneven terrain more easily than those with hard-rubber tires. Strap the material to the dolly for stability. Sometimes it's easier to pull, rather than push, the dolly.

Take a walk. You can move large square planters, landscaping stones, and heavy outdoor furniture by walking them to their destination. With the object balanced on

two legs or two points, move one leg ahead a few inches, then the other. Repeat until you've reached your goal.

Strappingly strong straps. If you watch piano and furniture movers, you'll notice they work in pairs and use furniture moving straps. The straps loop over one person's shoulder, fit under the object, and then loop over the other person's shoulder on the opposite side. Some systems use the forearms for support. They make the moving process way easier on the arms, back, hands, and legs.

Use leverage. Archimedes maintained that if you gave him a place to stand with a lever he could move the whole world. While your task is probably smaller than that, levers are amazingly handy when it comes to jobs like pulling out old fence posts or fine-tuning the positions of large objects. The longer the lever and the shorter the distance from the fulcrum point to the load, the more leverage you'll create.

Shoulder the burden. While it takes practice to get a heavy plank or bag of concrete onto your shoulder, once it's there, the hauling becomes much easier. To get it onto your shoulder, squat to grab the object, keep your back straight, and then stand quickly using your legs. As the object rises use your arms and the momentum to "clean" (as in *clean and press*) the object onto your shoulder.

Levers are amazingly handy when it comes to jobs like pulling out old fence posts or fine-tuning the positions of large objects.

**Rolling heavy objects
over flat ground using
PVC pipe**

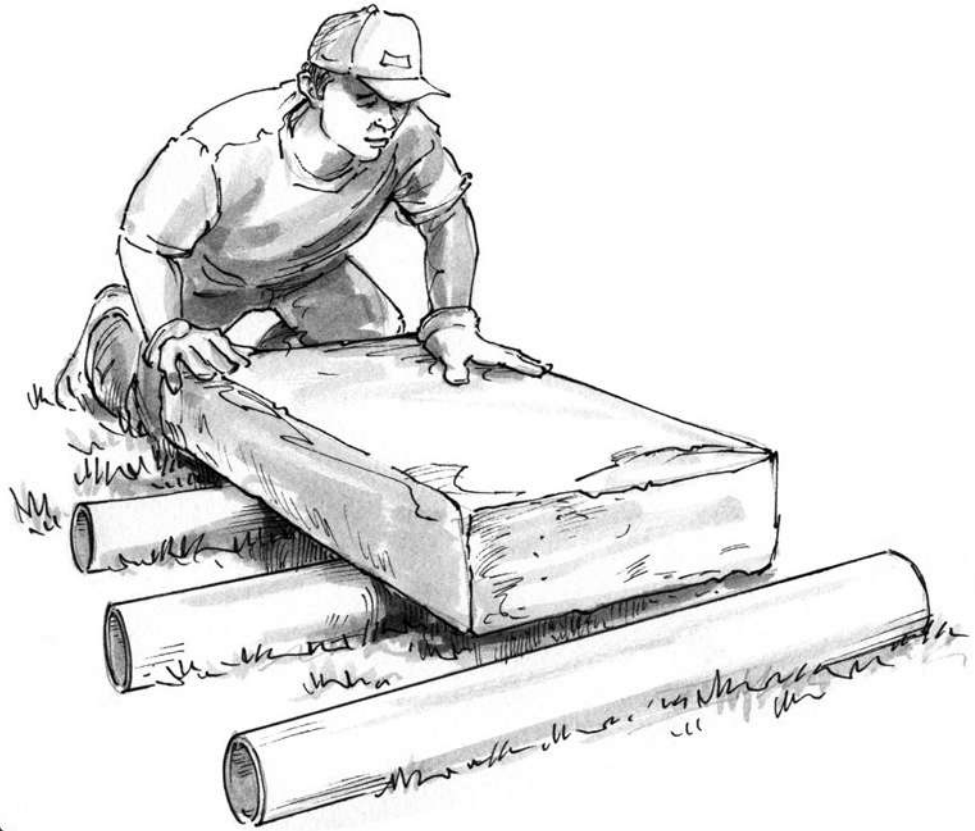

**Using leverage to pull
an old fence post**

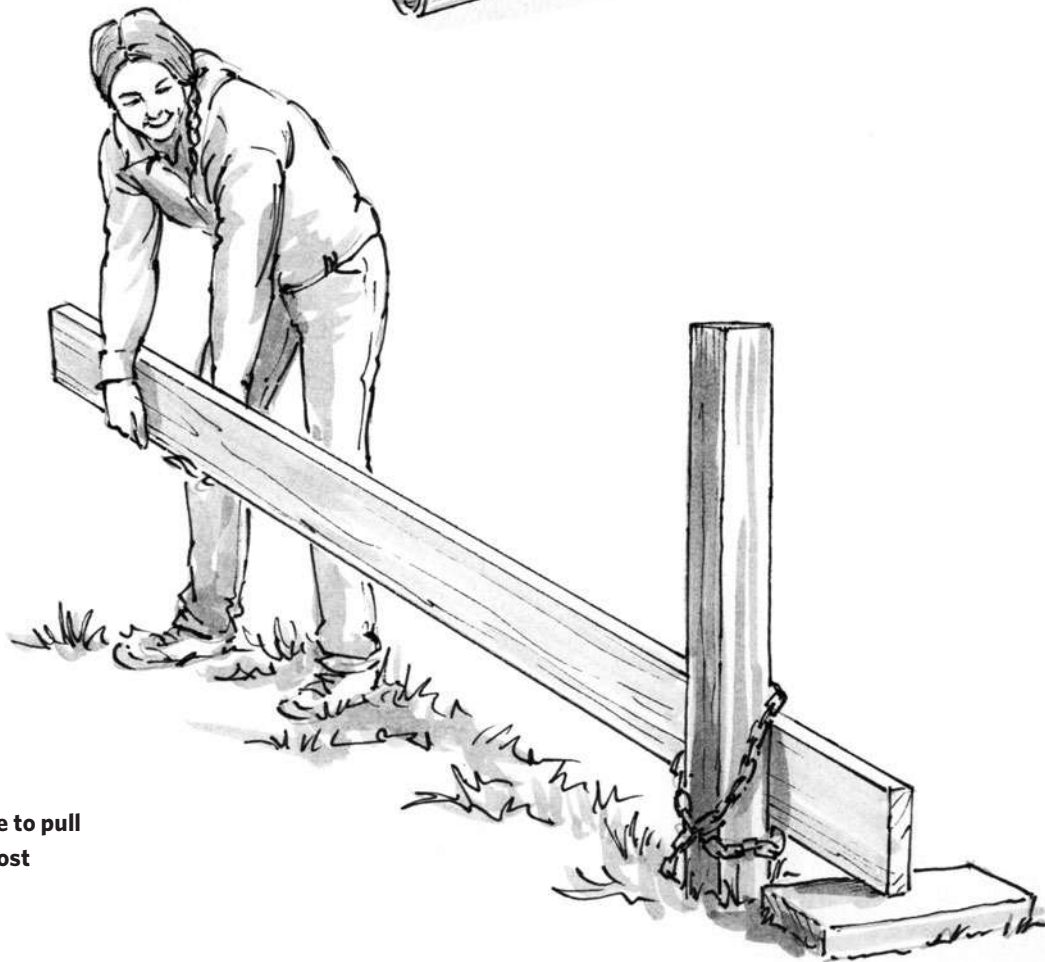

Woods and Plywoods

Lumber-aisle lingo and more

To find a 2×4 that actually measures 2" by 4", you'll have to hop into your pickup truck and drive back 80 years or more. These days, a 2×4 may start life at those dimensions, but by the time

it's been kiln-dried and planed, the dimensions have shrunk. Here we'll take a brief look at lumber, plywood, and the best woods to use for outdoor projects.

The True Dimensions of Dimensional Lumber

In the materials list included with most projects in this book, the lumber will be listed by its *nominal* dimensions (its common name), but the given dimensions in the project, parts, and cutting lists and illustrations will be based on the *actual* dimensions. What we call a 2×4 actually measures about 1½" thick by 3½" wide. See Nominal vs. Actual Lumber Dimensions, right, for translations of common lumber sizes.

A word about length: Most dimensional lumber runs ¼" to ¾" longer than the given "lumberyard length." Notable exceptions include 92⅝" studs and other boards with very specific lengths.

Selecting the Best Exterior Wood

Many of the projects in this book are for outdoor use; you should pick your lumber accordingly.

Treated lumber can't be beat for strength, price, and longevity. It's commonly available in a wide range of dimensions. On the downside, it's often so saturated with preservatives that it spits at you when you drive a nail through it, it's heavy, and it doesn't take stain well until it dries out (see The Dirt on Treated Lumber, page 73). Some treated lumber also tends to twist and warp as it dries, so nail it down as soon as you can after buying it.

Nominal vs. Actual Lumber Dimensions

THICKNESS

Nominal Size	Actual Size
1"	¾"
2"	1½"
4"	3½"
6"	5½"

WIDTH

Nominal Size	Actual Size
2"	1½"
4"	3½"
6"	5½"
8"	7¼"
10"	9¼"
12"	11¼"

Note: The width of 8", 10", and 12" material can vary up to ¼" from the "actual size" listed here.

Be Aware of Deck Board Dimensions

Decking material, sometimes referred to as ¾" or five-quarter material, can range in thickness from ⅞" to 1¼". It's a great material to use for furniture and other projects since it's usually straight, dry, and relatively knot-free. Several projects in the book call for it; make sure to tweak the given dimensions based on the actual thickness of your material.

There are different levels of treatment that help wood stand up to different conditions. The stamp or tag on the lumber yields some information: lumber treated to 0.40 has more preservative than that treated to 0.25. Some tags will also tell you whether it's suitable for "belowground use" or simply for "ground contact."

TAKE NOTE Avoid lumber that's tagged "Treated to Refusal" or "No Warranty." You really can't tell what you're getting.

Composite lumber is usually made from a combination of plastic resin, recycled plastic, chemicals, and wood fibers. It's commonly used for deck-top boards and furniture but rarely for structural purposes. It comes in a wide variety of colors and has great longevity. It's also very expensive.

Cedar (as well as redwood and cypress) has great natural color and is dimensionally stable (less likely to warp). The darker heartwood (not the lighter sapwood) is naturally rot-resistant. You can apply a clear finish to help preserve the color or let it turn a natural silvery gray. It's not as structurally strong as treated lumber, so it's most often used in places where appearance is important. It's lightweight and accepts nails and screws with minimal splitting.

Tropical hardwoods, like ipe, are becoming more commonly available. They're extremely rot-resistant, dense, heavy, and expensive. Nail and screw holes must be predrilled. Left unfinished, these weather to a silvery gray.

How to Read Plywood

You'll find a heck of a lot of plywood, with a heck of a lot of variation in price, when you stroll down the plywood aisle. There are a few key pieces of information you need before you start loading your material.

Exposure rating. Plywood rated for "Interior" use should be kept free of moisture. "Exterior" plywood is made to withstand some exposure to the elements; it's most commonly used for roofs, floors, and walls that will be left unprotected for a week or two during construction. Treated plywood can withstand constant exposure to the elements; some types, but not all, are rated for direct ground contact.

Face grade. The two faces of a sheet of plywood are graded A through E. Use A and B plywoods when appearance is important. Use C and lower grades for structural applications like roof and floor sheathing.

Span rating. Two numbers separated by a slash (such as 32/16) refer to how far a sheet of plywood can span between support members. The first number refers to the span when used for roof sheathing, the second when used as floor sheathing.

Thickness. Most plywood stamps list the actual thickness of the plywood. While the lumberyard staff (and the materials list in this book) may call it $\frac{5}{8}$ " plywood, the stamps on the plywood panel will tell you the actual thickness is $2\frac{3}{32}$ ".

Composition. The more plies a sheet of plywood has, the stronger it is. Usually the number of plies is an odd number, but some $\frac{1}{2}$ " panels have four plies; others have three. You pay for what you get.

TAKE NOTE When you walk down an aisle and see a pile of $\frac{1}{2}$ " CDX plywood, the label is telling you that each sheet is (1) about $\frac{1}{2}$ " thick, (2) has one face that's C grade and another that's D, and (3) is rated for exterior use (that's the "X") and can withstand short-term exposure to the elements.

Oriented strand board (OSB) is commonly substituted for plywood. Both are manufactured to the same structural specifications and are interchangeable in most cases. OSB does not stand up to moisture as well as plywood does.

Harvesting Wild Lumber

BY DAVE MUNKITTRICK

Furniture makers are a little like chefs; as their skills grow, so does their dissatisfaction with store-bought ingredients. Great chefs often end up growing their own. Here in rural Wisconsin I'm surrounded by the raw materials of my trade; trees are everywhere. Why go to a store? I had to try my hand at harvesting my own boards.

I started small. A 12"-diameter red pine had gone down in my yard. Armed with a chainsaw and a chalk line, I managed to slice up the trunk into several 3"-thick slabs. It took forever and the "boards" looked like something hacked out of the tree with stone tools, but I was hooked.

My first upgrade was a \$100 guide for my saw that tracked on aluminum rails screwed to the log. Now my boards looked like real lumber. Muscling the saw through the cuts was still a chore. Then I discovered rip chains. These specialized blades have aggressive teeth

that cut faster with less effort. Now I was cooking.

Every time I open a log I feel like a kid on Christmas morning. It never gets old. I've found many a hidden treasure: amazing figures, surprising colors, and even grown-over fire damage from some long-ago lightning strike. You just don't see wood like that at an ordinary lumberyard. On the down side, I've also found buried bullets, nails, and barbed wire. Kinda hard on the chainsaw blades. I've added a metal detector to my equipment list.

For big trees, I enlist the help of a pro with a portable sawmill. Dan is my man. Found him in the Yellow Pages. For \$60 an hour Dan will bring his bandsaw mill to the log and slice it up any way I like. Dan's mill has hydraulics that lift and position the log on the mill. My back is so happy. All I have to do is grab the boards as they come off the mill, and I have wood that costs about 50 cents a board

foot — a tenth of what I'd pay for oak, walnut, or maple at a lumber retailer.

Of course, slicing boards from a log is only the beginning. Green wood must be dried to be useful. Once the boards are liberated from the log, it's imperative to get them stacked and stickered quickly to minimize checks, splits, and twists. Trust me, you can't cut up the log and come back a few days later to stack. It's gotta be done now. Air-drying wood is not a set-it-and-forget-it proposition. Be sure to read up on how to do it properly. The USDA has a great (and free) guide to drying lumber (see Recommended Reading).

Harvesting wild wood can be a rich and rewarding experience. Yes, it can even save you money, but it'll cost you time and effort. The rewards come when you go to build your projects. There's a thrill to using the wood that you remember as a tree. It puts some history into each piece you build. Happy harvesting!

DAVE MUNKITTRICK *has designed and built furniture since 1983. His shop is in an old pig barn, where he is currently building furniture from locally harvested wood. You can see his tables and much more on his website (see Resources).*

Glues and Caulks

Use all the right stuff for strong, long-lasting projects

Glues, adhesives, and caulks shouldn't be an afterthought; they often work as hard as, or harder than, the fasteners used along with them. Select adhesives carefully and your projects will last a long time and look good.

Glues

There are dozens of different glues on the market, each with its own strengths and weaknesses. Some can be used outside, some have long "open times" (giving you more time for assembly), and some can be used in low temperatures. Before buying any glue, read the label and see if it jibes with your project. There are a few basic types.

White and yellow carpenter glues are ideal for interior projects. They often create a bond stronger than the wood itself. They're easy to apply and clean up. Standard white and yellow glues won't stand up to exterior use.

Waterproof glues, such as Titebond II and Titebond III, have qualities similar to those of yellow and white glues but are formulated for outdoor use. They cost a little more but are a better choice for an all-around wood glue because they are suitable for both indoor and outdoor projects.

Polyurethane glues are waterproof and strong, and they bond to most materials, including wood, stone, metal, and plastics. They need moisture to create a bond, so you may have to wipe one surface with a damp rag. On the downside, they're expensive and messy in liquid form, and they have a short shelf life.

Construction adhesive, the stuff that comes in caulk tubes, is available in a wide variety of formulations. Some excel at bonding wood to wood, while others stick to stone, cement-based materials, and foam. Construction adhesives are commonly used for joining plywood and dimensional lumber. Most types remain somewhat flexible, something to keep in mind when using them for furniture projects.

Caulks

Caulk shouldn't be used as a substitute for tight-fitting joints or missing flashings, but it can help your projects look good and last a long time. Here's the lowdown.

Silicone caulk is flexible, long-lived, and impervious to water. It's an incredibly tenacious adhesive and clings well to tile, glass, metal, and other nonporous surfaces. It does, however, have a few drawbacks. Many silicone caulks have a distinct odor; can't be painted; and, since they're not water soluble, require mineral spirits or denatured alcohol for cleanup. They're the most expensive of the caulks but have the greatest longevity (20 years or more).

Acrylic latex caulk is easy to apply, can be used on most surfaces, is available in a variety of colors, and can be painted over in as little as 30 minutes. Most acrylic latex caulks have a life span of 10 to 15 years.

Latex, or painters' caulk, is easy to apply, cleans up with water, and is easy to smooth with a damp fingertip. It's best suited for dry indoor applications. It's the cheapest of all the caulks and has a life span of 5 to 10 years.

Tips for Neater Caulking

- Use a utility knife to cut the tip of the caulk tube at a slight angle. Create an opening the approximate size of the bead you wish to apply. Puncture the inner seal with a long nail or, if your caulk gun has one, the swing-out poker attached to the gun.
- Squeeze the handle slowly and move the nozzle at a steady rate. Use the angled tip to smooth the caulk.
- When you're done with each use, click the plunger release button or rotate the pressure shaft to relieve the pressure. Otherwise, you'll wind up with little blobs of caulk everywhere you set down your gun.
- The best tool for smoothing a bead of caulk is a damp finger. Keep a rag in your pocket to wipe off caulk that gets on your hands or other surfaces.
- Seal the tip of partially used caulk cartridges with either the supplied cap, a long drywall screw, masking tape, or even a large wire nut.

Fastest Glue in the West

Use an old toothbrush for spreading glue along the ends and edges of boards. When you're done, rinse it off and stick it in a travel case. For applying large swaths of glue, use a 4" foam roller or brush.

Exterior Fasteners

The right fastener = sturdy projects

Using the wrong fastener for your projects, especially those exposed to the elements, is penny-wise, dollar-foolish. You may save a few bucks up front, but your project won't last as long, look as good, or be as sturdy as it would be if you'd used the right fastener.

Screws

There are several types of exterior screws; use the information below to select the right one for your project.

Galvanized. A zinc coating protects galvanized screws from wood preservatives, moisture, and tannic acids in wood. Those of the hot-dipped variety (characterized by their rough or chunky texture) have better durability than those that have been electroplated. Galvanized screws are the least expensive of the exterior fasteners but can eventually "bleed," leaving dark streaks on the wood. If appearance is important, use one of the alternatives.

Coated. Screws protected by a ceramic or plastic coating are available in tan, gray, and other woodsy colors. Many manufacturers supply a special Phillips or square-drive bit designed to minimize damage to the screw head and coating. Cost-wise they fall in the middle of the exterior screw choices.

Stainless steel. These are the most corrosion-resistant of the exterior screws and the least likely to bleed. Since they're made of relatively soft material, the heads are susceptible to stripping, and the screws can actually snap as they're being installed; both of these problems, however, can be eliminated by screwing into predrilled pilot holes.

Epoxy-coated. A corrosion-resistant epoxy coating is often used on timber screws, which can range in length up to 10". Timber screws are skinny and self-tapping; they also have coarse threads and hex-drive heads, making them excellent for joining large timbers or thick materials.

Nails

There are three common types of exterior nails.

Hot-dipped galvanized. These chunky-looking nails offer better protection than their smooth electroplated cousins. Their rough texture gives them extra holding power.

Electroplated or electrogalvanized. These nails have a bright, smooth, silvery surface. They're the least durable of the galvanized nail choices. They're not recommended for use with today's ACQ or CCA treated lumber (see *The Dirt on Treated Lumber*, page 73).

Stainless steel. These are durable and won't bleed, but they are the most expensive of the three choices (they're like driving dimes into your boards). They're also the most likely to bend, so drive with care.

Exterior nails that have spiral or ring shank shafts have better holding power than those with smooth shanks. **Casing** nails have small heads and are used for installing siding and trim where appearance is important. **Box** and **common** nails have the traditional flat head and have better holding power than casing nails. Box nails are thinner than commons and typically are used for light construction, such as fastening 1-by lumber, plywood, and trim. Common nails are used for joining framing members and other structural connections.

Nail Lengths

Common Name	Length
16d	3½"
10d	3"
8d	2½"
6d	2"
4d	1½"
3d	1¼"

Bolts and Lag Screws

Galvanized bolts and lag screws cost about twice as much as their nongalvanized counterparts but offer greater durability.

Lag screws have pointed tips and coarse threads and work like big wood screws. Most lags are made of unhardened metal, and thinner ones can snap if muscled in. Predrill holes to avoid damaging screws and your workpieces. A **pilot hole** (for the threaded portion of the screw) that's 75 percent the diameter of the screw's shank is about the right size. The **clearance hole** through the top board should be the same size as the screw's smooth shank; this allows the top board to pull down tightly to the mating piece and helps prevent splitting.

Carriage bolts have a smooth head and fine threads and work in conjunction with a washer and nut. The bolt has a square section just beneath the head that prevents it from turning as the nut and washer are installed. They're an excellent choice for exterior applications where looks and strength are important.

Metal Connectors

There is a wide array of joist hangers, L-shaped and T-shaped straps, ties, plates, and anchors that can add substantial strength to your projects. They can also be real problem solvers when it comes to making certain connections.

Most of these metal connectors are galvanized or plated to make them suitable for exterior use. Always use the manufacturer's specified fastener(s) to install connectors. Spend a few minutes browsing through the metal connector section of your hardware store or home center; you'll find a doodad for nearly every application.

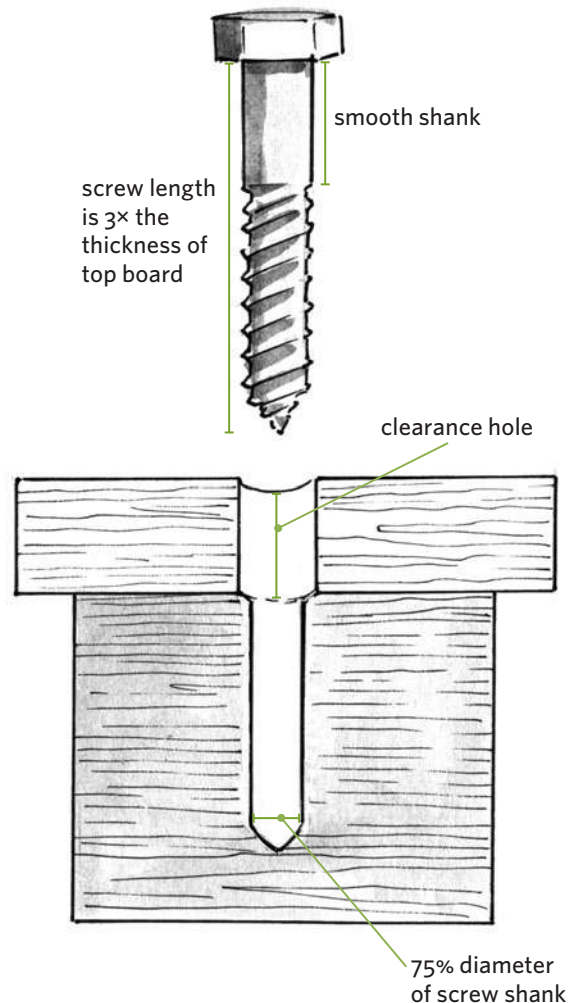

Predrilled hole for a lag screw

The Right Length of Fastener

As a rule of thumb, use a screw or nail three times as long as the thickness of the piece being joined (the "top" board). In other words, use a 2¼"-long nail (7d) or screw when installing a ¾" board. At the same time, make sure the fastener is ¼" shorter than the combined thickness of the boards so the tip doesn't pop through the opposite side.

Drilling Holes and Driving Screws

Make your drill your new best friend

The most widely owned power tool is the portable drill, with the cordless variety reigning supreme. This one tool can bore holes, drive screws, mix paint, hang photos, sand curves, assemble furniture, wind kite string, and perform dozens

of other tasks. With the right bits, drivers, and techniques, your projects will go together quickly, with little hassle, and be strong to boot. Here are a few tips for getting the most from your drill.

Driving Screws

Once you've used your drill to drive screws and tighten bolts, your screwdrivers will spend a lot more time in the junk drawer. A few tips:

- The standard slotted screw is becoming a thing of the past. Why? The more surfaces or surface area a screw head has for the bit to press against, the easier it is for the driver to do its job without stripping and slipping. Phillips-, square-, Torx-, and hex-drive screws have that extra surface area. Choose one type of drive and purchase screws with only that type of head to avoid lots of hunting around for the right bit, changing bits, and frustration.
- Most cordless drills have adjustable clutches that disengage the driver when a preset level of torque is reached. This comes in handy when you want to drive multiple screws at a consistent depth, like when you're hanging drywall or installing deck boards, or when you want to avoid stripping or snapping screws.
- The new breed of impact drivers are things of beauty. Most are small and lightweight, and many shine a beam of light so you can see what you're doing. At a certain point, they automatically switch over to impact mode, which makes driving screws nearly effortless. They accept only hex-shaft bits, but hex-shafted driver bits and drill bits are widely available.

10 Great Drill Tips

Every drill owner has his or her favorite drill tips and hints. Here are some I find most useful:

1. When a bit exits the far side of a board, it tends to blow out the fibers, leaving a jagged exit hole. Clamp a scrap piece of wood, called a backerboard, to the back of your workpiece to prevent blowout, especially when boring large holes.
2. Pre-drill pilot holes to avoid splitting wood when driving screws. A good rule of thumb is to drill a hole 75 percent the diameter of the screw shank. Drilling a larger clearance hole through the top board to accommodate the upper part of the screw shank will result in a tighter joint (see *Pre-drilled hole for a lag screw*, page 21).
3. When using dark wood, place masking tape down first and mark the hole on the tape so you can see and hit your mark more easily.
4. Use a nail for a drill bit. Snip the head from a nail, using a side cutter (heavy-duty wire cutters or pliers), chuck the nail shank into your drill, and bore away. The nail won't drill as quickly as a real drill bit, and too much pressure will bend the nail shank, but this is a great emergency substitute when you need a bit (especially in place of those smaller ones you always lose or break).

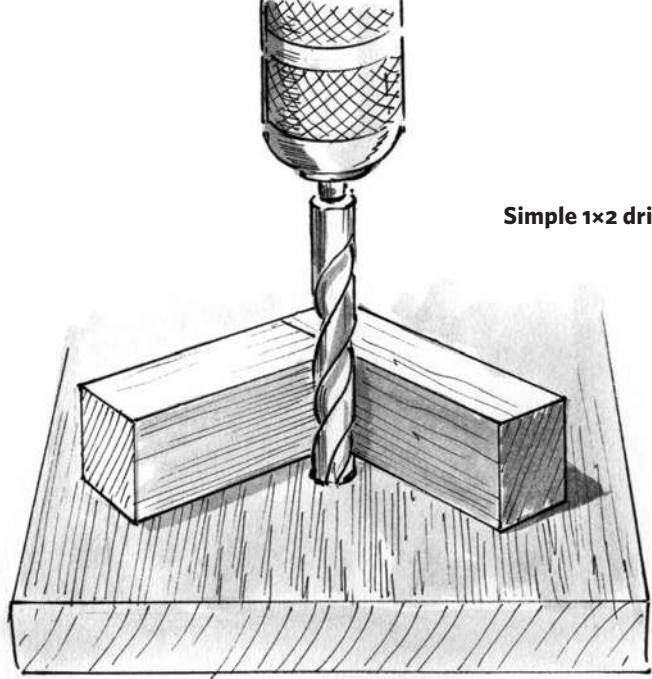

Simple 1x2 drill bit guide

5. Create a mini drill press for boring straight holes by nailing a couple of 1x2s together to form an L. Use this as a guide for your bit.
6. Lubricate your screws with soap or wax to prevent squeaking and minimize the chance of screws snapping. A bar of soap or an inexpensive wax toilet ring is easy to tote around and will provide lubrication for hundreds of screws.
7. Wrap masking tape around your bit to serve as a depth guide. This will allow you to drill multiple holes of equal depths and prevent you from accidentally boring all the way through a piece.
8. Use a magnetic tip holder for your bits when driving screws. It's like having a third (tiny) hand to help out.
9. Place a washer on the shaft of a spade bit and keep an eye on it as you bore horizontally. Raise and lower the drill handle to keep the washer balanced on the bit shaft, and you'll keep the bit boring straight.
10. Accessorize! There are rasp bits for shaping, drum bits for smoothing, paddle bits for mixing, and self-centering bits for drilling precisely centered holes (for hinges and the like). Special attachments can turn your drill into anything from a small water pump to a tool that bores holes at right angles. Browse the drill bit aisle of your home center or hardware store to explore your options.

Boring Large Holes

There are numerous times you'll need to drill large holes, and you have numerous drill bit options available.

Spade bits, which look a tad like a canoe paddle, are inexpensive, easy to store, and good for boring holes up to about 1½" in diameter. They dull easily, especially if you hit a nail, but can be sharpened with a file. The exit side of the hole tends to be ragged, unless it's supported by a backerboard. Spade bits are best for rough work.

Hole saws, which look like little shot glasses with teeth on the rim, come in sizes up to 6" in diameter. They're great for tasks like drilling holes for PVC plumbing pipe, doorknobs, and locks. Hole saw cylinders of various sizes mount to a special universal drive bit, called a mandrel; this is the part that you chuck into your drill.

Auger-type bits usually have long shanks and a tip that pulls them into the wood so that they work quickly. They excel at boring holes up to about 1" in diameter. They're a little rough around the edges, but because of their aggressiveness, people who need to drill lots of holes, like electricians, use them a lot.

Forstner bits are cylindrical and excel at drilling flat-bottom holes. They're expensive and often used by woodworkers when appearance and accuracy are important. These bits are almost always used with a drill press.

Tool Sharpening and Maintenance

Keep your tools in tip-top shape for tip-top work

Tools make our lives easy; all they ask in return is a little sharpening, maintenance, and general care. Performing those tasks is time well spent. It's important to remember that a dull tool is a dangerous tool. You wind up pushing or thrusting

harder, which increases the chances of you slipping or the tool breaking, causing injury to you and the tool. Basic maintenance will help your tools last a long time and perform well. Here are a few basic tips for maintaining a wide array of tools.

Sharpening Shears and Clippers

Shears and clippers will cut faster and cleaner when sharp. In both cases, begin by removing the bolt that holds the two blades together. Wear thick leather gloves, and be careful!

Clippers: One by one, secure the blades in a vise. Rock a mill bastard file back and forth along the edge to “feel” the existing bevel of the blade. Once you’ve established the correct angle, push the file along the entire length of the blade in long, even strokes. Unless your tool is extremely dull, it should take fewer than a dozen strokes to restore each edge.

Pruning shears: Clamp the curved-blade (sharp) half of the shears in a vise. As with clippers, feel the angle with your bastard file, and then make one large swooping stroke along the entire cutting edge. Check your work after each stroke; a smile of bright, shiny steel should be growing along the bevel with each pass. Clamp the crescent-moon-shaped half in the vise and use a half-round file to flatten the inside of the curve.

Sharpening Screwdrivers

You can easily restore the tip of a chipped or worn screwdriver.

Straight-slot screwdrivers: Position the tool rest of your grinder square to the wheel, and then grind the tip of the screwdriver flat. Finish by adjusting the rest to a very steep angle and tapering the tip. You can also do this by gripping your tool in a vise and sharpening with a hand file.

Phillips screwdrivers: Use a file to slightly flatten the tip, and then use the square edge of the same file to deepen the four side grooves.

Square-drive screwdrivers: Use a file to flatten the tip, and then give each of the four tapered sides a few strokes to flatten them and restore the original size of the tip.

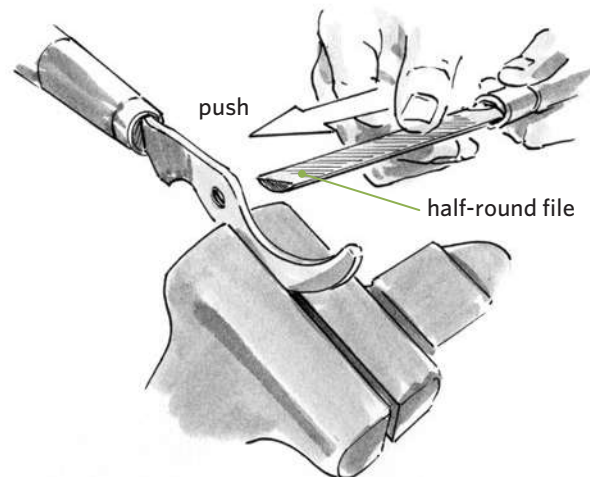
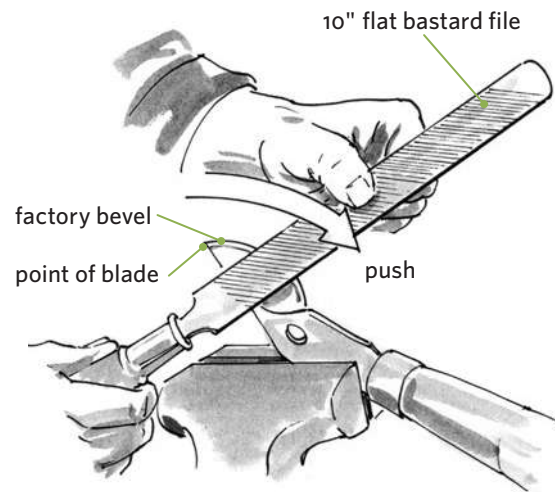

Sharpening pruning shears

Sharpening Drill Bits

To sharpen a **spade bit**, begin by clamping it vertically in a vise. Rest a fine-tooth file on one of the flats of the bit and adjust it until it matches the angle of the existing bevel. Give four or five light strokes to that side, then an



Sharpening a drill bit tip with a bench grinder

equal number of strokes to the opposite side. Use the same technique for sharpening the edges that create the point.

Twist bits are tricky to sharpen since they have so many cutting edges. You can sharpen the tip, the part that dulls soonest, by restoring the angle using a bench grinder with a tool rest set at the correct angle.

Sharpening Shovels

Most people don't think about sharpening shovels or post-hole diggers, but you'll be amazed at how quickly they cut through dirt and roots with a sharp edge. Sharpening requires two simple steps:

1. Use an angle grinder or belt sander with a coarse belt, held at 90 degrees to the blade, to remove nicks and restore the profile.

Markers Make Better Bevels

Before you sharpen a tool, run the tip of a wide marker along the blade edge. You can check your progress by noting how evenly you're removing the marker and can then adjust the angle of your file or sharpening tool accordingly.

2. Use a mill bastard file to create the bevel. Hold the file at a 60- to 70-degree angle to the *back* of the shovel or blade, and apply pressure while making repeated strokes.

Note: Separate the two halves of a posthole digger before sharpening.

Warding Off Rust

Keep hand tools rust-free by storing a container of silica desiccant in your toolbox to absorb excess moisture. Some desiccants can be recharged by drying them out in the oven. You can also store a lump or two of charcoal with your tools to absorb moisture.

To keep rust at bay on larger stationary tools and saw blades, apply a coat of automotive paste wax to the large flat surfaces.

Replacing a Power Tool Cord

If you use handheld power tools, eventually you'll have to replace a power cord. Since many have special cord retainers and connectors, your first step is to find the correct replacement cord. You can purchase them through a factory-authorized dealer or an online parts supplier (see Resources). To replace a cord, open the tool and make a sketch or take a digital photo of how the old cord is attached; then, one by one, remove the old cord wires and replace them with the new ones.

No Nasty Surprises

Always unplug your tools when changing bits, blades, or belts to avoid serious accidents. Make a habit of placing the plug next to the tool as you work as a visual confirmation.

Extension Cord Sizing

Nothing will burn out a power tool faster than a wimpy extension cord. Select the size of your extension cord based on the distance you'll be working from the power source and the power or amperage of the tool. The higher the amperage and longer the distance, the larger cord you need. Cord size is indicated by its **gauge**. The smaller the gauge number, the larger the cord. Here are some typical distances and recommended cord gauges for a few common power tools.

Cord Length	Drill (6–8 amps)	Circular Saw (12–15 amps)	Portable Table Saw (15+ amps)
50 feet	14 gauge	14 gauge	12 gauge
100 feet	14 gauge	12 gauge	12 gauge
150 feet	12 gauge	10 gauge	10 gauge

Digging Holes and Setting Posts

It helps to be smarter than the shovel

What do a simple job like installing a mailbox and a massive job like building a pole barn have in common? Digging holes and setting posts. While these tasks don't fall into the rocket-science category, there are right and wrong, easy and hard, and long-lived and short-lived ways of doing this.

Digging Holes

Setting posts in deep holes accomplishes two important goals. First, it makes the portion of the pole aboveground more stable. A deeply buried pole is less likely to wiggle than one set in a shallow hole. One rule of thumb is to have 1 foot of buried post for each 2 feet of aboveground post. Second, in cold regions where the ground freezes and thaws, expands and contracts, structures or posts resting on the soil move along with it, sometimes dramatically. Posts with bases installed below the freeze-thaw level (called the frost line) won't be as affected by soil movement. In Canada and the upper Midwest, the frost line can be as deep as 60"; in southern climes, frost heave isn't an issue.

What's the Best Way to Get Down?

It's always better to dig a hole larger than what you need. This gives you more play for positioning the post as well as space for a wider support footing, if called for. The following are the main options for hole-digging tools.

Hand posthole diggers. A shovel will get you down a foot or two, but to get deeper, you'll need a **clamshell** or **auger-type** posthole digger. The latter works great in soft soils but is more difficult to use in rocky soils. Most posthole diggers can bore holes 8" to 10" in diameter. To get a larger hole, you need to shave the sides with a shovel or digger and then scoop out the loose soil.

Power augers. You can rent one- and two-person gas-powered augers, with diameters ranging from 6" to 12". Some have the motor mounted on top; others have a motor that sits on the ground and rotates the auger via a cable. Both types have their pros and cons, and both can be exhausting to use. With any power auger, you'll need to use a hand digger to remove the remaining bits of loose soil from the bottom of the hole.

Machine-mounted augers. Without question, the easiest way to get the job done is to use an auger attachment mounted to a tractor, skid steer loader, or backhoe — one you own, rent, or hire. These can bore holes up to 24" in diameter in minutes, saving you days on large projects. If you can afford it, go this route.

Setting Posts

Just as there's more than one way to dig a hole, there's more than one way to set a post. Your approach will depend on what your post will be used for, and what your local building code and inspector dictate. Four common ways to set a post are shown here, although you can also use a combination of methods. Whatever you do, always place an uncut end of a treated post into the ground for greatest longevity. (For help with laying out posts, see *Measuring, Leveling, and Squaring*, page 30.)

Call 811 Before You Dig In

Before you start digging — in fact, before you even start planning — make one important phone call: 811. That number connects you to the national "Call Before You Dig" hotline, which in turn puts you in touch with a regional agency that will arrange for someone to come out and mark the locations of all your underground electric, telephone, cable, gas, and water lines. The service is free. It could save you a world of physical, financial, and legal hurt. Plan ahead; sometimes it takes a day or two for a locator to get out.

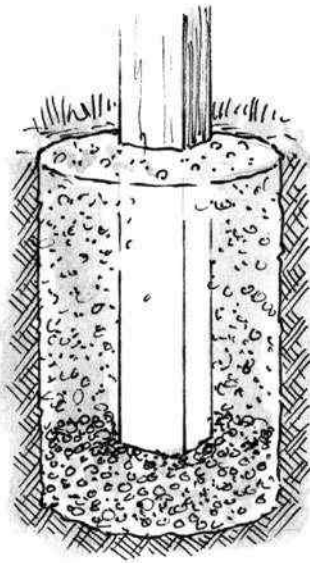

Gravel footing with gravel backfill

COMMON USES: Solid fences and lightweight structures subject to wind forces

PROS: Good drainage, good lateral stability, no concrete to mix

CONS: Less stable than if set in concrete, minimal load-bearing capacity

concrete collar (optional)

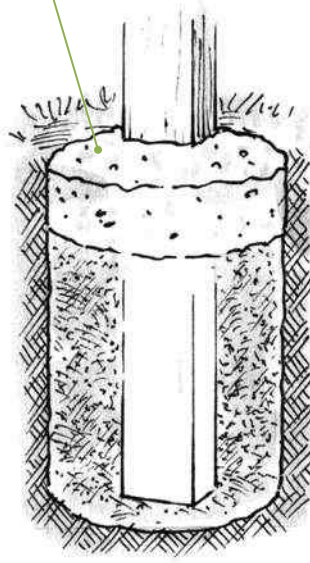

Soil footing with soil backfill

COMMON USES: Split rail and picket fences, mailboxes, light structures

PROS: Fast, inexpensive; optional concrete collar helps shed water and stabilize post

CONS: Wobbling can occur if earth isn't tightly packed; may not meet local codes

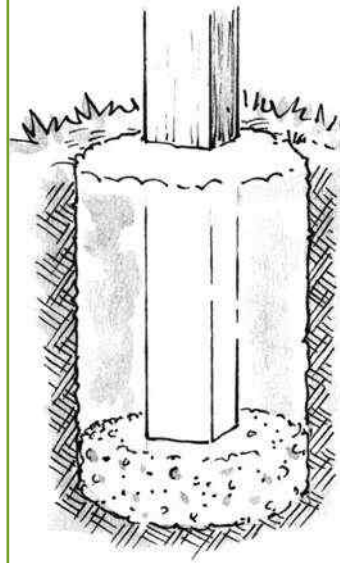

Concrete footing with concrete backfill

COMMON USES: Pole barns, additions, decks

PROS: Excellent lateral stability

CONS: Lots of concrete to mix; poor drainage, which can accelerate post rot; hard to remove later on

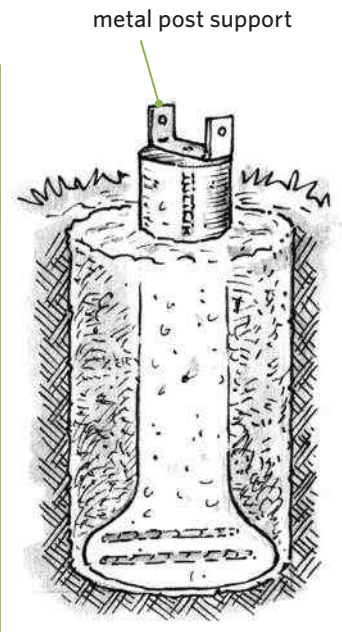

Poured concrete footing and pier

COMMON USES: Decks, additions, and other heavy structures

PROS: Provides substantial footing, no belowground wood

CONS: No lateral bracing of aboveground post provided by backfill, expensive, labor-intensive, requires form (often a large cardboard tube)

Overcoming Obstacles

Unless you're digging through pure sand or soil, you're going to encounter some of Mother Nature's obstacles. Common ones include the following.

ROOTS: Cut through them with a reciprocating saw with a long, coarse blade. It's way easier than chopping your way through.

BIG ROCKS: Use a digging bar — a heavy-duty, 4- or 5-foot-long, pointed bar — to dislodge or pulverize them. Once they're loose, lift them from the side or bottom of the hole with a clamshell-style posthole digger.

CLAY: Keep a 5-gallon bucket of water nearby and dunk your clamshell digger in before each bite so the soil doesn't stick to the digger.

Wrap It Up

If you want to minimize the chance of frozen soil pinching the sides of your post and pushing it out of the ground, wrap it in 6-mil polyethylene sheeting. The plastic will create a slippery barrier that the frozen soil can't readily grab.

Circular Saw Basics

Some standard techniques for using this indispensable tool

Since you'll find yourself with a circular saw in hand for most projects in this book, it makes sense to learn how to use one safely. Here are a few general guidelines to follow.

Getting Ready

- Adjust the base or bed of your saw so the teeth of the blade extend no more than 1/2" below the workpiece you're cutting. Your saw will cut more efficiently, and you'll decrease the chance of accidents.
- Stand to the side of, not directly behind, the blade as you cut; if the saw kicks back toward you, you'll be out of the path of a spinning blade.
- Support your workpiece properly. If you're making a short cutoff from a longer piece, make certain the scrap piece can fall away freely and not bind on the saw blade. If you're cutting plywood, make certain the sheet is well supported along the length of the cut. Never allow the blade to get pinched between the two sides of a cut.
- When starting a cut, line up the notch or indentation in the base of your saw with your cut mark. Then, making sure the blade is *not* contacting the wood, pull the trigger. Slowly and firmly push the blade into the wood.
- Position plywood and other materials good side down to minimize splintering on what will be the exposed side of the material. Circular saw blade teeth cut upward, so the wood tends to splinter on the surface that's face up when cutting.

Sighting Cuts

Since the motor on most saws blocks the view of the line you're attempting to cut along, you need to lean left or right to follow the path of your cut. Leaning right and peering over the saw allows you to see the entire line and the bulk of the blade so you can help guide its path. This is a little awkward, but you can get the hang of it with practice. (Note: *Wear safety glasses*, because leaning often puts your eyes in the line of flying dust and chips.) By leaning left and crouching down a little, you can sight the front part of the blade and a small portion of your cut line. It's a more comfortable position for many people, but it's harder to guide the saw straight, especially for long cuts.

Square End Cuts

When making square cuts on the end of a board, use a Speed Square (see page 10) to guide the edge of your saw's base as you cut. There are other guides on the market you can use, but a Speed Square is easy to carry and handy for lots of other things.

Pick the Right Blade for Safer, Faster, Cleaner Cuts

Whether you're cutting cherry plywood, nail-filled 2x4s, or concrete pavers, you'll work faster and safer by starting with the right blade. A good blade for day-to-day use, for cutting things like construction lumber and plywood, is a 24- to 30-tooth carbide **combination blade**. To cut into less-standard materials, you'll want these less-standard blades in your arsenal.

FINISHING BLADE. These 60- to 80-tooth blades excel at making splinter-free cuts in veneer-face plywood, laminates, and trim.

DIAMOND BLADE. These blades are ideal for cutting or scoring concrete, stone, and ceramic tile. Some have wide, square-edge teeth, while others have a continuous rim of diamond grits.

ABRASIVE BLADES. Often designated for use on either metal or concrete, these blades grind away, rather than cut through, material.

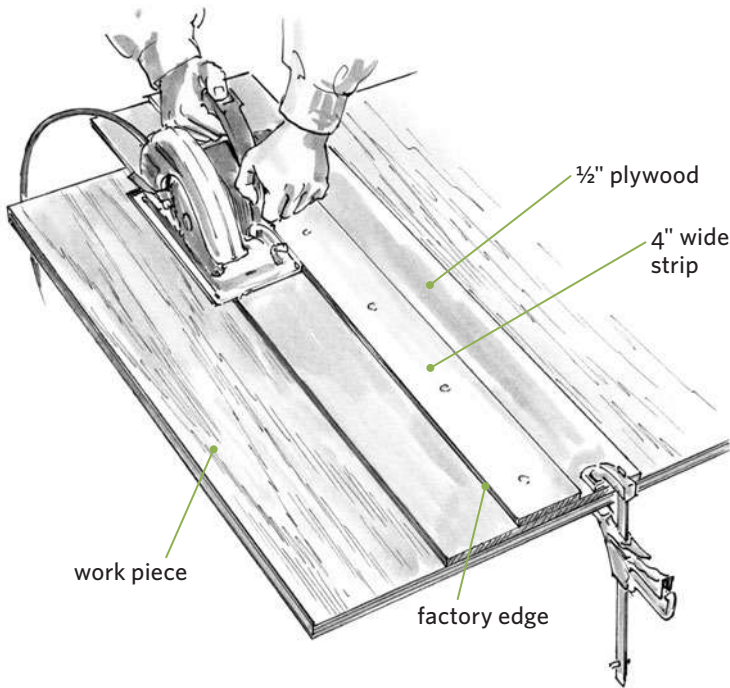

Using a straight-cutting jig

Straight-Cutting Jig

Build a straight-cutting jig for making accurate long cuts. Rip a 4"-wide strip from the factory edge of a 16"-wide piece of 1/2" plywood; then secure the 4" strip to the remaining 12" piece. Position the strip so the factory edge is oriented as shown. Run the base of your saw against the 4" strip so the blade cuts a straight edge on the lower piece. Whenever you need to make a straight cut, simply align the straight edge of the jig even with your cut line, secure the jig to your workpiece with clamps or screws, and then run the saw against the 4" factory strip. Make your jig 8 feet long so you can cut full sheets of plywood.

Angled and Beveled Cuts

To create an angled cut across the face of a board, draw the required angle and then retract the blade guard with your thumb as you guide your saw along the line. (Retract the guard by hand, since it tends to hang up and not move out of the way smoothly on angled cuts.)

To create a beveled cut, loosen the bevel-adjustment wingnut or lever and adjust the saw's base to the correct angle. Use the degree scale, which is usually near the front of the saw by the adjustment lever, to set the correct angle. Again, you'll need to manually retract the blade guard as you cut.

Dado Cuts

You can create dados (grooves across the width of a board) or rabbets (grooves along the edge or ends of a board) by making a series of shallow cuts with your circular saw, whapping the resulting fingers of remaining material sideways with a hammer to loosen them, and then using a sharp chisel to remove the waste material. See step 1 on page 186 for more information on this technique.

Plunge Cuts

To make a cut in the center of a sheet of plywood, tilt the saw onto its nose, retract the blade guard, pull the trigger, and let the saw come to full speed. Firmly lower the spinning blade into the plywood. Stay out of the projected kickback, or backward, path of the blade in case the saw jumps back toward you as you cut.

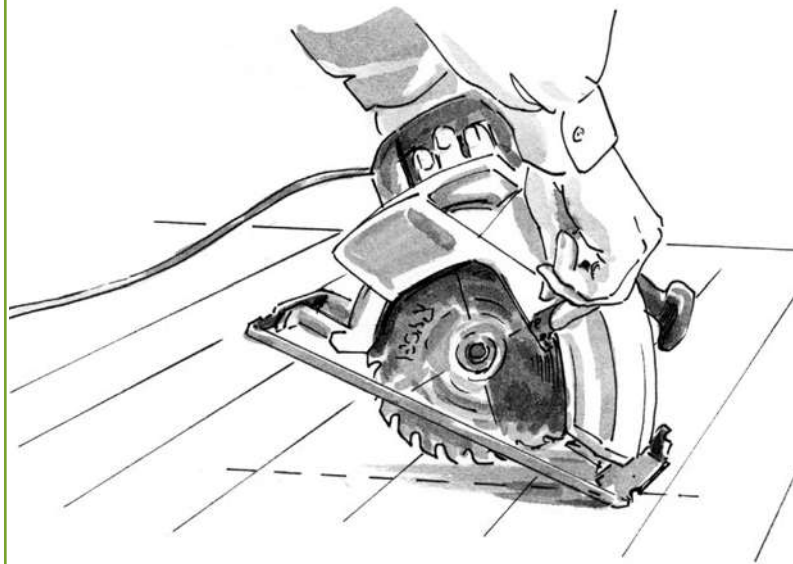

Preparing for a plunge cut

Measuring, Leveling, and Squaring

Tips for accurate, well-built projects

By making sure boards are the right length, plywood panels are the right dimensions, and things are level and square, you can make your projects go together easily and look good.

Squaring

Whether you're building a king-size shed or a pint-size seedling tray, time and again in this book you'll read the words "square things up before heading to the next step." This is critical. There are two main ways of squaring things up.

Cross-taping. This involves measuring the diagonals of a square or rectangular project or object to make sure the numbers are equal. For example, when building a frame from 1x4s, measure the diagonals and then compress the corners that form the long diagonal until the two measurements are equal. When they're equal, the frame is square.

Pythagorean theorem. This involves measuring 3 feet along one edge, measuring 4 feet along another edge, and then measuring the diagonal. If it reads 5 feet, you have a square corner. If not, adjust one leg inward or outward until the diagonal measures 5 feet.

The Art of the Batter Board

Use batter boards to lay out the perimeter of a large structure and to make sure it's square (see illustration, opposite page). Construct a batter board assembly at each of the four corners by driving three stakes into the ground and connecting them with two horizontal 1x3 boards to create an L shape. Locate the batter boards so they're outside the perimeter of your intended structure; the strings that run between them wind up mimicking the exact footprint of your planned structure. It takes some trial and error to get the stakes and boards positioned right.

This system has two advantages: (1) it allows you to slide the strings along the horizontal 1x3s in order to fine-tune your measurements and square up the project, and (2) since the batter boards are outside your project's perimeter, they allow you to leave your guide strings in place while you dig holes, set posts, or build forms.

If you screw the horizontal 1x3s to your stakes, you can easily disassemble the batter boards to use them on future projects.

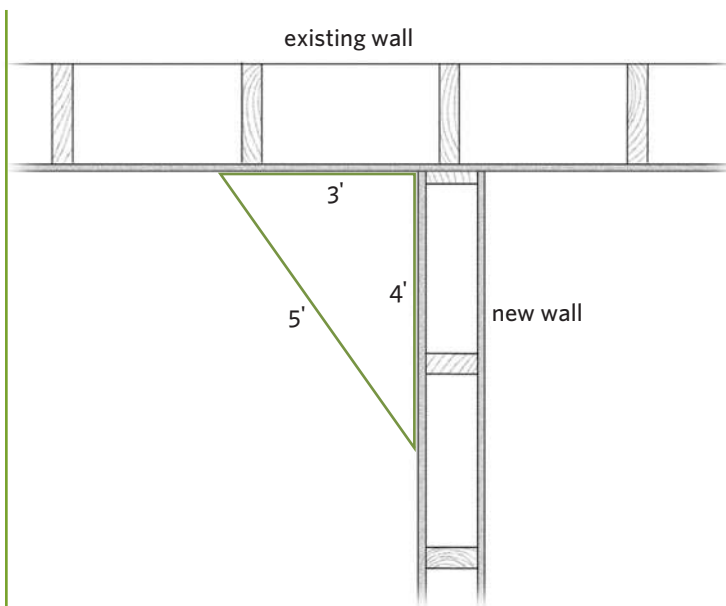

Squaring a corner with the Pythagorean theorem

Mark Your Cut Line with a V, Your Scrap Piece with an X

When marking boards to length, get in the habit of making a V (also called a crow's foot or carrot), with the tip of the V exactly on the number or fraction on your tape measure. Follow up by using a square to draw the cut line through the point of the V.

Mark the scrap side of your cut with an X so you remember on which side of the line to cut. This may not seem like a big deal, but when you're using a carbide blade, cutting to the wrong side of the line can make a board $\frac{1}{8}$ " longer or shorter than you want — and those fractions add up.

Long-Distance Leveling

On large projects, such as sheds or shelters, you'll need to level posts or forms over long distances. You have several options.

- Tape a 4-foot level to a long, straight 2×4 to create a makeshift level as long as your 2×4. This works for leveling distances of up to 16 feet. Just make sure your 2×4 is straight.
- Fill a clear hose with water to create a water level. Since water seeks its own level, the water in both upturned ends of the hose will be of equal heights. Use the water level as a reference mark for creating height marks.
- A laser level provides the most accurate results; you can purchase or rent one. Most laser levels emit a spinning beam of light you can use as a reference point for long-distance leveling.
- Hook a line level, a 2" vial in a small metal casing, to a taut mason's string or chalk line. Position the line level so it's in the center of the string to get the truest reading. This is the least accurate of the options.

Drawing a Large Arc or Circle

A drafting compass is good for creating circles and arcs of up to 5" or 6" in diameter, but for larger circles you need a different game plan: Drive a drywall screw into the centerpoint of your intended circle, and then hook the end of your tape measure over the screw. Position your pencil next to the radius measurement on your tape and draw your circle. It may take a few tries to get the swing of things, but once you have it down you can draw a circle of any size.

Marking It in Place

Sometimes the best way to measure a board is to simply mark it in place. For instance, if you're installing a piece of trim, rather than measuring, remeasuring, and marking, place an overly long piece of trim in its final resting place and mark it at the desired length. It's a mistake-proof way of getting the correct length.

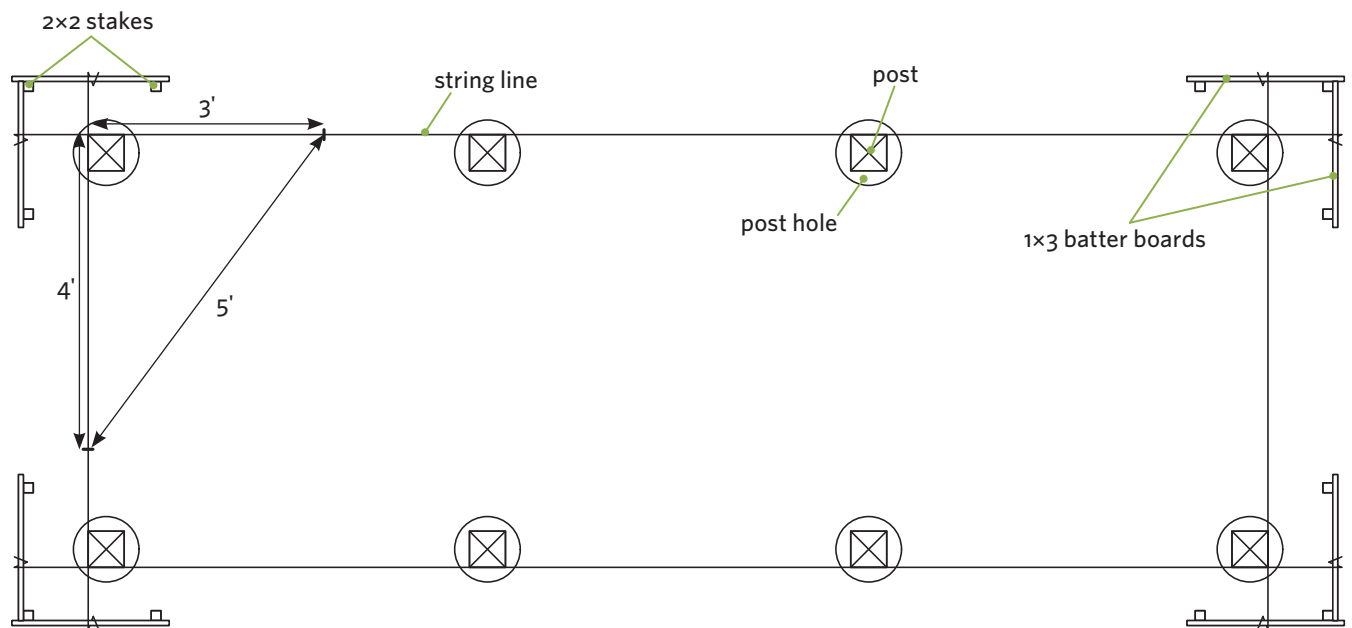

Project layout using batter boards

Paints and Finishes

The trade-offs: appearance, cost, maintenance, longevity

Paints, stains, and other finishes make a big impact on how a project looks and how long it will last. There are dozens of options encompassing a wide range of costs, application methods, and maintenance. One key in selecting a finish is to remember that the finish is sacrificial. In other

words, the finish, rather than the wood, will degrade when exposed to sunlight, moisture, and abrasion. Generally speaking, the thicker and more opaque the finish, and the more pigment it has, the better the protection it offers. But there are trade-offs.

Treated wood; the heartwood of cedar, redwood, cypress, and teak; and some other woods are naturally rot-resistant and don't require a protective finish (though finish will increase their longevity and help maintain their original coloring, depending on the finish you use). To minimize maintenance you can leave these woods unfinished, and they'll naturally weather to a silvery gray within a year or two. Here's a look at the four most commonly used outdoor finishes.

Paint. Water-based **acrylic** paints are easy to use and clean up with water. They also breathe and remain flexible over time. **Oil-based** paints soak into bare wood better than acrylics, and they smooth out easier (primarily because they take longer to dry and allow you more time to even them out). When going over previously painted surfaces, it's best to stay with the type of paint that's already on the surface. Use an appropriate primer to ensure good adhesion. Don't paint decks or other horizontal exterior surfaces, as constant scuffing and moisture quickly take their toll, and you'll be scraping and repainting your project every year or two.

Stain. Most stains are simply thinned paints. On the plus side, being thinner than paint, they penetrate bare wood better, which results in less peeling. They also allow the grain and texture of the wood to show through. On the downside, they don't offer as much protection from the elements as paint and may need to be reapplied as often as every two or three years. Solid and semisolid stains offer better coverage and protection than semitransparent versions.

Clear and translucent finishes. These finishes let the wood shine through and often impart a rich amber look; conversely, they let the sun shine through, which eventually fades and discolors the wood. You'll have to reapply the finish as often as every two or three years. Top-notch finishes (such as Sikken's) last longer than lower-quality ones, but involve a three-coat process and are very expensive. If you use a varnish or polyurethane, make certain it's formulated for exterior use.

Water sealers and repellants. Clear water repellants are economically priced and easy to apply. They make wood projects look great initially, but because of their transparency and lack of pigment, they must be reapplied frequently, sometimes as often as twice a year.

Red Barns and Big Yarns

There are lots of explanations as to why barns are traditionally painted red. One theory is that red paint was the cheapest and thus the most commonly used. Another posits that barns were painted red because it was the color most easily spotted by farmers trying to find their way home during driving snows and blizzards. And there's the story that blood from slaughtered animals, mixed with milk

and lime, created an economical paint. The most widely accepted school of thought is that the red paint pigment (ferrous oxide, also known as rust) was plentiful on the farm. Red paint could be concocted by mixing rust with linseed oil and other ingredients. Ferrous oxide was also a natural deterrent to mold, moss, and fungi.

Smart Finishing Tips

1. When you build a project with legs — whether it's a potting table, a chair, or a rabbit hutch — take an extra step to preserve the ends of the legs, which tend to soak up moisture and rot quicker than other parts of the project. Half fill a coffee can or plastic tub with your finish of choice; then set each leg in the container

and allow the end grain to soak up a super-dose of finish for a few minutes. If you're leaving the wood natural and not applying a finish, water down exterior glue (about 50/50) and brush several coats onto the bottoms of the legs to help them last longer.

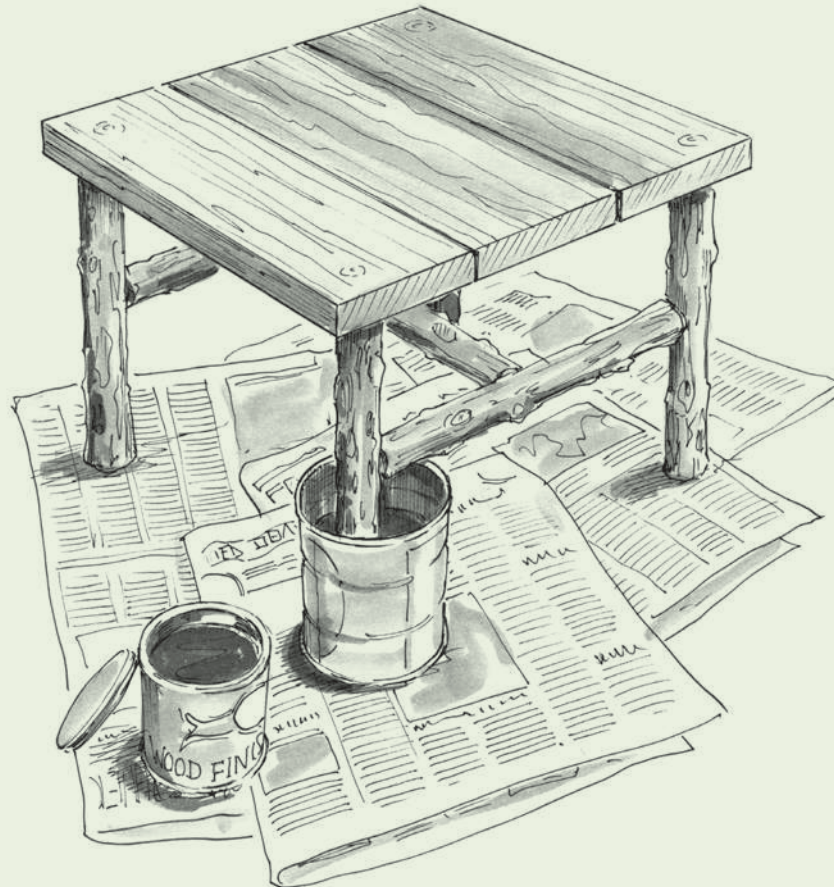

2. Before painting cedar, redwood, or pine, apply an exterior stain-blocking primer (paying special attention to the knots) to prevent tannic acids and other chemicals from bleeding through your finished paint.
3. If you're going to use your rollers and brushes the next day and prefer not to clean them, you can stick the whole works (tray, brushes, and roller) in a plastic bag to keep them fresh overnight. You can keep oil-based tools fresh by wrapping them in aluminum foil and storing them in the freezer.
4. Use high-quality brushes and rollers. They'll carry more paint from the tray or can to the surface, meaning less work for you. Treated and cleaned correctly, they'll last for years. Use a 2" angled sash brush for detailed work and a 4" standard brush for larger areas.
5. Don't follow the sun. Plan your painting day so you're not applying paint in direct sunlight or in extremely windy conditions; the paint will dry too fast, leaving lap marks.
6. When masking off surfaces with painter's tape, use the edge of a putty knife to firmly press the edges in place. You'll get less bleeding underneath the tape, yielding straighter lines.



Five Simple Plant Supports, 74

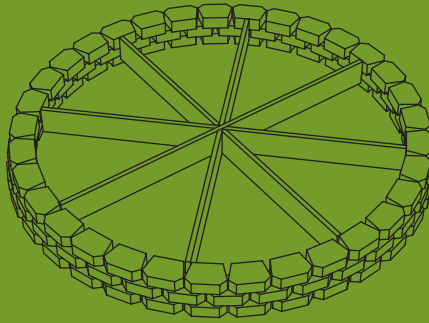

Five Raised-Bed Gardens, 69

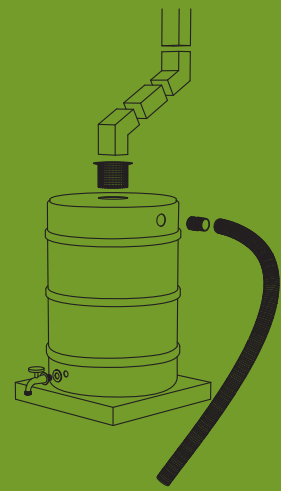

Rain Barrel Basics, 82



Hoop Greenhouse, 90

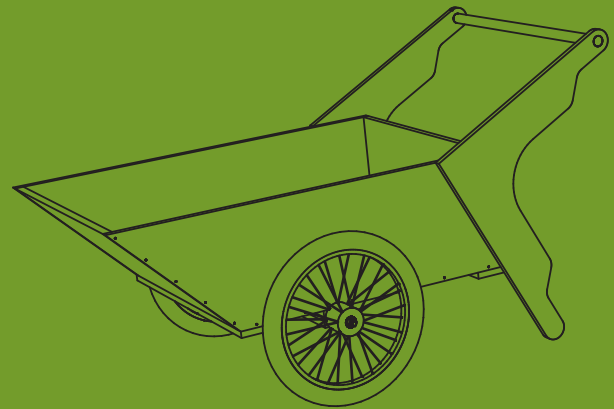

Two-Wheel Garden Cart, 36

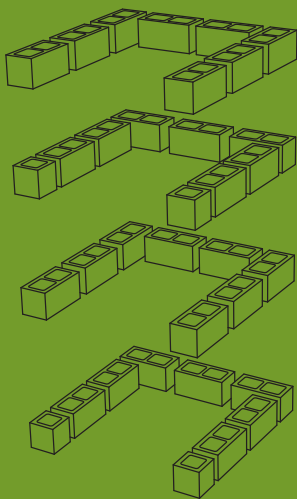

Compost Bin Trio, 44

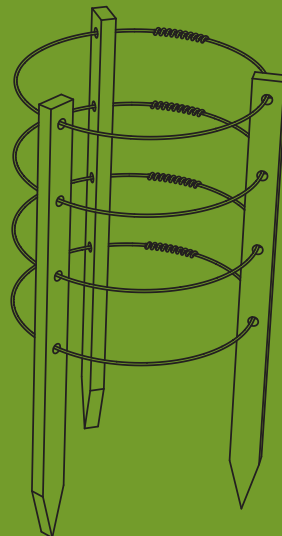

Five Simple Plant Supports, 74

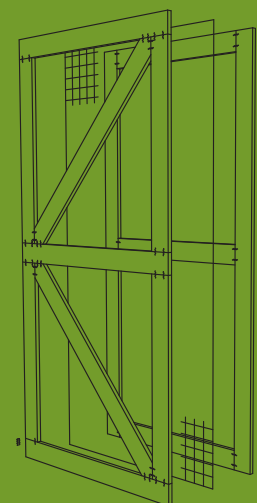

Critter-Proof Fence, 50

For the Garden

If you enjoy vegetable and fruit gardening, you've got plenty of company. A recent survey by the National Gardening Association (see Recommended Reading) shows that more than 40 million households, or about 38 percent of all folks in the United States, maintain some sort of food garden. The average garden size is about 600 square feet, and the average amount of time spent in that garden comes to about five hours per week. The most commonly grown vegetable is the good old tomato; grown in 85 percent of all gardens, it wins over the second-place finisher (cucumbers) by a landslide. Your backyard garden will help keep dollars in your pocket, too: on average, the \$70 spent for seeds and other supplies yields about \$600 worth of produce.

Whether or not you fall within the statistical norms doesn't really matter. Nor does it matter if your garden consists of a fenced-in acre or a few plants sitting in a pot on the back porch. What matters is the fresh produce you get out of your garden and the satisfaction you get from growing it.

The projects in this chapter are aimed at making your time in your garden more enjoyable and more productive. You'll find garden carts for hauling compost, cold frames for getting a head start on the growing season, and plenty of other projects for helping you grow more food with less hassle. Bon appétit.

Two-Wheel Garden Cart

A one-sheet wonder for hauling, planting, and cleaning up

Sure, you can throw 50 pounds of bone meal over one shoulder, tuck a hoe under another, and wrestle with a tray of seedlings as you teeter out to the garden – or you can build this all-purpose garden cart to make the journey *way* more convenient.

The bicycle wheels make negotiating rough terrain easy, and the plywood construction makes it sturdy, lightweight, and simple to build. The cart is well balanced, so it will stay put in both horizontal and tilt-down positions, allowing for easy loading or unloading of materials.

You can build your cart from treated plywood for greater longevity, but that material is harder to work with than standard plywood. I suggest using exterior-grade plywood, which is lighter, smoother, flatter, easier to glue, and easier to work with than treated plywood. To protect the plywood, give it a coat of primer, followed by two or three coats of exterior paint. You'll also increase longevity by storing the cart inside or covering it with a tarp when not in use.



See page 3 for a photograph of this project.

Materials

- One 4 × 8-foot sheet $\frac{3}{4}$ " exterior-grade plywood
- Two strips $\frac{1}{2}$ " exterior-grade plywood, $1\frac{1}{2}$ " × $31\frac{1}{2}$ " minimum (from sheet above)
- One piece 1" × 4" × $31\frac{1}{2}$ " pine lumber
- One $1\frac{1}{4}$ " × 33" closet rod (wood dowel)
- $\frac{1}{2}$ " × 48"-long threaded rod
- Four $\frac{1}{2}$ " fender washers
- Two 20" spoked wheels
- Two $\frac{1}{2}$ " lock nuts
- Two $\frac{1}{2}$ " cap nuts
- $1\frac{1}{4}$ " exterior screws
- 2" exterior screws
- Construction adhesive
- 8d finish nails

Parts and Cutting List

Part	Size and Material	Quantity
(A) right side	$\frac{3}{4}$ " × 14" × 48" plywood ¹	1
(B) left side	$\frac{3}{4}$ " × 14" × 48" plywood ¹	1
(C) back	$\frac{3}{4}$ " × 14" × 30" plywood	1
(D) front	$\frac{3}{4}$ " × $19\frac{3}{4}$ " × 30" plywood ²	1
(E) bottom	$\frac{3}{4}$ " × 33" × 30" plywood ²	1
(F) front brace	$\frac{3}{4}$ " × $3\frac{1}{2}$ " × $31\frac{1}{2}$ " plywood	1
(G) middle brace	$\frac{3}{4}$ " × $3\frac{1}{2}$ " × $31\frac{1}{2}$ " plywood ³	1
(H) rear brace	$\frac{3}{4}$ " × $3\frac{1}{2}$ " × $31\frac{1}{2}$ " plywood	1
(I) axle	$\frac{1}{2}$ " × 48" threaded rod	1
(J) side axle braces	$\frac{1}{2}$ " × $1\frac{1}{2}$ " × $31\frac{1}{2}$ " plywood	2
(K) wheel washers	$\frac{1}{2}$ " fender washers	4
(L) wheels	20" spoked wheels ⁴	2
(M) wheel nut	$\frac{1}{2}$ " lock nut	2
(N) axle cap	$\frac{1}{2}$ " cap nut	2
(O) outer axle brace	$\frac{3}{4}$ " × $3\frac{1}{2}$ " × $31\frac{1}{2}$ " pine	1
(P) leg/handle	$\frac{3}{4}$ " × 28" × 30" plywood	2
(Q) cross handle	$1\frac{1}{4}$ " × 33" closet rod	1

¹Ends angle-cut.

²End(s) bevel-cut at 45 degrees.

³Use oak board instead of plywood for extra strength.

⁴Wheels can be scrounged from old bikes, or purchased at bike shops or hardware retailers like Northern Tool + Equipment (see Resources).

NOTES FROM THE TEST TRACK

Cart Smarts

I've always been a wheelbarrow guy. But after using the prototype I built to haul dirt, brush, mulch, and firewood, I've become a garden cart guy.

Why? The cart is stable in any position, even when fully loaded. I can push it with one hand. I can pivot the front

down for loading and unloading everything from mulch to four neighborhood kids. (Yup, we tried it.) The large-diameter wheels make it easy to negotiate rough terrain and low steps. And because of the balance, there's much

less strain on the arms and back than with a wheelbarrow.

When hauling concrete, rocks, and other superheavy rough stuff, I'll revert to my wheelbarrow. But for everything else, I'll grab my two-wheeled wonder.

Plywood cutting diagram

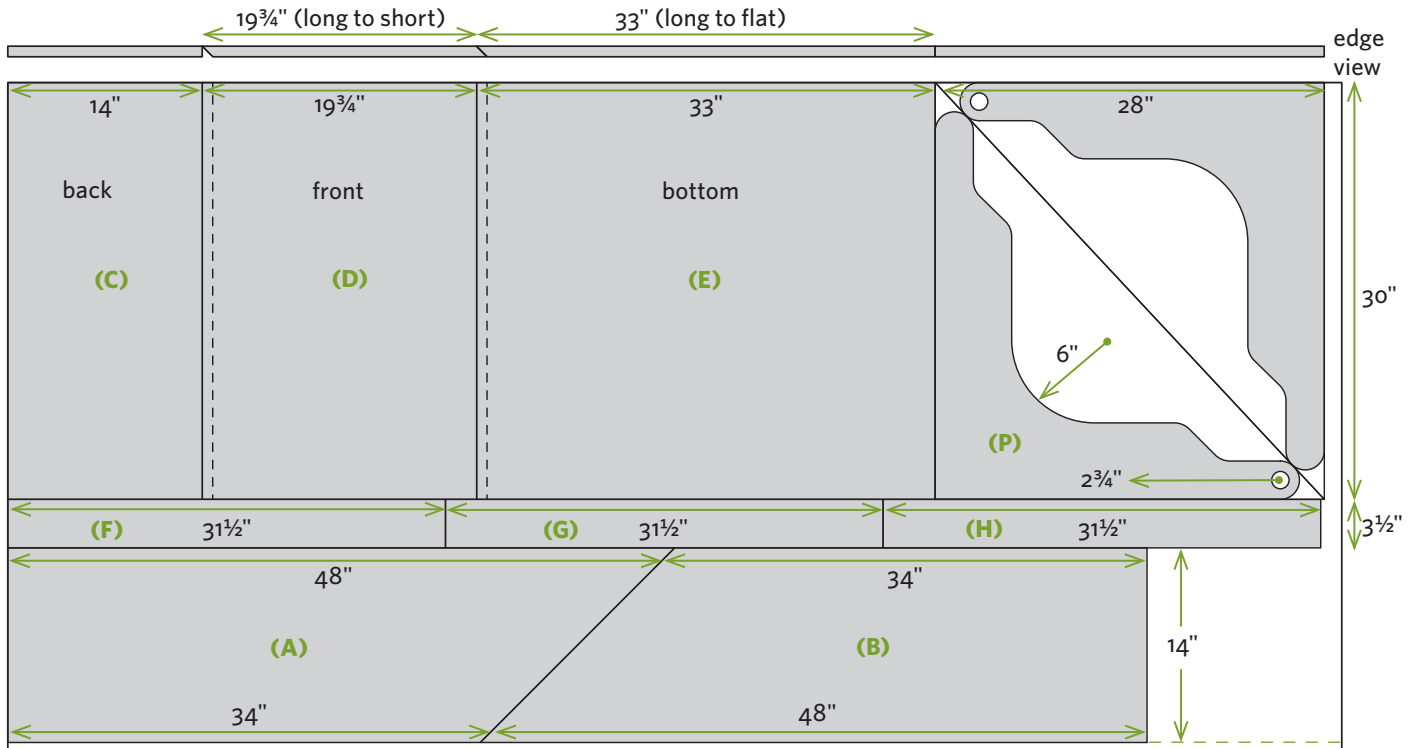

1. Lay out the plywood parts as shown in *Plywood cutting diagram*, and cut them to size using a circular saw. Cut the side axle braces (J) from $\frac{1}{2}$ " plywood. (See page 29 for information on using a straight-cutting jig for accurate cuts.)

TAKE NOTE To make the 45-degree bevel cuts on both ends of the front panel (D) and on one end of the bottom panel (E), you'll have to make a separate straight-cutting jig or make the cuts without one.

2. Drill $\frac{3}{8}$ " holes through the edges of side pieces (A, B) for the screws used to secure the back, front, and bottom.
3. Stand the side pieces facing each other (a helper comes in handy here), and install the back panel (C) using construction adhesive and 2" screws. Next, position the front panel (D), making sure the 45-degree end cuts of the panel and the 45-degree cuts on the sides are even, then install that panel using construction adhesive and 2" screws.
4. Set the box you've created on a flat surface and test-fit the bottom (E). It should be a snug fit, but trim the square end if it's too long. Apply construction adhesive on all four sides and secure the bottom to the sides, front, and back with 2" screws.

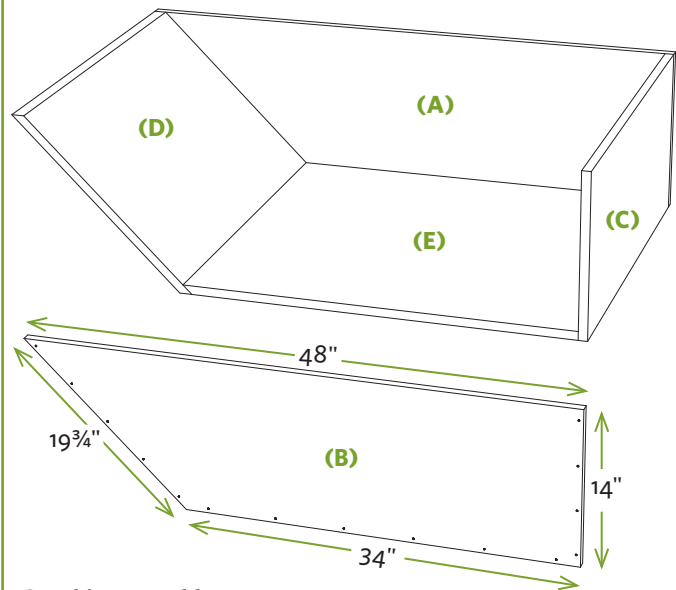

Cart bin assembly

5. Flip your cart bin upside-down. Add the three $\frac{3}{4}$ " bottom braces (F, G, H) as shown using construction adhesive and $\frac{1}{4}$ " screws. The location of the middle brace (G) is critical since it determines the location of the axle and affects the balance of the cart.

Axle assembly

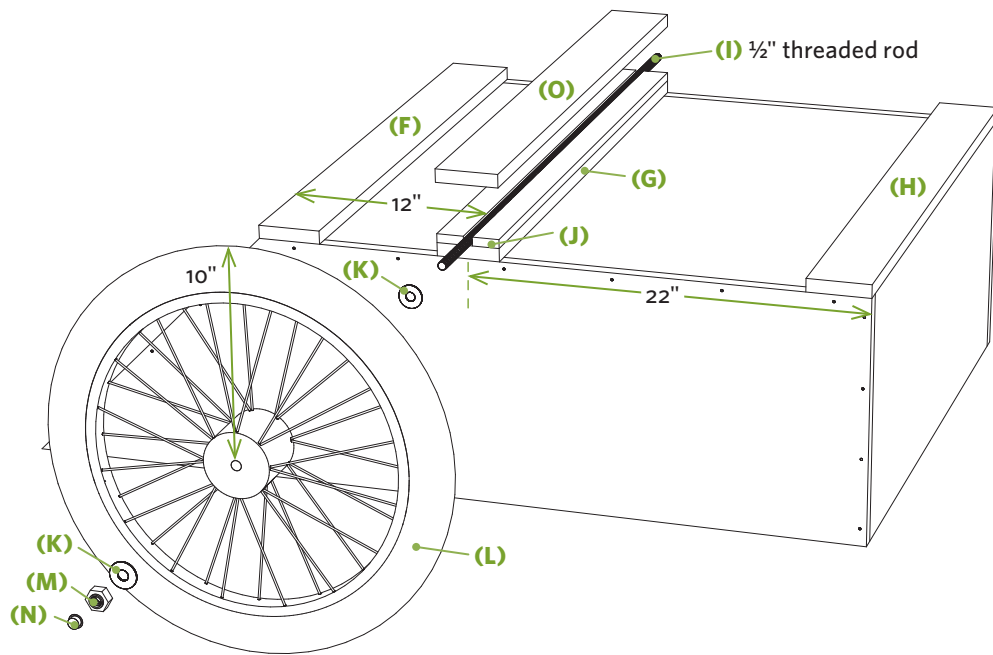

TAKE NOTE If you have chosen wheels that aren't 20", experiment with the position of the middle brace and axle location to make sure your cart tilts correctly and feels well-balanced.

6. Center the axle (I) on the middle brace (G). Install the side axle braces (J) tightly on either side of the axle, and secure them with construction adhesive and 1 $\frac{1}{4}$ " screws. Install a washer (K), wheel (L), washer (K), lock nut (M), and axle cap (N) on one end of the axle and push the wheel assembly over until it makes solid contact with the side of the cart. Determine how far the axle will extend past the other side of the cart once the wheels and hardware on that side are installed; then use a hacksaw to cut the axle to its final length. Reinstall the axle, along with all the wheels and hardware. Make sure everything fits tightly; then install the outer axle brace (O) using construction adhesive and 2" screws. For added strength, use an oak board, instead of pine, for the axle brace.

TAKE NOTE Before cutting the threaded rod to length, install a standard $\frac{1}{2}$ " nut on the threaded rod to the inside of your cutting point. After the cut is made, twist this nut off; it will reshape the threads on the rod so your lock nut will go on easier.

7. Cut out the leg/handle assemblies (P) shown in *Plywood cutting diagram* (page 38). Use a couple of screws to temporarily hold the assemblies in the position shown. Take the cart for a test spin, and see how the legs and handles feel in terms of length and angle. Adjust the angle, or cut the legs or handles shorter, based on your height and a comfortable wheeling angle. Once you find the right position, install the leg/handle pieces using screws only; after using the cart a few times to make certain it feels right, permanently install the leg/handle pieces using construction adhesive and screws.
8. Drill holes through the ends of the leg/handle to match the diameter of your closet rod, and insert the cross handle (Q). Pin each end of the dowel to the handle with 8d finish nails.

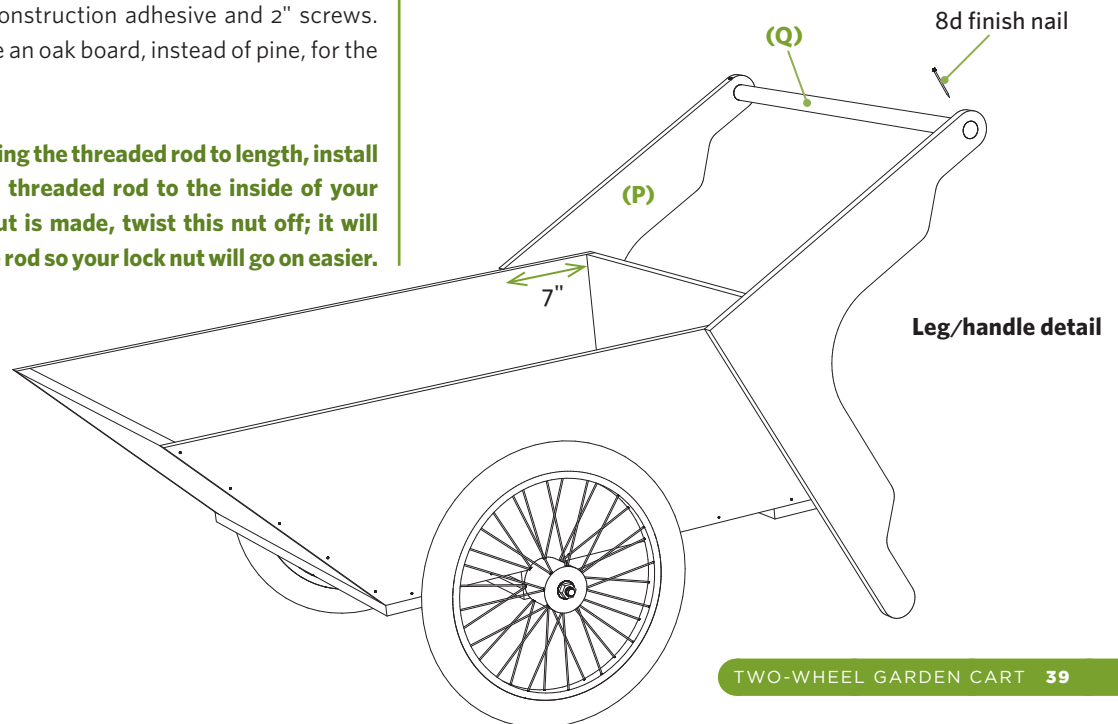

Cold Frame

Big, simple, and cheap

One complaint you often hear about cold frames is “Mine’s not big enough.” Well, you can’t say that about this one. It utilizes a cast-off storm door for the glazing and provides nearly 20 square feet of planting room.

This design is based around a standard aluminum storm door – the type that’s mounted in a frame – but the details are easy to modify to accommodate other types of doors or casement, slide-by, double-hung, or storm windows.

Most storm doors are made to fit 32” × 80” or 36” × 80” entry doors. Since sizes can vary, I don’t provide exact dimensions here. Measure your storm door frame – outside edge to outside edge in both directions – and build your cold frame based on those measurements. Your goal is to have the outside edges of the storm door frame flush, or even, with the outside edges of the cold frame box.

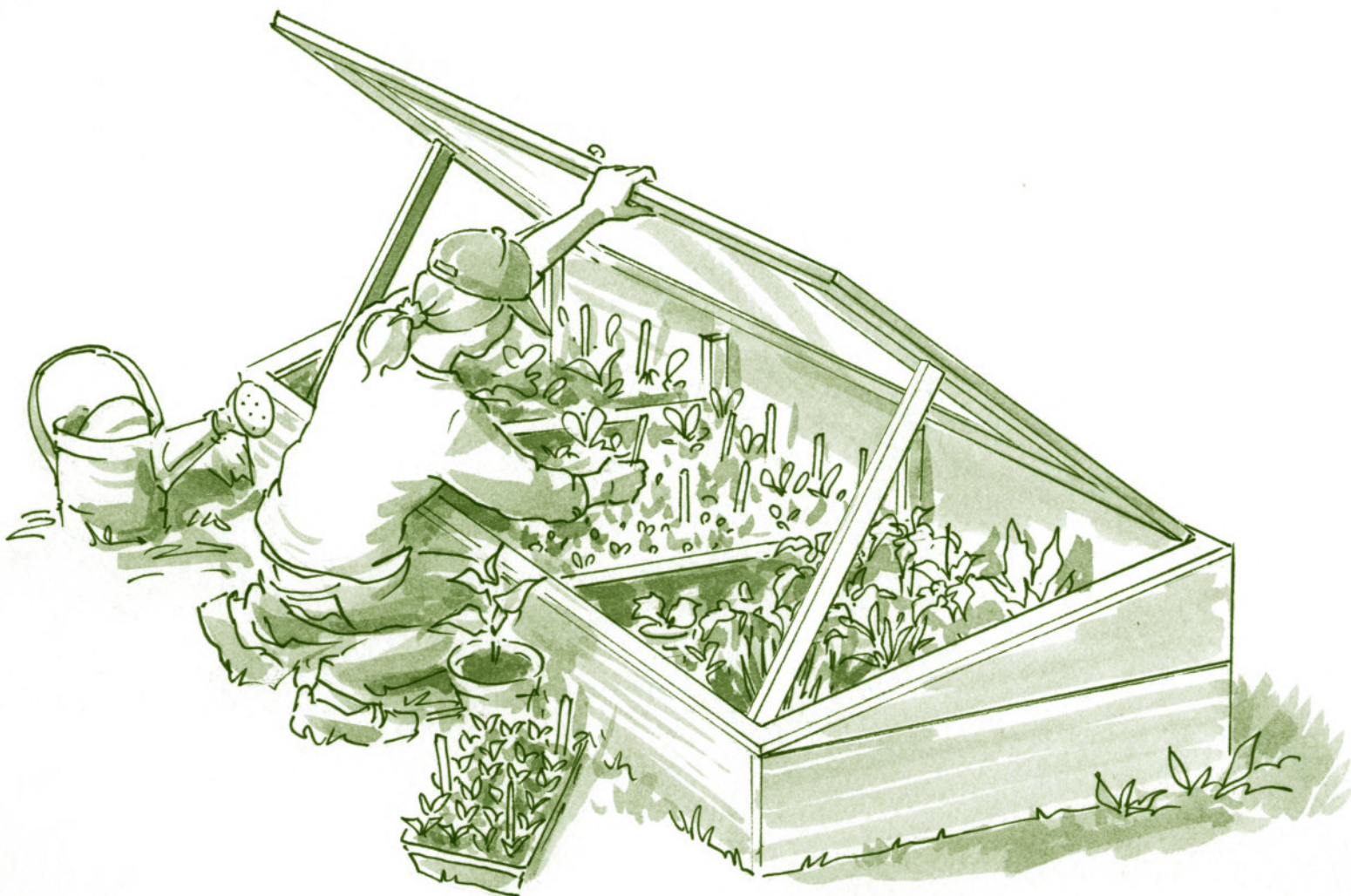

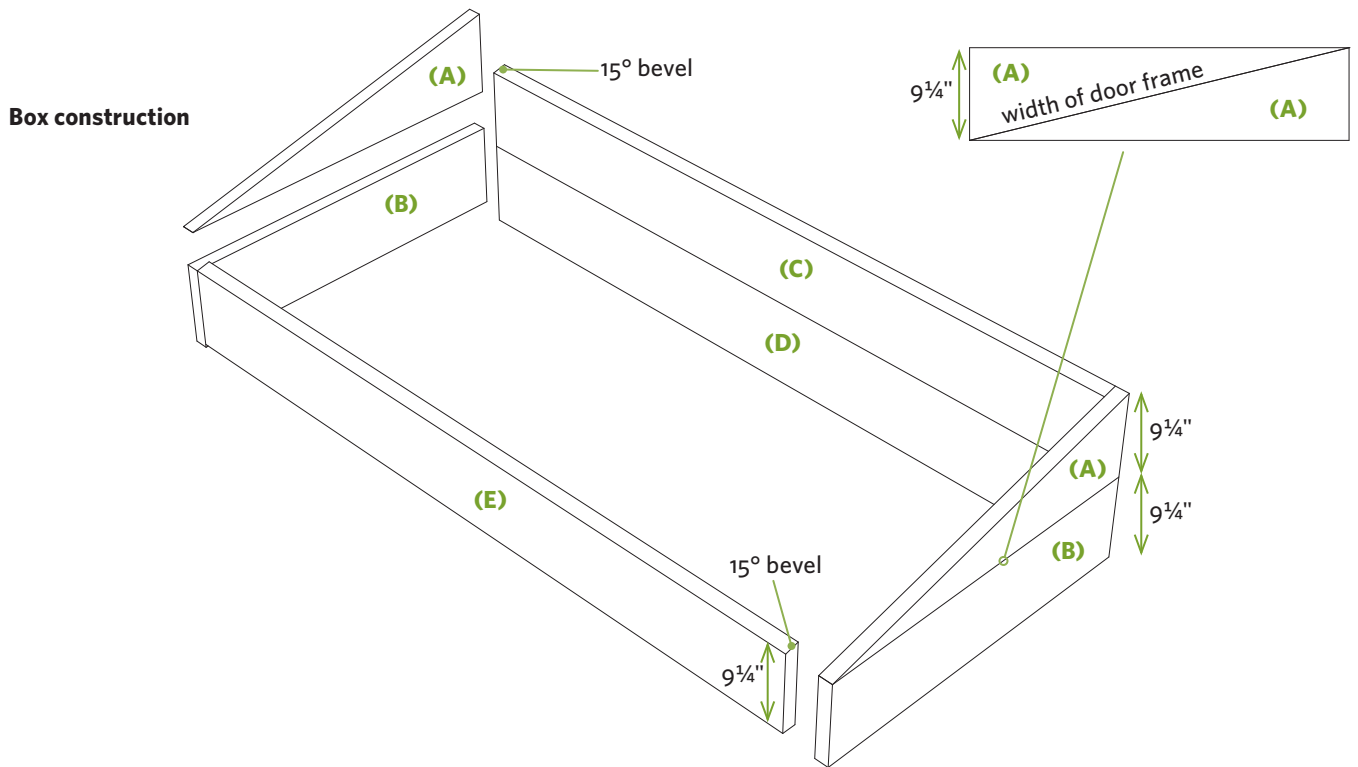

Materials*

- Three 10-foot pressure-treated 2×10s
- One 6-foot pressure-treated 2×10
- Three 8-foot pressure-treated 2×2s
- 32" or 36" storm door
- 16d galvanized nails
- 3" and 4" galvanized screws

*All lumber should be pressure-treated material rated for ground contact.

1. To create the sloped sides (A) of the box, start by marking a diagonal line that equals the width of the storm door frame, on a 2×10 (see drawing detail). Cut the angle using a circular saw and straight-cutting jig (see page 29).
2. Cut the lower side pieces (B) to length. Use a few nails to tack parts A and B together; you'll make more secure connections using 2×2 cleats later on.

Cold Frame Whens, Wheres, Hows, and Whys

When you use your cold frame, as well as where you position it and how long you use it, are all based on growing zone, what you plant, and what your goals are:

- In most areas, you'll gain four to eight weeks of growing time by using a cold frame to start plants and harden off seedlings.
- The ideal temperature in a cold frame is 65 to 75°F during the day and 55 to 65°F in the evening. Keep a cheap thermometer in the box (preferably out of direct sunlight) so you can monitor temperature. To release heat on a sunny day, prop open the door slightly (or open one of the sliding windows). If a freeze is forecast, cover the box with a quilt, leaves, or hay.
- Some plants thrive in a cold frame environment; others die. For more information, look online or consult a good guide on the subject, such as *Building & Using Cold Frames* (see Recommended Reading).
- For maximum sun exposure, orient your cold frame facing south. Some people paint the inside of the cold frame white to reflect more sun and prevent seedlings from overreaching in one direction.
- A cold frame helps keep moisture within the confines of the box, but it also prevents rain from getting in. Monitor the moisture content.

Cold frame assembly

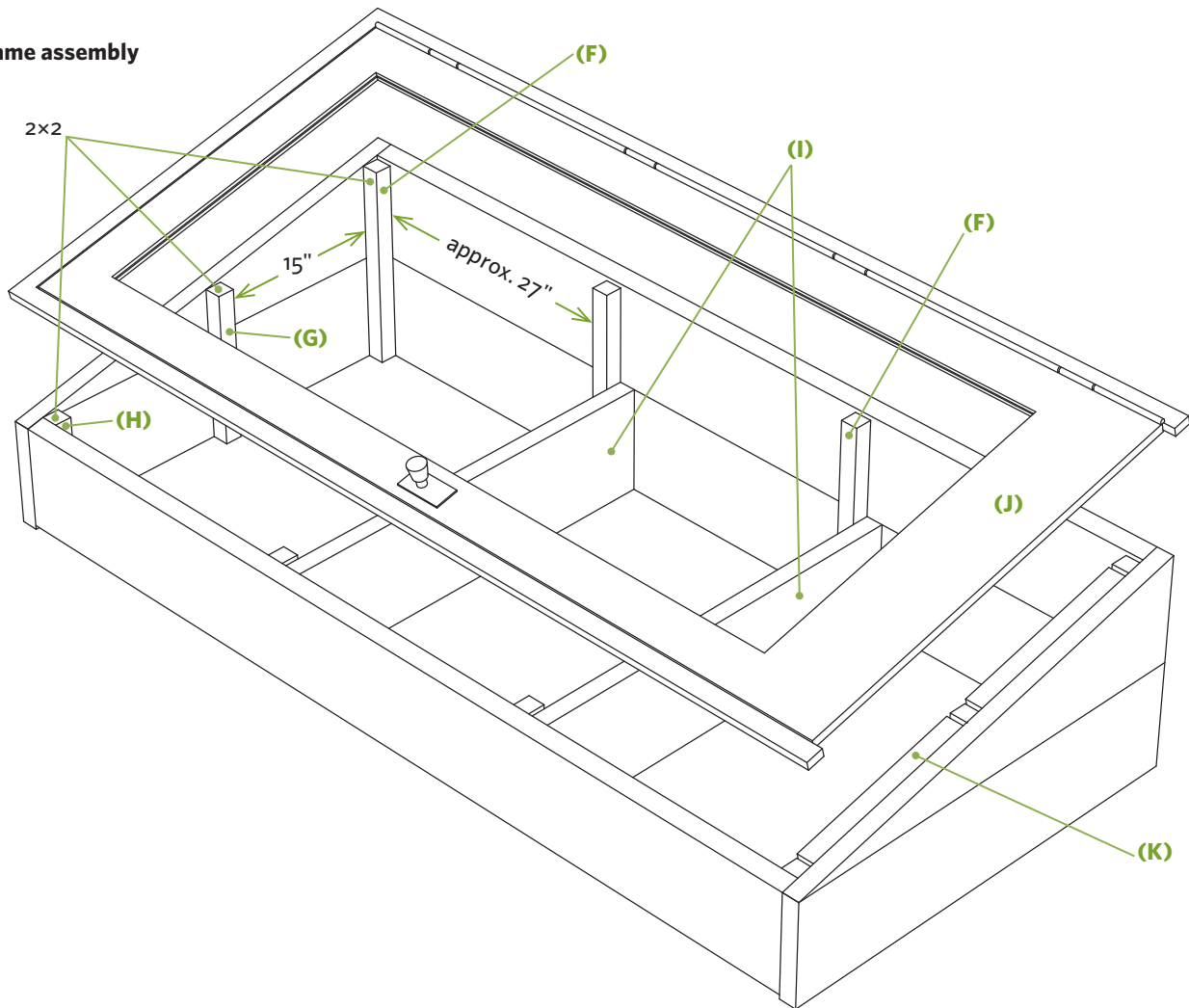

3. Set your circular saw to cut a 15-degree bevel. Rip the edge from a 2x10 for the top board for the back of the box (C). Use the straight-cutting jig or table saw for a straight, accurate cut. Cut the lower back piece (D) to length and tack it to C with a few nails. With your saw set at 15 degrees, rip the angle on the top of the front board (E).
4. Use 4" galvanized screws to assemble the box as shown in *Box construction* (page 41). Take care to align the tops of angled ends (A) with the tops of the beveled front (E) and back (C) to create a flat plane for your storm door frame. It's okay for your frame to be uneven at the bottom, but not on the top where the storm door frame rests.
5. Cut the 2x2 cleats (F, G, H) to the lengths needed for them to join the boards they connect. Secure them to the corners and all sides of the box with 3" screws as shown. Space the cleats along the front and back so they're directly across from one another.

6. Cut the intermediate dividers (I) to fit snugly between the front and back of the box, using the 6-foot 2x10. Install the dividers by fastening them to the sides of the 2x2 cleats.
7. Position and level the cold frame box. You can dig it into the ground a few inches or let it sit directly on the ground. Measure the diagonals to make sure the box is square, and adjust the box as needed. With the assistance of a helper, set the storm door (J) in place. Make any necessary adjustments to ensure that the door opens and closes properly; then screw the door frame to the frame of the cold frame box.

TAKE NOTE The top and sides of the door are supported by the door frame, but the bottom is not; screw a pair of 2x2s (K) to the cold frame box to support it.

Safety, Safety, Safety

Whenever you use something like a storm door in a novel way, safety becomes a concern. Storm doors were created to stand upright, not lie horizontally, so keep the following safety issues in mind.

GLAZING. The glass in most storm doors is single strength (to keep the weight down) and untempered (to keep the cost down). If you live in an area subject to hail, if the cold frame is near trees that drop branches or nuts, or if it's in an area where there's lots of activity, consider replacing the glass with Plexiglas. You may also want to cut a piece of Styrofoam and keep it on hand to secure over the door in the event of an impending hailstorm or hard freeze.

DOOR STABILITY. A gust of wind can catch a partially open door and swing it back with great force. Use limiting

chains to prevent this. Make sure they're long enough to allow you to open the door far enough to work comfortably and safely. And use a pair of stout 2x2s (one on each end) to keep the door propped open while you're working.

PINCHED FINGERS. The door is heavy and the edges are sharp. Prop the door up solidly when working in the cold frame. You can also install a pair of piston closers (one on each end) and use the opening clips on the closer rods to hold the door open.

CURIOUS KIDS. Teach your kids that a cold frame isn't a playhouse, doghouse, or plaything. Unless they're working alongside you, kids should stay clear of cold frames.

LESSONS FROM THE HOMESTEAD

Cold Frame and Careful Moments

BY MICHAEL PERRY

Adapted from *Coop: A Family, a Farm, and the Pursuit of One Good Egg*

Unseasonably warm weather arrives and the bare ground reminds me that I have promised my wife, Anneliese, I will make a cold frame for the garden. I wander around the sheds rustling up scrap lumber and an old storm window, a box of drywall screws, and two rusty hinges. In about 20 minutes I clatter together what could pass for the junior high shop project of a three-fingered monkey, but then I cut myself some slack and declare it evocative of a sculpture I once stumbled across in a stairwell in New York City. My 8-year-old daughter, Amy, and I scratch up a patch of ground near the spot where Anneliese's mother had last year's garden, and then we plant lettuce, radishes, carrots, and some parsley.

A few days later I find the glass lid of the cold frame smashed. I suspect Fritz the Dog. He was nosing around earlier. Fortunately I have a fair collection of old storm windows, so I gather the broken glass, install a replacement, and prop it open again. When I see him lurking in the same spot again later, this time with a chewy dog treat in his jaws, I holler at him and shoo him away. But when the day cools and I go to lower the lid, all the dirt and most of the seedlings have been scraped into a mound in one corner. I realize now he's been looking for a soft patch of dirt to bury his treasures — I'll lay odds there's a dog treat under that mound of dirt. The dog is nowhere to be found, so I can do him no harm, but I'm

ashamed to say I storm into the house and slam the door and say something very loud and forbidden. I can't defend my rage, but it is tied to the fact that in the midst of all that has been going on, and all my absences, that little plot of dirt with its sprouts was a tangible manifestation of some careful moments spent with Amy. I don't care about the stupid plants, but I care what it meant to kneel down there with my daughter. Later, when I have cooled down some, I go back out and notice the dog has missed about six radish sprouts. I lower the lid and figure maybe they've got a shot.

MICHAEL PERRY — author, humorist, singer/songwriter, and amateur pig farmer — lives in northern Wisconsin. He is the author of *Population: 485* — Meeting Your Neighbors One Siren at a Time and *Truck: A Love Story*. His most recent book, *Visiting Tom*, features Mike's 82-year-old cannon-shooting neighbor (see Resources for more information).

Compost Bin Trio

Three projects for turning trash into treasure — or at least good, rich soil

Compost is one of those win-win scenarios Mother Nature hands us; it allows us to get rid of kitchen, yard, and garden waste while creating rich organic matter for the garden.

Here we'll show you three different compost bins for three different situations. Feel free to modify these designs as needed, but bear in mind that

the optimum size for a compost pile is somewhere between 3 × 3 feet and 5 × 5 feet. Smaller, and your pile may not heat up adequately for efficient decomposition; larger, and not only will your pile be harder to turn, but air will have difficulty reaching the center material, resulting in less-efficient composting.

Bin #1: Simple and Portable

This compost bin can be built to be portable or staked to the ground for a more permanent installation. You can adjust the suggested dimensions; just keep in mind the optimum size for compost bins mentioned earlier.

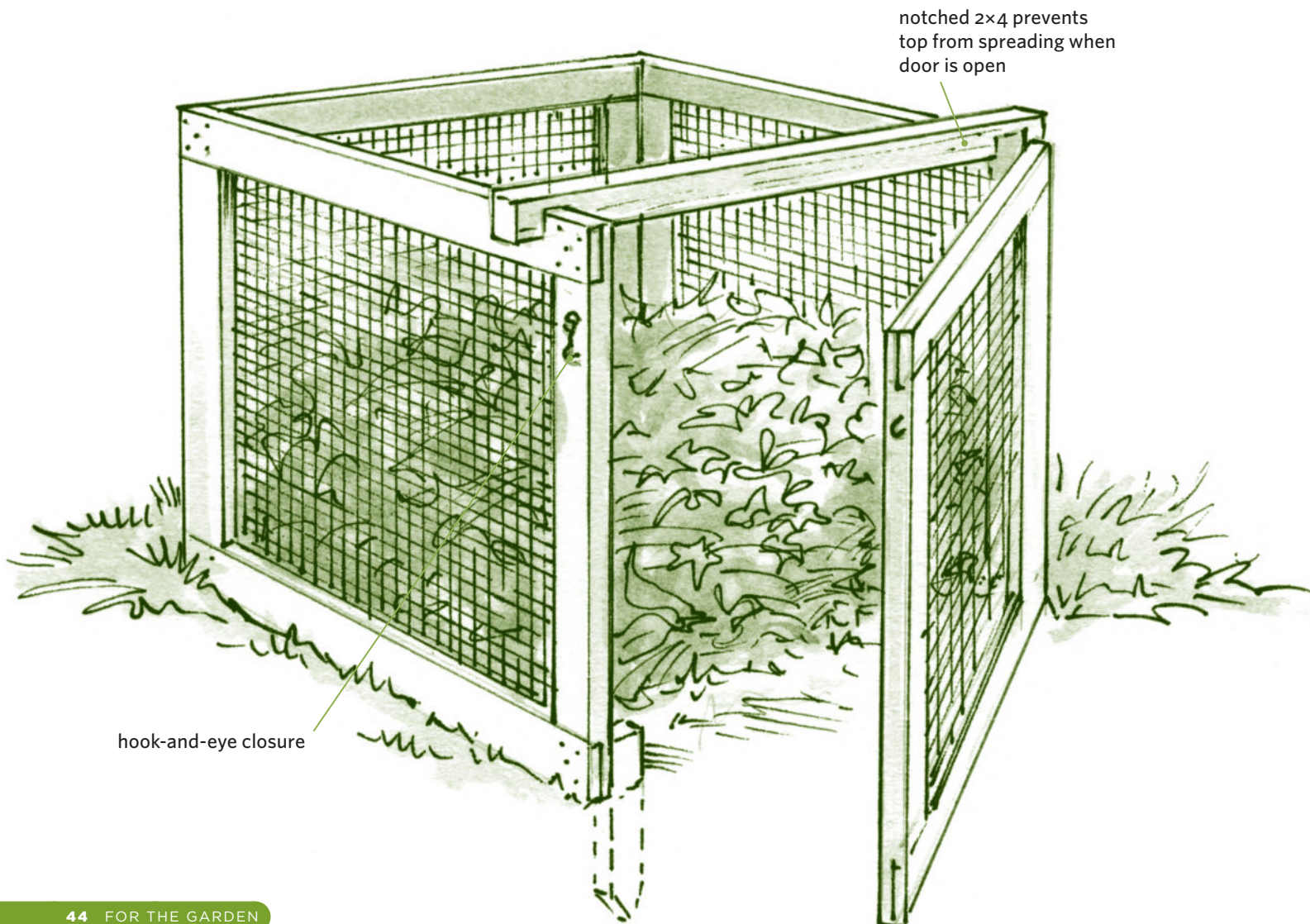

Materials

- Four 14-foot pressure-treated 2×4s
 - One 5-foot pressure-treated 2×4
 - Sixteen linear feet $\frac{1}{2}$ " galvanized hardware cloth, 36" wide
 - Two 3" hinges with screws
 - Two hook-and-eye latches
 - $1\frac{1}{4}$ " exterior screws
 - 3" exterior screws
 - $1\frac{1}{4}$ " fence staples
1. Cut each 14-foot 2×4 into two 36" pieces and two 48" pieces; you'll have 16 boards total.
 2. Make a mark $3\frac{1}{2}$ " in from each end of each board. (That means 32 ends!) Set your circular saw to cut at a depth of $\frac{3}{4}$ ", and then make a series of cuts about $\frac{1}{2}$ " apart on both ends of all the boards. Use a chisel to remove the material to create half-lap joints on each end.

TAKE NOTE Speed things up by positioning several boards side by side, lining up the ends, and then making your series of cuts across the ends of all the boards at the same time.

3. Build each of the 3×4-foot side panels. Apply construction adhesive to the half-lap joints, overlap the ends of the boards to assemble the joints, and fasten the joints with $1\frac{1}{4}$ " screws. Make sure each panel is square before driving the screws.
4. Cut the hardware cloth to size, and then use fence staples to secure it to one side of each panel.
5. To create the sides of the bin, secure three of the panels together at the corners using 3" screws. Install the door using the two hinges, and then install the two hook-and-eye latches.

TAKE NOTE For a more permanent installation, pound stakes into the ground at the corners.

6. Cut the spreader bar. Notch the 5-foot 2×4 so it fits over the tops of the side panels. This piece prevents the sides from spreading apart when the door is open.

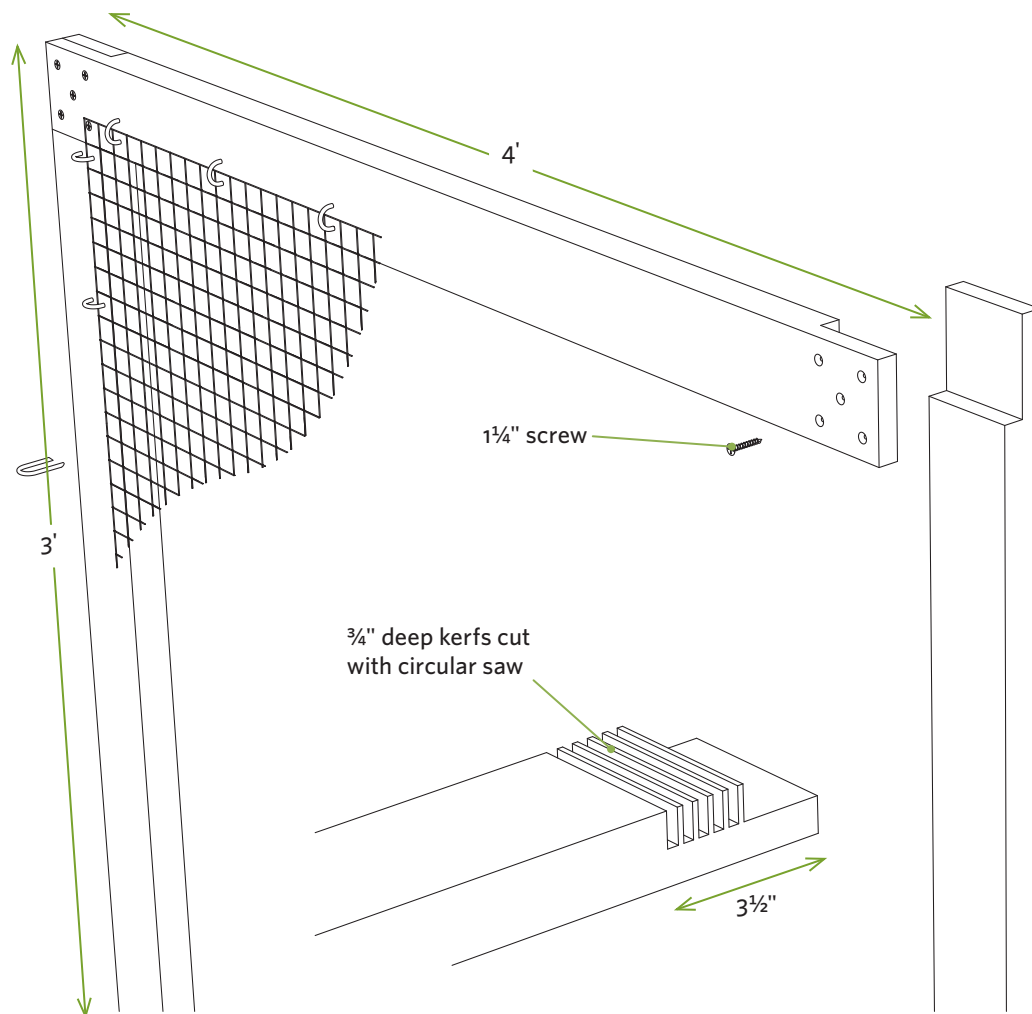

Panel construction

Bin #2: Rock-Solid and Maintenance-Free

If you want a compost bin that's solid and easy to maintain, build this version out of modular concrete block (standard "cinder" blocks used for building walls and so on). It'll never rot, and you can even plant flowers, herbs, or veggies in the open cores on the tops of the blocks.

Materials

- **Thirty 8" × 8" × 16" concrete blocks¹**
- **Four 8" × 8" half concrete blocks**
- **Four 1-pint tubes concrete block adhesive**
- **½ cubic yard compactible base material (see step 1)**

¹Concrete block measures slightly smaller than its nominal dimensions; dimensions shown in project drawings are approximate.

1. Dig a U-shaped trench about 12" deep and about 60" long on each side of the bin area. Fill the trench with 8" of compactable base material (such as Class 5 gravel). Use a hand tamper to pack down the material, checking with a 4-foot level as you work to create a flat, level base.
2. Install the first row of blocks, leaving gaps as shown. Add about 4" of soil to the trench to help lock the first row of blocks in place.
3. Apply concrete block adhesive to the tops of the first row of blocks, and then install the second row of blocks as shown.

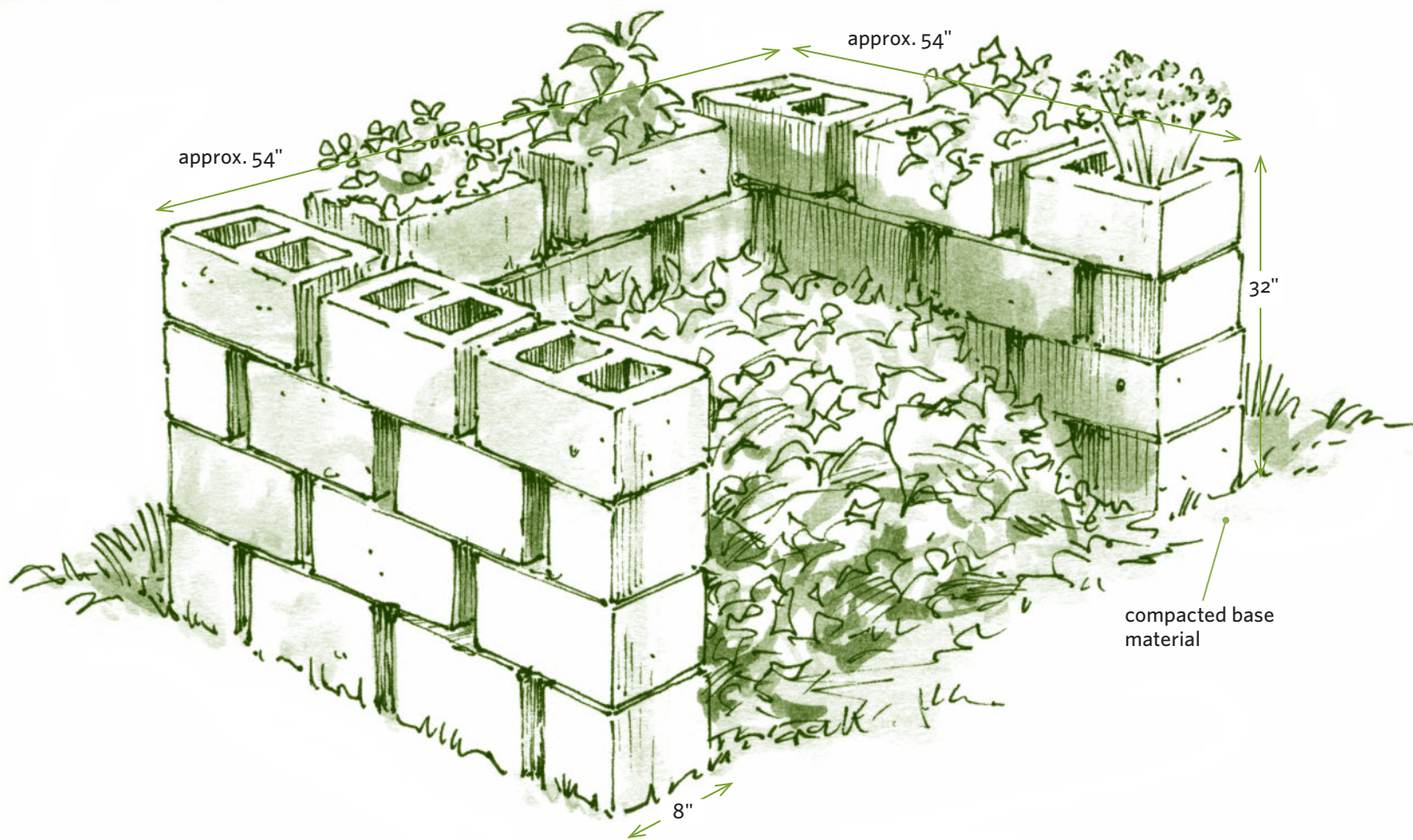

- Install the third row of blocks with construction adhesive, using the same spacing you used for row 1.
- Install the fourth and final row with adhesive, following the same spacing you used for row 2. Let the adhesive cure as directed.

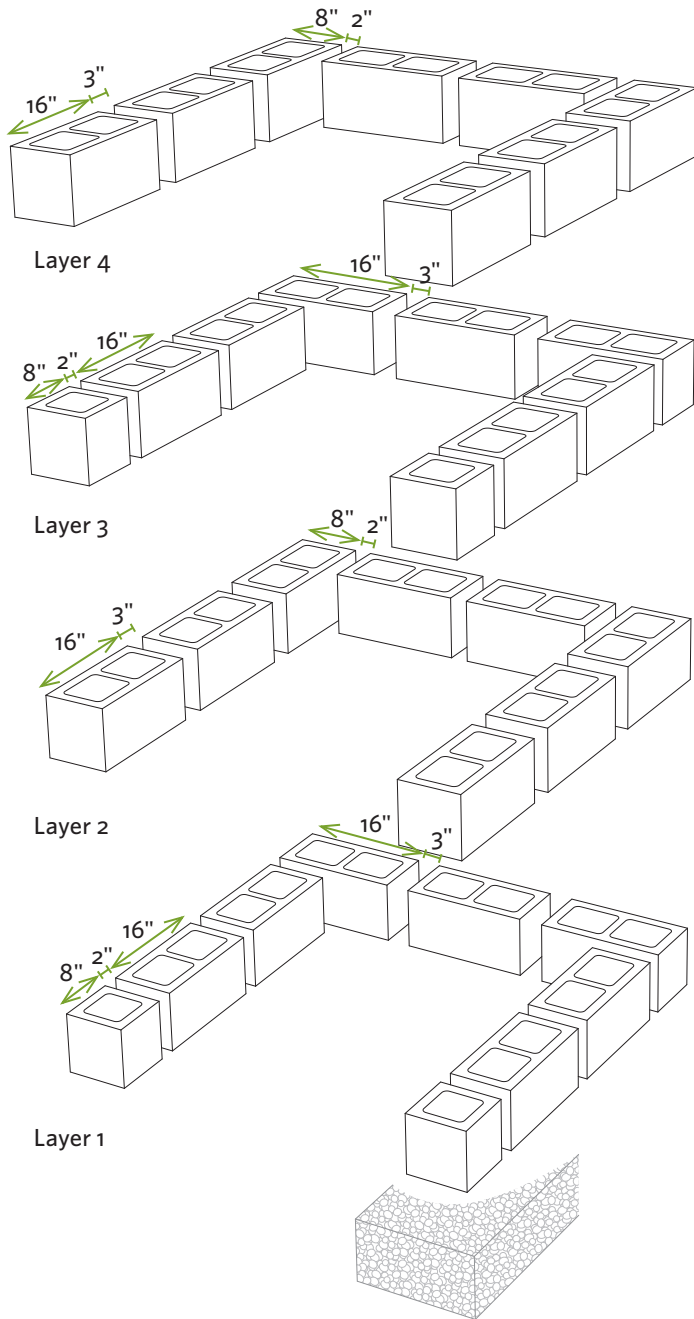

Bin construction with block spacing

Compost Yeas, Maybes, and Nays

Anything organic will eventually decompose, but that doesn't mean anything and everything is fodder for your compost bin. Some items take too long to decompose, others contain harmful pathogens, and still others can smell bad or attract pests. Here's a list of yeas, maybes, and nays (see Resources for more information):

YEA

You can add the following material to your compost bins in unlimited quantities. Alternate layers of different materials for efficient composting:

- straw
- shredded paper (nonglossy)
- fruit
- fresh and dried garden debris
- fresh and dried leaves and grass clippings
- coffee grounds
- crushed eggshells
- manure
- blood and bone meal

MAYBE

Most of these items are slow to decompose or can negatively alter the balance of the compost. In most cases they can be used if chopped into small pieces, applied in thin layers, or mixed with other materials:

- wood chips
- wood ash
- sawdust
- corncobs and stalks
- lime
- pinecones and pine needles
- walnut and rhubarb leaves

NAY

These items are slow to decompose, create odors, attract pests, or throw off the balance of the compost pile:

- bones
- dairy products
- meat and fish scraps
- oils and oily foods
- pet and human waste
- pernicious weeds and weeds that have gone to seed

Bin #3: Expandable and Flexible

If you want a compost bin that will last for years and provide flexibility, build this three-bin model. It will allow you to keep three batches of compost brewing at various stages of readiness. Once you have your eight posts in place, you can fill in the blanks with either screen panels or slats. Screen panels allow for more air circulation, while slats provide better side support for heavier compost.

The bins are constructed to allow you to deposit or withdraw materials from any side by sliding the panels or slats up and out of the way. This feature also helps you move compost material from one bin to the other. Each bin measures about 4 × 4 × 3 feet. Adjust the size and number of bins according to your needs. Follow the given dimensions exactly if you want all your screen panels and slats to be the same size and thus easily interchangeable.

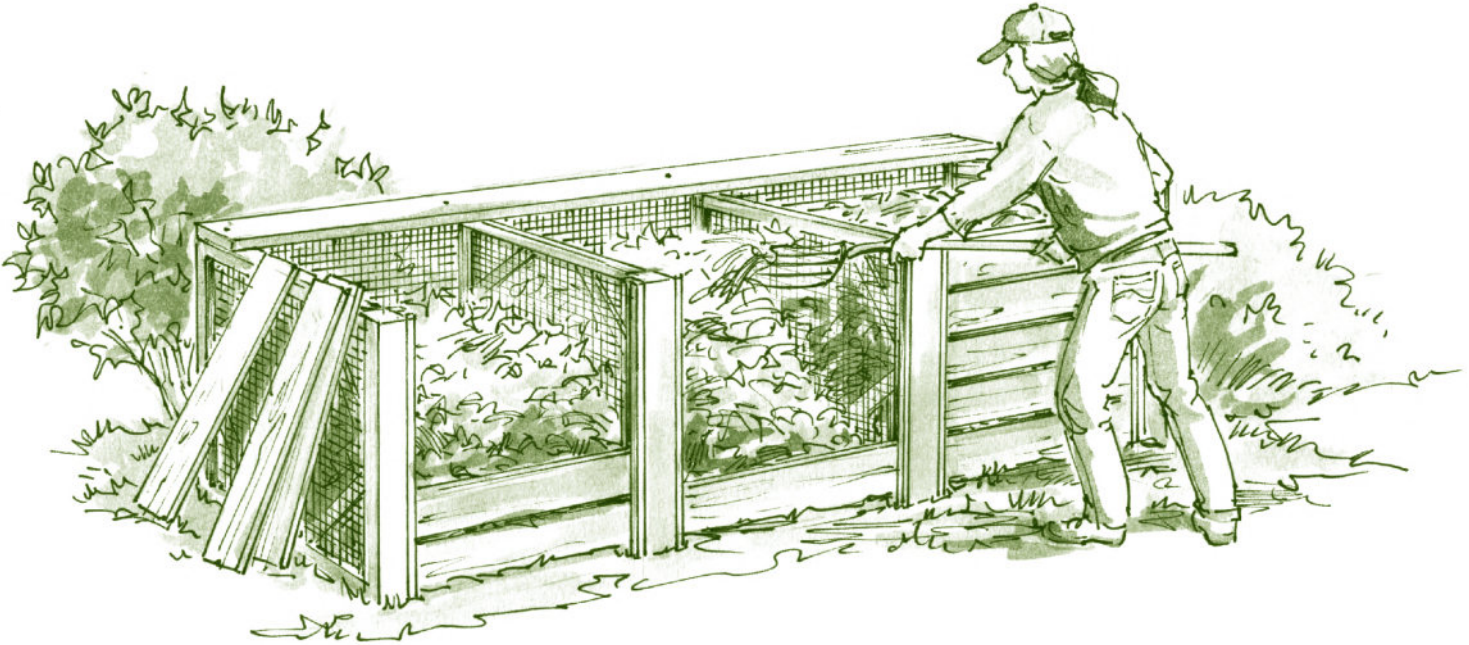

Materials

- Eight 6-foot pressure-treated 4×4s
- Two 8-foot pressure-treated 2×2s (per screen panel section)
- Six 5/4 × 6 × 41" pressure-treated decking boards (per slat section)
- Forty 1" × 1" × 36" pressure-treated lumber
- Eight 60-pound bags concrete mix
- Four linear feet 1/2" galvanized hardware cloth, 36" wide (per screen panel)
- 6d galvanized nails
- 1 1/4" fence staples
- 10d galvanized nails

Parts and Cutting List

Part	Size and Material	Quantity
FRAMEWORK		
uprights	3 1/2" × 3 1/2" × 72" (4×4) post	8
panel channels	1" × 1" × 36" PT pine	40
SLATTED SECTION		
slats	1" (approx.) × 5 1/2" × 41" PT pine	6 per panel
spacers	1/2" × 3/4" × 3" PT pine	10 per panel
SCREEN PANELS		
horizontal members	1 1/2" × 1 1/2" × 41" (2×2) PT pine	2 per panel
vertical members	1 1/2" × 1 1/2" × 33" (2×2) PT pine	2 per panel
panel screen	1/2" × 36" × 41"	1 per panel

TAKE NOTE Before doing anything, call 811, the "Call Before You Dig" hotline, to have all utility lines marked on your property (see page 26).

1. Use string or rope to lay out the grid work for the postholes. For accuracy, use the batter board system shown on page 31. Dig a 2- to 3-foot-deep hole for each 4x4 post.
2. Position each 4x4 in a hole and use stakes and scraps of lumber to brace them vertically. When all the posts are positioned, measure the spacing and adjust the posts in the holes as necessary. Mix one bag of concrete per post and dump it into the hole. Remove the braces once the concrete has set. Backfill the holes with dirt.
3. Use a table saw or straight-cutting jig to cut 1"-wide strips from 5/4x6 decking materials (they'll be approximately 1" square). Nail pairs of these strips on two sides of each corner post and to three sides of each intermediate post to create channels as shown. Make sure the channels are over 1 1/2" wide so the screen panels or slats will easily slide in and out.

4. Build the screen panels from 2x2s and hardware cloth as shown, or cut the slats and slide them into the channels. Cut the small spacers from scrap material and insert them between the slats; they can be glued to the tops of the slats or simply left loose.

Location, Location, Location

One thing that can make or break the success of a compost bin is location. If your bin is located too far from the action, you'll be less likely to make deposits and withdrawals, so select an area that's close enough for convenience but doesn't interfere with day-to-day activities. When scouting for a good location, look for:

- A level area that has soil with good drainage
- An area out of the path of direct sunlight and strong winds; both can dry the pile too quickly (a half-day of direct sun is ideal)
- An area away from direct contact with wood buildings, fences, and trees (compost will accelerate decay)

Post layout and bin construction

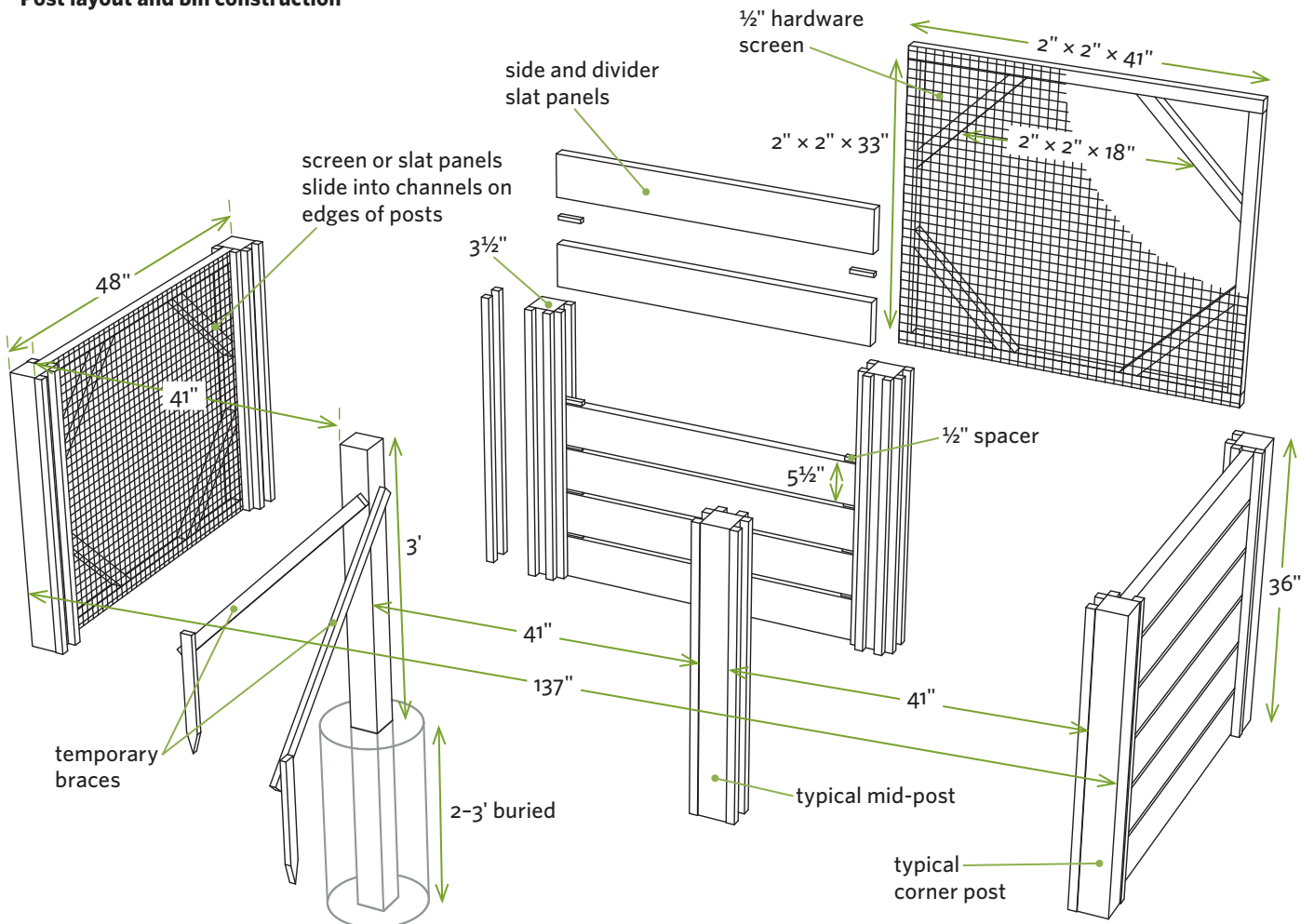

Critter-Proof Fence

Tall, sturdy, and attractive

You're not the only one who enjoys the fruits and vegetables of your labor. Deer, rabbits, raccoons, and other critters love to share in the bounty, too.

This critter-proof fence is tall enough to prevent deer from jumping over it, deep enough to keep rabbits and other burrowers from digging under it,

and sturdy enough to handle most anything nature throws at it. If you don't need all the modes of protection, just use the parts that make sense. You can also customize this project by adding a shadow box fence panel or two (see page 54).



Fence Materials*

(per 8-foot fence section)

- One or two 12-foot 4×4
- Three 8-foot 2×4s
- One 8-foot 2×6
- Twenty-four 3" × 42" fence pickets
- Two or three 60-pound bags concrete mix
- 4" exterior screws
- 1¼" exterior screws
- Two inverted-flange hangers with fasteners (optional)
- Eight linear feet 90" to 96" "deer-proof" fencing
- ¾" fence staples
- 1¼" fence staples
- Eight linear feet 24" woven wire mesh (for base guard)

Gate Materials*

- Six 10-foot 1×4s
- Three linear feet 76" "deer-proof" fencing
- Three exterior hinges with screws
- Gate latch with screws
- Corrugated fasteners
- Construction adhesive
- 1¼" exterior screws
- ¾" fence staples

*Wood should be cedar, pressure-treated pine, or other rot-resistant wood. The polypropylene fencing shown has an expected life span of 8 to 10 years. You can also use fixed-knot, woven wire fence with a life span of up to 30 years, but it's more expensive.

Fence

TAKE NOTE Before doing anything, call 811, the "Call Before You Dig" hotline, to have all utility lines marked on your property (see page 26).

1. Lay out the perimeter of your fence using stakes and string. You'll make best use of materials by working in increments of 8 feet.
2. Use a shovel to remove a divot of dirt where each post will be located. Then remove the string and use a posthole digger to dig all the holes. A 3-foot-deep hole will offer good stability. (See Digging Holes and Setting Posts, page 26, for more information and options.)
3. Set each of the four corner posts in place, hold them plumb, and brace them by using scrap lumber secured to stakes driven into the ground. Reset the strings to make sure the posts are positioned correctly. Then pour concrete in the holes and allow it to harden.
4. Reset your string once again, running it from corner post to corner post. Use this string as a guide for installing the intermediate posts and your door post.

5. Determine the overall height of one post, mark it, and then use a level and a long 2×4 (or other leveling device) to transfer this measurement to the other posts. (See Measuring, Leveling, and Squaring, page 30, for information on leveling over long distances.) Use a circular saw to cut the posts so the tops are all level with one another.
6. Cut the 2×4 and 2×6 rails to fit; then secure them to the posts using 4" screws as shown. Position the bottom, intermediate, and top rails on edge and the top cap flat. Keep the outer edges of these rails flush with the outer edges of the posts.

TAKE NOTE For added strength, use inverted flange hangers for securing the rails to the posts.

7. Use a jigsaw and 2×8 or 2×10 scrap lumber to create the arched braces that connect the posts to the top rails. Secure them in place using long galvanized screws. These are partly decorative, but they also help wiggle-proof the posts.

Fence construction

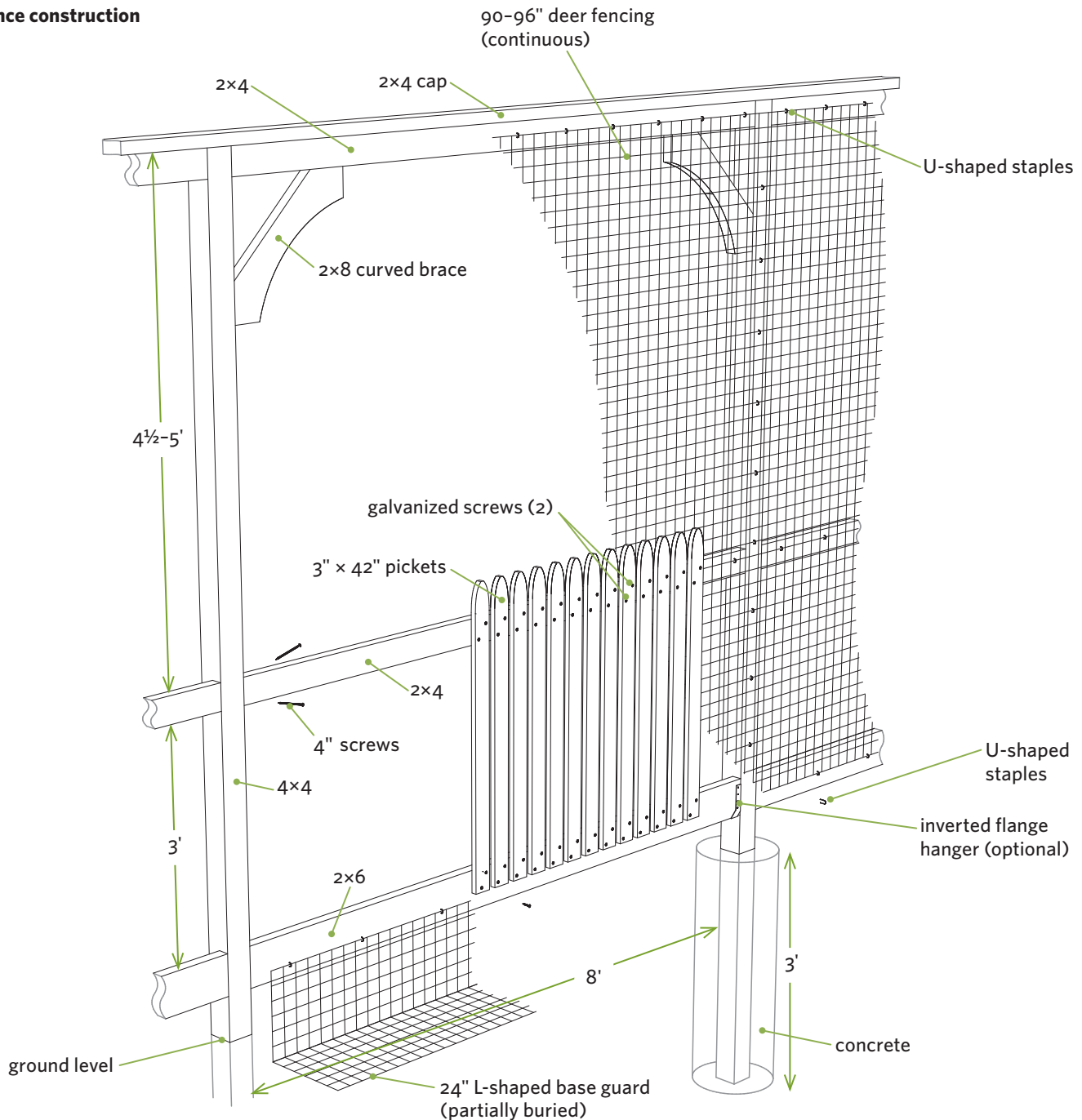

8. Bend 24"-wide strips of wire mesh into the L-shaped base guard. Dig a trench at least 6" deep and secure the base guard to the bottom rail as shown, using fence staples. Cover the underground horizontal leg of the guard with dirt, and compact the area.
9. Install the deer fencing using fence staples. This is a two-person job. One person should roll out the fencing and keep it taut, while the other installs the staples. Wrap it continuously around the perimeter of your fenced area.
10. Install the 1x3 pickets as shown, spacing them 1" apart, and fastening them to the bottom and intermediate rails with 1/4" exterior screws. Increase or decrease picket spacing based on the kinds of critters you're trying to keep out. Once they're installed, use staples to secure the deer fencing to the backs of the pickets for added strength.

Door

The door consists of two 1×4 frames with deer fencing sandwiched in between. You can make it any height or width you want, to accommodate wheelbarrows, carts, or garden tractors. For openings exceeding 40", build double doors.

1. Cut the members for the top and bottom frames. Note that the members of the upper frame overlap those of the lower frame at the corners and center crossbar to provide rigidity and strength. Lay out the pieces of the lower frame on a flat, solid surface; check to make sure the frame is square; and then fasten the corner joints with corrugated fasteners.
2. Secure deer fencing to the lower frame using $\frac{3}{4}$ " fence staples.

3. Apply construction adhesive to the face of the lower frame. Then install the members of the top frame, securing them with $1\frac{1}{4}$ " exterior screws. The joints should overlap at the corners and at the crossbar.
4. Position a 1×4 diagonally from the bottom corner of the door to the center crosspiece. Mark the angles on the ends, cut the piece to the right length and angles, and then secure it in place with corrugated fasteners or metal nailing plates.
5. Mount the door to the door post using strap or T-hinges. Orient the door so the lower diagonal brace points toward the lowest hinge. Install the gate latch of your choice.

Door — exploded view

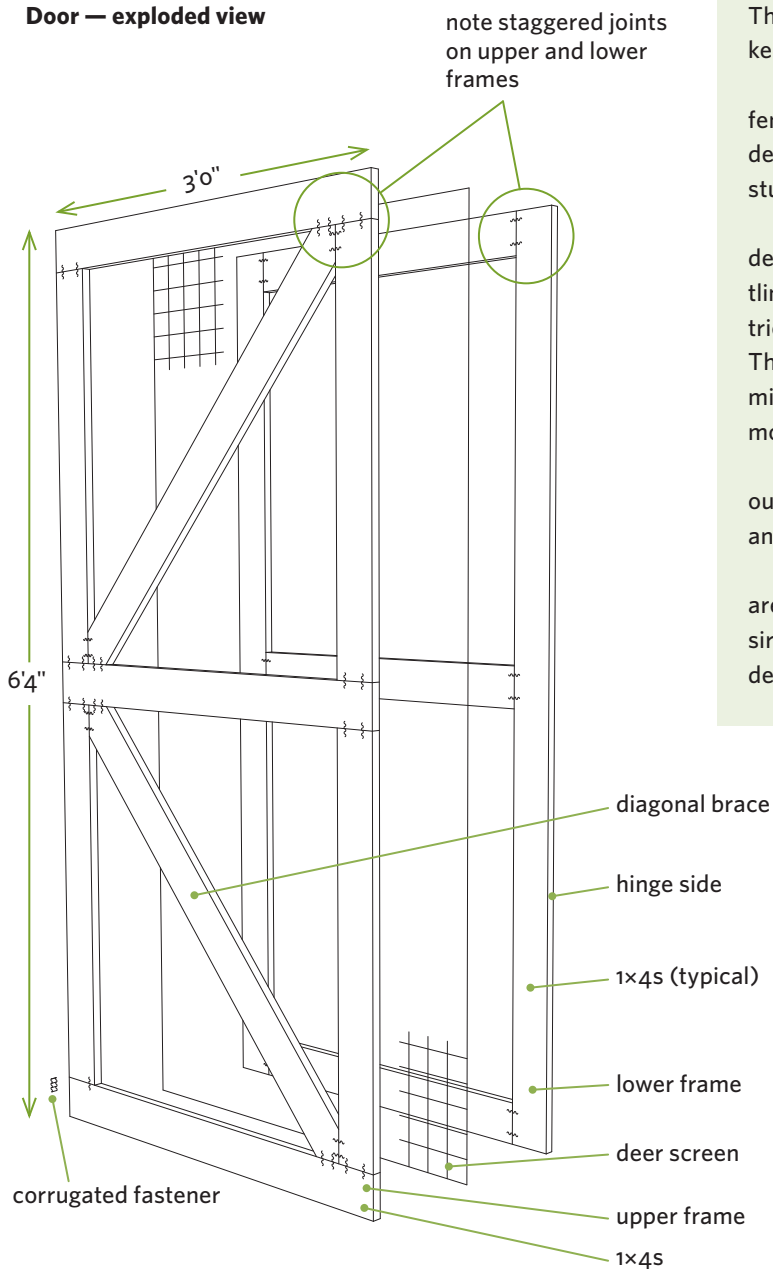

Deer Deterrenting Options

There are other fence designs and tricks you can use for keeping deer at bay. Here are a few of them.

DOUBLE FENCE. Install two parallel 4-foot-high fences spaced 40" to 48" apart. This visually confuses deer and instills wariness since deer don't want to get stuck between two fences.

BAITED ELECTRIC FENCES. These fences attract deer with a scented solution and then give them a startling, yet safe shock when their noses contact the electric fence. Most consist of two or three strands of wire. They shouldn't be used in situations where kids or pets might come in contact with them. See Resources for more information.

SLANT FENCE. These 4- to 6-foot-tall fences slant outward at a 45-degree angle, visually confusing deer and making them less likely to attempt jumping over it.

MOTION-DETECTOR DEVICES. These deterrents are triggered by movement and set off an ultrasonic siren or sprinkler to drive away deer. People using these devices report mixed results.

Shadow Box Fence Panel

A place for your gardening stuff (and imagination)

This shadow box fence panel is a smart, creative way to store and organize your most often used garden tools and materials. You can incorporate the panel (or panels) into the Critter-Proof Fence (page 50) or any other fence design. You can even build it as a stand-alone structure in a fenceless garden.

Here we present how to construct a basic panel, but you can use your imagination to accessorize it to fit your needs. Since the panel has to withstand the extra weight and jostling of a storage center, make certain to bury the posts at least 3 feet in the ground for stability. If you're going to use it for hanging heavier items, increase the post size to 6×6 and horizontal rail size to 2×6 or larger.

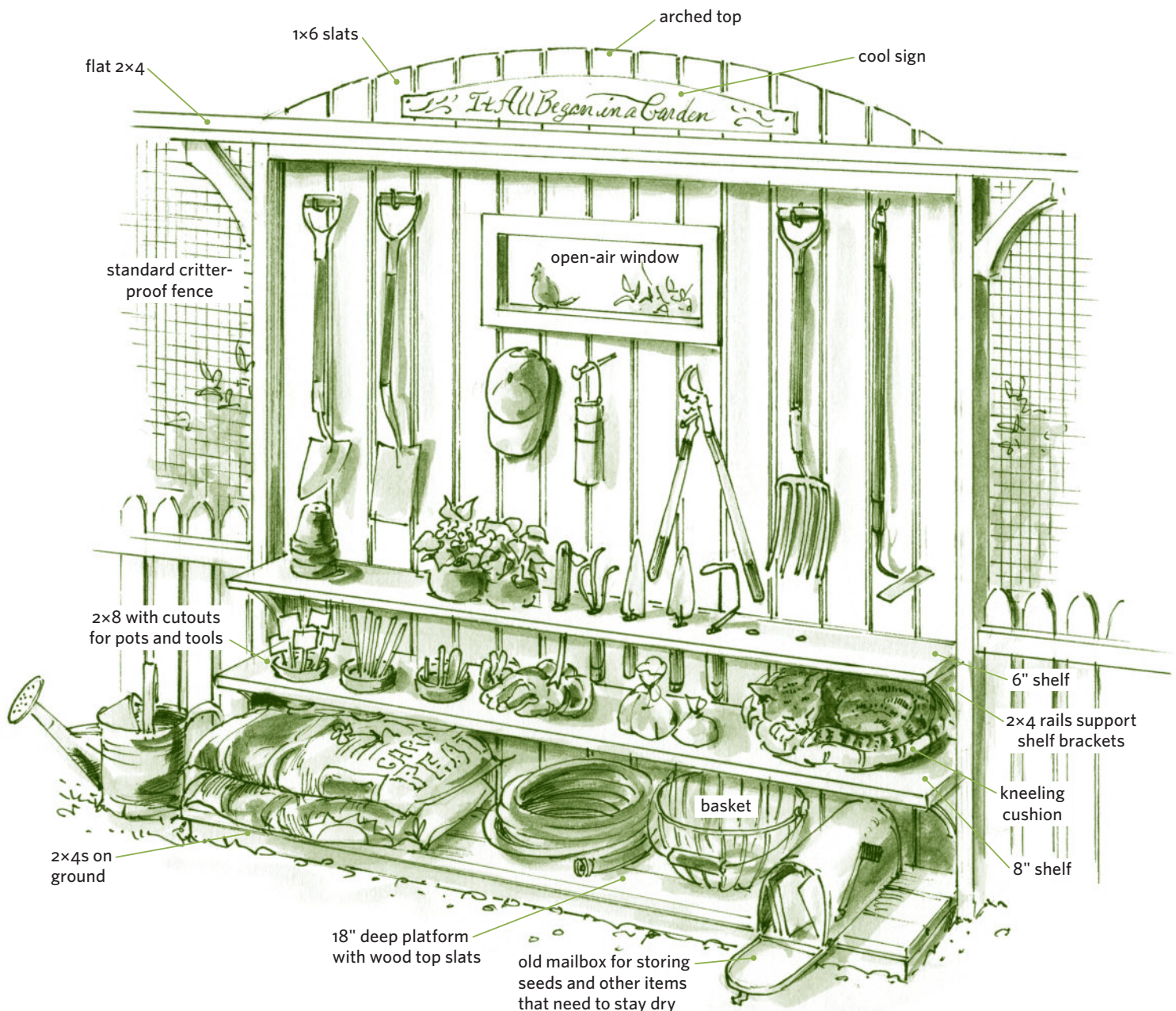

Materials* (per 8-foot fence section)

- Two 12-foot pressure-treated 4×4s
- Six to eight 8-foot pressure-treated 2×4s (or 2×6s or 2×8s)
- Eighteen 8-foot 1×6 fence pickets
- Deck boards (as needed)
- Four to six 60-pound bags of concrete
- Optional accessories and shelves (see steps 3 and 5)
- 4" exterior screws
- 2" exterior screws

*Materials will vary according to your design.

1. Dig two holes no more than 8 feet apart, and at least 3 feet deep. Set the posts in the holes, brace them vertically, and then pour concrete in the holes. Let the concrete cure overnight.

2. Install at least three horizontal rails (top, middle, bottom), and then secure the pickets to them. To create the arched top, flex a thin piece of wood from post to post, trace along it, and then use a jigsaw to cut the pickets in place.
3. Create shelves by securing flat 2×6s and 2×8s to the tops of the horizontal rails. If you're going to include holes for flowerpots, cut them out before installing the shelves. Add homemade or store-bought brackets as needed to support the shelves.
4. Build the lower platform using 2×4s for the framework. Cover the frame with deck boards, spacing them at least ¼" apart.
5. Add hooks, clips, and other storage doodads. A rural mailbox provides a moisture-proof enclosure for seeds, gloves, and other items you want to keep dry. If you cut in an open-air window or peephole, "picture-frame" it with wood trim on both sides to hold the pickets in place at the perimeter.

LESSONS FROM THE HOMESTEAD

Fences: Closing in the New Frontier

BY SUSAN WAUGHTAL

Fencing has been one of our biggest challenges as new farmers and probably one of our greatest expenses. When we moved to our farm with its vintage chain link fence along the perimeter of the property we naively thought it was "fenced." We got in pretty good shape that first year chasing escaped cows!

We have since had many adventures with all kinds of fencing and gate projects — to keep cows in the pasture, dogs on the property, chickens in the yard, chickens out of the garden, turkeys off the patio, cows out of the orchard and the garden, and livestock safe from hungry wildlife. We now use a repertoire of chain link, cattle panel, garden mesh,

buried electric dog fence, cedar picket fence, hardware cloth, and electric fencing strategies.

Fencing animals has made us advocates of the belt-and-suspenders "fence within a fence" approach — and we've grown to appreciate the simplicity of electric fencing. For example, in some areas we've run two electric wires inside the chain link pasture fence. If the electric fence loses power, at least the outer fence delays the escape.

We rotate our cows between pastures and use movable electric fences with step-in posts to divide the pasture or move the cows to our front yard. Braided nylon electric wire is easier to

handle and more visible than aluminum or steel wire, but not nearly as easy to find the bad spot when the electric fence fails.

We've also used two strands of electric wire to contain pigs in a large area. Just one experience touching a moist snout to the wire was a lesson well-remembered for the pigs, and they never tried to get out again. The cows, however, always seem to know when the fence is not working and take advantage of it.

In a nutshell, good fences make good neighbors — and for a heck of a lot of less chasing around.

SUSAN WAUGHTAL (see Resources) and her husband, Roger, left the big city six years ago to establish Squash Blossom Farm near Rochester, Minnesota. Today, they raise chickens, bees, cattle, and most of their own food. (For their hoop greenhouse adventures, see page 95.)

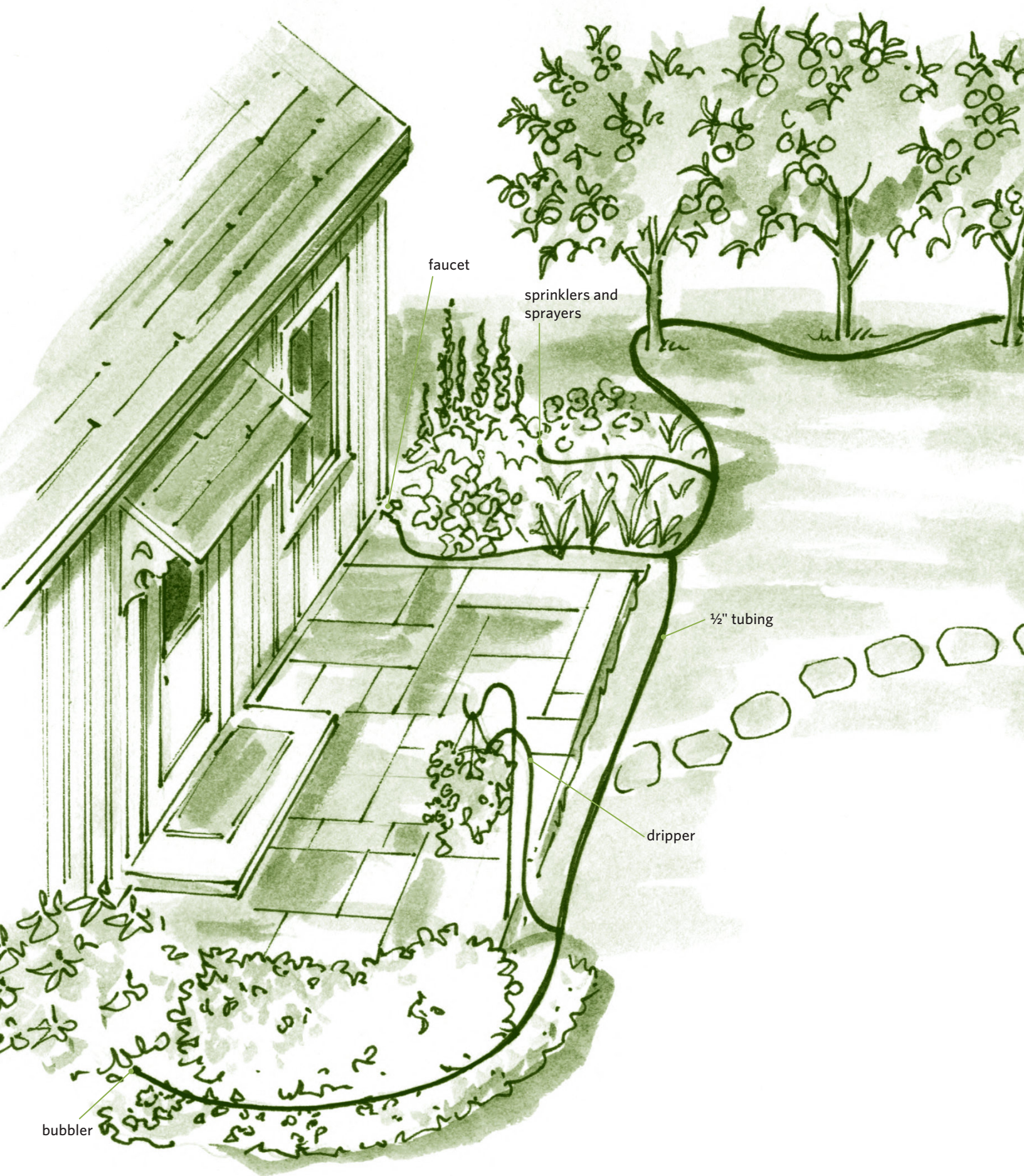

Drip Irrigation Basics

*Save time, conserve water,
grow healthier plants*

Drip irrigation, also called micro-irrigation or trickle irrigation, puts water where you want it, when you want it, at the rate you want. It does this through a system of tubes, Ts, and emitters that apply water directly to the plants and their roots. The results are less water waste, more efficient watering, and less hassle, especially if you use a timer. You can use the system to water vegetable and flower gardens, fruit trees, ornamental shrubs, and even hanging plants.

Since soil and weather conditions, types of plants, and layout differ from homestead to homestead, every drip irrigation system is different. Here are the basics to get you started.

The Overall Plan

If you're new to drip irrigation, install a system in one area of your yard, and then expand it once you learn how the system works.

Begin by making a sketch of your yard and garden on graph paper. Make it roughly to scale so you can use it to help order materials when the time comes. Include all the plants, shrubs, and trees you want to water. Figure out where you want to install the main $\frac{1}{2}$ " supply lines, the smaller $\frac{1}{4}$ " feeder lines, and the emitters. You can control the amount of water delivered to each plant or planting area via the emitter you select.

A FEW BASIC GUIDELINES:

- Each emitter has a gallons per hour (gph) rating. When you add up the gph of all the emitters on a $\frac{1}{2}$ " line, the total should be somewhere between 150 and 200 gph.
- When you add up the gph on the smaller $\frac{1}{4}$ " branch feeder lines, the total shouldn't exceed 30 gph.
- The maximum length of your $\frac{1}{2}$ " tubing should be 200 feet.
- Add another zone when your system begins pushing the limits of the guidelines above.
- The more clayey your soil, the less water you should apply. For example, in heavy clay you may want to select emitters that disperse only $\frac{1}{2}$ gph, while in sandy or quick-draining soils your devices may disperse 2 gph.



Faucet Setup

It all starts with the water source, and the most common source is the standard outside faucet. The following are the main components you need to install.

Y adapter with shutoff valves (optional). This adapter screws directly into your faucet and allows you to run your drip irrigation system off one leg and a standard hose or a second drip irrigation system off the other.

Timer (optional). The simplest timers automatically turn the water off 2 hours after you turn it on. More sophisticated versions have programs that completely automate the watering system and/or run two systems at once.

Backflow preventer. This device prevents water and possible contaminants in the irrigation lines from inadvertently backing up into your domestic water supply. They're inexpensive, easy to install, and mandatory (according to regulations in most areas).

Filter (optional). A filter removes small particles that might block the small outlets and hoses of your system. This may not be a factor if you're on municipal water, but it's cheap insurance against potential problems.

Pressure regulator. This reduces the relatively high water pressure of the house supply to the lower pressure required by the irrigation system.

Hose adapter. This little device allows you to connect the $\frac{1}{2}$ " plastic tubing to the threaded connections of the other devices.

Faucet setup components

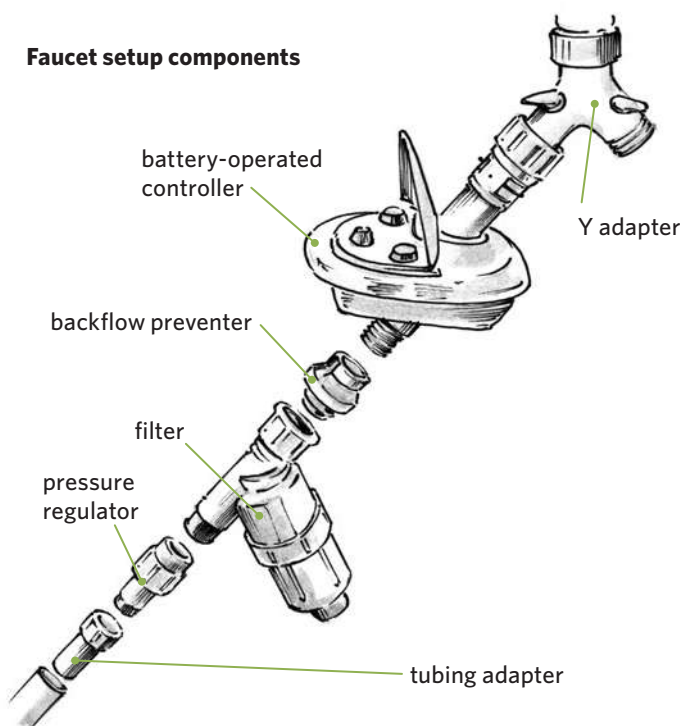

Tubing and Emitters

You can't vary the amount of time individual plants on a single zone receive water, but you can determine the amount of water they receive based on the emitters you select. The following are the most commonly available emitters and watering devices.

Drippers. As the name implies, drippers dispense water at a slow, steady rate. Most systems offer multiple drippers with gallons per hour ratings ranging from $\frac{1}{2}$ gph to 4 gph. Many are color-coded to indicate flow rate.

Bubblers. These stick up out of the ground and disperse water through multiple outlets. Many have flow rates of 30 gph or more, making them ideal for fruit trees, shrubs, and large plants like squash and roses.

Soaker drip lines. Available in $\frac{1}{4}$ " and $\frac{1}{2}$ " diameters, soaker drip lines contain a series of built-in drippers, making them ideal for watering rows of vegetables and flowers.

Rotating sprinklers. These dispense water in a circle with a radius of 25 feet or more at a rate of 30 gph or more.

Stationary sprayers can be adjusted to spray water in a variety of arcs and patterns. These are excellent for watering ground covers or dense flower gardens.

TAKE NOTE Drip irrigation systems are just that — systems. It's best to use components from a single manufacturer. Most manufacturers and retail outlets offer excellent installation brochures or online videos.

Installation and Maintenance

The basic installation tools are pruning shears for cutting the tubing to length and a hole punch for creating the openings for branch lines and emitters. A few installation tips:

- Unroll the $\frac{1}{2}$ " tubing and let it warm in the sun for an hour or two before installation, to make it more flexible and easier to work with.
- Start at the faucet and work outward. Install the main $\frac{1}{2}$ " supply lines first, then the $\frac{1}{4}$ " feeder tubes.
- Most manufacturers recommend you install emitters, branch lines, Ts, and elbows by creating a hole in the tube with the hole punch, then inserting a barbed or friction-fit fitting.
- You can bury $\frac{1}{2}$ " tubing in a shallow trench as you work or cover it later with mulch if you want it out of sight. In high-traffic areas you can sleeve the tubing in lengths of PVC pipe for protection.

- Use U-shaped stakes or hold-downs, available through most manufacturers, for holding the tubing firmly in place every 4 to 6 feet.
- Once your system is up and running, check it periodically to see if any of the joints or connections are leaking profusely. If you installed a filter, clean it once a month.

Dealing with Old Man Winter

If you live in an area with below-freezing temperatures, you'll need to take a few precautions to prevent damage to your system. Before the first freeze, remove the timer, filter, and adapter connected to your outside faucet and store them inside. You also need to drain the system. If your system is installed on a slope, you may be able to simply remove a few downhill emitters and let the water drain out of the system. A more thorough approach is to use an air compressor set at low pressure to blow the water out of the system.

Drip irrigation emitters

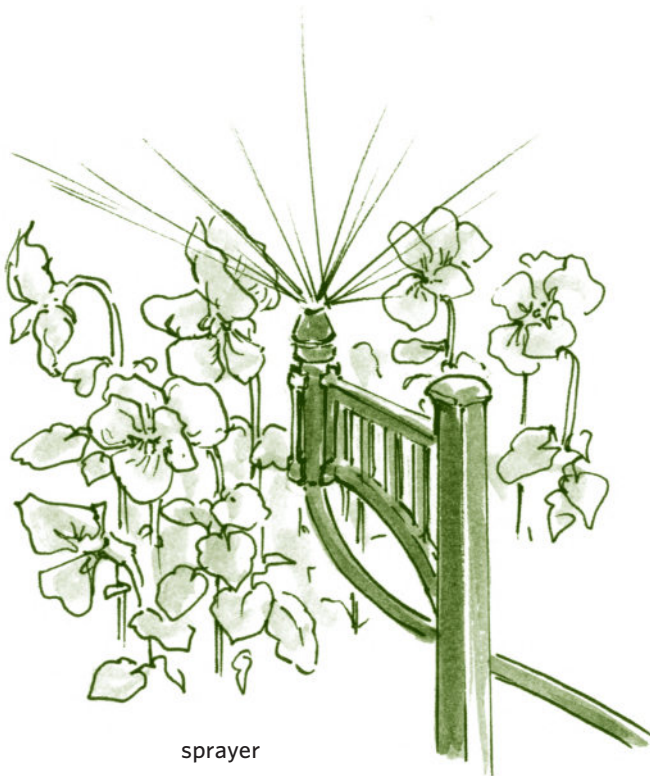

sprayer



dripper



bubbler

Simple Hose Guides

Minimize damage to your plants, hoses, and nerves

It's pretty easy to inflict major damage on flowers, vegetables, low-voltage lights, and garden accents by dragging a hose across them. These four simple guides will help minimize damage to both your plants and hoses, and help keep your hoses tangle-free.

Copper Pipe (A)

Cut a piece of $\frac{3}{8}$ " soft copper pipe about 24" long. Create a loop on one end by bending it around a pint paint can or something of similar size. Make a sharp bend 6" to 8" from the other end, and then use two pliers to twist the free end around the stem to create "threads." Twist the hose guide into the ground like a giant corkscrew; the threads will help prevent the guide from twisting when the hose is pulled through it.

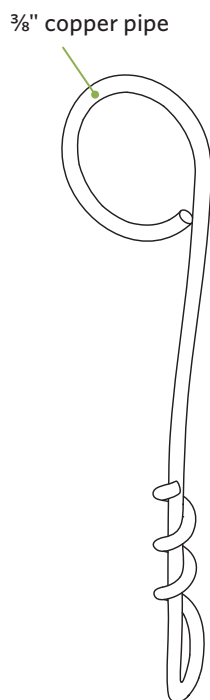

Roller Stake (B)

If you need to guide your hose around sharp corners, a roller will allow you to pull the hose more easily. To create the wooden spool:

1. Use a compass to draw one 3" circle and two 5" circles on a 2x6. Drill a $\frac{1}{2}$ "-diameter hole through the center of each circle.
2. Use a jigsaw to cut out each of the circles. Then set your jigsaw to 30 degrees and cut the bevel on the lower half of the larger circles as shown.
3. Apply exterior glue to the three discs; then clamp them together to create a spool. Slide a $\frac{1}{2}$ " dowel or piece of pipe through the center holes to keep them aligned while the glue sets.
4. Once your glue has set, place the roller on a stake made from two pieces of threaded iron pipe, a connector, and a cap.

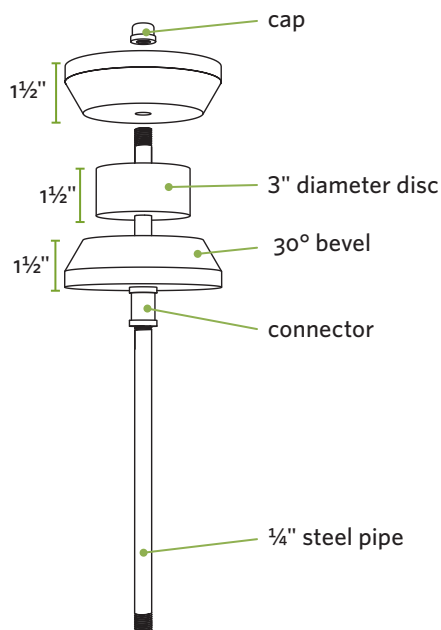

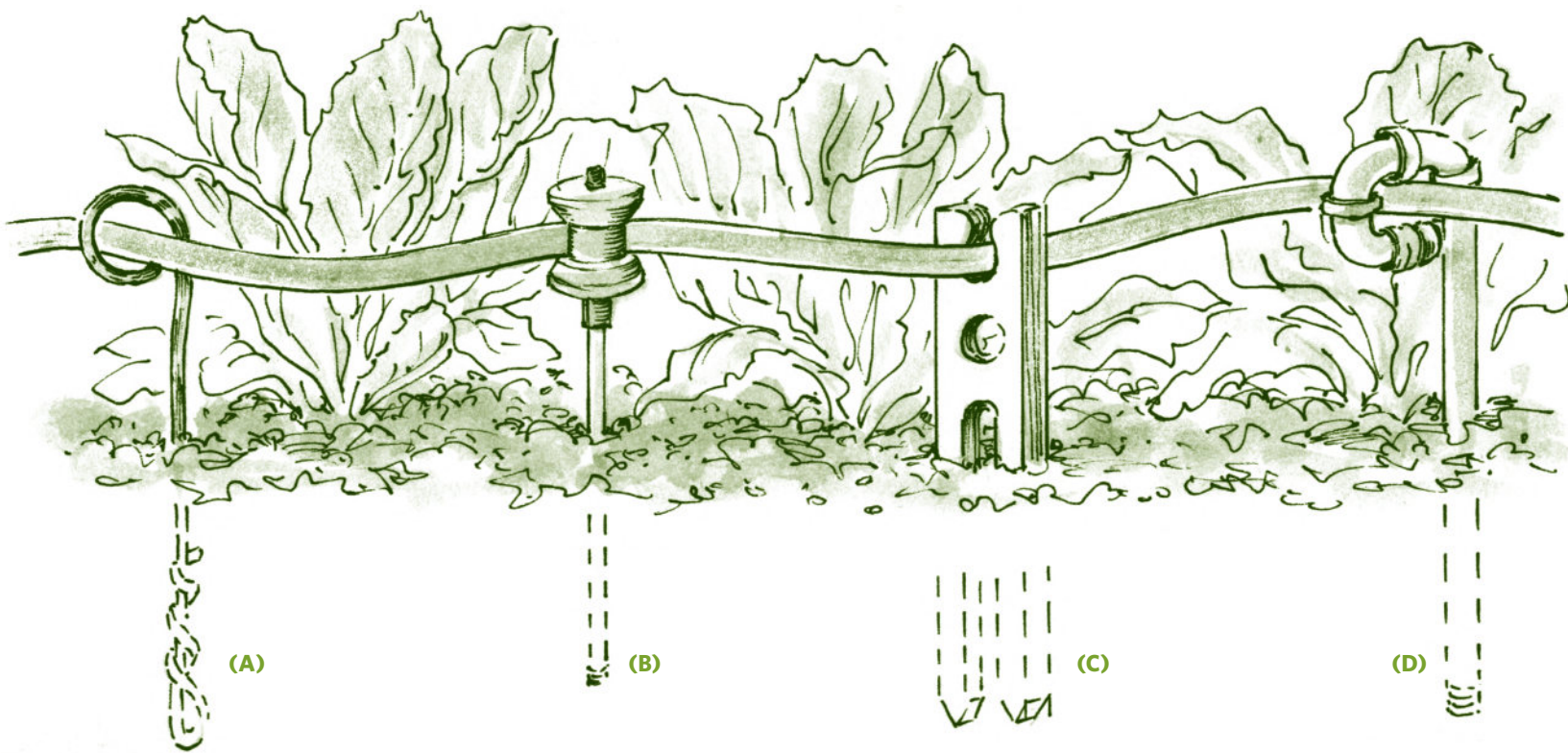

Wooden Stake (C)

Drill a trio of $1\frac{1}{2}$ " holes through a 12"-long piece of pressure-treated 2x4. Use a jigsaw to cut the 1"-wide slot to the top hole and to cut the legs that extend from the bottom hole. For temporary use, slip the hose into the top hole; for more long-term use, feed the hose through the middle hole.

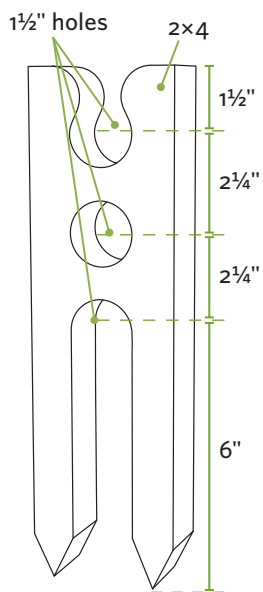

Threaded Iron Pipe (D)

Purchase $\frac{3}{8}$ " threaded iron pipe and fittings, and then assemble them to create a loop as shown. Experiment with different fittings and configurations to create the right size of opening.

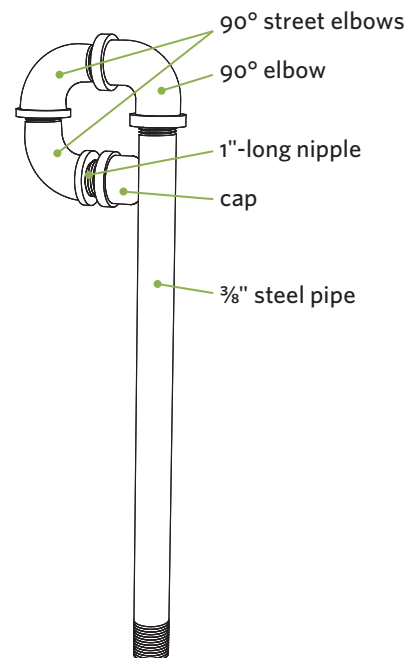

Garden Marker/ Stepping-Stone

A cheap, fun way to leave an impression

These garden markers can be functional, directional, informative, decorative, or just plain fun. We made our circular form by cutting off the top 3" of a 5-gallon bucket, but you can use nearly anything for yours.



Materials

- One 5-gallon plastic bucket
- $\frac{1}{2}$ " plywood, 12" \times 12" minimum
- Three drywall screws
- Extruded foam insulation board
- Double-sided tape
- Vegetable oil
- Concrete mix

1. Create the form by using a jigsaw to cut off the top 3" of a 5-gallon bucket. Place the form on a scrap piece of $\frac{1}{2}$ " plywood and trace around the inside. Use your jigsaw to cut out the disc. Place the plywood disc in the bottom of your form and secure it in place by driving three short drywall screws through the side of the form into the edge of the plywood.
2. Cut the design, pattern, or words you want from $\frac{1}{4}$ " extruded foam insulation using a sharp utility knife or jigsaw. Use double-sided tape or a dab of hot melt glue to secure the shapes or letters to the plywood disc. Remember: If you're creating words, arrange the letters backward!

TAKE NOTE Use a computer to find or create the letters, shapes, or objects you want. Then enlarge them to the size you need and print them out. Use carbon paper or a pointed awl to transfer the images to the foam.

3. Brush vegetable oil or concrete form oil onto the sides and bottom of the form and your pattern to prevent the concrete from sticking. Mix the concrete to a loose peanut butter consistency, add concrete colorant (if you want), and then pour the concrete into the mold. Tap the sides with a hammer and tamp the material down so it nestles around the foam shapes. You'll be able to get three or four markers from each bag of concrete mix.

TAKE NOTE Use premixed mortar — the stuff without gravel in it — if you want crisp details on your markers.

4. Let the concrete harden overnight. Once it's hard, carefully turn the form over. Remove the screws holding the plywood disc in place and gently push on the bottom until the concrete comes out. If it's stuck, run a flexible putty knife between the form and the concrete to loosen the marker. Remove the plywood disc from the concrete by gently twisting it as you pull up. Your foam letters or shapes will stay embedded in the concrete.
5. Use a putty knife or screwdriver to remove the embedded foam shapes. Round and clean up the edges of the shapes and the marker with an old file. Let your markers cure for two or three days before setting them outside.

Concrete form — exploded view

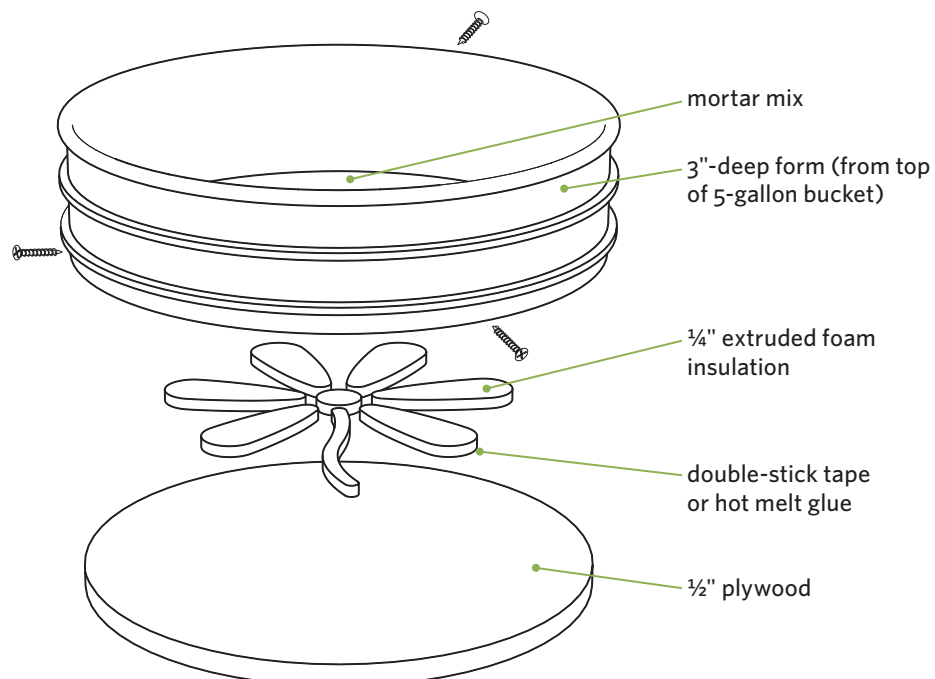

Super-Simple Path

Easy on the budget, feet, and back

A path can be as simple as a trail worn across the lawn or as heavy-duty as a truckload of flagstone set on a gravel base. This path leans toward the simple. You can build it in the garden, across the lawn, or through the woods. The cedar shakes used

as the border are naturally rot-resistant and have a life span of 10 years or more. The materials are available through most garden and home centers (though you may have to special-order the cedar shakes). You can build most paths in an afternoon.

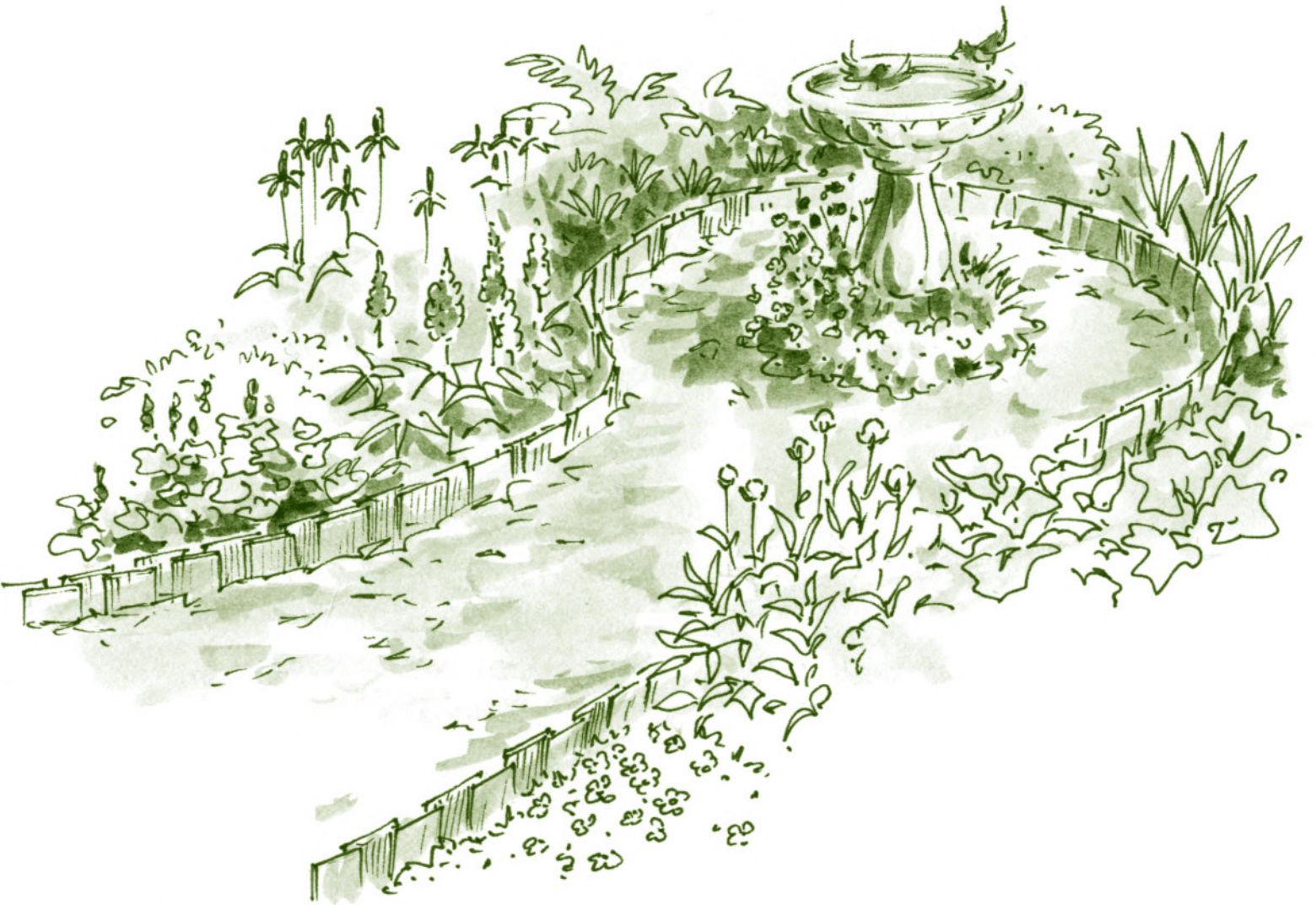

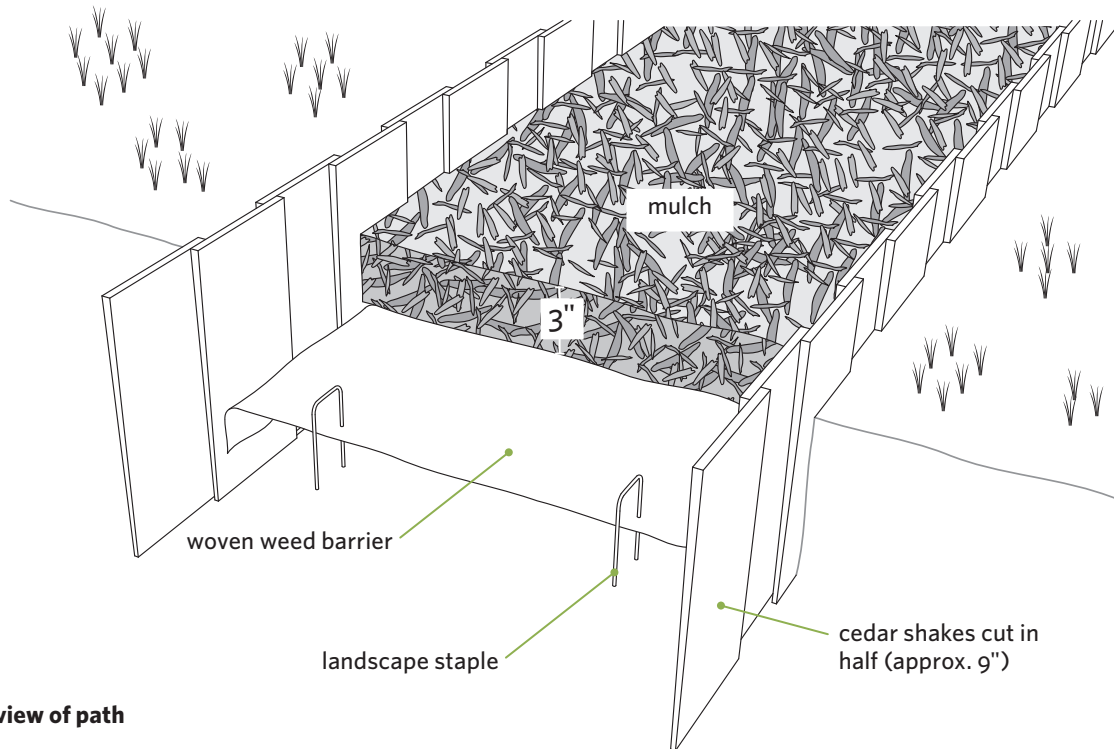

Cutaway view of path

Materials*

- 18" cedar shakes or shingles
- 36"-wide woven landscape fabric (weed barrier)
- Landscape staples
- Mulch, stone, or other path surface material

*Amounts vary based on length of path.

1. Use a pair of garden hoses to mark the edges of your path. The path can be straight as an arrow or crooked as a snake. Since the base will be 36"-wide landscape fabric, keep the path width to 30" or less.
2. For the border, cut the cedar shakes in half lengthwise using a miter saw, circular saw, jigsaw, or handsaw; you'll use both halves. Using the hose as your guide, pound the first shake into the ground. Install the second shake, overlapping the side of the first one by about 1". Continue staggering and pounding in the shakes. Complete both sides of the path.

TAKE NOTE To minimize damage to the tops of the shakes, use a scrap 2×4 as a pounding block between the shake and hammer. In tough soils you may need to loosen the soil beforehand with the blade of a shovel.

3. Roll out the landscape fabric between the shake borders. Where the path curves, fold the material onto itself to make the turns. Use landscape staples — normally used to keep sod and erosion-control fabrics in place — to secure the material to the ground as needed. Use the tip of a shake to tuck the edges of the material down in between the soil and the border shakes; the tighter you can make the fit, the fewer weeds you'll have to pull.
4. Cover the landscape fabric with an even 3"- to 4"-thick layer of mulch, stone, or other loose-fill path material to complete the path. Renew the mulch as needed.

Sitting and Kneeling Garden Stool

Whether you're pruning, planting, or shucking, this bench provides the just-right height

Gardening can put you in a lot of different, sometimes awkward positions: one minute you're kneeling, the next you're sitting, the next you're standing. This bench will make life easier on all three counts. Flip it into high mode for sitting, then into low mode for weeding and planting. Use

the sides and handholds to help you stand or move from one position to another. The stool also has a compartment for stowing a kneeling pad, loops for holding hand tools, and a handhold for carrying it to and fro.



Materials*

- One 4-foot 1×12
- One 4-foot 1×10
- One 4-foot 1×2
- Exterior glue
- 6d galvanized casing nails
- 1½" exterior screws
- 2" exterior screws
- Four 2" L-brackets with screws

*All lumber is pine or pressure-treated pine.

1. Cut the two sides (A) to length. Use the dimensions as shown to mark the locations of the sitting board (B) and kneeling board (C), handhold cutouts, curved bottom, and tapered sides. Use a 1½" spade bit to create the rounded ends of the handholds, and use a jigsaw to cut the tapered sides and arched bottom.
2. Cut the sitting board (B) and kneeling board (C) to length. Use a 1½" spade bit and jigsaw to cut out the handhold in the sitting board.



Parts and Cutting List

Part	Size and Material	Quantity
(A) sides	¾" × 11¼" × 18" pine	2
(B) sitting board	¾" × 9¼" × 20" pine	1
(C) kneeling board	¾" × 9¼" × 20" pine	1
(D) back frame support	¾" × 1½" × 20" pine	1
(E) side frame support	¾" × 1½" × 8½" pine	2
(F) support brackets	2" L-brackets	4

Side detail

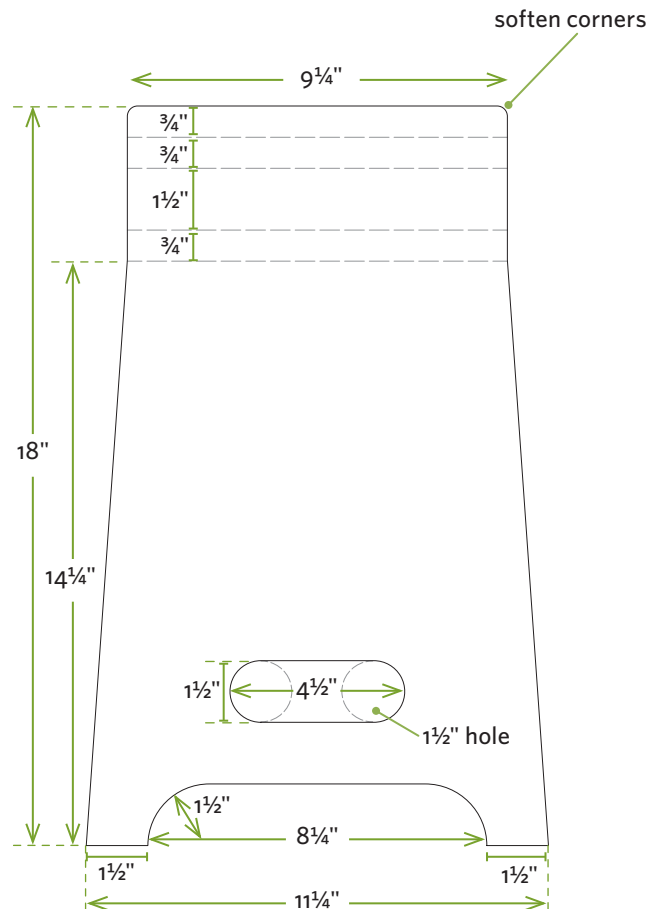

- Cut the three support frame members (D, E) to length and assemble the 3-sided frame using 2" screws. Use exterior glue and 6d galvanized casing nails to secure the sitting and kneeling boards to each side of the frame to create an open-ended box.
 - Secure the open-ended box in place by applying glue to the side frame supports (E), and drive 1½" exterior screws through the sides of the bench into the support frame. Drive 2" screws into the ends of the sitting and kneeling boards.
 - Install the four L-brackets (F) to connect the kneeling board to the sides. These are important: they not only help support the seat assembly but also prevent the sides from splaying out when you use the bench to move from kneeling to standing positions.
 - Soften the edges and corners using sandpaper or a router with a roundover bit.
- TAKE NOTE** Paint your bench or apply a clear finish to increase longevity.

Stool assembly

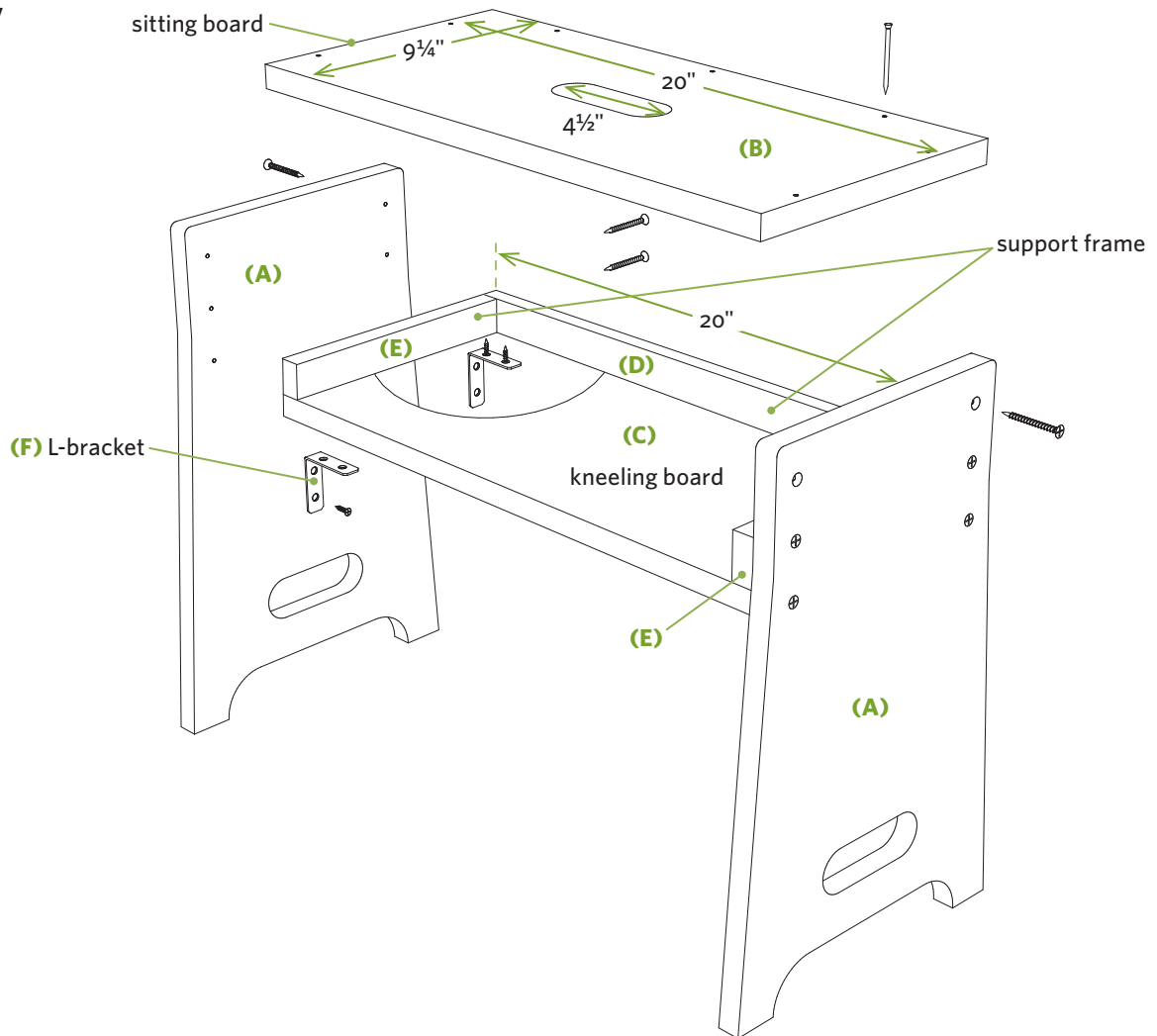

Accessorizing Your Garden Stool

You can make your garden stool even more useful by adding a few accessories.

- Slip a foam kneeling pad into the narrow storage compartment between the sitting and kneeling boards.
- Use a rubber bungee cord to create loops just large enough to snugly hold hand tools that you commonly use. Cut the ends from the cord. Use screws and washers to secure the cord to the side of the bench.
- Add a bicycle water bottle holder to one side so you can bring plenty of water with you on hot days.

Five Raised-Bed Gardens

Cramped space? Crummy soil? Aching back? Solve these problems with raised-bed gardens

If you've been putting off starting a garden because of limited space, poor soil, or an aching back, or because the thought of a big garden is overwhelming, consider building raised beds. They can solve a multitude of problems. You can fill them with fresh soil and amendments to create rich growing soil regardless of the natural soil

beneath you. Since the raised beds reduce the need to stoop, you'll experience less back and knee strain. And having a well-defined space makes gardening more manageable.

Here are five concepts for raised beds. There are no specific measurements, since all are easily adjusted to fit your space, needs, and budget.

Option #1: Timber Beds

Pressure-treated retaining wall timbers are a natural for creating raised beds; they're sturdy, rot-resistant, and easy to install. The timbers we used are 4x6s. You can use larger timbers, but they're rarely required for strength.

KEY BUILDING POINTS:

- Spend time carefully leveling the first row of timbers; it will make the rest of the job easier and your beds will look better. Bury the first row a couple of inches for stability.

- Overlap the corners for strength. Secure the timbers to one another with long spikes or hex-head timber screws.
- If your walls are longer than 8 feet, install timbers across the middle to prevent the sides from bulging outward.
- If you like the idea of "square-foot gardening," these beds provide the perfect venue.

Three types of timber beds

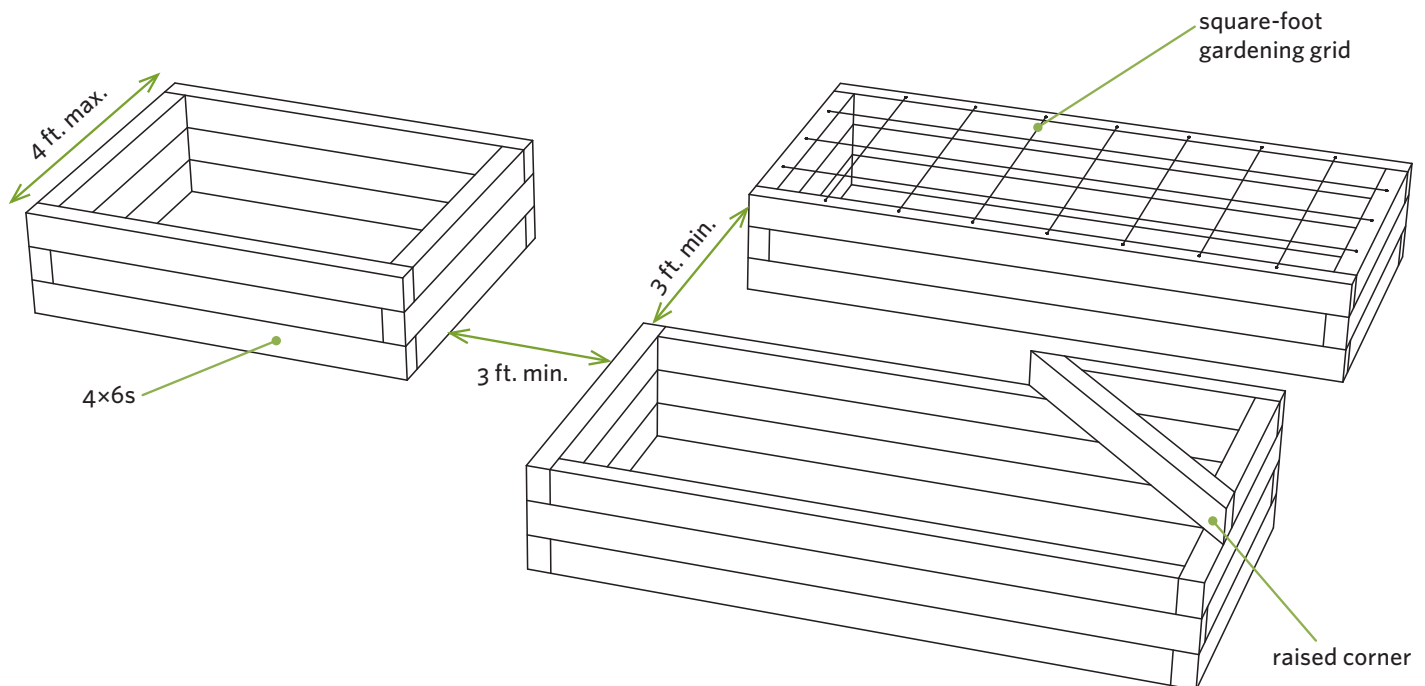

Option #2: Post and Plank Beds

One of the easiest ways to establish a raised bed is to install 4×4 corner posts and connect them with 2×12s. You have total flexibility in the length, width, and height of your beds. By extending the back posts upward and installing wire or mesh, you can create a sturdy plant trellis.

KEY BUILDING POINTS:

- Bury the short posts at least 12" into the ground and the tall posts 3 feet or more for stability. After digging the holes, add a few inches of crushed rock to the bottom, install the posts, and then fill around them with more crushed rock, tamping as you go. The rock on the bottom will provide good drainage to minimize rot, and the rock on the sides will bite into the posts to minimize wiggle.
- Use $\frac{3}{8}$ " × 4" lag bolts (or 4" timber screws) to secure the 2×12s to the 4×4s. Install two bolts and washers, one high and one low, to secure each board to each 4×4.
- If your bed is more than 8 feet long, install one or two 2×12 crosspieces or add an intermediary 4×4 post to prevent the sides from bulging outward.
- To create taller beds, install taller 4×4 posts and secure a second row of 2×12s (or other width of lumber) on top of the first row.

Trick Out Your Planters

Your raised beds look great. Here are a few ways to make them look and perform greater still.

- Add a drip irrigation system (see page 57). A single run of supply hose down the center, along with a few sprinkler heads, is all you need to water most raised beds.
- Create a mini-hoop greenhouse to extend the growing season. Install U brackets along the outside edges of your bed; then bend $\frac{1}{2}$ " PVC pipe into an arch to fit into these brackets. (See Hoop Greenhouse, page 90, to get a general idea.) Cover the hoops with plastic, and you have an instant greenhouse. Remove the hoops and plastic when the temperature is warm enough.
- Plant by the square foot. Pound in a nail every 12", and then weave string between the nails to create a gridwork for planting (see Timber Beds illustration, page 69).

Post and plank bed

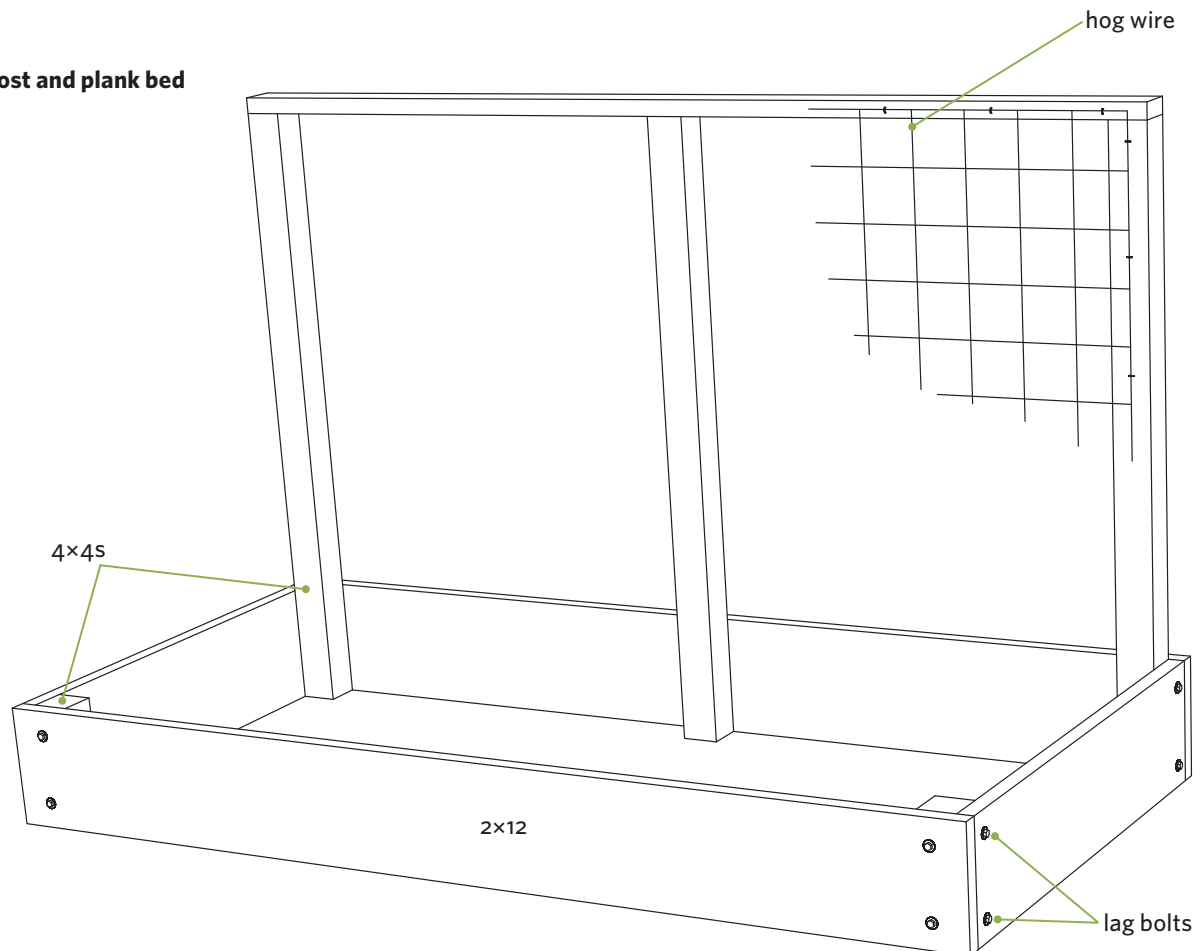

Option #3: Modular Block Beds

Modular retaining-wall blocks allow you to create beds of nearly any size, height, or shape. Most blocks come as systems that include a decorative cap block you can use for topping off the raised bed. As shown here, you can use treated 2x10s to divide your bed into "pie slices" for planting eight different varieties. Divide yours up as you see fit, or not at all.

KEY BUILDING POINTS:

- Create an outline of the bed with a garden hose. Then dig a shallow 12"- to 16"-wide trench and fill it with coarse sand or compactable base material. Level the material; then carefully level each block in the first row. If your base row is level, the other rows will go down fast.
- If you need blocks cut to size, you can get the job done with a hammer and chisel or a circular saw equipped with a diamond blade. Some landscape supply yards and rental stores have machines available for getting the job done faster.
- Once all your blocks are installed, use block adhesive to set the top caps if you wish to use them.

Raised-Bed Guidelines

Raised beds can be any size, shape, or height you want, but keep these dimensions in mind:

- Leave at least 3 feet between beds so you have room for walking, working, and navigating a wheelbarrow.
- Spread gravel or mulch in the space between your beds to keep weeds down and appearances up.
- Limit the width of your beds to 4 feet or less so you don't have to reach farther than 2 feet from either side. Greater widths mean more difficult access.

Modular block bed

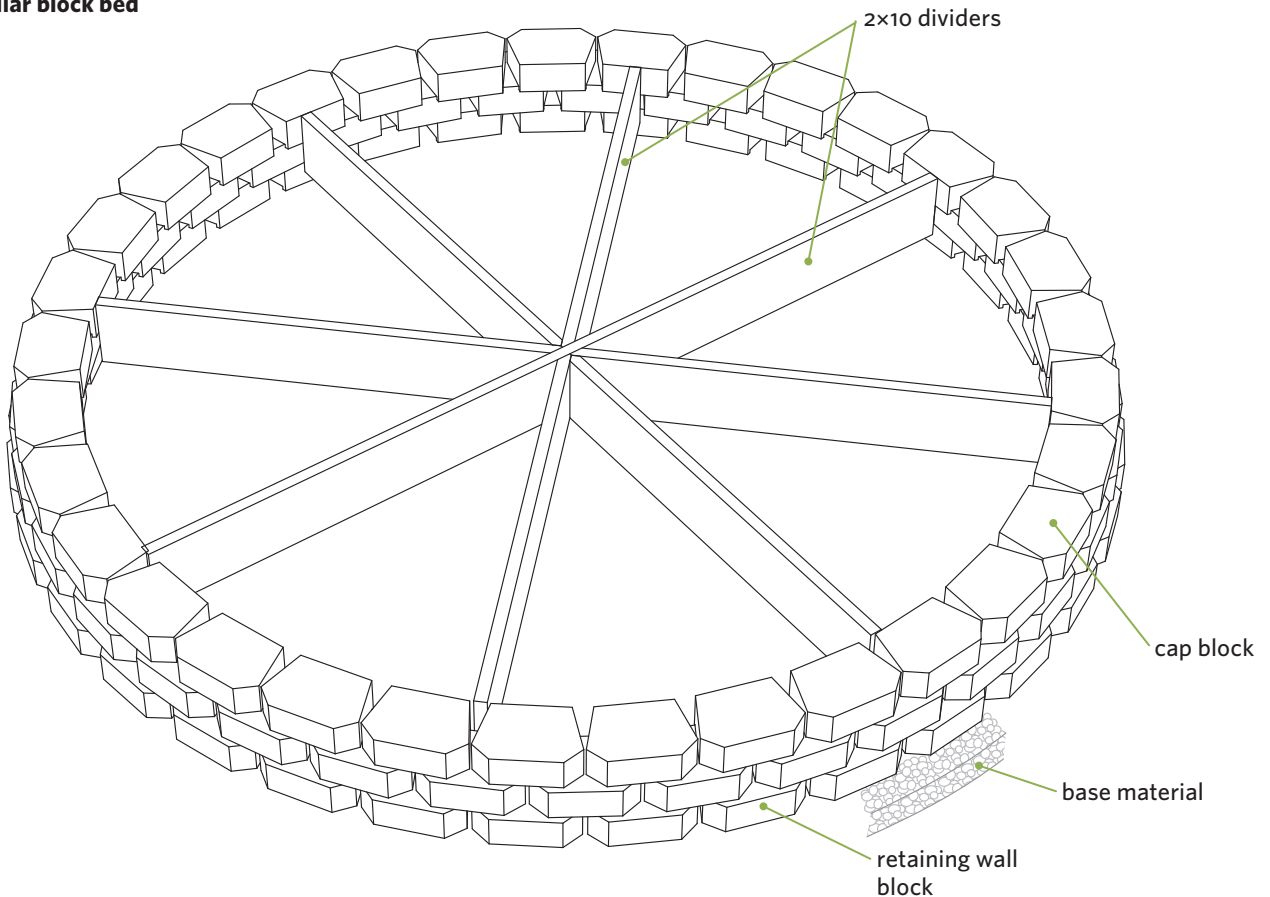

Option #4: Plywood Beds

If you need a raised-bed planter small enough to fit on your back stoop or patio, build this one from treated plywood and treated 2×4s. You can eliminate the bottom plywood and use the same techniques to create larger on-the-ground planters, too.

Key building points:

- Build and sheathe the four walls while they're lying flat on the ground; then stand them up and secure the corners to one another. You'll save time and hassle.
- Nail 2×2 cleats along the bottoms of the walls; then drop in the plywood bottom. If your planter exceeds 3 feet in width or length, add an extra support 2×2 in the middle. Drill holes in the bottom for drainage; a layer of landscape fabric will prevent dirt from washing through the holes.
- Install a 2×6 cap piece to cover the edges of the plywood and frame the planter.

Found Raised Planter Beds

When it comes to raised planters, anything solid enough to hold dirt is fair game. A few of the more novel versions I've seen include:

- Old wading pools and water troughs with the bottoms removed
- Two U-shaped metal window wells with their legs bolted together
- Framed walls (like those shown in Plywood Bed, below) but with metal roofing used for the sides
- Stacked-up old tires (but beware: tires absorb a lot of heat from the sun!)

Plywood bed

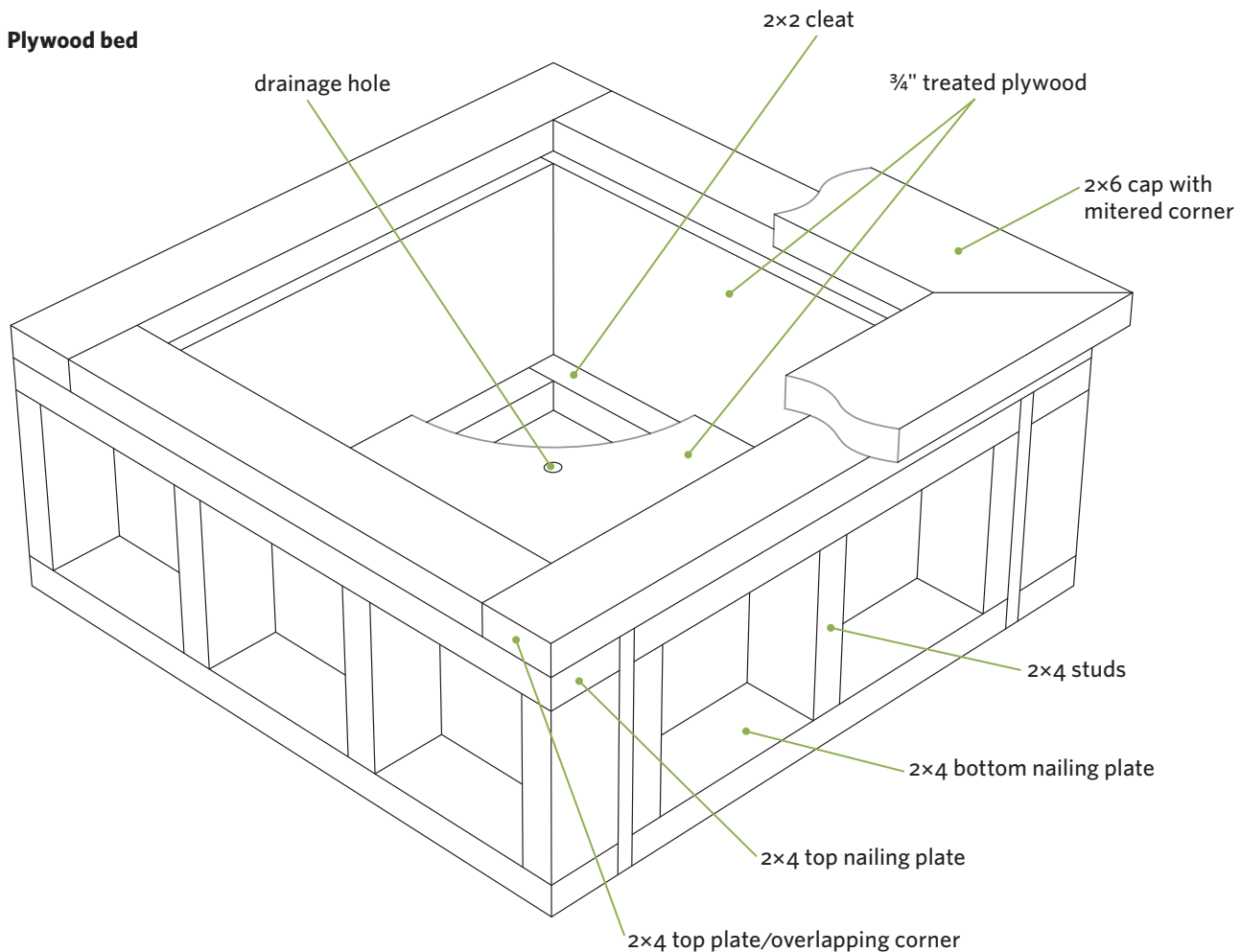

Option #5: Tiered Beds

Tiered beds are not only attractive but functional as well. They give plants with deep roots more depth and plants that spread out a little more elbow room.

Key building points:

- Build each upper tier so the ends lock into the lower tier as shown. In this example, the sides of the second tier are 2×10s, and the ends are 2×8s, allowing it to lock together with the one below. This also helps keep the dirt in place.
- For spans exceeding 8 feet, install cross bracing to prevent the sides from bowing out.
- Be creative: build your tiers at angles, as steps, or any other way you choose.

The Dirt on Treated Lumber

A decade ago, most exterior lumber was treated with chromated copper arsenate (CCA) or other heavy-duty chemicals. They did a great job of preventing wood from rotting, but there were safety concerns about the chemicals used.

Since around 2002 most lumber has been treated with a more environmentally friendly chemical called **alkaline copper quarternary (ACQ)**. The jury's still out on whether the wood will last as long, but studies have shown that ACQ is safer to handle than CCA. These studies also show some leaching may occur, but that the chemicals are mostly bound into the soil, and, if taken up by plants, are mostly taken up by the parts we don't eat.

Still, you should use certain precautions:

- Wear gloves when handling treated wood.
- Wear a safety mask and goggles when cutting it.
- Don't burn scraps, and don't use sawdust or chips for compost or mulch.
- There are alternatives to treated lumber — most commonly cedar, redwood, and synthetic lumber — but be prepared to spend three times as much for them.

Tiered bed

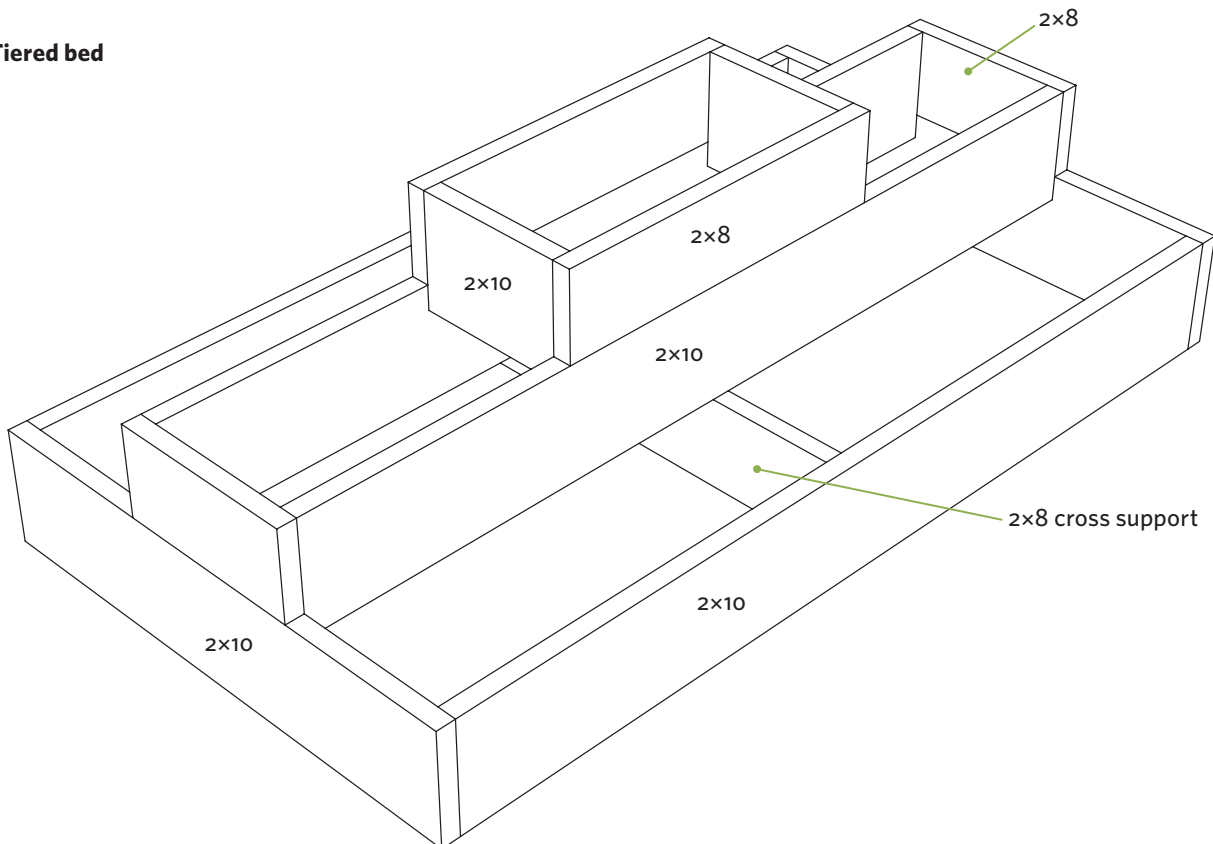

Five Simple Plant Supports

Easy-to-build props for keeping your veggies healthy

Getting seeds planted and seedlings growing is just part of the battle. For your tomatoes, beans, peas and other veggies to thrive, you need to offer them support, of the wood and wire kind.

Some plants, like peas and beans, are natural climbers and have tendrils and holdfasts to support the fruits of their labor. Others, like tomatoes, need to be tied to supports as they grow. Here are five projects for commonly grown plants.

Option #1: Folding Trellis

This trellis is easy to build, easy to set up, and easy to store. All you need are 2x2s, twine or wire, a couple of hinges, and a couple of hours to build each one.

KEY BUILDING POINTS:

- Before assembling the trellis, lay all the horizontal crosspieces side by side, mark the positions of the string holes on one crosspiece, and then use a Speed Square to transfer the marks across all the crosspieces. Drill $\frac{1}{4}$ " holes at the centers of the marks.

- Predrill holes in the 2x2 uprights so they don't split when you install the screws for the crosspieces. Use two screws in each end of each crosspiece to prevent them from twisting.
- Cut corner braces from scrap wood; then glue and screw them in place.
- Add hinges to hold the tops of the legs to each other. Use rope to prevent the bottoms of the legs from splaying out too far.

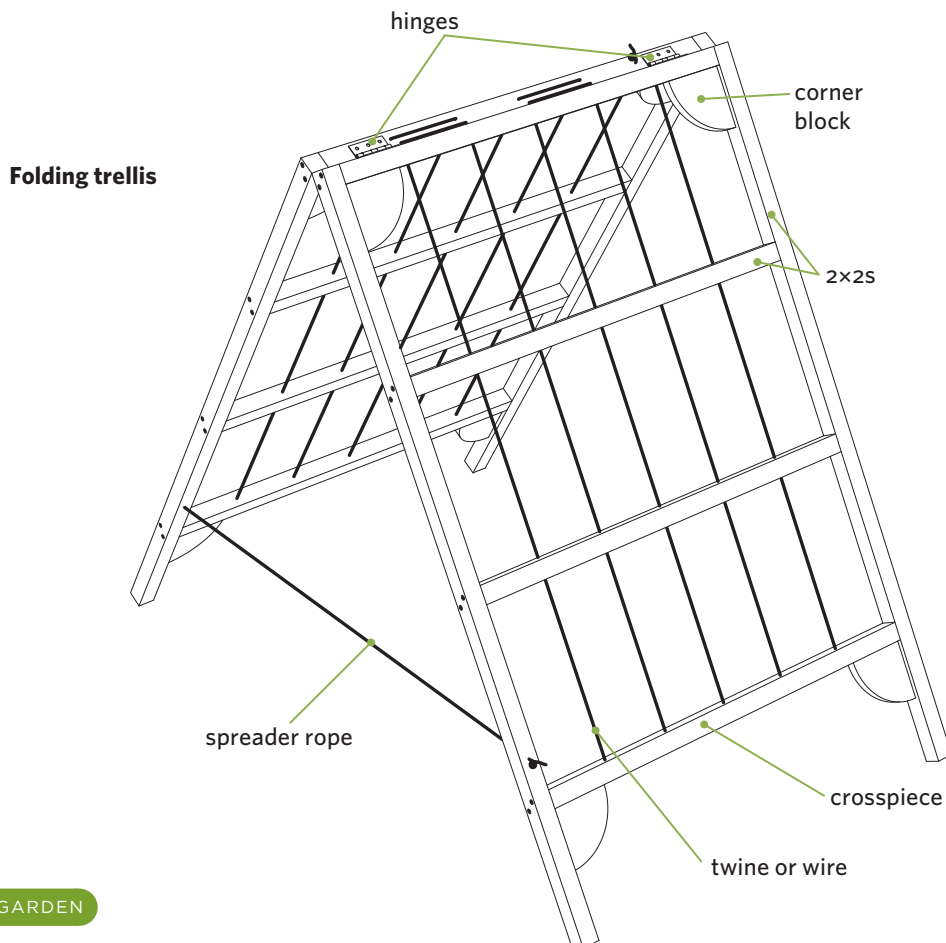

Option #2: Tomato Stakes

This is probably the simplest project you'll ever tackle, but a worthwhile one indeed. The side pegs provide good anchors for your tomato ties, and the top dowel and ball add a decorative touch, plus a place to stash extra wire and ties for securing the plant to the stakes.

Drill holes through the 2x2 stake, spacing them as shown. Secure the dowels in place with glue or by driving a small finish nail through the side of the stake into the dowel. Use a handsaw or power saw to create the point on the end of the stake.

Drill holes into the top of the stake and decorative ball, then use a dowel to secure the ball to the stake.

Drive the stakes into the ground at the same time you plant the tomatoes to avoid inflicting root damage later on.

TAKE NOTE Use a curtain rod finial end for the top ball.

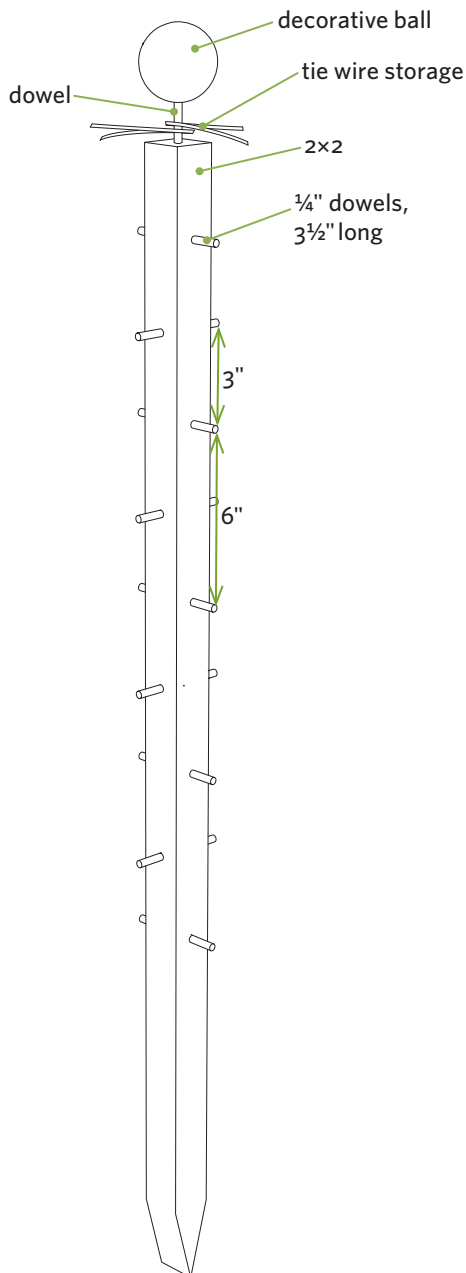

Option #3: Veggie Cages

These plant supports are sturdy in use and collapsible for winter storage. To erect them, position the stakes equally around the loops and drive them into the ground. To store them, pull the cage out, nestle the stakes side by side, and then lower the loops so they lie flat.

KEY BUILDING POINTS:

- Use pine lath, scrap lumber, or construction stakes.
- Stack the three stakes on top of one another and drill the holes for the wire loops through all of them at the same time for consistency.
- Preform the loops by wrapping 45" lengths of stiff wire around a 5-gallon bucket. Slide the wires through the stake holes, overlap the ends, and then twist them together with pliers to complete the loops.

Collapsed storage mode

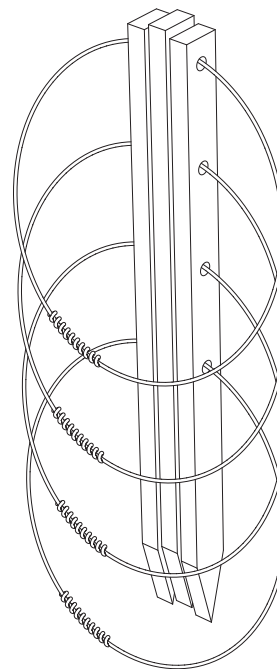

In-use mode

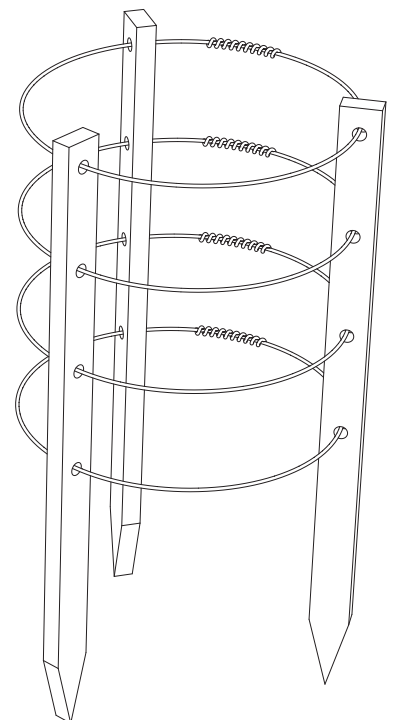

Option #4: Copper Trellis

Plant supports don't need to be boring. Or made of wood. This trellis, crafted from copper plumbing fittings and pipe, is a great use for those odds-and-ends plumbing parts lying around.

KEY BUILDING POINTS:

- Cut and dry-fit the pieces together before permanently securing them to one another.
- You can use propane and solder to secure the joints, especially if you need to practice your plumbing skills. But you can also secure the joints with epoxy or metal adhesive.
- Don't limit yourself to copper pipe: you can use iron, PVC, and other types of pipe, too. You can also build the outer frame from wood and incorporate pipe for the inner supports.

Copper trellis

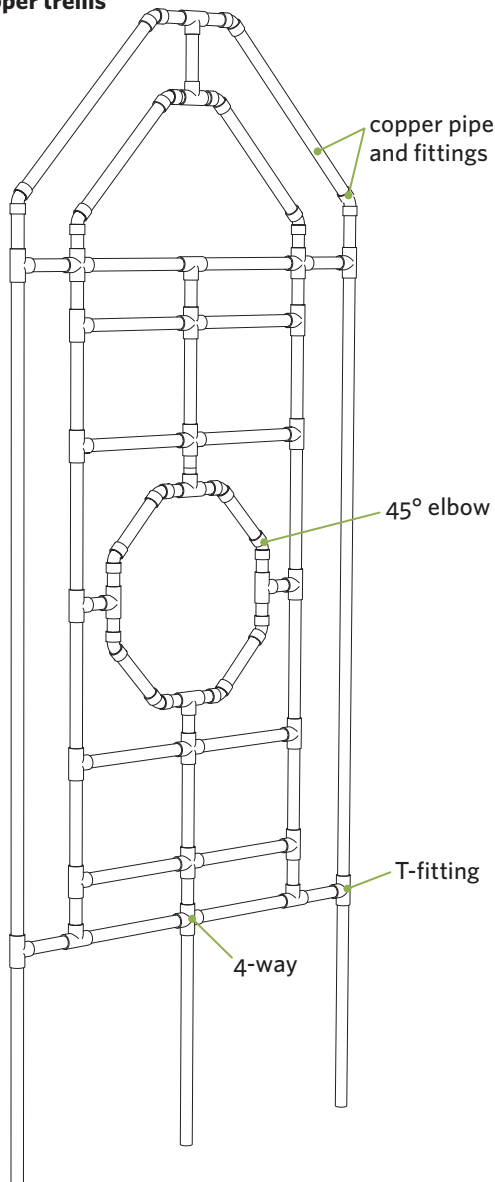

Option #5: Horizontal Gridwork

If you're a plant-'em-then-forget-to-stake-'em person, consider this horizontal plant support. Once you've guided the plants — tomatoes are a prime candidate — through the openings in the wire grid, they're free to stretch out and grow. The grid will keep your vegetables off the ground and less likely to spoil. You can also stake the plants vertically.

KEY BUILDING POINTS:

- Cut the wire mesh to size, and then build the box; that way you'll have solid support for the mesh and staples around the entire perimeter.
- Use U-shaped fence staples for holding the wire to the box.
- Install cross supports every couple of feet to help prevent the wire mesh from sagging. Install short stakes in each corner to secure the box to the ground.

Horizontal gridwork

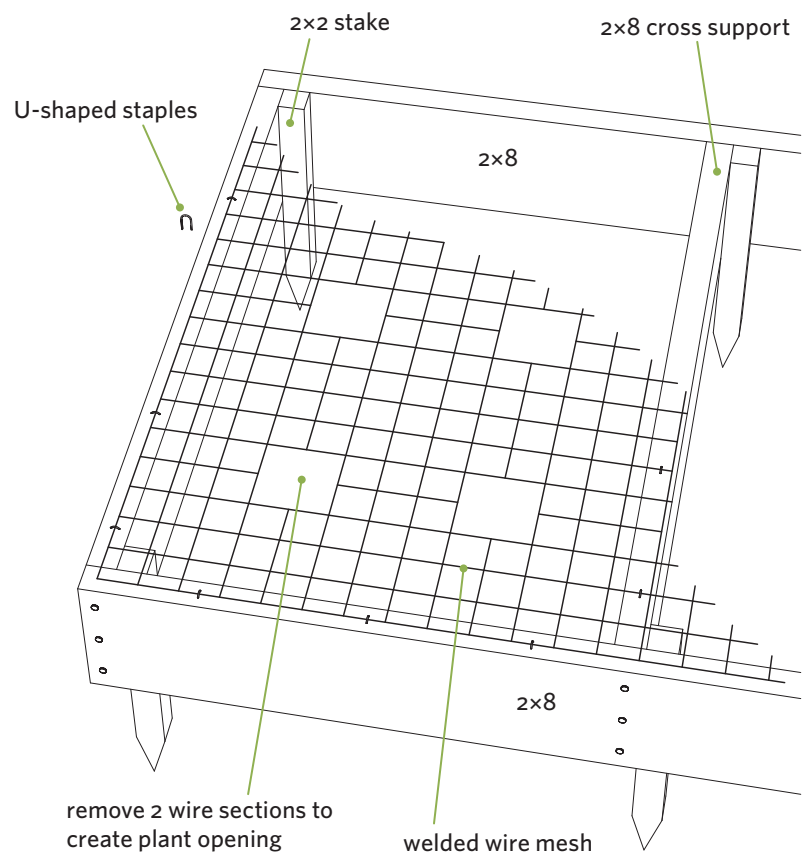

Bent Rebar Pergola

Use rugged masonry materials to build this shady retreat

A pergola can be wood or metal, large or small, decorative or functional. It can be used for supporting vines or creating a shady retreat. And it can be expensive! But not this one. This pergola uses inexpensive rebar and wire ladder mesh to create an attractive centerpiece for your garden or backyard.

One of the most time-consuming parts of this project is building the bending jig, or form, but once that's done the rest of the project moves forward quickly.

If you need an arbor or arched entryway for your garden, build and install just one set of loops.



Materials

- Two 4 × 8-foot sheets $\frac{3}{4}$ " plywood (for bending form)
- Four 10-foot 2×4s (for bending form)
- Two 8-foot 2×4s (for hold-down blocks)
- Scrap 2×8 lumber or five 8" concrete blocks (temporary spacers)
- Four 20-foot pieces $\frac{1}{2}$ " (#4) rebar
- Rebar tie wire (3.5-pound roll)
- Four pieces 8" × 10-foot ladder mesh (see step 7)
- One wood or metal finial (as desired)
- Eight 60-pound bags concrete (optional; see Take Note, after step 8)
- $1\frac{5}{8}$ " drywall screws (for bending form)
- 2" drywall screws (for bending form)

1. Build the 8 × 8-foot bending jig platform by positioning two sheets of $\frac{3}{4}$ " plywood over four evenly spaced 10-foot 2×4s and securing them with drywall screws.

TAKE NOTE If you have a large, open wood floor or deck, you can turn that into a bending jig, too. Just be aware that you'll wind up with lots of screw holes in it.

2. Using a nail as a centerpoint and a tape measure as a large compass, draw the 42" radius arch on the platform as shown. Use a drywall square or straight board to draw in the two 48"-long legs.
3. Create the grooved hold-down blocks by cutting a $\frac{1}{2}$ " × $\frac{1}{2}$ " groove along one edge of the 8-foot 2×4s, using a table saw, circular saw, or router with a rabbeting bit. Cut the 2×4s into 6" pieces.
4. Use 2" drywall screws to secure hold-down blocks every 12" along the *inside* edge of the layout lines for the hoop. Position one end of the rebar on the form, letting the bar extend about 3" beyond the bottom of the platform. Add more hold-down blocks along the *outside* of the straight portion of layout line to pinch the rebar and hold it place.

Bending jig

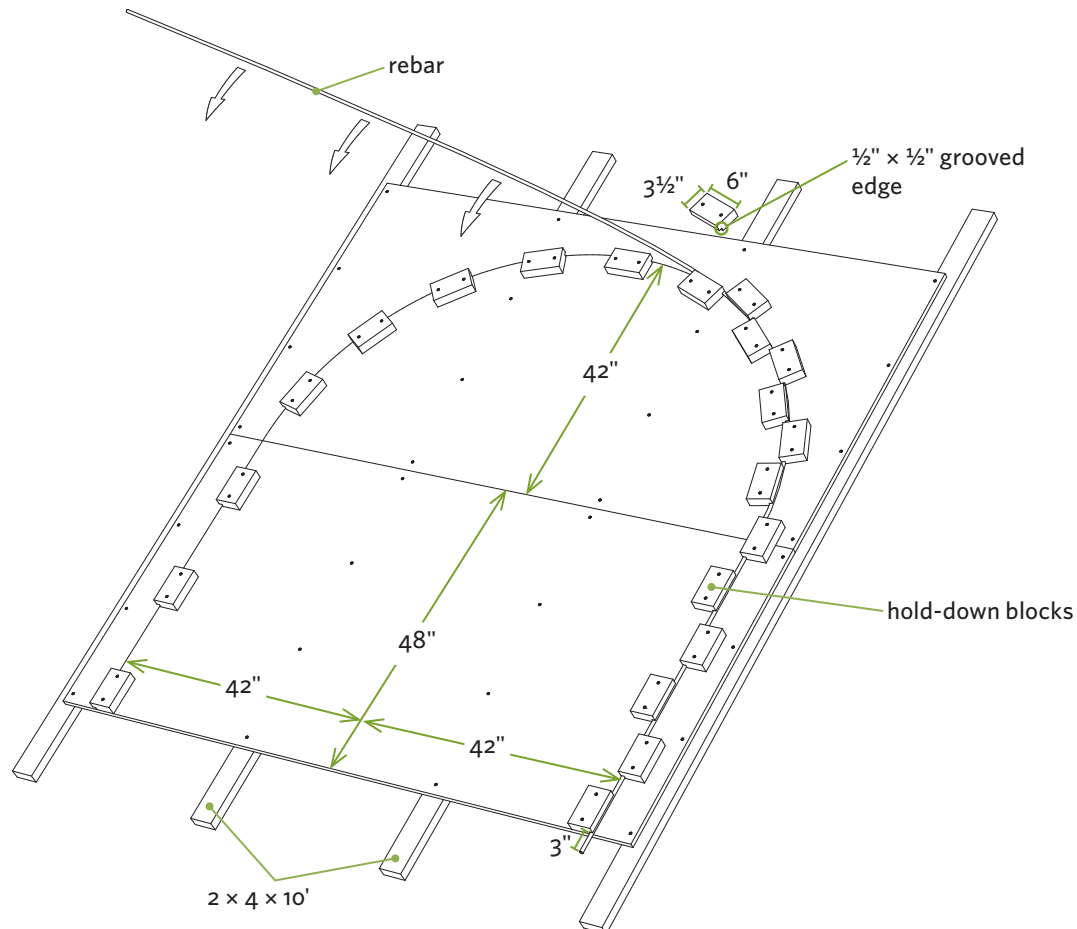

Tying on ladder mesh to create the arches

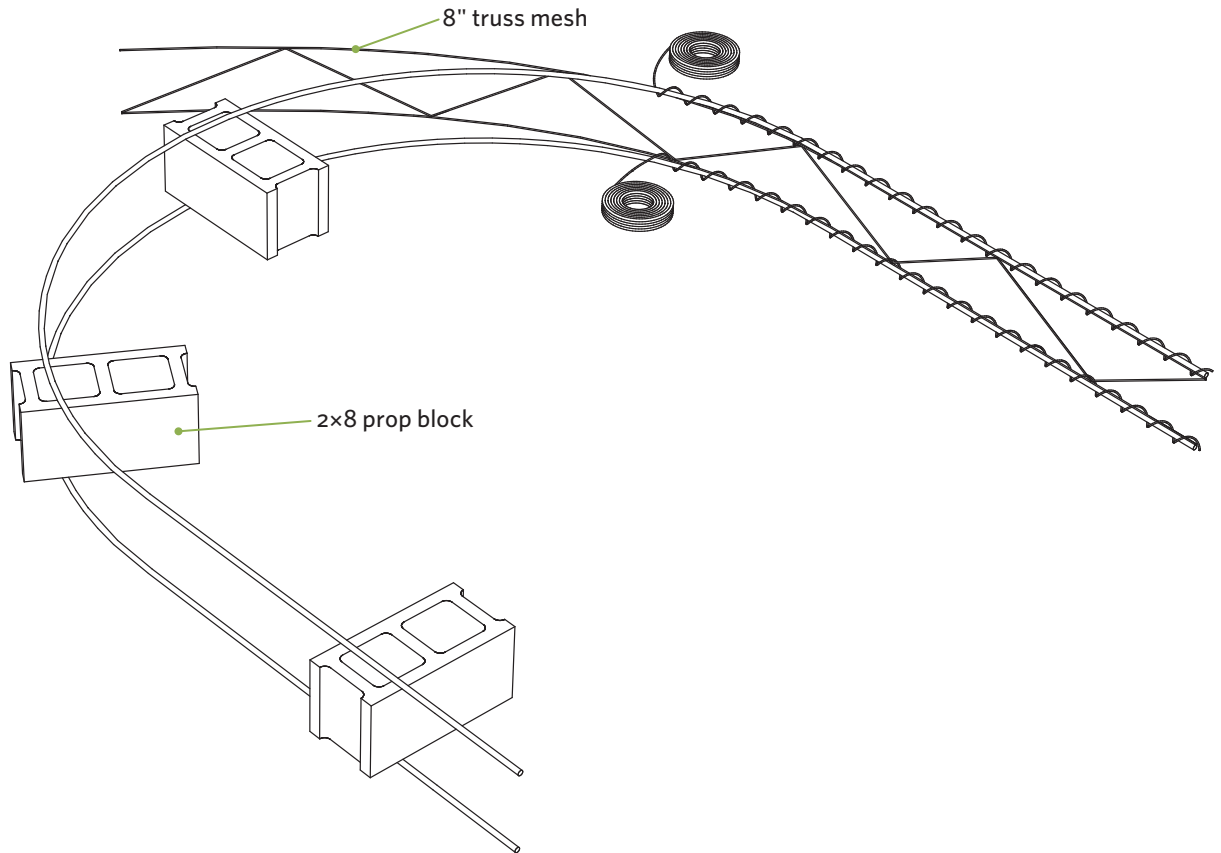

5. Put on gloves, grab the free end of the rebar, and start bending it around the curved part of the form. If the entire form moves, secure it to the ground or have a helper hold it in place. As you work, have a helper screw hold-down blocks to the outer edge of the hoop layout marks to hold the rebar in place.
6. When you approach the bottom of the arch on the opposite side, overbend the rebar a bit since it will tend to spring back; then, reposition the rebar against the inside blocks, and continue to have a helper add hold-down blocks until you've created the entire hoop. Use a hacksaw to cut off the end of the rebar so both legs are of equal length. Remove the outer hold-down blocks and then the rebar hoop. Repeat this three more times!
7. Place one hoop on the ground, position 2x8 scraps or 8" concrete blocks on top of it, and then place another hoop on top. Position a piece of ladder mesh near one end, and use rebar tie wire to secure the mesh to the hoops. Since it's hard to continuously wrap the wire around the bottom hoop, secure it with a few short pieces of wire. Then, once the top arch is fully secured, flip the arch over and finish wiring the other side. Build both hoop assemblies.

TAKE NOTE Ladder mesh is normally used for reinforcing the mortar line between rows of concrete block. It's available through lumberyards, home centers, and masonry suppliers but may need to be special-ordered in some areas.

8. Install your pergola by crisscrossing the tops of the hoop assemblies, wiring the tops together, and then wiggling the ends of the legs into the dirt. Add a decorative fence post finial or other doodad (use your imagination!) to the top for a finishing touch.

TAKE NOTE For a more permanent installation, set the legs in concrete. To do this, dig four holes to accommodate the legs. Wire the tops of the arches together, and then position the arches so the legs descend 6" to 8" into the holes. You'll need to have a helper or two to help you position the pergola and to slide scraps of rebar through the ladder mesh to hold the legs at the desired height. Check to make sure everything is plumb and level; then mix and pour the concrete into the holes.

Golf Cart Garden Dolly

An above-par use for a flea market find

If you've given up golf and taken up gardening, here's the perfect use for that old pushcart. Even if you don't have a cart sitting around, you can often buy one at a garage sale or flea market for a few bucks.

The bottom golf bag rest gives you the perfect place for perching a homemade plywood tray, the big wheels allow you to navigate rough or muddy terrain, and the overall design makes the dolly

easy to steer and push. You can customize yours to haul garden tools, pots, hoses, mulches, chicken feed, or anything else you want.

Every golf cart is a little different, so before you pick up your tools, scratch your head a little. Figure out how much space you have between the wheels and how you're going to attach the tray to the cart. Once you have the basics figured out, go at it.



Materials

(quantities as needed)

- Scrap $\frac{1}{2}$ " or $\frac{3}{4}$ " plywood
- One 4- to 6-foot 2x2
- One 12" to 18" 2x4
- $1\frac{1}{8}$ " or 2" screws
- Waterproof glue
- Pipe straps with screws
- U-bolts (with washers and nuts)
- L-brackets (optional)
- Hooks and other hardware, as desired

1. Build the open-front box or tray out of $\frac{1}{2}$ " or $\frac{3}{4}$ " plywood. Reinforce the box by gluing and screwing 2x2s into the corners or using metal L-brackets.
2. Secure the plywood box to the cart in at least three places for stability. Use U-bolts, pipe straps, or screws.
3. Accessorize your dolly. Add pairs of pipe clamps to hold long-handled tools and hooks for hauling hoses, ropes, and wire. Drill holes through 2x4 scraps and secure them to the box to create hand tool holders. Remove the upper curved bag rest, or leave it in place to help support tall objects you're hauling.

Exploded view of open-front box

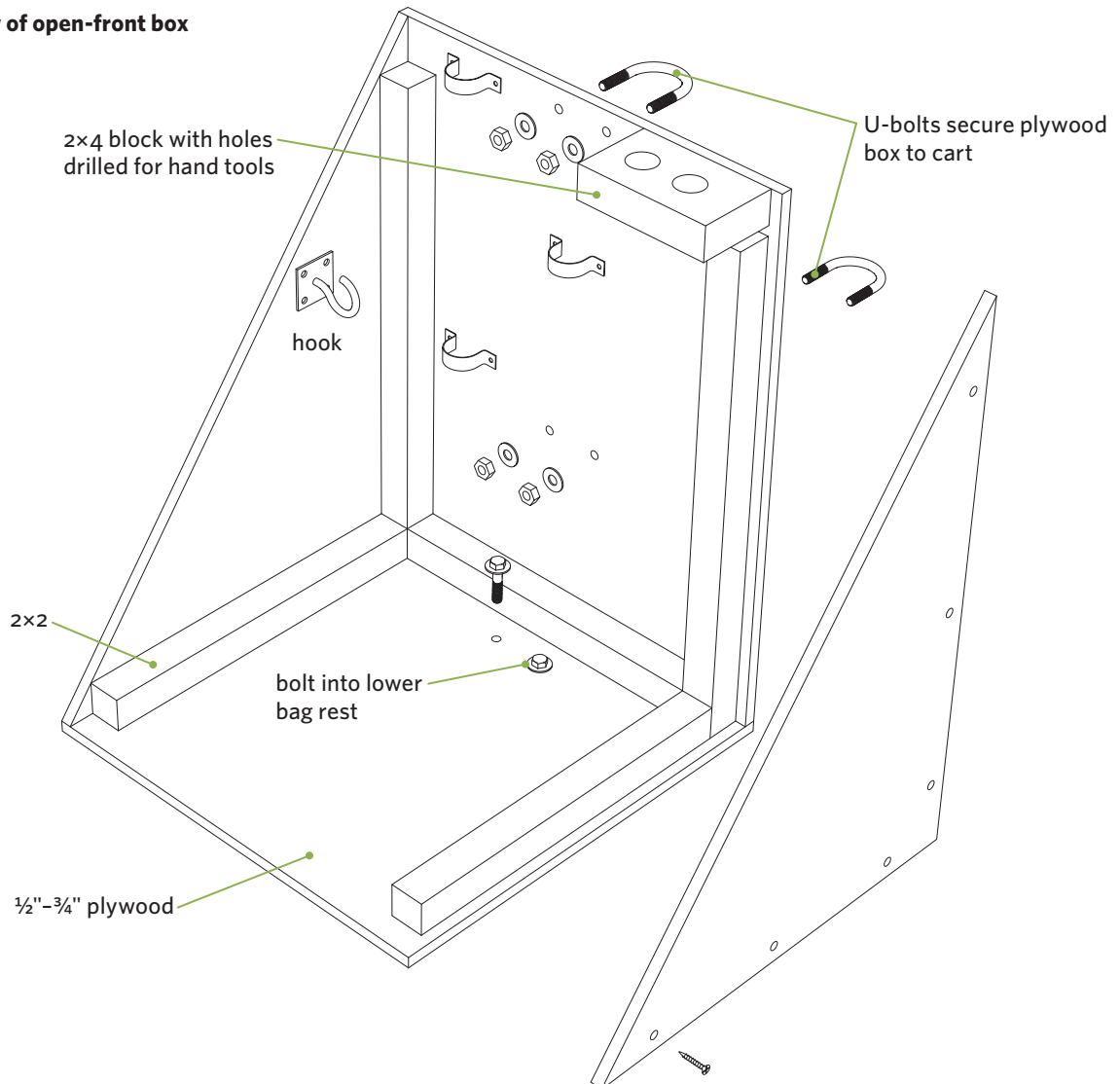

Rain Barrel Basics

Catch some falling water and save it for a rainless day

During an average rainfall, the average roof sheds more than 150 gallons of water per hour. Why let all that precious moisture go to waste? Rain barrels conserve not only water but dollars to boot.

Prior to breaking out the tools, picture an imaginary rain barrel in place and ask yourself some questions. Can you position it high enough so the water will flow naturally when you turn on the

spigot? Can you conveniently access the spigot? Does it look okay? Is it a convenient distance from the garden? Where will you divert the overflow? Another question is: Does local code allow this? Some areas have codes that restrict the use of rain barrels. Once you're satisfied with your answers, forge ahead.



Exploded view of rain barrel system

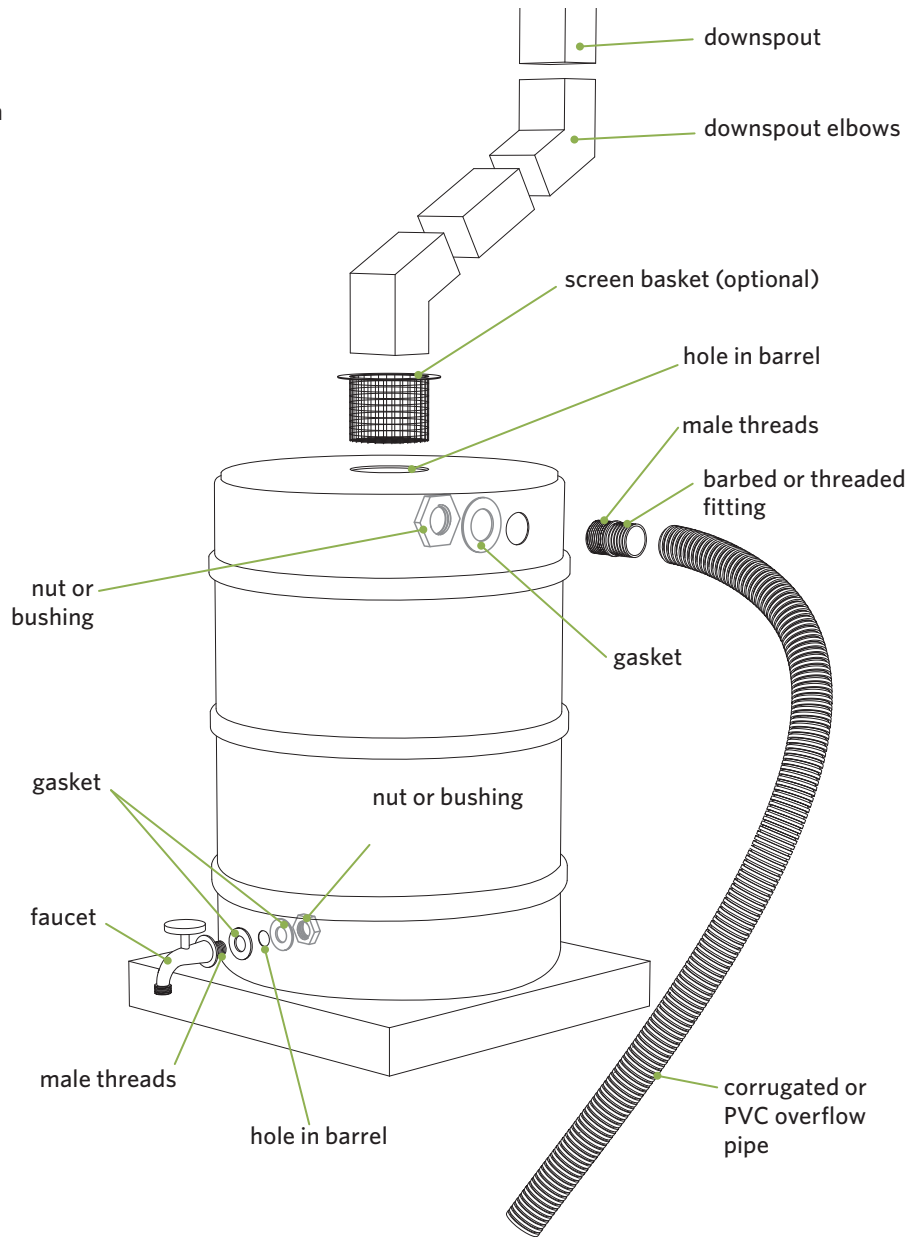

Building the Rain Barrel

Before starting the project, purchase faucet, downspout, and overflow fittings. You can buy them through hardware stores, home centers, and online retailers (see Resources). Some companies offer complete kits with all the needed parts for the three openings. Obtain a 30- to 80-gallon plastic barrel (see Barrel Considerations, page 84); cut the openings and install the fittings. There are many ways of tackling each assembly, so improvise as needed.

Faucet Assembly

For materials, you'll need a faucet with a threaded male nipple, two rubber gaskets, and a nut or bushing to fit the threaded nipple.

Use a hole saw to drill an opening near the bottom of the barrel that matches the diameter of the faucet nipple (threaded end). Slide a gasket over the faucet nipple, insert the nipple through the opening, slide a second gasket over the nipple inside the barrel, and secure the faucet to the barrel with a nut or bushing. You can heat the area with a hair dryer to soften the plastic so the fittings seat more tightly, and use silicone caulk to fill any gaps.

Downspout Inlet Assembly

You'll need a pair of downspout elbows or a flex connector to direct rainwater from the drainpipe into the barrel. A screen or screened basket to help keep debris and mosquitoes out of your tank is optional.

Determine the location of your downspout inlet. Trace around a short section of downspout (or the screen basket), and then use a jigsaw to cut the opening in the top of the barrel. Cut the downspout to the appropriate length, then use the elbows or flexible fitting to direct the water into the barrel.

Overflow Assembly

You'll need a fitting with threads on one end and a barbed, threaded, or gluable fitting or connector on the other. The outside connector should be able to accommodate an overflow pipe that's at least 1½" in diameter. You'll also need a nut for securing the fitting on the inside of the barrel and a hose clamp or other device to secure the overflow pipe to the fitting.

Drill a hole on the side of the barrel near the top, insert the threaded end of the fitting, apply a bead of silicone caulk, and secure it with the nut on the inside of the barrel. Connect the overflow pipe to the outside end of the fitting, making sure the pipe discharges to a well-drained area.

When you're done, and all caulk has dried, fill the barrel with water and check the fittings for leaks. You can stop minor leaks with a bead of caulk.

TAKE NOTE You can buy a device that will divert water into your rain barrel when it's less than full and through your standard downspout when the barrel is full (see Resources). Such devices require a different drainpipe inlet assembly than the one shown.

TAKE NOTE You can link two or more barrels together to expand capacity. This can be done with fittings similar to those used for the overflow assembly.

Barrel Considerations

You can purchase specialized rain barrels starting at about \$100, but if you're adventurous or thrifty you can track down yours for much less:

- Almost any container will work, though the more opaque, the less risk of algae growth. Plastic or wood barrels that hold 30 gallons and up are good candidates. You may be able to obtain a "food-safe" plastic barrel from a bulk food distributor for a reasonable price.
- Some communities offer rain barrel subsidies or barrels at reduced prices to qualified homeowners; search online or make a few calls to learn about programs in your area.
- Make sure the barrel didn't contain any pesticides or chemicals that could be harmful to people, plants, pets, or wildlife. If you're not sure what it contained, don't use it.
- You can use a heavy-duty plastic garbage can for your barrel. Make certain the lid fits securely and the sides are thick enough to support the weight of several hundred pounds of water.
- To minimize the chance of the barrel being used as a breeding ground for mosquitoes, add a tablespoon of vegetable oil from time to time to coat the top surface of the water.

How Safe Is the Water?

Most experts agree that you shouldn't directly drink water collected in a rain barrel. Beyond that there's little consensus as to which roofing materials, and what's on them, affect water purity, or to what extent. Below are some roofing materials and situations that could (I repeat, *could*) affect water purity and therefore the purity of the garden fruits and vegetables watered by the supply. If these possibilities concern you, use your water only for lawns and ornamental plants:

- Roofs composed of wood shingles or shakes that have been treated with chromated copper arsenate (CCA) or a fire retardant may leach harmful chemicals.
- Roofs with copper sheathing, flashing, or gutters, or with zinc antimoss strips, may leach harmful chemicals.
- Roofs that are frequented by birds, raccoons, and other animals may harbor droppings.

Some people prefer to let the first few heavy spring rainfalls flush debris and droppings from the roof before hooking up their rain barrels to collect water for the summer.

Potting Bench

A workbench for plant lovers

Where do you repot your plants and divide your hostas? In the laundry room sink? On your knees in the garage? On your picnic table? Well, here's a permanent substitute for those improvisational places. This handy bench allows you to work at a convenient height and to stash all your tools and supplies in one central place. The tubs or bins on the sides give you a place to stash your peat, soil, compost, waste, and other materials.

If you're building this for outside use, build it from cedar (like I did) or use treated pine or

other rot-resistant lumber (see *Selecting the Best Exterior Wood*, page 16). For inside use, any lumber is fair game.

Before building your bench, purchase the storage tubs or baskets you'll be using for the cantilevered wings; then tweak the dimensions of the bench parts accordingly. The project is broken into separate sections for the bench and cabinet construction; if you need just one of the components, you can build only that part of the project.



See page 1 for a photograph of this project.

Bench Materials

- Ten 8-foot cedar 2×4s
- Four 10-foot cedar decking boards
- Construction adhesive
- 10d galvanized nails
- 3½" exterior screws
- 8d galvanized nails

Building the Bench

1. Cut the 2×4 legs (A, B) and leg blocks (C, D) to length; then secure them to one another using construction adhesive and 10d galvanized nails. Make the space between the blocks wide enough to tightly sandwich the platform and slats that fit between. A too-big gap will result in a wobbly bench; a too-small gap will result in you having to persuade the parts together with a hammer or having to cut the blocks shorter while in place.
2. Build the frames (E, F, G) for the top and bottom platforms, fastening the corner joints with 3½" exterior screws. Check to make sure the openings on the ends of the top platform will accommodate your tubs. (You bought the tubs first, right?) If the openings are too large, use 1×4s or 2×4s to fill in the extra space.

Bench Parts and Cutting List

Part	Size and Material	Quantity
(A) back legs	1½" × 3½" × 80" cedar	2
(B) front legs	1½" × 3½" × 30" cedar	2
(C) bottom leg blocks	1½" × 3½" × 3½" cedar	4
(D) middle leg blocks	1½" × 3½" × 18½" cedar	4
(E) lower platform, front/back	1½" × 3½" × 46" cedar	2
(F) upper platform, front/back	1½" × 3½" × 84" cedar	2
(G) platform crosspieces	1½" × 3½" × 24" cedar	8
(H) upper and lower platform slats	1" × 5½" × 28¾" cedar decking	16

3. Check to make sure the platform frames are square; then install the 1×6 slats (H) using 8d galvanized nails. To prevent splitting, predrill the nail holes.
4. Lay the two back legs on a solid, flat surface, and fit the bottom platform into the notches you created between the blocks. Position the top platform on top of the middle leg blocks (D). Secure the platforms to the back legs with 3" exterior screws. Use construction adhesive if you want to increase rigidity. Install the front legs and secure them in place with screws.

TAKE NOTE If all you need is a bench, stop here. Add open shelves to the back uprights and support them with brackets. If you want a storage cabinet, read on!

**Bench construction —
exploded view**

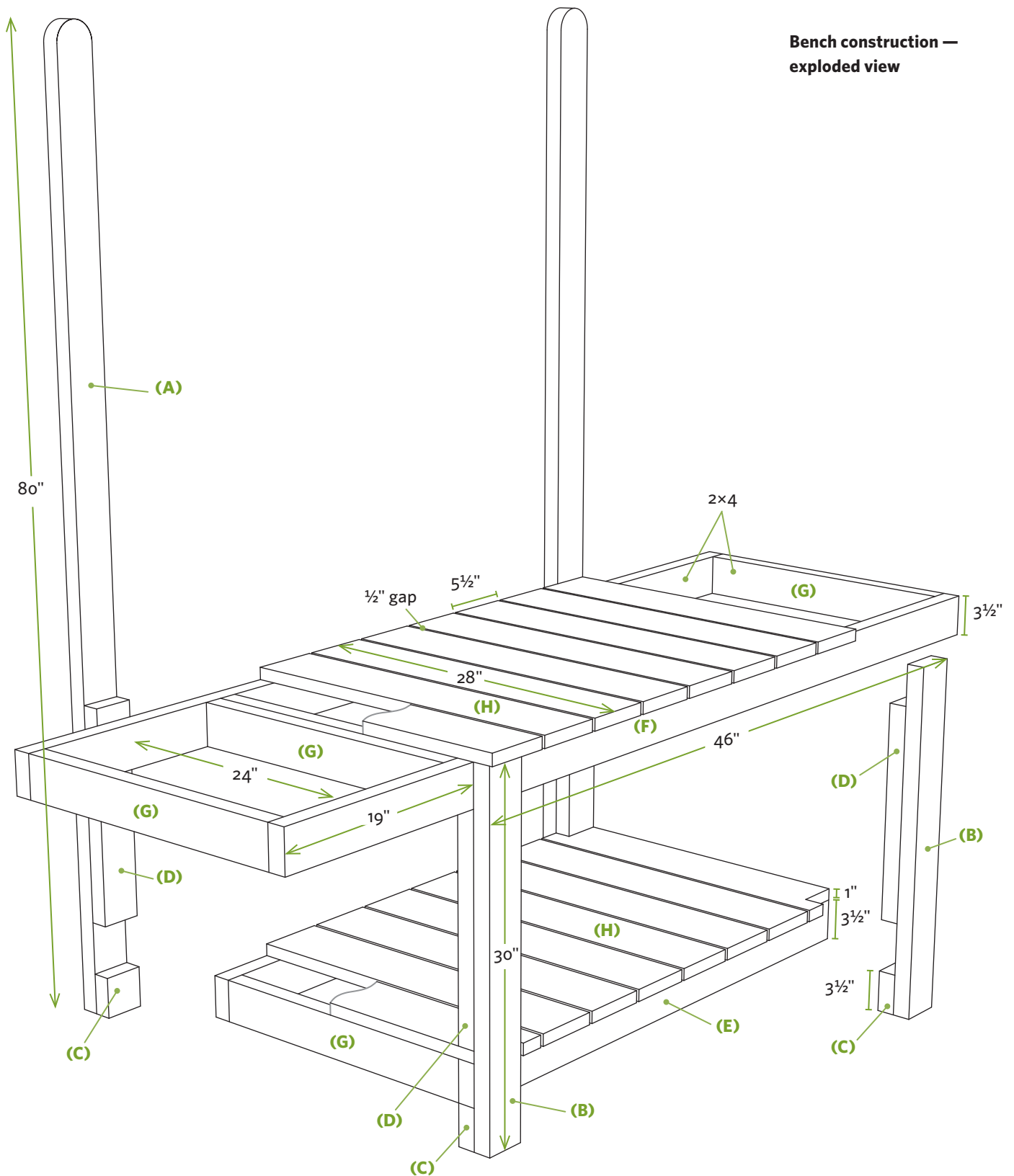

Stay Mud-Free

To prevent the soil or other potting materials in the plastic bins from turning muddy, save the plastic tops and snap them in place when you're done for the day. You can also drill a few holes in the bottom of each tub to provide drainage.

Cabinet Materials*

- Two 10-foot cedar 2×10s
- Five 10-foot cedar tongue-and-groove 1×6 boards
- One 4-foot cedar 1×12
- Three 8-foot cedar 1×4s
- One 4-foot cedar 2×4
- One 3-foot cedar 2×2
- 4" exterior screws
- 1¼" exterior screws
- Four 3" no-mortise hinges
- One door hasp or other latch, with screws

*All lumber materials are cedar. Cedar board dimensions aren't as uniform as those of pine and treated pine; adjust your measurements accordingly. Most deck board material (H) is a true 1" thick.

Building the Cabinet

1. Build the cabinet box by securing the bottom, top, and shelves (K) to the cabinet sides (J) using 4" exterior screws. You can alter the spacing of the shelves according to your needs.
2. Check the cabinet box to make sure it's square by measuring the diagonals; then install the tongue-and-groove backboards (L). You'll need to rip the last board lengthwise to fit.
3. Secure the cabinet top cap (M) in place. Position it so the back edge is flush with the back of the tongue-and-groove boards and the ends overhang the sides equally.
4. Install the 2×2 door divider (T). Measure from the edge of the cabinet to the divider and make your doors about ¼" smaller in width. Fit five of the 1×6 tongue-and-groove boards (N) together to create a door panel wider than you

Cabinet Parts and Cutting List

Part	Size and Material	Quantity
(J) cabinet sides	1½" × 9¼" × 28"	2
(K) cabinet top/ bottom/shelves	1½" × 9¼" × 43"	4
(L) cabinet backboards	¾" × 5½" × 28" (tongue-and-groove)	9
(M) cabinet top cap	¾" × 11¼" × 48"	1
(N) door boards	¾" × 5½" × 28" (tongue-and-groove)	10
(O) door battens	¾" × 3½" × 23"	4
(P) door cross battens	¾" × 3½" × cut to fit	2
(Q) upper leg blocks (back only)	1½" × 3½" × 14"	2
(R) cabinet support brackets	1½" × 9¼" × 12"	2
(S) cabinet top rail	¾" × 3½" × 46"	1
(T) cabinet door divider	1½" × 1½" × 28"	1

need. Mark out the width of the actual door on this panel; then separate the boards and rip one or both end boards to width so when the boards are reassembled the door will be the correct width. Fit together the boards again and lay them on top of your cabinet opening to make sure they're the right dimensions.

5. Place 1×4 door battens (O) near the tops and bottoms of the doors, check to make sure everything fits right, and then secure the battens to the 1×6 door boards (N) with 1¼" exterior screws. Lay the cross battens (P) in place, mark them, cut them to the correct angle and length, and then secure them in place.
6. With the cabinet still on its back and the doors still in place, secure the doors to the cabinet using 3" hinges. Install pulls for opening the doors and a hasp for keeping them shut.

**Cabinet construction —
exploded view**

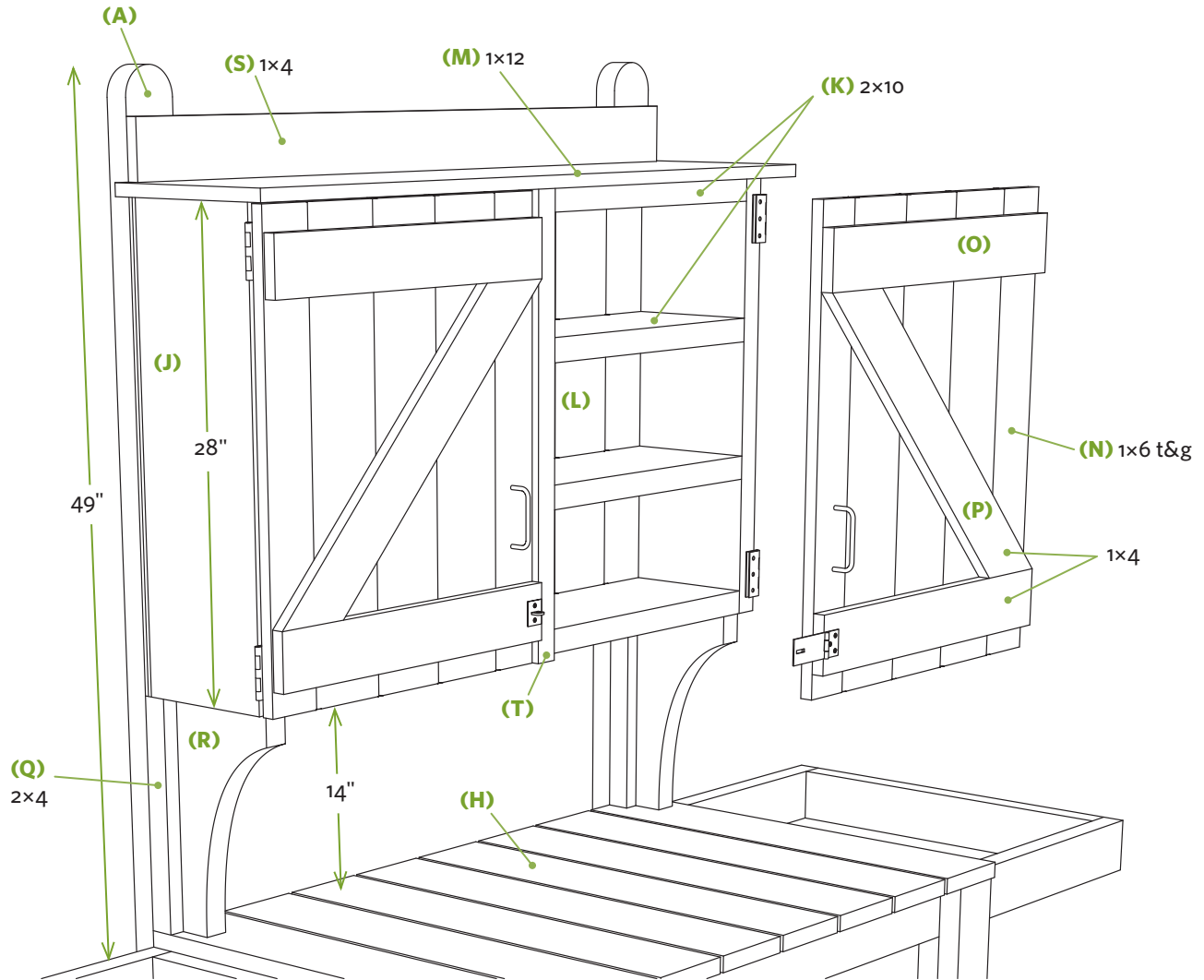

Assembling the Bench and Cabinet

1. With the bench on its back, position the cabinet on the back legs (A) 14" above the top platform. Secure the cabinet to the legs by driving screws through the cabinet back and sides.
2. Cut the upper leg blocks (Q) and secure them to the back legs (A) to support the bottom of the cabinet.
3. Create and install your own cabinet support brackets (R) or use store-bought metal shelf brackets. Install the top rail (S) to add rigidity to the cabinet and prevent objects placed on top of the cabinet from falling off the back.

Play It Safe

To secure your potting bench and prevent it from tipping due to unequal loading or climbing kids and cats, anchor it to a wall, railing, tree, or fence with screws. You can also secure the legs to a concrete slab with L-brackets and concrete fasteners.

Hoop Greenhouse

Extend your growing season with this easy-to-build greenhouse

If you yearn for a longer growing season, you don't have to pack up and head south: you can simply head to your nearest home center and pick up materials to build this hoop greenhouse. It's designed to be

assembled in a weekend, and it can easily be made larger by adding more hoops. It's also easy to adapt this basic design to enclose the timber raised-bed garden (page 69).

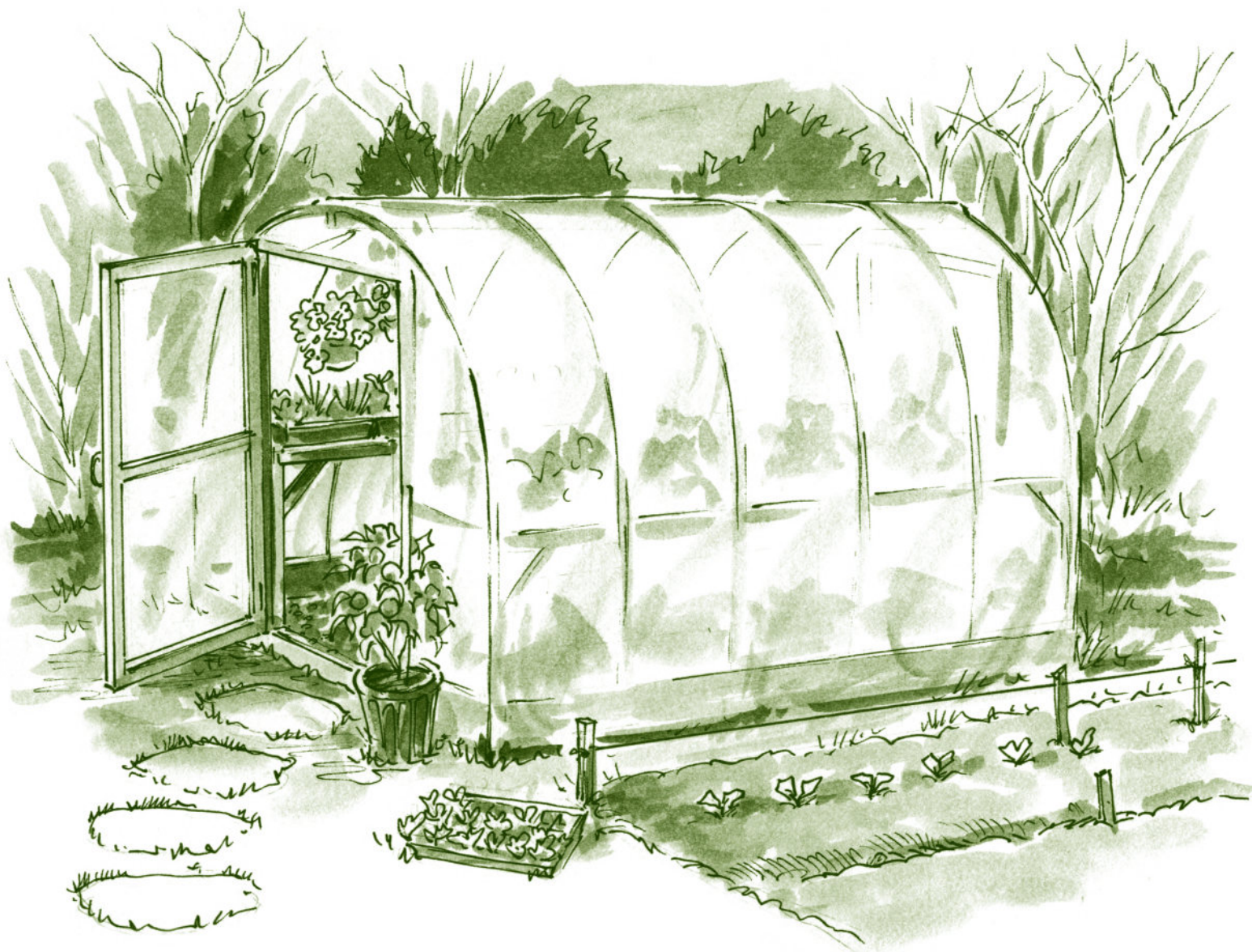

See page 5 for a photograph of this project.

Materials

- Two 10-foot pressure-treated 2×12s
- Two 8-foot pressure-treated 2×12s
- Three 10-foot pine 2×4s
- Ten to twelve 8-foot 2×3s (pressure-treated if available)
- One 8-foot pressure-treated 1×2
- Twelve ¾" × 10-foot thin-wall PVC pipes
- Six ¾" PVC couplings
- Two ¾" × 10" metal reinforcing straps
- Twenty-four ¾" conduit clamps
- One 20 × 25-foot roll 6-mil polyethylene sheeting
- Thirty polyethylene U-clips
- 1¼" exterior screws
- 1⅝" exterior screws
- 3" exterior screws
- 5" timber screws

Building the Greenhouse Base

1. Lay the two base sides (A) and the ridge board (C) side by side with the ends even, as shown in *Side and ridge board layout*, page 92. Make marks 1" in from each end, and in addition mark every 24" along the edge of one board. Use a framing or drywall square to extend the lines across all the boards. Make a second set of marks 1" away from each of the first lines, and draw a second set of lines (except for on the ends).

Parts and Cutting List

Parts	Size and Material	Quantity
(A) base sides	1½" × 11¼" × 120" PT lumber	2
(B) base ends	1½" × 11¼" × 96" PT lumber	2
(C) ridge board	1½" × 3½" × 120" pine	1
(D) ridge connectors	¾" PVC couplings	6
(E) reinforcing strap ¹	¾" × 10" metal strap	2
(F) hoop end holders	¾" conduit clamps	24
(G) hoops	¾" × 120" thin-wall PVC pipe	12
(H) stakes	1½" × 2½" × 36" pine	8
(I) end wall framing	1½" × 2½" × 84" pine	6-8
(J) roof & wall sheeting ²	20 × 25-foot 6-mil polyethylene	1 roll
(K) polyethylene anchors ³	U-clips	30
(L) door flap weight	¾" × 1½" × 36"-48"	1-2
(M) base blocking	1½" × 2½" × 22"-24"	10
(N) solid end wall braces	1½" × 3½" × 32"	4
(O) door frame bracing	1½" × 3½" × 36"	2
(P) door end wall angle studs	1½" × 3½" × approx. 72"	2

¹Reinforcing straps (E) can be found in the joist hanger section of lumberyards and home centers.

²Standard 6-mil polyethylene (J) is widely available. Special types that are reinforced, have anticondensate additives, and have other features are available through farm supply retailers (see Resources).

³U-clips (K) can be purchased from online hardware suppliers (see Resources).

2. To drill 1⅜" holes in the center of the ridge board (C) for holding the PVC couplings, start by drawing crosshairs through the center of each pair of layout marks to establish the center of the hole. Drill the holes, keeping your bit or hole saw as vertical as possible. Insert the couplings and drill a ⅜" hole through the top of the ridge board into the center of each coupling. Use a 1⅝" drywall screw to secure the coupling to the ridge. Bend and nail the metal reinforcing straps (E) over and around the ends to prevent the ends of the ridge board from splitting.

Side and ridge board layout

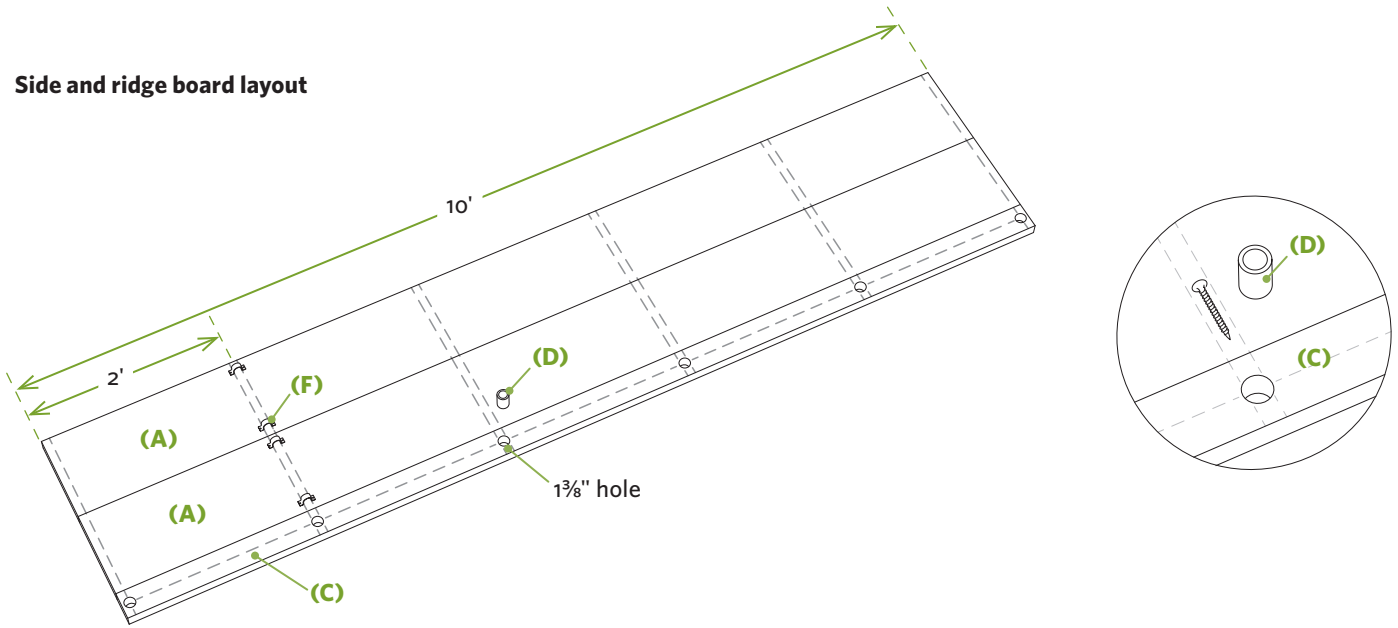

Greenhouse framework

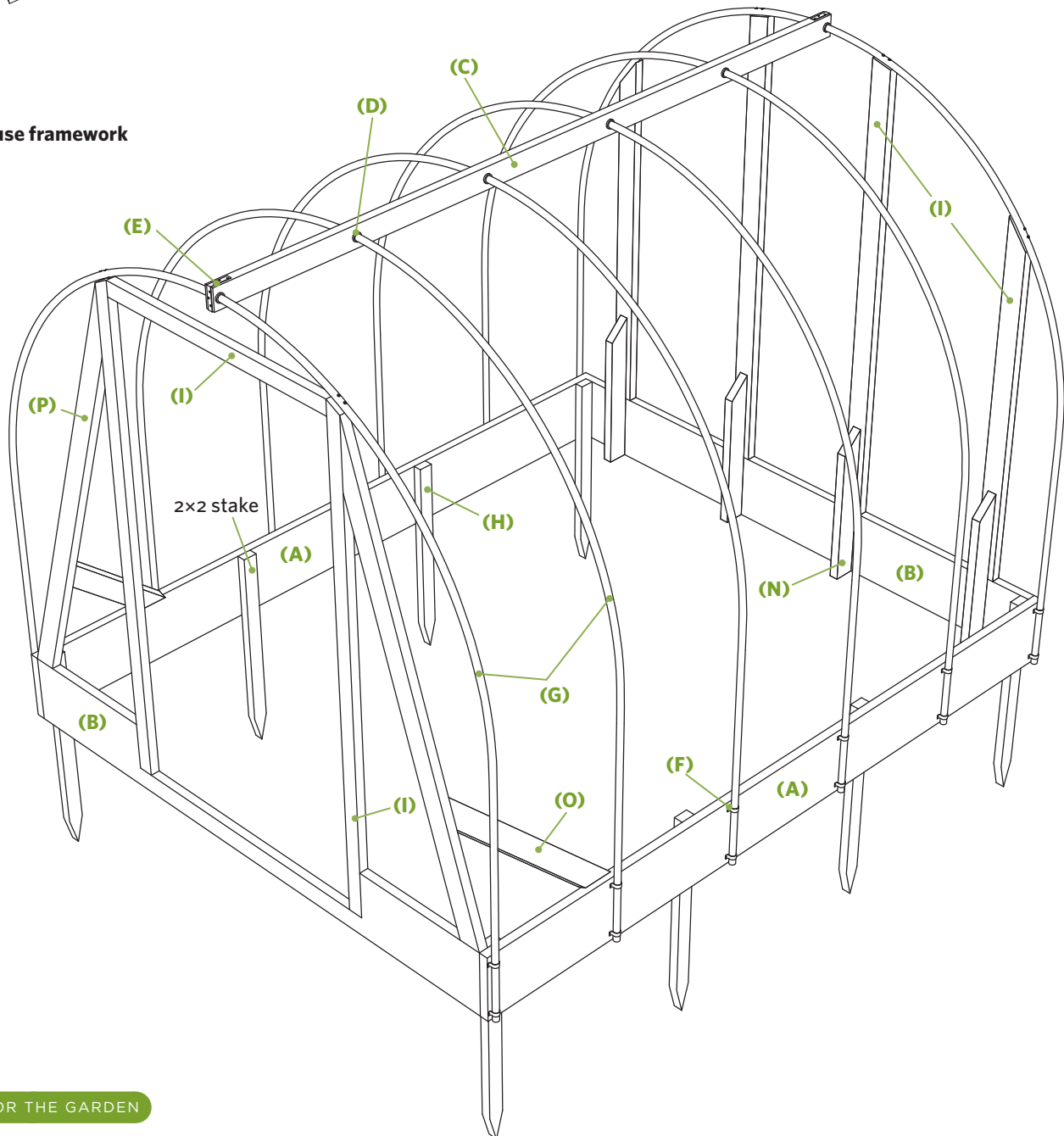

TAKE NOTE Buy your couplings before you drill the holes; diameters can vary, and you want a tight fit.

3. Install the hoop end holders (F; U-shaped conduit clamps) on the base sides (A) for holding the hoop ends. For each hoop end, install two clamps, each about 1" from the top or bottom edge of the 2×12 sides and centered on each layout line, and loosely drive a 1¼" screw through each hole; you'll tighten them after the hoops are installed.
4. Cut the end boards (B) for the greenhouse base and use 3" screws to secure them between the side boards (A) as shown in *Greenhouse framework* (facing page). Position the frame where your hoop greenhouse will be located.

TAKE NOTE You'll make the doorway cutouts on one or both ends (B) after the framework of the house is up.

5. Measure diagonally from one corner of the frame to the opposing corner; when the measurements are equal, your base is square. Use a level to check the frame for level on all four sides. If it's not level, use spray paint to mark the perimeter of the frame, set the frame aside, and then use a shovel to level the area. Reposition the frame, check again for level, and repeat until your frame is square and level. Pound in stakes (H) at the corners and at least two other places along each side; then secure the base frame to the stakes with 3" exterior screws.

Completing the Greenhouse Structure

1. Lay the ridge board (C) in a large flat area. Insert and twist the ends of each 10-foot PVC pipe for the hoops (G) into the coupling on each side of the ridge. Make sure the pipes are inserted all the way, until they hit the little lip inside the coupling. Give the ends of the pipe a shot of spray lubricant if you're having trouble sliding them in. Drill a ⅛" hole through the edge of the coupling and secure each pipe using 1¼" screws. When you're done, the assembly will look like a 10 × 20-foot rib cage.
2. Set a couple of stepladders in the center of the greenhouse frame, and set the ridge beam on the ladders. Starting at one end of the house, have two helpers grab opposite ends of the PVC pipes, bend them, and insert the ends through the hoop end holders (F). (You left the clamps loose, right?) Bend and install the pipes on the other end of the house; then install the intermediate ribs. Tighten the screws in the hoop end holders. The main structure is up.

3. You need to take the "wiggles" out of your structure before framing the end walls. Measure from the ground to the bottom of the ridge board near each end, then cut and secure temporary 2×4s of that length near each end to keep the ridge from sagging. Install angle braces from these temporary 2×4s to stakes pounded into the ground to hold the ends of the ridge board plumb with the end walls below. Keep these temporary braces in place until the end walls are framed and permanently braced (see Step 7).
4. Determine the width of the door. You can have a door on one or both ends of the house, and they can be anywhere from 36" to 44" wide. Cut the 8"-deep notch for each doorway in the base end (B) with a circular saw or jigsaw.
5. Frame each door opening by standing up a 2×3 (I) at one side of the planned opening; plumb it, and then use a pencil to mark the angle where the hoop crosses it (see *Door frame and house covering details*, page 94). Cut the angle. Secure the bottom of this wall stud to the edge of the door opening with 5" screws. Drill a pair of holes where the wall stud (I) meets the hoop, and secure it with two 3" screws. Install a horizontal 2×3 to create the top of the door. Install the angled studs (P).
6. Frame the solid wall, starting with 2×3 studs (I) spaced 12" on each side of the ridge board (C). Fasten each stud to the ridge and base end with 3" screws. Install one more stud spaced 24" to each side of these studs; you have to mark and cut the top ends of these like you did with the door studs.
7. To permanently brace the solid wall studs, screw 2" × 4" × 32" blocks (N) to the base end (B) and the end studs (I) as shown in the illustration. Use at least four 3" screws per stud (two in the base end and two in each stud). On the "door" side, run 36"-long angle braces (O), with 45 degree cuts on each end, from the angled studs to the side base pieces (A) as shown.

Door frame and house covering details

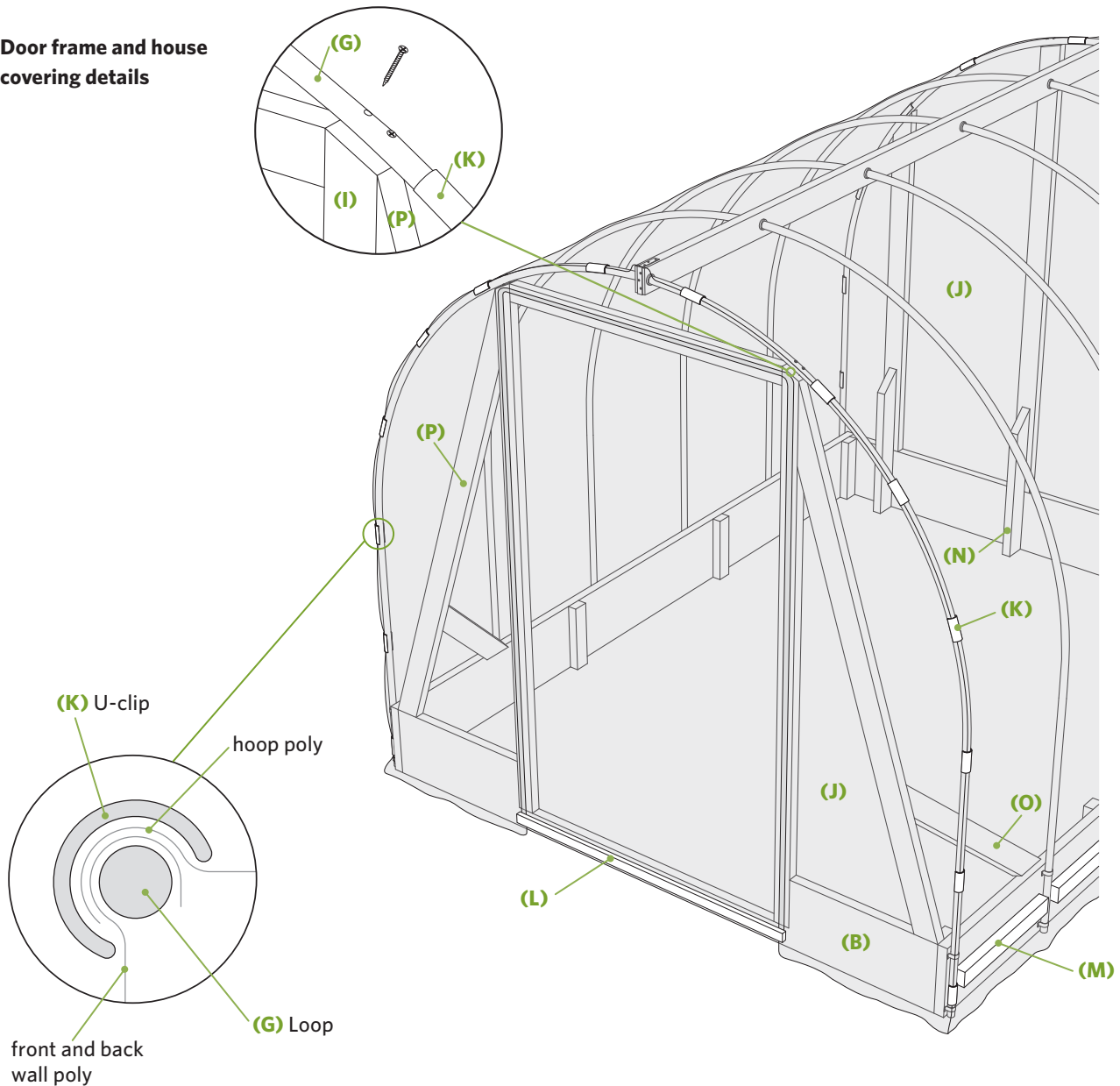

Installing the Plastic Cover

1. Cover the ends with polyethylene (poly) sheeting (J) as shown. Begin by cutting a 9 × 9-foot piece of poly for each end. Use a staple gun to secure the poly along the bottom edge of the base end (B) on the *outside* of the board. Have a helper stretch the poly upward as you secure it to the vertical 2×3s with staples. Initially hold it in place with just a few staples; then once it's stretched tight, install additional staples. Wrap the poly around the end hoops, and hold it temporarily in place with duct tape. Trim any excess poly with a sharp utility knife.

2. Cut out the poly in the door opening, leaving 2" to 3" of extra material so you can wrap it around the door framing to secure it better. Create the door flap by cutting a piece of poly a few inches larger than the door opening in each direction and stapling it to the outside top of the door frame. On the bottom, wrap the poly around a 1x2 door flap weight (L) and staple it.

TAKE NOTE You can construct a more elaborate swinging door from 1×3s or 2×3s and poly for convenience.

3. To cover the hoops, start by cutting a piece of poly to size at 12 × 20 feet; roll it up to create a 12-foot-long tube. Center the roll along one side, and use staples to secure the leading edge to the bottom of the side board (A); the poly will bulge a little where it crosses over each hoop. Using a helper, unroll the poly up and over the ribs. Staple it at the ridge, and then run it down to the base side board on the other side of the house. Install a few more staples to hold it in place. Wrap the plastic around the hoop ends, and secure it and the end-wall poly to the hoops with the U-clips (K). You can use gigantic binder clips to hold the poly in place while installing it or wherever extra grip is needed.

TAKE NOTE I used clips from Lee Valley (see Resources). Enterprising souls can make their own clips by cutting stiff polyethylene tubing into short lengths, then slitting it. However, I found it way easier, and almost the same price, to use the store-bought clips.

3. Once the plastic is pulled taut and the ends are secure, install blocking (M) between the hoops on each base piece. Make sure the ends of your blocks don't puncture the plastic.

LESSONS FROM THE HOMESTEAD

A King-Size Hoop House for Year-Round Produce

BY ROGER NELSON

We loved the idea of growing and eating fresh produce year-round. So with the help of friends, over two weekends, we erected a 24' × 36' "high tunnel" hoop house kit from FarmTek (see Resources). The project was made financially feasible through a USDA matching grant available at the time for high tunnel greenhouses. It's worth your time to look into similar programs and options in your area. The size is actually much smaller than the 48' × 96' size used by other local growers, but that seemed dauntingly large to us. We didn't want to lose pasture for our cows or have such a huge visual impact on our little farm.

Our hoop house has two layers of plastic and a small pump — that costs only pennies a day to run — to blow air between the layers to increase insulation. Growing in the unheated hoop house is like being in an area two growing zones warmer. During our first full season, to play it safe, we decided to plant cool season crops like chard, radishes, spinach, beets, carrots, kale, scalions, tatsoi, broccoli raab, and pansies. In November, we covered the plants with Agribon row covers, which added another 4 degrees protection. Being in Minnesota, we expected the veggies to be done by Thanksgiving, but during the mild winter were able to reap the bounty year-round.

We love working inside the hoop house during the winter — a warm, sunny spot with an earthy smell and all that green. The size has turned out to be just right. We grew plenty of fresh produce for ourselves, plus for a few farm customers. We have enjoyed great beginner's luck so far — no weeds, no freezing, no insects. However, now that we've begun to open up the sides for ventilation as warm weather approaches, the chickens have discovered the yummy greens growing inside. Our latest project? Erecting garden fencing along the walls of the hoop house to keep the critters out.

ROGER NELSON and his wife, Susan Waughtal, revived an existing farmstead in southern Minnesota into Squash Blossom Farm, where they live today. They grow most of their food and host regular Sunday get-togethers at which they serve up pizza, cheese, fresh produce, and live country music. They also host an annual Blessing of the Cows. (See Resources for more information.)

Rustic Trellis

A natural home for climbing vines

This simple bent-branch trellis gives climbing plants of every kind a place to stretch out and grow: morning glories, pole beans, ivy, you name it. Best of all, if you have access to branches and a couple of sheets of plywood lying around for the form, you can build it for the cost of the fasteners, about \$5.

You can mount the finished trellis to a wall or fence, or install it as a freestanding structure. Here you'll learn how to build a fan trellis, but you can use the same techniques, tools, and materials to build a trellis of any size and shape; hearts,

diamonds, and ovals are other popular motifs. The most suitable branches are those ranging from 1" to 2" in diameter. (See *Locating the Right Branches: Which, When, Where, and How*, page 99, for more specific information.)

You can build your trellis free-form, but if you want symmetry, or two or more trellises of a similar shape, create the form shown using two pieces of $\frac{3}{4}$ " \times 4 \times 8-foot plywood secured to each other. A wood floor or deck (one you don't mind driving screws into) will also work.



Materials

- Two 4 × 8-foot sheets $\frac{3}{4}$ " plywood (for form)
- Three 8-foot 2×4s or scrap lumber (for form)
- Branches
- $1\frac{5}{8}$ " screws
- 3" exterior screws

1. Build the form by laying two sheets of plywood side by side and joining them with $1\frac{5}{8}$ " screws and 2×4s or scrap lumber positioned on the back sides of the panels. Draw a centerline on your form (or use the joint between pieces of plywood) as shown, and then install a screw 12" up from the bottom. Using that screw as a centerpoint and your tape measure as a compass, draw the four arched horizontal arms of the trellis with 50", 60", 70", and 80" radii.

Trellis form layout

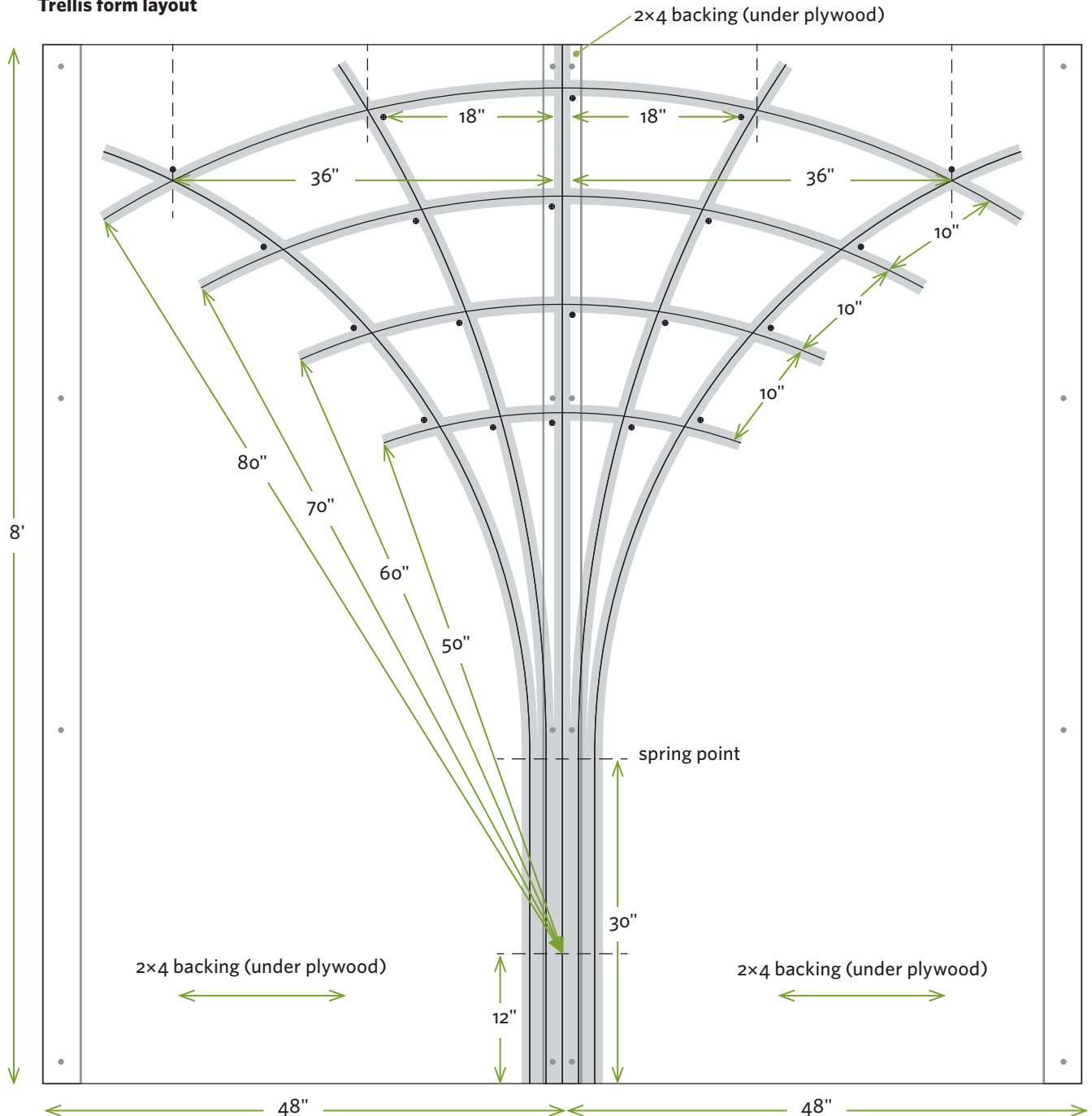

2. Make a mark 30" up from the bottom of the centerline to serve as the spring point. Make marks 18" and 36" on each side of the centerline where they intersect the uppermost arched arms, as shown in *Trellis form layout*, page 97. Bend a thin strip of wood between these points and the spring point (a helper will make this easier), adjusting the tension until you get the right curve. Then trace along an edge to create the pattern for the uprights.

3. Install 3" screws to serve as pivot points where the arms and uprights intersect, as shown below. Note that the pivot screws on the ends of the arms are installed above the marks, and the rest below; this helps create leverage points when bending the branches. If your branches are exceptionally stiff, you may need to screw down blocks instead of just using screws.

Trellis assembly

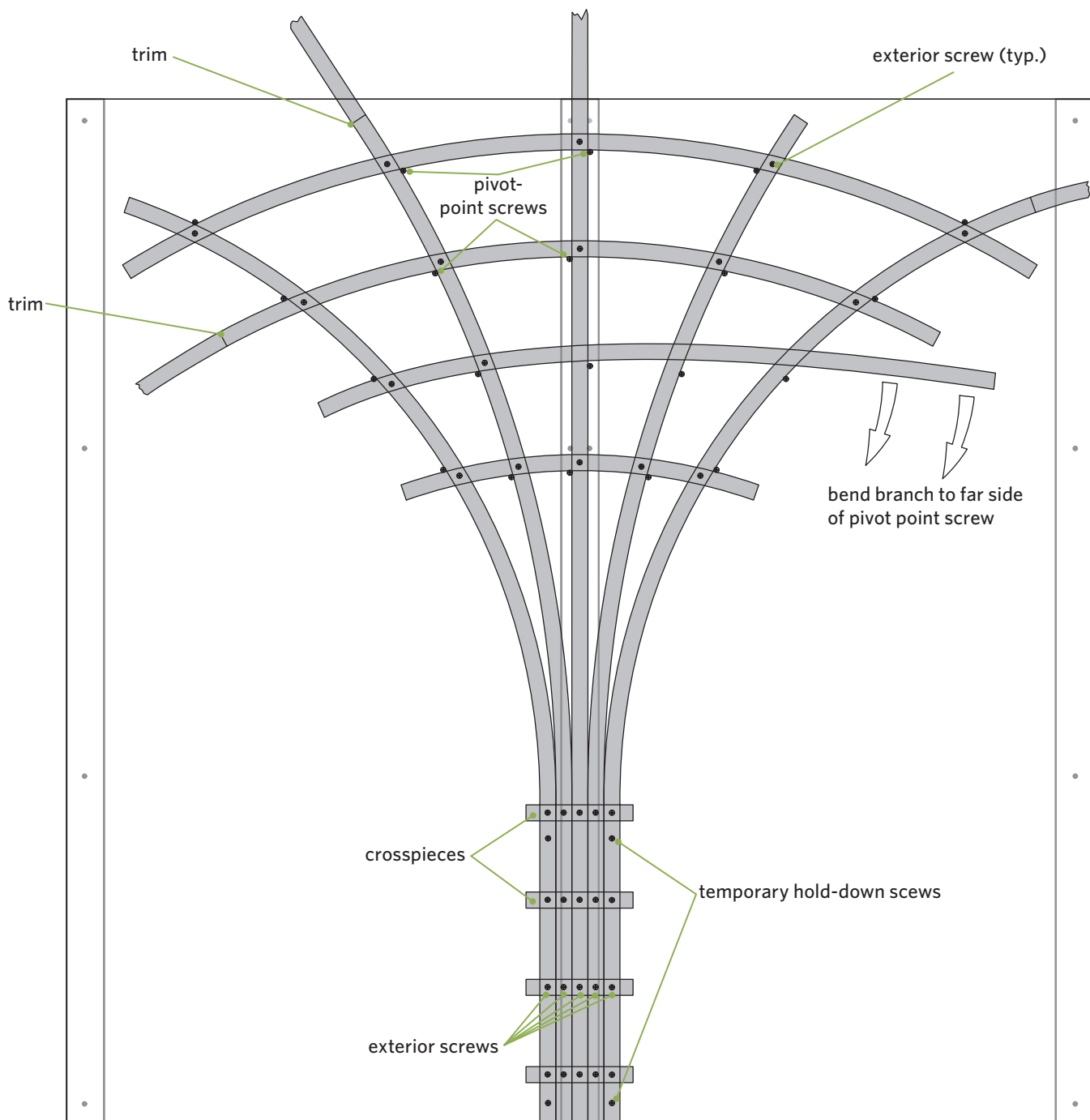

4. Lay five branches of approximately the same diameter side by side along the centerline of the form. Make sure they're extra long; you'll trim them later. Use 3" exterior screws (or longer or shorter ones, depending on your branch thickness) to secure three or four short crosspieces, spaced about 10" apart, across the lower portion of these uprights. If the wood splits, predrill the holes before driving the screws.

TAKE NOTE If you're going to install your trellis as a free-standing structure, rather than securing it to a wall or fence, use longer branches to create a longer lower leg so you can bury the base at least 2 to 3 feet in the ground.

5. Install temporary hold-down screws at the bottom of the upright assembly to prevent this end from shifting as you bend the branches. Bend the two outer uprights to the approximate shape of your pattern, and use additional pivot point screws or blocks to hold them temporarily in place. If the branches are stiff, you may need a helper for this step. Repeat this procedure to curve and secure the other uprights. If the branches pop up and off the form, temporarily secure them to the form with screws.

6. Bend and secure the upper curved arm to the uprights, using exterior screws. Start at one end, bending the branch and installing the screws as you go. Install the other three curved arms the same way.
7. Once the trellis is assembled, use a lopping shears to trim the ends of the uprights and arms. For freestanding trellises or those that need to support a lot of weight, flip the trellis over and add another set of curved arms and short crosspieces to the other side to create a beefier structure.
8. Install the trellis by securing it to the side of your house, out-building, or fence, using exterior screws. You may want to add 2x4 spacer blocks between the trellis and the mounting surface to create a gap for vines to twine and moisture to escape. If you're installing the trellis as a freestanding garden structure, dig a hole least 25" to 30" deep, position the trellis, and then backfill with small, sharp-edged rock, tamping the rock periodically as you fill the hole. The rock will not only stabilize and support the trellis but also promote drainage so your structure will last longer.

Locating the Right Branches: Which, When, Where, and How

Any bendable branch is fair game for the trellis project, but there are a few things to keep in mind when harvesting materials:

WHICH: Sandbar and weeping willow, birch, cedar, dogwood, and fruit trees are all good prospects. Remember, branches with curves, knobs, and crooks aren't rejects; they're materials with character!

WHEN: Harvest the wood in winter or early spring if possible. The branches will be more pliable, and the bark will be tougher. Since the branches are leafless, you'll be better able to spot good branches, and you won't have to strip off lots of leaves.

WHERE: If you don't have suitable trees on your property, try contacting tree trimmers, nurseries, or orchards (which often have piles of pruned limbs and branches); power companies (which thin out trees growing near power lines); or local farms and housing developments where land is being cleared.

HOW: You can cut most branches with a lopping shears. Use a coarse-tooth pruning saw or a bow saw for larger branches.



Outdoor Workbench, 112

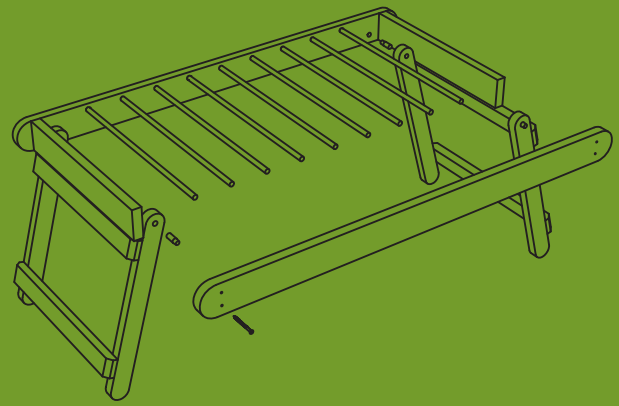

Foldaway Countertop Rack, 104

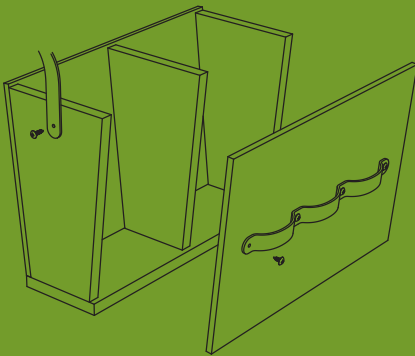

Harvesting Tote, 102



Flowerpot Smoker, 133

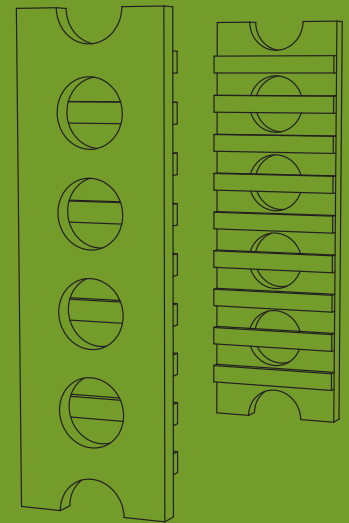

Multipurpose Produce Rack, 116

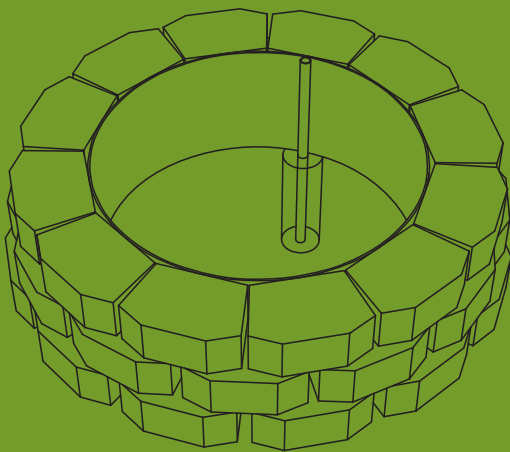

Fire Pit Grilling Station, 121

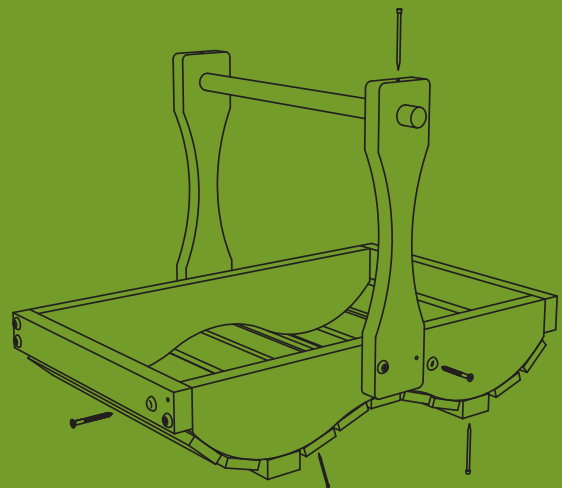

Harvest Trug, 107

Harvesting and Food Preparation

Raising your own food has its rewards, but harvesting, preparing, and storing this bounty is equally rewarding. Munching on fruit slices you dried an hour ago or opening a jar of peas you canned a year ago are all a big part of the payoff.

In this chapter we'll present a wide variety of projects that help you get your food out of the garden and into the pantry or kitchen. You'll find a foraging tote for picking berries and mushrooms, a root cellar for storing produce, and even a mini-smoker for cooking meat.

Sure, some days you or your family members may feel like the characters in "The Little Red Hen" — you know, the dog, the cat, and the duck that were *very* interested in eating the bread but less enthusiastic about the harvesting, milling, and baking that came before. But when approached with the right attitude (and projects), food preparation can be a true adventure.

Harvesting Tote

A carryall for hand tools and edible treasures

You can use this multipurpose tote for ferrying tools into the garden or woods and for carrying berries, vegetables, and mushrooms back out. It's lightweight and easy to sling over one shoulder so

that both hands are free for carrying or picking. And it's large enough to hold a wide array of hand tools, kneeling pads, gloves, and foods you've plucked along the way.



See page 2 for a photograph of this project.

Accessorizing Your Tote

You can accessorize your tote according to how you intend to use it. A few options:

- Add a bicycle water bottle in its cage to one end so you can quench your thirst during long forays into the garden, fields, or woods.
- Install additional dividers for more sorting options, or, if you need one big compartment, eliminate the center divider completely; just be sure to replace it with a small cross-brace to help support the sides.
- Drill holes in the bottom to allow air to circulate and moisture to drain if you're using the tote for picking berries or mushrooms.

Materials

- One 40" pine 1×8
- One 18" pine 1×6
- One piece $\frac{3}{8}$ " plywood, 25" × 18" minimum
- Exterior glue
- 6d galvanized box nails
- 3d galvanized box nails
- Two leather or nylon straps or belts (see steps 3 and 4)
- $\frac{3}{4}$ " screws
- Four 1" machine bolts with washers (two for each bolt) and cap nuts

1. Cut the ends (A) and divider (A) to the angles and dimensions shown, using 1×8 pine, and cut the 18" long bottom (B) from 1×6 material. Secure the bottom to the ends and divider, using glue and 6d box nails. The bottom will extend $\frac{3}{8}$ " beyond the side edges of the ends and divider.
2. Cut the two plywood sides (C) to size at $12\frac{1}{4}$ " × 18". Secure the plywood sides to the frame and divider using exterior glue and 3d nails. Make certain the divider is square to the bottom before nailing the sides to it.
3. Install the tool strap onto one of the plywood sides, as desired. I positioned the tools on the side of my tote, so I laid an old leather belt over the handles to determine the size of the loops, and used screws to secure the loops to the sides.
4. Install the shoulder strap: Experiment with the length and position before cutting the strap material to length; an across-the-body strap may need to be 6 feet or longer. You can use a leather or nylon strap, a thick rope, or a strap from a duffle bag. Once you've found a comfortable length, secure the strap to the tote ends with screws or machine bolts, washers, and nuts.

Cutting and assembling tote

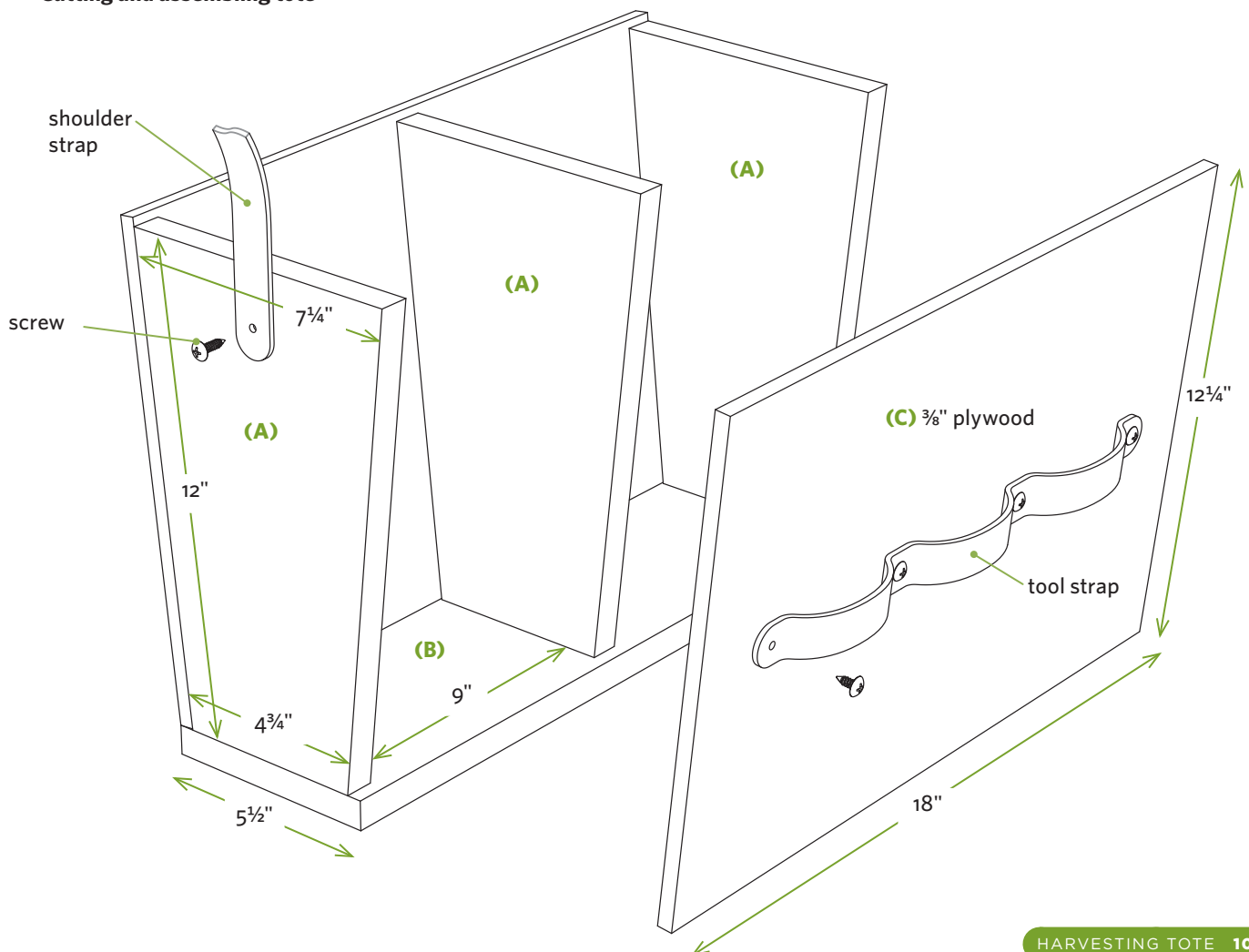

Foldaway Countertop Rack

A helping hand for pasta making, jelly straining, and herb drying

You'll find lots of uses for this foldaway rack in the kitchen, the laundry room, and other places. (See *10 Things You Can Do with Your Foldaway Rack*, page 106.) When open, the legs will span a standard 32" kitchen sink. When closed, the rack

can be stowed out of the way next to your cutting boards and cookie sheets.

I made my rack from pine, but you can use oak, maple, or other hardwood for strength and appearance.

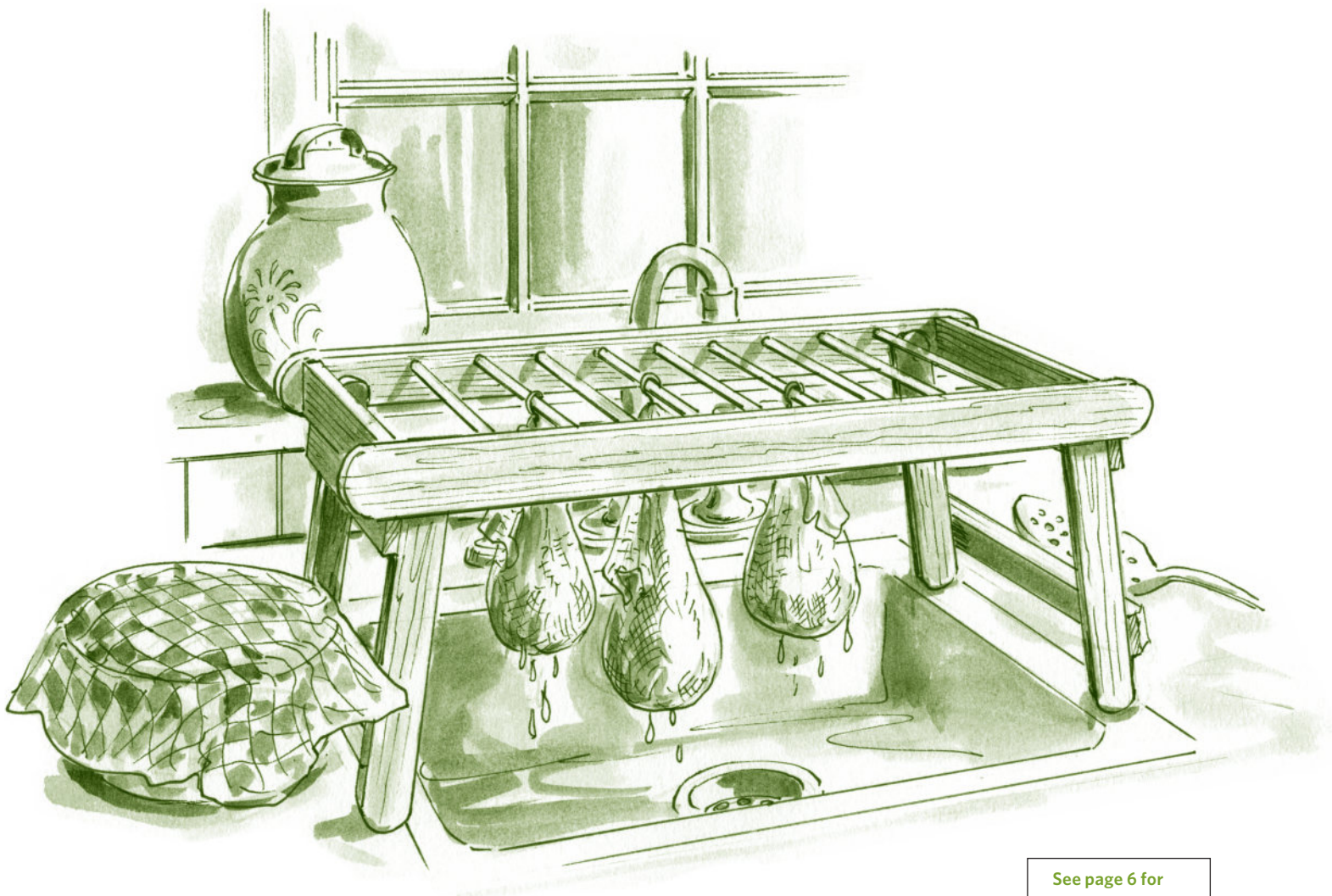

See page 6 for a photograph of this project.

Materials

- Two 6-foot pine 1×3s
- Two 6-foot pine 1×2s
- Four 3/8"-diameter × 4-foot-long hardwood dowels
- Exterior wood glue
- 2" trim head screws
- Polyurethane wood finish

1. Cut the rack sides (A) to length. Mark the positions of the 3/8"-diameter holes for the dowels as shown. Use a drill press or a drill with a stop collar (see illustration below) to bore the holes. Use a brad-point bit for accuracy, and make the holes 7/16" deep.

TAKE NOTE The position of the leg pivot holes is critical, since it determines how far the legs splay out when the rack is in use.

2. Use a compass to draw the 1 1/4"-radius semicircles on the ends of the rack sides. Use a jigsaw to cut them to shape, and sandpaper to smooth the edges.
3. Cut the rack ends (B) and spindles (C) to length. Tap the dowels into the holes on one of the rack sides (A), then lay the assembly on a flat surface. Position the other side piece across from it; then, starting at one end, fit the dowels into the holes of the second side piece. Don't use glue for this part.

TAKE NOTE You can simplify the task by using a pair of bar clamps to gently squeeze the sides toward each other as you fit the dowel ends in. You can also slightly round the ends of the dowels so they slip into the holes more easily.

4. Drill pilot holes for the rack ends (B), and then secure the ends between the sides (A) using two 2" trim head screws for each joint. Drive the screw heads slightly below the surface.

Parts and Cutting List

Part	Size and Material	Quantity
(A) rack side	3/4" × 2 1/2" × 36"	2
(B) rack end	3/4" × 2 1/2" × 15"	2
(C) spindle	3/8" × 15 3/4" dowel	9
(D) leg	3/4" × 1 1/2" × 15"	4
(E) leg crosspiece	3/4" × 1 1/2" × 14 7/8"	4
(F) leg pivot	3/8" × 1 1/8" dowel	4

5. Cut the legs (D) to length; then mark and drill the pivot holes all the way through the legs as shown. Mark the 3/4" radius on the leg ends, and shape them with a jigsaw and sandpaper. Cut the leg crosspieces (E) to length, and slightly bevel the ends. Secure the crosspieces to the legs using glue and 2" trim head screws; predrill holes to avoid splitting. Use a square to make sure the leg assemblies are square as you fasten the parts.

Cutting details

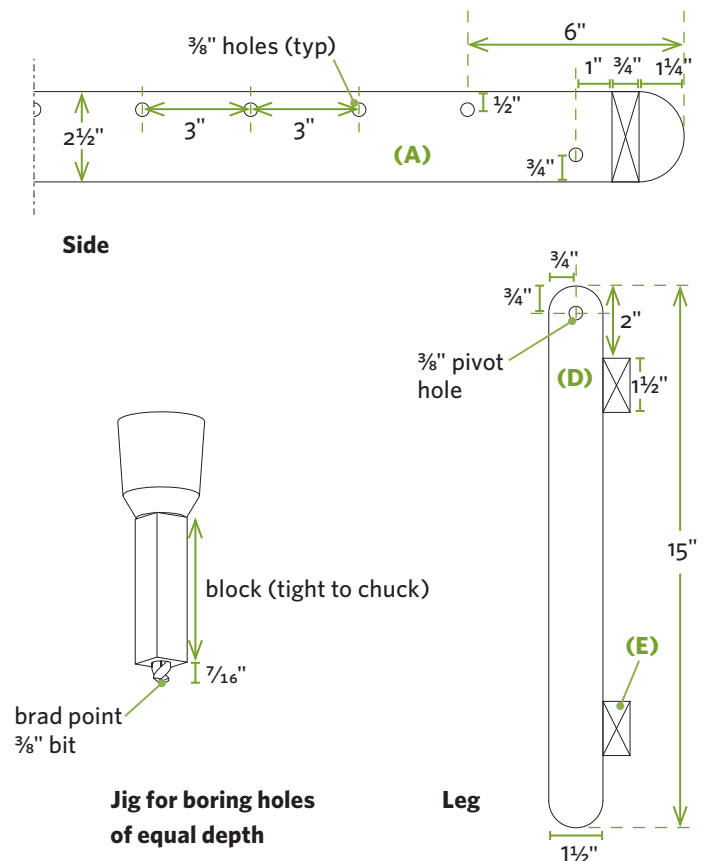

6. Create the four small leg pivots (F) by cutting dowels to length and then using sandpaper to slightly taper one end as shown. (The tapered ends allow the legs to swing easily.) To install each leg assembly, apply a dab of wood glue to the pivot holes in the legs (D), line up the leg pivot holes with the side pivot holes, and then tap the leg pivots (F) through the legs and into the sides, with the tapered ends toward the sides (A).

TAKE NOTE If you've measured, cut, drilled, and assembled correctly, the distance between the bottoms of the legs when swung out should be a little over 33" and the legs should fold neatly into the rack for storage.

7. Finish the rack with two coats of paint or polyurethane to protect the wood from moisture.

10 Things You Can Do with Your Foldaway Rack

1. Dry homemade pasta noodles.
2. Hang your jelly-straining bag over a bowl or sink.
3. Place the rack over a heat vent and dry damp mittens and hats.
4. Dry dishtowels and washrags.
5. Air-dry dishes on a crowded counter. (Use it to build a second story!)
6. Place a tray on the rack to serve breakfast in bed.
7. Hang freshly cut herbs and spices for drying.
8. Use the rack as a laptop desk for working on the floor.
9. Air-dry delicate laundry.
10. Cool pies.

Assembly details

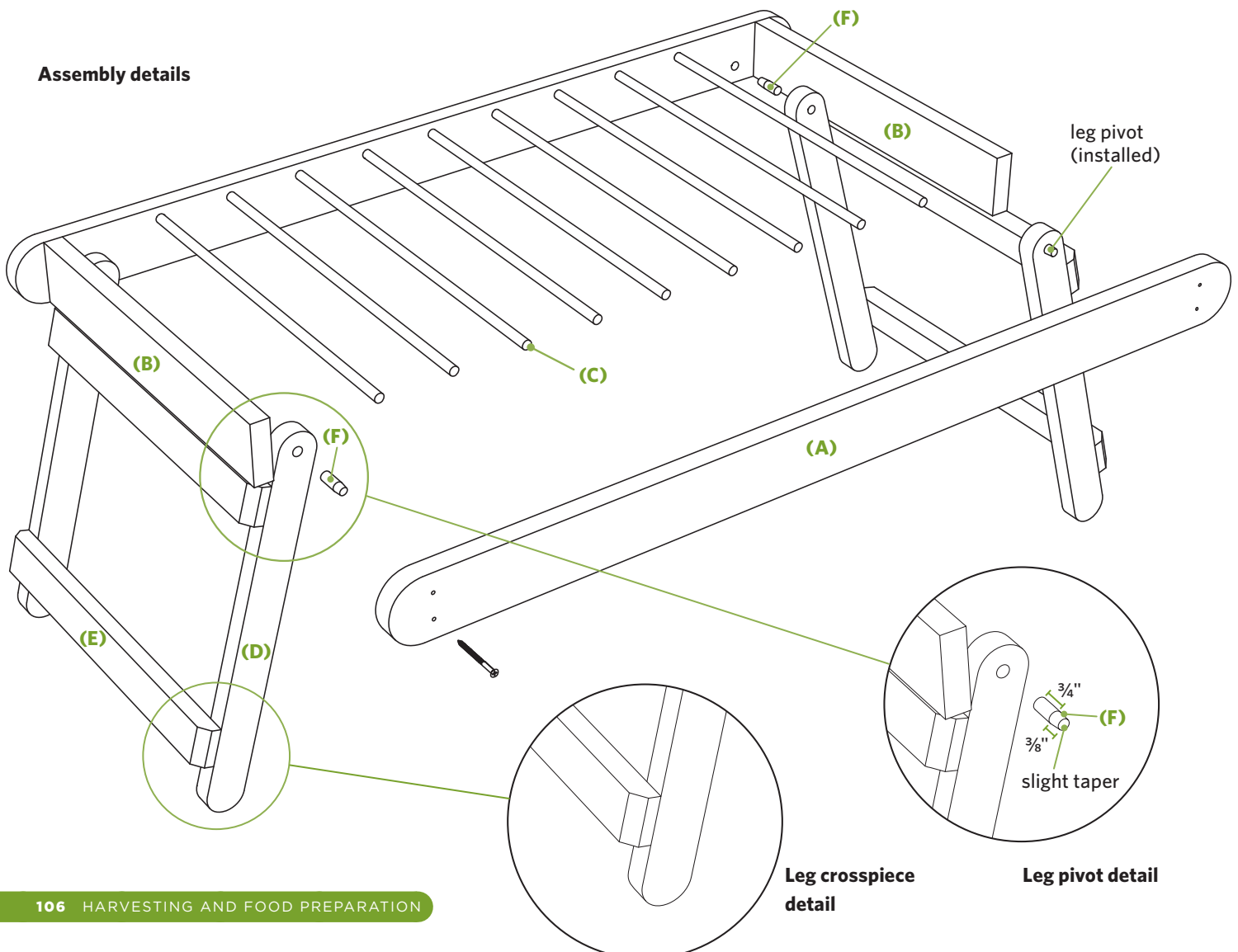

Harvest Trug

Sturdy enough for the garden; attractive enough for the table

The term *trug* comes from the ancient word *trog*, which refers to a wooden or boat-shaped item. This trug is more of a catamaran, but its function is similar to that of its traditional ancestors: a lightweight, airy basket for harvesting flowers, berries, and tomatoes and other vegetables. The long handle makes it convenient to set down and pick up the trug, while the double hull allows you

to separate two harvests and creates a sturdy base. As a bonus, the trug is attractive enough to go straight from the garden to the dining room table.

Note: Painting or finishing the parts before assembly will provide better protection and result in a smoother finish (see step 5).

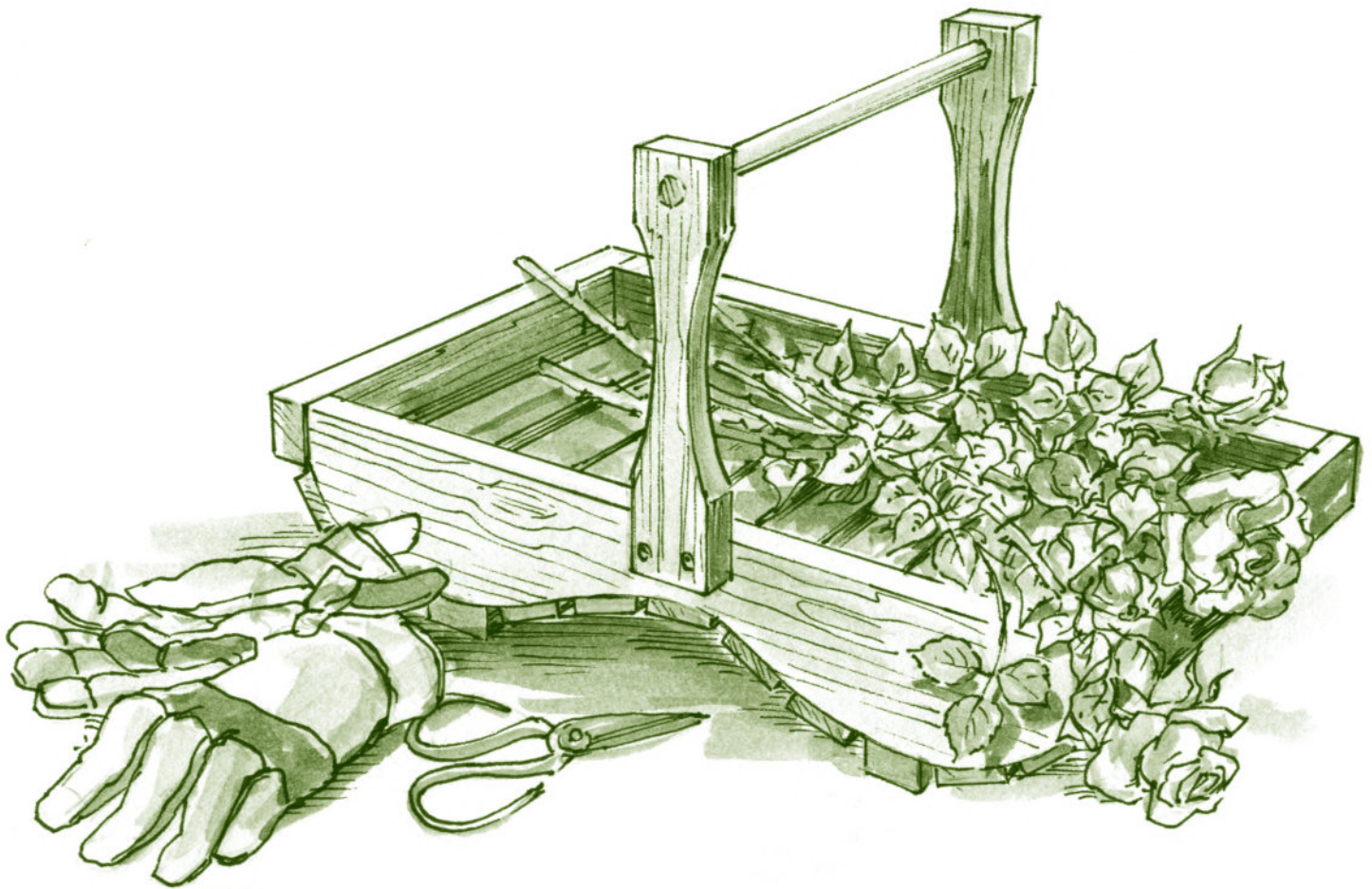

Materials

- One 4-foot pine 1×4
- One 5-foot pine 1×2
- Two 6-foot $\frac{3}{8}$ " × $1\frac{1}{2}$ " pine lattice slats
- One 3-foot pine 1×3
- $\frac{3}{4}$ " × 15" hardwood dowel
- 6d galvanized casing nails
- 3d galvanized casing nails
- Eight 2" wood screws with decorative washers
- Four $1\frac{1}{2}$ " wood screws with decorative washers
- Exterior wood glue

1. Follow the dimensions shown in *Cutting details* to draw the outline for the trug sides (A). You can draw the three curves by tracing around the bottom of a 5-gallon bucket (about a $5\frac{1}{4}$ " radius). Before marking, make tick marks 2" up and 4" over from the lower corners; then set the edge of the bucket on these marks and trace around it. For the inner arch, position the bucket so it just kisses the two outer circles, and then trace around it. Carefully cut out this piece with a jigsaw, and then use it as a pattern for marking the other side piece. Cut the other side, and sand all the edges smooth.
2. Position the sides (A) upside down and install the two end supports (B) as shown. Secure them using glue, grommet washers, and 2" screws. Check to make sure the frame is square; then install the two bottom supports (B), using glue and 6d nails. Position the bottom slats (C) between the supports and adjust them until the spacing is equal; $\frac{3}{8}$ " is ideal. Shave a little off the edges of a slat or two if they fit too tightly. Secure the slats with glue and 3d nails.

Parts and Cutting List

Part	Size and Material	Quantity
(A) sides	$\frac{3}{4}$ " × $3\frac{1}{2}$ " × 18" pine	2
(B) end and bottom supports	$\frac{3}{4}$ " × $1\frac{1}{2}$ " × 12" pine	4
(C) bottom slats	$\frac{3}{8}$ " × $1\frac{1}{2}$ " × 12" lattice	9
(D) handle uprights	$\frac{3}{4}$ " × $2\frac{1}{2}$ " × 12" pine	2
(E) handle grip	$\frac{3}{4}$ " × 15" dowel	1

3. Mark the handle uprights (D) as shown in *Handle upright* (opposite), creating the edge curves by bending a thin slat of wood or metal against three nails and tracing along the edge. Make the side cutouts with your jigsaw. Bore a $\frac{3}{4}$ " hole through each upright for the handle grip.
4. Drill two $\frac{1}{8}$ " pilot holes for each handle upright and secure the uprights (D) to the basket sides using glue, grommet washers, and $1\frac{1}{2}$ " wood screws. Use sandpaper to slightly round over the ends of the $\frac{3}{4}$ " handle grip (E); then slide it through the holes in the uprights. The handle will protrude about $\frac{3}{4}$ " beyond the uprights on both sides. Drill small holes through the tops of the handles, and secure the dowel to each upright with a single 6d nail.
5. Apply a clear finish to help protect the trug from moisture. You can also finish it by applying a coat of primer and two coats of exterior paint. Milk paint will produce a vintage look.

Trug assembly

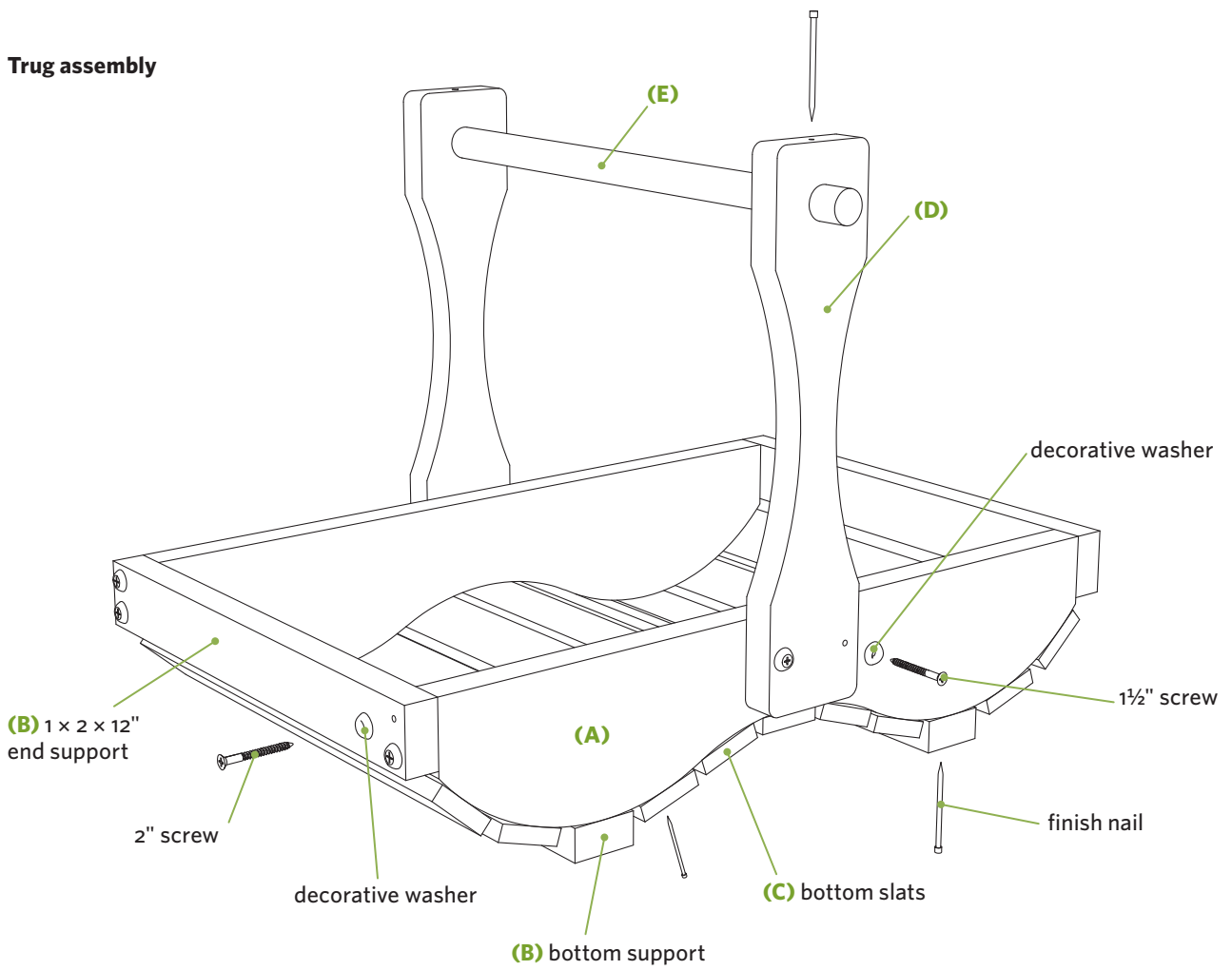

Cutting details

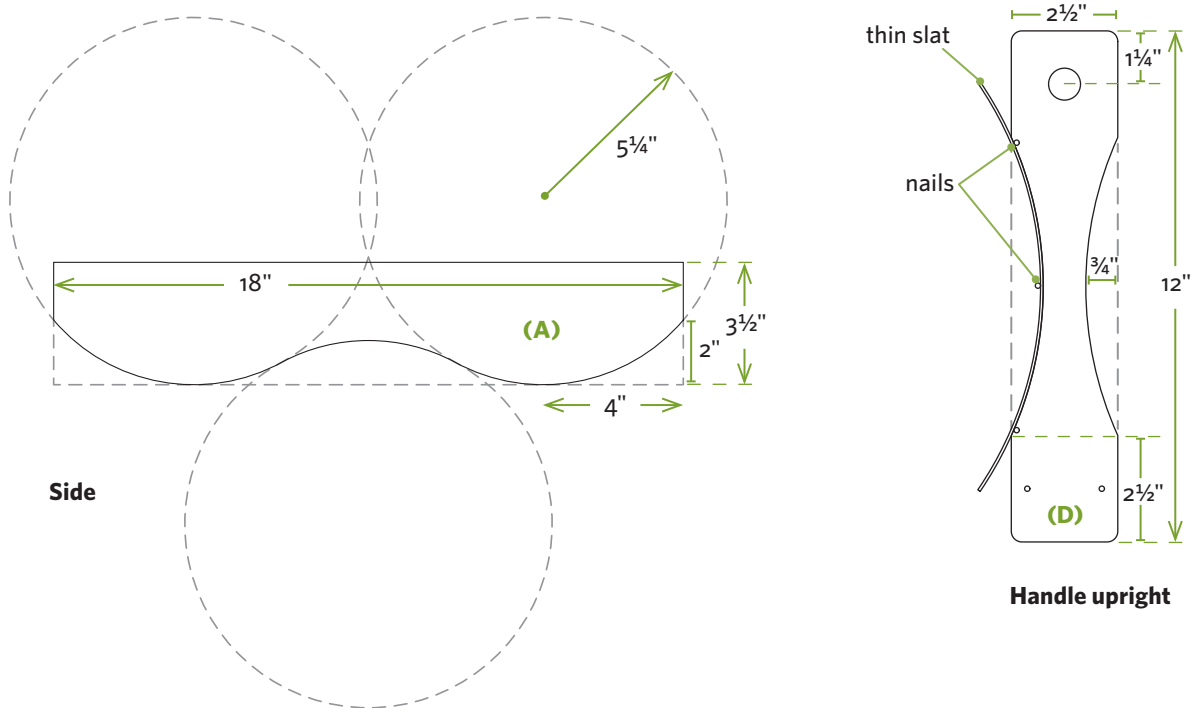

Shoulder Bucket Yoke

Carry twice as much stuff with half the effort

Five-gallon buckets are the container de rigueur for hauling everything from water to maple syrup to garden produce. And why not? They're lightweight, strong, and just the right size for holding what most mere mortals can carry with one arm. Here's a throwback project that makes hauling even more convenient. With the handle

of a bucket looped over each end, this simple yoke helps distribute the load across your shoulders, frees up your hands, and allows you to easily negotiate tough terrain.

You can build the yoke in a couple of hours from a single piece of wood. A router is nice, but the only must-have tool is a jigsaw.



Materials*

- One 5-foot 2×10

*The wood can be pine, fir, treated wood, or oak — as long as it's knot-free and straight-grained. Avoid lighter-weight, less substantial woods, like cedar or redwood, unless you plan on hauling only light loads.

1. Mark the outline of the yoke onto the 2×10 as shown. To draw the curved neck part, drive a screw into the edge of the board in the center, hook the end of your tape measure over it, and use your pencil to swing arcs of 4" and 7½". Use the bottom of a 5-gallon bucket to create the transitional curves between the curved and straight parts of the yoke.

2. Use a jigsaw to cut out the yoke. You can use a circular saw on the straight parts if you want, but you can easily make all the cuts with your jigsaw.
3. Mark the little handle notches on each end as shown in *Yoke cutting details* (below), and use the jigsaw to cut them out. Draw the curved ends of the yoke using a pint paint can as a guide for each corner, and shape the ends using a jigsaw.
4. Use a router with a roundover bit to soften the edges on both sides of the yoke. This isn't mandatory, but your shoulders will thank you. If you don't have a router, round over the edges with sandpaper.
5. Test-fit your yoke. You can sand and smooth the neck area for increased comfort.

Yoke cutting details

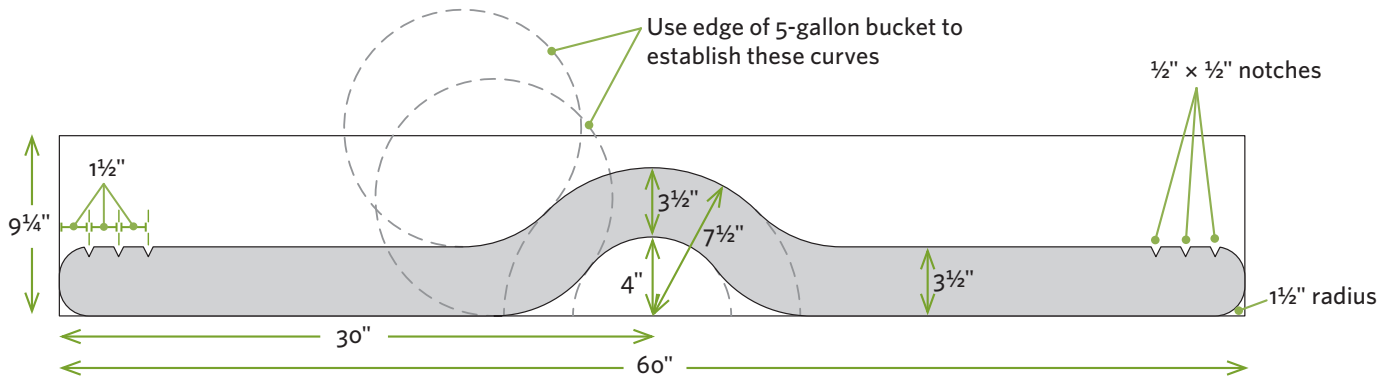

NOTES FROM THE TEST TRACK

That Ain't No Yoke

As with most of the projects in this book, I built the bucket yoke, test-drove it, refined it, and then tested it some more. Here are some things I discovered:

- Installing a short chain with large S hooks on each end of the yoke makes it easier to hook the bucket handles on. However, the farther down a bucket dangles, the more it sways and the harder it is to haul.
- The easiest way to load up the yoke is to place the buckets 4 or 5 feet apart from each other on a table or a pair of stools, slip each end of the yoke into a raised bucket handle, and then lift and go!
- If you're hauling buckets of different weights, shift the heavier bucket a notch closer to you and the lighter one farther away. (Remember your high school physics?)
- Hooking your hands over the back of the yoke and stabilizing the buckets with your forearms makes hauling *much* easier.
- For a deluxe version, add canoe portaging pads (available at camping stores) to the area of the yoke where it sits on your shoulders. Foam pipe insulation works, too.

I found it effortless to carry two buckets weighing 30 pounds apiece, but could manage buckets weighing up to 50 pounds. Just know the limits of your back, and your yoke!

Outdoor Workbench

A hardworking workspace or a high-top picnic table

Passionate woodworkers, mechanics, cooks, and artisans have their own workspaces dedicated to their craft. Why shouldn't passionate backyard homesteaders have the same: a space of one's own, where everything is organized, convenient, and at the right height?

Here's an outdoor workbench that provides a solid, protected surface for scrubbing, chopping, plucking, packing, cleaning, sorting, sharpening, and/or fixing. The roof overhead offers you protection from sun and rain, and the tool tray

gives you a place to stash your most-often-used tools in an out-of-the-way place. When you're done building the project, you might consider adding a built-in outlet and spigot to give you ready access to water and electricity (see *Customizing Your Workbench*, page 115).

And, heck, if you don't need an outdoor workbench, use the design to create a roadside produce stand, or an outdoor high-top table for dining, serving, and entertaining. Just add bar stools.

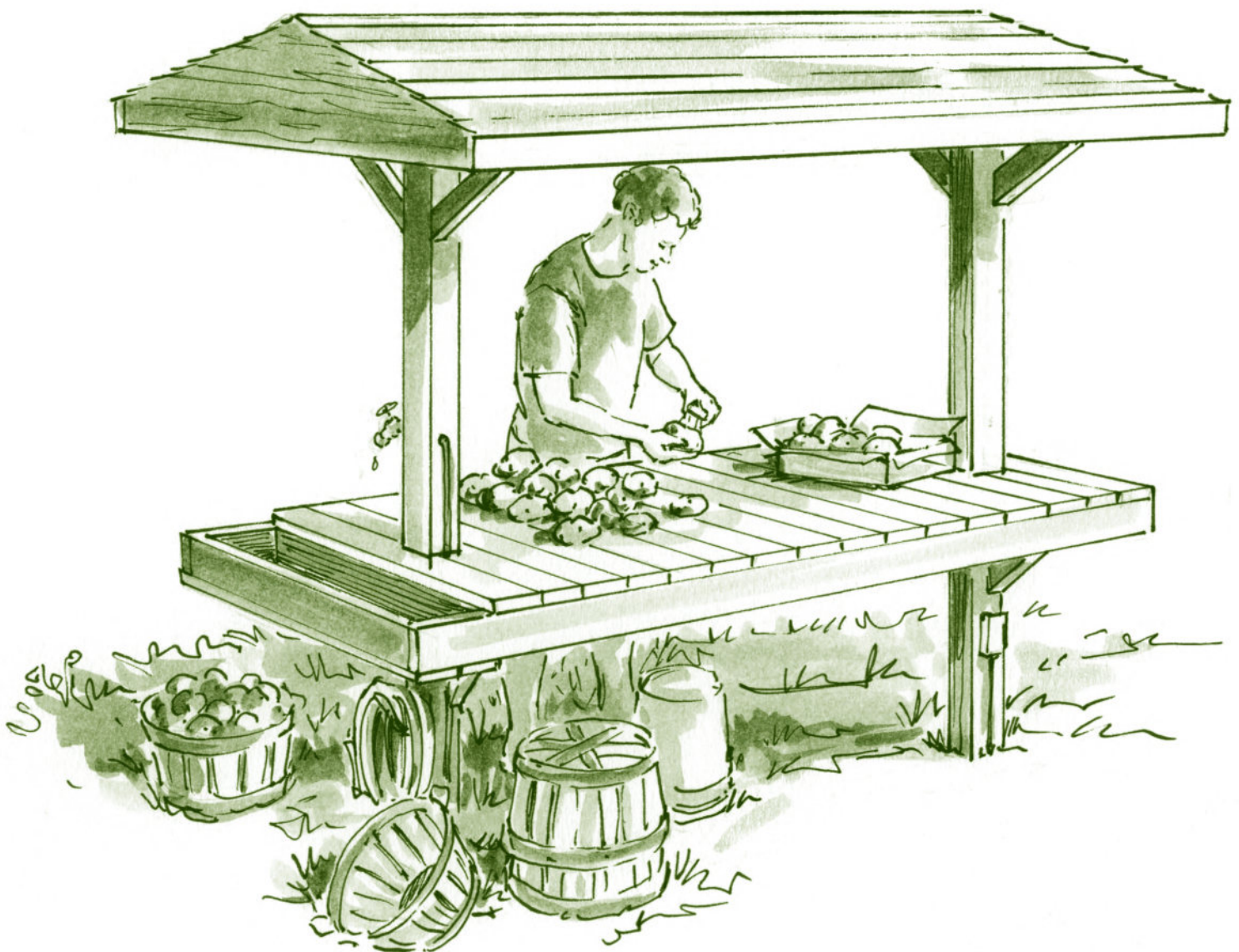

Materials*

- Two 10-foot pressure-treated 6×6s
- Five 8-foot pressure-treated 2×6s
- Three 8-foot pressure-treated 2×4s
- Eight or nine 8-foot cedar 2×6s
- Six 8-foot pressure-treated 2×12s
- Twenty 8-foot ½" × 6" pieces cedar lap siding
- Four to eight 60-pound bags concrete mix
- Construction adhesive
- 3" exterior screws
- 4" exterior screws
- 1½" roofing nails
- One 8-foot length 8"-wide metal flashing

*All wood is pressure-treated except for the workbench top and roof slats, which are cedar.

1. Dig a pair of 36"-deep 16"-diameter holes. Position the holes so when the 6×6 posts (A) are installed, the measurement from the outside of one post to the outside of the other is 72". Set the posts in the holes, and install temporary braces to hold them plumb in both directions and aligned with each other. Mix the concrete and shovel it into the holes, compacting it with a scrap 2×4 as you go. Let the concrete set up for 24 hours.
2. Use a 4-foot level and a long, straight 2×4 to mark the tops of the posts level to each other. (Make them as tall as possible.) Cut them to length using a circular saw and handsaw. Make a pair of marks 5½" down from the top on the outside face of each post. Use the level and 2×4 to establish another pair of level marks 32" to 36" above the ground (or a comfortable working height for you). Measure down 5½" from these marks and make a second pair of marks. Create 1½"-deep × 5½"-wide notches at the top and midsection of the posts, using a circular saw and the dado technique described on page 29.

TAKE NOTE Your roof and work surface will only be as level as these marks and notches; be accurate!

Parts and Cutting List

Part	Size and Material	Quantity
(A) post	5½" × 5½" × 120" PT timbers	2
(B) workbench crosspiece	1½" × 5½" × 45" PT lumber	6
(C) angle support	1½" × 3½" × 20" (long-to-long dimension) PT lumber	8
(D) workbench rim	1½" × 5½" × 96" PT lumber	2
(E) workbench top slat	1½" × 5½" × 48" cedar	16 or 17
(F) roof rafter	1½" × 11¼" × 69" PT lumber	6
(G) roof rim	1½" × 3½" × 96" PT lumber	2
(H) roof slat	½" × 5½" × 96" cedar lap siding	20
(I) roof ridge	8"-wide × 96"-long metal flashing	1

3. Install two workbench crosspieces (B), using construction adhesive and 4" exterior screws to secure one into each of the lower notches as shown in *Framing details* (page 114). Make sure they're centered on the posts. Add the lower 45-degree angle supports (C), securing them with 4" screws.
4. Secure the workbench rims (D) to the crosspieces (B), making sure the rims extend equally beyond the crosspieces on both ends (about 12"). Add the end and intermediate crosspieces (B) to complete the basic framework for the workbench.
5. Install the workbench top slats (E), using 3" screws to secure them to the workbench frame. You can install the slats tightly against one another or leave a gap of up to ¼", depending on how you intend to use the workbench. On one (or both) ends, secure the two outermost slats to the bottom of the bench frame to create a tool tray. You'll need to notch some of the slats to fit around the 6×6 posts and lower angle braces.

Framing details

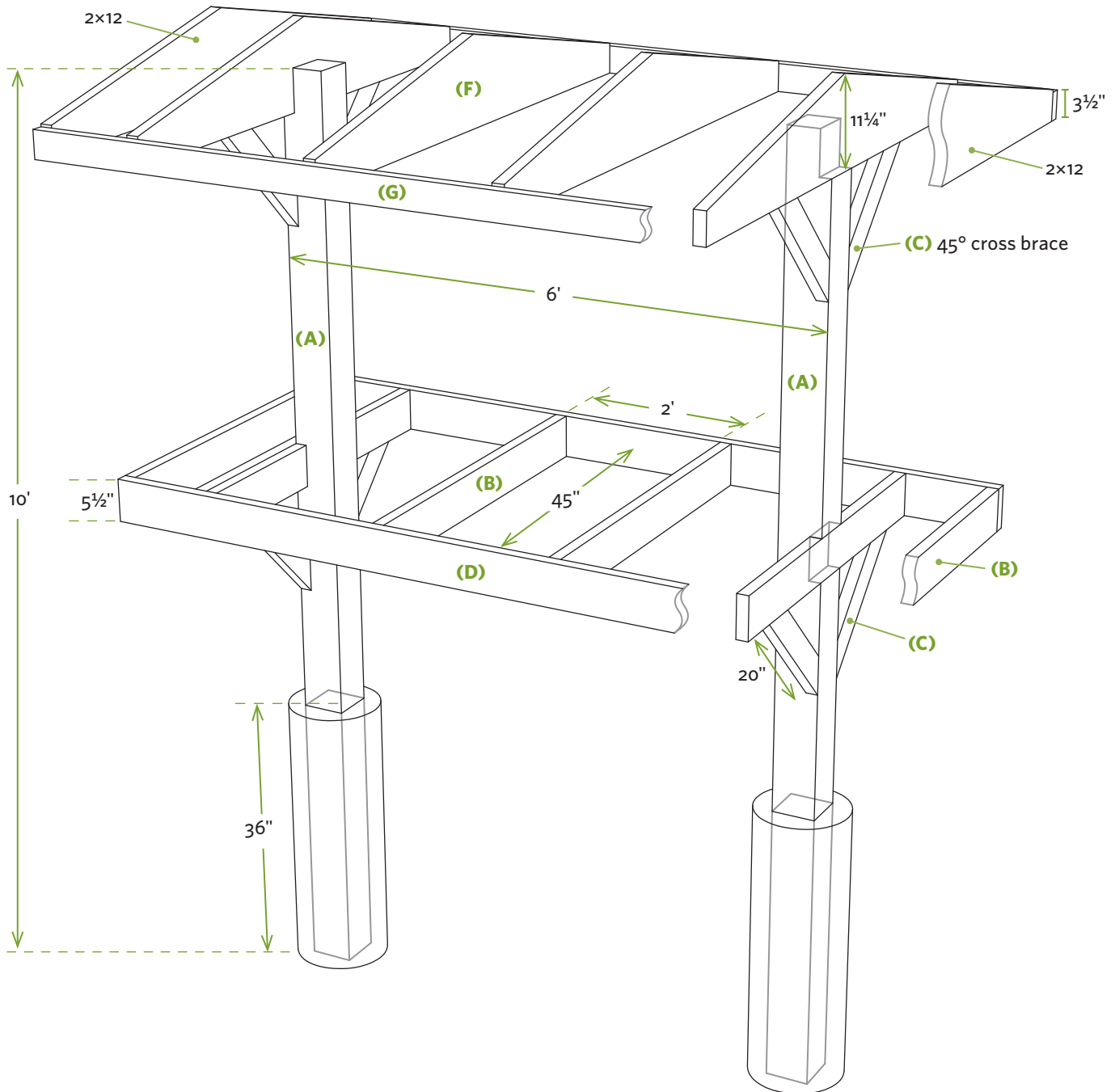

6. Cut the six roof rafters (F) to length, and cut the tops at the angle shown in *Framing details*. Secure two of these into the 5½" upper notches using construction adhesive and 4" screws. Add the upper 45-degree angle supports (C).
7. Secure the long 2×4 roof rims (G) to the ends of the two rafters now in place. Make sure the rims extend equally beyond the posts on both ends (about 12"). Add the end and intermediate rafters (F) to complete the basic framework for the roof.
8. Install the lap siding (H) for the roofing, overlapping the pieces by about 1" as you work your way up to the peak. Secure each piece to each rafter with roofing nails driven near the top and bottom edges. Install the metal flashing for the roof ridge (I) for making the peak watertight.

Workbench top and roof details

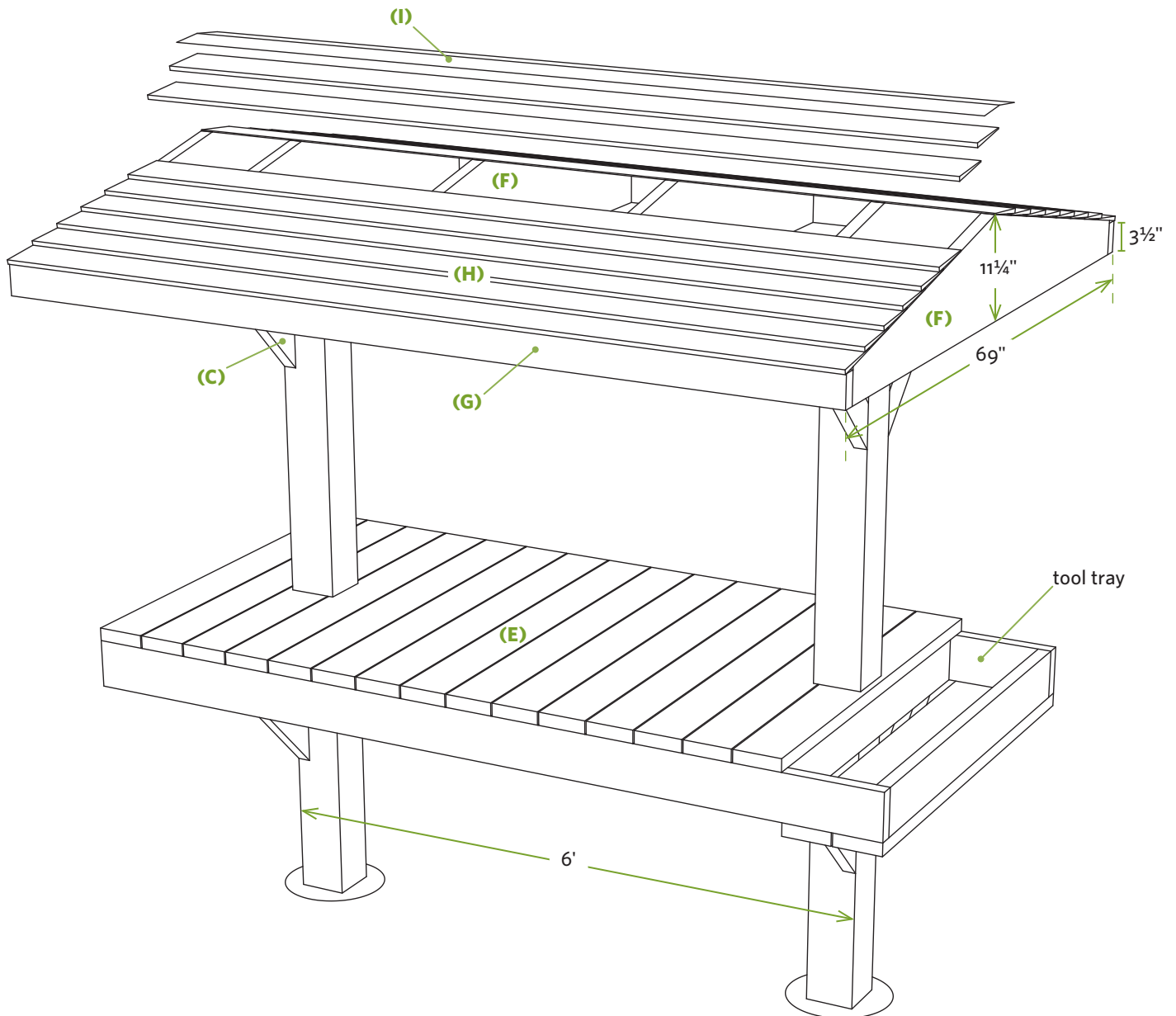

Customizing Your Workbench

You've created a sturdy workbench for your outdoor projects. Now consider the following options to customize it and make it even more convenient.

ELECTRICAL. Install an electrical outlet for powering tools and other devices. You can add an exterior light for late-night work sessions. The circuitry must be protected by a ground-fault circuit interrupter (GFCI) for safety. See *Outdoor Outlets, Switches, and Lights* (page 204) for more

information. If you don't have experience with electricity, hire a pro for this part of the project.

PLUMBING. Install a remote spigot so you have access to water for cleaning, soaking, and other jobs. For a temporary setup, run a standard garden hose from your existing spigot to a

spigot mounted on one of the uprights. For a permanent installation, install underground pipe. Make certain to drain the system in cold climates.

VICES. If you do a lot of outdoor woodworking or repair projects, install a vise to hold lumber while cutting and tools while sharpening.

Multipurpose Produce Rack

For drying, ripening, rinsing, and more

This project started as an open-air rack for drying spices, fruits, and vegetables. Then someone suggested using it for ripening and rinsing produce. Yet another thought it might make a good rack for starting seedlings. You'll find plenty of uses for this multilevel rack. And when the growing season is over, remove the bolts, stack the parts, and stash it away.

You can set up your rack to contain as many as nine trays, depending on how you're using it. The round cutouts in the sides help increase ventilation, minimize weight, and provide a bunch of little round discs you can use for something else (see *10 Things You Can Do with Little Round Cutouts*, page 119).

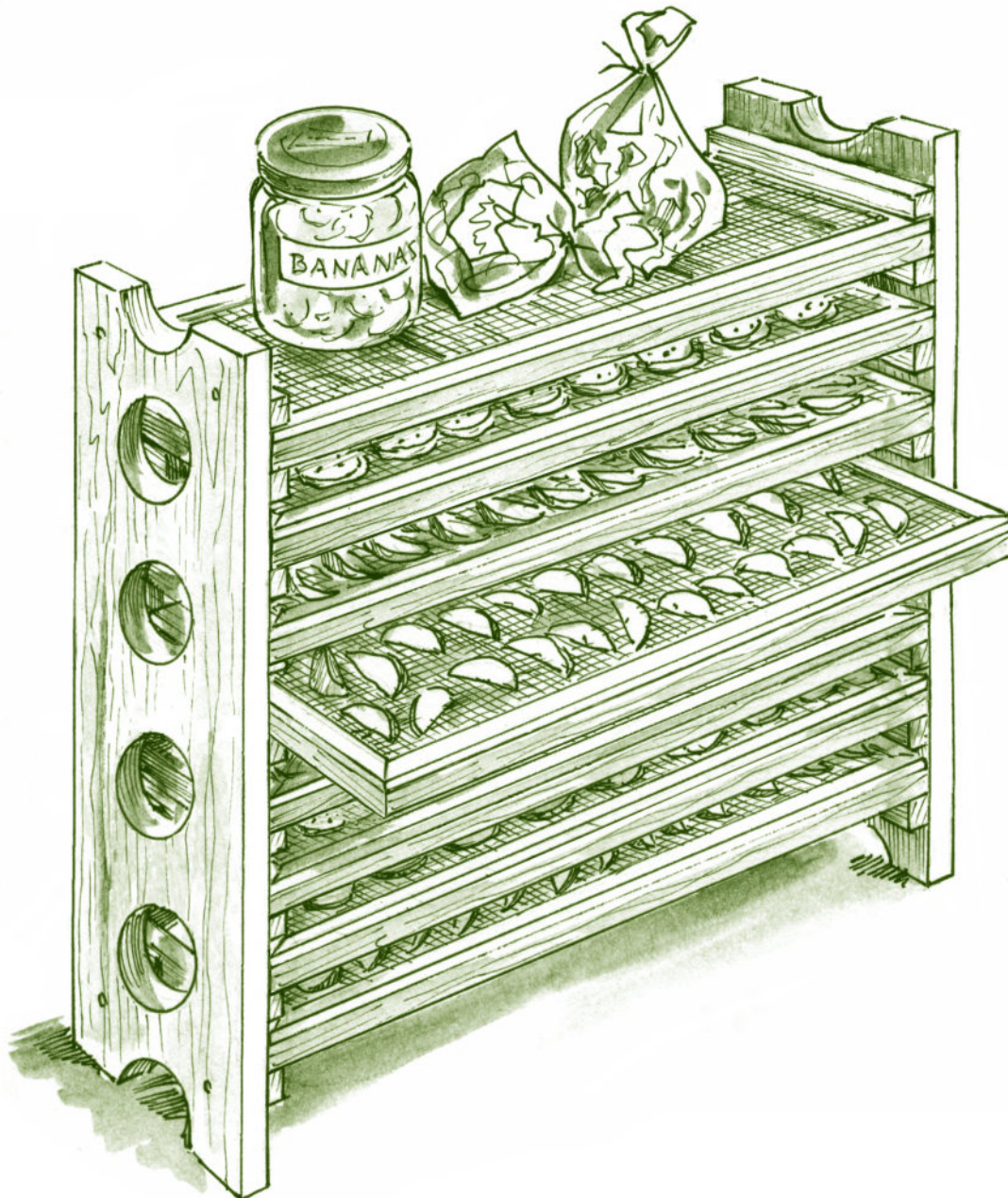

Materials

- One 8-foot cedar 2×12
- Six to ten 8-foot cedar 1×2s (quantity based on number of trays)
- ¼" × ¾" cedar or pine (quantity based on number of trays)
- Metal screen (quantity based on number of trays)
- Exterior wood glue
- 6d galvanized casing nails
- 8d galvanized casing nails
- Staples
- 1" brads
- Eight ¼" × 3" bolts with nuts and sixteen washers

1. Cut the two sides (A) to length, lay them side by side, mark the locations of the runners as shown, and then use a framing or drywall square to extend the marks across the faces of both boards. Next, mark the centerpoints of the circular ventilation cutouts and use a compass to draw the circles. If you've marked everything correctly, the center of every other runner will bisect the center of a circular cutout.
2. Use a jigsaw to cut out the circles. Create a starting slot for each interior hole by drilling two ⅛" holes side by side on the edge of the marked circle, and insert the blade to begin the cut. Smooth the edges of the cutouts with a sanding block made from a piece of sandpaper wrapped around a curved section of wood cut from one of the disks.

Parts and Cutting List

Part	Size and Material	Quantity
(A) side	1½" × 11¼" × 35½" cedar	2
(B) runner	¾" × 1½" × 11" cedar	18
(C) tray side	¾" × 1½" × 34½" cedar	2 per tray
(D) tray end	¾" × 1½" × 11" cedar	2 per tray
(E) tray crosspiece	¾" × 1½" × 9½" cedar	2 per tray
(F) metal screen	15" × 40" metal screen	1 per tray
(G) long screen molding	¼" × ¾" × 36" cedar/pine	2 per tray
(H) short screen molding	¼" × ¾" × 11" cedar/pine	2 per tray
(I) crosspiece molding	¼" × ¾" × 9½" cedar/pine	2 per tray
(J) top and bottom tray bolts	¼" × 3" bolts, nuts, washers	8 sets

3. Flip the sides over and use exterior glue and 6d galvanized nails to secure the runners (B) on the layout lines.
4. Build the frames (C, D, E) for the trays as shown. Secure the corners and crosspieces (E) with glue and 8d galvanized nails; drill pilot holes to prevent splitting. Check the frame to make sure it's square. Center a section of screen or hardware cloth (F) on top of the frame. (The screen is oversize so you can trim it to size after the screen molding is in place.) Stretch the screen taut, and secure it with staples.

TAKE NOTE If desired, apply a protective clear finish to the frame parts before installing the screen. This will help preserve the wood and make the racks easier to clean. Preapply finish to the screen molding pieces (G, H, I), too.

Side piece details

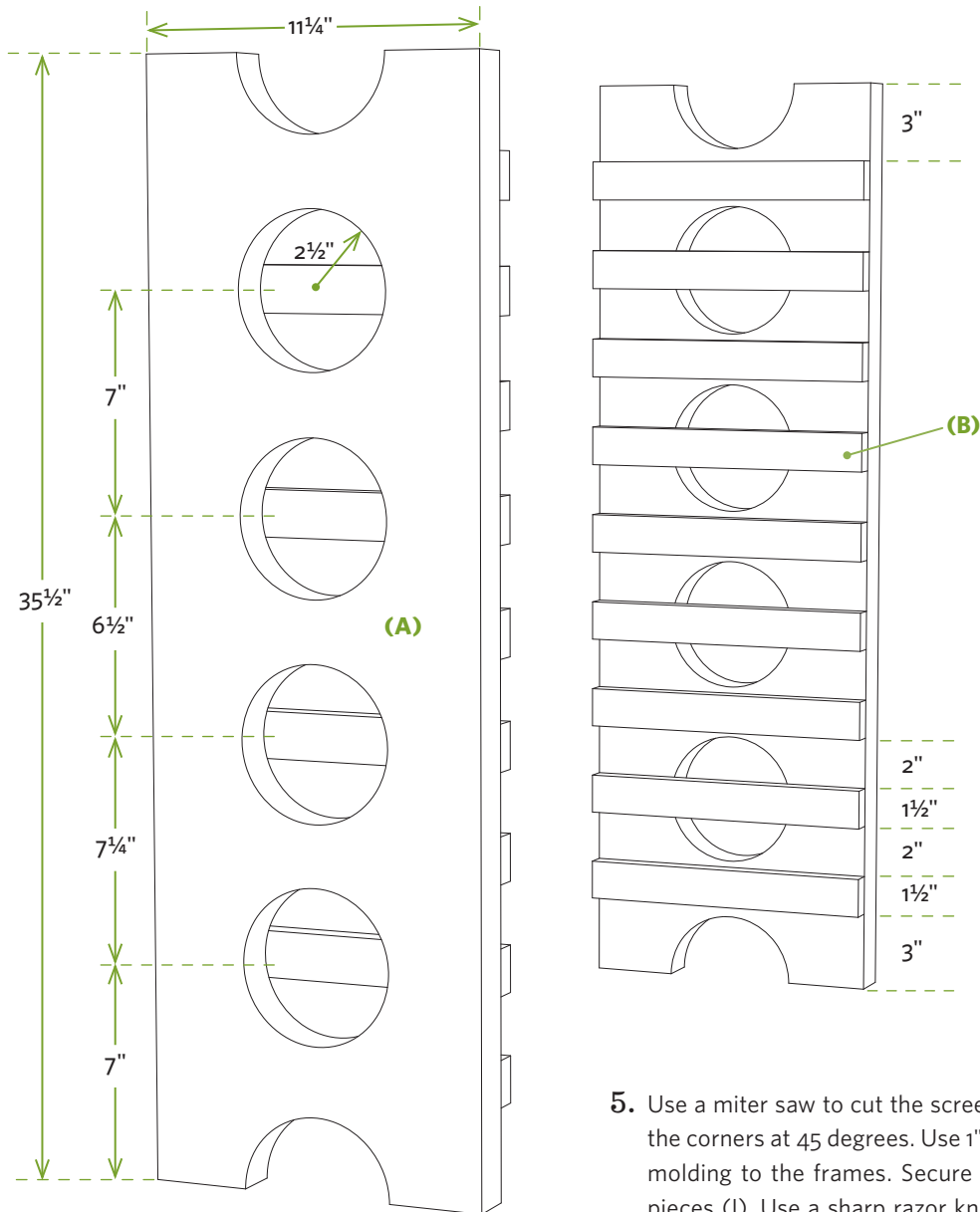

5. Use a miter saw to cut the screen molding (G, H), mitering the corners at 45 degrees. Use 1" brads to secure the screen molding to the frames. Secure the screen molding cross-pieces (I). Use a sharp razor knife to trim the overhanging edges of screen.
6. Use clamps or a helper to hold the sides (A) vertically. Position the top and bottom trays; bore holes through the sides and trays; then secure them together with bolts, nuts, and washers. You need to bolt only the top and bottom trays to hold the rack together; the remaining trays can remain movable.

TAKE NOTE The "spacer" washers between the uprights and the top and bottom trays make the stand wide enough so the other trays can slide in and out more easily.

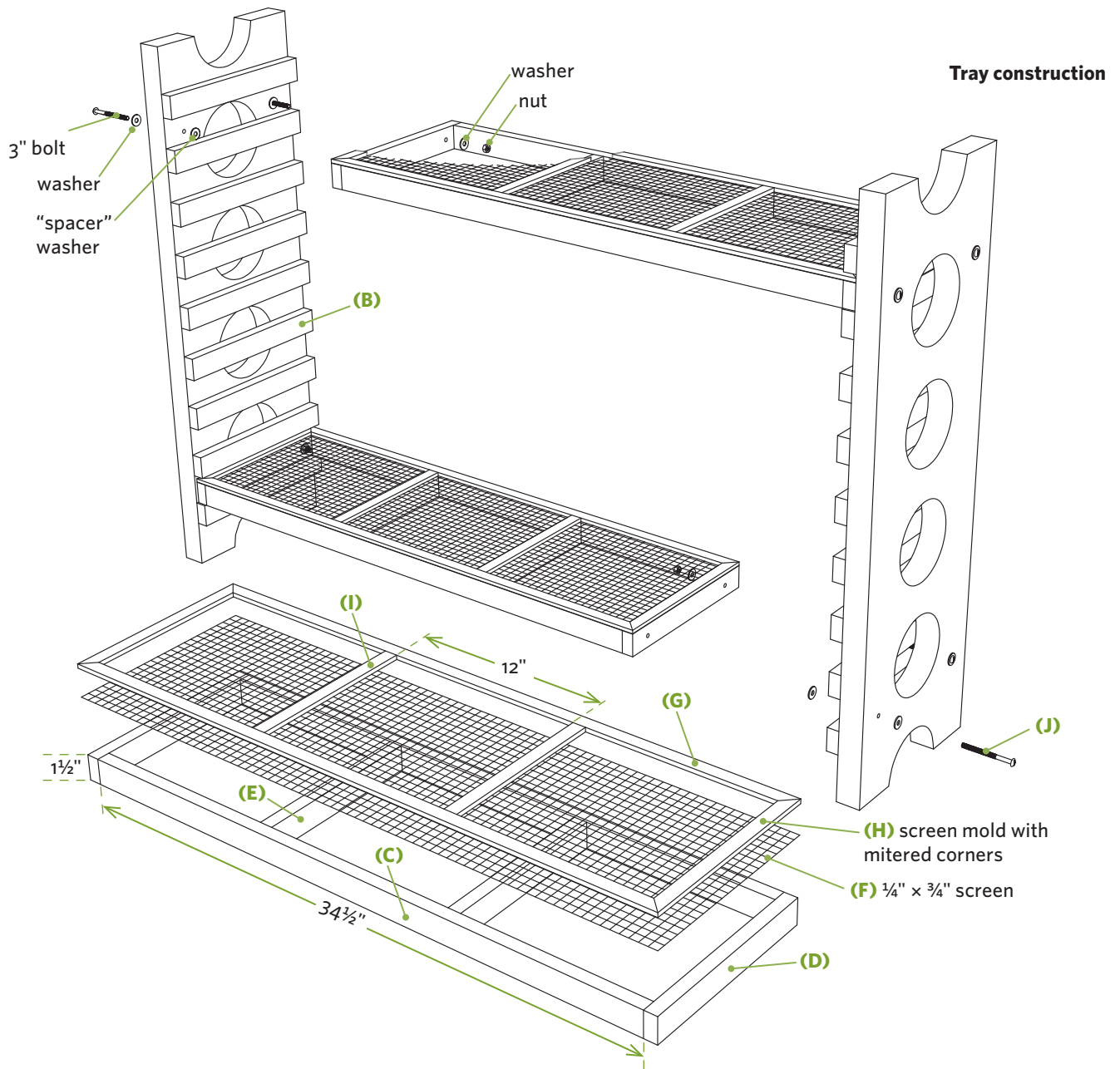

10 Things You Can Do with Little Round Cutouts

You can't let those cool round cutouts go to waste! But what can you do with them? Here are a few ideas that come to mind:

1. Spools for rolling up and storing extension cords or hoses: Nail a block between two discs to create the spool.
2. Trivets for hot pans in the kitchen.
3. Little flowerpot stands.
4. Pieces for a huge checkers set.
5. Gigantic coasters for your picnic table.
6. Fence post caps to prevent tops from rotting.
7. Wheels for pull toys.
8. Smiley faces on a stick.
9. Plant-row markers: Attach each disc to a stake and staple on seed packs.
10. If all else fails, fancy kindling!

My Knock-Together, Cardboard-Box, Tabletop Dehydrator

BY TERESA MARRONE

Dehydrating is a great way to preserve fruits, vegetables, and other foods; with relatively little work, some basic equipment, and a bit of time, you can reduce pounds of food to ounces. Properly dehydrated foods keep for a long time, and as an added bonus they're lightweight and don't require refrigeration.

Dehydrators are generally pretty foolproof, though I've managed to make trouble for myself on occasion. Let me explain. We were doing a day hike from base camp, and I'd tucked some snacks into a fanny pack. Our lunch break turned into a fiasco, however, when I discovered that instead of the dehydrated strawberry-apple leather I'd meant to bring, I'd grabbed a roll of spicy tomato-sauce leather instead. (Note to self: Always label dehydrated stuff.)

The main principle of dehydrating is simple: Warm air circulates over food that's been cut into small or thin pieces and spread out to allow maximum exposure to the air. The main parts of a seat-of-the-pants dehydrator I've used include:

- large, sturdy cardboard box from a computer or other large device for the enclosure
- cake-cooling racks to hold the food
- incandescent light to serve as the heat source

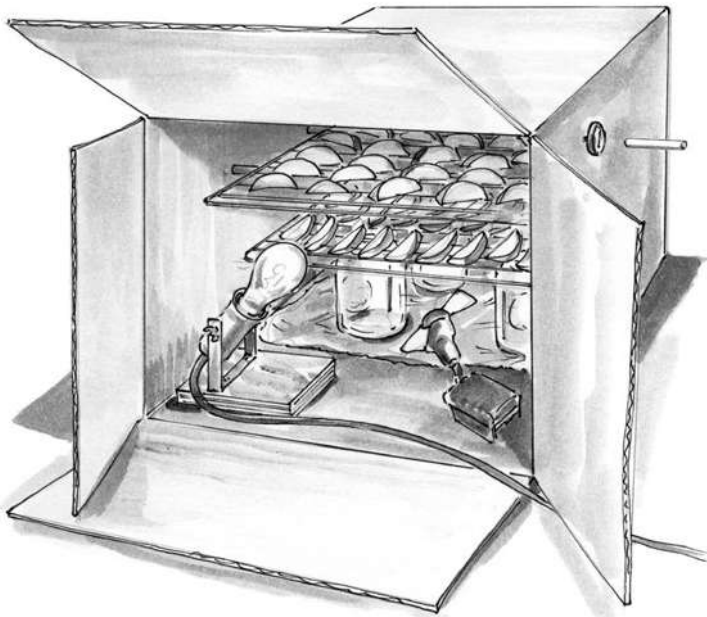

- small battery-operated fan to keep the air moving (not essential, but really helpful)
- probe thermometer

Close and tape the flaps on the bottom of the box, then set it on the kitchen counter with the open end facing you. Use four jars or cans of equal height to support the bottom rack; lay a piece of foil underneath if the food is drippy. To support additional racks, cut or drill holes in the sides of the box and insert pairs of horizontal wooden dowels, pipe, or even well-scrubbed sticks. A 20"-square box has enough room for two or three racks. Position them toward the back of the box to allow room in the front for the light and fan.

A clamp-on portable light or small gooseneck lamp works well to hold the bulb. Cut a notch in one of the box flaps to make room for the cord. Place the fan on the opposite side of the box from the light, pointing upward. Finally, punch the probe thermometer through the side of the box, near the center. Once everything is in position, loosely close the flaps, allowing a bit of a gap between them for air circulation.

The ideal temperature is 125°F to 140°F, although anything between 90°F and 145°F will work. You may have to experiment with bulb wattage. Start with a 100-watt bulb and monitor the temperature; it takes a while for the temperature to stabilize. If your box isn't warm enough after an hour, switch to a higher wattage. If the box gets too hot, reduce the wattage, open a flap slightly or cut a few vent holes near the top of the box.

For your first experiment, I suggest apples, sliced in wedges about ¼" thick. Arrange them on the racks, keeping a little space between them. Two pounds will yield about 3 ounces of dehydrated slices, which will take 5 to 8 hours to dehydrate. Rotate the racks and switch their positions every hour or two. My little clip-on fan uses rechargeable batteries, which I switch for a fresh set as the fan slows down (about 4 hours). Although it's unlikely the light will generate enough heat to cause a problem, keep an eye on the dehydrator to ensure the box doesn't show scorch marks or other signs of getting too hot.

Most fruits can be dehydrated with no preparation other than slicing; vegetables generally need to be blanched for a minute or so in boiling water, then refreshed in cold water first. Consult a book on dehydrating for specific instructions, or look for information online.

TERESA MARRONE is a graphic designer, photographer, cook, editor, and author. Her books include *The Seasonal Cabin Cookbook*, *Dressing & Cooking Wild Game*, *Slow Cookers Go Wild*, and, most recently, a series of field guides and cookbooks focused on wild berries and fruits. (See Resources for more information.)

Fire Pit Grilling Station

A place to kick back and cook up a storm

A fire pit is the perfect place for gathering, chatting, burning brush, and warming up. It can also be the perfect place for cooking, and you don't have to limit your menu to marshmallows and hot dogs. The pivoting, adjustable grate makes your outdoor cooking, baking, and grilling options endless.

You can create this fire pit and grill in a weekend using readily available retaining wall blocks, iron pipe, and other materials. If you wish to build only the fire ring, complete just the first section of the project instructions. Here's how to get cooking.



Materials*

- Retaining wall blocks, ten to twenty per course
- One 40" to 48" metal fire ring insert
- Gravel
- Concrete block adhesive
- Iron pipe and fittings (see Building the Grate Holder, page 123)
- Cooking grate
- Galvanized wire
- One ¼" × 2" galvanized bolt

**The lengths of the iron pipe and the number of iron pipe fittings vary according to grill size.*

Building the Fire Ring

1. Start by going shopping. Most home centers, farm supply stores, and garden centers sell metal fire rings in sizes up to 48" in diameter. You can also create your own by cutting down a culvert or 55-gallon drum. Also, select the trapezoid-shape retaining wall blocks for the surround. Check the manufacturer's literature or lay some out in a circle to make certain they can create a tight enough ring to surround your fire ring insert. Purchase enough blocks for your project.
2. Lay out the site: First determine the overall dimensions of the fire pit by adding the diameter of the fire ring insert and the width of the retaining wall blocks. Pound a stake into the ground to indicate the center of the ring. Hook one end of your tape measure on a nail driven into the center of that stake and use it as a gigantic compass to scratch two circles in the ground (or mark the perimeters with stakes): one ring indicates the circumference of the metal fire ring; the other marks the outside of the blocks. The area in between the circles is where you will excavate.
3. Excavate the area to a depth of 6". Add 4" of gravel, and level the gravel using a level taped to a long straight 2x4. Note: If you're going to build the metal cooking grate, install the pipe collar in concrete (see step 1, page 123) before proceeding to the next step.

TAKE NOTE You can excavate, and add gravel to, a much larger area if you want. A larger gravel area creates a fire-break between your pit and surrounding vegetation, and gives you an easy-to-level material for setting benches and chairs.

4. Position and level your metal insert. Set the first course of retaining wall blocks around the perimeter. If the last block doesn't fit, reposition each block an inch or so farther away from the metal insert and try again until the blocks come full circle. Use a level to make sure the first course of blocks is level. To raise an area, remove the block, sprinkle a little more gravel over the area, and then set the block back in place. To lower a block, shuffle it back and forth a bit or whap it with a sledgehammer buffered by a scrap block of wood (to prevent chipping or breaking the block). Add a couple more inches of gravel along the outer perimeter of the first course to lock the blocks in place.
5. Apply concrete block adhesive to the top of the first course of blocks. Position the first block of the second course so it's centered over a joint between the blocks below. Add the remaining blocks for that course. Keep adding courses to reach your desired height; three or four courses is typical.

TAKE NOTE Some retaining wall systems include cap blocks that create a more finished look for the top course. Determine ahead of time whether you want to install these; if so, then take them into account for your final height.

Fire ring construction

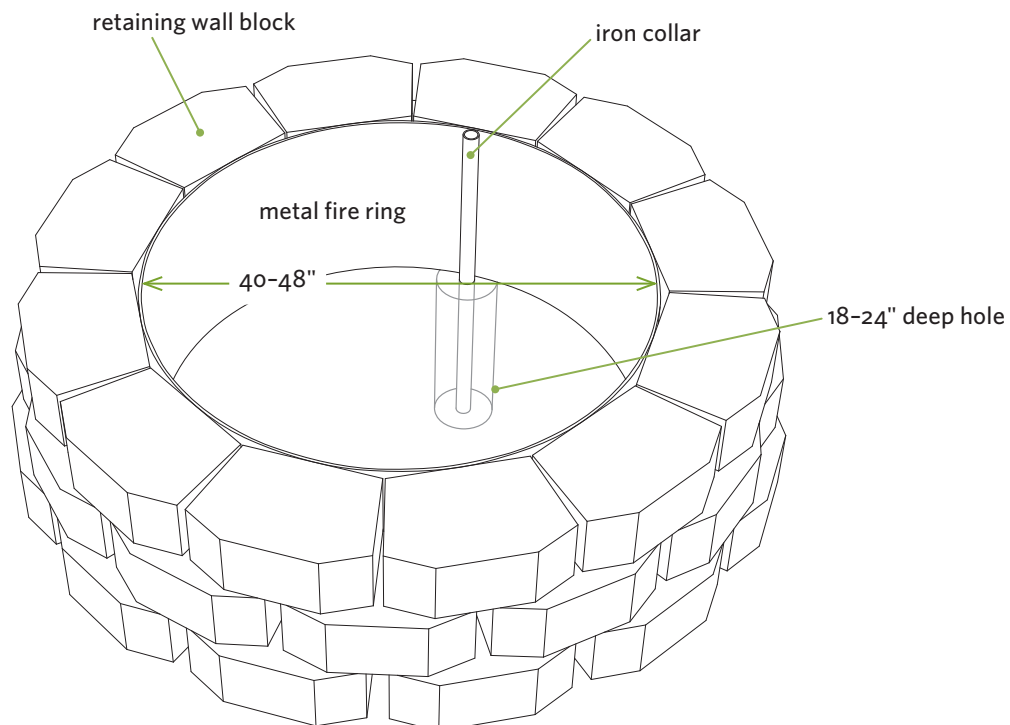

Building the Grate Holder

1. Use a posthole digger to dig a 6"- to 8"-diameter hole 18" to 24" deep. The ideal position for the pipe collar of the grate assembly is just kissing the inner surface of the metal ring, as shown. Insert the iron pipe collar so it's level with the top of the fire ring (or slightly taller) and stands perfectly plumb. Mix and pour the concrete to fill the hole around the pipe; keep the top of the concrete low enough so it won't interfere with the metal fire ring and blocks when you install them.
2. Build the pivoting grate mechanism using standard iron pipe, as shown in *Metal grate details*. Thread the parts together and tighten all joints firmly with pipe wrenches.

TAKE NOTE Fittings and pipe sections with prethreaded ends are available in a range of sizes at home centers and plumbing supply retailers. Since there's evidence that galvanized pipe can emit harmful fumes when heated, use the "black pipe" variety.

3. Install the grill. I used a 22" replacement grill (see Resources) and wired it to the arms of the mechanism in four places. Make the height of your grate adjustable by drilling a few $\frac{5}{16}$ "-diameter holes spaced 2" apart near the bottom of the

Burning Codes, Really?

Many communities have burning codes. This may seem like overregulation, but not if it prevents your house or wooded area from catching fire. Here are a few regulations you might encounter:

FUEL AREA refers to how large the fire can be. In many communities the maximum diameter of the actual fire is 3 feet, with flames no higher than 2 feet.

FUEL TYPE refers to what can and can't be burned. Most communities permit seasoned firewood. No-nos include garbage and things made from petroleum.

LOCATION refers to distance between the fire and any structure or combustible material. A minimum buffer zone of 15 to 25 feet is common.

Fires should always be attended. Watch the wind, be a good neighbor, and keep a fire extinguisher or garden hose nearby.

pipe leg as shown below; use a $\frac{1}{4}$ " bolt to peg the height you need.

Metal grate details

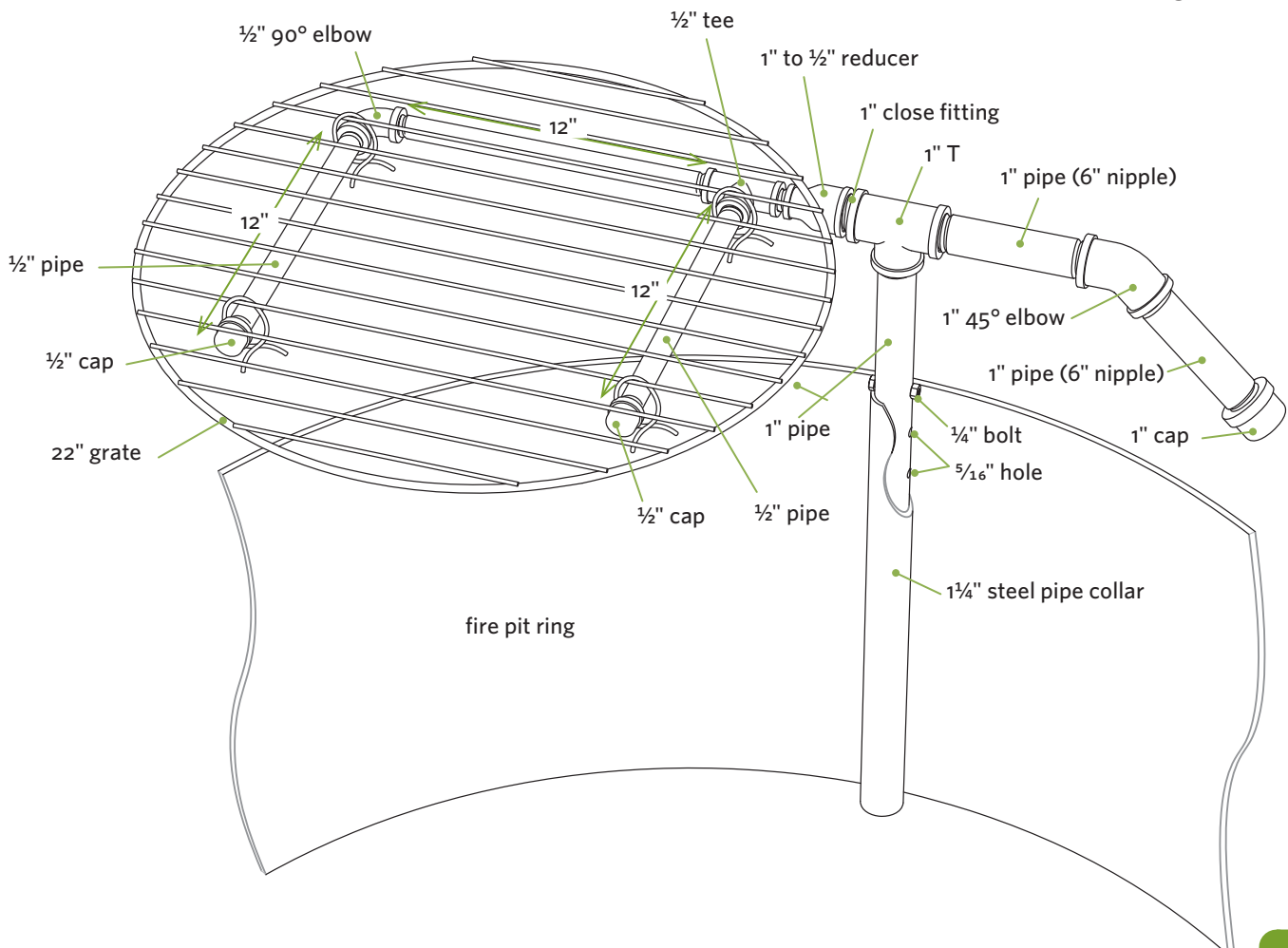

Root Cellar

Store fruits and veggies by harnessing Mother Nature's cool

Root cellars provide the perfect place to store a summer's worth of produce to get your family through the long, cold off-season. A properly organized 80- to 100-square-foot root cellar can provide enough space to store up to 60 bushels of produce.

There are dozens of structures you can build, or use, as a root cellar: a trash can or refrigerator buried in the earth, an underground concrete

bunker, and everything in between (see *Root Cellar Options*, page 126). Here you'll see how to create a root cellar within an existing basement space. Since setups will vary depending on your needs and the size, shape, location, and construction details of your basement, the object here is to provide general ideas rather than specific measurements. It all starts with selecting the best location.



Selecting the Best Location and Design

Design a structure large enough to accommodate your summer's bounty but small enough to be easily maintained and controlled. Figure out what and how much you want to store, and how you want to store it. Then begin doodling on paper. You may want to allow extra space for wines, cheeses, and canned goods, since these items also fare well in a root cellar environment. Figure out your shelving or storage system ahead of time so you can make optimal use of space. (The Root Cellar Storage System, page 129, is one option.)

It's best to construct the cellar in the northeast or northwest corner of your basement, as far away from your furnace or other heating equipment as possible. The more exterior masonry wall you can incorporate, the more of Mother Nature's natural cooling power you'll be able to harness. If possible, select an area that includes a basement window high on one wall; the opening provides the ideal place for running your intake and exhaust vents (see *Ventilation details*, page 127). If an existing window isn't an option, you can run these vents through the rim joist or foundation wall; it's just more work.

Root cellar construction

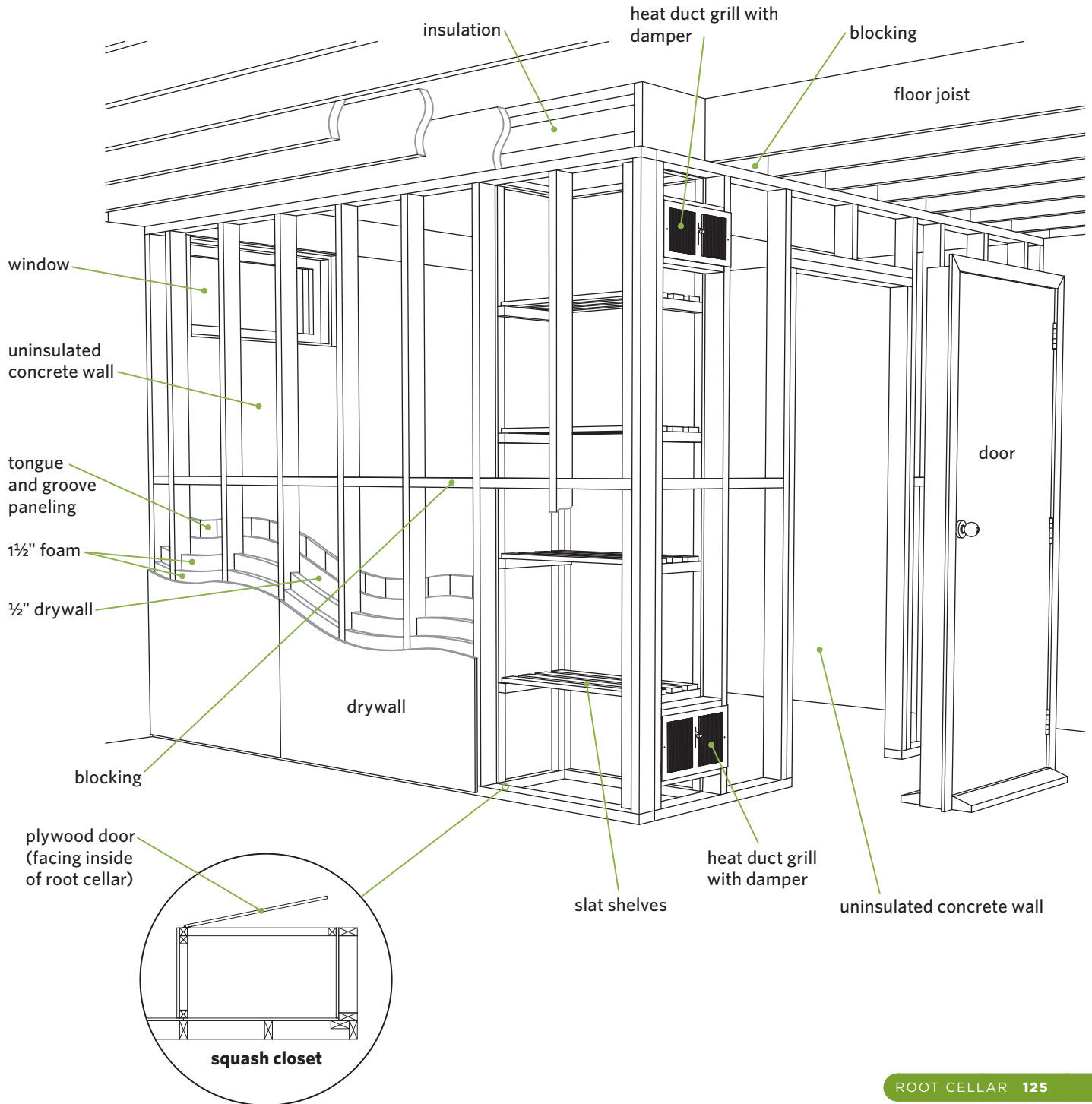

Building the Enclosure

Once you've selected the size and location for your root cellar, mark the position of the walls on the floor with a pencil, or lay 2×4s on the floor to represent the walls. Stand back and ask yourself a few questions: Will the walls you build interfere with any pipes, ducts, dampers, or shutoff valves now in the ceiling? Is the structure going to block access to other parts of the basement? Does it seem way too big or small? Is it best to use the existing joists as the ceiling, or is there so much existing ceiling clutter that it would be better to build an independent "dropped" ceiling?

ONCE YOU'VE TWEAKED YOUR DESIGN, GO TO WORK:

1. Secure the treated 2×4 bottom nailing plates to the floor using construction adhesive and concrete nails. Fasten standard 2×4s to the ceiling directly over the bottom plates to serve as the top nailing plates. (Use a level and a long 2×4 to get these positioned right.) Lay out the location of the studs — every 16" or 24" is standard — and frame in the rough opening for the door. Cut the studs to length, plumb them with a level, and then toenail them to the top and bottom plates with 16d nails. (Use hot-dipped galvanized nails for the bottom plates.)
2. Nail blocking between the overhead floor joists to close off any open spaces over the walls.
3. Insulate the ceiling area with extruded foam. If there are shutoff valves or dampers, box them off and create an access panel.
4. Install water-resistant drywall to the inside surface of the cellar walls and ceiling you just framed; leave the exterior concrete walls unfinished. Finish the drywall seams and corners with drywall tape and compound. As an option, install plywood or tongue-and-groove boards over the drywall; this isn't mandatory, but the wood surface helps prevent damage to the drywall and creates a solid nailing surface for installing shelves and bins later on. It also looks more root cellar-ish. Add a row of 2×4 blocking halfway up the wall to provide an additional nailing surface for the paneling.
5. Cut and install two layers of 1½" rigid extruded insulation (foam insulation board), and fit it between the studs of your framed walls from the outside. Extruded foam provides excellent insulation and isn't affected by moisture. Install standard drywall to the exterior surface of the walls.
6. Frame in the optional "squash closet" as shown in *Root cellar construction* (page 125), if desired. You might want one of these if your harvest includes produce that needs slightly warmer temperatures and/or better ventilation. The door can be built from plywood or tongue-and-groove boards, or you can install a small prehung door. Install two heat register grills with dampers on the exterior wall of the squash closet: one high and one low. You can open and close these dampers to tweak temperatures, humidity, and airflow.
7. Install the root cellar door. A prehung insulated steel garage service door is reasonably priced and easy to install; most come complete with weatherstripping, a threshold, and a predrilled hole for a doorknob. Install the door so it swings out of, rather than into, the cellar room.

Root Cellar Options

Root cellars of long ago often were simple affairs, and they can be today, too. Here are a few options.

WINDOW WELL. Cover the top with screen or hardware cloth to keep out critters; then make a sturdy lid from wood and rigid foam insulation. Cover the lid with hay. Access your stored produce from inside through the window. Open the window a crack to let warmer air into the well in the winter.

BARRELS AND BUCKETS. Bury them with their lids even to the surface, then cover them with bales of hay.

OUTSIDE CELLAR STEPS WITH A CELLAR DOOR. Store vegetables that need the coldest temps on top steps; those that require less cold on lower steps. (Note that this is the opposite to the placement in a basement root cellar.)

Installing the Intake and Exhaust Vents

The saying "Passive solar energy is for active people" holds true for passive root cellaring, too; both systems involve seasonal, and sometimes daily, manipulation for maximum efficiency. You'll need to monitor the cellar and make adjustments for optimum efficiency and minimal spoilage based on inside and outside temperatures. The main activity is moderating the temperature using the intake and exhaust vents. Vents are also important for creating good ventilation and whisking away odors. Installing the vents correctly from the start is an important key to making your root cellar a success:

1. Remove the window and create a replacement panel as shown by building a frame out of 2x2s and then cutting a piece of rigid foam to fit inside. Use construction adhesive and nails to secure ½" plywood to both sides of this frame. Test-fit the panel in the opening to make sure it fits snugly.
2. Purchase venting materials and blast gates (often used in dust collection systems and available through woodworking suppliers); you'll use these to control airflow into and out of the cellar. Measure the outside diameter of the pipes and mark two holes on the panel, separating them as far apart as you can without hitting the 2x2 frame. Make the cutouts with a jigsaw equipped with a long blade (starting with a ½"

starter hole drilled inside the marked circle, for inserting the saw blade).

3. Dry-assemble the pipes and blast gates, position them in the panel openings, and then place the panel in the window opening. Adjust the length of the pipes and elbows until the parts fit properly. Once everything looks okay, glue, clamp, or screw the parts together. Use long screws to secure the panel into the window frame opening. Use expanding spray foam to fill the gaps around the vent pipes and the panel itself.
4. Install screens on the outside of the vent openings to keep out insects and mice.
5. Install several inexpensive thermometers at various places in your cellar: high, low, near an exterior wall, near an interior wall, and so on. These will give you a general reading of varied temperatures within the room. Install a humidity gauge to keep tabs on moisture levels, too.

TAKE NOTE As outdoor temperatures cool, leave both vents open. If the temperature dips below freezing, partially or completely shut one gate; you'll still get some air circulation, but you'll minimize cold air inflow. If it dips way below freezing, close both gates.

Ventilation details

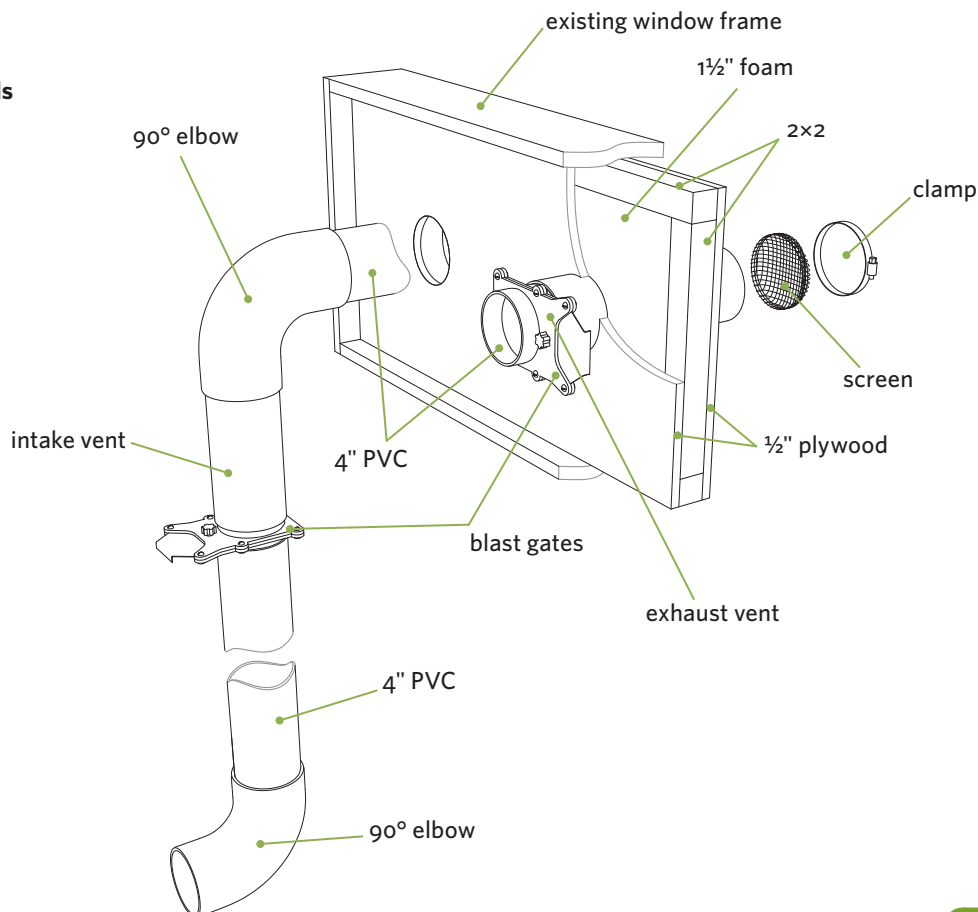

What, Where, and How Long to Store Stuff

All fruits and vegetables are not created, or stored, equally. Since different vegetables and fruits like different storage conditions, you'll need to figure out the best placement of each in your cellar. Higher storage areas will be warmer and dryer, while lower shelves will be cooler and moister. Temperatures can vary as much as 15 degrees from the top to the bottom shelf. The chart below offers some general guidelines for storing common types of produce. Here are some more storage tips for best results (see Recommended Reading for more information):

- Shake off clumps of dirt, but don't clean vegetables. Cut off leafy stems, but leave root tips and vegetables uncut to ward off bacteria.

- Apples, pears, peaches, and tomatoes emit ethylene gas, which can cause problems for tomatoes and some root crops. Place ethylene producers up high near the vents, or wrap them in paper.
- Onions and cabbages can emit pungent odors that affect their neighbors. Store odor producers high up in remote corners and/or near ventilation.
- Store root crops in containers of sawdust or loose soil to protect them from their ethylene- and odor-producing neighbors.

Produce	Ideal Temperature/ Relative Humidity	Maximum Storage Time
Apples, pears	32-40°F/80-90%	3-4 months
Beans (dry)	32-50°F/60-70%	varies
Beets	32-40°F/90-95%	2-3 months
Broccoli	32-40°F/90-95%	1-2 weeks
Brussels sprouts	32-40°F/90-95%	3-5 weeks
Cabbage	32-40°F/90-95%	3-4 months
Carrots	32-40°F/90-95%	4-6 months
Cauliflower	32-40°F/80-90%	2-4 weeks
Cucumbers	40-45°F/85-90%	2-3 weeks

Produce	Ideal Temperature/ Relative Humidity	Maximum Storage Time
Eggplant	40-45°F/85-90%	1-2 weeks
Onions	35-40°F/60-70%	5-8 months
Parsnips	32-40°F/90-95%	1-2 months
Potatoes	32-40°F/80-90%	4-6 months
Pumpkins	50-60°F/60-70%	2-3 months
Radishes	32-40°F/90-95%	2-3 months
Rutabagas	32-40°F/90-95%	2-4 months
Winter squash	50-60°F/60-70%	4-6 months
Tomatoes	50-60°F/60-70%	1-2 months

Root Cellar Storage System

Bins, shelves, and drawers for all

If you've built a top-notch root cellar (see page 124), you'll want to build a top-notch storage system. Since you can't predict your harvest from year to year, build a system with flexibility. This version includes ventilated shelves, drawers, and bins to accommodate different types of produce.

Follow the basic techniques described here to build a custom system to fit your space and storage needs, and include as many shelves, drawers, and bins as you like. The same system also works well for pantries and other spaces.



See page 4 for a photograph of this project.

Materials*

- 4 × 8-foot sheets $\frac{3}{4}$ " plywood
- Pine 1×2s
- Pine 1×3s
- $\frac{1}{2}$ " plywood
- Pine 1×10s
- Pine 2×2s
- Wood glue
- $1\frac{1}{4}$ " drywall screws
- L-brackets
- 3d finish nails
- 6d finish nails

*All quantities are as needed, depending on the size of your shelving system and the number of shelves, bins, and/or drawers.

1. Rip 4 × 8-foot sheets of $\frac{3}{4}$ " plywood into 16"-wide strips, then cut them to length based on the height of your root cellar. You'll need two strips for each shelf upright, or standard. Apply wood glue to one face of one strip, position another strip on top, and secure the two together using $1\frac{1}{4}$ " drywall screws.
2. Make a story stick as shown in *Shelf standard diagrams*, below; this helps ensure that all the cleats on the standards are spaced equally. Position the top of the story stick flush to the top of a standard, and transfer the tick marks from the story stick to the edge of the panel. Use a drywall or framing square to extend these marks all the way across the panel. Use the story stick on each side of each standard to ensure uniform spacing. Mark all of the standards in the same fashion.

TAKE NOTE The cleats that hold the shelves are $1\frac{1}{2}$ " wide; the spaces between the cleats are $1\frac{3}{4}$ " wide to allow a little wiggle room so the bins and shelves can slide in and out easily.

Shelf standard diagrams

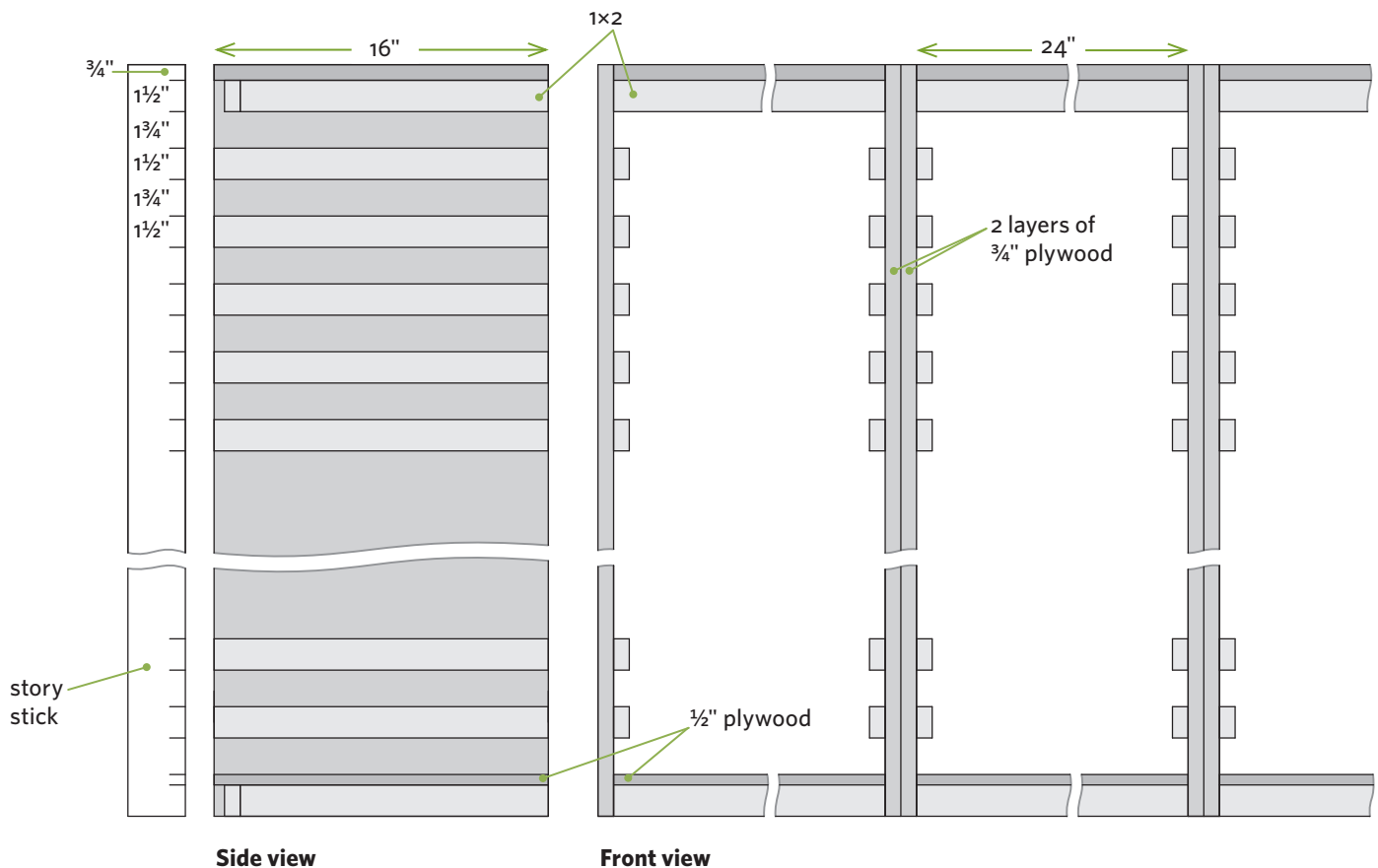

- Cut the 1×2 cleats to length at 16". Install the cleats to the faces of the standards, using wood glue and 1¼" drywall screws. If your cleats tend to split, drill pilot holes for the screws.
- Secure the standards to the walls, ceiling, and floor using L-brackets, screws, and concrete anchors as needed. Leave 24" to 28" between each pair (ours are 24"). The dimensions of the shelves, drawers, and bins you will build are determined by the spacing of your plywood standards.
- Create the **ventilated shelves** by cutting the 1×3 side supports and slats to length, as shown in *Shelf detail* below; make the slats about ¼" shorter than the distance between pairs of standards. Position the slats atop the two side supports, spacing them about ⅝" apart to create gaps for ventilation. Use a framing square or the square edge of a work surface to make sure the supports are square to the slats. Assemble the parts with wood glue and 3d finish nails driven through the slats and into each support.

TAKE NOTE Create or find a spacer that's the same thickness as the space between the slats, and use that as a spacing guide; often a 16d nail works well.

- Build each **solid-bottom drawer** by cutting a ½" plywood bottom as shown in *Drawer detail*, below. The width of the bottom should be about ¼" narrower than the distance between the standards. Cut oval finger grips along the front edge, using a 1" spade bit to create the ends and a jigsaw to create the straight edges. Build the 1×4 drawer box narrow enough so the plywood will extend past the sides and front by ½", as shown. Use glue and screws to assemble the box frame. Apply glue to the bottom of the frame, lay the plywood on top of it, and fasten through the plywood and into the frame with 6d finish nails.

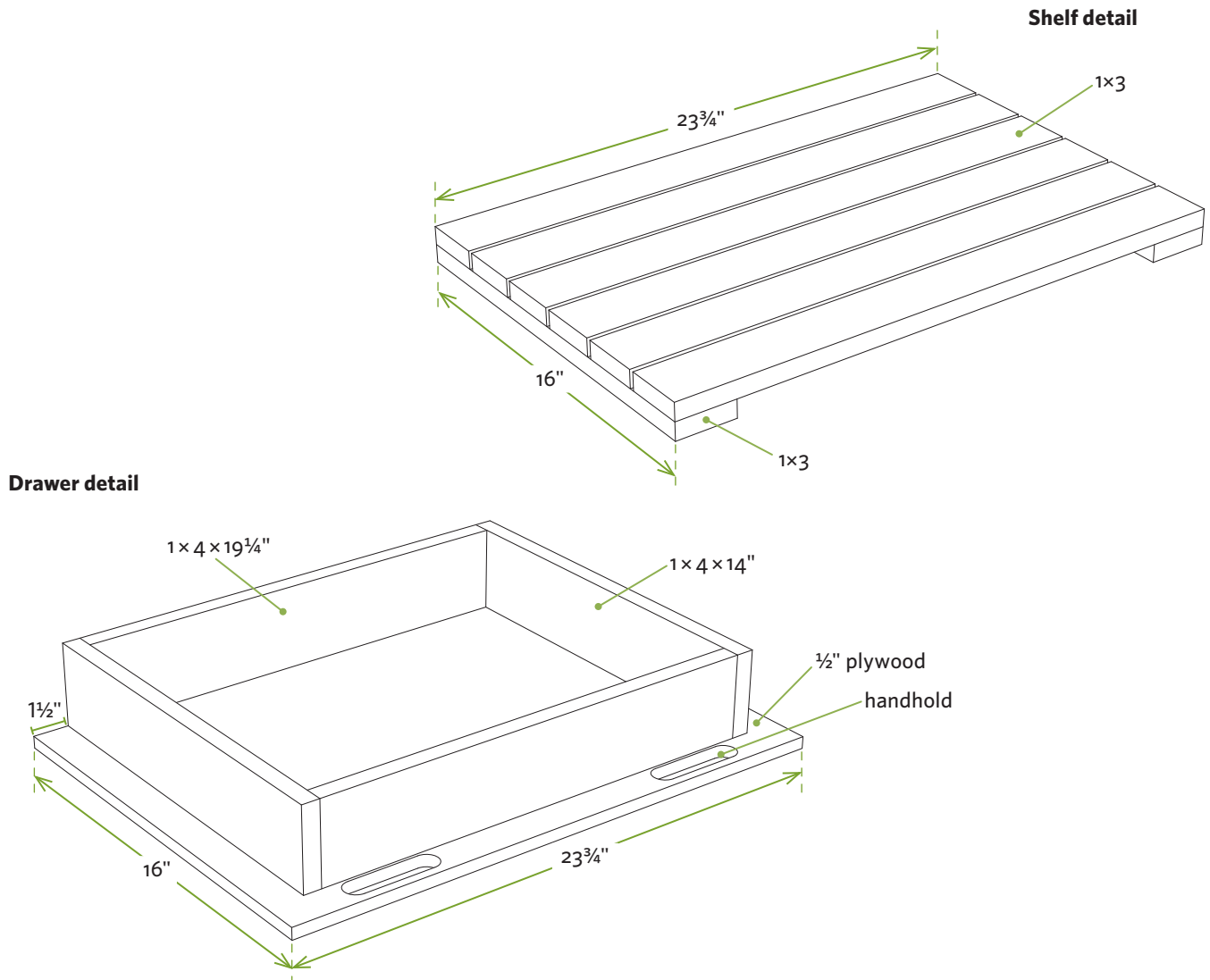

7. Create each **bin** by cutting the 1×10 sides to the length and angle shown in *Bin detail*, below. Cut the 2×2 runners to length at 16", and secure them to the sides with glue and screws. Cut the 1×3 slats to length (about 3½" shorter than

the distance between standards). Position the two side pieces upside down and install the bottom, front, and back slats with glue and screws, using spacers to gap the slats evenly.

Bin detail

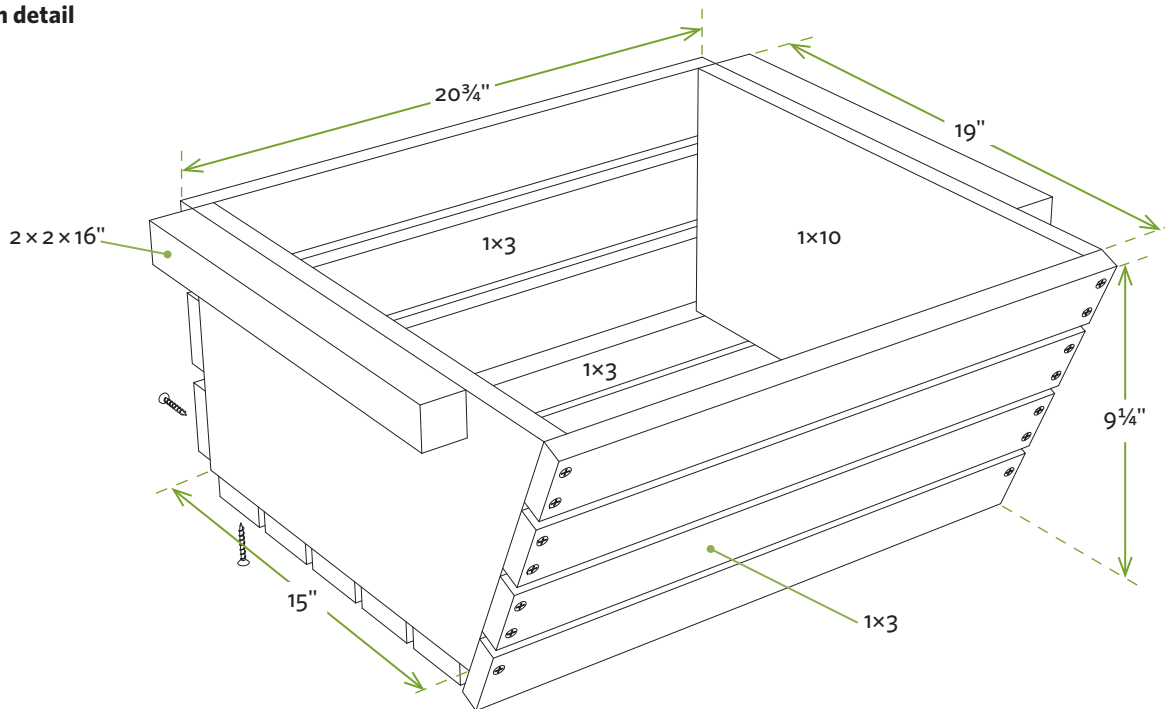

Optimum Storage Conditions for Optimum Veggies and Fruits

Root cellars protect against the three food-spoiling Ms: moisture, mold, and mice. Using your root cellar and storage shelves is a learning process. Take notes the first year or two as to what, when, where, and how you stored your produce.

Store only healthy, undamaged vegetables and fruits. Check produce every week, and cull any fruits or vegetables that are spoiling or softening. Also, clean your root cellar prior to harvest season. Scrub out all your containers and let the area dry out for several days before starting to restock it.

Flowerpot Smoker

Slow-cooked meat in a clay pot!

If the thought of smoking meat and fish conjures up images of heaps of hardwood, a large smokehouse, and a big investment of time and cash, think again. You can smoke food on a much smaller scale: in a clay pot smoker.



See page 3 for
a photograph of
this project.

Materials

- One 1,000-watt (or greater) hot plate
 - One 12"- to 16"-diameter ceramic pot
 - Round grill grate (sized to smoker pot interior)
 - One ceramic pot or tray (for smoker lid)
 - One eyebolt with two washers and nuts
 - One 6"-long wood dowel
 - Two to four pieces of 2"-thick brick or patio block
 - Pie pan
 - Three scrap wood blocks
 - Thermometer
1. Purchase your materials. Since you'll acquire them from a variety of sources, measure as you go and purchase the parts in this order:
 - **Hot plate.** The smaller the better, but it should be at least 1,000 watts. Anything smaller may not maintain the needed temperature.
 - **Flowerpot.** Make certain the bottom is large enough to accommodate the hot plate and control knob, plus a little elbow room.
 - **Grate.** It should nestle about $\frac{3}{4}$ of the way up the tapered sides of the pot. Grates are sold as replacement grills and can be found at hardware stores and online (see Resources).

NOTES FROM THE TEST TRACK

Get Smokin'

For my test drive I smoked a 5-pound brisket. The results? Fabulous, according to my unbiased wife and friends! We wound up with enough meat to make about a dozen shredded barbecue sandwiches.

Here are a few tips I picked up along the way:

- It took some trial and error to find the settings that kept the smoker at the desired 210 to 220°F. As the smoker warmed up and the pot retained more heat, I turned the dial down.
- A few temperature spikes are okay. The main thing is to keep the temperature in the desired range most of the time.
- Soaking mesquite wood chips in water for about 30 minutes before placing them in the pan, and replacing them every hour or so, produced a great flavor.

- **Cover.** This can be another pot or a pot tray. It can fit over, inside of, or directly on the lip of the pot; just make sure it seals fairly well and doesn't slide off. Make sure the handle hardware will work with your cover.
2. Use a masonry or glass-and-tile drill bit to create a hole (or enlarge an existing hole) in the bottom of the pot for the plug of the hot plate to pass through.

TAKE NOTE To minimize the chance of damage, place the pot on a bag of sand to cradle and support the area as you drill the hole.

3. Assemble a handle for the lid using an eyebolt, two washers, two nuts, and a 6" length of wood or wood dowel. Be creative; there are lots of ways to make the handle.
4. Test-fit your parts. Place a few 2"-thick brick or patio block scraps inside the pot to prop up the hot plate for air circulation. Place the wood chip pan on the hot plate, insert the grate, and then position the top. Prop the pot on three blocks. When everything fits, you're ready to start smokin'.

TAKE NOTE If your grate wobbles or tilts, create three support lips for the grate to rest on using dabs of silicone caulk on the inside of the flowerpot.

5. Position the smoker outside on a noncombustible surface in an area sheltered from the elements. Make sure the hot plate is protected from moisture, and always plug it into a GFCI-protected outlet. Don't leave the smoker unattended. Keep curious pets, kids, and neighbors away from the designated "smoking area."

- I found myself dealing with lots of hot things: a hot plate, hot meat, hot wood chips, and hot pots. I kept leather gloves nearby and worked carefully.
- Be patient and plan ahead! I brined the meat in a mixture of water, salt, and honey for 6 hours before placing it in the smoker. It took 4½ hours to get the meat to the recommended 180°F internal temperature.
- Search online using the words *flowerpot smoker* to learn more about other designs, experiences, and recipes.

Cutaway view of completed smoker

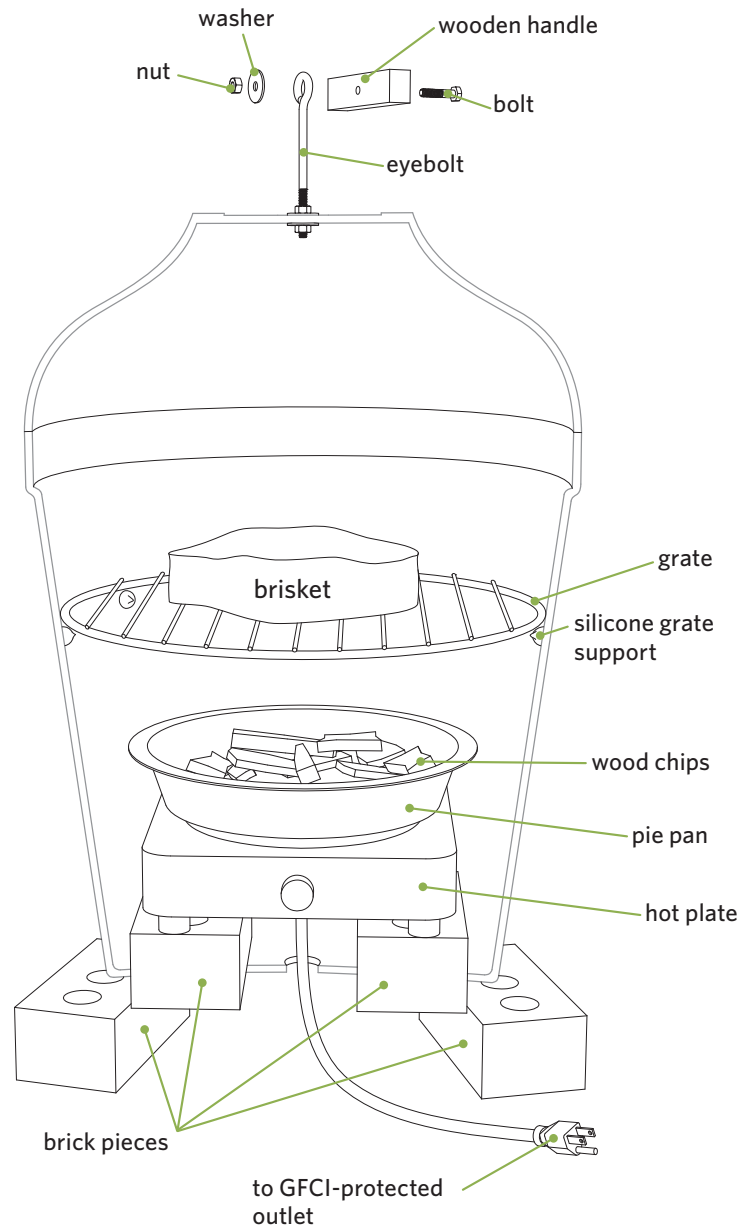

Smoking-Hot Alternatives

A quick online search yields dozens of homemade smoking devices. Anything that can take the heat and hold the meat is fair game. The following are a few of the more novel designs I've come across.

FILING CABINET SMOKER. The bottom drawer of a four-drawer cabinet holds the heat source, while the drawers above hold the meat. A metal vent pipe from the top exhausts the smoke.

REFRIGERATOR SMOKERS. These are made from old refrigerators, ones made of metal, not plastic. The rockwool insulation helps hold the heat. The heat source (either electric or wood) sits in the bottom, and the refrigerator shelves hold the meat.

55-GALLON BARREL SMOKERS. These come in a variety of shapes, sizes, and configurations. Some consist of a 55-gallon drum positioned vertically. One-third of the side is cut away and then hinged back in place to create a door. Grill racks are added to hold the heat sources and meat.

There are also designs utilizing old ovens, garbage cans fired by a turkey fryer burner, and even a toolbox!

Warning: Beware of harmful fumes released from heated galvanized or painted metal surfaces.



Mini Tool Shed, 158

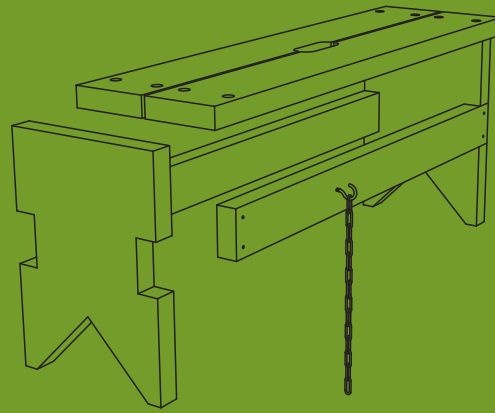

Sawbuck Bench, 140

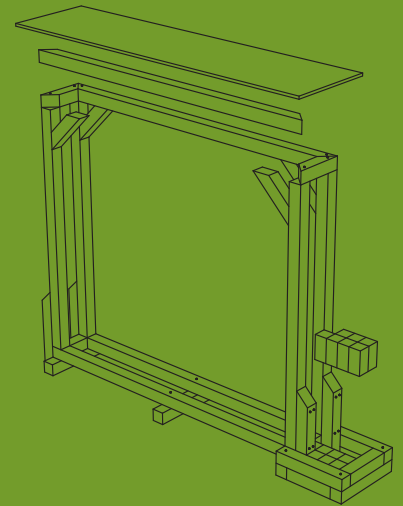

Firewood Storage and Splitting Station, 143

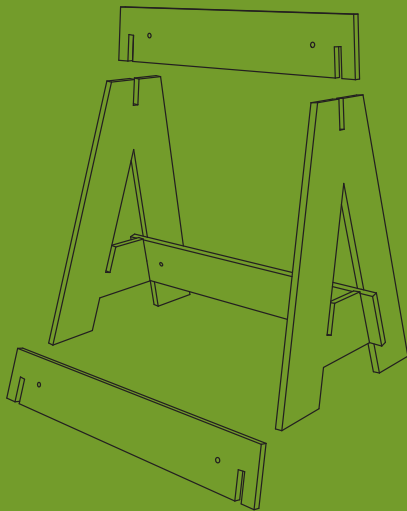

Knockdown Sawhorses, 147

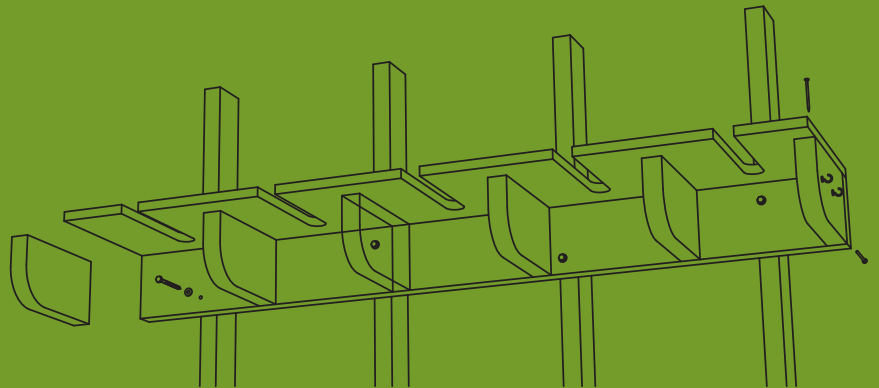

Wall-Hung Tool Rack, 156

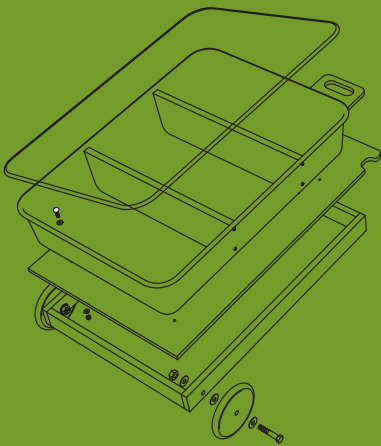

Homestead Emergency Cart, 170

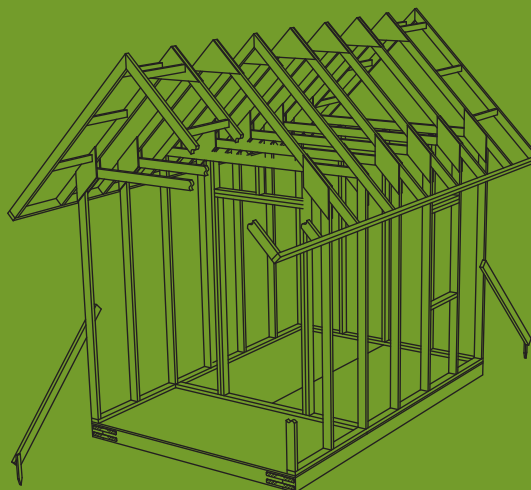

Modular Shed, 163

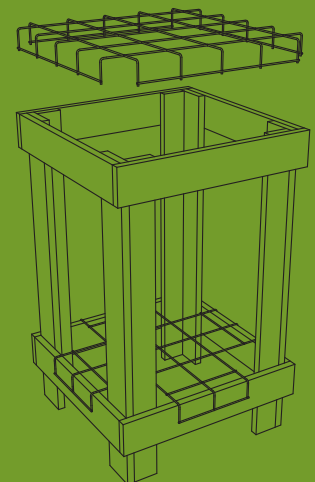

Stand-Up Tool Rack, 150

Storage and Workspaces

“A place for everything and everything in its place.” I *hate* sayings like this that make it all sound so simple and easy. But, alas, it’s true. In the short run, creating well-organized storage and workspaces isn’t easy, but in the long run they’ll allow you to make better use of your time and keep better track of your stuff.

Spending an hour building one of the tool racks in this chapter will save you hours of searching for, picking up, and untangling tools later down the road. You may even avoid twisting an ankle or getting a poked eye. You’ll find cutting and chopping wood a lot easier and a lot safer when you build and use the simple sawbuck. And when you’ve got way too much stuff — or way, way, way too much stuff — one of the sheds can help protect your tools, equipment, and sanity.

Some projects, like the Ultimate Yard Shed, are among the most difficult in the book. The basic design and key building steps are provided, but unless you have prior building experience, you should call on other resources and people to help fill in the missing information. If you’re just getting comfortable with a hammer and saw, tackle the parts you can and hire someone else when you’re stumped.

That said, most of the projects shown here can be built by those with beginning and intermediate skills. Work carefully, think ahead, and you’ll wind up with a place for everything and everything . . . Oh, well.

Overhead Storage Cradles

Up-and-out-of-the-way storage for odds and ends

If you have a jungle of PVC pipe, moldings, and plant stakes encroaching on the corners, shelves, and floor of your garage, here's a solution: Store all that rarely used lightweight stuff up and out of the way. You can easily build and install all the cradles you'll need in an afternoon.

Before you start, measure from floor to ceiling to make sure you have enough overhead space for the racks to fit without getting in the way of you,

your garage door, or your vehicles. You can make single-arm cradles in spaces with low headroom. Also, since you'll be bolting the cradles to the overhead structural members, make sure they're stout enough to handle the extra weight. Most rafters, joists, and trusses will be solid enough, but if they're sagging, rotting, or cracking, pass on this project. And remember, this is for lightweight stuff; store your barbells somewhere else.

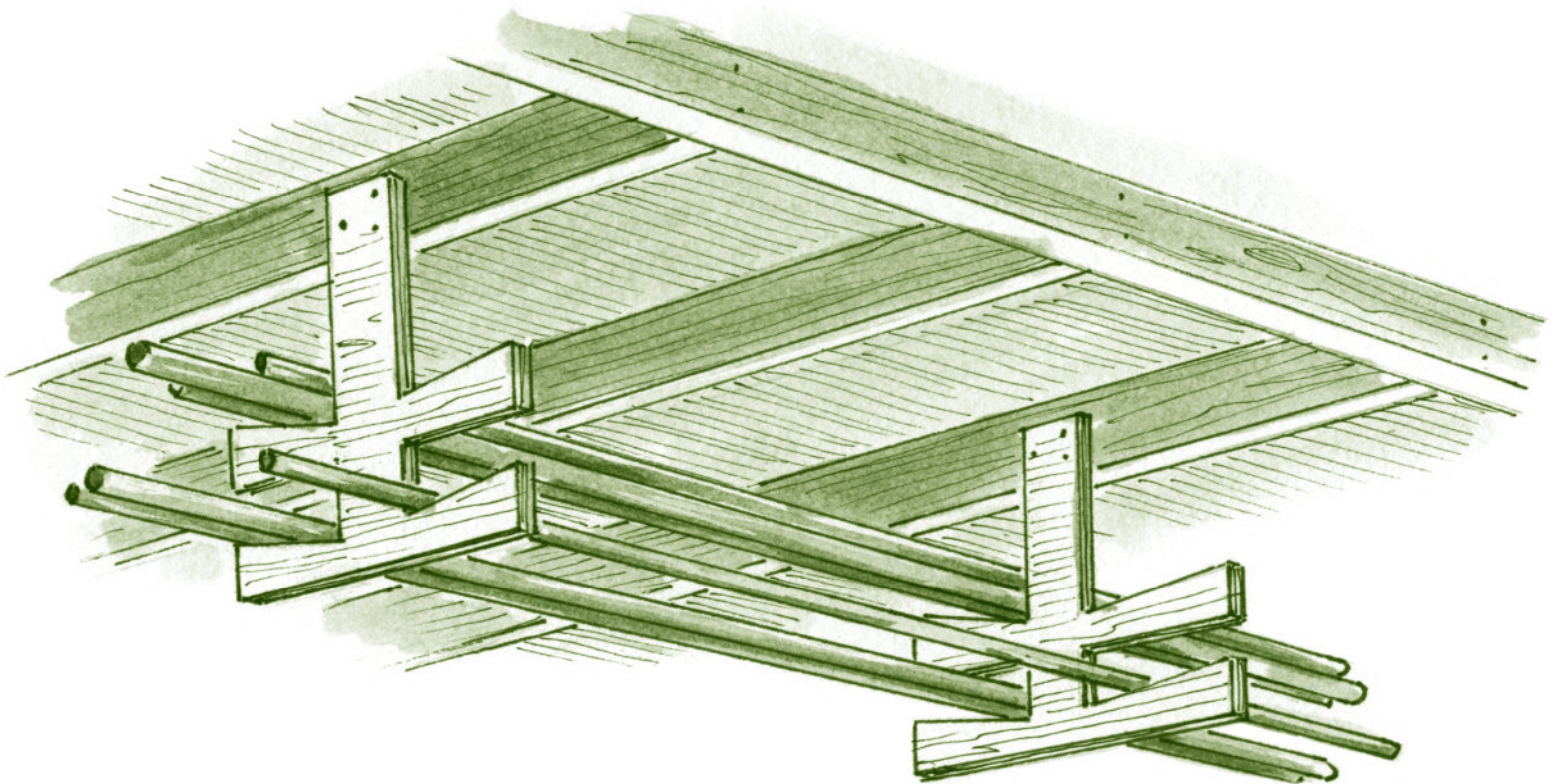

Materials

- One 24" x 24" piece $\frac{3}{4}$ " plywood (for each cradle; see step 1)
- Three $\frac{1}{4}$ " x 3" carriage bolts with washers and nuts (per cradle)

1. Use the measurements shown to lay out the cradles on $\frac{3}{4}$ " plywood. You can make optimum use of longer material by nesting and overlapping the arms as shown. Make enough cradles so you can install them at 4-foot intervals along the ceiling.

TAKE NOTE Make sure the tops of the arms slant inward; this prevents stuff from rolling or falling off.

2. Cut out the cradles. Cut as far as you can with a circular saw, and then finish the cuts with a jigsaw.
3. Temporarily clamp a cradle in place (to a suitable overhead joist, truss member, or rafter) to make sure the height and location are right. Use a $\frac{1}{4}$ " bit to drill three holes through the upright of the cradle and the joist. Insert three carriage bolts with washers, and then secure the bolts with nuts. Install the remaining cradles at 4-foot intervals, making sure that all uprights are aligned and that the cradles are level with one another. For a permanent installation, apply construction adhesive before bolting the cradles.

If you have a jungle of PVC pipe, moldings, and plant stakes encroaching on the corners, shelves, and floor of your garage, here's a solution: Store all that rarely used lightweight stuff up and out of the way.

Cradle cutting details

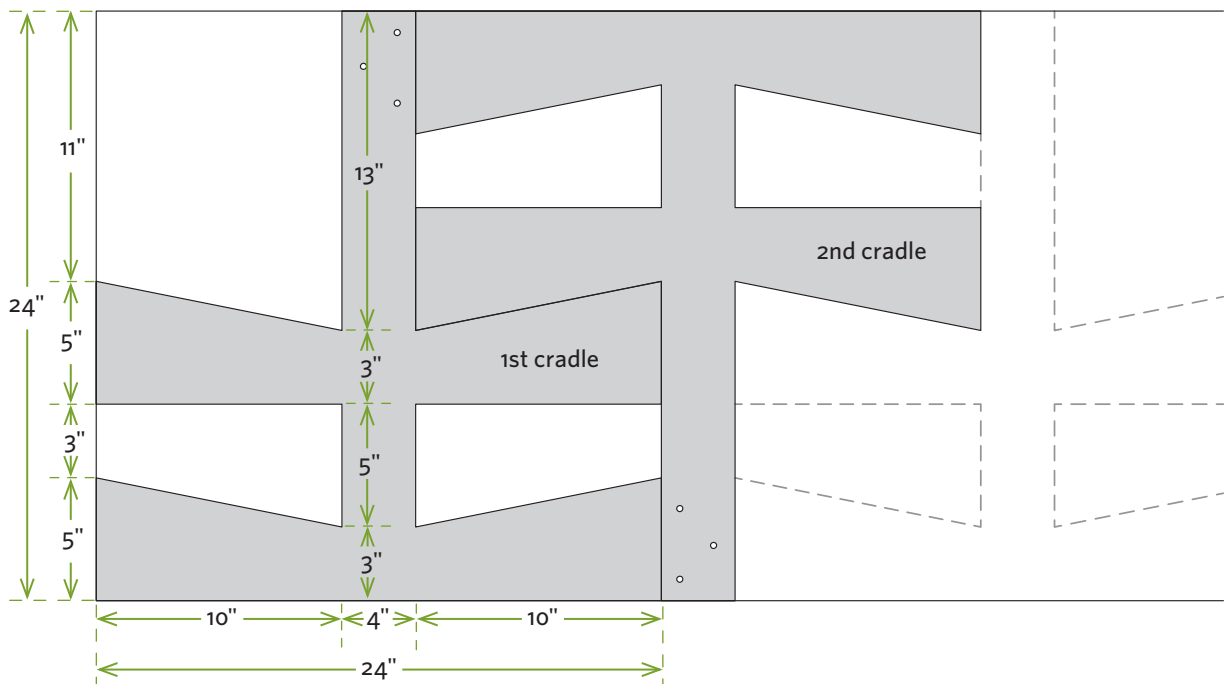

Sawbuck Bench

A workhorse for cutting, plunking, and sharpening

Holding branches and small logs when cutting or limbing them can be a hassle. Because of that, people are often tempted to put hands, feet, and chain saws in places they shouldn't be. Finding a good place to plunk while sharpening or tuning up

a chain in the woods can be another inconvenience. This bench helps you in both tasks: It's a sawbuck for cutting and a solid portable bench for working on your saw.



Materials

- One 4-foot pressure-treated 2×12
- One 8-foot pressure-treated 2×4
- One 8-foot pressure-treated 2×6
- Sixteen $\frac{1}{4}$ " × $3\frac{1}{2}$ " lag bolts with washers
- Two $\frac{3}{8}$ " × 3" eye hooks
- One 24" length heavy-duty chain (sized to fit over eye hooks)

Parts and Cutting List

Part	Size and Material	Quantity
(A) leg	$1\frac{1}{2}$ " × $11\frac{1}{4}$ " × 16" PT pine	2
(B) crosspiece	$1\frac{1}{2}$ " × $3\frac{1}{2}$ " × 36" PT pine	2
(C) top board	$1\frac{1}{2}$ " × $5\frac{1}{2}$ " × 40" PT pine	2

Bench construction

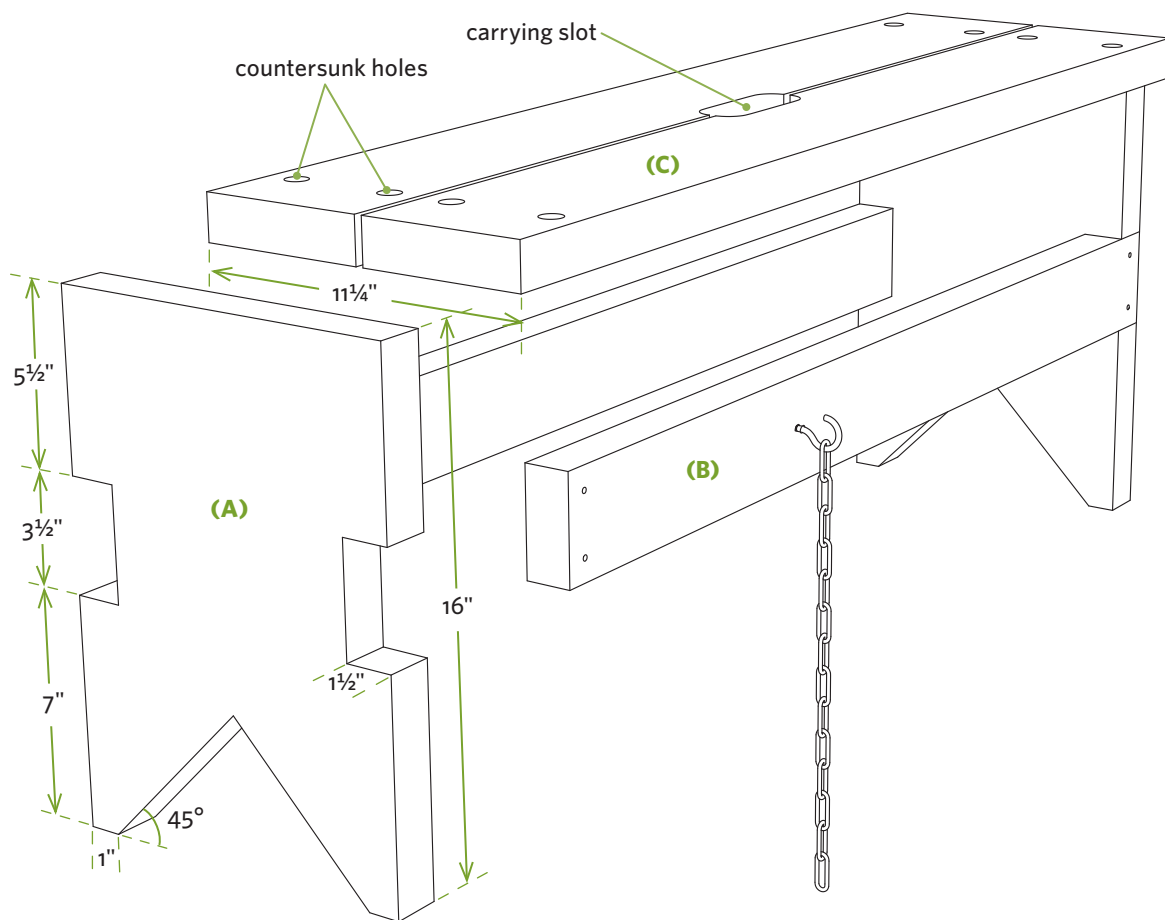

1. Cut two legs (A) to length. Create the notches in the side edges of the legs by setting your saw to cut $1\frac{1}{2}$ " deep and making a series of cuts about $\frac{1}{2}$ " apart. Give the kerfs a solid whack with your hammer, to knock them over like a row of

dominoes, and then clean up and square up the cuts with a chisel. Make the V-shaped cradle cutouts at the bottoms of the legs, using a circular saw or jigsaw for the straight portions and a jigsaw for the top of the V.

TAKE NOTE Make the side notches the exact width as the 2×4 crosspieces (B). The tighter the fit, the sturdier your bench will be — and you want a sturdy bench.

2. Secure the crosspieces (B) in the leg notches using construction adhesive and lag bolts with washers driven into pilot holes. Pre-drill the holes to prevent splitting, and make sure the crosspieces are square to the legs when installing them.
3. Secure the two top boards (C) to the legs using lag bolts. Countersink the bolt heads and washers below the surface. Cut an oval slot into the top to create a carrying handle.
4. Install an eye hook into each crosspiece, 12" away from one end. The hooks will hold the chain to help secure logs for cutting. (See Using Your Sawbuck, below.)



Using Your Sawbuck

This sawbuck is for holding small, lightweight branches. Heavy or exceedingly long logs will cause the sawbuck to tilt, creating a hazard. Experiment with the size and weight of branch your sawbuck will hold before putting it to work. You can use your sawbuck in either standard or cantilevered mode.

STANDARD MODE: Lay a log in the cradle created by the leg cutouts, and saw away as you would with any sawbuck.

CANTILEVERED MODE: Position the log with one end under the chain and the other end projecting beyond the leg farthest from the chain. The chain is adjustable

to accommodate branch diameter. Add a ballast log (see drawing on page 140) to stabilize the sawbuck. Cut as many lengths of firewood as you can with the log in that position; at some point the physics will change so the chain no longer holds the log. At that point, reposition the log so it extends over the leg closest to the chain. This should allow you to make the final shorter cut or cuts. Depending on the length of wood you need for your firebox, you may want to position the chain more or less than the 12" distance shown.

When you need a convenient place to sit while sharpening your chain or taking a break, flip over the sawbuck into *bench mode*.

Firewood Storage and Splitting Station

A headquarters for splitting, stacking, and storing

When you heat with wood, it warms you twice: once when you cut it and once when you burn it. This project will help cool down the first part of this old saw by allowing you to handle and move your firewood more efficiently.

The station gives you a place to store firewood and related tools, as well as a place to split logs. The base of the splitting pad is made from short lengths of 4×4 that rest directly on the ground. This has three advantages: (1) it provides a rock-solid

base for splitting; (2) if your splitting maul makes it all the way through (or misses), it will hit wood instead of dirt; and (3) when the 4×4s get too beat up and splintered, you can remove them and insert new ones.

It's easy to modify the width of this project to accommodate shorter or longer logs, or double-wide stacks. The storage area as shown holds 16"-long firewood.

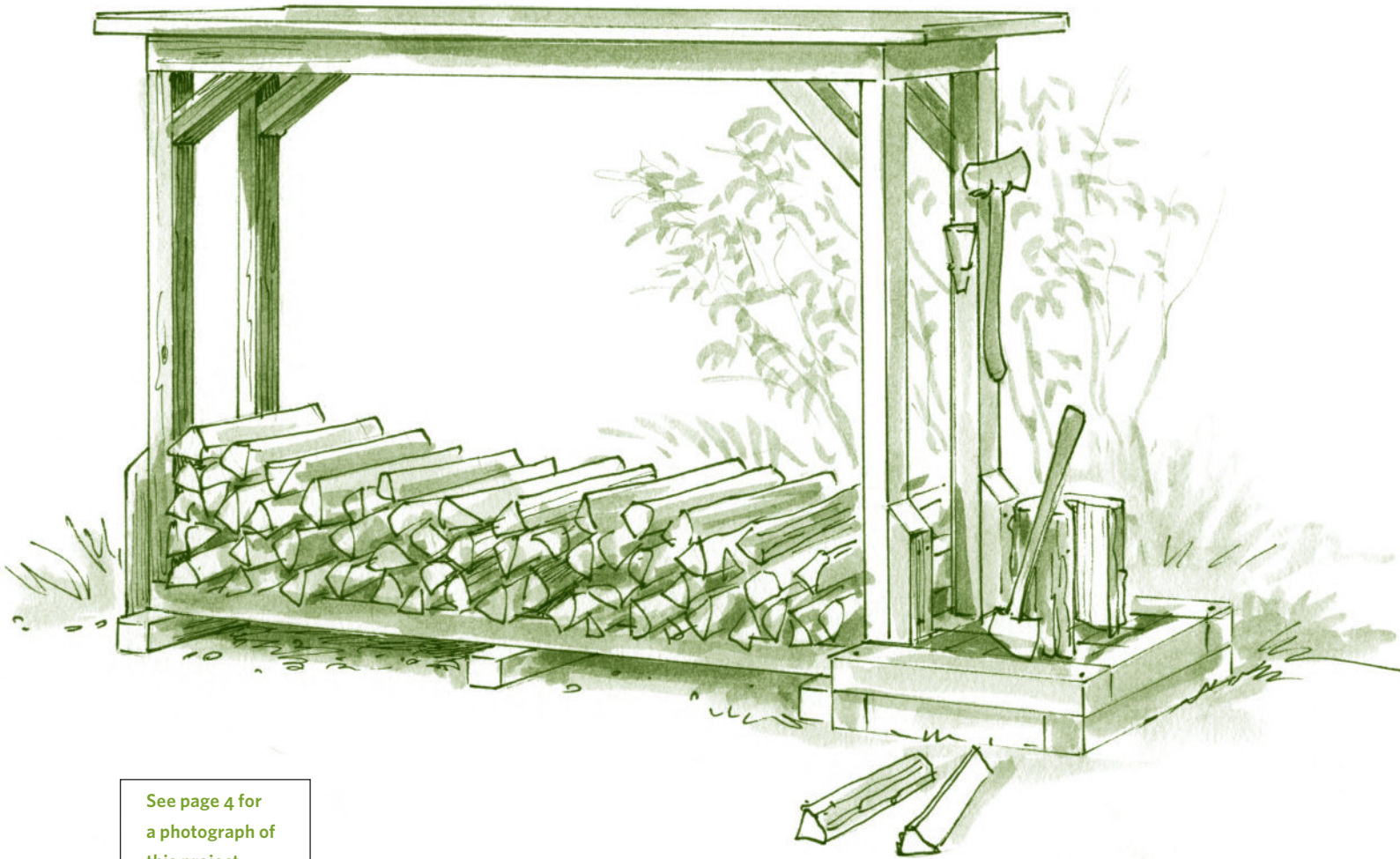

See page 4 for a photograph of this project.

Materials

- Fourteen 8-foot pressure-treated 4×4s
- One 2 × 8-foot piece ¾" pressure-treated plywood
- Gravel (see step 1)
- Fifty 6" timber screws
- 16d galvanized nails
- 2" exterior screws
- Exterior hooks or other hanging hardware (optional; see step 6)

Parts and Cutting List

Part	Size and Material	Quantity
(A) rack base tie	3½" × 3½" × 21" PT lumber	2
(B) splitting platform base ties	3½" × 3½" × 21" PT lumber	2
(C) short base cross tie	3½" × 3½" × 14" PT lumber	2
(D) long runner	3½" × 3½" × 90" PT lumber	2
(E) short cross runner	3½" × 3½" × 7" PT lumber	2
(F) short runner	3½" × 3½" × 21" PT lumber	2
(G) long cross runner	3½" × 3½" × 14" PT lumber	1
(H) post	3½" × 3½" × 48 to 72" PT lumber	4
(I) lower post brace	3½" × 3½" × 24" PT lumber	4
(J) long roof support	3½" × 3½" × 90" (45-degree cuts) PT lumber	2
(K) short roof support	3½" × 3½" × 14" (45-degree cuts) PT lumber	2
(L) angle braces	3½" × 3½" × 16" (45-degree cuts) PT lumber	4
(M) roof	¾" × 24" × 96" PT plywood	1
(N) splitting pad blocks	3½" × 3½" × 7" PT lumber	14

1. Locate a good firewood storage spot (see Storing Firewood: Where, How, and, Why page 146), and create a flat area measuring about 4 × 12 feet. Cover the area with a 2" to 4" layer of gravel, raking it level; this provides a solid base for the station and promotes drainage.
2. Position the rack (A) and splitting platform (B) base ties as shown. Use a sledgehammer to level the ties to create a flat, solid base. Secure the short base cross ties (C), long runners (D), short runners (F), and cross runners (E) and (G) to one another using 6" timber screws.

TAKE NOTE For your splitting pad blocks (N) to fit snugly, the splitting pad opening should be just a hair over 14" × 14".

3. Cut the four posts (H) to the desired length and tack them in place with 16d galvanized nails. Cut the angled tops of the lower post braces (I), and use timber screws to secure them to the posts and 4×4 base framework. Use a level to make sure the posts are plumb (or close to plumb).

TAKE NOTE If you want a slight slant to your roof to promote water runoff, make the front pair of posts a couple of inches longer than the back posts.

4. Miter the ends of the roof supports (J, K). Use timber screws to secure these to the uprights and to one another. Cut the angle braces (L) and secure them to the posts and roof supports as shown in *Roof construction* illustration page 146. Position the plywood roof (M) so it's centered over the roof support frame, and secure it with 2" exterior screws.
5. Install the splitting pad blocks (N) by inserting them on-end between the timbers that form the perimeter of the splitting pad. Use a sledgehammer to tamp the blocks solidly and evenly into the gravel.
6. Install hooks on the posts, as desired, for storing splitting wedges, a splitting maul, a wheelbarrow, or any other firewood tools you might need.

Frame construction

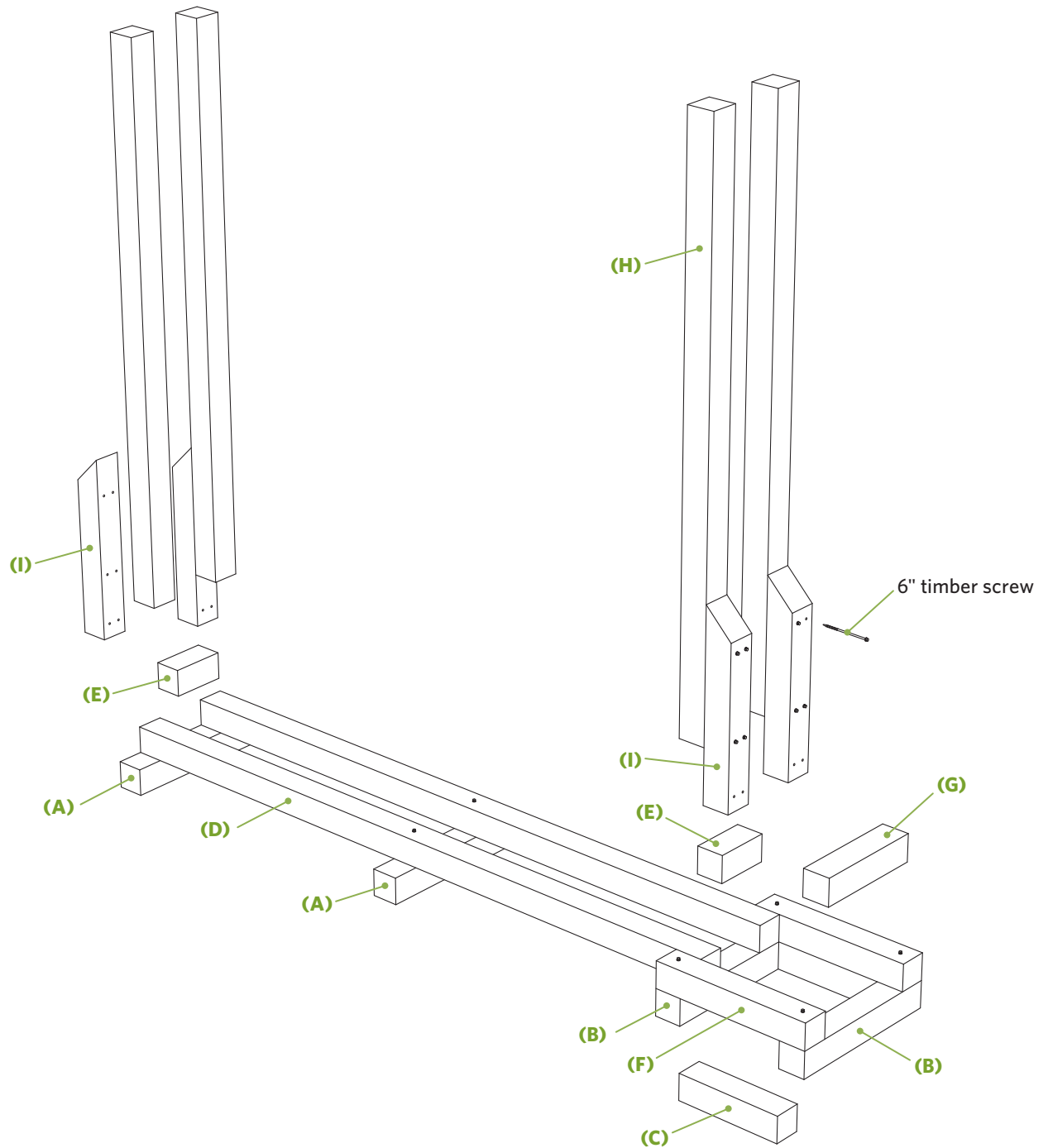

More Firewood, Less Backache

To avoid a lot of bending and lifting when splitting large logs, place the logs inside an old car tire. The tire will keep the split halves upright, so you won't have to bend over and fetch the larger pieces to split them again.

Roof construction

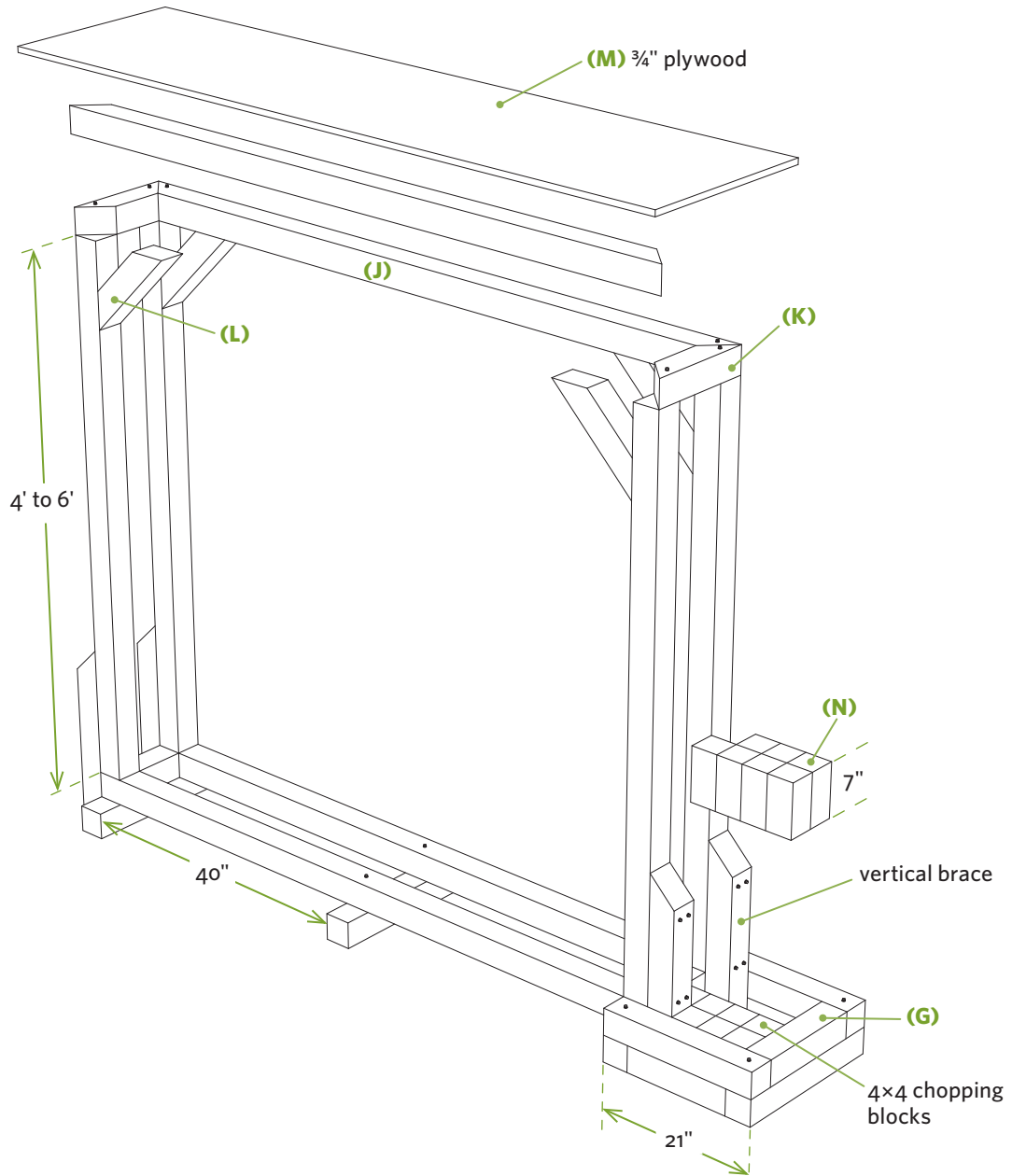

Storing Firewood: Where, How, and Why

Dry (seasoned) firewood is lighter, generates less creosote, and burns more efficiently than green (unseasoned) wood. It's estimated that 15 percent of the energy in wet wood is wasted turning moisture into steam instead of generating heat for your home. If possible, let your wood dry for a full year before burning it. A few other tips:

- Wood dries fastest when exposed to both wind and sun. If you live in a rainy area, install roll-down tarps on one or both sides of your storage rack for protection during heavy storms.
- Don't store firewood directly against the house. Many insects like munching on wood, and they don't differentiate between firewood and house wood. Firewood piles also provide an ideal nesting space for little critters you don't want near your house.
- Build more than one rack, or build a double-wide rack, so one batch of wood can dry while the wood in the other rack is being used.

Knockdown Sawhorses

Easy-to-stow, easy-to-build from one sheet of plywood

If you do any amount of cutting, painting, drilling, assembling, or anything-ing, you need a pair of solid sawhorses to work on. You get better results working at a comfortable height, and your knees and back will thank you.

You can build this pair of interlocking sawhorses from less than a single 4 × 8-foot sheet of $\frac{3}{4}$ " plywood, and they require zero fasteners.

They're solid as a rock in use, and when you need to stow them away, simply knock 'em apart and hang them on a long hook. (This requires drilling holes in the six crosspieces.)

The key to building these sawhorses is to create joints that are tight and thus wiggle-free. Take time to carefully mark out the cuts, and keep your eye on the marks as you cut the notches.

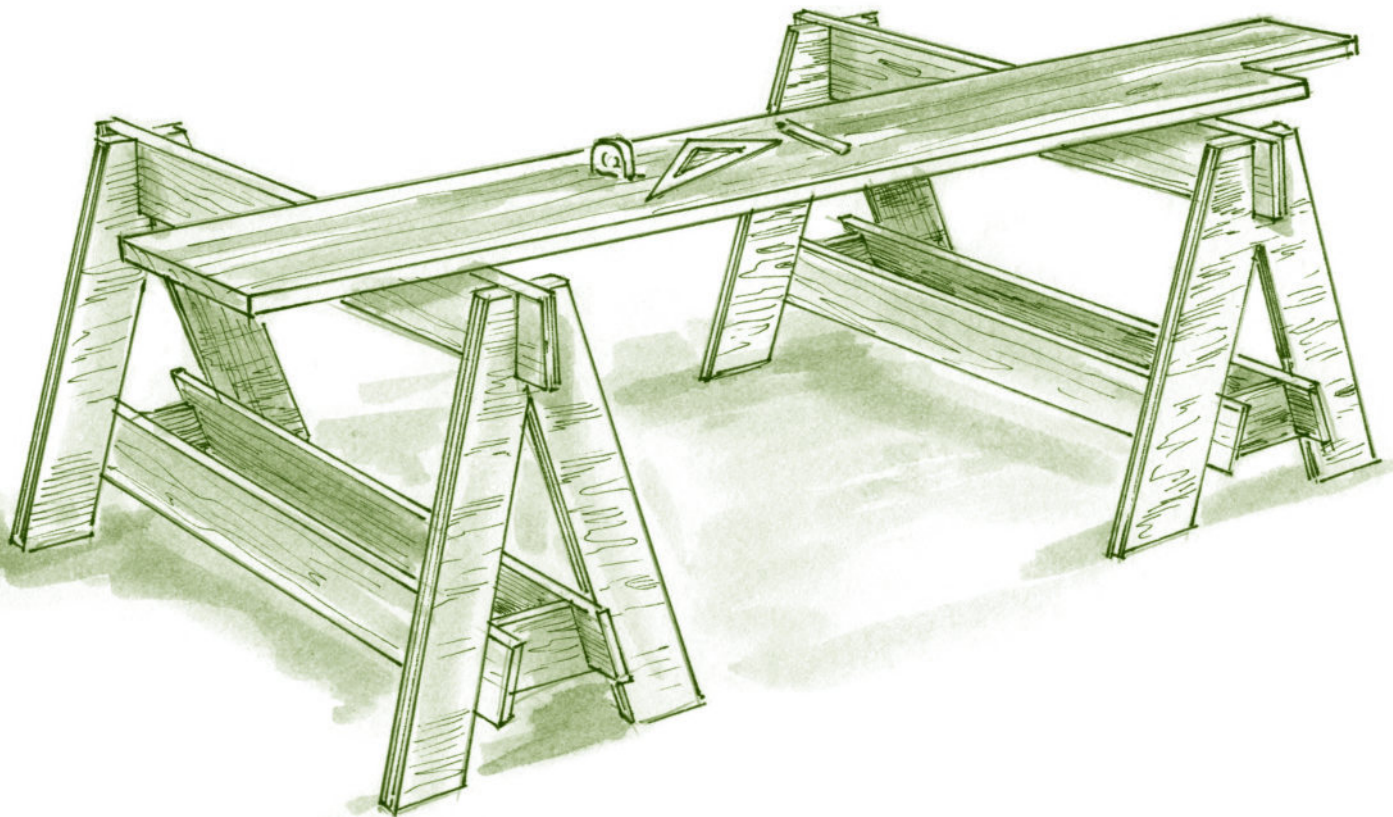

Cutting layout

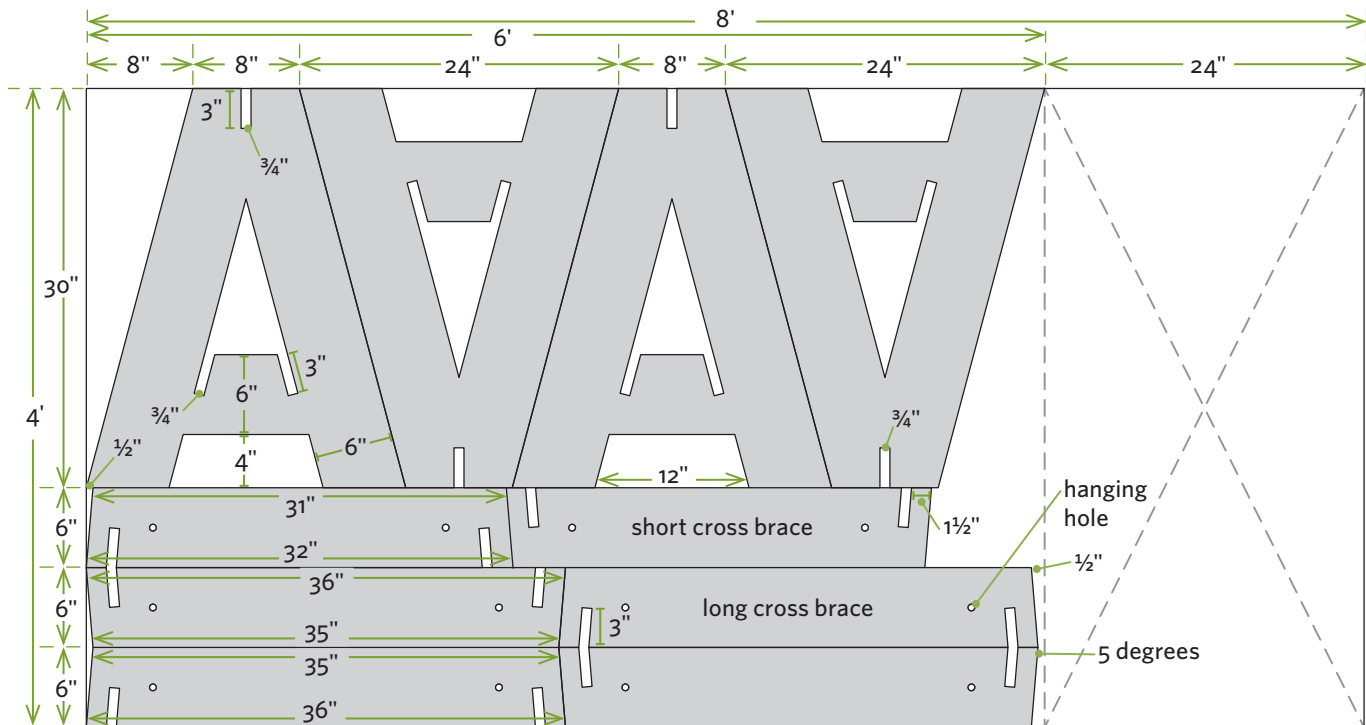

1. Use a circular saw with a straight-cutting jig (see *Circular Saw Basics*, page 28) to cut the sheet of plywood to 72" in length; you'll wind up with an extra, usable 2 × 4-foot piece of plywood. Use the saw and jig to cut the three 6"-wide strips from one long edge of the panel, as shown.
 2. Cut out the A-frame sides using the circular saw and straight-cutting jig. Make plunge cuts with the circular saw (page 28) to cut out the triangular-shaped opening in one of the frames. Use a jigsaw to finish these cuts and to cut out the 3/4"-wide × 3"-long notches. Use this A-frame to mark out the interiors of the other three frames, then cut those out. If you're not comfortable making plunge cuts, drill a starter hole and then use a jigsaw to cut out the interiors.
- TAKE NOTE** The notches in the construction drawings are specified as 3/4", but yours may need to vary slightly from this, depending on the actual thickness of your plywood. Remember to cut the notches conservatively and to use a scrap piece of the plywood to test-fit the notches as you work; this is the best way to ensure a snug fit.
3. Cut and notch the two short and four long cross braces. The ends, as well as the notches near the ends, are angled at 5 degrees. To get this angle, use either a Speed Square or protractor. You can double-check your work by measuring; there is a 1/2" difference in length between the long and short side of each cross brace end, as shown in *Cutting layout* above. Mark the angled ends of the cross braces first. Use the edge of a scrap 2×4 to mark the 1 1/2" distance to the notch, and use the edge of a plywood scrap to mark the width of the actual notch. Use a jigsaw to cut out the notches.
 4. Before assembling the sawhorses, slide a scrap piece of plywood into each notch to confirm a good, snug fit. If a notch is too small, use a jigsaw or rasp to widen the notch as needed. Install the two lower cross braces and the upper cross brace partway; then continue to push them, or lightly tap them with a hammer, until the notches interlock. You want a fit that's tight enough to create a wiggle-free sawhorse but not so tight that you have to use a sledgehammer to knock them apart later on. If you want to hang up your knocked-down horses, drill 1/2" holes in the six crosspieces.

TAKE NOTE You can use your 2 × 4-foot scrap of plywood to make a shelf for the bottom of each sawhorse or to create slats to protect the sawhorse tops from errant cuts.

Sawhorse assembly

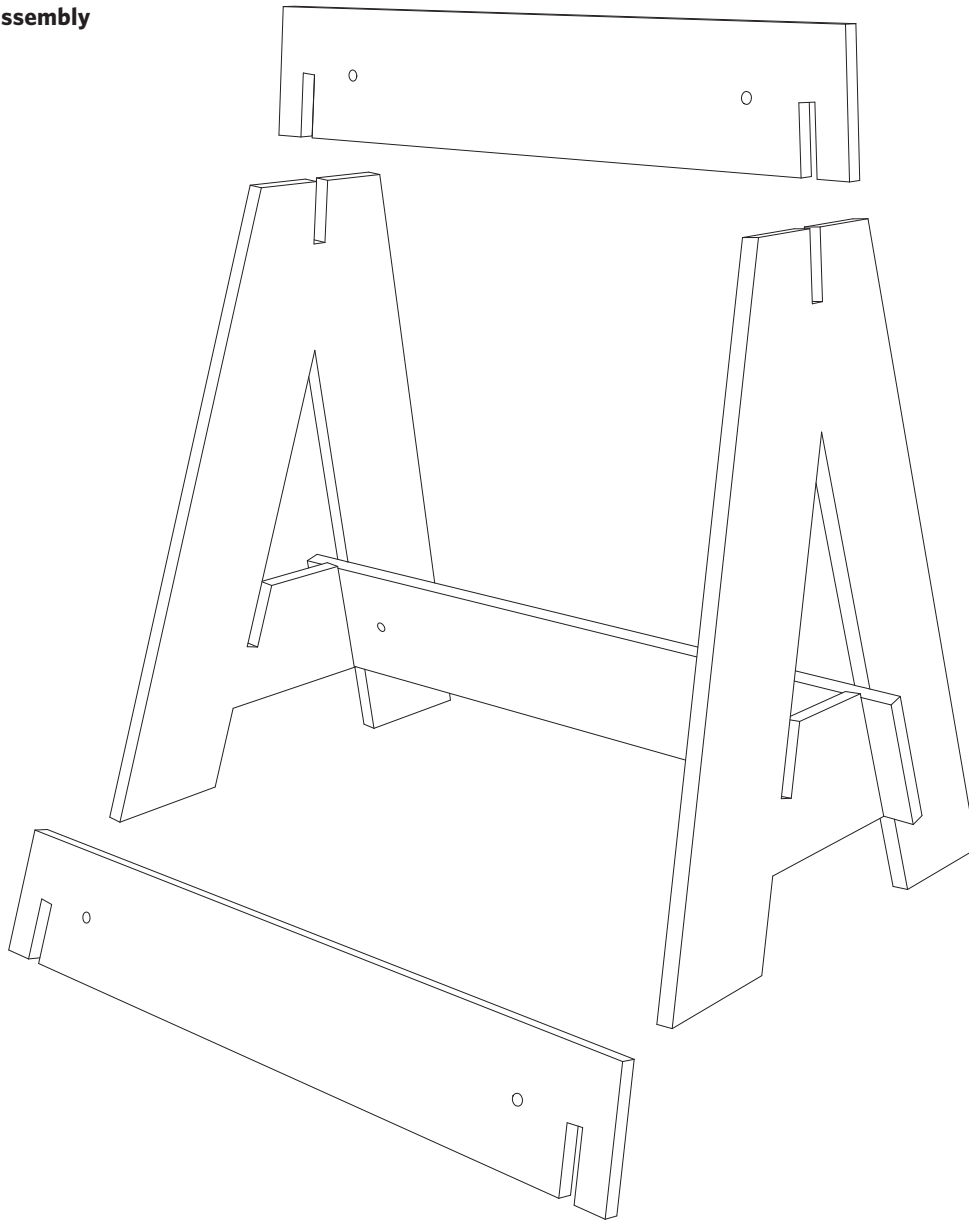

Emergency Sawhorses

You're probably wishing you already had sawhorses so you didn't have to kneel and stoop while cutting out the pieces for these sawhorses! Well, never fear. Makeshift sawhorses are never far away. Here are a few make-do options:

- Set two large plastic trash cans a few feet away from each other, and then lay a couple of scrap 2×4s across them to create a flat surface.
- Large cardboard boxes make excellent sawhorses. For stability, tape both ends shut. It's easy to remove the tape, flatten the boxes, and store them away for future use.
- Professional drywallers often use this trick: Lightly score a 2 × 4-foot scrap of drywall down the middle; then snap it (without breaking the paper on one side) and bend it into an L shape. Position two of these Ls facing each other, and then place another drywall scrap on top to create a make-do workbench (though it won't make do for long).
- Plastic-top tables with folding metal legs provide a large working surface and are easy to stow when not in use. Most home centers sell 6-foot and 8-foot versions at a reasonable price.

Stand-Up Tool Rack

Organize that tangle of brooms, rakes, and shovels

If you're tired of tripping over spare garden tools and searching for missing ones, welcome to the club. You can bring order to this chaos, and minimize the risk of tool avalanches, by building

this simple stand-up rack for long-handled tools. Add a few pegs to the side, and you'll have a place to hang small garden hand tools to boot.

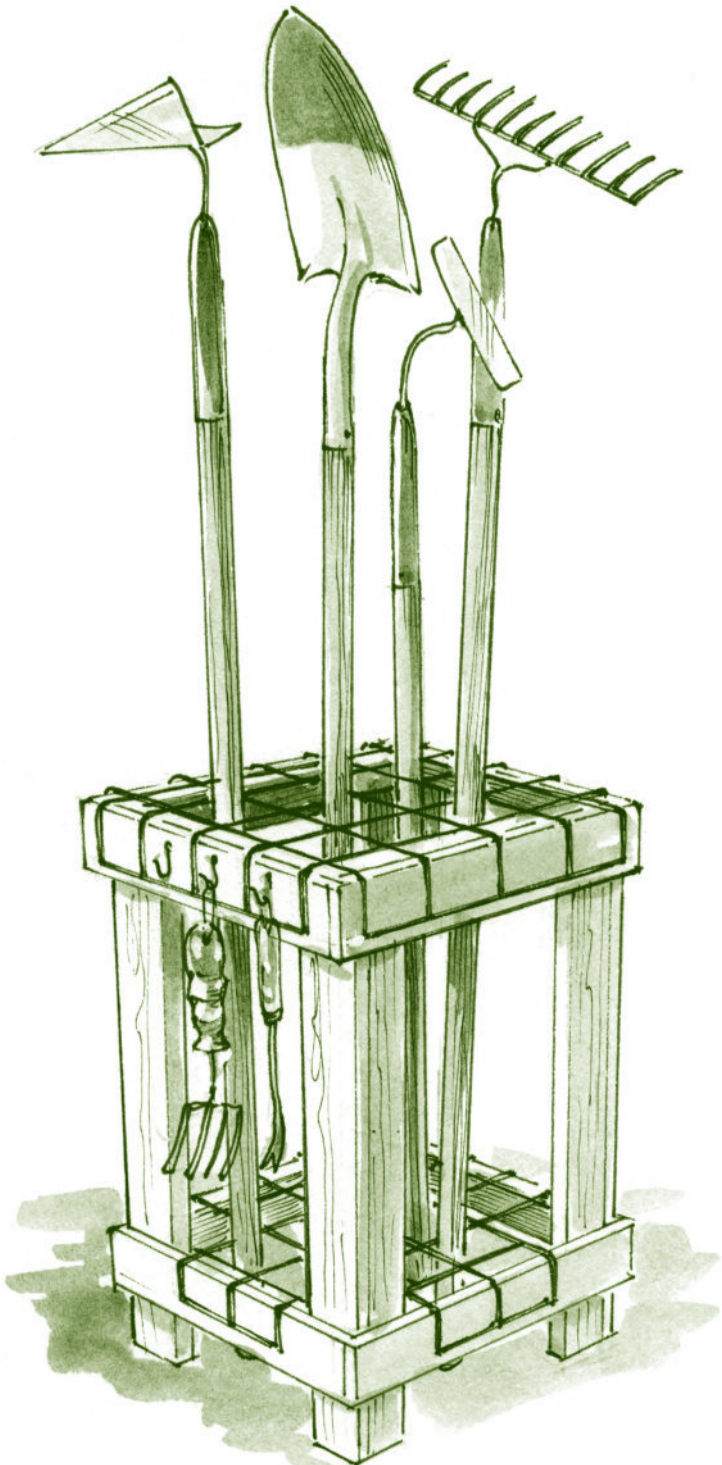

Materials

- Four 6-foot pine 1x4s
- Two 6-foot pine 1x3s
- Wood glue
- 6d galvanized casing nails
- Fence staples
- 1¼" exterior screws
- One 24" x 48" piece 4" welded wire mesh
- Miscellaneous hardware (see step 6)

Parts and Cutting List

Part	Size and Material	Quantity
(A) wide leg member	¾" x 3½" x 32"	4
(B) narrow leg member	¾" x 2½" x 32"	4
(C) short frame pieces	¾" x 3½" x 18½"	4
(D) long frame pieces	¾" x 3½" x 20"	4
(E) wire panel	24" x 24" welded wire mesh	2

1. Create the L-shaped legs by applying glue to the edges of the narrow leg members (B) and securing them to the sides of the wide leg members (A) with 6d nails. Make sure the ends are even as you join the two pieces.
2. Use the short and long frame pieces (C, D) to assemble two 20" x 20" frames, fastening the corners with 6d casing nails.
3. Lay the frames on their sides so they're spaced 21" apart. Position the first two legs in the inside corners of the frames, and use glue and screws to secure each leg to each frame. Add the other two legs.
4. Position the rack upright. Notch the corners of one wire panel (E) so they fit around the legs, and position the panel on the lower frame. Bend the wire overhanging each edge of the frame, and then secure this excess to the outsides of the frame with fence staples.
5. Position the second wire panel on the top frame, snip the corners, and bend the overhanging wire down along the sides of the 1x4 frame. Secure it in place with fence staples.
6. To prevent the rack from tipping, secure it to the wall or wall studs with long screws. Add hooks or pegs to the upper frame for hanging hand shovels, clippers, and other small tools.

Construction details

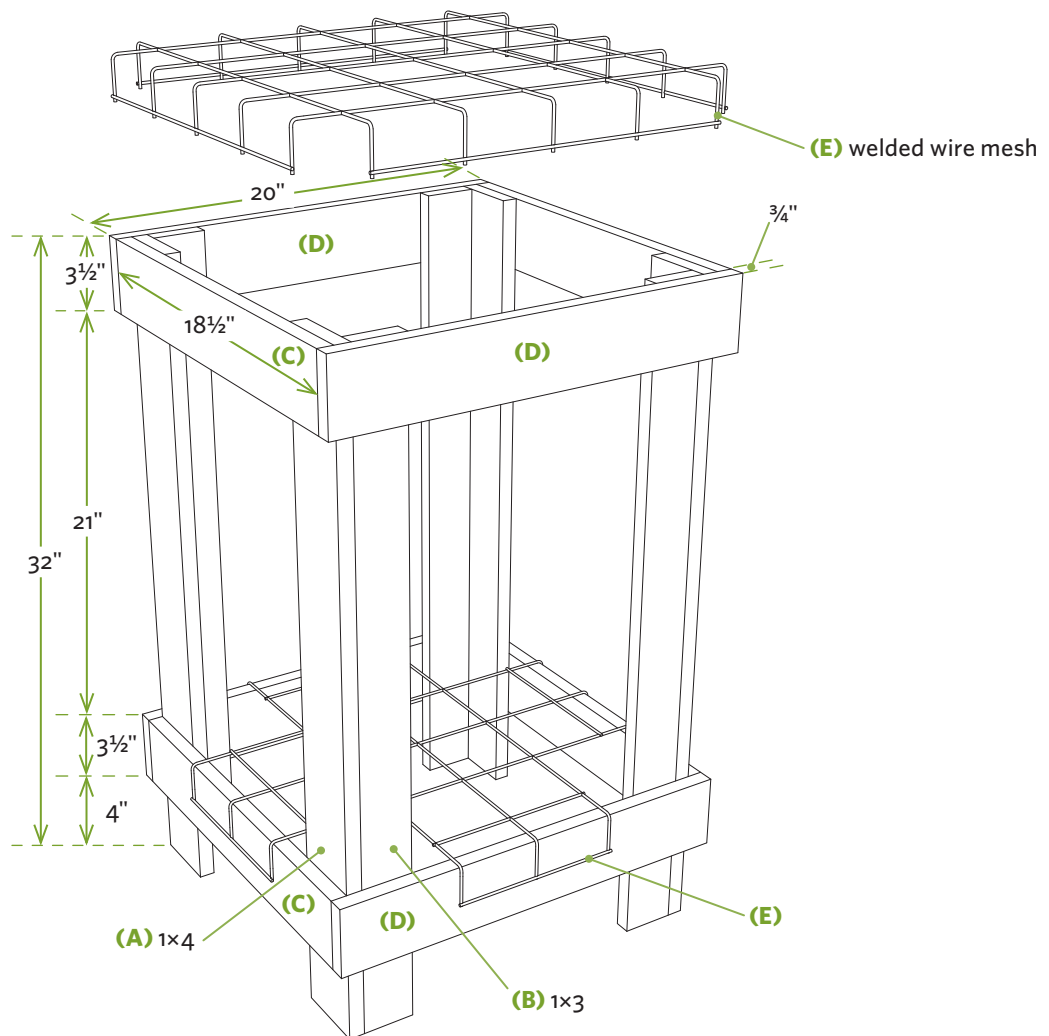

Clean, Rust-Free Tools

Fill a 5-gallon bucket with clean, dry playground sand and mix one or two cups of vegetable oil into the top half the sand. When you're done using a shovel, hoe, posthole digger, or other bladed tool for the day, give it a couple of quick thrusts into the bucket before putting it in your storage rack. The coarse sand will help remove caked-on dirt and mud, while the vegetable oil will give the blade a light coating of oil to inhibit rust. Replace the sand as needed.

Patio Storage Chest

A place to stow cushions, grilling supplies, and more

Ah, summer! Don't you love lounging, barbecuing, and gardening? Argh, winter! Don't you hate figuring out where to stow the chair cushions, charcoal, and watering cans? This outside storage chest is large enough to hold lots of stuff, and has a slatted bottom for ventilation and a curved top that sheds water.

You can modify the dimensions of the chest to accommodate specific items or to fit into a particular place on your deck or patio. See [An Idea with Legs](#) (page 155) for another modification option.

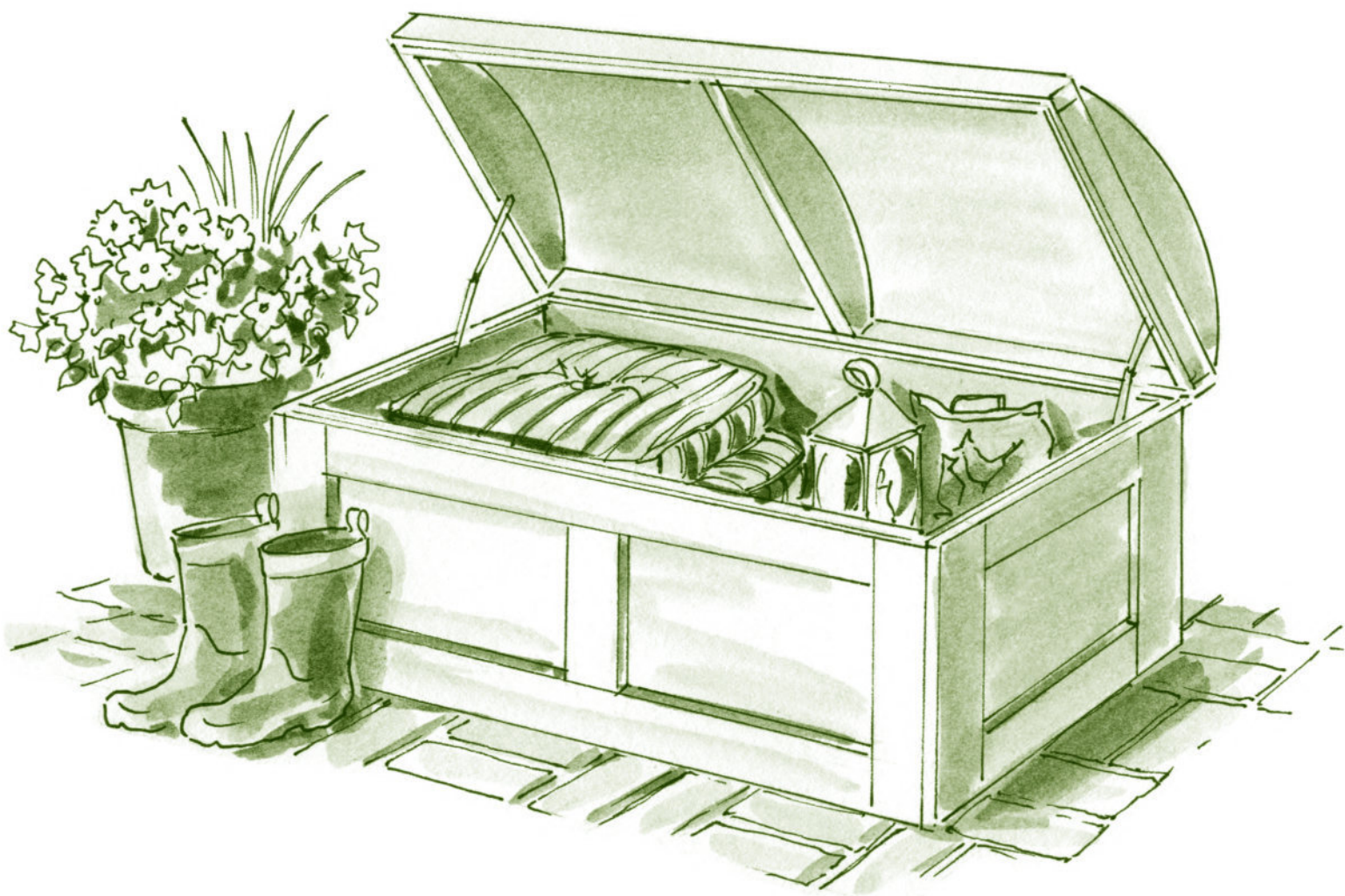

Materials*

- One 4 × 8-foot sheet ½" plywood
- Three 8-foot cedar 1×4s
- One 8-foot cedar or pressure-treated 2×2
- Two 8-foot cedar 1×6s
- One 8-foot cedar 1×8
- Two 8-foot cedar 1×3s
- One 8-foot ¾" × 1½" cedar slat
- Exterior silicone caulk
- 1" exterior screws
- 2½" exterior screws
- 3d galvanized nails
- 6d galvanized nails
- Three exterior strap hinges with screws
- One exterior hasp with screws
- Two lid supports with screws

*Pressure-treated plywood will weather the elements better and last longer than standard plywood. Standard plywood will be smoother and accept paint or stain better than treated plywood.

Building the Chest

1. Cut the front and back plywood panels (A) to size, and the end and middle stiles (B, D) and rails (C) to length. Lay the plywood flat, and position the 1×4s to make sure everything fits and overlaps as shown. Remove the 1×4s, apply beads of exterior caulk to the backs and ends of the pieces, and secure them in place by driving 1" screws through the plywood into the backs of the 1×4s. Build both the front and back panels; they're identical.

Parts and Cutting List*

Part	Size and Material	Quantity
(A) front/back panel	½" × 18" × 36" plywood	2
(B) end stile	¾" × 3½" × 17½" cedar	8
(C) long rail	¾" × 3½" × 30" cedar	4
(D) middle stile	¾" × 3½" × 10½" cedar	2
(E) floor support	1½" × 1½" × 36" cedar or PT pine	2
(F) end panel	½" × 18" × 24" plywood	2
(G) short rail	¾" × 3½" × 18½" cedar	4
(H) floor slat	¾" × 5½" × 23" cedar	7
(I) curved lid rib	¾" × 7¼" × 24⅛" cedar	3
(J) front/back lid rail	¾" × 2½" × 38⅝" cedar	2
(K) side lid rail	¾" × 2½" × 25⅝" cedar	2
(L) lid top	½" × 28" × 38⅝" plywood ¹	1
(M) lid batten strip	¼" × 1½" × 28"¹	3

*Dimensions are based on 1×4s that are ¾" thick and 3½" wide. Some cedar boards are wider and thicker than this; adjust the dimensions of your pieces accordingly.

¹Measurements are approximate.

TAKE NOTE Make sure to use caulk when securing parts; it acts as a strong glue and will help keep the chest watertight. Silicone caulk is particularly tenacious.

Front and back panels

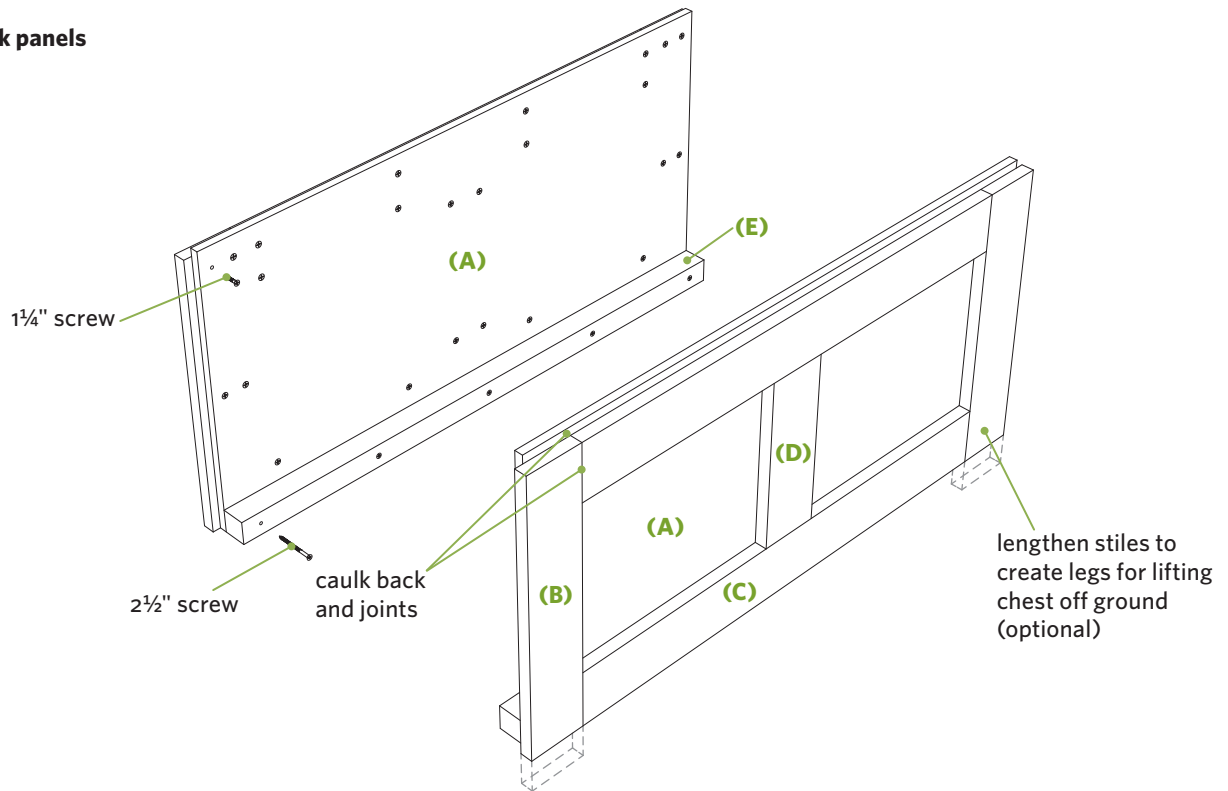

2. Install the 2x2 floor support members (E) to the insides of the panels, securing them with 2½" screws.
3. Cut the end plywood panels (F) to size, apply caulk to the edges, and secure them to the ends of the front and back panels with 3d galvanized nails, as shown. Apply caulk to the backs of the remaining end stiles (B) and secure them to the end panels. (They'll overlap the edges of the stiles on the front and back panels.) Secure the short rails (G) to the end panels.
4. Lay out the floor slats (H) over the floor supports (E) so they're spaced about ½" apart. Secure the slats to the supports with 6d galvanized nails, as shown in *Chest construction details*, below.

Chest construction details

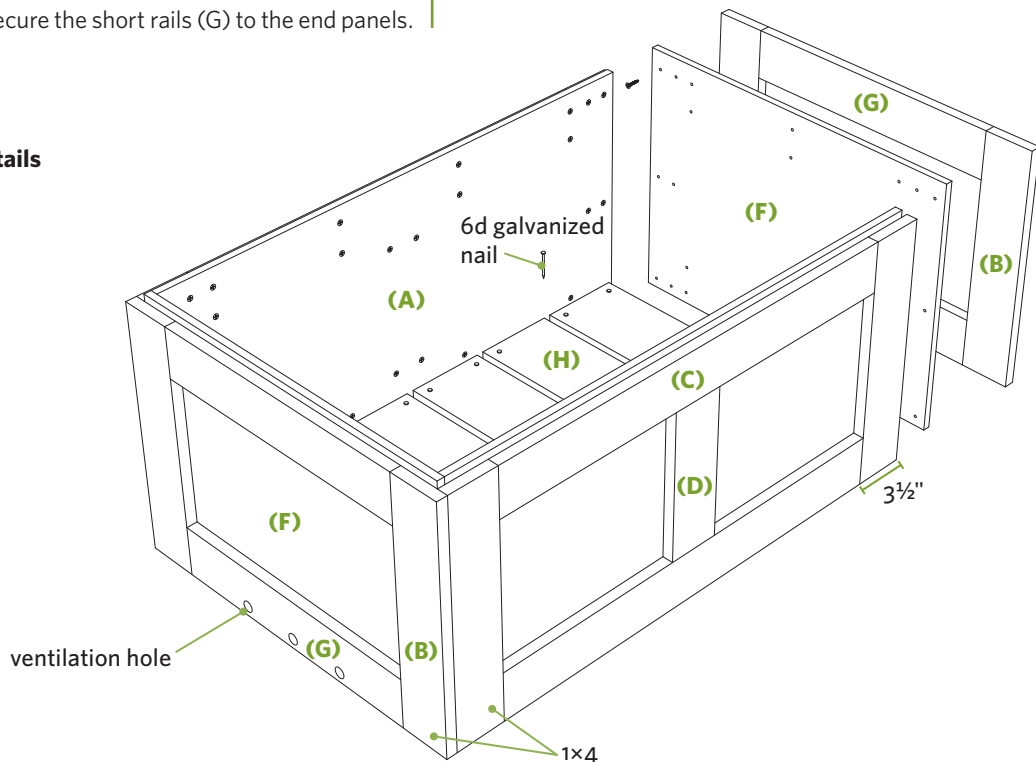

Lid construction details

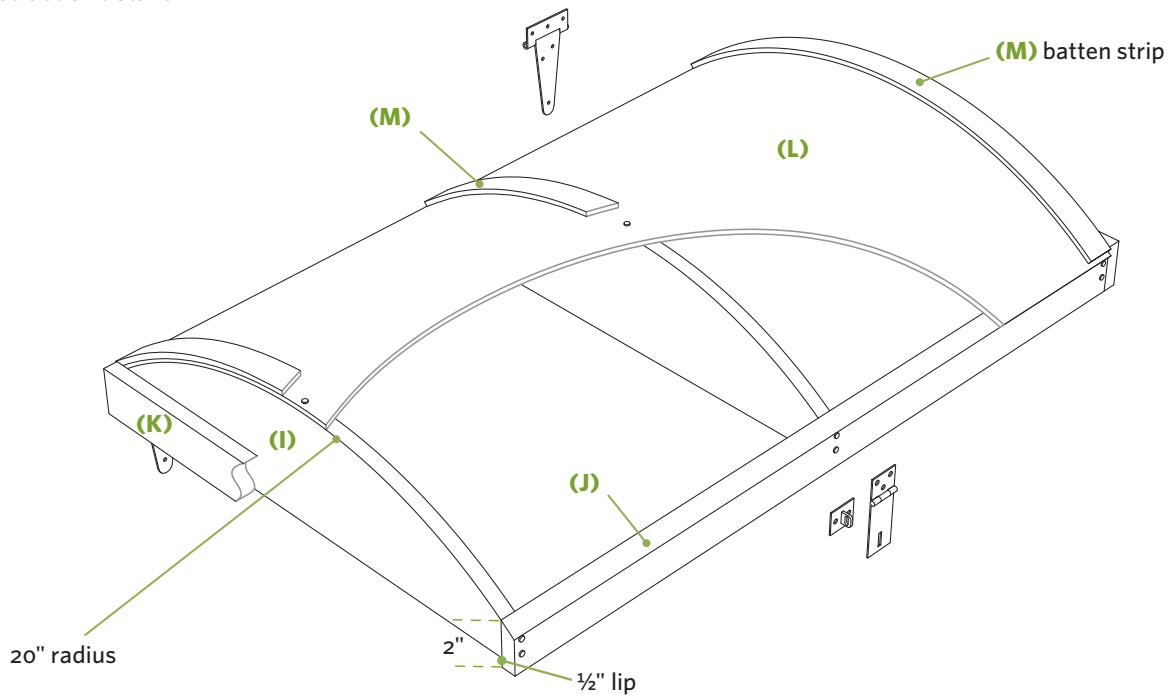

Building and Installing the Lid

1. Use a screw as a center point and your tape measure as a large compass to draw the 20"-radius arches on the face of a 1x8 to create the curved lid rib (I) as shown. Draw the arcs so there are 2" flat surfaces on each end of the board.
2. Use a table saw or a circular saw with a straight-cutting jig (page 29) to rip a 35-degree bevel along the length of the front and back lid rails (J). Secure them to the lid ribs (I) so the rails' beveled top edges align with the curves on top of the lid ribs and there's a 1/2" lip on the bottom. Test-fit this frame to make sure it fits snugly on the chest.
3. Cut the lid top plywood (L) to size, and use clamps to bend and test-fit it to the curved lid framework. Remove the plywood, apply caulk to the tops of the ribs (I), and then secure the front edge of the plywood to the front edge of a rail (J). Kneel on the plywood to help it conform to the rib arches, and secure it to the ribs with 6d galvanized nails. Install the side lid rails (K).
4. Use silicone caulk and 6d nails to secure the thin batten strips (M) in place to cover the nails used to hold the plywood top (L) to the ribs (I).
5. Install the three strap hinges and the hasp as shown in *Lid construction details* above. Install lid supports to hold the trunk open when in use and to prevent the lid from swinging back too far (see page 152). If you're worried about pinched fingers, install soft-closing supports.
6. Caulk any gaps on the outside of the chest. Apply stain, paint, or a clear finish to help protect the wood.

An Idea with Legs

You can easily raise the patio storage chest off the ground by lengthening the eight end stiles (B) so they extend beyond the bottom of the chest to

create legs. Raising it up a few inches will allow more moisture to escape from underneath the chest, minimizing water damage.

You can also add vertical partitions to help organize the interior space.

Wall-Hung Tool Rack

Triple your storage space, fast!

This simple storage rack can help you get organized and triple your storage space. And you can build it in an hour or two out of scrap lumber. The design is extremely easy to modify to accommodate the tools and space you have; just make certain it's bolted securely to the wall.

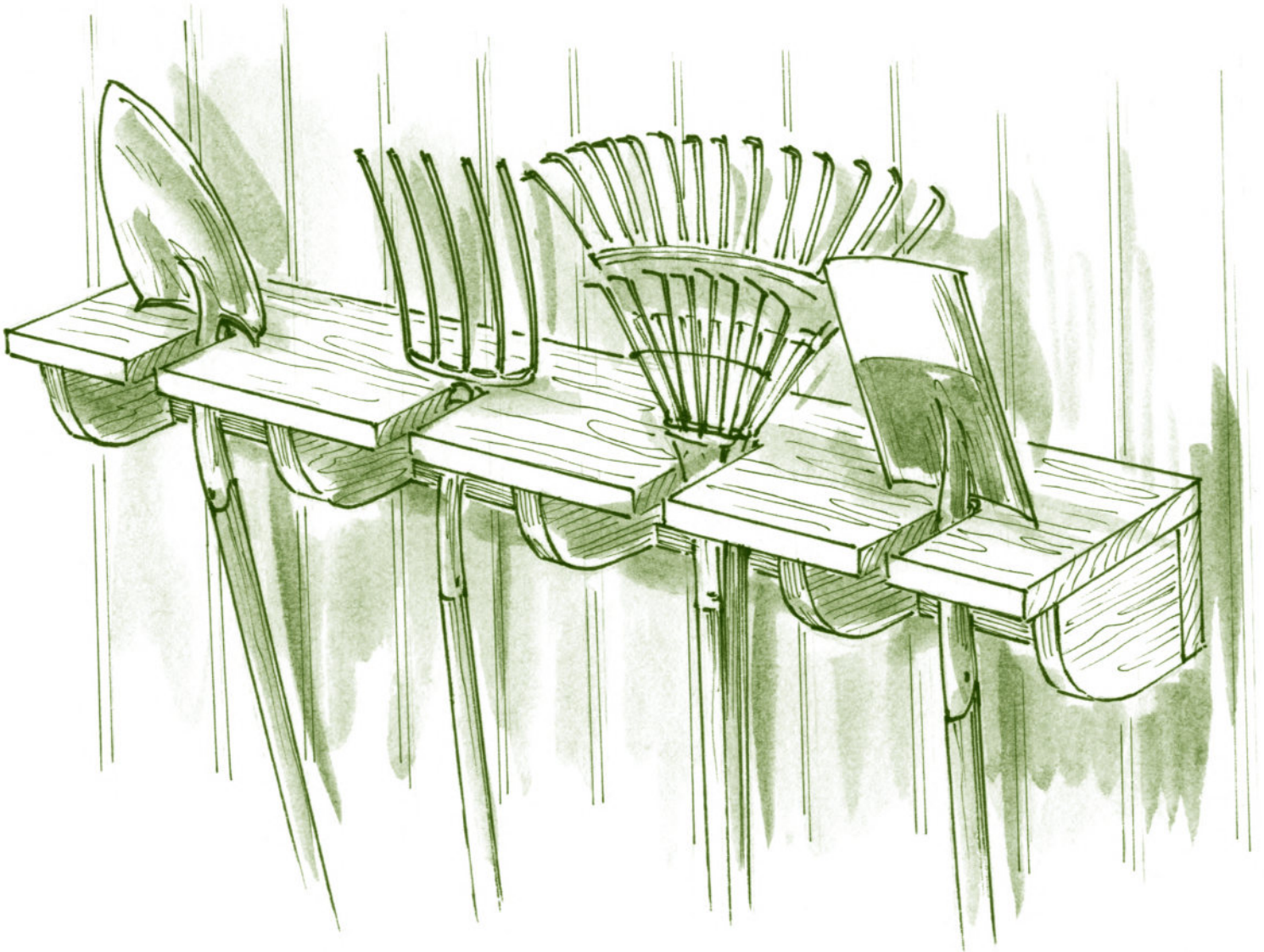

Materials

- One piece $\frac{3}{4}$ " plywood, 14" x 60" minimum
- Two 8-foot pine 2x6s
- 8d galvanized nails
- 16d galvanized nails
- Three or four $\frac{3}{8}$ " x 4" lag bolts with washers
- Cup hooks

1. Cut the plywood for the slotted rack (A) to size. Use a tape measure and square to mark out the position, width, and length of the slots as shown. A slot width of $1\frac{1}{2}$ " will accommodate most tool handles, but adjust any of the slot widths to meet your needs. Use a $1\frac{1}{2}$ " spade bit to create the curved end of the slot, and use a jigsaw to cut the straight edges.
2. Cut the six rack supports (C) to length. Trace around the edge of a pint- or quart-size paint can to mark the curved front corner on each support, and cut the shapes with a jigsaw.

Parts and Cutting List

Part	Size and Material	Quantity
(A) slotted rack	$\frac{3}{4}$ " x 14" x 60" plywood	1
(B) back brace	$1\frac{1}{2}$ " x $5\frac{1}{2}$ " x 60" pine	1
(C) rack support	$1\frac{1}{2}$ " x $5\frac{1}{2}$ " x 10" pine	6

3. Nail the slotted rack (A) to the top of the 2x6 back brace (B) using 8d nails. Position the two outside rack supports (C) flush with the ends of the slotted rack, and secure them with 8d nails through the top and 16d nails through the back. Add the four intermediate braces.
4. Fasten the rack to the wall using lag bolts, alternating them high and low along the face of the back brace, as shown in *Construction details* (below).
5. Add cup hooks to the end rack supports for hanging small hand tools.

Construction details

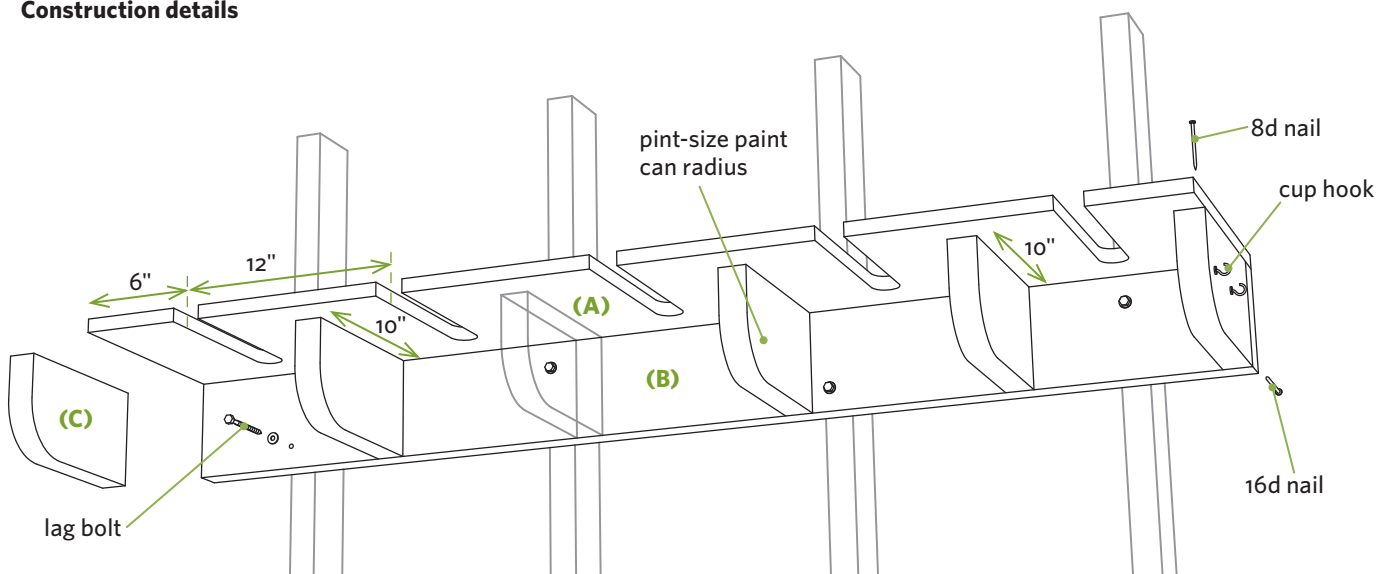

Mini Tool Shed

A mini tool shed with maxi space

Some folks need more storage space than a wall-hung rack (page 156) but less than an ultimate yard shed (page 172). This mini tool shed fits that niche. Measuring 18" × 40", it may have a small footprint, but with shelves, hooks, and racks, it holds and organizes an amazing amount of stuff.

Although it's small and designed for simplicity, you should set aside a good weekend to build it. You can prebuild the three main components (shed, roof, and doors) in the comfort of your garage or workshop, then mount and assemble everything in one fell swoop.

See page 8 for a photograph of this project.



Materials*

- One 4 × 8-foot sheet ¼" plywood
- Two 4 × 8-foot sheets ¾" plywood
- One 10-foot 2×4
- Seven 8-foot 2×3s
- Five 10-foot 1×4s
- Two 8-foot 1×3s
- Two 8-foot 1×2s
- One 4 × 8-foot sheet ½" plywood
- One 4-foot 2×6
- 6d galvanized nails
- 2" exterior screws
- 3" exterior screws
- Tar paper
- Shingles (16 square feet of coverage; type as desired)
- Two pieces 8-foot style-D roof edging
- Construction adhesive
- 5" lag bolts
- Six exterior hinges with screws
- Door latch hardware (as desired)

*All lumber materials can be pine or cedar.

1. Cut the plywood back (A) and sides (B) to size using a table saw or straight-cutting jig (page 29). Stand the sides on edge and secure the back as shown, using construction adhesive and 6d nails; a helper comes in handy here. Carefully rotate the cabinet onto its back and install the back cleats and front header (C). Cut the shelf parts (D, E, F) for the lower shelves, and assemble them using 3" screws. Install the shelves about 12" apart, securing them with 2" screws driven from the outside. This completes the basic cabinet box.

Parts and Cutting List

Part	Size and Material	Quantity
(A) back	¼" × 40" × 80" plywood	1
(B) sides	¾" × 16" × 80" plywood	2
(C) back cleats/header	1½" × 3½" × 38½"	3
(D) shelf fronts/backs	1½" × 2½" × 38½"	4
(E) shelf sides	1½" × 2½" × 13"	4
(F) shelves	¾" × 16" × 38½"	2
(G) roof chord	1½" × 2½" × 48"	3
(H) roof rafter	1½" × 2½" × 34" (45-degree end cuts)	6
(I) fascia board	¾" × 3½" × 28¼"	2
(J) roof sheathing	½" × 34" × 28¼" plywood	2
(K) top trim	1½" × 2½" × 40"	1
(L) wide vertical door trim	¾" × 2½" × 77½"	2
(M) narrow vertical door trim	¾" × 1½" × 77½"	2
(N) door panel	¾" × 18¼" × 77½" plywood	2
(O) door stile	¾" × 3½" × 77½"	4
(P) door rail	¾" × 3½" (cut to fit)	4
(Q) roof front panel	¾" plywood (cut to fit)	1 or 2
(R) bottom mounting cleat	1½" × 5½" × 40"	1

2. Prebuild the roof as a single unit, and hoist it in place with a helper or two; you'll save yourself a lot of ladder climbing. Cut the roof chords (G) and rafters (H), and assemble the three triangular roof trusses using 3" screws. Stand the trusses upright, and secure the tails to the fascia boards (I). Space the trusses as shown in *Shed and roof framework* (page 161); the face of the middle truss will line up with the face of the cabinet.

3. Cut and install the plywood roof sheathing (J). Install the style-D roof edging (also called drip edge) to cover the edges of the plywood on the front and sides. Install tar paper and the shingles of your choice.

TAKE NOTE You can install the tar paper and shingles now, or wait until after the roof is installed.

4. With the cabinet lying on its back, nail the top trim piece (K) to the header (C). Fasten the wide (L) and narrow (M) door trim boards to the front edges of the cabinet, nailing them to the plywood edges, the header (C), and the shelf fronts (D).
5. Measure the opening to verify the dimensions for the doors; chances are, they'll vary slightly from the given dimensions (see *Door detail* diagram). To determine the door height, measure from the bottom of the trim piece (K) to the bottom of the bottom shelf frame (D). To determine the door width, divide the width of the opening — the distance between the wide trim pieces (L) — in half and subtract $\frac{1}{4}$ " for each door. Once the plywood doors are cut to size, set them in the opening. Adjust the width and height as needed. Install the stiles (O) at the edges of the doors, noting how they overlap the door panels. Get this right, because it affects how the doors seal and operate. Keep test-fitting the doors and adjusting the trim (O and P) as you work. Don't install the doors and hinges yet.

6. Use 5" lag bolts to secure the 2×6 bottom mounting cleat (R) to the wall of the house, garage, or sturdy fence post, making sure it's level. With the assistance of a friend or two, set the cabinet box onto the cleat. Secure the cabinet to the wall studs or post by driving 5" lag bolts through the back cleats (C) and backs of the shelves (D). Use shingle tins (see *Assembled shed diagram*, page 162) to prevent water from seeping between the house and shed, if needed.

TAKE NOTE Instead of a 2×6 cleat, you can support your shed on a pair of 4×4 blocks laying flat. You should still secure it to a wall or fence pad to prevent tipping.

7. With the assistance of your friends, lift the roof unit onto the top of the cabinet and secure it to the cabinet below with 3" screws. Cut and fit the roof front panel (Q) to the roof truss that's even with the front of the cabinet. You can cut and secure a panel to the outer truss, add decorative brackets or leave that space open.
8. Set the doors in the opening, and use blocks and shims to level and position them. Secure the doors with three strap hinges each. Install latching hardware of your choice.

Door detail (overhead view)

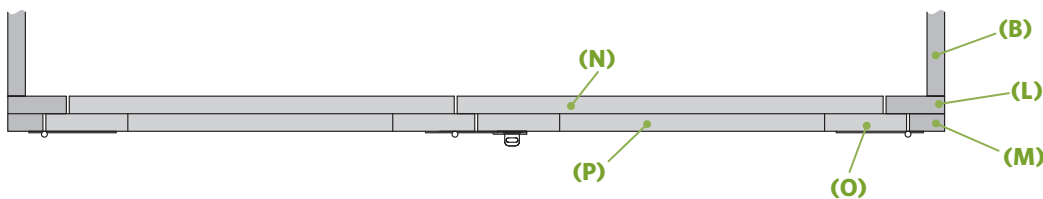

NOTES FROM THE TEST TRACK

A Spacious, Small Space

We built a small, simple cabin in northern Minnesota, and we intend to keep it small and simple. The trade-off is that there's no place to store outside stuff. I built a mini tool shed nearly identical in size and shape to this one, and I'm amazed how much stuff actually fits inside.

Out of curiosity I took everything out and took inventory; it was like circus clowns climbing out of a Mini Cooper. I extracted three shovels, two rakes, two splitting mauls, one sledgehammer, one push broom, a 100-foot extension cord, 50 feet of hose, two bags of charcoal, a busted fishing rod, a kayak paddle,

pruning shears, a bow saw, a rope, and a bag of birdseed. Not bad for a 48" × 16" shed. Another bonus of a small shed is that it forces you to be organized; the doors won't shut if everything isn't stowed in its proper place.

Shed and roof framework diagram

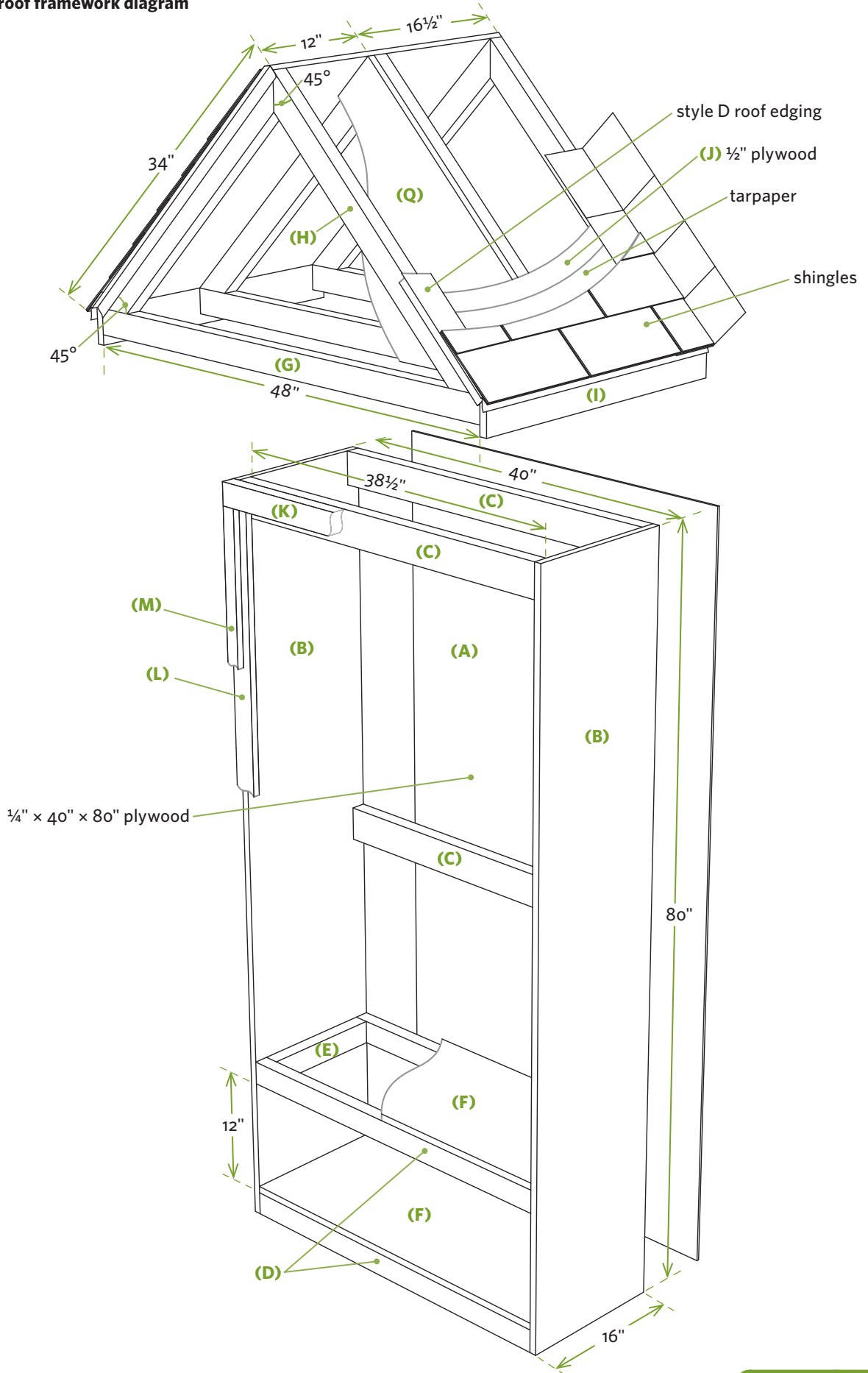

Assembled shed diagram

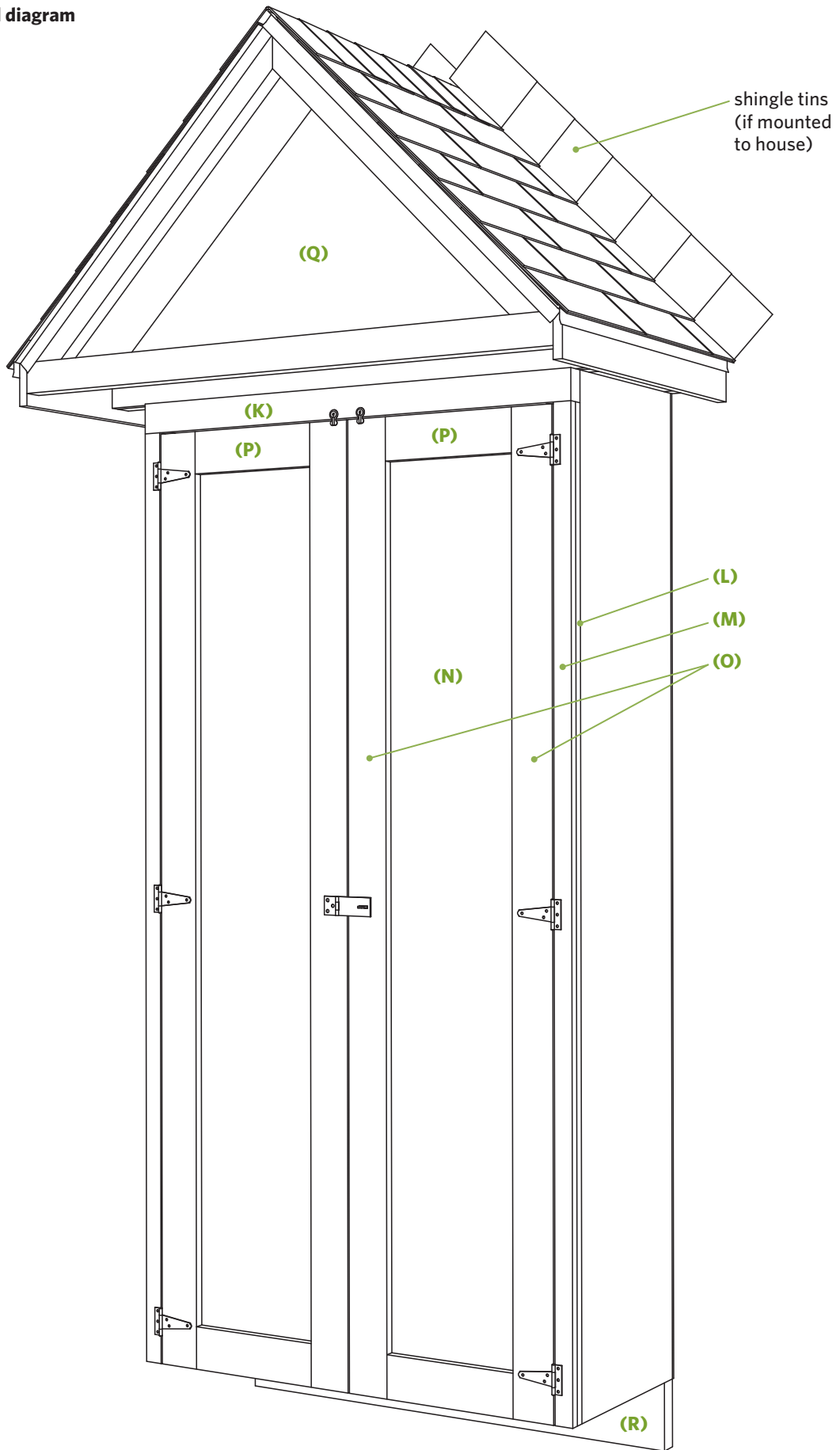

Modular Shed

Straightforward to build, easy to expand

Most homebuilders use trusses for framing roofs for three good reasons: they're strong, they're easy to install, and they're reasonably priced. The same advantages apply when building this modular shed. Once your shed floor is complete, you'll use it as a platform for manufacturing the combination

wall-roof trusses. Once you've installed these, the basic framework is done. The rest is filling in the blanks.

The texture 1-11 (or T-1-11) siding we used is another time- and money-saver, since it acts as both structural sheathing and exterior wall finish.

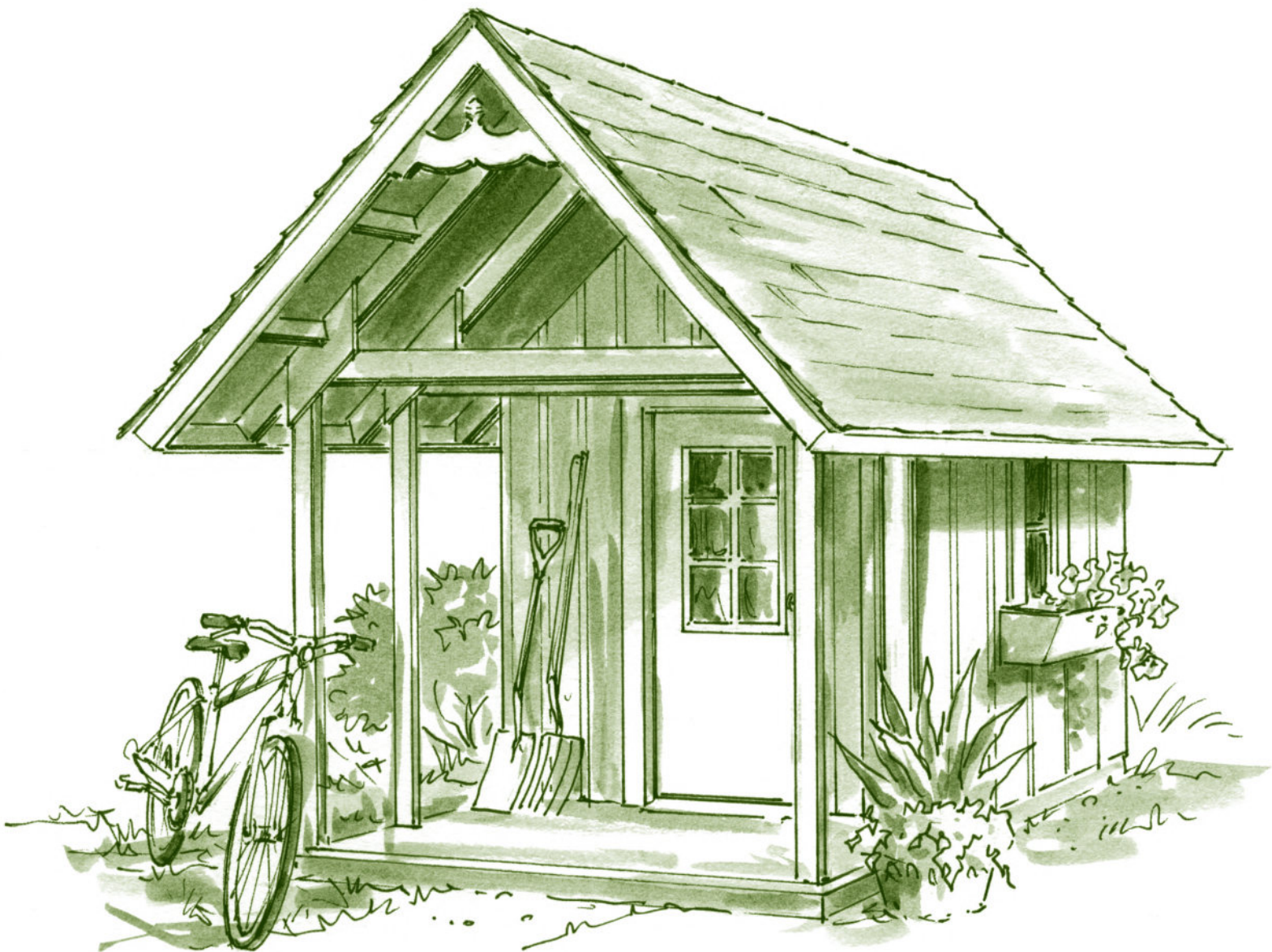

Materials*

- Two 12-foot pressure-treated 6×6s
- Two 8-foot pressure-treated 6×6s
- Five 8-foot pressure-treated 2×6s
- One 12-foot pressure-treated 2×6 (for floor blocking)
- Three 4 × 8-foot sheets ¾" pressure-treated plywood
- Thirty-five (approx.) 8-foot 2×4s
- Nine 4 × 8-foot sheets ½" plywood
- Two 12-foot pressure-treated 2×4s
- Two 16-foot pressure-treated 2×4s
- Four 8-foot 2×3s
- Twelve to fifteen 10-foot 2×4s
- Nine 4 × 9-foot sheets ⅝" T-1-11 siding
- Washed gravel, approx. 2.6 cubic yards
- Eight 12"-long metal straps (framing connectors) with nails
- Ten joist hangers (for 2×6s) with nails
- 2" exterior screws
- Construction adhesive
- 1½" shingle nails
- 16d galvanized common nails
- 8d galvanized common nails
- Two 8-foot pieces galvanized Z-flashing
- Prehung steel exterior door (size as desired)
- Window (optional)
- 1×3 and 1×4 cedar trim (see Installing the Door, step 2, page 169)
- Exterior caulk
- Sixty linear feet style-D roof edging
- One 100-foot roll 36"-wide tar paper
- Three hundred square feet (3 squares) asphalt roof shingles
- 1" roofing nails
- Finish materials (as desired)

*Length and number of 2×4s will vary depending on the number and sizes of doors and windows.

Parts and Cutting List

Part	Size and Material	Quantity
(A) long floor rim	5½" × 5½" × 144" PT lumber	2
(B) short floor rim	5½" × 5½" × 85" PT lumber	2
(C) floor joists	1½" × 5½" × 85" PT lumber	5
(D) floor sheathing	¾" × 48" × 96" PT plywood	3
(E) wall studs	1½" × 3½" × 96" pine ¹	14
(F) roof rafters/ fly rafters	1½" × 3½" × 84" pine ¹	18
(G) roof cross tie	1½" × 3½" × 89" pine ²	7
(H) peak gusset plate	½" × 16" × 16" plywood	12
(I) cross tie gusset plate	½" × 8" × 14½" plywood	24
(J) bottom wall plate	1½" × 3½" × 144" PT lumber	2
(K) eave plates	1½" × 3½" × 192" pine	2
(L) end studs, nailing plates	1½" × 3½" × 108"* pine (cut to fit)	12-15
(M) siding	⅝" × 48" × 108" T-1-11 siding	9
(N) roof sheathing	½" × 4 × 8-foot CDX plywood	8
(O) tar paper	36"-wide tar paper	
(P) roofing	36" asphalt singles	3 squares

¹Square on one end, 45° on the other.

²45° on both ends.

Floor construction

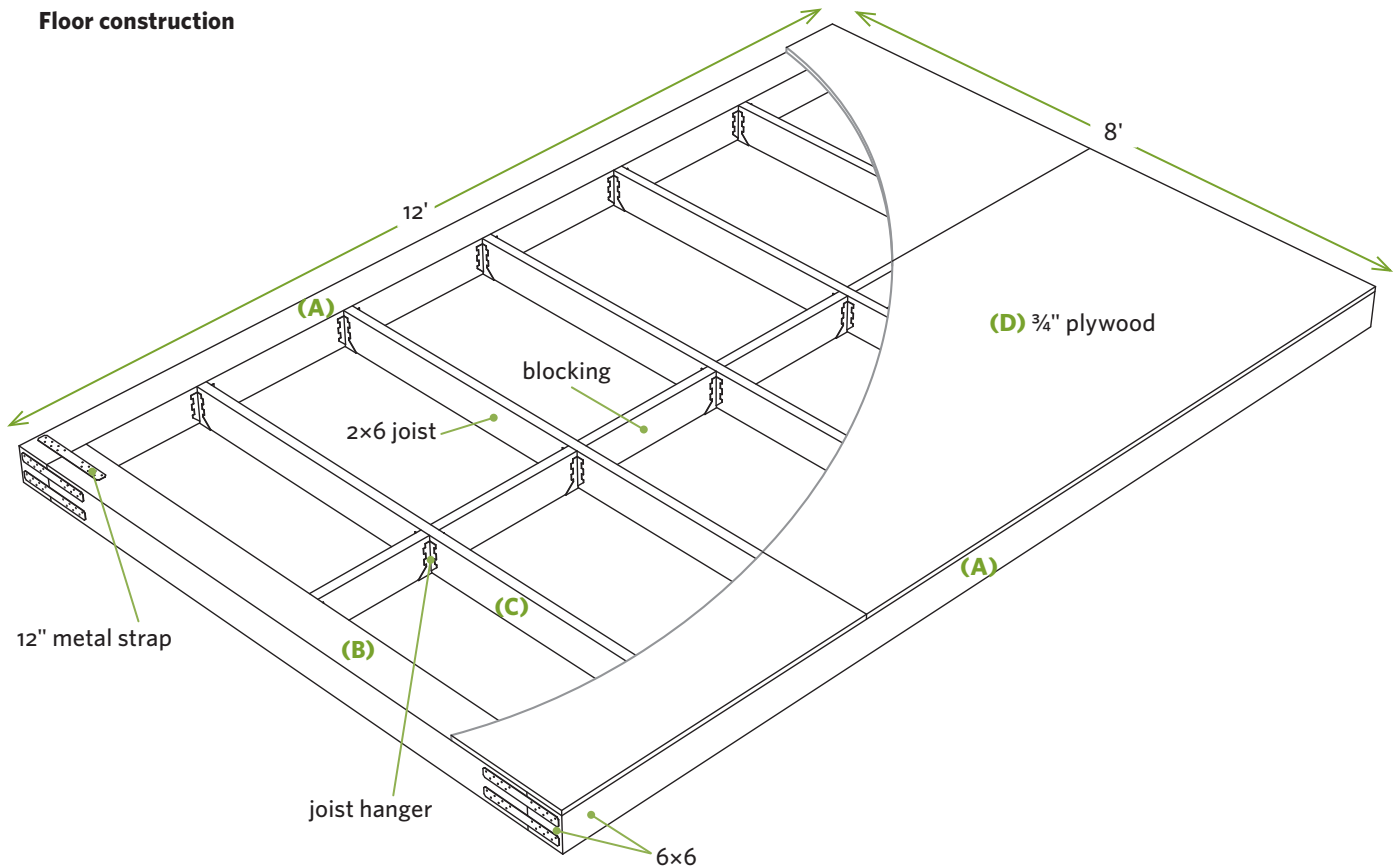

Building the Floor

1. Stake out the location of your shed, using batter boards (see page 30), and remove 8" of soil, 12" beyond the footprint of the shed in every direction. Add a layer of washed gravel to create a bed about 6" deep. Tape a 4-foot level to a straight, 8-foot-long 2x4, and use that to level the gravel to create a flat surface. Do it right; your shed will be only as level as this base.
2. Build the perimeter of the floor using treated timbers (A, B) as shown. Secure the corners with metal straps on the tops and sides, using the manufacturer's specified nails. (Be sure to use hot-dipped galvanized fasteners for all connections in pressure-treated lumber.) Check the perimeter for level, and measure the diagonals. If it's not square, whack one of the "long" corners with a sledgehammer until the measurements are equal. Walk on the timbers and tamp them down with a sledgehammer so they make solid contact with the gravel.
3. Measuring from one end of the floor perimeter, make marks every 24" to indicate the centers of the joists. Install joist hangers and joists (C). Add blocking (all but the two end ones will be 22½" long) at the midway point in each joist bay, as shown in *Floor construction* (above).
4. Run a bead of construction adhesive down the middle of each joist and perimeter beam. Position a sheet of plywood (D) in one corner, and secure it to the joists and beams with 2" exterior screws. Install the rest of the plywood, making sure the edges are supported by the blocking.

TAKE NOTE The squareness of a floor is critical since you'll be relying on it to build the trusses.

TAKE NOTE Before you apply construction adhesive, flop the first sheet of plywood down to make sure the platform is square and that the end of the plywood winds up in the middle of a joist. If everything aligns right, then apply the glue.

Congratulations! The floor, the platform you'll use to build the trusses, is complete.

Truss details

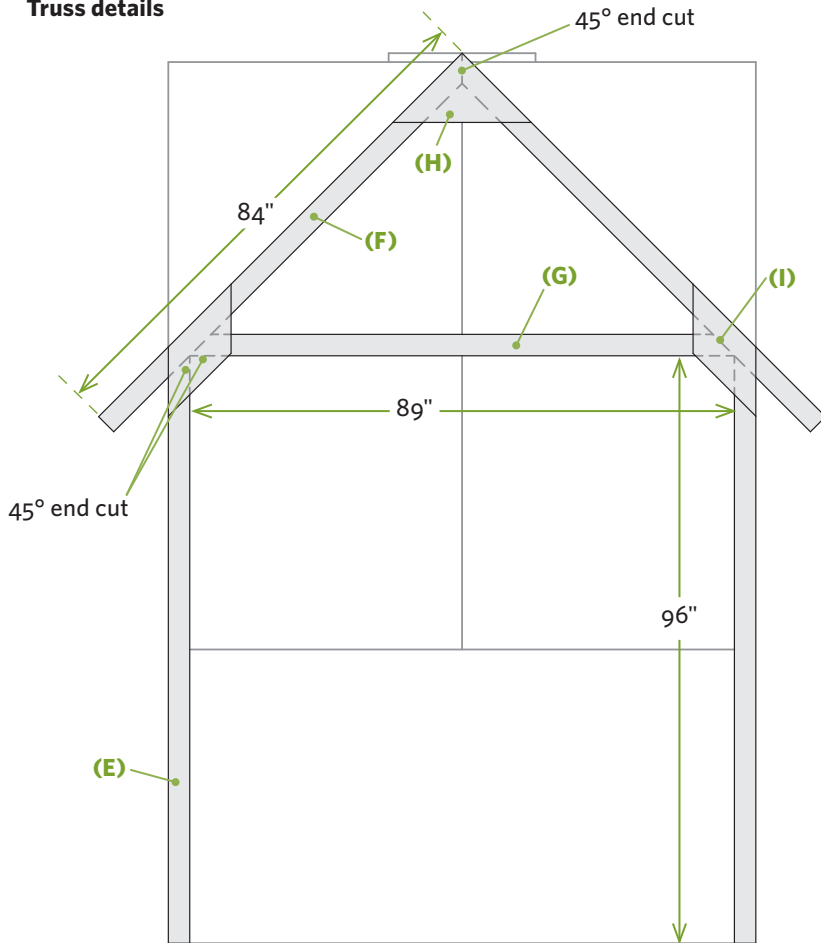

Gusset details

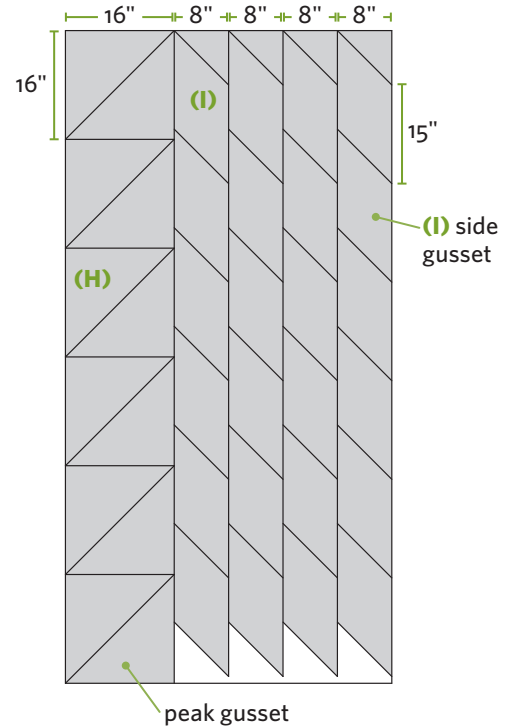

Building and Erecting the Trusses

1. Cut two wall studs (E) with 45-degree angles on one end, one roof cross tie (G) with 45-degree angles on both ends, and two roof rafters (F) with 45-degree angles on one end, as shown. Position the wall studs on the floor platform so the ends and sides are even with one end and two sides of the platform. Position two roof rafters, making sure the peak is centered and the eaves extend equally past the studs in both directions. The peak will extend a hair beyond the edge of the floor; add a temporary 2×4 block in that area to accommodate the peak. Position the cross tie.
2. Stand there and ponder things: Do all the components fit tightly and symmetrically? When you measure from the bottoms of the wall studs to the peak of the rafter, are the measurements equal in both directions? Once everything looks good, use a felt marking pen to trace along the edges of all the members to create a template on the floor for building the remaining trusses. Take one rafter, one wall stud, and

the cross tie and mark "PATTERN" on each. Use them as patterns to mark and cut the rest of the studs (E), rafters (F), and cross ties (G).

3. Make the plywood gusset plates (H, I) by marking a sheet of ½" plywood as shown in *Gusset details* (above) and then cutting out the pieces. If you have a table saw and miter saw, use them!
4. You're ready to go into truss manufacturing mode. Position the five 2×4 components (two "E"s, two "F"s, and one "G") for one truss on the pattern, making sure the joints are tight. Apply construction adhesive to the backs of two cross tie gussets (I); then nail the gussets in place, driving at least four 1½" shingle nails in each wall, rafter, and cross tie member. Apply adhesive to a peak gusset (H), and nail that in place. (See *Hand-Nailing versus Power Nailing*, page 169, for a few thoughts on truss assembly.)

Wall and roof framework

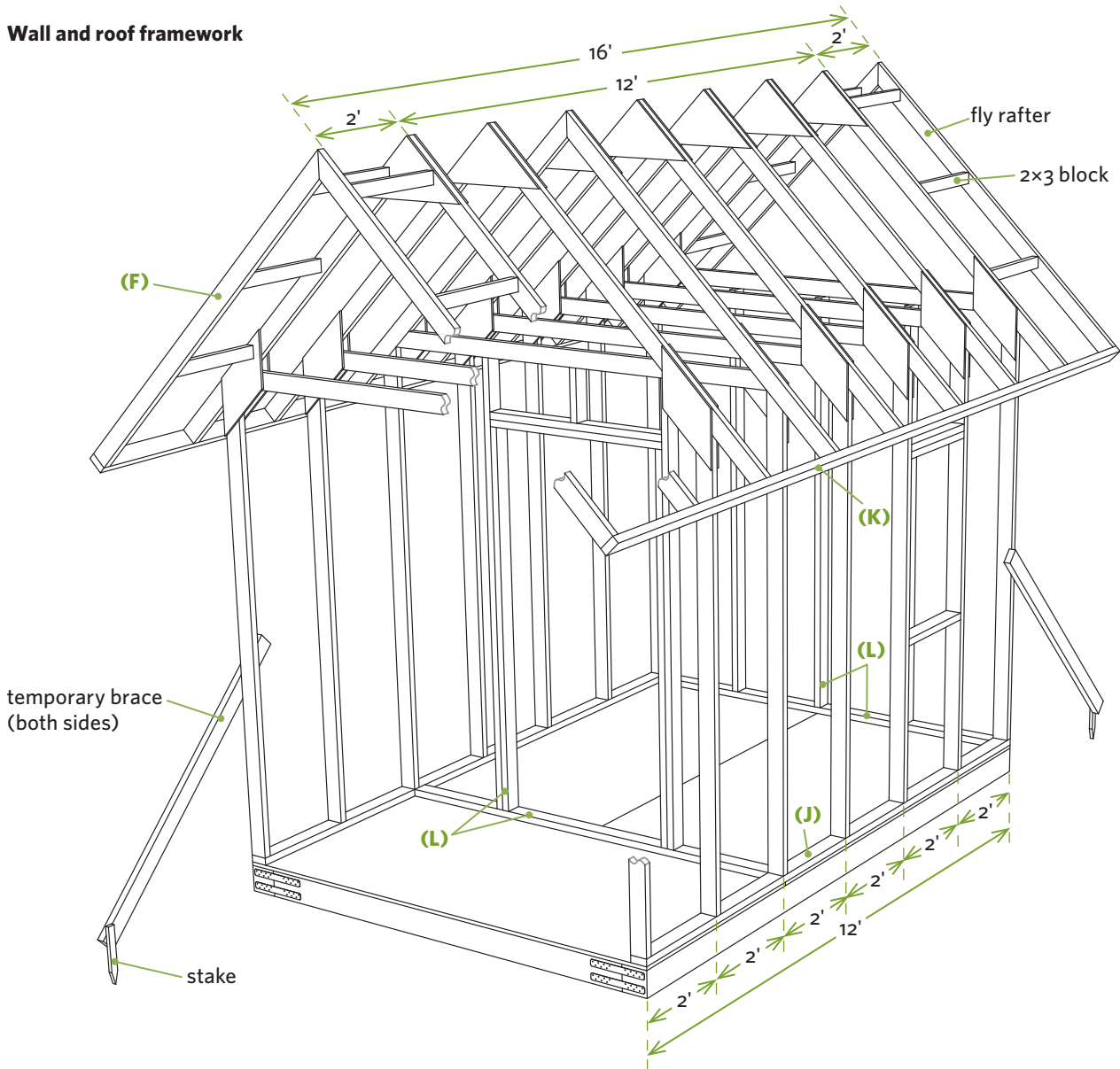

5. With the assistance of a helper, flip the truss over and install another set of gusset plates on the other side. Carefully move the truss off the platform and repeat this six more times.

TAKE NOTE The two outer wall trusses get gussets only on one side; the gussets get in the way of the siding if you put them on both sides.

6. Secure the bottom wall plates (J) to the long edges of the platform with 16d nails. Measure from one end and make marks on the plates every 24" to indicate the centers of the trusses. With a helper, stand the back end truss and toenail the bottoms to the nailing plates. (The side with the gussets should face inside the shed.) Pound stakes into the ground, and then install braces to hold this end truss plumb. Stand the front end truss and brace it, too.

7. Set the two eave plates (K) side by side, measure 24" from one end, and then make a series of layout marks (identical to those on the nailing plates (J) for the walls) to indicate the position of the rafters (F). Secure one eave plate to the two end trusses, using 16d nails. Install the rest of the trusses, securing them to both nailing plates and the eave plate. Once all the trusses are in place, install the other eave plate.
8. Install "fly rafters" (F) to support the overhangs on the ends. (You should have four rafters left from the parts you precut.) Secure the peaks of the fly rafters to one another with 16d nails, and then nail the rafter ends to the eave plates (K). Use short 2x3 blocks to connect the fly rafters to the end trusses as shown in *Wall and roof framework* (above).

Finish details

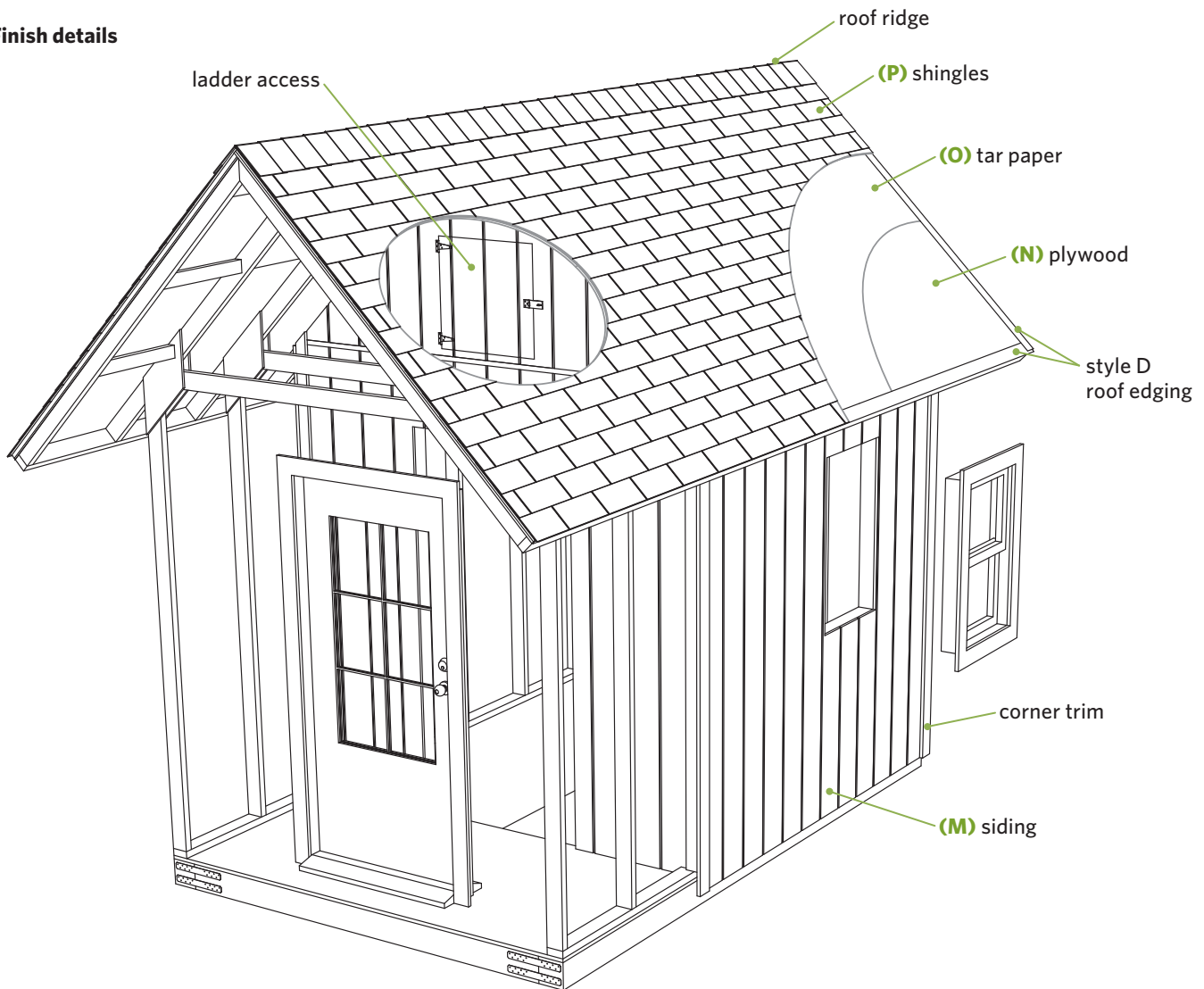

Framing the End Walls and Window and Door Openings

1. Secure nailing plates (L) to the floor for the back wall and the front wall, as shown in *Wall and roof framework* diagram, page 167. To create the front porch, install the front nailing plate 48" back from the front of the floor platform (flush with the truss positioned there); if you don't want the porch, install the plate at the outer edge of the platform.
2. Measure and cut the end studs (L). Notch the tops of the wall studs so when you install them they're flush with the front of the cross ties and nailing plates. For the door opening, leave enough space for the "rough opening" specified by the door manufacturer.
3. If you're going to install windows, purchase them first so you can create the right size openings. For ease, they should have a rough opening width of less than 22" so they can fit between the trusses. Install horizontal 2x4s to create the rough openings for any windows.

Sheathing the Walls and Roof

1. Check to make sure the wall trusses are plumb, and adjust the temporary braces as needed. Measure the spacing of the rafters at the top of each side wall; then cut notches (they'll be about 1½" wide and 4½" tall) on the top edges of the

T-1-11 siding (M). The notches allow the siding to fill the gaps between the tops of the walls and bottom face of the roof sheathing. Trim the bottoms of the 9-foot-long siding sheets so they'll extend at least 3" down onto the perimeter floor beams, but keep it at least 2" above ground level to prevent moisture absorption. Install the siding with 8d galvanized nails every 6" along each wall stud; this adds to the rigidity of the walls.

2. Measure, cut, and fit the end-wall siding. Install Z-flashing along the top edge of the lower sheets before installing the sheets above.

TAKE NOTE You can include a square opening in the gable end(s) for storing an extension ladder or other long things. Build the door from scrap lumber and pieces of T-1-11 siding.

3. Install the first row of the roof sheathing (N) so the lower edge is even with the edge of the eave plate (K) and the inside end breaks in the middle of a rafter. Continue cutting, fitting, and installing the plywood sheathing.

TAKE NOTE The roof pitch is steep; if you're uncomfortable with heights, hire someone to do the high-altitude work.

Installing the Door, Window, Trim, and Shingles

1. Position the doors and windows in their openings, check to make sure they're square and operate properly, and then nail through the nailing fins or brick molding to secure them to the siding and framework, following the manufacturer's directions.
2. Install 1×4 and 1×3 trim at the corners, as shown in *Finish details* (page 168), and add trim around the door and window(s). Add other 1×4 trim boards along the tops and bottoms of the walls as needed to cover gaps. Caulk all seams.
3. Install style-D roof edging (also called drip edge) along all the edges of the roof to cover the exposed edges of the plywood. Staple tar paper (O) to the roof, and then install the shingles (P). Use 1" nails so the tips don't protrude too far below the roof sheathing. Shingle wrappers come plastered with good installation directions; follow them. At the peak, install the roof ridge, which consists of short shingle segments overlapping one another.
4. Paint or stain the T-1-11 siding and trim for protection.

Make It Yours

There are dozens of ways to modify this basic plan to make it fit your site, needs, and budget. Here are a few ideas:

- If you need a bigger shed, just add more trusses. Each truss you add creates another 16 square feet of storage space.
- If you don't need a porch, move the front wall forward; you'll gain another 32 square feet of enclosed storage space.
- You can increase or decrease the number of windows; just make sure they're 22" or less in width so they fit between the trusses.
- You can use a variety of siding materials, but the advantage of T-1-11 is that it serves as both structural sheathing and decorative siding. It's available in pine (the logical choice if you'll be painting your shed) or cedar (the best choice if you want a natural look). If you use lap, board-and-batten, shingle, or other siding, install ½" plywood or oriented strand board (OSB) sheathing first.
- This project calls for standard asphalt shingles, but you can use roll roofing to bring the cost down, or use wood or metal roofing to match your house or other outbuildings.

Hand-Nailing versus Power Nailing

You can use 1½" shingle nails for securing the gusset plates for the wall/roof trusses, but if you own (or can borrow or rent) an air compressor and nail gun or staple gun, your accuracy and speed will improve dramatically. Nail guns allow you to position parts with one hand while driving nails with the other. There's less shaking and bouncing with nail guns than with hand-nailing, so your parts will fit tighter and stay tighter as you work. Plus, you won't go crazy driving in hundreds of short nails. You'll install a dozen nails through each gusset plate; that adds up to more than 70 nails per assembly. Your thumb will thank you.

Homestead Emergency Cart

A ready-for-anything kit on wheels

In her memoir, *Hit by a Farm*, Catherine Friend writes about the plastic container stocked with medicines and paraphernalia her partner keeps at the ready for frequent trips to the barn during lambing season. While most of us don't need those particulars, we all need supplies for the inevitable surprises and emergencies that arise in the home, barn, and field as well as on the road.

Here's a homestead emergency cart that can be customized to fit your needs. You can stock it with supplies for:

- Power outages and natural disasters
- First-aid situations
- Homestead repairs
- Animal care
- Roadside emergencies

It's easy to pull around, hang on the wall for storage, or throw in the trunk of a car or bed of a pickup. Everything is stowed in one convenient, and remember-able, place. (Note: If it has matches, flares, or medicines in it, keep it out of the reach of children.) Buy the plastic bin ahead of time and base your cart on its dimensions. Your bin should be sturdy and have a watertight snap-on or hinged lid.

See page 2 for a photograph of this project.

Materials

- One heavy-duty plastic bin with lid, 20" x 30" or larger
- One 2 x 4-foot piece ½" plywood
- Two 8-foot pine 1x3s
- One pine 1x4 or 1x6 (see step 4)
- Wood glue
- ¼" exterior screws
- Two 6" wagon or lawn mower wheels
- Two 2" or 2½" axle bolts with washers and lock nuts
- Four 1" carriage bolts with washers and lock nuts
- Miscellaneous mounting hardware (see step 5)

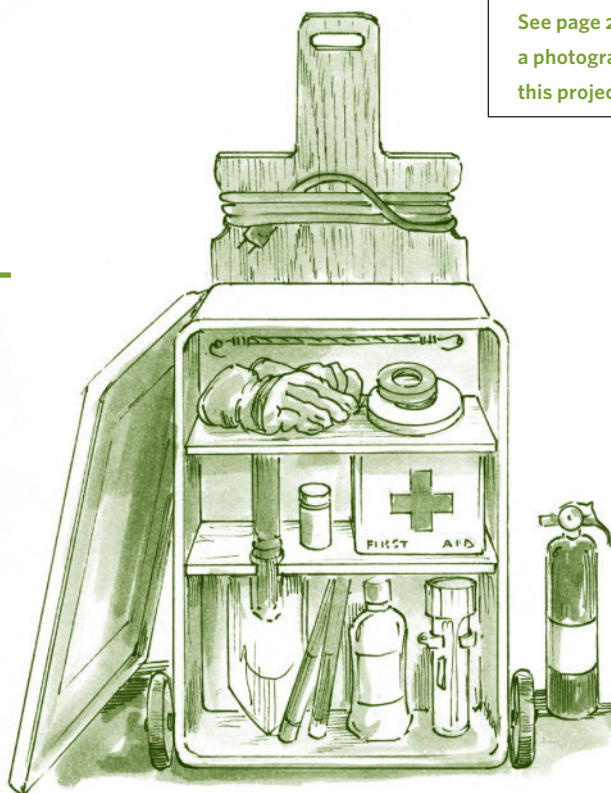

Emergency Cart Supplies

If you want to be ready for anything and everything, consider including all or most of these items:

- flashlight, candles, matches
- bottled water, snacks
- first-aid kit and book
- animal care supplies
- small fire extinguisher
- duct tape
- rubber and leather gloves
- emergency blanket and raincoat
- hand air pump
- camping shovel
- solar-powered radio
- flares
- bungee cords/ extension cords
- multi-tool
- 3-day supply of medicines
- paper towels, garbage bags, wet wipes

1. Cut a piece of ½" plywood for the cart platform, as shown. Make the square/rectangular body section slightly larger than the bin, and make the tongue (the extended end that serves as a handle) at least 8" long × 6" wide. If you want room for an extension cord wrap, make the body a few inches longer. Cut out a 2" × 4" handhold near the end of the tongue.
2. Construct a 1×3 frame that's the same size as the plywood platform. Secure it to the plywood using wood glue and 1¼" exterior screws. Drill two holes for the axle bolts.
3. Install the wheels by sliding bolts with washers through the wheel axle holes and then slipping the bolts through the holes drilled in the 1×3 frame. Install a washer and lock nut from the other side to hold the wheels in place.
4. Cut dividers from 1×4s or 1×6s, and round the bottom corners to conform to the profile of the bottom of the bin. Use ¼" screws to secure the dividers to the sides and bottom of the bin.
5. Position the plastic bin on the plywood platform and drill holes 1" to 2" in from each corner through the bin and plywood. Use 1" carriage bolts, washers, and lock nuts to secure the bin to the plywood. Add clamps, straps, and hooks to the bin, as desired, for holding supplies. Mount larger items, like fire extinguishers, under the cart.

Cart construction — exploded view

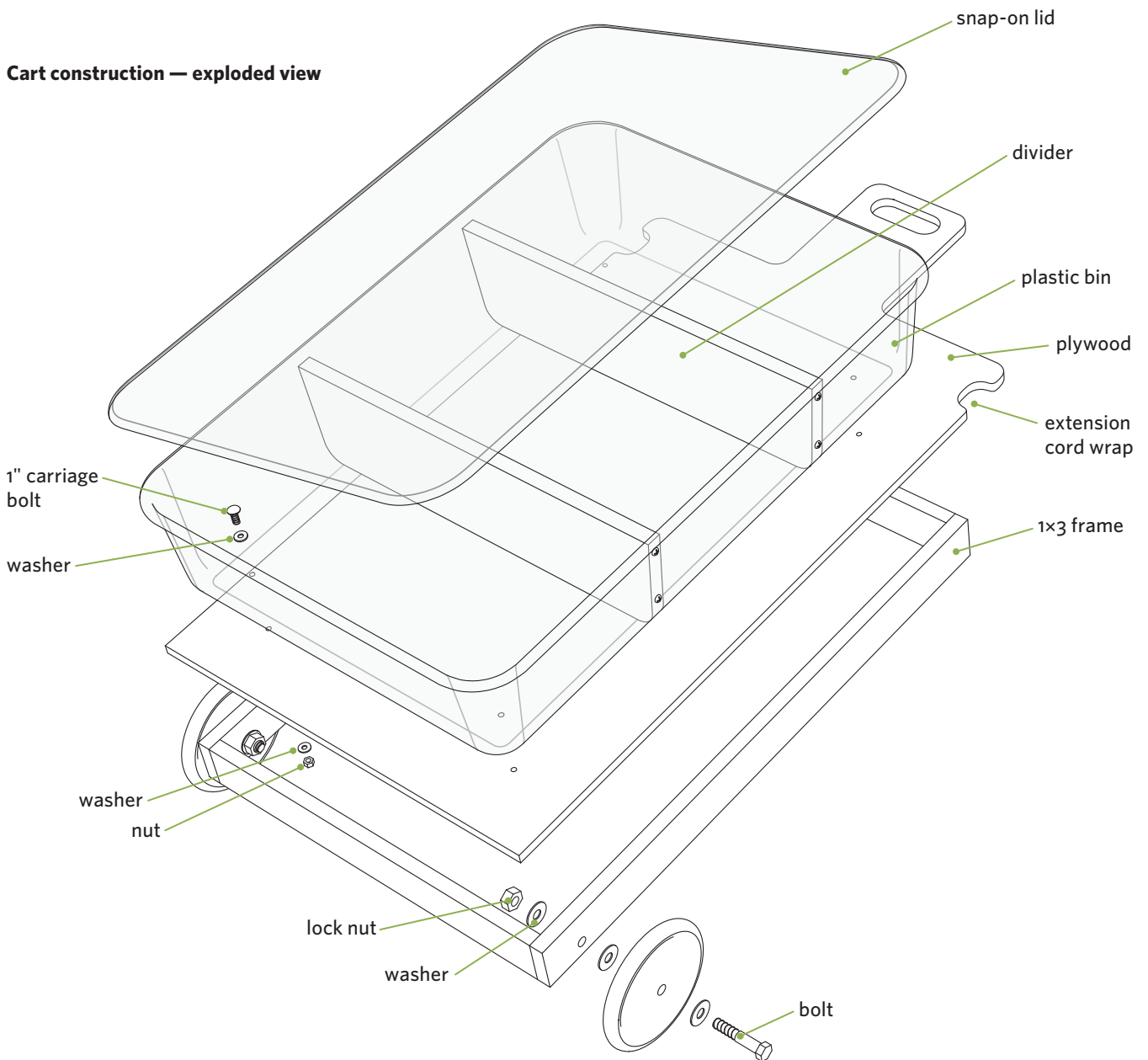

Ultimate Yard Shed

Tons of storage space, inside and out

If you need to store a few rakes and shovels, you probably can get by with the Stand-Up Tool Rack (page 150). When you outgrow that, you may need to graduate to the Modular Shed (page 163). But when you outgrow that, you need to start thinking big – really big. You need to start thinking: ultimate yard shed.

This shed provides more than 250 square feet of enclosed space and 250 square feet of covered storage space. Plus it has a garage door large enough to drive a small tractor or riding lawn mower through. It's a big project, but there's a huge payoff: You'll finally have room to store all your stuff. In addition, this project will introduce you to the basics of stick framing, the standard carpentry method used to build most houses and garages today.

This is one of the largest, most complex projects in the book. Since complete instructions would

consume half the book, we'll supply only the basic measurements and steps. Advanced do-it-yourselfers will be able to work their way through the project, but if that's not you, enlist the services of an experienced mason and carpenter to get you through the rough spots.

This project is also large enough to require a building permit in many areas. Check with your local building official to determine the required setbacks from property lines and learn about permits, inspection schedules, fees, building code specifications, and other requirements. You'll most likely need to submit a survey of your property with the location of the shed drawn in, along with a basic blueprint. Once the legalities are squared away – and you've called 811, the national "Call Before You Dig" hotline – you can dig in.

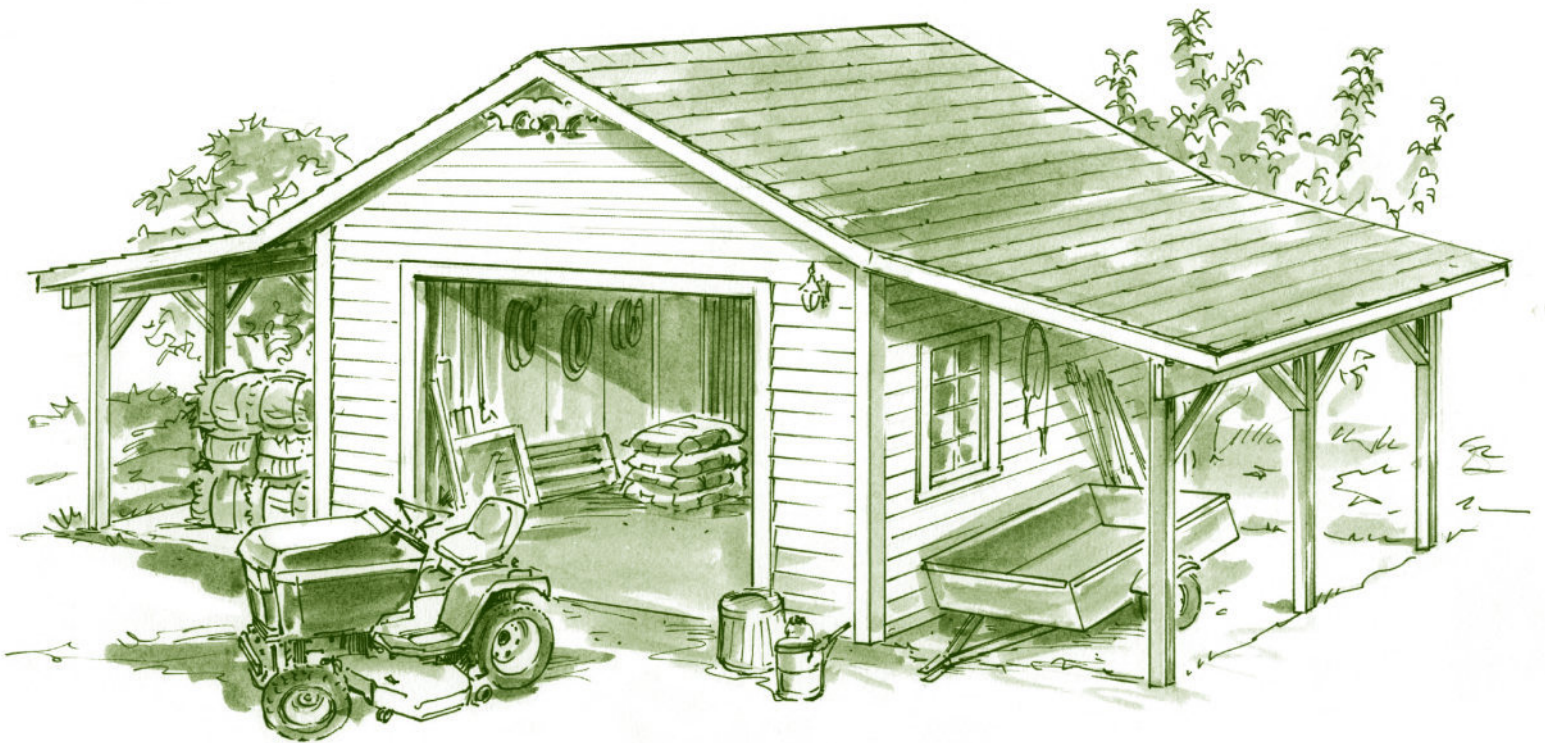

Shed foundation

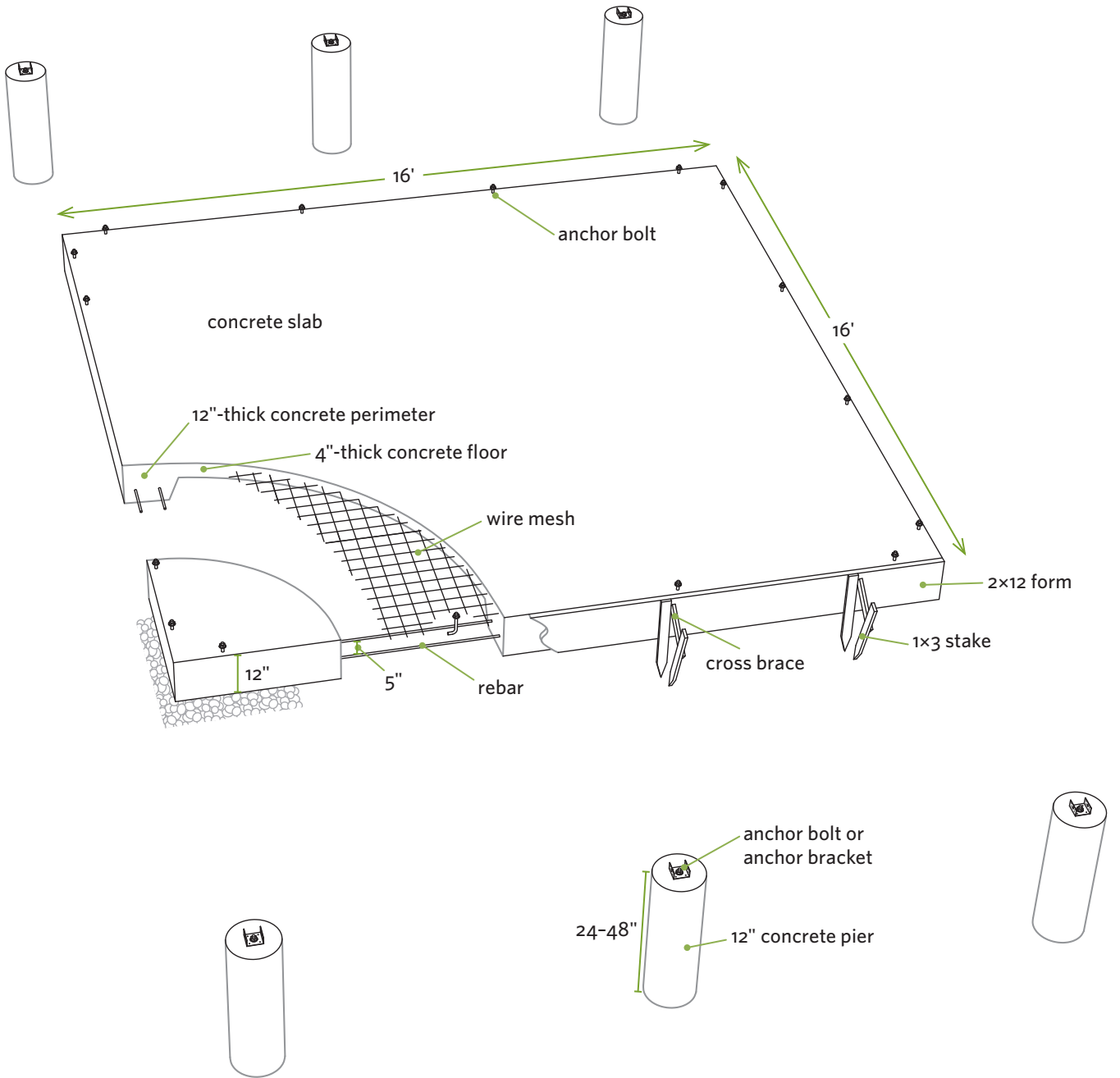

Pouring the Concrete Slab and Post Piers

The floor of this shed is a floating, or thickened-edge, slab. The thick, rebar-reinforced perimeter helps support the weight of the walls and adds strength to the slab to prevent it from cracking if the ground shifts due to frost heaves or settling. The reinforcing mesh in the floor also contributes to the overall strength of the slab.

If you've never worked with concrete before, hire someone for this part of the job. Creating a smooth, level slab is harder than it looks, and any mistakes are set in, well, concrete. Even if you've worked with concrete before, this project is large enough to warrant the assistance of two or three helpers. Here we'll just touch on the basic steps, but you can find more detailed concrete information online (see Resources).

THE BASIC STEPS ARE:

1. To establish the perimeter of the slab, use batter boards and strings (see *Measuring, Leveling, and Squaring*, page 30). Remove the topsoil and level the area. Dig out an area at least 10" deep for the center of the slab, surrounded by a 12"-wide trench that's 4" to 6" deeper for the thickened edge, as shown in *Shed foundation* (page 173). Add a 4" or 5" layer of gravel over the excavated area.
2. Use the batter board strings as a guide to install 2×12 form boards around the perimeter of the slab area. Secure the forms to stakes using double-headed nails or screws. Use a manual, digital, or laser level to level the tops of the 2×12s as you work. Install additional diagonal braces to prevent the centers of the form boards from bowing out when the concrete is poured.
3. Install the rebar reinforcing rods around the perimeter of the slab, as shown in *Shed foundation* (page 173). Hold the rebar in place by wiring it to short sections of rebar driven into the ground near the center of the trench. Cut and install the wire mesh, holding it off the ground using wire mesh standoffs (available at lumberyards and home centers).
4. Dig the six holes for the concrete post piers that will support the posts for the outer eave beams.
5. Check the weather, make sure your workforce is ready, and then bring on the concrete trucks. Start pouring concrete in the far corner of the form, screeding, or leveling, it with a long, straight 2×4 as you progress across the form. Install four L-shaped anchor bolts along each side to hold the walls in place, but don't place bolts in any future doorways.
6. Use a bull float (a large, flat plate connected to a long, sturdy handle) to fill in low spots and smooth the ridges and marks left over from screeding. Stand outside the form and make two or three passes from different angles. This is all easier written than done; getting concrete flat and smooth is a fine art.
7. Once the slab is hard enough to support your weight as you kneel on a small plywood pad, begin smoothing the surface of the concrete. Start with a darby (a long wood trowel) to remove ridges and force down large aggregate. Finish smoothing the slab by using a hand float, a hand trowel, and an edger.
8. Cover the slab with plastic, and let it cure and harden for a day or two.

9. Pour concrete into the six pier holes. You can use cylindrical cardboard tubes (Sonotube is one brand) to form the concrete if the soil is loose or the holes are too large. Insert an anchor bolt or hardware for a metal post base at the top of each pier.

Framing the Walls

In order to show the various stages of wall construction, *Wall framing diagrams* (opposite) shows the walls lying on the ground outside the shed. But the best way to build the walls is to use the slab you just poured as a framing platform and then tilt up the walls from the inside. Here's a look at each wall section shown in *Wall framing diagrams*, along with the basics of wall framing.

West wall. This shows the top and bottom nailing plates, lying side by side, as viewed from above. The bottom plate is pressure-treated to ensure longevity. Both plates have been laid out with the stud positions, following 24" on-center spacing; this ensures that the edges of 4-foot-wide plywood sheets will break in the middles of the studs. The positions of the anchor bolt holes have been transferred to the bottom plate. Holes have been drilled so when the wall is stood up, the bolts will fit through the holes, and nuts and washers can be installed to hold the wall firmly to the slab.

East wall. This shows the wall being framed, or assembled. The top and bottom plates have been separated. Each stud has been nailed to the bottom plate with two 16d nails. The window rough opening has been framed according to manufacturer's specifications. The 2×8 double header will help support the weight of the roof where it rests across the opening. The trimmers support the header from below, while the king studs support it from the side. The cripples fill in the space above and below the rough opening. The top nailing plate is then secured using two 16d nails per stud.

North wall. This shows a wall that's been framed. Diagonal measurements have been taken from corner to corner to square up the wall, and a temporary 1×4 cross brace has been installed to hold the wall square until the wall is installed and the plywood sheathing is added. The corners have studs in an L-shaped configuration; this creates a solid corner and a good nailing surface for securing the adjacent walls after they've been raised.

South wall. This wall is also finished and ready to stand. The rough opening for the garage door has been framed in. This wall, like the other three, should also be squared and have cross braces installed to hold it rigid until the plywood sheathing is installed.

North wall

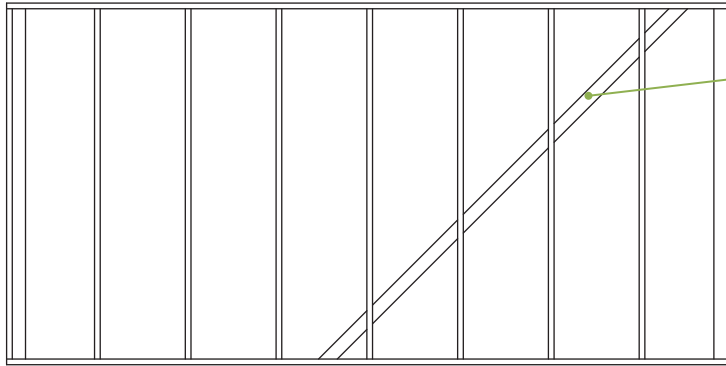

temporary brace

hole for anchor bolt

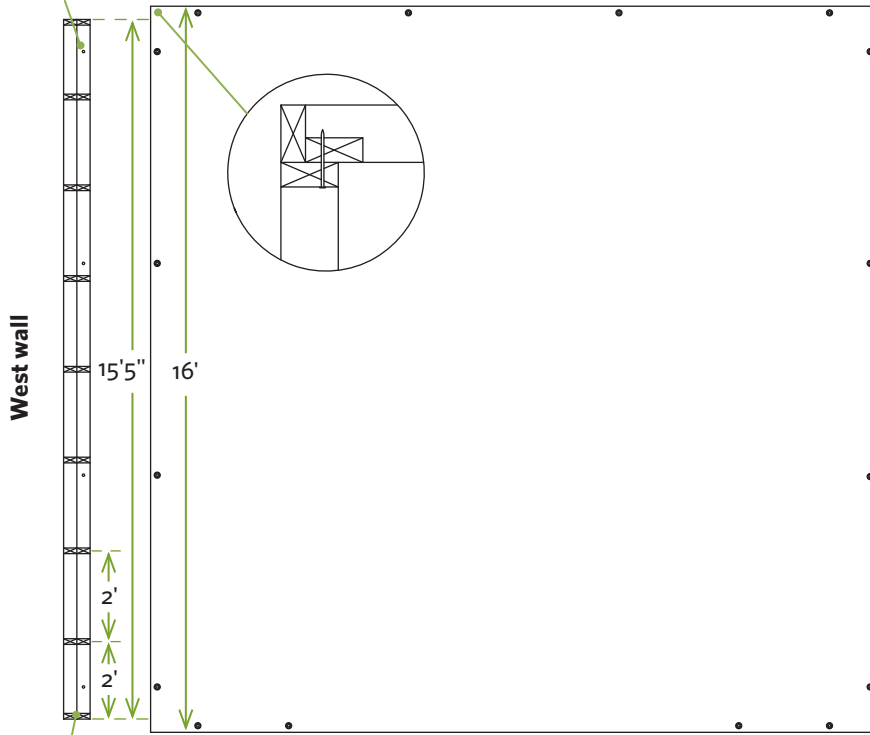

West wall

15'5"

16'

2'

2'

South wall

lay out plates together, then separate and install studs

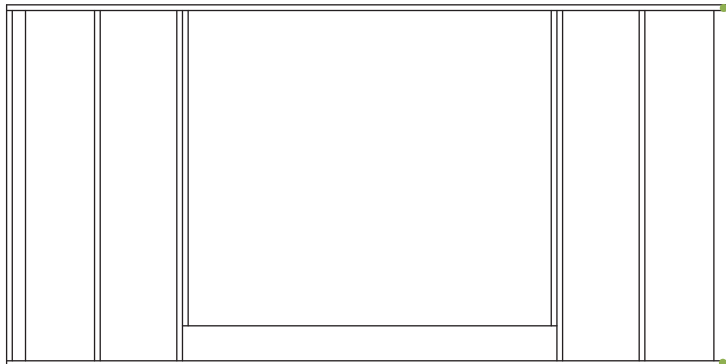

16'

2x4 bottom plate

2x4 top plate

East wall

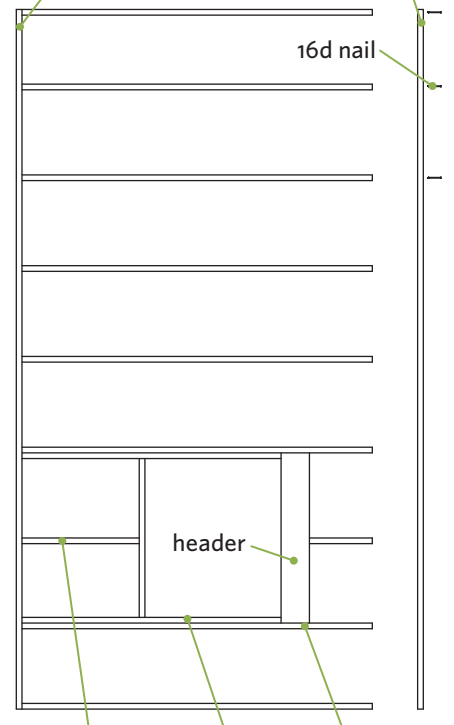

16d nail

header

cripple

trimmer

king stud

bottom of wall

top of wall

Wall framing diagrams

Framing the Walls (continued)

If you're using your slab as a framing platform, frame the north wall first. Place sill sealer (a strip of flexible foam) on the edge of the slab where the wall will sit, and then tilt the wall up into position. The bolts in the slab will fit through the holes in the bottom plate you drilled. Install temporary braces extending from the top of the wall to stakes in the ground to keep the wall from falling over. Then frame, stand, and brace the south wall. Frame and stand the east wall next (it will fit between the north and south walls), followed by the west wall.

Once all the walls are erected and the corners nailed together, install the second set of 2x4 top plates (sometimes called double top plates), overlapping the corners to help tie the walls together. This gives you two 2x4s at the top of each wall. Add a temporary brace in the center of each wall to hold it plumb. Finally, install the 1/2" plywood wall sheathing.

Installing the Roof for the Shed and Eaves

The next step is to install the roof rafters and basic framework for the large eaves.

Cutting and installing roof rafters requires some fairly complex carpentry skills. It involves cutting rafters at an angle where they meet the ridge board and cutting bird's-mouths, or notches, where they rest on the walls or beams. It also involves high-altitude work. You need to make sure the rafters are spaced correctly. The details at the eaves can be particularly time-consuming (and head-scratchers).

Following are the basic steps of cutting and installing rafters and installing the roof sheathing and roofing materials. Remember, all measurements shown are approximate; measure and fit as you go. If you're not comfortable with heights or don't fully understand what you're doing, enlist experienced help.

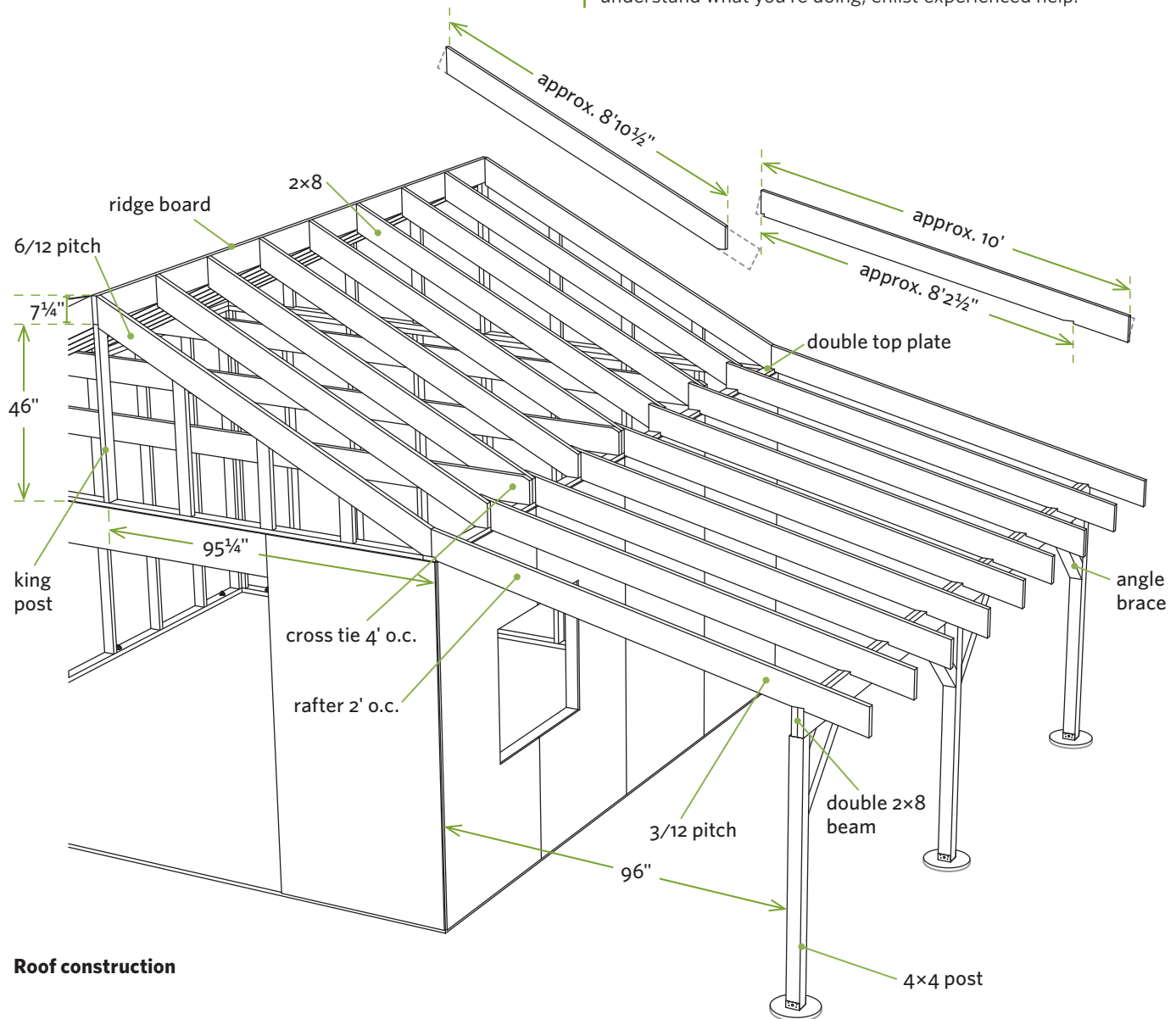

Roof construction

1. Install the ridge board (also called a ridge beam). Begin by cutting and installing the king posts that will support the ridge board on each end. Once they're installed, level and brace them in both directions so they stay absolutely plumb. Set the 2×8 ridge board on top of the king posts, and connect them with flat metal straps on each side.
2. Cut the shed rafters. There are two ways of figuring the angles for the rafters: (1) The "mathematical" method, which uses formulas and rafter squares, and (2) the "fit-and-cut" method, which involves finding the length and cut angles of the rafter on-site, using a bit of trial and error. We're going to use the second approach. For more information on the first approach, study a book like *Framing Roofs* (see Recommended Reading).

Begin by temporarily tacking a 10-foot 2×8 in the position shown in *Roof construction* (facing page), letting the ends extend beyond the ridge beam and the outer wall; this is your trial rafter. Use a pencil to scribe the ridge beam angle onto the back of the rafter; do the same with the wall at the bottom of the rafter. Cut the rafter according to your marks. Test-fit the rafter on both sides of the ridge board and on both ends of the shed. Adjust the rafter cuts as needed until the rafter fits snugly on both sides of both ends; you may need to cut a second trial rafter to get a good fit.

Once you get the length and angles right, write "PATTERN" on the trial rafter. Use this rafter as a template to mark the cuts for the remaining rafters, and then make the cuts.

3. Install the roof rafters by toenailing them into the sides of the ridge beam and the tops of the walls. They should be spaced 24" on center, positioned over the wall studs below.
4. Position and brace the 4×4 posts that will support the double 2×8 beam for the lean-to roof. Let the posts run extra long so you can cut them off at the correct height while in place. You want the tops of the 2×8 beams to be about 21½" lower than the tops of the exterior walls (see *Roof construction*, opposite), so don't forget to subtract the height of the beam when marking and cutting off the tops of the posts. Install the double 2×8s that form the beam, as well as the 45-degree 4×4 angle braces that run from the posts to the beam; these will add rigidity.

5. Install the lean-to rafters. Figure out the exact length and angle of these rafters using the same method you used for the shed rafters. Install these rafters so they rest on the shed wall directly next to the shed rafters. On the ends you'll need to cut these rafters so they're in line with the outermost shed rafters. Toenail the rafters in place.
6. Cut and install a 2×8 cross tie, spanning from one wall to the next, every 48". Secure them to the sides of the rafters where they sit on the wall. The cross ties will prevent your walls from bowing outward due to the weight of the rafters, shingles, and snow loads.
7. Sheathe the roof with plywood, staggering the panel joints between rows. Install the roofing materials, starting at the bottom and working upward, following the manufacturer's directions. If you want to include overhangs on the gable ends, let the plywood extend past the gables and then trim the edges evenly after all the plywood is installed.

Installing the Windows, Door, and Siding

Install the windows and entry doors following the manufacturer's instructions. If you're installing an overhead garage door, add the side and top jambs first. Once the garage door is hung, you can then install the gasketed trim pieces along the sides and top.

You can install any type of siding you wish. You may want to match the siding on your house or other existing outbuildings. If you're going for function and low cost, consider metal siding. The project as shown has wood lap siding.

If you're installing lap siding, install the 1×4 corner boards and trim around the windows and doors first; then butt the lap siding up to the sides of the trim.

Install blocking between the rafters where they rest on the shed walls to keep out moisture and bugs.

Use caulk to seal any cracks and gaps; then prime and paint your new shed. Accessorize the building to your liking.

This shed provides more than 250 square feet of covered storage space. It's a big project, but there's a huge payoff: you'll finally have room to store all of your stuff.

Finish details

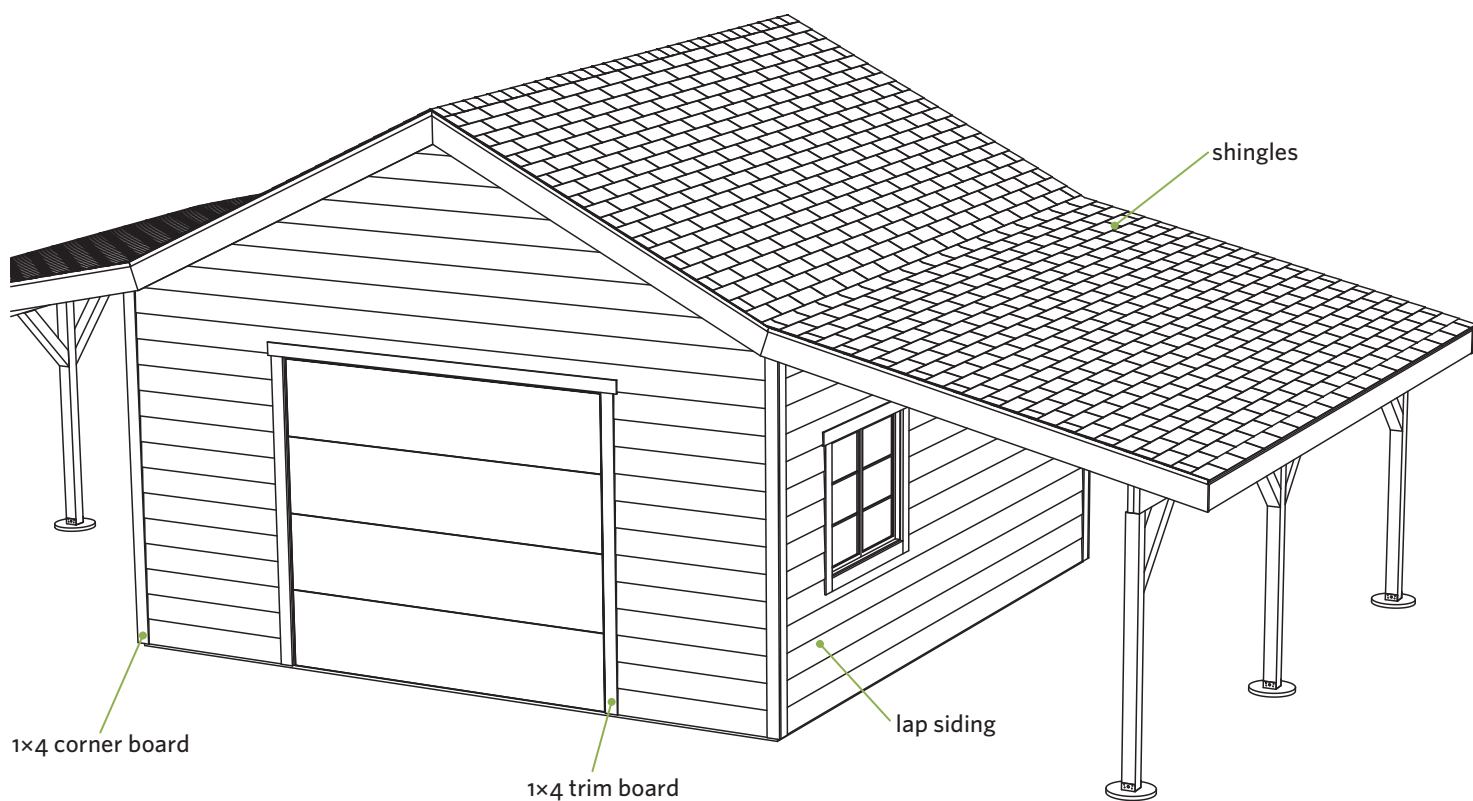

Hose Headquarters

A roost for hoses, nozzles, sprinklers, and sprayers

For some gardeners, watering involves untangling the hose, searching for the nozzle, and tripping over the sprinkler. And where, oh, where did you put those little hose gasket thingies? This hose HQ can help you organize all this stuff and more. You need only a few basic materials and an hour or two of time.

Materials

- One plastic 5-gallon bucket with lid
 - Three or four $\frac{3}{4}$ " screws
 - One 1"-diameter wood dowel or pipe (approx. 18" long)
 - Three or four $\frac{1}{4}$ " x 2" lag bolts with washers
1. Use a jigsaw to cut away part of the bucket lid as shown. Snap the remaining lid section over the bucket opening, and then use three or four $\frac{3}{4}$ " screws to hold it in place. If you want a watertight container, leave the lid whole.
 2. Use a 1" drill bit to bore a pair of holes across from each other about two-thirds up the side of the bucket. Use a jigsaw to slightly enlarge the holes, and then slip the dowel or pipe through. You want the dowel to be long enough to hold the hose in place but short enough to let you loop the coiled-up hose over it.
 3. Bore $\frac{1}{4}$ " holes through the bottom of the bucket and use lag bolts with large washers to secure your bucket to a wall, post, fence, or other solid surface. You can add 2x12 blocking between studs to create a more solid fastening surface. Drill a few holes in the down-facing side of the bucket for drainage.
 4. Fill up the bucket with stuff, though nothing too heavy. You can add S-hooks to the hoop handle for hanging hand tools. Or create a twine or wire dispenser by prying off one side of the handle, slipping the spool over the end, and then snapping the handle back in place.

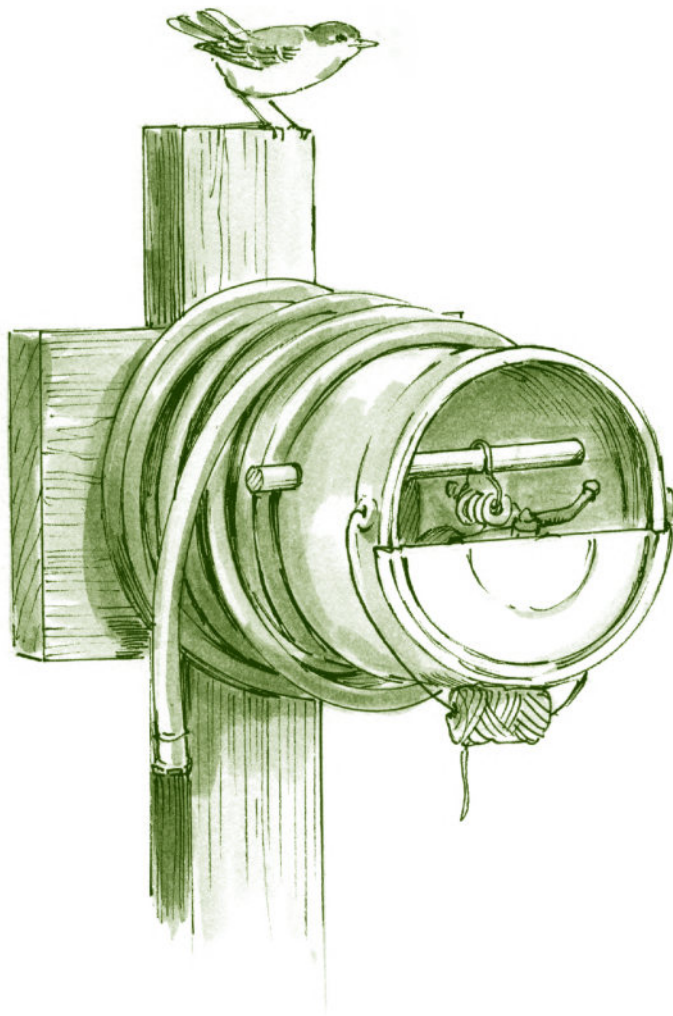



Animal Shelter, 192

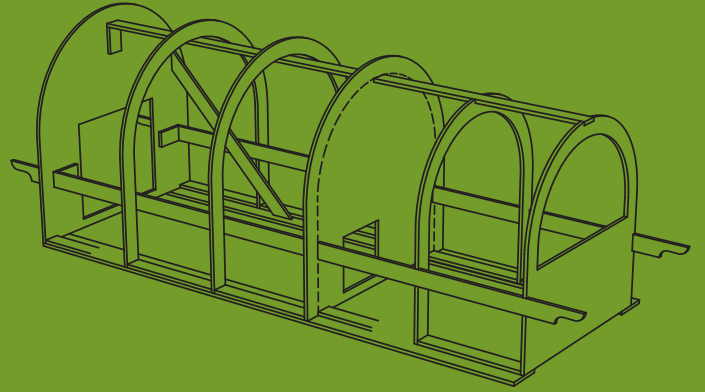

Chicken Ark, 198

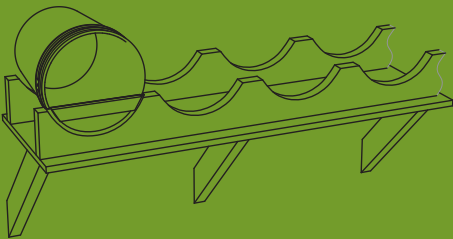

Nesting Box Buckets, 182

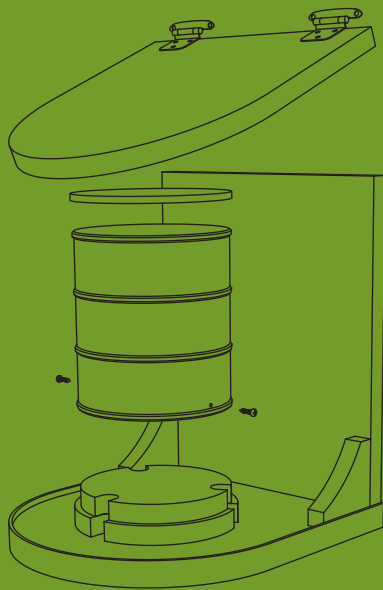

Coffee Can Bird Feeder, 221

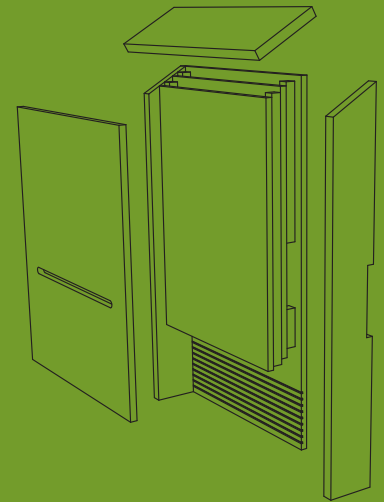

Bat House, 189

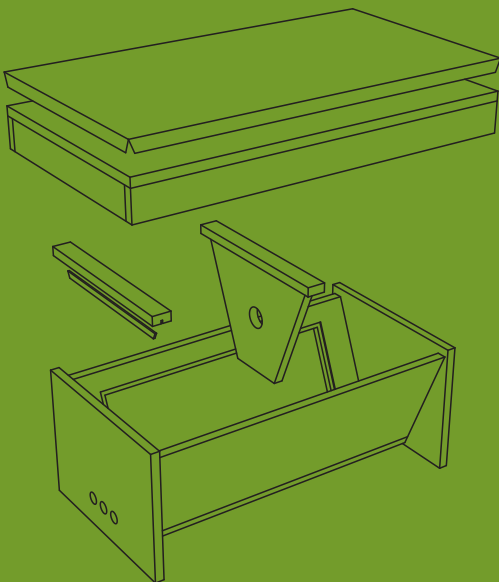

Top Bar Beehive, 224

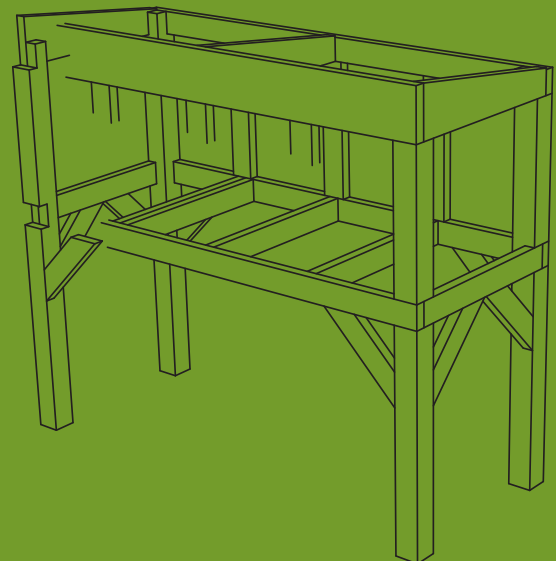

Rabbit Hutch, 184

Animal Shelters and Feeders

Ten years ago, keeping backyard chickens in some communities was grounds for suspicion; today it's grounds for lively conversation. Hundreds of thousands of city, suburban, and country dwellers have joined the ranks of gentleman (or gentlewoman) chicken farmers. And it hasn't ended there. Backyard enthusiasts are raising bees, rabbits, and other small animals as well.

This chapter contains projects for housing, sheltering, and feeding your four-legged and two-winged compatriots. Even if you're not ready to start raising chickens or sheep, this chapter contains projects, like the bat house and the coffee can bird feeder, that anyone can build and use.

Before diving into this area of backyard homesteading, check local ordinances and building codes. Some communities have an anything-goes policy; others have more of a nothing-goes policy. But most fall somewhere in between. There are usually guidelines as to how many animals you can keep, how large and how far from your and your neighbor's house their shelters can be, and so on. Some communities require the consent of a certain percentage of neighbors in a defined area before issuing a permit. Others allow chickens but no roosters. It'll pay to do your homework.

Nesting Box Buckets

Easy to build, easy to clean

Chicken nesting boxes come in all shapes and sizes. They can be custom-built using new lumber or crafted from discarded apple crates or old dresser drawers. Susan Waughtal and Roger Nelson of Squash Blossom Farm (see pages 55 and 95) tried a variety of nesting boxes but in the end wound up using good old 5-gallon buckets. Why? The materials were free; the only tool they needed

was a jigsaw; and when it comes time to clean the buckets out they simply remove the screws that secure the buckets to the cradles, grab the handles, carry the buckets outside, and spray them out with a hose.

You can find your 5-gallon buckets free at many construction sites and restaurants.

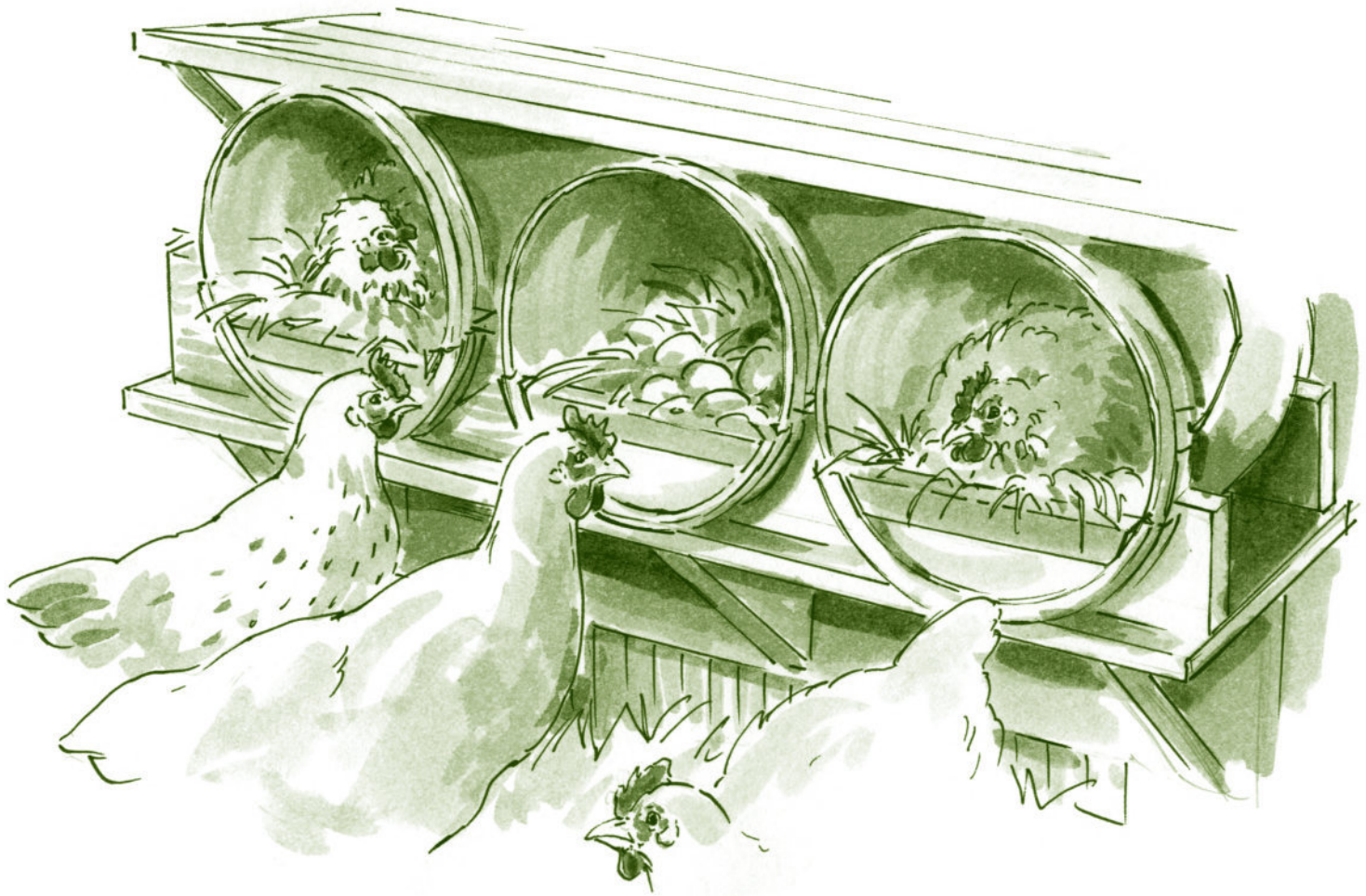

Materials*

- 5-gallon plastic buckets
- 1×2 lumber
- 2×6 lumber
- ½" screws

*Sizes and/or quantities are as needed.

1. For each 5-gallon bucket, use a jigsaw to cut a semicircular slice from the lid. The slice should be 3" to 4" tall at the widest part.
2. Snap the semicircular front onto the bucket. Cut a 1×2 the same length and with the same angles as the top of the slice. Use ½" screws (driven through the plastic lip into the back of the 1×2) to secure the 1×2 in place.
3. Trace around the top of a bucket to create a series of equally spaced cradles on the edge of a 2×6. Create a matching series of cradles in another 2×6 using the bottom of the bucket. Cut out the shapes with a jigsaw.
4. Secure the 2×6 cradles to the front and back of a shelf with long all-purpose screws, set the buckets horizontally in the cradle indentations, and then use one or two drywall screws to secure the buckets to the cradles.

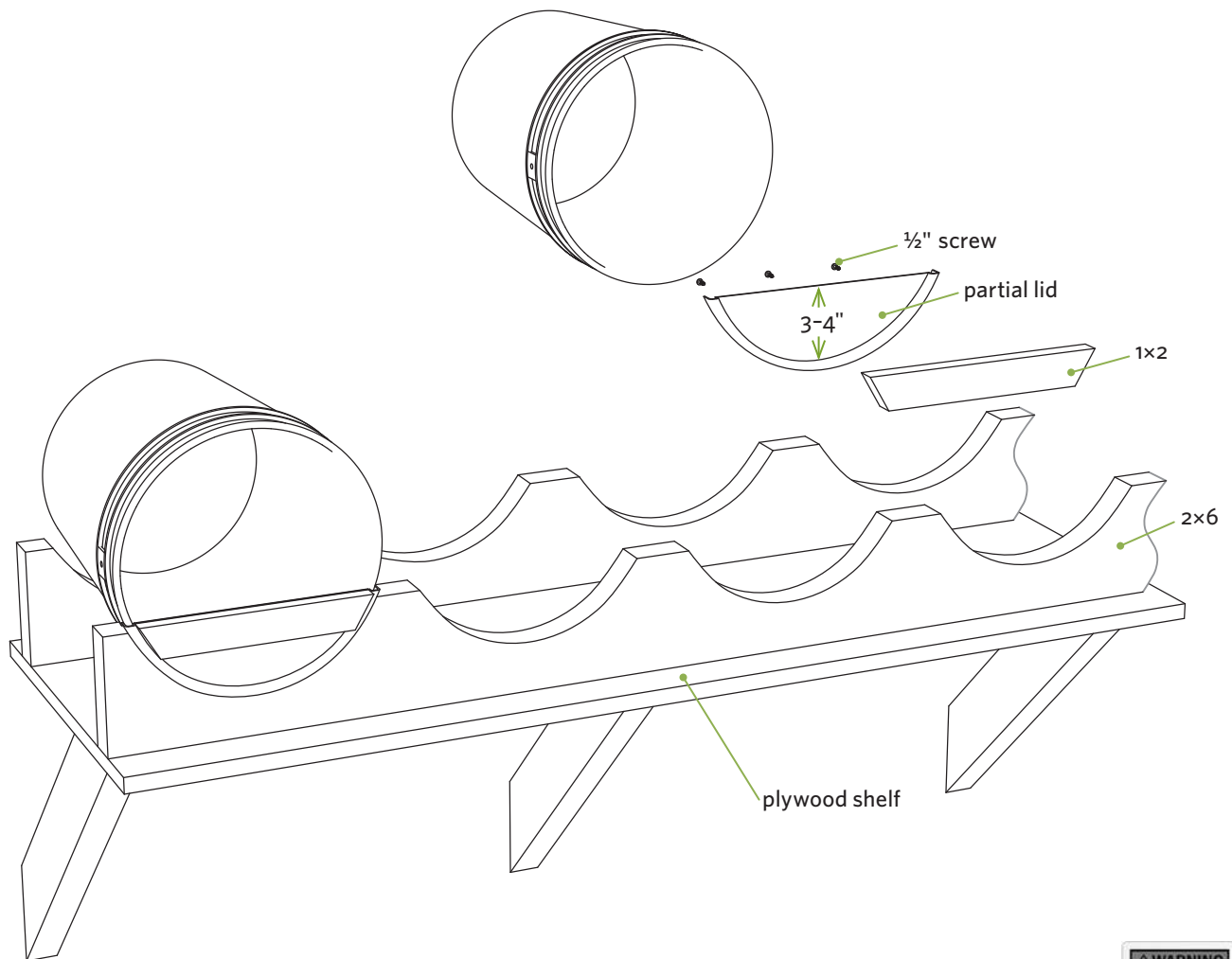

Play It Safe with Buckets

Every year around 25 children drown in buckets. A 5-gallon bucket is particularly dangerous: it is about the same height as a toddler's center of balance and, when filled with 2 or more gallons of water, is very stable. When a curious tot reaches into a bucket, loses his or her balance, and falls in, the bucket

may stay upright and allow the child's mouth and nose to be submerged.

To prevent accidents, never leave a bucket of liquid unattended when small children are around. And always empty a bucket, or keep the lid firmly snapped in place, when it's not in use.



Rabbit Hutch

A place your rabbits can call home

This rabbit hutch isn't just a great place for your rabbits to live; it's also a great place for you to hone your carpentry skills. It can be built with a circular saw, a drill, basic hand tools, and readily available materials.

You have three options for lumber, each with its own pros and cons. *Cedar* is stable, rot-resistant, and easy to work with, but it's also the most expensive and gnaw-able choice. *Pressure-treated*

lumber is strong, rot-resistant, and inexpensive, but there are safety concerns over rabbits gnawing on chemically treated wood. *Pine* is cheap, strong, and widely available but not rot-resistant. (See Recommended Reading for more information on rabbits and hutches.)

The initial step in this project, creating dadoes in the 4×4 legs, is time-consuming. But once that part is done, the rest goes together fairly easily.



Materials

- Four 8-foot 4×4s
- Eight 8-foot 2×4s
- Two 8-foot 2×8s
- One 4 × 8 sheet ¾" pressure-treated plywood
- One 4-foot 1×2
- One 4 × 8-foot sheet texture 1-11 (T-1-11) siding
- One 8-foot 1×2
- 16d nails
- 8d nails
- 1¼" exterior screws
- 3" exterior screws
- Four exterior hinges with screws
- Four exterior bolt latches with screws
- Roofing material (or plastic or canvas sheeting; see step 5 on page 187)
- Five linear feet ½" × 1" welded wire mesh, 36" wide
- Ten linear feet 1" × 2" welded wire mesh, 24" wide
- U-staples

Parts and Cutting List

Part	Size and Material	Quantity
(A) leg	3½" × 3½" × 60"	4
(B) long frame & rear roof member	1½" × 3½" × 72"	3
(C) front roof member	1½" × 7¼" × 72"	1
(D) floor crosspiece	1½" × 3½" × 27"	6
(E) roof rafter	1½" × 7¼" × 27" ¹	3
(F) wall stud	1½" × 3½" × 20½"	6
(G) angle brace	1½" × 3½" × 16" ²	8
(H) floor	¾" × 18" × 30" PT plywood	1
(J) end/middle panel	⅝" × 30" × 31¼" T-1-11 siding	3
(K) door	(cut from part J)	2
(L) door stops	¾" × 1½" × 8"	6
(M) front & back panels	⅝" × 18" × 27½" T-1-11 siding	2
(N) roof panel	¾" × 36" × 78" PT plywood	1
(O) floor mesh	½" × 1" (cut to fit) welded wire mesh	1
(P) wall mesh	1" × 2" (cut to fit) welded wire mesh	2

¹Roof rafters (E) taper from 7¼" on one to 3½" on the other.

²Angle braces (G) have 45-degree cuts on each end.

NOTES FROM THE TEST TRACK

The Houdini Rabbit versus the Rookie Builder

My very first building project was constructing a hutch for my little sister's newly acquired rabbit, Eloise. I was 10 years old. I spent the better part of a day cobbling together a hutch from chicken wire and scrap 2×2s. I set the hutch in

the backyard, placed Eloise in her new digs, and then went inside and told my family to look out the window at the new rabbit mansion. There sat Eloise — not in the enclosure, but on top of it. It had

taken Houdini Eloise all of 5 minutes to escape.

Rabbits love to dig, claw, and gnaw. Make certain your pens and hutches are dig-proof, claw-proof, and gnaw-proof.

Notching the legs

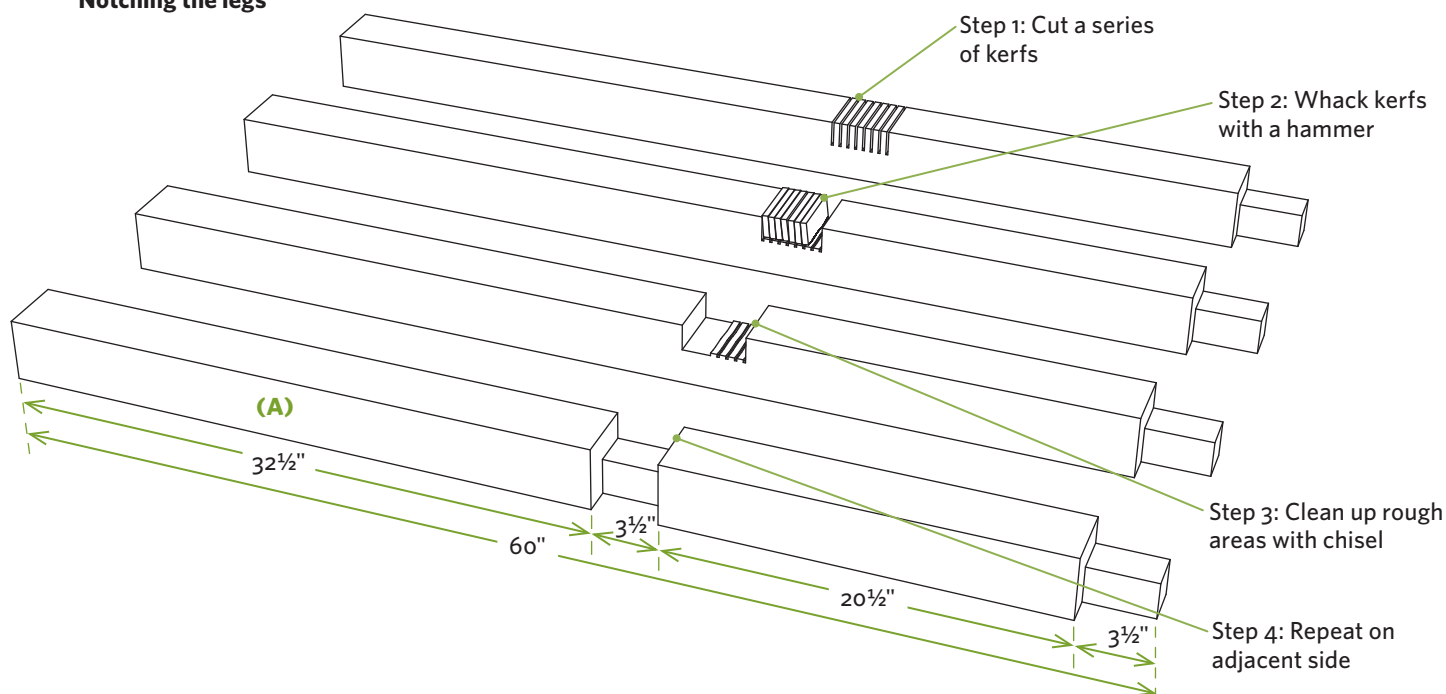

Building the Basic Framework

1. Cut the legs (A) to length, position them side by side, and then mark the locations of the notches as shown above. Set your circular saw to cut 1½" deep, and make a series of cuts spaced about ½" apart between each set of marks, as shown in *Notching the legs*. You can cut across all four legs at the same time or cut them individually. Give the kerfs a whack with a hammer; then use a chisel to remove the nubs and smooth the notches. Roll the legs 90 degrees onto an adjacent side, and create the adjacent set of kerfs and grooves.
2. Position two legs (A) on a flat surface so the notches on one side are facing up and the notches on the other sides are facing away from each other. Position two long frame members (B) in the middle and top notches so the ends are even with the outside edges of the legs, as shown, and secure them with 16d nails. Repeat with the other pair of legs, except nail the wider front roof member (C) into the top notches to help create the slope for the roof.
3. Have a helper stand up the two leg assemblies, position the outside floor crosspieces (D) in the middle post notches, and nail them in place, as shown in *Hutch frame* (opposite). Nail the remaining crosspieces (D) to the long frame members (B) at 18" spacing. The double crosspieces toward one end provide nailing surfaces where the plywood and mesh floors meet.

4. Angle-cut the roof rafters (E) as shown in *Hutch frame* (opposite). Install one on each end (in the notches) and one in the middle to create the framework for the slanted roof.
5. Use 8d nails to toenail the wall studs (F) to the front and back of the hutch. Center them above the floor crosspieces (D).
6. Add the 4×4 angle braces (G) to strengthen the structure.

Installing the Floor, Roof, Siding, and Mesh

1. Cut the plywood floor (H) for the enclosed area to size, notch the corners to fit around the posts and studs, and secure it to the lower platform (B, D) with 8d nails, as shown in *Finish details* diagram (page 188).

TAKE NOTE You can install metal or plastic trays to make the floor easier to keep clean. Another option is to use slats or tightly woven hardware cloth for the floor to promote drainage.

2. Cut the end and middle panels (J); the tops are angled to follow the roof slope, as shown in *Finish details* (page 188). Use a jigsaw to cut out the door openings in the two end panels; cut carefully because the cutouts will become the doors (K). Install the end panels, using 1¼" screws. Use 1¼" screws to secure the doorstops (L) to the backside of the openings. Install the doors with hinges, and add the latches.

Hutch frame

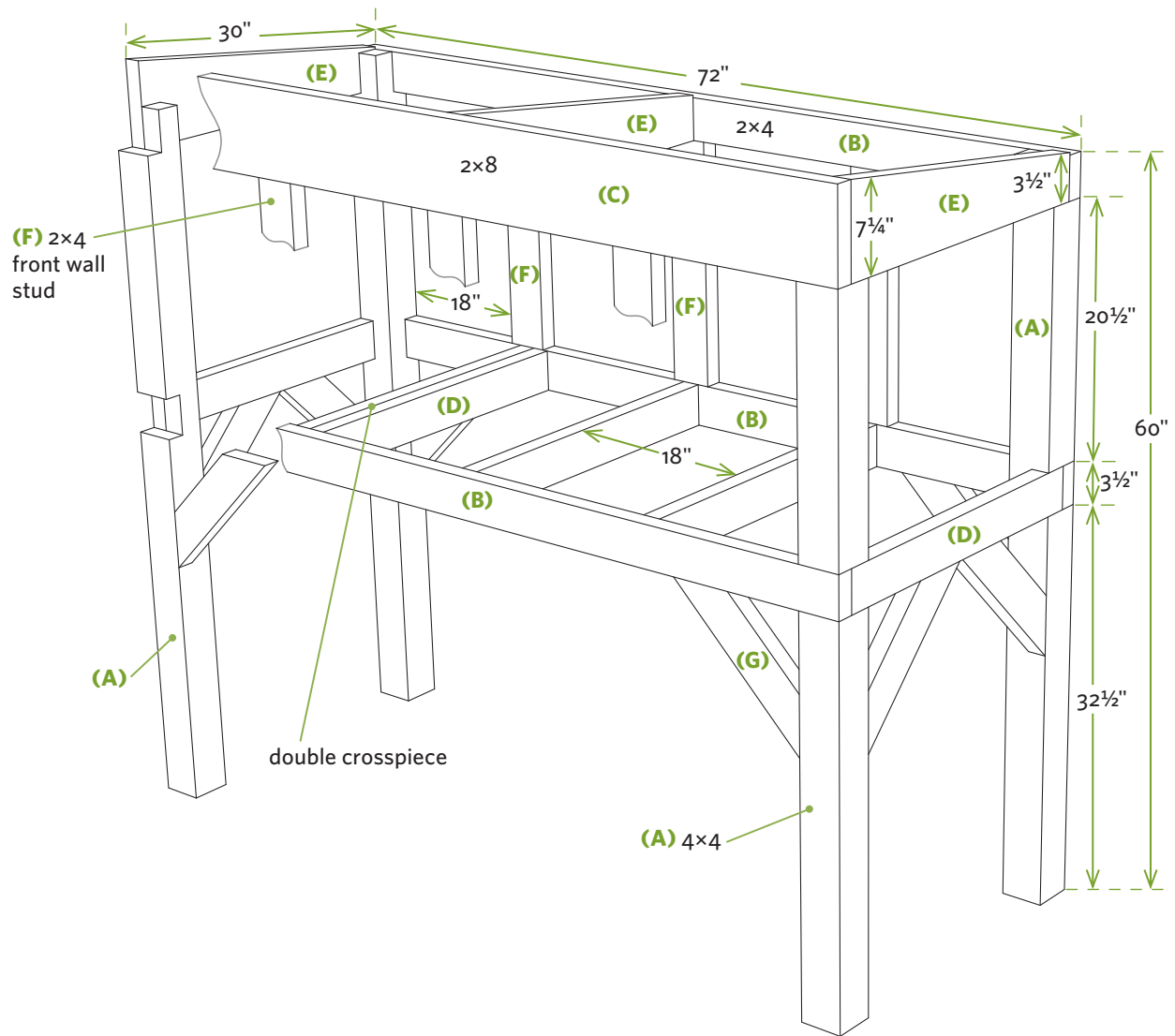

3. Cut a round or square rabbit-size entry hole in the middle panel, and then install the panel. You'll need to add small cleats to the wall studs (F) on each side to provide a nailing surface for the middle panel.
4. Cut the front and back panels (M) for the enclosed area, and nail them in place with 8d nails.
5. Cut the roof panel (N) to size and secure it to the rafters with 8d nails. It should overhang the hutch about 3" on all sides.
6. Cut $\frac{1}{2}$ " \times 1" welded wire mesh (O) for the floor. Cut notches to fit around the 4x4 legs and the 2x4 wall studs. Secure the floor to the framework (B, D) and crosspieces (D) using fence staples. Cut 1" \times 2" mesh (P) for the front and back walls and use fence staples to secure these panels to the hutch framework.
7. If desired, add 1x3s to the corners to cover the exposed edges of the plywood siding.

TAKE NOTE The plywood will shed water on its own, but for appearance or added protection, install shingles or roll roofing. You can also use a plastic tarp to waterproof the roof (see page 184); use one large enough so it can drape down over both sides to act as a wind barrier. Use ropes or bungee cords to secure the rolled-up tarp to the edge of the roof when not in use.

Finish details

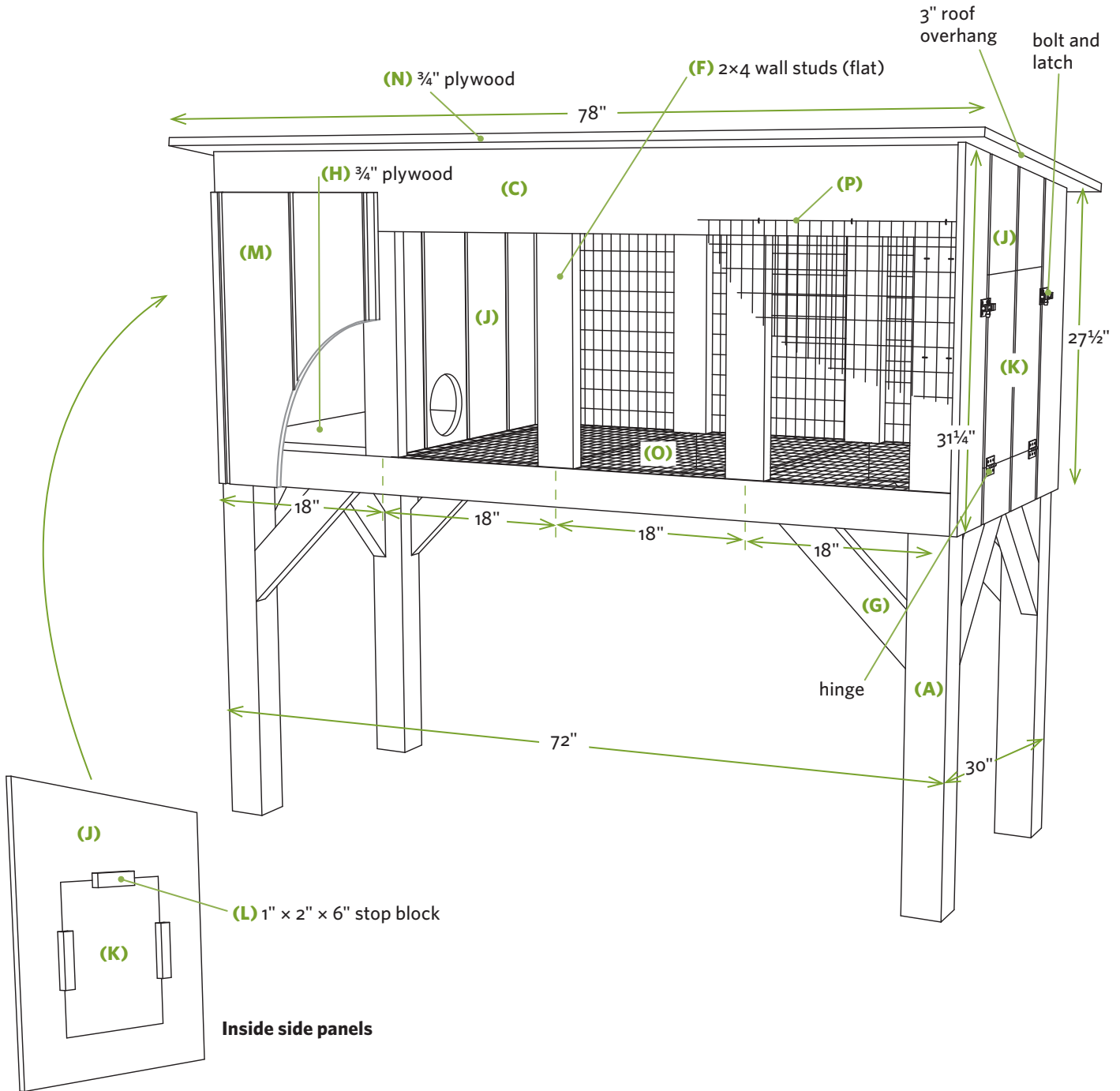

Rabbit Hutch Rules of Thumb

There aren't as many hutch designs as there are rabbits, but you do have hundreds of options. If you design your own hutch, keep the following guidelines in mind:

- The hutch should have a runway long enough so your rabbits can take four big hops before hitting an end wall.
- The hutch should be wide enough so your rabbits can use the runway without running into food and water dishes.
- The hutch should be tall enough so your rabbits can stand on their hind legs to stretch.
- Rabbits thrive on fresh grass, so if possible, create a secure ground-level pen for your rabbits. Heat can be a concern, so position the hutch in the shade.

Bat House

A simple abode for these essential creatures

Bats are incredible creatures. They constitute one-fifth of the mammal species on earth, inhabit nearly every region of the planet, and can range from bumblebee size to bald eagle size. They're incredibly beneficial, too. A single brown bat can eat up to 1,000 mosquitoes an hour and, since many bats feed on nectar or fruit, they play a vital role in pollinating plants and disseminating seeds.

If you want to attract more of these natural helpers, build a bat house or two. They're great

beginner projects and an excellent way to use up odds and ends. This bat house is larger than the ones often seen at garden centers; the larger dimensions are based on research done in the United States, Canada, and the Caribbean that shows bats are more likely to use larger houses than smaller ones. (See Resources for more information on bats and bat houses, including a source for downloadable plans for single- and four-chamber houses.)



Materials

- One 6-foot cedar 1×4
- One 4 × 4-foot sheet ½" plywood
- Two 6-foot pine 1×1s (¾" × ¾" actual dimensions)
- One 18" piece cedar 1×6
- Water-based exterior primer and opaque, exterior stain (see step 2)
- 1¼" exterior screws
- 2" exterior screws
- 3d galvanized nails
- Exterior caulk

Parts and Cutting List

Part	Size and Material	Quantity
(A) side	¾" × 3½" × 28" cedar	2
(B) back panel	½" × 16" × 28" plywood	1
(C) front panel	½" × 16" × 20" plywood	1
(D) partition	½" × 14½" × 20" plywood	2
(E) medium spacer	¾" × ¾" × 11½" pine	2
(F) short spacer	¾" × ¾" × 3" pine	2
(G) long spacer	¾" × ¾" × 20" pine	2
(H) roof	¾" × 5½" × 18" cedar	1

Cutting details

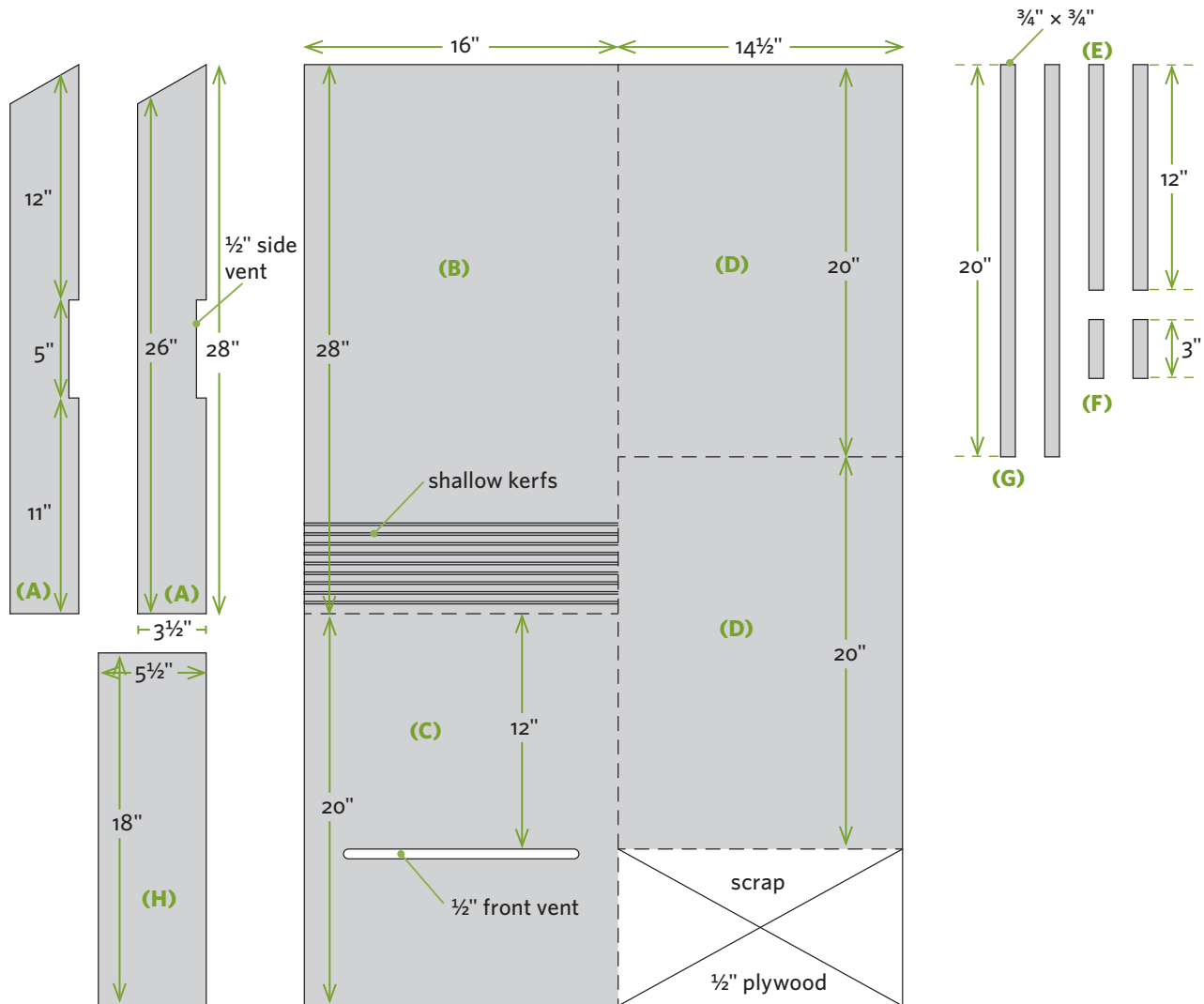

House assembly — exploded view

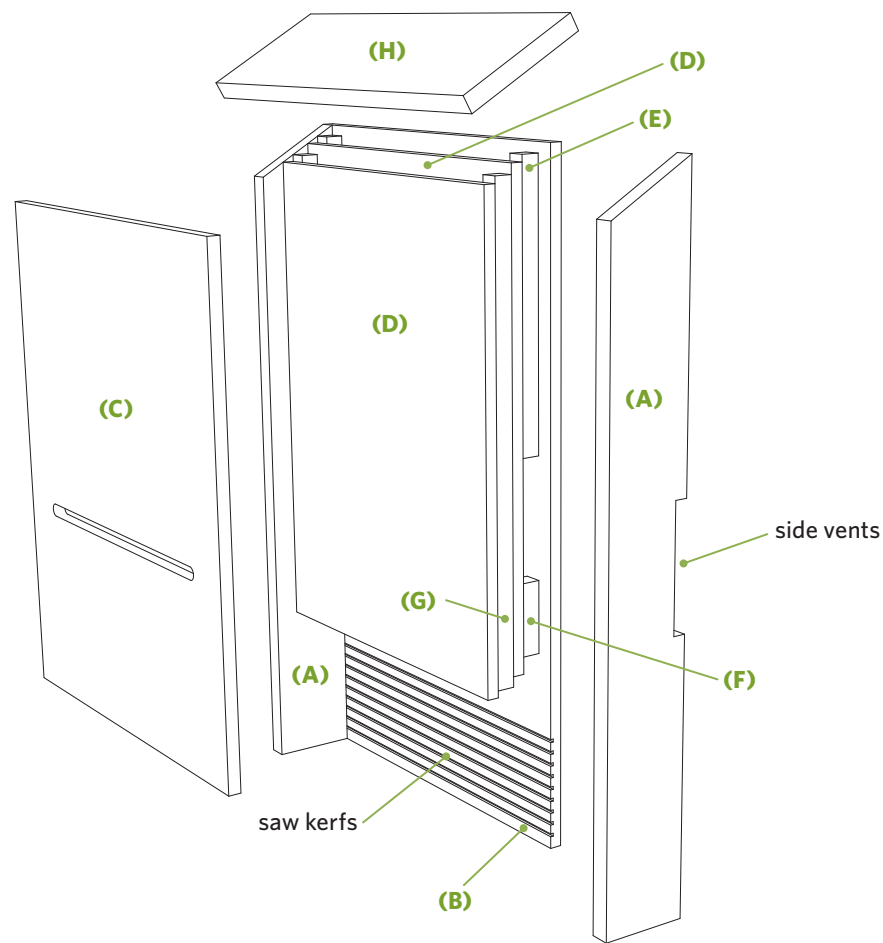

1. Cut all of the wood parts to size as shown in *Cutting details*, opposite. Use a jigsaw to cut the vents in the sides (A). To cut the vent on the plywood front panel (C), drill $\frac{1}{2}$ " holes for the ends of the slot; use a jigsaw to connect the holes.
2. Set your circular saw to cut a hair under $\frac{1}{8}$ " deep; then make a series of shallow cuts, spaced $\frac{1}{2}$ " apart along the bottom 4" or 5" of the back panel (B) to create a roughened landing area. Prime and stain all of the wood parts. (See *Location, Location, Location, and Color*, at right, for color recommendations.)

TAKE NOTE Finishing the parts now is much easier than after assembly, and your bat house will be better protected from the elements.

3. Secure the back panel (B) to the sides (A) as shown, using $1\frac{1}{4}$ " screws. Lay the house on its back and use a thin bead of exterior caulk and 3d nails to secure the medium (E) and short (F) spacers in the back corners, leaving space for the side vent holes. Install a partition (D), the long spacers (G), and the second partition panel (D) using 3d nails.
4. Use screws to secure the vented front panel (C) in place.
5. Apply caulk to the tops of the sides, spacers, and panels. Position the roof (H), and secure it to the sides with 2" screws.

Location, Location, Location, and Color

Once you've built a bat house correctly, it's important to install it in the correct place. Here are a few guidelines:

- Bats like to hang out in environments ranging between 80 and 100°F. In all but the hottest regions, position your bat house so it receives at least 10 hours of direct sunlight a day. The color you paint or stain the bat house can help moderate temperatures. In cold climates use black, in moderate climates use dark gray, and in the hottest climates use white or another light-reflective color.
- Install bat houses at least 12 feet above the ground; 15 to 20 feet is even better.
- Mount bat houses to the sides of wooden buildings (preferably under the eaves) or to poles. Avoid trees, and avoid buildings with metal siding.
- If possible, locate the house within a quarter-mile of water, in an area where there's a mixture of agricultural or open land and natural vegetation.

Animal Shelter

A versatile shed for midsize animals

Whether you're raising sheep, goats, pigs, or other midsize animals, this midsize shelter gives you the space and flexibility you need. Three features make it particularly versatile:

1. It's built on skids so you can tow it from place to place. You can move it if one location gets overgrazed or overtrampled. And you can move it into the shade during the hot months or to an area sheltered from wind during the colder months. If you prefer to leave your shelter in one place, you can opt to build it with a solid-wood or concrete-slab floor instead of skids.

2. The two front gates and the center divider are movable. You can use them in different combinations to create two small pens or one large

pen, or remove them all for open access. When you're not using panels, you can store them out of the way on the skids.

3. It has simple sliding windows so you can easily control the ventilation. You can increase or decrease the size of the window openings according to your needs.

Here you'll get approximate, rather than exact, measurements so you can adjust the size of your structure to meet your needs, finances, and space. Pay attention to the basic building guidelines so your structure is sturdy and safe. This is one of the more challenging projects in the book; make certain you have a thorough understanding of how the shed goes together before starting.

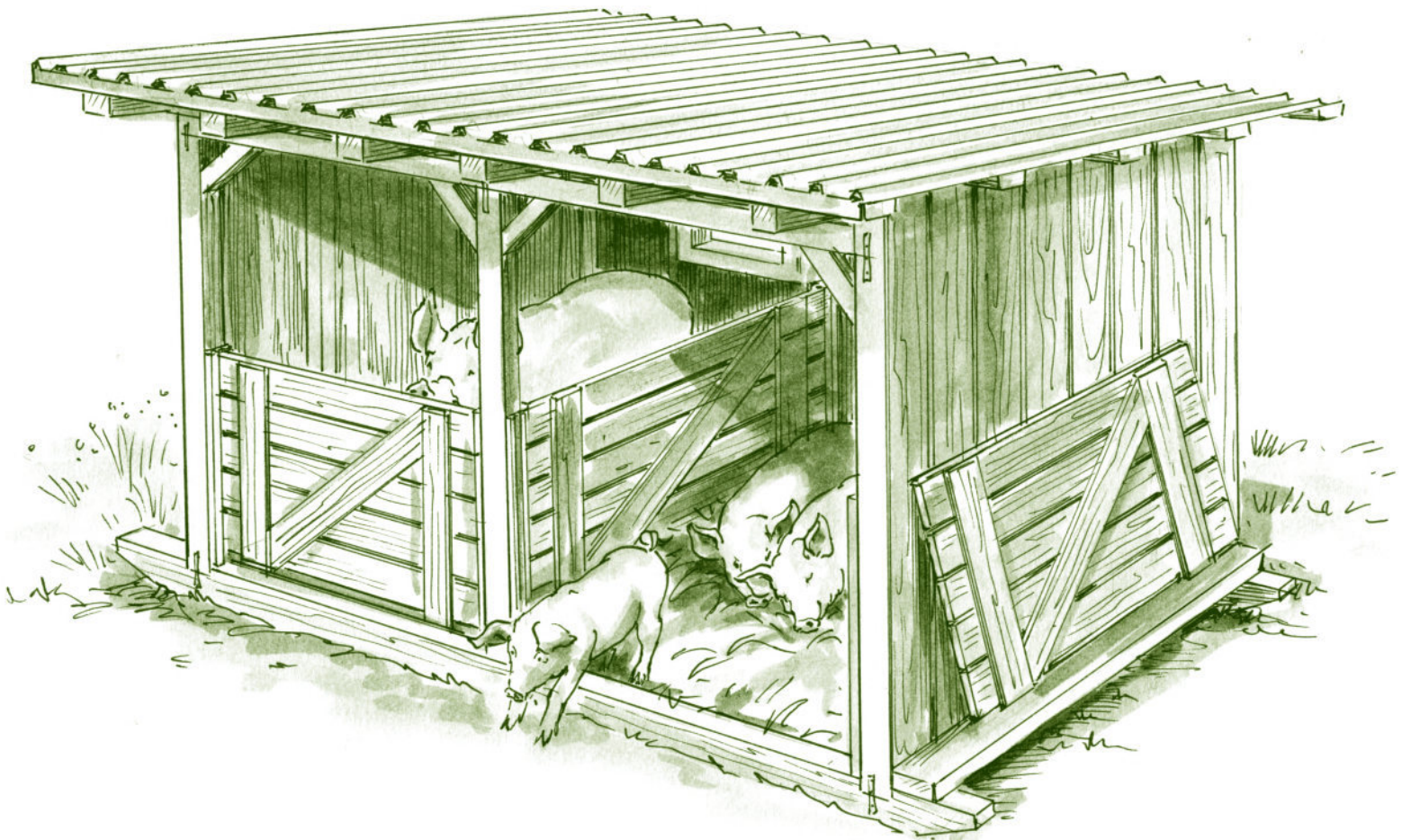

Materials*

- 6×6 timbers
- 4×6 timbers
- 2×4 lumber
- 4×4 timbers
- 2×6 lumber
- 2×2 lumber
- 5/4×6 lumber
- 2×3 lumber
- 1×3 lumber
- Corrugated or ribbed metal roofing
- T-1-11 siding
- 1½" × 8" metal straps
- 8" × 8" metal T-straps
- 5" timber screws
- 16d galvanized nails
- 8d galvanized nails

*Use pressure-treated lumber for all wood materials. Refer to Parts and Cutting List (right) for quantities and approximate sizes.

Parts and Cutting List*

Part	Size and Material	Quantity
(A) long skid	5½" × 5½" × 144"-168"	2
(B) cross skid	3½" × 5½" × 72"-96"	2
(C) back wall stud	1½" × 3½" × 60"-84"	6-7
(D) back wall nailing plates	1½" × 3½" × 120"-144"	2
(E) headers/sills	1½" × 3½" × TBD	4
(F) front wall top plate	3½" × 3½" × 120"-144"	1
(G) front wall posts	3½" × 3½" × 72"-96"	3
(H) front wall angle brace	3½" × 3½" × 24"	4
(I) straight metal strap ¹	1½" × 8"	8
(J) metal T-strap	8" × 8"	4
(K) roof rafter	3½" × 3½" × 96"-120"	6-7
(L) roof purlin	1½" × 3½" × 144"-168"	5-7
(M) metal roofing	corrugated or ribbed panels	TBD
(N) end wall bottom plate	1½" × 3½" × TBD	2
(O) end wall stud	1½" × 3½" × TBD	6-8
(P) siding	5/8" × 4 × 8-foot T-1-11 siding	TBD
(Q) gate/divider stop	1½" × 1½" × TBD	TBD
(R) gate slat ²	1" × 5½" × TBD	TBD
(S) gate leg ²	1" × 5½" × TBD	TBD
(T) gate cross brace ²	1" × 5½" × TBD	TBD
(U) window runner	1½" × 1½" × TBD	TBD
(V) window stop	1½" × 2½" × TBD	TBD
(W) window slat ²	1" × 5½" × TBD	TBD
(X) window cleat	¾" × 2½" × TBD	TBD
(Y) backer	1½" × 5½" × TBD	2

*Exact measurements aren't given for most of the parts of this project; use this list as a general guideline. *TBD* indicates "to be determined" by builder, depending on desired size.

¹Bend to L shape as needed.

²Parts R, S, T, and W are sold as decking material and may range in thickness from 7/8" to 1¼".

Building the Base and Front and Back Walls

1. Create the notches in the long skids (A) by making a series of $1\frac{3}{4}$ "-deep dado cuts, spaced $5\frac{1}{2}$ " from side to side. (See *Circular Saw Basics*, page 28, for more on this technique.) Do the same on the 4×6 cross skids (B). The bottoms of the cross skids are higher than those of the long skids, so the former won't catch on the ground if the structure is skidded to a new location.
2. Assemble the skid framework on a solid, flat surface. Position the notched ends of the cross skids (B) into the notches of the long skids (A); the tighter the fit, the better. Secure each joint with four 5 " timber screws.
3. The height of the walls can vary; just make sure the front wall is 12 " to 24 " taller than the back wall. Build the back wall

by nailing 2×4 studs (C) spaced 24 " on center to the top and bottom nailing plates (D), using $16d$ nails. Frame in the window headers and sills (E) as shown in *Base and front/back wall framing* (below); you can make the openings larger or smaller as needed. Build the wall on the ground, cross-tape it (see page 30), and add a diagonal brace to ensure it stays square. Raise the wall, and secure it to the outer edge of the back skid (A) with $16d$ nails. Use a level to plumb each end of the wall, and install temporary diagonal braces to hold it plumb.

4. Build the front wall, consisting of three 4×4 posts (G) and the top plate (F). Build the wall on the ground, check it for square, and then add the diagonal 4×4 angle braces (H) before standing it. Use metal straps (I, J) to secure the posts to both sides of the top plate and skid. (You'll need to bend a couple of straps into L shapes before installing them.) Plumb and brace both ends of the wall.

Base and front/back wall framing

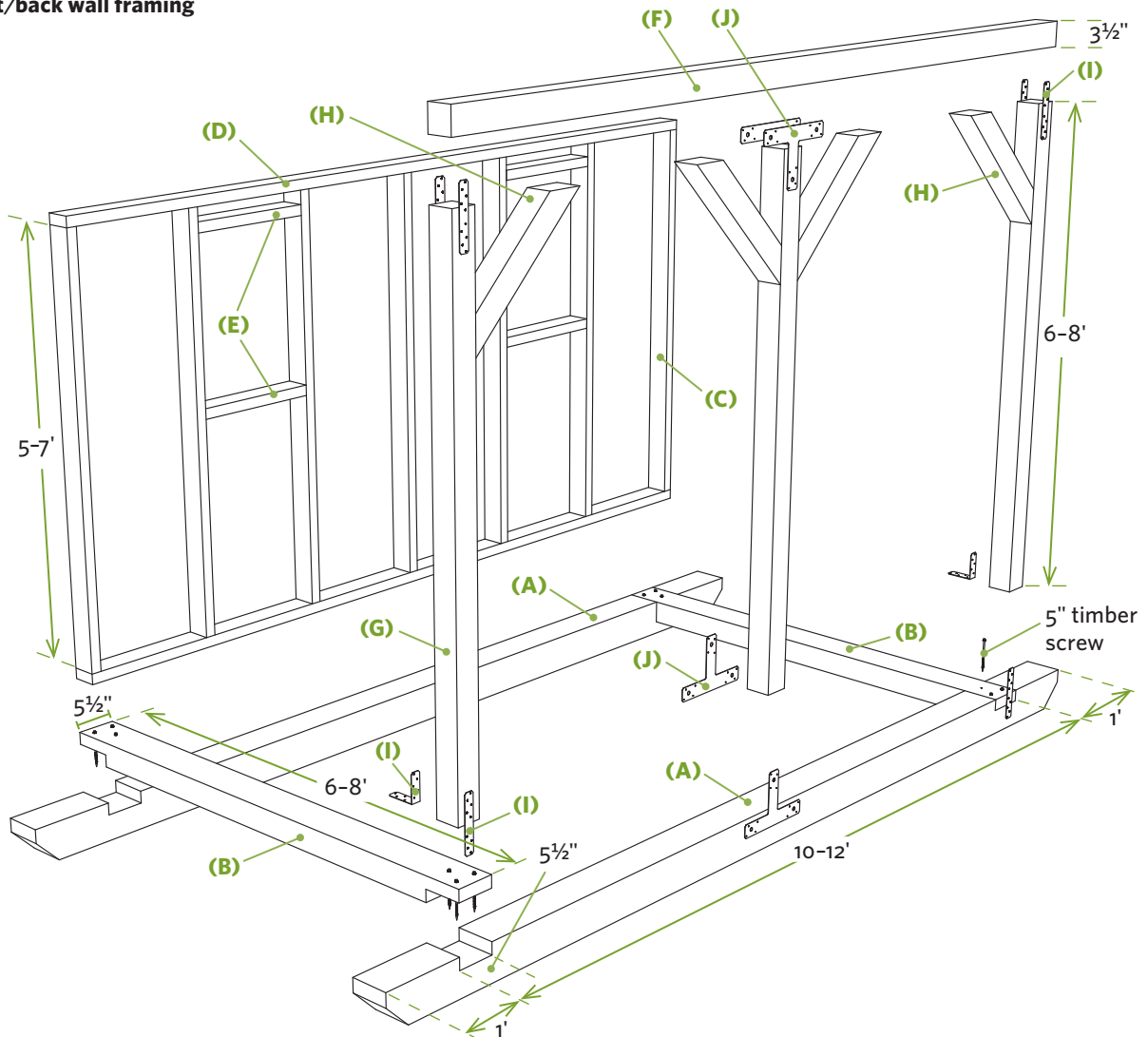

Building the Roof and End Walls

In more refined forms of construction, the rafters would have bird's-mouth cuts where they rest on the walls. For this shelter, you simply screw the rafters to the front and back walls with long timber screws.

TAKE NOTE Don't remove the temporary cross braces until the siding has been installed.

1. Rest a 4x4 rafter (K) on the front and back walls on one end of the shed; let it overhang both walls by at least 6". Use 5" timber screws to secure it to the front and back walls. Position the remaining rafters every 24", making sure the overhangs are equal to those of the first rafter.
2. Install the 2x4 purlins (L) perpendicular to the rafters (K), spaced 24" on center, so they overhang the end walls by at

least 12". Install the metal roofing (M), following the manufacturer's directions.

3. Nail the end wall bottom plates (N) to the cross skids (B). Position, mark, cut, and install the end wall studs (O), spacing them 24" on center: To get the correct length and top angle, position the bottom of the stud on your layout mark, plumb it using a 4-foot level, and then mark the top of it where it hits the 4x4 rafter. Cut the stud to the length and angle indicated by your mark. Do this for all the studs.
4. Sheathe the end and back walls with T-1-11 siding (P). Install the siding so it runs from the tops of the rafters to the bottom of the skids (but no farther) to lock the roof, walls, and floor together. Notch the lower corners of the siding to fit around the skids. Use plenty of 8d nails, since the T-1-11 panels serve as both structural sheathing and siding.

End wall and roof construction

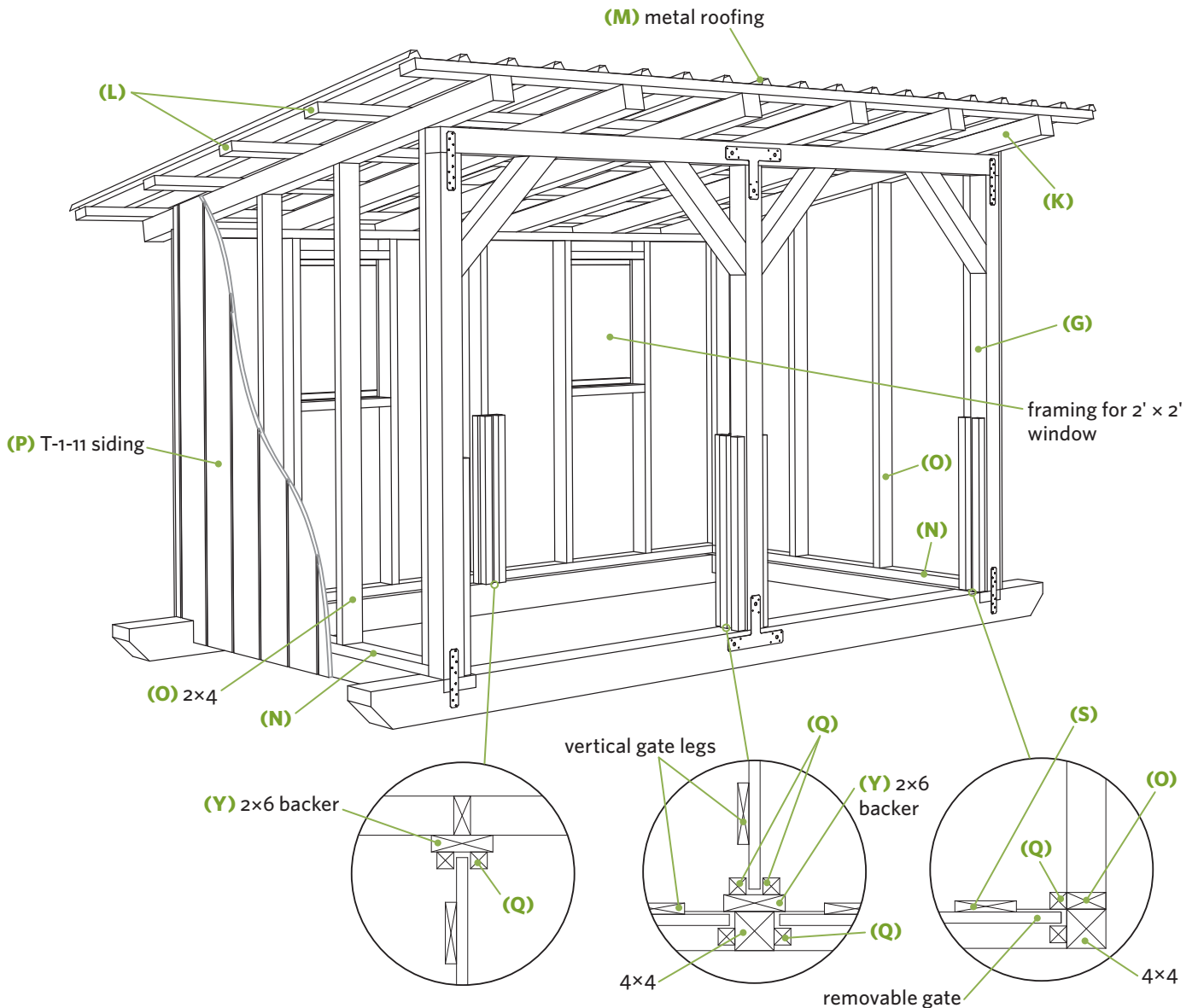

Constructing the Channels and Gates

The gates operate by sliding in channels created by the stops (Q). Make sure to allow plenty of space between the stops so the gates can slide easily up and down in those channels.

1. Secure the long vertical backers (Y) to the center 4×4 of the front wall and the center stud of the back wall.
2. Nail the 2×2 stops (Q) that will hold the panels in place to the 2×6 backers (Y) and 4×4 front posts (G).

TAKE NOTE The stops should be long enough to hold the panels in place but not so long as to prevent you from lifting the panels up and out when you want to remove them.

3. Measure the space between posts (G) for the front gates and between the 2×6 backers (Y) for the center divider; then construct the gates as shown in *Movable gate* (below). Make the length of the gates about $\frac{1}{2}$ " less than the width of the opening so you can easily slide them in and out of place. To build the gates, lay the horizontal slats (R) on a flat surface, space them equally, and then install the two vertical legs (S). Cross-tape the gates and adjust them as needed to make sure they're square; then cut and install the diagonal cross brace (T).

Movable gate

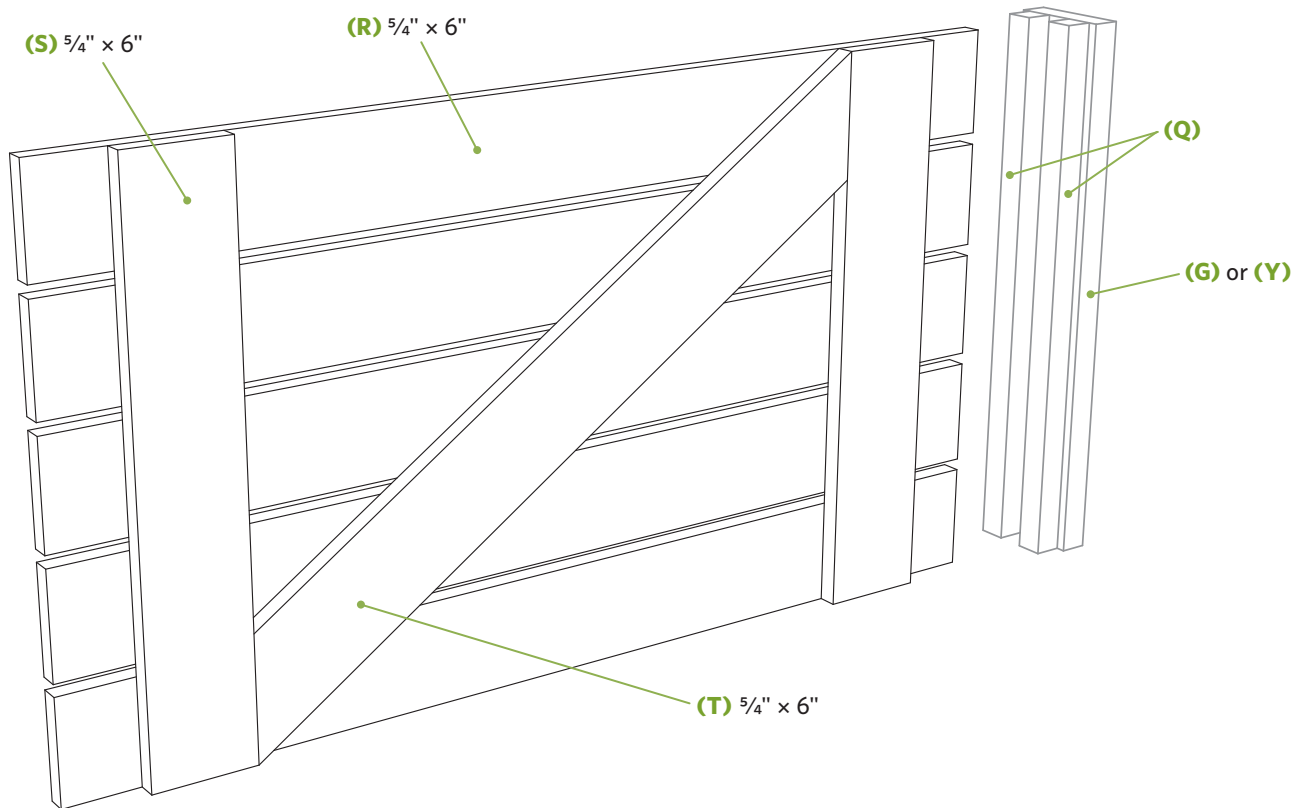

Sliding windows

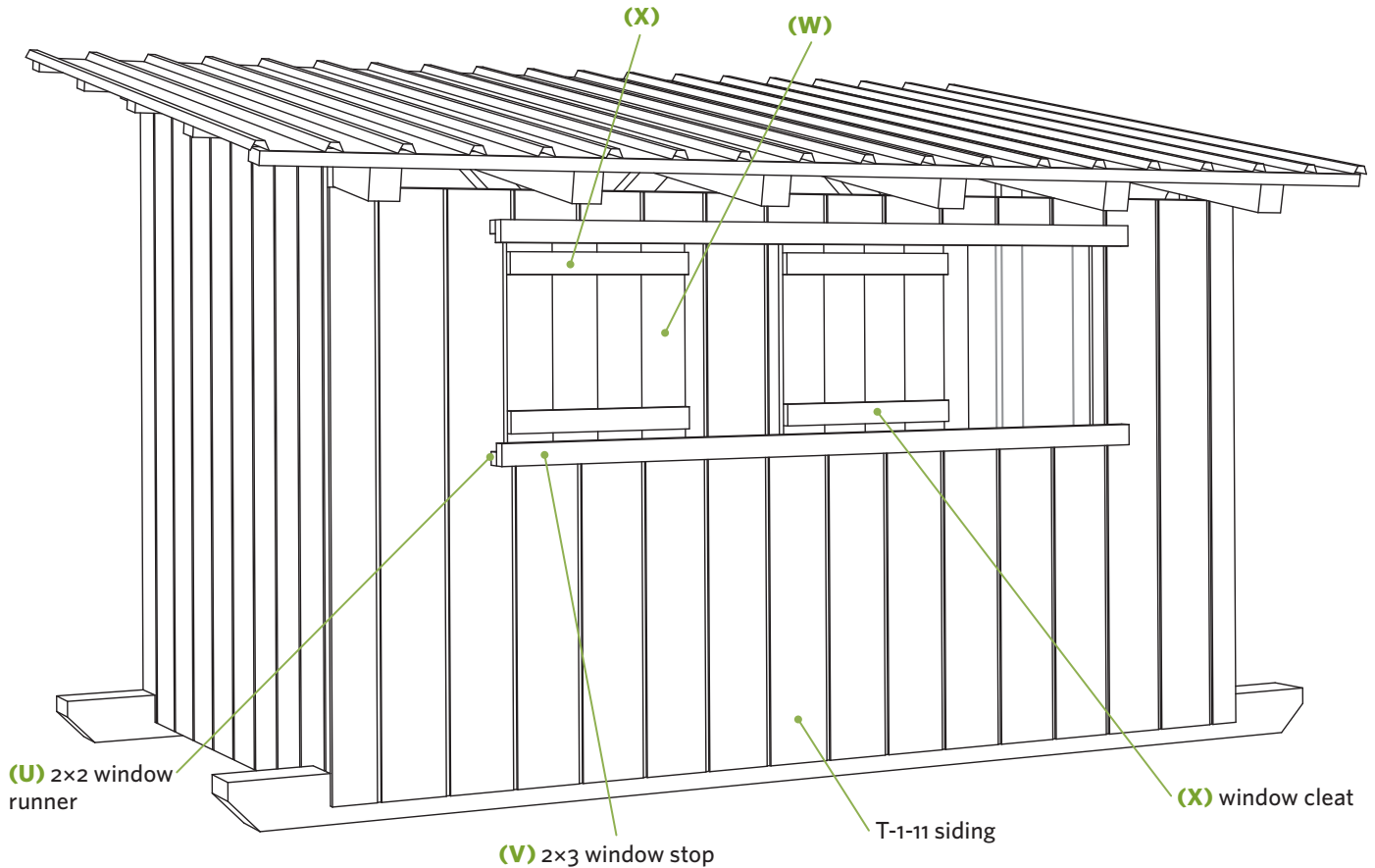

Creating the Windows

The sliding windows operate by sliding in channels. Make sure to allow for some wiggle room so the windows can slide easily within the channels.

1. Install the long continuous 2x2 window runners (U) and 2x3 window stops (V) along the tops and bottoms of the window openings to create the channels for the sliding windows.
2. Build the window panels by securing the window slats (W) to the window cleats (X). Make the panels about ½" shorter than the space between the L-shaped channels you just built so they can slide easily.
3. Slide the windows into the channels from one of the ends. You can add 2x2 stops to the ends of the channels to prevent the windows from sliding out or being removed.

A Moving Experience

Before moving your shelter, install temporary diagonal cross braces from one corner of the floor frame to the other to prevent racking, that is, jarring the structure out of square.

Chicken Ark

A sturdy, mobile pen for poultry

You may look at the curved design of this chicken ark and ask, “Why should I spend two or three hours behind a jigsaw when I could build something simpler and squarer?” There are three good answers:

1. By cutting the hoops you’re also getting the wall, the roof structure, and the doors ready to go. When all is said and done, this ark takes no more time to build than many other designs.

2. An arch-shaped structure is extremely strong and wind-resistant.

3. It looks cool.

Since the ark is mobile (it’s a four-person job), you can move your poultry to fresh pastures as needed. Your yard or pasture, in turn, will reap the benefits of the natural fertilizer left behind.

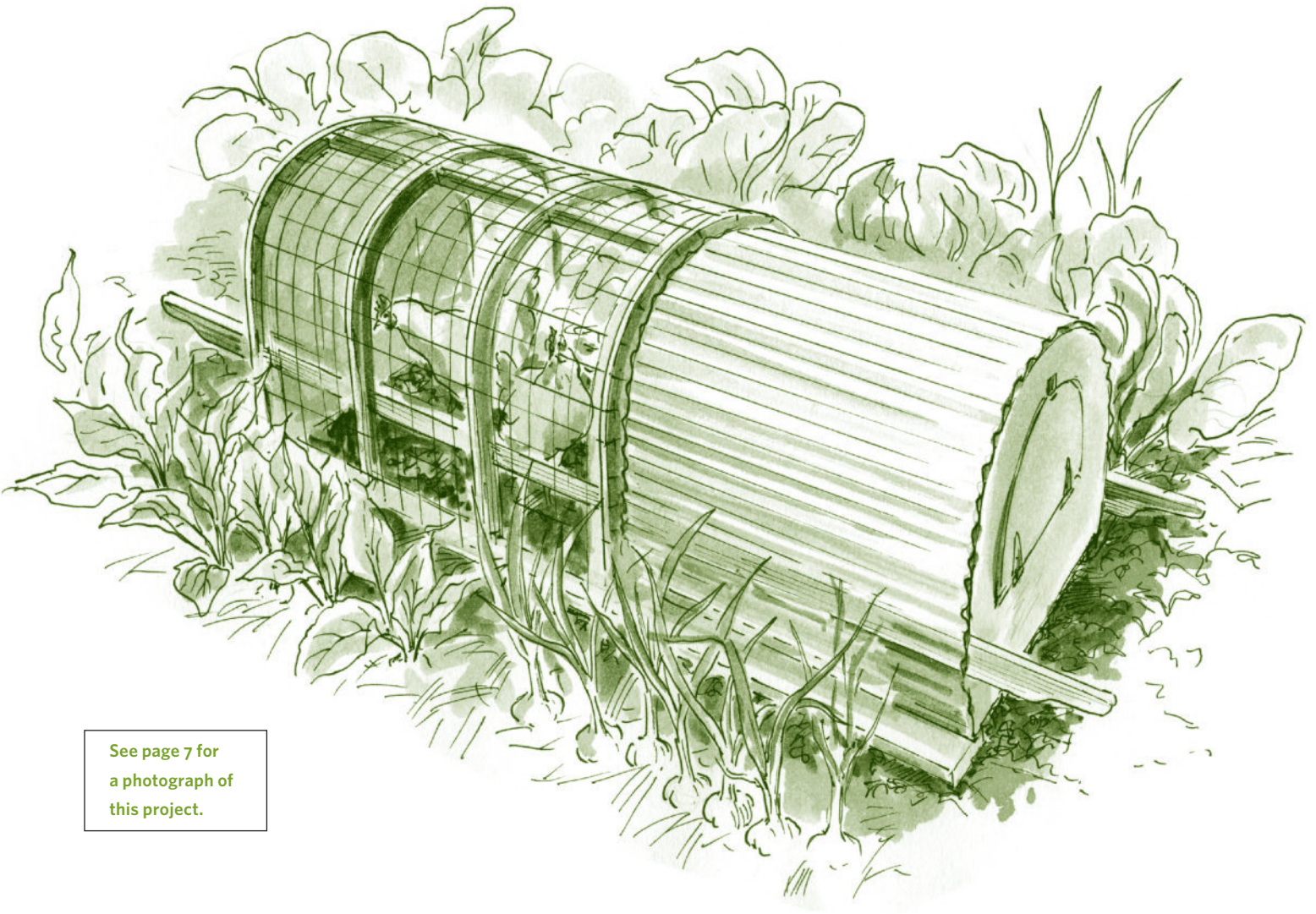

See page 7 for a photograph of this project.

Materials*

- Two 4 × 8-foot sheets ¾" plywood
- Two 10-foot 1×8s
- One 10-foot 1×4
- Two 12-foot 1×4s
- Two 8-foot 2×2s
- ¾" pressure-treated plywood, 48" × 48" minimum
- Ten 8-foot pieces pine or cedar 1×4 tongue-and-groove paneling (or alternate roof material)
- Four 10-foot ¼" × 1" batten strips
- Roofing material, 50 square feet (see step 5 on page 203)
- Welded metal mesh, 70 square feet (mesh size as desired)
- Construction adhesive
- Foam board adhesive
- 1¼" exterior screws
- 2" exterior screws
- 6d galvanized casing nails
- Fence staples
- Six strap hinges with screws
- Latches and hasps as needed (see step 3 on page 202)

*Use pressure-treated lumber wherever possible. Plywood can be either pressure-treated or exterior-grade; treated will last longer but is heavier and more expensive.

Parts and Cutting List

Part	Size and Material	Quantity
(A1) enclosure hoop (with door)	¾" × 41" × 44½" plywood	1
(A2) enclosure hoop	¾" × 41" × 44½" plywood	1
(A3) partition hoop	¾" × 48" × 48" plywood	1
(A4) open hoop	¾" × 48" × 48" plywood	1
(A5) open hoop	¾" × 48" × 48" plywood	1
(A6) open hoop (end)	¾" × 48" × 48" plywood	1
(A7) curved blocking	¾" × 3½" × as large as possible	2
(A8) straight blocking	¾" × 3½" × 24" ¹	2
(B) base plate	¾" × 7¼" × 120" pine	2
(C) ridge board	¾" × 3½" × 120" pine	1
(D) side handle	¾" × 3½" × 144" pine	2
(E) nailing block	¾" × 3½" × 23⅞" plywood	10
(F) floor cleat	1½" × 1½" × cut-to-fit pine	4
(G) floor insulation	1½" × cut-to-fit foam insulation board	1
(H) enclosure floor	¾" × cut-to-fit PT plywood	1
(I) enclosure roof boards	¾" × 3½" × 48" T&G pine/cedar boards ²	20
(J) roofing	shingles, roll roofing, or metal roofing	—
(K) mesh	welded metal mesh	—
(L) hoop battens	¼" × 1" × 120" (approx.) batten strips	4

¹Cut to fit.

²Or metal roofing.

Marking and Cutting the Hoops

1. Lay out the two sheets of plywood for the six hoops, as shown in *Hoop diagrams*. To draw the semicircles, install a drywall screw at the center point, hook the end of a tape measure over it, and then swing arcs with a pencil. The outside radius of the large hoop is 24"; the outside radius of the small hoop (and inside radius of the large hoop) is 20½"; the inside radius of the small hoop is 17". Note: On hoops A3 and A6, mark and cut only the outer 24" radius; on hoop A1, cut out only the upper arched door part of the 17" radius.

TAKE NOTE When you swing your arcs, rest your fingertips on the tape measure and snug your pencil or marker against the tape for stability as you draw.

2. Cut out the hoops. Use a circular saw for the straight legs and a jigsaw for the curved parts. Follow your layout lines and arcs carefully. If you get off track, back up your saw until you're back on your mark; then forge ahead.

3. Once all the hoops are cut, cut out the notches in the sides and top of hoops A1 and A2 to accommodate the ridge board (C) and side handles (D). Hoops A3 and A6 also have three slots cut in them to accommodate the ridge board and side handles.

TAKE NOTE To cut the slots, bore a ½" starter hole somewhere along the edge of the slot, insert your jigsaw blade, and then make a series of short cuts and turns to cut out the ¾" × 3½" slot.

4. Cut out the door openings in hoops A1, A3, and A6. Save the cutouts; you'll use them for the doors later on.

5. Use the leftover piece of plywood from the inside of hoop A2 to cut the blocking (A7, A8) shown in *Hoop diagrams* below. These blocks will be screwed to hoop A3 to support the end of the roof sheathing or metal roofing (I).

Hoop diagrams

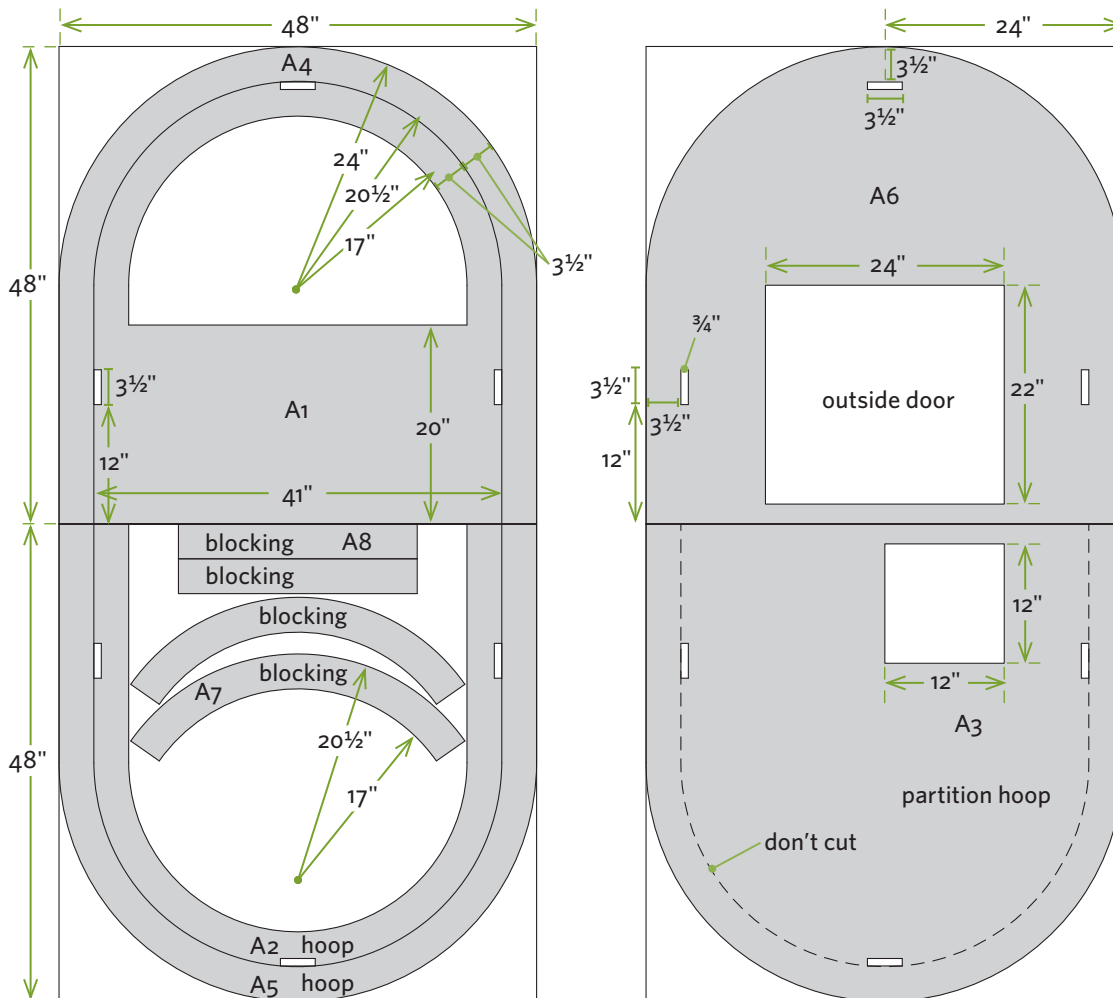

Assembling the Skeleton

1. Mark out the two 1×8 base plates (B), the 1×4 ridge board (C), and the two 1×4 side handles (D) all at the same time, following *Plate, ridge, and handle diagrams* (below). Use a framing square to mark the layout lines across all five boards for consistency. Cut the handgrips on the ends of the side handles.
2. Begin assembling the skeleton as shown in *Skeleton construction* (below) by securing a nailing block (E) $\frac{3}{4}$ " in from each end of each base plate (B), using construction adhesive and $1\frac{1}{4}$ " screws. Note that the blocks (E) on the enclosed end of the ark are positioned on the inside edge of the base plate (B), while those on the open-air end are positioned to the outside edge. Use 2" galvanized screws to secure the small end hoop (A1) and the large end hoop (A6) to the ends of these blocks.
3. Use temporary cross braces to hold both end hoops plumb. (Only one brace is shown in the drawing, but you should brace both end hoops.)
4. Add two more nailing blocks (E) with adhesive and screws, and then install hoop A2. Keep doing this until you have installed all of the hoops and blocks.

Plate, ridge, and handle diagrams

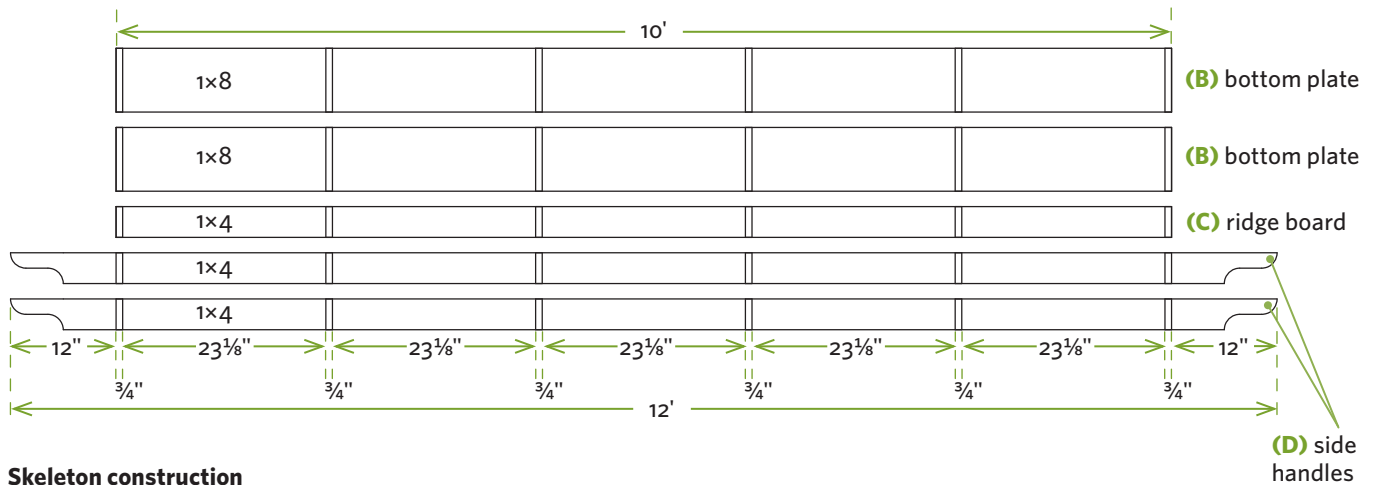

Skeleton construction

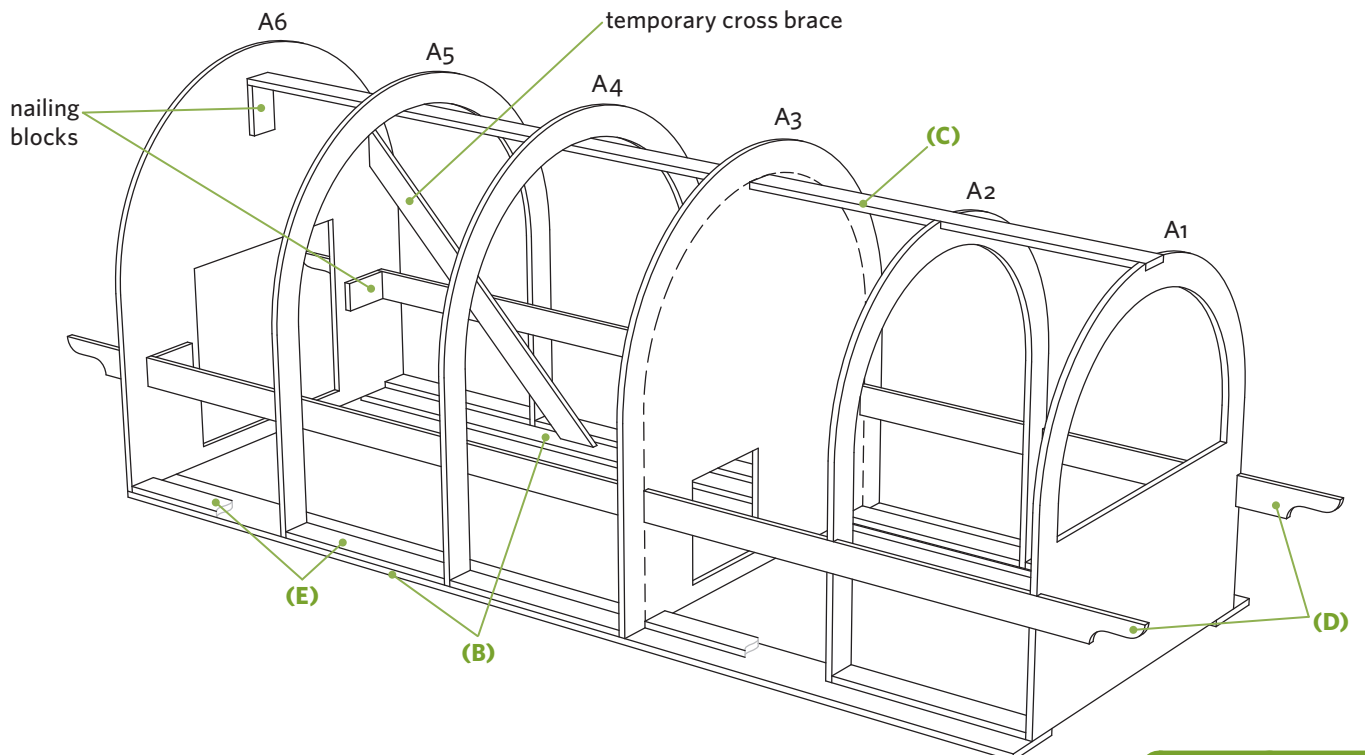

Installing the Roof, Floor, and Doors

5. Install the ridge board (C), as shown in *Skeleton construction* (page 201): It fits into the notches in the tops of hoops A1 and A2, into the slots in hoops A3 and A6, and just kisses the bottoms of hoops A4 and A5. Check to make sure the end hoops are still plumb; then screw each hoop to the ridge board (C) with 2" screws, following the layout marks on the ridge.
6. Install the side handles (D) in the same manner as the ridge board, allowing the end of each handle to protrude 12" beyond the end hoops. Make sure each hoop is on its layout mark, and then screw them to the side handles. Install short nailing blocks (like the ones shown on hoop A6) to beef up the connections where possible.

1. Use screws to secure 2x2 cleats (F) around the bottom of the enclosed area, as shown in *Finish details* (below). The tops of these cleats will be even with the tops of the 1x4 blocks (E) you installed between the hoops.
2. Cut a piece of 1½" extruded foam insulation (G) to fit between the cleats (this is optional, but the coop will stay warmer). You can lift the ark and insert the insulation piece through the bottom or cut it in half to install it from the top. Cut two pieces of ¾" plywood for the floor (H). Apply foam board adhesive to the top of the foam; then secure the two pieces of plywood to the tops of the cleats, using 1¼" screws, to create the floor.
3. Install the door on the open-air side of the ark (hoop A6) using strap hinges. If you hinge it on the bottom, it can double as a ramp for the chickens.

Install the optional middle partition door (hoop A3) so it swings into the open-air side of the arc. This can be hinged on the top, side, or bottom.

Install the arched door on the enclosed side of the ark (hoop A1), hinging it on the bottom. Install 1x2 stops on the back-sides of the openings to prevent the doors from swinging in too far. Add latches or hasps as needed.

Finish details

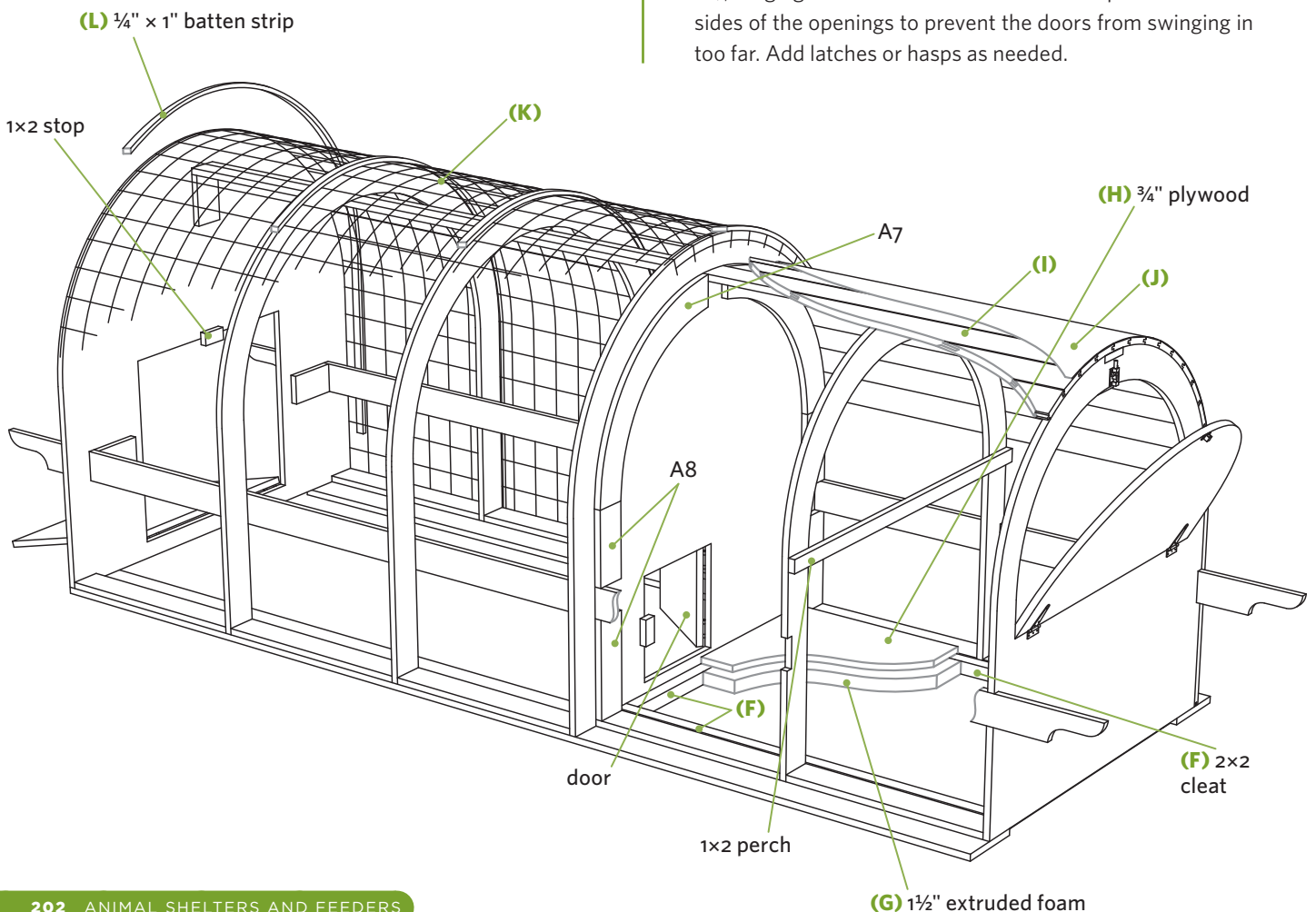

TAKE NOTE **Securing corrugated plastic or metal roofing directly to the plywood hoops (see photo, page 7) is the fastest, lightest, and cheapest way to roof your coop. And you can skip installing the roof boards (I). If you want something fancier (and substantially heavier), follow steps 4 and 5 below.**

4. To sheathe the enclosed side, begin by cutting the 1×4 tongue-and-groove roof boards (I) to length. Start at the bottom on one side, and install the first board with its tongue edge facing up. Use 6d casing nails to secure it to the hoops and to the blocking (A7, A8) you installed on the side of hoop A3. Install the second board so the tongue of the first board fits into the groove, and keep working upward. When you reach the curved part, you'll discover the tongues and grooves don't fit quite as tightly and the boards don't conform exactly to the curve; just keep going. You may need to rip the last board to width when you reach the opposite side.
5. Install the roofing (J), using standard shingles or roll roofing, following the manufacturer's instructions. Use ¾" or 1" roofing nails so the tips don't protrude too far through the roof sheathing. If you use standard shingles, use dabs of roofing tar to hold down the bottoms of the tabs at the curved part. If you're installing metal or corrugated plastic roofing, skip the roof boards (I) and run the material lengthwise.
6. Install the wire mesh (K) with fence staples. Use a heavy-gauge mesh of the size you want; just make sure it keeps your poultry in and predators out. Run the mesh lengthwise (horizontally) across the hoops, and overlap each row by a few inches. Install batten strips (L) to help protect the exposed upper edges of the plywood hoops using 6d casing nails.

TAKE NOTE **Soak the batten strips (L) in warm water for 10 minutes if you're having trouble making them conform to the curve; a section of rain gutter with two end caps makes a great soaking tray.**

Adding the Accessories

Accessorize the chicken ark as you see fit. (For more information on ventilation, heat, and other vital factors, consult one of the books listed in Resources for Chicken Raisers, page 218.) A few thoughts:

- Position the perch (see *Finish details*, opposite) away from the nesting boxes.
- Locate the nesting boxes so you have convenient access to the eggs. If they're open-top nesting boxes, position them below the arched door. If they're open-front boxes, position them along the side.
- If you have a predator problem, install mesh in the bottom of the open-air part of the ark. If your chickens complain it's not as homey as an all-grass floor, remind them that they're alive.
- Add light bulbs for heat and roof vents for ventilation based on your climate and region.
- With a little ingenuity you can add wheels to one end of your coop to make it easier to move around. To get ideas, type the words "chicken," "tractor," and "wheels" into your search engine and browse the images.

NOTES FROM THE TEST TRACK

The Author's Gigantic Chicken Ark

I drew inspiration for this chicken ark from a house I built more than 25 years ago. This house also had a skeleton made from ¾" plywood, but it required more than 250 sheets of the stuff! Each 32-foot-wide truss consisted of three layers of 14"-wide plywood arches, laminated together. The house was featured in *Mother Earth News* and was, and still is, a novel form of construction. It was quite an attention-getter in the traditional area where we built it, but most people loved the unique outer shape and inner space. The house is still standing strong.

Outdoor Outlets, Switches, and Lights

Bring power and light to outbuildings and outlying areas

As your backyard homestead grows, so will your need for power and lights in outbuildings and outlying areas. Rather than running extension cords across your yard (a time-consuming, dangerous, and merely temporary solution), do it once and do it right: install permanent outlets (receptacles), switches, and lights. You'll find the outlets indispensable for plugging in power tools, tank heaters, transformers for low-voltage lights and other devices, while the lights are handy for illuminating your yard and chicken coops and other structures.

This project gives you the basics. It doesn't provide actual wiring details, since there are dozens of potential wiring scenarios. For example, you may need several outside outlets, or want the ability to switch on an outdoor light from inside the house rather than from an outdoor pole.

Also, wiring *must* be done right. Done correctly, it will provide years of trouble-free convenience. Done incorrectly, it will create a shock and fire

hazard. You need to run the right gauge of wire and use the correct boxes and devices. The circuit must be protected by a ground-fault circuit interrupter (GFCI) for safety. You also must be sure not to overload the existing circuit with the new devices you install. Unless you're familiar with wiring, call in a pro. You can still do the bull work like digging the trench, installing the conduit, pulling the wire, and mounting the boxes, but let a pro map out the system and make the final connections.

In most areas, installing outside wiring requires a permit and having your work inspected. Talk to your local building department or an electrical inspector to find out the details.

If you do decide to tackle the actual wiring of devices, you can find information in reference books (see Recommended Reading). Make sure to consult the most up-to-date edition of any reference materials.

Here we explain a few key steps for each leg of the journey.

From Garage Receptacle to Outdoor Receptacle

Pulling power from an existing garage outlet makes sense since the wiring in a garage is often exposed for easier access, and the garage outlet or circuit (at least if it was installed after 1981) should be GFCI-protected.

- Mount a weatherproof exterior box to the outside wall of your garage. Keep it in the same stud space as the garage receptacle to minimize the need to drill holes and fish wire.
- Use duct-sealing putty to keep moisture and elements out of any wiring holes not sealed by gaskets or connectors.
- Properly mount your box and conduit using PVC adapters and conduit straps.
- Install an in-use receptacle cover.

From Outdoor Receptacle to Remote Post-Mounted Receptacle

Your electrical inspector will want to check the depth of your trench; don't backfill it until it has been okayed.

- If you're encasing your wire in schedule 80 PVC pipe, you should bury the pipe 12-18" deep; confirm the depth with your inspector. You can get by with a shallower trench if you use metal conduit.
- Run thermoplastic heat- and water-resistant, nylon-coated (THWN) insulated wire inside the pipe. The gauge of the wire, most likely #12 or #14, will depend on the gauge of the wiring you're tying into in the garage, as well as the amperage of the existing circuit.
- Run the wire through the conduit as you assemble the pipe and fittings. It's easier than trying to fish a long section of wire through the twists and turns of a completed conduit run.

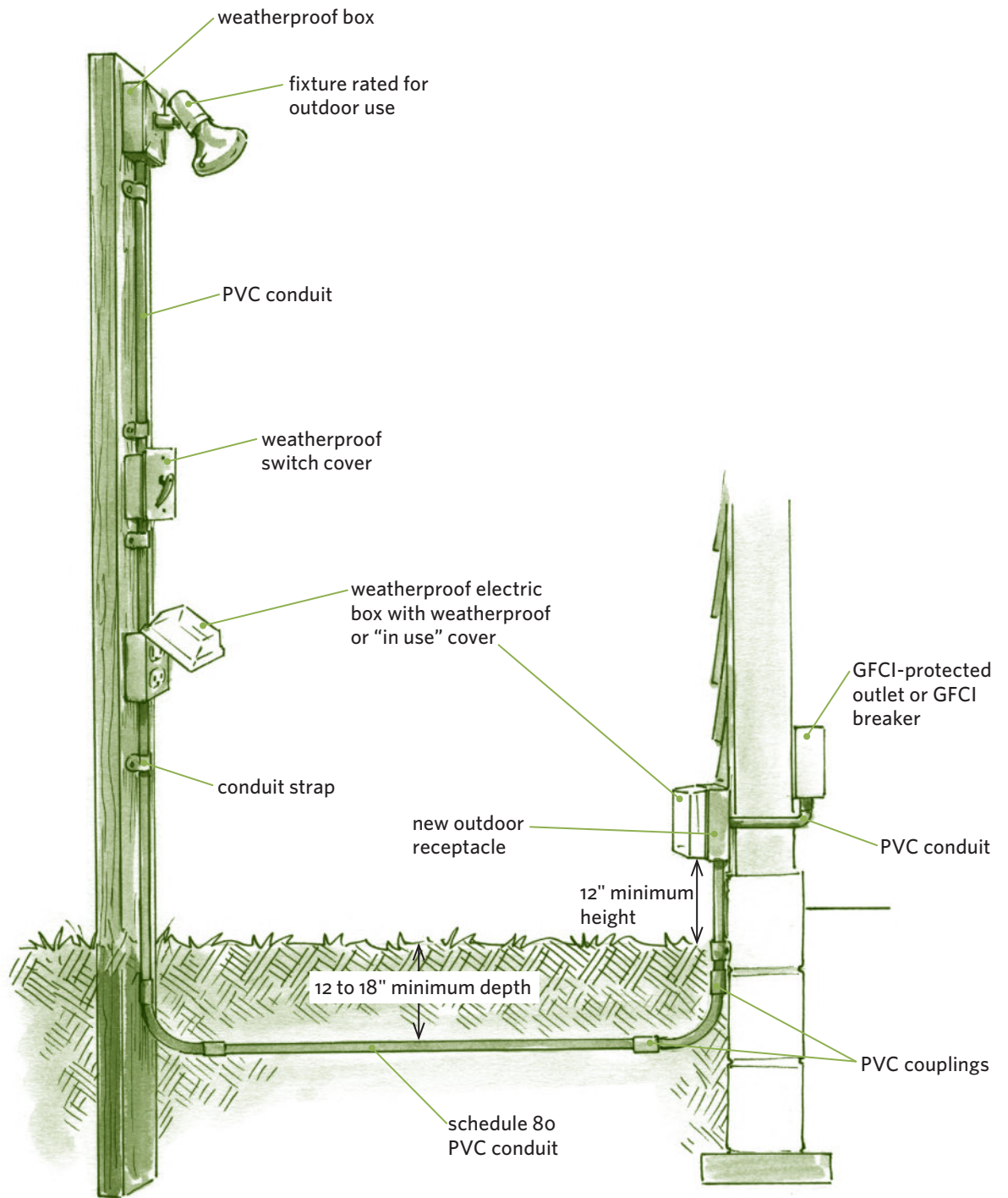

From Post-Mounted Receptacle to Switch and Light

If you want to switch the light on and off from inside the house or garage, you'll need to run extra wires; have the big picture in mind before you start pulling wire.

- Use weatherproof exterior boxes and covers for the switches and light fixtures.

- Enclose all wires in schedule 80 PVC conduit for protection and safety.
- Use only switches and light fixtures rated for exterior use.

Run-In Shelter

A spacious shelter using basic pole barn construction

This run-in shelter provides what the name implies: an open shelter for animals to run into while seeking refuge from rain, sleet, snow, blazing sun, or chilling wind. Of course, the shelter is great for storing tractors, tools, and materials, too. It employs pole barn construction, a useful technique you can apply to other projects, large and small, down the road.

We show you the basic steps in building an 8 × 20-foot shed with an enclosed storage area. You can build larger or smaller sheds using the same basic techniques.

Study the illustrations to get a general sense of how everything goes together, and then draw

up your exact plan. There are numerous ways to build a pole shed: many systems use fewer and larger poles (posts); others rely on trusses connected directly to the posts for the overall system. For more detailed building information, consult a knowledgeable pole barn dealer (also see *Recommended Reading*).

A project this size will often require a building permit. Talk with your local building department ahead of time to learn about all building code specifications, property-line setbacks, and other requirements that may apply.

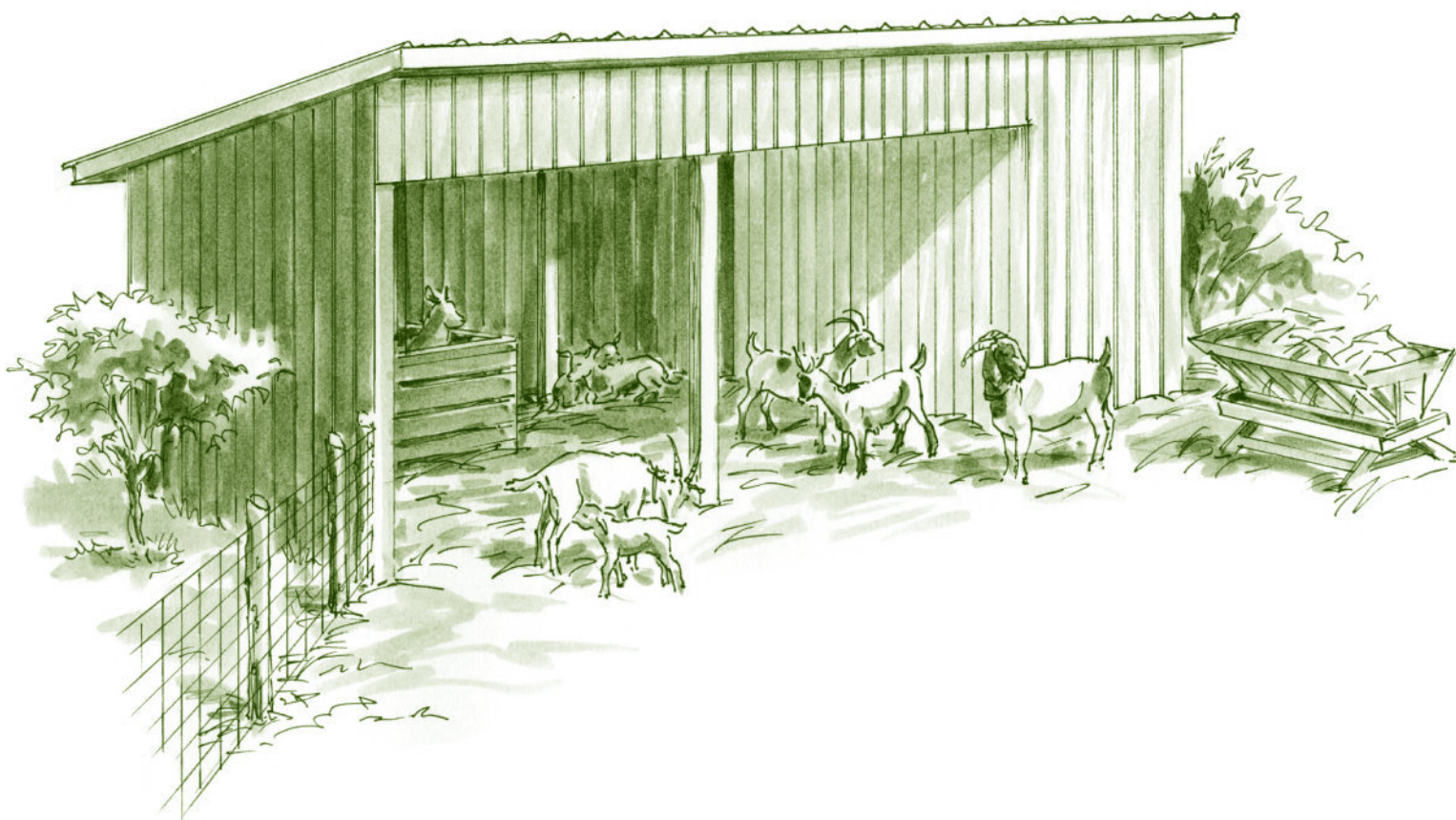

Materials*

- Four 14-foot 4×4s (for front posts)
- Nine 12-foot 4×4s (for back and middle posts)
- Eight 8-foot 4×4s (angle braces)
- Eight 16-foot 2×6s (beams)
- Nine 16-foot 2×8s (beams)
- Eleven 10-foot 2×8s (rafters)
- Twenty-eight 16-foot 2×4s (purlins and girts)
- Twelve or more 16-foot 2×6s (kick boards)
- Gravel
- Concrete mix
- Seven 36" × 10-foot heavy-gauge metal roofing panels
- Eighteen 36" × 10-foot light-gauge ribbed metal wall panels
- Metal trim and flashing for roofing and siding
- Galvanized lag bolts with washers
- 16d galvanized nails
- Rubber-gasket nails or self-tapping screws (for metal roofing and siding)
- Pole barn nails or screws

*All wood should be treated; 4×4 posts should be rated for "in-ground" use. Sizes and quantities are for rough estimation only; the materials you use may vary. Many home centers, lumberyards, and metal roofing/siding suppliers will generate exact material lists based on your (or their) plans.

Lay Out the Footprint and Install the Poles

It's critical that the footprint of your pole barn be square and straight. Spend the needed time getting this right, and the rest of your project will go together more smoothly. Orient your shelter with its back to the wind to provide maximum protection from the elements. Before you start, call 811, the national "Call Before You Dig" hotline (see page 26).

1. Install two sets of batter boards and stretch a string between them to establish the front wall as shown in *Post layout* below. Install two more sets of batter boards and string to establish the back wall, 8 feet from the front wall. Stretch strings between the other legs of the batter boards to establish the positions of the end walls. Readjust the locations of the batter boards and strings until you've established the exact outline of the shed. Measure diagonals or use the 3/4/5 method (see *Measuring, Leveling, and Squaring*, page 30) to ensure that the string layout is square. It'll take some trial and error to get it right. Use a felt marking pen to mark the exact locations of the strings on the batter boards.

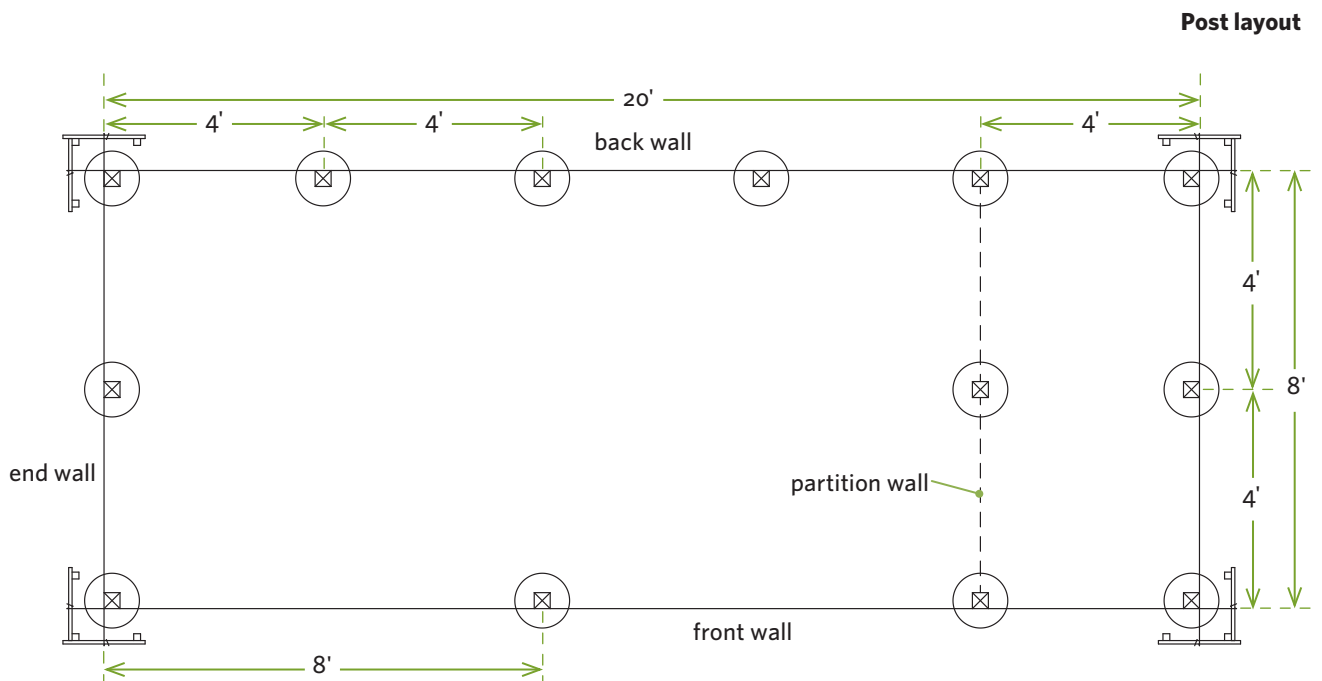

2. Attach tape to the batter board strings to mark the positions of the intermediate posts. Set short scraps of 4×4s where all posts will be located. Study the correlation of the string, the 4×4s, and the holes you'll be digging: you want the posts to wind up in the centers of 12"-diameter holes. (A common error is to dig the holes centered on the string.) Use a shovel to remove a 12"-diameter disc of earth where each hole will be. Remove the strings, and use a manual or power posthole digger to dig the holes (see Digging Holes and Setting Posts, page 26). The holes should be at least 4 feet deep so the poles are well supported and the bases are below the frost line so they're less vulnerable to frost heave. Set the batter board strings back up, and check to make sure the holes are in the right locations.

TAKE NOTE If the holes are angled, you won't be able to position the poles where you want. It's a good idea to check the holes with a level as you work.

3. Dump 3" or 4" of gravel into the bottom of each hole to promote drainage, and then pour in enough concrete to create an 8"-deep pad. Once the concrete has set, position a post in one of the corner holes. Make sure the post is long enough; the four posts along the front of the shed should extend at least 10 feet above the ground, while all the others should extend at least 8 feet. Have a helper plumb the post in both directions; he or she will need to position the post so the edges are just kissing the batter board strings. It'll take some goofing around to get it right. Once everything aligns, install temporary cross braces in both directions to keep the post in place.

TAKE NOTE It's better to use screws than nails when installing braces. Nailing tends to loosen stakes and jar posts, making it more difficult to keep them solid.

4. Fill the posthole with concrete, packing it firmly with a scrap 2×4 as you go. Add the concrete until it's slightly mounded above ground level; as the concrete hardens, use a hand trowel to taper the edges downward, as on a little volcano (this helps shed water away from the post). Repeat this for the three other corner posts. Let the concrete set for at least a day.
5. Install the remaining posts using the same techniques as with the corner posts. In some cases you can screw the lower ends of the temporary braces to the corner posts, rather than stakes, for ease.

6. Use a water level, laser level, or 4-foot level taped to a long, straight 2×4 to mark all the front posts at the same height. The height can be slightly more or less than 10 feet, but what's critical is that the posts are all the same height. Use a circular saw to cut them to the correct height. Make a mark 24" down from the top of one of the posts. Use a level, transit, or laser level to transfer that mark to one of the back posts; then use that mark as a guide for marking all the other posts. In a nutshell, you want the four tall front posts to all be the exact same height and all of the other posts exactly 2 feet shorter.

TAKE NOTE Use caution when cutting the tops of the posts. It's better to stand on sturdy planks spanning a pair of sawhorses or in the bed of a pickup truck than to work from a ladder. Circular saws can kick as they cut and easily knock you off the ladder.

Installing the Beams, Cross Braces, and Girts

Your next task is to install the horizontal members for supporting the roof structure and securing the siding, as well as the angle braces for keeping the structure rigid.

1. Install the 3-piece beams (two 2×6s and one 2×8) that connect the tops of the posts, as shown in *Beam, girt & cross brace details* (opposite). The 2×6s rest on top of the posts except for where they butt into the front corner posts. Overlap the members as shown in the detail drawings for strength. The 2×8 members bolted to the sides of the posts help tie the 2×6s to the post, add strength, and also serve as nailing girts for the siding later on.
2. Use your leveling method of choice to establish a level line within a few inches of the base of the posts. Make marks at 24" increments up from this line on the corners, then use a chalk box to snap lines across the intermediate posts. Use these marks as a guide for installing the 2×4 horizontal girts. Install them on the two end walls, the back wall, and the partition wall.
3. Install 4×4 diagonal cross braces from the beams to the posts. These will help prevent the structure from racking and twisting under strong wind or heavy snow. The longer they are, the better.

Beam, girt & cross brace details

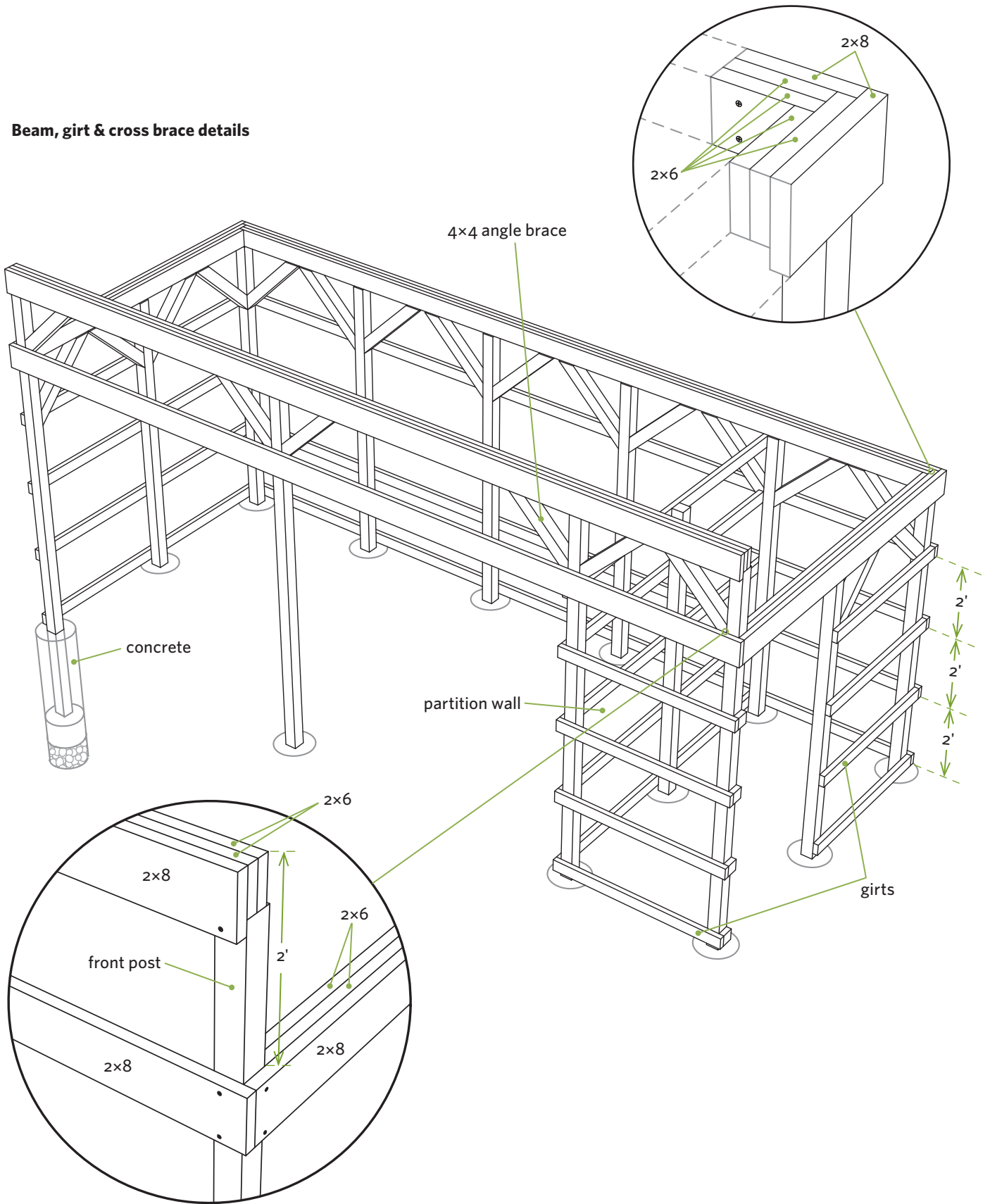

Roof and siding details

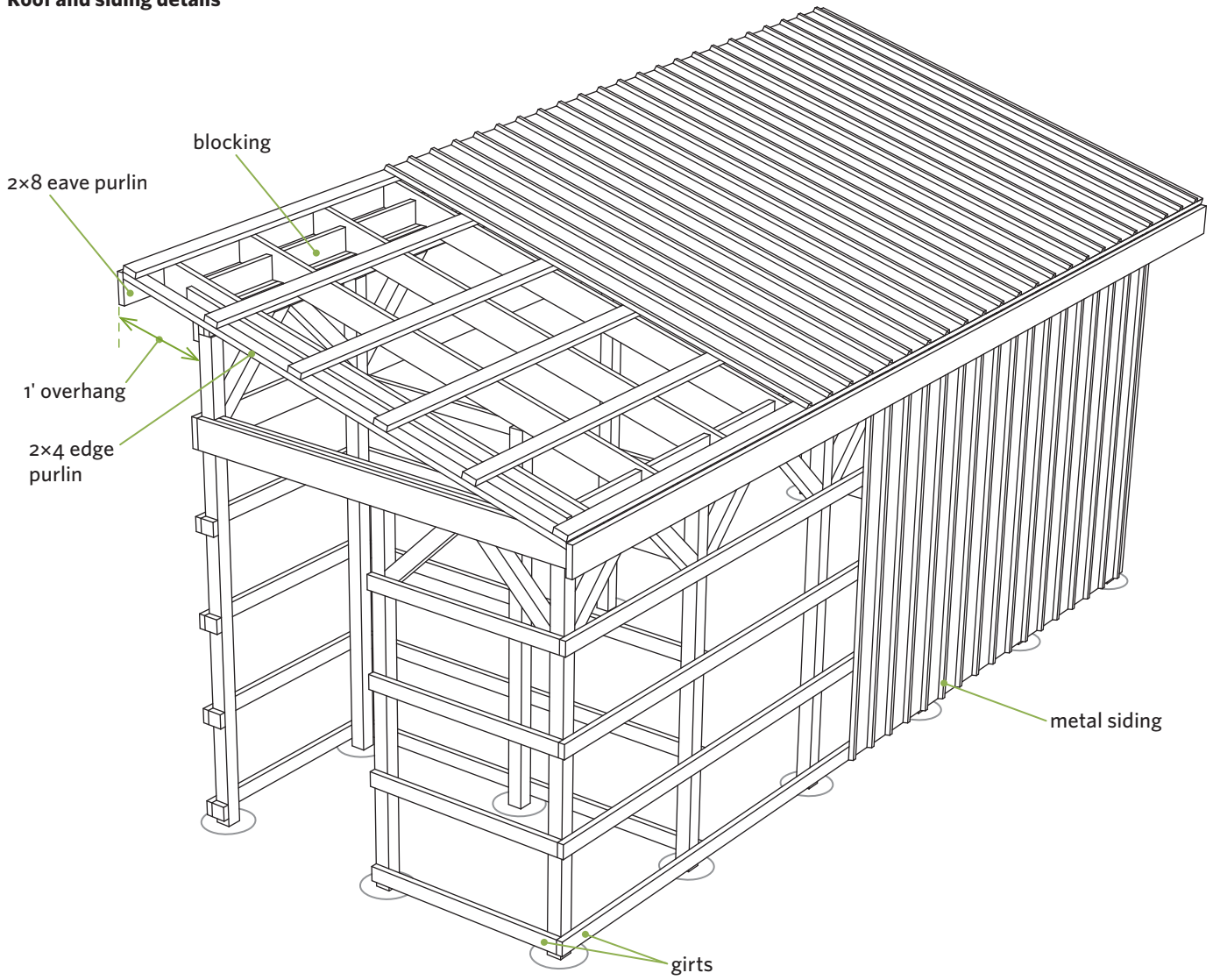

Rafter details

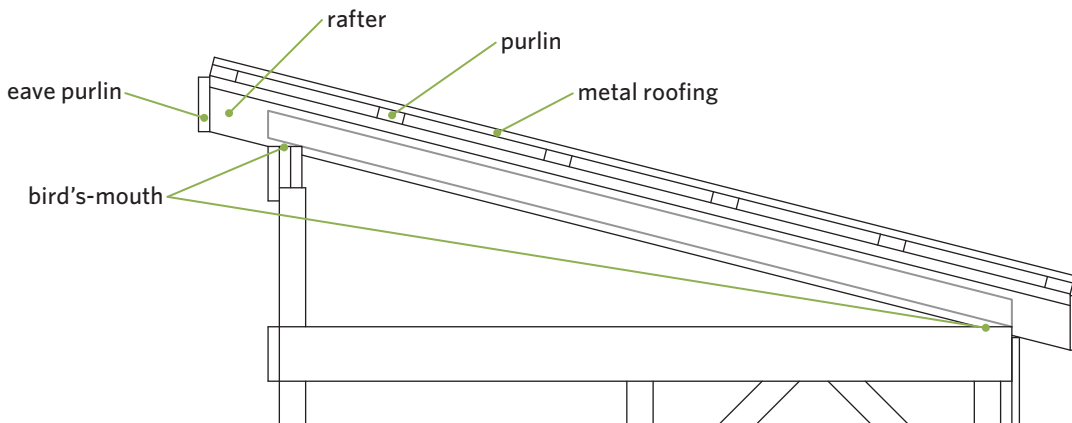

Installing the Rafters, Purlins, Roofing, and Siding

The next phase involves high-altitude work and therefore requires ladders and a helper or two. Work carefully.

1. To determine the rafter length, the end angles, and the locations of the bird's-mouths (the little cutouts you make near the ends of the rafters so they can rest squarely on the support beams), start by creating a pattern rafter: Tack a 2×8 to the sides of the front and back beams on one end of the shed; position it so the bottom is about 1½" below the tops of the beams. Use a pencil to trace the location of the bird's-mouths onto the back of the 2×8. Use a level to make plumb marks to indicate the angle cuts on the ends of the rafter. Cut out the pattern rafter, using a circular saw for the straight and angled cuts and a jigsaw or handsaw to finish the bird's-mouths. Test-fit the pattern at both ends of the shed and a couple of places in the middle. Use the pattern to mark all the remaining 2×8 rafters, and make the cuts.

2. Starting at one end, make marks every 24" on top of the front and back beams to indicate the centers of the rafters. Install the rafters, securing them with 16d nails toenailed in from each side. Cut 2×6 blocks (all but the end blocks should be 22½" long) and install them between the rafters directly over the front and back beams. These blocks will keep the rafters plumb and will close in the space to keep out the elements.
3. Make marks every 24" on the end rafters to indicate the positions of the purlins. Snap a chalk line between each set of marks to mark the positions on the rafters in between. Install the purlins. Cut them so the ends break in the middle of a rafter. The purlins should extend 12" past the rafters on the ends of the shed.

TAKE NOTE The 2×4 roof purlins are installed on the flat, with their broad faces against the rafters. The 2×8 eave purlins are installed with their broad faces vertical.

4. Install the 2×4 edge purlins and the 2×8 eave purlins to complete the perimeter of the roof.

The Scoop on Metal Siding and Roofing

You can purchase siding and roofing panels at a home center, a lumberyard, or an agricultural building supply store. You'll have lots of options in terms of color, style, strength, flashings, and accessories. It's best to stick with one manufacturer so all the components fit together properly. Find a salesperson who's familiar with the materials; he or she can be an invaluable resource during your project. A few general guidelines:

- Many metal siding and roofing panels can be ordered precut to length, which minimizes waste and hassle. You can order roof and front/back wall panels cut to length; the end walls, where you need to cut an angle to accommodate the slope of the rafters, will need to be cut on-site.
- Different rib heights and panel contours determine the look of the panel, as well as its strength. Keep both appearance and function in mind when ordering.
- Some metal panels are only strong enough to be used as siding, while other multipurpose panels can be used for both roofing and siding. Some roof panels must be installed over solid-wood sheathing. Make sure you're ordering the right materials for the right application. Many panels are available in two or three thicknesses; 26- and 29-gauge materials are common. Remember, the smaller the gauge, the thicker the metal (26-gauge is stronger than 29-gauge).
- The most economical panels are those that use exposed fasteners. Standing-seam and some other types of panels are installed using concealed fasteners that involve nailing strips, special edges, or clips. Concealed-fastener systems are more expensive and labor-intensive.
- Install a translucent skylight panel or two; they're no harder to install than solid panels, and they let in a substantial amount of light.

5. Position a roof panel at one end of the roof structure, making certain the ends and edges align with the edges and ends of the perimeter purlins below (see *The Scoop on Metal Siding and Roofing*, page 211, and *The Art of Cutting Metal Panels*, below). Use rubber-gasket nails or self-tapping screws to fasten the panel to the purlins. Drive a fastener through each raised rib and into the purlin below, but don't fasten along the edge of the rib where the next panel will overlap it. Start on whichever edge you choose. (Most right-handed people find it easiest to work from left to right; vice versa for lefties.) Position the second sheet with one rib overlapping the rib of the first sheet. Continue working your way across the roof.
6. Install the wall siding using the same basic techniques as with the roof. Use a level to plumb the first panel so the rest go on straight and plumb. Install the short panels that enclose the top of the front wall. Cut the end wall panels at an angle to accommodate the roof slope. Frame in an opening for the door on the end of the shed with the enclosure.
7. Install the special flashings along the sloped sides and front edge of the roof as well as the siding corner trim pieces.
8. Install 2×6 kickboards around the interior of the shed. Install them to whatever height makes sense for your situation. As an alternative, you can install pressure-treated plywood.

TAKE NOTE You'll absolutely want to enlist a helper for this part of the job. Don't even think about installing panels on a windy day. And if you're not comfortable with heights, hire someone to install the roof panels.

TAKE NOTE Patrol the area and pick up any metal shards, fasteners, or scraps. You don't want these blowing around, you don't want to mow them, and you surely don't want people or animals stepping on them.

The Art of Cutting Metal Panels

The same qualities that make metal siding and roofing so darn durable also make them so darn challenging to cut. You have a variety of options, each with their own pros and cons.

HAND SHEARS OR TIN SNIPS. These create a clean cut and are relatively inexpensive; use 12" shears for the best results. Getting a smooth cut across the ridges or ribs can be difficult.

ELECTRIC METAL SHEARS. Some work like mini-circular saws, and others by removing a ¼" swath of metal as they cut. They work quickly and smoothly but, costing \$200 or more, may be better to rent than to purchase.

POWER NIBBLERS. These, as the name implies, nibble away the metal. They can make tight turns and negotiate ridges well. They're expensive and specialized, so consider renting. Nibbler attachments for power drills also are available.

CIRCULAR SAW WITH METAL-CUTTING BLADE.

These cut quickly but are noisy and can leave a jagged edge. Make sure to wear gloves, a full-face shield, a long-sleeve shirt, and hearing protection. Cut good-side-down for best results. Since the heat and sparks can damage the coating, cutting this way will often void the manufacturer's warranty.

CIRCULAR SAW OR GRINDER WITH ABRASIVE BLADE. These get the job done quickly but can damage the roof coating in the process, again voiding the manufacturer's warranty.

Some builders cut metal panels using a carbide-tipped blade installed backward in a circular saw; I don't recommend this. The method is loud, leaves a jagged cut, and can damage the coating. Also, the carbide teeth can easily detach and become airborne, possibly injuring the user or bystanders.

Classy, Classic Chicken Coop

Clever skylight, simple roof, lots of room

The equation is simple: a well-built coop + well-adjusted chickens = happy homeowners + lots of eggs. This spacious coop provides plenty of open and enclosed space, a convenient hatch for collecting eggs, and a clerestory opening in the roof that can be left open for summer ventilation or closed for winter warmth. This project is designed for simplicity but is still one of the more ambitious

projects in the book. To make sure you have the chutzpah to see the project through to completion, review the illustrations and text before you dig in. When you're done, you'll be rewarded with a coop that's attractive, functional, and easy to maintain. Feel free to embellish and expand on this design as you see fit.

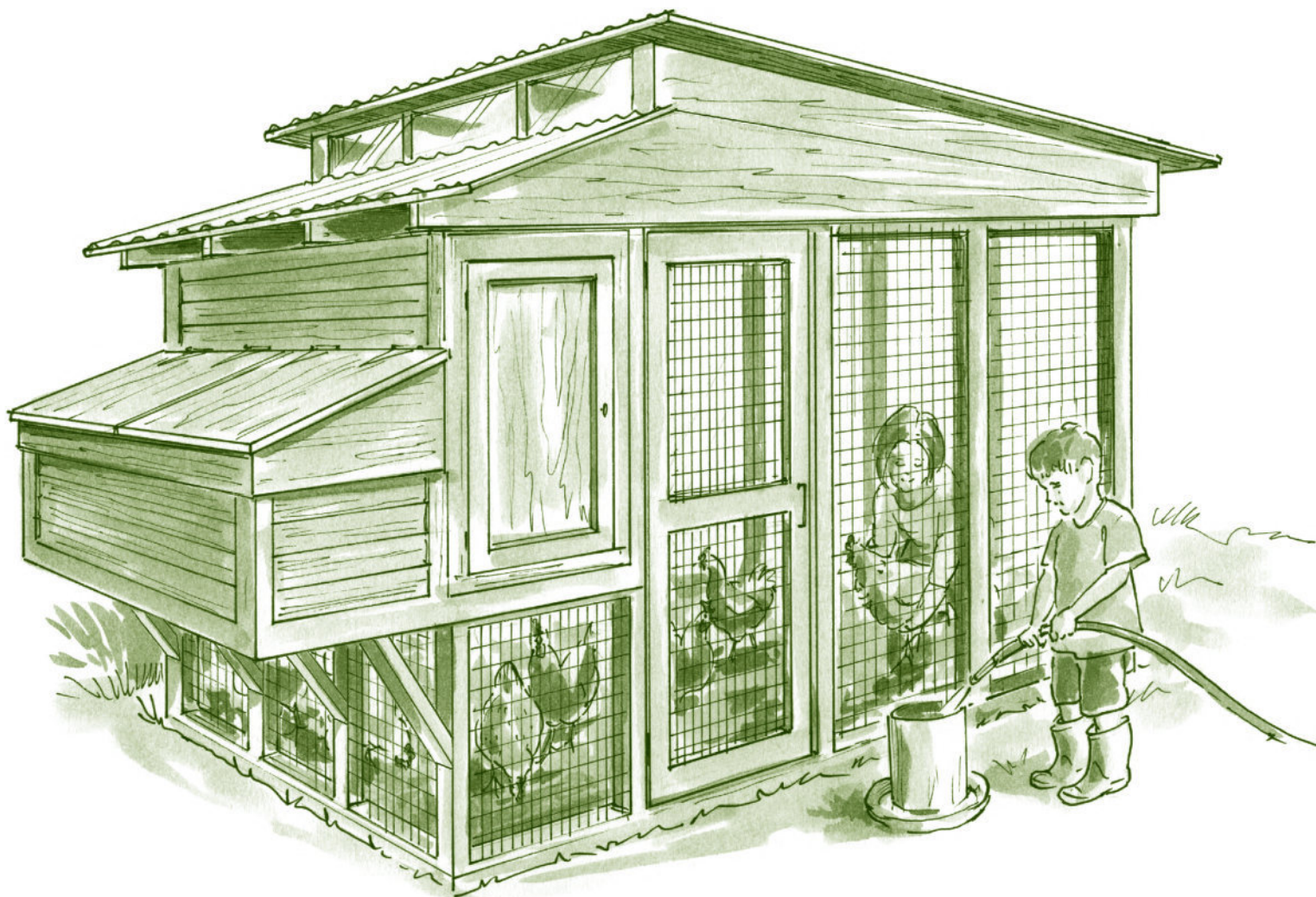

Materials*

- Six 8-foot 2×4s
- Four 10-foot 2×4s
- Fourteen 12-foot 2×4s
- Four 14-foot 2×4s
- Fourteen 8-foot 4×4s
- Four 12-foot 2×12s
- Three 4 × 9-foot sheets ½" OSB
- Siding material (see step 6, page 218)
- Roll roofing, 140 square feet
- Three 10-foot 1×4s
- Ten ¾" × 6" × 8' deck boards
- Four 10-foot 2×2s
- Three 4 × 8-foot sheets ½" pressure-treated plywood
- One 8-foot 2×8
- Twenty-four 8-foot 1×2s
- Wire mesh or chicken wire (see Confessions of a First-Time Chicken Farmer, page 220)
- Two ¾" hanger straps with fasteners
- Two 1½" hanger straps with fasteners
- 16d galvanized nails
- 8d galvanized nails
- 6", 8", and 10" timber screws
- Exterior screws
- Fence staples (for wire mesh)
- Four exterior strap hinges with screws
- Three exterior door hinges with screws
- Exterior hasps or latches (as needed; see step 6, page 220)

*All wood materials are pressure-treated.

Parts and Cutting List*

Part	Size and Material	Quantity
(A) short wall nailing plate	1½" × 3½" × 91"	4
(B) long wall nailing plate	1½" × 3½" × 129½"	4
(C) wall stud	3½" × 3½" × 72"	14
(D) short wall top/ bottom plate	1½" × 3½" × 98"	4
(E) long wall top/ bottom plate	1½" × 3½" × 122½"	4
(F) roof truss	1½" × 11¼" × 144"	4
(G) roof sheathing	½" × 48" × 108" OSB	3
(H) roll roofing		
(I) framing angle bracket	¾" hanger strap	2
(J) inverted 2×4 hanger	1½" hanger strap	2
(K) long inner floor support	1½" × 3½" × 91"	1
(L) long outer floor support	1½" × 3½" × 96½"	1
(M) short outer floor support	¾" × 3½" × 55½"	2
(N) short inner floor support	¾" × 3½" × 56"	4
(O) nesting box floor	¾" × 6" × 8" treated decking	10
(P) nesting box stud	1½" × 1½" × 15"	5
(Q) nesting box nailing plate	1½" × 1½" × 98"	2
(R) nesting box front and back wall sheathing	½" × cut-to-fit PT plywood	2
(S) nesting box side wall sheathing	½" × cut-to-fit PT plywood	2
(T) nesting box lid front	1½" × 3½" × 46½"	2
(U) nesting box lid back	1½" × 7¼" × 46½"	2
(V) nesting box roof	½" × cut-to-fit PT plywood	1
(W) short panel stop	¾" × 1½" × 28"	18
(X) long panel stop	¾" × 1½" × 70½"	18
(Y) short panel member	1½" × 3½" × 24¾"	27
(Z) long panel member	1½" × 1½" × 71¾"	18
(ZZ) Wire mesh	32" × 76"	9

*Dimensions and quantities are provided for most parts, but for best results you should field-verify all specifications and make needed changes as you go.

Building the Walls

1. Cut and mark pairs of nailing plates (A, B) for each of the four walls as shown. Your goal is to create uniform 28" openings between the 4×4 wall studs so all your wire panels can be made the same size and are thus interchangeable. Once your pairs of plates are laid out, separate them and install the 4×4 studs (C), using three 16d nails on each end. Note that the front and back walls have only two intermediate studs and no end studs for now; this will all make sense once the walls are completed and erected in the next steps.
2. Install the second pairs of top and bottom plates (D, E) so there are two 2×4 horizontal members at the top and bottom of each wall. Note that these plates are inset 3½" on two long side walls and overhang 3½" on two short end walls.
3. Erect the walls on a flat surface, interlocking the bottom and top plates, and then nailing them together. Use a level to plumb the walls in each direction. Install temporary cross braces to hold them plumb.

Wall framing

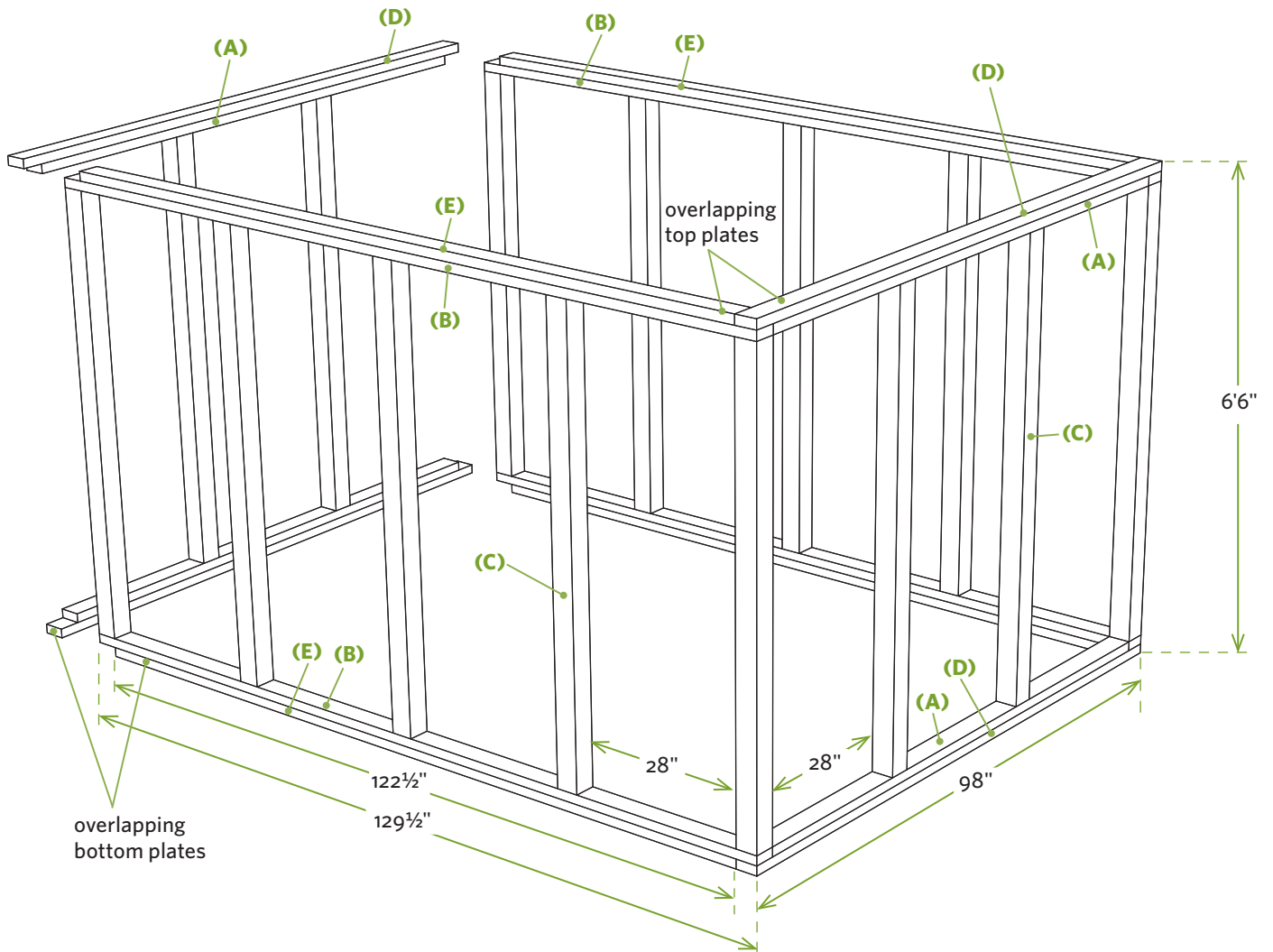

Building the Roof and Skylight

Building the four trusses (F) will take an hour or two, but there are multiple payoffs: you'll wind up with skylights (in this case, three clerestory openings about 7" tall near the roof peak) and a roof that looks good and sheds water, as well as parts of the lid for your nesting box bump-out (see opposite page).

1. Cut the four 2×12s for the roof trusses (F) to length. Measure 108" from one end, make a mark on the top edge of each truss board, and then make another mark 3½" directly below. Measure 3½" from the bottom on each end and make marks. Use a long, straight 2×4 to connect the marks as shown in *Truss details*.
2. Use a circular saw to cut the long wedges from the 2×12s. Use your circular saw and a handsaw to make a square cut at the 108" mark to separate the long and short wedges. Use a sharp blade in your circular saw, work slowly, and steer your saw so the blade cuts right down the middle of the line.
3. Flip the long wedges end for end. Position them on the main truss so the two cut edges are against each other. Use 6", 8", and 10" timber screws to secure the boards to one another. Set the shorter wedges aside for later use.
4. Install your trusses so one is even with each side wall and one is centered over each of the two intermediate 4×4 wall studs. Secure them in place with 6" and 10" timber screws.
5. Install the roof sheathing (G) across the short and long roof sections formed by the trusses. Use 9-foot-long sheets so you can use continuous material on the long spans. You'll wind up with an overhang of about 5" on each side.
6. Install roll roofing (H), fiberglass shingles, or metal roof panels, following the manufacturer's instructions. You can leave the skylight (clerestory) areas open; install wire mesh across them, install a strip of Plexiglas, or install a strip of oriented strand board (OSB).

Truss details

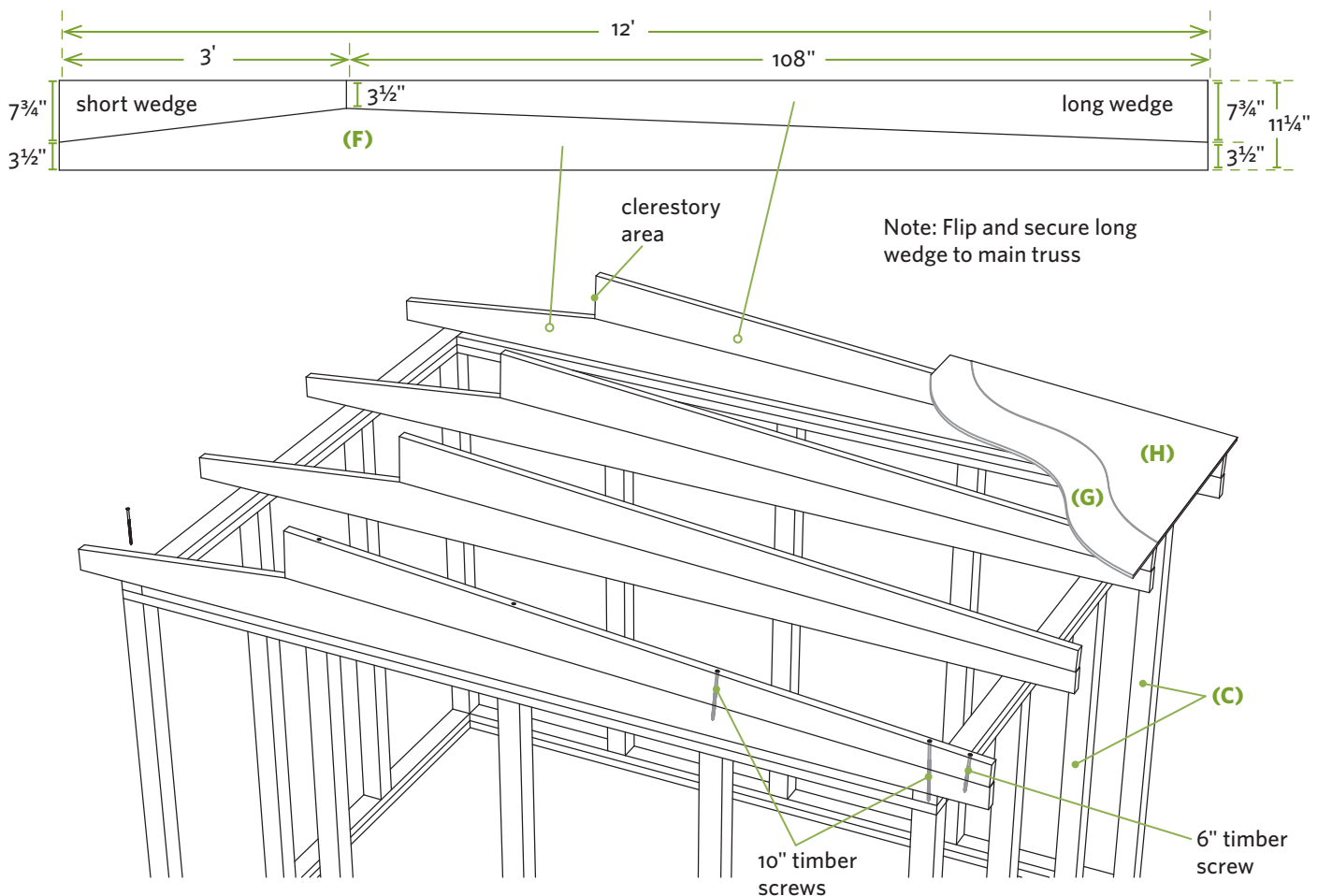

Building the Nesting Box Bump-Out

Study the drawing here to gain an overall view of what you're doing and building. The special metal connectors used for parts of the floor framework simplify the building process.

1. Make marks $26\frac{1}{2}$ " and 30" up from the bottom of each of the two corner studs. Set your circular saw to a depth of $\frac{3}{4}$ ", and then make a series of cuts (see *Notched 4x4* detail below). Use a chisel to knock out the fingers between these cuts to create the notches.

Nesting box construction

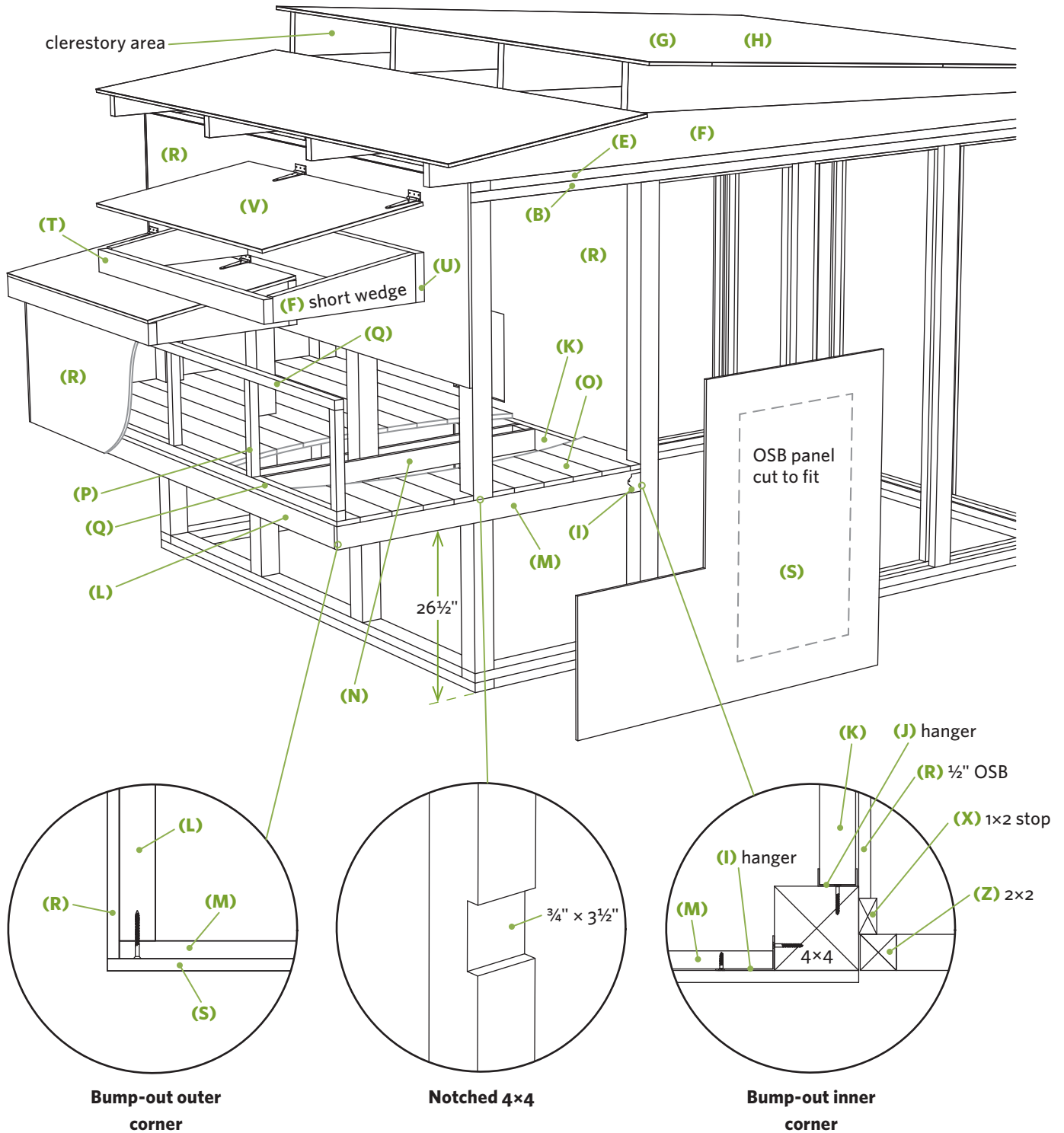

2. Install the narrow framing angle bracket (I), made for a 1×4, and inverted hanging bracket (J), made for a 2×4, on the two posts at the coop side of the nesting box (see *Bump-out inner corner* detail on previous page). Install the short outer and inner floor supports (M, N) and the long inner and outer floor supports (K, L) to create the framework for the floor of the coop. Sheathe the floor of the nesting box with treated deck boards (O) cut to fit the space.
3. Build the 18"-tall outer wall of the nesting box by securing the 2×2 studs (P) to the nailing plates (Q) using 8d galvanized nails, and then set it in place.
4. Cut ½" OSB sheathing (R) to cover the outer wall of the nesting box area and inner wall of the coop. Create a doorway on the coop side for your poultry. Save the door cutout so you can create the door with it later, if you want one. Cut and install the side sheathing (S). You can sheathe the three outer walls directly beneath the nesting box to enclose the area or install chicken wire so it's open.
5. Create the two hinged roof sections of the nesting box bump-out: Cut the small wedges left over from the roof trusses (F) to length at 24". Use two of these wedges to create each hinged section. Determine the length of each roof section, cut the 2×4 nesting box lid fronts (T) and 2×8 nesting box lid backs (U) to that length, and then nail the wedges between them. Sheathe the top with ½" OSB (V), and then secure each section to the coop with a pair of strap hinges. Install the same roofing you used on the other part of the roof.
6. Install the siding of your choice to cover the wall sheathing. You can use lap siding, metal siding, wood shingles, or any other type of siding. Bend over any siding nails that might protrude into the inside. You can simply paint the OSB, but within a year or two, it will start looking shabby.
7. Build a ramp or sloped ladder so your chickens have easy access to the enclosure.

TAKE NOTE Sheathing the lower walls will add rigidity to the structure. If you don't sheathe them, make sure to add corner cross braces as shown on page 213.

Resources for Chicken Raisers

It's a good idea to purchase a book or two before you build your coop, since the information may impact some of the details you include. And building your coop is just the start of your adventure. There are hundreds of books and Internet sites you can tap to get more information on the care and raising of chickens, as well as on supplies. (See Recommended Reading for more information on the following sources, as well as helpful websites for chicken raisers.)

BOOKS

Chick Days, by Jenna Woginich. Chronicles the life journey of three chickens from newly hatched butterballs to laying hens. Informative and amusing.

Storey's Guide to Raising Chickens, 3rd Edition, by Gail Damerow. Everything you need to know about successfully raising chickens, from choosing breeds to batching chicks to keeping birds healthy and safe.

Backyard Chickens Guide to Coops and Tractors, edited by David Thiel. Plans and photos for 16 custom coops built by real chicken owners.

SUPPLIES

RANDALL BURKEY COMPANY. Day-old baby chicks of many breeds, coops, netting, medications, and everything else related to chickens. In business since 1947.

MURRAY MCMURRAY HATCHERY. Baby chicks, waterfowl, and other fowl as well as a complete line of equipment, supplies, and feed. Free catalog.

STROMBERG'S CHICKS AND GAME BIRDS. More than 200 breeds and varieties of birds as well as supplies, books, and gifts. Free catalog.

Chicken wire panel

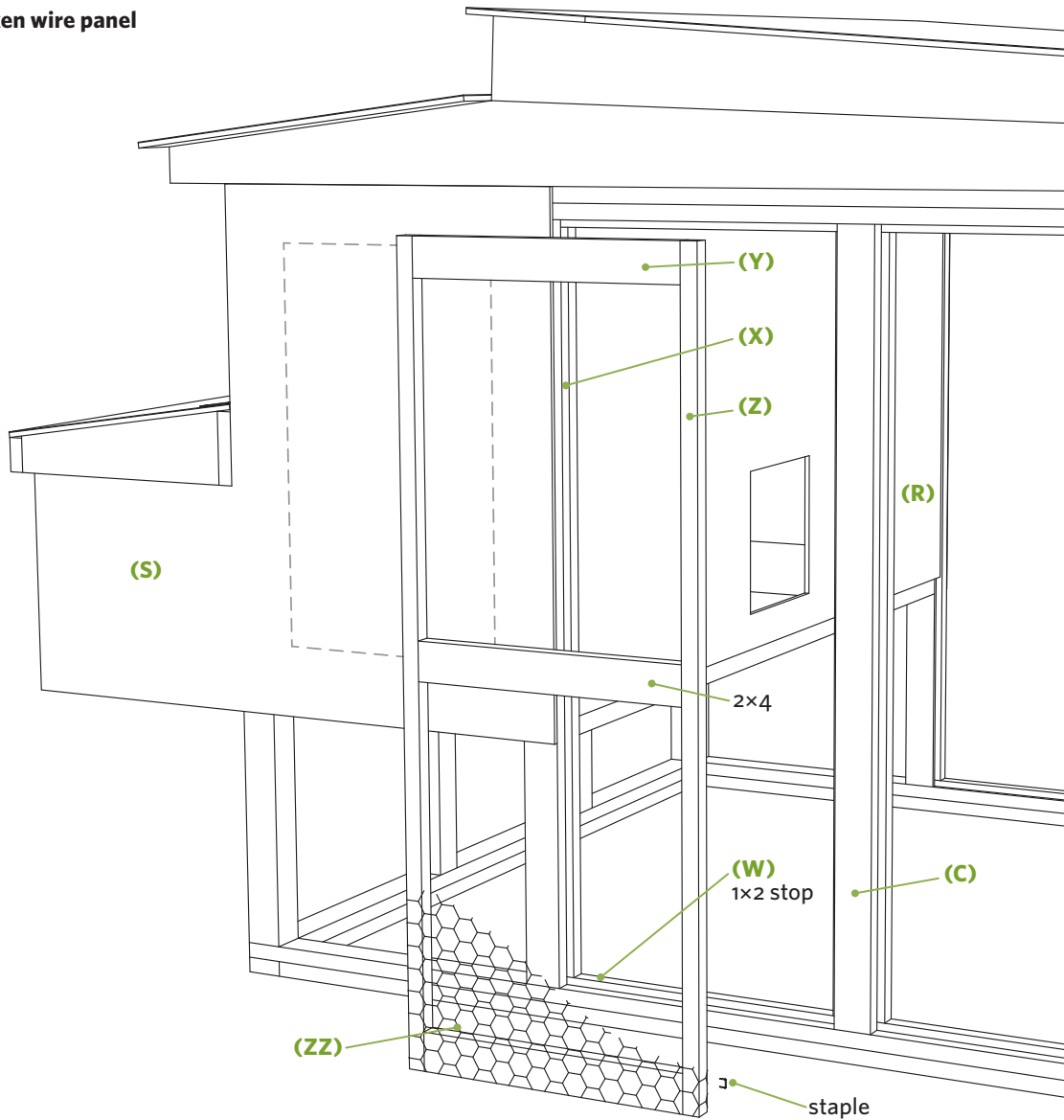

Building the Chicken Wire Panels and Door

Instead of building individual panels as shown, you can simply wrap the chicken wire or wire mesh around the 4×4 wall framework you've built. Read "Confessions of a First-Time Chicken Farmer" (page 220) before deciding to go with lightweight chicken wire or heavy-duty hardware cloth. Overlap the rows of wire by at least 4" and hold it in place using fence staples. The advantages of individual panels are that they make it easier to replace damaged sections, you can stretch the wire tauter, and it creates a clean look.

1. Install 1×2 stops (W, X) around the interior of each frame, setting them back 1½" from the outer faces of the 4×4 studs.

2. Cut the vertical (Z) and horizontal members (Y) of the wire panel frames. The finished wood frames should be about ¼" smaller in each direction than the openings themselves. Build the frames by driving nails through the sides of the vertical 2×2s and into the ends of the horizontal members.

TAKE NOTE All the openings should be the same size, but before going into mass-production mode, build and install the wire on one panel and test-fit it into each of the openings. You may find you need to make some panels a little larger or smaller.

3. Cut the chicken wire (ZZ) into sections 32" wide × 76" long. Place the wire on top of the screen panels and bend it so it folds over onto the edges of the frame. Use fence staples (or pneumatically driven staples) to secure the wire to the edges of the panels. Trim the excess wire mesh.
4. Set the panels into the openings, predrill holes about every 12", and secure the panels in place by driving screws through the sides of the frames into the sides of the studs (C). Leave off one panel for the door, which you'll install in step 6.
5. Brace the walls by installing 2×4 cross braces at each corner of the coop (not shown) and/or sheathing the lower walls below the enclosed coop area as previously discussed. Then you can remove the temporary braces.
6. Create a door to the coop by simply mounting one of the wire panels to one of the 4×4 studs with hinges. Install latches or hasps to keep the door closed.

PERSONAL POINT OF VIEW

Confessions of a First-Time Chicken Farmer BY JASON AMUNDSEN

Two years ago, my wife, Lucie, wrote an article for a local magazine about our city's new chicken ordinance. The next thing I knew, we had a peeping bunch of chicks living in a kiddie pool under a heat lamp in the garage. But this was no long-term solution; the "ladies" would require real housing, fast.

After much research, I learned chickens need extra light in the winter to help them lay eggs. So, left unattended at a flea market, I bought a slightly cracked 4 × 8-foot skylight to serve as the coop's roof. Working with a neighbor, I built walls for the skylight to rest on. Constructed of sheet metal, insulation, plastic and OSB, the coop was clearly a better-insulated structure than our 100-year-old house.

To create a run for exercising, we pounded 6-foot metal poles in the ground and connected them with bird netting. We learned the hard way that

this simple design was great at keeping chickens in, but failed to keep predators out. Living in the city, we'd been lulled into thinking our ladies were safe from wild animals. Raccoons were able to slip into my makeshift run and ravage our flock. It was gruesome. Those lovely hens paid the price for my completely inadequate defenses.

In response, I built a micro-fortress. Since chicken predators like to dig, I started with a tight foundation. I partially buried 2×10s in trenches, then stapled chicken wire to them and the posts. Then, since hardware cloth is much stronger than chicken wire, I added a layer of that around the base as a second line of defense. I stapled hardware cloth to the screen door, as well. When that was done, I covered the perimeter of the coop and run with concrete. Overkill?

Probably. Have any predators gotten in? Nope.

A few other things I learned along the way:

- For putting on chicken wire and hardware cloth, a compressor-powered stapler is your best friend. The staples go in so much faster and are stronger than those driven by hand.
- Make sure there's lots of ventilation. Chickens breathe faster than humans and their lungs are more sensitive. Also, most poultry-related diseases are respiratory in nature. As a result, don't skimp on fresh air.
- Chickens like to sleep up high. To prevent them from using your nesting boxes as roosts — which results in nesting boxes full of excrement and soiled eggs — build your roosts higher than your nesting boxes.

JASON AMUNDSEN is a writer living in Duluth, Minnesota. He and his wife, Lucie, leveraged their initial backyard experience with chickens into a full-fledged egg business and now have 1,800 laying hens, all named Lola. They vow never to use the term eggs-cellent in any promotional material. (See Resources for more information on their operation, Locally Laid Egg Company.)

Coffee Can Bird Feeder

A fly-in diner for your feathered friends

If you're a bird-watcher, here's a simple project to increase your bird traffic and bird-watching pleasure. You'll need a coffee can, a couple of cedar boards, a jigsaw, a drill, and a few other items. I built a feeder based on a 39-ounce coffee can, but you can easily adapt these plans to fit a smaller or larger container.

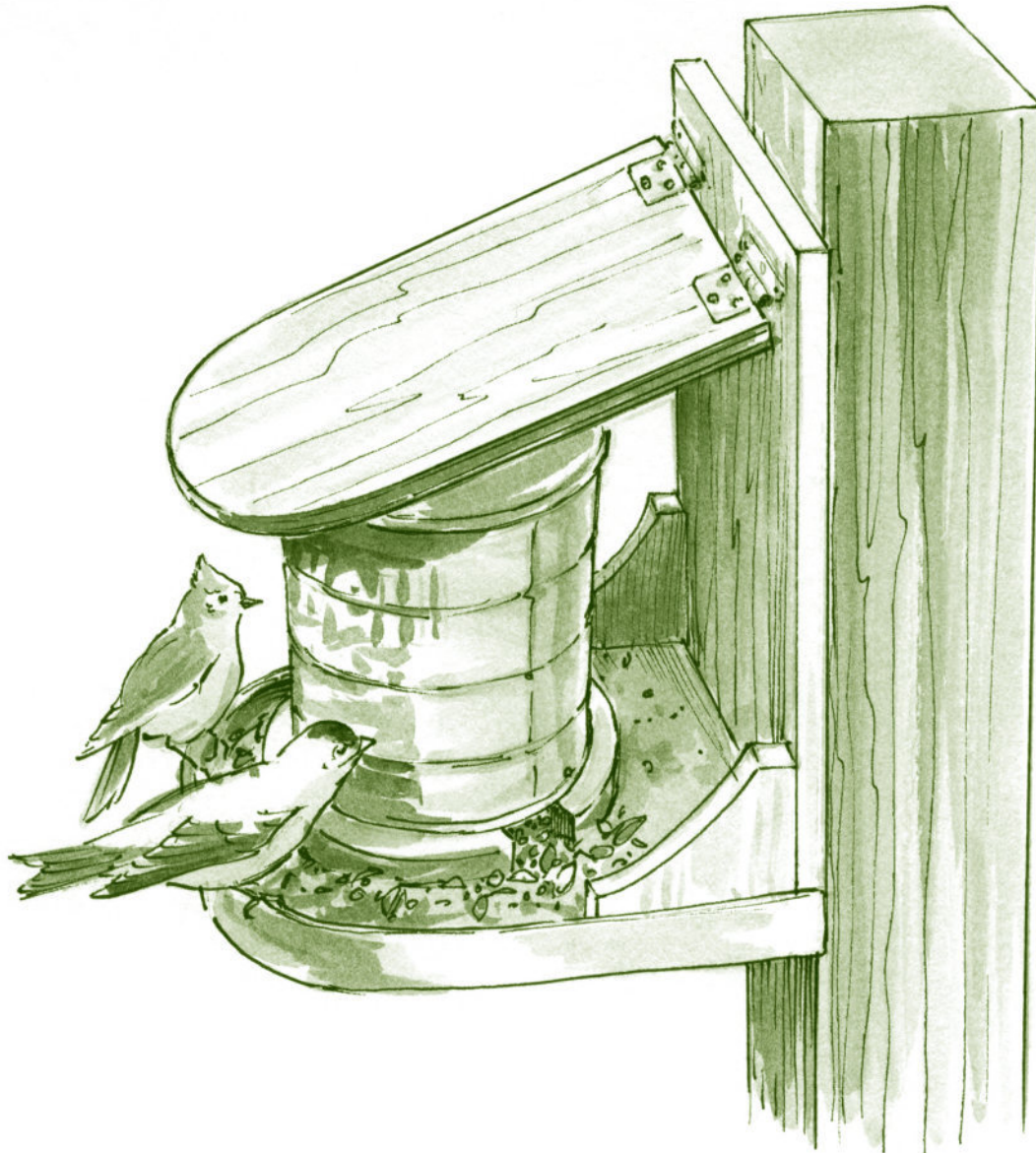

Materials

- One 6-foot cedar 1×12
- One 39-ounce coffee can (with both ends removed)
- Scrap of leather belt or vinyl tile base molding (see step 8)
- Exterior wood glue
- 1¼" exterior screws
- 1⅝" exterior screws
- 3d galvanized box nails

1. Use a compass to draw circles for the inner (A) and outer base (B) as shown. One should be the same diameter as the inside of your can; the other a diameter ½" larger (a radius of ¼" more). With your compass set at the respective radius measurement, walk the compass around the perimeter of each circle; by the time you circle back to the starting point you'll have six tick marks with identical spacing. Draw lines connecting the tick marks so your circle looks like a pie with six slices.
2. Cut out the bases with a jigsaw. Use a drill and ¾" bit to drill three holes that just kiss the perimeter of the inner base disc (A), using every other tick mark as a guide. Mark the hole centers for the outer base (B) as shown in *Cutting diagrams* (opposite), and drill those holes. Use your jigsaw to remove the little plywood lips between the edges of the holes and the edges of the base pieces.

TAKE NOTE My feeder openings were designed for sunflower seeds. If you plan on using smaller birdseed, create smaller holes.

3. Set the inner base (A) on top of the outer base (B), and align the edges of the cutouts (they should line up). Secure the discs to each other with glue and 1¼" screws.
4. Drive a screw in the very center of the platform (C), hook the end of a measuring tape over the screw, and use a pencil to draw the curved edge as shown in *Cutting diagrams* (opposite). Do the same for the roof (D). Make the cuts with a jigsaw, and save the arch-shaped cutoffs; you'll use them for braces later on.

Parts and Cutting List

Part	Size and Material	Quantity
(A) inner base	¾" × 5⅞" (circle) cedar	1
(B) outer base	¾" × 6⅜" (circle) cedar	1
(C) feeder platform	¾" × 11¼" × 12" cedar	1
(D) feeder roof	¾" × 11¼" × 12" cedar	1
(E) feeder back	¾" × 11¼" × 14" cedar	1
(F) platform brace	¾" × 3" × 3" cedar	2

5. Glue and screw the circular base pieces (A, B) to the center of the platform (C), orienting the feeding holes as shown.
6. Secure the back (E) to the platform (C) with 1⅝" screws. Use glue and screws to secure the braces (F) in the corners as shown in *Feeder assembly* (opposite).
7. Position the coffee can on the base and secure it to the inner base with a couple of 1¼" screws. Secure the roof (D) to the back (E) with a pair of self-closing cabinet hinges. Install the roof so it slants down and hits the front edge of the can in the lowered position.
8. Create the seed lip on the edge of the platform by nailing an old leather belt or piece of flexible vinyl tile base molding to the perimeter.
9. Fill your feeder with food, and snap on the plastic lid to the can to protect the birdseed from moisture. Secure the feeder to a pole, post, or tree.

Cutting diagrams

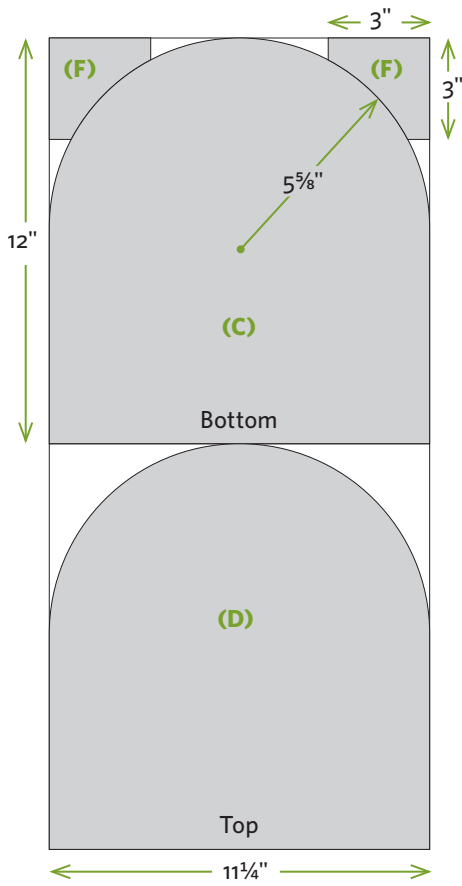
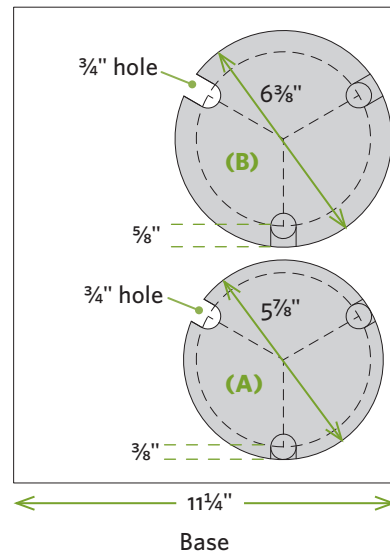
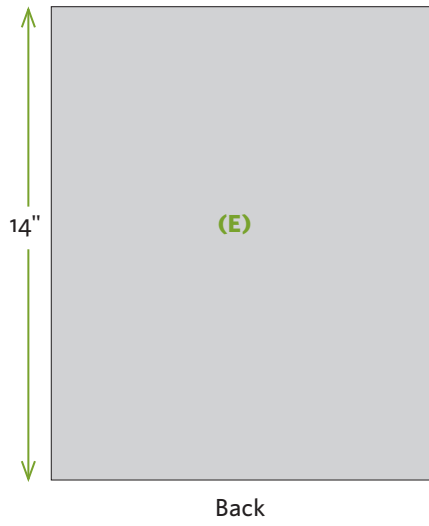

Feeder assembly

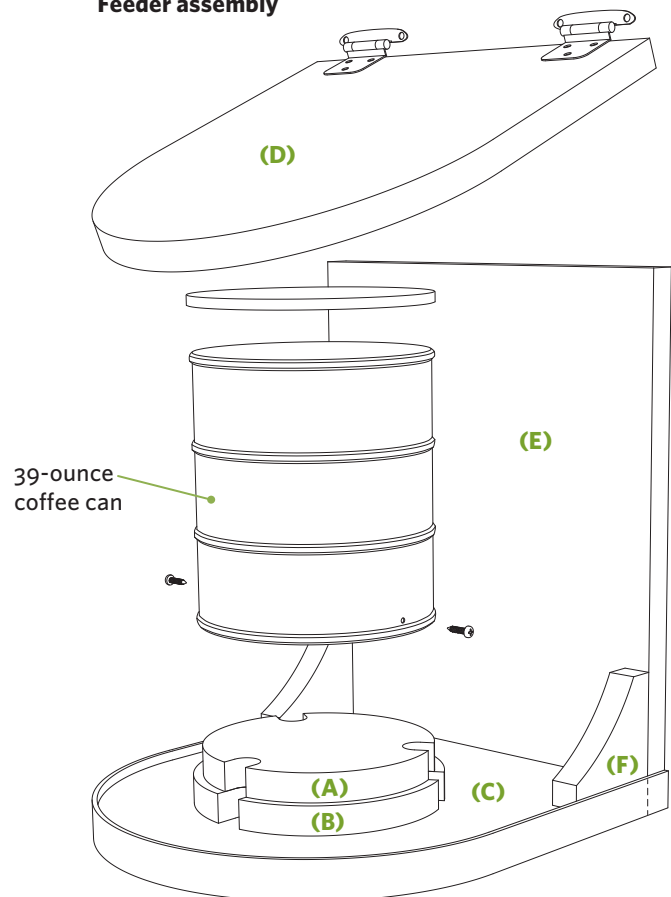

Top Bar Beehive

A simple hive for beginning beekeepers

Few backyard homestead projects are sweeter than the one that lets you harvest honey from your own hive. Serious beekeepers usually use classic Langstroth-style hives, the stacked boxes you often see in fields and yards. But if you want to dip your toe into the world of beekeeping, start with a top bar hive. It's relatively simple to build and, while it won't generate as much honey as a Langstroth hive, it will supply an education, some honey, some entertainment, and plenty of bees for pollinating your garden and trees.

Every project has two parts: Building it correctly and using it correctly. Here, we'll show you how to build a basic hive, but this is only the start. You'll need to set up your hive correctly, order bees, and perform periodic maintenance and other tasks. Educate yourself, find a mentor, and prepare to make the commitment before you build your hive. See *Setting Up Your Hive* (page 229), and then read Ed Simon's book or *Build Your Own Beekeeping Equipment* by Tony Pisano for full "operating instructions."



See page 2 for a photograph of this project.

Materials

- One 3-foot piece pine 1×12
- One 4 × 4-foot piece ¾" plywood
- One 8-foot pine 1×3
- Three 8-foot pine 1×2s
- One 2 × 2-foot piece ⅛" plywood
- Exterior wood glue
- 2" exterior screws
- Beekeeping supplies as needed (see [Setting Up Your Hive](#), page 229)
- 20-24" × 36" metal flashing (optional)

Parts and Cutting List

Part	Size and Material	Quantity
(A) end	¾" × 11¼" × 15¼" pine	2
(B) side	¾" × 10½" × 27¼" plywood	2
(C) bottom	¾" × 6½" × 27¼" plywood	1
(D) lid	¾" × 17½" × 31½" plywood	1
(E) lid rim (long)	¾" × 2½" × 31½" pine	2
(F) lid rim (short)	¾" × 2½" × 16" pine	2
(G) separator	¾" × 9½" × 13" plywood	1
(H) top bar	¾" × 1½" × 14½" pine	18
(I) starter strip	⅛" × ½" × 12¾" plywood	17

Hive body assembly

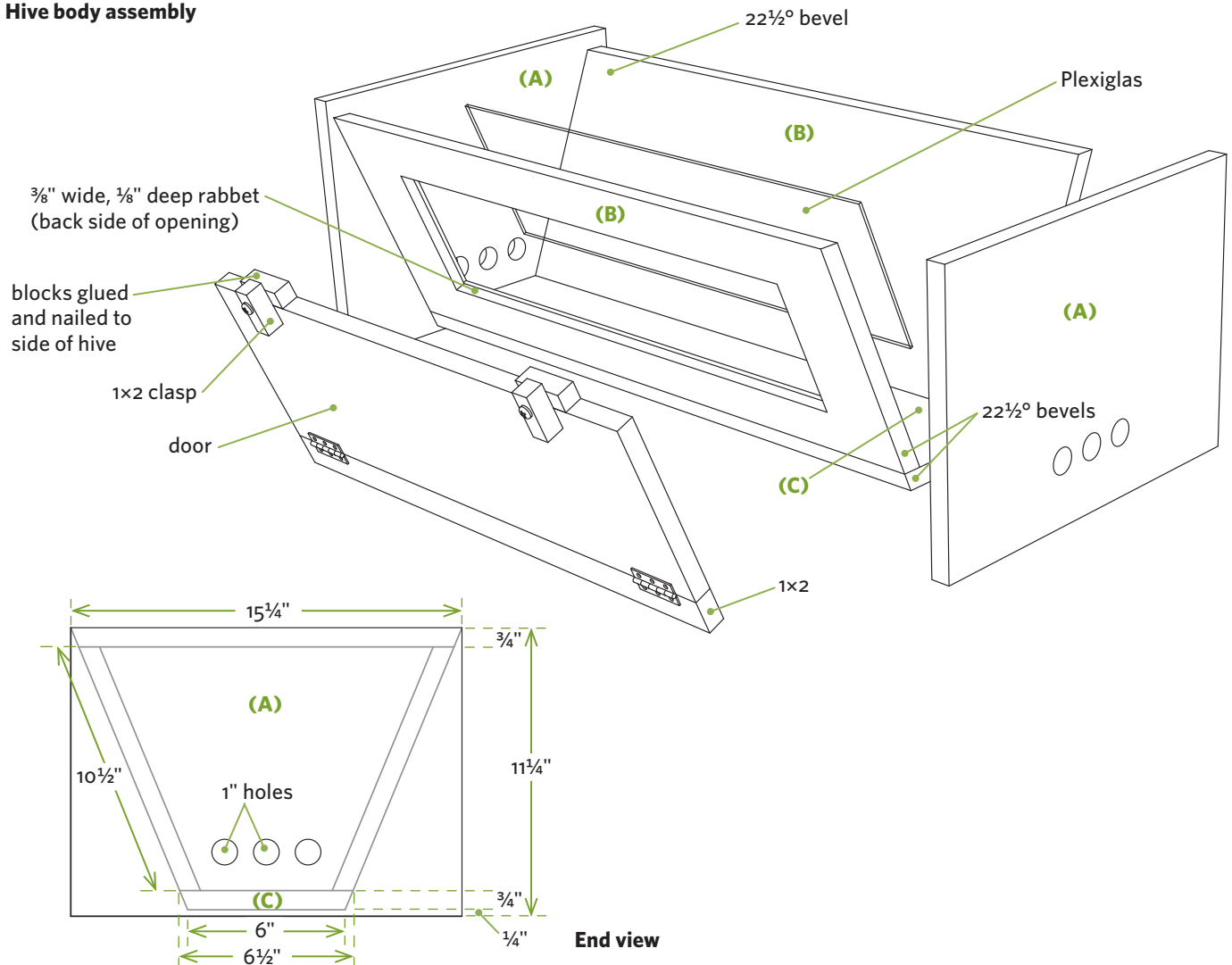

1. Mark and cut out the ends (A), sides (B), and bottom (C) as shown. Note that the bevels on the top and bottom edges of the sides (B) are cut at parallel 22½-degree angles (in cross-section, like a parallelogram, for you geometry buffs); measure the width dimension (10½") from long point to short point. The bevels on the long edges of the bottom (C) are cut at converging, or opposing, 22½-degree angles (like a trapezoid); measure the width from long point to long point. Buy, borrow, or rent a table saw for this project; it will simplify cutting the bevels and create a tighter fit. It's highly recommended you create a viewing window on one of the side pieces (see Room with a View, page 228).
2. Position the sides (B) on the ends (A) to test the fit; there should be a ¾" space at the top of the end piece to accommodate the thickness of the top bars and a 1" space at the bottom of the end piece to accommodate the bottom (C)

plus the ¼" overhang. Secure the sides to the end pieces using exterior glue and 2" screws.

3. Secure the bottom (C) using exterior glue and 2" exterior screws.
4. Cut out the parts for the lid (D) and the lid rim (E, F), and create the shallow lid as shown. Join the parts with glue and screws. Add the optional metal flashing to further weather-proof the roof.

TAKE NOTE The inner area of the finished lid should be ½" larger in each direction than the top of the hive; this creates some wiggle room so you can easily pry off the top. This is important since the bees will glue the two together with propolis, a mixture of tree resin, wax, and other substances.

Hive construction — exploded view

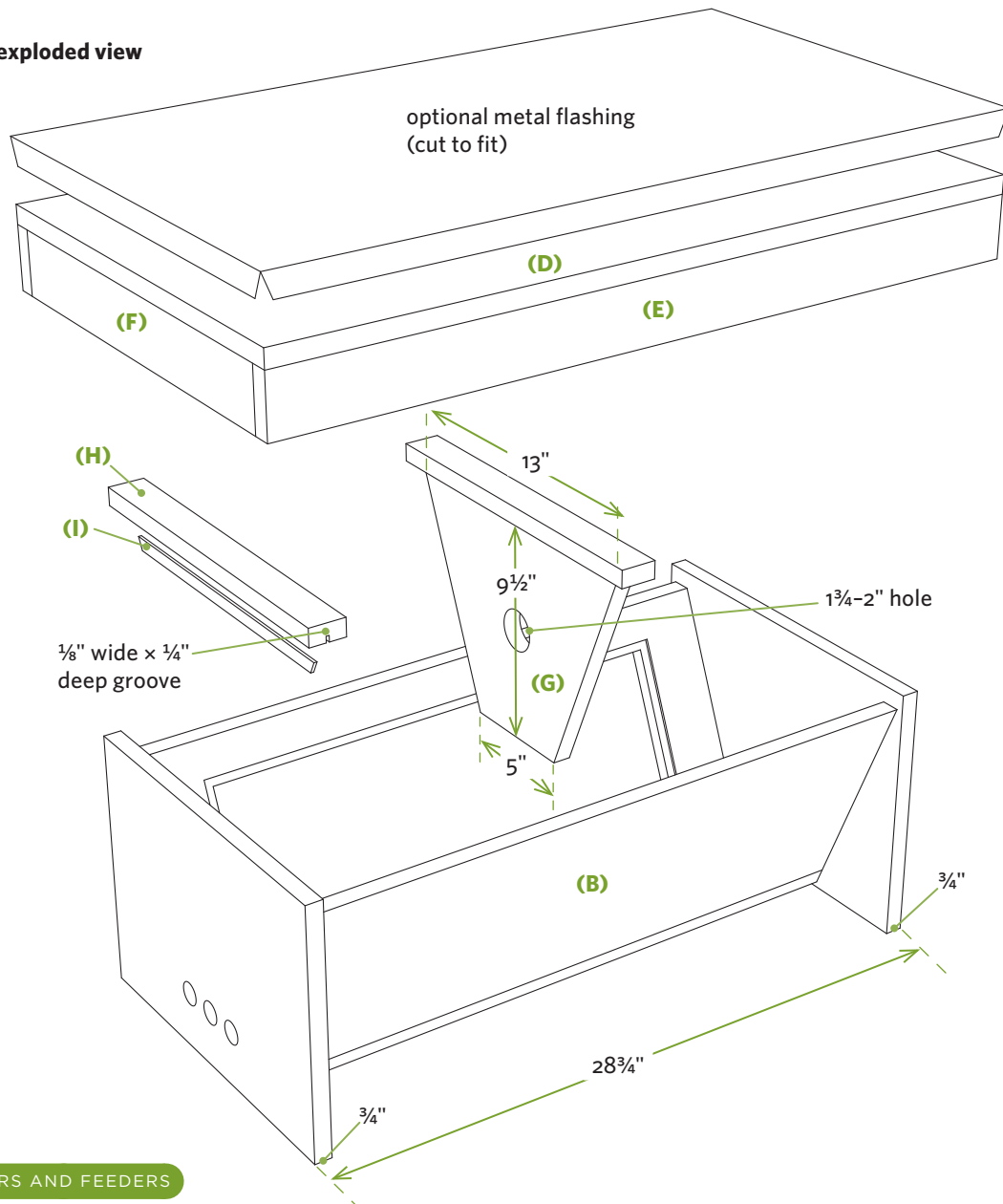

5. Cut the 18 top bars (H) to length. Set one aside to serve as the top bar for the separator you'll create in step 7. Use a table saw to cut a $\frac{1}{8}$ "-wide \times $\frac{1}{4}$ "-deep groove down the center of the remaining 17 bars. You may need to adjust the table saw fence and make two cuts to create the $\frac{1}{8}$ "-wide groove.
6. Cut the 17 starter strips (I) from $\frac{1}{8}$ " plywood, angling each end at $22\frac{1}{2}$ degrees to accommodate the sloped sides of the hive. Use exterior glue to secure the strips into the grooves of the top bars.
7. Cut the trapezoid-shaped separator (G), angling the side edges at $22\frac{1}{2}$ degrees. Make it a little oversize, test-fit it, and then trim it for a tight fit. Use glue and 2" screws to secure a top bar to the top of the separator.
8. Drill three 1"-diameter bee entry holes on each end piece as shown. See *Setting Up Your Hive* (page 229) for additional steps and materials needed to get your hive up and running.
9. Install legs as shown in the opening illustration or secure it to some other sturdy base.

NOTES FROM THE TEST TRACK

The Case for Keeping It Simple, Stupid (KISS)

While working on the design and building the prototype for the top bar beehive, I decided to be clever. I made clever use of materials and created a clever-looking hive, one with a peaked roof and other fine features. But it turns out clever isn't necessarily better; in fact, it can be much "worsen."

I sent photos and a description of my "new and improved" hive to consultant and beekeeper extraordinaire Ed Simon (see *Setting Up Your Hive*, page 229) to get feedback on the modifications I'd made to his tried-and-true plan. He kindly explained, "Well, it may look pretty, but it won't work." He pointed out that the peaked roof wasn't waterproof, was hard

to build, and created a space above the top bars that shouldn't be there. And, since it was hinged, the top would cause the hive to topple when opened. What's more, the "ingenious" system I'd created for holding the top bars would make it impossible to remove the bars for inspecting the hive and removing the combs.

A little knowledge can be a dangerous thing. The lesson learned? If you plan on modifying plans for any project, make sure you understand the big picture first. Fancier, bigger, more ingenious, and more complicated isn't necessarily better.

Setting up your hive

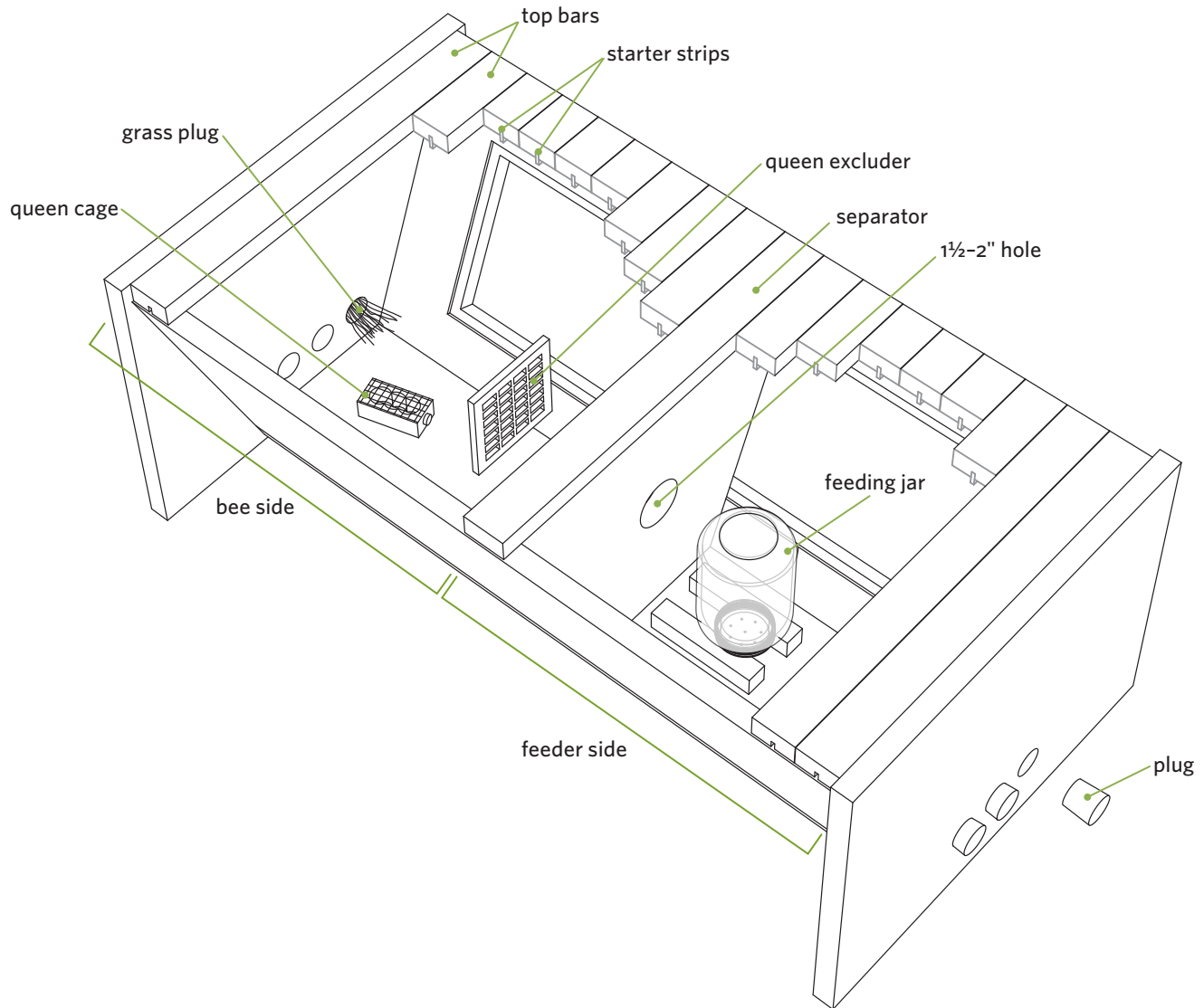

Room with a View

According to Ed Simon (see *Setting Up Your Hive*, page 229), one of the great pleasures of keeping bees is watching how they work inside the hive, and showing them to visitors. Including a viewing window will allow you to do just that. If you wish to add one, modify one of the sides before assembling your hive. Here's how:

1. Before assembling the hive, cut a rectangular hole in one of the sides (B). It can be any size, but leave at least 2" of solid wood on the top, bottom, and sides for rigidity.
2. Use a router with a $\frac{3}{8}$ " rabbeting bit to create a $\frac{3}{8}$ "-deep recess along all four sides of the opening. If you don't own a router and/or aren't familiar with using it, call in a favor from a friend. Use a chisel to square off the corners of the recess.
3. Cut a piece of Plexiglas to fit in the recess, and test-fit it. Permanently install the window using silicone caulk.
4. Create a window cover, and secure it to the outside of the hive with hinges. Install a pair of clasps or other hardware to keep the door shut when it's not in use.

Setting Up Your Hive

BY ED SIMON

If you're new to keeping bees, the first thing you should do is find a mentor through a local beekeeping club. That person will help you work your way through the ins and outs of beekeeping. Following is the "Quick Start-up" version of getting your hive up and running. It's impossible to present more than the basics, so rely on your mentor to explain anything you don't understand. Bee packages and queen excluders can be purchased through outlets such as Miller Bee Supply and B&B Honey Farm (see Resources).

Setting Up

Set up your hive where it's convenient but not where the bees will be a nuisance to neighbors or those walking by. The top of the hive should be at a comfortable working height. Secure it to a sturdy base or build a stand for it; both wind and animals will try toppling it.

- Drill a 1½" to 2" hole in the separator, then cover this hole with a portion of grid cut from a plastic queen excluder. This will keep the queen on the "bee side" of the separator, away from your feeder jar.
- Build a feeder jar by puncturing very small holes in the lid of a canning jar. Mix one part sugar to one part water and fill the jar. Put some of this syrup in a spray bottle to be used later to calm the bees while adding them to the hive.
- Put the separator into the top bar hive at the halfway point. On the "feeder side" of the separator, close off the entrance holes completely with rubber or cork plugs. These corks will stay in place the entire season. Turn the feeder jar upside down and place it on a couple of blocks of wood to allow the bees to get to the syrup.
- Coat each of the starter strips with beeswax. Place half of the top bars over the "feeder side" of the hive.
- On the "bee side" of the separator, use grass to plug the entrance holes.

Adding the Bees

There are lots of ways to add bees to a hive; here's one:

1. Don your beekeeping apparel. Spray your package of bees with the sugar water; this will keep some of them from flying.
2. Open the package and remove the feeder can and queen cage. Put the queen cage in your pocket.
3. Shake the worker bees into the "bee side" of the hive. Spray them again with sugar water.
4. Remove the cork from the queen cage while keeping your finger over the opening so the queen can't escape. Place the queen and cage directly in the middle of the cluster or mass of bees. The queen will walk out of the cage, and the worker bees will start building comb. Set the remaining top bars in place; there should be enough top bars on each side of the separator to cover the entire top opening. Install the lid and place a few bricks on top to hold it in place.

Making Honey!

Now the real fun begins:

- The next day remove one of the grass plugs on the bee side so the bees can roam freely. At this time, make sure the queen is not still in the cage, then remove the cage.
- As the bees build comb and the queen starts laying eggs, you have to keep the feeder jar filled with plenty of syrup. There is a fantastic amount of energy used to build comb, and the workers need this food in addition to what they gather outside of the hive.
- As the combs are built, remove a top bar from the feeder side of the hive, shift the separator toward the feeder, then replace the top bar on the bee side of the separator. Eventually you'll remove the feeder jar.

There are many ways of hiving bees; none of them are wrong, just different. Enjoy your bees.

ED SIMON tends 30 hives that produce more than 1,000 pounds of honey yearly, and he raises queen bees as a hobby. A retired IBM programmer and instructor, Ed is a frequent contributor to Bee Culture magazine and is active in his local beekeeping club. His book, *Bee Equipment Essentials* (see *Recommended Reading*), contains detailed instructions on building hives and beekeeping equipment.

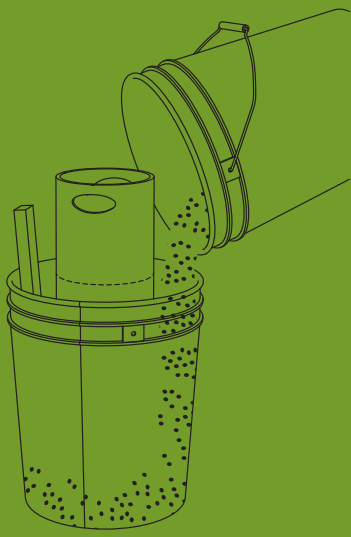

Concrete Planter, 262

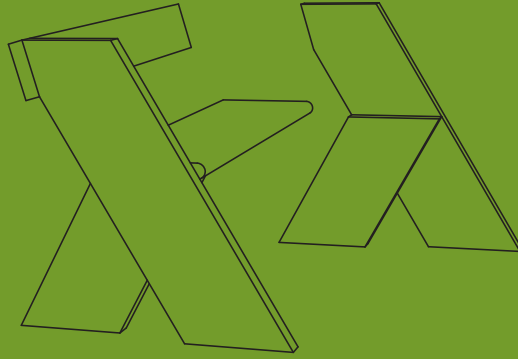

Leopold Bench, 236

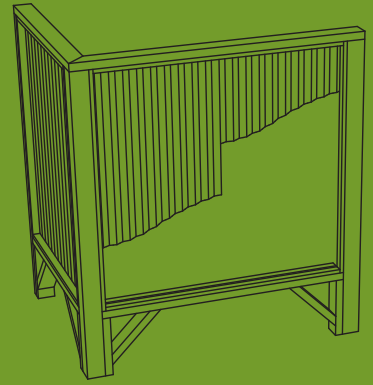

Outdoor Shower, 269

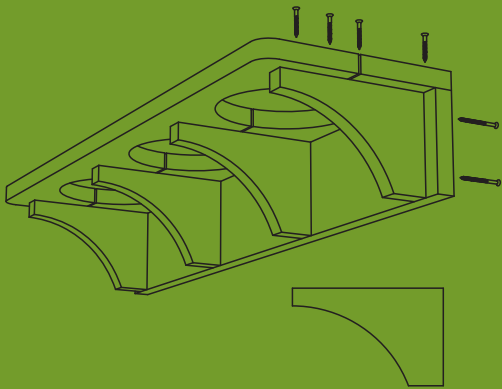

Spice Planter, 255

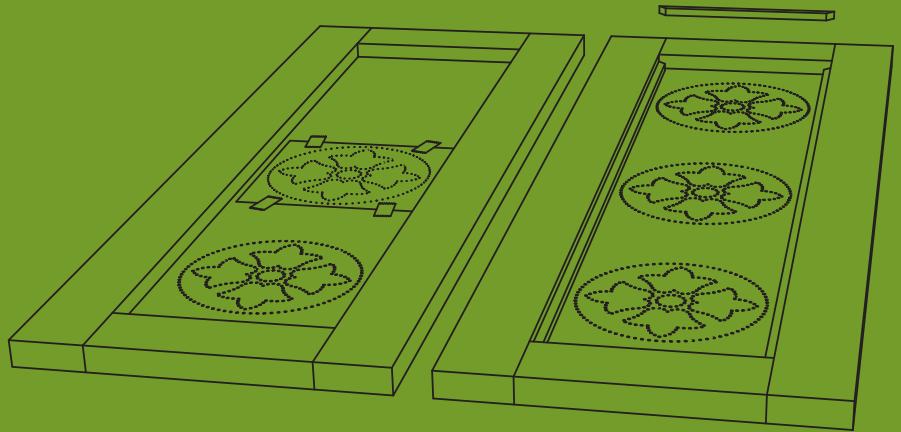

Punched Tin Jelly Cabinet, 248

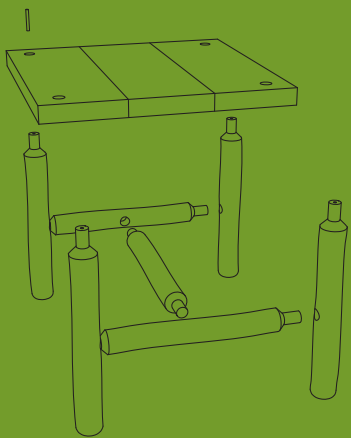

Rustic Garden Table, 258

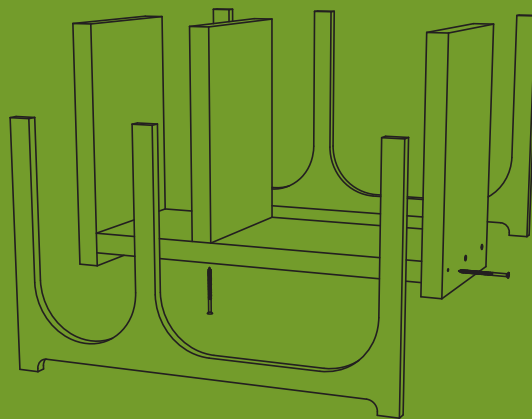

Firewood Cradle and Carrying Sling, 239

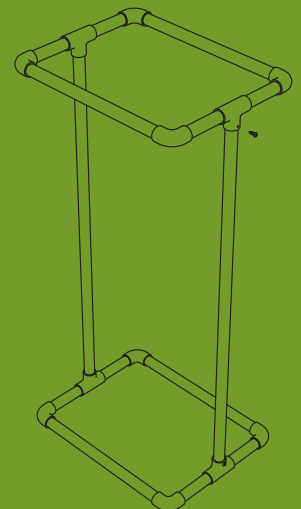

Lawn Bag Stand, 242

For the House and Yard

The backyard-homestead life doesn't stop at the back door; it marches around the backyard, through the garage, and into the kitchen. In this chapter, we'll present projects for making life in these realms easier, more functional, and better organized.

A few of the projects, like the boot scraper and backdoor storage locker, will help prevent you from tracking your backyard homestead enthusiasm too far into the house — and across the kitchen floor. Others, like the leaf bag stand and firewood cradle, will save you hassle and back pain. Still others, like the concrete planter, the spice planter, and the seedling rack, will allow your green thumb to keep active even in the house or on the backdoor stoop.

This may be the final chapter in the book, but our hope is that it's the beginning of a long chapter in a lifestyle of self-sufficiency and of do-it-yourself projects. Hammer on!

Boot Scraper and Jack

A place to scrape, brush, and stow mucky boots

It usually takes one muddy spring, one track of boot prints across the floor, and one good scolding to put the wheels in motion for this project. But once it's built, you'll have a place to stomp, scrape, and remove that mucky footwear. It's a boot cleaner, bootjack, and boot-drying rack all in one: the posts provide grips to hold on to while you're using it, and they double as racks to stow your boots upside down while they dry or air out.

We suggest using oak or some other hardwood for the platform and sides for durability. You can use pine or treated lumber, but neither will stand up to the wear and tear like oak or maple. Feel free to modify this basic design to accommodate the boots, and foot sizes, in your family.

Materials

- One 40" piece hardwood 2x8
- One 21" piece hardwood 1x12
- One piece 1½" x 8 ¼" angle iron
- Three or four ¼" x 1" x 9" hardwood strips
- Two 3" x 10" stiff-bristle deck brushes
- One 1¼"-diameter wooden handrail (with one flat side), 60" to 72" long
- Six 1¼" conduit clamps
- Two curtain rod finial balls
- One hardwood 2x3, 14¼" minimum length
- Exterior wood glue
- 1¼" exterior screws
- 2½" exterior screws
- ¾" exterior screws
- ¾" brads
- 4" exterior screws
- Exterior polyurethane

HINT

An old charcoal grill brush — one of those gizmos with a long handle, stiff bristles, and metal scraper — is a great makeshift boot scraper.



Parts and Cutting List

Part	Size and Material	Quantity
(A) small side wedge	1½" × 2¼" × 20" hardwood ¹	2
(B) large side wedge	1½" × 6½" × 20" hardwood ¹	2
(C) platform	¾" × 11¼" × 21" hardwood	1
(D) scraper	1½" × 8¼" angle iron	1
(E) grip strip	¼" × 1" × 9" hardwood	3-4
(F) boot brush	3" × 10" deck brush	2
(G) post	1¼"-diameter × 30"-36" handrail	2
(H) post support	1¼" conduit clamps	6
(I) post cap	curtain rod finial balls	2
(J) crosspiece	1½" × 2½" × 14¼"	1

¹Pieces taper as shown in *Cutting details*.

1. Mark the 2×8s for the sides as shown, and make the angled cuts with a circular saw to create the small (A) and large (B) side wedges. Lightly round over the upper edges of the larger wedges with sandpaper.
2. Use wood glue and 2½" screws to secure the small wedges (A) to the large ones (B) to create each side, as shown in *Cutting details* (below). Pre-drill holes to prevent splitting. Note that the two sides are mirror images of each other.
3. Mark the keyhole shape on the platform (C). Use a drill and a 3" hole saw to create the circular part of the keyhole and a jigsaw to make the rest of the cutout (or you can use a jigsaw with a narrow blade for the whole thing). Test-fit the heel of a boot in the cutout; if it's too small or the wrong angle, enlarge the opening as needed. Secure the platform to the two sides as shown, using glue and 1¼" and 2½" screws. Use longer screws as the wedges get deeper.

TAKE NOTE You may want to initially make the keyhole smaller than the one shown, then test-fit and enlarge the opening as needed. If there are little feet in the family, you may need to make a second bootjack!

Cutting details

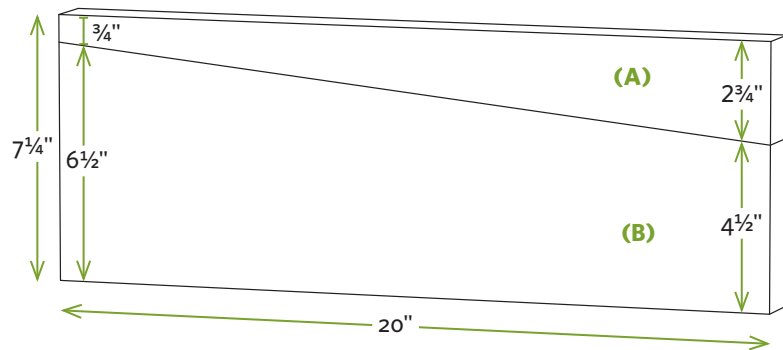
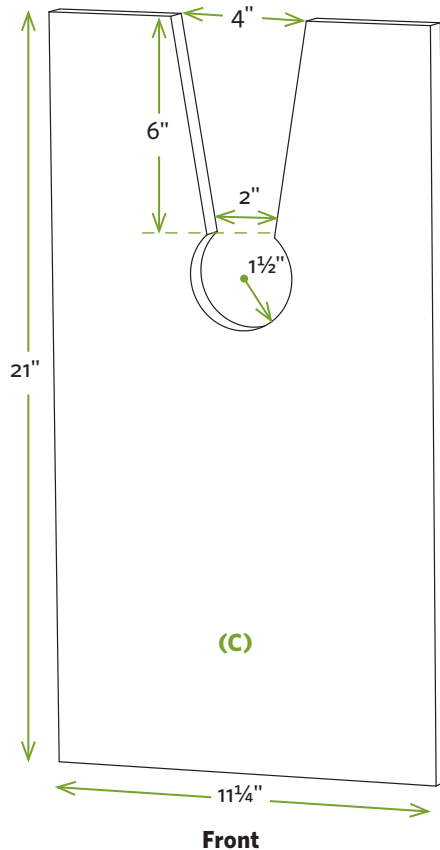

Wedge dimensions

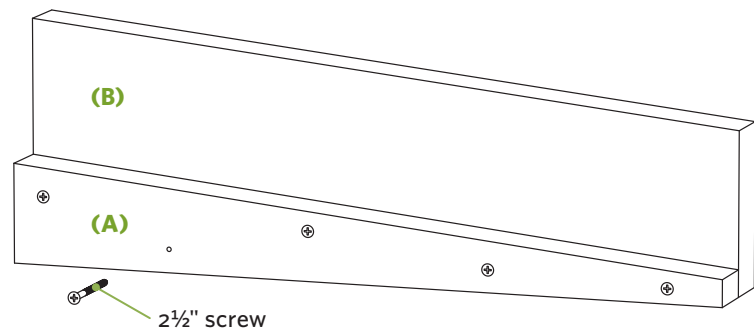

Assembled view

- Cut the angle iron for the boot scraper (D) to length with a hacksaw, bore mounting holes, and use a file to round over sharp corners. With one leg of the angle iron hooked *under* the platform, secure it from below using $\frac{3}{4}$ " screws and from the front using $1\frac{1}{4}$ " screws. Secure the brushes (F) to the sides with $2\frac{1}{2}$ " screws; experiment to find the right height before installing them permanently.
- Secure three or four grip strips (E) to the platform using glue and $\frac{3}{4}$ " brads, spacing the strips 1" to 2" apart.
- Use glue, a couple of $1\frac{1}{4}$ " screws, and conduit clamps (post supports; H) to secure the handrail posts (G) to the sides (B),

positioning the flat section of the handrail against the sides. Drill a hole in the top of each post, and screw on the post caps (I).

- Secure the crosspiece (J) about halfway up the posts, using 4" screws. (The flat area on the handrail gives you an ideal surface for securing the crosspiece.)
- Apply two or three coats of exterior polyurethane to protect your project from the elements.

TAKE NOTE The posts and crosspieces are for maintaining balance and hanging boots, *not* for tugging, pulling, or sitting. Spread the word.

Boot scraper and jack assembly

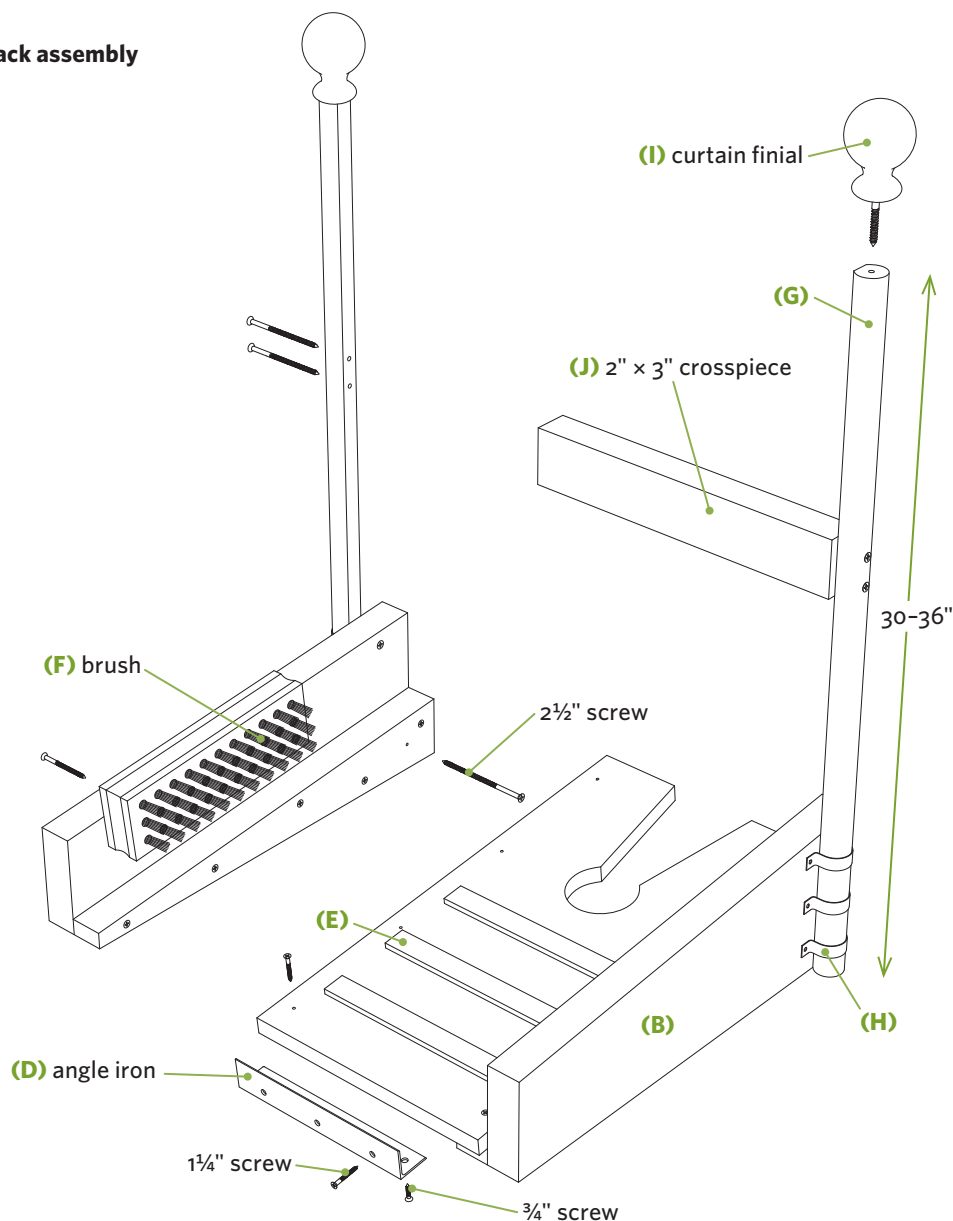

Of Boots and Boundaries

BY CATHERINE FRIEND

When we moved onto our farm in southeastern Minnesota, my mother gave us an odd metal thing, with two long spikes at one end and a small arch at the other. "It's a boot scraper," she said. "You'll need it."

Huh. The rustic item didn't go with our outside decor. It clashed with our inside decor. I stashed it in the closet.

Then the farming began. I didn't realize how hard it is to stop the farm from following you into the house. Your clothes trap so much hay and straw that when you drop your overalls at the end of the day, there's a ring of organic matter on the floor. Straw in underwear is very common. How does that even happen? Between the dogs and your Red Wing work boots, even more stuff appears in the house.

You quickly develop the need for a strong boundary between sheep manure and living space; sheep manure is to be kept outside. It's a simple rule and perfectly easy to follow. Family and friends dutifully shuffle across your new doormat,

leaving behind clumps of moist brown matter where it should be — until someone else steps into that moist brown matter and brings it into the house. If there's anything that clashes with our interior decor, it's mud and sheep manure.

I dug out Mom's gift and picked a spot along the sidewalk. I pounded the spikes in deep, which left exposed an iron arch about seven inches high. I began training my family to scrape-scrape-scrape before approaching the door. Stuff was still tracked into the house, but it was reduced to those bits stuck in boot treads. We eventually left a stick near the boot scraper so we could sit on the step and clean out our treads, too.

My mother, of course, was right. When beginning a farm, people remember to buy tractors and feed bins and pitchforks. The one item they don't consider is a boot scraper. Doesn't need to be iron. Doesn't need to match your decor — outside or inside. It just needs to be there, ready and willing to stop the farm from following you into the house.

CATHERINE FRIEND and her partner started a sustainable sheep farm 18 years ago. She's written about their adventures in two memoirs: *Hit by a Farm: How I Learned to Stop Worrying and Love the Barn*, and *Sheepish: Two Women, Fifty Sheep, and Enough Wool to Save the Planet*. She also writes children's books and fiction for adults. (See Resources for more information.)

Leopold Bench

2 hours + 6 boards = 1 heck of a useful bench

If you're looking for a project to kick off your backyard homestead building journey, you can't beat this one. It's cleverly designed, easy to build, fun to show off, and (best of all) comfortable. A deck stair tread, available at most home centers, for the

seat and a uniform angle cut for the legs make this a project anyone can tackle with success.

The benches are the right size (and cost!) for setting in the garden, around the fire pit, in the woods, or on the back porch.



Materials

- One 10-foot pressure-treated 2×8
- One 36" pressure-treated 2×12 stair tread
- One piece pressure-treated 2×6, 39" minimum
- One 2×4 scrap (for alignment)
- Construction adhesive
- 2½" exterior screws
- 3½" exterior screws

1. Cut the front (A) and back (B) legs to the lengths shown. Since all the angles are the same, you'll get a few "free" cuts as you work your way down the board. Use a Speed Square (page 10), angle finder, or protractor to establish the 30-degree angle. You can cut all four leg members from one 10-foot 2×8.

Parts and Cutting List

Part	Size and Material	Quantity
(A) front leg/ backrest	1½" × 7¼" × 33" ¹ PT lumber	2
(B) back leg	1½" × 7¼" × 18" ¹ PT lumber	2
(C) seat	1½" × 11¼" × 36" PT stair tread	1
(D) backrest	1½" × 5½" × 39" PT lumber	1

¹Measurements are from long point to short point of a 30-degree angle.

2. Position the short legs on top of the long legs as shown. Use a straight 2×4 or a 4-foot level to align the bottoms of the legs. Check to make certain left and right side assemblies are identical mirror images of one another. Secure the short legs to the long legs using construction adhesive and 2½" screws.

Leg cutting diagram

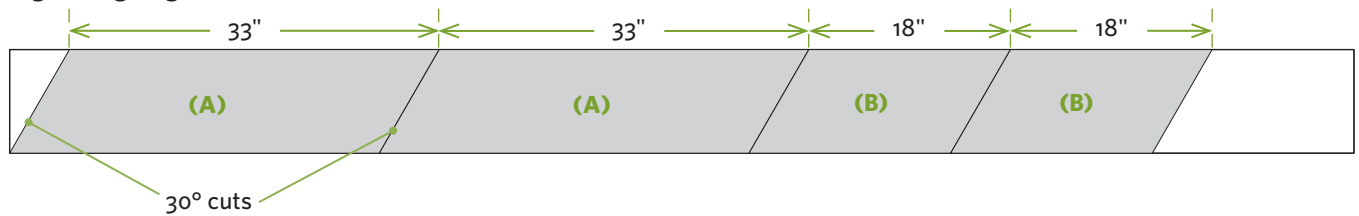

Bench assembly

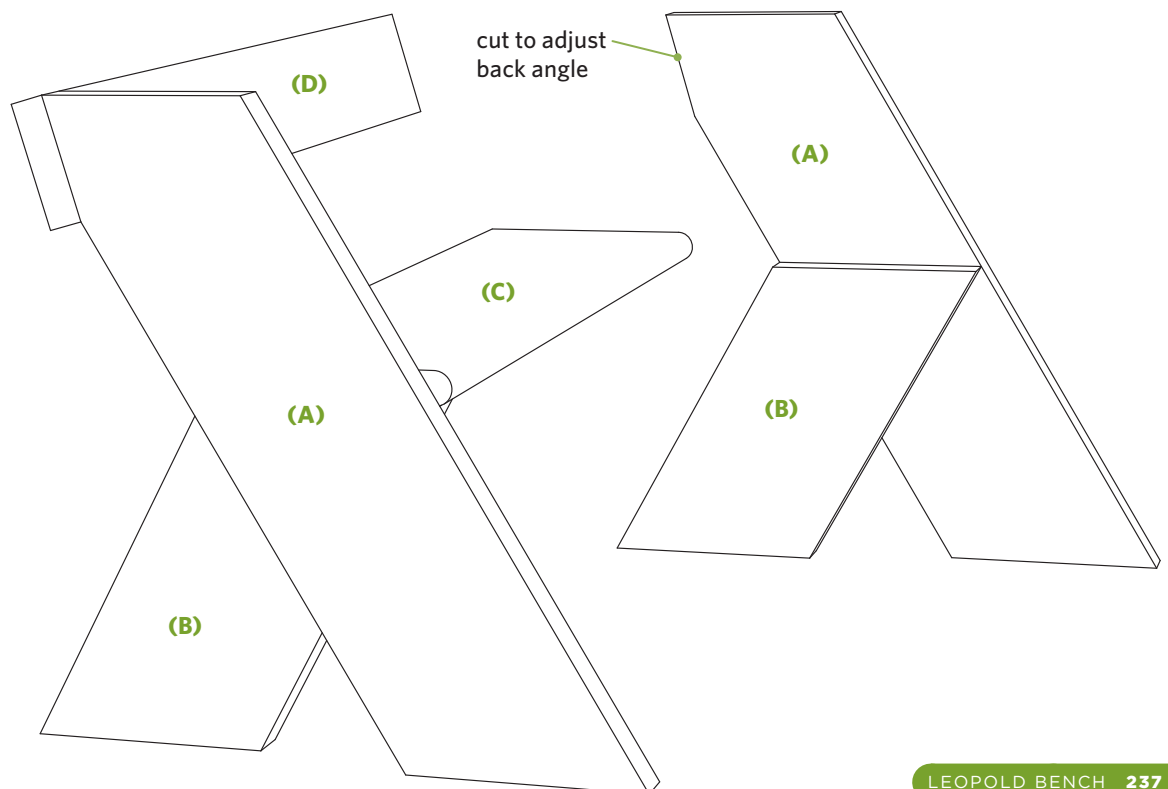

Legend has it, Aldo Leopold designed the bench so those seated on it had to sit upright and pay attention to the natural world around them. Others say the bench was inspired more by an old set of stairs salvaged from the dump.

3. Stand the leg assemblies upright with the short legs facing inward; an assistant comes in handy here. Set the seat (C) in place and adjust the parts so the back of the seat just kisses the back of the back legs. Drive four 3½" screws through the seat on each end into the tops of the short legs. Drive a few long screws through the bench sides into the ends of the treads.
4. Lay the bench facedown and position the backrest (D) flush to the top of the front legs (A). Use a square to check that the seat and backrest are square to the leg assemblies, and secure the backrest to the legs with three 3½" screws on each end.

TAKE NOTE You can adjust the angle of the backrest by making slight angle cuts at the top of the legs as shown in *Bench assembly* (page 237).

Who the Heck Is Aldo Leopold?

Rand Aldo Leopold is considered by many to be the most influential American conservationist of the twentieth century. He was a forester, teacher, scientist, environmentalist, and nature writer. He worked for the U.S. Forest Service, taught at the University of Wisconsin, and helped found the Wilderness Society. His book *A Sand County Almanac*, written in 1949, has sold more than 2 million copies. The book was based on his experience purchasing 80 acres of depleted, overgrazed land in central Wisconsin and restoring it to health by practicing what he preached.

Leopold built his original bench while working on his farm in Wisconsin, where he and his family spent weekends in a restored chicken coop, affectionately nicknamed "The Shack." Legend has it, he designed the bench so those seated on it had to sit upright and pay attention to the natural world around them. Others say the bench was inspired more by an old set of stairs salvaged from the dump. Either way, both Leopold and his bench have become enduring classics.

Firewood Cradle and Carrying Sling

A dynamic duo for less hassle, less mess

If your normal method of moving firewood involves stacking five or six logs in a bent arm, tracking bark and debris across the floor, and then dumping it on the floor, well, here's a project for you. The cradle gives you a convenient place to

store firewood and kindling, and the canvas sling gives you an easier way to haul it. Load up the sling at the woodpile, carry it into the house, and then place the sling and firewood in the cradle. Less fuss, less muss, less arm strain.

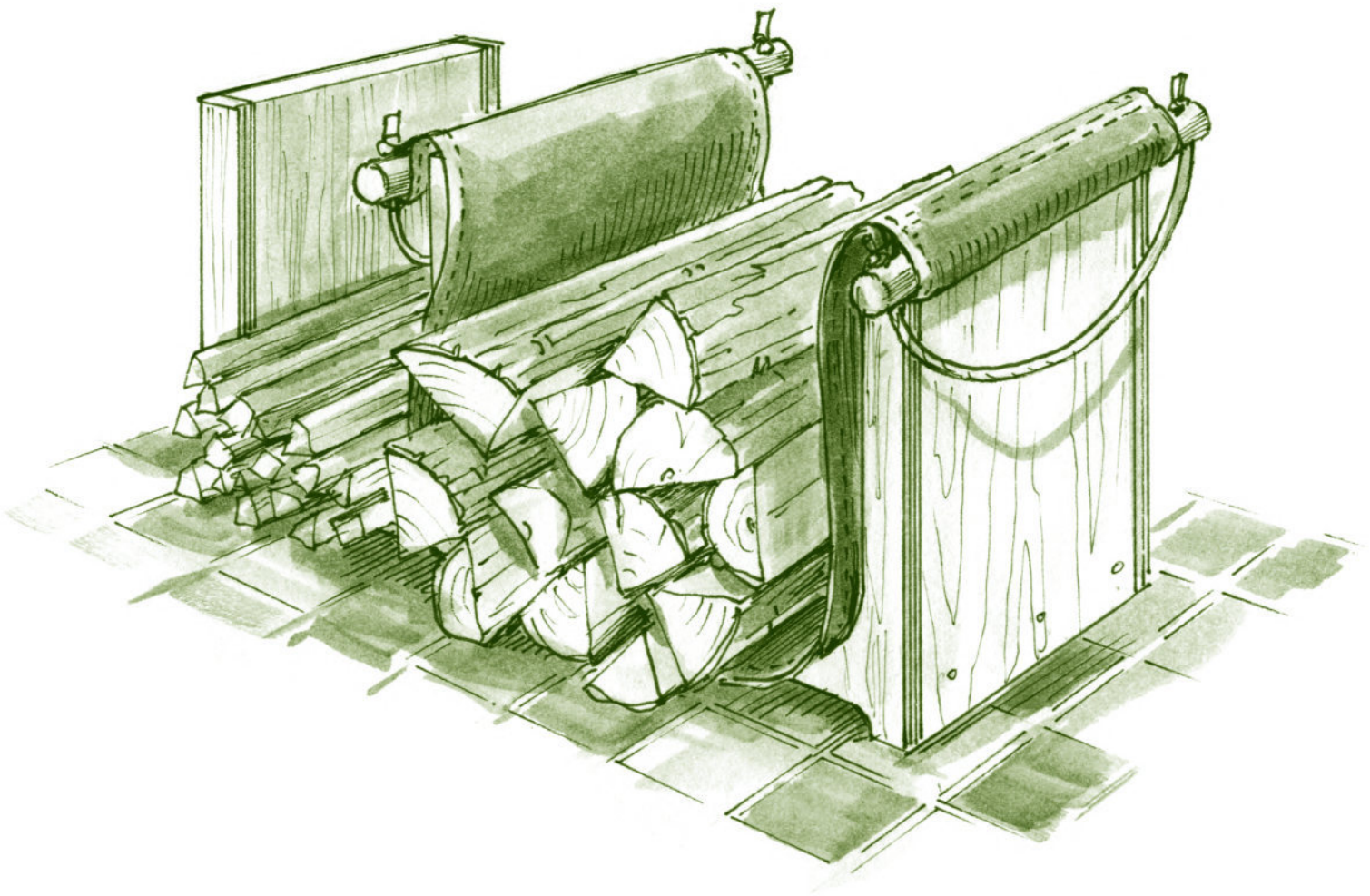

Materials

- One 8-foot pine 2×12
- One 4 × 4-foot sheet $\frac{3}{4}$ " plywood
- One 1"-diameter × 36"-long wood dowel or closet rod
- One 18" × 60" piece heavy canvas (see step 4, opposite)
- $3\frac{1}{2}$ " screws
- Wood glue
- 6d finish nails
- Heavy-duty upholstery thread
- Sturdy rope

1. Cut the base (A), sides (B), and partition (C) to length, and secure them to one another with $3\frac{1}{2}$ " screws as shown. Assemble the cradle frame so the sides extend 1" below the base to create the legs.

Parts and Cutting List

Part	Size and Material	Quantity
(A) base	$1\frac{1}{2}$ " × $11\frac{1}{4}$ " × $25\frac{1}{2}$ " pine	1
(B) side	$1\frac{1}{2}$ " × $11\frac{1}{4}$ " × 18" pine	2
(C) partition	$1\frac{1}{2}$ " × $11\frac{1}{4}$ " × $15\frac{1}{2}$ " pine	1
(D) front/back panel	$\frac{3}{4}$ " × 18" × $28\frac{1}{2}$ "	2
(E) handle rod	1" × 18" dowel	2
(F) sling	18" × 60" canvas	1

2. Mark and cut the front and back panels (D) as shown in *Cradle construction* (below). The goal is for the plywood uprights to align with the 2×12 frame uprights. Use a circular saw with the straight parts and a jigsaw to cut the curves. Smooth and slightly round the edges by hand sanding or by using a power sander.

Cradle construction

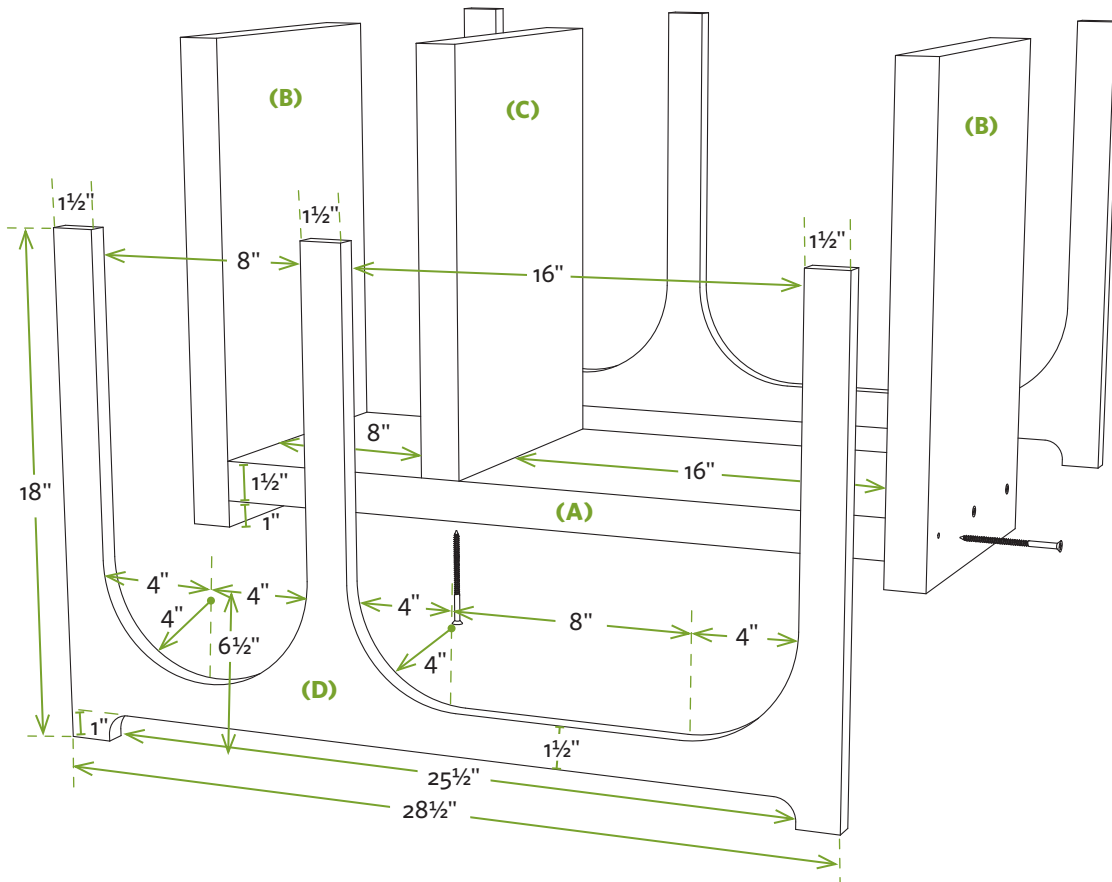

3. With the cradle frame assembly (A, B, C) lying on its back, position the front panel (D) on top of it to make sure everything aligns and fits properly. Remove the panel, apply generous beads of wood glue to the front edges of the cradle frame pieces, and use 6d finish nails to secure the plywood to the frame. Flip the cradle over, and install the other back panel in the same way. Sand any rough edges, and apply a clear finish or paint, if desired.
4. Cut a piece of heavy-duty canvas for the sling (F) as shown. Fold over the long edges and stitch them to create a rolled edge. Position the handle rods (E) near the ends of the canvas, and loop the canvas over the rods. Double-stitch the seam. Drill holes in the ends of the handle rods and loop rope through them to create handles.

TAKE NOTE Experiment with the ergonomics of your wood-carrying style before cutting the canvas to length. A finished sling length of 48" to 54" works well for most people. Lengthen or shorten the sling according to your preference, making sure to account for the extra material needed for folding and stitching the ends.

Sling details

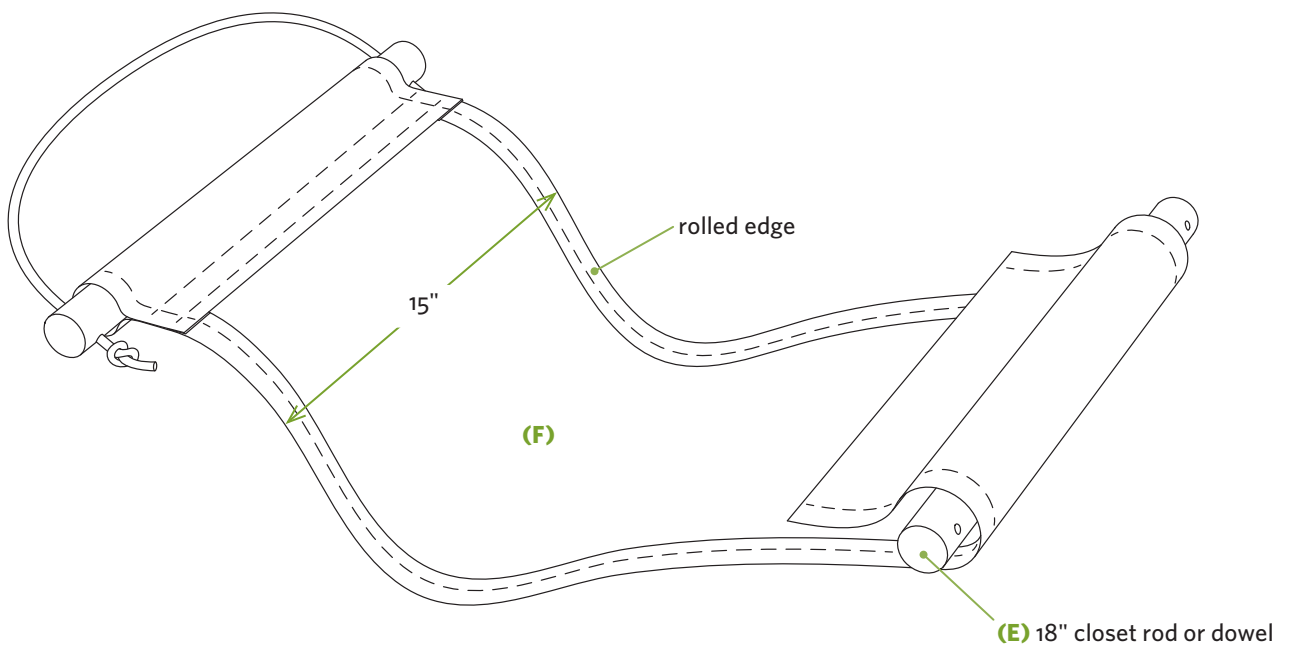

Lawn Bag Stand

Work faster with less frustration

Raking leaves and cleaning up the vegetable garden are enough work without having to hassle with keeping cleanup bags upright and open. You can build this simple PVC leaf bag stand in an hour or two.

To use it, open the mouth of the leaf bag and then turn the bag upside down as you slide it over the frame. Flip the stand and bag over, and go to work. If you like to lay bags on their sides and rake leaves

and debris directly into them, it will work in that position as well. Remove the stand once the bag is partially full and able to stand on its own, before you start packing the leaves tightly, or you may have trouble removing it later.

When you're done using it for the season, simply remove four screws, take off the legs, and store the pieces on a shelf until the next fall.



Materials

- Two 10-foot pieces $\frac{1}{2}$ " PVC pipe
- Eight $\frac{1}{2}$ " PVC 90-degree elbows
- Four $\frac{1}{2}$ " PVC T-fittings
- PVC primer and solvent glue
- 1" screws

1. Cut the long (A) and short (B) frame pieces and legs (C) to length using a hacksaw, miter saw, or pipe cutter.

TAKE NOTE The stand is designed to prop open a fairly standard 11" x 15" x 34", 30-gallon leaf bag. Before cutting the PVC pieces, measure your bags and adjust the lengths of your pipe pieces accordingly. PVC fittings also can vary slightly in size.

2. Glue the parts of the upper and lower frames together as shown, using PVC primer and solvent glue (sometimes called PVC cement), following the manufacturer's directions. Make certain the elbows are all aligned with one another and that the legs of the Ts are positioned 90 degrees to the frames.
3. Slip the two legs into the T-fittings on the frames. Drill a small hole through the side of each T and into the end of the legs, and install a 1" screw to complete the stand assembly. These are the screws you can remove for disassembling the stand for flat storage.

Parts and Cutting List

Part	Size and Material	Quantity
(A) long frame	$\frac{1}{2}$ " x 13" PVC pipe	4
(B) short frame	$\frac{1}{2}$ " x 4" PVC pipe	8
(C) leg	$\frac{1}{2}$ " x 30" PVC pipe	2
(D) elbow	$\frac{1}{2}$ " PVC elbow	8
(E) Ts	$\frac{1}{2}$ " PVC T-fitting	4

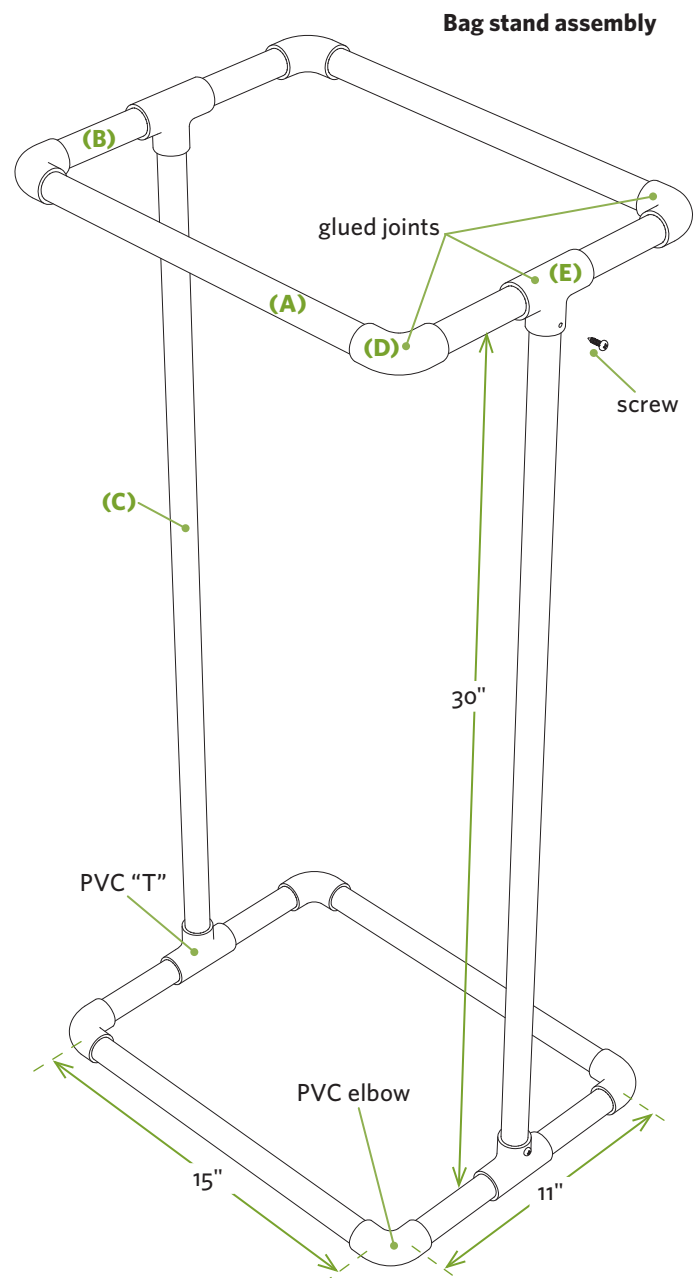

Backdoor Storage Locker

Organize mudroom clutter

This freestanding cabinet was inspired by the lockers found in almost every school hallway and locker room in North America. The top shelf provides plenty of storage for hats and gloves, and the bottom tray-shelf gives you a place for stashing muddy or soggy footwear. In between, there's plenty of room for jackets, backpacks, and other items.

Build one for each member of your clan, then join the lockers side by side and/or build a bench between them as shown.

The general plan is to build a box with a front opening $\frac{1}{4}$ " larger in both directions than a single bifold door (G). Our door measured $1" \times 14\frac{3}{4}" \times 80"$. Buy your door before starting the project – if the size differs, alter your parts dimensions accordingly. If your bifold door is 79" tall, subtract 1" from the length of the side pieces (A).



Materials*

- Two 10-foot pine 1x12s
- Five 8-foot pine 1x2s
- One 8-foot pine 1x4
- One 1" x 14³/₄" x 79-80" bifold door panel
- One ¼" x 16½" x 80" plywood
- Wood glue
- 8d finish nails
- 1" brads or finish nails
- 1¼" drywall screws
- One 6-foot-long piano hinge with screws
- One door handle with screws
- One door latch with screws

*For one locker

Parts and Cutting List*

Part	Size and Material	Quantity
(A) side	¾" x 11¼" x 83" pine	2
(B) top/bottom	¾" x 11¼" x 15" pine	2
(C) support frame front/back	¾" x 1½" x 15" pine	8
(D) support frame side	¾" x 1½" x 8½" pine	8
(E) back cleat	1" x 3½" x 15" pine	2
(F) shelf slat	¾" x 1½" x 15" pine	12
(G) louvered door	1" x 14¾" x 79-80" door panel	1
(H) back paneling	¼" x 16½" x 80" plywood	5

Locker Room Options

These lockers are so convenient, you may want to build one for each member of the family, including the dog. Here are a few options:

- Join multiple lockers side by side to create a bank of lockers. If you want a little more elbow room between units, insert 1x2s or 1x3s between them to serve as spacers.
- Separate lockers with a simple seat with cubbyholes beneath (see facing page). The seat provides a convenient place to sit while putting on shoes and boots, and the cubbies provide even more storage space.
- Add an extra slatted shelf about 12" to 24" below the upper slatted shelf so school-age kids have access to a place to stash gloves and mittens. As a kid gets taller, it's easy to raise that shelf.
- There are a variety of bifold doors you can use. Some, like the ones shown, are fully louvered; others are completely solid; and still others are solid at the bottom and louvered at the top.
- Paint or stain your lockers, as desired, to match your decor. If you stain them or leave them natural, apply a couple of coats of polyurethane to help protect the wood.
- Build a locker for Fido. It's a great place for stashing leashes, pickup bags, doggy-wear, food, and toys.

1. Cut the sides (A), top, and bottom (B) to length from 1×12 lumber. Position the side pieces side by side, mark the locations of the top and bottom shelves and support frames, and use a framing square to extend lines across the faces of both boards. Secure the top and bottom (B) to the sides with glue and 8d finish nails.
2. Cut the parts for the four support frames (C, D), and assemble them using 8d finish nails.

Cabinet box construction

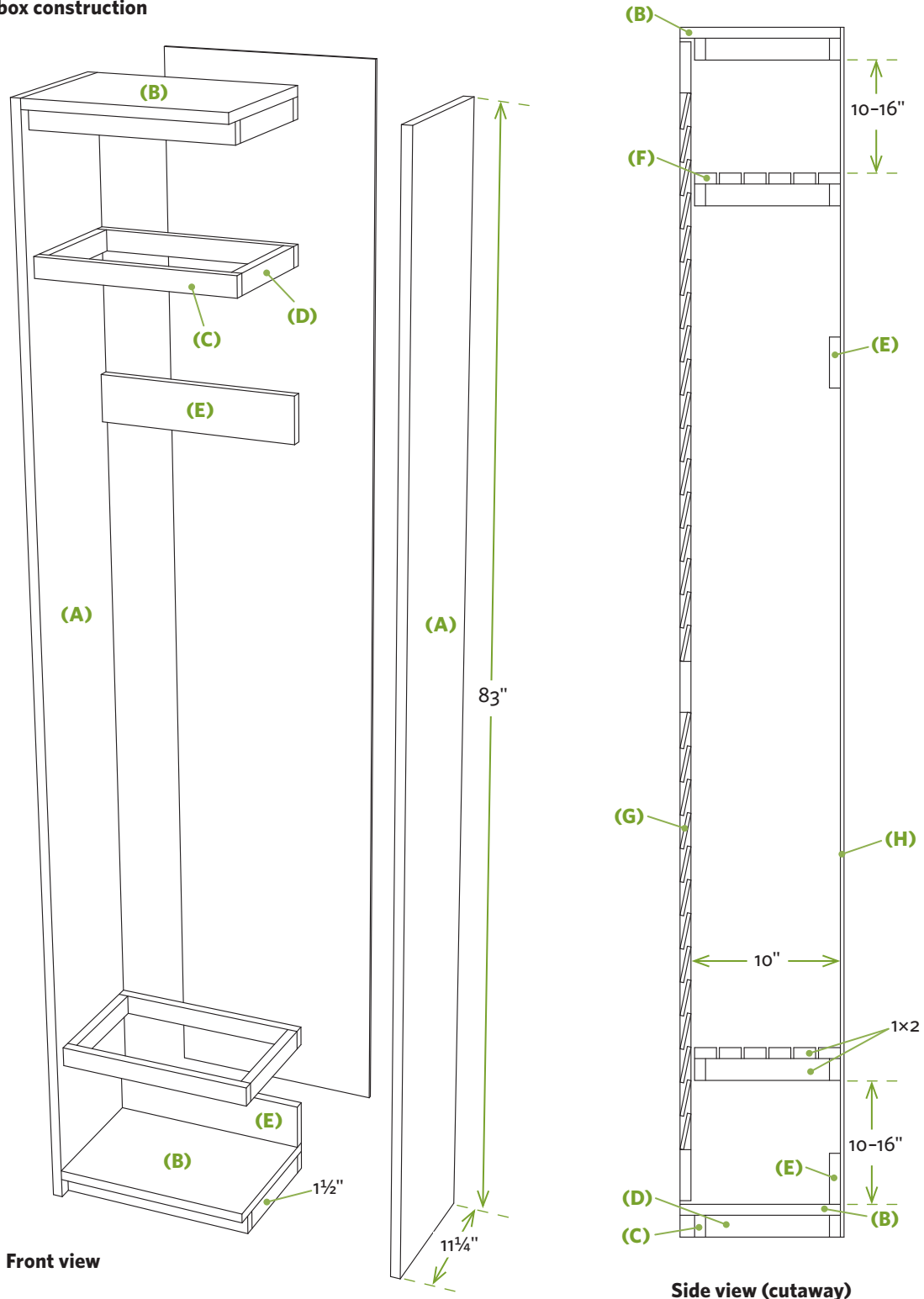

3. Use wood glue and 1¼" drywall screws to secure the frames to the layout lines on your cabinet sides. One frame adds support to the top (B), and another supports the bottom (B). The intermediate shelves can be arranged to suit your needs.

TAKE NOTE Leave 1" to 1¼" of space between the front of each support frame and the front of the cabinet to accommodate the inset door.

4. Install the back cleats (E), flush with the back of the cabinet. Position the top cleat at "coat hanging" level.
5. Square the cabinet, and install the ¼" back plywood (H). Nail the plywood to the backs of the frame, support frames, and the back cleats with 1" nails.
6. Cut the 1×2 shelf slats (F) to length, and nail them to the support frames as shown.
7. Mount the door in the opening using a piano hinge. Add a door handle and latch. If you need to trim the door lengthwise or widthwise to fit before installing it, use a straight-cutting jig (page 29).

Door and shelf details

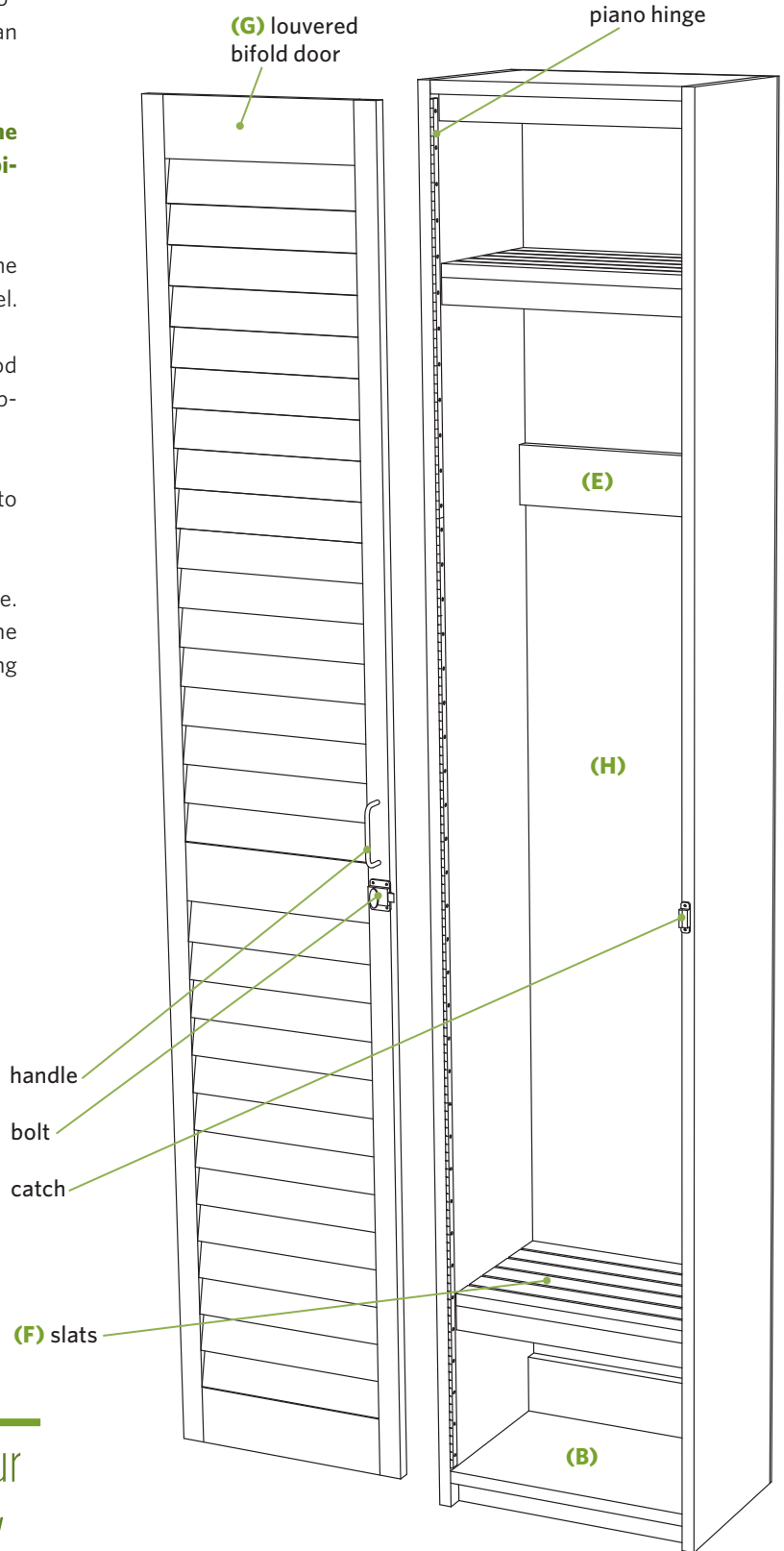

Build one for each member of your clan, then join the lockers side by side or add a bench between them.

Punched Tin Jelly Cabinet

Home center cabinets + flashing = vintage storage

This project takes two vintage concepts, the jelly cabinet and the pierced tin pie cabinet, and rolls them into one. Jelly cabinets were popular because they provided a convenient place to store abundant amounts of canned goods. Pierced tin pie cabinets were popular because they provided a well-ventilated, fly-free area to cool and store baked goods prior to the invention of metal screening.

Though this cabinet is based on vintage ideas, it doesn't make it any less useful today. It's the perfect place for storing kitchen and pantry overflow. It's easy to build, too. I used two wall cabinets from a home center as the core of the project, and then completed it using oak plywood and solid-oak trim boards. You don't have to be an old-world craftsman to create the pierced tin front. The material is galvanized flashing, and the inexpensive patterns (along with other tools and materials) are available from the sources listed at the end of the project.



See page 6 for a photograph of this project.

Materials*

- Two stock cabinets
- ¼" plywood
- ¾" oak plywood
- 1×2 or 1×3 oak boards
- ¾"-thick solid oak panel (for cabinet top)
- 1×4 oak board
- Metal flashing
- Oak screen molding
- Wood glue
- 2" screws
- 4d finish nails
- Construction adhesive
- ½" or ¾" brads
- One punched tin pattern (more if desired)
- Door pulls (optional)

*Materials quantities will depend on the size of your cabinets.

Choosing Cabinets

This project is an opportunity to let your inner designer cut loose. I stacked 12"- and 30"-tall wall cabinets, but you can make your cabinet taller, deeper, or wider. Selecting the right type of cabinet is important if you want to follow the design given here. The cabinets I chose, widely available at home centers, include:

- Face frames with "partial overlay" doors. This allowed me to add a face frame (C, D, E, F) to the cabinet front for a clean look.
- Concealed hinges. This allowed the doors to swing freely without hitting the face frame that was added.
- Frame-style doors with flat panels. This allowed me to inset the flashing used for the punched tin panels and cover the edges with molding (K, L).

You can use old cabinets or cabinets of a different style, but experiment beforehand to make certain the doors will operate and that the overall design will work.

Parts and Cutting List

Part	Size and Material	Quantity
(AA) cabinets	(see Choosing Cabinets, below)	2
(A) furring strip	¼" × cut-to-fit oak plywood	8
(B) cabinet side	¾" × cut-to-fit oak plywood	2
(C) face frame long stile	¾" × 1½"-2½" solid oak	2
(D) face frame rail	¾" × 1½"-2½" solid oak	2
(E) face frame base	¾" × 3½" solid oak	1
(F) face frame center stile	¾" × 1½"-2½" solid oak	2
(G) top	¾" solid oak	1
(H) bracket	¾" × 3½" × 6" solid oak	4
(I) punched metal panel	cut-to-fit metal flashing	2
(J) punched metal pattern	pattern	1-2
(K) short panel molding	cut-to-fit oak screen molding	4
(L) long panel molding	cut-to-fit oak screen molding	4

The cutting list doesn't include specific measurements since cabinets and projects will differ. But follow along, and you can create a cupboard to fit your space and needs. You'll find it easier to paint or stain your cabinet before installing the punched tin panels.

Building the Jelly Cabinet

1. Position one cabinet (AA) on top of the other and secure them using glue and 2" wood screws. If the face frame of your cabinet has lips that extend ¼" past the sides, add ¼" furring strips (A) to the sides as shown in *Cabinet construction* diagram (page 250).
2. Cut plywood sides (B) long enough to cover the cabinet sides and extend 3½" below the cabinet to create the legs. Use a jigsaw to create the leg "cutouts". Use wood glue and 4d finish nails to secure the side panels to the edges of the front stiles and back edges of the cabinets, making sure the front edges are flush.

3. "Picture-frame" the front of the cabinet with wood boards, using glue and 4d finish nails. Leave a $\frac{1}{4}$ " space between the edges of the doors and the edges of the rails and stiles you install so the doors can swing freely. The two vertical side stiles (C) should extend from the top of the cabinet to the bottom of the plywood legs and be wide enough to cover the face frame of the cabinet and the exposed edges of the plywood side panels. The upper and lower face frame rails (D) and face frame base (E) should fit snugly between the long stiles (C). Cut the arch into the base before installing it. If your cabinets require stiles between the doors (F), add them.

TAKE NOTE Before installing any of the picture frame pieces, lay the assembled cabinets on their backs and position the frame pieces just as you would if you were installing them. Check to make sure the doors operate okay and that everything aligns before fastening the parts.

Cabinet construction

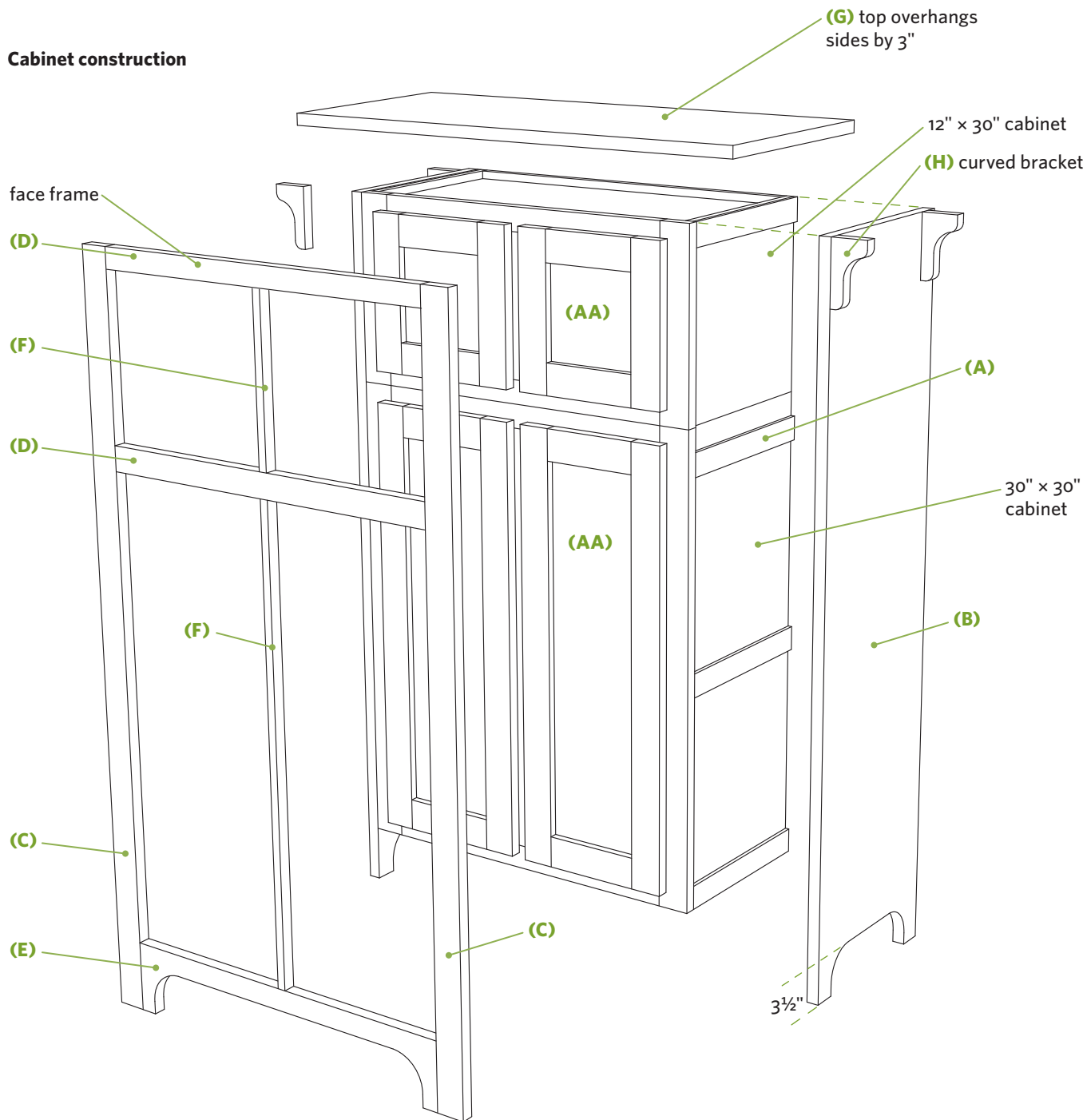

4. Secure the solid-wood top (G) in place using finish nails driven in from above or screws driven in from below. You can either purchase wide solid wood panels at a home center or create your own by gluing narrower boards side by side. Let the top extend 3" beyond each side and 1" beyond the front, and then add arched brackets (H) for a Craftsman- or country-style look.
5. Remove the doors. Cut galvanized or copper flashing (I) to fit the sunken panel areas of the doors. Secure the flashing to the door fronts using contact adhesive. Protect the edges of the flashing, and hold it in place by installing thin moldings (K, L) around the perimeter of the sunken panels, secured in place with short brads.
6. Play around with the position of your punched tin pattern (J) until you arrive at a design you like. Tape the pattern in place as shown. Position the door over a piece of extruded foam insulation or plywood to support the back of the panel as you punch the holes. Use a nail set, special punch (see Punched Tin Panels: Patterns and Suppliers Galore, below), or 16d nail to punch the holes of the pattern. Most patterns can be used only two or three times; if you're going to repeat the pattern more than that, purchase or print out extra patterns.
7. Remount and adjust the doors; then add the pulls of your choice. To add more shelf capacity to your cabinet, you can install narrow, slotted bookshelf standards to the sides of the cabinet to support additional shelves.

Punched tin details

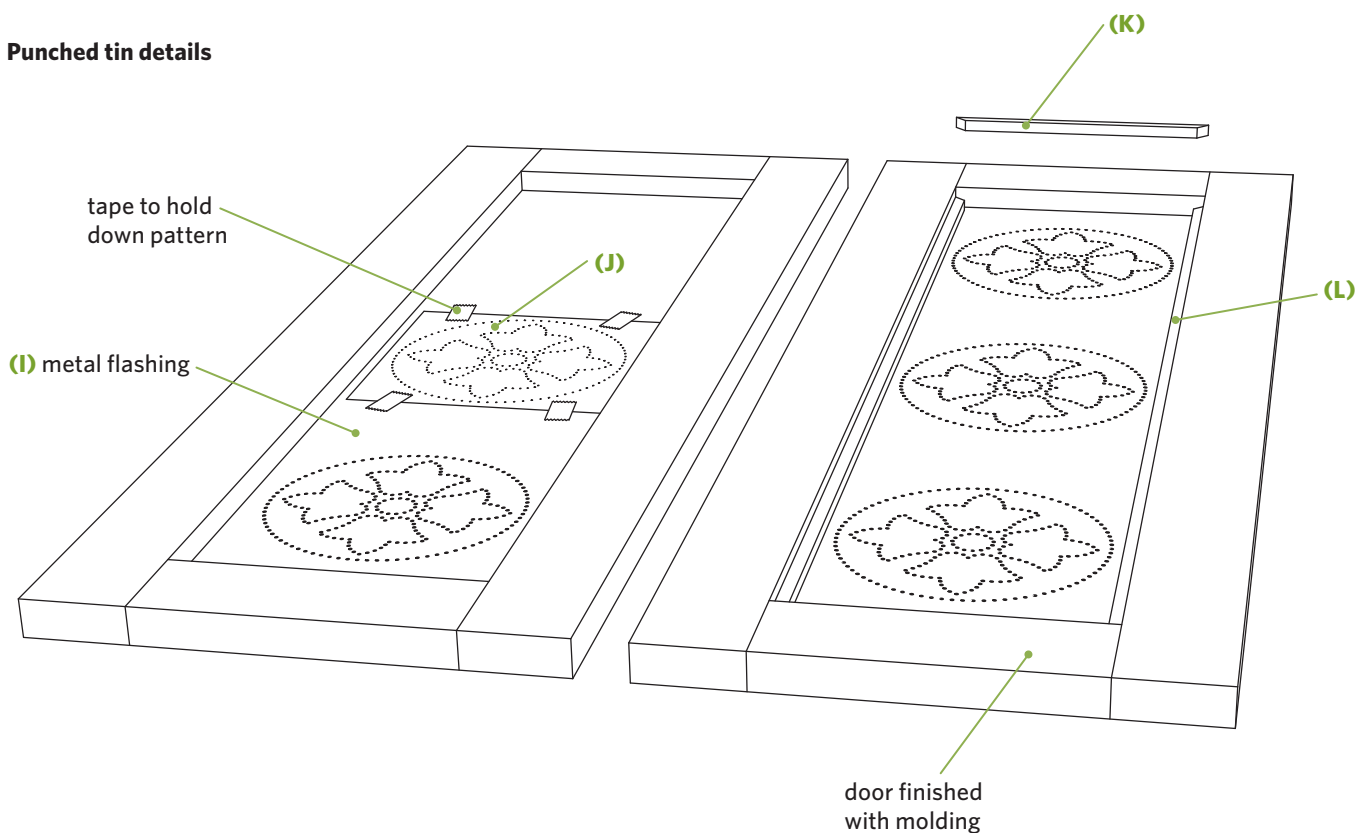

Punched Tin Panels: Patterns and Suppliers Galore

You can purchase patterns, punches, metal sheets, and even completed panels from a variety of specialty suppliers (see Resources). There are dozens of patterns available (some you can print out from sources on the Internet), including those with diamonds, wheat, weeping willows, and stars. Once you've selected a pattern you like (I used the "Bluebells" pattern), find out which punching tool or tools are recommended. With some patterns you can use 16d nails or a nail set; with others, using specialty punches will result in a more attractive, authentic-looking cabinet.

Clothes Pole Trellis

A natural way to dry clothes

These poles support not just your clotheslines but your climbing vines as well. Build a single pole if you plan to have your clotheslines connected to the house; two if your lines will be freestanding. I built a set of poles from cedar, but you can use treated material to save money. You can use eye hooks for a stationary clothesline or pulleys that let you reel in your laundry. Adjust the height of

the poles to fit your needs (setting your pole so the crossbar and lines are 4 to 6 inches above your head is a comfortable height for most people). The absolute maximum spacing between poles (or a pole and your house) should be around 18 feet.

Your vines can be strictly for looks or be of the more productive kind (see *Plant the Right Vine!*, page 254).



Materials* (per pole)

- One 10-foot cedar 4×4
- One 4-foot cedar 4×4
- Gravel
- Wood preservative
- Scrap 2×4s (or other lumber; see step 4)
- Concrete mix
- Two 3" lag bolts
- Sixteen ¼" × 2" screw eyes
- Braided ⅝" cable
- Four cable clamps
- Two turnbuckles
- Five ⅜" × 2" screw eye bolts or clothesline pulleys
- Clothesline
- One decorative fence post cap per post

*All hardware and cable/wire must be rust-resistant.

TAKE NOTE Before doing anything, call 811, the "Call Before You Dig" hotline, to have all utility lines marked on your property (see page 26).

1. Cut each 4×4 upright and crossbar to length. Mark 3½"-wide notches in each, as shown. Set a circular saw to cut 1¾" deep, and make a series of cuts between your marks. To create the notches, use a hammer and chisel to remove the fingers of wood.

TAKE NOTE The tighter the notches fit together, the more solid and wobble-free the crossbar will be. Err on the side of making the notches too narrow, test-fit the pieces, and then gradually widen the notches as needed.

2. Fit the notch of the crossbar into the notch of the upright to create a T, and use two 3" lag bolts to secure the crossbar and upright to each other.

3. Dig a 36"-deep × 8"-diameter hole for each pole. Add a few inches of gravel to the bottom of the hole to promote drainage. Position the pole in the hole, determine the best height for your clothesline, and remove the pole and cut the bottom to length as needed. Soak the cut end in wood preservative, to extend the life of your pole.

Upright and crossbar notches

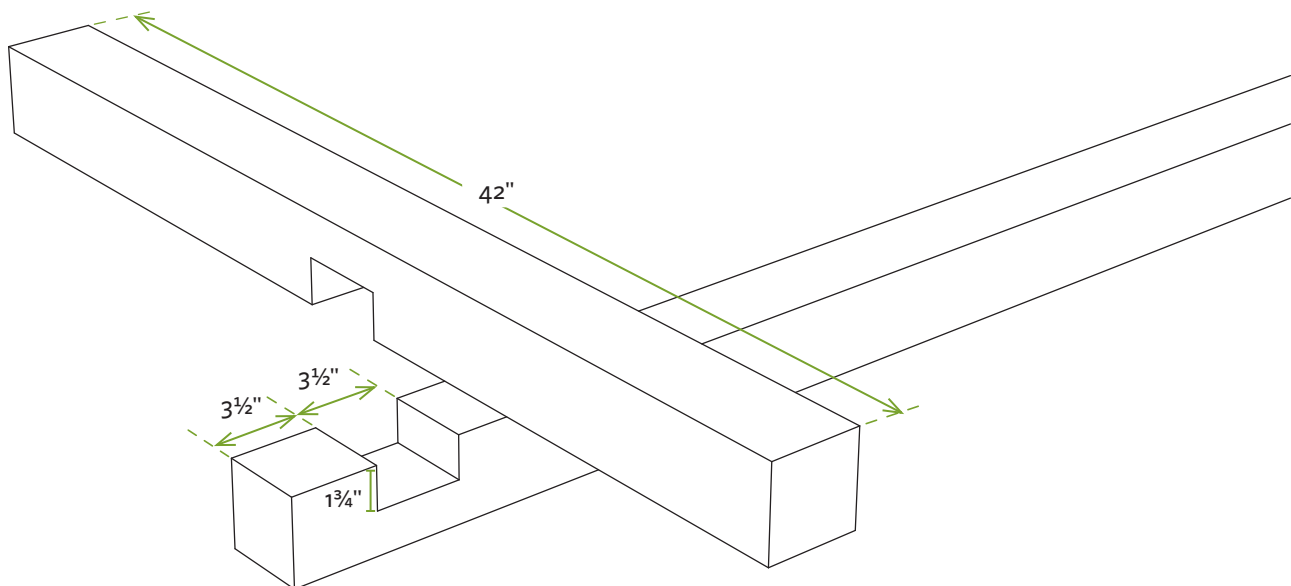

4. Place the pole in the hole, and brace it plumb with 2×4 cross bracing. Fill the hole with concrete, checking the post with a level to make sure it remains plumb in both directions. Overfill the hole slightly, and shape the concrete into a mound that slopes down and away from the post to help shed water. Let the concrete harden overnight before moving on to the next step.
5. Add screw eyes to the crossbar and upright as shown. Use small cable clamps to secure one end of the braided cable to the uppermost eye on the upright. Thread the cable through the eyes as shown, keeping tension on the cable. Secure the other end of the cable to a turnbuckle hooked onto the lowest eye. Use the turnbuckle to tighten the cable. Tighten the turnbuckles evenly on both sides so you don't rack the crossbar out of whack. Install a wood or copper fence post cap to the top of the upright to protect the end grain and add a decorative touch.
6. Install the screw eyes or clothesline pulleys to the crossbar, and then install the clothesline.

Clothes pole and trellis wire construction

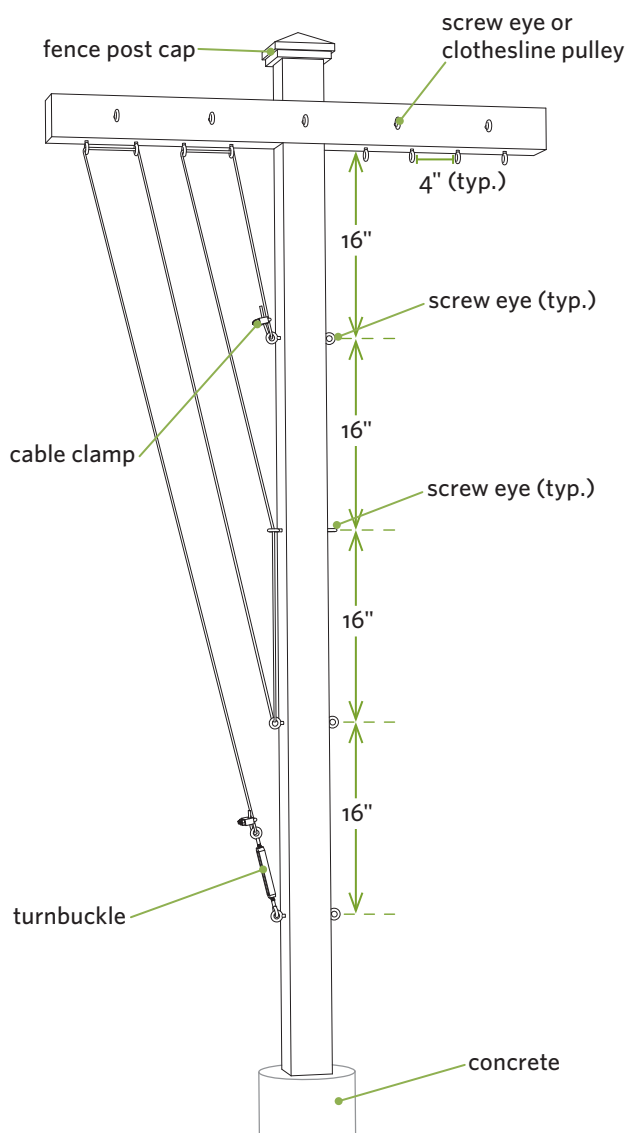

Plant the Right Vine!

There are dozens of vines that would love to call your clothesline trellis home, but some make better occupants than others. You may want to avoid vines that attract swarms of bees, produce messy berries, or have thorns that could scratch you or your clothes.

All vines have their pros and cons. Here are some factors to consider:

- Climbing rose vines, calamus, and bougainvillea are gorgeous but have hooks or thorns to help them climb—and scratch you.
- Beans and peas will provide beauty and food but require some maintenance and training throughout the growing season.
- Flowering vines such as clematis, morning glory, and honeysuckle are beautiful but can attract bees.
- Boston and English ivy can grow in shady places, but they grow so vigorously that in some parts of the country they're considered invasive species.
- Grape and other fruit vines grow vigorously, but the fruits can stain your newly washed clothes.

Whatever you plant, be patient. There's truth to the adage that vines sleep the first year, creep the second, and leap the third.

Spice Planter

A mini herb garden you can hang anywhere

Here's a garden you can create even if you live in an apartment on the fourth floor. This planter holds three standard-size pots for growing your most-loved herbs and spices. It's designed to mount to a wall, deck rail, or fence so you can easily step outside and snip a few sprigs for cooking.

You can expand your garden by lengthening the platform boards and ledger strip, then adding more braces and cutting additional holes.



Materials

- Three 6-foot $\frac{5}{4} \times 6$ cedar deck boards
- $2\frac{1}{2}$ " exterior screws
- $3\frac{1}{2}$ " exterior screws
- Three label holders (optional; see Resources)

Parts and Cutting List

Part	Size and Material	Quantity
(A) platform board	1" \times $5\frac{1}{2}$ " \times 36" cedar	2
(B) ledger board	1" \times $5\frac{1}{2}$ " \times 36" cedar	1
(C) brace	1" \times $5\frac{1}{2}$ " \times $8\frac{1}{2}$ " cedar	4

Platform cutting diagram

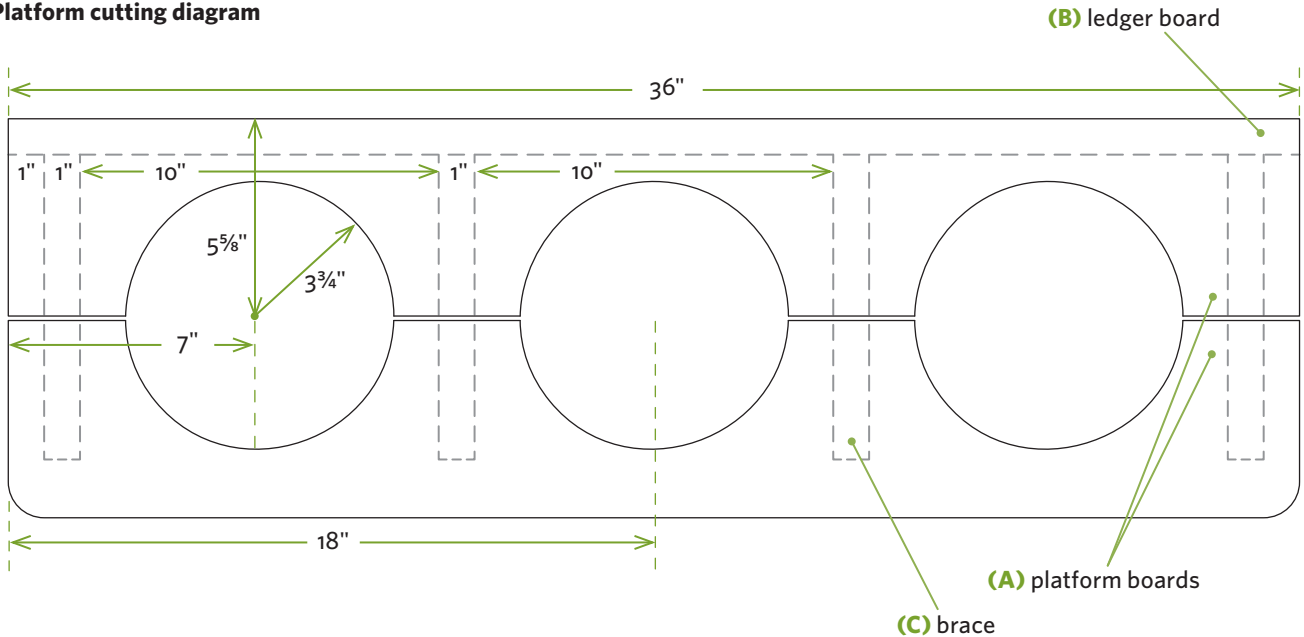

1. Temporarily clamp the two platform boards (A) side by side. Lightly draw in the positions of the ledger board and braces on the platform boards for reference. Use a compass to draw the three circles as shown. If the size of your pots differs from the ones indicated here, adjust the radius of the circles so the lips of your pots rest on the circumference of the cutouts.
2. Separate the boards, and use a jigsaw to cut out the semi-circles. Save the scraps; you might find a unique use for them later.
3. Cut the braces (C) to length; then mark and cut the arched bottom as shown. Feel free to improvise on the shape.

- Secure the braces to the ledger board (B) by driving $3\frac{1}{2}$ " screws through the backside of the ledger, as shown in *Planter construction* (below). Position the platform boards and fasten them to the tops of the braces with $2\frac{1}{2}$ " screws, checking to make sure the braces are square to the ledger as you go.
- Mount the planter to your deck railing, fence, or house by driving $3\frac{1}{2}$ " screws through the ledger strip. If you're securing it to an exterior wall, make certain to drive the screws into underlying wall studs. Add metal label holders (available at office supply stores and specialty woodworking stores) to the front of your planter if you want to label your spices or herbs.

Planter construction

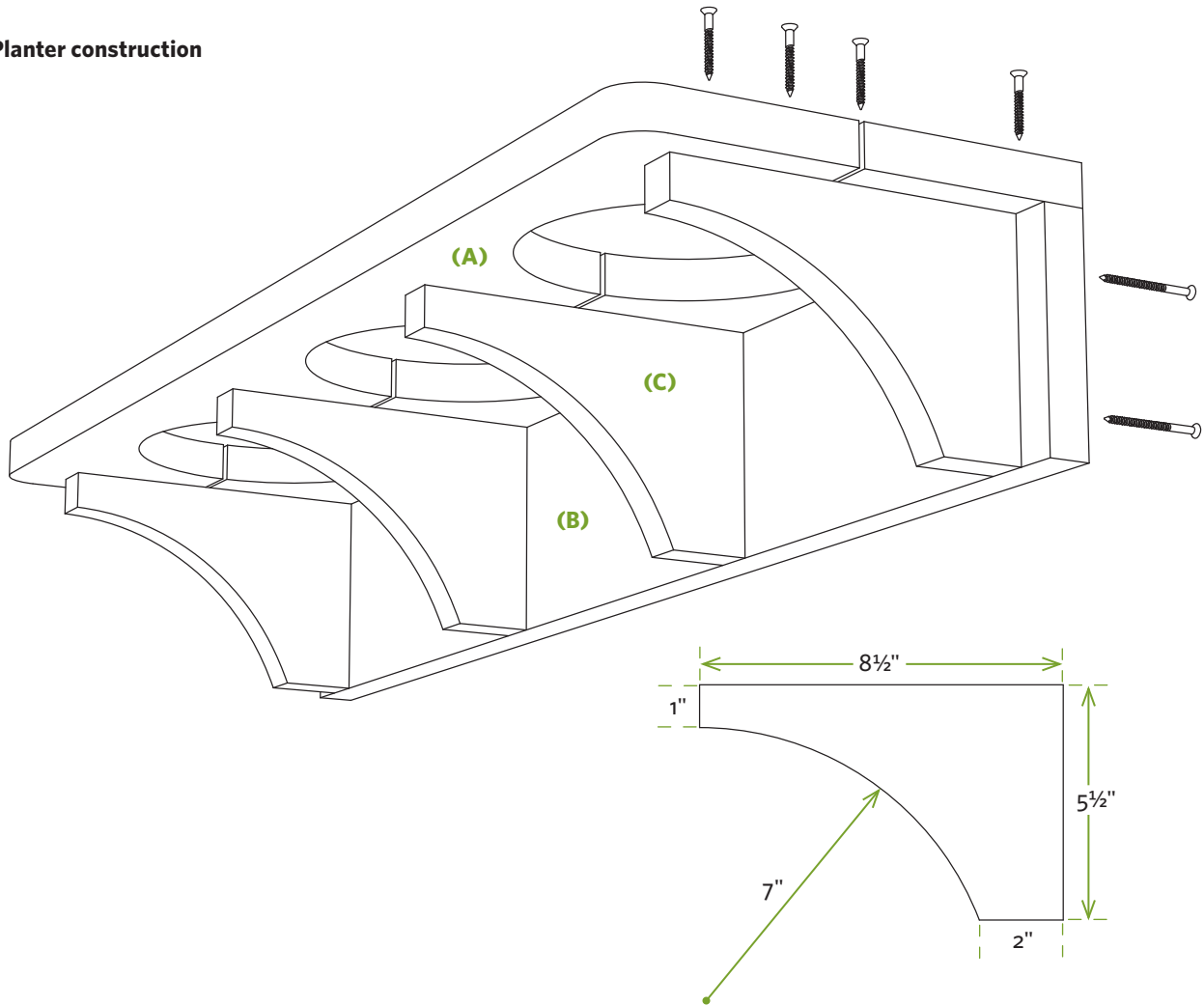

Rustic Garden Table

A table from branches, with a clever way to make joints

Somewhere (on a neighbor's porch, at a craft show, in a magazine) you've admired a piece of rustic furniture and said to yourself, "I wish I could build that!" Well, you can. Using only basic tools, basic drill bits, and the techniques shown here, you can craft not only this table but also benches, chairs, and other furniture or structures as well.

Since every tree branch is different, use the dimensions shown here as approximate guidelines rather than gospel truth. You'll need to measure and tweak your dimensions as you go to make everything fit properly.

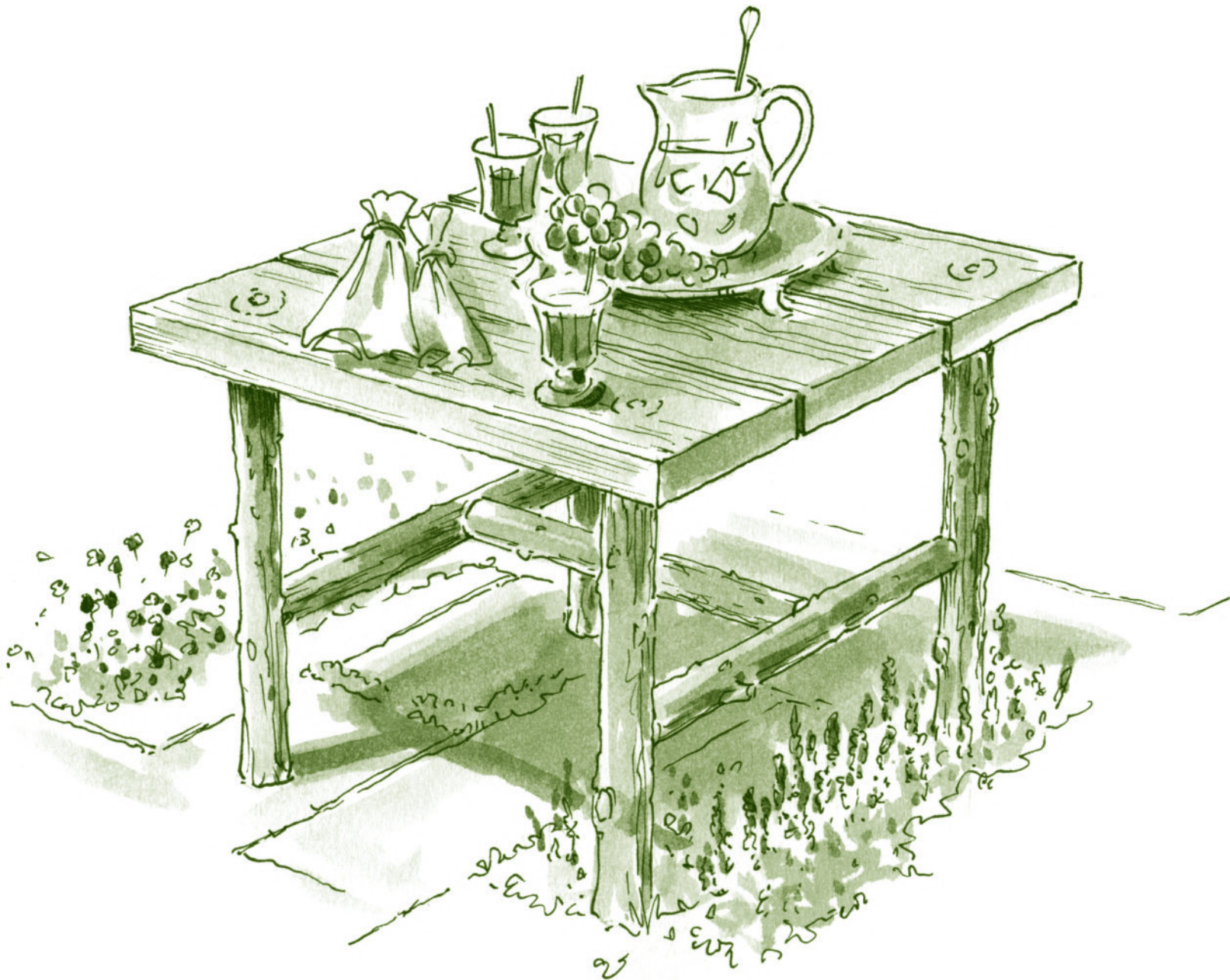

Materials

- One 8-foot pine (or other) 2×8
- 2"- to 2½"-diameter tree branches¹
- One 12" length of ¼" dowel
- Exterior wood glue

¹For the tree branches, dry hardwoods like oak, hickory, and maple are best. Wet woods or softwoods like pine will gum up your hole saw bit, making the work much harder.

Parts and Cutting List

Part	Size and Material	Quantity
(A) tabletop	1½" × 7¼" × 24" (approx.) pine	3
(B) leg	2"-2½" × 16"-18" branch	4
(C) side crosspiece	2"-2½" × 16"-18" branch	2
(D) center crosspiece	2"-2½" × 16"-18" branch	1
(E) leg hole plug	¼" × 2" dowel	4

Preparing the legs

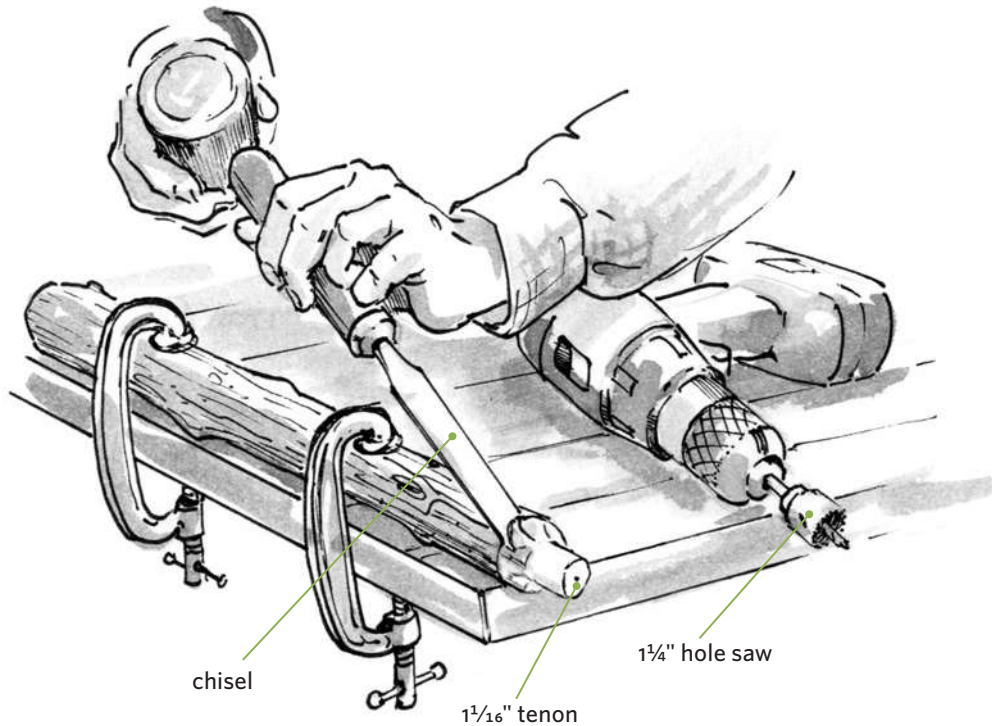

1. Glue the three tabletop boards (A) side by side, and clamp them together (be sure to use exterior glue). After the glue has set, remove the clamps and trim the ends so the tabletop is about 21¾" square.
2. Measure 2" in from each edge at each corner of the tabletop and draw crosshairs as a center for your drill bit. Use a 1½" spade bit to drill holes through the four corners. If you have a drill press, use it.
3. Cut four branches 16" to 18" long to create the legs (B) of your table. Firmly clamp one leg to your work surface, and use a 1¼" hole saw to drill a 2"-deep hole in the center of one end of each leg.

TAKE NOTE Your branches *must* be dry, and you *must* use a sharp, high-quality hole saw or you'll be doomed to frustration. Hole saws come in deep and shallow styles; you'll need the deep style.

Measure 2" from the drilled end, and use a handsaw or jigsaw to carefully cut through the branch until it hits the outer perimeter of the circle cut by the hole saw. Your goal is to remove the outer cylinder of wood to create the round tenon. You can remove it in pieces or try to remove it in a single piece (in which case you'll get a free rustic napkin ring out of the deal). Repeat for the remaining three legs. Use a sharp chisel or handsaw to taper the edges around the bases of the tenons as shown in *Preparing the legs* (above).

Table assembly

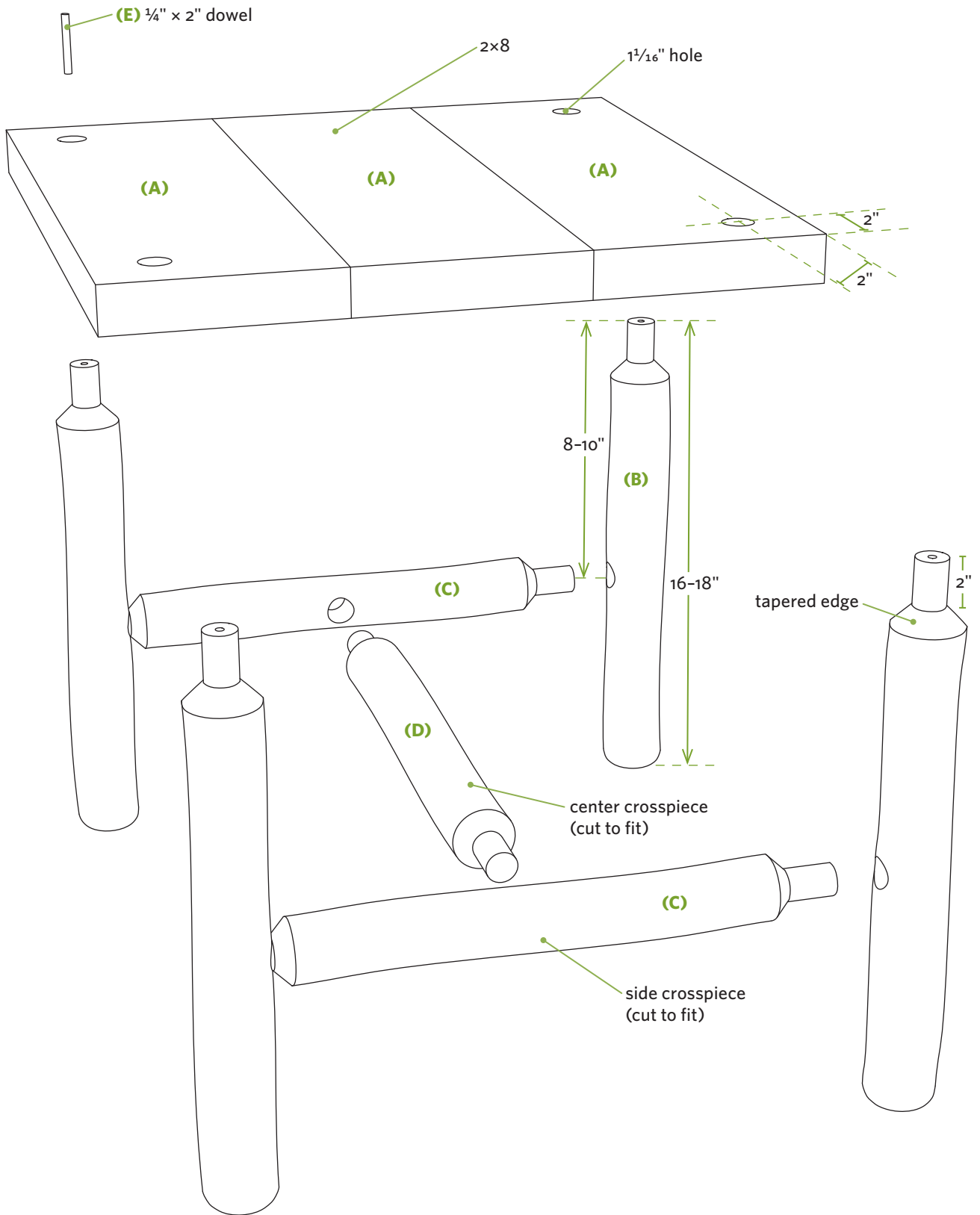

4. Use your $1\frac{1}{16}$ " spade bit to bore a $1\frac{1}{2}$ "-deep hole in the side of each leg, 8" to 10" down from the end of the tenon (the top of the leg). Follow the tip in *Get Plumb with a Little Help from Your Friend* (below) to create vertical holes here. These holes are for inserting your side crosspieces (C).
5. Partially insert the round tenons of the legs into the holes in the tabletop. Take measurements for the two side crosspieces (C) that will hold the pairs of legs together, taking into account the length of the tenons that will go into the leg holes. Create the tenons on each end of each crosspiece, just as with the leg tenons. Use your $1\frac{1}{16}$ " spade bit to drill a $1\frac{1}{2}$ " deep hole in the center of each crosspiece; these holes are for inserting the center crosspiece (D).
6. Insert the side crosspieces (C) into the holes in the legs, and then once again partially insert the leg tenons into the tabletop holes. Fine-tune the lengths of the end crosspieces as needed. Measure and cut the tenons on each end of the center crosspiece (D); then test-fit all of the pieces as shown. If your tenons fit too loosely, you can use epoxy or polyurethane glue to help fill the gaps (step 7). If the fit is too tight, use a utility knife or file to shave the tenon a little smaller.

Using only basic tools, basic drill bits, and the techniques shown here, you can craft not only this table but benches, chairs, and other furniture or structures as well.

7. Apply glue to all the tenons and assemble the table. Use a hand mallet to persuade the pieces together if necessary. Once the table is assembled, apply glue and pound the $\frac{1}{4}$ " dowels for the leg hole plugs (E) into the holes created by the hole saw pilot bit on the ends of the leg tenons (the ones protruding through the tabletop). Saw or sand any part of the leg tenon protruding through the tabletop so it's flush with the surface.
8. Once the glue is dry, set your table on a flat surface. If it wobbles or sits at a slight slant, cut one or more of the legs shorter until the table sits flat and level.

Get Plumb with a Little Help from Your Friend

You can drill very vertical holes by hand with the help of a partner. Grasp the drill, position the tip of the bit on the mark, and then position the drill so the shaft of the bit is vertical. Have a friend position himself or herself at a 90-degree angle to your sight line and also grasp the drill handle. Have your friend move the handle until the shaft is vertical from his or her point of view. Pull the trigger, and drill away. As you bore the hole, each person is responsible for keeping the bit vertical from his or her own perspective. The result is a vertical hole, even in a crooked branch.

Concrete Planter

A heavy-duty planter at a lightweight price

Concrete is the most widely used manmade material in the world: for every person on the face of the earth, nearly 30 cubic feet of concrete is used each year. Here's a simple project for using up a couple of your cubic feet.

Concrete may not be lightweight, but it certainly is versatile and cheap. We show you how to build a simple round planter, but its size, shape, and look are limited only by your imagination (see *Customize Your Planters*, page 264).



See page 7 for a photograph of this project.

Materials

- One 5-gallon plastic bucket
- Duct tape
- One 6"- to 8"-diameter concrete tube form or PVC pipe, 18" minimum length
- One plywood scrap, at least 7" square
- One wood dowel, 1" diameter × 2" long
- Drywall screws
- Concrete form release oil or vegetable oil
- One 60- or 80-pound bag concrete or mortar mix (see step 4)

1. Use a jigsaw or circular saw to cut a 5-gallon bucket in half lengthwise, as shown. Use duct tape to secure the halves back together again; apply 8" horizontal pieces of tape every few inches to secure the halves together, followed by long continuous pieces to seal the seam. If you want a shorter planter, cut the top few inches off the bucket. If you want to add some special details to your planter, install panels or other objects to the inside(s) of the bucket halves before assembling them (see *Customize Your Planters*, page 264).

TAKE NOTE Don't skimp on the duct tape; the concrete exerts more pressure than you might think.

2. Build the inner form as shown in *Inner and outer form details*, right. Begin by cutting the round concrete form (made of cardboard, commonly available at home centers and lumberyards) or PVC pipe to length and rough-cutting a couple of handholds near the top. (You'll use these for twisting and removing the form later on.) Cut a plywood disc to match the diameter of the inside of the form. Cut a 2"-long section of 1"-diameter dowel, and secure it to the center of the disc with a drywall screw (this will create the drainage hole.) Push the plywood disc into the bottom of the form (with the dowel pointing away from the tube), and secure it with three or four drywall screws.

TAKE NOTE You can also use a sturdy pail or bucket for the inner form. You still need a dowel to create a drainage hole.

3. Coat the inside of the bucket and the outside of the inner form with concrete form release oil or vegetable oil so the forms won't stick to the concrete. Use lots of it if you use the cardboard tube form, because the cardboard is absorptive.

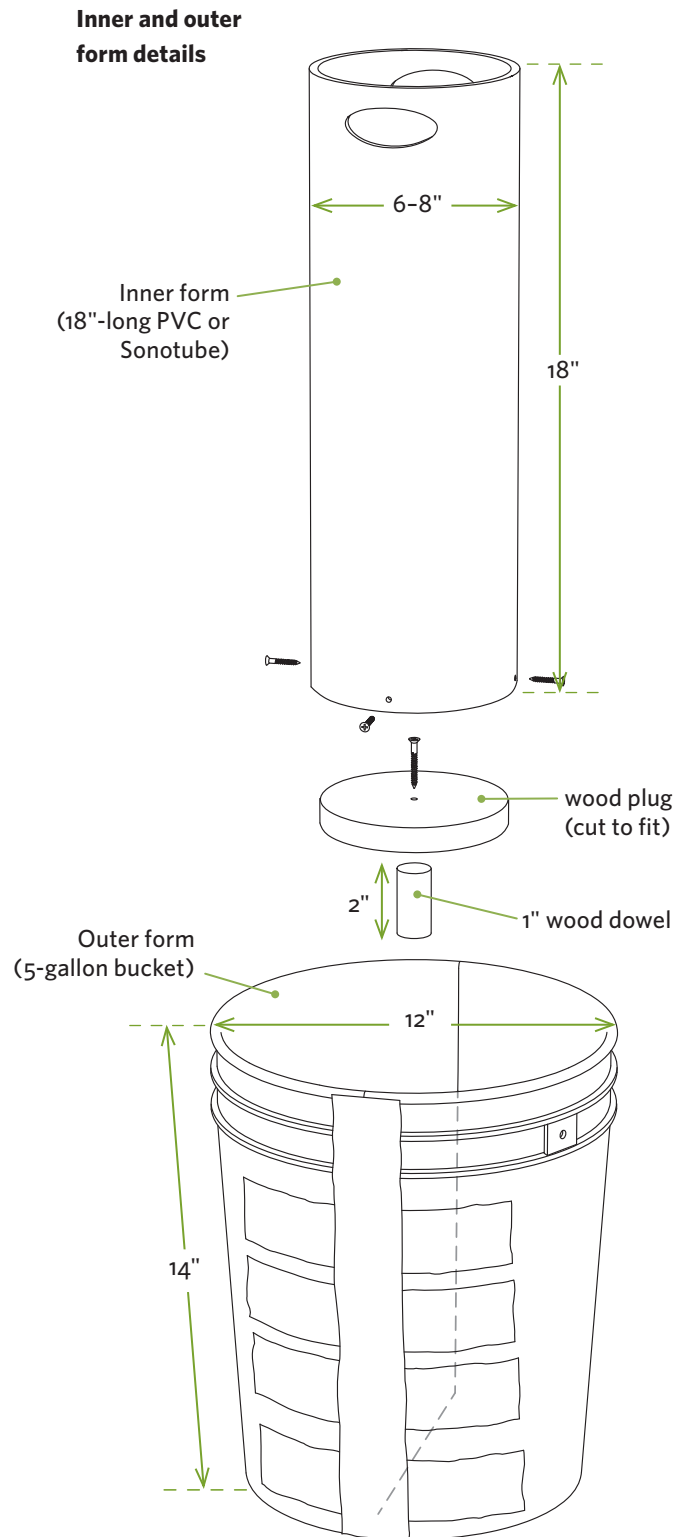

Pouring the concrete

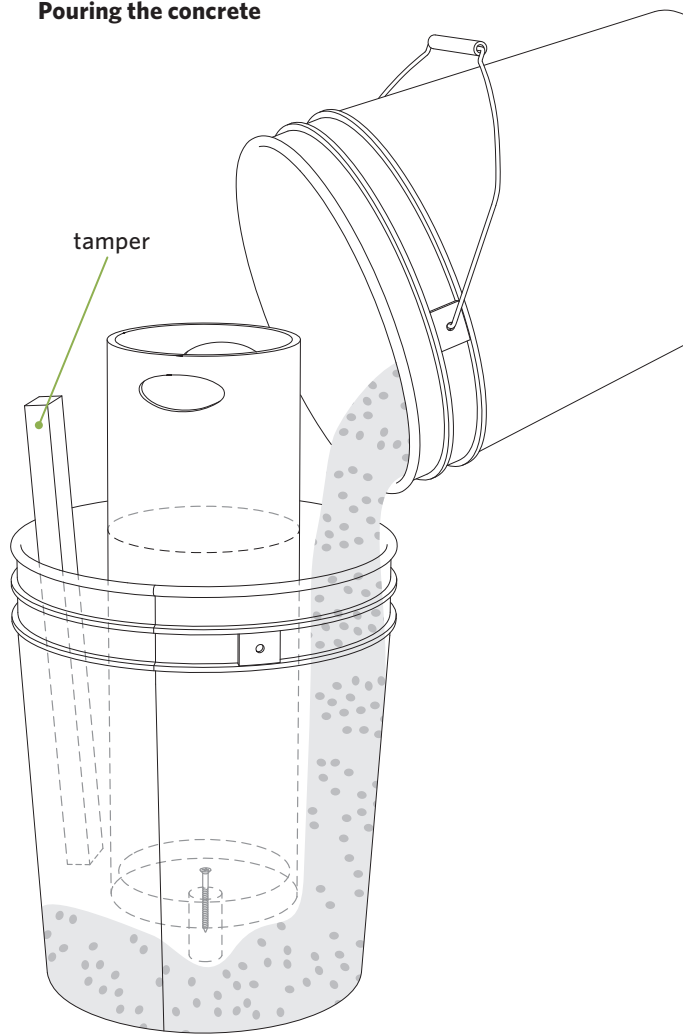

4. Dump $\frac{1}{2}$ bag of mortar or concrete mix into a mixing tray or bucket, add water gradually, and mix until the contents are thoroughly blended and the mix has the consistency of peanut butter. Pour 2" of mix into the bottom of the bucket,

as shown. Position the inner form in the middle of the bucket; then push and twist it until the drainage hole dowel hits bottom. Continue packing concrete around the tube until the bucket is no more than half full. If the form tends to float upward, fill it with rocks or concrete mix. To help settle the concrete as you work, tap the sides of the bucket with a hammer or lift the bucket 1" off the ground, and let it drop.

TAKE NOTE Mortar mix will create a smooth pot; concrete mix will create a pot with a more rustic look.

5. Let the concrete set for 60 minutes; then grab the inner form by the handholds and twist it a half turn. Do this every 30 minutes for a while to prevent the concrete from adhering to the cardboard.
6. Let the concrete harden; this will take 10 to 20 hours depending on the conditions. Remove the duct tape holding the two sides of the bucket together and gently pry the halves apart to remove the outer mold. You may need a helper for this part. Twist and remove the inner mold, plywood disc and drainage hole dowel. If they don't come out easily, try again after the concrete has cured. You may need to remove the cardboard form in pieces, and remove the plywood disc and "drainage dowel" by hand. Use a coarse, damp sponge to smooth the outside of the planter.
7. Place the planter on a piece of plastic in an out-of-the-way place, cover it with more plastic, and let it cure and harden for four or five days. Then plant away.

TAKE NOTE Concrete planters can easily crack if water or moist dirt left in them expands during the winter. Before the first freeze, bring them inside or remove the soil, turn them upside down, and cover them with a plastic bag.

Customize Your Planters

You can make your planters as plain or as decorative as you want. Here are a few ideas:

- Create recessed patterns by securing bevel-edged 1x4s or plywood panels to the inner bucket wall before adding the concrete. Drive drywall screws from the outside of the bucket to hold them in place. Think ahead so the panels won't make it difficult to remove the outer form later on. Make sure to coat them with concrete form release oil, vegetable oil, or another suitable release agent. You can also use rope and other objects to make custom designs.
- Color your concrete by using liquid coloring agents (see Resources), adjusting the intensity by the amount you add.
- Antique your planter using a mixture of dry, crumbled moss and buttermilk. Paint the mixture onto your pot; then place your pot in a sealed plastic bag and set it in a cool shady spot for about a week. Remove it from the bag, and in a few weeks your pot will sport a mossy coating.
- Use epoxy adhesive to secure pieces of broken tile, beads, dishes, mirrors, or other objects to the outside of the pot (see page 262).

Seedling Rack

Get a jump on the growing season

A seedling rack provides a space-saving vertical garden to give your plants an indoor head start. This rack, made primarily from inexpensive PVC pipe and fittings, can accommodate grow lights to give your seedlings an even better jump start. Since seedling racks can be space wasters for the

10 months of the year you don't need them, this PVC rack is designed to be easily disassembled and stowed.

You can adjust the height and spacing of the platforms by adjusting the length of the legs (D, E).



Materials*

- Six 10-foot pieces 1" PVC pipe
- Twenty-four 1" PVC T-fittings
- Four 45-degree 1" PVC elbows
- Two 1" × 1" × 1" PVC side outlet elbows
- One and a half 4 × 8-foot sheets ¾" plywood
- White silicone caulk

*Buy T-fittings in packs of 10 to save money. Instead of two Ts at each corner, you can use a single 4-way side outlet T. These simplify the project but cost three to four times as much as a pair of standard Ts. (See Resources for online sources of 4-way side outlet Ts and side elbow Ts, both of which might not be sold at your local building supply store.)

1. Cut the PVC pipe sections (A, B, C, D, E, F) to length, using a hand miter box, power miter saw, or fine-tooth handsaw. To make the best use of pipe materials (which normally come in 10-foot lengths), cut the 48" and 18" horizontals first, then the legs, and finally the short stub connectors. Watch your fingers when you're working with short pieces! Use sandpaper to smooth the cut edges. If you want to remove the factory markings on the pipe, rub the area with a cloth dampened in acetone. Wear gloves, and do this outside.

TAKE NOTE Adjust the length of the long (D) and short (E) legs according to the heights of the seedlings you intend to grow.

Parts and Cutting List

Part	Size and Material	Quantity
(A) long horizontal	1" × 48" PVC pipe	7
(B) short horizontal	1" × 18" PVC pipe	6
(C) short stub connector	1" × 1½" PVC pipe	12
(D) long leg	1" × 12"-16" PVC pipe	8
(E) short leg	1" × 6"-8" PVC pipe	4
(F) top angle	1" × 12½" PVC pipe	4
(G) T-fitting	1" PVC T-fitting	24
(H) angle connector	1" PVC 45-degree elbow	4
(I) peak connector	1" × 1" × 1" PVC side outlet elbow	2
(J) platform	¾" × 21" × 51" plywood	3

2. Cut the three plywood platforms (J) to size as shown. Use a jigsaw to cut the curved notches in the corners.
3. Secure Ts (G) to both ends of the long (A) and short (B) horizontals. Use white silicone caulk, rather than pipe cement, since your joints don't need to be watertight, and caulk will give you more time to fiddle with the orientation of the pieces. When you're done, you'll have a dozen pieces of pipe with Ts on both ends; six of these frame assemblies will be long, and six will be short.

Grow It Safe

If you have climbing kids or curious cats, or just want to play it safe, prevent your rack from tipping by securing it to the wall using pipe straps or L brackets. Also, make certain the cord or cords running from the lights to the outlet don't create a tripping hazard.

Piping assembly

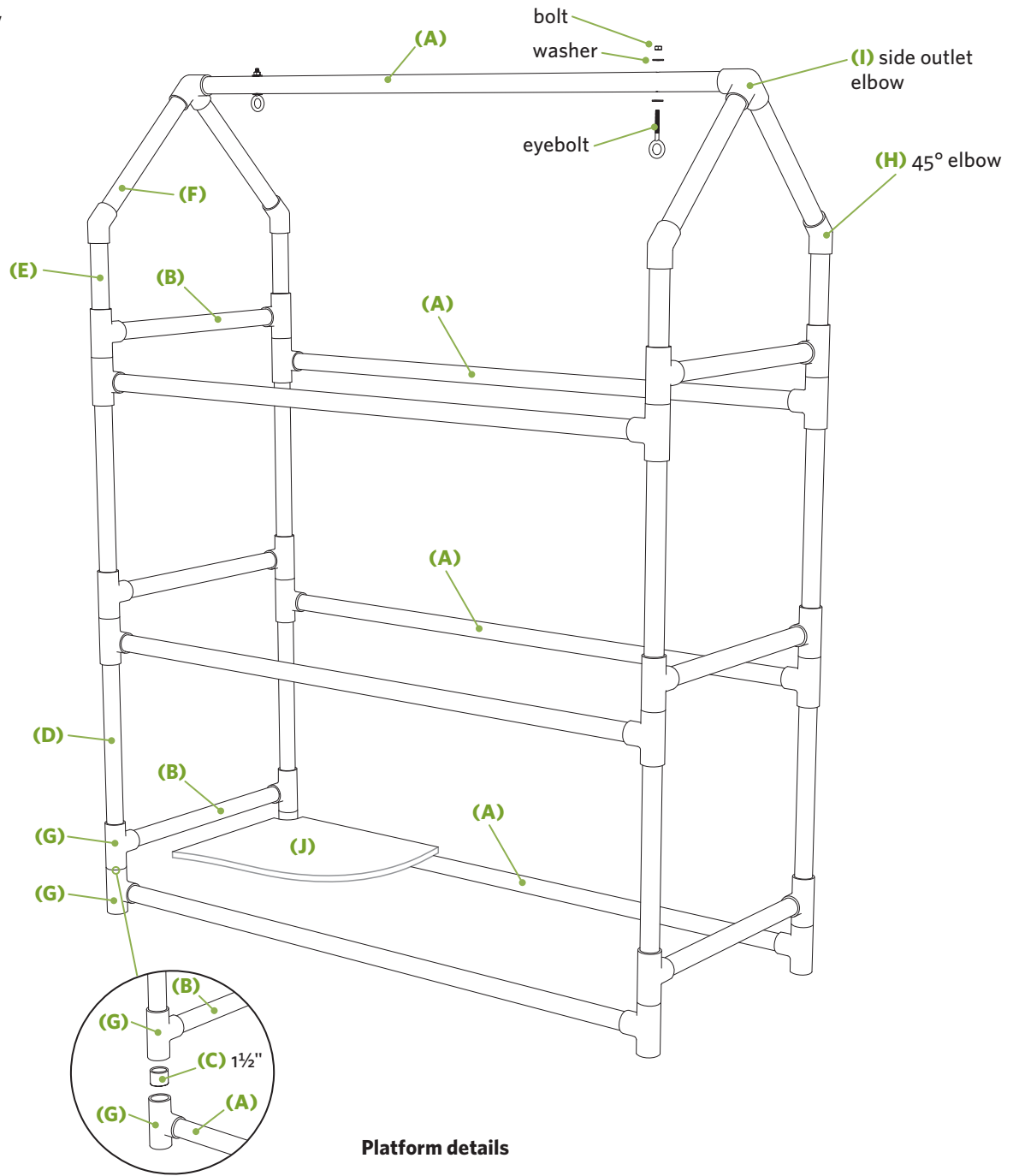

Platform details

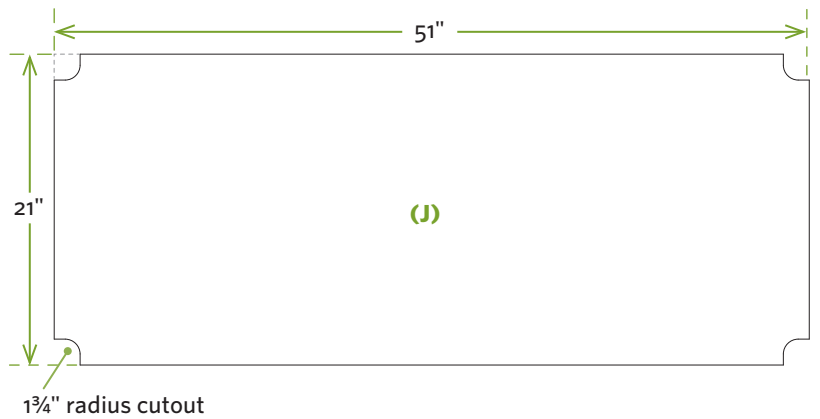

HINT

For optimum results, adjust the lights so they're 2 to 3 inches above the tops of the plants.

- Slide the 1½" stubs (C) into the tops of the Ts at the ends of the long frame assemblies (A, G). **Note:** *Do not glue or caulk these or any remaining joints if you want to be able to disassemble the rack for storage.* Slip one short frame assembly (B, G) over the stubs of two long frame assemblies (A, G) to create a U shape. Lay a platform (J) in place, and then add the second short frame assembly (B, G) to complete the rectangular frame of piping. You must assemble the rack in this order so that you get the platforms in place.
- Insert the legs (D) into the top sockets of the Ts; then work upward, assembling the frames and inserting the plywood platforms as you go. Create the peak by assembling the parts as shown in *Piping assembly* (page 267).
- Hang the lower two grow lights from eye bolts secured near the ends of the platforms. Hang the upper grow light from eye bolts secured to the upper long horizontal (A). Adjust the heights of the lights by moving the S-hooks to different links in the chain. Use tape to secure the lights' cords to the legs to keep them organized.

TAKE NOTE Even when they're not cemented together, PVC pipe and fittings can be a bear to take apart. To make the legs easier to remove for storage, apply furniture wax to the ends and then buff with a rag before assembling the parts.

To minimize the number of cords running across the floor, mount a multi-outlet strip to the rack for plugging in the lights, and then run a single extension cord to the wall outlet. You can add a timer to automate the on-off cycles.

It's a Greenhouse, Too

As the weather warms, you can move your seedling rack outdoors, cover the framework with plastic film, and use it for a greenhouse. The peaked roof comes in handy for shedding rain. Secure it to something sturdy so it doesn't topple.

Outdoor Shower

A place to wash your mud, and worries, away

Ah, an outdoor shower: a place to rinse off after a muddy day, to wash the dog, to cool off, to give your outdoor plants their annual shower. It's an attractive idea, and here's a simple design.

Unlike most projects in this book, this one leaves a few critical details to you — like how to get warm water to the shower and how to usher it away. This is no small feat, nor should it be an afterthought (*Plumbing Your Outdoor Shower*, page 272). Since each climatic area, house, plumbing setup, and community differs, we leave the details of the plumbing to you. For the shower shown, we tied into existing hot and cold water lines, and the

existing sewer or septic lines. But, as the saying goes, it's complicated. If you're pursuing the idea of an outside shower, talk to a local plumber and your local building official *before you start*.

The site for your shower and your needs will dictate the size of your enclosure; therefore, the construction details presented here are intended to be more inspirational than exact.

Note: Don't start this project unless you've figured out the plumbing details. Better yet, don't build the surround until the plumbing is installed and operating.

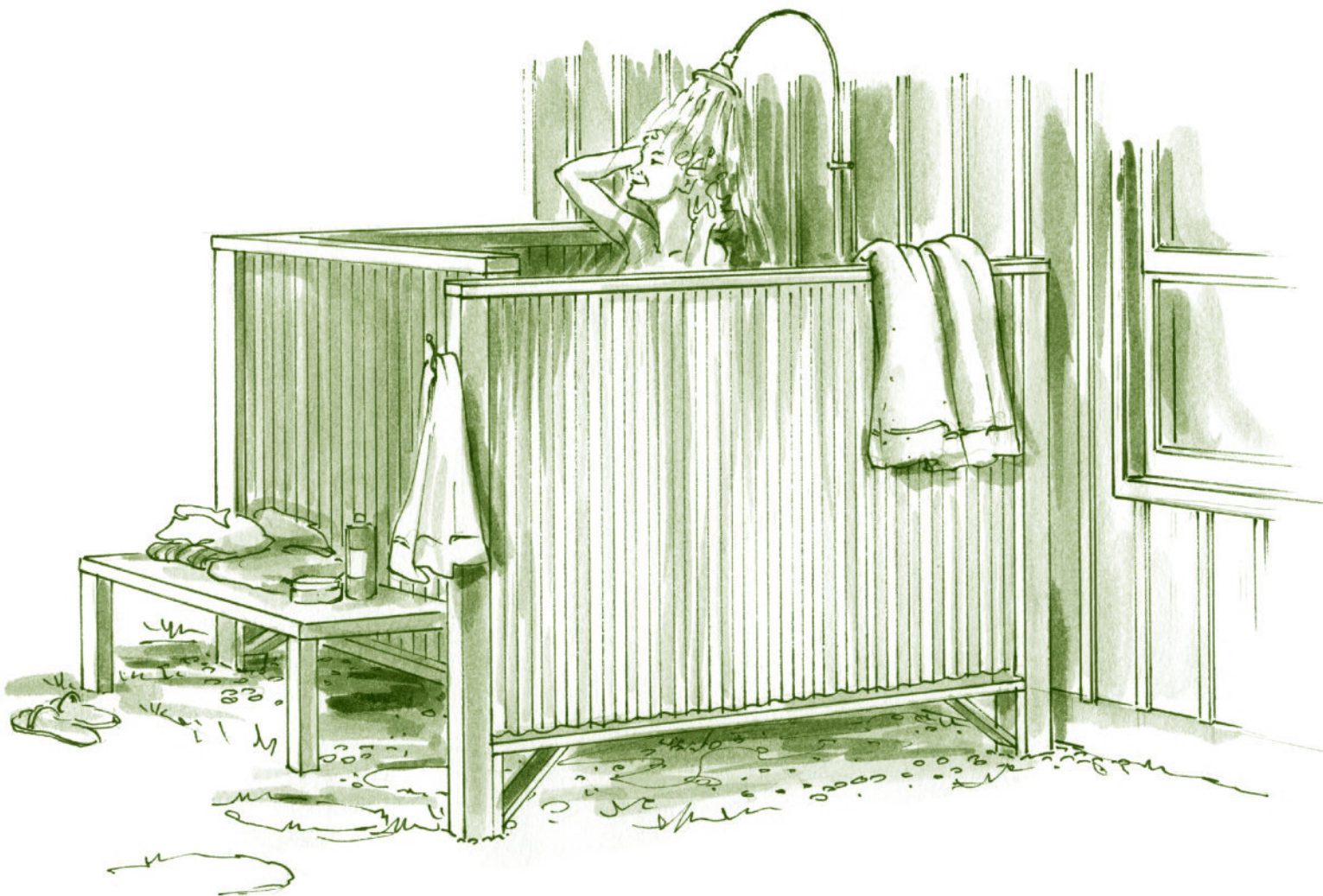

Materials*

- Three 8-foot 4×4s
- Scrap 2×4 lumber (for post bracing)
- Eight 8-foot 2×4s
- Nine 8-foot 1×2s
- 26"-wide corrugated metal panels
- Gravel
- Concrete mix
- 16d galvanized nails
- 6d galvanized nails

*All lumber is pressure-treated, cedar, or other rot-resistant wood.

1. Use string or 2×4s to determine the position of the walls and support posts. Adjust the size of the shower surround according to your needs and building site.
2. Dig a 36"-deep hole for each 4×4 post (A). Add 6" of concrete to the bottom of each hole, and let it harden. Set the posts, make sure they're plumb, and brace them in both directions. Backfill the holes with gravel to within 8" of the top; then add more concrete, slightly mounding the top so water runs away from the posts. Let the concrete dry for 24 hours or so.
3. Determine the height of the shower walls, and mark this height onto one of the posts. Use a level and straight 2×4 to transfer this height to the other posts and also to the wall of the house where the wall ledgers and panels will be secured. Use a circular saw to cut the tops of the 4×4s to the correct height.

Parts and Cutting List

(FOR AN ENCLOSURE APPROX. 4 × 6 FEET)

Part	Size and Material	Quantity
(A) posts	3½" × 3½" × 96" (approx.) PT lumber	3
(B) wall ledgers	1½" × 3½" × 72" (approx.) PT lumber	2
(C) bottom rail support blocks	1½" × 3½" × 10"-12" PT lumber	6
(D) bottom rails	1½" × 3½" × TBD ¹ PT lumber	3
(E) bottom rail angle braces	1½" × 3½" × 14" PT lumber	6
(F) top rails	1½" × 3½" × TBD ¹ PT lumber	3
(G) panel stops	¾" × 1½" × TBD ¹ PT lumber	24
(H) panels	26" corrugated metal	TBD

¹TBD means "to be determined"; measurements and quantities will vary according to the size and height of the enclosure.

TAKE NOTE Keeping the walls at shoulder height provides both privacy and good ventilation, as well as good sightlines so you can see who's coming!

4. Secure two vertical wall ledgers (B) to the house so they're level with the tops of the 4×4 posts. Use 16d nails to secure the short 2×4 support blocks (C) to the bottoms of the posts and wall ledgers, making sure the tops of the blocks are level. Position the horizontal bottom rails (D) on the blocks and nail them in place. Add the short 45-degree angle braces (E) to help support the bottom rail, and brace the overall structure. Finally, install the horizontal top rails (F), nailing them to the tops of the 4×4s and 2×4 ledgers.

Shower surround framing

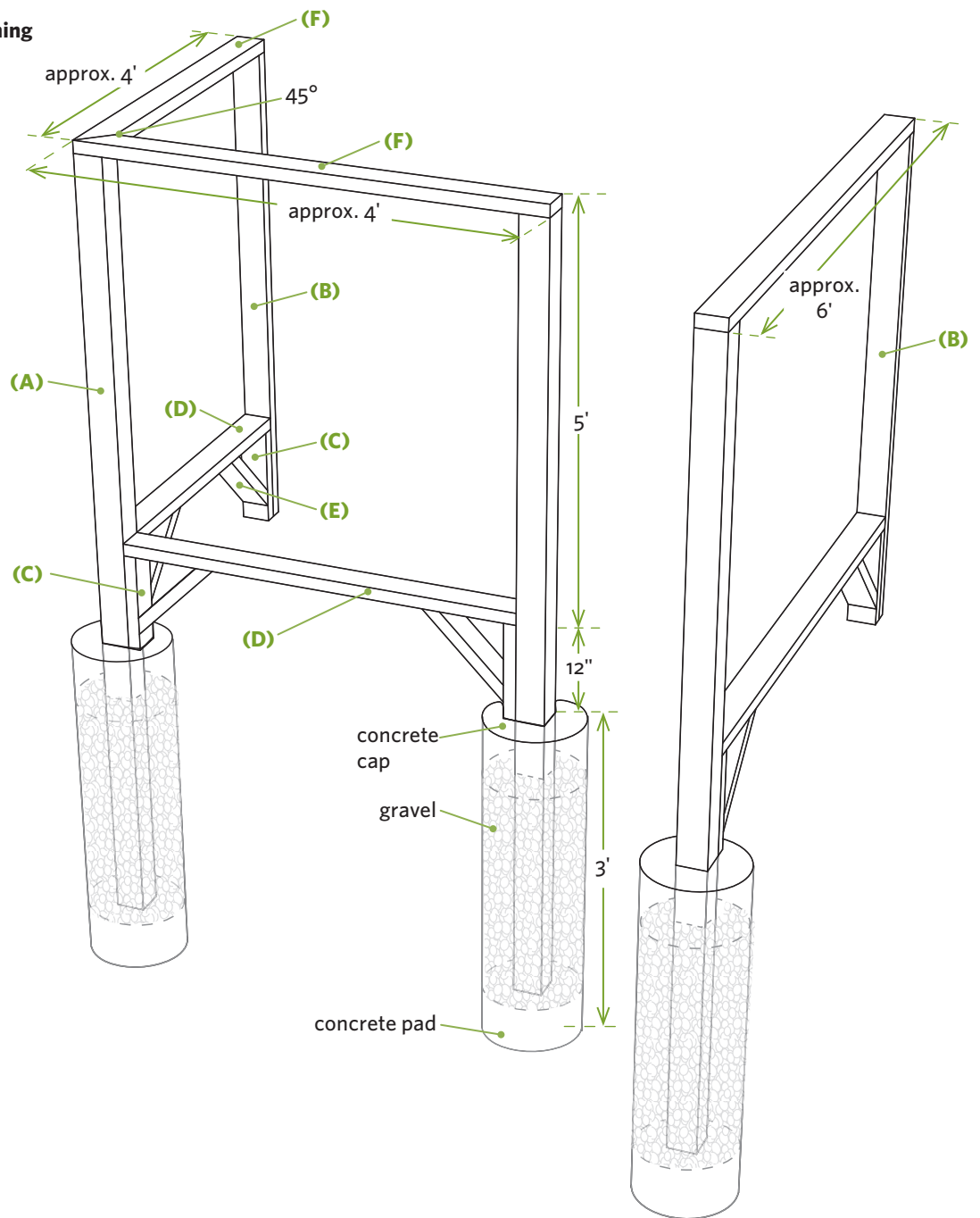

Customize Your Shower

Now that you've built your shower surround, customize it according to your needs. Here are a few ideas:

- Install a shower control valve that allows you to include a shower handset with a sliding bar. This setup allows you to adjust the height of the showerhead for kids and adults, and to use the showerhead in handheld mode for washing pets, rinsing boots, and doing other chores.
- Install benches, inside and/or out. Use the shower support posts (A) for the back legs of the bench, and add two more legs for the front.
- Install hooks for towels, clothes, and scrub brushes. Add trays for soaps, shampoos, and other outdoor showering supplies.
- Add a door, using gate hinges mounted to one of the support posts. Build the door using cedar slats or galvanized paneling like the rest of the surround.

- Nail the inner set of panel stops (G) to the 2×4 rails, wall ledgers, and 4×4 posts using 6d nails to create one side of the frame for the metal corrugated wall panels, as shown. Cut and set the panels (H) in the openings, holding them in place with the outer set of stops (G.)
- Build the shower base in accordance with your planned drainage system. If you're channeling your runoff into the house's main drain-waste-vent system, you'll need a concrete floor with floor drain. If you're draining your runoff into a gravel-filled trench or catch basin, the floor may consist of a gravel base with a wood-slat floor perched on top.

TAKE NOTE Some metal panel suppliers will cut panels to length for you. If you use 26"-wide panels and overlap them strategically, you may not have to cut them width-wise.

Wall panel construction

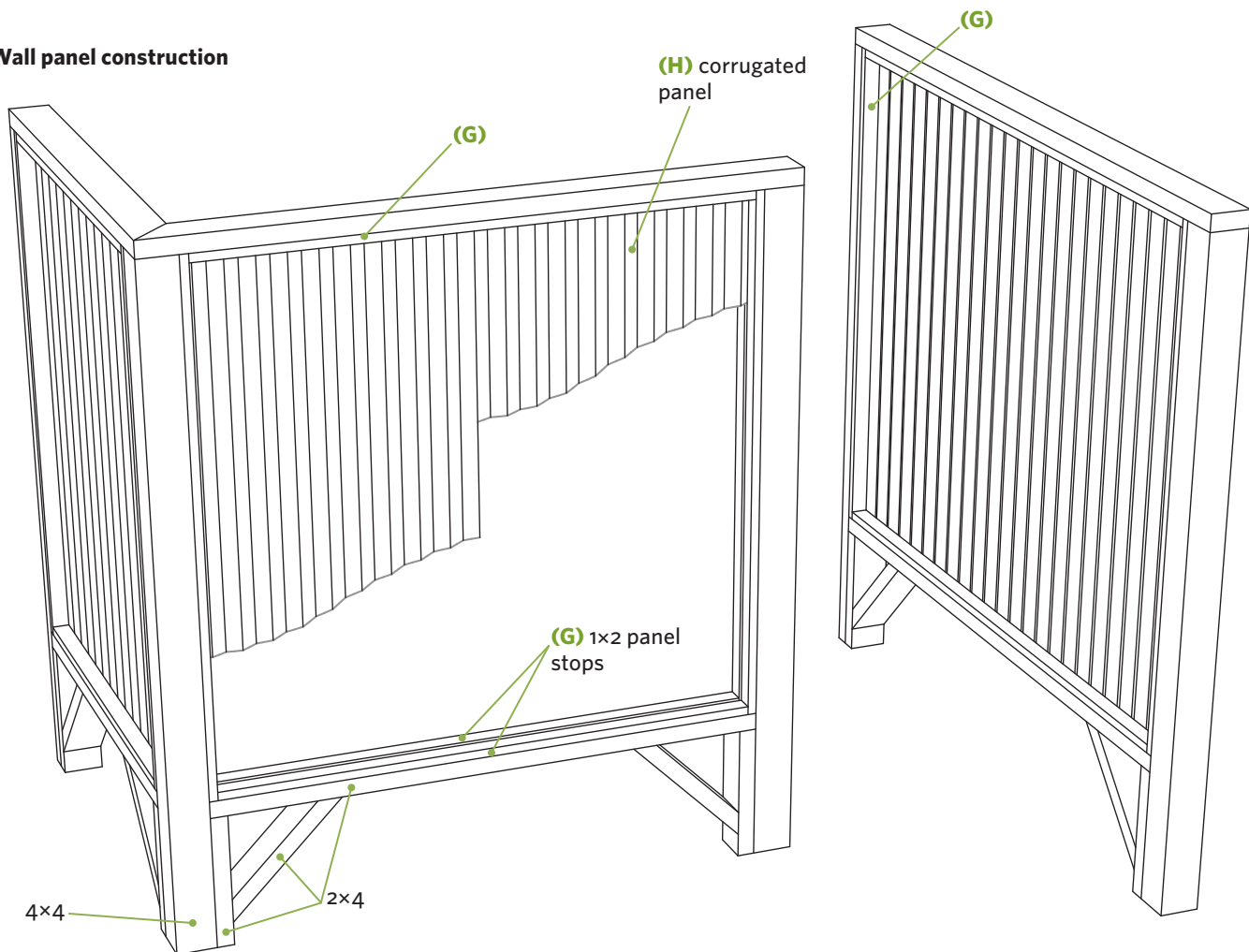

Plumbing Your Outdoor Shower

Water directly from the outside faucet is usually too cold, and water from a simple makeshift passive solar device can be too variable. Tying into existing hot and cold water lines is your surest bet, but it gets complicated in regions where water lines can freeze. If you're going to tap into existing lines, your task will be much easier if your shower backs up to a kitchen, bathroom, or laundry room with plumbing in place.

Then there's the question of where and how to get rid of the wastewater. In some cases it can be directed into the

main sewer or septic system; in other cases it can drain to a gravel pit under or near the shower. Gray water can even be directed to the lawn or flower garden, but some communities are very picky about this last option.

For more complete information on options, check out the book *The Outdoor Shower*, by Ethan Fierro; for practical information on plumbing, check out: *The Complete Guide to Plumbing* (see Recommended Reading).

Your Own Private Slice of Aquatic Heaven

BY ETHAN FIERRO

If you derive pleasure from relaxing in the natural world of flowing water, dappled sunlight and sumptuous verdant surroundings, then look no further than your own personal outdoor shower. Creating a structure that brings immense satisfaction from daily use, as well as the design and construction process, is actually quite simple for the backyard homestead crowd. By employing a basic set of plumbing and carpentry skills, you can create your own backyard sanctuary for bathing and delighting in nature.

I grew up showering in a semicircular wooden enclosure draped with thick English ivy. In the summer, migratory songbirds roosted while raising their young, chatting and flying about. By night I watched fireflies glowing in the steam against a backdrop of Northern constellations, and heard the last delicate notes stroked out by a cricket.

These memories are deeply poignant as I look back, recalling the poetic beauty emanating from a simple daily routine. And the focal point of this touching-in-to-nature centers on a structure of three easily combined elements: plumbing, a structure to attach the plumbing, and drainage. All three elements include a host of variables you can fine-tune for your own personal tastes.

To enclose or not enclose, this is the question. To what extent do you desire privacy in your surroundings? Are there sightlines that may leave an exposed bather ducking for cover from second-floor vantages? Or are you the free-spirited type who could not care less? Either way — open shower or enclosed — comes with benefits, and regardless of how enclosed an outdoor shower is, viewing portals will enable the most prudent bather to enjoy the scenery without feeling “on center stage.”

With the continuing depletion of our freshwater, I recommend making the most of the used gray water, by collecting it and irrigating nearby vegetation. Local regulations will dictate what parameters you must abide by, but it is the conscientious bather who goes the extra mile in creating a simple filtration system to reuse a limited resource.

If you are confident in your own construction skills, then put your imagination to work and build yourself a dream shower that will serve you for years. But even if you require professional assistance with the design and construction, by all means supplement your talent where you want. Join the ranks of thousands of delighted outdoor bathers and give yourself the gift of your own private slice of aquatic heaven.

ETHAN FIERRO is the author of *The Outdoor Shower* (see *Recommended Reading*). He grew up on the island of Martha's Vineyard, following in the footsteps of his artistic parents. He now resides with his wife of 23 years, Phyllis, on Maui, enjoying the plentitude of showering opportunities.

Creating a structure that brings immense satisfaction from daily use, as well as the design and construction process, is actually quite simple for the backyard homestead crowd.

Pickin' and Grinnin' Chair

Easy to build, easy to tote

Whether you're pickin' peas from a pod or tunes from a guitar, you'll be grinnin' while you sit in this chair. You'll be smiling while you build it, too, since it only takes a few boards, a few tools, and a few hours of time. When you're done you'll have a seat you can use when camping, husking corn, or sitting out under the stars. The pieces slide apart and nest flat so you can carry them easily and stash them just about anywhere.

Seats similar to this have gone by dozens of names in the past: backpacking chair, plank seat, stargazer chair, campfire roost. And they've been made from all sorts of woods in all sorts of shapes and sizes. I made this Pickin' and Grinnin' Chair from oak; you can use pine, but your chair won't be as sturdy or last as long.



Materials

- One 6-foot oak or hardwood 1x12
- 1¼" wood screws
- Wood glue
- Clear exterior wood finish

1. Cut the 1x12 seat plank and back plank to length as shown. Drive a screw 16" away from one end of each plank (as shown in the *Back* detail below), centered across the width of the board; then use your tape measure and pencil to swing arcs to mark the 16" radius for the ends. Swing smaller arcs with 12½" and 14" radii for the handholds. Drill 1½"-diameter holes at the ends of each opening, and then use a jigsaw to cut out the curved openings.
2. Mark the bottom cutouts on the opposite ends of the boards, as shown in *Cutting diagrams* (below). Use a quarter to draw the rounded corners, and then cut them to shape with a

jigsaw. Smooth the edges by hand- or power-sanding them. If you have a router, round over the edges of the seat to create a more butt-friendly surface.

3. Mark the 2"-wide side cutouts to create the tongue in the seat board, as shown. Make the cuts with a circular saw and jigsaw.
4. Cut two 11"-long braces from the tongue cutoff pieces, and bevel the ends at 45 degrees. Use glue and 1¼" screws to secure one of these braces to the back of the seat board, as shown.
5. Mark the position of the slot in the back plank as shown. Drill a ¾" hole on each end, and then cut the ¾"-wide slot with a jigsaw, squaring off the corners. Test-fit the pieces; if the fit is too tight, use sandpaper or a jigsaw to slightly enlarge the slot. Use glue and screws to secure the other 11" brace just above the slot, as shown.
6. Apply a clear exterior finish to the seat and back for protection.

Cutting diagrams

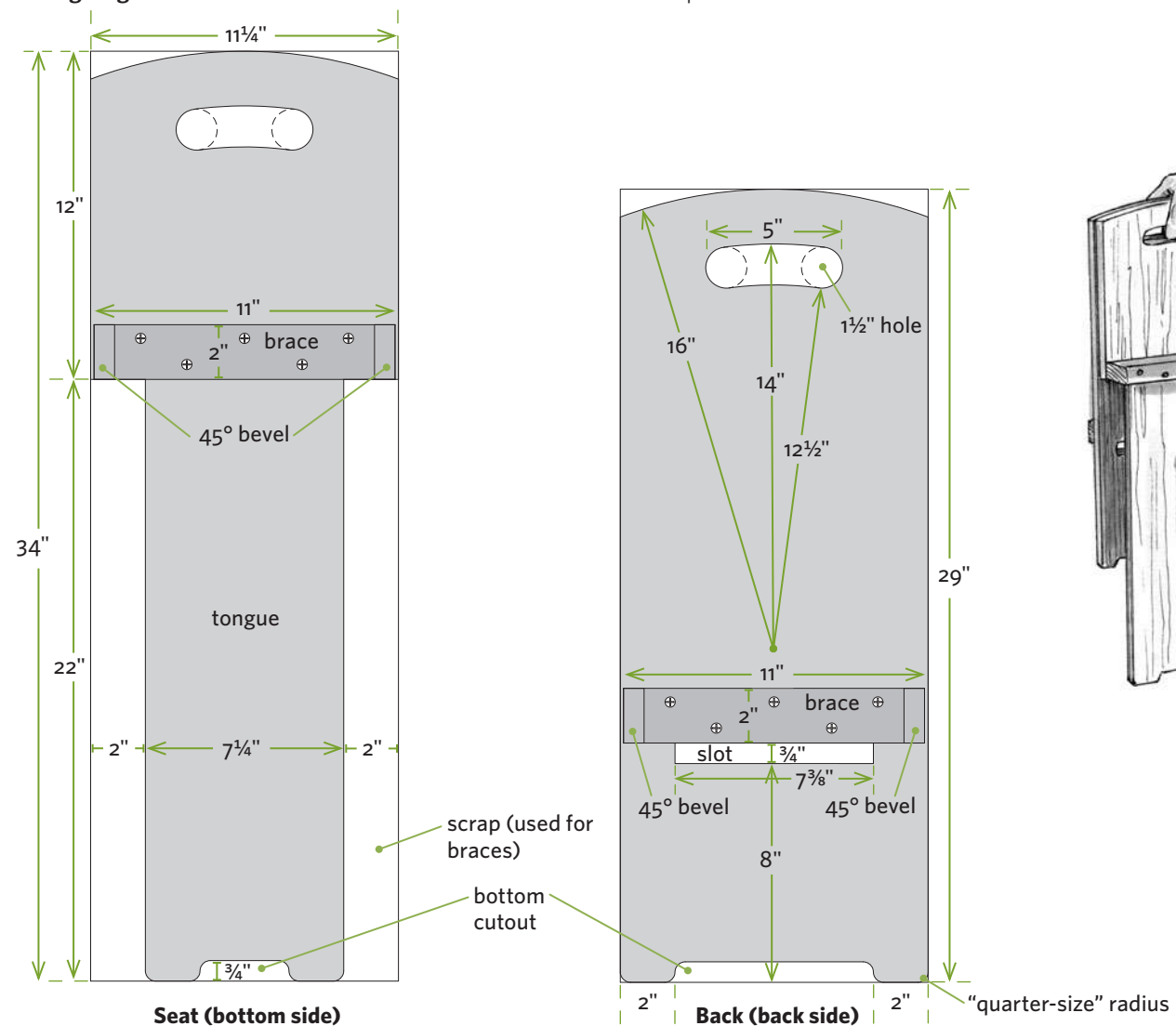

Solar Window Heater

Cheap heat for your home, barn, or workshop

To build and install some types of solar heating systems, you need to be a rocket scientist; to build this one, all you need to be is handy with a hammer and saw. This project is made from readily available material, purchased or scrounged. It's a simple solar collector that operates by drawing cool room air down through the bottom chamber, warming it as it passes through the upper chamber, and releasing it back into the room. If you plan properly and build your heater the right width, length, and angle, installing it is as easy as opening and shutting a south-facing window.

(Your window must be a single-hung or double-hung version for this to work.)

Before starting, study the illustrations and read the instructions to gain an overall understanding of how everything goes together and works. We don't provide exact measurements since the collector's size is based on the window dimensions, installation angle, and other factors. If in doubt, construct your collector without adhesives to make sure everything fits right, make any necessary adjustments, and then assemble it for real using adhesives and caulk.



Materials

- Pressure-treated 1×10s
- ½" pressure-treated plywood
- Pine 1×3s
- ¾" plywood
- Pine 1×8
- ¾" extruded foam insulation board
- Corrugated metal roofing panel
- Metal primer
- Flat black paint
- 1½" metal roofing screws
- Corrugated panel sealing strip
- Construction adhesive
- 1¼" exterior screws
- 2" exterior screws
- Foam adhesive
- Silicone caulk

Parts and Cutting List*

Part	Size and Material	Quantity
(A) collector box long side	¾" × 9¼" PT lumber	2
(B) collector box short side	¾" × 9¼" PT lumber	2
(C) collector box splice	¾" × 9¼" PT lumber	2
(C1) collector box end panel	¾" × 9¼" PT lumber	1
(D) side insulation	¾" extruded foam	2
(E) collector box bottom panel	½" PT plywood	1
(F) bottom insulation	¾" extruded foam	1
(G) side spacer	¾" × 2½" pine	2
(H) divider insulation	¾" extruded foam	1
(I) collector panel support	¾" × 2½" pine	4-5
(J) collector panel	corrugated metal roofing	1
(K) glazing panel support	¾" × 2½" pine	3-5
(L) glazing	clear corrugated roofing	1
(M) end sealer	corrugated panel sealing strip	2
(N) interior collector support	¾" × 2½" pine	1
(O) face panel	¾" plywood	1
(P) top door	¾" × 7¼" pine	1

*Material sizes and quantities will vary based on window width, collector angle, collector height, and other factors.

Building the Collector

Read *The Right Size, the Right Angle* (page 281) to determine the optimum angle for your solar collector. You can build it so it lies flat against the house if space is tight, or build it at a 45-degree slant for simplicity, but using the formula in the sidebar will produce the best bang for your buck and the best heat for your efforts.

1. Determine how far off the ground you want the base of your collector to rest; in snowy climates, we suggest a minimum of 8". Open the window, rest the base of a long 1×10 board for the collector box long side (A) on your temporary block, and lean the board against the windowsill, as shown in *Determining collector angle*, below. Adjust the block and angle of the board until the board is at the correct angle (55 degrees in our example). Use a large protractor or digital level to establish the correct angle.

2. Rest a short length of 1×10 (for part B) horizontally through the window opening and let it extend at least 6" into the room. Mark the intersection where the two 1×10s cross, and cut the boards to that angle (in our example, 27½ degrees). Cut a splice (C) and use construction adhesive and 1¼" screws to join parts A and B together to create a dogleg. Build the other box side assembly so it's the mirror image of this.
3. Test-fit the two box sides in the window opening to confirm the overall length and box angle. The splices (C) should face outward. Measure the distance between the outside faces of the dogleg sides (C), and subtract ½"; this is the maximum width your collector can be and still fit through your window opening.
4. Lay the dogleg sides on a flat surface, and use foam adhesive to secure extruded foam insulation (D) to the inside faces of each piece, as shown in *End view*, page 279. Make sure to use foam adhesive; construction adhesive and other glues can dissolve the foam rather than secure it!

Determining collector angle

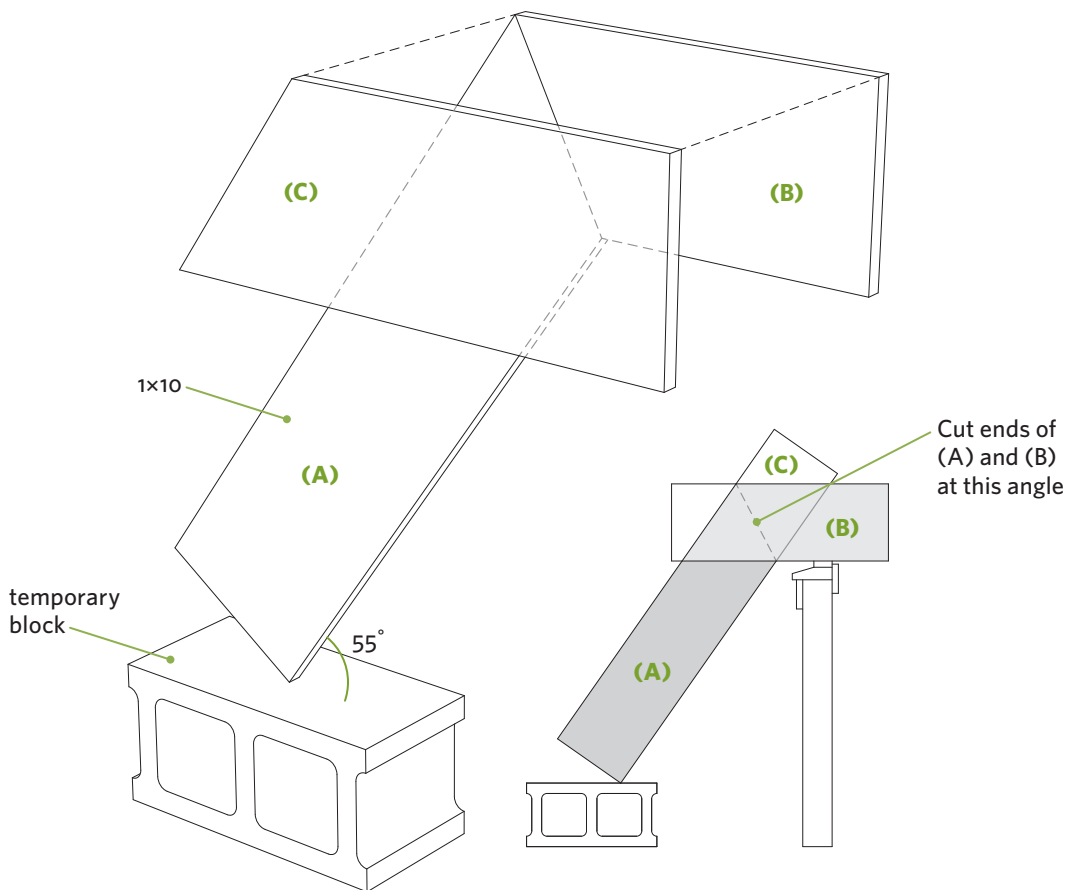

5. Install the 1x10 end (C1) between the two side pieces (A), securing it with construction adhesive and 2" screws.
6. Lay the collector frame upside down and install the 1/2" plywood panel (E) to join the bottoms of parts A and B. Use construction adhesive and 1 1/4" screws.

TAKE NOTE As you work, continue to add the same components (D, E, F, G, H, and I) to the part of the short horizontal leg of the collector created by part B as you do for the main collector.

7. Flip the collector box over. Install foam insulation (F) in the bottom of the collector using foam adhesive.
8. Install the side spacer strips (G) that create the lower cold-air chamber. They should end 4" from the bottom of the collector. Use foam adhesive and 2" screws that can penetrate through the foam and into the box sides (A, B).
9. Install the divider foam panel (H) to create the top of the cold air chamber. This should also end 4" from the bottom of the chamber.

Collector — side and end cutaway views

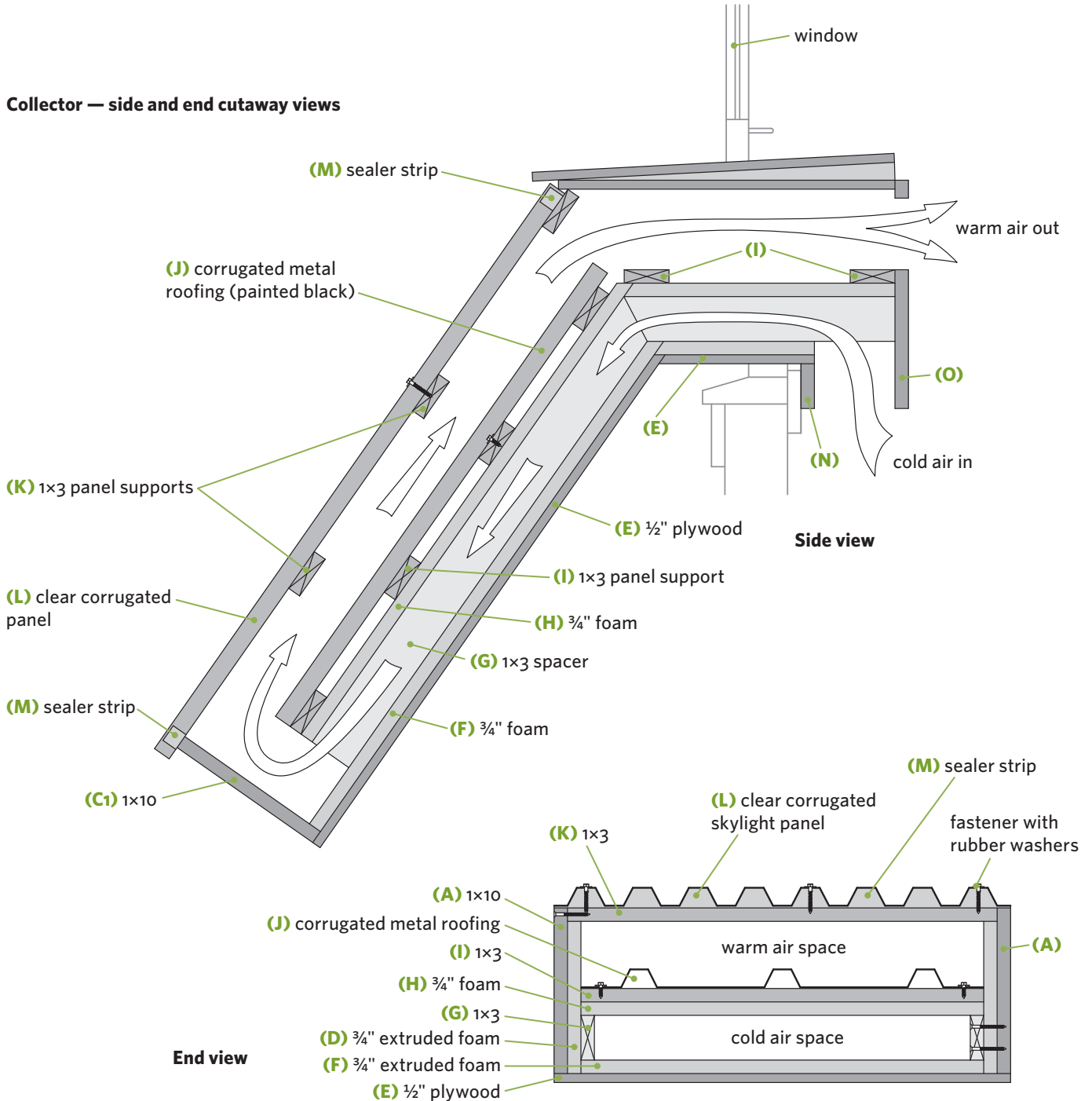

10. Apply foam adhesive to the undersides of the panel supports (I); secure them with 2" screws driven through the supports and the foam divider (H) and into the spacer strips (G). The adhesive on the 1x3s will help support the foam divider (H) below.
11. Cut the metal roofing (J) to the correct width and length. (Again, this should end 4" from the bottom of the collector to allow for airflow.) Apply metal primer and flat black paint to the upper side of the metal roofing. Install the roofing panel using metal roofing screws that penetrate into the 1x3 panel supports (I).
12. Use silicone caulk to seal all cracks and openings. Paint the sides, bottom, and other exposed parts of the collector (inside and out) that will be exposed to the sun black.

TAKE NOTE Some spray paints will dissolve or degrade foam insulation. Use a spray-on or brush-on paint that's compatible with foam.

13. Install the 1x3 glazing panel supports (K) that help support the clear glazing (L), as shown in *Collector — side and end cutaway views* (page 279). Notch the side foam (D) so the ends of the panel supports (K) make solid contact with the side pieces (A, B). Fasten the supports with screws driven through the side pieces.
14. Install sealer strips (M) to close in the ends of the clear corrugated panel (L); then install the panel using self-tapping screws with gaskets.

TAKE NOTE Before cutting and installing the glazing panel, read *Building the Upper Window Chamber (facing page)*. You'll want to create a tight seal at the top that will shed water. The details will vary based on your window construction.

15. Install legs made from leftover lumber on the bottom of the collector to raise it off the ground the same height as the temporary block used in step 1. Open your window and install the unit.

LESSONS FROM THE HOMESTEAD

Me and My Heat Wall

BY GEORGE VONDRISKA

I've got a 1,000-square-foot shop that's heated by a natural gas furnace. I've also got 10-below-zero winds swirling around outside in the winter. Ever on the lookout for a way to save some dough, it occurred to me that I might be able to take advantage of the south-facing wall of the shop. A friend of mine told me about Trombe walls, and this became the core of my idea.

At some point in my scavenging career, I'd picked up a 4 x 7-foot sliding glass door panel; this became the glazing for my solar heater. I used cementboard panels, commonly used under floor tiles, as the collector for absorbing and radiating the heat. The

panels would also serve as the thermal mass for storing heat so the wall could still "coast" and put out heat when the sun wasn't shining. I built the collector box out of plywood and installed it at a 10-degree angle directly against the south-facing wall of the shop. It's just one big chamber. A hole near the bottom pulls cool air from the shop into the collector, and a hole near the top channels the warm air back in. I insulated it to the max and painted everything, except the glass door, black. With a little more scrounging I found a thermostatically controlled duct-booster fan that turns on when the temperature

reaches a certain level. It wasn't built very scientifically, but it was built!

I installed the heater a number of years ago, and it's been my best friend ever since. My natural gas bill for my shop is about 30 percent lower, and even on the coldest days of winter my heat box is kicking out 90 to 100°F warm air. It doesn't "coast" as well as I had hoped, so I could have used more thermal mass. And I wish I'd run a few copper pipes through it so I could have experimented with preheating water with it. But I've recouped the 8 hours in labor and \$250 spent on materials many times over.

GEORGE VONDRISKA runs a shop in western Wisconsin. In addition to experimenting with solar heat, he offers woodworking classes, hosts guitar-building events, and manages the Woodworkers Guild of America magazine and website (see Resources).

Building the Upper Window Chamber

There are a variety of ways to finish the short horizontal leg of the collector that extends through the window. The configuration of your windowsill and other factors will impact the detailing. The main objectives are to maintain two separate air chambers (one for the cold air entering the collector at the bottom, and one for the warm air exiting at the top) and to provide openings into the room for each. A few key points:

- For the solar window heater I made, I cut an opening through the foam and plywood (E) at the bottom of the collector box to allow cold air to enter the bottom chamber. I added a 1x3 support (N) on the interior side of the window opening to help support the collector and prevent drafts. You can add foam weatherstripping to create a tighter seal.

- I also installed a $\frac{3}{4}$ " plywood face panel (O) across the main opening. Before installing it, I cut an opening near the top for the warm air from the collector to enter the room.
- Install a hinged flap (P) to block the "exhaust" opening in the evening or at times your solar collector isn't putting out heat. If cold air is drifting through the "intake" opening when the collector isn't in use, create a hinged flap for that opening, too.

Once your unit is installed, create a sloped surface on the top horizontal part of the collector (B) so it will shed water. I installed a horizontal sheet of $\frac{1}{2}$ " plywood, some wedges, then another layer of $\frac{1}{2}$ " plywood that extended beyond the clear corrugated glazing (L).

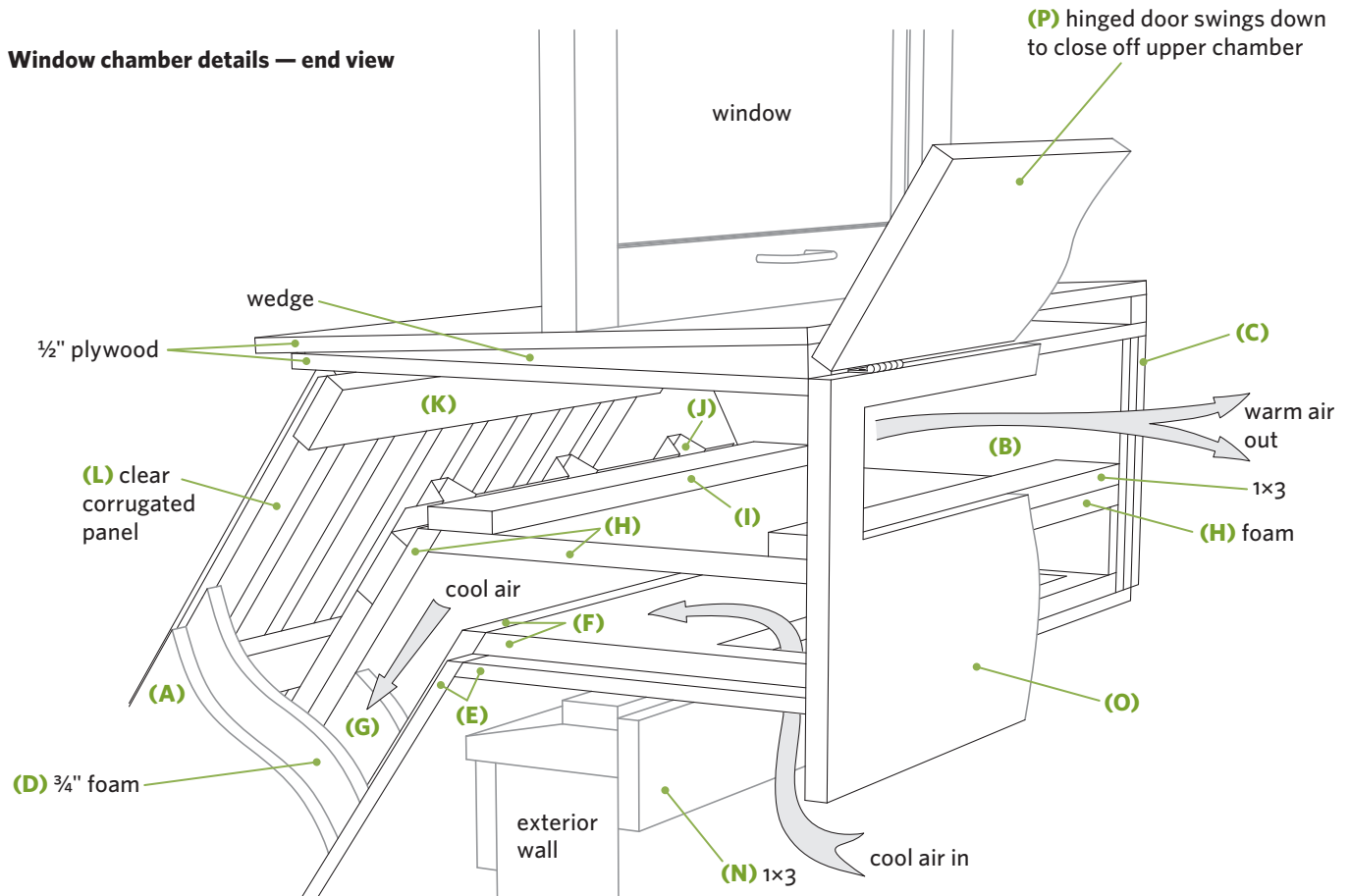

The Right Size, the Right Angle

The optimum angle of the collector is based on where you're located. The formula for the ideal angle is as follows: latitude + 10 degrees, measured from horizontal. (In other words, the farther you are from the equator, the more upright your collector will sit.) To find your latitude, simply search online using the name of the nearest city and the keyword *coordinates* or *latitude*. I angled mine at 55 degrees, making it suitable for northern regions of the United States.

Recommended Reading

Chapter 1

Rietz, Raymond C. and Rufus H. Page. *Air Drying of Lumber*, rev. ed. USDA Forest Service, 1999. Downloadable PDF. www.fpl.fs.fed.us/documnts/fplgr/fplgr117.pdf.

Chapter 2

National Gardening Association. *The Impact of Home and Community Gardening in America*. 2009. www.community-wealth.org/sites/clone.community-wealth.org/files/downloads/report-butterfield.pdf.

Siegchrist, Charles. *Building & Using Cold Frames*, A-39. A Storey Country Wisdom Bulletin. Storey Publishing, 1980.

Chapter 3

Food Harvesting and Preparation

Chadwick, Janet. *The Beginner's Guide to Preserving Food at Home*, 3rd ed. Storey Publishing, 2009.

Editors of Storey Publishing. *The Vegetable Gardener's Book of Building Projects*. Storey Publishing 2010.

Fryer, Julie. *The Complete Guide to Your New Root Cellar*. Atlantic Publishing, 2011.

Gush, Rick. "Root Cellars." *Hobby Farms*. 2003 June/July. www.hobbyfarms.com/food-and-kitchen/root-cellar-14908.aspx.

McPeake, Richard W. *Backyard BBQ: The Art of Smokology*. Self published, 2005. Lots of great recipes for brines, rubs, sauces, and marinades.

Marshall, Roger. *How to Build Your Own Greenhouse*. Storey Publishing, 2006.

Maxwell, Steve. "Build a Basement Root Cellar." *Mother Earth News*. 2004/2005 December/January. www.motheearthnews.com/do-it-yourself/basement-root-cellar-zmozo4zsie.aspx.

Maxwell, Steve and Jennifer MacKenzie. *The Complete Root Cellar Book*. Robert Rose, 2010.

Chapter 4

Editors of *Fine Homebuilding*. *Framing Roofs*. Taunton Press, 2010.

Books on Home Wiring

Cauldwell, Rex. *Wiring a House*, 4th ed. Taunton Press, 2010.

The Complete Guide to Wiring, 5th ed. Creative Publishing International, 2011.

Stanley Complete Wiring, 2nd ed. Meredith Books, 2008.

Chapter 5

Raising chickens, rabbits, and bees

Bennett, Bob. *Storey's Guide to Raising Rabbits*, 4th ed. Storey Publishing, 2009.

Damerow, Gail. *Storey's Guide to Raising Chickens*, 3rd ed. Storey Publishing, 2010.

Isbell, Connie and Audrey Pavia. *Rabbits for Dummies*, 2nd ed. Wiley, 2009.

Simon, Ed. *Bee Equipment Essentials*. Wicwas Press, 2011.

Thiel, David, ed. *Backyard Chickens Guide to Coops and Tractors*. Betterway Home Books, 2011.

Woginrich, Jenna. *Chick Days*. Storey Publishing, 2010.

Books on Home Wiring

Cauldwell, Rex. *Wiring a House*, 4th ed. Taunton Press, 2010.

The Complete Guide to Wiring, 5th ed. Creative Publishing International, 2011.

Stanley Complete Wiring, 2nd ed. Meredith Books, 2008.

Additional Resources on Animal Housing and Other Structures

Burch, Monte. *How to Build Small Barns & Outbuildings*. Storey Publishing, 1992.

Damerow, Gail, ed. *The Backyard Homestead Guide to Raising Farm Animals*. Storey Publishing, 2011.

Ekarius, Carol. *How to Build Animal Housing*. Storey Publishing, 2004.

Pisano, Tony. *Build Your Own Beekeeping Equipment*. Storey Publishing, 2013.

Seddon, Leigh. *Practical Pole Building Construction*. Williamson Publishing, 1985.

Chapter 6

Editors of Creative Publishing International. *The Complete Guide to Plumbing*, 4th ed. Creative Publishing International, 2008.

Fierro, Ethan. *The Outdoor Shower*. Storey Publishing, 2006.

Books

Bartholomew, Mel. *Square Foot Gardening: A New Way to Garden in Less Space with Less Work*. Rodale Books, 2005.

Carlsen, Spike. *Woodworking FAQ: The Workshop Companion*. Storey Publishing, 2012.

Conway, Sean and Lee Alan Buttala. *Sean Conway's Cultivating Life*. Artisan, 2009.

Gehring, Abigail R. *The Back to the Basics Handbook*. Skyhorse Publishing, 2011.

Matheson, Betsy. *DIY Projects for the Self-Sufficient Homeowner*. Creative Publishing International, 2011.

Additional Reading

Magazines

Backwoods Home Magazine

541-247-8900

www.backwoodshome.com

Practical ideas for self-reliant living; comprehensive bookstore and website with blogs, links, forums, and more.

The Family Handyman

800-374-3515

www.familyhandyman.com

Home improvement, outdoor, and woodworking projects; tons of hints, tips and ideas.

Grit

Ogden Publications, Inc.

866-803-7096

www.grit.com

Over 125 years young; topics relate to country living, gardening, projects, and rural lifestyle.

Hobby Farms

800-627-6157

www.hobbyfarms.com

Information on starting up a hobby farm and keeping it running smoothly.

Mother Earth News

Ogden Publications, Inc.

800-234-3368

www.motheearthnews.com

"The original guide to living wisely."

Newsletters, fairs, workshops and more; website features projects, blogs, and articles.

Resources

Chapter 1

David A. Munkittrick
Furniture Maker, LLC
<http://davidmunkittrick.com>

eReplacement Parts.com, Inc.
866-802-6383
www.ereplacementparts.com
Online tool parts retailer

Chapter 2

Circo Innovations
877-762-7782
www.snapclamp.com
U-clips

Composting for the Homeowner
University of Illinois Extension
<http://web.extension.illinois.edu/homecompost/materials.html>

FarmTek
800-327-6835
www.farmtek.com
Specialty polyethylene sheeting; hoop house kit

Garden Watersaver
440-840-3415
<http://gardenwatersaver.com>
Rainwater downspout diverters

How to Compost Your Organic Waste
Minnesota Pollution Control Agency
www.reduce.org/compost
Information on composting and composting bins

Lee Valley Tools Ltd. and Veritas Tools Inc.
613-596-0350
www.leevalley.com
U-clips for Hoop Greenhouse; item #EA273

Michael Perry
www.sneezingcow.com

Northern Tool + Equipment
800-221-0516
www.northerntool.com
20" bicycle wheels

RainHarvest Systems LLC
770-889-2533
www.rainharvest.com
Rain barrels and related supplies

Squash Blossom Farm
Susan Waughtul and Roger Nelson
www.squashblossomfarm.blogspot.com

wildlifeline.org
203-393-1050
www.wildlifeline.org
Information on electric fences; assistance in dealing with injured and orphaned wildlife and wildlife conflicts, especially for urban and sub-urban dwellers

Chapter 3

Amazon
www.amazon.com
Flowerpot smoker grate: Weber 22" replacement grill, Weber part #72501

Teresa Marrone
Northern Trails Press
www.northerntrailspress.com/teresa_marrone.htm

Chapter 4

Form and Pour a Concrete Slab
The Family Handyman
www.familyhandyman.com/masonry/pouring-concrete/form-and-pour-a-concrete-slab/step-by-step
Concrete slab tutorial

Chapter 5

APB Pole Barns
210-650-2276
www.pole-barn.info
Excellent source for plans, kits, general information, and pole building construction tips

B&B Honey Farm
507-896-3955
www.bbhoneymfarms.com
Bee packages and queen excluders

Bat Conservation International
800-538-2287
www.batcon.org
Plans for single- and four-chamber bat houses; general information about bats

Building Plans
North Dakota State University Extension
www.ag.ndsu.edu/extension-aben/buildingplans
Thousands of free, downloadable building plans relating to animals, crops, machinery, and construction

Catherine Friend
www.catherinefriend.com

Jason Amundsen
Locally Laid Egg Company
www.locallylaid.com

Miller Bee Supply
336-670-2249
www.millerbeesupply.com
Bee packages and queen excluders

Murray McMurray Hatchery
800-456-3280
www.mcmurrayhatchery.com

Randall Burkey Company
800-531-1097
www.randallburkey.com

Stromberg's Chicks and Game Birds
800-720-1134
www.strombergschickens.com

Additional resources for raising chickens

BackYard Chickens
www.backyardchickens.com
Information, forums, reviews, and supplies

ChickenCrossing.org
www.chickencrossing.org
Chicken basics, message boards, "health center," photos, and links

Raising Chickens.org
www.raising-chickens.org
Information on feeding, raising, and breeding chickens, and chicken diseases

Chapter 6

PVCFittingsDirect.com
877-777-8421
www.pvcfittingsdirect.com
4-way side outlet, T-fittings, and side outlet T-fittings

Quikrete
800-282-5828
www.quikrete.com
Concrete coloring agents

Rockler Woodworking and Hardware
800-279-4441
www.rockler.com
Label holders, item #28027

Woodworkers Guild of America
855-253-0822
www.wwgoa.com

Sources for Punched Tin Patterns

Country Accents
570-478-4127
www.piercedtin.com

The Tin Bin
717-569-6210
www.thetinbin.com

Tin 'N' Treasures
717-768-0681
www.tinntreasures.com

Index

A

accident prevention, 13
adhesives, 19
alkaline copper quarternary (ACQ), 73
Amundsen, Jason, 220
angled cuts, 29
animal shelter, 180, 192-97
 base and front/back wall framing, 194
 channels and gates, 196
 roof and end walls, 195
 windows, 197
ark, chicken. See chicken ark

B

backdoor storage locker, 244-47
 cabinet box construction, 246
 door/shelf details, 247
 locker room options, 245
backfill, post setting and, 27
barns, red, 32
bat house, 180, 189-191
 assembly, 191
 cutting details, 190
 location and color, 191
batter boards, 30, 31
beehive, top bar, 2, 180, 224-28
 hive
 body assembly, 225
 construction, 226
 setup, 228, 229
 KISS principle and, 227
 viewing window, 228
bench
 Leopold, 230, 236-38
 potting, 1, 85-89
 sawbuck, 140-42
bent rebar pergola, 77-79
beveled cuts, 29
bevels, markers and, 25
bird feeder, coffee can, 180, 221-23
blades, circular saw, 28
bolts, 21
boot scraper and jack, 232-34
building codes/permits, 26, 181, 206
burning codes, 123

C

cabinet. See punched tin jelly cabinet
cages, veggie, 75
"Call Before You Dig" hotline, 26
cardboard-box tabletop dehydrator, 120
carriage bolts, 21
carryall. See harvesting tote
cart. See also two-wheel garden cart
 golf cart garden dolly, 80-81
 homestead emergency, 2, 170-71
caulks, 19
cedar, 17
chair, pickin' and grinnin', 274-75
chest. See patio storage chest
chicken ark, 7, 180, 198-203
 accessories, 203
 hoops, marking/cutting, 200
 roof/floor/doors, 202-3
 skeleton, assembling, 201-2
chicken coop, classic, 180, 213-220
 chicken wire panels/door, 219-220
 nesting box bumpout, 217-18
 roof and skylight, 216
 walls, framing/building, 215
chicken nesting boxes, 182-83
chicken raisers, resources, 218
chromated copper arsenate (CCA), 84
circular saw basics, 28-29
 angled cuts, 29
 beveled cuts, 29
 blades, 28
 dado cuts, 29
 getting ready, 28
 plunge cuts, 29
 sighting cuts, 28
 square end cuts, 28
 straight-cutting jig, 29
clearance hole, 21
clippers, sharpening, 24
clothes pole trellis, 252-54
coffee can bird feeder, 180, 221-23
cold frame, 40-43
 assembly, 42
 considerations, 41
 homestead lesson, 43
 safety and, 42
composite lumber, 17

compost bins, 34, 44-49
 expandable/flexible, 48-49
 location for, 49
 rock-solid/maintenance-free, 46-47
 simple/portable, 44-45
compost items, 47
concrete
 footings, 27
 garden markers/stepping stones, 62-63
 planters, 7, 230, 262-64
connectors, metal, 21
copper trellis, 76
cords, power tool
 extension cords and, 25
 replacing, 25
countertop rack, foldaway, 6, 100, 104-6
cows, fencing and, 55
critter-proof fence, 34, 50-53
 door, 53
 fence, 51-52
cross-taping, 30

D

dadoes, 29
deck board dimensions, 16
deer-detering fencing options, 53
dehydrator, cardboard-box tabletop, 120
digging holes/setting posts, 26-27
dimensional lumber, 16
drill bits
 sharpening, 25
 types, 23
drilling holes, 22-23, 261
 in branches, 261
 drill tips, 22-23
 driving screws, 22
 large, boring, 23
drip irrigation, 56-59
 below-freezing temperatures and, 59
 bubblers, 56, 59
 drippers, 56, 58, 59
 faucet/faucet setup, 56, 58
 installation/maintenance, 58-59
 plan, overall, 57
 planters and, 70
 soaker drip lines, 57, 58

sprinklers/sprayers, 56, 58, 59
tubing and emitters, 58, 59
drying rack. *See* produce rack,
multipurpose

E

electrical outlets, 204-5
emergency cart, 2, 170-71
emergency sawhorses, 149
extension cord sizing, 25

F

fasteners, exterior, 20-21
fence
 critter-proof, 34, 50-53
 deer-detering options, 53
fence panel, shadow box, 54-55
Fierro, Ethan, 273
finishes
 paints and, 32-33
 tips on, 33
fire pit grilling station, 100, 121-23
 burning codes and, 123
 fire ring, 122
 grate holder, 123
 metal grate, 123
firewood
 cradle and carrying sling, 230,
 239-241
 storage and splitting station, 4,
 143-46
 frame construction, 145
 roof construction, 146
 tips, 146
first aid. *See* emergency cart
5-gallon bucket
 concrete planter and, 262-64
 nesting box buckets, 182-83
 organizer made from, 10
 safety and, 183
 stepping-stones, 62-63
flowerpot smoker, 3, 100, 133-35
foldaway counter-top rack, 6, 100, 104-6
folding trellis, 74
footings, post setting and, 27
freezing temperatures
 drip irrigation and, 59
 post setting and, 27

Friend, Catherine, 235
fruit storage, 128, 132. *See also* root cellar

G

garden, herb. *See* spice planter
garden cart, two-wheel, 36-39
garden dolly, golf cart, 80-81
gardening statistics, 35
garden markers, 62-63
garden path, 64-66
gardens, raised-bed, 34, 69-73
 found items, using, 72
 modular block beds, 71
 plywood beds, 72
 post and plank beds, 70
 tiered beds, 73
 timber beds, 69
garden stool, sitting/kneeling, 66-69
garden table. *See* rustic garden table
glues, 19
golf cart garden dolly, 80-81
greenhouse. *See also* hoop greenhouse,
 seedling rack as, 268
grilling station. *See* fire pit grilling station
ground-fault circuit interrupter (GFCI),
 115, 134, 135, 204, 205

H

hand tools, 10-11
hardwoods, tropical, 17
harvesting tote, 2, 100, 102-3
harvest trug, 100, 107-9
hearing protection, 12
heater. *See* solar window heater
herb drying. *See* foldaway countertop
 rack
herb garden. *See* spice planter
holes
 digging/setting posts, 26-27
 drilling, 22-23
 clearance holes, 21
 pilot holes, 21
homestead emergency cart, 2, 170-71
homestead lessons
 boots and boundaries, 235
 cold frames, 43
 fences, 55
 harvesting wild lumber, 18

hoop houses, 95
outdoor shower, 273
tools and, 11

honey. *See* beehive, top bar
hoop greenhouse, 5, 34, 90-95
 base, 91
 framework, 92
 planters and, 70
 plastic cover, installation, 94-95
 structure, completing, 93
 year-round produce and, 95
hose guides, 60-61
 copper pipe, 60
 iron pipe, threaded, 61
 roller stake, 60
 wooden stake, 61
hose headquarters, 179

I

irrigation. *See* drip irrigation

J

jelly cabinet, punched tin, 6, 230
jelly straining. *See* foldaway countertop
 rack

K

KISS principle, 227
knockdown sawhorses. *See* sawhorses

L

ladder mesh, 78, 79
ladders/heights, 13
lag screws, 21
lawn bag stand, 230, 242-43
Leopold, Rand Aldo, 238
Leopold bench, 230, 236-38
leveling
 batter board and, 30, 31
 long-distance, 31
levers/leverage, 14, 15
lifting heavy stuff, 14, 15
lights, 204-5
livestock, fencing and, 55
location
 for bat house, 191
 for compost bins, 49
 for root cellar, 125

locker. See backdoor storage locker

long-distance leveling, 31

lumber

composite, 17

dimensional, 16

treated, 16-17, 73

wild, harvesting, 18

M

Marrone, Teresa, 120

measuring, 30-31

metal connectors, 21

metal panels, cutting, 212

metal siding and roofing, 211

mini tool shed, 8, 158-162

assembled shed diagram, 162

door detail, 160

shed/roof framing, 161

modular shed, 163-69

end walls, 168

finish details, 168

floor construction, 165

hand-nailing vs. power nailing, 169

modifications to, 169

sheathing walls/roof, 168-69

shingles, installation, 169

trim installation, 169

trusses, 166-67

wall and roof framework, 167

windows/doors

installation, 169

openings, 168

moving heavy stuff, 14, 15

multipurpose produce rack. See produce

rack, multipurpose

Munkittrick, Dave, 18

N

nails

exterior, types of, 20

hand-nailing vs. power nailing, 169

Nelson, Roger, 95

nesting box buckets, 182-83

O

oriented strand board (OSB), 17

outdoor shower, 230, 269-273

customization, 271

plumbing, 272

shower surround, 271

wall panel construction, 272

outdoor workbench, 100, 112-15

framing details, 114

top and roof details, 115

outlets, electrical, 204-5

overhead storage cradles, 138-39

P

paints, 32-33

pasta making. See foldaway countertop

rack

path, super-simple, 64-65

patio storage chest, 152-55

building, 153-54

lid, building/installing, 155

pergola, bent rebar, 77-79

Perry, Michael, 43

pickin' and grinnin' chair, 274-75

picnic table. See workbench, outdoor

pigs, fencing and, 55

pilot hole, 21

planter

concrete, 7, 262-64

spice, 255-57

planter beds. See gardens, raised-bed

plant supports, 34, 74-76. See also per-

gola, bent rebar

copper trellis, 76

folding trellis, 74

horizontal gridwork, 76

tomato stakes, 75

veggie cages, 75

plunge cuts, 29

plywood

garden cart, 3, 34, 36-39

how to read, 17

overhead storage cradles, 138-39

raised-bed planters, 72

sawhorses, 147-49

portable sawmill, 18

posthole diggers, 26

posts, setting, 26-27

potting bench, 1, 85-89

bench, building, 86-87

bench and cabinet, assembling, 89

cabinet, building, 88-89

power, electric, 204-5

produce rack, multipurpose, 100, 116-19

round cutouts and, 119

side piece details, 118

tray construction, 119

pruning shears, sharpening, 24

punched tin jelly cabinet, 6, 230, 248-251

cabinets, choosing, 249

details, punched tin, 251

jelly cabinet, building, 249-251

panels, patterns/suppliers, 251

PVC pipe. See also hoop greenhouse

lawn bag stand, 242-43

for moving objects, 14

seedling rack, 265-68

storage, 138-39

Pythagorean theorem, 30

R

rabbets, 29

rabbit hutch, 180, 184-88

finish details, 188

floor/roof/siding/mesh, 186-87

framework, building, 186

hutch frame, 187

notching legs, 186

rules of thumb, 188

rack, foldaway counter-top, 6, 100

rain barrels, 34, 82-84

barrel considerations, 84

building, 83-84

raised-bed gardens. See gardens,

raised-bed

rebar pergola, bent, 77-79

respiratory protection, 12-13

roofing, metal, 211

root cellar, 124-28

construction, 125

enclosure, 126

location and design, 125

options, 126

storage system, 4, 129-132

bin detail, 132

drawer detail, 131

shelf detail, 131

shelf diagrams, 130

ventilation, 127

roots, cutting through, 27

run-in shelter, 206-12

beams/cross braces/girts, 208-9

metal panels, cutting, 212

metal siding and roofing, 211
post layout/installation, 207–8
rafters and purlins, 210, 211–12
roofing and siding, 210, 211–12
rust, warding off, 25, 151
rustic garden table, 230, 258–262
 drilling holes, 261
 legs, preparing, 259
 table assembly, 260
rustic trellis, 96–99
 assembly, 97–99
 branches, locating, 99
 layout, 97

S

safety. *See also* ground-fault circuit interrupter (GFCI)
 5-gallon buckets, 183
 “Call Before You Dig” hotline, 26
 cold frames and, 43
 rain barrel water, 84
 safety equipment and, 12–13, 28
 unplugging tools and, 25
saw, circular, 28–29
sawbuck bench, 140–42
 construction, 141–42
 using, 142
sawhorses
 emergency, 149
 knockdown, 147–49
 assembly, 149
 cutting layout, 148
sawmill, portable, 18
scaffolds/heights, 13
screwdrivers, sharpening, 24
screws
 drilling, 22–23
 exterior, 20
 lag, 21
seedling rack, 265–68
setting posts, 26–27
shadow box fence panel, 54–55
sharpening tools, 24–25
shears, sharpening, 24
shed. *See* animal shelter; mini tool shed; modular shed; run-in shelter; ultimate yard shed
shelter, animal. *See* animal shelter
shelter, run-in. *See* run-in shelter

shoulder bucket yoke, 110–11
shovels, sharpening, 25
shower. *See* outdoor shower
siding, metal, 211
sighting cuts, 28
Simon, Ed, 227, 228, 229
smoker, flowerpot, 3, 100, 133–35
solar window heater, 276–281
 building collector, 278–280
 collector angle, 278
 cutaway views, 279
 size and angle, 281
 upper window chamber, 281
spice planter, 255–57
square end cuts, 28
squaring, 30–31
stain, 32
stakes
 hose guides, 60–61
 tomato, 75
stand-up tool rack, 150–51
stepping-stones, 62–63
storage. *See also* backdoor storage
 locker; patio storage chest; root cellar
 cradles, overhead, 138–39
 firewood, 4, 143–46
 fruit and vegetable, 128
storage chest. *See* patio storage chest
straight-cutting jig, 29
switches, 204–5

T

table. *See* outdoor workbench; rustic garden table
tomato stakes, 75
tool(s)
 clean, rust-free, 151
 hand, 10–11
 sharpening/maintenance, 24–25
tool rack
 stand-up, 150–51
 wall-hung, 156–57
tool shed. *See* mini tool shed; modular shed
top bar beehive. *See* beehive, top bar
tote, harvesting, 2, 100, 102–3
trellis
 clothes pole, 252–54
 copper, 76

folding, 74
rustic, 96–99
tropical hardwoods, 17
trug, harvest, 100, 107–9
two-wheel garden cart, 3, 34, 36–39
 axle assembly, 39
 cutting diagram, 38
 leg/handle detail, 39

U

ultimate yard shed, 137, 172–78
 finish details, 178
 foundation and piers, 173
 roof construction, 176–77
 wall framing, 174–76
 window/doors/siding, 177

V

vegetable storage, 128, 132. *See also* root cellar
veggie cages, 75
vines, 254
Vondriska, George, 280

W

wall-hung tool rack, 156–57
watering. *See* drip irrigation
water sealers and repellants, 32
Waughtal, Susan, 55
weather. *See* freezing temperatures
wild lumber, harvesting, 18
window heater. *See* solar window heater
woods, 16–18
 branches, locating, 99
 dimensional lumber, 16
 exterior, 16–17
 plywood, 17
 wild lumber, harvesting, 18
workbench, outdoor, 100, 112–15
 customization, 115
 framing details, 114
 top/roof details, 115

Y

yard shed. *See* ultimate yard shed
yoke, shoulder bucket, 110–11

Other Storey Titles

ALSO BY SPIKE CARLSEN



Woodworking FAQ

304 pages. Paper with partially concealed wire-o.
ISBN 978-1-60342-729-6.

OTHER BACKYARD HOMESTEAD TITLES YOU WILL ENJOY



The Backyard Homestead

edited by **Carleen Madigan**
368 pages. Paper.
ISBN 978-1-60342-138-6.



The Backyard Homestead Guide to Raising Farm Animals

edited by **Gail Damerow**
360 pages. Paper.
ISBN 978-1-60342-969-6.

These and other books from Storey Publishing are available
wherever quality books are sold or by calling 1-800-441-5700.

Visit us at www.storey.com or sign up for our newsletter
at www.storey.com/signup.