

# CATHODIC PROTECTION OF STEEL IN CONCRETE

Edited by P.M. Chess

**E & FN SPON**  
An imprint of Routledge

## Cathodic Protection of Steel in Concrete

Also available from E & FN Spon

Steel Corrosion in Concrete

A.Bentur, S.Diamond and N.Berke

Corrosion of Steel in Concrete

J.Bloomfield

Cement-based Composites

A.M.Brandt

High Performance Fiber Reinforced Cement Composites 2

Edited by A.E.Naaman

Prediction of Concrete Durability

Edited by J.Glanville and A.Neville

Mechanisms of Chemical Degradation of Cement-based Systems

Edited by K.L.Scrivener and J.F.Young

Introduction to Eurocode 2

D.Beckett and A.Alexandrou

Alternative Materials for the Reinforcement and Prestressing of Concrete

Edited by J.L.Clarke

Reinforced Concrete Designer's Handbook

C.E.Reynolds and J.Steedman

Design Aids for Eurocode 2

Edited by The Concrete Societies of The UK, The Netherlands and Germany

Non-Metallic (FRP) Reinforcement for Concrete Structures

L.Taerwe

Examples of the Design of Reinforced Concrete Buildings to BS8110

C.E.Reynolds and J.C.Steedman

# Cathodic Protection of Steel in Concrete

Edited by

Paul Chess, Grønvold and Karnov,  
*Cathodic Protection International, Copenhagen, Denmark*

**E & FN SPON**

An imprint of Routledge

London and New York

First published 1998  
by E & FN Spon, an imprint of Routledge  
11 New Fetter Lane, London EC4P 4EE

This edition published in the Taylor & Francis e-Library, 2005.

“To purchase your own copy of this or any of Taylor & Francis or Routledge’s collection of thousands of eBooks please go to [www.eBookstore.tandf.co.uk](http://www.eBookstore.tandf.co.uk).”

Simultaneously published in the USA and Canada  
by Routledge  
29 West 35th Street, New York, NY 10001

© 1998 E & FN Spon  
Chapter 6, Transport Research Laboratory

All rights reserved. No part of this book may be reprinted or reproduced or utilized in any form or by any electronic, mechanical, or other means, now known or hereafter invented, including photocopying and recording, or in any information storage or retrieval system, without permission in writing from the publishers.

*British Library Cataloguing in Publication Data*  
A catalogue record for this book is available  
from the British Library

ISBN 0-203-22303-9 Master e-book ISBN

ISBN 0-203-27729-5 (Adobe eReader Format)  
ISBN 0 419 23010 6 (Print Edition)

# Contents

List of Contributors	xiv
<b>1 Corrosion in reinforced concrete structures</b> <i>Paul ChessG&amp;K</i>	<b>1</b>
1.1 Introduction	1
1.2 Electrochemical corrosion	3
1.3 Corrosion of steel	4
1.4 Steel in concrete	6
1.4.1 Mechanisms	10
1.4.1.1 <i>Alkalinity and chloride concentrations</i>	12
1.4.1.2 <i>Oxygen level</i>	15
1.4.1.3 <i>Cement type</i>	15
1.4.1.4 <i>Aggregate type and other additives</i>	16
References	16
<b>2 Appraisal of corrosion-damaged structures</b> <i>Sam BeamishSaid El-BelbolG MaunsellPartners Ltd</i>	<b>18</b>
2.1 Introduction	18
2.2 Corrosion of reinforcements in concrete	19
2.2.1 Background	19
2.2.2 Principal causes	19
2.2.2.1 <i>Carbonation</i>	19
2.2.2.2 <i>Chloride contamination</i>	19
2.3 Methods of assessing extent and causes of corrosion damage in reinforced concrete	20

2.3.1	Introduction	20
2.3.2	Initial investigation	20
2.3.3	Detailed investigation	20
2.3.4	Methods of testing	21
2.3.4.1	<i>Delamination and visual surveys</i>	21
2.3.4.2	<i>Covermeter survey</i>	22
2.3.4.3	<i>Half-cell potential survey</i>	22
2.3.4.4	<i>Chloride ion content</i>	23
2.3.4.5	<i>Carbonation depth measurements</i>	24
2.3.4.6	<i>Measurement of corrosion rates</i>	25
2.3.4.7	<i>Stray current</i>	26
2.3.5	Assessment of results of investigation	26
2.4	Factors to be considered in determining appropriate repair strategy	27
2.4.1	Introduction	27
2.4.2	Structural considerations	28
2.4.3	Options for repair	29
2.4.3.1	<i>Patch repairs</i>	29
2.4.3.2	<i>Repair by removal of all chloride- contaminated concrete</i>	30
2.4.3.3	<i>Element replacement</i>	30
2.5	Reasons for and against the choice of cathodic protection	30
2.5.1	General	30
2.5.2	Effectiveness of cathodic protection	31
2.5.3	Cost	32
2.5.4	Adverse side effects	32
2.6	Need for and limitations on patch repairs in cases where cathodic protection is to be used	33
2.7	Reinforcement continuity checks and other preliminaries	34
2.7.1	Reinforcement continuity	34

2.7.2	Substrate condition	34
2.7.3	Embedded metals and fixings	34
2.7.4	Sufficient concrete cover	35
	References	35
Appendix 2.1	Cathodic protection of reinforced concrete	36
3	<b>Design of a cathodic protection system</b>	38
	<i>Paul ChessG&amp;K CPI</i>	
3.1	Introduction	38
3.2	System design	38
3.2.1	Overall system philosophy	39
3.2.2	Current density requirement	39
3.2.3	Current distribution	40
3.2.4	Trials and testing	42
3.2.5	Zones	43
3.2.6	Anode selection	44
3.2.7	Cabling	44
3.2.8	Reference electrodes and other measuring devices	46
3.2.9	Interaction	49
3.2.10	Continuity and negative connections	49
3.3	Case history	51
3.3.1	Introduction	51
3.3.2	Concrete basin	52
3.3.3	Support columns	52
3.3.4	Beams	54
3.3.5	Radial bents	55
	Reference	58
4	<b>Impressed current cathodic protection systems for reinforced concrete</b>	59
	<i>Kevin DaviesK.Davies Consultancy</i>	

4.1	Introduction	59
4.2	Application of impressed current cathodic protection	60
4.3	Requirements of impressed current cathodic protection anode systems	61
4.3.1	Aesthetics	61
4.3.2	Physical attributes	62
4.3.3	Chemical attributes	63
4.3.3.1	<i>Oxygen evolution at the anode</i>	63
4.3.3.2	<i>Chlorine evolution at the anode</i>	63
4.3.4	Performance characteristics	63
4.4	Impressed current cathodic protection anodes currently available	65
4.4.1	Materials	69
4.4.2	Primary anodes	71
4.4.2.1	<i>Platinized titanium or niobium wires</i>	71
4.4.2.2	<i>Platinized, mixed metal-oxide-coated titanium and brass or stainless-steel plates</i>	71
4.4.2.3	<i>Titanium wires and strips</i>	72
4.4.2.4	<i>Carbon-fibre tapes</i>	72
4.4.3	Surface-mounted anodes	73
4.4.3.1	<i>Conductive coatings</i>	73
4.4.3.2	<i>Conductive polymer-modified cementitious mortar</i>	76
4.4.3.3	<i>Metal spray coatings</i>	76
4.4.3.4	<i>Other surface-mounted anode systems</i>	77
4.4.4	Discreet anodes	78
4.4.4.1	<i>Platinized titanium wire/graphite paste systems</i>	79
4.4.4.2	<i>Mixed metal-oxide-coated titanium mesh, strip or ribbon and conductive ceramic systems</i>	80
4.4.4.3	<i>Slotted systems</i>	80
4.4.5	Embeddable surface-mounted anodes	80

4.4.5.1	<i>Mixed metal-oxide-coated titanium mesh systems</i>	81
4.4.5.2	<i>Catalysed titanium strip</i>	82
4.4.5.3	<i>Metal-oxide-coated titanium ribbons</i>	82
4.4.5.4	<i>Conductive polymeric wires</i>	83
4.4.5.5	<i>Cementitious overlay materials</i>	83
4.4.6	Anodes for submerged and buried structures	84
4.4.6.1	<i>Groundbeds</i>	85
4.4.6.2	<i>Consumable anodes</i>	85
4.4.6.3	<i>Non-consumable anodes</i>	86
4.4.6.4	<i>Sacrificial anodes</i>	86
4.4.7	Selection of anode type and materials	87
4.4.7.1	<i>Technical considerations</i>	87
4.4.7.2	<i>Economic considerations</i>	89
4.5	The future	90
	References	91
	Acknowledgements	92
<b>5</b>	<b>Power supplies</b>	93
	<i>Paul ChessG&amp;KFritz GrønvoldIb Nojensen</i>	
5.1	General	93
5.2	Types of power supplies	94
5.2.1	Manual tap transformer plus rectifier	94
5.2.2	Transformer plus rectifier plus smoothing circuit	95
5.2.3	Thyristor controlled	96
5.2.4	Linear	96
5.2.5	Switch-mode	98
5.3	Features of power supplies	98
5.3.1	Protection against transients and lightning	98
5.3.1.1	<i>Metal oxide varistor (MOV)</i>	99

5.3.1.2	<i>Transient protection diodes</i>	99
5.3.1.3	<i>Surge arrester</i>	100
5.3.2	Cabinet selection	100
5.3.3	Reading output currents, voltages and potentials	103
5.3.4	Galvanic separation of power supplies	104
5.3.5	Power supply layout	105
5.3.6	Electromagnetic interference (EMI)	106
5.3.7	Efficiency	106
5.4	Automatic systems	107
<b>6</b>	<b>Monitoring cathodic protection of steel in concrete</b>	<b>113</b>
	<i>Chris Naish; AEATechnology and Malcolm McKenzie, Transport Research Laboratory</i>	
6.1	Introduction	113
6.2	Basis of cathodic protection	114
6.3	Cathodic protection of steel in concrete	118
6.4	Electrical criteria	119
6.4.1	Absolute potential	120
6.4.1.1	<i>Basis of criterion</i>	120
6.4.1.2	<i>Measurement of absolute potentials</i>	122
6.4.2	Polarization curves (E-log i)	122
6.4.2.1	<i>Basis of polarization curves</i>	122
6.4.2.2	<i>The measurement of polarization curves</i>	123
6.4.3	Depolarization	124
6.4.3.1	<i>Basis of depolarization criterion</i>	124
6.4.3.2	<i>The measurement of depolarizations</i>	126
6.4.4	Other criteria	126
6.4.4.1	<i>Embedded probes</i>	127
6.4.4.2	<i>Isolated reinforcing bars</i>	127
6.4.4.3	<i>Macrocell probes</i>	127
6.4.4.4	<i>Electrical resistance probes</i>	128

6.4.4.5	<i>AC impedance response</i>	129
6.5	Discussion of possible electrical criteria	129
	References	133
	Bibliography	133
7	<b>New reinforced concrete: upgrading and maintaining durability by cathodic protection</b> <i>Richard Palmer</i>	134
7.1	Introduction	134
7.2	Upgrading and maintaining durability	135
7.3	Alternative technologies to CP	137
7.4	CP using MMO anodes	139
7.5	Design considerations	141
7.6	Examples of new structure CP	146
7.7	Operation and maintenance	149
7.8	Economics	152
	Notes	152
	References	152
8	<b>Current developments and related techniques</b> <i>Donald HudsonSage Engineering</i>	154
8.1	Realkalization	154
8.1.1	Overview	154
8.1.2	Description of electro-osmosis	155
8.1.3	Initial survey of structure	156
8.1.4	Surface preparation	157
8.1.5	Rebar connections	157
8.1.6	Anode mesh	157
8.1.7	Anode connections	158
8.1.8	Electrolytes	158
8.1.9	Electrolyte reservoir	158

8.1.10	Cellulose fibre	159
8.1.11	Felt cloth	159
8.1.12	Coffer tanks	159
8.1.13	Application of the electric field	160
8.1.14	Performance monitoring	160
8.1.15	Dismantling	161
8.1.16	Post-treatment	161
8.1.17	Practical considerations	161
8.1.18	Comparison with other methods of treating carbonated concrete	161
8.2	Desalination	162
8.2.1	Overview	162
8.2.2	Anode mesh	163
8.2.3	Electrolytes	163
8.2.4	Testing	163
8.2.5	Post-treatment	164
8.2.6	Comparison with other methods of treating chloride contaminated concrete	164
8.2.7	Possible detrimental side effects of realkalization and desalination	165
8.2.8	Alkali aggregate reaction (AAR)	166
8.2.9	Bond strength	166
8.2.10	Hydrogen embrittlement	167
8.2.11	Microcracking	167
8.3	Electrochemical inhibitor injection	168
	References	169
<b>9</b>	<b>Avoidance of potential side effects</b>	<b>170</b>
	<i>David EyreSpencerPartners</i>	
9.1	Hydrogen embrittlement of prestressing wires	170
9.2	Corrosion interaction	173

9.3	Reduction in bond strength and alkali silica reaction	174
	References	175
<b>10</b>	<b>Economic aspects</b>	<b>177</b>
	<i>Paul Lambert/Mott MacDonald</i>	
10.1	Introduction	177
10.2	General cost implications of repair	178
10.3	Conventional repair versus cathodic protection	178
10.3.1	Direct costs	178
10.3.2	Indirect costs	180
10.3.3	Maintenance costs	180
10.4	Cost implications of anode type	181
10.5	Cost comparisons	182
10.6	Cathodic prevention	182
10.7	Protecting the investment	184
	References	185
	Index	186

# List of Contributors

Sam Beamish BSc, C Eng, MICE, principal engineer, G.Maunsell and Partners, Birmingham, UK.

Paul Chess, PhD, C Eng, FIM, managing director, Cathodic Protection International Aps and Grønvold and Karnov AS, Copenhagen, Denmark.

Kevin Davies BSc, M I Corr, principal, Kevin Davies Consultancy, Manchester, UK.

Said El-Belbol BSc, MSc, PhD, C Eng, MICE, M I Corr, cathodic protection specialist, G.Maunsell and Partners, Birmingham, UK.

David Eyre BSc, PhD, M I Corr, principal engineer, Spencer and Partners, Penspen Group, London, UK.

Frits Grønvold BSc, MSc, technical director, Grønvold and Karnov AS, Copenhagen, Denmark.

Donald Hudson BSc, MSc, C Eng, MIM, M I Corr, commercial manager, Sage Engineering, Bath, UK.

Paul Lambert BSc, PhD, C Eng, MIM, F I Corr, regional associate, Mott MacDonald, Manchester, UK.

Ib Mogensen BSc, principal electronics engineer, Grønvold and Karnov AS, Copenhagen, Denmark.

Malcolm McKenzie BSc, MSc, M I Corr, senior researcher, Transport Research Laboratory, Bracknell, UK.

Chris Naish BSc, D Phil, M I Corr, principal consultant, AEA, Bristol, UK.

Richard Palmer BSc, C Eng, MICE, private consultant, Divonne-les-Bains, France.

# Corrosion in reinforced concrete structures

*Paul Chess, G&K, CPI*

## 1.1

### INTRODUCTION

Steel and concrete have become the most common materials for manmade structures over the last hundred or so years with the use of the composite material, concrete reinforced with steel, becoming one of the most popular methods for civil construction. The historical reasons for steel-reinforced concrete's popularity are not hard to find: its cheapness, high structural strength, mouldability, fire resistance and its supposed imperviousness to the external environment, while requiring little or no maintenance, provide a virtually unbeatable combination. In order to harness these properties, both national and international standards have been developed. The standards for both concrete and steel were initially defined principally by compositional limits and strength, and this has continued to be the primary means of quality control to date.

Until the 1950s it was assumed that when steel was encased in the alkaline concrete matrix, neither would suffer from any degradation for the indefinite future. However, evidence of degradation was noted as early as 1907 (Knudsen, 1907) where it was observed that chlorides added to concrete could allow sufficient corrosion of the steel to crack the concrete. The implicit assumption to this day by many civil engineers of reinforced concrete's virtually infinite durability has proven to be true in several cases, with structures reaching their design lives without any evidence of structural degradation. However, it is now evident that in areas where there is an aggressive atmosphere, the concrete can be damaged or the steel can corrode in a dramatically shorter time period than that specified as a design life. For UK highways the current design life was originally set at 120 years and despite all the evidence of highway structures showing significant problems after a short time period it is still set at this extremely hopeful figure even though no corrosion design life analysis is required. This head-in-the-sand approach can be contrasted with the reality illustrated by research (Bamforth, 1994) showing that the estimated time to corrosion activation of steel reinforcement in modern concrete with the designated cover can be as low as

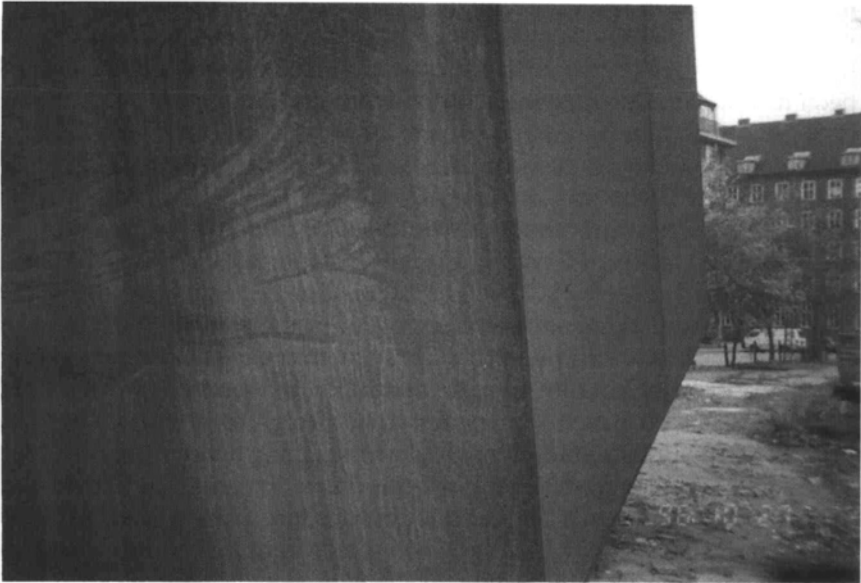

**Fig. 1.1** Typical example of a corroding reinforced concrete structure.

five and a half years at the 0.4% chloride level with modern concrete. These research findings are in good accordance with site investigations. A substantial number of structures have been found to have their steel reinforcement sufficiently corroded within 20 years of construction to be structurally unsound.

Even after the publicity surrounding the large number of structures exhibiting acute signs of distress 25 or so years into a designed 120-year life-span, there is still a body of engineers who believe that all that is required to achieve any specified design life in a hostile environment is to provide a higher concrete grade with the same design and maintenance of the structure. This contention does not correspond with the facts and means that publications such as this book will not only be dealing with civil engineering miscalculations of the past but also those perpetrated in the future.

The traditional use of cathodic protection has been to prevent corrosion of steel objects in the ground or water and this is still its most common application. It is now almost universally adopted on ships, oil rigs and oil and gas pipelines. Over the last 50 years cathodic protection has advanced from being a black art to something approaching a science for these applications.

Over the past 30 or so years there has been a steady increase in the use of cathodic protection for the rehabilitation of reinforced concrete structures which are exhibiting signs of distress. The most common damage mechanism is chloride-induced corrosion of the steel reinforcement and this is normally what cathodic protection systems are intended to stop. Initially the cathodic protection techniques for

reinforced concrete followed the practice of ‘traditional’ impressed current systems closely but, particularly over the past decade or so, there have been significant developments which have allowed the protection of concrete structures to become a legitimate and yet distinctly different part of the cathodic protection mainstream with its own protection criteria, anode types and even power supplies.

The object of this volume is to be an introduction to the current state of the art in cathodic protection of concrete and outline other related electrochemical techniques for stopping corrosion of steel reinforcement. Some guidelines on what cathodic protection is, and how and when to use it, are also discussed in order that a practising civil engineer or owner should have an introduction into the murky world of the cathodic protection of reinforced concrete.

## 1.2

### ELECTROCHEMICAL CORROSION

Electrochemical reactions are widely used by mankind for industrial processes such as anodizing, or the production of chloride, and indeed are used directly by most people every day of their lives when using a battery. A surprising number of engineers vaguely remember an explanation in chemistry classes of how a battery operates. This is normally reiterated as being about electrolytes with ions swimming about, with anodes and cathodes making an appearance, and then dismissed as not being of importance in ‘proper’ civil or mechanical engineering. Unfortunately for those who do not like electrical circuits, corrosion is also an electrochemical process and is of great economic importance, as those with old cars will testify, and has been estimated to consume 4% of the Gross National Product of, for example, the United States (Bennett *et al*, 1978). This percentage is likely to be of the same order globally.

In all low-temperature corrosion reactions, and all the processes given above, for the reactions to occur an electrochemical cell is needed. This cell comprises an anode and cathode separated by an electrolytic conductor (electrolyte) with a metallic connection. This is shown schematically in [Figure 1.2](#). A practical definition of an anode is the area where corrosion is occurring while the cathode is the area where no corrosion is occurring.

When a metal such as steel is in an electrolyte (this is an aqueous solution which can carry ions such as water with some rock salt in solution) then a corrosion cell can be formed. Part of the steel in the electrolyte forms the anode and part of the steel also in the same electrolyte forms the cathode. Corrosion in this case would be occurring at all the anode points which are dispersed around the steel (see [Figure 1.3](#)). This gives the appearance of general or uniform corrosion.

If steel is physically attached (i.e. welded, bolted or cast) to a piece of zinc and they are both placed in an electrolyte, then the zinc will form all the anode and the steel will only form the cathode. The result of this will be that all the corrosion reaction will occur to the zinc which will be consumed and a balancing reduction reaction

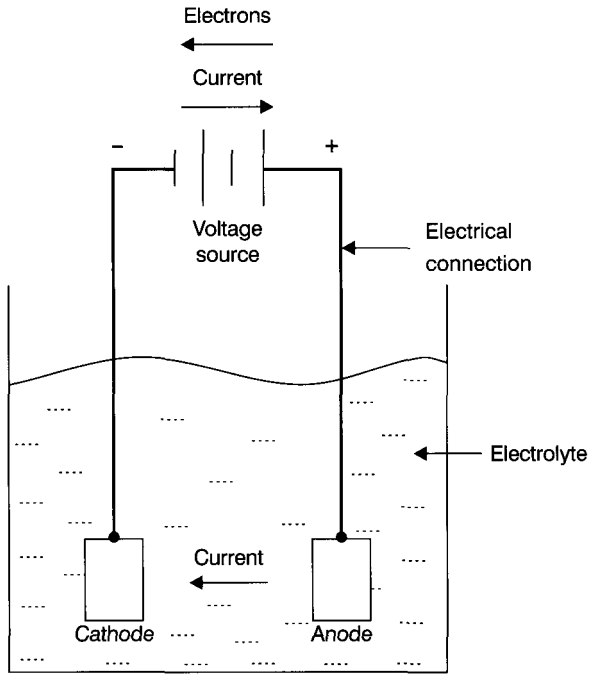

**Fig. 1.2** Schematic of a corrosion cell. In a driven cell cations migrate towards the cathode, anions towards the anode. Current is defined as the flow of positive charge and moves in a direction opposite to the flow of electrons.

(non-corrosion) will occur to the steel which will not be affected by its immersion in the electrolyte. This is the basis of cathodic protection. When you cathodically protect steel or any other metal you make it change from acting either just as an anode or both an anode and cathode to acting totally as a cathode. This is done by the imposition of an external anode which will corrode preferentially (see [Figure 1.4](#)).

### 1.3

#### CORROSION OF STEEL

Steel, in common with all engineering metals, is intrinsically unstable in that it wants to return to its stable state where it came from as an ore. The result of this reversion is rust (commonly iron oxide, but it can be iron sulphide or other compounds) which, while having considerably greater chemical stability, also has considerably reduced mechanical properties such as strength, compared with the original steel. As there is this tendency to corrode, the principal question is not will steel rust, but how fast will it rust?

The corrosion rate of steel is normally decided by the environment and also the stability of the oxide layer on the surface. If this layer forms a protective skin which is

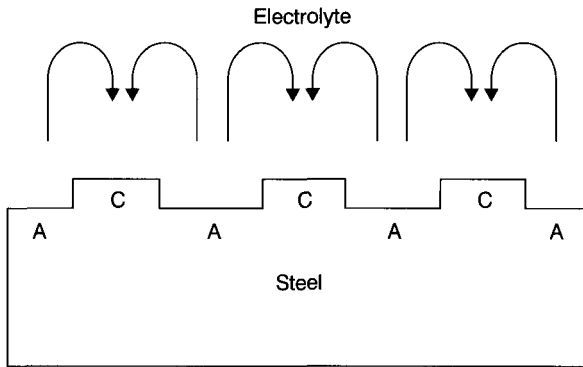

**Fig. 1.3** Schematic of micro-corrosion cells on steel's surface. Regions labelled A are the anodic areas where metal is dissolving. Regions labelled C are cathodic areas where no corrosion is occurring. The arrows represent the current flow.

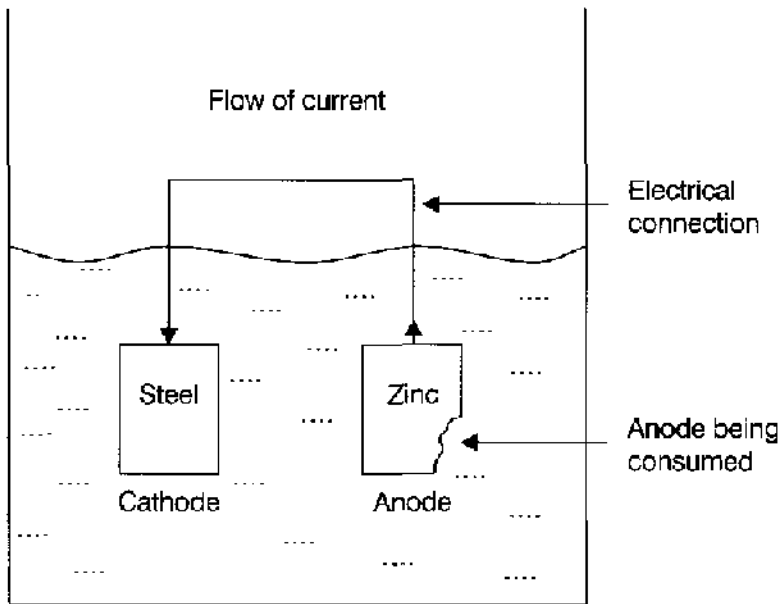

**Fig. 1.4** Sacrificial anode cell

not breached then the rate of reaction is very slow. If, however, the oxide layer is opened at many places and sloughs off the surface providing access for more oxygen (which is normally dissolved in water) to the unreacted steel surface, then a high corrosion rate can be expected.

Straight carbon and high-yield steels are the most commonly used grades for rebar in normal civil engineering projects. Neither of these types has a particularly

protective oxide film and both rely on the alkalinity of the concrete to stabilize this skin.

When steel corrodes in a normal atmosphere, i.e. outdoors, there will be a very rapid change in colour. This is known as 'flash' rusting. As an example, blast-cleaned steel in a moist environment changes colour in the time between the contractor's finishing the blasting operation and opening the paint pots. This rusting is evidenced by a change in the surface colour from silver to orangey red over all the exposed surface. In this case the corrosion is very rapid because of the presence of ample fuel (oxygen) and the absence of a protective oxide film. In a saline environment the flash rusting is even quicker as chloride helps the water to conduct current. If the steel were examined visually under a microscope it would all look the same colour, as in this case the individual anode and cathode sites are very small, perhaps within a few microns of each other.

In cases where the steel is exposed directly to the atmosphere and is at a normal (neutral) pH and there is a reasonable supply of oxygen there will be widespread and uniform corrosion. This is normally observed when large sections of steel are rusting and can be seen on any uncovered steel article particularly on beaches and other places with an aggressive atmosphere. An example is given in [Figure 1.5](#).

When the access of oxygen to the steel is reduced, and this becomes the corrosion limiting step, i.e. when there are sufficient aggressive ions present at the steel interface so that the corrosion reaction itself can happen very quickly, then other forms of corrosion may occur. The most common is pitting corrosion. This, for example, will occur when there is a surface coating on the steel which is breached, allowing oxygen and moisture access to a relatively small area. In older cars these are commonly seen as rust spots. This situation is shown schematically in [Figure 1.6](#).

## 1.4

### STEEL IN CONCRETE

Concrete normally provides embedded steel with a high degree of protection against corrosion. One reason for this is that cement, which is a constituent of concrete, is strongly alkaline. This means that the concrete surrounding the steel provides an alkaline environment for the steel. This stabilizes the oxide or hydroxide film and thus reduces the oxidation rate (corrosion rate) of the steel. This state with a very low corrosion rate is termed passivation. The other reason that concrete provides embedded steel with protection is that it provides a barrier to the outside elements which are aggressive to the steel. The most common agent for depassivation of the steel in concrete is the chloride ion.

The traditional wisdom was that concrete of low water-cement ratio which was well cured would have a sufficiently low permeability to prevent significant penetration of corrosion-inducing factors such as oxygen, chloride ions, carbon dioxide and water. Unfortunately, this has not been found to be the true position.

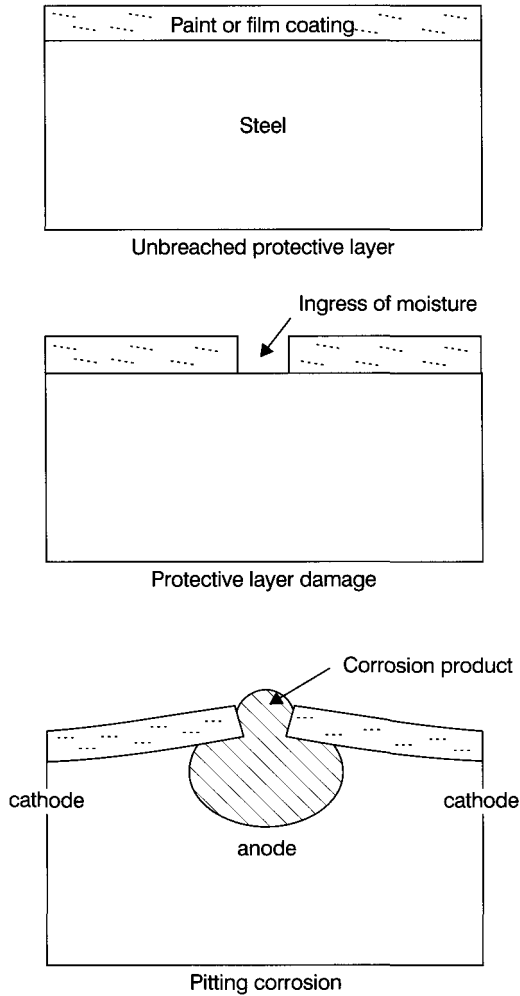
*Steel in concrete*

**Fig. 1.6** Example of pitting corrosion.

Some of this can be explained by the fact that concrete is inherently porous, whatever its composition, and if there is a concentration gradient then at some time a sufficient quantity of aggressive ions will be passed through the concrete to initiate corrosion. The crux is at 'some time' as this might be sufficiently long to achieve the design life or it might not. Another reason is probably that cracks exist on all full-scale structures and these provide preferential pathways for corrosion-inducing factors.

Fortunately in the majority of steel-reinforced concrete structures corrosion does not occur in the design life. However, this is a situation which occurs more by luck



**Fig. 1.5** Uncoated steel showing uniform corrosion in an exposed coastal environment.

than judgement. With concrete of a suitable quality, corrosion of steel can be prevented for a certain time period, provided that the structure or element is properly designed for the intended environmental exposure.

In instances of severe exposure, such as in bridge decks exposed to deicing salts or pilings in sea-water, the permeability of concrete conforming to certain standards has been measured and using this data the time required for the onset of corrosion has been calculated as shown in [Table 1.1](#).

Table 1.1 Estimated time for corrosion to be initiated with different concrete grades

Concrete	Minimum cover (mm)	Time to activation (years)	
		With chloride concentration of 0.4%	With chloride concentration of 1%
Old pre-cast standard	38	23.7	53.8
BS 8110 (general)	50	5.5	12.4
BS 5400 (bridges)	65	9.2	20.9
BS 6349 (maritime)	75	12.3	27.9

Source: Bamforth (1994).

As can be seen, a corrosion initiation period of only five and a half years is possible when using a modern concrete in compliance with the current standard in a particular environment.

Where the concrete quality and cover of a new structure are not sufficient to provide the required design life there are several measures which may be used such as corrosion inhibitors, coatings on the steel, coatings on the concrete or cathodic protection. The correct choice should be determined after an evaluation of all the options for their cheapness, reliability and effectiveness over the design life of their structure as discussed in [Chapter 2](#).

If the structure is not properly corrosion-designed for the anticipated environment, or the environment and other factors were not as anticipated or change during the life of the structure, there might be problems. Instances of distress due to corrosion can be found in almost all applications of modern reinforced or prestressed concrete; buildings, silos, beams, bridge decks, piles, other supports, tanks and pipes are some common examples.

Normally the first evidence of distress is brown staining of the concrete surface nearest to the corroding embedded steel. This staining is caused by the permeation of iron ions through microcracks in the concrete to the surface and is often accompanied by macrocracking of the concrete shortly afterwards. The cracking occurs because certain corrosion products of steel, such as the iron oxides, have a volume which is substantially greater than the metallic element (iron) from which it was formed. The forces generated by this expansive process exceed the tensile strength of the concrete with resulting cracking.

Steel corrosion not only causes structural distress or disfigurement because of staining, cracking and spalling of the concrete. It also reduces the compressive strength of the structure (because of the damaged concrete) but often more critically can cause structural failure due to the reduced cross-section and hence reduced tensile capacity of the steel. This reduced tensile capacity is normally only significant in localized areas and is more structurally critical with prestressing steel tendons than

reinforcing bars. The reason for this is that the load cannot be easily redistributed in a pre- or post-tensioned structure unlike cast in-situ structures. As an example of the extreme damage which can occur with steel in cracked and stained concrete it is common to find that 60 or 70% of the cross-section has corroded through. All concrete corrosion engineers have their apocryphal stories describing structures where there has been a 100% section loss of the steel reinforcement and this can in certain circumstances be seen at many points.

### 1.4.1

#### Mechanisms

When reinforcement steel in concrete corrodes, the process is similar to taking power from an ordinary battery. In a battery, and when steel corrodes, a metal dissolves and this leads to the production of a small current between the +pole and the • pole.

For steel reinforcement which is corroding in the concrete, one very small area is the +pole (anode) and another much bigger area is the pole (cathode). The corrosion current flows out of the steel at the anode, the part corroding, through the concrete and into another part of the steel where there is no corrosion occurring, i.e. the cathode. This flow is called a corrosion circuit. Steel is dissolved at the anode and eventually forms iron oxide at this location.

For a battery, the electrical connection between + and • can be disconnected. The circuit is then broken with the result that the current is stopped and thus the dissolution of metal stops.

For steel reinforcement in concrete the ionic flow running through the concrete and attachment between the steel cannot be disconnected as the corrosion circuit is buried in the structure. Instead it is possible by using an 'artificial' anode to add a new and higher current to the original corrosion circuit which runs in the opposite direction of the corrosion current. This makes all the previous +poles (anodes) into current receivers. Thus all the steel reinforcement is made into a negative pole, i.e. cathodic, hence the name 'cathodic protection'.

In electrochemical corrosion a flow of electrical current and one or more chemical processes are required for there to be metal loss. The flow of electrical current can be caused by 'stray' electrical sources such as from a train traction system, or from large differences in potential between parts of the structure caused by factors such as differential aeration from the movement of sea-water (the mechanism for this is still uncertain but it could be that very large cathode areas are built up in the tidal zone because of oxygen charging). The incidence of electrochemical corrosion by these electrical current sources only is rare but can be serious when it occurs. Often this process can contribute to the corrosion process when there are other aggressive factors.

It is likely that the passivation on the steel by the alkalinity would allow a certain amount of current discharge from the steel without metal loss. The critical factor in this is the resupply of the alkalinity as relative to the current drain. Instances of stray current corrosion occurring have been recorded. An example was a jetty where the piles were being cathodically protected and the reinforced concrete deck was being used as the system negative. Unfortunately several of the piles were electrically discontinuous and corrosion occurred at a secondary anode point formed on these piles as the current attempted to flow back to the system negative.

The vast majority of the potential gradients found between different areas of the steel in concrete are caused by the existence of physical differences or non-uniformities on the surface of the steel reinforcement (different steels, welds, active sites on the steel surface, oxygen availability, chloride contamination). These potential gradients can allow significant electrical current to flow and cause under certain circumstances, i.e. with aggressive ions in the concrete, corrosion of the reinforcement.

Even though the potential for electrochemical corrosion might exist because of the non-uniformity of the steel in the concrete, this corrosion is normally prevented even at nominally (i.e. more negative in potential than cathodic area) anodic sites by the passivated film which is found on the steel surface in the presence of moisture, oxygen and water-soluble alkaline products formed during the hydration of the cement.

There are two mechanisms by which the highly alkaline environment and accompanying passivation effect may be destroyed, namely:

1. The reduction of alkalinity by the leaching of alkaline substances by water or partial neutralization when reacting with carbon dioxide or other acidic materials.
2. Electrochemical action involving aggressive ions acting as catalysts (typically chloride) in the presence of oxygen.

Reduction of alkalinity by reaction with carbon dioxide, as present either in air or dissolved in water, involves neutralizing reactions with the sodium and potassium hydroxides and subsequently the calcium system which are part of the concrete matrix. This process—called carbonation—although progressing increasingly slowly may in time penetrate the concrete to a depth of 25mm or so (depending upon the quality of the concrete and other factors) and thereby neutralize the protective alkalinity normally afforded to steel reinforcement buried to a lesser depth than this. This form of damage is particularly apparent in low-grade concrete structures where the builders were economical with the cement and liberal with the water.

The second mechanism where the passivity of the steel in the concrete can be disrupted is by electrochemical action involving chloride ions and oxygen. As previously mentioned this is by far the most important degradation mechanism for

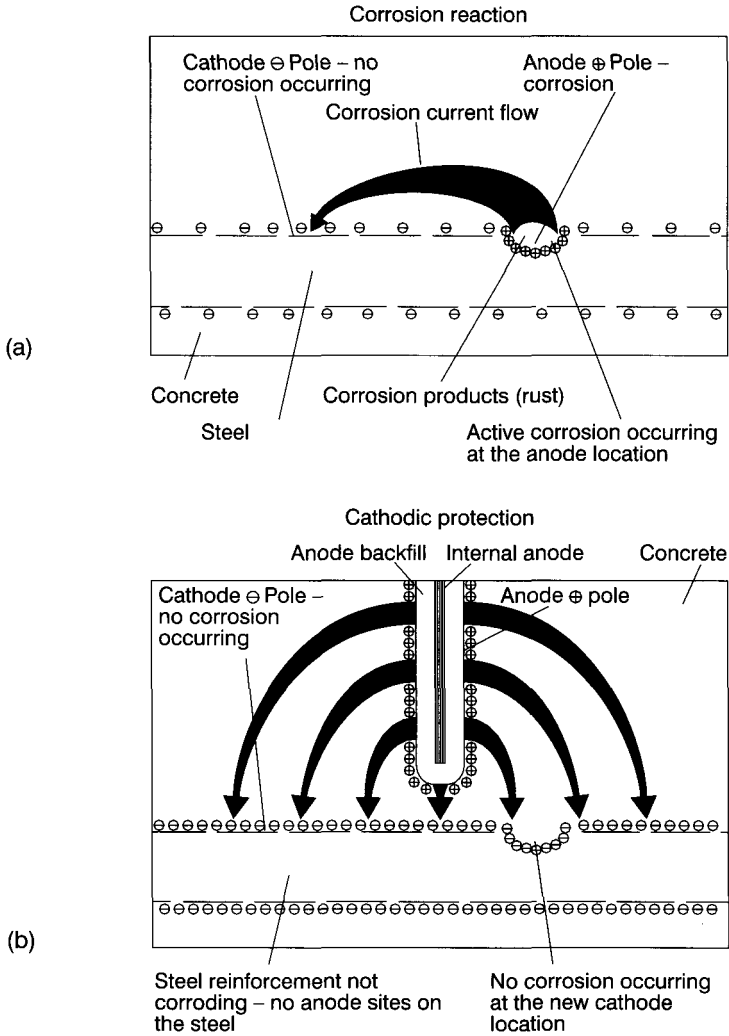

Fig. 1.7 Corrosion cell in steel reinforcement and the effect of applying cathodic protection.

reinforced concrete structures and the most significant factors influencing this reaction are discussed below.

1.4.1.1

*Alkalinity and chloride concentrations*

The high alkalinity of the chemical environment normally present in concrete protects the embedded steel because of the formation of a protective film which could

be either an oxide or a hydroxide or even something in the middle depending on which research paper you read. The integrity and protective quality of this film depend upon the alkalinity (pH) of the environment. The bulk alkalinity of the concrete depends on the water-soluble alkaline products. The principal soluble product is calcium hydroxide, and the initial alkalinity of the concrete is at least that of saturated lime water (pH of about 12.4 depending upon the temperature). In addition, there are relatively small amounts of sodium and potassium oxides in the cement which can further increase the alkalinity of the concrete or paste extracts, and pH values of 13.2 and higher have been reported.

The higher the alkalinity, the greater the protective quality of this film. Steel in concrete becomes potentially more susceptible to corrosion as the alkalinity is reduced. Also steel in concrete becomes more at risk with increasing quantities of soluble chlorides present at the iron-cement paste interface. Chloride ions appear to be a specific destroyer of the protective oxide film.

Chloride can be present in the 'as-manufactured' concrete as a set accelerator (calcium chloride) or through contamination of the mix but more commonly the chloride has come from an external source such as de-icing salts or marine environments. In these latter cases the salt diffuses through the concrete cover to the steel. It is worth noting that in practice the rate of diffusion in an exposed marine or de-icing salt environment can be much higher than might be estimated when using cement or concrete disc ion diffusion tests. This is because the transport process will also utilize convection and capillary movements in real structures.

Although chloride ions are soluble in the cement paste most of the chlorides will not actually be in solution in the liquid within the paste. The reason for this is that the chlorides react with hydrated tricalcium sulfoaluminate which is a constituent of the paste to produce a corresponding tricalcium chloroaluminate compound. It has been shown that as much as 75–90% of the chloride present in the cement paste exists in the chloroaluminate compound and is thus 'bound' and unable to interact with the steel reinforcement. This concentration depends upon the total amount of chloride present, the tricalcium aluminate ( $C_3A$ ) content and the degree of hydration of the cement. Although only a fraction of the chloride is in solution, it is in a dynamic equilibrium and thus the chloroaluminate compound present would allow resupply if the free chloride was leached out.

The relationship between the onset of corrosion of steel and the alkalinity and chloride concentration in the environment has not been fully defined for in-situ concrete and is unlikely to be so without definition of the aggregate and cement types and quantities. It has been suggested and seems reasonable that there is a threshold concentration of chloride ions which must be exceeded in an oxygen rich environment before there is a significant level of steel reinforcement corrosion occurring. Some of the defined values for this level are given in [Table 1.2](#).

As can be seen, there is a very large range of defined critical values. Part of the reason is that what a scientist would define as the onset of corrosion is probably the

Table 1.2 Critical concentrations for chloride induced corrosion of steel in concrete.

<i>Authority</i>	<i>% of Cl by weight of cement</i>
Wiegler	0.40
BS CP11 1979	0.36
Clear	0.20
Knofel	0.20
ACI Committee 201	0.15–0.10
Vassie	0.10

Source: Klinghofer (1994).

moment when sufficient chloride is at the rebar to catalyse the corrosion reaction, whereas in a site investigation of commercial structures if there is a low rate of corrosion then visual inspection would infer that no corrosion was occurring. This observation would allow the erroneous conclusion that the threshold had not been reached. Whatever the critical concentration level is, it appears certain that both the structural environment and the concrete have a significant effect on the critical concentration of chlorides required to get corrosion properly underway.

It is likely that these critical values can be more accurately described by a ratio between the hydroxide and chloride concentrations. This has been given among others by Hausmann (1967) as:

It is sometimes found that reinforced concrete with uniformly high levels of chloride contamination (often over 3%) does not have significant corrosion of the rebar. This typically would happen where there are constant environmental conditions around the concrete, for example, internal walls of a building or structures buried below a saline water table. Conversely, in areas where there are cyclical environmental conditions, such as where concrete is exposed to strong tidal flows of aerated salt water or where there are diurnal weather conditions, e.g. where there is direct sunlight in the day and high humidity and low temperatures in the night, there can be significant damage at low chloride concentrations.

Various ideas on what the chloride is doing to cause this depassivation have been proposed but there seems to be agreement that in localized areas the passive film is broken down with pitting resulting. In the pits an acid environment exists and when concrete is stripped from the corrosion sites on the steel, green-black and yellow-black compounds can often be observed. These are probably intermediate complexes which contain chloride and allow a lower activation energy for the oxidation process. In the corrosion process the chloride is not held as a final product and can be thought of as acting as a catalyst.

Any increase in chloride ion concentration beyond the initiation level is likely to increase the rate of corrosion. At some point other factors will become the rate-limiting step. This rate-limiting step in reinforced concrete is commonly the availability of sufficient oxygen.

$$\text{Critical chloride ratio} = \frac{C_{\text{Cl}^-}}{C_{\text{OH}^-}} \leq 0.61$$

where  $C_{\text{Cl}^-}$  is concentration of chloride ions

$C_{\text{OH}^-}$  is concentration of hydroxide ions

#### 1.4.1.2

##### *Oxygen level*

An essential factor for the corrosion of steel in concrete is the presence of oxygen at the steel to cement paste interface. The oxygen is required in addition to chloride or reduced alkalinity. If oxygen is not present then there should not be any oxidation. For example sea-water has been used successfully as mixing water for reinforced concrete which is continually and completely submerged in sea-water at this seabed. This is because of the maintenance of high alkalinity due to the sodium chloride (this boosts the concrete's alkalinity due to sodium ions' higher solubility in the cement paste), low oxygen content in the sea-water at the seabed and the very slow diffusion rate of oxygen through the water-saturated paste. There would initially be a high corrosion rate when the critical chloride ratio was achieved. This would deplete the available oxygen and then the corrosion rate would dramatically reduce, despite an increasing chloride concentration. This slowing of the corrosion rate is assisted by a reduction in the oxygen solubility of water at very high chloride saturation levels which would further reduce the availability of oxygen. In most cases when the structure is submerged, the oxygen diffusion process is the rate controlling step in the speed of the corrosion.

The level of oxygen supply or resupply also has an effect on the corrosion products formed. A black product (magnetite) is formed in low oxygen availability and a red brown material (haematite) favoured in high oxygen availability. The pore sizes of these oxides are different with the red product forming a more open structure with bigger pores. The formation of haematite imparts a higher bursting pressure on the concrete because of its greater volume and allows a quicker reaction to occur because of its greater porosity as relative to magnetite. For these reasons the presence of haematite rather than magnetite tends to indicate general corrosion rather than pitting and vice versa.

#### 1.4.1.3

##### *Cement type*

Concrete composition has a significant bearing on the amount of corrosion damage which occurs at a chloride concentration. One example of this is that hardened concrete appears to have a lower chloride tolerance level than concrete which is contaminated during mixing. This is practically evident in pre-cast units which tend to

corrode less than might be anticipated even when heavily dosed with a calcium chloride set accelerator (this is probably at least partially explainable due to their higher quality relative to cast in-situ reinforced concrete of the same vintage and the absence of any potential differences caused by concentration gradients).

Although cement composition and type can effect corrosion, this effect is relatively small compared to the concrete quality, cover over the steel and concrete consolidation. Having said that, the use of a cement having a high  $C_3A$  content will tend to bind more chlorides and thus reduce the amount of chloride which is free to disrupt the oxide film on the steel reinforcement. Also a cement of high alkali content would appear to offer advantages because of the higher inherent alkalinity provided. In general it is observed that cements high in  $C_3A$  afford greater corrosion protection to reinforcing steel but it is thought that other factors such as fineness and sulphate content may have at least as significant an effect. One study by Tuutti (1982) found that Portland cement had a higher initiation level than a slag cement but a lower diffusion resistance and thus postulated that in certain exposure conditions, a certain mix design with a Portland cement would be superior while under other conditions the reverse was true and a slag cement would be superior. It was noted that a sulphate resisting cement was always less effective than a Portland cement.

#### 1.4.1.4

##### *Aggregate type and other additives*

In general the higher the strength of the aggregate the more likely it is to be resistant to the passage of ions. But this is not always so. For example, granite aggregate has been used for several major projects because of its high strength, but concrete made with this material has been found to provide relatively poor diffusion resistance results. This is probably because of microcracks in the aggregate.

It is likely that a substantial amount of the diffusion which occurs in concrete proceeds along the interface between the aggregate and the cement paste and this region may well prove to be more critical than the bulk diffusion resistance of the aggregate. Certain aggregates have a smoother profile than others and this will have an affect on the apparent diffusion path.

The addition of additives, such as microsilica, to the concrete is beneficial as it increases the diffusion path by tending to block the pores in the concrete. The only real problem with this and other additives is the additional care required when it is being cast on the construction site and the assumption that with additive X the concrete will change into a totally impermeable covering. This is not a safe assumption as the concrete will still retain a degree of porosity.

## REFERENCES

Bamforth, P. (1994) *Concrete*, Nov–Dec, 18.

- Bennett, L.H. *et al.* (1978) *Economic Effects of Metallic Corrosion in the US*, NBS Special Publications 511-1, Washington DC, US Gov.Print.Off.
- Hausmann, D.A. (1967) Steel Corrosion in Concrete, Materials Protection, November, 19-23.
- Klinghofer, O. (1994) Beton som Korrosionsmiljø, Force Institute, Denmark, March.
- Knudsen, A.A. (1907) *Trans.Amer.Inst.Elect.Engrs*, **26**, 231.
- Tuutti, K. (1982) Corrosion of Steel in Concrete,. CBI Research, Stockholm, 4.82, 129-34.

# Appraisal of corrosion-damaged structures

*Sam Beamish and Said El-Belbol, G.Maunsell & Partners Ltd*

## 2.1

### INTRODUCTION

There are many causes of concrete deterioration. Common among these are reinforcement corrosion due to chloride attack or carbonation, freeze/thaw cycling, alkali-silica reaction (ASR) and poor quality of detailing, materials or workmanship. Other causes are sulphate attack, structural defects such as excessive flexural cracking (due to overloading, under-capacity or severe reinforcement corrosion) or differential settlement and defects arising during construction such as plastic or thermal cracking. Corrosion of reinforcing steel is by far the most widespread problem facing those responsible for the management of reinforced concrete structures. Steel in concrete is normally in a passive state due to the high alkalinity of the surrounding cement paste, but reduction in alkalinity by atmospheric carbon dioxide (carbonation), or the presence of chloride ions, may initiate corrosion. Once initiated, corrosion soon causes cracking and subsequent spalling of concrete cover which further accelerates deterioration.

This chapter describes and discusses the methods of assessing the extent and causes of corrosion damage in reinforced concrete, the factors to be considered in determining the most appropriate repair strategy with particular reference to the most common rehabilitation methods for structures suffering as a result of chloride-induced corrosion. It also reviews the effectiveness of cathodic protection (CP) and preliminaries that need to be carried out prior to the application or the installation of the cathodic protection system.

## 2.2

### CORROSION OF REINFORCEMENT IN CONCRETE.

#### 2.2.1

##### **Background**

The corrosion of embedded steel in reinforced concrete has become a major problem world-wide. Although corrosion of steel in concrete due to acid attack, hydrogen embrittlement or electrolysis due to 'stray' electrical current has been reported, the vast majority of such corrosion occurs as a result of electrochemical processes. Good quality concrete provides reinforcing steel with sufficient corrosion protection by the high alkalinity ( $\text{pH} > 12$ ) of the cement paste. When reinforcement is placed in concrete, the alkaline condition leads to a passive layer forming on the surface of the steel. However, if the pH value is reduced by the penetration and reaction of acidic gases (carbonation) or if chloride ions are present at the steel surface, the protective film may be disrupted, leading to corrosion of the reinforcement. The products of corrosion (rust) usually occupy a greater volume than the original steel. The forces generated by this expansive process can far exceed the tensile strength of the concrete resulting in cracking and spalling of concrete cover. Corrosion can also cause structural distress resulting from the loss of both concrete and reinforcement sectional area and consequent loss of capacity.

#### 2.2.2

##### **Principal causes**

##### *2.2.2.1*

##### *Carbonation*

Carbonation is the process by which atmospheric carbon dioxide slowly enters concrete. In the presence of moisture, it forms weak carbonic acid which reacts primarily with calcium hydroxide to form calcium carbonate ( $\text{CaCO}_3$ ). The consequent removal of hydroxyl ions from the cement paste pore solution results in reduced alkalinity to the extent that passivity of embedded steel may be affected which can lead to reinforcement corrosion (Currie and Robery, 1994). However, the specification of an appropriate depth of good-quality concrete cover together with good workmanship is generally sufficient to limit carbonation to an insignificant level.

##### *2.2.2.2*

##### *Chloride contamination*

The effect of chlorides in reinforced concrete has received much attention due to their role in promoting reinforcement corrosion. Chloride may be present either as

an ingredient of the original mix, or may have penetrated the concrete from an external source such as a marine environment or de-icing salt exposure. British Standard 8110 (1985) states that calcium chloride and chloride-based admixtures should never be added to concrete containing embedded metal and strictly limits the total percentage of chloride ion which can be introduced as a contaminant of the aggregate or mixing water. More recently it has become apparent that, under certain conditions, the external chlorides can penetrate even a relatively high-quality concrete to the depth of reinforcement within a fraction of the design life of the structure (El-Belbol, 1990).

## 2.3

### METHODS OF ASSESSING EXTENT AND CAUSES OF CORROSION DAMAGE IN REINFORCED CONCRETE

#### 2.3.1

##### **Introduction**

Where corrosion of reinforcement is suspected, a 'pilot' investigation should be carried out to confirm the cause of the problem and to gain an initial insight on the extent of the problem. The 'pilot' investigation is normally followed by a more detailed and extended investigation process to assess the extent of the problem and future performance.

#### 2.3.2

##### **Initial investigation**

The initial investigation is normally undertaken to establish the likely cause of the deterioration and to provide the information from which a detailed survey can be planned.

The initial investigation is normally based on a close visual inspection of typical elements which are readily accessible. Limited testing can be also carried out in areas of obvious damage. The testing could include carbonation depth measurements and chloride ion content determinations.

#### 2.3.3

##### **Detailed investigation**

Using the information from the initial investigation, a programme for the detailed investigation would be prepared. Such an investigation normally requires that between 10% and 20% of the elements that are at risk are selected for testing (Concrete Society, 1984).

The first question that must be addressed is whether the observed deterioration is a local problem or one that occurs widely around the structure (Currie and Robery, 1994). Deterioration of the concrete will vary from member to member, with orientation of each elevation of the structure (e.g. north/south), surface (e.g. horizontal or vertical faces) and the severity of the environment (proximity to the sea, wind direction, precipitation and temperature). In particular, the protection offered by the cover zone concrete and its thickness may vary from one part of the structure to another (BRE, 1982, Digests 263–5).

Within the detailed investigation, it is also most important to collect information on material properties and to confirm structural details such as articulation of joints etc. to provide input to any subsequent structural assessment carried out to determine whether the structure has adequate reserves of strength to be fit for its intended use.

### 2.3.4

#### Methods of testing

The sections below present and discuss the most common test methods and interpretation of results that are relevant where corrosion of reinforcement is considered likely.

##### 2.3.4.1

##### *Delamination and visual surveys*

Deterioration of concrete structures due to corrosion of reinforcement may, in general, be divided into three stages. The first consists of changes in appearance, such as discoloration with local blemishes and staining. The second stage affects surface texture and is marked by cracking. The third stage of deterioration is disruption with major spalling of concrete.

Signs of poor compaction of concrete, stains or discoloration, cracking, spalling, pop-outs, erosion and softening of concrete should be observed and recorded. The position and orientation of cracks must be considered in relation to loadings and restraint to shrinkage and thermal movement. If structural cracking is suspected, due to overload or weakening of a reinforced element, advice should be sought from an experienced structural engineer. Cracks which follow the line of the reinforcing bar are usually caused by plastic settlement or corrosion. If brown stains are associated with cracks then corrosion of reinforcement is probable.

Examining the reinforcement for corrosion products should give some indication of the reason for and the extent of the problem. General corrosion with flaking layers of rust over a long length of the bar is generally due to carbonation related corrosion. Short lengths of steel with deep penetrating (pitting) corrosion with uncorroded steel on either side are normally associated with chloride-induced corrosion. The extent

and the effects of any loss of cross-section due to corrosion must be considered. Examination of the worst-affected areas of spalling and steel corrosion may identify the need for immediate actions such as the provision of temporary structural support or placing of limits on live loads.

The visual survey is normally accompanied by a hammer survey to detect 'hollow' areas, i.e. those where delamination of the concrete cover has taken place.

It should be noted that visual and delamination surveys will not necessarily detect localized (pitting) corrosion, since the products of such corrosion are not always expansive. However, as the localized corrosion product may be soluble, rust stains on the concrete surface may be indicative of this type of corrosion.

#### 2.3.4.2

##### *Covermeter survey*

Concrete cover provides protection to the reinforcement against the effects of carbonation, or aggressive chemicals. To provide such protection it needs to be of an adequate thickness and composed of sound concrete. Recommendations on the minimum cover to reinforcement in concrete based on concrete grades, cement content and exposure conditions are given in BS 8110: PART 1: 1985. The depths of concrete cover to the reinforcement are normally measured at the surface of the concrete, using the same grid as the half-cell potential surveys.

#### 2.3.4.3

##### *Half-cell potential survey*

Electropotential measurements, commonly referred to as half-cell potential measurements, can indicate the probability of corrosion being active in reinforcement embedded in concrete. The method is described in ASTM C876–91 (1991). It should be noted that, while this form of testing can theoretically be used to determine the rate of corrosion (Chess and Grønvold, 1996), in practice sufficient accuracy cannot be achieved to provide anything but generalizations on the corrosion rate.

Van Deveer (1975) found that there was a 95% probability of corrosion in regions where the potential was more negative than  $-350$  mV with respect to a copper/copper sulphate reference electrode and a 5% probability where the potential was less negative than  $-200$  mV. These criteria are indicative rather than absolute and do not imply for example, that 95% of all the steel within areas where potential is more negative than  $-350$  mV will be corroding. Opinions differ as to the significance of potentials falling within the range  $-200$  mV to  $-350$  mV; some references suggest the range to be indicative of a 50% probability of active corrosion while others suggest that any potential more negative than  $-200$  mV should be regarded as significant in terms of active corrosion. Maunsell experience (Boam and Unwin, 1990) tends to confirm the latter view.

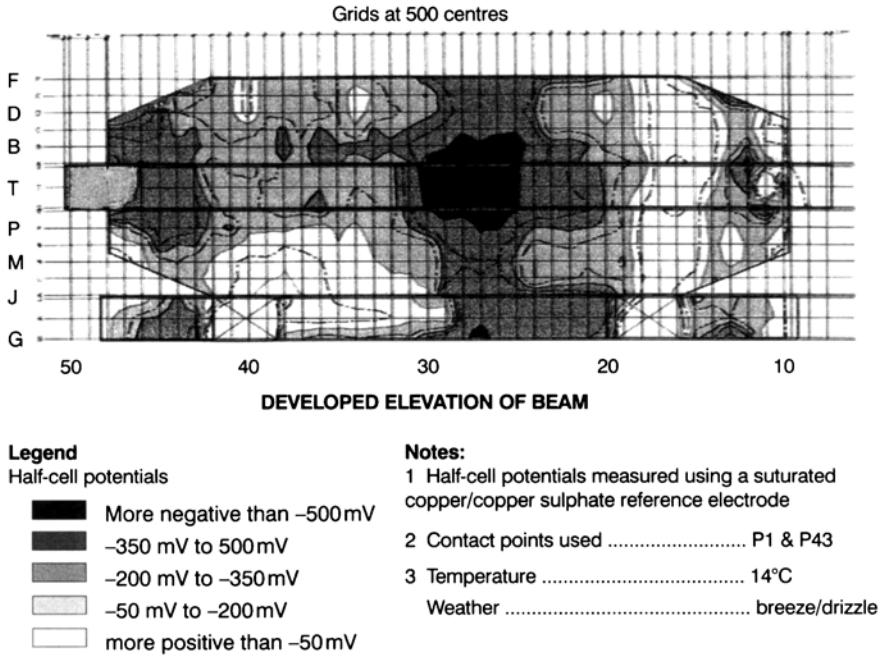

Fig. 2.1 Sample schematic of half-cell data.

Generally, areas of localized pitting corrosion and areas of general corrosion can be identified from equi-potential contour maps (Figure 2.1). Pitting corrosion is generally associated with ‘whirlpools’ which occur on relatively small areas of the equi-potential contour map; negative potentials within the ‘whirlpools’ are often numerically high, i.e. less negative than -350 mV, and increased potential gradients occur in the vicinity. In contrast, general corrosion usually occurs where potential gradients are relatively shallow.

#### 2.3.4.4

##### Chloride ion content

Chloride contents can be determined from dust samples removed from the concrete element at incremental levels using rotary percussive drilling. The chloride contents can be determined by acid extraction of the powdered concrete, followed by a chemical determination of the chloride contents. The method is described in BRE Information Sheets IS-12/77 and IS-13/77 and in BS 1881, Part 124 (1988).

There is no simple relationship between chloride concentration in concrete and the occurrence of reinforcement corrosion in the sense that all values exceeding some threshold will cause corrosion. Instead there is a probabilistic relationship between

chloride concentration by weight of cement and corrosion risk (Vassie, 1987). Building Research Establishment, Digest 264 (1982) provides initial assessment of chloride ion content in concrete. Low corrosion risks are associated with concentrations below 0.4% by weight of cement, medium risks with concentrations between 0.4% and 1% and high risks above 1%. However, it is worth noting that the chloride concentration at which depassivation occurs depends on whether the concrete is carbonated and whether the chlorides were present at the time of mixing (Table 2.1(a)) (Pullar-Strecker, 1987) or entered the concrete afterwards (Table 2.1(b)) (Clear, 1975).

Table 2.1 Interpretation of chloride and carbonation test data, in terms of corrosion risk

**Table 2.1(a) Chloride added at mixing – similar in all drilling increments**

<i>Chloride by weight of cement</i>	<i>Condition of concrete adjacent to reinforcement</i>	<i>Corrosion risk</i>
less than 0.4%	1. Carbonated	high
	2. Uncarbonated made with cement containing less than 8% tricalcium aluminate ( $C_3A$ )	moderate
	3. Uncarbonated made with cement containing 8% or more tricalcium aluminate ( $C_3A$ ) in total cementitious material	low
0.4–1%	1. as above	high
	2. as above	high
	3. as above	moderate
more than 1%	all cases	high

Note: Where sulphate is present at more than 4.0% by weight of cement, or where chloride has entered the concrete after it has hardened (rather than being incorporated at the time of mixing), the risk of corrosion is increased in all cases (see Table 2.1(b)).

Source: after Pullar-Strecker (1987).

#### 2.3.4.5

##### *Carbonation depth measurements*

The depth and extent of carbonation should be assessed either on site or in the laboratory using the technique described in BRE Information Paper IP-6/81 (1981). Phenolphthalein is used as an indicator to determine the depth of carbonation on freshly fractured or drilled concrete surfaces. Phenolphthalein remains colourless

Table 2.1(b) Chloride content decreases with depth into the surface: proposed threshold limits for corrosion, due to the ingress of chloride ions

<i>Chloride content by weight of cement</i>	<i>Corrosion risk</i>
Less than 0.2%	negligible
0.2–0.4%	moderate (uncertain)
greater than 0.4%	high

Source: after Clear (1995).

when in contact with carbonated concrete but turns pink where the concrete has retained sufficient alkalinity to protect the reinforcement from corrosion.

Preferably, a freshly fractured surface should be used for the determination. If this is not possible, the depths of carbonation could be determined by testing dust samples removed at increment levels using a percussive hammer drill. In this case it is recommended that upon commencement of the work at a structure the latter test method is calibrated at not less than three locations by comparing the results found with those obtained from testing the freshly fractured surface. Certain concretes, particularly those made with white cement or those in older structures, may contain particles of unhydrated cement which may break up upon drilling to give an apparent, but false, low depth of carbonation.

#### 2.3.4.6

##### *Measurement of corrosion rates*

Several methods are in use or under development for the measurement of corrosion rates. The techniques can be physical or electrochemical.

Physical methods include the use of weight-loss coupons and resistance probes, which both measure an integrated or averaged rate over a period of time. The weight-loss method is not suitable for frequent monitoring in reinforced concrete as it is destructive and time-consuming. However, the technique is simple in principle. The resistance probe method involves embedding a metal probe in the concrete and then inferring the rate of metal loss from the resulting increase in electrical resistance. By using calibrated probes and measuring equipment an estimate of total loss can be obtained and monitoring can be performed as often as required.

The electrochemical methods for measuring the corrosion rate operate by applying an external stimulus (i.e. electrical signal) and measuring the response of the steel-concrete system.

These methods include linear polarization (also known as polarization resistance), AC impedance and electrochemical noise (Dawson, 1983). However, the latter two methods are still, largely, laboratory-based since there are difficulties in transferring

$$\text{Corrosion rate} = \text{constant}/R_p$$

these methods to the field. Hence the rest of this section will concentrate on the linear polarization method.

In its simplest form, linear polarization utilizes reference and auxiliary electrodes and a variable low voltage direct current (DC) power supply. First, the corrosion (rest) potential ( $E_{\text{corr}}$ ) is measured. Then one or more fixed small levels of current are passed from the auxiliary electrode to the reinforcement and the corresponding change in potential is measured (galvanostatic approach). Alternatively, the current is increased to achieve one or more target potentials (potentiostatic approach). The corrosion current is related to the change in potential by the equation (Stern and Geary, 1957):

where:

the constant is dependant on the contribution of anodic and cathodic reaction;

$R_p$  is the polarization resistance=(change in potential)/(applied current).

The change in potential must not exceed 20 mV from  $E_{\text{corr}}$  for the above equation to remain valid. This technique is becoming more widely used on site. However, care needs to be taken in interpreting the measurement taken. Although reasonable readings can be obtained at high corrosion rates, these readings can be misleading when the corrosion rates are localized (i.e. pitting corrosion). One other drawback with this technique is the difficulty in accurately determining the area of steel being polarized. In one commercial device a guard ring system is utilized to confine the area of the impressed current in order to overcome this problem and thus the area of steel being polarized can be determined more accurately.

#### 2.3.4.7

##### *Stray current*

The risk of stray current from the proposed CP system to adjacent reinforced concrete (RC) structures or other CP systems should be assessed at the survey stage; interaction tests should be performed in accordance with the requirements of BS 7361 Part 1 (1991) and if necessary, appropriate measures can be undertaken.

### 2.3.5

#### **Assessment of results of investigation**

Following the investigation stage, the results should be processed and assessed to provide information on the risk and extent of corrosion. It is most important that the interpretation of results encompasses the data from all the test methods; assessing the condition in isolation, from only one test method, can be misleading. Some test methods can be influenced by external environmental conditions which can change

from day to day. Relying on one set of readings could lead to an incorrect conclusion being reached. Equally, factors such as different aggregate types and sizes can have a significant effect on the test results obtained. Even where test data is less sensitive to environmental conditions or material characteristics, several indicators of corrosion or potential corrosion can allow greater confidence in application of the results of the investigation.

An example of the use of different indicators of risk of corrosion is in the use of half-cell potential and chloride contamination threshold values and in the calibration of both against visual examination of the reinforcement. It is the authors' experience that for certain structures, threshold values of half-cell potential of -200 mV and chloride contamination of 0.2% by weight of cement are necessary to achieve a satisfactorily low risk of future corrosion. However, on other structures the more commonly used chloride threshold of 0.4% by weight of cement is appropriate.

Another factor to be considered here is the interaction between different indicators of risk of corrosion. For example, the risk of corrosion in chloride-contaminated and carbonated concrete is higher than in chloridecontaminated and uncarbonated concrete (Currie and Robery, 1994). This occurs because of the release of bound chloride at the carbonation front.

## 2.4

### FACTORS TO BE CONSIDERED IN DETERMINING APPROPRIATE REPAIR STRATEGY

#### 2.4.1

##### **Introduction**

The essential pre-requisites of any maintenance or rehabilitation regime are a detailed knowledge of the condition of structural elements and a clear understanding of the likely effectiveness of the rehabilitation options available. A repair strategy should be developed to enable costeffective repairs and maintenance to be carried out such that the integrity of the structures is maintained. It is worth noting that the economics of the various maintenance or rehabilitation options depend not only on the initial capital costs but also on the subsequent maintenance costs.

Ideally, maintenance and rehabilitation measures should be implemented on the affected structures as soon as practically possible. However, the rate of rehabilitation will be influenced by a number of factors. These may include: availability of funds, accessibility, degree of disruption and loss of facility, age, anticipated life, future intended use of structures, and in the case of highways structures, the need for traffic management. Therefore, a prioritized programme is essential. Logically, and in the simplest form, the structures that are most affected by corrosion should be dealt with first, with the less affected and those where future corrosion is considered likely being

dealt with thereafter. However, the extent and degree of deterioration and the likelihood of future deterioration are likely to vary between the elements or the structures being considered. Therefore, a classification of conditions can be drawn up according to the extent of corrosion damage and the likelihood of future corrosion damage as both these factors have a significant influence on the choice of rehabilitation methods and repair costs. A classification of conditions which has been adopted for the maintenance and repairs of the sub-structures on the Midland Links Motorway Viaducts (Boam and Unwin, 1990) where chloride contamination is the principal cause of deterioration is given below.

Classification 1: Uncorroded—no sign of deterioration.

Classification 2: Corroding but not delaminated.

Classification 3: Corroding with delamination of cover.

Classification 4: Severe corrosion with delamination.

Classification 5: Delamination under the main reinforcement causing loss of bond and structural integrity.

Each of the main classifications above can be sub-divided according to the extent of chloride contamination. For example the condition of a particular structure might be given a classification of 3/10/50 (Boam and Unwin, 1990) indicating that the beam is corroding with 10% of the surface area delaminated and 50% of the surface area contaminated by chloride at levels sufficient to cause corrosion of the reinforcement.

### 2.4.2

#### Structural considerations

Before determining a repair and maintenance strategy for a structure it is important that a structural assessment is carried out in order to ensure that appropriate resources will be implemented. For instance, there would be little value in reinstating a structure to its as-built condition if its current or anticipated future loading conditions exceed its original structural capacity. Many factors will influence the extent and depth of this assessment. These include the condition and age of the structure, any change in loading conditions, its structural complexity and its anticipated life.

The structural assessment should assess the effect of any loss of reinforcement cross-section in addition to that of concrete section. However, the full extent of the actual loss is very rarely known, particularly when pitting corrosion, occurring as a result of chloride contamination, can cause a significant loss of section with little visual evidence. Consequently, where pitting corrosion is suspected, it would be necessary to expose the reinforcement and to assess the extent, if any, of the pitting corrosion and the resulted loss of steel cross-section. It is also important to assess the effects of delamination on the bond capacity of the reinforcement.

Assessing the effects of repairs is equally important to assessing the effects of corrosion damage. At its simplest, this may mean assessing the effects of any additional load imposed by the installation of a cathodic protection system. Where the scale of repairs is large, or where there is a need to restore full load capacity to a member, it may be necessary to install temporary support systems which can be jacked to relieve stresses on the reinforcement while repairs are carried out.

The results of the assessment will allow appropriate repair options to be identified with confidence and will provide the basis for detailed design of the concrete repair process including reinforcement repair, where necessary, and any temporary support required.

### 2.4.3 Options for repair

The principal options for the repair of concrete damaged by reinforcement corrosion are:

- coatings
- concrete repair
- replacement
- electrochemical techniques:
  - (a) cathodic protection
  - (b) desalination (for chloride-contaminated concrete)
  - (c) realkalization (for carbonated concrete)
- corrosion inhibitors

The selection of the appropriate technique will depend upon a variety of factors including the extent of deterioration, the degree of carbonation or chloride contamination, the characteristics of the concrete, accessibility and aesthetic consideration. A full review of all of the above techniques is beyond the scope of this chapter. Only features related to concrete repair and element replacement methods are discussed below. The cathodic protection technique is described in detail in sections 2.5 and 2.6.

#### 2.4.3.1 *Patch repairs*

As a short-term remedy, patch repairs could be carried out to delaminated and spalled areas using hand placed mortars or concretes. Chlorides will remain in concretes surrounding the repair. Once repairs have been carried out, the reinforcement in

surrounding areas can quickly corrode and cause further deterioration. With this method, it is accepted that further repair will be needed at regular intervals in order to reach the required life of the structure.

#### 2.4.3.2

##### *Repair by removal of all chloride-contaminated concrete*

Repairing the structure by removing chloride-contaminated concrete and replacing it with fresh concrete is more likely to succeed than simply patching visual defects. However, it is considered that to achieve a high probability of long-term repair, it is important that all areas of concrete affected by chloride contamination are removed and replaced and that the reinforcement is cleaned to a high standard. This method may result in the removal of large quantities of concretes which are contaminated but otherwise sound. This is likely to require the repairs to be carried out in a piecemeal fashion with a large number of sequences in order to ensure the structural integrity of the member both during and after repair. It may also entail the use of temporary support to carry some or all of the loading on a member during repair. The cost of adopting this method will depend largely upon the minimum number of sequences that elements can be repaired in and whether temporary support is required. In many cases this method can be relatively expensive and would be impractical in structures with cast-in chlorides.

#### 2.4.3.3

##### *Element replacement*

Where a reinforced concrete element is so extensively damaged that it is beyond repair (e.g. the reinforcement is so badly corroded that it cannot be satisfactorily reinstated), or where deterioration is so extensive that repair becomes very expensive, then replacement of the element may be a cost-effective option. This is likely, however, to entail temporary support to the structure and is likely to require considerable design input to ensure that the temporary support is technically and practically feasible.

## 2.5

### REASONS FOR AND AGAINST THE CHOICE OF CATHODIC PROTECTION

#### 2.5.1

##### **General**

A cathodic protection system comprises a number of basic components which include an anode, a DC electric supply, the protected steel and surrounding concrete, a

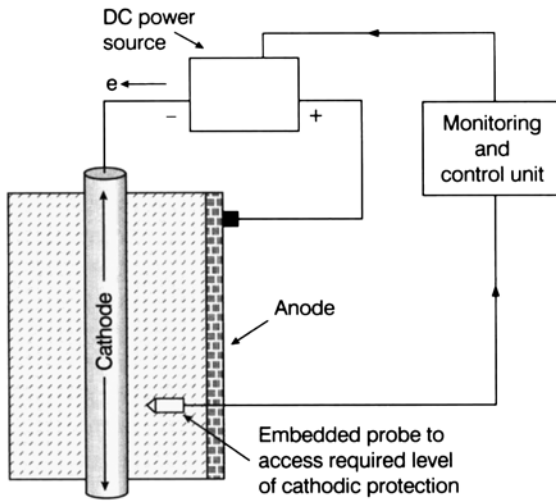

Fig. 2.2 Schematic illustration of cathodic protection process

monitoring system which is likely to include reference electrodes, and cabling to carry the system power and the monitoring signals. A schematic illustration of the cathodic protection process is given in Figure 2.2. The positive terminal of a direct current power source is connected to a conductive material (anode). The negative terminal is connected to the reinforcement (cathode) and a small DC is applied. This causes a flow of electrons from the anode through the concrete to the reinforcement. The applied current is then increased to a level which will oppose the electrons flow from the most active corrosion sites. Hence the application of a DC renders the reinforcement cathodic relative to the surface anode allowing control of corrosion. The anodic reaction to some extent now occurs at the external (or concrete embedded) anode which should be designed to resist such attack.

A wide range of anode materials have been developed which can be applied to a wide range of structures. The anodes include conductive mesh with overlay, conductive paints, internal discrete anodes, conductive overlays, sprayed metallic coating and others. Experience has shown that these systems have met with varying degrees of success (Gower and El-Belbol, 1996).

### 2.5.2

#### Effectiveness of cathodic protection

The application of cathodic protection to steel in atmospherically exposed concrete has been developed during the past 30 years or so, and is now well documented and verified through trials and full-scale site installations including the cathodic protection installations on the Midland Links Viaducts (Gower and Beamish, 1995).

Cathodic protection was first applied to reinforced concrete structures on a corroding bridge in California in 1973 (Stratfall, 1974). This system was reported to be still working in 1992 (Broomfield, 1992).

It is worth noting that the principal aim of cathodic protection is to arrest corrosion and to remove the hazards of spalling concrete rather than to restore strength. Providing that the structure has sufficient reserves of strength, cathodic protection can, in many cases, be the most appropriate and cost-effective repair option.

Cathodic protection is most suited to remedial works on chloride-contaminated reinforced concrete structures. The chloride contamination within the concrete tends to reduce its resistivity and thereby reduces the driving voltage necessary to supply adequate current flow to provide cathodic protection to the reinforcement. Conversely, the carbonation process increased the resistivity of the concrete and, therefore, will increase the driving voltage necessary for cathodic protection. This should not, however, preclude the use of cathodic protection for carbonated reinforced concrete, but its use will require more careful consideration for these applications.

### 2.5.3

#### Cost

The principal advantage of cathodic protection over traditional repair is that only the damaged areas (i.e. spalled, delaminated or severely cracked) need to be repaired. Concrete which is contaminated with chloride, but is still sound, can remain since the possibility of subsequent corrosion will be prevented by the appropriate electrochemical process. Although there will be additional costs involved in the installation and operation of the cathodic protection system, these are more than offset by the savings which result from the reduction in concrete repair quantities. In some case it may even obviate the need for temporary support with consequent reduction in costs.

Typical cost information for cathodic protection is given in [Appendix 2.1](#), together with some examples of how the cost of repair can be compared with cathodic protection. (The unit costs quoted should be treated with caution since they are likely to vary considerably according to the nature of the structure, accessibility, size etc.)

### 2.5.4

#### Adverse side effects

Cathodic protection involves the transport of positively charged alkali ions towards the reinforcement, forcing them, which in theory could result in local concentrations of alkali. This could be detrimental in concretes containing aggregates which are susceptible to ASR. However, there is no evidence to indicate that the reaction has developed in a structure as a result of the application of cathodic protection. Recent

research (Sergi and Page, 1995) concluded that deleterious ASR caused by electrochemical rehabilitation of concrete is unlikely to be a problem at typical cathodic protection current densities.

It has also been suggested that the chemical reactions occurring at the reinforcement may result in a reduction in the bond strength. However, there is no evidence available to confirm that this will happen at the current levels typically applied in cathodic protection.

The electrochemical reaction at the anode surface generates acid products. It has been suggested that excessive evolution of acid causing softening of the concrete surface has been responsible for the failure of some anode systems. However, this is unlikely to be a major problem provided that the anode system is properly selected and maintained (Gower and El-Belbol, 1996).

## 2.6

### NEED FOR AND LIMITATIONS ON PATCH REPAIRS IN CASES WHERE CATHODIC PROTECTION IS TO BE USED

The cathodic protection current cannot pass through an air gap and is normally transmitted to the reinforcement via the pore solution of concrete or mortar materials. It is therefore necessary to make good any areas of delaminated concrete on the structure to be protected.

Materials used for repairs must be ionically conductive and, in order to achieve a reasonably uniform current distribution, they should have resistivities of the same order as the parent concrete. The specifier should, however, recognize that the heterogeneous nature of the parent concrete and the variable degree of chloride contamination are likely to mean that there will be wide variations in the resistivity of any particular member; resistivity will also vary with ambient conditions.

A proprietary cementitious mortar is the best option currently available for repairs of relatively small areas. However, most of these mortars include polymers to improve bonding and to reduce shrinkage. Unfortunately, the polymers also increase the electrical resistivity. For larger repair areas a shrinkage compensated repair concrete is recommended. Whether mortar or concrete materials, an assessment should be carried out of the electrical resistivity and mechanical properties of specimens prepared from the proposed repair materials prior to carrying out any repairs.

The use of adhesion promoters, curing membranes or any other materials in conjunction with concrete repairs are not recommended where cathodic protection is to be applied as these materials normally possess constituents with a high resistance which may shield the areas of the structure underneath from the applied current.

Once any concrete defects have been made good, the surface of the member should be cleaned. In addition, where the anode system includes a paint or cementitious overlay, the concrete surface should be roughened to provide a key.

Grit blasting is a convenient and practical means of both cleaning and texturing concrete.

## 2.7

### REINFORCEMENT CONTINUITY CHECKS AND OTHER PRELIMINARIES

Prior to the installation of the anode system, a number of checks and other preliminaries should be carried out as described below.

#### 2.7.1

##### **Reinforcement continuity**

For cathodic protection to be effective and to prevent stray current corrosion, the reinforcement embedded in the member to be protected must be electrically continuous. In most civil engineering structures the main reinforcement cage (which is normally in contact with secondary distribution steel or shear reinforcement etc.) will usually provide a high degree of electrical continuity as a matter of course. Continuity checks should nevertheless be carried out between different areas on the reinforcement cage to confirm this. Corrosion products can also impair continuity and a continuity check should also be carried out in these areas. Measuring DC resistance is the most common method of checking continuity. Any isolated reinforcement should be made continuous.

#### 2.7.2

##### **Substrate condition**

No coatings or other materials should exist on the surfaces which would affect the performance of a cathodic protection system. Coatings or materials which have high resistance, and therefore could prevent the passage of electric current, should be removed by grit blasting or any other appropriate methods.

#### 2.7.3

##### **Embedded metals and fixings**

In order to avoid the risk of cathodic protection causing stray current corrosion it is necessary to ensure that any metal fixings into the concrete, such as drain pipes fixings and bearing holding bolts, are electrically connected to the reinforcement.

It is also important to remove any metallic objects such as tying wire, nails etc. on the surface of the concrete which might be in contact with the reinforcement in order to avoid any short circuits in the cathodic protection system or stray current corrosion of these objects where they are not in contact with the reinforcement.

## 2.7.4

### Sufficient concrete cover

Concrete cover and reinforcement position should be determined to allow comparison to be made of the current flow through high and low. In order to prevent short circuit between reinforcing steel and anodes, areas of low cover should be built up with repair mortar to give a minimum cover of 15mm.

### REFERENCES

- American Society for Testing and Materials (1991) *Test Method for Half-cell Potentials of Uncoated Reinforcing Steel in Concrete*, Standard C876–91.
- Boam, K.J. (1993) Impact of cathodic protection on civil engineering, in Googan, C. and Ashworth, V. (eds), *Cathodic Protection Theory and Practice*, Ellis Horwood, Chichester, 297–292.
- Boam, K.J. and Unwin, J. (1990) *The Midland Links—A Maintenance Strategy*, IHT Workshop, Leamington Spa.
- British Standard Instituion (1985) BS 8110: Part 1:1985, *Structural Use of Concrete: Code of Practice for Design and Construction*.
- British Standard Instituion (1988) BS 1881: Part 124:1988, *Analysis of Hardened Concrete*.
- British Standard Instituion (1991) BS 7361: Part 1:1991, *Cathodic Protection, Code of Practice for Land and Marine Applications*.
- Broomfield, J.P. (1992) Field survey of cathodic protection on North American Bridges, *Material Performance*, **32**, (9), 28–33.
- Building Research Establishment (1977) *Simplified Method for the Detection and Determination of Chloride in Hardened Concrete*, Information Sheet IS-12/77.
- Building Research Establishment (1977) *Determination of Chloride and Cement Content in Hardened Portland Cement Concrete*, Information Sheet IS-13/77.
- Building Research Establishment (1981) *Carbonation of Concrete Made with Dense, Natural Aggregates*, Information Paper IP-6/81.
- Building Research Establishment (1982) The durability of steel in concrete, Parts 1, 2 and 3, *Digests* 263–5.
- Chess P. and Grøvold F. (1996) *Corrosion Investigation: A Guide to Half-cell Mapping*, Thomas Telford, London.
- Clear, K. (1975) Permanent bridge deck repair, *Public Roads*, **39**, (2), 53–6.
- Concrete Society (1984) *Repair of Concrete Damaged by Reinforcement Corrosion*, Technical Report No. 26.
- Concrete Society/Corrosion Engineering Association (1988) *Cathodic Protection of Reinforced Concrete*, Technical Report No. 36.
- Currie, R.J. AND Robery, P.C. (1994) *Repair and Maintenance of Reinforced Concrete*, BRE Report.
- Dawson, J.L. (1983) Corrosion monitoring of steel in concrete, in Crane A.P. (ed.), *Corrosion of Reinforcement in Concrete Construction*, The Society of Chemical Industry/Ellis Horwood Ltd, 175–92.
- Department of Transport, G. Maunsell & Partners and WS Atkins & Partners (1988) *Repair and Maintenance of the Midland Links Viaducts*, Working Party Report.

- El-Belbol, S.M.T. (1990) Acceleration of Chloride ion Diffusion in Concrete, PhD thesis, University of London, Imperial College.
- Gower, M.R. and Beamish, S.W. (1995) Cathodic protection on the Midland Links Viaduct, *Construction Repair*, July, 10–13.
- Gower, M.R. and El-Belbol, S.M.T. (1996) Cathodic protection of reinforced concrete—which anode? Expected in *International Congress, Concrete in the Service of Mankind, Conference 5, Concrete Repair, Rehabilitation and Protection*.
- McKenzie, S.G. (1986) Techniques for monitoring of steel in concrete, *Seminar on Corrosion in Concrete—Monitoring, Surveying and Control by Cathodic Protection*, London Press Centre.
- Pullar-Strecker, P. (1987) *Corrosion Damaged Concrete—Assessment and Repair*, CIRIA, Butterworths, 98.
- Sergi, G. and Page, C. L (1995) Advances in electrochemical rehabilitation techniques for reinforced concrete, *Proceedings of UK Corrosion 95, Day 1*, SP Conferences.
- Stern, M. and Geary, J. (1957) *Journal of the Electrochemical Society*, **10**.
- Stratfull, R.F. (1974) *Experimental Cathodic Protection of Bridge Deck*, Transport Research Board, Transport Research Record, No. 500, 1–15.
- Van Deveer, J.R. (1975) *Journal of the American Concrete Institute*, **12**, 597.
- Vassie, P.R.W. (1987) *The Chloride Concentration and Resistivity of Eight Reinforced Concrete Bridge Decks after 50 Years Service*, Transport and Road Research Laboratory, Research Report 93.

## APPENDIX 2.1

### CATHODIC PROTECTION OF REINFORCED CONCRETE

Typical cost for a conductive paint anode: £65/m<sup>2</sup> Includes:

- anode paint+topcoat
- cables and conduits
- embedded monitoring sensors
- power supply+control equipment
- documentation
- commissioning
- operation for 12 months

Does not include:

- preliminaries (site establishment, overheads etc.)
- access
- surface preparation
- removal of metallic objects
- concrete repairs

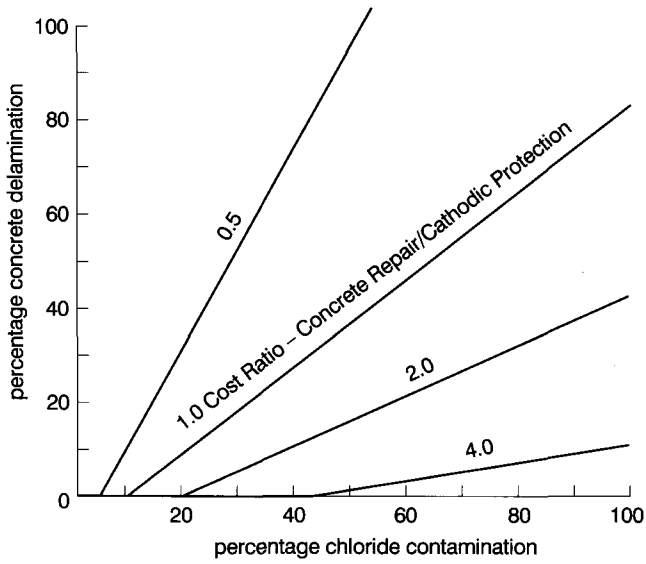

**Fig. A2.1** Cost ratio between concrete repair and cathodic protection with respect to delamination and chloride contamination.

## Design of a cathodic protection system

*Paul Chess, G&K, CPI*

### 3.1

#### INTRODUCTION

Cathodic protection (CP) design of ‘conventional’ steel structures in soil or water is a well-established discipline which involves an estimate of the size and geometry of the structure to be protected, current requirement calculations and a design of the most suitable type and size of groundbed.

Unfortunately the design of a CP system for reinforced concrete is not as well documented as for ‘conventional’ CP systems but in compensation, there are some variables in the design of an underground or undersea system which are relatively fixed for or protecting steel in concrete above ground level.

The purpose of this section is to discuss the various factors which the designer should consider and give some pointers to provide a satisfactory CP design. An example of a CP design for a corrosion-damaged structure is also given at the end of the chapter.

### 3.2

#### SYSTEM DESIGN

The two most important factors for the designer of a CP system for steel in concrete to consider are the current density required on the steel and the current distribution path, i.e. the steel reinforcement where protection is required. Beyond these requirements the designer has a myriad of other concerns, such as cost, aesthetics, weight, durability, life expectancy, maintainability and track record to name but a few. These secondary factors may often conflict and the correct solution will be a compromise of a commercially available anode which most satisfactorily resolves the problems. The different anodes and their characteristics are discussed in [Chapter 4](#). In contrast to the juggling of the secondary considerations, the first two factors, i.e. current density and distribution should not be compromised as the only purpose of the system is to stop, reduce or prevent corrosion of the steel reinforcement and if

there is insufficient current density or inadequate current distribution this objective may not be achieved.

### 3.2.1

#### Overall system philosophy

The first part of any cathodic protection design is to liaise with the client and understand what is required in terms of the corrosion rate reduction of the steel, i.e. does the owner want all corrosion on the rebar stopped or, at the other end of the spectrum, will a reduction in rate of 90% be sufficient? Other factors to be decided at the outset are: the life expectancy of the anode, likely future maintenance, what other refurbishment is going to be undertaken and—probably most critically—budget.

The CP system should be designed so that the desired reduction of the corrosion rate is achieved and continued for the design life of the system. Any other refurbishment of the structure is also of critical importance in determining what anode system is selected, e.g. is localized strengthening going to be used?; is the repair area going to be broken out to below the first level of reinforcement steel?; how are the repairs going to be made?

All of the above factors have a profound influence on the type and design of the CP system and should be determined as soon as practicable.

### 3.2.2

#### Current density requirement

The selection of a suitable current density output is critical for the CP designer. Unfortunately there is very little or no specific written information in national or international standards to help. Indeed, some publications are misleading in that they imply that a fixed current density is sufficient to provide CP in all circumstances.

In documents such as the Concrete Society Technical Report No. 37 (1991) current densities between 10 and 20mA/m<sup>2</sup> of steel reinforcement are given as typical values. The author's practical experience has shown that the current density requirement is extremely dependent on the steel's corrosion state before CP is applied which is generally related to the environment surrounding the steel.

For example, if the concrete surrounding the steel is alkaline, there is little chloride present, the diffusion rate is very low and the steel is not actively corroding, a very low current density will be sufficient to prevent any corrosion occurring in the future. At the opposite extreme, areas with minimal concrete cover, a warm, wet, fluctuating environment with high oxygen and chloride levels will have a very high current density requirement. An example of this is a sea-water intake in the Arabian Gulf. Often a hundred times greater current density is required on this structure than the first example to control corrosion.

Table 3.1 Practical CP current density requirements for varying steel conditions

<i>Environment surrounding steel reinforcement</i>	<i>Current density mA per m<sup>2</sup> of reinforcement</i>
Alkaline, no corrosion occurring, low oxygen resupply	0.1
Alkaline, no corrosion occurring, exposed structure	1–3
Alkaline, chloride present, dry, good quality concrete, high cover, light corrosion observed on rebar	3–7
Chloride present, wet, poor quality concrete medium-low cover, widespread pitting and general corrosion on steel	8–20
High chloride levels, wet fluctuating environment, high oxygen level, hot, severe corrosion on steel, low cover	30–50

A practical guide, from the author's experience, is given in [Table 3.1](#) to achieve about a two-decade reduction in corrosion activity (99%). It should be noted, however, that the most accurate and effective way of defining the required current density is to undertake a CP trial as discussed in [section 3.2.4](#).

### 3.2.3 Current distribution

Of equal or perhaps greater importance than the total current density applied is the way that it is distributed. The optimum current distribution requirement should be assessed from the steel reinforcement arrangement, the extent of corrosion spread and the level of activity. The client's requirements on how much residual corrosion activity is tolerable and where this can be allowed is also needed at this point.

As part of a CP survey, the areas of active corrosion should be defined. Normally, the highest level of current should be injected at these locations.

The 'localized' current distribution is very dependent on the anode type and, even more importantly, on variations in the concrete resistivity. When there are limited changes in resistivity of the concrete, surface-mounted anodes such as meshes and conductive coatings give an even, lateral distribution from the surface while discrete anodes embedded into the concrete give a spheroidal or sometimes 'rugby ball shaped' distribution around the central axis of the anode rod. This latter system can be made to achieve a relatively even lateral distribution, if sufficient anodes are used.

It is difficult to describe, in mathematical terms, the current distribution in reinforced concrete. This is due to the large changes which occur, first in the resistivity of the concrete, secondly on the resistivity of the steel to concrete interface as current is passed and thirdly the profound effect of orientation and density of the steel reinforcement. However, as it is very important for a CP designer to know

where the protection current is likely to spread, some examples of typical distributions are discussed:

- (a) In a simple slab with touch dry concrete and a laterally uniform chloride penetration from the outside to a depth of 70mm into the concrete, and where there is 50mm of cover and a second layer of steel at 300 mm depth, the following current distribution can be anticipated. With an anode uniformly spaced on the top of the concrete a reasonable current density to design on is the steel top surface mat surface area multiplied by 1.5. This multiplication factor takes into account links and tie wire on the top mat. Due to the chloride penetration it is unnecessary to allow sufficient output to cathodically protect the lower reinforcement. The lower mat has only to be considered as a current drain and about 10% of the total current applied may be expected to reach here. This drain is relatively low because of the absence of chloride, high cover and limited oxygen resupply.
- (b) In a simple slab as in (a) where there are also a substantial amount of shrinkage cracks, it is likely that chloride has penetrated deeper into the slab at the cracks and these areas will require a localized higher current density. As there is, in effect, a lower cover depth and a higher oxygen availability at these locations, a higher current density is required to prevent further corrosion of the steel near the cracks. In these areas twice the current output may be needed. This can be achieved by doubling the output of the anode system over the entire slab, or more economically achieved by anticipating an increase in the output of the anodes in these localized areas.

The ability to increase the current output in a localized area depends on the anode type. Coated titanium mesh output can be increased by welding a second layer to the original mesh or by using a thicker anode mesh in the localized area. Conductive coatings can have more primary feeders installed at these locations and the conductive layer applied more thickly. Discrete anodes can be increased in size or more can be installed in the same area. Sometimes it may also be possible to apply additional CP anodes on other faces of the structure to protect these particular locations or even use embedded anodes along with surface applied anodes.

- (c) Where access to apply the CP anode on a structure is limited and yet there are several layers of reinforced steel with the concrete contaminated with chlorides, the designer has a severe problem. One example of this type of structure is an immersed tunnel where chloride has permeated in from the outside but the oxygen flow is from the inside out.

In this case CP will be unlikely to stop all the corrosion occurring and may move the anodic sites deeper into the concrete. This may not always be a problem as the corrosion rate will be significantly lower in this area due to the low oxygen availability. If CP is still considered suitable despite these caveats,

then the current distribution requirement may be based on corrosion prevention of the innermost layers of reinforcement steel only. In this example there will still be a substantial current drain to the outer layers of steel. Thus allowance should be made for protecting at least two and a half times the area of the innermost steel layer, in order to provide sufficient current density for the protection of the most at risk (the inner layer) steel.

It should be evident from these examples that it is difficult to generalize on the current distribution in real structures. It is thus recommended, particularly when the structure is different to those which have been protected previously, that a trial is undertaken during the CP design survey to enable an assessment of current distribution.

### 3.2.4

#### **Trials and testing**

It is apparent that there are several significant factors which impact on the current output required from the anode, as discussed in sections 3.2.2 and 3.2.3. In order to minimize the likelihood of over or under design, it is good practice to install a trial on the structure at pertinent points during the design survey. The trial system should comprise at least  $1\text{m}^2$  of concrete surface area. The minimum size of the trial is dependent on the amount of steel and the resistivity of the concrete. The reason for this is that with low-resistance concrete and dense steel reinforcement, there will be a large current drain to outside the protected area, which could lead to a substantial reduction in potential changes recorded on the steel, i.e. a substantial under-estimate of the effect of the trial CP system. For instance, trials on the example in section 3.2.3(a) need to be a minimum of  $1\text{m}^2$  in area. It may be necessary to trial a  $10\text{m}^2$  area on 3.2.3(c) to reduce this effect. A power supply (dry cell batteries may be sufficient) and a negative connection are required to complete the circuit. A portable reference electrode is required for measuring potential changes on the steel reinforcement. The anodes normally used for such trials are either conductive coatings or discrete anodes, due to their ease and speed of installation (mesh and overlay require a significant amount of plant to install).

Before powering up the trial system, the ideal is to take several surface half-cell measurements, on and around the protected area, and construct an iso-potential map. After energizing the system make another iso-potential map representation of the structure. The changes in potentials over the trial area can then be calculated. This will demonstrate that all areas are now net cathodes and that particular potential criteria, notably potential 'shift', are being met.

It is most satisfactory to run the trial initially at the 'best-guess' current level considered necessary for protection and make changes in the current level as required before leaving the system for a protracted period (at least a week) at the same output. Unfortunately this ideal is frequently impractical and valuable information on the

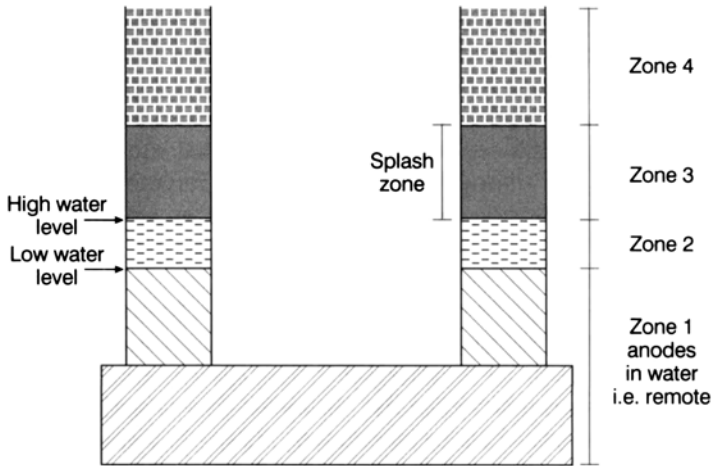

Fig. 3.1 Zoning on a marine support structure.

current density requirement and current distribution can be obtained in a day, if necessary.

### 3.2.5 Zones

For the CP system to be effective continuously, individual areas where there is a significant change in the environment of the steel reinforcement should be protected by separate CP circuits, i.e. separate CP zones. These changes are normally discerned in the CP survey by large variations in the resistance of the concrete and potential of the steel. These can be caused by changes in moisture content, chloride contamination, cover or geometry of the component in a structure.

When using an anode system where only a limited amount of current increase can be imparted at specific areas, or the anode type is prone to large changes in resistance in accordance with environmental factors, i.e. wetting and drying, provision should be made for an increased number of zones.

Typically, zones of the order of 50–100m<sup>2</sup> are recommended but this is dependent on the structure's form and environment. For example, in selecting zones on a marine structure, as shown in Figure 3.1, it is common to split the structure into separate zones relative to the water level. If the areas at the individual level are small, as in this example, it is normal practice to connect the anode areas together electrically even if they are physically separated on the structure.

### 3.2.6 Anode selection

The various anodes types which are commercially available are discussed in [Chapter 4](#) but it is important that the designer considers closely the anodes' characteristics and ensures that the overall design reflects this. For example, a conductive coating will require several positive feeder wires and a discrete anode system may require distribution boxes.

The anode selection has implications for the size, layout and number of zones and also has important implications in the current distribution and maximum density that can be applied.

### 3.2.7 Cabling

It has been common practice to specify cabling for DC negative, DC positive and reference electrode cabling in accordance with mechanical strength requirements. This practice came from 'traditional' CP experience where cables were often placed directly in the soil.

For an atmospherically exposed reinforced concrete structure, the cabling should be run in conduit or buried in the structure at all locations. Mechanical damage to the cabling is thus likely to be limited to during the installation phase. In this case, if thorough quality control on site is adhered to (necessary whatever cable dimensions are selected) then the most logical approach is to use cable cores with the minimum size necessary to pass the maximum design current. These minimum dimensions can be determined from voltage drop calculations.

The voltage drop of the circuit is calculated from the cable resistance for the selected conductor cross-section, multiplied by the cable length taking into account the required driving voltage of the anode. As a rule of thumb, for both DC positive and DC negative feeder cables, the total voltage drop should be less than 3V. The driving voltage required by the anode system depends on the ease with which it passes the current on to the steel reinforcement. This is dependent on the concrete resistivity and other factors; however, a rough guide is given in [Table 3.2](#). This table gives the required voltage to pass 10 mA/m<sup>2</sup> of steel (which is a high level of protection) after a few years' operation of the CP system on a surface dry concrete which has some chloride contamination.

Normally, a few years after a CP system is energized the current demand required to prevent corrosion of the reinforced steel is significantly reduced. At this point the current density the system is delivering should be lowered by reducing the driving voltage.

The most suitable cables for use in concrete CP installations are doubleinsulated with a hard and abrasion resistant sheath. There is little point in specifying the cable

Table 3.2 Driving voltages required by different anode types

<i>Anode type</i>	<i>Driving voltage required after 2 years</i>
Mesh and gunite	6V
Mesh and special overlay	7V
Conductive coating solvent-based	8V
Conductive coating water-based	8–15V
Internal anode	11V
	(5V of which is preresistor)
Sprayed zinc	>15V
Conductive mortar proprietary system	>15V

type on the insulation's thermal properties (as indicated in IEE regulations) as the wiring system should not be designed to operate at the maximum temperature limit of the insulation. Concerns have been expressed about the durability of PVC in concrete over a protracted period but no failures have yet been reported for this material so both this and cross linked polyethylene (XLPE) seem suitable for direct burial in concrete along with the more expensive fluorocarbon insulation types.

Positive connection damage is the most common failure mode in a CP system. Second to this are cable failures. These can normally be attributed to; mechanical damage during installation, having unprotected cable in the structure, i.e. run without conduiting, overtensioning in installation, i.e. stretched cables which are then thermally cycled and finally bio-interference such as marine attack. Other common failures encountered are at line splices which are often woefully underspecified and at junction boxes. These are often located in areas where they are liable to be flooded.

Most of these problems can be prevented by good design and site practice. As contractors try to use multicore whenever possible, for cost-saving reasons, it is normally impractical for the designer to specify glanding sizes and numbers on the junction boxes and power supplies, but they can specify that they are sited in as dry a location as possible and the glanding is all facing downwards. Site supervision should ensure that the glands are the correct size for the cable. When in doubt about the durability of junction boxes in exposed areas they should be filled with a non-acid, petroleum jelly to preserve the integrity of the connections. epoxy potting should not be used.

It is good practice to separate the DC positive and DC negative feeder cables as much as is practically possible, preferably putting them into separate junction boxes, to prevent the possibility of galvanic corrosion. When inline splices are required, the joints should be made with a mechanical sleeve splice, faired with a suitable mastic epoxy putty and at least one mastic heat shrink sleeve and preferably two for anode feeder connections. Soldered joints are excellent if they are protected from mechanical stress.

### 3.2.8

#### Reference electrodes and other measuring devices

There are several types of reference electrodes which are commercially available and claim to be suitable for burial in concrete. Due to the relatively poor performance of reference electrodes over protracted periods in the early days of applying CP to reinforced concrete, a significant amount of work has been undertaken on assessing how reliable the particular types are, and some of this research has been published (Schell *et al*, 1989).

Reference electrodes can be categorized into two types for burial into concrete, namely, true half cells and noble or 'inert' reference electrodes.

True half cells can be defined as an element in a stable and reproducible dynamic balance with its ions. For example, the silver/silver chloride reference electrode has a silver rod or mesh coated with silver chloride in the middle of the unit with a saturated electrolyte of silver chloride solution which is normally made into a gel to prevent or slow down leakage. This gel forms the electrolytic connection between the concrete with the interface made through a porous plug either on the flat face or in some designs over all the cylinder shape.

Inert electrodes are units where the active element has an extremely small dynamic equilibrium coefficient between the element and its ions in concrete. Graphite, platinum or a mixed metal oxide coating have been found to be effectively inert in concrete, whether it contains chloride or not, and thus maintain a relatively stable potential. As these three elements can withstand some anodic discharge there is little material loss when a potential measurement circuit is left open even for a period of time.

If the CP system is operated using 4-hour and 24-hour 'decay' criteria then inert electrodes are perfectly satisfactory and have the advantage of offering greater robustness and a longer theoretical life. If the system is operated using absolute potential criteria or has the possibility of reaching very negative potentials then true half-cell reference electrodes are required. The true half-cell type of reference electrode should also be specified if comparisons are to be made between the steel reinforcement potential before energization and after CP has been applied.

At present the most ideal arrangement is to specify a mix of true half cells and inert reference electrodes for a single structure which are placed in pairs with the true half cell used for direct measurements and the inert electrodes checking the calibration of the half cells.

The most commonly used reference electrodes and their categories are given in [Table 3.3](#).

There are significant differences in the stability and reliability of products from different manufacturers, with some failing in a matter of months.

Assuming a reputable brand has been specified, the most important practical factor determining the satisfactory performance of the reference electrodes is the integrity of

Table 3.3 Common electrodes specified for burial in concrete

<i>Type</i>	<i>Abbreviations</i>	<i>Potential compared to CSE</i>	<i>Category</i>
Silver/silver chloride	Ag/AgCl	-70 mV	true half cell
Silver/silver chloride/potassium chloride	Ag/AgCl/KCl	-120 mV	true half cell
Manganese/manganese dioxide	Mn/MnO <sub>2</sub>	+95 mV	true half cell
Graphite	Gr or C	-50 (approx)	inert
Mixed metal-oxide-coated titanium	MM(Ti)	+110 (approx)	inert
Platinum coated titanium	Pt(Ti)	+100 (approx)	inert

the interface between it and the concrete into which it is embedded. If there are voids in the electrolytic contact, and these dry out after the cement cures, the resistance of the circuit increases and new electrical pathways may occur so that spurious readings result. To minimize this possibility, the interface area, i.e. the size of the porous plug for a true half cell or exposed element for an inert cell, of the reference electrode specified should be maximized.

The way in which the reference electrode is connected electrolytically to the original concrete is very important. There has been significant debate on the merits of using a mortar which is dosed with chloride to replicate the resistance of the concrete or whether to use a 'clean' mortar which will provide a worst-case measurement of the potential change. The reason that there are likely to be less potential changes around the reference electrode and the steel it is being measured against is because the clean mortar will be more electrically resistive, reducing the current flow through this volume. There are merits in both sides of the argument, i.e. adding chloride or not. From a practical point of view, ensuring the correct level of chloride is added when minor patches are made (as is often the case when placing reference electrodes) is very difficult and over addition is easily done. Thus when dosing with chloride there is a possibility that an over-optimistic estimate of the level of protection being achieved is recorded. This is a worse situation than that of an under-estimation of the protection level being imparted and on balance a 'clean' proprietary mortar with minimal anti-shrink agents is a more satisfactory choice. An alternative is to pre pot the reference electrode within a small diameter concrete cylinder where the concrete can be dosed with chloride under strict quality control conditions.

The location of the reference electrode is of great importance, as this has a large influence on the extent and location of the steel reinforcement measured by the reference electrode. In early practice in the UK, where a large amount of reference electrodes were put into relatively small volumes of concrete, it was considered reasonable to strap the reference electrodes to the steel reinforcement, however, this

had the disadvantage of putting the steel which had the greatest potential influence in new fresh mortar and restricting the area of the reference electrode readings. Unfortunately, this placement technique for reference electrodes is still prevalent, whereas the correct approach should be to place the reference electrodes in the concrete in as electrically remote a location to the steel as is possible to try and maximize the steel area being monitored and minimize the effects of the mortar in which the reference electrode is embedded.

Monitoring connections to the steel reinforcement near to the reference electrodes are commonly specified to minimize the error from the flow of current in the steel reinforcement when being cathodically protected. This is reasonable but not vital if the steel is continuous. On no account should the DC negative power return for the CP system be used to complete the reference electrode as the voltage flow within the CP circuit will affect the readings recorded from the reference electrode measuring (or monitoring) circuit.

When the reference electrodes have been installed it is of value to designate an area on the surface near their individual location and determine their potential against a calibrated portable reference electrode placed on the surface. If substantial drifting of the potential occurs then the internal reference electrodes should be replaced or ignored.

Reference electrodes are by far the most common method of determining the effectiveness of CP, however other methods are also used. In BS7361: Part 1:1991 an isolated bar arrangement is shown, where a section of reinforcement steel is cut and electrically isolated still within its original concrete, and the current flow between the steel to the remainder of the reinforcement steel case is measured through a 1 ohm resistor. This arrangement can be improved substantially by using a zero resistance ammeter (ZRA) to measure the current rather than a resistor and voltmeter (DVM). The concept of the electrically isolated section of reinforcement steel is that the corroding sections would be a net current provider to the remainder of the steel reinforcement in the structure. As the CP system is energized, the current flow between the isolated section and the remainder of the steel reinforcement would reduce and eventually it would be a net receiver of current. At this point corrosion activity would be stopped and previous anodic (corroding) areas within the isolated bar would become cathodic. This information would then imply that other similar areas had received sufficient current and could be used to set up the system.

A similar concept has been used for 'current pick-up probes' where a drilled hole was made in the concrete, a steel bar was inserted and grouted into place using a mortar having a higher chloride level than the original concrete. The steel bar was electrically connected to the structure with a low value resistor and the corrosion current measured as the CP system was energized progressively. When the bar became cathodic then sufficient current was deemed to be provided to ensure protection of all the rest of the reinforcement. This can be used to derive the worst-case current

density required from the CP system for design purpose. This is required for the anode and the DC power supply design criteria.

Other measurement systems have been tested in a laboratory and field trials but do not appear to be in widespread use on commercial CP systems as yet.

### 3.2.9

#### Interaction

When designing the CP system, attention must be given to the possibility of interaction with or from other components. The most problematic forms of interaction are large DCs and these, typically, can be caused by electrically generated train or tram traction systems often found at the ground/air interface. There is also often a significant amount of electrical 'noise', particularly at 50 Hz frequency, where there is grounding from nearby electrical apparatus. This occurs quite often on marine structures. Reference electrodes in the tidal zone can pick up this electrical 'noise'. AC 'noise' is not normally a problem from a protection point of view but can give problems with readings from reference electrodes if the cables run in parallel with unshielded AC cables. This can often be overcome by understanding the likelihood of the problem occurring and using suitable electronic filtering or cable screening.

If interaction problems are encountered, the solution is normally the same as in a 'traditional' system. These include bonding the nearest part of the interaction circuit to the system cathode, either directly or by using resistors or diodes. Another approach is to put sacrificial anodes connected to the reinforcement into the electrolyte and use them as preferential current receivers. Sometimes cables, particularly those carrying reference electrodes potentials, can pick up induced currents and when this occurs screened cables are required.

### 3.2.10

#### Continuity and negative connections

Unlike a 'conventional' CP systems for pipes or other buried metallic components, electrical integrity of the cathode for a steel-reinforced concrete structure is often tenuous and cannot be checked completely, as removal of all the concrete cover is not practical and often precisely the reason the CP system is installed. An integral part of the design, therefore, is to estimate the electrical continuity of the steel reinforcement and thus determine the amount of current which can be carried by each of the DC negative connections to the steel. In the design survey, this can and should be tested directly, rather than using the very limited voltages (in resistance mode) that digital voltmeters output.

Assuming that the steel has been conventionally tied with wire, the most critical factor is to estimate the amount of corrosion which has occurred between the rebar

and tie wire. If there is a significant amount of corrosion, then the current which can be passed at this connection may only amount to a few milliamps and either additional reinforcement continuity bonding will be required, or a large number of individual DC negative connections need to be made. As a guide, a DC negative every 50m<sup>2</sup> should be provided with this number quadrupled if any concerns on the likelihood of poor continuity are expressed. There should always be at least two negative connections, however, for electrical redundancy.

When designing a CP system, particular care should be taken to ensure that there is electrical continuity across expansion joints, dry joints or other discontinuities such as, for example, where there are different concrete colours which are indicative of separate pours.

In general it is recommended that the entire DC negative system is made electrically common. For example, when there are pre-cast components which are electrically discontinuous these should be electrically commoned.

Particular examples where it may not be pertinent to common a structure electrically are rare and normally involve CP systems where there is concern that the current distribution will be excessive or variable or there is the possibility of stray current interaction. An example of the former is individual piers for a marine bridge where the deck is isolated from the sub-structure by the bearings. In this case, each pier can be protected with their own DC negative and DC positive circuit. Ideally, a small capacity 'balancing' DC negative should be run between all the piers to avoid differences in 'touch' potential occurring. An example of the latter is seen when designing a CP system for a tunnel which has individual pre-cast segments and there is an electrical traction system which is ground-earthed. It is likely, in this case, that if the segments were electrically commoned, then substantial interaction stray currents would be induced on to the reinforcement which could, in localized areas, overwhelm the CP system and thus cause a high level of corrosion. In this case the solution could be to limit the length of the CP zone by not commoning the segments. This would limit the stray current pick-up path.

The DC negative circuit can be made in different configurations, i.e. a spur circuit, a ring circuit or a combination of the two. The designer should normally decide on the most economical arrangement by considering the size of the cables required and their number. Whatever arrangement is chosen there should always be electrical redundancy. It is usually the case that the higher the requirement for reliability and life expectancy, the more DC negative connections to the steel reinforcement are used. These can be made in a number of ways, such as thermite welding, pin brazing, electrical arc welding of a plate to the reinforcement, using a percussive nail gun, drill and tap or more often than not, drill and self-tapping screw. Each of these processes has its adherents and the most important thing is to make sure they are undertaken properly. Pin brazing is fast, positive, easy to test (hit the stud with a hammer—if it doesn't fall off it is OK) and reliable. The installation of a pin-brazed DC negative connection does require the use of the correct machine which could be a

substantial investment. Whatever joint system is used the DC negative connection should be covered by a non-conductive epoxy or mastic to prevent corrosion of the copper core. Normal good practice is to have at least two DC negatives per zone.

### 3.3 CASE HISTORY

#### 3.3.1 Introduction

Palo Verde Power Station is the largest nuclear electricity generating station in the USA and is located outside the city of Phoenix, Arizona. Due to the shortage of water in this region, the cooling water used for the station is effluent with a high proportion of chloride ions and other soluble salts.

The water is provided to the power station through a canal and is used to cool the secondary heat exchange circuits. To economize on the use of water this effluent is recycled several times with the chloride becoming more concentrated on each pass.

The power station uses nine cooling towers with forced induction fans to promote heat exchange between the cooling water and air. The cooling towers are proprietary pre-cast units which have been used successfully in many power stations in the USA and indeed around the world.

In this particular example, the high chloride level of the cooling water has caused the pre-cast elements to exhibit signs of corrosion of the steel reinforcement. The principle reason for this corrosion was the permeation of chloride ions from the cooling water through the concrete to the steel reinforcement.

Despite the pre-cast concrete's high quality, the corrosion rate of the reinforcement steel was high because of the high ambient temperatures, high humidity and mechanical liveliness (i.e. the structure is noticeably shaking when in operation) of the towers.

In order to prevent further corrosion of the steel reinforcement, trials were started in 1993 using CP on the columns in the tower. On completion of the trials, the supporting columns in seven cooling towers were covered with a conductive coating type anode. Despite being found to be functionally effective in applying CP it was considered that this anode system was practically difficult and expensive to install. This was because the concrete had to be dried out before paint application, there was limited cover of the concrete over the steel reinforcement and a very large amount of exposed tie wire. This required the surface to be built up with a mortar before the conductive coating was applied. Another problem was oil contamination of the concrete surface caused by leakage from the fan gearboxes. This was resolved by steam cleaning.

After these problems, other CP systems were considered for the columns and other pre-cast components in the structure.

The cooling tower comprises several separate pre-cast components and a cast in-situ basin, all with problems caused by chloride induced corrosion of the steel reinforcement. The design brief was to look at each of these components and recommend a CP repair strategy. On discussion with the client, a suitable area for an initial installation was deemed to be 90m linear length of beams, five columns and five radial bent stacks comprising a 36° arc of a cooling tower.

In looking at the optimum CP design, the total history of the anode systems on the columns would have been very useful. Unfortunately no details of the system's electrical performance and effect on the steel were made available.

### 3.3.2

#### Concrete basin

This structure was heavily chloride contaminated and continuously immersed in aerated water. There was limited visual evidence of corrosion of the reinforcement and it was not leaking seriously. As the basin was not considered structurally important to the integrity of the structure, was still working effectively and could be patch repaired easily, it was decided not to protect the component using CP.

### 3.3.3

#### Support columns

The spirally wound pre-cast units are 15m high and support the fan deck of the cooling towers and are structurally vital. Corrosion of the reinforcement was apparent and it was considered necessary to apply CP to these components. Previous CP trials had used slotted anodes and conductive coatings. Both had been relatively unsuccessful in installation. The slotted anodes were unsuccessful because of the low cover and large amounts of tie wire close to the surface which caused severe electrical shorting problems. This resulted in its being withdrawn from the remainder of the initial trial. Conductive coatings were more successful although they again suffered (albeit to a lesser extent) from electrical shorting problems, drying constraints and then delamination in service.

The columns up to 1.5m are continually immersed and above this level are continuously splashed all the way to the fan deck.

For the immersed environment with the high salinity of the water the most economical solution was to use a sacrificial anode placed on the floor of the concrete basin and attached to the steel in the base of the column above the water line through a double-insulated cable. Normally the saturation of the concrete and high chloride concentration, would favour zinc or aluminium anodes being used, however as there was a plentiful supply of magnesium anodes available on site for protecting buried

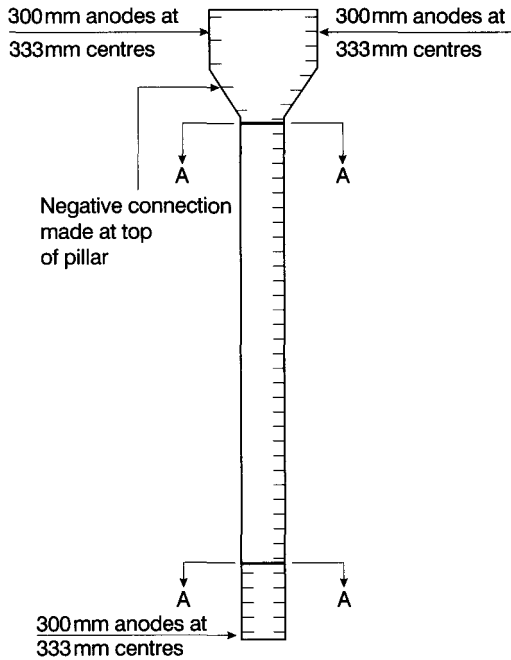
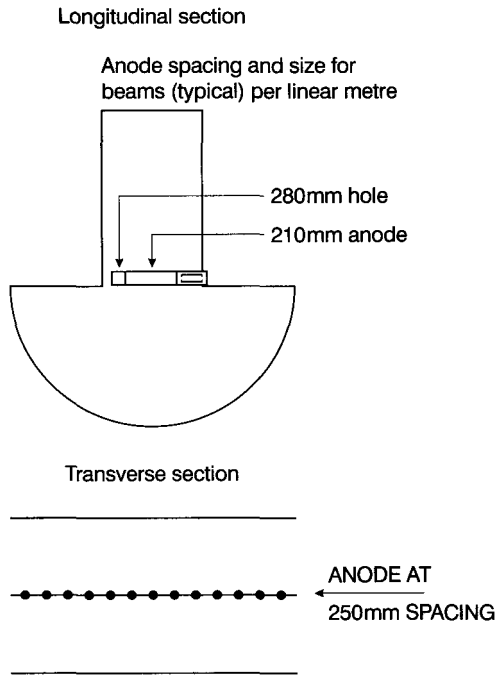

Fig. 3.2. Showing anode placement and spacing on column.

pipelines, this latter type were selected. They were designed to have a minimum of five years' life.

Above the water level, an internal anode system was selected for the following reasons. They are simple and quick to install, they do not add any dead weight and they do not require the concrete to be surface prepared. From a current distribution point of view, the anodes could be placed from the outside, past the centre of the column and radiate their current outwards on to the radially wound reinforcement. From the original drawings the steel: concrete surface ratio of the columns was calculated at 1.7:1. The total current requirement of each column at a current density of  $20\text{mA/m}^2$  of steel surface area was  $280\text{mA}$ .

There was additional reinforcing steel at the base of the columns and at the castelated tops and thus extra anodes were used for these areas. Knowing the current requirement per linear metre of column ( $10\text{mA/m}$ ) it was then possible to estimate the number and size of anodes. For an internal anode a maximum current output of  $3\text{mA}$  per  $100\text{mm}$  length is recommended. Thus a metre of column required  $630\text{mm}$  linear length of anode as a minimum. The current distribution with internal anodes is critical to their success with a maximum of  $450\text{mm}$  allowed between anodes. A compromise between more even distribution (i.e. more anodes with less output current) and economy (vice versa) was reached with anodes of  $300\text{mm}$  active length placed in the centre of the columns.



**Fig. 3.3** Anode placement and spacing in a beam.

DC negative connections were made by welding studs to the steel reinforcement and running the wires to a junction box on the fan deck roof.

True half cells of silver/silver chloride and inert electrodes of mixed metal-oxide-coated titanium were placed in the columns to allow the potential of the steel reinforcement to be measured and monitored.

### 3.3.4 Beams

The pre-cast beams run between the columns to support the fan deck with attendant live as well as dead loading. Corrosion was observed on several areas of the beams with the top surface being exposed to the sun and touch-dry, wicking chloride-contaminated water through the beams. The only access available was through a 'cherry picker' portable platform from the basin floor and thus the CP anode system had to be simple to install in both plant and time requirements. The solution chosen was to use internal anodes, due to their ease and speed of installation, and the fact that they do not add additional dead loading to the structure. The structural engineers for the client stated that the uppermost reinforcement steel had been severely corrosion damaged and for their test loadings on scaled beams and calculations of strength, they had been ignored, and thus should only receive a low priority for CP.

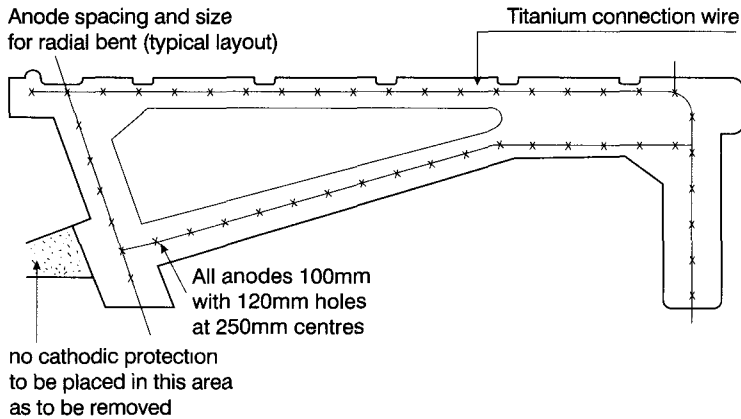

Fig. 3.4 Anode location in a typical radial bent.

A current density ( $15\text{mA}/\text{m}^2$  of steel) lower than that for the columns was used to reflect the drier environment of the beams. This gave a total current requirement of  $14\text{mA}/\text{m}$  of beam. For the sake of commonality it would have been simpler to use the same length of anode as in the columns and it was originally proposed to drill vertically upwards into the beam. In practice the drilling crew found this tiring and it caused difficulties with the dust in the mechanics of the cherry pickers and a horizontal positioning was used with closer spacings to compensate for the reduced current distribution.

### 3.3.5 Radial bents

These pre-cast units supported glass-reinforced plastic (GRP) screens used to disturb the carrier water flow and encourage heat transfer. Some cracking caused by corrosion was apparent, but due to their continuous and complete saturation it appeared that they had been spared major corrosion to date, despite heavy chloride contamination. To complicate matters the units had a post-tensioned rod passed down through the stack and grouted up inside a conduit. This rod was tied electrically into the cathodically protected circuit. Access to the radial bents could only be obtained on one side of the units which constrained the type of anode that could be used. Internal anodes were again selected despite there being congestion of the steel in two parts of the unit and the structures' thinness (250 mm). The slim section meant that short anodes of 100mm had to be used and thus at the desired current density of  $20\text{mA}/\text{m}^2$  of steel reinforcement, an anode frequency of 250 mm was required.

The layout used for each of the 30 radial bents is given in [Figure 3.4](#).

Once the anode layouts on the columns, beams and radial bents were calculated, an estimate of the total current requirement for each of the various pre-cast units was

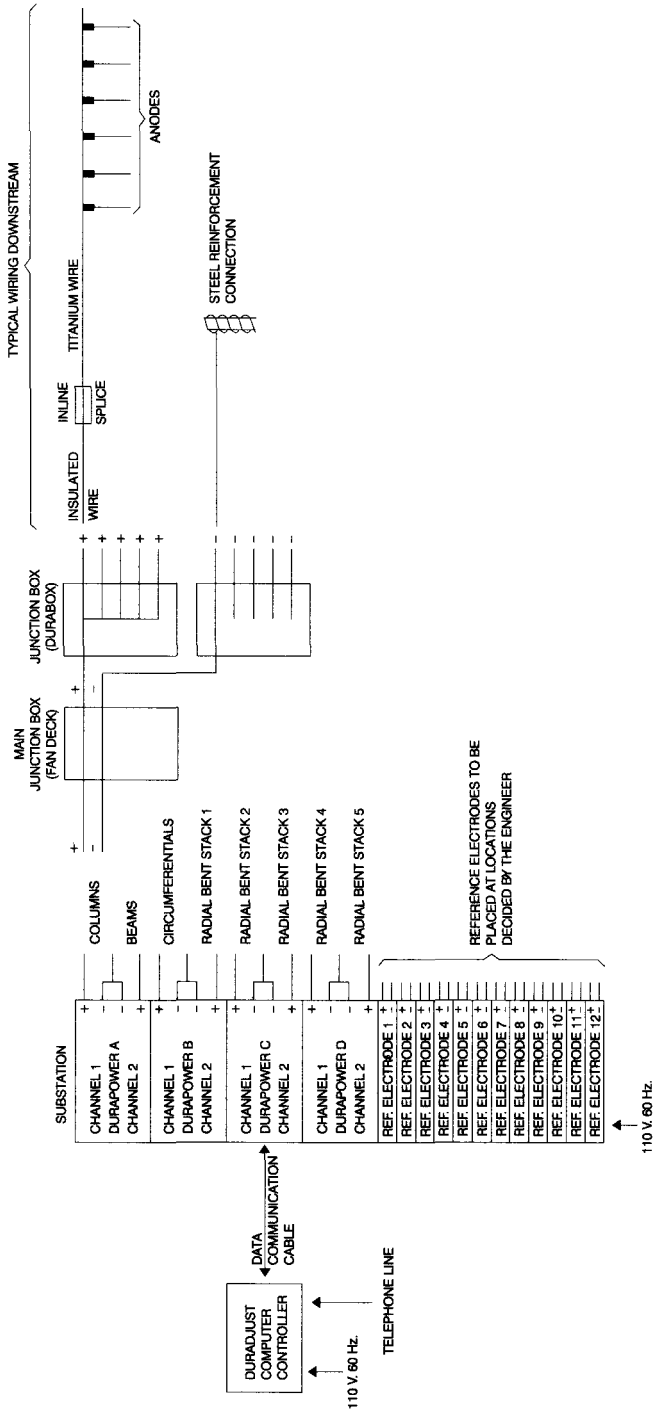
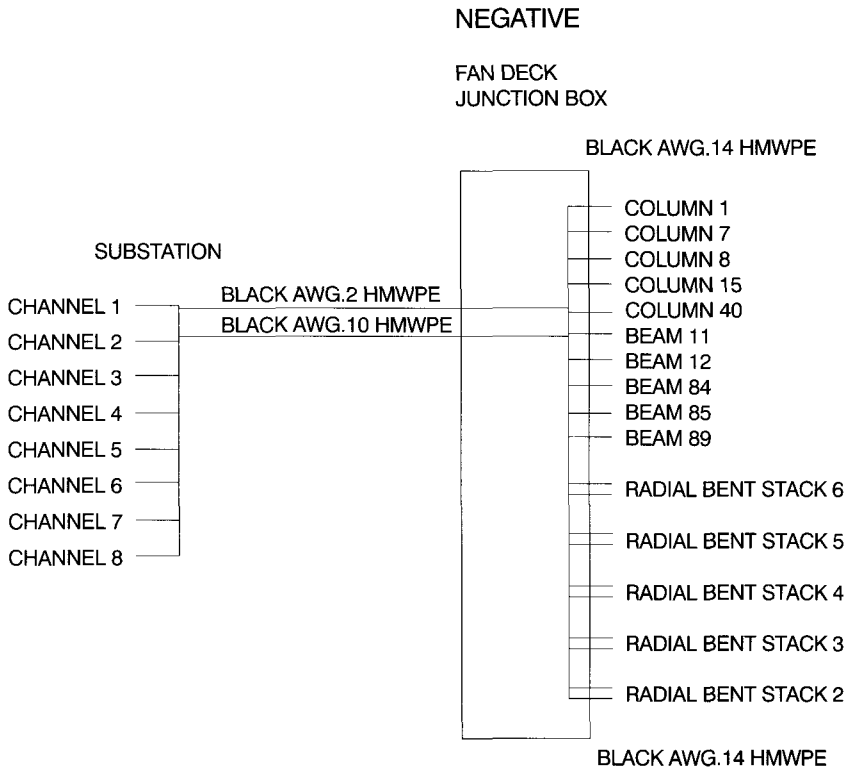

Fig. 3.5 Schematic of total system.



**Fig. 3.6** Fan deck junction box.

made. The various environments likely when the system was operating and shut down were then considered, i.e. changes in humidity level in different parts of the structure. Using this data, the number and locations of anode zones were detailed. For this structure, this was a reasonably simple arrangement, with the beams forming one zone, the columns forming another and each of the radial bent stacks forming an individual zone, seven anode zones in total.

An overall schematic of the CP system is given in [Figure 3.5](#).

The cabling requirements for the individual runs were then determined and the cabling details for the junction box were drawn up. The client had surplus cabling available and wherever possible this was used for the system, despite this being oversized for the electrical duty in some areas. An example of the fan deck junction box schematic is given in [Figure 3.6](#).

As the system was to be installed in an area where access was limited and with the plant operators in favour of limited maintenance requirements, the system was designed to be automatically self-regulating to within a set of predefined parameters and data on the systems performance made accessible to remote operators. The CP

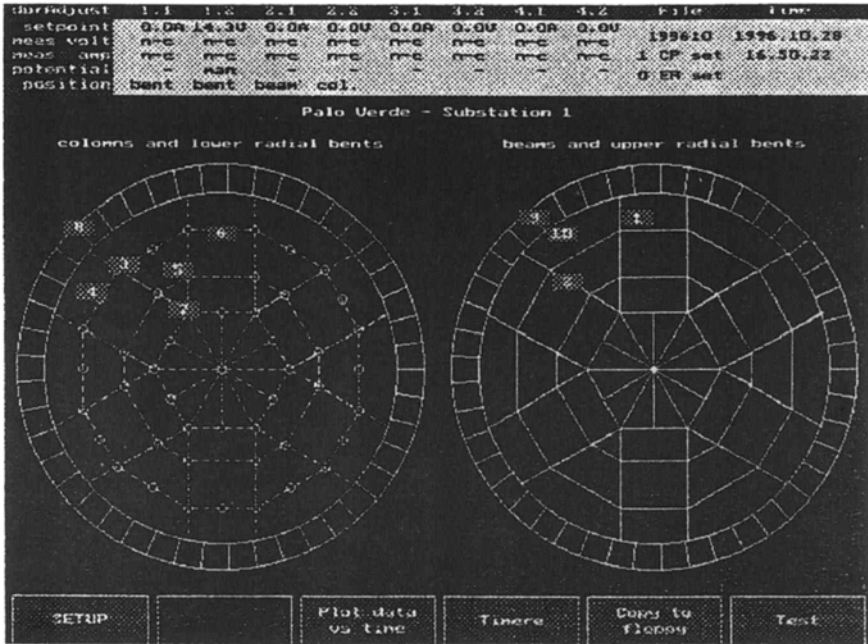

Fig. 3.7 Front screen of the computer-controlled system on the Palo Verde CP system.

system also allowed readjustment of the protection parameters remotely. The front screen of the operating system is given in [Figure 3.7](#).

The system has been operating successfully for six months or so with the current requirement dropping from 90% of the maximum output to around 60% of the maximum output. The potentials of the radial bent stacks which are completely saturated are very negative and are being operated in a constant potential mode with the potential being held at  $-770\text{mV}$  wrt copper/copper sulphate using 'instant-off' readings. The beams and columns are being operated at constant voltage with a current limit in order to give a minimum of  $200\text{mV}$  decay after 24 hours. This is tested automatically by the system at monthly intervals.

## REFERENCE

- Schell, H.C., Manning, D. and Pianca, F. (1989) *Transportation Research Record*, 1989-04-01 N1211, ISN 036-1981.

# Impressed current cathodic protection systems for reinforced concrete

*Kevin Davies, K.Davies Consultancy*

## 4.1

### INTRODUCTION

Ever since its first real trial in the mid 1970s, impressed current cathodic protection (ICCP) has developed as a practical corrosion control technique for reinforcement steel in concrete.

The earliest documented installations for above-ground structures were carried out in California, USA. These involved placing anode materials in saw-cut slots in roadway bridge decks. The original anode materials were conductive carbon loaded asphalt overlays. Later they advanced to resins and other polymers cast into the slots around platinized niobium-coated copper-cored wires (primary anodes). DC to power the system was supplied from transformer rectifier units. Restrictions on the output current density achievable and the impracticality of applying these original anode materials on anything but a horizontal, easily accessible, deck surface encouraged developers to look for alternative materials and application techniques. A great deal of research, effort and funding has since been directed at improving the durability and ease of application of ICCP anodes for reinforcement concrete and the success of these developments, in both commercial and technical terms, can now be seen world-wide.

The reasons why corrosion of reinforcement steel in concrete occurs and the mechanism whereby cathodic protection is able to control this problem are now well understood. For atmospherically exposed reinforced concrete ICCP is usually the most appropriate corrosion mitigation technique. For submerged or buried structures, sacrificial anode cathodic protection (SACP) systems can sometimes be used effectively. Most practical ICCP applications to date have, however, been applied to above-ground structures such as bridges, car parks, marine structures and now, more commonly, buildings. This section concentrates mainly on anodes for ICCP systems as these are by far the most important.

## 4.2

## APPLICATION OF IMPRESSED CURRENT CATHODIC PROTECTION

ICCP is normally applied in conjunction with traditional remedial techniques, such as break-out and repair, and can often be technically and economically justifiable for chloride-contaminated or carbonated structures where excessive, or on-going break-outs, are best avoided. A well designed, installed and operated ICCP system should provide a substantially extended service life for the structure by slowing down the corrosion of the reinforcement steel to an acceptable rate.

In order to apply cathodic protection to a reinforced concrete structure, a number of fundamental design and material selection decisions must be made and one of the most important is the selection of the most appropriate anode (material, shape and type).

An ICCP system comprises four main components which, together, constitute an electrical circuit, namely:

- a controllable DC power source—usually a purpose-made transformer rectifier;
- an applied anode—a material placed onto or into the concrete or surrounding electrolyte to enable current flow;
- an electrolyte—normally the pore water present within the concrete or, in the case of remote anodes, also the water, soil or mud in which the anodes are placed;
- a return electrical path—normally the electrically continuous reinforcement steel to be protected.

The low voltage (<24V) and current (<10A) DC power supply is normally derived from a transformer rectifier unit with a number of in-built characteristics to enhance performance and control of the DC output current. Transformer rectifier units are usually AC mains voltage powered with full control of the DC output currents and voltages. Cyclic switching and data acquisition (monitoring) devices are often fitted to the DC power source and the units can usually be operated in either constant current or constant voltage mode.

The anode is required to pass the controllable corrosion control current uniformly into the reinforced concrete. It is at the interface between the anode and the electrolyte that the applied, or impressed, current changes from electrical current flow to ionic transfer flow.

In most cases the electrolyte is the pore water within the concrete matrix. This pore water containing calcium-based alkalis allows the ionic transfer of current between the anode and the reinforcement steel. Pore water is almost always present in concrete. The material composition, shape, type and orientation of the anodes are all of fundamental importance to the performance of the cathodic protection system.

There are a number of aspects to take into account when considering the use of ICCP as a corrosion control technique for reinforced concrete structures.

- ICCP must be reasonably practical, safe and economical to install. In most applications the selection of the correct anode type will be the single most important consideration.
- Depending on the type of anode used, the installed ICCP system will add a certain amount of dead weight loading to the structure. This must be catered for in the system design.
- The ICCP system must be physically capable of polarizing the embedded reinforcement steel adequately by passing a uniform, controlled current to the targeted steel at an acceptably low DC output voltage.
- The ICCP system components must be sufficiently durable to withstand the installation process and to fulfil the design service life under the operating conditions. They should not fail nor deteriorate to an unacceptable level, even under reasonably varying environmental conditions.
- The installed ICCP system should not adversely affect other components or structures.
- The installed ICCP system should, on completion, be aesthetically acceptable, taken in context with the particular structure.
- The ICCP system should be relatively easy to operate and the design of the system should address inspection and maintenance requirements adequately.

### 4.3

## REQUIREMENTS OF IMPRESSED CURRENT CATHODIC PROTECTION ANODE SYSTEMS

### 4.3.1

#### **Aesthetics**

In most cases the aesthetics of the installed ICCP system are important. Recent applications of ICCP to publicly accessible buildings have been carried out in such a way so that, on completion, the installation is almost invisible to the casual observer.

To achieve this, the selection of the correct anode type and careful routing of the cables, monitoring system and DC power supplies are considered important.

With some applications such as to basements of utility buildings, culverts, some bridges and other out-of-the-way structures, the aesthetics of the structure may be less important.

### 4.3.2

#### Physical attributes

Atmospherically exposed reinforced concrete generally has a high electrical resistivity, normally within the range 10k .cm to 50 .cm, but sometimes as high as 100 .cm. The geometric arrangement of the reinforcement steel within the concrete is such, that to achieve adequate and uniform cathodic protection flow to the target steel, a high anode area coverage is often required.

'Hot spot' cathodic protection can be provided to localized areas of reinforcement steel at risk from corrosion, but generally some level of overall protection is required. The anode must be able to distribute the design corrosion control current to the targeted reinforcement steel uniformly and continuously at an acceptably low DC voltage level throughout its service life.

The anode system must not add an unacceptable dead weight loading to the structure. This is particularly important for the application of ICCP to existing structures where additional weight loading may not be tolerable. For new structures the anode system can often be included into the design loading calculations.

The consumption rate of anodes is particularly important for ICCP systems for reinforced concrete. For immersed or buried structures where the anodes can sometimes be placed remotely in the water, mud, seabed or soil surrounding the structure, the electrolyte is usually able to remain in electrical contact with the anode surface even after some change in physical dimensions with anode consumption.

For anodes embedded within concrete or within spray-applied cementitious overlays, this may not be the case, however, and consumption of part of the anode will lead to an increase in the output current density elsewhere, an increased electrical circuit resistance and often premature failure of the ICCP system.

For permanent embedment in concrete, only relatively non-consumable anodes are of practical use. This limits the range of suitable anode materials.

The anodes must be reasonably practical to install and must be capable of site connection to the DC positive cable system.

Electrical connections to the anode are often made under difficult conditions with limited access. The DC positive connections to the anode are critical to the success of the system's long-term operation and great care is required to design a practical, fully electrically insulated, but durable, DC positive connection system which must remain corrosion-free for the life of the system.

The anodes should possess adequate mechanical strength to withstand the rigours of installation and should be sufficiently durable to withstand the operating and local environmental conditions imposed on it during its service life.

The structure to which the anode is to be applied, is usually drawn with straight edges, definite corners etc. In practice this is rarely the case and the anode must be both flexible in its design as well as being robust. Expanded titanium meshes, ribbons and other anodes embedded within spray-applied cementitious mortars, for example,

must have catalytic coatings sufficiently durable to withstand the abrasion from the guniting process. The anode must be fixed easily to the concrete without the requirement for an impractical number of fixings, and these fixings must not impair the anode efficiency during operation nor affect the adhesion of the overlay.

### 4.3.3

#### Chemical attributes

During normal ICCP system operation, the predominant chemical reaction taking place around the anode is either the release of oxygen or the evolution of chlorine. In most well-designed and operated systems, oxygen evolution is most common.

#### 4.3.3.1

*Oxygen evolution at the anode*



#### 4.3.3.2

*Chlorine evolution at the anode*

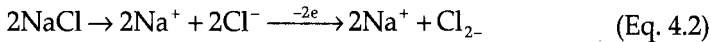

(Eq. 4.2)

The resulting development of  $\text{H}^+$  ions during the anodic reaction reduces the high pH (alkaline) nature of the concrete and acids are generated.

To minimize the affect of acid generation, anode manufacturers have placed restrictions on the maximum output current density achievable in practice from their anodes. These restrictions are dependent on the type of anode material, anode surface area to concrete surface area ratios, and the shape of the anode.

High current density output anode systems such as embedded wires, meshes or ribbons are likely to generate more local acidity than high coverage anode systems such as surface coatings, conductive mortars or metallized sprays and are more likely to free themselves from intimate contact with the concrete at an early stage and become surrounded by a pocket of stagnant acidic electrolyte, particularly if the ICCP system is not designed or operated correctly.

### 4.3.4

#### Performance characteristics

In most reinforced concrete structures the steel is distributed throughout the structure, although the steel surface area to concrete surface area ratio will vary

considerably with high steel concentrations at critical areas such as beam-to-beam or beam-to-column intersections, half joints or beneath bearing plates. The design of the ICCP system, and in particular the design of the anode system, must allow for distribution of the DC output current to these target areas.

Because of the high electrical resistivity of the concrete, and the desire for a low operating voltage from the DC power source (for safety reasons), the 'throwing power' of the anodes is relatively low, hence the anodes have to be positioned close to the targeted steel which generally means a high area coverage for uniform distribution purposes. The concrete itself is almost always non-homogenous throughout and the depth of concrete cover to the steel is variable with the result that the output current density required from the anode is very rarely uniform over its entire area. The anode, and indeed the design of the system, must take this into consideration, particularly when the design cathodic protection current demand approaches the maximum theoretical anode output current density.

The DC positive power supply is usually connected to the anode at discrete locations. The anode itself is required to distribute the cathodic protection current to its entire surface interface with the concrete. The anode must, therefore, be sufficiently conductive and coherent to allow this current distribution. For mesh, wire and ribbon type anodes, this is achieved by electrical distribution along the wires, for conductive coatings this is by conduction across the filler particles throughout the cured film; for conductive mortars, this is by electrical contact of the conductive filler components within the mortar layer; and for discrete anodes this is by individually insulated wires or in newer systems via a titanium wire distributor.

The design of a cathodic protection system anode must cater for electrical attenuation across or around the anode zone and must ensure that sufficient DC positive connections are made or a network of primary anodes is used, to ensure that the electrical attenuation is kept within acceptable levels.

The anode must be sufficiently durable and robust to prevent cracking or other damage which would adversely affect electrical distribution. Specifications often include clauses stating the maximum anode area failure allowable but this should be kept to a minimum by correct design.

Anodes are generally rated to operate up to a specified output current density. This is usually calculated on an average over the anode surface areas basis. In recognition of the limitations associated with this method of design, a number of safeguards are normally applied.

- The anode surface area powered by a single DC power supply should be kept as small and well-defined as practical.
- The current density requirements of an anode over an area powered by a single DC power supply should be similar throughout. Local high-output density areas should not be included within a lower-output density area without special considerations, for example, additional anode thickness over such areas.

- It is sometimes possible to ‘split’ the single DC positive feed to subsections of the anode via resistor boxes, secondary control boxes or varying resistance cables but great care should be taken when doing this.

Even with these safeguards applied, the anode may still be subject to varying current demands and it must be capable of tolerating these.

The DC power supply is usually provided from a rectified AC power supply which means that it may still be subject to some voltage ‘spiking’. The mean DC output to the anode is seen on a digital voltmeter (DVM) as a smooth, regular supply, while it is in fact still subject to AC ripple. Most modern transformer rectifier units contain electrical components to smooth out AC ripple and any other surges or electrical ‘spikes’, and such requirements are often specified. Smoothing devices can have an adverse affect on the efficiency of the transformer rectifier unit, but because of the low power required for cathodic protection of reinforced concrete, this can usually be tolerated. The anode must be resistant to damage from the remaining AC ripple or electrical ‘spikes’.

During installation, great care must be taken to ensure that the DC connections are made correctly—DC positive to anode and DC negative to cathode (steel). Even so, it is possible that the connections may be swapped and the system could be energized incorrectly for a short while. Reverse polarity sensing units can be included into the transformer rectifier circuitry to prevent this but the anode should be resistant to damage from such an occurrence.

The most important function of the anode is that it must be able to pass the required DC output current to the concrete. The anode must be able to pass the current without itself breaking down throughout its working life.

During operation, the anodes should not form oxide films on its surface which could increase electrical resistance and restrict DC output, nor should they become detached from their fixings or produce unacceptable discolourations. Because of these requirements, only certain materials are practical. For a summary of the anode materials for ICCP systems for reinforced concrete, see [Table 4.1](#).

#### 4.4

### IMPRESSED CURRENT CATHODIC PROTECTION ANODES CURRENTLY AVAILABLE

The manufacture of ICCP anodes is, by its very nature, commercially orientated and as the market in such systems is growing continually, the desire for improved materials performance and manufacturing techniques is increasing all the time. As a result of this, available anodes are usually proprietary in material, shape and design. Consequently, it is difficult to describe anodes and components and the design of systems without referring to specific, commercially available anode systems. In

Table 4.1 Practical ICCP anode systems

Anode material	Anode type	Primary anodes	Estimated design life of system (yrs)	Anode output current density (mA/m sq.)	Estimated anode installed cost (£/m sq) (1996)	Comments	Possible failure mechanism
Carbon-based materials	Solvent- or water-based coatings	<ul style="list-style-type: none"> <li>● Pt/Ti wires</li> <li>● Pt/Ni wires</li> <li>● carbon fibre tapes</li> </ul>	10	10–20	50–60	Useful for most lightly reinforced concrete structures. Not for wearing surfaces. Good for walls, soffits and large areas. Not for variable weathered surfaces. Good aesthetic qualities. Requires primary anodes at max. 2 m spacings	Oxidation, chlorination disbondment, blistering incompatibility of top coat, cracking, primary anode contact, increasing electrical circuit resistance, adhesion failure, bleeding of coating through top coat, short circuit to exposed wires or rebar
Mixed metal-oxide-coated titanium	Conductive resins and polymers	<ul style="list-style-type: none"> <li>● Pt/Ti wires</li> <li>● Pt/Ni wires</li> </ul>	10–15	5–10	40–50	Useful for horizontal deck slabs that are lightly reinforced	Oxidation, chlorination and disbondment, primary anode contact problems, drying out and thermal movement
	MMO expanded mesh	<ul style="list-style-type: none"> <li>● MMO/Ti strip</li> <li>● MMO/Ti rods</li> <li>● MMO/Ni strip</li> </ul>	+25	15–60	60–90	Useful for large or small reinforced concrete structures, can provide high current outputs, very flexible. Requires primary anodes and many fixings. Requires overlay. Adds weight to structure	Overlay disbondment, DC positive connection problems, acidic attack, mechanical damage in service
	Wires, rods, ribbons and strips		+25	10–20	50–80	Useful for horizontal deck slabs, small areas and for supplementary output at edges when used in conjunction with mesh	Overlay disbondment, DC positive connection problems, mechanical damage in service

Table 4.1 Practical ICCP anode systems

Anode material	Anode type	Primary anodes	Estimated design life of system (yrs)	Anode output current density (mA/m sq.)	Estimated anode installed cost (£/m sq) (1996)	Comments	Possible failure mechanism
Metal and metal alloys	Zinc metallizing	<ul style="list-style-type: none"> <li>● Pt/Ti wires</li> <li>● Pt/Ni wires</li> <li>● Brass plates</li> <li>● Stainless-steel plates</li> </ul>	10–15	5–15	50–60	Useful in most areas that conductive coatings are effective. Requires primary anodes but at wider spacings. In very wet conditions zinc anode can provide sacrificial protection to the steel	Oxidation, uneven wear rates, primary anode connection problems, aesthetics, earthing metal surface on concrete gaseous build-up under metallized layer, increasing circuit resistance
Platinized titanium	Discrete anodes in graphite paste infill	N/A	+20	<10	40–50	Useful for small areas or for additional protection to high steel density areas. Useful for ICCP to steel deep in the structure, not suited for larger flat slabs and walls	Electrical short-circuiting to the steel detachment of graphite paste infill from hole.
	Rods for immersion in water	N/A	10–20	<5A/anode	150Ea	Useful for providing ICCP to submerged structures in sea-water or saline groundwater	Uneven wear rates and electrical connection problems. Mechanical damage
	Rods in carbonaceous backfill	N/A	10–15	2–5A/Anode	150Ea	Useful as land groundbeds for buried substructures, supporting structures	Uneven wear rates and electrical connection problems

Table 4.1.3.1 (continued) Practical ICCP anode systems

Anode material	Anode type	Primary anodes	Estimated design life of system (yrs)	Anode output current density (mA/m sq.)	Estimated anode installed cost (£/m sq) (1996)	Comments	Possible failure mechanism
Conductive mortars	Metal-coated carbon-filled spray-applied mortar	<ul style="list-style-type: none"> <li>● Pt/Ti wires</li> <li>● Pt/Ni wires</li> <li>● MO/Ti ribbon</li> </ul>	+25	20-50	50-60	Could be very useful for medium reinforced structures, mortar applied 4-8 mm thickness, can have decorative top coat, retains cementitious appearance of structure	Primary anode contact problems, adhesion to base concrete, oxidation of filler particles, incorrect mixing and application techniques, acid damage at interface, mechanical damage, electrical resistance may increase
Conductive ceramics and fibre-glass	Discrete surface mounted tiles	N/A	10	<5 mA/anode	40	May not have suitable aesthetic qualities or be particularly useful for larger areas	Acid damage to grout at interface, poor DC connection details. May suffer from uneven wear and output rates, high circuit resistance.
	Discrete ceramic rods	Pt/Ti wires	+25	<8 mA/anode	60	Useful for small areas or for additional protection to high steel density areas. Useful for ICCP to steel deep in the structure, not suited for larger flat slabs and walls. Not for congested steel areas	New product - gas blocking unless gas irrigation system is used
Iron-based alloys	High silicon iron anodes (FeSiCr) magnetite anodes	N/A	10-15	2-5 A/anode	150 Ea	Useful as land groundbeds for buried structures	Self-corrosion, high consumption and uneven wear rates, brittle anodes, DC positive connections can be problematic
Conductive polymeric wire	Wire and overlay	N/A	5-10	<10	50	Useful for flat areas of lightly reinforced concrete with steady dryish conditions, not suitable for running water conditions. Adds dead load to structure	Uneven wear rates, mechanical damage to polymer may result in accelerated corrosion of the copper-cored cable. Oxidation, chlorination and acid damage to coating

preparing this section, assistance and co-operation of the major anode manufacturers was sought and in most cases received.

#### 4.4.1 Materials

In cathodic protection systems for pipelines, buried or submerged structures, almost any metallic or conductive material can be used as an anode in theory. Some materials are more useful than others, however. Scrap iron or steel can be used for short periods but, because of their high consumption rate, large quantities are required for actual installations. Old railway lines etc. can be used. For most reinforced concrete structures, however, it would be totally impractical to consider such anode materials and, consequently, the range of suitable anode materials is severely restricted. As with many other aspects of the modern world, the use of composite materials, where a number of material types are mixed to compensate for inadequacies in performance characteristics of some, is common. There is virtually no single component material capable of performing the task of an ICCP anode system for reinforced concrete on its own because of the intricate and complicated requirements. The anode must be capable of:

- being fabricated to a range of sizes and shapes;
- being connected to a copper-cored (or similar) cable—(DC positive connection);
- being applied or installed on site to a reinforced concrete structure without damage;
- passing the required cathodic protection current over its working life;
- being maintained, repaired and replaced during and at the end of its working life; fe;
- not damaging other components;
- not producing unsuitable health and safety problems;
- being visually acceptable.

Single component materials (Warne, 1986) capable of being made into practical anodes are:

- carbon; spherical, graphite and films;
- aluminium; spray-applied coatings, alloys and plates;
- nickel; spray-applied coatings, alloys and plates;
- zinc; spray-applied coatings, alloys and plates.

Composite materials are used to overcome deficiencies in the performance of single component materials when used as an anode. These can be coatings applied to base materials for example, where the base materials are able to distribute the current and

provide the mechanical strength and shape of the anode, while the coating is able to transfer the current to the concrete. The base materials are often unable to pass current to the concrete without a catalytic coating but which allow the composite anode to retain its strength. Such anode materials include:

- platinum, plated or clad onto titanium or niobium substrates;
- precious metal oxide coated onto titanium or niobium substrates, e.g. ruthenium or iridium oxides;
- composite materials as above incorporated onto copper-cored cables for improved electrical distribution properties.

Mixed material composites can also be used where conditions demand that the composite materials require additional characteristics. The anode materials can be combined with other materials which are not able to conduct the electrical current on their own but which provide the spreading or dispersant properties required for application, often to large areas. These materials include:

- paint binders and coatings which, when heavily filled with carbon materials, are able to be applied as a coating and when dry or cured, can distribute the current by virtue of carbon-to-carbon contact;
- plastics and polymers which, when heavily filled, can produce a conductive plastic or polymer; these can be coated onto a copper or other metallic core for electrical distribution purposes; the electrical flow is from the metallic core to the conductive plastic or polymer which is in intimate contact with the concrete;
- Asphalts, resins or bitumens which can be heavily filled and can be cast in a saw-cut slot around a titanium strip, rod or tube primary anode current feeder;
- cementitious materials which can be heavily filled with conductive powders and, more recently, metal-coated carbon fibres; the cementitious material provides the mechanical strength and a protective function while the filler allows electrical conductivity;
- conductive ceramics often in rod or plate form.

For anodes buried in soil, mud, seabed or immersed in water, the DC positive connections are usually made directly to the anode itself or sometimes by way of a cable ring main system for electrical redundancy purposes.

With cathodic protection systems for reinforced concrete the geometric arrangement and layout of the anodes is invariably more complicated than for a land- or sea-based groundbed system and it is usual for these anode systems to be installed as independent components with all electrical connections and fixings being made on site at the time of installation. Because of the number and physical differences of the components which make up a cathodic protection system, it is important to design the ICCP system from an installation, as well as theoretical performance, point of

view. In most ICCP systems for reinforced concrete, the anode system is made up from composite materials.

#### 4.4.2 Primary anodes

Primary anodes are required by most ICCP systems for reinforced concrete. They permit site connection to the DC positive cables and distribute the current to the secondary anode. The design and type of primary anode, spacing and frequency is dependent on the secondary anode system used.

##### 4.4.2.1

##### *Platinized titanium or niobium wires*

These are one of the most commonly used primary anodes at present. They can be used as primary anodes for conductive coatings, titanium meshes and titanium strip anodes. They are usually a very thin, <5mm, platinum or mixed metal oxide coating onto a niobium coated coppercored wire or a thin platinum coating onto a solid titanium wire. They can vary in overall diameter from 0.8mm to 10mm or more. For most cathodic protection systems the smaller diameter wires appear to be suitable.

Electrical connection to platinized titanium or niobium wires can be achieved by in-line crimp connection between the DC positive cable and the primary anode wire with the connection enclosed within mastic-filled heat-shrink sleeving. If possible DC positive to primary anode connections should not be buried or inaccessible. For mesh and strip anode systems the DC cable connection can be made to a short length (80mm) of primary anode wire in a similar fashion. The short length of primary anode wire can then be site-welded (spot-welded) to the mesh or conductor strip distributor at the appropriate spacings. The design of electrical connection spacings is dependent on a number of factors including the output current density required, the type of secondary anode, the design life, the local environmental conditions, the steel density and total surface area, the geometric layout of the structure, the importance of the structure and the DC positive cable layout.

Most primary anodes are either encapsulated within, or welded to, the secondary anode (see [Table 4.1](#)). They are usually applied before a conductive coating or cementitious overlay but after a mesh or strip anode system.

##### 4.4.2.2

##### *Platinized, mixed metal-oxide-coated titanium and brass or stainless-steel plates*

These primary anodes are not used regularly because of aesthetic reasons. The plates are normally glued onto the concrete surface and connected into the DC positive

electrical system, The secondary anode is then applied directly onto the plates as part of the system. The size, spacing and layout of the plates is dependent on the nature of the secondary anodes, as well as the factors discussed above. For metallized spray anodes (zinc, nickel or titanium metals), brass or stainless-steel studs are attached to the plates in order to distribute the DC power to the anode.

#### 4.4.2.3

##### *Titanium wires and strips*

Titanium wire or strip (uncoated) can be used as the primary anode for mixed metal-oxide-coated titanium mesh anode systems as it can be site-welded. The strips are usually 10–15 mm in width and 0.5–0.9 mm in thickness and can be spot-welded directly to the mesh secondary anode. They are also useful for interconnecting mesh panels and for electrically connecting two or more layers of mesh for localized increase in anode current density. Such strips have an electrical resistance of between 0.04 and 0.11  $\Omega$ /m (Eltech Systems Corporation, 1990) and can be used to assist with current distribution along a length of mesh. As they are uncoated, they form a strong oxide surface layer in service and provided the applied voltage does not exceed the threshold voltage (usually regarded as  $<12V$ ), this oxide layer remains intact, preventing current loss or damage to the titanium wire or strip.

Site connections to the DC positive cables can be made by an encapsulated in-line crimp to a short length of titanium wire which is then spot-welded to the titanium strip or wire primary anode.

These primary anodes can also be catalytically coated and can be used as secondary anodes in saw-cut slots or embedded within a cementitious overlay as a stand-alone anode system.

#### 4.4.2.4

##### *Carbon-fibre tapes*

Woven carbon-fibre tapes can be used as primary anodes for conductive coating anode systems. The nature and shape of the carbon-fibre tapes makes them suitable for application to uneven surfaces. Site connections are not as easy to perform and require a degree of skill. In addition, the electrical resistance is substantially higher along their length than metal primary anodes, so more frequent connections are required. They must also be placed onto an epoxy or similar bedding material to prevent current dumping to the concrete. The conductive coating anode should be applied directly onto the carbon-fibre tape allowing electrical transfer from the primary anodes directly to the coating film.

Carbon-fibre tapes are produced as long carbon films interwoven with glass fibre to retain the thickness and weight dimensions. Various thicknesses are available ranging from 0.25 to 0.4mm.

Tapes 25 mm wide have been used successfully as primary anodes for cathodic protection systems in the UK.

The use of carbon-fibre primary anodes does provide distinct installation advantages over titanium or niobium wires which are exceedingly 'springy' and require a great deal of care in fixing to uneven concrete surfaces.

### 4.4.3

#### Surface-mounted anodes

As their title suggests, surface mounted anodes are those placed onto the surface of the concrete and these are probably the most widely used single anode type at present. To achieve adequate current transfer, an intimate electrical contact between the anode and the concrete is essential. This requires a degree of surface preparation and the selection of suitable fixing methods. Access to all the concrete surface area is required to install such anodes effectively.

#### 4.4.3.1

##### *Conductive coatings*

The most widely used secondary anode materials to date are conductive coatings. There are a number of proprietary manufacturers of these materials and new manufacturers and suppliers are appearing. Conductive coatings are heavily filled, water-based or solvent-based proprietary paint coatings developed specifically for cathodic protection of reinforced concrete. The conductive filler is carbon-based, spherical carbon in some cases, graphite fibres in others.

The coatings are usually applied by roller, brush or spray to provide a dry film thickness of between 250 µm and 500 µm onto correctly prepared surfaces. The basic application sequence is as follows:

- Prepare surface by dry or wet blast-cleaning to remove all foreign matter, laitance, old paint or other surface contaminants.
- Place primary anodes at design pitch and spacings. Primary anodes may be applied to a non-conductive bedding or may be embedded within the paint coating. A non-reactive scrim tape is sometimes used to hold the primary anode in place.
- Apply adhesion promoter (this may not be used on all proprietary systems and is becoming less widely used).
- Apply one or more coats of the conductive anode material to achieve the manufacturer's recommended dry film thickness. Overcoating times must be adhered to.
- Allow to cure/dry and apply decorative top coat, if applicable.

All conductive coating anodes are, to date, black by virtue of their carbon filling, hence they are usually overcoated with a decorative, compatible top coat. As they are also heavily filled, dispersion of the filler within the coating during application is very important and a paddle mixer/agitator must be used continuously.

A conductive coating material can generally provide current at up to 20mA/m<sup>2</sup> and should have a major maintenance-free service life of at least ten years.

The conductive coating must adhere firmly to the concrete surface and an intimate contact along the length of the primary anode and the conductive coating is essential. The main function of the conductive coating material is to distribute the current over the surface to which it is applied. The conductive coating must have a low-volume electrical resistivity, typically <10<sup>6</sup>.cm. Another way of expressing the electrical resistance is as a sheet resistance or film resistance which can be determined as follows:

Sheet resistance is

$$\Omega / \text{square} = \frac{\text{Volume resistivity } (\Omega \cdot \text{cm}) \times 10\,000}{\text{Wet film thickness (mm)} \times \text{solids content (\%)}} \quad (\text{Eq. 4.3})$$

A conductive coating should generally have a fully dry sheet resistance less than 40 / square and a minimum dry film thickness of 250–500 μm, although this will vary between manufacturers and products.

The conductive coating should also be resistant to weathering and, in particular, the electrical resistivity should not alter appreciably after weathering. To test this, manufacturers subject coated samples to quantitative ultra violet (QUV) weatherometer machines with tests on electrical resistivity before and after exposure. The coating should have good adhesion properties. Specifications often call for ‘pull-off’ tests to be carried out on actual installations with results in excess of 0.5 MPa often specified.

The conductive coatings must be resistant to damage from acids, oxidation, alkalis and chlorination. They should also be able to withstand, and not promote, bacterial attack and mould growth.

Solvent and water-based conductive coatings are generally formulated to be applied by brush, roller or airless spray. In order to achieve these application requirements, the anode paints must have carefully designed viscosity properties (PermaRock Products Ltd, 1992). Under conditions of high shear stress, such as when the paint is being stirred prior to application, or when the paint is being brushed onto the surface or is passing through the spray gun nozzle, the paint must have a low viscosity so that it flows readily. As soon as the paint has been painted out or sprayed onto the concrete surface, and this is of particular importance on vertical surfaces and soffits, the paint must regain its structure and achieve a sufficiently high viscosity to remain on the surface and not run. In addition, the freshly applied coating should not suffer from sagging and should flow sufficiently to smooth out any brushmarks etc.

The incorporation of rheology modifiers into the formulation allows these properties to be achieved.

At low temperatures water is slow to evaporate and drying times can become quite protracted. Freezing can create serious problems—as the water content freezes, it expands and causes cracking of the film. Also, low temperatures can prevent or severely restrict the process of coalescence. Coalescence is the process whereby the polymer particles (submicron spheres) move closer and closer together, eventually fusing into a coherent, continuous film which binds the conductive (or otherwise) pigment together. Coalescence is accelerated by an increase in the rate of water evaporation from the wet coating and is strongly influenced by the incorporation of coalescing solvents, which assist in bringing the polymer particles together. Coalescing solvents themselves must eventually evaporate from the coating.

In conditions of high humidity, water loss from a wet coating film can be a slow process. In inadequately formulated coatings, a 'skin' can form on the coating surface. This skin is effectively a semi-dry coating film which restricts the further loss of water from the remainder of the wet paint film. Thus, in humid conditions, particularly where skin formation is encouraged by relatively high temperatures, the coating will not dry. To overcome this problem, a humectant—a solvent which maintains the surface of the paint film in a 'water-vapour-open' state, allowing the further loss of water vapour from the wet paint film to occur—can be incorporated. The humectant remains in the coating long enough for complete evaporation of the water and then slowly evaporates away itself.

In order to produce pigmented coatings, dispersing agents are required to support the pigment particles in the aqueous phase. After complete evaporation of the water and any solvents from the coating, these dispersants and surfactants can remain in the dry film for some considerable time.

Since these materials are hygroscopic, there is a tendency for dry, water-based paint films to be sensitive to water and humidity. The coatings abstract water from their surroundings (atmosphere and substrate) and swell to varying degrees, introducing tensile stresses which can lead to disbondment etc. Eventually, the water-solubles will be leached out of the coating so that all that should remain is a polymer film containing pigment particles and voids.

Current output from conductive coating anodes is greatly affected by varying moisture contents within the concrete and the anodes are over-coated with a decorative and protective coloured top coat in most cases. This top coat must be vapour permeable to allow diffusion of gases produced during the anodic reactions. The top coat must adhere firmly to the conductive anode coating and should be applied at sufficient thickness to hide and cover the anode totally, generally  $>70\mu\text{m}$ , again dependent on the manufacturer and product. Care must be taken to ensure that the anode coating is adequately cured or dried before applying the top coat.

#### 4.4.3.2

##### *Conductive polymer-modified cementitious mortar*

This anode system comprises highly conductive metal coated carbon fibres distributed throughout a polymer-modified cementitious mortar. The electro-catalytic coating on the fibres exhibits very low consumption rates and the anode interfacial reactions are distributed uniformly throughout the thickness of the mortar layer which increases its service life (Thoro System Products Ltd, 1994).

The material is supplied as two components (one dry and one wet) which are mixed on site and applied directly onto the fully prepared concrete surface. The anode is designed to be applied using wet spray application methods to a uniform dry film thickness of between 4 and 8 mm.

The material should be allowed to cure by itself but under poor curing conditions, i.e. rain, wind, cold or very hot conditions, additional curing measures may be needed.

It is claimed that the cured material, under normal conditions has a volume resistivity less than 10  $\Omega\cdot\text{cm}$  (Thoro System Products Ltd, 1994) and can provide an output current density of up to 50 mA/m<sup>2</sup> with shortterm excursions to 200 mA/m<sup>2</sup> although this would not be recommended in most circumstances.

Primary anodes are required to distribute the cathodic protection current to the conductive mortar. Coated titanium or niobium wire and ribbon primary anodes with a maximum of 2m spacings between them have been used successfully.

#### 4.4.3.3

##### *Metal spray coatings*

A number of cathodic protection systems, particularly in North America, have used metal spray coatings (aluminium, zinc and nickel predominantly and more recently titanium) as the anode material. Catalysts may be required to assist current transfer.

To achieve electrical connection between the DC positive cables and the anode, primary anodes are required. The earlier primary anodes were brass or copper stud plates fixed to the concrete surface using an epoxy bedding layer which acted as an electrical barrier to prevent current dumping and consumption of the plates. The metallized spray was applied directly onto the stud plate primary anode and the abrasively blast-cleaned concrete surfaces.

Of the metallized coatings tried, zinc proved to have the best adhesion characteristics and appears to be the most appropriate metallized anode material. A number of important bridges were protected using a metallized zinc spray-applied coating as the anode (Apostolos *et al.*, 1987).

Metallizing is a technique which utilizes a metal or metal alloy in the form of a wire or powder, melting it into a liquid form, which is then sprayed onto the surface by compressed air. Flame spray is a method using a hand-held gun through which feeds a

metal wire. The wire is melted by an oxygen acetylene gas flame and blown onto the concrete surface by compressed air where it solidifies into a continuous metallized film.

Another method, called the arc-spray process, passes two metal wires through a gun. Each wire is charged with the opposite polarity of a high DC output. At the point of convergence the two wires contact each other and melt. This molten metal is then blown onto the concrete surface by compressed air to form a continuous metallized film.

The output from either of the processes can be controlled so that a film of a specific thickness can be developed. For ICCP of reinforced concrete the thickness would be in the order of 200–400mm for a 10–15-year design life.

It has been reported that the metallized zinc forms a dull grey layer not unlike the normal concrete appearance.

One of the drawbacks of the metallized process is the health and safety aspect. Special ventilation equipment is required while the zinc material is being applied. This should not, however, be a major problem and although the use of metallized anodes for ICCP of reinforced concrete is not widely used in the UK, it should be considered as an alternative to conductive coatings and conductive mortars.

Consumption of zinc during service is calculated theoretically at 10.9kg/A year. So, at 10mA/m<sup>2</sup> output current density, a 200mm layer should theoretically provide 13.5 years service life. This system does not have an extensive track record in UK and consequently the long-term performance of such systems is not known. There have been some queries raised on zinc/concrete interface chemical changes resulting in the requirement for higher driving voltages.

#### 4.4.3.4

##### *Other surface-mounted anode systems*

Various other surface-mounted anode systems have been tried with varying degrees of success. Most surface-mounted systems fail due to difficulty in making adequate DC positive electrical connections, increases in circuit resistance or for aesthetic reasons. If the cathodic protection system is to be applied to out-of-sight structures, then ‘bolt-on’ type systems can be acceptable but for most applications the sight of plates of material with electrical connections between them is not appealing. For completeness, however, a few of the more successful surface-mounted anode systems are discussed here.

##### *(a) Conductive ceramic tiles*

A few manufacturers have developed conductive ceramic tiles which can be mounted onto the concrete surface with titanium fixing screws and an acid resistant grout.

Current distribution is achieved by ‘stringing’ together an array of these ceramic tiles using a titanium strip or rod interconnecting the fixing screws to make the electrical contact. Tiles of approximately 50 mm×50 mm×5 mm in size have been tested in field trials but with limited success. The aesthetics of the structure fitted with such a system also has to be considered.

*(b) Zinc plates*

A system based on ‘bolt-on’ zinc plates has been trialled in Japan (Shunichiro, 1990). Large zinc plates were anchor-bolted to the prepared concrete surface and connected to a DC power supply. The joints between the plates were grouted with a special acid-resistant grout material. The ultimate success, or otherwise, of this system has not been fully established but it is suspected that the difficulty of installing large zinc sheets, the aesthetics of the installation and the resulting barrier to escaping anode-produced gases, may limit its applications.

*(c) Conductive fibre-glass tiles*

These are similar in application to the conductive ceramic tile system discussed above. The conductive fibre-glass tiles can be fabricated as larger units than the ceramic tiles and are considerably lighter but still retain the limitations, i.e. difficult electrical connections and poor aesthetic qualities.

#### 4.4.4

#### Discrete anodes

Discrete anodes have a special place in cathodic protection of reinforced concrete and their use is becoming more and more widely accepted. They can be used by themselves to provide localized protection, distributed to provide a more widespread protection, or together with a surface-mounted or embedded anode system to supplement protection to certain areas or components. They hold some distinct aesthetic advantages but also have some disadvantages from output current density and installation points of view. Because they are embedded into the concrete structures, they can be used to distribute the protection current deeper into the concrete. Whereas surface-mounted or surface-embedded anodes distribute current predominantly to the outer layers of reinforcement steel, discrete anodes can be used to target steel deep within the concrete. They can also be used to target steel on the other side of the structural component when access to the nearest concrete surface is unavailable or difficult.

Another benefit from the use of discrete anodes is that it enables the design engineer to design a cathodic protection system to protect certain components but not others. This is particularly important when a structure comprises both normal and prestressed steel reinforcement, for example.

Cathodic protection systems based on discrete anodes have recently been used for the protection of embedded metals within historic and listed buildings, churches and stone or brick-clad steel-framed buildings. The final ICCP installation can be carried out with minimal visual impact on the structure. Primary anode wires and cabling can be chased into reinforced concrete or pointed up in between bricks or stones.

#### 4.4.4.1

##### *Platinized titanium wire/graphite paste systems*

This proprietary anode system was developed primarily to protect small corrosion problem areas such as columns, beams or brackets or to provide local 'hot-spot' protection (Cathodic Protection International Aps, 1994). These anode types are generally not appropriate for slabs or walls but can be used in conjunction with other anode systems.

The discrete anodes can comprise a length of platinized titanium wire fitted with a bush electrical connection at one end to a cable tail. This connection is made in the factory so it can be properly tested eliminating the requirements for site connection to the anodes. The cable tails can be made to any length, normally sufficient to be taken back to a junction box for connection to the DC positive cable ring main or header cable.

As the platinized titanium wires are small-diameter (<3mm), they are normally used in conjunction with a carbon graphite paste backfill. The backfill has a very low electrical resistivity (<50 $\cdot$ .cm) and is used to fill a hole some 12mm in diameter drilled to the designed depth. The platinized titanium anode is then pushed into the graphite paste which is allowed to dry out. The graphite paste is a mixture of water, graphite and binding agents, formulated in different ratios for various applications. To promote adhesion to the perimeter of the drilled hole, a primer paste can be used after cleaning out of the hole. Such an anode system can provide a current density of up to 0.25 mA/cm of anode length.

One possible disadvantage of the discrete anode system is with the drilling of the hole, particularly in steel-congested concrete. Great care must be taken to ensure that the anode is embedded into the concrete only and it does not make electrical contact with the steel. Special precautions, including the use of a purpose-built hole covermeter placed within the drilled holes should be carried out prior to insertion of the graphite paste and anodes.

An array of these anodes to varying depths and drilling orientations can be used to provide the design current output to even the most difficult steel areas.

#### 4.4.4.2

##### *Mixed metal-oxide-coated titanium mesh, strip or ribbon and conductive ceramic systems*

Metal-oxide-coated titanium mesh, strip or ribbon can be embedded as discrete anodes within drilled holes which are then filled with a conductive, flowable or pourable, non-shrink grout. The maximum achievable anode output is based on the contact surface area of the anode itself.

Mesh anodes can be rolled up to provide increased surface areas but current outputs are generally restricted.

Filling of the drilled holes must be carried out after insertion of the rolled mesh strip, conductive ceramic or ribbon anode which can be difficult to achieve, particularly in soffits or vertical surfaces. An air-bleed tube is required to drain the air during filling and some 'jiggling' of the anode may be required to remove trapped air.

#### 4.4.4.3

##### *Slotted systems*

Some of the very earliest applications of cathodic protection for reinforced concrete used slotted anode systems. Although they may be regarded as discrete anode systems, their layout in applications such as deck surfaces was intended to distribute the current as uniformly as possible.

Anodes placed in saw-cut slots or chases can also be used to provide additional protection to certain areas such as at the edges of slabs or against walls or intersections where additional current drain is imposed on the anode system from inaccessible steel.

Slotted anode systems using anodes based on carbon-loaded asphalts, resins or other polymers with primary feeder anode wires are only practical for application to the upper deck surface but there are limitations on current outputs and longevity. They may, however, be used in conjunction with other anode systems to provide additional localized current output.

#### 4.4.5

##### **Embeddable surface-mounted anodes**

After surface-mounted conductive coatings, the next most commonly used anode systems for reinforced concrete are embeddable surface-mounted anode systems. The anodes are normally fixed directly to the prepared concrete surface and, after installation of all of the DC negative (steel), DC positive (anode) connections, the monitoring system and cables, they are embedded within a cementitious mortar overlay. This overlay is either cementitious mortar or polymer-modified cementitious

material which can be spray-applied (shotcrete or gunite), hand-applied, poured or cast (within formwork).

By their very nature embeddable surface-mounted anode systems can cover a high percentage of the accessible concrete surface area and can be designed to provide varying current outputs to different areas. Such systems can be applied in virtually any orientation, horizontal, vertical or overhead. The cementitious overlay provides both an electrical path for the ionic current to flow and a degree of mechanical protection to the embedded anode. It does, however, increase the dead weight loading to the structure by some 50–80 kg/m<sup>2</sup>, depending on the overlay thickness.

#### 4.4.5.1

##### *Mixed metal-oxide-coated titanium mesh systems*

These are the most commonly used anode systems in this category and have established for themselves the most successful track record. There are currently only a small number of manufacturers producing such anodes as they are proprietary materials, although it is anticipated that this will change in the future. These anodes were originally developed for the chlorine generation industry where they are capable of passing currents of the order of 1000 A/m<sup>2</sup>. For reinforced concrete the maximum output current density is restricted to 110 mA/m<sup>2</sup> at the anode surface to reduce acidification of the surrounding concrete. Each manufacturer produces a range of materials with differing mesh and wire sizes permitting various current outputs for practical installations, nominally 15mA/m<sup>2</sup>, 25 mA/m<sup>2</sup> or 35 mA/m<sup>2</sup> at the concrete surface.

Mixed metal-oxide-coated titanium mesh can be applied in double or even triple layers but unless the DC current is fed directly to each multiple layer area, it is doubtful that the current output achieved will be doubled or trebled, as may be initially expected. However, it is quite reasonable to place multiple layers to provide overlap in corners or over areas of known higher steel current density to compensate for the additional current drain on the anode at these locations.

The mesh type anodes are particularly suited for application to large concrete surface areas. They are normally supplied in rolls approximately 0.8–1.2m wide and 90–100m long so they can be readily applied to large flat surfaces. They are cut back easily around metallic objects, cut to shape on irregular structures and can be doubled back on themselves. Having a specific surface area of some 0.14/0.2 :1, the chances of electrically contacting a small, exposed tie wire is reduced from that of a total surface area coverage anode such as conductive coating or cementitious overlay.

Mixed metal-oxide-coated titanium mesh anodes are very robust. They are, however, very sharp to handle and can cut hands or cable insulation very easily. Widths of mesh can be interconnected on site by spot-welding to each other, or by spot-welding titanium conductive strips. The mixed-metal-oxide catalytic coating is only a few microns thick but is relatively tough and damage resistant. Tests on applied

mesh anodes have shown that the coating is still relatively intact after application of the spray-applied cementitious mortar. Provided the applied voltage is kept below the threshold ( $<12$  V), the exposed titanium in small areas of coating damage will be protected by the formation of the oxide film under normal operating conditions.

Mixed metal-oxide-coated titanium mesh anodes are fixed to the prepared concrete surface by way of non-metallic cleats or fasteners driven into 5–6 mm diameter, 15–20 mm deep holes at approximately 15–30 fixings per  $\text{m}^2$  depending on orientation.

The mesh wire is approximately 1 mm in diameter and the diamond shaped apertures range in size from approximately  $40\text{mm}\times 25\text{mm}$  to  $60\text{mm}\times 30\text{mm}$ , depending on the anode grade. The shape of the anode, particularly its thickness of approximately 1mm, allows embedment within a thin cementitious overlay.

The mesh can also be used in new structures where it can be cast into the concrete. Care must be taken to ensure that before, during and after casting, the anode remains electrically isolated from the steel. The mixed metal-oxide-coated mesh is unaffected by concrete and can remain unpowered for many years. This is important for new construction where the anode is cast into the concrete during manufacture but may not be powered up for a number of years.

Mixed metal-oxide-coated titanium mesh anodes have developed a successful track record with applications in excess of ten years. Operational life in excess of 25 years are anticipated if the ICCP systems are installed and operated correctly.

#### 4.4.5.2

##### *Catalysed titanium strip*

Catalysed titanium strips similar to the primary anode current distributors discussed previously can be used as an embeddable anode system. To retain them in place they can be fixed to the concrete surface with special fasteners or they can be grouted into saw-cut slots or embedded within a cementitious overlay.

Such anode systems are able to pass approximately 2–3mA per linear metre so the spacing between the runs of the anode strips will determine the maximum output current density achievable over an area.

#### 4.4.5.3

##### *Metal-oxide-coated titanium ribbons*

To overcome the potential problem of overlay disbondment using solid conductor strips, a coated perforated mesh ribbon anode has been developed which is able to pass up to 5mA per linear metre but which is embeddable within the cementitious overlay. In effect, the ribbon is a very dense mesh approximately 20mm in width, 1mm in thickness. It can be used as an anode by itself but its more common use is at the edges of a mesh anode systems where additional current drain is anticipated.

Perimeter layers of ribbon, spot-welded to the mesh, can be used to satisfy additional current demand without exceeding the  $110\text{mA}/\text{m}^2$  output limitation at the anode surface. face.

Generally, a distributed anode system based specifically on catalytically coated ribbon would probably not be economical when compared to the cost of a mixed metal-oxide-coated titanium mesh system.

#### 4.4.5.4

##### *Conductive polymeric wires*

Some of the earlier distributed anode systems were based on conductive polymeric wires fixed to the prepared concrete surface embedded within cementitious overlays. The wires were some 6–8 mm in diameter consisting of a stranded copper core around which was cast a heavily carbon-filled polymer. Because of the larger diameter of the wire, a rather thick layer of overlay was required for embedment, up to 40mm. The wire was laid in a regular geometric pattern with minimum radiused bends of approximately 200 mm.

The systems appear to have been quite successful in some applications but less so in others. In recent years the recommended DC output current density for these anode systems has been reduced to  $50\text{mA}/\text{m}^2$  anode surface area and the number of strands per unit area has been limited to improve embedment characteristics. This has, in effect, made the use of such a system almost impractical for anything but the lightest reinforced concrete structures. One of the inherent weaknesses of the system was the difficulty in achieving a uniform current distribution through its length as the 'feeders' to the anode were essentially only to each end of any length. Electrically conductive cleats to improve current distribution were added but the feeder was still only at each end. Any mechanical damage to the polymer can expose the copper core which can result in accelerated corrosion of the copper in contact with the cementitious overlay, and premature failure.

#### 4.4.5.5

##### *Cementitious overlay materials*

Cementitious overlay materials for embedment of surface-mounted anode systems must themselves have specific performance characteristics. They must be able to accept and transfer the ICCP current from the embedded anode to the base concrete. They must also provide a protective function by physically preventing anode damage. They must be capable of adequate adhesion to the base concrete and should not delaminate, shrink or crack to an unacceptable degree during their service life.

The cementitious overlay materials are usually in two types—non-modified (sand/cement/aggregate mixes) and modified (latex, epoxy, acrylic, SBR or other modifying agents).

To pass the ICCP current, overlays should be sufficiently conductive after curing. Electrical resistivity greater than 100k $\Omega$ -cm may be problematic. This restricts the level and the materials permissible. Modifying agents are added to improve other characteristics, in particular, adhesion of the overlay to the base concrete. Because of the restrictions on electrical conductivity, most epoxy-based, modified overlays would be considered unsuitable. Successful polymer-modified cementitious overlays for ICCP are acrylic and styrene butadiene rubber (SBR) modified.

Some experimentation has been carried out to include salts to improve electrical conductivity.

It is generally accepted that the pull-off strength (an indication of the adhesion characteristics) between the overlay and the base concrete should be in excess of 1MPa although some specifications use 0.7MPa as the pass/fail criterion. The overlay, when cured, should be relatively uniform, compact and dense and must completely envelop the embedded anode.

There has been a great deal of debate on the necessity for float finishing the overlay to improve the aesthetic qualities of the installation. It is the author's opinion that unless the finish is critical to the installation, the least amount of working of the overlay, the better—mainly from an adhesion viewpoint.

Most cementitious overlay materials, other than the traditional gunite, are proprietary mixes with specific mixing ratios, water contents, shelf and pot life etc.

For most surface-mounted anode systems the overlays are either applied in thick layers (25–40 mm) tending to be gunite or shotcrete or thin layers (15–25 mm) tending to be proprietary mortars. The additional dead weight loading is an important consideration.

Poured and flowable grouts placed within formwork can be used in certain applications although the surface finish is generally smooth. The formwork and compaction required does add to the cost of the installation. It is useful for immersed or semi-immersed reinforced concrete structures.

#### 4.4.6

#### **Anodes for submerged and buried structures**

For submerged and buried structures other methods of applying ICCP can sometimes be used, for example, placing the anodes in the surrounding electrolyte remote from the structure. This has advantages and limitations.

The main advantage is that the anodes are able to distribute the current in a more uniform manner provided the steel reinforcement within the structure can 'see' the anode. The current can be made to flow into and through the electrolyte (water, soil or seabed) and then via the concrete to the steel. The anodes can be semi-consumable as the electrolyte in these situations is able to follow the changing shape of an anode as it is consumed, particularly in water.

The disadvantage of such an arrangement is that the corrosion control current cannot be targeted towards any particular component or steel area, and any barriers in the way, such as coatings on the concrete, water-proof membranes or tanking, will severely restrict cathodic protection of the steel. It is also difficult to prevent stray current interference on other buried or submerged structures within the vicinity with this anode system arrangement and it may be necessary to introduce remote metallic components into the ICCP system which will increase the demands on the anodes and the DC power supply.

A number of submerged and buried reinforced concrete structures have, however, been successfully and economically protected using remote anode systems.

For buried or submerged reinforced concrete structures the use of remote anodes should always be considered at the initial design stage as they can often be cost-effective but care should be exercised when designing the ICCP system to ensure that all metallic components are included in the design calculations. Other metallic components could include electrical grounding systems and pipework, for example.

#### 4.4.6.1

##### *Groundbeds*

In soils, anodes are often installed as groundbeds rather than as individual anodes. Groundbeds may be long horizontal or vertical trenches comprising a number of individual anodes, they may be deep wells or a distributed array of discrete anodes. In many cases, high silicon iron (FeSiCr) anodes in the form of solid rods or tubes can be used. These anodes are often packed within a carbonaceous backfill to increase the contact surface area between the anode and the soil. Design of groundbeds follows traditional design formulae, depending on the soil type and anode distribution pattern. In suitable soils, anodes can be placed many metres away from the structure to be protected.

Recently, mixed metal-oxide-coated titanium mesh, ribbon and strip anodes in carbonaceous backfills have also been used. They are considerably lighter than FeSiCr materials. The long-term value of the anode in this type of installation is not yet established, however. Discrete anodes are generally 1–2 m in length and approximately 50–75 mm in diameter and can each pass between 2 and 5 A, depending on soil conditions.

#### 4.4.6.2

##### *Consumable anodes*

Most anodes are consumable to a certain degree. Anodes made from scrap iron, for example, are completely consumable and suffer significantly from self-corrosion during their operational life. Others, such as FeSiCr and graphite, are semi-

consumable and are less susceptible to self-corrosion. Mixed metal-oxide-coated mesh, ribbon and strip anodes are almost non-consumable.

When designing anode systems, the degree of anticipated consumption has to be taken into account. This is usually achieved by employing an efficiency factor. During service, an anode may be consumed irregularly. If wasting were to occur just below the DC positive connection, for example, the anode may be rendered useless even though the bulk of the material is still present.

This does not mean that consumable anodes have no place—in fact their use may well be cost-effective in some cases. At the end of their life the groundbeds can be replaced. A knowledgeable estimate of their efficiency should be included into the ICCP design.

#### 4.4.6.3

##### *Non-consumable anodes*

Catalytically coated mesh, ribbons or strips and even platinized titanium or niobium anodes can be used in groundbeds. Again, these are usually placed in carbonaceous backfills with bulk resistance  $<50\text{W-cm}$  to increase the contact surface area. They have advantages from handling, transport and installation points of view as they are significantly lighter and less brittle than traditional FeSiCr anodes. They are, however, also less massive and so intimate contact with the carbonaceous backfill is more important for uniform current distribution.

Platinized and catalytically coated titanium anodes have been used successfully in sea-water applications where anodes can pass up to 5A even with very low ( $<8\text{V}$ ) impressed DC voltages. A number of important reinforced concrete structures, such as sea-water pump stations, pump houses and other facilities have been successfully protected using ICCP systems with catalytically coated titanium anodes.

#### 4.4.6.4

##### *Sacrificial anodes*

The throwing power of most commonly used sacrificial anode materials such as zinc, aluminium or magnesium alloys is very limited except in sea-water or very saline ground water conditions and so the use of sacrificial anodes is generally restricted to submerged reinforced concrete structures.

Sacrificial anodes based on aluminium or zinc alloys can be connected directly to the reinforcement steel in submerged conditions. The amount of anode material required is dependent on the amount of steel, the rate of flow and oxygen content of the water, the design life of the system and the depth of the structure.

Recently, attempts have been made to provide sacrificial anode cathodic protection (SACP) to the tidal or splash zones in submerged structures, an area where it is most

often needed. For these areas, an SACP system using surface-mounted or discrete anodes should be considered, possibly in conjunction with an ICCP system.

Aluminium or zinc alloy anodes are manufactured as proprietary products and can be cast virtually to any shape. The most efficient shape, however, for submerged reinforced concrete structures is probably long, slender 'D' sections as these provide the least electrical resistance between the anode and the electrolyte.

#### 4.4.7

#### **Selection of anode type and materials**

The selection of the anode type and materials is probably the most important single decision to be made in a particular ICCP design. The choice of anode types and materials is ever-increasing and manufacturers are continuing to develop new systems. The ICCP designer should consider both the technical and economic implications of the system before making final decisions.

##### 4.4.7.1

##### *Technical considerations*

##### *(a) Design criteria for anodes*

The designer must first decide what anode system is to be used, whether this be discrete embedded anodes, sprayed metal coating, conductive paint coating or embedded mesh systems, for example. This decision would be based on the nature of the structure, the design life of the ICCP system and, more often than not, the owner/client requirements.

Other technical aspects to be considered are; the design life, the dead weight loading, the aesthetics of the structure, the general layout of the proposed anode systems, the layout of the associated cabling, monitoring system and the method of making DC positive and DC negative connections.

##### *(b) Performance and operating characteristics*

For surface-mounted anode systems, the designer must first calculate the current density per square metre required from the anode. This is the steel surface area to be protected divided by the available concrete surface area in the immediate vicinity multiplied by the design current demand at the steel surface. For atmospherically exposed concrete, the current demand is generally 5–20mA/m<sup>2</sup> of steel surface area. This will provide the basis for anode selection. The design of the anode type must also consider the arrangement of the reinforcement steel, for example, whether only the outer layer is to receive protection. An 'allowance' for current distribution to second and third layers of steel may be required. One approach is to assume a split, say 70%

of the current is distributed to the outer layer, 20% to the second layer and 10% to the third layer etc.

Once the type of anode system is selected, it becomes necessary to check that the selected anode system is capable of performing its function.

For embedded discrete anodes, the number, depth and arrangement of the anodes would be determined from the surface area of reinforcement steel each anode would be targeting multiplied by the current demand.

Table 4.1 provides anticipated anode operating parameters for the more commonly used reinforced concrete ICCP anodes operating under normal conditions.

*(c) Aesthetics*

The aesthetics of the ICCP anode system must be taken into consideration. With the new materials and compatible top coats currently available, a good design can 'hide' the anode. If this is important, it must be considered.

*(d) Practical installation considerations*

The selected anode type and material must be suitable for the job. It must be capable of being installed on site without undue damage. It must be reasonably practical to install and capable of performing its function. It would be of little use to install a soft conductive coating on a car park wearing deck surface, for instance—it is not normally practical to require a significant chasing out of concrete to install slotted anodes on a slab soffit. Whichever anode type is chosen, site DC positive connections are required. These must be planned as they are a critical installation item with a high risk of failure. They should not be buried within the concrete, if possible.

It should also be noted that saw-cut chases can introduce cracks and places of weakness, particularly in slabs.

*(e) Limitations*

Besides the restrictions on current output, each anode type, shape and material has its limitations—some more important than others. Most of the limitations relate to service life, lack of resistance to acidic conditions, production difficulties, current distribution properties associated with varying environmental conditions and difficulty with site installation.

Some anode systems, for example mesh/overlay systems or slotted anode systems, can in some cases be used as a wearing trafficked surface while others cannot. Problems associated with differential thermal expansion and contraction may render some anode materials inappropriate. Some anodes may not be physically capable of bridging 'live' cracks while others can. All these aspects need to be considered when selecting the anode system.

#### 4.4.7.2

##### *Economic considerations*

The economic considerations will always affect the selection of anode type. Installed ICCP costs for reinforced concrete structures, at 1996 costs, in the UK, following reinstatement of damaged concrete, and exclusive of sophisticated monitoring systems, are estimated to range from approximately £85/m<sup>2</sup> for conductive coating type anodes to £125/m<sup>2</sup> for mesh/overlay systems. The degree of control, monitoring and operation will greatly affect costs. The choice of anode will often, therefore, be dictated not only by technical, but also by economic factors.

##### *(a) Life-cycle costs*

The difficulty with providing life-cycle costs for various anode systems for reinforced concrete emanates from the lack of actual track records of such systems. Conductive coating and metallized anode systems have been in operation for some 15 years and mesh/overlay systems for some ten years. Anticipated projections, based on records to date and expected performance, can be produced, however.

Table 4.1 lists the anticipated design service life (the time before major maintenance of the anodes is required) for the more commonly used anode systems. These are anticipated and have not all yet been proven so are provided for indicative comparative purposes only. Major maintenance is deemed to entail substantial renewal and/or replacement of the anode system and possibly the DC positive cables and connections.

##### *(b) Maintenance*

Most anode systems would be designed so that no major maintenance is required during its service life. However, it is possible that some physical damage could occur resulting in small area damage. Regular inspection is strongly recommended. Some maintenance may be required to repair small damaged areas or small areas of overlay disbondment, for example. Metallic components such as pipework, conduit, fixings, brackets, stairways etc. must not be attached to the anode surface. This could result in short-circuiting of the ICCP system which would severely affect its performance. The owner/operator of the structure must be made aware of this requirement.

##### *(c) Replacement*

At the end of the service life the anode systems would normally be replaced. Depending on the anode wear rate, only certain areas of the anode may require replacement or, in some cases, the entire anode may have to be renewed.

Replacement would generally entail removal of the existing anode, re-preparation of the surface profile, replacement of the anode system and reconnection of the DC positive connections. For discrete anode systems it may be more economical to leave

the existing anodes in place and install new anodes alongside them using the existing DC positive cabling.

*(d) Salvage value*

In general, anode systems for reinforced concrete would have little salvage value at the end of their design life.

## 4.5

### THE FUTURE

There is still a necessity for anode manufacturers and developers to produce more durable, cheaper anodes with improved performance characteristics and which are easier to install on site. The ultimate performance of single component anode materials appears to have been reached and it is likely that the development of new, comparable or even multi-composite anodes will be the way forward.

Saying this, however, there are many anode types (including composites) currently available which are able to perform better than their required output levels. The problems associated with acid generation, for example, manifests itself in the concrete or cementitious overlay covering the anode. The anode itself is not always the problem.

One of the more obvious future development directions in the case of embedded, surface-mounted anode systems is to improve the quality and performance characteristics of the cementitious overlay or surround. The surrounding overlay or embedment material must be made less susceptible to damage from acid generation and disbondment. They should be made more electrically conductive and their adhesion characteristics should be improved where possible.

The fixing arrangements for commonly used mesh systems are still cumbersome and time-consuming to install, often requiring significant access. Better fixing arrangements would go a long way to making the mesh/overlay systems more attractive from an installation point of view.

Conductive coatings also require further development work. The long-term ability for coatings to distribute current throughout its film is not yet fully established. Increasing circuit resistances on some projects have indicated that the performance of some of these coatings may not be fully understood and resolved yet. Coatings cannot, at present, be applied when the ambient temperature is below 5°C or when the temperature is near the dew point. If this could be overcome then the application of conductive coatings during the autumn, winter and early spring would become a much more attractive proposition.

Another drawback with conductive coatings is the relationship between the primary anodes and the coating film. It may be possible to introduce a second level of current distributors within the coating to provide a better current distribution network.

Modern DC power supplies developed specifically for ICCP of reinforced concrete structures have been dramatically improved in terms of providing cleaner DC outputs, but at a cost. Anode systems that are less prone to damage from AC ripple, electrical surges or even total incorrect connection, may help to reduce the DC power source specifications which may prove cost-effective for certain installations.

A number of anodes, although very effective from a performance viewpoint, cannot realistically be used because of their inherent poor aesthetic qualities. Anode manufacturers must also consider the intended installation and should produce the anodes accordingly.

The DC positive connections are often the weak point of an anode system. More research and development work must be carried out to improve the quality of these connections. Site connections are sometimes difficult to achieve and cannot be tested as effectively as those made in a laboratory or factory. Better site connection systems should be developed.

Technical considerations apart, the most important developments must be related to economics which in turn is subdivided into two sections; the cost of the anode system and the cost of installing the anode system in practice.

The future of anode manufacturing must be to produce cheaper anode systems which are easier to install and connect up to the other ICCP components. The cost of an anode system usually represents about 25–40% of the installed ICCP cost with installation of the anode roughly the same again. It can be seen, therefore, that the anode system is the most important single component of an ICCP installation.

## REFERENCES

- Apostolos, John A. *et al.* (1987) Cathodic protection using metallized zinc, *Corrosion of Metals in Concrete*, NACE Corrosion/87, Paper No. 137.
- Cathodic Protection International Aps (1994) *Cathodic Protection of Concrete Structures Using the durAnode System*, October 1994, revised April 1996, and private correspondence from Dr Paul Chess (1995).
- Eltech Systems Corporation (1990) Anode Ribbon Data Sheet, Material Specification.
- PermaRock Products Ltd (1992) private correspondence from Dr Jeremy Richings.
- Shunichiro Mita (1990) *Galvanic Cathodic Protection for Reinforced Concrete—The Protection of Concrete*, University of Dundee, 11–13 September.
- Thoro System Products Ltd (1994) Thoro CP Anode 60—Application Guide/07–94 and private correspondence from Dr Roger Hardon.
- Warne, M.A. (1986) Application of cathodic protection—requirements for anode materials, *Seminar on Corrosion in Concrete—Monitoring, Surveying and Control by Cathodic Protection*, London Press Centre, 13 May.

### ACKNOWLEDGEMENTS

The author would like to thank Dr John Broomfield for the information and advice provided on the zinc metallizing process, particularly relating to North American practice.

## Power supplies

*Paul Chess, G &K, CPI, Frits Gronvold, G&K and Ib Mogensen, G&K*

### 5.1

#### GENERAL

When cathodically protecting steel-reinforced concrete structures the need for power is normally modest compared to that required for cathodically protecting steel structures in water or soil. For concrete it is normal to use several small power supplies, each with an output of around 0.5 to 5 amps and a maximum output voltage in the region of 10 to 20 volts (depending on the anode type). This can be compared to steel cathodic protection (CP) systems where 200 amps transformer rectifiers are common and the protection of processing plants where single power supplies can have a capacity of 1000 amps or more.

The types of power supplies that are relevant to use for CP of steel in concrete generally require a higher degree of control in their operation than that in 'traditional' CP. For these reasons the traditional tap changing switched transformer rectifier is normally considered obsolete although the author has seen a recently installed example on a US structure. The 'typical' traditional manual system uses thyristor-controlled transformer rectifiers as these are efficient and can be operated using electronics. With the advent of the microprocessor there has been a general move to different technologies such as linear power supplies and switched mode power supplies as these are more space efficient, have a cleaner output and are simpler to interface with other electronics. This change in power supply technology has been accelerated for reinforced concrete CP systems by the increasing popularity of remote and computer controlled installations. These driving forces have produced significant differences in the physical construction of 'a traditional' and 'reinforced concrete' power source.

The objective of this chapter is to outline the principles behind each of the popular power supplies, explain the choices that a CP designer should be aware of when specifying power supplies and finally illustrate the design of a typical remote-controlled power supply system for a CP project.

## 5.2

## TYPES OF POWER SUPPLIES

For CP of steel in concrete a relatively small DC delivered between 1 and up to 20 volts is normally required. Generally this is obtained by transforming and rectifying a mains electricity supply but the power may also be delivered from batteries charged by solar cells, windmills and other electricity generators. The reinforced concrete structures where CP is to be made normally have some form of mains electricity available and only this will be further considered.

There are two forms of power source available, i.e. single- and three-phase. In general, concrete power supplies tend to use a single-phase supply due to their limited current output and the fact that they tend to have some electronics, though this is not universal. In public structures such as swimming pools, where power supplies and their feed wires may be near the public, it is not uncommon for the CP designer to require that a step-down transformer (which is normally 48 volts) is used to supply the various localized power supply units (substations), which are distributed around the structure.

All the various types of power supplies are designed to reduce the voltage and convert the AC into a DC output. The CP engineer may require that the supply can be adjusted in current output level, or in voltage output level. Sometimes, more interactive forms of adjustment are required such as potentiostatic or potential decays. The various systems which are commercially available as power supplies are discussed below. The correct power supply type for a particular application should be considered by the CP engineer. The parameters which should be considered are reliability, control, output ripple, efficiency, size and compliance with regulations

## 5.2.1

**Manual tap transformer plus rectifier**

A power supply comprising of a transformer plus rectifier is a simple and very robust unit. A transformer inputs the AC mains voltage and reduces the voltage to a desired amount depending on the proportion of windings around a soft iron core. Adjustment in the output voltage level is obtained by using a switch to choose between different outlets, i.e. the various separated windings, of the transformer. There are normally called 'taps'. Finer adjustment can be obtained by using a moving coil transformer where the direct mechanical switches are replaced.

The reduced voltage AC from the transformer is then passed through a 'bridge'-type circuit where the current is rectified, i.e. converted into a DC output.

It should be noted that the output power from a unit comprising a transformer and rectifier is not a pure DC but only a rectified AC which may be felt like electric shocks even at very low voltages. Some anode materials are reputed to be damaged if there is a lot of ripple in the current (ripple is the amount of change in the wave form). This is

the primary reason why the amount of ripple allowed is specified in a standard CP power supply specification.

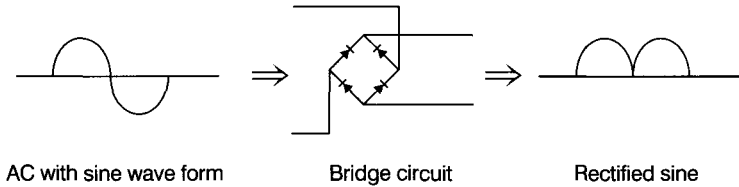

Fig 5.1 Full wave rectification using bridge circuit.

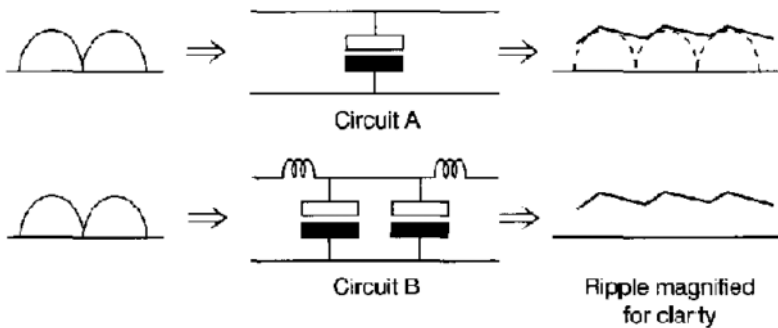

Fig 5.2 Smoothing circuits with results.

### 5.2.2

#### Transformer plus rectifier plus smoothing circuit

The AC supply circuit is passed into a transformer which reduces the voltage. The various output voltages are obtained by having separate windings on the transformer and by energizing or removing these from the circuit. The low voltage alternating current is then passed through a rectifier circuit so that it is rectified. This is then smoothed normally using electrolytic capacitors as shown in Figure 5.2.

The current can be smoothed out with a single capacitor as in circuit 'A' or by several capacitors and conductors in so called LC links as shown in circuit 'B'.

Normally electrolytic capacitors are used as they are cheap to buy and have a high capacity and thus are economic. However, the service life of electrolytic capacitors is relatively short and they are normally the life determining part of the power supply.

### 5.2.3

#### Thyristor controlled

A thyristor is a controlled rectifier. It is used to adjust the output level by placing this electronic device in the rectification circuit and controlling the conduction which the device either prevents or allows current to pass. This is more simple to describe schematically as shown in [Figure 5.3](#) for full and partial conduction.

The amount of current passed depends on when the phase-angle control unit of the thyristor is energized. This in turn is energized by a DC input thus control can be effectively achieved by adjusting a control potentiometer. Other methods of using thyristors are to put them on the primary side of the circuit or to use them in groups. Both of these are uncommon. The thyristor controlled power supply is probably, at present, the most commonly used power supply for reinforced concrete applications and has proven itself to be tough, durable and energy efficient (up to 90% efficient). It does, however, have some deficiencies. These are that a large smoothing circuit is required, the power density is not that large, and the control circuit feedback control is not particularly exact.

### 5.2.4

#### Linear

This system is so called because the transistors in the voltage regulator are all working in their linear region. It uses the same basic circuit as in [section 5.2.2](#). with a transformer then a rectifier and some smoothing capacitors but then has a voltage regulator at the end of the circuit. This electronic voltage regulator works on the 50 or 60 Hz rectified and smoothed AC. It works by comparing a reference voltage and the output. This error signal controls the output of the regulator. This can be thought of as a variable resistor where the resistance is very rapidly being changed. The output voltage can be controlled using this technique to provide almost pure DC with a ripple of a few mV

The major disadvantage of a linear power supply is that it is not very efficient, particularly when operating at low voltage. This is because the voltage regulator is operating in a high resistance mode. This causes substantial amounts of heat to be generated in the voltage regulator which has to be dissipated. The service life of the electronic voltage regulator very much depends upon its temperature. At approximately 120°C in continuous use the circuit will eventually be destroyed. Therefore suitable cooling is necessary for this type of supply with the maximum output capacity dependent on the heat sink size.

Most modern voltage regulators have a thermal shutdown, i.e. the current is switched off when the temperature of the electronics is critically high but still not damaging. When the temperature has decreased the electronics will again act

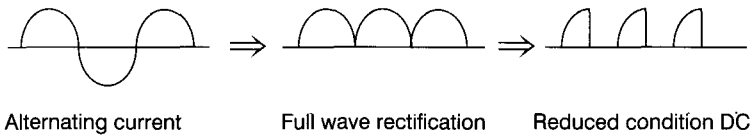

Fig. 5.3 Thyristor control allowing full and partial conduction.

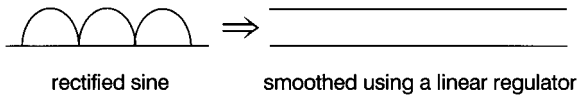

Fig 5.4 Effect of a linear voltage regulator on voltage form.

normally. There is normally also protection with thermal cut out fuses which will blow over at a certain temperature.

The use of passive cooling fins on the voltage regulator is normally sufficient for this cooling. If mechanical cooling is added there will also be a need for regular maintenance of the ventilator and filters and therefore this would not usually be recommended for CP as the power supplies are often in hostile environments.

The heat generation limitation is not a problem when the power supply is placed in a suitably large enclosure and is used in relatively low ambient temperatures but it tends to limit this power supply's application to low current situations, say of up to 1 amp.

A power supply with electronic voltage stabilizing may be adjusted in different ways:

- Manual adjustment of the voltage using for instance a potentiometer.
- Manual adjustment of the current. This is done by using an electronic circuit to measure the output current and adjusting the voltage until the output current corresponds to the desired current.
- Potentio static control. By potentio static control the protection potential voltage is measured and the current is adjusted via a single comparator until the measured potential corresponds to what is desired.
- Control of voltage, current and potentio static control using a microprocessor. This may be achieved by exchanging the potentiometer with a digital-analogue converter, that converts the digital data of the microprocessor to an analogue voltage (or current) and a large program from a personal computer (PC) can be used.

### 5.2.5 Switch-mode

A switch-mode supply is so called because it takes its power input from AC mains power without using a low-frequency (50/60 Hz) isolating transformer to reduce the voltage. This is the normal situation though to complicate matters these are secondary switch-mode units which use a step-down transformer before acting like a primary switch-mode power supply. These secondary switch-mode units have some significant advantages over primary units for use as CP power supplies.

The system rectifies AC by passing it through a ‘chopper’ primary switcher which provides a square wave signal at approximately 100KHz. This is then passed through a transformer (primary side). The benefits of this are that the transformer for 100KHz can be much smaller than that used for 50Hz and as this is the largest part of a power supply there will be substantial size savings. The secondary side is then again rectified and smoothed. This output voltage is used to control the duty cycle on the primary switch transistor. This gives a relatively smooth output immediately. The advantages of this type of unit are a high compatibility with electronic control and measuring devices, high current output to size ratio, very smooth output (ripple less than 0.1%) and relatively low electromagnetic emissions. Against this the units are complex with a large amount of components, fragile and by consequence likely to be more unreliable. They are not particularly efficient as they have a lot of associated electronics. These units are fast becoming the most used power supply in general (not CP) use and this is likely to become more closely reflected in CP systems, particularly those which use computer control, in the near future.

Switch-mode and linear power supplies can be adjusted in the same ways as described at the end of [section 5.2.4](#).

## 5.3

### FEATURES OF POWER SUPPLIES

#### 5.3.1

#### **Protection against transients and lightning**

Any electrical apparatus connected to the mains supply is exposed to transient surges coming down the supply cables. For instance these could be caused by lightning. Transients are damaging for most electronic components which is the reason why it is normally necessary to protect power supplies against them.

Power supplies for CP are more exposed than most electrical apparatus as they are often outside, connected to the steel reinforcement and the anodes. The reinforcement may have a considerable extent and may easily pick up external electrical fields. Also, and perhaps of most significance, the anodes on the surface of the concrete can be hit by lightning and pass the current down the output cables.

Lightning causes potential differences along cables and consequently a large current flow.

Thus there is a need to protect the line input, measuring inputs and direct outputs against transient surge pulses. Depending on the location of the equipment, the level of risk may vary dramatically. Factors such as indoor or outdoor installation, as well as geographical location and heavy machinery levels should determine the transient protection design. The incidence of lightning is statistically recorded by weather stations and should be made available to the designer so that the appropriate measures can be taken. Transients over 5kV in a low exposure area can be expected once a year but there may be 100 to 1000 transients that exceed 1.5kV. We have learnt that with a direct lightning strike there is very little one can do to protect the components in an enclosure and this is a strong incentive to use physically separated components, i.e. separate enclosures in areas where lightning is a common phenomenon.

The basic principle of transient protection is to drain the transient to ground. It is not possible to stop transients through the use of fuses as the rise time of a transient can be very fast and thus they will often pass through the circuit before the fuse blows.

There are several components which can be used when designing a surge protection system. All of them have various drawbacks and benefits. Often transient protection is combined with a line filtering function. A description of the more common components is given below.

#### 5.3.1.1

##### *Metal oxide varistor (MOV)*

This is a commonly used device because of its low cost and relatively high transient energy absorption capability. It is a non-linear voltage-dependent resistor. Below the threshold voltage the impedance is very high and over the threshold voltage the impedance decreases and loads the transient. The drawback of this device is a high slope resistance in the clamping region that means the clamping voltage is dependent on the current caused by the transient. Another drawback of the varistor is that it ages each time a transient is suppressed. Exposing the varistor to high-energy transients ages it more quickly and it is not possible to predict when the suppressor needs to be replaced.

#### 5.3.1.2

##### *Transient protection diodes*

Transient protection diodes are semiconductors using the avalanche property of semiconductors. They can be uni- or bi-directional for different purposes. Like the varistor this diode exhibits a non-linear action but in the clamping region the slope resistance is very much lower. Therefore the clamping is more effective. If exposed to

transients much bigger than that designed for it, it will short circuit and therefore release the circuit breaker or the fuse. The drawbacks of this device are its high costs and comparatively limited low current capability.

### 5.3.1.3

#### *Surge arrester*

A gas-filled surge arrester comprises a spark gap within a sealed highpressure inert gas environment. When the striking voltage of the arrester is sufficient an ionized glow discharge is developed, as the current increases an arc discharge is produced, giving a low-impedance path between the electrodes. The arc drop voltage is relatively constant but the striking voltage to energize it is much higher. The device has a very high current capability but is relatively slow acting. Therefore it is usually backed up by a fast-acting device with very definite clamping voltage. A major drawback is that they tend to remain in the conducting state after the transient has vanished. This requires that a fuse or a circuit breaker is put in series with the surge arrester.

## 5.3.2

### **Cabinet selection**

The cabinet has several functions. Its primary function is to act as a heat exchanger, protect the electronics and other electrical items from damage by the environment and other requirements, and has to be easily openable to permit access to measure or look at the voltage and current outputs, act as a heat exchanger and be aesthetically acceptable. Typically the cabinet is fully enclosed with no cooling vents. It is sometimes possible when placing the unit in an indoor environment to allow cooling vents and thus reduce the installation size. In general the units are sealed to a protection rating of IP65. This means that the unit is sealed to a level where dust and sprayed water should not penetrate. Normally, glanding is provided by the contractor or electrical specialist on site and in our experience ingress of the environment will be seen most commonly in this problem area. A second common cause of failure is damage to the hinges. It is very important that the hinges should be of good quality and at least of the same corrosion resistance as the rest of the cabinet. The IP rating guide is given in [Box 5.1](#) overleaf.

The cabinet is normally sized according to the heat transfer requirements of the electrics, though certain consultants size the units on historical precedence. Generally the sizing of the cabinet is left to the power supply manufacturer to determine. It is very important for installation and maintenance that there is reasonably good spacing for glands and terminals and plenty of heat dissipation. This may mean that more cabinets have to be used or they may have to be enlarged for this requirement alone.

The CP designer will normally specify the cabinet material. The advantages and disadvantages of the materials which are commonly available are discussed briefly below.

Glass-reinforced plastic (GRP) or other filled plastic cabinets are commonly used and have excellent corrosion resistance especially in saline environments and are reasonably cheap. Their disadvantages are that the cabinets are prone to damage during transport, have a low vandal resistance, poor heat transfer, and only fair rigidity which makes racking systems more difficult. The cabinets are also likely to be illegal under the

### **BOX 5.1**

#### **SUMMARY OF IP PROTECTION NUMBERS**

**First number**—*Protection against solid objects*

##### **IP Tests**

- 0 No protection
- 1 Protected against solid objects up to 50 mm, e.g. accidental touch by hands.
- 2 Protected against solid objects up to 12mm, e.g. fingers.
- 3 Protected against solid objects over 2.5 mm (tools, wires).
- 4 Protected against solid objects over 1 mm (tools, wire and small wires).
- 5 Protected against dust limited ingress (no harmful deposit).
- 6 Totally protected against dust.

**Second number**—*Protection against liquids*

##### **IP Tests**

- 0 No protection.
- 1 Protection against vertically falling drops of water, e.g. condensation.
- 2 Protection against direct sprays of water up to 15° from the vertical.
- 3 Protected against direct sprays of water up to 60° from the vertical.
- 4 Protection against water sprayed from all directions—limited ingress permitted.
- 5 Protected against low pressure jets of water from all directions—limited ingress permitted.
- 6 Protected against low pressure jets of water, e.g. for use on shipdecks—limited ingress permitted.
- 7 Protected against the effect of immersion between 15cm and 1m.
- 8 Protects against long periods of immersion under pressure.

**Third number**—*Protection against mechanical impacts (commonly omitted)***IP Tests**

- 0 No protection
- 1 Protects against impact of 150 g weight falling from 15 cm height.
- 2 Protected against impact of 250 g weight falling from 15 cm height.
- 3 Protected against impact of 250 g weight falling from 20 cm height.
- 4 Protected against impact of 500 g weight falling from 40 cm height.
- 5 Protected against impact of 1.5 kg weight falling from 40 cm height.
- 6 Protected against impact of 5 kg weight falling from 40 cm height.

European Union (EU) regulation for electro magnetic interference (EMI) as discussed more fully in [section 5.3.6](#).

Mild steel cabinets are normally provided with a polyester powder coating and are tough, have a high heat transfer coefficient, are cheap to buy and allow EMI compatibility. Their single problem is that in corrosive environments they start to stain within one to three years of installation and after a few more look aesthetically disastrous. Perforation of the cabinets follows in about seven to ten years which can be an unacceptably short time period. This propensity can be reduced by maintenance with washing and overcoating.

Stainless-steel cabinets are normally available in two grades namely 304 and 316. Recently duplex stainless steel has started being offered. We have found that the 304 grade stains very quickly in a salt laden atmosphere with 316 grade being red rust stained within six months. The resistance to chloride induced corrosion of a duplex grade stainless-steel enclosure is likely to be significantly better and might be suitable for long-term use without any additional coating. Stainless-steel cabinets can be additionally corrosion protected with a clear lacquer dosed with inhibitors on a three-year maintenance cycle, or for longer maintenance periods, polyester powder coated. Stainless-steel cabinets are tough and vandal resistant. They have a heat transfer coefficient between GRP and mild steel and allow EMI compliance to be achieved. Their biggest disadvantage is that they are the most expensive of the cabinets in common use.

There have been instances of using cast-iron pillars in vandal-prone areas and these have proved remarkably successful in that they attract little attention and the worst damage encountered has been graffiti. Normally, the enclosure protection rating (IP) rating of these cabinets is too low to afford satisfactory protection to electrics and electronics for a power supply and additional environmental shielding is required inside this enclosure.

Some small power supplies use die-cast aluminium boxes which are powder coated. In most ways these are ideal as they have excellent heat transmission characteristics,

are corrosion resistant, are tough, cheap and have good EMI compatibility. The only disadvantage is that they are only available in small sizes.

### 5.3.3

#### Reading output currents, voltages and potentials

Most power supplies also have the associated reference electrodes terminated in the same enclosure. Thus, there is a requirement for reading the output voltage, output current and reference electrode potentials. The reference electrode potentials are normally required with the CP system energized, ‘instant-off’ and after a certain amount of time off. The simplest, cheapest and crudest way of providing these values is the direct use of a portable, digital voltmeter. The output of the power supply can have a permanent shunt built in to measure the current output. Manually interrupting the current by disconnecting the DC output positive wire can then be used to obtain the instant-off potentials. This procedure is not used widely because of the difficulties in recording data consistently and its requirement for technicians with some understanding of what they are doing.

A modification of this is to use a timer interrupter in the output circuit to provide a simpler means of obtaining ‘instant-off’ potentials on the reference electrodes. This is the form of system that is recommended in the forthcoming CEN/TC262 standard. This standard still advocates the use of a portable meter which is inserted into various sockets in the power supply.

To avoid potential drop problems potential measurements are taken as ‘instant-off’ measurements, i.e. the potential is measured when the resistive (Ohmic) voltage drop from the protection current is gone. This voltage drop occurs as quickly as the current can be switched off, i.e. in a few hundredths of a second. However there will still be a potential gradient caused by the protection current having separated the positive and the negative ions in the concrete (electro-osmosis). The decay of this gradient happens so slowly that it can be compared to the decay of the protection film at the concrete to steel interface. Thus it is not possible to measure the protection potential of reinforced steel without errors if the ‘instant-off’ time is not fixed. Relying on manual instruments to take ‘instant-off’ measurements with the operator selecting arbitrarily the ‘instant-off’ potential is not a correct procedure as in certain locations the errors might be of the order of hundreds of millivolts.

To minimize the errors, a system controlled or monitored on the basis of potential measurements should have the possibility of adjusting the time that passes from closing down the power supply until the potential measurement is taken to an optimum level from a corrosion engineers viewpoint, and then allow this time to be used for all subsequent measurements. This requires that control of the power supply and the potential measurement unit are connected.

We consider that modern power supplies should provide built-in metering of at least the current and voltage outputs as this dramatically reduces the likelihood of

operator error in taking readings. The choices of meter are moving coil (analogue) and, light emitting diode (LED), liquid crystal display (LCD) and backlit LCD. These latter are digital meters and each one has advantages over each other. The moving coil is reliable, does not require an additional power supply and gives a good intimation of the general output level; however, accurately and consistently reading the meters has proved to be difficult, and it has a low input impedance ( $20\text{ k } \Omega$ ) which can influence a potential reading from a reference electrode. LEDs are accurate and fairly reliable but are difficult to read in direct sunlight. LCD displays are accurate and can be read in direct sunlight but are difficult to read in low light conditions and have temperature limitations (maximum is normally  $60^\circ\text{C}$ ). Backlit LCDs are easy to read in the dark but still have the same temperature limitation problem.

There is one problem to using integral meters and this is the fact that they, in common with all meters, need to be calibrated at regular intervals in order to comply with the quality assurance (QA) testing requirements, unless the readings are categorized 'for information only'. This can be met by the manufacturer's providing documentation of the calibration of the meters against a traceable standard and testing the calibration at regular intervals on site. These intervals can be for example, five-years as the accuracy required is relatively low ( $\pm 5\text{mV}$ ) and they do not tend to drift.

The next level of sophistication above the manual power supplies described above has automatic measurement of the output current and voltage and reference electrode inputs, measurement of the reference electrode inputs should be taken after the supply output has been interrupted, i.e. 'instant-off'. This information should be stored in a digital form for further future analysis. This information is normally taken in a disc format from the system and allows a detailed analysis of the system's performance over a protracted time period. The next level of sophistication after this is automatic control systems where the system is controlled using the readings being taken in a dynamic feedback loop according to definable parameters which can be amended through software. This is discussed in more detail in [section 5.4](#).

#### 5.3.4

#### Galvanic separation of power supplies

Concrete structures are often built up in sections, or elements. For several reasons it may be necessary to have galvanic separation, i.e. electrical isolation, between the sections, for instance in tunnels or other structures with electric rails. This is because the induced currents can be very large if the structure is electrically continuous. In this case the currents in certain areas could be much bigger so CP current or anodic discharges may occur with the result that corrosion is possible. Induced currents can also play havoc with earthing arrangements. In the event that the structure is electrically separate then it is desirable to use separate power supplies with separate negative connections for each section or element. This means that a galvanic separation must be maintained throughout the power supply units. To comply with

the EMI regulations (see [section 5.3.7](#)) everything in the cabinet must be grounded to a common ground. Consequently the only way to achieve compliance with this EU directive and to have full galvanic separation is to use individual cabinets.

### 5.3.5 Power supply layout

When a new installation is energized and commissioned, to be started up a certain number of control measurements are necessary. These are the continuity of the reinforcement connections needs to be tested, the reference electrode potentials should be measured and the anode system tested for short or open circuits.

The possibilities of errors occurring in this wiring, i.e. the external part outside the power supply enclosure are large. Often the energizing of the system takes place within a time limit such as scaffolding removal and the commissioning engineer not only has to cope with the probabilities of failures in the external wiring but also to analyse and rectify faults in the control cabinet (normally in the connections from the external wiring to the Deutsches Institut für Normung (German Standards Institute) DIN rail).

To make this procedure as painless as possible the power supply should be constructed in a systematic way using components that are well arranged and easy to operate. All cables from the CP system should be led in to spacious cabinets and terminated in DIN-type terminals so that it is easy to undertake measurements with portable tools such as a multimeter. The same cable colorations should be used for the same purpose throughout the power supply, and where possible should be related to the external wiring.

During commissioning of an automatic system it is much simpler if the installation can initially be operated 100% manually. In this mode it should be possible to connect one anode zone at a time, measure—or even better—read voltage and current from the individual power supplies, measure the current to each zone and measure the potential difference on the individual reference electrodes with the power switched both on and off. As commissioning progresses, the system should then be tested in a systematic way for all its automatic functions.

During the operational phase of a CP system, ideally it should be possible to control the installation without using any special instruments apart from a key to unlock the cabinet. Thus each power supply should have its own identification, a log book with desired values (minimum and maximum current or voltage or potential), a lamp showing whether the desired current/voltage is being obtained or a display showing the current and voltage output.

### 5.3.6

#### Electromagnetic interference (EMI)

The passage of electrical current creates a magnetic field around the conductor. The electromagnetic field surrounding one electrical device can interfere with another device and cause unintended malfunction. These electromagnetic fields are transmitted by radiated emission, or if the electrical devices are connected to each other by a mains cable, by conducted emission.

All power supplies emit electromagnetic fields, but the amount and the frequency spectrum can be very different. Manual tap transformer rectifiers and linear power supplies generates a little low-frequency conducted emission but do not radiate much energy. Thyristor-controlled power supplies generate both a lot of conducted and radiated energy in the low-frequency range. Switched-mode power supplies generate both a lot of conducted and radiated energy in the high-frequency range.

A lot of interference can be avoided by careful design of the printed circuit boards and filtering at the source. The rest can be shielded with an electrical shield or a Faraday screen.

To satisfy a correct function of electronic equipment, standardization organizations like BS, VDE, IEC, CISPR, FCC, CSA etc. have specified the maximum EMI which is permitted to be radiated and conducted to the environment. In EU countries a law from January 1996 was adopted by the member countries. From that date every device has to pass a test where the maximum EMI it is permitted to radiate and conduct is specified and the minimum limit of EMI each electronic device must be capable of resisting is also prescribed. When the tests have been passed the equipment is allowed to carry a 'Certificate Europe' (CE) label. From January 1997 all electronic equipment must carry the CE label when entering the EU market.

This legislation is divided in two environmental classes. Part 1 is for electronic devices in residential, commercial and light industry applications and Part 2 is for industrial environments. Each environment class has one generic standard for emission (EN 50081) and one for immunity (EN 50082). The emission standard for residential, commercial and light industry (EN 50081-1) is more rigorous than the industry standard (EN 50081-2). For immunity the industry standard (EN 50082-2) is more rigorous than the residential, commercial and light industry standard (EN 50082-1). The most rigorous combination is thus (EN 50081-1 EN 50082-2).

### 5.3.7

#### Efficiency

Normally the consumption of electricity on a concrete CP system is not of great importance to the overall running cost of the installation and thus the total efficiency of the power supply is of interest only in the amount of heat which has to be dissipated in the individual cabinet. In some countries however there is an

‘environmental audit’ to minimize the consumption of resources and in these locations high-efficiency power supplies may be required.

Similarly on the unusual occasion where mains electricity is not available and solar, wind or other power is required, then the efficiency of the power supplies should be maximized.

In both these cases the choice of most suitable power supply type as outlined in [section 5.2](#) may have to be amended.

## 5.4

### AUTOMATIC SYSTEMS

Larger structures often have a large number of zones with individual power supplies and reference cells. For each zone it would be desirable actively to control the maximum voltage, the maximum and minimum current, the optimum potential and the maximum or minimum depolarization.

The current demand of the CP system may be expected to fluctuate during each hour of the day and seasonally; consequently there is a need for continual current adjustment. Ideally the system should be able to undertake these adjustments using the same information as an experienced CP engineer and make qualified judgements on both the systems performance at that point and relate this data to the previous performance. Another system ideal is that it should be able to adjust for failures; for example, buried reference electrodes commonly start giving ‘spurious’ readings which a CP engineer would ignore. Other common failures are of the anode connections, cathode connections and power supplies. Ideally these failures should be recorded with the system readjusting itself to accommodate these problems in the most efficient way possible.

Where a client decides that it requires a system which is automatically controlled and remotely operated there are several factors which should be considered to arrive at a logical specification which fits the project.

The normal practice is for the corrosion engineer to specify what he or she wants the system to do and then specify some design specifications it should be in compliance with. This arrangement absolves the designer from specifying a single system and allows several competing systems to be proposed. The principal matter for the designer then is to decide what he or she requires the system to do. It is necessary that the designer keeps a firm hand on reality at this point as each individual additional feature costs money and probably adds to the unreliability of the control system. We consider that an intelligent system should ideally give information and control on several levels:

- The system is actively controlling using data from reference electrodes (and other monitoring equipment) to provide optimal protection levels with minimal anode damage. To do this an automatic system needs some form of data storage facility, a

computer processor and a way of interfacing with potential, current and voltage inputs. This in practice requires that the system is based on some form of PC technology.

- The system should be simple to operate and allow the operating parameters to be changed easily.
- Historic operational data should be directly accessible in a simple form. Ideally this should be converted directly to a graphical presentation so that no data manipulation is required to see how the system is performing.
- Is the installation functioning correctly? Yes/no
- If no—what is occurring to prevent the installation from functioning correctly (i.e. hardware damage, data communications damage, software crash)? Also when and where did the problem arise?
- It should be possible to copy data to another computer where a full record of the operation of the system can be examined in as detailed a manner as that required.

The system should be constructed in the most modular way possible to permit simple servicing and maintenance.

In order to undertake this task the automatic system has to have several components and these are outlined below.

- **Modem:** to transmit data and upload commands, updated software. This should be robust and able to work at the maximum speed of the telephone lines in order to minimize telephone bills.
- **Control unit:** it is usual to use PC technology as it is common and cheap and powerful. In the event that these units are used, 'industrial quality' components should be used to give higher reliability and future compatibility.
- **Data storage facility:** this is commonly a hard disk or occasionally flash RAM. At present flash RAM has too limited a capacity to store sufficient data but in the future it will become more common due to the advantages offered by its solid state construction.
- **Input analogue to digital convertors:** there are several systems on the market. These preferably should be designed for industrial use and have as high noise rejection levels as practically possible. There is a requirement that all the potential values from the reference electrodes on the system are taken with the current output of the anodes simultaneously disconnected. To obtain these 'instant-off' values 'holding' circuits are required where the information is captured at the predetermined time and then released in series through the digital system to the controller.
- **Software:** this is probably the most critical part of the unit. The program should be stable and reliable and written to assist a corrosion or other engineer in running the system. The system should be simple to operate and make it simple to record and display the data.

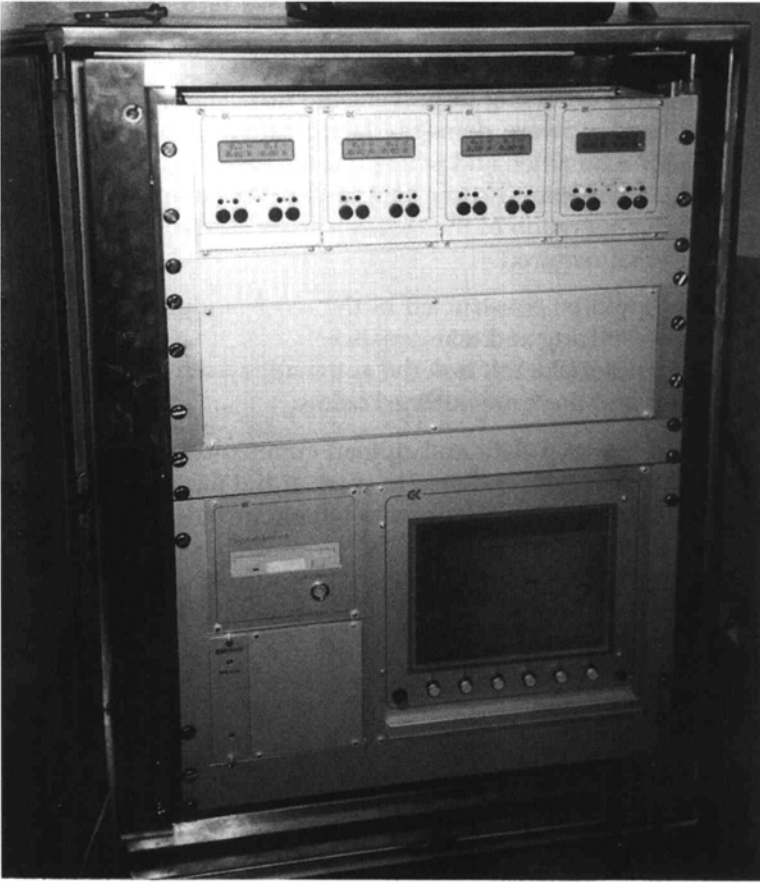

**Fig. 5.5** Computer controller for system having up to 2000 output current channels and 4000 reference electrode inputs (courtesy of Grønvold & Karnov).

- **Connections to power supplies:** these are required to allow the program in the computer to adjust and monitor the output of the power supplies. They normally conform to an industry standard such as RS232 and RS485.

A typical modern system which conforms with these requirements is shown in [Figure 5.5](#).

A modern automatic system can easily store a vast quantity of data. By storing data as integrals in binary form there are no practical problems in recording literally millions of figures. If there is too much data then there is a big risk that the collation of data becomes too troublesome for the user as relative to the benefit and it is ignored. To try and avoid this occurring, data compression should be used early in the system

to try and filter the relevant information from other data which is not practically relevant.

Data compression is especially important when there is a need to transfer data via modem from a remote location, as the rate of transfer of data may then be very low, maybe even down to 100 measuring values per second corresponding to transfer of binary ciphers with 2400 baud.

Data may be compressed by:

- saving the average value and the standard deviation over a suitable time period, this for instance could be 24 hours if no essential variations in the environment are occurring; every three hours if there is a small tide influence; one hour if there is a large influence by concrete temperature, rain, tidal water, air temperatures etc;
- only saving data when there are considerable changes relative to the last data set saved.

This is illustrated in [Figure 5.6](#).

Data compression showing the 24-hour average data from a bridge pile over a four and a half month time period from June to the middle of October is given in [Figure 5.7](#).

The peaks that appear each month in [Figure 5.7](#) are 24-hour depolarization tests which are being executed automatically by the system. The level of depolarization achieved can be read from the curve and it is the average of the 24-hour reference electrode decays. It should be noted that the reference electrode Ref. 2-2 is the only electrode placed within the protected area and its potential got less negative in the middle of summer even though at the same time there was an increase of current.

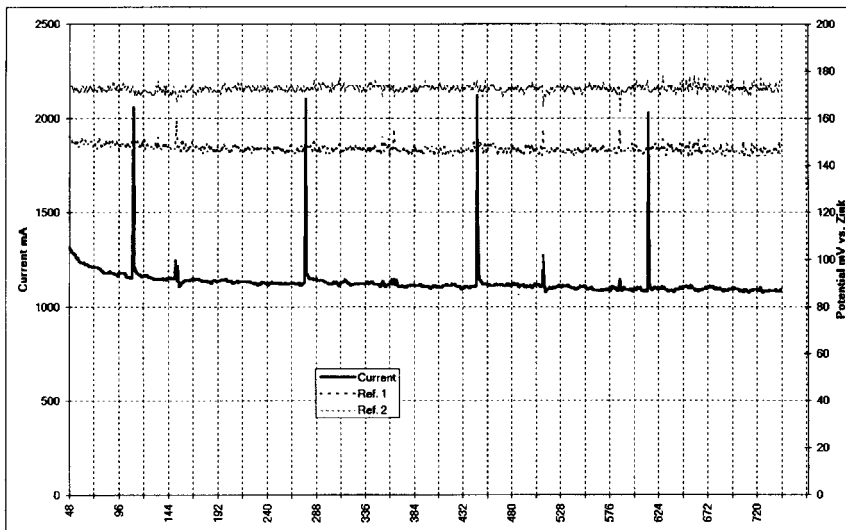

Fig. 5.7 Data compression chart 2.

This allows the inference that to maintain a constant potential at a higher temperature the current requirement is increased. The main point of this is to show that the amount of data which is the optimum to show trends and yet accurately delineate testing regimes such as depolarization can be limited.

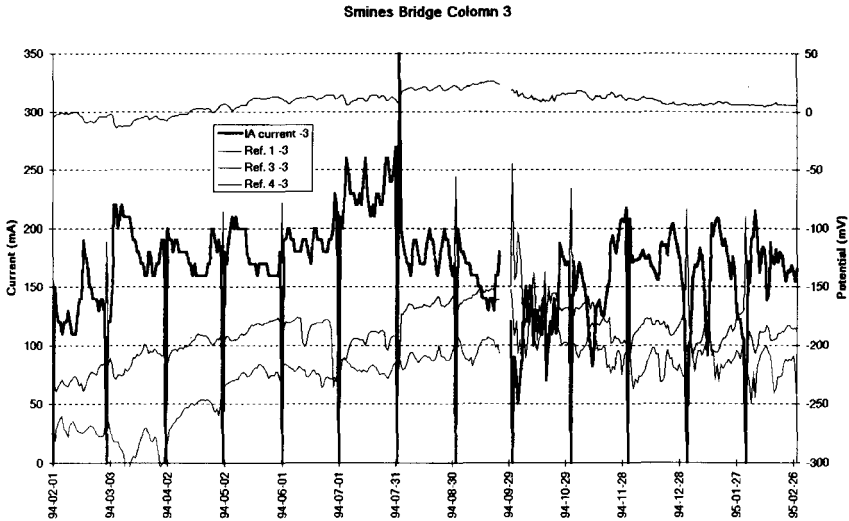

Fig. 5.6 Data compression chart 1.

A second example is one month's data from a filter tank in a public swimming pool.

The points are average potential values for each hour. In the first 24 hours of the data a monthly depolarization test is being executed. The big peaks in the current requirement occur at approximately weekly intervals. On investigation this was found to require an increased level of protection after the system was backflushed with a return flow to clean the filter tanks. In this example normally there are no essential variations and data may be compressed considerably without losing any information of substance.



# Monitoring cathodic protection of steel in concrete<sup>1</sup>

*Chris Naish<sup>2</sup> and Malcolm McKenzie<sup>3</sup>*

## 6.1

### INTRODUCTION

The corrosion of steel in concrete is a major cause of degradation in above-ground reinforced concrete structures. The corrosion process (Figure 6.1) is electrochemical and is initiated by changes in the chemical environment at the steel-concrete interface of which there are two main causes: the reduction of the local alkalinity by carbonation and the breakdown of passivity of the reinforcing steel by chloride ions. Both of these are exacerbated by poor construction practices such as low concrete cover to the reinforcement and poor-quality, porous concrete. Reinforced concrete structures made with adequate cover and good quality concrete are resistant to both the above corrosion-inducing processes for prolonged periods of time. Chloride-induced corrosion will eventually initiate on structures with good levels of cover and this is the form of corrosion that is normally considered as controllable by cathodic protection.

Once corrosion has initiated it will proceed at a rate dependent on the local environmental conditions and the concrete quality. The expansive nature of the corrosion product and the very limited tensile strength of concrete mean that only a small amount of corrosion is required to 'spall' the concrete cover away from the reinforcement, exposing the steel, allowing further corrosion to proceed.

Once corrosion has occurred, remedial repairs are often limited in effectiveness. In the case of chloride-induced corrosion, all the concrete contaminated above a specified chloride level needs to be replaced to ensure a durable repair. Even then the

---

<sup>1</sup> The authors of this report are employed at AEA Technology, Harwell and at the Transport Research Laboratory, Crowthorne. The views expressed are those of the authors and not necessarily those of AEA Technology plc or the Transport Research Laboratory. This chapter is copyright of Transport Research Laboratory.

<sup>2</sup> AEA Technology, Harwell.

<sup>3</sup> Transport Research Laboratory, Crowthorne.

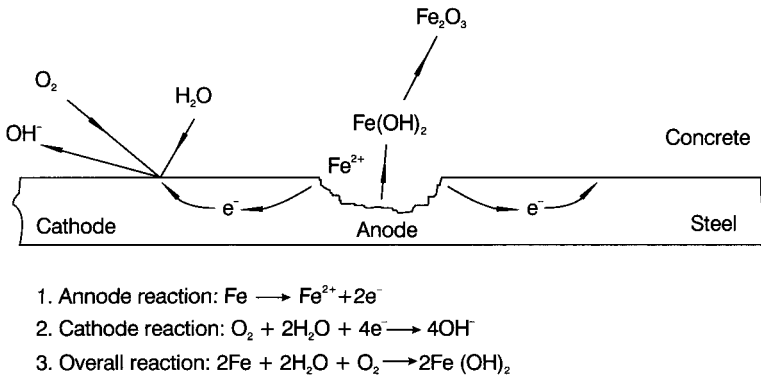

Fig. 6.1 Mechanism of steel corrosion in chloride-contaminated concrete.

removal of chloride from small, deep pits cannot be ensured (Vassie, 1988) and these can act as initiating sites for further corrosion which can locally eat through reinforcing bars. While this repair work is being carried out temporary support might be needed.

For a severely chloride-contaminated or carbonated structure there comes a point where demolition and rebuilding becomes the most economic long-term answer. However there are structures for which the consequences of removal from service and demolition carry very severe penalties both in economic and other ways. These include road bridges (severe traffic disruption) and office/accommodation blocks (loss of rents, loss of prestige building).

For such structures a remedial technique that requires the minimum of disruption to the present structure and its surroundings is desirable. Cathodic protection offers the possibility of halting or reducing the rate of corrosion without having to remove sound but chloride-contaminated concrete. As such it is an attractive repair option for the type of structures identified above.

This chapter firstly describes the basic principles of cathodic protection and then describes the particular problems associated with cathodic protection of steel embedded in concrete. The various methods presently used, or proposed, for assessing the level of cathodic protection to be applied to a structure are then described and discussed with particular relevance to the steel in concrete system.

## 6.2

### BASIS OF CATHODIC PROTECTION

The basic principle of cathodic protection is that by making the entire area of metal to be protected cathodic relative to a sacrificial or driven anode (see later) the anodic (corrosion) reaction on the metal is halted or reduced to a much lower level.

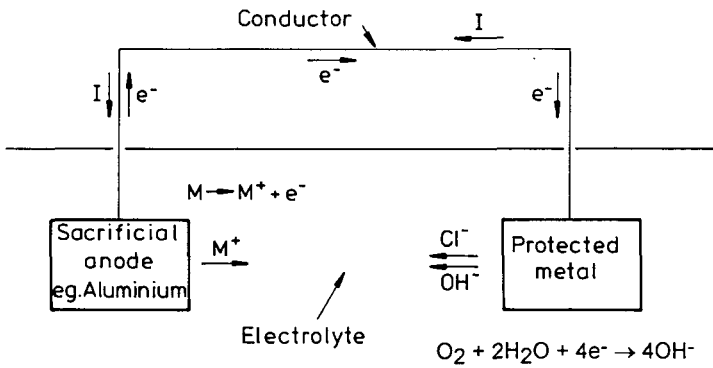

Fig. 6.2(a) Sacrificial cathodic protection

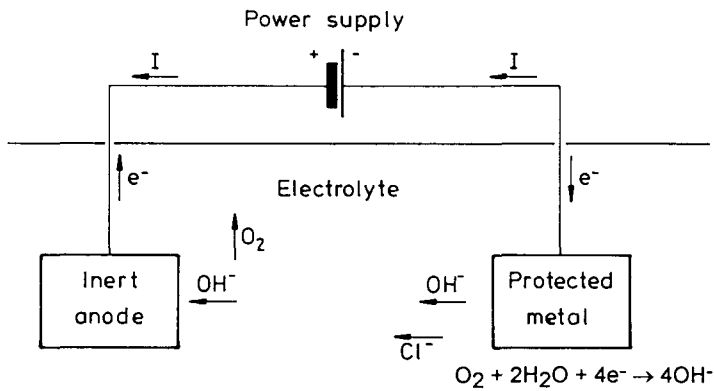

Fig. 6.2(b) Driven cathodic protection

There are two types of cathodic protection, one a passive system, the other driven by an external power source:

- (a) **sacrificial anode cathodic protection** where the anode reaction occurs on a sacrificial active metal (such as aluminium or magnesium), [Figure 6.2\(a\)](#); and
- (b) **impressed current cathodic protection** where electrical current is applied from a power source connected between an 'inert' anode electrode and the metal to be protected, which is connected as the cathode, [Figure 6.2\(b\)](#).

Aqueous corrosion is an electrochemical process. Areas on the metal surface are oxidized, releasing positive metal ions into solution and releasing electrons into the metal. This oxidizing reaction must be balanced by a reduction reaction to consume the electrons released into the metal and maintain overall charge neutrality. This

reduction reaction occurs simultaneously with the oxidation reaction either very locally to it (microcell corrosion) or on distinct, separate areas (macrocell corrosion).

The reactions can be represented by chemical equations:

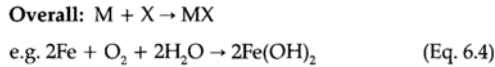
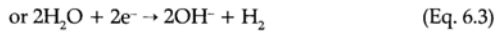
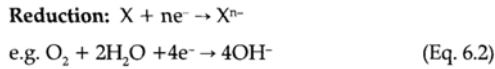
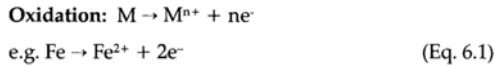

Under normal free corrosion circumstances a metal surface supports both the anodic (metal dissolution) reaction and the balancing cathodic reduction reaction, which is usually the reduction of dissolved oxygen gas, reaction (Eq 6.2). In such a situation charge is conserved within the corroding system and no net current flows. Reaction (Eq 6.3), the reduction of water occurs in cathodic protection systems when they are overprotecting the embedded steel. The reaction results in significant waste of energy and in the longer term could cause degradation of the steel to concrete interface.

The kinetics of the anodic and cathodic processes can be represented schematically on an Evans' (current-potential) diagram, [Figure 6.3](#). In the diagram the potential (against a reference electrode) is plotted on the ordinate and the log of the current is plotted on the abscissa.

Point 'A' shows the freely corroding situation where the anode and cathode reaction are supplying equal and opposite currents and no external current is flowing to, or from, the metal.

The effect of an impressed cathodic protection current (either from a sacrificial or driven electrode) is to displace the potential of the metal being protected to a more negative value as the external cathodic protection anode supplies more electrons to it. In the course of this the rates of the anodic and cathodic reactions are affected as shown in [Figure 6.3](#). The cathode reaction rate increases as the potential is displaced negatively, (line 'B') and the anode reaction rate decreases (line 'C').

The **protection potential** is a term usually used to define a potential value at which the corrosion current on the protected metal, i.e. the anode reaction, has been reduced to an acceptably low value.

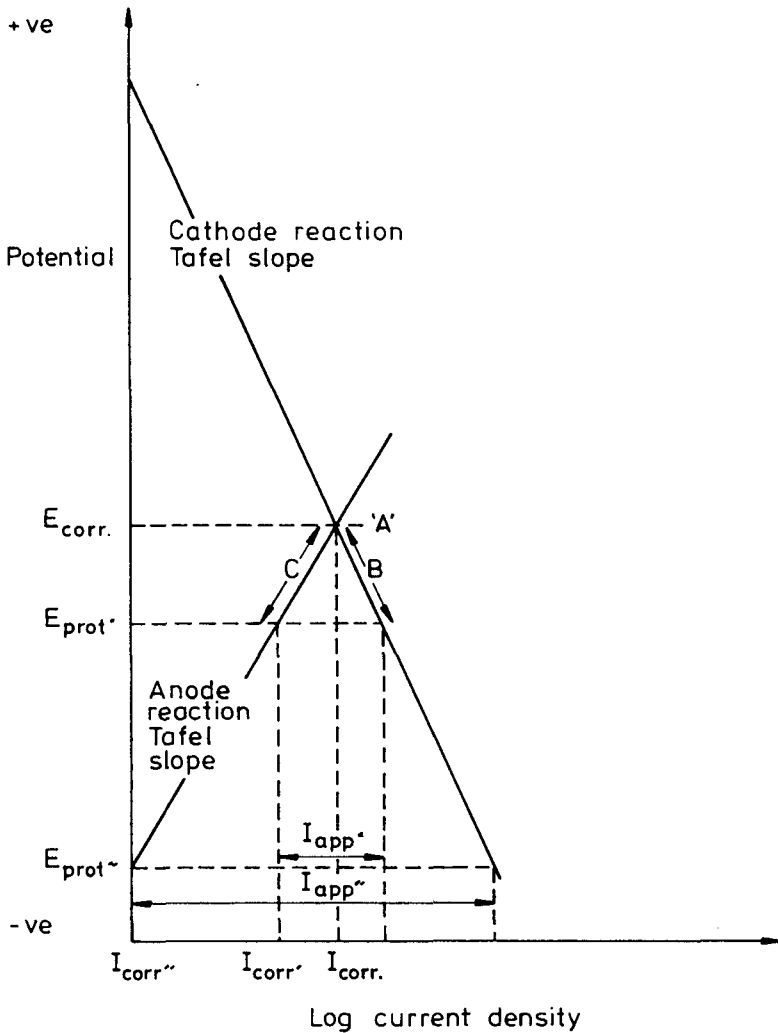

Fig. 6.3 Effect of cathodic protection on potential and current.

The protection potential can also be defined in thermodynamic terms as the potential at which the metal becomes immune to corrosion, i.e. the potential below which it becomes thermodynamically impossible for corrosion to occur. However, this value is often not practically attainable or desirable because of the large current requirement and the introduction of cathodic reactions that are deleterious to the metal or its local environment, e.g. hydrogen gas evolution.

Two important consequences follow from the above:

- (a) The logarithmic relationship between current and potential for an activation controlled process means that the relative reduction in corrosion rate diminishes with each incremental negative step in potential.
- (b) Concurrent with (a) the cathodic current, and therefore the power required to drive the system, increases logarithmically.

The result of these is that there is a decreasing return in increasing the level of cathodic protection and some arbitrary point must be chosen that gives a satisfactory level of protection without the provision of excessive current. These considerations more normally apply to impressed current systems. Sacrificial systems cannot reach a potential more negative than their own free corrosion potential; hence the risk of overprotection, although still present, is much reduced.

The cathodic protection current flows between the metal being protected and the protecting electrode through the surrounding medium as an ionic current. Only the areas of metal which have a direct electrolytic pathway to the protecting electrode can therefore be protected by the current from that electrode. Cathodic protection requires that the area of metal to be protected is completely immersed in a continuous, conducting electrolyte into which the sacrificial or driven electrode system is placed. The commonest examples of cathodic protection are steel structures immersed in sea-water where this is obviously the case.

Buried metal structures are often protected by cathodic protection. Under these circumstances water in the soil becomes the electrolyte carrying the cathodic protection current. The conductivity in these situations is usually lower and hence the positioning of the cathodic protection anodes becomes more important in obtaining a satisfactory level of protection over the structure. Should the conductive pathway to a particular area be too resistive, the protection current will be reduced and corrosion may occur.

The situation of steel in concrete is similar to soil in that the resistivity of the electrolyte (now cement pore water) is of major importance. However, there are also major differences that have to be taken into consideration which result in cathodic protection of above-ground reinforced concrete structures requiring a quite different technology and set of rules for its application.

### 6.3

#### CATHODIC PROTECTION OF STEEL IN CONCRETE

In subsea or buried soil cathodic protection applications, the metal to be protected is steel which is in a near neutral electrolyte of relatively high conductivity and infinite dimensions (relative to the dimensions of the structure to be protected).

Reinforcing steel, on the other hand, is in contact with highly alkaline cement gel and pore water solution, in combination with sand and aggregates which can be treated as non-conducting. The quantity of electrolyte is therefore limited and

constrained within the finite geometry of the structure. In addition, the properties of the electrolyte show a strong dependence on the local ambient environment. The anodes for such a steel in concrete protection system must be placed directly onto, or just below, the surface of the structure so that a short electrolytic path exists between them and the steel to be protected.

It is also worth noting at this point that although cathodic protection can be applied without replacing chloride-contaminated concrete (its major advantage) delaminations and macroscopic cracks in the concrete severely constrain the flow of protective current to the reinforcement. It is therefore necessary that all delaminations must be detected and repaired prior to the application of the cathodic protection anode system.

Concrete, being an inhomogeneous material, has a variable electrical resistance, permeability etc; these factors mean that the anodes need to be carefully designed and placed on the structure to ensure all the steel-work that requires protection is protected. The high electrical resistivity of concrete (1000-100000 .cm) means that a relatively short electrolytic pathway can have a significant resistance, which can give a large potential drop in the concrete and subsequently an insufficient level of protection at the steel.

These differences in the concrete environment, in comparison to other electrolytes in which cathodic protection is routinely employed as an accepted or preferred means of corrosion protection, mean that the established cathodic protection criteria for steel in near-neutral or acid aqueous solutions are not necessarily applicable to steel in concrete.

## 6.4

### ELECTRICAL CRITERIA

A number of criteria are presently used to assess whether a satisfactory level of cathodic protection is being applied to an above-ground reinforced structure. These are criteria developed for use in sea-water or soil and, as outlined above, are not necessarily applicable to steel embedded in concrete.

There are two bases on which the adequacy of cathodic protection can be judged. The first involves the thermodynamic considerations and relies on placing the steel in what is referred to as the 'immune' area of the Pourbaix diagram for steel (see next section). The second method for assessing the satisfactory level of cathodic protection is to examine the kinetics of the reactions involved and to choose the level based on experimental measurements of the current to potential relationships of both the metal dissolution and cathodic reactions. A range of experimental methods are used to assess these criteria. Each one will be described and then its merits and de-merits for steel in concrete discussed.

## 6.4.1 Absolute potential

### 6.4.1.1

#### *Basis of criterion*

Absolute potential measured against a standard reference electrode is the criterion with the best theoretical base. The protection potential can be calculated thermodynamically or obtained from presently available data in Pourbaix diagrams. Fixing the potential criterion in this way it is possible to select a potential value where it is thermodynamically impossible for the metal to corrode, given that chemistry, temperature and pH conditions are those used to determine the potential value.

The Pourbaix diagram for iron is shown in [Figure 6.4](#). From this it can be seen that given a pH in the range 12.5 to 13.5 the potential against a standard hydrogen electrode (SHE) would need to be more negative than  $-820$  mV ( $-1130$  mV copper sulphate reference electrode (CSE)) to move the iron into the potential region where corrosion was thermodynamically impossible (the 'immune' range). Such potential values are in the range where hydrogen evolution could occur at the steel surface possibly resulting in large currents being drawn from the cathodic protection system. This could lead to both accelerated anode degradation and possible longer term problems at the embedded steel-cement interface. The latter could include degradation of the steel-cement bond and hydrogen ingress into the steel, possibly resulting in embrittlement in the case of high-strength steels. For these reasons such potentials are undesirable.

It should also be noted that the potential required to place steel embedded in concrete in the immune region ( $-1130$  mV CSE) is more negative than that required for steel immersed in sea-water ( $-850$  mV CSE). This suggests that the level of cathodic protection for steel in concrete based on a thermodynamic criterion may be more demanding than that in sea-water. It also means that any argument for similar criteria for the two systems will have to be kinetically based, the thermodynamics indicating quite different potential requirements for protection.

A recent variation of absolute potential measurements is to measure the 'instant-off' potential between the cathodic protection anode and the cathodically protected steel. The basis of this criterion is explained below.

The oxygen evolution potential and the hydrogen evolution potential are at opposite ends of the range of stability of water, i.e. if the potential is more negative than the hydrogen evolution potential (i.e. the water reduction potential) then water is reduced and hydrogen gas is produced. At the other extreme, if the potential is more positive than the oxygen evolution potential (i.e. the water oxidation potential) then water is oxidized and oxygen gas is evolved. The thermodynamic potentials of these two reactions are separated by 1.23 volts (see [Figure 6.4](#)), i.e. the potential range of the thermodynamic stability of water.

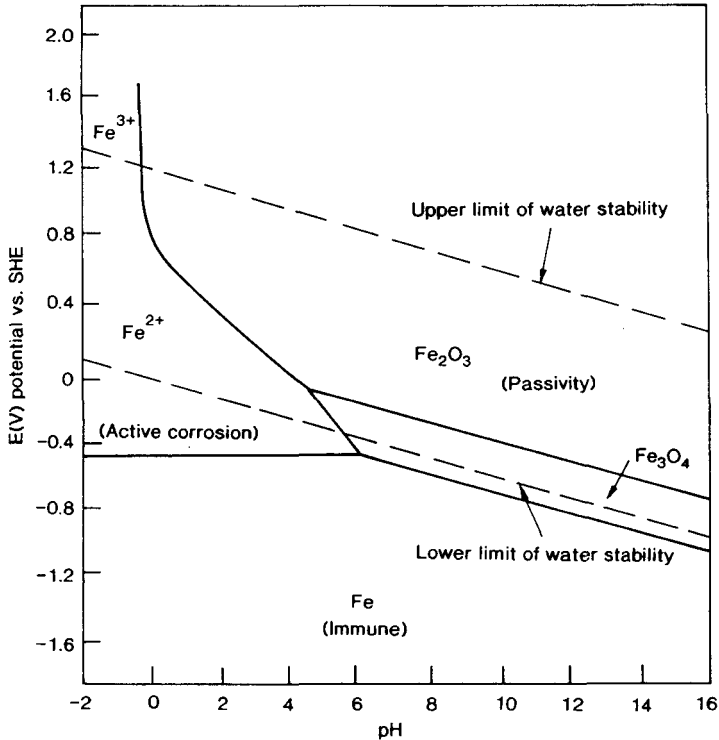

Fig. 6.4 Schematic Pourbaix diagram for iron.

By using this measurement in association with measurements relative to a reference electrode the possibility of excessive overprotection can be avoided. The cathodic protection anode, if it is working effectively, will require very little overpotential before it provides significant current to the cathodic protection system, therefore when the difference between the anode and cathode approaches or exceeds 1.3 volts it is reasonable to assume that the steel is adequately protected and approaching a potential at which energy will be wasted through the evolution of hydrogen gas.

It should be noted in the above that it is 'instant-off' potentials that are measured. The potential between the cathodic protection anode and the steel it is protecting can be significantly more than 1.23 volts when the system is being driven because of the voltage drops caused by the protection current flowing through the concrete ( $V = I_{\text{protection}} R_{\text{concrete}}$ ). When  $I_{\text{protection}}$  is switched off the associated potential  $V$  disappears allowing the true anode to steel potential to be measured.

### 6.4.1.2

#### *Measurement of absolute potentials*

The measurement of the corrosion potential of steel in concrete is not trivial. The steel is commonly embedded below 20 to 50mm of electrically resistive concrete through which corrosion currents are flowing and hence introducing potential drops related to  $I_{\text{corr}}R$ , where  $I_{\text{corr}}$  is the corrosion current and  $R$  the resistance of the current pathway. The potential drops cause significant errors in equating surface-measured potentials to the true potential at the steel to concrete interface.

Reference electrodes embedded at the reinforcement depth yield more accurate results but there are practical problems associated with the numbers required, their placement and long-term stability. The areas which should be monitored for judging whether the correct level of cathodic protection is being supplied (pre-supposing a protection potential has been agreed) can only be accurately determined by making a potential mapping survey, and possibly corrosion rate measurements (see elsewhere in this publication), of the structure to define the critical areas where corrosion is occurring at a significant rate prior to the application of cathodic protection.

## 6.4.2

### **Polarization curves (E-log i)**

#### 6.4.2.1

##### *Basis of polarization curves*

If the polarization characteristic (i.e. the relationship between current and potential) of the steel in concrete system over the potential range of interest is known then the depolarization required to give a certain (say tenfold) reduction in the corrosion current can be calculated.

Figure 6.5 shows schematic polarization characteristics for activation controlled anodic and cathodic reactions. The free corrosion potential is indicated along with the corrosion current. It can be seen that the effect of applying cathodic protection to the previously freely corroding system increases the cathodic reaction rate and decreases the anodic rate.

The lines 'X' and 'Y' can be experimentally measured on a laboratory sample and, with a greater degree of difficulty and care, on sections of a real structure by using a potentiostat to drive the reactions either in a cathodic or anodic direction, away from the free corrosion potential and then recording the resulting current. Extrapolation of the anodic line to the chosen protection potential will indicate the metal corrosion current at this point (assuming that the Tafel slope is constant into and over the extrapolated region).

This technique has been used in the field to assess cathodic protection levels by driving the steel up the cathodic curve by increasing the applied current in a linear

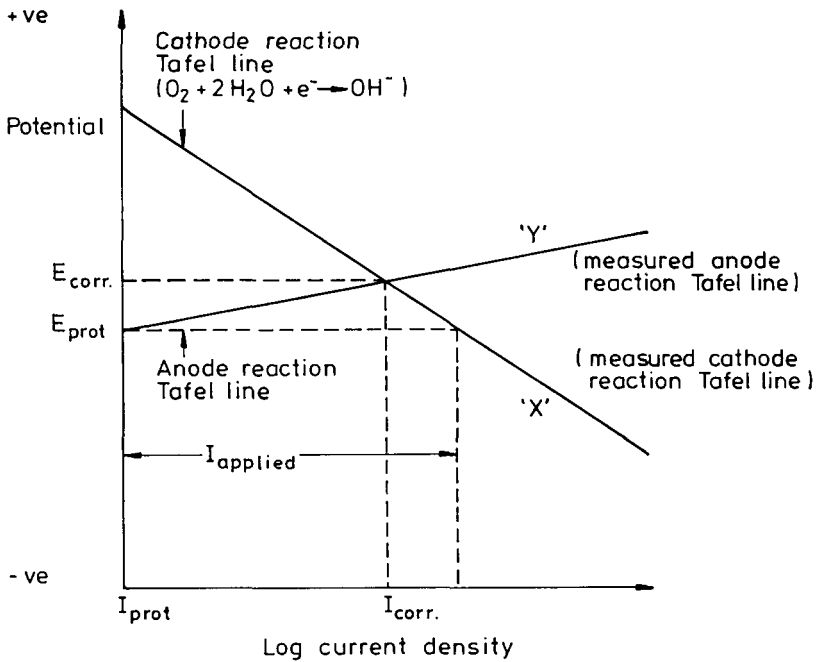

Fig. 6.5 Schematic polarization characteristics for activation controlled processes.

manner. The correct level of protection is judged to be at the point of inflection where the curve becomes a straight line, the so called 'Tafel' region, the theory being that at the point where the line becomes straight the anodic reaction has become insignificant, i.e. the cathode kinetics are dominating.

#### 6.4.2.2

##### *The measurement of polarization curves*

The problem with this method is the measurement of the polarization characteristics for representative steel in concrete systems. The polarization characteristics for a laboratory sample of corroding steel in concrete is shown in Figure 6.6. It can be seen that the characteristic has no extended Tafel region. In addition the result obtained is highly dependent on how it is measured. In a laboratory sample the area of steel being polarized is controlled by the sample size. However, in a real structure it is constrained by concrete resistance, with a progressive decrease in the effect of the imposed potential as the distance between the counter electrode supplying the current and the embedded steel reinforcement increases. In this case the polarized area is uncontrolled and not easily calculable. Usually no inflection point is seen and hence the protection level is impossible to judge. The technique is therefore difficult

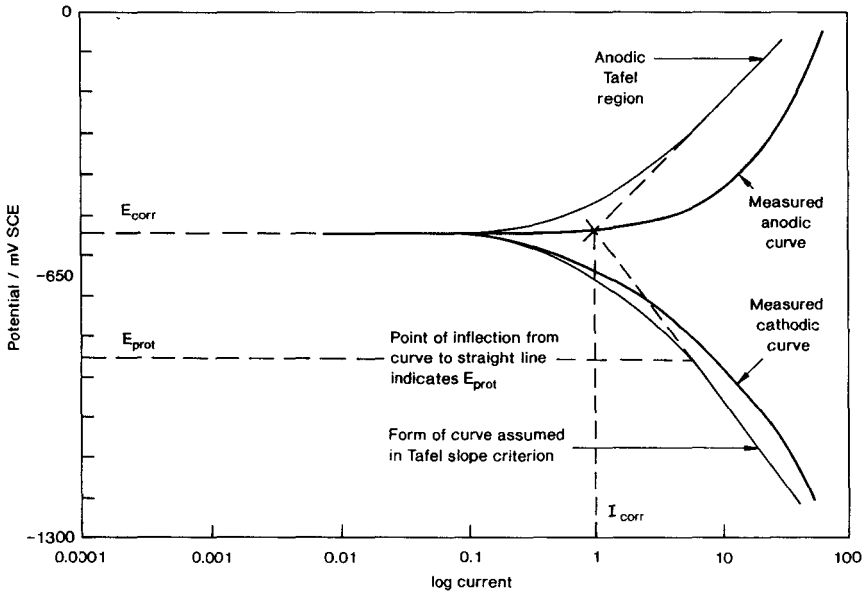

Fig. 6.6 Carbon steel polarization curves indicating basis of cathodic Tafel slope cathodic protection criterion.

to perform on real structures and the interpretation of the results obtained is not straightforward.

### 6.4.3 Depolarization

#### 6.4.3.1

##### *Basis of depolarization criterion*

The degree of change in potential with time of a metal when the cathodic protection is switched off is a widely used means of assessing cathodic protection levels in the field. The most commonly used criterion based on this method is the 100mV in four hours criterion. This is applied in practice by adjusting the current in the system over time to provide a difference in potential (a decay) of 100mV from the time immediately after removing the current (the instant-off value) and a period four hours later.

To examine the theoretical base of such criteria the changes that occur at the steel-concrete interface when the protection current is removed must be considered.

First, consider the above schematic system with activation controlled anodic and cathodic reactions which has been displaced from its free corrosion potential by the

application of a cathodic protection current to a new potential,  $E_{(\text{prot})}$ . On removal of the cathodic protection the system will return to its previous free corrosion potential,  $E_{(\text{corr})}$ , if the following are true:

- (a) the anodic area (pre-cathodic protection) re-activates and corrodes at its old rate;
- (b) the cathodic reactant is available at its pre-cathodic protection level;
- (c) the application of cathodic protection has not affected the rate at which the cathodic reaction occurs (for example by causing a film to form on the metal).

In reality all these criteria are unlikely to be fully met.

The original anodic area may have been changed by the application of cathodic protection such that the local chemistry will no longer support an anodic site. The cathodic current is known to transport the deleterious chloride ion away from the steel. This phenomenon is the basis of electrochemical chloride removal which can be described in basic terms as cathodic protection with a higher current applied for a fixed period of time. The technique is described in detail in [Chapter 8](#) of this book.

The cathodic reactant, because of its increased consumption during the application of cathodic protection, will be depleted from the region immediate to the metal surface and, depending on its diffusion rate and local convection, this depleted region will extend for some distance away from the interface.

Even if the conditions have not changed to a great extent the recovery will take time, while reactant concentrations, diffusion layers and local chemistry adjust to the new steady state.

The results obtained using this type of criterion on reinforced concrete structures would suggest that the dominant factor in deciding the magnitude of any potential change and the time taken for the potential to alter after removal of cathodic protection, is the depletion of oxygen at the protected steel during the application of cathodic protection. The depletion of oxygen, in combination with the lack of convection and slow diffusion in concrete, can result in large variations in the time taken for potentials to move a given amount.

In addition to the factors identified above, any potential movement following removal of a cathodic protection current depends on the relative quantities of oxidizing and reducing species present to exert a rest or corrosion potential on the system. If there is still a strong driving force for corrosion then the potential will move to the corrosion potential which will be fixed in a given region by the activity at corroding anodic sites and the local availability of oxygen. The rate at which the system moves to such a potential will depend on the factors discussed above, in the main, the rate at which oxygen can diffuse to the cathodic sites from which it has been depleted by the increased rate of its reduction brought about by the imposed cathodic protection current.

Where cathodic protection has been applied for a prolonged period it is quite likely that some areas that were originally anodic will have become inactive because:

- (a) the alkalinity generated by the application of cathodic protection has neutralized local acidity at the corrosion site.
- (b) the chloride level that originally initiated the passive film breakdown and subsequently allowed the corrosion to propagate has been lowered below the level required to initiate and support corrosion by the enforced migration of (chloride) anions away from the steel, driven by the impressed cathodic protection current.

In this case there will no longer be a strong redox couple exerting a definite corrosion potential on the system, the local potential being fixed by the balance between the passive current and the local oxygen level. The time taken to assert this potential, which will be more positive than a still corroding site potential, will again be dependent on the back diffusion of oxygen following the removal of cathodic protection.

#### 6.4.3.2

##### *The measurement of depolarizations*

The measurement of depolarization criteria requires the presence of a reference electrode, either at the concrete surface or buried close to the network of bars to be monitored. A surface electrode records the depolarization over a larger area of embedded bar but includes a greater element of loss due to current travel (IR) and hence potential error. The buried electrode is specific to the immediate area of steel close to it, limited by concrete resistivity. In each case the IR loss can be allowed for by measuring an 'instant-off' potential, i.e. the potential recorded immediately the cathodic protection current is removed but before any significant potential movement due to changing electrochemical kinetics can occur.

#### 6.4.4

##### **Other criteria**

A number of other ways of assessing cathodic protection systems have been used. In many cases these involve measuring the electrical current flow to an isolated section of metal which has been purposely embedded or isolated from the main reinforcing network. Such methods suffer from the problem that, although they indicate that the isolated metal has been satisfactorily protected, they in no way can represent the entire area of the structure and hence can only be regarded as a local indicator of a satisfactory level of protection.

#### 6.4.4.1

##### *Embedded probes*

Samples of steel can be embedded at selected points in a structure and their corrosion potential and the current supplied to them by the cathodic protection system monitored. Such measurements give an indication that the system is operating, however they are of limited use in determining the effectiveness of the applied cathodic protection. This is mainly because unless they are embedded at the time of construction, such samples are unlikely to be experiencing conditions representative of the steel reinforcing.

#### 6.4.4.2

##### *Isolated reinforcing bars*

In a similar manner to embedded probes, lengths of reinforcing bar can be isolated and the potential and current flow monitored. This method suffers similar problems to that above; the isolated sections only give an indication of conditions local to them and will not be representative of all parts of the structure.

#### 6.4.4.3

##### *Macrocell probes*

The macrocell probe is based on creating a local aggressive corrosion cell around an isolated section of steel. This is usually done by cutting out an area of concrete and purposely replacing it with steel embedded in chloride contaminated concrete. This steel is then tied to the main reinforcing network via a zero resistance current meter (a meter that presents no load to the system being measured). The current flowing to this purposely anodic region to the main network can be monitored ([Figure 6.7\(a\)](#)). When the cathodic protection system is switched on the current flow will be reduced as the system current is increased and the potential of the system becomes more negative. The satisfactory level of protection is taken as when the current between the artificial macrocell and the main network passes through zero and changes sign. At this point a net cathodic current is flowing through the macrocell from the anodes of the cathodic protection system ([Figure 6.7\(b\)](#)). Assuming the purposely created anode (the macrocell probe) is representative of the worst of the corroding areas on the structure and that the current distribution is representative for that of all the steel in the structure that is at risk, then it can be assumed that a satisfactory level of protection has been achieved.

6.4.4.4

Electrical resistance probes

Electrical resistance probes can be used to measure metal loss and hence corrosion rates by following the resistance of a steel wire as it corrodes and compensating the measured value for the effects of temperature. The resistance of a conducting wire being proportional to its length and inversely proportional to its cross-sectional area. However severe localized corrosion of the probe can lead to a pessimistic indication of corrosion rate. Resistance-based probes are at their best in predicting general corrosion rather than the localized corrosion that usually occurs in chloride contaminated concrete.

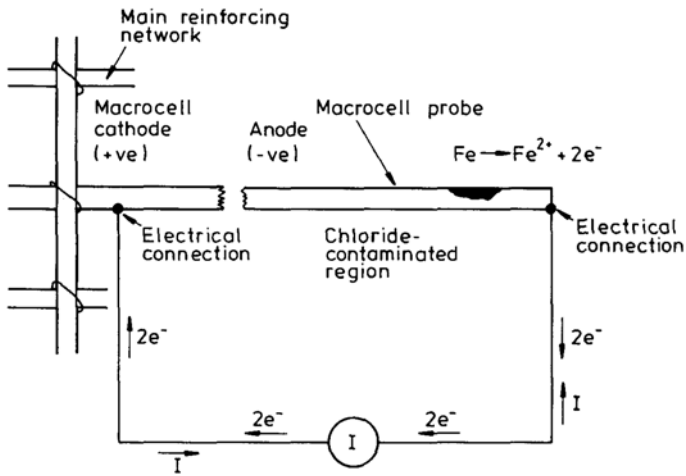

Fig. 6.7(a) Macrocell corrosion probe prior to the application of cathodic protection.

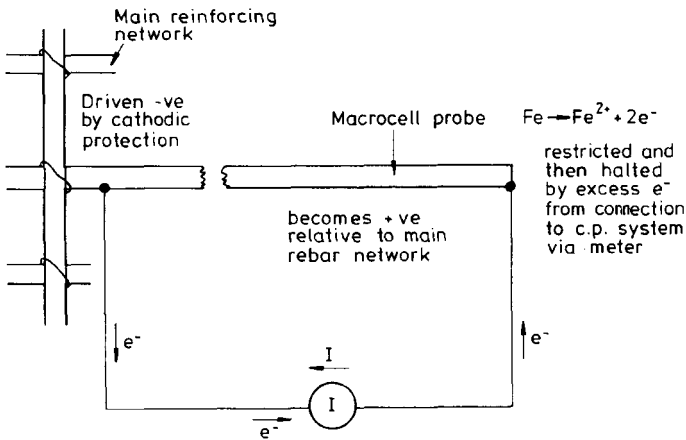

Fig. 6.7(b) Macrocell corrosion probe on application of cathodic protection.

## 6.4.4.5

*AC impedance response*

It has been reported (Thompson *et al.*, 1989) that the level of cathodic protection applied to a reinforcing bar in concrete can be determined by measuring its AC impedance response. AC impedance analysis is a well-established laboratory method for investigating electrochemical processes. The main features of an experiment are that a constant potential (or current) is applied to the electrode of interest, and then a small alternating signal superimposed. The phase and amplitude of the resulting current (or voltage) is measured between 100kHz and 1mHz.

The resulting current-voltage-frequency response can be plotted in a number of ways and the shape obtained interpreted to assess corrosion rate etc. In practice the data is difficult both to measure and interpret for many corroding systems even in the laboratory. Field measurements would require great care both in their measurement and interpretation before they could be relied upon to assess the level of protection achieved. It is also not clear that the theory has been sufficiently developed to allow an assessment of suitable levels of cathodic protection by this method.

## 6.5

## DISCUSSION OF POSSIBLE ELECTRICAL CRITERIA

In considering the successful application of cathodic protection to steel in concrete it is useful to consider the form of the Pourbaix diagram for iron. This has already been presented as [Figure 6.4](#). In [Figure 6.8](#) an experimentally measured diagram (Marrh *et al.*, 1988) is shown which indicates the effects of different levels of chloride on the passive, active and immune regions. From this figure it can be seen that there is a region which the steel is most likely to move into when cathodic protection is applied where the likelihood of chloride pitting corrosion is much reduced or removed. There is still a possibility of general corrosion, although this will only occur at a low rate and in a more uniform manner than the highly intense form of corrosion typical of chloride-induced pitting attack. It is most likely that it is this move which most steel in concrete cathodic protection systems rely upon. In most cases only a small change in potential is required to move into this region and this effect, plus the additional benefit of reducing the amount of current that can flow from the cathode macrocells surrounding the corroding anode, decreases the corrosion rate by a significant amount.

A further consideration is the acidification of the corrosion pit. As the corrosion reaction proceeds ferrous or ferric ions are produced in the pit. To maintain charge neutrality hydroxyl and chloride ions must flow into the pit. The hydroxyl ions combine with the iron and precipitate out as a solid when the saturation limit is reached.

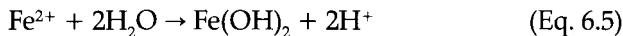

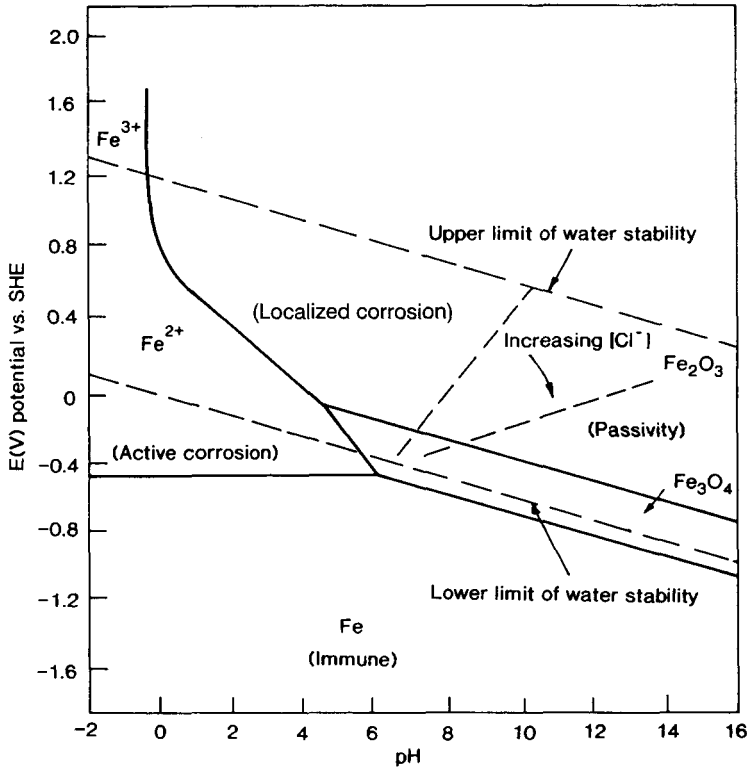

Fig. 6.8 Schematic Pourbaix diagram for iron in the presence of chloride ions.

The chloride ions are left in solution and, in combination with the protons left from the iron hydrolysis, cause acidification of the local pit area.

This acidification is important in deciding the thermodynamic potential at which corrosion becomes impossible, i.e. the potential at which the corroding area moves into the immune region on the Pourbaix diagram.

From Figure 6.4 it can be seen that for a pH of less than 6, the potential at which immunity occurs is a constant and has a value of approximately  $-500\text{mV SHE}$  ( $-850\text{mV CSE}$ ) i.e. the value used to protect steel in seawater and in soil (approximately neutral electrolytes). The implication of this is that once corrosion has initiated and is occurring at a significant rate then acidification will have also occurred at the steel-electrolyte interface and the  $-850\text{mV CSE}$  immunity criterion will apply. It should therefore not be necessary to take the cathodic protection potential at the steel-concrete interface below this level to ensure protection from chloride pitting corrosion. It should be noted that there is still the possibility of active general corrosion. However the rate of this reaction is very low.

The areas of steel in concrete that remain passive, usually the significant majority of the reinforcing network, will not polarize in the same manner as the actively corroding areas. This will be for two main reasons; the inherently different polarization characteristic and secondly the likely lower electrical resistance to current flow through the concrete in the corroding areas. In practice the cathodic protection current is applied through the concrete and no easy discrimination can be made between corroding and non-corroding areas, especially where they are adjacent to one another. Hence the same current flows to both types of area. The result of this is that the passive areas, because they have no strong electrochemical process occurring on them, are more strongly polarized than the corroding areas and therefore more likely to be overprotected resulting in hydrogen gas evolution.

From the above it can be seen that there is no single truly satisfactory way of assessing the correct level of cathodic protection on a corroding reinforced concrete structure, the major reason being that generally large areas of the structure that are being 'protected' by the cathodic protection system do not have depassivating species, such as chloride, present in them. They therefore have no tendency to corrode and are quite different in their electrochemical behaviour compared to the usually relatively small areas that are the subject of active corrosion. The criteria for assessing whether a satisfactory level of cathodic protection is being applied have been developed for the corroding sites; their application in regions where no corrosion is occurring can often lead to misleading results. This factor, the inherent inhomogeneity of the steel-cement interface in steel in concrete structures, along with the high electrical resistivity of concrete, is what makes cathodic protection of steel in concrete significantly more difficult to assess than steel in sea-water or other conductive, homogeneous media.

From the previous discussion it can be seen that the application of any significant level of cathodic protection is beneficial and also that the achievement of complete protection across a total structure will never be easy because of the range of possible local environments at the steel-concrete interface. It therefore appears that the best that can be practically achieved is to retard corrosion as much as possible without causing an undue penalty either in introducing other deleterious effects such as cathodic disbondment at the steel-cement interface or reduced life of the external cathodic protection anode. Both of which will result from excessive levels of protection.

It is probably best to consider cathodic protection of steel in concrete as a method of re-establishing passivity in the vast majority of corroding areas rather than a method of completely stopping corrosion over the entire structure. The pursuit of the latter objective will almost certainly result in significant wasted energy from excessive cathodic protection currents along with overprotection and its potentially deleterious effects occurring in a number of areas.

The different chemical environment and other factors (concrete resistivity, electrolyte geometry constraints etc.) mean that the electrical criteria used to judge that a satisfactory level of cathodic protection is being applied to a steel in concrete

structure will not be the same as those used to define correct levels in the applications where cathodic protection has been widely used and accepted in the past, these being in sea-water and buried structures.

The role of cathodic protection and its application over time in reducing the size and number of actively corroding areas while promoting the extension of passivity should be stressed. There are two major effects at the steel-cement interface resulting from the application of cathodic protection of steel in concrete. One is the production of alkalinity at the previously corroding anode and the subsequent promotion of a return to the passive state (Glass and Chadwick, 1994). The second is the removal of chloride from the interface as it is drawn by the imposed potential gradient towards the cathodic protection system anode.

These effects persists for some time after cathodic protection is removed and therefore introduce the possibility of extending the lifetime of cathodic protection systems by operating them intermittently, as long as adequate monitoring is carried out to ensure significant corrosion is not occurring. Similarly, because the application of cathodic protection and the resultant potential gradient acts as a highly effective barrier to chloride ingress through the concrete cover to the embedded steel (Glass *et al.*, 1994), it can be proposed for structures at risk from corrosion caused by chloride exposure but which are not yet suffering from such attack.

In summary, the electrochemical behaviour of steel in concrete is strongly influenced by the properties of the embedding concrete: its low permeability, retardation of diffusion and convection and variable oxygen permeability all lead to a slow achievement of equilibria. Any criteria must take this variability into account.

The best criterion has to balance the practical considerations of ease of measurement and simple equipment with the requirement for a scientific basis and a reproducible reliable result. On these grounds, a combination of current-off depolarization and a minimum potential limit (the hydrogen evolution potential) would seem to offer the best practically achievable criteria that have some basis in electrochemical theory. The minimum potential limit can be substituted with monitoring the cathodic protection anode to steel reinforcement 'instant-off' potential to ensure it does not exceed an absolute potential of approximately 1.3 volts (this would ensure significant hydrogen evolution is not occurring).

If it is assumed that the corrosion reactions are under activation control, then a potential decay in the range 60–150mV should, based on electrochemical principles, result in a significant (order of magnitude or more) reduction in corrosion rate. Within this range the greater the potential decay that can be achieved the better as long as the minimum potential or the not greater than 1.3 volts. In many cases attempting to achieve decays in excess of this range will lead to overprotection in at least some areas of the structure.

The imposition of an arbitrary time limit (e.g. the four-hour decay) on the depolarization can only be justified on practical grounds. It is always beneficial to measure the rate of change of potential with time, and should the potential still be

changing after (e.g.) four hours the measurement continued, or at least the fact that the potential is still decaying recorded.

## REFERENCES

- Glass, G.K. and Chadwick, J.R. (1994) *Corrosion Science*, **36** (12) 2193–2209.  
 Glass, G.K., Zhang, J.-Z. and Buenfeld, N.R. (1994) *Eurocorr* 94.  
 Marsh, G.P., Bland, I.D. and Taylor, K.J. (1988) *British Corrosion Journal*, **23** (3).  
 Thompson, N.G., Lawson, K.M. and Beavers, J.A. (1988) Monitoring cathodically protected steel in concrete structures with electrochemical impedance techniques, *Corrosion*, **44** (8).  
 Vassie, P.R. (1988) The influence of steel condition on the effectiveness of repairs to reinforced concrete, *UK Corrosion*, 183.

## BIBLIOGRAPHY

- Apostolos, J.A., Parks, D.M. and Carello, R.A. (1987) *Materials Performance*, **26** (12).  
 Berkeley, K.G.C. and Pathmanaban, S. (1989) *Cathodic Protection of Reinforced Steel in Concrete*, Butterworths, London.  
*Cathodic Protection of Steel Reinforced Concrete* (1989) Concrete Society Technical Report No. 36.  
 Cherry, B.W. and Kashmirian, A.S. (1983) *Brit. Corros. J.*, **18** (4).  
 Funahashi, M. and Bushman, J.B. (1991) *Corrosion*, **46** (5).  
 Gummow, R.A. (1986) *Corrosion* '86, paper #343, NACE Houston, USA.  
 Hausmann, D.A. (1969) *Materials Protection*, **8** (10), 23.  
 Kendall, K. (1986) The cathodic protection of reinforced concrete using polymeric anodes in the European context, *UK Corrosion* '86, Birmingham, England, I.Corr.S & T.  
 Lehmann, J.A. (1987) Cathodic protection of reinforced concrete structures, *Materials Performance* **26** (12).  
 Lewis, D.A. and Chess, P.M. (1988) *Industrial Corrosion*, Sept., 11.  
 NACE Standard Recommended Practice (1987) *Design Considerations for Corrosion Control of Reinforcing Steel in Concrete*, RP0187–87, Dec.  
 Pithouse, K.B. (1986) *Corrosion Prevention and Control*, **33** (5).  
 Schell, H.C. and Manning, D.G. (1985) *Materials Performance*, **24** (7).  
 Slater, J.E. (1971) Protection methods, in *The Corrosion of Metals in Association with Concrete*, ASTM STP #818, ASTM.  
 Slater, J.E. (1979) Criteria for adequate cathodic protection of steel in concrete, *Corrosion* '79 Atlanta USA, Paper #132, NACE.  
 Thompson, N.G., Lawson, K.M. and Beavers, J.A. (1989) *Corrosion*, **44** (8).  
 Unz, M. (1955) *Corrosion*, **11** (2), 80.  
 Unz, M. (1956) *Corrosion*, **12** (10), 526.  
 Vrable, J.B. and Wilde, B.E. (1979) *Corrosion* '79, paper 135, NACE Houston, USA.  
 Wyatt, B.S. and Irvine, D.J. (1986) Cathodic protection of reinforced concrete, *UK Corrosion* '86, Birmingham England, I.Corr.S & T.  
 Wyatt, B.S. and Irvine, D.J. (1987) *Materials Performance*, **26** (12).  
 Wyatt, B.S. and John, D.G. (1988) *Industrial Corrosion*, Sept., 15.

# New reinforced concrete: upgrading and maintaining durability by cathodic protection

*Richard Palmer, Consultant*

## 7.1

### INTRODUCTION

Reinforced concrete is an excellent material for cost-effective construction of structures. The material is capable of achieving the required strengths and, with care, the necessary durability. The reserve within this statement is due to recent evidence that reinforced concrete is vulnerable to damage from the environment. This increased vulnerability is believed to result from changes in the manufacture of Portland cement concrete. The indications are that these changes, aimed at developing higher strengths, have decreased the beneficial ageing effects found with older concrete. To reduce the risk of substantial deterioration within the planned lifetime of the structure, designers are now including other durability enhancements such as cement replacements, cathodic protection (CP) and coated reinforcement, to name but a few. The designer is free to incorporate one or more of these techniques according to the degree of deterioration risk considered acceptable. In this chapter the technique of CP will be reviewed with particular emphasis on the use of mixed-metal-oxide (MMO) anodes and their use in providing additional protection to new reinforced concrete structures.

Throughout the 1970s and '80s there was an increased awareness that under certain environmental conditions reinforced concrete could deteriorate, principally due to corrosion of the reinforcement. After much research, today's design codes offer improved guidance with regard to design for durability. This new awareness, together with advances in concrete technology, has led to improvement in the durability provision for concrete structures. Notwithstanding this improved awareness, the existing codes only assist with rules aimed at providing required properties such as cover depth, cement content and water/cement ratio. They do not give guidance on the service life that the above properties will achieve or on the maintenance requirements. The financial significance of this situation is demonstrated by ongoing BRITE EURAM research work (BRITE EURAM Project, 1998). This

project, undertaken by leading research groups within the European Community, aims to remove many uncertainties with regard to design for durability.

## 7.2

### UPGRADING AND MAINTAINING DURABILITY

Repair and maintenance are necessary considerations throughout the life of a concrete structure. An industry has grown up to provide these services at varying levels of sophistication. A large element of this work is aimed at remedies for reinforcement corrosion damage due to inadequacy of the concrete cover zone in protecting embedded reinforcement.

The principal cause of this corrosion damage is penetration of aggressive agents from the environment. Of these the major problems arise from carbon dioxide in the atmosphere and chloride ions in de-icing salt or sea-water.

Carbon dioxide penetrates pores in the concrete cover and combines with water to produce carbonic acid. This action, termed carbonation, results in converting the normal level of internal alkali reserves found within fresh concrete to inert carbonates. Concrete so effected (or carbonated) no longer has the necessary alkalinity to maintain embedded reinforcement in a passive state and hence, once carbonation has penetrated to the reinforcement, corrosion can start. This form of deterioration can be readily evaluated and treated. If damage is slight then carbonated concrete can be replaced and anti-carbonation coatings applied. If damage is extensive, the electrochemical technique of re-alkalization may be used before applying a protective coating. The 'inert' nature of the carbonated concrete hence enables a generally straightforward repair approach to be coupled with future maintenance of applied coatings.

Chloride ion attack is more difficult to combat. Chloride ions arrive at the concrete surface in solution, either from sea-water or de-icing salt solution, and are transported into the concrete pores by diffusion as described by Bamforth (1994a). Chloride ions can penetrate even well-designed concrete mixes and with time will build up around the reinforcing steel. At a critical concentration of chloride ions, corrosion will commence. The penetration of chloride ions does not, as in carbonation, result in a static and inert zone of damaged concrete. The variability of concrete properties, even within a single casting, and the high mobility of chloride ions within the concrete pore structure enable contamination to variable depths and concentration levels. There is an absence of effective on-site tests to determine the extent of chloride damage. Furthermore the continued mobility of chloride ions makes it difficult to calculate the corrosion risk for a damaged structure. In essence, chloride contamination presents more of a moving target. The initial repair approach of cutting out and replacing contaminated concrete from spalled areas has been found not to work due to continuing chloride activity. This situation has given rise to a difficult maintenance task for chloride contaminated structures. A typical example

would be a circa 18000m<sup>2</sup> CP installation to a reinforced concrete jetty in Hong Kong. This structure, well designed in accordance with relevant codes of practice, was 16 years old when a major programme of refurbishment was needed to secure the structure for its remaining lifetime. Patching of spalled concrete areas had already been tried but without success. Then a CP system was applied to the structure. The system comprises a MMO anode within a cementitious overlay. The remedial works have arrested the rapid corrosion decay of the reinforced concrete sub-structure and provided an effective durability upgrade.

While CP can be used to treat carbonation damage its principal application and the subject of this text is its use for protection against chloride damage and in particular for new structures. The procedure for evaluating repair strategies for existing structures has been thoroughly documented by Schiessl (1992).

The marine and de-icing salt environment can prove particularly harsh for concrete structures, subjecting them to continuous cycles of saltwater wetting and drying. The vulnerable areas are those within the tidal and splash zone where wetting cycles result in excessive build-up of chloride contamination within the concrete pore structure. The high chloride concentrations set up diffusion gradients allowing chloride ions to move into the concrete, eventually arriving at the reinforcement surface. In sufficient quantities the chloride ions are then able to disrupt the normal passive conditions for steel in concrete, causing reinforcement corrosion. The steel corrodes to occupy a greater volume and exerts tensile stresses on the cover concrete resulting in spalling. If allowed to proceed unchecked, corrosion damage can lead to structural weakening. The time period from construction to initial corrosion damage will vary as a function of type of cement, water-cement ratio, depth of cover and the local environment. To indicate the extent of the problem, periods of 10 to 15 years to first corrosion damage are typical for reinforced concrete in exposed locations. The time for major maintenance will depend upon local environmental conditions and the particular structure. Continued function is usually the major consideration, although aesthetics often influence the onset of the maintenance programme.

When dealing with new structures, many designers now include additional durability enhancement in very high-risk areas. A good example of this might be the tidal and splash zone of bridge piers in a marine environment. In this situation, the life-cycle cost of additional protection is generally small in comparison to the cost of future access and repair. The technique of CP is ideally suited for this application as it can be specifically designed to target areas of the structure that are at risk from the environment. The aforementioned MMO anode is equally suitable for CP of new structures, both due to its stability in operation and to its long life. The design and practical installation of CP using MMO anodes is discussed later in this chapter.

## 7.3

## ALTERNATIVE TECHNOLOGIES TO CP

From the previous discussion it is clear that the durability of reinforced concrete is largely a measure of the concrete's ability to control penetration of aggressive agents from the local environment. The principal area of concrete for improvement of durability is hence the reinforcement cover zone. Concrete permeability is a fundamental characteristic for improvement as reductions in permeability considerably enhance the degree of protection. A further consideration is the ability of concrete to neutralize chemically and combine chlorides, thereby increasing the time taken for chlorides to initiate corrosion. The durability of reinforced concrete, particularly with regard to chloride attack, may be improved by several classes of treatment:

- modifying the concrete mix;
- enhancing the curing process;
- applying physical surface barriers (coatings) to concrete;
- applying electrochemical barriers, e.g. CP, inhibitors;
- applying coatings to the reinforcement.

These classes of additional durability enhancement should be selected on the basis of cost-effectiveness over the life of the structure. To assess this for the chosen technique (s) it is necessary to look at the initial capital cost of application together with its effective lifetime and maintenance costs.

The first two classes of treatment are integral to design and production of the required concrete and it is assumed that for a new structure, the best practices will be employed. These include the use of cement replacements as described by Bamforth (1994b). Concrete admixtures also fall within this group. There are a range of these admixtures such as acrylic polymers, stearates etc., which impart water reducing, waterproofing and other properties designed to improve various qualities of hardened concrete. The function of such admixtures is described in most comprehensive texts on concrete such as that by Neville (1975).

The impact of concrete curing on permeability is well-documented (Neville, 1975), hence it is clear that measures to ensure adequate curing are fundamental to optimizing durability. A further technique utilizing this principal is the use of permeable formwork ('Zemdrain' Permeable Formwork, 1993). The ability of the formwork to optimize the quantity of water required for cement hydration results in a concrete cover zone of enhanced durability together with an improved surface finish.

Coatings, the third treatment class, fall into two general categories. These are either penetrative or surface coatings. Penetrative coatings such as silane, are shown to waterproof the concrete thereby resisting the uptake of chloride-bearing water. Surface coatings are available in many formulations. They comprise combinations of

up to four constituents, a binder, inert fillers or pigments, liquid solvents/dispersants and additional additives for particular properties. Typical binders include chlorinated rubber, epoxy resin, polyurethane resin, all of which have particular uses in the construction industry. The choice of coating constituents dictate the resultant performance characteristics such as adhesion, permeability, wear resistance, ease of application and cost. The large variety of available coatings now available necessitate preliminary research before selection. The reader is recommended to consult the Paint Research Association for background information together with manufacturers and users for accurate lifetime and cost data. Typically the life of a coating system can vary from circa 5 to 15 years depending on the material type. When comparing different systems, allowance should then be made for the cost of re-gaining access to the structure and of maintaining/renewing the coating. While coatings may be advantageous in protecting and decorating buildings they are less suitable for low maintenance protection of exposed marine civil engineering structures against chloride attack.

The last two classes of treatment, electrochemical barriers and reinforcement coatings, adopt an alternative strategy. The contaminants are allowed to penetrate towards the reinforcement but their corrosive effect within the concrete is either neutralized or reduced.

Three forms of electrochemical applications are currently in use: CP, chloride removal and re-alkalization. Re-alkalization is a technique designed to treat carbonated structures while electrochemical chloride removal is a technique derived from CP but using much higher applied current densities to move chloride ions away from the reinforcing steel and out of the concrete. Both techniques are intended for short-term use with subsequent coating application to avoid subsequent re-contamination. Both chloride removal and re-alkalization are described in detail in another chapter.

The oldest electrochemical technique is CP. The CP mechanism is more fully described in other chapters of this book. Particular applications using MMO anode systems will be reviewed later. Initial guidance on the use of electrochemical refurbishment techniques can be obtained from the Society for the Protection of Reinforced Concrete.<sup>1</sup>

Also within the category of electrochemical barriers are chloride inhibitors. These work by producing electrochemical conditions at the rebar-concrete interface which inhibit corrosion reactions by contaminants. There are a number of treatments currently available. These comprise chemicals such as sodium monofluorophosphate (MFP) and calcium nitrite. A more detailed review of these systems and their relative performances is given elsewhere (Pressman *et al.*, 1991).

The last of the listed classes of treatment proposed for durability enhancement is to apply a barrier coat directly to the reinforcement. This process, referred to as Fusion Bonded Epoxy Coated Reinforcement (FBECR), entails the use of factory a prepared and coated bar. The FBECR should be manufactured in accordance with the

guidelines issued by the British Standards Institute (BSI) (BS 7295,1992). It is important to use high-quality product and to be cognisant of the possible effects both of poor installation handling and of interaction with uncoated reinforcement. For a state of the art review of future developments in this area the reader is referred to current work being undertaken on behalf of the Federal Highways Authority (FHWA), USA (FHWA Project, 1993–98).

#### 7.4

#### CP USING MMO ANODES

CP is a well-established technique for long-term protection of new and existing concrete structures exposed to corrosive conditions. A list of significant milestones in the history of CP is given in [Table 7.1](#). The technology, which has been applied to a large variety of structures world-wide, enjoys a 20-year experience base. The use and specification of CP for reinforced concrete is described in Concrete Society reports No. 36 and 37 (Concrete Society 1989 and 1991) and in NACE Standard RP0290–90 (1990).

CP is successful in treating attack by chloride because it operates upon the ‘as found’ contaminated state of reinforced concrete and subsequently modifies the electrochemical state causing corrosion so as to prevent further deterioration. The CP approach avoids the expensive removal of large quantities of chloride contaminated concrete and minimizes the downtime associated with repair. It provides a long-term rehabilitation method and requires only minimal maintenance.

While there are many proprietary anode systems available today this section describes the characteristics and uses of high performance MMO anodes, specifically those using a titanium substrate. This anode type is alternately referred to as the DSA<sup>®</sup> anode. Discovered by Henry Beer, the anode was first patented in the USA and Europe between 1966 and 1973 (Beer, 1966; Nora *et al.*, 1973). These anodes were found to perform with great stability at very high applied current density levels in aggressive environments. Over the following ten years MMO anodes largely replaced graphite anodes for use in the chlor-alkali industry.

Readers seeking a detailed description of the electrochemistry of a MMO anode are recommended to consult Trassati (1981). Briefly, the anode comprises a substrate valve metal (typically titanium) with a MMO coating applied to the surface. A valve metal is one which will passivate (form a protective metal oxide and hence stops current flow) if connected in circuit as an anode. This property gives titanium exceptional corrosion resistance. Of course it also means that, in order to persuade titanium to work as an anode, the surface has to be activated in some way such that current can flow. In order to do this, a thin layer of MMO (electrocatalytic) coating is applied to the titanium substrate. It is this coating which provides the active anode surface. The coating consists of one or more oxides of the platinum group metals such as iridium, ruthenium, palladium etc. It is applied to a prepared surface and heat

treated to form a MMO film of exceptional electronic conductivity. It has the further benefit of being resistant to accidental current reversal and tolerant of AC ripple from power supplies. The combination of substrate metal and MMO coating provides a durable anode, physically tough, easy to handle and inert to corrosion attack, and suited for long-term protection of reinforcement in concrete. The MMO anode surface is hard (around 6 on the Mohs scale) and hence resistant to abrasion. In this respect the anode will stand a good amount of physical handling on site including being subjected to shotcrete impact where this technique is used to encapsulate the anode.

The MMO anode initially found favour due to its ability to withstand high current densities in aggressive environments. In its original environment, electrolysis cells within the chlor-alkali process, the anode is required to operate for a period of six months to one year at an anode surface current density of between 1 and 12kA/m<sup>2</sup>. The MMO anode coating is consumed at a very low rate during this process (hence the original designation of DSA or dimensionally stable anode) further indicating its suitability as an embedded anode for CP of reinforced concrete. When used within reinforced concrete the anode is set to operate at a maximum surface current density of circa 108 mA/m<sup>2</sup> and at this current density the lifetime is estimated at in excess of 40 years. The MMO anode will deliver a certain amount of charge (current×time) as determined by the applied coating and its operating environment. As the current density demand reduces during CP operation, so the lifetime extends. MMO anodes are tested for suitability in accordance with NACE standard TM0294–94 (NACE, 1994). This is an accelerated test designed to ensure that the anode will provide a minimum charge density of 38500Ah/m<sup>2</sup> (40 yrs at 108mA/m<sup>2</sup>) during its lifetime, and will endure current reversal (fault) conditions for one month with no adverse effects, all within three different aqueous solutions to mimic various environments in concrete. The MMO anode exhibits a linear relationship between lifetime and current density as plotted on a log-log scale. Thus for each anode type it is possible to derive a relationship of the form:

$$\text{Log Life (yrs)} = A \cdot B \times \text{Log Current Density (A/m}^2\text{)}$$

where A=Constant and B=Curve gradient

Put simply, less current density from the anode results in longer lifetimes. Using the above characteristics it is possible to design MMO anodes for long life operation in reinforced concrete environments.

The lifetime versus current density characteristic is useful to bear in mind when considering the mechanism of CP in reinforced concrete. Under operation the following effects can be measured:

- an immediate shift of reinforcement potential to more negative values thereby arresting corrosion activity,
- a migration of chloride ions away from the reinforcing bar surface,

- a cathode reaction which generates hydroxyl ions (OH)<sup>-</sup> at the bar surface.

The later two effects lead to a continual improvement in the environment around the reinforcement with a corresponding reduction in the current density required for continued CP. Hence MMO anodes protecting existing contaminated structures need less and less current density throughout their lifetime. As the current density reduces the lifetime of the anode is further extended. Given a lifetime of circa 40 years for a MMO anode at maximum rated current density it is clear that with a reduction in required output the lifetime will become far greater. In the case of CP designs for new structures, the CP anode system is designed to protect against worst-case scenarios which should not arise while the system functions. This gives a similarly long lifetime to CP anodes used to protect new structures.

## 7.5

### DESIGN CONSIDERATIONS

MMO anodes are produced in a variety of configurations by manufacturers based either in the USA or Europe. Typically MMO anodes for CP of reinforced concrete are produced in an expanded metal mesh format. These are available in sheets of approximate width 1–1.2 metres and also in a narrower expanded metal ribbon format at widths of between 10 and 20mm.

The mesh anode format was initially developed for the CP of existing structures. However it has subsequently been successfully used for protection of new structures. The anode is lightweight and easily handled. It is produced in various output grades by varying the ratio of actual anode surface area to the projected planar surface of the anode. That is to say, if one square metre of anode mesh has a measured surface area of 0.15m<sup>2</sup> and the current density on the anode surface is limited to 108mA/m<sup>2</sup> (see below) then the anode output is quoted as 108×0.15=16.2mA/m<sup>2</sup> per square metre of concrete. Typically, mesh anodes are available in outputs of between 16 and 40 mA/m<sup>2</sup> at the quoted upper limit of applied surface current density. These anode sheets are applied in single or multiple layers to achieve the required current densities for protecting embedded reinforcement. An illustration showing the use of multi-layered anode material is given in [Figure 7.1](#). In this photograph, a double layer of anode mesh can be seen fastened around steel piles during protection of an existing jetty structure at Kwai Chung in Kowloon, Hong Kong. Note that it is also possible to combine mesh and ribbon anode materials. Electrical current is generally introduced to the anode mesh via a primary gridwork of current distributor (cd) bars. This material is fabricated from grade 1 titanium and supplied in strips of between 10 to 15mm width. It is joined to the anode mesh by spot-welding using a standard electrical resistance spot-welder.

While the use of multi-layered anode provides a means of varying the current density to correspond with differing reinforcement densities, research has shown that



**Fig. 7.1** Kwai Chung Jetty, Kowloon, Hong Kong. A double layer of anode mesh can be seen fastened to the concrete surface to provide a locally increased CP current. This increased current requirement is due to the greater embedded steel surface of the steel piles.

the application of  $n$  layers does not provide a full  $n \times$  increase over the single layer output (Pastore *et al.*, 1992). Investigation and practical experience indicate that the introduction of subsequent anode layers can reduce the maximum layer efficiency to between 60 and 80%.

The anode may be fixed to a prepared concrete surface and then secured by encapsulation within a cementitious overlay. Alternatively it may be cast into the concrete element. The recommended cover to the MMO anode is not less than 10mm. It is important to note, however, that in locations where the anode will be embedded in an offshore environment such that it will be at times below the surrounding water level, additional precautions should be taken. In this situation it is necessary to avoid the possibility of CP current flowing preferentially outside the structure through low resistivity sea-water. Discontinuities in the anode cover will allow the current to take a lower resistance return path and hence create a condition of local high-current flow from the anode. This will reduce both the current density provision to surrounding reinforcement as well as the anode lifetime. In a 1991 report describing CP installation to the Tay Bridge (Walters, 1991), it was concluded that concrete cover to the anode be increased to greater than 20mm and that a wellcured and high-resistivity concrete be used. An illustration from this successful project is given in [Figure 7.2](#) overleaf. This shows the base of a bridge pier which is

being strengthened and provided with CP. The anode is fastened deeply within the structure prior to pouring concrete. The anode and additional reinforcement were cast in concrete in one operation. A subsequent review of CP applied to this structure by Glass (Baldo, 1991) reports that in 1996, CP is providing continued protection while demonstrating that the technique is improving the environment for existing reinforcement. Various solutions have been used in order to insulate the anode. These have included the use of cast-in-place fibre-glass or glass-fibre cement shuttering panels. The solution will depend on the particular project.

For CP of new or old structures the anode is fastened with the aid of special non-metallic fixings prior to encapsulation or casting in by concrete. It is essential to avoid electrical contact between anode and cathode (rebar). A minimum spacing of 13mm is recommended between anode and reinforcement. Particular details for installation are given in the model specification published by the Concrete Society (1991).

Concrete separating the anode and reinforcement (cathode) provides the electrolyte which allows current to flow through the CP circuit. It is required to provide a secure means of fastening the anode prior to and after encapsulation, and also to form an uninterrupted path for ionic current to pass between it and the reinforcement.

The ribbon anode type is well suited to the CP of new concrete structures. The anode may be fastened to the reinforcement cage during assembly using special fastenings. For reasons of economy and uniform current distribution, the general practice is to connect the anode to a primary current distribution network of current distribution bars. The ribbon anode is then spot-welded to the bars. The anode spacing is calculated on the basis of required current density at the rebar. One should ensure that the ribbons are not too widely spaced. Using higher output ribbon at too great a spacing leads to an unacceptably uneven current distribution across the reinforcement cage. Applied research indicates that a maximum ribbon spacing of between 200 to 400 mm centre to centre should be adopted depending on the parameters of the structure to be treated (Strategic Highway Research Program, 1993; Biagioli *et al.*, 1993).

Ribbon anode is easily and rigidly fixed to the reinforcement cage so as to present a minimum profile to flowing concrete. Thus the possibility of anode displacement during the concrete pour is minimized. Nonetheless, it is recommended that the anode is electrically monitored during the concrete pour in order to ensure that no short circuits develop between it and the reinforcement. This straightforward operation is carried out with a high-impedance voltmeter. Simply connect the voltmeter between anode and cathode in the area of the pour and set initially to the 0–200 mV range or thereabouts. Where the installation has been carefully done there will be no contact between the anode and cathode and hence no initial voltage reading. Before and during pouring concrete it is customary to place a wet between anode and rebar. This will enable the meter to register potential differences across the cell so created between the anode and the reinforcement. As soon as the concrete

pour starts there will be a steady change in recorded potential difference as the concrete electrolyte encloses more of the anode and reinforcement surface area. A short-circuit condition is marked by a dramatic switch to a potential difference of or very close to zero mV. Experience in recognizing this situation is easily gained. In the event of a short-circuit condition it is necessary to temporarily halt the concrete pour and displace the anode local to the pour position until the short-circuit condition is removed.

In the event of a short-circuit condition being discovered after the concrete has hardened, a number of solutions are available. The first approach is to apply a high current density, circa  $2A/m^2$  of concrete for a period of not greater than one minute. This action will generally destroy the short-circuit contact. In the event of continuing short-circuit conditions it is necessary to locate the fault. This may be achieved by measuring and plotting the anode potential contours across the surface of the CP zone containing the short circuit. The potential contours indicate the location of the short circuit. Once located the area can be broken out, the fault repaired, and concrete reinstated.

Typically the current density provided at the MMO anode surface is limited to a value of  $10mA/ft^2$  of anode ( $108mA/m^2$ ) resulting from early work by the FHWA in the USA. This current limitation was introduced to avoid any risk of damage to cement paste in contact with the anode surface as a result of acid generation. While this value is generally adhered to it should be noted that the MMO anode manufacturers have commissioned independent test programmes which verify that these anodes can be run at far higher surface current densities, of the order  $400mA/m^2$ , for a limited time without damage to the anode or surrounding concrete.

The above consideration is less important when designing anode systems for new structures as the initial current demands are low. The requirements when designing an anode system for a new structure are:

- selection of anode zone based generally on the local environment and on ease of control of the CP system;
- calculation of the reinforcement area influenced by the CP;
- calculation of the required current density for CP.

The guidance given by the Concrete Society is for anode zone sizes to be limited to between  $200$  and  $500m^2$  of concrete in size. It is not possible to be precise with this figure as it depends on the particular structure. Say, for example, a pier is to receive CP, and that there exists a small zone around the pier footing where the concrete is wetter due to capillary rise from groundwater, then that area will generally require a higher current density for protection. In this instance it is preferable to create a separate CP zone at the base in order to allow better control of the installation. Selection of anode zones is largely a question of experience, taking into consideration the structure and the local environment.

The depth to which CP current will flow has been evaluated by several researchers. The majority of research in this area has been directed at the distribution penetration of current in existing concrete structures. Hunkeler (1992) presents a resistivity model for use in calculating the division of current density between top and bottom rebar in the case of a reinforced concrete slab, following his work evaluating a CP installation at the San Bernardino Tunnel in Switzerland. His site measurements indicate that for a circa 300mm thick slab, approximately 70% of the current will flow to the top mat of steel with the remaining 30% to the bottom. He also presents a model for calculation of the current penetration which again uses the concrete resistivity as the controlling factor. This is in general agreement with Bennett (1994) and with Pedferri (1992).

Bennett's work, also directed at existing concrete structures, shows the current density required for CP to be proportional to the level of the chloride contamination. Using Bennett's example, the CP current for the zone is calculated using the formula:

$$\text{mA/m}^2_{\text{concrete}} = (\text{mA/m}^2_{\text{top mat steel}}) \times (\text{m}^2_{\text{top mat steel}}/\text{m}^2_{\text{concrete}})$$

for double mat of steel divide  $\text{mA/m}^2_{\text{top mat steel}}$  by 0.7 to get total current requirement per concrete area.

However, Pedferri's work (1992) relates specifically to new structure CP. He presents data which clearly indicates that CP currents will flow to far greater depths in new concrete structures due to the absence of chloride and the consequent corrosion activity. Italy has been foremost in the development of this application having installed circa 100 000m<sup>2</sup> of CP to several new post-tensioned highway viaducts in Italy (Biagiolli *et al.*, 1993). The PIARC Technical Committee on Road Bridges (Baldo, 1991), published a document in 1991 which acknowledges this technique for new structures and gives broad guidelines for its use. To summarize, current literature indicates that reinforcement within non-chloride-contaminated concrete, i.e. new structures, and located at depths of up to 40cm from the anode may be cathodically protected.

The current requirement per area of reinforcing steel may be graphically estimated from knowledge of the chloride concentration. Later work underway at Imperial College (Glass and Buenfeld, 1995) confirms this general relationship while further demonstrating the significance of the electrochemical displacement of chloride ions and generation of alkali conditions; further important effects of applying CP to reinforcement in concrete.

Practical evidence of the relationship between chloride level and the current density required for is reported for a circa 100 000m<sup>2</sup> CP installation to several new post-tensioned highway viaducts in Italy (Biagiolli *et al.*, 1993). Data showed that the polarization criteria are met in the case of uncontaminated new concrete structures by current densities between 1 and 2mA/m<sup>2</sup> steel with concurrent voltage requirements of 2–3.5 volts. Conversely, in the case of high chloride levels (1–3% by weight of

cement), current densities of between 15 and 20mA/m<sup>2</sup> of steel area are required with typical corresponding voltages of between 10 and 15 volts.

Other design considerations, such as cable connection integrity, reference probe selection etc., are common to all CP systems and are dealt with in other chapters of this book.

## 7.6

### EXAMPLES OF NEW STRUCTURE CP

While some project references have been made in the above text the following section provides further examples of particular CP installations to reinforced concrete of new structures or newly cast elements.

The aforementioned Tay Bridge has been undergoing a programme of CP repairs for which evaluation work started in 1986. While this is clearly an existing structure the CP installations have entailed installing a CP system comprising a MMO mesh anode fixed to a prepared concrete substrate beneath supplementary reinforcing steel. Refer to [Figure 7.2](#) for installation. Both the anode and additional reinforcement were then cast within fresh concrete. Using this technique the base of bridge piers within the tidal and splash zone has been increased in section while at the same time a CP system has been introduced to enhance the durability. Another UK installation of CP to new reinforced concrete was the Felixstowe Ro-Ro ferry bridge project carried out in 1991. For this structure a combination of mesh and ribbon anode was cast into the reinforced concrete to provide continuous corrosion protection.

In France, an innovative CP installation was carried out in 1989 to provide CP to a new 650m<sup>2</sup> bridge deck at Hauteville-sur-Fier. A MMO mesh anode was embedded during prefabrication of deck slab units. This was easily achieved during the pre-casting process. After pouring concrete to cover the top reinforcement layer adequately, panels of mesh anode, together with the pre-welded current distributor bar, were placed. [Figure 7.3](#) shows the mesh anode being placed and clamped to the pre-casting frame prior to the final concrete pour to level. The pre-cast slabs were then installed onto a steel sub-structure. After placing the slabs the anode panels were electrically connected on site prior to finishing the deck. The system was subsequently energized to provide corrosion protection.

Italy has been the biggest user of CP for preventative maintenance with a significant number of new motorway bridges where the decks and parapets are cathodically protected. The majority of these new bridges are along the A32 Turin-Frejus motorway. The bridges are all constructed from pre-cast post-tensioned reinforced concrete box girders. CP has been applied in a variety of different and innovative ways: either to box girder units following casting or to finished bridges. The optimized CP application to box girder units took place as a separate operation in the pre-casting facility. Immediately after casting, a MMO mesh anode was bonded to



**Fig. 7.2** Tay Bridge, Scotland. The base of a bridge pier which is being strengthened and provided with CP.

the deck surface by embedment within a polymer-modified overlay. [Figure 7.4](#) shows the box girder units in the pre-casting shed complete with the applied mesh anode, immediately prior to overlay application. Once the overlay had been placed the units were transported to site and launched. Following completion of civil engineering works to erect the span, the individual CP units were electrically connected. The reinforced concrete bridge parapets were also provided with CP. The optimum method of installation of these units was to secure a MMO ribbon anode to the reinforcing cage and then cast concrete using movable formwork. This installation is illustrated by [Figure 7.5](#) which shows a section of reinforcement cage complete with



**Fig. 7.3** A mixed metal oxide CP anode being cast into a newly constructed precast reinforced concrete element. These elements were used to form the pre-cast deck of a road bridge at Hauteville-sur-Fier, France.

attached anode in front of a recently cast cathodically protected parapet. By this method, minimal preparation work, high output and a good-quality finish was assured. The electronics for both power supply and microprocessor control of these CP installations are located within the box girders. Specific computer software provides safe control of the installation with facilities for remote monitoring.

In the United Arab Emirates, there are two notable CP installations to new structures; the first being CP of the structural reinforced concrete frame of the Juma Bin Usayan Al-Mansouri building, Abu Dhabi, and the second being CP of the replacement coping to the quayside of Port Rashid in Dubai.

In the USA, elements of the World Trade Centre parking garage, repaired following a recent terrorist bomb attack, have been replaced with integral CP systems to protect against future corrosion. In addition a number of American bridge decks have been rebuilt to incorporate CP, for example the 1300m<sup>2</sup> CP installation to the deck of the Old Lyme Bridge in Connecticut. This structure was protected using ribbon anode.

More recently a CP system has been cast into the piers and columns supporting the Rambler Channel Bridge in Hong Kong. This structure will carry the MTRC rail link to the new Lantau Airport facility that is currently under construction. The client requested the inclusion of CP to enhance the durability of high-risk zones of this key communications link, namely the tidal and splash zones of reinforced concrete piers in sea-water.

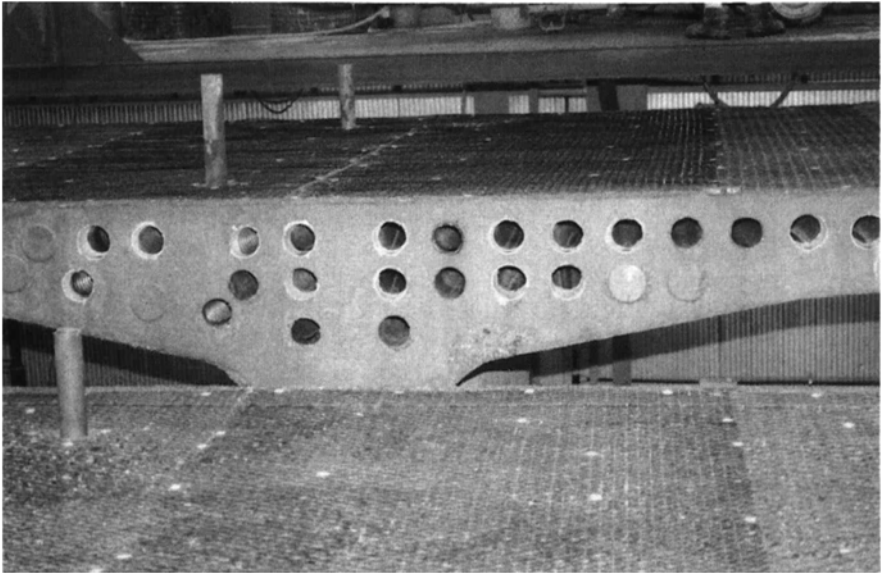

**Fig. 7.4** CP of new segmented post-tensioned reinforced concrete bridges along the A32 Turin-Frejus motorway. This illustration shows the box girder units in the pre-casting shed complete with the applied mesh anode, immediately prior to overlay application.

The practice of including CP to enhance durability of key reinforced concrete elements has even extended to recent refurbishment work to the Sydney Opera House sub-structure. This well-known Sydney landmark has recently needed maintenance work to the reinforced concrete structures supporting the visitor walkways which encircle the Opera House. The foundation and sub-structure elements of the Opera House were constructed in the mid-60s and have deteriorated over time due to chloride penetration to the reinforcement. The refurbishment work on the Opera House includes CP to new and existing concrete elements.

Table 7.1 lists a number of new reinforced concrete structures where CP has been used as a means of increasing durability.

## 7.7

### OPERATION AND MAINTENANCE

Once the CP system has been installed it is necessary to operate and maintain it. Operation of the CP system involves an element of routine visual inspection. This is simply done as a general maintenance operation involving simple checks to ensure no physical damage to the installation. Maintenance of the electrochemical function is the work of more specialist personnel. This involves periodic checks of system response in accordance with the aforementioned guidance documents.



**Fig. 7.5** Further CP application to the Turin-Frejus motorway bridges. This illustration shows a section of reinforcement cage complete with attached anode in front of a recently cast cathodically protected parapet.

To make this task easier, many of the electrochemical control operations can be automated and operated by specific software, for example, the operations to periodically monitor reinforcement potentials and reset applied current densities against given criteria. Not only can the reporting functions be automated but a number of error conditions, such as interrupted OF excessive current flow, can be signalled.

The electronics used to operate and control CP systems have borrowed many functions from automatic process plant control as well as from advanced network

Table 7.1 Milestones in CP applications to reinforced concrete

<i>Date</i>	<i>Event</i>
1824	Sir Humphrey Davy discovers CP after work on ship hull corrosion After a further delay CP was then used extensively for buried and submerged steel protection
1965	Development and evaluation of MMO anodes (DSAs)
1973	CP system applied to top deck of Sly Park Crossing Bridge Deck in California, USA. This coke/asphalt anode system operated for 11 years
1974–5	California installs coke/asphalt systems to bridge decks
1975–80	FHWA establishes Demonstration Project installing bridge deck systems
1974	Ontario Ministry of Transportation installs coke/asphalt CP to bridge deck
1987	Conductive overlay applied to bridge deck in Virginia, USA
1977–84	Development and application of slotted CP systems for bridge decks
1981	Development and application of mounded grid conductive CP systems with cementitious overlay.
1982	Development and evaluation of conductive coatings as anodes for concrete sub-structure CP in UK DoT.
1984	Application of Ferex anode (copper-cored carbon polymer)
1984	CP applied to first parking structure in USA
1985	Application of MMO anodes (DSAs) to bridge decks and sub-structures world-wide.
1985	Application of first UK conductive coating CP to sub-structure
1987–92	Application of CP to pre-cast post-tensioned bridge decks in Italy
1993	20 year anniversary of concrete CP celebrating successful treatment of over 1 million square metres of exposed concrete surface

theory. This latter addition allows large CP installations to be fully remotely controlled either by trained on-site maintenance staff or by corrosion engineers in another town or even another country.

CP systems can be designed with acceptably long lifetimes. Anode lifetimes of 40 years or more are easily attainable. The associated hardware, ie. the cables, electrical connections, reference electrodes and electronic equipment for power supply and monitoring are more vulnerable to breakdown but, with careful design, these components can still be sufficiently durable and are easily replaced where the design allows.

The electronic equipment used to power and monitor a CP installation can be designed for lifetimes of circa 20 years. Equipment should be chosen for ease of maintenance. Some manufacturers use modular designs which readily allow replacement of circuit boards in the event of premature failure.

## 7.8 ECONOMICS

An impressed current CP system comprises:

- an anode;
- a power supply;
- a monitoring system.

The specifier has several choices for each of the above, depending on the required durability, the level of maintenance proposed and, finally, the available budget. For inclusion into new structures it is necessary to allow for the cost of fixing the anode, cabling and other hardware. In addition it is important to have a corrosion engineer in attendance during certain operations, such as checking connections, pouring concrete and commissioning.

The approximate 1995 materials cost of a typical CP system designed to protect around 5000m<sup>2</sup> of jetty sub-structure was as follows:

- CP Anode    US\$ 35/m<sup>2</sup>
- CP System    US\$70/m<sup>2</sup>

The CP system comprises anodes and all electrical and electronic components required for CP. The system cost will depend on the complexity of the installation.

These are values based on recent (1995) tender prices for large projects. The CP system cost comprises typically 10% of the overall project price.

The technique of CP provides a secure method for long-term corrosion protection to vulnerable areas of new reinforced concrete structures.

The author gratefully acknowledges the assistance given by Elgard Corporation, USA, and by DeNora Permelec, Italy, in the preparation of this chapter.

## NOTES

1. The Society for Cathodic Protection of Reinforced Concrete, Association House, 235 Ash Road, Aldershot, Hampshire GU12 4DD.

## REFERENCES

- BRITE EURAM Project (1998) 'Duracrete'.
- Bamforth, P. (1994a) Admitting that chlorides are admitted, *Concrete*, Nov./Dec.
- Scheissl, P. (1992) Repair strategies for concrete structures damaged by steel corrosion, *RILEM Conference*, Keynote paper, Melbourne.
- Bamforth, P. (1994b) Specification and design of concrete for protection of reinforcement in chloride contaminated environments, *UK Corrosion & Eurocorr 94*, Bournemouth.

- Neville, A.M. (1987) *Properties of Concrete*, Pitman, London.
- Zemdrain Permeable Formwork, DuPont de Nemours, ch Pavillon 2, CH-1218 Grand-Sacconex, Switzerland.
- Dressman, S., Osiroff, T., Dillard, J.G. *et al.* (1991) A screening test for rebar corrosion inhibitors, Transportation Research Board, Paper No. 91, Jan., Washington DC, USA.
- BS 7295 (1992) *Epoxy Coated Rebar*.
- FHWA Project (1993–98) *Corrosion Resistant Reinforcement for Concrete Components*, Dec. 1993–Feb. 1998, Project leader: P. Virmani, performing organization: Wiss, Janey, Elstner Associates, Inc.
- Concrete Society (1989) *Cathodic Protection of Reinforced Concrete*, Concrete Society and Corrosion Engineering Association Report No. 36, The Concrete Society, London.
- Concrete Society (1991) *Model Specification for Cathodic Protection of Reinforced Concrete*, Concrete Society and Corrosion Engineering Association Report No. 37, The Concrete Society, London.
- NACE, Cathodic Protection of Reinforcing Steel in Concrete Structures, NACE, RP 0290–90, NACE, Houston, Texas, USA.
- Beer, H.B. (1966) US Appl. 549 194,
- Nora, O. De, Nidola, A., Trisoglio, G. and Bianchi, G. (1973) Brit Pat 1 399 675.
- Trassati, S (1981) *Electrodes of Conductive Metallic Oxides*, Elsevier, Amsterdam.
- NACE (1992) Testing of Embeddable Anodes for Use in Cathodic Protection of Atmospherically Exposed Steel-Reinforced Concrete, NACE Standard TM 0294–94, NACE, Houston, Texas, USA.
- Pastore, X, Pedefferri, P. and Bolzoni, L. (1992) Current distribution problems in the cathodic protection of reinforced concrete structures, Dipartimento di Chimica Fisica Applicata, Politecnico di Milano, *Rilem Conference*, Melbourne, Aug./Sept.
- Strategic Highway Research Program (1993) *Cathodic Protection of Reinforced Concrete Bridge Elements: A State of the Art Report*, SHRP-S-337, The Strategic Highway Research Program, Washington DC.
- Biagiolli, M.A., Tettamanti, M., Rossini, A. *et al.* (1991) Anodic system for cathodic protection of new reinforced concrete structures : laboratory experience *NACE Corrosion Conference*, 1993.
- Hunkeler, F. (1992) *Etudes de la protection cathodique du beton armé dans le tunnel San Bernardino*, Octobre, Département fédéral des transports, des communications et de l'énergie, Office fédéral des routes, Switzerland.
- Bennett, J. (1994) Criteria for the cathodic protection of reinforced concrete bridge elements, Thomas Turk SHRP-S-359 *The Strategic Highway Research Program*, Washington DC.
- Pedefferri, P. (1992) Cathodic protection of new concrete constructions, *International Conference 2–3 June 1992*, organized by Inst. of Corrosion in association with IBC Technical Services Ltd.
- Glass, G.K. and Buenfeld, N.R. (1995) On the current density required to protect steel in atmospherically exposed concrete structures, *Corrosion Science*, 37 (10), 1643–6.
- Watters, A. (1991) Cathodic protection of Tay Road Bridge substructure, *Construction Maintenance and Repair Magazine*, Jan./Feb.
- Baldo, P. (1991) *Cathodic Protection of Bridge Decks*, PIARC Technical Committee on Road Bridges, drafted by P. Baldo.

## Current developments and related techniques

*Donald Hudson, Sage Engineering*

There are a number of other electrochemical techniques which are used for treating concrete suffering from reinforcement corrosion. These include realkalization, desalination and electrochemical inhibitor injection.

Realkalization and desalination are accepted rehabilitation methods with a commercial track record and over 150000m<sup>2</sup> treated to date. They are patented processes owned by Fosroc International Limited, operated by appointed licensees and are marketed internationally under the trade mark Norcure™.

Electrochemical inhibitor injection is a less developed method and has to date been restricted to experimental work although inhibitor treatments either as a concrete additive or spray applied are available in the market.

Each of the techniques is considered in detail below.

### 8.1

#### REALKALIZATION

##### 8.1.1

##### Overview

Realkalization is a method used to stop and permanently prevent reinforcement corrosion in carbonated concrete by increasing its pH to a value greater than 10.5, which is sufficient to restore and maintain a passive oxide film on the steel.

It is performed by connecting a temporary DC source between the reinforcement steel in the concrete and an externally mounted anode. The anode is surrounded in an alkaline electrolyte, normally a sodium carbonate solution, which is held in a reservoir in contact with the concrete. The current density used is a nominal 1A/m<sup>2</sup> of concrete surface area which requires an applied voltage of 10–40 volts.

During treatment, the alkaline solution is transported into the carbonated concrete by means of electro-osmosis. Simultaneously, electrolysis produces a very alkaline environment at the reinforcement surface. This is shown in [Figure 8.1](#).

In some situations, electro-osmosis is not effective and where alkali susceptible aggregates are present, the introduction of sodium carbonate into the concrete may

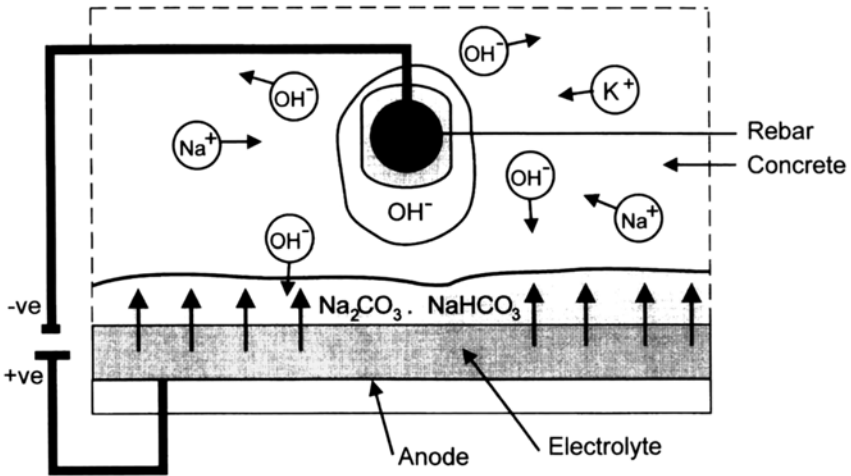

Fig. 8.1 The realkalization process.

not be desirable. In these cases, a variation of the treatment allows realkalization by electrolysis alone.

Treatment time is typically 4–10 days. For realkalization solely by electrolysis, a longer time is needed, normally 10–20 days.

### 8.1.2

#### Description of electro-osmosis

Electro-osmosis is the process where if an electric current is impressed across a porous material, liquid within the pores has a tendency to move towards the negative electrode. This can be explained by considering a single pore in concrete, greatly magnified, as shown in Figure 8.2.

Most materials have a surface which is electrically charged with a tightly absorbed water film which can be described as an electrical double layer. This is because the layer has two main parts, one immediately adjacent to the pore wall which is very tightly bound by electrical charges and a less rigidly bound outer layer with an opposite charge. The thickness of the electrical double layer depends upon several factors such as the zeta potential, which is a material constant and the nature of the free liquid in the pores. If the latter is distilled water, the double layer may be up to 3000 molecules thick. If the liquid is a strong salt solution, the layer will only be a few molecules. The actual polarity of the charges will depend on the material concerned and the composition of the pore water. For the majority of materials, including normal concrete, the signs are as shown.

When a current is applied, the mobile outer layer is attracted towards the negative electrode with a velocity distribution as shown in the diagram. This movement results

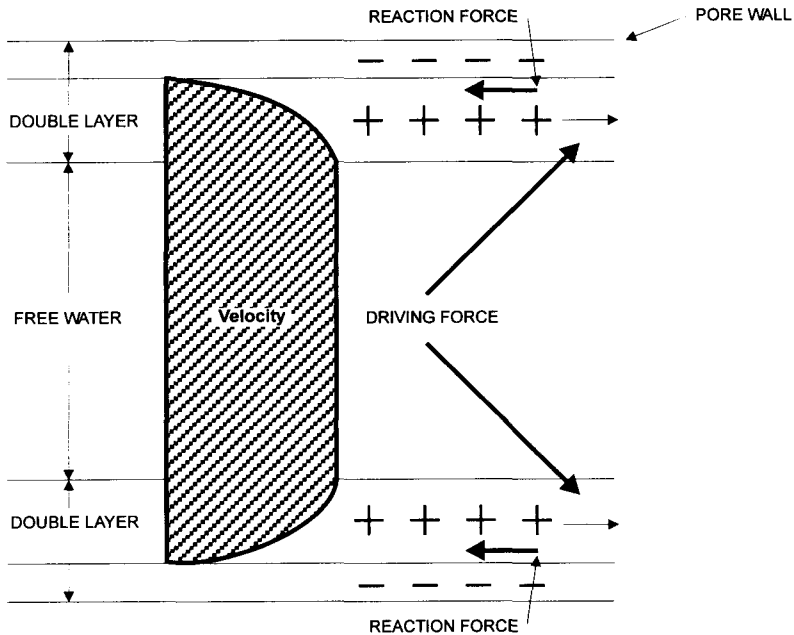

Fig. 8.2 Schematic of electro-osmosis.

in the free liquid pore water being pulled along en masse. As this pore water moves, it is replaced by more liquid being sucked into the pore.

Electro-osmotic transport does not always occur. In carbonated concrete which is also contaminated with chlorides, little or no effect is noticed. This is believed to be related to the extremely reduced thickness of the double layer on the pore walls when salt is present in the pore water. When realkalizing concrete which has had a hydrophobizing agent applied, e.g. silane, little contribution from electro-osmosis has been observed which is thought to be due to the breakdown of the continuity of the electrical double layer.

### 8.1.3

#### Initial survey of structure

Prior to carrying out realkalization, an initial survey would be undertaken similar to that for any concrete repair works.

This would determine the extent and cause or causes of damage encompassing visual inspection and chemical examinations of drilled concrete cores. On conclusion that the structure suffered from carbonation, a more detailed survey to assess rebar continuity, position of bars, cover, concrete humidity, cracking/delamination, the

susceptibility of aggregates to alkalis and the existence and location of pre-stressed and post-tensioned reinforcement, if any, would be made.

#### 8.1.4

### Surface preparation

Loose, spalled or large areas of delaminated concrete are broken out and repaired in accordance with normal practice. The repair material used needs to be compatible with the process, i.e. allow the transport of sodium carbonate and be resistant to solutions of up to pH 14. A number of proprietary materials are available for this purpose.

Depending upon average cover and concrete quality, areas of very low cover, i.e. less than 10mm, are covered with a screed of high-resistance mortar to avoid current drainage.

Existing concrete surface coatings are removed prior to realkalization as coatings may increase the treatment time. In circumstances where this is not practical, a minor realkalization trial in a laboratory or the field is undertaken to establish the treatment period. Certain coatings will not permit the passage of the electrolyte and in such cases the coating would have to be removed.

Locations of test areas to be drilled during and after treatment are marked, typically at each discrete area being treated or one per 10m<sup>2</sup> for larger areas. Where a shutter reservoir system is used, the test locations are marked between the shutters to avoid having to remove them for sampling during treatment.

#### 8.1.5

### Rebar connections

The number of rebar connections depends upon the geometry and size of the area being treated and the electrical continuity of the reinforcement but there would be at least one for each 50m<sup>2</sup> of concrete surface area. The continuity is determined by means of resistance measurements performed during the set-up phase of the application. The resistance between two rebar connection points should ideally be less than 1 ohm, but up to 10 ohms may be acceptable. Flexible, suitably sized cables, coloured black for identification, are connected to the rebars and are electrically insulated by encapsulation in epoxy or similar.

#### 8.1.6

### Anode mesh

The anode mesh is generally made of either steel or titanium coated with a precious metal oxide although other metals, e.g. copper have also been employed. Steel mesh will corrode during the process and can leave some staining on the concrete surface

which would need to be cleaned on completion of the treatment. Coated titanium, which is inert, avoids this problem but is more expensive. The titanium mesh can be theoretically reused a number of times depending upon the grade and treatment time. However, the practical difficulties in dismantling, storing etc. without damaging the mesh make this impractical and titanium mesh is predominantly used for realkalization only with a shutter electrolyte reservoir system.

### 8.1.7

#### **Anode connections**

Anode connections, coloured red for identification, are made at a minimum of one per  $10\text{m}^2$  for steel mesh and one per  $6\text{m}^2$  for titanium mesh. A minimum of two connections are made to each discrete anode section, independent of its actual size. The connections are electrically insulated by encapsulating in epoxy.

### 8.1.8

#### **Electrolytes**

A 1 molar sodium carbonate solution is normally used as the electrolyte. If electro-osmosis does not occur, as discussed in the section describing the phenomenon, or the introduction of sodium carbonate is undesirable, realkalization is undertaken solely by electrolysis using a saturated calcium hydroxide solution. The sodium carbonate solution introduced will only react to a minor extent with carbon dioxide in the atmosphere. Under normal conditions, about 12% of 1 molar solution sodium carbonate will convert to sodium bicarbonate resulting in an equilibrium pH of 10.5 (Freier, 1978) which is sufficient to maintain the regained passive properties of the reinforcement. If realkalization is carried out solely by electrolysis, this results in the formation of sodium hydroxide, which in the presence of carbon dioxide will form sodium carbonate.

### 8.1.9

#### **Electrolyte reservoir**

The electrolyte needs to be held in contact with the concrete surface. This could be done in a variety of ways but in practice there are three principal methods: cellulose fibre which is spray applied with the electrolyte onto the concrete surface, a felt cloth blanket which is applicable for horizontal surfaces and an enclosed coffer tank system. The choice of reservoir is dependent upon the cost of installation and geometry of the structure. Installation procedures for each type are described.

### 8.1.10 Cellulose fibre

1. Wooden battens (typically 25mm×25mm) are attached to the concrete surface using plastic plugs. The wooden battens act as spacers between the concrete and the external electrode mesh.
2. The cellulose fibre can be applied in one or two layers. If the latter method is used, the first layer of cellulose fibre mixture saturated with electrolyte is sprayed onto the concrete surface to the same thickness as the wooden battens.
3. The external electrode mesh is fastened to the wooden battens.
4. A layer of fibre mixture is sprayed to cover the electrode mesh. The thickness above the mesh is typically about 20 mm.
5. Anode connections are made using suitably sized flexible red coloured cables at one cable per 6 m<sup>2</sup> for titanium mesh and one cable per 10 m<sup>2</sup> for steel. The connections are electrically insulated using an epoxy or similar.
6. Additional electrolyte is sprayed onto the fibre to keep it moist as required.

### 8.1.11 Felt cloth

1. A first layer of felt cloth is rolled onto the concrete surface.
2. The anode mesh is then rolled onto the felt cloth. If necessary the mesh can be fixed to the concrete surface with non-metallic fasteners.
3. A second layer of felt cloth is rolled on top of the mesh.
4. Anode connections are made to the mesh in the same manner as for the cellulose fibre reservoir system.
5. The blankets are filled with electrolyte solution and are maintained in a wet condition by periodical topping up.

### 8.1.12 Coffer tanks

1. The coffer tanks are constructed of a galvanized steel frame and perspex sheet with a seal for contacting the concrete surface which is able to retain the electrolyte as shown in [Figure 8.3](#). Within the shutter is a coated titanium anode mesh with two cables connected which protrude from the shutter. The size of the tanks vary but are typically of the order of 2.0m<sup>2</sup>.
2. The tanks are attached to the concrete surface using either non-metallic fasteners, bolt and plug fittings or clamps with a maximum separation between tanks of 75 mm.

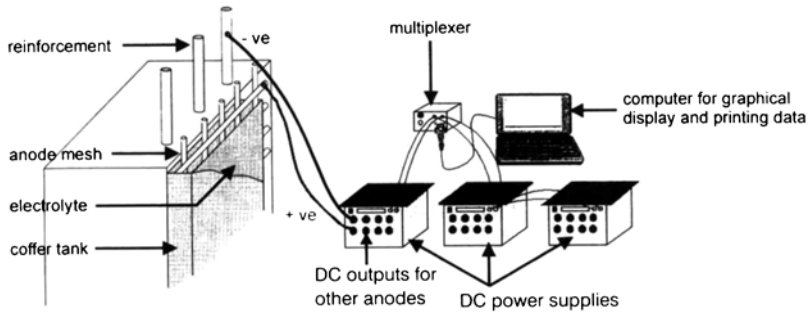

Fig. 8.3 Typical arrangement for realkalization using coffer tank anodes.

3. The tanks are filled with the electrolyte and checks are made for leaks and the presence of air bubbles. Leaks are sealed and any air found, removed by inserting a syringe.
4. Extender cables are joined to the integral anode connections.

#### 8.1.13

### Application of the electric field

The cables from the rebars (cathode) and the electrode mesh (anode) are connected to the negative and positive pole of an AC/DC converter respectively.

The power supply is switched on and adjusted to give a current density of  $1 \text{ A/m}^2$  of concrete surface.

#### 8.1.14

### Performance monitoring

During the treatment period, the system is continually monitored by means of current and voltage readings (and by calculating the resistance) carried out either manually or by using a datalogger. Additionally, concrete dust samples are obtained at the previously marked test locations and analysed for sodium content. On completion, small sections of concrete can be broken out and tested with phenolphthalein to confirm the extent of realkalization. When the realkalization has been completed, as defined by agreed parameters prior to treatment (usually when the concrete has been realkalized to the first level of reinforcement), the power supply is switched off.

### 8.1.15

#### Dismantling

When the treatment is finished, all the cables are disconnected. The anode/electrolyte system is removed and the surface cleaned with water. Remaining cavities and test sites are then repaired.

The electrolyte used for the felt cloth and shutter reservoirs is neutralized by the addition of an acid and can then be disposed of through the storm drainage system. The cellulose fibre is classified as 'normal waste' for disposal purposes.

### 8.1.16

#### Post-treatment

As discussed in the section on electrolytes, realkalization is a permanent, one-off treatment and, once complete, the concrete may be left in its natural state. Alternatively, a coating can be applied, if desired, for aesthetic reasons.

### 8.1.17

#### Practical considerations

Realkalization can be performed under all weather conditions as long as the electrolyte does not freeze but extraction efficiency decreases with lower temperature. Strong winds may interrupt the application of the spray-applied cellulose fibre. High temperatures and low humidity will increase the need for topping up the electrolytic reservoir during treatment.

### 8.1.18

#### Comparison with other methods of treating carbonated concrete

Cathodic protection is not recommended as a technique for reinforcement suffering from corrosion due solely to carbonation of concrete because the increased resistivity as a result of carbonation makes it difficult to impress current to the reinforcement (Concrete Society, 1989). Therefore, with the exception of realkalization, the only options for repair are conventional methods which are detailed below:

1. Carry out a periodic or ongoing patch repair programme removing only spalled and delaminating concrete and repairing with either new concrete or the proprietary repair materials available in the market as applicable to the size/location of the repair.
2. Remove all carbonated concrete and recast in concrete.
3. Repair spalled and delaminated concrete and then apply an 'anti-carbonation coating' to all carbonated parts of the structure.

The first option does not address the cause of the problem but is suitable if there are initially only limited funds available. The disadvantage with this approach are the likelihood of corrosion reoccurring adjacent to the repairs a short time after completion due to incipient anode affect and long-term disturbance and high total cost incurred because of ongoing/repeat repairs.

The second option, although it would appear to be the ideal solution, has several drawbacks:

- (a) the difficulty in accurately determining the extent of affected concrete to ensure that no areas are missed;
- (b) the cost, which in addition to the large volume of break-out and repair will also generally entail substantial temporary works and often necessitate temporary transfer of occupants/staff or placing the structure out of commission;
- (c) the disturbance in terms of noise and dust generated.

The third option relies on preventing further carbonation by prohibiting the future passage of carbon dioxide into the structure. By doing so, the carbonation front is arrested before it reaches the steel. This widely used, relatively cheap method, causes the minimum of disturbance to the site and performs well if the coating is applied in the early stages of carbonation. However, it requires an accurate assessment of the depth of the carbonation front to ensure against future corrosion of the steel where the steel is in carbonated concrete but no physical signs of corrosion are evident at the time of examination. This is extremely difficult to carry out in practice. Additionally, a coating will not be fully able to bridge live cracks and in this event there will be a path for carbon dioxide to penetrate.

Realkalization offers the certainty of option 2 while restricting the amount of break-out to the same level required as when an anti-carbonation coating is applied. However, the additional work associated with the realkalization process necessitates a longer time on site and consequently will be more expensive than simply applying a coating.

## 8.2 DESALINATION

### 8.2.1 Overview

Desalination, also known as chloride extraction or chloride removal, is a method employed for reinforced concrete suffering or at risk from chloride-induced corrosion. The practical set-up is the same as for realkalization but the duration is

longer, typically four to eight weeks, and a variety of electrolytes are used dependent upon conditions.

During treatment, chlorides are transported out of the concrete, towards the positively charged external electrode mesh by means of migration and are collected in the electrolyte reservoir. At the same time, hydroxyl ions are produced at the surface of the reinforcement, repassivating the steel, and dissipation of the corrosion product away from the steel occurs. Additionally it has been found that as beneficial side effects of the process, the resistance of the concrete to water absorption, gas and chloride diffusion and the resistivity, are all increased (Buenfeld and Broomfield, 1994). The principles of desalination are shown in [Figure 8.4](#).

### 8.2.2

#### **Anode mesh**

The same materials employed for realkalization can be used for desalination. However, steel mesh will corrode during the process, necessitating replacement after approximately four weeks of treatment with consequent additional labour costs. Steel mesh is not recommended for upward facing horizontal surfaces as the corrosion product formed can migrate under gravity into the concrete, blocking pores and impeding the efficiency of the process.

### 8.2.3

#### **Electrolytes**

Potable water is the most efficient electrolyte because extraneous ions which compete as current carriers are kept to a minimum. However, in water, the dominant reaction at the anode will be the production and evolution of chlorine gas which is a safety concern in enclosed areas. Where this is considered a problem, an alkaline solution is used because the favoured electrochemical reaction at the anode will then be production of oxygen. A saturated calcium hydroxide reaction has been found empirically to be the most practical solution for site use in this case. Where there are alkali susceptible aggregates, lithium compounds have been used

### 8.2.4

#### **Testing**

After two to three weeks of treatment, concrete cores or dust samples are obtained at the previously marked test locations as well as aliquots of the electrolyte. These are analysed for chloride content to determine the extent of desalination. When sufficient desalination has occurred to reduce the chloride level to a previously agreed objective, the power supply is switched off.

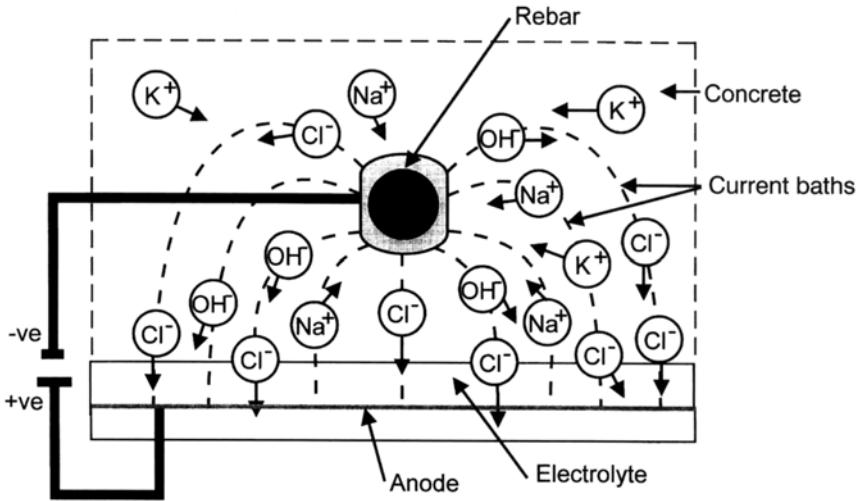

Fig. 8.4 The desalination process.

### 8.2.5

#### Post-treatment

If the source of contamination of the concrete has been eliminated during the course of the repair works, e.g. by repair of failed joints or the installation of gutters, there is no need for any further action. However, if there is danger of future chloride ingress into the structure, a chloride protective coating should be applied to limit future risk to the structure.

### 8.2.6

#### Comparison with other methods of treating chloride contaminated concrete

Both patch repairs and total removal of all affected concrete and recasting are viable options for repairing chloride-contaminated concrete but suffer from the same limitations as described previously for treating carbonated concrete.

Following patch repairs, the application of hydrophobizing materials to the concrete surface, which form a water-repellent but vapour-permeable layer which should permit the concrete to dry out and thereby arrest the corrosion process, are advocated by some people within the concrete repair industry. However there is a danger that corrosion will continue to occur before the concrete dries out sufficiently, leading to cracking/delamination and therefore paths for moisture to penetrate. Furthermore, the results based on field application of these materials have

been mixed and research has indicated that they lose their efficiency with time (Cabrera and Hassan, 1994).

Cathodic protection is a widely used remedial technique and is compared with desalination below. The advantages of desalination are as follows:

1. No continuing maintenance or monitoring programme is necessary.
2. The very specific detailing that is carried out for cathodic protection as a permanent installation is not required.
3. There is no risk that the long-term effectiveness of the system will be negated by third-party action, e.g. vandalism.
4. The performance criteria, i.e. reduction in chloride levels below the corrosion threshold is more simple and better understood than that for cathodic protection.
5. There is no additional long-term load imposed on the structure as a result of the process.
6. As the method is short term, it may be possible to treat structures with steels that would be susceptible to hydrogen embrittlement by temporarily supporting the structure.
7. When all the costs involved are considered, it is a generally cheaper technique (Collins and Fahrina, 1991).

The disadvantages are:

1. If there will be further contamination with chlorides, the future integrity of a structure will be dependent upon the performance of the protective coating applied and monitoring and maintenance may be necessary.
2. It may not be possible to remove chlorides from below the first level of reinforcement, e.g. where the chlorides are cast in. In such cases there would be some uncertainty as to whether corrosion could be activated in the future. This could occur as a result of dissipation of hydroxyl ions over time from around the steel causing an increase in the ratio of chloride ions to hydroxyl ions above that necessary for corrosion.

### 8.2.7

#### **Possible detrimental side effects of realkalization and desalination**

From experience with cathodic protection, it was known that there could be detrimental side effects associated with electrochemical techniques applied to steel in concrete and during the development of realkalization and desalination. These were studied to establish whether the concerns were valid and under what limitations, if

any, the methods needed to be operated within to avoid problems. As realkalization and desalination are similar in operation, they are considered together below:

### 8.2.8

#### Alkali aggregate reaction (AAR)

The danger of initiating AAR as a side effect of electrochemical treatments is connected with the production of hydroxyl ions at the rebar surface and the redistribution of alkali metal ions. For each concrete mix, a specific critical concentration of alkali metal is required to initiate AAR, but as a general guide, concrete containing alkali reactive aggregates will be susceptible if the alkali metal content expressed as  $\text{Na}_2\text{O}$  is more than 3 kg per cubic metre of concrete and the pH is sufficiently high.

During the realkalization process it is unlikely that the final pH of the realkalized concrete will be high enough to initiate AAR despite the fact that sufficient sodium ions are introduced into the concrete.

If the realkalization process is run for too long, there could be a danger of sodium ions being transported beyond the carbonated zone and into the uncarbonated concrete with its original, higher pH. Although no evidence of such transport has been found (Odden and Miller, 1993), any additional alkali could increase the danger of alkali silica reaction (ASR). To avoid this problem, sodium levels are monitored during treatment.

In the case of desalination, no alkali metal ions are added to the concrete. However, there will be a tendency for alkali metal ions to migrate towards the reinforcement. As simultaneously, the production of hydroxyl ions causes an increase in pH, it could be surmised that AAR would be initiated. A number of investigations have shown that in fact, this is not the case (Bennet and Schue, 1990; Netesaiyer, 1990) whereas others (Page and Yu, 1994) have shown that in some cases AAR has been initiated. The use of lithium compounds (Bennet *et al.*, 1995) has been found to suppress the problem.

When considering the danger of AAR, it should be borne in mind that where the structure is contaminated with chlorides, the existing level of accompanying sodium ions may well be above the level necessary to initiate AAR without any deleterious effect. The triggering of AAR is of concern only when it occurs in the interior masses of concrete structures and this is unlikely to be the case for electrochemical treatments which are carried out in the cover zone.

### 8.2.9

#### Bond strength

This is not considered a problem during realkalization due to the low total charge passed during the process.

Test results of bond strengths for ribbed reinforcement at current densities and total charge typical for desalination show no significant changes (Bennett *et al.*, 1995).

Recently, work has been carried out funded through the UK Department of Transport on the effect of desalination on the bond strength of smooth rebars (Buenfeld and Broomfield, 1994). They found that in test specimens, the bond strength of corroding bars was up to 57% higher than those of non-corroding bars. On application of desalination, it was found that there was a reduction in bond strength of the corroded bars to the same level as the non-corroded bars due to removal of the corrosion product. There was no change in the bond strength of the noncorroded bars when desalinated.

### 8.2.10

#### Hydrogen embrittlement

At the applied voltages typical for desalination, hydrogen atoms will be produced at the cathode (reinforcement) from the electrolysis of water. These may migrate through the atomic matrix of the steel and be temporarily trapped at dislocations, grain boundaries, voids and nonmetallic inclusions resulting in weakening of the metal to metal bonds and premature failure under load. If the dislocations are pinned by the hydrogen, they will not allow plastic deformation; this is known as hydrogen embrittlement.

It is generally considered that this problem is limited to high-tensile prestressing steels under load (Scannel and Hart, 1987) and that normal reinforcing steels will not be effected. Fortunately, in most cases the hydrogen atoms will rapidly diffuse out of the steel when the production of hydrogen ceases and the steel recovers its original ductility. This allows the possibility of treating a structure with high-tensile steels if it is supported during the desalination process, though obviously this must be done with extreme caution.

### 8.2.11

#### Microcracking

It has been thought that the desalination and realkalization may adversely affect the concrete and possibly cause a system of cracks to develop.

An early investigation of desalination (Karlsson, 1990) found that for salt contents of up to 6% by weight of cement and current densities of  $2\text{A}/\text{m}^2$  concrete surface area, applied for a period of eight weeks, there was some minor microcracking. However, this was a severe application, employing twice the current density that would be used in a commercial project.

An examination by Taywood Engineering Ltd concluded that desalination at current densities of  $1\text{A}/\text{m}^2$  concrete surface area applied for a period of 40 days produced no significant increase in microcracking. By comparison, microcracking

arising when patch repair techniques were used was found to be significant (Law and Wan, 1992).

### 8.3

#### ELECTROCHEMICAL INHIBITOR INJECTION

Electrochemical inhibitor injection has to date only been used in the field on one structure, in a trial on a bridge over the Potomac Bridge in Virginia, USA. No results have been published from the project. Experimental work has been carried out with mixed results.

The practical application of the technique is similar to realkalization and desalination with a temporary DC source connected between the reinforcement and an anode on the concrete surface in contact with a reservoir containing the inhibitor. Those researchers who have obtained the best results for injection consider that the main use for the technique will be a complementary one to desalination, making the process more efficient and maybe acting as an impediment to further corrosion when a treated structure will be subjected to future chloride ingress.

The most successful work has been carried out by the Stanford Research Institute (SRI) (Asaro *et al.*, 1990). In this work a number of compounds were synthesized which SRI alleged were unique in that they became more efficient as the chloride concentration increased. These were tested for their effectiveness by examining the rate at which they passed through a 1 cm thick mortar disk under an electric field and also by estimating corrosion currents of test specimens, with chloride added to them, during and after treatment.

Tetraethylphosphonium nitrate was found to be the most effective of the compounds, which was claimed to afford a 78–85 % protection rate with the possibility of being improved to give 90–100%. The injection rate was found to increase with increasing current density, with a doubling of the initial one used causing a three to four times increase in rate. A practical value was determined to be  $1\text{mA}/\text{cm}^2$  ( $10\text{A}/\text{m}^2$ ). Following treatment, the potential of the reinforcement in a chloride laden sample was found to have shifted in a positive direction when compared to the original state and this shift was found to be more positive than that of a control where the inhibitor was not included in the reservoir. No results for long-term testing of the specimens have been published.

Other work carried out under the Strategic Highways Research Project (SHRP) programme (Bennet *et al.*, 1995) trialled a variety of possible corrosion inhibitors as concurrent protection with desalination. These comprised complexing materials, electrophoretic coatings and a tetraethylphosphonium compound.

Aluminium phosphate was selected as it was thought that it might complex with the chloride ion to form an insoluble chloroaluminate, rendering the chloride harmless. A zinc compound was also used. In practice, it was found that as the

treatment progressed, the pores at the concrete surface became plugged, resulting in excessive voltages and eventually breakdown.

Electrophoretic coatings were considered which it was hoped would migrate under the field to the steel surface and then polymerize and a number of proprietary materials were tried. However, none of these proved successful, either because they did not penetrate sufficiently into the concrete or because they polymerized before they reached the steel surface.

Work using the same compounds developed by SRI was looked at but the cost of tetraethylphosphonium nitrate was considered too high to be commercially feasible and the base chloride form from which the nitrate compound is formed was used as an alternative. This work was unable to replicate the results of SRI with no emplacement of the tetraethylphosphonium compound being observed.

## REFERENCES

- Asaro M.F., Gaynor A.T. and Hettiarachchi S. (1990) *Electrochemical Chloride Removal and Protection of Concrete Bridge Components (Injection of Synergistic Corrosion Inhibitors)*, SHRP-S/FR-90-002.
- Bennet, J. et al. (1995) *Electrochemical Chloride Removal and Protection of Concrete Bridge Components: Laboratory Studies*, SHRP-S-657
- Bennet J.E. and Schue T.J. (1990) *Electro-chemical Chloride Removal From Concrete*. A SHRP Status Report, Corrosion 90, April.
- Buenfeld, N.R. and Broomfield, J.P. (1994) *Effect of Chloride Removal on Rebar Bond Strength and Concrete Properties*, Sheffield.
- Cabrera, J.G. and Hassan, K.E.G. (1994) *Assessment of the Effectiveness of Surface Treatments Against the Ingress of Chlorides into Mortar and Concretes*, Sheffield.
- Collins, F.G. and Fahrina, P.A. (1991) Repair of concrete in the marine environment: cathodic protection vs chloride extraction, *Civil Engineer*, 1, Feb.
- Concrete Society (1989) *Cathodic Protection of Reinforced Concrete*, Technical report No. 36, Concrete Society.
- Freier R.K. (1978) *Aqueous Solutions*, vol 2, Walter de Gruyter, Berlin.
- Karlsson F. (1990) Klorideutdrivning ur betong, *Nordisk Betong*, 4.
- Law D.W and Wan R. (1992) *Analysis of Microcracking in Chloride Contaminated Concrete Subjected to Electrochemical Chloride Extraction and Comparison with Concrete Treated with Conventional Patch Repair*, Taywood Engineering Report No. 1303/92/6116.
- Netesaiyer K C (1990) *The Effects of Electric Currents on Alkali-Silica Reactivity in Concrete*, PhD Dissertation, Cornell University, New York, Jan.
- Odden L and Miller J B (1993) Migration of Alkalis in Electro-chemically Realkalised Concrete, *Engineering Solutions to Industrial Corrosion Problems*. Paper No. 54., NACE conference, Norway, June.
- Page C.L. and Yu S.W (1994) The Effect of Chloride Removal on Alkali Silica Reaction (abstract), *SCI Conference on Electrochemical Repair of Reinforced Concrete*, London, Sept.
- Scannel W T and Hart W H (1987) Cathodic Polarisation and Fracture Property Evaluation of a Pretensioned Steel Tendon in Concrete, *Corrosion of Metals in Concrete*, T-3K: pp. 86-98.

## Avoidance of potential side effects

*David Eyre, Spencer & Partners*

There are a number of potential side effects of the application of cathodic protection which can have a detrimental effect on either the structure being protected, ancillary equipment or adjacent structures.

### 9.1

#### HYDROGEN EMBRITTLEMENT OF PRESTRESSING WIRES

The application of cathodic protection to the steel in concrete may cause hydrogen generation on the cathode (steel surface) resulting in hydrogen charging of the steel if the potential achieved is sufficiently negative. It is widely recognized that hydrogen charging can cause embrittlement of high-strength steels (Oriani, 1987).

For steel in concrete the predominant cathodic reaction at low levels of cathodic protection is oxygen reduction (Scannell and Hartt, 1987; Hartt *et al.*, 1989; Frecke, 1982).

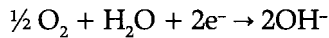

At excessive negative potentials, i.e. if the cathodic polarization exceeds the hydrogen potential value, a second reaction, the reduction of water, also occurs:

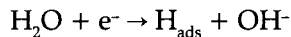

The adsorbed hydrogen can either continue to form hydrogen gas or can dissolve on the metal:

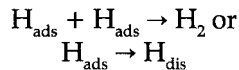

In the latter case the hydrogen dissolved in the steel can interact with the stressed steel lattice leading to brittle fracture of the steel.

While it may be demonstrated that the introduction of hydrogen into low-strength steels may adversely influence some mechanical properties, such as fatigue resistance, it is apparent that the ingress of hydrogen has a markedly more deleterious effect in the response of higher strength steels. Moreover, those high-strength steels that

derive their strength from heat treatments are most susceptible to hydrogen-induced cracking than those that are strengthened by cold work.

While hydrogen embrittlement of steels can occur without any external loading, most cases of embrittlement occur when components are stressed in excess of 75% of their yield stress.

It is clear therefore that prestressing wires may well be susceptible to embrittlement if the conditions are such that hydrogen is evolved on the surface of the wires.

The hydrogen recombination reaction and the uptake of adsorbed hydrogen reaction compete. The extent to which the atomic hydrogen enters the steel or is discharged as gas depends upon various factors, one of which is the presence or otherwise of substances that hinder the combination of atoms making gas formation more difficult and thereby facilitating hydrogen entry into the steel; sulphur and phosphorous-containing species, among others, react in this way.

Usually these substances are not present in concrete environments and this reduces the risk of hydrogen uptake under protected potentials.

The potential at which hydrogen evolution occurs is difficult to predict accurately as it will depend on a number of factors (Trecke, 1982). At a pH of 12.6 to 14.6 the hydrogen evolution potential, at a hydrogen pressure of one atmospheric, varies between  $\bullet 0.730$  and  $\bullet 0.840V$ . If over voltages due to hydrogen concentration, surface condition of the steel, current density and temperature are taken into account then hydrogen evolution probably does not occur until potential values of 200 to 300 mV more negative than the equilibrium potential are reached. Thus it could be considered that the risk of hydrogen uptake is probably small even at relatively negative potentials.

Considerable work has been carried out in an effort to quantify the risk. One experiment where a pre-tensioned tendon was placed in a concrete slab (Scannell and Hartt, 1987) which was initially subjected to an anodic current followed by cathodic polarization to  $\bullet 1.37V$  with respect to a copper/copper sulphate reference electrode (wrt CSE), found that there was no significant difference in fracture load to that of a tendon polarized to approximately  $\bullet 0.47V$  wrt CSE. The potential of  $\bullet 1.37V$  was achieved using a current density of around  $4A/m^2$  which is significantly greater (about three decades) than the current densities typically used for cathodic protection of concrete.

Other studies (Hartt *et al.*, 1989) have found that with stress relieved tendons in a calcium hydroxide solution there was a definite reduction in strength above  $\bullet 970$  mV wrt CSE at stress concentrators. This experimental regime was less like a site environment than the study described in Hartt *et al.* (1989), but could be considered as a 'worse-case' environment. Recommended site practice for cathodically protecting, for example, prestressed concrete pipe is in good agreement (Ameron Design Manual 301, 1986) with the above research findings in that the 'maximum interrupted current potential should not exceed  $\bullet 1000$  mV CSE to avoid evolution

of hydrogen and possible embrittlement of the prestressing wire', although some other authors quote a slightly less conservative value of  $\bullet$  1100mV (Ellis, 1973; Gourley and Moresco, 1987).

A further consideration is the extent of existing corrosion on prestressed tendons. There is evidence to suggest that if tendons are locally corroded such that notch-like pits exist then they are more susceptible to hydrogen embrittlement and brittle fracture than if they have suffered more uniform corrosion (Klisowski and Hurtt, 1996).

In order to reduce the risk of overprotection and any subsequent embrittlement sacrificial anode cathodic protection has been specified almost exclusively for prestressed concrete pipelines. However this is not an option for above-ground prestressed structures where impressed current remains the only viable cathodic protection technique.

Therefore before cathodic protection is applied to a prestressed structure the suitability of the structure must be considered.

The installation of a cathodic protection system on prestressing steel is not recommended if a highly susceptible prestressing steel, e.g. of a quenched and tempered type, is used (Isecke, 1982).

If the prestressing steel is not highly susceptible then its condition should be assessed. A qualification system has been proposed (Klisowski and Hartt, 1996) based on an inspection of the structure:

- (a) If no corrosion induced concrete cracking and spalling are evident, then the structure is automatically qualified.
- (b) If corrosion related cracking and spalling is evident then the tendon should be exposed and inspected for uniform and localized corrosion. The structure is qualified for cathodic protection if:
  - the remaining cross-section is at least 85% in an area of uniform corrosion;
  - the remaining cross-section is at least 90% in areas of localized attack.

Of course in new structures cathodic prevention may be considered. On older structures where chloride contamination is significant cathodic protection may be the only option.

The cathodic protection system design should include Baldo *et al.* (1991):

- (c) Measures to encourage uniform current distribution such as zoning of the anode system so that the IR drop within the anode system is less than 100 mV, and matching the anode system layout to the density of the steel surface area in the concrete.
- (d) Installing reliable and stable reference electrodes near prestressed steel cables.

- (e) Installing a remote control and continuous monitoring system capable of adjusting the system output and storing operating data. The system should be fitted with failsafe current limiting devices.

## 9.2

### CORROSION INTERACTION

Cathodic protection of a structure may cause accelerated corrosion of a neighbouring structure if that structure is in the same electrolyte. This is known as corrosion interaction. This is particularly so for buried or immersed steel structures where the flow of cathodic protection current from the anode to the structure through the earth or water can traverse other structures in the vicinity. The corrosion rate on these other structures increases where the current leaves the structure to return to the cathodically protected structure.

The amount of damage likely to occur from stray current corrosion of a steel structure can be calculated using Faraday's law, and for 1A passing for one year some 9 kg of steel will be corroded. In practice it is not possible to measure the amount of current being discharged from a structure and so when testing for interaction a potential shift criterion is adopted.

This is done by measuring the change of potential of the unprotected structure as the cathodic protection system is energized. A change in the positive direction indicates current leaving the structure at that point and BS 7361 (1991) gives a maximum value of +20mV for all structures apart from steel in concrete, before mitigation measures are required.

The position is more complex if the secondary structure is steel in concrete because steel when immersed in a sufficiently caustic solution (around pH 11 and higher) can be made to discharge current without any apparent metal loss. This is because the current discharge leads to a loss of alkalinity in preference to the oxidation of steel and the alkalinity from the bulk of the electrolyte, i.e. concrete, migrates sufficiently quickly to replenish that consumed at the point of anodic discharge. This has been demonstrated in the laboratory where a 25V DC source was applied to steel rods cast in concrete for more than a year with no damage to the steel occurring (Benedict, 1990).

It has been speculated that a steel to concrete potential of +0.5V wrt CSE may be an appropriate limiting criterion being the potential at which the disruptive effect of oxygen evolution becomes noticeable. In practical terms however it is often better to adopt a cautious approach and utilize the 20mV criterion. This is because the behaviour of steel may be affected by the presence of chlorides in the concrete.

These considerations only apply to steel fully enclosed in sound concrete. If the steel is only partially encased in concrete and part immersed in another electrolyte such as soil then a cell may be found with the steel in soil acting as an anode. Under the latter circumstances the potential of the structure is likely to be more positive

near the concrete and corrosion of the structure may well be occurring near the interface. This will occur whether or not any interaction is occurring (1991).

While each situation must be considered on its own merits, in general terms it is unlikely that above ground cathodically protected concrete will create interaction problems with secondary structures. This is because of the close proximity of anode and cathode and the relatively high resistivity of the concrete. The cathodic protection current will tend to flow between anode and cathode, i.e. between the anode and the rebar, and is unlikely to flow into secondary structures.

However, if the anode system is some distance from the structure as could be the case with buried reinforced structures, e.g. pile caps, prestressed concrete pipe etc., then interaction is far more likely.

Although secondary structures may not suffer interaction, metallic items on the cathodically protected structure which are not connected to the rebar cage may well do so. Tie wires which are connected to the rebar and which protrude through the concrete cover will short-circuit the anode and cathode of the cathodic protection system and these must be removed prior to installation of the anode. Tie wires which are not connected to the rebar but which are lying on the surface of the concrete, particularly on soffits, will almost certainly corrode, unless they are removed, given their close proximity to the anode. On thin film anode systems the resultant rust staining can be unsightly. Metallic anchors for junction boxes and cable ducts also face a similar problem.

In all cases the risk of interaction should be considered at the design stage and the design should cater for any high-risk items. Low-risk items can be tested when the cathodic protection system is commissioned. If interaction does occur, then possible remedial measures include making a resistive bond to the secondary structure to alleviate the positive shift in potential.

### 9.3

#### REDUCTION IN BOND STRENGTH AND ALKALISILICA REACTION

The current flow between the anode and cathode comprises anions and cations flowing through the concrete carrying their respective charges which are discharged at the anode and cathode by undergoing a chemical reaction. At the cathode, reactions will tend to promote the formation of hydroxides and at higher potentials the evolution of hydrogen, with a net result that the alkalinity of the concrete is likely to be raised and there will be a change in the chemical morphology around the concrete/steel interface.

The magnitude and the time over which the current is applied will have an effect on the degree of change found at the cathode. The changes to the concrete which have most concerned investigators are the possibility of the bonds being reduced between the concrete and steel and the possibility of an alkali silica reaction being triggered by

the increased alkalinity. A previous trial in the UK (McKenzie and Chess, 1989) assessed the effect of cathodic protection on the steel/concrete bond strength at commercial cathodic protection current densities and could find no discernible bond strength difference between the various specimen groups operated at differing current densities.

Alkali silica reaction has been observed in certain structures for many years and is caused by a chemical reaction between active silica constituents of the aggregate and the alkalis in the cement. The reactive forms of silica are opal, chalcedony and tridymite which occur in several types of rocks. The reaction begins with the siliceous mineral being attacked by alkalis and forming an alkali-silicate gel, which then attracts water by osmosis and increases in volume. This volume increase causes an internal pressure in the concrete which will eventually lead to cracking and disruption of the mortar cover. This will mitigate the effectiveness of the mortar as an anti corrosion coating.

The application of cathodic protection would tend to enhance this reaction as the increased alkalinity around the cathode may initiate the reaction. Trials are underway at present in the UK to assess and categorize this risk.

In practice cathodic protection has been applied successfully for many years to reinforced concrete structures and at the current densities typically used (between 0.1 and 20mA/m<sup>2</sup>) there has been no indication that there is a significant risk of causing additional damage to the concrete by triggering ASR unless the aggregate is already active before cathodic protection is applied.

## REFERENCES

- Ameron Design Manual 301 (1986) Prestressed concrete cylinder pipe, 74.
- Baldo, P. *et al.* (1991) Cathodic protection of bridge viaduct in the presence of prestressed steel: an Italian case history; *Corrosion 1991*, Paper 119, Cincinnati.
- Benedict, R.L. (1990) Corrosion protection of concrete cylinder pipe, *Materials Performance*, Feb., 28.
- BS 7361 (1991) *Cathodic Protection: Part 1 Code of Practice for Land and Marine Applications*.
- Ellis, W.J. (1973) Corrosion control of concrete cylinder pipes, *Western States Corrosion Seminar*.
- Gourley, J.T. and Moresco, F.E. (1987) The sacrificial anode protection of prestressed concrete pipe, *Corrosion*.
- Hartt, W.H.*et al.* (1989) Cathodic protection and environmental cracking of pre-stressing steel, *Corrosion Conference*, Paper No. 382, NACE, New Orleans.
- Isecke, B. (1982) Cathodic protection of prestressed structures—considerations, *Conference on Structural Improvement Through Corrosion Protection of Reinforced Concrete*, June.
- Klisowski, S. and Hurtt, W.H. (1996) Qualification of cathodic protection for corrosion control of pretensioned tendons in concrete, *Corrosion of Reinforcement in Concrete Construction*, SCI.
- McKenzie, M. and Chess, P.M. (1989) The effectiveness of cathodic protection of reinforced concrete and the effect on bond strength, *UK Corrosion Conference*.
- Oriani, R.A. (1987) Hydrogen—the versatile embrittler, *Corrosion*, **43**(7), 390.

Scannell, W.T. and Hartt, W.H. (1987) Cathodic polarisation and fracture property evaluation of a pretensioned steel tendon in concrete, *Materials Performance*, Dec., 32.

## Economic aspects

*Paul Lambert, Mott MacDonald*

### 10.1

#### INTRODUCTION

The effectiveness of cathodic protection for the full and long-term repair of corrosion-damaged reinforced concrete is now well-established. However, for the technique to develop and flourish into a mature and commercially successful repair strategy it must be seen to be both technically and economically attractive. The support of internationally recognized bodies, such as the UK-based Concrete Society and the American Concrete Institute, is an important first step. As the number of installations increases the opportunity exists to judge how the expectations compare with the reality. Overall, the comparison is favourable with significant cost savings being reported compared with conventional repair.

While cathodic protection can be used as part of the repair strategy in virtually any instance of reinforcement corrosion, it is in the area of chloride contamination where the cost advantages are most apparent, as the technique avoids the need to remove sound but chloride-contaminated concrete while still providing an essentially permanent repair solution. Consequently, the following discussion on the economic aspects largely concentrates on the use of cathodic protection with chloride-contaminated concrete.

Whereas traditional cathodic protection on pipelines, ships, rigs and jetties tends to be predominantly applied from new, with reinforced concrete, it has most commonly been employed as part of a repair strategy for structures already at risk of serious reinforcement corrosion. The success of the relatively small number of applications to new structures (so-called 'cathodic prevention') has not significantly changed this balance, yet it is in this area where some of the greatest technical and economic benefits may be expected in the future. Properly designed and applied, an integral system operating from new should be expected to demonstrate clearly that prevention is indeed better than cure. It is also significantly cheaper and less disruptive.

## 10.2

## GENERAL COST IMPLICATIONS OF REPAIR

Conventional repair of chloride-contaminated reinforced concrete can be a very expensive and time-consuming exercise. In the USA alone it is estimated that the annual repair bill for bridges and multi-storey car parks is around \$500 million (Transportation Research Board, 1991). It is often necessary to remove large quantities of material before the level of chloride remaining in the structure is below some critical concentration at which corrosion is no longer capable of being initiated. This can have major cost implications in a number of areas, both directly and indirectly associated with the repair process. In many circumstances, cathodic protection can offer significant financial benefits when compared with conventional repair strategies.

The UK Department of Transport estimated in 1989 that over half a billion pounds was needed to be spent on cathodic protection of its motorway and trunk road bridges alone, which constitutes only 10% of the total UK bridge stock (Wallbank, 1989). The USA, with around 300000 bridges suitable for cathodic protection, would require more than \$20 billion to complete the works, an estimated saving of around 75% on replacement (Wyatt, 1993). The potentials for cost saving are discussed more fully in [section 10.5](#).

Growing acceptance of cathodic protection as a viable economic alternative to conventional repair of chloride-induced corrosion by those charged with maintaining the infrastructure, should ensure a continuing expansion of the cathodic protection market for reinforced concrete well into the next century

## 10.3

## CONVENTIONAL REPAIR VERSUS CATHODIC PROTECTION

The choice of remedial techniques to be applied to a contaminated or corrosion-damaged reinforced concrete structure will have influence on a range of costs associated with the repair. These can generally be divided into three areas: costs directly associated with the repair technique; indirect costs necessitated by the choice of repair technique, and ongoing maintenance costs following repair.

## 10.3.1

**Direct costs**

Direct costs should be relatively easy to estimate and can readily be compared for various repair options. For conventional repairs of chloridecontaminated concrete, direct costs include:

- (a) identification of chloride-contaminated concrete;
- (b) removal of chloride-contaminated concrete;
- (c) surface preparation of reinforcement;
- (d) replacement of badly corroded reinforcement;
- (e) reinstatement of the concrete;

For cathodic protection direct costs include:

- (a) initial system design costs;
- (b) break-out of cracked or spalled concrete only;
- (c) surface preparation of exposed reinforcement;
- (d) replacement of badly corroded reinforcement;
- (e) continuity testing;
- (f) bonding of discontinuous reinforcement;
- (g) reinstatement of concrete;
- (h) installation of anode and monitoring/control system.

At first view it can appear that there is significantly more effort and therefore cost associated with the installation of a cathodic protection system. However, this is not necessarily the case. In instances where isolated chloride contamination is present over relatively small areas, it is usually the case that conventional local break-outs and reinstatement to the contaminated areas is the most suitable route to a successful and cost-effective repair.

Structures that have undergone a very high degree of deterioration and require the removal of large volumes of concrete, regardless of the repair technique adopted, may show no cost advantage from employing cathodic protection rather than conventional means. In such cases it is usually prudent to undertake a cost-benefit analysis to determine the most long-term economic repair strategy. This should help to identify the relative importance of factors such as the cause of deterioration and the likelihood of preventing further contamination. Such factors can adversely affect the durability of conventional repair but are not always immediately obvious.

Potentially, the most interesting set of circumstances from a cathodic protection viewpoint is where repairs are required to structures that contain high levels of chloride contamination, but which have yet to undergo extensive deterioration through reinforcement corrosion and delamination. In these cases the fact that large quantities of contaminated concrete can remain in place by adopting cathodic protection as the principal repair method can dramatically reduce costs. At present in the UK it is not uncommon to pay several thousand pounds per cubic metre for hydro-demolition and reinstatement with a good-quality gunite repair material. Every cubic metre saved from replacement constitutes a considerable saving.

### 10.3.2

#### Indirect costs

It is often with regard to indirect costs that cathodic protection shows benefits over conventional patch repair. If one considers a contaminated reinforced concrete bridge structure suffering from serious chloride contamination, then conventional repair of such a structure will often require the design, approval, installation, maintenance and removal of a temporary support structure. This is inevitably an expensive and time-consuming exercise and the presence of such temporary supports, no matter how well designed, may require load and speed restrictions to be applied to the traffic on the carriageway above. Where complete demolition and replacement are required, the level of intrusive traffic management associated with such works may be so disruptive as to make it unacceptable except where absolutely unavoidable. The use of cathodic protection can dramatically reduce the need for such measures.

Buildings incorporating reinforced concrete structural members or pre-cast units such as cladding panels are further potential candidates for the benefits of cathodic protection. While now largely forbidden or controlled in most countries, chloride-based admixtures were widely used as set accelerators until comparatively recently. While allowing faster, more economic production rates, especially in cold weather, the addition of chloride to fresh concrete can have serious consequences with regard to the durability of the structure.

Once constructed, the cost of major repair or replacement of such elements with the inevitable disruption to tenants and other users of the building is often prohibitive in all but the most exceptional cases. Under these circumstances, cathodic protection offers an economic alternative with minimal disruption to the tenants, particularly in non-domestic structures where work can be programmed for nights and weekends.

### 10.3.3

#### Maintenance costs

It is a popular assumption that once a conventional repair has been properly undertaken there should be little or no future maintenance costs and that the structure is somehow better than new. This clearly cannot be the case except in the most exceptional circumstances. Even where potential sources of future contamination have been dealt with, such as through the replacement of leaking movement joints or the application of a protective coating system, a continuing level of maintenance will be required periodically during the full life of the structure. Where the source of contamination has not been properly addressed, the whole sequence of remedial works will start again within a very short timescale.

Cathodic protection is no different in requiring a commitment to longterm maintenance but in general the associated costs are relatively small and can be readily identified and quantified. The costs associated with the maintenance of a cathodic

protection system fall into two areas. The first is the cost of providing the electrical current used by the system to protect the steel reinforcement. Typically, protection currents are very low (between 5 and 20mA/m<sup>2</sup> of reinforcement) which means that many systems consume about as much power as a domestic light bulb. While the cost of the electricity is virtually negligible, there may be ongoing costs associated with maintaining the security of supply, for example, repair of damage to cable runs.

The second ongoing source of expense is associated with the monitoring and control of the system. For a manual system this will involve periodic site visits to carry out monitoring and adjust controls. Alternatively, a data-logging system can be used to collect data and transfer it to an office-based computer via a modem link. The software-based system can then be used to adjust the system output. Over a period of time such a remote monitoring and control system should save significant expenditure, especially if the system is difficult to access due to location or operating restrictions. Additionally, the use of digital communications can drastically reduce the amount of multiple conductor cabling otherwise required by all but the smallest cathodic protection installations.

Current prices for such systems range from around £20 000–£30 000 for a moderate-sized cathodic protection system. There is considerable activity in this area at the moment with the prospect of novel and imaginative developments leading to the availability of more adaptable, userfriendly and ultimately cheaper systems.

While the benefits of all such remote monitoring and control systems should be taken full advantage of, it is clearly important to ensure that a minimum level of hands-on site inspection is maintained to confirm the proper operation of the system and to help identify potential problems at an early stage.

## 10.4

### COST IMPLICATIONS OF ANODE TYPE

The anode selected for a cathodic protection system has implications for both the direct costs and possible future maintenance costs associated with the system. Numerous types and variants of anode are available but these generally fall into one of five generic categories as shown in [Table 10.1](#).

In the majority of cases the selection of an anode type is based on design factors such as protection current requirements, design life, additional weight constraints and familiarity with a particular material. The direct cost of buying and installing the anode system is often secondary, particularly when considered as a proportion of the overall cost of the remedial work. There are also differences between the various systems with regard to resistance to damage and ease of repair. Such factors will have particular importance where a structure is considered to be at high risk of accidental damage or vandalism.

## 10.5 COST COMPARISONS

The extent of cost saving that can be achieved by adopting a cathodic protection-based solution to structural repair is dramatically illustrated by the recent experience of the Oregon DOT in the USA where three historically significant bridges designed by Conde B. McCullough in the 1930s were repaired using a sprayed zinc anode system. The cathodic protection systems for the three bridges at Cape Creek, Depoe Bay and Yaquina Bay cost a total of less than \$20 million, compared with an estimate of at least \$70 million for their replacement (Strategic Highway Research Program, 1996).

In the UK, an analysis of repair costs was undertaken for two reinforced concrete support piers based on full replacement, conventional repair or cathodic protection. The contract involved remedial works to chloride-contaminated concrete, bearing replacement, road deck water-proofing and resurfacing to a value of approximately £500 000 (Lambert *et al*, 1994).

Comparing costs for the project as a whole, cathodic protection was found to result in a 25% reduction in the contract price compared with full replacement. The saving for cathodic protection over conventional repair was calculated to be 50%. When a straightforward comparison of the reinforced concrete remedial works was undertaken, with other elements of the works ignored, cathodic protection offered a 40% reduction in costs compared with full replacement and a 75% reduction compared with conventional repair.

In another instance the relative costs of cathodic protection and complete repair to a deck support beam were found to be virtually identical. However, the reduction in capacity associated with the full replacement option would have necessitated significant traffic restrictions on the road above. Due to the critical nature of the structure in maintaining traffic flows and lack of alternative routes, such traffic restrictions were deemed unacceptable. Cathodic protection was therefore selected for the remedial works (Haywood, 1995).

A more detailed analysis based on discounted cash flow techniques for the maintenance of elevated motorway structures in the UK showed even greater cost benefits for cathodic protection when considered over a 40-year period (Unwin and Hall, 1993). When compared with replacement, conventional repair showed a 10% saving, whereas cathodic protection saved 85%. Significantly, if the installation of cathodic protection was delayed for ten years, the calculated saving against replacement reduced to 50%.

## 10.6 CATHODIC PREVENTION

The approach by which cathodic protection is applied to new reinforced concrete structures in order to prevent future corrosion rather than control existing corrosion

Table 10.1 Performance characteristics and budget costs for various anode systems

System	Coated titanium mesh and cementitious overlay	Conductive coating	Discrete anode	Thermal sprayed zinc	Conductive cementitious overlay
<b>Property</b>					
<b>Installation</b>	Fixing of mesh can be time-consuming. Roughened substrate required for overlay	Surface preparation of concrete must be correct and coating applied in good weather conditions	Care must be taken to avoid hitting steel when drilling holes to accept anodes	Minimal surface preparation required to give good adhesion. Possible environmental concerns	Correct surface preparation to ensure adequate bond to substrate. Very uneven substrates may require levelling
<b>Typical service life<sup>a</sup></b>	25–50 years	10–15 years	20–25 years	Up to 10 years	20–25 years
<b>Ease of repair or replacement</b>	Difficult as both overlay or mesh has to be removed and reinstated	Familiar technology. Re-coating is generally relatively easy	Anode can be drilled out and replaced in the event of a defect	Re-apply to existing coating. No decorative or protective top coat required	Relatively simple as overlay can be removed and re-sprayed
<b>Budget cost<sup>b</sup></b>	£125/m <sup>2</sup>	£60–75/m <sup>2</sup>	£70–80/m <sup>2</sup>	Dependant on thickness and application method	£100/m <sup>2</sup>

**Notes**

<sup>a</sup> Service life based on average current output. Life will be reduced at unduly high currents or for inadequately designed, installed or maintained systems. Replacement systems may be able to use some of the original wiring and connections.

<sup>b</sup> Figures do not include for concrete repairs prior to installation of system (Society for the Cathodic Protection of Reinforced Concrete, 1995).

is commonly referred to as cathodic prevention. Cathodic prevention has been used fairly extensively on elevated road structures in Italy for a number of years and is now being seriously considered for installation on bridges in the UK where corrosion damaged elements are subject to complete reconstruction (Bazzoni *et al.*, 1994). Cathodic prevention has many cost advantages over cathodic protection. The current requirements are much lower at approximately 2–5mA/m<sup>2</sup> of steel as opposed to 5–20mA/m<sup>2</sup> of steel for cathodic protection. The relative installation costs are also lower on new-build structures, typically 3 to 5% of the cost of the works.

The presence of a properly designed, installed, monitored and controlled cathodic prevention system should ensure the total prevention of any future corrosion-related problems, thus dramatically reducing the long-term maintenance costs of the structure.

## 10.7

### PROTECTING THE INVESTMENT

As with many areas of civil works, obtaining meaningful guarantees for remedial works is often impractical. Insurance-backed guarantees are becoming more common but are not yet generally available for cathodic protection installations on existing structures. By far the best way of ensuring a durable repair is to ensure that all stages of the cathodic protection installation, from initial investigation to daily operation, are undertaken to the highest technical standards under rigorous quality assurance procedures.

Two approaches regularly undertaken for cathodic protection works are the traditional consultant-led route and the more recent design and install by a specialist contractor. Design and install contracts are often the simplest to arrange but do not give the client the benefit of independent expert advice. While this may not be as important for small and simple projects, it can lead to problems on more complex projects where works may be required to be phased over a number of years. In such cases the independent consultant working on behalf of the client can provide continuity plus an impartial troubleshooting service should problems arise.

The use of specialist consultants for larger or phased works allows the most appropriate type of remedial works to be specified and designed (which may or may not be cathodic protection), followed by competitive tendering based on the specific design. Such practices allow phased works to be let to different contractors at competitive and market-tested prices.

Regardless of the increasing number of successful cathodic protection installations being reported, cost will always dominate the repair and protection of reinforced concrete and it is the technique's proven costeffectiveness that remains the most powerful argument for its continuing and growing use.

## REFERENCES

- Bazzoni, B., Lazzari, L., Grandi, M. *et al.* (1994) *NACE Corrosion '94*, Baltimore, Paper 283.
- Haywood, D. (1995) Approach shot, *New Civil Engineer*, 25 March, 26–7.
- Lambert, P., Shields, M.A., Wyatt, B.S. *et al.* (1994) Runcorn Approach Viaduct: A case study in assessment and cathodic protection of reinforced concrete, *Eurocorr/UK Corrosion '94*, **3**, 1–23.
- Society for the Cathodic Protection of Reinforced Concrete (1995) *Cathodic Protection of Reinforced Concrete*, Report No 001.95, SCPRC, Leighton Buzzard.
- Strategic Highway Research Program (1996) Oregon saves landmark bridges and millions of dollars —with cathodic protection, *Focus*, Sept., SHRP, 1–2.
- Transportation Research Board (1991) *Highway Deicing*, National Research Council Special Report 235, Washington DC.
- Unwin, J. and Hall, R.J. (1993) Development of maintenance strategies for elevated motorway structures, *Proceedings of Fifth International Conference on Structural Faults and Repair*, **1**, 23–32.
- Wallbank, E.J. (1989) *The Performance of Concrete in Bridges*, HMSO.
- Wyatt, B.S. (1993) Cutting the cost of corrosion of reinforced concrete highway structures, *Proceedings of Fifth International Conference on Structural Faults and Repair*, **1**, 29–42.

# Index

- Accelerators 11
- AC impedance 24, 128
- Admixtures 16
- Aggregates 15–16
- Alkalinity 5, 11, 11
- Alkalinity reduction 11
- Alkali-silica reaction (alkali aggregate reaction)
  - 32, 165–5, 173–4
- Anode 2, 9, 59, 61, 64–91
  - aesthetics 60
  - carbon based materials 65, 72
  - conductive mortar 65, 75–6
  - conductive polymer 50, 51, 65, 73–5
  - discrete anode 56, 78–80
  - driving voltages 45
  - embeddable surface mounted 80–4
  - external 3, 10, 84
  - groundbeds 85
  - iron based alloys 65
  - metal spray 65, 76–7
  - mixed metal oxide coated titanium 65–70, 133, 138–40, 144, 156, 162
  - new structures, *see* Cathodic prevention
  - platinised titanium 65–70
  - primary 70
  - reaction 62
  - ribbon 142–2, 146, 148
  - sacrificial 52, 86, 114
  - selection 43, 87
  - slotted systems 51
  - surface mounted 77–8
  - titanium (uncoated) 72
- Automatic systems 107
- Battery 2, 9
- Bond Strength 32, 166, 173–4
- Bridges 148
- Cabling 43–4
- Carbonation 11, 18, 24–5, 134, 135, 161
- Cathode 2, 9
- Cathodic disbondment 131
- Cathodic protection 3, 10, 29, 30–2, 125, 140
  - case studies 50–8, 135, 142, 145–9
  - comparison 36, 88
  - criteria 171
  - traditional 1, 37, 58
- Cathodic prevention 38, 131, 141–52, 164, 176, 182
- Cement type 15
- Chloride
  - catalyst 11, 14
  - concentration 13, 14, 23–4
  - contamination 18
  - diffusion 134, 135
  - inhibitors 138
  - ion content 6
  - migration 11
  - removal, *see* Desalination
  - soluble 11
- Chlorine evolution 62
- Coatings
  - on concrete 137, 161, 163
  - on steel 137, 138
- Concrete 5, 133
  - additives 136
  - cracking 9, 21
  - damage 17, 20
  - durability 134
  - permeability 7, 136

- repair materials 33
- staining 9, 21
- Continuity 48–50
- Corrosion 2
  - activation 1, 13, 135
  - cell 3
  - chloride induced 2, 112
  - circuit 9
  - damage 9, 27
  - inhibitors, *see* Inhibitors
  - kinetics 123
  - micro 4
  - pitting 5, 6, 15, 129
  - rate 14, 38, 112, 131
  - uniform 3, 5, 6, 15
- Costs 149–1, 176–82
  - cathodic prevention 182–3
  - comparisons 181–2
  - indirect 179
  - maintenance 180
  - repair 177
- Cover meter survey 22
- Current
  - density 37, 38–9, 52, 54, 63, 143, 145, 174
  - distribution 37, 39–41, 53, 63, 144
  - pick up probes 47
- Data storage and analysis 109, 111
- Degradation of concrete xiv
- Deicing salts 11
- Delamination survey 21
- Depolarization 124–4, 131, 132
- Desalination of concrete 162–4
- Design life xiv, 7, 20
  - corrosion 1, 7
- Differential aeration 10
- Double layer 154
- Drainage of stray currents, *see* Stray electrical current
- Driving voltages 45
- Electrical criteria 118–31
  - absolute potential 119–20
  - measurement of depolarization 126
  - other criteria 126
  - polarisation curves (Elog I) 121–4
- Electrical resistance probes 47
- Electrochemical
  - cell 3
    - chloride removal, *see* Desalination
    - noise 24
    - reactions 2
      - inhibitor injection, *see* Inhibitors
- Electrochemistry 2, 115, 137, 145, 153
- Electrolyte 2, 59, 60, 117–17, 158, 162
- Electro-osmosis 153, 154–5
- Elog I testing, *see* Polarisation curves
- Epoxy-coated reinforcement 138
- Evans diagram 115
- Film stabilisation 6
- Guard-ring 26
- Half cell potential survey 22
- Hydrogen
  - embrittlement 166, 169–72
  - evolution 121, 170, 173
- Immersed structures 58
- Inhibitors 167–7
- Interaction 48, 172–3
- Investigation
  - detailed 20–6
  - initial 20
- Intermittent cathodic protection 145
- IP rating 100
- Isolated bar 47, 126–5
- Linear polarisation resistance 24
- Localised corrosion, *see* Corrosion, pitting
- Macrocell probes 127, 128
- Maintenance strategies 89, 149
- Marine environments 11, 135, 136
- Microcracks 166
- Modelling and simulation
  - corrosion initiation 135
  - whole-life cost 136, 149
- Monitoring
  - cathodic protection 118–27
  - cathodic prevention 131
  - corrosion rates 24–6

- realkalisation and desalination 160, 163
- Mortars 33, 84, 146
- Negative connections 48–50, 53, 156
- Oxidation 115
- Oxide layer 5
- Oxygen 14
  - evolution 62, 121
  - level 14–16
  - reduction 65
- Passivation 6
- Patch repairs 29
- Phenolphthalein 24
- Pitting corrosion, *see* Corrosion pitting
- Polarization curves 121–4
- Pore water 15, 155
- Post-tensioned concrete 56, 146
- Potential movement 125
- Potential for protection 131
- Pourbaix diagram 118, 119, 129
- Power supplies 59, 92–106
  - cabinets 100–102
  - computer controlled 57
  - efficiency 106
  - electromagnetic interference 105
  - galvanic separation 104
  - layout 102–4
  - linear 95–6
  - manual tap 93
  - protection 98
  - switchmode 97
  - thyristor 95
  - transformer rectifier and smoothing circuit 94
- Pre-cast units 146
- Prestressed tendons 170, 171
- Protection potential 115, 116
- Realkalization 153–61
- Rebar connections, *see* Negative connections
  - reinforcement continuity 33, 59
  - reduction 115
- Reference electrodes 45–7, 121
- Repassivation 162
- Rust 4
  - flash 5
- Sacrificial anodes, *see* Anodes, sacrificial
- Set accelerator 11
- Short circuit 143
- Silicafume, *see* Concrete additives
- Stray electrical current 10, 26, 48, 49
- Stress-corrosion cracking 171
- Structural considerations 28
  - load-bearing capacity 28
- Survey 155
- Tafel slope 121, 123
- Tidal exposure 110
- Time to corrosion, *see* Corrosion activation
- Transient and lightning protection 98
  - metal oxide varistor 99
  - transient protection diodes 99
  - surge arrestor 99
- Trial 20, 41, 50
- Tunnels 40–1
- Visual survey 21
- Wicking 54
- Whole-life cost, *see* Cathodic protection, cost
  - comparison
- Zero resistance ammeter 47
- Zinc alloy anodes, *see*, Anodes, sacrificial
- Zinc coatings, *see* Anodes, metal spray
- Zones 42, 144

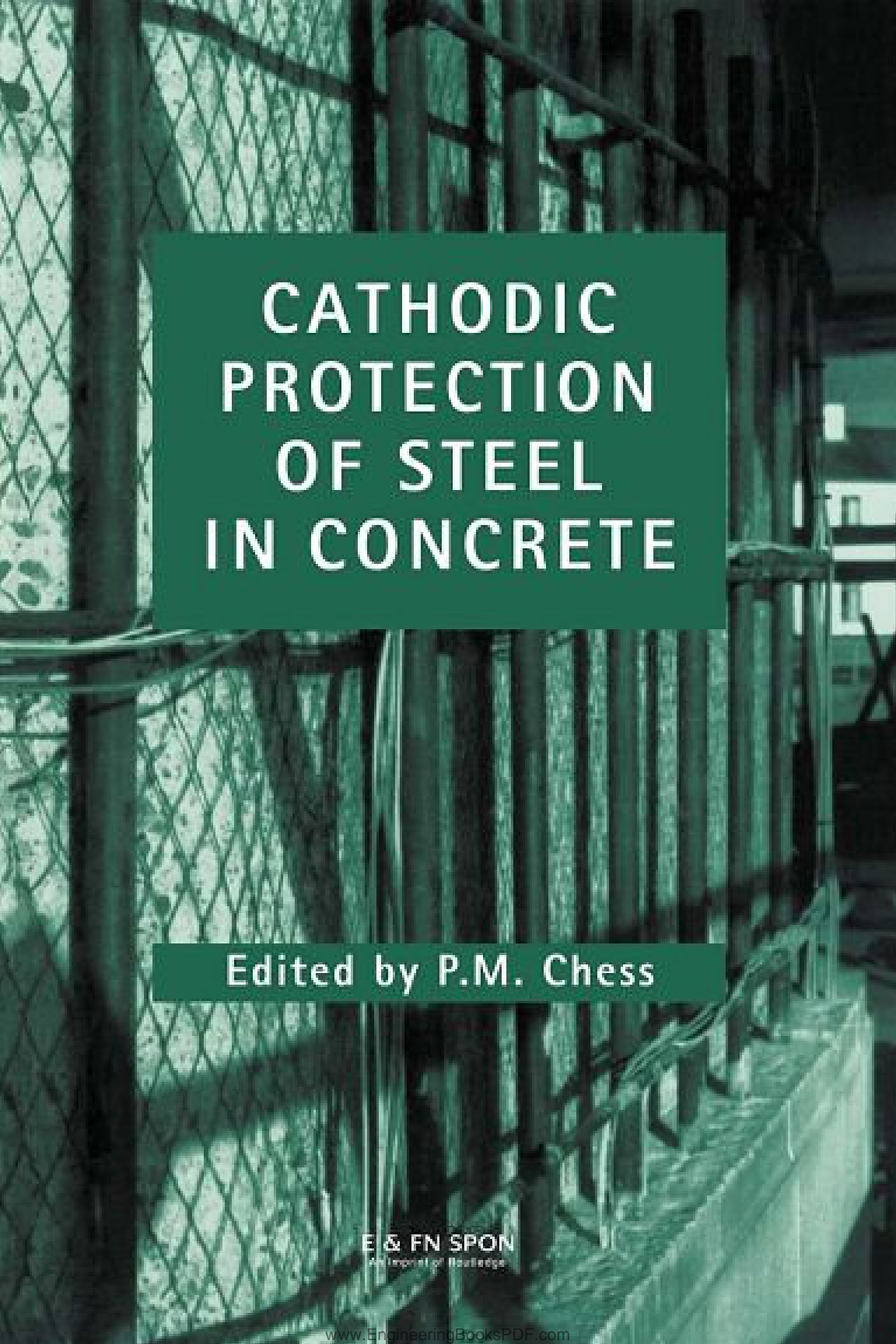

# CATHODIC PROTECTION OF STEEL IN CONCRETE

Edited by P.M. Chess

**E & FN SPON**  
An imprint of Routledge