

THE MODEL RAILWAY DESIGN MANUAL

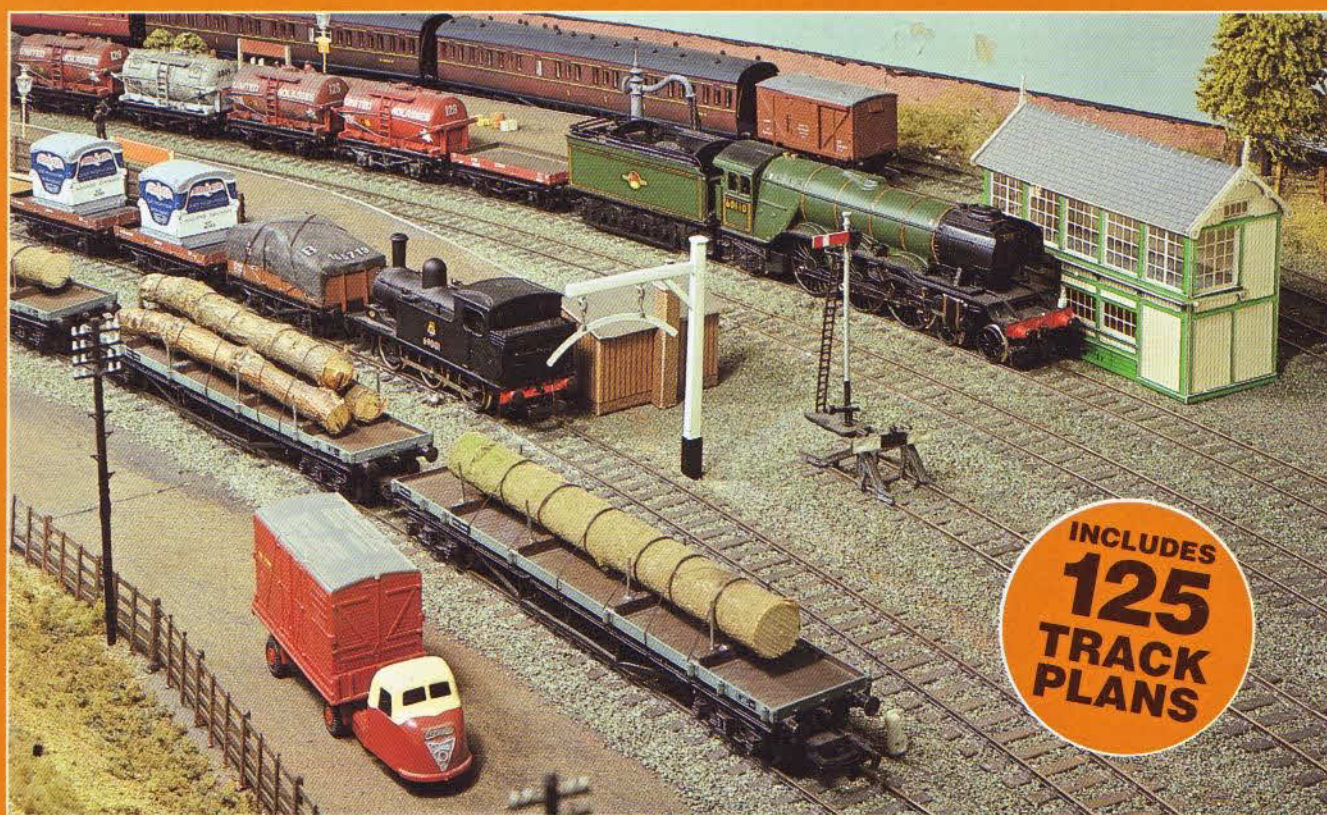

INCLUDES
125
TRACK
PLANS



How to plan and build a successful layout
C. J. FREEZER

**THE
MODEL
RAILWAY
DESIGN MANUAL**

THE MODEL RAILWAY DESIGN MANUAL

How to plan and build a successful layout

C. J. FREEZER



Patrick Stephens Limited

Also by C. J. Freezer, in the same series:

The Model Railway Manual

A step-by-step guide to building a layout

The Garden Railway Manual

A step-by-step guide to building and operating an outdoor model railway

Cover illustrations

Front, main picture: A corner of Nik Wilson's OO gauge 'Brackenridge' layout. (Brian Monaghan, courtesy *Railway Modeller*)

Front, below, left to right: A diesel era layout. The author's drawing board during a planning session. A steam age motive power depot.

Back: The Railway Modellers Club of Worcester's 'Moreton-in-Marsh' layout.

© C. J. Freezer 1996

All rights reserved. No part of this publication may be reproduced, stored in a retrieval system or transmitted, in any form or by any means, electronic, mechanical, photocopying, recording or otherwise, without prior permission in writing from the publisher.

First published 1996

Reprinted 1998, 1999 (twice), 2000, 2001, 2002 (twice), 2003 and 2004 (twice)

British Library Cataloguing-in Publication Data:

A catalogue record for this book is available from the British Library

ISBN 1 85260 538 3

Patrick Stephens Limited is an imprint of Haynes Publishing, Sparkford, Yeovil, Somerset BA22 7JJ, UK.

Tel: 01963 442030 Fax: 01963 440001

Int. tel: +44 1963 442030 Int. fax: +44 1963 440001

E-mail: sales@haynes.co.uk

Website: www.haynes.co.uk

Typeset by J. H. Haynes & Co. Ltd.

Printed in Great Britain by J. H. Haynes & Co. Ltd.

While every effort is taken to ensure the accuracy of the information given in this book, no liability can be accepted by the author or publishers for any loss, damage or injury caused by errors in, or omissions from, the information given.

Contents

Introduction	6
Preliminary considerations	
Chapter 1 It's your railway!	7
Chapter 2 The train is the key	10
Chapter 3 Prototype and period	14
Chapter 4 Baseboard considerations	18
Chapter 5 Time, space and cost	26
The details	
Chapter 6 Fundamental formations	30
Chapter 7 Basic train operation	38
Chapter 8 Track formations	45
Chapter 9 Platforms and facilities	55
Chapter 10 Goods yards	67
Chapter 11 Locomotive depots	74
Chapter 12 Civil engineering	82
Chapter 13 Rail-linked industries	103
Chapter 14 Beyond the railway fence	111
Chapter 15 The fiddle yard	118
The layout plans	
The compact oval Lochaber and Wrightdale	125
The branch theme Widdecombe, St Denys and Ahern	127
City stations Watergate and Avon	133
Tailchasers Yarlington Junction and Beeching	136
Portability Dugdale and Bluddeigh, Butte and Bowd	140
The 'dumb-bell' Barchester	141
The system layout Laurenceton, Metheven and Southern	143
Narrow gauge Rabbits and Tiefencastel	145
Appendix 1 Scale and gauge	149
Appendix 2 Basic dimensions	153
Appendix 3 Further reading	157
Index	158

Introduction

There are two ways of designing a model railway. The idealistic method lays down a basic specification and, from this, evolves the final design; this is strongly favoured by the 'true-to-scale, true-to-prototype' school, but was also employed by Edward Beal, who in his later years had a tendency to produce elaborate layout designs, then find out the size of room needed for their execution. He had some excuse – as a Minister of the Church of Scotland, he was accustomed to living in large manses and the sort of railway rooms most of us dream about were, to him, commonplace realities.

My preference is for the second, more pragmatic approach, where one begins by establishing just how little room one has for the layout, then goes on to assess the probable amount of equipment one can afford in the foreseeable future. While this could be regarded as opting for second best, it has produced some superb model railways. I also favour the *gestalt* school, where rather than slavishly copying a small section of the prototype, one selects various features of the full-sized railway that appeal to one and assembles them into a congruent whole. Hence I am providing a series of sketches showing prototype arrangements I have noted and thought of interest.

As a matter of interest the sketches were drawn on a metric grid, using a modest CAD

program, Turbocad 2.3 for Windows, on a 486DX100 personal computer, and printed on a Hewlett Packard Deskjet 520. Drawing on a computer has many advantages, not the least of which is that you don't get ink on your fingers!

Except for the final layout plans, which are provided with a squared grid, the drawings are not to be regarded as being to scale. Furthermore, throughout the bulk of the book I have made little reference to scale or gauge since the principles are universal. British prototype practice is followed throughout unless otherwise stated.

This brings me to measurement, or to be more exact, the relationship between metric and imperial measurements. A great deal of confusion is created by well-meaning but ill-informed individuals who insist that exact conversions must be applied at all times. In practice, this only applies in very rare cases and, outside an engineering workshop, where a difference of 0.4 mm is very significant, one can apply rounded conversions without any dire consequences.

Virtually every dimension discussed in this book is nominal, for I am talking in round figures as a general guide and not providing precise instructions. I am using as my unit of comparison the 'metric foot' of 300 mm, or the 'metric inch' of 25 mm. I have used ISO units, but imperial equivalents are

provided for those who are happier with feet and inches. There are a couple of cases, in particular the 6 x 4 and 8 x 4 solid baseboards, where a nominal size is given in imperial units because the board manufacturers keep to these sizes. Agreed, to a purist a sheet of plywood measuring 8 ft x 4 ft x 12 mm is an abomination, but that's how it is sold in every DIY store and timber yard I know. The important point is that although there are occasions when it is helpful to work to the nearest millimetre on a model railway, baseboards can be an inch adrift without anyone being one whit the wiser.

Finally, as I see it model railway design is not solely about layout planning, although this is undoubtedly the core of the subject. Other factors need to be taken into consideration, such as the type of trains that will run on the completed model, the method of operation, the choice of prototype and so on. I could go on at length, but these points will be raised throughout the rest of the book.

C. J. Freezer
Hemel Hempstead
1996

Chapter 1

It's your railway!

Prototype railways vary in detail, but share several common characteristics: they are complex organisations, they require a large workforce to keep them running, and, above all, they are *very big*. It is clearly impossible for one individual to make a complete model of an actual railway, and even where several individuals work together to produce a joint system, only a small part of the prototype can be fitted into the available space. Therefore a great deal of the prototype has to be omitted.

Just what parts are left out and what should be included must be

left to the individual. Agreed, there are certain arrangements that are commonly followed, largely because they have been shown to produce an effective model. However, it is very rare that a slavish copy of a successful model layout is anywhere near as effective as the original; carbon copies are usually smudged. Likewise, models that follow a rigid set of rules are often rather disappointing when compared to those where the builder has let his imagination moderate the harsher realities of life.

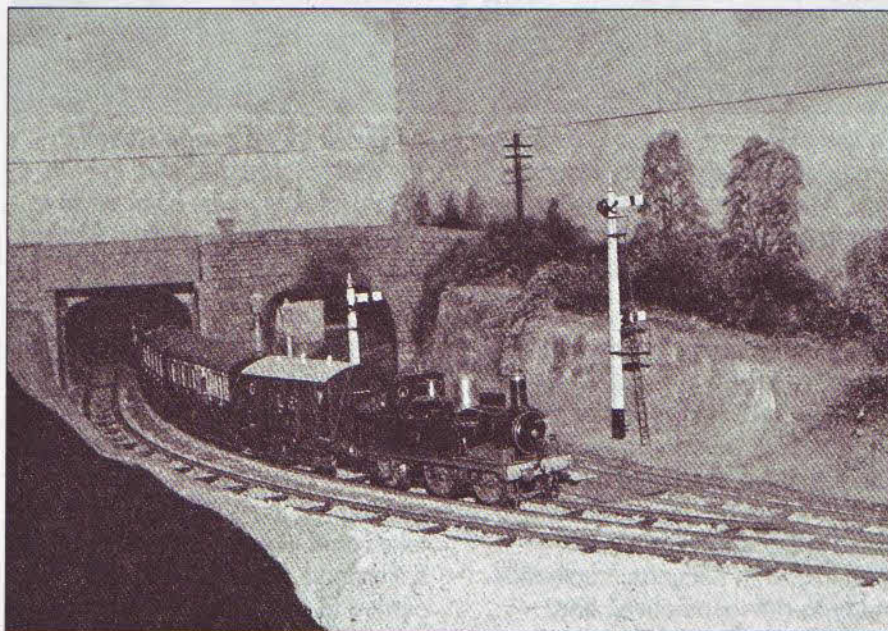

Bob Harper's 7 mm scale GWR layout is, to the majority of people, a perfect example of strict prototype modelling set in Cornwall around the turn of the century. However, although many of the models represent GW practice of the early 1900s, there are mixed gauge tracks and broad gauge locomotives and rolling-stock, all of which went in 1892. This is how Bob likes it, which is the best reason of all for doing things that way.

Personal preferences

If it were more widely appreciated that what I do on my own layout has no direct bearing on what you do on yours – and *vice versa* – a lot of acrimonious argument would be avoided. Your own likes and dislikes, coupled with your personal strengths and weaknesses, should have a very strong bearing on how you set about modelling a railway.

The most important point to grasp is that you are under no obligation to reveal your weaknesses. Very few of us can excel in every branch of modelmaking, so it makes good sense to avoid those bits you do badly and concentrate on the areas you do well. Of course, it takes some time to sort out which is which, but the principle needs to be recognised. There is some disagreement as to what constitutes the least profitable of human activities, but all agree that making rods for one's own back ranks high in any listing.

Establishing a balance

It is a simple fact that one cannot build and operate a model railway simultaneously. As one's spare time is limited, it is necessary to establish a balance between the two, which I have portrayed graphically in Figure 1/1. The two conflicting aspects of the hobby are equal in mass and are neatly balanced against each other; the scales are steady with the pointer on zero. Wonderful!

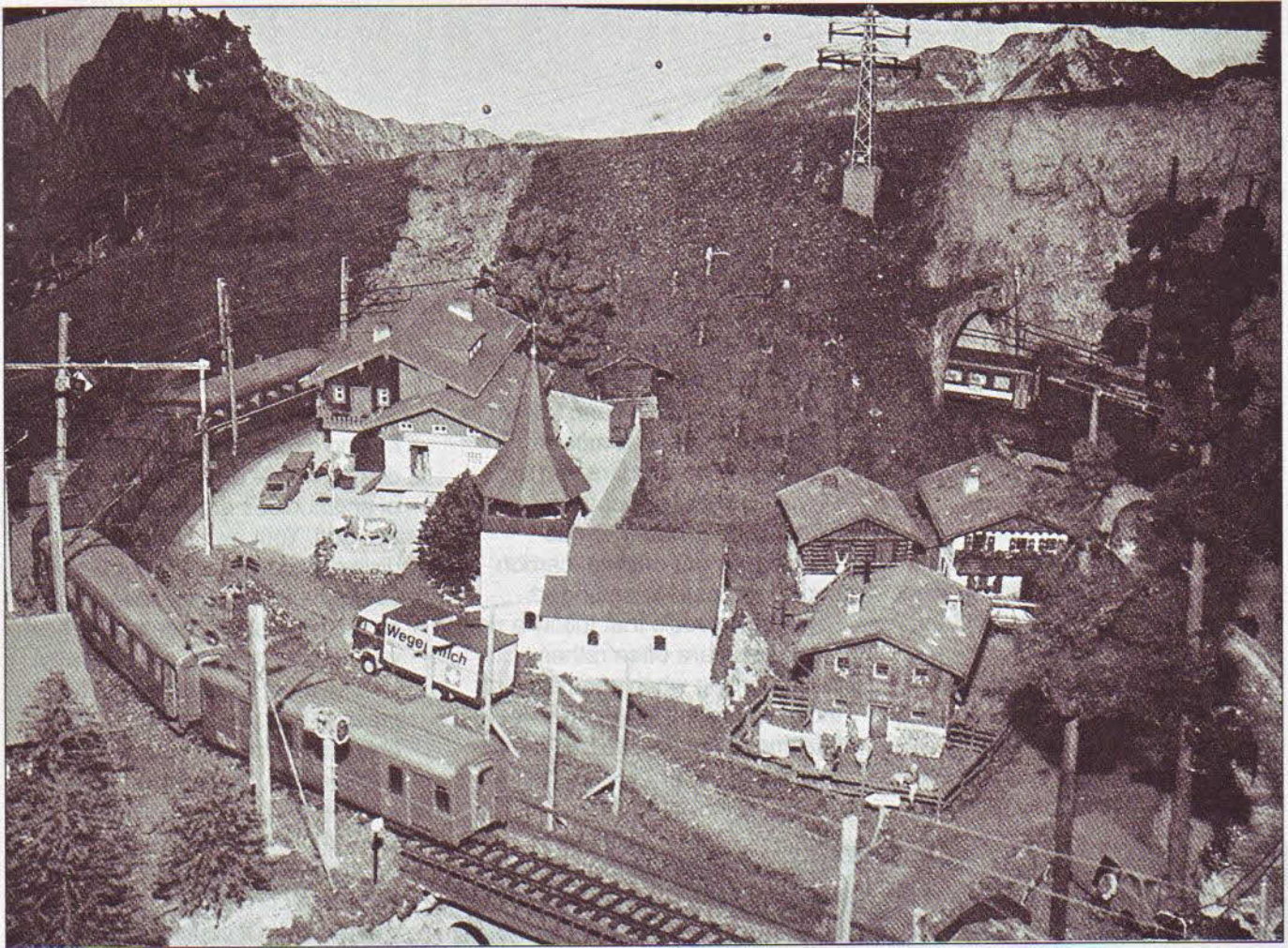

Mike Poleglaze's 'Via Mala' is a model of a line that never was, the extension of the Swiss metre gauge Rhaetian railway from St Moritz to Chiavenna in Italy. Most of the layout represents the Via Mala Gorge, reduced in both length and height, but the Wegerhaus Spiral, shown here, is a complete work of fiction; it takes trains back down to the base level so they can enter the fiddle yard behind the scenes. On this model, a popular feature on the exhibition circuit, the prototype background is taken as a foundation on which to arrange various features of the Swiss scene that appealed to the builder.

It isn't quite like that because, keeping the weight analogy, the two aspects are not equal, and there is inevitably a bias in favour of one or the other. The arrangement in Figure 1/2 is more realistic; here we see construction bulking larger than operation, as happens when the hobbyist is happiest when creating something. In extreme cases, operation amounts to no more than checking that the model can be made to work; thoughts of timetable operation are put to one side in

favour of the next kit to be assembled.

Of course, the proportions can be reversed, with operation taking pride of place. Here it is more than likely that the model will be largely assembled from commercial products, with sectional track and ready-to-run locomotives and rolling-stock. Although scorned upon in some circles, this is a valid approach to the subject, provided that the track layout allows prototypical operation.

Before we get too smug, glance

at Figure 1/3, where construction and operation are balanced against research, for even if this is no more than a matter of reading some of the many books about the shape and form of the prototype, it still takes time. Research is a very satisfying aspect of the hobby, but if carried to extremes the most likely product is a monograph rather than a layout. Many detailed histories of branch lines began as a project to build a model, but got out of hand somewhere along the line.

This is only one side issue,

since we must also consider maintenance. This, on a large layout, can often be a very time-consuming affair. I have known several ambitious projects falter because at a certain point so much time was spent keeping the model working that little further construction could be undertaken, and running was limited to the odd half-hour left after the track had been thoroughly cleaned.

The discouragement factor

Even a straightforward ready-to-run system, using easily assembled sectional track, takes several hours to assemble and connect to the controls, assuming a ready-made baseboard is to hand. An extensive, fully scenic system, laid with fine-scale track, with kit-built locomotives and rolling-stock, will take considerably longer; five to ten years is the usual timescale. Sustaining interest over so long a period can be difficult and many

otherwise excellent schemes have failed because the builder became discouraged halfway through the project.

Fortunately, a model railway is made up from a combination of many items that are models in their own right. It is possible to break even the largest project into tiny bite-sized jobs, which can be finished in anything from a couple of hours to a fortnight's steady slog. Even the major tasks, such as the assembly of an advanced etched-brass locomotive kit, can be subdivided into smaller units that can be quickly finished.

Changing course

Many writers have stressed that one should not only have a master plan, but also that changing course midstream leads nowhere. The facts tell a somewhat different story.

Very few established railway modellers have kept the same layout they began with. A few get it right on the second attempt, but others chop and change at regular

intervals. There are many enthusiasts who have built a succession of small layouts, spending from three to five years on each before exhausting its potential and moving on to something new.

Often, a change of circumstances can be the opportunity for a fresh start. Moving house, for example, can provide a fresh challenge. Although there is a temptation to reassemble the old layout as quickly as possible, putting the reassembly on hold for a couple of months gives one time to rethink the project.

This is even more advisable on retirement. Starting a 25-year project is not a particularly good idea, unless you are able to retire before your 40th birthday. On the other hand, an experienced modeller with a well-thought-out plan, able to devote at least 40 hours a week to his hobby, can complete a layout in two years that would have taken him at least 12 when he had the joint responsibilities of a career and a young family.

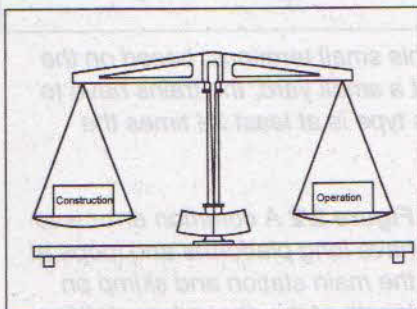

Figure 1/1 Time spent on the mutually exclusive occupations, construction and operation, needs to be kept in balance to ensure that full enjoyment is gained from the hobby. Here we see both sides getting equal treatment.

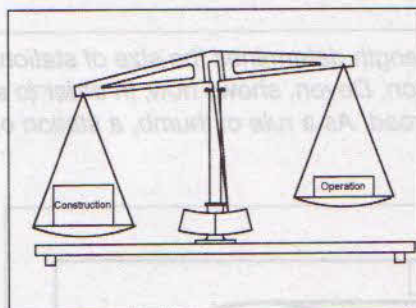

Figure 1/2 In most cases, time will not be apportioned equally. Here construction has the major share of the time, a common situation in the early stages of a layout. The danger lies in allowing construction to dominate, so that it becomes irrelevant whether the trains run at all!

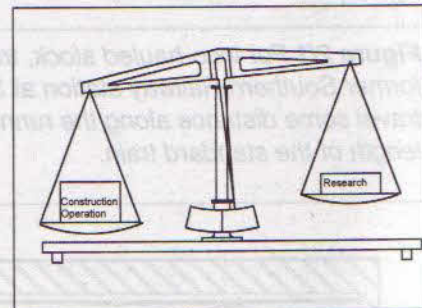

Figure 1/3 While operation and construction are the main themes of the hobby, a certain amount of research is needed to discover how the prototype looked, or – with a contemporary model – looks. Another feature of an operating layout is maintenance. Here the danger lies in skimping this essential task. As has been said before, striking a balance is never a simple matter.

Chapter 2

The train is the key

Although the worst insult you can inflict on a railway modeller is to talk about his 'train set', we should never lose sight of the fact that the main purpose of our hobby is to enable us to run trains over a modelled railway. Ideally they should be run in accordance with a prototypical schedule. I use this term rather than 'timetable' since,

except on the larger and more complex of systems, there is no need to run to the clock. It is sufficient to say that when the 08:15 leaves, it is a quarter past eight in the morning. Only the more pedantic would say that since nothing ever runs to time, when the 08:15 departs it is actually five-and-twenty to nine.

They have to go somewhere

We need to begin our design by considering the trains we intend to put on our tracks, because if we don't we may end up discovering that our treasured scheme falls short of anticipation. We first need

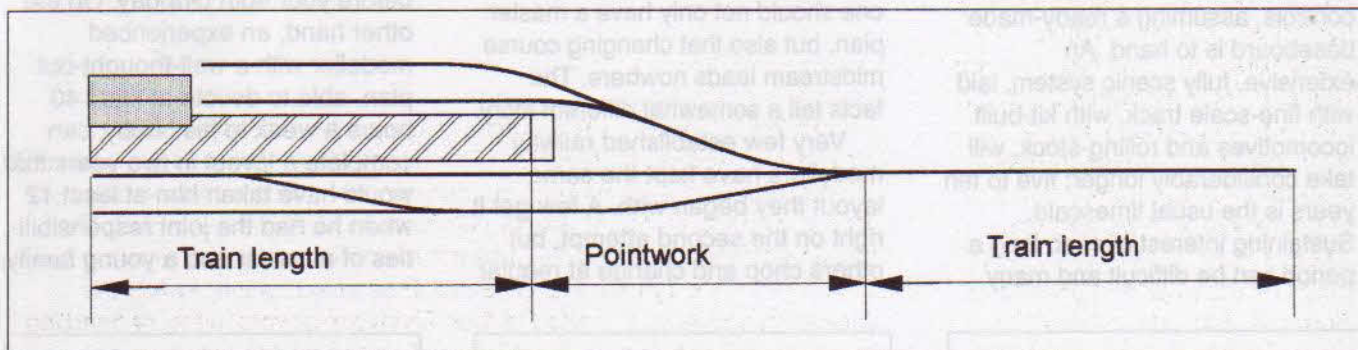

Figure 2/1 For loco-hauled stock, train length determines the size of stations. This small terminus, based on the former Southern Railway station at Seaton, Devon, shows how, in order to shunt a small yard, the trains have to travel some distance along the running road. As a rule of thumb, a station of this type is at least 2½ times the length of the standard train.

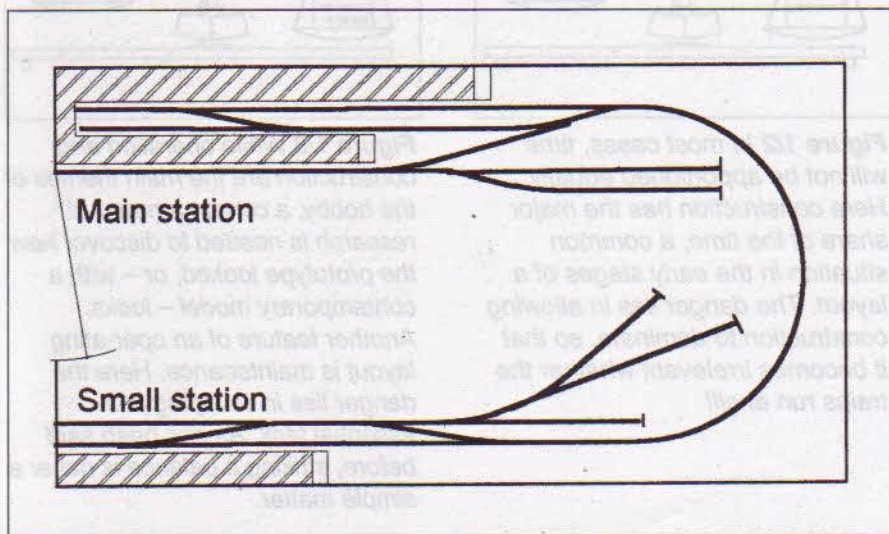

Figure 2/2 A common error is to have long platforms and loops at the main station and skimp on length at the secondary stations. This can end, as this example shows, by reducing the effective length of trains to the capacity of the smallest station.

to ensure that the layout can accommodate all the trains we want to operate a realistic schedule, which means providing enough storage sidings.

Few of us have sufficient space for full-length main-line trains, so some compromise is needed. A secondary route, where shorter trains were the norm, is one answer, but where operation is the keynote, one can get by with under-length trains. One telling argument for modelling turn-of-the-century prototypes is that a five-coach train made up from 50-foot-long bogie coaches, headed by a 4-4-0 or even a 2-4-0, was the norm on all but the major trunk routes.

It is sometimes thought that modern practice does not lend itself to short trains. Almost all the feeder branches and cross-country routes so popular with steam age modellers have gone, and such services as survive are largely in the hands of 'Sprinters'. However, in the recent past we had the Class 37-plus-three-Mk 1-coach trains on the Highland division of Scotrail, while others have discovered the delights of a mineral feeder where the main interest is the freight traffic, but where a 'Pacer' set provides a passenger service.

Figure 2/5 At **A** we have the prototype proportions of a platform: it is very wide, anything up to 20 feet (6 m) to give ample room for passengers to stand well clear of the train doors and not trip over the luggage trolleys at the same time. Reducing only the length, while keeping the station building the same size, creates the unrealistic appearance at **B**. By shortening the building and making the platform narrower, as at **C**, the general proportions of the original remain intact.

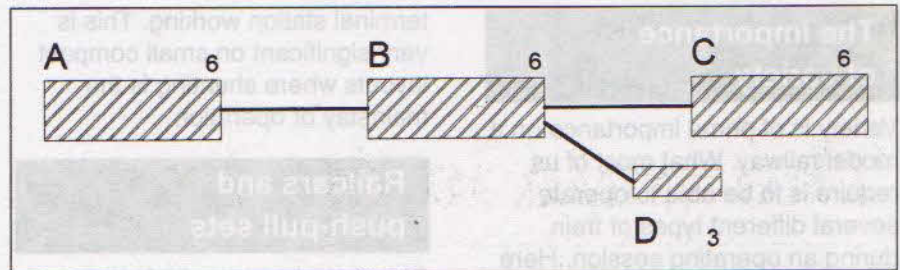

Figure 2/3 A variation in station length is permissible when the smaller one is only served by secondary services. Here stations **A**, **B** and **C** can handle six-coach trains, which are the norm for through express services. The branch terminus can only handle three coaches, so the through services from the main station, **A**, are restricted to this length.

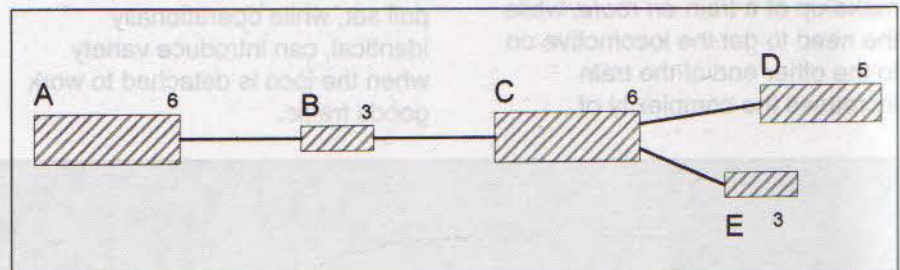
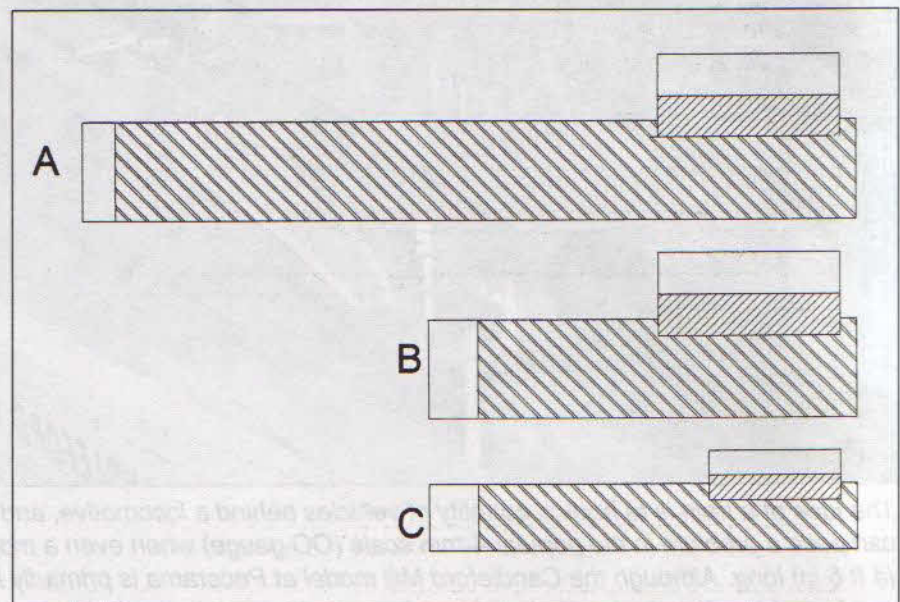

Figure 2/4 Continuing the theme in 2/3, we have added some extra stations and recast the services. The intermediate station, **B**, will only hold three coaches in its platforms, but only the short local services stop here. This is a very convenient way of differentiating between services. The junction station, **C**, is now the only other station capable of handling six-coach trains; the branch station is still three coaches long, while the secondary terminus is limited to five. There are several ways of handling this arrangement, but the most interesting is to split the six-coach sets at **C**.



The importance of variety

Variety is of prime importance on a model railway. What most of us require is to be able to operate several different types of train during an operating session. Here the rule is straightforward – the more, the merrier.

Loco-hauled trains

Loco-hauled trains introduce the opportunity to re-arrange the make-up of a train *en route*, while the need to get the locomotive on to the other end of the train increases the complexity of

terminal station working. This is very significant on small compact layouts where shunting is the mainstay of operation.

Railcars and push-pull sets

Diesel or electric multiple unit sets do not need reversing, running equally well in either direction. This reduces station working, and is extremely convenient for secondary services on a large layout. The steam-worked push-pull set, while operationally identical, can introduce variety when the loco is detached to work goods traffic.

Steam age train types

Steam age passenger trains can be loosely grouped into seven categories:

- Principal expresses, usually named and, for most of this century, including a restaurant car.
- Secondary expresses, which may have refreshment facilities.
- Cross-country services, which rarely had refreshment facilities.
- Suburban services, with non-corridor coaches and almost invariably hauled by tank locomotives.
- Local and branch-line trains, similar to suburban services,

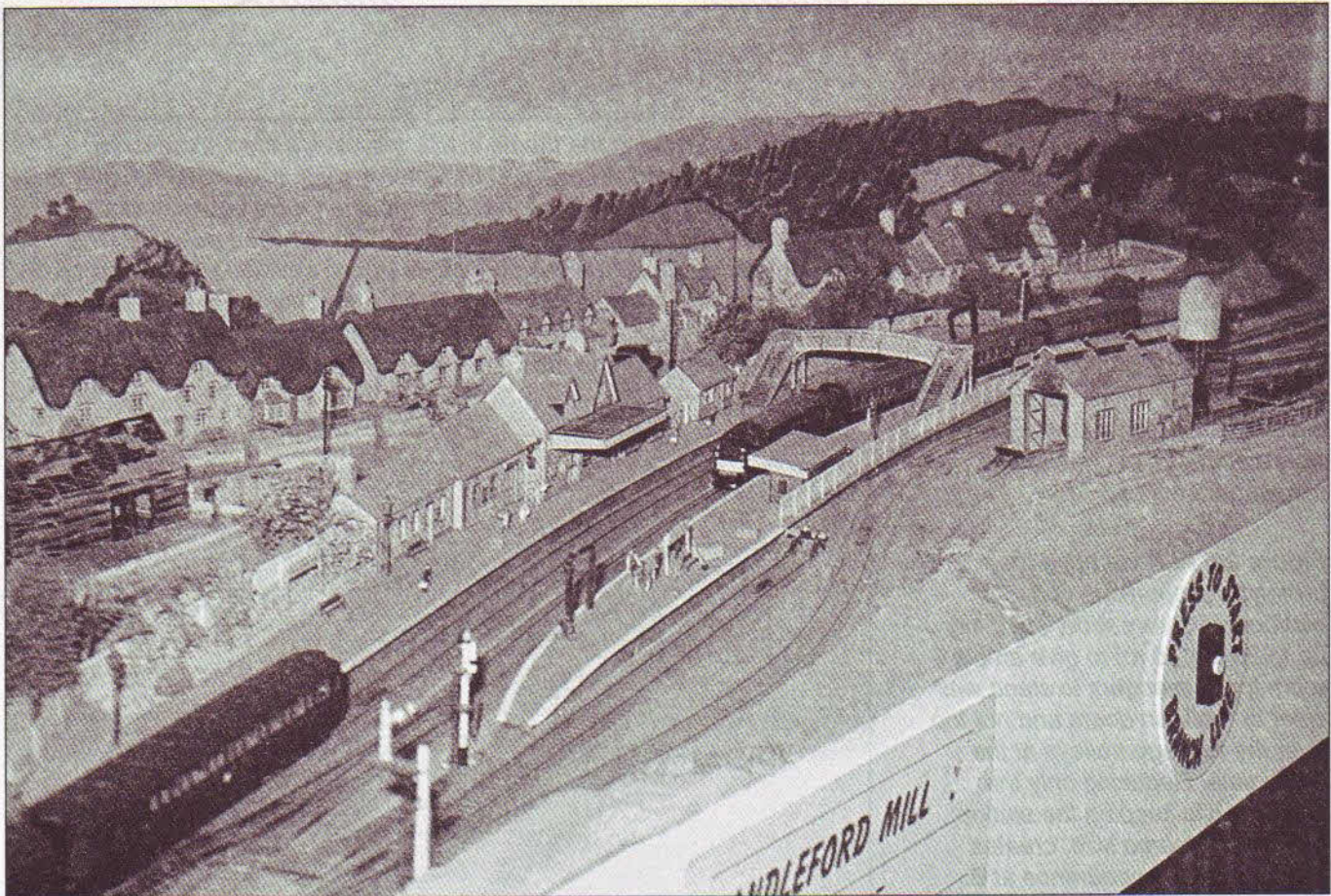

The idea of a train is to hook a quantity of vehicles behind a locomotive, and as a result they are fairly long. This can pose a problem in the popular 4 mm scale (OO gauge) when even a modest four-coach train is around 1.5 m (4 ft 6 in) long. Although the Candleford Mill model at Pecorama is primarily intended to demonstrate how a railway can be set in a townscape, it also shows how much space is needed to provide room for reasonable-sized trains.



The smaller N gauge not only requires roughly a quarter the area of a comparable OO gauge model, but also makes the provision of scale-length trains that much easier within the confines of a normal-sized home. There is also greater scope for setting the railway in the landscape without having extremely wide baseboards.

but running at less frequent intervals.

- Excursion and similar special trains.
- Parcels and van trains – although not strictly passenger, they ran at passenger speeds.

Goods trains fell into four categories:

- Local 'pick-up' trains, collecting and dropping wagons at each station with sidings.
- Through goods trains, normally working between marshalling yards.
- Block trains, carrying one specific product between producer and user.
- Express goods trains,

comprised in the main of vacuum-fitted wagons able to run at higher speeds.

The diesel era

The above pattern persisted into the early diesel era, when both forms of motive power worked side by side. This is a very exciting period to model, since most of the locomotives, coaches and wagons are available from the ready-to-run manufacturers. During this transitional period the steam age track layouts remained almost untouched, although there was a steady reduction in the variety of trains offered.

The latest developments

Today most local and cross-country passenger traffic has been handed over to multiple unit stock, while on the East and West Coast routes loco-hauled trains are equipped with driving trailers at the other end of the train. Elsewhere long-distance traffic is largely in the hands of HST sets with a power car at either end. Although all this has eliminated the old station working pattern, the current generation of diesel era modellers are coming up with some very exciting layouts.

Chapter 3

Prototype and period

For as long as I can remember, it has been accepted that one should begin by selecting a specific prototype and a target date for the model. Indeed, I have in the past often made these very points, but experience has led me to doubt the wisdom of this principle. A surprisingly large number of very effective model railways began with a completely heterogeneous collection of equipment and were none the worse for it. Some maintained an eclectic approach and ran whatever the owner fancied, while others slowly targeted a specific prototype.

Prototype modelling

There are two good reasons for strict prototype and period modelling. The first is that it greatly reduces the area of choice: if you say to yourself that everything on the model will be appropriate to, say, a model of the Western Division of the Southern Railway between 1930 and 1938, you have at a stroke eliminated many excellent prototypes from your shopping list. Whether you decide to scratchbuild, work from kits or have the models built to your specification, you have brought it down to more manageable proportions.

The second reason is that when everything on the model is coherent in respect of both time and place, the effect should be convincing. Although 50 years ago I considered this the real justification for strict adherence to a prototype, I have

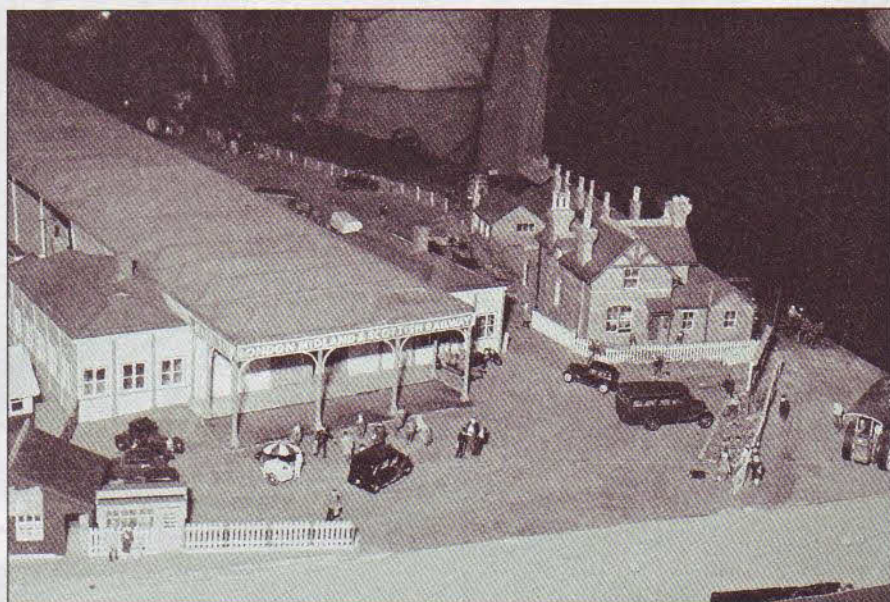

The Oxford MRC's model of 'Rewley Road', the ex-LNWR station in Oxford, is a reasonably faithful reproduction of the prototype in LMS days. It is also very large – at this point the baseboards are roughly 2 metres wide. This is fine for a club project, but less convenient for the single-handed modeller.



Caledonian Road tube station on the MRC's 'Copenhagen Fields' 2 mm scale model depicts the prototype in the 1930s and is based on a combination of site survey for the basic dimensions and general architectural construction and old photographs for the finer detail.

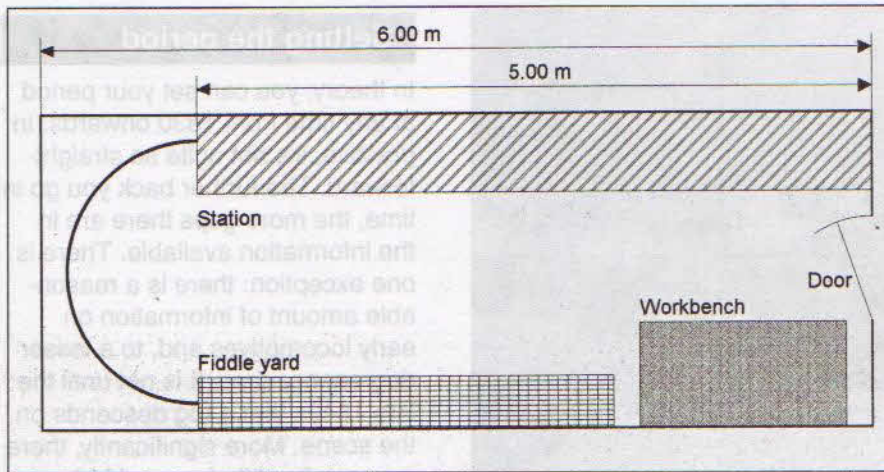

Figure 3/1 The 'last quarter-mile' principle does require a fair amount of room to get 440 yards in 4 mm scale between the start of the 'real' part of the model and the terminus stops. This sketch gives some idea of the overall size involved.

grown less and less sure over the years that this is necessarily so. This is in no small way due to a rash of very accurate exhibition layouts that I know to be correct, but which fail to excite me, whereas models with a more imaginative approach have me standing by the barrier for half an hour or more. There is a great deal to be said for the *gestalt* approach, where the layout may be loosely based on an actual prototype, but the individual structures are taken from other sites. This acknowledges the fact that interesting station buildings are not always married to interesting track layouts.

Time bands

Many established model railways are set in a fairly narrow time band, so that it is often suggested that the newcomer should settle on this at the outset. This is easy where the model starts out to represent current practice; instead of spending hours poring over books and delving into archives to find out how the railway looked, you go to the local line and take copious notes and photographs. The only snag is that when you've

got the model into shape, you discover that the prototype has altered. The once contemporary model has now become an historical record.

Selecting an ideal time slot from the past is more difficult since there are so many possibilities open to you. However, most of the features that set an exact date to the railway scene are either loose accessories or comparatively small touches. The main structures, track formation and signals remained almost unaltered for half a century in extreme cases. Ladies' fashions tend to change fairly quickly, but men's dress is less subject to change; road vehicles also suggest period, as do posters. Most of these details are added quite late in a layout's development.

The principal features that set the time band are the locomotives, coaches and wagons, none of which are permanent fixtures. Not only is it feasible slowly to change the collection, it is even possible to have two or three distinct sets of locomotives, coaches and wagons allowing you to shift period at will.

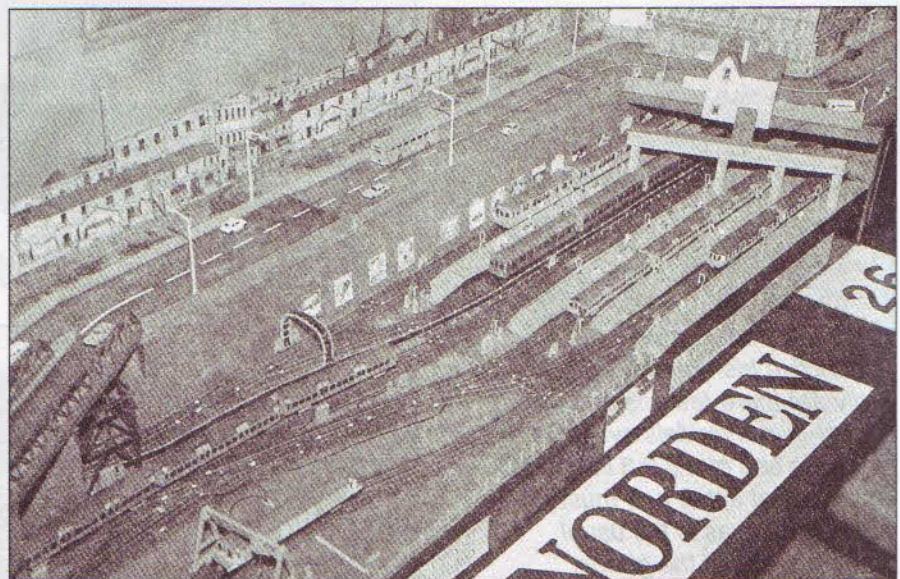

While most railway modellers follow the more obvious prototypes, the more adventurous look further afield. 'Norden' follows London Transport practice, with an imaginary setting. The rear tracks carry 'surface line' stock of the District and Metropolitan lines, while in the foreground the smaller deep-level tube trains appear. Not only is this arrangement completely imaginary, but the tube stock spans a wide time-scale, with early 'standard' cars appearing alongside modern aluminium-bodied sets that did not start running before the older coaches were withdrawn.

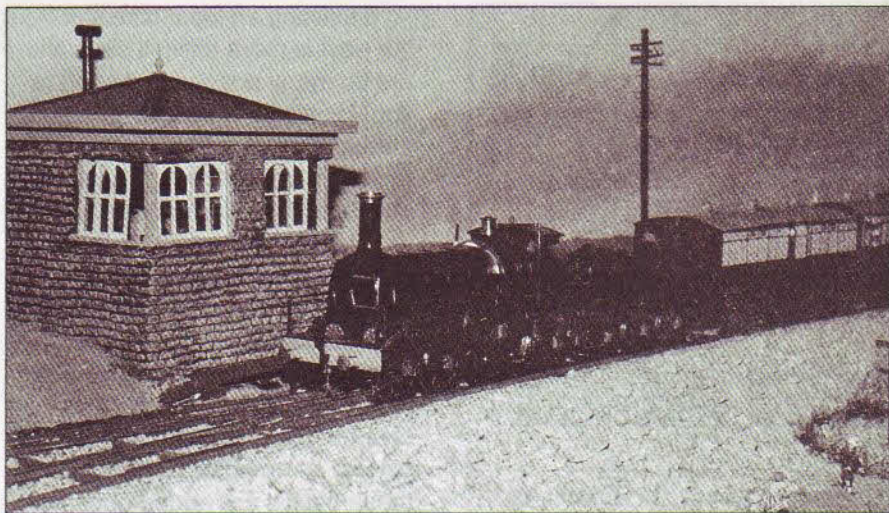

A conventional approach to a different prototype is exemplified by Bob Harper's GWR Gooch broad gauge 4-2-2 and its train of late-period broad gauge coaches. Modeller's licence has brought this machine into Cornwall, whereas in practice they never worked west of Newton Abbot – the stiff grades of the South Devon line were too much for a single driver.

A GWR 2-4-0 of the 3323 class approaching Coldrenick Junction on Bob Harper's O gauge layout.

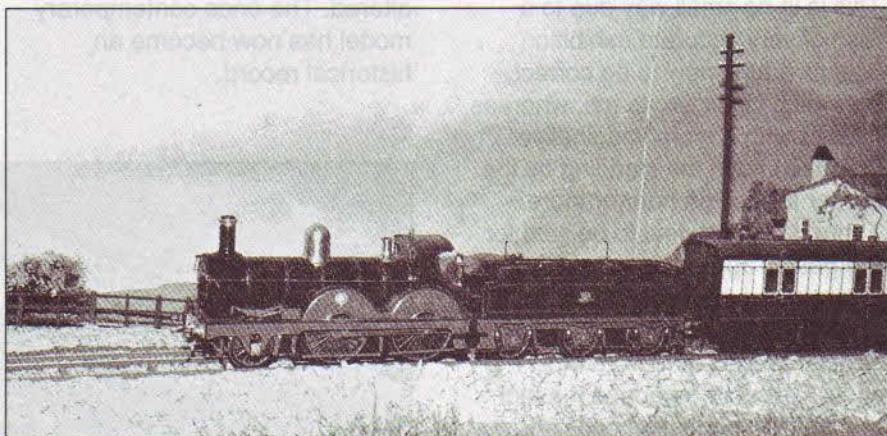

Very few people model the distinctive Irish railways since not only are there few kits and no ready-to-run models available, but also the use of a 5 ft 3 in gauge means that either one must juggle the scale or, as is the usual practice, adjust the gauge. Richard Chown's 7 mm scale model was for many years the sole example of Irish steam on the exhibition circuit.

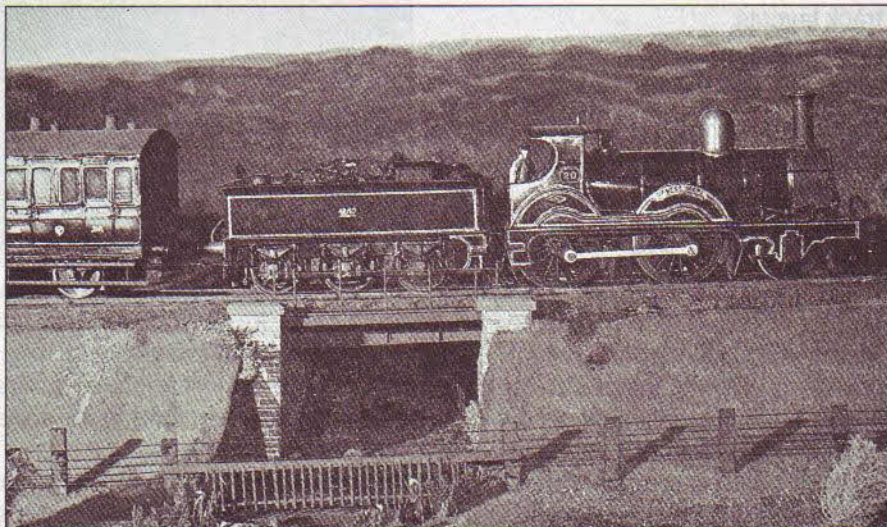

Setting the period

In theory, you can set your period at any time from 1830 onwards. In practice, it's not quite so straightforward. The further back you go in time, the more gaps there are in the information available. There is one exception: there is a reasonable amount of information on early locomotives and, to a lesser degree, coaches. It is not until the late 1840s that a fog descends on the scene. More significantly, there are very few kits for pre-1900 prototypes, while thereafter the situation improves, although anyone choosing the 1900–1920 time slot will need to be an accomplished kitbuilder, as ready-to-run models are extremely rare.

Anachronisms

The most important point, in my opinion, is to avoid obvious anachronisms such as a TV aerial on a pre-1948 layout set other than in the London area. This is more significant in the non-railway sections, since these are the areas where visitors are more likely to find fault. Road vehicles are a notorious problem: the years of introduction of various models are widely known, and even when this hazard is overcome there is the little matter of correct registration letters. Buses are even more awkward: fleet records are unusually comprehensive with the result that the years specific models ran in particular parts of the country are known to bus enthusiasts. This wouldn't be quite so serious if it were not for the fact that the interests have a natural affinity, as is demonstrated by the growing number of model railway exhibitions that are linked to the

nearby station by a vintage bus service. The present rule is that it's OK to put an approximately correct diecast model on the station forecourt, but when the bus is built from a kit, then it must be absolutely right.

Above all, take care with the costume of your figures. This is one point where most viewers are thoroughly clued up, thanks in no small way to costume dramas on TV.

Prototype limitations

Although at first sight modelling an actual station ought to be the ideal approach, there are two inbuilt flaws. The first is that logically you should not only operate the model strictly to the prototype timetable, but only run those locomotives, coaches and wagons that ran through the station. The second is that there is a definite cut-off point in the modelling process, where no further development is possible because everything on the model is absolutely correct.

Of course if you have the space, time and resources to model a major traffic centre, then it is highly unlikely that you will ever get to the point where you can't add something to the model. If you choose a small branch terminus, however, it is possible to reach the cut-off point within a year. You could add locomotives and rolling-stock that never ventured along the branch, and devise a more complicated operating pattern than the simple one offered by the prototype – but surely this is not strict prototype modelling. A better proposition is to accept that the model will have a relatively short life, after which you can start again, possibly with an entirely different prototype and period.

Is it essential?

Is it absolutely necessary to follow a specific prototype, let alone fix the model in a set period? A lot depends on your own viewpoint – if mixing models from different eras and different parts of the world offends you, clearly you don't do it. On the other hand, most of us have a favourite locomotive or train that doesn't fit into the overall picture. If you're fascinated by the 'Orient Express', why not have an HO model to run over your OO gauge rural branch line now and then?

Taking this a stage further, why not amass a collection of interesting trains of all periods, then operate them over a museum line? The critics who say in horror 'You can't do that!' are completely wrong. This is something the model can do that the prototype cannot – but wouldn't it be wonderful if it could! We should never lose sight of the fact that model railways are supposed to be fun.

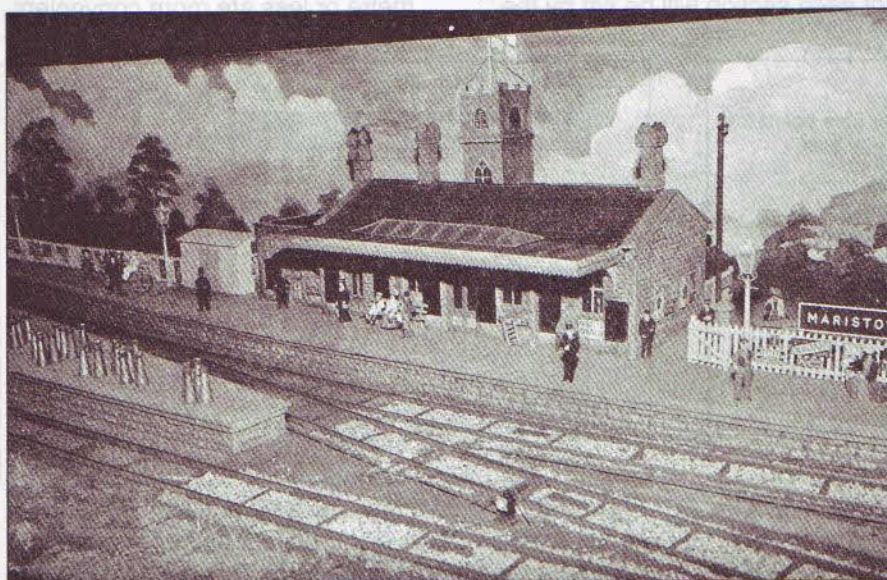

Bob Harper's 'Maristow' is an imaginary terminus set in the 1890–1910 period. The track is laid with bridge rails on longitudinal sleepers, the old broad gauge standard, but reduced to standard gauge. The period setting is excellent, with no obvious anachronisms. Maristow itself is suggested on the backscene by the church tower, flying the flag of St George.

Chapter 4

Baseboard considerations

It is often suggested that the distinction between a true model railway and a simple train set is that the former is built on a baseboard while the latter is laid down on the carpet. As many developed train sets are fixed to a baseboard to save time and trouble, the borderline is delightfully fuzzy – as indeed it should be. A more subtle difference is that with the train set the tendency is to make the baseboard first, then fit the tracks on to it, while on a model railway the layout is planned first and the baseboard built to fit the design. However, we need at the start to consider the overall arrangement of the substructure to ensure that we can build the model.

There are three basic types of baseboard: portable, transportable and permanent. Again, the distinctions are blurred at the boundaries, but the underlying principles are very distinct.

Portable baseboards

The portable layout is one that is normally stored in a dismantled form. It therefore needs to be erected in less than an hour and dismantled in much the same time so that there is time for an operating session in between. It is broken down into sections that are easy to carry about and can be stored neatly and tidily in an unobtrusive place. The overall size of each section will be set by the

space in which it is stored. Six to eight sections is the usual upper limit, and these are preferably arranged in pairs so that two units can be stored face-to-face. It is essential that each unit, or pair of units, can be easily taken by one individual through standard-sized door openings, along normal passageways, up stairs and, if possible, can be taken through the ceiling hatch into the loft for long-term storage.

As the result of practical experience, Peter Denny once said that the largest baseboard unit that can be readily moved around the home measured 4 ft x 2 ft, or in metric units 1.2 m x 0.6 m. My own opinion is that overall lengths of 1 metre or less are more convenient.

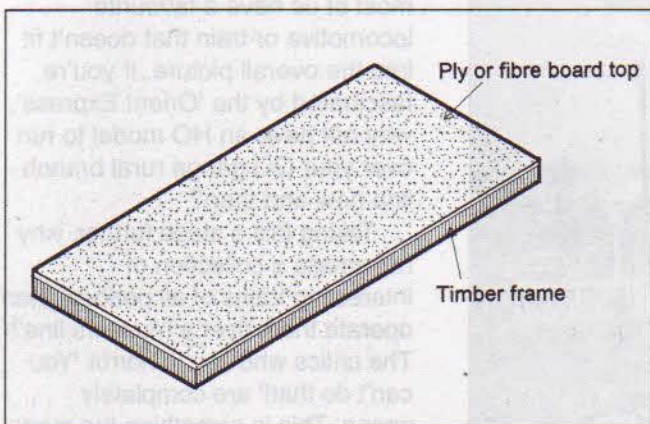

Figure 4/1 The basic rectangular baseboard unit, comprising a timber frame and a top from man-made board: plywood, chipboard, high-density fibreboard but not hardboard. For private use a size between 1.2 m x 0.6 m (4 ft x 2 ft) and 0.5 m x 0.3 m (2 ft 6 in x 1 ft) will be best; larger units tend to be too unwieldy for single-handed use. Often the actual size will be determined by the dimensions of the storage space.

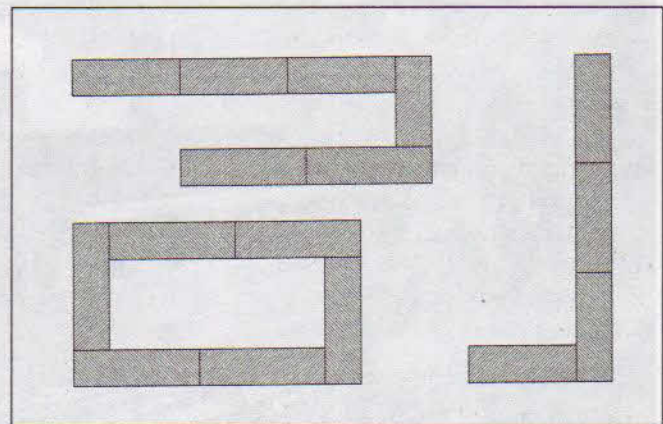

Figure 4/2 The complete portable layout is built on a series of baseboard units, bolted together or held by fasteners for speedier assembly. The simple rectangular frame can be arranged in a variety of ways to conform to the layout design. For full portability a maximum of eight units is advisable; anything more takes too long to erect. With a transportable layout any reasonable number of sections can be used.

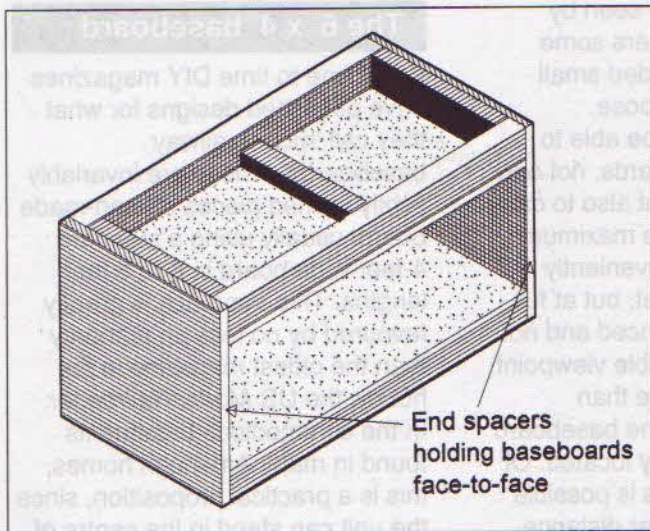

Figure 4/3 Although the units need not be identical in size, it helps considerably if they are standardised in pairs. This allows two units to be transported and stored face-to-face with bolt-on end spacers, usually made from 12 mm chipboard. A pair of hand holes in each end board makes transportation easier. Where the sections are not rectangular, the units are made as mirror image pairs.

A relatively small unit is much easier to take up a flight of stairs; indeed, if there are winders, even a metre-long baseboard may be troublesome. Shorter units are also easier to manhandle into a modern loft, where prefabricated roof principals obstruct the available space. Above all, such units will fit readily into the overwhelming majority of family cars. I am inclined to the theory that unless you can load the layout into your car and still have room for one passenger, it isn't a portable system.

Transportable baseboards

The transportable layout is normally erected and ready for use at any time. It is similarly built on a number of baseboards, but as it does not need to be erected before each running session and then dismantled and stored away,

the units can be larger and more cumbersome. It can be assumed that a second person will be available to help move the units.

Transportable layouts do not necessarily need to fit into the family car, though this is an advantage where the layout is suitable for exhibition. In such instances, a large estate car is the preferred vehicle. I would suggest that transportable layouts should be so designed that the units can be safely stowed into a Transit-type van, since these are available for hire almost everywhere at competitive rates.

A club layout can have larger baseboard units, since one can assume that a team of at least four members will be on hand to move them to the club's exhibition. It is still essential to ensure that the units can be taken safely through the doorway! Not all clubrooms have a double door, let alone a convenient loading bay.

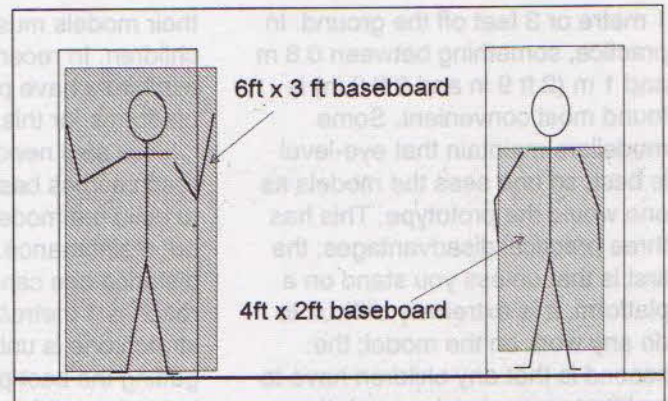

Figure 4/4 It must be possible to get baseboard units through a standard door opening, otherwise there will be problems when the time comes to move – as will inevitably happen. A 1.8 m x 0.9 m (6 ft x 3 ft) unit is really too much for one person to handle, but a 1.2 m x 0.6 m (4 ft x 2 ft) section is easily carried through the home. If the length is no more than 1 metre (3 ft 3 in) it will also fit into the rear of a small hatchback.

Permanent baseboards

The permanent layout is one that is built into the railway room, with no provision for easy dismantling. Although this might seem to rule out the possibility of a move, advanced baseboard and layout design will allow the model to be broken down into its major units, with only relatively straightforward sections of landscape needing to be destroyed.

Baseboard height and width

Baseboard heights are set by the dimensions of the human frame. Although we come in various shapes and sizes, most adults are near enough the same size for two basic dimensions to be generally applied.

The first is baseboard height. The most convenient figure is waist level, which is roughly

1 metre or 3 feet off the ground. In practice, something between 0.8 m and 1 m (2 ft 9 in and 3 ft 3 in) is found most convenient. Some modellers maintain that eye-level is best, so one sees the models as one would the prototype. This has three practical disadvantages: the first is that unless you stand on a platform, it is extremely difficult to do any work on the model; the second is that any children have to be lifted up or stood on a platform in order to see anything; and the third, and to my mind the most telling argument against this principle, is that any foreground models completely block the view of anything further back.

Having said that, I agree that it is good to view models from eye level, but this is most easily arranged by providing a couple of stools on which adults can sit. Layouts intended for exhibition must take into account the fact that

their models must be seen by children. In recent years some exhibitors have provided small platforms for this purpose.

You also need to be able to reach across baseboards, not only to build the model, but also to carry out maintenance. The maximum distance one can conveniently reach is 1 metre/3 feet, but at full stretch one is unbalanced and not getting the best possible viewpoint. Indeed, anything more than 600 mm/2 feet from the baseboard edge is inconveniently located. Of course, where access is possible on both sides a greater distance can be spanned. This is where sectional baseboards score – when you need to work on a section you simply take it out and carry it to the workbench. On permanent layouts, it is necessary to provide access holes on wide baseboards, particularly near the corners.

The 6' x 4' baseboard

From time to time DIY magazines have published designs for what they call 'model railway baseboards'. These are invariably lightly framed pieces of man-made board, usually using a standard 4-foot-wide board in 6 or 8 feet lengths. This approach is greatly favoured by no less an authority than the oldest magazine in the hobby, the *US Model Railroader*. In the commodious basements found in many American homes, this is a practical proposition, since the unit can stand in the centre of the space on a pair of trestles. Although such a unit can be poked into the corner of a spare room, it does not make best use of the space; it is far better to use narrower units around the walls, leaving the centre of the room free for the operators.

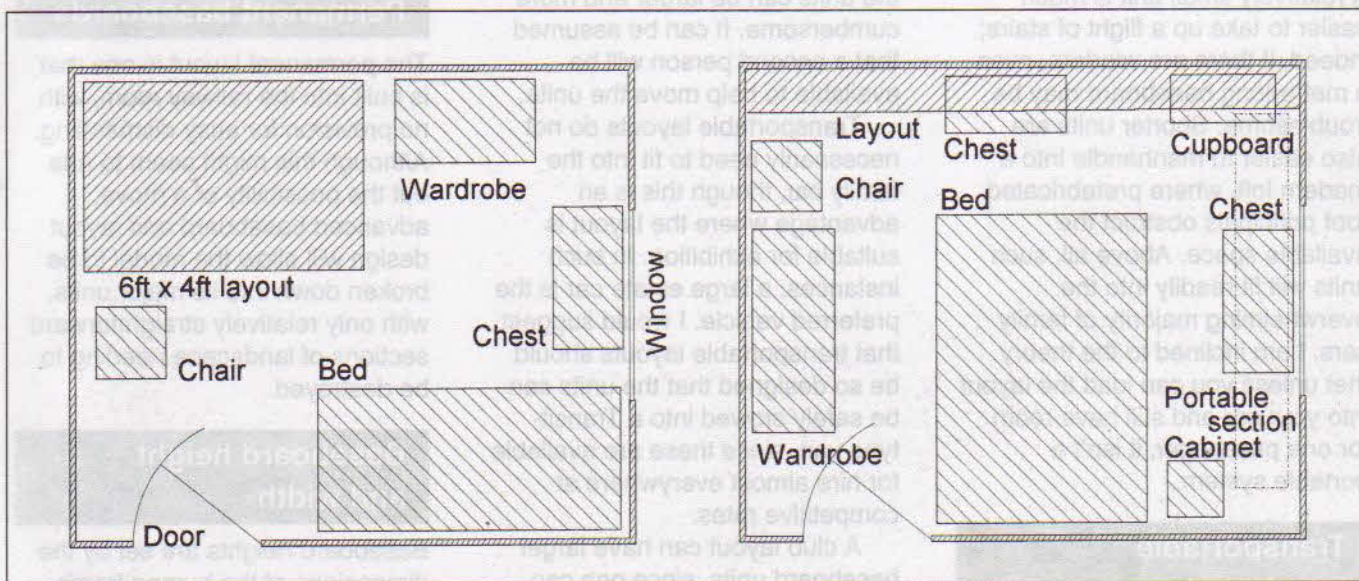

Figure 4/5 The solid 6 x 4 baseboard makes a considerable impact on even a fair-sized bedroom. While it is still possible to find room for a teenager's basic requirements, as can be seen from the plan, left, there is not a lot of space left. If a wall-hugging scheme is adopted, the impact on the room is reduced, and in the plan, right, we have, in addition to the layout, a double bed, a large wardrobe, two chests of drawers and a low cupboard. There is room for bookcases as well, although the space under the layout in the top left-hand corner is best reserved for the portable section across the window.

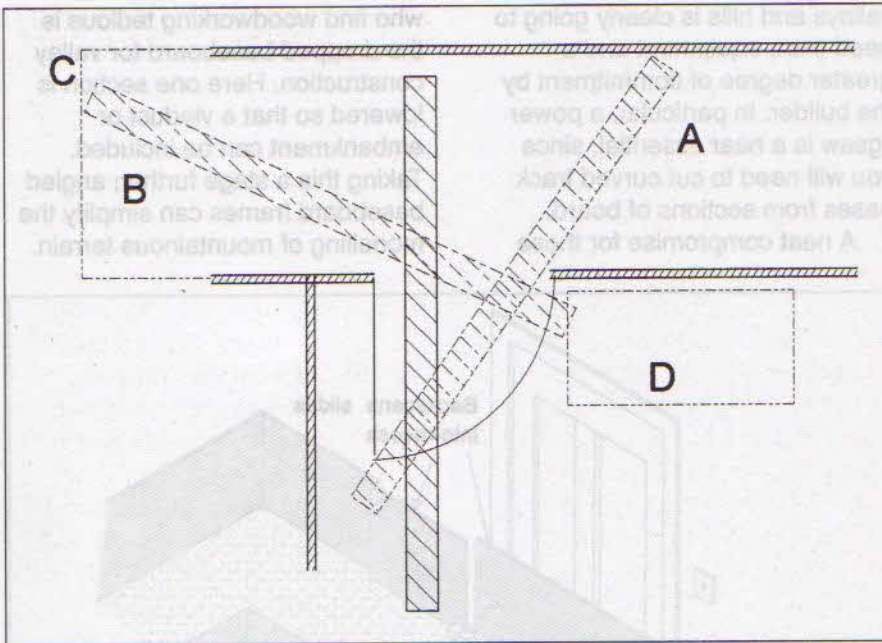
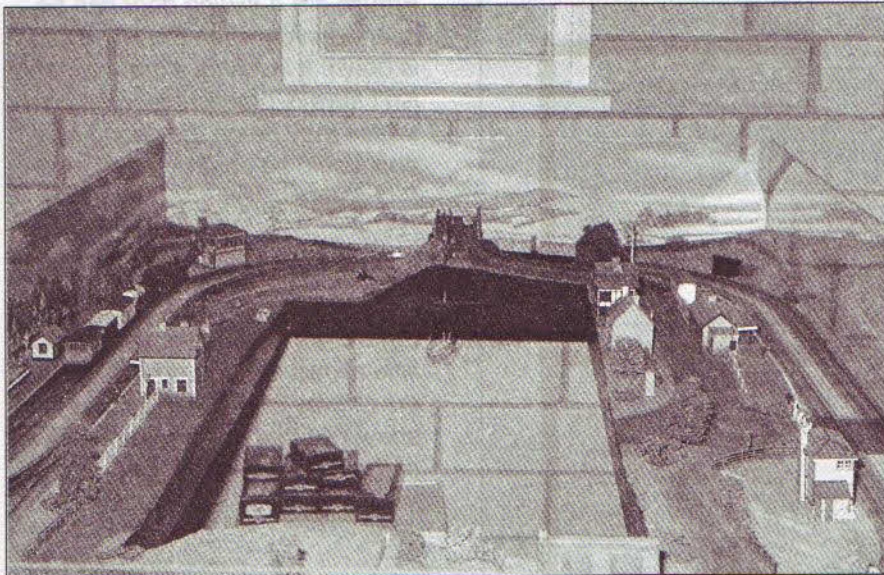

Figure 4/6 Although a 6 x 4 takes up a lot of room, the main disadvantage is that it is difficult to get out of the room it was built in. The 8 x 4, while making economical use of a standard man-made board, is even worse, since it can only pass through the doorway on its side. If, as is usual, the door opens on to a passageway, there are further problems. There is no way that it can be got out in one direction, as shown by position A. It will just go the other way, if there is no obstruction at C. A chest of drawers at D will get in the way and need moving before the shift begins. Two strong men are essential.



The little 6 x 4 layout at Pecorama features a hollow centre where the operator can stand. The baseboards are arranged in two halves and can be folded for transit. The model is not portable – its size and weight means that at least two fit men are needed to move it about – but the shape makes it reasonably easy to manoeuvre through doorways and along corridors.

Access to the layout

This brings me to the business of access. For a start, you need to be able to reach any part of the layout with reasonable comfort, hence in the main all parts need to be within an arm's length of a baseboard edge. Certainly, no turnout should be located more than 700 mm (2 ft 6 in) from an access point so that it can be repaired *in situ*. With a sectional layout it is always possible to dismantle the baseboard, but except on a portable layout this can be a confounded nuisance. On large permanent layouts, access holes must be provided; these can be covered with a scenic feature on a light frame that can be removed without too much trouble.

Lifting sections

For many years the standard method of bridging a doorway was to arrange a lifting flap, hinged to allow the section to swing clear. Clearly, it is not a good idea to have sidings on this section, since any wagons on the flap will need to be removed before the section is raised, and inevitably this will be forgotten at some time or other. Equally, it is inadvisable to arrange a lifting flap immediately behind an inward opening door, since it will form a very effective barrier when lowered. I would suggest that except in very small sites, a clear access from the doorway to the main operating area should be maintained. Ideally, all operating areas should be interconnected without any form of obstruction. This not only makes it easier to operate the layout single-handed, but also means that an evening's running session can be easily punctuated with a coffee break.

Although the actual construction of baseboards is outside the remit of this book, clearly this detail needs to be

considered at the design stage. Perhaps the most important factor is your interest in carpentry. A simple rectangular one-level solid-top system calls for the absolute minimum degree of skill and requires very few tools. An elaborate multi-level scheme with

valleys and hills is clearly going to need extra equipment and a greater degree of commitment by the builder. In particular, a power jigsaw is a near essential, since you will need to cut curved track bases from sections of board.

A neat compromise for those

who find woodworking tedious is the dropped baseboard for valley construction. Here one section is lowered so that a viaduct or embankment can be included. Taking this a stage further, angled baseboard frames can simplify the modelling of mountainous terrain.

Figure 4/7 Although it is best to avoid obstructing the door, it isn't always possible. A hinged flap is the classic answer and works well, although three points need to be noted. First, the electrical circuits to the adjoining tracks need to be interlocked with the flap so that power is cut off when the flap is raised. Second, there should be no sidings on the lifting section, or eventually you'll have a spill. Last, but most important of all, the hinges have to be raised above rail level so that the rails don't clash when the flap is raised. Apart from this, the general construction of a lifting flap can be studied in almost every pub in Britain.

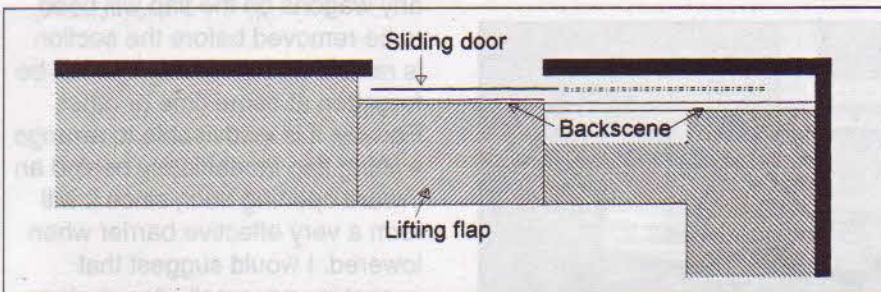
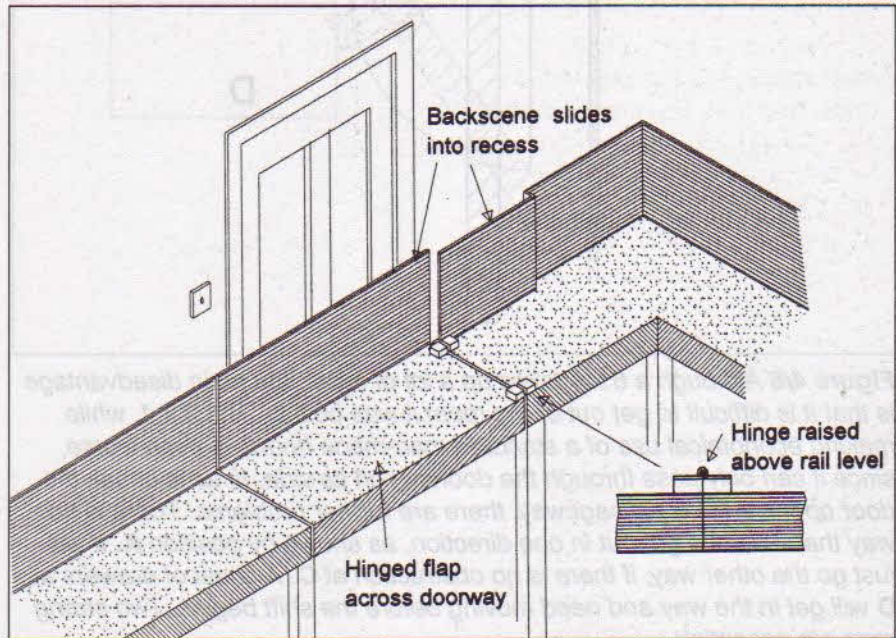

Figure 4/8 A sliding door can be opened even when the lifting flap is down. It involves extra work and isn't always practicable – the light switch may be on the wrong side and would be obstructed. A multi-fold door is another possibility.

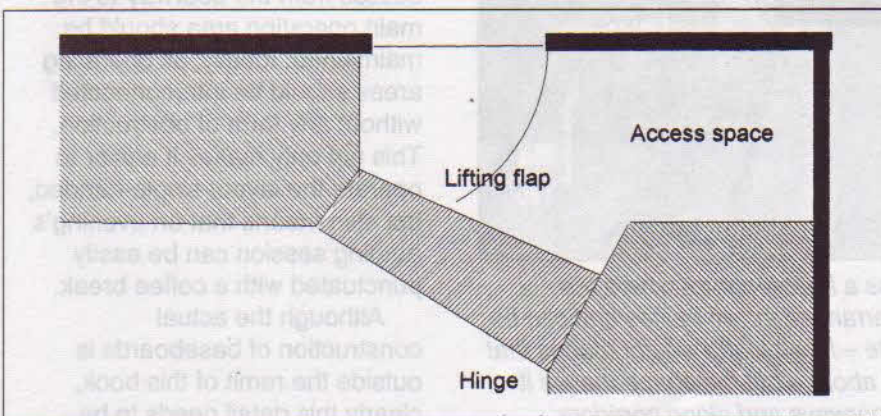

Figure 4/9 Setting the flap back a little allows the door to open while the railway is in use. A recess is shown so that one can move clear of the door before ducking under the flap.

The mock-up

Finally, it can be extremely useful to make a small-scale mock-up of the layout once the design of tracks is more or less finalised.

This can be a very flimsy affair made from cut-down cereal cartons held together with adhesive tape, or a more substantial timber structure with the landscape moulded from

modelling clay. The mock-up not only gives you a better idea of how the model must be constructed, but can also form a useful 3D working 'drawing' throughout the gestation of the layout.

Figure 4/10 A duck-under need be no more than a reasonably clear space one can get through when bent low. The provision of a pair of handrails – well-smoothed timber battens are ideal – and a piece of thick-pile carpet make the passage easier. The deep section frame is there to prevent damage to the layout should someone come up too quickly. A padded edge would also not come amiss.

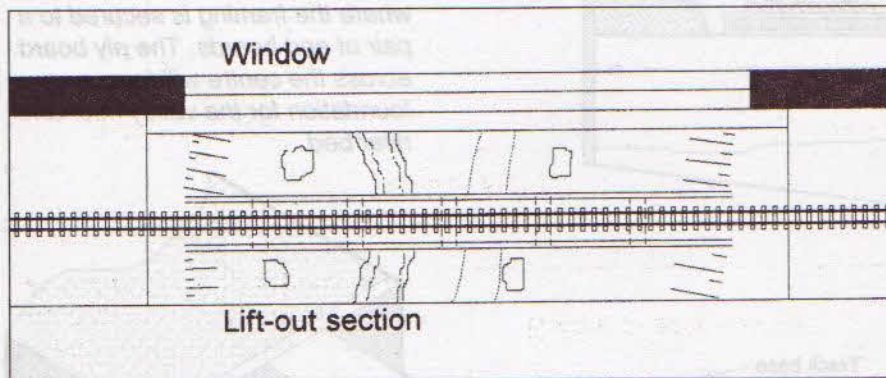
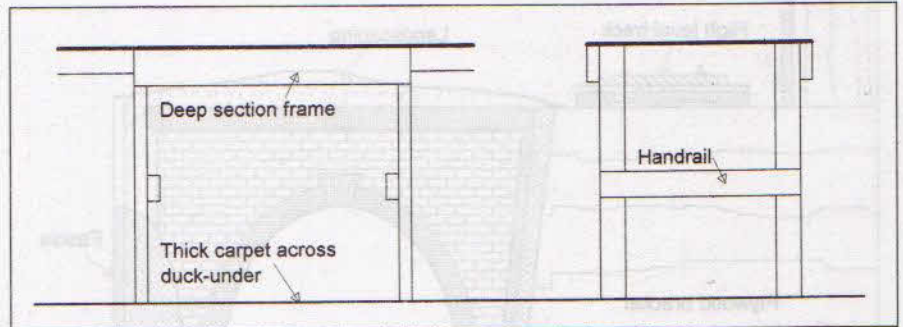

Figure 4/11 Access to the window is often ignored, and as window panes do need the occasional clean, it's a good idea to make any section across the window opening easily removable. Here I've suggested a lift-out section with a viaduct. This is one type of feature that does not need a backscene; the brain expects to see a viaduct against the sky and accepts the window as a substitute.

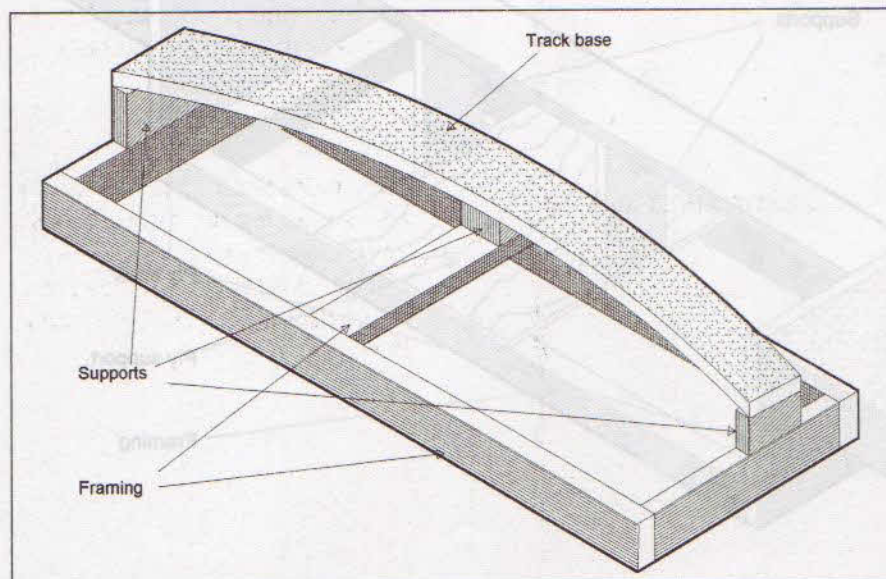

Figure 4/12 By dispensing with the solid top and providing bases to carry the track, not only is it possible to carry the landscape below the track level, but the all-up weight of the unit is reduced. However, the loss of the solid top means that the corners should be reinforced with metal angle brackets, obtainable in any DIY store.

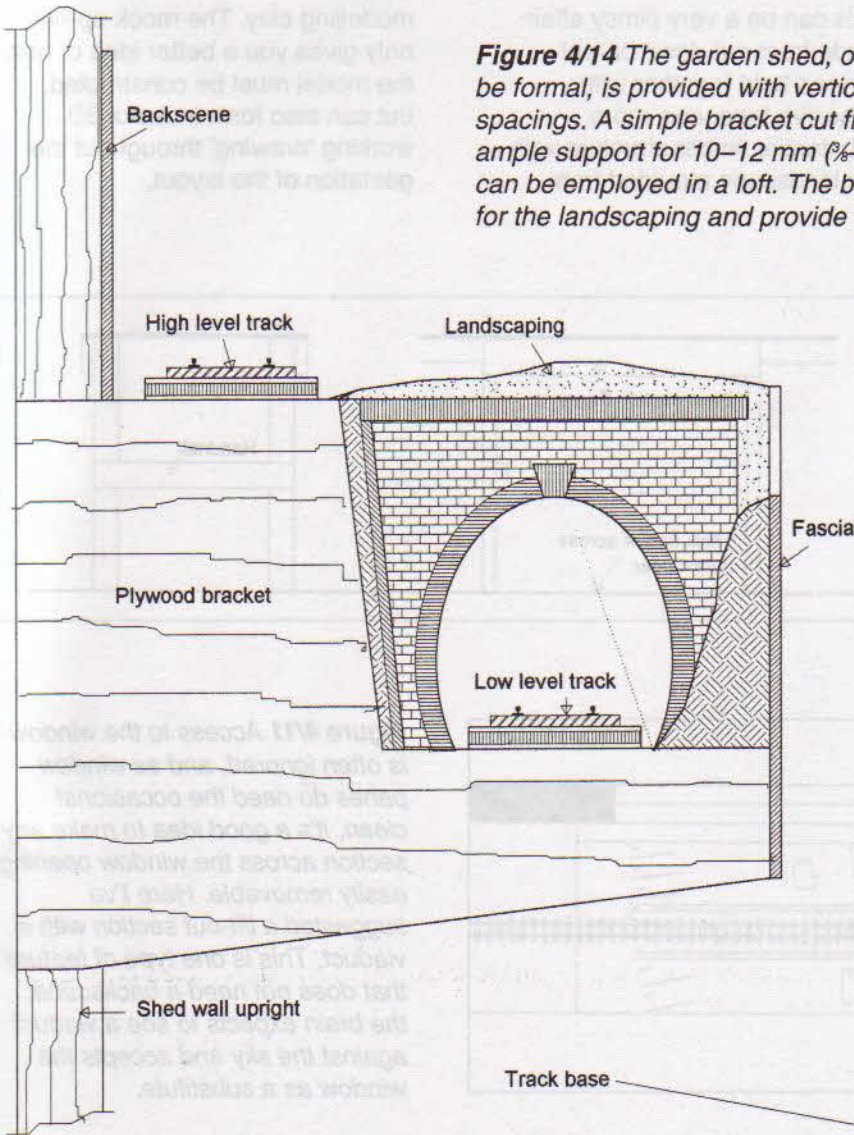

Figure 4/14 The garden shed, or sectional timber outbuilding if you want to be formal, is provided with vertical framing at approximately 0.6 m (2 feet) spacings. A simple bracket cut from 10 mm ($\frac{3}{8}$ in) thick ply will provide ample support for 10–12 mm ($\frac{1}{2}$ – $\frac{1}{2}$ in) thick track bases. A similar system can be employed in a loft. The brackets can also be shaped to form profiles for the landscaping and provide for multi-level tracks.

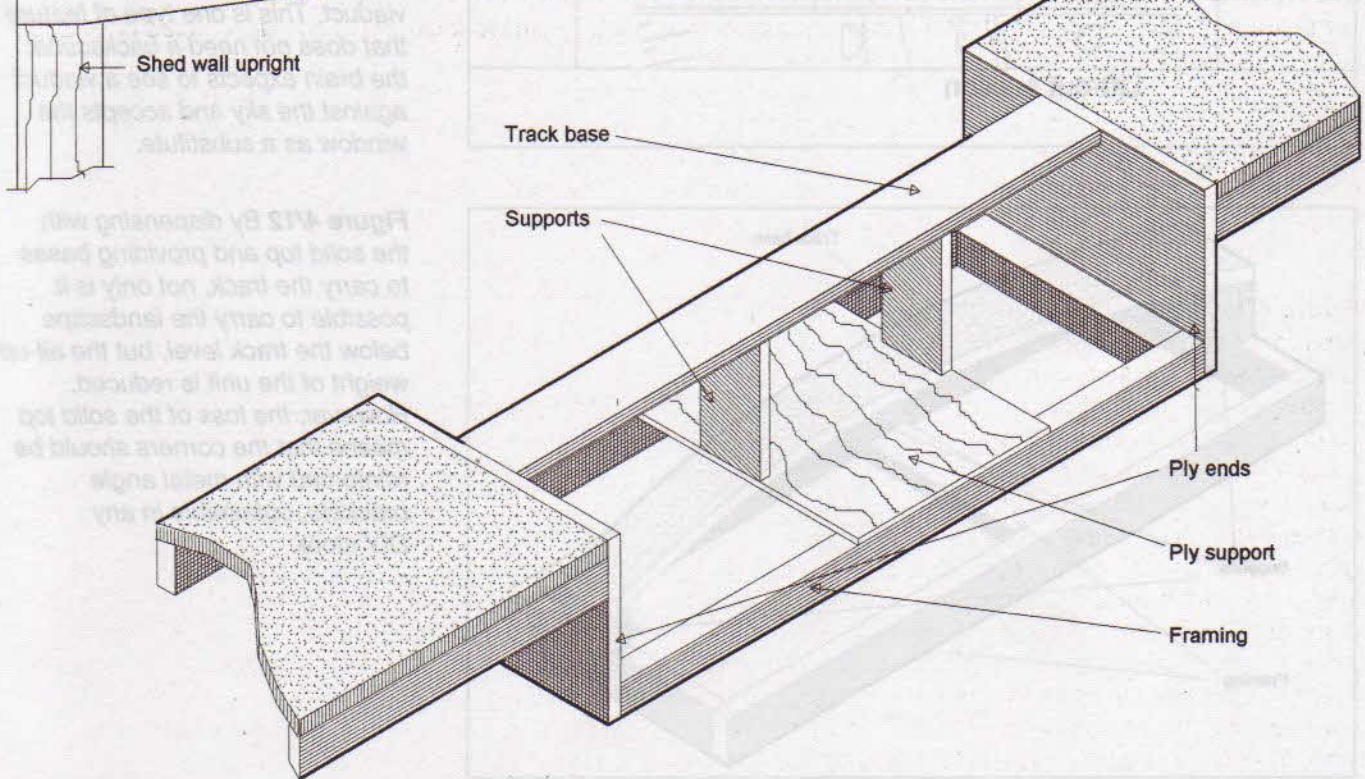

Figure 4/13 Where considerable depth is required, for example to accommodate a bridge or viaduct, a dropped baseboard unit is used, where the framing is secured to a pair of end boards. The ply board across the centre will form a foundation for the valley floor and river bed.

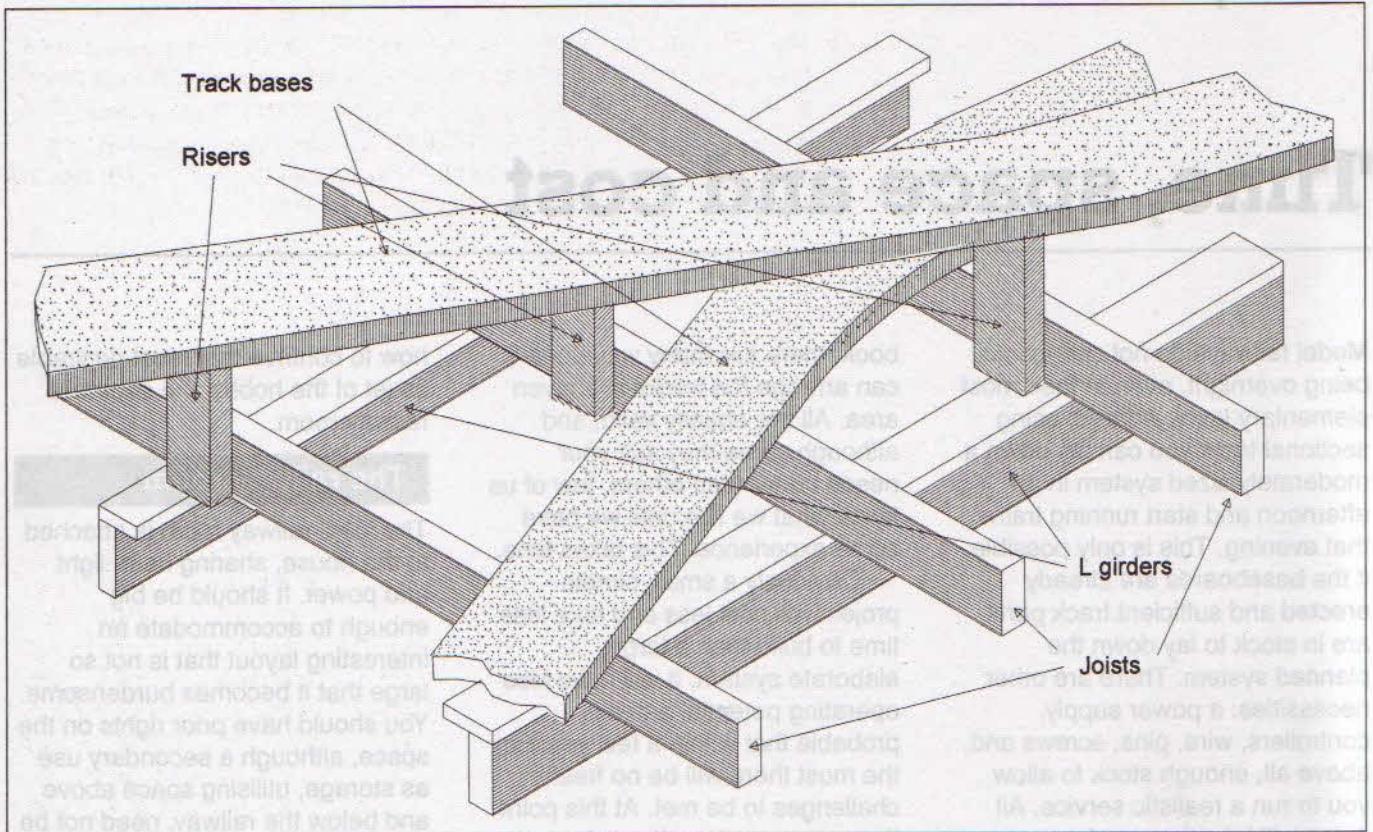
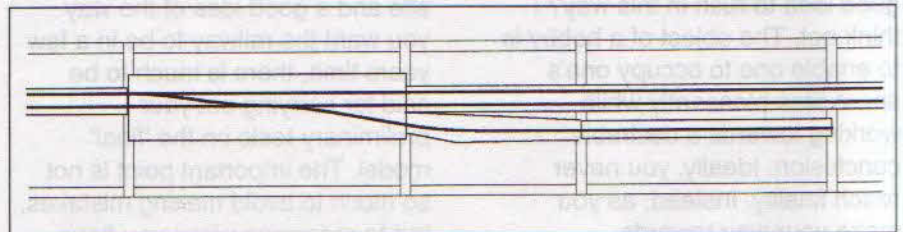

Figure 4/15 For permanent layouts, the L-girder system, devised by Linn Westcott, offers considerable flexibility. The L girders are made from two lengths of timber, generally 70 mm x 21 mm (3 in x 1 in planed) for the vertical, and 45 mm x 10 mm (2 in x 1/2 in) for the top, glued and pinned securely. The 38 mm x 19 mm (1 1/2 in x 3/4 in) joists are screwed from underneath, the track bases supported on risers. Pointwork can be bench-assembled on shaped bases, fully wired and connected to a tag strip by an umbilical cable, simplifying wiring.

With this form of construction, in the event of a change of mind, units can be unscrewed and relocated. The entire layout, apart from the landscaping, can be dismantled into separate units, the track bases carefully boxed so that the whole can be reassembled in a new site. Some modifications to track bases will be needed, but this is easily achieved. The major tracklaying, the point assemblies, should need no modification even where – as is usually the case – the new site is completely different.

Figure 4/16 Many of the tracklaying problems that arise on large permanent layouts can be eliminated with a combination of open-top construction and well-planned track bases. Large pointwork assemblies are carried on a suitably shaped board, which is constructed on the workbench. Point controls and wiring are done at the same time, with a long built-up cable to a tag strip, which can be mounted towards the front to simplify subsequent connection. The point base is fixed in place and further trackbases connected. This form of construction takes little if any more time than working in situ, since it is much easier to carry out all the work when you can turn the trackbase around as required. The biggest advantage comes should a move be necessary. The most time-consuming part of tracklaying can be easily removed and re-used on the new layout. This gives greater flexibility than conventional sectional baseboards, since intervening tracks can be adjusted to fit the new site, which is never the same size as the old.



Point controls and wiring are done at the same time, with a long built-up cable to a tag strip, which can be mounted towards the front to simplify subsequent connection. The point base is fixed in place and further trackbases connected. This form of construction takes little if any more time than working in situ, since it is much easier to carry out all the work when you can turn the trackbase around as required. The biggest advantage comes should a move be necessary. The most time-consuming part of tracklaying can be easily removed and re-used on the new layout. This gives greater flexibility than conventional sectional baseboards, since intervening tracks can be adjusted to fit the new site, which is never the same size as the old.

Chapter 5

Time, space and cost

Model railways do not spring into being overnight, even at their most elementary level. Agreed, using sectional track you can lay down a moderately sized system in an afternoon and start running trains that evening. This is only possible if the baseboards are already erected and sufficient track parts are in stock to lay down the planned system. There are other necessities: a power supply, controllers, wire, pins, screws and, above all, enough stock to allow you to run a realistic service. All these will take time to plan, purchase and prepare. Even with unlimited funds and no other demands on your time, you would be hard-pressed to do all this in a month, assuming a suitable site for the railway was immediately available.

Taking your time

The question now arises – is it a good idea to rush in this way? I think not. The object of a hobby is to enable one to occupy one's spare time pleasantly while working towards a desirable conclusion. Ideally, you never reach finality. Instead, as you make your way towards successive vantage points, new vistas are opened up, allowing you to discover innumerable attractive side issues worth exploring.

There are many areas where it pays to take one's time. The most obvious instance is the track plan. As we shall see throughout this

book, there are many ways one can arrange the tracks in a given area. All are equally valid, and although some may suit your needs better than others, few of us know what we like until we have some experience. This takes time.

Obviously a small, simple project will cost less and take less time to build than a large, elaborate system. It will have less operating potential and it is probable that within a few years at the most there will be no fresh challenges to be met. At this point the owner can happily start a new project that will be an improvement on the old. Indeed, there is a strong body of opinion in favour of the small, expendable preliminary 'test track' as a first step towards a larger and more elaborate layout. It is certainly a sound way of finding out which aspects of the hobby you find most appealing.

I am not wholly convinced of this, however. Given a permanent site and a good idea of the way you want the railway to be in a few years time, there is much to be said for carrying out your preliminary tests on the 'final' model. The important point is not so much to avoid making mistakes, but to recognise when you have gone wrong *and then recast your ideas and methods accordingly.*

The virtue of the small 'test track' lies in the fact that you do not need the permanent site at the outset. Being small and simple, it can be fitted into most homes. Above all, it buys time to work out

how to contrive that most desirable asset of the hobby, the separate railway room.

The railway room

The ideal railway room is attached to the house, sharing heat, light and power. It should be big enough to accommodate an interesting layout that is not so large that it becomes burdensome. You should have prior rights on the space, although a secondary use as storage, utilising space above and below the railway, need not be ruled out.

The spare room

These conditions are most readily met by a spare room. Unfortunately, in the typical British home this simply doesn't exist; the average family requires all the rooms for normal living. Even where a spare bedroom is available, there is no guarantee that it will remain so indefinitely. It is feasible to fit a transportable system into a guest-room, provided that it is possible to store the sections unobtrusively when the railway room is needed for other purposes.

The loft

The loft is frequently the largest unused space in the home. Unfortunately, modern house construction favours the prefabricated roof principle, which not only creates innumerable obstructions, but is accompanied

by a shallower slope, giving very restricted headroom.

Where loft conversion is feasible, one has a large area with the added bonus of an entry through the floor, in the middle of the railway. This makes the cost of conversion worthwhile, but be warned – it is not a job that can be done on the cheap.

The garage

The standard garage, which is usually at least 4.8 m x 2.4 m (16 ft x 8 ft) internally, makes a good railway room, although it is rarely possible to connect it to the household heating system. Sharing the space with the car puts a premium on the smaller car, but as a modern super-mini provides more room for the passengers and considerably more room for luggage than a pre-war 'large family car', this is not a serious matter. Large, prestigious company cars can stand on the drive, leaving even more room for the railway.

Of course, an ideal arrangement is the double garage, half for the car, half for the railway. Even better is the twin, single garage featured in some modern developments, which effectively keeps the car, with its dirt and damp, separate from the layout.

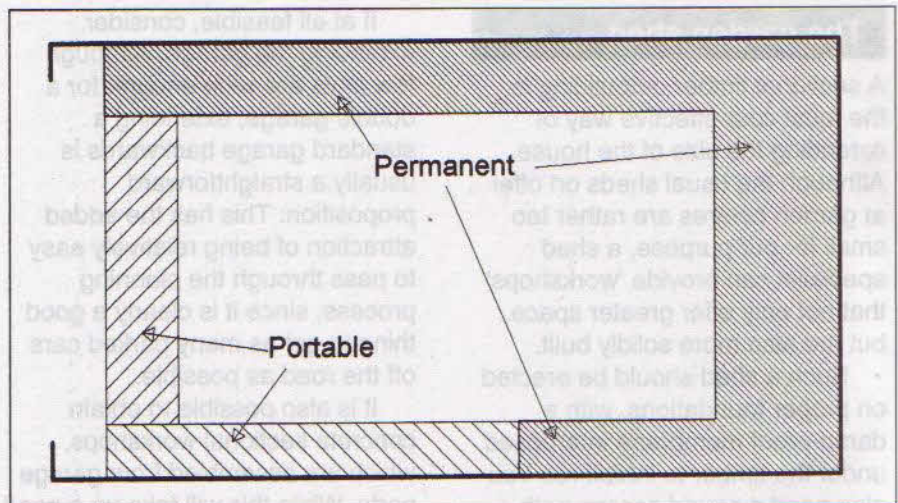

Figure 5/1 There is a reasonable amount of space around the walls of a garage for a model railway, leaving room for a small family saloon. Note that part of the layout needs to be removed to allow the driver to get in and out. With the car clear, there is plenty of room for operators and visitors to stand inside.

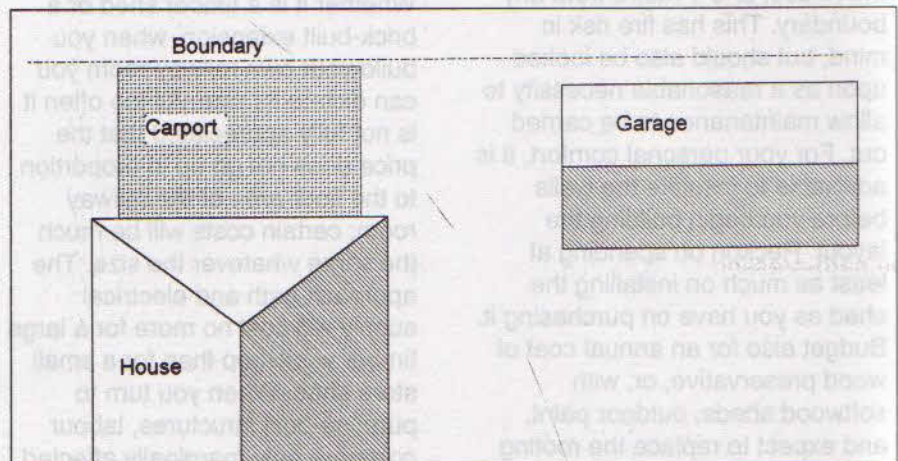

Figure 5/2 Where the garage is set back behind the house, as was common practice in the 1930s, a carport can be provided over the side drive and the whole garage turned over to the railway.

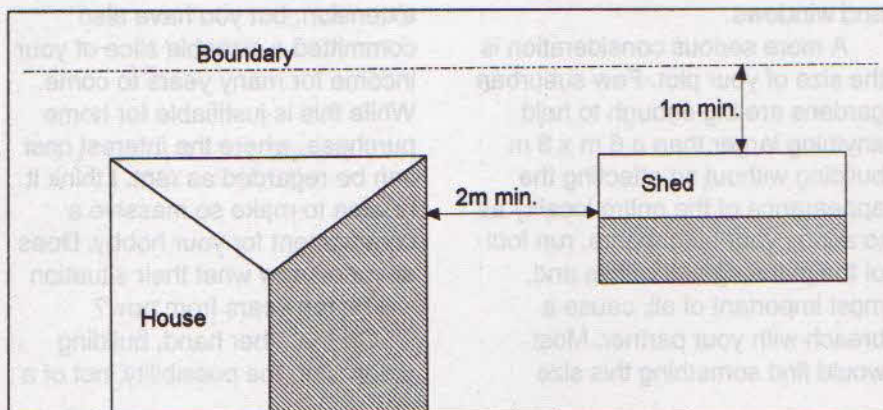

Figure 5/3 Sectional timber sheds provide a low-cost site for a layout. Classed as temporary buildings, they are not tightly regulated, but need to be sited at least 2 metres from the house and 1 metre from the boundary fence. This allows one to get to the back for maintenance, an essential matter if the 'temporary' building is to last for 50 years.

The garden shed

A sectional timber outbuilding is the most cost-effective way of extending the size of the house. Although the usual sheds on offer at garden centres are rather too small for our purpose, a shed specialist can provide 'workshops' that not only offer greater space, but are also more solidly built.

Such a shed should be erected on proper foundations, with a damp-proof membrane interposed under the timber to inhibit rot. You also need a sound access path, and electrical power must be installed in strict accordance with the current regulations. Building regulations stipulate that the shed should be at least 2 metres from the house, and 1 metre from any boundary. This has fire risk in mind, but should also be looked upon as a reasonable necessity to allow maintenance to be carried out. For your personal comfort, it is advisable to insulate the walls before you begin building the layout. Reckon on spending at least as much on installing the shed as you have on purchasing it. Budget also for an annual coat of wood preservative, or, with softwood sheds, outdoor paint, and expect to replace the roofing felt after five years' exposure.

The house extension

Extending the home calls for a good deal of thought before you expend any hard cash on the project. Forget 'investment' – only a handful of very carefully designed additions can increase the resale value by anything approaching the first cost of the structure. Another factor to bear in mind is that any alteration directly connected with the living space will inevitably create havoc with family life while the work is being carried out.

If at all feasible, consider extending the garage. Although few plots are wide enough for a double garage, extending a standard garage backwards is usually a straightforward proposition. This has the added attraction of being relatively easy to pass through the planning process, since it is clearly a good thing to get as many parked cars off the road as possible.

It is also possible to obtain concrete sectional workshops, which are assembled from garage parts. While this will take up a good deal of the garden, you can look on this as something of a bonus – there will be less grass to mow.

How big?

Whether it is a timber shed or a brick-built extension, when you build your own railway room you can dictate its size. All too often it is not fully appreciated that the price does not go up in proportion to the floor area of the railway room; certain costs will be much the same whatever the size. The approach path and electrical supply will cost no more for a large timber workshop than for a small store shed. When you turn to purpose-built structures, labour costs are only marginally affected by the size, while the increase in materials for the walls is relatively small and you will still have the same number and size of doors and windows.

A more serious consideration is the size of your plot. Few suburban gardens are big enough to hold anything larger than a 6 m x 3 m building without so affecting the appearance of the entire locality as to annoy your neighbours, run foul of the planning authorities and, most important of all, cause a breach with your partner. Most would find something this size

oppressive, and a structure the size of a standard garage is more in keeping.

Fortunately, a standard garage is large enough to house an interesting 4 mm scale layout. Indeed, when you get to a railway room larger than 6 m x 3 m, you find the running costs for heat and light escalating, while it is probable that it will move the house up a band for Council Tax. The system is too new for absolute certainty on this point, but I have little doubt that the Council Treasurer will be only too ready to increase the revenue.

It is one thing to make use of a large space that happens to be available, but something else to spend good money on a very large railway room, bearing in mind that the cost of baseboards and track also escalates with an increase in floor area. While I know of some successful large layouts, in every case the owner had a large disposable income and was able to devote a good 20 years or more to the project.

Financing the extension

Various firms not only offer to build home extensions, but also put forward attractive financing deals. At least, these deals seem attractive when the salesman is talking, but in the cold light of the following day you may come to realise that not only will you be paying twice over for the extension, but you have also committed a sizeable slice of your income for many years to come. While this is justifiable for home purchase, where the interest cost can be regarded as rent, I think it unwise to make so massive a commitment for your hobby. Does anyone know what their situation will be ten years from now?

On the other hand, building dreams on the possibility, not of a

lottery jackpot, but of a more modest windfall from a newspaper or magazine promotion is not going to get you very far. Starting a savings plan with inbuilt flexibility to provide enough cash to build your railway room is a practical approach with the added benefit that, should real troubles arise, you have something tangible to fall back on.

The cost of the layout

I have already mentioned that a large model railway costs a sizeable sum. The expenditure falls into three main groups. The first is the basic substructure, baseboards, track and landscaping, together with the wire needed to connect the tracks to the control panel. The second

section covers buildings, bridges, signals and a host of other small fittings, which, while relatively cheap on their own, amount to a large sum when taken *en masse*. The third group consists of the locomotives, coaches and wagons needed to build the railway.

With the exception of the baseboard timber, which would take up enough room to house a modest layout, everything else is small enough to store against the day when you have the chance to construct the layout of your dreams. Indeed, an excellent way for preparing for a big layout is to make a small 'test track', then get down to building locomotives, coaches and wagons from kits, or, if you prefer, ready-to-run models, modelling the buildings you will need in due course.

Time is the essence

Building a model railway takes time. You can sometimes use money to speed matters up; you can certainly use it to buy extra space. Mainly you will use your spare time enjoyably in creating a little world that runs the way you want. You will have the opportunity to make friends; you may also have the chance to bring pleasure to others by exhibiting your models, or writing about them in a magazine. You will get a lot of satisfaction exercising a whole range of skills you did not realise you possessed at the start.

As I said at the beginning of this chapter, model railways do not spring into being overnight. If they did, the hobby would lose most of its attractions.

O gauge is usually regarded as a size for larger sites, but Gordon Gravett's 'Ditchling Green', a popular performer on the exhibition circuit, is no larger than the general run of 4 mm scale branch-line termini. The compact nature of the model in turn means that very little rolling-stock can be accommodated, keeping the cost in both time and money to a very reasonable level. As the detail can be readily seen with the naked eye, it is very satisfying for the scratchbuilder or kit assembler. You may not get a lot, but you certainly get value for money and enormous satisfaction from what you do have.

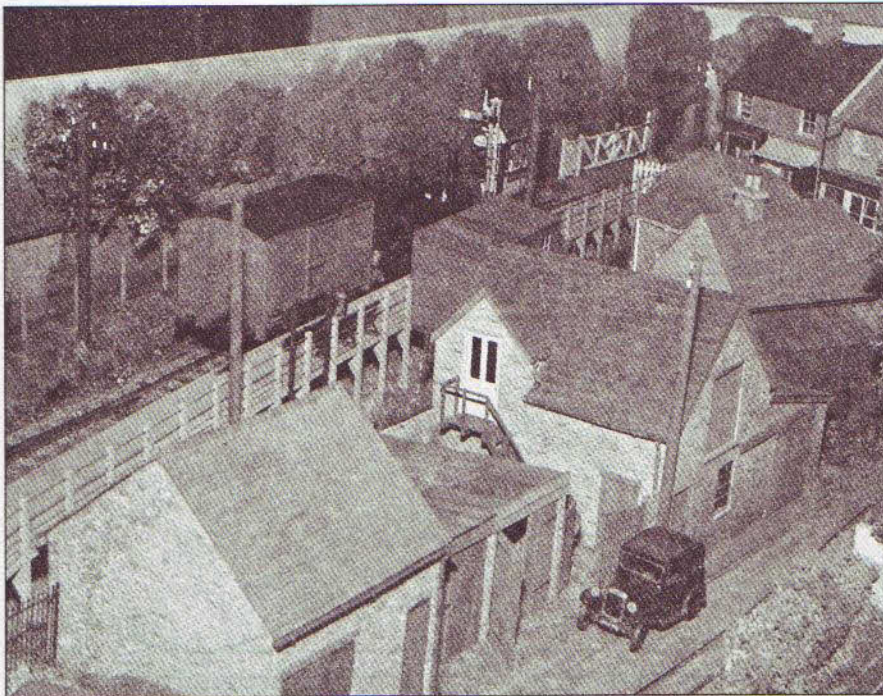

Chapter 6

Fundamental formations

There are several well tried and tested ways of arranging the basic track formation of a model railway, ranging from the simple oval associated with the train set to extremely complicated systems with a number of stations, allowing a group of friends to operate the line to a full timetable. Many need a reasonable amount of space and some demand a large railway room; only a few are suited for small, compact layouts.

Most arrangements have an implied operating pattern. Since the whole object of layout construction is the eventual operation of trains, it is as well to check if the pattern meets your requirements. For example, the small terminus-fiddle yard layout can be operated exactly as the prototype, but so far as the actual run is concerned, the train takes a fisherman's walk – two steps and overboard. Or, to be more accurate, two coach lengths beyond the platform end and you're into the fiddle yard. If this is not to your taste, you must think again. There are plenty of alternatives. (Newcomers to the hobby who are puzzled by the term 'fiddle yard' should refer to Chapter 15, where all is revealed.)

As the easiest way to describe a track arrangement is to draw a diagram, we will now go straight into the sketches.

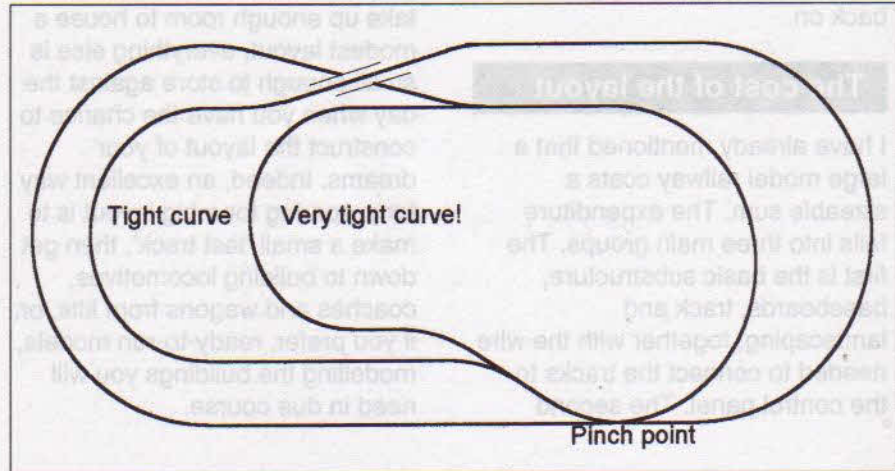

Figure 6/1 How not to arrange a layout. The idea was to provide as many routes as possible on a relatively small single baseboard, but with every loop connected to the one 'pinch point', only one train can run at any given moment. Worse, as the usual 6 ft x 4 ft board is only just wide enough to swing an OO/HO large-radius curve, you not only have one tight curve, but also another that is extremely tight. It could be laid with flexible track, but whether anything would get round it is another matter.

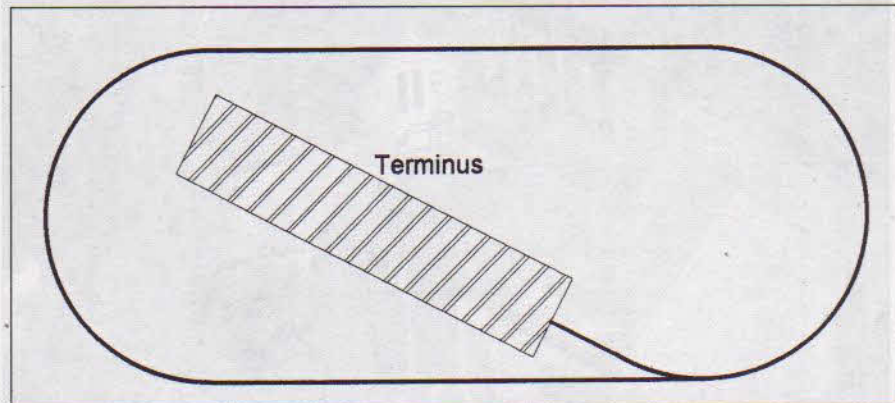

Figure 6/2 A common arrangement on solid baseboards is to have a terminus located inside the main oval. It is restricted in capacity, but we can ignore this – two-coach trains are the norm on such layouts. The problem is that, having got out of the terminus, how does the train get back again?

This is a fine example of the sort of layout most newcomers would love to own, a large area almost completely filled with railway tracks. However, the control panel at the lower left of the picture reveals that it is essentially a 'looped eight' formation. Although most of the structures are standard commercial kits, they have been so deployed as to provide individuality to the whole. One should not enquire too closely as to how passengers get to either station, let alone how the inhabitants of the town get in and out. The absence of cars around the central green tells its own story. Unfortunately, the operating pattern is very basic – one can do little apart from running trains round in circles.

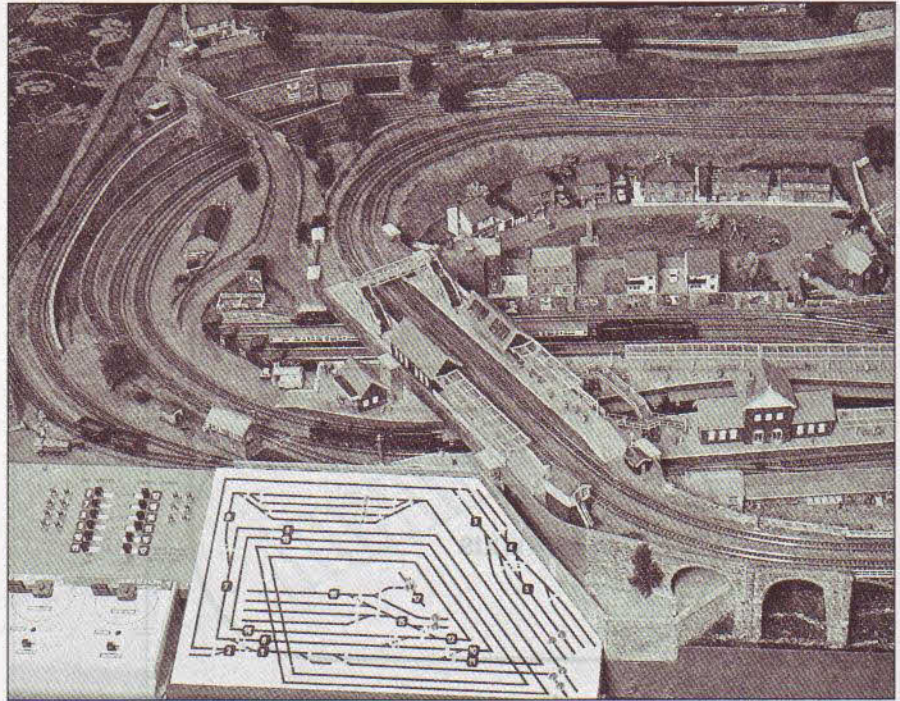

Figure 6/6 The terminus-fiddle yard arrangement in its most basic form is ideally suited for compact portable layouts. Operation consists in the main of shunting movements, but with a minimum of three roads in the fiddle yard a prototypical timetable can be simulated.

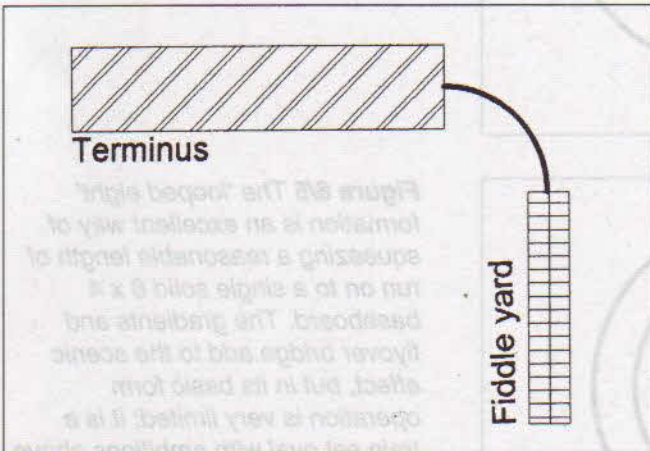
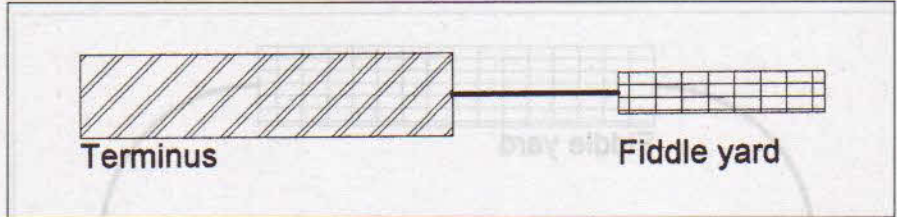

Figure 6/7 With terminus and fiddle yards at right angles we have the classic L-shaped layout. It is easier to fit into the majority of rooms, and if the fiddle yard detaches and is stored under the terminus, the impact on the household is minimised.

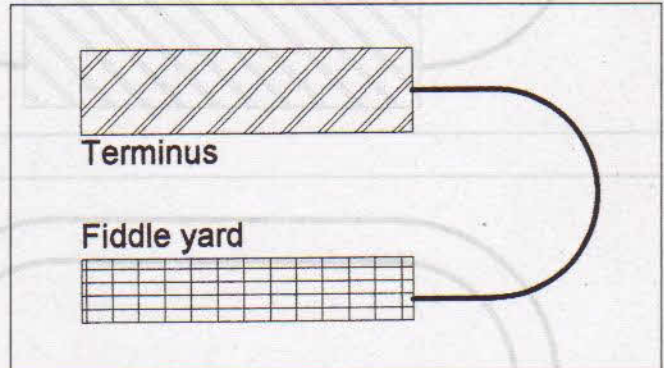

Figure 6/8 The U-shaped terminus-fiddle yard not only provides a reasonable length of main line and space for scenic development, but is also easier for a single individual to operate, as he only needs to turn around to switch from the station to the fiddle yard.

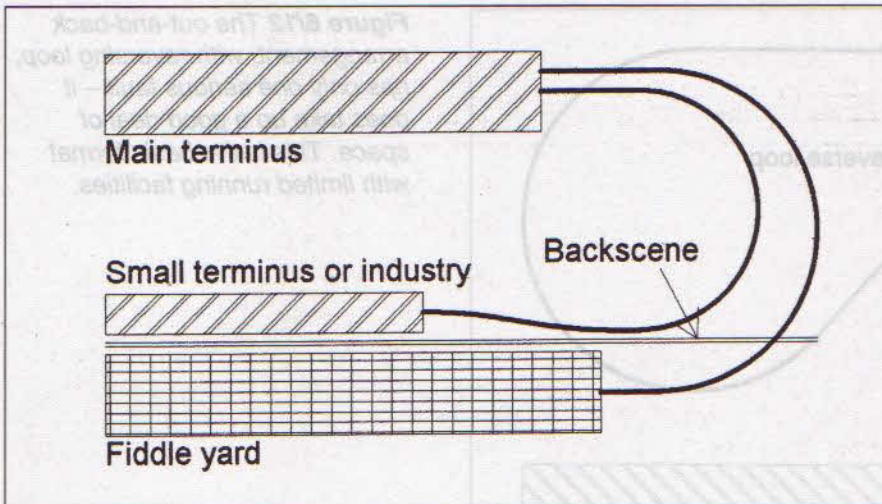

Figure 6/9 As the fiddle yard is rather uninteresting, it is a good idea to arrange for a small rail-served industry or branch terminus to stand in front. Frequently this design develops from the simple schemes in earlier diagrams.

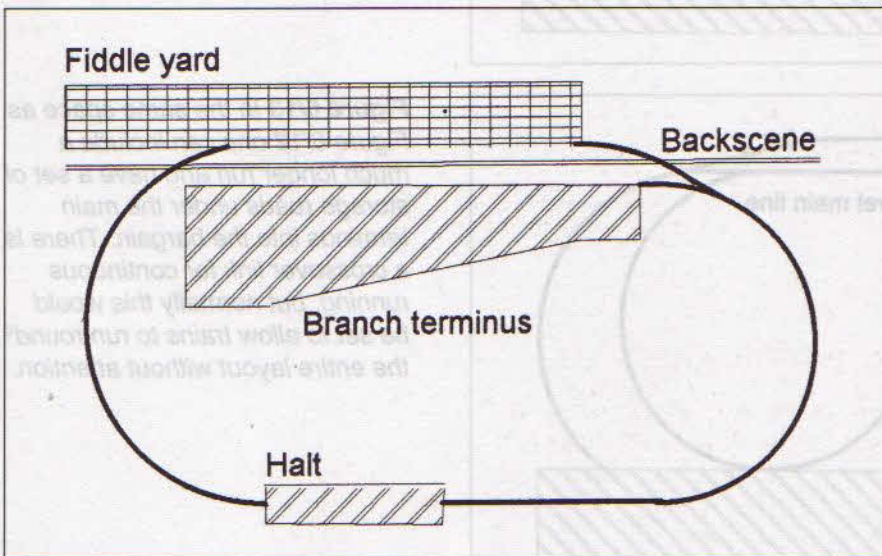

Figure 6/10 Maurice Dean devised this variant on the terminus-fiddle yard, where the hidden sidings are behind the terminus, and connected to form a continuous run, the offshoot siding being disguised as an industrial spur. The backscene is removable for operating convenience.

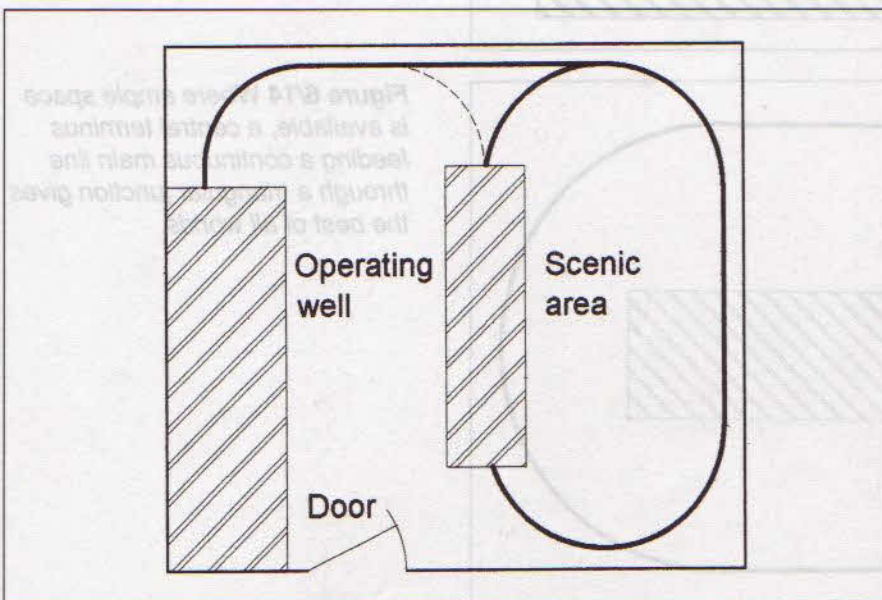

Figure 6/11 Where a layout can be erected in a spare room, it helps if the operating well is in direct communication with the door. In this formation, the two stations are on either side of the well, making single-handed operation a straightforward matter. If space permits, the dotted connection provides out-and-back running.

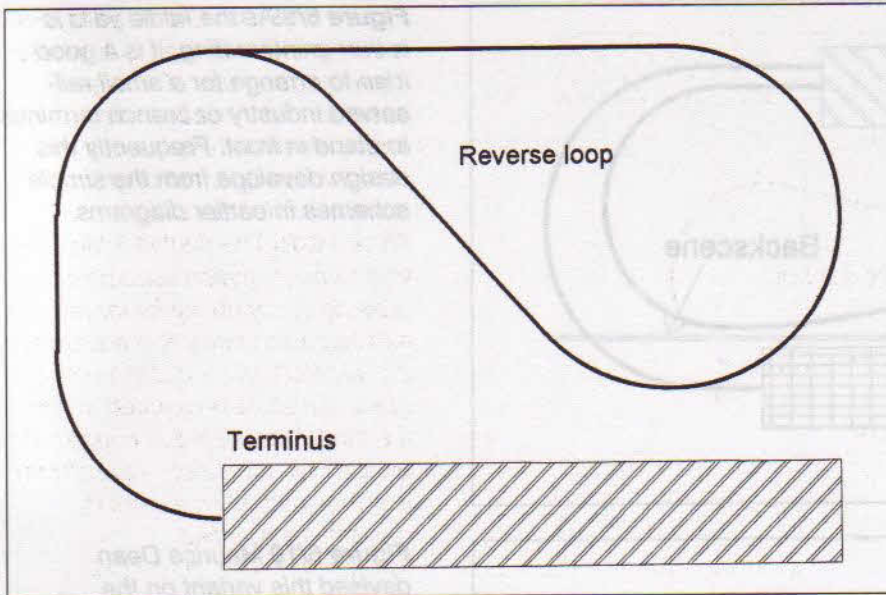

Figure 6/12 The out-and-back arrangement, with reversing loop, has only one serious fault – it does take up a good deal of space. This is the basic format with limited running facilities.

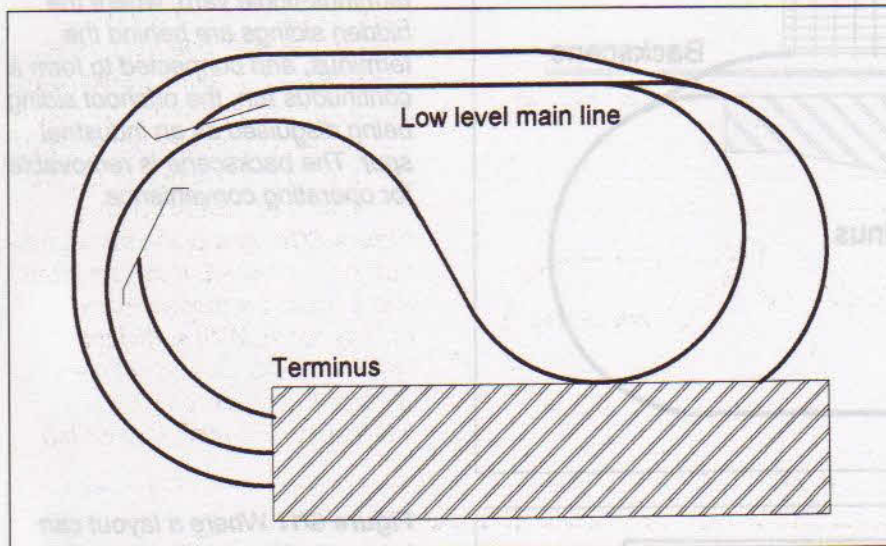

Figure 6/13 In the same space as Figure 6/12 one can include a much longer run and have a set of storage roads under the main terminus into the bargain. There is a crossover link for continuous running, but normally this would be set to allow trains to run round the entire layout without attention.

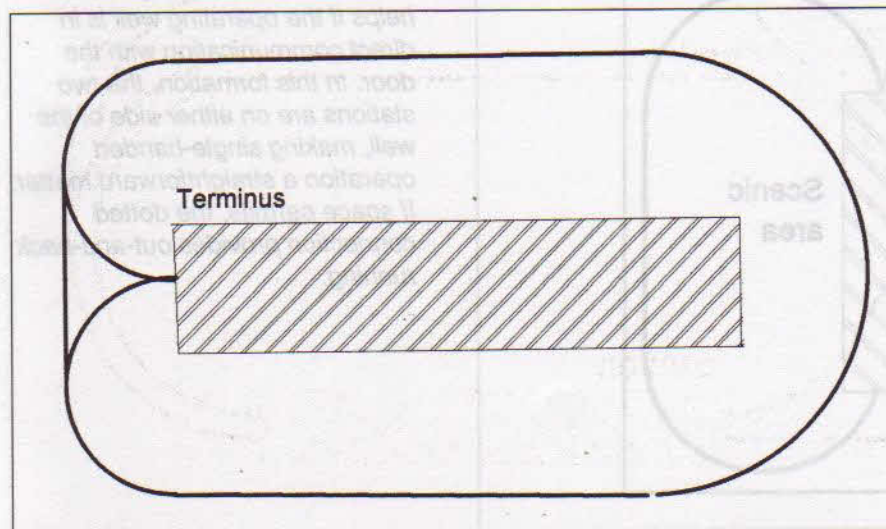

Figure 6/14 Where ample space is available, a central terminus feeding a continuous main line through a triangular junction gives the best of all worlds.

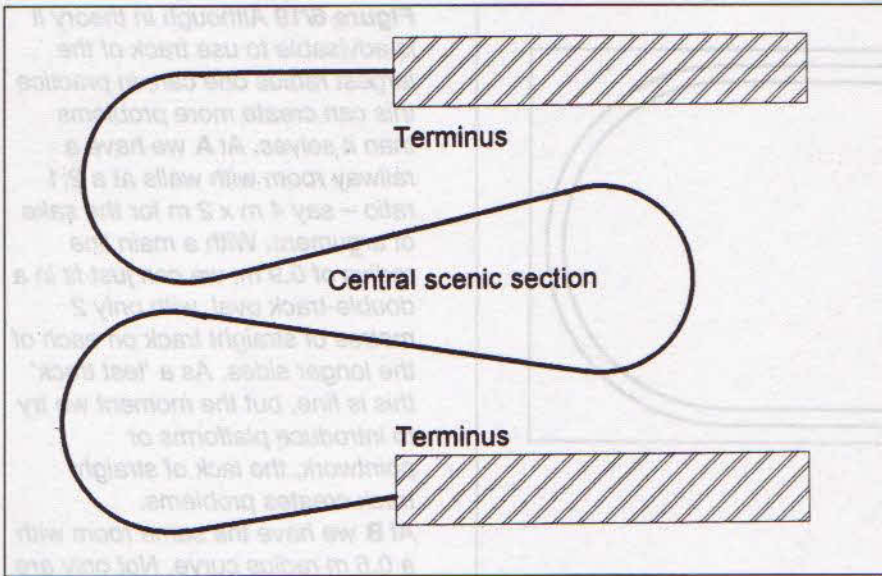

Figure 6/15 The E-shaped layout is very popular in the USA, where it makes good use of a large basement. In N gauge this arrangement is feasible in a standard garage, although no room is left for the car.

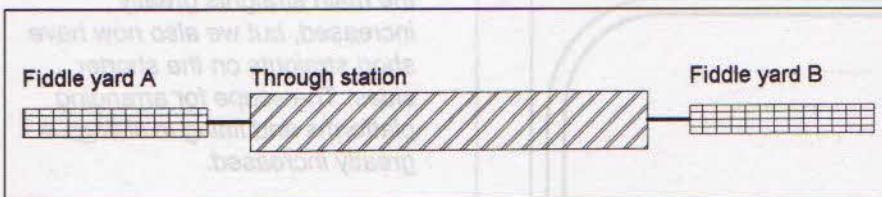

Figure 6/16 The double fiddle yard with through station scheme is growing in popularity for large exhibition schemes. It is essentially a club effort, since a minimum of three operators is required to run the model, and five are needed at exhibitions. As a train returns from the imaginary town it went to, realism is enhanced.

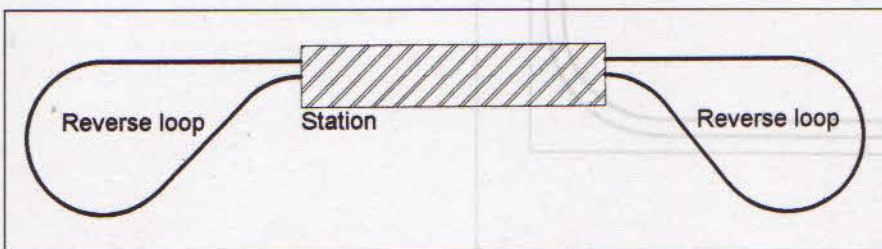

Figure 6/17 The 'dumb-bell' formation, with a pair of reversing loops at each end of a through station, has only one serious fault, it needs a lot of room, particularly in the form shown in this diagram. In practice it is an elongated oval with the centre pinched in to give the illusion of double track.

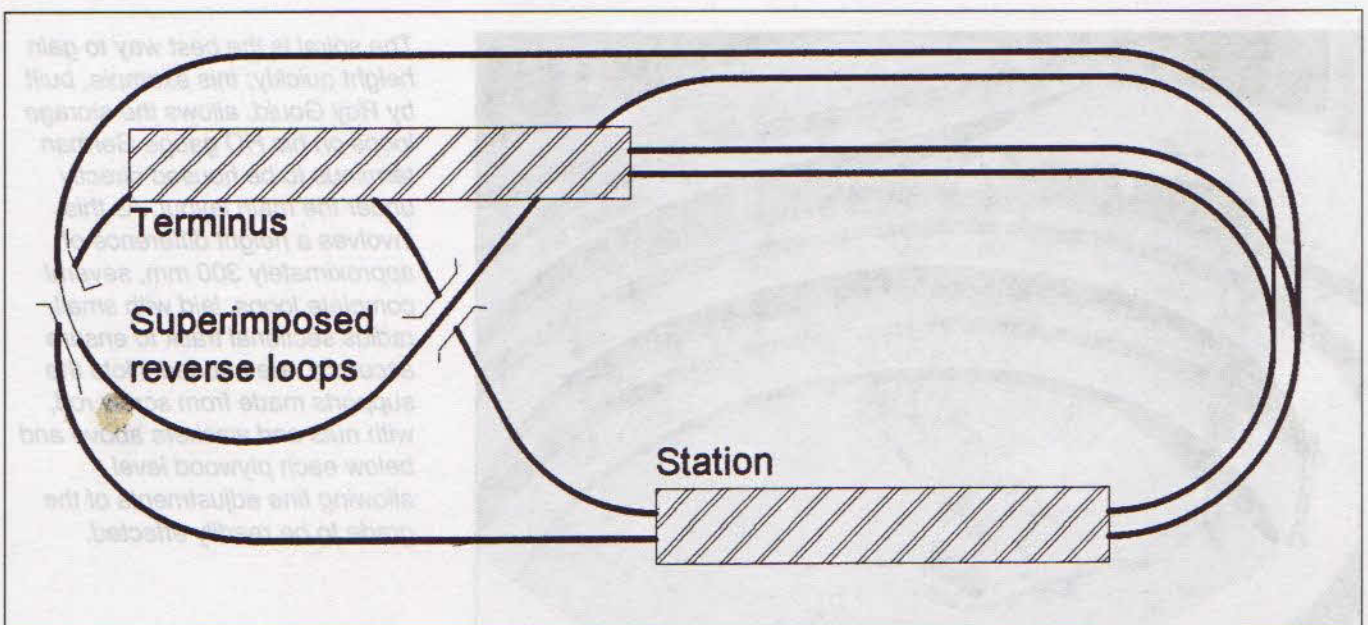

Figure 6/18 By looping the 'dumb-bell' back on itself, it can be fitted into a relatively modest-sized railway room. With sufficient storage tracks on each of the reverse loops, extremely interesting operation is possible.

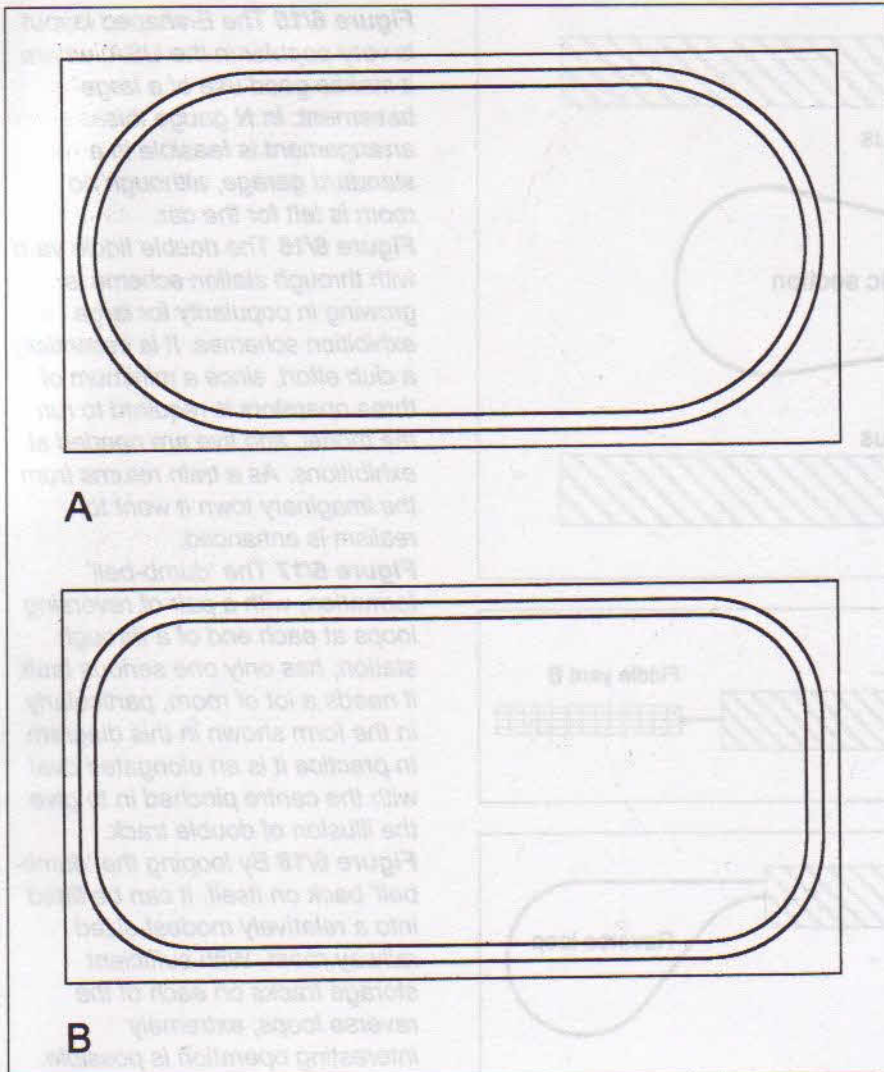
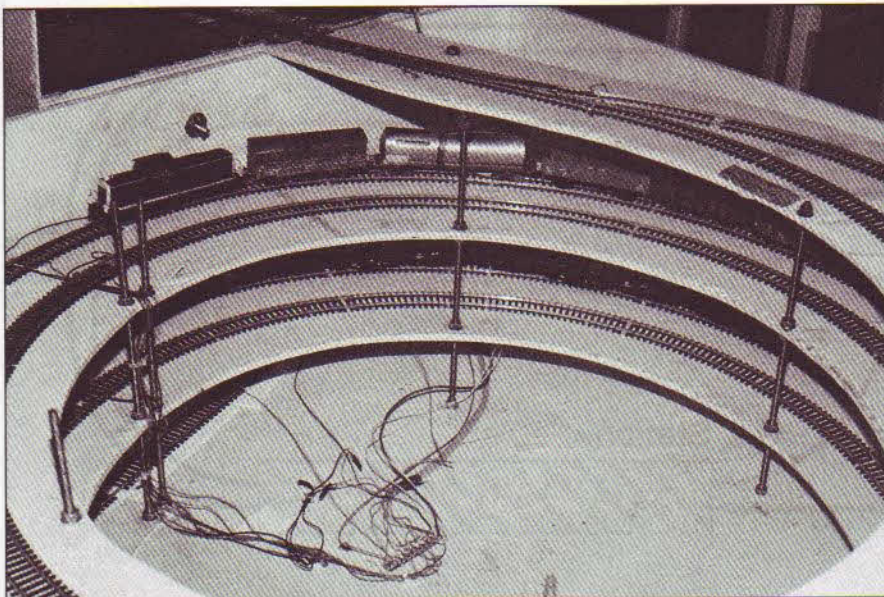

Figure 6/19 Although in theory it is advisable to use track of the largest radius one can, in practice this can create more problems than it solves. At **A** we have a railway room with walls at a 2:1 ratio – say 4 m x 2 m for the sake of argument. With a main line radius of 0.9 m, we can just fit in a double-track oval, with only 2 metres of straight track on each of the longer sides. As a ‘test track’ this is fine, but the moment we try to introduce platforms or pointwork, the lack of straight track creates problems.

At **B** we have the same room with a 0.6 m radius curve. Not only are the main straights greatly increased, but we also now have short straights on the shorter sides. The scope for arranging platforms and fitting in sidings is greatly increased.



The spiral is the best way to gain height quickly; this example, built by Roy Gould, allows the storage loops on his HO gauge German terminus to be housed directly under the main layout. As this involves a height difference of approximately 300 mm, several complete loops, laid with small-radius sectional track to ensure accuracy, are needed. Note the supports made from screw rod, with nuts and washers above and below each plywood level, allowing fine adjustments of the grade to be readily effected.

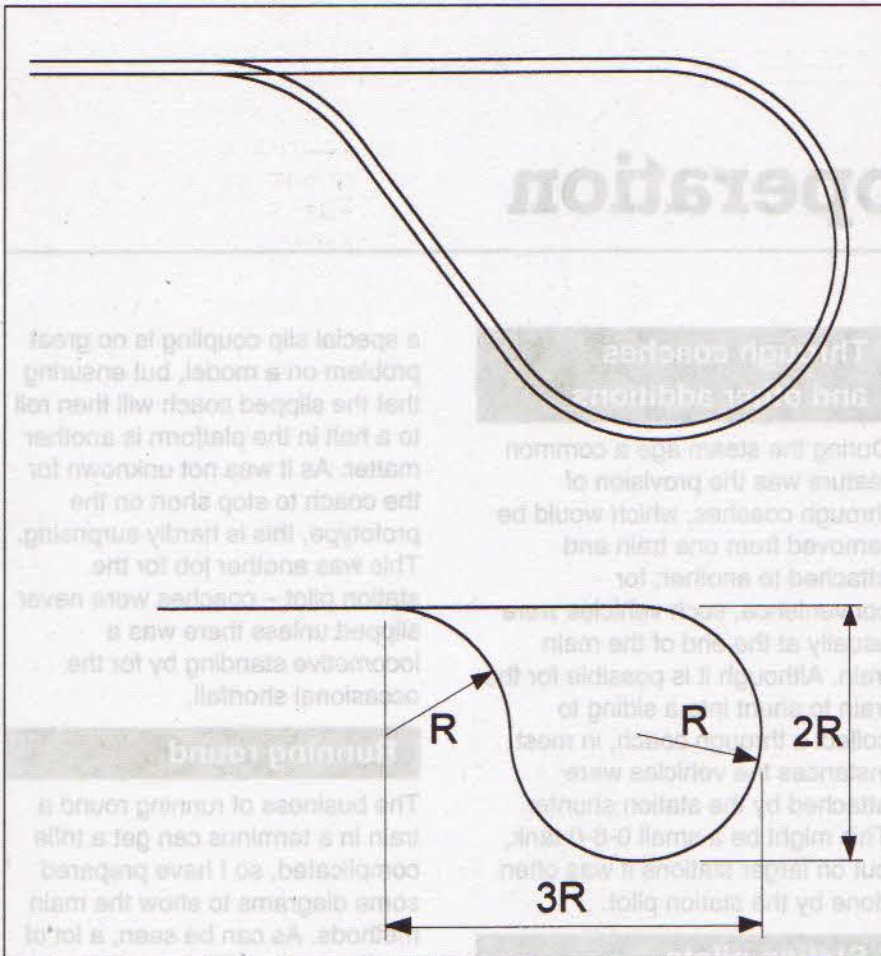

Figure 6/20 The reversing loop is, on paper, the most convenient way of reversing a train to return it to the terminus. It introduces some electrical problems with two-rail wiring, but these are readily overcome. What is less easy to deal with is the sheer size of the formation. As the lower diagram shows, the minimum length of a reverse loop is three times the radius used, but to this one must add the approach track, which means it requires even more room. Unless very sharp curves can be used, you need an extremely large room to take a reverse loop.

Chapter 7

Basic train operation

The great attraction of locomotive-hauled trains on the model is the need to shunt the train from time to time. There are two main areas of this facet of operation, straight-forward shunting to rearrange the composition of the train, and the very important business of getting the locomotive on the other end of the train at the end of its journey. This is less popular on the prototype and is largely abandoned in modern practice.

Simple shunting

Most shunting takes place in the goods yard and consists of dropping full wagons, and removing empty stock and wagons and vans that have been loaded with fresh freight. The main thing to observe when laying out a goods yard is that the wagons lie between the locomotive and the buffers. If the loco is nearer the buffers, it can't drop the wagons. Obvious? It's surprising how often this point is overlooked.

On the prototype one can often find sidings pointing the other way. This is held by some to be a justification, but it overlooks the fact that in such cases the wagons were shunted by other means. For most of the steam age, the preferred motive power was a draught horse. There was also the rope shunt, officially barred, although on awkward stations a special dispensation was given.

Through coaches and other additions

During the steam age a common feature was the provision of through coaches, which would be removed from one train and attached to another; for convenience, such vehicles were usually at the end of the main train. Although it is possible for the train to shunt into a siding to collect a through coach, in most instances the vehicles were attached by the station shunter. This might be a small 0-6-0 tank, but on larger stations it was often done by the station pilot.

Station pilots

The station pilot was a feature of the larger stations in the steam era, and was frequently an older express locomotive that was kept in steam primarily to move spare coaches and vans around the station. Its main function was an insurance, since in the event of a locomotive failure it would be called upon to take over an express at short notice.

Slip coaches

The slip coach came into being at the end of the 19th century as a way of allowing intermediate stations to be served by a non-stop express. The coach had a special coupling hook that could be released by a guard riding in the slip coach, who then controlled the coach on its brakes. Arranging

a special slip coupling is no great problem on a model, but ensuring that the slipped coach will then roll to a halt in the platform is another matter. As it was not unknown for the coach to stop short on the prototype, this is hardly surprising. This was another job for the station pilot – coaches were never slipped unless there was a locomotive standing by for the occasional shortfall.

Running round

The business of running round a train in a terminus can get a trifle complicated, so I have prepared some diagrams to show the main methods. As can be seen, a lot of shuffling of locomotives and stock is involved, which adds to the fun.

This is fine on the model; indeed, the compact terminus-fiddle yard scheme would be utterly boring if it were not for these manoeuvres. However, on the prototype they are labour-intensive and time-consuming, which explains why modern European passenger trains are increasingly being made up of a permanently coupled rake of coaches with a power car at either end, or a locomotive and driving trailer. With this arrangement, the coaches are cleaned in the platform, and the solitary driver walks from one end to the other while the shunting locomotive has gone for scrap and its crew have been made redundant.

Isn't it a good thing model railways don't have to be 'efficient'?

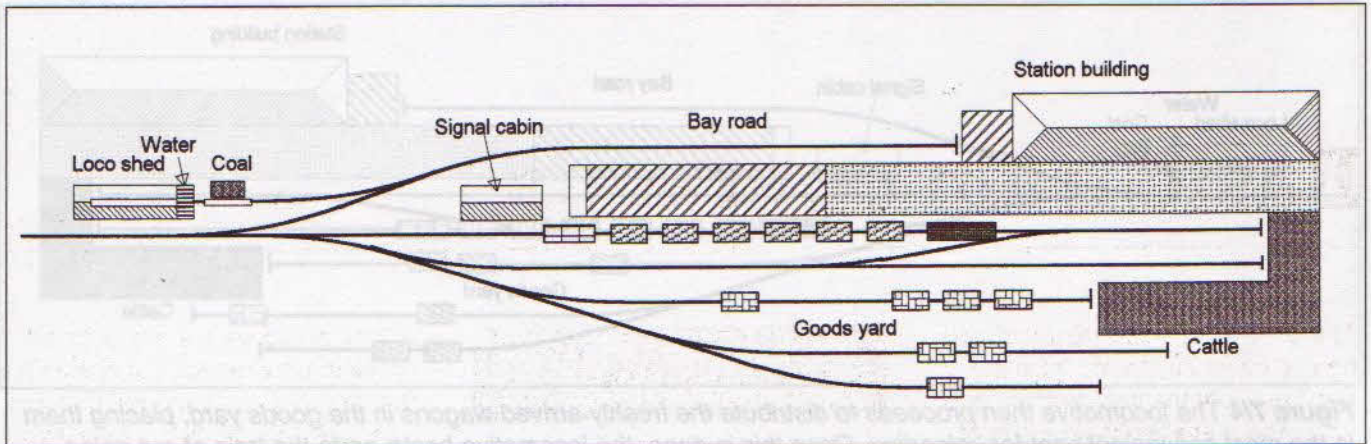

Figure 7/1 Shunting freight traffic: a goods train, headed by a steam or diesel loco and rounded off with the old-pattern brake-van, arrives at the main platform. The locomotive stops with the train between the sets of points so that there is no need to back up before running round.

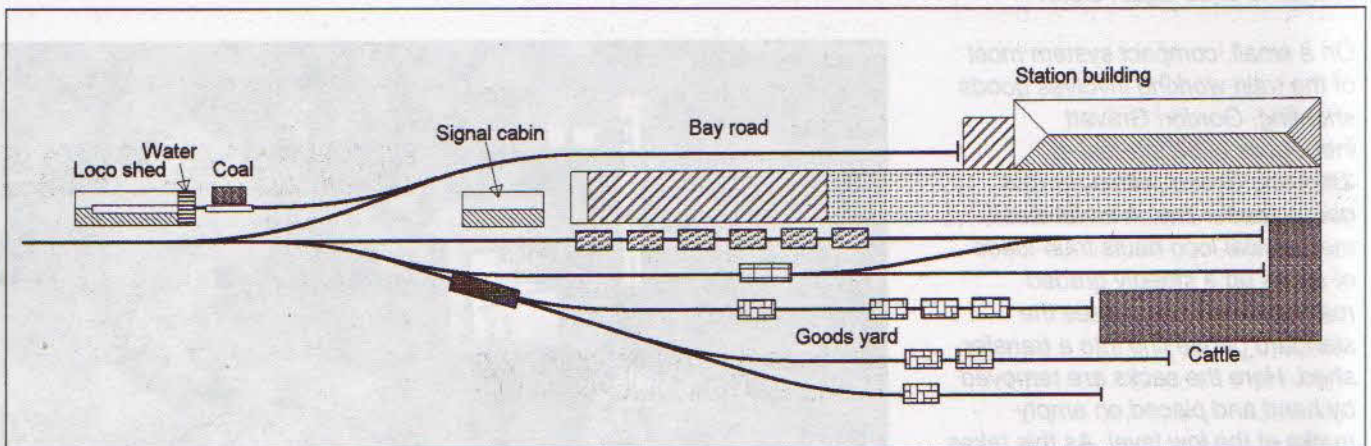

Figure 7/2 After running round, the locomotive detaches the brake van and shunts it into the loop. It then goes on to collect the wagons that are in the yard and will form the outgoing goods train. Meantime the newly arrived wagons wait alongside the platform.

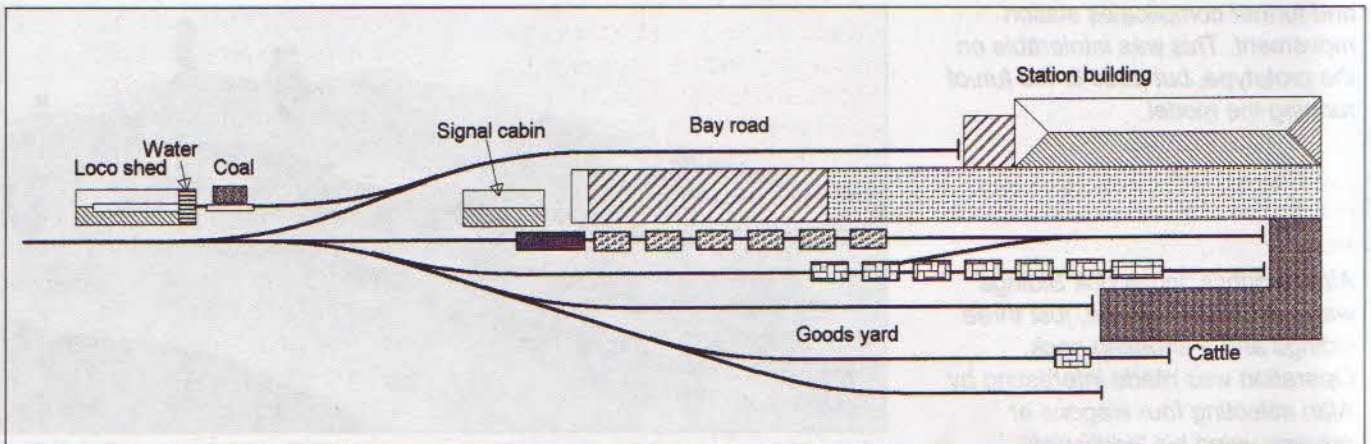

Figure 7/3 When all the wagons have been assembled, they are backed on to the brake-van in the loop road. One wagon remains – this is because it will be needed for a special load arriving the following day. Or week, or month, as the case may be.

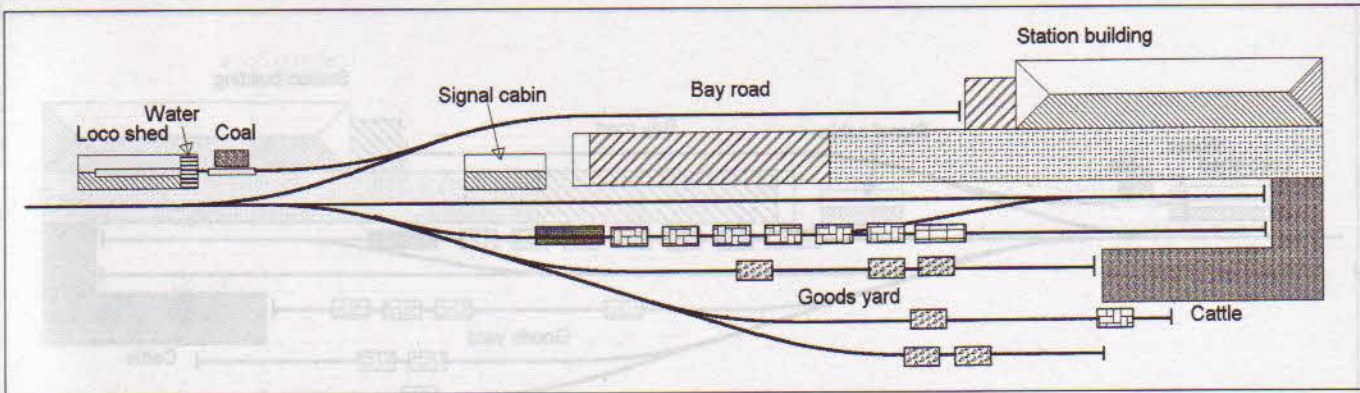
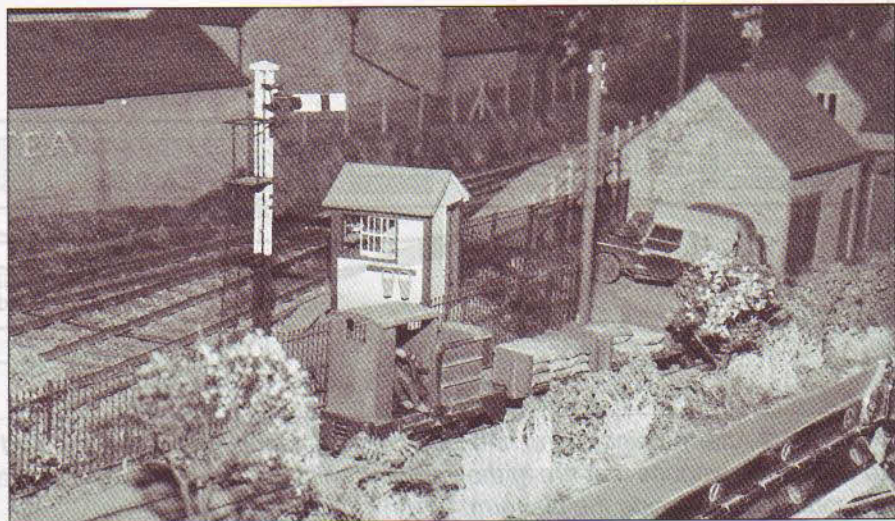

Figure 7/4 The locomotive then proceeds to distribute the freshly arrived wagons in the goods yard, placing them in the most convenient spot for unloading. Once this is done, the locomotive backs on to the train of out-going wagons in the loop. At this point the various consignees of the recently arrived goods can enter the goods yard to collect their property. No one other than railway staff should be in the yard while shunting is taking place. It is probable that the new goods train will have to wait until the next passenger train arrives and the single-track branch is once again clear.

On a small, compact system most of the train working involves goods shunting. Gordon Gravett introduces extra interest at 'Ditchling Green' with a narrow gauge feeder line. A small diesel-mechanical loco hauls train-loads of sacks up a steeply graded roadside line that crosses the standard gauge line into a transfer shed. Here the sacks are removed by hand and placed on empty trucks at the low level. As this takes place out of sight of the viewers at exhibitions, it makes an extremely effective display. It also plays havoc with the standard gauge operation, and further complicates station movement. This was intolerable on the prototype, but adds to the fun of running the model.



Alan Wright's 'Inglenook Sidings' was deceptively simple, just three sidings and a shunting neck. Operation was made interesting by Alan selecting four wagons at random using his 'tiddlywink computer': each of the distinctive wagons was allocated a token, then all were placed in a cup and shaken before four were taken out. These four wagons then had to be assembled in the order drawn. This was rarely easy and, on occasions, took a dozen or more train movements to effect. It was the model railway equivalent of Rubik's Cube.

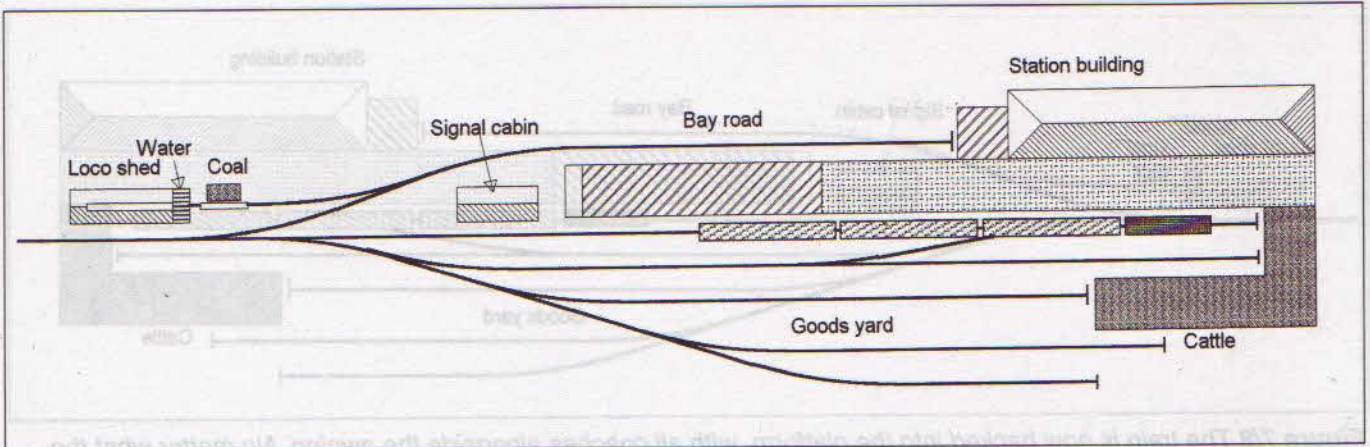

Figure 7/5 The most basic of train operations is running round a train at a terminus. Using the same layout as that illustrating goods shunting, we start with the arrival of a loco-hauled passenger train, which runs into the main platform.

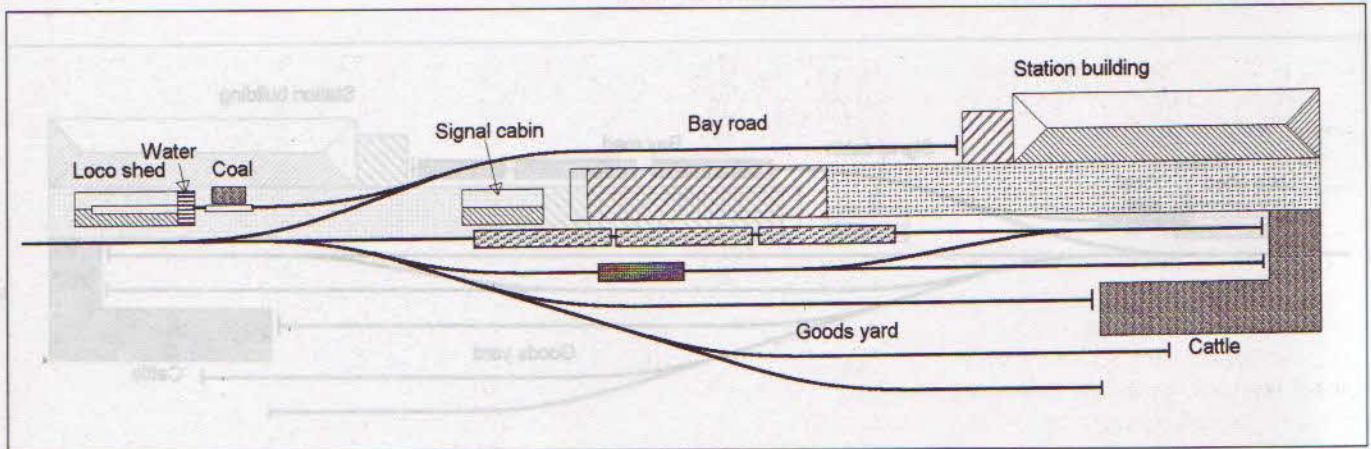

Figure 7/6 After a suitable pause for the passengers to alight and for parcels and other goods to be taken from the van, the coaches are pushed back into the loop. The locomotive is detached, runs into the end spur, then reverses over the release crossover and passes the coaches on the loop. These are held in place since the brakes were applied when the vacuum hoses were disconnected.

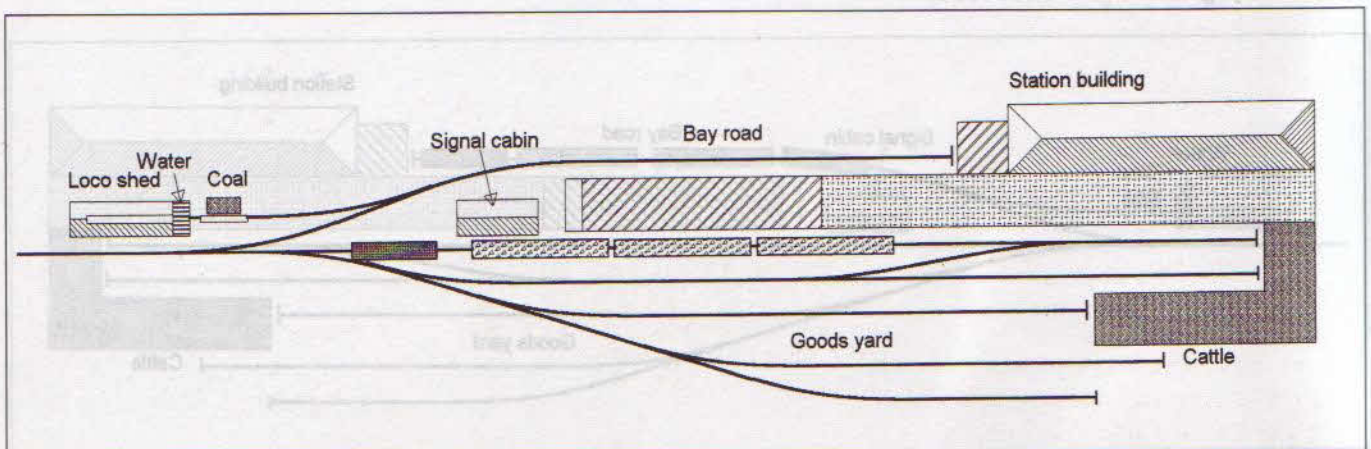

Figure 7/7 The locomotive runs out beyond the entry point and waits. The points are reversed and the loco then backs on to the train and couples up, restoring the vacuum in the train brake pipes.

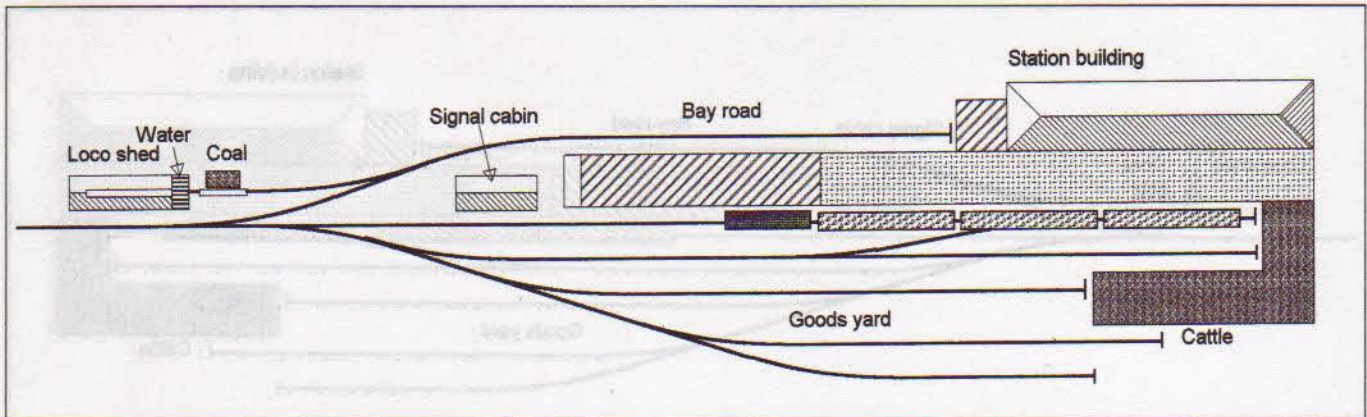

Figure 7/8 The train is now backed into the platform, with all coaches alongside the awning. No matter what the weather, passengers can join the train in some comfort. Usually the Brake 3rd coach would be at the buffer end so that this was always under the awning and the parcels could be removed in the dry. As newspapers and magazines were an important source of revenue, it was essential that they should not be unloaded on an exposed part of the platform. The staff found it more comfortable as well.

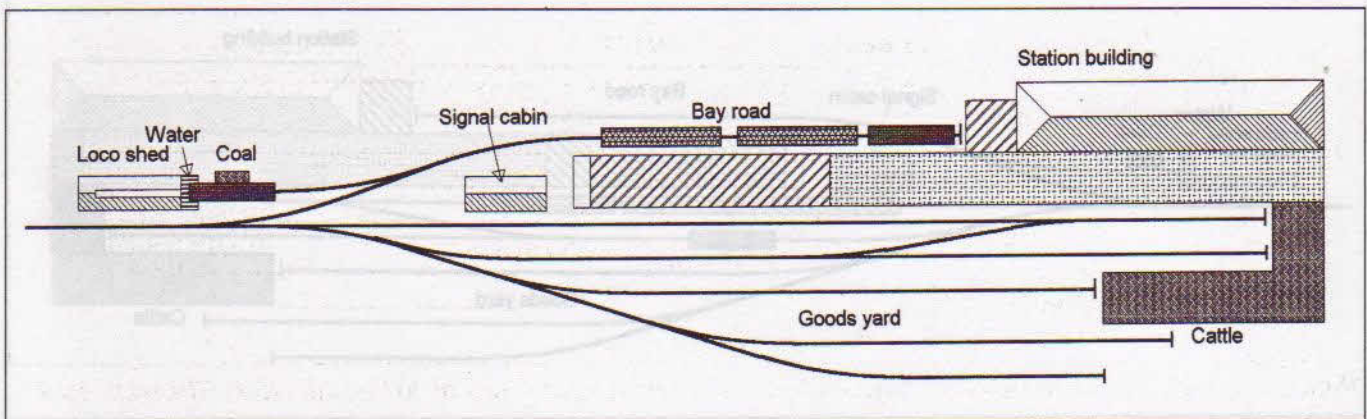

Figure 7/9 If the bay road is used for passenger traffic it is more than likely that the train will either be a push-pull steam set or a diesel railcar. However, working a normal loco-hauled train in and out of the bay usually involves some complex moves. The train has first to be shunted into the loop so that the locomotive can run round, then set back into the bay. However, if an intensive loco-hauled working is required, a spare locomotive is used, and this is shown waiting on the loco shed road.

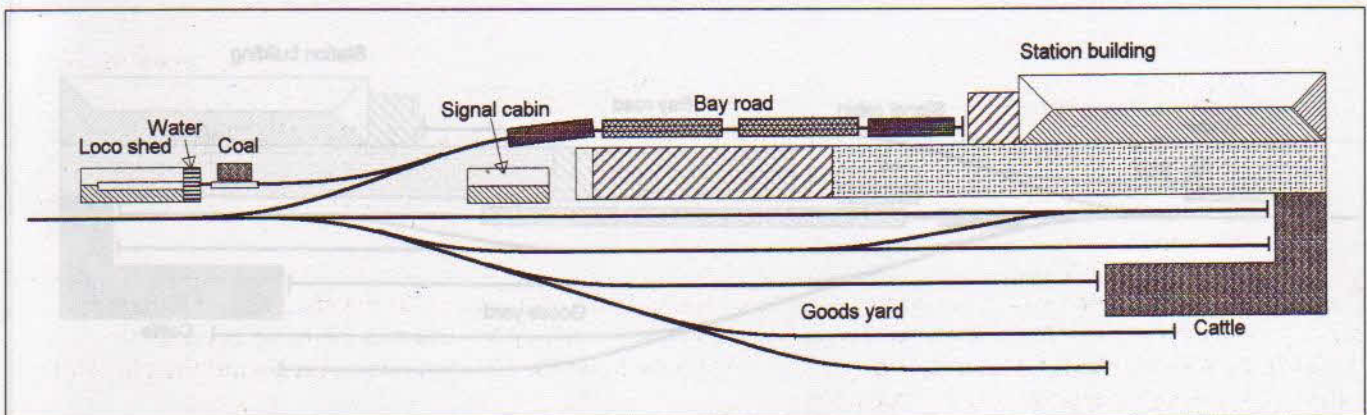

Figure 7/10 The spare loco now backs on to the train and couples up. The original locomotive is uncoupled, its handbrake screwed down, and its driver takes life easy while the fireman polishes the locomotive.

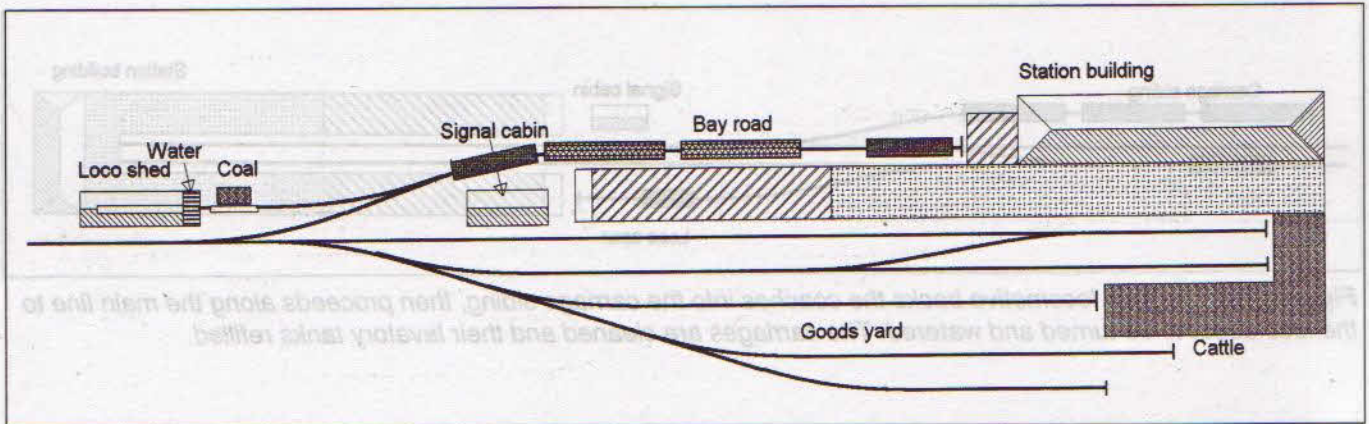

Figure 7/11 The train now has the right of way and sets off on its journey. The first crew get back on to their locomotive and release the handbrake.

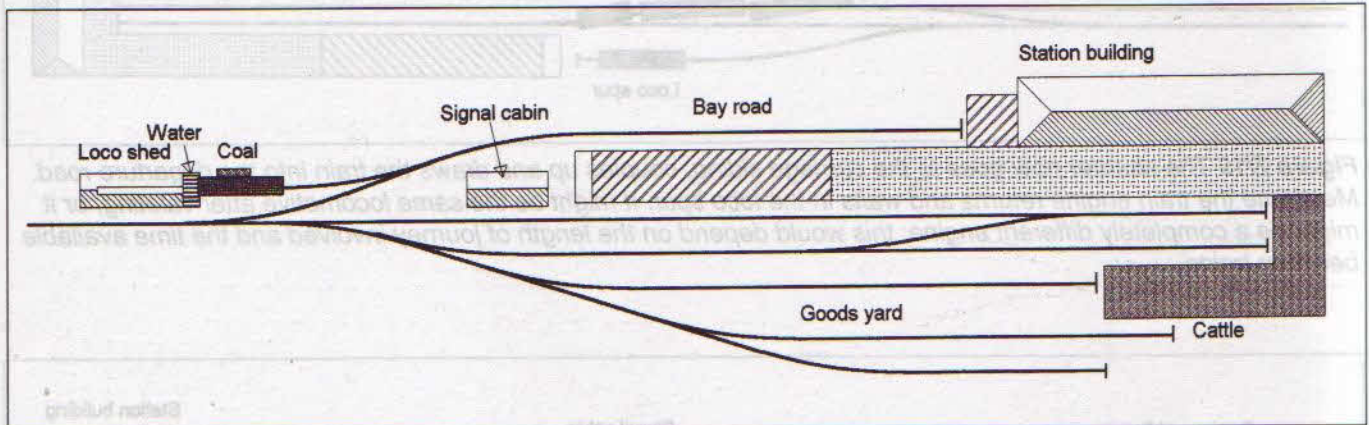

Figure 7/12 With the train clear of the bay, the first loco, now the spare, runs on to the shed road. The water tank will be refilled, the fire cleaned and any necessary oiling and adjustment carried out while waiting to repeat the cycle with the next train. In point of fact this type of operation is very unusual at a branch terminus, and is more commonly associated with suburban stations. However, as the track layout allows it to be done, it seemed as well to describe this form of reversal at the basic terminus, rather than on a new station layout.

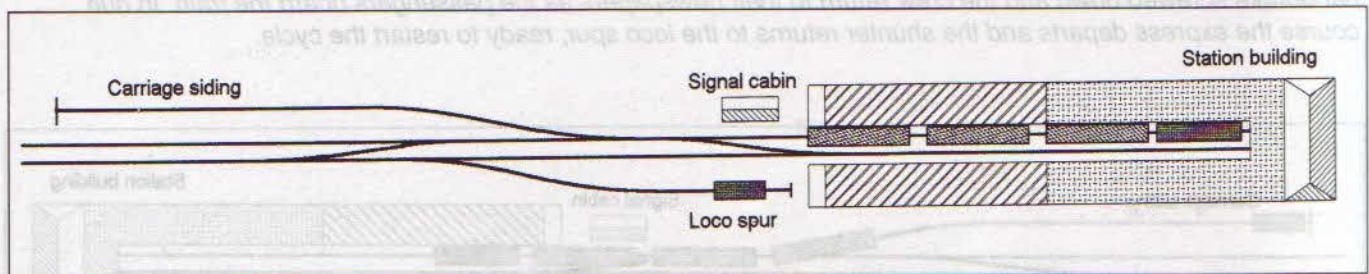

Figure 7/13 At a major terminus, serving long-distance trains, it was not unusual in the steam age for there to be separate arrival and departure platforms. Train reversal involved not only the use of a shunting locomotive, generally an 0-6-0 tank, but a carriage siding as well. Here we have the situation immediately after the arrival of an express. The shunter is waiting in the loco spur.

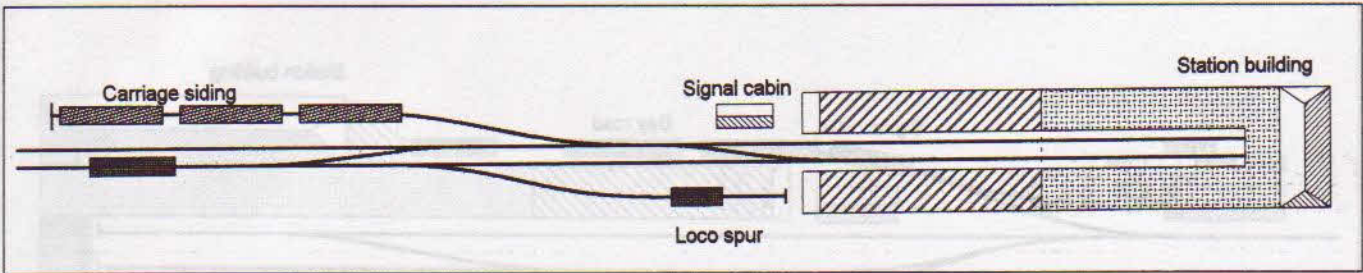

Figure 7/14 The train locomotive backs the coaches into the carriage siding, then proceeds along the main line to the loco depot to be turned and watered. The carriages are cleaned and their lavatory tanks refilled.

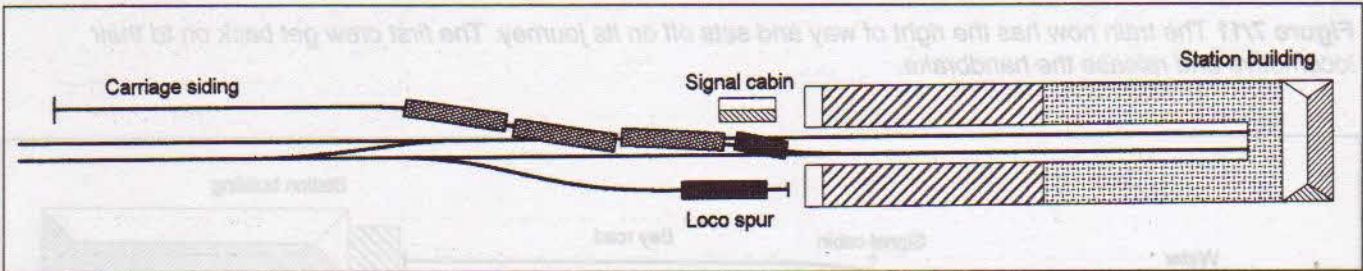

Figure 7/15 The shunter now goes to the carriage siding, couples up and draws the train into the departure road. Meantime the train engine returns and waits in the loco spur. It might be the same locomotive after valeting, or it might be a completely different engine; this would depend on the length of journey involved and the time available between trains.

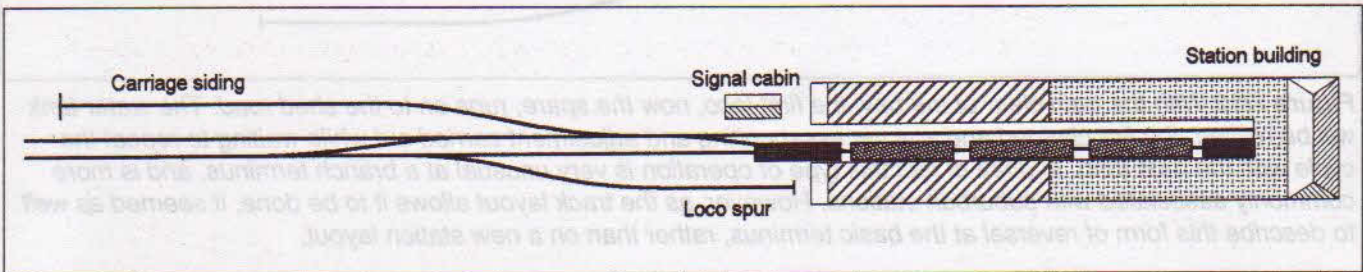

Figure 7/16 The train loco now backs on to the coaches and couples up. Meantime the shunter is unhooked, its handbrake screwed down and the crew return to their newspapers as the passengers board the train. In due course the express departs and the shunter returns to the loco spur, ready to restart the cycle.

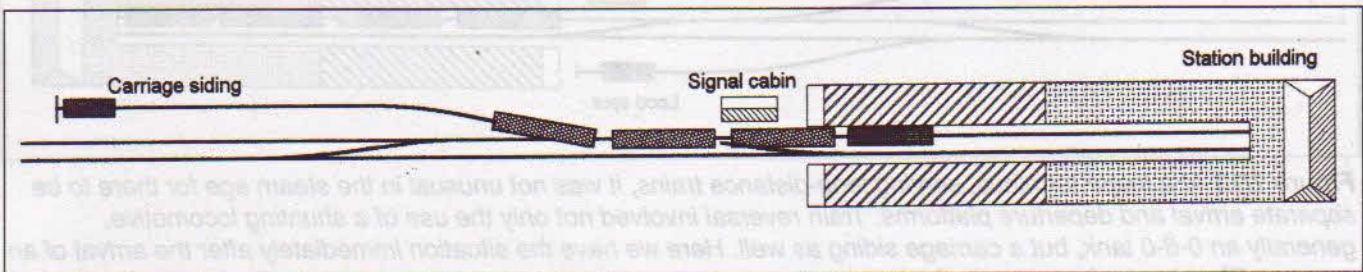

Figure 7/17 A possible variant is where the shunter waits at the end of the carriage siding, then, when the train loco has pushed the coaches in behind and left for the loco depot, the shunter pushes the coaches back into the departure road.

Chapter 8

Track formations

Points and crossings may be arranged in many ways to create track formations for specific purposes. This is yet another case where explanations are unintelligible unless accompanied by a diagram.

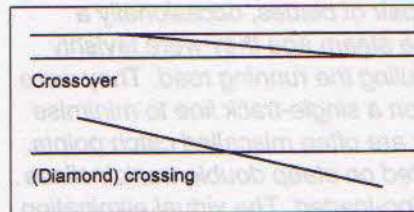

Figure 8/1 There is a considerable degree of confusion between a crossing – or, as it is often called, a diamond crossing – and a crossover. The former passes one track across another, the latter links a pair of parallel tracks.

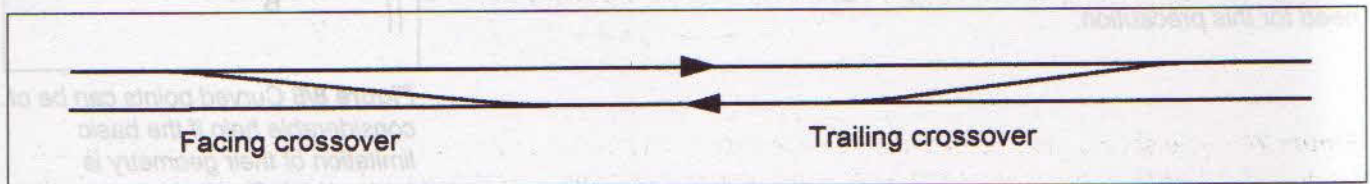

Figure 8/2 Facing crossovers allow a train to pass directly on to the adjacent track, which looks very useful, but means that the train is then travelling on the wrong road, or, in laymen's terms, going the wrong way up a one-way street. This is potentially dangerous, so facing crossovers are normally only provided at important stations to give direct access to platform faces on the opposite side of the track. They also require to have a system of positive locking before trains carrying passengers can be taken over them.

The trailing crossover allows a train to get back on to its proper track by a reversing movement and does not require positive locking. It is invaluable for shunting movements.

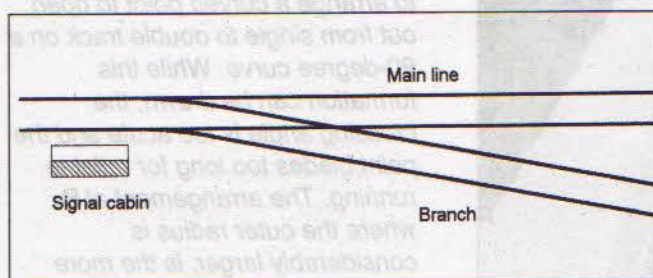

Figure 8/3 The standard double junction incorporates two turnouts and a diamond crossing. While the crossings can be curved, it is more economical, in full-size and model practice, to introduce a straight diamond; this enables standard components to be used and gives better running, but it increases the length of the junction. With mechanical point operation, the traditional signal cabin was sited alongside the junction.

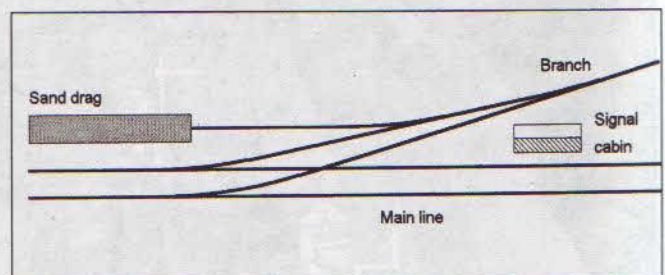

Figure 8/4 The traditional single to double junction was a complicated affair, with a full double junction that reverted to single track immediately after the junction. Frequently a trap road was provided to prevent a branch train overrunning the junction signals and blocking the main line in the face of an oncoming train. The trap frequently ended in a sand drag, which hopefully slowed the train down before it ran out of track. The signal cabin was usually located on the branch side so that the single-line tablet could be picked up or dropped without too much difficulty.

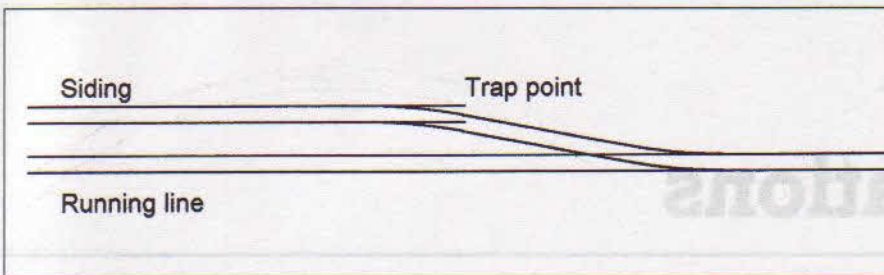

Figure 8/5 Having mentioned trap sidings and sand drags, we can look at trap points. These were no more than a pair of blades, occasionally a single blade, which derailed a train. In the steam age they were lavishly provided to prevent a runaway wagon fouling the running road. They were also fitted at the head of a passing loop on a single-track line to minimise the chances of a head-on collision. They are often miscalled catch points. These are physically similar, but were fitted on steep double track inclines to derail runaway wagons, and were spring-loaded. The virtual elimination of the steam age unbraked, loose-coupled goods train has eliminated the need for this precaution.

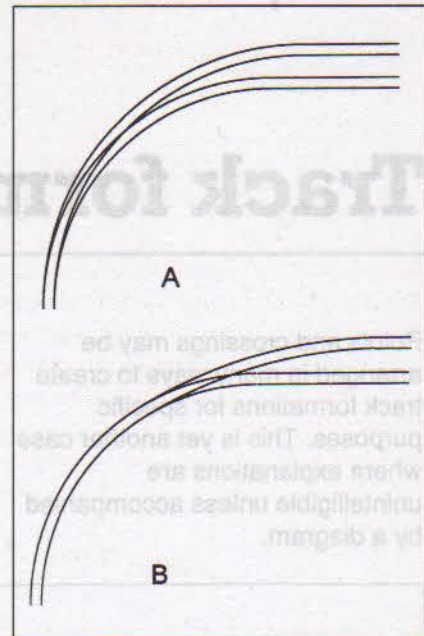
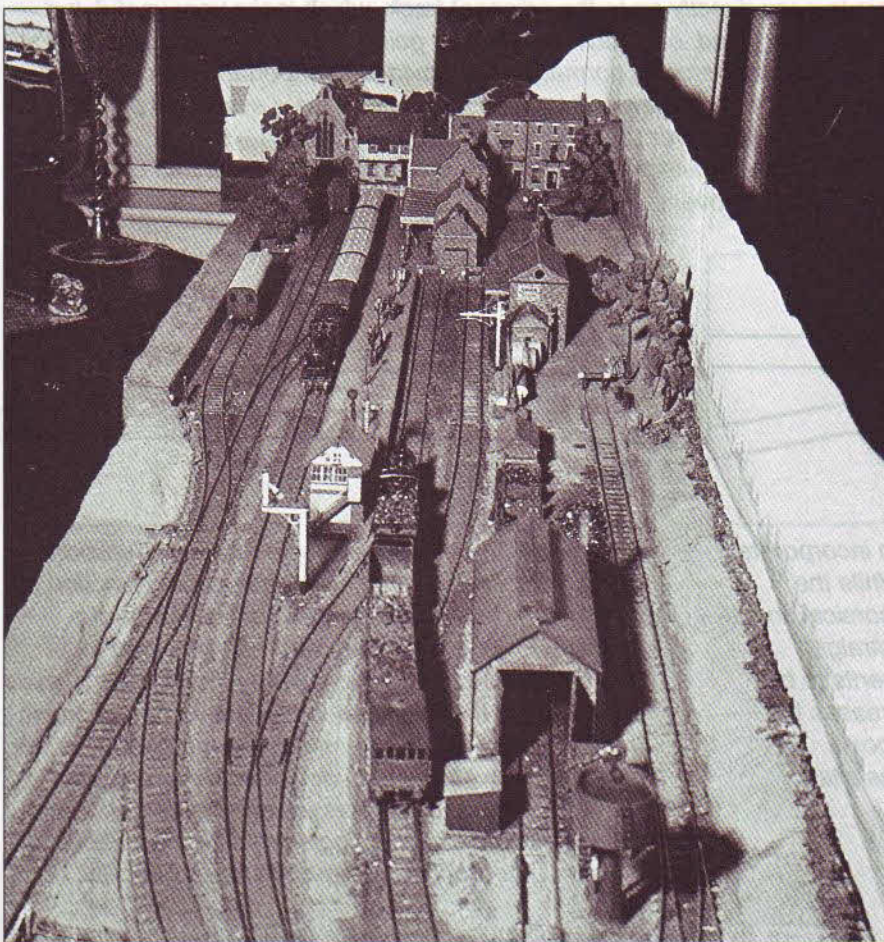

Figure 8/6 Curved points can be of considerable help if the basic limitation of their geometry is understood. One limitation ought to be obvious, but isn't always appreciated by newcomers: you can't arrange a curved point inside a minimum radius curve. Less obvious is the fact that you require a large differential between the two radii. In case **A** we have attempted to arrange a curved point to open out from single to double track on a 90-degree curve. While this formation can be drawn, the crossing angle is too acute and the point blades too long for reliable running. The arrangement at **B**, where the outer radius is considerably larger, is the more practical arrangement. Commercial curved points take this form.



Peter Denny's 'Buckingham Mk II' as it was just before he left London for his pastoral duties in Cornwall. The track is scratchbuilt – at that time there was no alternative – and incorporated both straight and curved turnouts, all neatly arranged to produce a layout that was both pleasing to the eye and smooth running.

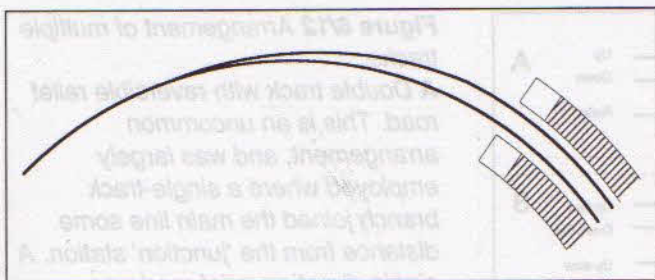

Figure 8/7 The curved point not only allows part of the station pointwork to be fitted into the corner of the baseboard, but also improves the appearance of the track and gives trains a smoother run into the loop.

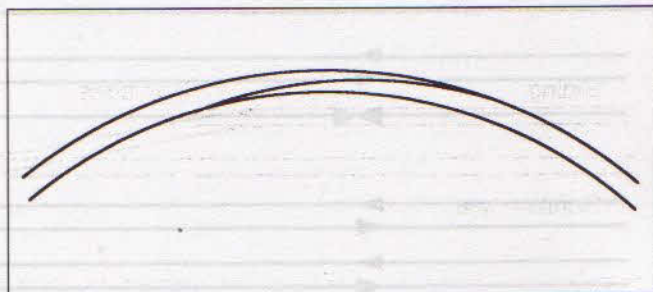

Figure 8/8 Two curved points can be arranged to form a crossover on a double-track curve, saving a lot of space on the layout.

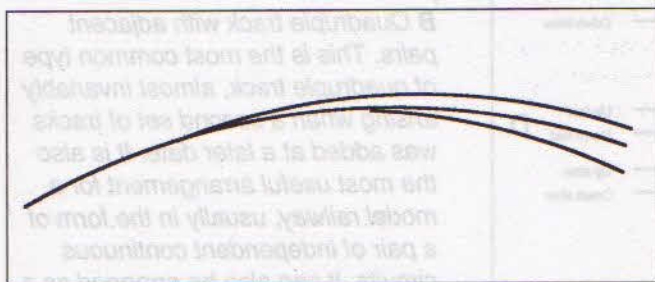

Figure 8/9 Curved points also allow longer storage loops on a tailchaser-type layout.

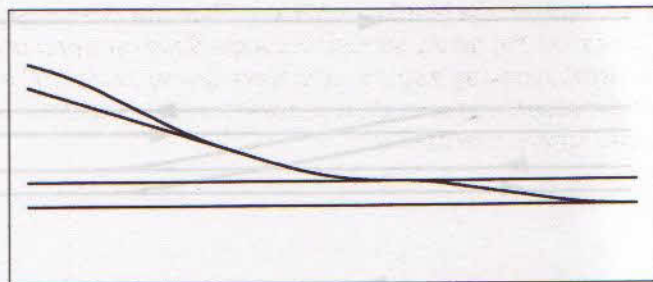

Figure 8/10 Reverting to junctions, modern practice has replaced the double junction with 'ladder' crossovers. With multiple-aspect signalling from remote centralised control boxes, the signal cabin has also been eliminated. This arrangement has come in for criticism since it can allow a train to get on to the wrong road, although it has to be said that the conventional flat junction is also open to criticism on safety grounds, but as it has been there in the memory of man, this is discounted.

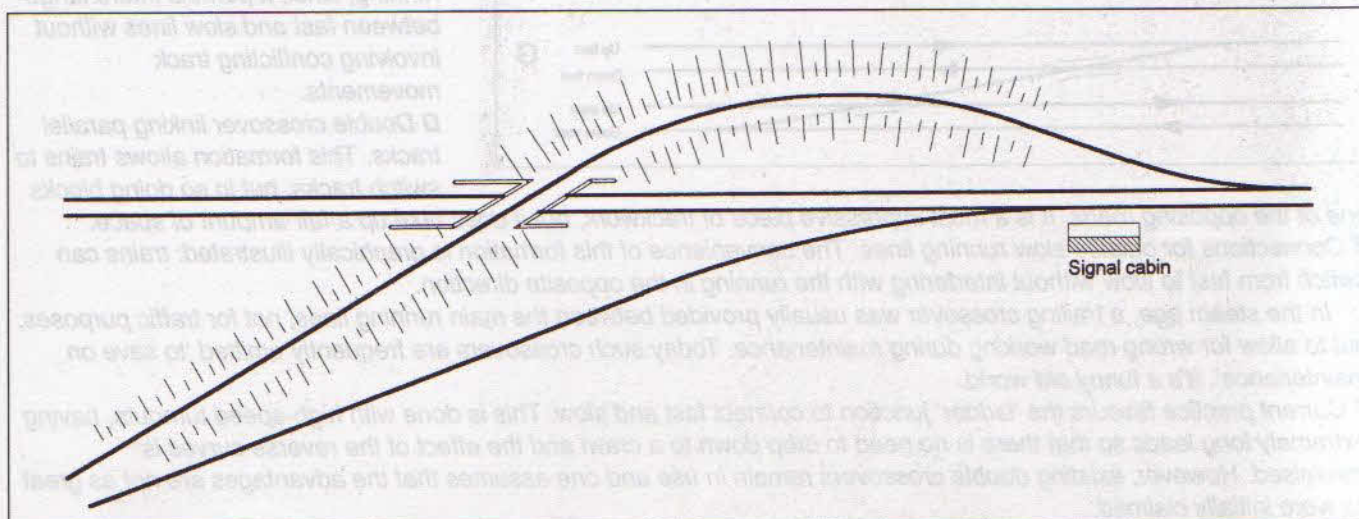

Figure 8/11 The flying junction is the most satisfactory means of linking two routes, since by carrying the branch train over the main line, head-on conflicting movements are eliminated completely. It is at its most effective when it feeds into quadruple track, which then eliminates all converging moves as well. It is clearly more costly, though in the model the cost is spatial rather than financial. This type of junction is preferred by modellers largely for its visual advantages.

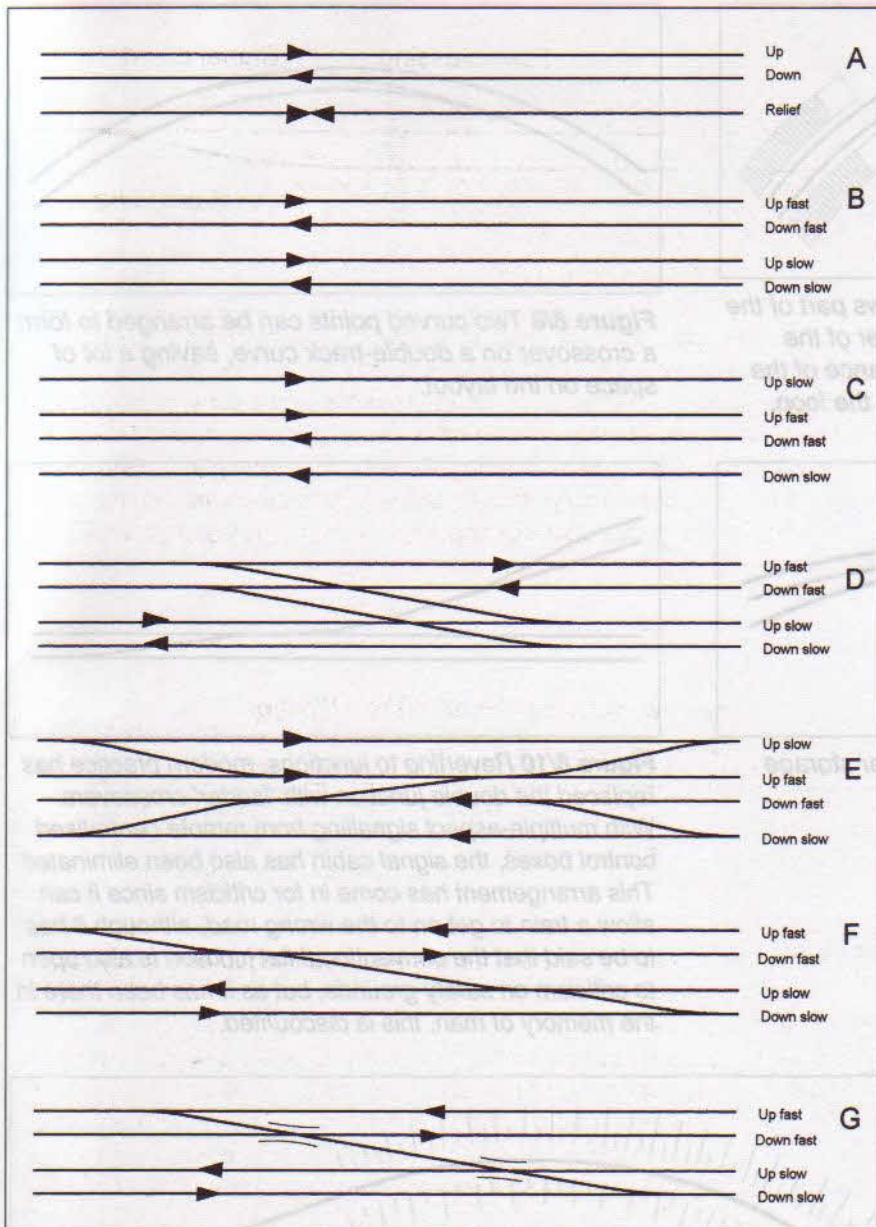

Figure 8/12 Arrangement of multiple tracks.

A Double track with reversible relief road. This is an uncommon arrangement, and was largely employed where a single-track branch joined the main line some distance from the 'junction' station. A single-direction relief road was occasionally used on the approach to a busy station, relieving pressure on the inward road. In such a case, the relief normally led directly to the local platforms.

B Quadruple track with adjacent pairs. This is the most common type of quadruple track, almost invariably arising when a second set of tracks was added at a later date. It is also the most useful arrangement for a model railway, usually in the form of a pair of independent continuous circuits. It can also be arranged as a spiral, doubling the effective length of run. True quadruple track working is extraordinarily difficult to arrange on a model because there simply isn't the length fully to exploit its advantages.

C Quadruple track with outside slow lines. This is the more sophisticated arrangement for quadruple track running, since it permits interchange between fast and slow lines without involving conflicting track movements.

D Double crossover linking parallel tracks. This formation allows trains to switch tracks, but in so doing blocks

one of the opposing roads. It is a most impressive piece of trackwork, but it does take up a fair amount of space.

E Connections for outside slow running lines. The convenience of this formation is graphically illustrated: trains can switch from fast to slow without interfering with the running in the opposite direction.

In the steam age, a trailing crossover was usually provided between the main running lines, not for traffic purposes, but to allow for wrong road working during maintenance. Today such crossovers are frequently omitted 'to save on maintenance'. It's a funny old world.

F Current practice favours the 'ladder' junction to connect fast and slow. This is done with high-speed turnouts, having extremely long leads so that there is no need to drop down to a crawl and the effect of the reverse curves is minimised. However, existing double crossovers remain in use and one assumes that the advantages are not as great as were initially claimed.

G The ladder 'slip' connection saves space and reduces the zig-zag effect of a ladder junction. These advantages are of considerable importance on the model, for although the slip point is more costly, it is not significantly different from two standard turnouts. The amount of space saved is almost always crucial to the success of the design. The formation is greatly favoured on the Continent, where few large stations are without at least one of these arrangements.

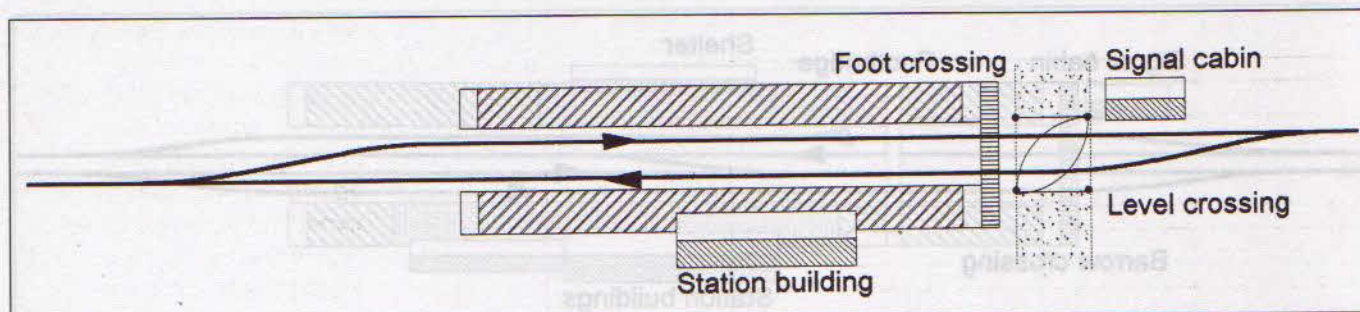

Figure 8/13 The passing loop allows trains travelling in opposite directions on single-track lines to pass one another. Usually, but by no means invariably, the loop was provided with flanking platforms for the use of passengers. These passing stations were located adjacent to a road and, where possible, not too far from a village or hamlet. Owing to a lack of foresight among our ancestors, the village was often some distance from the best line for the railway, and this might be acknowledged by calling the station Littlebury Road, rather than just Littlebury. A signal cabin was always provided in the days of mechanical working, the signaller not only controlling the crossing of trains and handing out single-line tablets or staffs, but also working level crossing gates, if provided. Often no footbridge was provided, with passengers crossing the track by a foot crossing.

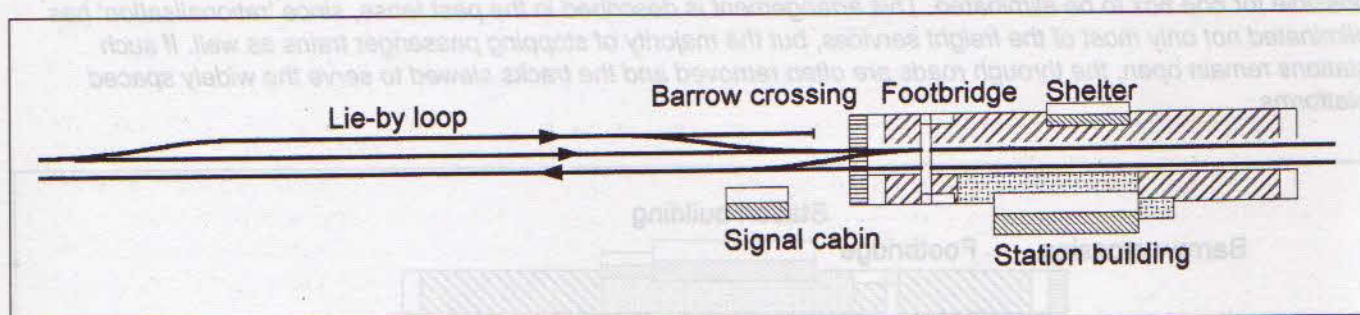

Figure 8/14 The lie-by loop is found on busy double track main lines, and permits a goods train to be rapidly run out of the way of a following passenger train. It was a comparatively late introduction in Britain because the length of the loop was restricted by the comparatively short distance that points could be mechanically worked from a lever frame. Once electric operation of points became feasible, this restriction no longer applied. In a few cases, where no electric supply was available, the signaller was provided with a hand-cranked generator and the points were wound over by whirling the handle. In passing, this problem did not affect Continental railways, where points were operated by the twin wire system, which can work over greater distances than the heavy rodding required under British regulations. Where the loop was adjacent to a station, as shown here, it might also serve as an arrival road for the goods yard.

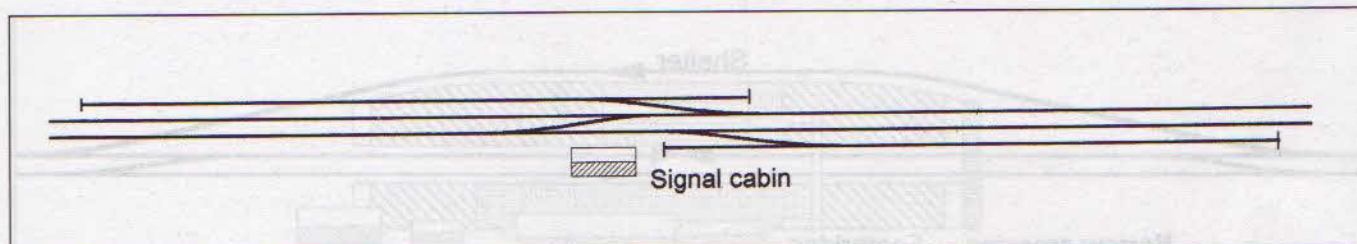

Figure 8/15 The traditional British method of moving slow freight trains off the main line was the refuge or relief siding. This was a long siding arranged in the trailing direction, into which a goods train could be reversed. This was of necessity a slow process and was unpopular with the freight crews. It is rarely used on models since the distances between the terminal points of even a large layout are too small to make it necessary. However, as the visual part of an exhibition tailchaser, an intermediate block post with up and down refuge sidings, as shown here, could be a very effective feature.

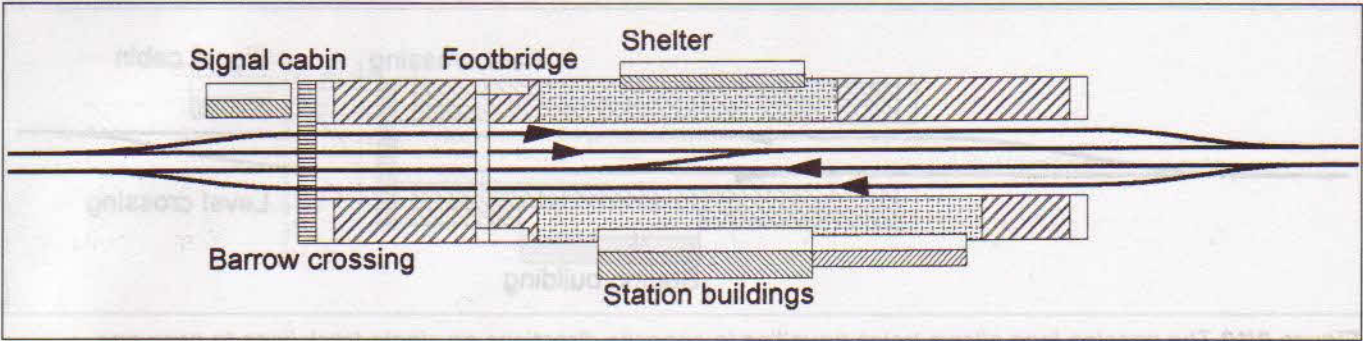

Figure 8/16 As traffic increased at the end of the 19th century, it was realised that the slower stopping passenger trains were holding up the non-stop expresses. To avoid this, intermediate stations were rebuilt with the platform tracks on loops. The stopping passenger train could then wait as the express passed though on the centre roads, a process commonly known as 'looping'. However, when a passenger train had to overtake a freight train, it was more usual for the freight to stand in the centre roads while the passenger train stopped to allow passengers to leave or join the train.

Initially, two signal cabins were provided, one at each end of the station, since the length of the loop was generally too great for manual working. The introduction of electrically operated point mechanisms made it possible for one box to be eliminated. This arrangement is described in the past tense, since 'rationalisation' has eliminated not only most of the freight services, but the majority of stopping passenger trains as well. If such stations remain open, the through roads are often removed and the tracks slewed to serve the widely spaced platforms.

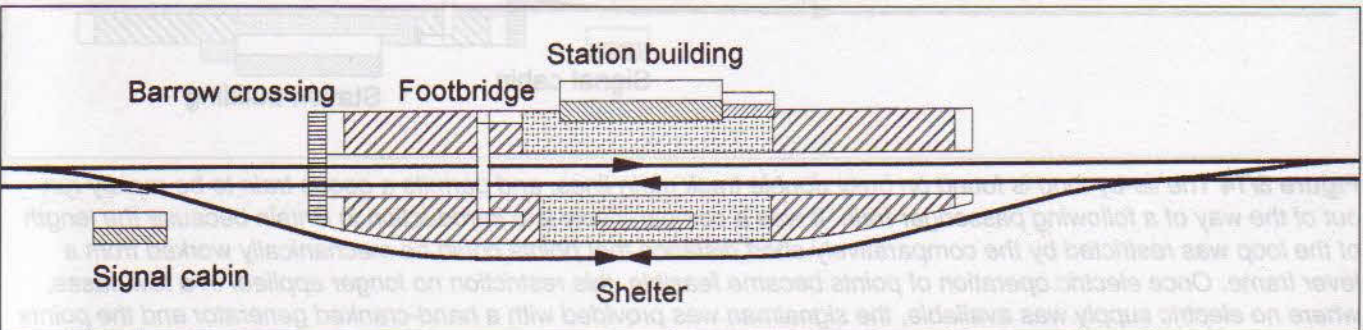

Figure 8/17 Another arrangement that has all but vanished in the diesel era is a loop road served by an island platform. This track could be used for reversing passenger trains, or more commonly to handle goods trains. It was easy to arrange sidings off this loop, and link a branch to it as well. This formation is a very popular base for a cross-country station model.

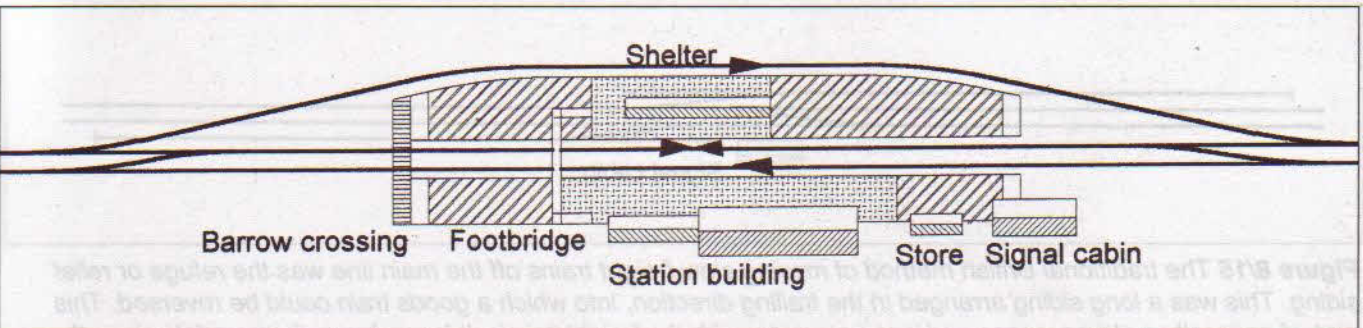

Figure 8/18 While this looks similar to Figure 8/17, here the centre road is the reversible one. It is of greatest value on a large system layout where it provides reversal for suburban services, although it has advantages on a simple continuous system. It is very rare on the prototype.

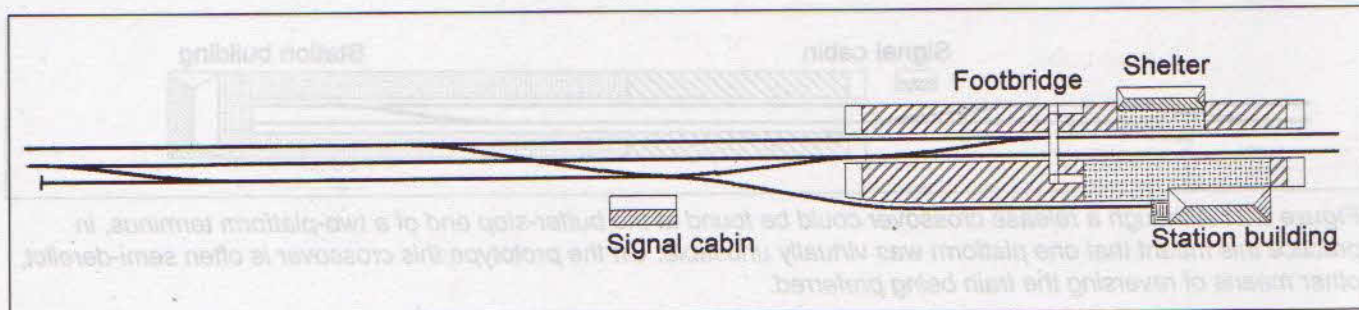

Figure 8/19 A more conventional means of reversing a passenger service at a through station is to run the trains into a bay platform. Here the bay is combined with a loop that also serves the goods yard. Facing entries to both the bay and loop are provided to ease model operation; despite a common belief that facing entries to goods facilities were outlawed, they did occur where traffic on the main line was at all intensive.

The regulation concerning facing points is simple: when used by passenger trains they must be provided with a lock to prevent movement while the train is passing. This adds to the cost, therefore such turnouts are only used when absolutely necessary.

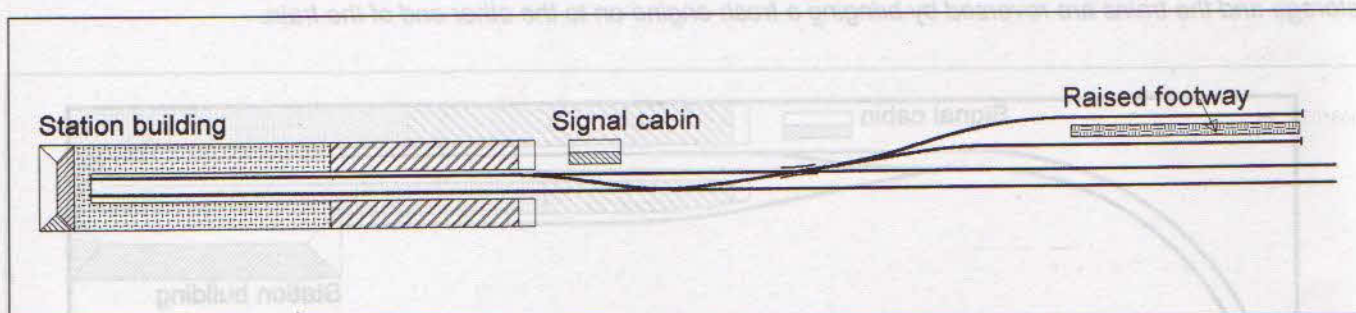
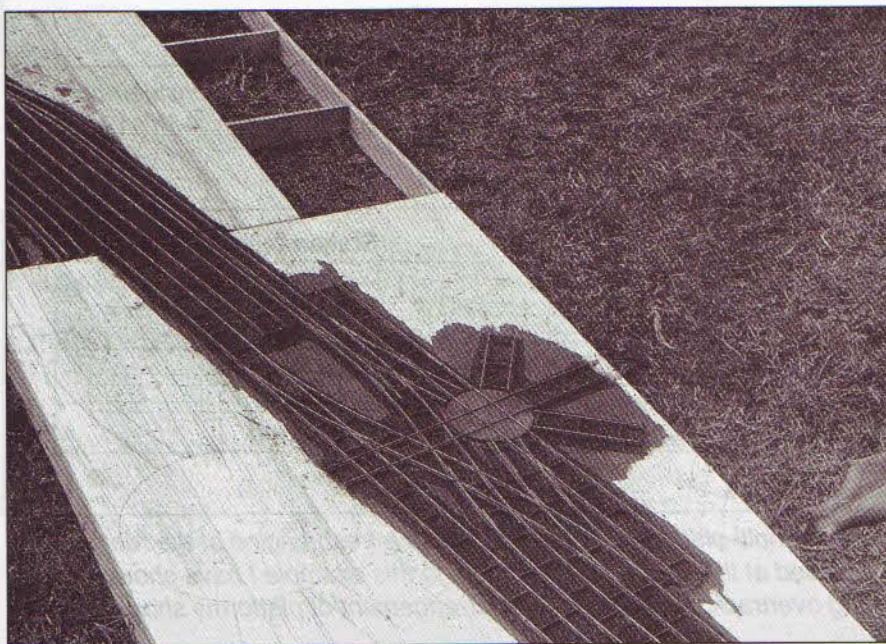

Figure 8/20 We encountered carriage sidings in the previous chapter. While these sidings could be no more than straightforward storage roads, they were frequently provided with raised walkways, generally timber-built, to make it easier to clean the compartments. This makes for a more interesting model.



Mike Sharman's main interest lies in modelling unusual locomotives from the early days of railways – he claims that 'Modern Image' begins around 1880! Here he set out to model one of Brunel's single-sided stations for broad gauge working, discovering on the way that it was, in the context of 1840 train working, a very practical arrangement, as the central turntable allowed carriage trucks to be attached or detached from the rear of express trains. This involved a good deal of manhandling, but in Victorian times manpower was no problem.

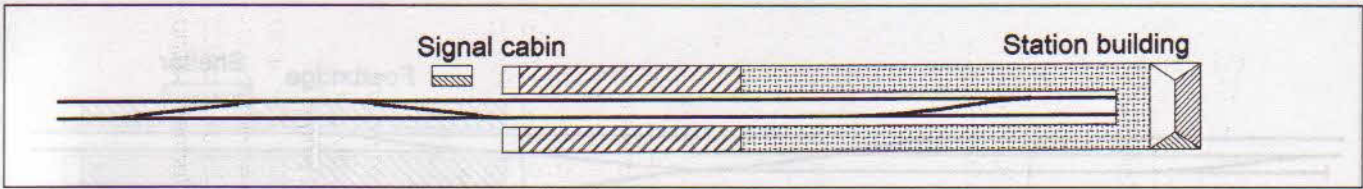

Figure 8/21 Although a release crossover could be found at the buffer-stop end of a two-platform terminus, in practice this meant that one platform was virtually unusable. On the prototype this crossover is often semi-derelict, other means of reversing the train being preferred.

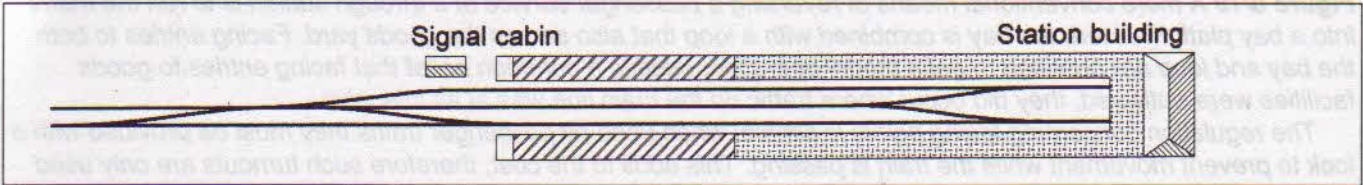

Figure 8/22 Where it is desired to release locomotives from the ends of trains in multi-platform termini, it is best to arrange a centre run-round loop as shown here. However, on the prototype this loop is frequently used for stock storage and the trains are reversed by bringing a fresh engine on to the other end of the train.

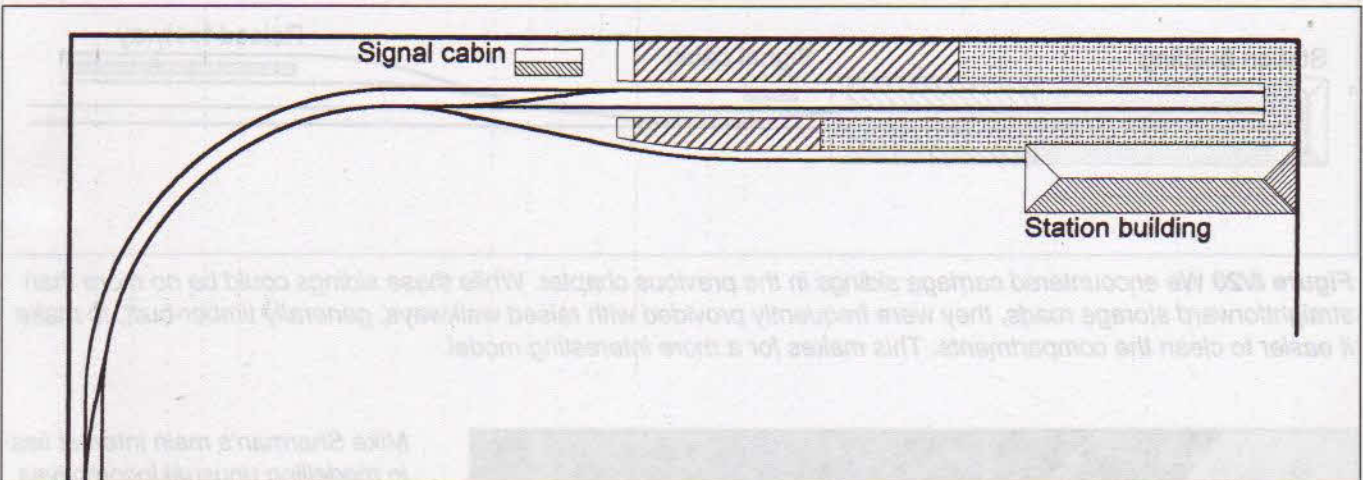

Figure 8/23 Alternatively, the run-round loop can be beyond the platforms. On the model, space considerations mean that a 90-degree curve often abuts the platform ends, and this provides an elegant solution: with a crossover at each end of the curve, a useful loop is achieved.

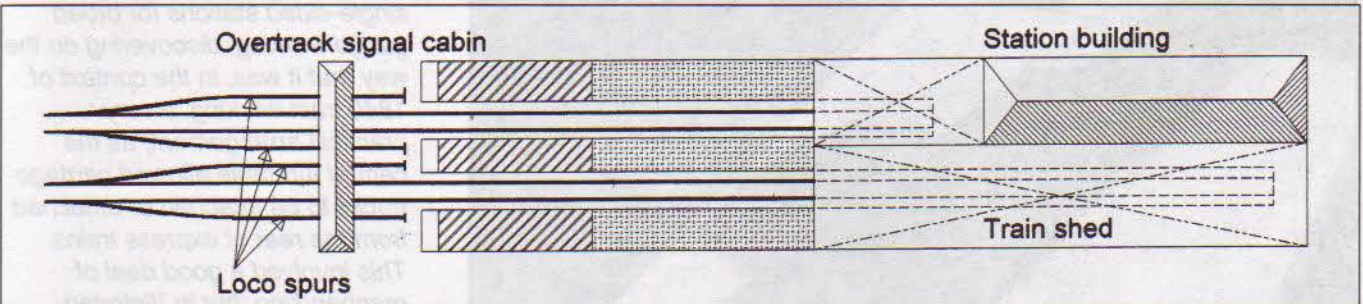

Figure 8/24 The ideal way of reversing trains in multi-platform termini is to attach a fresh engine at the rear of the train. To do so effectively, loco spurs are provided at the end of the platforms. In this example I have shown unequal platform lengths and a space-saving overtrack signal cabin. This arrangement of platforms should suffice for all but the largest of model railways.

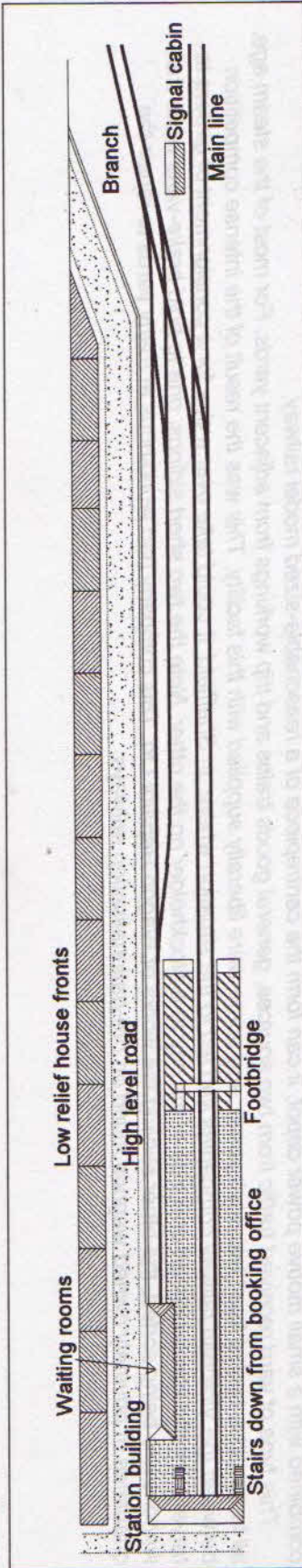

Figure 8/25 This arrangement of a platform bay is closely based on the former layout of East Ham station on the old Tilbury line. Here the run-round loop is formed in the double track of the branch; the loco ran round, propelled the coaches back into the bay and awaited the all-clear. The branch was worked by a Stanier 2-6-2 tank and three LMS non-corridor compartment coaches and ran to either Kentish Town or, occasionally, St Pancras. This service has long since ceased.

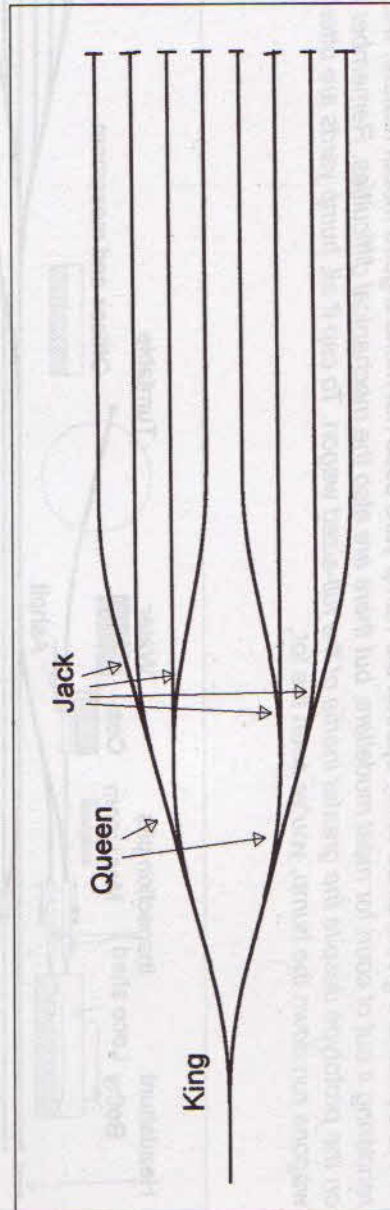

Figure 8/27 The compound lead ensures that all sidings in an eight-road yard are of roughly the same length. The initial turnout is known as the king point, with the next set queen, and the next jack. There is a slight touch of bigamy present, with two queens, possibly the second point could be termed 'mistress' and its dependant points would then be the 'knaves'. This arrangement was commonly employed in hump marshalling yards.

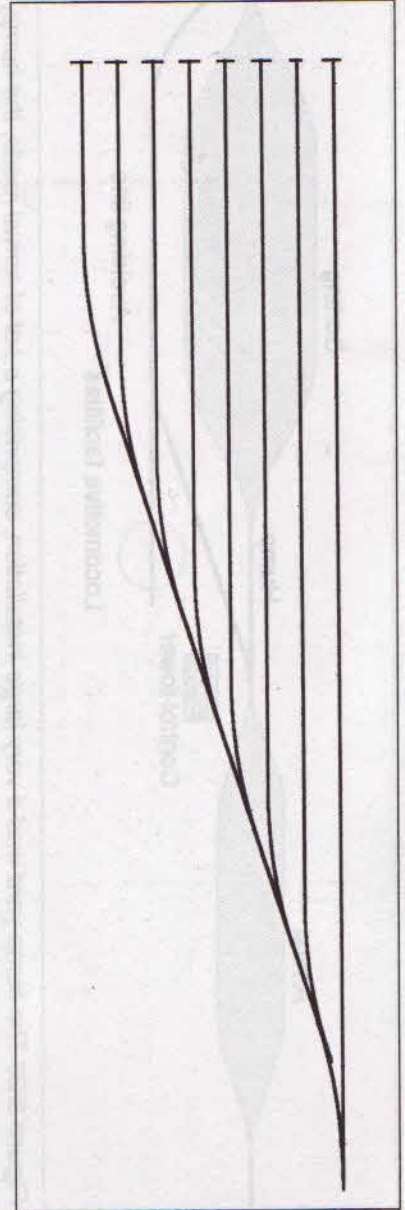

Figure 8/26 Turning now to freight yards, the obvious way to lay out a yard is the ladder track, a single straight lead linking all roads. For up to four tracks of reasonable length this is fine, but when there are, for example, eight tracks as here, the furthest siding is very short.

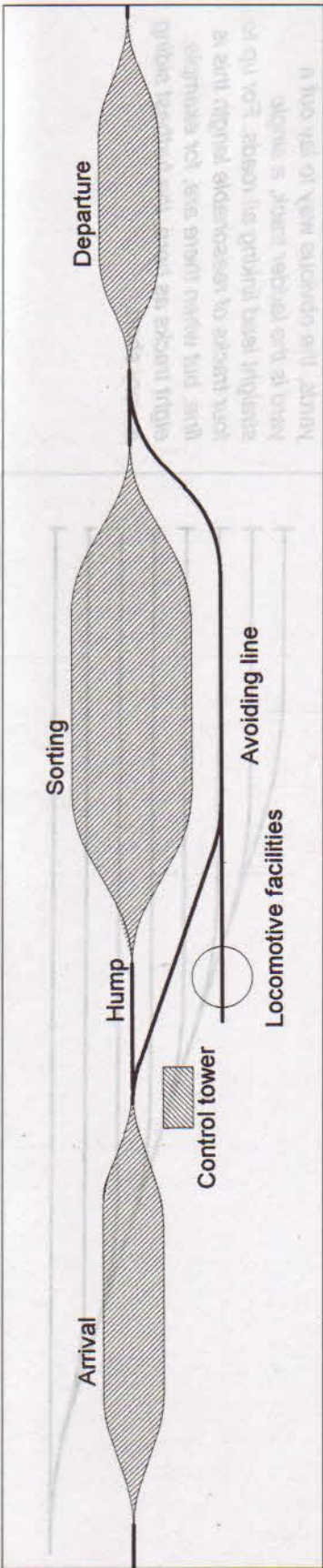

Figure 8/28 The hump yard was a very large installation, comprising a set of arrival roads, the hump, the sorting roads and the departure roads. Locomotive facilities and an avoiding line were also in evidence.

No details are given, since in my opinion the hump yard does not make a good model feature. It is not merely the sheer size of the set-up, rendering it out of court for most modellers, but there are also the mechanical difficulties. Remember that derailments were a daily occurrence on the prototype despite the greater inertia of the full-sized wagon. To cap it all, hump yards are utterly boring – when you’ve seen one cut of wagons run down the hump, you’ve seen the lot.

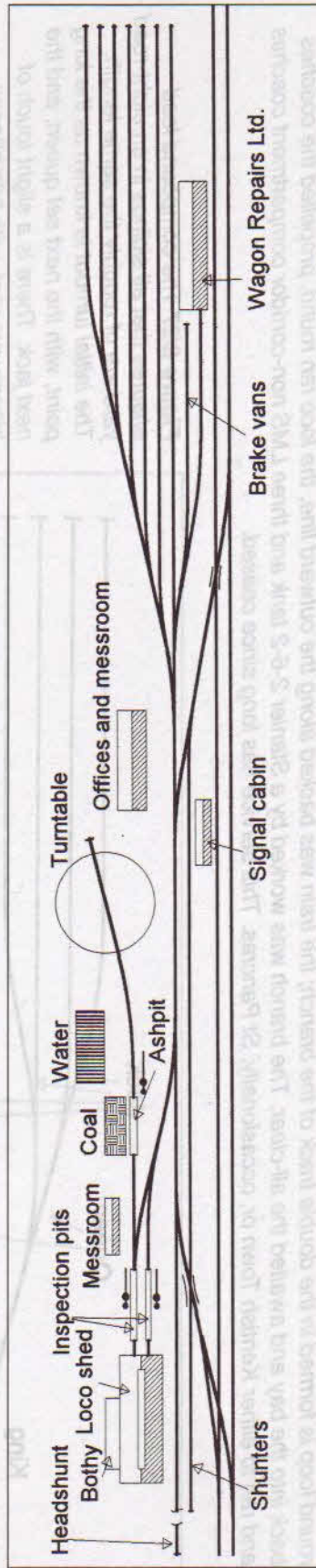

Figure 8/29 The flat marshalling yard is not merely a smaller affair, it is much more interesting to operate. When, as in this example, it is combined with a small motive power depot, it can form the centrepiece of a reasonable-sized model railway.

This type of yard received traffic from two sources, general goods trains and trip workings from adjacent yards. For most of the steam age, all large cities had at least two such yards, and some were liberally supplied with this facility. This was the result of the intense competition between the Victorian railway companies and led to the situation where, in Sheffield, it could take over a day for a consignment of girders to travel from the steelworks on one side of the city to a stockholder on the other. Note the two short sidings, one to hold brake-vans while the wagons are being sorted, the other serving the works of Wagon Repairs Ltd. This company had workshops at many yards to repair the quantities of privately owned wagons found on pre-nationalisation railways.

Chapter 9

Platforms and facilities

Platforms and their associated structures form a prominent part of most modelled stations. Indeed, some people believe that they are the station. They take many varied forms, the following selection of sketches showing the more common ones.

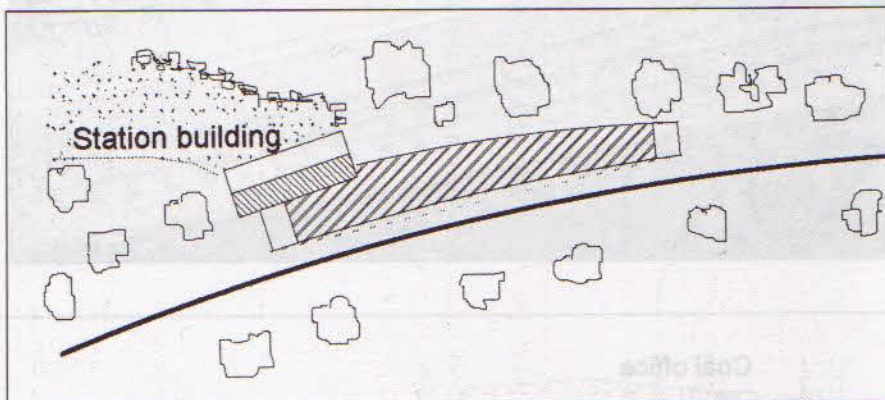

Figure 9/1 The simplest possible passenger station is the single-platform halt. Only the bare minimum of facilities is provided, just the raised platform and some form of shelter; signals were not necessary. During the steam age ticket-vending facilities were provided, but today these are sold on the train. Because it is small and simple, this type of station is sometimes put forward as the ideal space-saving prototype. However, a basic rule of the hobby is that if you make a model of a station where very little happens on the prototype, very little happens on the model. The simple halt is only suited as a secondary station.

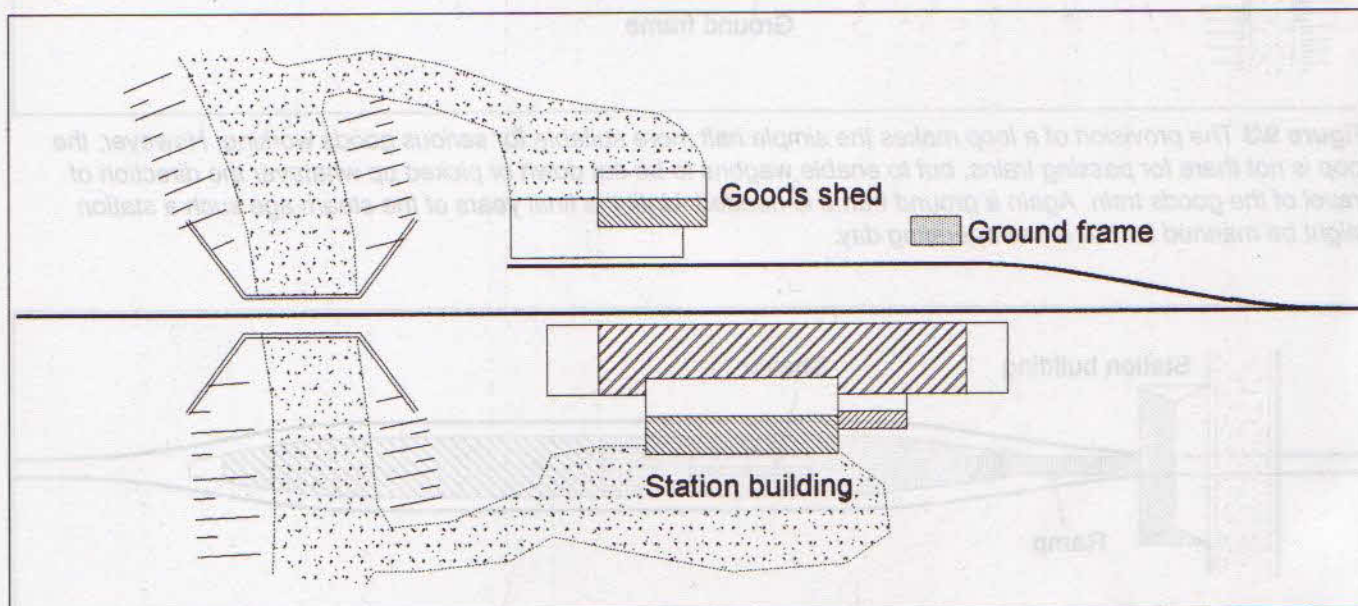
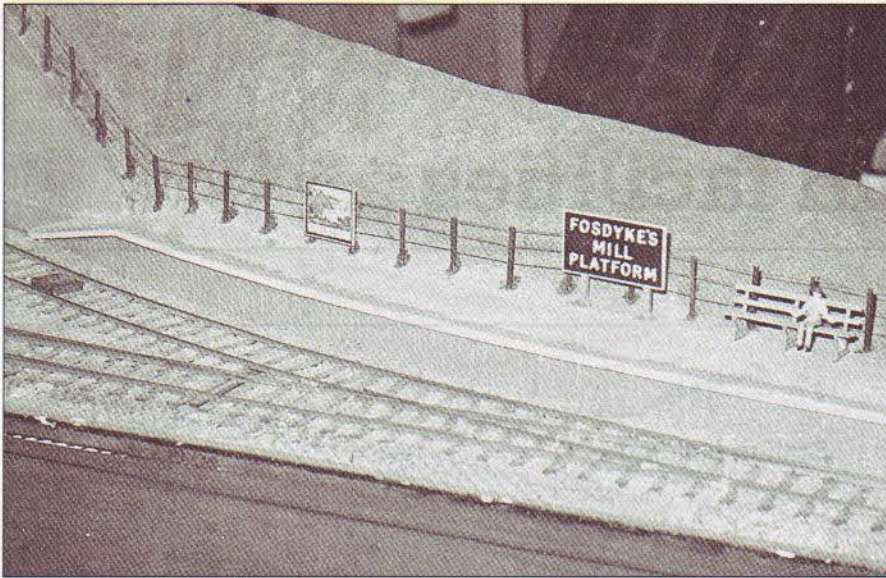

Figure 9/2 The provision of a goods siding at a halt adds to the operating potential, since the goods train now has the opportunity to shunt. As shunting can only take place in one direction, loads travelling the opposite way must be taken to an adjacent station with run-round facilities. This adds to the complexity of operation.

The station will now require a ground frame. This may be no more than an exposed four-lever frame, but could be housed in a small building. Signals may be provided, but because there are no passing facilities, it is not a block post.



Fosdyke's Mill Platform is a basic steam age halt, a platform devoid of all but the most rudimentary facilities. These 'stations' were added in the early part of the century to tap specific local traffic, in this instance workers from a nearby industry.

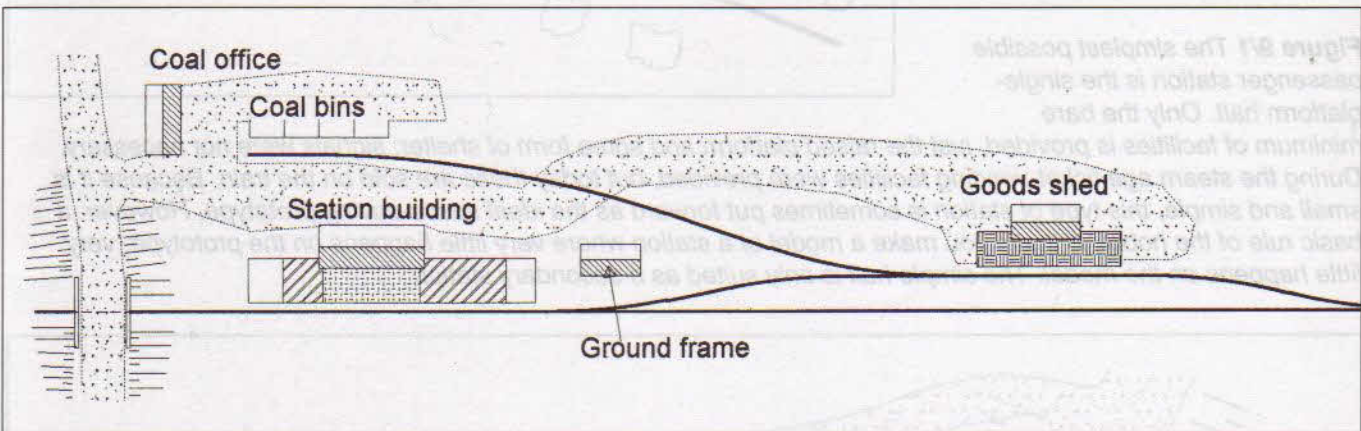

Figure 9/3 The provision of a loop makes the simple halt more suitable for serious goods working. However, the loop is not there for passing trains, but to enable wagons to be set down or picked up whatever the direction of travel of the goods train. Again a ground frame is needed. Until the final years of the steam age such a station might be manned for the entire operating day.

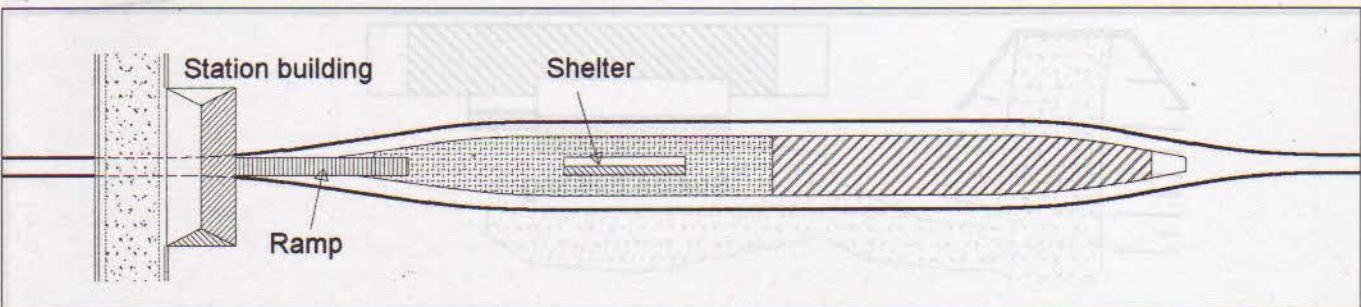

Figure 9/4 Although halts are associated with sleepy branch lines, they are also to be found on double track suburban main lines. This plan is based on the arrangements at Upney on the London Underground District Line, where the booking office is situated over the tracks on a road bridge and linked to an island platform by a long sloping ramp. A waiting room, toilets and porters' room are provided on the platform and an awning covers half of the platform length. The long ramp allows the tracks to close in to pass under the double-track arch of the road bridge.

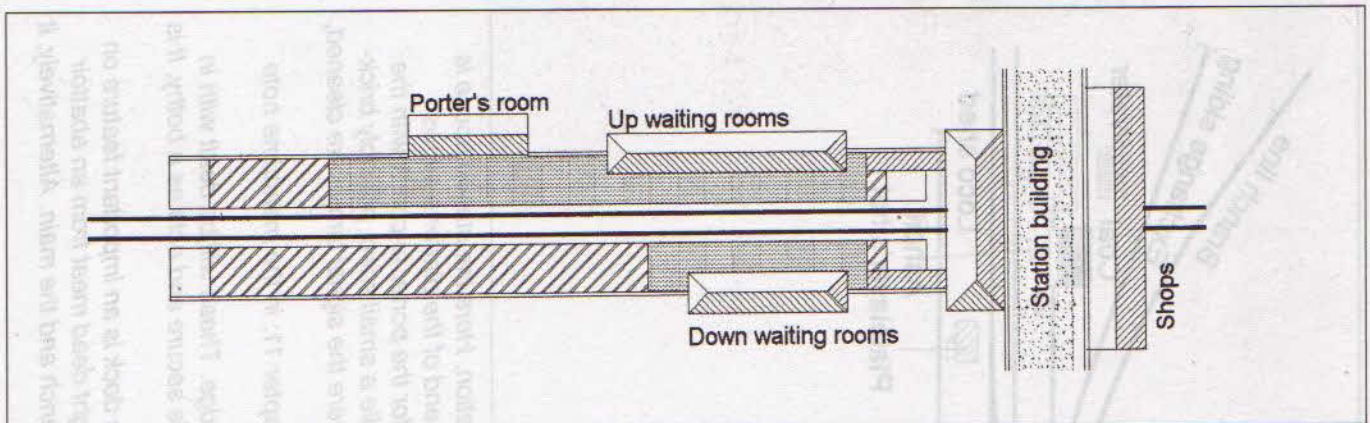

Figure 9/5 A more common type of suburban halt is shown here. Once again the booking office is situated on a road bridge, but with flanking platforms, stairway access is supplied. Furthermore, the up platform has a larger awning and waiting room, while the down platform is more spartan. The reason for this disparity is that the commuters join up trains, and therefore this platform is well loaded with people who have either arrived in good time, or cut things too fine and have seen their train leave as they pass through the barrier in the booking office. On the return journey, no one lingers around the station.

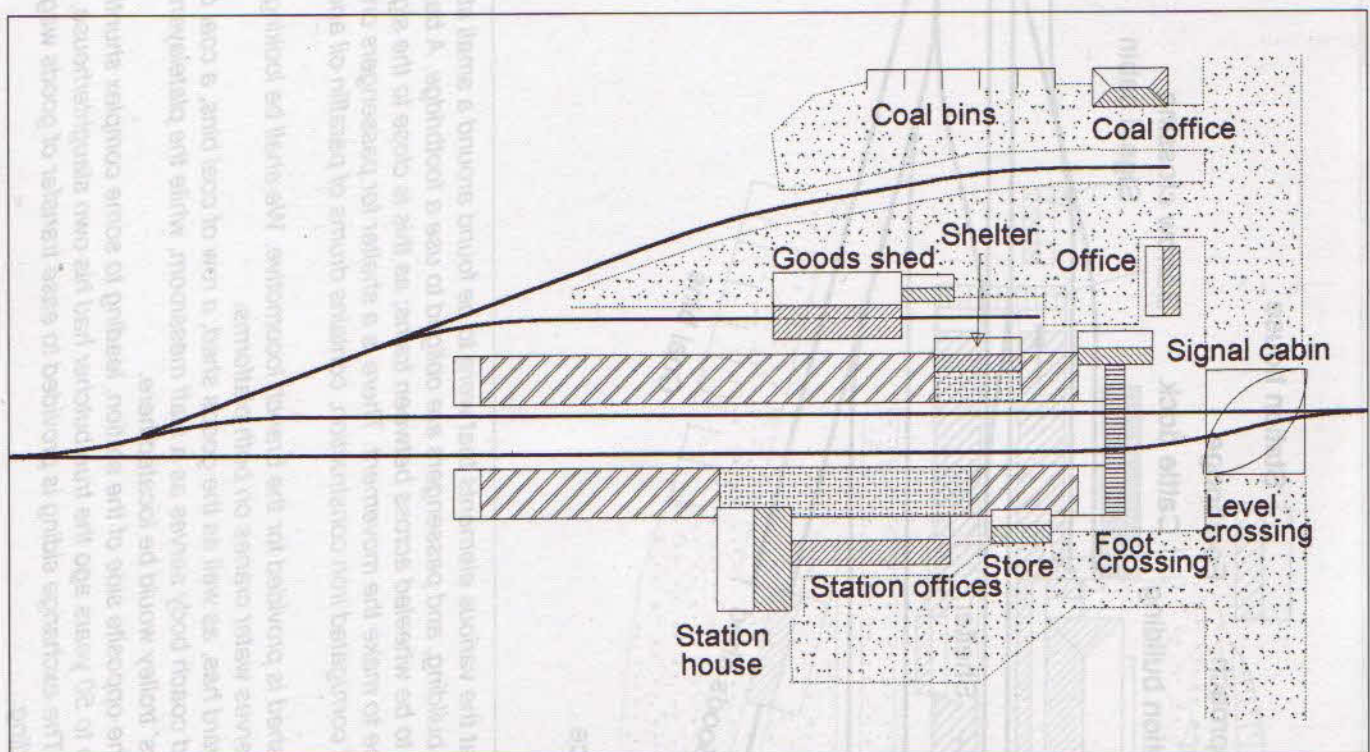

Figure 9/6 We now come to a typical steam-age single-track passing station. The facilities comprise a passing loop with two goods sidings, a level crossing, signal cabin with full block instruments, and the basic station offices. The main block comprises a single-storey booking office/waiting room/porters' room and a two-storey station house where, in the heyday of steam, the stationmaster resided. This was not an altruistic gesture – in this way he was on call 24 hours a day! No footbridge is provided; with a light service of perhaps six passenger and one goods trains a day in each direction, crossing the tracks is safer than crossing the adjacent road. The small store room is provided for railway equipment, and a lock-up shed holds valuable consignments overnight.

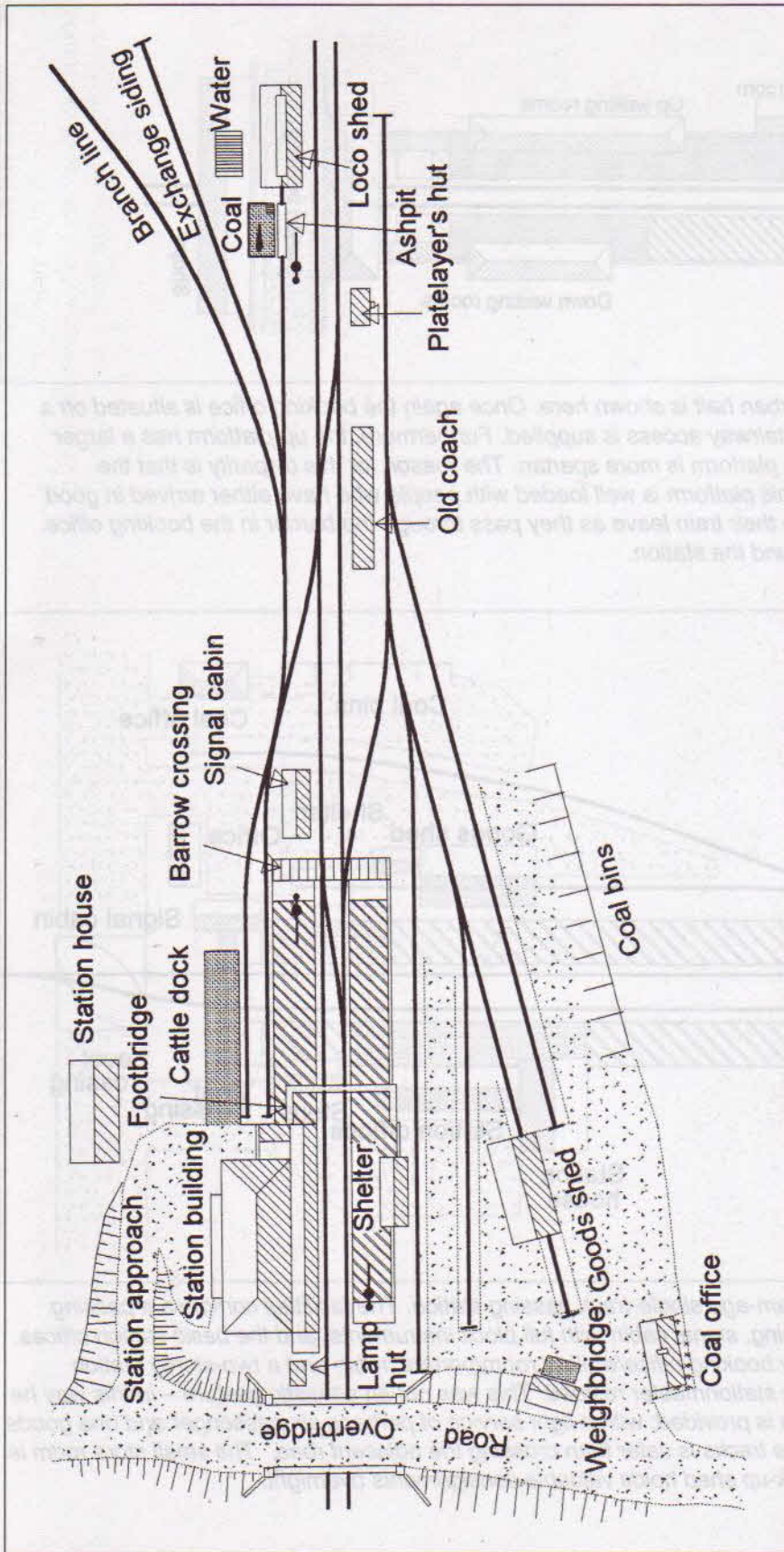
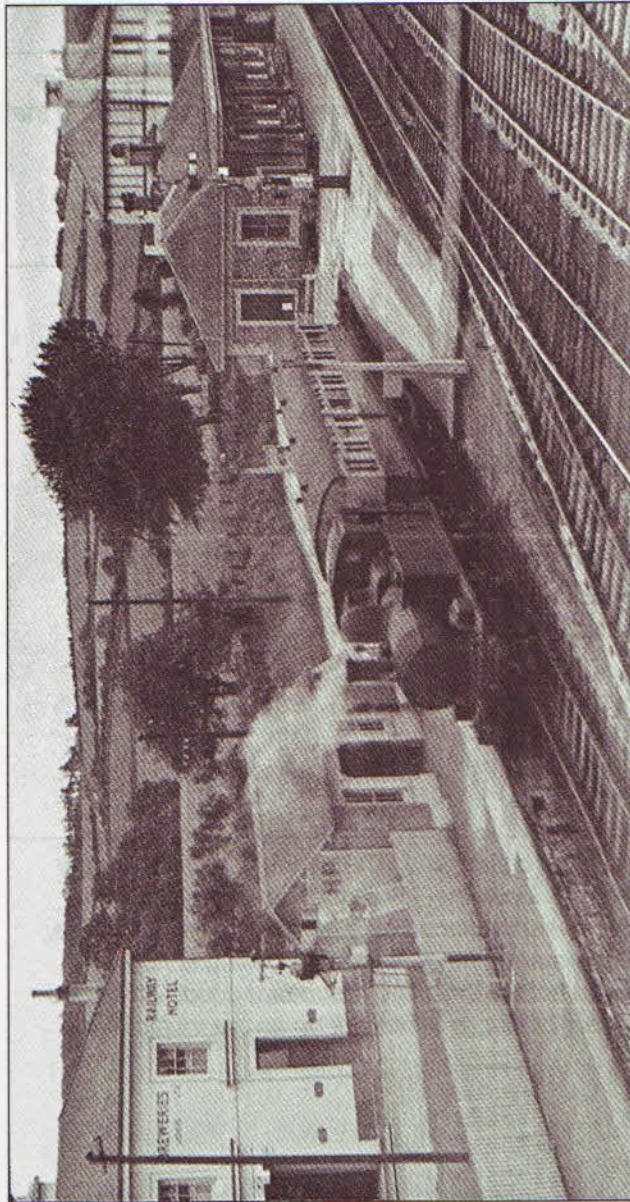

Figure 9/7 We now look at the various elements that were to be found around a small steam-age junction station. Here the station house is separate from the station building, and passengers are obliged to use a footbridge. A barrow crossing at the end of the platform allows luggage and other goods to be wheeled across between trains; as this is close to the signal cabin, it is easy for the porter to check with the signalman that he has time to make the movement. There is a shelter for passengers on the far platform, while a small shed, possibly brick-built but more probably of corrugated iron construction, contains drums of paraffin oil and a greasy bench where the signal lamps are cleaned, refilled and maintained.

A single-track engine shed is provided for the branch locomotive. We shall be looking at this facility in Chapter 11; in the meantime note that the water tank also serves water cranes on both platforms.

The extensive goods yard has, as well as the goods shed, a row of coal bins, a coal office and a weighbridge. These will be dealt with in Chapter 10. The grounded coach body serves as a staff messroom, while the platelayers' hut holds their tools secure and acts as a bothy. It is probable that a platelayers' trolley would be located here.

The cattle dock is on the opposite side of the station, leading to some complex shunting movements. This dock is an important feature on any steam age station; up to 50 years ago the true butcher had his own slaughterhouse, and those who bought dead meat from an abattoir were termed 'purveyors'. The exchange siding is provided to ease transfer of goods wagons between the branch and the main. Alternatively, it could act as a carriage siding.



Churston station had the Brixham branch bay platform as an extension of the main down platform. The Brixham train, a '14XX' 0-4-2T with a single auto-coach trailer, stands waiting for passengers from the main line in this 1949 view.

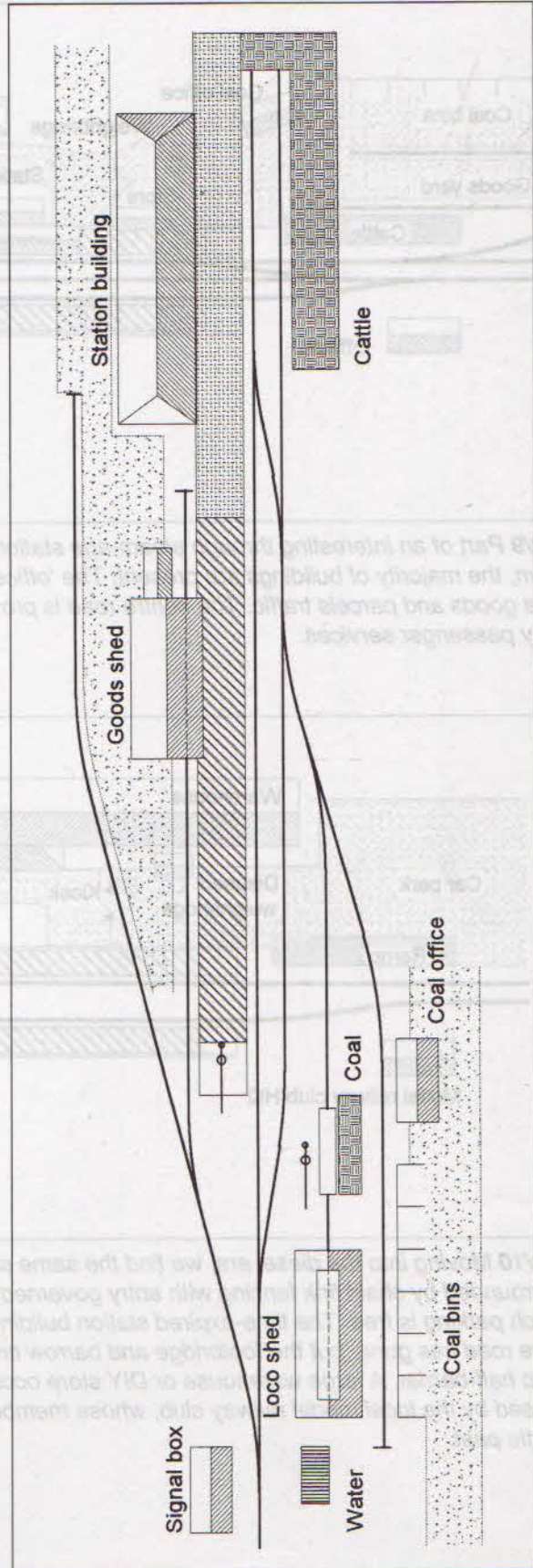

Figure 9/8 This compact steam-age branch terminus introduces the deliberate snarl by setting the coal siding on the opposite side of the station from the goods yard. Similarly the cattle dock is a separate feature. Goods shunting will therefore get a trifle complicated, adding to the operating interest.

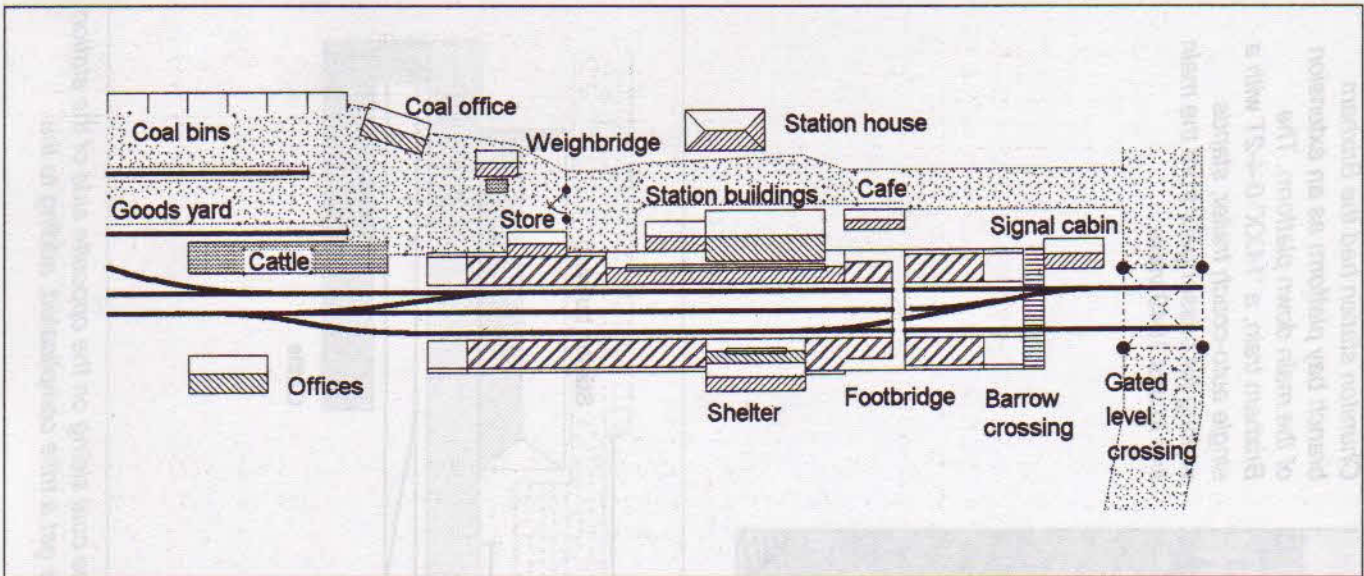

Figure 9/9 Part of an interesting through steam-age station serving a large town. While the full arrangements are not shown, the majority of buildings are present. The 'offices' are a late addition to accommodate staff handling the extensive goods and parcels traffic. The centre road is provided primarily to hold goods trains which are being looped by passenger services.

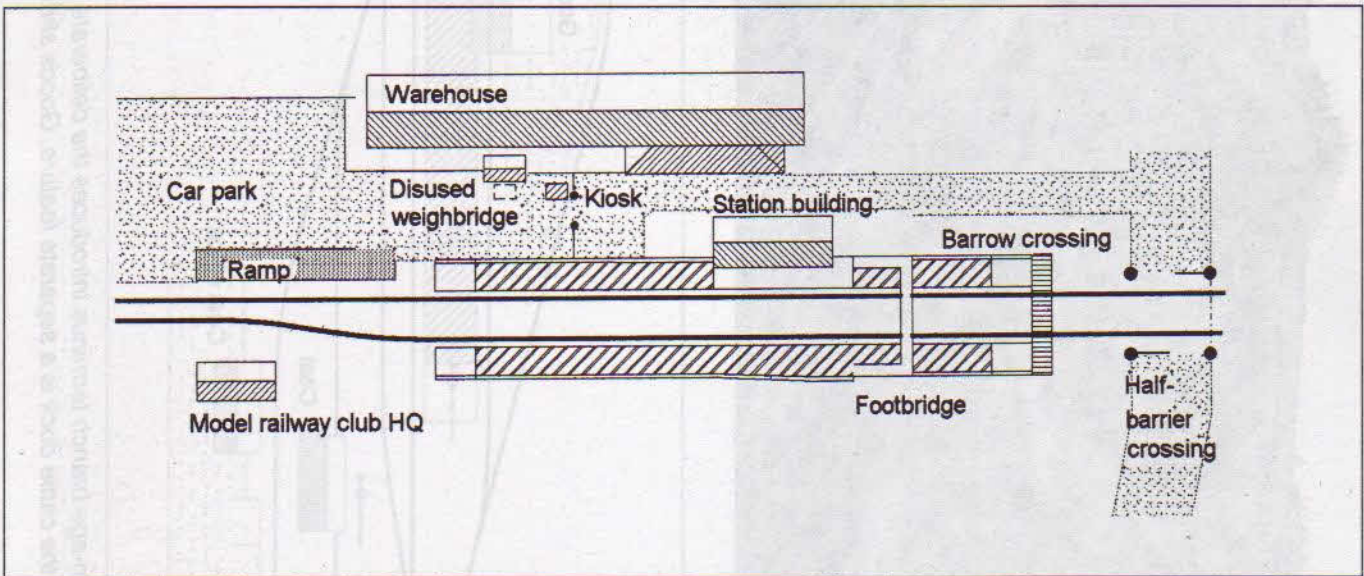

Figure 9/10 Moving into the diesel era, we find the same station sadly diminished. The goods yard is now a car park, surrounded by chain link fencing with entry governed by a small kiosk that is manned up to about 11 am, after which parking is free. The time-expired station buildings have been replaced by a more utilitarian structure, the centre road has gone, but the footbridge and barrow crossing remain. The gated level crossing is now an automatic half-barrier. A large warehouse or DIY store occupies part of the site. The redundant goods office has been leased by the local model railway club, whose members rarely bother to even look up as the multiple unit trains rattle past.

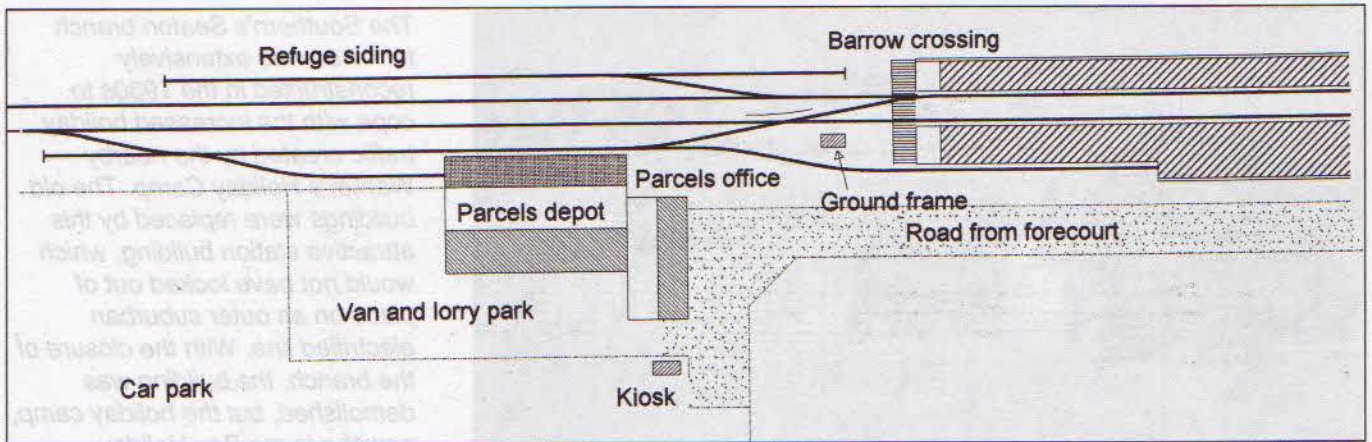

Figure 9/11 A diesel era through station need not be without sidings. This plan is based on the parcels depot at Hemel Hempstead, and the only omission is the fast tracks and the associated double crossover. Although the main tracks are electrified, current practice is for parcels services to be diesel-hauled.

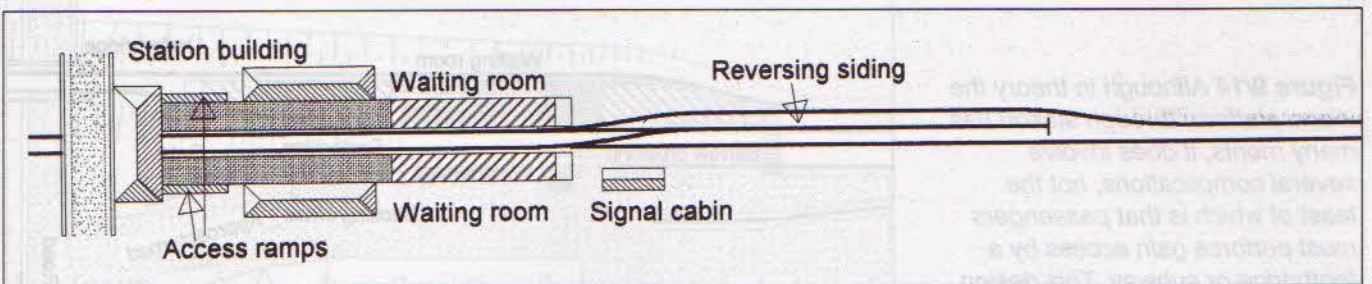

Figure 9/12 This particular arrangement for a central reversing siding is associated with multiple unit working, since reversing a loco-hauled set requires the provision of a run-round loop.

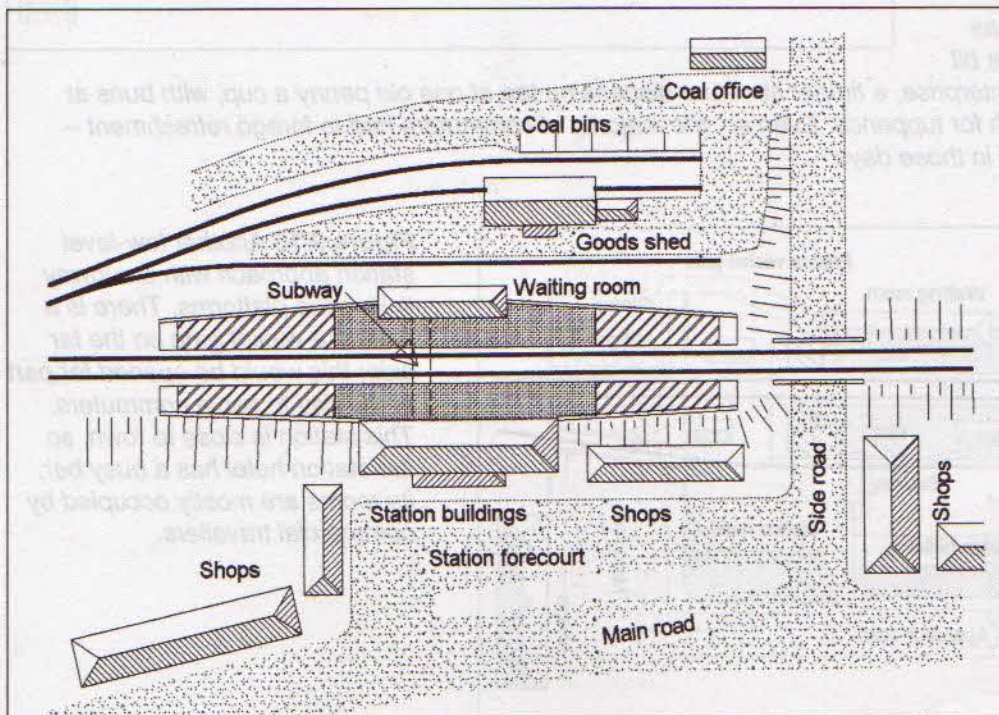

Figure 9/13 Passenger facilities at a busy steam-age outer-suburban station. I have shown a low-level road approach with the railway on an embankment, since this allows the lock-up shops lining the station approach to be below the rail level, giving viewers a clear line of sight on to the trains. This is a very important factor in successful scenic modelling – one should never let the sideline mask the real purpose of the model.



The Southern's Seaton branch terminus was extensively reconstructed in the 1930s to cope with the increased holiday traffic created by the nearby Warner's Holiday Camp. The old buildings were replaced by this attractive station building, which would not have looked out of place on an outer suburban electrified line. With the closure of the branch, the building was demolished, but the holiday camp, now the Lyme Bay Holiday Village, remains.

Figure 9/14 Although in theory the island platform through station has many merits, it does involve several complications, not the least of which is that passengers must perform gain access by a footbridge or subway. This design represents one of those stations that are a good 2 or 3 miles away from the towns they 'served', hence the provision of a row of railwaymen's cottages as well as the station house. The café is a bit of between-the-wars private enterprise, a timber structure dispensing tea at one old penny a cup, with buns at the same price and a sandwich for tuppence. Even so, the majority of commuters had to forego refreshment – pennies were hard to come by in those days.

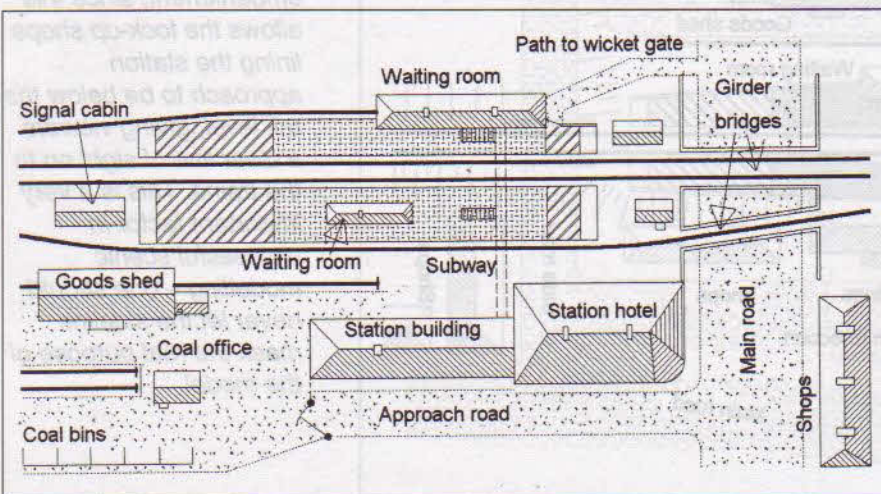
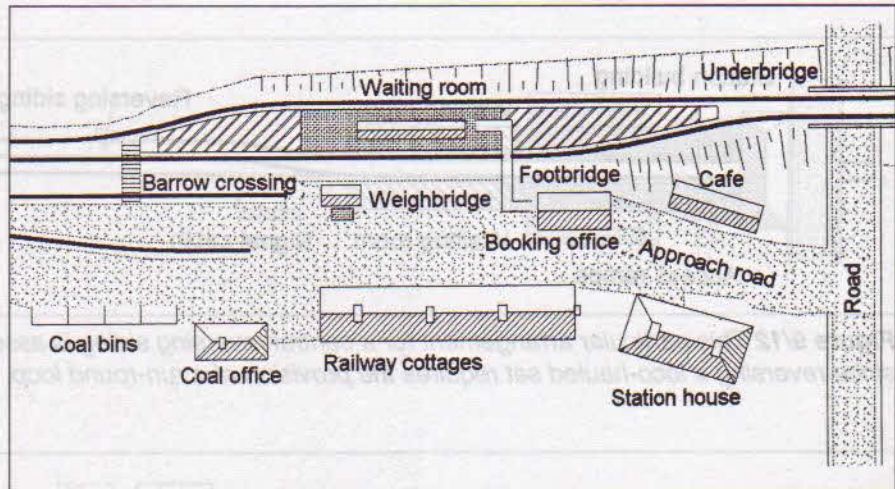

Figure 9/15 Another low-level station approach with a subway linking the platforms. There is a path to a wicket gate on the far side; this would be opened for part of the day to serve commuters. This station is close to town, so the station hotel has a busy bar; its rooms are mostly occupied by commercial travellers.

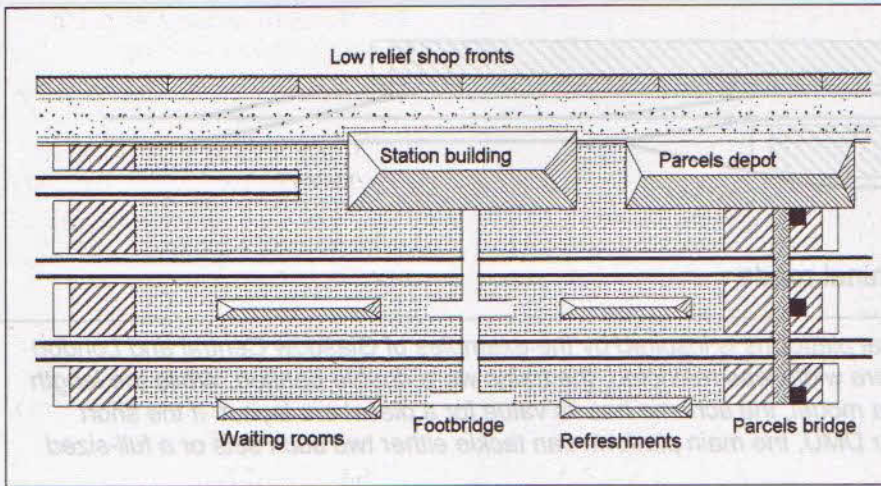

Figure 9/16 A large through station with fast and slow platforms and a set of short bays for local traffic. The parcels office is linked to the platforms by means of a separate overbridge with goods lifts. This facility would remain today, since the station is a Red Star depot.

Once a popular feature on the exhibition circuit, 'Leominster' has gone into retirement. It was a good example not only of a model closely based on a busy prototype, with ample variation in its operating pattern, but also of a large four-platform station. The unusual raised signal cabin is a faithful replica of the prototype.

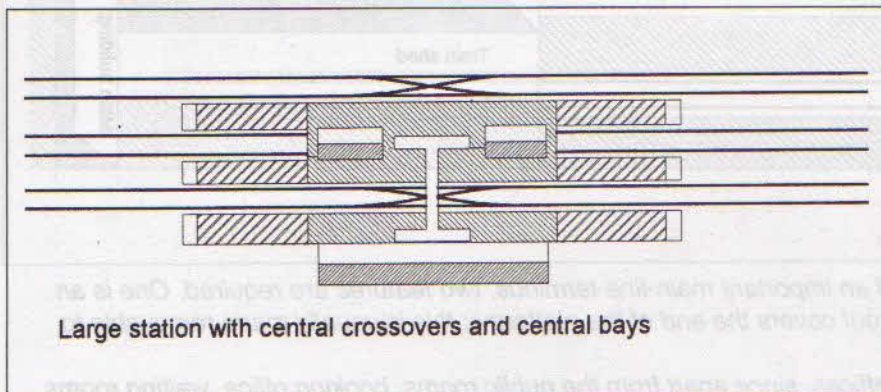
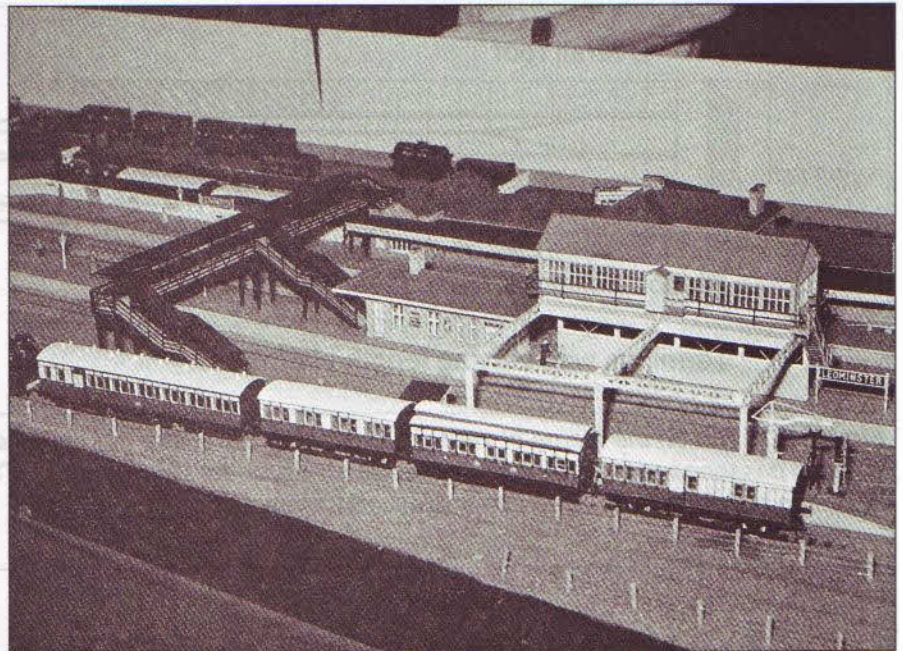
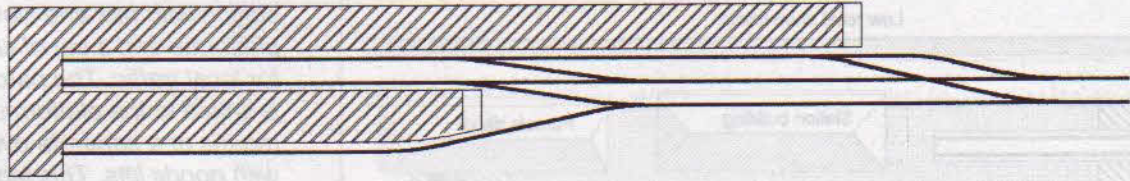
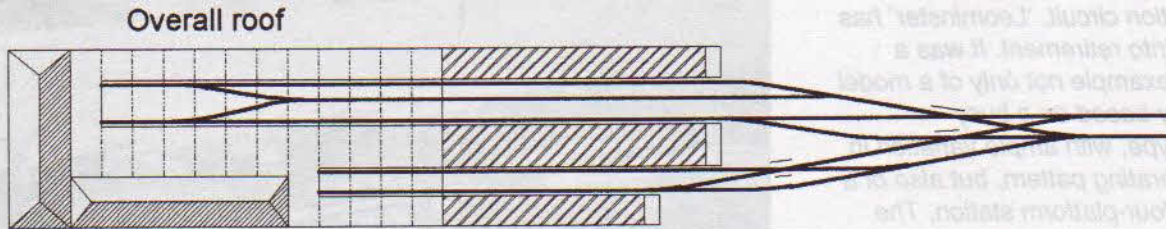

Figure 9/17 This is more a pipe-dream than a realisable model, since the platforms are long enough to hold two trains on either side of the scissors crossovers, while the terminal bays will hold sizeable rakes as well. As the core of a large club tailchaser, this arrangement has something to offer.



Two-train capacity terminal roads

Figure 9/18 This arrangement of terminal platforms is inspired by the examples of Glasgow Central and London Victoria where, to increase capacity where width was restricted, the trains were double-banked. While the length involved might seem to rule this out for a model, the scheme has its value for a diesel era layout. If the short platform is set out for a three- or four-car DMU, the main platform can tackle either two such sets or a full-sized HST unit.



Station buildings

Terminus with varying length platforms

Figure 9/19 Still on the theme of variable-length terminal roads, we have here a station with two long platforms for express passenger workings and two shorter roads for the local services. This allows space for an impressive set of station buildings to be fitted into a relatively narrow site.

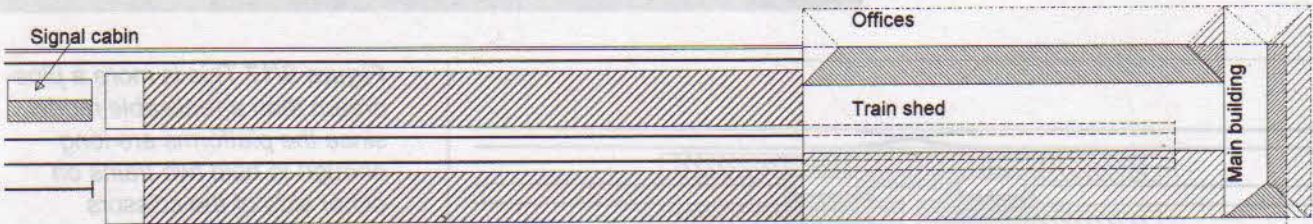

Figure 9/20 To provide the impression of an important main-line terminus, two features are required. One is an impressive train shed, where an overall roof covers the end of the platforms; this is usually made removable to ease uncoupling.

Even more important are the station offices, since apart from the public rooms, booking office, waiting rooms, refreshments and toilets, there will be extensive offices for the railway staff, and these require a good deal of space if modelled in the round. The same visual results can be achieved by modelling the sides facing the platforms in low relief; the amount of space saved is considerable, while there is less modelmaking involved.



Many small termini had quite elaborate station buildings, with either offices or living accommodation above the waiting rooms, ticket and parcel offices and porters' room. Here a single island platform provides sufficient accommodation for a moderately intensive service.

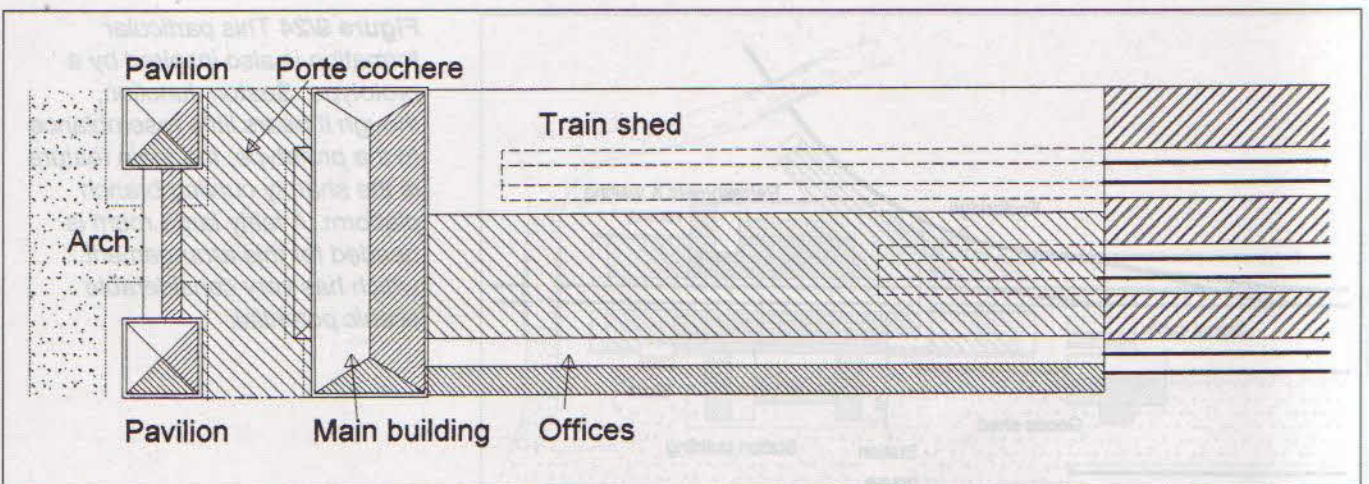

Figure 9/21 Here we go to the other extreme, with an extremely elaborate set of buildings incorporating a triumphal arch, a pair of pavilions and a porte cochere where carriages can set down their occupants under cover. Clearly, not only would this be a major modelling project in its own right, but will also take up a lot of space. This is where the exhibition-oriented layout can score. In its normal home the model will end where the train shed stops; the booking offices, porte cochere, arch and pavilions are forgotten and a simple flat facade substituted. Meantime the buildings, which form an impressive model in their own right, are built to fit on to the end when the layout is on show in a public hall, where another half metre is always available to display an interesting model. In the club context, the resident architectural modeller (there usually is at least one) can spend many happy hours at home creating his masterpiece while the others get on with constructing the layout.

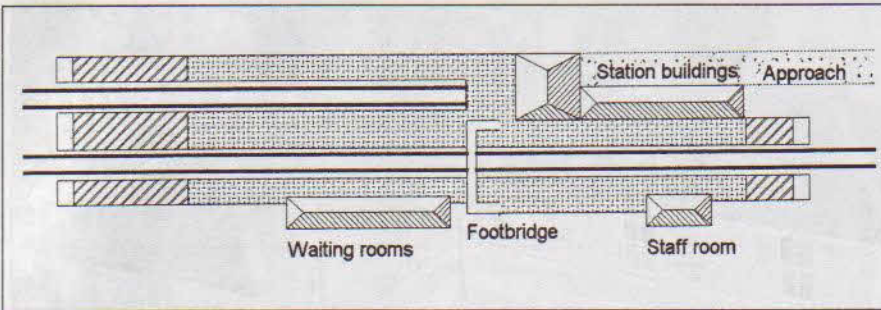

Figure 9/22 The through terminus is a useful design, either in its own right or as part of a larger system. When the terminal roads can be kept short, there is room for a small complex of station buildings as mentioned earlier.

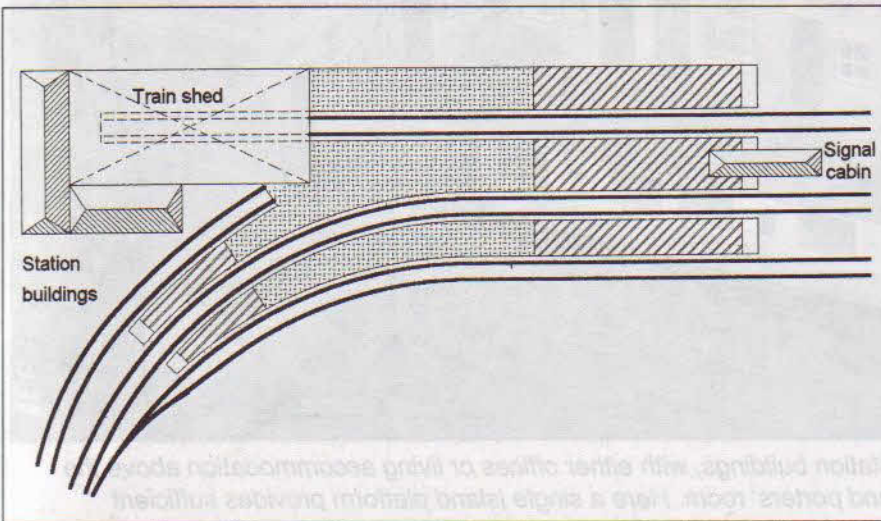

Figure 9/23 This arrangement of through and terminal tracks is one of my favourites. Inspired by, rather than based on, Bristol Temple Meads, before the old station was closed to traffic and partially demolished, it allows one to concentrate all the workings of a medium-sized layout into one impressive station, since the inner through road can be arranged to reverse trains. We will see this more fully realised in a later chapter.

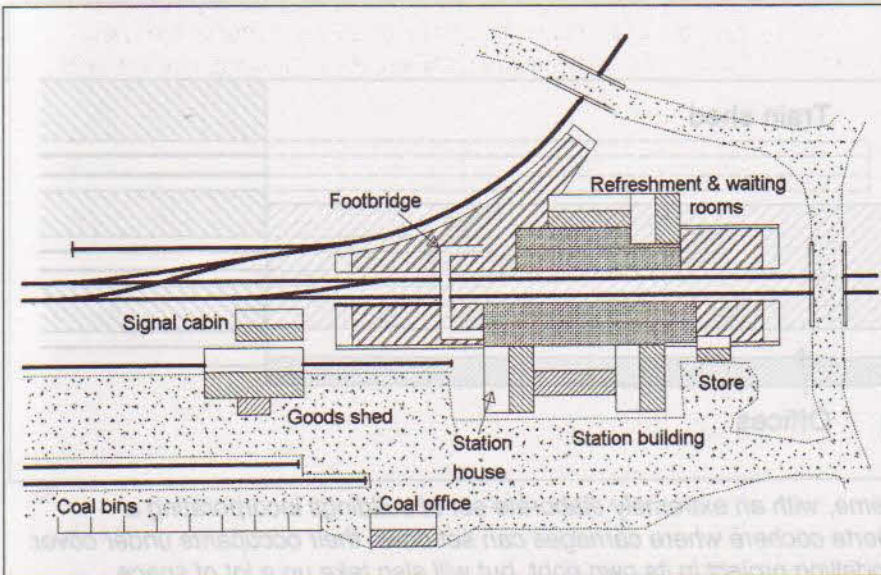

Figure 9/24 This particular formation is also inspired by a prototype, Seaton Junction, though it bears little resemblance to the prototype; the main feature is the sharply curving branch platform. A fairly large room is needed for this arrangement, which has very considerable scenic potential.

Chapter 10

Goods yards

Most steam-age stations had a goods yard, comprising one or more sidings to deal with the freight traffic, but today only a handful of specialised sidings remain in use. The following diagrams show some of the more common arrangements.

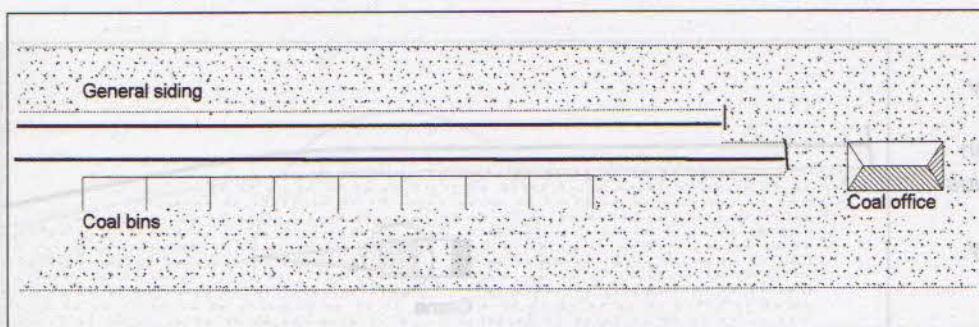

Figure 10/1 Coal was the most significant traffic in the steam age, since in addition to powering the locomotives, it also provided heat and, indirectly through the local gasworks, light to the home. While some industries – notably the local gasworks – had their own sidings, the bulk of the coal was distributed, by horse and cart, from the coal yard. The main feature of the coal yard was the coal bins – often miscalled staithes – which were usually built from discarded sleepers. They stored the bulk of the coal, which was then bagged in hundredweight and half-hundredweight sacks for delivery to the user. A small office was provided for the clerk, who took the bulk orders, issued invoices and ordered the coal. The conventional arrangement of bins on the model is flanking the coal siding as shown, the idea being that the coal was unloaded directly into them.

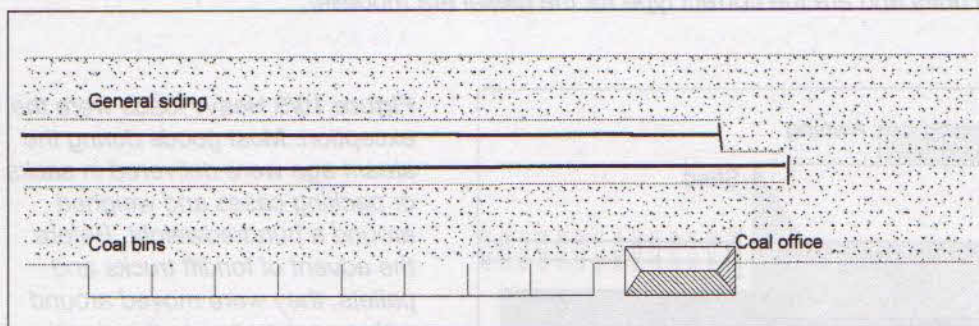

Figure 10/2 In practice the bins were as often as not on the other side of the yard. This also explains why so much coal was delivered in privately owned wagons rather than railway vehicles; when the wagons were owned by the coal merchant, they could be left on the siding and unloaded as required.

Coal was, and for that matter still is, weighed on specialised scales that are set to trip at the required weight, formerly 112 and 56 lbs (hundredweight and half-hundredweight), nowadays at 50 and 25 kg. The coal is shovelled into a large scoop until the scale trips, whereupon the scoop is released and tipped into the waiting bag. It was less effort to shovel the coal from the wagon directly into the scoop than to unload it on to the ground, then lift it again on to the scales. The bins were filled with surplus coal at slack moments and during summer months, acting more as a reservoir than a ready-use store.

Figure 10/3 The logical way to unload the 6 or more tons of coal in a wagon is to drop it out of the bottom into a pit. This is the current method with modern hopper wagons, but apart from the old North Eastern Railway, which used this method and supplied its own coal hopper wagons from the outset, the arrangement of coal drops found little favour. This is a pity since they do make a very effective model.

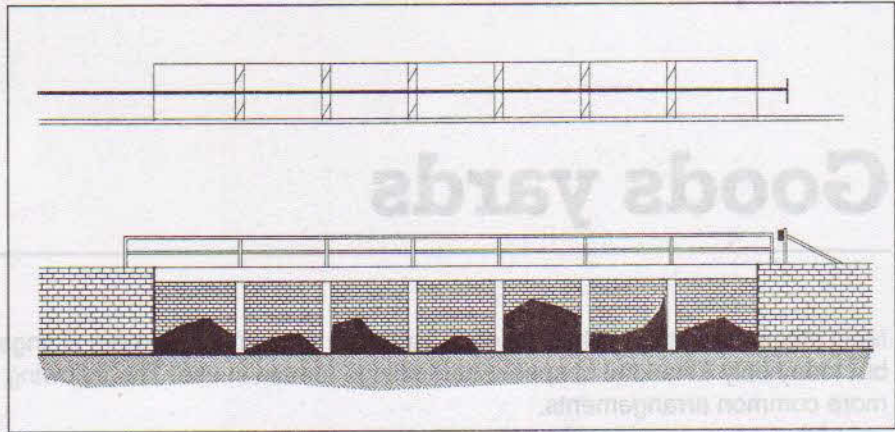
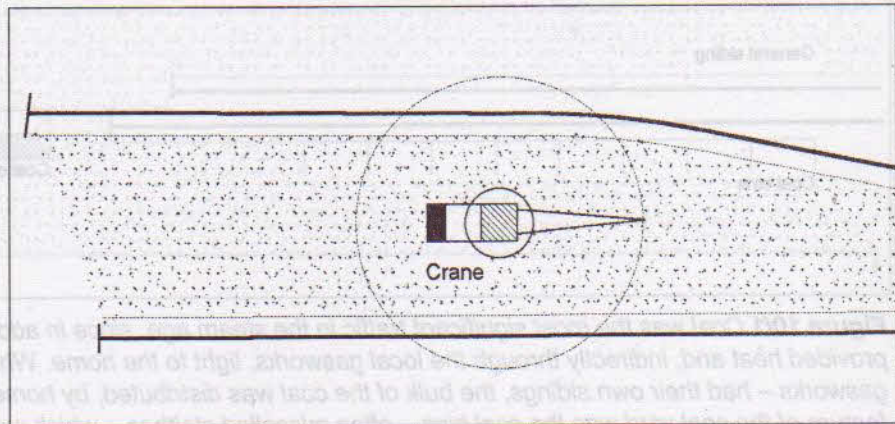

Figure 10/4 Some railway loads were bulky and too large to lift by hand. The yard crane was a common facility and many remain to this day. They had a fixed radius jib and were hand-operated by means of a geared winch. Ideally the crane was located so that it could readily swing over two adjacent tracks, lift the load and deposit it on to the waiting cart or lorry.



At the larger yards, power-worked cranes were provided.

Initially these were hydraulically powered, using a fixed installation with a separate pump-house and a hydraulic accumulator. By the turn of the century electric power came into favour. However, this type of crane was only found in the large city yards. I'll deal with this later.

In recent years the wheel has turned full circle and hydraulic cranes are once again commonplace, but these are generally self-propelled road units and are the correct type for the diesel era modeller.

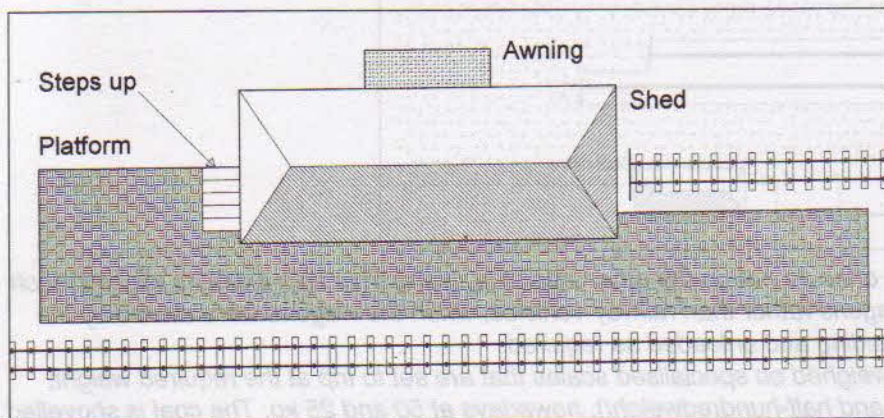
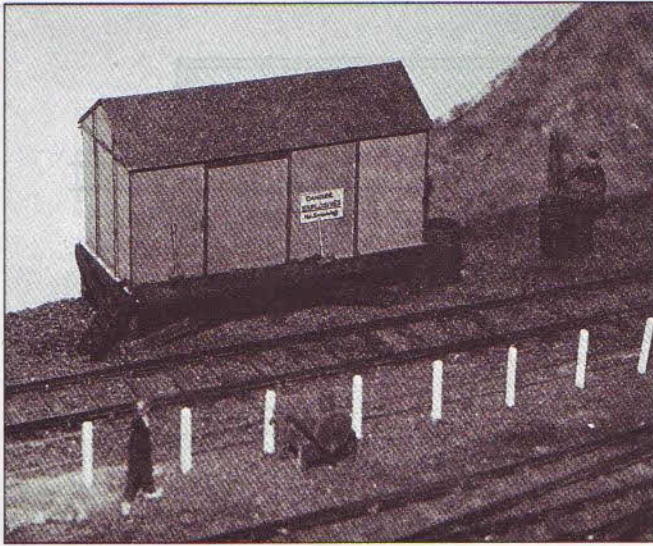
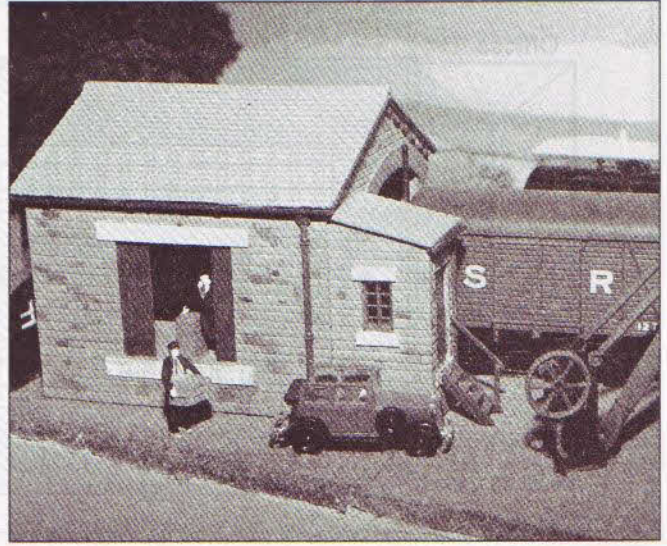

Figure 10/5 Heavy loads were the exception. Most goods during the steam age were delivered in sacks or packing cases and weighed around a hundredweight. Before the advent of forklift trucks and pallets, they were moved around with a sack trolley, to this day the most effective method of moving a moderately heavy load by hand with minimal cost. This required the provision of a raised loading bank, which flanked the railway track on one side and had a cart or

lorry loading facility on the other. The merchandise could then be simply wheeled across. A secure shed for overnight storage was usually provided so that merchandise that was not collected the same day could be secured from thieves.



The gunpowder store on Geraint Hughes's model based on the Cromford & High Peak Railway. Industrial explosives were once a common traffic on the railways, usually conveyed in iron vans. This was not to contain a possible explosion, but because wooden stock soon became saturated with loose powder and became so highly flammable that a single spark could start a fire, and steam locomotives provided plenty of sparks. Most gunpowder vans were based on the GWR 'Iron Mink' van of the 1880s.



'New Inglebrook' boasts a small goods shed. A very small shed indeed, it can only hold one wagon, while the lean-to office is extremely cramped. This is a case of modelling the spirit rather than the letter of the prototype.

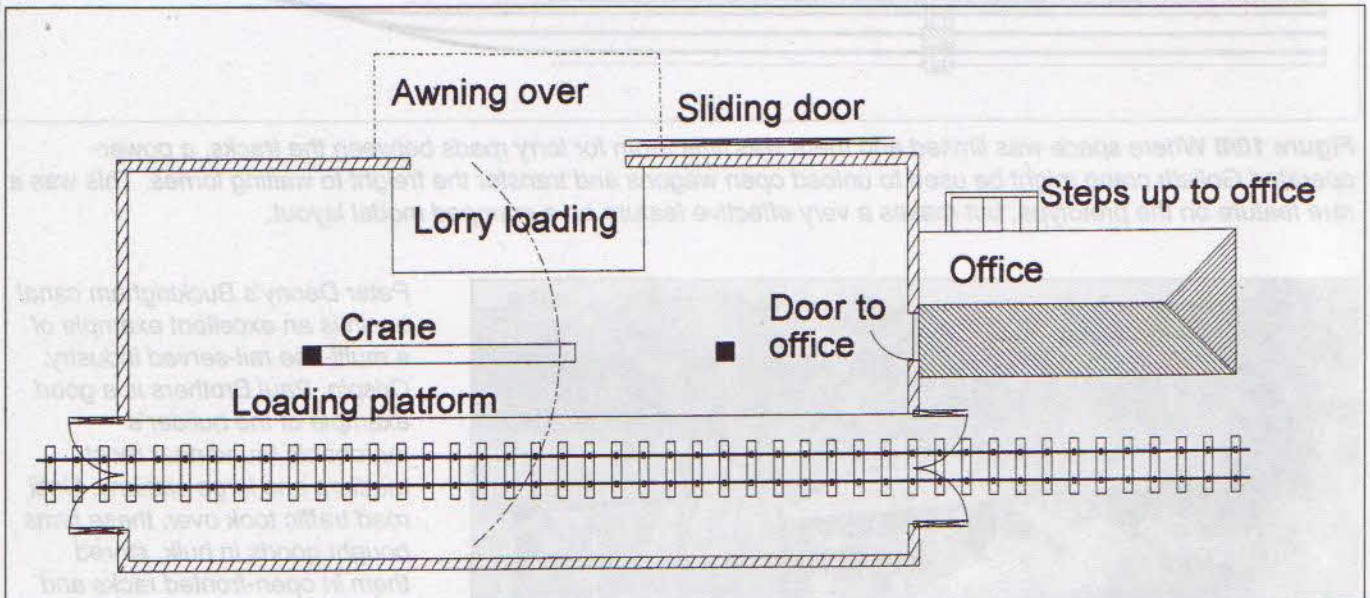

Figure 10/6 Security was taken a stage further by the traditional over-track goods shed. Here all loading and unloading took place under cover, and the entire building could be secured with heavy doors. Towards the end of the steam age these doors were usually left open, more from lack of maintenance than from a fall-off in dishonesty. There was often a simple crane pivoted from one of the central roof supports, while lorry loading frequently incorporated a small inset in the raised platform so that the tail end was under cover; this was to protect the merchandise rather than the workers.

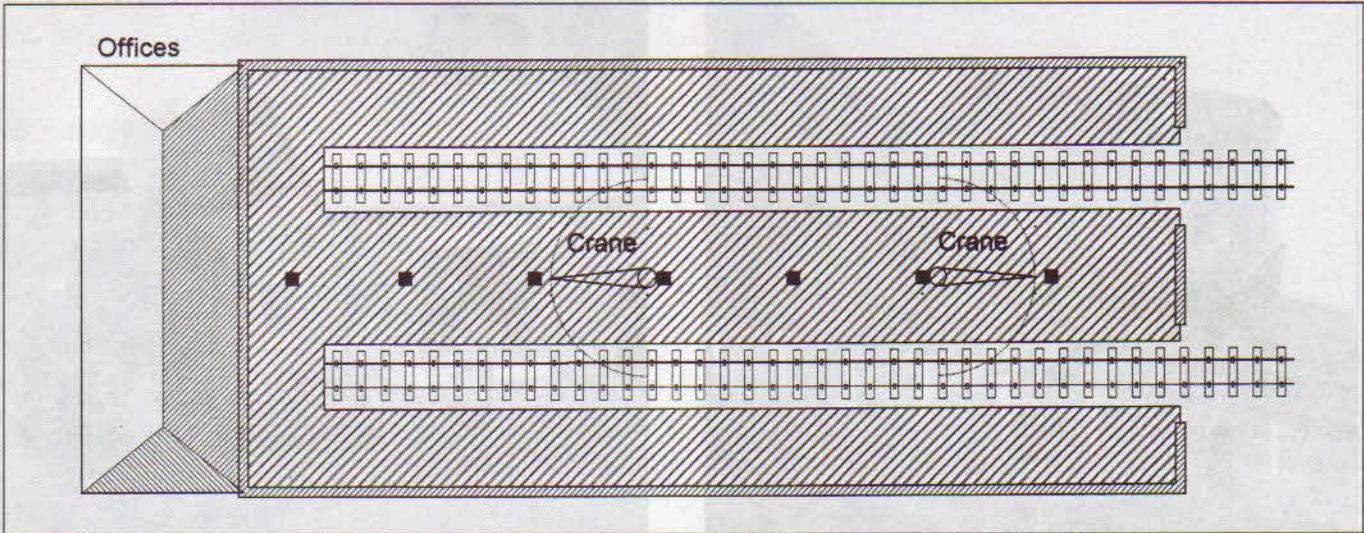

Figure 10/7 At major stations, merchandise traffic was dealt with in large sheds with raised platforms on either side of the tracks. Several cranes were provided, usually electrically operated. Much mechanical assistance was provided, but as everything took place under the roof of the shed, all this detail is completely hidden on a model. This type of large goods shed makes a useful adjunct to a busy city station and lends itself to simplified operation, since one simply runs complete cuts of wagons out of sight, to collect them later.

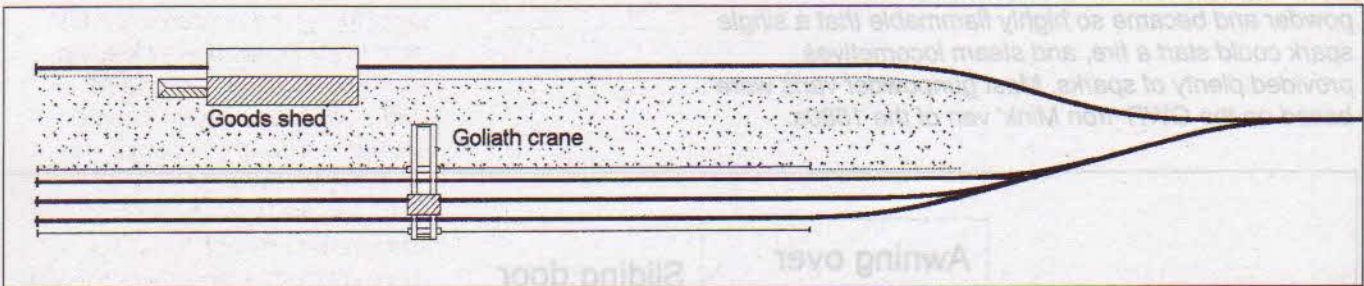
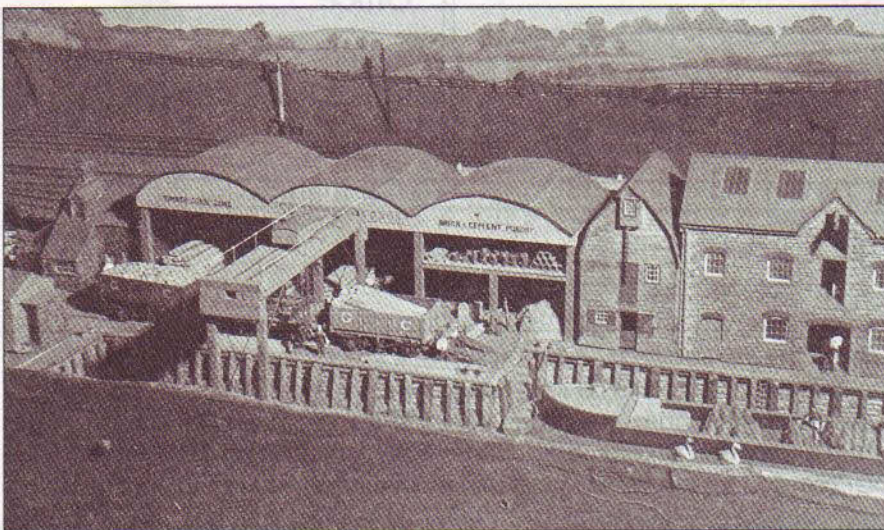

Figure 10/8 Where space was limited and there was little room for lorry roads between the tracks, a power-operated Goliath crane might be used to unload open wagons and transfer the freight to waiting lorries. This was a rare feature on the prototype, but makes a very effective feature on a cramped model layout.



Peter Denny's Buckingham canal basin is an excellent example of a multi-use rail-served industry. Crispin, Paul Brothers is a good example of the builder's merchants found near most medium and large stations. Until road traffic took over, these firms bought goods in bulk, stored them in open-fronted racks and distributed them in small lots to local builders and householders. Frequently, the firm sold coal and coke as well. Note the overhead crane.

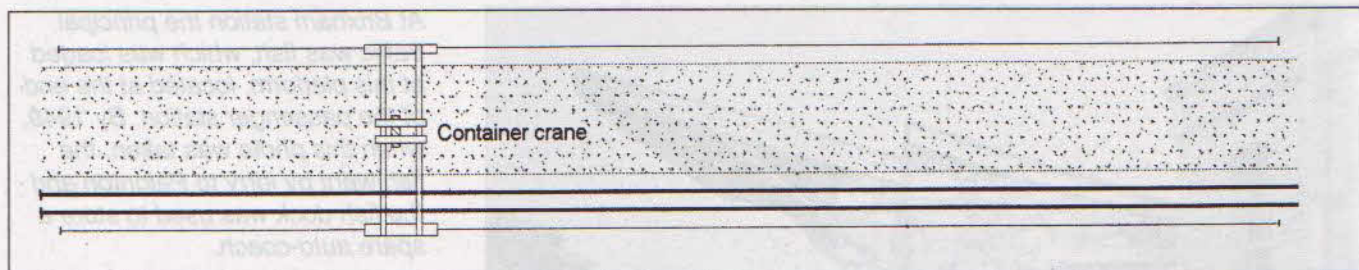

Figure 10/9 Modern container traffic takes the principle of the Goliath crane to its logical conclusion. The specialised container cranes are more massive, since they are designed for a much heavier lift, but the principle remains the same.

Hornby produced a working container crane, which was manually operated and called for a good deal of care in its use. It should be possible to make an electrically operated model, but although the mechanics are reasonably straightforward, precision craftsmanship is essential if it is to function at all reliably.

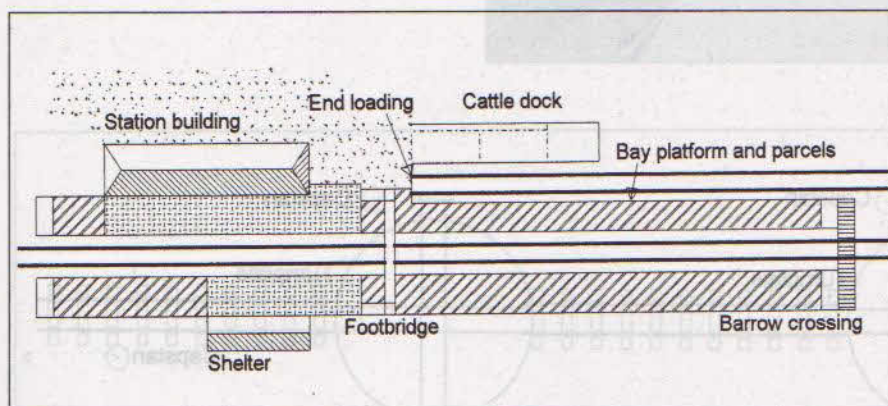
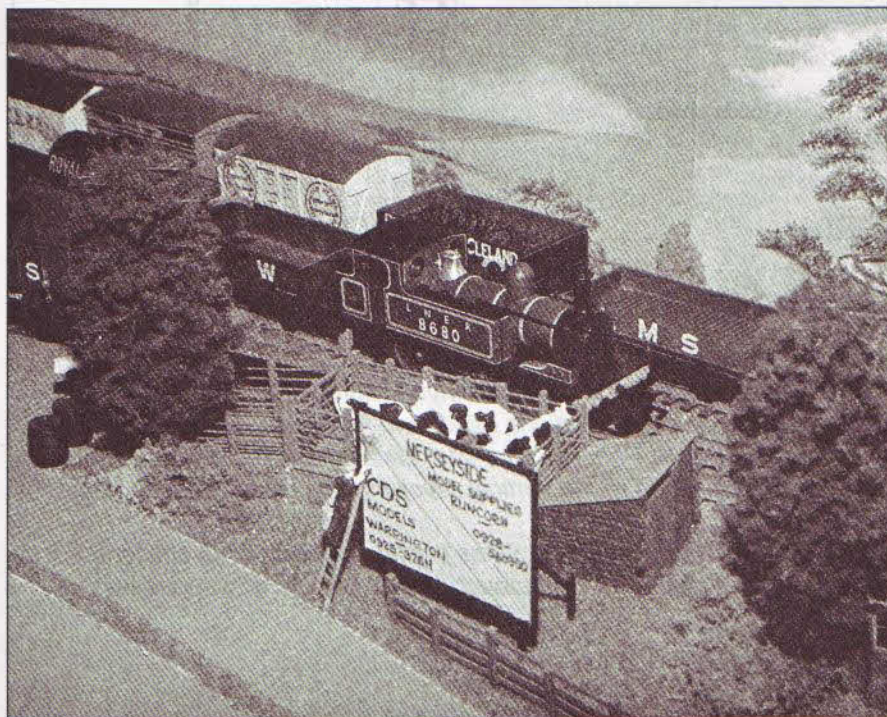
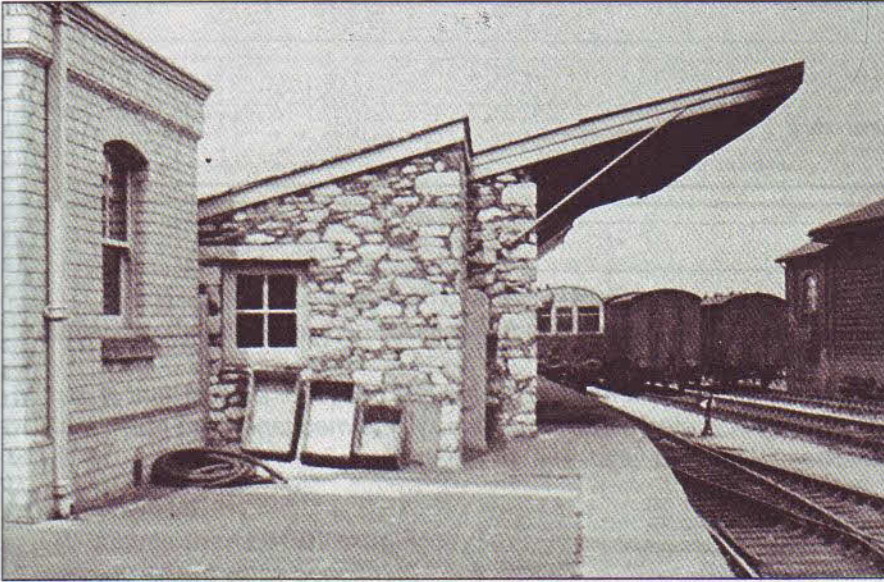

Figure 10/10 I have already mentioned cattle traffic, once an important part of goods working. The raised dock was sub-divided into pens, each with a door on the rail side that corresponded to the doors on the cattle trucks; this provided some degree of control over the animals during loading and unloading. Rail-borne cattle traffic ceased abruptly when more stringent regulations concerning watering and rest periods were enforced, leaving this traffic to road transport, which is much more difficult to regulate. This is a case where well-meant regulations have had the opposite effect to that intended.



After Alan Wright sold the original 'Inglenook Siding' he rather regretted its loss, so another was built, a mirror image of the first. The scenic arrangements were different and rather more loading facilities were provided than on the original. Here we see the cattle dock, just large enough to handle a single cattle wagon.



At Brixham station the principal traffic was fish, which was loaded at this platform, located at the end of the passenger station. By 1949, when this photo was taken, the fish went by lorry to Paignton and the fish dock was used to store a spare auto-coach.

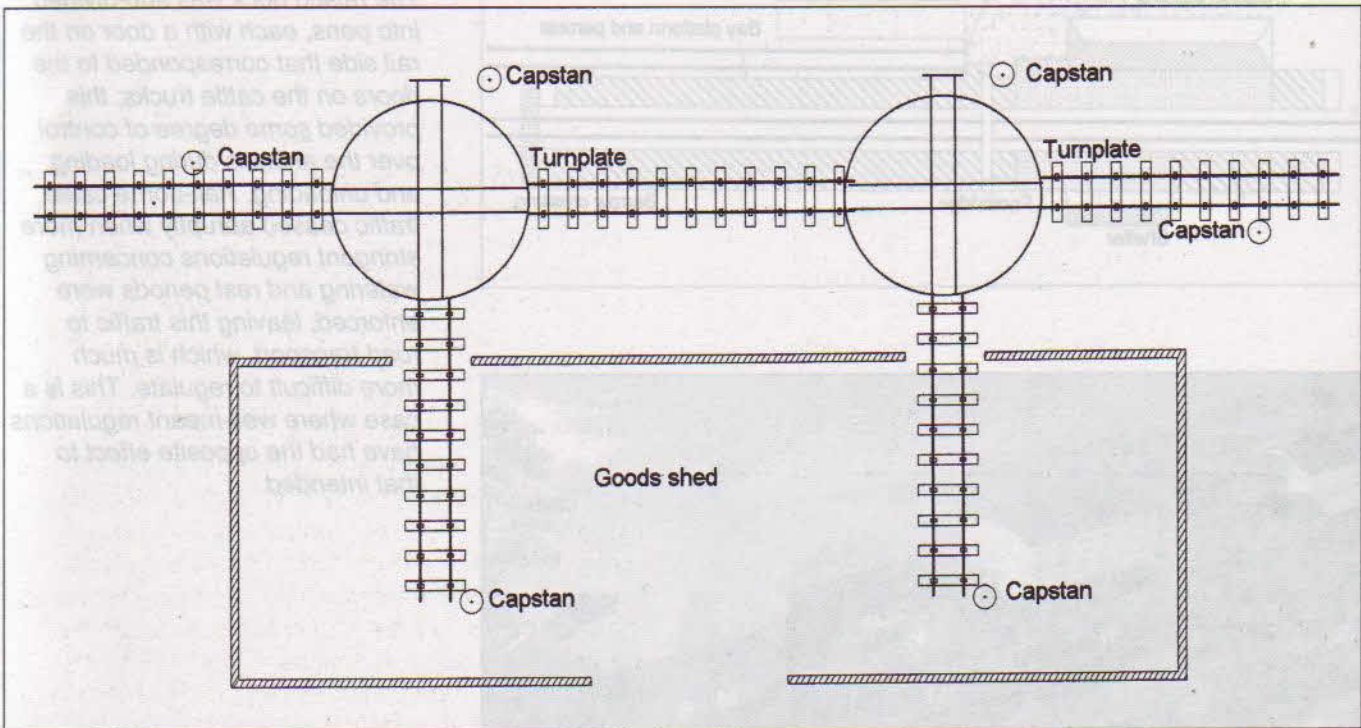

Figure 10/11 The wagon turntable or turnplate was an important feature of early rail layouts, but fell into disuse around the 1890s. However, some remained where space considerations ruled, and there was even a new coal handling yard equipped in this fashion built in the 1950s at St Pancras. The later installations relied on capstan power for shunting, the wagons being moved by ropes passed round vertical revolving spindles. Modern safety regulations would rule this out.

From a modelling viewpoint, a capstan-worked yard with wagon turnplates poses a considerable challenge. It is not impossible – I've seen two examples in operation at exhibitions – although the movement of wagons was effected by other means.

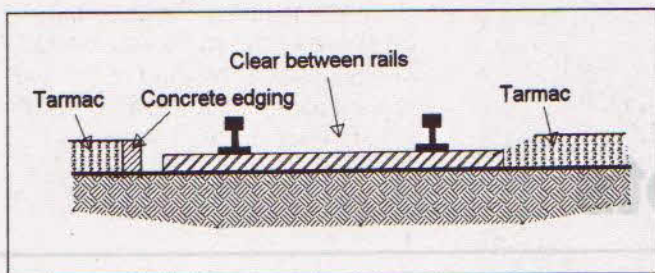

Figure 10/12 Goods yards are always provided with metallised surfaces between the tracks so that carts and lorries can drive alongside the wagons. In the majority of cases this is plain tarmac brought up to the edge of the sleepers; concrete block edging is sometimes provided.

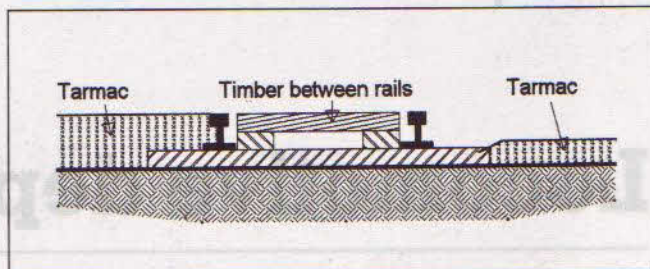

Figure 10/13 Where the road needs to cross the tracks, the tarmac is brought up to rail level, and in most cases timber balks are laid between the rails; occasionally timber is laid outside the rails as well, but there is no hard and fast rule about this.

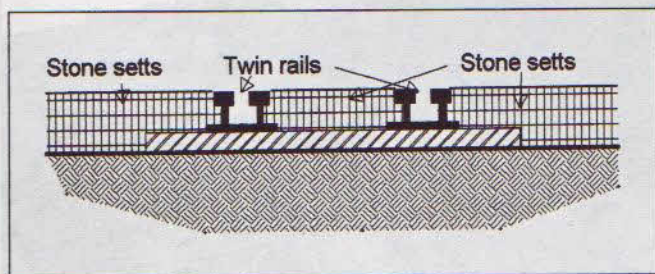

Figure 10/14 At quaysides and alongside warehouses, inset tracks are common. Here inner checkrails maintain the flangeways and, in the older installations, the tracks were inset with stone setts.

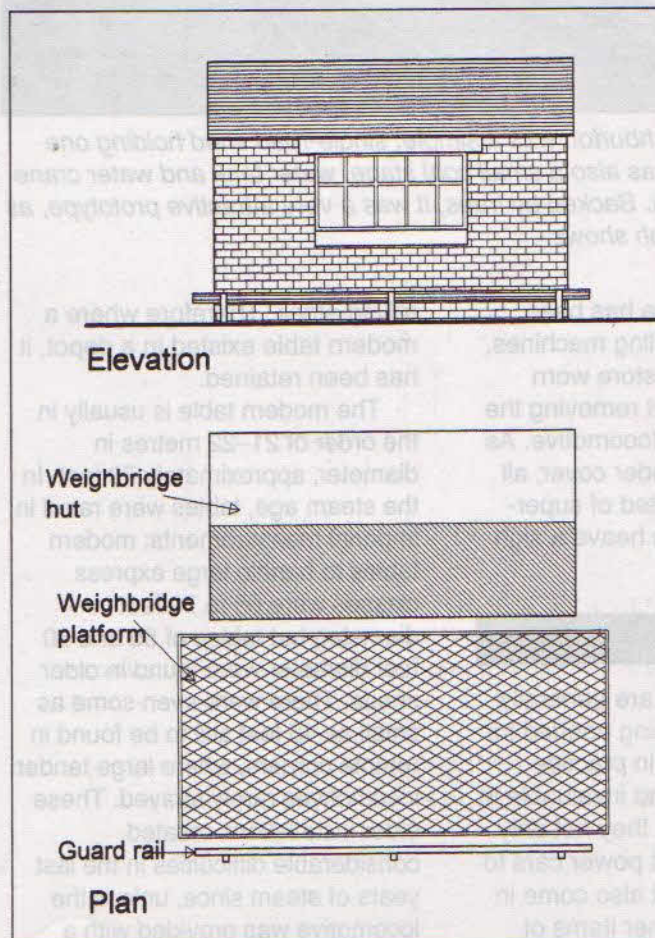

Figure 10/15 Before we leave the goods yard, a word about the weighbridge. This is provided so that carts or lorries can be weighed empty and loaded to determine the weight of the goods delivered. The weighbridge is often available for public use at a suitable fee.

The older mechanical weighbridge had its cast-iron platform balanced on a series of levers, each delicately poised on hardened steel knife-edges. A carelessly applied load could jolt the table off its pivots; this not only involved an expensive visit from the maker's fitter, but a recalibration by the local Weights & Measures Officer. Hence many mechanical weighbridges are protected from sideways loading by a low rail-built barrier. The modern weighbridge, mounted on one or more load cells, is more robust but looks much the same as the traditional designs. In both cases, the mechanism is underground and the dials or indicators housed in a small, substantial building.

Wagon weighbridges were to be found near mineral depots, and were used for weighing wagons empty and full. Frequently locomotives were barred from travelling across the bridge, which was usually only capable of taking loads up to 20 tons. Modern load-cell devices are less delicate. Initially, weighing was static, but after a century's solid experimentation, it is now possible to weigh individual wagons on the move, and this facility is employed in the 'merry-go-round' coal carriage systems at mines and power stations.

Chapter 11

Locomotive depots

Locomotive sheds, or, to give them their correct name, motive power depots (MPDs), are an important part of any railway system since it is here that the day-to-day maintenance needed to keep the machines in good working order is carried out. Once plentiful, the advent of dieselisation has reduced their number while increasing their size and importance. Although on a model railway maintenance is carried out on a workbench, the provision of a loco shed is regarded as all but essential. This is less so with a diesel era model, which in view of the size of even a modest diesel MPD, is just as well.

The shed

Paradoxically, the one feature of an MPD that most modellers regard as essential, the shed itself, is in practice the least important. Although it is believed that its main function is to provide all-weather protection, the most important purpose is the maintenance of the machines. The shed usually houses a well-equipped workbench and tool store, together with an inspection pit to allow work to be carried out underneath. The larger steam depots had a full machine shop, often including a wheel lathe in addition to the centre lathes, drilling machines and other machine tools found in general engineering works.

Diesel depots have a different set-up, since much maintenance is done on a unit replacement basis,

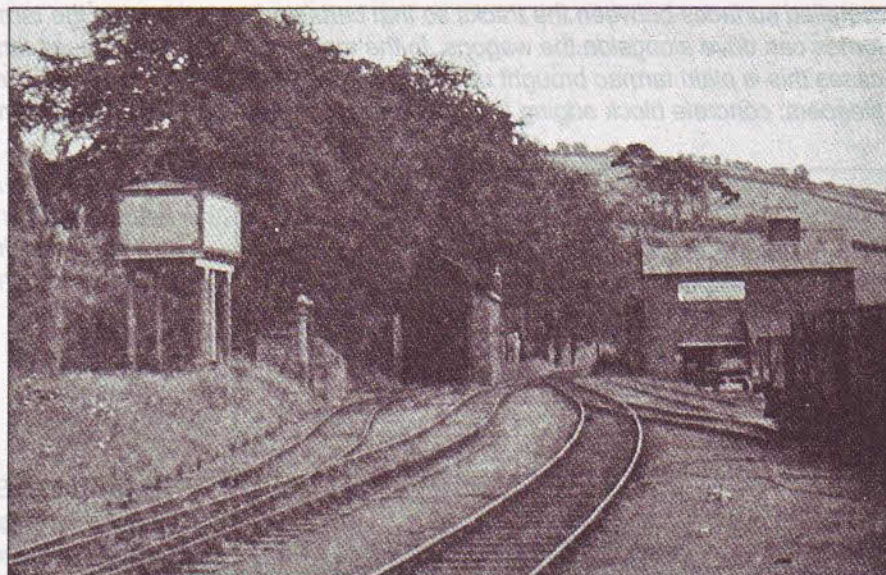

The sub-shed at Ashburton was a simple, single-road shed holding one locomotive; there was also a small coal stage, water tank and water crane built into a low bank. Backed by trees, it was a very attractive prototype, as this 1949 photograph shows.

while the wheel lathe has been superseded by profiling machines, which are able to restore worn wheel treads without removing the wheelsets from the locomotive. As this equipment is under cover, all but the most dedicated of super-detail modellers can heave a sigh of relief.

Turntables

Although turntables are generally regarded as only being needed for steam locomotives, in practice they have been found invaluable in diesel depots, since they not only enable single-ended power cars to be turned about, but also come in useful for turning other items of

rolling-stock. Therefore where a modern table existed in a depot, it has been retained.

The modern table is usually in the order of 21–22 metres in diameter, approximately 70 feet. In the steam age, tables were rated in imperial measurements: modern tables to handle large express classes were 65 to 70 feet in diameter, but tables of 55 and 60 feet diameter were found in older sheds. There were even some as small as 45 feet still to be found in remote corners, where large tender locomotives rarely strayed. These older installations created considerable difficulties in the last years of steam since, unless the locomotive was provided with a

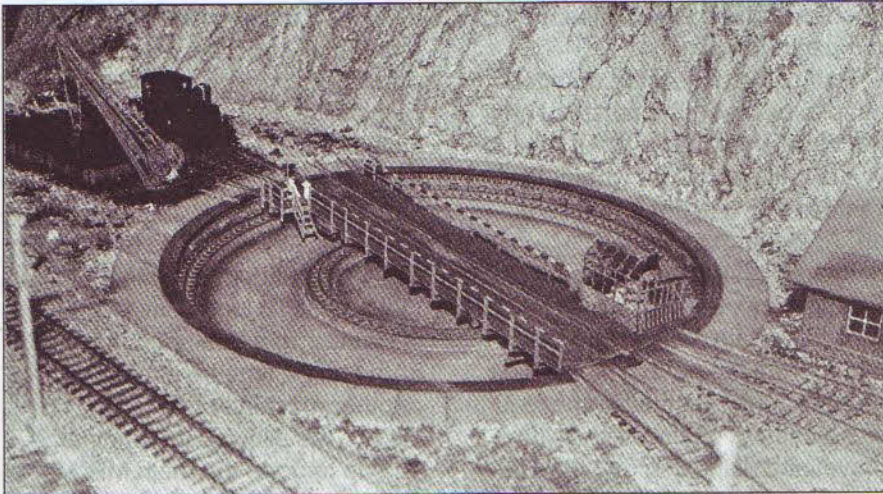

Turntables, an essential feature of the larger steam-age shed, not only need a lot of space, they are difficult to motorise if more than one road is involved. One answer is the Fleischmann turntable, which provides accurate indexing around the entire periphery – at a price. Although based on a German prototype, it has been successfully Anglicised. In this instance, on a model of Vallorbe station, Switzerland, it is at home, even though not strictly conforming to the table on the prototype.

A simpler solution, used by many railway modellers, is a manually operated table, using a worm drive. Meccano is still the favoured source of gears and housing, but the small parts are less easy to find these days.

tender cab, it was not regarded as suitable for reverse running. Apart from anything else, at anything above a slow jog-trot, the crew were smothered in coal dust blown back at them by their backward motion.

Refuelling

All locomotives need refuelling. Diesels are straightforward: a high-capacity fuel hose only has to be connected to the tank filler and the pump switched on. The same arrangement applied to the few oil-fired locomotives, but coal was another thing altogether.

Like all solid fuels, coal is easily stored in an open heap. However, it is easily stolen from such heaps, hence the practice of whitewashing coal stacks – it didn't stop theft, but it showed when it happened.

Getting the coal from the heap into the tender or bunker of a locomotive is the difficult part. The simplest arrangement was a raised

platform on to which coal was shovelled directly from a wagon. It would then be loaded into baskets, which were lifted up and emptied

into the bunker. On better-equipped depots a small crane was provided to lift a larger skip. Occasionally, a grab crane was provided.

Gravity coal loading was soon arranged. Initially this took the form of a raised ramp up which coal wagons were pushed, with a large shed at the top, provided with railed skips that were loaded directly from the wagon and wheeled across to be tipped into the locomotive's bunker.

The elevated coal bunker over the track was a more modern arrangement. This was usually filled by lifting the whole wagon on a special cage that tipped it over at the top of the run. The substantially simpler arrangement whereby the coal was dumped into a low-level hopper and taken to the main hopper by a bucket chain was surprisingly rare in Britain.

Today, preserved steam is usually coaled by means of a portable bucket loader, but it is not unknown on the smaller lines for this job to be carried out by volunteers, using the primitive basket system.

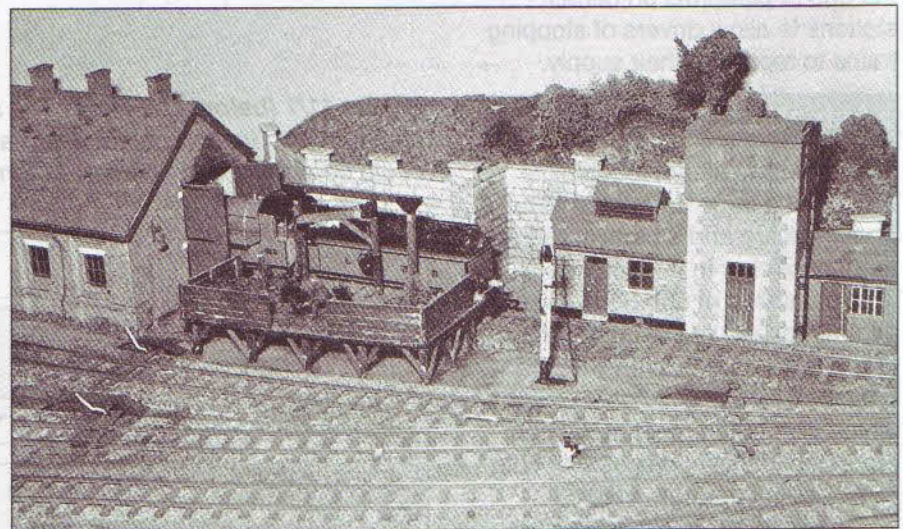

The basic arrangement of shed, coal stage and water is shown here in model form. The coal stage is possibly a shade large for a single-engine shed and is provided with a hand-operated gallows crane for loading. The water tank forms part of a small array of storehouses and offices. The shed is wide, with ample space for workbenches and enginemen's mess on the near side.

Water

The steam locomotive requires prodigious quantities of water, an express locomotive needing up to 40,000 litres each working day. The tender tanks, which rarely held above 18,000 litres, needed frequent refilling. This was carried out in two ways, by means of water troughs – almost exclusively a British device – or by means of the water crane. The latter consisted of a pivoted large-bore pipe ending in a large leather hose, which was dropped into the tank through a large filler hole. The crane was fed from a very large high-level tank, which was in turn refilled from the main supply. As the feed pipes were around 250 mm (10 inches) in diameter, the flow was extremely rapid and if the driver was not quick enough with the stop valve, the fireman got a soaking; this is why the driver worked the stop valve! The only good point was that a soaked fireman could dry off fairly easily in the cab.

Water cranes were provided at the end of platforms on certain stations to allow drivers of stopping trains to replenish their supply.

Ash and char

The coal-fired steam locomotive produced a large amount of ash under the fire and a considerable amount of char in the smokebox. This consisted of unburnt fuel and ash carried out of the firegrate by the fierce draught. Even with the later 'self-cleaning' smokeboxes, which distributed most of the char along the lineside, disposal of char remained a chore on shed.

These by-products needed to be removed regularly, usually after as little as 8 hours work. If the ashpan was over-full, air could not get to the grate and the locomotive lost steam. If char built up, the

tubeplate could get overheated and begin to leak.

Ash could usually be dumped into pits between the rails, but char had to be shovelled out. As the fire was usually still alight when this was done, it was not a pleasant job. At the larger sheds mechanical means of disposal were to hand, usually some form of bucket chain that carried the ash up from the ashpit into waiting open wagons. At smaller sheds it was a case of getting down with a shovel and disposing of the stuff with the help of wheelbarrows.

Sub-sheds

Locomotives are allocated to specific depots, which are then responsible for supplying the necessary motive power to work the section of railway for which they are responsible. With diesel and electric locomotives, which do not require a lot of tinkering to keep them working, the depot is able to send machines to the more remote corners of its district and let the driver take care of the chores.

Steam locomotives required more mollycoddling, so it was the practice to provide small sheds at convenient locations that were satellites of the main depot and known as sub-sheds. The locomotives held at these depots were officially allocated to the main MPD, and although it might appear that a specific locomotive was 'allocated' to a sub-shed, it would from time to time be exchanged for another machine of the same class. This allowed the original engine to go to the main MPD for a general check-over by the depot's fitters and boilermakers. Whenever possible, these minor overhauls took place before serious trouble arose; often the exchange was the direct result of a serious fault being detected in the original machine.

Because sub-sheds were small and simple, they are the favoured prototypes for modellers. As we shall see, a complete MPD, whether steam or diesel, makes a large model in its own right. For a locomotive builder, or an ardent collector, such a model has a very real attraction.

Figure 11/1 (below and right) The sub-shed for a single locomotive was a characteristic feature of the steam-age branch line. The main elements could be arranged in a variety of forms.

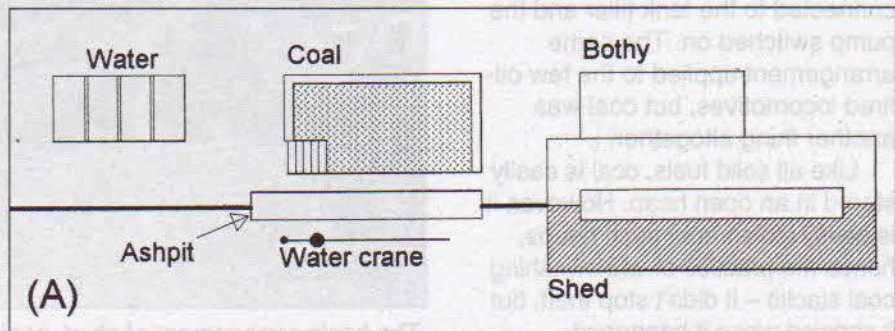

A The basic shed for use with tank engines. The ashpit is alongside the coaling stage, as is the water crane, while an inspection pit is hidden inside the shed. The bothy is a lean-to appendage that could be a mess room for the crew, or a small fitters' workshop.

B The addition of a turntable permits tender engines to be turned to run smokebox-first. It is located before the shed so that it may be used without the need to enter the building, which might already be occupied.

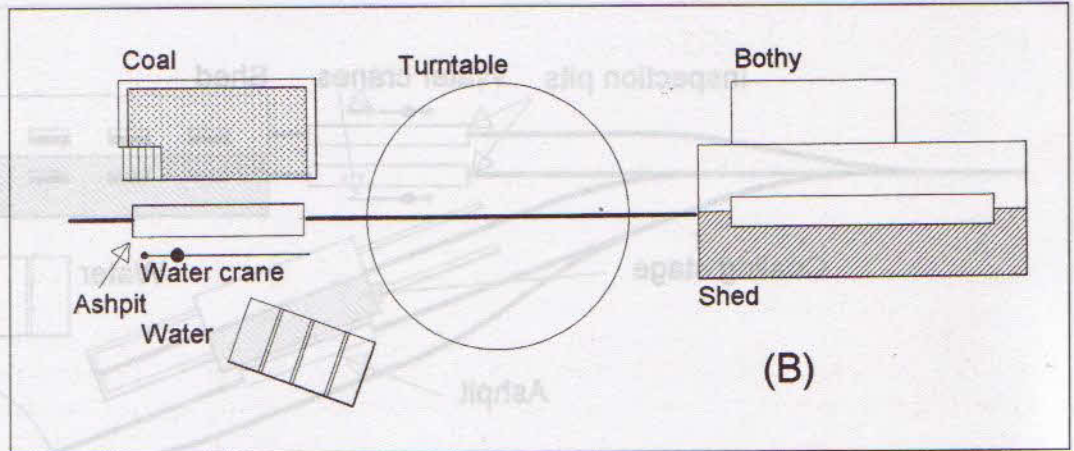

C Occasionally the shed was angled off the turntable – Swanage is a case in point. This is extremely convenient for the modeller, as it allows the sub-shed to be fitted neatly into a corner.

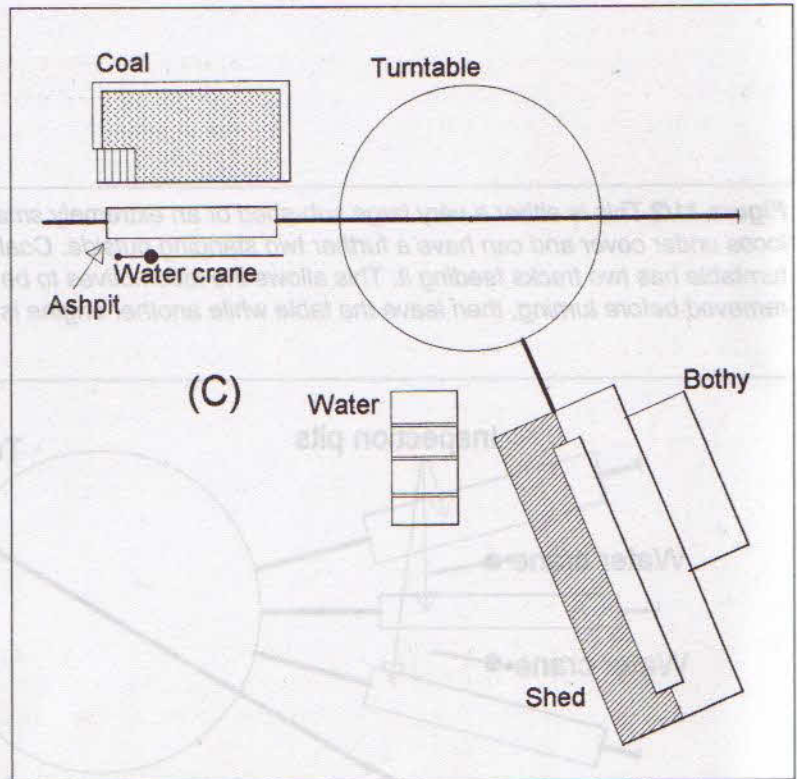

D An avoiding road could be provided so that a loco can get to the turntable without passing through the shed.

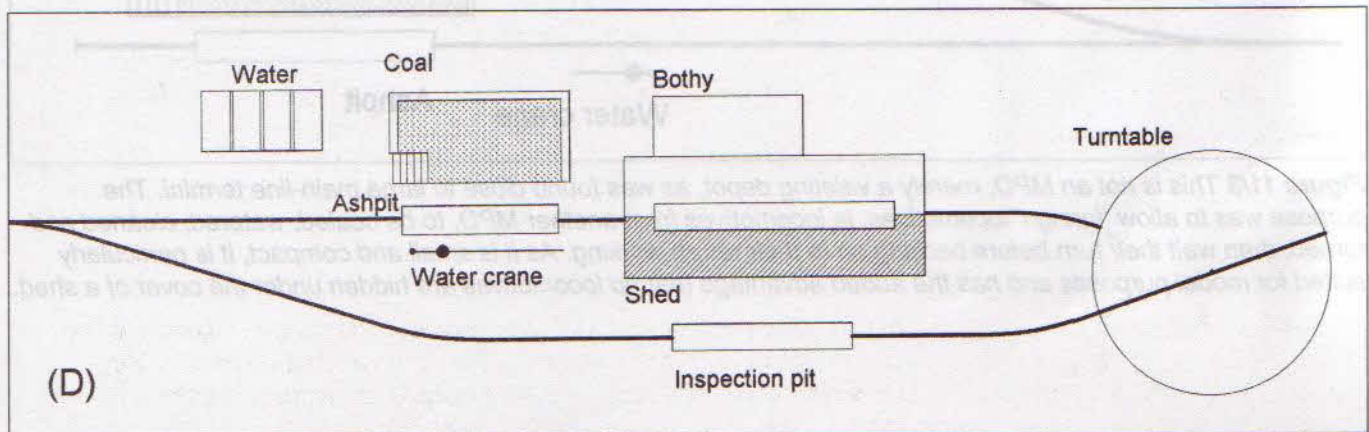

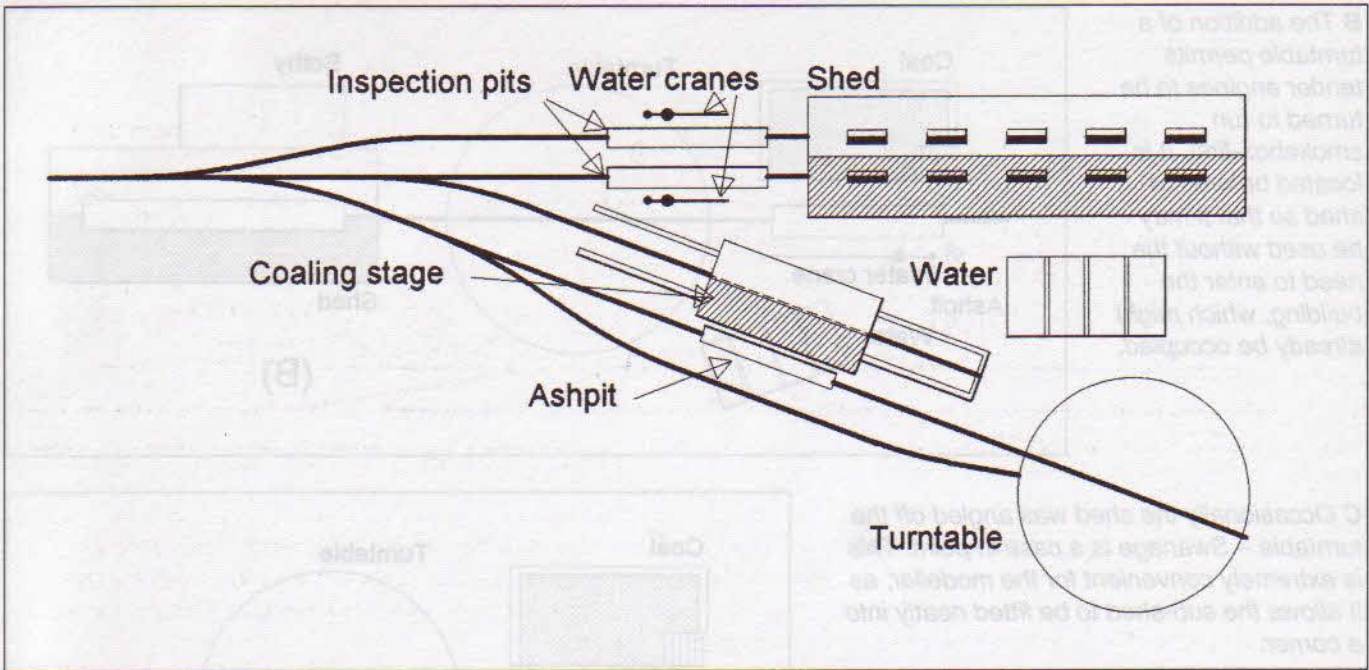

Figure 11/2 This is either a very large sub-shed or an extremely small loco depot. The shed accommodates four locos under cover and can have a further two standing outside. Coaling is by means of a raised shed, while the turntable has two tracks feeding it. This allows the locomotives to be coaled, watered and have their ash and char removed before turning, then leave the table while another engine is being attended to.

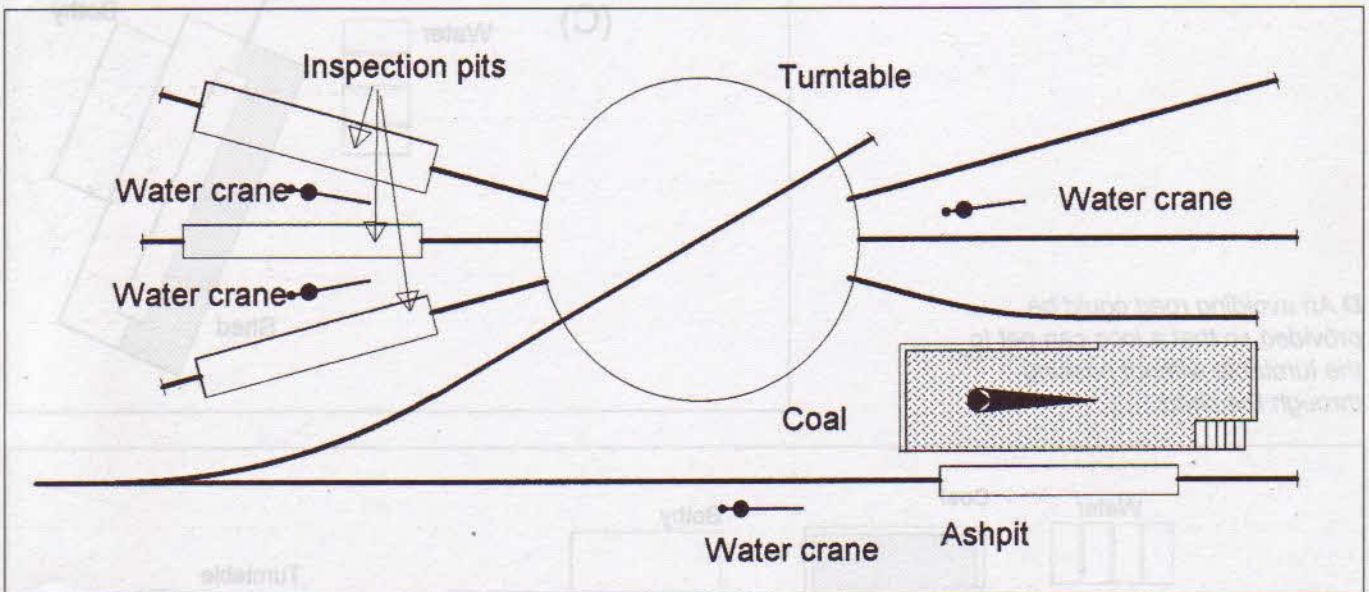

Figure 11/3 This is not an MPD, merely a valeting depot, as was found close to large main-line termini. The purpose was to allow 'foreign' locomotives, ie locomotives from another MPD, to be coaled, watered, cleaned and turned, then wait their turn before backing on to their return working. As it is small and compact, it is particularly suited for model purposes and has the added advantage that no locomotives are hidden under the cover of a shed.

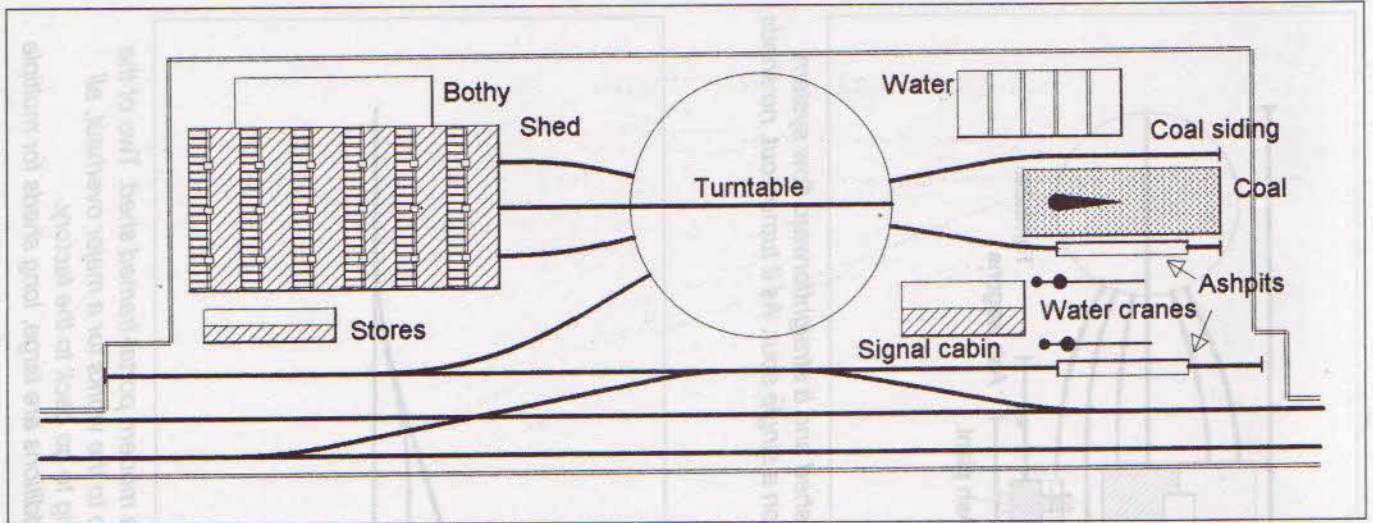

Figure 11/4 This arrangement for a small shed is loosely based on a former depot at Carlisle. While strictly speaking a roundhouse shed, since all roads are accessed by the turntable, it looks like a regular rectangular shed. This arrangement is more common on model railways for precisely the same reason that it was adopted here: sheer lack of space for the turnout entry to a standard shed.

Figure 11/5 The true roundhouse shed has radial stalls set around a turntable. Although widely adopted in the rest of the world, this type of shed has rarely found favour in Britain. Its main disadvantage in model form is the relatively large amount of space required.

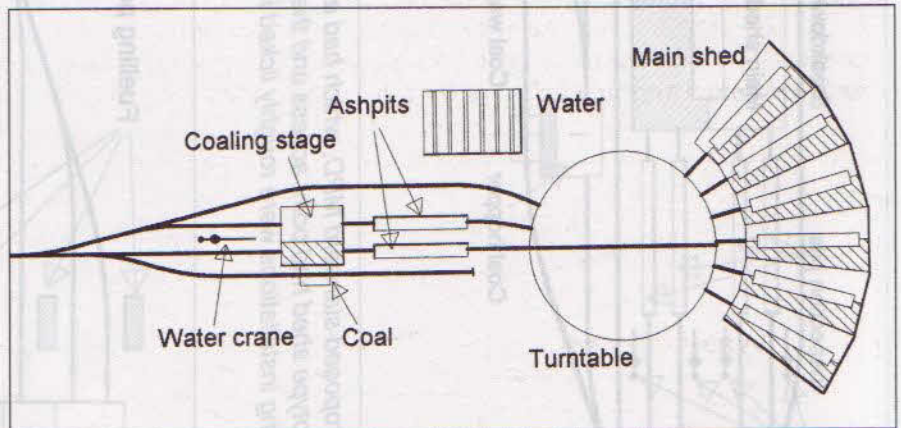
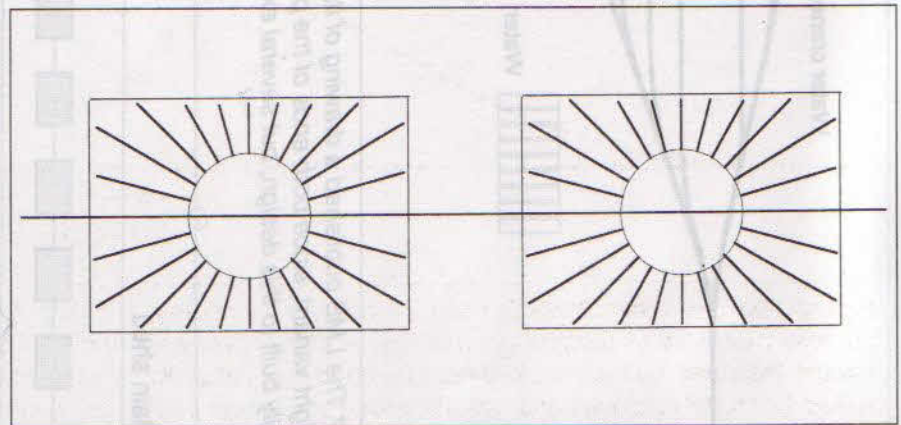

Figure 11/6 Although the true roundhouse shed is rare in Britain, the enclosed rectangular 'roundhouse' shed was fairly common. The design is extremely old; the London & Birmingham shed at Camden, now The Roundhouse, originally had its turntable in the centre of the circular building. However, rectangular sheds were preferred, as the roof is a more straightforward proposition. The layout of this type of shed can be seen at York Railway Museum, which was originally the York MPD; however, the present roof is new. The design does not lend itself to modelling, since it is impossible to see what is going on unless the roof is removed.



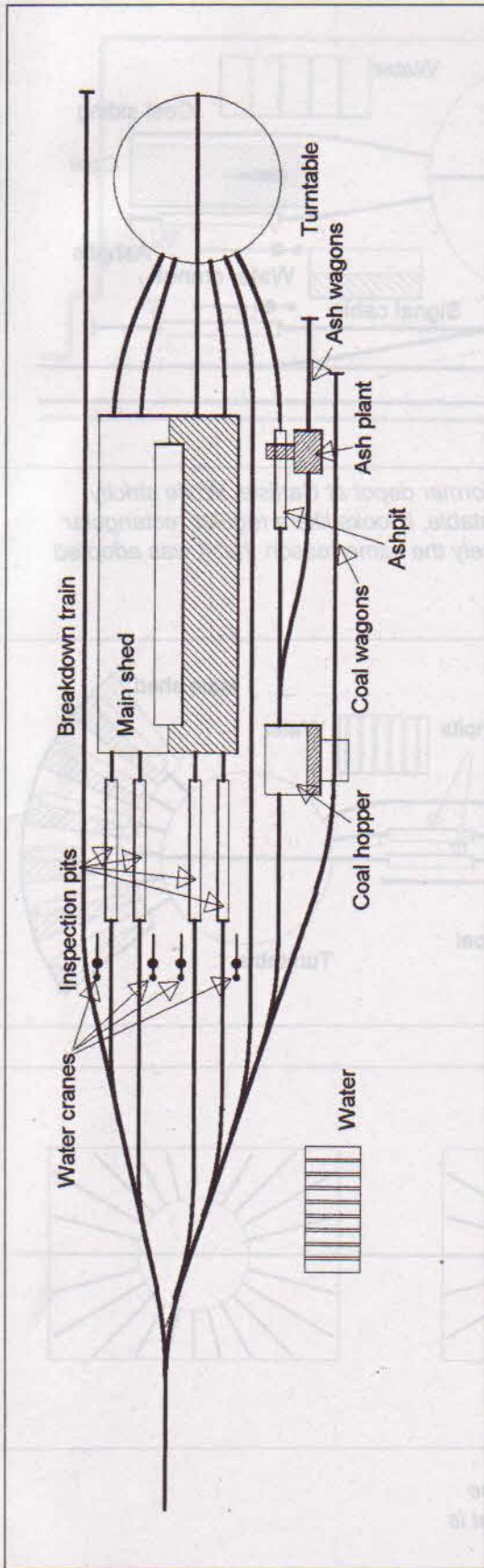

Figure 11/7 The LMS published a drawing of its proposed standard MPD, which had a double-ended shed and a straightforward flow system. This is a slight variant, since both ends of the prototype shed had point access and the turntable was on a single spur. As it turned out, no sheds were actually built to this design, but several existing installations were roughly licked into shape.

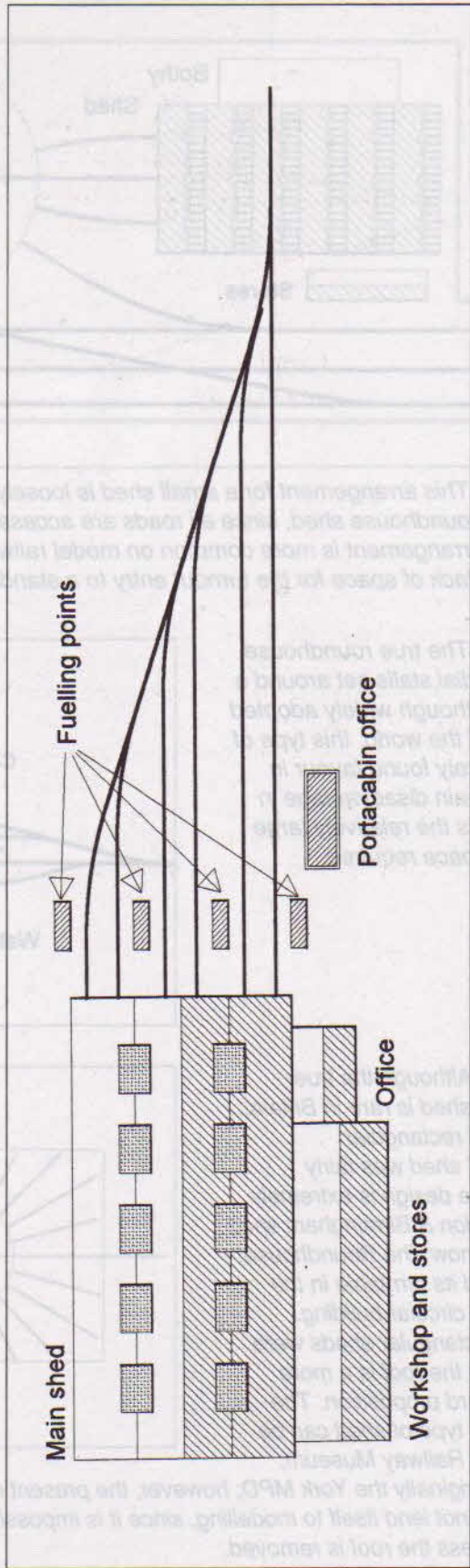

Figure 11/8 In conclusion we have a simple purpose-built small diesel MPD, just six parallel roads in a modern portal-framed shed. Two of the tracks are equipped for heavy maintenance since, unlike steam, where the entire locomotive had to go to the works for a major overhaul, all working parts of a diesel can be stripped out and replaced, with only the individual components needing to go back to the factory. However, most large diesel MPDs are converted from the more modern steam sheds. The principal additions are large, long sheds for multiple unit stock and HST sets.

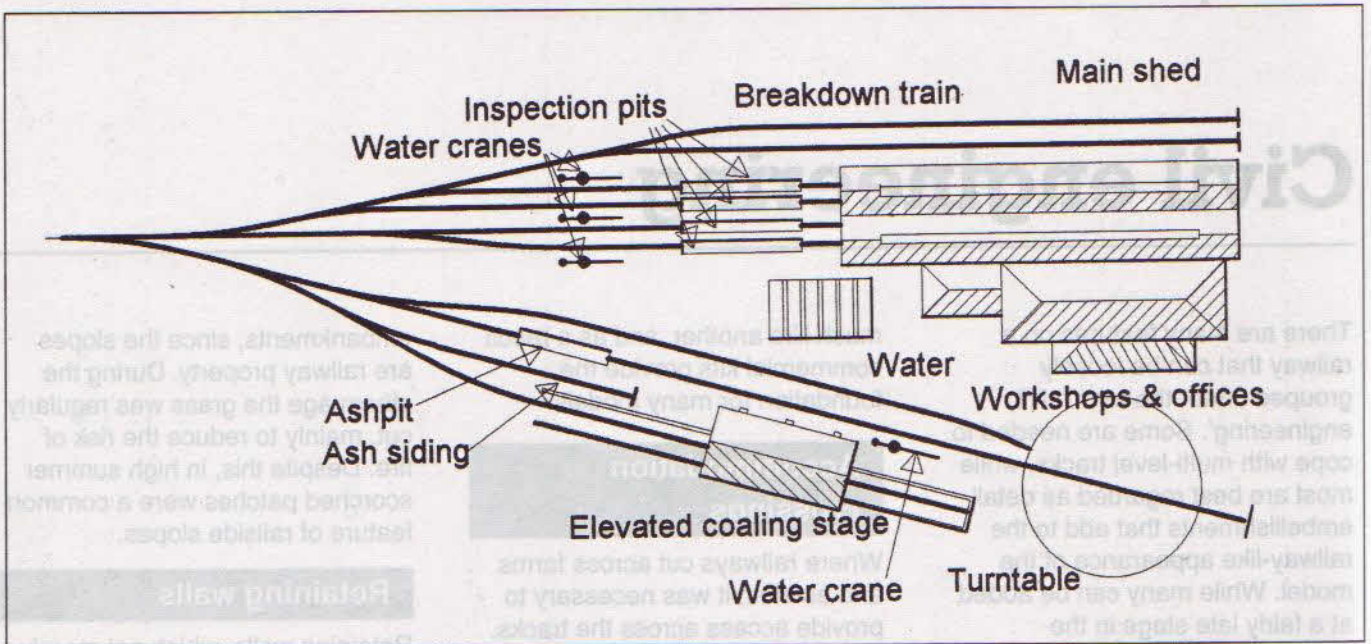

Figure 11/9 From around 1890, the Great Western Railway evolved a standard small motive power depot that followed this basic design, with a four- or six-road parallel shed flanked by a raised coaling stage with two tracks to the turntable, allowing a flow path to be set up. Although the dead-end shed meant that a certain amount of shuffling was needed on occasions, the design was highly convenient and, with minor modifications, was widely adopted throughout the system.

The GWR's adherence to raised coaling stages stemmed from its use of very friable Welsh steam coal, which when dropped from a great height in a coaling hopper tended to turn to dust. The manually operated raised shed also allowed a degree of control over the type of coal put into any locomotive; the best wagon loads were reserved for the more arduous duties, and the rubbish was emptied into lightly used locomotives. With the coal hopper it was a matter of luck whether one got a bunker full of good or poor coal.

Tunnels

On the prototype, tunnelling is undertaken as a last resort, due to the cost of making the bore. On a model railway there is virtually no extra cost, but maintenance is more difficult. Ready access should be arranged for track cleaning, extracting the occasional detailed piece of rolling stock or producing a replacement locomotive. It is not true that most deterioration occurs in long tunnels; it is merely that one tends to remember them when they happen. It is inadvisable to buy points; they should always be under a readily removed scenic feature.

Cuttings and embankments

Although on the prototype cuttings and embankments are in rough balance, on a model railway the balance should fall in favour of cuttings. Since cuttings have the undesirable effect of hiding things from view, as it is necessary to arrange for passenger lighting to be below track level in order to model embankments, whereas one can always build cuttings on a level bedrock, the preference of providing cuttings cannot be overstated. It should also be noted that the railway fence is found at the top of cuttings and the foot of

Bridges are by far the most common civil engineering feature on a railway. Not only do they carry the tracks over rivers and valleys, but they also carry roads and paths over and under the railway. Although they can be divided into four basic types: masonry (including brick), plate girder, spaced girder and reinforced concrete, each of these types are to be found in a variety of forms. Timber bridges are now extremely rare, and only suitable for period models.

Crossings

Level crossings are a means of carrying roads across railways on the level. They fall into two distinct types: the old gated crossing and the modern lifting barrier. Unlike bridges, one level crossing is very

Chapter 12

Civil engineering

There are many features on a railway that can be loosely grouped under the term 'civil engineering'. Some are needed to cope with multi-level tracks, while most are best regarded as detail embellishments that add to the railway-like appearance of the model. While many can be added at a fairly late stage in the proceedings, the more spectacular aspects of the civil engineer's work need to be catered for at the preliminary planning stage. The sketches tell the story, but a few preliminary remarks will help set the scene.

Bridges

Bridges are by far the most common civil engineering feature on a railway. Not only do they carry the tracks over rivers and valleys, but they also carry roads and paths over and under the railway. Although they can be divided into four basic types, masonry (including brick), plate girder, braced girder and reinforced concrete, each of these types are to be found in a variety of forms. Timber bridges are now extremely rare, and only suitable for period models.

Crossings

Level crossings are a means of carrying roads across railways on the level. They fall into two distinct types, the old gated crossing and the modern lifting barrier. Unlike bridges, one level crossing is very

much like another, and as a result commercial kits provide the foundation for many models.

Accommodation crossings

Where railways cut across farms and estates, it was necessary to provide access across the tracks. Where the track was more or less level with the original ground, a simple flat crossing was provided. Subways under embankments and light bridges over cuttings are only employed when unavoidable – they cost real money! When ownership of the land on one side changed, the railway usually managed to close the crossing. However, where a public right of way has been established, this is not possible.

Cuttings and embankments

Although on the prototype cuttings and embankments are in rough balance, on a model railway the balance should fall in favour of embankments, since cuttings have the undesirable effect of hiding trains from view. As it is necessary to arrange for baseboard framing to be below track level in order to model embankments, whereas one can always build cuttings on a flat baseboard, the importance of pre-planning cannot be over-stressed.

It should also be noted that the railway fence is found at the top of cuttings and the foot of

embankments, since the slopes are railway property. During the steam age the grass was regularly cut, mainly to reduce the risk of fire. Despite this, in high summer scorched patches were a common feature of railside slopes.

Retaining walls

Retaining walls, which not merely eliminate space-consuming slopes, but form an excellent backdrop to model trains, are much more evident on model railways than they are on the prototype. They are only used where the cost of land for cutting slopes exceeds the cost of erecting a retaining wall, and are mainly confined to urban areas.

Tunnels

On the prototype, tunnelling is undertaken as a last resort, due to the cost of making the bore. On a model railway there is virtually no extra cost, but maintenance is more difficult. Ready access should be arranged for track-cleaning, extracting the occasional derailed piece of rolling-stock or prodding a recalcitrant locomotive into life. It is not true that most derailments occur in long tunnels – it is merely that one tends to remember them when they happen. It is inadvisable to bury points; they should always be under a readily removed scenic feature.

Figure 12/1 The basic brick-built overbridge, carrying a road across the railway. To add some relief to the structure, there are a pair of piers and the semi-circular arch rests on a string course, while the parapet has decorative strings. These need be no more than simple overlays, adding a little relief to the plain brick finish. The most important feature is, of course, the brick arch, which is the only thing supporting the roadway.

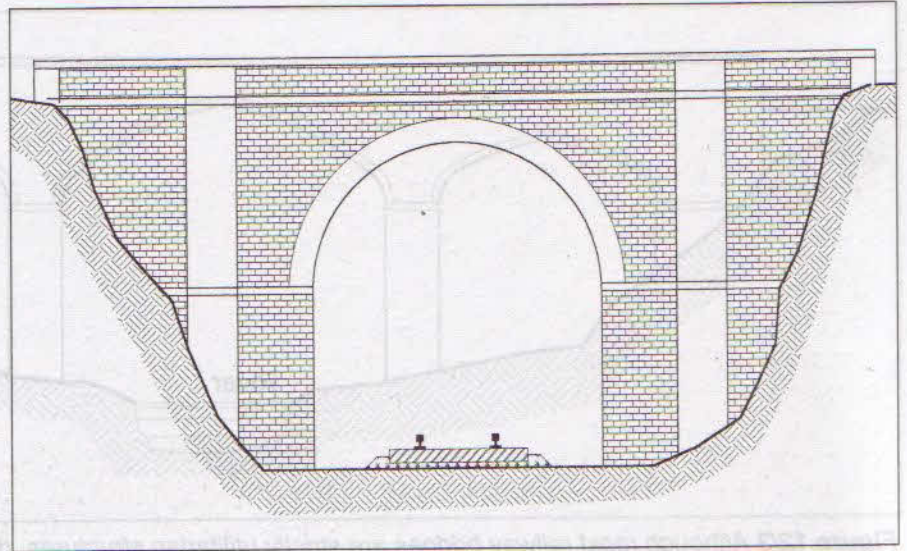

A simple masonry underbridge on the former GWR Brixham branch.

Figure 12/2 A plate girder overbridge is a more straightforward modelling proposition, and is favoured as a replacement for a weak masonry arch, since it can be lifted into place on prepared abutments by a large crane.

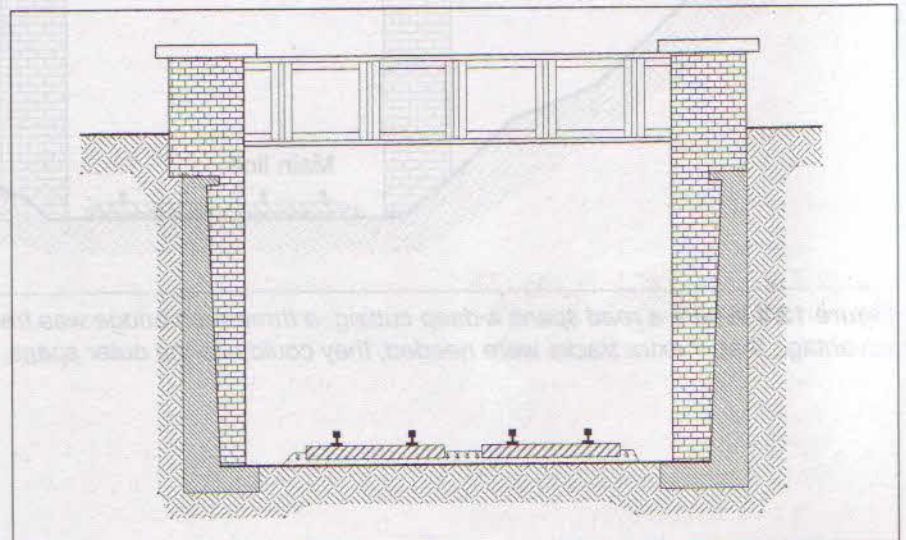

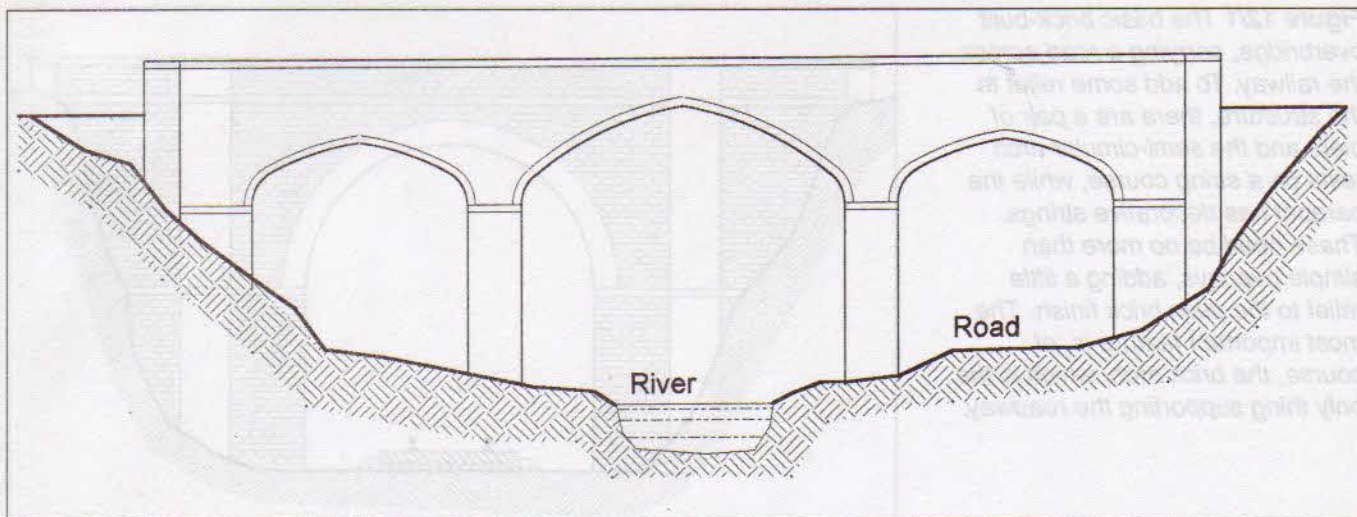

Figure 12/3 Although most railway bridges are strictly utilitarian structures, designed with an eye on the total cost, there are exceptions. These were generally found near to cities, where the bridge would be seen by many people, but other examples were found on or near large estates where the influential owner insisted on a design in keeping with his country seat. This sketch is loosely based on Brunel's Avon bridge, near Bristol. The two side arches have an important function, providing relief for the waters in case of floods, while the pointed arches are primarily decorative.

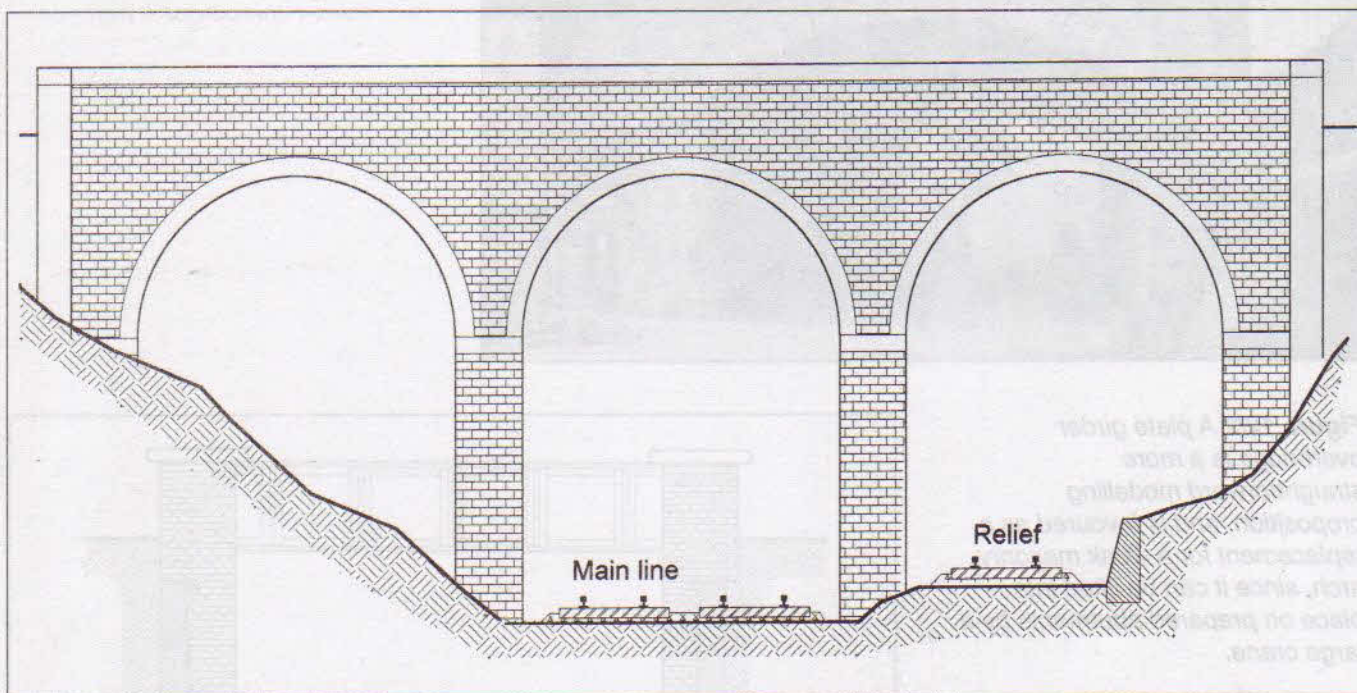

Figure 12/4 Where a road spans a deep cutting, a three-arch bridge was frequently adopted. It had the added advantage that, if extra tracks were needed, they could use the outer spans.

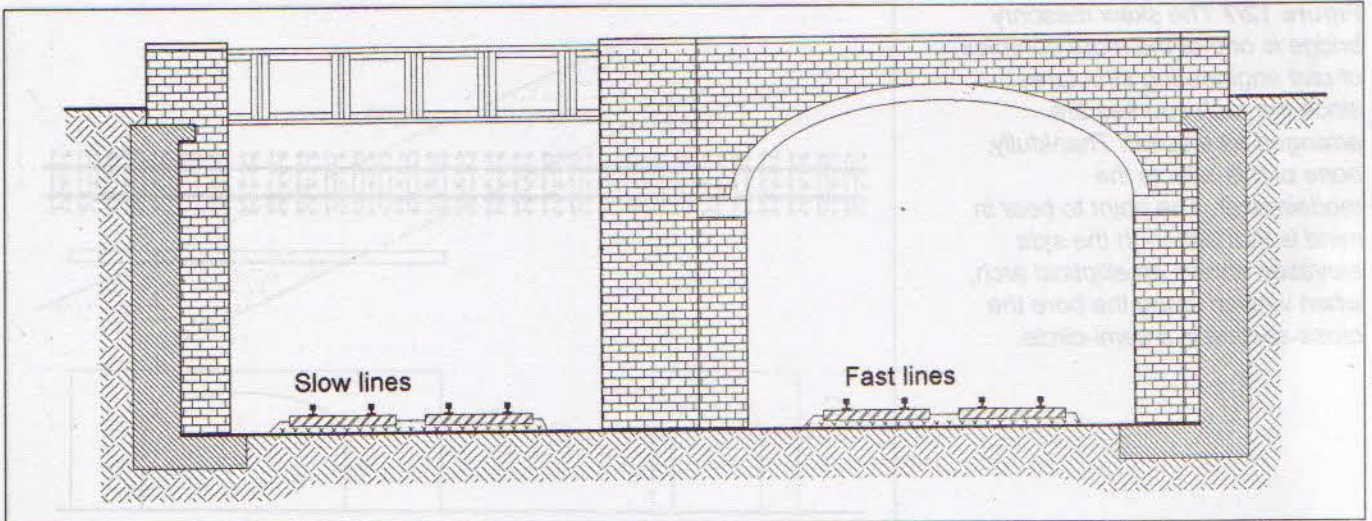
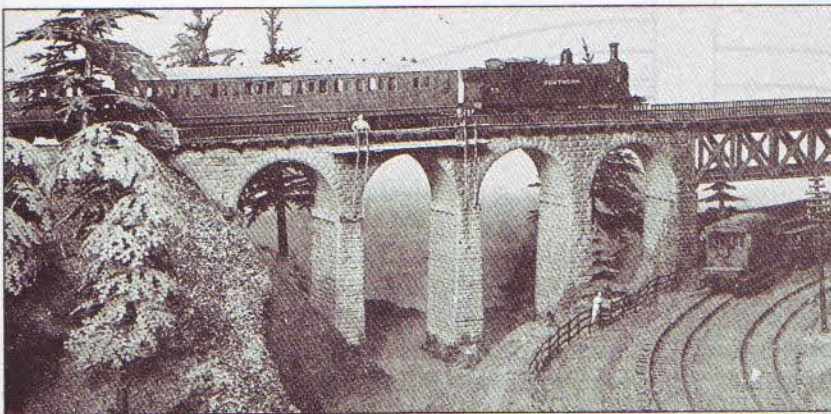

Figure 12/5 The usual practice when widening from double to quadruple track was to lay a fresh pair of rails alongside the original route. Overbridges received another span, which might match the original but could quite easily be a totally different design. Here we see the original elliptical arch bridge flanked by a plate girder.



A combined masonry and girder viaduct on the Poole club's OO gauge layout of the '60s. This is a very fine example of what can be done with several commercial bridge kits, a little imagination and a good deal of effort.

Figure 12/6 (below) A variant on the three-arch bridge crossing quadruple tracks. Here the two side arches are additions, and the original cutting has been widened with the use of toe walls.

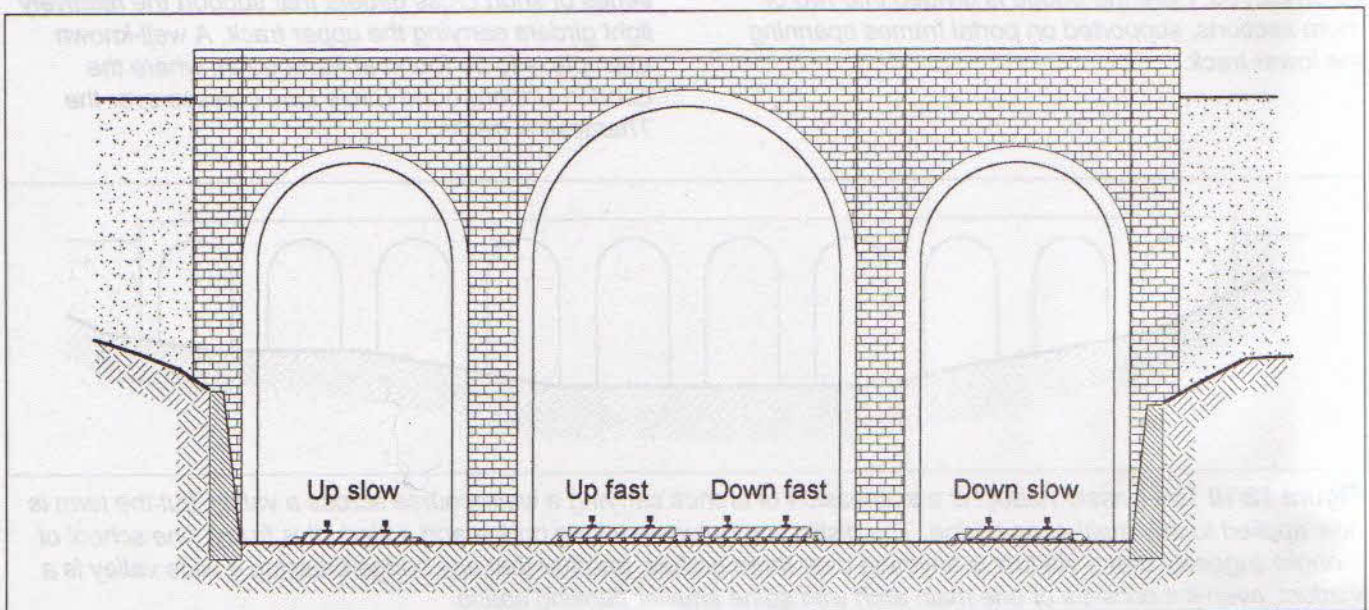

Figure 12/7 The skew masonry bridge is one of the more complex of civil engineering structures, since the arch courses are arranged as a spiral. Thankfully, none of this affects the modelmaker. The point to bear in mind is that although the side elevation shows an elliptical arch, when viewed along the bore the cross-section is a semi-circle.

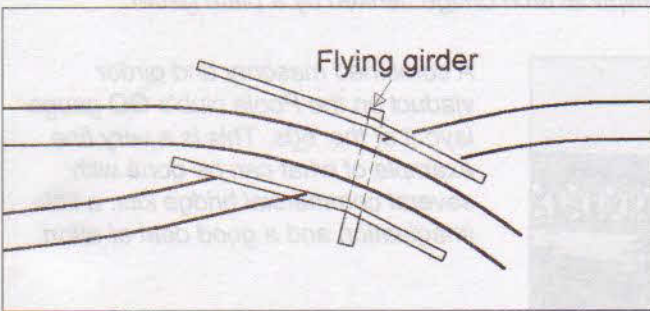
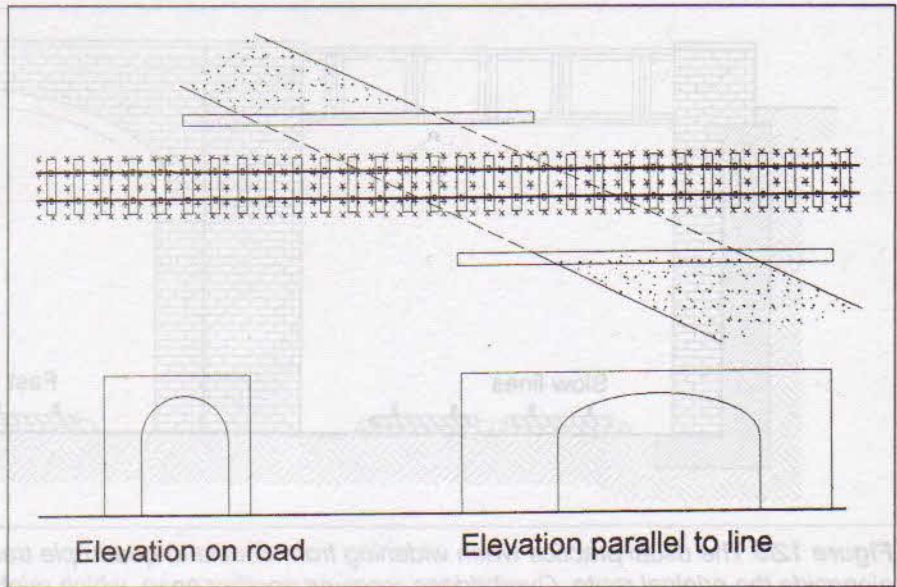

Figure 12/8 Skew bridges are more readily constructed with steel or pre-stressed concrete girders, today the favoured solution. In situations where curved tracks cross one another, more common on the model than on the prototype, a flying girder can be employed. Here the bridge is divided into two or more sections, supported on portal frames spanning the lower track.

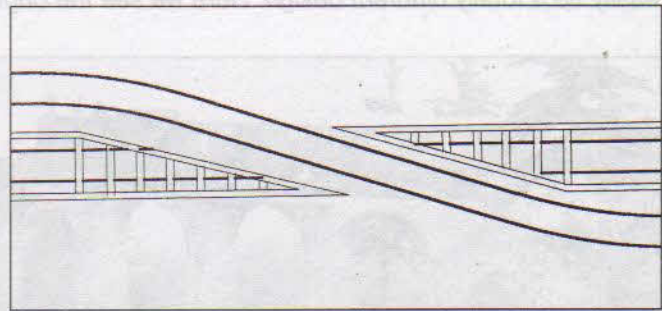

Figure 12/9 Flying junctions frequently cross the lower track at an acute angle. While a single girder could carry the upper roads, it would have to be very deep and correspondingly expensive. An alternative is the gridiron bridge, where the lower track is spanned by a series of short cross girders that support the relatively light girders carrying the upper track. A well-known example is to be found at Farringdon, where the London Underground Circle Line crosses over the Thameslink tracks.

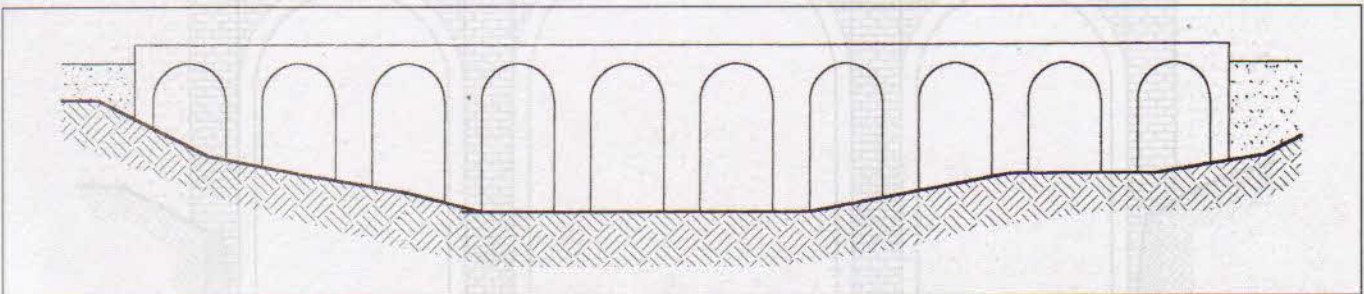

Figure 12/10 The classic viaduct is a succession of arches carrying a watercourse across a valley, but the term is now applied to any multi-span bridge. The distinction between a long bridge and a viaduct is fuzzy; one school of thought suggests that a viaduct is anything over three arches, another that any bridge crossing a wide valley is a viaduct, even if it consists of one main arch with some smaller flanking spans.

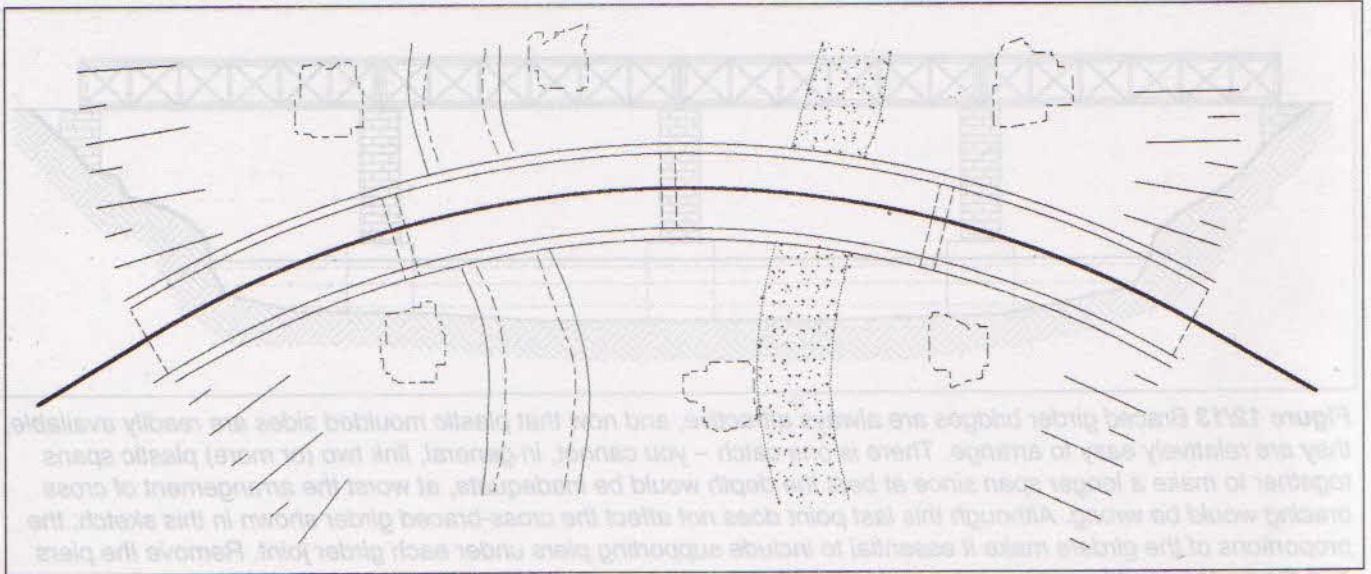

Figure 12/11 Curved viaducts are only theoretically feasible with masonry arches, and even so are normally laid out on very easy curves. This hasn't stopped kit manufacturers making them fit the sharp radii of commercial sectional tracks!

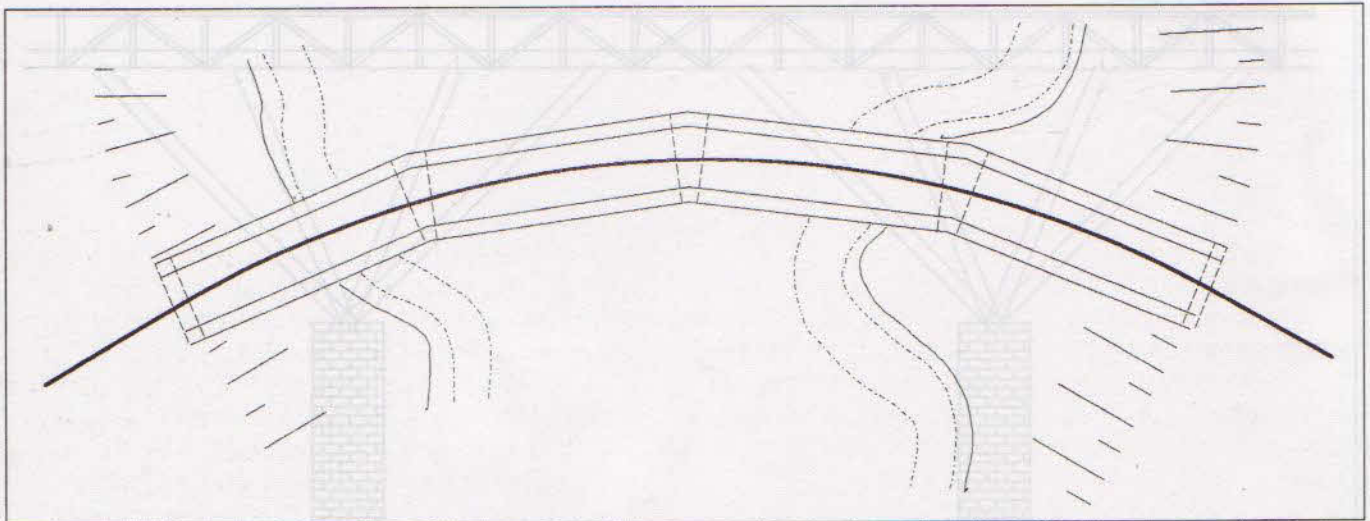
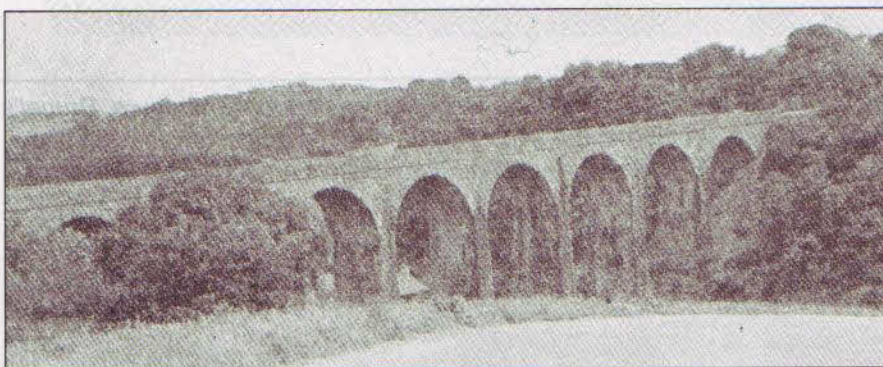

Figure 12/12 In practice most curved viaducts are made up from a succession of short straight spans built on tapered piers. This type of construction is essential where girders are concerned, and greatly simplifies the construction of masonry arches.



A single-track masonry viaduct on the line from Paignton to Kingswear.

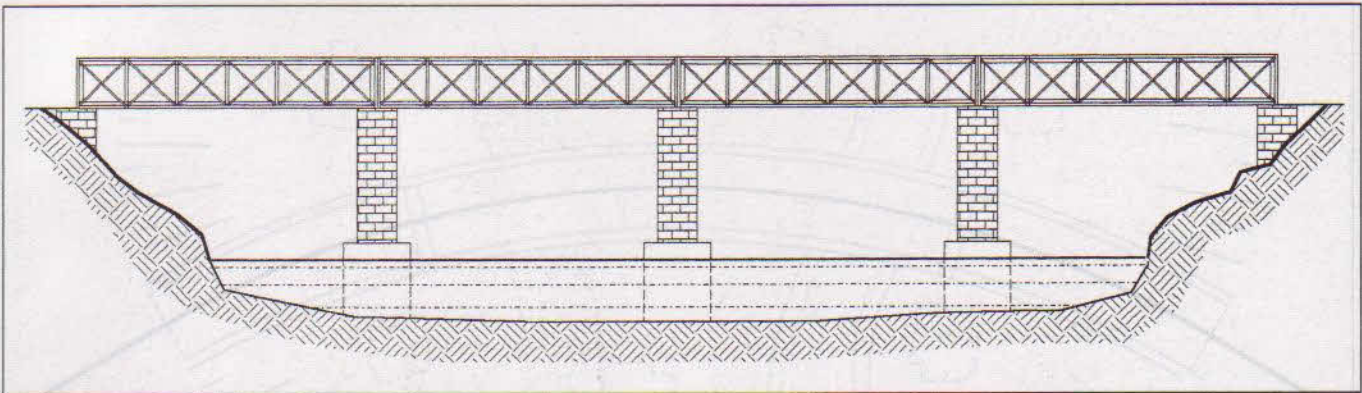

Figure 12/13 Braced girder bridges are always attractive, and now that plastic moulded sides are readily available, they are relatively easy to arrange. There is one catch – you cannot, in general, link two (or more) plastic spans together to make a longer span since at best the depth would be inadequate, at worst the arrangement of cross bracing would be wrong. Although this last point does not affect the cross-braced girder shown in this sketch, the proportions of the girders make it essential to include supporting piers under each girder joint. Remove the piers and the bridge would appear on the point of collapse.

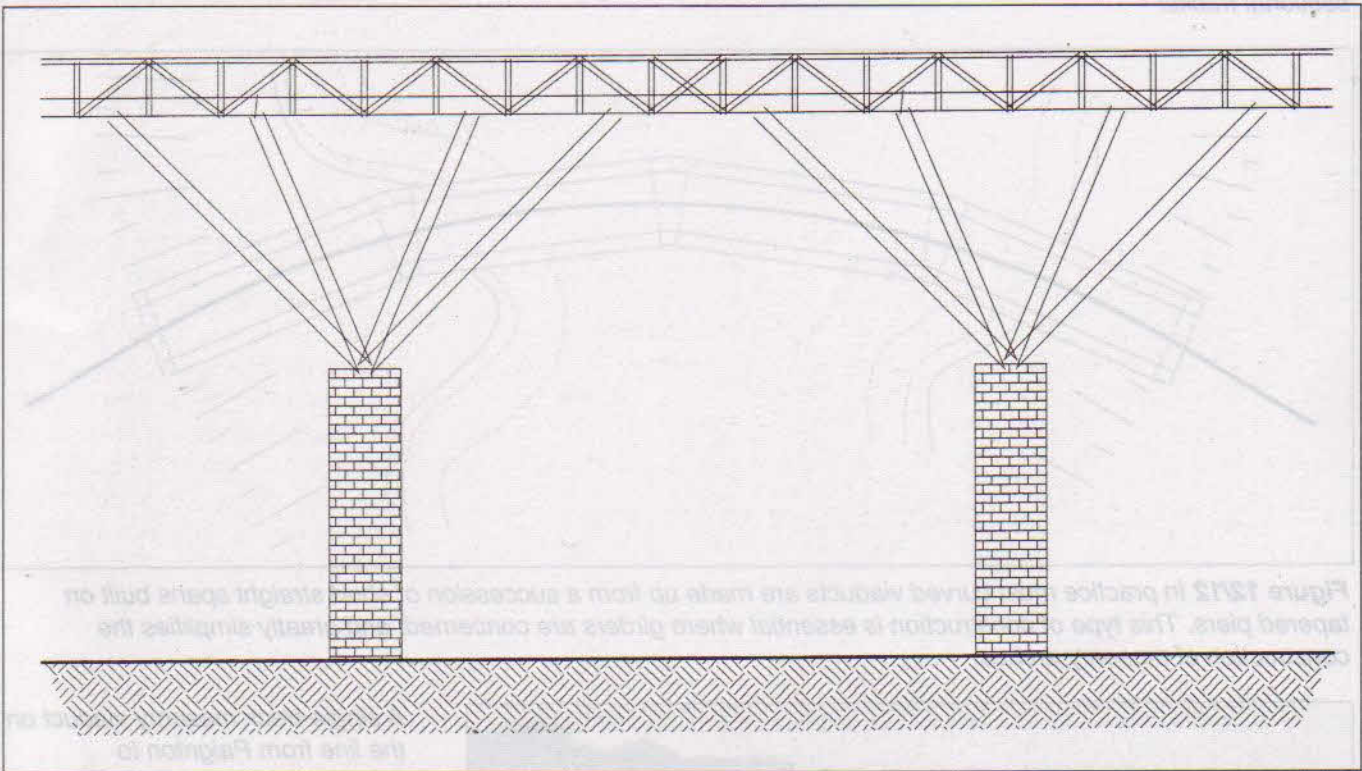
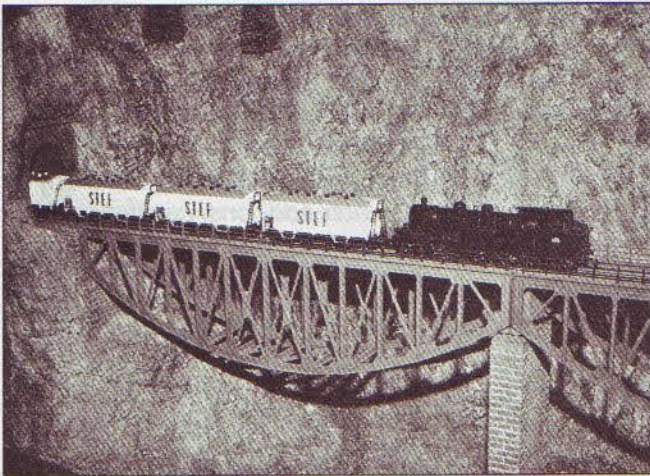
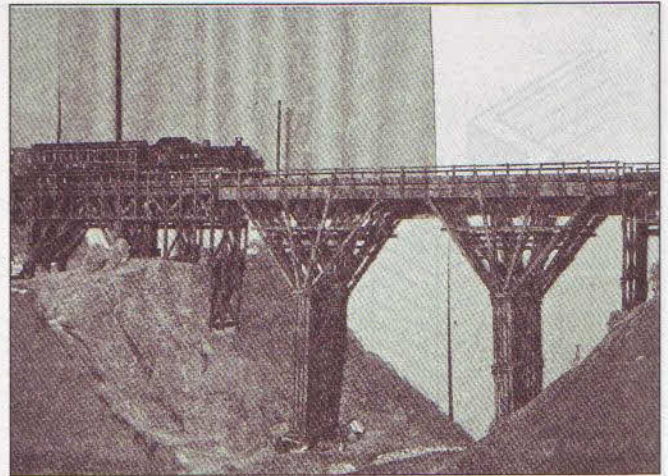

Figure 12/14 In the early days of railways many bridges were made from timber as an economy measure. Brunel's fan viaducts were not only the most graceful of these structures, but were also among the longest lived, with one South Wales example remaining until nationalisation. They have proved popular subjects among Great Western branch-line modellers.



Here two bowstring girder bridges have been combined, another good use of commercial kits to create an effective model. Of particular interest is the fact that this particular kit can be erected either way up!



An imaginative use of several of the long-discontinued Ratio timber viaduct kits on Graham Overton's old West of England Railway. The central portion is the 'Brunel' timber fan kit, carried on timber piles, while the two flanking portions were made from the trestle viaduct kit. This photo shows the model almost completely devoid of backdrop; this, whilst noticeable in the photo, was less obvious on the model. The brain expects a viaduct to be seen against the sky and edits out any obtrusive backing.

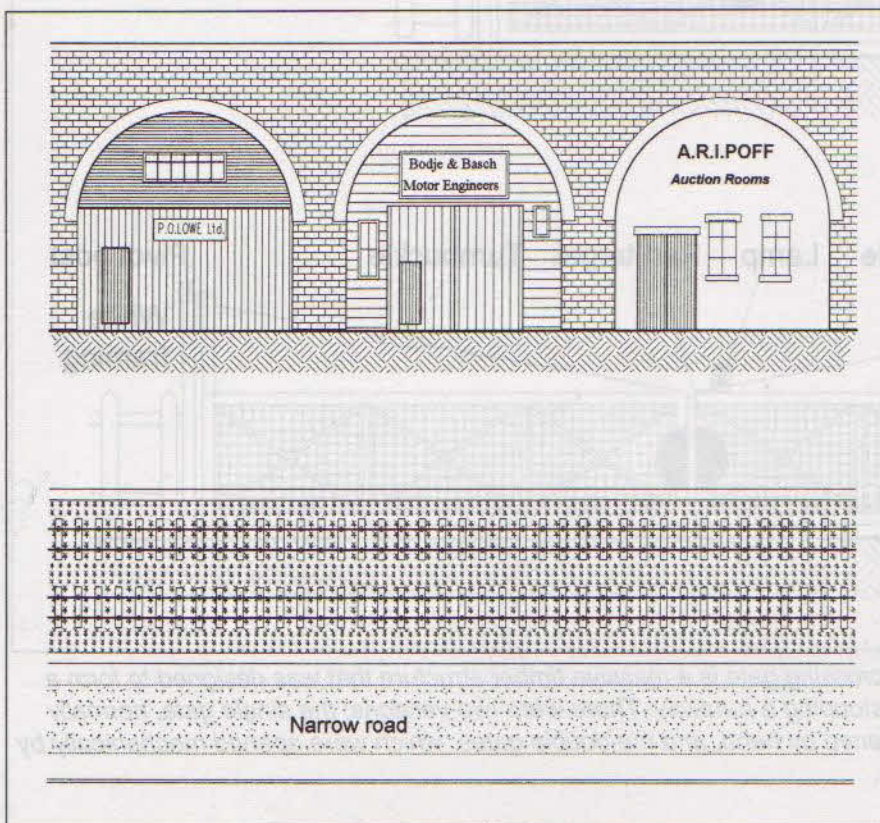

Figure 12/15 The London & Greenwich Railway was built on a continuous brick viaduct, initiating a style of construction that has made a permanent mark on Britain's urban scene. Initially it was hoped that the arches would be used as homes, but train noise ruled that out of court. They have since found favour for a variety of commercial uses, three of which are suggested in this diagram. (If you're wondering, P. O. Lowe makes the holes for washers.) The original L&G arches were flanked by two access lanes, but with subsequent widenings one disappeared. Often this original roadway can still be traced, but subsequent developments have blurred the detail.

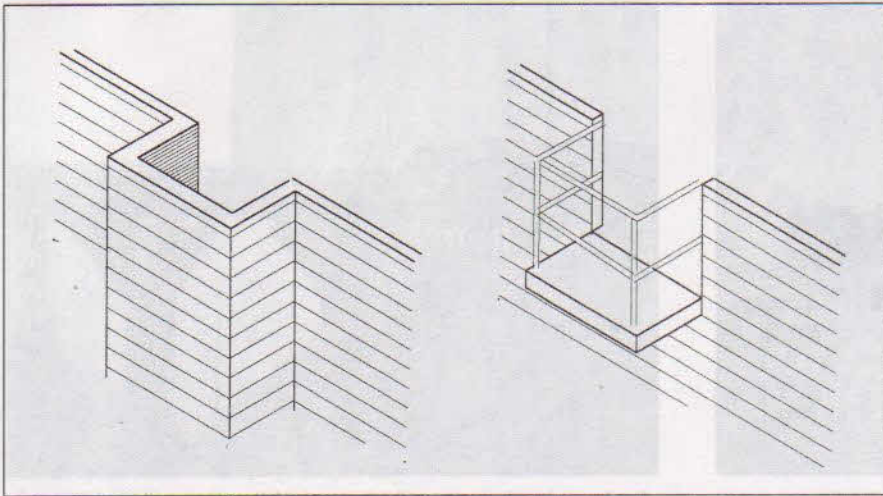

Figure 12/16 As most viaducts are only just wide enough, refuges must be provided at regular intervals so that workers can get clear of trains. Sometimes they form part of a buttress, but many are later additions, cantilevered out from the main structure and provided with a pipe handrail.

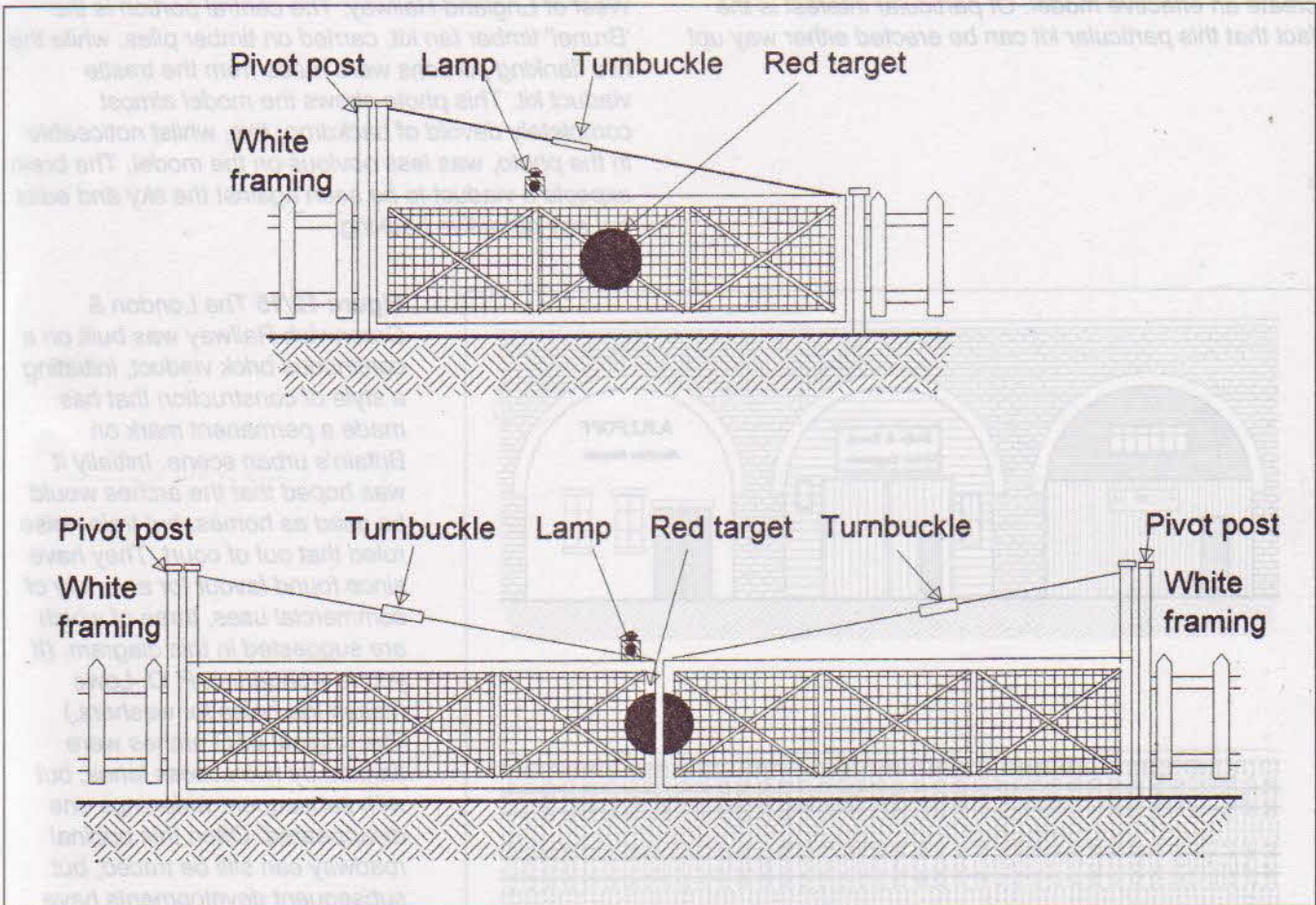

Figure 12/17 The traditional British level crossing gate is a massive timber structure that was designed to form a firm barrier across the tracks, capable of stopping a runaway. There were two versions: the single gate, normally found on single-track lines, which was opened by hand, and the double gates, which were opened mechanically by a large wheel in the adjacent signal cabin.

Figure 12/18 The tracks crossing the road have continuous checkrails to maintain the flange gap. Usually the tracks are sunk in tarmac, but on lightly used roads, timber baulks, usually old but serviceable sleepers, were used. This made subsequent track renewal much easier.

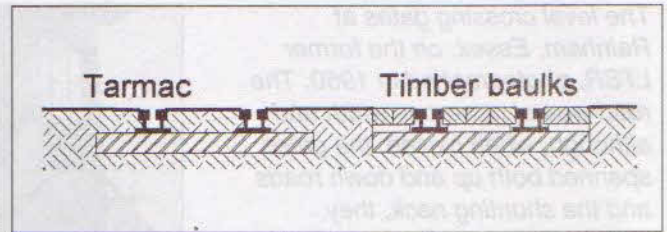

Figure 12/19 All traditional gated crossings were either alongside a signal cabin or a gatekeeper's cottage. The simple single gated crossing was operated by the signaller/crossing keeper who went to point A, unhitched the gate and walked with it to B. He (or she) could now latch the first gate, release the second and walk with it back to A, returning to the signal box to give 'line clear'. Occasionally a footpath with 'kissing gates' was provided alongside to allow pedestrians to cross after the gates had been closed to road traffic.

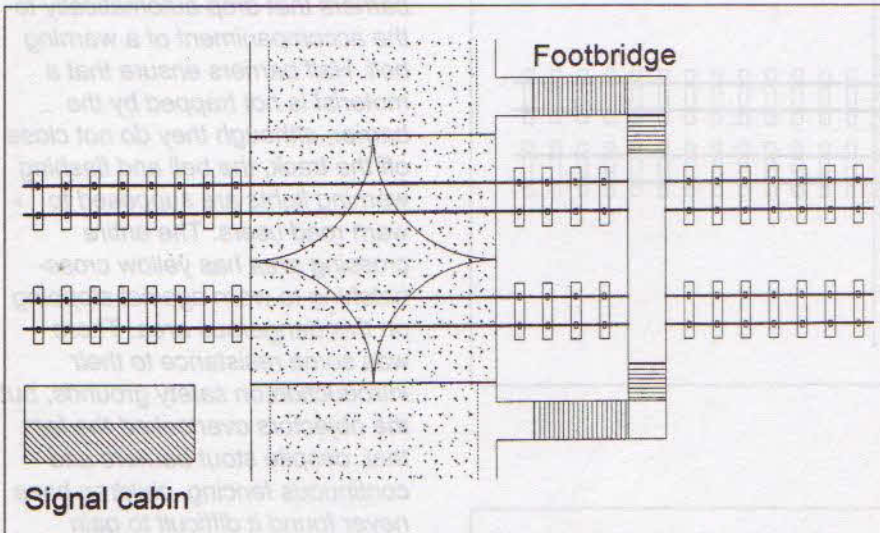
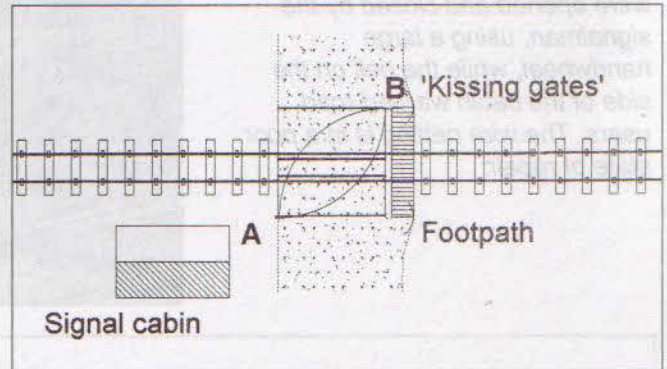

Figure 12/20 Double gates were worked mechanically from the relative comfort of the signal box by means of rodding and bevel gears; it took many turns of a large iron wheel to open and close them. Here a footbridge is provided to allow pedestrians to cross the line when the gates are closed. This could be quite important if you were caught on the wrong side of the line when you were hurrying to catch your train.

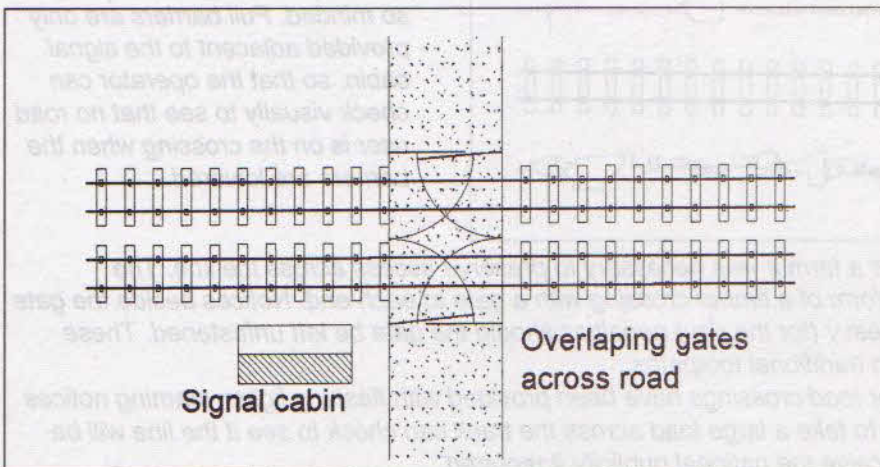

Figure 12/21 Where a narrow road crossed double track, the gates were made wide enough to close across the railway, which meant they overlapped when shut across the road.

The level crossing gates at Rainham, Essex, on the former LTSR, photographed in 1950. The road was of generous width and although, when closed, the gates spanned both up and down roads and the shunting neck, they overlapped as shown here. They were opened and closed by the signalman, using a large handwheel, while the bell on the side of the cabin warned road users. The wire netting is in a poor state of repair.

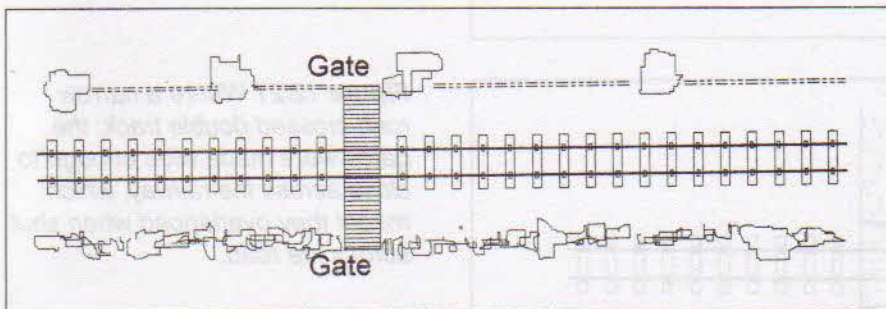
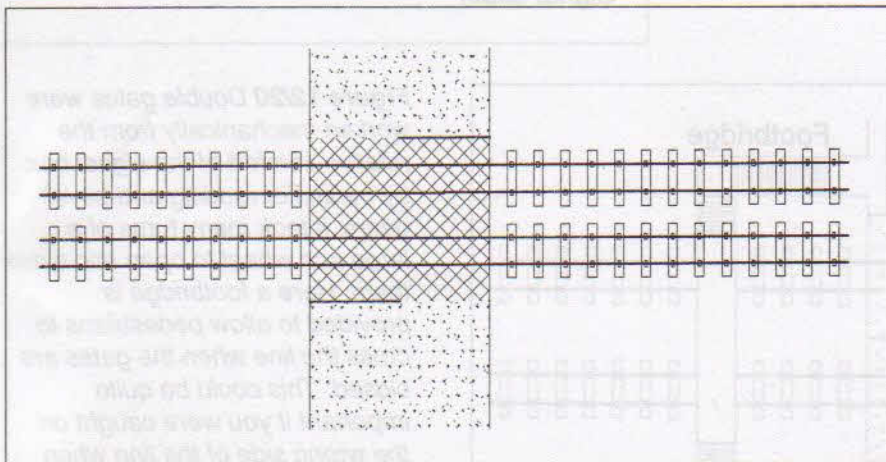
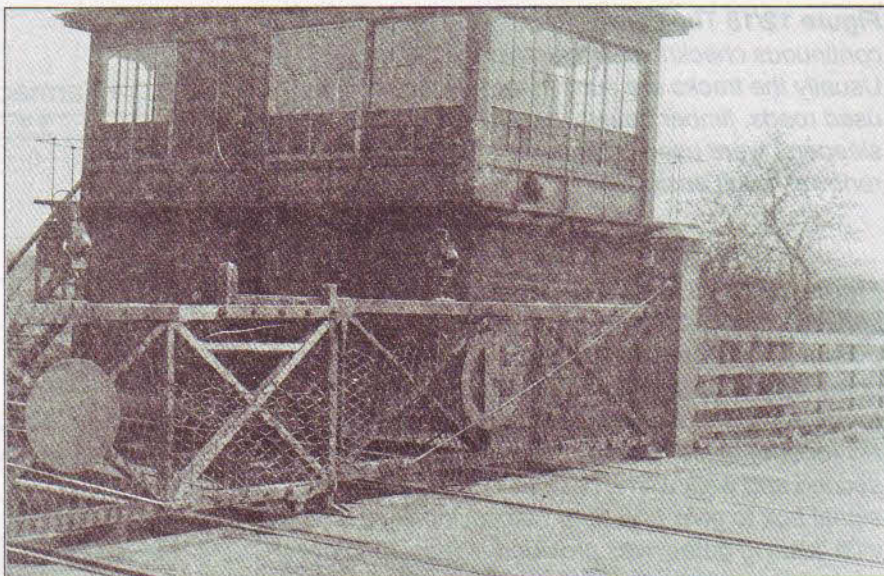

Figure 12/22 Modern level crossings are provided with half barriers that drop automatically to the accompaniment of a warning bell. Half barriers ensure that a motorist is not trapped by the barrier; although they do not close off the track, the bell and flashing warning lights are supposed to warn road users. The entire crossing area has yellow cross-hatching to warn against stopping on this dangerous area. There was some resistance to their introduction on safety grounds, but the objectors overlooked the fact that, despite stout barriers and continuous fencing, children have never found it difficult to gain access to railway tracks if they are so minded. Full barriers are only provided adjacent to the signal cabin, so that the operator can check visually to see that no road user is on the crossing when the barriers are lowered.

Figure 12/23 Where a railway cut across a farm it was necessary to preserve access across the line. The accommodation crossing often took the form of a timber crossing with a gate at each end. Notices beside the gate warned against trespass and imposed heavy (for the day) penalties should the gate be left unfastened. These crossings were also provided to maintain traditional footpaths.

Since the early diesel era some minor road crossings have been provided with flashing lights, warning notices and a telephone so that anyone wishing to take a large load across the track can check to see if the line will be clear. Regrettably this change did not receive the national publicity it required.

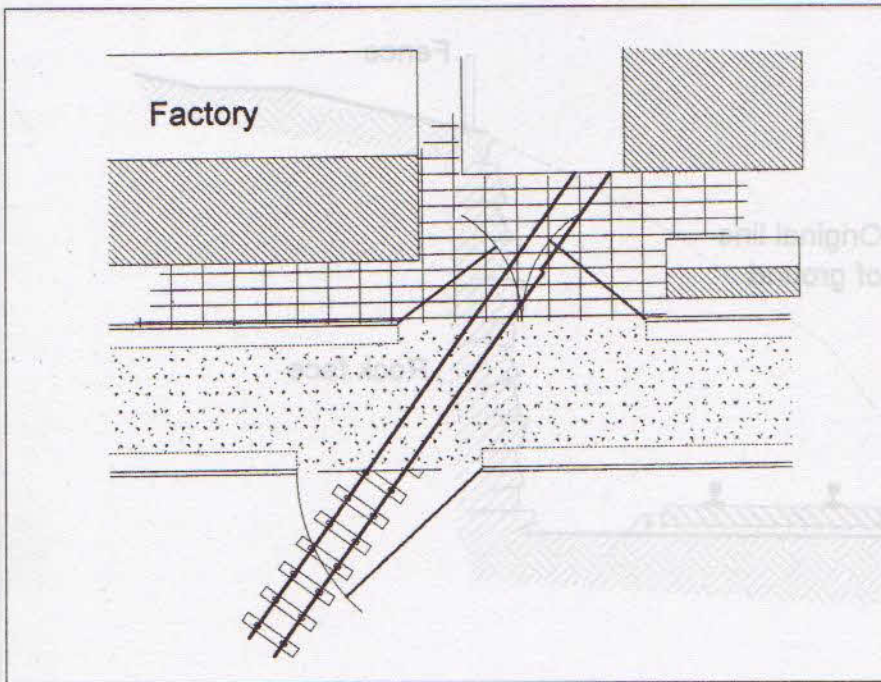

Figure 12/24 The rule that road crossings should be completely closed when a train was to pass did not apply to industrial railways. Tracks into factory yards were only closed off against the road; when a train was taken across, a flagman was sent to warn road traffic. In addition, whistles were blown and, where possible, bells were rung as well. This worked well in the steam age, when road users were accustomed to such happenings and the 30 mph limit was widely observed (mainly because over half the cars on the road had to be driven hard to achieve anything over 45 mph!).

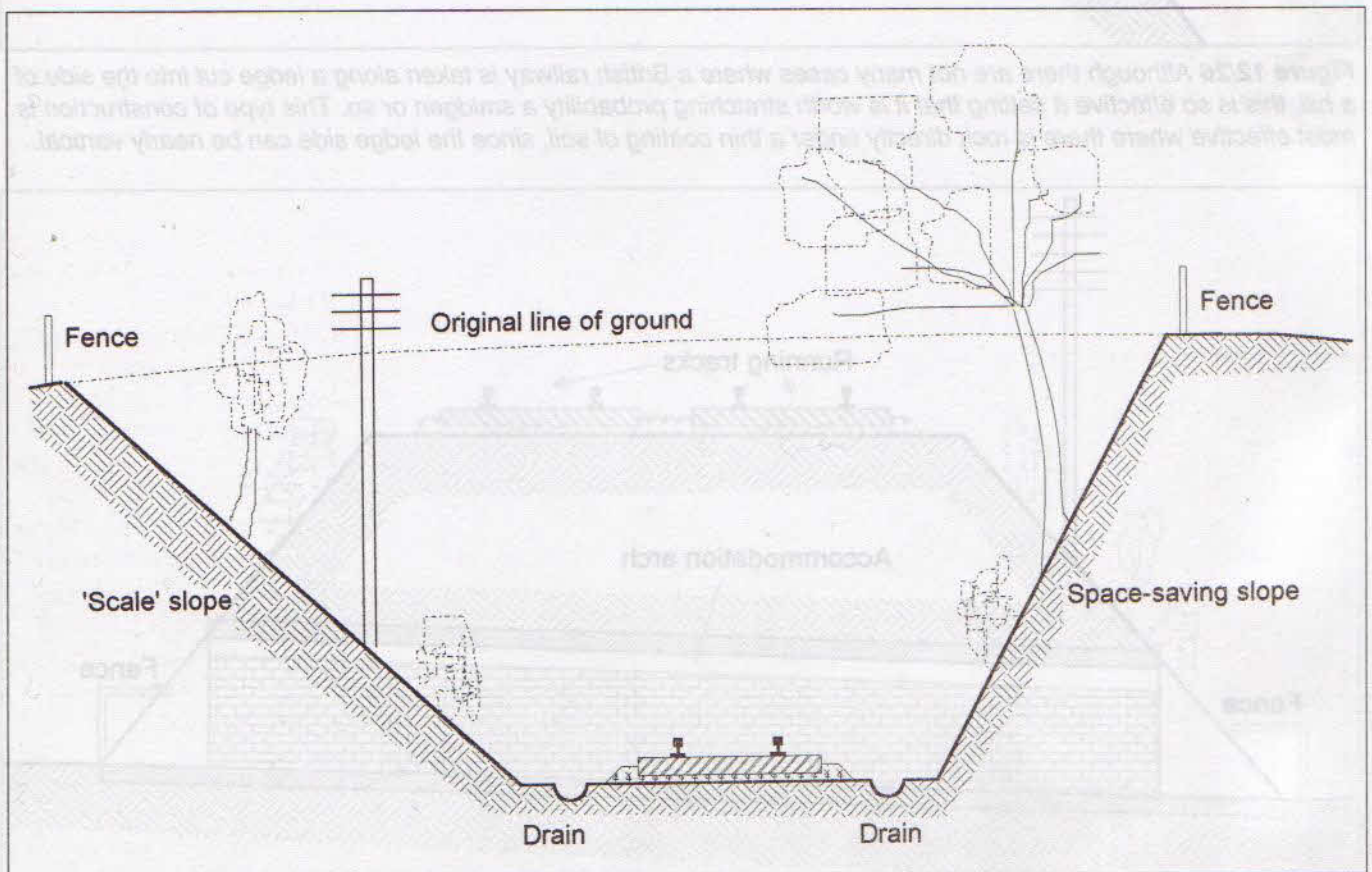

Figure 12/25 This cross-section of a cutting shows on the left the slope required in normal soil. This takes up a good deal of space and, on most model railways, can be made steeper, as on the right, without this being too obvious. The boundary fence runs along the top of the cutting, since the railway has bought the entire strip of land. Drains are generally provided in cuttings to carry ground water away.

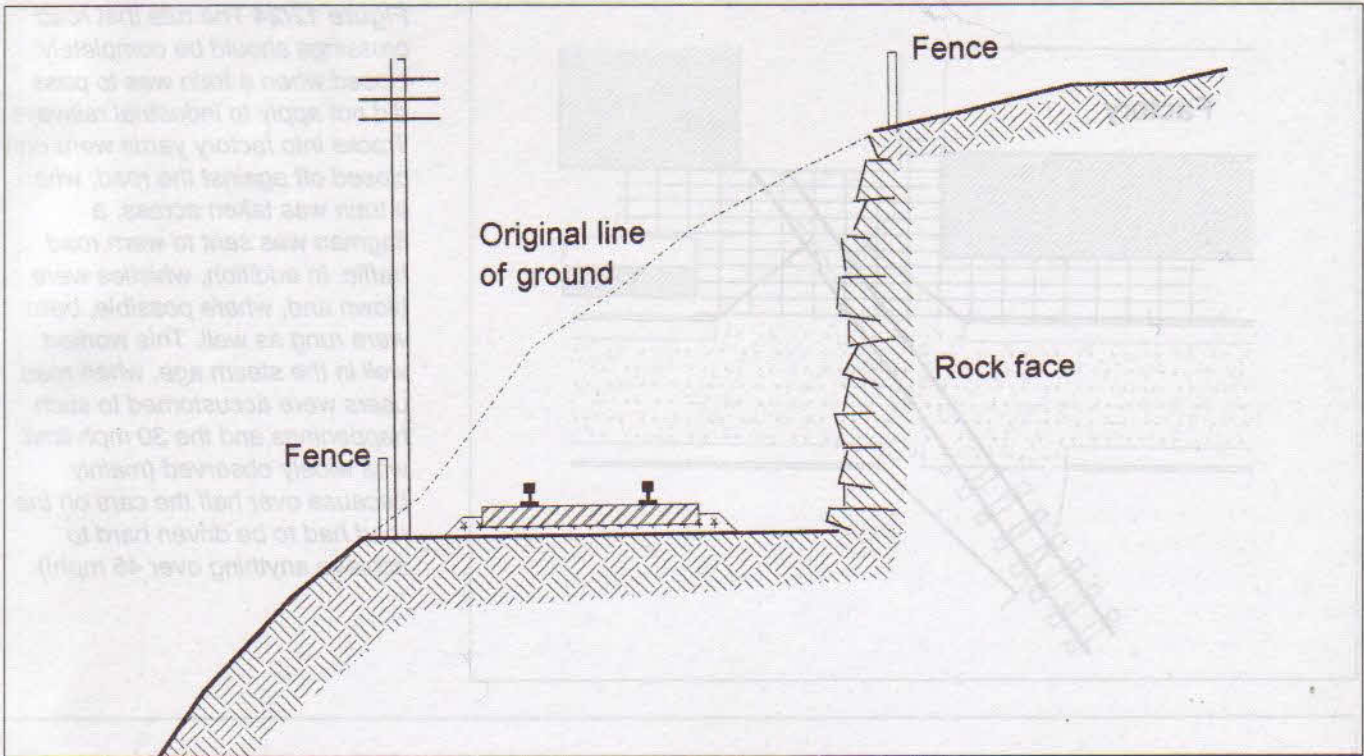

Figure 12/26 Although there are not many cases where a British railway is taken along a ledge cut into the side of a hill, this is so effective a setting that it is worth stretching probability a smidgen or so. This type of construction is most effective where there is rock directly under a thin coating of soil, since the ledge side can be nearly vertical.

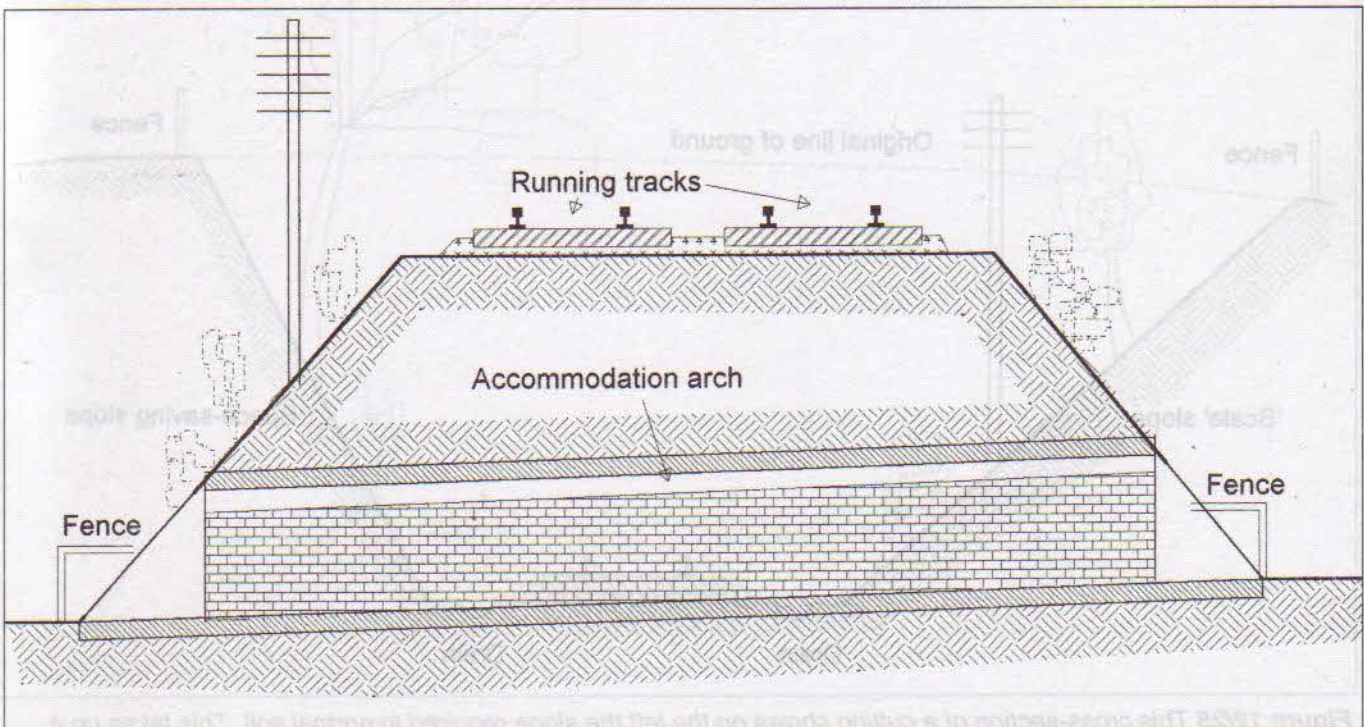

Figure 12/27 Embankments are made from tipped spoil, and are normally much wider than they are high. Again some steepening of the slope is advisable to save width on the model. In this sketch I have shown an accommodation arch passing through the embankment to provide passage for a farmer.

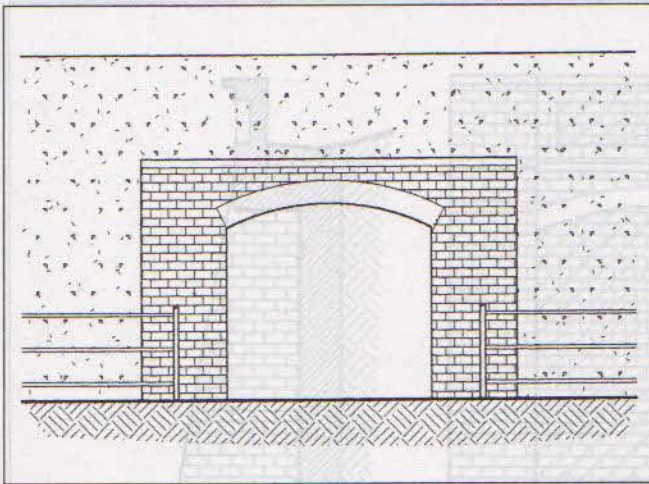

Figure 12/28 Accommodation arches are relatively small, usually around 3 metres square in cross section. They are not intended for heavy traffic, but were set to take a typical farm cart of the 19th century. Similar arches were built for small watercourses and drainage ditches. It is rare to have any length of embankment without a culvert, since it would otherwise form a very effective dam – until it burst with the water pressure.

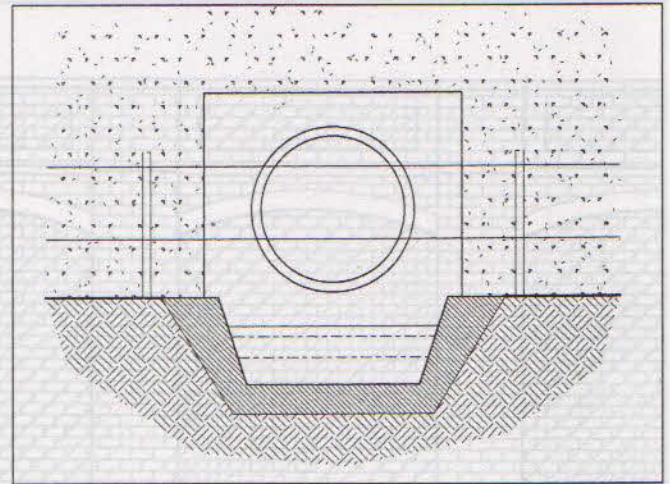

Figure 12/29 Today, culverts are made from pre-cast concrete pipes. These are rarely smaller than 1.5 metres in diameter, so it is possible to crouch and shuffle through to clear obstructions, as culverts are prone to blockage. They are frequently closed with steel grilles, which in turn are often dislodged.

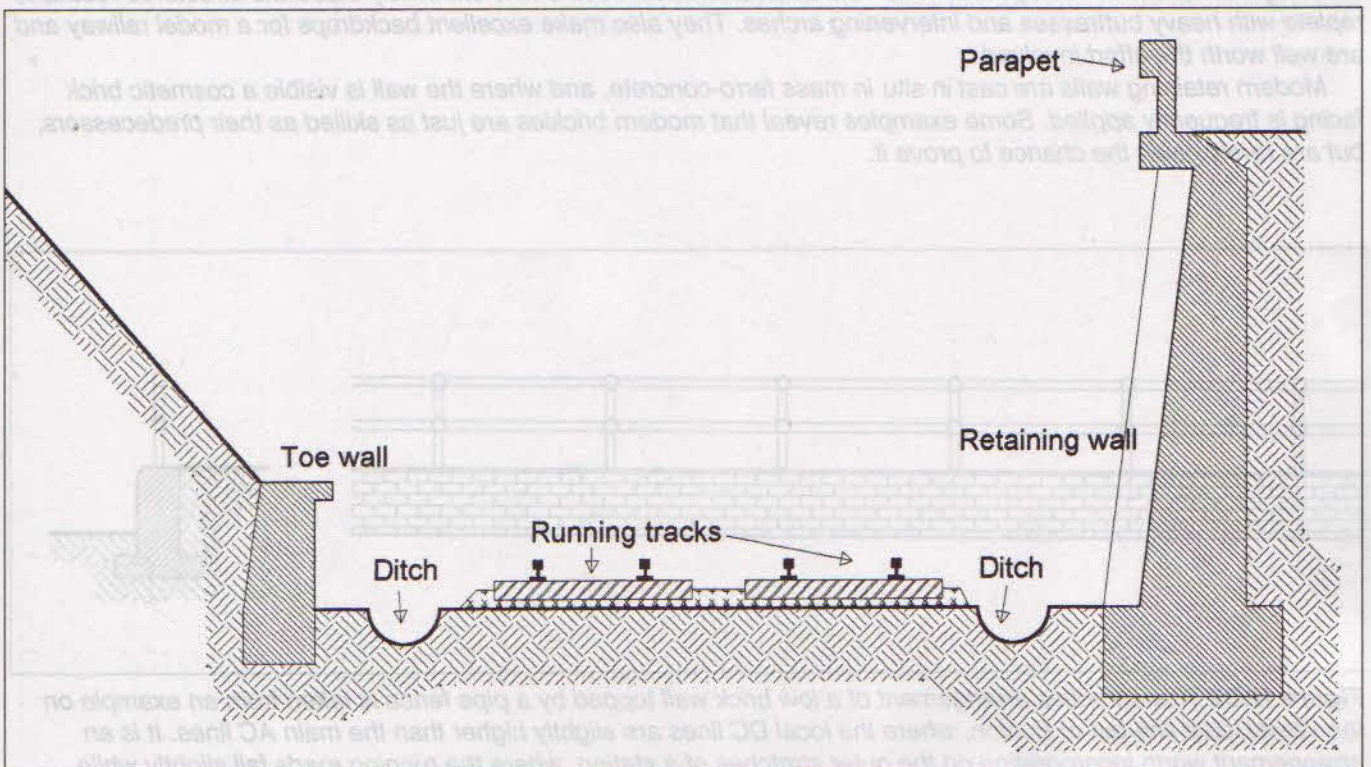

Figure 12/30 Retaining walls are more common on model railways than they are on the prototype, where cost considerations restrict their use to urban areas. The smaller toe wall is usually employed to widen an existing cutting, but has also been used when the angle of rest for the soil turns out to be shallower than first expected. The toe wall then reduces the risk of a landslip blocking the tracks.

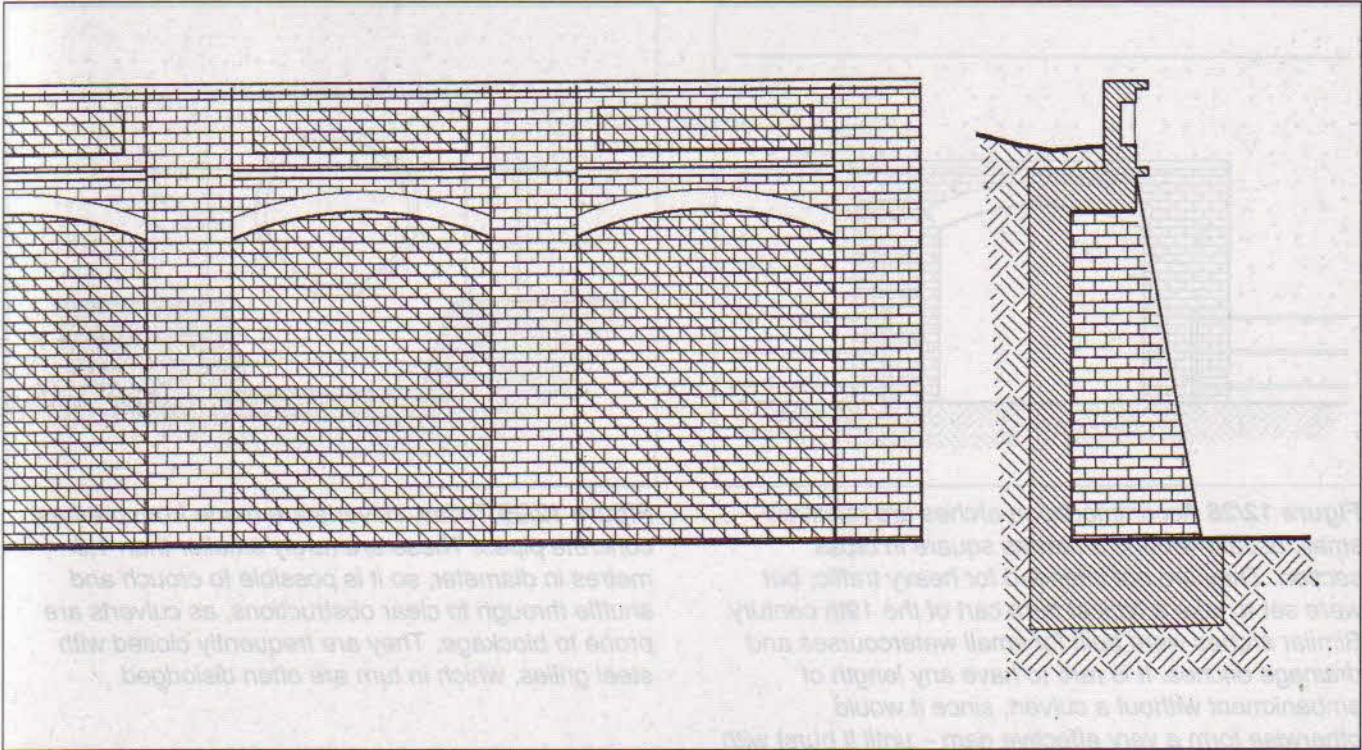

Figure 12/31 The brick-built retaining wall is a monument to the skill of 19th century bricklayers, most of whom could lay bulk brickwork at a phenomenal rate at an affordable cost. Some extremely elaborate structures resulted, replete with heavy buttresses and intervening arches. They also make excellent backdrops for a model railway and are well worth the effort involved.

Modern retaining walls are cast in situ in mass ferro-concrete, and where the wall is visible a cosmetic brick facing is frequently applied. Some examples reveal that modern brickies are just as skilled as their predecessors, but are rarely given the chance to prove it.

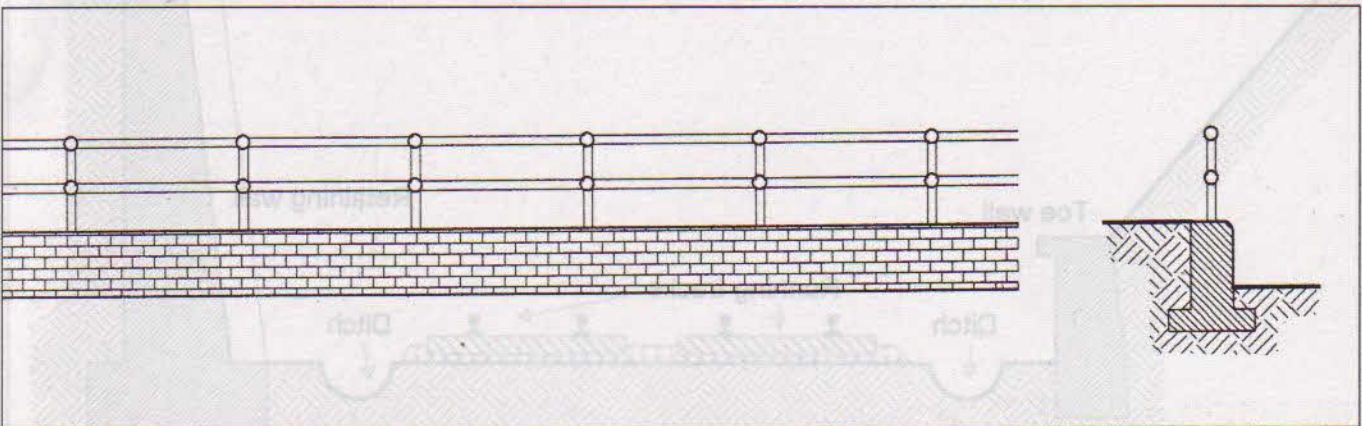

Figure 12/32 This attractive arrangement of a low brick wall topped by a pipe fence is taken from an example on the West Coast line out of Euston, where the local DC lines are slightly higher than the main AC lines. It is an arrangement worth incorporating on the outer stretches of a station, where the running roads fall slightly while sidings are kept level.

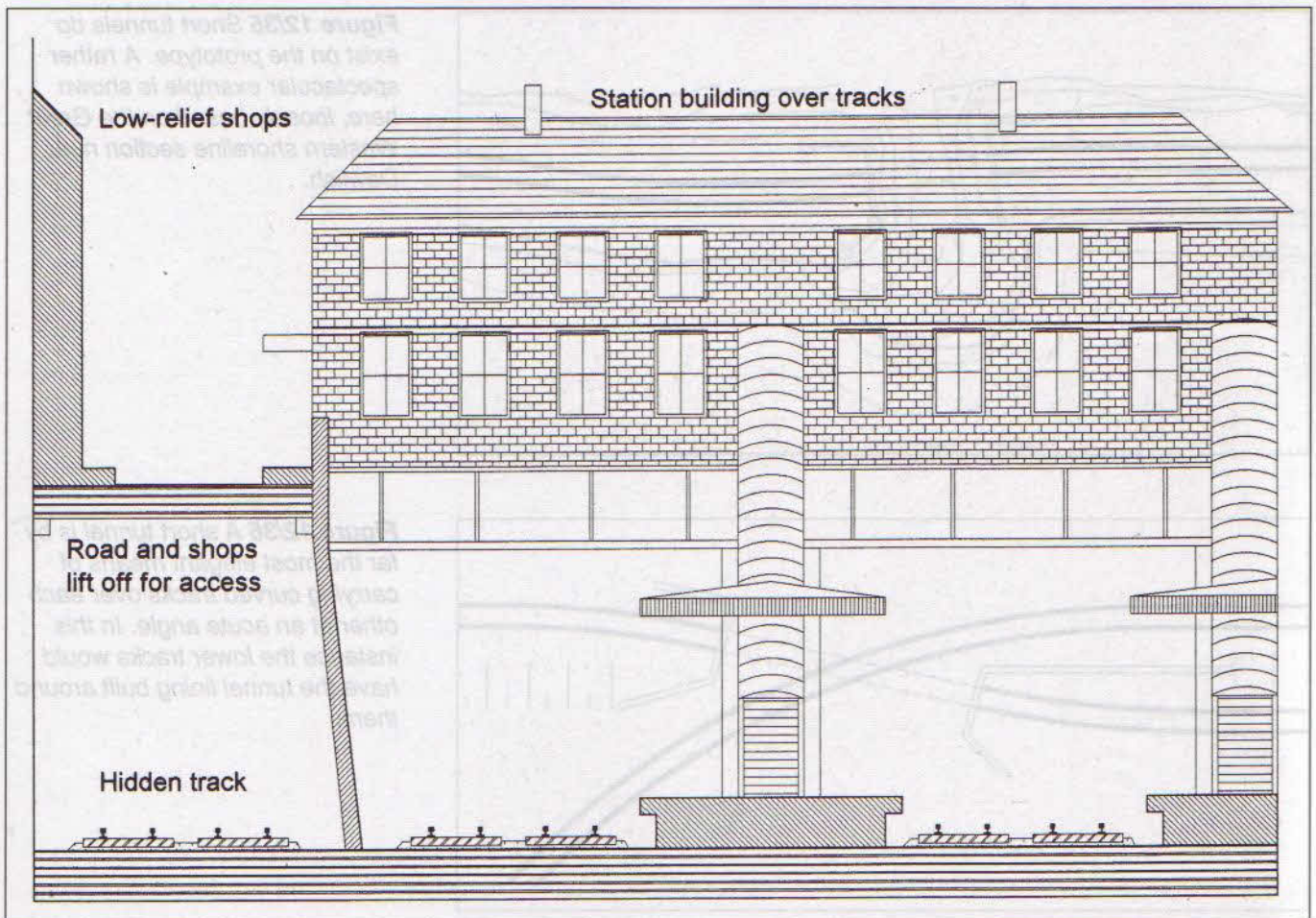

Figure 12/33 Occasionally, where width is limited on the prototype, station buildings are built over the tracks. Custom House and Canning Town stations on the GER line to North Woolwich in East London are extreme cases, since one had to climb stairs to reach the booking office from the road at track level. The more usual situation is where the station is in a cutting. In this example I show a road at high level, with low relief shops, covering hidden tracks. Note the very substantial girders supporting the station building.

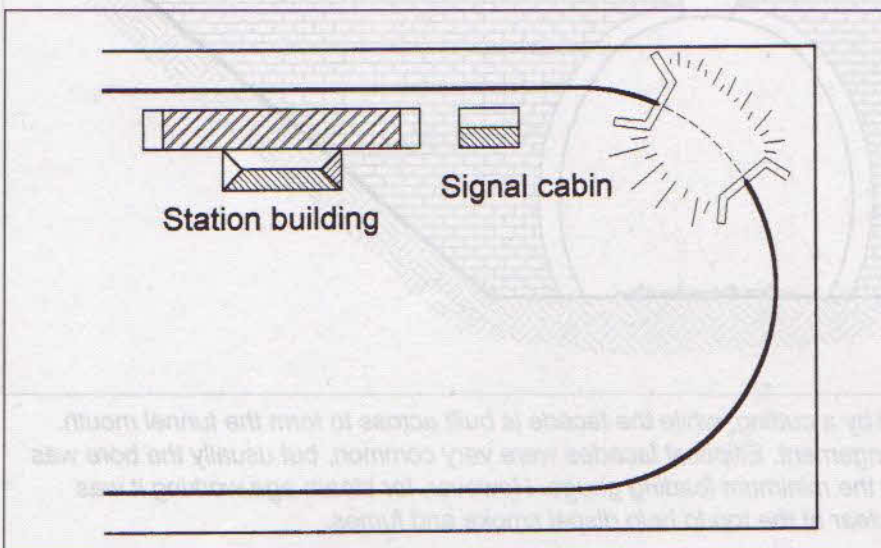

Figure 12/34 Tunnels are very popular with railway modellers. However, this can be taken too far, as this diagram reveals. A simple oval scheme on a 6 x 4 board has acquired a 'tunnel', but the impression is that the engineer headed straight for the only hillock on an otherwise flat plain. There is just one merit in this scheme: the tunnel is short enough not to give problems when something comes off the track.

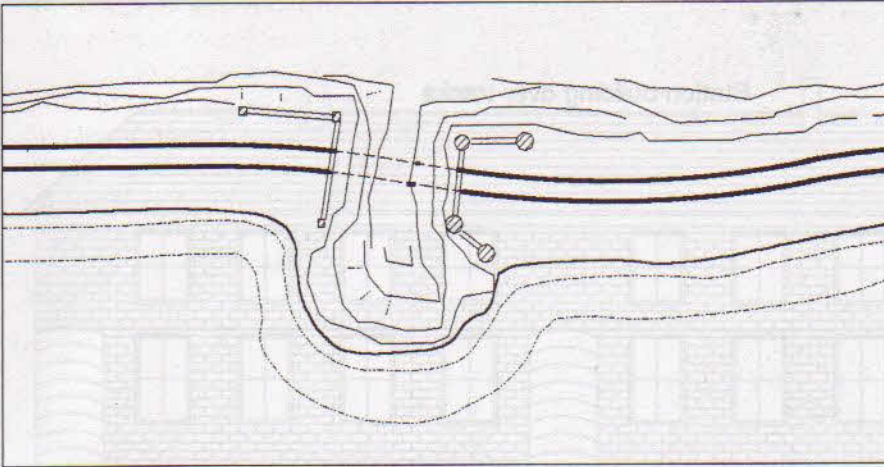

Figure 12/35 Short tunnels do exist on the prototype. A rather spectacular example is shown here, loosely based on the Great Western shoreline section near Dawlish.

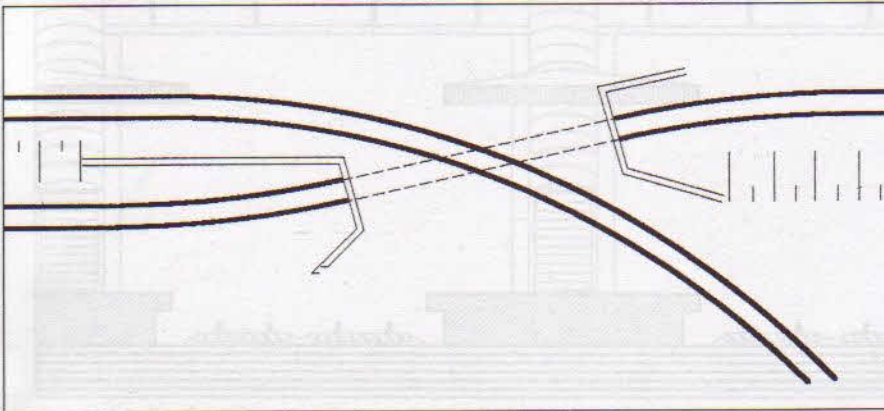

Figure 12/36 A short tunnel is by far the most elegant means of carrying curved tracks over each other at an acute angle. In this instance the lower tracks would have the tunnel lining built around them.

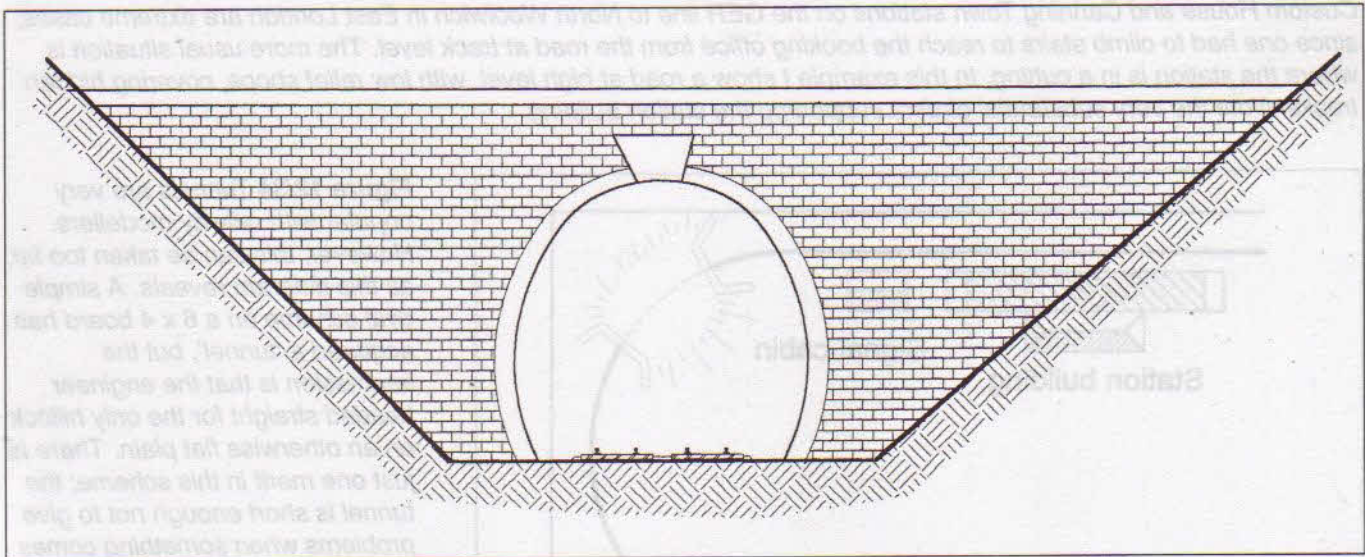
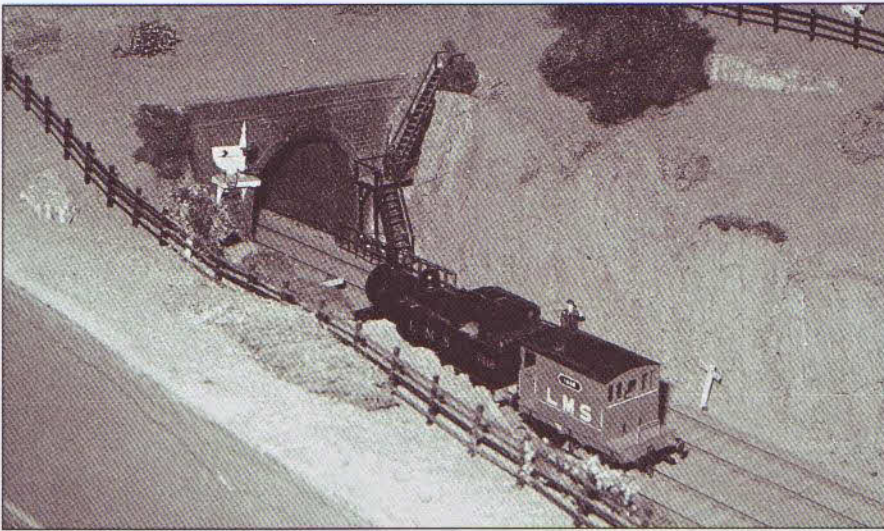

Figure 12/37 Most tunnels are preceded by a cutting, while the facade is built across to form the tunnel mouth. Utilitarian brick is the most common arrangement. Elliptical facades were very common, but usually the bore was soon reduced to something approaching the minimum loading gauge. However, for steam age working it was considered wise to allow about a metre clear at the top to help dispel smoke and fumes.



In this 7 mm tunnel facade on the Ilford & West Essex club layout, the plain appearance of a standard masonry frontage is enlivened by a distant signal with backing plate to improve visibility, and a timber access staircase for maintenance workers.

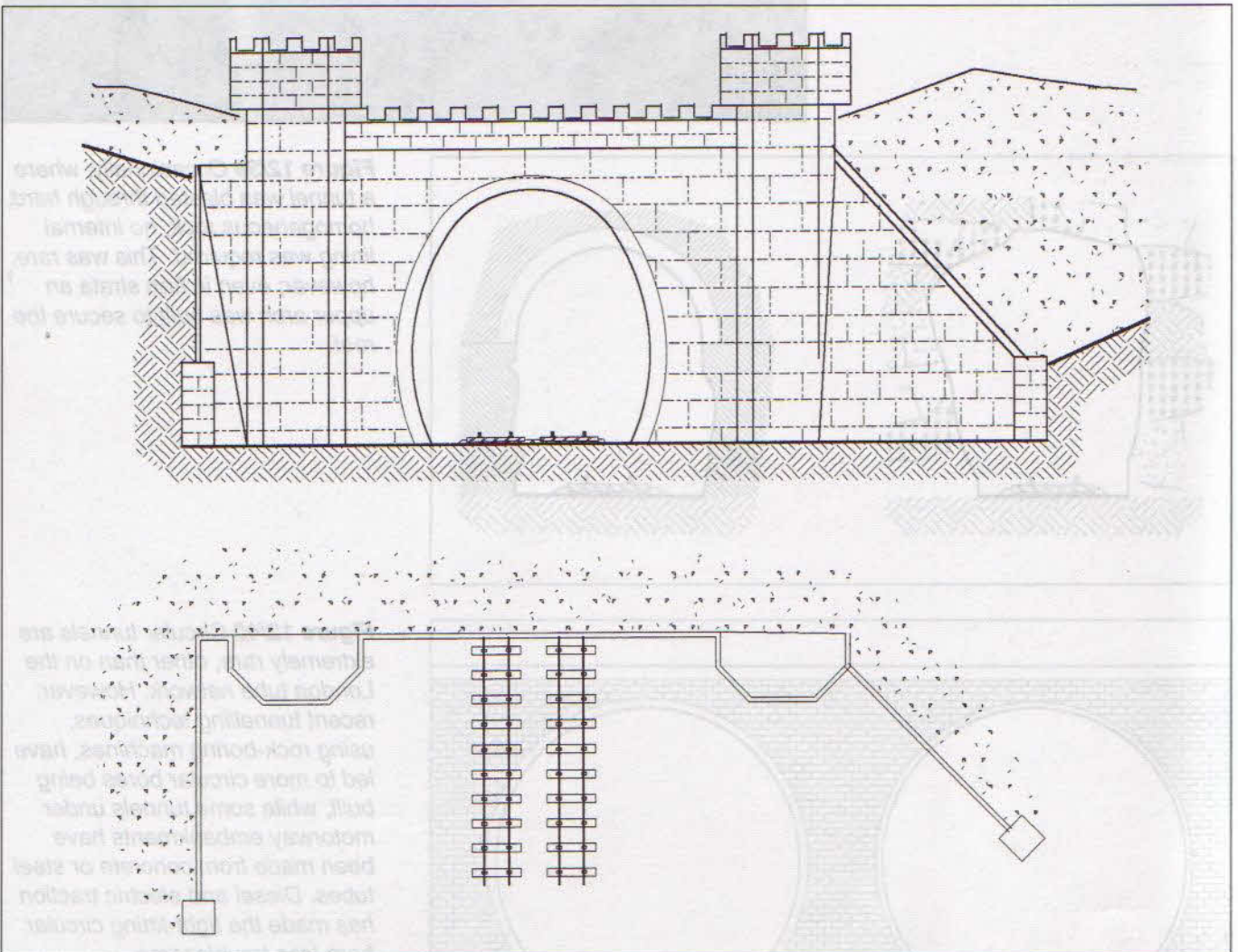

Figure 12/38 Although the castellated tunnel facade appears little more than a folly, in practice this design, with its dummy towers, formed an extremely strong structure to hold back loose ground. That few people could see such structures seems not to have deterred early engineers.

The Faller 'Lorelei' tunnel mouth kit is one of those rare examples where a model of a well-known prototype has been gleefully used in any location. It is an excellent example of the exuberant early-19th century Romantik style, a castellated facade that is best described as being in the 'Ludwig II/Disney' style.

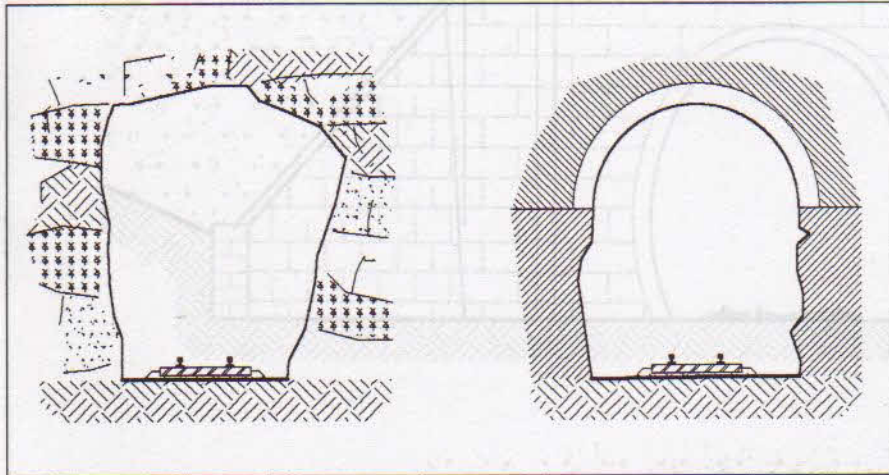
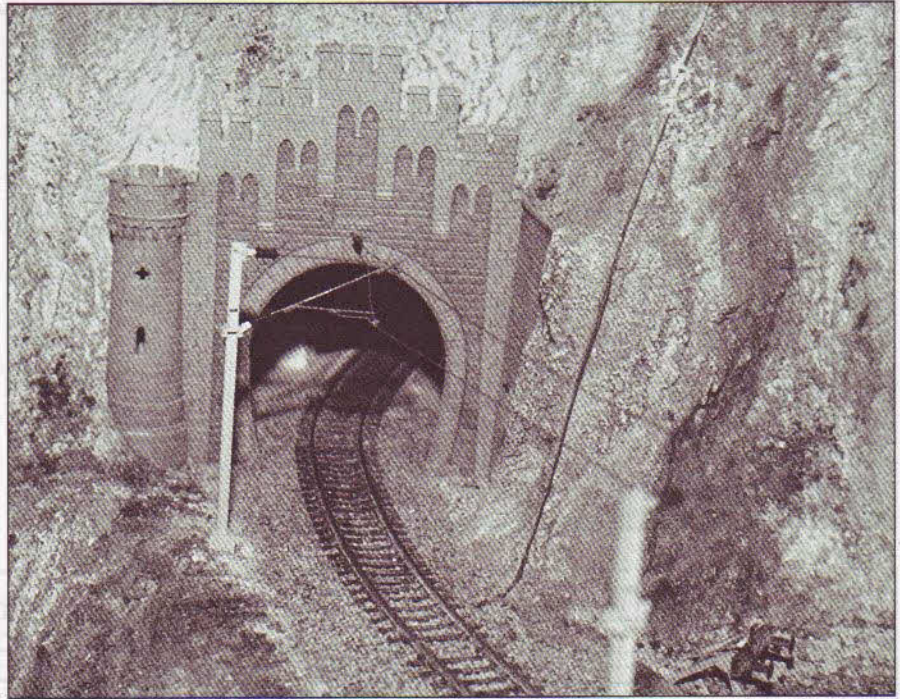

Figure 12/39 Occasionally, where a tunnel was blasted through hard, homogeneous rock, no internal lining was required. This was rare, however; even in firm strata an upper arch was built to secure the roof.

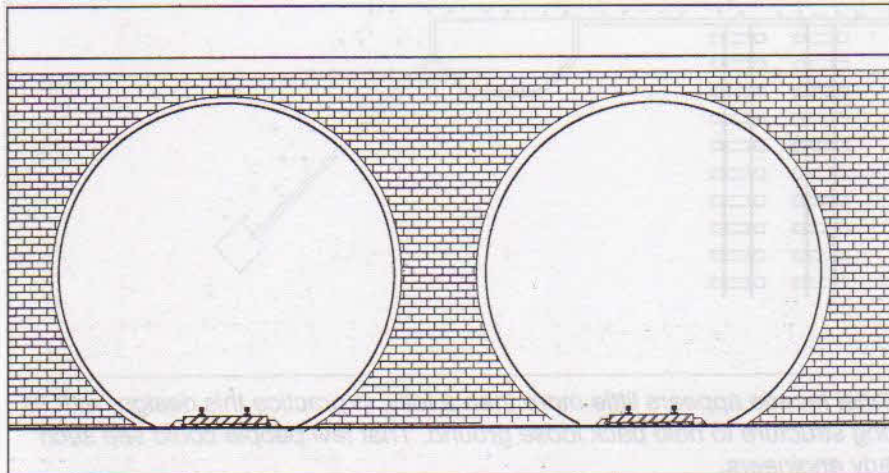

Figure 12/40 Circular tunnels are extremely rare, other than on the London tube network. However, recent tunnelling techniques, using rock-boring machines, have led to more circular bores being built, while some tunnels under motorway embankments have been made from concrete or steel tubes. Diesel and electric traction has made the tight-fitting circular bore less troublesome.

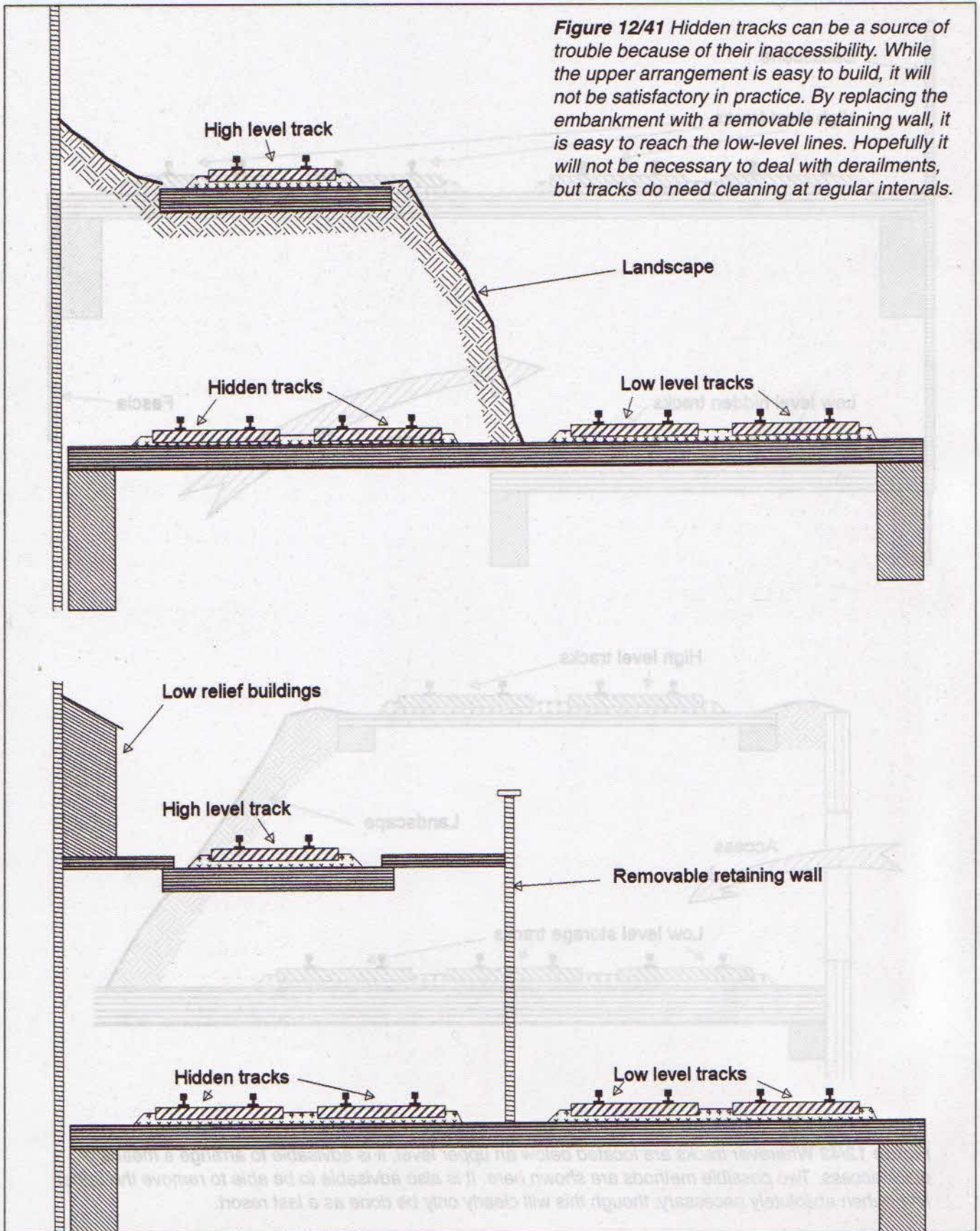

Figure 12/41 Hidden tracks can be a source of trouble because of their inaccessibility. While the upper arrangement is easy to build, it will not be satisfactory in practice. By replacing the embankment with a removable retaining wall, it is easy to reach the low-level lines. Hopefully it will not be necessary to deal with derailments, but tracks do need cleaning at regular intervals.

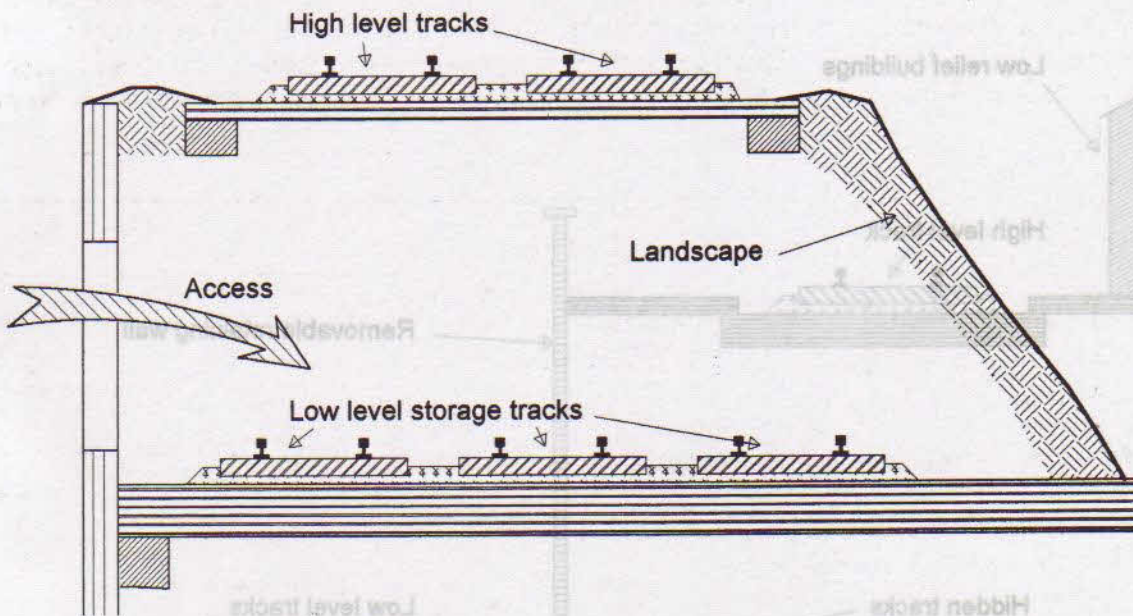
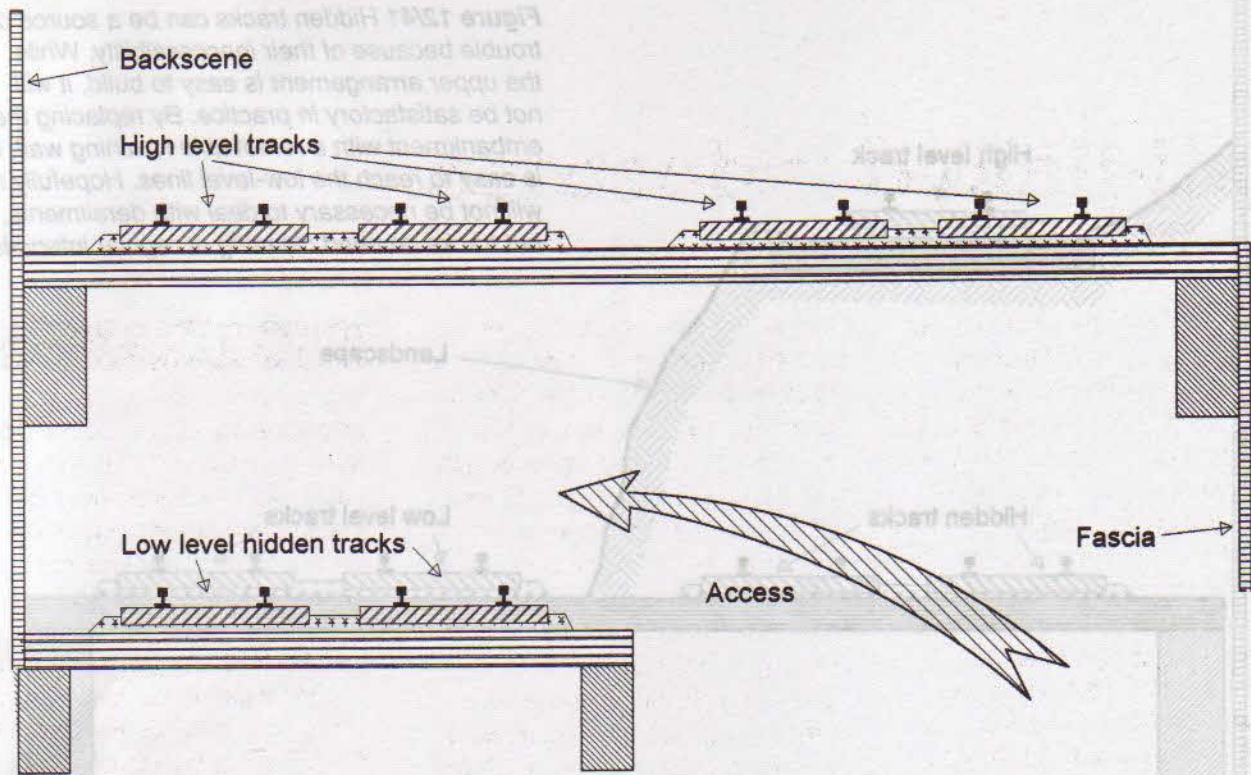

Figure 12/42 Wherever tracks are located below an upper level, it is advisable to arrange a means of quick access. Two possible methods are shown here. It is also advisable to be able to remove the upper level when absolutely necessary, though this will clearly only be done as a last resort.

Chapter 13

Rail-linked industries

Throughout the 19th century it was the aim of any forward-looking industrial concern to have its own link to the rail network. Large factories had a sizeable internal rail network and a small locomotive stud to shunt the wagons. There were also extensive industrial networks, mainly serving mineral sites and large docks; some even operated passenger services. However, in this section we are primarily concerned with the industries one could find alongside the main-line railways.

Gasworks

Until the construction of the gas grid (which predated North Sea gas by nearly a decade), most

towns had their own gasworks, which was usually located as close to the railway as possible since it needed a bulk supply of coal in wagon-loads and had to despatch coke and, usually, coal tar in tanks. Consequently the first lineside industry that should be considered is the gasworks. Although a good representation is achieved with nothing more than the characteristic gasholder, the full range of equipment does make a very attractive model. Peter Denny has studied the subject in some depth and his account in the second volume of *The Buckingham Branch Lines* (Wild Swan, 1995) provides sufficient information for most modellers.

Mineral traffic

Mineral traffic was rail-borne before railways as we know them were invented. While much of this traffic has since gone over to roads, a goodly proportion is still carried by rail. Coal was the predominant mineral, but limestone, ironstone, slate and latterly china clay have played an important part in our railway history. Many of these industries have been the subject of monographs.

Docks

The advantage of a dock setting is that any type of traffic can be justified. The disadvantage is that docks are very large. Despite this

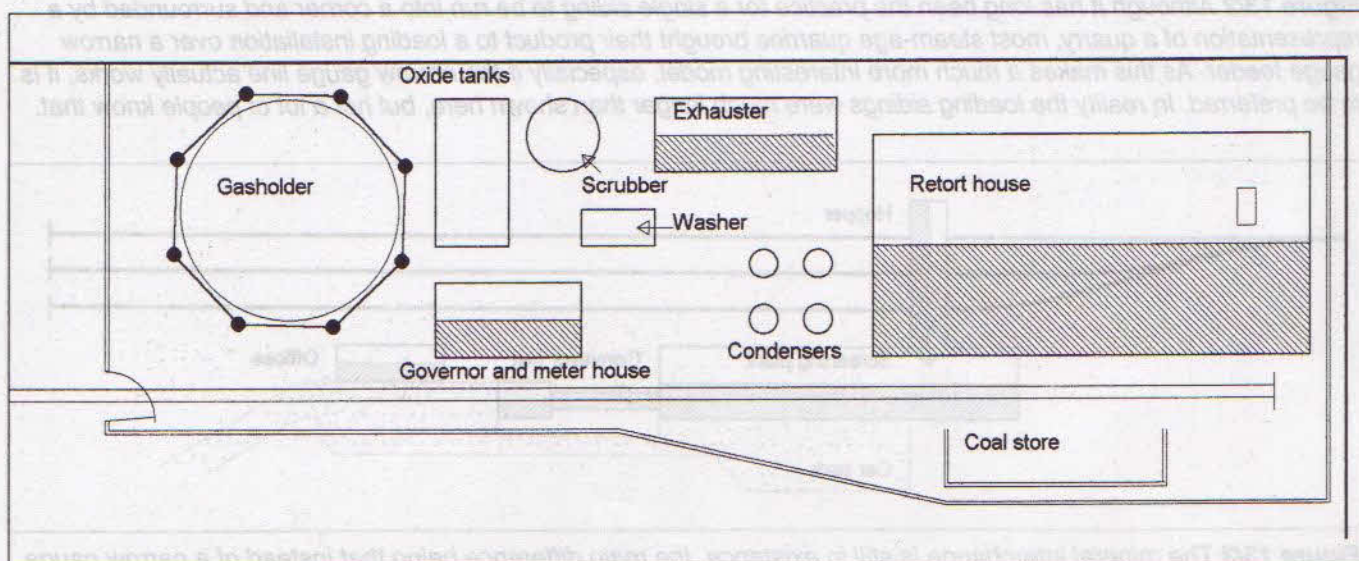

Figure 13/1 A simplified plan for a lineside gasworks, showing the principal parts of the complex. In practice, the retort house, governor house and above all the gasholder – usually miscalled the gasometer – are the essential features. This plan is based on information supplied by Peter Denny, who has no less than three gasworks on his 'Buckingham' layout – one at each station.

there have been many successful models where docks and harbours have been simulated to good effect. Although those of Britain's docks that remain active ports have been completely transformed in recent years, not only has our maritime history been well recorded, but many of our smaller ports, which have turned to the tourist trade, retain most of the dockside features, albeit in a tidy, some might say sanitised, form. For all that, they retain their fascination and provide ample inspiration for the modeller.

Industry in general

The main reason for having industry on a model railway is to generate traffic in a logical manner. It is not necessary to go into great detail: one industrial building is very much like another, and most manufacturing processes take place under cover and have no direct impact on the model.

It is often suggested that, in order to include an industry on a model railway, one should make an in-depth study of the subject. The snag with this idea is that it

can take a long time to ferret out details, especially when the firm you wish to model went out of business over 30 years before. Never forget the golden rule of research: it takes up a lot of valuable modelling time. There are some excellent kits for industrial buildings – all you need add is a personalised nameboard.

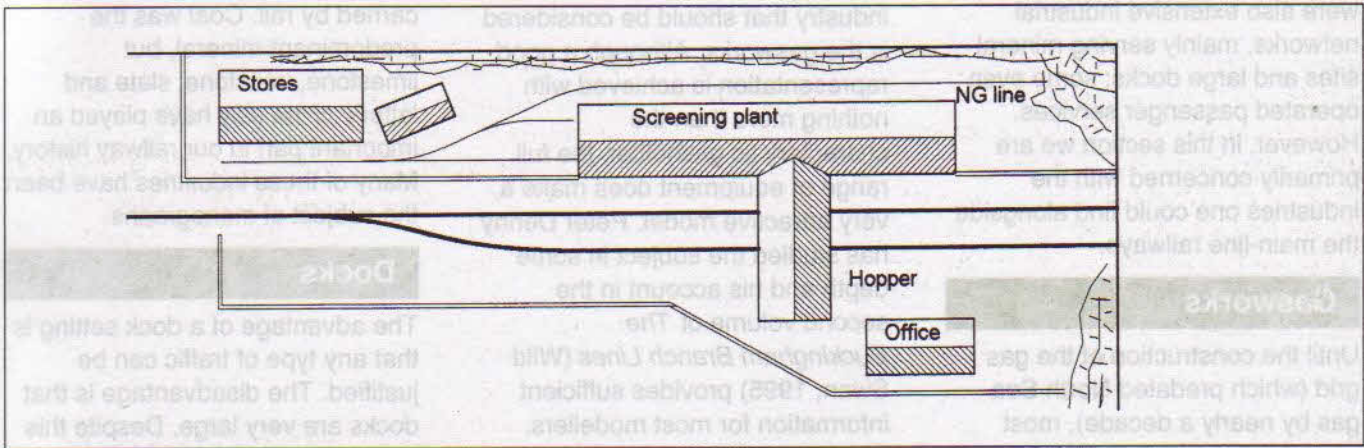

Figure 13/2 Although it has long been the practice for a single siding to be run into a corner and surrounded by a representation of a quarry, most steam-age quarries brought their product to a loading installation over a narrow gauge feeder. As this makes a much more interesting model, especially if the narrow gauge line actually works, it is to be preferred. In reality the loading sidings were much longer than shown here, but not a lot of people know that.

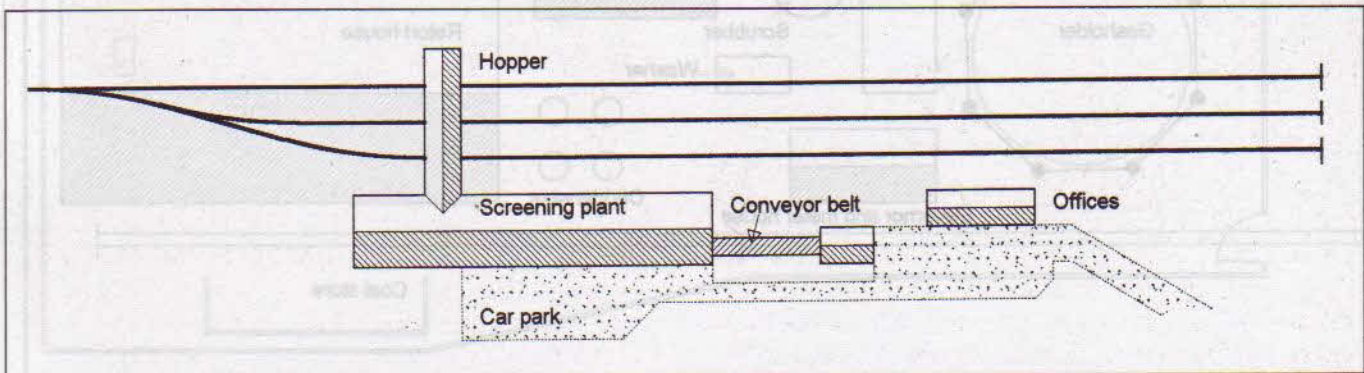

Figure 13/3 The mineral interchange is still in existence, the main difference being that instead of a narrow gauge feeder, dumper trucks bring the mineral to the loading facility. The graded minerals are loaded into high-capacity hopper wagons and, in the best-known example, that of Yeoman, hauled over Railtrack metals by privately owned diesels. The only snag is that the loading sidings need to be much longer since everyone knows just how long the trains are.

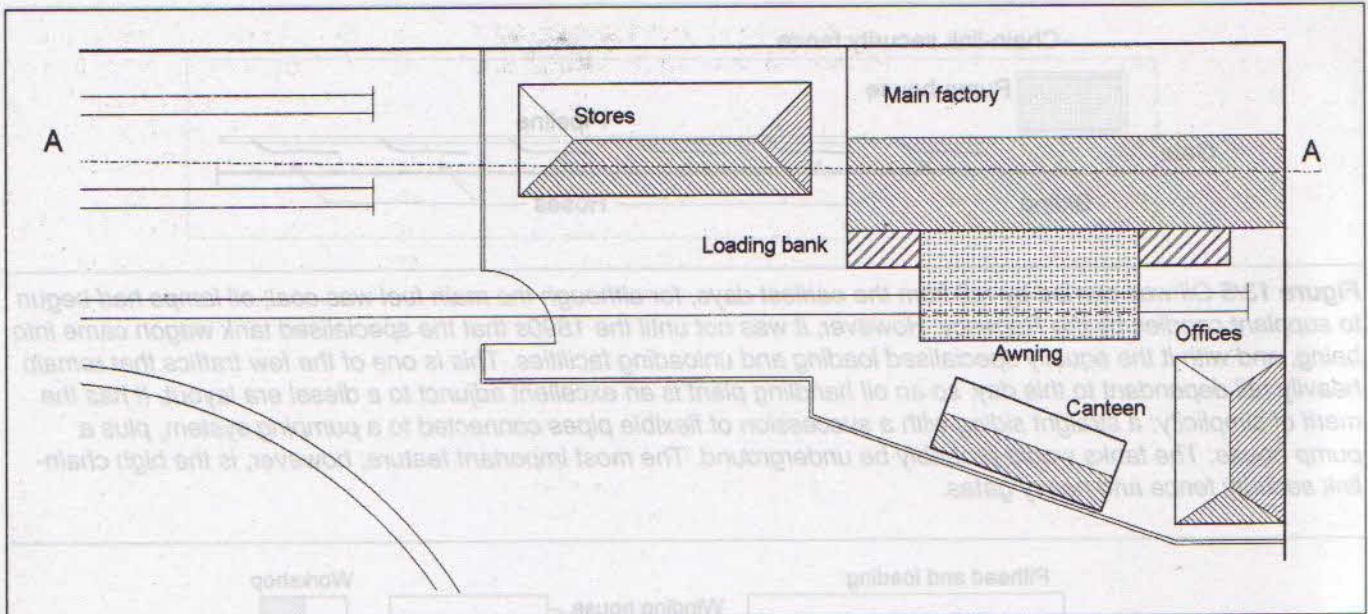
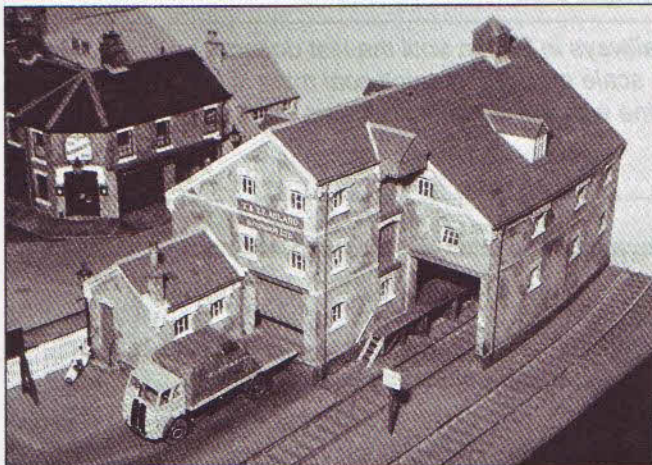
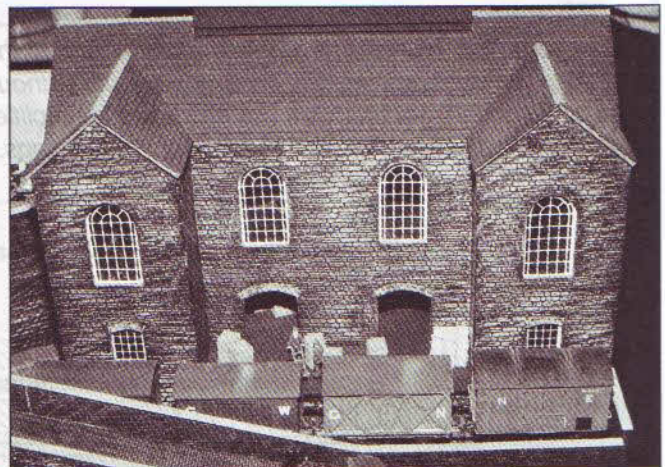

Figure 13/4 The rail-connected factory makes a good feature for a corner site. The main item should be the loading platform, but even this can be dispensed with if the principal use of the siding is to bring in coal for the factory's boilers. It is not fully appreciated that many small market towns, which were on the face of it solely concerned with farming, supported thriving engineering works, which needed ample supplies of coal and produced heavy loads for the railway. There were also breweries; while we tend to think of traffic in beer, we should not forget that they required good supplies of coal in addition to the obvious malt and hops. In Scotland there are distilleries, requiring coal and grain. Keeping to the farming theme, dairy depots with their trains of glass-lined milk tanks were prominent features from the mid-'30s to recent times.

Your factory's products can be whatever your imagination decrees. However, it is a pity that the widget, once the archetypal joke product, has now been brought into being in, of all things, a can of beer.



A neat example of a rail-linked industry of indeterminate nature. With the rail loading taking place under cover and the road loads neatly sheeted against the weather, anything could be made or handled here.



This mid-Victorian warehouse is provided with a large loading platform with a rail siding, but also has no indication of purpose. The model's character is created by the two projecting ends and the interesting windows, while the roof line is broken with a louvred ventilator. Little touches like this add to the interest, while the anonymity of the building makes it easy to account for special loads.

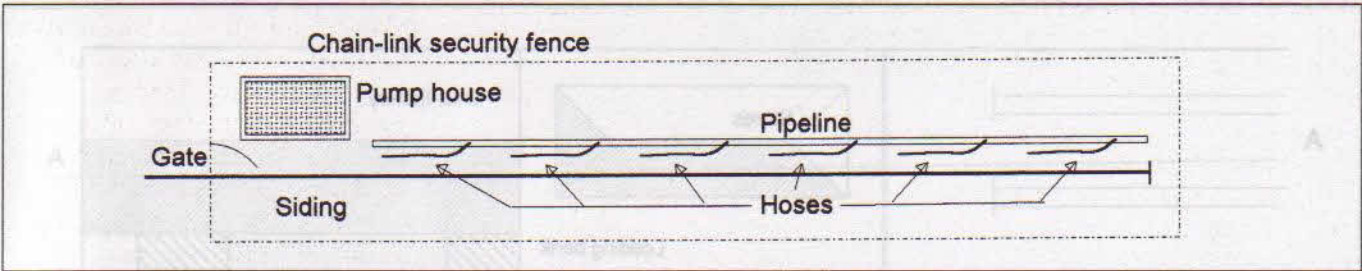

Figure 13/5 Oil was carried by rail from the earliest days, for although the main fuel was coal, oil lamps had begun to supplant candles by the Regency. However, it was not until the 1890s that the specialised tank wagon came into being, and with it the equally specialised loading and unloading facilities. This is one of the few traffics that remain heavily rail dependant to this day, so an oil handling plant is an excellent adjunct to a diesel era layout. It has the merit of simplicity: a straight siding with a succession of flexible pipes connected to a pumping system, plus a pump house. The tanks would probably be underground. The most important feature, however, is the high chain-link security fence and heavy gates.

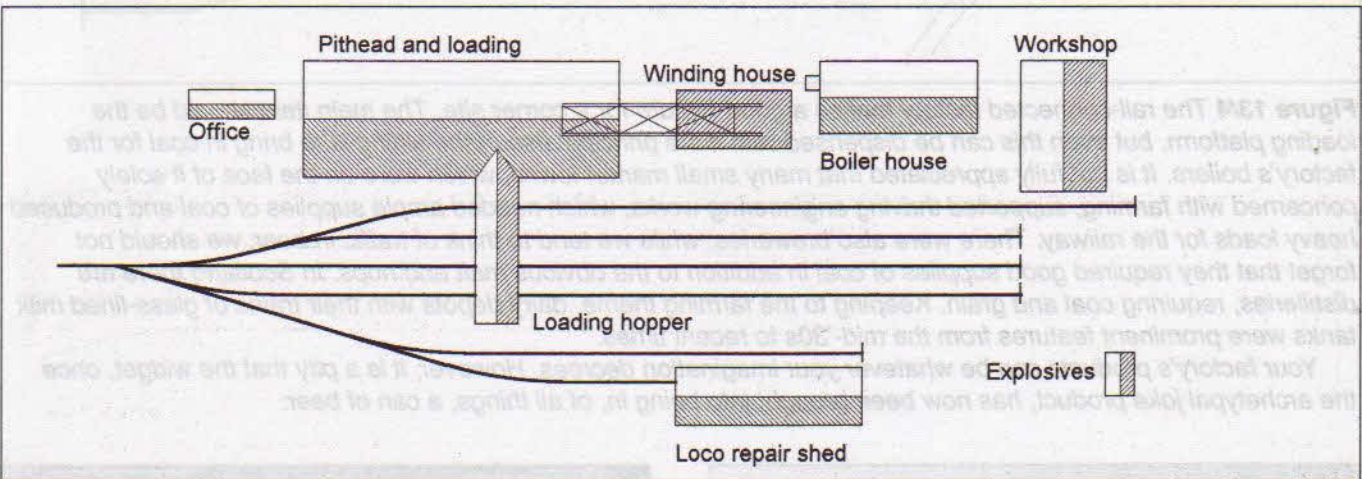

Figure 13/6 Coal has been a staple traffic from the birth of railways in Britain until the last decade, and coal mines have long featured prominently on larger layouts, although a scale model of a small coal mine is larger than most of us could accommodate. This sketch shows a simplified mine with the essential features marked. Note the explosive shed, well away from the rest of the buildings.

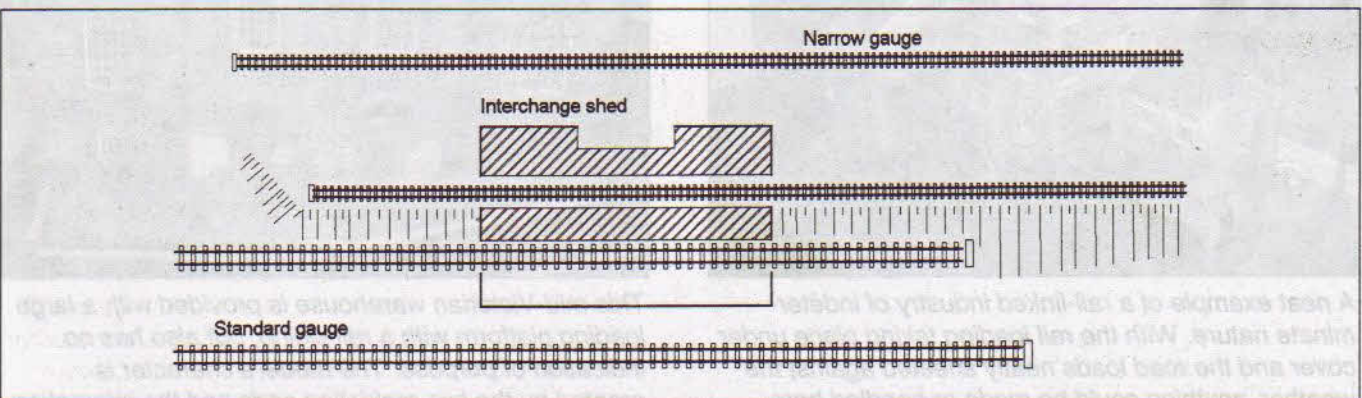

Figure 13/7 While not strictly an industry, the fact that most British narrow gauge lines were primarily built to bring a mineral to the standard gauge railhead allows us to consider the mechanics of interchange. British practice was based on moving the product from narrow to standard gauge by hand rather than by mechanical means. At the most an interchange shed was provided.

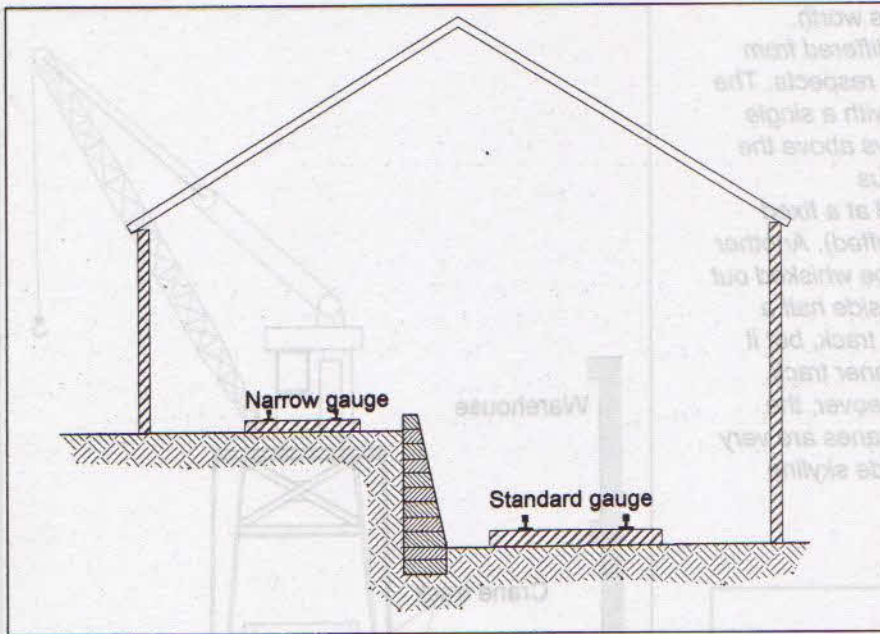

Figure 13/8 Since mineral transfer between narrow and standard gauge was in one direction, gravity was frequently called in to assist the transfer, and many interchange sheds took this form. As a two-level system is visually attractive, it makes a good prototype to follow. As the transfer was carried out under cover, the static nature of the display is not immediately apparent.

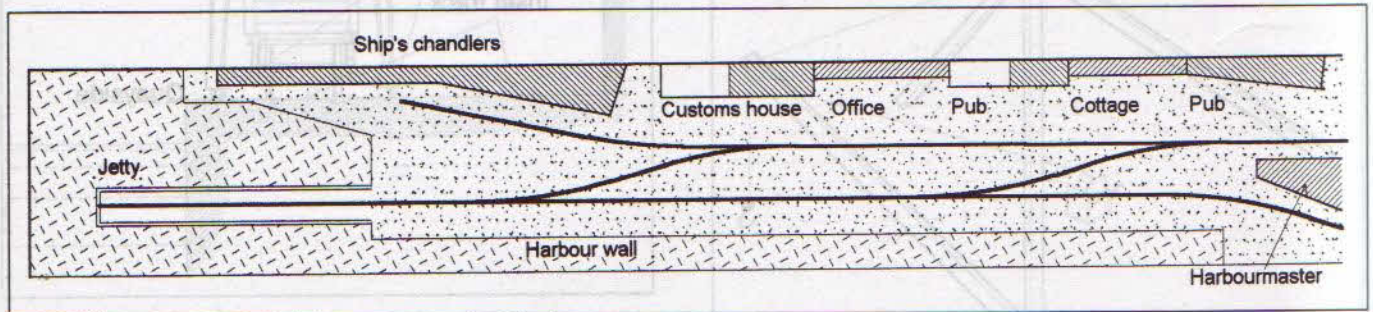

Figure 13/9 Most docks were rail connected and many had their own railway system. However, the sheer size of the installations makes this type of rail-connected industry only suitable as a model in its own right. However, several small ports had rails on the quayside, the best-known example being the Weymouth Tramway, which still survives, albeit as an occasional railfan venue. The main attraction is the wide range of buildings found along such quays. Although many buildings have changed their purpose, enough remains for the architectural modeller to be able to recreate the ambience of these attractive industries.



Dockside scenes are always of interest, so much so that one tends to overlook improbabilities. While this model avoids the common mistake of introducing a large vessel and so swamping the model, the arrangement of the pier, with platform for ferry services, parallel to the quayside is decidedly unusual. On the other hand it does make an attractive model.

Figure 13/10 Before we leave docks, it is worth mentioning that dockside cargo cranes differed from the dockyard crane in several significant respects. The most important feature was the high jib with a single fall to a plain hook or shackle. The pulleys above the cab are the level luffing gear, an ingenious arrangement whereby the load remained at a fixed height as the jib was brought in or out (luffed). Another feature was speed: a 1½-ton load could be whisked out of the hold and into the waiting wagon inside half a minute. The crane straddled one railway track, but it was more usual to load wagons on the inner track. This drawing is taken from memory; moreover, the crane is somewhat underscale. Cargo cranes are very large items and still dominate the dockside skyline even where they are no longer in use.

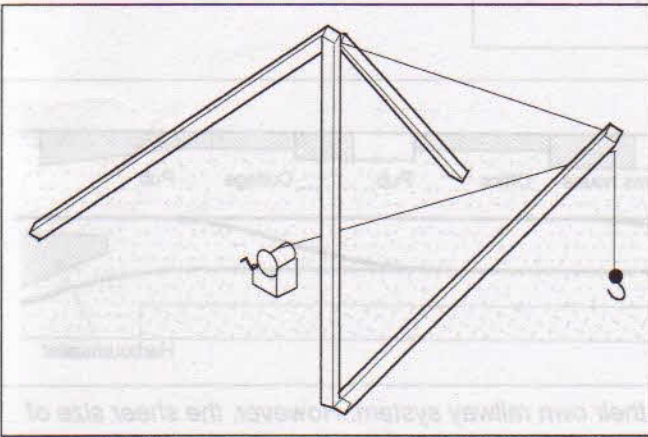
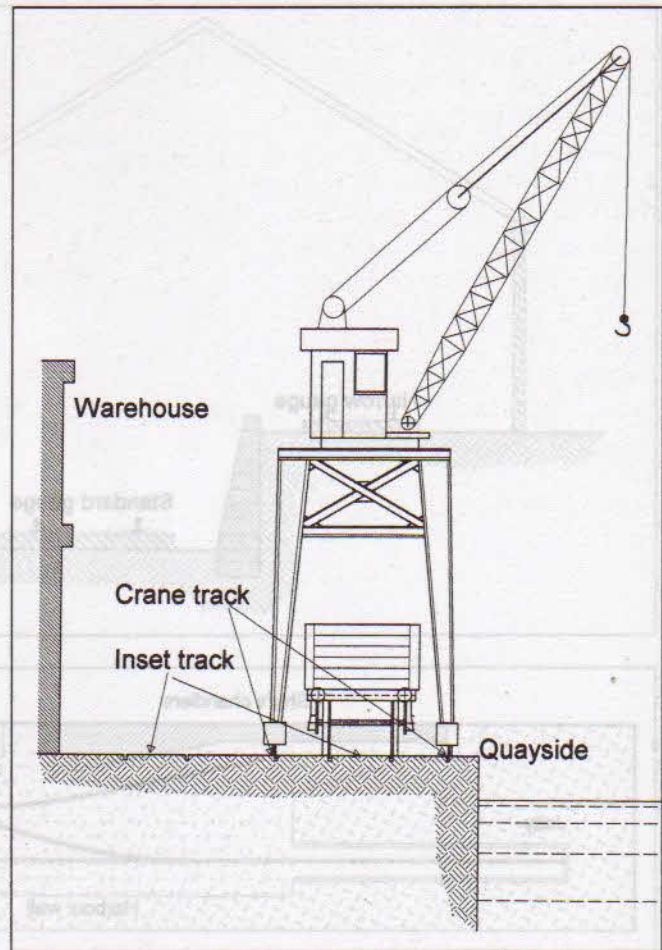

Figure 13/11 Talking of cranes, a common feature of steam-age railside industries was the scotch derrick. It consisted of four large balks of timber, one vertical, two attached to the vertical and arranged at right angles, and the fourth pivoted at the base of the vertical to form the jib. A winch, possibly steam-powered, possibly driven by an oil engine but, in many cases, a simple hand-worked winch, provided the lift. It was simple, but highly effective.

Figure 13/12 A loading bank with scotch derrick. This arrangement was used for any moderately heavy load, but was most closely associated with timber and stone blocks.

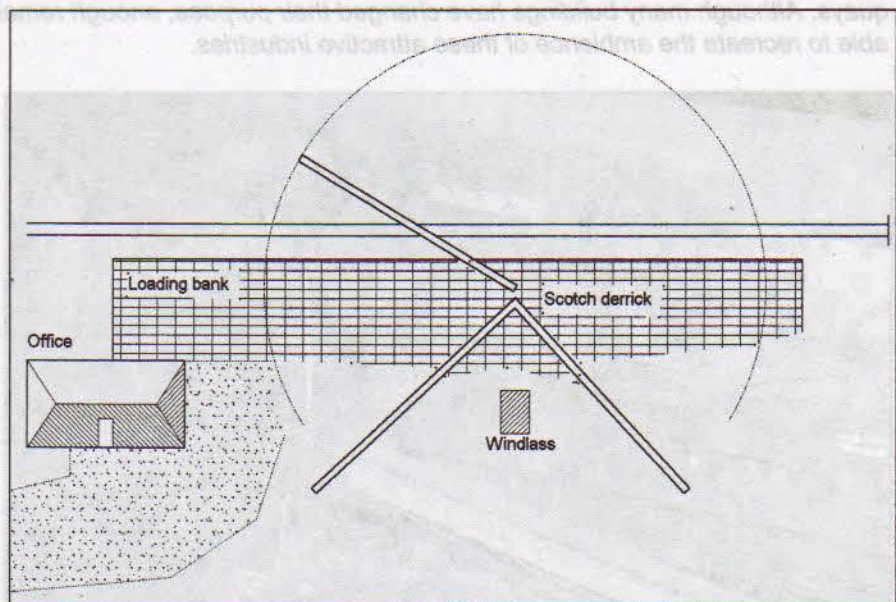

Figure 13/13 A more advanced form of craneage is the high-level gantry crane, which we have already met as the Goliath. This drawing shows a simpler arrangement, where a 'crab' slides along an RSJ (rolled steel joist), which can run up and down rails held on a pair of raised RSJs supported by further joists. Most modern installations are electrically driven, with a set of push-button controls suspended by a cable from the crab. The gantry cranes of my youth were worked by hand with continuous chains.

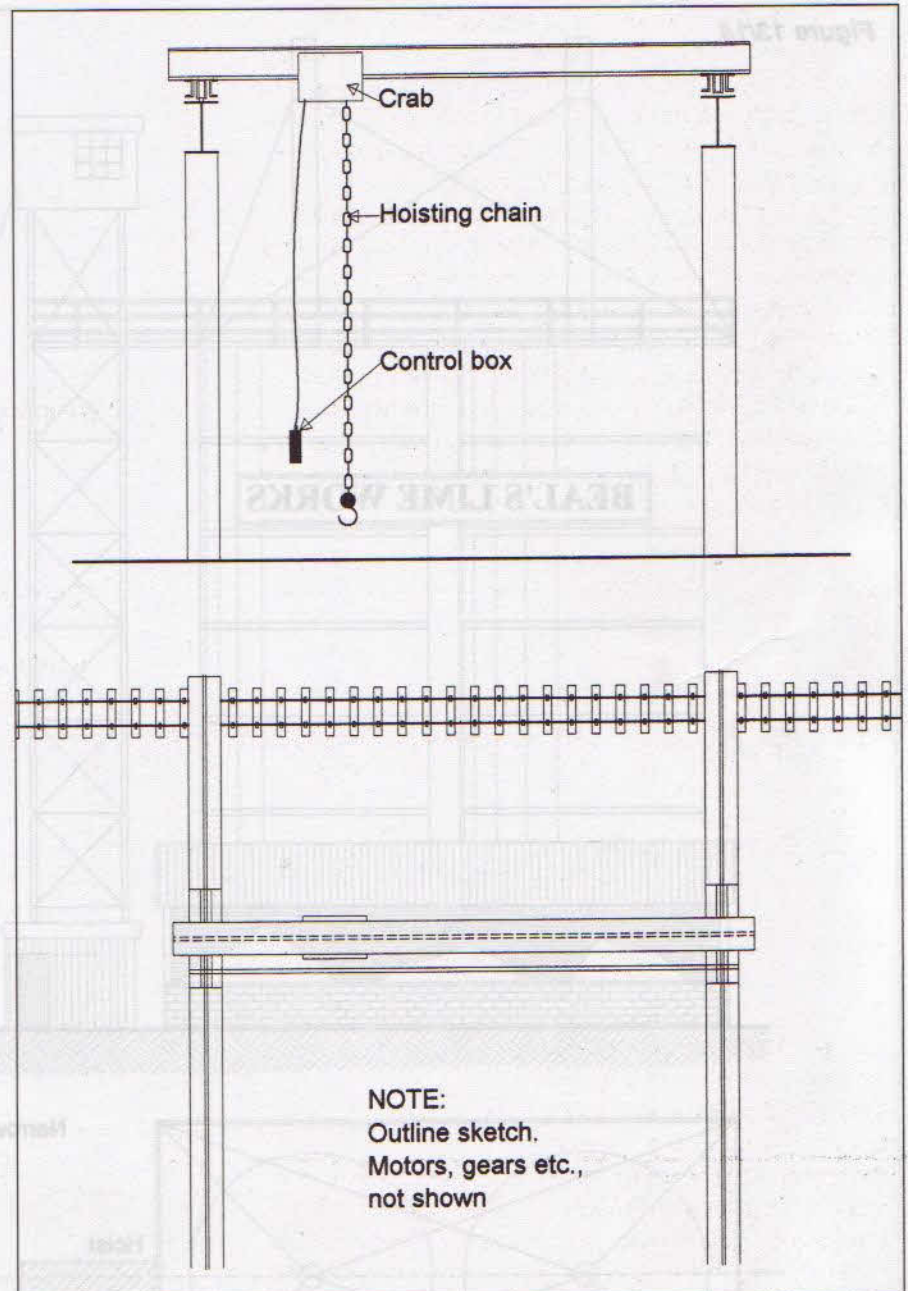

Figure 13/14 (next page) I cannot leave rail-linked industries without this tribute to my old mentor and latterly pen friend, Edward Beal. His lime works is something of a classic, but as all versions of his original drawing are now in out-of-print books and magazines, I've redrawn the essence of the design.

The history is interesting. A letter in *Model Railway News* asked, plaintively, what could be done with cylindrical scouring powder containers. Edward Beal took up the challenge, and after listing a series of possible uses in the next issue, he produced his drawing of the lime works a couple of months later. I've made a reasonably faithful copy, but added the nameboard.

The only point is that I've not seen a carton of scouring powder for several years. However, we do now have a wide selection of plastic tubes and bottles, so I see no reason why this very effective model should not get a fresh lease of life. Of course, were a kit manufacturer to take it up it would make a wonderful tribute to the man who, more than anyone else, put small-scale model railways on the map.

Figure 13/14

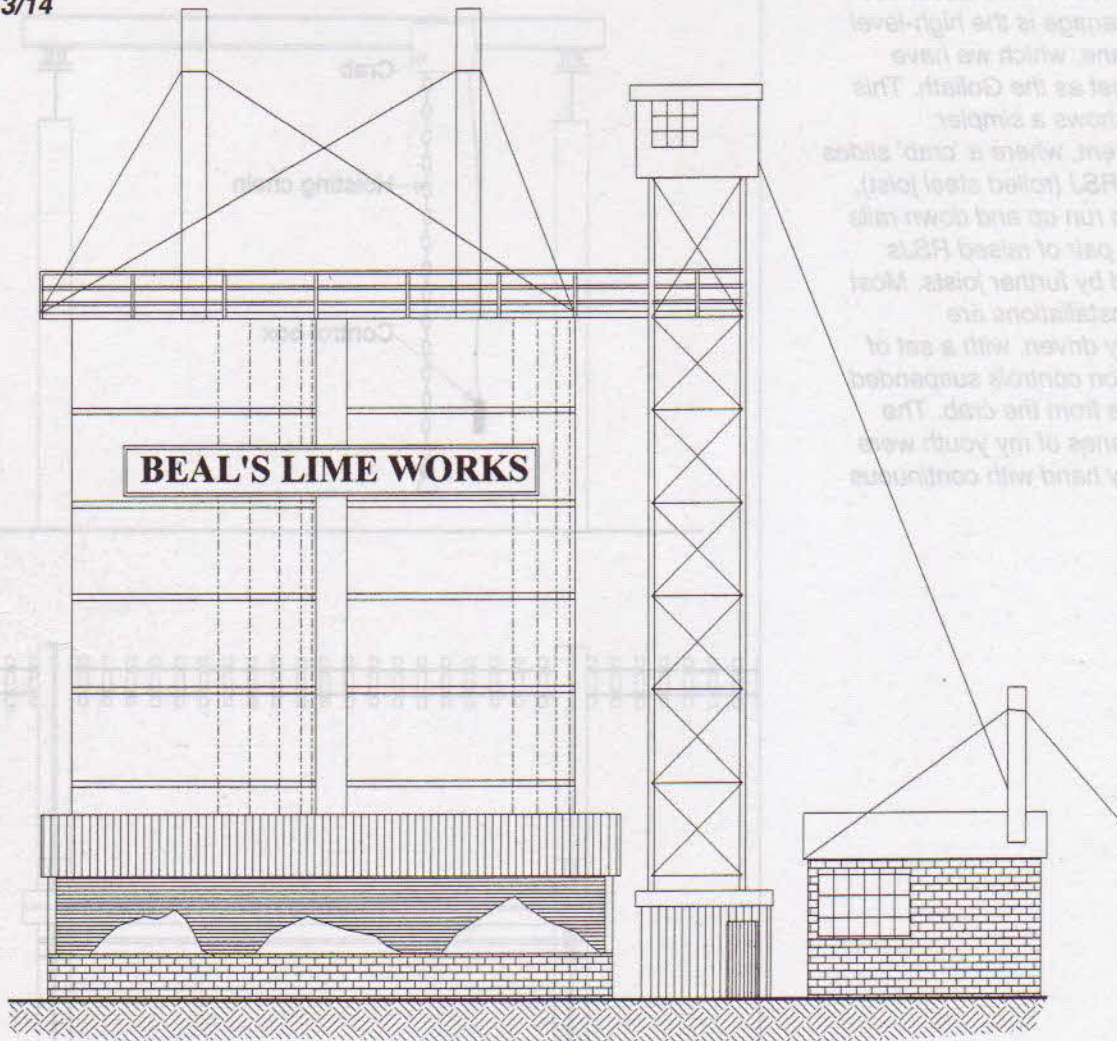
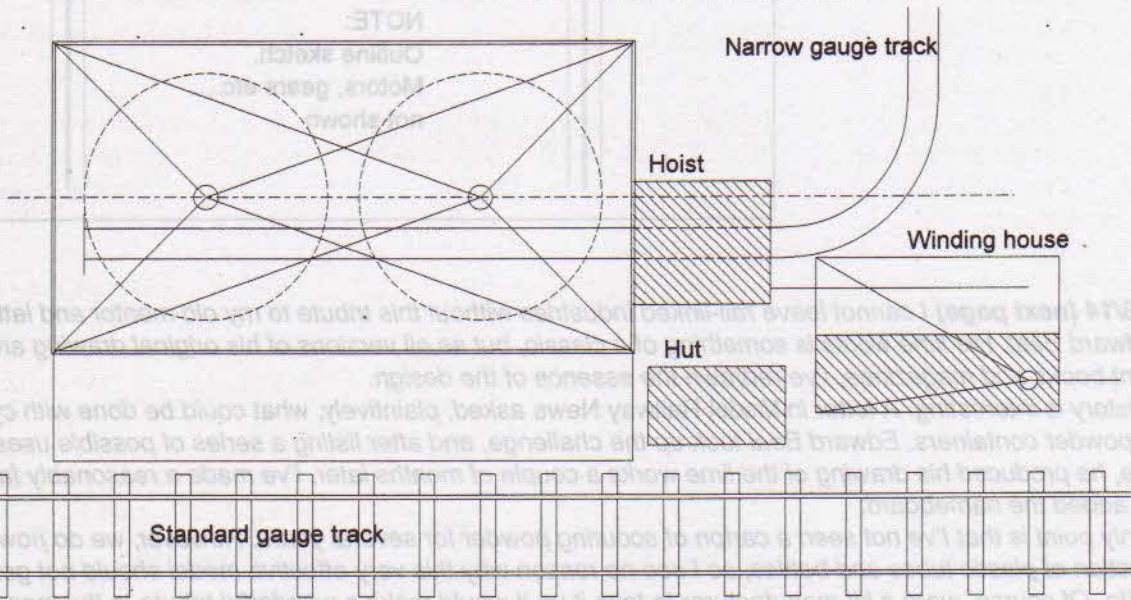

Figure 13/14 A more advanced form of carriage is the high-level gandy crane, which we have already met as the Goliath. This drawing shows a simpler arrangement where a 'cab' slides along an RSL (rolled steel joist), which can run up and down rails held on a pair of raised RSLs supported by further joists. Most modern installations are electrically driven with a set of push-button controls suspended by a cable from the cab. The gandy cranes of my youth were worked by hand with continuous chains.



Chapter 14

Beyond the railway fence

For the first 40 years of the hobby it took so much effort and time to lay the track from basic components, then build the locomotives, coaches and wagons to run over them that even the railway buildings were something of an afterthought. Anything outside the railway fence was unthinkable, not that there was over-much room to spare for anything other than tracks when you had to fit an O gauge system into anything smaller than a barn. At the most, there might be a scenic corner. This would be made by covering the bare boards with a piece of virulent green cloth grazed by a couple of leaden cows. That these beasts, from Britain's range of farm animals, were $\frac{3}{8}$ inch scale (1:32), whereas the railway was 7 mm to the foot, was immaterial; should anyone question it, one could always mumble something about the nourishing nature of chenille.

The advent of OO gauge began to change this, although in Britain the big impetus towards scenic modelling began in the 1940s, when wartime shortages brought conventional model railway development to a halt. Scenic and architectural modelling, which could be carried out with what materials were available, became the only way a modelmaker could progress. John Ahern's 'Madder Valley Railway', happily preserved in Pendon Museum, began the principle of setting the railway within a modelled community.

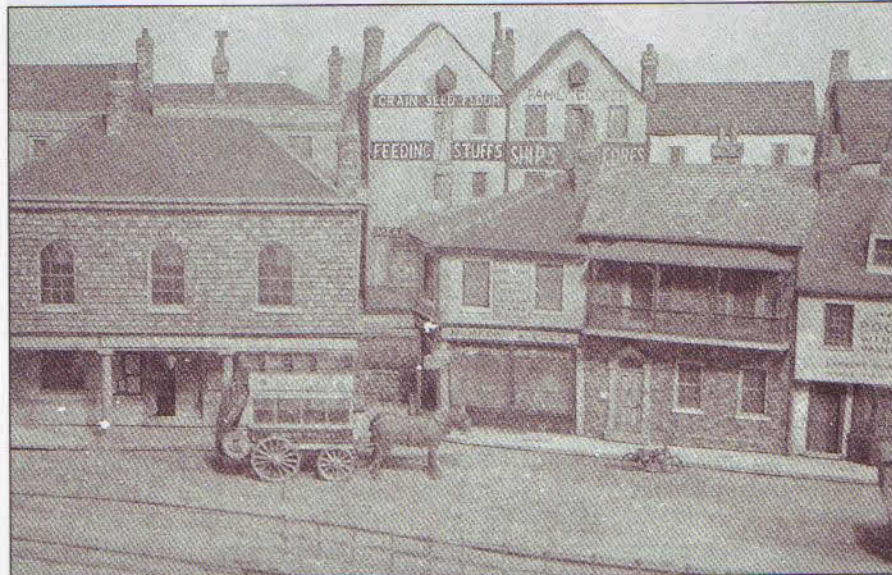

Although there had been earlier examples of model railways with numerous buildings 'outside the railway fence', the genre did not begin to attract mainstream attention until, in the dark days of the Second World War, John Ahern unveiled the 'Madder Valley Railway', a delightful rural system that served the fictitious Madderport. Happily preserved at the Pendon Museum, the models remain to demonstrate how observation, coupled with imagination, can create a little world that has a life of its own.

Just as it is

In recent years a number of modellers have begun to model selected sections of the prototype 'just as it is' – or, since most are set in the steam age, 'just as it was'. Every detail that can be tracked down is faithfully reproduced to the minutest detail, *provided that it falls within the limit of the baseboards.*

Anyone who wishes to follow this particular discipline is, of course, completely free to do so. By the same token I feel free to

say that I find most examples of this type of model extremely dull. The snag is that the long-departed steam-age branch terminus was frequently just far enough away from the community it served for the nearest building to be a good 200 mm away from the baseboard edge when reproduced to 4 mm scale! As a result, although the model is technically accurate, it fails to show why the station is there in the first place.

Of course, should there be sufficient space for the station and most of its village to be modelled



For some reason, the pub is one of the more popular themes for a non-railway building, and even the most compact of layouts can usually find a corner for one. Alan Wright's 'The Ingle Nook' looks absolutely right in its setting, although in point of fact it is so small as to lay claim to being the smallest pub in Britain.



Most lineside structures are either factories or shops; not only are these more varied than straightforward housing, but they also add to the interest. It is a long-established principle that small businesses should be named after friends or, as in this example on 'Benfieldside', prominent modellers. Here P. D. Hancock, whose 'Craig & Mertonford' took over where the 'Madder Valley' left off, is commemorated.

exactly to scale, then the end result can be breathtaking. However, even at the architectural scale of 1:150, which is close enough to any of the scales used for N gauge (1:160, 1:148, 1:152, take your pick), for there to be no discernible difference to the eye you need a very large area to model a small hamlet. Don't take my word for it. Go outside, pace out the length and width of your own road, use your own house as a rough measure of depth and, with the aid of a pocket calculator, find out how big it is in your chosen scale. Unless you've already done some calculations along these lines, you're in for a shock.

Suspending disbelief

One of the more endearing traits of the human race is its willingness to believe in a dozen improbable things over breakfast; hence the popularity of tabloid newspapers. This has an important bearing on the business of creating a convincing setting for our layouts. We have to make it easy for the viewer willingly to suspend disbelief and think that, although he or she is, in strict scale terms, standing on top of a tall building some distance away from the railway, the model is being viewed from the lineside.

The illusion of reality is created, not by painstaking attention to minor detail, but by putting the memorable features of the prototype in their proportionate positions. The twin roofs and facade of King's Cross station are instantly recognisable, making it very easy to persuade all but a handful of pedantic sleeper-counters that a four-track terminus, with an undersized model of the distinctive roof and a tunnel just beyond the end of the approach pointwork, is a good representation of the prototype.

Low relief

Buildings in the round take up a good deal of space, something that is notoriously lacking on most model railways. Low-relief structures along the backscene create the illusion of a townscape without taking up too much room. This is only the start: only one side of the building has to be modelled in full, and since this is usually the most interesting facade, the modelling is that more enjoyable.

What is not so widely appreciated is that low-relief models can replace much of what has traditionally been painted on the backscene. A coat of 'sky blue' emulsion paint over a sheet of board is sufficient if the middle ground of the overall picture is modelled in low relief. The depth required can be minimal: 3 mm ($\frac{1}{8}$ inch) is sufficient to allow the facade of a factory to be created, complete with inset windows. 12 mm ($\frac{1}{2}$ inch) permits the inclusion of a modelled shop window and its contents. This compression can be applied to a roadway: a carriage-way as narrow as 4 scale metres (12 feet) is acceptable along the rear of a station, although the prototype would be at least twice as wide. Footpaths can similarly be reduced in width.

The scenic corner

On most model railways, where space is at a premium, the only reasonably large space available is in the corner, a point recognised from the early days of the hobby. The scenic corner not only has a long pedigree, but is one of those timeless ideas that always comes up fresh. There are two approaches. The first is to utilise the corner to help create the appearance of a length of track away from stations, industrial

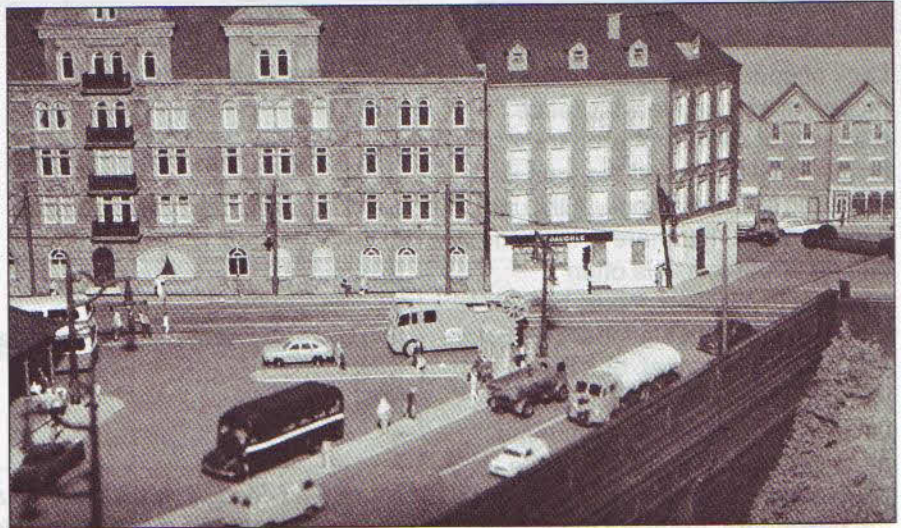

It is clearly impossible to model an entire hamlet to scale in anything smaller than a large industrial building, and even a town square takes up a considerable amount of space. A simple solution, growing in popularity, is to mount the buildings above a section of tracks, as in this case. The model then forms a scenic break while, at the same time, justifying the size of the modelled station.

sidings and other traffic creating features as a reminder of the fact that most of the prototype consists of unencumbered main line. The second approach is to appreciate that most corner curves are much too sharp and so are best hidden. One sound method is to build a townscape on to a light frame that fits neatly over the offending curve. In this way not only are the tracks readily exposed for routine track cleaning, but also the townscape can be worked on away from the railway.

Diorama modelling

The true diorama employs perspective modelling to create the illusion of depth. This works well when it is possible to confine the viewing angle and has been successfully exploited by military modellers. Their models are relatively small: anything over half a metre (1 ft 6 in) is exceptional. A model railway diorama is rarely less than 2 metres in length, even when the smaller scales are

preferred. Full perspective modelling is ruled out by the fact that viewers can take up a position anywhere along the front, but the illusion of depth can be enhanced by making the buildings and figures at the back to a smaller scale than the main foreground models.

Most of the small, richly detailed layouts to be seen at model railway exhibitions are effectively dioramas. Many are enhanced by the provision of fascias, which also serve to carry layout lighting. The underlying principle owes much to the theatre: the model is framed by a proscenium while the lighting is arranged to enhance the effect. It is well worth considering this approach for any model railway, but as it is usually an add-on rather than an integral part of the model, it isn't necessary to do more than consider the principle during the planning stage of the model. However, as good lighting makes modelling more comfortable, it is a good idea to arrange this at an early stage of construction.

The scenic break

Lack of space means that most model railways have little space for a stretch of unencumbered track to create the illusion that the train is travelling some distance. Although it might seem that there is little one can do about this, it is often possible to create a scenic break between adjacent stations. This can be a short tunnel, or even a viaduct spanning a relatively deep valley. The simplest and often the most effective method is to put a double-sided backscene across the baseboard, breaking the model into two distinct areas. In this way you can switch abruptly from a heavily built-up inner city scene to a leafy suburb, then perhaps to a stretch of open countryside. In effect, the intervening section of railway has been 'edited out'. Only a petty-minded pedant is going to quibble; most viewers accept what has been done and go along with the illusion.

The important thing is to add to the illusion by providing a suitable disguise at the point where the trains go through a hole in the backscene, and I have sketched four tried and tested methods, two of which work by providing a focus for the eye just far enough away from the hole to allow the viewer to ignore it.

A little-appreciated side effect of this process is that by dividing the layout into separate scenes, the job of creating a complete picture is broken down into more manageable units. On very large layouts, some sections can be given a quick cover-up to hide the bare framework while most attention is given to the part with the highest priority.

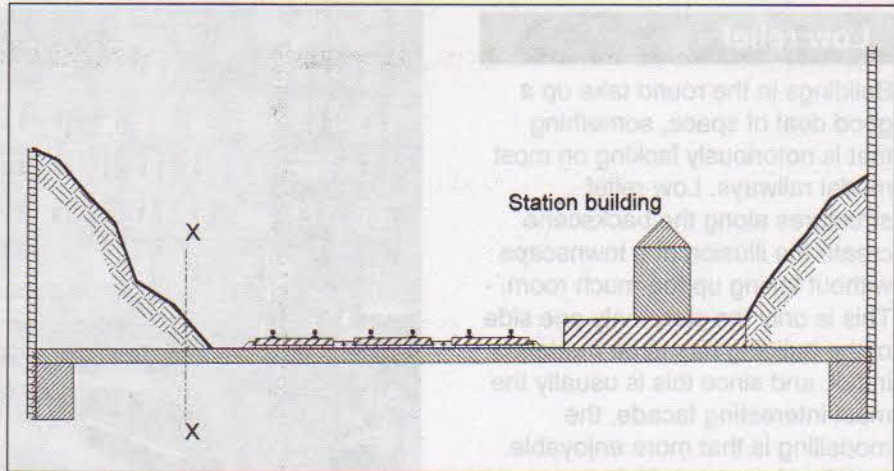

Figure 14/1 Modelling a station 'exactly as it is' can create problems. Where the station is in a cutting, it is all too easy to forget that one cutting side will cut off the view of the train. By thinking ahead, the baseboard may be narrowed to the line X-X and so provide a good sight of the important feature, the trains. This error has been made by several advanced groups aiming for absolute authenticity.

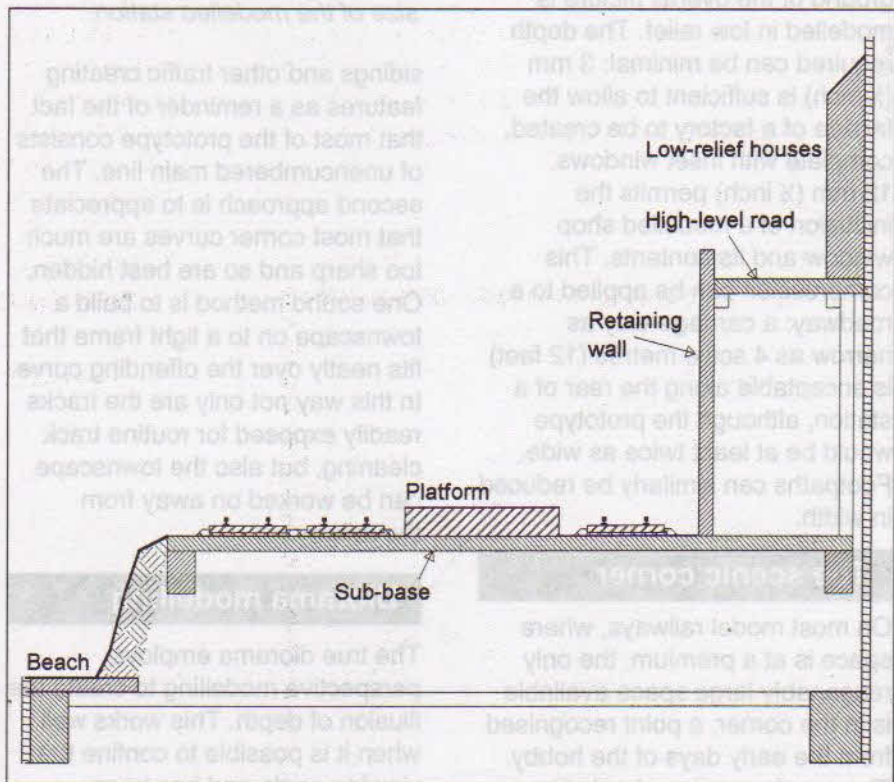

Figure 14/2 It is a good idea to raise the rear scenic features above track level so that the low-relief buildings are not masked by the trains. This is very important where these models are highly detailed – never hide a good model. Likewise, the foreground interest is best brought below track level. Here I've suggested a beach, complete with bathing figures. Lest anyone feels I have introduced an air of fantasy, this arrangement is based on the layout at St Ives, Cornwall.

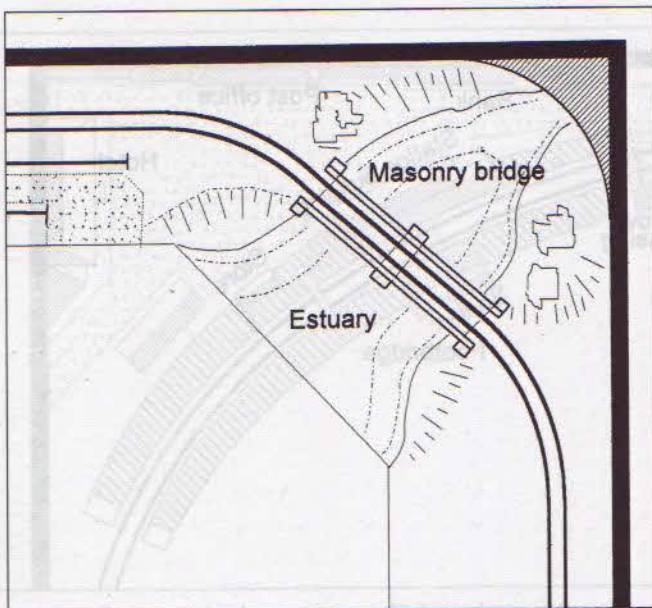

Figure 14/3 As the first of my suggestions for scenic corners, I have turned to one proposed by Henry Greenly in his 1924 book *Model Railways*. A two-arch masonry bridge spans the lower reaches of a small estuary – the waterway runs off into the corner. The backscene has been carried round the corner on a curve to eliminate the vertical line through the 'sky'.

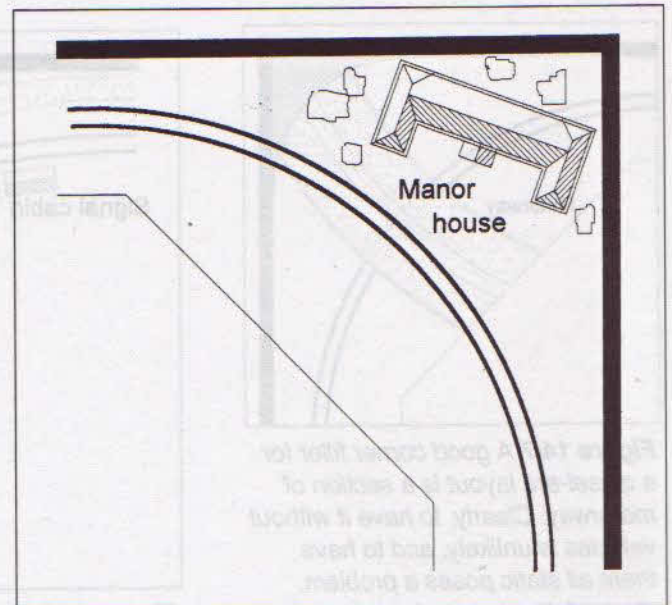

Figure 14/4 Locating a manor house in this fashion is faintly ridiculous: no landowner would allow the tracks to come so close, and no experienced engineer would even think of so foolish a trick. This sort of vandalism was left to the modern Department of Transport. Having said that, it makes a very good model and, for a pre-1914 layout, would justify the occasional special train bringing guests for a house party. By the early 1920s, they came by car.

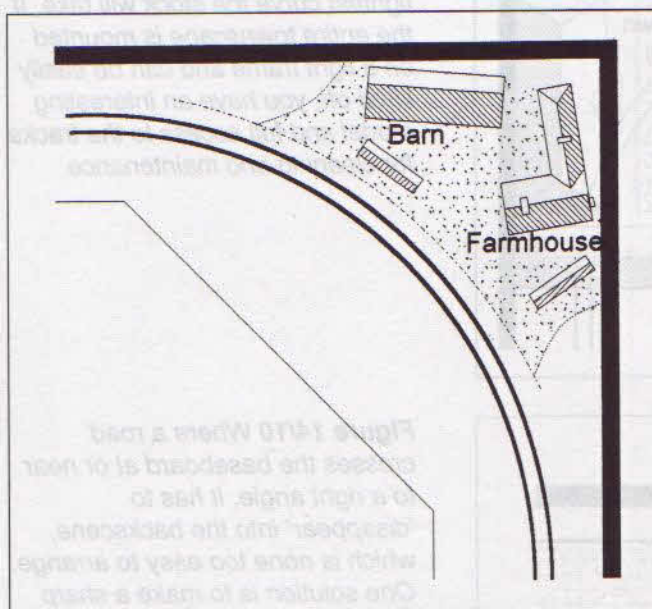

Figure 14/5 An excellent feature for the corner site is a farmhouse and its associated buildings. Again it is rare for the tracks to run quite as close as this, but modeller's licence comes in very handy.

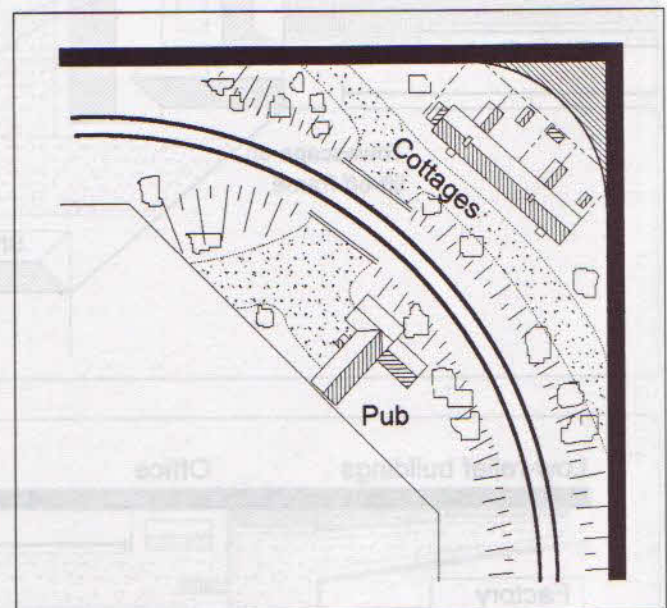

Figure 14/6 It is not unusual to find a row of farm cottages this close to the railway track; when the railway was built the inhabitants' opinions were neither sought nor considered of any value. The pub could even have appeared after the railway was built.

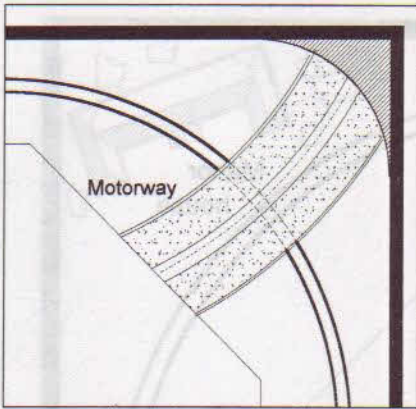

Figure 14/7 A good corner filler for a diesel-era layout is a section of motorway. Clearly, to have it without vehicles is unlikely, and to have them all static poses a problem. One solution is to put some work vehicles on one carriageway, a contraflow on the other, then set out model vehicles bumper-to-bumper in a typical tailback.

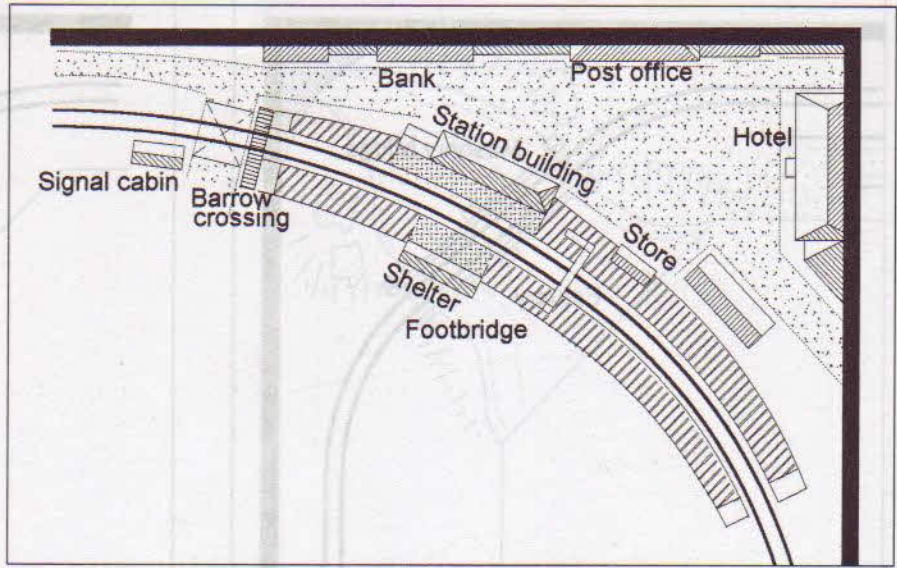

Figure 14/8 By sweeping the station platforms around a large-radius curve, sufficient space is left for a small townscape. In this instance the buildings would have sprung up after the railway was built on a green-field site on the edge of the town, so no building earlier than 1860 ought to be seen. Again we can invoke modeller's licence.

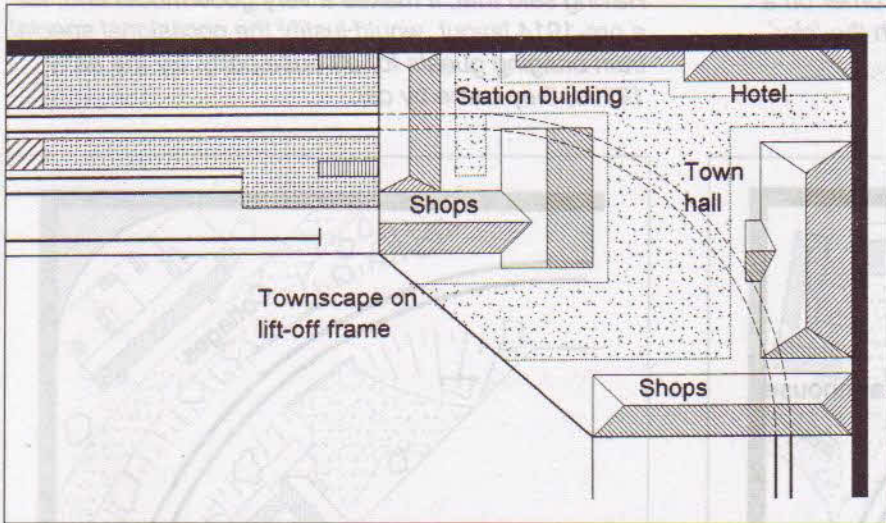

Figure 14/9 There is ample room for an interesting townscape over the top of a corner curve, which in this instance can be down to the tightest curve the stock will take. If the entire townscape is mounted on a light frame and can be easily lifted off, you have an interesting model and full access to the tracks for cleaning and maintenance.

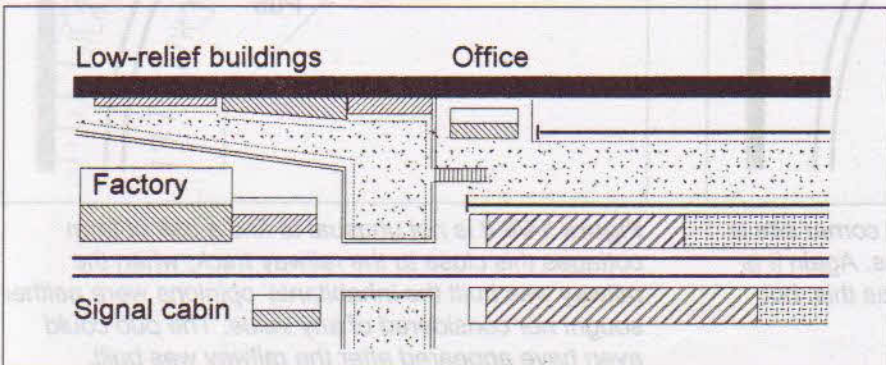

Figure 14/10 Where a road crosses the baseboard at or near to a right angle, it has to 'disappear' into the backscene, which is none too easy to arrange. One solution is to make a sharp turn so that the road then tapers away behind a tall building.

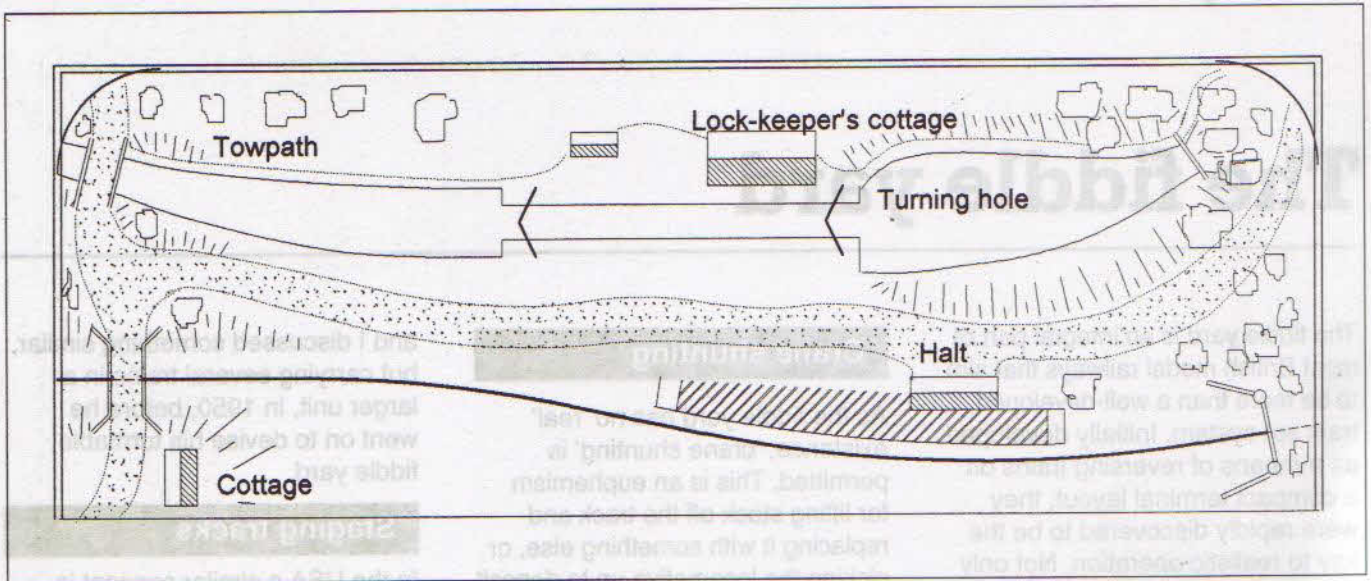

Figure 14/11 One solution to the lack of space is to build a scenic diorama where the railway is present to provide movement. This type of model is frequently built into a glass case, the necessary loops to provide a hidden oval track being hidden behind screens when the model appears at an exhibition. Here I've suggested a canal lock as the scenic feature. On the right both railway and canal tunnel into a range of hills, while on the left a pair of road overbridges cover the exits.

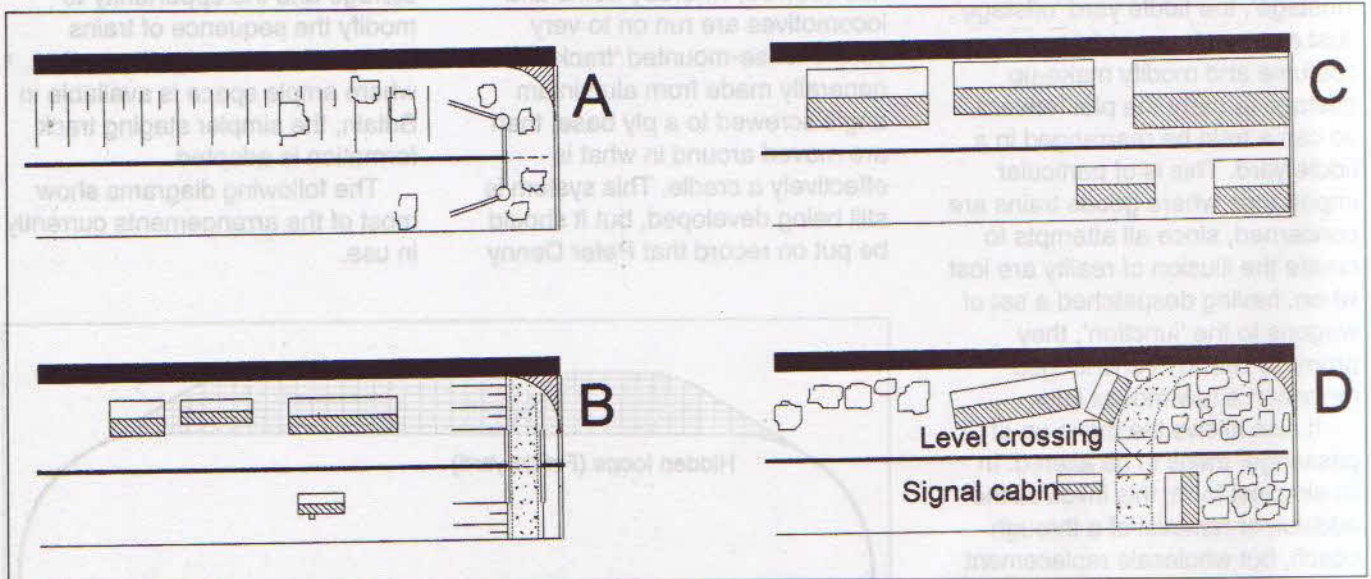

Figure 14/12 Where the tracks pass through a scenic break, as happens when the tracks enter a fiddle yard, it is necessary to disguise the 'hole in the sky'. The most obvious solution, **A**, is to run into a tunnel, but tunnels are not that common on single-track branch lines. At **B** we have the more credible alternative, a road overbridge immediately in front of the hole. This is now the most favoured method, since overbridges are reasonably common. At **C** the hole is hidden between a pair of tall buildings, an invaluable arrangement in an urban or industrial setting, while in **D** the railway runs into a dense wood. In this case I've provided a distraction in the form of a small crossing together with a group of buildings. This gives the viewer something better to look at than a hole in a piece of hardboard.

Chapter 15

The fiddle yard

The fiddle yard is an integral part of most British model railways that aim to be more than a well-developed train set system. Initially developed as a means of reversing trains on a compact terminal layout, they were rapidly discovered to be the key to realistic operation. Not only can they provide space-effective storage for five or more trains, they represent the rest of the railway system.

Their function is best understood by a theatrical analogy: the modelled station, or stations, are 'onstage', the fiddle yard 'offstage'. Just as an actor can change costume and modify make-up offstage to carry the plot forward, so can a train be rearranged in a fiddle yard. This is of particular importance where goods trains are concerned, since all attempts to create the illusion of reality are lost when, having despatched a set of wagons to the 'junction', they promptly return in unchanged formation a few moves later.

It also allows the make-up of passenger trains to be altered. In its simplest form, this involves the addition or removal of a through coach, but wholesale replacement is possible. Where this has to be done on a regular basis, it is a clear indication that the fiddle yard lacks capacity and needs enlargement.

The fiddle yard is extremely convenient at exhibitions, since it provides a place where defective locomotives and rolling-stock can be removed for repair without drawing viewers' attention to the fact.

Crane shunting

As the fiddle yard has no 'real' existence, 'crane shunting' is permitted. This is an euphemism for lifting stock off the track and replacing it with something else, or picking the locomotive up to deposit it at the other end. This process, acceptable where ready-to-run equipment is involved, is clearly out of place with finely detailed kit-built or scratchbuilt models.

From this the 'cassette' system has evolved, whereby trains and locomotives are run on to very simple loose-mounted 'tracks', generally made from aluminium angle screwed to a ply base, then are moved around in what is effectively a cradle. This system is still being developed, but it should be put on record that Peter Denny

and I discussed something similar, but carrying several trains in a larger unit, in 1950, before he went on to devise his turntable fiddle yard.

Staging tracks

In the USA a similar concept is known as 'staging tracks'. It has been said, by *Model Railroader*, to be less sophisticated, but this is because most US layouts live in large basements and the need to do more than provide offstage storage and the opportunity to modify the sequence of trains hardly exists. It is significant that where ample space is available in Britain, the simpler staging track formation is adopted.

The following diagrams show most of the arrangements currently in use.

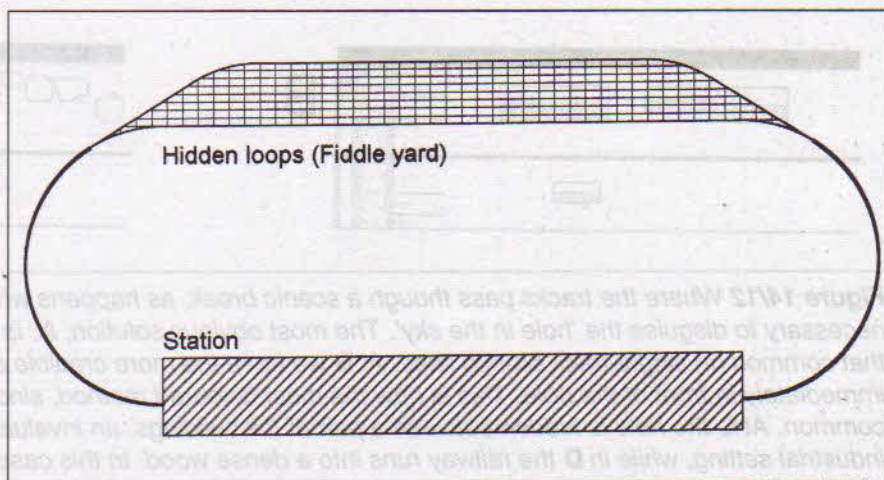

Figure 15/1 The least complicated type of fiddle yard is where hidden loops allow a succession of trains to be brought out to parade through the visible through station. This is the same arrangement as the American staging track.

Figure 15/2 Hidden loops for double track can be arranged as simple up and down sidings, but the provision of a reversible central road permits train reversal. This type of yard cannot readily be covered since it requires the full attention of the operator. As drawn the loops are of different length, but as will be seen in the layout plan section, this can be avoided by fanning the pointwork around the approach curve.

The simplest form of fiddle yard is a set of three or more parallel tracks linked by a ladder track. Such a yard is shown as complementing an N gauge branch terminus at Pecorama under the title 'The No-Space Railway'.

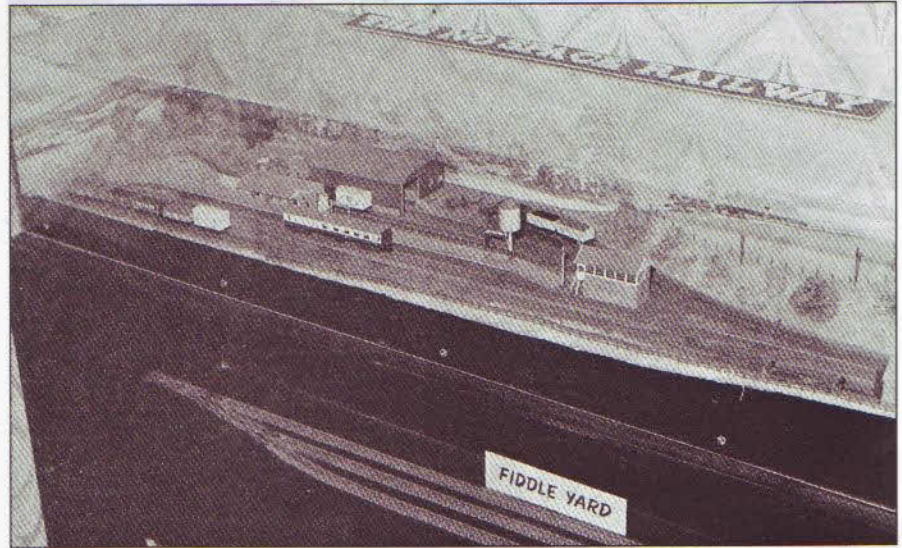
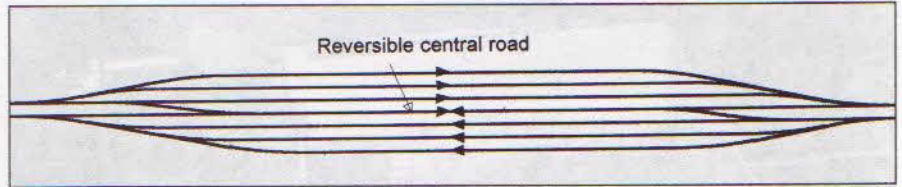

Figure 15/3 Where the hidden loops back a long through station, as is often the case with club layouts, this arrangement not only provides twice as many loops of equal length in a given width, but also allows at least one up and down track to be double the normal length. The most effective use I have seen of this device is the running of steam-age 80–100-wagon coal trains.

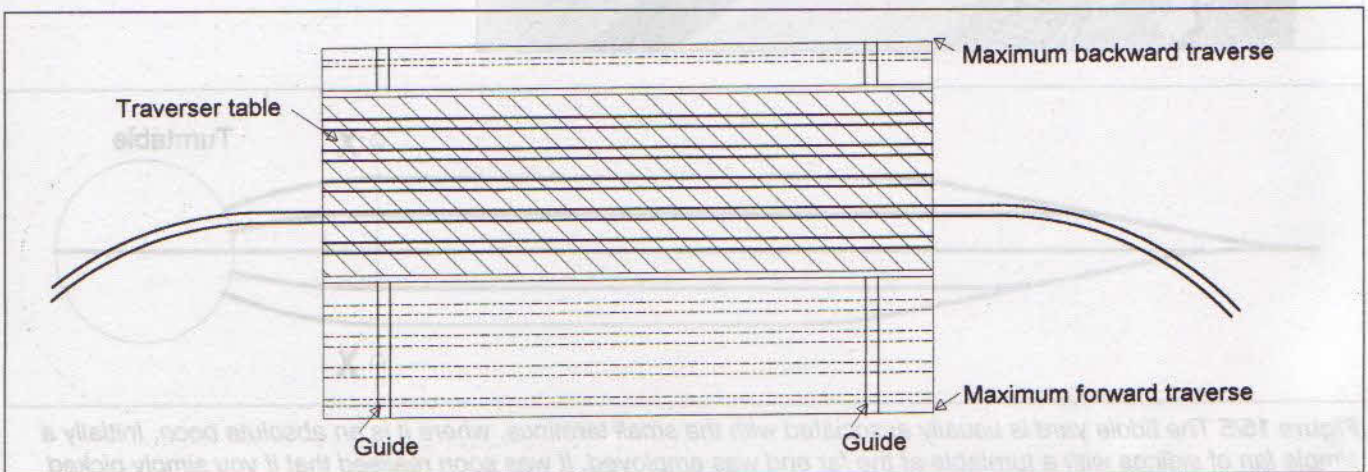
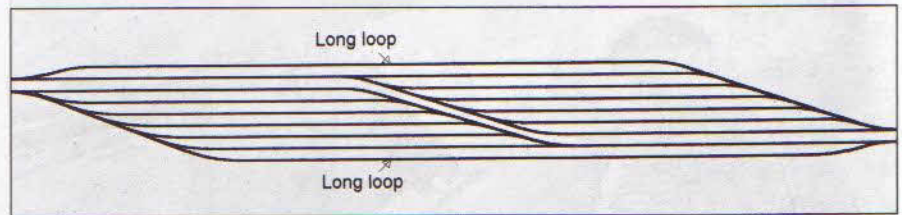
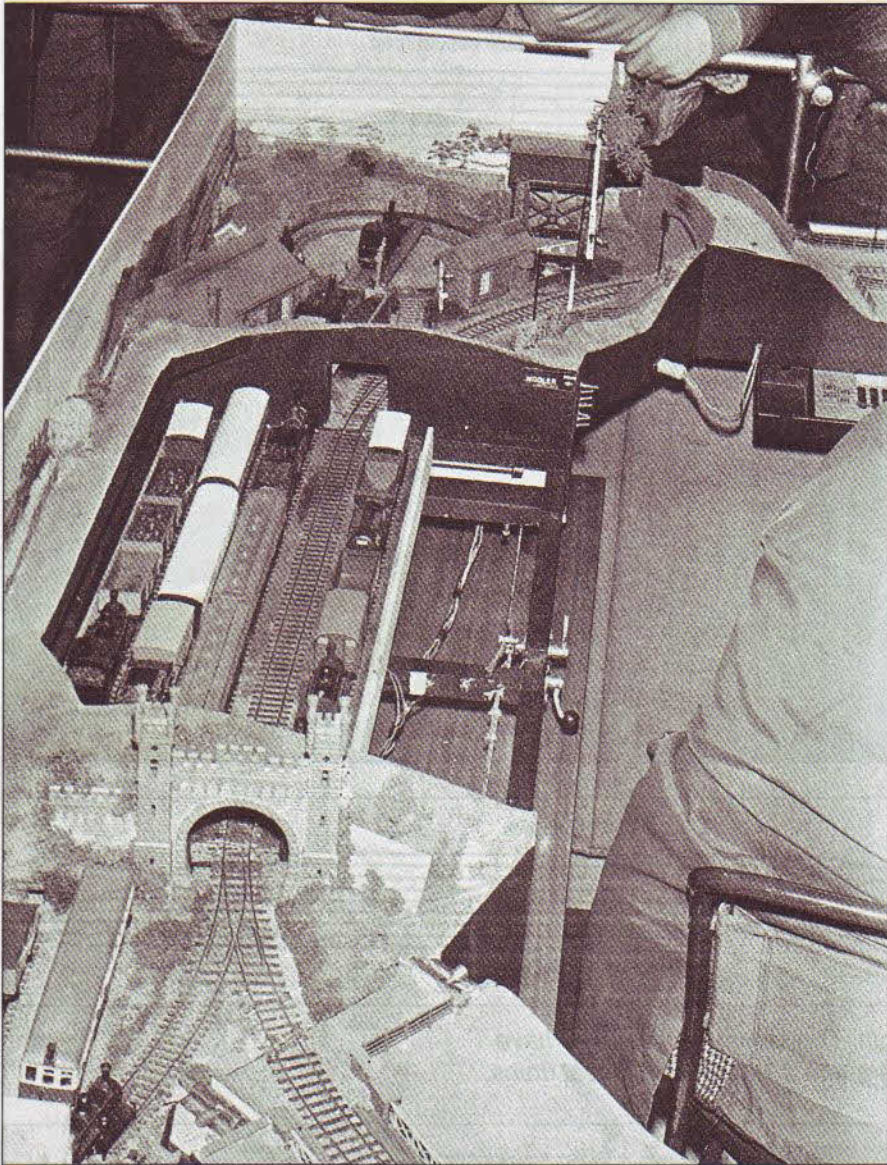

Figure 15/4 Going to the other extreme, where length is very limited a traverser gives a good capacity and economises on pointwork as well as space. Most examples are manually operated, but remote mechanical traversing is certainly possible, given sound craftsmanship throughout. The provision of loco spurs at each end of the traverser enables locomotives to be changed and trains reversed with the minimum amount of fuss.



Alan Wright's 'Cheviotdale' had a five-track traverser on the far side. This provided plenty of variety when operating this extremely compact model. The extensive loco depot at the top of the photo was used to store spare locos while the sidings in the foreground served a similar purpose. Changing a locomotive altered the appearance of a standard train. The Faller tunnel mouth kit covers the entry to the traverser, and did not look out of place on a model based on North Eastern practice.

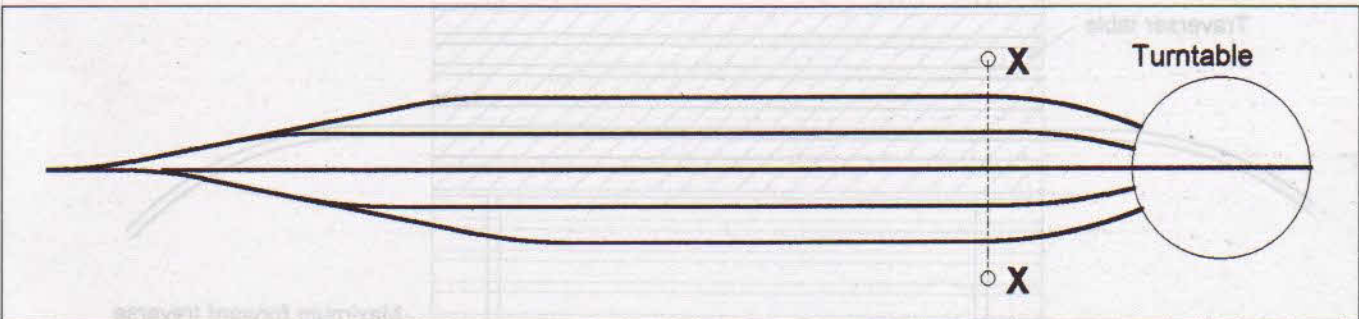

Figure 15/5 The fiddle yard is usually associated with the small terminus, where it is an absolute boon. Initially a simple fan of sidings with a turntable at the far end was employed. It was soon realised that if you simply picked the locomotive up, turned it around and put it on the other end, not only was operation simplified, but the fiddle yard could also be shortened. This was the genesis of the true fiddle yard.

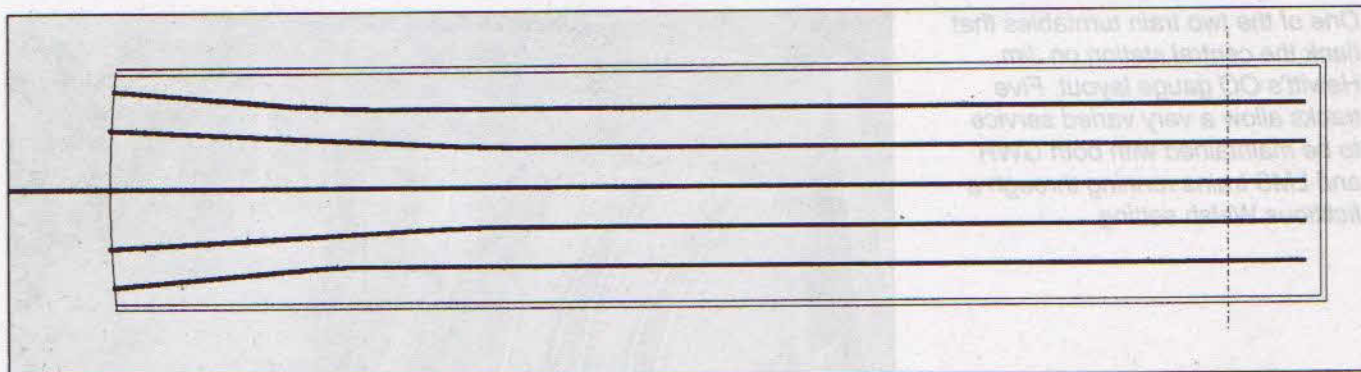

Figure 15/6 It didn't take long to realise that if the fiddle yard tracks were mounted on a pivoted board to form a sector plate, the points could be eliminated as well, saving both space and money. This elementary arrangement remains the most common form of fiddle yard to this day. It has its snags – a good deal of on-the-spot manual work is required – but its relative simplicity endears it to many.

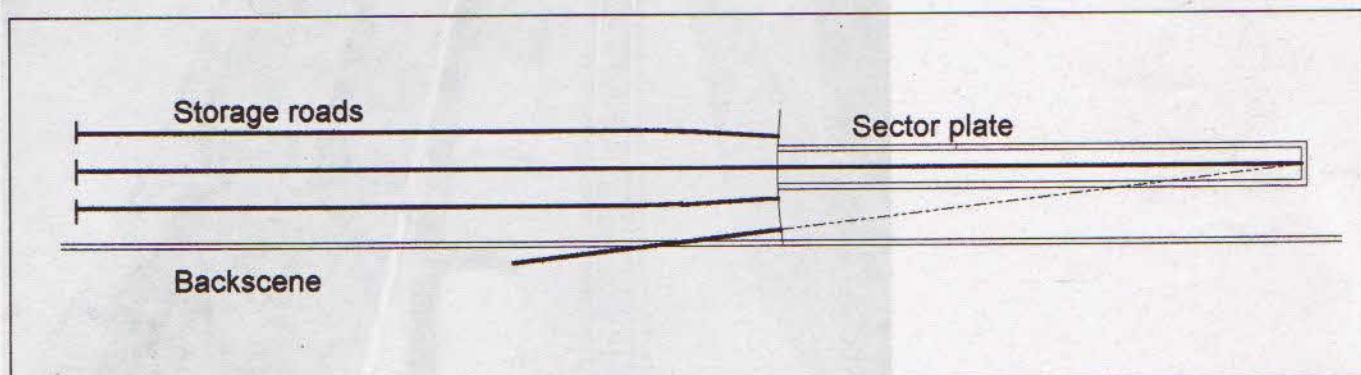

Figure 15/7 The kick-back sector plate fiddle yard is a very popular arrangement for compact exhibition-oriented layouts. The hidden tracks are behind the station, while the sector plate has just one track and is used to collect or deliver a train from the storage roads. There are several clear advantages: no blank area at the exhibition, one operator can work both station and fiddle yard, and there is space for a larger goods yard in front of the sector plate. Many 7 mm scale diorama layouts use this arrangement to excellent effect.

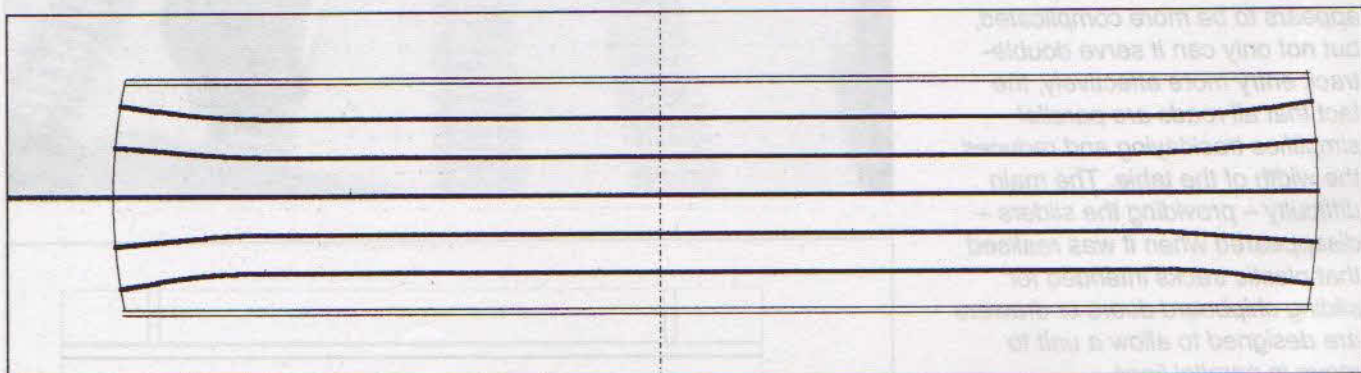

Figure 15/8 The full-train turntable is the most convenient development of the sector plate, since instead of lifting locomotives from one end of the train to the other, you simply turn the complete train end for end. It is more effective at exhibitions, where width is no problem, but rejected for home use because all too often the wall gets in the way. However, it will still function as a sector plate, allowing an exhibition-oriented layout to be used in the home.

One of the two train turntables that flank the central station on Jim Hewitt's OO gauge layout. Five tracks allow a very varied service to be maintained with both GWR and LMS trains running through a fictitious Welsh setting.

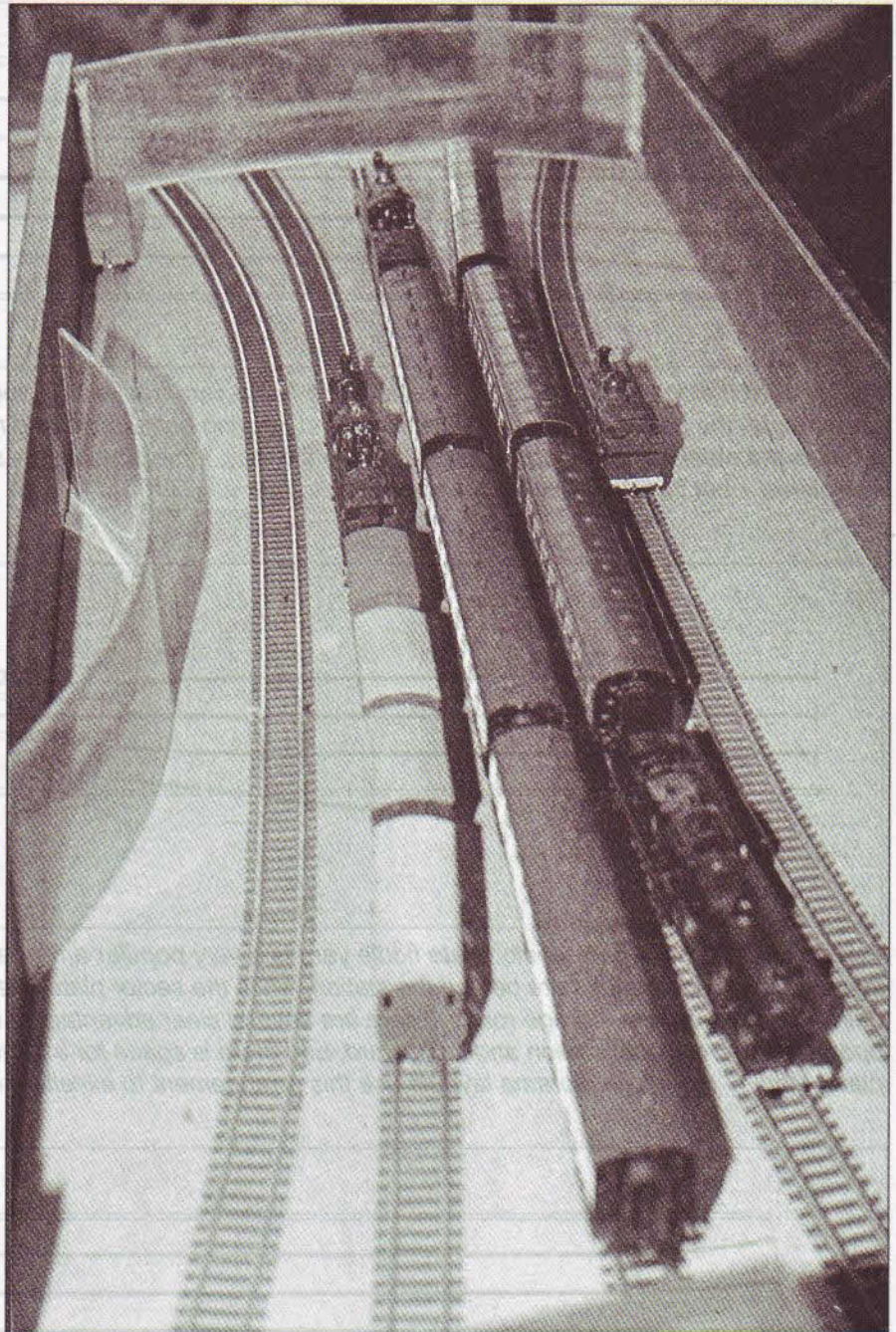

Figure 15/9 The traverser is just as effective as the sector plate. It appears to be more complicated, but not only can it serve double-track entry more effectively, the fact that all roads are parallel simplifies tracklaying and reduces the width of the table. The main difficulty – providing the sliders – disappeared when it was realised that plastic tracks intended for sliding chipboard doors or drawers are designed to allow a unit to move in parallel lines. Incidentally, the presence of the tracks on the diagram brings home a feature of both sector plates and traversers: they need space on either side to allow tracks to align properly.

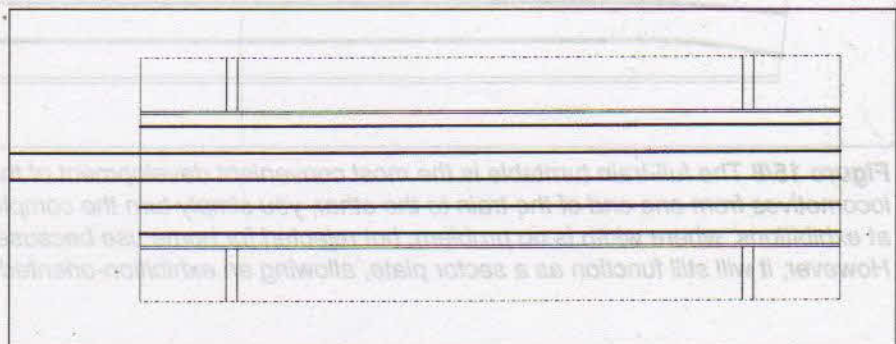

Figure 15/10 The parallel movement of the traverser makes it much easier to connect auxiliary features. In this elaborate arrangement not only is there a turntable for tender locomotives at the far end, but also a series of loco spurs is provided at the other end. This appears something of a complication, but as it gives the fiddle yard operator more to do, it makes the job much less boring.

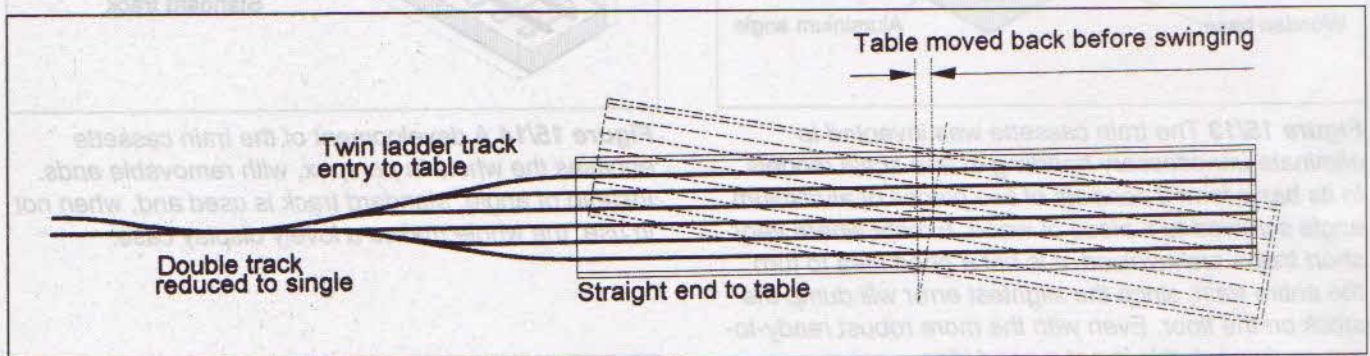
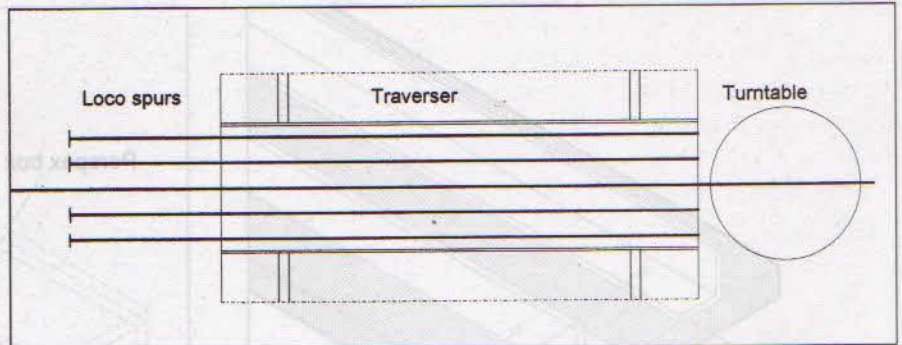

Figure 15/11 The most sophisticated type of train turntable is that devised by Peter Denny. Here the tracks are fed by a fan of points and the table has straight ends. Before turning, the pivot point is wound back, allowing the table to be turned. With a five-track table and a well-planned timetable it is only necessary to make two reversals in a 'day's' operation. The entry points are readily worked by remote control from the main panel or, as with the 'Buckingham' yard, by computer. The electro-mechanical device used at 'Buckingham' just meets this definition, but it is more accurately described as a programme machine, being identical in principle to those used on the London Underground.

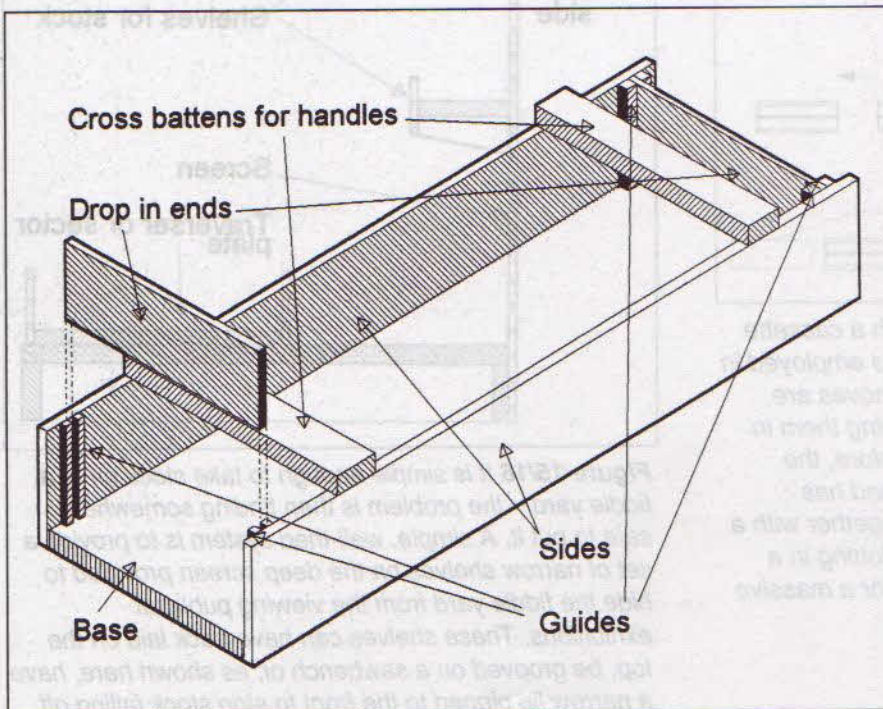

Figure 15/12 The basic construction of a traverser box has hardly changed since its first introduction. What is not immediately apparent is that it not merely holds three, four or five trains, but also serves as a stock box. This can save an enormous amount of time when setting up and breaking down a portable layout, and was used in this way by Peter Denny in the late 1940s. If the slides are correctly placed equidistant from each end, it is possible to reverse the entire box end-for-end. Peter Denny considered this arrangement before opting for his full turntable. What neither of us realised at the time was that we had anticipated the principle of the train 'cassette' by some 50 years.

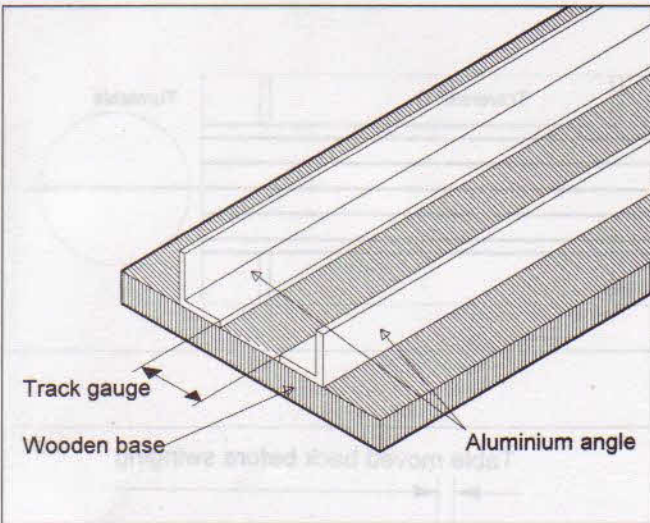

Figure 15/13 The train cassette was invented to eliminate unnecessary handling of fine-scale models. In its basic form it consists of two pieces of aluminium angle screwed to a piece of wood. Except where very short trains are involved, it is not a good idea to turn the entire train, since the slightest error will dump the stock on the floor. Even with the more robust ready-to-run equipment, this is not a good idea.

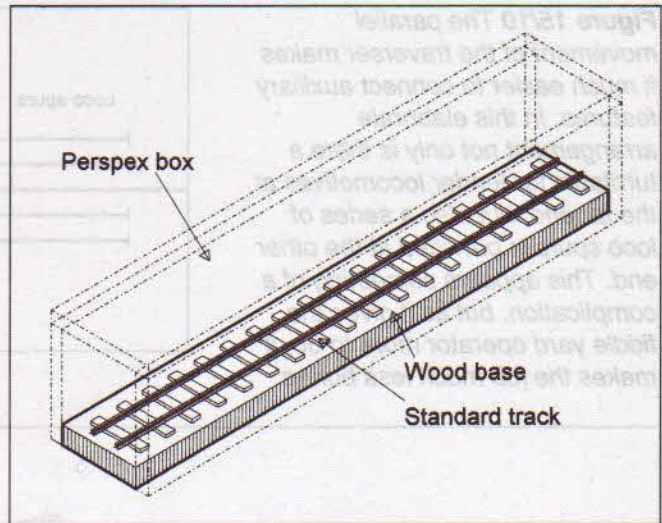

Figure 15/14 A development of the train cassette encases the whole in perspex, with removable ends. Instead of angle, standard track is used and, when not in use, the whole makes a lovely display case.

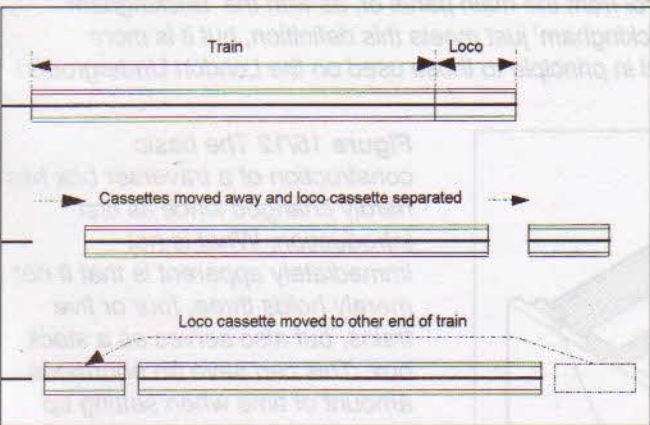

Figure 15/15 To reverse locomotives with a cassette fiddle yard, a shorter loco-long cassette is employed in addition to the main train cassette. The moves are fairly obvious, but I thought it worth showing them in diagrammatic fashion. As I mentioned before, the cassette principle is comparatively new and has considerable potential, either alone, or together with a conventional fiddle yard as a means of slotting in a range of special trains without the need for a massive increase in capacity of the basic yard.

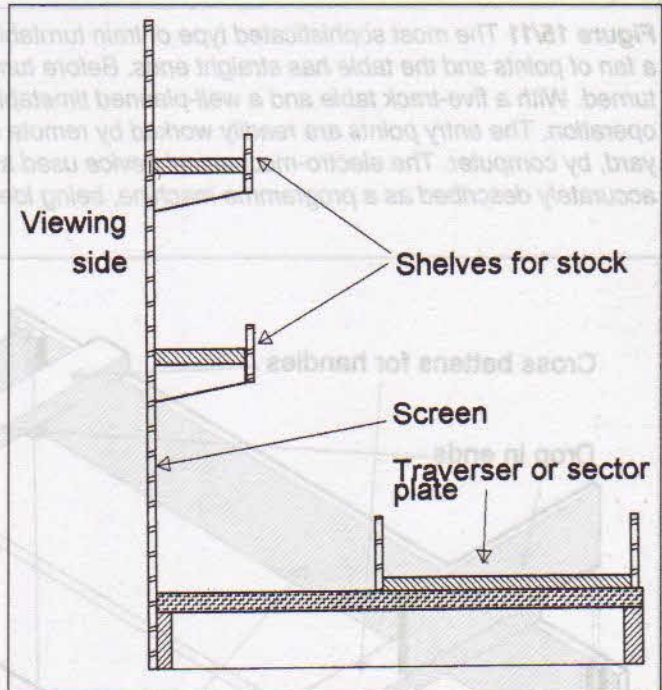

Figure 15/16 It is simple enough to take stock off of a fiddle yard – the problem is then finding somewhere safe to put it. A simple, well-tried system is to provide a set of narrow shelves on the deep screen provided to hide the fiddle yard from the viewing public at exhibitions. These shelves can have track laid on the top, be grooved on a sawbench or, as shown here, have a narrow lip pinned to the front to stop stock falling off.

The layout plans

Project drawings

The time has now come to put the pieces together to produce the project plan for the layout. This needs to be drawn with care, taking particular note of the size of turnouts, since these are in practice fixed units; this applies whether you are using complete commercial units or scratchbuilding your own formations. It is advisable at this stage to overestimate the size of pointwork by at least 5% and underestimate the size of the room.

It is more convenient to draw track plans to a relatively small scale, such as 1:12 (1 inch to the foot) or 1:10, which is not only best for metric units, but is also convenient if you are using a school-type ruler rather than a draughtsman's scale. In any case, imperial standard draughtsman's scales are difficult to find nowadays.

At these scales one cannot do more than approximate the final dimensions on the drawing board, and the track lines are no more than a general guide to position. Agreed, if you are using CAD it is possible to achieve far greater accuracy, but as you would need to add dimension lines to the drawing, you will need a good deal of expertise to avoid producing an unintelligible mess. It is much easier to set the layout out at full size, on the baseboards, on the floor, or, in the traditional way, on the back of a roll of cheap wallpaper or a pack of wide fanfold computer print-out.

Although the drawings appear highly detailed, most of the scenic details are put there for effect. The object of a project drawing is not so much to provide a detailed working drawing as to sell the general idea, leaving the details to later.

Standards used

All the following layouts have been designed with 16.5 mm gauge in mind. The majority follow British practice and are basically for OO gauge. Where I think it possible to use the scheme for EM or P4, I mention this in the text. The theory of dividing all sizes by two to arrive at N gauge has a serious flaw: one's waistline remains the same and gangways and operating spaces, which are adequate for the larger gauge, are frequently impractical when reduced by 50%.

The squared grid was drawn at 300 mm spacing or, if you prefer imperial sizes, 1 foot. Agreed, when we are considering a complete layout the difference is appreciable, but as the original plans were drawn to the smaller size, the error is on the safe side.

With one exception, the plans are 'freelance', following no specific prototype station. However, they are all based on prototype principles and, in several instances, were inspired by actual prototypes. This is mentioned in the text. I believe that slavishly following an actual prototype is not a good idea, unless the prototype has a reasonable operating potential and, for steam-age

layouts, can justify a varied selection of locomotives.

The compact oval

The majority of railway modellers have, at one time or another, played with a basic oval layout. It has the merit of simplicity, but in OO/HO gauge does need a fairly large space. I am offering two suggestions, one for a solid single baseboard, the other for a small garden shed. Both are essentially steam-age branch line projects, but the early diesel era could be accommodated. You could even run 'Pacers', but it might get a trifle monotonous.

Layout 1: Lochaber (2.1 m x 1.2 m; 7 ft x 4 ft)

In 1938 I was able to acquire, by combining birthday and Christmas presents and saving what I could of my pocket money, the nucleus of a Trix Twin layout. As I was born in June, it was a long-term scheme, and came to fruition just after Meccano Ltd announced Hornby Dublo. It was my first encounter with Murphy's Law.

It was at this point that I realised that the various schemes I had drawn up, to a scale of 1:10, incorporating various Trix track formations, were a little beyond my pocket, but with the addition of two or three points and a little extra track I could model a simple halt with a loop behind the backscene. The Second World War put a stop to that idea, but I did get so far as

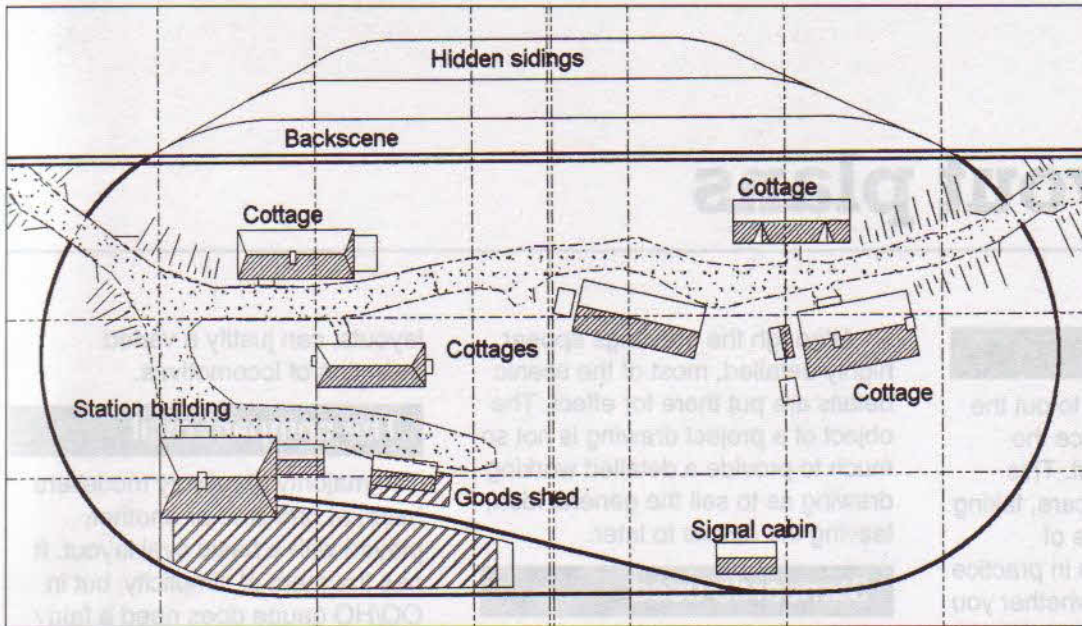

Layout 1 Lochaber (2.1 m x 1.2 m; 7 ft x 4 ft)

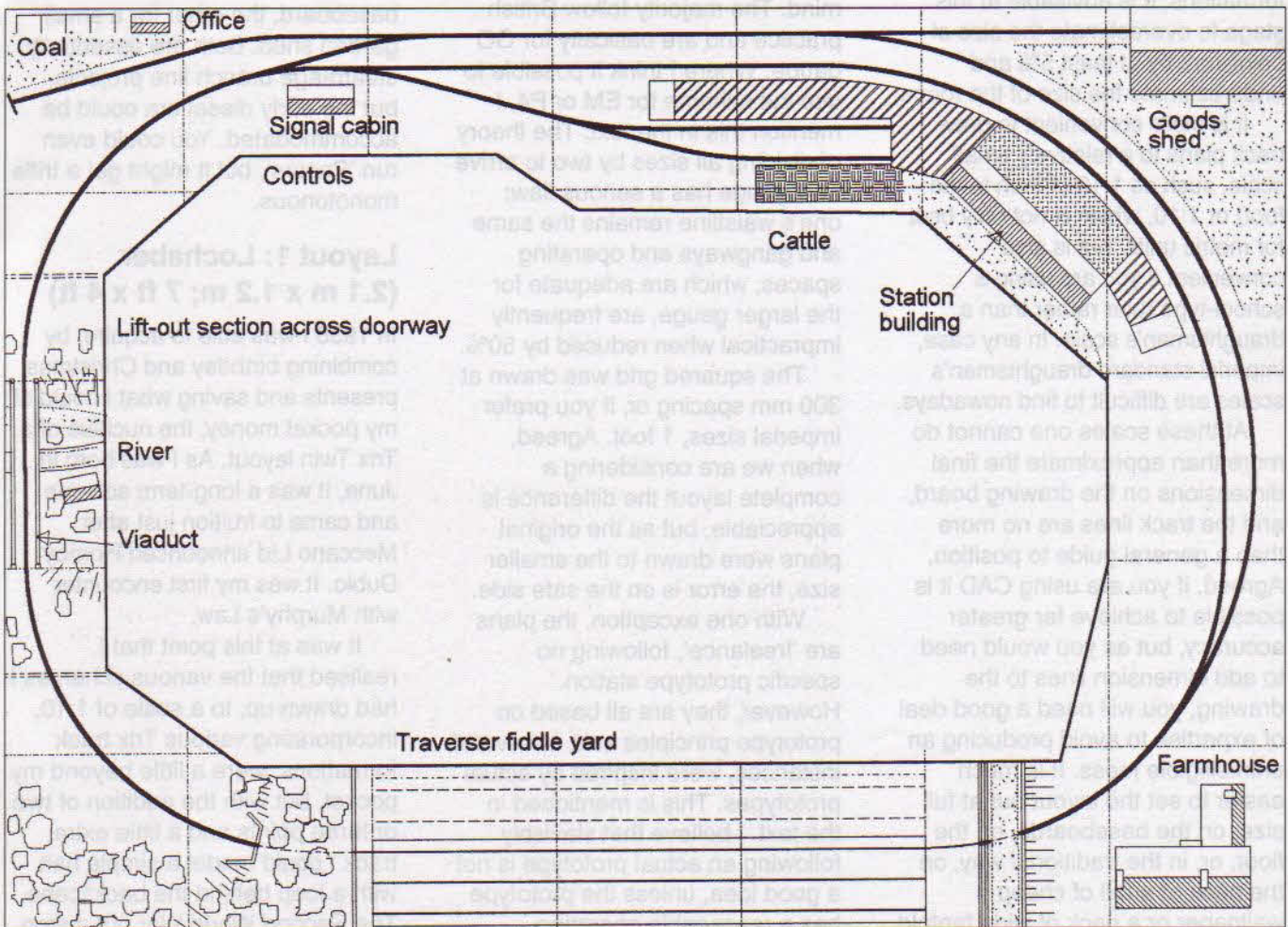

Layout 2 Wrightdale (2.1 m x 1.5 m; 7 ft x 5 ft)

to produce a plan and decided on the name for the station, Lochaber. I had no connection with Scotland, but I did know that the LMS had a single-track main line through the Highlands. I was also avidly reading John Buchan's novels and the whole thing seemed very romantic.

The present plan reveals something I'd not grasped at the time, that to provide staging loops behind the backscene takes up a fair amount of space. The layout would best be built on two equal-sized sections, while open-top construction with lightweight landscaping should enable the weight to be brought down to reasonable proportions. It is not really a serious scheme, more an illustration of just how much space is wasted with this type of layout. Its main value would be to provide movement in a scenic diorama and would be a lot more practical in N or Z gauges, where it could fit comfortably into a glass-fronted cabinet in an inglenook.

Layout 2: Wrightdale (2.1 m x 1.5 m; 7 ft x 5 ft)

The trouble with the large 'solid' baseboard is that the centre is largely wasted space, while unless the layout can stand in the centre of the railway room, access to two sides is restricted by the wall. It's not a lot of use saying that it can be easily pulled out, when the whole assembly is so heavy to begin with.

If the centre is made hollow, the layout becomes more manageable, while the illusion of distance is greatly increased by the fact that the trains now travel around 360 degrees relative to the operator. This scheme is based on a test track I built around my workshop in Devon, with a variation based on Alan Wright's 'Cheviotdale' where the number of trains on the line was increased by providing a five-

track traverser. My drawing only shows three, but some juggling of the large-radius curve could increase this if desired.

I postulate a shed with an end door, and show a lift-out section across the entrance. This is the ideal place to model a valley crossed by a short viaduct or long bridge – three arches is the break point. One corner has a small wood, the other has a farmhouse. It is unlikely that one would find this so close to the railway, but it makes an attractive finish to a corner.

Although it seems a very simple station, the fact that the goods sidings are split into three means that shunting the branch goods is going to involve a lot of juggling. With up and down passenger trains to alternate – this is not a passing station – there is plenty to while away the odd hour or so. If the baseboards are set reasonably high, say 1.2 metres or 4 feet from the floor, there is ample room for a workbench underneath in a nominal 8 ft x 6 ft sectional shed. This represents a good starting point for a beginner.

The branch theme

Fifty years ago, when we were picking ourselves up after the war, there were two serious problems facing railway modellers. The first was material shortage. We had rail, wheels and a limited range of cast white metal axle-guards and bogie sides together with a small selection of motors – on paper. In practice one could spend many hours patiently scouring local model shops for supplies. The second problem was the space shortage. Homes were in short supply, and the spec-built suburban semi that one could get for £50 down and 28s 6d a week for 25 years had been an early wartime casualty.

The answer was the portable layout, which could be stored out of the way and erected in the living room. Peter Denny showed how effective this could be, since not only could a model branch terminus be made to look attractive, but it could also be worked by a very small locomotive stud. Indeed, as many branch lines

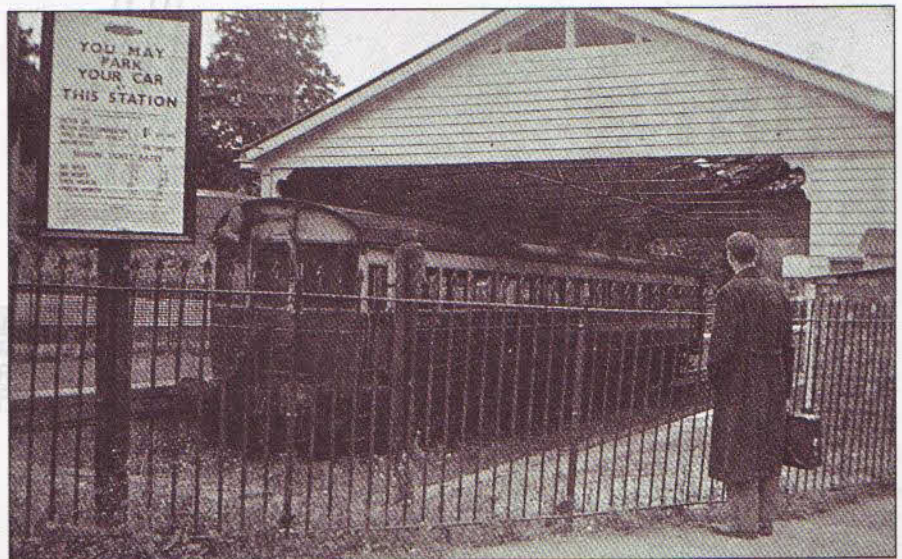

The extreme end of the Ashburton branch, showing the 'Brunel' timber roof. The trailer car, W135W, is standing on the far track, once used for merchandise traffic, but at the time this photo was taken it was little used for this purpose.

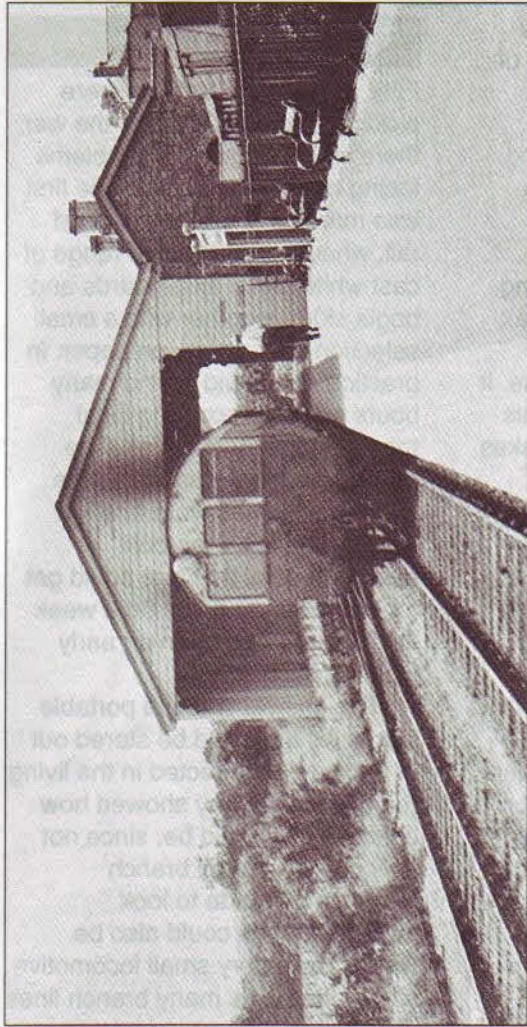

Moretonhampstead is less well-known than Ashburton, which it resembled greatly. As this photo shows, it had a similar train shed, but arranged on the opposite hand. The station layout is better for model operation, having more sidings and a less awkward shunting pattern. Situated on the outskirts of the town, it lacked the building backdrop that added to the visual effect of Ashburton.

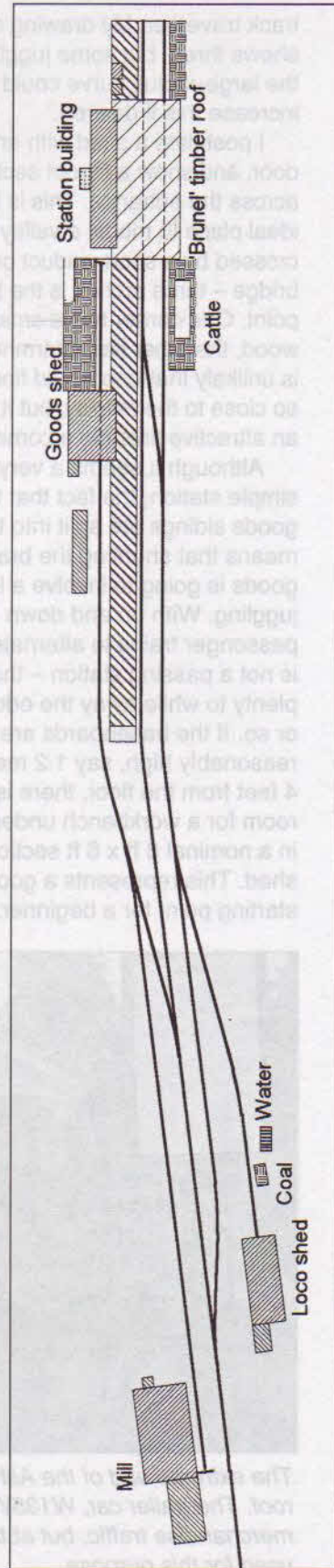
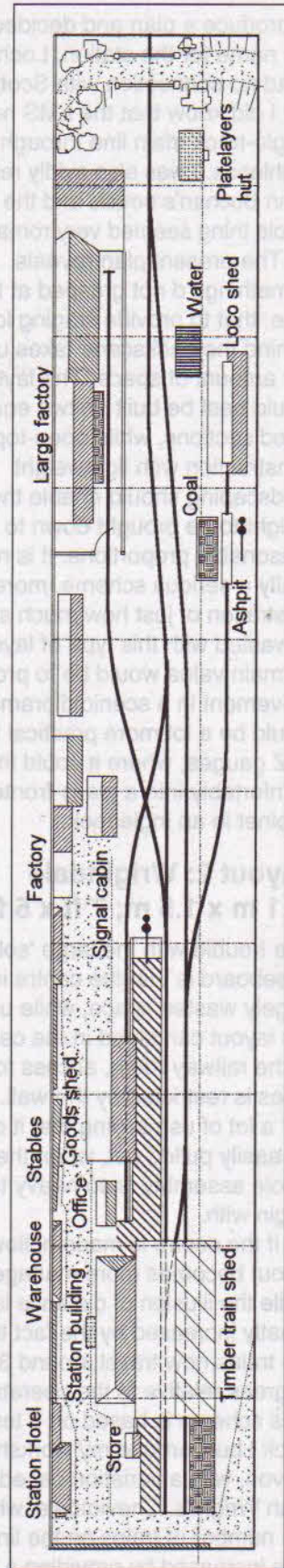

Figure 16/1 Track plan of Ashburton station, GWR (not to scale).



Layout 3 Widdecombe (3 m x 450 mm; 10 ft x 1 ft 6 in)

were worked by one locomotive, which alternated between passenger and goods, you didn't need a lot. This was a great help when it was necessary to scratch-build every item of rolling-stock.

I discovered Ashburton, at about the same time as Peter Denny came across it on his honeymoon. The station looked commendably compact, and with just six turnouts and a lovely overall roof, it seemed the ideal prototype for the space-starved modeller. As I came to realise later, Ashburton is actually very long – the platform would just take six coaches, providing none of them were 70-footers – and to make matters worse it was one of the few stations where rope shunting was officially permitted; it was next door to impossible to propel a wagon into the mill siding by any other means. On top of that, it did not have a signal box, just a very-open-air ground frame. Even Swindon didn't know this – they cast a plate for 'ASHBURTON SIGNAL BOX'.

Although a few diesel-worked branches exist, they are often no more than spurs served by a diesel railcar. Branch-line modelling is generally confined to the steam age, though some convincing diesel era lines have been built. Scotrail is very popular since, until a few years ago, the usual Highland train comprised three Mk 1 coaches headed by a Class 37 Co-Co diesel-electric. However, longer trains did run, but we'll overlook that. Today, the ubiquitous 'Sprinters' have taken charge.

Layout 3: Widdecombe (3 m x 450 mm; 10 ft x 1 ft 6 in)

With a few modifications, Ashburton can be made more convenient to operate; all that is needed is for the private siding to

be taken off the platform road, crossing over the main siding as it does. As the GWR had, to my certain knowledge, diamond crossings at Clevedon and Moretonhampstead, we have a precedent, and it makes for an attractive bit of 'busy' pointwork. Incidentally, Moretonhampstead is a much better station if you must follow a prototype, and both have been recorded in some detail.

Widdecombe-in-the-Moor, to give the village its full name, is a mirror image of Ashburton, with a similar row of structures forming a natural backdrop. The exit to the fiddle yard is masked with an overbridge, which is perverse, since Ashburton had a short tunnel under the mid-'30s A38 by-pass. In passing, the trackbed between Ashburton and Buckfastleigh is now buried under the present A38 expressway, and instead of forming the terminus of the Dart Valley, the 'Brunel' timber roof now houses a garage.

Layout 4: St Denys (2.8 m x 2.5 m; 9 ft 3 in x 7 ft 4 in)

Adding a fiddle yard to Widdecombe will make it a good 4.5 metres long, which is more than most people can accommodate. Introducing a corner to form 'the Classic L' brings the project into a more practical form. At the same time, I have masked the fiddle yard with a kick-back extension. Originally this was going to be a quay, but in the end I opted for a 'through' station, giving the 'branch off a branch' arrangement. As the secondary route ran into the loop road, a full platform is provided here.

Between operating sessions, the fiddle yard sidings are covered with a townscape, with two or possibly three sections of plywood spanning the space above the

tracks. This not only provides a wonderful excuse for an elaborate cover story, but, more importantly, gives one ample scope for some interesting architectural modelling. Since the sections are removable, much of the work can be carried out on an old occasional table in the living room.

It is my belief that unless one can see something of the town a branch terminus serves, realism flies out of the window. Even where the station was built on a green-field site a little way from the town, it was usually possible to see its outskirts from the railway. Through branch stations might be several miles from the place they were supposed to serve, but termini invariably came as close as possible to the town.

A turntable, capable of handling a 4-6-0, has been provided. I've not shown a loco shed because at several branch termini the original shed was pulled down, often just before it fell down of its own accord. While this loses an attractive model, it does leave the locomotives in full view.

Layout 5: Ahern (3.75 m x 3 m; 12 ft 6 in x 10 ft)

There is absolutely no reason why a branch line layout need be small, so for our final look at this theme we have taken over the second bedroom of an older house, where we encounter the inevitable chimney-breast, and offer two uses of this feature. In view of the size of the room, easy access is provided – the door can be opened during running sessions.

The main terminus has three platform faces – the fourth is a siding and is fenced off. The loco shed is in the corner; the fact that it is a very long way from the baseboard edge is unimportant since we do not have to shunt

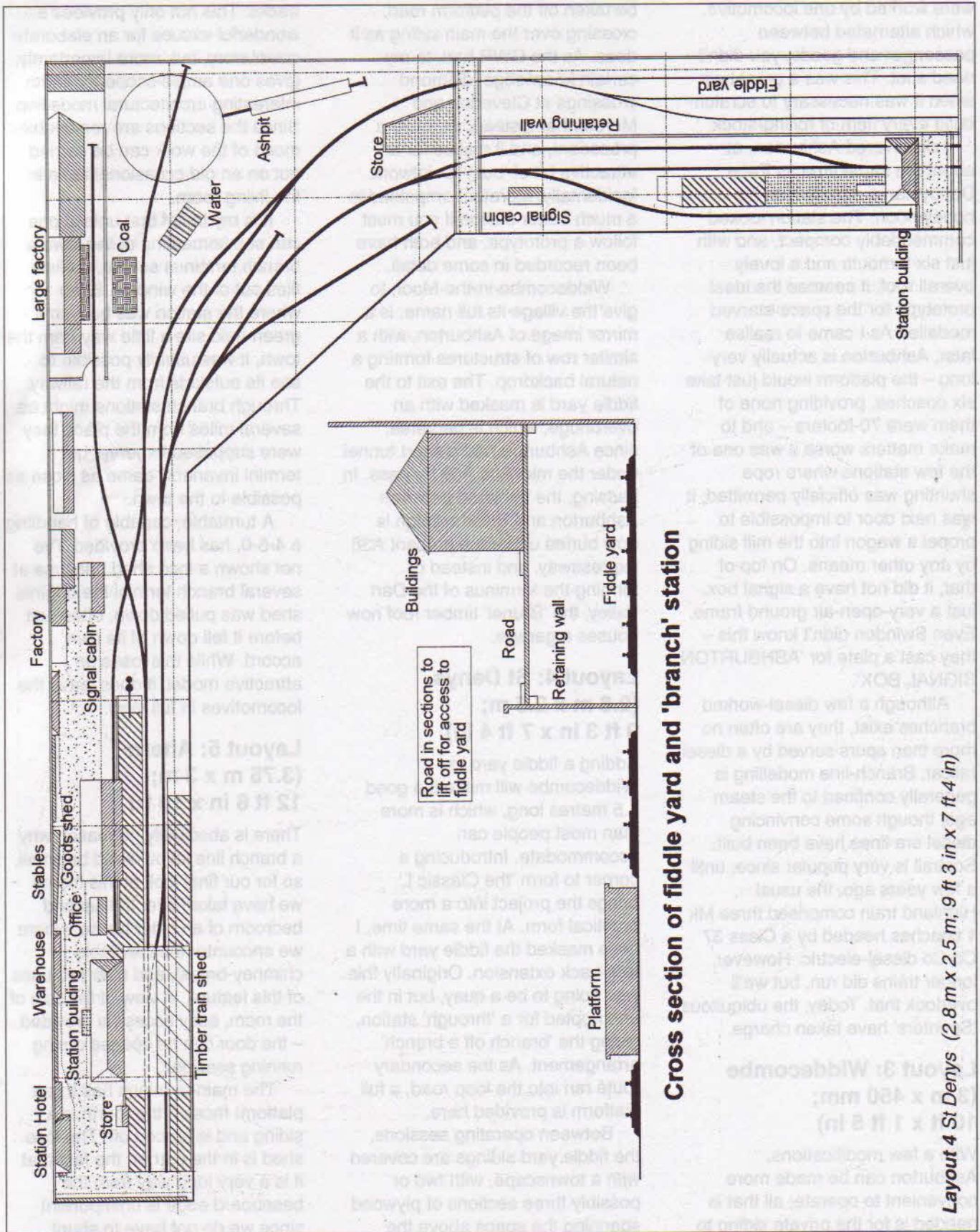

Layout 4 St Denys (2.8 m x 2.5 m; 9 ft 3 in x 7 ft 4 in)

vehicles or mess around with couplings. Agreed, coal ought to be delivered from time to time, but as it blocks the road to the shed, we can keep the wagon coupled to the loco for the time it is deemed to take to unload.

The goods yard has its own entry loop; the middle crossover not only allows wagons to be run around while all three platform faces are full, but also provides an extra movement when a train is run round. The two platforms nearest to the wall are the principal pair, while the longer platform is

the 'excursion' road, but has a long enough spur beyond the release crossover to hold a couple of parcels vans; this would be its main purpose.

The line now falls to the intermediate passing station. Again the goods yard is provided with a headshunt so that it is not necessary to block the main line; the central crossover allows for running round without the need to obtain both single-line tablets.

The line crosses the entrance to the room with a lifting flap. As the tracks are now 100 mm lower

than the terminus, there is no need to arrange the hinges above baseboard level, so a piano hinge can be used. The space behind the door is given over to the town square. This ought to be at least a quarter of a mile away, but modeller's licence allows a little foreshortening. In case you're wondering why this fairly large area is devoid of tracks, the answer is that they would be too far from the operator. I've shown the memorial to Queen Victoria's Jubilee: this can take the form of a clock tower, a drinking fountain or

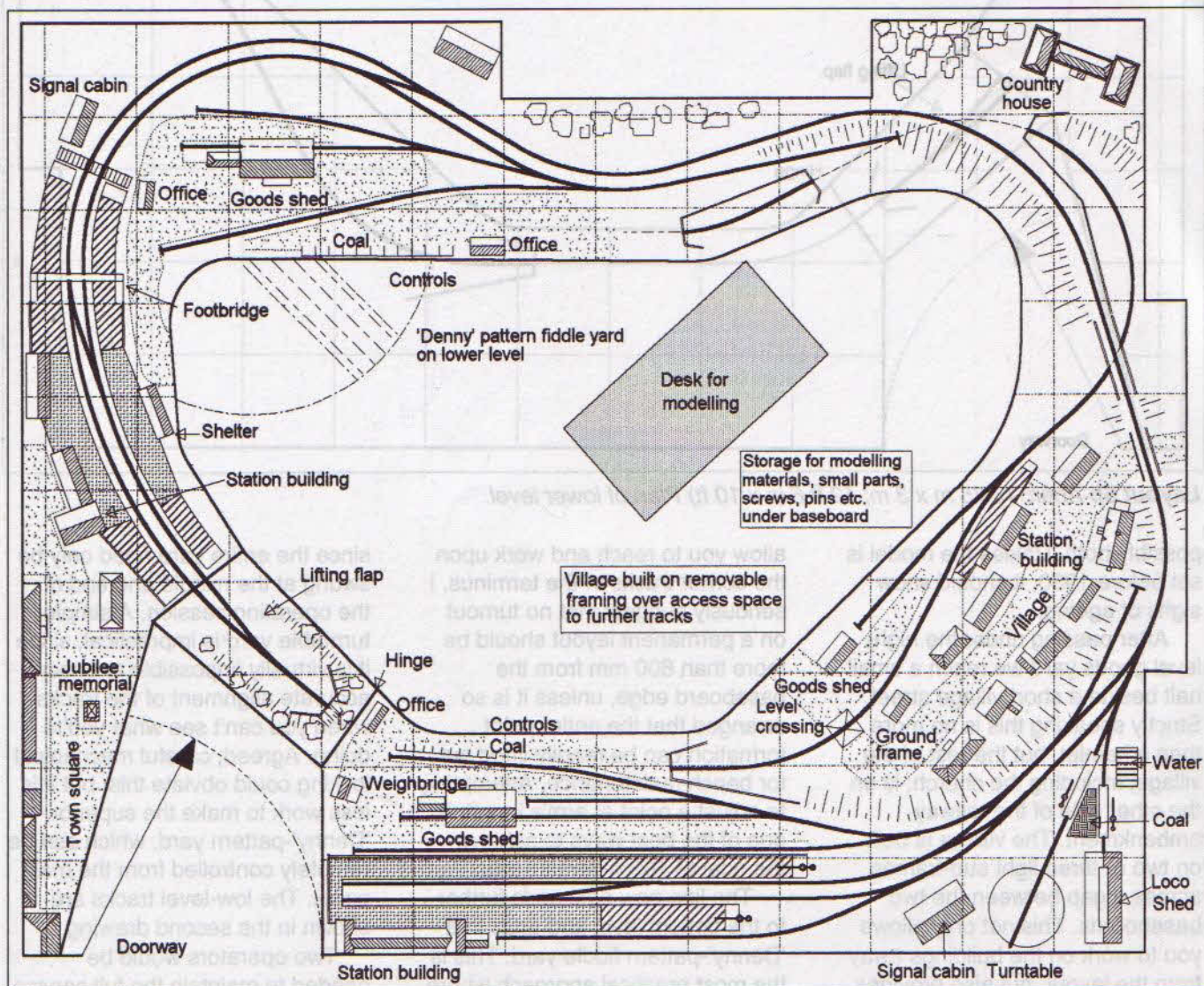

Layout 5a Ahern (3.75 m x 3 m; 12 ft 6 in x 10 ft)

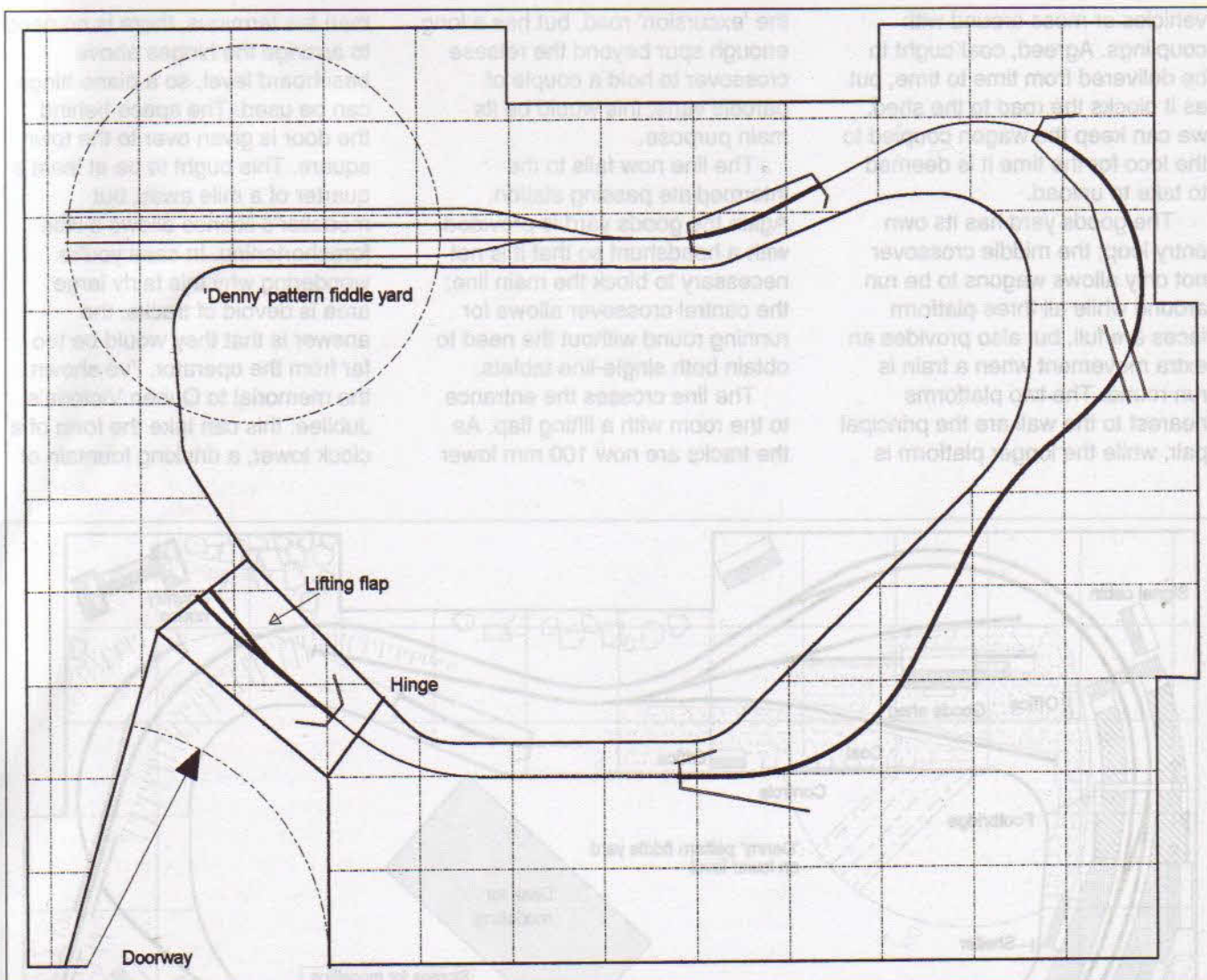

Layout 5b Ahern (3.75 m x 3 m; 12 ft 6 in x 10 ft) Plan of lower level.

possibly both. Unless the model is set before 1930, it should show signs of ageing.

After passing under the high-level goods yard we reach a small halt beside a short village street. Strictly speaking this is no more than a hamlet, but the rest of the village, including the church, is on the other side of the railway embankment. The village is built on two or three light sub-frames across a gap between the two baseboards. This not only allows you to work on the buildings away from the layout, but also provides a much-needed access space to

allow you to reach and work upon the corner tracks of the terminus. I seriously suggest that no turnout on a permanent layout should be more than 600 mm from the baseboard edge, unless it is so arranged that the entire point formation can be readily lifted out for bench maintenance. Attempting to adjust a point at arm's length is one of the best ways to achieve the goal of 100% derailments.

The line now descends further to the bottom level and ends in a 'Denny'-pattern fiddle yard. This is the most practical approach where the yard is buried beneath tracks,

since the entire yard need only be swung at the middle and end of the operating session. A simple turntable yard is impractical, since it is virtually impossible to ensure accurate alignment of the tracks when you can't see what you're doing. Agreed, careful mechanical locking could obviate this, but it is less work to make the superior 'Denny'-pattern yard, which can be remotely controlled from the main panel. The low-level tracks are shown in the second drawing.

Two operators would be needed to maintain the full service on this line, but with suitable

switchgear, the passing loop could be controlled from the main panel.

The advantage of following the branch-line theme in a reasonably large room is that there is more opportunity for non-railway modelling. There is space for a low-relief townscape and a fully modelled section of a village, while the townscape by the door is ideally located for viewing – until someone else wants to get into the room! Furthermore, there is sufficient room in the central area to accommodate a small desk on which you can both construct the many buildings needed for this model, and maintain locomotives and rolling-stock in comparative comfort.

Let us now return to the chimney breast. I've shown a highly improbable asymmetric arrangement to demonstrate that although it is possible to curve tracks into a wide recess, a narrower one is only suitable for scenic developments. In the latter I have suggested a country house; it is too near the railway and much too small, so it should be to 1:100 or 1:150 scale to give the illusion of distance.

With so many non-railway buildings, I've named the main station after John H. Ahern who first popularised this genre.

City stations

It is not generally appreciated that many city stations are slightly smaller than the general run of branch stations; this has everything to do with the fact that low-cost green-field sites are not to be found in urban areas. Although the usual run of city termini have anything from 10 to 20 platforms and need a large space, there are the odd exceptions, sufficient to provide justification for a small but busy urban setting. With this type of layout there is no restriction on

the motive power one can run, although space considerations mean that full-length trains are difficult to accommodate in the home. However, a five-coach train can usually be squeezed into a moderately small space. What is more to the point, it is feasible to model the diesel era with reasonable ease, although one really needs to steer clear of HSTs because everyone knows that they have at least seven Mk 3 coaches plus two power cars. A Class 45 and five Mk 2s or Mk 1s is more acceptable.

Layout 6a: Watergate – diesel era (4.2 m x 0.6 m; 14 ft x 2 ft)

Layout 6b: Watergate – steam age (4.2 m x 0.9 m; 14 ft x 3 ft)

Many years ago I was doodling away, trying to adapt Liverpool Street (Met) into model form, when I hit by chance on an elegant arrangement of a facing and trailing crossover to access three terminal roads. Thus was 'Minories' born. It has been modelled on many occasions, often with additions, and although originally conceived as a tank-engine-only terminus, is even better as a diesel era station.

Watergate takes the basic Minories formation and adds a further feature, a river crossing. This is inspired by Charing Cross, Blackfriars and Cannon Street, although it is shorter and has only three tracks, and the river is about the width of the Ouse in York rather than the Thames. The extra track provides a goods headshunt as well as a very attractive scenic feature. The story is that the single-track was added at a later date and the bridge girders are thus to a different design, but of

similar span. Diesalisation has reduced the goods yard to a two-track Railfreight depot, and the loco depot is just two holding spurs for diesels.

For comparison, the steam age layout at Watergate is shown. The main difference is the large train shed, the impressive goods shed and the small loco depot. The story goes that at diesalisation the loco depot was demolished and the site occupied by a large office block, while the goods shed also went and the third platform track was shortened to make room for a range of Portacabins or other prefabricated offices that have replaced the more elegant goods offices of the steam age. The old manual box has been replaced by a modern power box.

The layout is built on five rectangular baseboards, a pair of relatively short ones at each end flanking a longer central board carrying most of the pointwork. The platforms are split in the centre; this allows for the insertion of a lengthening unit, extending the station's capacity. This would only be practicable in an exhibition hall; indeed, I envisage this scheme as being a club project primarily intended for the exhibition circuit.

Londoners will appreciate that I have provided a second embankment on the 'south' bank, and transferred the spirit of the north bank across the river. This has a reason, for although the fact that the tracks pass through the backscene is masked by a pair of tall buildings, the small park, with its working fountain, and the river landing stage with a pleasure boat moored alongside will draw the eye away from the 'hole in the sky'.

The treatment on the 'north' side is less elaborate, so that the viewer is not distracted. In the diesel era the frontage is taken up by a second-hand car dealer. The

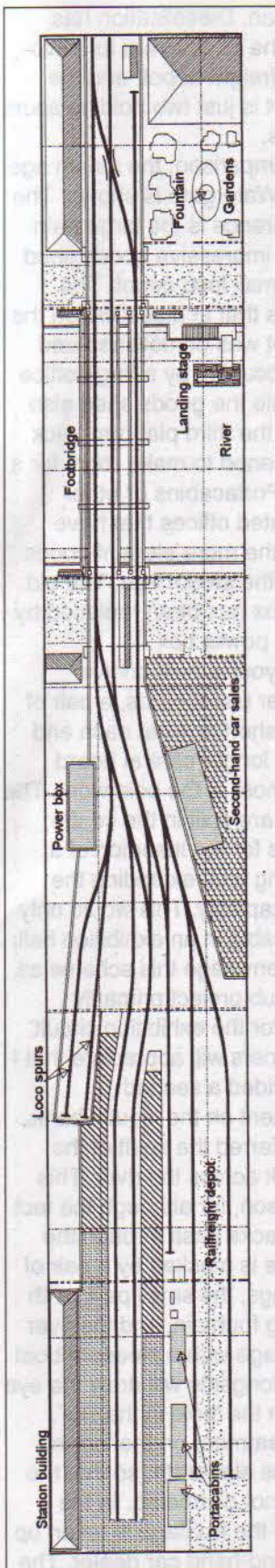

Layout 6a Watergate – diesel era (4.2 m x 0.6 m; 14 ft x 2 ft)

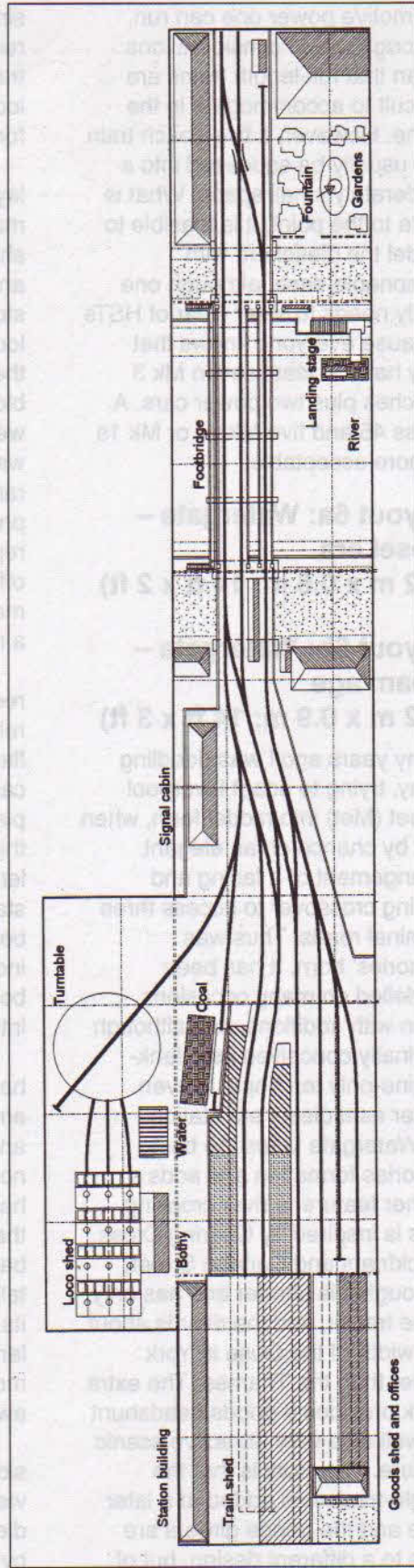

Layout 6b Watergate – steam age (4.2 m x 0.9 m; 14 ft x 3 ft)

steam age setting is more mundane. However, there is another option: the ancient walls suggested by the station's name. That the railway would breach these walls is of no moment, since the obsession with 'heritage' is quite recent; we had nothing to do with such things when I was a lad, and Watergate was built a good 70 years before that. As for the car dealer, a wartime bomb provided his yard.

The problem with Watergate is that it really needs more space than most homes can provide, unless the loft is readily adaptable. As a club or syndicate project it has considerable potential, the more so since the various aspects of the scheme can be tackled by individuals with an interest in that particular part of the hobby. Apart from the obvious case of the architectural modeller and the man who is happy building lattice girders in elaborate fixtures, there is a lot of work for the individual who enjoys painting tiny figures under a magnifying glass, since several hundred people will be needed to give life to this model.

Layout 7: Avon (3 m x 2.4 m; 10 ft x 8 ft)

I first saw Bristol Temple Meads during the war, and thought what a wonderful prototype it could make for a large single station layout. I was slightly misled, having read McDermott's *History of the GWR*, and thought that something of the original Bristol & Exeter platforms remained, but closer acquaintance showed me that there was another way to make the station accept terminating trains in either direction.

I have used this theme frequently. It puts a reasonably large station into a relatively small room, allowing for five-coach loco-hauled trains, or six-coach DMUs. Although this is well short of

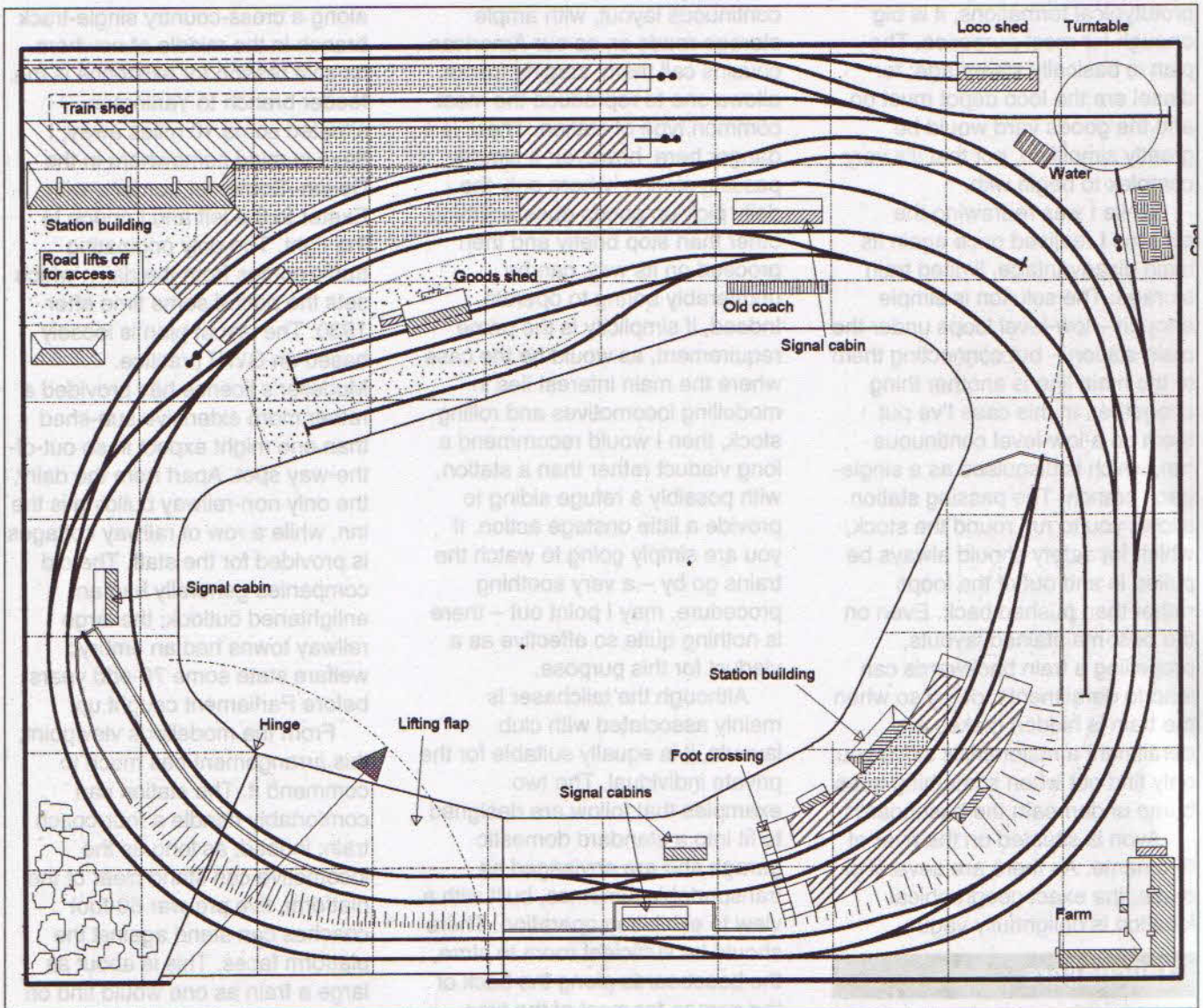

Layout 7a Avon
(3 m x 2.4 m; 10 ft x 8 ft)

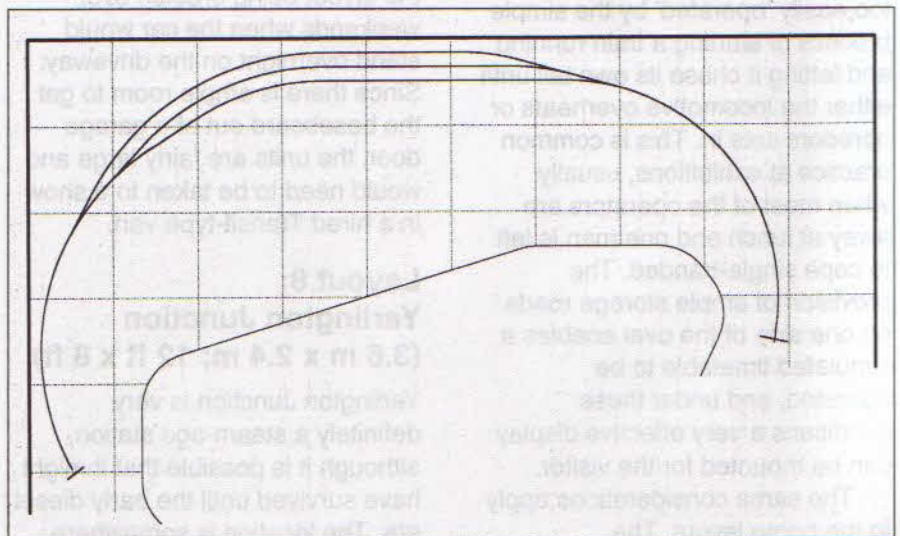

Layout 7b Avon
(3 m x 2.4 m; 10 ft x 8 ft) Low level

prototypical formations, it is big enough for most purposes. The plan is basically steam age; for diesel era the loco depot must go and the goods yard would be greatly simplified, not that it's very complex to begin with.

While I was redrawing the scheme I realised once again its main disadvantage, limited train storage. The solution is simple enough – low-level loops under the main station – but connecting them to the main line is another thing altogether. In this case I've put them on a low-level continuous run, which is disguised as a single-track branch. The passing station allows you to run round the stock, which for safety should always be pulled in and out of the loops rather than pushed back. Even on the best-maintained layouts, propelling a train backwards can lead to derailments; doing so when the train is hidden makes any derailment a major crisis since you only find out when something goes bump underneath the baseboards.

Avon is situated on the river of that name. As there are several of these, the exact geographical location is delightfully vague.

Tailchasers

The small continuous layout is all too easily 'operated' by the simple process of starting a train running and letting it chase its own tail until either the locomotive overheats or boredom sets in. This is common practice at exhibitions, usually when most of the operators are away at lunch and one man is left to cope single-handed. The provision of ample storage roads on one side of the oval enables a simulated timetable to be operated, and under these conditions a very effective display can be mounted for the visitor.

The same considerations apply to the home layout. The

continuous layout, with ample storage roads or, as our American cousins call them, staging tracks, allows one to reproduce the most common type of station. There is a danger here, however: a simple passing station, where only the daily pick-up goods does anything other than stop briefly and then proceed on its way, can be unutterably boring to operate. Indeed, if simplicity is the prime requirement, as would be the case where the main interest lies in modelling locomotives and rolling-stock, then I would recommend a long viaduct rather than a station, with possibly a refuge siding to provide a little onstage action. If you are simply going to watch the trains go by – a very soothing procedure, may I point out – there is nothing quite so effective as a viaduct for this purpose.

Although the tailchaser is mainly associated with club layouts, it is equally suitable for the private individual. The two examples that follow are designed to fit into a standard domestic garage and are envisaged as transportable schemes, built with a view to exhibition operation. There should be sufficient room to store the baseboards along the back of the garage for most of the time, the layout being erected over weekends when the car would stand overnight on the driveway. Since there is ample room to get the baseboard out of a garage door, the units are fairly large and would need to be taken to a show in a hired Transit-type van.

Layout 8: Yarlington Junction (3.6 m x 2.4 m; 12 ft x 8 ft)

Yarlington Junction is very definitely a steam-age station, although it is possible that it might have survived until the early diesel era. The location is somewhere

along a cross-country single-track branch in the middle of nowhere. Its sole reason for existence is the feeder branch to Yarlington, situated some 10 miles away; I have in mind somewhere in the Devon–Somerset borders, with Exeter to the left and London to the right. The only originating traffic comes from the dairy, which sets the period some time after 1930. The layout plan is loosely based on GWR practice. Modeller's licence has provided a rather more extensive sub-shed than one might expect in so out-of-the-way spot. Apart from the dairy, the only non-railway building is the inn, while a row of railway cottages is provided for the staff. The old companies generally had an enlightened outlook; the large railway towns had an embryo welfare state some 70-odd years before Parliament caught up.

From the modeller's viewpoint, this arrangement has much to commend it. The station can comfortably handle a four-coach train; indeed, as long as the locomotive can stand clear of the platform, five pre-war 60-foot coaches can stand against the platform faces. This is about as large a train as one would find on such a line except on Sundays, when permanent way work on the main line would lead to expresses being diverted on to the single-track route. The branch fiddle yard can also take a five-coach train, which is feasible if we assume that Yarlington is a seaside resort.

The station is alongside the former turnpike road; the inn once provided fresh horses for the coaches and is situated at the point where the old Yarlington Road joins the turnpike. A toll-house could be fitted in if the fancy takes you, but I've assumed it was demolished during the construction of the railway. It's fun building up a

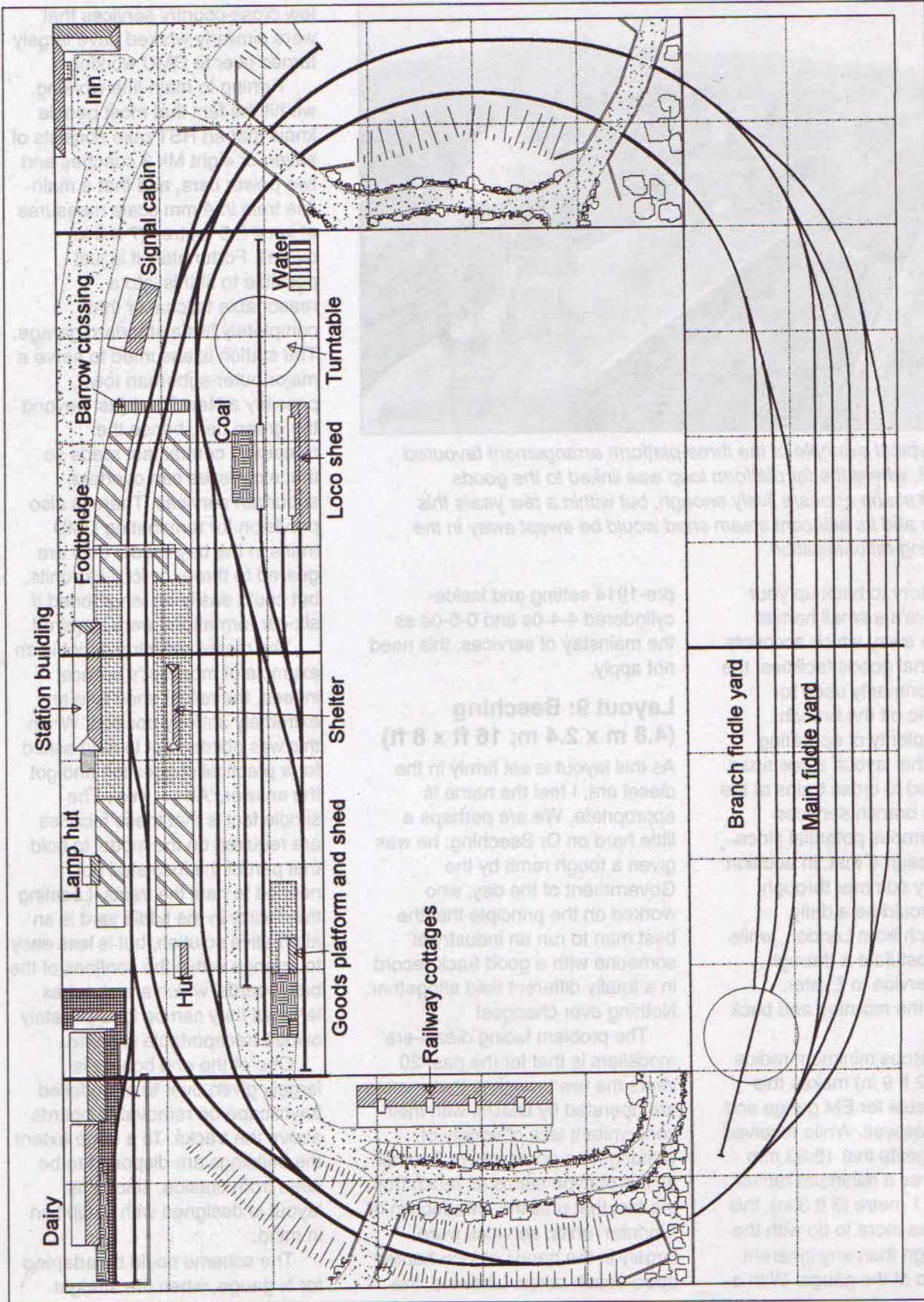

Layout 8 Yarlington Junction (3.6 m x 2.4 m; 12 ft x 8 ft)

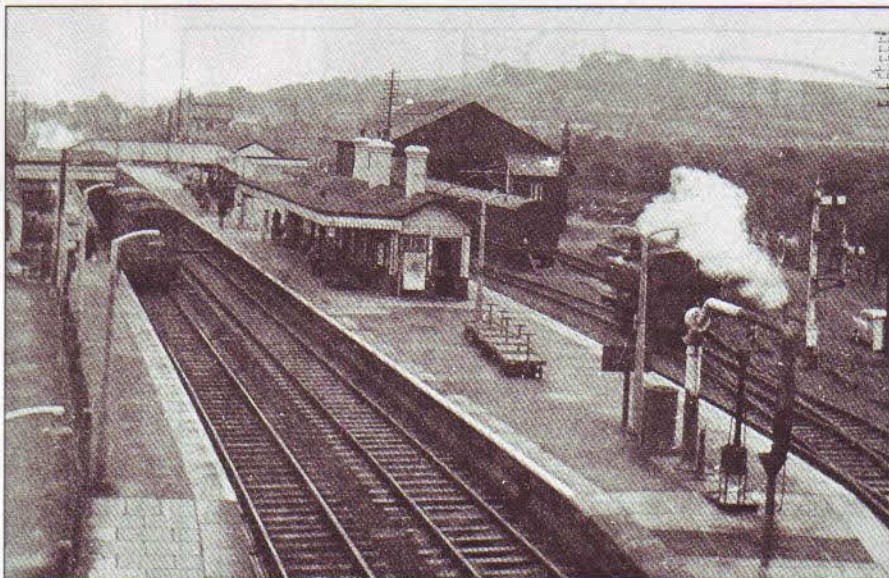

Par was a typical example of the three-platform arrangement favoured by the GWR, where the far platform loop was linked to the goods sidings. The scene appears lively enough, but within a few years this busy station and its adjacent steam shed would be swept away in the post-Beeching rationalisation.

fictitious history to back up your railway. There's a small hamlet about a mile away which accounts for the minimal goods facilities; the sidings are primarily used for transfer traffic off the branch.

There is plenty of operating potential in this layout, since apart from the need to cross trains at the junction, the branch services provide enormous potential since one could assume that, in addition to the weekly summer through train there would be a daily through coach from London, while one could postulate a through commuter service to Exeter, outwards in the morning and back at night.

The generous minimum radius of 850 mm (2 ft 9 in) makes this scheme suitable for EM gauge and possibly P4 as well. While received wisdom suggests that 18.83 mm gauge requires a minimum radius in excess of 1 metre (3 ft 3 in), this frequently has more to do with the chassis design than any inherent characteristic of the gauge. With a

pre-1914 setting and inside-cylindrical 4-4-0s and 0-6-0s as the mainstay of services, this need not apply.

Layout 9: Beeching (4.8 m x 2.4 m; 16 ft x 8 ft)

As this layout is set firmly in the diesel era, I feel the name is appropriate. We are perhaps a little hard on Dr Beeching; he was given a tough remit by the Government of the day, who worked on the principle that the best man to run an industry is someone with a good track record in a totally different field altogether. Nothing ever changes!

The problem facing diesel-era modellers is that for the past 20 years the few branches that remain are operated by DMUs, with their concomitant lack of variety of working. The popularity of Scotrail as a prototype stems as much from the fact that until the introduction of 'Sprinter' units, services were largely in the hands of loco-hauled three-coach rakes. Likewise, the

few cross-country services that were similarly worked have largely turned over to DMU working.

Turning to main-line working, we hit the fact that most people know that an HST rake consists of seven or eight Mk 3 coaches and two power cars, and that a main-line train in 4 mm scale measures at least 2.5 metres (7 ft 6 in) overall. Fortunately it is just possible to fit this into a reasonable tailchaser that completely fills a standard garage. The station is assumed to serve a major outer-suburban town, possibly a New Town just beyond the green belt, hence the remaining central fast roads so that expresses can overtake suburban services. There is also provision for terminating DMU trains in the bay roads; they are geared to three- or four-car units, but could easily be lengthened if six-car formations were required.

The diesel servicing depot is an example of modeller's licence; indeed, the railcar shed is in an extremely unlikely position. When this was pointed out to me I asked for a practical suggestion and got the answer, 'Ah . . . yes'. The simple fact is that these facilities are required on the model to hold that part of the loco stud not needed to haul the trains. Locating this facility in the fiddle yard is an alternative solution, but is less easy to arrange within the confines of the baseboards, which are about as large as they can be for a privately owned transportable scheme.

One of the end boards is largely given over to a modelled townscape on removable boards above the tracks. To a large extent the buildings are disposed to be seen from outside, since this layout is designed with exhibition in mind.

The scheme could be adapted for N gauge, when the straight

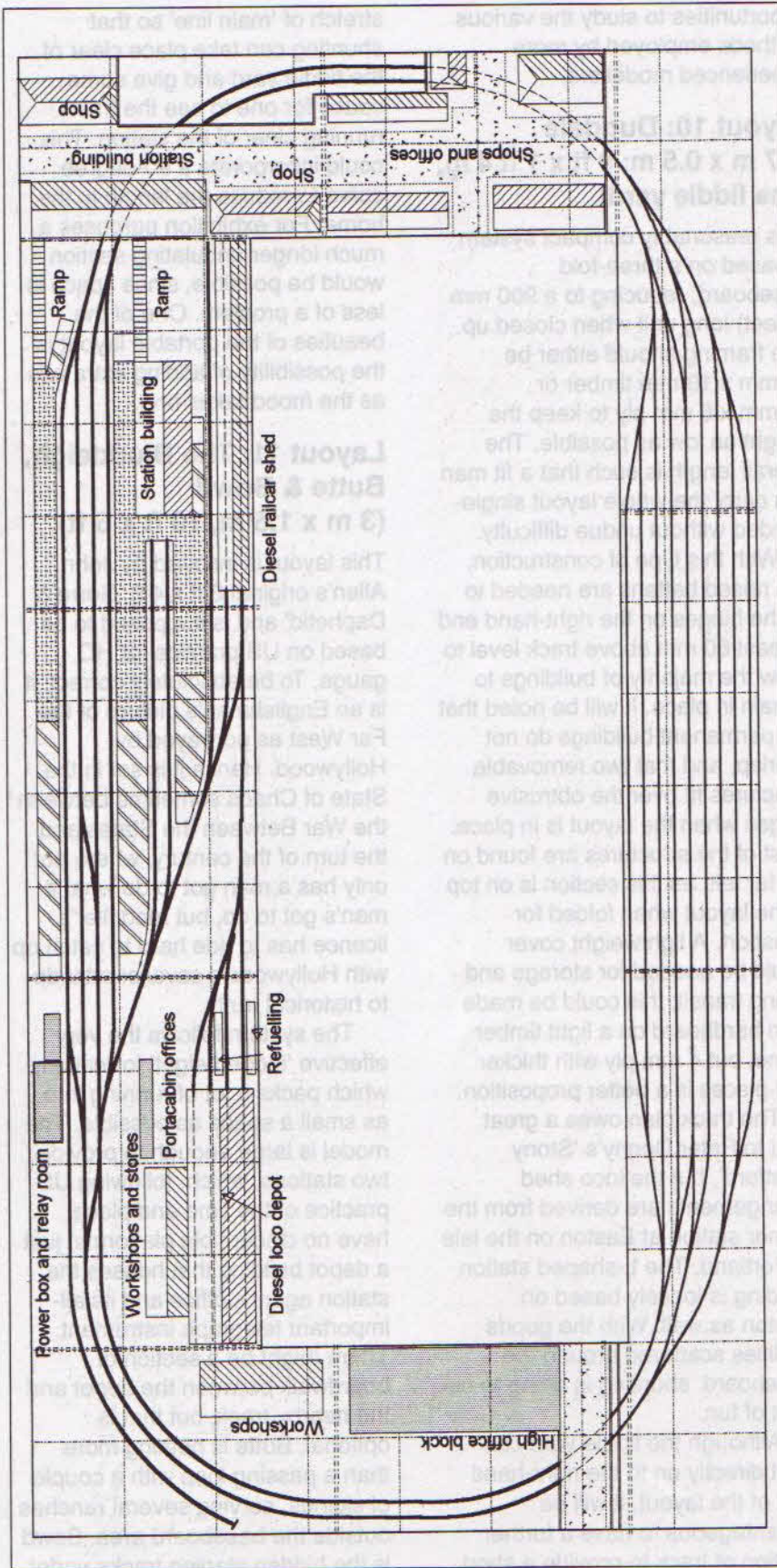

Layout 9 Beeching (4.8 m x 2.4 m; 16 ft x 8 ft)

Layout 10 Dugdale (2.7 m x 0.5 m; 9 ft x 1 ft 4 in, plus fiddle yard)

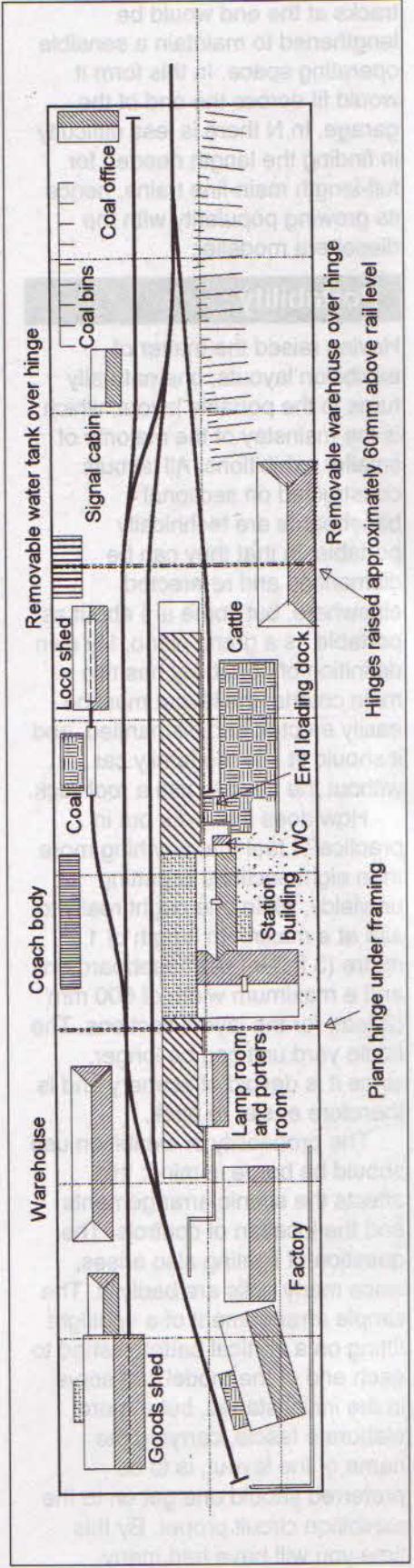

tracks at the end would be lengthened to maintain a sensible operating space. In this form it would fit across the end of the garage. In N there is less difficulty in finding the length needed for full-length main-line trains, hence its growing popularity with the diesel-era modeller.

Portability

Having raised the matter of exhibition layouts, one naturally turns to the portable layout, which is the mainstay of the majority of smaller exhibitions. All layouts constructed on sectional baseboards are technically portable, in that they can be dismantled and re-erected elsewhere, but some are about as portable as a grand piano. My own definition of portability has two main criteria: the layout must be easily erected and dismantled, and it should fit into the family car without the need to use a roof-rack.

How does this work out in practice? I feel that anything more than eight sections is getting unwieldy, while one ought really to aim at a maximum length of 1 metre (3 ft 3 in) per baseboard unit and a maximum width of 600 mm (2 feet) for the layout sections. The fiddle yard unit can be longer, since it is devoid of scenery and is therefore easier to pack.

The probability of exhibition use should be borne in mind: this affects the scenic arrangements and the location of controls. The question of lighting also arises, since many halls are badly lit. The simple arrangement of a spotlight fitting on a vertical batten lashed to each end of the model can serve in the initial stages, but a more elaborate fascia, carrying the name of the layout, is to be preferred should one get on to the exhibition circuit proper. By this time you will have had many

opportunities to study the various methods employed by more experienced modellers.

Layout 10: Dugdale (2.7 m x 0.5 m; 9 ft x 1 ft 4 in, plus fiddle yard)

This reasonably compact system is based on a three-fold baseboard, reducing to a 900 mm (3 feet) long unit when closed up. The framing should either be 45 mm x 19 mm timber or 75 mm x 6 mm ply to keep the weight as low as possible. The overall length is such that a fit man can carry the whole layout single-handed without undue difficulty.

With this type of construction, two raised battens are needed to lift the hinges on the right-hand end at least 60 mm above track level to allow the majority of buildings to remain in place. It will be noted that the permanent buildings do not overlap, and that two removable structures fit over the obtrusive hinges when the layout is in place. Most of the structures are found on the far left, as this section is on top of the layout when folded for transport. A lightweight cover would be needed for storage and during transit; this could be made from hardboard on a light timber frame, but 4 mm ply with thicker end-pieces is a better proposition.

The track plan owes a great deal to Peter Denny's 'Stony Stratford', but the loco shed arrangements are derived from the former station at Easton on the Isle of Portland. The L-shaped station building is loosely based on Easton as well. With the goods facilities scattered around the baseboard, shunting is going to be a lot of fun.

Although the fiddle yard can abut directly on to the right-hand end of the layout, it will be advantageous to have a further section of track to provide a short

stretch of 'main line' so that shunting can take place clear of the fiddle yard and give some space for one to see the trains running clear of the station. This could incorporate a 90-degree curve to reduce the length in the home. For exhibition purposes a much longer undulating section would be possible, since space is less of a problem. One of the beauties of the portable layout is the possibility of adding extra bits as the mood takes one.

Layout 11: The Bluddeigh, Butte & Bowd (3 m x 1.5 m, 10 ft x 5 ft)

This layout is inspired by John Allen's original 8 ft x 4 ft 'Gorre & Daphetid' and is supposed to be based on US practice for HO gauge. To be absolutely correct, it is an Englishman's picture of the Far West as portrayed by Hollywood. Hence it is set in the State of Chaos sometime between the War Between the States and the turn of the century, where not only has a man got to do what a man's got to do, but modeller's licence has to ride hard to catch up with Hollywood's cavalier attitude to historical truth.

The system follows the very effective 'looped eight' formation, which packs a lot of running into as small a space as possible. The model is large enough to provide two stations, which, following US practice of the time and place, have no discernible platforms, just a depot building that houses the station agent's office and its all-important telegraph instrument. There might be a section of boardwalk between the depot and the nearby track, but that is optional. Butte is nothing more than a passing loop with a couple of sidings, serving several ranches outside the baseboard area. Bowd is the hidden staging tracks under

the mountains behind Bluddeigh.

This is a mining community, with the fabulous Jorsan Mine alongside with its own tracks. There is also space for the entire township, which consists of the depot, the general store, a barber's shop, the sheriff's office, a corral and the saloon. A little way off is the livery stable/blacksmith. There are no other buildings; indeed, I am a little doubtful about the barber's shop, since it does not always appear in the movie. Note the boardwalk, provided for people to scurry away from when the goodies confront the baddies, and the balcony beside the saloon for that fellow with the rifle who never manages to hit anyone of importance before he is taken down by a single shot from a Colt. The roof of the livery stable serves a similar purpose.

The line can comfortably handle four trains – a pair of passenger and freight trains in each direction – and 4-4-0s and 2-6-0s are the order of the day. Suitable ready-to-run models are available though the specialist model shops that cater for US modellers in Britain.

With eight sections and very deep scenery, the layout is at the extreme end of my definition of portable.

The 'dumb-bell'

The 'dumb-bell' layout, where a through station is flanked by a pair of reverse loops, just falls short of the ideal basic layout in one respect: it needs a lot of space. Apart from this, the fact that trains now return in the opposite direction from which they departed adds to the realism and, when sufficient storage roads are provided on the reverse loops, a very satisfying representation of main-line working is possible.

This particular formation is known in the US as a 'dog-bone'.

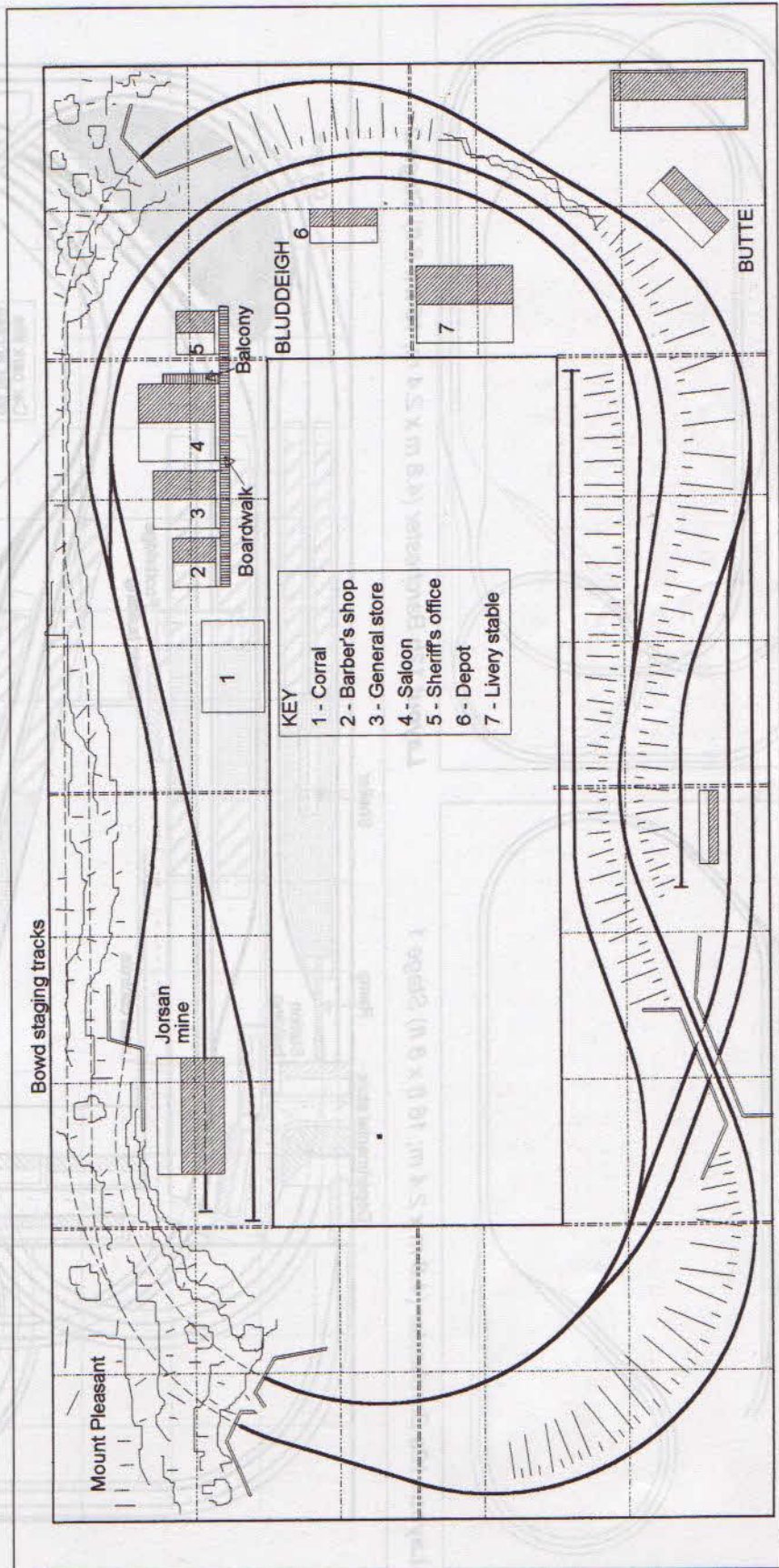

Layout 11 The Bluddeigh, Butte & Bowd (3 m x 1.5 m, 10 ft x 5 ft)

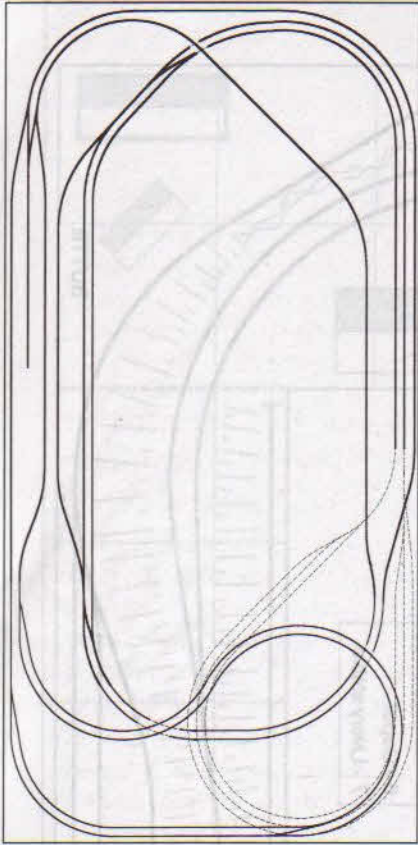

Layout 12a Barchester (4.8 m x 2.4 m; 16 ft x 8 ft) Stage 1

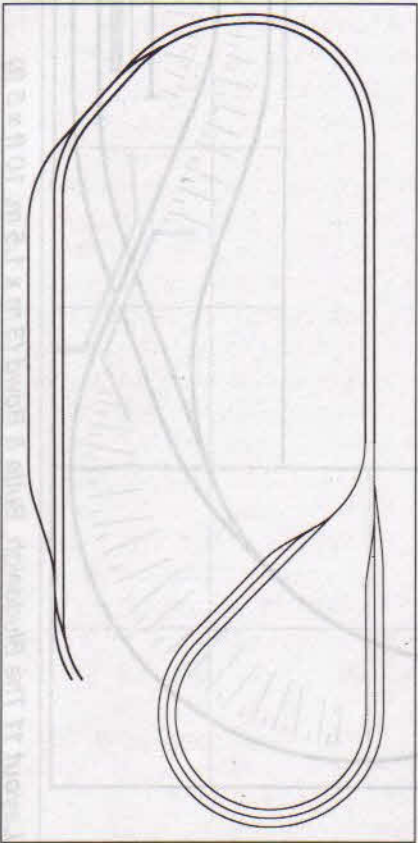

Layout 12b Barchester (4.8 m x 2.4 m; 16 ft x 8 ft) Stage 2

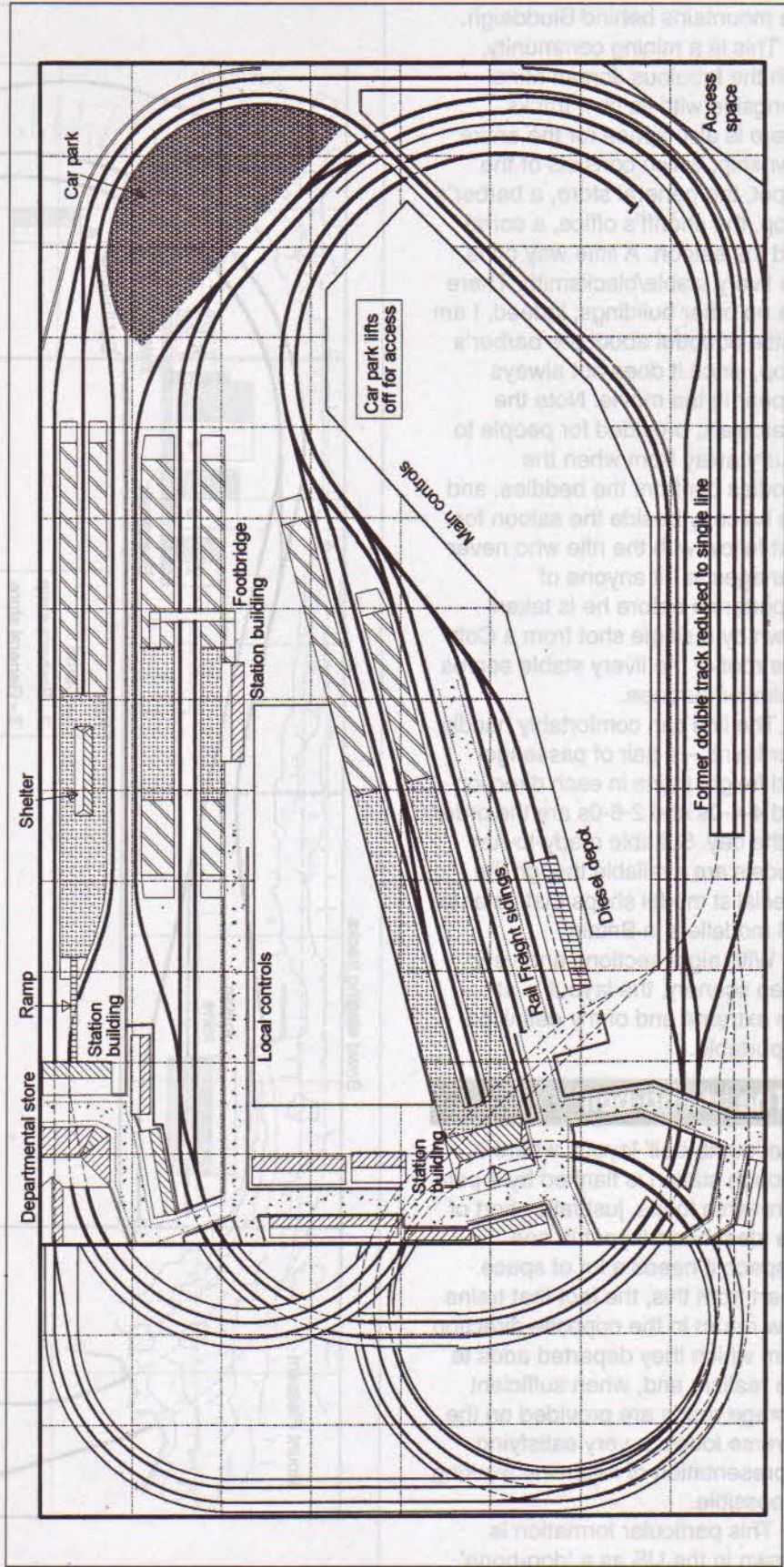

Layout 12c Barchester (4.8 m x 2.4 m; 16 ft x 8 ft) Stage 3

Layout 12: Barchester (4.8 m x 2.4 m; 16 ft x 8 ft)

I have based this drawing on a design that has appeared before, but have brought it into the diesel era. This has two advantages: there is less need to provide for freight traffic, while the ability of a double-bogie diesel locomotive to negotiate sharp curves enables one to use fairly small radii on the hidden loops.

The layout is strictly permanent, for although it is technically feasible to break it down into units, the task of dismantling and re-erection would be formidable. Using an L-girder frame with the track assembled on sub-bases that can be readily removed and re-used, the only part that would have to be scrapped would be the landscaping. Most of the buildings are arranged on lightweight covers over parts of the track, and should be arranged to lift off for maintenance.

Construction can take place in three stages, as shown by the accompanying drawings. While full-scale running could not take place until the completion of stage 2, a limited amount of working will be possible as soon as the low-level through station has its tracks laid down and connected to the controls.

The main concession to the diesel era has been the removal of most goods sidings; in one instance what, on earlier plans, was the goods yard is now a car park. This has the distinct advantage that it can be made to lift out to provide access to the high-level station's pointwork.

The branch to the terminus has been reduced to single track, although part of the original track now forms a long headshunt; the line is slewed across part-way to the junction. This reduction greatly simplifies the terminus pointwork

without placing any real restraint on operation on the model. Unless loco-hauled trains are reversed at the low-level through station, everything can be controlled by one operator.

The reverse loops are only hidden from view by a backscene; they are fully exposed with ample room for access to the stock. This means that the operator can view them through a strategically located mirror or, if a high-tech solution is preferred, through closed-circuit TV. The cost of black and white CCTV units is low enough for this to be a possible solution. However, detector circuits are needed to show on the control panel which loops are occupied. For those with an electrical bent, semi-automatic working will add to the fun.

The system layout

In the early days of the hobby the ideal layout aped the prototype by having one main terminus from which tracks eventually reached a major centre further down the line. A model based on the West Coast route (LNWR) would begin at 'Euston', then pass through 'Rugby' and 'Crewe' to arrive at 'Holyhead' and 'Liverpool'. Frequently the tracks spiralled round the room, rising as they did. In many cases you would find that 'Liverpool' was situated a foot above 'Rugby', while 'Crewe' was a similar distance below 'Holyhead'. Frequently the baseboards criss-crossed the railway room, leaving a few cramped wells from which the operators could just about reach the locomotives to wind them up.

This type of layout fell into disfavour. Although some of the decline began with a desire for greater realism, lack of space had more to do with it than any theoretical fault with the concept. In the USA, where commodious

basements are common enough to make it feasible for a determined model railroader to insist on getting a large railroad room with a home attached, this type of model, frequently based on an actual section of railroad, is extremely popular. Furthermore, the designs are increasingly sophisticated, making excellent use of spaces that British railway modellers can only consider in their dreams.

Layout 13: Laureceton, Metheven and Southern (5.4 m x 3.6 m; 18 ft x 12 ft)

Although I have given this layout the name of one of Edward Beal's freelance systems, it owes everything to the best US design in that the main operating area is a single unit disposed around an E-shaped system. This enables the owner to run a skeleton service over the entire system, since the three termini and the nodal junction are linked by a common passageway. I have adopted a 900 mm minimum radius on the double-track main line.

In the US track occupancy on much of the prototype is fairly low, and although the single-handed operator could not really handle a full service, it does not fall short enough to be blindingly obvious. Any attempt to operate this British layout prototypically with less than four operators would lead to utter frustration, not to mention a fair number of accidents. With six stations, six operators could be kept fairly busy.

This is very much a preliminary plan, and suffers from a distinct lack of storage capacity. Two possibilities arise: low-level hidden sidings coming off the line from the main terminus, or exposed carriage sidings located (rather improbably) somewhere between the junction station and the main-line through station.

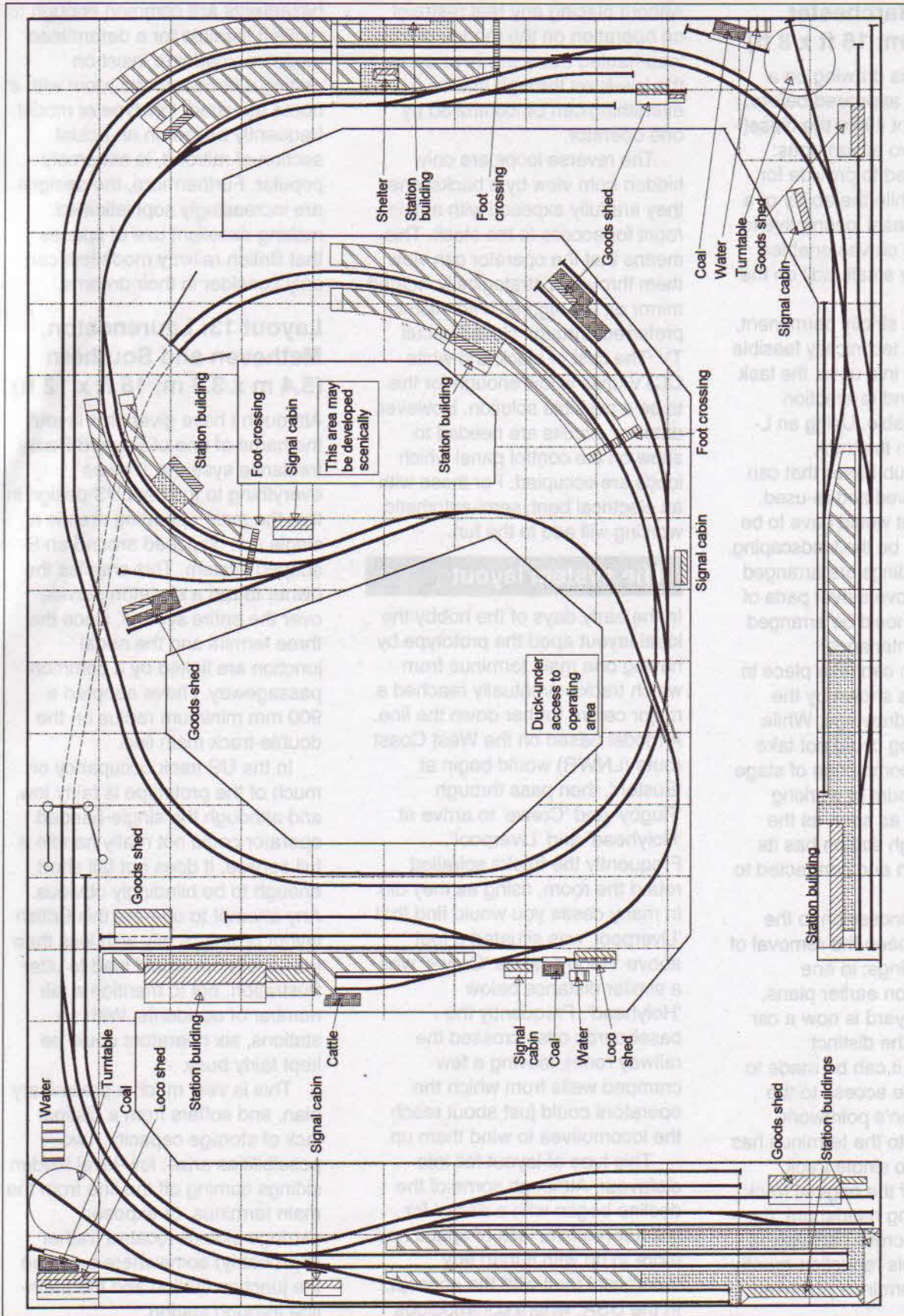

Layout 13 Laurenceton, Metheven and Southern (5.4 m x 3.6 m; 18 ft x 12 ft)

No scenic suggestions are given, although there is ample scope for this.

Narrow gauge

Narrow gauge is generally defined as any system with a track gauge less than the 'standard' gauge of 4 ft 8½ in (1.435 m). As in large parts of the world 3 ft 6 in or metre gauge is the *de facto* standard, the common British association of narrow gauge with short feeder lines is not wholly valid. I am providing some notes on the main narrow gauge options for the modelmaker in an appendix. In this section I propose to explore two contrasting themes.

Layout 14: Rabbits (1.5 m x 0.9 m, 5 ft x 3 ft)

When ready-to-run 9 mm narrow gauge became available it was seized upon avidly by numerous modellers, and to be honest some

pretty awful models came into being. A lot were convoluted arrangements cutting through mountain sides which, when they worked reliably, were great fun. I once called them 'rabbit layouts', since the trains popped in and out

of burrows, and the term stuck. This little scheme for a 9 mm gauge OO9 or HOe layout is a reasonable example of the genre, designed with exhibition in mind. It is shown on a single baseboard and is just at the practical limit of

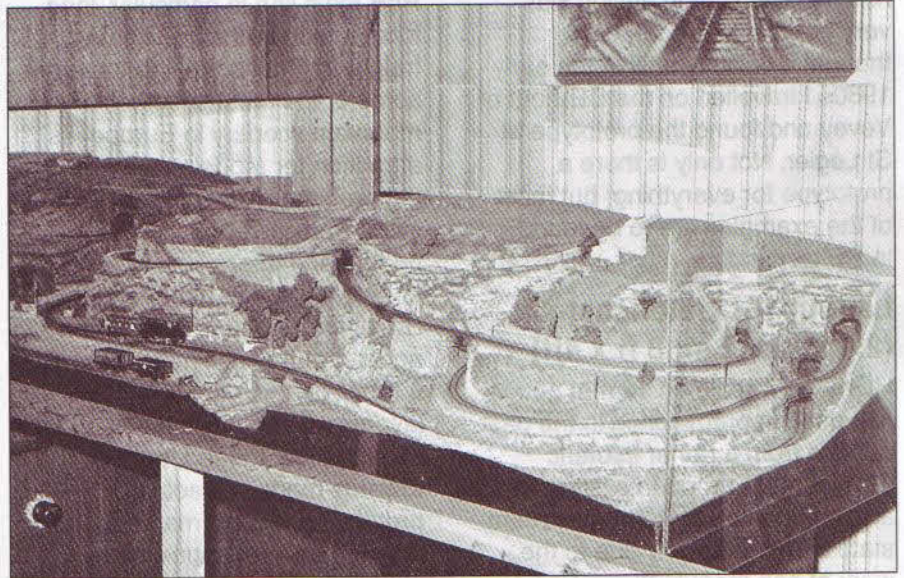

This OO9 layout at Pecorama is a fine example of the 'rabbit layout' genre.

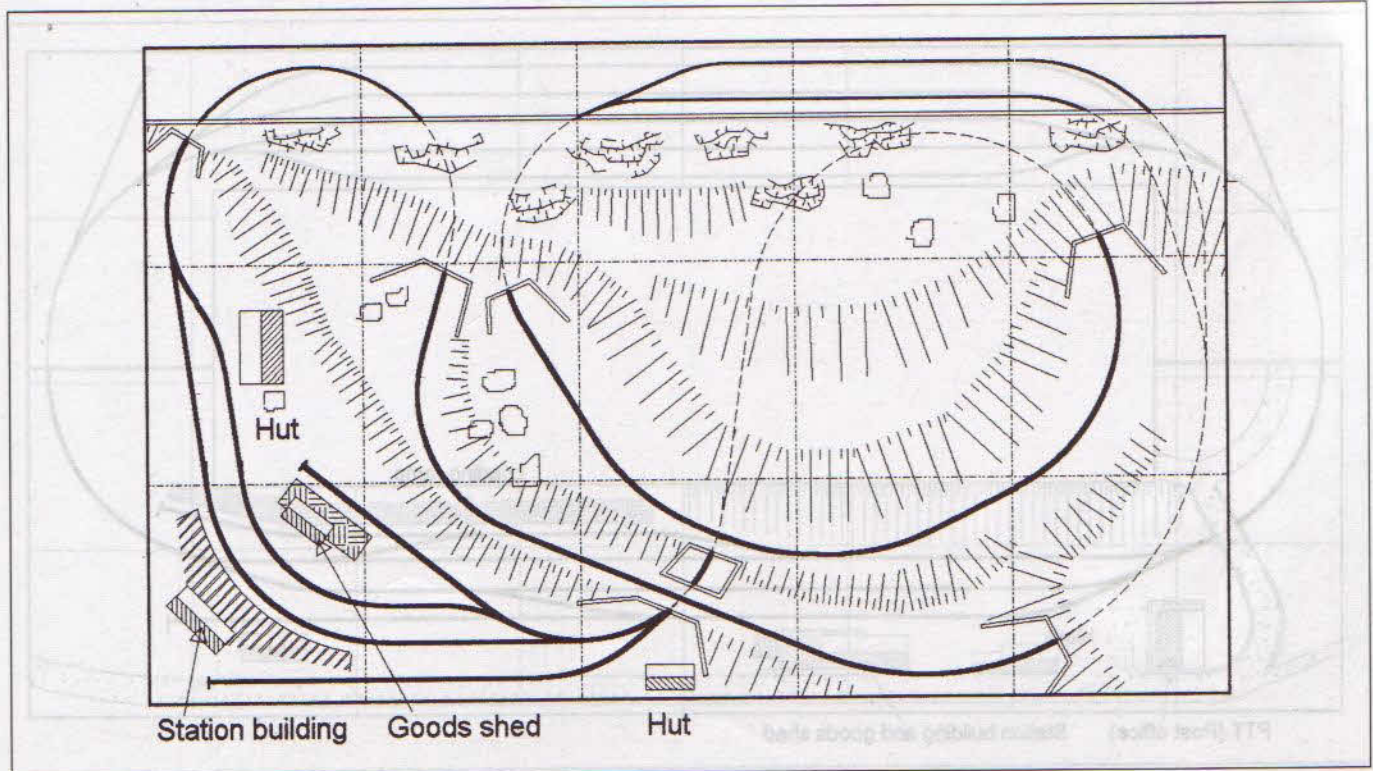

Layout 14 Rabbits (1.5 m x 0.9 m, 5 ft x 3 ft)

removability, although as two people would be needed to lift it, it falls outside my definition of portable. You'd need a large estate car as well.

There is a passing loop at the rear, behind a backscene; this is preferable to hiding it under the hillside. The station design was very popular in the 1960s. I thought it unlikely until in the early 1980s I travelled on the CEV out of Vevey and found the prototype at St L gier. Not only is there a prototype for everything, but most of the examples are to be found in Switzerland.

Layout 15: Tiefencastel (2.4 m x 1.2 m; 8 ft x 4ft)

HOM, 1:87 scale on 12 mm gauge, has risen in prominence in the past decade from a rather esoteric Continental European system into a strong contender for mainstream status. This is largely due to the work of one manufacturer, Bemo, who began with German-based

HOe (1:87 scale on 9 mm gauge) equipment and branched out into 12 mm gauge models of Swiss Rhaetian Railway stock. Unlike other European narrow gauge railways, the Swiss metre gauge is very much a main-line system with high traffic densities and, on the RhB main line in particular, long loco-hauled trains and heavy freight traffic. As the line traverses some of the most spectacular mountain scenery in Europe, its attraction for modelmakers, once the problem of obtaining rolling-stock was solved, is understandable.

Paradoxically, although the Swiss metre gauge lines do dive in and out of tunnels in the manner of a rabbit layout, very few HOM layouts attempt this type of construction. Indeed, the trend towards modelling actual prototypes is most marked, and this has been encouraged by the publication of an excellent series of prototype track plans, in

particular the Bemo book of RhB track plans, supplemented by another range of bridge drawings.

The accompanying layout is a somewhat foreshortened version of Tiefencastel on the RhB Albula line. For the record it is over 50% too short, so that instead of handling the 14 coaches found on the heaviest trains, one is down to five. On the other hand the model will fit into the end of a garage and can be broken down into four units for exhibition purposes. I would suggest the same arrangement as on David Broomfield's 'Majola', four L-shaped sections, making the location of pointwork much easier.

The five-track storage sidings will just handle the basic five-coach train. Loco spurs are provided at each end to simplify offstage train reversal. With up to 20 coaches at anything between £20 and £50 apiece, and at least seven locomotives from just under £100 to just over £200 apiece, plus a selection of goods wagons at

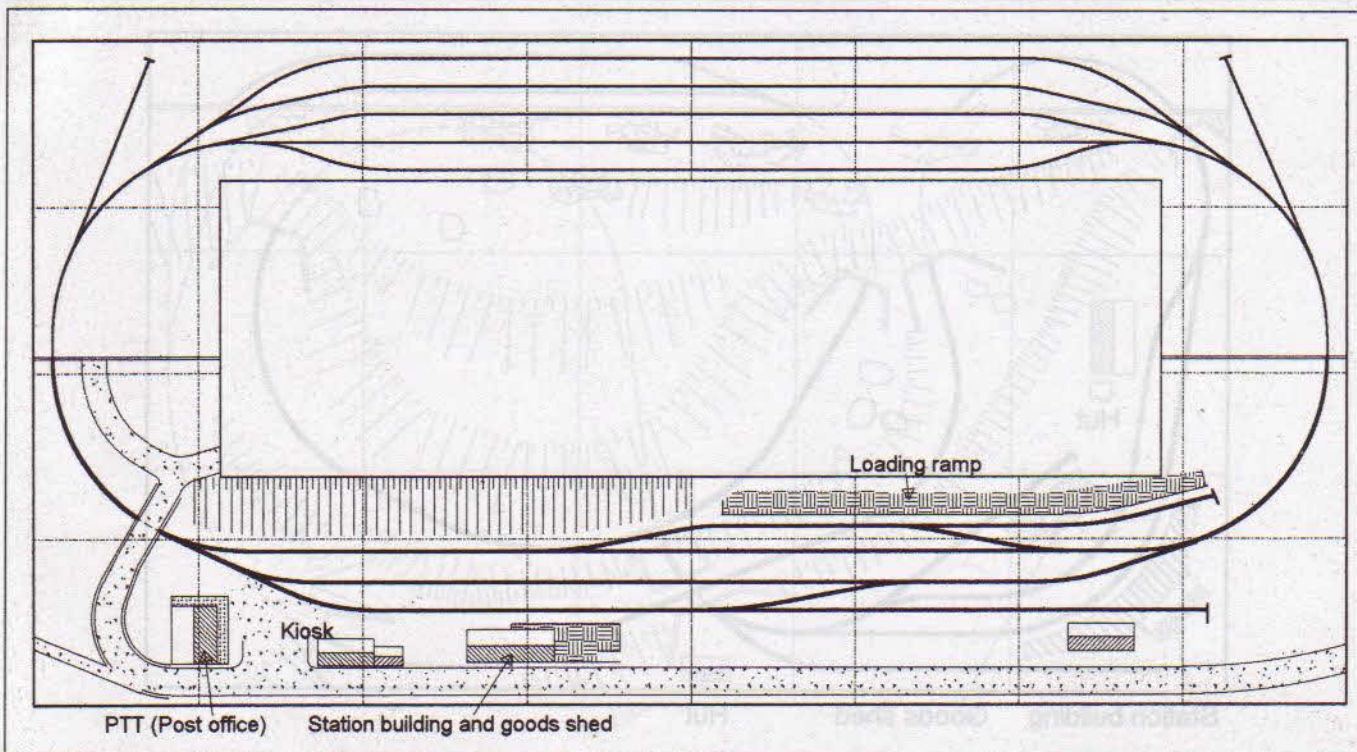

Layout 15 Tiefencastel (2.4 m x 1.2 m; 8 ft x 4ft)

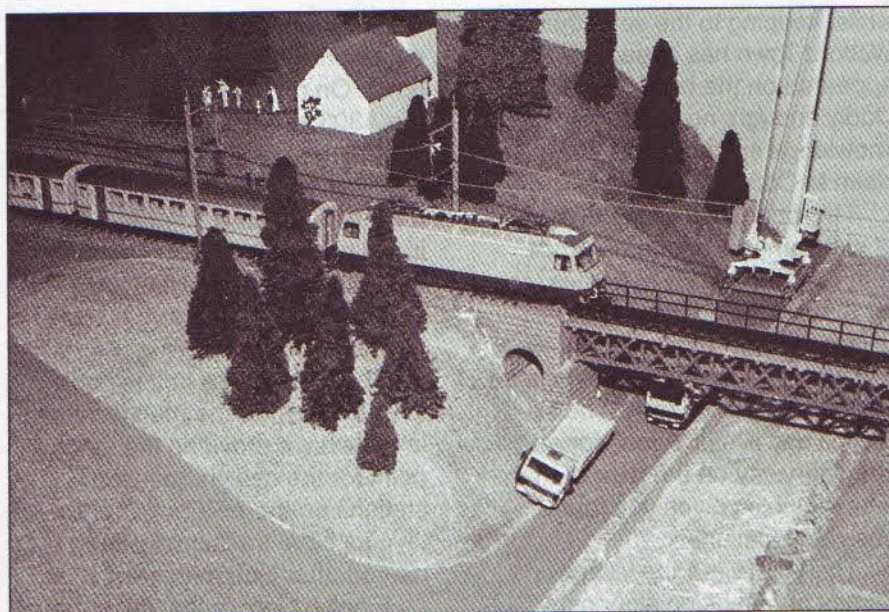

Graham Watson's 'Albula Bahn' is an imaginary station set somewhere between Tiefencastel and Bergün on the line from Chur to St Moritz. The setting is typical of the region, down to the fast-flowing alpine river in the foreground. The locomotive is a model of the latest Ge4/4III class electric locomotives introduced in 1994 and available, ready to run, in HOm at the beginning of 1995.

around £15 a time (1995 prices), we are looking at a substantial investment. I would hesitate to suggest this were it not for the fact that most of the HOm modellers of my acquaintance have a somewhat larger collection.

The plan shows the older (though not the original) layout. Today the loop has been extended beyond the road overbridge, which has been rebuilt, and the space between the two running roads is widened to provide a slightly raised platform. One still has to cross the tracks on foot.

Tiefencastel is located part-way up the foothills above the town; it's a good 5-minute walk down and a fairly stiff 7 to 8 minutes climb back. The station is the focal point of two postbus routes and most trains are greeted by two bright yellow buses standing in front of the PTT building. The principal



An avalanche gallery on Mike Polglaze's HOm 'Via Mala'.

freight traffic is ballast from a nearby quarry. As with most small Swiss stations, the loop nearest the station building is for freight, while the main tracks form the longest loop. Most trains stop here.

Although illustrations of the station can be found in books on the RhB (mostly German text), the ideal arrangement is to visit the prototype – but be warned. Switzerland in general and the RhB in particular are habit forming.

What's in a name?

One cogent argument for modelling an actual prototype station is that you do not need to think up an appropriate name. On the other hand, choosing a name can be an interesting exercise. I've mentioned Lochaber already, and another possible Scottish name would be 'Buchan (for Tweedsmuir)', although I suspect that many readers are unacquainted with John Buchan's novels. Still on a literary theme, both Trollope and Hardy have provided names for many model railways: Casterbridge and Barchester have a fine ring. So, for that matter, has Borchester,

while, keeping to the soap theme, Walford Town has already appeared on the exhibition circuit. Oddly enough, no one to my knowledge so far has staked a claim to Coronation Street.

This brings me to the question of city names. London abounds with resounding street names, as for that matter do most of our ancient cities – although I fancy few would choose 'Shambles' for a station situated in York. One I particularly like is 'Avon', for an imaginary city on the river of that name – which gives you four possible locations.

Then there are the village names one sees on signposts. Winston Graham found the names for two characters in the Poldark series on Cornish signposts, and I once reversed the process by naming the stations on a plan for an expandable GWR branch after several of his characters. My wife not only suggested that I build a model based on St Ives, but even provided its name, Tregunna – her mother's maiden name was Tregunno.

One name that has long fascinated me is Emborough,

which I passed through on many occasions before the M5 was open. On my way to Seaton along the A303 in 1995 I passed a notice informing me that Yarlinton Junction was closed. As I wasn't driving at the time, I noted it down in my pocketbook. You need to jot these things down when you spot them – 10 to 1 you'll forget them by the following day.

Several stations in this book are named after the friends whose layouts have provided the starting point for the design. Indeed, stations on the MRC's 4 mm scale layouts have traditionally been named after club members.

Finally, there is the 'might-have-been' line. From 1830 to around 1910 proposals were made for railways that, for one reason or another, were not built. Indeed, as late as 1935 the GWR began work on a new branch to Looe, work on which was suspended in 1939, never to be resumed. Any of these can be revived in model form, providing a totally imaginary line serving an actual location. The best known of these railways is Peter Denny's 'Buckingham'.

Appendix 1

Scale and gauge

While the question of scale and gauge undoubtedly is important, it is all too easy to over-emphasise the theoretical aspects of the subject to the detriment of more practical considerations. You can agonise for hours on the subject, trying to decide which combination is best. The available space for the model has an influence, as does the availability of equipment, but your personal preferences must be the main consideration.

The following notes are a personal assessment of the situation as it appears today.

Commercial standard gauge

OO gauge (4 mm scale, 1:76, 16.5 mm gauge)

Specifically a British system, this scale/gauge combination is very well provided with ready-to-run models and kits. Although, for historic reasons, the track gauge is underscale, it is still on most model railways the most accurate measurement on the track!

Because the products are aimed at different markets there can be some problems with wheel standards. However, these pale into insignificance beside the problems faced in the 'more accurate' gauges for 4 mm scale.

HO gauge (3.5 mm scale, 1:87, 16.5 mm gauge)

This is the major system in the rest of the world, and the scale/gauge

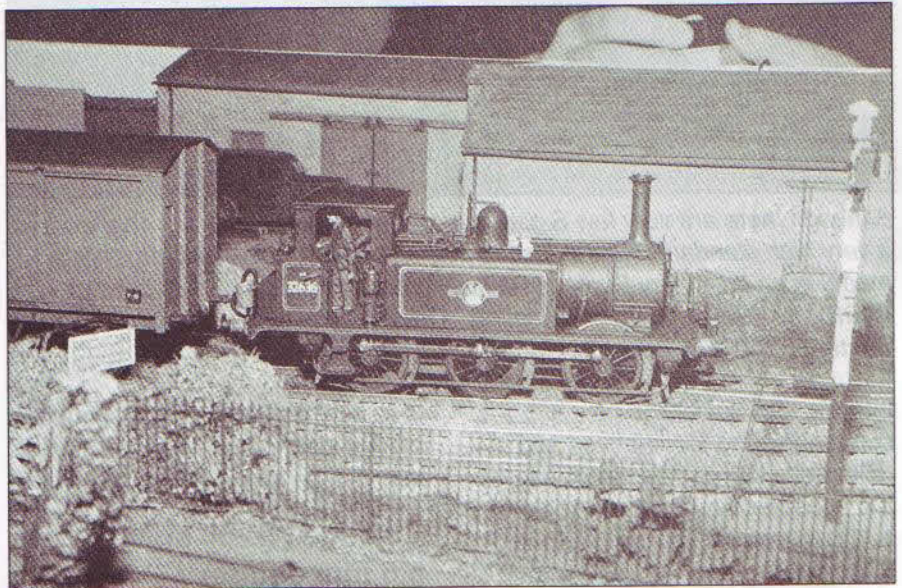

O gauge, 7 mm scale on 32 mm gauge tracks, is large enough to allow the finer details of the individual models to be easily seen at arm's length, even by those viewers whose eyesight is not quite as sharp as once it was. I was reminded of this when I was photographing Gordon Gravett's 'Ditchling Green' at York, only to find that P. D. Hancock was standing alongside. We agreed that, despite our own commitment to 4 mm scale, this larger size certainly made it easier to see where the hairs had been split.

ratio is almost 100%. As European and US prototypes are larger than British, the models look about the same size, so a lot of people believe that HO is what those funny foreigners call OO. As Continental HO stock runs happily over a British OO layout, they have cause. Larger US steam locomotives can be too big to pass under bridges and beside raised platforms. The supply of HO ready-to-run is extremely good, but there are fewer kits and components to be found. These two factors are clearly connected.

Models of broad gauge prototypes – primarily Spanish

and Russian – are made for 16.5 mm gauge.

Before we leave this size, a word about OO/HO. Applied to track this indicates 16.5 mm gauge. Applied to models, and in particular to scale, it suggests that someone is trying to pull the wool over your eyes.

N gauge (1:160 scale: 9 mm gauge except in Britain where the scale is nominally 1:148)

N gauge equipment is not so easily located as OO or HO. Its obvious virtue is size, but against

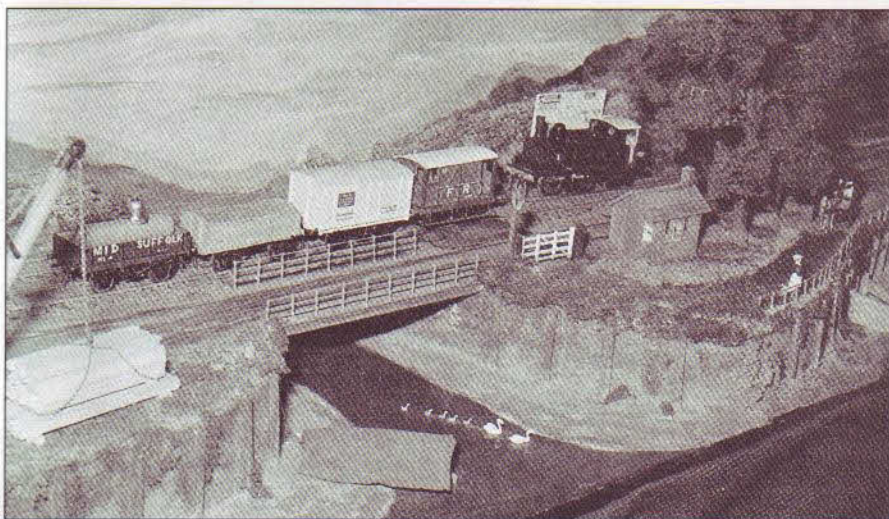

Although there are very few S gauge modellers around, they not only work to a very high standard, but are also strong on co-operation. This rather fine model of an imaginary Furness Railway branch terminus was stocked at IMREX by a small group of modellers. This explains the presence of a Great Eastern 0-6-0 tank against a Furness brake-van.

this it is less suited for scratchbuilding locomotives and rolling-stock. It is close in size to the accepted architectural scale of 1:150 to make it impossible to tell, at arm's length, which is which.

Its supporters claim it is the gauge of the future, but they've been saying this for the past quarter of a century, and it is just possible that before long N could take over from OO. The trouble is that most OO and HO equipment is fractionally cheaper and it is perceived at the train set end of the market that the larger models are more robust. But then they said that about O gauge 50 years ago. And Gauge 1 25 years before that.

O gauge (7 mm scale; 1:43.5, 32 mm gauge)

O gauge is really on the borderline between commercial and non-commercial. Very little ready-to-run equipment is available, but kits and components can be obtained through specialist model shops. Where the larger scale scores is in its suitability for scratchbuilding and high-class modelmaking generally. It

is all very well splitting hairs, but it is a good idea to do so at a size where they can be seen to have been split.

Z gauge (1:200 scale, 6.5 mm gauge)

In so far as Z gauge is manufactured by the oldest firm in the business, Märklin, it is a commercial gauge. In so far as the range is restricted to a very few Continental models and an even smaller selection of US prototypes, it is hardly of interest to British modellers.

Non-commercial standard gauge

2 mm scale (2 mm scale, 9.5 mm gauge)

Sometimes considered an accurate version of N, 2 mm scale antedates the commercial half-HO gauge by several decades, as the first models appeared in the early 1930s. It commands a small but dedicated following. You have to be dedicated to build such tiny models *and get them to work*.

TT gauge (3 mm scale, 12 mm gauge)

This size originated in the USA, where a scale of 2.5 mm to the foot was used. Some East German models followed, and these remained in production until a short while after the fall of the Wall, when an attempt to reintroduce the scale into the USA flopped.

In Britain Triang produced a small number of ready-to-run models, mostly a shade crude, but with a couple of quite delightful examples that were more or less to 3 mm scale. Some commercial support, including a range of wagon kits from Peco and flexible track from GEM, followed, but when Triang abandoned a system that did not appeal to the mass market, the main support was through the specialist 3 mm Scale Society.

It is a very nice size for the keen modelmaker who is happy to make 90% of his models from scratch or from a limited selection of kits. Fortunately it has not been seriously infected by the exact-scale, full-detail virus.

EM gauge (4 mm scale; 18.2 mm gauge)

EM is the first serious attempt to create a more accurate scale/gauge ratio for 4 mm scale models. It is reasonably easy to convert the better OO gauge ready-to-run models by fitting 'scale' wheels on different axles. Now that ready-assembled track is available, it is not too difficult to make the changes oneself.

It has been said that it takes no longer to model in EM than it does in OO gauge. This is based on the idea that locomotives and rolling-stock are either scratchbuilt or assembled from kits. However, there is an appreciable difference between opening a box and placing a ready-to-run model on the track

and taking an identical model from another box and *changing the wheels before putting it on the track.*

Accepted wisdom has it that EM models need a larger radius than OO. This is only true if, at the time of conversion, substantial changes took place in the chassis design. Unfortunately, this does happen with outside-cylindere steam locomotives, but on the other hand a 4 mm scale commercial diesel locomotive that went round 400 mm radius curves when built will still go round 400 mm radius curves when it is fitted with a different set of wheels in the same bogies.

P4 gauge (4 mm scale, 18.83 mm gauge)

P4 is claimed to be the only accurate gauge for 4 mm scale, and this is undeniably true, although I have reservations about the actual gauge since I don't think

that the materials and techniques involved can achieve a consistent accuracy of 10 microns.

The use of very narrow wheels and shallow flanges makes it imperative to fit compensation to all vehicles. As this has to be done by the individual, the success of P4 depends on one's ability to work with extremely fiddly parts. Even where the builder has the ability, it is undoubtedly time-consuming.

There is also a psychological disadvantage: having adopted a very accurate measurement for the track gauge, most P4 modellers feel impelled to apply the same level of accuracy to everything else. Highly involved modelling techniques are preferred to simple straightforward craftsmanship, and the fact that much of the 'improvement' is indistinguishable at arm's length is not always taken into account. I said earlier that splitting hairs is pointless if you cannot see that they have been split.

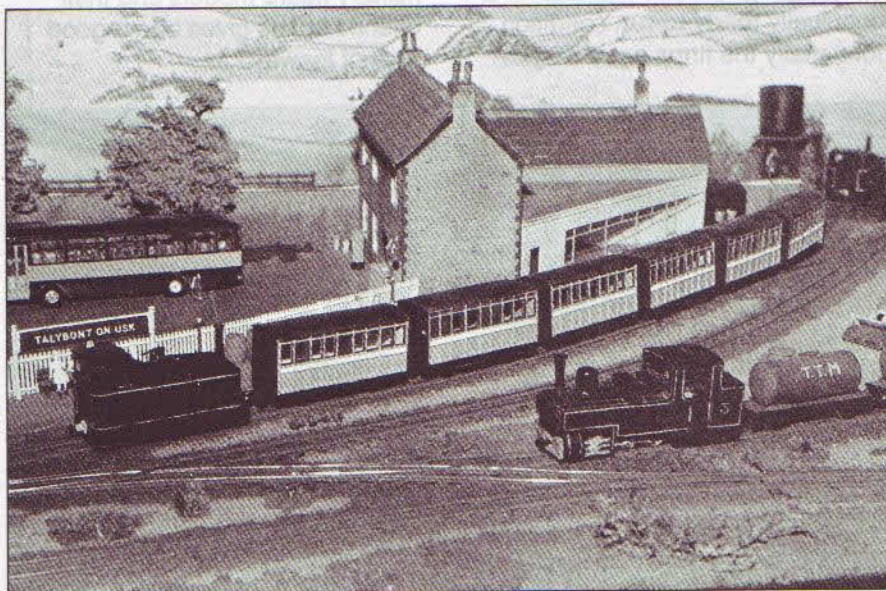

OO9, 4 mm scale on 9 mm gauge track, gives a scale track gauge of 2 ft 3 in, used on the Welshpool & Llanfair Railway and, in this delightful model, on a fictitious line Talybont-on-Usk. The charm of the British narrow gauge scene is accurately portrayed in this model. Anyone who considers that the Zillertalbahn loco in the foreground is out of place should remember that the Austrian narrow gauge is 750 mm gauge, or 2 ft 3 in in imperial size, and the stock is interchangeable.

Scale Seven (7 mm scale, 32.95 mm gauge)

This system involves a slight increase in track gauge and exact scale wheel profiles, but is only distinguishable from O gauge by the large notices attached to the layouts at exhibitions.

Gauge 1 (10 mm scale, 45 mm gauge)

As ready-to-run Gauge 1 equipment is available in limited quantities this size teeters on the brink of being commercial. However, most of the nearly affordable models are of German or Swiss prototypes, while the few British ready-to-run models are Aster live-steam locomotives that are well outside most individuals' pockets, so it cannot be equated with O gauge, let alone OO or N. Having said that, it is a lovely size for anyone who has a strong affinity for model engineering rather than modelmaking. It is primarily an outdoor size, and ideally suited for live steam propulsion.

In addition one should mention 2 and 3 gauge, 2-inch and 2½-inch gauges respectively. The small difference between 2 gauge and 1 gauge led to its early demise, while 3 gauge moved over into model engineering for small live steam. Some efforts have been made to revive interest in this size as a model railway gauge, but whether they succeed is open to question.

Commercial narrow gauge

OO9, HOe (4 mm or 3.5 mm scale, 9 mm gauge); represents 2 feet and 2 ft 3 in gauge

This is a case where the British use one name and the Continentals another, since the ready-to-run models in this size

are indiscriminately used for either scale. Any minor discrepancies are easily explained; prototype manufacturers provided locomotives and coaches of similar design for various gauges.

Although the supply of inexpensive ready-to-run models is nothing like it was in the 1960s, a plentiful supply of kits, mostly made to fit over N gauge chassis, makes this a useful scale/gauge combination.

H0m (1:87 scale, 12 mm gauge); represents metre gauge

Commercial H0m is confined to models of Swiss prototypes. The coverage of the Rhaetian Railway is particularly thorough, with every main-line class of locomotive available, together with a wide range of accurate models of coaches. The other major metre gauge lines, the Furka Oberalp, Brig Visp Zermatt, Montreux Oberland Bernoise and Brünig railways, are catered for by reasonably priced ready-to-run models. A selection of brass kits and ready-assembled models of specialist stock rounds out a well-developed system. The only objection is expense, although visiting the prototype is part and parcel of the fun.

H0n3 (1:87 scale, 10.5 mm gauge)

This is exclusively North American; most models are fairly expensive, and the supply in Britain is patchy. However, its devotees get round these difficulties.

Nm (1:160 scale, 6.5 mm gauge)

This size is very costly and exclusively based on Swiss prototypes. However, as ready-to-run models are available it must be classed as commercial.

G gauge (scales varied, 45 mm gauge)

This is essentially a garden gauge, with models for 2 feet, 2 ft 3 in, 3 feet and metre gauge prototypes being available from specialist suppliers. There are two categories, the quality models, mainly from LGB and Bachman, and the toylike Playmobile products, which form a cheap and cheerful basis for hacking. Although the individual items appear costly, they are much cheaper than most Gauge 1 models. The sheer size makes them eminently suited for garden use.

Non-commercial narrow gauge

Several scale/gauge combinations are in wide use, but are mainly scratchbuilt or kit-assembled. A growing range of live-steam locomotives for both 32 and 45 mm gauge is now available in a technically ready-to-run condition, but usually the firms carry very

small stocks and the locomotives are more bespoke products. The similarity to prototype narrow gauge construction is all the more marked by a common style to the catalogues.

For British prototypes there is OOn3 (4 mm scale, 12 mm gauge), used for models of Irish and Isle of Man prototypes, O-16.5 (7 mm scale, 16.5 mm gauge) and SM32 (16 mm scale, 32 mm gauge) used for models of 2-foot gauge prototypes. Kits are available, but the relatively small number of locomotives and coaches owned by most narrow gauge systems makes it feasible for a keen modelmaker to adopt any scale/gauge combination he fancies and create the models in his own workshop. It is, however, a good idea to choose a scale that is supported by a range of figures, the single most difficult feature to scratchbuild. However, with the plethora of large-scale military figure models and their offshoots, this gives one a good deal of leeway.

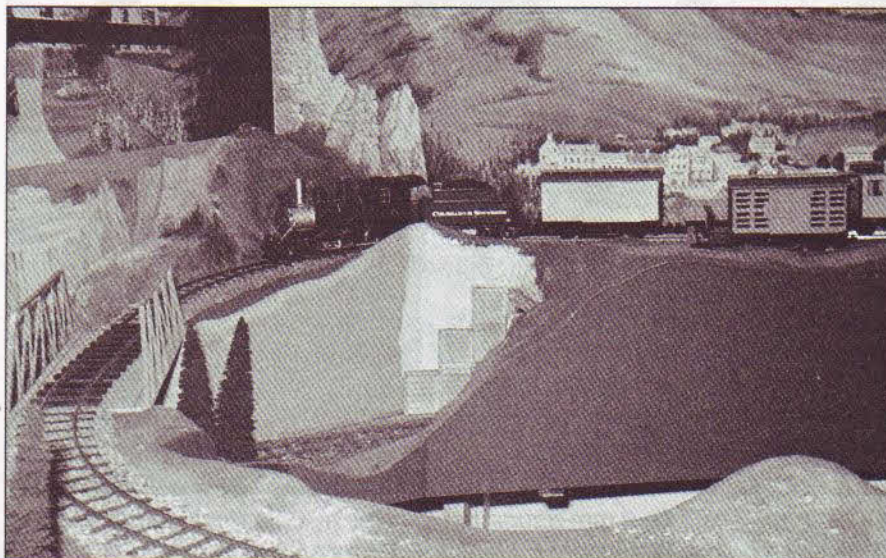

G Gauge is very large, officially 1:22.5 scale on 45 mm gauge track. As such it is generally regarded as a garden railway gauge, but at Pecorama a 'looped eight' layout has been accommodated in a prefabricated garage. There is no room for the car and not overmuch space for anything more than the operator. The theme is a western US 3-foot gauge railroad.

Appendix 2

Basic dimensions

Although the dimensions of layout details are largely governed by the scale size of the feature being modelled, certain basic dimensions are set by the chosen scale/gauge combination. Primarily these are track radii, gradients and overall length of pointwork. There is also the most serious limit of all, the actual space available for the layout.

Surveying the site

During a site survey we must always bear in mind certain facts. The first is that builders are not precision engineers. It is all too easy to talk up the simple business of measuring a room into a highly technical subject, but corners may not be true right-angles, and walls may not even be straight. At the same time it is notoriously difficult to make a precise measurement of a 4-metre-long room with a 3-metre-long tape.

For the preliminary paper planning, round down every measurement to the nearest 25 mm or 1 inch below the size measured. Furthermore, be consistent with your standards. It matters little whether you use metric or imperial measurements so long as you don't mix them. While it is unlikely that you will mistake a metre for a foot, it is a shade difficult to work out how many items 126 mm long will fit into a space 4 ft 8½ in long! Metric units make life much easier, as very few pocket calculators can deal with vulgar fractions. On the other hand, imperial measurements

make it easier to round down.

It is only when construction begins that exact measurements are needed, and then only when you are building a baseboard to fit precisely into a permanent site. A portable or transportable unit needs to be undersize so that it can be removed without damage to walls or models.

Pointwork

The precise dimensions of any track formation depend on the product chosen, and can be ascertained from the manufacturer's catalogue or, better still, by laying the formation down using the actual products and measuring the resulting assembly. Some manufacturers, notably Peco, provide paper templates as an aid to the planning process, and these are almost as good as the real thing so long as you take pains when cutting out and, above all, when aligning the numerous bits of paper. It's best to work on a piece of softboard and pin each piece down.

When drawing the layout, over-estimate the size of point formations and allow a generous clearance along walls and backscenes.

Curves

Ready-to-run models are designed to negotiate the standard curves of the several commercial sectional track systems now available. In many cases, to be on the safe side the model will actually go round a much tighter curve – or should one call it a corner? The same condition does not apply to a kit-built model, let alone a high-class scratchbuilt locomotive.

Table 1 should therefore be taken as a general guide rather than a rigid set of regulations. Four categories of curve are shown. A tight curve is one suited to ready-to-run equipment and is only shown where such equipment exists. The small-radius curve should suit most models other than outside-cylindrical steam locomotives, which are notoriously difficult to get round corners. The

Table 1: Recommended curve radii

Gauge	1	O	S	P4	EM	OO	TT	N
Tight curve	*	*	*	*	*	380	*	160
Small curve	1500	1250	800	*	750	500	300	200
Medium curve	2000	1750	1250	1250	950	750	450	400
Large curve	3000	2000	1750	1750	1250	1000	600	500

Measurements in millimetres. * Not recommended

medium radius is generally satisfactory, but where fine-scale models are involved the large radius should be aimed at.

In all cases, it is best to aim for the largest curve possible; this applies even more strongly where it is necessary to locate a platform on a curve. In most cases pointwork should be laid out with the more generous medium- or large-radius turnouts.

Gradients

Gradients can be expressed as a per mille figure (o/oo) or as a ratio. The latter is more generally used in Britain, and as it is more readily applied in practice, I am using the convention where the gradient is given by the number of units of length needed to climb one unit in height. Strictly speaking, the length is measured along the level, but with the gradients used on railways the difference between that and a measurement along the gradient is negligible, since the convention is to increase the base figure in units of five.

Gradients are introduced for two reasons. One is cosmetic: a gentle climb in or out of the station past sidings on the level can be very effective. In such cases the gradient should be made reasonably gentle – nothing steeper than 1 in 50 should be considered.

The more usual application is where one track has to pass over another. There are several considerations here. The first is whether all the difference is made on one track, or if the climb is equalised. The latter arrangement halves the distance needed, but is more difficult to arrange unless open-top construction is favoured. The second is the clearance needed between the two tracks.

There are three basic situations. A tight clearance is possible when the upper track is

Table 2a: Gradients for Gauge 1

1 in	30	40	50	60	70	80
Single						
Tight	5.16	6.88	8.60	10.32	12.04	13.76
Standard	5.91	7.88	9.85	11.82	13.79	15.76
Full	6.66	8.88	11.10	13.32	15.54	17.76
Double						
Tight	2.58	3.44	4.30	5.16	6.02	6.88
Standard	2.96	3.94	4.92	5.91	6.89	7.88
Full	3.33	4.44	5.55	6.66	7.77	8.88

Table 2b: Gradients for O Gauge

1 in	30	40	50	60	70	80
Single						
Tight	3.72	4.96	6.20	7.44	8.68	9.92
Standard	4.32	5.76	7.20	8.64	10.08	11.52
Full	5.22	6.96	8.70	10.44	12.18	13.92
Double						
Tight	1.86	2.48	3.10	3.72	4.34	4.96
Standard	2.16	2.88	3.60	4.32	5.04	5.76
Full	2.61	3.48	4.35	5.22	6.09	6.96

Table 2c: Gradients for S Gauge

1 in	30	40	50	60	70	80
Single						
Tight	2.73	3.64	4.55	5.46	6.37	7.28
Standard	2.97	3.96	4.95	5.94	6.93	7.92
Full	3.48	4.64	5.80	6.96	8.12	9.28
Double						
Tight	1.36	1.82	2.27	2.73	3.19	3.64
Standard	1.49	1.98	2.48	2.97	3.46	3.96
Full	1.74	2.32	2.90	3.48	4.06	4.64

carried on a piece of thin plywood; generally speaking this should only be used in extreme cases. A more practical approach is to assume a thick track base, this will also allow a realistic clearance for a bridge. We must also add the depth of the track. The third situation is where the track passes under a station or point complex and, for maintenance purposes, the upper tracks are carried on a framed sub-base that can be readily removed.

The accompanying tables start at 1 in 30 and end at 1 in 80; for general purposes something between 1 in 40 and 1 in 60 is advisable. Below 1 in 40 train lengths are severely restricted, but as such gradients are generally needed because space is limited there is a tendency for the two factors to cancel each other out.

Other dimensions

There are a number of other dimensions that need to be kept in mind when drawing up a track plan. Most are shown in Table 3; these refer to track centres and essential clearances and are offered as a guide rather than as hard and fast rules. For example, although some time in the 19th century the Board of Trade laid down that there should be a minimum of 6 feet between any fixed obstruction and the platform edge, there are plenty of examples where this rule has been waived.

Track centres can also vary. At the one extreme we have the correct scale distance of 6 feet between the rails, but this is normally widened on most layouts to allow for underscale curves. The idea that there must be a wider track centre in OO than for EM is a fallacy; you can use the closer centres to advantage on straight sections. Conversely, a GWR through station on the old broad

Table 2d: Gradients for OO/EM/P4 Gauge

1 in	30	40	50	60	70	80
Single						
Tight	2.10	2.80	3.50	4.20	4.90	5.60
Standard	2.52	3.36	4.20	5.04	5.88	6.72
Full	2.91	3.88	4.85	5.82	6.79	7.76
Double						
Tight	1.05	1.40	1.75	2.10	2.45	2.80
Standard	1.26	1.68	2.10	2.52	2.94	3.36
Full	1.46	1.94	2.42	2.91	3.40	3.88

Table 2e: Gradients for TT Gauge

1 in	30	40	50	60	70	80
Single						
Tight	1.62	2.16	2.70	3.24	3.78	4.32
Standard	1.98	2.64	3.30	3.96	4.62	5.28
Full	2.37	3.16	3.95	4.74	5.53	6.32
Double						
Tight	0.81	1.08	1.35	1.62	1.89	2.16
Standard	0.99	1.32	1.65	1.98	2.31	2.64
Full	1.19	1.58	1.98	2.37	2.77	3.16

Table 2f: Gradients for N Gauge/2 mm scale

1 in	30	40	50	60	70	80
Single						
Tight	1.14	1.52	1.90	2.28	2.66	3.04
Standard	1.50	2.00	2.50	3.00	3.50	4.00
Full	1.89	2.52	3.15	3.78	4.41	5.04
Double						
Tight	0.57	0.76	0.95	1.14	1.33	1.52
Standard	0.75	1.00	1.25	1.50	1.75	2.00
Full	0.94	1.26	1.58	1.89	2.21	2.52

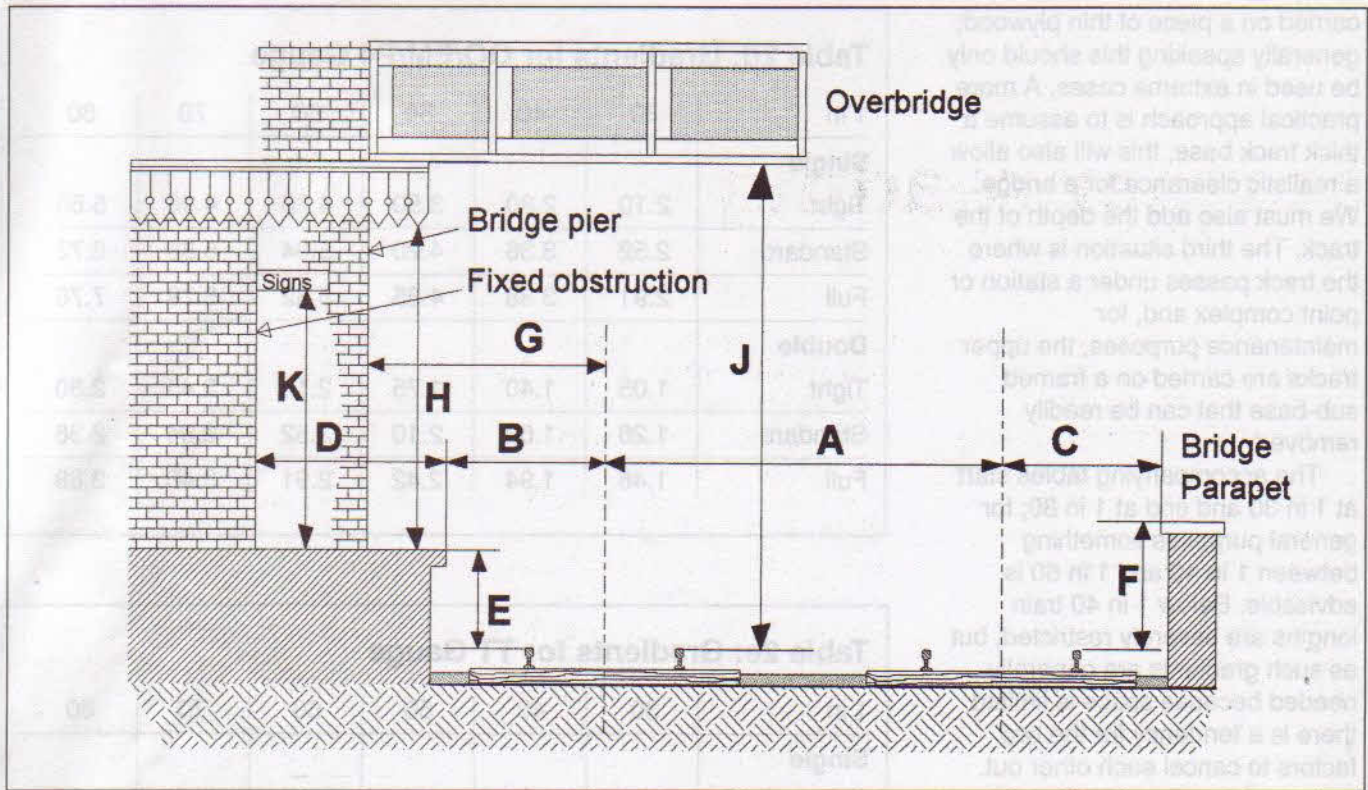

Table 3: General dimensions

All dimensions in millimetres. * Minimum dimension

	A	B	C*	D*	E	F	G	H	J*	K
1	125	45	50	60	30	40	75	100	150	80
0	88	32	35	42	21	28	53	70	105	56
S	63	23	25	30	15	20	36	50	75	40
00/EM/P4	50	18	20	24	12	16	30	40	60	32
TT	38	14	15	18	9	12	23	30	45	24
N/2 mm	25	9	10	12	6	8	15	20	30	16

gauge routes has, to this day, a wider spacing since, on conversion, the platforms were not moved. These small details are best left for final detail adjustment; for track-planning purposes the dimension given in Table 3 is good enough. Indeed, unless you are using CAD, where a line can be plotted to the nearest micron without too much bother, the inherent errors in drawing to 1:10 or 1:12 scale are slightly greater than the

differences in track centres. Even using the finest stylus pencil, your line is 0.3 mm wide.

An important dimension not given is the width of the platforms. True scale width should be at least 20 feet (6 metres), but unless you are blessed with ample room, you will have to compromise. The important factor is that 6 feet (2 metres) clearance from fixed obstructions, which can be very tricky on island platforms. A

common error on beginner's layouts is having the footbridge steps occupy over 50% of the width of an island platform, leaving an impossibly narrow space on either side.

It is a great help during the planning stage to draw full- or half-size cross-sections of the layout, locating platforms, bridge piers and nearby buildings to ensure there is room for everything on your planned baseboard.

Appendix 3

Further reading

The subject matter is so vast that a conventional bibliography should list at least half of the books published on British railways since 1900. Yet just to hunt out most of these books, most of which have been out of print for many years, would take up a good deal of valuable modelling time.

For information on the current scene, the best source is the railway itself. A warm, slightly overcast day spent by the lineside will provide a wealth of information, while a daytime journey in a window seat will supply a mass of interesting detail. Commuting by rail is an excellent way of amassing information.

The steam-age modeller will need to study books. There is ample information on locomotives. For the newcomer the Ian Allan series of illustrated accounts of the work of recent (post-1900) British locomotive engineers will be found invaluable. Coaches and wagons are not so extensively covered, but the amount on offer is a great improvement on what was available when I began studying the subject nearly 60 years ago.

When it comes to information on stations and their track plans, the change is even more dramatic. Here publishers are the best guide: Oxford Publishing Co, Oakwood Press, Atlantic, Wild Swan, Irwell, Challenger, Silver Link, the Historical Model Railway Society and (for locomotives), the Railway Correspondence & Travel Society are the major players.

For the complete newcomer, the best starting point must be the local public library. While the railway books on the shelves only represent a small fraction of those currently in print, they do provide a cross-section of recent publications. Most librarians are only too delighted to help an interested reader locate books on specific subjects. Another source of information is the Science Museum and its 'sub-shed', the National Railway Museum at York. Any reader who can regularly visit Islington in north London on a Thursday evening would be well advised to join the Model Railway Club in order to consult the most extensive accessible railway library in Britain, while

Manchester-based readers will find the MMRS Library at Sale almost as comprehensive.

However, nothing can equal the value of a personal library, where the books are permanently available for reference. Buying books is less easy today than it was in my youth, since the small bookseller has largely given way to the major chains who tend to push so-called 'bestsellers' at the expense of their non-fiction list. To be fair, they do provide more extensive cataloguing by computer and, perhaps, in time will make a terminal available to customers so one can browse through the current listings. But it's not the same as having the actual books to handle. Happily, several specialist booksellers now take space at major model railway exhibitions, and occasionally you can find a second-hand dealer as well, with a selection of recent titles and a few rare collectors' items. There are also a number of mail order specialists that advertise most new titles regularly in the railway press.

Index

- 2mm scale 150
6 x 4 layout problems 20
- Access to tunnelled tracks 102
Access to the layout 21
Accommodation arch 94,95
Accommodation crossing 82
Anachronisms 17
Architectural modeller 65
Arrival and departure platforms 43
Ash 76
Assembling baseboard units 18
Avoiding road to turntable 77
- Backscene 113
Balance, establishing a 7
Barrow crossing 58
Baseboard height and width 19
Baseboard unit 18
Basic fiddle yard with turntable 120
Basic loco shed 76
Bay platform 51
Beal's Lime Works 110
Block trains 12
Boundary fence 82
Bowstring girder bridge 89
Braced girder bridge 88
Branch line trains 12
Branch off a branch 129
Branch terminus, steam age 59
Branch theme 127
Brick-built overbridge 83
Bridges 82
Bridges for quadruple track 85
Brittain's farm animals 111
Broad gauge 7,51
Brunel timber viaduct 88
Buses 17
- CAD 6,125
Canal lock diorama 117
Coal scales 67
Car park on goods yard site 60
Car port 27
Cargo crane 108
Carriage sidings 51
Carriage siding, use of 44
Catch point 46
Cattle dock 58,71
Ceiling hatch 18
Centre release road 52
Centre reversing siding 61
Changing course 9
- Char 76
Choice of radii 36
City stations 133
Club layouts 19
Coal bins 58,67
Coal drops 68
Coal mine 106
Coal sidings 67
Coal stage 75
Combination overbridge 85
Compact oval 125
Compound lead 53
Container crane 71
Circular tunnels 100
Corner location for turntable 77
Cost of layout 29
Cottages in corner 115
Council tax 28
Crane shunting 118
Cross country services 11, 12
Crossing, diamond 45
Crossover 45
Crossover, curved 47
Culvert 95
Curved branch platform 66
Curved point 46
Curved viaduct 87
Curves 153
Cutting, station in 114
Cuttings 82,93
- Denny pattern fiddle yard 123
Diamond crossing 45
Diesel depot turntables 74
Diesel depot, small 80
Diesel depot 74
Diesel era 12
Diorama modelling 113
Discouragement factor, the 9
Disguised fiddle yard 33
Disguised scenic break 117
Docks 103
Dog-bone 141
Double junction 45
Double track halt with
 island platform 56
Double-banked loops 119
Double fiddle yard 35
Drains in cuttings 93
Dropped baseboard 22,24
Duck-under 23
Dumb-bell 35,141
- Elaborate station buildings 65
Electric point operation
 on prototype 49
EM gauge 150
Embankments 82,94
End loading dock 71
E-shaped layout 35
Establishing a balance 7
Estate car 19
Exchange siding 58
Excursion trains 12
Express goods trains 12
Extending a garage 28
Eye-level baseboards 20
- Facing crossover 45
Factory in corner 105
Farm in corner 115
Fiddle yard 30,118
Fiddle yard screening 124
Financing an extension 28
Fish dock 72
Fisherman's walk 30
Flat marshalling yard 54
Flying girder bridge 86
Flying junction 47
Footbridge 58
Fosdyke Mill platform 56
Foundations for sheds 28
Four-track loops 50
Full-length main line trains 11
- G gauge 153
Gantry crane 109
Garage 27
Garden shed 24,27,28
Gasworks 103
Gated level crossing 60
Gauge 149
Gauge 1 151
Gestalt design 6,15
Goliath crane 70
Goods loading platform 68
Goods shed 58
Goods shed, large 70
Goods shed, internal details 69
Goods train types 12
Gradients 154
Gridiron bridge 86
Grounded coach 58
Guest-room 26
GWR loco shed 81

- Half barrier crossing 60,92
Halt with loop and siding 56
Halt with siding 55
Hand worked level crossing 91
Hidden loops on continuous track ... 118
Hidden tracks 101
Highland stations, modern 129
HO gauge 149
HOe 151
HOM 152
HON3 152
Horse shunting 38
House extension 28
How big? 28
Hump yard 54
- Ilford & W. Essex MRC 99
Industrial road crossing 93
Industry, general 104
Inset tracks 73,91
Irish railways 15
Is it essential? 17
Island platform 62
Island platforms with loops 50
ISO units 6
- Jack point 53
Junction station, steam age 58
Junctions 45,47
Just as it is 111
- Kick-back fiddle yard 121
King point 53
Kissing gates 91
L-girder construction 25,143
L-shaped layout 32
Ladder junction 47,48
Ladder track 53
Lady's fashions 15
Lamp hut 58
Large junction station 66
Large station with central
crossovers 63
Large through station 63
Last quarter mile principle 15
Latest prototype developments 13
- Layout designs:**
1 Lochaber 125
2 Wrightdale 127
3 Widdecombe 129
4 St Denys 129
5 Ahern 129
6 Watergate 133
7 Avon 134
8 Yarlington Junction 136
9 Beeching 138
10 Dugdale 140
11 Bluddeigh, Butte & Bowed ... 140
12 Barchester 143
13 Laureceton, Methven &
Southern 143
14 Rabbits 145
15 Tiefencastel 146
- Layouts:**
Albula Bahn 147
Benfieldside 112
Buckingham 46,70,148
Candleford Mill 12
Cheviotdale 120,127
Coldrenick Road 7,15
Copenhagen Fields 14
Cromford & High Peak 69
Ditchling Green 29,40,149
Inglenook Sidings 40,69,71
Leominster 63
Madder Valley 111
Majola 146
Norden 15
Rewley Road 14
Via Mala 8,147
West of England Railway 89
- Ledge tracks 94
Level crossing gates 90
Level crossing 82
Lie-by loop 49
Lifting sections 21
Lift-out section across window 23
Lift-out section with viaduct 126
Lighting fascia 140
Lime works 110
LMS loco shed (proposed) 80
Loading bank with scotch derrick .. 108
Loco-hauled trains 12
Local trains 12
Loco spurs 52
Loco valeting depot 78
Locomotive refuelling 75
Locomotive shed 74
Loft 26
Loft construction 24
London Transport 15
Looped eight 31
Looping trains 50
Lorelei tunnel mouth 100
Low-level road approach 61,62
Low relief 113
Low relief station buildings 64
Low retaining wall 96
- Manchester Model**
Railway Society 157
Manor house in corner 115
Masonry underbridge 83
Mechanically worked level
crossings 91
Medium sized loco shed 78
Mineral exchange sidings 104
Mineral traffic 103
Minories 133
Mock-up 23
Model Railroader 20
Model Railway Club 157
Modern mineral sidings 104
Motive Power Depot (MPD) 74
Motorway in corner 116
Moving house 9
MPD workshops 74
Multi-platform terminus 52
- Multiple tracks 48
N gauge compared to OO 13
N gauge 149
Narrow gauge feeder 40
Narrow gauge interchange 106,107
Narrow gauge 145
Nm 153
- O gauge 150
Occupation crossing 92
Occupied arches 89
Oil depot 106
One-sided stations 51
OO gauge 149
OO9 151
Open top construction 23
Operating pattern 30
Operation 8
Optimum size of baseboard units .. 18
Orient Express 17
Out-and-back 34
Outer suburban station, steam age . 61
Oval with fiddle yard 31
Overbridge scenic break 117
Overlapping crossing gates 91
Overtrack signal cabin 52
Overtrack station building 97
- P4 gauge 151
Parcels depot 61
Parcels trains 12
Passageways, problems with large
baseboards 21
Passing loop 49
Passing station, steam age 57
Pecorama 12,21,119,153
- People:**
Ahern, John 111,133
Beal, Edward 6,109,143
Broomfield, David 146
Chown, Richard 15
Deane, Maurice 33
Denny, Peter . 18,46,70,123,127,148
Gould, Roy 36
Gravett, Gordon 29,40,149
Greenly, Henry 115
Hancock, PD 112,149
Harper, Bob 7,15
Hughes, Geraint 69
Overton, Graham 89
Polglaze, Mike 8,147
Sharman, Mike 51
Watson, Graham 147
Wright, Alan 40,69,71,120,127
- Period, setting the 15
Permanent baseboards 19
Personal preferences 7
Pick-up goods trains 12
Pinch point 30
Pipe fence 96
Plate girder overbridge 83
Platelayers' hut 58
Platform proportions 11
Platform widths 155

Platforms for children	20	Running round	38	Through steam age station	60
Point rodding limitations		Running round a train	41	Through terminus	66
on prototype	49	Run-round loop on main line	53	Tiddlywink computer	40
Pointwork	153	Run-round loop on curve	52	Time bands	15
Poole MRC	85	Rushing, why?	26	Time is the essence	29
Portability	140			Time, taking your	26
Portable baseboards	18	Salesmen's patter	28	Timetable	10
Porte cochere	65	Sand drag	45	Toe wall	95
Power car	38	Savings plan	29	Town square in corner	116
Principal expresses	12	Scale	149	Track bases	25
Project drawings	125	Scale Seven	151	Track centres	155
Prototype	7	Scenic break	114,117	Trailing crossover	45
Prototype limitations	17	Scenic corner	111,113,115,116	Train cassette	124
Prototype modelling	14	Schedule, prototypical	10	Train length	10
Prototype stations:		Scotch derrick	108	Train set	10
Ashburton	127,128	Screening fiddle yard	124	Train shed	52,64
Bristol Temple Meads	66,134	Secondary expresses	12	Train types	12
Brixham	72	Sector plate fiddle yard	121	Transit-type van	19,136
Canning Town	97	Setting the period	15	Transportable baseboards	19
Churston	59	Shop windows	113	Trap point	46
Custom House	97	Short tunnel	98	Traverser box	123
East Ham	53	Shunting a yard	39	Traverser fiddle yard, complex	123
Hemel Hempstead	61	Shunting locomotive	38	Traverser fiddle yard, simple	122
Glasgow Central	64	Shunting, simple	38	Traverser for continuous track	119
London Victoria	64	Siding door	22	Triangular junction to terminus	34
Moretonhampstead	128	Signal cabin	58	Triumphal arch with pavilions	65
Par	138	Signal cabins, double	50	TT gauge	150
Rainham (Essex)	92	Simple halt	55	Tunnel access	102
St Ives (Cornwall)	114	Simple oval	30	Tunnel mouth, brick	98
Seaton	62	Single to double junction	45	Tunnel mouth, castellated	99
Seaton Junction	66	Size of railway rooms	28	Tunnel scenic break	117
Upney	56	Skew bridge	86	Tunnels	82
Prototypical schedule	10	Slip coaches	38	Tunnels through rock	100
Publishers	157	Small loco shed with turntable	77	Turbocad	6
Pubs	112	Somewhere to go	10	Turntable fiddle yard	121
Push-pull sets	12	Southern Railway	14	Turntables	74
		Spare room	26	TV aerials	17
Quayside details	107,108	Special trains	12	Two termini and oval	31
Queen point	53	Spiral tracks	26	Two-train capacity terminal roads	64
		Squared grid	125		
Radi, choosing	26	Staging tracks	118	U-shaped layout	32
Railcars	12	Station hotel	62	Umbilical cable	25
Rail-linked industry	105	Station house	57,58	Unrealistic tunnel	97
Railway cottages	62	Station lengths, varying	11	Use of carriage siding	44
Railway room	26	Station pilots	38		
Ready-to-run system	9	Stations: Seaton	10	Valley construction	22
Refuelling	75	Steam age train types	12	Van trains	12
Refuge siding	49	Storage above fiddle yard	124	Variety, importance of	12
Refuges	90	Sub-shed	76	Viaduct, masonry	86,87
Release crossover	52	Suburban commuter station	57	Viaduct, timber	88
Relief siding	49	Suburban services	12	Viaducts on lift out section	23
Research	8	Surveying the site	153		
Retaining walls	82,95,96	Suspending disbelief	112	Wagon Repairs Ltd	54
Retirement	9	Switzerland	146	Wagon turntable	72
Reversible centre track	50			Water crane	76
Reversing loop size	37	Tag strip	25	Water for locomotives	76
Reversing siding	61	Tailchasers	136	Water tank	58
Reversing with spare loco	42	Terminus and oval	33	Weighbridge	58,73
River bridge	84	Terminus-fiddle yard	32	West coast route	143
River bridge in corner	115	Test track, preliminary	26,29	What's in a name?	148
Road exit, disguising	116	Theatrical approach	113		
Roof rack	140	Three-arch bridge	84	Yard crane	68
Rope shunting	38	Three-level scene	114		
Roundhouse loco shed	79	Through coaches	38	Z gauge	150
Rubick's Cube	40	Through goods trains	12		

THE MODEL RAILWAY DESIGN MANUAL

Before you can begin to build a worthwhile model railway, you first need a design. This centres round the track plan but also involves the types of train you wish to run and the aspects of the hobby that have most personal appeal, as well as your individual skills. It is also necessary to take into account the available resources of time, money and, above all, space, for a model railway can be large and complex and does not spring into being overnight.

Here, Cyril Freezer draws on over 50 years study of both model and prototype railways to explain what can be achieved and points out the inherent snags in various approaches towards creating an illusion of virtual reality. He shows that, with careful planning, a successful layout can be created that will bring enjoyment and satisfaction, both to the modeller and to those who see it in operation.

Subjects covered include:

- Time, space and cost considerations
- Track formations
- Choosing a prototype
- Steam era v modern image
- Types of train
- Basic train operation
- Locomotive depots
- Goods yards
- Stations and facilities
- Rail-linked industries
- The fiddle yard

Cyril Freezer was formerly editor of *Railway Modeller*, *Model Railways* and *Swiss Express*. He has written extensively on most aspects of the hobby, with many other books on the subject published by Patrick Stephens, including *The Model Railway Manual* and *The Garden Railway Manual*.



UPC CODE



ISBN 1 85260 538 3 £15.99 RRP

