

Practical design of timber structures to Eurocode 5

Hans Larsen and Vahik Enjily



Published by Thomas Telford Limited, 40 Marsh Wall, London E14 9TP, UK.
www.thomastelford.com

Distributors for Thomas Telford books are
USA: ASCE Press, 1801 Alexander Bell Drive, Reston, VA 20191-4400
Australia: DA Books and Journals, 648 Whitehorse Road, Mitcham 3132, Victoria

First published 2009

Also available from Thomas Telford Limited

Better places to work (ABE and Llewelyn Davies Yeang). ISBN: 978-0-7277-3398-6
ICE design and practice guides: contaminated land – investigation, assessment and remediation, 2nd edition. J. Strange and N. Langdon. ISBN: 978-0-7277-3482-2
Energy and environmental issues for the practising architect. I. Ward. ISBN: 978-0-7277-3216-3

A catalogue record for this book is available from the British Library

ISBN: 978-0-7277-3609-3

© Thomas Telford Limited 2009

Translated and updated from the original Danish publication
TrÆ OG trækonstruktioner 1 and 2 © TOP 2007

All rights, including translation, reserved. Except as permitted by the Copyright, Designs and Patents Act 1988, no part of this publication may be reproduced, stored in a retrieval system or transmitted in any form or by any means, electronic, mechanical, photocopying or otherwise, without the prior written permission of the Publisher, Thomas Telford Limited, 40 Marsh Wall, London E14 9TP.

This book is published on the understanding that the authors are solely responsible for the statements made and opinions expressed in it and that its publication does not necessarily imply that such statements and/or opinions are or reflect the views or opinions of the publishers. While every effort has been made to ensure that the statements made and the opinions expressed in this publication provide a safe and accurate guide, no liability or responsibility can be accepted in this respect by the authors or publishers.

Typeset by Academic + Technical, Bristol
Index created by Indexing Specialists (UK) Ltd, Hove, East Sussex
Printed and bound in Great Britain by Antony Rowe Limited, Eastbourne

Contents

Introduction		1
1	Basis of design	8
1.1	Overview of UK and European design principles	8
2	Construction products	32
2.1	The tree	32
2.2	Structural timber	52
2.3	Glulam	59
2.4	Wood-based panel products	67
2.5	Joints and fasteners	80
3	Structural examples	96
3.1	Introduction	96
3.2	Main and secondary members	96
4	Straight members and beams with varying depth	106
4.1	Tension and compression	106
4.2	Tapered beams	122
4.3	Shear	127
5	Columns	134
5.1	Introduction	134
5.2	Axially loaded columns	134
5.3	Laterally loaded columns	138
5.4	Lateral torsional buckling of laterally loaded columns	143

6	Curved beams and frames	144
6.1	Curved beam	144
6.2	Pitched cambered beam	148
6.3	Arches and frames	154
7	Trusses and bracings	161
7.1	Introduction	161
7.2	Structural design of trusses	162
7.3	Bracings	169
8	I, T and box-beams	174
8.1	Introduction and background theories	174
8.2	Transformed (composite) cross-sections	174
8.3	Beams with thin webs	177
8.4	Beams with thin flanges (stress skin panels)	185
9	Connections and fasteners	194
9.1	Design of multi-fastener joints	194
9.2	Load-carrying capacity of dowel-type fasteners	199
9.3	Nailed connections	210
9.4	Connections with staples	223
9.5	Bolted connections	225
9.6	Connections with dowels	230
9.7	Connections with screws	231
9.8	Joints with connectors	237
10	Diaphragms	247
10.1	Introduction	247
10.2	Roof diaphragm (simply supported diaphragm)	248
10.3	Wall diaphragm (cantilever diaphragm)	249
	References	255
	Index	259

Introduction

Design basis for [BS 5268]

[BS 5268], *Structural use of timber*, is based on permissible stress design, and this phrase appears in the title of Part 2. However, it does not include a description of the design principles equivalent to those in [EN 1990]. Grade stress values for properties of materials, most of which are given in tabular form in [BS 5268-2] itself, incorporate safety factors so that they represent the stress that the material is considered able to bear over the life of a building with a reasonable level of safety. The grade stresses are considered for 50–60 years' load duration. A series of modification factors are then applied to the mechanical properties, generally increasing the load-bearing capacity for shorter load durations. The permissible stress in service for a particular type and duration of load to the element is thus established, and verified against the stress applied by the design loads. These design loads are normally obtained from the parts of [BS 6399].

In addition to supporting normal loads, [BS 5268-2] requires timber structures to withstand accidental damage without catastrophic collapse. The Approved Document A gives guidance for the requirements of disproportionate (progressive) collapse design.

[BS 5268-2] has been the key code in the series, covering structural design of timber in general. The other parts provided subsidiary information. [BS 5268-2] specified how timber structures may be designed to withstand applied loads. [BS 5268] includes several parts as listed below:

- Part 2: 2002, *Code of practice for permissible stress design, materials and workmanship*
- Part 3: 1998, *Code of practice for trussed rafter roofs*
- Part 4.1: 1978, *Fire resistance of timber structures. Recommendations for calculating fire resistance of timber members*
- Part 4.2: 1990, *Fire resistance of timber structures. Recommendations for calculating fire resistance of timber stud walls and joisted floor constructions*

- Part 5: 1989, *Code of practice for the preservative treatment of structural timber*
- Part 6.1: 1996, *Code of practice for timber frame walls. Dwellings not exceeding seven storeys*
- Part 6.2: 2001, *Code of practice for timber frame walls. Buildings other than dwellings not exceeding seven storeys*
- Parts 7.1 to 7.7: *Recommendations for the calculation basis for span tables for various elements*

The appropriate loads to be used for design purposes were given in [BS 6399] with three parts covering dead, imposed and wind loads.

Definitions

Element and component

There is great confusion in definition of elements and components at European level. The UK's definition of elements and components is reversed in the Eurocode and the rest of Europe. For clarity the following are definitions which the UK must adopt:

Element is a structure or part of the structure which consists of members or components. For example, a trussed rafter is an 'element' because it includes members/components which are rafters, internal web, ceiling tie and punched metal plate connectors. Another example would be a wall panel which is termed 'element' because it consists of elements or components such as studs and sheathing.

Component or *member* is a part of an element.

System is a structure which consists of elements.

Notation

Introduction

The symbols and notations are very vital and important as the UK is used to different symbols and notations than those given in Eurocode. Many major errors can occur if these notations are mixed when used in design.

Member axes

The UK has been used to $x-x$, $y-y$ and $z-z$ being the major, minor and out-of-plane axes respectively. These have been changed into $y-y$, $z-z$ and $x-x$ respectively in the Eurocode (see Fig. 1).

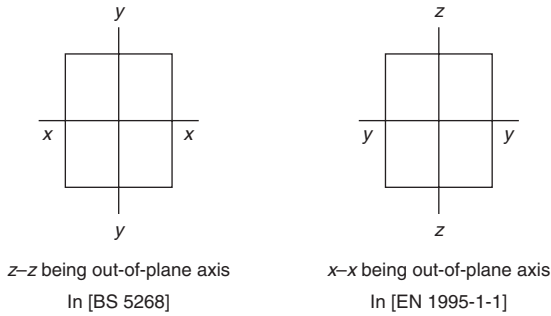

Fig. 1 Differences between axes according to [BS 5268] and Eurocode 5

Decimal symbols

The UK uses a full point (.) to denote a decimal place, whereas in the Eurocodes this is seen as a comma (,). For example:

In [BS 5268]

1,000.00 means one thousand; 1.000 means one

In [EN 1995-1-1]

1,000 means one; 1.000,00 means one thousand

Symbols

General

Symbols usually consist of a main symbol with one or more indices separated by commas. For example $f_{c,0,k}$ which is the characteristic compression strength parallel to the grain (where 'f' is strength, 'c' is compression, 0 is parallel to the grain and 'k' is characteristic).

In accordance with Eurocode 5, the following general symbols are used. Symbols not mentioned are defined where used and their meaning may vary.

Main symbols

A	cross-sectional area
E	modulus of elasticity
F	force, action
G	permanent action; or shear modulus
I	second moment of area, sometimes called moment of inertia
M	bending moment

N	axial force
Q	variable action
V	shear force or also sometimes used as volume
W	section modulus
a	distance
b	width
d	diameter or also sometimes used as side length (nails)
e	eccentricity
f	material strength
h	height
i	radius of gyration
k	constant
l	length
r	radius
t	thickness
u, v, w	deflections parallel to the axes
x, y, z	coordinates
α	angle
γ	partial coefficient
λ	slenderness ratio
ρ	density
σ	normal stress
τ	shear stress

Indices

apex	apex
mean	mean or average
c	compression
cr	critical
d	design
def	deformation (deflection)
eff	effective
fin	final
h	embedment
inst	instantaneous
k	characteristic
m	bending
ser	serviceability
t	tension

tor	torsion
ult	ultimate
v	shear
vol	volume
x, y, z	axes
y	yield

→ Symbol for fibre direction

Axes, forces and moments

For beams a coordinate system as shown in Fig. 2 is used.

Combined stress index (verification)

In order to verify the adequate strength of a structural member, all the applied stresses should be combined. For example, if a structural timber member is under bending, compression and tension, for strength verification the sum of the ratios of stress to strength for particular loads must be less than or equal to 1.0. For example, if a timber beam is in both tension and bending, then:

$$\sigma_t/f_t + \sigma_m/f_m \leq 1 \quad (1)$$

where σ_t is the tensile stress and f_t is the tensile strength, σ_m is the bending stress and f_m the bending strength.

Construction products

Building materials and products are covered by the EU Construction Products Directive (Council Directive 89/106/EEC). The purpose of

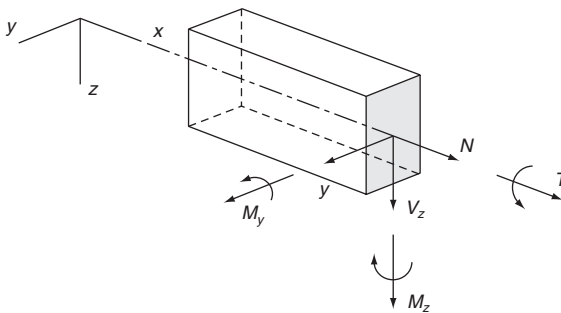

Fig. 2 Coordinate system (axes, forces and moments)



Fig. 3 CE mark

the directive is to ensure the free market in the building sector that has traditionally been one of the most nationally regulated.

For building products, compliance with the Construction Products Directive must be demonstrated when they are marketed for permanent incorporation in buildings or civil engineering works and have influence on:

1. mechanical resistance and stability
2. safety in case of fire
3. hygiene, health and the environment
4. safety in use
5. protection against noise
6. energy economy and heat retention.

National building authorities are only permitted to put requirements in relation to these six so-called 'Essential Requirements'. This means that it cannot be requested that 'convenience standards' are followed. Example of a convenience standard can be a standard for timber sizes.

Products meeting the requirements of the harmonised standard (see below) may be marked with the CE mark, see Fig. 3.

Most European countries, but excluding the UK and a few other European countries, will require manufacturers to mark their product with the CE mark. However, it is prudent for UK users to specify and request CE marking which will be proof of compliance with the Harmonised Standard, thereby complying with the Construction Products Directive.

The CE mark allegedly tells the consumer that the product meets all legal essential requirements in all EU member states.

The Building Products Directive applies to all products whether they are produced within or outside the EU. The basis for the CE marking is either:

- a harmonised European standard, i.e. a standard produced by CEN (Comité Européen de Normalisation), the European Organisation for Standardisation, or

- a European technical approval guideline (ETAG) produced by EOTA, the European Organisation for Technical Approval.

In both cases they are based on a request called a 'Mandate' by the EU Commission.

A harmonised European standard is compulsory and contains:

- technical requirements for the product
- requirements for initial type testing to ensure that the product may be able to fulfil the requirements
- requirements for the producers' quality assurance system
- the level of attestation of conformity, i.e. who is responsible for the initial testing and the tasks in relation to the producers' quality assurance system.

Decisions about initiation of the work, scope, acceptance etc. are taken by the EU Commission.

An ordinary European standard contains normally only the technical part and its use is voluntary. All decisions about initiation of the work, scope, acceptance etc. are taken by CEN. For products not expected to be covered by a harmonised standard in the near future a European Technical Approval (ETA) may be granted. An ETA is a favourable technical assessment of the fitness for purpose of a product for an intended use made by a technical body notified by a member state on the basis of technical guidelines (ETAGs) produced and adopted by EOTA. An ETA issued in one EU country is automatically valid in all member countries.

The following products may be CE marked:

- fasteners, connectors and nail plates
- structural timber
- glulam
- LVL (laminated veneer lumber)
- prefabricated elements assembled with punched metal-plate fasteners
- prefabricated wall, roof and floors
- light composite wood-based beams and columns (i.e. I-beams, box beams, others).

1

Basis of design

1.1 Overview of UK and European design principles

1.1.1 General

In the UK, the design of civil and structural engineering works has generally been based on a series of Codes of Practice, drafted by committees within the British Standards Institution (BSI), and published by BSI. The BSI structural Codes of Practice are widely respected and used in many other countries. However, most major countries have their own codes or equivalent documents. As a result, different design procedures have been required for structures according to the country in which they are built.

As part of the European Union's (EU's) initiative to facilitate trade within the construction sector, the EU has commissioned a common set of codes to be used for construction throughout the EU. Drafting of these codes was initially overseen directly by the EU, but later it was passed to the European Standards Organisation (CEN). Membership of CEN includes the National Standards Organisations of countries belonging to the European Union and the European Free Trade Association (EFTA). Hence, a complete suite of Codes for civil and structural engineering design has been developed, termed the Eurocodes. These codes will replace the existing national codes by the end of 2010.

The Eurocodes aim to:

- provide a common basis for the design of structures within EU Member States
- facilitate the exchange of construction services between Member States
- facilitate the marketing and use of structural components
- improve the competitiveness of the European construction industry in countries outside the European Union.

The Eurocodes cover ten main subjects listed in Table 1.1. Many of these codes are subdivided into a series of parts. [EN 1995], *Design of*

Table 1.1 The structural Eurocodes

EN number	The structural Eurocodes
EN 1990	Eurocode: Basis of structural design
EN 1991	Eurocode 1: Actions on structures
EN 1992	Eurocode 2: Design of concrete structures
EN 1993	Eurocode 3: Design of steel structures
EN 1994	Eurocode 4: Design of composite steel and concrete structures
EN 1995	Eurocode 5: Design of timber structures
EN 1996	Eurocode 6: Design of masonry structures
EN 1997	Eurocode 7: Geotechnical design
EN 1998	Eurocode 8: Design of structures for earthquake resistance
EN 1999	Eurocode 9: Design of aluminium structures

timber structures, has three parts:

1. [EN 1995-1-1] *General. Common rules for buildings*
2. [EN 1995-1-2] *General rules. Structural fire design*
3. [EN 1995-2] *Bridges*

The introduction of the key Eurocode for the design of timber structures, [EN 1995-1-1] (called Eurocode 5), will have a major impact on the design of future timber structures in the UK. The Eurocodes are based on limit state design, while timber is the only principal construction material for which the UK Codes are not limit state design codes but permissible stress design.

1.1.2 The Eurocodes

Background

The Commission of the European Community decided in an action programme in the field of construction that 'The Eurocodes are to establish a set of common technical rules for the design of buildings and civil engineering works which will ultimately replace the differing rules in the various Member States'.

Relationship between the Eurocodes and National Regulations/Public Authority Requirements

There is a clear and vital distinction between design codes and National Regulations/Public Authority Requirements. Harmonisation of National Regulations is outside the scope of Eurocode development. It is the

objective however that the Eurocodes, together with their appropriate National Annexes, should be recognised in National Regulations as one of the routes for meeting compliance. The legal status of the Eurocodes under the Building Regulations will be exactly the same as that of the current National Codes of Practice. In accordance with normal rules following the introduction of European Standards, Eurocodes will be called up in public procurement specifications, and to be used for the design of products for the purpose of obtaining a CE (Conformité Européen) mark.

The Eurocode programme and the relationship between various Eurocodes

The structural Eurocodes are shown in Table 1.1. Each Eurocode generally consists of a number of parts, which cover the technical aspects of the structural and fire design of buildings and civil engineering structures, with specific parts relating to bridges. A list of the various parts and the publication date of each EN are continuously being updated on the Thomas Telford website www.eurocodes.co.uk.

The Eurocodes are a harmonised set of documents that have to be used together. Their linked relationship is shown in Fig. 1.1. In accordance with Fig. 1.1 [EN 1995-1-1] has to be used with [EN 1990], the head key Eurocode, the appropriate parts of [EN 1991] and relevant parts of the other Eurocodes.

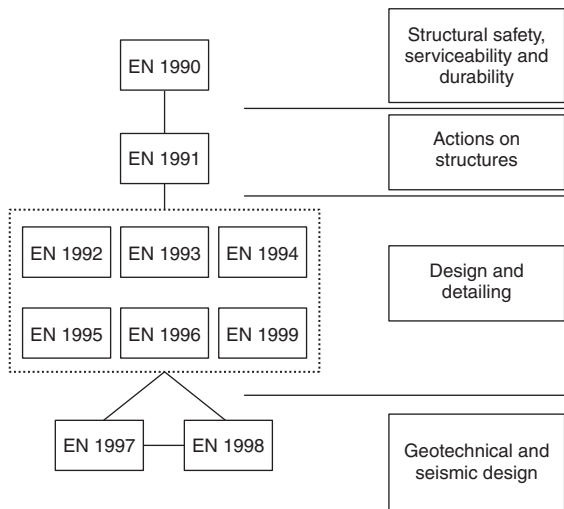

Fig. 1.1 Relationship between the Eurocodes

Supporting and related documents (product standards, etc.)

The following standards are required for the use of [EN 1995-1-1]:

- General reference Eurocodes:
 - [EN 1990]: Basis of structural design
 - [EN 1991]: Actions on structures (all parts)
 - [EN 1995-1-2]: Structural fire design
 - Other reference standards.
 - Harmonised standards (hENs). hENs are Harmonised Product Standards. They give the rules by which products can meet the requirements for CE marking to be placed on the market. hENs reference (call up) all other relevant CEN standards covering a particular product, including (but not limited to) the following:
 - fire requirements
 - test methods
 - classification standards
 - production standards
 - material specifications
 - grading standards.
- hENs are written (or being written) for:
- solid timber [EN 14081]
 - all panel products [EN 13986]
 - glulam [EN 14080]
 - laminated veneer lumber, LVL [EN 14374]
 - fasteners/connectors [EN 14592] and [EN 14545]
 - trusses/trussed rafters [EN 14250]
 - timber frame wall, floor and roof elements [EN 14732].

The following CEN standards are probably also needed, depending on the sector:

- [EN 338] Timber strength classes
- [EN 1912] Visual grades (assignment to strength classes)
- [EN 336] Timber size tolerances
- [EN 1194] Glulam strength classes
- [EN 12369: Part 1] Strength properties of oriented strand board (OSB)/chipboard/fibreboards
- [EN 12369: Part 2] Strength properties of plywood

Role of National Annex – Using EN Eurocode at a national level

It is the responsibility of each National Standards body (e.g. the British Standards Institution (BSI) in the UK) to implement Eurocodes as

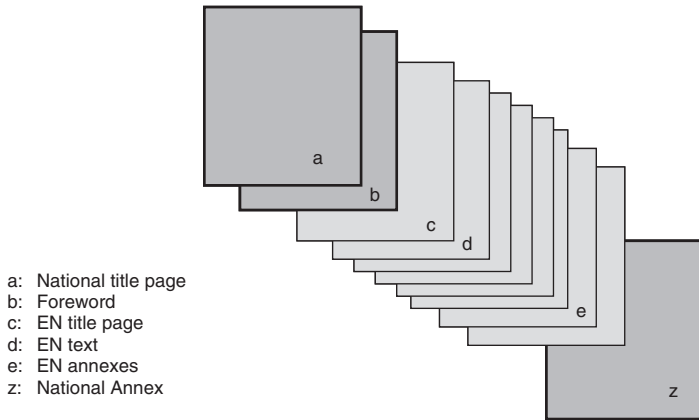

Fig. 1.2 National Standards implementing Eurocodes

National Standards. The National Standard implementing each Eurocode part will comprise, without any alterations, the full text of the Eurocode and its annexes as published by the CEN (Fig. 1.2, boxes c, d...). This is preceded by a national title page (box a) and national foreword (box b), and may be followed by a National Annex (box z).

Rules and contents of National Annexes for Eurocodes

The European Commission, recognising the responsibility of regulatory and national competent authorities in each EU Member State, has safeguarded their right to determine values related to safety matters at national level through a National Annex. These safety matters include different levels of protection that may prevail at national, regional or local level and ways of life.

A National Annex may only contain information on those parameters which are left open in the Eurocode for national choice, known as Nationally Determined Parameters, to be used for the design of buildings and civil engineering works to be constructed in the country concerned. Where a Eurocode clause allows choice, a recommended value or method is given.

Nationally determined parameters (NDPs)

NDPs will allow Member States to choose the level of safety applicable to their territory. The values, classes or methods to be chosen or determined at national level are:

- values and/or classes where alternatives are given in the Eurocode (e.g. levels of safety)
- values to be used where only a symbol is given in the Eurocode (e.g. partial factors)
- country-specific data, e.g. geographical, climatic (snow maps for instance)
- procedures to be used where alternative procedures are given in the Eurocodes.

National Annexes

The National Standards bodies (i.e. BSI in the UK) publish the NDPs in a National Annex. In addition to NDPs a National Annex may also contain:

- decisions on the application of informative annexes
- references to non-contradictory complementary information (NCCI) to assist the user in applying the Eurocode. The NCCI is sometimes referred to as 'Rump Standards' or 'Residual Standards' in the UK.

It should be noted that in Eurocode 5, NDPs are used for situations other than just to safeguard Member States' rights to define safety. They have been also been used to cover situations where there is no possibility of a consensus view being reached on an issue (e.g. for most of the serviceability section and the sections on detailing rules in [EN 1995-1-1]).

Principles – Application Rules

Eurocode 5 has two main notations throughout its contents for certain rules and requirements:

1. 'Principle requirements' are annotated by the suffix 'P'. This means that you **must** comply with the requirement. They are general statements and definitions for which there is no alternative permitted unless specifically stated.
2. 'Application Rules' are generally recognised rules which comply with and satisfy the 'Principle requirements'.

The UK National Annex requirements are included in this publication which may differ from those required by other countries. When a structure is designed for countries other than the UK, the National rules of that country must be adopted.

Informative and Normative Annexes in the Eurocode are defined as non-compulsory and compulsory requirements respectively. Informative Annexes can become Normative if they are recommended by the National Annexes. For example, Annexes A, B and C of Eurocode 5 for buildings and civil engineering works are recommended for use in the UK by the UK National Annex.

1.1.3 Basis of structural design (the use of [EN 1990] for timber structures design)

It is recommended that [EN 1990] is studied separately in detail. However, this section introduces the principles of [EN 1990] and describes the objectives of [EN 1990], lists the requirements and provides information on the representative values of the loads to be used in the combination of actions for use with the design and detailing clauses of Eurocode 5. It also gives the values adopted by the BSI National Annex to [EN 1990].

Note: The principal differences between EN 1990 and UK practice are all listed and explained in Gulvanessian, Calgaro and Holicky, 2005, who provide a comprehensive description, background and commentary to EN 1990. Guidance on EN 1990 [BRE, 200] describes the background to the selections made in the BSI National Annex to EN 1990.

Design link to [EN 1990]

[EN 1990] is the head key Eurocode for the harmonised Structural Eurocodes and is required for the verification of both ultimate and serviceability limit states as it provides the information for safety factors for actions and combination of superimposed actions.

[EN 1990] establishes and provides comprehensive information and guidance for all the Eurocodes, on the principles and requirements for safety and serviceability, describes the basis of their design and verification and gives guidelines for related aspects of structural reliability and durability of structures. It is based on the limit state concept and used in conjunction with the partial factor method. [EN 1995] does not give the material-independent clauses required for design. These are only included in [EN 1990]. Hence it is very important that [EN 1990] is used with all the Eurocode parts.

The limit state concept and the partial safety factor method used in [EN 1995] constitute a big change from the traditional British Standard

approach for timber. In the Eurocode system the safety and reliability concept is to be chosen and developed by the designer.

Requirements of [EN 1990]

The requirements of [EN 1990] which need to be adhered to by [EN 1995] are:

- Fundamental requirements. These relate to safety, serviceability and robustness requirements.
- Reliability differentiation.
- Design situations. [EN 1990] stipulates that a relevant design situation is selected taking account of the circumstances in which the structure may be required to fulfil its function. [EN 1990] classifies design situations for ultimate limit state verification as follows:
 - persistent situations (conditions of normal use)
 - transient situations (temporary conditions, e.g. during execution)
 - accidental situations
 - seismic situations.
- Design working life. For buildings and other common structures the recommended design working life (i.e. the assumed period for which a structure is to be used for its intended purpose with anticipated maintenance but without major repair being necessary) is 50 years. Design working life needs to be considered for material property deterioration, life-cycle costing and evolving maintenance strategies.
- Durability.
- Quality assurance.

1.1.4 Limit state design

General

In the Eurocodes, the safety requirements for structures are formulated in terms of limit states. A limit state is a state where the structure is on the point of not fulfilling the required performance requirements.

A distinction is made between serviceability and ultimate limit states.

Serviceability limit states

Serviceability limit states concern:

- the functioning of the construction works or parts of them
- the comfort of people
- the appearance.

Serviceability limit state failure occurs when:

- deflection of a structure or a member is visually or functionally unacceptable (e.g. it may result in cracks of ceiling and walls or leakage of roofs)
- sway or vibrations are unacceptable or uncomfortable
- there are incipient attacks of rot or corrosion that may eventually contribute towards or lead to failure if remedial steps are not taken.

Eurocode 5 contains some recommended deflection and vibration limits, but it is the designer's responsibility in consultation with the client to detail the requirements.

Ultimate limit states

Ultimate limit states are associated with collapse or with other forms of structural failure and concern:

- the safety of people
- the safety of the structure and its contents.

Ultimate limit state failure occurs when:

- uplift, overturning or sliding of the whole or part of the structure takes place
- failure of materials is evident
- instability of members or structures (i.e. column failure, lateral torsion instability, overturning, etc.) occurs.

1.1.5 The partial coefficient method

General

The basic elements are characteristic actions (commonly known as loads in UK) and characteristic material parameters (mechanical properties). The basic principles are that:

- design actions are found by multiplying the characteristic actions by partial safety factors (load factors); the design action effects are found from prescribed combinations of design action
- design material parameters are found by dividing the characteristic parameters by other partial coefficients (material factors) and design resistance is calculated with these design parameters
- it shall then be verified that the design resistance is not less than the design action effects.

Actions

A distinction is made between four types of actions that are classified by their variation in time:

1. permanent actions (G), e.g. self-weight, fixed equipment and actions caused by shrinkage and uneven settlements
2. variable action (Q), e.g. imposed loads, wind and snow
3. accidental actions (A), e.g. explosions or impact from vehicles
4. seismic actions.

In addition to the characteristic value of an action (G_k , Q_k and A_k) which is similar to the British Standards' definition, other representative values are specified in [EN 1990] for variable and accidental actions. Three representative values commonly used for variable actions are the combination value $\psi_0 Q_k$, the frequent value $\psi_1 Q_k$ and the quasi-permanent value $\psi_2 Q_k$. The factors ψ_0 , ψ_1 and ψ_2 are reduction factors of the characteristic values of variable actions, and each are defined below, and their numerical values are given in Table 1.2.

Table 1.2 Factors for the representative values of actions

	ψ_0	ψ_1	ψ_2
Imposed loads			
A: Domestic and residential areas	0.7	0.5	0.3
B: Office areas	0.7	0.5	0.3
C: Congregation areas	0.7	0.5	0.6
D: Shopping areas	0.7	0.5	0.6
E: Storage areas, including lofts	1.0	0.9	0.8
H: Roofs*	0.7	0	0
Snow loads on buildings			
Situated up to 100 m above sea level	0.5	0.2	0
Wind loads on buildings	0.5	0.2	0

* The roof imposed load should not be applied at the same time as wind or snow.

The combination value $\psi_0 Q_k$ is associated with the combination of actions for ultimate and irreversible serviceability limit states (the serviceability limit states where some consequences of actions exceeding the specified service requirements will remain when the actions are removed) in order to take account of the reduced probability of simultaneous occurrence of the most unfavourable values of several independent actions.

The frequent value $\psi_1 Q_k$ is primarily associated with the frequent combination in the serviceability limit states and it is also assumed to be appropriate for verification of the accidental design situation of the ultimate limit states. In both cases the reduction factor ψ_1 is applied as a multiplier of the leading variable action.

The quasi-permanent value $\psi_2 Q_k$ is mainly used for the assessment of long-term effects, for example in checking cracking or deflection. But they are also used for the representation of variable actions in accidental and seismic combinations of actions (ultimate limit states) and for verification of frequent and quasi-permanent combinations (long term effects) of serviceability limit states.

Design actions

For permanent actions (dead load):

$$G_d = \gamma_G G_k \quad (1.1)$$

For variable loads:

$$Q_d = \gamma_Q Q_k \quad (1.2)$$

The load factors are different for permanent actions (γ_G) and variable actions (γ_Q) – otherwise the method would be identical to the permissible stress method with a load factor of 1.0 which has been used until now in the UK.

Action (load) combinations

In most cases permanent actions and one or more variable actions act simultaneously. According to [EN 1990] the following combination rules shall be used (a part of the equation in [EN 1990] prestressing has been omitted because this is never applicable for ordinary timber structures).

There are two main design situations: fundamental and accidental. These are now discussed in turn.

1. Fundamental (persistent and transient) design situations (strength or equilibrium):

$$\sum_{i \geq 1} \gamma_{G,i} G_{k,i} + \gamma_{Q,1} Q_{k,1} + \sum_{j > 1} \gamma_{Q,j} \psi_{0,i} Q_{k,j}$$

[EN 1990] Expression (6.10) = (1.3)

where $Q_{k,1}$ is the so-called leading variable action (live load). For most materials the leading action is that which results in the largest action effect, but this is not necessarily so for timber structures because of the factor k_{mod} , see below.

Where it is not obvious which is the leading action, each action should in turn be taken as $Q_{k,1}$ to determine the combination which produces the worst effect.

2. Accidental design situations (fire, impact or explosion):

$$\sum_{i \geq 1} G_{k,j} + (A_d) + \psi_{1,1} Q_{k,1} + \sum_{j > 1} \psi_{2,i} Q_{k,j}$$

[EN 1990] Expression (6.11a) = (1.4)

The accidental action is in parenthesis because it should only be included when considering the direct effects on the structure of an explosion or impact. It should not be included when considering the situation after the event or after a fire.

Expression (1.3) may, if it is less demanding, be replaced by the following equations:

$$\sum_{i \geq 1} \gamma_{G,i} G_{k,i} + \gamma_{Q,1} \psi_{0,1} Q_{k,1} + \sum_{j > 1} \gamma_{Q,j} \psi_{0,i} Q_{k,1}$$

[EN 1990] Expression (6.10a) = (1.5)

$$\sum_{i \geq 1} \xi \gamma_{G,i} G_{k,i} + \gamma_{Q,1} Q_{k,1} + \sum_{j > 1} \gamma_{Q,j} \psi_{0,i} Q_{k,1}$$

[EN 1990] Expression (6.10b) = (1.6)

where $\xi = 0.925$.

Expressions (1.5)–(1.6) may only be used:

- for fundamental (not accidental) design situations
- for strength (not equilibrium) verifications
- when the leading variable action is wind or snow and it is unfavourable and its characteristic value exceeds 13.5% of the characteristic value of the permanent actions, or when

the leading action is any other type of variable action except storage and its characteristic value exceeds 22.5% of the characteristic value of the permanent actions.

Material parameters (mechanical properties)

For strength properties, modulus of elasticity and density, the characteristic value m_k is taken as the 5 percentile, i.e. a probability of 5% of getting lower values is accepted. For stiffness values (e.g. modulus of elasticity), the mean value E_{mean} is normally taken as the characteristic value.

Design material parameters

Design material parameters, m_d , are determined as:

$$m_d = k_{mod} \frac{m_k}{\gamma_M} \quad (1.7)$$

where:

k_{mod} is a modification factor taking into account different conditions such as load duration, moisture content, temperature and size. In Eurocode [EN 1990] the notation η is used instead of k_{mod} ;

m_k is the characteristic value of the material parameter m ;

γ_M is the partial coefficient covering the uncertainty in determining of m .

Similarly, for stiffness:

$$E_d = k_{mod} \frac{E_k}{\gamma_M} \quad (1.8)$$

For γ_M the values in Table 1.3 are to be used in the UK.

The calculation of the design action effect is the same for all materials and reference is made to [EN 1990]. On the resistance side of the equation there are several features that are material dependent. The following describes how the design resistance is determined for timber structures.

Service classes

To take into account the moisture content in the timber- and wood-based materials, structures shall be assigned to one of the three service classes given below.

Table 1.3 Partial coefficients for actions (load factors), ultimate limit states

	Permanent actions, γ_G		Variable actions, γ_Q	
	Unfavourable	Favourable	Favourable	Unfavourable
Strength verification	1.35	1.00	1.50	0
Equilibrium verification	1.10	0.90	1.50	0
Combined strength and equilibrium verification*	1.35	1.00	1.50	0

*The combined check is an optional alternative to separate calculations for equilibrium and strength verifications when both have to be carried out. However, if it is employed then it must also be verified that setting γ_G to 1.00 for both the favourable and unfavourable parts of the permanent load does not produce a less favourable effect.

- Service class 1 is characterised by a moisture content in the materials corresponding to a temperature of 20°C and the relative humidity of the surrounding air only exceeding 65% for a few weeks per year. In service class 1 the average moisture content in most softwoods will not exceed 12%.
- Service class 2 is characterised by a moisture content in the materials corresponding to a temperature of 20°C and the relative humidity of the surrounding air only exceeding 85% for a few weeks per year. In service class 2 the average moisture content in most softwoods will not exceed 20%.
- Service class 3 is characterised by climatic conditions leading to higher moisture contents than in service class 2.

Examples of assignments to service classes in the UK is given in Table 1.4.

Table 1.4 Service classes

Service class	Type of construction
1	Warm roofs Intermediate floors Internal and party timber walls of buildings
2	Cold roofs Ground floors External timber-frame walls External uses where member is protected from direct wetting
3	External uses, fully exposed

Table 1.5 Load-duration classes

Load-duration class	Duration	Examples of loads
Permanent	More than 10 years	Self-weight
Long-term	6 months to 10 years	Storage loading (including in lofts) Water tanks
Medium-term	1 week to 6 months	Imposed floor loading
Short-term	Less than 1 week	Snow Maintenance or man loading on roofs Residual loading after accidental event
Instantaneous		Wind Impact loading and explosion

To take into account the influence of load duration on strength, loads shall be assigned to one of the five load-duration classes of Table 1.5.

The factor k_{mod} as a function of service class and load duration is given in Table 1.6.

Verification

For static equilibrium (EQU*), it shall be verified that:

$$S_{d,\text{dst}} \leq R_{d,\text{stb}} \quad (1.9)$$

where:

$S_{d,\text{dst}}$ is the design value of the destabilising actions;
 $R_{d,\text{stb}}$ is the design value of the stabilising actions.

* EQU limit states. These involve loss of static equilibrium in the considered structure, either as a whole rigid body or in any one of its constituent parts. In such situations, the mechanical and resistance properties of the material are not generally determining factors, while even modest geometric variations in the distribution of actions or their points of application may be crucial.

** STR limit states. These concern the failure or excessive deformation of a structure or its constituent members. In such cases, it is the resistance of the materials that is the determining factor in verification.

† GEO limit states. These involve failure or excessive deformation of the soil. The critical factor in ensuring safety for such limit states is the mechanical characteristics of the ground. In the case of the design of structural members (footings, piles, basement walls) involving geotechnical actions and resistance of the ground (STR and GEO), three separate approaches are recommended.

Table 1.6 Values of k_{mod}

Material	Standard	Service class	Load-duration class				
			Perm- anent action	Long- term action	Medium- term action	Short- term action	Instan- taneous action
Timber, glulam and LVL	[EN 14081-1]	1	0.60	0.70	0.80	0.90	1.10
	[EN 14080]	2	0.60	0.70	0.80	0.90	1.10
	[EN 14374], [EN 14279]	3	0.50	0.55	0.65	0.70	0.90
Plywood	[EN 636, Part 1]	1	0.60	0.70	0.80	0.90	1.10
	[EN 636, Part 2]	2	0.60	0.70	0.80	0.90	1.10
	[EN 636, Part 3]	3	0.50	0.55	0.65	0.70	0.90
OSB*	[EN 300], OSB/2	1	0.30	0.45	0.65	0.85	1.10
	[EN 300], OSB/3 and OSB/4	1	0.40	0.50	0.70	0.90	1.10
	[EN 300], OSB/3 and OSB/4	2	0.30	0.40	0.55	0.70	0.90
	[EN 300], OSB/3 and OSB/4	2	0.30	0.40	0.55	0.70	0.90
Particle- board	[EN 312, Part 4 and 5]	1	0.30	0.45	0.65	0.85	1.10
	[EN 312, Part 5]	2	0.20	0.30	0.45	0.60	0.80
	[EN 312, Part 6 and 7]	1	0.40	0.50	0.70	0.90	1.10
	[EN 312, Part 7]	2	0.30	0.40	0.55	0.70	0.90
Fibreboard, hard	[EN 622-2] HB.LA, HB.HLA1 or HLA.2	1	0.30	0.45	0.65	0.85	1.10
	[EN 622-2] HB.HLA1 or HLA2	2	0.20	0.30	0.45	0.60	0.80
Fibreboard, medium	[EN 622-3] MBH.LA1 or 2,	1	0.20	0.40	0.60	0.80	1.10
	MBH.HLS1 or 2	1	0.20	0.40	0.60	0.80	1.10
	MBH.HLS1 or 2	2	–	–	–	0.45	0.80
Fibreboard MDF**	[EN 622-5] MDF.LA and MDF.HLS	1	0.20	0.40	0.60	0.80	1.10
	MDF.HLS	2	–	–	–	0.45	0.80

* OSB, oriented strand board. ** MDF, medium density fibreboard.

For verification for internal failure or excessive deformation of the structure or structural members, including footings, piles, basement walls, etc., where the strength of construction materials governs (STR**); and for failure or excessive deformation of the ground where the strength of soil or rock is significant in providing resistance

(GEO[†]), it shall be verified that:

$$S_d \leq R_d \quad (1.10)$$

where:

S_d is the design value of the effect of action such as internal force, moment or a vector representing several internal forces or moments;

R_d is the design value of the corresponding resistance.

Note: [EN 1990] used symbol E with various subscripts for design actions and design resistance. To avoid confusion with modulus of elasticity the symbols S and R have been preferred.

1.1.6 Serviceability

Design stiffness values

For serviceability limit states, mean stiffness values are used directly to obtain the best estimates of expected deformations. In Eurocodes this is expressed more formally as follows:

The mean values should be used with a partial coefficient:

$$\gamma_M = 1 \quad (1.11)$$

Serviceability limit states verification

For the serviceability limit states verification [EN 1990] stipulates that:

$$S_d \leq C_d \quad [\text{EN 1990}] \text{ expression (6.1) =} \quad (1.12)$$

where:

S_d is the design value of the effects of actions specified in the serviceability criterion, determined on the basis of the relevant combination;

C_d is the limiting design value of the relevant serviceability criterion.

Combination of actions for the serviceability limit states

For serviceability limit states verification, [EN 1990] requires the three combinations to be investigated which are shown below. [EN 1990] gives three expressions for serviceability design: characteristic, frequent and quasi-permanent.

1. The characteristic (rare) combination is used mainly in those cases when exceedance of a limit state causes a permanent local damage or permanent unacceptable deformation.

$$\sum_{j \geq 1} G_{k,j} + Q_{k,1} + \sum_{i > 1} \psi_{0,i} Q_{k,i}$$

[EN 1990] Expression (6.14b) = (1.13)

2. The frequent combinations are used mainly in those cases when exceedance of a limit state causes local damage, large deformations or vibrations which are temporary.

$$\sum_{j \geq 1} G_{k,j} + \psi_{1,1} Q_{k,1} + \sum_{j > 1} \psi_{2,i} Q_{k,i}$$

[EN 1990] Expression (6.15b) = (1.14)

3. The quasi-permanent combinations are used mainly when long-term effects are of importance.

$$\sum_{j \geq 1} G_{k,j} + \sum_{i \geq 1} \psi_{2,i} Q_{k,i}$$

[EN 1990] Expression (6.16b) = (1.15)

Creep

When a structure is loaded it will get an instantaneous deformation u_{inst} which should be calculated with mean values determined by standardised short-term tests.

When a load is maintained constantly (e.g. a permanent load), the deformation of the structure or member will increase in principle as shown in Fig. 1.3. This phenomenon is called creep. During the early stages of loading, the deformation increases fast, but with time the rate of increase will decrease asymptotically to a final value u_{fin} . The deformation at time t may be expressed as:

$$u(t) = u_{inst}[1 + \varphi(t)] \quad (1.16)$$

where $\varphi(t)$ is called the creep function.

In Eurocode 5, Expression (1.16) is written as:

$$u_{fin} = u_{inst}(1 + k_{def}) \quad (1.17)$$

where k_{def} is a modification factor for deformation which depends on the material, the moisture content and the load-duration class. Examples of k_{def} are given in Table 1.7.

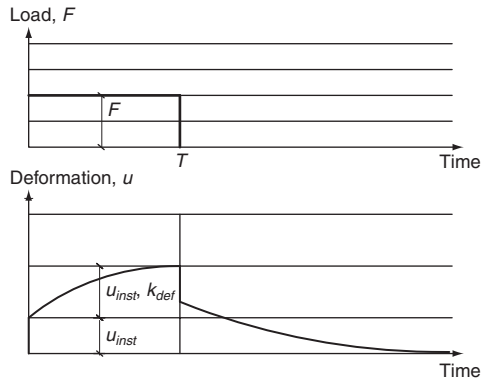

Fig. 1.3 Constant load F and deformation u with time t of a simply supported beam followed by unloading at time T

If a load after a time T is removed, the deformation will be reduced by the same u_{inst} as when it was loaded. This will be followed by a creep recovery deformation until the deformation stops at a permanent deformation. It should be noted that if the stress level is less than about 50% of the characteristic strength (and this will most often be the case), the permanent deformation will be small and may in practice be disregarded if the total loading period is smaller than the unloaded period, e.g. snow loading in the UK.

Over a period, the deformations depend on the average load that in most cases is considerably smaller than the characteristic load. The average load is called the ‘quasi-permanent’ part of the load. The deformation from a variable load is, therefore, calculated as:

$$u_{fin} = u_{inst}(1 + \psi_2 k_{def}) \quad (1.17)$$

where ψ_2 is given in Table 1.2 and Table 1.8.

If two or more constant loads are applied at different periods, see Fig. 1.4, they will each induce deformations as described above. For more than one load, the deformations calculated for each load should be added together.

Shear deformations

In most cases only deformations from bending are of importance, but since the shear modulus is rather low there are situations where it is also necessary to take shear deformations into account, e.g. for thin webbed I-beams – see Example 6.1 in Chapter 6.

Table 1.7 The factor k_{def}

Material	Standard	Service class		
		1	2	3
Structural timber	[EN 14081-1]	0.60	0.80	2.0
Glulam	[EN 14080]			
LVL	[EN 14373] and [EN 14279]			
Plywood	[EN 336-1]	0.80	–	–
	[EN 336-2]	0.80	1.00	–
	[EN 336-3]	0.80	1.00	2.50
OSB	[EN 300]			
	OSB/2	2.25	–	–
	OSB/3 and OSB/4	1.50	2.25	–
Particleboard	[EN 312]			
	Type P4	2.25	–	–
	Type P5	2.25	3.00	–
	Type P6	1.50	–	–
	Type P7	1.50	2.25	–
Fibreboard, hard	[EN 622-3]			
	MHB.LA1 and MHB.LA2	2.25	–	–
	MHB.HLS1 and MHB.HLS2	2.25	3.00	–
Fibreboard, medium	[EN 622-2]			
	HB.LA	3.00	–	–
	HB.HLA1 and HB.HLA2	3.00	4.00	–

Notes: For timber which is installed at or near its fibre saturation point, and which is likely to dry out under load, these values shall be increased by 1.0. It is a known fact that dried timber is stiffer than wet timber. However, when a timber structure or a member with high moisture content is loaded, the deformations will not be reduced during drying of the structure or the member. In fact the deformation will increase further. In addition, if a timber beam which is near its fibre saturation moisture content, is exposed to alternating load, the deformations will continue to increase.

Deformation contributions from joints

Joints in timber structures are rather flexible and in trussed structures their contribution to the deflections may be larger than those from deformations of the timber part.

The slip g for a load F should be calculated from:

$$g = F/K \quad (1.19)$$

where K is the slip modulus. Table 1.9 contains expressions for the slip modulus for some common fasteners. Reference is also made to Chapter 9 for further information.

Table 1.8 Quasi-permanent factor

	ψ_2
Imposed loads	
A: Domestic and residential areas	0.3
B: Office areas	0.3
C: Congregation areas	0.6
D: Shopping areas	0.6
E: Storage areas, including lofts	0.8
H: Roofs*	0
Snow loads on buildings	
Situated up to 100 m above sea level	0
Wind loads on buildings	0

* The roof imposed load should not be applied at the same time as wind or snow.

Limiting values for deflection of beams

The serviceability criteria should be specified for each project and agreed with the client. In the UK National Annex, the values in Table 1.10, which take into account creep deformations, are given for guidance.

Vibrations

Loads applied on structures should not cause vibrations that can impair the function of the structure or cause unacceptable discomfort to the users.

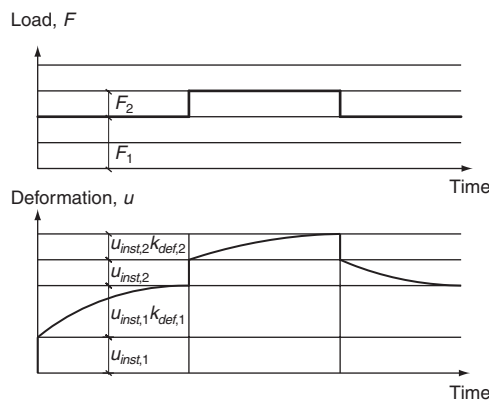

Fig. 1.4 Deformations for a structure over a period with two different constant loads

Table 1.9 Slip modulus K in N/mm for dowel-type fasteners with diameter d

Dowels	$\frac{\rho_m^{1.5}}{23} d$
Screws	
Tight-fitting bolts*	
Nails with pre-drilling	
Nails without pre-drilling	$\frac{\rho_m^{1.5}}{30} d^{0.8}$
Staples	$\frac{\rho_m^{1.5}}{80} d^{0.8}$

* For bolts the clearance should be added separately.

Note: ρ_m is the density of the wood (mean value) in kg/m^3 .

For residential floors with a fundamental frequency $f_1 \leq 8$ Hz, a special investigation should be made.

For floors, unless other values are proven to be more appropriate, a modal damping ratio of $\zeta = 0.02$ (i.e. 2%) should be assumed.

The fundamental frequency for a rectangular floor, $l \times b$, simply supported along all four edges and with timber beams having a span l , can be calculated as:

$$f_1 = \frac{\pi}{2l^2} \sqrt{\frac{(EI)_t}{m}} \quad (1.20)$$

where:

- m is the mass per unit area in kg/m^2 ;
- l is the floor span in m;

Table 1.10 Limiting values of individual beams

Type of member	Limiting value for final deflections of individual beams, w_{fin}	
	A member of span l between two supports	A member with a cantilever l
Roof or floor member with a plastered or plasterboard ceiling	$l/250$	$l/125$
Roof or floor member without a plastered or plasterboard ceiling	$l/150$	$l/75$

Note: w_{fin} should be calculated as u_{fin} in accordance with [EN 1995-1-1], 2.2.3(5).

$(EI)_t$ is the equivalent plate bending stiffness of the floor about an axis perpendicular to the beam direction, in Nm^2/m .

For residential floors with a fundamental frequency $f_1 \leq 8 \text{ Hz}$, Eurocode 5 gives very advanced design methods. The UK National Annex however states that floors with a span up to 6 m will normally behave satisfactorily provided the deflection a under a point load is smaller than:

$$a \leq \begin{cases} 1.85 \text{ mm/kN} & \text{for } l \leq 4500 \text{ mm} \\ \frac{68\,200}{l^{1.25}} \text{ mm/kN} & \text{for } l > 4500 \text{ mm} \end{cases} \quad (1.21)$$

where the floor deflection should be calculated as:

$$a = \frac{k_{dist} l_{eq}^{3.2} k_{shear}}{k_{comp} (EI)_{joist}} \text{ mm/kN} \quad (1.22)$$

where:

- k_{dist} is proportion of point load acting on a single joist
 $= \max \begin{cases} 0.42 - 0.09 \ln \left[\frac{14(EI)_b}{s^4} \right] \\ 0.35 \end{cases}$
- l_{eq} is equivalent floor span in mm
 $= 1.0l$ for simply supported single span joists
 $= 0.9l$ for the end spans of continuous joists
 $= 0.85l$ for the end spans of continuous joists
- k_{shear} is amplification factor to account for shear deflections
- k_{comp} is factor to account for composite action between joist and floor decking
- $(EI)_{joist}$ is bending stiffness of a joist in Nmm^2 (calculated using E_{mean})
- $(EI)_b$ is floor flexural rigidity perpendicular to the joists in Nmm^2/m
- s is joist spacing in mm
- l is span between supports in mm
- k_{shear} $= 1.05$ for simply supported solid timber joists
 $= 1.10$ for continuous solid timber joists
 $= 1.15$ for simply supported glued thin-webbed joists
 $= 1.30$ for continuous glued thin-webbed joists
- k_{comp} $= 0.3$ for floor decking nailed or screwed to the joists in accordance with the decking manufacturer's recommendations

= 0.325 for floor decking nailed or screwed, and glued to the joists at standard centres and glued in accordance with the manufacturer's recommendations

$(EI)_b$ is calculated as the flexural rigidity of the floor decking perpendicular to the joists, using E_{mean} for E . Discontinuities at the edges of floor panels or the ends of floor boards may be ignored. $(EI)_b$ may be increased for plasterboard, strutting and strongbacks as follows:

add $0.34 \cdot 10^9 \text{ N/mm}^2/\text{m}$ for standard plasterboard

add $0.53 \cdot 10^9 \text{ N/mm}^2/\text{m}$ for standard strutting

add for a single continuous strong-back fastened to all joists within 0.1l of mid-span its bending stiffness in Nmm^2 divided by the span l in metres.

1.1.7 Robustness

All structures are required to be reasonably robust, i.e. they should not be sensitive to unintended incidents or small deviations from the design assumptions, e.g. small deviations from the intended geometry due to execution errors, or foundation settlements.

Robustness (sometimes called safety against disproportionate or progressive collapse) requirements are those that, in the case of an accident, the structure does not fail disproportionate to the cause of the accident, i.e. failure in a small part of the structure must not result in failure of the whole structure.

Robustness may be ensured by the design of the statical system, e.g. by choosing statically indeterminate structures where there is more than one path for the loads to the supports, by choice of materials and joints and by control of the construction execution. It should be noted that increase of the safety factors, by itself rarely has an important effect, even though the safety codes sometimes accept this as a possible way of compliance.

The codes are rather vague regarding implementation of the robustness requirements into practice and it is usually left to the designer. In the UK, Building Regulations Approved Document A (Communities and Local Government, 2000) provides some design guidance for robustness (disproportionate collapse or progressive collapse), which should be used.

2

Construction products

2.1 The tree

2.1.1 *Structure of the tree*

Living trees consist of foliage, stem, branches and roots. The foliage (leaves or needles) contains chlorophyll that, with energy from the sun, can decompose the carbon dioxide (CO₂) in the air into oxygen and carbon which are the basic elements in cellulose, hemicellulose and lignin as the main chemical components of wood. The stem and branches carry the foliage and contain vessels for transport of liquids between the root and top of the tree and is a store for nourishment (see Fig. 2.1).

Pith

The pith is a narrow wood bar (about 10 mm in diameter) in the centre of the stem. It consists of loosely bounded dead cells that are oriented along the tree. Pith rays from the pith to the bark are able to transport liquids and nourishment.

Bark

The stem and the branches are covered by the bark which protects the wood against drying out, attacks of fungi, beetles and physical damage. Under the bark there is a thin growth layer called the cambium where new bark cells are formed outward and new wood cells inward. Every year the tree produces a new annual ring.

Annual rings

The inner part of the annual rings is called early wood or spring wood and is formed during the spring, often with relatively high growth rate. Its purpose is to ensure an early transport of liquids. Early wood is light in colour and has relatively low density, stiffness and strength

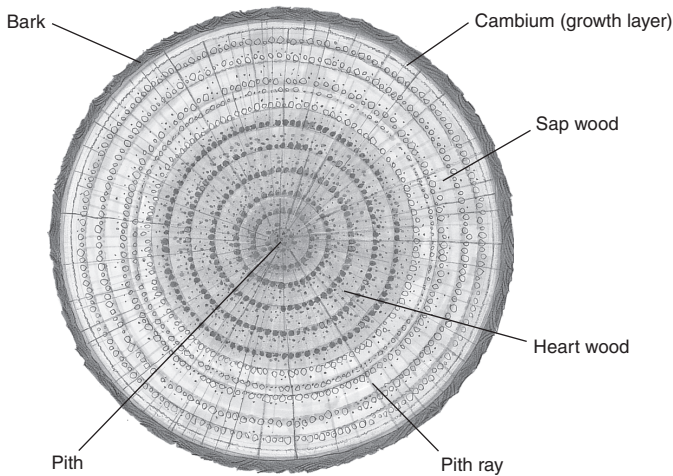

Fig. 2.1 Cross-section of a tree stem

because of thin fibre walls and big lumens (cell holes/voids). The outer part of the annual rings is called late wood and is formed relatively slowly during the summer. It is darker than the early wood and has higher density, stiffness and strength.

For conifers the thickness of late wood is almost constant and trees with narrow annual rings are preferred because the amount of spring wood is relatively small. For deciduous trees (often a little misleadingly called hardwoods) the thickness of early wood is almost constant and trees with broad annual rings are preferred because the amount of late wood is relatively large. The width of the annual rings is in the range 2–10 mm.

Wood cells

The basic element of wood is the wood cells. They consist of cell walls surrounding the cell lumen. The cells are oblong and oriented essentially in the lengthwise direction of the tree and grow at lengths of 2–4 mm and their thickness varies between 10–50 μm . The cells are squeezed between each other and connected through pores so that long tubes, called wood fibres, are formed, serving in the living tree to transport liquids.

Tree growth

The growth of a tree is shown schematically in Fig. 2.2.

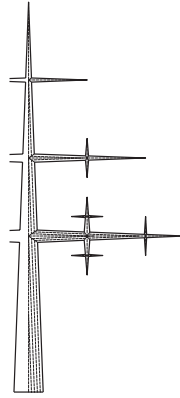

Fig. 2.2 Schematic growth of a conifer

Early in the spring a top shoot grows lengthwise and creates a narrow year shoot on the top of the tree. Similarly, side shoots grow out from the pith as small individual trees. The side shoots become branches and their anchorage in the stem form knots. Branches that are overgrown so that they do not get sunshine die and will eventually break off.

Knots

A knot is the embedded part of a branch. At areas close to the knots the wood fibres in the stem change direction and continue into the branches. The fibre direction can be heavily distorted as shown in Fig. 2.3. When a

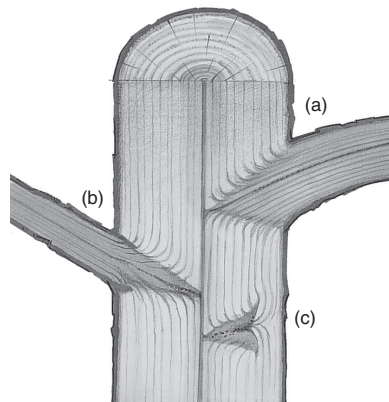

Fig. 2.3 Radial cross-section in a tree stem and knots: (a) living knot; (b) knot from a dead branch – near to the surface the knot will become loose; (c) embedded knot

branch dies it often breaks off close to the surface of the tree. When the tree continues to grow, the knot becomes embedded into the stem. A distinction is made between dead and living knots.

- Dead knots are the dead part of a branch and are not integrated with the stem. They will often become loose and fall out when the tree stem is cut up because the wood in the branches shrinks more than ordinary wood.
- Living knots are integrated into the stem and will usually not fall out, but can crack during drying.

The knots in pine wood are concentrated at the same height around the trunk and spaced corresponding to a year's growth, typically 250–800 mm. For spruce the knots are more randomly dispersed along the tree stem. When the tree is cut, the knot pattern on the board surface will vary (see Fig. 2.4). The knots are denoted after their location such as edge knots, (narrow) side knots and (wide) face knots. Furthermore, they are denoted after their shape as round, horn or leaf knots.

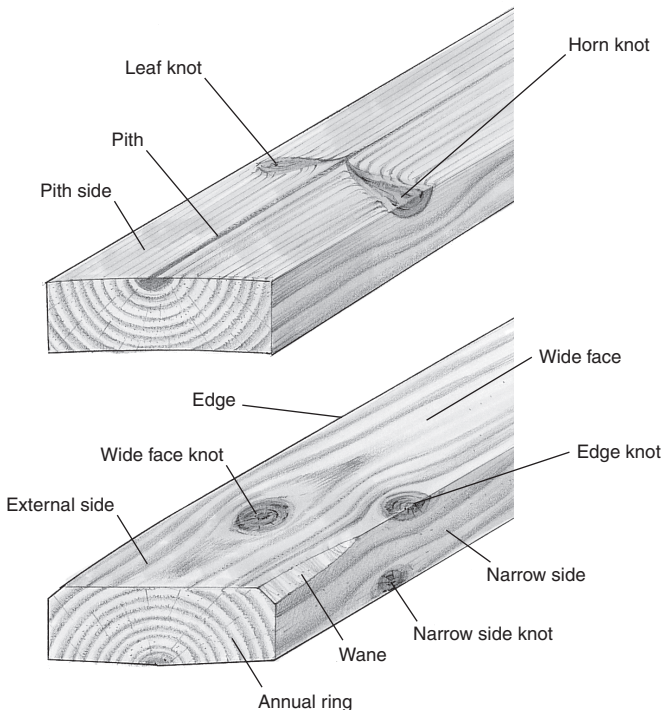

Fig. 2.4 Different types of knots

Sapwood and heartwood

The outer material in the tree stem is denoted sapwood. It contains many living cells that can transport liquids from the bottom to the top of the tree. When the tree becomes old, the old wood cells die and resin, sugar composites, tannin and oils are deposited in the cavities. This is when a heartwood core is formed in the central area of the tree (see Fig. 2.1). The heartwood is often darker and more durable than the sapwood. It is, however, not always the case. As an example, it is not possible with the naked eye to detect the core of spruce and it has poor durability.

Density

The density of the wood cell wall is about 1550 kg/m^3 . The density of wood is smaller due to the voids within the cells. The density of spruce and pine is typically in the range $300\text{--}600 \text{ kg/m}^3$ corresponding to a void percentage of 80–60.

Cracks and shakes

Cracks and shakes often arise during drying of solid timber products, but sometimes they may be initiated in the living tree because of growth stresses.

Main directions of wood

Due to the wood structure with annual rings, three main material directions may be identified, i.e. longitudinal (L), tangential (T) and radial (R) (see Fig. 2.5). The longitudinal direction refers to the fibre direction and the radial direction radiates from the pith to the bark and finally the tangential direction is perpendicular to these two.

2.1.2 Moisture content

General

Wood always contains water in the cells, either as free water in the cell lumens or as bonded water in the cell walls. The weight of the water as a percentage of the weight of the dry wood is called the moisture content:

$$u(\%) = 100 \frac{\text{weight of water}}{\text{weight of dry wood}} \quad (2.1)$$

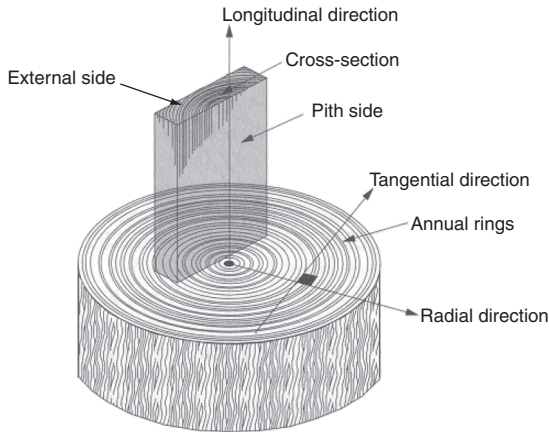

Fig. 2.5 Material directions and side definitions in tree stem and solid board (Courtesy Erik Serrano, SP, Sweden)

The moisture content may be determined by weighing a piece of wood, drying it at 105°C until weight equilibrium is reached and then weighing it again. The moisture content is found as the weight loss (i.e. weight of water) relative to the weight of the dried wood:

$$u(\%) = 100 \frac{\text{wet weight} - \text{dry weight}}{\text{dry weight}} \quad (2.2)$$

In practice the moisture content is determined by an electric moisture meter. The principle is that the electric resistance is measured between two electrodes pressed into the wood. Electric moisture meters can, however, only be used for moisture contents between about 6 and 30%.

Just after felling of the tree the moisture content is high; in some wood species higher than 100%. When the wood is dried, the free water in the cell lumens disappears first, followed by the water bonded to the cell walls. The moisture content when all free water has been removed is called the fibre saturation point. This point differs between wood species and varies normally between 25 and 30%. The moisture content in dried wood may be increased again, by placing it in a moist atmosphere or by exposing it directly to water. In the former case the moisture content cannot exceed the fibre saturation point.

If a piece of wood is placed in a constant climate for long time the moisture content in the wood will reach an equilibrium moisture content (EMC). As an approximation it may be assumed that the

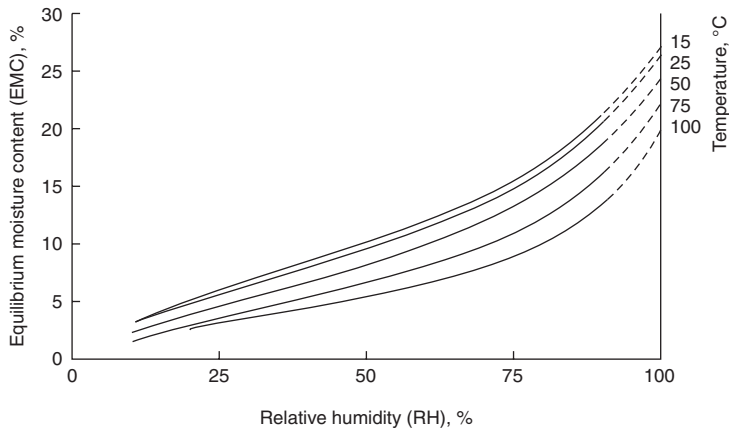

Fig. 2.6 Influence of RH and temperature on EMC in Nordic conifers

EMC in wood only depends on the relative humidity (RH) and the temperature of the surrounding air as shown in Fig. 2.6.

It may take some time for wood to reach the equilibrium moisture content, especially for members with large cross-sections. For an ordinary floorboard it will take some days to reach equilibrium, whereas it may take months for a large timber member. The moisture content at the surface of a glulam beam follows the short-term climatic variation, but the moisture content inside the member will correspond to the long-term variations over the year. For large glulam members, the inside moisture content will be almost constant, corresponding to the average RH over the year.

The indoor EMC of wood will typically vary between 12 and 15% during summer and between 7 and 10% during winter because of the heating. The outdoor EMC of wood is about 15% during summer and it increases during the winter to:

- 18–25% if the timber is exposed to the weather
- 16–20% if the timber is protected against direct weather exposure, e.g. by a roof
- 14–17% in façades, windows and doors.

Moisture-related deformations

Moisture variation above the fibre saturation point will not cause dimension changes in wood products because it is only the free water content in the lumen that is changed. Moisture changes below the fibre saturation

Table 2.1 Shrinkage/swelling strains for Nordic conifers for every unit change in the moisture percentage

Longitudinal strain: %	Tangential strain: %	Radial strain: %
0.01	0.3	0.15

point will on the other hand result in dimensional changes. Wood shrinks when it is dried and swells during wetting. The shrinkage/swelling strains in the longitudinal, radial and tangential directions of wood are assumed to be proportional to the values shown in Table 2.1.

The longitudinal strain is relatively small compared to the other strain components. However, the effect cannot always be disregarded, as for a 30 m long beam the length change will be about 30 mm for a change in the moisture percentage of 10.

In practice the direction of the sawn cut wood relative to the annual rings is random and usually an average strain value of 0.2% is used for the shrinkage/swelling strains perpendicular to the fibre direction. The difference between the tangential and radial strains results in distorted cross-sections when solid timber is dried (see Fig. 2.7). The distortion is highly affected by the annual ring pattern of the individual piece – see Fig. 2.7 where:

- (a) the growth rings are running in the radial direction and perpendicular to the wide faces, therefore the board will keep its shape but become thinner and shorter;

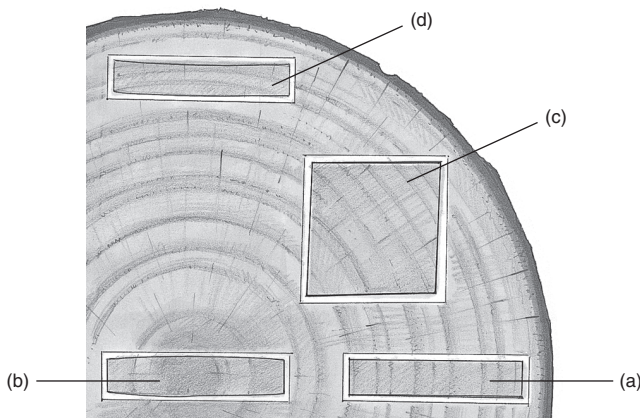

Fig. 2.7 Sawn cut patterns and shape distortion of timber cross-sections caused by shrinkage being larger in the tangential than in the radial direction

- (b) the growth rings at the ends are running in the tangential direction but in the radial direction in the middle, thus the thickness changes are largest at the ends;
- (c) this cross-section will shrink less in the radial direction than in the tangential and it becomes skew, and timber cut in this way should not be used in structures;
- (d) the wide growth rings are running more 'tangential' in the outer side than in the inner, so the outer side will shrink more than the inner and the cross-section will become concave with the concave side outwards. If this cross-section is pressed flat (e.g. when planed) the outer side will crack.

Solid timber will often crack during drying, especially if it is dried fast. The drying starts in the outer layer and the shrinkage will be prevented by the inner core that is still wet. This internal constraint can result in high tensile stresses that can cause significant crack damage of the material. Due to unavoidable changes in the temperature and RH, wood will always be changing its size and shape during its service life and it is necessary to take this into consideration in the design of timber structures. To reduce the problems, timber should be conditioned to the climatic conditions where it is going to be used. The following maximum moisture content values should be specified:

- indoor 10–13%
- outdoor, under cover 14–18%
- outdoor exposed to weather 20–25%.

If higher moisture contents cannot be avoided, shrinkage should be allowed to take place freely to avoid damage to the structure. Eurocode 5 permits the use of wood with high moisture content during construction but only if it is ensured that the wood can dry without risk of attack from fungi and that it is possible to replace members subject to unacceptable distortions.

2.1.3 Density

Since both mass and volume vary with moisture content, different density measurements are used. The two most common density definitions are:

- dry density, $\rho_0 = m_{dry}/V_{dry}$ determined from mass and volume of completely dried wood
- moist (wet) density, $\rho_u = m_u/V_u$ determined from mass and volume at the moisture content u (%).

Often ρ_{12} determined from mass and volume at a moisture content of 12% (corresponding to a climate of about 20°C and 65% RH) is taken as reference. For spruce and pine the following expression may be used for u between 8 and 18%.

$$\rho_{12} = \rho_u[1 - 0.05(u - 12)] \quad (2.3)$$

2.1.4 Durability

If wood is not treated correctly it is a perishable material. It can be destroyed by insects, bacteria and fungi. On the other hand wood is resistant to many chemicals and is often used in storages for aggressive agents such as salt and soda and in swimming halls (chlorine). However, in these cases it is often necessary to use fasteners of stainless steel or other especially durable materials.

Fungi

In buildings it is possible to find about 30 species of wood-destroying fungi. This number is much higher in woodlands and forests. Although some of the fungi are harmless, their presence should be regarded as a warning sign. They indicate that the moisture level is high and that there is risk of attack by wood-destroying fungi. Fungal spores are found everywhere in the air. They are minute (thousandths of a millimetre) and are carried by the air movement until they find a place where the growth conditions are favourable. The spores shoot with a so-called hypha that takes root, grows into the wood and develops into a mycelium. From the tip of the hypha, enzymes are secreted. They convert the wood to food substances that can nourish continued growth of fungi. Under the right conditions mushroom- or chanterelle-like fruits may develop from the mycelium. In these, spores may be formed, and the life-cycle begins again.

Fungi growth requires food, oxygen, a reasonable temperature and moisture. Most fungi prefer temperatures around 20–30°C but some require higher temperatures. At temperatures below 5°C all fungi growth stops. In saturated wood (moisture content above about 75%), the oxygen content is insufficient for most fungi to grow. This explains why timber pile foundations below the groundwater table do not rot.

Fungi do not attack sound wood at moisture contents below 20% and the attack will normally stop if the moisture content is reduced

below 20%. There are, however, some fungi that can attack wood at lower moisture contents when the wood has been affected by fungi previously.

Rot

The result of a fungi attack is rot. Often no distinction is made between dry rot and brown (wet) rot.

- Dry rot is the result of a normally slow destruction of the wood caused by fungi or bacteria under prolonged high moisture content, e.g. due to insufficient maintenance or inappropriate structural detailing. Building insurance may not cover dry rot because it could be taken by insurers as a sign of lack of proper maintenance.
- Brown (wet) rot normally results from a sudden influx of water or entrapment of water during the building process.

Mould and discolouring fungi

Wood exposed to moisture may be attacked by mould or discolouring fungi, e.g. blue stain. These attacks are harmless and the strength and stiffness are not reduced but the appearance is impaired and indicates that the moisture level is so high that there is risk of attack of wood-destroying fungi. Mould live on the surface of the wood and growth may start if the air moisture content at the surface is higher than 16% in the wood itself. Mould has been attracting increased attention because it may be carcinogenic and allergenic, even when the fungi are dried out and dead. Therefore, wood with visible mould should not be used indoors.

Blue stain fungi create black or blue discolouring on the surface which cannot be removed easily without extensive planing. In the trade, blue stain is regarded as a blemish that should be avoided if the surface is to stay untreated. Blue stain can be avoided if the wood is dried immediately after cutting or sprayed with or dipped in a fungicide.

Insects and marine borers

Insects normally pose only small problems, with the exception of house longhorn beetles which may cause great damage to the structure. House longhorn beetles are most commonly found in the south-west area of London (mainly Surrey) where special Building Regulations exist to protect structural timber and prevent further spread. The best way to

avoid problems is to keep the wood dry as house longhorn beetles cannot live in wood with moisture contents below 10%. For all other insects the limit is about 15%.

Attacks from shipworm that live in saltwater may be disastrous for marine structures.

Natural durability

According to the European standard [EN 350-1] a five-class system is used to describe the natural durability of wood and wood-based products to wood-destroying fungi:

1. very durable
2. durable
3. moderately durable
4. slightly durable
5. not durable.

[EN 350-2] lists the natural durability of solid wood for selected wood species which are important for design and construction. Examples are shown in Table 2.2.

Table 2.2 Natural durability classes for certain species

Wood species	Durability class
Ash	5
Azobé	2
Birch	5
Beech	5
Douglas	3–4
Oak, European	3
Oak, American	4
Greenheart	1
Larch	3–4
Merbau	1–2
Scots pine	3–4
Fir	4
Sitka	4–5
Thuja, North American	2
Thuja, European	3
Western Red Cedar	2
Wallaba	1
Sapwood, all species	5

Table 2.3 Definition of hazard classes according to EN 335-1

Hazard classes (biological use class)	Typical service conditions	Examples
1	Wood indoor in dry conditions	Furniture, wall panels
2	Wood not directly exposed to outdoor climate or ground contact, but brief wetting is possible	Roof structures. Wood outdoor under cover
3	Wood exposed to outdoor climate and condensation, but without ground contact and not permanently wet, provided damaged wood may be replaced without significant problems and provided consequences of failures are small	3.1 Windows and exterior doors 3.2 External claddings and garden components above ground
4	Wood in permanent contact with ground or freshwater or especially exposed to weather. Parts critical to safety that may be difficult to replace	Poles for overhead lines, sleepers, fence posts, wood flag stones, exterior stairs and balconies, beams in crawl spaces, sills on foundation walls
5	Wood in saltwater and parts having special requirements for strength and durability	Quay wharfs, moorings, poles

[EN 335-1] defines five hazard classes, also called biological use classes. They are described in Table 2.3. It should be noted that the hazard classes are not the same as service classes which take into account only the influence of the moisture content on the strength and stiffness properties.

Design for durability

Fungi attacks can be avoided if the wood is dried immediately after cutting and kept dry during all phases of the construction and in use. This is possible by proper design and construction which is called 'Design for durability'. Examples are given in Table 2.4.

Table 2.4 Examples of design for durability

Protect outdoor structures from getting wet, e.g. by effective roof overhangs and eaves

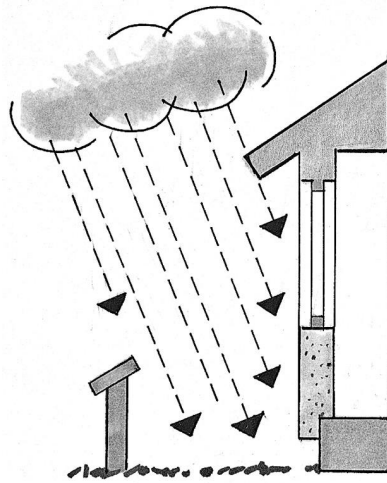

Ensure external surfaces are treated properly to repel water and dirt

Slant-cut top of members exposed to weather so that water can run off

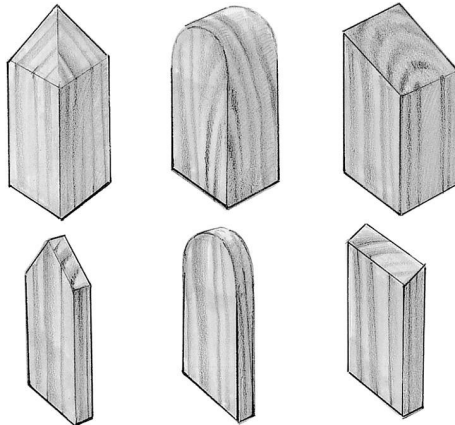

Cover ends of posts and cantilevered beams

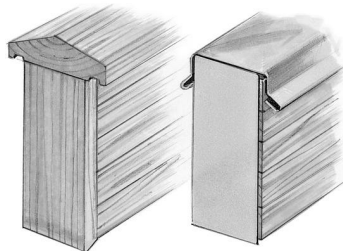
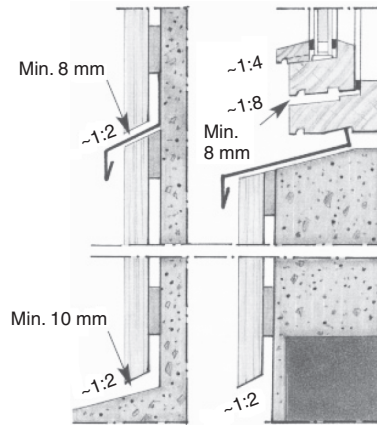
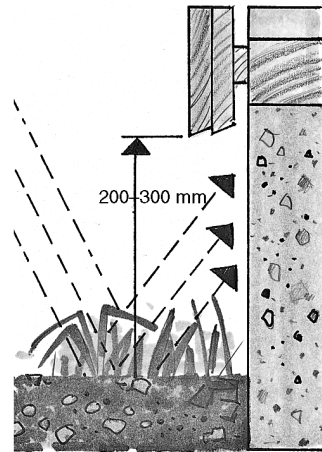

Table 2.4 Continued

Use drip trays or ledgers so water can run off



Keep wooden members away from ground and vegetation



Make sure the pith side is outwards as the heartwood is more durable than sapwood, the pith side gets fewer fissures and it is a better base/surface for painting

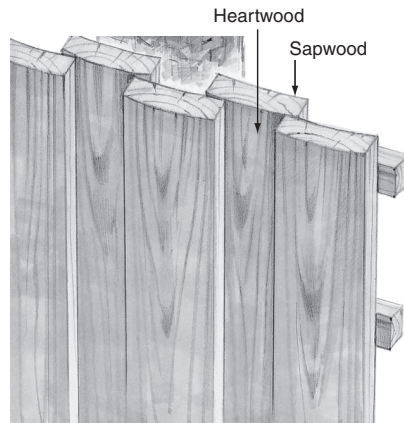
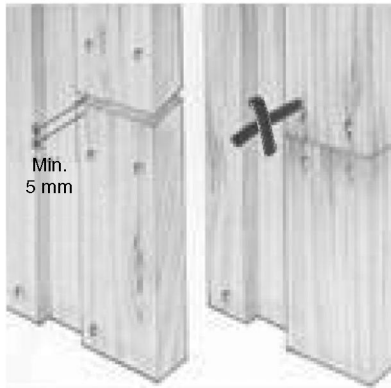
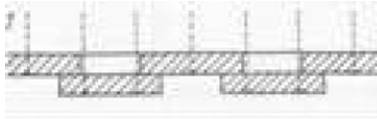

Table 2.4 Continued

Use vertical claddings so water can run off and not become trapped



Ensure that the wood can move freely; use overlap joints rather than butt joints



Nail correctly in order to reduce cracks around the nails
Nail heads shall just be flush with the surface of the wood member

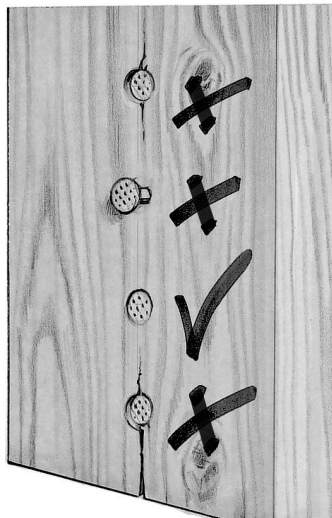

Chemical wood protection

Where it is not possible by other means to prevent decay of timber by fungi and insects etc., wood should be chemically treated by pressure or vacuum impregnation.

Pressure impregnation

Pressure impregnation is a process whereby wood is placed in a pressure cylinder and a vacuum is created to extract air out of the cells before the cylinder is filled with preservative liquid and exposed to high pressure for a period of time. The wood is then dried and the preservative agents are fixed to the wood and become insoluble. Note: The wood should not leave the plant before the preservative agents are fully fixed.

The active preservative agents are organic fungicides and heavy metal salts dissolved in water. In the past the active agents were based on copper, chromium and arsenic (CCA). Nowadays however, arsenic and chromium are prohibited in most European countries because they may cause allergies and cancer. They are replaced by less harmful copper compounds.

Creosote is also used to preserve timber, especially for poles and railway sleepers. However, impregnation with creosote is no longer permitted in some European countries, although the creosote treated products may be used.

Vacuum impregnation

The penetration of the preservative that is decisive for the protection depends on the preservative and the wood species. For some species it is possible to fully penetrate the wood or at least the sapwood. This is the case for the sapwood of fir, larch and Douglas, but not for heartwood that has high natural durability.

Spruce is very difficult to treat because the penetration both in its sapwood and the heartwood (which is not very durable) is only a few millimetres; therefore spruce is not normally treated.

Pressure-impregnated wood shrinks and swells as untreated wood. Therefore, it should be dried to a moisture content corresponding to the environmental conditions of its end-use and service life. It should be noted that pressure treatment may reduce the strength of wood. The producers shall declare the reduction if it is more than 10%.

Vacuum impregnation is a process developed for components (i.e. doors, windows, façade elements, etc.).

In the vacuum treatment, the penetration in the sapwood is about 5–10 mm from the surface and about 50 mm from the ends.

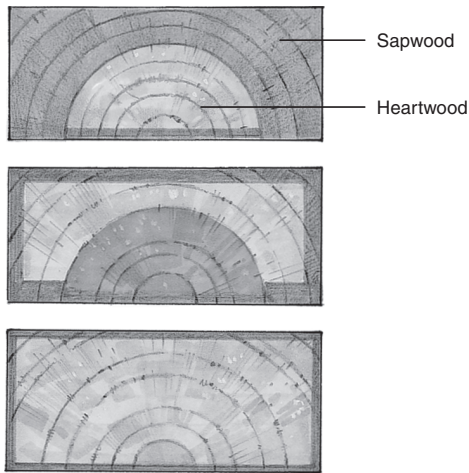

Fig. 2.8 The extent of penetration by (from top): pressure treatment, vacuum treatment, surface treatment

Vacuum-impregnated structures should not be processed or shaped (machined) after treatment. The same applies in principle to pressure-treated wood, because there is a risk of exposing small unprotected zones in the border between the pith and the core.

Figure 2.8 shows the extent of penetration by pressure, vacuum and surface treatment.

The recommended protection depending on the hazard classes and durability classes in accordance with [EN 460] is shown in Table 2.5.

Table 2.5 Guide for selection of materials according to [EN 460]

Hazard classes (biological use class)	Durability class				
	1	2	3	4	5
1	•	•	•	•	•
2	•	•	•	(•)	(•)
3	•	•	(•)	(•)–(i)	(•)–(i)
4	•	(•)	(i)	i	i
5	•	(i)	(i)	i	i

- Durability acceptable
- (•) Durability normally acceptable
- (•)–(i) May be acceptable
- (i) Impregnation normally advisable
- i Impregnation necessary

Note: Judgement depends on the degree of exposure and the surface treatment.

CEN has published standards for treated timber where nine classes are distinguished and are very open to methods and preservatives. Guidance should be sought from the producers.

Heat treatment

Heat treatment with temperatures about 200°C in closed tanks may increase durability. Heating causes sugar ingredients in the wood to be broken down and changed to tar compounds colouring the wood brown and increasing moisture stability and durability against fungi. The strength and stiffness are reduced by 10–30%. Heat-treated wood is marketed as an environmentally friendly product for façades, playgrounds and garden furniture and accessories. As understanding of its durability and performance in use is still in its infancy, the suppliers recommend using a surface treatment similar to those used for untreated wood for the time being until more experience is gained from its performance in service.

2.1.5 Fire

Wood is classed as a combustible material but it has in many respects good fire properties because its behaviour is predictable and the reduction of strength and stiffness is slow. With the introduction of performance-based building regulations it is now possible to build wooden houses up to four, five, six and seven stories high in certain European countries. The UK Standard [BS 5268: Part 6] now provides guidance for building timber-frame dwellings up to seven storeys high, which is the result of a prestige research project called TF2000 (see Enjily, 2001) carried out jointly by the Building Research Establishment (BRE), Timber Technology Ltd (TTL) and industry.

To be able to assess the behaviour of building products during fire, they are classified based on their contribution to fire, smoke generation and giving off of droplets and particles:

- their reaction to fire, which is specially important for cladding and wood-based panels
- their resistance to fire.

Reaction to fire is determined according to [EN 13823]. According to this standard, building products are classified in the following classes, based on:

- Classes A to F (Class A covers products that do not contribute to fire (i.e. non-combustible materials)).

- Classes s1 to s3 for their smoke generation (where s1 is the best i.e. generates less smoke).
- Classes d0 to d2 for the giving-off of burning droplets and particles (where d0 is the best i.e. gives less burning droplets and particles).

Structural timber with a minimum mean density of 350 kg/m^3 and a minimum thickness of 22 mm is, without further testing, classified as:

- Class D: Building products whose contribution to fire is acceptable.
- Class s2: Limited smoke generation.
- Class d0: No burning droplets or particles.

The following notations are used for European reaction to fire in terms of their performance criteria:

- R for structural resistance
- E for integrity
- I for isolation.

The measured time for maintaining the required performance under a standardised fire test is expressed in minutes, e.g. 30, 60, 90, 120. It is also possible to combine the classes, for example RE30 means that both load-carrying capacity and integrity are maintained for 30 minutes.

Wood and wood-based panels can be classified as Classes 0, 1 and 2 (Classes 0 and 1 can be achieved by treating them with fire-retardant chemicals). European classification can be obtained in accordance with [EN 13501-2] using the fire resistance test data.

The fire resistance may be verified by testing and calculations according to [EN 1995-1-2], [BS 476], and [EN 13501-2]. However, there are other ways of demonstrating fire resistance by calculations to [BS 5268-4], Section 4.2 and [BRE Report BR128].

Reaction to fire may be verified by testing according to [BS 476-6], [BS 476-7] and [EN 13823].

Joints with steel parts may be weak spots in the structure if not designed properly, not only because the steel strength is temperature sensitive but also because the steel transmits the heat into the wood. Joints with unprotected steel parts cannot be assumed to have a fire resistance of more than 15 minutes. However, steel parts in joints may be protected by countersinking them into the wood or by covering them with plasterboard or other board materials.

The fire resistance and reaction to fire of timber may be improved by surface or pressure treatment using fire retardants which delay the fire rather than prevent the wood from burning completely. It should be

noted that it is cheaper to increase the sizes of timber members (for higher fire resistance) rather than using fire retardants, especially in heavy structures. Fire-retardant impregnation reduces the strength and stiffness of timber, especially in some products that are hygroscopic, and they may cause damp and salt spots in rooms with varying RH.

2.2 Structural timber

2.2.1 Sawing and marketing

Sawing

Structural timber (i.e. solid timber that has been strength graded) has in most cases a rectangular cross-section (sawn/cut on four sides), see Fig. 2.9.

The sawing starts with two or more parallel cuts along the length of the log, giving waste side-boards and a centre block. The centre block is then turned 90° and split with two or more parallel cuts into waste side-boards, boards and planks. Other sawing patterns may also be used to obtain cut members with certain shrinkage or appearance properties. Examples are shown in Fig. 2.10.

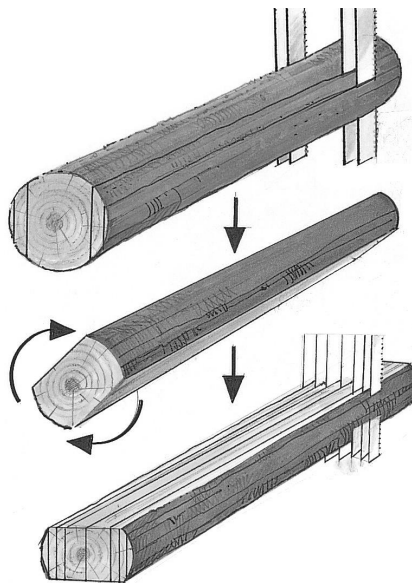

Fig. 2.9 A typical sawing practice for solid timber

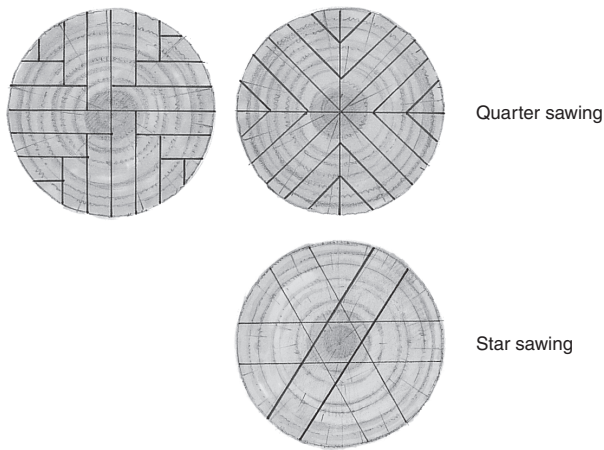

Fig. 2.10 Sawing patterns

Standard sizes

Specifications of sizes for structural timber are based on target sizes and tolerances. Target sizes are the actual sizes used in design calculations and are therefore the size required from the supplier, with no deviations outside the specified tolerance class being permitted. Two tolerance classes are specified in EN 336:

1. For tolerance class 1 the acceptable deviations are -1 mm to $+3$ mm for thicknesses and widths less or equal to than 100 mm and -2 to $+4$ mm thereafter.
2. For tolerance class 2 the acceptable deviations are -1 mm to $+1$ mm for thicknesses and widths less than or equal to 100 mm and -1.5 to $+1.5$ mm thereafter.

If graded timber is machined beyond these limits, it should be regraded and its size reclassified.

Timber structures can be designed using any size of timber. However, since producers are not normally aware of the specific end use of timber at the time of production it has become practice to produce a limited range of sizes, which have therefore become the most readily available sizes in the UK. These commonly available sizes are listed in Table 2.6. Unless otherwise specified, sawn timber will meet the requirements of tolerance class 1.

Timber is often machined (processed) on two opposing sides or on all four sides to get more precise dimensions meeting tolerance class 2.

Table 2.6 Commonly available target sizes of sawn softwood timber

Thickness: mm	Width: mm									
	75	100	125	150	175	200	225	250	275	300
22		✓	✓	✓	✓	✓	✓			
25	✓	✓	✓	✓	✓	✓	✓			
38	✓	✓	✓	✓	✓	✓	✓			
47	✓	✓	✓	✓	✓	✓	✓	✓		✓
63		✓	✓	✓	✓	✓	✓			
75		✓	✓	✓	✓	✓	✓	✓		✓
100		✓		✓		✓		✓		✓
150				✓		✓				✓
250								✓		
300										✓

Note: Certain sizes may not be obtainable in the customary range of species and grades.

Timber is often planed (processed) on one or more sides for the sake of appearance, use and more uniform sizes. Planing on two opposite sides will result in the following size losses:

- 22–100 mm: 3 mm (4 mm) or where the surface quality is especially important 4 mm.
- 120–300: 5 mm.

The number in brackets applies if there are special requirements to the surface quality and straightness. If only a thickness adjustment is needed, the loss will be about 2 mm for all sizes.

Boards for formworks or underlay boards for roofing felt are often only planed on one of the wide sides. The planing shall only ensure that the boards have a uniform thickness.

A complete specification of sizes may read: 35 (T2) · 100 (T1) or 38 (T1) · 145 (T2).

Commonly available North American timber (lumber) sizes (to tolerance class 2) are shown in Table 2.7.

Standard lengths are a multiple of 0.3 m, with a minimum length of 1.8 m. Lengths up to 5.4 m are common, but lengths up to 7.2 m can be obtained at cost. Lengths of 5.7 m and over may not be readily available without finger jointing. Minus tolerance on lengths are not permitted.

For special purposes, timber boards are only cut on the two wide sides. They have higher bending strength than ordinary sawn boards because

Table 2.7 Commonly available softwood structural timber surfaced to the Canadian Lumber Standard (CLS)/American Lumber Standard (ALS) sizes

Thickness: mm	Width: mm					
	63	89	114	184	235	285
38	✓	✓	✓	✓	✓	✓

Note: CLS/ALS surfaced structural timber has rounded arises not exceeding 3 mm radius.

the wood fibres are not cut and are often used in scaffolds. Tongue-and-groove edging is used to ensure connection between boards. The tongue and grooves for planks used in sheet piling may be shaped as shown by the left diagram in Fig. 2.11.

Normal planks and timber often have waness. In cases when this is not acceptable it is necessary to specify square-edged cross-section, which can be expensive.

2.2.2 Strength classes

General

Wood is a natural material with strong variation in its material properties such as density, stiffness and strength. To ensure a more uniform quality, timber is graded. The aim of the grading may be to achieve a desirable appearance; this is relevant for joinery, or to ensure a specified strength and stiffness.

The grading may be either visual (i.e. based on an assessment of the growth defects visible on the surface) or mechanical (machine). The two methods may also be combined. The most common mechanical strength grading methods are based on the simple statistical fact that strength and stiffness are correlated. Machine grading may therefore be performed by loading a piece of timber in bending (for practical

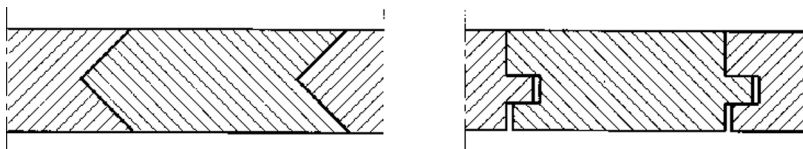

Fig. 2.11 Planks for sheet piling and ordinary tongue-and-groove plank

reasons about the weak axis) and measuring the deflection or by measuring the force necessary to obtain a specified deflection. There are also other grading machines which expose the timber to vibrations or use gamma rays.

Most timber-producing countries have national visual grading rules linked to local traditions for use, sawing practice or wood species and it has not been possible to agree on common European rules. There is, however, a European standard, [EN 14081-1], describing minimum requirements to visual grading standards.

The optimum utilisation is obtained by giving strength and stiffness values for each species and grade, but this is not practical. Normally several species and grades are used, often mixed. Therefore, a system with strength classes has been established. A strength class is defined by the characteristic values for the most important properties, normally bending and compression strength and modulus of elasticity. Based on tests, a species and grade is then referred to a strength class if its basic properties are equal to or better than the class values. For the other properties, such as tension and shear conservative values are used.

The European strength class system is described in [EN 338]. For softwood it covers nine classes with characteristic bending strengths between 14 and 30 N/mm². For hardwoods there are six classes with characteristic bending strengths between 30 and 70 N/mm². In the UK the most common softwood classes are: C16 and C24. The C indicates softwood (conifer), while hardwoods are denoted D (deciduous). The values refer to the characteristic bending strengths in N/mm². The characteristic values for some classes according to [EN 338] are given in Table 2.8. While characteristic values for some hardwood strength classes are given in Table 2.9 together with examples of species belonging to the classes.

Marking

Each structural timber piece shall be marked. The following information shall be given in the mark or in accompanying documents:

- Year of marking.
- Name or identifying mark (logo) of certification body/grading company.
- Company or grader's reference.
- Species: type of timber graded.
- Grading code: the code on which grading was based.

Table 2.8 Softwood, characteristic strength stiffness and density values

Strength class	C30	C27	C24	C18	C16	C14
Strength values in N/mm ²						
bending	$f_{m,k}$	27	24	18	16	14
tension in the fibre direction	$f_{t,0,k}$	16	14	11	10	8
tension perp. to the fibre direction	$f_{t,90,k}$	0.6	0.5	0.5	0.5	0.4
compression in the fibre direction	$f_{c,0,k}$	22	21	18	17	16
compression perp. to the fibre direction	$f_{c,90,k}$	2.6	2.5	2.2	2.2	2.0
shear	f_{tk}	3.0	2.5	2.0	1.8	1.7
		(4.0)*	(4.0)*	(3.4)*	(3.2)*	(3.0)*
Stiffness values in N/mm ²						
E parallel, mean	E_0	11 500	11 000	9000	8000	7000
G , mean	G	720	700	600	500	500
Density in N/mm ²						
mean	ρ_{12}	450	420	380	370	350
characteristic	$\rho_{12,k}$	370	350	320	310	290

Note: The most common grades in the UK are in bold.

* The values in () are under discussion in CEN at the time of publication and will probably be accepted as the final figures by the end of 2009.

Table 2.9 Hardwoods, characteristic strength stiffness and density values

Strength class		D30	D40	D60	D70
Examples of species		Oak	Beech Basralocus	Azobé	Greenheart
Characteristic strength values N/mm ²					
bending	$f_{m,k}$	30	40	60	70
tension in the fibre direction	$f_{t,0,k}$	18	24	32	32
compression in the fibre direction	$f_{t,90,k}$	23	26	32	34
compression perpendicular to the fibre direction	$f_{c,0,k}$	8	8	8	8
Mean stiffness values N/mm ²					
E parallel to the fibre direction	E_0	10 000	11 000	17 000	20 000
Density kg/m ³					
Characteristic	$\rho_{12,k}$	530	590	700	900

- Grading condition. Dry if the timber has intentionally been graded at a mean moisture content of 20% or less, without any measurement exceeding 24%.
- Bending strength, compression strength, tension strength, shear strength and modulus of elasticity. Normally by reference to one of the strength classes of [EN 338], e.g. C16, C24.
- Reaction to fire. For softwood with a minimum density of 350 kg/m³ and a minimum thickness of 22 mm: class D-s2,d0.
- Durability. For timber not treated against biological attack, one of the classes 1-5 in [EN 350-2] or NPD (no performance determined) which means that the durability is not determined. For treated timber, information about the treatment can be found in [EN 15288].

An example of a mark is shown in Fig. 2.12; the markings are explained as follows:

Grading company (EHAB).

General structures (GS).

Strength class (C16).

Reference number (S1 1 1V).

Species of timber (EW/ER – European whitewood or redwood).

The British Standard on which the grading has been based [BS 4978].



Fig. 2.12 Example of a mark

2.3 Glulam

2.3.1 Introduction

Glulam (glued laminated timber) is produced by gluing thin wood lamellas together on their wide faces to produce members with sizes limited only by the production facilities and transport considerations.

Since the starting-point is thin flexible lamellas, it is possible to produce curved members that would be expensive for other materials. Examples of structures and typical beam sizes are given in Chapter 3.

Production and delivery

Production is shown schematically in Fig. 2.13.

The basic material is strength-graded boards dried to a uniform moisture content of about 12%. The boards are planed and their ends are finger-jointed and glued to produce long boards (laminations or lamellas), see Fig. 2.14.

The end-jointed lamellas are cut in lengths corresponding to the member length. Glue is applied on the faces of lamellas and these are placed in a jig and pressed together. For curved members, the jig is made by bolting vertical posts to the base, corresponding to the form of the component (Fig. 2.15) and the clamping pressure is applied by bolts. Straight beams are normally pressed by hydraulic presses in stationary jigs.

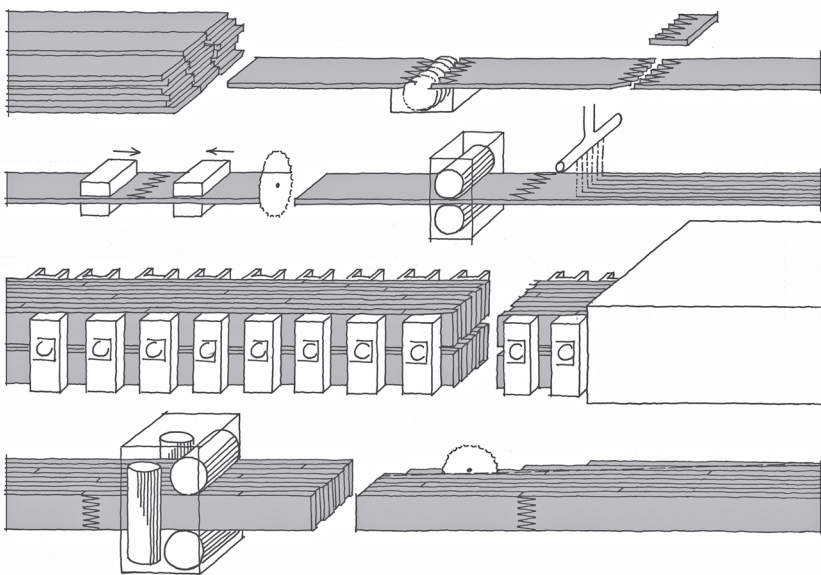

Fig. 2.13 Production process for glulam members

The clamping pressure shall be maintained until the glue is cured. To obtain a shorter curing time and a more reliable curing, the temperature in the curing chamber is normally increased to about 40°C or the glue lines are heated by high-frequency excitation. After curing, the components are finished by clean cutting on depth, planing on the wide faces, shaping, surface treatment, mounting of fittings, etc. Most glulam members are produced from Norway spruce because it has good strength properties and a light and uniform appearance. Also its moisture

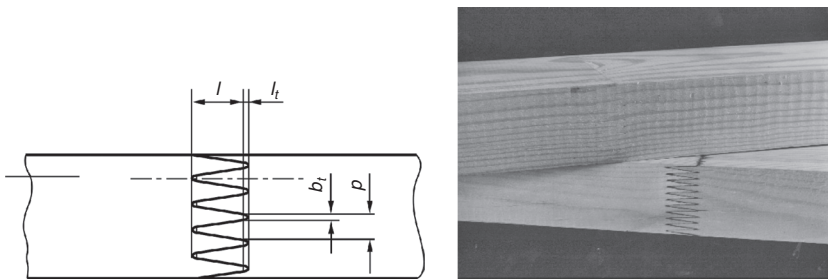

Fig. 2.14 Finger joint. p = pitch, l = finger length, b_t = tip width, l_t = tip gap. The top board has finger joints with colourless glue on the wide face

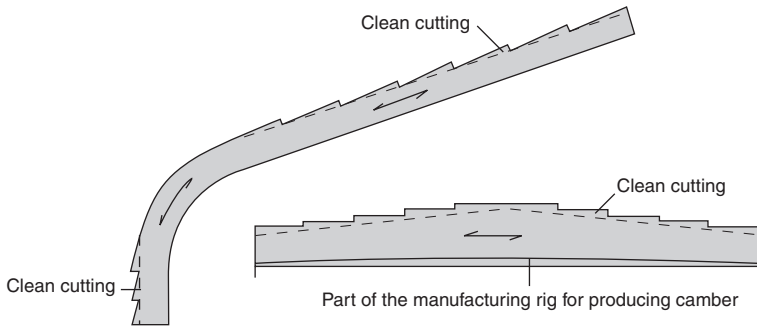

Fig. 2.15 Plan view of production of curved structure and beam with varying height

changes are rather slow, and shrinkage and swelling are moderate. However, spruce has low natural durability and is difficult to impregnate. For moist environments, pressure-treated fir is sometimes specified but the improvement is only small and rarely worth the extra cost. The heartwood and the impregnated parts of the sapwood are of course durable but there is a risk that small unprotected areas of sapwood in the border areas are exposed by planing of the lamellas.

The glues used in glulam are at least as durable against weather, moisture and fire as the wood used and they do not give off harmful agents, even when burned. Traditionally, resorcinol glues that give a dark glue line have been regarded the best and most durable, but the use of colourless polyurethane glues is increasing because of appearance requirements by architects. In service classes 1 and 2, it is also permitted to use the cheap melamine-urea glues if it can be guaranteed that the temperature in the structure will not exceed 50°C. They also give almost colourless glue lines.

In principle, glulam beams can be produced with any rectangular cross-section and even I-shaped. In most cases the most economical solution is, however, a solid rectangular cross-section with one of the standard widths 65, 90, 115, 140, 160 or 185 mm (Scandinavian practice, based on Imperial sizes) or 60, 80 . . . 200 mm (Continental European practice). They correspond to the widths of boards with a planing loss of 10 mm for widths up to 150 mm and 15 mm for wider boards. Beams wider than 185 mm are normally produced by gluing two or more boards side by side (see Fig. 2.16). The top and bottom laminations are edge glued; the others are just placed side by side. Wide beams are more difficult to produce and therefore more expensive. Beams

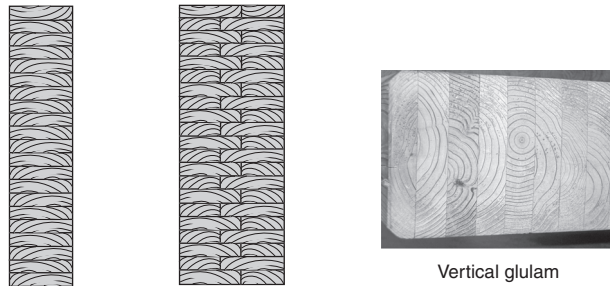

Fig. 2.16 Cross-sections of glulam beams

with width 65 mm or less are normally produced by sawing of wider beams along their lengths. This gives an unfavourable knot pattern and the strength values should be reduced by 20%.

For beams it is economical to choose a high ratio between depth h and width b . The higher the h/b ratio, the more important it becomes with an effective bracing to avoid lateral instability. With a normal bracing, a ratio up to 6–7 may be used.

To reduce moisture stresses the laminations should be used with their pith in the same direction through the thickness. However, because of the increased risk of splits of the sapwood, both top and bottom laminations are normally placed with their pith outwards.

To reduce stresses in curved beams when the laminations are pressed in place, the lamination thickness t should not exceed t_{\max} :

$$t_{\max} = \frac{r}{250} \left(1 + \frac{f_{m,k}}{80} \right) \quad (2.4)$$

where r is the radius and $f_{m,k}$ the characteristic bending strength of the lamination. The maximum lamination thicknesses depending on bending radius are shown in Table 2.10.

Table 2.10 Maximum lamination thickness (t) depending on bending radius r

Glulam	max t
GL36	0.006 r
GL28	0.0055 r
GL24	0.0052 r

Table 2.11 Glulam tolerances according to [EN 390] at 12% moisture content

Width	+2 mm	All widths
	-2 mm	
Depth	+4 mm	$h \leq 400$ mm
	-2 mm	
	+1%	$h > 400$ mm
	-0.5%	
Length	+2 mm	$l \leq 2.0$ m
	-2 mm	
	+0.1%	$2.0 \text{ m} < l \leq 20$ m
	-0.1%	
	+20 mm	$20 \text{ m} < l$
	-20 mm	
Cross-section angle	Deviation from right angle	$\leq 1:50$

Unless otherwise agreed, glulam is delivered with the tolerances given in Table 2.11.

The sizes of glulam members are limited by the production equipment and the time permitted from glue application on the first lamination to finished clamping. Normally members with volume over about 10 m^3 and more than 25 m long will require special measures. The size may also be limited by transport restrictions. The height from the road to the top point of the load is normally limited to 4.95 m, see Fig. 2.17, and normal allowable overhang is 3.5 m, 2.00 m and 1.00 m at rear, front and sides respectively. Anything outside these limits and lengths over 35–40 m require special permissions.

Camber may be used for beams to compensate for the deflections. Since the correct camber depends on factors normally not known by the producer, beams are delivered without camber, i.e. with straight underside, unless otherwise specified by the client.

Glulam factories shall be subject to third-party external control. The control shall comprise:

- grading and moisture content of the laminations

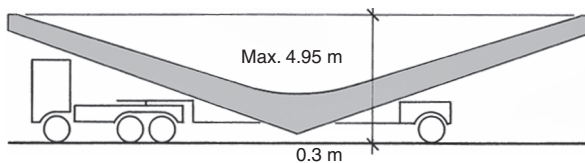

Fig. 2.17 Size limits by road transport

- strength of finger joints
- quality of the lamination planing
- mixing and application of glue
- gluing times and clamping
- curing conditions, temperature and air moisture content
- glue line quality.

The strength of finger joints shall be controlled regularly by bending tests to failure. The glue line quality is controlled by so-called delamination tests where 100 mm long cut-offs are impregnated with water under high pressure and then dried fast. The length of delaminated glue lines is taken as an indication of the glulam quality.

Delivery and handling on site

Glulam beams are normally delivered on trucks with a crane that may be used to offload and also to erect light structures. Glulam shall be handled with care on site and checked to ensure it has not been damaged during transport and handling. Glulam is often delivered wrapped in plastic as a protection against water and soil. If there is water under the plastic, e.g. from condensation, the glulam may be discoloured due to mould and the plastic should be removed so the wood may dry. For outdoor storage the glulam shall be stacked on a flat and dry support base and protected against the rain. To ensure ventilation, battens shall be placed between the glulam beams and under the covering. The battens shall be placed vertically above each other otherwise the members may be permanently deformed by prolonged storage.

2.3.2 Properties

Moisture-related properties

Glulam is regarded as more moisture stable than timber because it is delivered dry and moisture changes are slower due to the larger dimensions.

Sun exposure may result in a rapid drying out at the surface. This may lead to surface cracks and with time to destruction of the surface. Cantilevered beam-ends, especially south facing, require special protection (see Fig. 2.18).

The moisture content at delivery is about 12%. If glulam is exposed to moisture, e.g. if stored outdoor during winter, the moisture content may

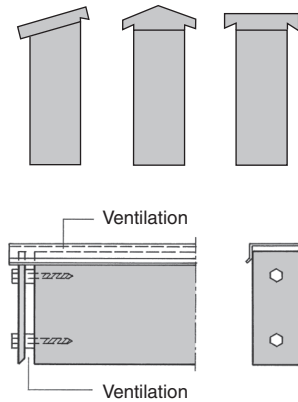

Fig. 2.18 Examples of protection of cantilevered beams by profiled boards or metal plates

increase to 18–20%. If glulam is built in with this high moisture content it is important that the building is not suddenly heated to high temperature since this may lead to severe cracking because the wet core will prevent shrinkage of the outer part of the members.

Density

A density of 500 kg/m^3 or more should be assumed when calculating dead load from glulam structures.

Strength and stiffness

Glulam has higher mean strength and smaller variation than ordinary timber. EN 1194, *Timber structures – Glued laminated timber – Strength classes and determination of characteristic values*, gives strength classes for glulam. There are four classes for so-called homogeneous glulam and four for composite glulam. In homogeneous glulam the lamination quality is the same in the whole cross-section. In composite glulam the lamination quality in the middle two-thirds may be of a lower class than outer laminations. The classes are denoted GL (glulam) followed by the characteristic bending strength in N/mm^2 and by h for (homogeneous) or c for (composite). The characteristic strength and stiffness values are given in Table 2.12.

For rectangular cross-sections the reference depth in bending and width in tension is 600 mm.

Table 2.12 Characteristic strength and stiffness values for glulam

Glulam class	GL24		GL28		GL32		
	h	c	h	c	h	c	
Strength: N/mm ²							
bending	f_m	24	24	28	28	32	32
tension, parallel	$f_{t,0}$	16.5	14	19.5	16.5	22.5	19.5
compression, par.	$f_{c,0}$	24	21	26.5	24	29	26.5
compression, perp.	$f_{c,90}$	2.7	2.4	3.0	2.7	3.3	3.0
Shear	f_v	2.7	2.2	3.2	2.7	3.8	3.2
Mean stiffness: N/mm ²							
E_{mean}	E_0	11.6	11.6	12.6	12.6	13.7	13.7

For smaller depths and widths, h , the bending and tension strengths may be multiplied by:

$$k_h = \min \left\{ 1.1, \left(\frac{600}{h} \right)^{0.1} \right\} \quad (2.5)$$

Since the bending properties depend especially on the properties of the outer laminations it is assumed that the load-carrying capacity of a glulam column is the same for homogeneous and composite glulam.

For glulam loaded in tension or compression without column effect the strength of composite glulam is smaller than for homogeneous. Normally the producers will deliver composite glulam. If the higher axial strength is needed, it is necessary to specify homogeneous glulam.

Specifications

In addition to requiring that glulam shall be produced according to [BS EN 14080]. The following should be specified:

- special requirements to wood species, e.g. fir
- any special requirements to glue, e.g. colourless glue to finger joints or in general
- any special requirements to moisture content
- any special requirements to lamination thickness
- any special requirements to protection against biological attacks.

2.4 Wood-based panel products

2.4.1 Introduction

Wood-based panels play an important role for timber structures, for example as:

- floors and roofs
- underlay for flooring and roofing
- stabilising walls and roofs (bracing)
- webs and flanges in I- and box-beams
- gusset plates
- diaphragms.

The first wood-based panel product produced was plywood in about 1900. Plywood was in the beginning produced with joiner's glues such as animal and casein glues, which had little moisture resistance. Later, around 1930, particleboards were produced using the first synthetic glue (urea formaldehyde). Wood fibreboards were introduced a short while after particleboards.

2.4.2 Plywood

Production

Plywood is made by gluing together 1.5–3 mm thick plies (veneers), usually with their grain direction perpendicular to each other (see Fig. 2.19). The direction parallel to the grain direction of the outer plies is called the panel grain direction. The plies perpendicular to this direction are called cross-ply. In plywood with an even number of plies, the fibres in the two middle plies are parallel.

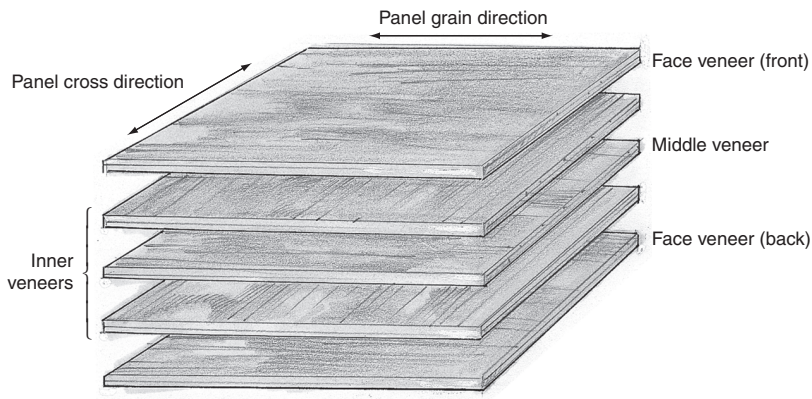

Fig. 2.19 A typical layout of plywood

Structural plywood is mainly made from spruce, fir and birch. Different species and qualities are also used, e.g. one species for the outer plies and another for the inner (combi plywood) or a better quality for the outer plies. To avoid bow, plywood shall be symmetric about the middle plane, both with regard to thickness of the veneers and their material properties.

Plyies are rotary peeled from straight logs with large diameter. The logs are cut in lengths that correspond to the final pressing plate length. After softening by water storage, timber logs are mounted in the mill so that they can rotate about their central axis. By pressing a knife against the log a long thin veneer sheet is cut out. The veneer is dried and cut in smaller lengths that are graded in different quality classes. If necessary, defects are cut out and repaired by glued-in patches. Glue is applied on veneers and the sheets are pressed together in a hot press. After pressing, the panels are climatised and cut to the desired dimensions. The panels may be sanded to improve appearance. For structural plywood, sanding may be a doubtful advantage because it is often made so imprecise that one of the outer plies is removed partially or completely.

According to [EN 314-2], a distinction is made between three gluing classes:

- class 1: only for use in dry indoor condition (Service class 1)
- class 2: for use in outdoor condition if protected against direct weather and water, and in moist indoor climate (Service class 2); the glue is resistant to direct water exposure for a limited period of time, e.g. during construction
- class 3: for use in outdoor conditions (Service class 3).

Plywood is produced in three corresponding classes according to standard [EN 636].

Properties

Because of the crossing fibres, moisture-related deformations in the panel plane are only slightly larger than for wood in the grain direction. The following free shrinkage/swelling strain values may be used for a unit percentage change in moisture content:

- in the thickness direction: about 0.2%
- in the length direction: about 0.010% (~ 0.1 mm/m)
- in the cross direction: about 0.015% (~ 0.15 mm/m).

In principle the strength and stiffness properties for plywood may be estimated by the usual methods for composite materials based on the geometry, the material properties and fibre orientation of the individual veneers. It can, however, only be a rough estimation and the structural properties shall be verified through tests.

Plywood products

The panel surfaces are normally untreated, but they may be sanded, sandblasted or profiled. The top ply may be plugged or filled to make the surface smooth; this is important if the plywood is to serve as underlay for thin flooring or roofing. Plywood may be surface treated or coated and the outer plies may be impregnated with polymers. Peeled plywood has a tendency to acquire fine surface fissures. They have no influence on the strength properties of the final product but may be visible through paints; this, however, may be counteracted by applying a film to the outer surfaces during production. Structural plywood is mainly imported from Scandinavian countries, Canada and the USA. With the exception of Finnish birch plywood there are only small differences between the products from these countries.

The standard dimension for European plywood is 1200 · 2400 mm and for plywood from the USA is 1220 · 2440 mm. Panels with tongue-and-groove edges are about 15 mm smaller. Normal thicknesses vary from about 8 to about 30 mm.

Strength and stiffness

The properties vary considerably and it is necessary to obtain the specific properties from the producer. As an example, for Europly plywood, available throughout most of Europe, the values in Table 2.13 may be used.

The shear strengths and stiffnesses for all thicknesses are:

$$f_{v,k} = 3.2 \text{ N/mm}^2$$

$$f_{v,rolling,k} = 0.9 \text{ N/mm}^2$$

$$G = 500 \text{ N/mm}^2$$

The mean density is 400 kg/m³.

There are two essentially different shear types. One of the shear types is when plywood acts as a panel or diaphragm (see Fig. 2.20). The panel shear strength is denoted f_v . The other type is when the plywood is

Table 2.13 Characteristic strength and mean stiffness values for Europly

Thickness: mm	No. of plies/ veneers*	Characteristic strength values: N/mm ²				Mean stiffness values: N/mm ²			
		Bending		Tension and compression		Bending		Tension and compression	
		$f_{m,0,k}$	$f_{m,90,k}$	$f_{t,0,k}$	$f_{t,90,k}$	$E_{m,0}$	$E_{m,90}$	$E_{t,0}$	$E_{t,90}$
9	5/5	20	10	15	10	9750	1800	6000	3850
12	5/5	26	15	15	13	7000	3100	5900	4650
15	5/5	18	12	15	10	9400	2800	6100	4100
15	7/7	30	15	14	10	70000	3900	4700	4400
16	7/5	29	11	18	7	8000	1800	7300	2900
16	7/7	20	12	14	10	6400	2600	5800	4400
18	7/7	22	14	14	10	7100	5100	5800	4400
18	9/9	25	12	13	11	8200	3700	5700	4500
19	9/7	25	10	16	12	8900	2300	6800	4700
19	9/9	18	12	14	11	6000	3000	5700	4500
21	7/7	22	12	14	10	8900	4500	5800	4400
21	9/9	23	14	14	11	7600	4800	5700	4500
21	11/11	17	12	13	11	5700	3300	5500	4600

* If number of plies are bigger than number of veneers, the two outer veneers on both sides are glued together with parallel grain directions.

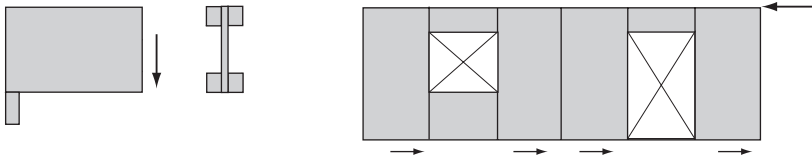

Fig. 2.20 Panel shear in an I-beam and in a wall panel

acting as a slab (see Fig. 2.21). It is called plate shear or rolling shear (because the fibres are rolling on each other), and is denoted $f_{v,rol}$.

Further information about plywood can be found in [Digest 477, Part 4, 2003].

2.4.3 Particleboards

Production

Many types of particleboard are produced for building purposes. The main raw materials in particleboards are wood and glue. Particleboard production is a resource-effective industry process; it uses waste materials from processing of timber, e.g. shaving, sawdust and wood particles from sawmills, furniture and window factories. Thinning chopped into particles is also used. The particles are dried and graded normally into two fractions by sieving: fine shavings for the outside and coarse particles for the interior of the boards. The glue is mixed into the wood particles and the mixture is spread on a steel conveyer belt that passes under another steel belt where the particles are gradually pressed together and heated to the curing temperature (about 250°C). The most common glue types are urea, phenol and melamine formaldehyde. Adhesives based on isocyanate are also used.

In ordinary particleboards the particles are oriented randomly, but it is possible to orient them. This is utilised in the so-called OSB boards

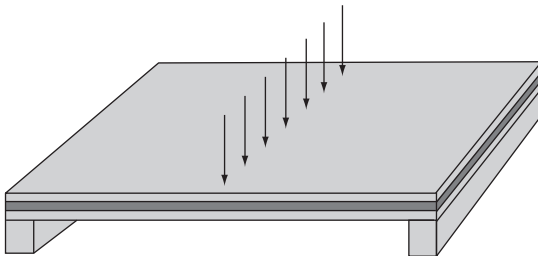

Fig. 2.21 Plate shear (rolling shear)

Table 2.14 Minimum qualities of particleboards in Service classes 1 and 2. (Note that particleboards are not allowed to be used under Service class 3 conditions)

		Service class	
		1	2
EN312			
Type P4	Load-bearing boards for use in dry conditions	✓	–
Type P5	Load-bearing boards for use in humid conditions	✓	✓
Type P6	Heavy-duty load-bearing boards for use in dry conditions	✓	–
Type P7	Heavy-duty load-bearing boards for use in humid conditions	✓	✓
EN 300			
OSB 1	General-purpose boards for use in dry conditions	✓	–
OSB 2	Load-bearing boards for use in dry conditions	✓	–
OSB 3	Load-bearing boards for use in humid conditions	✓	✓

(oriented strand board), a board type developed especially for the building industry. OSB is made with relatively long fibres normally placed in three layers, where the particles in the outer layers are oriented mainly in the board direction whereas the middle layer is oriented mainly perpendicular to them. OSB is thus in principle similar to plywood.

The standard dimension of OSB is 1200 · 2400 mm but it is possible to get board up to 2.7 · 12 m. The thickness range is 6–40 mm. The requirements for ordinary particleboards are given in [EN 312] and for OSB in [EN 300]. The different panel types may be used as shown in Table 2.14.

Properties

The average density varies between 500 and 650 kg/m³ and is highest for thin boards. The moisture-related deformations are considerably higher than for wood and they are only partly reversible because some of the bonds between particles are broken during moisture expansion. This is especially pronounced for the thickness direction. By repeated wetting and drying the boards become thicker and thicker. It is therefore essential that the boards are conditioned to the climatic conditions where they will be used during their service life.

The size changes are almost proportional to the changes in the relative air humidity RH. A change of 10% in RH results in length and width changes of 0.06% (0.6 mm/m) and thickness changes of

Table 2.15 Characteristic strength values and mean stiffnesses in N/mm^2 for particleboard type P7 according to [EN 312]

Thickness, t : mm	Plate bending, $f_{m,k}$	Tension, $f_{t,0,k}$	Com- pression, $f_{c,0,k}$	Shear		Plate bending, E_m	Tension/ com- pression, $E_{t,0}, E_{c,0}$	Density, ρ : kg/m^3
				$f_{v,k}$	$f_{v,rol,k}$			
$6 \leq t \leq 13$	18.3	11.5	15.5	8.6	2.4	4600	2600	650
$13 < t \leq 20$	16.7	10.6	14.7	8.1	2.2	4200	2500	600
$20 < t \leq 25$	15.4	9.8	13.7	7.9	2.0	4000	2400	550
$25 < t \leq 32$	14.2	9.4	13.5	7.4	1.9	3900	2300	550
$32 < t \leq 40$	13.3	9.0	13.2	7.2	1.9	3500	2100	500
$40 < t$	12.5	8.0	13.0	7.0	1.8	3200	2000	500

0.3–0.4% (3–4 mm/m). By soaking in water for 24 hours, the thickness may increase by about 10%.

Strength and stiffness

Examples of strength and stiffness values are given in Tables 2.15 to 2.17. There are, as for plywood, two shear strength values corresponding to panel (panel shear) and plate behaviour (rolling shear).

Further information about particle boards and OSB can be found in [Digest 477, Part 2, 2003] and [Digest 477, Part 1, 2003].

2.4.4 Wood-fibre boards

Production

The raw materials are the same as those for particleboards. There are two production methods: the wet method (the original and most common method) and the dry method. In the wet method, the fibres

Table 2.16 Density (in kg/m^3) and characteristic strength values (in N/mm^2) for OSB/2 and OSB/3 according to [EN 300]

Thickness, t : mm	Density, ρ	Bending		Tension		Compression		Shear	
		$f_{m,0,k}$	$f_{m,90,k}$	$f_{t,0,k}$	$f_{t,90,k}$	$f_{c,0,k}$	$f_{c,90,k}$	$f_{v,k}$	$f_{v,rol,k}$
> 6 to 10	550	18.0	9.0	9.9	7.2	15.9	12.9	6.8	1.0
> 10 to 18	550	16.4	8.2	9.4	7.0	15.4	12.7	6.8	1.0
> 18 to 25	550	14.8	7.4	9.0	6.8	14.8	12.4	6.8	1.0

Table 2.17 Stiffness values (mean values) in N/mm^2 for OSB/2 and OSB/3 according to [EN 300]

Thickness, t: mm	Bending		Tension and compression	
	$E_{m,0}$	$E_{m,90}$	E_0	E_{90}
>6 to 25	9000	2000	3800	2200

are kept and transported in water after the raw material has been decomposed into fibres. Two decomposition processes are used:

1. The 'masonite' method. Wood chips are steamed under high pressure. A sudden removal of the pressure makes the chips 'explode' into fibres.
2. The 'defibrator' method. Wood chips are decomposed by grinding. The fibre mass that contains about 70% water is placed on a net conveyor belt with a layer of sawdust or paper mass on top. The mass is pressed in a stack press. Normally the net is only removed after pressing which leaves a characteristic surface pattern on one side, with the other surface being smooth.

No glue is added but the lignin in the cell walls acts as a thermo-setting glue which is cured by the heat in the press at about $200^{\circ}C$ for 5–10 minutes followed by curing in a chamber at about $165^{\circ}C$ for about 5 hours. When leaving the curing chamber the moisture content is very low and the boards are, therefore, conditioned in a normal-use climate followed by cutting into the required dimensions. Hard oil tempered boards are dipped in or sprayed with oil before curing.

The production of porous fibreboards is simpler. The wood-fibre mass, after being pressed to the chosen thickness, is cured at a temperature of $165\text{--}180^{\circ}C$ and the moisture content is adjusted by sprinkling water on both sides. It is possible to impregnate the boards during the process, e.g. by adding asphalt to the fibre mass or by giving them a surface treatment after curing.

Fibreboards are marketed in many sizes where length and width are multiples of 610 mm, with a maximum dimension of 2.44×6.10 m. For structural boards a distinction based on density is made between hard and medium boards:

- Hard boards have a density above 800 kg/m^3 . Standard thickness are 3.2, 4.8 and 6.4 mm. The requirements for their production are given in [EN 622-2].

Table 2.18 Minimum quality of fibreboard for use in Service classes 1 and 2.
(Fibreboards should not be used in Service class 3)

BS EN				Service class	
				1	2
622-2	Hard boards	HB.LA	✓	–	
			HB.HLA	✓	✓*
622-3	Medium boards	MBH.LA	✓	–	
			MBH.HLS	✓	✓*
622-5	MDF	MDF.LA	✓	–	
			MDF.HLS	✓	✓*

Notes: HB: hard board; MB: medium board; L: for structural use (load bearing); A: all load durations; H: also Service class 2 (humid); S: only short term.

*Not as underlay for roofing felt or foil or in crawl spaces.

- Medium boards have a density of between 600 and 800 kg/m³. Standard thicknesses are 9, 11 and 12 mm. The requirements for their production are given in [EN 622-3].

A new board type is MDF (medium-density fibreboard) which is produced in a similar way to particleboards by mixing glue and a dry fibre mass that is pressed between two hot steel plates. The result is a homogeneous panel with two smooth faces. These boards were originally aimed for the furniture industry but have also found a market in the building sector. The boards may be produced with thickness between 9 and 50 mm. The requirements to their production are given in [EN 622-5]. The density of these boards is about 700 kg/m³.

A board type called HDF (high-density fibreboard) is a traditional wet process board, but with two smooth sides.

Fibreboard and MDF are produced in many qualities (see Table 2.18, which also indicates where they may be used according to Eurocode 5).

Properties

The moisture-related deformations are quite similar to those of plywood. Traditional boards will bow if the moisture content is changed and it is necessary to condition them under pressure to the service life conditions.

Strength and stiffness

Examples of strength and stiffness are given in Tables 2.19 and 2.20.

Table 2.19 Characteristic strengths and mean stiffness and density values for medium-density board

Thickness, t: mm	Strength values in N/mm ²					Stiffness values in N/mm ²			Density: kg/m ³
	Plate bending, $f_{m,k}$	Tension, $f_{t,k}$	Com- pression, $f_{c,k}$	Shear $f_{v,k}$ $f_{v,rol,k}$		Bending, $f_{v,rol,k}$	Tension, $E_{t,k}$	Com- pression, $E_{c,k}$	
≤ 10	7.4	3.9	3.9	2.4	0.13	3100	3100	3100	650
> 10	6.5	3.5	3.5	1.9	0.11	2900	2900	2900	600

Further information about fibreboards may be found in [Digest 477, Part 5] and [Digest 477, Part 6, 2003].

2.4.5 LVL and other wood-based products

LVL

LVL (laminated veneer lumber) is most often made of 2–3 mm thick spruce veneers with a length of 2.5 m and a width of 900 mm. The veneers are dried, graded and placed after glue application on a conveyor belt with the fibres essentially parallel to the panel direction. In some types there are, however, also some cross-plyes to improve the shear strength. The veneer package is fed into a hot press to cure the glue and a continuous panel with thickness of 25–75 mm is formed. The outer veneers are scarf end jointed whereas the inner veneers are butt jointed. Finally, the panels are cut into either panels or beams with depths up to 900 mm and lengths up to 20 m.

Table 2.20 Characteristic strengths and mean stiffness and density values for MDF.LA

Thickness, t: mm	Strength values in N/mm ²					Stiffness values in N/mm ²		Density: kg/m ³
	Bending, $f_{m,k}$	Tension, $f_{t,k}$	Com- pression, $f_{c,k}$	Shear $f_{v,k}$ $f_{v,rol,k}$		Bending, $f_{v,rol,k}$	Tension/ compression, $E_{t,k}/E_{c,k}$	
≤ 12	12.4	9.2	9.2	3.2	4.8	3700	3100	690
12 < t ≤ 19	12.4	8.4	8.4	3.2	4.8	3200	2800	600
19 < t ≤ 30	12.4	7.6	7.6	3.2	4.8	3200	2700	550
30 < t	11.8	6.0	6.0	3.0	3.6	2100	2400	500

Table 2.21 LVL, characteristic strength and stiffness values in N/mm^2 for Kerto

Strength value: N/mm^2		
Bending, flatwise	$f_{m,0,k}$	38
Bending on edge	$f_{m,0,k}$	35
Tension in the fibre direction	$f_{t,0,k}$	27
Tension perpendicular to the fibre direction	$f_{t,90,k}$	7
Compression in the fibre direction	$f_{c,0,k}$	27
Compression against narrow side	$f_{c,90,k}$	12
Compression against wide face	$f_{c,90,k}$	3.5
Panel shear	$f_{v,k}$	5.5
Rolling shear	$f_{v,rol,k}$	1.5
Mean stiffness values: N/mm^2		
Bending flatwise or on edge	E_0	10 000

In Europe, LVL is produced under trade names; for example, in Finland the brand name is Kerto while in Sweden the brand name is Swedlam. They are produced in accordance with [EN 14374]. LVL is used in line with structural timber and glulam. Due to the glued thin veneers, the strength properties in the fibre direction are rather high, typically between 35 and 50 N/mm^2 , as shown in Table 2.21.

Examples of structures made with Kerto are shown in Fig. 2.22.

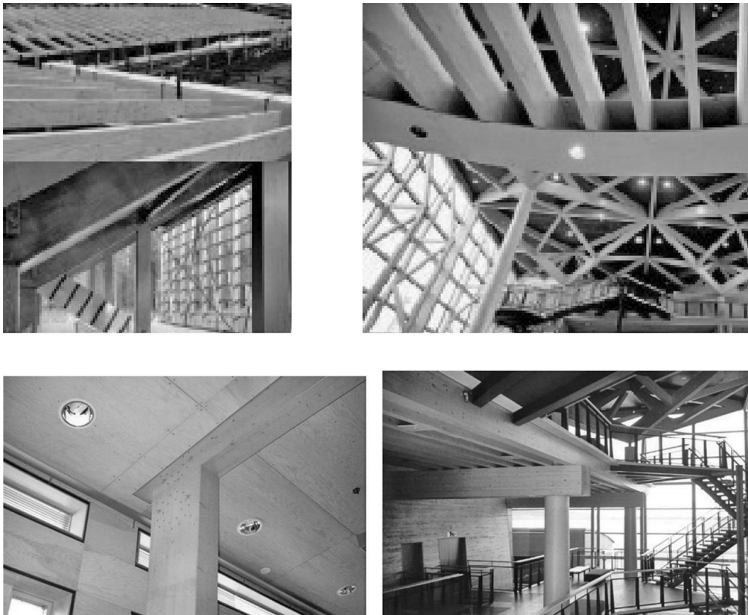

Fig. 2.22 Structures made with Kerto products

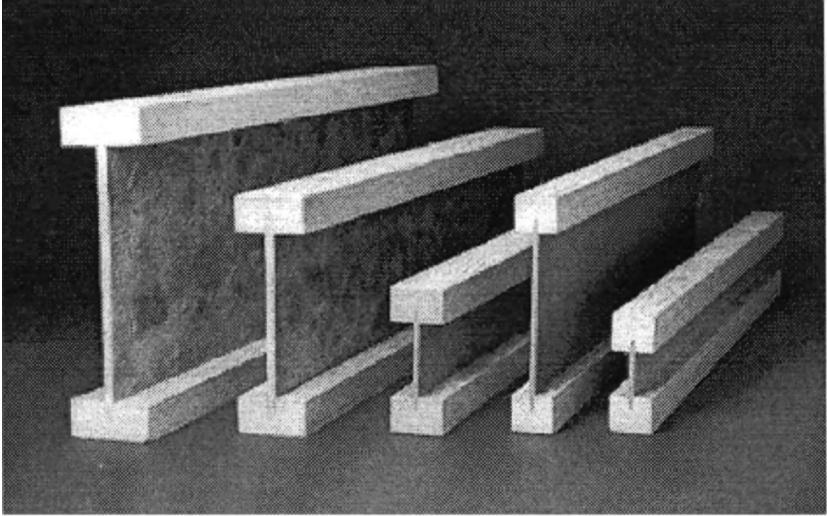

Fig. 2.23 Geometry of typical I-beams and metal web beams

I-beams

I-beams with flanges made of timber LVL and web made of hard fibre-board or OSB are produced as a standard product in the UK and other countries (see Fig. 2.23).

The depths of the I-beams vary between 200 and 500 mm and the standard lengths are 6/7/9/12 m.

Parallel strand lumber and laminated strand lumber

Parallel strand lumber (PSL) is produced from slender ply strips that are mixed with glue. A strip bundle is pressed to the desired shape in a hot press until the glue is cured. Laminated strand lumber (LSL) is produced similarly from long chips. Both products are used in line with structural timber (see Figs 2.24–2.26).

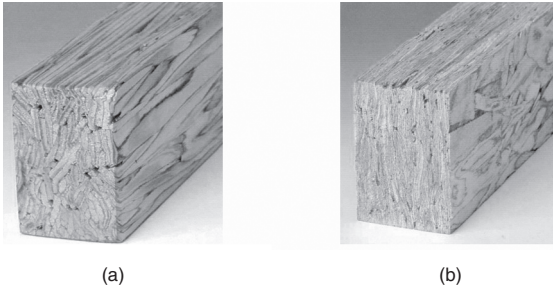

Fig. 2.24 (a) Parallel strand lumber; (b) laminated strand lumber. Both are proprietary products

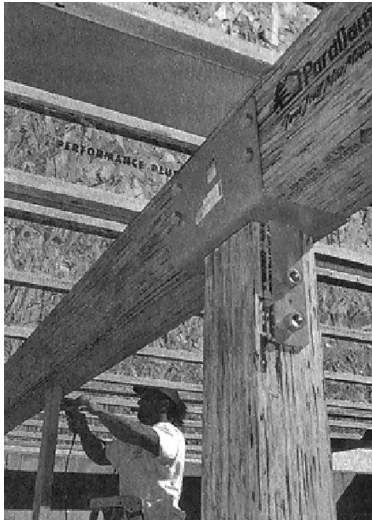

Fig. 2.25 PSL column and beam



Fig. 2.26 LSL beam

2.5 Joints and fasteners

2.5.1 Introduction

In timber structures there are generally many joints and they are often crucial points and part of design, because they take up considerable space and have a tendency to become complex. Normally joints dictate the final size of timber members and components. Joints are often made as lap joints or with gusset plates of steel, or wood-based panels fastened either by glue or by laterally loaded mechanical fasteners. The load-carrying capacity of glued lap joints is limited due to stress concentrations at the glue line borders.

Traditional timber joints have been out of use for some time but due to the introduction of computer numerically controlled (CNC) wood-working machines some traditional joint types may again become of interest because of their fire resistance, or for use in structures with many similar compression members, e.g. lattice shell structures. Examples are shown in Fig. 2.27.

In the following the most common fasteners will be described with examples of their load-carrying capacity. A more detailed description of strength and stiffness and requirements for spacing and end and edge distances is given in Chapter 9.

2.5.2 Nails

Nails consist of a metal rod or shank which is usually made of steel, although it can be made of aluminium, brass or many other metals, or even plastic. The shank is usually designed to be round and smooth. The most common nail types are smooth nails with circular cross-section. Shanks with annular grooves, spiral, or helical threads are used when a stronger, more permanent grip is required. There are nails specific to their end-use, e.g. tile roofing, flooring, shingles, guttering, panel products, gypsum panels, sheet metal and concrete. Some nails are designed to be driven by air-powered nail guns rather than by a hammer.

Steel wire is usually drawn from coils of metal wire and fed into a nail-making machine. They can be further twisted or formed to the desired type. According to the European standard [EN 14592], a minimum ultimate tensile strength of 600 N/mm^2 is required. The head is normally round with a diameter of about $2.5d$, where d is the diameter or side of a square cross-section shank. For brads the head is only a little larger than d .

Nails other than smooth nails are produced from special steel so that they have the same bending strength as smooth nails.

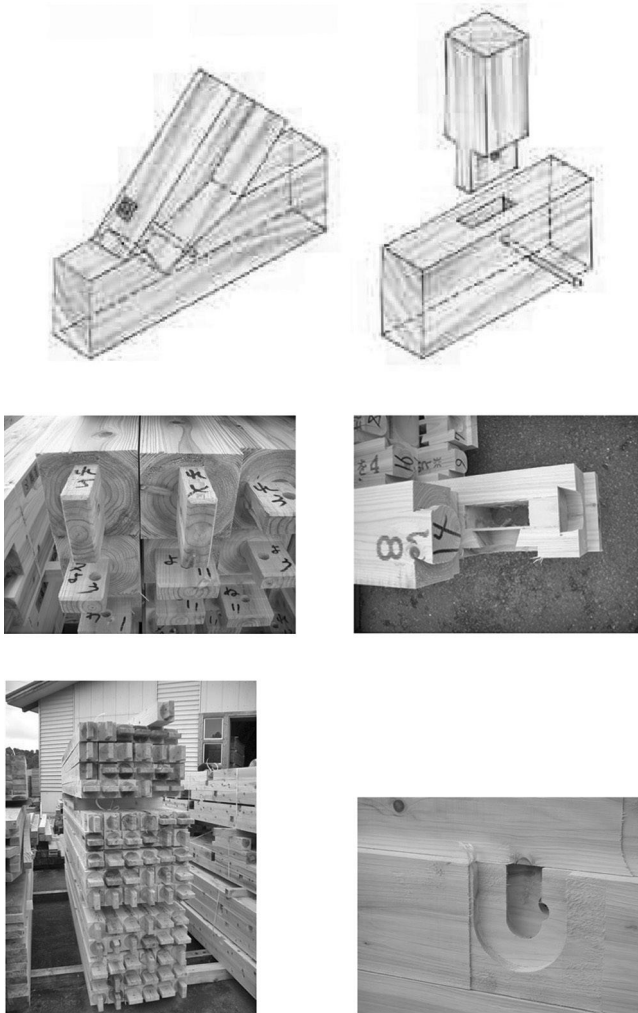

Fig. 2.27 Traditional timber joints

The sizes for some commonly used nails are given in Tables 2.22 and 2.23. Annular ring shank nails are especially aimed at joints with thin steel plates and are less slender than common nails. Square twisted nails are also used, but they have poorer properties than screw and ring shank nails (see Fig. 2.28).

In some countries, round nails with a rolled thread with high pitch are also used. They rotate when they are hammered in and act to some extent similar to screws. Staples, although used to a lesser extent in the UK, may be used to join thin wood members (see Fig. 2.28).

Table 2.22 Commonly used smooth round wire nails

Diameter, d: mm	Length, l: mm								
	25	40	50	65	75	90	100	125	150
2.36	✓	✓							
2.65			✓						
3.0			✓						
3.25				✓					
3.75					✓				
4.5							✓		
5.0								✓	
5.6									
6.0									

Table 2.23 Annular ring shank nails (Strongtie). Dimensions: diameter, d; length, L; ringed length, L_1 ; and head diameter, D. The point length is about 1.5d

Description	d	L	L_1	D
2.5 × 35	2.5	35	25	5.0
2.8 × 60	2.8	60	50	5.6
3.1 × 22	3.1	22	15	6.2
3.1 × 40		40	30	
3.1 × 60		60	50	
3.4 × 60	3.4	60	50	6.8
3.7 × 50	3.7	50	40	7.4
4.0 × 35	4.0	35	25	8.0
4.0 × 40		38.5	30	
4.0 × 50		48.5	40	
4.0 × 60		58.5	50	
4.0 × 75		73.5	65	
4.0 × 100		98.5	70	
6.0 × 60	6.0	60	50	12.0
6.0 × 80		80	70	
6.0 × 100		100	70	

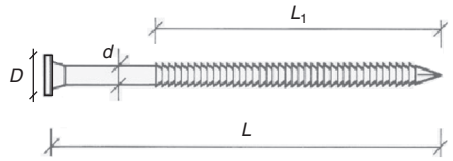

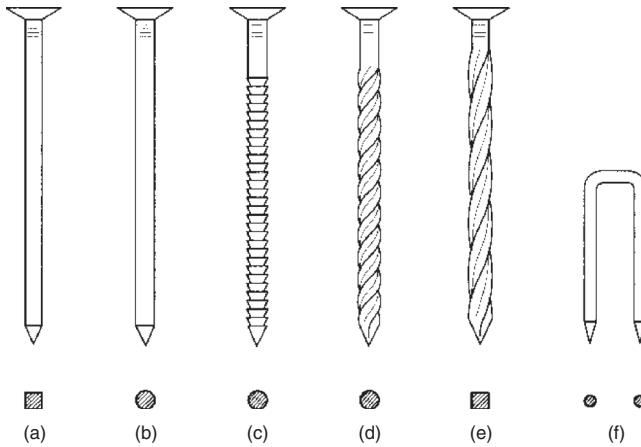

Fig. 2.28 Nail types: (a) Smooth square nail; (b) smooth round nail; (c) annular ring shank nail; (d) screw nail; (e) square twisted nail and (f) staple

The characteristic load-carrying capacities of some round nails are given in Table 2.24. It is seen that strength-wise it is advantageous to use slender nails, but the labour cost becomes higher. Even though the load-carrying capacity of one nail is small, nailed joints are very effective because they do not require shaping of the timber and because nails can be placed close to each other (minimum net pattern $5d \times 10d$).

Nails are flexible fasteners with a slip in the order of $0.1d$ at the serviceability load.

The tensile load-carrying capacity of smooth nails is small and not reliable. The characteristic tensile load-carrying capacity of one smooth nail 3.4.90 is about 0.15 kN and tensile loaded smooth nails should only be used in secondary structures (possibly as skew nailing), otherwise annular ring shank nails should be used. The tensile load-carrying capacity of an annular ring shank nail 4.0 \times 75 is about 1.2 kN.

Nailed joints are common in light structures such as truss structures, see Fig. 2.29.

Table 2.24 Load-carrying capacity $F_{v,k}$ for one laterally loaded nail in C18 and the area A needed to transfer 1 kN (shear) force

d : mm	F_k : kN	A needed per nail: mm ²	A needed for 1 kN: mm ²
2.5	0.5	350	700
4.0	0.8	1050	1300
8.0	2.6	4150	1600

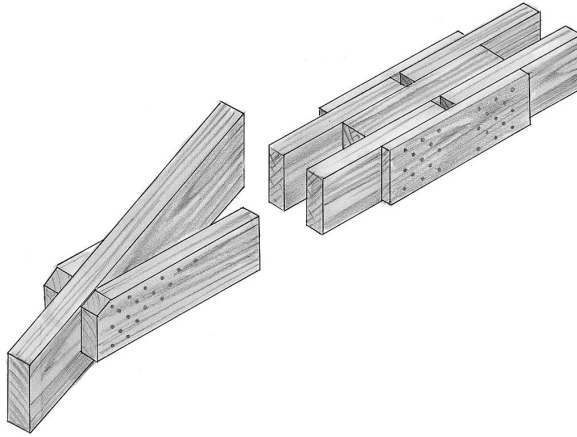

Fig. 2.29 Nailed joints in a truss

Nails used indoors (service class 1) are normally not corrosion protected but the Eurocode 5 has protection requirements for other service classes as listed in Table 2.25. For specially corroding environments Fe/Zn 40, hot-dip zinc coating or stainless steel should be used. This also applies for nails in contact with corroding material, e.g. some wood species (oak, western red cedar and thuja for instance) and some types of preservative.

2.5.3 Bolts

Bolted joints are often used in heavy timber structures, e.g. glulam structures. The most common bolts are M10–M24 bolts which are normally hot-rolled, with coarse threads. They are available in total lengths and thread lengths almost as desired. They are always used

Table 2.25 Minimum corrosion protection requirements of nails and screws

Description	Service class		
	1	2	3
Nails and screws with $d \leq 4$ mm	None	Fe/Zn12c Z275	Fe/Zn25c Z350
Nails and screws with $d > 4$ mm	None	None	Fe/Zn25c Z350
Staples	Fe/Zn12c Z275	Fe/Zn12c Z275	Stainless steel

Fe/Zn, electro zinc coating; Z, hot-dip zinc coating.

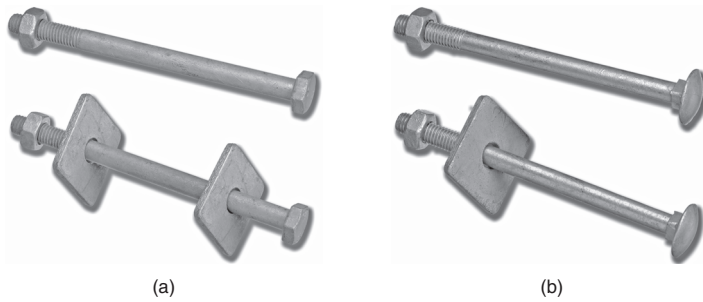

Fig. 2.30 Bolt types: (a) machine bolts without and with washers; (b) coach bolts without and with washers under the nut

with washers with side length $3d$ and thickness $0.3d$ under both head and nut and may therefore be used for lateral as well as axial loads.

Coach bolts or carriage bolts are used in secondary structures. They have a smooth curved head and a square part under the head to prevent the bolt from turning when tightening. It is thus not possible to use washers under the head unless washers are purpose-made with a square hole. Different bolt types are shown in Fig. 2.30.

Examples of bolted structures are shown in Fig. 2.31.

Eurocode 5 requires bolts to be fitted tightly in the holes in the timber; however, in practice, to ease the fitting, the holes are always drilled about 1 mm larger than the diameter of the bolts. Bolts may be placed in a pattern about $4d \cdot 10d$. Examples of load-carrying capacities for bolted timber-to-timber joints are given in Table 2.26 and the minimum requirements to corrosion protection are given in Table 2.27.

2.5.4 Dowels

Dowels with diameter 8–20 mm are often used instead of bolts. They shall fit tight in the holes and are therefore often made from turned special steel with bevelled ends (see Fig. 2.32). The use of dowels usually



Fig. 2.31 Bolted structures

Table 2.26 Characteristic load-carrying capacities F_k for bolted timber-to-timber joints and the necessary areas to transfer a load of 1 kN. The values are per shear for double-shear joints where the thickness of the side members is $t = 47 \text{ mm}$ and the thickness of the middle member is $2t$

d : mm	F_k : kN	A needed per 1 bolt: mm^2	A needed for 1 kN: mm^2
8	3	2200	750
16	8	9000	1100
24	15	20 000	1300

Table 2.27 Minimum corrosion protection requirements for bolts and dowels

	Service class		
	1	2	3
Bolts and dowels	None	None	Fe/ZN25c Z350

results in a nicer appearance and a stiffer joint because the slip due to the oversized holes is avoided. An example of a dowelled joint is shown in Fig. 2.33. The holes should be drilled in one operation unless CNC equipment is used.

The lateral load-carrying capacity of dowel joints are the same as for a corresponding bolted joint, but the spacing along the grain may be reduced to $7d$. The required corrosion protection is the same as for bolts.

2.5.5 Screws

Screws are often used instead of nails in joints where appearance is important, where it should be possible to separate the timber parts again and where higher load-carrying capacity is required than could be achieved by using nails. The most common screws have been slotted

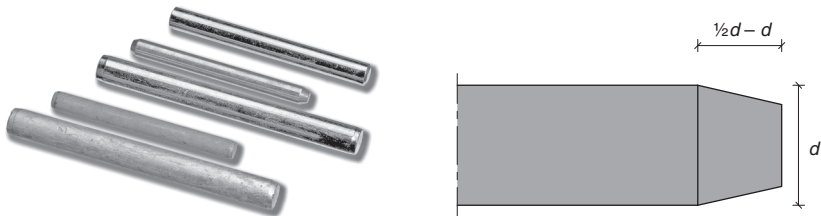

Fig. 2.32 Dowels



Fig. 2.33 Dowelled joint between glulam arch and cast-in steel plate

screws with diameter d between 2 and 6 mm, length between $3d$ and $12d$ and with threaded length about 60% of the total screw length. Coach screws/lag screws with hexagonal head and diameter between 6 and 20 mm are often used for larger timber connections. Examples of lag screws and slotted screws are shown in Fig. 2.34. For diameters above 5 mm pre-drilling is required.

Screws have advantages where small members have to be fastened to large timber members as shown in Fig. 2.35(a) and (b). Bolts would be more expensive and become less effective when shrinkage of timber members takes place if no retightening is scheduled.

A new development is long (up to 1000 mm) self-drilling and self-tightening screws that can be screwed in by light electric hand tools; these screws are made from high-strength steel. Examples are shown in Fig. 2.36.

These screws have slightly higher lateral load-carrying capacity than corresponding nails but their main advantage is their high axial load-carrying capacity, making them suitable for anchorages and reinforcements (see Fig. 2.35(c) and (d)).



Fig. 2.34 Screw types: (a) lag screws; (b) slotted screws

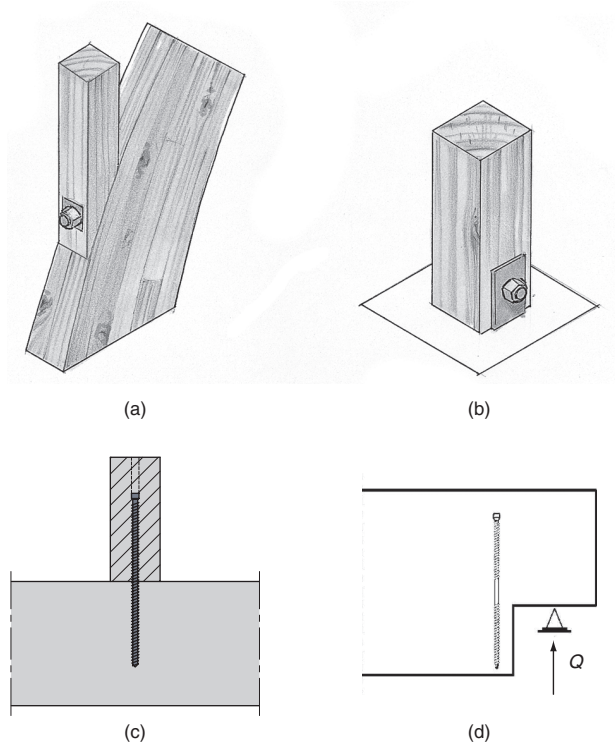

Fig. 2.35 Screwed joints: (a) a post fastened to a ghlum arch with lag screw with hexagonal head; (b) column fastened to a steel anchor; (c) joist fastened by a long screw; (d) screw used as reinforcement of notched beam

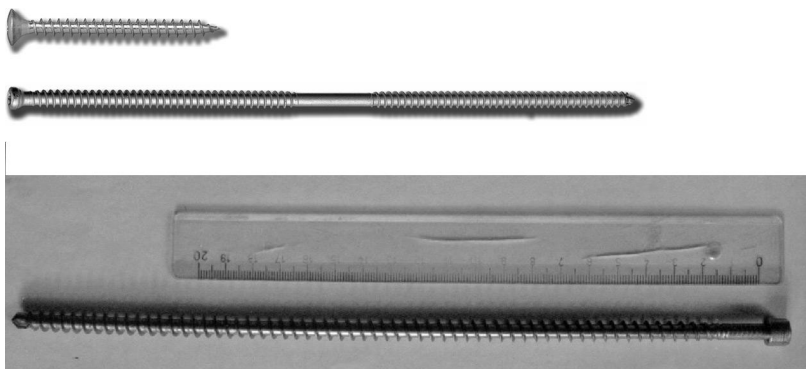

Fig. 2.36 Top: self-drilling spun screw 6×150 mm. Middle: SFS screw with thread both under the head and at the end (the pitches are a little different resulting in the parts being drawn tight together). Bottom: self-drilling screw 6×300 mm

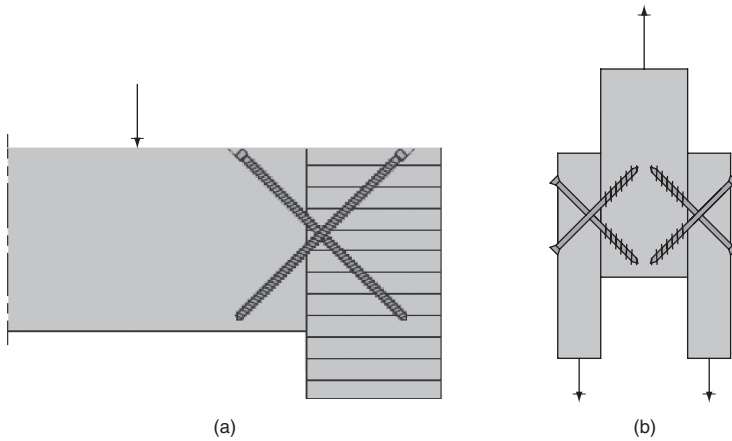

Fig. 2.37 (a) Screws used to fasten a joist to a header beam; (b) lateral loads transferred by inclined screws

The high axial load-carrying capacity means that many laterally loaded joints may be made as screwed tension/compression joints (see Fig. 2.37(b)).

Steel plate connectors (i.e. joist hangers, brackets, etc.) are known in Europe as 'three-dimensional connectors'. They are usually fastened with 3.7 mm or 4–5 mm connector screws with a cone under the head (see Fig. 2.38). The cone causes the nails or screws to be rigidly held in the plate.

The requirements for corrosion protection are given in Table 2.27.

2.5.6 Glued-in bolts

Steel rods glued into holes in solid timber may obtain a high load-carrying capacity both laterally and axially. These joints, often called

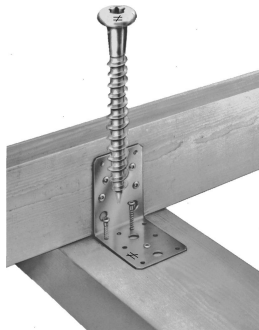

Fig. 2.38 Angle bracket with connector screw

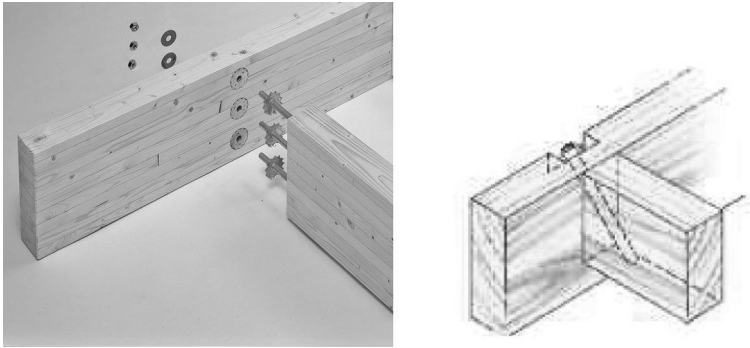

Fig. 2.39 Joints made with glued-in bolts in end grain

glued-in bolts (sometimes referred to as glued-in rods), may be made with the hole direction parallel, perpendicular and at an angle to the grain direction. Glued-in bolts give several structural possibilities and are being used more and more in glulam structures (see examples in Figs 2.39 and 2.40). Smooth rods may be used but normally threaded rods are preferred. The most frequently used glues are polyurethane or epoxy glues, which (as opposed to resorcinol glues) also bond to steel.

The axial load-carrying capacity of glued-in bolt joints increases approximately with \sqrt{l} where l is the glued-in length. The joint is relatively stiff and failure is often brittle and stress redistribution between the bolts not possible. In joints with several bolts there is a risk for

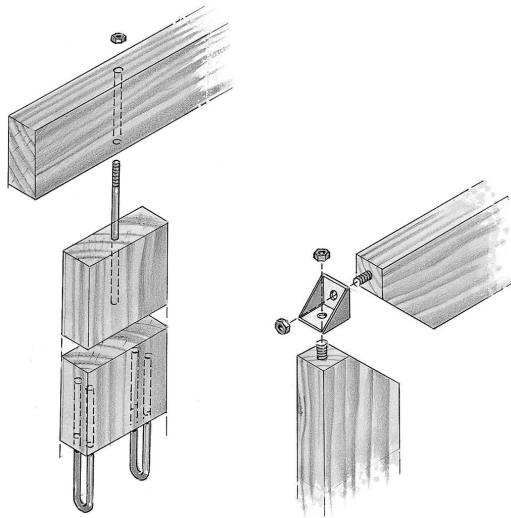

Fig. 2.40 Joints made with glued-in bolt

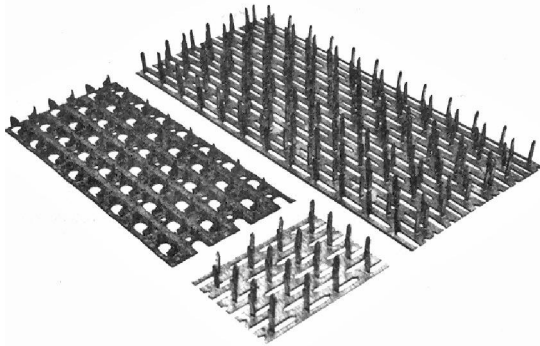

Fig. 2.41 Punched metal plate fasteners

uneven load distribution over the bolts: if a bolt is overloaded and fails, progressive failure may take place (zipper failure). The anchorage length should be sufficient to ensure that initial failure is ductile yielding in the steel and normally mild steel is recommended.

2.5.7 Punched metal plate fasteners

Punched metal plate fasteners (also called nail plates) are 1–2 mm thick steel plates with protruding teeth on one side. The plates on the market differ regarding the shape of the teeth and their pattern (see Fig. 2.41). Some plates have only one tooth type whereas others have two or more, e.g. short and stiff for high shear load and some long and slender that serve to anchor the plate into the wood. Nail plates are mainly used as gusset plates pressed into the surfaces of the timber sections they join. A typical area of usage is light trussed structures, e.g. roof trusses (an example is shown in Fig. 2.42), but the plates are also suitable for other structures made of boards and planks with the same width.

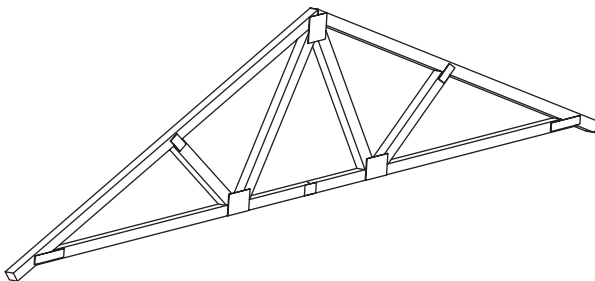

Fig. 2.42 Truss rafter with punched metal plate fastener joints

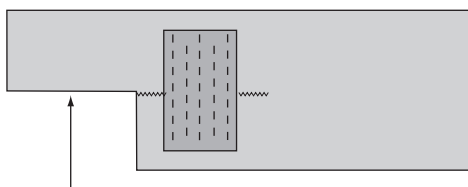

Fig. 2.43 Reinforcement of end notched beam

A typical shear load-carrying capacity is about 5 N/mm^2 , i.e. the area needed to transfer a load of 1 kN is about 200 mm^2 .

The external pressure needed to press the plates into the wood is considerable – about $5\text{--}6 \text{ N/mm}^2$ – and the whole plate should be pressed into the timber in one operation, which requires special press equipment. The punched metal plate connectors are normally produced in special factories operated by organisations which provide sophisticated design and detailing software for the trusses. On some occasions however, it is possible to mount the plates on site by hammering on a stiff steel plate – see Fig. 2.43 for an example.

Normally the plates are electro-zinc-plated before punching. Experience shows that there are no corrosion problems even though the edges and sides of the teeth are unprotected. The general requirements to protection of thin steel plates are shown in Table 2.28.

2.5.8 Nailing plates

It is possible to nail through $1\text{--}1.2 \text{ mm}$ steel plates without drilling. For thicker plates it is necessary to pre-drill the steel plate. Nailing plates with pre-punched 5 mm holes spaced at $10\text{--}20 \text{ mm}$ are available up

Table 2.28 Minimum protection requirements for nail plates and thin steel plates

Description	Service class		
	1	2	3
Nail plates and steel plates up to 3 mm	Fe/Zn12c Z275	Fe/Zn12c Z275	Stainless steel
Steel plates $3\text{--}5 \text{ mm}$	None	Fe/Zn12c Z275	Fe/Zn25c Z350
Steel plates thicker than 5 mm	None	None	Fe/Zn25c Z350

Fe/Zn, electro-zinc-plated; Z, hot-dip zinc coating

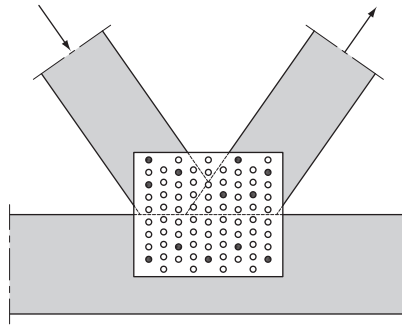

Fig. 2.44 Gusset plate cut from plate with pre-punched holes (4 mm ring shank nails or 5 mm connector screws are placed in the marked holes)

to $1.3 \cdot 3 \text{ m}^2$ from which plates or strips may be cut as desired. An example is shown in Fig. 2.44.

2.5.9 Connectors

Bolt and screw joints may be reinforced by connectors located between the faces of two timber parts. There are two connector types: inlaid and pressed-in connectors. The first type consists of cylindrical rings or discs placed in milled cut-outs. The second type consists of plates with teeth along the perimeter pressed into the wood. Inlaid ring connectors are shown in Fig. 2.45.

Pressed-in connectors are marketed under the brand name Bulldog. They are made from thin steel plates from which triangular teeth are pressed up along the edge(s) (see Figs 2.46 and 2.47). There are two types: two-sided and single-sided tooth-plate connectors. The two-sided tooth-plate connectors are used in wood-to-wood joints. The middle hole for the two-sided connectors is larger than the bolt diameter, i.e. the shear force in the joint is transferred from the timber parts through the teeth. The single-sided tooth-plate connectors are aimed at steel-to-wood joints but may also be used for timber-to-timber joints, making it possible to separate the parts if desired at some stage. They may also be used in pairs (back to back) where it is not possible to press the parts together during execution. The hole for the single-sided connectors is 0.5 mm larger than the bolt diameter, and the bolt edge is reinforced by a bulb, making it possible to transfer load from the connector to the bolt. Typically the lateral load-carrying capacity of the bolt connection is increased by a factor of 2–3.

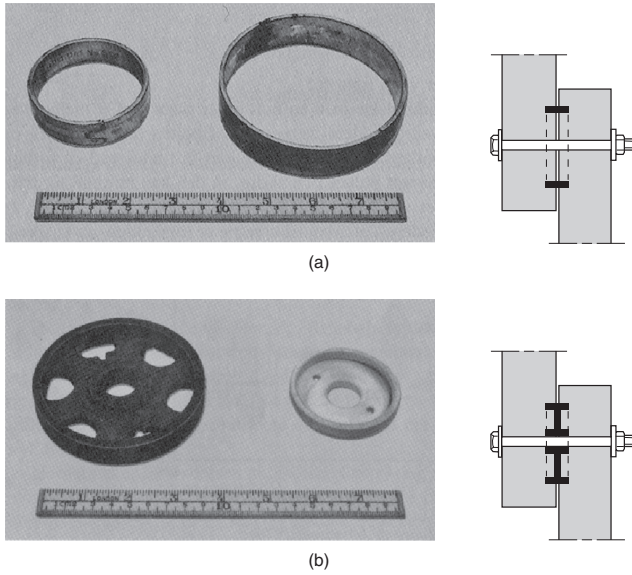

Fig. 2.45 Inlaid connectors: (a) split-ring; (b) shear plates

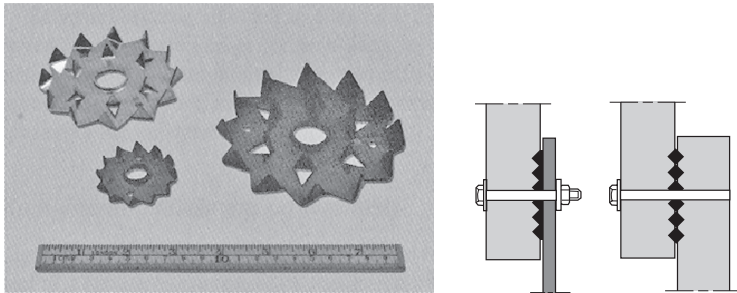

Fig. 2.46 Single-sided Bulldog connector. One connector is used in steel-to-wood joints. In wood-to-wood joints, two connectors are used if the parts need to be separated at a later stage

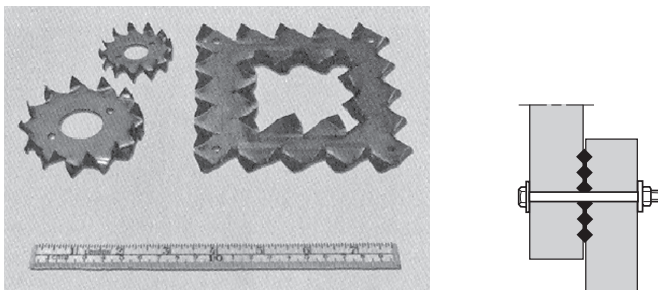

Fig. 2.47 Double-sided Bulldog connectors

Table 2.29 Dimensions of Bulldog connectors (mm)

Circular	50, 62, 75, 95, 117
Oval	70 × 130
Square	100 × 100, 130 × 130

Bulldog may be round, square or oval with diameter/side lengths between 50 and 130 mm (see Table 2.29).

In most cases connectors are delivered unprotected just oiled or oil varnished. It is, however, recommended to use hot-dip zinc treated connectors in severe environments.

3

Structural examples

3.1 Introduction

This chapter gives examples of timber structures. The purpose is not to cover all structural possibilities but merely to give a survey of often-used simple structures with typical dimensions as inspiration and help for drawing and design. More complicated structures made by combining straight and curved beams and panels are only dealt with briefly.

3.2 Main and secondary members

It is often possible to distinguish between a main and secondary members. In the example shown in Fig. 3.1 the main members are the glulam beams supported by concrete columns and the secondary members are the structural timber joists. In the example shown in Fig. 3.2, the main members are trusses with punched metal plate connectors, spanning from façade to façade and the secondary members are the members spanning between trusses. In the example shown in Fig. 3.3 the glulam arches are the main members and the glulam beams are the secondary members.

The secondary members themselves may in some cases be regarded as main members with secondary members. For example, in Fig. 3.1 the deck may be regarded as a secondary member relative to the joists.

If the distance between the main members is not determined by the layout of the structure, the following may be used as a guide. It is normally economical to have a large distance, a , between the main members. The moments and consequently the required section moduli increase proportionally to a , but the required section dimensions increase as an approximation only by $a^{1/3}$ and the required timber volume by $a^{2/3}$. The number of joints and foundations are the same, i.e. the costs per unit area will decrease with the distance. On the other hand, the costs of the secondary members increases as the distance between main members increases, as shown in Fig. 3.4 where an optimum distance can be found.



Fig. 3.1 Structural timber joists supported by glulam beams

The optimum distance a_{opt} for a span l of the main member with secondary structural timber members may be estimated from:

$$a_{opt} = 0.375l^{0.8} \quad (3.1)$$

For other materials acting as a secondary member, the optimum distance may be estimated from:

$$a_{opt} = 0.75l^{0.8} \quad (3.2)$$



Fig. 3.2 Trusses with punched metal plate connectors spanning from façade to façade. The members carrying the roof covering are not shown



Fig. 3.3 Glulam arches spanning 80 m at 8 m centres carry glulam joists

As an alternative, an often-used optimum distance is:

$$a_{opt} = \sqrt{l} \quad (3.3)$$

The above expressions are illustrated in Fig. 3.5.

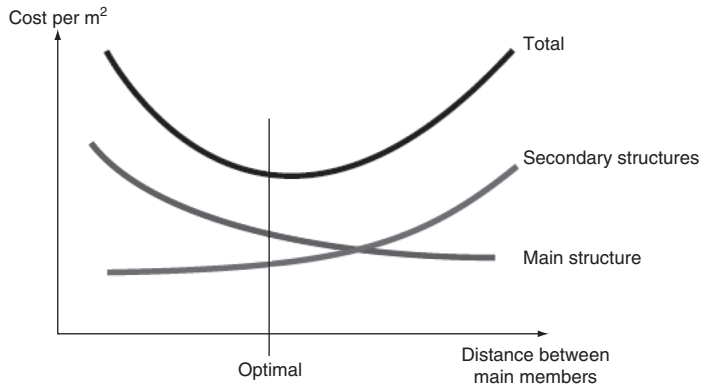

Fig. 3.4 The optimum distance is the one that results in minimum total costs

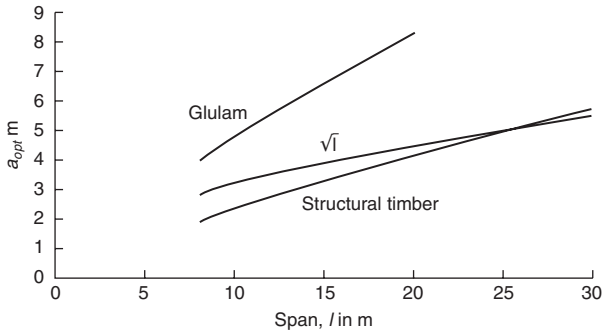

Fig. 3.5 Optimum distance between main structures

Examples of structural members are shown below.

Solid beams

Beams of structural timber with a distance of 1–2 m may be used for spans up to 7 m. Normally h/b is 4 to 8 where h is the depth and b is the width or thickness. Beams deeper than about $6b$ require special bracing to avoid lateral instability.

Glulam beams may be produced with any length but longer spans may utilise other types of structural components such as trusses.

Simply supported single-span beam

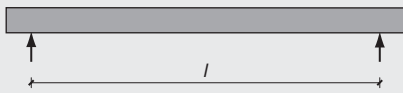

$$b > b/7$$

$$h \sim l/20 \text{ to } l/17$$

Continuous beam

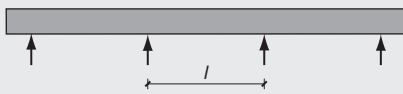

$$b > b/7$$

$$h \sim l/25 \text{ to } l/20$$

Continuous beams of structural timber may be made as coupled beams with the double cross-section over the support, where the moment is the largest. The beams are joined by nails or screws.

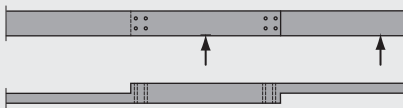

Glulam beams may be tapered or pitched.

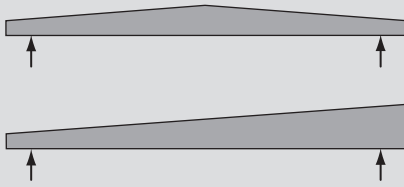

$$h_{middle} \sim l/20 \text{ to } l/10$$

Glulam beams may have one or several curved parts.

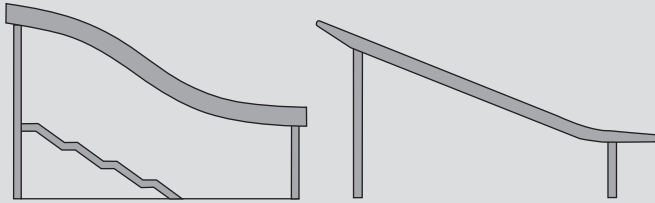

An architecturally interesting structure is called a boomerang beam, i.e. a pitched beam with curved underside. With downward load the moments will try to straighten the beam, which results in tension stresses perpendicular to the grains that weaken the beam considerably.

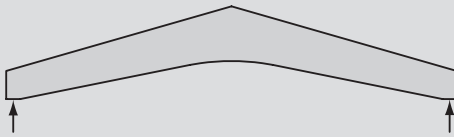

The problems may be avoided by using a tension tie, but it limits the space utilisation.

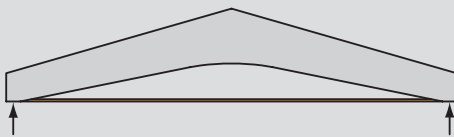

In houses it is common to use collar trusses with roof inclinations of 35–55° and spans up to 12 m. The horizontal reaction shall be taken by the deck or a tension tie. These are sometimes called raised tie trusses or 'A'-frame trusses.

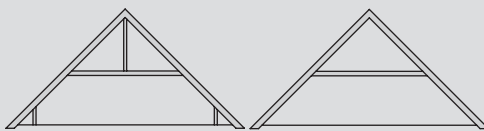

Trusses

Countless types of trusses are produced. Slender closely spaced trusses (usually at 0.6 m spacings) with spans up to about 20 m are almost always produced with punched metal plate fasteners.

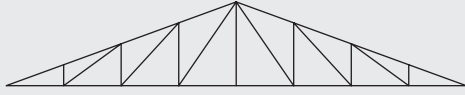

The roof inclination for spans up to 25 m should be greater than 15° , i.e. $h \sim l/7$.

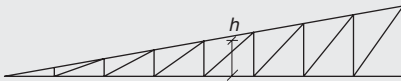
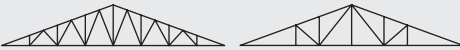
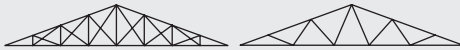
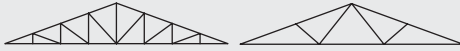

The mid-depth h should be about $l/7$ for mono pitch beams.



Scissor trusses are made with roof/ceiling inclinations of: $(25-30^\circ)/(10-15^\circ)$, i.e. $f \sim l/10$ and $(f + h) \sim l/5$

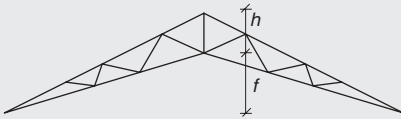

For parallel N- or V-trusses:



$h \sim l/9$ to $l/14$



Large trusses are produced with flanges of glulam or LVL and steel gusset plates or brackets with bolts or dowels.



V-girder trusses supporting sports hall roof
Types of trusses.

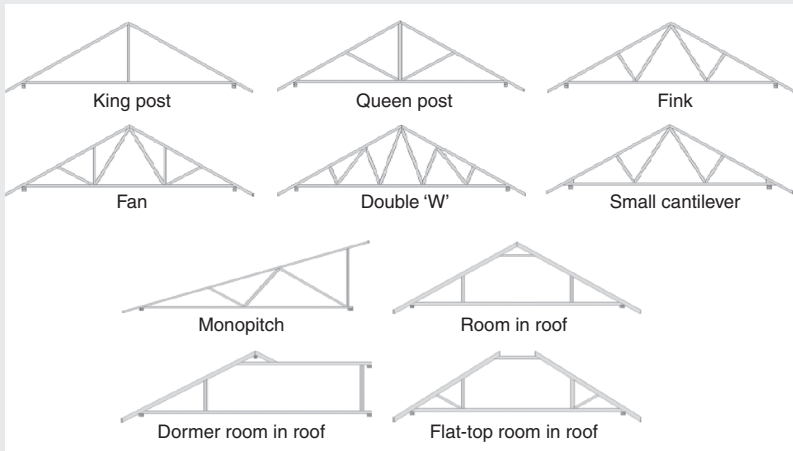

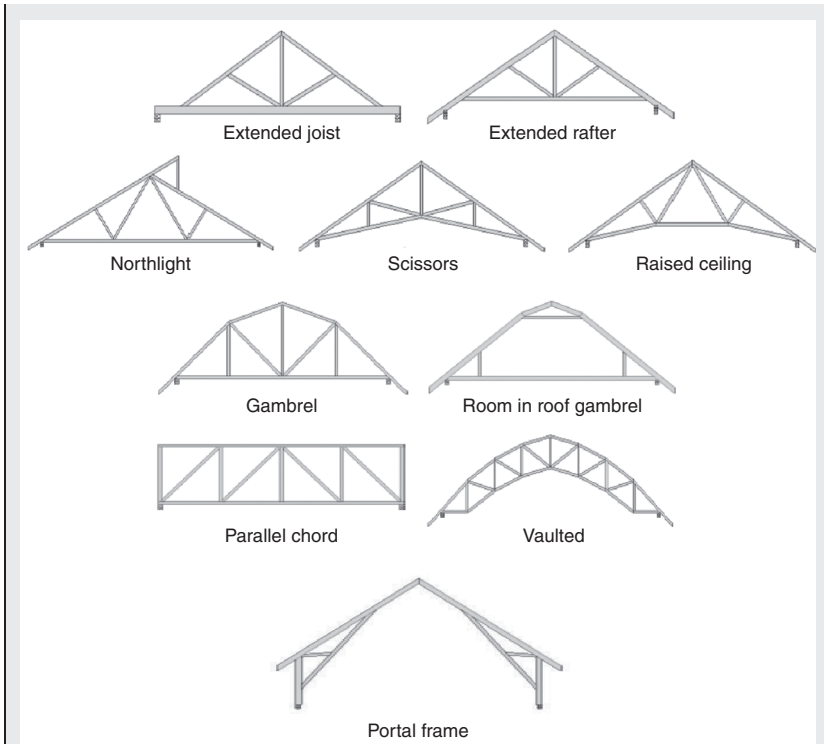

Frames and arches

Due to transport considerations and because of the problems with making joints moments stiff, frames and arches are often made as three-hinged frames or arches.

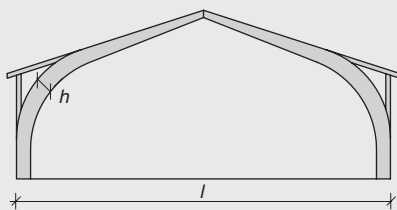

Typical dimensions for span l :

Maximum depth:

$$h \sim 0.03l$$

Depth at foot: $h_f \sim 0.9h$

Depth at top: $h_t \sim 0.5h$

Width: $b \sim 0.18h$

The curved corners that limit the usability may be avoided by joining straight beams with finger joints. The joints weaken the strength and the required depth is increased by 20%. To reduce the strength reduction a middle piece is often used. The two straight parts may also be joined by gusset plates with mechanical fasteners.

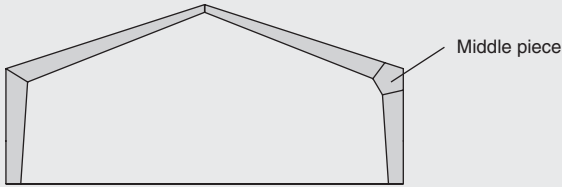

Arches and cupolas

With large-span (up to 120 m) arches with depths of about $0.02-0.01l$ are required. The closer the centre line is to the line of thrust the smaller the required depth, but the bigger the problems with unintentional deviations from the assumed geometry.

Beams – straight and curved – can be built together to form pyramids and cupolas.

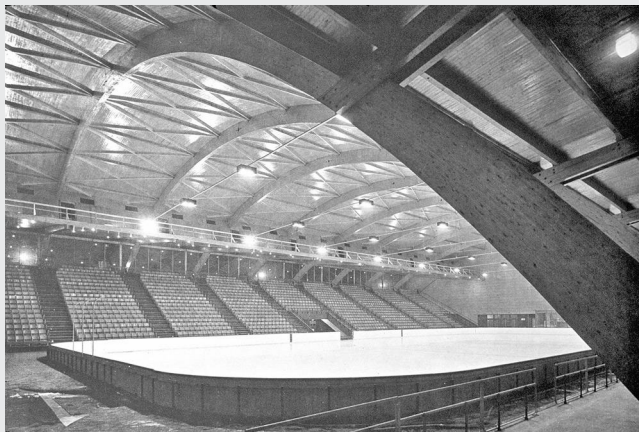
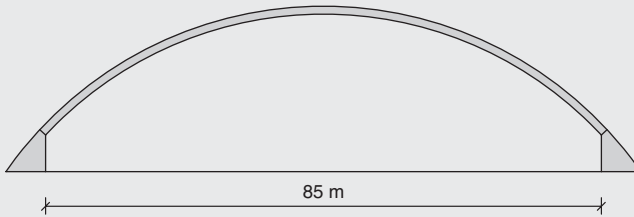

A glulam arch in a sports hall



Erection of glulam portal frames

4

Straight members and beams with varying depth

4.1 Tension and compression

4.1.1 Tension parallel to grain

For beams loaded by concentric tensile force parallel to grain $F_{t,0,d}$ it shall be verified that:

$$\frac{\sigma_{t,0,d}}{f_{t,0,d}} \leq 1 \quad (4.1)$$

$$\sigma_{t,0,d} = \frac{F_{t,0,d}}{A_{net}} \quad (4.2)$$

$\sigma_{t,0,d}$ is the design tensile stress parallel to grain and $f_{t,0,d}$ is the design tensile strength parallel to grain. A_{net} is the effective cross-sectional area, i.e. the total area reduced by areas of slots, notches, bolt and nail holes. Reductions of the cross-sectional area may be ignored for nails and screws with a diameter of 6 mm or less driven without pre-drilling. When assessing the effective cross-sectional area at a joint with multiple fasteners, all holes within a distance of half the minimum fastener spacing measured parallel to the beam from a given cross-section should be considered as belonging to that cross-section.

It should be remembered that for structural timber the design strength may be increased by the factor

$$k_h = \min \left\{ 1.3, \left(\frac{150}{h} \right)^{0.2} \right\} \quad (4.3)$$

Example 4.1

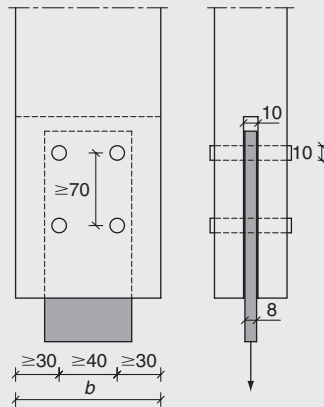

The tension member shown in the figure above is loaded in the member (grain) direction by a dead load of 8 kN and an imposed load of 25 kN.

The tension member is made of material C16 and it has a rectangular cross-section with thickness 75 mm and width b . The load is transferred to the member through an 8 mm thick steel plate in a 10 mm slot by four 10 mm dowels in 10 mm holes. The minimum width due to the required dowel distances is $30 + 40 + 30 = 100$ mm.

Service class 1 (indoor)

Find: The member width b .

The design tensile strength parallel to grain $f_{t,0,d}$ is with $f_{t,0,k} = 10$ N/mm² and $\gamma_M = 1.3$:

$$\text{Dead load } (k_{mod} = 0.6): f_{t,0,d} = 0.6 \cdot 10 / 1.3 = 4.61 \text{ N/mm}^2$$

$$\text{Imposed load } (k_{mod} = 0.8): f_{t,0,d} = 0.8 \cdot 10 / 1.3 = 6.15 \text{ N/mm}^2$$

The design loads:

$$\text{Dead load } \gamma_G = 1.35, F_d = 1.35 \cdot 8 = 10.8 \text{ kN}$$

$$\text{Dead + imposed } \gamma_G = 1.35, \gamma_Q = 1.5,$$

$$F_d = 1.35 \cdot 8 + 1.5 \cdot 25 = 48.3 \text{ kN}$$

For an estimated width $b = 125 \text{ mm}$ the effective area becomes:

$$A_{\text{eff}} = (75 - 10) \cdot (125 - 2 \cdot 10) = 6.83 \cdot 10^3 \text{ mm}^2$$

$$k_h = \left(\frac{150}{125} \right)^{0.2} = 1.04 < 1.3$$

The combined stress index:

for dead load:

$$\frac{(10.8 \cdot 10^3)/(6.83 \cdot 10^3)}{(1.04 \cdot 7.38)} = \frac{1.58}{7.67} = 0.21 < 1$$

for dead load and imposed load:

$$\frac{(48.3 \cdot 10^3)/(6.83 \cdot 10^3)}{(1.04 \cdot 9.85)} = \frac{7.08}{10.27} = 0.69 < 1$$

4.1.2 Compression parallel to grain

For a short column (with no risk of instability failure) loaded by a compressive concentric force $F_{c,0,d}$ parallel to the grain, it shall be verified that:

$$\frac{\sigma_{c,d}}{f_{c,0,d}} \leq 1 \quad (4.4)$$

where:

$$\sigma_{c,d} = \frac{F_{c,d}}{A_{\text{net}}} \quad (4.5)$$

The effective area A_{net} is calculated similar to a tension member. However, also holes in the compression area may be disregarded if they are filled with a material stiffer than the wood. For columns, reductions from symmetrically placed holes may also be disregarded.

4.1.3 Tension perpendicular to the grain

Where a volume, V , is exposed to a uniform tensile stress perpendicular to the grain (as in a curved beam), it shall be verified that:

$$\frac{\sigma_{t,90,d}}{k_{\text{vol}} f_{t,90,d}} \leq 1 \quad (4.6)$$

where:

$$k_{vol} = \left(\frac{V_{ref}}{V} \right)^{0.2} \quad (4.7)$$

$\sigma_{t,90,d}$ is the tensile stress perpendicular to the grain and V_{ref} is the reference volume for which $f_{t,90}$ is defined:

- for glulam: $V_{ref} = 0.01 = 10 \cdot 10^{-3} \text{ m}^3$
- for structural timber: $V_{ref} = 0.57 \cdot 10^{-3} \text{ m}^3$.

4.1.4 Compression perpendicular to the grain

Block bearing compression

Where a large surface area of a timber member is exposed to a uniform compression stress $\sigma_{c,90,d}$ perpendicular to the grain (e.g. at continuous supports), it shall be verified that:

$$\frac{\sigma_{c,90,d}}{f_{c,90,d}} \leq 1 \quad (4.8)$$

Rail bearing compression

Where a beam is exposed to a concentrated pressure over a small surface area, e.g. at a support, it has been shown experimentally that the compression capacity becomes larger than the pure material strength perpendicular to the grain. This is especially the case if the structure is not sensitive to the effect of deformations due to the compression. The reasons for this effect are that not only the wood fibres directly under the load carry the load but also the neighbouring material and that the resistance increases with increasing compressive deformation.

To take this into account, Expression (4.8) is replaced by:

$$\frac{\sigma_{c,90,eff,d}}{k_{c,90} f_{c,90,d}} \leq 1 \quad (4.9)$$

where the effective design stress perpendicular to the grain is calculated as:

$$\sigma_{c,90,eff,d} = \frac{F_{c,90,d}}{A_{eff}} \quad (4.10)$$

where:

A_{eff} is an effective contact area;

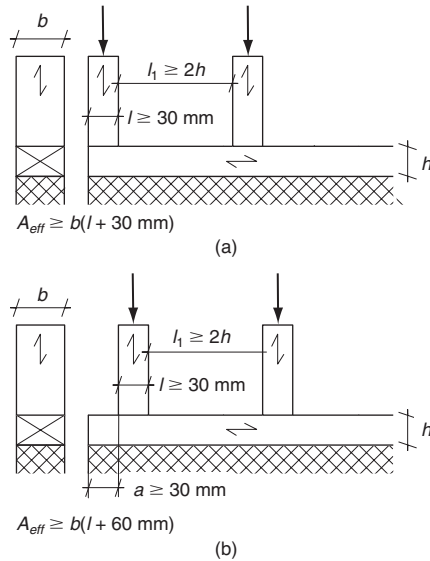

Fig. 4.1 Beam loaded perpendicular to the grain

$k_{c,90}$ is a factor taking into account the load configuration, the possibility of splitting and the degree of compressive deformation.

The effective area should be calculated as the actual compression length l increased at each end by 30 mm, but not more than a , l or $l_1/2$ (see Fig. 4.1(a)).

Unless otherwise specified in the following k_{90} shall be assumed to be unity.

For members on continuous full supports, provided that $l_1 \geq 2h$ (see Fig. 4.1(a)):

- $k_{90} = 1.25$ for solid softwood timber
- $k_{90} = 1.5$ for glued laminated softwood timber.

For members on simple supports, provided that $l_1 \geq 2h$ (see Fig. 4.1(b)):

- $k_{90} = 1.5$ for solid softwood timber
- $k_{90} = 1.75$ for glued laminated softwood timber

where h is the depth of the member and l is the contact length.

Example 4.2

A timber frame wall is made of studs with cross-sectional dimensions $t \times b = 44 \times 145$ mm and a centre-to-centre (c/c) distance of 600 mm. The bottom sill has the same width and is supported on a concrete foundation. The load on each stud is 2 kN from dead load and 8 kN from imposed load.

Service class 1 (indoor)

Verify that the load from the studs can be carried by the bottom chord.

The characteristic compression strength perpendicular to the grain is $f_{c,90,k} = 2.2$ N/mm². The design strength for load group M ($k_{mod} = 0.8$) and with $\gamma_M = 1.30$ for structural timber is given by:

$$f_{c,90,d} = k_{mod} f_{c,90,k} / \gamma_M = 0.8 \cdot 2.2 / 1.30 = 1.35 \text{ N/mm}^2$$

For dead load + imposed load, the design load for each stud is given by:

$$F_d = \gamma_G G + \gamma_Q Q = 1.35 \cdot 2 + 1.5 \cdot 8 = 14.7 \text{ kN}$$

With an effective compression length of $l_{eff} = t + 2 \cdot 30 = 44 + 60 = 104$ and $k_{c,90} = 1.25$ for structural timber on a continuous support the combined stress index is:

$$\begin{aligned} \frac{\sigma_{c,90,eff,d}}{k_{c,90} f_{c,90,d}} &= \frac{F_d}{k_{c,90} b l_{eff} f_{c,90,d}} = \frac{14.7 \cdot 10^3}{1.25 \cdot 145 \cdot 104 \cdot 1.35} = \frac{0.97}{1.69} \\ &= 0.58 < 1 \end{aligned}$$

4.1.5 Load at an angle to the grain

Tension

For a timber beam that is loaded in tension in an arbitrary direction defined by the angle α between the load and grain, it shall be verified that:

$$\frac{\sigma_{t,\alpha,d}}{f_{t,\alpha,d}} \leq 1 \quad (4.11)$$

where the tensile strength in the load direction should be taken as:

$$f_{t,\alpha,d} = \frac{f_{t,0,d} f_{t,90,d}}{f_{t,0,d} \sin^2 \alpha + f_{t,90,d} \cos^2 \alpha} \quad (4.12)$$

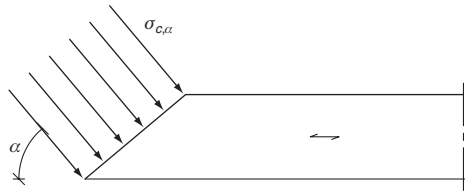

Fig. 4.2 Compressive stress at an angle α to the grain

Compression

For a timber beam that is loaded in compression, as shown in Fig. 4.2, it shall be verified that:

$$\frac{\sigma_{c,\alpha,d}}{f_{c,\alpha,d}} \leq 1 \quad (4.13)$$

where the compressive strength in the load direction should be taken as:

$$f_{c,\alpha,d} = \frac{f_{c,0,d} k_{c,90} f_{c,90,d}}{f_{c,0,d} \sin^2 \alpha + k_{c,90} f_{c,90,d} \cos^2 \alpha} \quad (4.14)$$

Figure 4.3 shows how the tensile and compressive strength properties for the material classes C16 and GL24h are influenced by the load

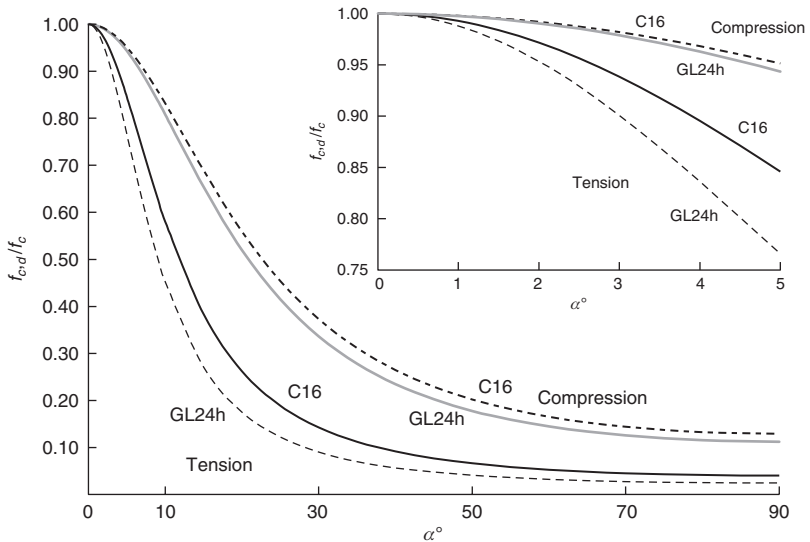

Fig. 4.3 Variation of tensile and compressive strength at an angle α to the grain direction for C16 and GL24h for angles between 0° and 90° . In the insert: angles between 0° and 5° . c = compression, t = tension

angle. It is seen that for tension even small angles reduce the strength considerably.

4.1.6 Bending

Bending about one main axis

For beams loaded in pure bending about one of the main axes it shall be verified that:

$$\frac{\sigma_{m,d}}{f_{m,d}} = \frac{M_d/W}{f_{m,d}} \leq 1 \quad (4.15)$$

where:

- $\sigma_{m,d}$ is the maximum stress caused by the design bending moment M_d ;
- W is the section modulus;
- $f_{m,d}$ is the design bending strength.

Bending about two main axes

For beams loaded in biaxial bending it shall, except for rectangular cross-section, be verified that:

$$\frac{\sigma_{m,d}}{f_{m,d}} = \frac{\sigma_{m,y,d}}{f_{m,d}} + \frac{\sigma_{m,z,d}}{f_{m,d}} \leq 1 \quad (4.16)$$

where the bending stresses $\sigma_{m,d}$, $\sigma_{m,y,d}$ and $\sigma_{m,z,d}$ are calculated as:

$$\sigma_{m,d} = \sigma_{m,y,d} + \sigma_{m,z,d} = \frac{M_{y,d}}{W_y} + \frac{M_{z,d}}{W_z} \quad (4.17)$$

where W_y and W_z are the section moduli.

For rectangular cross-sections and for other angular cross-sections it shall however only be verified that the following two conditions are fulfilled:

$$\frac{\sigma_{m,y,d}}{f_{m,y,d}} + k_m \frac{\sigma_{m,z,d}}{f_{m,z,d}} \leq 1 \quad (4.18)$$

$$k_m \frac{\sigma_{m,y,d}}{f_{m,y,d}} + \frac{\sigma_{m,z,d}}{f_{m,z,d}} \leq 1 \quad (4.19)$$

where the coefficient k_m equals 0.7.

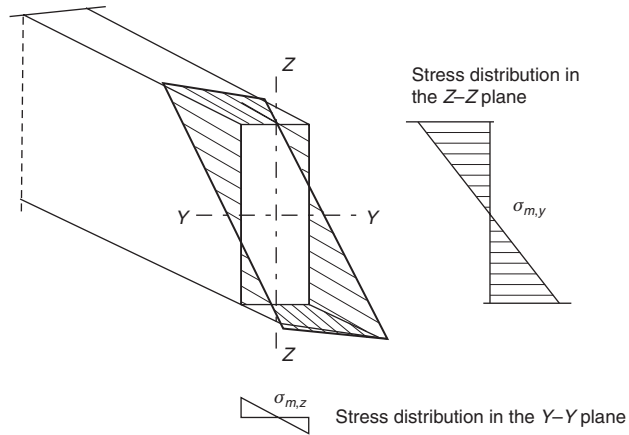

Fig. 4.4 Stress distribution in a rectangular beam subjected to biaxial bending

The background for the modification is that for these cross-sections the maximum stresses only act at small volumes close to the corners (see Fig. 4.4), and it is unlikely that the whole cross-section will fail if the bending stress exceeds the bending strength just in these small volumes. The bending strengths for bending about the axes may be different due to the depth factor k_h .

Lateral instability

High slender beams can fail due to lateral deflection and torsion when they are loaded in pure bending as shown in Fig. 4.5.

Example 4.3

The purlins in a roof with slope 1:3 ($\alpha = 18.4^\circ$) are spaced at 1.2 m (measured in the roof plane) and have a span of 4.8 m.

Timber C16. Service class 1.

Loads:

- dead load: $g = 0.3 \text{ kN/m}^2$ (measured along the roof)
- snow: $s = 0.4 \text{ kN/m}^2$ (measured horizontally)
- wind pressure: $w = 0.5 \text{ kN/m}^2$ (measured along the roof).

Find: an appropriate purlin size.

A purlin cross-section of $75 \times 200 \text{ mm}$ is estimated. The design moments from dead load ($\gamma_G = 1.35$) and snow load ($\gamma_Q = 1.5$) about a horizontal axis is calculated as:

$$M = 1.2 \cdot (1.35 \cdot 0.3 + 1.5 \cdot 0.4 \cdot \cos 18.4^\circ) \cdot 4.8^2 / 8 = 3.37 \text{ kNm}$$

$$M_y = 3.37 \cdot \cos 18.4^\circ = 3.19 \text{ kNm}$$

$$W_y = 500 \cdot 10^3 \text{ mm}^3$$

$$\sigma_{m,y,d} = 3.19 \cdot 10^6 / (500 \cdot 10^3) = 6.39 \text{ N/mm}^2$$

$$M_z = 3.37 \cdot \sin 18.4^\circ = 1.065 \text{ kNm}$$

$$W_z = 187.5 \cdot 10^3 \text{ mm}^3$$

$$\sigma_{m,z,d} = 1.065 \cdot 10^6 / (187.5 \cdot 10^3) = 5.68 \text{ N/mm}^2$$

$$\sigma_{m,d} = 6.39 + 5.68 = 12.07 \text{ N}^2/\text{mm}^2$$

The coefficient k_{mod} is determined by the short-term snow load $k_{mod} = 0.9$:

$$f_{m,d} = 0.9 \cdot 16 / 1.30 = 11.08 \text{ Nmm}^2$$

The ratio $\sigma_{m,d} / f_{m,d}$ is larger than 1 but the combination is acceptable because both (4.18) and (4.19) are satisfied.

For bending about the z -axis:

$$k_h = \left(\frac{150}{75} \right)^{0.2} = 1.15$$

$$\begin{aligned} \frac{\sigma_{m,y,d}}{f_{m,y,d}} + k_m \frac{\sigma_{m,z,d}}{f_{m,z,d}} &= \frac{6.39}{11.08} + 0.7 \frac{5.68}{1.15 \cdot 11.08} \\ &= 0.58 + 0.7 \cdot 0.45 = 0.89 < 1 \end{aligned}$$

$$\begin{aligned} k_m \frac{\sigma_{m,y,d}}{f_{m,y,d}} + \frac{\sigma_{m,z,d}}{f_{m,z,d}} &= 0.7 \frac{6.39}{11.08} + \frac{5.68}{1.15 \cdot 11.08} \\ &= 0.7 \cdot 0.58 + 0.45 = 0.85 < 1 \end{aligned}$$

Also the load combination $1.35g + 1.5s + 0.5v$ shall be investigated. Due to wind $\sigma_{m,y,d}$ is increased by:

$$1.5 \cdot 0.3 \cdot 0.5 \cdot 1.2 \cdot 4.8^2 = 1.17 \text{ N/mm}^2$$

For this case $k_{mod} = 1.1$, i.e. the strength is increased more than the stresses.

For the dead load, the maximum instantaneous deflection in the centre of the purlin is given by:

$$u_{g,inst} = \frac{5}{384} \frac{gl^4}{EI} = \frac{5}{384} \frac{0.3 \cdot \cos 18.4 \cdot 1.2 \cdot 4800^4}{8000 \cdot 50 \cdot 10^6} = 5.9 \text{ mm}$$

and the final deflection becomes:

$$u_{g,fin} = u_{g,inst}(1 + \psi_2 k_{mod}) = 5.9(1 + 1 \cdot 0.6) = 9.4 \text{ mm} < l/750$$

For the snow load where the load is given for the horizontal area the final deflection is calculated as:

$$u_{s,fin} = 5.9 \cdot \cos 18.4 \cdot 0.9/0.3 = 16.5 \text{ mm} < l/260$$

To calculate the load-carrying capacity of a straight elastic and simply supported beam, it is assumed that the torsion is prevented at the end supports and that the beam is loaded by two equal bending moments $M = M_y$ at the beam end. Under these conditions the beam will be stable for loads below a critical value $M = M_{cr}$. If this value is exceeded the beam will suddenly deflect as shown in Fig. 4.6. Solving the governing differential equations the following expression for the critical

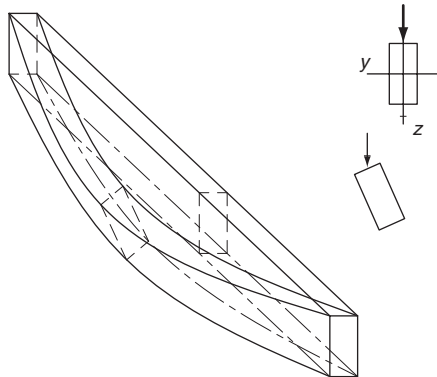

Fig. 4.5 Lateral torsional buckling deformation of a simply supported beam

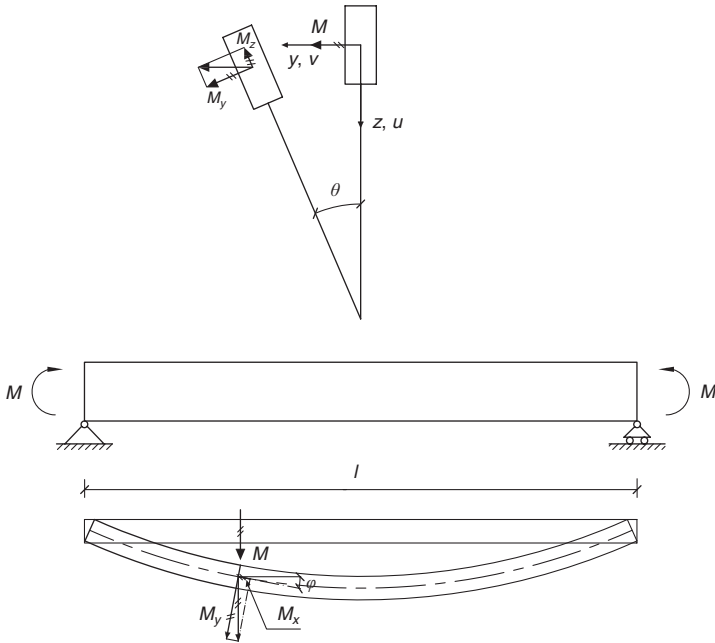

Fig. 4.6 Beam deflected in torsion and lateral deflection instability

buckling moment is found:

$$M = M_{cr} = \frac{\pi}{l} \sqrt{EI_z GI_{tor} \left[1 + \left(\frac{\pi}{l} \right)^2 \frac{EI_w}{GI_{tor}} \right]^2} \quad (4.20)$$

where I_{tor} is the moment of inertia for torsion and I_w is the so-called warping constant. The last term in the bracket is only of importance for open thin-walled cross-sections. For the majority of cross-sections in timber structures $I_w / (l^2 I_{tor}) \sim 0$ and the expression becomes:

$$M_{cr} = \frac{\pi}{l} \sqrt{EI_z GI_{tor}} \quad (4.21)$$

Expression (4.21) applies to beams with equal end moments. For other cases numerical methods, e.g. based on strain energy methods (virtual work), are required. The results can always be written in the form:

$$M_{cr} = \frac{\pi}{l_{eff}} \sqrt{EI_z GI_{tor}} \quad (4.22)$$

where l_{eff} is an effective length of the beam. Eurocode 5 gives some approximate values as shown in Table 4.1. As is apparent from Figs 4.5 and 4.6, the critical moment depends on the location of the load in

Table 4.1 Effective length l_{eff} as a function of beam length l and beam depth h (see Example 4.4)

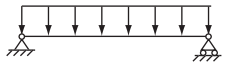
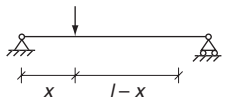
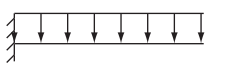
	Load acts in:		
	the bottom of the beam	the centreline	the top of the beam
		l	
	$0.9l - 0.5h$	$0.9l$	$0.9l + 2h$
	$0.8\alpha l - 0.5h$	$0.8\alpha l$	$0.8\alpha l + 2h$
$\alpha = 4 \frac{x}{l} \left(1 - \frac{x}{l} \right)$			
	$0.6l - 0.5h$	$0.6l$	$0.6l + 2h$

the cross-section. The higher the location, the bigger the driving effect and the smaller the critical load. Loads acting below the axis of rotation will even have a stabilising effect. This is taken into account in Eurocode 5 by reducing/increasing l_{eff} as shown by $0.5h$ and $2h$ respectively.

The torsion moment of inertia I_{tor} of a rectangular cross-section with side lengths b and $h (> b)$ is given by:

$$I_{tor} \sim \frac{hb^3}{3} \left(1 - 0.63 \frac{b}{h} \right) \quad (4.23)$$

For a closed box cross-section as shown in Fig. 4.7, I_{tor} is given by:

$$I_{tor} = \frac{2b^2(h - h_f)^2}{\frac{h - h_f}{t} \frac{G}{G_{web}} + \frac{h}{h_f}} \quad (4.24)$$

For a rectangular cross-section, Expression (4.22) can be rewritten as:

$$\frac{\sigma_{m,cr}}{f_m} = \frac{M_{cr}}{W f_m} = \frac{1}{\lambda_{m,rel}^2} \quad (4.25)$$

whereas for columns a relative beam slenderness ratio has been introduced.

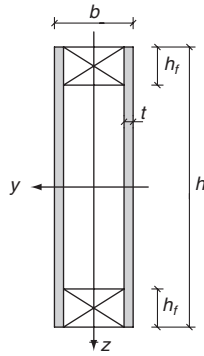

Fig. 4.7 Box beam geometry and notation

From Expression (4.22) with characteristic values inserted:

$$\sigma_{m,cr} = \frac{M_{cr}}{W_y} = \frac{\pi}{W_y l_{eff}} \sqrt{E_{0.05} I_z G_{0.05} I_{tor}} \quad (4.26)$$

For typical strength and stiffness values for structural timber:

$$\sigma_{m,cr} = \frac{0.78b^2}{l_{eff}h} E_{0.05} \quad (4.27)$$

Until now linear elastic behaviour has been assumed, i.e. $\sigma_{m,d}/f_{m,d} < \text{about } 0.5$ and $\lambda_{m,rel} > \text{about } 1.4$.

Tests to determine bending strength are normally performed on beams with $\lambda_{m,rel} \sim 0.75$. In Eurocode 5 the following expression for $\sigma_{cr,d}/f_{m,d}$ is given:

$$k_{cr} = \frac{\sigma_{cr,d}}{f_{m,d}} = \begin{cases} 1 & \lambda_{rel} \leq 0.75 \\ 1.56 - 0.75\lambda_{m,rel} & \text{for } 0.75 < \lambda_{m,rel} \leq 1.4 \\ 1/\lambda_{m,rel}^2 & 1.4 < \lambda_{m,rel} \end{cases} \quad (4.28)$$

Expression (4.28) is shown in Fig. 4.8.

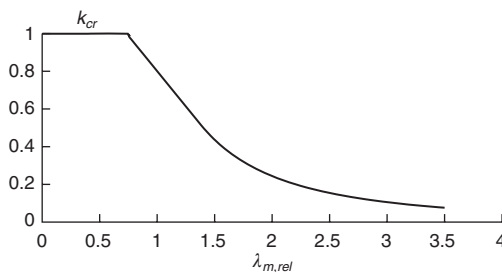
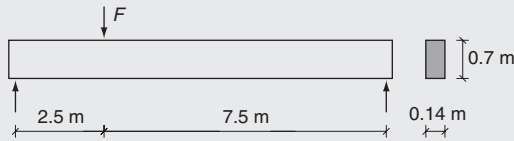

Fig. 4.8 $k_{cr} = \sigma_{cr,d}/f_{m,d}$ as a function of the relative slenderness ratio $\lambda_{m,rel}$

Example 4.4



A simply supported glulam beam (GL32c) with cross-section dimensions 115×700 mm has a length of 10 m. The load is a short-term load F acting on the top of the beam. The ends of the beam are restrained against torsion.

Service class 1.

Find: the maximum value F_{max} .

For a load acting at the centreline the effective length according to Table 4.1 is:

$$l_{eff} = (0.8 \cdot 4 \cdot 0.25 \cdot 0.75) \cdot 10 + 2 \cdot 0.7 = 7.4 \text{ m}$$

With $E_{0.05} = 11100$ and $f_{m,k} = 32 \text{ N/mm}^2$:

$$\sigma_{m,cr} = \frac{0.78b^2}{l_{eff}h} E_{0.05} = \frac{0.78 \cdot 115^2}{7400 \cdot 700} \cdot 11100 = 22.1 \text{ N/mm}^2$$

$$\lambda_{m,rel} = \sqrt{\frac{f_{m,k}}{\sigma_{m,cr,k}}} = \sqrt{\frac{32}{22.1}} = 1.20$$

For load acting on top of the beam:

$$\sigma_{cr,d}/f_{m,d} = 1.56 - 0.75\lambda_{m,rel} = 1.56 - 0.75 \cdot 1.20 = 0.66$$

$$\sigma_{m,cr,d} = 0.66 \cdot 32 \cdot 0.9/1.25 = 15.2 \text{ N/mm}^2$$

$$W = 115 \cdot 700^2/6 = 9.39 \cdot 10^6 \text{ mm}^3$$

$$M_{cr} = 15.2 \cdot 9.39 = 142.7 \text{ kNm}$$

$$M = 2.5 \cdot 7.5F_{max,d}/10 = 1.875F_{max,d}$$

$$F_{max,d} = 142/1.875 = 76 \text{ kN}$$

4.1.7 Combined bending and axial loading

Frames made of solid timber or laminated beams are often subjected to combined bending and axial loading.

Bending and axial tension

For beams with arbitrary cross-section and combined tensile load and bending it shall be verified that:

$$\frac{\sigma_{t,d}}{f_{t,0,d}} + \frac{\sigma_{m,y,d}}{f_{m,y,d}} + \frac{\sigma_{m,z,d}}{f_{m,z,d}} \leq 1 \quad (4.29)$$

For rectangular cross-sections Expression (4.29) may be replaced by the following two conditions:

$$\frac{\sigma_{t,d}}{f_{t,0,d}} + \frac{\sigma_{m,y,d}}{f_{m,y,d}} + k_m \frac{\sigma_{m,z,d}}{f_{m,z,d}} \leq 1 \quad (4.30)$$

$$\frac{\sigma_{t,d}}{f_{t,0,d}} + k_m \frac{\sigma_{m,y,d}}{f_{m,y,d}} + \frac{\sigma_{m,z,d}}{f_{m,z,d}} \leq 1 \quad (4.31)$$

where the bending coefficient k_m is equal to 0.7 for rectangular cross-sections.

Bending and axial compression

For beams with arbitrary cross-section and loaded in combined bending and axial compression it shall be verified that:

$$\left(\frac{\sigma_{c,d}}{f_{c,0,d}} \right)^2 + \frac{\sigma_{m,y,d}}{f_{m,y,d}} + \frac{\sigma_{m,z,d}}{f_{m,z,d}} \leq 1 \quad (4.32)$$

where $\sigma_{c,d} = F_{c,d}/A$ is the compression stress. For rectangular cross-sections Expression (4.32) is replaced by the following two conditions:

$$\left(\frac{\sigma_{c,d}}{f_{c,0,d}} \right)^2 + \frac{\sigma_{m,y,d}}{f_{m,y,d}} + k_m \frac{\sigma_{m,z,d}}{f_{m,z,d}} \leq 1 \quad (4.33)$$

$$\left(\frac{\sigma_{c,d}}{f_{c,0,d}} \right)^2 + k_m \frac{\sigma_{m,y,d}}{f_{m,y,d}} + \frac{\sigma_{m,z,d}}{f_{m,z,d}} \leq 1 \quad (4.34)$$

where the bending coefficient k_m is equal to 0.7 for rectangular cross-sections.

Combined bending, axial compression and buckling are dealt with in Chapter 5.

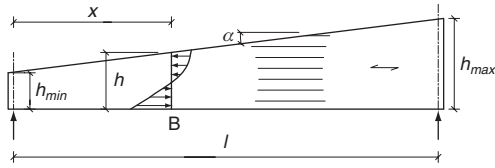

Fig. 4.9 Single tapered beam

4.2 Tapered beams

Beams are sometimes tapered in order to obtain a suitable geometry (e.g. roof slope) or to tailor the size to the force distribution or architecturally be attractive. Figures 4.9 and 4.10 show two types of beams commonly used in practice, namely single tapered and double tapered beams. It is common practice to cut/taper the fibres on only one side of the beams, normally the top/compression side and that the fibres on the other side (normally the bottom/tension face) are parallel to the span.

In derivation of some of the following equations, it is assumed that the beams are simply supported, but the equations may also be used as an approximation for other cases, e.g. for the calculation of the straight parts of arches, see Chapter 6.

4.2.1 Single tapered beam

The stress distributions in tapered beams differ significantly from those of beams with constant depth. Both the normal stresses and the shear stresses vary significantly over the cross-section depth and along its length (see Fig. 4.9).

In single tapered beams, the bending stress increases slightly at the bottom face and reduces at the top face. A lateral load also induces not only axial stresses but also stresses perpendicular to the fibres. The reason for this is that the normal stress parallel with the top surface requires a vertical stress component to fulfil the equilibrium conditions. These effects are taken into account by reducing the bending strength

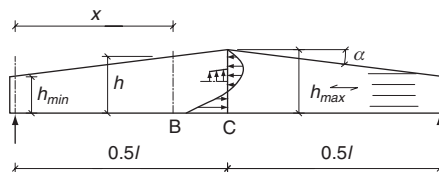

Fig. 4.10 Double tapered beam

by a factor k_m and it shall be verified that:

$$\frac{\sigma_{m,d}}{k_{m,\alpha} f_{m,d}} \leq 1 \quad (4.35)$$

where:

$\sigma_{m,d}$ is the design bending stress:

$$\sigma_{m,d} = \frac{6M_d}{bh^2} \quad (4.36)$$

For tensile stresses parallel to the tapered side:

$$k_{m,\alpha,t} = \frac{1}{\sqrt{1 + \left(\frac{f_{m,d}}{0.75 f_{v,d}} \tan \alpha\right)^2 + \left(\frac{f_{m,d}}{f_{t,90,d}} \tan \alpha\right)^2}} \quad (4.37)$$

For compressive stresses parallel to the tapered side:

$$k_{m,\alpha,c} = \frac{1}{\sqrt{1 + \left(\frac{f_{m,d}}{1.5 f_{v,d}} \tan \alpha\right)^2 + \left(\frac{f_{m,d}}{f_{c,90,d}} \tan \alpha\right)^2}} \quad (4.38)$$

The reduction factor $k_{m,\alpha}$ for compression and tension is shown in Fig. 4.11 for glulam GL32h and GL24c. The reduction factors for other grades of glulam will fall between the two grades.

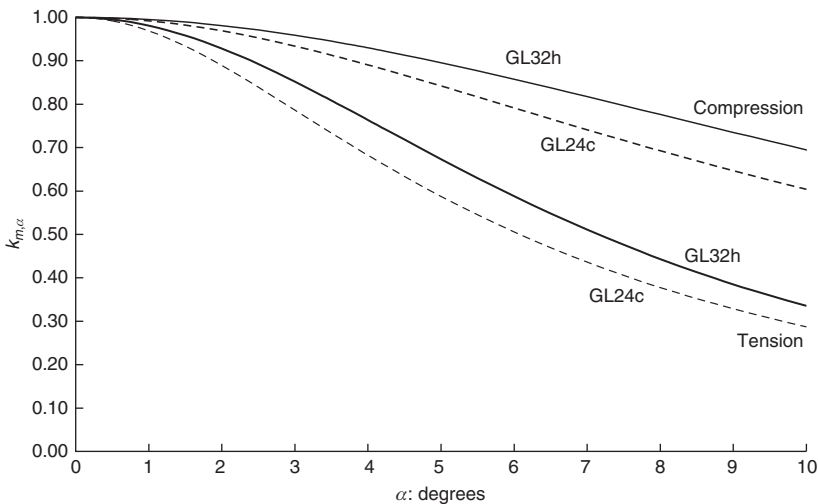

Fig. 4.11 Reduction factors $k_{m,\alpha}$ for glulam GL32h and GL24c

For single tapered beams, the maximum bending stress is often at a cross-section near the shallower end of the beam. The critical cross-section may be found analytically but it is often easier to calculate the stresses in several cross-sections along the beam. For a simply supported single tapered beam with a uniformly distributed load q , the distance x from the shallower end of the beam to the critical section is given by:

$$x = l \frac{h_{min}}{h_{max} + h_{min}} \quad (4.39)$$

where the stress is calculated as:

$$\sigma_m = \frac{0.75ql^2}{bh_{min}h_{max}} \quad (4.40)$$

The deflection may be found by the principle of virtual work. For the beams mentioned above, the largest deflection becomes:

$$u_{max} = k_{deflec}u_0 \quad (4.41)$$

where the deflection constant k_{deflec} is given in Fig. 4.12. The deflection u_0 is the deflection in a corresponding beam with constant depth equal to $h_{mean} = 0.5(h_{min} + h_{max})$.

4.2.2 Double tapered beams

For a simply supported beam (see Fig. 4.10) with uniformly distributed load, q , the distance x from the shallower end to the critical cross-section with the maximum stresses is:

$$x = l \frac{h_{min}}{2h_{max}} \quad (4.42)$$

and the maximum bending stress is:

$$\sigma_m = \frac{0.75ql^2}{bh_{min}(2h_{max} - h_{min})} \quad (4.43)$$

The bending deformation of the beam results in tension stresses perpendicular to the grain direction under the apex point (cross-section C in Fig. 4.10). The distribution of the tension stress, $\sigma_{t,90}$, is as shown in Fig. 4.10. The normal stress at the top becomes zero because of the discontinuity in the slope of the upper surface. The maximum tensile stress may be calculated by the expressions given in Chapter 5. They will, however, rarely be of any importance.

For the deflections, Expression 4.41 applies.

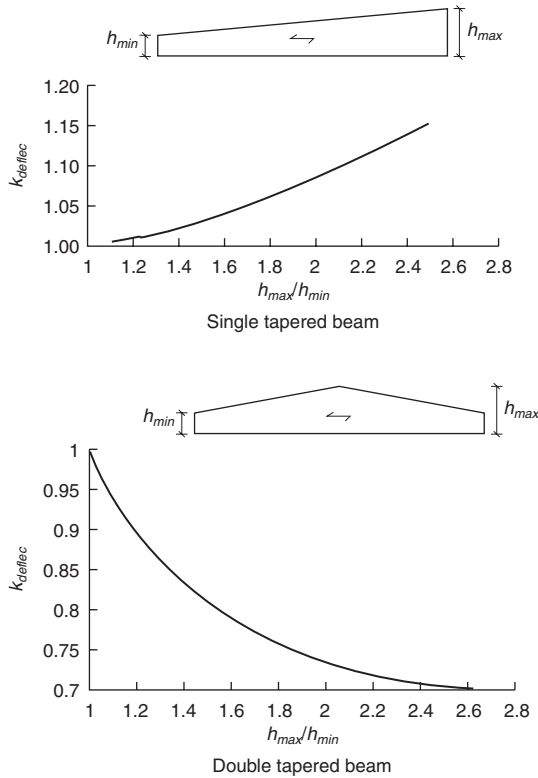
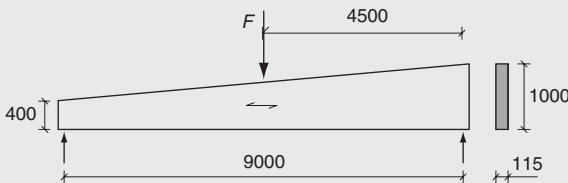

Fig. 4.12 Relation between the deflection factor k_{deflec} and the (taper) ratio h_{max}/h_{min}

Example 4.5



A simply supported glulam beam (GL32h) has a span of 9 m, the beam width is 115 mm, and the depth varies from 400 mm to 1000 mm (slope 1:15). The beam is held against lateral buckling and is loaded in the mid-span by a concentrated short-term load $F_d = 90$ kN.

Service class 1.

Show that the load-carrying capacity is sufficient.

The cross-section with the maximum stress is placed at a distance x from the middle towards the shallower end.

The moment is $0.5Fx$, the depth is $h(x) = 0.40 + 0.6x/9$, and the bending stress is:

$$\sigma(x) = \frac{0.5F}{bh(x)^2/6}$$

The maximum stress is found in the middle of the beam, see the table below.

x : m	4.0	4.25	4.50
σ : N/mm ²	21.13	21.37	21.56

The design strengths in N/mm² are:

- $f_{m,d} = 0.9 \cdot 32/1.25 = 23.04$
- $f_{t,0,d} = 0.9 \cdot 22.5/1.25 = 16.20$
- $f_{t,90,d} = 0.9 \cdot 0.5/1.25 = 0.36$
- $f_{c,0,d} = 0.9 \cdot 29/1.25 = 20.88$
- $f_{c,90,d} = 0.9 \cdot 33/1.25 = 23.8$

With $\alpha = 3.8^\circ$ the reduction factor on the top surface where the fibres are cut becomes $k_{m,\alpha,c} = 0.936$:

$$\frac{\sigma_{m,d}}{k_{m,\alpha,c,d}} = \frac{21.56}{0.936 \cdot 24.06} = 0.96 < 1$$

The instantaneous deflection in the middle of a beam with a constant depth of 700 mm is calculated as:

$$u_0 = \frac{Fl^3}{48EI} = \frac{12 \cdot 90 \cdot 10^3 (9 \cdot 10^3)^3}{48 \cdot 13.7 \cdot 10^3 \cdot 115 \cdot 700^3} = 30.4 \text{ mm}$$

From Fig. 4.12 with $h_{max}/h_{min} = 1000/400 = 2.5$, the deflection factor is found to be $k_{deflect} = 1.18$ and the deflection:

$$u_{mst} = 1.18 \cdot 30.4 = 36 \text{ mm}$$

The deflection for the characteristic load is approximately 70% of this value.

4.3 Shear

4.3.1 General

Timber beams can be subject to large shear stresses, especially close to concentrated forces and near supports. Shear stresses can also be caused by a torsion moment applied to the beam.

4.3.2 Shear stresses caused by bending

For beams with shear forces it shall be verified that:

$$\frac{\tau_d}{f_{v,d}} \leq 1 \quad (4.44)$$

The effect of an external shear force V_z in the z direction of a beam is illustrated in Fig. 4.13. H is the horizontal shear force induced by V_z on the cross-section with unit length. H is equal to:

$$H = \frac{S_y}{I_y} V \quad (4.45)$$

where S_y is the static moment of the shaded area about the y - y axis. The formula applies irrespective of how the cut is made.

To determine the corresponding shear stresses it is necessary to estimate the distribution over the cutting surface. For thin-walled cross-sections a uniform distribution over the thickness may be assumed. The same applies for rectangular beams for cuts parallel to one of the sides.

For a rectangular beam with the shear forces V_z and V_y and the cuts 1-1 and 2-2 shown in Fig. 4.14, the shear stresses are calculated as:

$$\tau_z = \frac{S_y}{bI_y} V_z \quad \text{and} \quad \tau_y = \frac{S_z}{hI_z} V_y \quad (4.46)$$

The resultant shear stress is found by vector addition as:

$$\tau = \sqrt{\tau_z^2 + \tau_y^2} \quad (4.47)$$

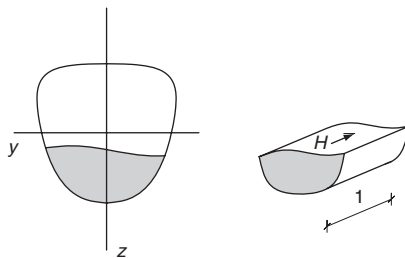

Fig. 4.13 Illustration of shear force H acting on an arbitrary cross-section

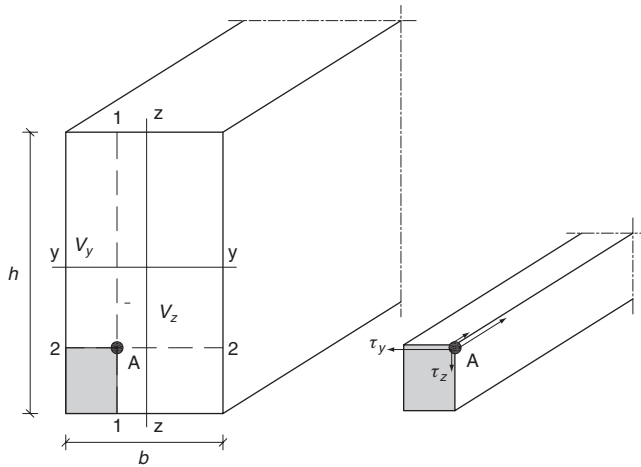

Fig. 4.14 Illustration of notation used for determination of shear stresses for a beam with rectangular cross-section

For a beam with rectangular cross-section with depth h and width b , and with a shear force V in the direction of h , it shall be verified that:

$$\frac{3}{2} \frac{V}{hk_{crack}b} \leq 1 \quad (4.48)$$

where k_{crack} is a factor that takes into account the effect of end cracks:

$$k_{crack} = \begin{cases} 0.67 & \text{for structural timber} \\ 0.67 & \text{for glulam} \\ 1 & \text{for other wood-based products} \end{cases} \quad (4.49)$$

According to Eurocode 5, loads within a distance h from the end may be disregarded (see Fig. 4.15). For beams this reduction applies only when the notch is on the opposite side of the support.

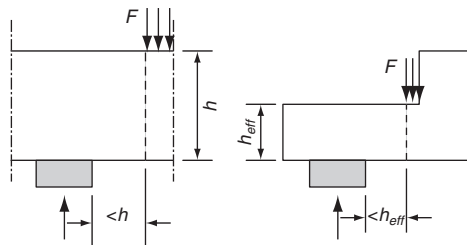

Fig. 4.15 For calculation of the shear force V , loads closer to the support edge than the beam depth h or h_{eff} may be disregarded

Example 4.6

The same beam as in Example 4.5 is studied.

Find: the shear capacity of the beam.

The maximum shear stress is found at the support at the shallower end:

$$V_d = 45 \text{ kN}$$

For GL32 and short-term loads the shear strength becomes:

$$f_{v,d} = 0.9 \cdot 3.8/1.25 = 2.74 \text{ N/mm}^2$$

$b = 115 \text{ mm}$, $h = 400 \text{ mm}$. The crack factor is $k_{crack} = 0.67$

$$\frac{\tau_d}{f_{v,d}k_{crack}} = \frac{1.5 \cdot 4500/[115/(0.67 \cdot 400)]}{2.74} = \frac{2.19}{2.74} = 0.80 < 1$$

4.3.3 Beams with end notches

For a beam with a notch at the support, there may be a risk of cracking failure along the paths shown in Figs 4.16(a) and (b), due to stress concentrations at the notched corner. Initially the crack is stable, but with increasing load the crack propagates and results in total collapse.

For the notched beams shown in Fig. 4.16, it shall be verified that:

$$\frac{\tau_d}{k_v f_{v,d}} = 1.5 \frac{V_d}{bh_{eff}k_v f_{v,d}} \leq 1 \tag{4.50}$$

For a beam with the end notch at the compression side (see Fig. 4.16(c)) the reduction coefficient $k_v = 1$, whereas for a beam with the notch at the tension side (see Fig. 4.16(a) and (b)), the reduction coefficient factor should be calculated as:

$$k_v = \min \left\{ 1, k_n k_i \frac{1}{\sqrt{h}} \left(\sqrt{\alpha - \alpha^2} + 0.8\beta\sqrt{\alpha^{-1} - \alpha^2} \right)^{-1} \right\} \tag{4.51}$$

where:

- a is the distance from the reaction to the corner of the notch;
- h is the beam depth (in mm)
- h_{eff} is the effective depth (in mm)
- $\alpha = h_{eff}/h$
- $\beta = a/h$
- i is the notch slope.

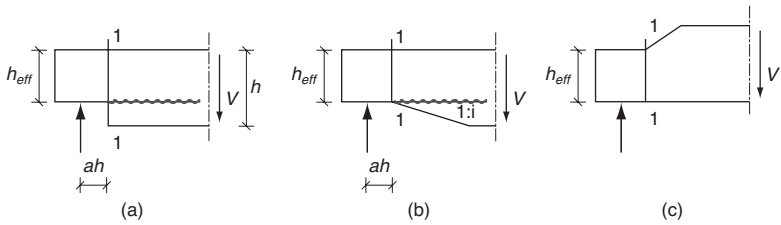

Fig. 4.16 Rectangular beam with end notches: (a) sharp notch at the tension side; (b) inclined notch at the tension side; (c) inclined notch at the compression side (it should be noted that there is no crack pattern as the notch is in compression)

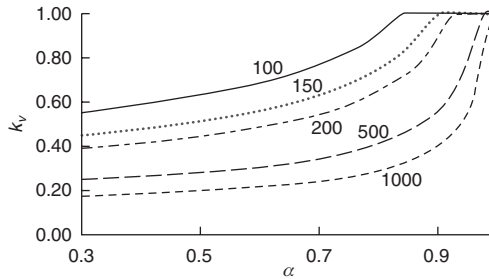
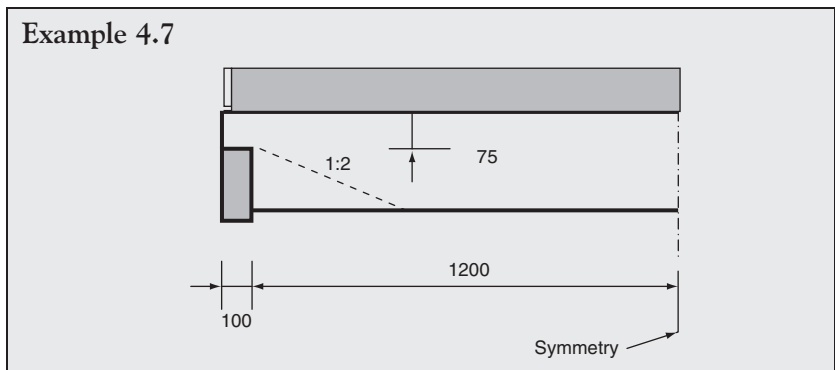

Fig. 4.17 The influence of beam depth and notch depth on the factor k_v for glulam beams. The figures are beam depth in mm

$$k_n = \begin{cases} 5 & \text{for structural timber} \\ 6.6 & \text{for glulam} \end{cases} \quad (4.52)$$

$$k_i = 1 + 1.1 \frac{i^{1.5}}{\sqrt{h}} \quad (4.53)$$

The influence of the beam depth and the notch depth on the factor k_v is illustrated in Fig. 4.17 that corresponds to $k_n = 6.5$ (for glulam) and $\beta = 0.5$.



A concrete form is supported by beams of class C18 with 500 mm centres. The beam span, measured between the centre points of the supports, is 2.5 m. The depth of the end notch is limited to 75 mm. The short-term design load is $q_d = 3.0 \text{ kN/m}^2$.

Service class 3 (outdoor).

Find a beam with sufficient strength and stiffness.

The design bending and shear strengths for C18 are:

$$f_{m,d} = 0.7 \cdot 18 / 1.3 = 9.69 \text{ N/mm}^2$$

$$f_{v,d} = 0.7 \cdot 3.4 / 1.3 = 1.83 \text{ N/mm}^2$$

The design bending moment is:

$$M_d = 0.5 \cdot 3.0 \cdot 2.5^2 / 8 = 1.17 \text{ kNm}$$

The necessary section modulus:

$$W = 1.17 \cdot 10^6 / 9.69 = 121 \cdot 10^3 \text{ mm}^3$$

Possible cross-sections:

$$\text{for } 38 \times 200: W = 253 \cdot 10^3 \text{ mm}^3, A = 7600 \text{ mm}^2$$

$$\text{for } 47 \times 175: W = 240 \cdot 10^3 \text{ mm}^3, A = 8225 \text{ mm}^2$$

$$V_d = 0.5 \cdot 3.0 \cdot 1.2 = 1.80 \text{ kN}$$

For 38×200 :

$$h = 200 \text{ mm}$$

$$h_{\text{eff}} = 75 \text{ mm}$$

$$a = 50 \text{ mm}$$

$$\alpha = h_{\text{eff}} / h = 0.375$$

$$\beta = a / h = 50 / 200 = 0.25$$

$$i = 0$$

$$k_i = 0$$

$$k_n = 5$$

According to Expression (4.51) the reduction factor is:

$$k_v = 5 \frac{1}{\sqrt{200}} \cdot \left(\sqrt{0.375 - 0.375^2} + 0.8 \cdot 0.25 \sqrt{\frac{1}{0.375} - 0.375^2} \right)^{-1}$$

$$= 0.44$$

$$k_{crack} = 0.67$$

$$\tau_d = \frac{1.5 \cdot 1800}{38 \cdot 75 \cdot 0.67} = 1.41 \text{ N/mm}^2$$

$$\frac{\tau_d}{k_v f_{v,d}} = \frac{1.41}{0.44 \cdot 1.83} = 1.75 > 1$$

Therefore the strength is insufficient.

For 47×175 :

$$k_v = 0.455$$

$$\tau_d = \frac{1.5 \cdot 1800}{47 \cdot 75 \cdot 0.67} = 1.14 \text{ N/mm}^2$$

$$\frac{\tau_d}{k_v f_{v,d}} = \frac{1.14}{0.455 \cdot 1.84} = 1.37 > 1$$

Therefore the strength is still insufficient.

Instead of using a bigger (wider) cross-section, the beam-ends are cut as shown in Fig. 4.16(b). For an inclination $1:i \sim 1:3$ the coefficient k_i becomes:

$$k_i = 1 + 1.1 \frac{3^{1.5}}{\sqrt{175}} = 1.43$$

and the strength is sufficient.

The deflection for the characteristic load that is estimated to 80% of the design load becomes:

$$\begin{aligned} u = u_{inst} &= \frac{5}{384} \frac{ql^4}{EI} = \frac{5}{384} \frac{0.5 \cdot 0.8 \cdot 3.0 \cdot 2500^4}{9000 \cdot 20.99 \cdot 10^6} \\ &= 3.2 \text{ mm} < l/750 \end{aligned}$$

4.3.4 Torsion shear stresses

Pure torsion

For beams loaded in torsion, the torsion shear stresses $\tau_{tor,d}$ must fulfil the following condition:

$$\frac{\tau_{tor,d}}{f_{v,d}} \leq 1.2 \quad (4.54)$$

For a circular cross-section with a radius r the maximum torsion shear stress is:

$$\tau_{tor,max} = \frac{2T}{\pi r^3} \text{ where } T \text{ is the twisting moment (or torque)} \quad (4.55)$$

For a rectangular cross-section $h \times b$ with $h > b$ the maximum torsion shear stress is:

$$\tau_{tor,max} = \frac{T(3h + 1.8b)}{h^2 b^2} \quad (4.56)$$

5

Columns

5.1 Introduction

A member loaded by a compression force is normally called a column.

5.2 Axially loaded columns

For a column with cross-section area A , loaded by an axial compression force F_c that induces a compressive stress of $\sigma_c = F_c/A$, it shall be verified that:

$$\frac{\sigma_c}{k_c f_c} \leq 1 \quad (5.1)$$

where k_c is a factor ($k_c \leq 1$) called the column factor, is derived in the following Expression for k_c .

For the column shown in Fig. 5.1 it is assumed that it may deflect in one of main axes directions. The corresponding second moment of area is I and the elastic buckling stress is equal to the Euler stress σ_E :

$$\sigma_E = \frac{\pi^2 EI}{l^2 A} = \frac{\pi^2 E}{\lambda^2} \quad (5.2)$$

where $\lambda = l/i$, l is the free column length, i is the radius of gyration: $i = \sqrt{I/A}$ and I is the second moment of area (moment of inertia). Traditionally, the slenderness ratio λ is used to describe the slenderness of the column. In the following it is, however, found more convenient to use the so-called relative slenderness ratio defined by:

$$\lambda_{\text{rel}} = \lambda \sqrt{\frac{f_c}{\pi^2 E}} \quad (5.3)$$

With this relative slenderness ratio, Expression (5.2) becomes:

$$\frac{\sigma_E}{f_c} = \frac{1}{\lambda_{\text{rel}}^2} \quad (5.4)$$

In practice, all columns have certain imperfections. They are often not perfectly linear, and the load can act with some eccentricity due

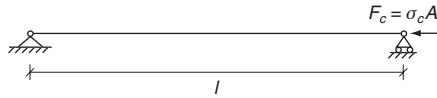

Fig. 5.1 Simply supported, axially loaded column

to knots. As an approximation it is, therefore, assumed that the column in the initial situation has a sinusoidal deflection with the eccentricity e in the middle of the column (see Fig. 5.2). This means that the axial force will give a moment $M_{mid} = F_c(e + u_{mid})$ in the middle of the beam where u_{mid} is the deflection of the beam.

The governing differential equation for static equilibrium of an initially deflected column is given by:

$$EI \frac{d^2 u}{dx^2} = -M = -F_c \left(u + e \sin \frac{\pi x}{l} \right) \quad (5.5)$$

The resulting centre deflection is given by:

$$u_{mid} = e \frac{\sigma_c}{\sigma_E - \sigma_c} \quad (5.6)$$

$$e + u_{mid} = e + e \frac{\sigma_c}{\sigma_E - \sigma_c} = e \frac{k_E}{k_E - \sigma_c/f_c} \quad (5.7)$$

where k_E is defined from the Euler stress as $k_E = \sigma_E/f_c$. In the mid-height of the column the normal stress is σ_c and the bending stress is:

$$\sigma_m = F_c(e + u_{mid})/W = \frac{\sigma_c A e}{W} \frac{k_E}{k_E - \sigma_c/f_c}$$

Failure corresponds, see Expression (4.29) to:

$$\frac{\sigma_c}{f_{c,0}} + \frac{\sigma_m}{f_m} = 1$$

giving:

$$\frac{\sigma_c}{f_{c,0}} + \frac{\sigma_c A e}{W f_m} \frac{k_E}{k_E - \sigma_c/f_c} = 1 \quad (5.8)$$

$$\sigma_c/f_c = k_c$$

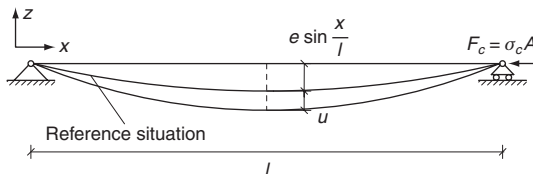

Fig. 5.2 Simply supported, axially loaded column with initial deflection

that is:

$$k_c \left(1 + \frac{eA}{W} \frac{f_{c,0}}{f_m} \frac{1}{1 - \lambda_{rel}^2 k_c} \right) = 1 \quad (5.9)$$

from which with:

$$k = 0.5 \left(1 + \frac{eA}{W} \frac{f_c}{f_m} + \frac{1}{k_E} \right)$$

then:

$$k_c = \frac{1}{k + \sqrt{k^2 - \lambda_{rel}^2}} \quad (5.10)$$

Since all grading rules for structural timber restrict the initial deflection to a fraction of the length l , and since λ_{rel} is proportional to l , it would seem natural to set e proportional to λ_{rel} ; but this results in $k_c < 1$ even for small values of λ , which is in contradiction to the fact that the compression strength is found by specimens with a slenderness ratio, λ , of about 15, corresponding to $\lambda_{rel,0} = 0.3$. It is instead assumed that:

$$\frac{eA}{W} \frac{f_c}{f_m} = \beta(\lambda_{rel} - \lambda_{rel,0}) \quad (5.11)$$

where:

$$\beta = \begin{cases} 0.2 & \text{for structural timber} \\ 0.1 & \text{for glulam} \end{cases} \quad (5.12)$$

$$\lambda_{rel,0} = 0.3 \quad (5.13)$$

that is:

$$k = 0.5[1 + \beta(\lambda_{rel} - 0.3) + \lambda_{rel}^2] \quad (5.14)$$

Figure 5.3 shows k_c as a function of λ_{rel} . For $\lambda_{rel} < 0.3$, $k_c = 1.0$.

The load-carrying capacity of columns depends very much on the stiffness of the column as a whole and local reductions in the cross-section area have only small effect. k_c is, therefore, calculated with the properties of the total cross-section. The stresses shall however be calculated for the reduced cross-section. The biggest reductions are normally found at the ends where it shall be verified that:

$$\frac{\sigma_{c,nett}}{f_c} = \frac{F_c}{f_c A_{nett}} \leq 1 \quad (5.15)$$

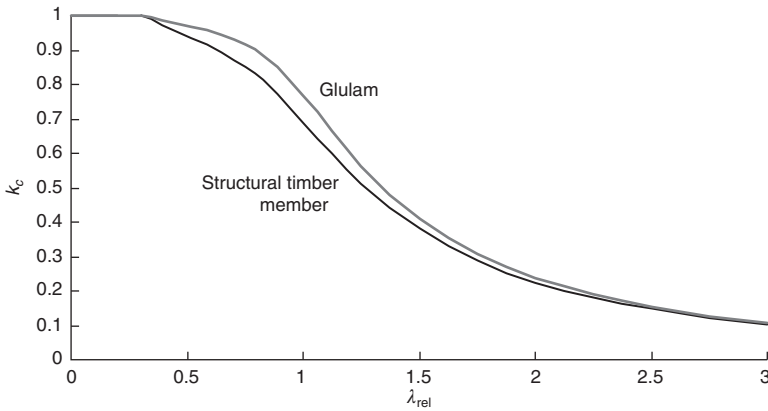

Fig. 5.3 Relationship between column factor k_c and λ_{rel} for structural timber and glulam

where A_{nett} is the reduced cross-section area. If the cross-section varies over the length, the calculations are normally made with the smallest cross-section over the middle third of the length.

For types of support (boundary) conditions other than simply supported, the same expressions are used as an approximation, with the free column lengths (effective lengths) corresponding to the support conditions. Where support restraints depend on mechanical fasteners the effects of slip in the joints shall be taken into account by using conservative values for the column length, see Fig. 5.4 unless a more stringent analysis is made.

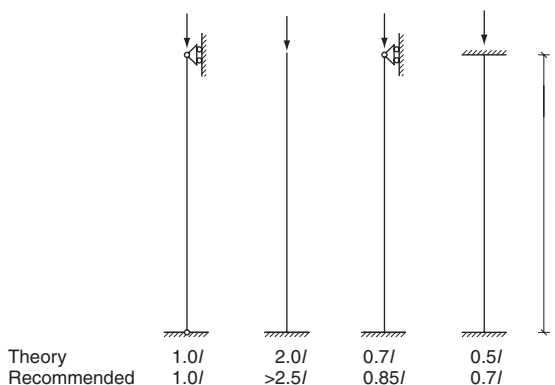

Fig. 5.4 Theoretical free column lengths and recommended effective lengths for columns with restraint support conditions made by mechanical fasteners

Example 5.1

A simply supported column of timber class C16, with length 4.0 m and cross-section dimensions of 150 × 150 mm is loaded by short-term load under service Class 1 conditions.

Find: the load-carrying capacity.

$$i = 150/\sqrt{12} = 43.3 \text{ mm}$$

$$\lambda = 4000/43.3 = 92.4$$

$$f_{c,0,d} = 0.9 \cdot 17/1.3 = 11.77$$

$$E_k = 5400 \text{ N/mm}^2$$

Since $\frac{f_{c,0,d}}{E_d} = \frac{f_{c,0,k}}{E_k}$ Expression (5.3) gives:

$$\lambda_{rel} = \frac{\lambda}{\pi} \sqrt{\frac{f_{c,0,k}}{E_k}} = \frac{92.4}{\pi} \sqrt{\frac{17}{5400}} = 1.65$$

From Expression (5.14):

$$k = 0.5(1 + 0.2(1.65 - 0.3) + 1.65^2) = 1.98$$

From Expression (5.10):

$$k_c = \frac{1}{1.98 + \sqrt{1.98^2 - 1.65^2}} = 0.326$$

$$F_{c,d} = k_c f_{c,0,d} A = 0.326 \cdot 11.77 \cdot 150^2 \cdot 10^{-3} = 86.4 \text{ kN}$$

5.3 Laterally loaded columns

A simply supported column that in addition to an axial force is loaded by a lateral load inducing a moment with a maximum value M_0 at the mid-height is considered. The bending stress from M_0 is σ_m . For practical reasons σ_m is defined differently from that than in Expression (5.8) where σ_m for the axially loaded column is the bending stress in the initially deflected column.

It is initially assumed that the column is loaded in the plane of one of the main axes and restrained against deflection perpendicular to this plane (see Fig. 5.5).

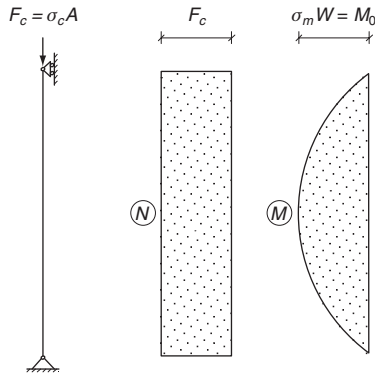

Fig. 5.5 Laterally loaded, simply supported column with initial moment M_0 in the mid-height of the column

In principle, the calculations are the same as for the concentrically loaded column, but with a formal initial eccentricity in the middle of $(e + M_0/F_c)$. Due to the axial force this moment is increased by the factor $\sigma_c/(\sigma_c - \sigma_E)$.

For a laterally loaded columns it shall be verified that:

$$\frac{\sigma_c}{k_{c,y} f_{c,0}} + \frac{\sigma_m}{f_m} \leq 1 \quad (5.16)$$

If the column is not simply supported or if the moment is not maximum in the middle, σ_m should be taken as the moment that is increased substantially due to the deflection.

For the general case with bending about two axes it shall be verified that:

$$\frac{\sigma_c}{k_{c,y} f_{c,0}} + \frac{\sigma_{m,y} + k_m \sigma_{m,z}}{f_m} \leq 1 \quad (5.17a)$$

$$\frac{\sigma_c}{k_{c,z} f_{c,0}} + \frac{k_m \sigma_{m,y} + \sigma_{m,z}}{f_m} \leq 1 \quad (5.17b)$$

where:

$k_{c,y}$ is the column factor for deflection in z axis direction (bending about the y - y axis);

$k_{c,z}$ is the column factor for deflection in the y axis direction (bending about the z - z axis);

k_m is the factor taking into account that it is unlikely that total failure takes place when the strength is exceeded in one cross-section corner only. Normally a value of $k_m = 0.7$ is used.

Note that even when the bending moment acts about the y - y axis both conditions shall be fulfilled to take into account any coupling effects between the deflections. In practice the main axes are not necessary parallel to the sides of the cross-section because of knots etc.

Example 5.2

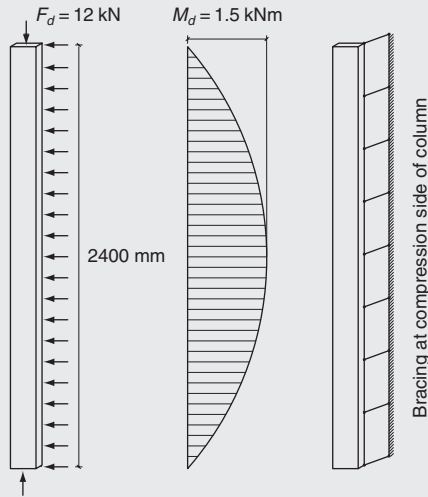

A simply supported rectangular column of C16 with planed cross-section 44×145 mm and length of $l = 2400$ mm, with a permanent concentric load of $F_d = 12.0$ kN and a uniformly distributed lateral wind load inducing a design moment of $M_d = 1.5$ kNm at mid-height about the strong axis is used outdoors to support a roof. The column is in a service Class 2 condition. The compression side of the column is braced in its full length.

Show that the column has sufficient load-carrying capacity.

$$\frac{f_{c,0}}{E} = \frac{17}{5400} = 0.00314$$

For axial compression load alone:

Permanent load:

$$\sigma_{c,0,d} = \frac{12\,000}{44 \cdot 145} = 1.88 \text{ N/mm}^2$$

$$k_{mod} = 0.6$$

$$\gamma_M = 1.3$$

$$f_{c,0,d} = 0.6 \cdot 17/1.30 = 7.85 \text{ N/mm}^2$$

$$i = 41.9 \text{ mm}$$

$$\lambda = 2400/41.9 = 57.3$$

$$\lambda_{rel} = \frac{\lambda}{\pi} \sqrt{\frac{f_{c,0,k}}{E_k}} = \frac{57.3}{\pi} \sqrt{0.00314} = 1.024$$

From Expression (5.14):

$$k = 0.5[1 + 0.2 \cdot (1.024 - 0.3) + 1.024^2] = 1.097$$

From Expression (5.10):

$$k_c = \frac{1}{1.097 + \sqrt{1.097^2 - 1.024^2}} = 0.671$$

From Expression (5.16):

$$\frac{\sigma_{c,d}}{k_c f_{c,0,d}} = \frac{1.88}{0.671 \cdot 7.85} = 0.36 < 1$$

For axial load and moment:

The wind, which is classed as instantaneous, determines k_{mod} . For service Class 2, $k_{mod} = 1.1$:

$$f_{c,0,d} = 1.10 \cdot (17/1.3) = 14.38 \text{ N/mm}^2$$

$$f_{m,d} = 1.10 \cdot (16/1.3) = 13.54 \text{ N/mm}^2$$

$$\sigma_{m,d} = 1.5 \cdot 10^6 \cdot 6 / (44 \cdot 145^2) = 9.73 \text{ N/mm}^2$$

From Expression (5.16):

$$\begin{aligned} \frac{\sigma_{c,d}}{k_{c,y} f_{c,d}} + \frac{\sigma_{m,d}}{f_{m,d}} &= \frac{1.88}{0.671 \cdot 14.38} + \frac{9.73}{13.53} = 0.19 + 0.72 \\ &= 0.91 < 1 \end{aligned}$$

Example 5.3

The same column as that in Example 5.2 is held against deflection in the weak direction in the mid-height only.

Show that the column has sufficient load-carrying capacity.

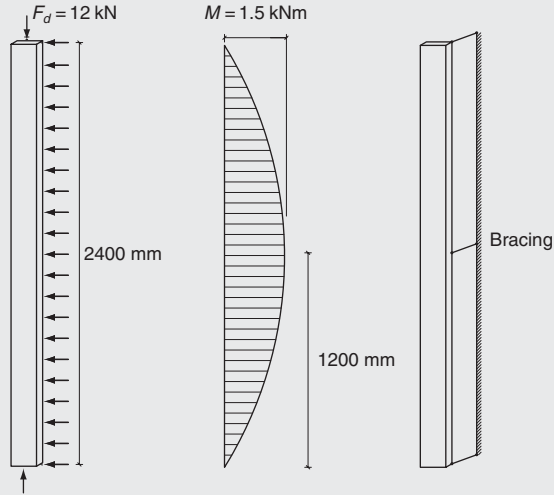

The column may deflect in both main directions. Deflection about the strong axis is already covered by Example 3.2. Only checking of deflection about the weak axis is required.

For axial load alone:

For $l = 1200$ mm, $i = 12.7$ mm:

$$\lambda_{\text{rel}} = \frac{1200}{12.7\pi} \sqrt{0.00314} = 1.69$$

$$k = 0.5[1 + 0.2(1.69 - 0.3) + 1.69^2] = 2.062$$

$$k_c = \frac{1}{2.062 + \sqrt{2.062^2 - 1.69^2}} = 0.308$$

$$\frac{\sigma_{c,d}}{k_c f_{c,0,d}} = \frac{1.88}{0.308 \cdot 7.85} = 0.77 < 1$$

For axial load and moment:

$$k_h = \left(\frac{150}{44}\right)^{0.2} = 1.28 < 1.3$$

From Expression (5.17b):

$$\begin{aligned} \frac{1.88}{0.308 \cdot 14.38} + \frac{0.7 \cdot 9.73}{1.28 \cdot 13.54} &= 0.42 + 0.7 \cdot 0.55 \\ &= 0.42 + 0.39 = 0.81 < 1 \end{aligned}$$

Therefore the load-carrying capacity of the column is adequate.

5.4 Lateral torsional buckling of laterally loaded columns

In the examples above it has been assumed that the failure takes place due to bending in the main direction. For deep, narrow cross-sections loaded in bending about the strong axis a failure mode with combined lateral deflection and torsion is possible or more likely. To take this into account it should for $\lambda_{m,rel} > 0.75$ be verified that:

$$\frac{\sigma_{c,d}}{k_{c,z} f_{c,0,d}} + \left(\frac{\sigma_{m,y,d}}{k_{cr} f_{m,d}} \right)^2 \leq 1 \quad (5.18)$$

where $k_{c,z}$ is the column factor for deflection in the weak direction and k_{cr} is the factor for lateral instability, see Expression (4.28).

6

Curved beams and frames

6.1 Curved beam

Loading a curved beam in bending will result in stresses both parallel and perpendicular to the beam (see Fig. 6.1). The normal stresses in the convex side of the beam are smaller than the stresses at the concave side and the stresses at the concave side are larger than the stresses in a corresponding straight beam. The reason for this is that even if the deformations vary linearly, the strains will not do so because of the varying fibre lengths. Normally these effects are disregarded, i.e. the stress is for a rectangular cross-section calculated as for a straight beam:

$$\sigma_{out} = \sigma_{in} = 6M/bh^2 \quad (6.1)$$

The bending stresses σ_m developed during the fabrication when the laminations with thickness t are formed to a curvature $1/r$ are theoretically rather high. In the outermost fibres:

$$\sigma_m = Et/(2r) \quad (6.2)$$

These internal stresses reduce the load-bearing capacity of the cross-section.

For an elastic modulus $E = 12\,000\text{ N/mm}^2$, a lamella thickness $t = 33\text{ mm}$ and a radius $r = 5000\text{ mm}$, the bending stress becomes $\sigma_m = 40\text{ N/mm}^2$, i.e. corresponding to the characteristic strength. Experimental results show, however, that the built-in stresses become significantly smaller, probably due to creep that occurs during the hardening process where moisture from the adhesive is added. According to Eurocode 5 the strength values for bending, tension and compression for $r/t < 240$ should be reduced by the factor:

$$k_{curve} = 0.76 + 0.001 \frac{r}{t} (\leq 1) \quad (6.3)$$

The bending moment results also in stresses perpendicular to grain. The following simplified derivation of the transversal stresses illustrates

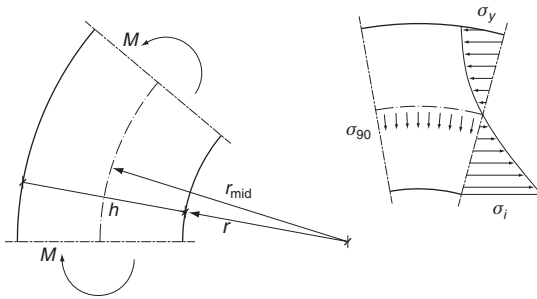

Fig. 6.1 Stress variation in a plane curved beam with constant bending moment

this effect. It is assumed that the normal stresses vary linearly over the beam depth (see Fig. 6.2), i.e. the influence of the non-linear stress distribution is disregarded. The force resultant F on one half of the cross-section is $F = 1.5M/h$. Equilibrium of the marked element loaded by F on both cross-sections and the stress σ_{90} requires:

$$Fd\theta = \sigma_{90}br_{mid}d\theta$$

$$\sigma_{90} = \frac{F}{br_{mid}} = 1.5 \frac{M}{bhr_{mid}} \quad (6.4)$$

where b is the thickness (width) of the beam.

When the moment distribution tends to reduce the curvature, as is the case in Fig. 6.3, the stresses perpendicular to the grain are tensile stresses and it is necessary to take into account that the strength perpendicular to grain depends on the stressed volume. The relevant

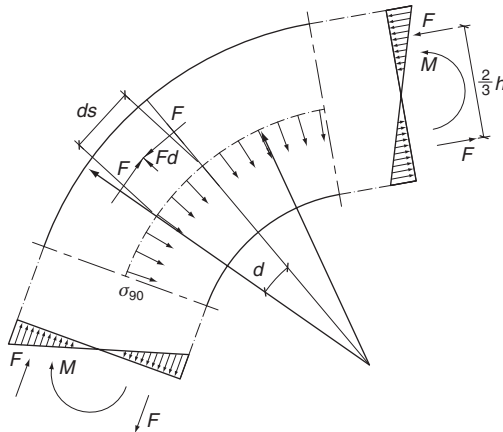

Fig. 6.2 Internal forces and tension stresses perpendicular to the grain direction in a curved beam

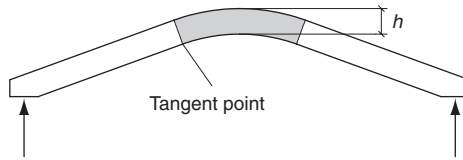

Fig. 6.3 For a curved beam consisting of two straight parts joined by a curved part the strength perpendicular to grain depends on the volume of the curved part

volume, V , is shaded in Fig. 6.3. To take into account the variation of stresses over the depth, the volume should not be taken higher than $2V_{total}/3$, where V_{total} is the total volume of the beam. It shall be verified that:

$$\frac{\sigma_{t,90,d}}{f_{t,90,d}} \leq k_{dis} \left(\frac{V_{ref}}{V} \right)^{0.2} \quad (6.5)$$

The reference volume for glulam is $V_{ref} = 0.01 \text{ m}^3$. The factor k_{dis} takes into account the stress variation over the depth. For a parabolic variation from zero at the surface to a maximum value in the middle $k_{dis} = 1.4$.

Example 6.1

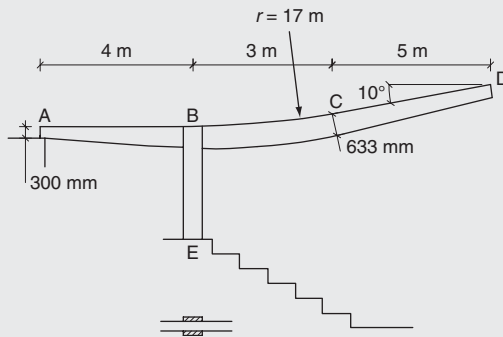

A glulam beam carrying a roof structure is supported by a double glulam column as shown in the figure above. The glulam is GL32h with a thickness of 160 mm. It has two straight parts AB and CD joined by a 633 mm deep curved part BC. The fibres of the straight parts are cut at the bottom. The radius is 17 m. The beam is simply supported at A and B and it is assumed that the roofing provides lateral stability.

The design load (dead load and snow) is 5 kN/m measured horizontally and the beam is in a service Class 2 (i.e. outdoor protected) condition.

Show that the beam has sufficient strength.

Reactions and internal forces:

$$R_{A,d} = -5 \cdot 12 \cdot (2/4) = -30 \text{ kN (uplift)}$$

$$R_{B,d} = 5 \cdot 12 \cdot (6/4) = 90 \text{ kN}$$

$$M_{b,d} = 5 \cdot (8^2/2) = 160 \text{ kNm}$$

$$V_{Bd} = \begin{cases} 5 \cdot 8 = 40 \text{ kN} \\ 40 - 90 = -50 \text{ kN} \end{cases}$$

Since $r/t = 17\,000/33.3 = 510.5 > 240$, the strength is not reduced due to the curvature, see Expression (6.3).

The design strengths are found using $k_{mod} = 0.9$ (for snow) and $\gamma_M = 1.25$ (for glulam):

$$f_{m,d} = 0.9 \cdot 32/1.25 = 23.04 \text{ N/mm}^2$$

$$f_{v,d} = 0.9 \cdot 3.8/1.25 = 2.74 \text{ N/mm}^2$$

$$f_{c,90,d} = 0.9 \cdot 3.3/1.25 = 2.38 \text{ N/mm}^2$$

$$f_{t,90,d} = 0.9 \cdot 0.36/1.25 = 0.26 \text{ N/mm}^2$$

Bending calculations are relevant in B. The angle of taper is calculated from:

$$\tan \alpha = (633 - 300)/4000 = 0.083 (\alpha = 4.76^\circ)$$

At the top where the cut fibres are loaded in tension:

$$\sigma_{m,d} = \frac{6 \cdot 160 \cdot 10^6}{160 \cdot 633^2} = 14.97 \text{ N/mm}^2$$

$$\begin{aligned} k_{m,\alpha} &= \frac{1}{\sqrt{1 + \left(\frac{f_{m,d}}{0.75f_{v,d}} \tan \alpha\right)^2 + \left(\frac{f_{m,d}}{f_{t,90,d}} \tan^2 \alpha\right)^2}} \\ &= \frac{1}{\sqrt{1 + \left(\frac{23.04}{0.75 \cdot 2.74} \tan 4.76^\circ\right)^2 + \left(\frac{23.04}{0.26} \tan^2 4.76^\circ\right)^2}} \\ &= 0.667 \end{aligned}$$

$$\frac{\sigma_{m,d}}{k_{m,\alpha} f_{m,d}} = \frac{14.97}{0.695 \cdot 23.04} = 0.94 < 1$$

The maximum stresses perpendicular to the grain in the curved part are:

$$\sigma_{t,90,d} = 1.5 \frac{M_d}{b h r_{mid}} = 1.5 \frac{160 \cdot 10^6}{160 \cdot 633 \cdot 17\,317} = 0.137 \text{ N/mm}^2$$

The stressed volume (corresponding to B–C) is approximately:

$$V = 0.160 \cdot 3.0 \cdot 0.633 = 0.30 \text{ m}^3$$

$$k_{dis} \left(\frac{V_{ref}}{V} \right)^{0.2} = 1.4 \left(\frac{0.01}{0.3} \right)^{0.2} = 0.71$$

$$\frac{\sigma_{t,90,d}}{f_{t,90,d} k_{dis} \left(\frac{V_{ref}}{V} \right)^{0.2}} = \frac{0.137}{0.26 \cdot 0.71} = 0.74 < 1$$

The shear strength is adequate since:

$$\frac{\tau_d}{f_{v,d}} = \frac{1.5 \cdot 50\,000}{160 \cdot 633 \cdot 2.74} = 0.27$$

6.2 Pitched cambered beam

The pitched beam shown in Fig. 6.4 consists of two single tapered beams A–B and D–E joined by a ‘triangle’ with curved underside with radius r . The fibres are cut on the top side of the beam.

The stresses in the triangle correspond in principle to those in a curved beam – the axial stresses do not vary linearly and the moment also induces stresses perpendicular to grain – but these effects are much more pronounced, especially near the apex where the normal stresses are zero because of the apex point. It is, therefore, not unusual to replace the construction by a curved beam with a separate ‘triangle’.

The maximum normal stress is found in the bottom side of the apex section and should be calculated as:

$$\sigma_{m,i} = k_0 \frac{6M_{ap}}{bh_{ap}^2} \quad (6.6)$$

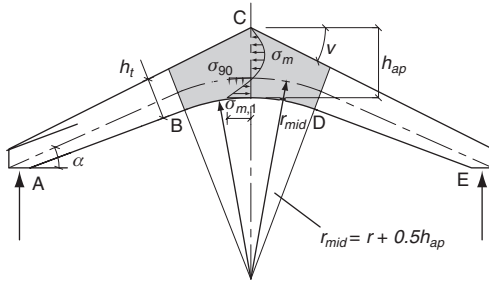

Fig. 6.4 Pitched beam with curved underside. B and D are tangent points

The maximum tensile stress perpendicular to the grain direction is found just under centreline in the apex section and should be calculated as:

$$\sigma_{t,90,max} = k_{90} \frac{6M_{ap}}{bh_{ap}^2} \quad (6.7)$$

where M_{ap} is the moment in the apex section where the beam depth is h_{ap} . The factors k_0 and k_{90} are:

$$k_0 = k_1 + k_2 \left(\frac{h_{ap}}{r_{mid}} \right) + k_3 \left(\frac{h_{ap}}{r_{mid}} \right)^2 + k_4 \left(\frac{h_{ap}}{r_{mid}} \right)^3 \quad (6.8)$$

$$k_{90} = k_5 + k_6 \left(\frac{h_{ap}}{r_{mid}} \right) + k_7 \left(\frac{h_{ap}}{r_{mid}} \right)^2 \quad (6.9)$$

where:

$$\begin{aligned} k_1 &= 1 + 1.4 \tan \alpha + 5.4 \tan^2 \alpha \\ k_2 &= 0.35 - 8 \tan \alpha \\ k_3 &= 0.6 + 8.3 \tan \alpha - 7.8 \tan^2 \alpha \\ k_4 &= 6 \tan^2 \alpha \\ k_5 &= 0.2 \tan \alpha \\ k_6 &= 0.25 - 1.5 \tan \alpha + 2.6 \tan^2 \alpha \\ k_7 &= 2.1 \tan \alpha - 4 \tan^2 \alpha. \end{aligned} \quad (6.10)$$

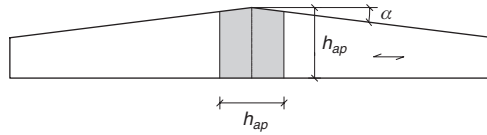

Fig. 6.5 Double tapered beam with straight underside

For a curved beam with $\alpha = 0$: $k_5 = 0$, $k_6 = 0.25$ and $k_7 = 0$ and, in accordance with Expression (6.4), the transversal stress becomes:

$$\sigma_{t,90} = 0.25 \cdot 6M / (r_{mid}bh)$$

For a double tapered beam with straight underside (see Fig. 6.5), $r = \alpha$ and the normal stresses in the apex section are, since α is small, given by:

$$\sigma_m = \frac{6M_{ap}}{bh_{ap}^2} \quad (6.11)$$

and

$$\sigma_{t,90} = 0.2\alpha \frac{6M_{ap}}{bh_{ap}^2} \quad (6.12)$$

The bending stress in Expression (6.6) shall fulfil the following requirement:

$$\frac{\sigma_{m,max,d}}{f_{m,d}} \leq k_{curve} \quad (6.13)$$

where k_{curve} is found from Expression (6.3) with the curvature of the innermost lamination.

For the tensile stress perpendicular to grain it shall be verified that:

$$\frac{\sigma_{t,90,d}}{f_{t,90,d}} \leq k_{dis} \left(\frac{V_{ref}}{V} \right)^{0.2} \quad (6.14)$$

where V is the volume corresponding to the shaded areas in Figs 6.4 and 6.5, and

$$k_{dis} = 1.4 \text{ for curved beams and for a tapered beam with straight underside (see Fig. 6.5)}$$

$$k_{dis} = 1.7 \text{ for pitch cambered beams (see Fig. 6.7).}$$

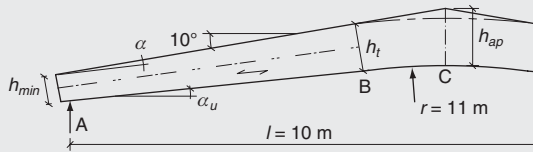
Example 6.2

A pitched cambered glulam beam of class GL28h is laterally braced. It is in a service Class 1 condition. The lamellas are cut at the top side. The beam thickness is 115 mm. The design load from dead load and snow is a short-term load $q = 10 \text{ kN/m}$ measured on the horizontal.

Show that the strength is sufficient.

The dimensions $h_{min} = 400 \text{ mm}$ and $h_t = 667 \text{ mm}$ are estimated. With the tangent points placed approximately 1 m from the middle, the angle of taper is found from:

$$\tan \alpha = (667 - 400)/4000 = 0.0668$$

$$\alpha = 3.8^\circ$$

$$\alpha_{ult} = 10 - \alpha = 6.2^\circ$$

$$V_d = (0.5l - h_{min})q \cos \alpha = (10/2 - 0.4) \cos 3.8^\circ = 46 \text{ kN}$$

$$f_{v,d} = 0.9 \cdot 3.2/1.25 = 2.30 \text{ N/mm}^2$$

$$\frac{\tau_d}{f_{v,d}} = \frac{1.5 \cdot V_d}{bh_{min} f_{v,d}} = \frac{1.5 \cdot 46000}{115 \cdot 400 \cdot 2.30} = \frac{1.49}{2.30} = 0.65$$

It is necessary to take into account the influence of the taper: For the zone between A and B with compressive stresses parallel to the tapered side. Therefore, over the length A–B, it should be verified that:

$$\frac{\sigma_{m,d}}{f_{m,d}} = \frac{q_d x(l-x)}{W f_{m,d} k_{m,\alpha}} \leq 1$$

where:

$$f_{m,d} = 0.9 \cdot (28/1.25) = 20.16 \text{ N/mm}^2$$

and from Expression (4.38)

$$k_{m,\alpha} = 0.932$$

The calculations are given in the following table.

x : mm	h : mm	M : kNm	W : 10^3 mm ³	$\sigma_{m,d}$: N/mm ²	$\sigma_{m,d}/(k_{m,\alpha} f_{m,d})$
0	400	0	3067	0.00	0.000
1000	467	45	4180	10.78	0.574
2000	534	80	5445	14.66	0.780
2500	567	94	6162	15.22	0.810
3000	600	105	6900	15.20	0.809
3500	634	114	7680	14.78	0.787
4000	667	120	8530	14.07	0.749
5000	843	125	13622	9.18	0.488

With a camber of the curved side of about 50 mm:

$$h_{ap} \sim 400 + 5000 \tan 10^\circ - 4000 \tan 6.2^\circ - 50 = 797 \text{ mm}$$

$$r_{mid} = r_{in} + 0.5h_{ap} = 11\,000 + 0.5 \cdot 797 = 11\,390 \text{ mm}$$

$$h_{ap}/r_{mid} = 0.07$$

$$k_1 = 1 + 1.4 \tan 10^\circ + 5.4 \tan^2 10^\circ = 1.415$$

$$k_2 = 0.35 - 8 \tan 10^\circ = -1.061$$

$$k_3 = 0.6 + 8.3 \tan 10^\circ - 7.8 \tan^2 10^\circ = 1.821$$

$$k_4 = 6 \tan^2 10^\circ = 0.187$$

$$k_5 = 0.2 \tan 10^\circ = 0.035$$

$$k_6 = 0.25 - 1.5 \tan 10^\circ + 2.6 \tan^2 10^\circ = 0.065$$

$$k_7 = 2.1 \tan 10^\circ - 4 \tan^2 10^\circ = 0.246$$

$$k_0 = k_1 + k_2 \left(\frac{h_{ap}}{r_{mid}} \right) + k_3 \left(\frac{h_{ap}}{r_{mid}} \right)^2 + k_4 \left(\frac{h_{ap}}{r_{mid}} \right)^3 = 1.346$$

$$k_{90} = k_5 + k_6 \left(\frac{h_{ap}}{r_{mid}} \right) + k_7 \left(\frac{h_{ap}}{r_{mid}} \right)^2 = 0.0414$$

$$\begin{aligned} \frac{\sigma_{m,max,d}}{f_{m,d}} &= k_0 \frac{6M_{ap}}{bh_{ap}^2 f_{m,d}} = 1.346 \frac{6 \cdot 125 \cdot 10^6}{115 \cdot 797^2 \cdot 19.38} \\ &= 0.72 < 1 \end{aligned}$$

$$\sigma_{t,90,max} = k_{90} \frac{6M_{ap}}{bh_{ap}^2} = 0.0414 \frac{6 \cdot 125 \cdot 10^6}{115 \cdot 797^2} = 0.420 \text{ N/mm}^2$$

$$f_{t,90,d} = 0.9 \cdot 0.45 / 1.25 = 0.32 \text{ N/mm}^2$$

The volume loaded in tension perpendicular to the grain is:

$$V = 0.115 \cdot (0.797 + 0.667) \cdot 1 = 0.17 \text{ m}^3$$

With $V_{ref} = 0.01 \text{ m}^3$:

$$k_{vol} = \left(\frac{0.01}{0.17} \right)^{0.2} = 0.57$$

$$k_{dis} = 1.7$$

$$\frac{\sigma_{t,90,d}}{f_{t,90,d} k_{vol} k_{dis}} = \frac{0.420}{0.32 \cdot 0.57 \cdot 1.7} = 1.35$$

Therefore the strength is inadequate because the ratio is > 1.0 .

If the top triangle is made separately and fastened with nails or screws, the stresses in the curved beam with depth 667 mm and mean radius 11.33 m are reduced to:

$$\sigma_{t,90,d} = 1.5 \cdot \frac{125 \cdot 10^6}{115 \cdot 667 \cdot 11333} = 0.14 \text{ N/mm}^2$$

and the stressed volume is reduced to:

$$V \sim 0.115 \cdot 0.667 \cdot 2 = 0.15 \text{ m}^3$$

that is:

$$k_{vol} = \left(\frac{0.01}{0.15} \right)^{0.2} = 0.58$$

$$k_{dis} = 1.4$$

$$\frac{\sigma_{t,90,d}}{f_{t,90,d} k_{vol} k_{dis}} = \frac{0.14}{0.32 \cdot 0.58 \cdot 1.4} = 0.54$$

Therefore, the strength for the changed structure is sufficient.

the distance between the bracing points. It shall be verified that

$$\frac{\sigma_{c,d}}{k_c f_{c,0,d}} + \frac{\sigma_{m,d}}{f_{m,d}} \leq k_{\text{bend}} \quad (6.16)$$

provided lateral instability is prevented.

The straight parts, for which the decisive load combination normally is unsymmetrical snow, are designed as tapered beam columns with an in-plane column length equal to the distance l_{CG} from point C to point G (where $M = 0$). The column depth is taken as the mean depth on the distance C–G. For out-of-plane deflection the column length corresponds to the distance between the bracing points. If the fibres are cut, the strength reduction should be taken into account (factor $k_{m,\alpha}$, Expressions (4.37) and (4.38)).

The support cross-section should be designed for shear. At point A the design shear stress is given by:

$$\tau_d = 1.5 \frac{R_{AH,d} \cos \alpha_f - R_{AV,d} \sin \alpha_f}{bh_f} \quad (6.17)$$

where α_f is the angle between the grain direction and the vertical axis. At the top hinge the shear stress is:

$$\tau_d = 1.5 \frac{R_{CV,d} \cos \alpha - R_{CH,d} \sin \alpha}{bh_f} \quad (6.18)$$

where α is the angle between the grain direction and the horizontal.

6.3.3 Three-hinged arch with sharp corners (triangulated corners)

By finger-jointing glulam beams it is possible to make three-hinged arches with triangulated corners (see Fig. 6.7). The timber volume is

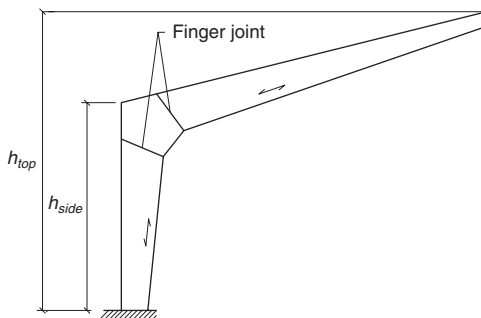

Fig. 6.7 Three-hinged symmetrical frame with triangulated corners formed by finger-jointing

larger than for curved corners because the moments become larger and because the finger joints have relatively low load-carrying capacity.

Finger-jointed arches are normally designed by the producer of the glulam.

Example 6.3

The glulam arch shown in Fig. 6.7 is made of glulam class GL24h in service Class 1 condition and has the following dimensions: $l = 25$ m, $h_{side} = 4$ m, $h_{top} = 7.2$ m, $r = 3.0$ m, $\alpha_{roof} = 15^\circ$ and lamination thickness of $t = 22$ mm. Dead load is $g = 2.5$ kN/m and snow load is either $s_1 = 4$ kN/m uniformly distributed over the whole roof or $s_2 = 2$ kN/m uniformly distributed over one side of the roof.

Find: adequate dimensions of the structure.

The following dimensions are estimated: corner depth $h \sim 0.03l \sim 0.748$ m corresponding to 34 laminations of thickness 22 mm, $h_{top} \sim 0.5h \sim 300$ mm, beam width $b \sim 0.18h \sim 140$ mm. In practice there may also be loads from cranes etc. These loads may normally not be decisive for the frame but may be important for steel parts used for anchorage and fittings. In rare cases wind may result in an opening moment and related tension stresses perpendicular to the fibres.

Since the span is moderate, the frame is placed directly on the foundation and supported laterally by a concreted-in steel U-beam. The span will be reduced slightly because the vertical reaction is placed a little inwards from the edges of the frame. This is disregarded because of the opposite effect of the horizontal reaction acting at a small distance from the top surface of the foundation.

Dead load:

$$R_{AV,d} = R_{BV,d} = gl/2 = 31.25 \text{ kN}$$

$$R_{AH,d} = R_{BH,d} = gl^2/(8h_{top}) = 27.1 \text{ kN}$$

Snow s_1 :

$$R_{AV,d} = R_{BV,d} = s_1 l/2 = 50 \text{ kN}$$

$$R_{AH,d} = R_{BH,d} = s_1 l^2/(8h_{top}) = 43.4 \text{ kN}$$

Snow s_2 on the right-hand side:

$$R_{AV,d} = s_2 l / 8 = 6.3 \text{ kN}$$

$$R_{BV,d} = 3s_2 / l = 18.8 \text{ kN}$$

$$R_{AH,d} = R_{AV,d} l / 2 / h_{top} = 10.9 \text{ kN}$$

$$R_{BH,d} = R_{AH,d}$$

The maximum forces at the corners are found for $g + s_1$:

$$R_{AV,d} = 31.3 + 50.0 = 81.3 \text{ kN}$$

$$R_{AH,d} = 27.1 + 43.4 = 70.5 \text{ kN}$$

$$R_{A,d} = \sqrt{R_{AV,d}^2 + R_{AH,d}^2} = 107.6 \text{ kN}$$

Based on the frame drawing and the action line for the reaction, the maximum eccentricity is measured to be approximately $e \sim 1.4 \text{ m}$, i.e.:

$$M_d \sim 107.6 \cdot 1.4 = 151 \text{ kNm}$$

$$\sigma_{m,z,d} = \frac{6 \cdot 151 \cdot 10^6}{140 \cdot 748^2} = 11.5 \text{ N/mm}^2$$

$$N = -107 \text{ kN}$$

$$\sigma_{c,0,d} = 107\,000 / (140 \cdot 748) = 1.03 \text{ N/mm}^2$$

$$V = 0$$

The deformations will increase the moments calculated for the initial geometry. This is taken into account by treating the corner as a column with length l_{AE} where E is the point between C–A with zero moment (see Fig. 6.6). The taper means that the angle between the system line and horizontal is a little larger than the slope of the roof. The angle of the system line is estimated to be 16° .

$$M = R_{CH} x_E \tan \alpha - (g + s_1) x_E^2 / 2 = 92.2 x_E \tan 16^\circ - (2.5 + 6) x_E^2 / 2$$

since $R_{CH} = R_{AH}$

$$x_E \text{ corresponds to } M = 0; x_E = 6.22 \text{ m}$$

$$l_{AE} = 8.3 \text{ m}$$

For glulam of class GL24h:

$$\lambda_{rel,z} = \frac{8300\sqrt{12}}{748} \sqrt{\frac{24}{\pi^2 \cdot 9400}} = 0.618$$

It is assumed that deflection of the frame out of plane is prevented by the façade at about 0.5 m over the support and about 2.5 m from the vertical line of stanchions, i.e. the column length for deflection perpendicular to the plane of the frame is approximately 5.0 m.

$$\lambda_{rel,y} = \frac{5000\sqrt{12}}{140} \sqrt{\frac{24}{\pi^2 \cdot 9400}} = 1.99$$

$$k_{c,z} = 0.982 \text{ and } k_{c,y} = 0.241$$

$$r/t = 3000/22 = 136$$

$$k_{curve} = 0.90$$

For glulam GL24h and short-term load the design strengths are:

$$f_{c,0,d} = 0.9 \cdot 24/1.25 = 17.28 \text{ N/mm}^2$$

$$f_{m,d} = 0.9 \cdot 24/1.25 = 17.28 \text{ N/mm}^2$$

For deflection about the strong axis it shall be verified that:

$$\frac{\sigma_{c,0,d}}{k_{c,z} f_{c,0,d} k_{curve}} + \frac{\sigma_{m,z}}{f_{m,d} k_{curve}} \leq 1$$

$$\frac{1.03}{0.982 \cdot 17.28 \cdot 0.90} + \frac{11.54}{17.28 \cdot 0.90} = 0.07 + 0.74 = 0.81 < 1$$

Deflection about the weak axis:

$$\frac{\sigma_{c,0,d}}{k_{c,y} f_{c,0,d} k_{curve}} + \frac{k_m \sigma_{m,z}}{f_{m,d} k_{curve}} = \frac{1.03}{0.241 \cdot 17.28 \cdot 0.90} + \frac{0.7 \cdot 11.54}{17.28 \cdot 0.90}$$

$$= 0.28 + 0.52 = 0.80 < 1$$

The shear force at point A with depth 500 mm and $\alpha_f = 14^\circ$ is:

$$V_d = R_{AH,d} \cos 14^\circ - R_{AV,d} \sin 14^\circ = 70.5 \cos 14^\circ - 81.3 \sin 14^\circ$$

$$= 48.8 \text{ kN}$$

With $f_{v,d} = 0.9 \cdot 2.7/1.25 = 1.94 \text{ N/mm}^2$:

$$\frac{\tau_d}{f_{v,d}} = \frac{1.5 \cdot 48\,800}{140 \cdot 500 \cdot 1.94} = \frac{1.046}{1.94} = 0.54 < 1$$

The axial force $R_{A,d} = 107 \text{ kN}$ and the moment $M = 107 \cdot 0.5/2 = 27 \text{ kNm}$ can easily be carried.

The straight beam parts correspond to tapered columns with column length l_{CG} equal to the distance from the top hinge (C) to the point with zero moment (G). For dead load and one-sided snow load:

$$R_{CV,d} = 6.3 \text{ kN}, R_{CH,d} = 27.1 + 10.8 = 37.9 \text{ kN}$$

$$M_G = 0 \text{ for } x_G = 7.62 \text{ m}$$

In point G the cross-section depth is calculated or measured to be 620 mm.

The cross-section with maximum bending stress is, according to Expression (4.39), found at a distance x from the symmetry line through C:

$$x = l \frac{h_{min}}{h_{min} + h_{max}} = 7.93 \frac{300}{300 + 620} = 2.59 \text{ m}$$

where the bending stress (see Expression 4.40) is:

$$\sigma_{m,d} = \frac{0.75(g + s_1)l^2}{bh_{min}h_{max}} = \frac{0.75 \cdot 4.5 \cdot 7620^2}{140 \cdot 300 \cdot 620} = 7.52 \text{ N/mm}^2$$

$$\begin{aligned} N_d &= -R_{CH,d} \cos 16^\circ + [R_{CV,d} - (g + s_2)x] \sin 16^\circ \\ &= -38.0 \cos 16^\circ + (6.3 - 4.5 \cdot 2.59) \sin 16^\circ = -36.5 - 1.5 \\ &= -38 \text{ kN} \end{aligned}$$

The slenderness ratio is determined for the minimum depth on the middle one-third, i.e. with $d = 406 \text{ mm}$:

$$\lambda_{rel} = \frac{7620\sqrt{12}}{\cos 16 \cdot 406} \sqrt{\frac{24}{\pi^2 \cdot 9400}} = 1.092$$

$$k_c = 0.715$$

With the taper angle $\alpha = 2.3^\circ$ at the tension side:

$$\begin{aligned} \frac{\sigma_{c,d}}{k_c k_{m,\alpha} f_{c,d}} + \frac{\sigma_{m,d}}{k_{m,\alpha} f_{m,d}} &= \frac{38\,000}{0.715 \cdot 0.91 \cdot 140 \cdot 403 \cdot 17.28} \\ &\quad + \frac{7.52}{0.91 \cdot 17.28} \\ &= 0.06 + 0.48 = 0.54 < 1 \end{aligned}$$

The distance between the points of bracing shall be chosen to be less than:

$$7.62 \cdot 140/406 = 2.64 \text{ m}$$

The compression strength and the strength of the top cross-section is ample since

$$\frac{\tau_{v,d}}{f_{v,d}} = \frac{1.5 \cdot (R_{CV,d} \cos 16^\circ + R_{CH,d} \sin 16^\circ)}{bh f_{v,d}} = \frac{0.58}{1.94} = 0.30 < 1$$

7

Trusses and bracings

7.1 Introduction

For lightweight structures with moderate spans it is common to use trusses made of timber members using punched metal plates as gussets (see Fig. 7.1).

Almost all punched metal plate truss rafters are fabricated in factories and the fabricators are usually responsible for the design of the trusses using a particular system owner's design software. System owners are usually organisations that fabricate punched metal plate connectors in addition to producing sophisticated design software that is licensed to the truss fabricators in return for using the punched plate connectors of the system owner. However, it is in principle possible for others to design them using Eurocode 5.

Trusses may also be produced traditionally from structural timber, glulam and LVL with gusset plates of wood-based panel products such as plywood or steel. These gusset plates are usually nailed, screwed or bolted to timber members at nodal points.

For many trusses it is necessary to prevent out-of-plane buckling of the top chords (rafters) and often also the compression web members.

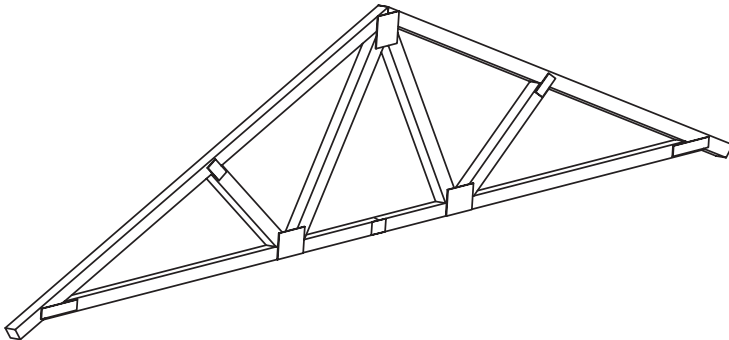

Fig. 7.1 Punched metal plate roof truss

7.2 Structural design of trusses

7.2.1 General

Trusses are normally statically indeterminate, even when the reactions are statically determinate. Eurocode 5 requires in principle that trusses are designed as frame structures taking into account the effect of deformations, slip in joints and eccentricities, e.g. at supports and nodal points. A full calculation may be very complicated and often a simple linear first-order calculation is used and the non-linear behaviour is taken into account by the design of the individual members (column effect). A simplified design method is described in the following.

7.2.2 Simplified design

The method is based on the following assumptions:

- part of the support length is placed vertically under the end node
- the height of the truss is greater than 0.15 times the span and greater than 10 times the chord depth, i.e. the truss is relatively stiff.

The structure is modelled as beam elements placed at the system lines of the truss members. Apart from the top and bottom chords where the centre/system lines shall coincide, it is only required that the system lines fall within the cross-section, but any eccentricities shall be taken into account in the design of individual members.

The axial member forces are found by the normal equilibrium conditions (e.g. framework analysis) assuming that the members are joined by frictionless hinges. All the loads are transformed into point loads at the

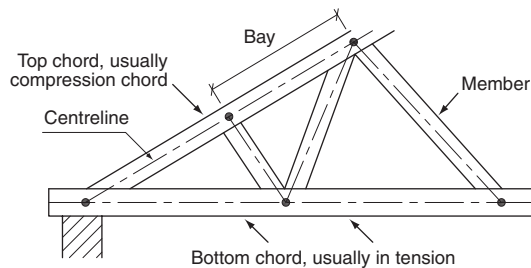

Fig. 7.2 Notation for trusses. Nodes are connected by system lines that only for the bottom and top chord have to coincide with member centrelines

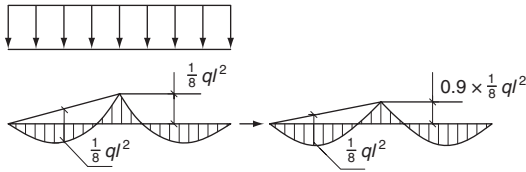

Fig. 7.3 Reduction of bending moments at nodes for continuous members

nodes. Experience has shown that this method results in very precise estimates of the axial forces.

Eurocode 5, however, requires that for strength verification of members in compression and connections, the calculated axial forces should be increased by 10%.

The bending moments in members spanning one bay should be determined assuming frictionless hinges at the nodes.

For continuous elements, the effect of deformations should be taken into account by a 10% reduction of the bending moments over the supports. These reduced moments should also be used in calculation of the bay moments. An example is shown in Fig. 7.3.

Often the load from the roof is transferred through tiles or roofing onto battens which have equal centres hence creating equally distanced point loads on rafters. If the batten spacing is less than 0.4 times the bay length, the row of point loads may be assumed to act as a uniformly distributed load.

For trusses that are loaded predominantly at the nodes the sum of the combined bending and axial compressive stress areas should be limited to 0.9.

For compression members, the free column length is generally taken as the distance between adjacent points of contraflexure. For fully triangulated trusses, the effective column length for members in compression should be taken as the bay length, if:

- members are only one bay long, without rigid end connections
- members are continuous over two or more bays and are not loaded laterally.

When a simplified analysis of a fully triangulated truss with punched metal plate fasteners is used, the following effective column lengths, as shown in Fig. 7.4, may be assumed:

1. For continuous members without significant end moments and where the bending stresses of the lateral load are at least 40% of the compressive stresses:

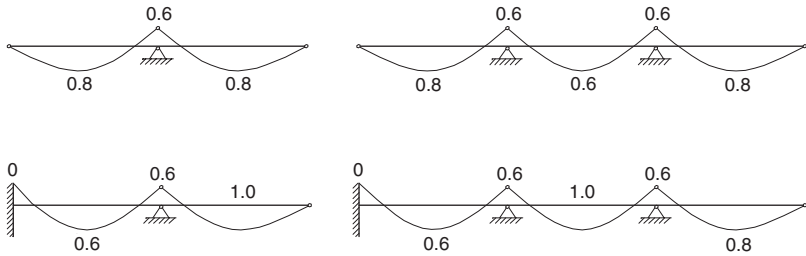

Fig. 7.4 Column length reduction factors

- in an outer bay: 0.8 times the bay length
 - in an inner bay: 0.6 times the bay length
 - at an internal node: 0.6 times the largest adjacent bay length.
2. For continuous members with significant end moments where the bending stresses of the lateral load are at least 40% of the compressive stresses:
- at the beam end with moment: 0 (i.e. no column effect)
 - in the penultimate bay: 1.0 times the bay length
 - remaining bays and nodes: as described above in (1)
 - all other cases 1.0 times the bay length.

It is best practice to place gusseted joints in the top and bottom chords where the moments are zero and further to ensure that the component does not become unstable if all joints act as hinges. It is assumed that the top chord (rafters) is held against lateral deflection by bracing and battens, i.e. the column length corresponds to the batten spacing. Laterally deflection of web members should also be prevented by the end nodes and additional bracing.

The strength variation of trusses is reduced because of the load sharing of members for which the strength may be increased by a load-sharing factor (system factor) $k_{sys} = 1.1$ provided the trusses are laterally connected by a continuous load distribution system capable of transferring the loads (assumed to be short-term) from one member to the neighbouring members. It should be ensured that the load distribution members are continuous over at least two trusses and the joints are staggered.

Example 7.1

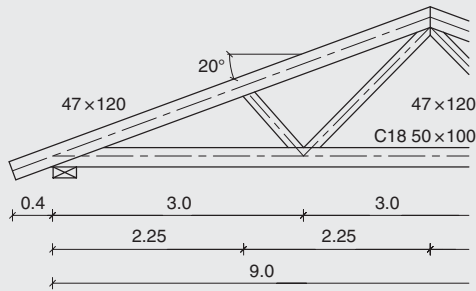

A W-truss in service Class 1 with geometry and member dimensions, as shown in the figure is used at centres $c = 600$ mm.

Verify that the truss using C16 has sufficient load-carrying capacity for the following assumed design loads:

- dead load on the top chord measured along its length:
 $g_{top} = 0.5 \text{ kN/m}^2$ (including the self-weight)
- dead load on the bottom tie (bottom chord):
 $g_{bot} = 0.4 \text{ kN/m}^2$ (including the self-weight)
- roof snow load, measured horizontally):
 $s = 0.405 \text{ kN/m}^2$ (characteristic snow load on ground
 $s_0 = 0.45 \text{ kN/m}^2$ and form factor 0.9).

Note: The assumed load in the example is very much simplified because the purpose is to demonstrate the design principles of trusses.

The determining load case is dead load + snow.

$$g_{top,d} = 1.35 \cdot 0.5 = 0.675 \text{ kN/m}^2$$

$$g_{bot,d} = 1.35 \cdot 0.4 = 0.54 \text{ kN/m}^2$$

$$s_d = 1.5 \cdot 0.405 = 0.608 \text{ kN/m}^2$$

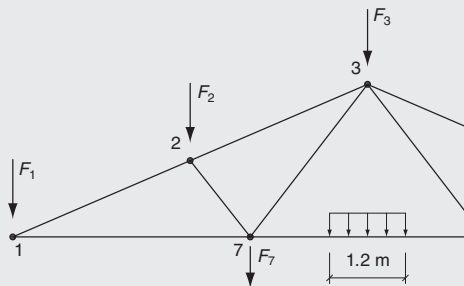

All calculations of forces and moments are for design loads. The uniformly distributed loads are replaced by point load at the nodes:

$$F_1 = 0.5c[l_{1-2} \cos 20^\circ (g_{top}/\cos 20^\circ + s) + l_{1-7}g_{bot}] = 1.38 \text{ kN}$$

$$F_7 = c[0.5(l_{1-7} + l_{6-7})g_{bot}] = 0.97 \text{ kN}$$

$$F_2 = F_3 = c \cdot 0.5 \cdot (l_{1-2} + l_{2-3})(g_{top} + s \cos 20^\circ) = 1.79 \text{ kN}$$

The axial forces are determined by equilibrium conditions (framework analysis or virtual work analysis). They are listed in the table below.

Initially the moments are found in the undeformed state and the node moments are then reduced by 10% (factor 0.9).

Top chord:

$$\begin{aligned} M_2 &= -0.9c(g_{top}/\cos 20^\circ + s)(l_{1-7} \cos 20^\circ)^2/8 \\ &= -0.9 \cdot 0.503 = -0.453 \text{ kNm} \end{aligned}$$

$$M_{1-2} = 0.503 - 0.453/2 = 0.277 \text{ kNm}$$

The *bottom chord* is treated as a continuous beam over three spans (moment factor 0.1). Any joints are placed near the points with zero moments:

$$\begin{aligned} M_7 &= -0.9c \cdot 0.10g_{bot}l_{1-7}^2 = -0.9 \cdot 0.6 \cdot 0.10 \cdot 0.54 \cdot 3^2 \\ &= -0.262 \text{ kNm} \end{aligned}$$

$$M_{1-7} = c0.125 \cdot g_{bot}l_{1-7}^2 - 0.262/2 = 0.365 - 0.131 = 0.262 \text{ kNm}$$

$$M_{6-7} = 0.365 - 0.262 = 0.103 \text{ kNm}$$

The axial forces and moments are summarised in the following table.

Member	N: kN (+ve tension, -ve compression)	M: kNm	
		Middle	Node
1-2	-10.69	0.28	-0.45
2-3	-9.38	0.28	-0.45
1-7	10.05	0.26	-0.26
6-7	6.69	0.10	-0.26
2-7	-1.82		
3-7	3.13		

For the main members the load combinations with snow are critical. For some of the secondary members the dead load alone may be dominating, but this is not investigated since the stress index is small. The required increase of the forces and moments by 10% and the system factor $k_{sys} = 1.1$ compensate each other.

Web member diagonal 3-7

Tension member C16 with $f_{t,0,d} = 0.9 \cdot 10/1.3 = 6.92 \text{ N/mm}^2$:

$$\frac{\sigma_{t,d}}{f_{t,0,d}} = \frac{3130}{47 \cdot 75 \cdot 6.92} = \frac{0.89}{6.92} = 0.13 < 1$$

Diagonal 2-7

Centrally loaded column with $l = 1.10 \text{ m}$:

$$f_{c,0,d} = 0.9 \cdot 17/1.3 = 11.77 \text{ N/mm}^2$$

$$\lambda_{rel} = \frac{1100 \cdot \sqrt{12}}{47\pi} \sqrt{\frac{17}{5400}} = 1.45; \quad k_c = 0.403$$

$$\frac{\sigma_{c,0,d}}{k_c f_{c,0,d}} = \frac{1820}{47 \cdot 75 \cdot 0.403 \cdot 11.77} = \frac{0.52}{4.74} = 0.11$$

Top flange 1-2

The top flange is a laterally loaded column. For deflection in the plane of the truss the column length is equal to the node distance. Perpendicular to the plane, the flange is held by the battens. Their distance is determined so that deflection in this direction is not critical.

$$f_{c,0,d} = 0.9 \cdot 17/1.3 = 11.77 \text{ N/mm}^2$$

$$f_{m,d} = 0.9 \cdot 16/1.3 = 11.08 \text{ N/mm}^2$$

Middle: $l_s = 0.8 \cdot 2.25 / \cos 20^\circ = 1.92 \text{ m}$

$$W = 47 \cdot 120^2 / 6 = 112.8 \cdot 10^3 \text{ mm}^3$$

$$\lambda_{rel} = \frac{1920 \cdot \sqrt{12}}{120\pi} \sqrt{\frac{17}{5400}} = 0.988; \quad k_c = 0.699$$

$$\frac{\sigma_{c,d}}{k_c f_{c,0,d}} + \frac{\sigma_{m,d}}{f_{m,d}} = \frac{10690}{0.699 \cdot 47 \cdot 120 \cdot 11.77} + \frac{0.45 \cdot 10^6}{112.8 \cdot 10^3 \cdot 11.08}$$

$$= 0.23 + 0.36 = 0.59$$

Node: $l_s = 0.6 \cdot 2.25 / \cos 20^\circ = 1.44 \text{ m}$

$$\lambda_{rel} = \frac{1440 \cdot \sqrt{12}}{120\pi} \sqrt{\frac{17}{5400}} = 0.742; \quad k_c = 0.857$$

$$\frac{\sigma_{c,d}}{k_c f_{c,0,d}} + \frac{\sigma_{m,d}}{f_{m,d}} = \frac{10690}{0.857 \cdot 47 \cdot 120 \cdot 11.77} + \frac{0.45 \cdot 10^6}{112.8 \cdot 10^3 \cdot 11.08}$$

$$= 0.19 + 0.36 = 0.55$$

To avoid deflection perpendicular to the truss plane becoming decisive it is required that:

$$\frac{\sigma_{c,d}}{k_c f_{c,0,d}} + \frac{k_m \sigma_{m,y,d}}{f_m} = \frac{1.90}{k_c \cdot 11.77} + 0.7 \cdot 0.36 \leq 1$$

$$k_c \geq 0.21, \text{ i.e. } \lambda_{rel} < 2.15$$

$$\lambda \leq 2.15\pi \sqrt{\frac{5400}{17}} = 120; \quad l_{batten} < 120 \cdot 13.5 = 1620 \text{ mm}$$

Bottom chord, node 7

$$\frac{\sigma_{t,d}}{f_{t,0,d}} + \frac{\sigma_{m,d}}{f_{m,d}} = \frac{6690}{4700 \cdot 6.92} + \frac{0.26 \cdot 10^6}{75.0 \cdot 10^3 \cdot 11.08}$$

$$= 0.21 + 0.31 = 0.52$$

Therefore, the truss is adequate for the loading and conditions given.

7.3 Bracings

7.3.1 Single column

The free length of a single column with length $2a$ shall be reduced to a by a support in the middle. A requirement for this is that the support has sufficient strength and stiffness. The requirements are as shown in Fig. 7.5 found by investigating a column that in the middle has the maximum permissible deflection e_{2a} . The force F that the lateral support shall be able to exert depends among other properties of its (spring)-stiffness C .

The axial force N results in a mid-point moment of $N(e_{2a} + u)$ where u is the elastic deflection. This moment is counteracted by a force $2aF/4$ from the support. Since $u = F/C$, $N(e_{2a} + F/C) = Fa/2$ or:

$$F = \frac{e_{2a}}{\frac{a}{2N} - \frac{1}{C}} \quad (7.1)$$

Theoretically, the minimum stiffness of the bracing member should be:

$$C = k_s \frac{N_d}{a} = 2 \left(1 + \cos \frac{\pi}{m} \right) \frac{N_d}{a} \quad (7.2)$$

where m is the number of spans. For two spans it is thus required that $k_s = 2$ and for several spans $k_s = 4$. In the UK $k_s = 4$ is required for all spans.

For $k_s = 4$ and for $e_{2a}/2a = 1/300$ which is the maximum permitted deviation from straightness for structural timber and $e_{2a}/2a = 1/500$ which is the maximum permitted deviation from straightness for glulam, the required strength is given in Table 7.1. Based on experience from existing structures, the values in Table 7.1 taken from the UK National Annex to Eurocode 5 may be used in practice.

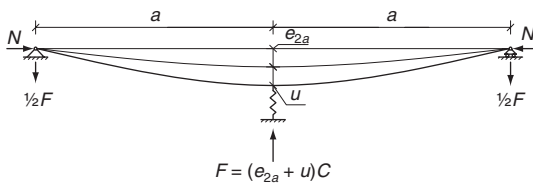
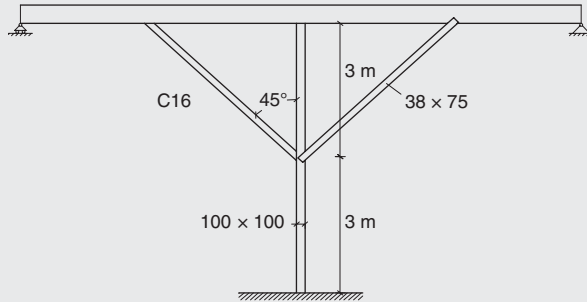

Fig. 7.5 Compression loaded column over two spans with initial mid-height deflection e_{2a} laterally supported at mid-height by a spring with stiffness C , where u is the resulting deflection and F the reaction force perpendicular to the column in the elastic support

Table 7.1 Theoretical requirements to the strength F expressed as F/N for $k_s = 4$

	$e_{2a}/2a$	F/N	
		Theoretically	UK National Annex to Eurocode 5
Structural timber	$l/300$	$1/37.5$	$1/60$
Glulam	$l/500$	$1/63$	$1/100$

Example 7.2



A 6 m long column of C16 timber in service Class 2 condition with cross-section 100×100 mm is braced at mid-height by two timber C16 members 38×75 nailed to either face of the column with n nails of diameter 3.35 mm and length of 75 mm, that are in turn nailed to a stiff top beam.

Find the required number of nails when the load on the column corresponds to its design load.

Note: It is assumed that the two bracing members are only for preventing the column from buckling and they should not be considered as a part of the main structure.

The slenderness ratio of the column is:

$$\lambda_{rel} = \frac{3000 \cdot \sqrt{12}}{100\pi} \sqrt{\frac{17}{5400}} = 1.86; k_c = 0.258$$

$$f_{c,o,d} = 0.9 \cdot 17/1.3 = 11.77 \text{ N/mm}^2$$

$$N_d = 0.259 \cdot 11.77 \cdot 100^2 \cdot 10^{-3} = 30.5 \text{ kN}$$

The strength and stiffness of the bracing should as a minimum be:

$$R_d = 30.5/60 = 0.51 \text{ kN}$$

$$C = 4N_d/a = 4 \cdot 30\,400/3000 = 40.6 \text{ N/mm}$$

Only one of the bracings is assumed to be active when the column starts to buckle (the one with tension).

For 3.35 mm diameter round nails the design load-carrying capacity with $k_{mod} = 0.9$, $\gamma_M = 1.3$ is (see Chapter 9) about 600 N. Therefore, at least one nail is required.

The stiffness for a nail is found from Table 1.7. For $\rho_m = 370 \text{ kg/m}^3$:

$$K_u = \frac{2}{3}K_{ser} = \frac{2}{3} \cdot \frac{\rho_m^{1.5}}{30} d^{0.8} = \frac{2}{3} \cdot \frac{370^{1.5}}{30} 3.35^{0.8} = 416 \text{ N/mm}$$

The stiffness of the bracing is $C_d = F_d/u_1$ where u_1 is the lateral deflection of the column at mid-height (bracing positions) for a force F_1 acting at the same point.

The force in the active bracing member is $\sqrt{2}F_1$. Since the elongation is small compared to the slip in the two joints (one in each end):

$$u_1 = \sqrt{2} \frac{F_1 \sqrt{2}}{nK_u} = F_1 \frac{2}{nK_u}$$

$$C = nK_u/2 = C = nK_u/2 = 208 \text{ N/mm}$$

Therefore, the stiffness is also sufficient. In practice the minimum number of nails to be used is two, even if one nail is sufficient.

7.3.2 Bracing of a structural system

A system of n identical parallel columns shall be braced by a structure that may be loaded by an external load q (see Fig. 7.6). An example is where the rafters (top compression chords) of a trussed rafter roof are braced by a beam at the gables. In Fig. 7.6 the bracing beam is shown as a separate truss, but the columns may act as flanges in the bracing truss.

It is required that the bracing shall be able to take a uniformly distributed load (additional to any external load) of:

$$q_d = n \frac{k_1 N_d}{k_{f,3} l} \quad (7.3)$$

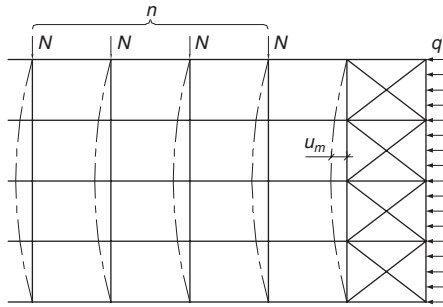

Fig. 7.6 System of n columns supported by a common bracing truss

where:

N_d is the mean (taken over the length) design compression force in the column;

$$k_l = \min \begin{cases} \sqrt{15/l} \\ 1 \end{cases} \quad (7.4)$$

l is the length of the columns.

In the UK National Annex to Eurocode 5 the following value is given:

$$k_{f,3} = \begin{cases} 50 & \text{for members spaced at 600 mm or less} \\ 40 & \text{for members spaced at more than 600 mm} \end{cases} \quad (7.5)$$

The factor k_l allegedly takes into account that for large structures you may expect a more careful erection. On the contrary, stricter requirements should apply, because secondary strength increasing effects will be relatively less important.

It is also required that the lateral deflection for any external load should be less than $l/500$, a requirement that will only in exceptional cases be decisive.

It is best practice that the force on the bracing, F_d , from each column should be necessary to hold the column in place as given by Expression (7.1). These forces are added over the length but since not all will get the maximum force the required support load may be estimated to be not more than:

$$F_{accumulated} = F_d \min \begin{cases} \sqrt{n} \\ 3 \end{cases} \quad (7.6)$$

Further, it should be possible to use the bending stiffness and strength of the columns to take and distribute part of the line load, e.g. half of them with 8 or more columns and $n^2/16$ for half of them for less than 8 columns.

Trusses should be checked for straightness and vertical alignment before fixing to the permanent bracing.

When trusses are fabricated, the members should be free from distortion within the limits given in EN 14250. However, if members which have distorted during the period between fabrication and erection can be straightened without damage to the timber or the joints and maintained straight, the truss may be considered satisfactory for use.

The maximum bow a_{bow} in any truss member after erection should, according to the UK National Annex to Eurocode 5, be limited to 10 mm provided that it is adequately secured in the completed roof to prevent the bow from increasing.

The maximum deviation a_{dev} of a truss from true vertical alignment after erection should, according to the UK National Annex to Eurocode 5, be limited to:

$$a_{dev,permitted} = \min \begin{cases} 10 + 5(H - 1) \text{ mm} \\ 25 \text{ mm} \end{cases} \quad (7.7)$$

where H is the height of the truss in metres.

7.3.3 Bracing of the compression side of a beam

The compression zone in a beam with moment M and depth h may be regarded as a column with a compression force $1.5M/h$. This is, however, very much conservative because first, a bracing placed at the top of the beam is more effective than the bracing placed at mid-depth of the beam; second, this means that the lateral and torsion stiffness is disregarded. It is, therefore, sufficient to design the column for:

$$N_d = (1 - k_{cr}) \frac{M_d}{h} \quad (7.8)$$

8

I, T and box-beams

8.1 Introduction and background theories

This chapter covers glued beams symmetrical about their z -axis with thin webs and or flanges loaded by an axial force N , a bending moment $M = M_y$ and a shear force $V = V_z$ (see Fig. 8.1).

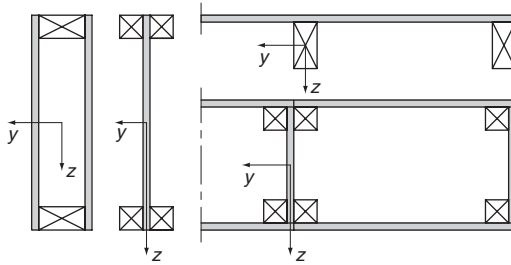

Fig. 8.1 Cross-section of 'I', 'T' and box-beams. The plate-like structures to the right are often called stressed skin elements

Normally two or more material types with different stiffness properties are used in these structural members, e.g. solid timber and wood-based panels. The distribution of the bending stress is highly dependent on the elastic modulus in the beam direction. The stress distribution is calculated by using the theory for 'transformed' cross-sections.

8.2 Transformed (composite) cross-sections

A cross-section composed of n layers (see Fig. 8.2) is regarded. The modulus of elasticity of layer i is denoted E_i and the modulus of elasticity of one of the layers is taken as reference modulus E_{ref} . Two coordinate systems are used: y_1-z_1 and $y-z$ through O_1 and O respectively. The relationship between the z -coordinates is given by:

$$z = z_1 - e \quad (8.1)$$

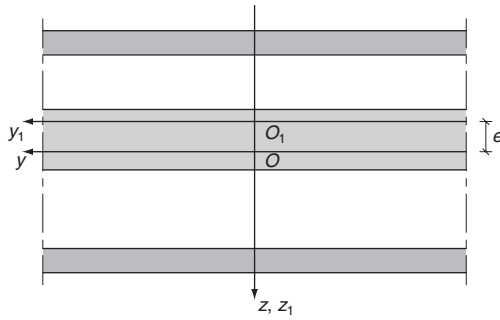

Fig. 8.2 Cross-section composed of layers with different E -values

The transformed area is defined by the integral:

$$A_t = \int_A \frac{E_i}{E_{ref}} dA \quad (8.2)$$

where the index t denotes transformed cross-section. The transformed first moment of area about the y_1 -axis is defined by:

$$S_{1t} = \int_A \frac{E_i}{E_{ref}} z_{1,i} dA \quad (8.3)$$

The transformed first moment of area about the y -axis is defined by:

$$S_t = \int_A \frac{E_i}{E_{ref}} z_i dA \quad (8.4)$$

It is assumed that the y - z coordinate system is located in the centre of gravity, O , for the transformed cross-section defined by the first moment of area being 0:

$$S_t = 0 = \int_A \frac{E_i}{E_{ref}} (z_{1,i} - e) dA = S_{1t} - eA_t$$

and the distance between the coordinate systems becomes:

$$e = \frac{S_{1t}}{A_t} \quad (8.5)$$

The transformed moment of inertia (second-order moment of area) about the y_1 -axis is defined by:

$$I_{1t} = \int_A \frac{E_i}{E_{ref}} z_{1,i}^2 dA \quad (8.6)$$

The transformed second moment of inertia about the y -axis is defined by:

$$\begin{aligned}
 I_t &= \int_A \frac{E_i}{E_{ref}} z_i^2 dA = \int_A \frac{E_i}{E_{ref}} (z_{1,i} - e)^2 dA \\
 &= \int_A \frac{E_i}{E_{ref}} z_{1,i}^2 dA + e^2 \int_A \frac{E_i}{E_{ref}} dA - 2e \int_A \frac{E_i}{E_{ref}} z_{1,i} dA \\
 &= I_{1t} - A_t e^2
 \end{aligned} \tag{8.7}$$

where $S_t = 0$ has been used.

The axial stress from a normal force N acting at O is:

$$\sigma(z) = \frac{E_i}{E_{ref}} \frac{N}{A_t} \tag{8.8}$$

The stress distribution is a stepwise constant for each material layer and the stresses are larger for the stiffer layers.

The stresses from a moment M are calculated as:

$$\sigma(z) = \frac{E_i}{E_{ref}} \frac{M_y}{I_t} z \tag{8.9}$$

and the related curvature is:

$$\kappa = \frac{M_y}{E_{ref} I_t} \tag{8.10}$$

The distribution of the stresses does not depend on the absolute E -values, but only on their relative values and it is therefore important that the ratios are as correct as possible. If a too low value is used in a layer, the stresses in this layer will be underestimated which may lead to premature failure. Therefore, the mean values are always used for all materials such as timber and wood-based panels.

If the materials have different creep properties the stress distribution will change with time. In the materials with large creep rate, the stresses will be relieved, whereas they will increase in the other parts. For very important structures it may be necessary to determine the stress distribution with both the initial (short-term) values and the values corresponding final values E_{fin} after creep. In analogy with deformation calculations E_{fin} may be estimated to:

$$E_{fin} = \frac{E}{1 + k_{def}} \tag{8.11}$$

According to Eurocode 5 it is only required to calculate with E_{fin} .

8.3 Beams with thin webs

8.3.1 General

This section covers beams with cross-sections as shown in Fig. 8.3. The flanges may be solid timber or laminated veneer lumber (LVL). It is assumed that the cross-section is symmetrical about a vertical plane and that the load acts in this plane. If this is not the case it is necessary to take the resulting torsion into account.

In the following it is assumed that the cross-sections are double-symmetrical and use the same materials for top and bottom flanges. It may in some cases be convenient to use different material for the tension and compression flanges but this requires very careful installation in construction practice so that they are not utilised inappropriately, which could result in failures.

Cross-section constants

The modulus of elasticity of the flanges is E and the modulus of elasticity of the webs is called E_w .

The transformed cross-section constants are:

$$A_t = 2bh + \frac{E_w}{E} b_w H \quad (8.12)$$

$$I_t = \frac{bh}{6} [h^2 + 3(H-h)^2] + \frac{E_w b_w}{12E} H^3 \quad (8.13)$$

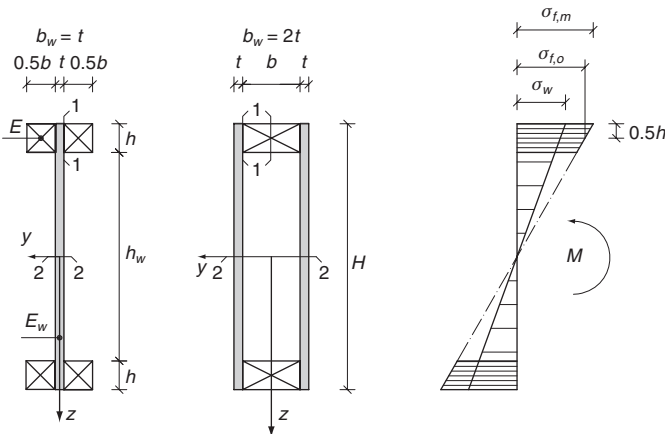

Fig. 8.3 Cross-section notations for double-symmetrical beams and typical bending stress distribution

8.3.2 Axial stresses

The stresses in the flanges from an axial force N and a bending moment $M_y = M$ are:

$$\sigma_f = \frac{N}{A_t} + \frac{M}{I_t} z \quad (8.14)$$

and for the web:

$$\sigma = \frac{E_w}{E} \left(\frac{N}{A_t} + \frac{M}{I_t} z \right) \quad (8.15)$$

The stresses in the top and bottom of the flanges are determined as:

$$\sigma_f = \frac{N}{A_t} \pm \frac{M H}{I_t 2} \quad (8.16)$$

and they shall fulfil the following condition:

$$|\sigma_f|/f_m \leq 1 \quad (8.17)$$

The stresses in the centre of the flanges are:

$$\sigma_{f,0} = \frac{N}{A_t} \pm \frac{M}{I_t} \left(\frac{H-h}{2} \right) \quad (8.18)$$

and they shall fulfil the following conditions:

$$\sigma_{f,0}/f_t \leq 1 \quad (\text{in the tension side}) \quad (8.19a)$$

$$|\sigma_{f,0}|/k_c f_c \leq 1 \quad (\text{in the compression side}) \quad (8.19b)$$

where k_c is the column factor corresponding to the following geometrical slenderness ratio:

$$\lambda = \frac{\sqrt{12} l_c}{b_+ b_w} \quad (8.20)$$

where l_c is the distance between the cross-section where the flanges are held against lateral deflection, i.e. the compression flange is treated as a column, that can deflect laterally. For box beams in particular, this is a very crude simplification and it is normally possible to find a higher load-carrying capacity by making a proper lateral instability calculation.

The stresses in the top and bottom of the webs are:

$$\sigma_w = \frac{E_w}{E} \left(\frac{N}{A_t} \pm \frac{M H}{I_t 2} \right) \quad (8.21)$$

and they shall fulfil the following condition:

$$|\sigma_w|/f_{w,m} \leq 1 \quad (8.22)$$

where $f_{w,m}$ is the bending strength of the web material for in-plane bending. If this strength property is not available the value may be estimated as the smaller value of $1.25f_{w,c}$ and $1.25f_{w,t}$ where $f_{w,c}$ and $f_{w,t}$ are the tension and compression strengths of the web material.

8.3.3 Panel shear stresses

I-sections

The shear stresses are also calculated by using transformed cross-section properties. For cross-section 1–1 in the I cross-sections in Fig. 8.3, the shear force is given by:

$$H_{1-1} = V \frac{S_{1-1,t}}{I_t} \quad (8.23)$$

where $S_{1-1,t}$ is the transformed first moment of area about the axis through the centre of gravity of the flange area outside the cross section 1–1:

$$S_{1-1,t} = \frac{E}{E_{ref}} \frac{bh}{2} \frac{H-h}{2} \quad (8.24)$$

If $h \leq 4t$, the shear force H_{1-1} may be assumed to be uniformly distributed over the thickness of the flange and the panel shear stress is given by:

$$\tau_{1-1} = \frac{H_{1-1}}{h} \quad (8.25)$$

If $h > 4t$, the shear stress will vary over the thickness and the maximum panel shear stress should be calculated as:

$$\tau_{max} = \frac{H_{1-1}}{h} \left(\frac{h}{4t} \right)^{0.8} \quad (8.26)$$

For the I cross-sections, the maximum panel shear force occurs in cross-section 2–2 and is found as:

$$H_{2-2} = V \frac{S_{2-2,t}}{I_t}$$

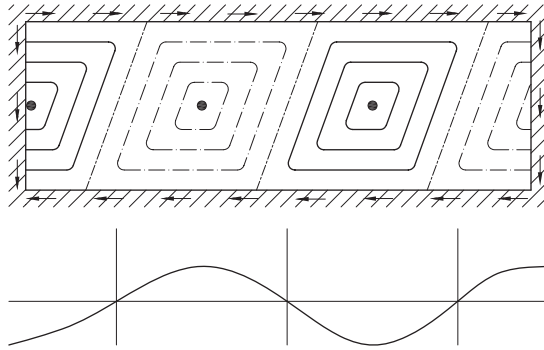

Fig. 8.4 Web buckling due to shear stresses

where $S_{2-2,t}$ is the transformed first moment of area about the axis through the centre of gravity of the cross-section above the cross-section 2-2:

$$S_{2-2,t} = 2S_{1-1,t} + \frac{E}{E_{\text{ref}}} \frac{tH}{2} \frac{H}{4} \quad (8.27)$$

If the shear force H_{2-2} is assumed to be uniformly distributed, the panel shear stress becomes:

$$\tau_{2-2} = \frac{H_{2-2}}{t} \quad (8.28)$$

Box cross-sections

By making the cut as shown in Fig. 8.3 through the symmetry axis where the shear stresses are zero, the beam can be treated as two I-beams.

Web buckling

Beams with high thin webs can fail in lateral (shear) buckling as shown in Fig. 8.4.

Buckling may be disregarded if $h_w \leq 70t$, provided it is verified that:

$$\frac{\tau_{2-2,d}}{f_{v,d}} \leq \left(1 + \frac{h}{h_w}\right) \quad \text{for } \frac{h_w}{t} \leq 35 \quad (8.29)$$

$$\frac{\tau_{2-2,d}}{f_{v,d}} \leq \frac{35b}{h_w} \left(1 + \frac{h}{h_w}\right) \quad \text{for } 35 < \frac{h_w}{t} \leq 70 \quad (8.30)$$

Example 8.1



$$\begin{aligned}
 b_1 &= 28 \text{ mm} \\
 b_2 &= 70 \text{ mm} \\
 b &= 2b_1 + b_2 = 126 \text{ mm} \\
 h &= 95 \text{ mm} \\
 H &= 800 \text{ mm} \\
 t &= 15 \text{ mm} \\
 B &= 2b_1 + b_2 + 2t = 156 \text{ mm}
 \end{aligned}$$

A double symmetrical box beam is in service Class 2 condition. Its compression flange is laterally restrained by the roof diaphragm at every 2.25 m along the span. The flanges are C24 timber and the webs are made of 15 mm thick Swedish spruce plywood with the following characteristic values:

$$f_{m,k} = f_{t,k} = f_{c,k} = 20 \text{ N/mm}^2$$

$$f_{v,k} = 2.0 \text{ N/mm}^2$$

$$f_{v,rol,k} = 0.5 \text{ N/mm}^2$$

$$E = 6000 \text{ N/mm}^2$$

The beam is simply supported with a span of 9.0 m and the load is uniformly distributed line loads:

Dead load: $g = 1.5 \text{ kN/m}$

Snow: $s = 3.0 \text{ kN/m}$

Verify the strength and stiffness of the beam.

Solution

The design load is:

$$q_d = \gamma_G G = \gamma_Q Q = 1.35 \cdot 1.5 + 1.5 \cdot 3 = 6.53 \text{ kN/m}$$

$$M_d = 0.124 \cdot 6.53 \cdot 9^2 = 65.6 \text{ kNm}$$

$$V_d = 0.5 \cdot 6.53 \cdot 9 = 29.4 \text{ kN}$$

The design strength values of the webs with $\gamma_M = 1.2$ and $k_{mod} = 0.9$:

$$f_{m,d} = f_{c,d} = f_{t,d} = 0.9 \cdot 20 / 1.2 = 15.0 \text{ N/mm}^2$$

$$f_{v,d} = 0.9 \cdot 2.0 / 1.2 = 1.50 \text{ N/mm}^2$$

$$f_{v,rol} = 0.9 \cdot 0.5 / 1.2 = 0.38 \text{ N/mm}^2$$

The design strength values of the flanges with $\gamma_M = 1.3$ and $k_{mod} = 0.9$:

$$f_{m,d} = 0.9 \cdot 24 / 1.3 = 16.62 \text{ N/mm}^2$$

$$f_{m,d} = 0.9 \cdot 14 / 1.3 = 9.69 \text{ N/mm}^2$$

$$f_{m,d} = 0.9 \cdot 2.5 / 1.3 = 1.73 \text{ N/mm}^2$$

Bending

From Expression (8.13) with $E = 11\,000 \text{ N/mm}^2$ and $E_w = 6000 \text{ N/mm}^2$:

$$\begin{aligned} I_t &= \frac{126 \cdot 95}{6} [95^2 + 3(800 - 95)^2] + \frac{6000 \cdot 2 \cdot 16}{12 \cdot 11\,000} 800^3 \\ &= (2.99 + 0.75) \cdot 10^9 \\ &= 3.74 \cdot 10^9 \text{ mm}^4 \end{aligned}$$

The flange (see Expressions (6.14)–(6.18)):

$$\frac{\sigma_{f,m,d}}{f_{m,d}} = \frac{65.6 \cdot 10^6 \cdot 400}{3.74 \cdot 10^9 \cdot 16.62} = 0.42 < 1$$

$$\frac{\sigma_{f,0,d}}{f_{t,0,d}} = \frac{6.74 \cdot 705}{800 \cdot 9.69} = 0.61 < 1$$

Instability of the compressed flange is controlled by treating it as an axially loaded column with free length $l_c = 2.25 \text{ m}$ and width $B = 158 \text{ mm}$.

From Expression (5.3):

$$\lambda_{rel} = \frac{2250}{156/\sqrt{12}} \sqrt{\frac{20}{7400\pi^2}} = 0.827$$

From Expression (5.9):

$$k_c = 0.849$$

$$\frac{\sigma_{f,0,d}}{k_s f_{c,0,d}} = \frac{5.94}{0.849 \cdot 14.54} = 0.48 < 1$$

The web (see Expression (8.15)):

$$\sigma_{f,d} = \frac{E_w}{E} \sigma_{f,d,flange} = \frac{6000}{11\,000} \cdot 6.74 = 3.68 \text{ N/mm}^2$$

$$\frac{\sigma_{f,d}}{f_{t,0,d}} = \frac{3.68}{15.00} = 0.25 < 1$$

Rolling shear

It is relevant to consider the cross-sections 1–1, 2–2 and 3–3 shown in the following figure.

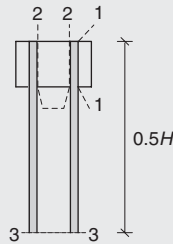

$$\tau_{2-2} > \tau_{1-1} \text{ because } b_2 = 70 \text{ mm} > 2b_1 = 56 \text{ mm}$$

$$\Delta S_2 = b_2 h \frac{H-h}{2} = \frac{1}{2} \cdot 70 \cdot 95 \cdot \frac{800-95}{2} = 1.2 \cdot 10^6 \text{ mm}^3$$

$$\begin{aligned} \Delta S_3 &= bh \frac{H-h}{2} + \frac{E_w}{E} 2t \frac{H}{2} \frac{H}{4} \\ &= 126 \cdot 95 \cdot \frac{800-95}{2} + \frac{8000}{11\,000} \cdot 2 \cdot 15 \cdot \frac{800^2}{8} \\ &= 5.96 \cdot 10^6 \text{ mm}^3 \end{aligned}$$

The width of cross-section 2–2 is $b_{cut} = 95 \text{ mm} > 4t = 60 \text{ mm}$, i.e. it is necessary to take into account that the stresses are not uniformly

distributed:

$$\tau_{2-2,d} = \frac{\Delta S_2 V}{I_t 2h} \left(\frac{h}{4t} \right)^{0.8} = \frac{1.2 \cdot 10^6 \cdot 29.36 \cdot 10^3}{3.92 \cdot 10^9 \cdot 2 \cdot 95} \left(\frac{95}{4 \cdot 15} \right)^{0.8}$$

$$= 0.007 \text{ N/mm}^2$$

$$\frac{\tau_{2-2,d}}{f_{v,rol,d}} = \frac{0.007}{0.38} = 0.184$$

$$\frac{\tau_{3-3,d}}{f_{v,d}} = \frac{\Delta S_3 V}{I_t 2t f_{v,d}} = \frac{5.53 \cdot 10^6 \cdot 29.36 \cdot 10^3}{3.92 \cdot 10^9 \cdot 2 \cdot 15 \cdot 1.50} = \frac{1.488}{1.50} = 0.92 < 1$$

Since $h_w = 610 \text{ mm} < 70t = 1120 \text{ mm}$, the risk of buckling may be disregarded.

Deflection

The deflection in the middle of the span is:

$$u = u_m + u_v = \frac{5}{384} \frac{ql^4}{EI_t} + \frac{1}{8} \frac{ql^2}{GA_w}$$

where $G = 500 \text{ N/mm}^2$ is the shear modulus of the webs.

$$A_w = 2t(H - h) = 2 \cdot 15 \cdot 705 = 21.15 \cdot 10^3 \text{ mm}^2$$

For snow load:

$$u_{inst,s} = \frac{5}{384} \cdot \frac{3 \cdot 9000^4}{11000 \cdot 3.92 \cdot 10^9} + \frac{1}{8} \cdot \frac{3 \cdot 9000^2}{500 \cdot 21.15 \cdot 10^3}$$

$$= 5.9 + 2.9 = 8.8 \text{ mm}$$

that is, the shear contribution is not marginal for beams with thin flanges.

Since $\psi_2 = 0$ for snow, $u_{fin,s} = u_{inst,s}$

$$u_{inst,g} = \frac{g}{s} u_{inst,s} = \frac{1.5}{3} 8.8 = 4.4 \text{ mm}$$

$\psi_2 = 1$ for permanent action

$k_{def} = 0.6$ for C24 and $k_{def} = 0.8$ for plywood; on average $k_{def} = 0.7$

$$u_{fin,g} = u_{inst,g} (1 + \psi_2 k_{def}) = 4.4 (1 + 1 \cdot 0.7) = 7.5 \text{ mm}$$

In total: $16 \text{ mm} \sim l/560$.

8.4 Beams with thin flanges (stress skin panels)

8.4.1 General

This section covers beams (wood-based panel elements) with cross-section as shown in Fig. 8.5. They are often called stressed skin components. The properties of the compression flange (modulus of elasticity E_c) may differ from those of the tension flange (modulus of elasticity E_t). The webs may be of solid timber or panel products or LVL or glulam.

The panels (skins) span from web to web and are acting together with the webs as a part of the structure that carries the loads in the beam direction (along the span). The skins may also be part of the braking system. The thickness of the panels is normally taken on the basis of experience since it is difficult to calculate them for the point loads (e.g. from persons walking on the roof) that will normally be decisive. There are, however, methods of testing and calculation given for concentrated loads on wood-based panels used for flooring and roofing in a CEN standard [EN 1195], and [EN 12872] gives guidance for particle boards.

For plywood and particle boards the following thicknesses may as a general rule be used (but users are recommended to seek more guidance from panel manufacturers for detailed specifications and design guidance):

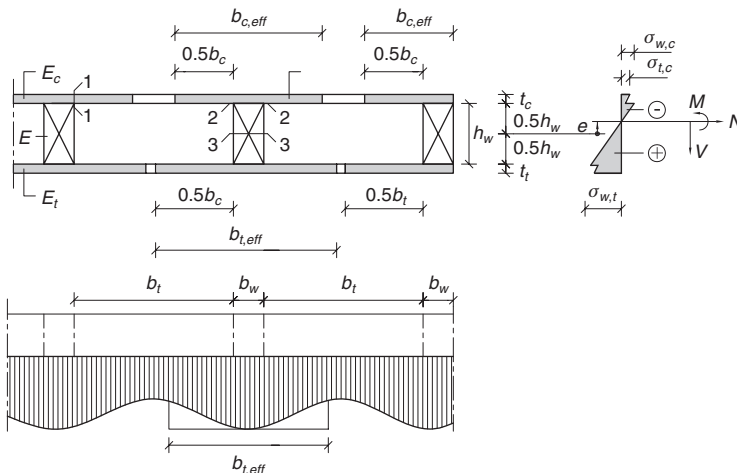

Fig. 8.5 Cross-section of beam with thin panel flanges (stress skin panel). Any axial force is assumed to act in the centre of gravity that is placed in the height e above the middle of the web

1. For domestic flat roofs without any access with spans 600 mm:
 - plywood: 15–16 mm thick
 - particle boards types P5 or P7: 18 mm thick.
2. For domestic floors with spans 600 mm:
 - plywood: generally 18 mm thick; however, for Canadian Douglas fir and Swedish and Finnish spruce plywood 15.5–16 mm
 - particle boards types P5 and P7: 22 mm thick.

The elements are calculated as a number of I-beams that each takes the load directly on the web and on half the web distance to each side.

Cross-section constants

The modulus of elasticity E of the webs is taken as reference modulus of elasticity.

The calculations are made for an effective cross-section as shown in Fig. 8.5. The reason why the full plate width is not used is that the normal stresses vary due to the low shear stiffness of the panel material. The stresses are maximum at the web junctions and minimum in the mid-span of the panel. This is taken into consideration by using an effective width $b_{eff,t}$.

In the compression side the effective width becomes:

$$b_{c,eff} = b_w + b_c \quad (\text{exterior web: } b'_w + 0.5b_c) \quad (8.31)$$

and for the tension side:

$$b_{t,eff} = b_w + b_t \quad (\text{exterior web: } b'_w + 0.5b_t) \quad (8.32)$$

The effective web width depends on, for example, the ratio E/G between the axial modulus of elasticity and the panel shear modulus and on the span. Small variations in the effective width have no great influence and normally very simplified rules are used. According to Eurocode 5, the values given in Table 8.1 should be used.

The maximum limit shall ensure that the failure will not be due to buckling and it therefore only applies for the compression side where the free distance between the webs is also limited to $2b_{c,max}$. The transformed cross-section constants with the modulus of elasticity of the web material as reference are given below.

Double symmetrical cross-section:

$$b_{eff} = b_{t,eff} = b_{c,eff}$$

$$t = t_t = t_c$$

Table 8.1 Effective flange width for beams with thin flanges where l is the plate span

Panel material	b_c and b_t	$b_{c,max}$
Plywood with the fibres in the outer veneers oriented: in the web direction	$0.1l$	$20t_c$
perpendicular to the web direction	$0.1l$	$25t_c$
OSB	$0.15l$	$20t_c$
Particleboards and fibreboards and MDF	$0.2l$	$30t_c$

$$E_f = E_t = E_c$$

$$e = 0$$

$$A_t = h_w b_w + 2 \frac{E_f}{E} b_{eff} t \quad (8.33)$$

$$I_t = \frac{1}{12} b_w h_w^3 + \frac{E_f}{2E} b_{eff} t (h_w + t)^2 \quad (8.34)$$

Single symmetrical cross section:

$$A_t = h_w b_w + \frac{E_c t_c b_{c,eff} + E_t t_t b_{t,eff}}{E} \quad (8.35)$$

$$e = \frac{E_c t_c b_{c,eff} (h_w + t_c) - E_t t_t b_{t,eff} (h_w + t_t)}{2EA_t} \quad (8.36)$$

$$I_t = \frac{1}{12} b_w h_w^3 + \frac{E_c t_c}{4E} b_{c,eff} (h_w + t_c)^2 + \frac{E_t t_t}{4E} b_{t,eff} (h_w + t_t)^2 - A_t e^2 \quad (8.37)$$

8.4.2 Axial stresses

For moments alone it shall be verified that the stresses in the web fulfil the following condition:

$$\frac{\sigma}{f_m} = \frac{M}{I_t f_m} z \leq 1 \quad (8.38)$$

In the flanges the stress variation over the thickness is disregarded and it shall be verified that the tension stress $\sigma_{f,t}$ in the middle of the plate fulfills the following condition:

$$\frac{\sigma_{f,t}}{f_t} = \frac{E_t}{f_t E} \frac{M}{I_t} (0.5h_w + 0.5t_t + e) \leq 1 \quad (8.39)$$

where f_t is the tension strength of the flange panel.

In the compression side it shall be verified that the stress $\sigma_{f,c}$ in the middle of the panel fulfils the following condition:

$$\frac{\sigma_{f,c}}{f_c} = \frac{E_c}{E} \frac{M}{f_c I_t} (0.5h_w + 0.5t_c - e) \leq 1 \quad (8.40)$$

where f_c is the compression strength of the flange material.

8.4.3 Shear stresses

The shear stresses may be assumed uniformly distributed over the cross-sections 1–1, 2–2 and 3–3 shown in Fig. 8.5. The conditions that shall be fulfilled for the compression side are given below. For the tension side similar conditions apply. The design shear strength for webs of wood is $f_{v,d}$ and for flange panels $f_{v,panel,d}$ for panel shear and $f_{v,rol,d}$ for plate shear (rolling shear).

For cross-section 1–1, panel shear stress in the flange:

$$\frac{\tau_{1-1,d}}{f_{v,d}} = V_d \frac{\frac{E_c}{E} \frac{b_c}{2} t_c \left(\frac{t_c + h_w}{2} - e \right)}{I_t t_c f_{v,d}} \leq 1 \quad (8.41)$$

For cross-section 2–2, rolling shear at the joint between panels and web:

$$\frac{\tau_{2-2,d}}{f_{v,rol,d}} = V_d \frac{\frac{E_c}{E} b_{c,eff} \left(\frac{t_c + h_w}{2} - e \right)}{I_t b_w f_{v,rol,d}} \leq 1 \quad (8.42)$$

If $b_w > 8t$, b_w shall be replaced by:

$$b_w \left(\frac{8t}{b_w} \right)^{0.8} \quad (8.43)$$

For cross-section 3–3, the shear stress in the web:

$$\frac{\tau_{3-3,d}}{f_{v,d}} = \frac{\tau_{2-2,d} + V_d \frac{(h_w - 2e)^2}{8I_t}}{f_{v,d}} \leq 1 \quad (8.44)$$

8.4.4 Deflections

The deflections are calculated with the bending stiffness EI_t . Normally any contribution from shear stresses is disregarded. Often the deflections due to moisture differences between bottom and top panels

(skins) are more significant. If the moisture content in the bottom is reduced by Δu the curvature becomes $\kappa = \varepsilon_1 \Delta u / h$, where h is the distance between the panels and a simply supported element with length l will get an upward deflection of $u = \kappa l^2 / 8$.

Example 8.2

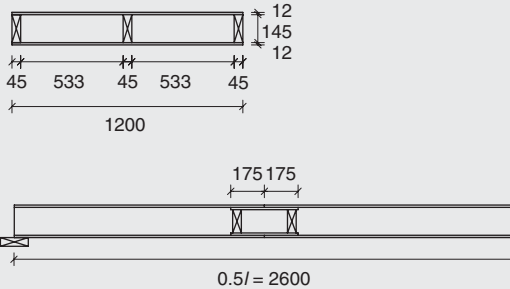

The stressed-skin element shown in the figure above is simply supported with a span of 5.2 m. Both flanges are 12 mm thick Canadian spruce plywood glued to webs of timber C16. The grain direction of the outer ply is parallel to the web direction. Due to the limited panel length the webs are spliced by a single gusset plate placed on the inner side. The top plate roofing felt is placed directly on the panel and consequently this panel shall be assumed to be placed in service Class 3. For the other parts of the element service Class 1 applies.

The design load from dead load and snow is 2.0 kN/m^2 (short-term load).

Verify the strength and stiffness of the component.

For plywood, the following characteristic values are assumed:

$$f_{c,0,k} = 20 \text{ N/mm}^2$$

$$f_{t,0,k} = 15 \text{ N/mm}^2$$

$$f_{v,panel,k} = 3.0 \text{ N/mm}^2$$

$$f_{v,rol,k} = 1.0 \text{ N/mm}^2$$

$$E_{mean} = 7000 \text{ N/mm}^2$$

For the compression flange with $\gamma_M = 1.2$ and $k_{mod} = 0.7$:

$$f_{c,0,d} = 0.7 \cdot 20/1.2 = 11.67 \text{ N/mm}^2$$

$$f_{v,panel,d} = 0.7 \cdot 3.0/1.2 = 1.75 \text{ N/mm}^2$$

$$f_{v,rol,k} = 0.7 \cdot 1.0/1.2 = 0.58 \text{ N/mm}^2$$

The stiffness should be reduced by a factor:

$$\frac{1 + k_{def,2}}{1 + k_{def,1}} = \frac{1 + 0.8}{1 + 1} = 0.9$$

$$E = 0.9 \cdot 7000 = 6300 \text{ N/mm}^2$$

For the tension flange with $k_{mod} = 0.9$:

$$f_{t,0,d} = 0.9 \cdot 15/1.2 = 11.25 \text{ N/mm}^2$$

$$f_{c,0,d} = f_{t,0,d} = 0.9 \cdot 15/1.2 = 11.25 \text{ N/mm}^2$$

$$f_{v,panel,d} = 0.9 \cdot 3.0/1.2 = 2.25 \text{ N/mm}^2$$

$$f_{v,rol,k} = 0.9 \cdot 1.0/1.2 = 0.75 \text{ N/mm}^2$$

$$E_{mean} = 7000 \text{ N/mm}^2$$

Webs:

$$f_{m,d} = 0.9 \cdot 16/1.3 = 11.08 \text{ N/mm}^2$$

$$f_{v,d} = 0.9 \cdot 3.2/1.3 = 2.22 \text{ N/mm}^2$$

$$E = 8000 \text{ N/mm}^2$$

The design moment and shear force for an interior I-beam are, respectively:

$$M_d = (0.533 + 0.045) \cdot 2.0 \cdot 5.2^2/8 = 3.91 \text{ kNm}$$

$$V_d = (0.533 + 0.045) \cdot 2.0 \cdot 5.2/2 = 3.01 \text{ kN}$$

Effective flange widths:

$$b_{c,eff} = \min \left\{ \begin{array}{lll} b_f + b_w = & 533 + 45 = & 578 \\ 0.1l + b_w = & 0.1 \cdot 5200 + 45 = & 565 \\ 20t_c + b_w = & 20 \cdot 12 + 45 = & 285 \end{array} \right\}$$

$$= 285 \text{ mm}$$

$$b_{t,\text{eff}} = \min \left\{ \begin{array}{l} b_f + b_w = 533 + 45 = 578 \\ 0.1l + b_w = 0.1 \cdot 5200 + 45 = 565 \end{array} \right\}$$

$$= 565 \text{ mm}$$

From Expression (8.35):

$$A_t = 145 \cdot 45 + \frac{(6300 \cdot 285 + 7000 \cdot 565) \cdot 12}{8000}$$

$$= 15.15 \cdot 10^3 \text{ mm}^2$$

From Expression (8.36):

$$e = \frac{(6300 \cdot 285 - 7000 \cdot 565) \cdot 12 \cdot (145 + 12)}{2 \cdot 8000 \cdot 15.15 \cdot 10^3}$$

$$= -16.8 \text{ mm}$$

From Expression (8.37):

$$I_t = \frac{1}{12} 45 \cdot 145^3 + \frac{6300}{4 \cdot 8000} \cdot 285 \cdot 12 \cdot (145 + 12)^2$$

$$+ \frac{7000}{4 \cdot 8000} \cdot 565 \cdot 12 \cdot (145 + 12)^2$$

$$- 15.15 \cdot 10^3 \cdot 16.8^2$$

$$= (11.43 + 16.60 + 36.56 - 4.27) \cdot 10^6$$

$$= 60.32 \cdot 10^6 \text{ mm}^4$$

The maximum (numerical) stress in the web (see Expression (8.38)):

$$\frac{\sigma_{m,d}}{f_{m,d}} = \frac{M_d}{I_t f_{m,d}} \chi = \frac{3.91 \cdot 10^6 \cdot (145/2 + 16.8)}{60.3 \cdot 10^6 \cdot 11.08}$$

$$= 0.523 < 1$$

Axial stress in the tension flange (see Expression (8.39)):

$$\frac{\sigma_{f,t,d}}{f_{t,0,d}} = \frac{E_{\text{mean}}}{E} \frac{M_d}{I_t f_{t,0,d}} \chi = \frac{7000}{8000} \cdot \frac{3.91 \cdot 10^6 \cdot (145/2 + 12 - 16.8)}{60.3 \cdot 10^6 \cdot 11.25}$$

$$= 0.34$$

Axial stress in the compression flange (see Expression (8.40)):

$$\frac{\sigma_{f,c,d}}{f_{c,0,d}} = \frac{E_{mean}}{E} \frac{M_d}{I_t f_{c,0,d}} \alpha = \frac{6300}{8000} \cdot \frac{3.91 \cdot 10^6 \cdot (145/2 + 12 + 15.8)}{60.3 \cdot 10^6 \cdot 10.77}$$

$$= 0.48$$

Flange splice

The moment at the splice in the quarter points is reduced by a factor of 0.75. Since the utilisation factor of the tension web is 0.26, the required strength of the splice is $0.75 \cdot 26 = 20\%$ of the tensile strength. Experience has shown that the strength is adequate.

Shear stresses

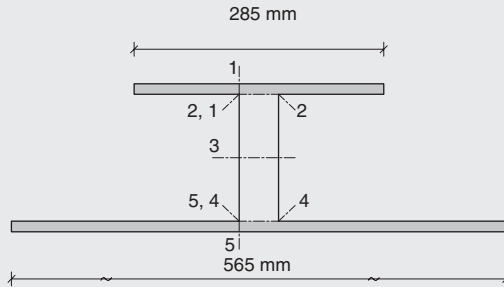

Cross-section 1–1, panel shear stress in the panel (see Expression (8.41)):

$$\frac{\tau_{1-1,d}}{f_{v,panel,d}} = 3006 \cdot \frac{6300}{8000} \cdot 120 \cdot \frac{\left(\frac{12 + 145}{2} - (-16.8)\right)}{60.3 \cdot 10^6 \cdot 12 \cdot 1.75}$$

$$= 0.21 < 1$$

Cross-section 2–2, rolling shear at the joint between the flange and the web (see Expression (8.42)):

With $b_w = 45 \text{ mm} < 8t = 96 \text{ mm}$:

$$\tau_{2-2,d} = \tau_{1-1,d} \frac{285}{120} \cdot \frac{12}{45} = 0.284 \text{ N/mm}^2$$

$$\frac{\tau_{2-2,d}}{f_{v,rol}} = \frac{0.284}{0.58} = 0.49 < 1$$

The calculation is a little on the safe side since the maximum rolling shear stress takes place in the second veneer glue line (i.e. one veneer from the panel face).

Cross-section 3–3, shear stress in the web (see Expression (8.44)):

$$\begin{aligned}\frac{\tau_{3-3,d}}{f_{v,d}} &= \frac{0.284 + 3006 \frac{45 \cdot [145 - 2 \cdot (-16.8)]^2}{8 \cdot 45 \cdot 60.3 \cdot 10^6}}{2.25} = \frac{0.28 + 0.20}{2.25} \\ &= \frac{0.48}{2.25} = 0.21 < 1\end{aligned}$$

Cross-section 5–5, panel shear stress in the tension flange (see Expression (8.41)):

$$\begin{aligned}\frac{\tau_{5-5,d}}{f_{v,panel,d}} &= 3006 \cdot \frac{\frac{7000}{8000} \cdot 260 \cdot 12 \cdot \left(\frac{12 + 145}{2} - 16.8\right)}{60.3 \cdot 10^6 \cdot 12 \cdot 2.25} = \frac{0.70}{2.25} \\ &= 0 < 1\end{aligned}$$

Cross-section 4–4, rolling shear at the joint between the web and compression flange (see Expression (8.42)):

$$\begin{aligned}\tau_{4-4,d} &= \tau_{5-5,d} \cdot \frac{565}{260} \cdot \frac{12}{45} = 0.41 \text{ N/mm}^2 \\ \frac{\tau_{4-4,d}}{f_{v,rd}} &= \frac{0.41}{0.75} = 0.55 < 1\end{aligned}$$

9

Connections and fasteners

9.1 Design of multi-fastener joints

Normally several fasteners such as nails, screws and bolts are used in typical timber connections. Initially the distribution of the internal forces between the individual fasteners is determined.

9.1.1 Concentrically loaded connection

If the external load is acting in the geometrical centre of gravity of the timber connection, the forces acting on the individual fastener are equal and parallel to the external load. An example is shown in Fig. 9.1.

9.1.2 Eccentrically loaded joint

Known line of action

The external force R acting on the structure shown in Fig. 9.2 is transferred by n identical fasteners with coordinates (x_i, y_i) . The coordinate system used is chosen in such a way that the origin is located in the geometrical centre of gravity, defined by:

$$\sum_{i=1}^n x_i = 0 \quad \sum_{i=1}^n y_i = 0 \quad (9.1)$$

The external force $\bar{R} = (R_x, R_y)$ acts at a distance r from the origin. It is assumed that the deformation in the joint corresponds to a translation (u_0, v_0) of the origin and a rotation θ . The translation of fastener i is denoted (u_i, v_i) and calculated as:

$$u_i = u_0 - \theta y_i \quad v_i = v_0 + \theta x_i \quad (9.2)$$

Assuming that the force acting on a fastener is proportional to its total translation (linear elastic behaviour), the force components become:

$$F_{i,x} = K(u_0 - \theta y_i) \quad F_{i,y} = K(v_0 + \theta x_i) \quad (9.3)$$

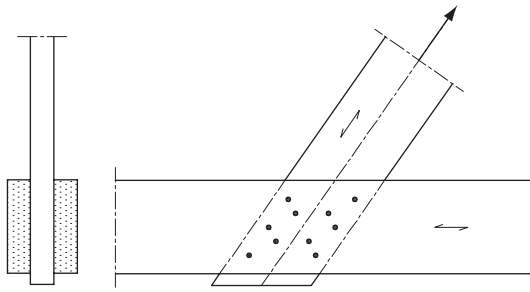
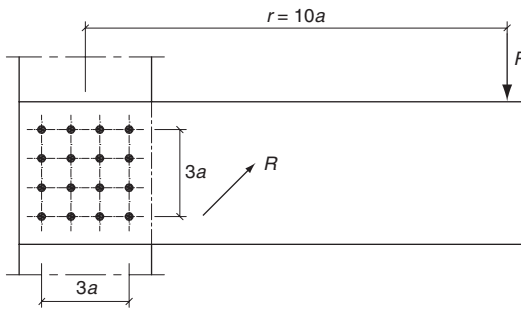

Fig. 9.1 Example of a centrally loaded connection

Static equilibrium requires that:

$$R_x = \sum_{i=1}^n F_{i,x} = Knu_0 \tag{9.4}$$



(a)

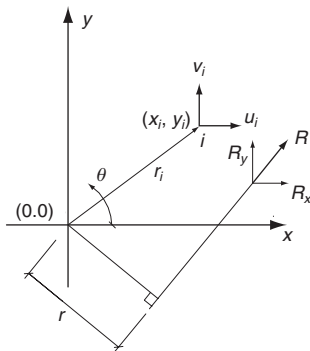

(b)

Fig. 9.2 Plane connection with known line of action: (a) example of joint; (b) model of a joint with notations

$$R_y = \sum_{i=1}^n F_{i,y} = Knv_0 \quad (9.5)$$

$$Rr = \sum_{i=1}^n (F_{i,y}x_i - F_{i,x}y_i) = K\theta \sum_{i=1}^n (x_i^2 + y_i^2) \quad (9.6)$$

where Expression (9.1) has been used.

By determining u_0 , v_0 and θ by these equations and using Expression (9.3), the forces on the fasteners are found as:

$$F_{i,x} = \frac{R_x}{n} - \frac{Rr}{I_p}y_i \quad F_{i,y} = \frac{R_y}{n} + \frac{Rr}{I_p}x_i \quad (9.7)$$

$$F_i = \sqrt{F_{i,x}^2 + F_{i,y}^2} \quad (9.8)$$

where I_p is the fastener group's polar moment of inertia defined by:

$$I_p = \sum_{i=1}^n (x_i^2 + y_i^2) \quad (9.9)$$

The force acting on fastener i may also be expressed as a force $F_{r,i}$ parallel to the external force R

$$F_{R,i} = R/n \quad (9.10)$$

and a force from the moment acting perpendicular to the radius vector r_i :

$$F_{m,i} = \frac{rR}{I_p}r_i \quad (9.11)$$

Unknown line of force

An example with two groups of fasteners is shown in Fig. 9.3. A rigorous analysis of the load on the individual fasteners may be difficult, and it is often simpler to estimate the line of action and take the load-carrying capacity as the smaller of the values calculated for the two groups. If the values were very different, the calculations should be repeated with a new estimate of the line of action. For the structure shown in Fig. 9.3, where the external load, R , is assumed to be parallel to the top chord, it is, however, possible to give a precise solution. The final force expressions will be given below without detailed calculations.

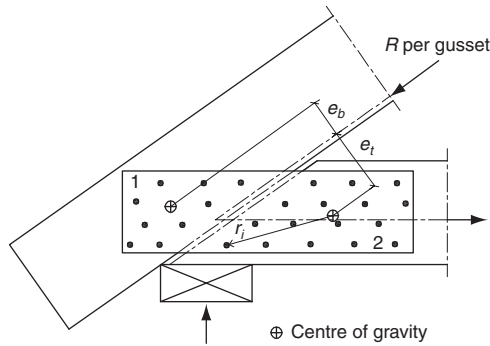

Fig. 9.3 Truss connection between the top and the bottom chord with two groups of fasteners, one in the top chord, the other in the bottom chord

The distance between the centres of gravity of the fastener groups is (e_t, e_b) . The load on each fastener is a force F_R acting in the direction of R and a force F_m perpendicular to the line from the individual fastener to the centre of the fastener group. For group 1 with n_1 fasteners and a polar moment of inertia $I_{p,1}$:

$$F_{r,i} = \frac{R}{n_1} \quad F_{m,i} = \frac{R(e_t + e_b)}{I_{p,1} + I_{p,2}} r_i \quad (9.12)$$

For group 2 with n_2 fasteners and a polar moment of inertia $I_{p,2}$:

$$F_{r,i} = \frac{R}{n_2} \quad F_{m,i} = \frac{R(e_t + e_b)}{I_{p,1} + I_{p,2}} r_i \quad (9.13)$$

9.1.3 Plastic load-carrying capacity of timber connection

By a linear elastic calculation, the load-carrying capacity is determined by the most heavily loaded fastener. As shown below, fasteners typically display pronounced plastic behaviour and it is normally possible to increase the load beyond the elastic limit. It may be difficult to find the exact plastic load-carrying capacity but it is relatively easy to determine a value on the safe side by estimating a load distribution fulfilling the equilibrium conditions (i.e. a statically permissible load distribution) with the forces on all fasteners less than the yield load-carrying capacity (i.e. a safe load distribution).

Example 9.1

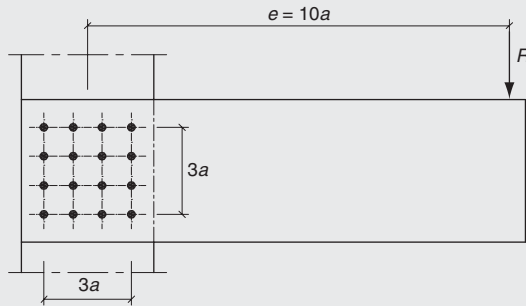

A cantilever beam carries a load R acting at distance $e = 10a$ from the centre of gravity of the connections. The cantilever is, as shown in the above figure, fastened to the column with 16 fasteners. The fasteners are assumed to have an elastic-plastic behaviour with the yield capacity R_y .

Find the elastic load-carrying capacity and the yield capacity of the joint.

Elastic calculation

$$I_p = [4 \cdot (1.5^2 + 1.5^2) + 8 \cdot (1.5^2 + 0.5^2) + 4 \cdot (0.5^2 + 0.5^2)]a^2$$

$$= 40a^2$$

$$F_r = R/16$$

$$F_m = \frac{10aR}{40a^2} 1.5a\sqrt{2} = 0.53R$$

The maximum force on a fastener is found for the fastener in the upper right or lower right corners, where vector addition (not shown) gives $F_{max} = 0.58R = R_y$. The elastic load-carrying capacity is:

$$R_{elast} = \frac{R_y}{0.58} = 1.72R_y$$

Plastic calculation

It is assumed that the vertical load is carried by the four central fasteners and that the other fasteners take the moment. The plastic

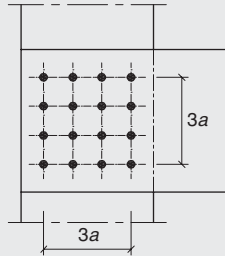

load-carrying capacity is limited by:

$$R_{plast} = 4R_y$$

and

$$R_{plast} = \frac{(8 \cdot 1.5a + 4 \cdot 1.5a\sqrt{2})}{10a} R_y a = 2.05R_y$$

The load-carrying capacity is thus increased by at least 17% by taking the plastic behaviour into account. A marginally higher value may be found by also using the central fasteners to take part of the moment.

9.2 Load-carrying capacity of dowel-type fasteners

9.2.1 General theory

This chapter describes the theoretical basis for the Eurocode 5 expressions for the load-carrying capacity of dowel-type fasteners (i.e. nails, bolts, dowels and screws) loaded perpendicular to their axis (laterally loaded).

The principal behaviour is illustrated in Fig. 9.4 for a so-called double shear connection (two side members and one middle member). The main part of the load is transferred by contact pressure between the

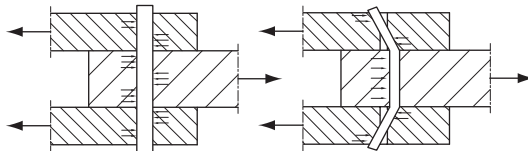

Fig. 9.4 Double shear dowel connections. Thick dowels remain straight and the load is transferred almost solely by shear in the dowel. Slender dowels bend and part of the load may be taken by tension in the inclined dowel parts and by friction between the timber parts that are pressed together by the tension forces

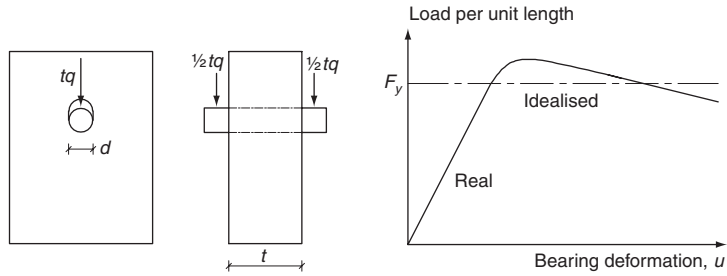

Fig. 9.5 Dowel pressed into a timber member, and the real and ideal-plastic load–deformation curve

timber members and the dowel that is exposed to shear and bending. A part of the load may be taken by direct tension in the inclined dowels and by friction between the timber members.

A simple theory for calculation of the plastic load-carrying capacity without the effect of tension force in the dowel (and thereby also friction) was proposed by K. W. Johansen. It was published in Danish in 1941 and in English in 1949 (Johansen, 1949). The theory is often called the European Yield Model (EYM). It is only valid if the failure is ductile and not brittle (e.g. caused by splitting). This is normally ensured by the structural detailing rules and minimum requirements to member thicknesses.

It is assumed that the dowel acts as a beam laterally loaded by a constant contact pressure q per unit length. The relation between the contact pressure and the deformation may be found by the test set-up sketched in Fig. 9.5 where a stiff steel cylinder in a hole in a timber member is loaded by a force F . The figure shows a typical load–deformation curve. At the beginning there is a linear relationship that is followed by a curved part after which the load falls slightly by increased deformation. In practice a fully plastic behaviour with yield value F_y may be assumed.

The so-called embedding is defined by:

$$f_h = \frac{q_y}{d} \quad (9.14)$$

where q_y is the external load (N/m) acting on the dowel when the wood material starts to yield (permanent deformation because of some type of fibre damage) and d is the dowel diameter. The embedding strength depends first and foremost on the compression strength (and thereby on the density ρ of the wood) and on the angle α between the load

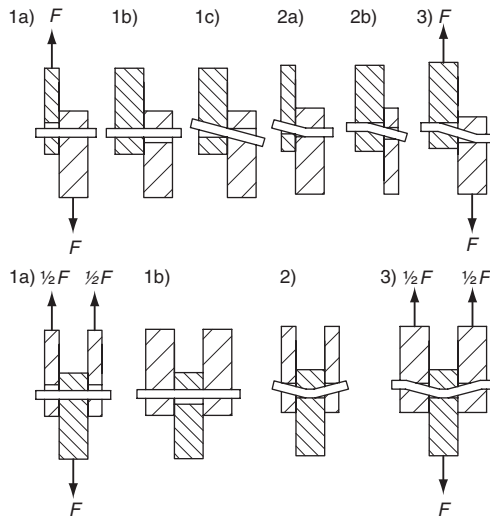

Fig. 9.6 Failure modes for single (upper row) and double (lower row) shear joints

and the fibre direction. Also the dowel form and diameter play a significant role.

The load-carrying capacity also depends on the yield moment M_y of the dowel. Assuming ideal-plastic behaviour of both wood and dowel, the dowel behaves either as a stiff unit without bending deformation or as stiff dowel parts that are joined by yield hinges. The possible failure modes for single and double shear joints are shown in Fig. 9.6.

In the single shear joint, the dowel will either remain straight (failure mode 1) or bend in one or two yield hinges (failure modes 2 or 3 respectively). For the double shear joint failure, mode 1 corresponds to a movement of the dowel either in the side members or the middle member. In failure mode 2, two yield hinges occur in the middle member while the dowel remains straight in the side members. In failure mode 3, four yield hinges are formed within the dowel: two in the middle member and one in each outer part.

It is relatively simple to derive expressions for the load-carrying capacities for the described failure modes using only the equilibrium conditions. As an example, the load-carrying capacity of a dowel cantilevered from a timber member loaded by a force R acting at a distance e from the surface is used. With $e = 0$ this situation is the same as failure mode 3 for a single shear joint because of symmetry.

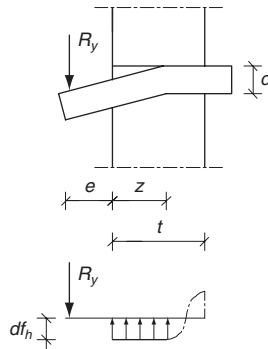

Fig. 9.7 Geometry and the contact load distribution between wood and dowel for a dowel loaded by a force R_y acting at a distance e from the surface of a timber member

With the ideal assumptions the dowel will remain straight until a yield hinge is formed at a distance z from the surface. Since the moment M_y is a maximum moment, the shear force is equal to 0 in that point. Vertical equilibrium and moment equilibrium about the yield hinge would give:

$$R_y = z f_h d \quad (9.15)$$

$$R_y(z + e) - z d f_h / 2 = M_y \quad (9.16)$$

$$R_y = \left[\sqrt{(t + 2e)^2 + t^2} - (t + 2e) \right] d f_h \quad (9.17)$$

If the force R_y acts at the surface of the member ($e = 0$), the load-carrying capacity of the dowel becomes:

$$R_y = \sqrt{2M_y f_h d} \quad (9.18)$$

For the failure modes a , b , g and h , the load can be increased after yielding. The reason is that because of the large deformations there will be tension in the dowel that will act as a rope and part of the load can be taken directly by the tension component parallel to the load. Further load can be transferred by friction. The friction contribution is proportional to the tension force and the sum of the two contributions is, for short, called the rope contribution. The biggest contribution is of course obtained for dowels with head and nut and for screws, but it can also be substantial even for smooth nails and dowels.

9.2.2 Wood-to-wood or wood-based panel-to-wood connections

Single shear joints:

$$R_{v,k} = \min$$

$$\left\{ \begin{array}{l} f_{h,k,1}t_1d \quad (9.19a) \end{array} \right.$$

$$f_{h,2,k}t_2d \quad (9.19b)$$

$$\left\{ \begin{array}{l} \frac{f_{h,1,k}t_1d}{1+\beta} \left[\sqrt{\beta + 2\beta^2 \left[1 + \frac{t_2}{t_1} + \left(\frac{t_2}{t_1} \right)^2 \right] + \beta^3 \left(\frac{t_2}{t_1} \right)^2} - \beta \left(1 + \frac{t_2}{t_1} \right) \right] \\ \quad + T \quad (9.19c) \end{array} \right.$$

$$\left\{ \begin{array}{l} 1.05 \frac{f_{h,1,k}t_1d}{2+\beta} \left[\sqrt{2\beta(1+\beta) + \frac{4\beta(2+\beta)M_{y,k}}{f_{h,1,k}dt_1^2} - \beta} \right] + T \quad (9.19d) \end{array} \right.$$

$$\left\{ \begin{array}{l} 1.05 \frac{f_{h,1,k}t_2d}{1+2\beta} \left[\sqrt{2\beta^2(1+\beta) + \frac{4\beta(1+2\beta)M_{y,k}}{f_{h,1,k}dt_2^2} - \beta} \right] + T \quad (9.19e) \end{array} \right.$$

$$\left\{ \begin{array}{l} 1.15 \sqrt{\frac{2\beta}{1+\beta}} \sqrt{2M_{y,k}f_{h,1,k}d} + T \quad (9.19f) \end{array} \right.$$

Double shear joints:

$$R_{v,k} = \left\{ \begin{array}{l} f_{h,k,1}t_1d \quad (9.20a) \end{array} \right.$$

$$\left\{ \begin{array}{l} 0.5 f_{h,2,k}t_2d \quad (9.20b) \end{array} \right.$$

$$R_{v,k} = \left\{ \begin{array}{l} 1.05 \frac{f_{h,1,k}t_1d}{2+\beta} \left[2\beta(1+\beta) + \frac{4\beta(2+\beta)M_{y,k}}{f_{h,1,k}dt_1^2} - \beta \right] + T \quad (9.20c) \end{array} \right.$$

$$\left\{ \begin{array}{l} 1.15 \sqrt{\frac{2\beta}{1+\beta}} \sqrt{2M_{y,k}f_{h,1,k}d} + T \quad (9.20d) \end{array} \right.$$

with:

$$\beta = \frac{f_{h,2,k}}{f_{h,1,k}} \quad (9.21)$$

$$T = \frac{R_{ax,k}}{4} \quad (9.22)$$

where:

$R_{v,k}$ is the characteristic load-carrying capacity per shear plane per fastener;

- t_1 is the timber or wood-based panel thickness or penetration depth, with i either 1 or 2;
- $f_{h,k}$ is the characteristic embedding strength in timber member i ;
- d is the fastener diameter;
- $M_{y,k}$ is the characteristic fastener yield moment;
- β is the ratio between the embedding strength of the members;
- T is the contribution from the rope effect;
- $R_{ax,k}$ is the characteristic axial withdrawal capacity of the fastener.

Correction factors

In Expressions (9.19) and (9.20), the first terms on the right-hand side without the factors 1.05 and 1.15 are the load-carrying capacities according to the Johansen yield theory, while the second term $T = F_{ax}/4$ is the contribution from the rope effect.

The factors are correction factors to compensate for the very simple way the design values are derived from the characteristic value, *viz.* $R_{y,d} = k_{mod} R_{y,k} / \gamma_M$ (see Section 9.2.8), whether the load-carrying capacity depends solely on timber properties or partly also on the steel properties. In the latter case It would be more correct to introduce k_{mod} and the partial safety factors directly on the material parameters:

$$R_y \approx \sqrt{M_y f_h} = \sqrt{\frac{M_k}{\gamma_{M,steel}} \frac{k_{mod,wood} f_{h,k}}{\gamma_{M,wood}}} = \frac{R_k}{\sqrt{\gamma_{M,steel} \gamma_{M,wood} / k_{mod,wood}}}$$

Typically $\gamma_{M,wood} / \gamma_{M,steel}$ is about 1.2 and k_{mod} about 0.9, i.e.:

$$R_{y,d} \approx 1.15 \frac{k_{mod,wood} R_k}{\gamma_{M,wood}}$$

For the other failure modes with bending in the dowel, the effect is smaller and a factor of 1.05 has been chosen.

Limitation of rope effect

The contribution to the load-carrying capacity due to the rope effect should be limited to the following percentages of the Johansen part of the load-carrying capacity:

- round smooth nails 15%
- square smooth nails 25%
- other nails 50%
- screws 100%
- bolts 25%
- dowels 0%.

If $R_{ax,k}$ is not known, then the contribution from the rope effect should be taken as zero.

For single shear fasteners the characteristic withdrawal capacity, $R_{ax,k}$, is taken as the lower of the capacities in the two members.

For the withdrawal capacity, $R_{ax,k}$, of bolts, the resistance provided by the washers may be taken into account.

9.2.3 Steel-to-wood connections

General

The characteristic load-carrying capacity of a steel-to-timber connection depends on the thickness of the steel plates. Steel plates of thickness less than or equal to $0.5d$ are classified as thin plates and steel plates of thickness greater than or equal to d with the tolerance on hole diameters being less than $0.1d$ are classified as thick plates. The characteristic load-carrying capacity of connections with steel plate thickness between a thin and a thick plate should be calculated by linear interpolation between the limiting thin and thick plate values. The strength of the steel plate shall always be verified.

Thin steel plate in single shear:

$$R_{y,k} = \min \left\{ \begin{array}{l} 0.4 f_{h,k} t_1 d \\ 1.15 \sqrt{2 M_{y,k} f_{h,k} d} + T \end{array} \right. \quad \begin{array}{l} (9.23a) \\ (9.23b) \end{array}$$

Thick steel plate in single shear:

$$R_{v,k} = \left\{ \begin{array}{l} f_{h,k} t_1 d \\ f_{h,k} t_1 d \left(\sqrt{2 + \frac{4 M_{y,k}}{f_{h,k} d t_1^2}} - 1 \right) + T \\ 2.3 \left(\sqrt{M_{y,k} f_{h,k} d} + 1 \right) + T \end{array} \right. \quad \begin{array}{l} (9.24a) \\ (9.24b) \\ (9.24c) \end{array}$$

Steel plate of any thickness as middle member in a double shear connection:

$$R_{v,k} = \min \left\{ \begin{array}{l} f_{h,1,k} t_1 d \\ f_{h,1,k} t_1 d \left(\sqrt{2 + \frac{4 M_{y,k}}{f_{h,1,k} t_1^2 d}} - 1 \right) + T \\ 2.3 \sqrt{M_{y,k} f_{h,1,k} d} + T \end{array} \right. \quad \begin{array}{l} (9.25a) \\ (9.25b) \\ (9.25c) \end{array}$$

Thin steel plates as the outer members in a double shear connection:

$$R_{v,k} = \min \begin{cases} 0.5 f_{h,2,k} t_2 d & (9.26a) \\ 1.15 \sqrt{2 M_{y,k} f_{h,2,k} d} + T & (9.26b) \end{cases}$$

Thick steel plates as outer members of a double shear connection:

$$R_{v,k} = \min \begin{cases} 0.5 f_{h,2,k} t_2 d & (9.27a) \\ 2.3 \sqrt{M_{y,k} f_{h,2,k} d} + T & (9.27b) \end{cases}$$

$$T = \frac{R_{ax,k}}{4} \quad (9.28)$$

where:

- $R_{y,k}$ is the characteristic load-carrying capacity per shear plane per fastener;
- $f_{h,k}$ is the characteristic embedding strength in the timber member;
- t_1 is the smaller of the thickness of the timber side member or the penetration depth;
- t_2 is the thickness of the timber middle member;
- d is the fastener diameter;
- $M_{y,k}$ is the characteristic fastener yield moment;
- T is the rope effect contribution;
- $R_{ax,k}$ is the characteristic withdrawal capacity of the fastener.

Failure modes

The failure modes for steel to timber joints are illustrated in Fig. 9.8.

The contribution from the rope effect is limited to that for wood-to-wood joints.

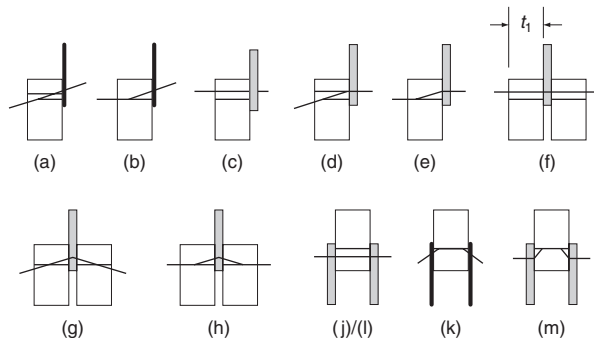

Fig. 9.8 Failure modes for steel to timber joints

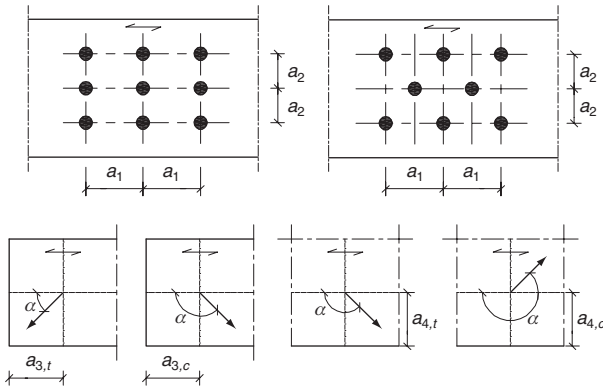

Fig. 9.9 Notations for spacing between fasteners and distances from fasteners to end and edges of the timber member. α is the angle between the force direction for the fastener and the wood grain direction

It shall be taken into consideration that for joints close to an end, the load-carrying capacity may be reduced because of failure along the perimeter of the group of fasteners.

9.2.4 Minimum spacing and distances

The expressions given above presume that failure is ductile, which can be ensured by sufficient timber dimensions, spacings, and distances to end and edges of timber members. The detailed requirements are given in the specific chapters with basis in Fig. 9.9.

9.2.5 Splitting

When wood is loaded with a tension component perpendicular to the grain through bolts or nails, in order to prevent splitting failure, it shall be verified that:

$$V_d \leq R_{90,d} \tag{9.29}$$

where:

$$R_{90,d} = 14b \sqrt{\frac{h_{eff}}{\left(1 - \frac{h_{eff}}{h}\right)}} \tag{9.30}$$

V_d is the maximum design shear force caused by the fasteners (V_1 or V_2);

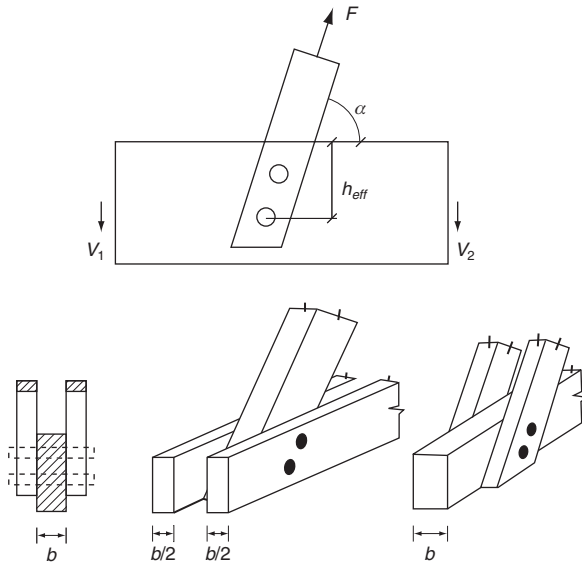

Fig. 9.10 Joints with a load component perpendicular to grain

b is the thickness of the timber member loaded perpendicular to the grain, in mm;

h_{eff} is the effective depth, taken as the distance perpendicular to the grain from the loaded edge to the centre of the furthest fastener in mm, as shown in Fig. 9.10. Note that the shear force V depends on the load configuration; see as an example Fig. 9.11.

For a load outside the supports, $V = F$. For a load in the mid-span between supports, $V = 0.5F$, i.e. the splitting load-carrying capacity is doubled.

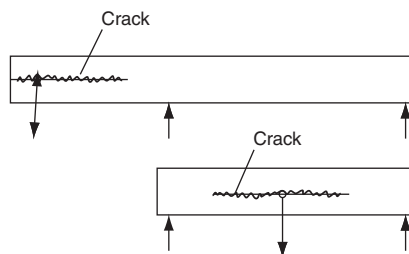

Fig. 9.11 Loads acting on fasteners at an overhang/cantilever (top) and at a position within the supports (bottom)

9.2.6 Multiple shear plane connections

In multiple shear plane connections the resistance of each shear plane should be determined by assuming that each shear plane is part of a series of three-member connections. To be able to combine the resistance from individual shear planes in a multiple shear plane connection, the governing failure mode of the fasteners in the respective shear planes should be compatible with each other and should not consist of a combination of failure modes 1 with the other failure modes.

9.2.7 Multiple fastener joints

The arrangement, sizes of the fasteners and the fasteners' spacings, edge and end distances shall be chosen so that the expected strength and stiffness can be obtained in a joint. It shall be taken into account that the load-carrying capacity of a multiple fastener joint, consisting of fasteners of the same type and dimension, may be lower than the summation of the individual load-carrying capacities for each fastener.

When a connection comprises different types of fasteners, or when the stiffness of the connections in respective shear planes of a multiple shear plane connection is different, their performance as a group of fasteners should be verified.

For one row of fasteners parallel to the grain direction, the characteristic load-carrying capacity parallel to the row, $R_{y,eff,k}$, should be taken as:

$$R_{y,eff,k} = n_{eff}R_{y,k} \quad (9.31)$$

where:

- n_{eff} is the effective number of fasteners in a line parallel to the grain direction;
- $R_{y,k}$ is the characteristic load-carrying capacity of each fastener parallel to the grain direction.

For a force acting at an angle to the direction of the row, it should be verified that the force component parallel to the row is less than or equal to the load-carrying capacity calculated according to Expression (9.31). It should also be verified that the force perpendicular to grain is less than or equal to the perpendicular load-carrying capacity calculated according to Expression (9.29).

9.2.8 Design values

The design load-carrying capacities should be found from the characteristic values as:

$$R_d = k_{mod}R_k/\gamma_M \quad (9.32)$$

9.3 Nailed connections

9.3.1 Laterally loaded wood-to-wood

Load-carrying capacity

The symbols for the thicknesses in single and double shear connections (Fig. 9.12) are defined as t_1 which is:

- for a single shear connection: the head side timber thickness
- for a double shear connection: the head side timber thickness or the point side penetration whichever is smaller

and t_2 which is:

- for a single shear connection: the point side penetration
- for a double shear connection: the central member thickness.

Yield moment

For square and grooved nails, the nail diameter d should be taken as the side dimension. For smooth nails produced from wire with a minimum tensile strength of 600 N/mm^2 , the following characteristic values for

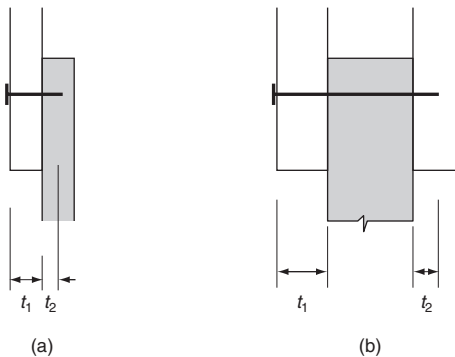

Fig. 9.12 Definitions of t_1 and t_2 for: (a) a single shear joint; and (b) a double shear joint

the yield moment should be used:

$$M_{y,k} = \begin{cases} \frac{180}{600} f_{u,k} d^{2.6} & \text{for round nails} \\ \frac{270}{600} f_{u,k} d^{2.6} & \text{for square nails} \end{cases} \quad (9.33)$$

where:

- $M_{y,k}$ is the characteristic value for the yield moment, in Nmm;
- d is the nail diameter, in mm;
- $f_{u,k}$ is the characteristic tensile strength of the wire, in N/mm².

Embedding strength

For nails with diameters up to 8 mm, the following characteristic embedding strengths in timber and LVL apply:

- without predrilled holes:

$$f_{h,k} = 0.082 \rho_k d^{-0.3} \text{ N/mm}^2 \quad (9.34)$$

- with predrilled holes:

$$f_{h,k} = 0.082(1 - 0.01d) \rho_k \text{ N/mm}^2 \quad (9.35)$$

where:

- ρ_k is the characteristic timber density, in kg/m³;
- d is the nail diameter, in mm.

Effective number of nails

For one row of n nails parallel to the fibre direction the load-carrying capacity parallel to the fibre direction should be calculated using the effective number of fasteners n_{eff} .

If the nails of the row are staggered perpendicular to grain by at least d (see Fig. 9.13):

$$n_{eff} = 1 \quad (9.36)$$

otherwise:

$$n_{eff} = n^{k_{eff}} \quad (9.37)$$

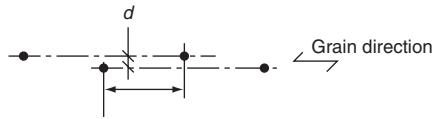

Fig. 9.13 Nails in a row parallel to grain staggered perpendicular to grain direction by d (1 = nail, 2 = grain direction)

where:

- n_{eff} is the effective number of nails in the row;
- n is the number of nails in the row;
- k_{eff} is given in Table 9.1.

Nails in end grain

Smooth nails may be used in secondary structures as, for example, in fascia board nailed to rafters. The design values of the load-carrying capacity should then be taken as 1/3 of the values for nails installed at right-angles to the grain.

Nails other than smooth nails may be used in structures other than secondary structures. The design values of the load-carrying capacity should be taken as 1/3 of the values for smooth nails of equivalent diameter installed at right-angles to the grain, provided that:

- the nails are only laterally loaded
- there are at least three nails per connection
- the pointside penetration is at least $10d$
- the connection is not exposed to service Class 3 conditions
- the prescribed spacings and edge distances given in Table 9.2 are satisfied.

Table 9.1 Values of k_{eff}

Spacing*	k_{eff}	
	Not pre-drilled	Pre-drilled
$a_1 \geq 14d$	1.0	1.0
$a_1 = 10d$	0.85	0.85
$a_1 = 7d$	0.7	0.7
$a_1 = 4d$	–	0.5

* For intermediate spacing, linear interpolation of k_{eff} is permitted.

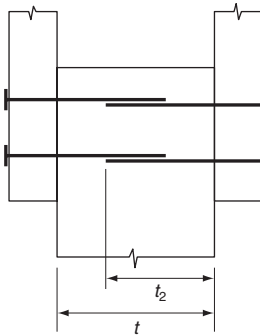

Fig. 9.14 Overlapping nails

Detailing rules

Timber should be pre-drilled with holes not exceeding $0.8d$ where d is the nail diameter, when:

- the characteristic density of the timber is greater than 500 kg/m^3
- the diameter d of the nail exceeds 8 mm.

In a three-member connection, nails may overlap in the central member provided $(t - t_2)$ is greater than $4d$ (see Fig. 9.14).

There should be at least two nails in a connection.

For smooth nails the point side penetration length should be at least $8d$. For other nails, the point side penetration length should be at least $6d$. Unless otherwise specified, nails should be driven in at right-angles to the grain and to such depth that the surfaces of the nail heads are flush with the timber surface.

Rules for the minimum spacing and minimum distances shown in Fig. 9.9 are given in Table 9.2.

Timber should be pre-drilled when the thickness of any timber members is smaller than:

$$t = \max \left\{ \begin{array}{l} 7d \\ (13d - 30) \frac{\rho_k}{400} \end{array} \right. \quad (9.38)$$

where:

- t is the minimum thickness of timber member to avoid pre-drilling, in mm;
- ρ_k is the characteristic timber density in kg/m^3 ;
- d is the nail diameter, in mm.

Table 9.2 Minimum distances for nails where the notation is defined in Fig. 9.9

Distance (Fig. 9.9)	Angle, α°	Minimum spacing or end/edge distance		
		Without predrilling		With predrilling
		$\rho_k \leq 420 \text{ kg/m}^3$	$420 < \rho_k \leq 500 \text{ kg/m}^3$	
Spacing, a_1 (parallel)	$0 \leq \alpha < 360$	$d < 5 \text{ mm:}$ $(5 + 5 \cos \alpha)d$ $d \geq 5 \text{ mm:}$ $(5 + 7 \cos \alpha)d$	$(7 + 8 \cos \alpha)d$	$(4 + \cos \alpha)d$
Spacing, a_2 (perpendicular)	$0 \leq \alpha < 360$	$5d$	$7d$	$(3 + \sin \alpha)d$
$a_{3,t}$, loaded end	$-90 \leq \alpha < 90$	$(10 + \cos \alpha)d$	$(15 + 5 \cos \alpha)d$	$(7 + 5 \cos \alpha)d$
$a_{3,c}$, unloaded end	$90 \leq \alpha \leq 270$	$10d$	$15d$	$7d$
$a_{4,t}$, loaded edge	$0^\circ \leq \alpha \leq 180^\circ$	$d < 5 \text{ mm:}$ $(5 + 2 \sin \alpha)d$ $d \geq 5 \text{ mm:}$ $(5 + 2 \sin \alpha)d$	$d < 5 \text{ mm:}$ $(7 + 2 \sin \alpha)d$ $d \geq 5 \text{ mm:}$ $(7 + 5 \sin \alpha)d$	$d < 5 \text{ mm:}$ $(3 + 2 \sin \alpha)d$ $d \geq 5 \text{ mm:}$ $(3 + 4 \sin \alpha)d$
$a_{4,c}$, unloaded edge	$180^\circ \leq \alpha \leq 360^\circ$	$5d$	$7d$	$3d$

Slip

The instantaneous slip should be determined as:

$$K_{ser} = d^{0.8} \rho_m^{1.5} / 30 \text{ (N/mm)} \quad (9.39)$$

where:

- d is the nail diameter (in mm);
- ρ_m is the characteristic wood density (in kg/m^3).

With typical values inserted, a slip value of about $0.1d$ is found at the serviceability limit.

9.3.2 Laterally loaded, wood-based panels-to-wood

Embedding strength

For nails with a head size of at least $2d$, the characteristic embedding strengths are:

For plywood:

$$f_{h,k} = 0.11\rho_k d^{-0.11} \quad (9.40)$$

where:

- $f_{h,k}$ is the characteristic embedding strength, in N/mm^2 ;
- ρ_k is the characteristic plywood density, in kg/m^3 ;
- d is the nail diameter, in mm.

For hardboard in accordance with EN 622-2:

$$f_{h,k} = 30d^{-0.3}t^{0.6} \quad (9.41)$$

where:

- $f_{h,k}$ is the characteristic embedding strength, in N/mm^2 ;
- ρ_k is the characteristic hardboard density, in kg/m^3 ;
- d is the nail diameter, in mm;
- t is the wood-based panel thickness in mm.

For particle board and OSB:

$$f_{h,k} = 65d^{-0.7-0.1} \quad (9.42)$$

where:

- $f_{h,k}$ is the characteristic embedding strength, in N/mm^2 ;
- d is the nail diameter, in mm;
- t is panel thickness, in mm.

Detailing rules

Minimum nail spacings for all nailed wood-based panel-to-timber connections are those given in Table 9.2 multiplied by a factor of 0.85. The end/edge distances for nails remain unchanged unless otherwise stated below.

Minimum edge and end distances in plywood members should be taken as $3d$ for an unloaded edge (or end) and $(3 + 4 \sin \alpha)d$ for a loaded edge (or end), where α is the angle between the direction of the load and the loaded edge (or end).

Hardboards should be predrilled to avoid damage on the underside caused by the piercing of the nail point which may reduce the load-carrying capacity by 20–25%.

9.3.3 Nailed steel-to-timber connections

Detailing rules

The minimum edge and end distances for nails given in Table 9.2 apply. Minimum nail spacings are those given in Table 9.2 multiplied by a factor of 0.7.

Slip

The slip for joints with thin steel plates should be taken the same as for wood. For thick steel plates the slips are reduced by a factor of 0.7.

9.3.4 Axially loaded nails (withdrawal)

Withdrawal load-carrying capacity

The withdrawal capacity for smooth nails is mainly caused by friction forces between the nail and the wood. For annular ring shank nails there is also a mechanical effect.

Smooth nails shall not be used to resist permanent or long-term withdrawal loads. For threaded nails, only the threaded part should be considered capable of resisting withdrawal load. Nails in end grain should not be considered capable of resisting withdrawal loads.

The characteristic withdrawal capacity of nails, $R_{ax,k}$, for nailing perpendicular to the grain (Fig. 9.15a) and for slant (skew) nailing (Fig. 9.15b), should be taken as the smaller of the values found from the following expressions.

For smooth nails:

$$R_{ax,k} = \begin{cases} f_{ax,k} dt_{pen} & (9.43a) \\ f_{ax,k} dt + f_{head,k} d_h^2 & (9.43b) \end{cases}$$

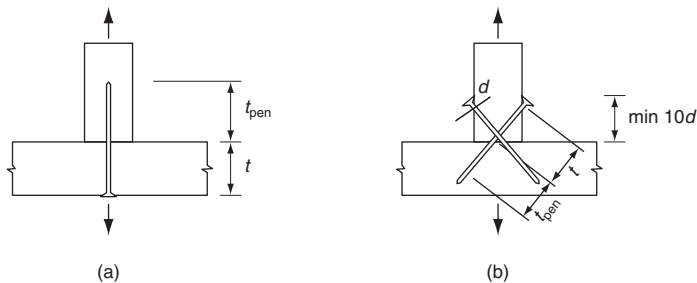

Fig. 9.15 (a) Nailing perpendicular to the fibre direction and (b) slant (skew) nailing

For other nails:

$$R_{ax,k} = \begin{cases} f_{ax,k} dt_{pen} & (9.44a) \\ f_{head,k} d_h^2 & (9.44b) \end{cases}$$

where:

- $f_{ax,k}$ is the characteristic point side withdrawal strength;
- $f_{head,k}$ is the characteristic head side pull-through strength;
- d is the nail diameter;
- t_{pen} is the point side penetration length or the length of the threaded part in the point side member;
- t is the thickness of the head side member;
- d_{head} is the nail head diameter.

The characteristic values of the parameters $f_{ax,k}$ and $f_{head,k}$ should be determined by tests according to [EN 1382], [EN 1383] and [EN 14358], unless otherwise specified in the following.

For smooth nails with a point side penetration of at least $12d$ the characteristic values of the withdrawal and pull-through strengths should be found from the following expressions:

$$f_{ax,k} = 20 \cdot 10^{-6} \rho_k^2 \quad (9.45a)$$

$$f_{head,k} = 70 \cdot 10^{-6} \rho_k^2 \quad (9.45b)$$

where:

- ρ_k is the characteristic density in kg/m^3 .

For smooth nails with a point side penetration t_{pen} smaller than $12d$ the withdrawal capacity should be multiplied by:

$$\left(0.25 \frac{t_{pen}}{2} - 2 \right)$$

For threaded nails with a point side penetration t_{pen} smaller than $8d$, the withdrawal capacity should be multiplied by:

$$\left(0.5 \frac{t_{pen}}{d} - 3 \right)$$

The friction decreases with time and with moisture content changes, especially for smooth nails. However, hot-dip zinc coating increases the withdrawal resistance of smooth nails. For annular ring shank nails

hot-dip coating may result in a reduction in the load-carrying capacity because the gap between the rings is filled with zinc material. Therefore, electro zinc coating should be used.

Slant (skew) nailing (see Fig. 9.15) may be used to take small anchorage loads. By slant nailing, the force acts at an angle to the nail axis and the nails are loaded in both tension and bending.

Detailing rules

The spacing and end and edge distances for laterally loaded nails apply. For slant (skew) nailing there should be at least two nails in a connection and the distance to the loaded edge (see Fig. 9.15) should be at least $10d$.

Moisture movements

By repeated wetting and drying, the nails will move out, resulting in protruding nail heads (sometimes called popping up of nails). The effect is most pronounced for long nails. After the first moisture cycle there is no difference between smooth nails and other nails, but after several cycles the effect is most pronounced for smooth nails. Annular ring shank nails and screw nails are, therefore, preferable not forgetting that shorter nails can be used.

9.3.5 Combined laterally and axially loaded nails

For connections loaded with a combination of axial load ($F_{ax,d}$) and lateral load ($F_{v,d}$) it should be verified that:

For smooth nails:

$$\frac{F_{ax,d}}{R_{ax,d}} + \frac{F_{v,d}}{R_{v,d}} \leq 1 \quad (9.46)$$

For other than smooth nails:

$$\left(\frac{F_{ax,d}}{R_{ax,d}}\right)^2 + \left(\frac{F_{v,d}}{R_{v,d}}\right)^2 \leq 1 \quad (9.47)$$

where:

$R_{ax,d}$ and $R_{v,d}$ are the design load-carrying capacities for axial load and lateral loads respectively.

Example 9.2

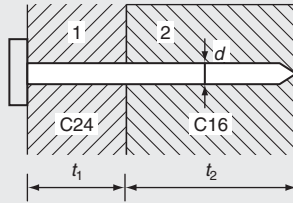

Two timber members C24 and C16 with thicknesses t_1 and t_2 are joined with an ordinary smooth nail with diameter $d = 4.2$ mm and $f_u = 600$ N/mm². The nail length is $l = t_1 + t_2 = 90$ mm.

Calculate the load-carrying capacity for t_1 between $4d = 16.8$ mm and $l - 8d = 90 - 33.6 = 56.4$ mm.

$$M_y = 0.3 f_u d^{2.6} = 0.3 \cdot 600 \cdot 4.2^{2.6} = 7510 \text{ N/mm}^2$$

Member 1:

$$\rho_k = 350 \text{ kg/m}^3,$$

$$f_{h,1} = 0.082 \rho_k d^{-0.3} = 0.082 \cdot 350 \cdot 4.2^{-0.3} = 18.7 \text{ N/mm}^2$$

$$f_{ax,1,k} = 20 \cdot 10^{-6} \rho_k^2 = 20 \cdot 10^{-6} \cdot 350^2 = 2.45 \text{ N/mm}^2$$

$$f_{head,k} = 70 \cdot 10^{-6} \rho_k^2 = 70 \cdot 10^{-6} \cdot 350^2 = 8.58 \text{ N/mm}^2$$

Member 2:

$$\rho_k = 310 \text{ kg/m}^3,$$

$$f_{h,1} = 0.082 \rho_k d^{-0.3} = 0.082 \cdot 310 \cdot 4.2^{-0.3} = 16.5 \text{ N/mm}^2$$

$$f_{ax,1,k} = 20 \cdot 10^{-6} \rho_k^2 = 20 \cdot 10^{-6} \cdot 310^2 = 1.92 \text{ N/mm}^2$$

The results of the calculations are shown in the following table.

N	Formula	Thickness t_1 , mm and (t_1/d)					
		16.8 (4)	25.2 (6)	33.6 (8)	42 (10)	50.4 (12)	56.4 (13.4)
$R_{v,k}$, without	a	1317	1975	2633	3292	3950	4420
	b	5081	4498	3915	3332	2749	2332
rope effect	c	1735	1539	1416	1372	1410	1487
	d	826	952	1117	1303	1501	1648
	e	1703	1531	1362	1198	1042	938
	f	1209	1209	1209	1209	1209	1209

N	Formula	Thickness t_1 , mm and (t_1/d)					
		16.8 (4)	25.2 (6)	33.6 (8)	42 (10)	50.4 (12)	56.4 (13.4)
	min	826	952	1117	1209	1042	938
$R_{ax,k}$	1	1120	1204	1290	1370	1460	1525
	2	590	523	455	332	114	0
Rope effect, $T = R_{ax,k}/4$		147	130	113	83	29	0
$R_{v,k}$		973	1082	1230	1282	1071	938

Example 9.3

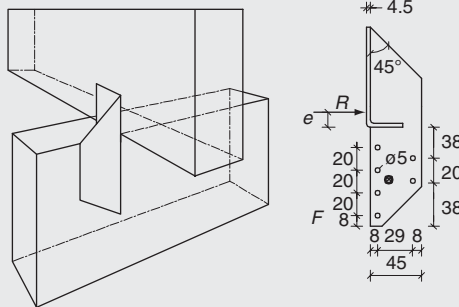

The joint between a purlin and a beam both of C24 is made with a 2 mm thick Simpson Strong-Tie universal bracket as shown in the figure. The fasteners used are annular ring shank nails 4.0×40 mm.

Determine the design load-carrying capacity for a short-term load in the direction of the purlin in Service class 1.

Elastic solution

The centre of gravity of the nail group is placed $29/3 = 9.7$ mm from the left line of nails, and $30 + 10/3 = 33$ mm over the lowermost nail. The polar moment of inertia is calculated to $I_p = 3455 \text{ mm}^2$.

The load-carrying capacity is found from Expression (9.22). Normally Expression (9.23) for thin plates should be used but tests

have shown that these nails will be held rigidly by the plate and that Expression (9.24) may be used.

$$M_{y,k} = 0.3 f_u d^{2.6} = 0.3 \cdot 600 \cdot 4^{2.6} = 6620 \text{ N/mm}^2$$

$$f_h = 0.082 \rho_k d^{-0.3} = 0.082 \cdot 350 \cdot 4^{-0.3} = 18.9 \text{ N/mm}^2$$

Without rope effect:

$$R_{v,k} = \min \left\{ \begin{array}{l} 2565 \\ 1628 \\ 1394 \end{array} \right\} = 1394 \text{ N} \quad \begin{array}{l} (9.19a) \\ (9.19b) \\ (9.19c) \end{array}$$

The withdrawal parameter is (determined by tests): $f_{ax,k} = 10.0 \text{ N/mm}^2$. The effective penetration depth is with a point length of $1.5d = 6 \text{ mm}$

$$l_{pen} = 30 - 6 = 24 \text{ mm}$$

$$R_{ax,k} = f_{ax,k} l_{pen} d = 10 \cdot 24 \cdot 4 = 960 \text{ N}$$

$$R_{v,k} = \min \left\{ \begin{array}{l} 1.5 \cdot 1394 = 2090 \text{ N} \\ 1394 + 960/4 = 1634 \text{ N} \end{array} \right.$$

$$R_{v,d} = k_{mod} R_k / \gamma_M = 0.9 \cdot 1634 / 1.3 = 1130 \text{ N}$$

It is estimated that the load is transferred by direct compression in a height of $e = 5 \text{ mm}$ over the beam, i.e. 93 mm over the lowermost nail. The load on the connection becomes:

$$R_x = R \quad R_y = 0 \quad M = -R(93 - 33) = -60R$$

The top nail is decisive. From Expressions (9.7) and (9.8):

$$F_y = -60R \cdot (-9.7) / 3455 = 0.17R$$

$$F_x = R/6 - (-60R \cdot 27 / 3455) = 0.64R$$

$$F = R \sqrt{0.64^2 + 0.17^2} = 0.66R$$

The design load-carrying capacity is found for $F = R_{v,d}$ from:

$$R_d = 1130 / 0.66 = 1710 \text{ N}$$

The compression perpendicular to grain becomes with a bracket width of 50 mm and a compression zone depth of $2e = 10 \text{ mm}$: $1710 / (50 \cdot 10) = 3.4$ that can easily be taken.

Plastic solution

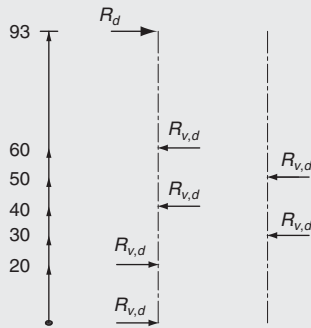

An estimated value on the safe side may be found by the plastic force system shown.

Lateral equilibrium:

$$R_k \geq 2R_{v,k}$$

Moment about the lowermost point:

$$R_k \geq R_{v,k}(60 + 50 + 40 + 30 - 20)/93 = 1.72R_{v,k} = 2840 \text{ N}$$

$$R_d = 0.9 \cdot 2840/1.3 = 1966 \text{ N}$$

By a rigorous plastic analysis a load-carrying capacity of about 2200 N may be calculated.

Example 9.4

Design the joint between top and bottom flange in the truss from Example 7.1.

Proposal

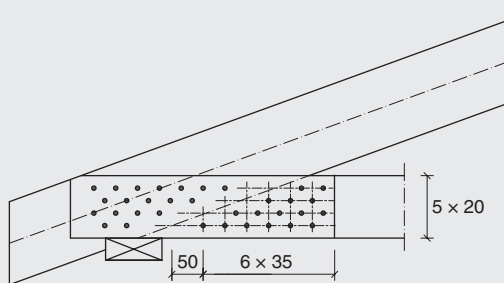

It is assumed that the support reaction is transferred directly to the top flange, i.e. the joint shall transfer the tension force in the bottom flange:

$$F_d = F_{1-7,d} = 10.05 \text{ kN (short-term load)}$$

The gusset plates are 9 mm Finnish combi plywood with a characteristic density of 560 kg/m^3 . Ring shank nails $3.1 \times 40 \text{ mm}$ are used.

The nail strength is $f_u = 600 \text{ N/mm}^2$. The withdrawal strength is, according to a European Technical Approval (ETA), $f_{ax} = 10 \text{ N/mm}^2$.

$$M_y = 0.3 f_u d^{2.6} = 0.3 \cdot 600 \cdot 3.1^{2.6} = 3410 \text{ N/mm}$$

$$f_{h,k} = 0.11 \rho_k d^{-0.3} = 0.11 \cdot 560 \cdot 3.1^{-0.3} = 43.9 \text{ N/mm}^2$$

$$f_{h2,k} = 0.082 \rho_k d^{-0.3} = 0.082 \cdot 310 \rho_k \cdot 3.1^{-0.3} = 18.1 \text{ N/mm}^2$$

The lateral load-carrying capacity without rope effect determined by Expression (9.19e): $R_{v,k} = 328 \text{ kN}$.

The penetration depth: $t_{pen} = 40 - 9 - 1.5 \cdot 3.1 = 26.4 \text{ mm} = 8.5d > 8d$.

The withdrawal capacity of the point side is $R_{ax,k} = f_{ax,k} d t_{pen} = 10 \cdot 3.1 \cdot 26.4 = 818 \text{ kN}$. The rope contribution is $R_{ax,k}/4 = 205$, however not more than $0.5R_{v,k} = 164 \text{ kN}$, i.e. $R_{v,k} = 328 \text{ N}$.

The design load-carrying capacity is:

$$R_{v,d} = k_{mod} R_{v,k} / \gamma_M = 0.9 \cdot 328 / 1.3 = 227 \text{ N}$$

The minimum number of nails required is $10.05/0.341 = 30$. It is assumed that the nails are staggered so that $n_{eff} = n$.

The nails may be placed as shown in the figure. The distances are determined by the bottom flange; the theoretical distances in the top flange are slightly smaller because of the inclined grains. The minimum edge distance is $5d = 16 \text{ mm}$; the minimum end distance is $15d = 57 \text{ mm}$; the minimum spacing in the grain distance is $8d$ ($0.8 \cdot 10d$); and the minimum distance to the plywood end is $4d$.

9.4 Connections with staples

9.4.1 General

For round or nearly round or rectangular staples with bevelled or symmetrical pointed legs the rules for nails apply with the following

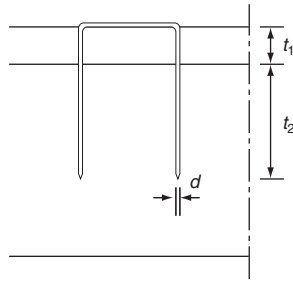

Fig. 9.16 Staple dimensions

exceptions:

- pre-drilling is not required
- the characteristic yield moment $M_{y,k}$ for staples with diameter d made from wire with a characteristic tensile strength of 800 N/mm^2 should be taken as:

$$M_{y,k} = 240d^{2.6} \quad (9.48)$$

For staples with rectangular cross-section, d should be taken equal to the square root of the product of the two dimensions, i.e. $d = \sqrt{ab}$ where a and b are the sides of the rectangle.

The lateral design load-carrying capacity per staple per shear plane should be considered as equivalent to that of two nails with the staple diameter, provided that the angle between the crown and the direction of the grain of the timber under the crown is greater than 30° , see Fig. 9.16. If the angle between the crown and the direction of the grain under the crown is equal to or less than 30° , then the lateral design load-carrying capacity should be multiplied by a factor of 0.7.

9.4.2 Effective number of staples

For n staples in a row parallel to the grain, the effective number n_{eff} should be calculated as for nails.

9.4.3 Detailing rules

The width b of the staple crown should at least be $6d$, and the point side penetration length t_2 should be at least $14d$, see Fig. 9.16. There should be at least two staples in a connection. Minimum staple spacings, edge

Table 9.3 Minimum spacings and end and edge distances for staples (see Fig. 9.17)

	Angle, α°	Minimum spacings and distances
a_1 parallel to the fibre direction For $\theta \geq 30^\circ$ For $\theta < 30^\circ$	$0 \leq \alpha \leq 360$	$(10 + 5 \cos \alpha)d$ $(15 + 5 \cos \alpha)d$
a_2 perpendicular to the fibre direction	$0 \leq \alpha \leq 360$	$15d$
$a_{3,t}$, loaded end	$-90 \leq \alpha \leq 90$	$(15 + 5 \cos \alpha)d$
$a_{3,c}$, unloaded end	$90 \leq \alpha \leq 270$	$15d$
$a_{4,t}$, loaded edge	$0 \leq \alpha \leq 180$	$(15 + 5 \sin \alpha)d$
$a_{4,c}$, unloaded edge	$180 \leq \alpha \leq 360$	$10d$

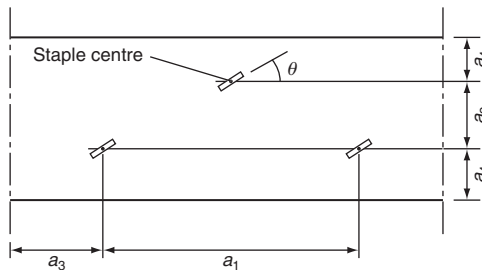

Fig. 9.17 Definition of distances between staples

and end distances are given in Table 9.3, and illustrated in Fig. 9.17 where θ is the angle between the staple crown and the grain direction.

9.5 Bolted connections

9.5.1 Laterally loaded bolts in wood-to-wood joints

Yield moment

The yield moment $M_{y,k}$ should be calculated as:

$$M_{y,k} = 0.3 f_{u,k} d^{2.6} \quad (9.49)$$

where:

- $f_{u,k}$ is the characteristic tensile strength in N/mm^2 ;
- d is the diameter in mm.

Embedding strength

The embedding strength, for $d \leq 30$ mm, should be calculated using:

$$f_{h,\alpha,k} = k_\alpha f_{h,0,k} = \frac{1}{k_{90} \sin^2 \alpha + \cos^2 \alpha} f_{h,0,k} \quad (9.50)$$

where:

$$f_{h,0,k} = 0.082(1 - 0.01d)\rho_k \quad (9.51)$$

$$k_{90} = \begin{cases} 1.35 + 0.015d & \text{for softwood} \\ 1.30 + 0.015d & \text{for LVL} \\ 0.90 + 0.015d & \text{for hardwood} \end{cases} \quad (9.52)$$

$f_{h,0,k}$ is the characteristic strength parallel to the grain direction in N/mm^2 ;

ρ_k is the characteristic wood density in kg/m^3 ;

α is the angle between the load and grain direction;

d is the bolt diameter in mm; and

k_α and $f_{h,\alpha,k}$ as a function of α and d in mm are shown in Fig. 9.18.

Effective number of bolts

For n bolts in a row parallel to the grain direction the effective bolt number should be taken as n_{eff} :

$$n_{\text{eff}} = \min \left\{ \begin{array}{l} n \\ n^{0.9} \sqrt[4]{\frac{a_1}{13d}} \end{array} \right. \quad (9.53)$$

where:

a_1 is the spacing between the bolts in the grain direction in mm;

d is the bolt diameter in mm.

Some examples of the factor n_{eff} are given in Table 9.4.

For load perpendicular to the grain direction, the effective number is:

$$n_{\text{eff}} = n \quad (9.54)$$

For angles α between the load and grain direction of between 0° and 90° , n_{eff} may be determined by linear interpolation using Expressions (9.53 and (9.54).

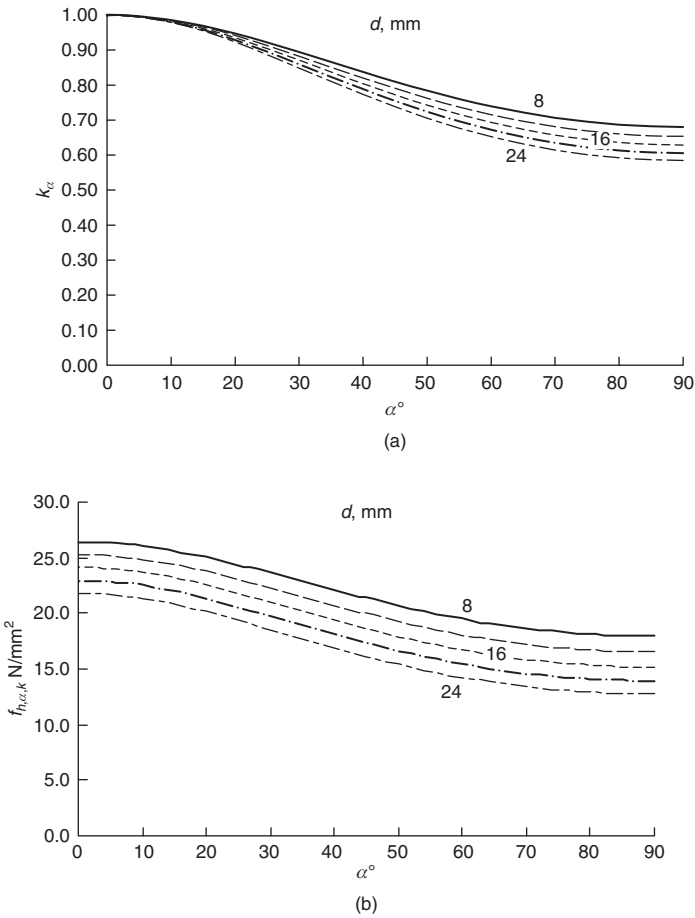

Fig. 9.18 The factor k_α (a) and the embeddings strength $f_{h,a,k}$ (b) as a function of the diameter d and the angle α between the force direction and the grain direction

Table 9.4 The factor n_{eff} depending on the number of bolts n after each other and their spacing a_1

n	a_1		
	$7d$	$10d$	$13d$
2	1.60	1.75	1.87
3	2.30	2.52	2.69
5	3.65	3.99	4.26
8	5.57	6.09	6.50
10	6.80	7.44	7.94

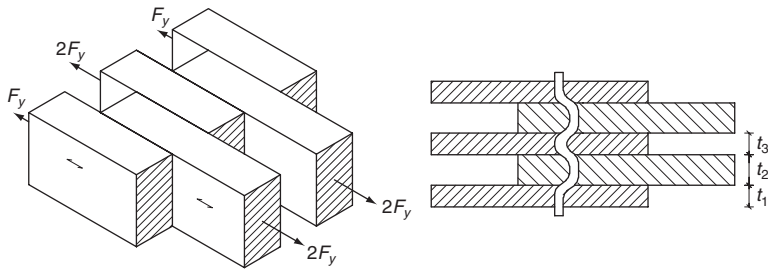

Fig. 9.19 Multi-shear joints

Multiple shear joints

The load-carrying capacity of multiple shear joints can often be determined by treating the joint as several double shear joints.

As an approximation, the joint in Fig. 9.19 may be treated as two double shear joints. The middle members with thickness t_3 limits the load-carrying capacity to:

$$2F_{y,k} = t_3 d f_{h,0,k} \quad (9.55)$$

where:

$F_{y,k}$ is the characteristic load transferred per shear in the bolts.

Structural detailing

Minimum spacing and end and edge distances as defined in Fig. 9.9 are given in Table 9.5. Bolt holes in timber should have a diameter of not more than 1 mm larger than the bolt diameter. Bolt holes in steel plates should not exceed the bolt diameter d by more than 2 mm or $0.1d$ (whichever is greater). This is for ease of fitting.

Washers with a side length or a diameter of at least $3d$ and a thickness of at least $0.3d$ should be used under the bolt heads and nuts. Washers should bear fully on timber. Bolts should be tightened so that the members fit closely, and they should be retightened if necessary when the timber has reached equilibrium moisture content to ensure that the load-carrying capacity and stiffness of the structure are maintained.

9.5.2 Laterally loaded bolted joints, wood-based panels-to-wood

Plywood

The following embedding strength, in N/mm^2 , should be used for all angles to the grain of the face veneer:

$$f_{h,0,k} = 0.11(1 - 0.01d)\rho_k \quad (9.56)$$

Table 9.5 Minimum spacing and end and edge distances for bolts

a_1 parallel to the grain direction	$0 \leq \alpha \leq 360$	$(4 + \cos \alpha)d$
a_2 perpendicular to the grain direction	$0 \leq \alpha \leq 360$	$4d$
$a_{3,t}$ loaded end	$-90 \leq \alpha \leq 90$	$\max \begin{cases} 7d \\ 80 \text{ mm} \end{cases}$
$a_{3,c}$ unloaded end	$90 \leq \alpha \leq 150$	$\max \begin{cases} (1 + 6 \sin \alpha)d \\ 4d \end{cases}$
	$150 \leq \alpha \leq 210$	$4d$
	$210 \leq \alpha \leq 270$	$\max \begin{cases} (1 + 6 \sin \alpha)d \\ 4d \end{cases}$
$a_{4,t}$ loaded edge	$0 \leq \alpha \leq 180$	$\max \begin{cases} (2 + 2 \sin \alpha)d \\ 3d \end{cases}$
$a_{4,c}$ unloaded edge	$180 \leq \alpha \leq 360^\circ$	$3d$

where:

- ρ_k is the characteristic density of the plywood in kg/m^3 ;
- d is the bolt diameter in mm.

Particle boards and OSB

The following embedding strength, in N/mm^2 , should be used:

$$f_{h,0,k} = 50d^{-0.6}t^{0.2} \quad (9.57)$$

where:

- d is the bolt diameter in mm;
- t is the wood-based panel thickness in mm.

9.5.3 Laterally loaded bolted joints, steel-to-wood

Joints as shown in Fig. 9.19 are commonly used in wind bracings for glulam structures.

9.5.4 Axially loaded bolts

Bolt strength

Bolts must have sufficient strength according to Eurocode 3 for steel structures (EN 1993), i.e.:

$$\frac{N_d}{A_s f_{u,dc}} \leq 1 \quad (9.58)$$

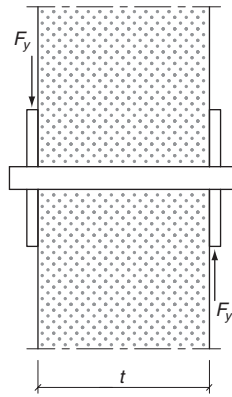

Fig. 9.20 Non-symmetric double-shear joint

where:

- N is the concentric tensile force;
- A_s is the cross-section area of the bolt;
- $f_{u,d}$ is the design tensile strength of the bolt material;
- $c = \begin{cases} 0.90 & \text{for rolled thread} \\ 0.85 & \text{for cut thread} \end{cases}$

Washers

Adequacy of the bending strength of washers must be checked and the bearing stress under the washer should fulfil the following condition:

$$\sigma_{c,d}/f_{c,90,d} \leq 3 \quad (9.59)$$

The bearing load-carrying capacity of bolts under a steel plate should not exceed that of a circular washer with the diameter of:

- $12t$, where t is the plate thickness
- $4d$, where d is the bolt diameter.

9.6 Connections with dowels

9.6.1 General

The dowel diameter should be greater than 6 mm and less than 30 mm.

9.6.2 Detailing rules

The rules for bolts apply, except that Table 9.5 should be replaced by Table 9.6.

Table 9.6 Minimum spacing and end and edge distances for dowels (see Fig. 9.9)

a_1 parallel to the grain direction	$0 \leq \alpha \leq 360$	$(3 + 2 \cos \alpha)d$
a_2 perpendicular to the grain direction	$0 \leq \alpha \leq 360$	$3d$
$a_{3,t}$ loaded end	$-90 \leq \alpha \leq 90$	$\max \begin{cases} 7d \\ 80 \text{ mm} \end{cases}$
$a_{3,c}$ unloaded end	$90 \leq \alpha \leq 150$	$\max \begin{cases} a_{3,t} \sin \alpha d \\ 3d \end{cases}$
	$150 \leq \alpha \leq 210$	$3d$
	$210 \leq \alpha \leq 270$	$\max \begin{cases} a_{3,t} \sin \alpha d \\ 3d \end{cases}$
$a_{4,t}$ loaded edge	$0 \leq \alpha \leq 180$	$\max \begin{cases} (2 + 2 \sin \alpha)d \\ 3d \end{cases}$
$a_{4,c}$ unloaded edge	$180 \leq \alpha \leq 360$	$3d$

9.7 Connections with screws

9.7.1 Laterally loaded screws

Load-carrying capacity

The effect of the threaded part of the screw shall be taken into account in determining the load-carrying capacity, by using an effective diameter d_{eff} . For smooth shank screws, where the outer thread diameter is equal to the shank diameter d , the effective diameter d_{eff} should be taken as the smooth shank diameter provided that the smooth shank penetrates into the member containing the point of the screw by not less than $4d$, otherwise d_{eff} should be taken equal to 1.1 times the thread root diameter.

For smooth shank screws with a diameter $d > 6$ mm, the rules for bolts apply.

For smooth shank screws with a diameter $d \leq 6$, the rules for nails apply.

Detailing rules

For all screws in hardwoods and for screws in softwoods with a diameter $d > 6$ mm, pre-drilling is required, with the following requirements:

- The lead hole for the shank should have the same diameter as the shank and the same depth as the length of the shank.

- The lead hole for the threaded portion should have a diameter of approximately 70% of the shank diameter.

For timber densities greater than 500 kg/m^3 , the pre-drilling diameter should be determined by tests.

9.7.2 Axially loaded screws

Load-carrying capacity

The following failure modes shall be taken into account:

- withdrawal failure of the threaded part of the screw
- tear-off failure of the screw head when screws are used in combination with steel plates; the tear-off resistance of the screw head should be greater than the tensile strength of the screw
- pull-through failure of the screw head
- tensile failure of the screw
- buckling failure of the screw when loaded in compression
- failure along the circumference of a group of screws used in conjunction with steel plates (block shear or plug shear). It should be noted that block shear or plug shear cannot be verified for nails and screws using Annex A of Eurocode 5.

For screws according to EN 14592 with $6 \text{ mm} < d \leq 12 \text{ mm}$ and $0.6 \leq d_1/d \leq 0.75$, the characteristic axial load-carrying capacity $R_{ax,\alpha,d}$ should, provided $\alpha \geq 30^\circ$, be taken as:

$$F_{ax,k} = \frac{n_{eff} f_{ax,k} d l_{eff} k_d}{1.2 \cos^2 \alpha + \sin^2 \alpha} \quad (9.60)$$

with:

$$f_{ax,k} = 0.52 d^{-0.5} l_{eff}^{-0.1} \rho_k^{0.8} \quad (9.61)$$

$$k_d = \min \left\{ \begin{array}{l} \frac{d}{8} \\ 1 \end{array} \right. \quad (9.62)$$

where:

- d is the outer thread diameter;
- d_1 is the inner thread diameter;
- $f_{ax,k}$ is the characteristic withdrawal strength perpendicular to the grain direction, in N/mm^2 ;

- n is the active number of screws acting together;
 n_{eff} is the effective number of screws;
 l is the penetration length of the threaded part, in mm;
 ρ_k is the characteristic density, in kg/m³;
 α is the angle between the screw axis and the grain direction.

For other screws, the characteristic axial load-carrying capacity should be taken as:

$$F_{ax,\alpha,k} = \frac{n_{\text{eff}} f_{ax,k}^* dl_{\text{eff}}}{1.2 \cos^2 \alpha + \sin^2 \alpha} \left(\frac{\rho_k}{\rho_a} \right)^{0.8} \quad (9.63)$$

where:

- $f_{ax,k}^*$ is the characteristic withdrawal strength perpendicular to the grain direction determined in accordance with EN 14592 for the associated density of ρ_a , in N/mm²;
 ρ_a is the associated density (i.e. the density used in testing) in kg/m³.

The characteristic pull-through resistance $R_{\text{head},\alpha,k}$ of a connection with axially loaded screws should be taken as:

$$R_{\text{head},\alpha,k} = n_{\text{eff}} f_{\text{head},\alpha,k} d_h^2 \left(\frac{\rho_k}{\rho_a} \right)^{0.8} \quad (9.64)$$

where:

- $R_{\text{head},\alpha,k}$ is the characteristic head pull-through capacity of the connection at an angle α that should not be less than 30°, to the grain direction, in N;
 $f_{\text{head},\alpha,k}$ is the characteristic head pull-through parameter determined in accordance with EN 14592 for the associated density ρ_a in N/mm²;
 d_h is the diameter of the screw head, in mm.

The characteristic tensile resistance of the connection (head tear-off or tensile capacity of shank) should be taken as:

$$R_{t,k} = n_{\text{eff}} R_{u,k} \quad (9.65)$$

where:

- $R_{u,k}$ is the characteristic tensile capacity of the screw determined in accordance with EN 14592;
 n_{eff} is the effective number of screws determined according to Expression (9.63) $n_{\text{eff}} = n^{0.9}$

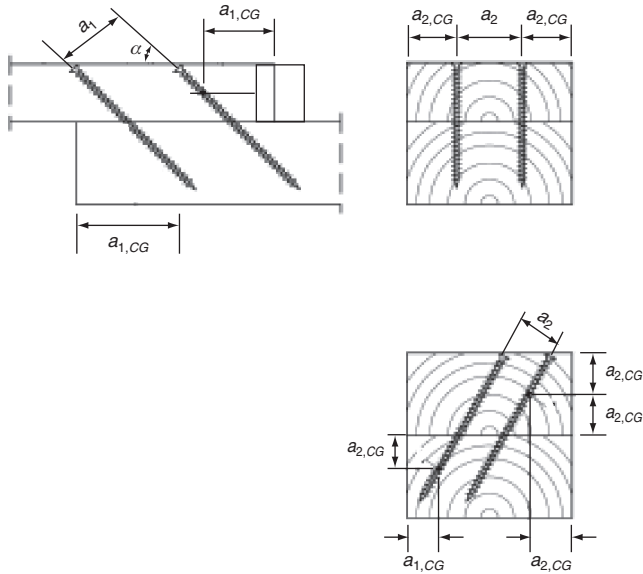

Fig. 9.21 Spacings and distances to end and edge

Detailing rules

- The angle α between the screw axis and the grain direction should not be less than 30° .
- The timber thickness should not be less than $12d$.
- The point side penetration should not be less than $6d$.

The minimum spacings and end and edge distances as shown in Fig. 9.21 are given in Table 9.7.

Table 9.7 Minimum spacing and distances to end and edge

Minimum spacing in a plane parallel to the grain direction	Minimum spacing perpendicular to a plane parallel to the grain direction	Minimum end distance of the centre of the threaded part of the screw in the member	Minimum edge distance of the centre of the threaded part of the screw in the member
a_1 $7d$	a_2 $5d$	$a_{1,CG}$ $10d$	$a_{2,CG}$ $4d$

Example 9.5

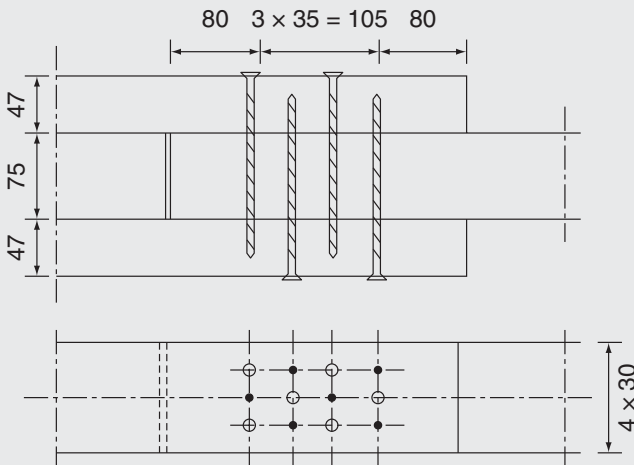

A joint in a tension member 75×120 mm of C24 with density $\rho_k = 350 \text{ kg/m}^3$ is made as shown with gussets 47×120 mm and 12 screws 8×160 mm with an inner thread diameter of 6 mm made of steel 4.6 service Class 1.

Calculate the load-carrying capacity for a short-term load.

The lateral load-carrying capacity is determined as the capacity of two double shear joints, one with $t_1 = 47$ mm and $t_2 = 75$ and one with $t_1 = 160 - 47 - 75 = 38$ mm and $t_2 = 75$ mm.

The calculations are made with an effective diameter $d_{\text{eff}} = 1.1 \cdot 6 = 6.6$ mm.

The yield moment with $f_u = 400 \text{ N/mm}^2$ is

$$M_{y,k} = 0.3 f_u d_{\text{eff}}^{2.6} = 0.3 \cdot 400 \cdot 6.6^{2.6} = 16\,200 \text{ Nmm}$$

The embedding strength for load parallel to grain is:

$$\begin{aligned} f_{h,k} &= 0.082(1 - 0.01d_{\text{eff}})\rho_k = 0.082(1 - 0.01 \cdot 6.6) \cdot 350 \\ &= 26.8 \text{ N/mm}^2 \end{aligned}$$

The load-carrying capacities in kN according to Expression (9.20) are shown in the table below. $f_{ax,d} = 12.7 \text{ N/mm}^2$, see Example 9.6, and the axial load-carrying capacity: $F_{ax,k} = 12.7 \cdot 8 \cdot 47 \cdot 10^{-3} = 4.78 \text{ kN}$. The rope contribution is $4.78/4 = 1.20 \text{ kN}$. The point side penetration length is $38 \text{ mm} < 6d$, i.e. the axial strength shall be taken as 0.

	Expression	Head side	Point side
$R_{v,k}$	(9.20a)	8.32	6.72
	(9.20b)	6.63	6.63
	(9.20c)	10.18	8.23
	(9.20d)	2.75	2.75
	min	2.75	2.75
T		1.20	0
R_k per shear		4.20	2.75
			6.70
R_k		$3 \cdot 2.74 \cdot 6.70 = 55.1 \text{ kN}$	
R_d		$0.9 \cdot 55.1 / 1.3 = 38.1 \text{ kN}$	

With four screws spaced at $5d$ the effective number of screws per row is:

$$n_{eff} = n^{0.9} \sqrt[4]{\frac{a_1}{13d}} = 4^{0.9} \sqrt[4]{\frac{5}{13}} = 2.74$$

With three rows, the characteristic load-carrying capacity becomes:

$$3 \cdot 2.74 \cdot 8.25 = 67.8 \text{ kN}$$

Example 9.6

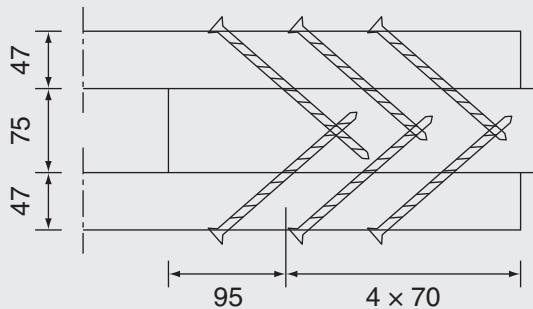

A joint corresponding to the one dealt with in Example 9.5 is made with 12 inclined tension screws in two lines (due to edge distance requirements).

Calculate the load-carrying capacity.

The full length of the screw is threaded. The anchorage depth is $l = 160 - 47\sqrt{2} = 93$.

$$f_{ax,k} = 0.52d^{-0.5}l_{eff}^{-0.1}\rho_k^{0.8} = 0.52 \cdot 8^{-0.5} \cdot 93^{-0.1} \cdot 350^{0.8} \\ = 12.67 \text{ N/mm}^2$$

$$k_d = 1$$

$$n_{eff} = 3^{0.9} = 2.69$$

$$R_{ax,k} = \frac{n_{eff}f_{ax,k}dl_{eff}k_d}{1.2\cos^2\alpha + \sin^2\alpha} = \frac{2.69 \cdot 12.67 \cdot 8 \cdot 93 \cdot 1}{1.2 \cdot 0.5 + 0.5} = 22.9 \text{ kN}$$

By projection on the member:

$$R_k = 4 \cdot 22.9 \cdot \frac{\sqrt{2}}{2} = 64.8 \text{ kN}$$

and

$$R_d = 0.9 \cdot 60.7/1.3 = 64.9 \text{ kN}$$

9.8 Joints with connectors

9.8.1 Grooved-in connectors (ring or shear plates connectors)

Load-carrying capacity

For connections made with ring or shear plate connectors and with a diameter not larger than 200 mm, the characteristic load-carrying capacity parallel to the grain, $R_{v,0,k}$ per connector and per shear plane should be taken as:

$$R_{v,0,k} = \min \begin{cases} 35k_1k_2k_3k_4d_c^{1.5} & (9.66a) \\ 31.5k_1k_3h_e d_c & (9.66b) \end{cases}$$

where:

$R_{v,0,k}$ is the characteristic load-carrying capacity parallel to the grain, in N;

d_c is the connector diameter, in mm;

h_e is the embedding depth, in mm;

k_i is the modification factor, with $i = 1$ to 4, defined below.

The minimum thickness of the outer timber members should be $2.25h_e$ and minimum thickness of the inner timber member should be $3.75h_e$ where h_e is the groove depth (see Fig. 9.22).

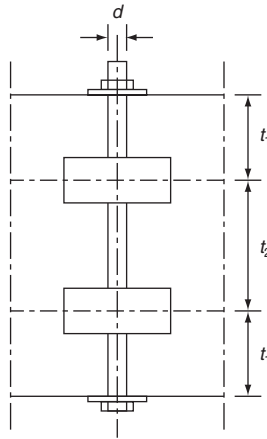

Fig. 9.22 Joints with grooved-in connectors

The factor k_1 is:

$$k_1 = \min \left\{ \begin{array}{l} 1 \\ \frac{t_1}{3h_e} \\ \frac{t_2}{5h_e} \end{array} \right. \quad (9.67)$$

where:

- t_1 is the thickness of the outer members;
- t_2 is the thickness of the middle member;
- h_e is the embedment depth, in mm.

The factor k_2 applies to a loaded end ($-30^\circ \leq \alpha \leq 30^\circ$) and should be taken as:

$$k_2 = \min \left\{ \begin{array}{l} k_a \\ \frac{a_{3,t}}{2d_c} \end{array} \right. \quad (9.68)$$

where:

$$k_a = \begin{cases} 1.25 & \text{for connections with one connector per shear plane} \\ 1.0 & \text{for connections with two connectors per shear plane} \end{cases}$$

$a_{3,t}$ is given in Table 9.8.

For other values of α : $k_2 = 1$.

The factor k_3 should be taken as:

$$k_3 = \min \left\{ \begin{array}{l} 1.75 \\ \frac{\rho_k}{350} \end{array} \right. \quad (9.69)$$

where:

ρ_k is the characteristic density, in kg/m^3 .

The factor k_4 should be taken as:

$$k_4 = \begin{cases} 1.0 & \text{for timber-to-timber connections} \\ 1.1 & \text{for steel-to-timber connections} \end{cases} \quad (9.70)$$

For joints with one connector per shear plane loaded in an unloaded end situation ($150^\circ \leq \alpha \leq 210^\circ$), the condition in Expression (9.65a) should be disregarded.

For a force at an angle α to the grain direction, the characteristic load-carrying capacity, $R_{v,\alpha,k}$, per connector per shear plane should be calculated as:

$$R_{v,\alpha,k} = \frac{R_{v,0,k}}{k_{90} \sin^2 \alpha + \cos^2 \alpha} \quad (9.71)$$

with:

$$k_{90} = 1.3 + 0.001d_c \quad (9.72)$$

where:

$R_{v,0,k}$ is the characteristic load-carrying capacity of the connector for a force parallel to the grain direction according to Expression (9.65),

d_c is the connector diameter, in mm.

Detailing rules

Minimum spacing and edge and end distances are given in Table 9.8, with the symbols illustrated in Fig. 9.9.

When the connectors are staggered (see Fig. 9.23), the minimum spacings parallel and perpendicular to the grain should comply with the following expression:

$$(k_{a1})^2 + (k_{a2})^2 \geq 1 \quad \text{with} \quad \begin{cases} 0 \leq k_{a1} \leq 1 \\ 0 \leq k_{a2} \leq 1 \end{cases} \quad (9.73)$$

Table 9.8 Minimum spacing and end and edge distances

	Angle α° to the grain direction	Minimum spacing and distances
a_1 parallel to the grain direction	$0 \leq \alpha \leq 360$	$(1.2 + 0.8 \cos \alpha)d_c$
a_2 perpendicular to the grain direction	$0 \leq \alpha \leq 360$	$1.2d_c$
$a_{3,t}$ loaded end	$-90 \leq \alpha \leq 90$	$1.5d_c$
$a_{3,c}$ unloaded end	$90 \leq \alpha \leq 150$	$(0.4 + 1.6 \sin \alpha)d_c$
	$150 \leq \alpha \leq 210$	$1.2d_c$
	$210 \leq \alpha \leq 270$	$(0.4 + 1.6 \sin \alpha)d_c$
$a_{4,t}$ loaded edge	$0 \leq \alpha \leq 180$	$(0.6 + 0.2 \sin \alpha)d_c$
a_{4c} unloaded edge	$180 \leq \alpha \leq 360$	$0.6d_c$

where:

- k_{a1} is a reduction factor for the minimum distance a_1 parallel to the grain direction;
- k_{a2} is a reduction factor for the minimum distance a_2 perpendicular to the grain direction.

The spacing parallel to grain, $k_{a1}a_1$ may be reduced further by multiplication by $k_{s,red}$ with $0.5 \leq k_{s,red} \leq 1$ provided that the load-carrying capacity is multiplied by:

$$k_{R,red} = 0.2 + 0.8k_{s,red} \quad (9.74)$$

For a row of n connectors parallel to the grain, the load-carrying capacity parallel to the grain should be calculated using the effective number of connectors n_{eff} where:

$$n_{eff} = 2 + (1 - 0.05)(n - 2) \quad (9.75)$$

Connectors should be considered parallel to the grain if $k_{a2}a_2 < 0.5k_{a1}a_1$.

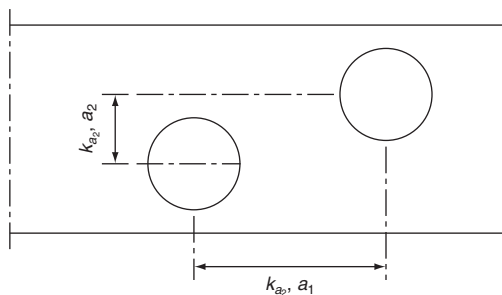

9.8.2 Pressed-in connectors (tooth-plate connectors)

Load-carrying capacity

The characteristic load-carrying capacity per shear, R_k , for a connection consisting of one plate and one bolt should be taken as:

$$R_k = R_{b,k} + R_{m,k} \quad (9.76)$$

where:

$R_{b,k}$ is the load-carrying capacity of the bolt;

$R_{m,k}$ is the load-carrying capacity contribution from the tooth-plate.

The characteristic load-carrying capacity of each tooth plate should be taken as:

$$F_{v,k} = \begin{cases} 18k_1k_2k_3d_c^{1.5} & \text{for single-sided types} \\ 25k_1k_2k_3d_c^{1.5} & \text{for double-sided types} \end{cases} \quad (9.77)$$

where:

k_i are modification factors, with $i = 1$ to 3, defined below

d_c is:

- the tooth-plate connector diameter for circular types, in mm;
- the tooth-plate connector side length for square types, in mm;
- the square root of the product of both lengths for rectangular and oval types, in mm.

The minimum thickness of the outer timber members should be $2.25h_e$, and minimum thickness of the inner timber member should be $3.75h_e$, where h_e is the tooth penetration depth (see Fig. 9.24).

The factor k_1 is:

$$k_1 = \min \begin{cases} 1 \\ \frac{t_1}{3h_e} \\ \frac{t_2}{5h_e} \end{cases} \quad (9.78)$$

where:

t_1 is the side member thickness, in mm;

t_2 is the middle member thickness, in mm;

h_e is the tooth penetration depth, in mm.

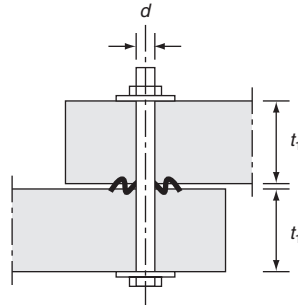

Fig. 9.24 Joints with pressed-in tooth-plate connectors

The factor k_2 should be taken as:

$$k_2 = \min \left\{ \begin{array}{l} 1 \\ \frac{a_{3,t}}{1.5d_c} \end{array} \right. \quad (9.79)$$

with:

$$a_{3,t} = \min \left\{ \begin{array}{l} 1.1d_c \\ 7d \\ 80 \text{ mm} \end{array} \right. \quad (9.80)$$

where:

d is the bolt diameter in mm.

The factor k_3 should be taken as:

$$k_3 = \min \left\{ \begin{array}{l} 1.5 \\ \frac{\rho_k}{350} \end{array} \right. \quad (9.81)$$

where:

ρ_k is the characteristic density in kg/m^3 .

Structural detailing

For bolts used with tooth-plate connectors, the rules for bolts apply but the minimum spacings and minimum end and edge distances should be those given in Table 9.9 with the symbols illustrated in Fig. 9.9.

Table 9.9 Minimum spacing and end and edge distances for tooth-plate connectors

	Angle α° to the fibre direction	Minimum spacings and distances
a_1 parallel to the grain	$0 \leq \alpha \leq 360$	$(1.2 + 0.3 \cos \alpha)d_c$
a_2 perpendicular to the grain	$0 \leq \alpha \leq 360$	$1.2d_c$
$a_{3,t}$ loaded end	$-90 \leq \alpha \leq 90$	$2.0d_c$
$a_{3,c}$ unloaded end	$90 \leq \alpha \leq 150$	$(0.9 + 0.6 \sin \alpha)d_c$
	$150 \leq \alpha \leq 210$	$1.2d_c$
	$210 \leq \alpha \leq 270$	$(0.9 + 0.6 \sin \alpha)d_c$
$a_{4,t}$ loaded edge	$0 \leq \alpha \leq 180$	$(0.6 + 0.2 \sin \alpha)d_c$
$a_{4,c}$ unloaded edge	$180 \leq \alpha \leq 360$	$0.6d_c$

When circular tooth-plate connectors are staggered Expression (9.73) applies.

Toothed connectors shall be pressed into the wood without cutting except that it is permitted to mill for the plate with a depth slightly smaller than the plate thickness. The mill is performed to avoid a gap in the joint.

Because the force needed to press the connector in is rather high, bolts with diameter of 16 mm or less must not be used for pressing in the connectors. For smaller diameters special bolts should be used for pressing in the connectors first and then replaced by the specified bolts. Washer with the same size as the connector (d_c) and thickness of not less than $0.1d_c$ shall be used. If needed, tooth-plate connectors can be pressed in by hammering using a stiff steel plate provided that care is taken not to damage the tooth-plate.

Deformations

For double-sided and single-sided tooth-plates the initial slip is about 1 mm and $(1 + 0.005d)$ respectively, where d is the bolt diameter.

Example 9.7

Design the joint between top and bottom flange in the truss designed in Example 7.1 with 16 mm spruce plywood gusset plates and bolts and pressed-in connectors (Bulldog), when the reaction is acting on the bottom flange as shown in the figure below.

The joint shall transfer the tension force in the bottom flange: $F_{1-7,d} = 10.05 \text{ kN}$, the compression force $F_{1-2,d} = 19.69 \text{ kN}$ and the reaction $R = 3.66 \text{ kN}$ (short-term loads).

Since the joint has a pronounced plastic behaviour there is great freedom to choose how the forces in the joint are distributed. As one extreme it may, as shown to the left in the figure below, be assumed that the force in the top flange is transferred to the gusset plates acting as cantilevers fastened to the bottom flange. Another extreme is shown to the right in the figure; here it is assumed that the reaction and the force in the bottom flange are transferred to the gusset plates acting as cantilevers fastened to the top flange.

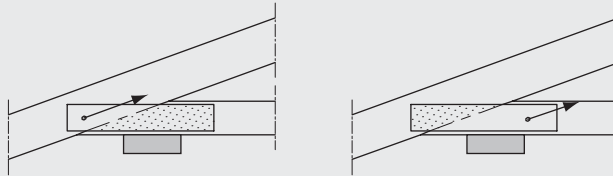

In the following figure it is assumed that the forces are transferred in the joint line.

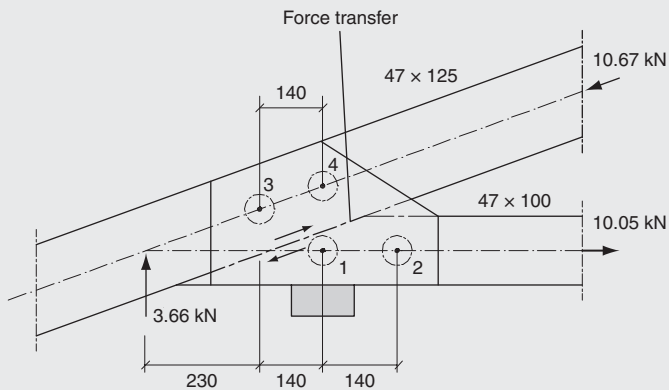

62 mm round Bulldog connectors with 12 mm bolts 4.6 are chosen.

$$k_1 = \min \left\{ \begin{array}{l} 1 \\ \frac{t_1}{3h_c} = \frac{16}{3 \cdot 7.5} = 0.71 \\ \frac{47}{5h_c} = \frac{47}{5 \cdot 7.5} = 1.25 \end{array} \right\} = 0.71$$

$$a_{3,t} > 1.5d_c$$

and

$$k_2 = 1$$

$$k_3 = \min \left\{ \begin{array}{l} 1.5 \\ \frac{\rho_k}{350} = \frac{310}{350} = 0.89 \end{array} \right\} = 0.89$$

$$F_{m,k} = 25k_1k_2k_3d_c^{1.5} = 25 \cdot 0.71 \cdot 1 \cdot 0.89 \cdot 62^{1.5}/1000 = 7.72 \text{ kN}$$

For the bolts with $f_u = 400 \text{ N/mm}^2$:

$$M_y = 0.3f_u d^{2.6} = 0.3 \cdot 400 \cdot 12^{2.6} = 76\,750 \text{ Nmm}$$

A density of 400 kg/m^3 is assumed for spruce plywood:

$$f_{h,k} = 0.11\rho_k d^{-0.3} = 0.11 \cdot 400 \cdot 12^{-0.3} = 20.9 \text{ N/mm}^2$$

The angle between the force and grain direction in the bottom flange member is estimated to be 65° :

$$k_{90} = 1.35 + 0.15d = 1.35 + 0.015 \cdot 12 = 1.53$$

$$\begin{aligned} f_{h,0,k} &= 0.082(1 - 0.01d)\rho_k = 0.082(1 - 0.01 \cdot 12) \cdot 310 \\ &= 22.4 \text{ N/mm}^2 \end{aligned}$$

$$\begin{aligned} f_{h,\alpha,k} &= \frac{f_{h,0,k}}{k_{90} \sin^2 \alpha + \cos^2 \alpha} = \frac{22.4}{1.53 \sin^2 65^\circ + \cos^2 65^\circ} \\ &= 15.58 \text{ N/mm}^2 \end{aligned}$$

From Expression (9.20a):

$$R_{b,k} = 4.01 \text{ kN}$$

Per shear: $R_k = R_{m,k} + R_{b,k} = 7.72 + 4.01 = 11.7 \text{ kN}$

$$R_d = k_{mod}R_k/\gamma_M = 0.9 \cdot 11.7/1.3 = 8.10 \text{ kN}$$

The load components on bolt 1 in the grain direction (x) and perpendicular to this direction (y) are:

$$F_{x,d} = 10.05/2 = 5.03 \text{ kN}$$

$$F_{y,d} = 3.66 \cdot 510/120 = 13.3 \text{ kN}$$

$$F_d = \sqrt{F_{x,d}^2 + F_{y,d}^2} = 14.2 \text{ kN} < R_d = 2 \cdot 8.1 = 16.2 \text{ kN}$$

The angle between force and grain direction is found from $\tan \alpha = 13.3/5.03 = 2.64$

$\alpha = 69^\circ$, i.e. close to the estimated value.

10

Diaphragms

10.1 Introduction

Diaphragms are often part of timber structures where one of their roles is to resist lateral forces such as wind. Diaphragms are normally parts of the structure with wood-based panels or gypsum plasterboards fixed to a timber framing on one or both sides. In most cases the panels are fastened by mechanical fasteners, but gluing may also be used which can enhance the stiffness of the structures. Structural gluing should only be done under factory-controlled conditions. Site gluing for structural purposes is not recommended.

Figure 10.1 shows a simple building where the lateral loads from wind or earthquakes are transferred to the supports by help of both horizontal and vertical diaphragms. The loads on the façades are transferred by the wall structure to the roof diaphragm and from that to the gable diaphragms and down to the ground. The roof diaphragms may be flat or pitched.

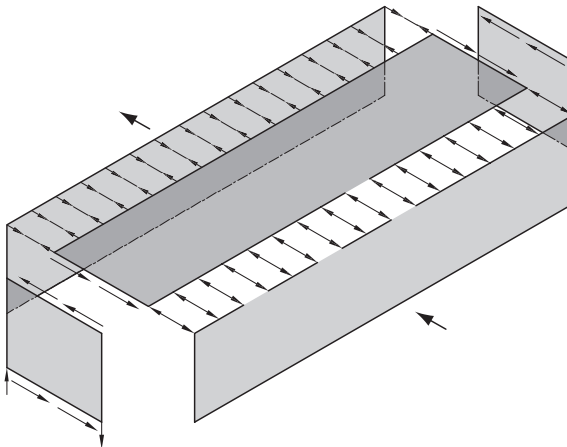

Fig. 10.1 Diaphragms in a simple building

10.2 Roof diaphragm (simply supported diaphragm)

For l between $2b$ and $6b$ (Fig. 10.2), it may be assumed that the moment is resisted as tension/compression by the edge beams:

$$F_{\text{edgebeam}} = \frac{vl^2}{8b} \quad (10.1)$$

where v is the uniformly distributed (wind) load on the edge beam. Provided the strength is determined by the fasteners and not the panels, the shear forces may be assumed to be evenly distributed over the width b , i.e. the load per nail becomes:

$$F = a\tau = a\frac{Q}{b} \quad (10.2)$$

where a is the nail spacing, τ is the shear stress and Q is the shear force. The nail load-carrying capacity may be taken 20% larger than the values calculated according to section 9.3, because the large number of nails reduces the variation. All nails shall be the same type at equal spacings of not more than 150 mm along the perimeter of the boards and 300 mm within the boards. All square-edges of panels must be supported and nailed to the supports (i.e. joists, beams or noggings) as shown in Fig. 10.3.

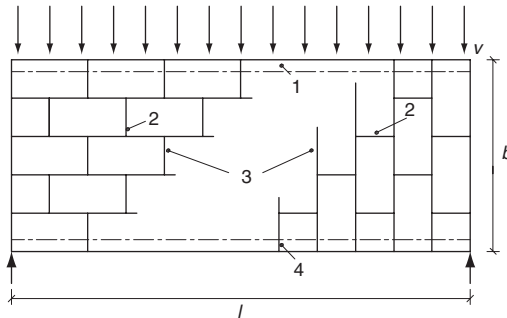

Fig. 10.2 Simply supported roof diaphragm: (1) edge beam; (2) staggered panel edge; (3) examples of panel lay-ups; (4) edge beam

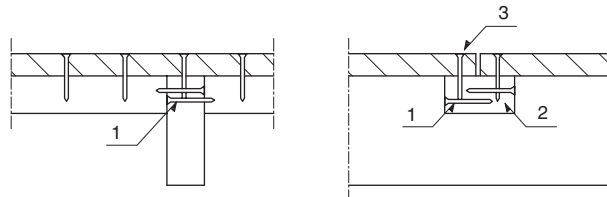

Fig. 10.3 Fixing of panels to supports: (1) skew nailing of noggings; (2) nogging skew nailed to beam; (3) panel nailed to edge batten

10.3 Wall diaphragm (cantilever diaphragm)

There are two design methods given Eurocode 5 for wall diaphragms, namely Method A and Method B. Both methods are described in this chapter where Method B is recommended to be used by the UK National Annex.

10.3.1 Method A

A requirement for using this method is that the end studs are connected directly to the ground or the construction below. It is assumed that (see Fig. 10.4):

- the end stud is anchored directly to the support structure
- the wall consists of wood-based panels fastened to one or both sides of the timber framing
- the spacing of fasteners along the perimeter of the wood-based panels is constant at not more than 150 mm for nails and 200 mm for screws
- the spacing of fasteners within the perimeter of sheathings should not be more than twice the perimeter spacings, i.e. less than 300 mm
- the width of a wood-based panel is not less than $h/4$, where h is the wall height
- the failure is caused by failure in the fasteners and not in the timber or in the sheathing.

The load-carrying capacity of a wall made of n wall panels (see Fig. 10.5) should be calculated as:

$$R_{v,d} = \sum_n R_{v,d,i} \quad (10.3)$$

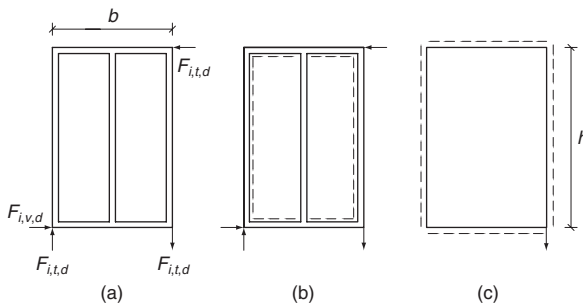

Fig. 10.4 A typical wall panel: (a) external loads; (b) timber framing; (c) shear stress on sheathing

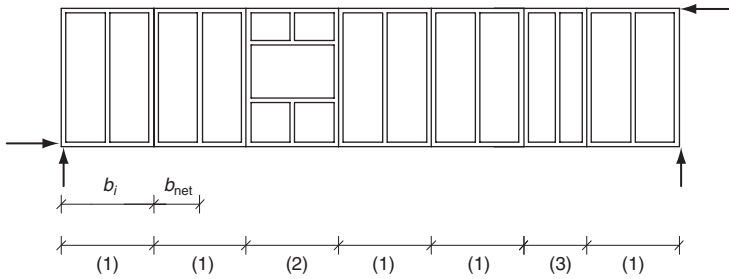

Fig. 10.5 Wall consisting of several wall panels of which panel (2) has openings and panel (3) has a smaller width than the others

The load-carrying capacity of the panel i with wood-based panel on one side should be calculated as:

$$R_{v,d,i} = \frac{1.2R_{f,d}b_i c_i}{a} \quad (10.4)$$

where:

$R_{f,d}$ is the design lateral load-carrying capacity of one nail calculated as in Chapter 9;

$$c_i = \begin{cases} 1 & \text{for } b_i \geq 0.5h \\ 2b_i/h & \text{for } b_i < 0.5h \end{cases} \quad (10.5)$$

a is the fastener spacing.

The contribution from panel elements with openings should be disregarded.

For wall panels with wood-based sheathing on both sides the following rules apply:

- If the sheathing and fasteners are of the same type and dimension, then the total load-carrying capacity of the wall should be taken as the sum of the load-carrying capacity of the individual sheathing on both sides.
- If different types of sheathing are used, 75% of the load-carrying capacity of the weaker side may be taken into consideration if fasteners with similar slip moduli are used. In other cases not more than 50% of the load-carrying capacity of the weaker side should be used.

The external forces

$$F_{i,c,d} = F_{i,t,d} = F_{i,v,d}h/b \quad (10.6)$$

can either be transmitted to the sheathing in the adjacent wall panel or transmitted to the structure situated above or below. When tensile

forces are transmitted to the structure situated below, the panel should be anchored by stiff fasteners.

Buckling of wall studs should be checked. Where the ends of studs bear on horizontal framing members (i.e. bottom rail), the compression perpendicular to the grain stresses in the bottom rail should be assessed.

The external forces that arise in wall panels containing door or window openings and in wall panels of smaller width (see Fig. 10.6) can similarly be transmitted to the structures situated above or below.

The buckling stability of the sheathing shall be verified. However, a buckling investigation may be omitted for the wood-based panels if the ratio of the clear stud distance b_{net} and the sheathing thickness t fulfil the condition:

$$b_{net}/t < 100 \quad (10.7)$$

10.3.2 Method B

Introduction

The UK National Annex recommends the use of Method B, instead of Method A, in the UK.

Figure 10.6 shows a wall assembly consisting of walls (6, 7 and 8) each made of wall panels (1, 2, 3, 4 and 5). Some of the panels (3 and 4) have openings for windows (12) and doors (13) respectively. The wall panels are made of timber frames covered by sheathing of wood-based panel products. The wall panels are linked by a head binder across the wall panel joints.

For a wall panel to contribute to the in-plane (racking) strength of a wall, the width of the wall panel should be at least the panel height

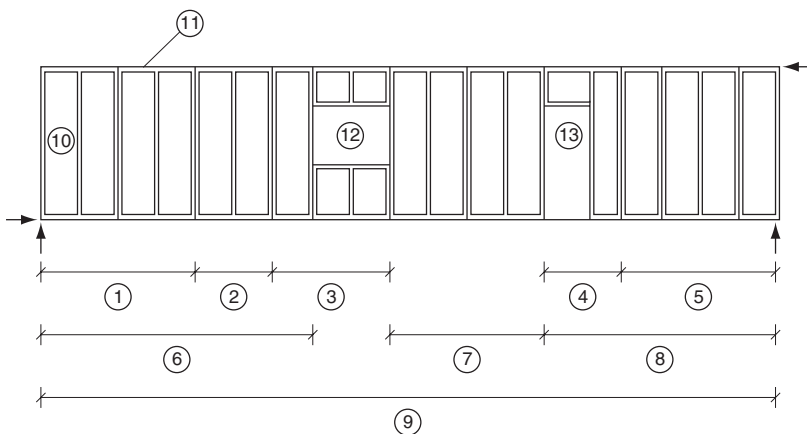

Fig. 10.6 Wall assembly

divided by 4. The fasteners of the sheathings to the timber frame should be by either nails or screws, equally spaced around the perimeter of the sheathings (wood-based panels) at not more than 150 mm centres for nails and 200 mm for screws. The spacing of fasteners within the perimeter of sheathings should not be more than twice the perimeter spacing.

Where an opening is formed in a wall panel, the lengths of the wall panel on each side of the opening should be treated as separate wall panels.

The required connection strength between the vertical joints of adjacent wall panels should be evaluated but should have a design strength of at least 2.5 kN/m. The wall panels when joined together to form a wall should be able to resist overturning and sliding forces by either anchorage to the supporting structure or the permanent actions applied to the wall or a combination of both effects. The wall is loaded at the top by a horizontal racking force $F_{v,d}$.

Load-carrying capacity

The racking strength $R_{v,d}$ should be calculated as:

$$R_{v,d} = \Sigma R_{i,v,d} \quad (10.8)$$

The contribution from wall i is:

$$R_{i,v,d} = \frac{R_{v,fastener,d} b_i}{s_0} k_d k_{i,q} k_s k_n \quad (10.9)$$

where:

$R_{v,fastener,d}$ is the lateral design load-carrying capacity of an individual fastener;

b_i is the wall length, in m;

s_0 is the basic fastener spacing, Expression (10.10) in mm;

k_d is the dimension factor for the panel, see Expression (10.11);

$k_{i,q}$ is the uniformly distributed load factor for wall i , see Expression (10.12);

k_s is the fastener spacing factor, see Expression (10.13);

k_n is the sheathing material factor, see Expression (10.14);

$$s_0 = \frac{9700d}{\rho_k} \quad (10.10)$$

d is the fastener diameter, in mm;

ρ_k is the characteristic density of the timber frame, in kg/m³;

$$k_d = \begin{cases} \frac{b_i}{h} & \text{for } \frac{b_i}{h} \leq 1 \\ \left(\frac{b_i}{h}\right)^{0.4} & \text{for } \frac{b_i}{h} > 1 \text{ and } b_i \leq 4.8 \text{ m} \\ \left(\frac{4.8}{h}\right)^{0.4} & \text{for } \frac{b_i}{h} > 1 \text{ and } b_i > 4.8 \text{ m} \end{cases} \quad \begin{matrix} (10.11a) \\ (10.11b) \\ (10.11c) \end{matrix}$$

where:

h is the height of the wall, in m;

$$k_{i,q} = 1 + (0.083q_i - 0.008q_i^2) \left(\frac{2.4}{b_i}\right)^{0.4} \quad (10.12)$$

where q_i is the equivalent uniformly distributed vertical load acting on the wall, in kN/m, see (10.14a) and (10.14b).

$$k_s = \frac{1}{0.86 \frac{s}{s_0}} + 0.57 \quad (10.13)$$

$$k_n = \begin{cases} 1 & \text{for sheathing on one side} \\ \frac{R_{i,v,d,max} + 0.5R_{i,v,d,min}}{R_{i,v,d,max}} & \text{for sheathing on both sides} \end{cases} \quad \begin{matrix} (10.14a) \\ (10.14b) \end{matrix}$$

where:

$R_{i,v,d,max}$ is the design racking strength of the stronger sheathing;
 $R_{i,v,d,min}$ is the design racking strength of the weaker sheathing;
 $R_{i,v,d,max}$ is the design racking strength of the stronger sheathing.

The equivalent vertical load, q_i , used to calculate k_i , should be determined using only permanent actions and any net effects of wind together with the equivalent actions arising from concentrated forces, including anchorage forces, acting on the panel. For the purposes of calculating k_i , concentrated vertical forces should be converted into an equivalent uniformly distributed load on the assumption that the wall is a rigid body, e.g. for the load $F_{i,vert,d}$ acting on the wall as shown in Fig. 10.7:

$$q_{i,vert,d} = \frac{2aF_{i,vert,d}}{b_i^2} \quad (10.15)$$

where:

a is the horizontal distance from the force F to the leeward corner of the wall;
 b is the length of the wall.

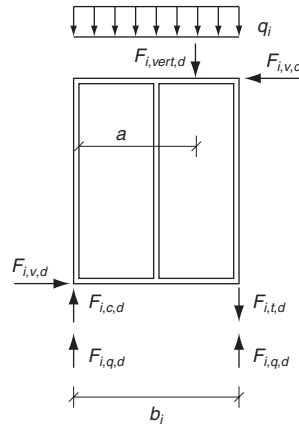

Fig. 10.7 Determination of equivalent vertical load, q_i , and reaction forces from vertical and horizontal loads

The reactions should be calculated as:

$$F_{i,c,d} = F_{i,t,d} = \frac{F_{i,v,d}h}{b_i} \quad (10.16)$$

where h is the height of the wall.

The external forces can be transmitted to the adjacent wall panel either via the vertical panel-to-panel connections or via the structure above or below the wall. When tensile forces are transmitted to the structure below, the wall panel should be anchored with stiff fasteners.

Compression forces in the studs should be checked for buckling. Where the ends of vertical members bear on horizontal framing members (i.e. bottom rails), the compression perpendicular to the grain stresses in the horizontal members should be assessed.

The buckling of the sheathings under the action of shear force $F_{v,d}$ may be disregarded provided:

$$\frac{b_{net}}{t} \leq 100 \quad (10.17)$$

where:

- b_{net} is the clear distance between studs;
- t is thickness of the sheathing.

The UK National Annex allows Annexes A, B and C of Eurocode 5 to be used if required.

References

British Standards

- British Standards Institution. *General requirements for components used in discharge pipes, drains and sewers for gravity systems*. BSI, London, BS 476-6.
- British Standards Institution. *Fire tests on building materials and structures. Method of test to determine the classification of the surface spread of flame of products*. BSI, London, BS 476-7.
- British Standards Institute. *Visual grading of softwood*. BSI, London, BS 4978.
- British Standards Institution. *Structural use of timber. Code of practice for permissible stress design, materials and workmanship*. BSI, London, BS 5268-2.
- British Standards Institution. *Code of practice for trussed rafter roofs*. BSI, London, BS 5268-3.
- British Standards Institution. *Structural use of timber. Fire resistance of timber structures. Recommendations for calculating fire resistance of timber members*. BSI, London, BS 5268-4.1.
- British Standards Institution. *Structural use of timber. Fire resistance of timber structures. Recommendations for calculating fire resistance of timber stud walls and joisted floor constructions*. BSI, London, BS 5268-4.2.
- British Standards Institution. *Code of practice for the preservative treatment of structural timber*. BSI, London, BS 5268-5.
- British Standards Institution. *Code of practice for timber frame walls. Dwellings not exceeding seven storeys*. BSI, London, BS 5268-6-1.
- British Standards Institution. *Structural use of timber. Code of practice for timber frame walls. Buildings other than dwellings not exceeding four storeys*. BSI, London, BS 5268-6-2.
- British Standards Institution. *Recommendations for the calculation basis for span tables for various elements*. BSI, London, BS 5268-7-1 to 7-7.
- British Standards Institution. *Loading for buildings. Code of practice for dead and imposed loads*. BSI, London, BS 6399-1.
- British Standards Institution. *Loading for buildings. Code of practice for wind loads*. BSI, London, BS 6399-2.
- British Standards Institution. *Loading for buildings. Code of practice for imposed roof loads*. BSI, London, BS 6399-3.

European standards (= British standards)

[Note: EN xxxx and EN BS xxxx are identical.]

European Committee for Standardisation. *Oriented Strand Boards (OSB) – Definitions, classification and specifications*. CEN, Brussels, EN 300.

European Committee for Standardisation. *Adhesives, phenolic and aminoplastic, for load-bearing timber structures – Classification and performance requirements*. CEN, Brussels, EN 301.

European Committee for Standardisation. *Particleboards – Specifications*. CEN, Brussels, EN 312.

European Committee for Standardisation. *Plywood – Bonding quality – Part 2: Requirements*. CEN, Brussels, EN 314-2.

European Committee for Standardisation. *Durability of wood and wood-based products – definition of hazard classes of biological attack. Part 1: General*. CEN, Brussels, EN 335-1.

European Committee for Standardisation. *Structural timber – Sizes, permitted deviations*. CEN, Brussels, EN 336.

European Committee for Standardisation. *Structural timber – Strength classes*. CEN, Brussels, EN 338.

European Committee for Standardisation. *Durability of wood and wood-based products – Preservative treated solid wood. Part 1: Classification of preservative penetration and retention*. CEN, Brussels, EN 350-1.

European Committee for Standardisation. *Durability of wood and wood-based products – Natural durability of solid wood. Part 2: Guide to natural durability and treatability of selected wood species of importance in Europe*. CEN, Brussels, EN 350-2.

European Committee for Standardisation. *Glued laminated timber – Sizes – Permissible deviations*. CEN, Brussels, EN 390.

European Committee for Standardisation. *Durability of wood and wood-based products – Natural durability of solid wood – Guide of the durability requirements for wood to be used in hazard classes*. CEN, Brussels, EN 460.

European Committee for Standardisation. *General requirements for components used in discharge pipes, drains and sewers for gravity systems*. CEN, Brussels, EN 476.

European Committee for Standardisation. *Fibreboards – Specifications – Part 1: General requirements*. CEN, Brussels, EN 622-1.

European Committee for Standardisation. *Fibreboards – Specifications – Part 2: Requirements for hardboards*. CEN, Brussels, EN 622-2.

European Committee for Standardisation. *Fibreboards – Specifications – Part 3: Requirements for medium boards*. CEN, Brussels, EN 622-3.

European Committee for Standardisation. *Fibreboards – Specifications – Part 5: Requirements for dry process boards (MDF)*. CEN, Brussels, EN 622-5.

European Committee for Standardisation. *Plywood – Specifications*. CEN, Brussels, EN 636.

European Committee for Standardisation. *Timber structures – Glued laminated timber – Strength classes and determination of characteristic values*. CEN, Brussels, EN 1194.

- European Committee for Standardisation. *Timber structures – Test methods – Performance of structural floor decking*. CEN, Brussels, EN 1195.
- European Committee for Standardisation. *Timber structures – Test methods – Withdrawal capacity of timber fasteners*. CEN, Brussels, EN 1382.
- European Committee for Standardisation. *Timber structures – Test methods – Pull through resistance of timber fasteners*. CEN, Brussels, EN 1383.
- European Committee for Standardisation. *Structural timber – Strength classes – Assignment of visual grades and species*. CEN, Brussels, EN 1912.
- European Committee for Standardisation. *Eurocode – Basis of structural design*. CEN, Brussels, EN 1990.
- European Committee for Standardisation. *Actions on structures*. CEN, Brussels, EN 1991.
- European Committee for Standardisation. *Eurocode 3: Design of steel structures – Part 1-8: Design of joints*. CEN, Brussels, EN 1993-1-8.
- European Committee for Standardisation. *Eurocode 5: Design of timber structures – Part 1-1: General – Common rules and rules for buildings*. CEN, Brussels, EN 1995-1-1.
- European Committee for Standardisation. *Eurocode 5: Design of timber structures – Part 1-2: General – Structural fire design*. CEN, Brussels, EN 1995-1-2.
- European Committee for Standardisation. *Eurocode 5: Design of timber structures – Part 2: Bridges*. CEN, Brussels, EN 1995-2.
- European Committee for Standardisation. *Wood-based panels – Characteristic values for structural design – Part 1: OSB, particleboards and fibreboards*. CEN, Brussels, EN 12369-1.
- European Committee for Standardisation. *Wood-based panels – Characteristic values for structural design – Part 2: Plywood*. CEN, Brussels, EN 12369-2.
- European Committee for Standardisation. *Wood-based panels – Guidance on the use of load-bearing boards in floors, walls and roofs*. CEN, Brussels, EN 12872.
- European Committee for Standardisation. *Fire classification of construction products and building elements – Part 2: Classification using data from fire resistance tests, excluding ventilation services*. CEN, Brussels, EN 13501-2.
- European Committee for Standardisation. *Reaction to fire tests for building products – Building products excluding floorings exposed to the thermal attack by a single burning item*. 2002, CEN, Brussels, EN 13823.
- European Committee for Standardisation. *Wood-based panels for use in construction – Characteristics, evaluation of conformity and marking*. CEN, Brussels, EN 13986.
- European Committee for Standardisation. *Timber structures – Glued laminated timber – Requirements*. CEN, Brussels, EN 14080.
- European Committee for Standardisation. *Timber structures – Strength graded structural timber with rectangular cross section – Part 1: General requirements*. CEN, Brussels, EN 14081-1.
- European Committee for Standardisation. *Timber structures – Product requirements for prefabricated structural members assembled with punched metal plate fasteners*. CEN, Brussels, EN 14250.

- European Committee for Standardisation. *Laminated Veneer Lumber (LVL) – Definitions, classification and requirements*. CEN, Brussels, EN 14279.
- European Committee for Standardisation. *Timber structures – Calculation of characteristic 5-percentile values and acceptance criteria for a sample*. CEN, Brussels, EN 14358.
- European Committee for Standardisation. *Timber structures – Structural laminated veneer lumber – Requirements*. CEN, Brussels, EN 14374.
- European Committee for Standardisation. *Timber structures – Connectors – Requirements*. CEN, Brussels, EN 14545.
- European Committee for Standardisation. *Timber structures – Fasteners – Requirements*. CEN, Brussels, EN 14592.
- European Committee for Standardisation. *Timber structures – Prefabricated wall, floor and roof elements*. CEN, Brussels, EN 14732.
- European Committee for Standardisation. *Structural timber – Structural timber treated against biological attack*. CEN, Brussels, EN 15288.

Other references

- Communities and Local Government. *Building Regulations 2000. Approved Document A: Structure*. NBS (part of RIBA Enterprise Ltd), London.
- Digest 477. Wood based panels. BRE.
- Part 1 Oriented strand board. 2003.
 - Part 2. Particle board (chipboard). 2003
 - Part 4. Plywood. 2003.
 - Part 5. Medium density fibreboard (MDF). 2004.
 - Part 6. Hardboard, medium board and softboard. 2004.
- Enjily, V. *The six-storey timber frame building project (TF 2000) at BRE Cardington*. Holzbau Forum 6, 6–8 December 2000. Garmisch Patenkirchen Germany. 2000.
- Gulvanessian, H., Calgaro, J.A. and Horlicky, M. *Designers guide to EN 1990 Eurocode: Basis of structural design*. Thomas Telford Ltd. 2002.
- Johansen, K.W. *Theory of timber connections*. International Association of Bridge and Structural Engineering (IABSE), Basel, 1949, Publication 9.
- Morris, W.A., Read, R.E.H. and Cooke, G.M.E. *Guidelines for the construction of fire-resisting structural elements*. BRE, 1988, BRE 128, ISBN 0851252931.

Index

Page numbers in italics refer to figures.

- accidental actions, 17–19
- actions
 - eccentrically loaded joints, 194–196
 - partial factor methods, 17–20
 - serviceability limit states, 24–25
 - see also* loads
- A-frame trusses, 100
- Annexes, 11–14
 - beam deflection, 28
 - flooring, 30
 - wall diaphragms, 251, 255
- annual rings, 32–33, 36
 - see also* shanks
- arches, 96, 98, 103–104, 105, 154–156
- axial-loading
 - bending, 112–115, 118, 121–122
 - bolts, 229–230
 - columns, 134–138, 140–141, 143
 - I-, T-, box-beams, 191–192
 - nails, 216–218
 - screws, 232–234
 - stresses, 112–115, 118, 121–122, 178–179, 187–188
- bark, 32
- battens, 96, 97, 163–164, 167
- beams, 106–133
 - bracings/compression, 116, 173
 - curvatures, 144–153
 - deflection, 28, 29
 - dowels, 200
 - end notches, 129–132
 - flanges, 185–193
 - glulam, 61–62
 - main/secondary members, 96, 97, 98, 99–101, 104
 - thin webs, 177–184
- bending
 - axial stresses, 112–115, 118, 121–122, 178–179
 - bracings, 173
 - columns, 135–136, 138–140, 143
 - compression/tension, 113–121, 125–126
 - correction factors, 204
 - curved beams/frames, 144–145, 159
 - deflection, 188
 - dowels, 199–200, 201
 - glulam, 64, 65–66
 - I-, T-, box-beams, 182–183
 - shear stresses, 127–129
 - single tapered beams, 122–124
 - strength classes, 55–56, 58
 - thin webs, 177
 - three-hinge arches, 154–155
 - trusses, 163–164
 - see also* deflection
- block compression, 109
- blue stain fungi, 42
- boarding, 54–55, 71–76, 185–186, 215, 229, 247–248
 - see also* oriented strand boards
- bolts, 83–85, 225–230, 227, 244–246
 - laterally loaded screws, 231
 - main/secondary members, 101
 - pressed-in connectors, 242–243
 - see also* connectors; fasteners; joints; nails; screws
- boomerang beams, 100
- borers, 42–43
- box-beams, 119, 174–193
- bracings, 161, 164, 169–173, 185, 229
- British Standards Institution (BSI), 8, 14
- brown rot, 42
- buckling
 - arches/frames, 154

- buckling (*continued*)
 - bracings, 171
 - columns, 134, 143
 - compression/tension, 116, 117, 125–126
 - panel shear stresses, 180
 - rolling shear, 184
 - stress skin panels, 186
 - trusses, 161
 - wall diaphragms, 251, 254–255
- Bulldog connectors, 94–95, 244–245

- camber, 63, 148–150
- cantilevers, 198, 201, 244, 249–255
- carriage bolts, 84
- carrying capacities
 - axial stresses, 178
 - axial/lateral loading, 217–218
 - axially loaded screws, 232–233
 - axially-loaded nails, 216–218
 - bending, 116, 125–126
 - bracings, 171
 - columns, 136, 138, 140–143
 - connectors/fasteners, 198–199, 219, 220–221, 223, 235–240
 - correction factors, 204
 - curved beams/frames, 144
 - design values, 210
 - double shear joints, 203
 - dowels, 199–210
 - eccentrically loaded joints, 196
 - effective nail number, 211
 - end grain/nails, 212
 - failure modes, 206–207
 - grooved-in connectors, 237–240
 - joints/fasteners, 79–83, 85–87, 89–91, 89, 94
 - lateral wood-to-wood connections, 210
 - lateral-loading, 215, 230–231
 - multiple fastener joints, 209
 - multiple shear joints, 228
 - plasticity, 197
 - pressed-in connectors, 241–242
 - shear stresses, 129
 - splitting, 207–208
 - staples, 224
 - steel-to-wood connections, 205–206
 - structural detailing, 228
 - trusses, 165
 - wall diaphragms, 249–250, 252–255
- casein glues, 67
- CEN *see* European Standards Organisation
- centrally-loaded connections, 194
- centres of gravity, 197, 198, 220
- characteristic actions
 - creep, 26
 - partial factor methods, 16–17
 - serviceability limit states, 24–25
 - see also* loads
- chemical wood protection, 48
- clamping pressures, 59–60
- CNC *see* computer numerically controlled wood machines
- coach bolts/screws, 84, 87
- collar trusses, 100
- colourless polyurethane glues, 61
- columns, 96, 97, 134–143, 178
- combination values, 17–18
- composite cross sections, 174–176
- composite glulam, 65–66
- compression, 106–121
 - axial loading/stresses, 121, 178–179, 188
 - bracings, 172, 173
 - connectors/fasteners, 221, 244
 - curved beams/frames, 160
 - end notches, 129, 130
 - grain/load, 112–113
 - I-, T-, box-beams, 182–183, 190, 192
 - roof diaphragms, 248
 - shear stresses, 193
 - single column bracings, 169
 - single tapered beams, 123
 - strength classes, 58
 - stress skin panels, 185, 186
 - thin webs, 177
 - trusses, 161, 163–164
 - wall diaphragms, 251, 254
 - see also* columns
- computer numerically controlled (CNC) wood machines, 80, 86
- Conformité Européen (CE) marks, 10–11
- connectors, 87, 89, 93–95, 93, 194–246
 - bolts, 225–230
 - design values, 210
 - dowels, 230–231
 - joints, 237–246
 - nails, 210–223

- plasticity, 197
- punched metal plates, 91–92, 96, 97, 101, 161, 163–164
- screws, 231–234
- staples, 223–225
- timber-to-timber, 85, 94, 203–205, 225–228, 239
- see also* bolts; fasteners; joints; nails; screws
- construction products, 32–95
 - density, 40–41
 - durability, 41–50
 - fasteners/joints, 79–95
 - fire, 50–52
 - glulam, 59–66
 - laminated veneer lumber, 76–77
 - marketing/sawing, 52–55
 - moisture content, 36–40
 - particleboards, 71–73
 - plywood, 67–71
 - strength classification, 55–59
 - structural timber, 52–59
 - tree structure, 32–52
 - wood-based panel products, 67–79
 - wood-fibre boards, 73–76
- continuous beams, 99
- corrosion
 - bolts/dowels, 86
 - nails/screws, 83, 84, 86, 87
 - punched metal plate fasteners, 92
- cracks, 36, 40, 64–65, 128–129
- creep, 25–26, 144, 176
- creosote, 48
- cross-section constants, 177, 186–187
- cupolas, 104
- curing, 60, 71, 74, 76, 78
- curved beams, 144–153

- dead knots, 34–35
- dead loads
 - compression/tension, 107–108, 111, 115–116
 - curved beams/frames, 147, 151, 156, 159
 - design actions, 18
 - I-, T-, box-beams, 189–190
 - three-hinge arches, 154
 - trusses, 165–167
- decomposition, 74
- deflection, 28, 29, 184, 188–189
 - axial stresses, 178
 - bending, 116–117, 126
- bracings, 171, 172
- camber, 63
- columns, 134–136
- compression/tension, 124
- curved beams/frames, 158
- end notches, 132
- flooring, 30
- laterally loaded columns, 138–140, 142, 143
- single column bracings, 169
- strength classes, 55–56
- tapered beams, 124, 125
- three-hinge arches, 155
- trusses, 167–168
- see also* bending
- deformations
 - compression/tension, 109, 124
 - creep, 25–26, 28
 - curved beams/frames, 144–145, 157
 - double tapered beams, 124
 - dowel load-carrying capacity, 200
 - dowels, 201–202
 - I-, T-, box-beams, 176
 - joints, 27
 - moisture content, 38–40, 75
 - plywood, 68, 72
 - pressed-in connectors, 243
 - shear, 26
 - trusses, 163
- 'defibrator' methods, 74
- delamination, 64
- density, 40–41, 65
 - particleboards, 73, 76
 - tree structure, 36
 - wood-fibre boards, 74–75, 76
- design, 14–15, 18
 - connectors/fasteners, 210
 - durability, 44–47
 - software, 161
- design loads, 131–132, 170, 221, 223, 224
 - see also* dead loads; snow loads
- detailing rules
 - axially-loaded nails/screws, 234
 - dowels, 230
 - grooved-in connectors, 239–240
 - lateral-loading, 215, 231–232
 - nails, 213–214, 216
 - pressed-in connectors, 242–243
 - staples, 224–225

- diaphragms, 247–255
- directions of wood, 36, 39–40
- discolouring fungi, 42
- distances
 - bolts, 229
 - connectors/fasteners, 207, 223
 - dowels, 231
 - edges/ends, 234
 - grooved-in connectors, 239–240
 - main/secondary members, 96–98, 99
 - multiple fastener joints, 209
 - nails, 212, 214, 216
 - pressed-in connectors, 243
 - staples, 225
 - wall diaphragms, 249, 252–253
- distortions, 39–40, 173
- double shear connections, 199–201, 203–206, 210, 228, 230
- double tapered beams, 122, 124, 125, 150
- dowels, 85–86, 101, 107, 199–210, 230–231
- dry density, 40
- dry rot, 42
- dry wood-fibre board production, 73–74
- drying, 40
- durability, 41–50, 58

- earthquake loads, 247
- eccentrically loaded joints, 194–197
- edge knots, 35
- elasticity, 58, 116–117, 119, 169
 - connectors/fasteners, 197, 198, 220
 - I-, T-, box-beams, 174
 - stress skin panels, 185, 186
 - thin webs, 177
- electric moisture meters, 37
- electro-zinc coating, 92, 218
- embedded knots, 34
- embedding strength
 - bolted connections, 226
 - connectors/fasteners, 211, 214–215, 229, 235
 - double shear connections, 205–206
 - dowels, 200–201
 - plywood, 228–229
- EMC *see* equilibrium moisture content
- end notches, 92, 129–132, 249
- epoxy glues, 89
- equilibria, 21–22, 197
 - connectors/fasteners, 222
 - curved beams/frames, 145
 - dowels, 201–202
 - eccentrically loaded joints, 195
 - structural detailing, 228
- equilibrium moisture content (EMC), 37–38
- Euler stresses, 134–135
- Eurocodes, 8–16
 - National Annexes, 11–12, 13
 - National Regulations, 9–10
 - Nationally Determined Parameters, 12–13
 - Public Authority Requirements, 9–10
- European design principles, 8–31
- European Standards Organisation (CEN), 8, 11–12, 50
- European Yield Model (EYM), 200, 204
- Europly plywood, 69–70
- EYM *see* The European Yield Model

- face knots, 35
- failure modes, 206–207, 209, 232
- fasteners, 79–95, 194–246
 - columns, 137
 - compression/tension, 106
 - design values, 210
 - dowels, 199–210
 - main/secondary members, 101, 104
 - nailed connections, 210–223
 - wall diaphragms, 249–253, 254
 - see also* bolts; connectors; joints; nails; screws
- fibre saturation points, 37–39
- fibreboards, 74–75
- finger-joints, 104, 155–156
- fire, 19, 50–52
- flanges
 - axial stresses, 178, 188
 - beams, 185–193
 - bracings, 171
 - connectors/fasteners, 222–223, 244–245
 - deflection, 184
 - I-, T-, box-beams, 177–179, 181–184, 189, 191
 - shear stresses, 179, 193
 - splicing, 192
 - thin webs, 177
 - trusses, 167
- flooring, 29–31, 185–186
- frames, 103–104, 105, 154–160, 251–252

- frequent actions, 24–25
friction, 162–163, 202, 216–218
fundamental design actions, 18–19
fungi, 41–42
- glued laminated timber *see* glulam
glues, 67–68, 71, 74–79, 89–90, 193, 247
glulam, 59–66
 arches/frames, 154
 bolts, 89, 229
 columns, 136, 137, 169–170
 compression/tension, 120, 123, 125–126
 curved beams/frames, 146, 147, 151, 158
 delivery, 59–64
 end notches, 130
 main/secondary members, 96, 97, 98, 99–101
 stress skin panels, 185
 three-hinged arches, 155–156
 trusses, 161
- grading, 55–56, 58, 136
grains, 111–113
 bolt connections, 226, 227
 compression, 108, 109–111, 221
 connectors/fasteners, 223, 235, 245–246
 curved beams/frames, 144–145, 146, 148, 153
 detailing rules, 213
 grooved-in connectors, 237, 239–240
 I-, T-, box-beams, 189
 multiple fastener joints, 209
 nails, 211, 212, 216
 pitched cambered beams, 148–150
 splitting, 207–208
 tension, 106–109, 124
 wall diaphragms, 251, 254
- gravity, 197, 198, 220
grooved-in connectors, 237–240
gussets, 93, 101, 104
 connectors/fasteners, 223, 235
 I-, T-, box-beams, 189
 trusses, 161, 164
gypsum, 247
- hard oil tempered boards, 74
hard-density fibreboards (HDF), 74–75
hardboards, 215
- hardwoods, 56, 58, 231–232
Harmonised standards (hENs), 11
hazard classes, 44, 49
HDF *see* hard-density fibreboards (HDF)
head tear-off capacity, 233
heartwood, 36
heat treatment, 50
hENS *see* Harmonised standards
homogenous glulam, 65–66
hot-dip zinc coating, 217–218
- I-beams, 77, 78, 174–193
imposed loads, 107–108, 111
inertia, 175–176, 196, 197, 220
informative Annexes, 14
inlaid connectors, 93
insects, 42–43
instability, 116–119, 143, 154–155, 178, 182–183
- joiner's glues, 67
joints, 79–95
 columns, 137
 connectors, 237–246
 deformations, 27
 fire, 51
 main/secondary members, 96, 97, 104
 shear stresses, 188
 trusses, 164
 see also bolts; connectors; fasteners; nails; screws
- Kerto veneer lumber, 76–77
knots, 34–35, 134–135
- lag screws, 87
lamellas *see* glulam; laminations
laminated strand lumber (LSL), 78, 79
laminated veneer lumber (LVL), 76–78, 79, 101, 161, 177, 185
laminations, 59, 144, 150, 151, 154–156
 see also glulam
large trusses, 101–102
lateral instability, 116–119, 143, 154–155, 178
lateral-loading, 210–215
 bolts, 225–229
 columns, 138–143
 nails, 218
 screws, 231–232
 torsional buckling, 143

- leading actions, 19–20
- limit states, 14–16, 21, 22–25, 28, 29, 186
- live knots, 34–35
- live loads, 19–20
- loads
 - bracings, 169–170, 171–172
 - central connections, 194
 - columns, 134–138, 169
 - compression/tension, 107–108, 109–113, 115–118, 120, 121–122
 - connectors/fasteners, 245–246
 - creep, 25–26, 28
 - curved beams/frames, 147–148, 151–153, 156–157, 158
 - eccentric joints, 194–197
 - end notches, 129, 131–132
 - flooring, 30
 - I-, T-, box-beams, 181, 189–190
 - lateral connections, 225–229
 - laterally loaded columns, 138–143
 - partial factor methods, 16–20, 21–22
 - shear stresses, 128
 - stress skin panels, 185
 - three-hinge arches, 154–155
 - trusses, 162–164, 165–168
 - see also* carrying capacities
- longitudinal directions *see* directions of wood
- LSL *see* laminated strand lumber
- LVL *see* laminated veneer lumber

- M10-M24 bolts, 83–84
- machine bolts, 85
- machined grading, 55–56
- machined wood production, 53, 79
- main members, 96–105
- marine borers, 42–43
- marketing, 52–55
- marking, 56, 58–59
- ‘masonite’ methods, 74
- material parameters, 16–17
 - see also* mechanical properties
- MDF *see* medium-density fibreboards
- mechanical fasteners, 104, 137
- mechanical grading, 55–56
- mechanical properties, 16–17, 20
- medium-density fibreboards (MDF), 74–75

- melamine formaldehyde, 71
- melamine-urea glues, 61
- metal plate connectors/fasteners, 91–92, 96, 97, 101
- mills, 243
- modal damping ratios, 29
- moisture content, 36–40
 - axially-loaded nails, 218
 - deflection, 188–189
 - fungi, 41–42
 - glulam, 61–62, 64–65
 - heat treatment, 50
 - particleboards, 72
 - plywood, 68
 - service classes, 20–21
 - structural detailing, 228
 - vacuum impregnation, 48
 - wood-fibre boards, 74, 75
- mould, 42
- multiple connections
 - fastener joints, 194–199, 209
 - shear, 209, 228

- N-trusses, 101
- nail/nailing plates, 92, 93
 - see also* punched metal plate connectors/fasteners
- nails, 81–83, 211–212
 - axial-loading, 216–218
 - bracings, 170–171
 - connections, 210–223
 - curved beams/frames, 153
 - end grain, 212
 - laterally loaded screws, 231
 - main/secondary members, 99
 - roof diaphragms, 248
 - steel-to-timber connections, 216
 - wall diaphragms, 249–252
 - see also* connectors; fasteners; joints
- National Annexes, 13, 14
 - beam deflection, 28
 - Eurocodes, 11–12
 - flooring, 30
 - wall diaphragms, 251, 255
- National Regulations, Eurocodes, 9–10
- National standards bodies, 11–12, 13
- Nationally Determined Parameters (NDPs), 12–13
- natural durability, 43–44
- NCCI *see* non-contradictory complementary information

- NDPs *see* Nationally Determined Parameters
- nearly round staples, 223–224
- nodes, 162–163, 166–168
- non-compulsory requirements, 14
- non-contradictory complementary information (NCCI), 13
- normative Annexes, 14
- on site glulam handling, 64
- optimum distances *see* distances
- oriented strand boards (OSBs), 71–72, 73–74, 215, 229
- overlapping nails, 213
- panel products, 67–79
- panel shear stresses, 179–180
- parallel N/V-trusses, 101
- parallel strand lumber (PSL), 78, 79
- partial coefficient/factor methods, 14–15, 16–24
- particleboards, 71–73, 185–186, 215, 229
- peeled plywood, 69
- permanent actions, 17–18, 19–20, 140–141, 253
- persistent fundamental design actions, 19
- phenol glue, 71
- pitched beams, 100, 148–150
- piths, 32
- planed timber, 53
- plasterboards, 247
- plasticity, 197, 198–199, 200–201, 222, 244
- plywood, 67–71
 - connectors/fasteners, 223
 - embedding strength, 215
 - I-, T-, box-beams, 181, 189–190
 - laterally loaded bolted joints, 228–229
 - stress skin panels, 185–186
- point loads, 30, 162–163, 185
- polar moments of inertia, 196, 197, 220
- polyurethane glues, 61, 89
- porous fibreboards, 74
- preservatives, 48, 50
- pressed-in connectors, 93–94, 241–243, 244–245
- pressure, 48–49, 51–52, 59–61, 91–92, 199–200
 - see also* compression
- processed wood production, 53–54, 79
- protection, 48–50
- PSL *see* parallel strand lumber
- Public Authority Requirements, 9–10
- pull-through resistance, 233
- punched metal plate connectors/fasteners, 91–92, 96, 97, 101, 161, 163–164
- pure bending/torsion, 116, 117, 132–133
- purlins, 114–116, 220
- quasi-permanent actions, 24–25, 28
- racking, 252–253
- radial directions *see* directions of wood
- rafters, 164, 171
- rail compression, 109
- raised tie trusses, 100
- rectangular beams/columns, 130, 140
- rectangular staples, 223–224
- relative humidity (RH), 37–38, 72–73
- ‘residual standards’, 13
- resistance, 22–24, 50–52, 233, 247
 - see also* diaphragms
- resorcinol glues, 61
- retardants, 51–52
- RH *see* relative humidity
- ring connectors, 81–83, 93, 216, 217–220, 223, 237–240
- robustness, 31
- rolling shear, 183–184, 188, 193
- roofing
 - curved beams/frames, 146
 - diaphragms, 247–248
 - I-, T-, box-beams, 181, 189
 - stress skin panels, 185–186
 - trusses, 161, 163
- rope effect, 204–206, 221, 223
- rot, 42
- round nails/staples, 82, 223–224
- ‘rump standards’, 13
- safety, 14–15, 31
- sanding, 68
- sapwood, 36
- sawing, 52–55
- scaffolding, 54–55
- scissor trusses, 101, 103
- screws, 82–83, 86–87, 88, 89
 - connectors/fasteners, 231–234, 236–237

- screws (*continued*)
 - curved beams/frames, 153
 - main/secondary members, 99
 - wall diaphragms, 252
 - see also* bolts; connectors; fasteners; joints; nails
- secondary members, 96–105
- section moduli, 113, 131
- seismic actions, 17–18
- self-drilling/tightening screws, 87, 88
- service classes, 20–22
- serviceability, 15–16, 18, 24–31, 82, 214
- SFS screws, 88
- shakes, tree structure, 36
- shanks, 81–83, 216–218, 220, 223, 231, 233
- shear, 203–204, 209, 228, 237–240
 - compression/tension, 127–133
 - connectors/fasteners, 93, 235, 245
 - curved beams/frames, 148, 158
 - deformations, 26
 - dowels, 199–201
 - lateral wood-to-wood connections, 210
 - plywood, 69, 71
 - punched metal plate fasteners, 91
 - rolling shear, 183–184
 - roof diaphragms, 248
 - rope effect, 205
 - steel-to-wood connections, 205–206
 - strength, 58
 - stress skin panels, 186
 - stresses, 179–180, 188, 192–193, 249
 - three-hinge arches, 155
 - torsion, 132–133
 - wall diaphragms, 255
- sheathing, 249, 250–253, 255
- sheet piling, 55
- short beams, 108
- shrinkage, 39, 48, 68
- side knots, 35
- sieving, 71
- simplified truss design, 162–164
- Simpson Strong Ties, 220
- single column bracings, 169–171
- single shear connections, 201, 203, 205, 210
- single tapered beams, 122–124, 148
- single-sided tooth-plate connectors, 94
- single-span beams, 99
- skew nailing *see* slant nailing
- skins, 185–193
- slant nailing, 216, 218
- slip
 - joint deformations, 27, 29
 - nails, 214, 216
 - pressed-in connectors, 243
- slotted screws, 87
- smooth nails, 81, 82–83
 - axial/lateral loading, 216–217, 218
 - connectors/fasteners, 219
 - detailing rules, 213
 - end grain, 212
- smooth rods, 89
- smooth screws, 231
- snow loads
 - compression/tension, 115–116
 - curved beams/frames, 147, 151, 156–157, 159
 - I-, T-, box-beams, 189–190
 - three-hinge arches, 154–155
 - trusses, 165–167
- software, 161
- softwoods, 56–57, 110, 231–232
- solid beams, 99–100
- spacing *see* distances
- spans, 185–187
- splicing, 192
- split-ring connectors, 93
- splitting, 192, 207–208
- square twisted nails, 81–82
- staples, 223–225
- statical systems, 21, 22, 31, 127, 162, 195
- steel, 51, 87, 92, 94
 - wiring, 81
 - wood connections, 205–207, 216, 229, 239
- stiffness
 - bending, 119
 - bracings, 171, 173
 - compression, 173
 - deflection, 188
 - diaphragms, 247
 - end notches, 131–132
 - glulam, 65–66
 - hardwood, 56
 - heat treatment, 50
 - I-, T-, box-beams, 181–182, 189–190
 - laminated veneer lumber, 77
 - multiple fastener joints, 209

- particleboards, 73–74, 76
- plywood, 69–70
- serviceability limit states, 24
- single column bracings, 169
- stress skin panels, 186
- wood-fibre boards, 75–76
 - see also* strength
- straight beams, 104, 116–117
- straight members, 106–133
- strand boards, 71–72, 73–74
 - see also* oriented strand boards
- strength
 - axially-loaded nails, 217
 - bending, 119
 - bolts, 226, 229–230
 - bracings, 171, 172, 173
 - classification, 55–59, 65–66
 - connectors/fasteners, 223, 235
 - curved beams/frames, 144–145, 146, 147, 148, 151–153, 160
 - dowels, 200–201
 - end notches, 131–132
 - flange splicing, 192
 - glulam, 65–66
 - hardwood, 56, 58
 - heat treatment, 50
 - I-, T-, box-beams, 181–182, 189–190
 - laminated veneer lumber, 77
 - lateral wood-to-wood connections, 211
 - lateral-loading, 214–215, 229
 - main/secondary members, 104
 - multiple fastener joints, 209
 - partial factor methods, 22–23
 - particleboards, 73, 76
 - plywood, 69–70, 228–229
 - roof diaphragms, 248
 - shear stresses, 129
 - single column bracings, 169
 - softwood, 56, 57
 - steel-to-wood connections, 205–206
 - three-hinge arches with curved corners, 154–155
 - trusses, 164
 - wall diaphragms, 252–253
 - wood-fibre boards, 75–76
- stress skin panels, 185–193
- stresses, 178–179
 - I-, T-, box-beams, 176
 - shear, 127–129, 179–180, 183–184, 188, 192–193
 - thin webs, 177
 - see also* bending; compression; tension
- structural timber, 52–59, 96–105
 - columns, 136, 137
 - end notches, 130
 - single column bracings, 169–170
 - trusses, 161
- surface fissures, 69
- surface treatment, 49, 51–52
- Swedlam veneer lumber, 76–77
- swelling, 39, 48, 68
- T-beams, 174–193
- tangential directions *see* directions of wood
- tapered beams, 100, 101, 122–126, 148, 151, 157
- tapered columns, 159
- temperature, 37–38, 41
- tension, 106–121
 - axial-loading, 121, 179, 187, 233
 - connectors/fasteners, 235, 236, 244
 - curved beams/frames, 145–146, 147–148, 153
 - double tapered beams, 124
 - dowels, 199
 - end notches, 129, 130
 - flange splicing, 192
 - grain/load, 111, 112, 124
 - I-, T-, box-beams, 190–191
 - main/secondary members, 100
 - pitched cambered beams, 149–150
 - roof diaphragms, 248
 - shear stresses, 193
 - single tapered beams, 123
 - splicing, 192
 - splitting, 192, 207–208
 - strength classes, 58
 - stress skin panels, 185, 186
 - thin webs, 177
 - wall diaphragms, 251, 254
 - see also* bending
- tension ties, 100
- The European Yield Model (EYM), 200, 204
- thickness
 - axial stresses, 187
 - connectors/fasteners, 219
 - curved beams/frames, 144–145, 156
 - detailing rules, 213
 - grooved-in connectors, 237–238

- thickness (*continued*)
 - lateral wood-to-wood connections, 210
 - particleboards, 72–73
 - pressed-in connectors, 241, 243
 - shear stresses, 127
 - splitting, 207–208
 - steel-to-wood connections, 205–206
 - stress skin panels, 185
- thin webs, 177–180
- threaded nails, 216, 217
- threaded rods, 89
- 'three dimensional connectors', 87
- three-hinge arches, 154–156
- three-member connections, 154–156, 209, 213
- tie trusses, 100
- timber-to-timber connections *see* connectors
- tolerances
 - glulam, 63
 - sawing/marketing, 53–54
- tongue-and-groove edges, 55, 69
- tooth-plate connectors, 241–243
- torsion, 116–118, 120, 132–133, 143, 177
- transformed cross sections, 174–176
- transient fundamental design actions, 19
- trees, 32–52
 - density, 40–41
 - durability, 41–50
 - fire, 50–52
 - growth, 33–34
 - moisture content, 36–40
 - structure, 32–36
- 'triangles', pitched cambered beams, 148, 153
- triangulated corners, three-hinged arches, 155–156
- triangulated trusses, 163–164
- trusses, 101, 161–168
 - bracings, 171, 172, 173
 - connectors/fasteners, 222–223, 244
 - main/secondary members, 96, 97, 99–103
 - rafters, 91
 - structural design, 162–168
- two-sided tooth-plate connectors, 94
- U-beams, 156
- UK design principles, 8–31
- ultimate limit states, 15–16, 21
- unity, 110
- urea glue, 71
- V-trusses, 101
- vacuum impregnation, 48–49
- variable actions, 17–18, 19–20
- veneers, 76–78, 79, 101
 - shear stresses, 193
 - stress skin panels, 185
 - thin webs, 177
 - trusses, 161
- verification, 22–23, 24
- vibrations, 28–30
- visual grading, 55–56
- wall diaphragms, 249–255
- warping constants, 117
- washers, 84, 85, 228, 230, 243
- water *see* moisture content
- webs, 177–180
- wet density, 40
- wet rot, 42
- wet wood-fibre board production, 73–74, 75
- wind loads, 115–116, 140–141, 229, 247–248, 253
- withdrawal capacities, 205, 216–218, 223
- wood cells, 33
- wood-based panel products, 161, 247, 251–252
- wood-based panel-to-wood connections, 203–205, 228–229
- wood-fibre boards, 73–76
- wood-to-wood connections *see* connectors
- W-trusses, 165
- yield capacities, 197, 198–202, 210–211, 225, 235
- zinc coating, 217–218
- zipper failure, 90