

DESIGN OF BLAST-RESISTANT BUILDINGS IN PETROCHEMICAL FACILITIES

Second Edition

PREPARED BY
Task Committee on Blast-Resistant Design of the
Petrochemical Committee of the
Energy Division of the
American Society of Civil Engineers

ASCE AMERICAN SOCIETY
OF CIVIL ENGINEERS
1801 ALEXANDER BELL DRIVE
RESTON, VIRGINIA 20191-4400

Library of Congress Cataloging-in-Publication Data

Design of blast-resistant buildings in petrochemical facilities / prepared by Task Committee on Blast-Resistant Design of the Petrochemical Committee of the Energy Division of the American Society of Civil Engineers. -- 2nd ed.

p. cm.

Includes bibliographical references and index.

ISBN 978-0-7844-1088-2

1. Petroleum refineries--Design and construction. 2. Petroleum refineries--Fires and fire prevention. 3. Explosions. 4. Buildings--Blast effects. I. Society of Civil Engineers. Task Committee on Blast Resistant Design.

TH4571.D47 2010

693.8'54--dc22

2010045567

American Society of Civil Engineers
1801 Alexander Bell Drive
Reston, Virginia, 20191-4400

www.pubs.asce.org

Any statements expressed in these materials are those of the individual authors and do not necessarily represent the views of ASCE, which takes no responsibility for any statement made herein. No reference made in this publication to any specific method, product, process, or service constitutes or implies an endorsement, recommendation, or warranty thereof by ASCE. The materials are for general information only and do not represent a standard of ASCE, nor are they intended as a reference in purchase specifications, contracts, regulations, statutes, or any other legal document. ASCE makes no representation or warranty of any kind, whether express or implied, concerning the accuracy, completeness, suitability, or utility of any information, apparatus, product, or process discussed in this publication, and assumes no liability therefore. This information should not be used without first securing competent advice with respect to its suitability for any general or specific application. Anyone utilizing this information assumes all liability arising from such use, including but not limited to infringement of any patent or patents.

ASCE and American Society of Civil Engineers—Registered in U.S. Patent and Trademark Office.

Photocopies and reprints.

You can obtain instant permission to photocopy ASCE publications by using ASCE's online permission service (www.pubs.asce.org/authors/RightslinkWelcomePage.html). Requests for 100 copies or more should be submitted to the Reprints Department, Publications Division, ASCE, (address above); email: permissions@asce.org. A reprint order form can be found at www.pubs.asce.org/authors/reprints.html.

Copyright © 2010 by the American Society of Civil Engineers.

All Rights Reserved.

ISBN 13: 978-0-7844-1088-2

Manufactured in the United States of America.

16 15 14 13 12 11

2 3 4 5 6 7

Table of Contents

Chapter 1: Introduction	1
1.1 Background.....	1
1.2 Purpose and Scope.....	2
1.3 Related Industry Guidelines, Specifications, & Codes.....	3
1.4 Blast Resistant Design Process.....	3
Chapter 2: General Considerations	6
2.1 Introduction.....	6
2.2 OSHA Requirements.....	6
2.3 Objectives of Blast Resistant Design.....	7
2.4 Buildings Requiring Blast Resistant Design.....	7
2.5 Siting Considerations.....	8
2.6 Offshore Facilities.....	9
2.7 Non-Building Structures, Equipment, & Infrastructure.....	9
Chapter 3: Determination of Loads	12
3.1 Introduction.....	12
3.2 Types of Explosions.....	12
3.3 Blast Wave Parameters.....	14
3.4 Determination of Vapor Cloud Design Overpressures.....	20
3.5 Building Blast Loading.....	24
3.6 Computational Fluid Dynamics.....	29
Appendix 3 Blast Load Example.....	31
Chapter 4: Types of Construction	34
4.1 Introduction.....	34
4.2 General Considerations.....	34
4.3 Common Systems for Petrochemical Buildings.....	35
4.4 Blast Resistant Modular Steel-Framed Buildings.....	39
4.5 Other Systems.....	45

Chapter 5: Dynamic Material Strength and Response Criteria.....48

5.1 Introduction.....48

5.2 Static Versus Dynamic Response48

5.3 Resistance-Deflection Function49

5.4 Material and Structural Element Types.....50

5.5 Dynamic Material Properties54

5.6 Deformation Limits61

Appendix 5.A Summary Tables for Dynamic Material Strength.....67

Appendix 5.B Summary Tables for Response Criteria.....69

Chapter 6: Dynamic Analysis Methods.....72

6.1 Introduction.....72

6.2 Key Concepts.....72

6.3 Equivalent Static Method.....76

6.4 Single Degree of Freedom Systems.....76

6.5 Multi-Degree of Freedom Systems.....90

6.6 Applications93

Appendix 6 Numerical Integration Method97

Chapter 7: Design Procedures100

7.1 Introduction.....100

7.2 General Design Concepts.....100

7.3 Member Design Process.....104

7.4 Reinforced Concrete Design.....106

7.5 Steel Design109

7.6 Reinforced Masonry Design113

7.7 Foundation Design.....114

7.8 Design Against Projectiles118

Chapter 8: Typical Details.....120

8.1 Introduction.....120

8.2 General Considerations120

8.3 Enhanced Pre-Engineered Metal Building Construction.....120

8.4 Masonry Wall Construction.....120

8.5 Metal Clad Construction121

8.6 Precast Concrete Wall Construction.....121

8.7 Cast-in-Place Concrete Wall Construction.....121

Chapter 9: Ancillary and Architectural Considerations	127
9.1 Introduction.....	127
9.2 General Considerations	127
9.3 Doors	127
9.4 Windows	131
9.5 Utility Openings.....	133
9.6 Interior Design Considerations	133
9.7 Exterior Considerations.....	134
Chapter 10: Evaluation and Upgrade of Existing Buildings	135
10.1 Introduction.....	135
10.2 Evaluation Strategies	135
10.3 Blast Resistant Upgrade Options	137
10.4 Upgrades for Structural Member Connections	139
10.5 Upgrades for Structural Framing Members	142
10.6 Upgrades for Metal Panel Wall and Roof Systems	144
10.7 Upgrades for Concrete Masonry (CMU) & Concrete Walls.....	146
10.8 Upgrade with Blast Resistant Shield Wall	152
10.9 Upgrades for Roof Systems	155
10.10 Wall and Roof Catch System Upgrades.....	156
10.11 Blast Resistant Shell Upgrades	157
10.12 Window Upgrades.....	159
10.13 Door Upgrades.....	161
Chapter 11: Shear Wall Building Design Example	164
11.1 Introduction.....	164
11.2 Structural System.....	164
11.3 Design Data.....	166
11.4 Exterior Walls (out-of-plane loads)	167
11.5 Roof Slab (in-plane loads)	174
11.6 Side Wall (in-plane loads).....	179
11.7 Roof Slab (out-of-plane loads).....	184
11.8 Roof Beams.....	191
11.9 Roof Beam Connection.....	197
11.10 Roof Girders	199
11.11 Roof Girder Connection.....	205
11.12 Columns	207
11.13 Column Base Plate and Anchor Bolt Design	213
11.14 Foundation	215

Chapter 12: Metal Building Design Example.....222

12.1 Introduction.....222

12.2 Structural System.....222

12.3 Design Data.....225

12.4 Roof Decking.....226

12.5 Wall Panels231

12.6 Roof Purlins235

12.7 Wall Girts.....244

12.8 Rigid Frames.....248

12.9 Braced Frames255

12.10 Foundation259

Chapter 13: Masonry Retrofit Design Example263

13.1 Introduction.....263

13.2 Structural System.....263

13.3 Design Data.....264

13.4 Existing Wall Evaluation265

13.5 Option #1: Reinforce Existing Wall268

13.6 Option #2: New Reinforced Concrete Wall271

13.7 Conclusion274

Nomenclature.....276

Glossary.....283

References.....287

Index.....297

CHAPTER 1 INTRODUCTION

The focus of this report is on structural aspects of designing or evaluating buildings for blast resistance. Generally this involves quantifying the blast overpressures that could result from accidental explosions, establishing the design blast loads from these overpressures, setting the structural performance requirements, and designing the building structure to withstand these loads within the required performance limits. For existing buildings a similar approach may be adopted. The performance of the structure is checked against structural performance limits.

Blast resistant design, or the structural strengthening of buildings, is one of the measures an owner may employ to minimize the risk to people and facilities from the hazards of accidental explosions in a plant. Other mitigative or preventive measures, including siting (adequate spacing from potential explosion hazards) and hazard reduction (inventory and process controls, occupancy limitations, etc.), are not covered in this report.

1.1 BACKGROUND

Process plants in the petrochemical industry handle hydrocarbons and other fuels that can and have produced accidental explosions. Plants are designed to minimize the occurrence of such incidents. Although such incidents may be relatively rare, when they do occur the consequences can be extremely severe involving personnel casualty and financial loss and potentially impacting public safety. In some instances the consequences have involved plant buildings. For example, the 1989 explosion in Pasadena, Texas, occurred during maintenance of a polyethylene unit and included the collapse of a control building. Losses included 23 fatalities and 120 injured. The 2005 explosion in Texas City, Texas, occurred during the restart of a isomerization unit and included the destruction of trailers used as temporary offices. Losses included 15 fatalities and 170 injured. Other recent petrochemical plant explosions have resulted in a significant number of fatalities from the severe damage or collapse of buildings. The concentration of such fatalities in buildings points to the need to design plant buildings to withstand explosion effects in order to protect the people inside so that, at least, the building does not pose an added hazard to the occupants. In addition to personnel safety, some companies in the industry also consider blast resistance for certain critical buildings such as control centers, even if unoccupied, to minimize the impact of accidental explosions on plant operation.

For buildings, usually the overpressure from the blast wave is the most damaging feature of an accidental explosion in a process plant. However, in addition to the air blast effects, such incidents can result in fires, projectiles and ground transmitted shocks that also can be damaging to buildings and their contents.

Historically, blast resistant design technology in the petrochemical industry has evolved from equivalent static loads and conventional static design methods (Bradford and Culbertson), to simplified dynamic design methods that take into

account dynamic characteristics and ductility of structural components, and based on TNT equivalent blast loading (Forbes 1982), and finally to more complex and rational methods involving vapor cloud explosion models to characterize the blast loading and nonlinear multi-degree of freedom dynamic models to analyze the building structure. Current practices within the industry appear to cover all these approaches. This report is intended to provide guidelines on the various methods available for the structural design of blast resistant buildings in petroleum and chemical process plants.

1.2 PURPOSE AND SCOPE

The purpose of this ASCE report is to provide a guide to design engineers and others in the petrochemical industry involved in the design of new blast resistant buildings and in evaluating existing buildings for blast resistance. It provides the basic considerations, principles, procedures and details involved in structural design and evaluation of buildings for blast overpressure effects.

This report focuses primarily on “how to” design or evaluate buildings for blast resistance once the blast loading is defined for a postulated explosion scenario. Chapter 2 discusses the basic philosophy and general considerations involved in establishing design requirements for blast resistance in buildings to resist the effects of accidental explosions in petrochemical processing plants. Chapter 3 describes the types of explosions that may occur and the general characteristics of the resulting blast load, but does not prescribe magnitudes for design. The chapter provides a brief review of the approaches used in the industry to quantify blast loads for design purposes and gives typical examples of such loads. In Chapter 4 the types of building construction appropriate for various levels of blast resistance are discussed. The dynamic ultimate strength design criteria, including the dynamic material properties and deformation limits applicable to blast resistant design are covered in Chapter 5.

The methods and procedures for blast resistant design can vary considerably in complexity, accuracy, cost and efficiency from simple conventional static design approach to complex transient nonlinear, multi-degree of freedom dynamic design methods. To assist engineers in striking a balance among these, Chapter 6 provides a discussion of the various blast resistant analysis methods, identifying the main features, advantages and disadvantages of each method. Chapter 7 outlines recommended procedures and provides aids for the design of the various components of reinforced concrete, reinforced masonry and structural steel buildings. Chapter 8 provides some typical structural details for doors and frames, wall penetrations, and connections for steel and reinforced concrete components. Blast protection considerations for non-structural items such as interior details, windows, openings, and HVAC ducts are covered in Chapter 9. Chapter 10 gives guidance on strategies for evaluating the blast resistance of existing buildings and provides practical measures for upgrading masonry and metal buildings, the most common types of building construction for plants in the petrochemical industry. Design examples are provided in Chapters 11 to 13 to illustrate the use of these procedures and tools in the design of typical buildings for blast resistance.

1.3 RELATED INDUSTRY GUIDELINES, SPECIFICATIONS, & CODES

Currently, there are no specific industry standards or guidelines for blast resistant design of process plant buildings. However, the design practices used by some operating companies and contractors are based on a number of existing documents dealing with this subject including:

- a. *Siting and Construction of New Control Houses for Chemical Manufacturing Plants*, (SG-22), Chemical Manufacturing Association. (withdrawn)
- b. *An Approach to the Categorization of Process Plant Hazard and Control Building Designs*, (CIA), Chemical Industries Association. (being revised)
- c. *Design of Structures to Resist Nuclear Weapons Effects*, (ASCE Manual 42), American Society of Civil Engineers
- d. *Structures to Resist the Effects of Accidental Explosions*, (UFC 3-340-02), Department of the Army, Navy, and Air Force. This manual was formerly designated as TM 5-1300.

The SG-22 and CIA documents are similar and cover the siting, design and construction of control buildings in petrochemical plants for a specified set of TNT equivalent blast loads and the simplified dynamic (elasto-plastic, single degree of freedom) design approach. The other documents cited above are more comprehensive but are generally geared to design for high-yield explosives for military and munitions applications. However, the fundamentals and design principles covered in these documents are applicable to designs for other types of explosions.

In addition to the publications cited above, the American Institute of Chemical Engineers, Center for Chemical Process Safety (CCPS) committee and the American Petroleum Institute (API) have addressed various aspects of blast protection technology relevant to this report. In particular, CCPS has developed *Guidelines for Evaluating the Characteristics of Vapor Cloud Explosions, Flash Fires, and BLEVEs* (CCPS Explosion Guidelines), and *Guidelines for Evaluating Process Plant Buildings for External Explosions and Fire* (CCPS Building Guidelines). API published a recommended practice titled *Management of Hazards Associated With Location of Process Plant Buildings* (API RP 752).

1.4 BLAST RESISTANT DESIGN PROCESS

The overall process involved in the evaluation and design of petrochemical plant buildings for explosion hazards is illustrated in Figure 1.1. This flowchart shows fifteen basic steps in the overall blast evaluation and design process, as follows:

- a. Define Scope: Steps 1 and 2 are to define the owner's requirements and needs for the building.

4 BLAST-RESISTANT BUILDINGS IN PETROCHEMICAL FACILITIES

- b. Analyze Explosion Hazards: Steps 3 and 4 are to identify the explosion scenarios to be used to quantify the design blast overpressures (refer to Section 5.6).
- c. Determine Performance Criteria: Step 5 is to determine how the building should perform during the explosion scenario (refer to Chapter 3).
- d. Determine Blast Loads: Step 7 is to determine the blast loadings for the various components of the building (refer to Chapter 3).
- e. Select Structural System and Material and Response Criteria: Steps 6, 8, and 9 are to choose the structural materials and systems for the building and the associated structural properties and response limits consistent with the performance requirements for the building (refer to Chapters 4 and 5).
- f. Perform Structural Analysis and Component Design: Steps 10 to 12 are to select and perform the level of structural calculations appropriate for the particular situation (refer to Chapters 6 and 7).
- g. Finalize and Detail Design: Steps 13 to 15 are to proportion and detail building components and document design (refer to Chapters 8 and 9).

It is expected that the owner will provide or direct items a, b and c, (steps 1 to 5). *CCPS Building Guidelines*, *CCPS Explosion Guidelines*, and *API RP 752* provide guidance on these steps. The design engineer's responsibilities fall in d to g (steps 6 to 15) of the process. These steps are the main focus of this ASCE report.

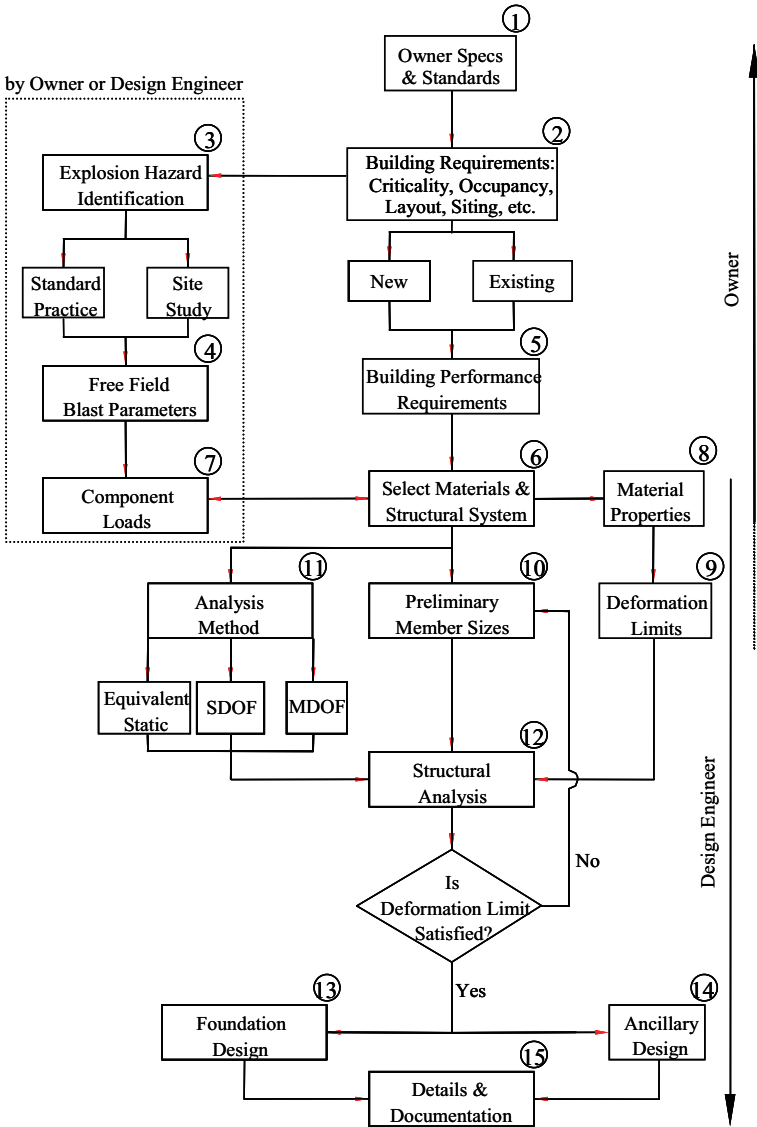

FIGURE 1.1: Petrochemical Buildings, Blast Resistant Design Process

CHAPTER 2 GENERAL CONSIDERATIONS

2.1 INTRODUCTION

The need and requirements for blast resistance in plant buildings within the petrochemical industry have evolved over recent years. Petrochemical processes have become more complex and plants have increased in size thus increasing the risk of accidental explosions. Such explosions have demolished plant buildings, in some cases resulting in substantial personnel casualties and business losses. Such events have heightened the concerns of the industry, plant management, and regulatory agencies about the issues of blast protection in plants having the potential for explosions. Generally, these issues relate to plant safety and risk management to prevent or minimize the occurrence of such incidents and to siting, design, and construction practices for plant buildings to mitigate the effects on plant workers and operations.

This chapter covers the general considerations pertaining to the design of plant buildings to resist the effects of accidental explosions in petrochemical plants. First the relevant regulatory requirements are briefly discussed. Next is a discussion of current industry practice and the objectives for providing blast resistance in plant buildings. In Section 2.4, some factors are discussed on how to identify the plant buildings that should be considered for blast resistance. Siting plays a key role in blast protection of buildings in a plant. Often the need for blast protection has to be weighed against functional or operational needs. These siting considerations are discussed in Section 2.5.

2.2 OSHA REQUIREMENTS

The General Duty Clause of the Occupational Safety and Health Act (OSHA) of 1970 states that "Each employer shall furnish to each of his employees, employment and a place of employment which are free from recognized hazards that are causing or are likely to cause death or serious physical harm to his employees;..." More specifically, Section (e)(3) of *29 CFR 1910.119* states that process hazard analysis shall address facility siting. OSHA has recognized and pointed out the potential hazards associated with process control centers of normal construction. Appendix C 13 of *29 CFR 1910.119* states "The use of process control centers or similar process buildings in the process area as safe areas is discouraged. Recent catastrophes have shown that a large life loss has occurred in these structures because of where they have been sited and because they are not necessarily designed to withstand overpressures from shockwaves resulting from explosions in the process area."

2.3 OBJECTIVES OF BLAST RESISTANT DESIGN

The primary objectives for providing blast resistant design for buildings are:

- a. personnel safety.
- b. controlled shutdown.
- c. financial consideration.

Blast resistant design should provide a level of safety for persons in the building that is no less than that for persons outside the building in the event of an explosion. Evidence from past incidents has shown that many of the fatalities and serious injuries were due to collapse of buildings onto the persons inside the building. This objective is to reduce the probability that the building itself becomes a hazard in an explosion.

Preventing cascading events due to loss of control of process units not involved in the event is another objective of blast resistant design. An incident in one unit should not affect the continued safe operation or orderly shutdown of other units.

Preventing or minimizing financial losses is another objective of blast resistant design. Buildings containing business information, critical or essential equipment, expensive and long lead time equipment, or equipment which, if destroyed, would constitute significant interruption or financial loss to the owner, should be protected.

2.4 BUILDINGS REQUIRING BLAST RESISTANT DESIGN

The decision regarding blast resistant requirements is made by the owner, typically through standard practice or by following a site specific methodology as described in *CCPS Building Guidelines* or *API RP 752*. Decision guidelines typically employ a plant classification or categorization approach based on the severity of blast hazards.

The requirements for the building are greatly influenced by the factors of distance from blast source, criticality of the function, and expected occupancy. For example, a critical building sited far enough from a potential blast source may not need increased blast resistance. But if a remote location is unavailable, or proximity of the building to the unit is important, then the choice may be to provide a high level of blast resistance.

One should keep in mind that every building has some level of blast resistance and the term is not synonymous with a bunker design. Blast resistant construction is sometimes referred to as "blast proof." This is a misnomer since it is not realistic to provide an absolute level of blast protection. In other words, there is always some probability that a design basis event can be exceeded or that a non-structural component may fail.

When a building or installation is not sited far enough away from a blast source, the building is potentially exposed to damaging overpressures. A blast resistant design is then recommended if either of the following applies:

- a. The building meets the owner's occupancy criteria (API RP 752). Even where evacuation is used as a mitigation strategy, blast resistance should be considered for occupied buildings because complete evacuation is unlikely in the short response time due to the number of occupants or size and layout of the building.
- b. The building or installation is expected to perform critical services. One critical service is where procedures require that personnel remain inside during an accident to regain or maintain control or to safely shut down operating units. Another critical service is where a building controls multiple units or controls a particularly high risk unit. A further critical service is protection of emergency response equipment such as fire fighting vehicles, spill control equipment, and firewater pumping equipment.

2.5 SITING CONSIDERATIONS

The siting of a typical plant building is unlikely to be based upon a single factor. Hazards, exposures, future expansions, and spacing establish the selected site.

Siting a plant building should consider the hazards in the adjacent and nearby processing operations and the possible results of an incident involving these hazards. The hazards from neighboring plants should also be considered.

As a minimum, blast resistant buildings should be sited to meet the appropriate guidelines for fires such as those in *IRI* and company engineering practices.

Blast protection can be provided by adequate spacing from a potential hazard or by strengthening the building. Spacing should be the primary choice in providing blast protection.

Generally, buildings designed for conventional loads can be sited in areas where the peak side-on overpressure is less than 1.0 psi (6.9 kPa) or the side-on impulse is less than 30 psi-ms (207 kPa-ms). This can be implied by the provisions of *DoD 6055.9-STD* and *UFC 3-340-02*. *DoD 6055.9-STD* states that at the "Inhabited Building Distance" (where peak side-on overpressure is 0.9 to 1.2 psi, or 6.2 to 8.3 kPa) unstrengthened buildings can sustain damage less than five percent of the replacement cost and personnel are provided a high degree of protection from death or serious injury.

When siting buildings one should consider the following:

- a. Buildings should be oriented such that the short side faces the most probable explosion source.

- b. Buildings housing personnel not required for actual operation of the unit should be sited as far away as possible.
- c. Buildings should be sited away from areas of congestion and confinement as these contribute to the severity of the explosion.
- d. Buildings should not be sited downhill from potential release sources of heavier than air materials.
- e. Buildings should not be sited in prevailing downwind direction from potential release sources.
- f. Buildings should not be sited in a location where flammable liquid could pool.

2.6 OFFSHORE FACILITIES

Blast loading can lead to partial or total collapse of an offshore platform and result in loss of life and environmental pollution. Guidelines and recommended practice for satisfactory design of offshore structures against blast loading are described in *API RP 2FB*, which contains an extensive list of references.

Many of the aspects of blast resistant design discussed in this book relate equally to either on-shore petrochemical facilities or to offshore facilities. Among these are dynamic material properties and analysis methods. The primary differences are in siting considerations and in details of the design overpressures.

On an offshore facility, available space is usually limited and costly, so that significant mitigation of blast effects by distance is often impractical. Consequently, control rooms, living quarters, escape routes, evacuation facilities (muster stations life boats), critical structural supports, and safety-critical items such as firewater lines and their supporting structures must be designed explicitly to resist blast effects. To mitigate the effects of blast, offshore facilities commonly employ blast walls, either built integrally with the rest of the structure or lightweight manufactured walls fitted later in the construction process.

Relative to an onshore petrochemical facility, an offshore facility is very congested. The explosion source is usually in a confined area and quite close to items that must survive the explosion. Preliminary design is often based on nominal overpressures and impulses based on typical similar degrees of congestion. Detail design usually relies on results of numerical models such as computational fluid dynamics (CFD) which solve equations describing gas flow, turbulence, and combustion processes.

2.7 NON-BUILDING STRUCTURES, EQUIPMENT & INFRASTRUCTURE

An overview of the historical performance record of non-building structures, equipment and infrastructure subjected to blast testing and accidental explosions is

presented in this section. Much of the data reported in the various public documents are based on atomic bomb tests conducted by the US during the 1950's. *Glasstone and Dolan* compiled a great deal of the performance data for a wide range of industrial structures, equipment, vehicles and infrastructure subjected to blast loads.

In 1970, the US Department of the Interior's Office of Oil and Gas published a handbook (Stephens) intended for use by the petroleum refining industry for the purpose of building additional protection into refineries against all forms of disaster, including nuclear attacks. An excerpt from this handbook reproduced in Figure 2.1 provides an overview of the performance of various non-building structures, equipment and infrastructure subjected to blast loading. Note that blast pressure is defined in terms of the overpressure, or free-field pressure.

Blast resistance data are also available in *TNO Green Book*. Table 2.1 is a reproduction of the data from this source. Most of the data listed in this table are based on *Glasstone and Dolan*. Here again, the blast pressure is given in terms of the overpressure.

Although it may be feasible to perform detailed structural analyses and damage evaluations of non-building structures, equipment and infrastructure, such efforts run the risk of becoming extremely complex in order to adequately address the many variables involved in such an undertaking. Utilizing screening data as presented herein, with an appropriate level engineering judgment and caution, can provide general information on the expected performance under blast loading conditions.

Equipment	Overpressure, psi (kPa)																									
	0.5 (3.4)	1.0 (6.9)	1.5 (10)	2.0 (14)	2.5 (17)	3.0 (21)	3.5 (24)	4.0 (28)	4.5 (31)	5.0 (34)	5.5 (38)	6.0 (41)	7.0 (48)	7.5 (52)	8.0 (55)	8.5 (59)	9.0 (62)	9.5 (66)	10 (69)	12 (83)	14 (97)	16 (110)	18 (124)	20 (138)	20.0 (137.24)	
Cooling tower	b	d				l							r													
Cone Roof Tank	c					i							r													
Instrument Cubicle	a					j, k						q														
Fired Heater			e	g						q																
Chemical Reactor			f				g			q		m					q									
Filter			f							q							s		q							
Regenerator					h					g, m					q											
Floating Roof Tank					i								r											c		
Cracking Reactor						h							g						q							
Pipe Support												p, l														
Gas Meter								n																		
Electrical Transformer								f						j			q									
Electrical Motor								r								j		q							s	
Blower								n										q								
Fractionation Column									a					q												
Horizontal Pressure Vessel											g, m						q									
Gas Regulator											g										k, n					
Extraction Column												g									s	q				
Steam Turbine													g								k, p					q
Heat Exchanger													g				q									
Spherical Tank														h								q	q			
Vertical Pressure Vessel																						n	q			
Pump																						n	q	s		

CODES:

a) Gauges break	h) Bracing fails	n) Case is damaged
b) Louvers fall	i) Unit uplifts (half-filled)	o) Frame cracks
c) Roof collapses	j) Power lines are severed	p) Piping breaks
d) Inner parts are damaged	k) Controls are damaged	q) Unit overturns or is destroyed
e) Brick cracks	l) Frame collapses	r) Unit uplifts (0.9 filled)
f) Debris-missile damage occurs	m) Frame deforms	s) Unit moves on foundation
g) Unit moves and pipes break		

FIGURE 2.1: Blast Overpressure Effects on Vulnerable Refinery Parts (from Stephens)

Two factors warrant special consideration. One of these factors is the effect of the blast loading duration. As mentioned above, most of the damage data cited herein is believed to have been obtained from nuclear explosion tests which have significantly longer durations than accidental explosions occurring in petrochemical facilities. Hence, impulse sensitive items would be expected to perform better than what may be indicated by the available data. Another factor to consider is the construction (i.e., materials and fabrication details) which may be significantly different from what had been tested.

**TABLE 2.1: Blast Damage to Equipment, Other Structures and Infrastructure
(from TNO Green Book)**

Description of Damage	Overpressure	
	psi	kPa
Roof of a storage tank has collapsed	1.0	7
Supporting structure of a round storage tank has collapsed	14.5	100
Cracking in empty oil storage tanks	2.9 - 4.4	20 - 30
Displacement of a cylindrical storage tank, failure of connecting piping	7.3 - 14.5	50 - 100
Damage to a fractioning column	5.1 - 11.6	35 - 80
Slight deformations of a pipe bridge	2.9 - 4.4	20 - 30
Displacement of a pipe bridge, breakage of piping	5.1 - 5.8	35 - 40
Collapse of a pipe bridge	5.8 - 8.0	40 - 55
Plating of cars and trucks pressed inwards	5.1	35
Breakage of wooden telephone poles	5.1	35
Loaded train carriages turned over	7.3	50
Large trees have fallen down	2.9 - 5.8	20 - 40

CHAPTER 3 DETERMINATION OF LOADS

3.1 INTRODUCTION

The preceding chapters discussed the considerations involved in deciding the need for blast protection for buildings located in petrochemical plants. Structural strengthening, or design to resist the effects of accidental explosions, was identified as one of the options available to achieve the appropriate level of blast protection. Blast resistant design requires that the loads from such events be quantified and that the structural performance requirements be established for buildings subjected to these loads. Methods to determine the blast loading and structural performance limits are well established in *UFC 3-340-02* for buildings exposed to explosions from TNT or other high-yield explosives in military applications and munitions plants. However, this is not the case for the kinds of accidental explosions that have occurred in petrochemical plants.

This chapter provides general information on the characteristics of blast loads. A detailed discussion can be found in several publications including *Baker* and *CCPS Explosion Guidelines*. The chapter also discusses how explosions that occur in process plants are characterized in order to determine the blast loads for structural design. First, Section 3.2 discusses the types of explosions that may occur in petrochemical plants. Section 3.3 provides a description of the basic parameters which define a blast wave. Some of the methods currently in use in the industry and some blast overpressure values for accidental explosions used for design are covered in Section 3.4. Finally, Section 3.5 provides a method for determining the blast loads on various parts of a rectangular building.

3.2 TYPES OF EXPLOSIONS

Explosions in the petrochemical industry can be classified into four basic types: Vapor Cloud Explosions, Pressure Vessel Explosions, Condensed Phase Explosions, and Dust Explosions. *Baker* and *CCPS Explosion Guidelines* also provide information for characterizing some of these types of explosions.

3.2.1 Vapor Cloud Explosions

Four conditions are necessary for a vapor cloud explosion (VCE) with damaging overpressures to occur (CCPS Explosion Guidelines).

First, there must be a release of a flammable material at suitable conditions of pressure or temperature. These include liquified gases under pressure, ordinary flammable liquids (especially at elevated pressures and/or temperatures), and flammable gasses. When a flammable liquid spills, some or all of it will vaporize and/or form an aerosol. This dispersion is called a vapor cloud.

Second, ignition must be delayed long enough for a vapor cloud of sufficient size to form. Maximum flammable cloud size is usually reached in 30 to 60 seconds, so the ignition delay is not long. If ignition occurs nearly instantly, a fire or fireball, but not a VCE, would occur.

Third, the fuel-air ratio of a sufficient amount of the vapor cloud must be in the flammable range. The more uniform the fuel-air mixture, near the stoichiometric fuel-air ratio, the stronger the explosion.

Finally, there must be a flame acceleration mechanism, such as congested areas, within the flammable portion of the vapor cloud. The overpressures produced by a vapor cloud explosion are determined by the speed of flame propagation through the cloud. Objects in the flame pathway (such as congested areas of piping, process equipment, etc.) enhance vapor and flame turbulence. This turbulence results in a much faster flame speed which, in turn, can produce significant overpressures. Confinement that limits flame expansion, such as solid decks in multi-level process structures, also increases flame speed. Without flame acceleration, a large fireball or flash fire can result, but not an explosion.

Thus, the center of a VCE is not necessarily where the flammable material is released, the point of ignition, or the center of the vapor cloud. Rather, the center of a vapor cloud explosion is usually an area of congestion/confinement within the vapor cloud. If there are multiple areas of congestion or confinement within the flammable portion of a vapor cloud, multiple explosions can occur as the flame front propagates through each congested/confined area.

3.2.2 Pressure Vessel Explosions

In petrochemical plants, vessel explosions may occur as one of several subtypes:

- a. Deflagrations and Detonations of Pure Gases Not Mixed with Oxidants: Acetylene is an example of a gas that would undergo a self-sustaining decomposition that releases energy. Acetylene can burn with the oxygen in the air as either a deflagration or a detonation. However, acetylene alone, with no oxygen, can also deflagrate or detonate.
- b. Combustion Deflagrations and Detonations in Enclosures: These can be fueled by gaseous, liquid, or dust particle fuels (refer to Section 3.2.4 Dust Explosions). If an enclosure is too weak to sustain the pressure resulting from the combustion, it will explode.
- c. Runaway Exothermic Chemical Reactions: Many industrial chemical reactions are exothermic, i.e. they release energy. Certain reactions can go into accelerated (runaway) conditions if the released energy is not removed fast enough. If a containment vessel has insufficient venting capabilities, considerable pressure can build up. If this pressure exceeds the pressure capabilities of the vessel, it will explode.

- d. Simple Overpressure of Equipment with Nonreactive Gaseous Contents: These are also called mechanical explosions. Rupture of pressure vessels due to overpressure may occur if human error or ancillary equipment failures allow too high an internal pressure to accumulate.
- e. Physical Vapor Explosions: Physical vapor explosions occur when two streams of widely differing temperatures mix suddenly, such that the cooler liquid flashes rapidly to vapor and generates a pressure beyond the pressure capability of the container. The container thus explodes. Foundries may experience such explosions if molten metal is accidentally poured into a moist mold, or water into hot oil.
- f. Boiling Liquid Expanding Vapor Explosions (BLEVE): This occurs when a large amount of pressurized liquid is suddenly vented to the atmosphere as the result of a containment vessel rupture. The rupture may be from a number of causes, but often it is from excessive heating by external fire that contacts the vessel walls above the liquid level. In this case, the vessel is not pressurized above its rated pressure, but is weakened by the heat. Much of the liquid flash vaporizes, and much of the remainder is broken up into aerosol droplets. The vapor aerosol mixture is typically ignited as the material is suddenly vented to the atmosphere. The combustion rate is limited to the rate at which air can mix into the fuel. In terms relative to the speed of flames, the rate of mixing with air is relatively slow. A huge, billowing, highly radiant fireball results, and a pressure wave may also occur.

3.2.3 Condensed Phase Explosions

Condensed phase materials are those in the liquid or solid phase, in contrast to gaseous phase. The classic example of condensed phase materials that can detonate are high explosives. Some materials found in petrochemical plants have properties that cause them to explode under upset process conditions.

3.2.4 Dust Explosions

Suspensions of finely divided combustible solids (flammable dusts) can explode in much the same fashion as flammable gases. It is significant that, in a dust suspension in air, small concentrations of flammable gas, even well below the lower flammable limit of the gas, can contribute to a more severe explosion than that of the dust alone. Such mixtures are called hybrid mixtures.

3.3 BLAST WAVE PARAMETERS

For blast resistant design, the most significant feature of an explosion is the sudden release of energy to the atmosphere which results in a pressure transient, or blast wave. The blast wave propagates outward in all directions from the source at supersonic or sonic speed. The magnitude and shape of the blast wave depends on the

nature of the energy release and on the distance from the explosion epicenter. The characteristic shapes of blast waves are shown in Figure 3.1.

The two types of blast waves are:

- a. Shock Wave: This has a sudden, almost instantaneous rise in pressure above ambient atmospheric conditions to a peak free field (side-on or incident) overpressure. The peak side-on overpressure gradually returns to ambient with some highly damped pressure oscillations. This results in a negative pressure wave following the positive phase of the blast wave.
- b. Pressure Wave: This has a gradual pressure rise to the peak side-on overpressure followed by a gradual pressure decay and a negative phase similar to that for a shock wave.

Shock waves in the near and far fields usually result from condensed phase detonations, or from an extremely energetic vapor cloud explosion. Most vapor cloud deflagrations will give rise to pressure waves in the near field which may propagate as a shock wave, or “shock-up,” in the far field.

The negative phase of a shock or pressure wave is usually much weaker and more gradual than the positive phase, and consequently is usually ignored in blast resistant design. For situations where the negative phase blast loading may be important, the reader is referred to *UFC 3-340-02* for the characterization and treatment of this loading.

In Figure 3.1, the time over which the blast wave overpressure lasts is referred to as the positive phase duration, or simply duration. The area under the pressure-time curve is the impulse of the blast wave. Consequently, the positive phase impulse, I_0 ,

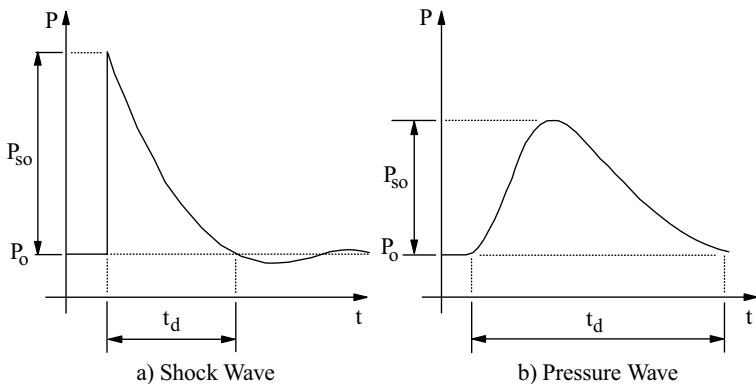

FIGURE 3.1: Characteristic Shapes of Blast Waves

is defined as follows:

$$\begin{aligned}
 I_o &= \int_0^{t_d} P(t) dt & (3.1) \\
 &= 0.5 P_{so} t_d, \text{ for a triangular wave} \\
 &= 0.64 P_{so} t_d, \text{ for a half-sine wave} \\
 &= c P_{so} t_d, \text{ for an exponentially decaying shock wave}
 \end{aligned}$$

where,

- $P(t)$ = overpressure function with respect to time
- P_{so} = peak, or incident, side-on overpressure
- t_d = duration of positive phase
- c = a value between 0.2 and 0.5 depending on P_{so}

3.3.1 Blast Wave Parameters For Blast Loading

For blast resistant design of buildings, the principal parameters of the blast wave required to define the blast loading for a building's components are:

- Peak side-on positive overpressure, P_{so} , positive phase duration, t_d , and the corresponding positive impulse, I_o .
- Peak side-on negative pressure (suction), P_{so}^- , negative phase duration, t_d^- and the associated negative impulse, I_o^- .

The blast wave attenuates as it propagates outward from the explosion epicenter. Consequently, the values of peak overpressure and impulse decrease with distance while the duration tends to increase. Values for these blast wave parameters can be determined from published data in the form of scaled values (overpressure, impulse or duration) as a function of scaled distance. *UFC 3-340-02* provides data on high energy condensed phase explosives while *Baker, TNO 1985*, and *CCPS Explosion Guidelines* provides values for vapor cloud explosions according to their respective models. These sources do not provide data on the negative phase of the blast wave from a vapor cloud explosion. Because negative phase pressures are relatively small, and oppose the primary lateral force, it is usually conservative to ignore them for design. The values of blast overpressure and duration appropriate for petrochemical design are discussed in Section 3.4.

In addition to peak overpressure, duration, and impulse, other blast wave parameters that may enter into the determination of the blast loads for a structure include:

- Peak reflected pressure, P_r
- Peak dynamic (blast wind) pressure, q_o
- Shock front velocity, U

- Blast wave length, L_w

Usually these secondary parameters can be determined from the primary blast wave parameters as discussed below.

3.3.2 Peak Reflected Pressure, P_r

When the free field blast wave from an explosion strikes a surface, it is reflected. The effect of this blast wave reflection is that the surface will experience a pressure much more than the incident side-on value. The magnitude of the reflected pressure is usually determined as an amplifying ratio of the incident pressure:

$$P_r = C_r P_{so} \quad (3.2)$$

where,

C_r = reflection coefficient

The reflection coefficient depends on the peak overpressure, the angle of incidence of the wave front relative to the reflecting surface, and on the type of blast wave. The curves in Figure 3.2 shows reflection coefficients for shock waves and pressure waves, for angles of incidence varying from 0° (wave front parallel to surface) to 90° (wave front perpendicular to surface), and for peak overpressures up to about 5 times atmospheric pressure.

For peak overpressures up to 20 psi (138 kPa), the expected range for most accidental vapor cloud explosions, *Newmark* provides a simple formula for the blast wave reflection coefficient at normal, 0° , incidence as follows:

$$\begin{aligned} C_r = P_r / P_{so} &\approx (2 + 0.05 P_{so}) && (P_{so} \text{ in psi}) \\ &\approx (2 + 0.0073 P_{so}) && (P_{so} \text{ in kPa}) \end{aligned} \quad (3.3)$$

The duration of the reflected pressure depends on the dimensions of the reflecting surface, up to a maximum time approximately equal to the positive phase duration of the incident blast wave. This upper limit corresponds to the total reflection of the entire blast wave without any diffraction around the edges of the reflecting surface. Further details of the duration are provided in Section 3.5.1.

3.3.3 Dynamic (Blast Wind) Pressure, q_o

This blast effect is due to air movement as the blast wave propagates through the atmosphere. The velocity of the air particles, and hence the wind pressure, depends on the peak overpressure of the blast wave. *Baker* and *UFC 3-340-02* provide data to compute this blast effect for shock waves. In the low overpressure range with normal atmospheric conditions, the peak dynamic pressure can be calculated using the following empirical formula from *Newmark*:

 **LIVE GRAPH**
[Click here to view](#)

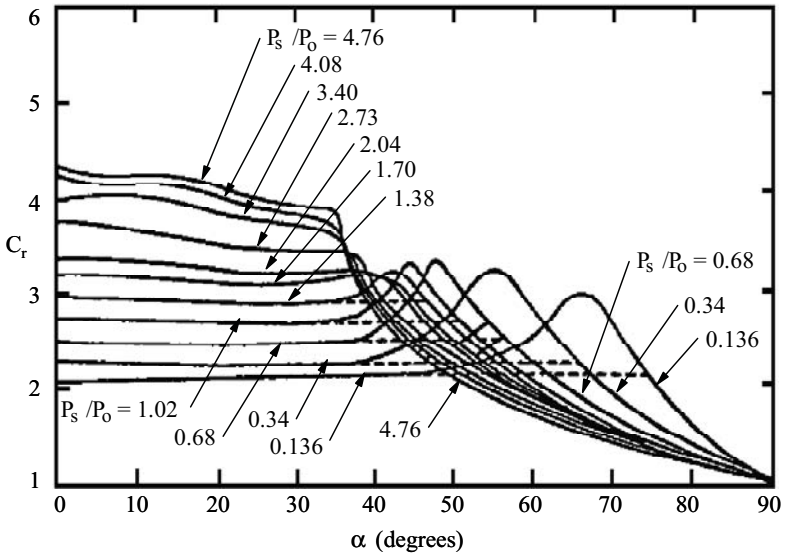

a) Shock Wave

 **LIVE GRAPH**
[Click here to view](#)

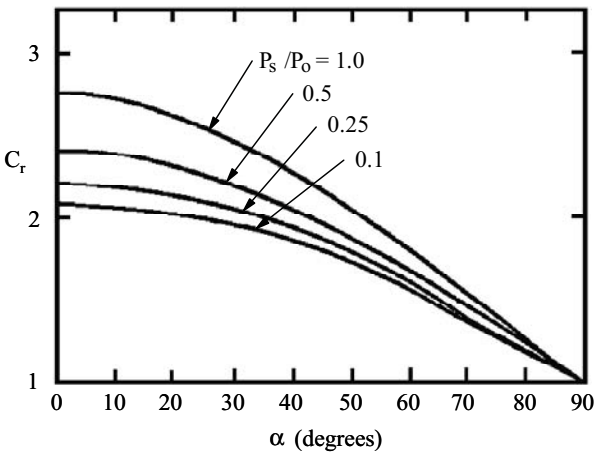

b) Pressure Wave

FIGURE 3.2: Blast Wave Reflection Coefficient vs. Angle of Incidence (from TNO Green Book)

$$q_o = 2.5 P_{so}^2 / (7 P_o + P_{so}) \approx 0.022 P_{so}^2 \quad (\text{psi}) \quad (3.4)$$

$$\approx 0.0032 P_{so}^2 \quad (\text{kPa})$$

where,

P_o = ambient atmospheric pressure.

The net dynamic pressure on a structure is the product of the dynamic pressure and a drag coefficient, C_d . The drag coefficient depends on the shape and orientation of the obstructing surface. For a rectangular building, the drag coefficient may be taken as +1.0 for the front wall, and -0.4 for the side and rear walls, and roof.

The dynamic pressure exerts the dominant blast effect on open frame structures, framed structures with frangible cladding, and on small structures or components such as poles, stacks, etc. The dynamic pressure also influences, but to a lesser extent, the net blast loads on the walls and roof of an enclosed building as discussed in Section 3.5.

3.3.4 Shock Front Velocity, U

In the free field, the blast wave from an explosion travels at or above the acoustic speed for the propagating medium. *UFC 3-340-02* provides plots of shock front velocity vs. scaled distance for high energy TNT explosives. There are no similar plots available for pressure wave propagation. However, for design purposes it can be conservatively assumed that a pressure wave travels at the same velocity as a shock wave. In the low pressure range, and for normal atmospheric conditions, the shock/pressure front velocity in air can be approximated using the following relationship from *Newmark*:

$$\begin{aligned}
 U &\approx 1130 (1 + 0.058 P_{so})^{0.5} && (\text{ft/s}) \\
 &\approx 345 (1 + 0.0083 P_{so})^{0.5} && (\text{m/s})
 \end{aligned}
 \tag{3.5}$$

3.3.5 Blast Wave Length, L_w

The propagating blast wave at any instant in time extends over a limited radial

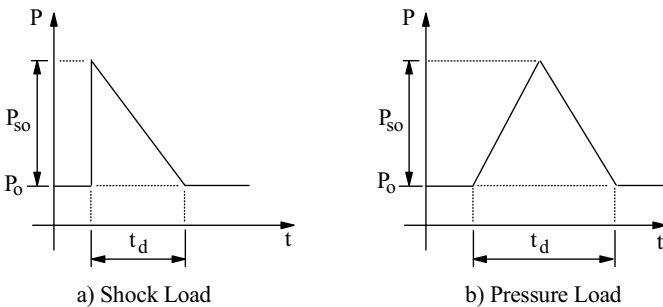

FIGURE 3.3: Idealized Shock and Pressure Loads

distance as the shock/pressure front travels outward from the explosion. The pressure is largest at the front and trails off to ambient over a distance, L_w , the blast wave length. Values of L_w for high energy explosives can be obtained from *UFC 3-340-02*. In the low pressure range, the length of the blast wave can be approximated by:

$$L_w \approx U t_d \quad (3.6)$$

3.3.6 Idealized Blast Wave Parameters

To simplify the blast resistant design procedure, the generalized blast wave profiles shown in Figure 3.1 are usually idealized, or linearized, as illustrated in Figure 3.3 for a shock wave and pressure wave. Furthermore, to use certain design charts and formulas in *UFC 3-340-02*, a pressure wave is simplified by using an equivalent shock loading which has the same peak overpressure and impulse. This simplification is shown in Figure 3.4. The blast loads on the various parts of a building based on these simplified blast wave parameters are discussed in Section 3.5.

3.4 DETERMINATION OF VAPOR CLOUD DESIGN OVERPRESSURES

Although there is a wide range of explosions types, vapor cloud explosions are a primary concern in the petrochemical industry. Because there are no codes or industry standards for determining what blast overpressures should be used, the design blast loads are usually supplied by the facility owner. Considering the wide variety of processes, it is easy to understand why these overpressures will be different from one owner to the next and even for different locations within a single facility. Some owners have several hazard levels which are used to classify different plant areas. These hazard levels are based on the material handled and the process used.

The actual design overpressures may be stated to the design engineer in two ways:

- a. The simplest is a set blanket statement such as; "All buildings shall be designed for a peak reflected overpressure of X psi (kPa), a peak side-on overpressure of Y psi (kPa), and duration of Z milliseconds."

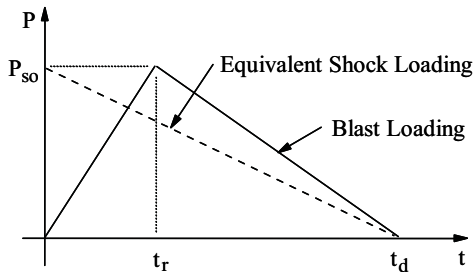

FIGURE 3.4: Idealized Equivalent Pressure Load

- b. A further refinement is to specify overpressures and durations based on the distance between the structure and a potential source. The distances may be given in stepped blocks or a continuous function. The building engineer would then determine design loads based on the appropriate distance.

The basis for the above design criteria may have been developed from a site specific study, from commonly used criteria, or from historical data.

A site specific study is the most comprehensive approach. Site specific studies to identify and quantify explosion hazards are usually conducted by the owner's process safety specialist or by specialty consultants. There are several steps which need to be taken, each of which may be done in a variety of ways. The steps are outlined below with some of the available methods. More detailed information is available in *CCPS Building Guidelines* and *API RP 752*.

1. Define the release: This step may be based on a worst possible case based on the maximum amount of material within a process loop, or a worst probable (credible) case selected from a hazards review.
2. Formation of an explosive cloud: This step is often done using two computer models. The first is a source emissions model which calculates what happens at the interface between the contained material and the atmosphere into which it is being released. The second is a dispersion model which calculates how the released material disperses and mixes with the air.
3. Amount of energy contributing to the explosion: This may be based on a fraction of the total amount of material available or by determining the mass of the cloud that is within the flammable limits. It may be further refined by looking at the level of confinement within the area of the cloud.
4. Calculation of blast overpressure parameters: There are three major methods in use today. One is the TNT Equivalency Method which gives inaccurate results for vapor cloud explosions. The other two methods are the Strehlow Curves from *Baker* and the Multi-Energy Method from *TNO 1985*. Both provide a family of curves based on flame speed or explosion strength. These curves are used to select dimensionless parameters which are then unscaled to determine the actual overpressures.

Overpressures may be determined at the point of the structure closest to the source and then applied to the entire structure. If the structure is large, the average overpressure on the surface or the overpressure at the centroid of the surface may be used. Normally a building should be designed considering the potential blast wave from any horizontal direction, but not all directions simultaneously.

Commonly used criteria includes *SG-22* (withdrawn), and *CIA* (being revised). Both documents specify at least two blast overpressures for buildings spaced 100 feet (30 meters) from a vapor cloud explosion hazard as follows:

- a. High pressure, short duration, triangular shock loading: Side-on overpressure of 10 psi (69 kPa) with a duration of 20 milliseconds.
- b. Low pressure, long duration, triangular loading: Side-on overpressure of 3 psi (21 kPa) with a duration of 100 milliseconds.

These blast loadings have been widely used in the past for blast resistant design throughout the industry. However, many owners have developed specific blast loading criteria more in line with their specific circumstances. With advances in the modeling of vapor cloud explosions (Baker, CCPS Explosion Guidelines), the trend is toward the use of VCE based blast loads.

Blast overpressures are specific to companies, processes and sites and it is therefore impractical to quantify a uniform minimum or maximum blast overpressure. A survey of the blast resistant design practices of some operating companies and contractors within the industry shows that blast resistant design is considered for buildings 50 to 1,200 feet (15 to 365 meters) from vapor cloud explosion hazards. However, most industry standards cover buildings in the 100 to 400 foot (30 to 120 meter) range. The blast loading specified varies considerably depending on plant type, spacing and model used to quantify the explosion. Overall, the specified blast loads used for design have side-on overpressures ranging from 1.5 to 15 psi (10 to 103 kPa) with positive phase duration ranging from 20 to 200 ms. These loads are for buildings spaced from 100 to 200 feet (30 to 60 meters) from an explosion source. Generally, the greater the spacing, the lesser the overpressure and impulse, but the longer the duration of the blast loading.

Historical data from industrial explosions are hard to accurately quantify as these can only be approximated by back calculating from observed deformations of structures. Blast overpressures from vapor cloud explosions are especially difficult to quantify because they tend to be directional, come from multiple sources, and vary with site conditions. Additionally, there is less information available than for high explosives. In one company's review of five recent vapor cloud explosion incidents, as measured at a range of 200 to 1,000 feet (60 to 300 meters), peak reflected pressures in the range from 2 psi (14 kPa) with a 35 ms duration to 12 psi (83 kPa) with a 33 ms duration have occurred. These pressures correspond to side-on overpressures ranging from 1 psi (7 kPa) to 5.5 psi (38 kPa). An extensive list of this type of explosion data is included in *Lenoir*.

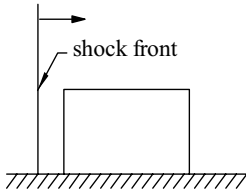

a) Shock front approaches structure

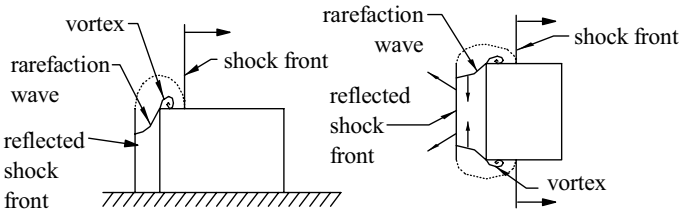
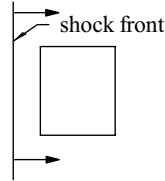

b) Shock reflected from front surface and diffracts over structure

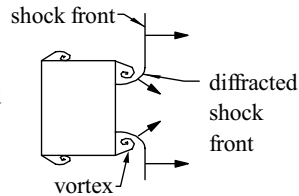
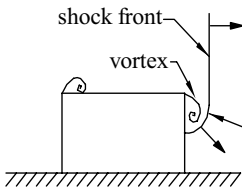

c) Diffraction continues across rear surface

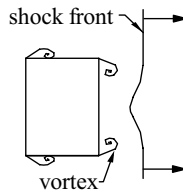
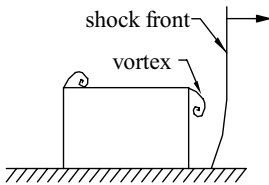

d) Diffraction is complete. Shock front passes beyond structure

FIGURE 3.5: Schematic of Blast Wave Interaction with a Rectangular Building (from TNO Green Book)

3.5 BUILDING BLAST LOADING

To design a blast resistant building, the design engineer first has to determine loads on the building as a whole and on each individual structural component such as wall, roof, frame, etc. from the free field blast overpressure usually provided by the facility owner. To establish these loads, the design engineer should understand the interaction of the propagating blast wave with the building.

When a blast wave strikes a building, the building is loaded by the overpressure and drag forces of the blast wave. The interaction between the blast wave and a structure is quite complex as shown schematically in Figure 3.5. For the purpose of design, the resulting blast loading can be simplified, as illustrated in Figure 3.6, based on the idealized shock wave discussed in Section 3.3.6. The blast wave in Figure 3.6 is shown traveling horizontally left to right. However, depending on the location of potential explosion hazards relative to the building site, the blast could strike the building from any direction and may, in the case of an elevated explosion source, slant downward towards the building.

Depending on its distance and orientation, relative to the blast source, the building and its components will experience various combinations of blast effects (reflected overpressure, side-on overpressure, dynamic pressure and negative pressure) discussed previously. Based on the owner specified side-on overpressure and duration, the design engineer can determine the blast loads for the various components of the building, as illustrated below, for a closed rectangular box-shaped building.

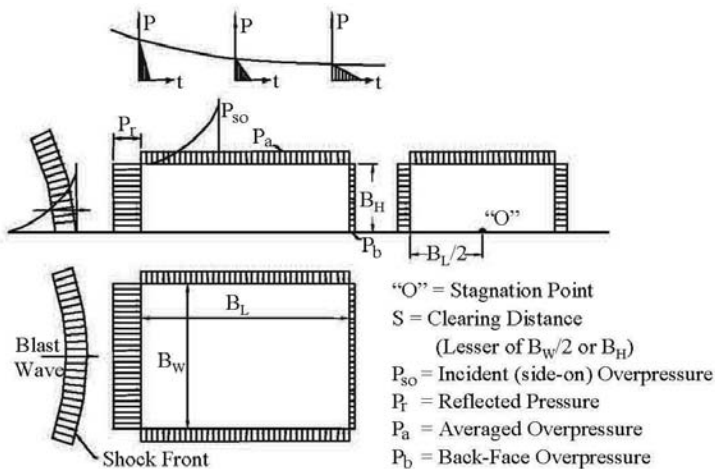

FIGURE 3.6: Blast Loading General Arrangement for a Rectangular Building (from Forbes 1998, with permission of American Concrete Institute)

3.5.1 Front Wall Loading

The walls facing the explosion source will experience a reflected overpressure. As discussed previously, the reflected overpressure amplification of the blast wave depends on the angle of incidence, α , and on the rise-time, t_r , of the side-on overpressure pulse. For design purposes, the normal shock reflection conditions ($\alpha = 0$, $t_r = 0$) should be assumed unless the specified design explosion scenario dictates otherwise. However, in some cases oblique reflection (about 30° to 60°) may be more critical to the overall building because the full reflected overpressure could load two adjacent sides of the building. The reflected overpressure decays to the stagnation pressure, P_s , in the clearing time, t_c , as defined below and illustrated in Figure 3.7.

$$P_s = P_{so} + C_d q_o \tag{3.7}$$

$$t_c = 3 S / U < t_d \tag{3.8}$$

where,

- S = clearing distance, the smaller of B_H , or $B_W/2$
- B_H = building height
- B_W = building width

As indicated in Equation 3.8 and Section 3.3.2, the duration of the reflected overpressure effect, t_c , should not exceed that of the free field positive overpressure, t_d .

In order to use the dynamic response charts based on a triangular shaped load, the bilinear pressure-time curve shown in Figure 3.7 can be simplified to an equivalent triangle. This equivalent load is computed by equating the impulse for each load shape and using the same peak pressure, P_r . The impulse, I_w , under the bilinear pressure-time curve is:

$$I_w = 0.5 (P_r - P_s) t_c + 0.5 P_s t_d \tag{3.9}$$

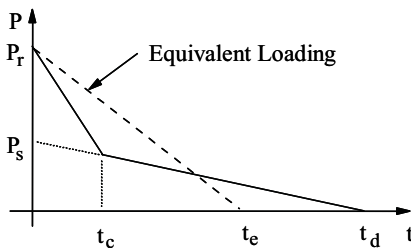

FIGURE 3.7: Front Wall Loading

The duration, t_e , of the equivalent triangle is determined from the following equation:

$$t_e = 2 I_w / P_r = (t_d - t_c) P_s / P_r + t_c \tag{3.10}$$

3.5.2 Side Walls

The side walls are defined relative to the explosion source as shown in Figure 3.6. These walls will experience less blast loading than the front wall, due to lack of overpressure reflection and to attenuation of the blast wave with distance from the explosion source. In certain cases, the actual side wall loading is combined with other blast induced forces (such as in-plane forces for exterior shear walls). The general form of side wall blast loading is shown in Figure 3.8.

As a blast wave travels along the length of a structural element, the peak side-on overpressure will not be applied uniformly. It varies with both time and distance. For example, if the length of the side wall equals the length of the blast wave, when the peak side-on overpressure reaches the far end of the wall, the overpressure at the near end has returned to ambient. A reduction factor, C_e , is used to account for this effect in design. Values for C_e , refer to Figure 3.9, are dependent on the length of the structural element, L_1 , in the direction of the traveling blast wave. If the blast wave is traveling perpendicular to the span, then L_1 should be equal to a nominal unit width of the element.

The equation for side walls is as follows:

$$P_a = C_e P_{so} + C_d q_0 \tag{3.11}$$

where,

P_a = effective side-on overpressure

The side wall load has a rise time equal to the time it takes for the blast wave to travel across the element being considered. The overall duration is equal to this rise time plus the duration of the free-field side-on overpressure.

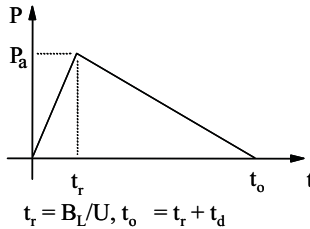

FIGURE 3.8: Roof and Side Wall Loading

3.5.3 Roof Loading

For a building with a flat roof (pitch less than 10°) it is normally assumed that reflection does not occur when the blast wave travels horizontally. Consequently, the roof will experience the side-on overpressure combined with the dynamic wind pressure, the same as the side walls. The dynamic wind force on the roof acts in the opposite direction to the overpressure (upward). Also, consideration should be given to variation of the blast wave with distance and time as it travels across a roof element. The resulting roof loading, as shown in Figure 3.8, depends on the ratio of blast wave length to the span of the roof element and on its orientation relative to the direction of the blast wave. The effective peak overpressure for the roof elements are calculated using Equation 3.11 similar to the side wall.

3.5.4 Rear Wall Loading

Rear wall loading is normally used only to determine the net overall frame loading. Because the rear wall load is opposite in direction to the front wall load, its inclusion tends to reduce the overall lateral blast force. For buildings where a blast load could occur from any direction, rear wall effects are many times conservatively neglected.

The shape of the rear wall loading is similar to that for side and roof loads, however the rise time and duration are influenced by a not well understood pattern of spillover from the roof and side walls and from ground reflection effects. The rear wall blast load lags that for the front wall by B_L/U , the time for the blast wave to travel the length, B_L , of the building. The effective peak overpressure is similar to that for side walls and is calculated using Equation 3.11 (P_b is normally used to designate the rear wall peak overpressure instead of P_a). Available references indicate two distinct values for the rise time and positive phase duration.

TNO Green Book and *ASCE Manual 42* use criteria that appear to be based on longer duration blast loads. The positive phase has rise time of $4S/U$ and a total duration of t_d (Figure 3.10a). Note that for blast loads of a moderate to short duration,

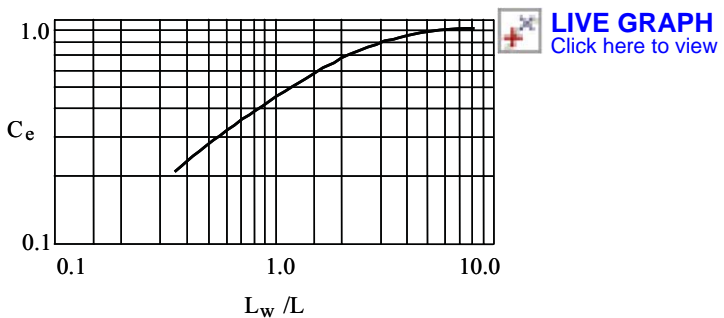

FIGURE 3.9: Effective Overpressure Values (from UFC 3-340-02)

the rise time may approach or exceed t_d . Information is not provided on dealing with this situation.

UFC 3-340-02 provides criteria computing the rear wall load as though it were an extension of the roof. Though graphs are provided to determine the rise time and duration, for most typical control buildings, the positive phase will have a rise time of approximately S/U followed by a duration of t_d (Figure 3.10b).

3.5.5 Frame Loading

In addition to the roof loading, the framing system for the building will experience the diffraction loading which is the net loading on the front and rear walls taking into account the time phasing. During the time, B_L/U , that it takes the blast wave to travel from the front to the back of the building the structural framing will be subjected to the large horizontal unbalanced pressure on the front wall. After that time the front wall loading is partially offset by the rear wall loading. Figure 3.11 shows the general form for the lateral frame loading.

3.5.6 Negative Pressure And Rebound Loading

The components of a building will also experience blast load effects, opposite in direction to the primary blast load effects, due to the negative phase (suction) of the blast wave as discussed in Sections 3.3.1 and 3.3.2, together with the rebound of the structural components from the inertial effects of the overpressure loading. As noted above, the negative pressure forces are generally ignored since they are relatively small or are unquantified for vapor cloud explosions. However, the structural components of the building should be adequately detailed to perform satisfactorily for the rebound effects. These effects can be quantified from the time history dynamic analysis of the structural components as discussed in Chapter 6, or approximated by use of design charts such as provided in *UFC 3-340-02* or *ASCE Manual 42*.

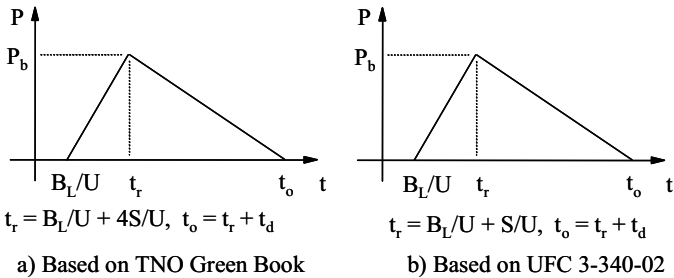

FIGURE 3.10: Rear Wall Loading

3.5.6 Negative Pressure And Rebound Loading

The components of a building will also experience blast load effects, opposite in direction to the primary blast load effects, due to the negative phase (suction) of the blast wave as discussed in Sections 3.3.1 and 3.3.2, together with the rebound of the structural components from the inertial effects of the overpressure loading. As noted above, the negative pressure forces are generally ignored since they are relatively small or are unquantified for vapor cloud explosions. However, the structural components of the building should be adequately detailed to perform satisfactorily for the rebound effects. These effects can be quantified from the time history dynamic analysis of the structural components as discussed in Chapter 6, or approximated by use of design charts such as provided in *UFC 3-340-02* or *ASCE Manual 42*.

3.5.7 Leakage Pressures

Blast loads applied to the building exterior can potentially expand into the building through openings in the walls or roof. These are typically referred to as leakage pressures. As a blast wave expands through an opening, the pressure level drops due to the restriction and sudden expansion into the building volume. Leakage pressures may cause direct bodily injury, injury due to falling objects such as light fixtures, and equipment malfunctions. Methods are available to compute the average pressure buildup inside a structure. The reader is referred to *UFC 3-340-02*, Section 2-15.5 for detailed procedures and *UFC 3-340-02*, Section 1-11 for information on pressures causing bodily injury.

3.6 COMPUTATIONAL FLUID DYNAMICS

Building blast loads can be determined through the use of computational fluid dynamics (CFD) computer programs. Effective CFD usage requires a blast design situation where cost-beneficial results can be realized, as well as experience, time, computer resources, and validation in order to obtain results accurate enough to justify the significant increase in computer modeling effort. The basic premise of

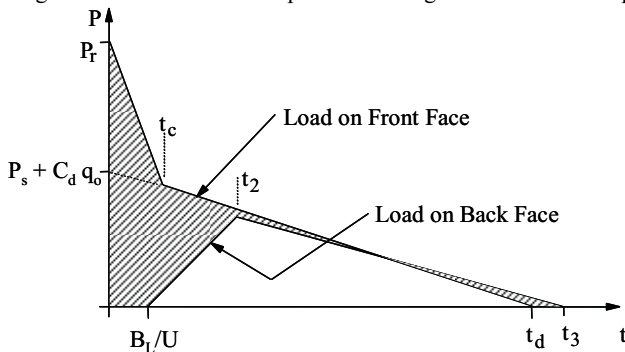

FIGURE 3.11: Net Lateral Load on a Rectangular Building (from TNO Green Book)

CFD modeling is to discretize the building and surrounding area encompassing the blast source and adjacent obstacles into small regular cells of finite volume and then solve the governing equations for conservation of mass, momentum, and energy within each cell, taking into account the effects of adjacent cells.

Among other uses, CFD could be used to simulate the propagation of blast waves in an environment of obstacles, to simulate unusually shaped buildings, to simulate leakage through openings into buildings, to simulate interior explosions, and to simulate near-field explosion effects. CFD is commonly used in offshore applications where compact, complex layouts are used. CFD is less commonly used in onshore facilities because confined compact layouts are not typical and standoff distances from blast source to the point of interest is large. Where applicable, CFD could be used as an alternative to the more commonly used empirical methods described in *UFC 3-340-02* and Section 3.5.

In making a decision to employ CFD, it should be understood that CFD results are sensitive to modeling techniques and the software used. CFD programs can employ a true first principles approach which includes turbulence modeling and detailed combustion, or a semi-empirical approach where simplifications of the explosion source are made, based on test data and guidance, to simplify and speed the analysis. Phenomenological models are sometimes used to simplify the analysis by using numerical modeling of selected explosion phenomena to capture important features of blast propagation. As with most simulations, the greater the detail of the model, the greater the potential accuracy of the result. For further information, refer to *Dhamarvaram, Gas Explosion Handbook, Hoorelbeke, Hanna, Geng, Wingerden, Herrmann 2005*, and *Herrmann 2006*.

**APPENDIX 3
BLAST LOAD EXAMPLE**

This example illustrates the calculation of blast loading on the components of a building subjected to a shock wave traveling horizontally. The building dimensions are as follows:

width, $B_W = 93 \text{ ft}$ (28.4 m)
 length, $B_L = 67 \text{ ft}$ (20.4 m)
 height, $B_H = 15 \text{ ft}$ (4.5 m)

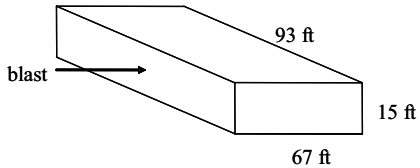

Blast Loading:

A blast wave has been given and will be applied normal to the long side of the building. It is further determined that the distance to the explosion and the length of the building are such that the overpressure and duration do not change significantly over the length of the building. The blast (shock) wave parameters are as follows:

peak side-on overpressure, $P_{so} = 6 \text{ psi}$ (41 kPa)

duration, $t_d = 0.05 \text{ s}$

shock front velocity,
 $U = 1130 (1 + 0.058 P_{so})^{0.5}$
 $= 1130 [1 + 0.058 (6 \text{ psi})]^{0.5}$
 $= 1,312 \text{ ft/s}$ (400 m/s)

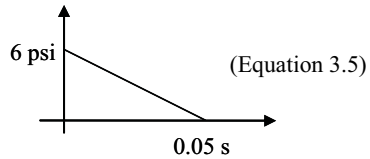

length of pressure wave, (Equation 3.6)
 $L_w = U (t_d) = (1,312 \text{ ft/s}) (0.05 \text{ s}) = 66 \text{ ft}$ (20.1 m)

peak dynamic wind pressure, (Equation 3.4)
 $q_o = 0.022 (P_{so})^2 = 0.022 (6 \text{ psi})^2 = 0.8 \text{ psi}$ (6 kPa)

Front Wall Loading:

The front wall is assumed to span vertically from foundation to roof. The design will be for a typical wall segment one foot wide.

reflected overpressure, (Equations 3.2 and 3.3)
 $P_r = [2 + 0.05 (P_{so})] P_{so} = [2 + 0.05 (6 \text{ psi})] (6 \text{ psi}) = 13.8 \text{ psi}$ (95 kPa)

clearing distance, (Section 3.5.1)
 $S = \text{minimum of } B_H \text{ or } B_W/2 = 15 \text{ ft}$ (4.5 m)

reflected overpressure clearing time, (Equation 3.8)
 $t_c = 3 (S / U) < t_d = 3 (15 \text{ ft}) / (1,312 \text{ ft/s}) < 0.05 \text{ s} = 0.034 \text{ s}$

drag coefficient, $C_d = 1.0$ (Section 3.3.3)

stagnation pressure, (Equation 3.7)

$$P_s = P_{so} + C_d (q_o) = (6 \text{ psi}) + (1.0)(0.8 \text{ psi}) = 6.8 \text{ psi} \quad (47 \text{ kPa})$$

front wall impulse, (Equation 3.9)

$$\begin{aligned} I_w &= 0.5 (P_r - P_s) t_c + 0.5 P_s t_d \\ &= 0.5 [(13.8 \text{ psi}) - (6.8 \text{ psi})] (0.034 \text{ s}) + 0.5 (6.8 \text{ psi}) (0.05 \text{ s}) \\ &= 0.289 \text{ psi-s} \quad (2 \text{ kPa-s}) \end{aligned}$$

effective duration, (Equation 3.10)

$$t_e = 2 I_w / P_r = 2 (0.289 \text{ psi-s}) / (13.8 \text{ psi}) = 0.042 \text{ s}$$

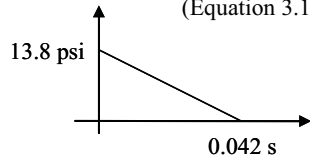

Side Wall Loading:

The side wall is the same as the front wall, spanning vertically from foundation to roof. Because the highest loads are on the front wall, a side wall analysis would only be necessary to check the interaction of in-plane and out-of-plane shear wall forces. This calculation will be for a wall segment, L_1 , 1 foot wide (0.3 m).

drag coefficient, $C_d = -0.4$ (Section 3.3.3)

equivalent load coefficient, (Figure 3.9)

$$L_w/L_1 = (66 \text{ ft}) / (1 \text{ ft}) = 66, \text{ therefore } C_e = \text{essentially } 1.0$$

equivalent peak overpressure, (Equation 3.11)

$$P_a = C_e P_{so} + C_d q_o = (1.0) (6 \text{ psi}) + (-0.4) (0.8 \text{ psi}) = 5.7 \text{ psi} \quad (39 \text{ kPa})$$

rise time, (Figure 3.8)

$$t_r = L_1 / U = (1 \text{ ft}) / (1,312 \text{ ft/s}) = \text{essentially } 0.0 \text{ s}$$

duration, $t_d = 0.05 \text{ s}$

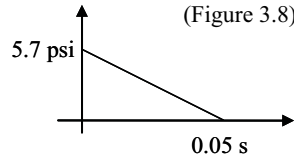

If an average overpressure over the entire side wall is needed, the value of L_1 would then be the length of the building. The value of C_e would then be less than one and thus reduce the value of P_a . The rise time would become significant.

Roof Loading:

The roof is a slab spanning between roof beams. For the design of the roof, a section 1 foot wide by 8 feet long will be used.

$$L_1 = 8.0 \text{ ft} \quad (2.4 \text{ m})$$

drag coefficient, $C_d = -0.4$ (Section 3.3.3)

equivalent load coefficient, (Figure 3.9)

$$L_w / L_1 = (66 \text{ ft}) / (8 \text{ ft}) = 8.25, \text{ therefore } C_e = 0.9$$

equivalent peak overpressure, (Equation 3.11)

$$P_a = C_e P_{so} + C_d q_0 = (0.9) (6 \text{ psi}) + (-0.4) (0.8 \text{ psi}) = 5.1 \text{ psi} \quad (35 \text{ kPa})$$

rise time, (Figure 3.8)

$$t_r = L_1 / U = (8 \text{ ft}) / (1,312 \text{ ft/s}) = 0.006 \text{ s}$$

time of duration, $t_d = 0.05 \text{ s}$

total positive phase duration,

$$t_o = t_r + t_d = (0.006 \text{ s}) + (0.05 \text{ s}) = 0.056 \text{ s}$$

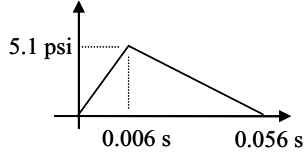

For a structural roof element oriented in the opposite direction, the length of the element in the direction of the traveling wave, L_1 would be only 1 foot (0.3 m). In this case, as for the side wall panel, there would be essentially no averaging necessary.

If an average overpressure over the entire roof is needed, the value of L_1 would then be the length of the building. The value of C_e would then be reduced along with the value of P_a . The rise time would be greater.

Rear Wall Load:

The rear wall is proportioned the same as the front and side walls, spanning vertically from foundation to roof. Because the highest loads are on the front wall, a rear wall analysis would only be necessary to determine a net loading on the overall building. The analysis will be for a wall segment 1 foot (0.3 m) wide.

drag coefficient, $C_d = -0.4$ (Section 3.3.3)

equivalent load coefficient, (Figure 3.9)

$$L_w / S = (66 \text{ ft}) / (15 \text{ ft}) = 4.4, \text{ therefore } C_e = 0.88$$

equivalent peak overpressure, (Equation 3.11)

$$P_b = C_e P_{so} + C_d q_0 = (0.88) (6 \text{ psi}) + (-0.4) (0.8 \text{ psi}) = 5.0 \text{ psi} \quad (34 \text{ kPa})$$

time of arrival, (Section 3.5.4)

$$t_a = B_L / U = (67 \text{ ft}) / (1,312 \text{ ft/s}) = 0.051 \text{ s}$$

rise time, (UFC 3-340-02)

$$t_r = S / U = (15 \text{ ft}) / (1,312 \text{ ft/s}) = 0.011 \text{ s}$$

duration, $t_d = 0.05 \text{ s}$

total positive phase duration,

$$t_o = t_r + t_d = (0.011 \text{ s}) + (0.05 \text{ s}) = 0.061 \text{ s}$$

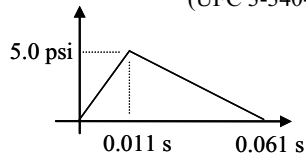

CHAPTER 4 TYPES OF CONSTRUCTION

4.1 INTRODUCTION

The design of blast resistant structures requires the use of good design and construction practices as well as knowledge of the characteristics of the blast loading and the behavior of structures and their components under these loadings. After determining the loading condition and the siting considerations, the engineer participates in selecting the type of construction that is required to withstand the potential loading condition. Although all types of construction provide some level of blast resistance there are some types of construction that are more appropriate than others.

Non-structural considerations such as safety, operation, architecture, cost and owner preference may dictate the shape, orientation, and layout of a plant building. In establishing these, however, the engineer should also consider the requirements for blast resistant construction.

4.2 GENERAL CONSIDERATIONS

The most important feature of blast resistant construction is the ability to absorb blast energy without causing catastrophic failure of the structure as a whole. Construction materials in blast protective structures must have ductility as well as strength. Furthermore, in a plant explosion, a building will be exposed to a lateral force resulting from the blast loading on one side. For a structure to exhibit any measure of blast resistance, its frame and foundation must be capable of absorbing this large lateral load. This requirement is similar to that for earthquake resistant design. In general, structures and types of construction which are earthquake resistant are also to some degree blast resistant. Structure component parts must possess adequate deformation capacity to form the yield mechanism.

Reinforced concrete is generally considered the most suitable and economical construction material for blast resistant buildings, especially for those close to a potential blast source where they are likely to be subjected to relatively high overpressure and thermal effects in the event of an explosion. However, pre-engineered metal buildings, if properly designed, can be used if sited at appropriate distances from hazards.

Brittle material is not suitable for blast resistant structures. Unreinforced concrete, brick, timber and unreinforced masonry are examples of this type of construction material. Besides being vulnerable to catastrophic sudden failure under blast overload, they provide a source of debris which can cause major equipment damage and serious personnel injuries when hurled by the blast. Timber and wood products used for plant buildings can become fire hazards. The principal criterion for evaluating such construction is its mode of failure if severe overloading occurs. This type of material should only be used in the exterior shell of a blast resistant structure

when adequate steel reinforcing is used to assure ductile behavior and ductile frames are provided to give the structure lateral resistance to blast loads. If, in an otherwise ductile structure, brittle behavior of some elements cannot be avoided, as is the case for axially loaded reinforced concrete columns or for shear walls, the margin of safety for these elements should be increased; that is, their capacity should be downgraded.

The plan (outline) and elevation profiles of a blast resistant building should be as “clean and simple” as possible. Reentrant corners and offsets, in particular, should be avoided. Such features create local high concentrations of blast loading. The orientation of the building should be such that the blast induced loads are reduced as much as possible. This requires that as small an area of the building as possible should face the most probable source of an explosion.

4.3 COMMON SYSTEMS FOR PETROCHEMICAL BUILDINGS

Conventional building construction may provide some level of blast resistance. However, certain features of ordinary building construction, such as large windows, unreinforced masonry walls, and weak structural connections, could make these buildings vulnerable to even low-level blast effects. Conventional construction includes pre-engineered steel framing with metal cladding and steel framing with masonry or precast concrete walls. Usually these buildings are designed only for dead, live, wind, and seismic loads. These types of structures could withstand (without collapse) blast loadings on the order of 1.0 psi (6.9 kPa) side-on overpressure. Outlined below are types of common construction appropriate for increasing levels of blast forces and decreasing spacing from potential hazards.

4.3.1 Pre-engineered Metal Building Construction

Enhanced pre-engineered metal buildings are comprised of steel frames with cold-formed steel panels supported on cold-formed steel girts and purlins as illustrated in Figure 4.1. The steel frame is designed to resist all vertical and lateral loads. Design improvements to enhance blast resistance can be achieved by:

- Specifying closer spacing of steel frames
- Using symmetric sections (back-to-back C-shapes) for girts and purlins and reducing their spacing.
- Increasing size of anchor bolts and strengthening wall panel connections at the foundation and at the roof.
- Increasing the number of cladding fasteners and using oversized washers to reduce tear-out of siding material.
- Fixed base of columns

With enhancements, these buildings have blast resistance ranging from 1 to 3 psi (6.9 to 21 kPa) side-on overpressure.

4.3.2 Masonry Wall Construction

Reinforced masonry clad buildings are very similar to conventional commercial buildings normally constructed to resist conventional loading. A structural steel or concrete frame is used to support vertical loads and in some cases to resist lateral forces. Reinforced masonry is used for the exterior walls and is designed to span either vertically or horizontally. The reinforced masonry walls that run parallel with a directional blast force can also be used as shear walls to transmit lateral forces to the foundation. The reinforced masonry wall is attached to the building frame to tie all components together and provide resistance to rebound forces. This type of building can be economically designed to withstand blast loadings on the order of 3 psi (21 kPa) side-on overpressure.

4.3.3 Metal Clad Construction

Metal clad buildings utilize conventional "stick-built" design and use hot-rolled structural shapes for frame, girts, and purlins. Metal siding or insulated sandwich panels, with thicker gauge metal and more connectors, are used for exterior walls. As for pre-engineered metal buildings, the steel frame resists all vertical and lateral loads. The connections are enhanced to develop the full plastic strength (ultimate moment and/or shear capacities) of the structural members. This type of building can be economically designed to withstand blast loadings on the order of 3 psi (21 kPa) side-on overpressure.

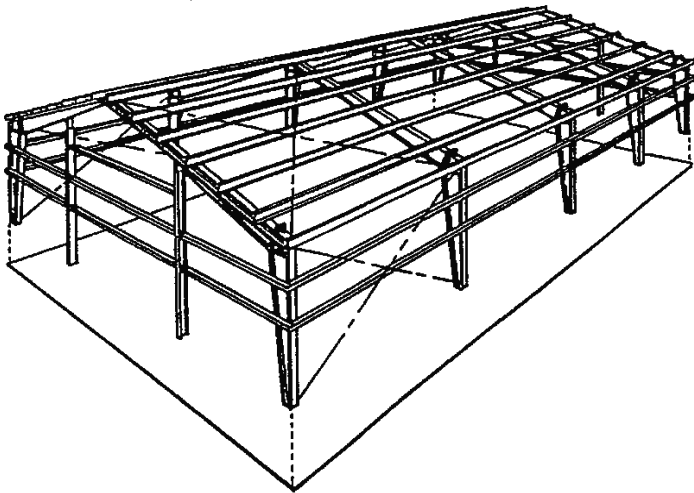

FIGURE 4.1: Enhanced Pre-Engineered Metal Building

4.3.4 Precast Concrete Wall Construction

This type of construction uses precast concrete walls with steel or concrete frames (Figure 4.2). The frame resists all vertical loads and precast shear walls resist lateral loads. Ductile connections for precast panels are an important consideration. Precast panels are made with embedded steel connection devices attached to the building frame by bolting or welding. The roof is usually a concrete slab on metal deck. The metal deck is attached to steel framing by studs or puddle welds. This type of construction can be economically designed to withstand blast loading on the order of 7 to 10 psi (48 to 69 kPa) side-on overpressure.

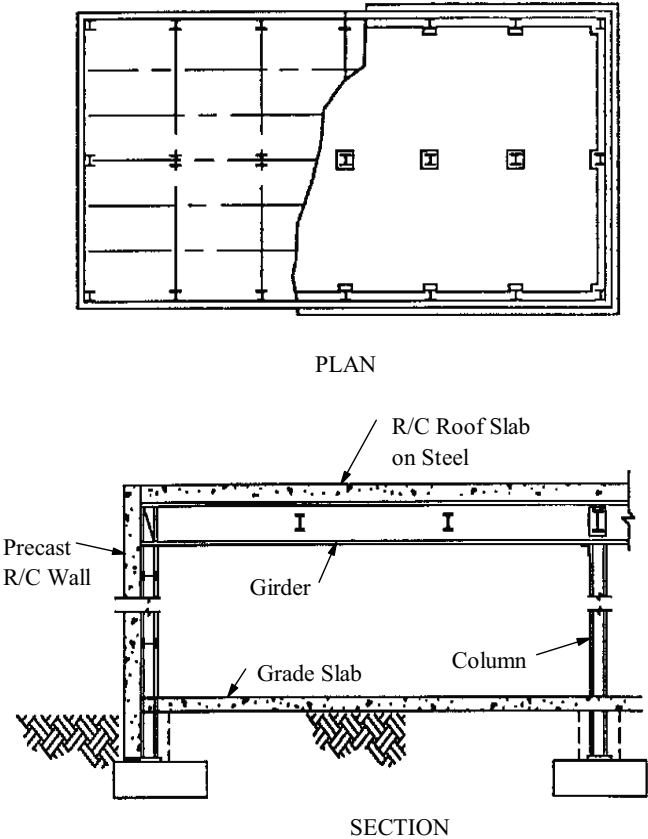

FIGURE 4.2: Precast Concrete Wall Building

4.3.5 Cast-in-Place Concrete Wall Construction

Cast-in-place concrete construction (Figures 4.3 and 4.4) is used to resist relatively high blast overpressures where precast concrete is not economical or practical. Horizontal loads are resisted by shear walls. The structure depends on a structural steel or concrete frame to support vertical loads. Thickness of the concrete walls and size and placement of the reinforcing steel can be chosen to provide resistance to any anticipated design blast loads. This type of construction would normally be required for side-on blast overpressures greater than 7 psi (48 kPa).

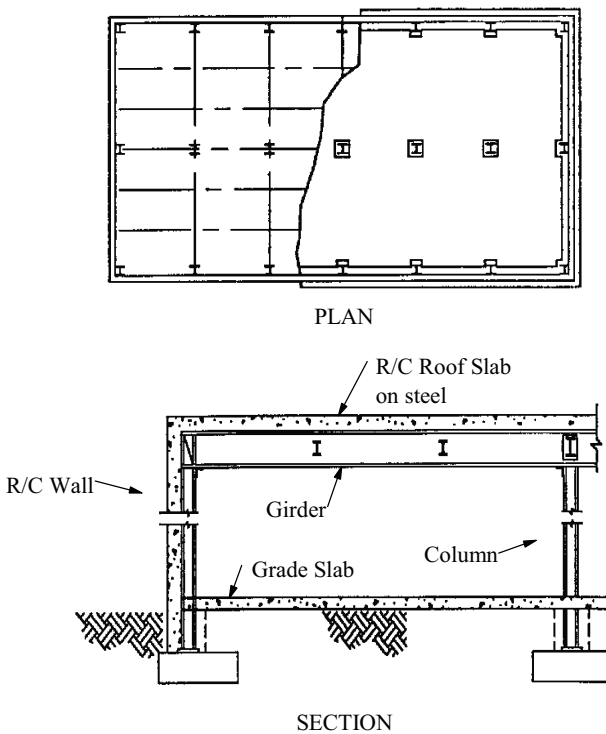
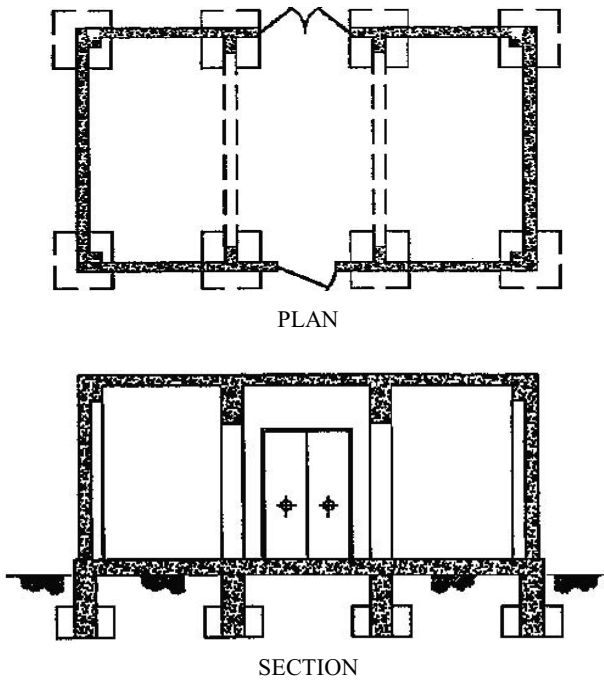

FIGURE 4.3: Cast-in-Place Concrete Wall Building (steel frame)



**FIGURE 4.4: Cast-in-Place Concrete Wall Building
(concrete frame)**

4.4 BLAST RESISTANT MODULAR STEEL-FRAMED BUILDINGS

Blast resistant modular (BRM) steel-framed buildings have been utilized in petrochemical facilities and are becoming more common – both for turnaround situations and as alternatives to conventional in-place construction. These modular buildings utilize steel structural frame members (usually HSS members that are ‘seismically’ compact per AISC 341) with crimped steel plate walls. The method of attaching the plate walls to the frame members typically does not utilize mechanical fasteners; rather, continuous welded construction is usually used. Roof joists and floor joists (usually seismically compact steel sections) typically support flat plate roofs and floors. BRM buildings have been designed to withstand blast loadings up to 20 psi (138 kPa). BRM buildings may be anchored or unanchored. If unanchored, they may slide which can result in additional risks (refer to Section 4.4.3). Typical ‘building blocks’ are 10 to 14 ft (3.0 to 4.3 m) wide by 20 to 50 ft (6.1 to 15.2 m) long. BRM buildings can range from single module structures to multi-module and multi-story, integrally-connected structures, with floor areas over 10,000 ft² (929 m²) (Figures 4.5- 4.7). Refer to *Gehring and Summers* for further details related to construction.



FIGURE 4.5: Single Blast-Resistant Module



FIGURE 4.6: One-Story, Five Module Complex

4.4.1 Design Approach

Steel-framed modular buildings may be designed using dynamic structural analyses ranging from the basic single degree of freedom analysis (SDOF) method to nonlinear transient dynamic finite element analysis. With fully-welded connections between the exterior steel cladding crimped wall panels and the structural frame members as well as the frame member-to-member connections, modular buildings

improve their blast capacity by providing a high level of continuity. This steel plate-member construction can be effectively modeled using either an SDOF or a finite element analysis (FEA) approach. The engineer should account for response/failure modes in the analysis, including tension membrane effects and plastic strain limitations, both of which can be more appropriately captured using the FEA approach. Refer also to Section 7.3.

Nonlinear finite element analysis methods may be used to evaluate the dynamic response to blast loads of a single building module or a multi-module assembly. This global approach can remove some of the conservatism associated with breaking the building up into its many components when using the SDOF approach. Geometric and material nonlinearity effects are normally utilized in such analyses. These analyses are typically carried out using a finite element program capable of modeling nonlinear material and geometric behavior in the time domain. Figure 4.8 shows a finite element model for a six-module complex. Doors and other openings can be explicitly modeled as shown.

4.4.2 Acceptance Criteria

Structural components (i.e., frame members, roof joists and exterior crimped wall cladding) are designed to meet the acceptance criteria associated with the desired level of protection. Acceptance criteria for structural members, as presented in Table 5.B.2, can be used to evaluate steel frame members used in modular building construction. Unlike light-gage material, the crimped panel walls employed in blast resistant modular buildings are usually a minimum 10 gage (approximately 1/8 in. [3.2 mm] thick), but are more often 3/16 to 5/16 in. (4.8 to 7.9 mm) thick structural steel plate material, often with a depth of 5 in. (127 mm) for onerous blast conditions. These wall panels exhibit greater levels of ductility and flexural capacity coupled with a much lower propensity to buckle (both locally and globally) than light gage

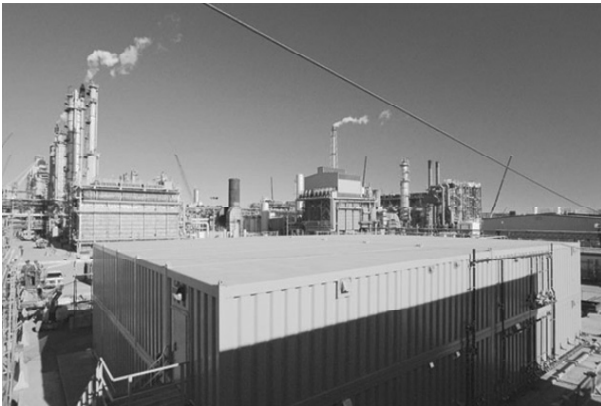

FIGURE 4.7: Two-Story Module Complex, 10,000 ft² (929 m²)

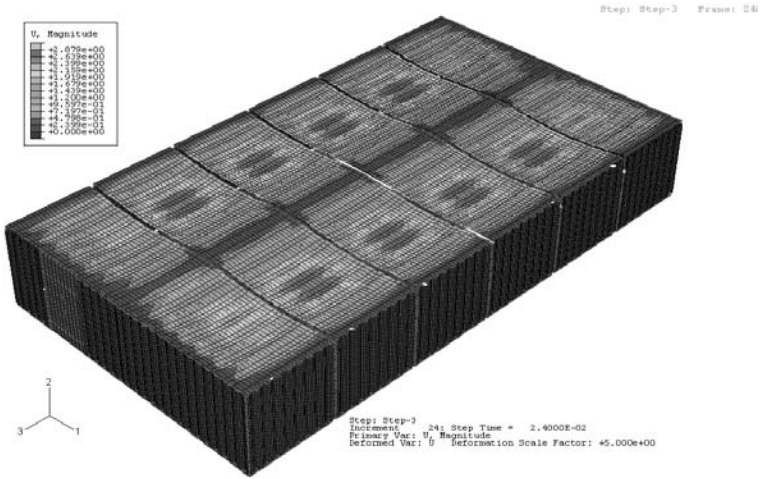

FIGURE 4.8: Deflected Shape under Roof Blast Loading on Six-Module Complex

corrugated metal panels used in conventional metal-clad building construction. This is because of a number of factors, including: a higher flexural strength of the panel cross section; a greater resistance against local buckling which allows greater ductility (before tensile membrane action occurs) than conventional light-gage metal panels; a symmetric, tight crimp pattern; and a relatively large thickness-to-corrugation depth ratio of typical panels. Therefore, higher values for response limits than those specified for cold-formed light gage panels in Table 5.B.2 can be justified for the crimped panel wall plates used in modular buildings. However, because the wall panels are crimped, rather than flat and are thicker, it is suggested that the response criteria be generally limited to values between those specified for cold formed light-gage panels and steel plates. If the engineer accounts for local buckling and other response modes in prediction of deformation, by analysis or test, the acceptance criteria for steel plates would be appropriate.

Further, it is also recommended that the allowable accumulative plastic strain during the complete analysis be evaluated for the crimped wall panels. Continuity of welded connections is critical to the performance of these types of structures and reduced ductility of the welds should be considered. Specifically, the effects of tension membrane fracture limits should be considered (refer to NORSOK). Refer to Section 5.6 for further details on response criteria.

Note that the objective of finite element analysis methods for this class of building is to predict global and member responses, but not necessarily to predict local stress/strain concentrations at small discontinuities around penetrations, and

therefore there is a high degree of sensitivity of predicted plastic strains to the mesh refinement used.

4.4.3 Anchored or Free to Slide?

Many blast resistant modular buildings are designed to be permanent installations with their anchorage and foundations designed to resist the total anticipated blast loads. This design approach can result in quite large foundations. Refer to Section 7.7 for a further discussion on foundation design strategy for blast resistant buildings.

However, in the case of modular blast resistant steel buildings, some owners have taken the approach that the foundations and anchorages need only be designed for normal design loads (loads other than blast). In this case, the building's anchorages are permitted to 'break' during a blast event (they act as anchorage 'fuses'), but are designed to remain intact under other design loads. Alternatively, the building can be designed to be completely unanchored (free to slide) for both blast and other loading effects, subject to the local building official's anchorage requirements for gravity, wind and earthquake loading. Whether a building should be anchored for blast, anchored for other loads (but not for blast) or completely unanchored (and free to slide), depends on the anticipated use of the building, whether or not potential down time is acceptable following a blast event, the amount of flexibility in the utility connections (power, water, wastewater, gas) and, most importantly, the owner's tolerance to risk. Owners should make this decision on many factors, including risk, safety, cost, magnitude and probability of blast.

If the building is unanchored (free to slide) for blast loading, or only anchored for conventional loads with a structural anchorage fuse, the maximum sliding displacement, velocity, and acceleration of the building can be estimated using impulse-momentum first principles, simplified numerical integration methods or finite element analysis. The contents and personnel within the building should be evaluated for these actions. In this case, the structural movement may result in impact/damage to attached utilities and building contents, as well as the possibility of injury to personnel, due to interaction with the structure, fixed equipment and internal moving objects (typically unrestrained and falling objects). In such interactions, the critical components of motion can be local accelerations, velocities and displacements that govern local forces and energies of impact, including the propensity to topple over and fall. Permanent fixtures and equipment should be designed to withstand the calculated local building motions as a result of blast loads. Anchorage and restraint techniques for nonstructural items have long been used for earthquake design (FEMA 412, FEMA 413, FEMA 414, SMACNA). Attached utilities should also be designed to accommodate expected movements or fail in a safe manner.

As stated above, the decision as to whether or not these displacements, velocities and accelerations are acceptable to an owner depends on the anticipated use of the building, whether or not potential down time is acceptable following an event, flexibility in the utility connections and, most importantly, the owner's tolerance to

risk. Since the building will act as an external pressure barrier, the design of internals need only consider the effects of movement. Definitive evaluation criteria for interactions with personnel are not available, but criteria do exist (Baker). Additional criteria for projectile impact (such as falling objects) are also available (TNO Green Book). Note that architectural and nonstructural components may become debris hazards. *UFC 3-340-02* provides some guidance on tolerance of mechanical and electrical equipment as well as personnel. For sensitive and critical equipment that must function during and after the event, verification by shock testing with the induced motions consistent with expected structural motions may be needed.

For modular buildings that are free to slide, the calculated permissible sliding displacement sometimes has been limited to 12 in. (300 mm), but as stated above, this is very much an owner decision and is specific to the building being designed. In all cases, buildings that are not anchored for blast must have a high margin against overturning and the propensity to uplift should be calculated. In the case of significant uplift, application of pressure to the underside of the building should be considered, as this further adds to the overturning moment and magnitude of uplift.

4.4.4 Elevated Modular Buildings

If the modular building is elevated and the ‘gap’ between the building and the foundation is judged to be significant, the blast load applied to the underside of the building should be considered. Calculation of pressures on the underside of modular buildings that are slightly raised above grade or in the small gap between stacked modules in multi-story applications can be determined through computational fluid dynamics (CFD) methods. Alternatively, blast resistant skirts can be provided. Such skirts may need to be removable or constructed with access portals in order to service the underside of the building, where there are often electrical penetrations. Accordingly, skirts may need to be bolted to the buildings.

4.4.5 Connection Design

If possible, joints and connections shall be designed to be capable of developing the full capacities of the connected members. Otherwise, the connection strength should be designed, at a minimum, with capacities in excess of the maximum transferable loads from the members framing into the connection. If a multi-module building is used, connections between adjacent modules are a critical aspect to consider. Racking of adjacent modules should be avoided.

The primary connections typically include the joints for the main framing members, the connections between beams/columns and base plates, and the connections between the base plates and the embedded plates at anchor points. The secondary connections typically include those between roof joists and roof perimeter beams, floor joists and floor perimeter beams, the roof plate and roof joists, plate and floor joists, and the crimped panel walls and the main framing beams and columns.

Connection designs at the foundation anchorage points are more critical if the building is designed to be anchored due to the difficulty of achieving significant energy absorption through plastic deformation for the blast loads transferred through these connections.

4.4.6 Projectile Resistance

Modular blast resistant buildings should be evaluated for projectile resistance if they are to provide a safety function for their occupants and if projectile impact is considered a credible scenario. Both *Baker*, and *UFC 3-340-02* provide methods of calculating likely impact speeds of projectiles as a function of blast overpressure. Explicit finite element analysis is one way to evaluate a BRM's capability to resist projectile impact at the calculated speeds. Fragment impact and perforation effects can also be evaluated using semi-empirical techniques, refer to *Baker*. Refer to Section 7.8 for additional guidance. Also note that if finite element analysis methods are used to predict the complex and highly nonlinear interaction between a projectile and its target, the results should be carefully reviewed and bounding calculations using empirical methods should be considered.

4.4.7 Transportation and Lifting Analysis

Interior modules of multi-module complexes tend to be flexible and, if this is the case, transportation and lifting analyses may be warranted to prevent possible damage to interior non-structural components during these phases of the life cycle. Temporary bracing may be required during transportation.

4.4.8 Temporary Buildings

Blast resistant modular buildings may be used as temporary structures and may be moved from site to site over their lifetime. If this is case, care should be taken to ensure that accumulated damage to the building's main structural components due to rugged service conditions and repeated transportation does not result in a compromised blast resisting system. Therefore, routine inspections should be performed to this end.

4.5 OTHER SYSTEMS

Under special circumstances the following types of construction may be considered.

4.5.1 Pre-Engineered Concrete Boxes

Pre-engineered concrete boxes can be used to provide smaller buildings. These buildings are manufactured in a factory, are pre-wired, come with HVAC installed and are truck delivered to the site ready to be secured to a foundation and connected to desired utilities. These buildings are economically designed to withstand 1 to 3 psi (6.9 to 21 kPa) side-on overpressures.

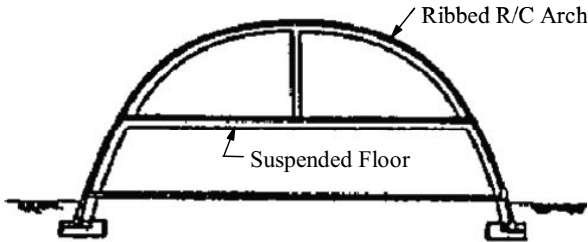

FIGURE 4.9: Arch Building

4.5.2 Arch and Dome Structures

Arches and domes (Figure 4.9) possess two advantages which can be exploited to obtain a high level of blast resistance. The first is a reduction in load, which comes from the curved surface being exposed to the blast wave. The second advantage is the high efficiency in strength which such structures possess from their geometry. Disadvantages of these types of structures arise from restricted interior space that is available for the same building footprint and the higher cost of construction.

4.5.3 Earth Embanked Structures

Earth embanked structures can be used if space is available (Figure 4.10). When possible, advantage can be taken of the high blast resistance of earth-covered structures either above or below ground since this form of construction is extremely resistant to high blast overpressures. Disadvantages include additional space required, non-conventional appearance, and effects of site conditions such as high water table.

4.5.4 Portable Buildings

Portable buildings are often used at petrochemical facilities on a temporary basis. These structures are typically designed and manufactured for wind and snow loads only but seldom contain any provisions to resist blast loads. Portable buildings are typically constructed with timber framing with aluminum or light gage steel wall and roof cladding. Wall studs are often notched to minimize section thickness further weakening the trailer's blast resistance. The structures referred to here are quite



FIGURE 4.10: Earth Embankment Building

different than steel framed modular buildings which are specifically designed for blast loads.

A recent accidental explosion resulted in multiple fatalities from the use of portable buildings located near the explosion center. As a result, significant changes in the use of portable buildings in petrochemical plants have been made. The American Petroleum Institute (API) has published *API RP 753* (Management of Hazards Associated with Location of Process Plant Portable Buildings) for siting of portable buildings. This document provides information regarding siting of this building type under blast conditions in explosion accidents. The reader is encouraged to consult this document for siting of portable buildings.

CHAPTER 5

DYNAMIC MATERIAL STRENGTH AND RESPONSE CRITERIA

5.1 INTRODUCTION

Design of structures to resist the effects of accidental explosions at petrochemical plants requires a knowledge of the dynamic properties of structural materials as well as the allowable responses of components and systems. Materials and structural systems respond differently to dynamic loads produced by explosions than to statically applied conventional loads and it is imperative that the engineer understand these differences. Under dynamic loading, materials achieve a strength increase which can significantly enhance structural resistance. Structures subjected to blast loads are typically allowed to undergo plastic (permanent) deformation to absorb the explosion energy, whereas response to conventional loads is normally required to remain in the elastic range.

Design of petrochemical facilities for accidental explosions is similar in many ways to design of facilities for high explosive detonations, nuclear weapons effects and nuclear power accidents for which design guides are available. However, blast design for petrochemical plants is different in that more structural damage may be tolerated, in accordance with a company's blast protection philosophy.

This chapter provides material properties and response criteria necessary to design facilities constructed of reinforced concrete, reinforced masonry, structural steel and cold formed steel. Static and dynamic properties are covered for the materials used in these facilities. Allowable response criteria are covered for both individual members and structural systems.

5.2 STATIC VERSUS DYNAMIC RESPONSE

Conventional loads, such as wind and live loads, are applied relatively slowly to a structure and remain constant for a relatively long period of time compared to the response time of the structure. Blast loaded structures experience a very rapid application of the load and a corresponding rapid rise in member stresses. This load is transient and will normally return to ambient conditions in a short period of time (typically milliseconds).

In conventional design, stresses are limited to the elastic range. In blast design, yielding is acceptable and in fact desirable for economic reasons. As the member is stressed in the plastic region, it continues to absorb the blast by balancing the kinetic energy of the explosion against the strain energy of the member. Total strain energy available is a function of dynamic material properties, section properties and the amount of plastic deformation permitted. The total amount of blast energy required to be absorbed is a function of the peak load and duration of the blast. Adequacy of a blast loaded member is based on maximum deformation rather than stress level.

Material response under dynamic loads is markedly different than for static loads. As a material is loaded rapidly, it cannot deform at the same rate at which the load is applied. This creates an increase in the stress level at which yield occurs as well as the ultimate stress achieved prior to rupture. In general, the faster the material is deformed (strain rate) the greater the increase in strength. The resulting strength increase allows members to develop structural resistance in excess of their static capacity. This increase can be on the order of 10-30%, thus it is too significant to ignore these effects when computing flexural response. Connection forces and loads on supporting members will be underestimated (unconservative) if this strength increase is ignored. This effect is accounted for in blast design by the use of a dynamic increase factor, or DIF (refer to Section 5.5.4).

5.3 RESISTANCE-DEFLECTION FUNCTION

Structural elements resist blast loads by developing an internal resistance based on material stress and section properties. To design or analyze the response of an element it is necessary to determine the relationship between resistance and deflection. In flexural response, stress rises in direct proportion to strain in the member. Because resistance is also a function of material stress, it also rises in proportion to strain. After the material in the outer fibers reaches the yield limit, the relationship between stress and strain, and thus resistance, becomes nonlinear. As the outer fibers of the member continue to yield, stress in the interior of the section also begins to yield and a plastic hinge is formed at the locations of maximum moment in the member. If premature buckling is prevented, deformation continues as the member absorbs load until rupture strains occur.

Variation in internal resistance can be related to the strain because stress in a member is a function of the strain experienced at a given point. Deformation of a key point on the member can also be related to the strain producing a relationship between resistance and deflection as shown by the curve in Figure 5.1. Elastic resistance is the level at which the material reaches yield at the location of maximum moment in the member. Beyond the point of first yield of a member, plastic regions are formed in the section and an elastic-plastic condition occurs. Internal resistance continues to increase as the stress in other locations of the member rises in response to the applied load although at a lower slope than the elastic region. During this period, portions of the member are responding plastically while other sections are responding elastically based on cross section and location along the member. As the response continues, other critical sections reach yield and additional plastic hinges are formed. Each yield point changes the slope of the resistance-deflection curve. When the last section yields, no additional resistance is available and the resistance-deflection curve is flat. The area under this curve represents the total strain energy available to resist load at a given deflection.

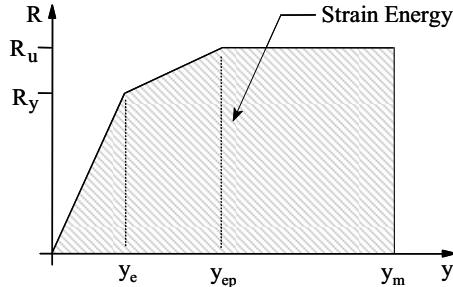

FIGURE 5.1: Typical Resistance-Deflection Curve

5.4 MATERIAL AND STRUCTURAL ELEMENT TYPES

A brief description of the materials and structural elements used in blast design applications is covered in this section. Response of each material to blast loads is described along with typical applications.

5.4.1 Reinforced Concrete

The high resistance and mass provided by reinforced concrete structures makes it particularly suited for buildings located in close proximity to explosion sources. Concrete also provides effective resistance to fire and projectile penetration which are important considerations in many explosion accidents.

Reinforced concrete is a complex material to model due to the brittle nature of concrete and non-homogenous properties. Although sophisticated methods are available to model crack propagation and other responses, simplified methods are normally used in blast design of facilities. These methods are based on a flexural response and rely on elimination of brittle modes of failure. To achieve a ductile response for concrete, proper proportioning and detailing of the reinforcing is necessary.

As the member is strained, the reinforcing bars yield and allow formation of plastic hinges. Concrete in these regions is cracked on the tensile face and subsequently reaches crushing strain on the compressive face. If rotation of the hinge increases beyond this point in a singly reinforced section, the concrete will be dislodged and will be incapable of providing a compressive component for the internal resisting couple. Additional rotation can be achieved in doubly reinforced sections if flexural reinforcing is sufficiently restrained by shear reinforcing. In these plastic hinge regions, the internal resistance of the section is provided by a couple formed between the reinforcing bars. Sections that are singly reinforced must be limited to a low response to avoid brittle failure and their use is discouraged in blast design. Rebound of a structural member under dynamic loads produces a reversal of the forces in the section and also dramatically reduces the resistance of a singly

reinforced member. Additional discussion of reinforced concrete response is provided in Chapter 7.

Prevention of brittle failure modes is accomplished by limiting concrete shear stresses or by increasing material strength, section thickness or shear reinforcing. The amount of flexural reinforcing in a member is also limited to assure that the tension reinforcing yields before concrete crushing can occur. Shear steel may be used to increase shear resistance, confine the flexural reinforcing and prevent buckling of the bars in compression.

UFC 3-340-02 indicates that Grade 60 reinforcing bars (No. 11 and smaller) have sufficient ductility for dynamic loading. Bars with a higher yield strength may not have the necessary ductility for flexural resistance and shop bending, thus straight bars should be used when possible for these materials. Welding of reinforcement is generally discouraged for blast design applications; however, it may be required for anchorage. In these cases, *ASTM A706* bars may be used.

A minimum concrete compressive strength of 3,000 psi (20.7 MPa) should be used to reduce the probability of shear failures. A value of 4,000 psi (27.6 MPa) is preferred.

5.4.2 Reinforced Masonry

Due to its relatively high mass, reinforced masonry buildings can be cost competitive with lightweight metal buildings for low range blast loads. Reinforced masonry responds to dynamic loads similar to reinforced concrete, with similar increases in dynamic strength as the strain rate increases. Limited options for placement of reinforcing and low shear strength of mortar joints are significant disadvantages as compared to reinforced concrete. Although unreinforced masonry structures are common in older facilities, they typically do not have sufficient ductility to resist any significant blast load and may be totally inadequate.

Hollow masonry units should conform to *ASTM C90*, Grade N. Joint reinforcing should meet the requirements of *ASTM A82* with a minimum yield stress of 70 ksi (483 MPa) and a minimum ultimate strength of 80 ksi (552 MPa). Grade 60 bars should be used for primary reinforcing.

5.4.3 Structural Steel

Low and medium carbon structural steels, such as *A36*, *A572*, *A500*, and *A992*, are sufficiently ductile for blast design applications. Use of high strength materials (greater than nominal 50 ksi, 350 MPa, yield) should be avoided in most applications to prevent problems with decreased ductility. *A572* and *A992* material is very common for conventional and blast loaded structures. A dual specification is currently being produced by several suppliers. Additionally, a maximum strength steel is being evaluated by the industry to guard against elements which possess greater resistance than calculated. This can produce a situation in which support

reactions may be greater than predicted. In certain situations, such as blast door latch bolts, high strength steel may be required to provide the required resistance. Brittle modes of failure, such as shear, should be examined carefully in these applications.

To achieve large deformations without failure, steel members must be sufficiently laterally braced and connected to avoid buckling and instability problems. As unstiffened elements buckle, the cross sectional properties are reduced and the resistance is lowered.

5.4.4 Cold Formed Steel

For low blast pressure applications, cold formed steel members can provide a cost effective cladding for buildings. Cold formed members include decking panels as well as "Z" and "C" shapes. Members complying with the requirements of *ASTM A653* have yield strengths ranging from 33 ksi (228 MPa) to 65 ksi (450 MPa).

A key consideration in the design of cold formed members for blast is premature buckling of the relatively thin webs. This response limits the ultimate resistance which can be obtained by reducing the load capacity due to a change in the cross section. A factor of 0.9 is recommended to be applied to the design resistance to model this reduction.

Special precautions must be taken regarding end bearing for these members to avoid crushing of the web at peak response. If end bearing controls, the allowable response is limited to reduce the chance for non-ductile failure. Connections for these members also present difficulty because of the thin web material. To develop the ultimate strength of a member, multiple fasteners may be required so that the shear strength of the material is not exceeded.

At large deflections, metal panels respond in membrane action. In this mode, resistance to blast loads is provided by stretching of the panel rather than flexure (Figure 5.2). Panels can be quite strong since this is a very efficient structural action; however, end anchorage is extremely important to achieving significant capacity. Resistance to blast loads of more than 2-4 psi (14-28 kPa) will normally require tensile membrane response.

Where fragment hazards are a concern, cold formed panels may not be suitable because they have a very low resistance to fragment penetration.

5.4.5 Open Web Steel Joists

Conventional reinforced masonry structures as well as steel frame buildings often utilize open web steel joists to provide support for roof decks. Principal concerns for these members are crushing of the web at the ends due to high shear forces and instability in the bottom chord during rebound of the section. Older steel joists have performed surprisingly well in many explosion accidents provided they are adequately attached at the supports. This typically requires additional welding of the

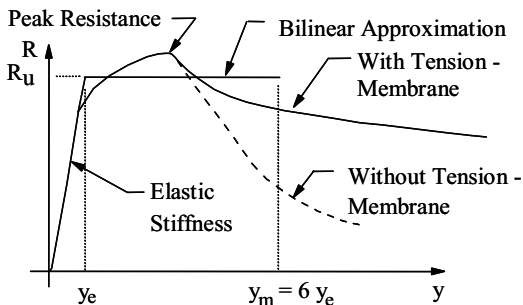

FIGURE 5.2: Typical Membrane Response (from UFC 3-340-02)

chord members to the embedded plate. Bracing for the bottom chord throughout the length of the member is not normally provided for conventional designs but is crucial to achieving acceptable response.

Quality of joist welds is also critical to achieving a ductile response. Welding is performed to Steel Joist Institute standards and the lack of specific criteria may prevent development of a predictable ultimate capacity. Special precautions must be taken to remedy this problem such as requiring manufacture in accordance with AWS criteria. Open web steel joists are intended for relatively low static loads and thus are suitable only for low dynamic loads as well.

5.4.6 Anchor Bolts

Blast loaded structures produce high reaction loads at column supports. This usually requires substantial base plates as well as high capacity anchor bolts. Achieving full anchorage of these bolts is of primary importance and will usually require headed bolts or plates at the embedded end of the bolts to prevent pullout. When anchor bolts are securely anchored into concrete, the failure mechanism is a ductile, tensile failure of the bolt steel. Insufficient edge distance or insufficient spacing between bolts results in a lower anchorage capacity and a brittle failure mode.

Post-installed bolts will be required at times for attachment of equipment which may be subjected to large accelerations during a blast. Expansion anchors should be avoided for most blast design applications unless the load levels are low. Typically "wedge" type anchors are qualified for dynamic loads although most of these ratings are for vibratory loads and are based on cyclic tests at low stress levels. These should only be used where ultimate loads are less than the rated capacity with a margin of safety. Epoxy anchors have shown excellent dynamic capacity and may be considered for critical applications.

Often anchor bolts are designed for the maximum axial and shear reactions at the base of the columns as a static load. This method requires a large number of bolts

even using dynamic material properties. In reality, the bolts will yield under tensile loads and to some degree, shear loads. That is why it is important to use ductile materials for bolts (ASTM F1554 is commonly used) to guard against sudden failure under peak stress. It is possible to model the tensile response dynamically and take advantage of the strain energy capacity of the bolts. This allows the bolts to respond to the load-time history rather than just a peak load. A dynamic analysis is warranted only for special situations, such as where the reuse of existing bolts is important. For typical designs, a dynamic analysis is not performed because there may not be a cost benefit over a static bolt design. Because shear deformations are more difficult to model and generally don't control bolt sizing, bolts are designed for the maximum predicted shear load rather than a time history response.

5.4.7 Soil

Blast accident experience has shown that foundation failures are rare. This appears to be the result of simplified conservative designs, underestimated soil strengths, and the large energy absorbing capacity of the soil. Soil properties should be obtained from a subsurface investigation. Properties from a subsurface investigation include recommended allowable bearing pressures, cohesion values, angle of internal friction as well as active and passive earth pressures for static loads. The values reported normally incorporate a factor of safety so that they can be used with service loads. This factor of safety can be used to convert service load capacities to ultimate strength values. A geotechnical engineer should be retained to provide soil properties for blast loads.

Soil lacks significant tensile capacity and friction strength drops off dramatically under dynamic loading. Provisions must be made in the design to resist uplift loads in column foundations and other areas where soil is placed in tension. The nonlinear nature of soil makes modeling of dynamic response difficult. Typically, foundations are designed to resist the peak blast load or the maximum dynamic reactions of the supported member applied as a static load. It is possible to model dynamic response but the engineer must be careful not to overestimate allowable response. "Weak" soil properties (low strength) should be used to conservatively determine maximum dynamic response of the soil and supported structure. "Strong" properties should be used for the same soil to obtain maximum bearing pressures and member forces. *TR 4921* provides a detailed discussion of soil behavior and recommendations for analysis and design.

5.5 DYNAMIC MATERIAL PROPERTIES

This section describes the dynamic properties of materials used in structures designed to resist blast loads at petrochemical facilities. Static properties are available from a number of references and are not repeated in this chapter, except to indicate minimum acceptable values. Dynamic response of these materials has been studied extensively; however, their dynamic properties are not as widely published. Procedures for obtaining these properties will be covered here in sufficient detail to permit an accurate determination for design and analysis of petrochemical structures.

5.5.1 Stress-Strain Relationships

Response of a material under static or dynamic load is governed by the stress-strain relationship. A typical stress-strain diagram for concrete is shown in Figure 5.3. As the fibers of a material are deformed, stress in the material is changed in accordance with its stress-strain diagram. In the elastic region, stress increases linearly with increasing strain for most steels. This relation is quantified by the modulus of elasticity of the material.

Concrete does not have well defined elastic and plastic regions due to its brittle nature. A maximum compressive stress value is reached at relatively low strains and is maintained for small deformations until crushing occurs. The stress-strain relationship for concrete is a nonlinear curve. Thus, the elastic modulus varies continuously with strain. The secant modulus at service load is normally used to define a single value for the modulus of elasticity. This procedure is given in most concrete texts. Masonry has a stress-strain diagram similar to concrete but is typically of lower compressive strength and modulus of elasticity.

For steel materials, the shape of the curve is much different than for concrete as can be seen in Figure 5.4. Steel is relatively ductile and is able to achieve large strains prior to rupture. Low carbon structural grade steels (e.g. A36, A572) exhibit a well defined yield point followed by a flat yield plateau. High strength steels do not have a sharp break at the elastic limit and the yield region is very nonlinear. Low carbon steel materials are particularly suited to blast resistant design because they are able to deform well beyond the elastic limit without rupturing. This produces a long

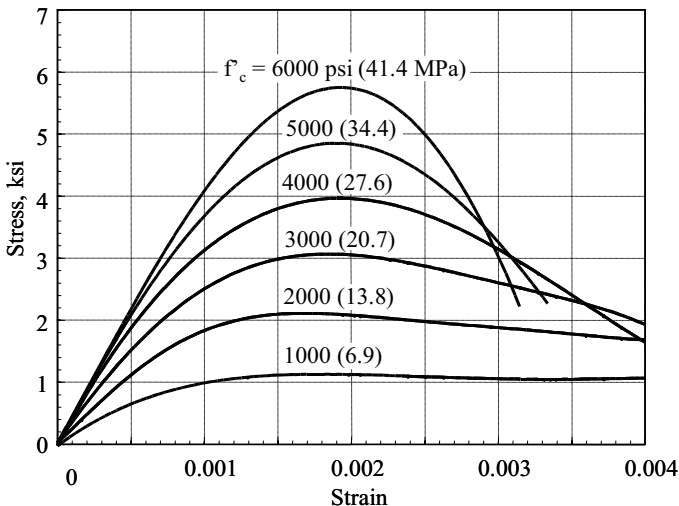

FIGURE 5.3: Typical Stress-Strain Curve for Concrete
(from ASCE Manual 42)

resistance-deflection curve to absorb the blast energy while avoiding brittle fracture problems. High strength steels should be avoided for general construction due to their low ductility. Special applications, such as blast doors and shields, may require high strength materials to achieve the desired resistance. Selection of static properties for high strength materials should be made conservatively.

Stress-strain relationships for soil are difficult to model due to their complexity. In normal practice, response of soil consists of analyzing compression and shear stresses produced by the structure, applied as static loads. Change in soil strength with deformation is usually disregarded. Clay soils will exhibit some elastic response and are capable of absorbing blast energy; however, there may be insufficient test data to define this response quantitatively. Soil has a very low tensile capacity; thus the stress-strain relationship is radically different in the tension region than in compression.

5.5.2 Strength Increase Factor (SIF)

Static properties are readily available from a variety of sources and are well defined by national codes and standards organizations. Specifications referenced in the codes define minimum mechanical properties for various grades of material. In practice, the average yield strength of steel materials being installed is approximately 25% greater than the specified minimum values. A *strength increase factor* is used to account for this condition and is unrelated to strain rate properties of the material. *UFC 3-340-02* suggests using a 1.1 strength increase factor applied to the minimum yield stress for structural steel with a yield of 50 ksi (345 MPa) or less and for Grade 60 reinforcing. Several references addressing nuclear facilities suggest ignoring these



LIVE GRAPH
Click here to view

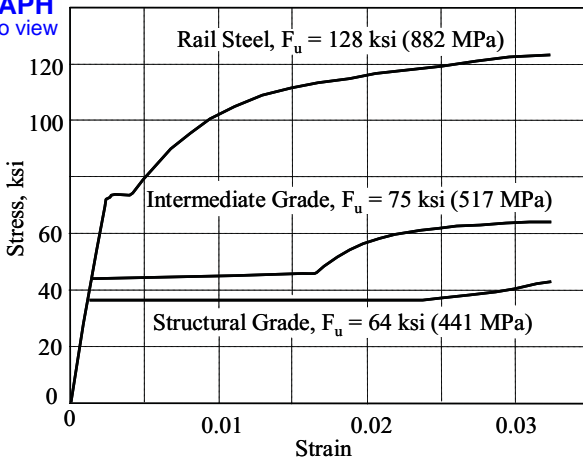

FIGURE 5.4: Typical Stress-Strain Curve for Steel (from ASCE Manual 42)

strength increase factors to add a larger margin of safety to the design. Application of the recommended 1.1 factor is warranted for petrochemical facilities where it is desired to reduce conservatism and make use of the full available blast capacity.

Cold-formed steel also exhibits an average yield strength well in excess of the specified minimum. *UFC 3-340-02* recommends a strength increase factor of 1.21 for this material.

Concrete strength is specified as minimum compressive strength at 28 days. This value is used for design and is not typically increased to account for an increase in strength with age. For evaluation of an existing structure, it may be worthwhile to determine the in-situ strength of the concrete to use in the analysis. This will not make a great difference in flexural capacity but it could be very important when examining shear resistance.

Strength increase factors are summarized in Table 5.A.1.

5.5.3 Dynamic Strength Increase

Concrete and steel experience an increase in strength under rapidly applied loads. These materials cannot respond at the same rate as which the load is applied. Thus the yield strength increases and less plastic deformation will occur. At a fast strain rate, a greater load is required to produce the same deformation than at a lower rate. This increase in the yield stress is quite significant for lower strength materials and decreases as the static yield strength increases.

For steel, the modulus of elasticity is the same in the elastic region and yield

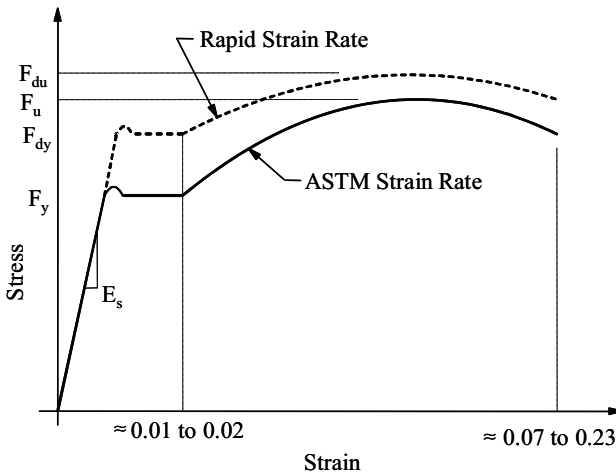

FIGURE 5.5: Effect of Strain Rate on Stress-Strain Curve for Steel (from UFC 3-340-02)

plateau for static and dynamic response. In the strain hardening region the slope of the stress-strain curve is different for static and dynamic response, although this difference is not important for most structural design applications.

A strength increase is also produced at ultimate strength, F_u , for steels; however, the ratio of dynamic to static strength is less than at yield. A typical stress-strain curve describing dynamic and static response of steel is shown in Figure 5.5. Elongation at failure is relatively unaffected by the dynamic response of the material.

Aluminum exhibits a modest increase with strain rate which is typically ignored. *Lindholm* surveyed available test data on dynamic properties for a number of materials. This is an extremely useful resource for information on less commonly used materials.

Ultimate strength for concrete is greater under dynamic loads. Though the modulus of elasticity is also greater, this difference is small and is usually ignored. Figure 5.6 describes the relationship between dynamic and static response for concrete.

The magnitude of dynamic increase is dependent upon several factors including static material strength and strain rate. In general, the higher the static strength of a material, the lower the increase in dynamic yield strength. The faster a material is strained, the higher the increase in dynamic yield and ultimate strength. Figure 5.7 describes the relationship between strain rate and the ratio of dynamic to static material strength for structural steel, concrete and reinforcing steel.

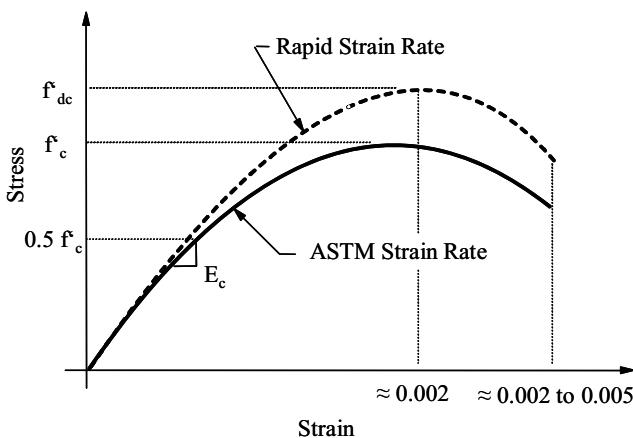

FIGURE 5.6: Effect of Strain Rate on Stress-Strain Curve for Concrete (from UFC 3-340-02)

Standard geotechnical test reports address typical static properties of soil such as shear strength and bearing capacity but may not provide dynamic properties unless they are specifically requested. In these situations, it is necessary to use the static properties. Dynamic soil properties which are reported may be based on low strain amplitude tests which may or may not be applicable to the situation of interest. Soils reports will generally provide vertical and lateral stiffness values for the foundation type recommended. These can be used along with ultimate bearing capacities to perform a dynamic response calculation of the foundation for the applied blast load.

5.5.4 Dynamic Increase Factor (DIF)

To incorporate the effect of material strength increase with strain rate, a dynamic increase factor is applied to static strength values. DIFs are simply ratios of dynamic material strength to static strength and are a function of material type as well as strain rate as described above. DIFs are also dependent on the type of stress (i.e. flexural, direct shear) because peak values for these stresses occur at different times. Flexural stresses occur very quickly while peak shears may occur relatively late in time resulting in a lower strain rate for shear.

It is possible to determine the actual strain rate of a material during calculation of dynamic response using an iterative procedure. A rate must be assumed and a DIF selected. The dynamic strength is determined by multiplying the static strength (increased by the strength increase factor) by the DIF. The time required to reach maximum response can be used to determine a revised strain rate and a revised DIF. This process is repeated until the computed strain rate matches the assumed value.

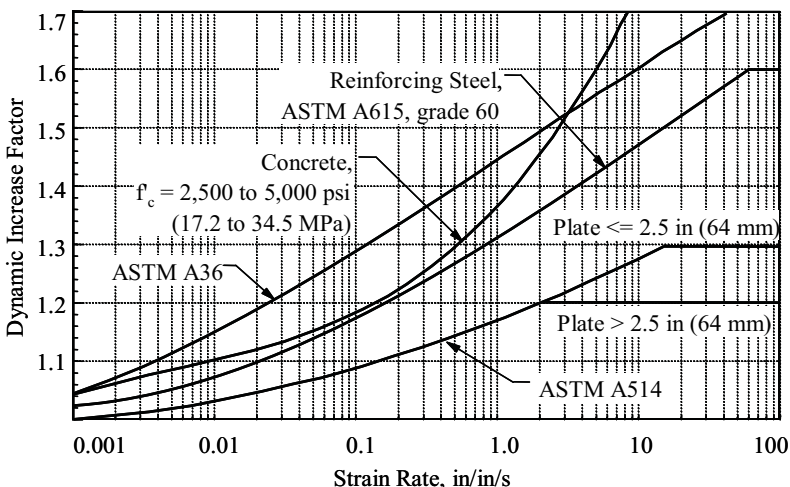

FIGURE 5.7: Effect of Strain Rate on Dynamic Material Strength



LIVE GRAPH
Click here to view

(from UFC 3-340-02)

There are uncertainties in many of the variables used to calculate this response and determination of strain rates with great accuracy is not warranted.

UFC 3-340-02 and other references suggest selecting DIF values based on pressure range or scaled distance to the explosion source. This method groups blast loads of less than a few hundred psi (100 psi = 690 kPa) into the low pressure category with a single DIF value for each stress type. For petrochemical facilities, the vast majority of structures will fall in this low pressure category.

DIF values vary for different stress types in both concrete and steel for several reasons. Flexural response is ductile and DIF values are permitted which reflect actual strain rates. Shear stresses in concrete produce brittle failures and thus require a degree of conservatism to be applied to the selection of a DIF. Additionally, test data for dynamic shear response of concrete materials is not as well established as for compressive strength. Strain rates for tension and compression in steel and concrete members are lower than for flexure and thus DIF values are necessarily lower.

Values for dynamic increase factors are presented in a variety of references although most are based on the same data source. Additional data has been produced in various test programs but has not been assembled into a central source. Much of the data that has been published is based on high strain rate tests and many of the recommended values are arbitrarily chosen. Table 5.A.2 provides recommended DIFs for reinforced concrete and masonry and Table 5.A.3 contains values for structural steel, cold-formed steel and aluminum.

Dynamic increase factors for steel member connections can be conservatively ignored. *UFC 3-340-02* suggests that the DIF value of steel material with similar yield stress to the welds or fasteners be used for the various types of connections. *UFC 3-340-02* recommends a DIF value of 1.05 for *ASTM A514* steel with yield stress of 90 to 100 ksi (620 to 690 MPa) for “tension or compression” and a DIF value of 1.07 to 1.09 for “bending”. Therefore, if necessary, a DIF value of 1.05 to 1.10 can be justified for steel connections using typical welds with yield stress of 50 to 100 ksi (345 to 690 MPa) and *ASTM A325* or *ASTM A490* high strength bolts.

5.5.5 Dynamic Design Stress

Strain hardening effects in steel members and concrete reinforcing are modeled in SDOF analysis by using a design stress which is greater than yield. During dynamic response, the stress level at critical sections in a member varies with strain of the section. In the elastic region, the strain across the section varies with location from the neutral axis of the member. Beyond this region, the member experiences plastic response in which the fiber stress of the entire section exceeds the elastic limit. At this point, the stress is constant over the cross section but is still changing with total member strain. Steel members experience an increase in stress in the strain hardening region until the ultimate dynamic material stress is reached. After this point, the fiber stress decreases with increasing strain until rupture occurs. Concrete exhibits an increasing stress until the maximum compressive stress is reached after which the

stress level decreases with additional deformation. Because of its brittle nature, strain hardening does not occur in concrete; however, reinforcing steel will exhibit this effect.

To predict true dynamic response, it would be necessary to continuously vary the material stress with deformation. This variation is difficult to model using SDOF analysis methods because it requires tracking a complex resistance-deflection curve at each time step. It is desirable to represent the design material stress as a bilinear stress-strain curve in which stress increases linearly with strain to yield and a constant value after yield (refer to Section 7.2.5). This produces a simple, bilinear resistance-deflection curve as shown in Figure 5.8 which can include strain hardening effects and is relatively easy to incorporate into the SDOF analysis. To achieve this simplification, while accurately modeling the dynamic response, it is necessary to select a design stress equal to the average stress occurring in the actual response. This can be done by estimating a maximum response range and using recommendations in Tables 5.A.4 and 5.A.5 for reinforcing and steel members.

At low response ranges, the maximum design stress is equal to the dynamic yield stress. At higher response ranges, the design stress is increased to account for strain hardening. In the initial portion of the response, this increased design stress will result in an overprediction of resistance. As greater deformations occur, the stress level, and thus resistance, will be underpredicted by the design stress.

Finite element methods (FEM) are capable of incorporating complex variations in material stresses in the time varying response. While these methods are widely available, they are quite complex and, in many cases, their use is not warranted due to uncertainties in blast load prediction. The dynamic material properties presented in this section can be used in FEM calculations; however, the simplified response limits in the next section may not be suitable. Most FEM codes contain complex failure models which are better indicators of acceptable response. Refer to Chapter 6, Dynamic Analysis Methods, for additional information.

5.6 DEFORMATION LIMITS

Response deformation limits are used to ensure that adequate response to blast loads is provided. These limits are based on the type of structure or component,

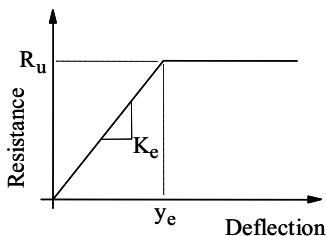

FIGURE 5.8: Bilinear Resistance-Deflection Curve

construction materials used, location of the structure and desired protection level.

The primary method for determining adequacy of a structure for conventional design is evaluation of the stress level achieved compared with the maximum stress permitted. Deflections are also checked for certain members although this is typically done for serviceability or architectural reasons rather than structural requirements. Blast loaded members, however, reach or exceed yield stresses to achieve an economic design. In general, the more deformation the structure or member is able to undergo without failure, the more blast energy that can be absorbed. As member stresses exceed the yield limit, stress level is not appropriate for judging member response as is done for static elastic analysis. In dynamic design, the adequacy of the structure is judged on maximum deformations. Limits on displacements are based on test data or other empirical evidence. A degree of conservatism is included to ensure adequate capacity because the applied loads are not "factored up" to provide a factor of safety.

The allowable response of individual frame components is less than that permitted for the same member responding as an isolated element. This is done to reduce the possibility of progressive collapse and to increase redundancy of the frame. Failure of individual girt and purlin components is not as catastrophic as failure of a frame member and thus a difference in criteria exists. Load bearing walls should normally be allowed less deformation than non-load bearing elements also because of the consequences associated with failure.

The structure's performance goal becomes an important factor in selection of maximum response values. If it is desired to provide a high degree of protection to personnel or equipment, a low response limit is chosen. This situation may be typical of a control room in which personnel are required to remain at their workstation during an emergency or for critical equipment which must be protected to implement a safe shutdown. On the other hand, if a building is frequently unoccupied or contains low value equipment, significant damage may be permitted, up to the point of failure. Structures which are required to be reusable following a blast are typically designed to remain elastic under the predicted loads.

The capacity of a member to deform significantly and absorb energy is dependent on the ability of the connections to maintain strength throughout the response. If connections become unstable at large responses, catastrophic failure can occur. The resistance will drop thereby increasing deflections. Connections often control blast capacity for structures which have been designed for conventional loads only.

Appropriate response (deformation) limits are selected based on the factors discussed above as well as company/owner safety philosophies, blast protection guidelines, and risk considerations. Risk assessments which evaluate accident probability and potential consequences can be helpful in making the appropriate selection. The deformation limits chosen relate to a specified degree of response which can be characterized as low, medium or high. At the highest response limits, catastrophic failure of the structure should not occur. Points of highest stress in the

members will be near incipient collapse and local failures may occur but the overall structure should remain intact. It is important to remember that predicted responses may not always account for local instabilities and the actual response can be significantly greater. The engineer must take these factors into consideration when designing or analyzing the structure to ensure the proper degree of protection is provided.

Many petrochemical companies have adopted a "neutral risk" philosophy for facilities where personnel are normally required to evacuate during an emergency. This philosophy prescribes that personnel are not to be placed in greater danger inside a building than if they were outside. Blast pressures and fragments entering the structure are not considered in the design since personnel would be exposed to these hazards outside the building. The performance goal for the structure then becomes incipient failure in which portions of the structure are damaged severely but do not tear loose and become missiles. Structural collapse is not permitted and suspended equipment must be adequately anchored within the structure. Chapter 2, General Considerations, contains additional discussion of protection philosophies.

5.6.1 Deformation Limit Parameters

Almost all published structural response criteria are presented in terms of parameters which are easily compared with simplified non-linear dynamic response calculations that involve one or several degrees of freedom models. These parameters include hinge rotations and ductility ratios, which are based on the peak deflection of the component.

Ductility ratio is defined as the maximum displacement of the member divided by the displacement at the elastic limit and is commonly designated by the symbol μ . For indeterminate members with multiple plastic hinges, the ductility ratio is typically based on the equivalent yield deflection. The equivalent yield deflection is the ultimate resistance divided by the equivalent elastic stiffness. Equivalent elastic stiffnesses are provided in Tables 6.1, 6.2 and 6.3. Ductility ratio is a measure of the degree of inelastic response experienced by the member.

Hinge rotation is another measure of member response which relates maximum deflection to span and indicates the degree of instability present in critical areas of the member. It is designated by the symbol θ and is defined in two ways in various references (refer to Figure 5.9). The first definition is the angle, θ_1 , formed between a line connecting the endpoints and a line between an endpoint and the closest interior hinge location. The other definition is the included angle, θ_2 , formed by two lines extending from the point of maximum deflection and the endpoints. Hinge rotations for fixed end members are calculated in a similar manner. It is important to note that the hinge rotation at the support is not related to the end curvature of the member. In the response limit tables in Appendix 5.B, hinge rotation refers to support rotation.

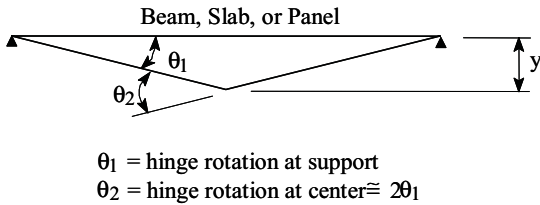

FIGURE 5.9: Hinge Rotation

Frame members have additional criteria. Sidesway limits are applied to frame systems to reduce the chance of progressive collapse and to minimize P-delta effects on columns. It is quite possible to maintain acceptable response of individual members but experience large lateral displacements of roofs and upper floors which cause collapse. The sidesway limits indicated in the tables are fairly liberal and should not be exceeded without detailed analysis or testing.

Finite element analysis (FEA) is becoming a more commonly used tool for estimating damage under extreme dynamic loading. FEA provides significantly more response information, such as displacements and rotations, and stress and strain due to both flexure and shear throughout the structural continuum. Specific boundary conditions at the component connections can also be discretely modeled. Evaluation of stress or strain at a single point, or finite element within a member, may not be indicative of overall performance and the ability of the component to provide the necessary level of protection. Because redistribution of stresses may occur during a dynamic response, it may be more appropriate to use global parameters such as span and ductility ratios. The values in Appendix 5.B are applicable for SDOF analysis and may also be applicable for FEA. Response limits based on applicable test data may supersede the published values in Appendix 5.B. The response criteria in Appendix 5B are appropriate for most structural components. Different limit criteria may be used if the analysis technique is sufficiently rigorous to capture potential nonlinear response modes and the response level provides the required protection.

Maximum rupture strain values for specific construction materials may be applicable for certain problems. Strain-rate effects models have been included in a number of these constitutive models. FEA models can also capture post rupture and post buckling responses which can better estimate the softening resistance of the member. Such an effect is difficult to include in SDOF methodology.

Due care must be taken by the analysts to ensure that FEA models adequately capture the required response characteristics (local and global) of the structure under consideration, which may include previous comparisons with applicable test data.

5.6.2 Deformation Limit Values

Maximum acceptable values for ductility and support rotation are presented in Appendix 5.B. Predicted response must be compared to ductility ratio and support rotation limits to ensure that neither is exceeded. The engineer must also determine if lower limits are appropriate. The values vary with material type, section type and required protection category. For reinforced concrete members, response limits are influenced by the shear reinforcing provided as well as the type of response (i.e., flexure, shear, compression). In general, for elements in which shear or compression is significant, the allowable response is quite low. Where adequate shear capacity is provided, large deflections are permitted.

The deformation limit values in Appendix 5.B are a combination of criteria developed for the original publication of this report and criteria in *PDC-TR 06-08* developed by the U.S. Army Corps of Engineers. The deformation limit values for medium and high component response of cold formed steel girts and purlins, reinforced concrete and masonry, and prestressed concrete components are based on similar values for moderate and heavy component damage levels, respectively, in *PDC-TR 06-08*. Values for low response of these component types are approximately one-half the values for medium response, since the lowest PDC deformation limit values apply to superficial component damage rather than low damage. The deformation limit values for all other component types in Appendix 5.B are the same, or very similar, to deformation limit values developed for the original publication of this report.

Deformation limits for different levels of blast damage to other component types, including wood and metal stud walls, are provided in *PDC-TR 06-08*. Limits on the actual deformation values should be used when there is a risk of a structural member (i.e. wall panel) impacting critical equipment. These limits must be imposed by the design engineer on a case-by-case basis, as applicable, in addition to the response criteria in Appendix 5.B. *PDC-TR 06-08* also contains a methodology to determine an overall building level of protection based on the highest component damage levels of primary and secondary type components in the building, as defined in the document. This approach may be helpful for evaluating overall building blast damage.

Deformation limit values for blast resistant design are also provided in a number of other publications by the U.S. government and industry committees. These limit values tend to be in the same range as values in Appendix 5.B, but are not identical. This reflects different definitions for damage or design response levels, different amounts of conservatism in the limits, considerations of different available component damage databases, and the approximate nature of all deformation limit values. Summaries and correlations between component support rotations and ductility ratios and component damage levels observed in specific blast tests, other dynamic tests, and static tests are available in numerous references. A summary of available blast test information is provided in *Oswald 2005*. Support rotations

correlate much better with damage levels than ductility ratios for some component types, such as non-prestressed reinforced concrete and masonry.

The deformation limit values in Appendix 5.B apply for the typical case where the component is designed using a procedure that explicitly considers the dynamic component response, such as the SDOF methodology described in this report or a method based on dynamic finite element analysis. Some components that are not directly loaded by blast and have a short response time compared to the expected rise time of their dynamic load, such as connections and primary framing members in pure axial loading, are usually designed using an equivalent static load approach. The equivalent static load is equal to the ultimate resistance of the supported members multiplied by their tributary areas and the connection or axial member must have an ultimate dynamic load capacity that is equal or greater than this load. The dynamic load capacity is calculated in the same manner as the static load capacity except that the yield strength is increased by applicable static and dynamic increase factors for blast design. The load capacity may include applicable strength reduction factors (i.e., ϕ factors) used in conventional static design at the discretion of the design engineer. If the dynamic analysis shows the supported member does not yield, the equivalent static load may be based on the maximum resistance of this member. However, this approach should be used with caution since it will be unconservative if the actual blast loads exceed the design blast load.

APPENDIX 5.A
SUMMARY TABLES FOR DYNAMIC MATERIAL STRENGTH

TABLE 5.A.1: Strength Increase Factors (SIF)

Material	SIF
Structural Steel ($F_y \leq 50$ ksi or 345 MPa)	1.1
Reinforcing Steel ($F_y \leq 60$ ksi or 414 MPa)	1.1
Cold-Formed Steel	1.21
Concrete ¹	1.0

Note 1: The results of compression tests are usually well above the specified concrete strengths and may be used in lieu of the above factor. Some conservatism may be warranted because concrete strengths have more influence on shear design than bending capacity.

TABLE 5.A.2: Dynamic Increase Factors (DIF) for Reinforcing Bars, Concrete, and Masonry

Stress Type	DIF			
	Reinforcing Bars		Concrete	Masonry
	F_{dy}/F_y	F_{du}/F_u	f'_{dc}/f'_c	f'_{dm}/f'_m
Flexure	1.17	1.05	1.19	1.19
Compression	1.10	1.00	1.12	1.12
Diagonal Tension	1.00	1.00	1.00	1.00
Direct Shear	1.10	1.00	1.10	1.00
Bond	1.17	1.05	1.00	1.00

TABLE 5.A.3: Dynamic Increase Factors (DIF) for Structural Steel, Cold-Formed Steel, and Aluminum

Material	DIF		
	Yield Stress		Ultimate Stress
	Bending/Shear	Tension/Compression	
	F_{dy}/F_y	F_{dy}/F_y	F_{du}/F_u
ASTM A36	1.29	1.19	1.10
ASTM A588	1.19	1.12	1.05
ASTM A514	1.09	1.05	1.00
ASTM A653	1.10	1.10	1.00
SAE AMS5501 (stainless steel)	1.18	1.15	1.00
SAE AMS4113 (aluminum)	1.02	1.00	1.00

TABLE 5.A.4: Dynamic Design Stress for Concrete Reinforcing Steel

Type of Stress	Type of Reinforcement	Maximum Support Rotation	Dynamic Design Stress (F_{ds})
Bending	Tension and Compression	$0 < \theta_1 \leq 2$	F_{dy}
		$2 < \theta_1 \leq 5$	$F_{dy} + (F_{du} - F_{dy}) / 4$
		$5 < \theta_1 \leq 12$	$(F_{dy} + F_{du}) / 2$
Diagonal Tension	Stirrups		F_{dy}
Direct Shear	Diagonal Bars	$0 < \theta_1 \leq 2$	F_{dy}
		$2 < \theta_1 \leq 5$	$F_{dy} + (F_{du} - F_{dy}) / 4$
		$5 < \theta_1 \leq 12$	$(F_{dy} + F_{du}) / 2$
Compression	Column	all	F_{dy}

TABLE 5.A.5: Dynamic Design Stress for Structural Steel

Type of Stress	Maximum Ductility Ratio	Dynamic Design Stress (F_{ds})
all	$\mu \leq 10$	F_{dy}
all	$\mu > 10$	$F_{dy} + (F_{du} - F_{dy}) / 4$

APPENDIX 5.B
SUMMARY TABLES FOR RESPONSE CRITERIA

The following descriptions apply to the response ranges mentioned in the tables:

TABLE 5.B.1.A: Building Damage Levels

Damage Level	Description
Low	Localized component damage. Building can be used, however repairs are required to restore integrity of structural envelope. Total cost of repairs is moderate.
Medium	Widespread component damage. Building should not be occupied until repaired. Total cost of repairs is significant.
High	Key components may have lost structural integrity and building collapse due to environmental conditions (i.e. wind, snow, rain) may occur. Building should not be occupied. Total cost of repairs approaches replacement cost of building.

TABLE 5.B.1.B: Component Response

Low	Component has none to slight visible permanent damage.
Medium	Component has some permanent deflection. It is generally repairable, if necessary, although replacement may be more economical and aesthetic.
High	Component has not failed, but it has significant permanent deflections causing it to be unrepairable.

TABLE 5.B.2: Response Limits for Steel Components¹

Component	Low Response		Medium Response		High Response	
	μ_a	θ_a	μ_a	θ_a	μ_a	θ_a
Hot Rolled Steel Compact Secondary Members (Beams, Girts, Purlins) ²	3	2	10	6	20	12
Steel Primary Frame Members (with significant compression) ^{2,3,4}	1.5	1	2	1.5	3	2
Steel Primary Frame Members (without significant compression) ^{2,3,4}	1.5	1	3	2	6	4
Steel Plates ⁷	5	3	10	6	20	12
Open-Web Steel Joists	1	1	2	3	4	6
Cold-Formed Light Gage Steel Panels (with secured ends) ^{5,8}	1.75	1.25	3	2	6	4
Cold-Formed Light Gage Steel Panels (with unsecured ends) ^{6,8}	1.0	-	1.8	1.3	3	2
Cold-Formed Light Gage Steel Beams, Girts, Purlins and Non-Compact Secondary Hot Rolled Members ⁸	2	1.5	3	3	12	10

Note 1: Response limits are for components responding primarily in flexure unless otherwise noted. Flexure controls when shear resistance is at least 120% of flexural capacity.

Note 2: Primary members are components whose loss would affect a number of other components supported by that member and whose loss could potentially affect the overall structural stability of the building in the area of loss. Secondary members are those supported by primary framing components.

Note 3: Significant compression is when the axial compressive load is more than 20% of the dynamic axial capacity of the member. Axial compression should be based on the ultimate resistance of the supported members exposed to the blast pressure. Refer to *PDC-TR 06-08* for detailed examples of calculation for axial compression and dynamic axial column capacity. Refer to Section 5.6.2 for analysis of members in pure axial compression.

Note 4: Sidesway limits for moment-resisting structural steel frames: low = (height)/50, medium = (height)/35, high = (height)/25.

Note 5: Panels must be attached on both ends with screws or spot welds.

Note 6: Panels are not attached on both ends (for example standing seam roof panels).

Note 7: Steel plate criteria can also be applied to corrugated (crimped) plates if local buckling and other response modes are accounted for in the analysis. Refer to Section 5.4.4.

Note 8: Light gage refers to material which is less than 0.125 inches (3 mm) thick.

TABLE 5.B.3: Response Limits for Reinforced Concrete (R/C) and Reinforced Masonry (R/M)¹

Component	Low Response		Medium Response		High Response	
	μ_a	θ_a	μ_a	θ_a	μ_a	θ_a
R/C Beams, Slabs, & Wall Panels (no shear reinforcement)		1		2		5
R/C Beams, Slabs, & Wall Panels (compression face steel reinforcement and shear reinforcement in maximum moment areas)		2		4		6
Reinforced Masonry		1		2		5
R/C Walls, Slabs, and Columns (in flexure & axial compression load) ²		1		2 ⁴		2 ⁴
R/C and R/M Shear Walls & Diaphragms	3		3		3	
R/C and R/M Components (shear control, without shear)	1.3		1.3		1.3	
R/C and R/M Components (shear control, with shear)	1.6		1.6		1.6	
Prestressed Concrete ($w_p \leq 0.15$) ³	1			1		2
Prestressed Concrete ($0.15 < w_p < 0.3$) ³	1		0.25/ w_p	1	0.29/ w_p	1.5

Note 1: Response limits are for components responding primarily in flexure unless otherwise noted.

Note 2: Applicable when the axial compressive load is more than 20% of the dynamic axial capacity of the member. Axial compression should be based on the ultimate resistance of the supported members exposed to the blast pressure. Refer to *PDC-TR 06-08* for detailed examples of calculation for axial compression and dynamic axial column capacity. Refer to Section 5.6.2 for analysis of members in pure axial compression.

Note 3: The reinforcement index, $w_p = (A_{ps} / b d_p) * (f_{ps} / f'_c)$

where,

A_{ps} = area of prestressed reinforcement in tension zone

b = the member width

d_p = the depth to center of prestressing steel

f_{ps} = calculated stress in prestressing steel at design load

f'_c = the concrete compressive strength

Note 4: A support rotation of 4 degrees is allowed for R/C components that have compression face steel reinforcement and shear reinforcement in maximum moment areas.

CHAPTER 6 DYNAMIC ANALYSIS METHODS

6.1 INTRODUCTION

This chapter discusses various analysis methods for determining the dynamic response of structural members subjected to blast loading. In order to perform the dynamic analyses, it is necessary to have previously defined the loading as well as member properties such as stiffness and mass. The design of new structures sometimes involves several iterations of the analysis, where trial member sizes are used and the resulting response quantities are compared against the acceptance criteria defined in Chapter 5.

Several dynamic analysis methods are used for blast resistant design ranging from simple hand calculations and graphical solutions to more complex computer based applications. One of the purposes of this chapter is to convey analysis methods which provide the necessary balance between sufficient accuracy and calculation simplicity.

6.2 KEY CONCEPTS

Several key concepts relating to the dynamic analysis of structures for blast loading are discussed below. The main objectives of the analysis are discussed followed by a general discussion on the level of accuracy used in typical blast design applications. The approach for separating integrally connected structural members into manageable parts for analysis purposes is described. A brief discussion on the treatment of live loads is also given.

6.2.1 Objectives

The overall objective of a dynamic blast analysis is to evaluate the capability of a structure to resist a specified blast load. To accomplish this goal, the analysis should be able to predict, with a fair degree of accuracy, the dynamic response of the structure. The analysis of a typical member begins with a given structural configuration, which includes the type of material, span length, support conditions and applied loading. Material properties are then used to estimate member stiffness, mass and section capacities. Determination of member stiffness and section capacities are described in Chapter 7. A resistance function, or applied force versus displacement relationship, is developed based on assumed failure mechanisms, the member configuration and estimated section capacities. The analysis proceeds to determine the response to a given blast load. Specifically, the analysis should provide:

- a. Maximum relative deflections of each structural element.
- b. Relative rotation angles at plastic hinge locations.
- c. Dynamic reactions transmitted to the supporting elements.
- d. Deflections and reactions due to rebound.

Once the analysis is complete, the design can proceed to determine the adequacy of the member through the application of the acceptance criteria.

6.2.2 Accuracy

A typical blast analysis contains a number of approximations which affect the accuracy of the results. Some of the approximations most often used are:

- a. Usually, the blast loads postulated in petrochemical company facilities are not accurately known and are at best an approximation. For other types of facilities, such as munitions plants, the blast load may be accurately predicted based on a known quantity and type of explosive.
- b. The blast pressure-time relationship is almost always approximated by a single straight line as is discussed in Section 3.3.6, which introduces additional inaccuracies.
- c. Structural modeling of uncoupled single degree of freedom (SDOF) system analyses for interconnected structural members neglects the deformation compatibility and equilibrium of forces at contact points between members. In other words, dynamic interaction effects which may increase or decrease the calculated responses are usually not considered.
- d. Approximate dynamic properties of the structural materials combined with simplified bilinear resistance-deflection curves are commonly used along with equivalent SDOF system approximations. The solution accuracy decreases for more complex materials and member configurations.

The degree of complexity of the structural representation and analyses can vary considerably, depending on the effort to which the engineer determines is necessary to achieve a safe, economical design. Except for the blast load, each of the above approximations could be improved through the use of more complex procedures. Such procedures would involve a greater engineering effort and still produce results limited by the blast load determination. The approach recommended herein is to use generally accepted procedures which maintain the blast load as the greatest approximation, produce the desired results, and utilize relatively simple calculations.

6.2.3 Interaction Of Structural Elements

For enclosed buildings, the blast loads are typically applied to the exterior walls and roof and are transmitted through various structural members to the foundation. The energy of the blast is absorbed through elastic and, more importantly, plastic deformation of the structure. The portion of blast energy not absorbed by the structure is transmitted into the ground. It is therefore necessary to establish a continuous load path with consistent tracking of the dynamic loads through the structure to ensure a safe design.

It is common practice to analyze a structure using a member by member approach. The envisioned load path, established using engineering judgment and experience, forms the basis for determining the member by member analysis sequence. Tracking of the member dynamic reactions and loads throughout the structure is performed manually. This basic approach is similar to the practice used in conventional static analyses. The major difference is the consideration of inertia forces which may act in any direction.

In less frequent situations a more comprehensive analysis approach is used to analyze the structure as a whole. For example, a finite element analysis of an entire building may be performed. Obviously, the load path need not be predetermined when such global analysis methods are used. However, the load path is influenced by the type and level of detail of the modeling so that engineering judgment and experience are also necessary to achieve a safe and economical design.

As mentioned above, it is common practice to separate a structure into its major components for purposes of simplifying the dynamic analyses. This uncoupled member by member approach approximates the actual dynamic response since dynamic interaction effects between major structural elements are not considered. Resulting calculated dynamic responses, which include deflections and support reactions, may be underestimated or overestimated, depending on the dynamic characteristics of the loading and the structure. This approximation occurs regardless of the solution method used in performing the uncoupled dynamic analyses.

Dynamic interaction effects are commonly neglected. Under certain circumstances, unconservative answers could result from neglecting the effects of coupling. Though some simple parametric studies can be made to evaluate these effects, coupling is normally expected to be negligible if the natural frequencies of connected elements differ by a factor of two or more according to the technical guidance given by *Biggs* (pp. 183-184 and 237-238). Frequencies of interconnected members are sometimes tuned by changing their stiffness or weight in order to achieve this separation of frequencies. If neglecting dynamic interaction effects cannot be justified, the connected members can be analyzed as a multi-degree of freedom system in which these effects are considered inherently.

Some studies on dynamic interaction effects for two degree of freedom systems have been done by *Baker* (pp. 415-418). Although these studies were made using a limited range of variables, results indicate that conservative responses can be obtained using uncoupled SDOF system approximations versus a coupled approach.

A series of separate SDOF dynamic analyses are performed for each of the primary structural components. For example, a typical roof system consists of a roof slab supported on structural steel roof beams which are in turn supported by roof girders. Separate SDOF dynamic analyses are performed for the slab, beams and girders using the reaction time history of the supported member as loading input to the supporting member.

The same member by member approach is commonly used for lateral analyses of buildings as illustrated by Figure 6.1. Front walls facing the blast are typically designed as a unit width, one-way member spanning vertically. Reaction time histories of a representative wall strip are used as the loading input to the horizontal roof diaphragm which is supported by side walls oriented parallel to the direction of the blast. These walls are typically reinforced concrete shear walls or braced steel frames. The analysis proceeds from the front wall to the roof diaphragm to the side walls and finally to the foundation. A consistent, continuous load path is thus established.

6.2.4 Live Loads

Live loads which would be blown away by a blast wave or which would not increase the inertia of a supporting member should not be included in the mass calculation. Additionally, some judgment is needed to estimate the portion of a design live loads which is normally present. For example, snow loads in cold climates may be present for relatively long durations and a portion of this live load should be included in the mass calculation. Another example is a floor live load representing personnel and furnishings which should not be included in the mass calculation.

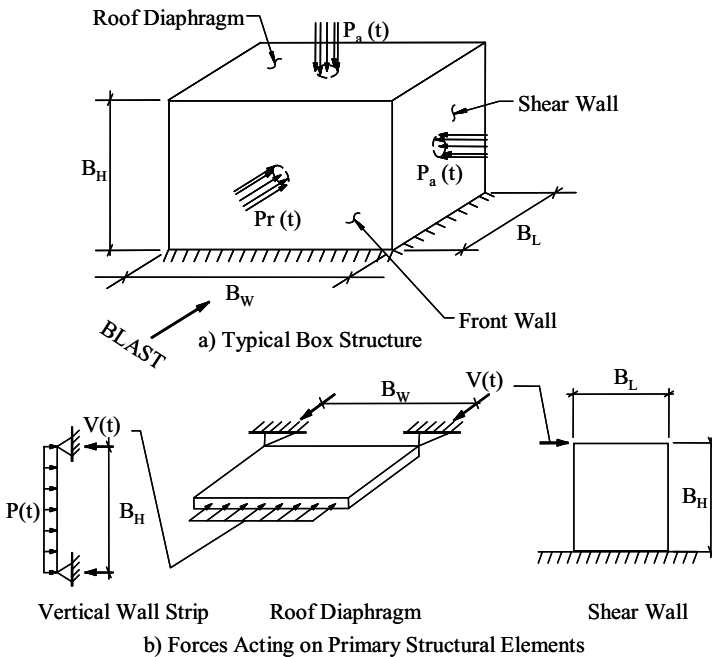

FIGURE: 6.1: Forces Acting on Primary Structural Elements

6.2.5 Confirmation of Assumed Failure Mechanisms

In establishing the model used to represent a structure, the usual approach is first to assume the locations of plastic hinges and then carry out the analysis. This approach is essentially an upper bound analysis which by definition provides a predicted collapse load that is either correct or too high. In most cases, fairly simple structural models are developed and it is obvious that the assumed mechanism is correct. For those cases involving irregular structural configurations and loading, a separate check should be made to confirm that no other possible failure mechanisms exist which may result in lower predicted collapse loads.

6.3 EQUIVALENT STATIC METHOD

One method of blast analysis which has been commonly used in the past, but which is no longer advocated, is the equivalent static method. As the name implies, this method employs a static analysis with an approximate applied load to simulate the dynamic response. This is sometimes called an “equivalent wind” approach. Dynamic parameters such as time varying loads, rapid strain rate material strengths, load amplification factors, mass, stiffness, period of vibration, and allowable plastic deformations are not used. The primary difficulty with this method is determining an appropriate static loading which will yield reasonable results. This method is not recommended for general use except for cases where the structure is far removed from the blast source, such that the blast loading resembles a wind gust.

6.4 SINGLE DEGREE OF FREEDOM SYSTEMS

The basic analytical model used in most blast design applications is the single degree of freedom (SDOF) system. A discussion on the fundamentals of dynamic analysis methods for SDOF systems is given below which is followed by descriptions on how to apply these methods to structural members.

6.4.1 Basics

All structures, regardless of how simple the construction, possess more than one degree of freedom. However, many structures can be adequately represented as a series of SDOF systems for analysis purposes. The accuracy obtainable from a SDOF approximation depends on how well the deformed shape of the structure and its resistance can be represented with respect to time. Sufficiently accurate results can be obtained for primary load carrying components of structures such as beams, girders, columns, wall panels, diaphragm slabs and shear walls.

The majority of dynamic analyses performed in blast resistant design of petrochemical facilities are made using SDOF approximations. Common types of construction, such as single story plane frames, cantilever barrier walls and compact box-like buildings are approximated as SDOF systems. Several examples of such structures are illustrated in Figure 6.2.

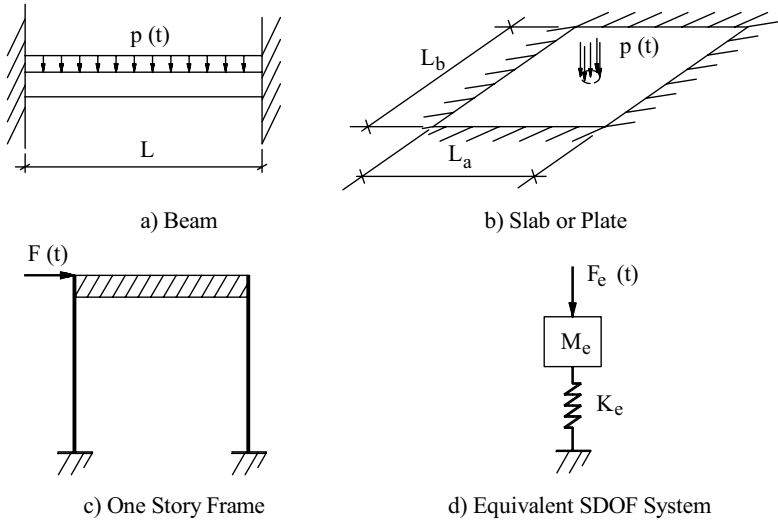

FIGURE 6.2: Typical Structures Represented as Equivalent SDOF Systems

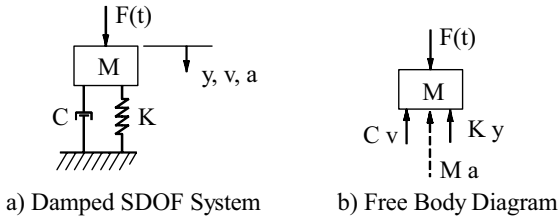

FIGURE 6.3: SDOF Model for Dynamic Analysis

The dynamic equilibrium of damped, linear elastic, SDOF system illustrated in Figure 6.3 is expressed mathematically as follows.

$$M a + C v + K y = F(t) \tag{6.1}$$

where,

- M = mass
- a = acceleration
- C = viscous damping constant
- v = velocity
- K = stiffness

y = displacement
 F = blast force
 t = time

Damping is usually conservatively ignored in blast resistant design. Due to the short time in which the structure reaches its maximum response, damping effects have little effect on peak displacements. Taking credit for energy dissipation through viscous damping during the plastic response phase is questionable, which is another reason to ignore damping.

When damping is ignored, the three forces then acting on the mass are the resistance, $K y$, the inertia force, $M a$, and the external applied force, F . The dynamic equilibrium equation for the undamped, elastic system then becomes,

$$M a + K y = F(t) \quad (6.2)$$

In blast analyses, the resistance is usually specified as a nonlinear function to simulate elastic, perfectly plastic behavior of the structure. The ultimate resistance, R_u , is reached upon formation of a collapse mechanism in the member. When the resistance is nonlinear, the dynamic equilibrium equation becomes:

$$M a + R = F(t) \quad (6.3)$$

where,

$$R = \text{lesser of } K y \text{ or } R_u$$

Solutions for Equation 6.3 can be obtained by various methods, depending on the complexity of the loading function, $F(t)$.

Rigorous analyses of SDOF systems are usually not required or warranted in typical blast design applications. However, special cases may arise where a more sophisticated solution is justified, perhaps to analytically qualify an existing structure for new increased loading conditions. Refinements can be made in the analyses in areas such as strain hardening, progressive hinge formation, equivalent replacement of arbitrary pulse loading and large deformations. Discussion of these methods is beyond the scope of this report, however, technical guidance can be found in *Stronge and Yu, ASCE Manual 42* (Section 9.2), *Krauthammer 1986*, and *Krauthammer 1990*.

6.4.2 Transformation Factors

Examples of some typical SDOF approximations were briefly introduced in Section 6.4.1 and illustrated in Figure 6.2. These SDOF models greatly simplify the dynamic analysis effort compared to that of structures having distributed mass. For structures having a single concentrated mass, the SDOF system can be defined without an approximation.

The procedure for obtaining an equivalent SDOF approximation for a structural component is based on its deformed shape under the applied loading and the strain energy equivalence between the actual structure and the SDOF approximation. The deformed shape of the member is usually dominated by blast loading rather than by normal design loads. In addition to strain energy equivalence, the motion of the SDOF system (displacement, velocity and acceleration) is equivalent to the selected control point on the actual structure. The control point is usually selected at a point of maximum response such as a plastic hinge location within the span. However, the spring force is not equal the support reactions of the actual member.

Equivalent mass, stiffness and loading are obtained through the use of transformation factors. Several widely used texts on blast design such as *Biggs*, (Chapter 5) and *UFC 3-340-02* (Chapter 3) contain tabulated transformation factors for typical structural elements such as beams and slabs. The derivations of the equations for these transformation factors are also given by these references. Transformation factors used to obtain appropriate properties for the equivalent SDOF system are as follows:

$$\text{Equivalent stiffness, } K_e = K_L K \quad (6.4a)$$

$$\text{Equivalent mass, } M_e = K_M M \quad (6.4b)$$

$$\text{Equivalent force, } F_e = K_L F \quad (6.4c)$$

$$\text{Equivalent resistance, } R_e = K_L R \quad (6.4d)$$

where,

K_L = load or stiffness transformation factor

K_M = mass transformation factor

The dynamic analysis can be performed using these equivalent parameters in place of the corresponding actual values. The alternate form of the bilinear dynamic equilibrium equation (Equation 6.3) then becomes:

$$M_e a + R_e = F_e \quad (6.5)$$

For convenience, Equation 6.5 is sometimes simplified through the use of a single load-mass transformation factor, K_{LM} , as follows:

$$K_{LM} M a + K y = F(t) \quad (6.6)$$

where,

$$K_{LM} = K_M/K_L$$

Shape functions, $\Phi(x)$, used in the transformation factor equations above are changed according to the stress range of the member. These changes are illustrated in

Figure 6.4 for a simply supported beam with uniform mass and uniform pressure loading. The resulting transformation factors are also shown in the figure.

Transformation factors also change as the structural member progresses from the elastic to plastic ranges and back to elastic response range. The resistance also changes for the plastic range as shown by Equation 6.3.

In actual practice, it is common to keep the transformation factors constant throughout the analysis. Engineering judgment is used to select the appropriate factors, depending on the predominant response mode anticipated. A trial and error approach may be used to evaluate the response mode behavior. An average of the elastic and plastic transformation factors is sometimes used.

Transformation factors for common one-way and two-way structural members are readily available from several sources (Biggs, *UFC 3-340-02*). Refer to Tables 6.1, 6.2, and 6.3 for a summary of such factors for one way members.

The mass of the structure includes its self weight and the weight of permanently attached equipment. Mass is simply weight divided by gravity. Approximations are sometimes used in determining mass distributions of members analyzed as SDOF systems in order to be able to use readily available tabulated transformation factors.

When performing dynamic analyses of a series of SDOF systems representing a structure, an estimate of the amount mass “riding along” with a supporting member often must be made. For example, a roof girder supports a portion of the mass of the roof beams it supports which needs to be added to the girder’s mass as illustrated in

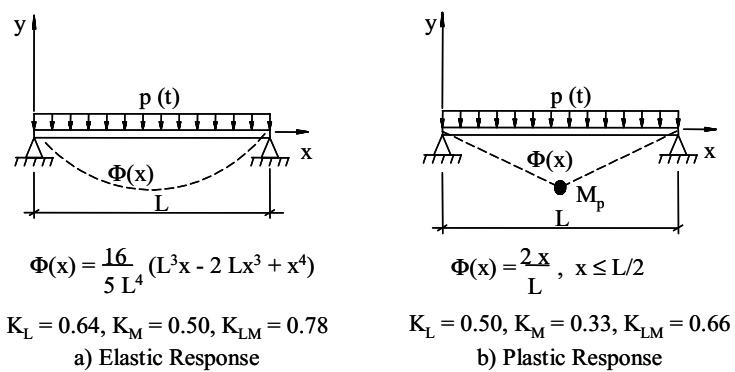
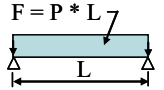
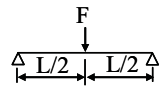
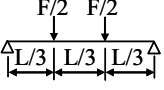

FIGURE 6.4: Shape Function and Transformation Factors for a Simply Supported Beam

**TABLE 6.1: Transformation Factors for One Way Members,
Simply Supported Boundary Conditions (from TM 5-856)**

Loading Diagram	Strain Range	Load Factor K_L	Lumped Mass Factor, K_M^1	Uniform Mass Factor, K_M	Bending Resistance, R_b	Spring Constant, K	Dynamic Reaction, V
	Elastic	0.64	---	0.50	$8M_{pc}/L$	$384 EI/5L^3$	$0.39R + 0.11F$
	Plastic	0.50	---	0.33	$8M_{pc}/L$	0	$0.38R_u + 0.12F$
	Elastic	1.00	1.00	0.49	$4M_{pc}/L$	$48 EI/L^3$	$0.78R - 0.28F$
	Plastic	1.00	1.00	0.33	$4M_{pc}/L$	0	$0.75R_u - 0.25F$
	Elastic	0.87	0.76	0.52	$6M_{pc}/L$	$56.4 EI/L^3$	$0.525R - 0.025F$
	Plastic	1.00	1.00	0.56	$6M_{pc}/L$	0	$0.52R_u - 0.02F$

Notes:

- (1) Equal portions of the concentrated mass are lumped at each concentrated load.
- (2) M_{pc} is the ultimate moment capacity at midspan.

**TABLE 6.2: Transformation Factors for One Way Members,
Fixed End Boundary Conditions (from TM 5-856)**

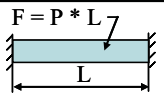
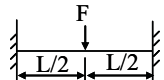
Loading Diagram	Strain Range	Load Factor K_L	Lumped Mass Factor, K_M^1	Uniform Mass Factor, K_M	Bending Resistance, R_b	Spring Constant, K	Dynamic Reaction, V
	Elastic	0.53	---	0.41	$12M_{ps}/L$	$384 EI/L^3$	$0.36R + 0.14F$
	E-P ³	0.64	---	0.50	$8(M_{ps}+M_{pc})/L$	$384 EI/5L^3$	$0.39R + 0.11F$
	Plastic	0.50	---	0.33	$8(M_{ps}+M_{pc})/L$	0	$0.38R_u + 0.12F$
	Elastic	1.00	1.00	0.37	$4(M_{ps}+M_{pc})/L$	$192 EI/L^3$	$0.71R - 0.21F$
	Plastic	1.00	1.00	0.33	$4(M_{ps}+M_{pc})/L$	0	$0.75R_u - 0.25F$

Notes:

- (1) Equal portions of the concentrated mass are lumped at each concentrated load.
- (2) M_{pc} is the ultimate moment capacity at midspan; M_{ps} is the ultimate moment capacity at support.
- (3) E-P is Elastic-Plastic

**TABLE 6.3: Transformation Factors for One Way Members,
Simple-Fixed Boundary Conditions (from TM 5-856)**

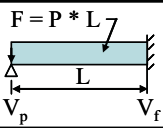
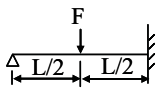
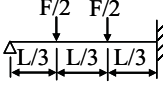
Loading Diagram	Strain Range	Load Factor K_L	Lumped Mass Factor, K_M^1	Uniform Mass Factor, K_M	Bending Resistance, R_b	Spring Constant, K	Dynamic Reaction, V
	Elastic	0.58	---	0.45	$8M_{pc}/L$	$185 EI/L^3$	$V_p = 0.26R + 0.12F$ $V_f = 0.43R + 0.19F$
	E-P ³	0.64	---	0.50	$4(M_{ps} + 2M_{pc})/L$	$384 EI/5L^3$	$0.39R + 0.11F \pm M_{ps}/L$
	Plastic	0.50	---	0.33	$4(M_{ps} + 2M_{pc})/L$	0	$0.38R_u + 0.12F \pm M_{ps}/L$
	Elastic	1.00	1.00	0.43	$16M_{ps}/3L$	$107 EI/L^3$	$V_p = 0.25R + 0.07F$ $V_f = 0.54R + 0.14F$
	Plastic	1.00	1.00	0.33	$2(M_{ps} + 2M_{pc})/L$ $2(M_{ps} + 2M_{pc})/L$	0	$0.78R - 0.28F \pm M_{ps}/L$ $0.75R_u - 0.25F \pm M_{ps}/L$
	Elastic	0.81	0.67	0.45	$6M_{pc}/L$	$132 EI/L^3$	$V_1 = 0.17R + 0.17F$ $V_2 = 0.33R + 0.33F$
	E-P	0.87	0.76	0.52	$2(M_{ps} + 3M_{pc})/L$	$56 EI/L^3$	$0.525R - 0.025F \pm M_{ps}/L$
	Plastic	1.00	1.00	0.56	$2(M_{ps} + 3M_{pc})/L$	0	$0.52R_u - 0.02F \pm M_{ps}/L$

Notes:

- (1) Equal portions of the concentrated mass are lumped at each concentrated load.
- (2) M_{pc} is the ultimate moment capacity at midspan; M_{ps} is the ultimate moment capacity at support.
- (3) E-P is Elastic-Plastic

Figure 6.5. Engineering judgments are often used in lieu of rigorous mathematical procedures. One recommendation for continuous reinforced concrete slab and beam type construction given by *UFC 3-340-02* (Section 4-43.1) is to include 20% of the supported member's mass with the mass of the supporting member. This would correspond to a supported member which is relatively flexible in comparison to the supporting member. For the structure illustrated in Figure 6.5, the full mass of the portion of the beam supported by the girder (i.e. 50% of the beam's total mass in this case) is considered to be lumped with the girder mass at the midspan of each girder. In this example, the beam is considered to be rigid in comparison to each girder. Each case is judged individually.

General transformation factor equations for distributed mass systems and multi-degree of freedom systems are given by *Biggs* (Chapter 5), and *Clough* (Chapter 2). These general methods can be used in determining transformation factors for nonprismatic members or members which have nonuniform mass distributions.

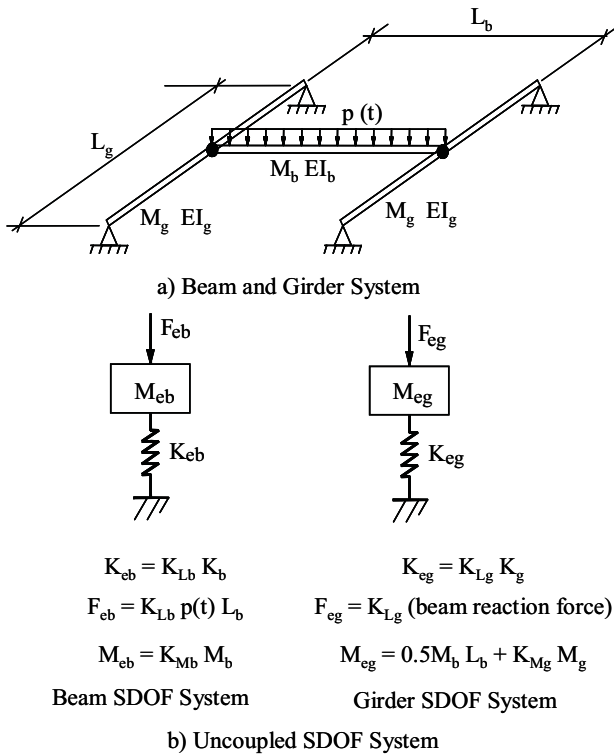

FIGURE 6.5: Mass Distribution of a Typical Multi-Member System



LIVE GRAPH
Click here to view

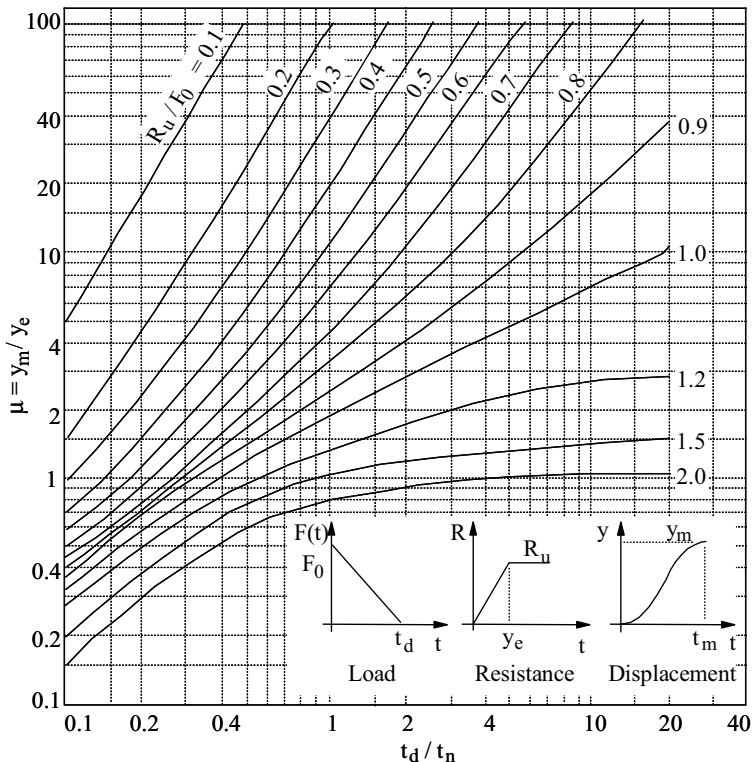

FIGURE 6.6: Typical Graphical Solution Chart For Elasto-Plastic SDOF System (from TM 5-856)

6.4.3 Graphical Solution Methods

Blast loadings, $F(t)$, act on a structure for relatively short durations of time and are therefore considered as transient dynamic loads. Solutions for Equation 6.3 are available in the form of nondimensional charts and graphs (UFC 3-340-02 and Biggs).

A typical graphical solution for a triangular pulse load with an elasto-plastic resistance function is shown in Figure 6.6. Additional charts covering other loading conditions and elastic rebound are available in Biggs, *ASCE Manual 42* and UFC 3-340-02. Such charts can be used to determine the maximum ductility demand, μ_d , and the time of maximum response, t_m . Parameters needed to enter Figure 6.6 include the maximum applied force, F_0 , the loading duration, t_d , ultimate resistance, R_u , and the period, t_n , of the equivalent SDOF system. This period is based on the deformed

shape of the member and therefore differs from the natural vibration period which is independent of the loading. The vibration frequency of the SDOF system is expressed in cycles per second:

$$f = \frac{1}{2\pi} \sqrt{K_c/M_c} \quad (6.7)$$

and the period is expressed in seconds as follows:

$$t_n = \frac{1}{f} = 2\pi \sqrt{M_c / K_c} \quad (6.8)$$

This method is suitable for obtaining maximum responses of elasto-plastic SDOF systems subjected to simple loading functions. It is generally not practical to develop solution charts when loads become more complex. A shortcoming of this method is that the time history of the response is not available to evaluate support reactions and rebound effects.

Another graphical method which is sometimes used in the evaluation of SDOF structural elements for blast loading is the Pressure-Impulse, or P-I, method. The P-I method combines both dynamic analysis and design evaluation into a single procedure which can be used to rapidly evaluate potential damage levels for certain types of structural members, such as reinforced concrete panels, steel beams, masonry walls and other common building elements. Damage levels are usually defined as low, medium or high which relate to increasing ductility demands.

The basic concept of the P-I method is to mathematically relate a specific damage level to a range of blast pressures and corresponding impulses for a particular structural element. Damage levels essentially correspond to deformation states within the member. The relationships, which may be theoretical or empirical, are plotted in graphical format as illustrated by Figure 6.7. P-I curves can be developed based on *Baker* or *Mays and Smith*. Knowing the blast pressure and impulse at a specific structure's location relative to the blast source enables the user to read the damage level directly from the P-I damage curves. P-I curves can be obtained from *CEDAW* (replacement for *FACEDAP*), and *SBEDS*.

Two basic types of P-I diagrams are commonly used. Traditionally, nondimensionalized P_{bar} and I_{bar} terms have been used to define the abscissa and ordinate values of the diagram. These terms contain parameters defining the stiffness, resistance and mass for a particular type of member. Refer to *Baker* and *CEDAW* manual which defines P_{bar} and I_{bar} terms for common structural member types. More recently, P-I diagrams similar to the one shown in Figure 6.7 in which the abscissa and ordinate values are given directly in terms of pressure and impulse have come into use for evaluation of building components and in some cases, an entire structure. The curves shown in Figure 6.7 define combinations of pressure and impulse which produce a constant damage level. Three regions defined by the constant damage

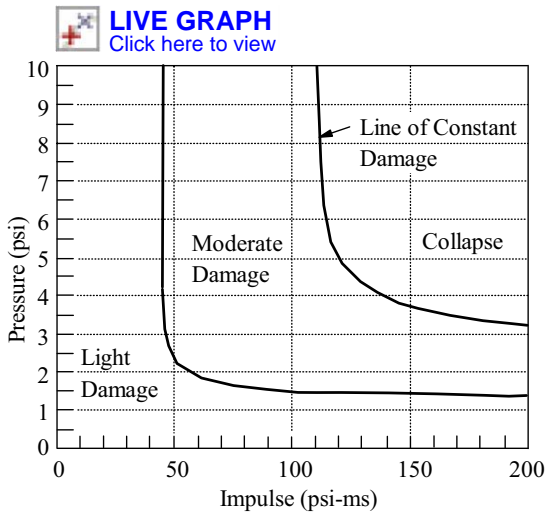

FIGURE 6.7: P-I Versus Structural Damage

curves are designated as light, medium and collapse in this particular figure. More or less refinement may be used in defining damage levels.

Theoretical solutions generally tend to underestimate blast resistance capacities of actual structures. Blast testing is therefore sometimes used to establish a series of data points for the purpose of developing realistic damage curves. However, when using test data to establish the damage curves, test scatter inevitably requires the introduction of some conservatism in order to produce smooth boundaries between the damage regions of the P-I diagram. Also, qualitative interpretations of the test specimen responses introduce some uncertainties in the definition of the damage levels. For these reasons, the P-I method has been used primarily as a screening tool.

6.4.4 Closed Form Solutions

Closed form solutions (i.e. equations) are available only for some simple loading cases for SDOF systems (Biggs, Clough, Paz 1991). Published solutions exist for both elastic and elastic-plastic responses, and for triangular and rectangular load pulses. The analysis can also be greatly simplified when the duration of the loading, t_d , is either very short or extremely long compared to the period, t_n .

When the loading duration is short compared with the member's natural period, $t_d / t_n < 0.1$, the shape of the load-time function becomes insignificant. The maximum response can be calculated using the impulse-momentum principle. The ductility demand, μ_d , can be determined in terms of the impulse, I_o , and the maximum resistance of the member:

$$\mu_d = 0.5 [(I_o / 2 \pi f / R_m)^2 + 1] \quad (6.9)$$

In the other extreme case, when the loading duration is long compared with the natural period, $t_d / t_n > 10$, the system responds as though the load were suddenly applied and constant. Again, the maximum ductility demand can also be expressed in convenient form:

$$\mu_d = 1 / [2 (1 - F_o/R_m)] \quad (6.10)$$

Empirical formulas have been developed to transition between these two extreme dynamic response cases. *ASCE Manual 42* provides the following relationship over the full response range of $\tau = t_d / t_n$:

$$F_o/R_m = \frac{\sqrt{(2\mu_d - 1)}}{\pi(\tau)} + \frac{(2\mu_d - 1)(\tau)}{2\mu_d(\tau + 0.7)} \quad (6.11)$$

Comparisons with more exact solutions show that this relationship yields results to within 5%, which is usually accurate enough for most applications. This formula does not lend itself to a direct calculation of ductility demand in terms of the other parameters. However, it can be solved for μ_d by trial iterations.

6.4.5 Numerical Integration

A versatile alternate to simple graphical, closed form and empirical solutions is to perform a numerical time integration. This method is also known as the time history method. Most texts on structural dynamics (Biggs, Clough, Paz 1991) provide extensive coverage on numerical solution methods for nonlinear, SDOF systems.

A brief summary will be given of the Newmark numerical integration procedure, which is commonly used to obtain the time history response for nonlinear SDOF systems. It is most commonly used with either constant-average or linear acceleration approximations within the time step. An incremental solution is obtained by solving the dynamic equilibrium equation for the displacement at each time step. Results of previous time steps and the current time step are used with recurrence formulas to predict the acceleration and velocity at the current time step. In some cases, a total equilibrium approach (Paz 1991) is used to solve for the acceleration at the current time step.

To ensure an accurate and numerically stable solution, a small time increment must be selected. A rule of thumb is to use a value less than or equal to 1/10th of either the natural vibration period of the structure or the load duration, whichever is smaller. Refer to Appendix 6 for an outline of the basic steps involved with solving the equation of motion using Newmark's method. Computer programs using numerical time integration methods for nonlinear analyses of SDOF systems (for example BIGGS, NONLIN, SBEDS, and CBARCS) are available. Refer to Chapter 11 for the implementation of numerical integration in a blast design.

6.4.6 Support Reactions

Perhaps the most commonly overlooked aspect of using SDOF approximations is the determination of the dynamic reactions for the actual member. The spring force in the SDOF system is not equal to the support reaction. In order to determine the dynamic reactions, the distribution of the inertia force within the member must be considered (Biggs, Chapter 5). The basic approach as illustrated in Figure 6.8 is to express the dynamic forces acting on the member, or a segment of the member, in terms of the displacement and acceleration at the control point. This displacement, $y(t)$ is determined in the solution of the time history analysis of the equivalent SDOF system.

Equations for the dynamic reactions of typical structural members are available from the same sources which provide the transformation factors. Refer to Tables 6.1, 6.2, and 6.3. These equations express the dynamic reaction in terms of the resistance and applied load, both of which vary with time.

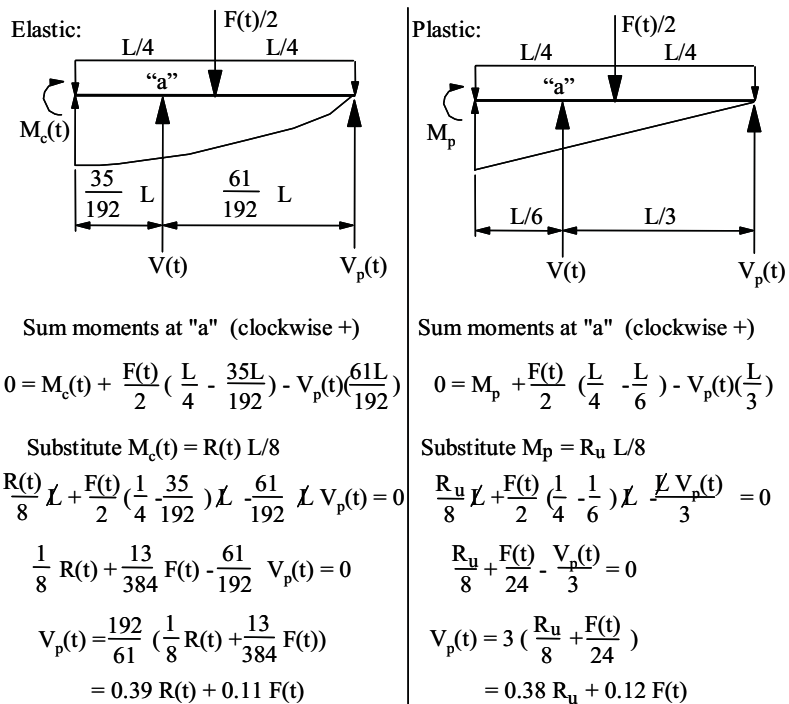

FIGURE 6.8: Reactions for a Flexural Member with Distributed Mass & Load

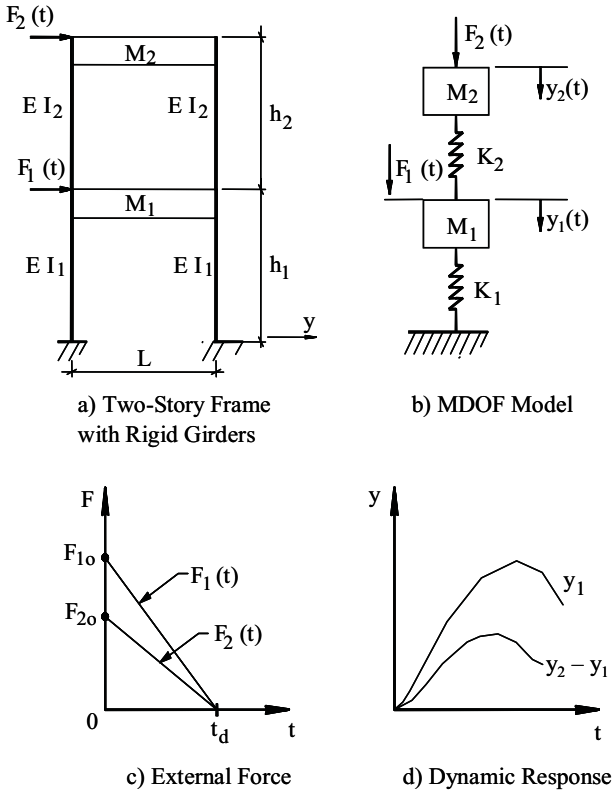

FIGURE 6.9: Typical MDOF Structure

6.5 MULTI-DEGREE OF FREEDOM SYSTEMS

This section provides technical guidance for multistory building frames, slab/beam/girder framing systems and structures having multiple concentrations of significant lumped masses. An example of a typical multi-degree of freedom structure is shown in Figure 6.9. This two story building is subjected to lateral impulse forces at the top of the first and second stories, as would be the case for blast loading. The methods and procedures for the non-linear FEA approach are described in Section 6.5.3. The extension of the dynamic analysis methods described in Section 6.4 for SDOF systems to multi-degree of freedom (MDOF) systems may be used if previous comparisons have shown acceptable correlations to test data or FEA analysis results.

6.5.1 Dynamic Equilibrium Equation

When the structural configuration is complex or, significant dynamic interaction between interconnected members can not be avoided, a coupled analysis approach can be used. The coupled analysis approach can include as few as two degrees of freedom to represent a structural system or it can involve the use of many degrees of freedom in a single, comprehensive dynamic analysis of the entire superstructure.

The MDOF approach will require the use of a computer program to perform the structural dynamic analyses due to the extensive computations. Frame analysis type programs using beam elements may be used if the structural configuration lends itself to this type of modeling. Use of general purpose finite element analysis programs may be necessary in order to accurately represent the structure with the appropriate type of element, such as plate and shell elements for continuum type structures.

A coupled analysis need not be all encompassing. For example, a two dimensional plane frame analysis of a building employing two or more degrees of freedom is considered a coupled analysis approach. Separate plane frames for each orthogonal horizontal direction can be used in lieu of a single comprehensive three dimensional model. Refer to Section 6.6.2 for a discussion on modeling considerations for this type of structure.

Responses of MDOF systems are determined from the solution of the following dynamic equilibrium equation. This equation is the matrix form of the equilibrium equation for a SDOF system (Equation 6.1).

$$[M]\{a\} + [C]\{v\} + [K]\{y\} = \{F(t)\} \quad (6.12)$$

For practical purposes, manual solutions of this equation can be obtained for only two or possibly three degrees of freedom. An example of an elasto-plastic, two degree of freedom system analysis is given by *Biggs* (pp. 237-242). Even this simple problem involves significant effort.

Solutions for MDOF systems are usually obtained through the use of finite element procedures. Due to nonlinearities associated with plasticity and possibly large displacements, the direct time integration method should be used. Various direct integration methods for time integration are employed but, the Newmark Method is perhaps the most common. Other methods, such as the Houbolt Method, Wilson-T Method and the Central Difference Method are commonly used in finite element applications. Refer to *Bathe* for further details.

6.5.2 Advanced Analysis Methods

In a strict sense, an “advanced analysis” is one in which the nonlinear geometric and material effects are accounted for in the analysis of the structure as a whole in determining its ultimate load carrying capacity. In addition, effects of local as well as overall global instability are considered such that it is not necessary to evaluate

individual members subsequent to the completion of the advanced analysis. In other words, all appropriate limit state design code requirements are incorporated into the analysis (White 1993, Chen).

A comprehensive list of behavioral phenomena and physical attributes affecting the strength and stability of steel frames is compiled in *White 1991*. Some of the items listed include initial imperfections, residual stresses, initial strains, construction sequence, effects of simultaneous axial force, shear and moment on section capacities, P-delta effect, local buckling and spread of inelastic zones in members. A similar list of items could be compiled for reinforced concrete and other structural materials. It is clear that a comprehensive advanced analysis can become quite complex.

The tools needed to perform such advanced analyses are not yet generally available. However, a number of commercially available finite element programs possess sophisticated nonlinear analysis capabilities. These analysis codes do not incorporate the design code checks for local member instabilities as is done in advanced analyses. In spite of this obvious and significant difference, the finite element analysis method is considered as an advanced analysis method for purposes of this report.

6.5.3 Finite Element Analysis Methods

A finite element analysis method is recommended when one or more of the following conditions exist:

- a. The ratio of a member's natural frequency to the natural frequency of the support system is in the range of 0.5 to 2.0, such that an uncoupled analysis approach may yield significant inaccurate results.
- b. Time varying support reactions or member forces are desired in order to evaluate the structure or its foundation in great detail in an effort to minimize costs of structural backfit modifications.
- c. Overall structural behavior is to be evaluated with regard to structural stability (frame buckling), gross displacements and P-delta effects.
- d. The structure has unusual features such as unsymmetrical or nonuniform mass and stiffness characteristics.

Many commercial computer programs are available to perform nonlinear finite element analysis with dynamic load application and may be suitable for use in blast resistant design. These programs include *ABAQUS*, *ADINA*, *ANSYS*, *LS-DYNA*, *MSC/NASTRAN* and *FLEX*. This list is only representative and does not constitute an endorsement of the programs or the techniques used. New capabilities are continually being developed and the analyst is encouraged to review the documentation for these

programs to understand the techniques and limitations. Of particular interest may be the solution formulation and the ability to resolve gaps, impacts, and contact surfaces.

Certain considerations should be given to achieve adequate results at a reasonable cost when using finite element analysis methods. One item to consider is the appropriateness and practicality of the element type. The most suitable element types from the simplest to the most complex include spring elements, line (beam) elements, plate/shell elements and solid elements.

Another important item is to consider how the finite element output data would be used to confirm compliance with acceptance criteria. For example, using stress output data from plate or shell elements to evaluate a reinforced concrete slab is not very practical. Some computer codes employ a yield criterion for plate and shell elements based on stress resultants (forces and moments), which is much more convenient for structural design purposes. Another difficulty arises when trying to determine relative displacements of a member in order to check its maximum deflection against the allowable deflection.

Finite element analysis (FEA) is becoming much more commonplace for building structures. This is driven by the improved user friendliness of programs and advances in computing power which make the analysis of nonlinear response problems feasible on microcomputers. A greater familiarity with FEA tools is also increasing their use on more conventional projects. It is important for the analyst to avoid a false sense of reliance on FEA results without an independent estimate of results. In spite of the increasing use of FEA, SDOF methods remain widely used for blast problems but limitations must be recognized.

6.6 APPLICATIONS

Dynamic analysis approaches for some typical applications are described below.

6.6.1 Shear Wall/Diaphragm Type Structures

Certainly the most common type of blast resistant structure at petrochemical facilities is a reinforced concrete or masonry, single story building with a rectangular foot print. The usual approach for designing for lateral blast loads is to design the wall facing the blast as a flexural member spanning vertically between the roof and the foundation. The roof system is designed as a horizontal diaphragm spanning between the side walls of the building. Side walls are then designed as shear walls which carry the lateral loads as well as the overturning effects to the foundation. This concept is illustrated in Figure 6.1.

Several considerations are essential when analyzing this type of structure. First, the usual load path described above may not be appropriate depending on the proportions of the building. The predominant mode of resisting lateral loads by a compact building may be through cantilever beam action as opposed to the shear

wall/diaphragm action described above. Refer to Section 6.6.3 for further discussion on modeling considerations for compact box-type structures.

Another consideration in the analysis of the shear wall/diaphragm systems is the effective width of the diaphragm flanges. Some portion of the front and rear walls can be expected to act as compression and tension flanges, respectively of the horizontal diaphragm slab. The effective width of the flange is usually taken as approximately six times the wall thickness (Derecho). Since the dynamic response of a member is affected by its natural frequency and maximum resistance, the flanges should be considered when determining the diaphragm's stiffness and strength.

A similar situation exists for the side shear walls. Some portion of the connecting front and rear walls will act as beam flanges as in a C-shaped cross section in plan. Here again, an effective width of six times the flange wall thickness may be used.

6.6.2 Frame Structures

Modeling of frame type structures generally involves use of a MDOF approach due to simultaneous application of lateral and vertical blast loads on the frame. A simultaneous application of these forces generally results in combined axial and bending load conditions in the individual frame members which significantly affect the member design. Otherwise, a conservative combination of the separate effects of each loading condition on the response of the frame must be used. Advantage can be taken of the fact that peak responses due to the vertical and lateral loads do not generally occur simultaneously.

Another consideration for frame type structures is whether to use a two or three dimensional model. The appropriate choice depends on the symmetry of the structural resistance, mass and the loading. If all three are symmetric, a two dimensional plane frame model will generally suffice.

Some studies of one and two story plane frames have examined the level of modeling detail required to obtain reasonable results which are summarized by *Baker* (pp. 442-453). These studies considered factors such as the number and spacing of joints, member loads versus joint loads, girder flexibility, sweeping roof loads and mass distribution among other factors. Due to the large number of variables studied, the reader is encouraged to refer to the referenced document to obtain a clear understanding and appreciation of the results.

Selection of the material model is another important factor to be considered. Some programs allow the user to specify plastic moment-rotation curves for beam elements. However, the more rigorous and most widely available method of defining nonlinear material properties is to specify the stress versus strain data. Plastic behavior is approximated at the section level in the former method whereas, the latter method tracks plastic behavior at the individual integration points (fibers) through the thickness of the member. Each method has its advantages and disadvantages.

The plastic hinge nonlinear material model is easier to use but usually can not consider axial load effects. Plastic hinge locations must usually be predetermined and are usually limited to the ends of the member. Analysis results which include displacements and plastic hinge rotations are directly comparable against acceptance criteria.

The more rigorous stress/strain nonlinear material model, often referred to as the plastic zone method, is theoretically capable of handling any general cross section. Both isotropic and kinematic hardening rules are usually available. This method is most practical for homogenous materials such as structural steel due to the complications involved with modeling composite materials such as reinforced concrete. Output results include stresses and strains at various locations along the length and through the thickness of each member. Obviously, the amount of output data that can be generated can become very large.

6.6.3 Slender Box-Type Structures

A typical slender box-type structure is a rectangular, reinforced concrete building having a width and length relatively small compared to its height. The response of such a building subjected to lateral loads is characterized by cantilever beam action rather than shear wall/diaphragm action as described in Section 6.6.1 above. In other words, the front and rear walls of the building act as the flanges of a vertical cantilever beam while the side walls act as beam webs. This behavior is sometimes discussed in terms of shear lag phenomena.

Some studies have been made to investigate when the cantilever beam mode becomes significant (Gupta). Guidelines are available for determining when such a structure can be analyzed as a cantilever beam, as opposed to a shear wall/diaphragm type structure. A cantilever type building can be analyzed as a SDOF system whereas the shear wall/diaphragm type structure is usually analyzed as a series of interconnected structural elements.

6.6.4 Walls With Openings

Openings in walls and roof sections can create a complex structural element in terms of dynamic response calculations. Plate type elements without openings, such as one-way span walls, can readily be represented by a simple SDOF system. Openings interrupt the distribution of stresses and reduce the ultimate resistance of a component. The resistance can be determined through a yield line analysis, which reflects the boundary conditions of the actual component including openings. The process consists of establishing a trial yield pattern, computing the resistance of each sector of the slab, and iterating the yield line locations until a convergence of the resistance in each segment is obtained. The reader is referred to *TM5-1300, Park & Gamble*, and *ASCE Manual 42* for more detailed information.

A more direct approach is use of FEA methods to determine the resistance function. This method can include the effects of openings. The resistance function

can be used to develop a SDOF system for computation of dynamic response through numerical integration or used to develop pressure-impulse diagrams. Alternatively, the FEA approach can be used to determine the dynamic response of the component directly. In either case, it is important to include the effects of coverings for openings such as a blast door or window. If the cover is relatively weak, as in the case of unimproved windows, the opening can be treated as uncovered with little error.

In some cases, the opening is relatively small and the loss of resistance is minor. In other cases, the perimeter of the opening can be designed with additional reinforcing to act as a support for the door or window and transfer loads to the supports. This “framing” configuration eliminates the weakening effect of the opening on the structural component.

6.6.5 Empirical Methods

Empirical methods based on structural damage data collected from tests and actual explosions are gaining use in evaluating existing structures for blast loading. Similar experienced-based methods of structural evaluation have been developed for seismic loading. Although these empirical methods are not yet common for blast resistant design, their use is expected to increase as more data is collected and evaluated.

As briefly mentioned in Section 6.4.3, the P-I Method is sometimes based on empirical relationships. Mathematical expressions of P-I damage curves are derived from test results. Refer to *Baker* and *CEDAW* manual for further details.

APPENDIX 6 NUMERICAL INTEGRATION METHOD

The basic steps for numerical integration using the linear acceleration method and a bilinear resistance-deflection function for compression and tension are outlined below. These steps are easily programmed for use with personal computers using spreadsheets. The following procedure is based on *Microcomputer-Aided Engineering: Structural Dynamics*, (Paz 1986). Implementation examples are included in Chapter 11. Other numerical integration methods are based on a range of approaches such as the constant velocity approach, multi-linear resistance-deflection functions, or other methods based on the Newmark beta method. Modest differences in the resulting response are not a cause for concern.

Initialize:

- a. Determine the stiffness, K , mass, M , positive resistance, R_u , rebound resistance, R_r , damping value, C , time increment, Δt , static load F_s , reaction resistance coefficient, C_R , and reaction force coefficient, C_F .

For blast design, the damping is usually set to zero.

Reaction resistance coefficients are needed only if dynamic reactions are to be calculated.

- b. At each time step (*step = 0 to last*), determine the value of the dynamic forcing function, $F_0 \dots F_{\text{last}}$
- c. For the initial time step (*step = 0*), initialize the displacement, velocity, acceleration, yield displacements, and resistance,

$$\begin{aligned} y_0 &= F_s / K \\ v_0 &= 0 \\ a_0 &= F_o / M \\ y_{e,0} &= R_u / K \\ y_{e,-0} &= R_r / K \\ R_0 &= F_s \end{aligned}$$

NOTE: The calculation of initial displacement has changed from the previous version of this report. In this version, the resistance is not reduced to account for static loads but rather the initial displacement if computed and the static load is added to the blast load.

- d. Initialize the response indicator,

$$\text{KEY}_0 = 0$$

NOTE: Values for KEY represent the following,

- KEY = 0 is elastic
- KEY = +1 is positive plastic
- KEY = -1 is rebound plastic

For each time step: (*step = i, beginning with i = 0*)

- a. Calculate the effective stiffness,

$$\begin{aligned} \text{if (KEY}_i = 0) \text{ then } K_{e,i} &= K + (6 / \Delta t^2) M + (3 / \Delta t) C & (6A.1) \\ \text{otherwise } K_{e,i} &= (6 / \Delta t^2) M + (3 / \Delta t) C \end{aligned}$$

- b. Calculate the effective incremental force,

$$\Delta F_{e,i} = (F_{i+1} - F_i) + [(6 / \Delta t) M + (3) C] v_i + [(3) M + (\Delta t / 2) C] a_i \quad (6A.2)$$

- c. Solve for the incremental displacement,

$$\Delta y_i = \Delta F_{e,i} / K_{e,i} \quad (6A.3)$$

- d. Calculate the incremental velocity,

$$\Delta v_i = (3 / \Delta t) \Delta y_i - (3) v_i - (\Delta t / 2) a_i \quad (6A.4)$$

- e. Calculate displacement, and velocity at the next time step (*step = i + 1*),

$$y_{i+1} = y_i + \Delta y_i \quad (6A.5)$$

$$v_{i+1} = v_i + \Delta v_i \quad (6A.6)$$

- f. Determine the calculation case indicator, Z, for the next time step, (Z is used as a switching mechanism in selecting the appropriate formulas for KEY, y_e , and y_e .)

$$\begin{aligned} \text{if (KEY}_i < 0) \text{ and } (y_{i+1} < y_i) \text{ then } Z_{i+1} &= 1 & (6A.7) \\ \text{if (KEY}_i < 0) \text{ then } Z_{i+1} &= 2 \\ \text{if (KEY}_i > 0) \text{ and } (y_{i+1} > y_i) \text{ then } Z_{i+1} &= 1 \\ \text{if (KEY}_i > 0) \text{ then } Z_{i+1} &= 3 \\ \text{if } (y_{i+1} < y_{e,i}) \text{ then } Z_{i+1} &= 5 \\ \text{if } (y_{i+1} > y_{e,i}) \text{ then } Z_{i+1} &= 6 \\ \text{otherwise } Z_{i+1} &= 4 \end{aligned}$$

NOTE: Values for Z represent the following:

- Z = 1 is increasing plastic deformation
- Z = 2 is end of rebound plastic deformation
- Z = 3 is end of positive plastic deformation
- Z = 4 is continued elastic deformation

$Z = 5$ is start of rebound plastic deformation

$Z = 6$ is start of positive plastic deformation

- g. Determine the response indicator for the next time step,

$$\begin{aligned} \text{if } (Z_{i+1} = 1 \text{ or } 4) \text{ then } KEY_{i+1} &= KEY_i & (6A.8) \\ \text{if } (Z_{i+1} = 5) \text{ then } KEY_{i+1} &= -1 \\ \text{if } (Z_{i+1} = 6) \text{ then } KEY_{i+1} &= 1 \\ \text{otherwise } KEY_{i+1} &= 0 \end{aligned}$$

- h. Determine the positive yield displacement at the next time step,

$$\begin{aligned} \text{if } (Z_{i+1} = 2) \text{ then } y_{e,i+1} &= y_i + (R_u - R_u-) / K & (6A.9) \\ \text{if } (Z_{i+1} = 3) \text{ then } y_{e,i+1} &= y_i \\ \text{otherwise } y_{e,i+1} &= y_{e,i} \end{aligned}$$

- i. Determine the rebound yield displacement at the next time step,

$$\begin{aligned} \text{if } (Z_{i+1} = 2) \text{ then } y_{e-,i+1} &= y_i & (6A.10) \\ \text{if } (Z_{i+1} = 3) \text{ then } y_{e-,i+1} &= y_i - (R_u - R_u-) / K \\ \text{otherwise } y_{e-,i+1} &= y_{e-,i} \end{aligned}$$

- j. Calculate the resistance at the next time step based on the value of KEY,

$$\begin{aligned} \text{if } (KEY_{i+1} = 0) \text{ then } R_{i+1} &= R_u - (y_{e,i+1} - y_{i+1}) K & (6A.11) \\ \text{if } (KEY_{i+1} = 1) \text{ then } R_{i+1} &= R_u \\ \text{otherwise } R_{i+1} &= R_{u-} \end{aligned}$$

- k. Calculate acceleration at the next time step,

$$a_{i+1} = [F_s + F_{i+1} - (C) v_{i+1} - R_{i+1}] / M \quad (6A.12)$$

- l. If desired, calculate the dynamic reaction,

$$V_i = (C_R) R_i + (C_F) F_i \quad (6A.13)$$

- m. Positive and rebound ductility ratios may be calculated as follows,

$$\mu_{d,i} = (y_i - y_{e,i} + y_{e,0}) / y_{e,0} \quad (6A.14)$$

$$\mu_{d-,i} = (y_i - y_{e-,i} + y_{e-,0}) / y_{e-,0} \quad (6A.15)$$

- n. Repeat the loop until the desired deformations are reached.

CHAPTER 7 DESIGN PROCEDURES

7.1 INTRODUCTION

The purpose of this chapter is to tie together all the subjects of the preceding chapters and to discuss design requirements for structural elements. General blast design concepts which apply to all structures are discussed. Next, a design sequence is outlined. Finally, specific design methods for blast resistant building construction are presented.

7.2 GENERAL DESIGN CONCEPTS

Several important concepts should be kept in mind while designing buildings for blast resistance. These concepts include energy absorption, safety factors, limit states, load combinations, resistance functions, structural performance considerations, and most importantly, redundancy. A design satisfying all required strength and performance criteria would be unsatisfactory without redundancy.

Although the structural design codes (i.e. AISC 360, ACI 318, and ACI 530) do not specifically cover blast resistant design, they remain the best design tools commonly available and are supplemented by these design recommendations.

7.2.1 Energy Absorption

The need for achieving ductile responses has been discussed previously in Chapter 5. However, both strength and ductility are necessary to achieve high energy absorption. Energy absorption capacity equates to the area under the load versus displacement diagram, or resistance function, of a member or overall structure (refer to Figure 5.1). High energy absorption capacity is achieved through the use of appropriate structural materials and details. These details must accommodate relatively large deflections and rotations in order to provide redundancy in the load path. High strength with low ductility is undesirable for conventional design, and is even less desirable for blast resistant design.

7.2.2 Safety Factors

Traditional definitions of safety factors in terms of strength requirements, such as load-resistance factors or allowable stresses, are not applicable in blast resistant design. Safety factors are more appropriately measured in terms of strain energy demand versus strain energy absorption capacity. Allowable deformations are a practical method to quantify energy absorption capacity.

Margins of safety against structural failure are achieved through the use of allowable deformation criteria as presented in Chapter 5. As long as the calculated deformations do not exceed the allowable values, a margin of safety against failure exists.

An additional method which has been used to achieve a margin of safety is to increase the design blast pressure loading. For example, *UFC 3-340-02* recommends adding 20% to the weight of the charge. However, increasing the blast load is not common, and is not recommended, for petrochemical explosions because of the methods used in load prediction.

7.2.3 Limit State Design

Limit state design methods are used in blast resistant design. These methods provide a comprehensive, reliable and realistic means of predicting failure mechanisms and structural capacities. Limit state design specifications are available for structural steel, cold formed steel, reinforced concrete, aluminum, and reinforced masonry. Details on the implementation of these methods are given in subsequent sections in this chapter for each class of material.

Each of the limit state design specifications contains special provisions for high seismic conditions, which are commonly used for blast resistant design. These provisions are intended to protect against nonductile failure modes, such as buckling or premature crushing of brittle materials, through use of special detailing and design requirements.

7.2.4 Loading Combinations

Limit state design specifications define the load factors and combinations of loads to be used for conventional loading conditions such as dead, live, wind and earthquake. However, no current limit state design specifications cover blast loading conditions. Blast loads are combined with only those loads which are expected to be present at the time of the explosion. Therefore, blast loads are not combined with earthquake and wind loads.

The basic limit state loading combination for all material types used in blast resistant design is as follows:

$$1.0(DL) + 1.0(LL) + 1.0(BL) \quad (7.1)$$

where,

DL = dead load

LL = live load

BL = blast load

All or part of the live load may not be used, refer to Section 6.2.4. Unit load factors are based on the presumption that the accidental blast loading condition is an extremely rare occurrence.

7.2.5 Resistance Functions

In order to determine the dynamic response of a system, one needs to develop generalized force versus deflection relationships for the overall structure or each member. These force versus deflection relationships are usually nonlinear (due to materials or geometry) and are called resistance functions. They are an essential input parameter for the analysis of equivalent single degree of freedom (SDOF) systems. Resistance functions are not usually needed for analyses of multi-degree of freedom (MDOF) systems. Material models employing nonlinear stress versus strain data, as discussed in Chapter 5, are used in MDOF systems.

The first step in developing a resistance function is to determine the plastic section capacities, such as plastic moment, M_p , as shown in Figure 7.1. The next step is to determine the sequence of plastic hinge formation and the corresponding load and deformation values. This is done by incrementally applying loads until a collapse mechanism is formed as illustrated in Figure 7.2 for a fixed end beam with a uniform load. Collapse loads for other common one way members are included in Tables 6.1 through 6.3. For a more complete treatment refer to Chapter 5 of *Biggs*.

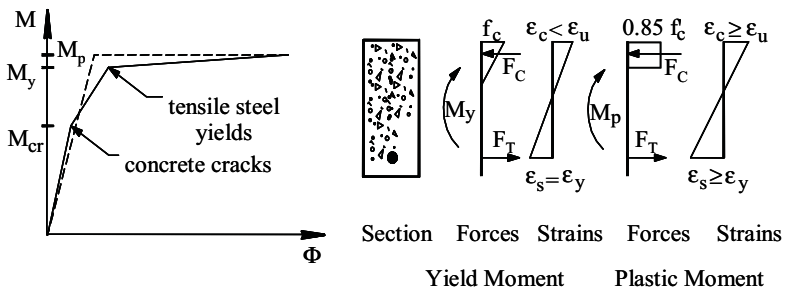

a) Moment Versus Curvature for R/C Section

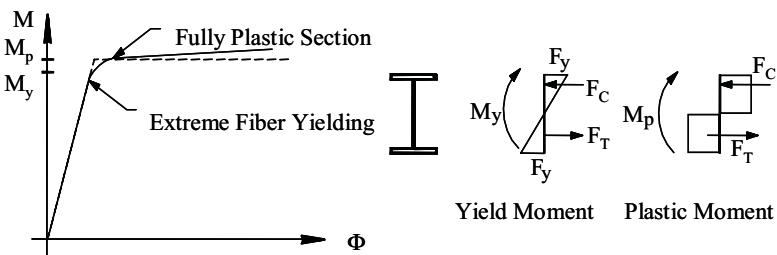

b) Moment Versus Curvature for Steel Wide Flange Section

FIGURE 7.1: Typical Moment Versus Curvature Diagrams

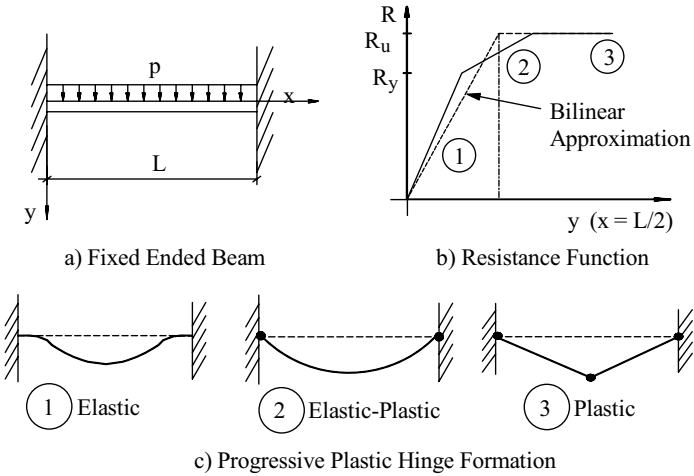

FIGURE 7.2: Resistance Function for Member With Sequential Plastic Hinges

The piecewise linear curve representing the resistance function shown in Figure 7.1 is an approximation made to simplify the analysis and design process. This approximation ignores some nonlinear effects such as:

- concrete and masonry - softening due to cracking, initial yielding
- reinforcing steel and structural steel - strain hardening
- structural steel - progressive yielding of fibers through the section thickness

Preloads are sometimes considered in developing resistance functions. Preloads are any dead or live loads which cause a deformation in the member and thereby use up some of the available strain energy. Effects of preload on equivalent SDOF system analyses are sometimes handled by reducing the calculated available resistance by the amount of the preload. Another approach is to simply superimpose the preload on top of the blast load.

Resistance functions can be further approximated by elastic, perfectly plastic bilinear functions which are used in the development of response charts and formulas. The approximation is made by maintaining maximum resistance and equating areas under the curve (strain energy) up to maximum resistance, R_u , as shown in Figure 7.2. Maximum resistance values may be different for the positive and negative

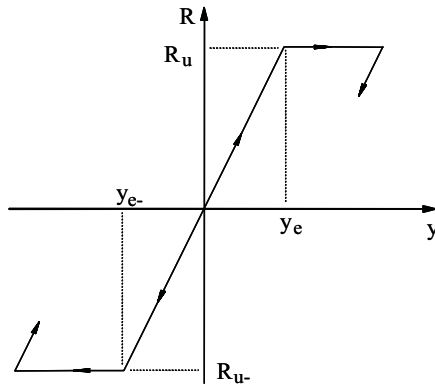

FIGURE 7.3: Typical Simplified Elasto-Plastic Resistance Function

loading directions. Strain hardening effects can be considered, refer to Section 5.5.5. A typical resistance function is illustrated in Figure 7.3.

The basic steps outlined above for the design of flexural members also apply for shear members. One major difference is the determination the initial stiffness (slope) of the resistance function. Shear deformations are as large or larger than flexural deformations for these types of members and therefore cannot be neglected as is the case of flexural members. Maximum resistance is determined in accordance with the shear strength design provisions of *ACI 318* without strength reduction factors ($\phi = 1.0$).

7.2.6 Structural Performance Considerations

Structural performance requirements for blast resistant design include limits imposed on member deflections, story drifts and damage tolerance levels. Conventional serviceability requirements are not applicable for the one-time severe blast loading conditions. Refer to Chapter 5 for additional information.

7.3 MEMBER DESIGN PROCESS

The following steps depict the design process for individual members. Descriptions of each individual step are given in the following sections.

- STEP 1: LOAD DETERMINATION
- STEP 2: DETERMINATION OF MEMBER PROPERTIES
- STEP 3: MODEL REPRESENTATION
- STEP 4: TRIAL MEMBER SELECTION

STEP 5: DYNAMIC ANALYSIS

STEP 6; DEFORMATION CRITERIA CHECK

STEP 7: CONNECTION DESIGN

These steps are described in the following sections.

7.3.1 Load Determination

For primary members (external walls, roof slabs, etc.), the load computation is performed in accordance with Chapter 3. Loads on supporting, or interior members, are determined either by 1, the tributary area method or 2, from a computed dynamic reaction. In the tributary area method, external blast pressures are multiplied by the exterior surface area tributary to a support location. The resulting force is then applied to the next member. Dynamic reactions result from a numerical time history analysis (refer to Section 6.4.5) and provide a more accurate time-varying load on the supporting member. Use of dynamic reactions in SDOF analyses should be limited to one supported component. Use for a sequence of supported members could result in erroneous results. Dynamic interaction and inherent damping in an actual structure cannot be properly captured through the use of SDOF methods.

7.3.2 Determination Of Member Properties

Member properties are determined in accordance with Chapter 5. Required dynamic properties usually include unit weight, modulus of elasticity, elastic yield strength, and allowable deformations. Additional properties include post-yield strength or membrane resistance.

7.3.3 Model Representation

Mathematical models for individual structural members will need to be developed. The engineer will then decide on the most appropriate structural representation, such as one-way versus two-way action, and loading distributions for each member. Individual members are usually idealized as simple one-way beams or two-way plates since these types of members can be adequately analyzed as equivalent SDOF systems with minimal engineering effort. One-way members are the most common.

Boundary conditions need to be evaluated based on the type of connections to be used for the member supports. The engineer must keep in mind that support details must provide sufficient strength, ductility and stability to enable the member to develop full collapse mechanism. Support capability to resist reaction forces for both the loading and rebound phases of the response must be considered when evaluating boundary conditions.

7.3.4 Trial Member Selection

Unlike most static design procedures, dynamic design requires a trial and error approach. Only in the verification of shear capacities and in the design of support connections can member proportions be directly determined. For the dynamic analysis, the needed nonlinear response properties are determined from a trial section. The analysis results then indicate the adequacy of the trial section. Experience on the part of the engineer will help in reducing the number of iterations. The use of simple computer based design approaches help to reduce the time required for each analysis iteration.

7.3.5 Dynamic Analysis

The dynamic analysis itself is then performed by one of a number of different methods ranging from simple chart or equation solutions to complex nonlinear finite element analysis. Analysis methods are covered in Chapter 6. The purpose of this step is to compute member deformations and reactions.

7.3.6 Deformation Criteria Check

Analysis results will indicate peak element deformations which should be compared to the allowable values given in Chapter 5. Deformations will be dealt with in terms of ductility ratios, support rotations, deflections, or as deflection-span ratios. If the allowable values are not met, then some changes to trial member sizes or to structural configurations must be made and the analysis repeated. Material specific criteria are provided in Sections 7.4 through 7.6.

7.3.7 Connection Sizing

Connections must be sized to transfer computed reaction forces and to ensure that plastic hinges can be maintained in the assumed locations. For reinforced concrete design, splices and development lengths must provide for the full yield capacities of reinforcing. For structural steel design, connections are designed for a capacity somewhat greater than that of its supported member. Further information is provided in later sections of this chapter. Typical connection details are provided in Chapter 8.

7.4 REINFORCED CONCRETE DESIGN

Reinforced concrete is often used in petrochemical buildings for the exterior faces directly exposed to blast effects. The exterior faces may be cast-in-place or precast.

Wall and roof elements are usually made of reinforced concrete for projectile penetration resistance. Roof and side wall structural elements may also use the inherent in-plane strength of concrete to resist lateral blast forces. Being relatively thin flexural elements, walls and roofs should be designed for a considerable ductile response in order to absorb blast energy without transmitting it to the supporting elements. Construction preferences often indicate the need to eliminate shear

reinforcing if at all possible to reduce field labor costs. The combination of these objectives leads to the need for higher strength concrete.

Precast walls are used for two reasons: to reduce the cost of the building through decreased field labor, and to shorten the schedule by constructing the walls and foundations simultaneously. The largest drawback for the use of precast structural elements is the design and detailing of connections. As in seismic design, special attention to ductility must be paid.

Foundations are always constructed of reinforced concrete. Blast resistant buildings can be supported on piled or soil supported mats. Spread footings are used with a grade beam system to minimize relative displacements between individual footings.

7.4.1 Design Principles

ACI 318 is used to extend standard concrete strength and ductility requirements to the design of blast resistant structures. The resistance of concrete elements is computed using the dynamic material strengths given in Section 5.4. Strength reduction factors are not applied (i.e. $\phi = 1.0$) to load cases involving blast. The plastic response used in blast design is similar in concept to the moment redistribution provisions in *ACI 318*, Section 8.4 and the seismic criteria provided in *ACI 318*, Chapter 21. The more extensive seismic detailing provisions are applied to provide the necessary ductile response.

7.4.2 Supplementary Design Requirements

In addition to *ACI 318* requirements, the following items should be considered for blast resistant design.

- a. Minimum reinforcing: The minimum reinforcing provisions of *ACI 318* apply, however the option to use one-third more reinforcing than computed should not be taken. The moment capacity of under-reinforced concrete members is controlled by the uncracked strength of the member. To prevent a premature ductile failure, reinforcing in excess of the cracking moment should be provided. In computing minimum reinforcing, the dynamic material strengths discussed in Chapter 5 should be used.
- b. Maximum reinforcing: Code provisions for maximum reinforcing are included to prevent crushing of concrete prior to yielding of steel. Code provisions also allow compression reinforcing to offset maximum tension reinforcing requirements. Because blast resistant concrete members typically have the same reinforcing on each face to resist rebound stresses, maximum reinforcing provisions should not be a problem.
- c. Substitution of higher grades of reinforcing: The substitution of higher grades of reinforcing should not be allowed. Stronger reinforcing tends to increase

the moment capacity of a concrete section while not affecting the concrete shear capacity. This could cause a ductile response to become non-ductile. Additionally, a higher moment capacity will tend to increase the dynamic reaction which the supporting member must resist. Because ASTM specifications provide minimum requirements, mill test reports should be reviewed for possible significant over-strength.

- d. Development lengths: Development lengths should not be reduced for excessive reinforcement. Because plastic hinges will cause over-designed reinforcing to yield, the full actual strength of reinforcing should be used in computing section capacities. The development of reinforcing should be computed accordingly.
- e. Serviceability requirements: Criteria intended to reduce cracking at service load levels need not be applied to load combinations including blast. Cracking, as well as permanent deformations resulting from a plastic range response, are an expected result of such an unusual type of load. The ductility limits of Chapter 5 are consistent with the performance requirements of the building under blast.
- f. Lacing: This a special type of shear reinforcing that uses a continuous zigzag shape to very effectively tie together longitudinal bars. Lacing is traditionally used only in highly special situations, such as containment walls, where very large deformations are tolerable. Recent reports on slabs indicate adequate plastic rotation capacity can be achieved with the use of standard tie bars or stirrups to restrain longitudinal reinforcing.
- g. Combined Forces: Some concrete elements are simultaneously subjected to out-of-plane bending loads in combination with in-plane shear loads. For example, side walls must resist side overpressures acting into the plane of the side wall. Additionally, reactions from the roof diaphragm acting in the plane of the side wall must also be resisted. There are three means of dealing with this situation:
 1. Separate sets of reinforcing may be determined for each type of force to be resisted. For example, exterior reinforcing may be sized to resist bending while a layer of center reinforcing may be used to resist in-plane shear. Care must be used to make sure hinge capacities are not changed as a result of reinforcing intended for other purposes.
 2. An interaction equation, based on criteria from *ASCE Manual 42* can be applied to determine acceptable behavior:

$$[\Delta_d/\Delta_a]_{ip}^2 + [\Delta_d/\Delta_a]_{op}^2 \leq 1.0 \quad (7.2)$$

where,

Δ_d	= computed deformation (ductility ratio or support rotation)
Δ_a	= allowable deformation (ductility ratio or support rotation)
ip	= (subscript) in-plane deformations
op	= (subscript) out-of-plane deformations

3. The time phasing of in-plane shear and normal loads can be determined from a numerical integration. Provided the peak forces are reached at different times, these forces can be treated separately. Judgment must be used to make this determination.

7.4.3 Failure Mechanisms

The primary failure mechanisms encountered in reinforced concrete buildings are flexure, diagonal tension, and direct shear. Of these three mechanisms, flexure is preferred under blast loading because an extended plastic response is provided prior to failure. To ensure a ductile response, sections are designed so that the flexural capacity is less than the capacity of non-ductile mechanisms.

Shear reinforcing is not commonly used in wall and roof elements even though reinforced elements can undergo an extended plastic response. Shear reinforcing increases the diagonal shear capacity of the member, but more importantly, it provides lateral restraint for the principal reinforcing. Such restraint is vital for large deformations where exterior protective concrete will spall.

Other failure mechanisms involve portions of structural elements or the transmissions of loads between elements. These other mechanisms must be sized so as not to control the overall structural response. Such failure mechanisms include failures of reinforcing development, precast connection, anchor bolt embedments, and door connections. These types of failures involve reinforcing development and anchor bolt embedment. Non-ductile failures are prevented by providing a concrete embedment strength greater than the material strength of the anchor bolt or reinforcing bar. Connection type failures involving precast connections or door and window frame embedment are avoided by designing these connections so that the plastic hinge occurs away from the connection.

Situations will occur where a ductile bending mechanism is not attainable. Deep roof diaphragms and side walls resisting in-plane shear are two examples. For these cases, the response must be limited accordingly. Refer to Chapter 5 for these limits.

7.5 STEEL DESIGN

Applications for structural steel in blast resistant design include beams and columns for the support of vertical loads, braced and rigid frames for the support of vertical and horizontal loads, and specialized elements such as doors, window frames,

decking, and protection for duct openings. For lower blast loads, steel siding can be used.

Structural steel has the advantage of quick assembly at the jobsite. Specialized elements, such as doors, are usually delivered in one piece ready for installation into concrete formwork or into the building frame. Being a factory produced material, steel has well controlled and predictable strength and post-yield properties. Unlike concrete, steel has good tensile as well as compressive strength.

The disadvantages of structural steel in blast design are twofold. The most significant is the inherent slenderness of steel and the possibility of premature local or general buckling. A less significant disadvantage is that steel siding has a lower resistance to projectile penetration.

7.5.1 Design Principles

The *AISC Specification for Structural Steel Buildings* (AISC 360) is used as the basis for blast resistant design. The resistance of structural steel elements is computed using the dynamic material strengths given in Section 5.4. Strength reduction factors are not applied (i.e. $\phi = 1.0$) to load cases involving blast. The resistance of structural steel elements is computed using plastic analysis techniques and seismic detailing provisions.

Slenderness considerations are of particular importance to the ductility of structural steel members. Steel, as compared to other building materials used in blast design, is considerably thinner, both in terms of the overall structure and the components of a typical member cross section. As a result, the effect of overall and local instability upon the ultimate capacity is an important consideration. Width-thickness provisions must be applied not only to the extent that a full plastic capacity can be achieved, but to the extent that higher ductility ratios can also be safely reached. The width-thickness ratios, from Table I-8-1 of *Seismic Provisions for Structural Steel Buildings* (AISC 341) are used for this purpose.

7.5.2 Supplementary Design Requirements

In addition to *AISC 360* requirements, the following should be considered for blast resistant design:

- a. Substitution of higher grades of steel: Substitutions of higher grades of steel should not be allowed. Higher grades of steel possess less effective resistance-deflection curves, may alter the relationship between flexural and shear capacity, and tend to increase the dynamic reaction which supporting members must resist.
- b. Cold formed steel: *AISI 2001* is used with several adjustments. The special provisions within these specifications pertaining to seismic design are adopted for blast resistant design.

- c. Diaphragms: In the design of walls to resist blast pressure loads, it is generally assumed that the walls are supported at opposite sides for one-way slab design or supported at four sides for two-way slab design. Therefore, the roofs or the floors should be designed adequately as diaphragms to resist the in-plane loads and transmit them to the resisting shear walls.

In addition to the above in-plane loads, the roof diaphragms also are subjected to normal positive overpressures and, to a less severe extent, normal negative pressures.

Roof diaphragms should be designed to resist lateral wall reactions applied as in-plane loads as well as blast overpressures applied as out-of-plane loads. Though Equation 7.2 could be used for this load interaction, separate structural bracing members are normally added to transfer lateral wall reactions. Refer to *AISI 2001* for further information.

- d. Connection design: To maximize the plastic response, the connection must not control the capacity of the member. Preferably, a moment connection will force a plastic hinge away from the connection and into the member. Connection strength is determined through *AISC 360* design methods. Ductility requirements are implemented through the use of appropriate connection details.

Both welded and bolted type connections are used in rigid and semi-rigid construction. There is no particular advantage of using one type over the other with regard to joint performance under blast loading conditions. Since plastic hinges are likely to be formed at member connections, special connection details require careful consideration of the effects of possible stress concentrations. Sharp corners and weld details prone to undercutting should be avoided. *AISC 360* fatigue criteria should be consulted for additional information.

Some insight on what types of details should be used or avoided can be obtained by referring to *AISC 341*. Additional discussions of the basic design concepts for structural steel connections are given in Chapter 6 of *TR 4837* and Chapter 5 of *UFC 3-340-02*.

Detailed evaluations of connection ductility are usually not performed. However, in some special cases it may be necessary to evaluate moment versus rotation characteristics. Theoretical methods for predicting connection behavior, as well as an electronic database of actual test data, are available from *Chen*. Useful information on moment versus rotation relationships for various types of connections can also be obtained from *Committee 43, White 1991*, and *ASCE Manual 41*.

- e. Cladding: Cold-formed light gauge sheet metal panels are a common cladding material used in petrochemical buildings. Prefabricated buildings with metal siding and roof deck panels are quite common in petrochemical facilities. These are used only in low blast pressure applications due to premature buckling of the relatively thin webs.

The *AISI LRFD Cold-Formed Steel Design Specification* (AISI 2001) is used as the basis for blast resistant design. Strength reduction factors are not applied (i.e. $\phi = 1.0$) to load cases involving blast. *ASTM A653* is the widely-used material by cold-formed steel fabricators. Properties of steel panels can be found from manufacturer catalogs. It is also to be noted that section properties of cold-formed steel panels will change with the increase of load intensity. As the load increases beyond the level of local buckling, properties like area and moment of inertia decrease and deflection increases. For large deflections, the steel panel acts as a membrane in tension. Therefore care must be exercised in selecting the proper section for the anticipated load.

The resistance of a cold-formed steel panel is computed using dynamic increase factors given in Chapter 5. Chapter 5 also suggests a factor of 0.9 in computing resistance in flexure and provides necessary equations.

The primary failure mechanisms encountered in cold-formed steel panels are bending and shear. Care must be exercised to preclude shear failure by increasing the span length etc. Since cold-formed steel panels will usually have thin webs, web crippling must be prevented by providing sufficient bearing area.

Acceptable response ranges are given in Chapter 5. Use low response range values when tension membrane action is not present. Use high range values when tension membrane action is permitted and steel panel end connections are properly designed.

7.5.3 Failure Mechanisms

Ductility limits for structural steel members are established such that gross member collapse due to failure of the member itself or its connections is precluded. It is presumed that local and gross member instabilities are prevented by providing adequate bracing and stiffeners. Shear failure modes are also to be precluded by design. Determination of failure mechanisms and corresponding capacities for flexural members and beam-columns are adequately covered by *AISC 360*.

Connections of structural steel members are generally designed to develop the full strength of the member. With regard to ductility evaluations for connections, explicit checks are generally not made. It is presumed that satisfaction of the gross member displacement ductility criteria ensures the integrity of the member connections.

7.6 REINFORCED MASONRY DESIGN

Masonry, both reinforced and unreinforced, is a common construction material in petrochemical facilities. However, unreinforced masonry is inappropriate in blast resistant design due to its limited strength and its nonductile failure mechanisms. Reinforced masonry walls with independent structural framing for vertical loads are commonly used in blast resistant design.

The blast capacity and ductility of reinforced masonry walls are much lower than can be achieved with reinforced concrete of comparable dimensions. The lower capacities are due to the limited available space for placing steel reinforcing, the lower compressive strength of the masonry, and the limited mortar bond strength.

7.6.1 Design Principles

ACI 530 is used to design blast resistant masonry structures. The resistance of masonry elements is computed using the dynamic material strengths given in Section 5.4. Strength reduction factors are not applied (i.e. $\phi = 1.0$) to load cases involving blast. Additionally, strength design principles for reinforced masonry are well documented in many texts such as *Schneider*. Ductility is achieved by adhering to *ACI 530* detailing provisions for high seismic zones.

7.6.2 Supplementary Design Requirements

Design requirements corresponding to *ACI 530* seismic criteria are used in blast resistant design of masonry structures, with some minor adjustments:

- a. Interaction: Interaction between in-plane and out-of-plane loading effects is considered by using Equation 7.2.
- b. Shear Walls: As is the case for reinforced concrete, it is not generally practical to achieve flexural failure modes for reinforced masonry shear walls. However, the use of shear reinforcing in the form of horizontal joint reinforcing does provide some limited ductility.

7.6.3 Failure Mechanisms

The failure mechanisms of interest in reinforced masonry wall elements include flexural, transverse shear, in-plane shear and in some cases, combined axial compression and flexure. Buckling failure modes of compression elements and connection failures are to be avoided.

7.6.4 Diaphragms

Diaphragms transfer blast loads to supporting members through in-plane action. The most common type of steel diaphragm is a cold-formed, corrugated floor or roof deck which transfers lateral loads to shear walls or braced frames. Very little

published technical guidance exists pertaining to the design of diaphragms for severe loading conditions. The recommended procedure is to design metal diaphragms elastically using conventional design methods outlined by *SDI* and *AISI 1967*. Refer to *Yu* (Chapter 9) for a comprehensive discussion including examples on the design of steel diaphragms. The design of metal cladding on the exterior surfaces of buildings for flexural action is discussed in Section 7.7.

Special considerations for attaching roof decking to the structural frame are listed in *UFC 3-340-02*, Sections 6-17 through 6-22 and in *NEFC*, Section 5.4 for blast loading conditions. These considerations include items such as material specifications, minimum recommended rib depth and sheet metal gage, side lap requirements and fastener details. The emphasis is on providing connections having adequate strength to secure the roof deck under combined inplane and normal loads.

In addition to the in-plane loads, roof diaphragms also are subjected to normal positive overpressures and, to a less severe extent, normal negative pressures. Diaphragms should be designed to resist simultaneous in-plane and normal blast loads in conjunction with other applicable loads. The time lag between in-plane and normal loads may be taken into account in the design. The deflection of the diaphragm should be checked to confirm that it does not exceed permissible deflections established for attached elements.

7.7 FOUNDATION DESIGN

Normally, the overall blast capacity of a building is not controlled by its foundation because there is usually adequate inherent strength to prevent a catastrophic failure or excessive movement. However, excessive dynamic movements from a blast load could result in unacceptable foundation damage, which because of inaccessibility, can be difficult and expensive to repair. As described in detail in Chapter 10, foundation analysis and design issues may also be more technically challenging in the case of existing older buildings that were originally designed for blast loadings that are lower than current practice, where changes in resultant loading levels could result in more severe foundation problems.

There are two basic approaches to foundation design: static and dynamic. The static design approach is almost always selected because of its simplicity. However, sometimes an overly conservative design could result. The dynamic approach involves a very complex analysis, although it should result in a more realistic design.

Typical structural foundation types used for blast resistant structures tend to be more rigid and tend to provide more continuity than those used for conventional design. Relative displacements between columns and walls need to be minimized in order to maintain structural integrity. This is similar to seismic design which is accomplished by using grade beams to tie together spread footings or pile caps, or by using combined mat foundations. Because lateral blast forces are quite high compared to conventional loads, battered piles may be required. Structural connections of lateral supporting elements such as battered piles should be properly detailed.

Under some conditions, high uplift forces transferred to the foundation exceed its uplift capacity. In this case anchor bolts should be designed for the weight of the individual foundation, including soil weight above the footing (if footing is buried) and the inertia effects of the foundation and soil, rather than the peak uplift reaction of the column as determined using an analytical model where uplift is restrained. Inertia effects can be estimated by constructing an isolated, simplified sub-model or free-body diagram of the foundation system, and applying the calculated dynamic reaction force as a time varying load. It is necessary to include some extensional flexibility of the column or anchor bolts in this simplified sub-model, otherwise the resulting rigid body model analysis will not yield any reduction in the anchor bolt design forces. An estimate of the maximum uplift for the foundation can be obtained by applying the impulse-momentum and work-energy principles.

In general, mat foundations should be the choice of foundation type for blast resistant buildings. Floating slabs should not be used as a diaphragm in foundation design due to inadequate lateral support for walls.

A preferred method of integrated foundation design is that foundation walls be poured monolithically with the slab and concrete or masonry walls that begin at the slab level. This design encapsulates the soil between the foundation walls which increases the mass of the foundation system and thereby provides greater resistance to blast forces, with resulting reduction in horizontal displacements.

A suitable connection between the foundation and prefabricated superstructure should be provided, to ensure that the foundation is an integral part of the blast load resistant system. The horizontal load on the connection should not exceed the friction force between concrete of the foundation and soil. The passive pressure on the side of foundation from adjacent grade down to 2 ft (0.6 m) below grade should not be considered in the calculation of lateral resistance. In some cases where site subsurface condition at structure locations are poor, i.e., consisting of soft compressible soils, pile foundations may be required to provide a portion of lateral resistance to blast loads.

In developing the soil and pile ultimate capacities, the rate of loading effect due to the impulse load, which typically results in greater resistance, may be considered.

7.7.1 Static Design Method

In the Static Design Method, foundations are typically designed for the peak reactions obtained from the superstructure dynamic analysis. These reactions are treated as simultaneous static loads, disregarding any time phase relationship. The basis for equivalent static design is discussed in *TM 5-856*.

Under blast conditions, maximum soil bearing and passive pressures are selected to prevent excessive foundation movement. The following factors of safety (defined as the ratio of ultimate capacity of the foundation element to the combined dead plus blast induced loads) are often used in equivalent static design for foundations:

- 1.2 for vertical loads on soil
- 1.2 for vertical loads on piles

- 1.5 for lateral loads on vertical piles with or without passive resistance
- 1.2 for lateral loads on battered piles without passive resistance
- 2.0 for lateral loads on battered piles with passive resistance

1.0 for lateral loads resisted by frictional resistance between soil and bottom of mat or footing.

1.5 for lateral loads (in excess of friction) resisted by passive resistance

1.2 for overturning

7.7.2 Dynamic Design Method

The static design procedure described above is widely used in the petrochemical industry. Occasionally, static design results in a foundation which is impractical or too costly. In this situation, the dynamic analysis method can be used. A dynamic analysis takes into account the inertia of the foundation mass in resisting the load, and will generally yield a more economical design. The procedure is described in detail in *TM 5-856* (Volume 4) and *TR 4921*. Another reference for a similar design approach is from *Principles of Soil Dynamics* (Das), Chapter 6, "Dynamic Bearing Capacity of Shallow Foundations". This has closed-form solutions and graphs for cases of shallow foundation rotation and vertical displacement.

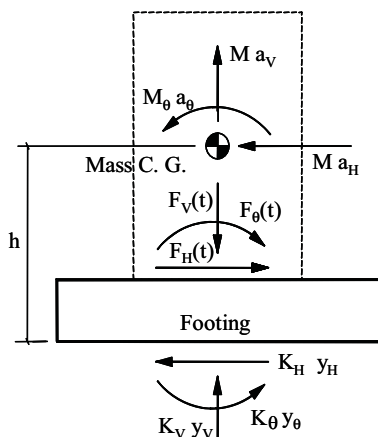

FIGURE 7.4: External Forces on a Foundation (from UFC 3-340-02)

The forces acting on a foundation are indicated in Figure 7.4. The equations of motion for the foundation can be derived from the equilibrium of forces and moments at the center of gravity:

vertical forces:

$$M a_v + K_v y_v = F_v(t) + F_s \quad (7.3)$$

horizontal forces:

$$M a_H + K_H (y_H - y_\theta h) = F_H(t) \quad (7.4)$$

rotations:

$$M_\theta a_\theta + K_\theta y_\theta - K_H (y_H - y_\theta h) h = F_\theta(t) \quad (7.5)$$

where,

- a_H = horizontal acceleration
- a_v = vertical acceleration
- a_θ = rotational acceleration
- F_H = horizontal dynamic load
- F_v = vertical dynamic load
- F_θ = rotational dynamic load
- g = acceleration of gravity
- h = height from lateral soil resistance to center of gravity
- K_H = horizontal soil stiffness
- K_v = vertical soil stiffness
- K_θ = rotational soil stiffness
- M = mass of structure
- M_θ = mass moment of inertia about center of gravity
- y_H = horizontal deflection
- y_v = vertical deflection
- y_θ = rotational deflection

As for other materials, the soil stiffnesses K_v , K_H , and K_θ are limited by ultimate soil capacities and the displacements required to develop them. Furthermore, reversals of movement and uplift can generate zero resistance and must be appropriately included in the analysis. Ultimate uplift resistance for buried shallow foundations and for pile foundations may be significant, although the displacement associated with such resistance may be different than in the case of compression or downward vertical loading. The lateral stiffness, K_H , is determined from friction, adhesion, and passive pressure as applicable with an appropriate moment arm, h . For shallow foundations subjected to simultaneous uplift and lateral forces, there may be a loss of lateral sliding friction along the foundation bottom, although passive soil resistance against the foundation will still be available.

Prior to undertaking a dynamic analysis, it should be verified that appropriate soil stiffness values for K_V , K_H , and K_θ are available from geotechnical engineering data and analysis.

Knowing the forcing functions and reactions from supported members, the translational and rotational movements of the footing can be calculated using a nonlinear numerical integration similar to that described in Section 6.4.5. Note that the lateral and rotational movements are coupled and require a modified numerical integration for two degrees of freedom. If maximum movements are found to be excessive, the foundation should be enlarged to increase its contact with the soil or deepened to increase the passive soil resistance. This trial and error approach is used until a satisfactory design is achieved.

Flexible frame type structures do not affect the foundation dynamics and the associated mass is not included. For shear wall type structures, the effect of the superstructure is more pronounced and should be included in the analysis. In general, the foundation model should include all structural elements which tend to move rigidly with the foundation. Refer to *TM 5-856* (Volume 7), Section 9.06, and *TR 4921* for further details.

Allowable foundation movements are usually left to the judgment of the foundation engineer. As for structural elements, it is usually impractical to limit foundations movements to elastic limits. Thus, a certain level of sliding and/or overturning is often tolerable. The building engineer should consider such things as repair and reusability of the building, the effect of foundation movement to underground utility penetrations, and the effect of differential foundation movement on structural elements.

7.8 DESIGN AGAINST PROJECTILES

There are two types of projectiles. Primary projectiles are caused by the disruptive failure of pressurized equipment or rotating machinery. Secondary projectiles are defined as accelerated unsecured objects which have been picked up by the blast from an explosion.

Defining the size and velocity of projectiles is beyond the scope of this document. In considering the problem of projectiles, it is necessary to link the probabilities of the following (SCI-P-112):

- the probability of a projectile occurring
- the probability of the projectile having or gaining sufficient energy to do damage
- the probability of the projectile impacting and doing damage leading to escalation

If the combined probabilities are unacceptable then a prevention or protection strategy will have to be implemented.

Projectile impact effects on a structural component are usually divided into two categories; local effects and overall response. Local effects are largely independent of the dynamic characteristics of the structure, whereas the overall response primarily depends on the dynamic characteristics of the structure. If projectile resistance is required, appropriate methods given in *SCI-P-112*, *UFC 3-340-02*, *DOE/TIC-11268*, *ASCE Manual 58*, *PIP STC01018*, and *Kennedy* may be used.

CHAPTER 8 TYPICAL DETAILS

8.1 INTRODUCTION

This chapter presents an overview of various details applicable to blast resistant structures. Many details for conventional steel and concrete structures, and specific details for seismic design, are applicable to these structures and are not included. Details should meet the requirements for design capacity, energy absorption, and ductility.

8.2 GENERAL CONSIDERATIONS

It is essential that the design engineer recognize the job is not complete until the structural system has been detailed in a manner that ensures the response will be consistent with the design intent. The development of details should also consider cost and constructability.

The details discussed or illustrated in this chapter are some that have been found to be cost effective and easily constructed. Structural steel connections are designed to move plastic hinge formation away from the connection and into the member. Reinforced concrete connections must provide full development of reinforcing with ties to permit extended plastic deformations. The design details included are not intended to limit the use of alternate designs.

8.3 ENHANCED PRE-ENGINEERED METAL BUILDING CONSTRUCTION

The enhancement of these types of buildings is achieved by using closer spacing for the building frames and girts and combining sections of the standard AISI cold-formed shapes to achieve symmetry.

Oversized washers are used to secure the cladding to the frames to minimize tearing under the effects of blast or rebound loads. Figure 8.1 illustrates the use of oversized washers. An alternative is to use conventional plug or puddle welds at spacings required to meet the load conditions.

8.4 MASONRY WALL CONSTRUCTION

All masonry must be reinforced and details typically used for reinforced masonry construction are applicable to blast resistant design.

However, one additional requirement for blast resistant design should be considered. The presence of negative pressures and rebound forces require that wall-to-frame connections be provided to ensure proper transfer of these outward acting forces. Figure 8.2 shows an application of anchor straps to handle rebound forces.

8.5 METAL CLAD CONSTRUCTION

Most details for this type of construction are not uniquely influenced by blast resistant design. For steel frame buildings, appropriate AISC steel details used for plastic design methods should be used. The attachment of the siding and roofing requires special attention and the details shown in Figure 8.1 are applicable.

8.6 PRECAST CONCRETE WALL CONSTRUCTION

This type of construction uses a steel or concrete frame and precast concrete wall panels. Many details have been developed for precast concrete walls. Details for precast walls should be in accordance with the seismic requirements of *ACI 318*, Chapter 21.

The precast details covered in this section can be grouped into two categories: conventional enhanced details and those that mimic cast-in-place details. Conventional enhanced details need to be strengthened for blast resistant design. Figures 8.3, 8.4, 8.5, and 8.6 are examples of these details. One way to provide a reliable degree of strength and ductility is to mimic cast-in-place construction. This approach has been suggested for conventional precast construction in seismic areas. Figures 8.7, 8.8, and 8.9 are examples of these details.

8.7 CAST-IN-PLACE CONCRETE WALL CONSTRUCTION

This type of construction may be totally reinforced concrete or may be a combination of concrete or steel frames with cast-in-place or precast walls. Shear wall details should be developed using the seismic provisions of *ACI 318*, Chapter 21. Figures 8.10 and 8.11 are typical cast-in-place details.

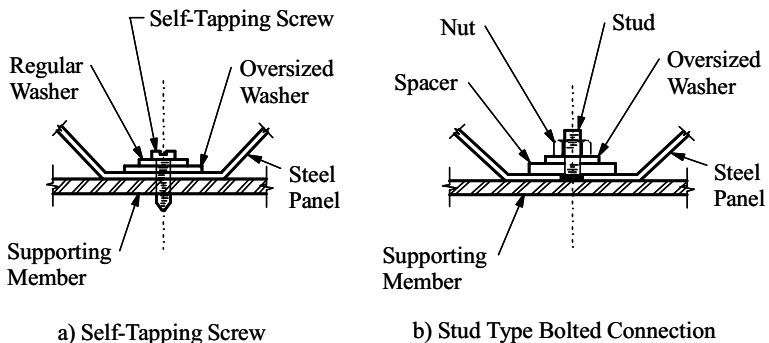

FIGURE 8.1: Use of Oversized Washers to Connect Cladding to Framing

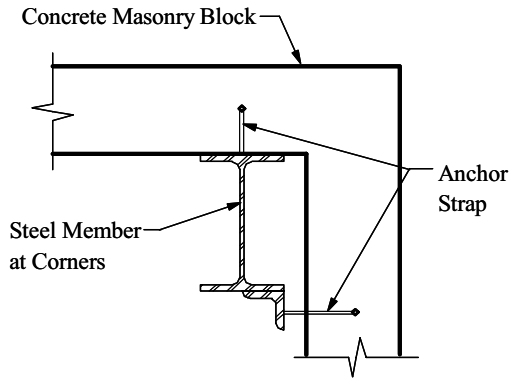

FIGURE 8.2: Masonry Anchors

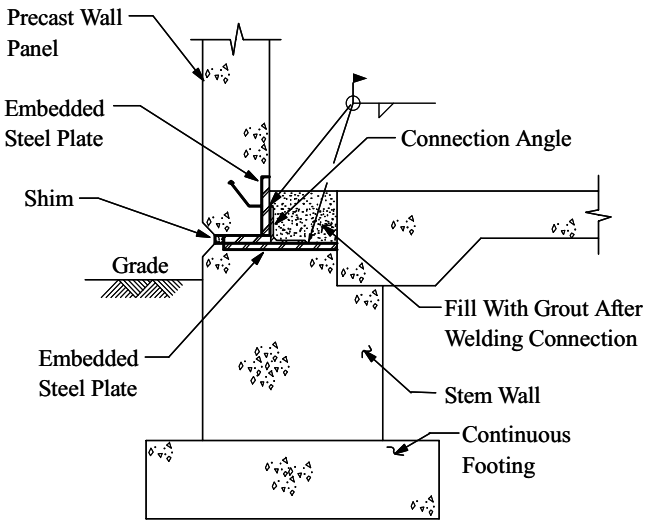

FIGURE 8.3: Precast Panel Connection to Foundation

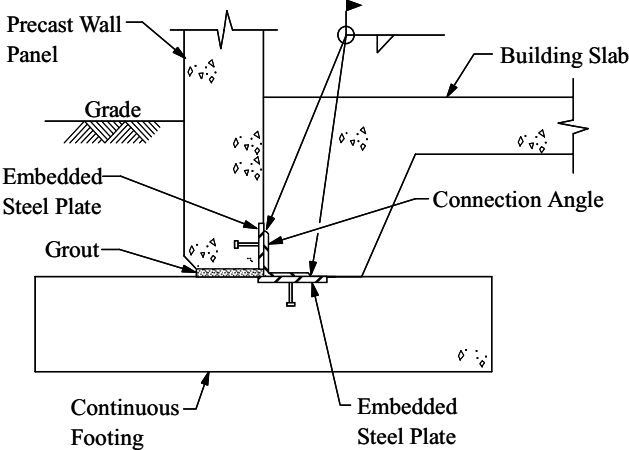

FIGURE 8.4: Precast Panel Connection to Foundation

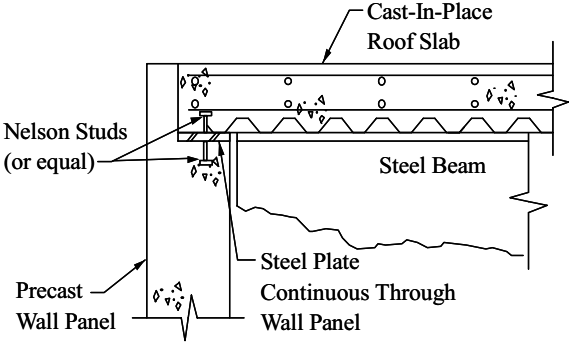

FIGURE 8.5: Precast Panel Connection to Roof Slab

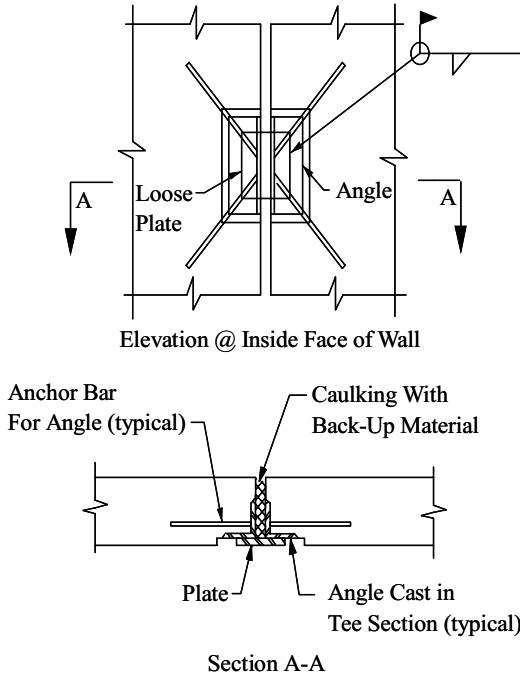

FIGURE 8.6: Precast Panel Vertical Joint

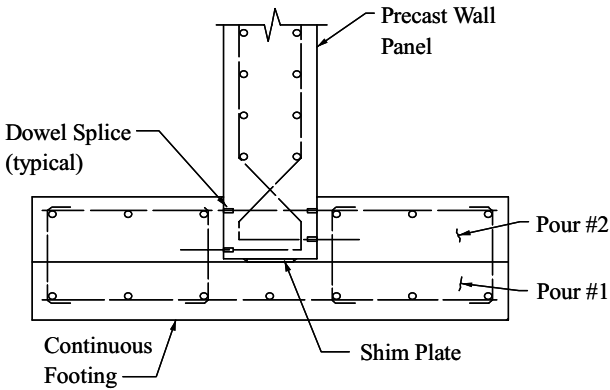

FIGURE 8.7: Precast Panel Connection to Foundation

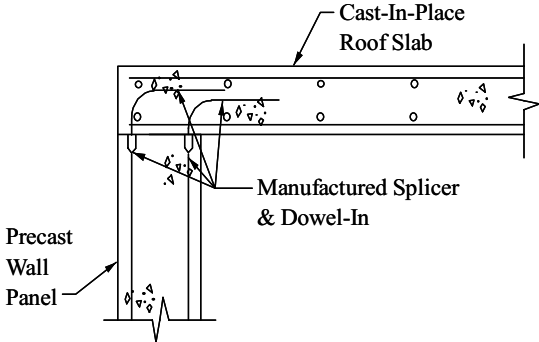

FIGURE 8.8: Precast Panel Connection to Roof Slab

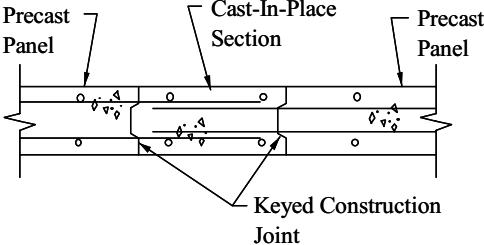

FIGURE 8.9: Precast Panel Vertical Joint

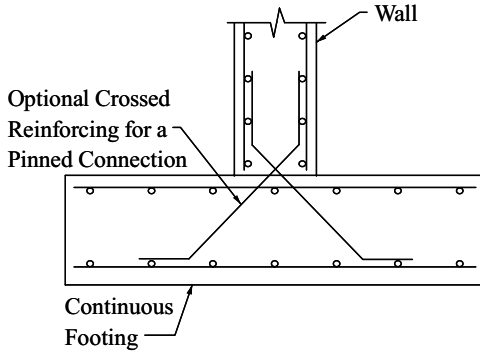

FIGURE 8.10: Cast-in-Place Wall to Foundation Joint

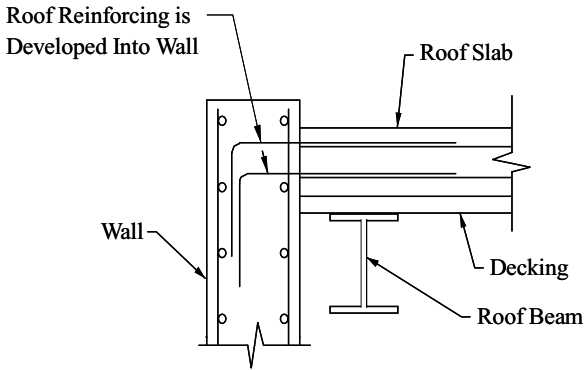

FIGURE 8.11: Cast-in-Place Wall to Roof Slab Joint

CHAPTER 9 ANCILLARY AND ARCHITECTURAL CONSIDERATIONS

9.1 INTRODUCTION

This chapter addresses blast resistant considerations for doors, windows and utility openings, and also addresses special exterior and interior requirements. These considerations should be jointly addressed by the different discipline members of the building design team.

9.2 GENERAL CONSIDERATIONS

When there is an opening in the blast resistant envelope, the blast wave will propagate inside and result in an increase in the interior pressure. *UFC 3-340-02* illustrates a method for calculating the change in pressure inside a building. The pressure increase should be evaluated for what is tolerable for people and non-structural items, and all interior walls should be designed accordingly.

If a maximum permissible interior pressure is specified in the building's design criteria, the design team must ensure that each opening either completely blocks the interior propagation or that the effects are suitably mitigated.

The design of the various devices used to protect building openings is a very specialized field. Normally, the detailed design of the different elements and components of doors, window glass and frames, blast valves and attenuators is performed by the manufacturer based on design criteria provided by the engineer.

9.3 DOORS

This section deals with door design for resistance against an accidental explosion. Types and applications of blast resistant doors are discussed, and design approaches are provided.

The building's doors, due to their functional requirements and associated hardware limitations, are a weak link in blast resistant design. Since doors are likely to be the largest opening into a building they provide the largest potential source of blast wave propagation if the opening fails. Doors need to be designed for the required blast load, specified damage, and operability requirements.

Blast doors are available from a limited number of manufacturers with a wide range of blast capacity. Low-range blast doors (refer to Section 9.3.1) are similar to hollow metal doors, but have special detailing to increase the blast capacity of the doors. Mid-range and high-range blast doors are designed to provide increased levels of blast load as the names imply. In general, all steel blast doors are heavier than common doors and the higher the blast capacity of a door generally the heavier the doors are. The additional weight causes these doors to move more slowly in manual operation than personnel are expecting and will be more difficult to operate.

Therefore, it is important to choose an appropriate door for a given situation and not use heavier doors than required when they are not needed. Operator assisted doors are available. An alternative is the use of lightweight blast doors, which are principally composed of structural fiberglass. These doors can have significantly greater deflection and lower blast capacity than commonly available steel doors but may be appropriate for low blast demand situations.

9.3.1 Definitions

Throughout this section the terms low-range, mid-range, and high-range are used to distinguish varying levels of blast pressures applied to blast resistant doors. The ranges come from the research of product literature of several blast resistant door manufacturers. The terms are loosely defined as:

Low-Range Door - A door designed to withstand an equivalent static pressure that is less than 3 psi (21 kPa).

Mid-Range Door - A door designed to withstand an equivalent static pressure in the range of 3 psi to 25 psi (21 kPa to 172 kPa).

High-Range Door - A door designed to withstand an equivalent static pressure that exceeds 25 psi (172 kPa).

For elastic behavior, an applied static force is half that of an applied dynamic force of infinitely long duration.

It is typical for manufacturers to have several models in each range. The doors may vary significantly in material, thickness, restraining hardware, frame profile and anchorage.

9.3.2 Performance Limitations of Commercial Industrial Doors

The average industrial personnel door is a hollow steel or composite door typically 1-3/4 in (44 mm) thick with 18-gauge steel facing. A composite door consists of a center sound-deadening noncombustible core, usually of polyurethane foam or slab. Light-gauge vertical reinforcement channels are used in hollow metal panels to add strength and rigidity.

These doors are often inappropriately considered as acceptable equipment for withstanding blast overpressures in the 0.7 psi (5 kPa) to 1.0 psi (7 kPa) range. When the initial direction of the blast wave tends to seat the door into the frame, these doors are susceptible to localized deformations or component failure that could render the door inoperable. If the magnitude of the blast is significant enough, catastrophic failure of the entire door assembly could occur. Rebound forces can also create concern. These doors are equipped with standard builder's hardware. This type of hardware has severe limitations for withstanding forces resulting from a blast. The forces created by the blast often exceed the load ratings of the most commonly used

latchsets and hinges. Knowing this, one realizes that there is little, if any, factor of safety when an untested common door is accepted as a suitable alternate to a certified blast resistant door.

9.3.3 Guidelines for Blast Resistant Door Design

Based on the desired end-use of the door, guidelines for acceptance have been classified into three categories:

Category I - The door is to be operable after the loading event and pre-established design criteria for stress, deflection, and the limitation of permanent deformation have not been exceeded. A ductility ratio of 1.0 or less (elastic range) and a door edge rotation of 1.2 degrees should be specified. This category should be specified when the door may be required to withstand repeated blasts or when entrapment of personnel is of concern and the door is a primary exit to the building.

Category II - The door is to be operable after the loading event but significant permanent deformation to the door is permitted. A ductility ratio in the range of 2 - 3 and a door edge rotation of 2.0 degrees is recommended. The door must remain operable and this category should be specified when entrapment of personnel is a concern.

Category III - Non-catastrophic failure is permitted. The door assembly remains in the opening. No major structural failure occurs in the door panel structure, the restraining hardware system, the frame or the frame anchorage that would prevent the door assembly from providing a barrier to blast wave propagation. However, the door will be rendered inoperable. A ductility ratio in the range of 5 to 10 and a door edge rotation of no greater than 8 degrees is recommended. This category should only be specified when entrapment of personnel is not a possibility.

Category IV - Outward rebound force and resulting hardware failure is acceptable.

9.3.4 Coordinating Efforts with a Blast Resistant Door Manufacturer

Since blast door designs interfaces with other structural components of a facility, it is wise to approach the preliminary design of the blast resistant door system early in the design stage of the project. As a minimum, door manufacturers will need the following information to furnish pricing and complete detail design of the doors:

1. Blast resistant door frames may be anchored into surrounding walls by several methods. They may be cast in place in new concrete, bolted in with concrete expansion anchors, welding to an existing steel embed or structure, or bolted to an existing structure. What method of anchorage will be used?
2. What is the wall's rough opening size and the door's jamb opening size?

3. Furnish the same information relative to peak incident overpressure, peak reflected pressure, and blast load duration that has been used for the structural components.
4. Does the direction of the blast force act to seat the door into the frame or unseat the door from the frame?
5. Must the door's material remain in the elastic or elasto-plastic range? Is permanent deformation permitted?
6. What is the limit for the ductility ratio?
7. What is the total permissible deflection at the mid-span of the door panel or the end rotation of the door panel?
8. Must the door be operable after the blast?
9. Furnish information about such architectural requirements as hardware functions, door closers, door opening assists, paint and finish, fire labeling requirements, etc.

The Process Industries Practices (PIP) consortium has developed a common specification for blast doors (PIP ARS08390) covering design, fabrication and installation. Data sheets for specifying principal requirements for blast doors are included in *PIP STC01018*.

ASTM has published *ASTM F2247*, "Standard Test Method for Metal Doors Used in Blast Resistant Applications (Equivalent Static Load Method)". The document describes a method of testing a door under static uniform pressure and provides guidance on the determination of an appropriate equivalent static load for a given design blast load.

9.3.5 Testing and Structural Analysis Methods

Most blast door manufacturers opt to perform static load tests on prototype assemblies of low-range blast doors to demonstrate that the assembly will resist the blast overpressure specified. Static tests should be accepted only if the dynamic structural response and dynamic load factors have been considered and the door, frame, and restraining hardware are manufactured using the same materials, dimensions, and tolerances as those in the prototype static test.

It is common practice among manufacturers to substantiate the structural integrity of mid- and high-range blast resistant doors by design calculations. Calculations supporting the ability of the door to meet performance criteria under the specified blast loading should be supplied to the specifier for review before manufacturing of the door proceeds. The calculations must cover the initial response of the door, rebound, and all secondary items such as stresses in welds and fasteners, local

buckling and web crippling in structural members, and the structural capacity of the hinges and latches, and frame anchorage to the surrounding structure.

9.3.6 Fire Labels and Fire Label Construction

Many blast resistant door manufacturers can offer 3-hour "A" and 1-1/2-hour "B" fire labels on low-range and mid-range doors that certify that the construction of the door has been fire tested by an agency such as Underwriters Laboratories. Few manufacturers offer a fire label on high-range doors. When a door design conflicts with a manufacturer's fire label procedure, often the manufacturer will offer a letter certifying that the doors are fabricated from fire resistant materials that will not contribute to flame spread. Often this method is accepted by fire protection authorities on the project, however the specifier should consult the authorities early in the design stages of the project to verify acceptance.

9.3.7 Delivery Lead Times

Blast resistant doors are not "off the shelf" items. They are built to order and manufacturers generally require 6 to 8 weeks after notification of approval of the shop drawings and design data to schedule and fabricate low-range doors, 10-12 weeks for mid-range doors, and 12 weeks or more for high-range doors.

9.4 WINDOWS

Historically, ordinary glass windows are not adequate for blast overpressures as low as 0.2 psi (1.4 kPa). Many injuries in explosion accidents result from glass fragments. Therefore, the use of windows should be discouraged.

When windows are necessary, there are higher strength type glass and glazing materials such as laminated glass, polycarbonate, and plastic interlayer that may be considered acceptable depending on the design overpressures. These materials may be used either by themselves or as components in a composite construction.

Wire glass is an annealed glass with an embedded layer of wire mesh used as a fire resistant barrier. Annealed glass is of relatively low strength when compared to tempered glass and tends to fracture into razor-sharp fragments. Although the wire helps bind fragments, wire glass should be avoided unless required by NFPA considerations.

Chapter 5 of the *ASCE Physical Security* report addresses the various types of glazing materials and structural components of window frames and should be referred to for a detailed discussion of the topic.

Windows should be designed to withstand the same blast loads as the walls. The engineer should define the structural design criteria and coordinate with the building's architect to ensure the manufacturer's correct interpretation.

Significant development of blast resistant windows has increased the options available to mitigate glass fragment hazards for new and retrofit designs. The Department of Defense (DOD) and General Services Administration (GSA) have developed minimum standards for protection of personnel which have resulted in development of products based on these requirements. Because the GSA and DOD are concerned with high-explosive terrorist attack with usually short duration loads, available products may not have been evaluated for longer duration loads anticipated in petrochemical facilities. However, these products can provide substantial protection from glass fragments from blast loads caused by vapor cloud explosion, BLEVES and vessel burst hazards. A typical minimum blast load standard used by the GSA for which many vendors have developed products is a short duration blast load of 4 psi (28 kPa) with an impulse of 28 psi-ms (193 kPa-ms). A second common load specification for DOD facilities is a peak pressure of 6 psi (41 kPa) with an impulse of 42 psi-ms (290 kPa-ms). Due to the longer duration of vapor cloud explosions, these products may be applicable at lower peak pressures.

Products developed to mitigate glass fragment hazards include laminated glass with interlayer thickness up to 0.090 inches (2.3 mm), blast shades, blast curtains, and safety film in daylight, mechanically anchored, and wet glazed configurations. Generally, laminated glass is used for new blast resistant window design or replacement window designs. Anchored safety film, daylight safety film with catch bars, and laminated glass replacement are generally used for retrofit situations. The specific blast capacity of these products is dependent on the load duration and the reader is urged to investigate product claims closely because often these products have only been tested for short duration loads representative of high explosive threats.

The GSA and DOD have developed performance criteria for windows to standardize specification of blast requirements. These criteria categorize glass fragment debris hazards in terms of throw distance. The reader is referred to Public Building Standard *PBS P100* for GSA criteria and Unified Facilities Criteria *UFC 04-010-01* for DOD criteria. These agencies have also developed specialized software for analysis and design of windows subjected to blast loads.

ASTM F1642 "Standard Test Method for Glazing and Glazing Systems Subject to Airblast Loadings" is available for evaluating blast resistant windows to any prescribed blast load using open-air testing or shock tube testing. *ASTM F2248* "Standard Practice for Specifying and Equivalent 3-Second Duration Design Loading for Blast Resistant Glazing with Laminated Glass" is available to provide a method of determining an equivalent static load for use in standard glass design charts provided in *ASTM E1300* "Practice for Determining Load Resistance of Glass in Buildings". The methodology described in *ASTM F2248* is the methodology prescribed for design of blast resistant windows in *UFC 04-010-01*.

9.5 UTILITY OPENINGS

Blast resistant buildings require the same openings for air intake, exhaust, power and control cables, and service piping as conventional buildings. For blast resistant buildings, it may be necessary to provide protection at the openings. Manufacturers of protective devices for these openings normally provide the detailed design.

Electrical and pipe penetrations may be brought into the building underground. Based on economy and design, this type of entry may be preferred.

9.5.1 Blast Dampers

HVAC blast dampers are devices with mechanical elements which close within milliseconds of the blast wave arrival. Blast dampers are available which will remain closed or which will reopen after pressures return to normal. Blast dampers are furnished in frames that require attachment to properly designed structural elements.

Because of the need to close within milliseconds, open blast dampers create a significant operating pressure loss. Therefore, the resulting blast damper opening is usually much larger than a normal duct penetration. This must be considered in the building opening layout.

9.5.2 Blast Attenuators

HVAC blast attenuators are similar to blast dampers except they do not have any moving parts. They are stationary devices used to reduce or lessen the blast wave effects by reducing the interior increase in pressure. They are intended for short blast durations. Manufacturers will provide the necessary design information.

9.5.3 Cable and Conduit Penetrations

Large concentrations of unprotected cable or conduit penetrations can result in significant entry of blast pressures. Through the use of proprietary devices, the annular space around cable or conduit can be completely sealed. Alternatively, custom designed closure plates may also be used.

9.6 INTERIOR DESIGN CONSIDERATIONS

Consideration should be given to certain interior items. Functional or decorative objects should not be mounted on the interior surface of an exterior wall. Rapid inward movement of the wall may dislodge objects causing injury to people or damage equipment. For the same reason, file cabinets and other furnishings should not be placed closer to the interior surface of a wall than the maximum predicted deflection of the wall.

Suspended ceiling components are particularly susceptible to being dislodged during a blast. Ceiling lighting fixtures, diffusers, etc should be supported independently of the suspended ceiling.

9.7 EXTERIOR CONSIDERATIONS

The peak reflected blast loading is calculated assuming the air can move around the structure and efficiently relieve the pressure. Buildings should be configured to prevent trapping of the blast wave and therein increasing the load above those specified. Items such as re-entrant corners and set back doors can experience loadings that are considerably higher than the peak reflected overpressures and should be avoided.

The building design should not contribute to the likelihood of flying debris. Canopies and vestibules should be avoided since they frequently become dislodged and could block critical means of egress.

CHAPTER 10 EVALUATION AND UPGRADE OF EXISTING BUILDINGS

10.1 INTRODUCTION

This chapter discusses structural evaluation strategies and upgrade options for buildings at petrochemical plants subjected to potential blast hazards. A number of actions can necessitate an evaluation, including a change in building occupancy or building function, addition of building floor space, change in process explosion hazard, change in corporate policy, or completion of a Process Hazards Analysis which indicates a problem may exist.

This chapter assumes that a decision has been made to evaluate and possibly upgrade a building that may not have adequate blast resistance. This decision depends on safety and economic considerations. Assistance in making this decision is provided in *API RP 752* and *CCPS Building Guidelines*.

If buildings do not have adequate blast resistance, their blast capacity can be increased with proven structural retrofits or upgrades that have been validated by open air and shock tube testing and analysis. Blast resistant upgrades for existing structures are discussed in numerous public domain documents. In many cases upgrades to increase seismic capacity are also applicable for blast design, or can be adapted to increase the blast resistance of a structural component. These retrofits are discussed in a number of documents including *FEMA 356*, *ASCE 41*, and *SAC*. However, there are also significant differences between seismic and blast design, so seismic upgrades should only be used as a basis for blast resistant upgrades by engineers with blast design experience.

Blast retrofits of existing buildings can range from minimal upgrades, such as window modifications, to very significant, such as providing a robust concrete shell, or “cocoon” around the existing building. It is important to remember that costs involve not only construction but also potential downtime due to the interruption of operations which may be necessary to implement the upgrades. These costs can increase significantly if the upgrades are installed during building operations and involve internal building strengthening as opposed to external building strengthening.

10.2 EVALUATION STRATEGIES

Typically, a blast protection study for existing buildings involves the following steps (refer to Figure 10.1):

1. **Hazard Identification and Quantification** - Determine the location and size of potential explosions, and establish the free-field overpressure at each building location.

2. **Building Screening** – To make the evaluation process efficient and focus the engineering efforts, buildings should be screened into the following categories:

a. **Buildings Not Requiring Structural Upgrade**

This category represents buildings subjected to a blast overpressure below a limiting threshold requiring structural upgrades. Individual companies may set this threshold based on company building construction standards, blast overpressure, analysis or data, injury tolerance, and performance requirements. If there is not better available guidance, the threshold may be based on information in Section 2.5 that indicates buildings of ordinary construction may be sited in areas subjected to a free field pressure of 1.0

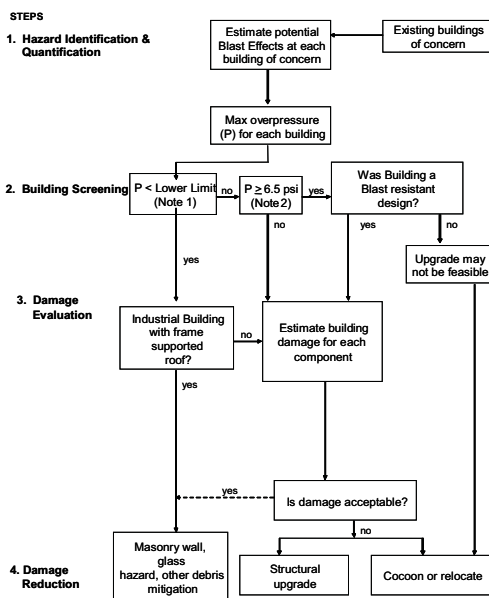

Notes:

- Individual companies may set lower limits for pressure thresholds. As indicated in Section 2.5, buildings designed for conventional loads can be sited in areas with peak side-on pressures less than 1.0 psi (6.9 kPa). This threshold is not intended to apply to temporary buildings or buildings with unreinforced masonry walls, which may fail at a free-field blast pressure of 1 psi (6.9 kPa) or less.
- At pressures greater than 6.5 psi (45 kPa), it may no longer be feasible or economical to upgrade a conventional building. In this situation, a reasonable approach would be to consider a blast resistant shell around the existing structure.

FIGURE 10.1: Methodology Flowchart for Existing Building Evaluations

psi (6.9 kPa). This threshold is not intended to apply to portable buildings or buildings with unreinforced masonry walls, which may fail at overpressures of 1.0 psi (6.9 kPa) or less.

b. Buildings Requiring Structural Upgrade

Buildings in this category require further analysis to define the required structural upgrades to meet the specified applied blast overpressure.

c. Buildings Requiring Replacement or a Structural Shell

At overpressures in excess of 6.5 psi (45 kPa), it may not be reasonable to attempt an upgrade of conventional construction. In this situation, a new blast resistant exterior structure that envelopes the existing building or a new robust building replacement may be the most feasible mitigation plan.

3. **Damage Evaluation** – For those buildings requiring further evaluation, a complete engineering evaluation should be conducted to determine the extent and consequence of the damage to each component. In certain cases, several components may exceed their deformation limits but in fact be of acceptable consequence to the building or occupants.
4. **Damage Reduction** – Upgrades to the building should reduce the expected damage to tolerable levels. Possible upgrades are discussed in the following sections of this chapter. At a minimum, even for those buildings not requiring structural modifications, steps should be taken to mitigate the consequences of glass breakage, interior masonry wall failure, roof collapse, and other debris hazards.

10.3 BLAST RESISTANT UPGRADE OPTIONS

A number of options are available to upgrade the blast capacity of an existing building. The choice of an upgrade option is generally based on the applied blast loads, characteristics of the existing structural component makeup, cost considerations, implementation approach around current operations, and building functionality requirements. The design of blast resistant retrofits to existing buildings can be subject to many limiting factors not typically applicable for the design of new blast resistant buildings. The engineer must consider the capacity of existing framing components to resist increased reaction loads from retrofitted wall and roof components, limitations on the achievable connection strengths between retrofitted and existing components, limits on available space for retrofits and accessibility for construction equipment, aesthetic considerations, and potential loss of building operational capability during and after construction. Retrofits may also increase the dead load on the building foundation and may need to resist loads transferred from attached components, such as retrofitted windows and doors.

TABLE 10.1: Summary of Blast Resistant Retrofit Concepts for Building Components

Retrofit Concept	Wall or Roof Retrofit	Retrofit Type¹	Additional Blast Capacity²
Strengthen connections of light metal components	Wall or Roof	Wall or Roof strengthening	Low
Weld or attach steel plate to existing steel and reinforced concrete framing members	Wall or Roof	Wall or Roof strengthening	Low
Add additional beams between existing beams to reduce cladding span and/or increase overall capacity from beams	Wall or Roof	Wall or Roof strengthening	Low
Attach high strength material to wall surface (i.e. Kevlar®, e-glass, or carbon fiber)	Wall	Wall strengthening	Medium
Attach new steel posts or heavy corrugated steel panel to masonry or concrete wall	Wall	Wall strengthening	High
Increase concrete wall thickness with new reinforced concrete section attached to wall with dowels	Wall	Wall strengthening	Medium to High
Place reinforced concrete panels outside building attached to foundation and building lateral load resisting system	Wall	Shield System	High
Place steel beam and heavy corrugated steel panel system above existing roof	Roof	Shield System	High
Build a blast-resistant shell around the existing building	Wall and Roof	Shield System	High
Place steel beam and grating below existing roof	Roof	Catch System	Medium
Place strengthened metal stud wall inside existing wall	Wall	Catch System	Medium
Place geotextile well attached to building framing or floor systems over inside surface of wall	Wall	Catch System	Medium
Note 1: Catch systems not applicable for buildings with load bearing walls.			
Note 2: Increase factors for blast capacity of conventional building component: Low (100%-150%), Medium (150% to 300%), High (greater than 300%)			

There are three basic approaches for blast resistant upgrades to existing building components: 1) strengthening existing components and/or connections, 2) allowing existing components to fail into a catch system that protects building occupants from debris, and 3) shielding existing component from blast load with a new exterior blast resistant component. Table 10.1 summarizes alternative concepts for these approaches, which are discussed in the following sections within the context of upgrades to different building systems and component types. This table is not meant to be a complete list of all available upgrade options. Any upgrade can be used that produces a structural system that meets an objective for limiting building blast damage and/or protecting building occupants against injury from applied blast loads. Approximate information is provided in Table 10.1 for the additional blast capacity

that can be provided by typical applications of the concept. The actual increase in blast capacity can vary significantly depending on the size, material strength, and other properties of the upgrades. *UFC 4-023-02*, which is currently at a final draft stage, provides detailed information on twelve retrofits including some of those in Table 10.1 and will be available as a public domain document from the U.S. Department of Defense in the near future.

Non-structural upgrades to reduce debris hazards should also be considered in addition to structural blast resistant upgrades. These upgrades include modifying or eliminating architectural sections of the building having heavy material that could fall, providing positive attachment for all overhead equipment, lights, and false ceiling to roof structural members, attaching book shelves to walls, eliminating exterior enclosures around doors that could fail and block doors, and replacing interior unreinforced concrete block partitions with lightweight gypsum board metal stud walls or reinforced concrete block that are well attached to the floor and roof systems. In general, all non-structural upgrades recommended for buildings subject to earthquake loads are also applicable for blast resistant design. Even though these methods do not increase the blast resistance of the building directly, they are effective in reducing the potential injury to the personnel inside the building.

10.4 UPGRADES FOR STRUCTURAL MEMBER CONNECTIONS

Strengthening of structural connections can be the most cost effective upgrade for existing buildings if it does not require removal of existing interior walls and equipment and if this upgrade is sufficient to resist the blast loads. This can be the case for members that have sufficient flexural capacity to resist the applied blast load, but their load capacity is limited by their connection capacity. For a member to absorb blast energy and be structurally efficient, it must develop its full plastic flexural capacity before reaching its shear and connection capacities. This can require a substantial increase in capacity of connectors or surrounding material that is in tension, compression, bearing, or local shear.

A typical shear connection for a wall girt consists of a shear tab with two bolts. As a blast load is applied to the girt, connection failure may occur due to bolt failure, failure of the girt web around the bolts due to bearing failure or block tearout, or failure of the shear tab due to insufficient weld capacity. Any connection failure will not allow a component to develop its plastic moment capacity and therefore will prevent member to reach its maximum blast resistance. An upgrade for this type of connection can consist of additional web material welded or bolted to the girt or additional weld on the shear tab connection to the column. Also, lower strength *ASTM A325* and *ASTM A307* bolts can be replaced with high strength *ASTM A490* bolts. Bolt holes can also be enlarged for larger diameter bolts.

Steel framing components often have moment resisting connections that are designed to resist elastic stresses based on their calculated conventional load demands rather than the maximum tension, compression, and/or shear loads delivered by the connected members when these members develop their ultimate moment capacity

under blast loads. Also, standard moment resisting frame connections are based on the elastic distribution of stress rather than a plastic distribution through the section. Connections for blast resistant steel framing components need to transfer the full dynamic yield strength of the beam flanges into the columns and horizontal column stiffeners are often required to transfer the tension and compression forces from the beam flanges through the column. Stiffeners or doubler plates may also be required to resist high shear demand in the webs of perimeter columns of moment resisting frames, or to prevent shear buckling of beams and columns with non-compact sections.

In addition, connections for blast loaded members need to have sufficient rotation capacity to deform under the applied blast load without failing. This is particularly a problem for moment resisting steel connections. A connection may have sufficient strength to resist the applied load; however, when significant deformation of the member occurs this capacity may be reduced due to buckling of stiffeners or flanges. Figure 10.2 is an example of a steel frame connection designed for large rotation capacity. *FEMA 356* and *ASCE 41* describe a number of upgrades to increase the strength and ductility of steel moment resisting frames subject to earthquake forces

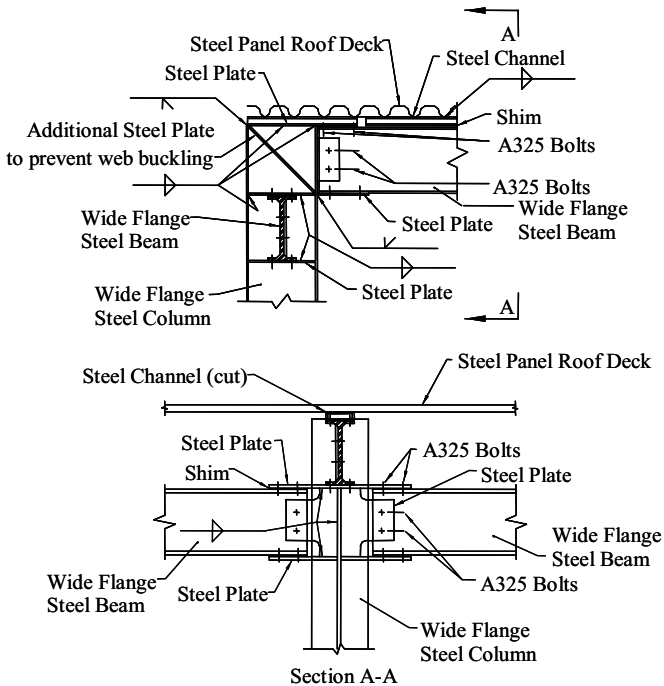

FIGURE 10.2: Large Rotation Connection Detail
(based on UFC 3-340-02)

that are also generally applicable for blast resistant design.

Connection and reinforcing steel splice details in blast resistant structures can also be designed to provide an alternative response mode if they allow tension membrane or catenary action to develop at large deflections. These response modes can increase the blast capacity of components that initially respond in flexure to blast loads. Also, steel and steel reinforced concrete and masonry components that respond in a brittle response mode, such as lateral torsional buckling, local buckling of noncompact steel section, or shear failure can continue to resist load in some cases if they are adequately attached to supporting components to develop tension membrane response and have continuous steel reinforcement along their span and all splices are full tension splices. Use of tension membrane response as an alternative response mode is discussed in *UFC 4-023-02*.

Load reversal is typically not considered in the design of connections for conventional loads. As discussed in Chapter 7, rebound forces produced in a member's response can be quite high. These forces are a function of the mass and stiffness of member as well as the ratio of blast load to peak resistance. Connections which provide adequate support during a member's positive phase, or inward response to blast load, must also be analyzed for the rebound load. If the member fails during rebound due to inadequate connections, it may fall into the building if it is an overhead member or it may cause progressive collapse if it is a load-bearing member.

Design of connections for reaction forces during rebound can be a particular concern with many connections used for roof components and precast concrete wall components. Headed studs are normally used to secure a roof slab to a structural steel framing system for rebound loads in new construction. These studs are usually not found in existing structures unless the roof girders were originally designed to be composite with the concrete deck. It may be necessary to provide through bolts to the structural frame with a backing plate on the top side of the slab if the composite metal deck is found not to be adequately attached to the roof framing elements. The addition of knee-bracing with bridging is sometimes required on the bottom flange of roof beams to reduce the unbraced compression flange length in rebound.

Precast concrete components that receive support from direct bearing during the positive phase response to blast load, such as the top of a wall slab that bears against a concrete roof deck, typically depend on the connection shear or tensile strength to resist rebound reaction forces that are much higher than those from conventional suction pressure loads. Typical wall panel connections with welded plates or bolts can often be used for blast resistant design if the size and/or number of connections are increased.

It is often desirable to utilize the in-plane capacity of precast panels to function as shear walls that resist lateral loads. The connections typically provided between adjacent precast members are often inadequate to develop the required in-plane capacity to resist the high lateral loads transmitted into the building by blast resistant wall components. In some cases, rectangular steel plates or steel ledger angles can be

bolted to precast wall and roof deck panels to increase the in-plane shear connection capacity.

10.5 UPGRADES FOR STRUCTURAL FRAMING MEMBERS

Framing members can be upgraded by increasing their cross section. This can take on many forms including welding cover plates onto steel members, bolting steel plates to the tension side of concrete beams, and welding or bolting steel angles, rods, rebar, or channels to the webs of steel beams near the flanges. Also, “knee struts” or haunch members can be added at corners where beams and columns frame together to reduce the effective frame member spans and add moment capacity to a simply supported connection. The compression capacity of steel I-beam columns members can be increased by welding plates onto the column flanges to create a box section. The capacity of concrete columns can be increased by jacketing the column with steel plates or additional reinforced concrete.

A particular problem can be pre-engineered frames with bolted moment connections that do not have sufficient moment capacity. A patented steel beam-to-column connection system that improves seismic resistance can be used to increase the flexural capacity and ductility of a steel moment connection (SidePlate Systems). It consists of vertical steel plates placed along both sides of the bolted connection that are welded to wide cover plates attached to both flanges of the connected beams.

In some cases, steel framing members can be upgraded by adding lateral bracing. Many roof beams, roof purlins, and wall girts in existing petrochemical structures are not capable of developing their full plastic moment capacity due to inadequate lateral support of the compression flange for both inbound and rebound responses. These elements may have only adequate bracing of their compression flanges for conventional gravity loads and very limited bracing for wind loads in the direction for blast rebound loads.

New lateral bracing can be lightweight structural steel shapes welded or bolted to the compression flanges of existing load carrying members. Material costs are very low. However, construction costs and plant operation interference generally prove to be deciding factors in whether or not a bracing upgrade can be feasible. In control rooms and laboratory facilities, the roof beams and purlins are typically below the primary roof and above an interior or dropped ceiling. The construction effort would have to be directed from inside the building, and may interfere with building operations.

Taking advantage of existing structural members, lateral bracing may include tying the flanges of the steel members to the elements that they support such as prestressed concrete decks, concrete decks on metal forms, and metal or fiber-reinforced plastic panels. Note that this bracing generally only increases moment capacity for downward blast loads. If analysis shows that upward rebound occurs, the bottom flanges may also need new bracing. Refer to Figure 10.3 for a typical bracing

configuration. Bracing rods can also be used to tie the bottom flange to the roof beams (Figure 10.4).

For plate girders, the addition of transverse intermediate stiffeners at various spacings along the span length will increase the web buckling strength, thereby increasing the web resistance to shear and moment. For deep web plates, longitudinal web stiffeners will also increase section capacity.

Upgrading lateral bracing is only effective if the full moment capacity of the component is sufficient to resist the applied blast loads. Existing components that are

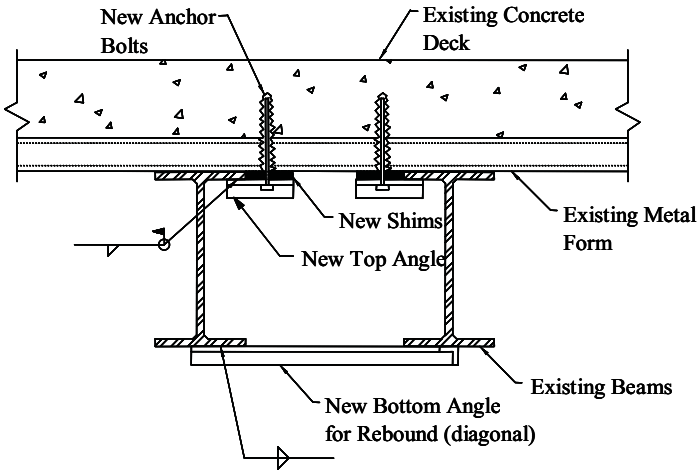
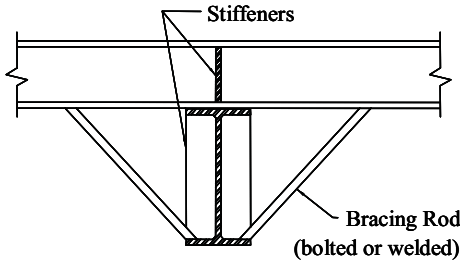

FIGURE 10.3: Typical Bracing Details



Notes:

Only one brace is needed, unless a rod is used.

Top stiffeners are to prevent web crippling & buckling.

Bottom stiffeners are to prevent web buckling and LTB.

Typical web stiffening & bottom flange bracing is shown.

FIGURE 10.4: Typical Bottom Flange Bracing

not well braced can be analyzed initially using a reduced flexural strength consistent with the maximum compressive strength that can be developed by existing lateral bracing and tension membrane resistance, depending on the existing connection strength, and including any effects from dead load. This analysis may show that the component is adequate to resist applied blast loads without failing, particularly for rebound response. The use of stiffeners to resist lateral torsional buckling should be considered for steel beams and girders with inadequate lateral bracing.

10.6 UPGRADES FOR METAL PANEL WALL AND ROOF SYSTEMS

Metal panel wall and roof systems consisting of corrugated metal panels and cold-formed wall girts and roof purlins are commonly used as exterior cladding. Metal panels are constructed of thin-gauge material that buckles in the compression flange at maximum moment regions before the panel cross section develops its ultimate plastic moment capacity. Resistance provided after buckling occurs in the maximum region is due to tension membrane response, which is characterized by stretching of the panel rather than flexure. This is described in Section 5.4.4. To achieve this type of response it is necessary to restrain the ends of the panel to provide the required in-plane reaction. A typical conventional design utilizes small self-drilling/tapping screws attached to base angles and wall girts to secure the panels in place. These screws are typically sufficient to develop enough membrane capacity to maintain the flexural resistance up to the maximum allowable deflection for low or medium damage. At larger deflections, the connections tend to fail due to tearout through the panel ends as well as pull-out over the head of the screws. Use of a flexible support will also limit the magnitude of load occurring at the ends of the member. This can be accomplished by developing a support which deforms in flexure and limits the end reaction. This type of connection is shown in Figure 10.5.

Reducing the span increases the capacity of metal panels in flexure. Since resistance is a function of the square of the span length, addition of intermittent

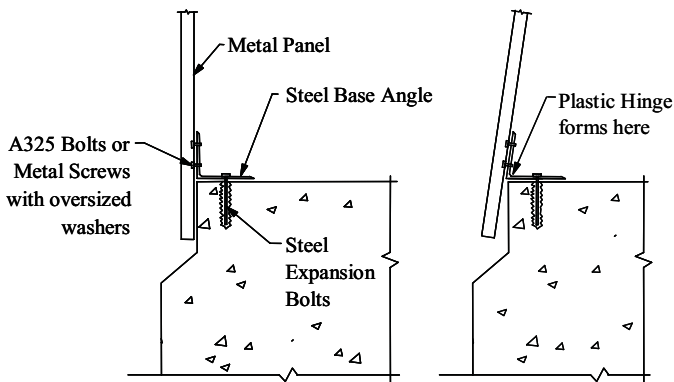

FIGURE 10.5: Base Angle Detail for Flexible Connection

supporting members can be very effective in increasing in blast capacity of panels. This can be accomplished by adding wall girts or roof purlins to the structure. This upgrade also increases the blast resistance of the supporting members since their tributary supported width is reduced. Cost for this upgrade can be quite high if the interior of the structural system is not easily accessible or if construction requires interruption of operations.

When strengthening of existing panels is not feasible, panels can be replaced with heavier gauge metal panels, two nested conventional panels, or specially designed blast resistant panels. There are also commercially available blast resistant panels that have been developed for protection against terrorist attacks. Girts and purlins can also be upgraded by replacing with a heavier member. These components can also be overlapped and connected so they act as a continuous component across interior supports. Typically, the girt or purlin connection must also be upgraded in these cases. Metal wall systems can also be upgraded with a blast resistant shield wall, as discussed in Section 10.8.

In some cases, large metal buildings with very low occupancy can be designed to resist blast loads using controlled release panels (*Oswald 2002*). Controlled release panels are conventional corrugated steel panels that are only continuous over one supporting member with limited strength connections to supporting members at the panel edges and a strong connection to the intermediate supporting member, so they fail by wrapping around the intermediate supporting member. These supporting members and the building framing can be designed for a lower blast load if controlled release panels are used because the failing panel transfers less blast load into the supporting members based on shock tube testing results. Attention must be devoted to securing interior building components and objects that can become hazardous debris due to interior blast loads. This upgrade with controlled release panels should only be considered when the free-field pressures will not directly cause serious injury to building occupants *Baker*.

Vent panels designed according to *NFPA 68* can be used to reduce blast loads from interior explosions of flammable materials. These panels can have restraint system (i.e. steel cable tethers) attached to the building framing so they do not become missile hazards.

10.7 UPGRADES FOR CONCRETE MASONRY UNIT (CMU) & CONCRETE WALLS

Many petrochemical structures include CMU walls with little or no steel reinforcement. This type of construction lacks ductility and has low resistance to blast loads. There are many ways to retrofit masonry walls to increase their blast resistance, including many that have been developed to resist blast loads from typical high explosive threats from terrorists. However, only a limited number of these retrofits have typically been considered practical for buildings subject to industrial explosion blast loads, which typically have much longer blast load durations than high explosives.

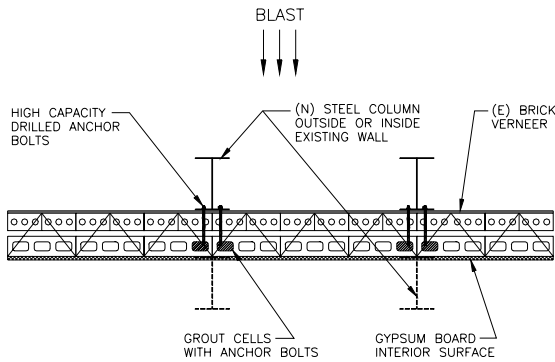

FIGURE 10.6: Masonry Wall Retrofit with Vertical Steel Posts

The most commonly used blast resistant retrofits for buildings subject to industrial explosions include attachment of vertical steel beams to the walls, placement of a exterior blast resistant wall outside the masonry wall, and bonding high strength fiber reinforced material to the wall surfaces. In all retrofits, the upgraded masonry walls perpendicular to the blast loads can also serve as shear walls. They should be analyzed for in-plane shear and bending according to the procedure outlined in Chapter 7. Connections between shear walls and diaphragms and the foundation must also be evaluated.



FIGURE 10.7: Exterior Tube Section Posts Bolted to Masonry Wall

10.7.1 Upgrade with Steel Posts

Figure 10.6 shows a cross section through a masonry wall retrofitted with vertical steel posts, which are not assumed to act compositely with the wall. This upgrade requires a minimum of available wall space compared to most other retrofits. The posts, which span between the floor and roof diaphragms, are usually placed at 4 to 7 ft (1.2 to 2.1 m) spacing depending on the capacity of the masonry wall to span between posts. They can be placed on the inside or outside of the wall. Typically posts are placed on the building exterior to avoid interior operational disruption and fixtures attached to the wall. In this case, the connections between the posts and the wall are more critical and the compression flange of the post is laterally unsupported during inward response to blast load. These posts can be notched at low moment regions or doglegged around existing conduit that typically run horizontally along the wall exterior. Galvanized steel may be considered for externally mounted posts.

Vertical post retrofits can be designed for very high blast capacities depending on the post size and spacing, although the lateral load resisting system of the building must resist the peak lateral load transferred by the upgraded walls. They also can resist blast loading effects during both inward and rebound response, as required for load bearing walls. The posts can also be positioned to support reaction forces from blast resistant windows and doors. Interior posts can be covered with light architectural panels for aesthetic reasons, but these panels must be well attached to any interior posts so that they are not thrown into the room by the sudden acceleration



FIGURE 10.8: Heavy Steel Panel on Blast Side of Retrofitted Wall

of the posts under blast loads. Exterior panels can also be covered by architectural cladding designed for conventional loads.

The maximum size of posts is often limited by the available strength of the connections of the post to the wall or the connections between the ends of the posts and the foundation and floor or roof diaphragm of the building. Through-bolts with plate washers can be used to attach posts to ungrouted CMU walls. Drilled anchor bolts that are recommended for dynamic loading can be installed into grouted CMU blocks and solid masonry walls. Placement of grout into ungrouted CMU walls requires attention to details; usually the face shells must be removed and the cells must be cleaned of any mortar to ensure placement of solid grout that acts together with the CMU block to resist pullout of anchor bolts connecting the posts to the wall. The summed tensile capacity of the anchor bolts should be greater than the ultimate load resistance of the post and there should be at least four to five bolts along the span of the connected post. The anchor bolt dynamic design capacity can be taken as 1.7 times the static allowable capacity recommended by the manufacturer, as recommended for connections in *UFC 3-340-02*. The attachments are also critical for interior posts on a load-bearing wall, since the posts must also support the wall during rebound response to blast load. The posts are usually designed for light to moderate damage because there is some concern regarding the ability of the drilled anchors on external posts to remain well attached to the wall at large post deflections.



FIGURE 10.9: Through-Bolts on Inside Surface of Retrofitted Wall

Horizontal beams can be used rather than vertical posts, but the vertical posts typically transfer their reactions directly into floor and roof diaphragms, which are part of the lateral load resisting system of the building. Horizontal beams typically transfer their lateral reaction loads into columns, which must also resist axial loads. Figure 10.7 shows exterior steel posts bolted to grouted cells of an unreinforced CMU wall. Figure 10.8 shows a heavy corrugated steel panel, which functions in a similar manner as closely spaced vertical posts, spanning vertically on the exterior side (i.e. blast loaded side) of an unreinforced, ungrouted CMU wall. Since the wall is ungrouted, through-bolts were used to connect the corrugated steel panel to the wall. Figure 10.9 shows the through-bolts and plate washers on the inside face of the wall. The vertical strap along the wall in Figure 10.9 is unrelated to the wall upgrade.

10.7.2 Upgrades with High Strength Fiber Bonded to Wall

High strength fiber strips or mats, including carbon fiber, Kevlar® (Figure 10.10), and E-glass (Figure 10.11) fibers, can be applied to the inside (i.e. non-blast loaded side) or to both sides of masonry walls to significantly increase the wall blast capacity. Parallel, very closely-spaced high-strength fibers are encased by the manufacturer in thin resin mats or strips that are bonded to the wall with the fibers oriented in the span direction. The fibers act compositely with the masonry similarly to steel reinforcement, where the tensile strength of the fibers and compression strength of the masonry form a resisting couple at the maximum moment regions. The proper application of the bonding agent and the high strength fiber mats or strips to the wall is critical and must be performed by a trained applicator.

The ultimate tension strength of the fibers per unit width is provided by the manufacturer, but typically only a fraction of the strength can be counted on for design due to debonding and/or environmental degradation factors. Also, the high



FIGURE 10.10: Kevlar® Wrap Retrofit to CMU Panel

strength fibers can not be counted on to significantly increase the compression or shear strength of the masonry. Therefore, the maximum blast resistance of a retrofit with high strength fibers is usually limited by crushing of the masonry block in the maximum moment region or shear failure of the masonry near the supports, which are both brittle failure mechanisms. Fiber tension failure, which is often initiated by debonding, is also brittle and thus this upgrade is always limited by a non-ductile response. Therefore, this type of retrofit is usually designed to resist blast load without yielding with a safety factor based on available blast test data, manufacturer's recommendations, and/or previous design experience.

An advantage for this retrofit is that it significantly reduces the potential deflection of masonry walls, which may be important for load bearing wall systems. Another advantage is that in most cases this retrofit approach does not significantly affect the aesthetics of the building, since it just changes the building surface. However, fiber attachment to the wall interior can present construction challenges and limit building operations during construction. Use of strips rather than a continuous mat can allow placement of retrofit around equipment attached to the wall as shown in Figure 10.12. Additional high strength fibers can be placed around window and door openings to resist loads transferred by blast resistant window and

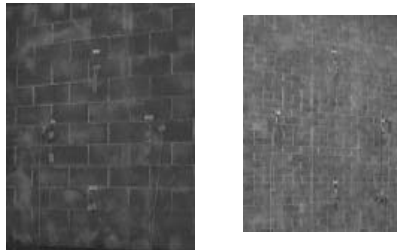

FIGURE 10.11: E-glass Retrofit to CMU and Brick Masonry Walls

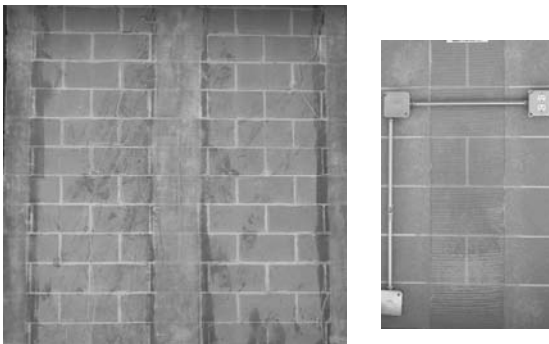

FIGURE 10.12: FRP Strips on Walls and Around Existing Interferences

door replacements. CMU walls strengthened with high strength fibers may need to be grouted so that the overall wall blast capacity is not controlled by the relatively low shear strength of ungrouted masonry. UngROUTED walls can be grouted by removing face shells at various locations, cleaning out any mortar from the cells, and pumping grout into the voids of the CMU blocks. Load bearing walls should be upgraded by attaching high strength fibers to both sides of the wall to prevent wall failure during rebound.

10.7.3 Increasing Wall Thickness with New Layer of Reinforced Concrete

Reinforced concrete panels can be upgraded by increasing the wall thickness on the exterior side with a layer of reinforced concrete that is well connected to the existing wall to create composite action between the new and existing wall sections. This upgrade can be installed by doweling into the existing concrete panel exterior and hanging a reinforcement grid parallel to the wall. A nozzle-applied shotcrete or cast-in-place concrete can then be placed to increase the overall wall thickness and flexural capacity. If shotcrete is used, the concrete surface must be prepared and existing conduit and piping should be shielded against overspray of the concrete. It is not recommended that existing conduit along the panel exterior be cast within the new wall thickness. This process is viable if the required thickness increase is only several inches and the additional wall weight does not require modification of the existing foundation. This upgrade also allows for casting concrete around existing wall penetrations.

10.8 UPGRADE WITH BLAST RESISTANT SHIELD WALL

Almost any wall system can be retrofitted by placing a blast resistant shield wall outside the existing wall. The shield wall can consist of a blast resistant precast concrete panel as shown in Figure 10.13. It can also consist of a blast resistant cast-in-place panel, or a blast resistant girt/steel cladding system as shown in Figure 10.14. Some vendors have developed prefabricated blast resistant wall systems that may be appropriate for a given upgrade depending on available test data validating the system for the given applied blast load. A third-party review of a vendor's design by an engineer familiar with blast testing and design is generally recommended.

A gap that is greater than the predicted shield wall deflection should be maintained between the shield wall and the existing building wall. This will prevent the shield wall from deflecting into the existing wall, and possibly failing it, as it responds to the blast load. The engineer should also verify that the sudden deflection of the shield wall does not decrease the void volume between the shield wall and existing wall such that there is an increased air pressure that can fail the existing wall. Small vent openings in the existing wall combined with adequate shield wall standoff from the existing wall, on the order of several feet, can be configured to prevent this potential problem. These vent openings can be covered with low-strength, lightweight

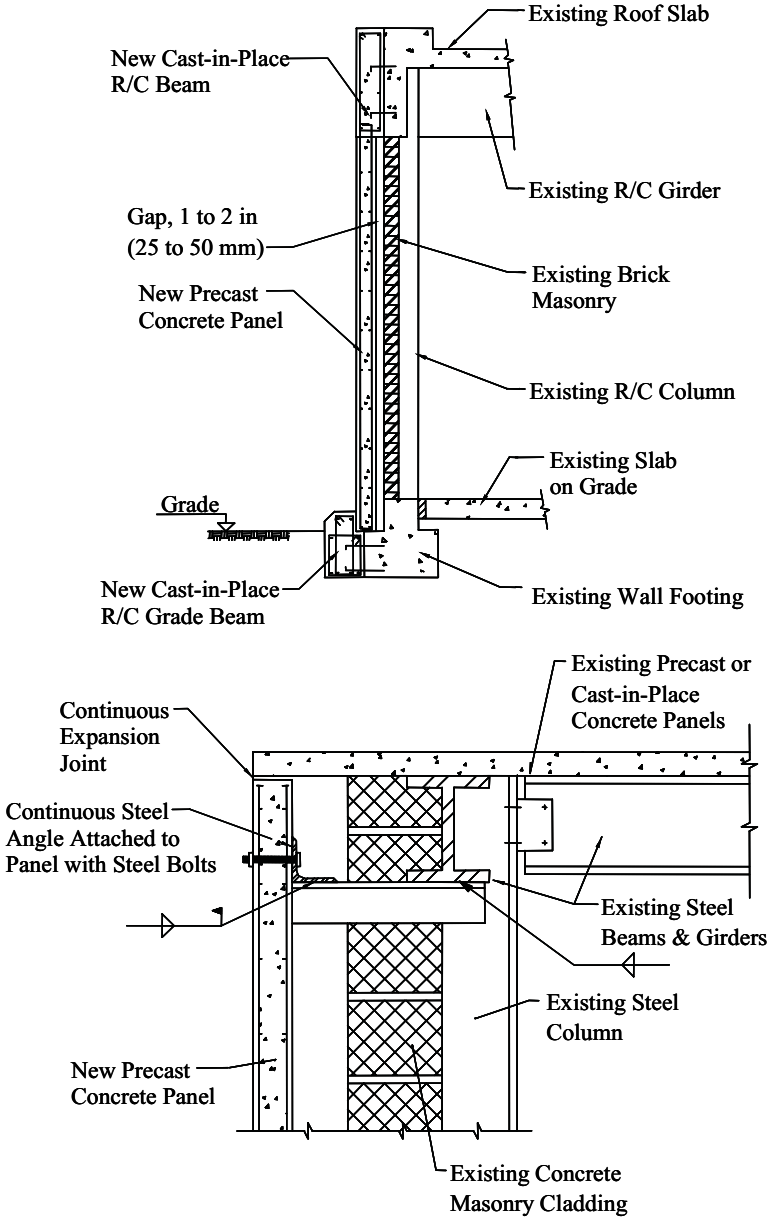

FIGURE 10.13: Wall Upgrade with Blast Resistant Precast Concrete Shield Wall

material if necessary.

The blast resistant shield wall panels can be supported at the base by an extension of the existing building foundation, or by a separate foundation, and at the top by the lateral load resisting system of the building. This retrofit can be designed to resist very large blast loads, depending on the strength of the lateral load resisting system of the building. It has the advantage of not requiring any construction work inside the building, but the building exterior must be accessible. The shield wall panels can be precast or prefabricated in a remote yard or on-site. Blast resistant doors and windows can be designed into the shield wall panels to line up with doors and windows in the existing wall. Any windows covered up by blast resistant shield walls should be removed to ensure that any pressure buildup between the shield walls and windows as the shield wall deflects does not fail the windows and throw glass into the building.

If a building without moment resisting frames has a shield wall, either the existing wall or the shield wall can be used as the shear wall. If the shield wall is used as a shear wall, the connections of the shield wall to the roof and floor diaphragms and foundation must be designed accordingly.

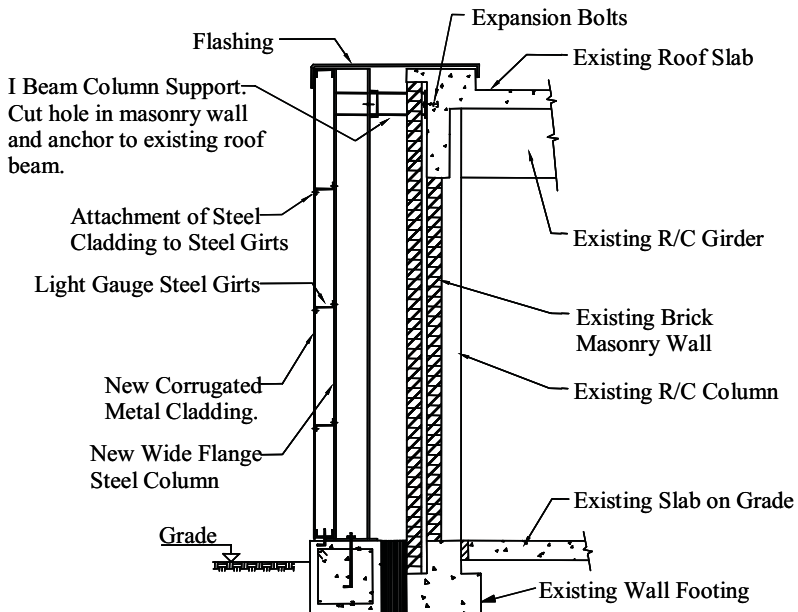

FIGURE 10.14: Wall Upgrade with Blast Resistant Steel Panel and Girt Shield Wall System

10.9 UPGRADES FOR ROOF SYSTEMS

Roofs are often particularly difficult to upgrade and usually represent a significant portion of a building upgrade cost. There are limited upgrade options that can be applied outside the building, and interior upgrades often require removing the drop ceiling, HVAC ducting, and other wiring systems, which results in significant disruption to building operations. If an interior upgrade is an option, applicable wall upgrade options described previously can be applied to the roof system. In the case where an external upgrade is required, the most practical option is often placement of new blast resistant shield roof system over the existing roof, which remains in place as an environmental barrier and structural diaphragm. The new roof system resists the blast load, shielding the existing roof from blast load. The spacer beams in the figure are sized to prevent beam and panel deformation into the existing roof. The spacer beams also act with the existing girders to transfer reaction loads from the shield roof into the columns. The columns may need to be upgraded for these increased reaction loads. The effect of the

Figure 10.15 shows an exterior roof retrofit, where a new blast resistant roof system is placed over the existing roof, which remains in place as an environmental barrier and structural diaphragm. The new roof system resists the blast load, shielding the existing roof from blast load. The spacer beams in the figure are sized to prevent beam and panel deformation into the existing roof. The spacer beams also act with the existing girders to transfer reaction loads from the shield roof into the columns. The columns may need to be upgraded for these increased reaction loads. The effect of the

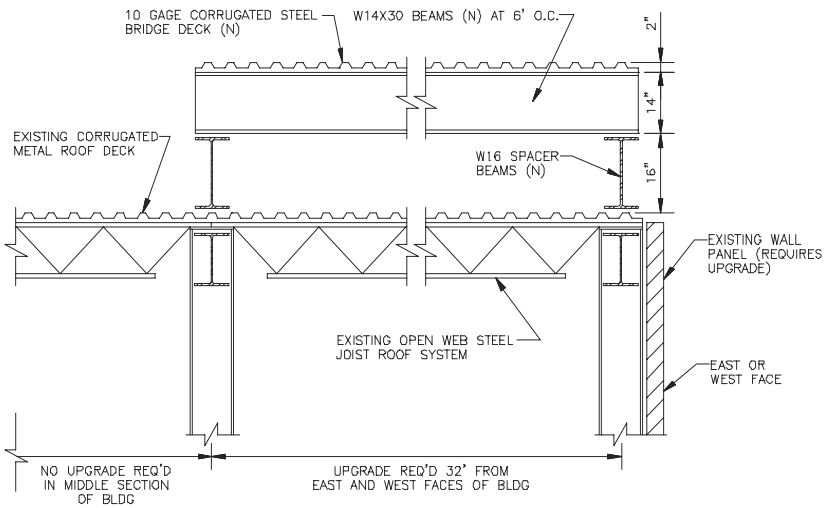

FIGURE 10.15: Shield Roof Over Part of Existing Building

additional dead load from the new roof on the foundation will also need to be considered.

As with the shield walls, the engineer should verify that sudden deflection of the shield roof retrofit will not create a significant dynamic pressure buildup within the void between the shield roof and existing roof. This is usually not a problem if the shield roof system is significantly stiffer than the existing roof system because the existing roof is flexible enough to deflect an amount equal to the relatively small deflections of the overlying shield roof system and alleviate a pressure buildup. In some cases, both the beams and girders in the shield roof can be placed directly over existing framing members, so that both the new and existing framing members deflect together and resist the blast load together as a superimposed structural system.

10.10 WALL AND ROOF CATCH SYSTEM UPGRADES

Various “catch wall” and “catch roof” systems can be placed inside the building that stop debris from failed wall and roof systems before injuring building occupants. These systems are typically used in small, heavily occupied areas, where the building framing can resist the blast load, but the overhead roof or adjacent wall panels cannot be upgraded to resist the applied blast load. Catch wall retrofit concepts include building an internal steel frame with heavy steel grating around the occupied area, placing an interior blast resistant wall system in front of occupied areas that is well attached to blast resistant framing, and installing a geotextile fabric behind a wall that is well attached to blast resistant framing or components. This latter reference is illustrated in Figure 10.16 and discussed in *UFC 4-023-02*, which is currently still in

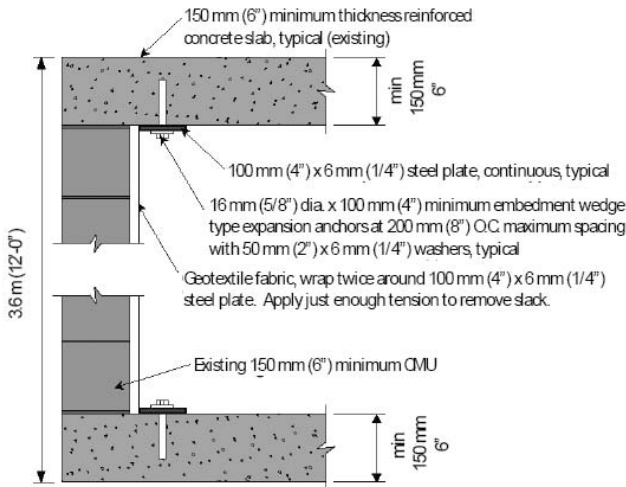

FIGURE 10.16: Geotextile Retrofit Behind Masonry Non-Load Bearing Wall

draft phase. The geotextile fabric is designed to resist the applied blast load in membrane action with the mass of the wall and the strain is limited to less than the material failure strain with a factor of safety. Fabrics with failure strains in the range of 7% to 12% are recommended. The capacity of the anchors should exceed the tensile capacity of the geotextile. Elastomeric based spray and continuous E-glass sheets can also be applied on the wall’s interior and anchored to the floor and roof to serve as catch systems, as described in *UFC 4-023-02*.

Additionally, Figure 10.17 shows a retrofit that consists of an interior steel roof catch system. The retrofit consists of new tube steel beams that support heavy steel grating, which hangs by steel cables from the tube steel beams at an elevation just above the false ceiling. The grating was designed to support the roof panel and joists, assuming they failed under blast load. The building framing could be strengthened to resist the blast load, but the existing joists and metal panel roof system could not be strengthened by the required amount to resist the design blast load.

10.11 BLAST RESISTANT SHELL UPGRADES

When options for reinforcing an existing structure are not feasible, an independent shell, or “cocoon” structure can be built around the existing building with reinforced concrete or a steel frame and blast resistant panels. The reinforced concrete option can be either cast-in-place or precast wall and roof panels. Obviously, this is usually the most expensive retrofit option. In some cases, large amounts of buried cables around the building may preclude placement of a new foundation system outside the building. However, factors that make shells an attractive option include:

- Interruption of interior ongoing operations is minimized because the bulk of the work is done outside of the building.
- A shell can meet almost any specific blast resistance criteria. This is not true

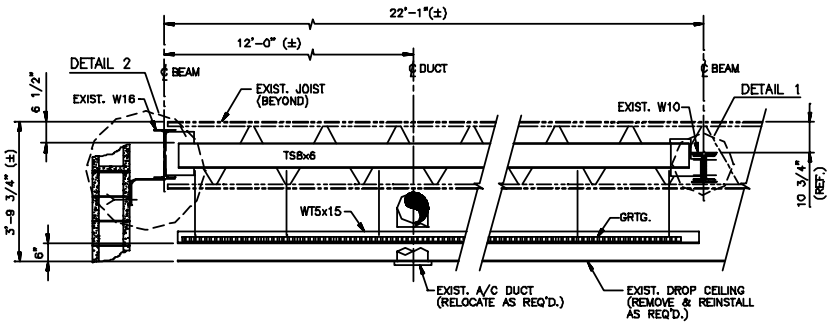

FIGURE 10.17: Elevation Section of Interior Roof Retrofit with TS Steel Beams and Steel Grating

for other upgrade options where certain upper limits will apply.

- Constructability of connections can be less of a problem for shell building upgrades. The logistics of adequately connecting new upgrade components to the existing building can be quite difficult. Access to the critical joints in buildings that require reinforcement to upgrade the building blast capacity can sometimes be virtually impossible.

Suggestions on some of the shell upgrade options are shown in Figure 10.18. A number of issues, however need to be addressed. The following considerations are not all-inclusive:

- Foundations: A gap should be maintained between the new and the existing wall to prevent the existing wall or blocks from being knocked into the building when the outside panel deflects under blast loading. The width of this gap affects the location of the footing for the outer shell. Ideally the shell will rest on its own new footing. But a thick wall required by high blast load may require a large footing which could encroach on the existing foundation. In

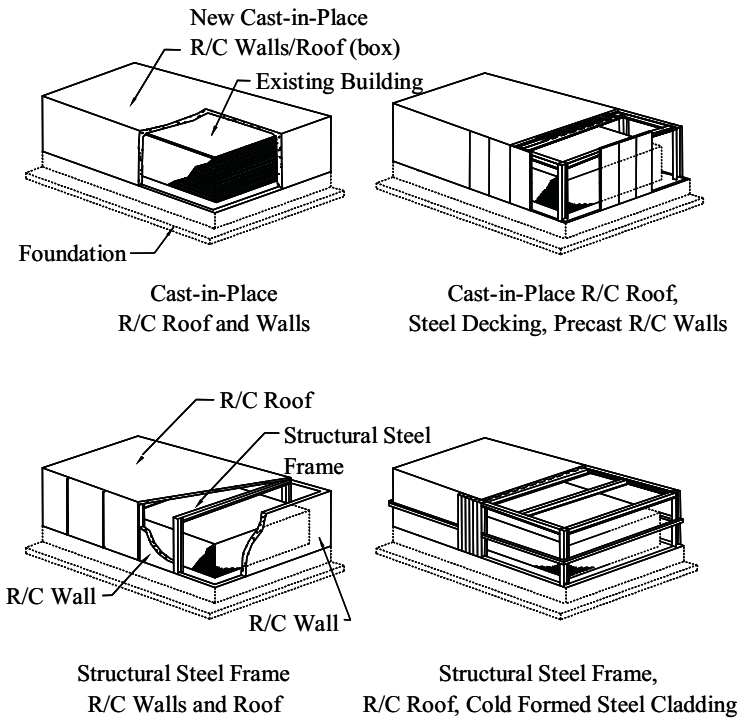

FIGURE 10.18: Blast Resistant Shell Around Existing Building

this case, techniques will include staggering the horizontal level of the footings, or perhaps using piers or piles adjacent to the existing footing.

- Structural: The depth of structural steel columns should fit in the gap between the new and the existing building walls.
- Ancillaries: Pipe racks and cable trays that are in place adjacent to the existing building will require attention. Penetrations in the new wall are necessary for power cables and instrument lines. These openings should not adversely affect the pressure rating of the building.
- The engineer should also check that the sudden deflection of the all the shell building walls or roof does not decrease the void volume between the shell building and existing building, and thus increase the air pressure, to the extent that any existing wall or roof components fail. Small vent openings, covered with low strength, lightweight material if necessary, can be designed into the existing wall to prevent this potential problem.
- Existing HVAC and air intake stack issues discussed previously must also be addressed with this upgrade approach.

10.12 WINDOW UPGRADES

Windows can be a significant hazard to the occupants of existing buildings. Choosing the most appropriate option to upgrade windows requires knowledge of the relationship between glass strength, blast loads, and the interior hazard from failed windows. Window failure from blast loads is sometimes acceptable with certain industry clients if the glass is not thrown into the building with sufficient velocity to injure building occupants. There is limited blast test data available from glazing manufacturers on specific window products that provide protection against glazing hazards. This data includes validation of specific applied blast loads on a specific window size, glazing layout, frame, bite, and frame anchorage.

In general, upgrading of windows may include the following options.

- Elimination of windows. A common requirement is that no window is allowed within 200 feet (61 m) from a potential blast source. A large number of petrochemical control rooms now use closed circuit TV monitors to watch the process units.
- Replacement of the windows with laminated glass, which consists of two or more plies of annealed or heat strengthened glass bonded by a clear inner layer of polyvinyl butyral. The glass must have a large bite into the frame (i.e., up to 1 in [25 mm]) or be attached to the frame with high strength structural silicone sealants so that they entire window is not thrown out of the frame into the building by a blast load. The frame attachment to the building wall must also resist high reaction forces.



FIGURE 10.19: Window Retrofit Using Mullions and Film

- Placement of minimum 4 mil (100 μm) thick safety film on windows. It should be noted that application of film does not improve the strength of the glass, but only reduces the number of glass fragments. Care must be exercised not to trade off small glass hazard with blunt impact hazard from a whole sheet of glass attached together by film. The film can be attached to the window frame with a batten system or with high strength structural silicone so that the whole sheet of filmed glass is not thrown into the building when the glass breaks. Film strength degrades with time and should typically be replaced at the end of the manufacturer's warranty period.
- Reduce the span width of the open glass area by adding support struts or mullions as shown in Figure 10.19.
- Installation of a "catch system" to block larger glass fragments, or even the entire window pane and frame. The system must be able to stop the entire window missile within a reasonable distance. Numerous catch systems are available or under development by vendors. These catch systems should only be used when there is test data validating the effectiveness of the catch system and the catch system attachments to the building for a blast load similar to the design blast load, or when the system is designed with an approach that is validated with test data. A more generic catch bar system as shown in Figure 10.20 has also been found to be effective when combined with a daylight film application. The bar requires very strong connections to the wall, so that it yields in flexure before the connection fails.

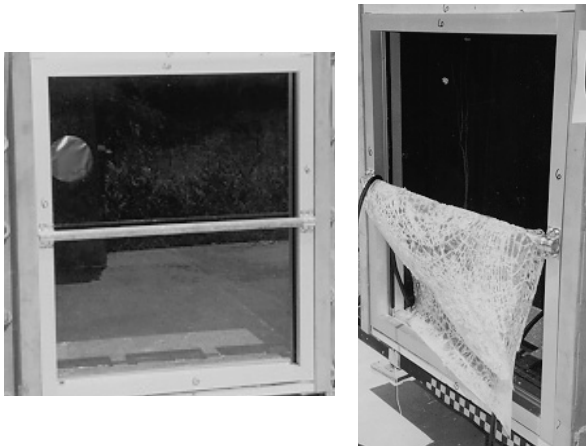

FIGURE 10.20: Window Film and Catch Bar Retrofit

- Narrow (e.g., 12 in [300 mm] wide) vertical orientated blast resistant windows placed in new shield, blocked-in, or cocoon walls allow light into the building without significantly sacrificing the blast resistant wall design.

The effects of negative pressure and rebound can be very important for glazing if there is concern regarding window fragments outside the building, and should therefore be included in the upgrade design. It should be noted that even if a window is upgraded with a higher strength glass type or a battened film system, the structural integrity of the window frame and the frame attachments to the building structure must be investigated. If the frame attachment to the wall is not able to withstand reaction forces from the blast resistant window, the entire window frame will become a hazard instead of the small glass fragments. The window frame, mullions, and the attachments of these components to the building should always be designed to have a larger blast capacity than the supported window system.

10.13 DOOR UPGRADES

Conventional hollow metal doors with a 1.5 hour fire rating (i.e., Class B fire doors) have a low blast capacity. These doors fail in a number of modes, beginning with failure during rebound in the unseating direction when the door is overloaded by blast to a moderate extent. If these doors have a cylindrical latch, they may withstand a rebound force of 50 psf (2.4 kPa). Doors with a mortised latch may be adequate for a rebound force of 100 psf (4.8 kPa). When conventional doors are severely overloaded by the blast load, the combined deformation of the door panel and the frame allow the door panel to be blown into the building. This is illustrated in Figure 10.21 for a blast load that was sufficient to deform the door through the frame, but not large enough to throw it as a missile.



FIGURE 10.21: Conventional Hollow Metal Door Damage Under Low Blast Load

In some cases, existing doors can be strengthened to resist the blast load. Attention must be paid to the light steel door frame, since large blast loads cause the door frame to deform, allowing the door to be pushed through the door frame into the building. Generally test data is necessary to show that an upgraded conventional door and frame can resist a specified blast load. In low occupancy buildings, doors may be attached to steel framing with cables that allow the door to fail, but catch the door before it is thrown well into the building. The cable attachment to the door must be made with through bolts and large plate washers that engage a large amount of door material, since conventional doors have very thin gage steel panels. Also, the steel cable must be designed to resist the portion of the blast load applied to the door before it is caught by the cable without yielding, since steel cable is manufactured from nonductile wire.

Typically, the most practical approach is to replace inadequate doors with blast resistant doors supplied by a specialty door vendor. Unlike conventional doors, blast doors are typically provided as a complete assembly including the door, frame, hardware and accessories. This is because all the components are dependent on each other to provide the overall blast resistance. Refer to Chapter 9 for performance requirements and design details for blast resistant doors. The primary challenge associated with using a new blast resistant door is an adequate attachment of the new door frame to the surrounding building. Figure 10.22 shows several concepts for attaching a new blast resistant door frame to an existing masonry or reinforced concrete wall. Conservatively, the door frame attachment can be designed to have an ultimate strength that resists twice the peak applied blast pressure on the door. This requirement can be reduced if there is a detailed analysis to determine the maximum dynamic forces transferred by the door panel to the door frame. A separate steel

frame supported by the building framing and the foundation can also be constructed inside the building to support a new blast resistant door.

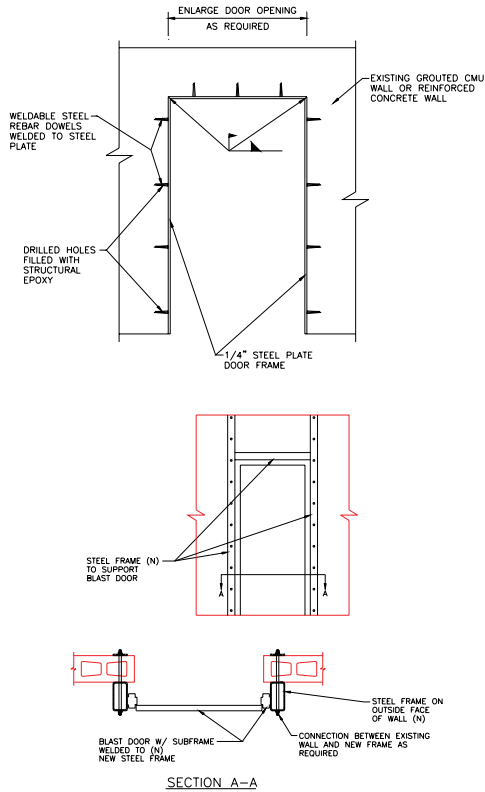

FIGURE 10.22: Concepts for Providing Blast Door Frame in Existing Masonry or Reinforced Concrete Wall

CHAPTER 11

SHEAR WALL BUILDING DESIGN EXAMPLE

11.1 INTRODUCTION

The following is a sample blast design for a control building using reinforced concrete walls, a structural steel frame for vertical support, and a pile foundation. There are two blast load cases, one applied to the long side of the building, and the other applied to the short side. The explosion source and side-on overpressure (6 psi [41 kPa] for 0.05 seconds) are determined by others with the blast design parameters coming from Appendix 3.

Structural code provisions, as applicable, are from,

- ACI 318-05, *Building Code Requirements for Structural Concrete*
- AISC 360-05, *Specification for Structural Steel Buildings*
- AISC 341-05, *Seismic Provisions for Structural Steel Buildings*

Additional references are,

- MacGregor, *Reinforced Concrete, Mechanics and Design*
- Roark, *Formulas for Stress and Strain*
- Biggs, *Introduction to Structural Dynamics*
- AISC Manual, *AISC Manual of Steel Construction*
- AISC Guide, *AISC Design Guide 1, Column Base Plates*
- Blodgett, *Design of Welded Structures*
- UFC 3-340-02, *Structures to Resist the Effects of Accidental Explosions*

For brevity, design for static loads is not included.

11.2 STRUCTURAL SYSTEM

The structure in this example is of Cast-in-Place Concrete Wall Construction as described in Section 4.3.5. Vertical loads are resisted by a structural steel frame. Lateral loads are resisted by the concrete roof diaphragm and by the side shear walls.

11.2.1 Description of Structure

A section through the reinforced concrete shear wall is shown on the following page. This section applies to each of the four sides of the building.

11.2.2 Framing Plan

Figure 11.1 shows the structural steel roof framing.

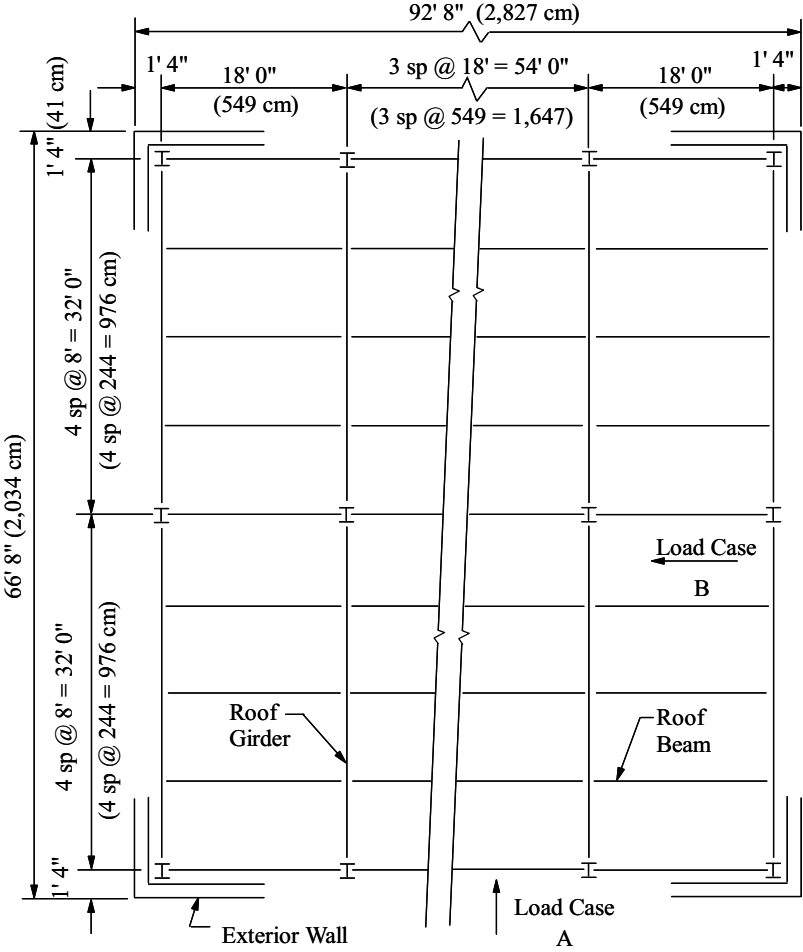

FIGURE 11.1: Roof Framing Plan

11.2.3 Components for Blast Design

The design will proceed component by component. The tracking of reactions to supported structural elements is not utilized. Each component will be designed as an independent uncoupled structural member.

Lateral load resisting components include the front wall, back wall, side wall, roof diaphragm, shear walls, and foundation (Figure 11.2). Vertical load resisting components include the roof slab, roof beam, roof girder, column, and foundation.

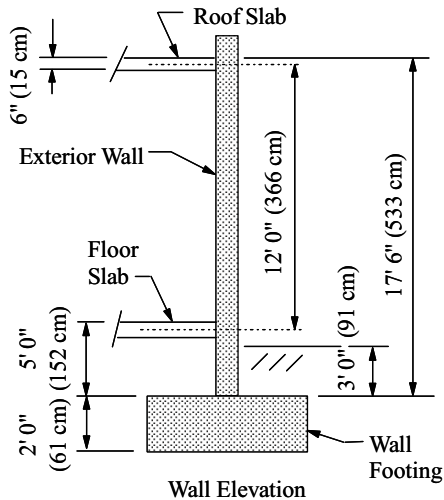

FIGURE 11.2: Wall Elevation

The foundation will be designed for vertical and lateral loads using equivalent static design method described in Section 7.7.1.

11.3 DESIGN DATA

11.3.1 Material Properties

As is typical for blast design in the petrochemical industry, commonly used structural materials will be used.

structural steel (W shapes): ASTM A992, $F_y = 50$ ksi (345 MPa)

structural steel (plates): ASTM A36, $F_y = 36$ ksi (248 MPa), $F_u = 58$ ksi (400 MPa)

reinforcing steel: ASTM A615, grade 60, $F_y = 60$ ksi (414 MPa)

concrete: $f'_c = 4,000$ psi (27.6 MPa)

DIF factors will be obtained from Table 5.A.3 using ASTM A588.

Because of the low permissible dynamic response, $F_{ds} = F_{dy}$. (Tables 5.A.4 and 5.A.5)

steel modulus, $E_s = 29,000,000$ psi (200,000 MPa)

concrete modulus, $E_c = 3,605,000$ psi (24,900 MPa)

$n = E_s / E_c = (29,000,000 \text{ psi}) / (3,605,000 \text{ psi}) = 8.04$

soil density: 115 pcf (18.1 kN/m³)

roof dead load: 25 psf (1,197 Pa)

Roof live loads are assumed to be negligible at the time of a potential blast incident.

11.3.2 Design Loads

The design load is taken from that calculated in Appendix 3.

Case A, explosion occurs on long side of building.

Case B, explosion occurs on short side of building.

11.3.3 Building Performance Requirements - Deformation Limits

The low response range (refer to Appendix 5.B) is selected to maximize reuse of the building with minimal cost of repairs.

Because low response limits (less than 2 degrees) will be used, dynamic design stresses will be equal to yield dynamic stresses. Refer to Table 5.A.4.

11.4 EXTERIOR WALLS (out-of-plane loads)

The exterior concrete walls are 12 ft (3,658 mm) from floor slab to roof. The shorter walls are 66.67 ft (20,320 mm) long, a 5.6 to 1 height to width ratio. Therefore all walls will be analyzed as one way beams pinned at the base by a crossed reinforcing configuration at the slab level (similar to Figure 8.10), and pinned at the top due to a thinner roof slab (Figure 8.11). The wall is assumed to be unrestrained (for axial forces) at the top end and will not respond in tensile membrane action.

NOTE: If the wall panel aspect ratio were less than 2 to 1, the panel would need to be analyzed as a two-way span using resistance equations and transformation factors from the applicable tables in UFC 3-340-02.

span, $L = 12$ feet or 144 in (3,658 mm) from floor slab to base of roof slab

use a nominal design width, $b = 1.0$ ft or 12 in (305 mm)

11.4.1 Front Wall (from Load Case A)

Front wall loading results in the maximum wall response.

from the Chapter 3 Appendix calculation,

$$P_r = 13.8 \text{ psi (95 kPa)}$$

$$P_s = 6.8 \text{ psi (47 kPa)}$$

$$t_c = 0.034 \text{ s}$$

$$t_d = 0.05 \text{ s}$$

$$t_e = 0.042 \text{ s}$$

The blast loaded area tributary to the exterior wall is the wall height of 144 in (3,658 mm) by the nominal design width of 12 in (305 mm).

The applied load is divided into two triangular components: "reflection load" and "stagnation load"

reflection load,

$$F_{RL} = (144 \text{ in span})(12 \text{ in width})(13.8 \text{ psi} - 6.8 \text{ psi}) / (1,000 \text{ k/lb}) \\ = 12.1 \text{ kips (53.8 kN)}$$

stagnation load,

$$F_{SL} = (144 \text{ in span})(12 \text{ in width})(6.8 \text{ psi}) / (1,000 \text{ k/lb}) = 11.8 \text{ kips (52.5 kN)}$$

total load,

$$F_o = F_{RL} + F_{SL} \\ = (12.1 \text{ k}) + (11.8 \text{ k}) \\ = 23.9 \text{ kips (106.3 kN)}$$

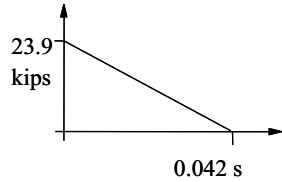

11.4.2 Side Wall

Side wall loading is used in an interaction check with shear wall response.

from the Appendix 3 calculation,

$$P_a = 5.7 \text{ psi (39 kPa)}$$

$$t_r = 0 \text{ s}$$

$$t_d = 0.05 \text{ s}$$

peak load,

$$F_o = (144 \text{ in span}) (12 \text{ in width}) (5.7 \text{ psi}) / (1,000 \text{ k/lb}) = 9.8 \text{ kips (44 kN)}$$

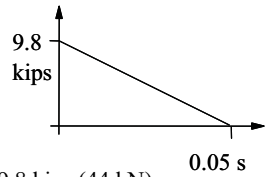

11.4.3 Rear Wall

Neglect this case because it will not control.

11.4.4 Trial Size

NOTE: The following trial dimensions and material proportions may be obtained from trial calculations, by inspection of similar structures, or from experience. The results of this dynamic calculation will determine the adequacy of the trial size.

wall thickness, 10 in (254 mm)

#5 @ 6 in (152 mm), each face, vertical

#5, area = 0.31 in² (200 mm²)

#5, diameter = 0.625 in (16 mm)

#3 @ 6 in (152 mm), each face, horizontal

vertical bars are inside of horizontal bars

11.4.5 Compute Bending Resistance

for dynamic bending, (Appendix 5.A)

$$F_{ds} = F_{dy} = (SIF)(DIF) F_y = (1.1)(1.17) 60 \text{ ksi} = 77.2 \text{ ksi} (532 \text{ MPa})$$

$$f'_{dc} = (SIF)(DIF) f'_c = (1.0)(1.19) 4 \text{ ksi} = 4.76 \text{ ksi} (33 \text{ MPa})$$

for the nominal design width,

$$A_s = (0.31 \text{ in}^2)(12 \text{ in/ft}) / (6 \text{ in bar spacing}) = 0.62 \text{ in}^2 (400 \text{ mm}^2)$$

for bending tension on the inside face,

(ACI 318, Section 7.7.1.c)

$$d = (10 \text{ in thick}) - (0.75 \text{ in clear}) - (0.375 \text{ in horiz bar}) - (0.625 \text{ in vert bar}) / 2$$

$$= 8.56 \text{ in} (217 \text{ mm})$$

$$A_{s, \min} = 3 \frac{\sqrt{f'_{dc}}}{F_{ds}} (b)(d) = 3 \frac{\sqrt{4,760 \text{ psi}}}{77,200 \text{ psi}} (12 \text{ in})(8.56 \text{ in}) \quad (\text{ACI 318, Section 10.5.1})$$

$$= 0.28 \text{ in}^2 (180 \text{ mm}^2) < A_s, \text{ OK}$$

$$A_{s, \min} = 200(b)(d) / F_{ds} = 200(12 \text{ in})(8.56 \text{ in}) / (77,200 \text{ psi}) \quad (\text{ACI 318, Section 10.5.1})$$

$$= 0.27 \text{ in}^2 (174 \text{ mm}^2) < A_s, \text{ OK}$$

$$d_{sb} = A_s (F_{ds}) / 0.85 (f'_{dc})(b) \quad (\text{MacGregor, Equation 4-9})$$

$$= (0.62 \text{ in}^2)(77.2 \text{ ksi}) / (0.85)(4.76 \text{ ksi})(12 \text{ in})$$

$$= 0.99 \text{ in} (25.1 \text{ mm})$$

$$M_p = A_s (F_{ds}) [d - d_{sb} / 2] \quad (\text{MacGregor, Equation 4-10a})$$

$$= (0.62 \text{ in}^2)(77.2 \text{ ksi}) [(8.56 \text{ in}) - (0.99 \text{ in}) / 2]$$

$$= 386 \text{ k-in} (43,612 \text{ kN-mm})$$

positive (inward) bending resistance based on pinned ends,

$$R_b = 8 M_p / L = 8 (386 \text{ k-in}) / (144 \text{ in}) = 21.44 \text{ kips} (95.37 \text{ kN}) \quad (\text{Table 6.1})$$

for bending tension on the outside face,

(ACI 318, Section 7.7.1.b)

$$d = (10 \text{ in thick}) - (1.5 \text{ in clear}) - (0.375 \text{ in horiz bar}) - (0.625 \text{ in vert bar}) / 2$$

$$= 7.81 \text{ in} (198 \text{ mm})$$

$$A_{s, \min} = 3 \frac{\sqrt{f'_{dc}}}{F_{ds}} (b)(d) = 3 \frac{\sqrt{4,760 \text{ psi}}}{77,200 \text{ psi}} (12 \text{ in})(7.81 \text{ in}) \quad (\text{ACI 318, Section 10.5.1})$$

$$= 0.25 \text{ in}^2 (161 \text{ mm}^2) < A_s, \text{ OK}$$

$$A_{s, \min} = 200(b)(d) / F_{ds} = 200(12 \text{ in})(7.81 \text{ in}) / (77,200 \text{ psi}) \quad (\text{ACI 318, Section 10.5.1})$$

$$= 0.24 \text{ in}^2 (155 \text{ mm}^2) < A_s, \text{ OK}$$

$$M_p = A_s (F_{ds}) [d - d_{sb} / 2] \quad (\text{MacGregor, Equation 4-10a})$$

$$= (0.62 \text{ in}^2)(77.2 \text{ ksi}) [(7.81 \text{ in}) - (0.99 \text{ in}) / 2]$$

$$= 350 \text{ k-in} (39,545 \text{ kN-mm})$$

rebound (outward) bending resistance based on pinned ends,

$$R_b = 8 M_p / L = 8 (350 \text{ k-in}) / (144 \text{ in}) = 19.44 \text{ kips (86.47 kN)} \quad (\text{Table 6.1})$$

11.4.6 Compute Shear Resistance

for dynamic shear,

(Appendix 5.A)

$$f_{dc} = (\text{SIF})(\text{DIF}) f_c = (1.0)(1.0) 4 \text{ ksi} = 4.0 \text{ ksi (27.6 MPa)}$$

Because positive or rebound bending can occur, calculate shear resistance based on the smaller of d based on inside tension or outside tension, in this case, use $d = 7.81$ in (198 mm).

$$\begin{aligned} V_n &= 2 \sqrt{f_{dc}} b d && (\text{ACI 318, Equation 11-3}) \\ &= 2 \sqrt{(4,000 \text{ psi})} (12 \text{ in})(7.81 \text{ in}) / 1,000 \\ &= 11.85 \text{ kips (52.7 kN)} \end{aligned}$$

the critical section for shear is d from the support,

$$\begin{aligned} R_s &= V_n L / (0.5 L - d) \\ &= (11.85 \text{ kips})(144 \text{ in}) / [0.5 (144 \text{ in}) - (7.81 \text{ in})] \\ &= 26.58 \text{ kips (118.2 kN)} \end{aligned}$$

11.4.7 Resistance & Permissible Response

Because $R_b < R_s$, bending controls

$$\text{positive resistance} = R_u = R_b = 21.44 \text{ kips (95.37 kN)}$$

$$\text{rebound resistance} = R_u = -R_b = -19.44 \text{ kips (-86.47 kN)}$$

$$\text{allowable ductility ratio, } \mu_a = \text{not applicable} \quad (\text{Table 5.B.3})$$

$$\text{allowable support rotation, } \theta_a = 1.0^\circ \text{ (based on no shear reinforcing)} \quad (\text{Table 5.B.3})$$

11.4.8 Compute SDOF Equivalent System

Moment of inertia will be based on positive (inward) bending.

gross moment of inertia,

$$I_g = b (h)^3 / 12 = (12 \text{ in})(10 \text{ in})^3 / 12 = 1,000 \text{ in}^4 \text{ (416,231,426 mm}^4\text{)}$$

transformed rebar area,

$$n A_s = (8.04)(0.62 \text{ in}^2) = 4.98 \text{ in}^2 \text{ (3213 mm}^2\text{)}$$

location of transformed neutral axis,

$$d_{na} = \frac{-n A_s + \sqrt{n A_s (n A_s + 2bd)}}{b}$$

$$= \frac{-4.98 \text{ in}^2 + \sqrt{4.98 \text{ in}^2 (4.98 \text{ in}^2 + 2(12 \text{ in})(8.56 \text{ in}))}}{12 \text{ in}}$$

$$= 2.28 \text{ in (58 mm)}$$

cracked moment of inertia,

$$I_{cr} = b (d_{na})^3/3 + n A_s (d - d_{na})^2$$

$$= (12 \text{ in})(2.28 \text{ in})^3/3 + (4.98 \text{ in}^2)(8.56 \text{ in} - 2.28 \text{ in})^2$$

$$= 244 \text{ in}^4 (101,560,468 \text{ mm}^4)$$

averaged moment of inertia,

$$I_a = (I_g + I_{cr}) / 2 = (1,000 \text{ in}^4 + 244 \text{ in}^4) / 2 = 622 \text{ in}^4 (258,895,947 \text{ mm}^4)$$

effective stiffness,

$$K_e = 384 E_c I_a / 5 L^3 \tag{Table 6.1}$$

$$= 384 (3,605 \text{ ksi})(622 \text{ in}^4) / 5(144 \text{ in})^3$$

$$= 57.67 \text{ k/in (10.1 kN/mm)}$$

beam mass,

$$M = (\text{wall weight}) / g$$

$$= (0.15 \text{ kcf})(0.83 \text{ ft thick})(1.0 \text{ ft nominal width})(12 \text{ ft span}) / (386 \text{ in/s}^2)$$

$$= 0.00387 \text{ k-s}^2/\text{in (0.00068 kN-s}^2/\text{mm)}$$

Because of the expected response, use an average of elastic and plastic values for K_{LM}

$$\text{elastic } K_{LM} = 0.5 / 0.64 = 0.78 \tag{Table 6.1}$$

$$\text{plastic } K_{LM} = 0.33 / 0.5 = 0.66$$

$$\text{average } K_{LM} = (0.78 + 0.66) / 2 = 0.72$$

equivalent mass,

$$M_e = (K_{LM})(M) = (0.72)(0.00387 \text{ k-s}^2/\text{in}) = 0.00279 \text{ k-s}^2/\text{in (0.00049 kN-s}^2/\text{mm)}$$

period of vibration,

$$t_n = 2 \pi \sqrt{(M_e/K_e)} = 2 \pi \sqrt{(0.00279 \text{ k-s}^2/\text{in}) / (57.67 \text{ k/in})} = 0.043 \text{ s} \tag{Equation 6.8}$$

11.4.9 Chart Solution (front wall)

NOTE: Both charts and numerical integration need not be used. A chart solution is presented for the front wall in order to illustrate implementation.

from the Chapter 3 Appendix calculation,

$$P_r = 13.8 \text{ psi (95 kPa)}$$

$$t_e = 0.042 \text{ s}$$

peak load,

$$F_o = (144 \text{ in span})(12 \text{ in width})(13.8 \text{ psi}) / (1,000 \text{ lb/k}) = 23.8 \text{ kips (106 kN)}$$

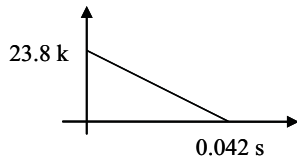

Figure 6.6 uses t_d to represent the time of duration, thus $t_d = t_e = 0.042 \text{ s}$

$$t_d / t_n = (0.042 \text{ s}) / (0.043 \text{ s}) = 0.98$$

$$R_u / F_o = (21.44 \text{ kips}) / (23.8 \text{ kips}) = 0.90$$

using the chart: $\mu_d = 3.1$ (Figure 6.6)

$$\text{elastic deflection, } y = R_u / K_e = (21.44 \text{ kips}) / (56.93 \text{ k/in}) = 0.377 \text{ in (9.6 mm)}$$

$$\text{maximum deflection, } y_m = (\mu_d)(y) = (3.1)(0.377 \text{ in}) = 1.17 \text{ in (29.7 mm)}$$

maximum support rotation, (Figure 5.9)

$$\theta_d = \arctan (y_m / 0.5L) = \arctan [(1.17 \text{ in}) / (0.5)(144 \text{ in})] = 0.93^\circ < \theta_a, \text{ OK}$$

11.4.10 Numerical Integration Solution (front wall) (Appendix 6)

NOTE: The numerical integration procedure can handle the bilinear loading in lieu of an equivalent triangular loading.

$$F_{RL} = 12.1 \text{ kips (53.8 kN)}$$

$$F_{SL} = 11.8 \text{ kips (52.5 kN)}$$

$$t_c = 0.034 \text{ s}$$

$$t_d = 0.05 \text{ s}$$

$$\text{time increment} = t_n / 10 = 0.0043 \text{ s}$$

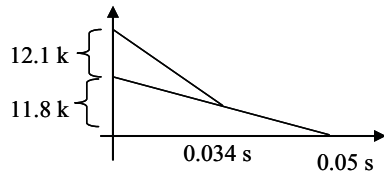

TABLE 11.1: Front Wall Numerical Integration

Analysis Case Description:		Chapter 11, Section 11.4.10, front wall										
Dynamic Loading Description:		max [12.1 - 12.1(time)/(0.034), 0] + max [11.8 - 11.8(time)/(0.05), 0]										
time increment =	0.004 s	KEY = 0 is elastic									Z = 1 is increasing plastic deformation	
mass =	0.00279 k-s ² /in	KEY = +1 is positive plastic									Z = 2 is end of rebound plastic deformation	
stiffness =	56.93 k/in	KEY = -1 is rebound plastic									Z = 3 is end of positive plastic deformation	
damping =	0 k-s/in										Z = 4 is continued elastic	
positive resistance =	21.44 kips										Z = 5 is start of rebound plastic deformation	
rebound resistance =	-19.44 kips										Z = 6 is start of positive plastic deformation	
static load =	0 kips											
time (s)	Dyn. Load (kips)	y (in)	v (in/s)	a (in/s ²)	ye+ (in)	ye- (in)	KEY	eff K (k/in)	incr F (kips)	incr y (in)	incr v (in/s)	Z
0.000	23.90	0.000	0.00	8,566	0.377	-0.341	0	1,103	69	0.063	30.00	
0.004	21.53	0.063	30.00	6,435	0.377	-0.341	0	1,103	177	0.160	17.49	4
0.008	19.16	0.223	47.50	2,312	0.377	-0.341	0	1,103	216	0.196	-0.43	4
0.012	16.80	0.419	47.07	-1,664	0.377	-0.341	1	1,046	181	0.173	-8.35	6
0.016	14.43	0.592	38.71	-2,513	0.377	-0.341	1	1,046	139	0.132	-11.75	1
0.020	12.06	0.724	26.96	-3,361	0.377	-0.341	1	1,046	82	0.079	-15.14	1
0.024	9.69	0.803	11.82	-4,210	0.377	-0.341	1	1,046	12	0.011	-18.54	1
0.028	7.33	0.814	-6.71	-5,058	0.377	-0.341	1	1,046	-73	-0.070	-21.93	1
0.032	4.96	0.745	-28.64	-4,487	0.814	0.096	0	1,103	-159	-0.144	-13.25	3
0.036	3.30	0.600	-41.89	-2,138	0.814	0.096	0	1,103	-194	-0.176	-2.05	4
0.040	2.36	0.424	-43.94	1,115	0.814	0.096	0	1,103	-175	-0.159	10.28	4
0.044	1.42	0.265	-33.66	4,023	0.814	0.096	0	1,103	-108	-0.098	19.42	4
0.048	0.47	0.167	-14.25	5,685	0.814	0.096	0	1,103	-13	-0.011	22.86	4
0.052	0.00	0.156	8.62	5,747	0.814	0.096	0	1,103	84	0.076	19.88	4
0.056	0.00	0.232	28.49	4,191	0.814	0.096	0	1,103	154	0.140	11.05	4

The rebound peak deflection is at $t = 0.044$ s,
 $y_m = -0.153$ in (-3.9 mm)

maximum support rotation, (Figure 5.9)
 $\theta_d = \arctan (y_m / 0.5L) = \arctan [(0.274 \text{ in}) / (0.5)(144 \text{ in})] = 0.22^\circ < \theta_a$, OK

Refer to the design for wall in-plane loads for the interaction check.

11.5 ROOF SLAB (in-plane loads)

The roof diaphragm is designed to transfer wall loads to the side shear walls. The diaphragm is fixed at both ends by continuous attachment to the walls. The center of mass coincides with the center of rigidity indicating no incidental torsion.

span, $L = (92.667 \text{ ft out-to-out}) - (10 \text{ in wall})/12 = 91.83 \text{ ft}$ or 1,102 in (27,991 mm)

depth = 66.67 ft or 800 in (20,320 mm), out-to-out

determine width of composite (wall) flange: (ACI 318, Section 8.10.3)

- a. $(1102 \text{ in span}) / 12 = 92 \text{ in}$ (2,337 mm)
- b. $(10 \text{ in wall}) 6 = 60 \text{ in}$ (1,524 mm) \leq controls
- c. $(144 \text{ in wall span}) / 2 = 72 \text{ in}$ (1,829 mm)

use effective width, $b = 60$ in (1,524 mm)

11.5.1 Load Case A (applied to long side of building)

from the Chapter 3 Appendix calculation,

$P_r = 13.8 \text{ psi}$ (95 kPa)

$P_s = 6.8 \text{ psi}$ (47 kPa)

$t_c = 0.034 \text{ s}$

$t_d = 0.05 \text{ s}$

The blast loaded area tributary to the roof diaphragm is half the exterior wall height of 144 in (3,658 mm) by the building width of 1,112 in (28,245 mm).

NOTE: The rear wall load, with the applicable arrival delay, could be applied to minimize the roof diaphragm response.

The applied tributary load is divided into two triangular components: "reflection load" and "stagnation load"

reflection load,

$$F_{RL} = (144 \text{ in height} * 0.5)(1,112 \text{ in width})(13.8 \text{ psi} - 6.8 \text{ psi}) / (1,000 \text{ lb/k}) \\ = 560 \text{ kips} (2,493 \text{ kN})$$

stagnation load,

$$F_{SL} = (144 \text{ in height} * 0.5)(1,112 \text{ in width})(6.8 \text{ psi}) / (1,000 \text{ lb/k})$$

$$= 544 \text{ kips (2,420 kN)}$$

11.5.2 Load Case B

(applied to short side of building)

neglect this case because it will not control

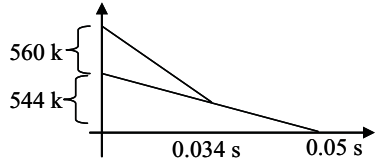

11.5.3 Trial Size

concrete roof slab

5 in (127 mm) thickness, plus 2 in (51 mm) steel decking for an average of 6 inches (152 mm)

roof reinforcing (used to resist shear)

#3 @ 8 in (203 mm), each face

#3, area = 0.11 in² (71 mm²)

chord reinforcing (used to resist bending)

10 in (254 mm) concrete walls

10 #8 bars

#8, area = 0.79 in² (510 mm²)

A_s = (10 each)(0.79 in²) = 7.9 in² (5,100 mm²)

11.5.4 Compute Bending Resistance

for dynamic bending,

(Appendix 5.A)

$$F_{ds} = F_{dy} = (SIF)(DIF) F_y = (1.1)(1.17) 60 \text{ ksi} = 77.2 \text{ ksi (532 MPa)}$$

$$f'_{dc} = (SIF)(DIF) f'_c = (1.0)(1.19) 4 \text{ ksi} = 4.76 \text{ ksi (33 MPa)}$$

$$d = (800 \text{ in depth}) - (10 \text{ in wall}) / 2 = 795 \text{ in (20,193 mm)}$$

$$A_{s, \text{min}} = 3 \frac{\sqrt{f'_{dc}}}{F_{ds}} (b)(d) = 3 \frac{\sqrt{4,760 \text{ psi}}}{77,200 \text{ psi}} (60 \text{ in})(795 \text{ in}) \quad (\text{ACI 318, Section 10.5.1})$$

$$= 128 \text{ in}^2 (82,580 \text{ mm}^2) \text{ not less than } A_s, \text{ NG}$$

$$A_{s, \text{min}} = 200(b)(d)/F_{ds} = 200(60 \text{ in})(795 \text{ in})/(77,200 \text{ psi}) \quad (\text{ACI 318, Section 10.5.1})$$

$$= 124 \text{ in}^2 (80,000 \text{ mm}^2) \text{ not less than } A_s, \text{ NG}$$

The response will be limited to the elastic range even though cracking will probably be caused anyway by out-of-plane bending. Such pre-cracking is not reliable enough for a design basis unless special construction details are provided to ensure behavior.

$$d_{sb} = (A_s)(F_{ds}) / (0.85)(f'_{dc})(b) \quad (\text{MacGregor, Equation 4-9})$$

$$= (7.9 \text{ in}^2)(77.2 \text{ ksi}) / (0.85)(4.76 \text{ ksi})(60 \text{ in})$$

$$= 2.51 \text{ in (64 mm), within thickness of wall}$$

$$\begin{aligned}
 M_p &= (A_s)(F_{ds})[d - d_{sb}/2] && \text{(MacGregor, Equation 4-10a)} \\
 &= (7.9 \text{ in}^2)(77.2 \text{ ksi}) [(795 \text{ in}) - (2.51 \text{ in}) / 2] \\
 &= 484,089 \text{ k-in} \quad (54,694,700 \text{ kN-mm})
 \end{aligned}$$

$$\begin{aligned}
 R_b &= 8 (M_{ps} + M_{pc}) / L = 16 M_p / L && \text{(Table 6.2)} \\
 &= 16 (484,089 \text{ k-in}) / (1,102 \text{ in}) \\
 &= 7,029 \text{ kips} \quad (31,266 \text{ kN})
 \end{aligned}$$

11.5.5 Compute Shear Resistance From Shear Friction Criteria

for shear friction: (Appendix 5.A)
 $F_{ds} = F_{dy} = (\text{SIF})(\text{DIF}) F_y = (1.1)(1.1)(60 \text{ ksi}) = 72.6 \text{ ksi} \quad (501 \text{ MPa})$

friction coefficient, (ACI 318, Section 11.7.4.3)
 $\mu_f = 1.0 \quad (\lambda) = 1.0 \quad (\text{intentionally roughened surface})$

$$A_s = (0.11 \text{ in}^2)(12/8 \text{ spacing/ft})(2 \text{ layers})(66.67 \text{ ft length}) = 22.0 \text{ in}^2 \quad (14,190 \text{ mm}^2)$$

$$\begin{aligned}
 V_n &= (A_s)(F_{ds})(\mu_f) && \text{(ACI 318, Equation 11-25)} \\
 &= (22.0 \text{ in}^2)(72.6 \text{ ksi})(1.0) = 1,597 \text{ kips} \quad (7,103 \text{ kN})
 \end{aligned}$$

$$R_s = 2 (V_n) = 2 (1,597 \text{ kips}) = 3,194 \text{ kips} \quad (14,208 \text{ kN})$$

11.5.6 Resistance & Permissible Response

NOTE: Roof diaphragm resistance could be controlled by deep beam action. Applicable code criteria is provided in ACI 318, Section 11.8.

because $R_s < R_b$, shear friction controls,

$$\text{positive and rebound resistance, } R_u = R_u = R_s = 3,194 \text{ kips} \quad (14,208 \text{ kN})$$

Because shear controls,

$$\text{allowable ductility ratio, } \mu_a = 1.3 \quad \text{(Table 5.B.3)}$$

$$\text{allowable support rotation, } \theta_a = \text{not applicable} \quad \text{(Table 5.B.3)}$$

11.5.7 Compute SDOF Equivalent System

Because the roof diaphragm is a deep and relatively short beam, the stiffness must include shear deformations. Compute the total midspan deflection for an arbitrary load of 1,000 lb/in (175 N/mm).

For moment of inertia calculations, to approximate the effect of roof cracking due to out-of-plane loads, use half the roof slab thickness.

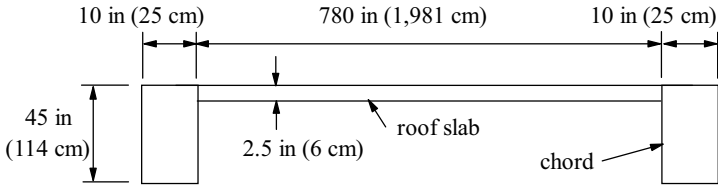

Chord width,

$$b = \text{say } 4(\text{wall thickness}) + (\text{roof thickness}) = 4(10 \text{ in}) + 5 \text{ in} = 45 \text{ in} \quad (1,143 \text{ mm})$$

include chord reinforcing,

$$n A_s = (8.04)(7.9 \text{ in}^2) = 63.52 \text{ in}^2 \quad (40,980 \text{ mm}^2)$$

moment of inertia,

$$\begin{aligned} I &= \Sigma (b)(h)^3 / 12 + \Sigma (\text{area})(\text{distance})^2 \\ &= 2(45 \text{ in})(10 \text{ in})^3 / 12 + (2.5 \text{ in})(780 \text{ in})^3 / 12 + 2 [(45 \text{ in})(10 \text{ in}) + 63.52 \text{ in}^2](395 \text{ in})^2 \\ &= 259,116,000 \text{ in}^4 \quad (1.0785 \times 10^{14} \text{ mm}^4) \end{aligned}$$

flexural deflection,

(AISC Manual, Beam Tables)

$$\begin{aligned} \Delta_f &= (\text{load})(L)^4 / 384 (E_c)(I) \\ &= (1,000 \text{ lb/in})(1,102 \text{ in})^4 / 384 (3,605,000 \text{ psi})(259,116,000 \text{ in}^4) \\ &= 0.0041 \text{ in} \quad (0.104 \text{ mm}) \end{aligned}$$

shear modulus,

$$G = E_c / 2(1 + \nu) = (3,605,000 \text{ psi}) / 2 (1 + 0.2) = 1,502,083 \text{ psi} \quad (10,357 \text{ MPa})$$

shear deflection,

(Roark, page 166)

$$\begin{aligned} \Delta_s &= 0.125 (6/5)(\text{load})(L)^2 / (\text{area})(G) \\ &= 0.125 (6/5)(1,000 \text{ lb/in})(1,102 \text{ in})^2 / (5 \text{ in})(795 \text{ in})(1,502,083 \text{ psi}) \\ &= 0.0305 \text{ in} \quad (0.775 \text{ mm}) \end{aligned}$$

effective stiffness,

$$\begin{aligned} K_e &= (\text{load})(L) / (\Delta_f + \Delta_s) \\ &= (1,000 \text{ lb/in})(0.001 \text{ k/lb})(1,102 \text{ in}) / (0.0041 \text{ in} + 0.0305 \text{ in}) \\ &= 31,850 \text{ k/in} \quad (5,578 \text{ kN/mm}) \end{aligned}$$

beam mass,

$$\begin{aligned} M &= [(\text{diaphragm weight}) + (\text{tributary wall weight})] / g \\ &= (0.15 \text{ kcf})(1,102 \text{ in})[(6 \text{ in})(800 \text{ in}) + (10 \text{ in})(144 \text{ in} \times 1/2)(2 \text{ walls})] \\ &\quad / (1,728 \text{ in}^3/\text{ft}^3)(386 \text{ in/s}^2) \\ &= 1.55 \text{ k-s}^2/\text{in} \quad (0.27 \text{ kN-s}^2/\text{mm}) \end{aligned}$$

Because of the expected response, use elastic values to compute K_{LM}

$$\text{elastic } K_{LM} = 0.41 / 0.53 = 0.77$$

(Table 6.2)

equivalent mass,

$$M_e = (K_{LM})(M) = (0.77)(1.55 \text{ k-s}^2/\text{in}) = 1.19 \text{ k-s}^2/\text{in} \quad (0.21 \text{ kN-s}^2/\text{mm})$$

period of vibration,

(Equation 6.8)

$$t_n = 2 \pi \sqrt{M_e / K_e} = 2 \pi \sqrt{(1.19 \text{ k-s}^2/\text{in}) / (31,850 \text{ k/in})} = 0.038 \text{ s}$$

11.5.8 Numerical Integration Solution (load case A)

(Appendix 6)

NOTE: The numerical integration procedure can handle the bilinear loading in lieu of an equivalent triangular loading.

$$F_{RL} = 560 \text{ kips (2,493 kN)}$$

$$F_{SL} = 544 \text{ kips (2,420 kN)}$$

$$t_c = 0.034 \text{ s}$$

$$t_d = 0.05 \text{ s}$$

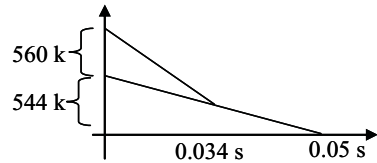

$$\text{time increment} = t_n / 10 = 0.0038, \text{ say } 0.002 \text{ s}$$

The calculated time increment of 0.002 seconds appears adequately short to properly define the dynamic load.

For the numerical integration, refer to Table 11.3.

TABLE 11.3: Roof Diaphragm Numerical Integration

Analysis Case Description:		Chapter 11, Section 11.5.8, roof diaphragm, case A										
Dynamic Loading Description:		max [560 - 560(time)/(0.034), 0] + max [544 - 544(time)/(0.05), 0]										
time increment =	0.002 s	KEY = 0 is elastic								Z = 1 is increasing plastic deformation		
mass =	1.19 k-s ² /in	KEY = +1 is positive plastic								Z = 2 is end of rebound plastic deformation		
stiffness =	31850 k/in	KEY = -1 is rebound plastic								Z = 3 is end of positive plastic deformation		
damping =	0 k-s/in									Z = 4 is continued elastic		
positive resistance =	3194 kips									Z = 5 is start of rebound plastic deformation		
rebound resistance =	-3194 kips									Z = 6 is start of positive plastic deformation		
static load =	0 kips											
time (s)	Dyn. Load (kips)	y (in)	v (in/s)	a (in/s ²)	ye+ (in)	ye- (in)	KEY -	eff K (k/in)	incr F (kips)	incr y (in)	incr v (in/s)	Z -
0.000	1.104	0.000	0.00	928	0.100	-0.100	0	1,816,850	3,257	0.002	1.76	
0.002	1.049	0.002	1.76	834	0.100	-0.100	0	1,816,850	9,210	0.005	1.49	4
0.004	995	0.007	3.25	652	0.100	-0.100	0	1,816,850	13,867	0.008	1.05	4
0.006	940	0.014	4.30	402	0.100	-0.100	0	1,816,850	16,736	0.009	0.51	4
0.008	885	0.024	4.81	109	0.100	-0.100	0	1,816,850	17,517	0.010	-0.09	4
0.010	830	0.033	4.73	-195	0.100	-0.100	0	1,816,850	16,127	0.009	-0.67	4
0.012	776	0.042	4.05	-478	0.100	-0.100	0	1,816,850	12,713	0.007	-1.19	4
0.014	721	0.049	2.86	-711	0.100	-0.100	0	1,816,850	7,633	0.004	-1.58	4
0.016	666	0.053	1.28	-870	0.100	-0.100	0	1,816,850	1,423	0.001	-1.81	4
0.018	612	0.054	-0.52	-937	0.100	-0.100	0	1,816,850	-5,266	-0.003	-1.84	4
0.020	557	0.051	-2.36	-905	0.100	-0.100	0	1,816,850	-11,729	-0.006	-1.68	4
0.022	502	0.045	-4.05	-778	0.100	-0.100	0	1,816,850	-17,286	-0.010	-1.35	4
0.024	448	0.035	-5.40	-570	0.100	-0.100	0	1,816,850	-21,354	-0.012	-0.87	4
0.026	393	0.024	-6.27	-301	0.100	-0.100	0	1,816,850	-23,503	-0.013	-0.30	4
0.028	338	0.011	-6.57	-1	0.100	-0.100	0	1,816,850	-23,509	-0.013	0.30	4
0.030	283	-0.002	-6.27	300	0.100	-0.100	0	1,816,850	-21,370	-0.012	0.87	4
0.032	229	-0.014	-5.40	568	0.100	-0.100	0	1,816,850	-17,312	-0.010	1.35	4
0.034	174	-0.024	-4.06	777	0.100	-0.100	0	1,816,850	-11,728	-0.006	1.71	4
0.036	152	-0.030	-2.35	932	0.100	-0.100	0	1,816,850	-5,074	-0.003	1.92	4
0.038	131	-0.033	-0.43	988	0.100	-0.100	0	1,816,850	1,983	0.001	1.93	4
0.040	109	-0.032	1.50	941	0.100	-0.100	0	1,816,850	8,702	0.005	1.74	4

The positive peak deflection occurs at $t = 0.018$ s.

$$y_m = +0.054 \text{ in (1.37 mm)}$$

$$\mu_d = 0.54 < \mu_a, \text{ OK}$$

The rebound peak deflection occurs at $t = 0.038$ s.

$$y_m = -0.033 \text{ in (0.84 mm)}$$

$$\mu_d = 0.33 < \mu_a, \text{ OK}$$

Refer to the design for out-of-plane loads for the interaction check.

11.6 SIDE WALL (in-plane loads)

The side shear wall is a cantilever which transfers roof diaphragm reactions to the floor slab and foundation. The 17 foot height is a bit conservative because some of the lateral force is removed at the floor slab level.

$$\text{height} = 17.0 \text{ ft, or } 204 \text{ in (5,182 mm)}$$

$$\text{length} = 66.67 \text{ ft, or } 800 \text{ in (20,320 mm)}$$

11.6.1 Load Case A (applied to long side of building)

from the Chapter 3 Appendix calculation,

$$P_r = 13.8 \text{ psi (95 kPa)}$$

$$P_s = 6.8 \text{ psi (47 kPa)}$$

$$t_c = 0.034 \text{ s}$$

$$t_d = 0.05 \text{ s}$$

The blast loaded area tributary to the side wall is half the exterior wall height of 144 in (3,658 mm) by half the building width of 1,112 in (28,245 mm).

reflection load,

$$\begin{aligned} F_{RL} &= (144 \text{ in height} * 0.5)(1,112 \text{ in width} * 0.5)(13.8 \text{ psi} - 6.8 \text{ psi}) / (1,000 \text{ k/lb}) \\ &= 280 \text{ kips (1,246 kN)} \end{aligned}$$

stagnation load,

$$\begin{aligned} F_{SL} &= (144 \text{ in height} * 0.5)(1,112 \text{ in width} * 0.5)(6.8 \text{ psi}) / (1,000 \text{ k/lb}) \\ &= 272 \text{ kips (1,210 kN)} \end{aligned}$$

11.6.2 Load Case B (applied to short side of building)

neglect this case because it will not control

11.6.3 Trial Size

Side wall should match front wall design

#3 @ 6 in (152 mm) horizontal, each face
 #3, area = 0.11 in² (71 mm²)

#5 @ 6 in (15 cm) vertical, each face
 #5, area = 0.31 in² (200 mm²)
 #5, diameter = 0.625 in (16 mm)

vertical bars are inside of horizontal bars

11.6.4 Compute Bending Resistance

for dynamic bending,

(Appendix 5.A)

$$F_{ds} = F_{dy} = (\text{SIF})(\text{DIF}) F_y = (1.1)(1.17) 60 \text{ ksi} = 77.2 \text{ ksi} \quad (532 \text{ MPa})$$

$$f_{dc} = (\text{SIF})(\text{DIF}) f_c = (1.0)(1.19) 4 \text{ ksi} = 4.76 \text{ ksi} \quad (33 \text{ MPa})$$

For bending, assume 12 bars at the corner provide the tension component for resisting in-plane moment. An accurate assessment of the contributing bars would be difficult because of out-of-plane bending tension on bars away from the building corners. Because of this approximation, the in-plane response will be limited to the elastic range.

$$A_s = 12 (0.31 \text{ in}^2) = 3.72 \text{ in}^2 \quad (2,400 \text{ mm}^2)$$

$$b = 10 \text{ in} \quad (254 \text{ mm})$$

$$d = \text{say } (800 \text{ in depth}) - (10 \text{ in wall}) + (1.5 \text{ in clear}) + (0.625 \text{ in bar})/2 \\ = 792 \text{ in} \quad (20,117 \text{ mm})$$

$$\rho = A_s / (b)(d) = (3.72 \text{ in}^2) / (10 \text{ in})(792 \text{ in}) = 0.0005, \text{ not greater than } 200 / F_{ds}$$

The response will be limited to the elastic range even though cracking will probably be caused by out-of-plane bending and by the construction joint at the base of the wall. Such pre-cracking is not reliable enough for a design basis unless special construction details are provided to ensure behavior.

b = say 24 in (610 mm) for width of beam flange at corner

$$d_{sb} = (A_s)(F_{ds}) / (0.85)(f_{dc})(b) \quad (\text{MacGregor, Equation 4-9}) \\ = (3.72 \text{ in}^2)(77.2 \text{ ksi}) / (0.85)(4.76 \text{ ksi})(24 \text{ in}) \\ = 2.96 \text{ in} \quad (75 \text{ mm}), \text{ less than thickness of intersecting wall}$$

$$M_p = (A_s)(F_{ds}) [d - d_{sb}/2] \quad (\text{MacGregor, Equation 4-10a}) \\ = (3.72 \text{ in}^2)(77.2 \text{ ksi}) [(792 \text{ in}) - (2.96 \text{ in})/2] \\ = 227,025 \text{ k-in} \quad (25,650,372 \text{ kN-mm})$$

$$R_b = M_p / L = (227,025 \text{ k-in}) / (204 \text{ in}) = 1,113 \text{ kips} \quad (4,951 \text{ kN})$$

11.6.5 Compute Shear Resistance From Shear Friction Criteria

for shear friction: (Appendix 5.A)

$$F_{ds} = F_{dy} = (\text{SIF})(\text{DIF}) F_y = (1.1)(1.1)(60 \text{ ksi}) = 72.6 \text{ ksi} \quad (501 \text{ MPa})$$

friction coefficient, (ACI 318, Section 11.7.4.3)

$$\mu_f = 0.6 (\lambda) = 0.6 \quad (\text{not intentionally roughened})$$

$$A_v = [(0.31 \text{ in}^2) / (6 \text{ in spacing})] (800 \text{ in depth})(2 \text{ faces}) = 82.67 \text{ in}^2 \quad (53,335 \text{ mm}^2)$$

$$\begin{aligned} R_s &= V_n = A_v (F_{ds})(\mu_f) && (\text{ACI 318, Equation 11-25}) \\ &= (82.67 \text{ in}^2) (72.6 \text{ ksi}) (0.6) \\ &= 3,601 \text{ kips} \quad (16,018 \text{ kN}) \end{aligned}$$

11.6.6 Resistance and Permissible Response

Because $R_b < R_s$, bending controls

positive and rebound resistance, $R_u = R_u = R_s = 1,113 \text{ kips} \quad (4,951 \text{ kN})$

Because shear controls,

allowable ductility ratio, $\mu_a = 1.3$ (Table 5.B.3)

allowable support rotation, $\theta_a = \text{not applicable}$ (Table 5.B.3)

11.6.7 Compute SDOF Equivalent System

The shear wall is effectively a single degree of freedom system.

Because the shear wall is a deep and relatively short beam, the stiffness must include shear deformations. Compute the total deflection for an arbitrary load of 1,000 kips.

For moment of inertia calculations, to approximate the effect of wall cracking due to out-of-plane loads, use half the wall thickness.

Chord height = say 4 (10 in end wall) + (10 in side wall) = 50 in (1270 mm)

include chord reinforcing,

$$n A_s = (8.04)(3.72 \text{ in}^2) = 29.91 \text{ in}^2 \quad (19,297 \text{ mm}^2)$$

moment of inertia,

$$\begin{aligned} I &= \Sigma (\text{width})(\text{height})^3 / 12 + \Sigma (\text{area})(\text{distance})^2 \\ &= 2(50 \text{ in})(10 \text{ in})^3 / 12 + (5 \text{ in})(780 \text{ in})^3 / 12 + 2[(50 \text{ in})(10 \text{ in}) + 29.91 \text{ in}^2](395 \text{ in})^2 \\ &= 363,096,750 \text{ in}^4 \quad (1.511 \times 10^{14} \text{ mm}^4) \end{aligned}$$

flexural deflection,

$$\begin{aligned} \Delta_f &= (\text{load})(L)^3 / 3(E_c)(I) && \text{(AISC Manual, Beam Tables)} \\ &= (1,000 \text{ k})(204 \text{ in})^3 / 3(3,605 \text{ ksi})(363,096,750 \text{ in}^4) \\ &= 0.002 \text{ in} \quad (0.051 \text{ mm}) \end{aligned}$$

shear deflection,

$$\begin{aligned} \Delta_s &= 1.2 (L)(\text{load}) / (\text{area})(G) && \text{(Roark, page 166)} \\ &= 1.2 (204 \text{ in})(1,000 \text{ k}) / (10 \text{ in})(800 \text{ in})(1,502 \text{ ksi}) \\ &= 0.0204 \text{ in} \quad (0.518 \text{ mm}) \end{aligned}$$

beam stiffness,

$$\begin{aligned} K &= (\text{load}) / (\Delta_f + \Delta_s) = (1,000 \text{ k}) / (0.002 \text{ in} + 0.0204 \text{ in}) \\ &= 44,643 \text{ k/in} \quad (7,818 \text{ kN/mm}) \end{aligned}$$

tributary front & rear wall weight,

$$\begin{aligned} \text{weight}_1 &= (0.15 \text{ kcf})(10 \text{ in})(1,112 \text{ in} * 0.5)(144 \text{ in} * 0.5)(2 \text{ walls}) / (1,728 \text{ in}^2/\text{ft}^2) \\ &= 69.5 \text{ kips} \quad (309 \text{ kN}) \end{aligned}$$

tributary roof weight,

$$\begin{aligned} \text{weight}_2 &= (0.15 \text{ kcf})(6 \text{ in})(1,112 \text{ in} * 0.5)(800 \text{ in}) / (1,728 \text{ in}^2/\text{ft}^2) \\ &= 231.7 \text{ kips} \quad (1,031 \text{ kN}) \end{aligned}$$

shear wall weight,

$$\begin{aligned} \text{weight}_3 &= (0.15 \text{ kcf})(10 \text{ in})(800 \text{ in})(204 \text{ in} * 0.5) / (1,728 \text{ in}^2/\text{ft}^2) \\ &= 70.8 \text{ kips} \quad (315 \text{ kN}) \end{aligned}$$

total mass,

$$\begin{aligned} M &= [\text{weight}_1 + \text{weight}_2 + \text{weight}_3] / g \\ &= [(69.5 \text{ k}) + (231.7 \text{ k}) + (70.8 \text{ k})] / (386 \text{ in/s}^2) \\ &= 0.964 \text{ k-s}^2/\text{in} \quad (0.169 \text{ kN-s}^2/\text{mm}) \end{aligned}$$

period of vibration,

$$t_n = 2 \pi \sqrt{M / K} = 2 \pi \sqrt{(0.964 \text{ k-s}^2/\text{in}) / (44,643 \text{ k/in})} = 0.029 \text{ s} \quad \text{(Equation 6.8)}$$

11.6.8 Numerical Integration Solution (load case A)

NOTE: The numerical integration procedure can handle the bilinear loading in lieu of an equivalent triangular loading.

$$\begin{aligned} F_{RL} &= 280 \text{ kips} \quad (1,246 \text{ kN}) \\ F_{SL} &= 272 \text{ kips} \quad (1,210 \text{ kN}) \\ t_c &= 0.034 \text{ s} \\ t_d &= 0.05 \text{ s} \end{aligned}$$

$$\text{time increment} = t_n / 10 = 0.0017 \text{ s}$$

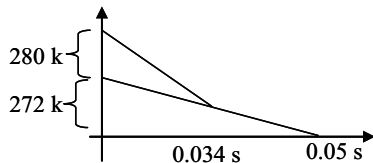

TABLE 11.4: Side Shear Wall Numerical Integration

Analysis Case Description: Chapter 11, Section 11.6.8, side shear wall, case A												
Dynamic Loading Description: max [280 - 280(time)/(0.034), 0] + max [272 - 272(time)/(0.05), 0]												
time increment =	0.001	s	KEY = 0 is elastic	Z = 1 is increasing plastic deformation								
mass =	0.964	k-s2/in	KEY = +1 is positive plastic	Z = 2 is end of rebound plastic deformation								
stiffness =	44643	k/in	KEY = -1 is rebound plastic	Z = 3 is end of positive plastic deformation								
damping =	0	k-s/in		Z = 4 is continued elastic								
positive resistance =	1113	kips		Z = 5 is start of rebound plastic deformation								
rebound resistance =	-1113	kips		Z = 6 is start of positive plastic deformation								
static load =	0	kips										
time	Dyn. Load	y	v	a	ye+	ye-	KEY	eff K	incr F	incr y	incr v	Z
(s)	(kips)	(in)	(in/s)	(in/s2)	(in)	(in)	-	(k/in)	(kips)	(in)	(in/s)	-
0.000	552	0.000	0.00	573	0.025	-0.025	0	5,828,643	1,642	0.000	0.56	
0.001	538	0.000	0.56	545	0.025	-0.025	0	5,828,643	4,797	0.001	0.52	4
0.002	525	0.001	1.08	493	0.025	-0.025	0	5,828,643	7,649	0.001	0.46	4
0.003	511	0.002	1.53	418	0.025	-0.025	0	5,828,643	10,067	0.002	0.37	4
0.004	497	0.004	1.90	324	0.025	-0.025	0	5,828,643	11,941	0.002	0.27	4
0.005	484	0.006	2.17	215	0.025	-0.025	0	5,828,643	13,184	0.002	0.16	4
0.006	470	0.008	2.33	96	0.025	-0.025	0	5,828,643	13,739	0.002	0.03	4
0.007	456	0.011	2.36	-27	0.025	-0.025	0	5,828,643	13,580	0.002	-0.09	4
0.008	443	0.013	2.28	-149	0.025	-0.025	0	5,828,643	12,716	0.002	-0.21	4
0.009	429	0.015	2.07	-265	0.025	-0.025	0	5,828,643	11,185	0.002	-0.32	4
0.010	415	0.017	1.75	-368	0.025	-0.025	0	5,828,643	9,058	0.002	-0.41	4
0.011	402	0.019	1.34	-454	0.025	-0.025	0	5,828,643	6,433	0.001	-0.49	4
0.012	388	0.020	0.85	-519	0.025	-0.025	0	5,828,643	3,429	0.001	-0.54	4
0.013	374	0.020	0.31	-561	0.025	-0.025	0	5,828,643	187	0.000	-0.57	4
0.014	361	0.021	-0.25	-576	0.025	-0.025	0	5,828,643	-3,146	-0.001	-0.57	4
0.015	347	0.020	-0.82	-565	0.025	-0.025	0	5,828,643	-6,417	-0.001	-0.55	4
0.016	333	0.019	-1.37	-529	0.025	-0.025	0	5,828,643	-9,475	-0.002	-0.50	4
0.017	320	0.017	-1.87	-468	0.025	-0.025	0	5,828,643	-12,180	-0.002	-0.43	4
0.018	306	0.015	-2.30	-385	0.025	-0.025	0	5,828,643	-14,407	-0.002	-0.33	4
0.019	292	0.013	-2.63	-285	0.025	-0.025	0	5,828,643	-16,053	-0.003	-0.23	4
0.020	278	0.010	-2.86	-171	0.025	-0.025	0	5,828,643	-17,045	-0.003	-0.11	4
0.021	265	0.007	-2.97	-50	0.025	-0.025	0	5,828,643	-17,334	-0.003	0.01	4
0.022	251	0.004	-2.96	73	0.025	-0.025	0	5,828,643	-16,910	-0.003	0.13	4
0.023	237	0.001	-2.82	194	0.025	-0.025	0	5,828,643	-15,790	-0.003	0.25	4
0.024	224	-0.002	-2.58	305	0.025	-0.025	0	5,828,643	-14,027	-0.002	0.35	4
0.025	210	-0.004	-2.22	402	0.025	-0.025	0	5,828,643	-11,701	-0.002	0.44	4
0.026	196	-0.006	-1.78	481	0.025	-0.025	0	5,828,643	-8,919	-0.002	0.51	4
0.027	183	-0.008	-1.27	538	0.025	-0.025	0	5,828,643	-5,810	-0.001	0.55	4
0.028	169	-0.009	-0.72	570	0.025	-0.025	0	5,828,643	-2,516	0.000	0.57	4
0.029	155	-0.009	-0.14	575	0.025	-0.025	0	5,828,643	812	0.000	0.57	4
0.030	142	-0.009	0.42	555	0.025	-0.025	0	5,828,643	4,021	0.001	0.53	4
0.031	128	-0.008	0.95	509	0.025	-0.025	0	5,828,643	6,962	0.001	0.47	4
0.032	114	-0.007	1.43	439	0.025	-0.025	0	5,828,643	9,502	0.002	0.39	4
0.033	101	-0.005	1.82	349	0.025	-0.025	0	5,828,643	11,523	0.002	0.30	4
0.034	87	-0.003	2.12	244	0.025	-0.025	0	5,828,643	12,941	0.002	0.19	4
0.035	82	-0.001	2.31	135	0.025	-0.025	0	5,828,643	13,723	0.002	0.08	4
0.036	76	0.001	2.38	21	0.025	-0.025	0	5,828,643	13,841	0.002	-0.04	4
0.037	71	0.004	2.35	-95	0.025	-0.025	0	5,828,643	13,291	0.002	-0.15	4
0.038	65	0.006	2.20	-206	0.025	-0.025	0	5,828,643	12,098	0.002	-0.26	4
0.039	60	0.008	1.94	-308	0.025	-0.025	0	5,828,643	10,316	0.002	-0.35	4
0.040	54	0.010	1.59	-396	0.025	-0.025	0	5,828,643	8,027	0.001	-0.43	4
0.041	49	0.011	1.16	-465	0.025	-0.025	0	5,828,643	5,337	0.001	-0.49	4
0.042	44	0.012	0.67	-513	0.025	-0.025	0	5,828,643	2,369	0.000	-0.53	4
0.043	38	0.012	0.14	-538	0.025	-0.025	0	5,828,643	-741	0.000	-0.54	4
0.044	33	0.012	-0.40	-537	0.025	-0.025	0	5,828,643	-3,849	-0.001	-0.52	4
0.045	27	0.012	-0.92	-512	0.025	-0.025	0	5,828,643	-6,813	-0.001	-0.49	4
0.046	22	0.011	-1.41	-464	0.025	-0.025	0	5,828,643	-9,497	-0.002	-0.43	4
0.047	16	0.009	-1.84	-394	0.025	-0.025	0	5,828,643	-11,776	-0.002	-0.35	4
0.048	11	0.007	-2.19	-306	0.025	-0.025	0	5,828,643	-13,548	-0.002	-0.26	4
0.049	5	0.005	-2.44	-204	0.025	-0.025	0	5,828,643	-14,729	-0.003	-0.15	4
0.050	0	0.002	-2.59	-93	0.025	-0.025	0	5,828,643	-15,261	-0.003	-0.03	4
0.051	0	-0.001	-2.62	28	0.025	-0.025	0	5,828,643	-15,096	-0.003	0.09	4
0.052	0	-0.003	-2.54	148	0.025	-0.025	0	5,828,643	-14,238	-0.002	0.20	4
0.053	0	-0.006	-2.33	261	0.025	-0.025	0	5,828,643	-12,726	-0.002	0.31	4
0.054	0	-0.008	-2.02	363	0.025	-0.025	0	5,828,643	-10,629	-0.002	0.40	4
0.055	0	-0.010	-1.61	447	0.025	-0.025	0	5,828,643	-8,043	-0.001	0.48	4
0.056	0	-0.011	-1.14	511	0.025	-0.025	0	5,828,643	-5,088	-0.001	0.53	4
0.057	0	-0.012	-0.60	551	0.025	-0.025	0	5,828,643	-1,899	0.000	0.56	4
0.058	0	-0.012	-0.05	566	0.025	-0.025	0	5,828,643	1,378	0.000	0.56	4
0.059	0	-0.012	0.52	555	0.025	-0.025	0	5,828,643	4,591	0.001	0.54	4

The calculated time increment of 0.001 seconds appears to be adequately short to properly define the dynamic load.

For the numerical integration, refer to Table 11.4.

The positive peak deflection occurs at $t = 0.014$ s

$y_m = +0.021$ in (0.53 mm)

$\mu_d = 0.82 < \mu_a$, OK

The rebound peak deflection occurs at $t = 0.058$ s

$y_m = -0.012$ in (-0.30 mm)

$\mu_d = 0.49 < \mu_a$, OK

side wall interaction,

(Equation 7.2)

$$[\Delta_d / \Delta_a]_{ip}^2 + [\Delta_d / \Delta_a]_{op}^2 = [(0.82) / (1.0)]_{ip}^2 + [(0.22) / (1.0)]_{op}^2 = 0.77 < 1.0, \text{ OK}$$

maximum demand / permissible = 0.82, USE side wall as assumed

11.7 ROOF SLAB (out-of-plane loads)

The roof panels are 18 ft (5,486 mm) by 8 ft (2,438 mm), a 2.3 to 1 ratio. Therefore the roof will be analyzed as a one way beam fixed at both ends by adjoining roof slab spans or by thicker side walls.

NOTE: If the roof panel aspect ratio were less than 2 to 1, the panel would need to be analyzed as a two-way span using resistance equations and transformation factors from the applicable tables in UFC 3-340-02.

A non-composite deck will be used as a form only. According to manufacturer's literature, composite metal decking is not intended for dynamic loads.

A 2 in (51 mm) deep metal deck, temporarily propped at mid-span, is selected.

span, $L = 8$ feet or 96 in (2,438 mm) from center to center of supporting beams

use a nominal design width, $b = 1.0$ ft or 12 in (305 mm)

11.7.1 Load Case A (explosion on long side of building)

Refer to the Chapter 3 Appendix for load determination,

$P_a = 5.1$ psi (35 kPa)

$t_r = 0.006$ s

$t_d = 0.05$ s

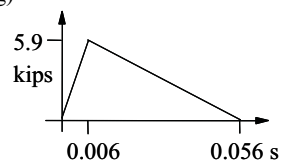

The blast loaded area tributary to the roof slab is the span of 96 in (2,438 mm) by the nominal design width of 12 in (305 mm).

peak load,

$$F_o = (96 \text{ in span})(12 \text{ in width})(5.1 \text{ psi}) / (1,000 \text{ lb/k}) = 5.9 \text{ kips} \quad (26.2 \text{ kN})$$

11.7.2 Load Case B (explosion on short side of building)

$L_1 = 1 \text{ ft}$ (305 mm), this leads to $C_e = 1.0$ and $t_r = 0.0 \text{ s}$

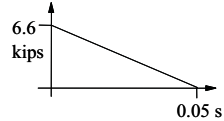

(Equation 3.11)

peak overpressure,

$$P_a = C_e (P_{so}) + C_d (q_o) = (1.0) (6 \text{ psi}) + (-0.4) (0.8 \text{ psi}) = 5.7 \text{ psi} \quad (39.3 \text{ kPa})$$

peak load,

$$F_o = (96 \text{ in span})(12 \text{ in width}) (5.7 \text{ psi}) / (1,000 \text{ lb/k}) = 6.6 \text{ kips} \quad (29.4 \text{ kN})$$

11.7.3 Trial Size

NOTE: The following trial dimensions and material proportions may be obtained from trial calculations, by inspection of similar structures, or from experience. The results of this dynamic calculation will determine the adequacy of the trial size.

5 in (127 mm) concrete slab plus metal deck

#3 @ 8 in (203 mm) each way, top & bottom

#3, area = 0.11 in^2 (71 mm²)

#3, diameter = 0.375 in (10 mm)

bars in span direction are outside of bars in perpendicular direction

11.7.4 Compute Bending Resistance

for dynamic bending,

(Appendix 5.A)

$$F_{ds} = F_{dy} = (\text{SIF})(\text{DIF}) F_y = (1.1)(1.17) 60 \text{ ksi} = 77.2 \text{ ksi} \quad (532 \text{ MPa})$$

$$f_{dc} = (\text{SIF})(\text{DIF}) f_c = (1.0)(1.19) 4 \text{ ksi} = 4.76 \text{ ksi} \quad (33 \text{ MPa})$$

$$A_s = (0.11 \text{ in}^2)(12 \text{ in}) / (8 \text{ in}) = 0.17 \text{ in}^2 \quad (110 \text{ mm}^2)$$

for bending tension on bottom face,

$$d = (5 \text{ in slab}) - (0.75 \text{ in clear}) - (0.375 \text{ in bar})/2 = 4.06 \text{ in} \quad (103 \text{ mm})$$

$$A_{s, \min} = 3 \frac{\sqrt{f_{dc}}}{F_{ds}} (b)(d) = 3 \frac{\sqrt{4,760 \text{ psi}}}{77,200 \text{ psi}} (12 \text{ in})(4.06 \text{ in}) \quad (\text{ACI 318, Section 10.5.1})$$

$$= 0.13 \text{ in}^2 (187 \text{ mm}^2) < A_s, \text{ OK}$$

$$A_{s, \min} = 200(b)(d)/F_{ds} = 200(12 \text{ in})(4.06 \text{ in})/(77,200 \text{ psi}) \quad (\text{ACI 318, Section 10.5.1})$$

$$= 0.14 \text{ in}^2 (181 \text{ mm}^2) < A_s, \text{ OK}$$

$$d_{sb} = A_s (F_{ds}) / 0.85 (f_{dc})(b) \quad (\text{MacGregor, Equation 4-9})$$

$$= (0.17 \text{ in}^2)(77.2 \text{ ksi}) / (0.85)(4.76 \text{ ksi})(12 \text{ in})$$

$$= 0.27 \text{ in} \quad (6.8 \text{ mm})$$

$$\begin{aligned}
 M_{p, \text{ bott}} &= A_s (F_{ds}) [d - d_{sb}/2] && \text{(MacGregor, Equation 4-10a)} \\
 &= (0.17 \text{ in}^2)(77.2 \text{ ksi}) [(4.06 \text{ in}) - (0.27 \text{ in})/2] \\
 &= 51.5 \text{ k-in} \quad (5,819 \text{ kN-mm})
 \end{aligned}$$

for bending tension on top face,

$$d = (5 \text{ in slab}) - (0.75 \text{ in clear}) - (0.375 \text{ in bar})/2 + (2 \text{ in deck})/2 = 5.06 \text{ in} \quad (129 \text{ mm})$$

$$\begin{aligned}
 A_{s, \text{ min}} &= 3 \frac{\sqrt{f'_{dc}}}{F_{ds}} (b)(d) = 3 \frac{\sqrt{4,760 \text{ psi}}}{77,200 \text{ psi}} (12 \text{ in})(5.06 \text{ in}) && \text{(ACI 318, Section 10.5.1)} \\
 &= 0.16 \text{ in}^2 \quad (103 \text{ mm}^2) < A_s, \quad \text{OK}
 \end{aligned}$$

$$\begin{aligned}
 A_{s, \text{ min}} &= 200(b)(d)/F_{ds} = 200(12 \text{ in})(5.06 \text{ in})/(77,200 \text{ psi}) && \text{(ACI 318, Section 10.5.1)} \\
 &= 0.16 \text{ in}^2 \quad (103 \text{ mm}^2) < A_s, \quad \text{OK}
 \end{aligned}$$

$$\begin{aligned}
 M_{p, \text{ top}} &= A_s (f_{ds}) [d - d_{sb}/2] && \text{(MacGregor, Equation 4-10a)} \\
 &= (0.17 \text{ in}^2)(77.2 \text{ ksi}) [(5.06 \text{ in}) - (0.27 \text{ in})/2] \\
 &= 64.6 \text{ k-in} \quad (7,299 \text{ kN-mm})
 \end{aligned}$$

positive (downward) and negative (upward) bending resistance based on fixed ends,

$$\begin{aligned}
 R_b = R_{b, \text{ min}} &= 8 (M_{p, \text{ bott}} + M_{p, \text{ top}}) / L && \text{(Table 6.2)} \\
 &= 8 [(51.5 \text{ k-in}) + (64.6 \text{ k-in})] / 96 \text{ in} \\
 &= 9.7 \text{ kips} \quad (43.1 \text{ kN})
 \end{aligned}$$

11.7.5 Compute Shear Resistance

for dynamic shear,

(Appendix 5.A)

$$f_{dc} = (\text{SIF})(\text{DIF}) f_c = (1.0)(1.0) 4 \text{ ksi} = 4.0 \text{ ksi} \quad (27.6 \text{ MPa})$$

Because positive or rebound bending can occur, calculate shear resistance based on the smaller of top or bottom tension. In this case, use $d = 4.06 \text{ in} \quad (103 \text{ mm})$.

$$\begin{aligned}
 V_n &= 2 \sqrt{f'_{dc}} b d && \text{(ACI 318, Equation 11-3)} \\
 &= 2 \sqrt{(4,000 \text{ psi})} (12 \text{ in})(4.06 \text{ in}) / 1,000 \\
 &= 6.16 \text{ kips} \quad (27.4 \text{ kN})
 \end{aligned}$$

the critical section is d from the support,

$$\begin{aligned}
 R_s &= V_n L / [0.5 L - d] \\
 &= (6.16 \text{ k})(96 \text{ in}) / [0.5 (96 \text{ in}) - 4.06 \text{ in}] \\
 &= 13.5 \text{ kips} \quad (60.1 \text{ kN})
 \end{aligned}$$

11.7.6 Resistance & Permissible Response

Because $R_b < R_s$, bending controls

positive resistance = $R_u = R_b = 9.7 \text{ kips} \quad (43.1 \text{ kN})$

rebound resistance = $R_u = -R_b = -9.7$ kips (-43.1 kN)

allowable ductility ratio, $\mu_a =$ not applicable (Table 5.B.3)

allowable support rotation, $\theta_a = 1.0^\circ$ (Table 5.B.3)

11.7.7 Compute SDOF Equivalent System

slab weight is based on a 5 in (127 mm) slab plus a 1 in (25 mm) average concrete in the deck,

weight = (0.15 kcf)(0.5 ft) = 0.075 ksf (3.6 kPa)

static load = (8 ft)(1 ft) [(0.075 ksf slab) + 0.025 ksf dead load] = 0.8 kips (3.6 kN)

moment of inertia will be based on positive (downward) bending.

gross moment of inertia,

$$I_g = b (h)^3 / 12 = (12 \text{ in})(5 \text{ in})^3 / 12 = 125 \text{ in}^4 \quad (52,029,000 \text{ mm}^4)$$

transformed rebar area,

$$n A_s = (8.04)(0.17 \text{ in}^2) = 1.37 \text{ in}^2 \quad (884 \text{ mm}^2)$$

location of transformed neutral axis,

(MacGregor, Page 308)

$$\begin{aligned} d_{na} &= \frac{-nA_s + \sqrt{nA_s(nA_s + 2bd)}}{b} \\ &= \frac{-1.37 \text{ in}^2 + \sqrt{1.37 \text{ in}^2 (1.37 \text{ in}^2 + 2(12 \text{ in})(4.06 \text{ in}))}}{12 \text{ in}} \\ &= 0.86 \text{ in} \quad (22 \text{ mm}) \end{aligned}$$

cracked moment of inertia,

$$\begin{aligned} I_{cr} &= b (d_{na})^3 / 3 + n A_s (d - d_{na})^2 \\ &= (12 \text{ in})(0.86 \text{ in})^3 / 3 + (1.37 \text{ in}^2)(4.06 \text{ in} - 0.86 \text{ in})^2 \\ &= 16.6 \text{ in}^4 \quad (6,909,442 \text{ mm}^4) \end{aligned}$$

averaged moment of inertia,

$$I_a = (I_g + I_{cr}) / 2 = (125 \text{ in}^4 + 16.6 \text{ in}^4) / 2 = 70.8 \text{ in}^4 \quad (29,469,185 \text{ mm}^4)$$

effective "bilinear" stiffness,

(Biggs, Table 5.2)

$$\begin{aligned} K_e &= 307 E_c I_a / L^3 \\ &= 307 (3,605 \text{ ksi})(70.8 \text{ in}^4) / (96 \text{ in})^3 \\ &= 81.6 \text{ k/in} \quad (14.3 \text{ kN/mm}) \end{aligned}$$

static deflection,

$$y_{st} = (\text{static load}) / K_e = (0.8 \text{ kips}) / (81.6 \text{ k/in}) = 0.01 \text{ in} \quad (0.25 \text{ mm})$$

slab mass,

$$\begin{aligned}
 M &= (\text{slab weight}) / g \\
 &= (0.15 \text{ kcf})(0.5 \text{ ft thick})(1.0 \text{ ft width})(8 \text{ ft span}) / (386 \text{ in/s}^2) \\
 &= 0.0016 \text{ k-s}^2/\text{in} \quad (0.00028 \text{ kN-s}^2/\text{mm})
 \end{aligned}$$

because of the expected response, use an average of values for K_{LM}

elastic $K_{LM} = 0.41 / 0.53 = 0.77$ (Table 6.2)

plastic $K_{LM} = 0.33 / 0.50 = 0.66$

average $K_{LM} = (0.77 + 0.66) / 2 = 0.715$

equivalent mass,

$$M_e = (K_{LM})(M) = (0.715)(0.0016 \text{ k-s}^2/\text{in}) = 0.0011 \text{ k-s}^2/\text{in} \quad (0.00019 \text{ kN-s}^2/\text{mm})$$

period of vibration,

(Equation 6.8)

$$t_n = 2 \pi \sqrt{M_e / K_e} = 2 \pi \sqrt{(0.0011 \text{ k-s}^2/\text{in})(81.6 \text{ k/in})} = 0.023 \text{ s}$$

11.7.8 Numerical Integration Solution (load case A)

$F_o = 5.9 \text{ kips} \quad (26.2 \text{ kN})$

$t_r = 0.006 \text{ s}$

$t_d = 0.05 \text{ s}$

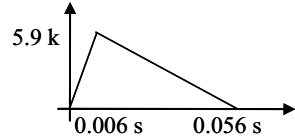

time increment = $t_n / 10 = 0.002$

The calculated time increment of 0.002 seconds appears to be adequately short to properly define the dynamic load.

For the numerical integration, refer to Table 11.5.

The positive peak deflection is at $t = 0.014 \text{ s}$,

$y_m = +0.141 \text{ in} \quad (3.6 \text{ mm})$

The rebound peak deflection is at $t = 0.074 \text{ s}$,

$y_m = -0.014 \text{ in} \quad (-0.4 \text{ mm})$

The selected rebound peak is the first to occur after dissipation of the applied load.

maximum support rotation,

(Figure 5.9)

$\theta_d = \arctan (y_m / 0.5L) = \arctan [(0.141 \text{ in}) / (0.5)(96 \text{ in})] = 0.17^\circ < \theta_a$, OK

roof slab interaction,

(Equation 7.2)

$[\Delta_d / \Delta_a]_{ip}^2 + [\Delta_d / \Delta_a]_{op}^2 = [(0.54) / (1.0)]_{ip}^2 + [(0.17) / (1.0)]_{op}^2 = 0.32 < 1.0$, OK

TABLE 11.5: Roof Slab Numerical Integration

Analysis Case Description:		Chapter 11, Section 11.7.8, Roof Slab Case A										
Dynamic Loading Description:		if(time<=0.006,5.9*time/0.006,max(5.9-5.9*(time-0.006)/0.05,0))										
time increment =	0.002 s	KEY = 0 is elastic					Z = 1 is increasing plastic deformation					
mass =	0.0011 k-s ² /in	KEY = +1 is positive plastic					Z = 2 is end of rebound plastic deformation					
stiffness =	81.6 k/in	KEY = -1 is rebound plastic					Z = 3 is end of positive plastic deformation					
damping =	0 k-s/in						Z = 4 is continued elastic					
positive resistance =	9.7 kips						Z = 5 is start of rebound plastic deformation					
rebound resistance =	-9.7 kips						Z = 6 is start of positive plastic deformation					
static load =	0.8 kips											
time (s)	Dyn. Load (kips)	y (in)	v (in/s)	a (in/s ²)	ye+ (in)	ye- (in)	KEY -	eff K (k/in)	incr F (kips)	incr y (in)	incr v (in/s)	Z -
0.000	0.00	0.010	0.00	0	0.119	-0.119	0	1,732	2	0.001	1.70	
0.002	1.97	0.011	1.70	1,704	0.119	-0.119	0	1,732	13	0.008	4.63	4
0.004	3.93	0.019	6.33	2,926	0.119	-0.119	0	1,732	33	0.019	6.25	4
0.006	5.90	0.037	12.58	3,320	0.119	-0.119	0	1,732	52	0.030	4.19	4
0.008	5.66	0.068	16.77	868	0.119	-0.119	0	1,732	58	0.033	-0.96	4
0.010	5.43	0.101	15.81	-1,829	0.119	-0.119	0	1,732	46	0.026	-5.84	4
0.012	5.19	0.127	9.97	-3,371	0.119	-0.119	1	1,850	22	0.013	-6.96	6
0.014	4.96	0.141	3.01	-3,585	0.119	-0.119	1	1,850	-2	-0.001	-7.39	1
0.016	4.72	0.139	-4.37	-3,704	0.141	-0.097	0	1,732	-27	-0.016	-6.47	3
0.018	4.48	0.124	-10.85	-2,766	0.141	-0.097	0	1,732	-45	-0.026	-3.81	4
0.020	4.25	0.098	-14.66	-1,046	0.141	-0.097	0	1,732	-52	-0.030	-0.08	4
0.022	4.01	0.068	-14.74	969	0.141	-0.097	0	1,732	-46	-0.026	3.68	4
0.024	3.78	0.041	-11.06	2,711	0.141	-0.097	0	1,732	-28	-0.016	6.40	4
0.026	3.54	0.025	-4.66	3,686	0.141	-0.097	0	1,732	-3	-0.002	7.31	4
0.028	3.30	0.023	2.65	3,619	0.141	-0.097	0	1,732	20	0.012	6.15	4
0.030	3.07	0.035	8.80	2,529	0.141	-0.097	0	1,732	37	0.021	3.25	4
0.032	2.83	0.056	12.05	723	0.141	-0.097	0	1,732	42	0.024	-0.56	4
0.034	2.60	0.081	11.48	-1,286	0.141	-0.097	0	1,732	33	0.019	-4.22	4
0.036	2.36	0.100	7.27	-2,933	0.141	-0.097	0	1,732	14	0.008	-6.68	4
0.038	2.12	0.108	0.58	-3,750	0.141	-0.097	0	1,732	-11	-0.006	-7.26	4
0.040	1.89	0.102	-6.67	-3,506	0.141	-0.097	0	1,732	-34	-0.020	-5.78	4
0.042	1.65	0.082	-12.45	-2,272	0.141	-0.097	0	1,732	-49	-0.028	-2.67	4
0.044	1.42	0.054	-15.12	-395	0.141	-0.097	0	1,732	-51	-0.030	1.20	4
0.046	1.18	0.024	-13.92	1,594	0.141	-0.097	0	1,732	-41	-0.024	4.73	4
0.048	0.94	0.001	-9.19	3,132	0.141	-0.097	0	1,732	-20	-0.012	6.92	4
0.050	0.71	-0.011	-2.28	3,784	0.141	-0.097	0	1,732	5	0.003	7.15	4
0.052	0.47	-0.008	4.87	3,367	0.141	-0.097	0	1,732	27	0.016	5.36	4
0.054	0.24	0.007	10.24	1,997	0.141	-0.097	0	1,732	40	0.023	2.06	4
0.056	0.00	0.031	12.30	63	0.141	-0.097	0	1,732	41	0.024	-1.62	4
0.058	0.00	0.054	10.68	-1,684	0.141	-0.097	0	1,732	30	0.017	-4.64	4
0.060	0.00	0.071	6.04	-2,956	0.141	-0.097	0	1,732	10	0.006	-6.35	4
0.062	0.00	0.077	-0.31	-3,391	0.141	-0.097	0	1,732	-12	-0.007	-6.26	4
0.064	0.00	0.070	-6.57	-2,868	0.141	-0.097	0	1,732	-31	-0.018	-4.40	4
0.066	0.00	0.052	-10.97	-1,534	0.141	-0.097	0	1,732	-41	-0.024	-1.30	4
0.068	0.00	0.028	-12.27	234	0.141	-0.097	0	1,732	-40	-0.023	2.17	4
0.070	0.00	0.005	-10.10	1,936	0.141	-0.097	0	1,732	-27	-0.016	5.03	4
0.072	0.00	-0.010	-5.08	3,090	0.141	-0.097	0	1,732	-7	-0.004	6.46	4
0.074	0.00	-0.014	1.39	3,371	0.141	-0.097	0	1,732	16	0.009	6.07	4
0.076	0.00	-0.005	7.45	2,698	0.141	-0.097	0	1,732	34	0.019	3.96	4

11.7.9 Numerical Integration Solution (load case B)

$P_o = 6.6 \text{ kips (29.4 kN)}$

$t_r = 0 \text{ s}$

$t_d = 0.05 \text{ s}$

time increment = $t_n / 10 = 0.002$

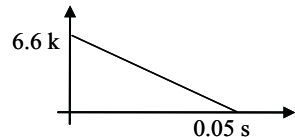

The calculated time increment of 0.002 seconds appears to be adequately short to properly define the dynamic load.

TABLE 11.6: Roof Slab Numerical Integration

Analysis Case Description:		Chapter 11, Section 11.7.9, Roof Slab Case B										
Dynamic Loading Description:		max(6.6-6.6*time/0.006,0)										
time increment =	0.002 s	KEY = 0 is elastic							Z = 1 is increasing plastic deformation			
mass =	0.0011 k-s ² /in	KEY = +1 is positive plastic							Z = 2 is end of rebound plastic deformation			
stiffness =	81.6 k/in	KEY = -1 is rebound plastic							Z = 3 is end of positive plastic deformation			
damping =	0 k-s/in								Z = 4 is continued elastic			
positive resistance =	9.7 kips								Z = 5 is start of rebound plastic deformation			
rebound resistance =	-9.7 kips								Z = 6 is start of positive plastic deformation			
static load =	0.8 kips											
time (s)	Dyn. Load (kips)	y (in)	v (in/s)	a (in/s ²)	ye+ (in)	ye- (in)	KEY	eff K (k/in)	incr F (kips)	incr y (in)	incr v (in/s)	Z
0.000	6.60	0.010	0.00	6,000	0.119	-0.119	0	1,732	20	0.011	10.92	
0.002	6.34	0.021	10.92	4,923	0.119	-0.119	0	1,732	52	0.030	7.38	4
0.004	6.07	0.051	18.30	2,454	0.119	-0.119	0	1,732	68	0.039	1.75	4
0.006	5.81	0.091	20.05	-709	0.119	-0.119	0	1,732	64	0.037	-4.38	4
0.008	5.54	0.127	15.67	-3,051	0.119	-0.119	1	1,650	41	0.025	-6.34	4
0.010	5.28	0.152	9.32	-3,291	0.119	-0.119	1	1,650	20	0.012	-8.82	1
0.012	5.02	0.164	2.50	-3,531	0.119	-0.119	1	1,650	-4	-0.002	-7.30	1
0.014	4.75	0.162	-4.80	-3,606	0.164	-0.074	0	1,732	-28	-0.016	-6.25	3
0.016	4.49	0.146	-11.05	-2,647	0.164	-0.074	0	1,732	-45	-0.026	-3.59	4
0.018	4.22	0.120	-14.64	-939	0.164	-0.074	0	1,732	-52	-0.030	0.10	4
0.020	3.96	0.090	-14.54	1,035	0.164	-0.074	0	1,732	-45	-0.026	3.75	4
0.022	3.70	0.064	-10.79	2,716	0.164	-0.074	0	1,732	-27	-0.016	6.34	4
0.024	3.43	0.048	-4.45	3,629	0.164	-0.074	0	1,732	-3	-0.002	7.14	4
0.026	3.17	0.047	2.70	3,516	0.164	-0.074	0	1,732	20	0.012	5.92	4
0.028	2.90	0.058	8.62	2,409	0.164	-0.074	0	1,732	36	0.021	3.03	4
0.030	2.64	0.079	11.65	621	0.164	-0.074	0	1,732	40	0.023	-0.72	4
0.032	2.38	0.102	10.93	-1,343	0.164	-0.074	0	1,732	31	0.018	-4.27	4
0.034	2.11	0.120	6.66	-2,927	0.164	-0.074	0	1,732	12	0.007	-6.61	4
0.036	1.85	0.127	0.05	-3,683	0.164	-0.074	0	1,732	-12	-0.007	-7.08	4
0.038	1.58	0.120	-7.03	-3,398	0.164	-0.074	0	1,732	-35	-0.020	-5.55	4
0.040	1.32	0.100	-12.58	-2,152	0.164	-0.074	0	1,732	-49	-0.028	-2.45	4
0.042	1.06	0.072	-15.03	-298	0.164	-0.074	0	1,732	-51	-0.029	1.34	4
0.044	0.79	0.043	-13.69	1,641	0.164	-0.074	0	1,732	-40	-0.023	4.76	4
0.046	0.53	0.020	-8.93	3,115	0.164	-0.074	0	1,732	-19	-0.011	6.82	4
0.048	0.26	0.008	-2.11	3,709	0.164	-0.074	0	1,732	5	0.003	6.96	4
0.050	0.00	0.011	4.85	3,254	0.164	-0.074	0	1,732	27	0.015	5.36	4

For the numerical integration, refer to Table 11.6.

The positive peak deflection is at t = 0.012 s,
 $y_m = +0.164$ in (4.2 mm)

The rebound peak deflection is at t = 0.048 s,
 $y_m = +0.008$ in (0.2 mm)

The selected rebound peak is the first to occur after dissipation of the applied load.

maximum support rotation, (Figure 5.9)

$$\theta_d = \arctan (y_m / 0.5L) = \arctan [(0.164 \text{ in}) / (0.5)(96 \text{ in})] = 0.20^\circ < \theta_a, \text{ OK}$$

roof slab interaction, (Equation 7.2)

$$[\Delta_d / \Delta_a]_{ip}^2 + [\Delta_d / \Delta_a]_{op}^2 = [(0.54) / (1.3)]_{ip}^2 + [(0.20) / (1.0)]_{op}^2 = 0.21 < 1.0, \text{ OK}$$

maximum demand / permissible = 0.54, USE roof slab/diaphragm as assumed.

NOTE: Reduction in roof slab/diaphragm proportions in order to achieve a higher ratio would be restricted by the need for a workable dimension between top and bottom reinforcing layers, and by minimum flexural steel code requirements.

11.8 ROOF BEAMS

Each interior roof beam supports a roof slab width of 8 feet (2438 mm).

The roof beam is connected to the roof slab to prevent separation during rebound. In this case, the connection is to be designed to prevent composite action between the roof slab and the roof beam.

NOTE: Because composite action greatly increases the bending capacity while not increasing the beam's shear capacity, neglecting this effect could be very unconservative.

span, $L = 18$ feet or 216 in (5,486 mm), pinned connections at each end

beam spacing, 8.0 feet or 96 in (2,438 mm)

11.8.1 Load Case A (perpendicular to span of beam)

from the Chapter 3 Appendix calculation,

$$P_{so} = 6 \text{ psi (41 kPa)}$$

$$q_o = 0.8 \text{ psi (6 kPa)}$$

$$t_d = 0.05 \text{ s}$$

$$C_d = -0.4$$

$$L_w = 792 \text{ in (20,117 mm)}$$

The blast loaded area tributary to a roof beam is the span of 216 in (5,486 mm) by the beam spacing of 96 in (2,438 mm).

$$L_1 = \text{spacing} = 96 \text{ in (2,438 mm)}$$

equivalent load coefficient, (Figure 3.9)

$$L_w / L_1 = (792 \text{ in}) / (96 \text{ in}) = 8.25, \text{ therefore } C_E = 0.9$$

equivalent peak overpressure, (Equation 3.11)

$$P_a = C_e P_{so} + C_d q_o = (0.9)(6 \text{ psi}) + (-0.4)(0.8 \text{ psi}) = 5.1 \text{ psi (35.2 kPa)}$$

equivalent peak load,

$$F_o = (P_a)(L)(\text{spacing}) = (5.1 \text{ psi})(216 \text{ in})(96 \text{ in}) / (1,000 \text{ lb/k}) = 105.8 \text{ kips (471 kN)}$$

rise time,

$$t_r = L_1 / U = (8 \text{ ft}) / (1,312 \text{ ft/s}) = 0.006 \text{ s}$$

11.8.2 Load Case B (parallel to span of beam)

$$L_1 = L = 216 \text{ in (5,486 mm)}$$

$$\begin{aligned} &\text{equivalent load coefficient,} && \text{(Figure 3.9)} \\ L_w / L_1 = (792 \text{ in}) / (216 \text{ in}) = 3.7, \text{ therefore } C_e = 0.85 \end{aligned}$$

$$\begin{aligned} &\text{equivalent peak overpressure,} && \text{(Equation 3.11)} \\ P_a = C_e P_{so} + C_d q_o = (0.85)(6 \text{ psi}) + (-0.4)(0.8 \text{ psi}) = 4.78 \text{ psi (33.0 kPa)} \end{aligned}$$

$$\begin{aligned} &\text{equivalent peak load,} \\ F_o = (P_a)(L)(\text{spacing}) = (4.78 \text{ psi})(216 \text{ in})(96 \text{ in}) / (1,000 \text{ lb/k}) = 99.1 \text{ kips (441 kN)} \end{aligned}$$

$$\begin{aligned} &\text{rise time,} \\ t_r = L_1 / U = (18 \text{ ft}) / (1,312 \text{ ft/s}) = 0.014 \text{ s} \end{aligned}$$

$$\begin{aligned} &\text{time of duration,} \\ t_d = 0.05 \text{ s} \end{aligned}$$

11.8.3 Trial Size W14x26 (AISC Manual)

$$\begin{aligned} &\text{beam depth, } d = 13.9 \text{ in (353 mm)} && \text{flange width/thickness, } b_f / 2t_f = \lambda_f \\ &= 5.98 \end{aligned}$$

$$\begin{aligned} &\text{web thickness, } t_w = 0.255 \text{ in (6.47 mm)} && \text{web depth/thickness, } h / t_w = \lambda_w = \\ &48.1 \end{aligned}$$

$$\begin{aligned} &\text{radius of gyration, } r_y = 1.08 \text{ in (27.4 mm)} \\ &\text{moment of inertia, } I_x = 245 \text{ in}^4 \text{ (101,976,700 mm}^4\text{)} \\ &\text{plastic modulus, } Z_x = 40.2 \text{ in}^3 \text{ (658,760 mm}^3\text{)} \end{aligned}$$

11.8.4 Compute Bending Resistance

$$\begin{aligned} &\text{for dynamic bending,} && \text{(Appendix 5.A)} \\ F_{ds} = F_{dy} = (\text{SIF})(\text{DIF}) F_y = (1.1)(1.19) 50 \text{ ksi} = 65.5 \text{ ksi (452 MPa)} \end{aligned}$$

Because roof beams are considered secondary members, width-thickness ratios do not need to meet AISC seismic requirements.

$$\begin{aligned} &\text{check flange,} && \text{(AISC 360, Table B4.1)} \\ \lambda_p = 0.38 \sqrt{E_s / F_{ds}} = 0.38 \sqrt{(29,000 \text{ ksi}) / (65.5 \text{ ksi})} = 8.00 > \lambda_{f5}, \text{ OK} \end{aligned}$$

$$\begin{aligned} &\text{check web,} && \text{(AISC 360, Table B4.1)} \\ \lambda_p = 3.76 \sqrt{E_s / F_{ds}} = 3.76 \sqrt{(29,000 \text{ ksi}) / (65.5 \text{ ksi})} = 79.1 > \lambda_{w5}, \text{ OK} \end{aligned}$$

roof beam is continuously braced from concrete roof slab, unbraced length is OK

moment capacity, (AISC 360, Equation F2-1)

$$M_p = Z_x (F_{ds}) = (40.2 \text{ in}^3)(65.5 \text{ ksi}) = 2,633 \text{ k-in} \quad (297,489 \text{ kN-mm})$$

$$R_b = 8 (M_p) / L = 8 (2,633 \text{ k-in}) / (216 \text{ in}) = 97.5 \text{ kips} \quad (434 \text{ kN})$$

11.8.5 Compute Shear Resistance

for dynamic shear, (Appendix 5.A)

$$F_{ds} = F_{dy} = (\text{SIF})(\text{DIF}) F_y = (1.1)(1.19) 50 \text{ ksi} = 65.5 \text{ ksi} \quad (452 \text{ MPa})$$

because $h/t_w < 260$, $k_v = 5$ (AISC 360, Section G2.1)

check web slenderness criteria, (AISC 360, Equation G2-3)

$$\lambda_v = 1.1 \sqrt{k_v E_s / F_{ds}} = 1.1 \sqrt{(5)(29,000 \text{ ksi}) / (65.5 \text{ ksi})} = 52 > \lambda_w, \text{ therefore } C_v = 1.0$$

$$\begin{aligned} V_n &= 0.6 (F_{ds})(d)(t_w)(C_v) && \text{(AISC 360, Section G2.1(a))} \\ &= 0.6 (65.5 \text{ ksi})(13.9 \text{ in} * 0.255 \text{ in})(1.0) \\ &= 139.3 \text{ kips} \quad (620 \text{ kN}) \end{aligned}$$

$$R_s = 2 V_n = 2 (139.3 \text{ kips}) = 278.6 \text{ kips} \quad (1,239 \text{ kN})$$

11.8.6 Resistance & Permissible Response

Because $R_b < R_s$, bending controls

positive resistance, $R_u = R_b = 97.5 \text{ kips} \quad (434 \text{ kN})$

rebound resistance, $R_{u-} = -R_b = -97.5 \text{ kips} \quad (-434 \text{ kN})$

allowable ductility ratio, $\mu_a = 3.0$ (Table 5.B.2)

allowable support rotation, $\theta_a = 2.0^\circ$ (Table 5.B.2)

11.8.7 Compute SDOF Equivalent System

$$\begin{aligned} \text{static load} &= (\text{beam weight}) + (\text{slab load}) \\ &= (0.026 \text{ klf})(18 \text{ ft}) + (8 \text{ ft})(18 \text{ ft})[(0.075 \text{ ksf slab}) + (0.025 \text{ ksf dead load})] \\ &= 0.5 \text{ kips} + 14.4 \text{ kips} = 14.9 \text{ kips} \quad (66.3 \text{ kN}) \end{aligned}$$

effective stiffness, (Table 6.1)

$$\begin{aligned} K_e &= 384 E_s I_x / 5 L^3 \\ &= 384 (29,000 \text{ ksi})(245 \text{ in}^4) / (5)(216 \text{ in})^3 \\ &= 54.1 \text{ k/in} \quad (9.5 \text{ kN/mm}) \end{aligned}$$

beam mass,

$$\begin{aligned} M &= [(\text{beam weight}) + (\text{tributary slab weight})] / g \\ &= [(0.5 \text{ kips}) + (14.4 \text{ kips})] / (386 \text{ in/s}^2) \\ &= 0.039 \text{ k-s}^2/\text{in} \quad (0.0068 \text{ kN-s}^2/\text{mm}) \end{aligned}$$

because of the expected response, use an average of values for K_{LM} (Table 6.1)

elastic $K_{LM} = 0.5 / 0.64 = 0.78$

plastic $K_{LM} = 0.33 / 0.5 = 0.66$

average $K_{LM} = (0.78 + 0.66) / 2 = 0.72$

equivalent mass,

$M_e = (K_{LM})(M) = (0.72)(0.039 \text{ k-s}^2/\text{in}) = 0.028 \text{ k-s}^2/\text{in}$ (0.0049 kN-s²/mm)

period of vibration,

(Equation 6.8)

$t_n = 2 \pi \sqrt{M_e / K_c} = 2 \pi \sqrt{(0.028 \text{ k-s}^2/\text{in}) / (54.1 \text{ k/in})} = 0.143 \text{ s}$

11.8.8 Numerical Integration Solution (load case A)

$F_o = 105.8 \text{ kips}$ (471 kN)

$t_r = 0.006 \text{ s}$

$t_d = 0.05 \text{ s}$

use time increment = $t_n / 10 = 0.014 \text{ s}$

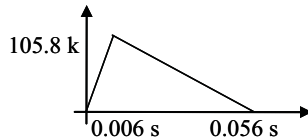

The calculated time increment of 0.014 seconds does not appear to be adequately short to properly define the dynamic load. Thus an increment of half the rise time (0.003 s) is used.

NOTE: With a spreadsheet numerical integration, the time increment can quickly be varied in order to provide a consistent response without an overly lengthy number of increments.

For the numerical integration, refer to Table 11.7.

The peak positive deflection is at $t = 0.060 \text{ s}$,

$y_m = +2.439 \text{ in}$ (62.0 mm)

$\mu_d = 1.35 < \mu_a$, OK

The peak rebound deflection is at $t = 0.132 \text{ s}$,

$y_m = -0.615 \text{ in}$ (-15.6 mm)

$\mu_d = 0.69 < \mu_a$, OK

maximum support rotation,

$\theta_d = \arctan (y_m) / (0.5 L) = \arctan [(2.439 \text{ in}) / (0.5)(216 \text{ in})] = 1.29^\circ < \theta_a$, OK

TABLE 11.7: Roof Beam Numerical Integration

Analysis Case Description:		Chapter 11, Section 11.8.8, roof beam, case A										
Dynamic Loading Description:		if(time<=0.006,105.8*time/0.006,max(105.8-105.8*(time-0.006)/0.05,0))										
time increment =	0.003	s	KEY = 0 is elastic				Z = 1 is increasing plastic deformation					
mass =	0.028	k-s2/in	KEY = +1 is positive plastic				Z = 2 is end of rebound plastic deformation					
stiffness =	54.1	k/in	KEY = -1 is rebound plastic				Z = 3 is end of positive plastic deformation					
damping =	0	k-s/in					Z = 4 is continued elastic					
positive resistance =	97.5	kips					Z = 5 is start of rebound plastic deformation					
rebound resistance =	-97.5	kips					Z = 6 is start of positive plastic deformation					
static load =	14.9	kips										
time (s)	Dyn. Load (kips)	y (in)	v (in/s)	a (in/s2)	ye+ (in)	ye- (in)	KEY	eff K (k/in)	incr F (kips)	incr y (in)	incr v (in/s)	Z
0.000	0.00	0.275	0.00	0	1.802	-1.802	0	18,721	53	0.003	2.83	
0.003	52.90	0.278	2.83	1,884	1.802	-1.802	0	18,721	369	0.020	8.43	4
0.006	105.80	0.298	11.25	3,735	1.802	-1.802	0	18,721	938	0.050	10.72	4
0.009	99.45	0.348	21.97	3,412	1.802	-1.802	0	18,721	1,511	0.081	9.66	4
0.012	93.10	0.429	31.63	3,029	1.802	-1.802	0	18,721	2,020	0.108	8.43	4
0.015	86.76	0.537	40.07	2,594	1.802	-1.802	0	18,721	2,455	0.131	7.06	4
0.018	80.41	0.668	47.13	2,114	1.802	-1.802	0	18,721	2,810	0.150	5.57	4
0.021	74.06	0.818	52.69	1,597	1.802	-1.802	0	18,721	3,079	0.164	3.97	4
0.024	67.71	0.982	56.67	1,052	1.802	-1.802	0	18,721	3,255	0.174	2.31	4
0.027	61.36	1.156	58.98	490	1.802	-1.802	0	18,721	3,338	0.178	0.61	4
0.030	55.02	1.335	59.59	-82	1.802	-1.802	0	18,721	3,324	0.178	-1.10	4
0.033	48.67	1.512	58.49	-651	1.802	-1.802	0	18,721	3,215	0.172	-2.79	4
0.036	42.32	1.684	55.70	-1,210	1.802	-1.802	0	18,721	3,011	0.161	-4.44	4
0.039	35.97	1.845	51.27	-1,665	1.802	-1.802	1	18,667	2,725	0.146	-5.34	6
0.042	29.62	1.991	45.93	-1,892	1.802	-1.802	1	18,667	2,407	0.129	-6.02	1
0.045	23.28	2.120	39.91	-2,119	1.802	-1.802	1	18,667	2,051	0.110	-6.70	1
0.048	16.93	2.229	33.22	-2,345	1.802	-1.802	1	18,667	1,657	0.089	-7.38	1
0.051	10.58	2.318	25.84	-2,572	1.802	-1.802	1	18,667	1,225	0.066	-8.06	1
0.054	4.23	2.384	17.79	-2,799	1.802	-1.802	1	18,667	757	0.041	-8.62	1
0.057	0.00	2.424	9.16	-2,950	1.802	-1.802	1	18,667	265	0.014	-8.85	1
0.060	0.00	2.439	0.31	-2,950	1.802	-1.802	1	18,667	-230	-0.012	-8.85	1
0.063	0.00	2.426	-8.54	-2,926	2.439	-1.166	0	18,721	-724	-0.039	-8.67	3
0.066	0.00	2.388	-17.20	-2,851	2.439	-1.166	0	18,721	-1,203	-0.064	-8.37	4
0.069	0.00	2.323	-25.57	-2,727	2.439	-1.166	0	18,721	-1,661	-0.089	-7.92	4
0.072	0.00	2.235	-33.50	-2,556	2.439	-1.166	0	18,721	-2,091	-0.112	-7.34	4
0.075	0.00	2.123	-40.84	-2,340	2.439	-1.166	0	18,721	-2,484	-0.133	-6.64	4
0.078	0.00	1.990	-47.48	-2,084	2.439	-1.166	0	18,721	-2,834	-0.151	-5.81	4
0.081	0.00	1.839	-53.29	-1,791	2.439	-1.166	0	18,721	-3,135	-0.167	-4.89	4
0.084	0.00	1.671	-58.18	-1,468	2.439	-1.166	0	18,721	-3,381	-0.181	-3.88	4
0.087	0.00	1.491	-62.06	-1,119	2.439	-1.166	0	18,721	-3,569	-0.191	-2.80	4
0.090	0.00	1.300	-64.86	-750	2.439	-1.166	0	18,721	-3,695	-0.197	-1.68	4
0.093	0.00	1.103	-66.54	-369	2.439	-1.166	0	18,721	-3,757	-0.201	-0.53	4
0.096	0.00	0.902	-67.07	19	2.439	-1.166	0	18,721	-3,754	-0.201	0.64	4
0.099	0.00	0.702	-66.43	406	2.439	-1.166	0	18,721	-3,686	-0.197	1.79	4
0.102	0.00	0.505	-64.64	787	2.439	-1.166	0	18,721	-3,554	-0.190	2.91	4
0.105	0.00	0.315	-61.73	1,153	2.439	-1.166	0	18,721	-3,360	-0.179	3.98	4
0.108	0.00	0.135	-57.75	1,500	2.439	-1.166	0	18,721	-3,108	-0.166	4.98	4
0.111	0.00	-0.031	-52.77	1,821	2.439	-1.166	0	18,721	-2,802	-0.150	5.90	4
0.114	0.00	-0.180	-46.87	2,110	2.439	-1.166	0	18,721	-2,448	-0.131	6.71	4
0.117	0.00	-0.311	-40.16	2,363	2.439	-1.166	0	18,721	-2,051	-0.110	7.41	4
0.120	0.00	-0.421	-32.76	2,574	2.439	-1.166	0	18,721	-1,618	-0.086	7.97	4
0.123	0.00	-0.507	-24.78	2,741	2.439	-1.166	0	18,721	-1,158	-0.062	8.40	4
0.126	0.00	-0.569	-16.38	2,861	2.439	-1.166	0	18,721	-677	-0.036	8.69	4
0.129	0.00	-0.605	-7.69	2,931	2.439	-1.166	0	18,721	-185	-0.010	8.82	4
0.132	0.00	-0.615	1.13	2,950	2.439	-1.166	0	18,721	311	0.017	8.80	4
0.135	0.00	-0.598	9.93	2,918	2.439	-1.166	0	18,721	801	0.043	8.63	4

11.8.9 Numerical Integration Solution (load case B)

$F_0 = 99.1$ kips (441 kN)

$t_r = 0.014$ s

$t_d = 0.05$ s

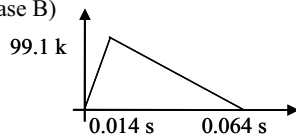

TABLE 11.8: Roof Beam Numerical Integration

Analysis Case Description:		Chapter 11, Section 11.8.9, roof beam, case B										
Dynamic Loading Description:		if(time<=0.014,99.1*time/0.014,max(99.1-99.1*(time-0.014)/0.05,0))										
time increment =	0.007	s	KEY = 0 is elastic	Z = 1 is increasing plastic deformation								
mass =	0.028	k-s2/in	KEY = +1 is positive plastic	Z = 2 is end of rebound plastic deformation								
stiffness =	54.1	k/in	KEY = -1 is rebound plastic	Z = 3 is end of positive plastic deformation								
damping =	0	k-s/in		Z = 4 is continued elastic								
positive resistance =	97.5	kips		Z = 5 is start of rebound plastic deformation								
rebound resistance =	-97.5	kips		Z = 6 is start of positive plastic deformation								
static load =	14.9	kips										
time	Dyn. Load	y	v	a	ye+	ye-	KEY	eff K	incr F	incr y	incr v	Z
(s)	(kips)	(in)	(in/s)	(in/s2)	(in)	(in)	-	(k/in)	(kips)	(in)	(in/s)	-
0.000	0.00	0.275	0.00	0	1.802	-1.802	0	3,483	50	0.014	6.10	
0.007	49.55	0.290	6.10	1,742	1.802	-1.802	0	3,483	342	0.098	17.72	4
0.014	99.10	0.388	23.82	3,322	1.802	-1.802	0	3,483	837	0.240	19.89	4
0.021	85.23	0.628	43.72	2,362	1.802	-1.802	0	3,483	1,234	0.354	12.41	4
0.028	71.35	0.982	56.12	1,182	1.802	-1.802	0	3,483	1,432	0.411	3.76	4
0.035	57.48	1.394	59.88	-108	1.802	-1.802	0	3,483	1,414	0.406	-5.24	4
0.042	43.60	1.800	54.64	-1,388	1.802	-1.802	0	3,483	1,181	0.339	-13.74	4
0.049	29.73	2.139	40.90	-1,888	1.802	-1.802	1	3,429	809	0.236	-14.95	6
0.056	15.86	2.375	25.95	-2,384	1.802	-1.802	1	3,429	409	0.119	-18.42	1
0.063	1.98	2.494	7.53	-2,879	1.802	-1.802	1	3,429	-63	-0.018	-20.40	1
0.070	0.00	2.476	-12.87	-2,914	2.494	-1.110	0	3,483	-554	-0.159	-19.33	3
0.077	0.00	2.317	-32.20	-2,607	2.494	-1.110	0	3,483	-992	-0.285	-16.32	4
0.084	0.00	2.032	-48.52	-2,057	2.494	-1.110	0	3,483	-1,337	-0.384	-11.80	4
0.091	0.00	1.648	-60.33	-1,315	2.494	-1.110	0	3,483	-1,558	-0.447	-6.18	4
0.098	0.00	1.200	-66.50	-451	2.494	-1.110	0	3,483	-1,634	-0.469	0.02	4
0.105	0.00	0.731	-66.49	456	2.494	-1.110	0	3,483	-1,557	-0.447	6.22	4
0.112	0.00	0.284	-60.27	1,320	2.494	-1.110	0	3,483	-1,336	-0.383	11.83	4
0.119	0.00	-0.099	-48.44	2,061	2.494	-1.110	0	3,483	-989	-0.284	16.35	4
0.126	0.00	-0.383	-32.09	2,610	2.494	-1.110	0	3,483	-551	-0.158	19.34	4
0.133	0.00	-0.542	-12.75	2,915	2.494	-1.110	0	3,483	-61	-0.018	20.53	4
0.140	0.00	-0.559	7.78	2,949	2.494	-1.110	0	3,483	434	0.125	19.80	4
0.147	0.00	-0.434	27.58	2,708	2.494	-1.110	0	3,483	889	0.255	17.23	4

use time increment = $t_n / 10 = 0.014$ s

The calculated time increment of 0.014 seconds does not appear to be adequately short to properly define the dynamic load. Thus an increment of half the rise time (0.007 s) is used.

NOTE: With a spreadsheet numerical integration, the time increment can quickly be varied in order to provide a consistent response without an overly lengthy number of increments.

For the numerical integration, refer to Table 11.8.

The peak positive deflection is at $t = 0.063$ s,
 $y_m = 2.494$ in (63.3 mm)
 $\mu_d = 1.38 < \mu_a$, OK

The peak rebound deflection is at $t = 0.140$ s,
 $y_m = -0.559$ in (-14.2 mm)
 $\mu_d = 0.69 < \mu_a$, OK

maximum support rotation, (Figure 5.9)

$$\theta_d = \arctan (y_m) / (0.5 L) = \arctan [(2.494 \text{ in}) / (0.5)(216 \text{ in})] = 1.32^\circ < \theta_a, \text{ OK}$$

maximum demand / permissible = 1.32 / 2.0 = 0.66, USE roof beam as assumed.

11.9 ROOF BEAM CONNECTION

The roof beams connect to the girder web or column flange.

roof beam resistance,

$$R_u = 97.5 \text{ kips} \quad (434 \text{ kN})$$

connection design load,

$$V_u = (R_u) / (2 \text{ beam ends}) \\ = (97.5 \text{ kips}) / (2 \text{ each}) = 48.8 \text{ kips} \quad (217 \text{ kN})$$

try:

AISC Standard All-Bolted Shear Connection

ASTM A325 bearing bolts, 3 rows

threads in shear plane

diameter, $d_b = 0.75 \text{ inch}$ (19 mm)

nominal shear strength, $F_{nv} = 48 \text{ ksi}$ (330 MPa)

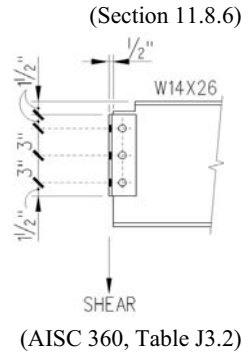

nominal unthreaded area,

$$A_b = \pi(d_b)^2 / 4 = \pi(0.75 \text{ in})^2 / 4 = 0.4418 \text{ in}^2 \quad (285 \text{ mm}^2)$$

11.9.1 Bolt Shear Strength (beam to clip angle)

SIF (A325 High Strength Bolt) = 1.0 (conservative value)

DIF (A325 High Strength Bolt) = 1.05

(Section 5.5.4)

bolt shear strength,

$$V_n = (SIF)(DIF)(F_{nv})(A_b)(N) \\ = (1.0)(1.05)(48 \text{ ksi})(0.4418 \text{ in}^2)(2 \text{ shear planes})(3 \text{ bolts}) \\ = 133.6 \text{ kips} \quad (594.3 \text{ kN}) > V_u, \text{ OK}$$

NOTE: The clip angle to girder connection uses twice the number of bolts in single shear and will not control shear strength.

11.9.2 Clip Angle Shear Strength

The critical section is a vertical plane at the bolt centerline.

Try: L3x3x3/8

length = 1.5 in + 2(3 in) + 1.5 in = 9 in (229 mm)

ASTM A36 steel

gross section,

$$A_g = (2 \text{ angles})(3/8 \text{ in, thickness})(9 \text{ in, length}) = 6.75 \text{ in}^2 \quad (4,355 \text{ mm}^2)$$

bolt hole diameter,

(AISC 360, Table J3.3, Section D3)

$$d_h = (13/16 \text{ in, nominal hole}) + (1/16 \text{ in}) = 0.875 \text{ in} \quad (22 \text{ mm})$$

net section at bolt holes,

$$A_{nv} = (6.75 \text{ in}^2) - (2 \text{ angles})(3 \text{ holes})(0.875 \text{ in, diameter})(3/8 \text{ in, thickness}) \\ = 4.78 \text{ in}^2 \quad (3,085 \text{ mm}^2)$$

for dynamic shear,

(Appendix 5.A)

$$F_{dy} = (SIF)(DIF)(F_y) = (1.1)(1.29)(36 \text{ ksi}) = 51.1 \text{ ksi} \quad (352 \text{ MPa})$$

$$F_{du} = (SIF)(DIF)(F_u) = (1.1)(1.1)(58 \text{ ksi}) = 70 \text{ ksi} \quad (483 \text{ MPa})$$

shear yielding strength,

(AISC 360, Equation J4-3)

$$V_n = (0.6)(F_{dy})(A_g) = (0.6)(51.1 \text{ ksi})(6.75 \text{ in}^2) = 207 \text{ kips} \quad (921 \text{ kN}) > V_u, \quad \text{OK}$$

shear rupture strength,

(AISC 360, Equation J4-4)

$$V_n = (0.6)(F_{du})(A_{nv}) = (0.6)(70 \text{ ksi})(4.78 \text{ in}^2) = 201 \text{ kips} \quad (893 \text{ kN}) > V_u, \quad \text{OK}$$

11.9.3 Clip Angle Bearing Strength

clear distance between holes,

$$L_c = (1 \text{ bolt})[(1.5 \text{ in, edge}) - 0.5(0.875 \text{ in hole})] \\ + (2 \text{ each})[(3 \text{ in, spacing}) - (0.875 \text{ in, hole})] = 5.31 \text{ in} \quad (135 \text{ mm})$$

bearing strength,

(AISC 360, Equation J3-6a)

$$V_n = \min \text{ of } 1.2(L_c)(t_p)(F_{du}) \text{ or } 2.4(d_b)(t_p)(F_{du}) \\ = \min \text{ of } 1.2(5.31 \text{ in})(3/8 \text{ in} * 2 \text{ each})(70 \text{ ksi}) \\ \text{ or } 2.4(0.75 \text{ in} * 3 \text{ each})(3/8 \text{ in} * 2 \text{ each})(70 \text{ ksi}) \\ = \min \text{ of } 334 \text{ kips or } 283 \text{ kips} = 283 \text{ kips} \quad (1,258 \text{ kN}) > V_u, \quad \text{OK}$$

11.9.4 Beam Shear Strength

The critical section is a vertical plane at the bolt centerline.

W14x26 properties,

(AISC Manual)

depth, $d = 13.9 \text{ in}$ (353 mm)

web thickness, $t_w = 0.255 \text{ in}$ (6.5 mm)

gross section, assuming beam flange is coped 1.25 in (32 mm),

$$A_g = (0.255 \text{ in})[(13.9 \text{ in}) - (1.25 \text{ in})] = 3.23 \text{ in}^2 \quad (2,084 \text{ mm}^2)$$

net section at bolt holes,

$$A_{nv} = (3.23 \text{ in}^2) - (3 \text{ holes})(0.875 \text{ in, diameter})(0.255 \text{ in, thickness}) \\ = 2.56 \text{ in}^2 \quad (1,590 \text{ mm}^2)$$

for dynamic shear,

(Appendix 5.A)

$$F_{dy} = (\text{SIF})(\text{DIF})(F_y) = (1.1)(1.19)(50 \text{ ksi}) = 65 \text{ ksi} \quad (448 \text{ MPa})$$

$$F_{du} = (\text{SIF})(\text{DIF})(F_u) = (1.1)(1.05)(65 \text{ ksi}) = 75 \text{ ksi} \quad (517 \text{ MPa})$$

web shear yielding strength, (AISC 360, Equation J4-3)

$$V_n = 0.6(F_{dy})(A_g) = 0.6(65 \text{ ksi})(3.23 \text{ in}^2) = 126 \text{ kips} \quad (560 \text{ kN}) > V_u, \text{ OK}$$

web shear rupture strength, (AISC 360, Equation J4-4)

$$V_n = 0.6(F_{du})(A_{nv}) = 0.6(75 \text{ ksi})(2.56 \text{ in}^2) = 115 \text{ kips} \quad (512 \text{ kN}) > V_u, \text{ OK}$$

11.9.5 Beam Bearing Strength

clear distance between holes,

$$L_c = (1 \text{ bolt})[(3 \text{ in edge}) - (1.25 \text{ in, cope}) - 0.5(0.875 \text{ in hole})] \\ + (2 \text{ bolts})[(3 \text{ in spacing}) - (0.875 \text{ in hole})] = 5.56 \text{ in} \quad (141 \text{ mm})$$

web bearing strength, (AISC 360, Equation J3-6a)

$$V_n = \min \text{ of } 1.2(L_c)(t_w)(F_{du}) \text{ or } 2.4(d_b)(t_w)(F_{du}) \\ = \min \text{ of } 1.2(5.56 \text{ in})(0.255 \text{ in})(75 \text{ ksi}) \text{ or } 2.4(0.75 \text{ in} \times 3 \text{ each})(0.255 \text{ in})(75 \text{ ksi}) \\ = \min \text{ of } 127 \text{ kips or } 103 \text{ kips} = 103 \text{ kips} \quad (458 \text{ kN}) > V_u, \text{ OK}$$

NOTE: Beam and girder web thicknesses are greater and will not control bearing strength.

NOTE: For brevity, other failure modes such as block shear failure are omitted.

11.10 ROOF GIRDERS

The roof girders are simply supported at both ends with loads from roof beams applied at quarter points.

The roof girder is connected to the roof slab to prevent separation during rebound. In this case, the connection is to be designed to prevent composite action between the roof slab and the roof girder.

NOTE: Because composite action greatly increases the bending capacity while not increasing the beam's shear capacity, neglecting this effect could be very unconservative.

span, $L = 32 \text{ ft}$, or 384 in ($9,754 \text{ mm}$), pinned connections at each end

girder spacing, $L_s = 18 \text{ ft}$, or 216 in ($5,486 \text{ mm}$)

11.10.1 Load Case A (parallel to span of girder)

from the Chapter 3 Appendix calculation,

$$P_{so} = 6 \text{ psi} \quad (41 \text{ kPa})$$

$$q_o = 0.8 \text{ psi} \quad (6 \text{ kPa})$$

$$t_d = 0.05 \text{ s}$$

$$C_d = -0.4$$

$$L_w = 792 \text{ in (20,117 mm)}$$

The blast loaded area tributary to the roof girder is the girder span of 384 in (9,754 mm) by the girder spacing of 216 in (5,486 mm).

$$L_1 = L = 384 \text{ in (9,754 mm)}$$

equivalent load coefficient, (Figure 3.9)
 $L_w / L_1 = (792 \text{ in}) / (384 \text{ in}) = 2.1$, therefore $C_e = 0.7$

equivalent peak overpressure, (Equation 3.11)
 $P_a = C_e P_{so} + C_d q_o = (0.7)(6 \text{ psi}) + (-0.4)(0.8 \text{ psi}) = 3.88 \text{ psi (26.8 kPa)}$

equivalent peak load,
 $F_o = (P_a)(L)(L_s) = (3.88 \text{ psi})(384 \text{ in})(216 \text{ in}) / (1,000 \text{ lb/k}) = 321.8 \text{ kips (1,431 kN)}$

rise time,
 $t_r = L_1 / U = (32 \text{ ft}) / (1,312 \text{ ft/s}) = 0.024 \text{ s}$

time of duration,
 $t_d = 0.05 \text{ s}$

11.10.2 Load Case B (perpendicular to span of girder)

$$L_1 = s = 216 \text{ in (5,486 mm)}$$

equivalent load coefficient, (Figure 3.9)
 $L_w / L_1 = (792 \text{ in}) / (216 \text{ in}) = 3.7$, therefore $C_e = 0.85$

equivalent peak overpressure, (Equation 3.11)
 $P_a = C_e P_{so} + C_d q_o = (0.85)(6 \text{ psi}) + (-0.4)(0.8 \text{ psi}) = 4.78 \text{ psi (33.0 kPa)}$

equivalent peak load,
 $F_o = (P_a)(L)(L_s) = (4.78 \text{ psi})(384 \text{ in})(216 \text{ in}) / (1,000 \text{ lb/k}) = 396.5 \text{ kips (1,764 kN)}$

rise time,
 $t_r = L_1 / U = (18 \text{ ft}) / (1,312 \text{ ft/s}) = 0.014 \text{ s}$

time of duration,
 $t_d = 0.05 \text{ s}$

11.10.3 Trial Size W21x147 (AISC Manual)

beam depth, $d = 22.1 \text{ in (561 mm)}$	flange width/thickness, $b_f/2 t_f = \lambda_f = 5.44$
web thickness, $t_w = 0.72 \text{ in (18 mm)}$	web depth/thickness, $h/t_w = \lambda_w = 26.1$

radius of gyration, $r_y = 2.95$ in (75 mm)
 moment of inertia, $I_x = 3,630$ in⁴ (1,510,920,000 mm⁴)
 plastic modulus, $Z_x = 373$ in³ (6,112,375 mm³)

11.10.4 Compute Bending Resistance

for dynamic bending, (Appendix 5.A)
 $F_{ds} = F_{dy} = (\text{SIF})(\text{DIF}) F_y = (1.1)(1.19) 50 \text{ ksi} = 65.5 \text{ ksi}$ (452 MPa)

Because girders are considered primary members, width-thickness ratios need to meet AISC seismic requirements.

check flange, (AISC 341, Table I-8-1)
 $\lambda_{ps} = 0.3 \sqrt{E_s/F_{ds}} = 0.3 \sqrt{(29,000 \text{ ksi})/(65.5 \text{ ksi})} = 6.31 > \lambda_f$, OK

check web, (AISC 341, Table I-8-1)
 $\lambda_{ps} = 2.45 \sqrt{E_s/F_{ds}} = 2.45 \sqrt{(29,000 \text{ ksi})/(65.5 \text{ ksi})} = 51.6 > \lambda_w$, OK

unbraced length for plastic design, (AISC 360, Equation F2-5)
 $L_p = 1.76 r_y \sqrt{E_s/F_{ds}}$
 $= 1.76(2.95 \text{ in}) \sqrt{(29,000 \text{ ksi})/(65.5 \text{ ksi})}$
 $= 109 \text{ in}$ (2,768 mm) $< L_s$, OK

moment capacity, (AISC 360, Equation F2-1)
 $M_p = Z_x (F_{ds}) = (373 \text{ in}^3) (65.5 \text{ ksi}) = 24,431 \text{ k-in}$ (2,760,331 kN-mm)
 $R_b = 8 (M_p) / L = 8 (24,431 \text{ k-in}) / (384 \text{ in}) = 509 \text{ kips}$ (2,264 kN)

11.10.5 Compute Shear Resistance

for dynamic shear, (Appendix 5.A)
 $F_{ds} = F_{dy} = (\text{SIF})(\text{DIF}) F_y = (1.1)(1.19) 50 \text{ ksi} = 65.5 \text{ ksi}$ (452 MPa)

$V_n = 0.6 (F_{ds})(d)(t_w)(C_v)$ (AISC 360, Section G2.1(a))
 $= 0.6 (65.5 \text{ ksi})(22.1 \text{ in} * 0.72 \text{ in})(1.0)$
 $= 625 \text{ kips}$ (2,780 kN)

$R_s = 2 V_n = 2 (625 \text{ kips}) = 1,250 \text{ kips}$ (5,560 kN)

11.10.6 Resistance & Permissible Response

Because $R_b < R_s$, bending controls

positive resistance, $R_u = R_b = 509 \text{ kips}$ (2,264 kN)

rebound resistance, $R_{u-} = -R_b = -509 \text{ kips}$ (-2,264 kN)

allowable ductility ratio, $\mu_a = 1.5$ (Table 5.B.2)

allowable support rotation, $\theta_a = 1.0^\circ$ (Table 5.B.2)

11.10.7 Compute SDOF Equivalent System

$$\begin{aligned} \text{static load} &= (\text{girder weight}) + (\text{beam weight}) + (\text{slab load}) \\ &= (0.147 \text{ klf})(32 \text{ ft}) + 3(0.026 \text{ klf})(18 \text{ ft}) \\ &\quad + (32 \text{ ft})(18 \text{ ft})[(0.075 \text{ ksf slab}) + (0.025 \text{ ksf dead load})] \\ &= 4.7 \text{ kips} + 1.4 \text{ kips} + 57.6 \text{ kips} = 63.7 \text{ kips} \quad (283 \text{ kN}) \end{aligned}$$

Table 6.1 does not include a case for three point loads. In lieu of a derivation of the needed values, the stiffness and transformation factors for uniform loading will be used as an approximation.

effective stiffness, (Table 6.1)

$$\begin{aligned} K_e &= 384 E_s I_x / 5 L^3 \\ &= 384 (29,000 \text{ ksi})(3,630 \text{ in}^4) / (5)(384 \text{ in})^3 \\ &= 142.8 \text{ k/in} \quad (25.0 \text{ kN/mm}) \end{aligned}$$

beam mass,

$$\begin{aligned} M &= [(\text{girder weight}) + (\text{beam weight}) + (\text{tributary slab weight})] / g \\ &= [(4.7 \text{ kips}) + (1.4 \text{ kips}) + (57.6 \text{ kips})] / (386 \text{ in/s}^2) \\ &= 0.165 \text{ k-s}^2/\text{in} \quad (0.0289 \text{ kN-s}^2/\text{mm}) \end{aligned}$$

Because of the expected response, use an average of values for K_{LM} (Table 6.1)

$$\begin{aligned} \text{elastic } K_{LM} &= 0.5 / 0.64 = 0.78 \\ \text{plastic } K_{LM} &= 0.33 / 0.5 = 0.66 \\ \text{average } K_{LM} &= (0.78 + 0.66) / 2 = 0.72 \end{aligned}$$

equivalent mass,

$$M_e = (K_{LM})(M) = (0.72)(0.165 \text{ k-s}^2/\text{in}) = 0.119 \text{ k-s}^2/\text{in} \quad (0.0208 \text{ kN-s}^2/\text{mm})$$

period of vibration, (Equation 6.8)

$$t_n = 2 \pi \sqrt{M_e / K_e} = 2 \pi \sqrt{(0.119 \text{ k-s}^2/\text{in}) / (142.8 \text{ k/in})} = 0.181 \text{ s}$$

11.10.8 Numerical Integration Solution (load case A)

$$\begin{aligned} F_o &= 321.8 \text{ kips} \quad (1,431 \text{ kN}) \\ t_r &= 0.024 \text{ s} \\ t_d &= 0.05 \text{ s} \end{aligned}$$

use time increment = $t_n / 10 = 0.018 \text{ s}$

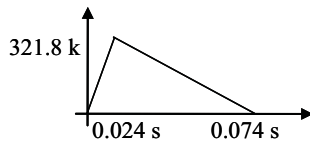

TABLE 11.9: Roof Girder Numerical Integration

Analysis Case Description:		Chapter 11, Section 11.10.8, roof girder, case A										
Dynamic Loading Description:		if(time<=0.024,321.8*time/0.024,max(321.8-321.8*(time-0.024)/0.05,0))										
time increment =	0.012	s	KEY = 0 is elastic				Z = 1 is increasing plastic deformation					
mass =	0.119	k-s ² /in	KEY = +1 is positive plastic				Z = 2 is end of rebound plastic deformation					
stiffness =	142.8	k/in	KEY = -1 is rebound plastic				Z = 3 is end of positive plastic deformation					
damping =	0	k-s/in					Z = 4 is continued elastic					
positive resistance =	509	kips					Z = 5 is start of rebound plastic deformation					
rebound resistance =	-509	kips					Z = 6 is start of positive plastic deformation					
static load =	63.7	kips										
time (s)	Dyn. Load (kips)	y (in)	v (in/s)	a (in/s ²)	ye+ (in)	ye- (in)	KEY	eff K (k/in)	incr F (kips)	incr y (in)	incr v (in/s)	Z
0.000	0.00	0.446	0.00	0	3.564	-3.564	0	5,101	161	0.032	7.89	
0.012	160.90	0.478	7.89	1,314	3.564	-3.564	0	5,101	1,099	0.215	22.33	4
0.024	321.80	0.693	30.22	2,408	3.564	-3.564	0	5,101	2,580	0.506	21.36	4
0.036	244.57	1.199	51.57	1,152	3.564	-3.564	0	5,101	3,403	0.667	5.12	4
0.048	167.34	1.866	56.70	-298	3.564	-3.564	0	5,101	3,190	0.625	-11.97	4
0.060	90.10	2.491	44.73	-1,697	3.564	-3.564	0	5,101	1,978	0.388	-27.05	4
0.072	12.87	2.879	17.68	-2,812	3.564	-3.564	0	5,101	35	0.007	-34.44	4
0.084	0.00	2.886	-16.76	-2,928	3.564	-3.564	0	5,101	-2,042	-0.400	-32.25	4
0.096	0.00	2.486	-49.01	-2,448	3.564	-3.564	0	5,101	-3,790	-0.743	-24.02	4
0.108	0.00	1.743	-73.03	-1,556	3.564	-3.564	0	5,101	-4,901	-0.961	-11.75	4
0.120	0.00	0.782	-84.79	-403	3.564	-3.564	0	5,101	-5,189	-1.017	2.49	4
0.132	0.00	-0.235	-82.30	818	3.564	-3.564	0	5,101	-4,605	-0.903	16.31	4
0.144	0.00	-1.138	-65.99	1,901	3.564	-3.564	0	5,101	-3,248	-0.637	27.39	4
0.156	0.00	-1.775	-38.60	2,665	3.564	-3.564	0	5,101	-1,345	-0.264	33.88	4
0.168	0.00	-2.038	-4.72	2,981	3.564	-3.564	0	5,101	784	0.154	34.67	4
0.180	0.00	-1.885	29.95	2,797	3.564	-3.564	0	5,101	2,781	0.545	29.64	4

The calculated time increment of 0.018 seconds does not appear to be adequately short to properly define the dynamic load. Thus an increment of half the rise time (0.012 s) is used.

NOTE: With a spreadsheet numerical integration, the time increment can quickly be varied in order to provide a consistent response without an overly lengthy number of increments.

For the numerical integration, refer to Table 11.9.

The peak positive deflection is at t = 0.084 s,
 $y_m = +2.886$ in (73.3 mm)

$\mu_d = 0.81 < \mu_a$, OK

The peak rebound deflection is at t = 0.168 s,
 $y_m = -2.038$ in (-61.3 mm)

$\mu_d = 0.57 < \mu_a$, OK

maximum support rotation,

(Figure 5.9)

$\theta_d = \arctan(y_m) / (0.5 L) = \arctan [(2.886 \text{ in}) / (0.5 * 384 \text{ in})] = 0.86^\circ < \theta_a$, OK

11.10.9 Numerical Integration Solution (load case B)

$F_o = 396.5$ kips (1,764 kN)

$t_r = 0.014$ s

$t_d = 0.05$ s

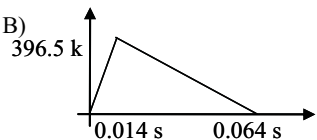

TABLE 11.10: Roof Girder Numerical Integration

Analysis Case Description:		Chapter 11, Section 11.10.9, roof girder, case B										
Dynamic Loading Description:		if(time<=0.014,396.5*time/0.014,max(396.5-396.5*(time-0.014)/0.05,0))										
time increment =	0.007	s	KEY = 0 is elastic								Z = 1 is increasing plastic deformation	
mass =	0.119	k-s ² /in	KEY = +1 is positive plastic								Z = 2 is end of rebound plastic deformation	
stiffness =	142.8	k/in	KEY = -1 is rebound plastic								Z = 3 is end of positive plastic deformation	
damping =	0	k-s/in									Z = 4 is continued elastic	
positive resistance =	509	kips									Z = 5 is start of rebound plastic deformation	
rebound resistance =	-509	kips									Z = 6 is start of positive plastic deformation	
static load =	63.7	kips										
time (s)	Dyn. Load (kips)	y (in)	v (in/s)	a (in/s ²)	ye+ (in)	ye- (in)	KEY	eff K (k/in)	incr F (kips)	incr y (in)	incr v (in/s)	Z
0.000	0.00	0.446	0.00	0	3.564	-3.564	0	14,714	198	0.013	5.77	
0.007	198.25	0.460	5.77	1,650	3.564	-3.564	0	14,714	1,376	0.094	16.99	4
0.014	396.50	0.553	22.76	3,204	3.564	-3.564	0	14,714	3,410	0.232	19.82	4
0.021	340.99	0.785	42.58	2,459	3.564	-3.564	0	14,714	5,165	0.351	14.11	4
0.028	285.48	1.136	56.89	1,571	3.564	-3.564	0	14,714	6,287	0.427	7.57	4
0.035	229.97	1.563	64.26	592	3.564	-3.564	0	14,714	6,710	0.456	0.60	4
0.042	174.46	2.019	64.85	-422	3.564	-3.564	0	14,714	6,409	0.436	-6.41	4
0.049	118.95	2.455	58.44	-1,411	3.564	-3.564	0	14,714	5,402	0.367	-13.05	4
0.056	63.44	2.822	45.39	-2,318	3.564	-3.564	0	14,714	3,747	0.255	-18.93	4
0.063	7.93	3.076	26.46	-3,090	3.564	-3.564	0	14,714	1,588	0.108	-22.32	4
0.070	0.00	3.184	4.15	-3,286	3.564	-3.564	0	14,714	-750	-0.051	-22.79	4
0.077	0.00	3.133	-18.64	-3,225	3.564	-3.564	0	14,714	-3,053	-0.207	-21.70	4
0.084	0.00	2.926	-40.34	-2,976	3.564	-3.564	0	14,714	-5,177	-0.352	-19.35	4
0.091	0.00	2.574	-59.70	-2,554	3.564	-3.564	0	14,714	-7,001	-0.476	-15.88	4
0.098	0.00	2.098	-75.57	-1,983	3.564	-3.564	0	14,714	-8,416	-0.572	-11.48	4
0.105	0.00	1.526	-87.05	-1,296	3.564	-3.564	0	14,714	-9,342	-0.635	-6.41	4
0.112	0.00	0.891	-93.46	-534	3.564	-3.564	0	14,714	-9,724	-0.661	-0.97	4
0.119	0.00	0.231	-94.42	259	3.564	-3.564	0	14,714	-9,539	-0.648	4.53	4
0.126	0.00	-0.418	-89.89	1,036	3.564	-3.564	0	14,714	-8,799	-0.598	9.77	4
0.133	0.00	-1.016	-80.12	1,754	3.564	-3.564	0	14,714	-7,546	-0.513	14.43	4
0.140	0.00	-1.529	-65.69	2,370	3.564	-3.564	0	14,714	-5,855	-0.398	18.26	4
0.147	0.00	-1.926	-47.43	2,847	3.564	-3.564	0	14,714	-3,822	-0.260	21.02	4
0.154	0.00	-2.186	-26.41	3,159	3.564	-3.564	0	14,714	-1,567	-0.106	22.56	4
0.161	0.00	-2.293	-3.86	3,286	3.564	-3.564	0	14,714	780	0.053	22.78	4
0.168	0.00	-2.240	18.93	3,223	3.564	-3.564	0	14,714	3,081	0.209	21.68	4

use time increment = $t_n / 10 = 0.018$ s

The calculated time increment of 0.018 seconds does not appear to be adequately short to properly define the dynamic load. Thus an increment of half the rise time (0.007 s) is used.

NOTE: With a spreadsheet numerical integration, the time increment can quickly be varied in order to provide a consistent response without an overly lengthy number of increments.

For the numerical integration, refer to Table 11.10.

The peak positive deflection is at $t = 0.070$ s,
 $y_m = +3.184$ in (80.9 mm)
 $\mu_d = 0.89 < \mu_a$, OK

The peak rebound deflection is at $t = 0.161$ s,
 $y_m = -2.293$ in (57.0 mm)
 $\mu_d = 0.64 < \mu_a$, OK

maximum support rotation, (Figure 5.9)

$$\theta_d = \arctan (y_m) / (0.5 L) = \arctan [(3.184 \text{ in}) / (0.5 * 384 \text{ in})] = 0.95^\circ < \theta_a, \text{ OK}$$

maximum demand / permissible = 0.95 / 1.0 = 0.95 USE assumed girder size

11.11 ROOF GIRDER CONNECTION

The roof girders connect to the column flange.

roof beam resistance,
 $R_u = 509 \text{ kips} \quad (2,264 \text{ kN})$

connection design load,
 $V_u = (R_u) / (2 \text{ beam ends})$
 $= (509 \text{ kips}) / (2 \text{ each})$
 $= 255 \text{ kips} \quad (1,134 \text{ kN})$

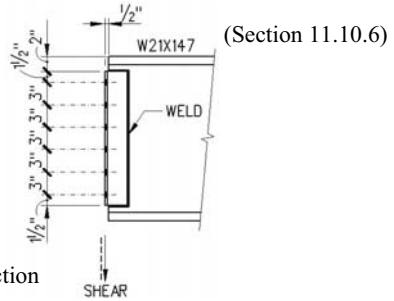

try:

AISC Standard Welded/Bolted Shear Connection

ASTM A325 bearing bolts, 6 rows

threads in shear plane

diameter, $d_b = 0.875 \text{ inch} \quad (22 \text{ mm})$

bolt nominal shear stress, $F_{nv} = 48 \text{ ksi} \quad (330 \text{ MPa})$ (AISC 360, Table J3.2)

nominal unthreaded area,

$$A_b = \pi(d_b)^2 / 4 = \pi (0.875 \text{ in})^2 / 4 = 0.6013 \text{ in}^2 \quad (388 \text{ mm}^2)$$

11.11.1 Bolt Shear Strength (clip angle to column)

SIF (A325 High Strength Bolt) = 1.0 (conservative value)

DIF (A325 High Strength Bolt) = 1.05 (Section 5.5.4)

bolt shear strength,

$$V_n = (SIF)(DIF)(F_{nv})(A_b)(N)$$

$$= (1.0)(1.05)(48 \text{ ksi})(0.6013 \text{ in}^2)(1 \text{ shear plane})(12 \text{ bolts})$$

$$= 363 \text{ kips} \quad (1,617 \text{ kN}) > V_u, \text{ OK}$$

11.11.2 Weld Strength (girder to clip angle) (Blodgett, Section 5.4.3)

try:

3/8 in (9.5 mm) fillet weld

E70XX electrode, $F_{EXX} = 70 \text{ ksi} \quad (483 \text{ MPa})$

4 in (100 mm) angle leg is outstanding, $L = 4 \text{ in} \quad (102 \text{ mm})$

horizontal weld leg length,

$$L_h = (4 \text{ in, angle}) - (0.5 \text{ in, set back}) = 3.5 \text{ in (89 mm)}$$

vertical weld leg length,

$$L_v = 1.5 \text{ in (2 ends)} + (3 \text{ in})(5 \text{ spaces}) = 18 \text{ in (457 mm)}$$

horizontal weld center,

$$n_w = L_h^2 / (2b + L_v) = (3.5 \text{ in})^2 / [2(3.5 \text{ in}) + 18 \text{ in}] = 0.49 \text{ in (12 mm)}$$

horizontal weld eccentricity,

$$c_h = L_h - n_w = (3.5 \text{ in}) - (0.49 \text{ in}) = 3.01 \text{ in (76 mm)}$$

vertical weld eccentricity,

$$c_v = L_v / 2 = (18 \text{ in}) / 2 = 9 \text{ in (229 mm)}$$

polar moment of inertia,

$$\begin{aligned} J_w &= [2L_h + L_v]^3 / 12 - L_h^2 [L_h + L_v]^2 / [2L_h + L_v] \\ &= [2(3.5 \text{ in}) + 18 \text{ in}]^3 / 12 - (3.5 \text{ in})^2 [3.5 \text{ in} + 18 \text{ in}]^2 / [2(3.5 \text{ in}) + 18 \text{ in}] \\ &= 1,076 \text{ in}^3 \text{ (17,632,481 mm}^3\text{)} \end{aligned}$$

torsional horizontal shear,

$$\begin{aligned} f_{vh} &= V_u (L - n_w)(c_v) / 2(J_w) \\ &= (255 \text{ k})(4 \text{ in} - 0.49 \text{ in})(9 \text{ in}) / 2(1,076 \text{ in}^3) \\ &= 3.74 \text{ k/in (0.65 kN/mm)} \end{aligned}$$

torsion vertical shear,

$$\begin{aligned} f_{v1} &= V_u (L - n_w)(c_h) / 2(J_w) \\ &= (255 \text{ k})(4 \text{ in} - 0.49 \text{ in})(3.01 \text{ in}) / 2(1,076 \text{ in}^3) \\ &= 1.25 \text{ k/in (0.22 kN/mm)} \end{aligned}$$

direct shear,

$$f_{v2} = V_u / 2[2L_h + L_v] = (255 \text{ k}) / 2[2(3.5 \text{ in}) + 18 \text{ in}] = 5.10 \text{ k/in (0.89 kN/mm)}$$

resultant,

$$\begin{aligned} R_u &= \sqrt{f_{vh}^2 + (f_{v1} + f_{v2})^2} = \sqrt{(3.74 \text{ k/in})^2 + (1.25 \text{ k/in} + 5.10 \text{ k/in})^2} \\ &= 7.59 \text{ k/in (1.33 kN/mm)} \end{aligned}$$

SIF (Weld) = 1.0 (conservative)

DIF (Weld) = 1.05

(Section 5.5.4)

weld capacity,

$$\begin{aligned} R_s &= 0.6(\text{SIF})(\text{DIF})(F_{EXX})(A_w) \\ &= 0.6(1.0)(1.05)(70 \text{ ksi})(0.375 \text{ in})(0.707) \\ &= 11.7 \text{ k/in (2.39 kN/mm)} > R_u, \text{ OK} \end{aligned}$$

11.11.3 Clip Angle Shear Strength

The critical section is a vertical plane at the bolt centerline.

Try:

L4x3.5x0.5

length = 1.5 in + 2(3 in) + 1.5 in = 18 in (457 mm)

ASTM A36 steel

gross section,

$$A_g = (2 \text{ angles})(0.5 \text{ in, thickness})(18 \text{ in, length}) = 18.0 \text{ in}^2 \quad (11,613 \text{ mm}^2)$$

bolt hole diameter,

(AISC 360, Table J3.3, Section D3)

$$d_h = (15/16 \text{ in, nominal hole}) + (1/16 \text{ in}) = 1.0 \text{ in} \quad (25 \text{ mm})$$

net section,

$$A_{nv} = (18.0 \text{ in}^2) - (2 \text{ angles})(6 \text{ holes})(1.0 \text{ in, diameter})(0.5 \text{ in, thickness}) \\ = 12.0 \text{ in}^2 \quad (7,742 \text{ mm}^2)$$

for dynamic shear,

$$F_{dy} = (\text{SIF})(\text{DIF})(F_y) = (1.1)(1.29)(36 \text{ ksi}) = 51.1 \text{ ksi} \quad (352 \text{ MPa}) \quad (\text{Appendix 5.A})$$

$$F_{du} = (\text{SIF})(\text{DIF})(F_u) = (1.1)(1.1)(58 \text{ ksi}) = 70 \text{ ksi} \quad (483 \text{ MPa})$$

shear yielding strength,

(AISC 360, Equation J4-3)

$$V_n = (0.6)(F_{dy})(A_g) = (0.6)(51.1 \text{ ksi})(18.0 \text{ in}^2) = 552 \text{ kips} \quad (2,455 \text{ kN}) > V_u, \quad \text{OK}$$

shear rupture strength,

(AISC 360, Equation J4-4)

$$V_n = (0.6)(F_{du})(A_{nv}) = (0.6)(70 \text{ ksi})(12.0 \text{ in}^2) = 504 \text{ kips} \quad (2,242 \text{ kN}) > V_u, \quad \text{OK}$$

11.11.4 Clip Angle Bearing Strength

clear distance between holes,

$$L_c = (1 \text{ bolt})[(1.5 \text{ in, edge}) - 0.5(1.0 \text{ in hole})] \\ + (5 \text{ bolts})[(3 \text{ in, spacing}) - (1.0 \text{ in, hole})] = 11.0 \text{ in} \quad (279 \text{ mm})$$

bearing strength,

(AISC 360, Equation J3-6a)

$$V_n = \min \text{ of } 1.2(L_c)(t_p)(F_{du}) \text{ or } 2.4(d_b)(t_p)(F_{du}) \\ = \min \text{ of } 1.2(11.0 \text{ in})(0.5 \text{ in} * 2 \text{ each})(70 \text{ ksi}) \\ \text{ or } 2.4(0.875 \text{ in} * 6 \text{ each})(0.5 \text{ in} * 2 \text{ each})(70 \text{ ksi}) \\ = \min \text{ of } 924 \text{ kips or } 882 \text{ kips} = 882 \text{ kips} \quad (3,923 \text{ kN}) > V_u, \quad \text{OK}$$

NOTE: The column flange thickness is greater and will not control bearing strength.

NOTE: For brevity, other failure modes such as block shear failure are omitted.

11.12 COLUMNS

The column is pinned at both ends.

length, $L = 12$ ft, or 144 in (3,658 mm)

11.12.1 Load Case A (parallel to roof girder)

from the Chapter 3 Appendix calculation,

$$P_{so} = 6 \text{ psi (41 kPa)}$$

$$q_o = 0.8 \text{ psi (6 kPa)}$$

$$t_d = 0.05 \text{ s}$$

$$C_d = -0.4$$

$$L_w = 792 \text{ in (20,117 mm)}$$

The blast loaded area tributary to an interior column is the girder span, $L = 384$ in (9,754 mm) by the girder spacing, $L_s = 216$ in (5,486 mm).

$$L_1 = L = 384 \text{ in (9,754 mm)}$$

equivalent load coefficient,

(Figure 3.9)

$$L_w / L_1 = (792 \text{ in}) / (384 \text{ in}) = 2.1, \text{ therefore } C_e = 0.7$$

equivalent peak overpressure,

(Equation 3.11)

$$P_a = C_e P_{so} + C_d q_o = (0.7)(6 \text{ psi}) + (-0.4)(0.8 \text{ psi}) = 3.88 \text{ psi (26.8 kPa)}$$

equivalent peak load,

$$F_o = (P_a)(L)(L_s) = (3.88 \text{ psi})(384 \text{ in})(216 \text{ in}) / (1,000 \text{ lb/k}) = 321.8 \text{ kips (1,431 kN)}$$

rise time,

$$t_r = L_1 / U = (32 \text{ ft}) / (1,312 \text{ ft/s}) = 0.024 \text{ s}$$

time of duration,

$$t_d = 0.05 \text{ s}$$

11.12.2 Load Case B (parallel to roof beam)

$$L_1 = L_s = 216 \text{ in (5,486 mm)}$$

equivalent load coefficient,

(Figure 3.9)

$$L_w / L_1 = (792 \text{ in}) / (216 \text{ in}) = 3.7, \text{ therefore } C_e = 0.85$$

equivalent peak overpressure,

(Equation 3.11)

$$P_a = C_e P_{so} + C_d q_o = (0.85)(6 \text{ psi}) + (-0.4)(0.8 \text{ psi}) = 4.78 \text{ psi (33.0 kPa)}$$

equivalent peak load,

$$F_o = (P_a)(L)(L_s) = (4.78 \text{ psi})(384 \text{ in})(216 \text{ in}) / (1,000 \text{ lb/k}) = 396.5 \text{ kips (1,764 kN)}$$

rise time,

$$t_r = L_1 / U = (18 \text{ ft}) / (1,312 \text{ ft/s}) = 0.014 \text{ s}$$

time of duration,
 $t_d = 0.05$ s

11.12.3 Trial Size W10x77 (AISC Manual)

area, $A_s = 22.6$ in² (14,581 mm²) flange width/thickness, $b_f/2t_f = \lambda_f = 5.86$
 radius of gyration, $r_y = 2.60$ in (66 mm) web depth/thickness, $h/t_w = \lambda_w = 14.8$

11.12.4 Compute Compression Resistance

for dynamic compression, (Appendix 5.A)
 $F_{ds} = F_{dy} = (SIF)(DIF) F_y = (1.1)(1.12) 50$ ksi = 61.6 ksi (425 MPa)

Because columns are considered primary members, width-thickness ratios need to meet AISC seismic requirements.

check flange, (AISC 341, Table I-8-1)
 $\lambda_{ps} = 0.3 \sqrt{E_s/F_{ds}} = 0.3 \sqrt{(29,000 \text{ ksi})/(61.6 \text{ ksi})} = 6.5 > \lambda_f$, OK

check web, (AISC 341, Table I-8-1)
 $\lambda_{ps} = 1.49 \sqrt{E_s/F_{ds}} = 1.49 \sqrt{(29,000 \text{ ksi})/(61.6 \text{ ksi})} = 32.3 > \lambda_w$, OK

slenderness ratio, (AISC 360, Section E2)
 $K_y L/r_y = (1.0)(144 \text{ in}) / (2.60 \text{ in}) = 55 < 200$, OK

$\lambda_c = 4.71 \sqrt{E_s/F_{ds}} = 4.71 \sqrt{(29,000 \text{ ksi})/(61.6 \text{ ksi})} = 102$ (AISC 360, Section E3)

$F'_e = \pi^2 E_s / (K_y L / r_y)^2 = \pi^2 (29,000 \text{ ksi}) / 55^2 = 94.6$ ksi (652 MPa)

compression stress (based on $K_y L/r_y < \lambda_c$), (AISC 360, Equation E3-2)
 $f_{cr} = (0.658)^{(F_{ds}/F'_e)} (F_{ds}) = (0.658)^{(61.6/94.6)} (61.6 \text{ ksi}) = 46.9$ ksi (323 MPa)

compression capacity, (AISC 360, Equation E3-1)
 $P_{nc} = A_s (f_{cr}) = (22.6 \text{ in}^2)(46.9 \text{ ksi}) = 1,060$ kips (4,715 kN)

11.12.5 Compute Tension Resistance

for dynamic tension, (Appendix 5.A)
 $F_{ds} = F_{dy} = (SIF)(DIF) F_y = (1.1)(1.12) 50$ ksi = 61.6 ksi (425 MPa)

tensile capacity, (AISC 360, Equation D2-1)
 $P_{nt} = A_s (F_{ds}) = (22.6 \text{ in}^2)(61.6 \text{ ksi}) = 1,392$ kips (6,192 kN)

11.12.6 Resistance & Permissible Response

positive resistance, $R_u = P_{nc} = 1,060$ kips (4,635 kN)

rebound resistance, $R_{ur} = -P_{nt} = -1,392 \text{ kips } (-6,192 \text{ kN})$

Table 5.B.2 does not cover cases of pure compression. Conservatively use an elastic response.

allowable ductility ratio, $\mu_a = 1.0$

allowable support rotation, $\theta_a = \text{not applicable due to lack of lateral deflection}$

11.12.7 Compute SDOF Equivalent System

roof slab = $(18 \text{ ft})(32 \text{ ft}) [(0.075 \text{ ksf slab}) + (0.025 \text{ ksf})] = 57.6 \text{ kips } (256 \text{ kN})$

beam weight = $(4 \text{ ea}) (0.026 \text{ klf}) (18 \text{ ft}) = 1.9 \text{ kips } (8.5 \text{ kN})$

girder weight = $(0.147 \text{ klf}) (32 \text{ ft}) = 4.7 \text{ kips } (20.9 \text{ kN})$

column weight = $(0.077 \text{ klf}) (12 \text{ ft}) / 2 = 0.46 \text{ kips } (2.0 \text{ kN})$

static load = (roof slab) + (beam) + (girder) + (column)
 $= (57.6 \text{ k}) + (1.9 \text{ k}) + (4.7 \text{ k}) + (0.46 \text{ k}) = 64.7 \text{ kips } (288 \text{ kN})$

stiffness,
 $K = (A_s)(E_s) / L = (22.6 \text{ in}^2)(29,000 \text{ ksi}) / (144 \text{ in}) = 4,551 \text{ k/in } (797 \text{ kN/mm})$

column mass,
 $M = [(\text{roof}) + (\text{beam}) + (\text{girder}) + (\text{column})] / g$
 $= [57.6 \text{ kips} + 1.9 \text{ kips} + 4.7 \text{ kips} + 0.46 \text{ kips}] / (386 \text{ in/s}^2)$
 $= 0.168 \text{ k-s}^2/\text{in } (0.029 \text{ kN-s}^2/\text{mm})$

The column is already a SDOF system, therefore no transformation factors will be applied.

period of vibration, (Equation 6.8)

$$t_n = 2 \pi \sqrt{M/K} = 2 \pi \sqrt{(0.168 \text{ k-s}^2/\text{in}) / (4,551 \text{ k/in})} = 0.038 \text{ s}$$

11.12.8 Numerical Integration Solution (load case A)

$F_o = 321.8 \text{ kips } (1,431 \text{ kN})$

$t_r = 0.024 \text{ s}$

$t_d = 0.05 \text{ s}$

use time increment = $t_n / 10 = 0.0038$, say 0.004 s

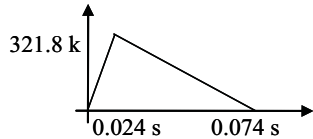

The calculated time increment of 0.004 seconds appears to be adequately short to properly define the dynamic load.

TABLE 11.11: Column Numerical Integration

Analysis Case Description:		Chapter 11, Section 11.12.8, column, case A										
Dynamic Loading Description:		if(time<=0.024,321.8*time/0.024,max(321.8-321.8*(time-0.024)/0.05,0))										
time increment =	0.004	s	KEY = 0 is elastic						Z = 1 is increasing plastic deformation			
mass =	0.168	k-s ² /in	KEY = +1 is positive plastic						Z = 2 is end of rebound plastic deformation			
stiffness =	4551	k/in	KEY = -1 is rebound plastic						Z = 3 is end of positive plastic deformation			
damping =	0	k-s/in							Z = 4 is continued elastic			
positive resistance =	1060	kips							Z = 5 is start of rebound plastic deformation			
rebound resistance =	-1392	kips							Z = 6 is start of positive plastic deformation			
static load =	64.7	kips										
time (s)	Dyn. Load (kips)	y (in)	v (in/s)	a (in/s ²)	ye+ (in)	ye- (in)	KEY	eff K (k/in)	incr F (kips)	incr y (in)	incr v (in/s)	Z
0.000	0.00	0.014	0.00	0	0.233	-0.306	0	67,551	54	0.001	0.60	
0.004	53.63	0.015	0.60	298	0.233	-0.306	0	67,551	354	0.005	1.55	4
0.008	107.27	0.020	2.14	475	0.233	-0.306	0	67,551	833	0.012	1.87	4
0.012	160.90	0.033	4.01	460	0.233	-0.306	0	67,551	1,297	0.019	1.44	4
0.016	214.53	0.052	5.45	260	0.233	-0.306	0	67,551	1,559	0.023	0.43	4
0.020	268.17	0.075	5.88	-46	0.233	-0.306	0	67,551	1,512	0.022	-0.76	4
0.024	321.80	0.097	5.12	-333	0.233	-0.306	0	67,551	1,097	0.016	-2.52	4
0.028	296.06	0.113	2.60	-926	0.233	-0.306	0	67,551	163	0.002	-4.14	4
0.032	270.31	0.116	-1.54	-1,145	0.233	-0.306	0	67,551	-991	-0.015	-4.09	4
0.036	244.57	0.101	-5.63	-901	0.233	-0.306	0	67,551	-1,899	-0.028	-2.39	4
0.040	218.82	0.073	-8.02	-292	0.233	-0.306	0	67,551	-2,194	-0.032	0.28	4
0.044	193.08	0.041	-7.74	434	0.233	-0.306	0	67,551	-1,756	-0.026	2.84	4
0.048	167.34	0.015	-4.90	985	0.233	-0.306	0	67,551	-763	-0.011	4.25	4
0.052	141.59	0.003	-0.65	1,138	0.233	-0.306	0	67,551	384	0.006	3.94	4
0.056	115.85	0.009	3.29	831	0.233	-0.306	0	67,551	1,221	0.018	2.04	4
0.060	90.10	0.027	5.32	188	0.233	-0.306	0	67,551	1,411	0.021	-0.69	4
0.064	64.36	0.048	4.64	-531	0.233	-0.306	0	67,551	875	0.013	-3.13	4
0.068	38.62	0.061	1.50	-1,035	0.233	-0.306	0	67,551	-168	-0.002	-4.31	4
0.072	12.87	0.058	-2.81	-1,121	0.233	-0.306	0	67,551	-1,285	-0.019	-3.61	4
0.076	0.00	0.039	-6.41	-682	0.233	-0.306	0	67,551	-1,960	-0.029	-1.16	4
0.080	0.00	0.010	-7.57	104	0.233	-0.306	0	67,551	-1,855	-0.027	1.90	4
0.084	0.00	-0.017	-5.67	848	0.233	-0.306	0	67,551	-1,001	-0.015	4.19	4
0.088	0.00	-0.032	-1.47	1,249	0.233	-0.306	0	67,551	259	0.004	4.79	4
0.092	0.00	-0.028	3.32	1,146	0.233	-0.306	0	67,551	1,413	0.021	3.45	4

For the numerical integration, refer to Table 11.11.

The peak positive deflection is at $t = 0.032$ s,

$$y_m = +0.116 \text{ in (2.9 mm)}$$

$$\mu_d = 0.50 < \mu_{as}, \text{ OK}$$

The peak rebound deflection is at $t = 0.088$ s,

$$y_m = -0.032 \text{ in (0.1 mm)}$$

$$\mu_d = 0.10 < \mu_{as}, \text{ OK}$$

11.12.9 Numerical Integration Solution (load case B)

$$F_o = 396.5 \text{ kips (1,764 kN)}$$

$$t_r = 0.014 \text{ s}$$

$$t_s = 0.05 \text{ s}$$

$$\text{time increment} = t_n / 10 = 0.0038 \text{ s}$$

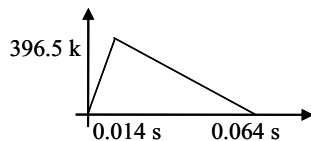

TABLE 11.12: Column Numerical Integration

Analysis Case Description:		Chapter 11, Section 11.12.9, column, case B										
Dynamic Loading Description:		if(time<=0.014,396.5*time/0.014,max(396.5-396.5*(time-0.014)/0.05,0))										
time increment =	0.0035	s	KEY = 0 is elastic						Z = 1 is increasing plastic deformation			
mass =	0.168	k-s ² /in	KEY = +1 is positive plastic						Z = 2 is end of rebound plastic deformation			
stiffness =	4551	k/in	KEY = -1 is rebound plastic						Z = 3 is end of positive plastic deformation			
damping =	0	k-s/in							Z = 4 is continued elastic			
positive resistance =	1060	kips							Z = 5 is start of rebound plastic deformation			
rebound resistance =	-1392	kips							Z = 6 is start of positive plastic deformation			
static load =	64.7	kips										
time (s)	Dyn. Load (kips)	y (in)	v (in/s)	a (in/s ²)	ye+ (in)	ye- (in)	KEY	eff K (k/in)	incr F (kips)	incr y (in)	incr v (in/s)	Z
0.000	0.00	0.014	0.00	0	0.233	-0.306	0	86,837	99	0.001	0.98	
0.004	99.13	0.015	0.98	559	0.233	-0.306	0	86,837	663	0.008	2.63	4
0.007	198.25	0.023	3.61	942	0.233	-0.306	0	86,837	1,613	0.019	3.45	4
0.011	297.38	0.042	7.06	1,029	0.233	-0.306	0	86,837	2,650	0.031	3.19	4
0.014	396.50	0.072	10.25	793	0.233	-0.306	0	86,837	3,322	0.038	0.67	4
0.018	368.75	0.110	10.92	-409	0.233	-0.306	0	86,837	2,910	0.034	-3.31	4
0.021	340.99	0.144	7.61	-1,482	0.233	-0.306	0	86,837	1,416	0.016	-6.25	4
0.025	313.24	0.160	1.36	-2,089	0.233	-0.306	0	86,837	-690	-0.008	-7.22	4
0.028	285.48	0.152	-5.87	-2,039	0.233	-0.306	0	86,837	-2,745	-0.032	-5.93	4
0.032	257.73	0.121	-11.79	-1,348	0.233	-0.306	0	86,837	-4,104	-0.047	-2.77	4
0.035	229.97	0.073	-14.56	-233	0.233	-0.306	0	86,837	-4,339	-0.050	1.26	4
0.039	202.22	0.023	-13.30	955	0.233	-0.306	0	86,837	-3,376	-0.039	4.90	4
0.042	174.46	-0.015	-8.40	1,843	0.233	-0.306	0	86,837	-1,518	-0.017	6.99	4
0.046	146.71	-0.033	-1.41	2,151	0.233	-0.306	0	86,837	651	0.007	6.89	4
0.049	118.95	-0.025	5.48	1,783	0.233	-0.306	0	86,837	2,448	0.028	4.62	4
0.053	91.19	0.003	10.09	854	0.233	-0.306	0	86,837	3,309	0.038	0.89	4
0.056	63.44	0.041	10.99	-343	0.233	-0.306	0	86,837	2,963	0.034	-3.11	4
0.060	35.68	0.075	7.88	-1,433	0.233	-0.306	0	86,837	1,519	0.017	-6.13	4
0.063	7.93	0.092	1.74	-2,072	0.233	-0.306	0	86,837	-550	-0.006	-7.03	4
0.067	0.00	0.086	-5.29	-1,948	0.233	-0.306	0	86,837	-2,505	-0.029	-5.45	4
0.070	0.00	0.057	-10.74	-1,166	0.233	-0.306	0	86,837	-3,681	-0.042	-2.07	4
0.074	0.00	0.015	-12.81	-18	0.233	-0.306	0	86,837	-3,699	-0.043	1.96	4
0.077	0.00	-0.028	-10.85	1,136	0.233	-0.306	0	86,837	-2,554	-0.029	5.37	4
0.081	0.00	-0.057	-5.49	1,933	0.233	-0.306	0	86,837	-606	-0.007	7.09	4
0.084	0.00	-0.064	1.61	2,122	0.233	-0.306	0	86,837	1,533	0.018	6.59	4
0.088	0.00	-0.046	8.20	1,643	0.233	-0.306	0	86,837	3,189	0.037	4.01	4

The calculated time increment of 0.0038 seconds does not appear to be adequately short to properly define the dynamic load. Thus an increment of one quarter of the rise time (0.0035) is used.

NOTE: With a spreadsheet numerical integration, the time increment can quickly be varied in order to provide a consistent response without an overly lengthy number of increments.

For the numerical integration, refer to Table 11.12.

The peak positive deflection is at t = 0.025 s,

$$y_m = +0.160 \text{ in (4.1 mm)}$$

$$\mu_d = 0.69 < \mu_a, \text{ OK}$$

The peak rebound deflection is at t = 0.084 s,

$$y_m = -0.064 \text{ in (1.6 mm)}$$

$$\mu_d = 0.21 < \mu_a, \text{ OK}$$

maximum demand / permissible = 0.69 / 1.0 = 0.69 USE assumed column size

11.13 COLUMN BASE PLATE AND ANCHOR BOLT DESIGN

A bolted base plate connects the column to the foundation.

column compression resistance,
 $R_u = 527.36$ kips (2346 kN) at $t = 0.032$ s

column tension resistance,
 $R_{ut} = 149.23$ kips (664 kN) at $t = 0.128$ s

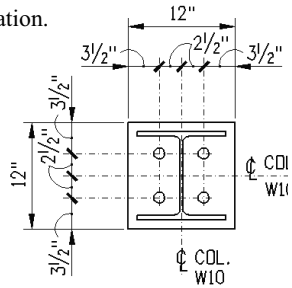

11.13.1 Anchor Bolt Design

try:

4 each, 1.5 in (38 mm) diameter bolts
 ASTM A307, $F_{nt} = 45$ ksi (310 ksi)

(AISC 360, Table J3.2)

SIF (A307 Anchor Bolt) = 1.0 (conservative)

DIF (A307 Anchor Bolt) = 1.05

(Section 5.5.4)

nominal bolt area,

$$A_b = \pi (1.5 \text{ in})^2 / 4 = 1.77 \text{ in}^2 \text{ (1140 mm}^2\text{)}$$

(AISC Manual, Table 7-18)

bolt tensile strength,

$$\begin{aligned} R_n &= (SIF)(DIF)(F_{nt})(A_b)(N) \\ &= (1.0)(1.05)(45 \text{ ksi})(1.77 \text{ in}^2)(4 \text{ bolts}) \\ &= 335 \text{ kips (1490 kN)} > R_{ut}, \text{ OK} \end{aligned}$$

(AISC 360, Equation J3-1)

11.13.2 Base Plate Design

try:

12 inch (305 mm) square plate
 thickness, $t_p = 1.0$ in (25 mm)
 ASTM A36 steel

for dynamic bending,

$$F_{ds} = F_{dy} = (SIF)(DIF)(F_y) = (1.1)(1.29)(36 \text{ ksi}) = 51.1 \text{ ksi (352 kPa)}$$

(Appendix 5.A)

Column W10X77,

$d = 10.0$ in (254 mm)

$b_f = 10.2$ in (259 mm)

$t_w = 0.53$ in (13.5 mm)

$t_f = 0.87$ in (22.1 mm)

(AISC Manual)

Condition 1: Column Tension on Base Plate

(AISC Guide)

select the appropriate equation from $\sqrt{2} b_f = \sqrt{2} (10.2 \text{ in}) = 14.4 \text{ in} > d = 10.0 \text{ in}$

$$t_{p \text{ reqd}} = \sqrt{\frac{R_u - g_b d}{F_y [d^2 + 2b_f^2]}} = \sqrt{\frac{(149.23 \text{ k})(5 \text{ in})(10 \text{ in})}{(51.1 \text{ ksi})[(10 \text{ in})^2 + 2(10.2 \text{ in})^2]}} = 0.69 \text{ in} < t_p, \text{ OK}$$

Condition 2: Column Compression on Base Plate (AISC Manual, Page 14-4)

base plate dimensions,

$$N_p = B_p = 12 \text{ in} \quad (305 \text{ mm})$$

$$m_1 = [N_p - 0.95 d] / 2 = [(12 \text{ in}) - 0.95(10.6 \text{ in})] / 2 = 0.97 \text{ in} \quad (25 \text{ mm})$$

$$n_1 = [B_p - 0.8 b_f] / 2 = [(12 \text{ in}) - 0.8(10.2 \text{ in})] / 2 = 1.92 \text{ in} \quad (49 \text{ mm})$$

$$n' = \sqrt{d b_f} / 4 = \sqrt{(10.6 \text{ in})(10.2 \text{ in})} / 4 = 2.6 \text{ in} \quad (66 \text{ mm})$$

conservatively using $P_u / P_p = 1.0$

$$\begin{aligned} X &= \{4(d)(b_f) / [d + b_f]^2\} (P_u / P_p) \\ &= \{4(10 \text{ in})(10.2 \text{ in}) / [(10 \text{ in}) + (10.2 \text{ in})]^2\} (1.0) \\ &= 1.0 \end{aligned}$$

$$\lambda_{bp} = \frac{2\sqrt{X}}{1 + \sqrt{1 - X}} = \frac{2\sqrt{1}}{1 + \sqrt{1 - 1}} = 2.0 \leq 1.0, \text{ therefore } \lambda = 1.0$$

$$\lambda_{bp} n' = (1.0)(2.6 \text{ in}) = 2.6 \text{ in} \quad (66 \text{ mm})$$

$$L = \text{largest of } m_1, n_1, \lambda_{bp} n' = 2.6 \text{ in} \quad (66 \text{ mm})$$

substituting R_u for P_u ,

$$\begin{aligned} t_{p, \text{ min}} &= L \sqrt{\frac{2(R_u)}{\phi(F_{ds})(B_p)(N_p)}} = (2.6 \text{ in}) \sqrt{\frac{2(527.36 \text{ k})}{1.0(51.1 \text{ ksi})(12 \text{ in})(12 \text{ in})}} \\ &= 0.98 \text{ in} \quad (25 \text{ mm}) < t_p, \text{ OK} \end{aligned}$$

Condition 3: Column Compression on Foundation Pier (ACI, Section 10.17)

Use 30 in (762 mm) square pier size for interior column

for concrete compression,

(Appendix 5.A)

$$f_{ds} = (\text{SIF})(\text{DIF})(f_c) = (1.0)(1.12)(4,000 \text{ psi}) = 4,480 \text{ psi} \quad (31.9 \text{ MPa})$$

$$A_1 = (B_p)(N_p) = (12 \text{ in})(12 \text{ in}) = 144 \text{ in}^2 \quad (92,903 \text{ mm}^2)$$

$$A_2 = (30 \text{ in})^2 = 900 \text{ in}^2 \quad (580,644 \text{ mm}^2)$$

bearing modification factor,

(ACI 318, Section 10.17)

$$\sqrt{A_2 / A_1} = \sqrt{(900 \text{ in}^2) / (144 \text{ in}^2)} = 2.5, \text{ therefore use maximum value of } 2.0$$

concrete bearing strength, (ACI 318, Section 10.17)

$$\begin{aligned} R_n &= (0.85)(f_{ds})(A_1) \sqrt{A_2 / A_1} \\ &= 0.85(4.48 \text{ ksi})(144 \text{ in}^2)(2.0) \\ &= 1,097 \text{ kips } (4,878 \text{ kN}) > R_u, \text{ OK} \end{aligned}$$

11.13.3 Column and Base Plate Weld Design

try:

5/16 in (8 mm) fillet weld

E70 Electrode, $F_{EXX} = 70 \text{ ksi } (483 \text{ kPa})$

SIF (Weld) = 1.0 (conservative)

DIF (Weld) = 1.05 (Section 5.5.4)

nominal weld strength, (AISC 360, Table J2.5)

$$F_w = 0.6(\text{SIF})(\text{DIF})(F_{EXX}) = 0.6(1.0)(1.05)(70 \text{ ksi}) = 44.1 \text{ ksi } (304 \text{ MPa})$$

effective weld area,

$$\begin{aligned} A_w &= [(b_f)(4 \text{ sides}) - (t_w)(2 \text{ sides}) + (2 \text{ sides})(d)] (\text{weld size})(0.707) \\ &= [(10.2 \text{ in})(2 \text{ sides}) - (0.52 \text{ in})(2 \text{ sides}) + (2 \text{ sides})(10 \text{ in})] (5/16 \text{ in})(0.707) \\ &= 8.70 \text{ in}^2 (5,610 \text{ mm}^2) \end{aligned}$$

Fillet Weld Effective Strength (AISC 360, Equation J2-3)

$$R_n = (F_w)(A_w) = (44.1 \text{ ksi})(8.7 \text{ in}^2) = 384 \text{ kips } (1,708 \text{ kN}) > R_u, \text{ OK}$$

minimum weld size for 1 in (25 mm) base plate = 5/16 in (8 mm)(AISC 360, Table J2.4)

11.14 FOUNDATION

The following design represents one way of handling a foundation for this situation. Other design options might include a combination of vertical piles and passive resistance. The Equivalent-Static Design Method will be used as described in Section 7.7.1.

Precast concrete piles will be used with an allowable compression force of 80 kips (356 kN) and an allowable tension force of 50 kips (222 kN), both with a safety factor of 3 against ultimate capacity. Because battered piles will resist all lateral forces without the need for passive soil pressure, a safety factor of 1.2 may be used. Permissible blast capacities will be adjusted accordingly.

permissible compression,

$$P_c = (80 \text{ kips}) (3/1.2) = 200 \text{ kips } (890 \text{ kN})$$

permissible tension,

$$P_t = (50 \text{ kips}) (3 / 1.2) = 125 \text{ kips } (556 \text{ kN})$$

Pile batter will be 3 horizontal to 12 vertical.

$$\text{resultant axial dimension} = \sqrt{3^2 + 12^2} = 12.4$$

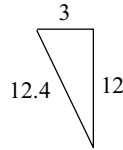

11.14.1 Load Case A (applied to long side of building)

Several methods are available to determine peak loads for the static design of the foundation. Such methods may be determined from the blast pressure applied to the building, the bending or shear capacities of supported structural elements, or dynamic reactions of supported elements. In this example, loads are determined based on the least of the applied load and the capacity of components directly supported by the foundation.

applied peak reflected overpressure, (Appendix 3)

$$V = (13.8 \text{ psi})(12 \text{ ft height})(92.67 \text{ ft width})(144 / 1000 \text{ ksf/psi}) \\ = 2,210 \text{ kips} \quad (9,831 \text{ kN})$$

from front wall capacity, (Section 11.4.7)

$$V = (21.44 \text{ klf})(92.67 \text{ feet}) = 1,987 \text{ kips} \quad (8,839 \text{ kN})$$

from roof slab (in-plane) capacity, (Section 11.5.6)

$$V = 3,194 \text{ kips} \quad (14,208 \text{ kN})$$

from side wall (in-plane) capacity, (Section 11.6.6)

$$V = (1,113 \text{ kips})(2 \text{ walls}) = 2,226 \text{ kips} \quad (9,902 \text{ kN})$$

from peak roof overpressure, (Appendix 3)

$$P = (5.1 \text{ psi})(66.67 \text{ ft} * 92.67 \text{ ft}) (144 / 1000 \text{ ksf/psi}) = 4,537 \text{ kips} \quad (20,182 \text{ kN})$$

from roof (out-of-plane) capacity, (Section 11.7.6)

$$P = (9.7 \text{ kips})(66.67 \text{ ft} * 92.67 \text{ ft}) / (8 \text{ ft} * 1 \text{ ft}) = 7,491 \text{ kips} \quad (33,322 \text{ kN})$$

from roof beam capacity, (Section 11.8.6)

$$P = (97.5 \text{ kips})(66.67 \text{ ft} * 92.67 \text{ ft}) / (18 \text{ ft} * 8 \text{ ft}) = 4,183 \text{ kips} \quad (18,607 \text{ kN})$$

from girder capacity, (Section 11.10.6)

$$P = (509 \text{ kips})(66.67 \text{ ft} * 92.67 \text{ ft}) / (32 \text{ ft} * 18 \text{ ft}) = 5,460 \text{ kips} \quad (24,287 \text{ kN})$$

from column capacity, (Section 11.12.6)

$$P = (1,060 \text{ kips})(66.67 \text{ ft} * 92.67 \text{ ft}) / (32 \text{ ft} * 18 \text{ ft}) = 11,370 \text{ kips} \quad (50,576 \text{ kN})$$

least lateral blast load = 1,987 kips (8,839 kN) from front wall capacity

least vertical blast load is 4,183 kips (18,607 kN) from roof beam capacity

11.14.2 Load Case B (applied to short side of building)

This case will not control.

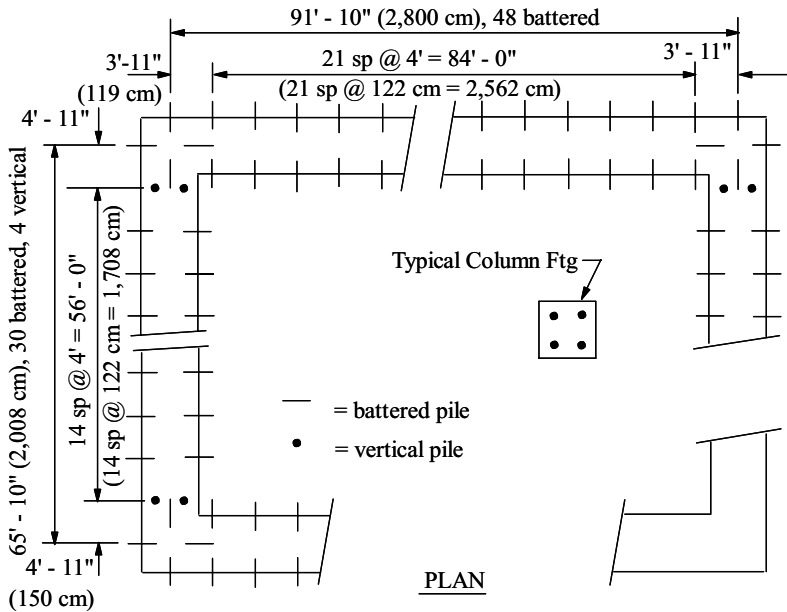

FIGURE 11.3: Foundation Plan

11.14.3 Layout

The floor slab will be designed to act as a diaphragm to evenly spread lateral forces to all piles battered in the direction of loading (refer to Figure 11.3). For load distribution purposes, the foundation is presumed infinitely stiff in comparison to the stiffness of piles in soil.

11.14.4 Lateral Load on Battered Piles

For loading case A (blast on long side of building), there are 48 pair of battered piles resisting blast loads.

lateral component of battered pile,
 $R_{HORIZ} = (1,987 \text{ k}) / (2 * 48 \text{ pair}) = 20.7 \text{ kips} \quad (92 \text{ kN})$

axial component of battered pile,
 $R_1 = (20.7 \text{ k}) (12.4 / 3) = 86 \text{ kips} \quad (383 \text{ kN})$

11.14.5 Front Wall Foundation

Analyze an 8 foot long (2,438 mm) section of wall with 4 piles.

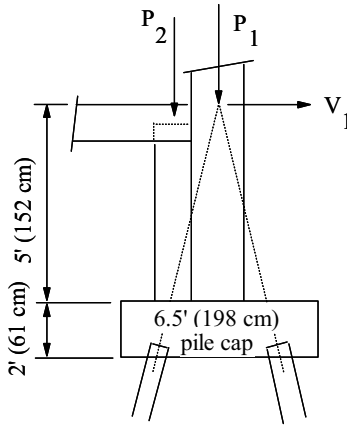

FIGURE 11.4: Side Wall Elevation

Neglect any small eccentricities involving P_2 or the slab weight.

static load from concrete wall,

$$P_1 = \text{wall weight} + \text{pile cap weight} + \text{soil weight} + \text{slab weight} = 53.8 \text{ kips} \quad (239 \text{ kN})$$

static load from steel column,

$$\begin{aligned} P_{2 \text{ STATIC}} &= \text{pier weight} + \text{side column roof load} && (\text{Sect } 11.12.7) \\ &= 0.9 \text{ kips} + (64.7 \text{ kips}) / 2 \\ &= 33.3 \text{ kips} \quad (148 \text{ kN}) \end{aligned}$$

blast load on a side column,

$$P_{2 \text{ BLAST}} = (4,183 \text{ k})(32 \text{ ft} * 9 \text{ ft}) / (66.67 \text{ ft} * 92.67 \text{ ft}) = 195 \text{ kips} \quad (867 \text{ kN})$$

total load on a side column,

$$P_{2 \text{ TOTAL}} = (33.3 \text{ k}) + (195 \text{ k}) = 228.3 \text{ kips} \quad (1,015 \text{ kN})$$

maximum axial pile load,

$$\begin{aligned} R_{\text{MAX}} &= (R_1) + (12.4 / 12) [P_1 + P_{2 \text{ TOTAL}}] / (\text{piles}) \\ &= (83 \text{ k}) + (12.4 / 12) [(53.8 \text{ k} + 228.3 \text{ k}) / (4 \text{ ea})] \\ &= 156 \text{ kips} \quad (694 \text{ kN}) < P_c, \text{ OK} \end{aligned}$$

Because reinforcing is determined using conventional equations, the details of this procedure are omitted for brevity.

11.14.6 Side Wall Foundation

$$N \text{ (number of piles)} = 38$$

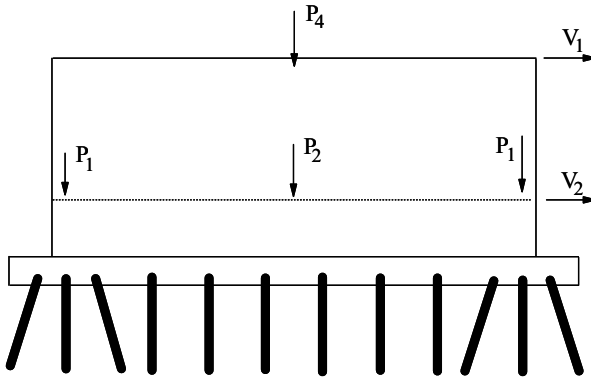

FIGURE 11.5: End Wall Elevation

distance from centerline to outer pile,
 $c_1 = (65' 10") / 2 = 32.92 \text{ ft}$

moment of inertia,

$$I = \Sigma(\text{area})(\text{distance})^2$$

$$= (4 \text{ piles})[(4 \text{ ft})^2 + (8 \text{ ft})^2 + (12 \text{ ft})^2 + (16 \text{ ft})^2 + (20 \text{ ft})^2 + (24 \text{ ft})^2 + (28 \text{ ft})^2]$$

$$+ (8 \text{ piles})(32.92 \text{ ft})^2$$

$$= 17,630 \text{ ft}^4 \quad (152.17 \text{ m}^4)$$

corner column static load,

$$P_{1 \text{ STATIC}} = 64.7 \text{ kips} * (\text{say } 0.25) = 16.2 \text{ kips} \quad (72 \text{ kN})$$

(Section 11.12.7)

corner column tributary blast load,

$$P_{1 \text{ BLAST}} = (4,183 \text{ k})(16 \text{ ft} * 9 \text{ ft}) / (66.67 \text{ ft} * 92.67 \text{ ft}) = 97.5 \text{ kips} \quad (434 \text{ kN})$$

corner column pier weight

$$P_{1 \text{ PIER}} = 0.9 \text{ kips} \quad (4.0 \text{ kN})$$

$$P_{1 \text{ TOTAL}} = (16.2 \text{ k}) + (97.5 \text{ k}) + (0.9 \text{ k}) = 114.6 \text{ kips} \quad (510 \text{ kN})$$

for side column, (use results from P₂, front wall calc)

$$P_{2 \text{ TOTAL}} = 228.3 \text{ kips} \quad (1,016 \text{ kN})$$

side column weight of wall and pile cap, (detailed calc omitted for brevity)

$$P_{3 \text{ WALL}} = 478 \text{ kips} \quad (2,126 \text{ kN})$$

lateral blast load at roof,

$$V_1 = (1,926 \text{ k})(6 \text{ ft} * 66.67 \text{ ft}) / (12 \text{ ft} * 66.67 \text{ ft}) = 963 \text{ kips} \quad (4,284 \text{ kN})$$

lateral blast load at floor,

$$V_2 = (V_1) - (4 \text{ battered piles at shear wall})(R_{\text{HORIZ}}) \\ = (963 \text{ k}) - (4 \text{ each})(20.1 \text{ k}) = 883 \text{ kips} \quad (3928 \text{ kN})$$

total vertical downward load,

$$P_5 = (2 \text{ each})(P_{1 \text{ TOTAL}}) + (P_{2 \text{ TOTAL}}) + (P_{3 \text{ WALL}}) \\ = (2 \text{ each})(114.6 \text{ k}) + (228.3 \text{ k}) + (478 \text{ k}) \\ = 935.5 \text{ kips} \quad (4,161 \text{ kN})$$

overturning moment at top of piles,

$$M_1 = (V_1) (\text{roof \& fdn height}) + (V_2)(\text{fdn height}) \\ = (963 \text{ k})(19 \text{ ft}) + (883 \text{ k})(7 \text{ ft}) = 24,478 \text{ k-ft} \quad (33,188 \text{ kN-m})$$

pile maximum axial compression,

$$R_{\text{MAX}} = R_1 + [(P_5 / N) + (M_1)(c_1) / I] (12.4 / 12) \\ = (86 \text{ k}) + [(935.5 \text{ k}) / (38 \text{ ea}) + (24,478 \text{ ft-k})(32.92 \text{ ft}) / (17,630 \text{ ft}^4)] (12.4 / 12) \\ = 159 \text{ kips} \quad (707 \text{ kN}) < P_c, \text{ OK}$$

maximum axial tension,

$$R_{\text{MIN}} = R_1 + [(P_5 / N) - (M_1)(c_1) / I] (12.4 / 12) \\ = (86 \text{ k}) + [(935.5 \text{ k}) / (38 \text{ ea}) - (24,478 \text{ ft-k}) (32.92 \text{ ft}) / (17,630 \text{ ft}^4)] (12.4 / 12) \\ = +64 \text{ kips} \quad (285 \text{ kN}), \text{ no tension, OK}$$

Because reinforcing is determined using conventional equations, the details of this procedure are omitted for brevity.

11.14.7 Column Foundation

Individual column foundations consist of a pier, pile cap, and four vertical piles,

$$N = 4$$

interior column static load,

$$P_1 = \text{roof load, weight of pier, pile cap, and soil} \\ = 56.4 \text{ kips} \quad (251 \text{ kN})$$

interior column tributary blast load,

$$P_2 = (4,183 \text{ k})(32 \text{ ft} * 18 \text{ ft}) / (66.67 \text{ ft} * 92.67 \text{ ft}) = 390 \text{ kips} \quad (1,735 \text{ kN})$$

maximum pile compression,

$$R_{\text{MAX}} = [P_1 + P_2] / N \\ = [(56.4 \text{ k}) + (390 \text{ k})] / (4 \text{ ea}) \\ = 111.6 \text{ kips} \quad (496 \text{ kN}) < P_c, \text{ OK}$$

Because reinforcing is determined using conventional equations, the details of this procedure are omitted for brevity.

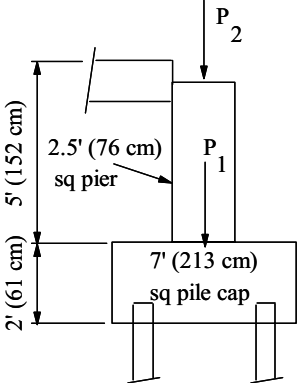

FIGURE 11.6: Column Foundation

CHAPTER 12

METAL BUILDING DESIGN EXAMPLE

12.1 INTRODUCTION

The following is a sample blast design for a control building using metal cladding, a structural steel frame, and a spread footing type foundation. Because of the relatively thin metal cladding, this building represents an example of neutral risk philosophy.

In this example, blast loads and dynamic properties are computed on a unit area basis in contrast to Chapter 11 calculations.

Structural code provisions, as applicable, are from,

- AISC 360-05, *Specification for Structural Steel Buildings*

Additional references are,

- Biggs, *Introduction to Structural Dynamics*
- AISC Manual, *AISC Manual of Steel Construction*

For brevity, evaluation of conventional loads is not included in this example.

Design of blast doors are not included in this example.

12.2 STRUCTURAL SYSTEM

The structure in this example is of Metal Clad Construction as described in Section 4.3.3.

12.2.1 Description of Structure

- One story metal frame/metal cladding.
- Plan dimensions are 50 ft (15.2 m) by 100 ft (30.5 m).
- Eave height is 16 ft (4.9 m).
- Rigid frames across short dimension, 20 ft (6.1 m) spacing.
- Braced frames on exterior walls, long dimension, 25 ft (7.6 m) spacing.
- Metal deck roof over structural steel purlins at 5% slope.
- Metal siding over structural steel girts.
- Foundation consists of shallow spread footings.

12.2.2 Framing Plan

For the framing plan, refer to Figure 12.1.

For the wall elevation, refer to Figure 12.2.

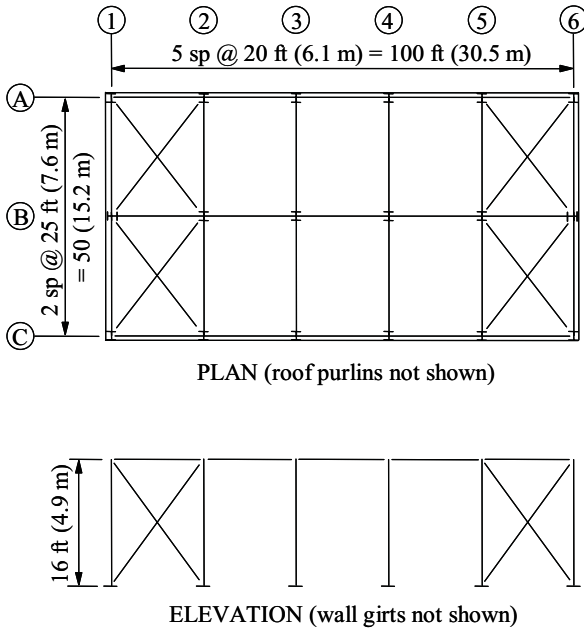

FIGURE 12.1: Framing Plan and Elevation

12.2.3 Components for Blast Design

The metal building cladding will fail in flexure at a low overpressure unless girt spacings are low. Tensile membrane response is possible; however, care must be paid to detailing to ensure that membrane response can be achieved. Tension membrane response can also be exhibited by girts and purlins. For this example problem, all elements will be designed for flexure.

Metal panels and girts along the long sides will load the main frames of the building. Loads on the back wall will be ignored to maximize sidesway. Reactions from these members will be transferred to the frame. Loads on the side walls will be resisted by braced frames in the end bays.

A preliminary design for each member will be accomplished through the use of required resistance formulas then check for response to time dependent loads. Final design would require evaluation of connections, bracing and other items which would prevent the members from reaching their plastic capacity.

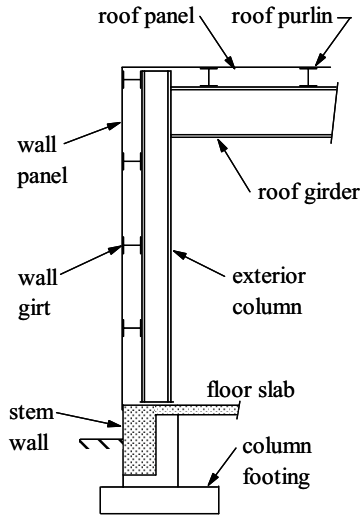

FIGURE 12.2: Wall Elevation

Determine required member sizes for:

1. Roof deck
2. Wall panels (facing blast)
3. Purlins
4. Girts (facing blast)
5. Rigid frame (facing blast)
6. Braced frame
7. Spread footing

12.2.4 General Solution Procedure

1. Determine dynamic material properties
2. Select trial sizes
3. Compute section properties
4. Compute SDOF properties (if applicable)
5. Compute response
6. Compare response to deformation limits
7. Revise section as required
8. Check secondary failure modes (shear, buckling, etc.)
9. Design connections for controlling reactions. (not included for brevity)

12.3 DESIGN DATA

12.3.1 Material Properties

for frame design:

Metal decking, $F_y = 50$ ksi (345 MPa)

Structural steel, $F_y = 36$ ksi (248 MPa)

soil properties:

Stiff silty clay, allowable bearing (service load) = 2500 psf @ 2 ft (120 kPa @ 0.6 m)

Factor of Safety, FS = 2 (for conventional loads from soil report)

Cohesion = 1,010 psf (48.4 kPa)

Dry Unit Weight, $\gamma = 85$ pcf (13.3 kN/m³)

Angle of internal friction = 22°

Coefficient of friction = 0.3

Active Earth Pressure Coefficient: $K_a = 0.55$

Passive Earth Pressure Coefficient: $K_p = 1.8$

Water Table at 15 ft (4.6 m) below grade

12.3.2 Dynamic Material Properties

$F_{ds} = F_{dy}$ because of low permissible dynamic response. (Tables 5.A.4 and 5.A.5)

Strength increase factors are from Table 5.A.1.

Dynamic increase factors are from Tables 5.A.2 and 5.A.3.

Material	F_y or f'_c	SIF	DIF	Modulus of Elasticity, E_s
Metal decking	50 ksi (345 MPa)	1.21	1.1	29,000 ksi (200,000 MPa)
Structural Steel	36 ksi (248 MPa)	1.1	1.29	29,000 ksi (200,000 MPa)

12.3.3 Design Loads

Dead Load:

Roof mechanical = 5 psf (239 Pa)

The following are initial estimates:

Roof deck = 3 psf (144 Pa)

Wall siding = 2 psf (96 Pa)

Roof framing = 3 psf (144 Pa)

Wall framing = 4 psf (192 Pa)

Blast Load:

The design blast direction is parallel to the main frames. The long (front) wall receives a reflected load. All other walls and roof receive side-on (free air) load. Free field blast wave parameters are assumed to have been provided by others. Calculations for blast pressures on the building surfaces are omitted for brevity (such a calculation is provided in the Chapter 3 appendix). The resulting blast loads

indicated in the following figures represent a far range (low pressure) load.

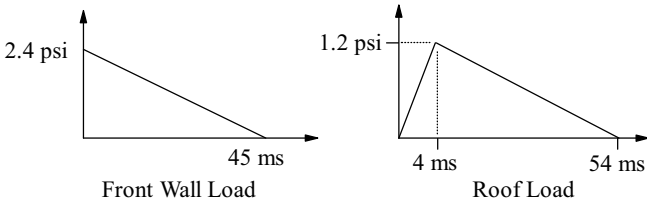

12.3.4 Building Performance Requirements - Deformation Limits

Damage level = Medium, reference Appendix 5.B.

Element	Support Rotation, θ_a	Ductility Ratio, μ_a
Roof decking	2°	3
Wall decking	2°	3
Purlins	6°	10
Girts	6°	10
Rigid frames	1.5°	2
Braced frames	1.5°	2

Maximum Sidesway at Eave, (Table 5.B.2)

$$X_a = B_H / 35 = (16 \text{ ft} * 12) / 35 = 5.5 \text{ in} \quad (14 \text{ cm})$$

12.4 ROOF DECKING

Worst case span is exterior, fixed-pinned boundary conditions. To add the effects of dead load to SDOF calculations, each pressure-time pair will be increased by the magnitude of the dead load and the initial displacement will be set equal to the dead load deflection. This will create a balanced condition at the start of the SDOF response calculation (refer to the pre-load discussion in Section 7.2.5).

Treat the roof deck as a 1 inch (2.5 cm) wide, one-way strip.

Response limits: $\theta_a = 2^\circ$, $\mu_a = 3$

Dead Load, (initial guess)
 DL = 3 psf, or 0.02 psi (0.14 kPa)

Blast Load,
 BL = 1.2 psi (8.27 kPa)

Impulse,
 $I_o = (1.2 \text{ psi})(54 \text{ ms}) / 2 = 32 \text{ psi-ms} \quad (223 \text{ kPa-ms})$

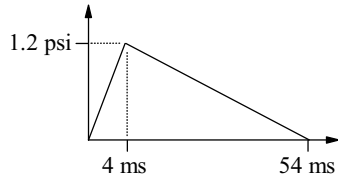

12.4.1 Dynamic Material Properties

for dynamic bending and shear, (Appendix 5.A)

$$F_{ds} = F_{dy} = (\text{SIF})(\text{DIF}) F_y = (1.21)(1.1) 50 \text{ ksi} = 66.5 \text{ ksi} \quad (459 \text{ MPa})$$

12.4.2 Calculate a Trial Size

Try 4 ft purlin spacing, $L = 4 \text{ ft}$ or 48 in (122 cm)

Let the ductility demand equal the limiting value, $\mu_d = \mu_a = 3$

As an initial guess, let $\tau = t_d / t_n = 3$ (in the dynamic range of response)

load/resistance ratio, (Equation 6.11)

$$F_o / R_m = \frac{\sqrt{(2\mu_d - 1)}}{\pi(\tau)} + \frac{(2\mu_d - 1)(\tau)}{2\mu_d(\tau + 0.7)} = \frac{\sqrt{2(3) - 1}}{\pi(3)} + \frac{(2(3) - 1)3}{2(3)(3 + 0.7)} = 0.91$$

peak load, $F_o = \text{BL} + \text{DL} = 1.2 \text{ psi} + 0.02 \text{ psi} = 1.22 \text{ psi}$ (8.41 kPa)

resistance,

$$R_m = F_o / 0.91 = (1.22 \text{ psi}) / 0.91 = 1.34 \text{ psi} \quad (9.22 \text{ kPa})$$

effective ultimate moment, from $R_b = 4 (M_{ps} + 2 M_{pc}) / L$ (Table 6.3)

$$M_p = R_m L / 12 = (1.34 \text{ psi} * 48 \text{ in} * 1 \text{ in}) / 12 = 257 \text{ in-lb} \quad (2,904 \text{ kN-cm})$$

ultimate moment,

$$M_p = M_p / 0.9 = (257 \text{ in-lb}) / 0.9 = 286 \text{ in-lb} \quad (3,231 \text{ kN-cm}) \quad (\text{Section 5.4.4})$$

section modulus,

$$S_x = M_p / F_{ds} = (286 \text{ in-lb}) / (66,500 \text{ psi}) = 0.0043 \text{ in}^3 \quad (0.070 \text{ cm}^3)$$

NOTE: The section modulus, S_x , is used to compute the moment capacity instead of the plastic section modulus, Z_x , mainly because section modulus values are readily available. The difference is minor due to relatively low response and due to capacity reductions from buckling of the thin web.

Select panel type and thickness from vendor catalog,

“R” panel, thickness = 24 gage

Weight = 1.25 psf (0.06 kPa)

$$I_x = 0.0548 \text{ in}^4/\text{ft} = 0.0046 \text{ in}^4/\text{in} \quad (0.075 \text{ cm}^4/\text{cm})$$

$$S_x = 0.0573 \text{ in}^3/\text{ft} = 0.0048 \text{ in}^3/\text{in} \quad (0.031 \text{ cm}^3/\text{cm})$$

$$A_v = 0.310 \text{ in}^2/\text{ft} = 0.0258 \text{ in}^2/\text{in} \quad (0.066 \text{ cm}^2/\text{cm})$$

Perform a detailed check of this section

12.4.3 Compute Section Properties

effective moment capacity, (Section 5.4.4)

$$M_p = 0.9 (S_x)(F_{ds}) = 0.9 (0.0048 \text{ in}^3) (66,500 \text{ psi}) = 287 \text{ in-lb} \quad (3,243 \text{ kN-cm})$$

shear capacity,

$$V_n = 0.55 (A_v)(F_{ds}) = 0.55 (0.0258 \text{ in}^2)(66,500 \text{ psi}) = 945 \text{ lb} \quad (4.2 \text{ kN})$$

12.4.4 Compute SDOF Properties

ultimate resistance, from $R_b = 4 (M_{ps} + 2 M_{pc}) / L$ (Table 6.3)

$$R_u = 12 (M_p) / L = 12 (287 \text{ in-lb}) / (48 \text{ in}) = 72 \text{ lb, or } 1.50 \text{ psi} \quad (10.3 \text{ kPa})$$

The numerical integration in this example uses a trilinear resistance-deflection curve, thus several additional values are needed:

elastic resistance, (Table 6.3)

$$R = 8 M_{pc} / L = 8 M_p / L = 8 (287 \text{ in-lb}) / (48 \text{ in}) = 48 \text{ lb, or } 1 \text{ psi} \quad (6.9 \text{ kPa})$$

elastic stiffness, (Table 6.3)

$$\begin{aligned} K &= 185 E_s I_x / L^3 \\ &= 185 (29,000,000 \text{ psi})(0.0046 \text{ in}^4) / (48 \text{ in})^3 \\ &= 223 \text{ lb/in, or } 4.65 \text{ psi/in} \quad (12.62 \text{ kPa/cm}) \end{aligned}$$

first yield deflection,

$$y = R / K = (1 \text{ psi}) / (4.65 \text{ psi/in}) = 0.22 \text{ in} \quad (0.56 \text{ cm})$$

elasto-plastic stiffness, (after first yield) (Table 6.3)

$$\begin{aligned} K_{ep} &= 384 E_s I_x / 5 L^3 \\ &= 384 (29,000,000 \text{ psi})(0.0046 \text{ in}^4) / 5 (48 \text{ in})^3 \\ &= 93 \text{ lb/in, or } 1.93 \text{ psi/in} \quad (5.27 \text{ kPa/cm}) \end{aligned}$$

final yield deflection,

$$\begin{aligned} y_{ep} &= (R_u - R) / K_{ep} + y \\ &= (1.49 \text{ psi} - 1 \text{ psi}) / (1.94 \text{ psi/in}) + 0.215 \text{ in} \\ &= 0.47 \text{ in} \quad (1.19 \text{ cm}) \end{aligned}$$

Compute the effective "bilinear" elastic stiffness and deflection to determine the natural period, ductility ratios, and hinge rotations.

effective "bilinear" elastic stiffness,

$$\begin{aligned} K_e &= 160 E_s I_x / L^3 && \text{(Biggs, Table 5.3)} \\ &= 160 (29,000,000 \text{ psi})(0.0046 \text{ in}^4) / (48 \text{ in})^3 \\ &= 193 \text{ lb/in, or } 4.02 \text{ psi/in} \quad (10.91 \text{ kPa/cm}) \end{aligned}$$

effective elastic yield deflection,

$$y_e = R_u / K_e = (1.49 \text{ psi}) / (4.02 \text{ psi/in}) = 0.37 \text{ in} \quad (0.94 \text{ cm})$$

weight = 1.25 psf (0.083 ft width)(4 ft length) = 0.417 lb, or 0.009 psi (0.062 kPa)

mass,

$$\begin{aligned} M &= \text{weight} / g \\ &= (0.417 \text{ lb}) / (386 \text{ in/s}^2) \\ &= 0.00108 \text{ lb-s}^2/\text{in}, \text{ or } 22.5 \text{ psi-ms}^2/\text{in} \quad (61.1 \text{ kPa-ms}^2/\text{cm}) \end{aligned}$$

load - mass factors,

(Table 6.3)

$$\begin{aligned} \text{elastic, } K_{LM} &= (0.45) / (0.58) = 0.78 \\ \text{elasto-plastic, } K_{LM} &= (0.50) / (0.64) = 0.78 \\ \text{plastic, } K_{LM} &= (0.33) / (0.50) = 0.66 \end{aligned}$$

use an average value, $K_{LM} = [(0.78 + 0.78) / 2 + 0.66] / 2 = 0.72$

equivalent mass,

$$M_e = K_{LM} (M) = 0.72 (22.5 \text{ psi-ms}^2/\text{in}) = 16.2 \text{ psi-ms}^2/\text{in} \quad (44.0 \text{ kPa-ms}^2/\text{cm})$$

natural period:

(Equation 6.8)

$$t_n = 2 \pi \sqrt{M_e / K_e} = 2 \pi \sqrt{(16.2 \text{ psi - ms}^2 / \text{in}) / (4.02 \text{ psi / in})} = 12.6 \text{ ms}$$

12.4.5 Compute Response (chart solution)

NOTE: Both charts and numerical integration need not be used, but are presented in this sample design to illustrate implementation.

In order to use Figure 6.6, an instantaneous load rise must be assumed.

$$\begin{aligned} t_d / t_n &= (54 \text{ ms}) / (12.6 \text{ ms}) = 4.3 \quad (3.0 \text{ was originally assumed}) \\ R_u / F_o &= (1.5 \text{ psi}) / (1.2 \text{ psi}) = 1.25 \end{aligned}$$

Using these values, $\mu_d \approx 2$

(Figure 6.6)

maximum deformation,

$$y_m = (\mu_d) (y_e) = (2) (0.37 \text{ in}) = 0.74 \text{ in} \quad (1.88 \text{ cm})$$

support rotation,

(Figure 5.9)

$$\theta_d = \arctan (y_m / 0.5 L) = \arctan [(0.742 \text{ in}) / (0.5)(48 \text{ in})] = 1.8^\circ < 2^\circ, \text{ OK}$$

NOTE: 0.5 L is used even for nonsymmetric boundary conditions.

12.4.6 Compute Response (numerical integration solution)

dead load deformation,

$$y_d = DL / K = (0.009 \text{ psi}) / (4.65 \text{ psi/in}) = 0.002 \text{ in} \quad (0.005 \text{ cm})$$

NOTE: Ordinarily a dead load this low would be insignificant, however this load will be included in order to illustrate implementation.

time increment = $t_n / 10 = 12.6 \text{ ms} / 10 \approx 1.0 \text{ ms}$, use 0.4 ms to obtain at least 10 increments of loading in the first section of the pressure-time history.

pinned end reaction,	fixed end reaction,
elastic, $V_p = 0.26R + 0.12F$	elastic, $V_f = 0.43R + 0.19F$
plastic, $V_p = 0.39R_u + 0.11F - M_p/L$	plastic, $V_f = 0.39R_u + 0.11F + M_p/L$

NOTE: $M_p/L = (287 \text{ in-lb})/(48 \text{ in}) = 6 \text{ lb} \quad (27 \text{ N})$

Roof Deck Analysis, 1.25 psf dead load

Equiv. Elastic Displac. = 3.731E-01	Max Force = 1.209E+00
Max Displacement = 6.600E-01	Min Force = 8.680E-03
Min Displacement = 2.004E-03	Max Resistance = 1.500E+00
Time of Max Displacement = 1.080E+01	Min Resistance = -4.435E-01
Time of Min Displacement = 1.000E-01	Max Shear A = 8.605E-01
MU = 1.769E+00	Min Shear A = -1.889E-01
	Max Shear B = 5.261E-01
	Min Shear B = -1.142E-01

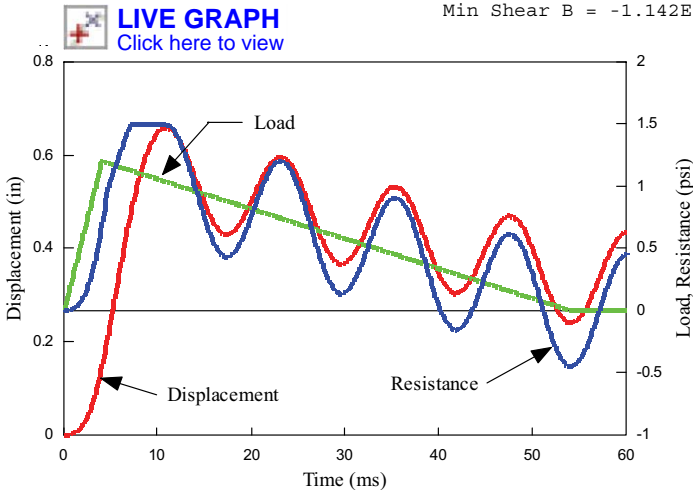

FIGURE 12.3: Roof Deck Numerical Integration

The positive peak deflection is $y_m = 0.66 \text{ in} (1.68 \text{ cm})$ at $t = 10.8 \text{ ms}$

The positive peak reaction is $20.6 \text{ lb/in} (36.1 \text{ N/cm})$ at $t = 10.8 \text{ ms}$

The peak rebound reaction is $10.6 \text{ lb/in} (18.6 \text{ N/cm})$ at $t = 54 \text{ ms}$

NOTE: The peak rebound reaction occurs after a number of cycles, and after the blast load disappears.

ductility,

$$\mu_d = (y_m) / (y_e) = (0.66 \text{ in}) / (0.37 \text{ in}) = 1.8$$

support rotation,

$$\theta_d = \arctan (y_m / 0.5 L) = \arctan [(0.66 \text{ in}) / (0.5)(48 \text{ in})] = 1.6^\circ$$

(Figure 5.9)

12.4.7 Compare Response to Deformation Limits

$$\theta_d = 1.6^\circ < 2^\circ \text{ OK}$$

$$\mu_d = 1.8 < 3 \text{ OK}$$

Response Is Adequate

12.4.8 Revise section as required

A revision is not necessary.

12.4.9 Check Secondary Failure Modes (in this case, shear)

reaction at ultimate resistance,

$$V_u = R_u / 2 + M_p / L = (72 \text{ lb}) / 2 + 6 \text{ lb} = 42 \text{ lb} \text{ (187 N)} < V_n, \text{ OK}$$

Check manufacturer's catalog for maximum permitted reaction.

Shear Capacity Is Adequate

12.5 WALL PANELS

Worst case span is top or bottom, fixed-pinned boundary conditions. Treat the wall panels as 1 inch wide, one-way strip.

Response limits: $\theta_a = 2^\circ, \mu_a = 3$

Dead Load, $DL = 0$

Blast Load,

$$BL = 2.4 \text{ psi} \text{ (16.5 kPa)}$$

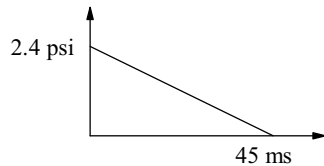

$$\text{impulse, } I_o = (2.4 \text{ psi})(45 \text{ ms}) / 2 = 54 \text{ psi-ms} \text{ (372 kPa-ms)}$$

12.5.1 Dynamic Material Properties

for dynamic bending or shear,

(Appendix 5.A)

$$F_{ds} = F_{dy} = (SIF)(DIF) F_y = (1.21)(1.1) 50 \text{ ksi} = 66.5 \text{ ksi} \text{ (459 MPa)}$$

12.5.2 Calculate a Trial Size

Try 3 ft girt spacing, $L = 3 \text{ ft}$ or 36 in (91 cm)

Let the ductility demand equal the limiting value, $\mu_d = \mu_a = 3$

As an initial guess, let $\tau = t_d / t_n = 3$ (in the dynamic range of response)

load/resistance ratio, (Equation 6.11)

$$F_o / R_m = \frac{\sqrt{(2\mu_d - 1)}}{\pi(\tau)} + \frac{(2\mu_d - 1)(\tau)}{2\mu_d(\tau + 0.7)} = \frac{\sqrt{2(3) - 1}}{\pi(3)} + \frac{(2(3) - 1)3}{2(3)(3 + 0.7)} = 0.91$$

peak load, $F_o = BL = 2.4 \text{ psi}$ (16.5 kPa)

resistance,

$$R_m = F_o / 0.91 = (2.4 \text{ psi}) / 0.91 = 2.6 \text{ psi}$$
 (17.9 kPa)

effective ultimate moment, from $R_b = 4 (M_{ps} + 2 M_{pc}) / L$ (Table 6.3)

$$M_p = R_m L / 12 = (2.6 \text{ psi} * 36 \text{ in} * 1 \text{ in}) / 12 = 281 \text{ in-lb}$$
 (3,175 kN-cm)

ultimate moment,

$$M_p = M_p / 0.9 = (281 \text{ in-lb}) / 0.9 = 312 \text{ in-lb}$$
 (3,525 kN-cm) (Section 5.4.4)

section modulus,

$$S_x = M_p / F_{ds} = (312 \text{ in-lb}) / (66,500 \text{ psi}) = 0.0047 \text{ in}^3$$
 (0.077 cm³)

NOTE: The section modulus, S_x , is used to compute the moment capacity instead of the plastic section modulus, Z_x , mainly because section modulus values are readily available. The difference is minor due to relatively low response and due to capacity reductions from buckling of the thin web.

Select panel type and thickness consistent with roof,

“R” panel, thickness = 24 gage

Weight = 1.25 psf (0.06 kPa)

$$I_x = 0.0548 \text{ in}^4/\text{ft} = 0.0046 \text{ in}^4/\text{in}$$
 (0.075 cm⁴/cm)

$$S_x = 0.0573 \text{ in}^3/\text{ft} = 0.0048 \text{ in}^3/\text{in}$$
 (0.031 cm³/cm)

$$A_v = 0.310 \text{ in}^2/\text{ft} = 0.0258 \text{ in}^2/\text{in}$$
 (0.066 cm²/cm)

Perform a detailed check of this section

12.5.3 Compute Section Properties

effective moment capacity, (Section 5.4.4)

$$M_p = 0.9 (S_x)(F_{ds}) = 0.9 (0.0048 \text{ in}^3) (66,500 \text{ psi}) = 287 \text{ in-lb}$$
 (3,243 kN-cm)

shear capacity,

$$V_n = 0.55 (A_v)(F_{ds}) = 0.55 (0.0258 \text{ in}^2)(66,500 \text{ psi}) = 945 \text{ lb}$$
 (4.2 kN)

12.5.4 Compute SDOF Properties

ultimate resistance, from $R_b = 4 (M_{ps} + 2 M_{pc}) / L$ (Table 6.3)

$$R_u = 12 (M_n) / L = 12 (287 \text{ in-lb}) / (36 \text{ in}) = 96 \text{ lb, or } 2.66 \text{ psi}$$
 (18.3 kPa)

The numerical integration in this example uses a trilinear resistance-deflection curve, thus several additional values are needed:

elastic resistance, (Table 6.3)
 $R = 8 M_{pc} / L = 8 M_p / L = 8 (287 \text{ in-lb}) / (36 \text{ in}) = 64 \text{ lb, or } 1.78 \text{ psi } (12.3 \text{ kPa})$

elastic stiffness, (Table 6.3)
 $K = 185 E_s I_x / L^3$
 $= 185 (29,000,000 \text{ psi})(0.0046 \text{ in}^4) / (36 \text{ in})^3$
 $= 529 \text{ lb/in, or } 14.7 \text{ psi/in } (40 \text{ kPa/cm})$

first yield deflection,
 $y = R / K = (1.78 \text{ psi}) / (14.7 \text{ psi/in}) = 0.12 \text{ in } (0.30 \text{ cm})$

elasto-plastic stiffness, (after first yield) (Table 6.3)
 $K_{ep} = 384 E_s I_x / 5 L^3$
 $= 384 (29,000,000 \text{ psi})(0.0046 \text{ in}^4) / 5 (36 \text{ in})^3$
 $= 220 \text{ lb/in, or } 6.1 \text{ psi/in } (16.6 \text{ kPa/cm})$

final yield deflection,
 $y_{ep} = (R_u - R) / K_{ep} + y$
 $= (2.66 \text{ psi} - 1.78 \text{ psi}) / (6.1 \text{ psi/in}) + 0.12 \text{ in}$
 $= 0.26 \text{ in } (0.66 \text{ cm})$

Compute the effective "bilinear" elastic stiffness and deflection to determine the natural period, ductility ratios, and hinge rotations.

effective "bilinear" elastic stiffness, (Biggs, Table 5.3)
 $K_e = 160 E_s I_x / L^3$
 $= 160 (29,000,000 \text{ psi})(0.0046 \text{ in}^4) / (36 \text{ in})^3$
 $= 457 \text{ lb/in, or } 12.7 \text{ psi/in } (34.5 \text{ kPa/cm})$

effective elastic yield deflection,
 $y_e = R_u / K_e = (2.66 \text{ psi}) / (12.7 \text{ psi/in}) = 0.21 \text{ in } (0.53 \text{ cm})$

weight = $1.25 \text{ psf } (0.083 \text{ ft width})(3 \text{ ft length}) = 0.312 \text{ lb, or } 0.0087 \text{ psi } (0.06 \text{ kPa})$

mass,
 $M = \text{weight} / g$
 $= (0.312 \text{ lb}) / (386 \text{ in/s}^2)$
 $= 0.000808 \text{ lb-s}^2/\text{in, or } 22.5 \text{ psi-ms}^2/\text{in } (61.1 \text{ kPa-ms}^2/\text{cm})$

load - mass factors, (Table 6.3)
 elastic, $K_{LM} = (0.45) / (0.58) = 0.78$
 elasto-plastic, $K_{LM} = (0.50) / (0.64) = 0.78$
 plastic, $K_{LM} = (0.33) / (0.50) = 0.66$

use an average value, $K_{LM} = [(0.78 + 0.78) / 2 + 0.66] / 2 = 0.72$

equivalent mass,

$$M_e = K_{LM} (M) = 0.72 (22.5 \text{ psi}\cdot\text{ms}^2/\text{in}) = 16.2 \text{ psi}\cdot\text{ms}^2/\text{in} \quad (44.0 \text{ kPa}\cdot\text{ms}^2/\text{cm})$$

natural period:

(Equation 6.8)

$$t_n = 2 \pi \sqrt{M_e / K_e} = 2 \pi \sqrt{(16.2 \text{ psi}\cdot\text{ms}^2/\text{in}) / (12.7 \text{ psi}/\text{in})} = 7.2 \text{ ms}$$

12.5.5 Compute Response (numerical integration solution)

time increment = $t_n / 10 = 7.2 \text{ ms} / 10 \approx 0.7 \text{ ms}$, use 0.4 ms to obtain at least 10 increments of loading.

pinned end reaction,

elastic, $V_p = 0.26R + 0.12F$

plastic, $V_p = 0.39R_u + 0.11F - M_p/L$

fixed end reaction,

elastic, $V_f = 0.43R + 0.19F$

plastic, $V_f = 0.39R_u + 0.11F + M_p/L$

NOTE: $M_p/L = (287 \text{ in}\cdot\text{lb}) / (36 \text{ in}) = 8 \text{ lb} \quad (36 \text{ N})$

Wall Panel Analysis, 0.0 psf dead load

Equiv. Elastic Displac. = 2.089E-01	Max Force = 2.400E+00
Max Displacement = 6.294E-01	Min Force = 0.000E+00
Min Displacement = 6.816E-04	Max Resistance = 2.660E+00
Time of Max Displacement = 7.000E+00	Min Resistance = -6.334E-01
Time of Min Displacement = 1.000E-01	Max Shear A = 1.574E+00
MU = 3.014E+00	Min Shear A = -2.724E-01
	Max Shear B = 9.636E-01
	Min Shear B = -1.647E-01

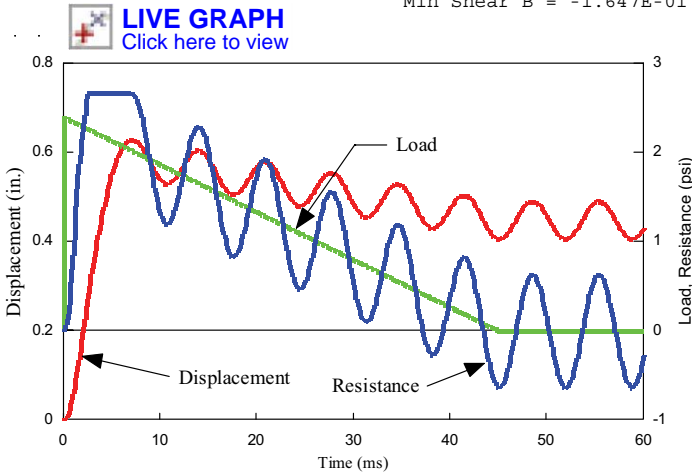

FIGURE 12.4: Wall Panel Numerical Integration

The positive peak deflection is $y_m = 0.63 \text{ in} (1.6 \text{ cm})$ at $t = 7 \text{ ms}$

The positive peak reaction is 28 lb/in (49 N/cm) at $t = 2.5$ ms

The peak rebound reaction is 4.9 lb/in (8.6 N/cm) at $t = 45$ ms

NOTE: The peak rebound reaction occurs after a number of cycles, and after the blast load disappears.

ductility,

$$\mu_d = (y_m) / (y_e) = (0.63 \text{ in}) / (0.21 \text{ in}) = 3$$

support rotation,

$$\theta_d = \arctan (y_m / 0.5 L) = \arctan [(0.63 \text{ in}) / (0.5)(36 \text{ in})] = 2^\circ$$

(Figure 5.9)

12.5.6 Compare Response to Deformation Limits

$$\theta_d = 2^\circ = 2^\circ \quad \text{OK}$$

$$\mu_d = 3 = 3 \quad \text{OK} \quad \underline{\text{Response Is Adequate}}$$

12.5.7 Revise section as required

A revision is not necessary.

12.5.8 Check Secondary Failure Modes (in this case, shear)

reaction at ultimate resistance,

$$V_u = R_u / 2 + M_p / L = (96 \text{ lb}) / 2 + 8 \text{ lb} = 56 \text{ lb} \quad (249 \text{ N}) < V_n, \quad \text{OK}$$

Check manufacturer's catalog for maximum permitted reaction.

Shear Capacity Is Adequate

12.6 ROOF PURLINS

Purlins are continuous over beams, worst case is at ends for fixed-pinned boundary conditions. Assume A36 rolled shapes. Loads are light enough that cold formed steel could also be used. The purlin is assumed to be laterally braced by the roof deck in tension.

To add the effects of dead load to SDOF calculations, each pressure-time pair will be increased by the magnitude of the dead load and the initial displacement will be set equal to the dead load deflection. This will create a balanced condition at the start of the SDOF response calculation (refer to the pre-load discussion in Section 7.2.5).

Span, $L = 20$ ft, or 240 in (610 cm)

Purlin spacing = 4 ft, or 48 in (122 cm)

Response limits: $\theta_a = 6^\circ$, $\mu_a = 10$

Two methods for applying blast loads will be used. The first is the Tributary Area Method which applies the roof panel pressure-time history to the loaded area of the purlin. The second method will use the dynamic reactions of the roof panel as the load applied to the purlin. The purlin load is determined at each time step as follows:

$$\text{Load, psi} = (2 \text{ sides}) [\text{roof panel reaction, lb/in}] / (48 \text{ in purlin spacing})$$

12.6.1 Dynamic Material Properties

for dynamic bending or shear, (Appendix 5.A)
 $F_{ds} = F_{dy} = (\text{SIF})(\text{DIF}) F_y = (1.1)(1.29) 36 \text{ ksi} = 51 \text{ ksi} \quad (352 \text{ MPa})$

12.6.2 Calculate a Trial Size

Use the Tributary Width Method for applying load to the purlin in initial sizing.

tributary width = 4 ft, or 48 in (122 cm)

Dead Load, (initial guess)
 $DL = 6 \text{ psf, or } 0.04 \text{ psi} \quad (0.28 \text{ kPa})$

Roof blast load:
 $BL = 1.2 \text{ psi} \quad (8.27 \text{ kPa})$

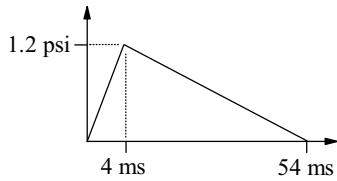

impulse,
 $I_o = (1.2 \text{ psi})(54 \text{ ms}) / 2 = 32 \text{ psi-ms} \quad (221 \text{ kPa-ms})$

Let the ductility demand equal the limiting value, $\mu_d = \mu_a = 10$

As an initial guess, let $\tau = t_d / t_n = 3$ (in the dynamic range of response)

load/resistance ratio, (Equation 6.11)

$$F_o / R_m = \frac{\sqrt{(2\mu_d - 1)}}{\pi(\tau)} + \frac{(2\mu_d - 1)(\tau)}{2\mu_d(\tau + 0.7)} = \frac{\sqrt{2(10) - 1}}{\pi(3)} + \frac{(2(10) - 1)3}{2(10)(3 + 0.7)} = 1.23$$

peak load, $F_o = BL + DL = 1.2 \text{ psi} + 0.04 \text{ psi} = 1.24 \text{ psi} \quad (8.55 \text{ kPa})$

resistance,
 $R_m = F_o / 1.23 = (1.24 \text{ psi}) / 1.23 = 1.01 \text{ psi} \quad (6.96 \text{ kPa})$

ultimate moment, from $R_b = 4 (M_{ps} + 2 M_{pc}) / L$ (Table 6.3)
 $M_p = R_m L / 12$
 $= (1.01 \text{ psi} * 240 \text{ in} * 48 \text{ in})(240 \text{ in}) / 12$
 $= 232,700 \text{ in-lb} \quad (2,629 \text{ kN-cm})$

plastic section modulus,
 $Z_x = M_p / F_{ds} = (232,700 \text{ in-lb}) / (51,000 \text{ psi}) = 4.56 \text{ in}^3 \quad (75 \text{ cm}^3)$

The moment capacity is based on Z_x because the target $\mu > 3$.

Select C6x8.2, (AISC Manual)

$$I_x = 13.1 \text{ in}^4 \quad (545 \text{ cm}^4)$$

$$Z_x = 5.13 \text{ in}^3 \quad (84.1 \text{ cm}^3)$$

$$r_y = 0.537 \text{ in} \quad (1.36 \text{ cm})$$

$$A_w \text{ (area of web)} = 1.2 \text{ in}^2 \quad (7.74 \text{ cm}^2)$$

Perform a detailed check of this section

12.6.3 Compute Section Properties

moment capacity, (AISC 360, Equation F2-1)

$$M_p = Z_x (F_{ds}) = (5.13 \text{ in}^3)(51,000 \text{ psi}) = 261,630 \text{ in-lb} \quad (2,956 \text{ kN-cm})$$

shear capacity, (AISC 360, Section G2.1)

$$V_n = 0.6 (A_w)(F_{ds})(C_v) = 0.6 (1.2 \text{ in}^2)(51,000 \text{ psi})(1.0) = 36,720 \text{ lb} \quad (163.3 \text{ kN})$$

12.6.4 Compute SDOF Properties

ultimate resistance, from $R_b = 4 (M_{ps} + 2 M_{pc}) / L$ (Table 6.3)

$$R_u = 12 (M_p) / L = 12 (261,630 \text{ in-lb}) / (240 \text{ in}) = 13,082 \text{ lb, or } 1.14 \text{ psi} \quad (7.86 \text{ kPa})$$

The numerical integration in this example uses a trilinear resistance-deflection curve, thus several additional values are needed:

elastic resistance, (Table 6.3)

$$\begin{aligned} R &= 8 M_{pc} / L = 8 M_p / L \\ &= 8 (261,630 \text{ in-lb}) / (240 \text{ in}) \\ &= 8,721 \text{ lb, or } 0.76 \text{ psi} \quad (5.24 \text{ kPa}) \end{aligned}$$

elastic stiffness, (Table 6.3)

$$\begin{aligned} K &= 185 E_s I_x / L^3 \\ &= 185 (29,000,000 \text{ psi})(13.1 \text{ in}^4) / (240 \text{ in})^3 \\ &= 5,084 \text{ lb/in, or } 0.44 \text{ psi/in} \quad (1.19 \text{ kPa/cm}) \end{aligned}$$

first yield deflection,

$$y = R / K = (0.76 \text{ psi}) / (0.44 \text{ psi/in}) = 1.72 \text{ in} \quad (4.37 \text{ cm})$$

elasto-plastic stiffness, (after first yield)

(Table 6.3)

$$\begin{aligned} K_{ep} &= 384 E_s I_x / 5 L^3 \\ &= 384 (29,000,000 \text{ psi})(13.1 \text{ in}^4) / 5 (240 \text{ in})^3 \\ &= 2,111 \text{ lb/in, or } 0.18 \text{ psi/in} \quad (0.49 \text{ kPa/cm}) \end{aligned}$$

final yield deflection,

$$\begin{aligned} y_{ep} &= (R_u - R) / K_{ep} + y \\ &= (1.14 \text{ psi} - 0.76 \text{ psi}) / (0.18 \text{ psi/in}) + 1.72 \text{ in} \\ &= 3.83 \text{ in} \quad (9.73 \text{ cm}) \end{aligned}$$

Compute the effective "bilinear" elastic stiffness and deflection to determine the natural period, ductility ratios, and hinge rotations.

effective "bilinear" elastic stiffness, (Biggs, Table 5.3)

$$K_e = 160 E_s I_x / L^3$$

$$= 160 (29,000,000 \text{ psi})(13.1 \text{ in}^4) / (240 \text{ in})^3$$

$$= 4,397 \text{ lb/in, or } 0.38 \text{ psi/in } (1.03 \text{ kPa/cm})$$

effective elastic yield deflection,

$$y_e = R_u / K_e = (1.14 \text{ psi}) / (0.38 \text{ psi/in}) = 3.0 \text{ in } (7.62 \text{ cm})$$

weight = (1.25 psf deck) + (8.2 plf purlin) / (4 ft trib. width) + (5 psf mechanical)

$$= 8.3 \text{ psf, or } 0.058 \text{ psi } (0.40 \text{ kPa})$$

initial deflection,

$$y_d = \text{weight} / K_e = (0.058 \text{ psf}) / (0.38 \text{ psi/in}) = 0.15 \text{ in } (0.38 \text{ cm})$$

mass,

$$M = \text{weight} / g$$

$$= (0.058 \text{ psi}) / (386 \text{ in/s}^2)$$

$$= 0.00015 \text{ psi-s}^2/\text{in, or } 150 \text{ psi-ms}^2/\text{in } (407 \text{ kPa-ms}^2/\text{cm})$$

load - mass factors, (Table 6.3)

elastic, $K_{LM} = (0.45) / (0.58) = 0.78$

elasto-plastic, $K_{LM} = (0.50) / (0.64) = 0.78$

plastic, $K_{LM} = (0.33) / (0.50) = 0.66$

use an average value, $K_{LM} = [(0.78 + 0.78) / 2 + 0.66] / 2 = 0.72$

equivalent mass,

$$M_e = K_{LM} (M) = 0.72 (150 \text{ psi-ms}^2/\text{in}) = 108 \text{ psi-ms}^2/\text{in } (293 \text{ kPa-ms}^2/\text{cm})$$

natural period: (Equation 6.8)

$$t_n = 2 \pi \sqrt{M_e / K_e} = 2 \pi \sqrt{(108 \text{ psi - ms}^2/\text{in}) / (0.38 \text{ psi/in})} = 106 \text{ ms}$$

NOTE: The roof panel has a period, t_n , of 12.6 ms. Analyzing the roof panel and purlin separately should be adequate with this difference in periods (refer to Section 6.5.3).

12.6.5 Compute Response (numerical integration of tributary area load)

Refer to Section 12.6.2 for the tributary area load.

time increment,

$$(106 \text{ ms period}) / 10 \approx 11 \text{ ms}$$

$$(4 \text{ ms rise time}) / 10 = 0.4 \text{ ms, use } 0.1 \text{ ms}$$

pinned end reaction,
 elastic, $V_p = 0.26R + 0.12F$
 plastic, $V_p = 0.39R_u + 0.11F - M_p/L$

fixed end reaction,
 elastic, $V_f = 0.43R + 0.19F$
 plastic, $V_f = 0.39R_u + 0.11F + M_p/L$

NOTE: $M_p/L = (261,630 \text{ in-lb})/(240 \text{ in}) = 1,090 \text{ lb (4.85 kN)}$

Purlin Analysis - Tributary Load

Equiv. Elastic Displac. = 3.007E+00	Max Force = 1.257E+00
Max Displacement = 4.602E+00	Min Force = 3.142E-02
Min Displacement = -3.422E-01	Max Resistance = 1.140E+00
Time of Max Displacement = 4.540E+01	Min Resistance = -8.727E-01
Time of Min Displacement = 9.070E+01	Max Shear A = 5.060E-01
MU = 1.531E+00	Min Shear A = -3.341E-01
	Max Shear B = 5.060E-01
	Min Shear B = -3.341E-01

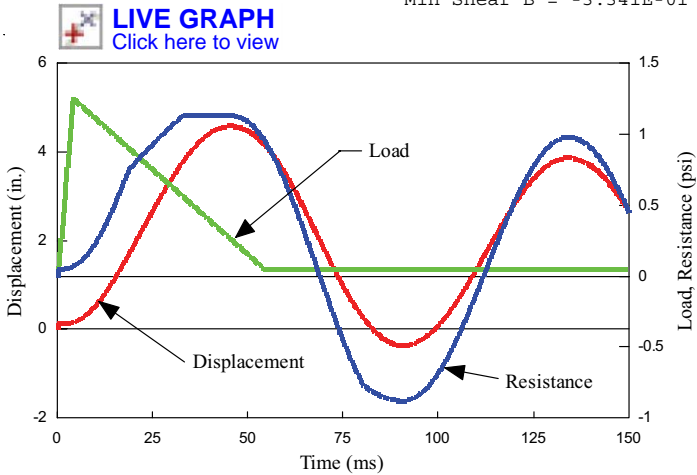

FIGURE 12.5: Roof Purlin Numerical Integration

The positive peak deflection is $y_m = 4.6 \text{ in (11.7 cm)}$ at $t = 45.4 \text{ ms}$

ductility,
 $\mu_d = (y_m) / (y_e) = (4.6 \text{ in}) / (3.0 \text{ in}) = 1.5$

support rotation, (Figure 5.9)
 $\theta_d = \arctan (y_m / 0.5 L) = \arctan [(4.6 \text{ in}) / (0.5)(240 \text{ in})] = 2.2^\circ$

12.6.6 Compute Response (numerical integration of dynamic reaction)

Refer to Figure 12.3 for the dynamic reaction load.

Purlin Analysis - Dynamic Reactions

Equiv. Elastic Displac. = 3.007E+00	Max Force = 9.060E-01
Max Displacement = 2.604E+00	Min Force = 0.000E+00
Min Displacement = -1.481E+00	Max Resistance = 9.178E-01
Time of Max Displacement = 4.100E+01	Min Resistance = -8.088E-01
Time of Min Displacement = 1.736E+02	Max Shear A = 4.844E-01
MU = 8.661E-01	Min Shear A = -3.478E-01
	Max Shear B = 2.956E-01
	Min Shear B = -2.103E-01

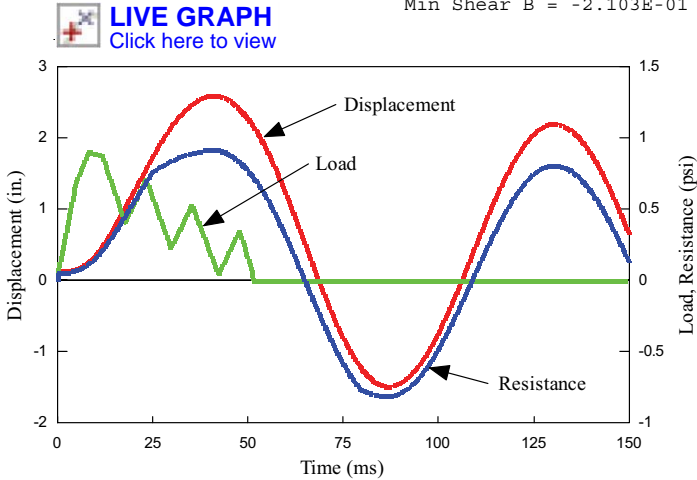

FIGURE 12.6: Wall Panel Numerical Integration

The positive peak deflection is $y_m = 2.6$ in (6.6 cm) at $t = 41.1$ ms

The positive peak reaction is 19.3 lb (85.9 N) at $t = 35.5$ ms

The peak rebound reaction is 15.1 lb (67.2 N) at $t = 86$ ms

ductility,

$$\mu_d = (y_m) / (y_e) = (2.6 \text{ in}) / (3.0 \text{ in}) = 0.9$$

support rotation,

$$\theta_d = \arctan (y_m / 0.5 L) = \arctan [(2.6 \text{ in}) / (0.5)(240 \text{ in})] = 1.2^\circ$$

(Figure 5.9)

NOTE: This response from the dynamic reactions is approximately half of that produced by applying the blast load by tributary area.

12.6.7 Compare Response to Deformation Limits

$\theta_d = 1.2^\circ < 6^\circ$ OK

$\mu_d = 0.9 < 10$ OK Response Is Adequate

12.6.8 Revise section as required

Revise size to get closer to the target deflection. Try a lighter channel. Use dynamic reactions.

Select C4x5.4, (AISC Manual)
 $I_x = 3.85 \text{ in}^4$ (160 cm⁴)
 $Z_x = 2.26 \text{ in}^3$ (37.0 cm³)
 $r_y = 0.449 \text{ in}$ (1.14 cm)
 A_v (area of web) = 0.74 in² (4.77 cm²)

Perform a detailed check of this section

12.6.9 Compute Section Properties

moment capacity, (AISC 360, Equation F2-1)
 $M_p = Z_x (F_{ds}) = (2.26 \text{ in}^3)(51,000 \text{ psi}) = 115,260 \text{ in-lb}$ (1,302 kN-cm)

The moment capacity is based on Z_x because the target $\mu > 3$.

shear capacity, (AISC 360, Section G2.1)
 $V_n = 0.6 (A_v)(F_{ds}) = 0.6 (0.74 \text{ in}^2)(51,000 \text{ psi}) = 22,644 \text{ lb}$ (101 kN)

12.6.10 Compute SDOF Properties

ultimate resistance, from $R_b = 4 (M_{ps} + 2 M_{pc}) / L$ (Table 6.3)
 $R_u = 12 (M_p) / L = 12 (115,260 \text{ in-lb}) / (240 \text{ in}) = 5,763 \text{ lb}$, or 0.50 psi (3.45 kPa)

The numerical integration in this example uses a trilinear resistance-deflection curve, thus several additional values are needed:

elastic resistance, (Table 6.3)
 $R = 8 M_{pc} / L = 8 M_p / L$
 $= 8 (115,260 \text{ in-lb}) / (240 \text{ in})$
 $= 3,842 \text{ lb}$, or 0.33 psi (2.28 kPa)

elastic stiffness, (Table 6.3)
 $K = 185 E_s I_x / L^3$
 $= 185 (29,000,000 \text{ psi})(3.85 \text{ in}^4) / (240 \text{ in})^3$
 $= 1,494 \text{ lb/in}$, or 0.13 psi/in (0.35 kPa/cm)

first yield deflection,
 $y = R / K = (0.33 \text{ psi}) / (0.13 \text{ psi/in}) = 2.54 \text{ in}$ (6.45 cm)

elasto-plastic stiffness, (after first yield) (Table 6.3)
 $K_{ep} = 384 E_s I_x / 5 L^3$
 $= 384 (29,000,000 \text{ psi})(3.85 \text{ in}^4) / 5 (240 \text{ in})^3$
 $= 620 \text{ lb/in}$, or 0.05 psi/in (0.14 kPa/cm)

final yield deflection,

$$\begin{aligned} y_{ep} &= (R_u - R) / K_{ep} + y \\ &= (0.50 \text{ psi} - 0.33 \text{ psi}) / (0.05 \text{ psi/in}) + 2.54 \text{ in} \\ &= 5.94 \text{ in} \quad (15.09 \text{ cm}) \end{aligned}$$

Compute the effective "bilinear" elastic stiffness and deflection to determine the natural period, ductility ratios, and hinge rotations.

effective "bilinear" elastic stiffness,

$$\begin{aligned} K_e &= 160 E_s I_x / L^3 && \text{(Biggs, Table 5.3)} \\ &= 160 (29,000,000 \text{ psi})(3.85 \text{ in}^4) / (240 \text{ in})^3 \\ &= 1,292 \text{ lb/in, or } 0.11 \text{ psi/in} \quad (0.30 \text{ kPa/cm}) \end{aligned}$$

effective elastic deflection,

$$y_e = R_u / K_e = (0.50 \text{ psi}) / (0.11 \text{ psi/in}) = 4.55 \text{ in} \quad (7.62 \text{ cm})$$

$$\begin{aligned} \text{weight} &= (1.25 \text{ psf deck}) + (5.4 \text{ plf purlin}) / (4 \text{ ft trib. width}) + (5 \text{ psf mechanical}) \\ &= 7.6 \text{ psf, or } 0.053 \text{ psi} \quad (0.37 \text{ kPa}) \end{aligned}$$

initial deflection,

$$y_d = \text{weight} / K_e = (0.053 \text{ psf}) / (0.11 \text{ psi/in}) = 0.48 \text{ in} \quad (1.22 \text{ cm})$$

mass,

$$\begin{aligned} M &= \text{weight} / g \\ &= (0.053 \text{ psi}) / (386 \text{ in/s}^2) \\ &= 0.000137 \text{ psi-s}^2/\text{in, or } 137 \text{ psi-ms}^2/\text{in} \quad (372 \text{ kPa-ms}^2/\text{cm}) \end{aligned}$$

load - mass factors,

(Table 6.3)

$$\begin{aligned} \text{elastic, } K_{LM} &= (0.45) / (0.58) = 0.78 \\ \text{elasto-plastic, } K_{LM} &= (0.50) / (0.64) = 0.78 \\ \text{plastic, } K_{LM} &= (0.33) / (0.50) = 0.66 \end{aligned}$$

$$\text{use an average value, } K_{LM} = [(0.78 + 0.78) / 2 + 0.66] / 2 = 0.72$$

equivalent mass,

$$M_e = K_{LM} (M) = 0.72 (137 \text{ psi-ms}^2/\text{in}) = 98.6 \text{ psi-ms}^2/\text{in} \quad (268 \text{ kPa-ms}^2/\text{cm})$$

natural period:

(Equation 6.8)

$$t_n = 2 \pi \sqrt{M_e / K_e} = 2 \pi \sqrt{(98.6 \text{ psi-ms}^2 / \text{in}) / (0.11 \text{ psi / in})} = 188 \text{ ms}$$

NOTE: The roof panel has a period, t_n , of 12.6 ms. Analyzing the roof panel and purlin separately should be adequate with this difference in periods (refer to section 6.2.3).

12.6.11 Compute Response (numerical integration of dynamic reaction)

time increment,

$$(188 \text{ ms period}) / 10 \approx 19 \text{ ms}$$

$$(4 \text{ ms rise time}) / 10 = 0.4 \text{ ms, use 0.1 ms}$$

pinned end reaction,

$$\text{elastic, } V_p = 0.26R + 0.12F$$

$$\text{plastic, } V_p = 0.39R_u + 0.11F - M_p/L$$

fixed end reaction,

$$\text{elastic, } V_f = 0.43R + 0.19F$$

$$\text{plastic, } V_f = 0.39R_u + 0.11F + M_p/L$$

NOTE: $M_p/L = (115,260 \text{ in-lb}) / (240 \text{ in}) = 480 \text{ lb} \quad (2,135 \text{ N})$

Purlin Analysis - Revised Section

Equiv. Elastic Displac. = 4.558E+00	Max Force = 9.150E-01
Max Displacement = 7.001E+00	Min Force = 0.000E+00
Min Displacement = -8.624E-01	Max Resistance = 5.000E-01
Time of Max Displacement = 6.820E+01	Min Resistance = -4.039E-01
Time of Min Displacement = 3.115E+02	Max Shear A = 2.760E-01
MU = 1.536E+00	Min Shear A = -1.737E-01
	Max Shear B = 1.687E-01
	Min Shear B = -1.050E-01

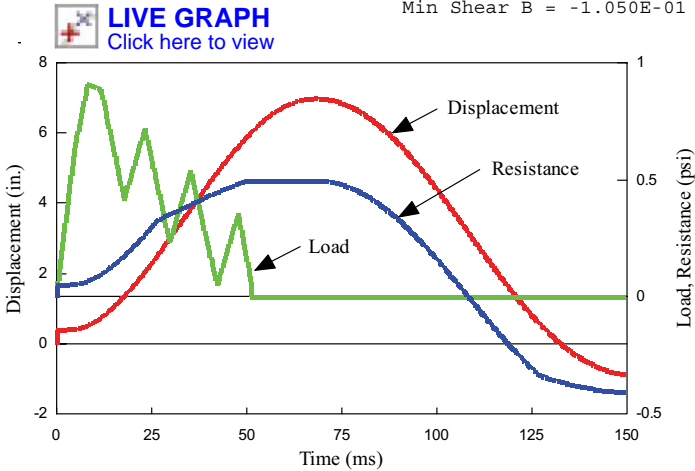

FIGURE 12.7: Roof Purlin Numerical Integration

The positive peak deflection is $y_m = 7.0 \text{ in} \quad (17.8 \text{ cm})$ at $t = 68 \text{ ms}$

The positive peak reaction is $12.5 \text{ lb/in} \quad (21.9 \text{ N/cm})$ at $t = 49 \text{ ms}$

The peak rebound reaction is $8.3 \text{ lb/in} \quad (14.5 \text{ N/cm})$ at $t = 150 \text{ ms}$

ductility,

$$\mu_d = (y_m) / (y_e) = (7.0 \text{ in}) / (4.55 \text{ in}) = 1.5$$

support rotation, (Figure 5.9)

$$\theta_d = \arctan (y_m / 0.5 L) = \arctan [(7.0 \text{ in}) / (0.5)(240 \text{ in})] = 3.3^\circ$$

NOTE: This response from the dynamic reactions is approximately half of that produced by applying the blast load by tributary area.

12.6.12 Compare Response to Deformation Limits

$$\theta_d = 3.3^\circ < 6^\circ \quad \text{OK}$$

$$\mu_d = 1.5 < 10 \quad \text{OK} \quad \underline{\text{Response Is Adequate}}$$

12.6.13 Revise section as required

Member size could be reduced but approaching minimize size for constructability and static loads. A heavier panel would allow a greater spacing and make the purlin more efficient. Cold formed members would work well for this load level.

A revision is not necessary.

12.6.14 Check Secondary Failure Modes (in this case, shear)

reaction at ultimate resistance,

$$V_u = R_u / 2 + M_p / L = (5,763 \text{ lb}) / 2 + 480 \text{ lb} = 3,362 \text{ lb} \quad (14.95 \text{ kN}) < V_n, \quad \text{OK}$$

Shear capacity is adequate.

12.7 WALL GIRTS

The girts are flush with the columns and are simply supported. Assume A36 rolled shapes. Loads are light enough that cold formed steel could also be used. The girts are assumed to be laterally braced by the wall panels in tension.

Span, $L = 20 \text{ ft}$, or 240 in (610 cm)

Response limits: $\theta_a = 6^\circ$, $\mu_a = 10$

Two methods for applying blast loads will be used. The first is the Tributary Area Method which applies the wall panel pressure-time history to the loaded area of the girt. The second method will use the dynamic reactions of the wall panel as the load applied to the girt. The girt load is determined at each time step as follows:

Load, $\text{psi} = (2 \text{ sides}) [\text{wall panel reaction, lb/in}] / (36 \text{ in girt spacing})$

12.7.1 Dynamic Material Properties

for dynamic bending or shear,

$$F_{ds} = F_{dy} = (\text{SIF})(\text{DIF}) F_y = (1.1)(1.29) 36 \text{ ksi} = 51 \text{ ksi} \quad (352 \text{ MPa}) \quad (\text{Appendix 5.A})$$

12.7.2 Calculate a Trial Size

Use the Tributary Width Method for applying load to the purlin in initial sizing.

tributary width = 3 ft, or 36 in (91 cm)

Dead Load, DL = 0

Wall blast load,
BL = 2.4 psi (16.55 kPa)

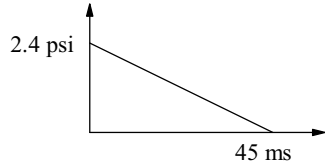

impulse,

$$I_o = (2.4 \text{ psi})(45 \text{ ms}) / 2 = 54 \text{ psi-ms} \quad (372 \text{ kPa-ms})$$

Let the ductility demand equal the limiting value, $\theta_d = \theta_a = 10$

As an initial guess, let $\tau = t_d / t_n = 3$ (in the dynamic range of response)

load/resistance ratio, (Equation 6.11)

$$F_o / R_m = \frac{\sqrt{(2\mu_d - 1)}}{\pi(\tau)} + \frac{(2\mu_d - 1)(\tau)}{2\mu_d(\tau + 0.7)} = \frac{\sqrt{2(10) - 1}}{\pi(3)} + \frac{(2(10) - 1)3}{2(10)(3 + 0.7)} = 1.23$$

peak load, $F_o = BL = 2.4 \text{ psi} \quad (16.55 \text{ kPa})$

resistance,

$$R_m = F_o / 1.23 = (2.4 \text{ psi}) / 1.23 = 1.95 \text{ psi} \quad (13.44 \text{ kPa})$$

ultimate moment, from $R_b = 8 (M_{pc}) / L$ (Table 6.1)

$$\begin{aligned} M_p &= R_m L / 8 \\ &= (1.95 \text{ psi} * 240 \text{ in} * 36 \text{ in})(240 \text{ in}) / 8 \\ &= 505,440 \text{ in-lb} \quad (5,711 \text{ kN-cm}) \end{aligned}$$

plastic section modulus,

$$Z_x = M_p / F_{ds} = (505,440 \text{ in-lb}) / (51,000 \text{ psi}) = 9.91 \text{ in}^3 \quad (162 \text{ cm}^3)$$

The moment capacity is based on Z_x because the target $\mu > 3$.

NOTE: The value of Z_x determined above is not a minimum requirement, but rather an initial estimate. Based on the results of the roof purlin calculation, a smaller trial size will be selected.

Select C6x8.2,

(AISC Manual)

$$I_x = 13.1 \text{ in}^4 \quad (545 \text{ cm}^4)$$

$$Z_x = 5.13 \text{ in}^3 \quad (84.1 \text{ cm}^3)$$

$$r_y = 0.537 \text{ in} \quad (1.36 \text{ cm})$$

$$A_v \text{ (area of web)} = 1.2 \text{ in}^2 \quad (7.74 \text{ cm}^2)$$

Perform a detailed check of this section

12.7.3 Compute Section Properties

moment capacity, (AISC 360, Equation F2-1)
 $M_p = Z_x (F_{ds}) = (5.13 \text{ in}^2)(51,000 \text{ psi}) = 261,630 \text{ in-lb} \quad (2,956 \text{ kN-cm})$

The moment capacity is based on Z_x because the target $\mu > 3$.

shear capacity, (AISC 360, Section G2.1(a))
 $V_n = 0.6 (A_v)(F_{ds}) = 0.6 (1.2 \text{ in}^2)(51,000 \text{ psi}) = 36,720 \text{ lb} \quad (163.3 \text{ kN})$

12.7.4 Compute SDOF Properties

ultimate resistance, from $R_b = 8 (M_{pe}) / L$ (Table 6.1)
 $R_u = 8 (M_p) / L = 8 (261,630 \text{ in-lb}) / (240 \text{ in}) = 8,721 \text{ lb, or } 1.0 \text{ psi} \quad (6.89 \text{ kPa})$

effective stiffness, (Table 6.1)
 $K_e = 384 E_s I_x / 5 L^3$
 $= 384 (29,000,000 \text{ psi})(13.1 \text{ in}^4) / 5 (240 \text{ in})^3$
 $= 2,111 \text{ lb/in, or } 0.24 \text{ psi/in} \quad (0.65 \text{ kPa/cm})$

effective elastic deflection,
 $y_e = R_u / K_e = (1.0 \text{ psi}) / (0.24 \text{ psi/in}) = 4.1 \text{ in} \quad (10.4 \text{ cm})$

weight = $(1.25 \text{ psf siding}) + (8.2 \text{ plf girt}) / (3 \text{ ft trib. width})$
 $= 3.98 \text{ psf, or } 0.028 \text{ psi} \quad (0.19 \text{ kPa})$

mass,
 $M = \text{weight} / g$
 $= (0.028 \text{ psi}) / (386 \text{ in/s}^2)$
 $= 0.000073 \text{ psi-s}^2/\text{in, or } 73 \text{ psi-ms}^2/\text{in} \quad (198 \text{ kPa-ms}^2/\text{cm})$

load - mass factors, (Table 6.1)
 elastic, $K_{LM} = (0.50) / (0.64) = 0.78$
 plastic, $K_{LM} = (0.33) / (0.50) = 0.66$

use an average value, $K_{LM} = (0.78 + 0.66) / 2 = 0.72$

equivalent mass,
 $M_e = K_{LM} (M) = 0.72 (73 \text{ psi-ms}^2/\text{in}) = 53 \text{ psi-ms}^2/\text{in} \quad (365 \text{ kPa-ms}^2/\text{cm})$

natural period: (Equation 6.8)
 $t_n = 2 \pi \sqrt{M_e / K_e} = 2 \pi \sqrt{(53 \text{ psi-ms}^2/\text{in}) / (0.24 \text{ psi/in})} = 93 \text{ ms}$

NOTE: The wall panel has a period, t_n , of 7.2 ms. Analyzing the wall panel and girt separately should be adequate with this difference in periods (refer to Section 6.2.3).

12.7.5 Compute Response (numerical integration solution)

time increment = $t_n / 10 = 93 \text{ ms} / 10 \approx 9 \text{ ms}$, however use 0.1 ms as for the girt design in order to catch all of the abrupt changes in the dynamic wall reaction.

end reaction,

elastic, $V = 0.39R + 0.11F$

plastic, $V = 0.38R_u + 0.12F$

Girt Analysis - Dynamic Reactions

Equiv. Elastic Displac. = 4.167E+00	Max Force = 1.570E+00
Max Displacement = 6.618E+00	Min Force = 0.000E+00
Min Displacement = -1.716E+00	Max Resistance = 1.000E+00
Time of Max Displacement = 1.649E+02	Min Resistance = -1.000E+00
Time of Min Displacement = 2.237E+02	Max Shear A = 4.463E-01
MU = 1.588E+00	Min Shear A = -3.900E-01
	Max Shear B = 4.463E-01
	Min Shear B = -3.900E-01

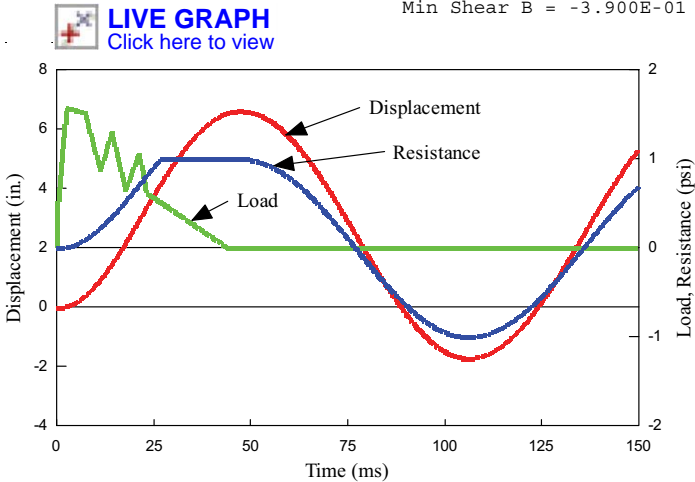

FIGURE 12.8: Wall Girt Numerical Integration

The positive peak deflection is $y_m = 6.6 \text{ in}$ (17 cm) at $t = 48 \text{ ms}$

The positive peak reaction is 16.1 lb/in (28.2 N/cm) at $t = 26 \text{ ms}$

The peak rebound reaction is 14.4 lb/in (25.2 N/cm) at $t = 106 \text{ ms}$

ductility,

$$\mu_d = (y_m) / (y_e) = (6.6 \text{ in}) / (4.1 \text{ in}) = 1.6$$

support rotation,

$$\theta_d = \arctan (y_m / 0.5 L) = \arctan [(6.6 \text{ in}) / (0.5)(240 \text{ in})] = 3.1^\circ$$

(Figure 5.9)

12.7.6 Compare Response to Deformation Limits

$\theta_d = 3.1^\circ < 6^\circ$ OK

$\mu_d = 1.6 < 10$ OK Response Is Adequate

12.7.7 Revise section as required

A revision is not necessary.

12.7.8 Check Secondary Failure Modes (in this case, shear)

reaction at ultimate resistance,

$V_u = R_u / 2 = (8,721 \text{ lb}) / 2 = 4,360 \text{ lb}$ (19.4 kN) $< V_n$, OK

Shear capacity is adequate.

12.8 RIGID FRAMES

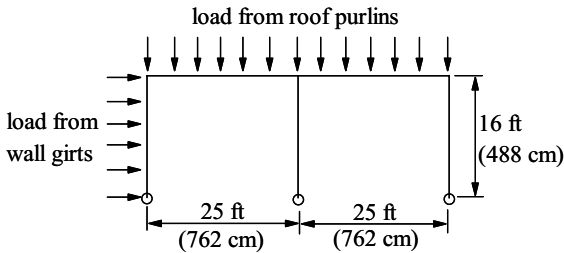

FIGURE 12.9: Frame Elevation

Frame Spacing = 20 ft, or 240 in (610 cm)

Column bases are pinned.

Allowable sidesway, $X_a = 5.5$ in (14 cm)

Initial member sizes for the rigid frame will be estimated using a SDOF approximation of the frame. These estimated sizes will be used in the more detailed MDOF frame analysis to verify adequacy. Maximum deflection of individual members as well as frame sidesway will be used to evaluate the adequacy of the selected members.

12.8.1 Dynamic Material Properties

for dynamic bending and shear,

$F_{ds} = F_{dy} = (SIF)(DIF) F_y = (1.1)(1.29) 36 \text{ ksi} = 51 \text{ ksi}$ (352 MPa)

(Appendix 5.A)

12.8.2 Trial Sizing (General)

Use tributary width method for applying load to frame for initial sizing (refer to Section 6.2.3). The tributary width will be equal to the frame spacing of 20 ft (610 cm). Blast loads will consist of the externally applied roof and wall loads (refer to Section 12.3.3).

The natural period of the frame and girt/purlins are sufficiently different to make this simplification valid. Girt response would not be significantly affected by including interaction, but column flexural response would probably be less. Dynamic reactions from the girts and purlins will have a lower pressure than the blast load but a longer duration. Because of the relatively slow global response of the frame, sidesway will be controlled by impulse and will not be significantly affected by load shape.

12.8.3 Trial Sizing (Column)

To get an initial column size, treat it as a fixed-pinned member supported at the floor and eave.

Blast Load, (front wall load)
 BL = 2.4 psi (16.5 kPa)

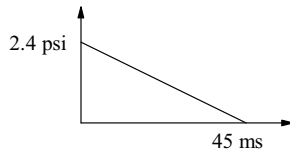

Response limits: $\theta_a = 1.5^\circ$, $\mu_a = 2$ (Table 5.B.2)

Let the ductility demand equal the limiting value, $\mu_d = \mu_a = 2$

As an initial guess, let $\tau = t_d / t_n = 1$

load/resistance ratio, (Equation 6.11)

$$F_o / R_m = \frac{\sqrt{(2\mu_d - 1)}}{\pi(\tau)} + \frac{(2\mu_d - 1)(\tau)}{2\mu_d(\tau + 0.7)} = \frac{\sqrt{2(2) - 1}}{\pi(1)} + \frac{(2(2) - 1)1}{2(2)(1 + 0.7)} = 1.0$$

peak load, $F_o = BL = 2.4 \text{ psi}$ (16.5 kPa)

resistance,

$$R_m = F_o / 1.0 = (2.4 \text{ psi}) / 1.0 = 2.4 \text{ psi}$$
 (16.5 kPa)

effective ultimate moment, from $R_b = 4 (M_{ps} + 2 M_{pc}) / L$ (Table 6.3)

$$M_p = R_m L / 12 = (2.4 \text{ psi} * 240 \text{ in} * 192 \text{ in}) / 12 = 1,769,472 \text{ in-lb}$$
 (19,992 kN-cm)

section modulus, (for selection purposes)

$$S_x = M_p / F_{ds} = (1,769,472 \text{ in-lb}) / (51,000 \text{ psi}) = 34.7 \text{ in}^3$$
 (569 cm³)

Select W10x30,

(AISC Manual)

$$I_x = 170 \text{ in}^4$$
 (7,076 cm⁴)

$$S_x = 32.4 \text{ in}^3$$
 (531 cm³)

$$Z_x = 36.6 \text{ in}^3 \quad (600 \text{ cm}^3)$$

$$A_s = 8.84 \text{ in}^2 \quad (57.0 \text{ cm}^2)$$

$$A_v \text{ (area of web)} = 3.14 \text{ in}^2 \quad (20.3 \text{ cm}^2)$$

moment capacity, (AISC 360, Equation F2-1)

$$M_p = Z_x (F_{ds}) = (36.6 \text{ in}^3)(51,000 \text{ psi}) = 1,866,600 \text{ in-lb} \quad (21,090 \text{ cm-kN})$$

Check sidesway response,

The columns are simply supported at the base and continuous at the beam-column connection. This configuration can be modeled as 3 cantilevered columns acting in parallel with a concentrated load and mass at the tip.

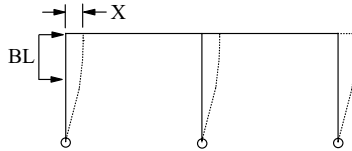

Tributary area for sidesway load is equal to $\frac{1}{2}$ the wall base to eave height. Use the wall blast load impulse for the forcing function.

Impulse,

$$I_o = (2.4 \text{ psi})(192 \text{ in} / 2)(240 \text{ in})(45 \text{ ms}) / 2 = 1,244,160 \text{ lb-ms} \quad (5,534 \text{ kN-ms})$$

Single column resistance,

$$R_u = M_p / L = (1,866,600 \text{ in-lb}) / (192 \text{ in}) = 9,722 \text{ lb} \quad (43.2 \text{ kN})$$

Total resistance = (3 cols)(9,722 lb) = 29,166 lb (129.6 kN)

Single column stiffness, (AISC Manual, Beam Diagrams)

$$K_e = 3 E_s I_x / L^3$$

$$= 3 (29,000,000 \text{ psi}) (170 \text{ in}^3) / (192 \text{ in})^3$$

$$= 2,090 \text{ lb/in} \quad (3.66 \text{ kN/cm})$$

Total stiffness = (3cols)(2,090 kN/cm) = 6,270 lb/in (10.98 kN/cm)

sidesway elastic deflection,

$$X_e = R_u / K_e = (29,166 \text{ lb}) / (6,270 \text{ lb/in}) = 4.65 \text{ in} \quad (11.8 \text{ cm})$$

Use 1/3 mass of walls + mass of roof

$$\text{weight} = [(2 \text{ walls})(16 \text{ ft height} / 3) + (50 \text{ ft roof span})] (20 \text{ ft width})(\text{say } 6 \text{ psf})$$

$$= 7,280 \text{ lbs} \quad (32.4 \text{ kN})$$

mass,

$$M = \text{weight} / g$$

$$= (7,280 \text{ lbs}) / (386.4 \text{ in/s}^2)$$

$$= 18.8 \text{ lb-s}^2/\text{in}, \text{ or } 18,800,000 \text{ lb-ms}^2/\text{in} \quad (32,924 \text{ kN-ms}^2/\text{cm})$$

Because the load can be treated as an impulse, use an energy balance method to determine response. (Biggs, Section 5.5b)

Kinetic energy of load,

$$\begin{aligned}
 KE &= (I_o)^2 / 2M_e \\
 &= (1,244,160 \text{ lb-ms})^2 / 2(18,800,000 \text{ lb-ms}^2/\text{in}) \\
 &= 41,168 \text{ lb-in} \quad (465 \text{ kN-cm})
 \end{aligned}$$

Strain energy of frame, where X is the sidesway at top of frame,
 $SE = R_u (X_e)/2 + R_u (X_m - X_e)$

Rearranging and substituting KE for SE,

$$\begin{aligned}
 X_m &= [KE + 0.5 (R_u)(X_e)] / R_u \\
 &= [(41,168 \text{ lb-in}) + 0.5 (29,166 \text{ lb})(4.65 \text{ in})] / (29,166 \text{ lb}) \\
 &= 3.73 \text{ in} \quad (9.47 \text{ cm}) < X_a, \text{ OK}
 \end{aligned}$$

12.8.4 Trial Sizing (Beam)

To get an initial beam size, treat it as a fixed-pinned member supported at the eave and center support.

Dead Load,

$$DL = 11 \text{ psf, or } 0.08 \text{ psi} \quad (0.53 \text{ kPa})$$

Blast Load,

$$BL = 1.2 \text{ psi} \quad (8.27 \text{ kPa})$$

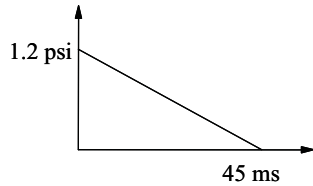

$$\text{impulse, } I_o = (1.2 \text{ psi})(45 \text{ ms}) / 2 = 27 \text{ psi - ms} \quad (186 \text{ kPa-ms})$$

As an initial guess, let $\tau = t_d / t_n = 1$

load/resistance ratio, (Equation 6.11)

$$F_o / R_m = \frac{\sqrt{(2\mu_d - 1)}}{\pi(\tau)} + \frac{(2\mu_d - 1)(\tau)}{2\mu_d(\tau + 0.7)} = \frac{\sqrt{2(2) - 1}}{\pi(1)} + \frac{(2(2) - 1)1}{2(2)(1 + 0.7)} = 1.0$$

$$\text{peak load, } F_o = DL + BL = 0.08 \text{ psi} + 1.2 \text{ psi} = 1.28 \text{ psi} \quad (8.83 \text{ kPa})$$

resistance,

$$R_m = F_o / 0.99 = (1.28 \text{ psi}) / 1.0 = 1.28 \text{ psi} \quad (8.83 \text{ kPa})$$

effective ultimate moment, from $R_b = 4 (M_{ps} + 2 M_{pc}) / L$ (Table 6.3)

$$\begin{aligned}
 M_p &= R_m L / 12 \\
 &= (1.28 \text{ psi} * 240 \text{ in} * 300 \text{ in})(300 \text{ in}) / 12 \\
 &= 2,304,000 \text{ in-lb} \quad (26,032 \text{ kN-cm})
 \end{aligned}$$

section modulus, (for selection purposes)

$$S_x = M_p / F_{ds} = (2,304,000 \text{ in-lb}) / (51,000 \text{ psi}) = 45.2 \text{ in}^3 \quad (741 \text{ cm}^3)$$

Try same member as used for column since load will be from dynamic reaction:

Select W10x30, (AISC Manual)

$$I_x = 170 \text{ in}^4 \quad (7,076 \text{ cm}^4)$$

$$S_x = 32.4 \text{ in}^3 \quad (531 \text{ cm}^3)$$

$$Z_x = 36.6 \text{ in}^3 \quad (600 \text{ cm}^3)$$

$$A_s = 8.84 \text{ in}^2 \quad (57.0 \text{ cm}^2)$$

$$A_v \text{ (area of web)} = 3.14 \text{ in}^2 \quad (20.3 \text{ cm}^2)$$

It is advisable to perform a dynamic analysis of the column and beam as isolated components to verify that flexural response is acceptable before analyzing the entire frame since this is much quicker than frame analysis. This step is not shown in this solution. Frame response will include the effects of axial loads which reduce the flexural capacity of members. This will increase response with respect to component analysis.

12.8.5 MDOF Analysis (Model)

A multi-degree of freedom (MDOF) plane frame analysis program is used to determine the response of the frame to the dynamic reactions from the girts and purlins. The structure is discretized into elements, and loads are applied to nodes. Input includes nodal coordinates, modal mass, member connectivity, member properties, supports, and solution control parameters (time step, duration of numerical integration, etc.). Dynamic material properties are input into the program by defining the elastic and ultimate yield strengths and associated strain or by defining member capacities. The latter approach will be used for this problem. Non-linear response will be included in the analysis through tracking of plastic hinge formation and reformulation of the stiffness matrix at each time point.

This analysis is similar to a conventional static analysis with the exception of non-linear member properties and pressure-time loadings. Member adequacy is judged by maximum deflection and support rotation rather than the member stress criteria used in static design.

Output includes node displacements, member end forces and support reactions. A three-dimensional model would produce more accurate results but a two-dimensional analysis normally is sufficient for this type of structure. Members will be subjected to loads from both long and short walls. The member capacity used in the model or the allowable deformation must be limited to account for the fact that the members will be subjected to simultaneous bi-axial loading. A typical capacity reduction factor is 25%. This factor reflects the fact that peak stresses from each direction rarely occur at the same time.

The model is shown below:

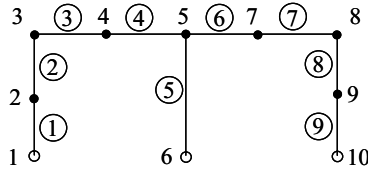

FIGURE 12.10: MDOF Model

Columns: W10x30 Beams: W 10x30

Two load cases were run. The first used blast loads applied over a tributary area. The second used dynamic reactions from the girts and purlins. Results of the analysis are indicated in the following sections.

12.8.6 - MDOF Analysis (Tributary Area Loading)

 **LIVE GRAPH**
[Click here to view](#)

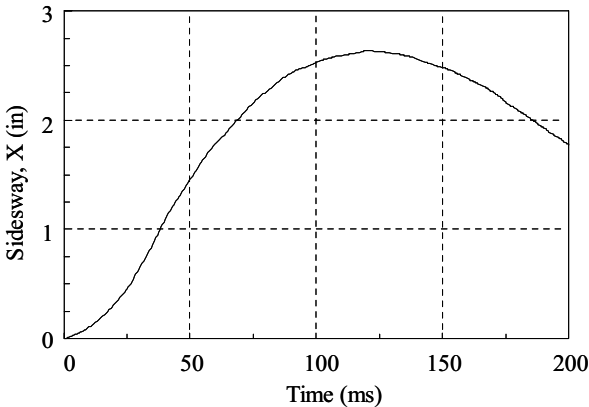

FIGURE 12.11: Plot of Node 3 Sidesway Response

Maximum sidesway, (node 3)
 $X_m = 2.64 \text{ in (6.7 cm)}$

Column response, (member 1)
 $\theta_d = 1.3^\circ$, $y_m = 2.9 \text{ in (7.4 cm)}$, $\mu_d = 0.63$

Beam response, (member 3)
 $\theta_d = 0.27^\circ$, $y_m = 1.4 \text{ in (3.6 cm)}$, $\mu_d = 0.38$

Peak support reactions,

Horizontal = 18.8 kips (83.6 kN) node 1

Vertical = 96.4 kips (428.8 kN) node 6

12.8.7 - MDOF Analysis (Dynamic Reaction Loading)

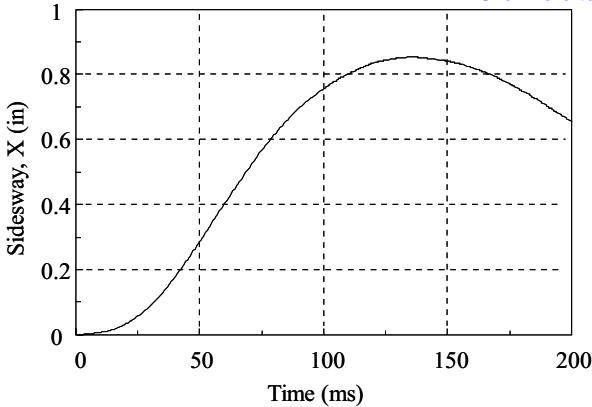

FIGURE 12.12: Plot of Node 3 Sidesway Response

Maximum sidesway, (node 3)

$X_m = 0.85$ in (2.2 cm)

Column response, (member 1)

$\theta_d = 0.15^\circ$, $y_m = 0.57$ in (1.5 cm), $\mu_d = 0.07$

Beam response, (member 3)

$\theta_d = 0.21^\circ$, $y_m = 0.45$ in (1.14 cm), $\mu_d = 0.06$

Peak support reactions,

Horizontal = 4.1 kips (18.2 kN) node 1

Vertical = 27.7 kips (123.2 kN) node 6

12.8.8 Check Adequacy of Member Sizes

Column,

$\theta_d = 0.15^\circ < 1.5^\circ$, OK

$\mu_d = 0.07 < 2$, OK

Beam,

$\theta_d = 0.21^\circ < 1.5^\circ$, OK

$\mu_d = 0.06 < 2$, OK

Use of dynamic reactions does make a noticeable difference in the maximum predicted response which would permit adjustment of sizes if desired.

12.8.9 Additional considerations

Connections - Design to develop ultimate strength of the members being connected. Peak member end forces from the frame analysis can be used; however, this can be extremely conservative since the peak force occurs for only a short time.

Bracing - Members should be braced in accordance with AISC specification requirements to develop full moment capacity of each member. Both flanges should be braced to accommodate rebound forces.

12.9 BRACED FRAMES

The lateral load resisting system for blast loads along the short side of the building is shown schematically in the following diagram.

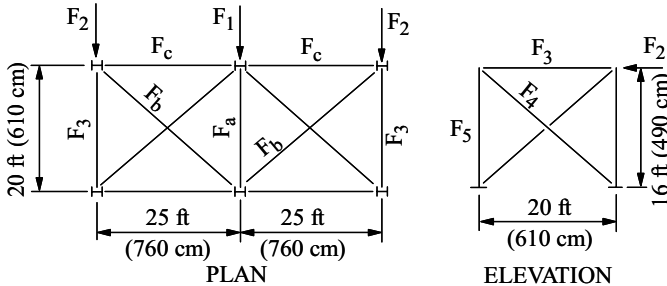

FIGURE 12.13: Braced Frame Layout

Loads applied to panels on the short wall will be resisted by the three end columns. The roof panels will act as a diaphragm to distribute the loads but they must also resist vertical blast loads in bending which reduces in-plane capacity. To avoid this problem, the top of the center column will be supported by a truss in the roof of the end bay. This truss will utilize the rigid frame beams as chord members with additional angles added to form the struts. Braced frames in the end bay wall will provide the support reaction for the roof truss as well as the load from the corner columns. The end bay braced frame will consist of the rigid frame columns and x-bracing. Since the columns must resist loads from both directions, the axial capacity in each direction is artificially reduced for the analysis.

The braced frame will be designed using static design process based on the capacity of supported members. Bracing provides a stiff system which responds to pressure without absorbing much energy.

12.9.1 Dynamic Material Properties

for dynamic bending and shear, (Appendix 5.A)
 $F_{ds} = F_{dy} = (SIF)(DIF) F_y = (1.1)(1.29) 36 \text{ ksi} = 51 \text{ ksi} \quad (352 \text{ MPa})$

for dynamic tension and compression, (Appendix 5.A)
 $F_{ds} = F_{dy} = (SIF)(DIF) F_y = (1.1)(1.19) 36 \text{ ksi} = 47 \text{ ksi} \quad (325 \text{ MPa})$

12.9.2 Determine Blast Load

The braced frame must develop the ultimate capacity of the members which it supports, namely the girts and end wall columns. The force applied to the top of the column is equal to the tributary area times the resistance as a static load. Each braced frame will be designed to resist the entire load even though there will be a frame at each end of the building. This will provide redundancy and will eliminate large axial forces in the top perimeter beams at the interior frames.

1) Load based on column capacity

Column ultimate moment, (Section 12.8.3)
 $M_p = 1,866,600 \text{ in-lb} \quad (21,090 \text{ cm-kN})$

Column resistance, (Table 6.3)
 $R_b = 4(M_{ps} + 2 M_{pc}) / L = 12 (M_p) / L$
 $= 12 (1,866,600 \text{ in-lb}) / (192 \text{ in})$
 $= 116,663 \text{ lb} \quad (519 \text{ kN})$

Column unit resistance,
 $R_u = R_b / (25 \text{ ft width})(16 \text{ ft height})$
 $= (116,663 \text{ lb}) / (300 \text{ in})(192 \text{ in})$
 $= 2.0 \text{ psi} \quad (13.8 \text{ kPa})$

2) Load based on girt capacity

Girt ultimate moment, (Section 12.7.3)
 $M_p = 261,630 \text{ in-lb} \quad (2,956 \text{ cm-kN})$

Girt resistance, (Table 6.3)
 $R_b = 8(M_{pc}) / L = 8 (M_p) / L$
 $= 8 (261,630 \text{ in-lb}) / (300 \text{ in})$
 $= 6,977 \text{ lb} \quad (31.0 \text{ kN})$

Girt unit resistance,
 $R_u = R_b / (3 \text{ ft width})(25 \text{ ft length})$
 $= (6,977 \text{ lb}) / (36 \text{ in})(300 \text{ in})$
 $= 0.65 \text{ psi} \quad (4.5 \text{ kPa})$

The larger column capacity controls, $R_u = 2.0 \text{ psi} \quad (13.8 \text{ kPa})$

12.9.3 Braced Frame Forces

Because of differences in stiffness, compression forces will be neglected in cross members.

Load on top of center column,

$$\begin{aligned} F_1 &= R_u (25 \text{ ft width})(16 \text{ ft height} / 2) \\ &= (2.0 \text{ psi})(300 \text{ in})(96 \text{ in}) \\ &= 57,600 \text{ lbs} \quad (256 \text{ kN}) \end{aligned}$$

Load at top of corner columns,

$$\begin{aligned} F_2 &= R_u (25 \text{ ft width} / 2)(16 \text{ ft height} / 2) \\ &= (2.0 \text{ psi})(150 \text{ in})(96 \text{ in}) \\ &= 28,800 \text{ lbs} \quad (128 \text{ kN}) \end{aligned}$$

Angle of roof brace,

$$\alpha_1 = \tan^{-1} (25 \text{ ft} / 20 \text{ ft}) = 51.3^\circ$$

Tension force in roof brace,

$$\begin{aligned} F_3 &= \frac{1}{2} F_1 / \cos (\alpha_1) \\ &= \frac{1}{2} (57,600 \text{ lb}) / \cos (51.3^\circ) \\ &= 46,060 \text{ lb} \quad (205 \text{ kN}) \end{aligned}$$

Axial force in roof truss chord member,

$$\begin{aligned} F_4 &= F_3 (\sin (\alpha_1)) \\ &= (46,060 \text{ lb}) (\sin (51.3^\circ)) \\ &= 35,950 \text{ lb} \quad (160 \text{ kN}) \end{aligned}$$

Load in top perimeter member along long wall,

$$\begin{aligned} F_5 &= F_2 + \frac{1}{2} F_1 \\ &= (28,800 \text{ lb}) + \frac{1}{2} (57,600 \text{ lb}) \\ &= 57,600 \text{ lb} \quad (256 \text{ kN}) \end{aligned}$$

Angle of vertical brace,

$$\alpha_2 = \tan^{-1} (16 \text{ ft} / 20 \text{ ft}) = 38.7^\circ$$

Load in vertical-brace will include contribution from roof truss,

$$\begin{aligned} F_6 &= F_5 / \cos (\alpha_2) \\ &= (57,600 \text{ lb}) / \cos (38.7^\circ) \\ &= 73,805 \text{ lbs} \quad (328 \text{ kN}) \end{aligned}$$

Load in column due to braced frame response:

$$\begin{aligned} F_7 &= F_6 (\sin (\alpha_2)) \\ &= (73,805 \text{ lb}) (\sin (38.7^\circ)) \\ &= 46,150 \text{ lb} \quad (205 \text{ kN}) \end{aligned}$$

12.9.4 Design Top Perimeter Member

Applied load, (Section 12.9.3)

$$P_u = F_5 = 57.6 \text{ kips} \quad (256 \text{ kN})$$

Try a W10x19 (AISC Manual)

$$A_s = 5.62 \text{ in}^2 \quad (36.3 \text{ cm}^2)$$

$$I_x = 96.3 \text{ in}^4 \quad (4,008 \text{ cm}^4)$$

$$I_y = 4.29 \text{ in}^4 \quad (178 \text{ cm}^4)$$

$$r_x = 4.14 \text{ in} \quad (10.5 \text{ cm})$$

$$r_y = 0.874 \text{ in} \quad (2.2 \text{ cm})$$

For compression, capacity is determined by buckling.

A brace will be provided at mid-span for the weak axis. Therefore the unbraced lengths are,

$$L_x = 20 \text{ ft, or } 240 \text{ in} \quad (610 \text{ cm})$$

$$L_y = 20 \text{ ft} / 2, \text{ or } 120 \text{ in} \quad (305 \text{ cm})$$

Use effective length factor, $K = 1.0$

$$K_x L_x / r_x = (1)(240 \text{ in}) / (4.14 \text{ in}) = 58$$

$$K_y L_y / r_y = (1)(120 \text{ in}) / (0.874 \text{ in}) = 137 \text{ (controls)}$$

Column slenderness factor, (AISC 360, Section E3)

$$\lambda_c = 4.71 \sqrt{E_s / F_{dy}} = 4.71 \sqrt{(29,000 \text{ ksi}) / (47 \text{ ksi})} = 117 < 137$$

Elastic critical buckling stress, (AISC 360, Equation E3-3)

$$F'_e = \pi^2 E_s / (K_y L_y / r_y)^2 = \pi^2 (29,000 \text{ ksi}) / (137)^2 = 15.2 \text{ ksi} \quad (105 \text{ MPa})$$

Flexural buckling stress, (AISC 360, Equation E3-3)

$$F_{cr} = 0.877 (F'_e) = 0.877 (15.2 \text{ ksi}) = 13.3 \text{ ksi} \quad (91.7 \text{ MPa})$$

Required area, (AISC 360, Equation E3-1)

$$A_n = P_n / F_{cr}$$

$$= (57.6 \text{ kips}) / (13.3 \text{ ksi})$$

$$= 4.3 \text{ in}^2 \quad (27.7 \text{ cm}^2) < A_s, \text{ OK}$$

USE W10x12**12.9.5 Design Vertical Cross Brace**

Applied load, (Section 12.9.3)

$$P_u = 73.8 \text{ kips} \quad (328 \text{ kN})$$

Required area for tension, (AISC 360, Equation D2-1)

$$A_n = P_n / F_y = P_u / F_{ds}$$

$$= (73.8 \text{ kips}) / (47 \text{ ksi})$$

$$= 1.57 \text{ in}^2 \quad (10.1 \text{ cm}^2)$$

for L3x3x5/16, $A_s = 1.78 \text{ in}^2$ (11.5 cm²) > A_n , OK

USE L3x3x5/16

12.10 FOUNDATION

Preliminary design of the foundation will include evaluating overturning, bearing pressures and lateral load resistance. The foundation must be able to resist the applied blast loads with a degree of safety to account for uncertainties in prediction of soil properties. Foundation failure can cause serious collapse hazards, thus it is prudent to maintain a conservative design. Also, should an incident occur, it is many times desirable to be able to remove the building structure and rebuild on the same foundation.

Since a conservative approach is used, it is quite common practice to design the foundation using static loads. Typically, this involves applying the resistance of the roof and walls as uniform static loads and computing reactions. Support reactions from frame analyses are also checked to ensure that local foundation failures don't occur. Dynamic analysis of foundations can be accomplished if appropriate soil properties are provided.

The foundation for this problem will be a spread footing for the wall columns and isolated interior column footings.

12.10.1 Foundation Loads

Roof and wall loads are determined by the lowest resistance for each of the members. The roof deck has a resistance of 1.5 psi (10.3 kPa) while the purlins have a resistance of 0.5 psi (3.45 kPa). Thus the greatest load which can be transmitted to the frame is 0.5 psi (3.45 kPa). The wall panel resistance is 2.66 psi (18.3 kPa) while the girt controls with 1.0 psi (6.89 kPa). These loads are shown in the figure below.

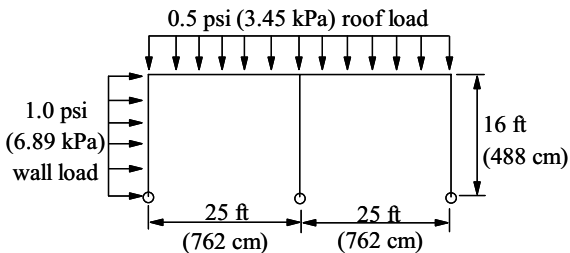

FIGURE 12.14: Foundation Loading

12.10.2 Gross Overturning

Gross overturning of the structure can be determined by summing moments about the leeward column support.

Overturing Moment,

$$OM = (1 \text{ psi})(144 \text{ in}^2/\text{ft}^2)(16 \text{ ft height})^2 / 2 = 18,432 \text{ ft-lb/ft} \quad (82.0 \text{ cm-kN/cm})$$

Resisting Moment,

$$RM = (0.5 \text{ psi})(144 \text{ in}^2/\text{ft}^2)(50 \text{ ft width})^2 / 2 = 90,000 \text{ ft-lb/ft} \quad (400.3 \text{ cm-kN/cm})$$

Factor of Safety Against Overturing,

(Section 7.7.1)

$$RM/OM = (90,000 \text{ ft-lb/ft}) / (18,432 \text{ ft-lb/ft}) = 4.9 > 1.2, \text{ OK}$$

12.10.3 Lateral Load

Friction resistance under the spread footings combined with passive resistance will be used to resist lateral forces. The following lateral forces are computed in terms of load per unit length of wall even though much of the loads will be resisted by individual spread footings. Frictional resistance is a function of vertical loads, not footing width.

Applied lateral load per unit length of wall,

$$V_1 = (1.0 \text{ psi} * 144 \text{ in}^2/\text{ft}^2)(16 \text{ ft height}) = 2,304 \text{ lb/ft} \quad (0.34 \text{ kN/cm})$$

Applied vertical load per unit length of wall,

$$\begin{aligned} P_1 &= \text{vertical load from resistance of roof members plus slab dead weight} \\ &= [(0.5 \text{ psi} * 144 \text{ in}^2/\text{ft}^2) + (0.5 \text{ ft slab})(150 \text{ pcf})] (50 \text{ ft width}) \\ &= 7,350 \text{ lb/ft} \quad (1,073 \text{ N/cm}) \end{aligned}$$

Frictional resistance from footing per unit length of wall,

$$\begin{aligned} V_2 &= P_1 (\text{coefficient of friction}) \\ &= (7,350 \text{ lb/ft})(0.3) \\ &= 2,205 \text{ lb/ft} \quad (322 \text{ N/cm}) \end{aligned}$$

Net unbalanced load per unit length of wall,

$$V_3 = V_1 - V_2 = (2,304 \text{ lb/ft}) - (2,205 \text{ lb/ft}) = 99 \text{ lbs/ft} \quad (14.4 \text{ N/cm})$$

Net unbalanced load to be resisted by passive pressure,

(Section 7.7.1)

$$V_4 = V_3 (\text{FS}) = (99 \text{ lb/ft}) 1.5 = 149 \text{ lb/ft} \quad (21.7 \text{ N/cm})$$

Required passive resistance for each frame

$$V_5 = V_4 (\text{frame spacing}) = 149 \text{ lb/ft} (20 \text{ ft}) = 2,980 \text{ lbs} \quad (13.26 \text{ kN})$$

Assume foundation will be stem walls along the exterior with spread footings at columns. Passive resistance will be provided by stem wall over length of spread footing. Passive resistance at center column will be ignored since the width of column support is small.

Required passive resistance at each footing,

$$V_6 = V_5 / (\# \text{ of stem walls}) = (2,980 \text{ lb}) / (2 \text{ each}) = 1,490 \text{ lb} \quad (6.63 \text{ kN})$$

Assume a footing depth of 3 ft (91 cm) and neglect the top 1 ft (30 cm).

Passive force at bottom of footing,

$$V_7 = K_p (\gamma)(\text{depth}) = (1.8)(85 \text{ pcf})(3 \text{ ft}) = 459 \text{ psf} \quad (22 \text{ kPa})$$

Passive force at 1 ft (30 cm) depth,

$$V_8 = K_p (\gamma)(\text{depth}) = (1.8)(85 \text{ pcf})(1 \text{ ft}) = 153 \text{ psf} \quad (7.3 \text{ kPa})$$

Available passive resistance per unit width of footing,

$$V_9 = (459 \text{ psf/ft})(3 \text{ ft}) / 2 - (153 \text{ psf/ft})(1 \text{ ft}) / 2 \\ = 612 \text{ lb/ft} \quad (89.3 \text{ N/cm})$$

Required width of footing,

$$W = V_6 / V_9 = (1,490 \text{ lb}) / (612 \text{ lb/ft}) = 2.5 \text{ ft} \quad (76 \text{ cm})$$

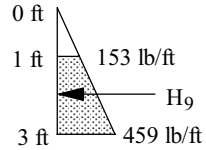

USE a 3 ft (91 cm) wide footing with a continuous stem wall to 3 ft (91 cm) depth

12.10.4 Vertical Load

Applied vertical load on exterior column per unit length of wall,

$$P_2 = [(0.5 \text{ psi} * 144 \text{ in}^2/\text{ft}^2) + 15 \text{ psf dead load}](50 \text{ ft} / 4) \\ = 1,088 \text{ lb/ft} \quad (159 \text{ N/cm})$$

Applied vertical load at each frame,

$$P_3 = P_2 (\text{frame spacing}) = (1,088 \text{ lb/ft})(20 \text{ ft}) = 21,760 \text{ lb} \quad (97 \text{ kN})$$

Allowable bearing pressure for blast load,

$$q = (\text{service load allowable})(\text{static FS}) / (\text{blast FS}) \\ = (2,500 \text{ psf})(2.0) / 1.2 \\ = 4,167 \text{ psf} \quad (200 \text{ kPa})$$

(Section 7.7.1)

Required area of footing,

$$\text{area} = P_3 / q \\ = (21,760 \text{ lb}) / (4,167 \text{ psf}) \\ = 5.22 \text{ sf} \quad (4,850 \text{ cm}^2)$$

Use 3 ft (91 cm) square footing

Applied vertical load on interior column,

$$P_4 = [(0.5 \text{ psi} * 144 \text{ in}^2/\text{ft}^2) + 15 \text{ psf dead load}](50 \text{ ft} / 2) \\ = 2,175 \text{ lb/ft} \quad (317 \text{ N/cm})$$

Applied vertical load at each frame,

$$P_5 = P_4 (\text{frame spacing}) = (2,175 \text{ lb/ft})(20 \text{ ft}) = 43,500 \text{ lb} \quad (193.5 \text{ kN})$$

Required area of footing,

$$\text{area} = P_5 / q \\ = (43,500 \text{ lb}) / (4,167 \text{ psf}) \\ = 10.43 \text{ sf} \quad (9,690 \text{ cm}^2)$$

USE 3 ft 6 in (107 cm) square footing

Check maximum dynamic reaction from frame analysis

$$V = 22,600 \text{ lbs} \quad (100.5 \text{ kN})$$

Assume this is resisted by the 3.5 ft square footing. Area = 12.25 ft² (11,381 cm²)

bearing pressure,

$$q = (22,600 \text{ lb}) / (12.25 \text{ sf}) = 1,845 \text{ psf} \quad (88.3 \text{ kPa}) < 4,167 \text{ psf allowable OK}$$

Additional design would include flexure and shear on footing.

CHAPTER 13

MASONRY RETROFIT DESIGN EXAMPLE

13.1 INTRODUCTION

This chapter provides an example of the evaluation and retrofit of the masonry walls of an existing reinforced concrete framed building using the principles outlined in Chapter 10. The explosion magnitude and front wall blast load are determined by others. Only the analysis of the exterior walls, and upgrade options, are presented in this example.

Structural code provisions, as applicable, are from,

- ACI 530-05, *Building Code Requirements for Masonry Structures*
- ACI 318-05, *Building Code Requirements for Structural Concrete*

Additional References are,

- NCMA, *TEK Manual for Concrete Masonry Design and Construction*
- MacGregor, *Reinforced Concrete, Mechanics and Design*

13.2 STRUCTURAL SYSTEM

Walls - Unreinforced masonry wall spanning between foundation and roof (one-way).

Roof - One-way reinforced concrete slab.

Structural framing - Reinforced moment-resisting concrete bents in each direction.

NOTE: Though unreinforced masonry is not recommended for blast design due to a lack of ductility, it is often encountered in existing buildings.

13.2.1 Description of Structure

One story reinforced concrete and masonry structure,

width = 80 ft (24.4 m)

length = 60 ft (18.3 m)

height = 10 ft (3.0 m)

area = 4,800 ft² (446 m²)

volume = 48,000 ft³ (1,359 m³)

13.2.2 Framing Plan

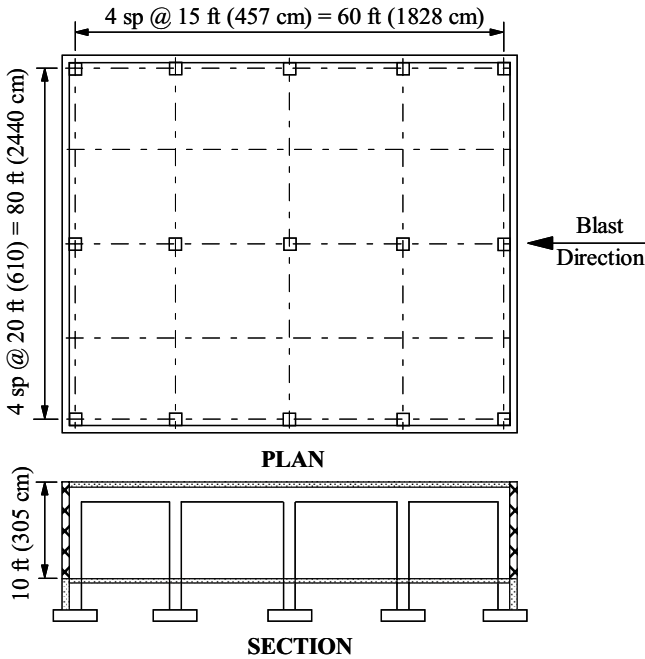

FIGURE 13.1: Framing Layout

13.3 DESIGN DATA

13.3.1 Material Properties

masonry: (hollow units, running bond) $f_m = 1,500 \text{ psi}$ (10.3 MPa)
 mortar: type M
 concrete: $f'_c = 4,000 \text{ psi}$ (27.6 MPa)
 reinforcing steel: ASTM A615, grade 60, $F_y = 60 \text{ ksi}$ (414 MPa)

13.3.2 Design Loads

The following loads are computed from free field blast wave parameters. Refer to Chapter 3 for load determination procedure.

Peak reflected overpressure, $P_r = 3.4 \text{ psi}$ (23.4 kPa)

Effective duration, $t_d = 0.09 \text{ s}$

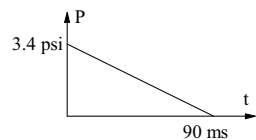

13.3.3 Building Performance Requirements - Deformation Limits

For unreinforced masonry, the failure mode is based on tensile cracking. To avoid the resulting catastrophic failure, the wall must remain elastic. Thus, $\mu_a = 1.0$

For upgrade options a medium response is selected in accordance with Appendix 5.B.

13.4 EXISTING WALL EVALUATION

Walls are 10 ft (3,050 mm) high by 30 ft (9,150 mm) between supports, a 3 to 1 ratio. Therefore the wall will be analyzed as a one way simply supported beam, spanning vertically between the grade beam and the roof beam.

span, $L = 10 \text{ ft}$, or 120 in (3,050 mm)

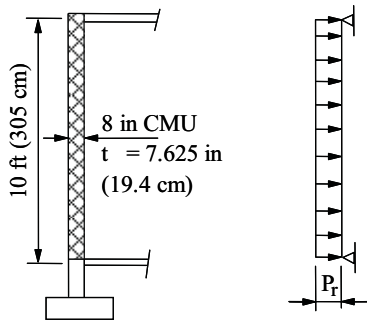

FIGURE 13.2: Wall Section

For an 8 inch nominal (203 mm) C.M.U wall with ungrouted cells, the following section properties are based on a one inch (25.4 mm) width of wall:

- actual thickness, $t_w = 7.625 \text{ in}$ (194 mm)
- area, $A_n = 4.18 \text{ in}^2$ (2,697 mm^2) (NCMA, Table 1b)
- moment of inertia, $I_g = 30.3 \text{ in}^4$ (12,612,000 mm^4) (NCMA, Table 1b)

13.4.1 Compute Required Resistance

for dynamic flexure, (Appendix 5.A)

$$f_{dm} = (\text{SIF})(\text{DIF}) f_m = (1.0)(1.19)(1,500 \text{ psi}) = 1,785 \text{ psi} \quad (12.3 \text{ MPa})$$

modulus of elasticity, ACI 530, Section 1.8.2.2.1)

$$E_m = 900 f_{dm} = 900 (1,785 \text{ psi}) = 1,606,500 \text{ psi} \quad (11,076 \text{ MPa})$$

effective stiffness,

(Table 6.1)

$$\begin{aligned} K_e &= 384 E_m I_g / 5 L^3 \\ &= 384 (1,606.5 \text{ ksi})(30.3 \text{ in}^4) / 5(120 \text{ in})^3 \\ &= 2.16 \text{ k/in} \quad (0.378 \text{ kN/mm}) \end{aligned}$$

unit stiffness,

$$K = (2,160 \text{ lb/in}) / (120 \text{ in span})(1 \text{ in width}) = 18 \text{ psi/in} \quad (4.9 \text{ kPa/mm})$$

weight of block wall,

$$\begin{aligned} \text{weight} &= (\text{density})(A_n)(L) \\ &= (0.144 \text{ kcf})(4.18 \text{ in}^2 / 144)(10 \text{ ft}) \\ &= 0.0418 \text{ kips} \quad (0.186 \text{ kN}) \end{aligned}$$

wall mass

$$\begin{aligned} M &= \text{weight} / g \\ &= (0.0418 \text{ kips}) / (386 \text{ in/s}^2) \\ &= 0.000108 \text{ k-s}^2/\text{in} \quad (0.0000189 \text{ kN-s}^2/\text{mm}) \end{aligned}$$

unit wall mass,

$$\begin{aligned} M &= (0.108 \text{ lb-s}^2/\text{in}) / (120 \text{ in span})(1 \text{ in width}) \\ &= 0.0009 \text{ psi-s}^2/\text{in} \quad (0.00024 \text{ kPa-s}^2/\text{mm}) \end{aligned}$$

because of the limited allowable response, use elastic values for K_{LM}

$$K_{LM} = 0.5 / 0.64 = 0.78$$

(Table 6.1)

equivalent mass,

$$\begin{aligned} M_e &= (K_{LM})(M) \\ &= 0.78 (0.0009 \text{ psi-s}^2/\text{in}) \\ &= 0.000702 \text{ psi-s}^2/\text{in} \quad (0.000019 \text{ kPa-s}^2/\text{mm}) \end{aligned}$$

natural period:

(Equation 6.8)

$$t_n = 2 \pi \sqrt{M_e / K} = 2 \pi \sqrt{(0.000702 \text{ psi-s}^2/\text{in}) / (18 \text{ psi/in})} = 0.039 \text{ s}$$

duration-period ratio,

$$\tau = t_d / t_n = (0.09 \text{ s}) / (0.039 \text{ s}) = 2.3$$

resistance ratio, let $\mu_d = \mu_a = 1.0$

(Equation 6.11)

$$F_o / R_m = \frac{\sqrt{(2\mu_d - 1)}}{\pi(\tau)} + \frac{(2\mu_d - 1)(\tau)}{2\mu_d(\tau + 0.7)} = \frac{\sqrt{2(1.0) - 1}}{\pi(2.3)} + \frac{(2(1.0) - 1) 2.3}{2(1.0)(2.3 + 0.7)} = 0.52$$

required resistance, with $F_o = P_r$

$$R_m = P_r / 0.52 = (3.4 \text{ psi}) / 0.52 = 6.54 \text{ psi} \quad (45 \text{ kPa})$$

Required resistance for rebound: Because of the symmetry of the wall system, the rebound resistance case will not control and is not included in this example.

13.4.2 Available Flexural Capacity

For unreinforced masonry, flexure is based on the cracking strength of the masonry.

modulus of rupture, $f_r = 63 \text{ psi}$ (434 kPa) (ACI 530, Table 3.1.8.2.1)

weight of wall above mid-point,

weight = $(0.348 \text{ psi})(120 \text{ in height} / 2)(1 \text{ in width}) = 20.9 \text{ lb}$ (93 kN)

cracking moment,

$$\begin{aligned} M_{cr} &= (f_r + \text{weight} / A_n) I_o / 0.5 (t_w) \\ &= [63 \text{ psi} + (20.9 \text{ lb}) / (4.18 \text{ in}^2)] (30.3 \text{ in}^4) / 0.5 (7.625 \text{ in}) \\ &= 540 \text{ lb-in} \quad (61,012 \text{ N-mm}) \end{aligned}$$

resistance at cracking moment,

$$R_b = 8 M_{cr} / L = 8 (540 \text{ lb-in}) / (120 \text{ in}) = 36 \text{ lb} \quad (160 \text{ N}) \quad (\text{Table 6.1})$$

unit resistance,

$$R_b = (36 \text{ lb}) / (120 \text{ in span})(1 \text{ in width}) = 0.3 \text{ psi} \quad (2.1 \text{ kPa})$$

13.4.3 Available Shear Capacity

for dynamic shear,

$$f'_{dm} = (\text{SIF})(\text{DIF}) f'_m = (1.0)(1.0)(1,500 \text{ psi}) = 1,500 \text{ psi} \quad (10.3 \text{ MPa}) \quad (\text{Appendix 5.A})$$

factored axial load,

$$P_u = 1.2 (\text{weight}) = 1.2 (20.9 \text{ lb}) = 25.1 \text{ lb} \quad (112 \text{ N})$$

nominal shear capacity,

$$V_{n1} = 3.8 A_n \sqrt{f'_m} = 3.8 (4.18 \text{ in}^2) \sqrt{1,500 \text{ psi}} = 615 \text{ lb} \quad (2,736 \text{ N}) \quad (\text{ACI 530, Section 3.2.4})$$

$$V_{n2} = 300 A_n = 300 (4.18 \text{ in}^2) = 1,254 \text{ lb} \quad (5,578 \text{ N})$$

$$V_{n3} = 56 A_n + 0.45 P_u = 56 (4.18 \text{ in}^2) + 0.45 (25.1 \text{ lb}) = 245 \text{ lb} \quad (1,090 \text{ N})$$

$$V_n = \text{least of } V_{n1}, V_{n2}, V_{n3} = 245 \text{ lb} \quad (1,090 \text{ N})$$

the critical section for shear is t_w from the support,

$$\begin{aligned} R_s &= V_n L / (0.5 L - t_w) \\ &= (245 \text{ lb})(120 \text{ in}) / [0.5 (120 \text{ in}) - (7.625 \text{ in})] \\ &= 561 \text{ lb} \quad (2,495 \text{ N}) \end{aligned}$$

unit resistance,

$$R_s = (561 \text{ lb}) / (120 \text{ in span})(1 \text{ in width}) = 4.68 \text{ psi} \quad (32.3 \text{ kPa})$$

13.4.4 Available Resistance

Because $R_b < R_s$, bending controls and $R_u = R_b = 0.3 \text{ psi}$ (2.1 kPa)

The existing wall only provides 5% of the required resistance for the specified blast loads. For adequate resistance, the existing wall must either be strengthened with steel reinforcement, or a new wall must be added next to the existing wall.

For this example, three options are feasible:

Option #1: Add reinforcing steel and fill wall cavities solid with concrete.

Option #2: Add new reinforced concrete wall exterior to the existing wall.

Option #3: Add a new girt/steel cladding system exterior to the existing wall.

The first two options will be discussed below. The concept of Option #3 is illustrated in Figure 10.14, and the analysis and design procedure is detailed in Chapter 12.

13.5 OPTION #1: REINFORCE EXISTING WALL

In this upgrade option, longitudinal #4 rebars are provided at 8 in (203 mm) on center and the wall cavities are filled solid with concrete.

For an 8 inch nominal (203 mm) C.M.U. wall with fully grouted cells, the following section properties are based on a one inch (25 mm) width of wall:

actual thickness, $t_w = 7.625$ in (194 mm)
 area, $A_n = 7.625$ in² (4,919 mm²) (NCMA, Table 1b)
 moment of inertia, $I_g = 36.9$ in⁴ (15,358,940 mm⁴) (NCMA, Table 1b)

#4, rebar area = 0.20 in² (129 mm²)
 rebar spacing = 8 in (203 mm)

13.5.1 Calculate Bending Resistance

for dynamic flexure, (Appendix 5.A)

$$F_{dy} = (\text{SIF})(\text{DIF}) F_y = (1.1)(1.17)(60 \text{ ksi}) = 77.2 \text{ ksi} \quad (532 \text{ MPa})$$

$$f'_{dm} = (\text{SIF})(\text{DIF}) f'_m = (1.0)(1.19)(1.5 \text{ ksi}) = 1.785 \text{ ksi} \quad (12.3 \text{ MPa})$$

for the nominal design width,

$$A_s = (0.20 \text{ in}^2)(1 \text{ in unit width}) / (8 \text{ in bar spacing}) = 0.025 \text{ in}^2 \quad (16.1 \text{ mm}^2)$$

$$d_{sb} = A_s (F_{dy}) / 0.8 (f'_{dm})(b) \quad (\text{ACI 530, Equation 3-28})$$

$$= (0.025 \text{ in}^2)(77.2 \text{ ksi}) / (0.8)(1.785 \text{ ksi})(1 \text{ in})$$

$$= 1.35 \text{ in} \quad (34.3 \text{ mm})$$

for bending tension on either face,

$$d = t_w / 2 = (7.625 \text{ in}) / 2 = 3.81 \text{ in} \quad (97 \text{ mm})$$

$$M_p = A_s (f_{dy}) [d - d_{sb} / 2] \quad (\text{ACI 530, Equation 3-27})$$

$$= (0.025 \text{ in}^2)(77.2 \text{ ksi}) [(3.81 \text{ in}) - (1.35 \text{ in}) / 2]$$

$$= 6.05 \text{ k-in} \quad (684 \text{ kN-mm})$$

M_p is greater than $1.3 M_{cr}$, OK (ACI 530, Section 3.3.4.2.2.2)

$$R_b = 8 M_p / L = 8 (6.05 \text{ k-in}) / (120 \text{ in}) = 0.40 \text{ kips (1.78 kN)} \quad (\text{Table 6.1})$$

unit resistance,

$$R_b = (400 \text{ lb}) / (120 \text{ in span})(1 \text{ in width}) = 3.33 \text{ psi (23.0 kPa)}$$

13.5.2 Calculate Shear Resistance

for dynamic shear, (Appendix 5.A)

$$f_{dm} = (\text{SIF})(\text{DIF}) f_m = (1.0)(1.0)(1.500 \text{ ksi}) = 1.5 \text{ ksi (10.3 MPa)}$$

$$\begin{aligned} V_n &= 4 A_n \sqrt{f_m} && (\text{ACI 530, Section 3.3.4.1.2}) \\ &= 4 (7.625 \text{ in}^2) \sqrt{1,500 \text{ psi}} / 1,000 \\ &= 1.18 \text{ kips (5.25 kN)} \end{aligned}$$

the critical section for shear is t_w from the support,

$$\begin{aligned} R_s &= V_n L / (0.5 L - t_w) \\ &= (1.18 \text{ kips})(120 \text{ in}) / [0.5 (120 \text{ in}) - (7.625 \text{ in})] \\ &= 2.7 \text{ lb (12 kN)} \end{aligned}$$

unit resistance,

$$R_s = (2,700 \text{ lb}) / (120 \text{ in span})(1 \text{ in width}) = 22.5 \text{ psi (155 kPa)}$$

13.5.3 Resistance & Permissible Response

because $R_b < R_s$, bending controls

$$R_u = R_b = 3.33 \text{ psi (23.0 kPa)}$$

allowable ductility ratio, $\mu_a = \text{not applicable}$ (Table 5.B.3)

allowable support rotation, $\theta_a = 2.0^\circ$ (Table 5.B.3)

13.5.4 Compute SDOF Equivalent System

masonry modulus of elasticity, (ACI 530, Section 1.8.2.2.1)

$$E_m = 900 f_{dm} = 900 (1,785 \text{ psi}) = 1,606,500 \text{ psi (11,076 MPa)}$$

rebar modulus of elasticity, (ACI 530, Section 1.8.2.1)

$$E_s = 29,000,000 \text{ psi (200,000 MPa)}$$

modular ratio,

$$n = E_s / E_m = (29,000,000 \text{ psi}) / (1,606,500 \text{ psi}) = 18.05$$

transformed rebar area,

$$n A_s = (18.05)(0.025 \text{ in}^2) = 0.45 \text{ in}^2 (290 \text{ mm}^2)$$

location of transformed neutral axis,

$$d_{na} = \frac{-nA_s + \sqrt{nA_s(nA_s + 2bd)}}{b}$$

$$= \frac{-0.45 \text{ in}^2 + \sqrt{0.45 \text{ in}^2 (0.45 \text{ in}^2 + 2(1 \text{ in})(3.81 \text{ in})}}{1 \text{ in}}$$

$$= 1.46 \text{ in} \quad (37.1 \text{ mm})$$

cracked moment of inertia,

$$I_{cr} = b (d_{na})^3 / 3 + n A_s (d - d_{na})^2$$

$$= (1 \text{ in})(1.46 \text{ in})^3 / 3 + (0.45 \text{ in}^2)(3.81 \text{ in} - 1.46 \text{ in})^2$$

$$= 3.5 \text{ in}^4 \quad (1,500,000 \text{ mm}^4)$$

averaged moment of inertia,

$$I_a = (I_g + I_{cr}) / 2 = (36.9 \text{ in}^4 + 3.5 \text{ in}^4) / 2 = 20.2 \text{ in}^4 \quad (8,400,000 \text{ mm}^4)$$

effective stiffness,

$$K_e = 384 E_m I_a / 5 L^3 \quad (\text{Table 6.1})$$

$$= 384 (1,606.5 \text{ ksi})(20.2 \text{ in}^4) / 5(120 \text{ in})^3$$

$$= 1.44 \text{ k/in} \quad (0.25 \text{ kN/mm})$$

unit stiffness,

$$K_e = (1,440 \text{ lb/in}) / (120 \text{ in span})(1 \text{ in width}) = 12.0 \text{ psi/in} \quad (3.26 \text{ kPa/mm})$$

beam mass,

$$M = (\text{wall weight}) / g$$

$$= (0.144 \text{ kcf})(0.64 \text{ ft thick})(0.083 \text{ ft unit width})(10 \text{ ft span}) / (386 \text{ in/s}^2)$$

$$= 0.000198 \text{ k-s}^2/\text{in} \quad (0.0000347 \text{ kN-s}^2/\text{mm})$$

unit beam mass,

$$M = (0.198 \text{ lb-s}^2/\text{in}) / (120 \text{ in span})(1 \text{ in width})$$

$$= 0.00165 \text{ psi-s}^2/\text{in} \quad (0.000448 \text{ kPa-s}^2/\text{mm})$$

Because of the expected response, use an average of values for K_{LM}

$$\text{elastic } K_{LM} = 0.5 / 0.64 = 0.78 \quad (\text{Table 6.1})$$

$$\text{plastic } K_{LM} = 0.33 / 0.5 = 0.66$$

$$\text{average } K_{LM} = (0.78 + 0.66) / 2 = 0.72$$

equivalent mass,

$$M_e = (K_{LM})(M)$$

$$= (0.72)(0.00165 \text{ psi-s}^2/\text{in})$$

$$= 0.001188 \text{ psi-s}^2/\text{in} \quad (0.000322 \text{ kPa-s}^2/\text{mm})$$

period of vibration,

$$t_n = 2 \pi \sqrt{(M_e / K_e)} = 2 \pi \sqrt{(0.001188 \text{ psi-s}^2/\text{in}) / (12.0 \text{ psi/in})} = 0.063 \text{ s} \quad (\text{Equation 6.8})$$

13.5.5 Chart Solution

$$t_d / t_n = (0.09 \text{ s}) / (0.063 \text{ s}) = 1.4$$

$$R_u / F_o = (3.33 \text{ psi}) / (3.4 \text{ psi}) = 1.0$$

using the chart: $\mu_d = 2.1$ (Figure 6.6)

$$\text{elastic deflection, } y = R_u / K_e = (3.33 \text{ psi}) / (12.0 \text{ psi/in}) = 0.28 \text{ in (7.1 mm)}$$

$$\text{maximum deflection, } y_m = (\mu_d)(y) = (2.1)(0.28 \text{ in}) = 0.59 \text{ in (15 mm)}$$

maximum support rotation, (Figure 5.9)

$$\theta_d = \arctan (y_m / 0.5L) = \arctan [(0.59 \text{ in}) / (0.5)(120 \text{ in})] = 0.56^\circ < 2.0^\circ, \text{ OK}$$

13.6 OPTION #2: NEW REINFORCED CONCRETE WALL

A new reinforced concrete wall has been determined to be a constructible solution to provide the required blast resistance. The new wall is simply supported at top and bottom.

span, $L = 10$ feet or 120 in (3,048 mm) from foundation to base of extended roof slab

use a nominal design width, $b = 1.0$ ft or 12 in (305 mm)

try:

8 inch concrete wall (203 mm)

#5 @ 16 in (406 mm) at center of wall, vertical

#4 @ 12 in (305 mm) at center of wall, horizontal

#5, $A_s = 0.31 \text{ in}^2$ (200 mm²)

13.6.1 Compute Bending Resistance

for dynamic flexure, (Appendix 5.A)

$$F_{dy} = (\text{SIF})(\text{DIF}) F_y = (1.1)(1.17)(60 \text{ ksi}) = 77.2 \text{ ksi (532 MPa)}$$

$$f'_{dc} = (\text{SIF})(\text{DIF}) f'_c = (1.0)(1.19)(4 \text{ ksi}) = 4.76 \text{ ksi (32.8 MPa)}$$

for the nominal design width,

$$A_s = (0.31 \text{ in}^2)(12 \text{ in/ft}) / (16 \text{ in bar spacing}) = 0.23 \text{ in}^2 \text{ (148 mm}^2\text{)}$$

$$d_{sb} = A_s (F_{dy}) / 0.85 (f'_{dc})(b) \quad (\text{MacGregor, Equation 4-9})$$

$$= (0.23 \text{ in}^2)(77.2 \text{ ksi}) / (0.85)(4.76 \text{ ksi})(12 \text{ in})$$

$$= 0.37 \text{ in (9.4 mm)}$$

for bending tension on either face,

$$d = t_w / 2 = 4.0 \text{ in (102 mm)}$$

$$A_{s, \min} = 3 \frac{\sqrt{f_{dc}}}{F_{dy}} (b)(d) = 3 \frac{\sqrt{4,760 \text{ psi}}}{77,200 \text{ psi}} (12 \text{ in})(4.0 \text{ in}) \quad (\text{ACI 318, Section 10.5.1})$$

$$= 0.13 \text{ in}^2 (84 \text{ mm}^2) < A_s \quad \text{OK}$$

$$A_{s, \min} = 200(b)(d)/F_{dy} = 200(12 \text{ in})(4.0 \text{ in})/(77,200 \text{ psi}) \quad (\text{ACI 318, Section 10.5.1})$$

$$= 0.12 \text{ in}^2 (77 \text{ mm}^2) < A_s \quad \text{OK}$$

$$M_p = A_s (F_{dy}) [d - d_{sb}/2] \quad (\text{MacGregor, Equation 4-10a})$$

$$= (0.23 \text{ in}^2)(77.2 \text{ ksi}) [(4.0 \text{ in}) - (0.37 \text{ in}) / 2]$$

$$= 67.7 \text{ k-in} \quad (7,650 \text{ kN-mm})$$

$$R_b = 8 M_p / L = 8 (67.7 \text{ k-in}) / (120 \text{ in}) = 4.51 \text{ kips} \quad (20.1 \text{ kN}) \quad (\text{Table 6.1})$$

unit resistance,

$$R_b = (4,510 \text{ lb}) / (120 \text{ in span})(12 \text{ in width}) = 3.13 \text{ psi} \quad (21.6 \text{ kPa})$$

13.6.2 Compute Shear Resistance

for dynamic shear,

(Appendix 5.A)

$$f_{dc} = (\text{SIF})(\text{DIF}) f_c = (1.0)(1.0)(4 \text{ ksi}) = 4.0 \text{ ksi} \quad (27.6 \text{ MPa})$$

$$V_n = 2 \sqrt{f_{dc}} b d \quad (\text{ACI 318, Equation 11-3})$$

$$= 2 \sqrt{(4,000 \text{ psi})} (12 \text{ in})(4.0 \text{ in})$$

$$= 6,072 \text{ lb} \quad (27.0 \text{ kN})$$

the critical section for shear is d from the support,

(ACI 318, Section 11.1.3.1)

$$R_s = V_n L / (0.5 L - d)$$

$$= (6,072 \text{ lb})(120 \text{ in}) / [0.5 (120 \text{ in}) - (4.0 \text{ in})]$$

$$= 13,011 \text{ lb} \quad (57.9 \text{ kN})$$

unit resistance,

$$R_s = (13,011 \text{ lb}) / (120 \text{ in span})(12 \text{ in width}) = 9.03 \text{ psi} \quad (62.3 \text{ kPa})$$

13.6.3 Resistance & Permissible Response

because $R_b < R_s$, bending controls

$$R_u = R_b = 3.13 \text{ psi} \quad (21.6 \text{ kPa})$$

allowable ductility ratio, $\mu_a =$ not applicable (Table 5.B.3)

allowable support rotation, $\theta_a = 2.0^\circ$ (Table 5.B.3)

13.6.4 Compute SDOF Equivalent System

gross moment of inertia,

$$I_g = b (h)^3 / 12 = (12 \text{ in})(8 \text{ in})^3 / 12 = 512 \text{ in}^4 \quad (213,110,000 \text{ mm}^4)$$

concrete modulus of elasticity, (based on flexure) (ACI 318, Section 8.5.1)

$$E_c = 57,000 \sqrt{f'_c} = 57,000 \sqrt{4,000 \text{ psi}} = 3,605,000 \text{ psi} \quad (24,900 \text{ MPa})$$

rebar modulus of elasticity, (ACI 318, Section 8.5.2)

$$E_s = 29,000,000 \text{ psi} \quad (200,000 \text{ MPa})$$

modular ratio,

$$n = E_s / E_c = (29,000,000 \text{ psi}) / (3,605,000 \text{ psi}) = 8.04$$

transformed rebar area,

$$n A_s = (8.04)(0.23 \text{ in}^2) = 1.85 \text{ in}^2 \quad (1,194 \text{ mm}^2)$$

location of transformed neutral axis,

$$\begin{aligned} d_{na} &= \frac{-nA_s + \sqrt{nA_s(nA_s + 2bd)}}{b} \\ &= \frac{-1.85 \text{ in}^2 + \sqrt{1.85 \text{ in}^2(1.85 \text{ in}^2 + 2(12 \text{ in})(4.0 \text{ in}))}}{12 \text{ in}} \\ &= 0.97 \text{ in} \quad (25 \text{ mm}) \end{aligned}$$

cracked moment of inertia,

$$\begin{aligned} I_{cr} &= b (d_{na})^3 / 3 + n A_s (d - d_{na})^2 \\ &= (12 \text{ in})(0.97 \text{ in})^3 / 3 + (1.85 \text{ in}^2)(4.0 \text{ in} - 0.97 \text{ in})^2 \\ &= 20.6 \text{ in}^4 \quad (8,574,000 \text{ mm}^4) \end{aligned}$$

averaged moment of inertia,

$$I_a = (I_g + I_{cr}) / 2 = (512 \text{ in}^4 + 20.6 \text{ in}^4) / 2 = 266 \text{ in}^4 \quad (110,700,000 \text{ mm}^4)$$

effective stiffness,

$$\begin{aligned} K_e &= 384 E_c I_a / 5 L^3 && \text{(Table 6.1)} \\ &= 384 (3,605 \text{ ksi})(266 \text{ in}^4) / 5(120 \text{ in})^3 \\ &= 42.6 \text{ k/in} \quad (7.46 \text{ kN/mm}) \end{aligned}$$

unit stiffness,

$$K_c = (42,600 \text{ lb/in}) / (120 \text{ in span})(12 \text{ in width}) = 29.6 \text{ psi/in} \quad (8.03 \text{ kPa/mm})$$

beam mass,

$$\begin{aligned} M &= (\text{wall weight}) / g \\ &= (0.15 \text{ kcf})(0.67 \text{ ft thick})(1.0 \text{ ft unit width})(10 \text{ ft span}) / (386 \text{ in/s}^2) \\ &= 0.0026 \text{ k-s}^2/\text{in} \quad (0.000455 \text{ kN-s}^2/\text{mm}) \end{aligned}$$

unit beam mass,

$$\begin{aligned} M &= (2.6 \text{ lb-s}^2/\text{in}) / (120 \text{ in span})(12 \text{ in width}) \\ &= 0.0018 \text{ psi-s}^2/\text{in} \quad (0.00049 \text{ kPa-s}^2/\text{mm}) \end{aligned}$$

Because of the expected response, use an average of values for K_{LM}

$$\text{elastic } K_{LM} = 0.5 / 0.64 = 0.78 \quad \text{(Table 6.1)}$$

plastic $K_{LM} = 0.33 / 0.5 = 0.66$

average $K_{LM} = (0.78 + 0.66) / 2 = 0.72$

equivalent mass,

$$M_e = (K_{LM})(M) = (0.72)(0.0018 \text{ psi-s}^2/\text{in}) = 0.0013 \text{ psi-s}^2/\text{in} \quad (0.00035 \text{ kPa-s}^2/\text{mm})$$

period of vibration,

$$t_n = 2 \pi \sqrt{(M_e/K_e)} = 2 \pi \sqrt{(0.0013 \text{ psi-s}^2/\text{in}) / (29.6 \text{ psi/in})} = 0.042 \text{ s} \quad (\text{Equation 6.8})$$

13.6.5 Chart Solution

$$t_d / t_n = (0.09 \text{ s}) / (0.042 \text{ s}) = 2.1$$

$$R_u / F_o = (3.13 \text{ psi}) / (3.4 \text{ psi}) = 0.92$$

using the chart: $\mu_d = 3.4$

(Figure 6.6)

elastic deflection, $y = R_u / K_e = (3.13 \text{ psi}) / (29.6 \text{ psi/in}) = 0.11 \text{ in} \quad (2.8 \text{ mm})$

maximum deflection, $y_m = (\mu_d)(y) = (3.4)(0.11 \text{ in}) = 0.37 \text{ in} \quad (9.4 \text{ mm})$

maximum support rotation,

$$\theta_d = \arctan (y_m / 0.5L) = \arctan [(0.37 \text{ in}) / (0.5)(120 \text{ in})] = 0.35^\circ < 2^\circ, \text{ OK} \quad (\text{Figure 5.9})$$

An illustration of this option is presented in Figure 10.13.

13.7 CONCLUSION

The analysis of the existing masonry wall revealed that the wall only provides a small percentage of the required resistance for the specified blast. Due to the symmetry of the wall and the reinforcement (for the upgrade system), the analysis for the rebound blast loads was not required.

A complete analysis of the walls will need to include the evaluation of the existing connection of the wall to the grade beam and roof. The evaluation may reveal that the connections are inadequate for the specified loads, thus a corrective procedure should be specified. For Option #1 where reinforcement is added to the existing wall, dowels should be specified and embedded in the masonry and the concrete beams. Alternatively continuous steel angles can be used to connect the walls to the roof and grade beam. This approach can also be applied to Option #2. However, if new concrete walls are added next to the existing wall, the wall can be directly bolted to the grade beam and roof beam (refer to Figure 10-13). In this case, the bolts should be checked for rebound pullout forces.

In this example, retrofit Option #1 is likely to be the most cost effective upgrade because of the minimal usage of new materials and formwork. This option might not be feasible due to existing obstructions, or due to extensive alterations required to achieve the proposed reinforcement scheme. If Option #1 is not practical or feasible,

one of the other options may be used. The cost differential between the options should be minimal.

GLOSSARY

Angle of Incidence - The angle between the direction of the blast wave movement and a flat surface.

Blast Wave - A transient change in the gas density, pressure, and velocity of the air surrounding an explosion.

BLEVE - Boiling Liquid Expanding Vapor Explosion

BRM - Blast Resistant Modular

CFD - Computational Fluid Dynamics

Conventional Loads - Load normally considered in structural design such as dead loads, live loads, wind loads, and seismic loads.

Deflagration - A propagating chemical reaction of a substance in which the reaction front advances into the unreacted substance rapidly but at less than sonic velocity.

Detonation - A propagating chemical reaction of a substance in which the reaction front advances into the unreacted substance at or greater than sonic velocity.

Ductility Ratio - A measure of the energy absorbing capacity of a structural member. The ratio is computed by dividing the element's maximum deformation by the yield deformation.

Duration - The time from initial change in pressure to return to ambient pressure.

Dynamic Increase Factor (DIF) - The ratio of dynamic to static strength which is used to compute the effect of a rapidly applied load to the strength of a structural element.

Dynamic Reactions - The support reaction of a structural component due to the dynamic blast loading, taking into account inertia effects.

Elastic Region - The deformation range from zero up to the formation of the first plastic hinge.

Elasto-Plastic Region - The deformation range from formation of the first plastic hinge up to formation of the final plastic hinge (i.e. ultimate capacity).

FEA - Finite Element Analysis

Flammable Range - The range of mixture of fuel and air that will support flame propagation.

Free Field - Air or ground blast waves which are unimpeded by obstructions in the path of the wave.

Hinge Rotation - A measure of the energy absorbing capacity of a structural member. This is the angle of deformation at a plastic hinge.

Impulse - The integrated area under the overpressure time curve.

Inelastic - Beyond the elastic response range.

Incident Side-On Overpressure - Initial peak pressure rise, above ambient, produced by a shock wave or pressure wave as felt by a flat surface oriented parallel to the direction of wave propagation.

Incipient Failure - The level of deformation where collapse can be expected to occur.

Linear - A response limited to the elastic range.

Lower Flammable Limit - The lowest mixture of fuel in air that will support flame propagation.

MDOF - Multi-Degree of Freedom

Negative Phase - The portion of the pressure-time history typically following the positive (overpressure) phase in which the pressure is below ambient pressure (suction).

Neutral Risk - The idea where a person inside a building should not be at greater risk of injury than another person just outside.

Nonlinear - A response which includes the elastic-plastic and/or plastic ranges.

OSHA - Occupational Safety Hazards Act (or Administration)

Overpressure - Pressure rise above ambient produced by a shock wave or pressure wave.

Plastic Region - The deformation range from ultimate capacity up to failure of the element.

Positive Phase - The portion of the pressure time history in which the pressure is above ambient pressure.

Pressure Wave - A blast wave that produces a gradual rise in pressure.

Rebound - The deformation in the direction opposing the initial blast pressure. This occurs after a component has reached a peak deformation and returns toward its initial position.

Reflected Overpressure - The rise in pressure produced by a shock wave or pressure wave as felt by a flat surface oriented perpendicular to the direction of wave propagation.

Resistance-Deflection Function - The value of the stress in a structural element as the deformation is increased from zero through the elastic range, the elastic-plastic range, ultimate capacity, and finally to failure of the element.

SDOF - Single Degree of Freedom.

Shockwave - A blast wave that produces a near instantaneous rise in pressure.

Side-on Pressure - The rise in pressure above ambient produced by a shock wave sweeping unimpeded across any surface (walls or roof) not facing the blast source.

Sideway - The lateral movement of a structure due to vertical or horizontal loads.

Strain Energy - The energy stored within a structural element deformed due to the application of load. The value of strain energy is the area under the resistance-deflection function.

Strain Hardening - The observed increase in strength as a material is deformed well into the plastic range.

Strain Rate - The speed at which a material is deformed. The higher the strain rate, the higher the observed material strength.

Strength Increase Factor (SIF) - The ratio of actual to nominal strength of a material. This factor takes into account conservatism in the manufacturing process.

Support Rotation - A measure of the blast absorbing capacity of a structural element. This is the same as hinge rotation except that the angle is computed at the member's support location.

TNT - Trinitrotoluene, a high explosive used as the basis for many charts describing blast effects.

TNT Equivalent - The amount of TNT which will produce similar effects as the actual amount of explosive material under consideration. An equivalence between two explosives can be determined by equating the quantity of energy released or by relating observed levels of damage.

Ultimate Capacity - The load applied to a structural element as the final plastic hinge, or collapse mechanism, is formed.

Ultimate Strength - A method of design in which structural members are proportioned by total section capacities rather than by extreme fiber allowable stresses.

Upper Flammable Limit - The maximum mixture of fuel in air that will support flame propagation.

Volatile - A word describing a substance which evaporates quickly or is unstable.

VCE - Vapor Cloud Explosion

NOMENCLATURE

a	= acceleration
a_H	= horizontal acceleration
a_V	= vertical acceleration
a_θ	= rotational acceleration
A_1	= bearing area
A_2	= pedestal area
A_b	= nominal bolt area
A_g	= gross area
A_n	= nominal area
A_{nv}	= net section area
A_{ps}	= area of prestressed reinforcing in tension zone
A_s	= area of steel
A_v	= shear area of steel
A_w	= weld area
b	= member width
b_f	= flange width
B_H	= building height
B_L	= building length
B_p	= plate width
B_W	= building width
BL	= blast load
c	= impulse factor for a decaying shock wave
c_1	= distance from center to edge of element
c_h	= horizontal weld eccentricity
c_v	= vertical weld eccentricity
C	= viscous damping constant
C_d	= drag coefficient
C_e	= side wall reduction factor
C_F	= loading reaction coefficient
C_r	= reflection coefficient
C_R	= resistance reaction coefficient
C_V	= shear coefficient
d	= depth
d_b	= bolt diameter
d_h	= hole diameter
d_{na}	= depth to neutral axis
d_p	= depth to center of prestressing steel
d_{sb}	= depth of concrete stress block
DL	= dead load
E	= modulus of elasticity
E_c	= modulus of elasticity of concrete

E_m	= modulus of elasticity of masonry
E_s	= modulus of elasticity of steel
f	= frequency of vibration
f_c	= concrete stress
f'_c	= concrete strength
f_{cr}	= compression stress
f'_{dc}	= dynamic concrete strength
f'_{dm}	= dynamic masonry strength
f'_m	= masonry strength
f_{ps}	= calculated stress in prestressing steel at design load
f_r	= modulus of rupture
f_{vh}, f_{v1}, f_{v2}	= shear stress
F	= blast force
$F_{1..F7}$	= blast force
F_{cr}	= flexural buckling stress
F_C	= compression force
F_{du}	= steel dynamic ultimate strength
F_{ds}	= dynamic design stress
F_{dy}	= steel dynamic yield strength
F_e	= equivalent force
F'_e	= elastic critical buckling stress
F_{EXX}	= weld electrode strength
F_H	= horizontal dynamic force
F_{nt}	= nominal bolt tension strength
F_{nv}	= nominal bolt shear strength
F_o	= peak blast force
F_{RL}	= reflection load
F_s	= static load
F_{SL}	= stagnation load
F_T	= tension force
F_u	= steel ultimate strength
F_V	= vertical dynamic force
F_w	= weld strength
F_y	= steel yield strength
F_θ	= rotational dynamic force
FS	= factor of safety
g	= acceleration of gravity
g_b	= bolt gage
G	= shear modulus
h	= height
J_w	= polar moment of inertia

i	= time step number
I	= moment of inertia
I_a	= averaged moment of inertia
I_{bar}	= nondimensionalized impulse
I_{cr}	= cracked moment of inertia
I_g	= gross moment of inertia
I_o	= positive phase impulse
I_o^-	= negative phase impulse
I_w	= equivalent triangular impulse
I_x	= moment of inertia about X axis
I_y	= moment of inertia about Y axis
ip	= (subscript) in-plane deformations
k_v	= shear width-thickness coefficient
K	= stiffness
K_a	= coefficient of active soil pressure
K_e	= equivalent, or effective stiffness
K_{ep}	= elastic-plastic stiffness
K_H	= horizontal soil stiffness
K_L	= load or stiffness transformation factor
K_{LM}	= load-mass transformation factor
K_M	= mass transformation factor
K_p	= coefficient of passive soil pressure
K_V	= vertical soil stiffness
K_x	= effective length factor for X axis
K_y	= effective length factor for Y axis
K_{θ}	= rotational soil stiffness
KE	= kinetic energy
KEY	= response indicator
L	= length
L_1	= length of surface parallel to traveling blast wave
L_c	= clear distance
L_h	= horizontal weld length
L_p	= limiting unbraced length for plastic design
L_s	= spacing
L_v	= vertical weld length
L_w	= blast wave length
L_x	= unbraced length in X axis
L_y	= unbraced length in Y axis
LL	= live load
m_1	= baseplate design dimension
M	= mass
M_1	= foundation moment
M_c	= midspan moment

M_{cr}	= cracking moment
M_e	= equivalent mass
M_p	= plastic moment
M_{ps}	= moment capacity at support
M_{pc}	= moment capacity at midspan
M_y	= yield moment
M_θ	= mass moment of inertia
n	= modular ratio
n'	= baseplate design dimension
n_1	= baseplate design dimension
n_w	= horizontal weld center
N	= number of structural elements
N_p	= plate length
N_u	= in-plane capacity of element
N'_u	= ultimate applied in-plane load
OM	= overturning moment
op	= (subscript) out-of-plane deformations
P	= pressure
$P_{1..P_5}$	= vertical static load on foundation
P_2	= vertical static load on foundation
P_3	= vertical static load on foundation
P_a	= effective side-on overpressure
P_b	= rear face overpressure
P_c	= permissible compression
P_{bar}	= nondimensionalized pressure
P_{nc}	= nominal compression capacity
P_{nt}	= nominal tension capacity
P_o	= ambient atmospheric pressure
P_p	= available strength
P_r	= peak reflected overpressure
P_s	= stagnation pressure
P_{so}	= peak side-on overpressure
P_{so}^-	= negative peak side-on overpressure
P_t	= permissible tension
P_u	= factored axial load
q	= bearing pressure
q_o	= peak dynamic pressure
Q_u	= shear capacity of element
Q'_u	= ultimate applied shear load
r_x	= radius of gyration about X axis
r_y	= radius of gyration about Y axis
R	= resistance

R_1	= axial component of battered pile
R_b	= bending resistance
R_{b-}	= negative bending resistance
R_e	= equivalent resistance
R_{HORIZ}	= lateral load component of battered pile
R_m	= maximum resistance
R_{MAX}	= maximum axial pile load
R_{MIN}	= minimum axial pile load
R_n	= nominal resistance
R_s	= shear resistance
R_u	= ultimate resistance
R_{r-}	= rebound resistance
R_y	= yield resistance
RM	= resisting moment
S	= clearing distance
S_x	= section modulus about X axis
SE	= strain energy
t	= time
t_a	= time of arrival
t_c	= clearing time
t_d	= positive phase duration
t_d^-	= negative phase duration
t_e	= equivalent duration
t_f	= flange thickness
t_m	= time of maximum response
t_n	= natural period
t_o	= total positive phase duration
t_p	= plate thickness
t_r	= rise time
t_w	= web thickness
U	= shock front velocity
v	= velocity
V	= dynamic reaction
$V_{1..V_9}$	= lateral load on foundation
V_f	= fixed end reaction
V_n	= nominal shear
V_p	= pinned end reaction
V_u	= ultimate shear
w_p	= reinforcement index
W	= width

X	= baseplate design factor
X_a	= allowable sidesway
X_e	= elastic sidesway
X_m	= maximum sidesway
y	= deflection
y_d	= dead load deflection
y_e	= yield deflection
y_{e-}	= rebound yield deflection
y_{ep}	= elastic-plastic deflection
y_H	= horizontal deflection
y_m	= maximum deflection
y_{m-}	= maximum rebound deflection
y_p	= plastic deflection
y_{st}	= static deflection
y_V	= vertical deflection
y_θ	= rotational deflection
Z	= calculation case indicator
Z_x	= plastic modulus about X axis
α	= angle of incidence
α_1	= angle
α_2	= angle
Δ_a	= allowable deformation (ductility ratio or support rotation)
Δ_d	= computed deformation (ductility ratio or support rotation)
Δ_f	= flexural deflection
Δ_s	= shear deflection
ϵ_u	= maximum strain
ϵ_c	= concrete strain
ϵ_s	= steel strain
ϵ_u	= ultimate concrete strain
ϵ_y	= steel yield strain
ϕ	= strength reduction factor
Φ	= curvature, or deflected shape
γ	= soil density
λ	= roughness coefficient
λ_{bp}	= baseplate design factor
λ_c	= compression slenderness factor
λ_f	= flange slenderness factor
λ_p	= limiting plastic slenderness factor

λ_{ps}	= limiting seismic plastic slenderness factor
λ_v	= shear slenderness factor
λ_w	= web slenderness factor
μ	= ductility ratio
μ_a	= allowable ductility ratio
μ_d	= demand ductility ratio
μ_{d-}	= demand rebound ductility ratio
μ_f	= friction coefficient
ν	= poisson's ratio
θ	= rotation, or hinge rotation
θ_a	= allowable support rotation
θ_d	= demand support rotation
θ_1	= support rotation
θ_2	= mid-span rotation
ρ	= tension reinforcing ratio
τ	= ratio of load duration to natural period (t_d / t_n)

REFERENCES

ACI 318, *Building Code Requirements for Structural Concrete (ACI 318-05) and Commentary (ACI 318R-05)*, ACI Committee 318, American Concrete Institute, Farmington Hills, MI, 2005

ACI 530, *Building Code Requirements for Masonry Structures (ACI 530-05/ASCE 5-05/TMS 402-05)*, American Concrete Institute, Farmington Hills, MI, 2005

AISC 341, *Seismic Provisions for Structural Steel Buildings*, American Institute of Steel Construction, Chicago, IL, 2005

AISC 360, *Specification for Structural Steel Buildings*, American Institute of Steel Construction, Chicago, IL, 2005

AISC Guide, *Design Series 1, Column Base Plates*, American Institute of Steel Construction, Chicago, IL, 2003

AISC Manual, *Manual of Steel Construction*, 13th Edition, American Institute of Steel Construction, Chicago, IL, 2005

AISI 1967, *Design of Light Gage Steel Diaphragms*, American Iron and Steel Institute, New York, NY, 1967

AISI 2001, *North American Specification for the Design of Cold-Formed Steel Structural Members*, American Iron and Steel Institute, Washington, DC, 2001

API RP 2FB, *Design of Offshore Facilities Against Fire and Blast Loading*, API Recommended Practice 2FB, American Petroleum Institute, Washington, DC, 2006

API RP 752, *Management of Hazards Associated with Location of Process Plant Buildings*, API Recommended Practice 752, American Petroleum Institute, Washington, DC, 2003

API RP 753, *Management of Hazards Associated with Location of Process Plant Portable Buildings*, API Recommended Practice 753, First Edition, American Petroleum Institute, Washington, DC, 2007

ASCE 41, *Seismic Rehabilitation of Existing Buildings*, American Society of Civil Engineers, Reston, VA, 2006

ASCE Manual 41, *Plastic Design in Steel: A Guide and Commentary*, ASCE Manual Number 41, Second Edition, American Society of Civil Engineers, Reston, VA, 1971

ASCE Manual 42, *Design of Structures to Resist Nuclear Weapons Effects*, Committee on Dynamic Effects, American Society of Civil Engineers, Reston, VA, 1985

ASCE Manual 58, *Structural Analysis and Design of Nuclear Plant Facilities*, Manual No. 58, American Society of Civil Engineers, Reston, VA, 1980

ASCE Physical Security, *Structural Design for Physical Security: State of the Practice Report*, Task Committee on Physical Security, American Society of Civil Engineers, Reston, VA, 1999

ASTM A36, *Standard Specification for Carbon Structural Steel*, ASTM International, West Conshohocken, PA, 2005

ASTM A82, *Standard Specification for Steel Wire, Plain, for Concrete Reinforcement*, ASTM International, West Conshohocken, PA, 2005

ASTM A307, *Standard Specification for Carbon Steel Bolts and Studs, 60 000 PSI Tensile Strength*, ASTM International, West Conshohocken, PA, 2004

ASTM A325, *Standard Specification for Structural Bolts, Steel, Heat Treated, 120/105 ksi Minimum Tensile Strength*, ASTM International, West Conshohocken, PA, 2006

ASTM A490, *Standard Specification for Structural Bolts, Alloy Steel, Heat Treated, 150 ksi Minimum Tensile Strength*, ASTM International, West Conshohocken, PA, 2006

ASTM A500, *Standard Specification for Cold-Formed Welded and Seamless Carbon Steel Structural Tubing in Rounds and Shapes*, ASTM International, West Conshohocken, PA, 2007

ASTM A514, *Standard Specification for High-Yield-Strength, Quenched and Tempered Alloy Steel Plate, Suitable for Welding*, ASTM International, West Conshohocken, PA, 2005

ASTM A572, *Standard Specification for High-Strength Low-Alloy Columbium-Vanadium Structural Steel*, ASTM International, West Conshohocken, PA, 2006

ASTM A588, *Standard Specification for High-Strength Low-Allow Structural Steel with 50 ksi [345 MPa] Minimum Yield Point to 4-in [100 mm] Thick*, ASTM International, West Conshohocken, PA, 2005

ASTM A615, *Standard Specification for Deformed and Plain Carbon-Steel Bars for Concrete Reinforcement*, ASTM International, West Conshohocken, PA, 2007

ASTM A653, *Standard Specification for Steel Sheet, Zinc-Coated (Galvanized) or Zinc-Iron Alloy-Coated (Galvannealed) by the Hot-Dip Process*, ASTM International, West Conshohocken, PA, 2006

ASTM A706, *Standard Specification for Low-Alloy Steel Deformed and Plain Bars for Concrete Reinforcement*, ASTM International, West Conshohocken, PA, 2006

ASTM A992, *Standard Specification for Structural Steel Shapes*, ASTM International, West Conshohocken, PA, 2006

ASTM C90, *Standard Specification for Loadbearing Concrete Masonry Units*, ASTM International, West Conshohocken, PA, 2006

ASTM E1300, *Standard Practice for Determining Load Resistance of Glass in Buildings*, ASTM International, West Conshohocken, PA, 2004

ASTM F1554, *Standard Specification for Anchor Bolts, Steel, 36, 55, and 105-ksi Yield Strength*, ASTM International, West Conshohocken, PA, 2007

ASTM F1642, *Standard Test Method for Glazing and Glazing Systems Subject to Airblast Loadings*, ASTM International, West Conshohocken, PA, 2004

ASTM F2247, *Standard Test Method for Metal Doors Used in Blast Resistant Applications (Equivalent Static Load Method)*, ASTM International, West Conshohocken, PA, 2003.

ASTM F2248, *Standard Practice for Specifying an Equivalent 3-Second Duration Design Loading for Blast Resistant Glazing Fabricated with Laminated Glass*, ASTM International, 2003

Baker, *Explosion Hazards and Evaluation*, W. E. Baker, Elsevier Scientific Publishing Company, New York, NY, 1983

Bathe, *Finite Element Procedures in Engineering Analysis*, K. Bathe, Prentice-Hall Inc., Englewood Cliffs, NJ, 1995

Biggs, *Introduction to Structural Dynamics*, J. M. Biggs, McGraw-Hill Book Company, New York, NY, 1964

BIGGS, *Biggs Version 2.0 User's Manual*, Wilfred Baker Engineering Inc., San Antonio, TX, 1990

Blodgett, *Design of Welded Structures*, The James F. Lincoln Arc Welding Foundation, Cleveland, OH, 1966

Bradford and Culbertson, "Design of Control Houses to Withstand Explosive Forces", W. J. Bradford and T. L. Culbertson, *Loss Prevention*, Vol. 1, American Institute of Chemical Engineers, New York, NY, 1967, pp 28-30

CBARCS, *CBARCS - Optimum Nonlinear Dynamic Design of Reinforced Concrete Slabs Under Blast Loading*, Program No. 713-F3-R0056, US Army Corps of Engineers, Waterways Experiment Station, Vicksburg, MS, 1980

CCPS Building Guidelines, *Guidelines for Evaluating Process Plant Buildings for External Explosions and Fires*, Center for Chemical Process Safety of the American Institute of Chemical Engineers, New York, NY, 1996

CCPS Explosion Guidelines, *Guidelines for Evaluating the Characteristics of Vapor Cloud Explosions, Flash Fires, and BLEVEs*, Center for Chemical Process Safety, American Institute of Chemical Engineers, New York, NY, 1994

CEDAW, *CEDAW (Component Explosive Damage Assessment Workbook)*, Protective Design Center, US Army Corps of Engineers, Omaha, NE (<https://pdc.usace.army.mil/software/cedaw>)

29 CFR 1910.119, 29 Code of Federal Regulation (CFR) 1910.119, Process Safety Management of Highly Hazardous Chemicals, National Archives and Records Administration, Washington, DC

Chen, *Advanced Analysis of Steel Frames; Theory, Software and Applications*, W. F. Chen and S. Toma (eds.), CRC Press, Inc., Boca Raton, FL, 1994

CIA, *An Approach to the Categorisation of Process Plant Hazard and Control Building Design*, Issued by the Safety Committee of the Chemical Industry Safety and Health Council, Chemical Industries Association, London, England, 1992

Clough, *Dynamics of Structures*, 2nd edition, R. W. Clough and J. Penzien, McGraw-Hill Book Company, New York, NY, 1993

Committee 43, *Semi-Rigid Connections in Steel Frames*, Council on Tall Buildings and Urban Habitat Committee 43, McGraw-Hill, Inc., New York, NY, 1993

Das, *Principles of Soil Dynamics*, Braja M. Das, PWS Publishing Company, Boston, MA, 1993

Derecho, *Analysis and Design of Small Reinforced Concrete Buildings for Earthquake Forces*, A. T. Derecho, D. M. Schultz and M. Fintel, Engineering Bulletin No. EB004.05D, Portland Cement Association, Skokie, IL, 1974

Dhamarvaram, "Consequence Analysis – Using a CFD Model for Industrial Sites", *Process Safety Progress*, S. Dhamavaram, S. R. Hanna, O. R. Hansen, Volume 24, Number 4, American Institute of Chemical Engineers, New York, NY, , December 2005, pp 316-327

DoD 6055.9-STD, *Ammunition and Explosives Safety Standards*, DoD 6055.9-STD, Change No. 3, Department of Defense, Washington, DC, 1991

DOE/TIC-11268, *Blast and Fragment Loadings on Structures*, US Department of Energy, Washington, DC, July 1992

FACEDAP, *FACEDAP (Facility and Component Explosive Damage Assessment Program)*, Protective Design Center, US Army Corps of Engineers, Omaha, NE (<https://pdc.usace.army.mil/software/facedap>)

FEMA 356, *Prestandard and Commentary for the Seismic Rehabilitation of Buildings (FEMA 356)*, Federal Emergency Management Agency, Washington, DC, November 2000

FEMA 412, *Installing Seismic Restraints for Mechanical Equipment*, Federal Emergency Management Agency, Washington, DC, 2002

FEMA 413, *Installing Seismic Restraints for Electrical Equipment*, Federal Emergency Management Agency, Washington, DC, 2004

FEMA 414, *Installing Seismic Restraints for Duct and Pipe*, Federal Emergency Management Agency, Washington, DC, 2004

Forbes 1982, "Design of Blast-Resistant Buildings in Petroleum and Chemical Plants", D. J. Forbes, *Safety and Accident Prevention in Chemical Operations*, 2nd edition, John Wiley & Sons, New York, NY, 1982, pp 489-506

Forbes 1998, "Protecting Petroleum Process Plant Buildings from Vapor Cloud Explosions", D. J. Forbes, *Concrete and Blast Effects*, SP-175, American Concrete Institute, Detroit, MI, 1998, pp 53-86

Gas Explosion Handbook, "Gas Explosion Handbook", *Gas Safety Programme 1990-1992 (GSP90-92)*, Christian Michelsen Research, Bergen, Norway, (available online at: <http://www.gexcon.com/index.php?src=handbook/GEXHBcontents.htm>)

Gehring and Summers, "Constructing and Designing Blast-Resistant Buildings: New Technology Improves Safety and Reliability for this Critical Plant Structure." *Hydrocarbon Processing*, G. Gehring and P. Summers, Gulf Publishing Company, Houston, TX, November 2005

Geng, "Simulation and Application of Blast Wave-Target Interactions", *Proceedings of the 41st Loss Prevention Symposium*, J.H. Geng and J.K. Thomas, American Institute of Chemical Engineers, New York, NY, 2007

Glasstone and Dolan, *The Effects of Nuclear Weapons*, S. Glasstone and P. J. Dolan (editors), US Department of Defense/US Department of Energy, Washington, D.C., third edition, 1977

Gupta, "Modeling of Shear Wall Buildings", A. K. Gupta, *Nuclear Engineering and Design*, Vol. 79, No. 1, Elsevier Science Publications, Lausanne, Switzerland, May 1984, pp 69-80

Hanna, "FLACS CFD Air Quality Model Performance Evaluation With Kit Fox, MUST, Prairie Grass, and EMU Observations", *Atmospheric Environment*, Steven R. Hanna, Olav R. Hansen, Seshu Dharmavaram, Elsevier, Amsterdam, Netherlands, Volume 38, Issue 28, 2004, pp 4675-4687

Herrmann 2005, "Developing a Sound Basis for the Design of Vented Explosion Barricades in Chemical Processes", *Process Safety Progress*, David D.Herrmann, Volume 24, Number 1, American Institute of Chemical Engineers, New York, NY, March 2005, Pages: 52-58.

Herrmann 2006, "Explosion Consequences of Low Velocity Releases of Dense Flammable Vapor Inside a Chemical Manufacturing Facility with a Complex Ventilation System", *Proceedings of the 40th Annual Loss Prevention Symposium*, David D. Herrmann, American Institute of Chemical Engineers, New York, NY, 2006.

Hoorelbeke, *Vapor Cloud Explosion Analysis of Onshore Petrochemical Facilities*, P. Hoorelbeke, J.R. Bakke, J. Renoult, and C. Izatt, ASSE-MEC 7th Professional Development Conference & Exhibition, Kingdom of Bahrain, March 18-22, 2006 (available online at: <http://www.gexcon.com/index.php?src=welcome/publications.html>)

IRI, *General Recommendations for Spacing in Refineries, Petrochemical Plants, Gasoline Plants, Terminals, Oil Pump Stations, and Offshore Properties*, Industrial Risk Insurers, Hartford, CT, 1984

Kennedy, "A Review of Procedures for the Analysis and Design of Concrete Structures to Resist Missile Impact Effects", P. P. Kennedy, *Nuclear Engineering and Design*, Vol. 37, No. 2, North Holland Publishing Company, Amsterdam, May 1976

Krauthammer 1986, "Modified SDOF Analysis of RC Box-Type Structures", T. Krauthammer, N. Bazeos, and T. J. Holmquist, *ASCE Structural Journal*, Vol. 112, No. 4, American Society of Civil Engineers, New York, NY, April, 1986, pp 726-744

Krauthammer 1990, "Response of Reinforced Concrete Elements to Severe Impulsive Loads", T. Krauthammer, S. Shahriar, and H. M. Shanaa, *ASCE Structural Journal*, Vol. 116, No. 4, American Society of Civil Engineers, New York, NY, April, 1990, pp 1061-1079

Lenoir, "A Survey of Vapor Cloud Explosions: Second Update", E. M. Lenoir, and J. A. Davenport, *Process Safety Progress*, Vol. 12, No. 1, Industrial Risk Insurers, Hartford, CT, January, 1993, pp 12-33

Lindholm, *A Survey of Rate Dependent Strength Properties of Metals*, U. S. Lindholm and R. L. Bessey, Southwest Research Institute, San Antonio, TX, 1969

MacGregor, *Reinforced Concrete, Mechanics and Design*, James G. MacGregor, Prentice Hall, Englewood Cliffs, NJ, 1988

Mays and Smith, *Blast Effects on Buildings - Design of Buildings to Optimize Resistance to Blast Loading*, G. C. Mays and P. D. Smith, Thomas Tedford Publications, London, GB, 1995

NCMA, *TEK Manual for Concrete Masonry Design and Construction*, National Concrete Masonry Association, Herndon, VA, January, 1995

Newmark, "An Engineering Approach to Blast Resistant Design", Nathan M. Newmark, *ASCE Transactions*, Vol. 121, Paper 2786, American Society of Civil Engineers, New York, NY, 1956, pp 45-64

NFEC, *Blast Resistant Structures*, Naval Facilities Engineering Command, Design Manual 2.08, Alexandria, VA, 1986

NFPA 68, *Standard on Explosion Protection by Deflagration Venting*, National Fire Protection Association, Quincy, MA, 2007

NONLIN, *Nonlinear Dynamic Time Histoy Analysis of Single Degree of Freedom Systems*, Advanced Structural Concepts, Inc., Golden, CO

NORSOK, *Design of Steel Structures*, NORSOK Standard N-004, Revision 2, Standards Norway, Lysaker, Norway, October 2004

Oswald 2002, "Test Data and Design Guidance for Steel Panels that Limit Blast Load Transferred Into Frame" *Proceedings from the 30th Annual Department of Defense Explosives Safety Seminar*, Prepared by BakerRisk, Atlanta, GA, August, 2002

Oswald 2005, *Component Explosive Damage Assessment Workbook (CEDAW)*, C.J. Oswald, Prepared by Baker Engineering and Risk Consultants for the U.S. Army Corps of Engineers, Protective Design Center, Contract No. DACA45-01-D-0007-0013, May, 2005

Park & Gamble, *Reinforced Concrete Slabs*, R. Park and W. Gamble, 2nd edition, John Wiley & Sons, New York, NY, 2000

Paz 1986, *Microcomputer-Aided Engineering: Structural Dynamics*, M. Paz, Van Nostrand Reinhold Company, New York, NY, 1986

Paz 1991, *Structural Dynamics: Theory and Computation*, third edition, M. Paz, Van Nostrand Reinhold Inc., New York, NY, 1991

PBS P100, *Facilities Standards for the Public Buildings Service*, U.S. General Services Administration, Washington, DC, March 2005

PDC-TR 06-08, *Single Degree of Freedom Structural Response Limits for Antiterrorism Design*, U.S. Army Corps of Engineers, Protective Design Center, 2006

PIP ARS08390, *Blast Resistant Doors and Frames*, Process Industry Practices, Austin, TX, October, 2002

PIP STC01018, *Blast Resistant Building Design Criteria*, Process Industry Practices, Austin, TX, October 2006

Roark, *Formulas for Stress and Strain*, seventh edition, Raymond J. Roark and Warren C. Young, McGraw-Hill Book Company, New York, NY, 2002

SAC, *Parametric Analytical Investigations of Ground Motion and Structural Response, Northridge Earthquake of January 17, 1994*, S. Campbell, M. Englehardt, J. Hall, G. Hart, L. Ho, S. Huang, A. Husain, W. Iwan, H. Kim, K. Kim, R. Lobo, T. Sabol, M. Skokan, J. Uzarski, SAC Joint Venture, Richmond, CA, December, 1995.

SAE AMS4113, *Aluminum Alloy, Extruded Profiles 1.0mg 0.6si 0.28cu 0.20cr (6061-T6) Solution and Precipitation Heat Treated*, SAE International, Warrendale, PA, 2003

SAE AMS5501, *Steel, Corrosion Resistant, Sheet, Strip, and Foil 19cf 9.5ni (304) Cold Rolled, 125 ksi (862 MPa) Tensile Strength*, SAE International, Warrendale, PA, 2002

SBEDS, *SBEDS (Single Degree of Freedom Blast Effects Design Spreadsheet)*, Protective Design Center, US Army Corps of Engineers, Omaha, NE (<https://pdc.usace.army.mil/software/sbeds>)

Schneider, *Reinforced Masonry Design*, second edition, R. R. Schneider and W. L. Dickey, Prentice-Hall, Inc., Englewood Cliffs, NJ, 1987

SCI-P-112, *Interim Guidance Notes for the Design and Protection of Topsides of Structures Against Explosions and Fire*, Document No. 443, Fire and Blast Information Group, Ascot Berkshire, UK, April 1993

SDI, *Steel Deck Institute Design Manual*, Steel Deck Institute, Canton, OH, 1987

SG-22, *Siting and Construction of New Control Houses for Chemical Manufacturing Plants*, Safety Guide SG-22, Manufacturing Chemists Association, Washington, DC, 1978

SidePlate Systems, *Blast Resistant Strengthening of Pre-Engineered Steel Frame Buildings Using SidePlateR Moment Connection Technology*, SlidePlate Systems, Inc., Prepared for Wilfred Baker Engineering, Inc, January 1998

SMACNA, *Seismic Restraint Manual: Guidelines for Mechanical Systems*, 2nd edition, Sheet Metal and Air Conditioning Contractor's National Association, Chantilly, VA, 1998

Stephens, *Minimizing Damage to Refineries from Nuclear Attack, Natural and Other Disasters*, M.M. Stephens, US Department of the Interior, Office of Oil and Gas, NTIS AD-773-048, Washington, DC, 1970.

Stronge and Yu, *Dynamic Models for Structural Plasticity*, W. J. Stronge and T. X. Yu, Springer-Verlag London, Ltd., London, England, 1993

TM 5-856, *Design of Structures to Resist the Effects of Atomic Weapons*, Technical Manuals 5-856-1 through 9 (9 volumes), Department of the Army, Washington, DC, January, 1960

TNO Green Book, *Method for the Determination of Possible Damage to People and Objects Resulting from Releases of Hazardous Materials (CPR 16E)*, Committee for the Prevention of Disasters Due to Dangerous Substances, The Director-General of Labour, The Hague, The Netherlands, 1992

TNO 1985, "The Multi-Energy Method - A Framework for Vapor Cloud Blast Prediction", A. C. Van Den Berg, *Journal of Hazardous Materials*, Vol. 12, No. 1, Elsevier Science Publications, Amsterdam, The Netherlands, September, 1985, pp 1-10

TR 4837, *Design of Steel Structures to Resist the Effects of HE Explosions*, Technical Report 4837, Picatinny Arsenal, Dover NJ, 1975

TR 4921, *Overturning and Sliding Analysis of Reinforced Concrete Protective Structures*, Technical Publication 4921, US Army Picatinny Arsenal, Dover, NJ, 1976

UFC 3-340-02, *Structures to Resist the Effects of Accidental Explosions*, Unified Facilities Criteria 3-340-02 (formerly Technical Manual TM 5-1300), U.S. Department of Defense, Washington, DC, 2008

UFC 04-010-01, *DoD Minimum Antiterrorism Standards For Buildings*, U.S. Department of Defense, Washington, DC, 2007

UFC 4-023-02, *Retrofit of Existing Buildings to Resist Explosive Effects (draft)*, Department of Defense, Washington, DC, January 2005

Wingerden, "Prediction of Blast Overpressures Caused by Vapor Cloud Explosions in the Vicinity of Control Rooms", *Process Safety Progress*, Kees Van Wingerden, Olaf Roald Hansen, and Pierre Foisselon, Volume 18, Number 1, American Institute of Chemical Engineers, New York, NY, 1999

White 1991, *Second-Order Inelastic Analysis for Frame Design: A Report to SSRC Task Group 29 on Recent Research and the Perceived State-of-the-Art*, D. W. White, J. Y. R. Liew, and W. F. Chen, Report No CE-STR-91-12, School of Engineering, Purdue University, West Lafayette, IN, 1991

White 1993, *Plastic Hinge Based Methods for advanced Analysis and Design of Steel Frames*, D. W. White and W. F. Chen (eds.), Structural Stability Research Council, Lehigh University, Bethlehem, Pennsylvania, 1993

Yu, *Cold-Formed Steel Design*, 3rd edition, Wei-Wen Yu, John Wiley & Sons, Inc., New York, NY, 2000

INDEX

<u>Index Terms</u>	<u>Links</u>
A	
arch structures	46
B	
blast resistant design: background	1–2
design process	3–5
exterior design considerations	134
interior design considerations	133–134
non-building structures	9–11
objectives of	7
offshore facilities	9
OSHA requirements	6
related industry guidelines	3
requirements for	7–8
siting considerations	8–9
blast resistant shells	157–159
blast resistant shield wall	152–154
blast wave parameters	14–20
blast wave length	20
blast wind	17–19
dynamic pressure	17–19

Index Terms

Links

blast wave parameters (<i>Cont.</i>)		
idealized	20	
peak reflected pressure	17	
shock front velocity	19	
types of blast waves	15	
bolts, anchor	52–53	213–215
braced frames	255–259	
buildings: enhanced pre-engineered metal	120	
evaluation of existing	135–137	
load determination	24–29	
metal building design example	222–262	
modular steel-framed	39–49	
portable	46–47	
pre-engineered metal	35–36	
shear wall building design example	164–221	
<i>see also</i> buildings upgrading		
buildings, upgrading	137–163	
blast resistant shells	157–159	
blast resistant shield wall	152–154	
blast resistant upgrade options	137–139	
concrete masonry	146–152	
concrete walls	146–152	
doors	161–163	
metal panel wall systems	144–145	
roof systems	144–145	155–156
structural framing members	142–144	

Index Terms

Links

buildings, upgrading (*Cont.*)

structural member connections	139–142
wall and roof catch systems	156–157
windows	159–161
<i>see also</i> buildings	

C

case studies: masonry retrofit design example	263–275		
metal building design example	222–262		
shear wall building design example	164–221		
column base plate and anchor bolt design	213–215		
columns	207–212	213–215	
computational fluid dynamics	29–30		
concrete: cast-in-place wall	38–39	121	126
creating new reinforced concrete wall	271–274		
masonry	146–152		
precast wall	37	121	122–125
response limits for reinforced concrete	71		
walls	146–152		
concrete, reinforced	50–51		
design procedures	106–109		
material properties	50–51		
response criteria	50–51		
construction types	34–47		
arch structures	46		
blast resistant modular steel-framed	39–49		
cast-in-place concrete wall	38–39		

Index Terms

Links

construction types (*Cont.*)

dome structures	46
earth embanked structures	46
general considerations	34–35
masonry wall	36
metal clad	36
portable buildings	46–47
precast concrete wall	37
pre-engineered concrete boxes	45
pre-engineered metal buildings	35–36

D

deformation limits	62–66
parameters	63–65
values	65–66
design examples: masonry	
retrofit design example	263–275
metal building design example	222–262
shear wall building design example	164–221
design procedures	100–119
design against projectiles	118–119
energy absorption	100
foundation design	114–118
general concepts	100–104
limit state design	101
loading combinations	101
member design process	104–106

Index Terms

Links

design procedures (<i>Cont.</i>)		
reinforced concrete design	106–109	
reinforced masonry design	113–114	
resistance functions	102–104	
safety factors	100–101	
steel design	109–112	
structural performance considerations	104	
details	120–126	
cast-in-place concrete wall	121	126
enhanced pre-engineered metal buildings	120	
masonry walls	120	
metal clad	121	
precast concrete wall	121	122–125
dome structures	46	
doors	127–131	
commercial industrial	128–129	
coordinating with manufacturer	129–130	
delivery lead times	131	
design guidelines	129	
fire labels	131	
performance limitations	128–129	
structural analysis methods	130–131	
testing	130–131	
upgrades to	161–163	

Index Terms

Links

dynamic analysis methods	72–99		
accuracy	73		
applications	93–96		
confirmation of assumed failure mechanisms	76		
diaphragm structures	93–94		
empirical methods	96		
equivalent static method	76		
frame structures	94–95		
interaction of structural elements	73–75		
live loads	75		
multi-degree of freedom systems.			
<i>see</i> multi-degree of freedom systems			
numerical integration	97–99		
objectives of	72–73		
shear wall structures	93–94		
single degree of freedom systems.			
<i>see</i> single degree of freedom systems			
slender box-type structures	95		
walls with openings	95–96		
dynamic design stress	60–61	68	
dynamic increase factor	59–60	67	68
dynamic material properties	54–61		
dynamic design stress	60–61		
dynamic increase factor	59–60		
dynamic strength increase	57–59		
strength increase factor	56–57		
stress-strain relationships	55–56		
dynamic strength increase	57–59		

Index Terms

Links

E

earth embanked structures	46
evaluation of existing buildings	135–137
examples. <i>see</i> design examples	
explosion types	12–14
condensed phase	14
dust	14
pressure vessel	13–14
vapor cloud	12–13

F

factors: dynamic increase	59–60	67	68
strength increase	56–57	67	
transformation	78–85		
foundations: design procedures	114–118		
metal building design example	259–262		
shear wall building design example	215–221		
frames: blast resistant modular steel	39–49		
braced	255–259		
loading	28		
rigid	248–255		
structures	94–95		

Index Terms

Links

L

load determination	12–33	
blast load example	31–33	
blast loading	16–17	31
blast wave length	20	
blast wave parameters	14–20	
blast wind	17–19	
building blast loading	24–29	
computational fluid dynamics	29–30	
dynamic pressure	17–19	
explosion types	12–14	
frame loading	28	
front wall loading	25–26	31–32
leakage pressure	29	
negative pressure	28	
peak reflected pressure	17	
rear wall loading	27–28	33
rebound loading	28	
roof loading	27	32–33
shock front velocity	19	
side wall loading	26	32
types of blast waves	15	
vapor cloud design overpressures	20–23	

Index Terms

Links

loading: blast	16–17	31	
building blast	24–29		
combinations	101		
frames	28		
front wall	25–26	31–32	
rear wall	27–28	33	
rebound	28		
roof	27	32–33	
side wall	26	32	173–174

M

masonry: concrete	146–152		
response limits for reinforced masonry	71		
retrofit design example	263–275		
walls	36	120	
masonry, reinforced	51		
design procedures	113–114		
masonry retrofit design example	263–275		
conclusions	274–275		
creating new reinforced concrete wall	271–274		
design data	264–265		
evaluation of existing wall	265–268		
reinforcing existing wall	268–271		
structural system	263		
material properties	48–71		
anchor bolts	52–53		
cold formed steel	52		
deformation limits	62–66		

Index Terms

Links

material properties (<i>Cont.</i>)	
dynamic design stress	68
dynamic material properties.	
<i>see</i> dynamic material properties	
dynamic material strength	67–68
materials	50–54
open web steel joists	52–53
reinforced concrete	50–51
reinforced masonry	51
resistance-deflection function	49–50
soil	52–53
static versus dynamic response	48–49
structural elements	50–54
structural steel	51–52
members: design procedures	104–106
design process	104–106
structural framing	142–144
structural member connections	139–142
upgrades to structural framing members	142–144
upgrades to structural member connections	139–142
metal building design example	222–262
braced frames	255–259
design data	225–226
foundation	259–262
multi-degree of freedom analysis	252–255
rigid frames	248–255
roof decking	226–231

Index Terms

Links

metal building design example (<i>Cont.</i>)		
roof purlins	235–244	
structural system	222–224	
wall girts	244–248	
wall panels	231–235	
metal panel wall systems	144–145	
modular steel-framed buildings	39–49	
acceptance criteria	41–43	
anchoring	43–44	
connection design	44–45	
design approach	40–41	
elevated	44	
projectile resistance	45	
temporary buildings	45	
transportation of	45	
multi-degree of freedom analysis	252–255	
multi-degree of freedom systems	90–93	
advanced analysis methods	91–92	
dynamic equilibrium equation	91	
finite element analysis methods	92–93	
N		
numerical integration	88	97–99
O		
offshore facilities	9	

Index Terms

Links

P

portable buildings 46–47

R

reinforced concrete 50–51

 design procedures 106–109

reinforced masonry 51

 design procedures 113–114

response criteria 48–71

 anchor bolts 52–53

 cold formed steel 52

 deformation limits 62–66

 dynamic design stress 68

 dynamic material properties.

see dynamic material properties materials 50–54

 open web steel joists 52–53

 reinforced concrete 50–51

 reinforced masonry 51

 resistance-deflection function 49–50

 soil 52–53

 static versus dynamic response 48–49

 structural elements 50–54

 structural steel 51–52

 summary tables 69–71

rigid frames 248–255

roof systems 144–145 155–156

 wall and roof catch systems 156–157

Index Terms

Links

roofs: beam connection	197–199	
beams	191–197	
decking	226–231	
girder connection	205–207	
girders	199–205	
loading	27	32–33
purlins	235–244	
roof systems	144–145	155–156
slabs	174–179	184–191
wall and roof catch systems	156–157	

S

shear wall building design example	164–221	
column base plate and anchor bolt design	213–215	
columns	207–212	
design data	166–167	
exterior walls	167–174	
foundation	215–221	
front wall	167–168	171–173
roof beam connection	197–199	
roof beams	191–197	
roof girder connection	205–207	
roof girders	199–205	
roof slab	174–179	184–191
side wall	168	179–184
side wall loading	173–174	
structural system	164–166	
shells	157–159	

Index Terms

Links

single degree of freedom systems	76–90
basics	76–78
closed form solutions	87–88
graphical solution methods	85–87
numerical integration	88
support reactions	89–90
transformation factors	78–85
siting considerations	8–9
soil	52–53
steel: cold formed	52
design procedures	109–112
open web joists	52–53
response limits for steel components	70
structural	51–52
stress-strain relationships	55–56
structural framing members	142–144
structural member connections	139–142

T

transformation factors	78–85
------------------------	-------

U

upgrading buildings	137–163
blast resistant shells	157–159
blast resistant shield wall	152–154

Index Terms

Links

upgrading buildings (*Cont.*)

blast resistant upgrade options	137–139		
concrete masonry	146–152		
concrete walls	146–152		
doors	161–163		
metal panel wall systems	144–145		
roof systems	144–145	155–156	
wall and roof catch systems	156–157		
windows	159–161		
utility openings	133		

W

walls: blast resistant shield	152–154		
cast-in-place concrete	38–39	121	126
concrete	146–152		
creating new reinforced concrete	271–274		
evaluation of existing	265–268		
exterior	167–174		
front	25–26	31–32	171–173
girts	244–248		
loading	25–28	31–32	33
masonry	36	120	
metal panel wall systems	144–145		
with openings	95–96		
panels	231–235		
precast concrete	37	121	122–125
rear	27–28	33	
reinforcing existing	268–271		

Index Terms

Links

walls: blast resistant shield (<i>Cont.</i>)			
and roof catch systems	156–157		
shear wall building design example	164–221		
shield	152–154		
side	26	32	168
	173–174	179–184	
windows	131–132		
upgrades to	159–161		