

# Accelerated Bridge Construction

Experience in Design, Fabrication  
and Erection of Prefabricated  
Bridge Elements and Systems

## *Final Manual*

Publication No. HIF-12-013

Publication Date: 11-01-11

List of Revisions:

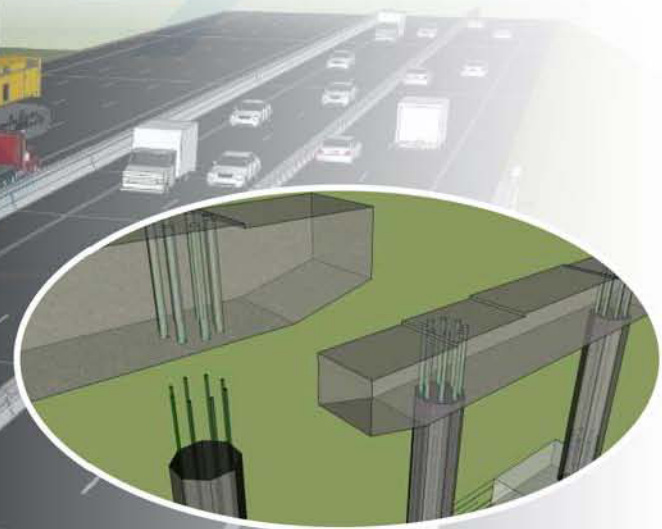

U.S. Department of Transportation  
**Federal Highway Administration**



Priority, Market Ready  
Technologies and  
Innovations

**HIGHWAYS FOR LIFE**

Accelerating Innovation for the American Driving Experience.



## Foreword

This manual has been developed for the purposes of enhancing the use of Prefabricated Bridge Elements and Systems (PBES) as part of accelerated construction projects. FHWA continues to focus on a need to create awareness, inform, educate, train, assist and entice State DOT's and their staff in the use of rapid construction techniques.

Users of this manual will be able to perform the following tasks:

- Understand the different types of ABC technologies that are in use today
- Understand the various types of prefabricated elements used in bridges
- Assess specific sites for the most appropriate ABC technology for the project
- Plan and implement an accelerated bridge construction program using PBES.
- Understand the construction aspects of PBES projects.
- Understand the long-term durability of bridges built with PBES

Byron Lord  
Program Coordinator, Team Leader  
Highways for LIFE Program

Myint Lwin  
Director  
Office of Bridge Technology

## Notice

This document is disseminated under the sponsorship of the U.S. Department of Transportation in the interest of information exchange. The U.S. Government assumes no liability for its content or use thereof. This report does not constitute a standard, specification, or regulation.

The U.S. Government does not endorse products or manufacturers. Trademarks or manufacturers' names appear in this report only because they are considered essential to the objective of the document.

**Technical Report Documentation Page**

1. Report No. FHWA-HIF-12-013		2. Government Accession No.		3. Recipient's Catalog No.	
4. Title and Subtitle Accelerated Bridge Construction - Experience in Design, Fabrication and Erection of Prefabricated Bridge Elements and Systems				5. Report Date November 1, 2011	
				6. Performing Organization Code	
7. Author(s) Michael P. Culmo, P.E.				8. Performing Organization Report No.	
9. Performing Organization Name and Address CME Associates, Inc. 333 East River Drive, Suite 400 East Hartford, CT 06108  Applied Research Associates, Inc. 100 Trade Centre Drive, Suite 200 Champaign, IL 61820				10. Work Unit No.	
				11. Contract or Grant No. <b>DTFH61-06-D-00038/T-09002</b>	
12. Sponsoring Agency Name and Address Office of Bridge Technology, HIBT-10 Federal Highway Administration 6300 Georgetown Pike McLean, VA 22101-2296				13. Type of Report and Period Covered Final Document	
				14. Sponsoring Agency Code	
15. Supplementary Notes FHWA's Contracting Officer's Technical Representatives were Byron Lord and Mary Huie. The Task Order Manager was Benjamin Beerman, P.E. The authors are thankful for the generous support help from various reviewers in completing this work.					
16. Abstract This document represents the "State of the Practice" with respect to all aspects of accelerated bridge construction (ABC). The intent of this manual is to fill in the gaps left by publication of the previous manuals. The manual covers ABC techniques, project planning and scoping, implementing ABC in a Transportation Agency, prefabricated elements, long-term performance of prefabricated elements, construction and design. The manual can be used by transportation agencies to establish a successful accelerated bridge construction program.					
17. Key Words Bridges, connections, details, elements, prefabricated, concrete, steel, timber, FRP, precast			18. Distribution Statement No restrictions. This document is available to the public through the National Technical Information Service, Springfield, VA 22161.		
19. Security Classif. (of this report) Unclassified		20. Security Classif. (of this page) Unclassified		21. No of Pages 346	22. Price

**Form DOT F 1700.7 (8-72)**

**Reproduction of completed pages authorized**

## SI\* (MODERN METRIC) CONVERSION FACTORS

APPROXIMATE CONVERSIONS TO SI UNITS				
SYMBOL	WHEN YOU KNOW	MULTIPLY BY	TO FIND	SYMBOL
LENGTH				
<b>in</b>	inches	25.4	millimeters	mm
<b>ft</b>	feet	0.305	meters	m
<b>yd</b>	yards	0.914	meters	m
<b>mi</b>	miles	1.61	kilometers	km
AREA				
<b>in<sup>2</sup></b>	square inches	645.2	square millimeters	mm <sup>2</sup>
<b>ft<sup>2</sup></b>	square feet	0.093	square meters	m <sup>2</sup>
<b>yd<sup>2</sup></b>	square yard	0.836	square meters	m <sup>2</sup>
<b>ac</b>	acres	0.405	hectares	ha
<b>mi<sup>2</sup></b>	square miles	2.59	square kilometers	km <sup>2</sup>
VOLUME				
<b>fl oz</b>	fluid ounces	29.57	milliliters	mL
<b>gal</b>	gallons	3.785	liters	L
<b>ft<sup>3</sup></b>	cubic feet	0.028	cubic meters	m <sup>3</sup>
<b>yd<sup>3</sup></b>	cubic yards	0.765	cubic meters	m <sup>3</sup>
NOTE: volumes greater than 1000 L shall be shown in m <sup>3</sup>				
MASS				
<b>oz</b>	ounces	28.35	grams	g
<b>lb</b>	pounds	0.454	kilograms	kg
<b>T</b>	short tons (2000 lb)	0.907	megagrams (or "metric ton")	Mg (or "t")
TEMPERATURE (exact degrees)				
<b>°F</b>	Fahrenheit	5 (F-32)/9 or (F-32)/1.8	Celsius	°C
ILLUMINATION				
<b>fc</b>	foot-candles	10.76	lux	lx
<b>fl</b>	foot-Lamberts	3.426	candela/m <sup>2</sup>	cd/m <sup>2</sup>
FORCE and PRESSURE or STRESS				
<b>lbf</b>	poundforce	4.45	newtons	N
<b>lbf/in<sup>2</sup></b>	poundforce per square inch	6.89	kilopascals	kPa

## SI\* (MODERN METRIC) CONVERSION FACTORS

APPROXIMATE CONVERSIONS FROM SI UNITS				
SYMBOL	WHEN YOU KNOW	MULTIPLY BY	TO FIND	SYMBOL
LENGTH				
<b>mm</b>	millimeters	0.039	inches	in
<b>m</b>	meters	3.28	feet	ft
<b>m</b>	meters	1.09	yards	yd
<b>km</b>	kilometers	0.621	miles	mi
AREA				
<b>mm<sup>2</sup></b>	square millimeters	0.0016	square inches	in <sup>2</sup>
<b>m<sup>2</sup></b>	square meters	10.764	square feet	ft <sup>2</sup>
<b>m<sup>2</sup></b>	square meters	1.195	square yards	yd <sup>2</sup>
<b>ha</b>	hectares	2.47	acres	ac
<b>km<sup>2</sup></b>	square kilometers	0.386	square miles	mi <sup>2</sup>
VOLUME				
<b>mL</b>	milliliters	0.034	fluid ounces	fl oz
<b>L</b>	liters	0.264	gallons	gal
<b>m<sup>3</sup></b>	cubic meters	35.314	cubic feet	ft <sup>3</sup>
<b>m<sup>3</sup></b>	cubic meters	1.307	cubic yards	yd <sup>3</sup>
MASS				
<b>g</b>	grams	0.035	ounces	oz
<b>kg</b>	kilograms	2.202	pounds	lb
<b>Mg (or "t")</b>	megagrams (or "metric ton")	1.103	short tons (2000 lb)	T
TEMPERATURE (exact degrees)				
<b>°C</b>	Celsius	1.8C+32	Fahrenheit	°F
ILLUMINATION				
<b>lx</b>	lux	0.0929	foot-candles	fc
<b>cd/m<sup>2</sup></b>	candela/m <sup>2</sup>	0.2919	foot-Lamberts	fl
FORCE and PRESSURE or STRESS				
<b>N</b>	newtons	0.225	poundforce	lbf
<b>kPa</b>	kilopascals	0.145	poundforce per square inch	lbf/in <sup>2</sup>

\*SI is the symbol for the International System of Units. Appropriate rounding should be made to comply with Section 4 of ASTM E380.  
(Revised March 2003)

# Table of Contents

Listing of Figures.....	13
Listing of Tables.....	18
Listing of Acronyms.....	19
ABC Definitions.....	22
Accelerated Bridge Construction (ABC)	
Conventional Bridge Construction	
Time Metrics for ABC	
Onsite Construction Time	
Mobility Impact Time	
Prefabricated Bridge Elements and Systems (PBES)	
Elements	
Deck Elements	
Beam Elements	
Pier Elements	
Abutment and Wall Elements	
Miscellaneous Elements	
Systems	
Superstructure Systems	
Superstructure/Substructure Systems	
Total Bridge Systems	
Glossary of Terms.....	38
Chapter 1 Introduction WHY ABC?.....	52
1.1. Purpose and Use of this Manual.....	55
1.1.1. Intended Users.....	55
1.1.1.1. Decision Makers.....	55
1.1.1.2. Project Managers.....	56
1.1.1.3. Bridge Designers.....	56
1.2. Why use Accelerated Bridge Construction?.....	57
1.2.1. Benefits of ABC projects using PBES.....	59
1.2.1.1. Reduced Road User Impacts.....	59
1.2.1.2. Improved Worker and Motorist Safety.....	60
1.2.1.3. Expedited Project Planning Process.....	61
1.2.1.4. Improved Quality.....	62
1.2.1.5. Improved Constructability.....	64
1.2.1.6. Reduced Cost to Society.....	64
1.2.2. Positive Public Perception of ABC.....	66
1.2.2.1. Public Response to ABC Projects.....	66
Chapter 2 Accelerated Bridge Construction Technologies.....	69
2.1. Foundation and Wall Elements.....	70
2.1.1. Continuous Flight Auger Piles (CFA).....	70
2.1.2. Geosynthetic Reinforced Soil Integrated Bridge System (GRS/IBS).....	71
2.1.3. Prefabricated Pier Cofferdams.....	73

2.2.	Rapid Embankment Construction.....	73
2.2.1.	Expanded Polystyrene (EPS) Geofoam .....	73
2.2.2.	Accelerated Embankment Preload Techniques.....	74
2.2.3.	Column Supported Embankment Techniques .....	74
2.3.	Prefabricated Bridge Elements and Systems .....	75
2.3.1.	Prefabricated Elements.....	75
2.3.2.	Prefabricated Systems .....	80
2.4.	Structural Placement Methods .....	80
2.4.1.	Self Propelled Modular Transporters (SPMTs) .....	80
2.4.2.	Longitudinal Launching .....	84
2.4.3.	Horizontal Skidding or Sliding.....	85
2.4.4.	Other Heavy Lifting Equipment and Methods .....	88
2.4.5.	Conventional Cranes.....	94
2.5.	Fast Track Contracting.....	95
2.5.1.	Accelerated Project Delivery .....	96
2.5.1.1.	Design-Build (DB).....	96
2.5.1.2.	Construction Manager General Contractor (CMGC) .....	100
2.5.2.	Contracting Provisions .....	103
2.5.2.1.	Best Value Selection .....	103
2.5.2.2.	A+B and A+B+C Bidding .....	105
2.5.2.3.	Continuity of the Construction Process .....	106
2.5.2.4.	Incentive/Disincentive (I/D) Clauses .....	106
2.5.2.5.	Warranties.....	108
2.5.2.6.	Lane Rental.....	109
2.6.	Applicability of ABC Technologies to Different Bridge Projects .....	109
2.6.1.	Rehabilitation of Existing Bridges .....	110
2.6.1.1.	Deck Replacement .....	110
2.6.1.2.	Superstructure Replacement.....	116
2.6.1.3.	Substructure Replacement .....	117
2.6.2.	Replacement of Existing Bridges and New Bridges.....	118
2.6.2.1.	Staging.....	118
2.6.2.2.	Full Closure and New Construction .....	119
2.6.3.	Effect of Structure Type on ABC Methods .....	119
2.6.3.1.	Curved, Skewed and Flared Bridges .....	119
	Bridges with Transverse Floor Beams.....	121
2.6.3.2.	(trusses and widely spaced girder bridges).....	121
2.6.3.3.	Box Culverts.....	122
Chapter 3	PBES for ABC – Planning and Scoping Projects.....	123
3.1.	ABC Decision Making Process .....	124
3.2.	Decision Process for Selection of Appropriate ABC Methods.....	124
3.2.1.	Defining the Problem.....	125
3.2.1.1.	Site Constraints .....	125
3.2.1.2.	Staging Areas.....	130
3.2.1.3.	Traffic Management.....	131
3.2.1.4.	Right of Way Issues.....	135
3.2.1.5.	Utilities.....	135
3.2.1.6.	Local Government Constraints .....	136
3.2.1.7.	Structure Type Options.....	136
3.2.2.	Flowcharts for Determination of Appropriate ABC Methods.....	139
3.2.2.1.	Example Project .....	144

3.2.3.	Structure Type Selection Analysis Including Overall Project Costs.....	150
3.2.3.1.	Cost Evaluation .....	150
3.2.4.	Public Involvement .....	158
Chapter 4	Implementing ABC in a Transportation Agency (A Case Study from the Utah DOT)160 .....	160
4.1.	General Approach: No Magic Bullet .....	160
4.1.1.	Strategic Layers of Implementation .....	162
4.1.2.	Upper Management and Politics .....	162
4.1.3.	Mid-Level and Organization .....	162
4.1.4.	Project Level .....	164
4.1.5.	Identify ABC Champions at All Levels .....	165
4.2.	Stakeholder Buy-in .....	165
4.3.	Scanning Tours.....	165
4.4.	Demonstration Projects.....	166
4.5.	The Role of Innovative Contracting .....	166
4.6.	PBES Decision Making Framework .....	167
4.7.	Establish a “Program of Projects”.....	167
4.8.	Develop Specifications, Standards, and Standard Details.....	168
4.9.	Communication.....	168
4.10.	Measure and Share Successes .....	169
4.11.	Conclusions .....	170
Chapter 5	Prefabricated Bridge Elements.....	171
5.1.	Materials.....	171
5.1.1.	Structural Steel .....	171
5.1.2.	Concrete (Normal Weight and Lightweight).....	171
5.1.3.	Timber.....	175
5.1.4.	Aluminum .....	176
5.1.5.	Fiber-Reinforced Polymer .....	176
5.1.6.	Grouts .....	176
5.1.6.1.	Grout Types.....	177
5.1.7.	Ultra High Performance Concrete .....	178
5.1.8.	Corrosion Resistant Reinforcing Steel.....	179
5.1.8.1.	Stainless Steel.....	179
5.1.8.2.	Low-carbon, Chromium, Steel Bars .....	180
5.1.8.3.	Coated and Galvanized Bars.....	180
5.1.8.4.	Fiber Reinforced Polymer (FRP) Bars .....	180
5.2.	Superstructure Elements .....	181
5.2.1.	Beams and Girders .....	181
5.2.1.1.	Steel.....	181
5.2.1.2.	Precast/Prestressed Concrete.....	181
5.2.2.	Stay-in-place Deck Forming .....	182
5.2.2.1.	Corrugated Steel .....	182
5.2.2.2.	Partial-depth Precast Concrete Deck Panels.....	182
5.2.3.	Full-Depth Deck Panels.....	184
5.2.3.1.	Precast/Prestressed Concrete.....	184
5.2.3.2.	Steel Grid .....	187
5.2.3.3.	Fiber Reinforced Polymer.....	194
5.2.4.	Modular Superstructure Systems .....	194
5.2.4.1.	Modular Steel Systems.....	195

5.2.4.2.	Modular Precast Concrete Superstructure Systems .....	199
5.2.4.3.	Modular Timber Superstructure Elements and Systems .....	201
5.3.	Substructure Elements.....	203
5.3.1.	Piers.....	203
5.3.1.1.	Open Frame Bents .....	203
5.3.1.2.	Wall Piers .....	206
5.3.1.3.	Seismic Requirements.....	207
5.3.2.	Abutments.....	210
5.3.2.1.	Cantilever .....	211
5.3.2.2.	Spill-Through.....	212
5.3.2.3.	Integral and Semi-Integral Abutments.....	212
5.3.2.4.	Geosynthetic Reinforced Soil Integrated Bridge System (GRS)....	214
5.3.2.5.	Seismic Requirements.....	215
5.3.3.	Wing Walls and Retaining walls .....	216
5.3.3.1.	Precast Concrete Cantilever .....	216
5.3.3.2.	Modular Precast .....	217
5.3.4.	Modular Culvert/Arch Systems .....	219
5.3.4.1.	Precast Arches and Three Sided Frames .....	219
5.3.4.2.	Steel Arches and Pipes .....	220
5.3.4.3.	Box Culverts .....	221
5.4.	Foundations .....	221
5.4.1.	Common Deep Foundations .....	221
5.4.2.	Foundation Challenges .....	222
5.4.2.1.	Earth Retention .....	222
5.4.2.2.	Deep Water .....	223
5.4.3.	Prefabricated Foundation Elements .....	223
5.4.3.1.	Spread Footings .....	223
5.4.3.2.	Pile Cap Footings .....	224
5.4.3.3.	Precast Pier Box Cofferdams .....	224
Chapter 6	Miscellaneous Bridge Elements .....	228
6.1.	Deck Overlays I Riding Surface Quality .....	228
6.2.	Bridge Deck Expansion Joints .....	229
6.3.	Bridge Bearings .....	229
6.4.	Drainage Assemblies .....	230
6.5.	Barriers and Railings.....	230
6.5.1.	Crash Testing Requirements.....	231
6.5.2.	Concrete Barriers .....	231
6.5.3.	Metal Railings .....	232
6.5.4.	Barriers on MSE and Modular Walls.....	232
6.6.	Utilities .....	233
Chapter 7	Construction.....	234
7.1.	Shoring Systems and Temporary Works.....	234
7.1.1.	Shoring for Large-scale Bridge Moves .....	234
7.1.2.	Geotechnical Investigations .....	237
7.2.	Acceleration of Submissions and Reviews .....	238
7.2.1.	Electronic Data Transfer.....	238
7.2.1.1.	Electronic Shop Drawing and Submittals .....	239
7.2.1.2.	Digital Stamps and Signatures .....	239
7.2.2.	“Intent to build” Drawings .....	239

7.3.	Materials Testing on ABC Projects.....	240
7.3.1.	Accelerated Testing Protocol.....	240
7.3.2.	Concrete Maturity Method .....	240
7.3.3.	Load Indicating Washers for Steel Structures.....	241
7.4.	Fabrication.....	241
7.4.1.	Plant Certification.....	241
7.4.2.	Near-site Casting Certification.....	242
7.4.3.	Tolerances .....	242
7.4.3.1.	Element Tolerances.....	242
7.4.3.2.	Dimensional Growth .....	243
7.4.3.3.	Hardware Tolerances .....	243
7.4.4.	Lifting/Moving Elements .....	244
7.4.5.	Workmanship .....	245
7.5.	Erection Issues .....	245
7.5.1.	Responsibilities .....	245
7.5.1.1.	Designer.....	245
7.5.1.2.	Contractor .....	246
7.5.1.3.	Fabricator .....	246
7.5.2.	Large-scale Bridge Lifting.....	246
7.5.3.	The Effect of Tolerances and Adjustability.....	248
7.6.	Field Inspection.....	248
7.6.1.	Accelerated Decision Making .....	248
7.6.2.	Staff Training.....	250
7.7.	Grout Placement and Curing.....	250
7.7.1.	Small Void Grouting .....	250
7.7.2.	Grouting of Post-tensioning Ducts.....	251
7.8.	High Early Strength Concrete .....	251
7.8.1.	Mix Design Approach .....	253
7.8.2.	Accelerated Curing.....	255
Chapter 8	Long Term Performance of Prefabricated Elements.....	257
8.1.	Inspection Preservation, and Maintenance .....	257
8.2.	Durability of Modular Systems .....	258
8.2.1.	Case Studies in Durability .....	259
8.2.1.1.	Joints in Substructure Elements .....	259
8.2.1.2.	Joints in Precast Concrete Deck Panels .....	260
8.2.1.3.	Large-scale Bridge Moves.....	261
Chapter 9	Design and Analysis .....	265
9.1.	LRFD Design .....	265
9.1.1.	Precast Substructure Elements.....	265
9.1.2.	Deck Panel Elements.....	266
9.1.3.	ABC Issues not Covered in the LRFD Bridge Design Specifications .....	267
9.1.4.	Design of Bridges with Large-scale Lifting Methods .....	268
9.2.	LRFR Ratings .....	270
9.3.	Design and Analysis of Temporary Works .....	270
9.4.	Evaluation of Existing Structures.....	270
References.....		270

Appendices .....	275
Appendix A: Design Examples.....	275
Appendix B: Standard and Proprietary Products.....	289
Appendix C: Sample Construction Specifications .....	290

## Listing of Figures

Figure Number	Description	Page
1.2-1	Cast-In-Place Concrete Bridge Construction Techniques	56
1.2.1.4-1	Precast Deck Construction in 1990	63
1.2.2.1-1	Sample Public Satisfaction Poll in Utah	67
2-1	Accelerated Bridge Construction Technologies	68
2.1.1-1	Continuous Flight Auger Pile Installation	69
2.1.2-1	Typical Section of a GRS/IBS Bridge Abutment	71
2.2.1-1	EPS Geofoam Embankment	73
2.3.1-1	Prefabricated Cantilever Abutment	76
2.3.1-2	Prefabricated Open Frame Pier Bent	76
2.3.1-3	Modular Steel Superstructure Element Installation James River Bridge, Richmond, VA	77
2.3.1-4	I-93 Superstructure Replacement Concept	78
2.3.1-5	I-93 Superstructure Replacement Construction	78
2.4.1-1	Sample Self Propelled Modular Transporter Configurations	80
2.4.1-2	SPMT Bridge Moves in Utah	81
2.4.1-3	SPMT Bridge Move in Rhode Island	81
2.4.2-1	Longitudinal Launching of a Utah Bridge	84
2.4.3-1	Lateral Bridge Slide in Utah	85
2.4.3-3	Lateral Bridge Slide in Oregon	86
2.4.3-2	Lateral Bridge Slide of the Oakland Bay Bridge Approach	87
2.4.4-1	Strand Jack Lifting of the Providence River Bridge	88
2.4.4-2	Vertical Axis Pivot Technique	89
2.4.4-3	Transverse Gantry Crane Installation Technique	90

Figure Number	Description	Page
2.4.4-4	Delivery of Modular Element using a Gantry Frame	90
2.4.4-5	Longitudinal Gantry Frame Installation Technique	92
2.4.5-1	Precast Deck Panel Installation using Cranes	93
2.4.5-2	Modular Element Installation using Cranes	94
2.5.1.1-1	Sample Design-Build Process	98
2.5.1.2-1	Sample CMGC Process	101
2.6.1.1-1	Full Depth Precast Concrete Deck Panels	111
2.6.1.1-2	Underside of Full Depth Precast Deck Panels (after 19 years in service)	111
2.6.1.1-3	Blind Pocket and Bar Slot Connection Details	113
2.6.1.1-4	Precast Deck Panel Project in Texas Based on NCHRP Report 584 Details	114
2.6.1.2-1	Superstructure Installation Using SPMTs	115
2.6.1.2-2	Completed Superstructure Replacement Constructed with Prefabricated Elements	116
3.2.1.2-2	Crane Access from Local Street	128
3.2.1.3-1	SPMT Bridge Move over another Bridge	130
3.2.1.7-1	Construction of Drilled Shafts (Prior to Removal of the Existing bridge)	137
3.2.2-1	Decision Flowchart for Superstructure Construction over Roadway or Land	139
3.2.2-2	Decision Flowchart for Superstructure Construction over Railroad or Transit	140
3.2.2-3	Decision Flowchart for Superstructure Construction over Water or Wetlands	141
3.2.2-4	Decision Flowchart for Substructure Construction	142
3.2.2.1-1	Existing Example Bridge Elevation	143

Figure Number	Description	Page
3.2.2.1-2	ABC Flowchart for Example Bridge Superstructure	145
3.2.2.1-3	ABC Flowchart for Example Bridge Substructure	146
4.1-1	Sample ABC Implementation Flow Chart for a State Agency	160
5.1.2-1	Transparent View of a Cantilever Abutment Showing Corrugated Pipe Voids	172
5.1.2-2	Transparent View of an Integral Abutment Showing Corrugated Pipe Voids	173
5.1.2-3	Sample Cast-in-place Closure Pour Detail	174
5.1.7-1	Potential UHPC Connection for the NEXT Beam (Northeast Extreme Tee)	178
5.2.3.1-1	Precast Full Depth Deck Installation	185
5.2.3.1-2	Precast Full Depth Deck Leveling System	185
5.2.3.2-1	Exodermic Deck Details	188
5.2.3.2-2	Exodermic Deck Installation	188
5.2.3.2-3	Underside of the Effideck™ system	189
5.2.3.3-1	Orthotropic Bridge Deck	190
5.2.3.3-2	Aluminum Deck Extrusion	191
5.2.3.3-3	Trial Steel Sandwich Panel Bridge Deck	192
5.2.4.1-1	Modular Steel Topped Multi-beam Units	195
5.2.4.1-2	Folded Plate Modular Bridge Element	196
5.2.4.1-3	Modular Orthotropic Deck Span	197
5.2.4.1-4	Modular Orthotropic T-Beam Bridge Details	197
5.2.4.2-1	Adjacent Deck Double Tee Beam Superstructure	198
5.2.4.2-2	Adjacent Deck Bulb Tee Beam Superstructure	199
5.2.4.3-1	Stress Laminated Timber Deck Span	201

Figure Number	Description	Page
5.3.1.1-1	Precast Open Frame Pier Bent	203
5.3.1.1-2	Precast Open Frame Pier Bent Sketch	204
5.3.1.1-3	Precast Open Frame Pier Bent	204
5.3.1.2-1	Precast Wall Pier	206
5.3.1.3-1	Plastic Moment Connection Test, Cast-in-place Concrete Column-to-Cap	208
5.3.1.3-2	Plastic Moment Connection Test, Precast Concrete Column-to-Cap	208
5.3.1.3-3	Grouted Post-tensioning Duct Connection	209
5.3.2.1-1	Precast Concrete Cantilever Abutment	211
5.3.2.3-1	Prefabricated Integral Abutment	212
5.3.2.3-2	Semi-Integral Abutment	213
5.3.2.4-1	GRS-IBS Bridge Example	214
5.3.3.1-1	Precast Concrete Cantilever Wingwall	216
5.3.3.2-1	Typical MSE Wall Details	217
5.3.3.2-2	Modular Block Wall Example (T-WALL®)	218
5.3.4.1-1	Con/Span® Bridge System	219
5.4.3.2-1	Precast Pile Cap Footing	223
5.4.3.3-1	Precast Concrete Pier Box Cofferdam	225
5.4.3.3-2	Precast Concrete Pier Box Cofferdam Installation	226
6.3-1	Adjustable Bearing Detail	229
6.5-1	Precast Deck Panel with Integral Barriers	231
7.1.1-1	Shipping Containers Used for Shoring	235
7.1.1-2	Support Framing for SPMT Moves	236
7.5.2-1	Strain Measurements During an SPMT Bridge Move	246

Figure Number	Description	Page
7.8-1	Cracking in Closure Pour Concrete	252
7.8.1-1	AASHTO Ring Test for Confined Concrete Shrinkage	254
8.1-1	Recessed and Grouted Footing Joint	257
8.2.1.1-1	Edison Bridge	259
8.2.1.2-1	Connecticut Bridge 03200	260
8.2.1.2-2	Underside of Bridge 03200 after 19 Years in Service	260
8.2.1.3-1	Utah DOT I-80 Westbound Bridge Installation	261
8.2.1.3-2	Typical Cracking on the I-80 Bridges	262
8.2.1.3-3	Side-by-side Comparison	263
A1.1-1	Typical Precast Concrete Deck Panel Installation	275
A1.2-1	Precast Pier Supported on Piles	276
A1.3-1	Precast Integral Abutment	278
A1.3-2	Typical Section Through Abutment	279
A1.4-1	Example Full Depth Precast Panel Lift	282

## Listing of Tables

Table Number	Description	Page
1	Deck Element Examples	29
2	Deck Beam Element Examples	31
3	Full Width Beam Element Examples	33
4	Pier Element Examples	34
5	Abutment and Wall Element Examples	35
6	System Examples	37
1-1	Planned SHRP2 Research Projects	53
7.6.1-1	Construction Issue Resolution Ladder	248
A1.5-1	Reference Documents that Include Design Information	287

## Listing of Acronyms

The following is a listing of typical acronyms that may be found in this document.

Acronym	Definition
ABC	Accelerated Bridge Construction
ACCT	Accelerated Construction Technology Transfer (FHWA Program)
ADT	Average daily traffic
AMVA	American Association of Motor Vehicle Administrators
AASHTO	American Association of State Highway and Transportation Officials
ACI	American Concrete Institute
AISC	American Institute of Steel Construction, Inc.
AISI	American Iron and Steel Institute
AMTRAK	National Railroad Passenger Corporation (Amtrak is not a governmental agency; it is a private company called the National Railroad Passenger Corporation)
ANSI	American National Standards Institute
ASBI	American Segmental Bridge Institute
ASCE	American Society of Civil Engineers
ASTM	American Society for Testing and Materials
BCA	Benefit-Cost Analysis
C SHRP	Canadian Strategic Highway Research Program
CD	Compact Disc
CERF	Civil Engineering Research Foundation
CFLHD	Central Federal Lands Highway Division
CFR	Code of Federal Regulations
CIP	Cast-in-place
CRP	Cooperative Research Program (TRB)
CSD	Context sensitive design
DOT	Department of Transportation
ECMT	European Conference of Ministers of Transportation
EFLHD	Eastern Federal Lands Highway Division
EIT	Electronic information and technology
EPS	Expanded Polystyrene
EU	European Union
EUREKA	European Research Coordination Agency
F SHRP	Future Strategic Highway Research Program (now known as SHRP 2)
FAA	Federal Aviation Administration
FAQs	Frequently Asked Questions

FHWA	Federal Highway Administration
FRP	Fiber-reinforced polymer
FY	Fiscal year
GIF	Graphic Interchange Format
GSA	U.S. General Services Administration
GRS IBS System	Geosynthetic Reinforced Soil Integrated Bridge System
HBP	Highway Bridge Program
HBRRP Program	Highway Bridge Replacement and Rehabilitation Program
HITEC	Highway Innovative Technology Evaluation Center
HRTS	Office of Research and Technology Services
HSIP	Highway Safety Improvement Program
HSS	Hollow Structural Section
HTML	HyperText Markup Language
IBRD	Innovative Bridge Research and Deployment
IBTTA	International Bridge, Tunnel and Turnpike Association
ISTEA 1991	Intermodal Surface Transportation Efficiency Act of 1991
ITE	Institute of Transportation Engineers
JPEG	Joint Photographic Experts Group
LCCA	Life Cycle Cost Analysis
LRFD	Load and resistance factor design
NAS	National Academy of Sciences
NBI	National Bridge Inventory
NBIS	National Bridge Inspection Standards
NCHRP	National Cooperative Highway Research Program
NCSRO	National Conference of State Railway Officials
NDE	Nondestructive evaluation
NEXTEA Efficiency	National Economic Crossroads Transportation Act of 1997
NHI	National Highway Institute
NHS	National Highway System
NHTSA	National Highway Traffic Safety Administration
NIST	National Institute of Standards and Technology
NRC	National Research Council
NSF	National Science Foundation
NTSB	National Transportation Safety Board
OSHA	Occupational Safety and Health Administration
PBES	Prefabricated Bridge Elements and Systems
PCA	Portland Cement Association
PCC	Portland cement concrete
PCI	Precast/Prestressed Concrete Institute
PDF	Portable Document Format
PI	Principal Investigator

QC/QA	Quality control/quality assurance
R&D	Research and development
ROI	Return on Investment
SAFETEA	Safe, Accountable, Flexible, and Efficient
Transportation	Equity Act of 2003
SCOBS	Subcommittee on Bridges and Structures (AASHTO)
SCOH	Standing Committee on Highways (AASHTO)
SCOR	Standing Committee on Research (AASHTO)
SHA	State highway administration
SHRP	Strategic Highway Research Program
TIFF	Tagged Image File Format
TIG	Technology Implementation Group
TRB	Transportation Research Board
TRIS	Transportation Research Information Services (TRB)
TRL	Transportation Research Laboratory
USACE	U.S. Army Corps of Engineers
USDOT	U.S. Department of Transportation
WFLHD	Western Federal Lands Highway Division

# Accelerated Bridge Construction (ABC)

## DEFINITIONS

### **Accelerated Bridge Construction (ABC):**

ABC is bridge construction that uses innovative planning, design, materials, and construction methods in a safe and cost-effective manner to reduce the onsite construction time that occurs when building new bridges or replacing and rehabilitating existing bridges.

ABC improves:

- Site Constructability
- Total project delivery time
- Material quality and product durability
- Work-zone safety for the traveling public and contractor personnel

ABC reduces:

- Traffic Impacts
- Onsite construction time
- Weather-related time delays

ABC can minimize:

- Environmental impacts
- Impacts to existing roadway alignment
- Utility relocations and right-of-way take

A common reason to use ABC is to reduce traffic impacts because the safety of the traveling public and the flow of the transportation network are directly impacted by onsite construction related activities. However, other common and equally viable reasons to use ABC deal with site constructability issues. Oftentimes long detours, costly use of a temporary structures, remote site locations, and limited construction periods present opportunities where the use of ABC methods can provide more practical and economical solutions to those offered if conventional construction methods were used.

### **Conventional Bridge Construction:**

Conventional bridge construction is bridge construction that does not significantly reduce the onsite construction time that is needed to build, replace, or rehabilitate a single, or group of bridge projects. Conventional construction methods involve onsite activities that are time consuming and weather dependent.

An example of conventional construction includes onsite installation of substructure and superstructure forms, followed by reinforcing steel placement, concrete placement, and concrete curing, all typically occurring in a sequential manner.

One of the reasons to minimize onsite construction activity is because the long-term presence of contractor related equipment, labor, and staging areas can present driver distractions and traffic disruptions that reduce the safety and mobility efficiencies of the transportation network.

**Time Metrics for ABC:**

To gauge the effectiveness of ABC, two time metrics are used:

**Onsite construction time:**

The period of time from when a contractor alters the project site location until all construction-related activity is removed. This includes, but is not limited to, the removal of Maintenance of Traffic items, construction materials, equipment, and personnel.

**Mobility impact time:**

Any period of time the traffic flow of the transportation network is reduced due to onsite construction activities.

Tier 1: Traffic Impacts within 1 to 24 hours

Tier 2: Traffic Impacts within 3 days

Tier 3: Traffic Impacts within 2 weeks

Tier 4: Traffic Impacts within 3 months

Tier 5: Overall project schedule is significantly reduced by months to years

*Note: "Total project" time is the period of time from when project planning begins until the time that all bridge work is completed. Total project time adds a planning time component to the onsite construction time period. It is not a focused metric because planning time is needed regardless of whether a project is planned using ABC or conventional construction methods. Owners recognize that the use of ABC may require varying degrees of planning effort and resource allocations, but choose the ABC approach due to the site constraints, the many benefits of ABC, or a combination of the two.*

**Prefabricated Bridge Elements and Systems (PBES):**

Use of prefabricated bridge elements and systems (PBES) is one strategy that can meet the objectives of accelerated bridge construction. PBES are structural components of a bridge that are built offsite, or near-site of a bridge, and include features that reduce the onsite construction time and mobility impact time that occur from conventional construction methods. PBES includes innovations in design and high-performance materials and can be combined with the use of "Fast Track Contracting" methods. Because PBES are built off the critical path and under controlled environmental conditions, improvements in safety, quality, and long-term durability can be better achieved.

Regardless of the reason(s) to choose PBES, On-site construction time and Mobility impact time are typically reduced in some manner relative to conventional construction methods.

**Elements:**

Prefabricated elements are a category of PBES which comprise a single structural component of a bridge. Under the context of ABC, prefabricated elements reduce or eliminate the onsite construction time that is needed to build a similar structural component using conventional construction methods. An element is typically built in a prefabricated and repeatable manner to offset costs. Because the elements are built under controlled environmental conditions, the influence of weather related impacts can be eliminated and improvements in product quality and long-term durability can be better achieved.

**Deck Elements**

Prefabricated deck elements eliminate activities that are associated with conventional deck construction, which typically includes onsite installation of deck forms, overhang bracket and formwork installation, reinforcing steel placement, paving equipment set up, concrete placement, and concrete curing, all typically occurring in a sequential manner.

Examples of Deck Elements include:

- partial-depth precast deck panels
- full-depth precast deck panels with and without longitudinal post-tensioning
- lightweight precast deck panels
- FRP deck panels
- steel grid (open or filled with concrete)
- orthotropic deck
- other prefabricated deck panels made with different materials or processes

**Beam Elements**

Prefabricated beam elements are composed of two types: “deck” beam elements” and “full-width” beam elements.

Deck beam elements eliminate conventional onsite deck forming activities as noted above. To reduce onsite deck forming operations, deck beam elements are typically placed in an abutting manner.

Examples of Deck Beam Elements include:

- adjacent deck bulb tee beams
- adjacent double tee beams
- adjacent inverted tee beams

- adjacent box beams
- modular beams with decks
- other prefabricated adjacent beam elements

*Note: Although not preferred under the context of ABC, a separate construction phase (performed in an accelerated manner) may be required to finish the deck. A deck connection closure pour, overlay, or milling operation using innovative materials can be used to expedite the completion of the deck. In some situations, the placement of overlays can be accomplished during off-peak hours after the bridge is opened to traffic.*

Full-width beam elements eliminate conventional onsite beam placement activities. They are typically rolled, slid, or lifted into place to allow deck placement operations to begin immediately after placement. Given their size and weight, the entire deck is not included.

Examples of Full-Width Beam Elements include:

- truss span without deck
- arch span without deck
- other prefabricated full-width beam element without deck

#### Pier Elements

Prefabricated pier elements eliminate activities that are associated with conventional pier construction, which typically includes onsite form installation, reinforcing steel placement, concrete placement, and concrete curing, all typically occurring in a sequential manner.

Examples of Pier Elements include:

- prefabricated caps for caisson or pile foundations
- precast spread footings
- prefabricated columns
- prefabricated column caps
- prefabricated combined caps and columns
- other prefabricated pier elements

#### Abutment and Wall Elements

Prefabricated abutment and wall elements eliminate activities that are associated with conventional abutment and wall construction, which typically includes form installation, reinforcing steel placement, concrete placement, and concrete curing, all occurring in a sequential manner.

Prefabricated abutment and wall elements may be built in a phased manner using conventional construction methods, but under or near an existing bridge without disrupting traffic.

Examples of Abutment and Wall Elements include:

- prefabricated caps for caisson or pile foundations
- precast footings, wing walls, or backwalls
- sheet piling (steel or precast concrete)
- prefabricated full height wall panels used in front, behind, or around foundation elements
- cast-in-place concrete abutments and walls used with or without precast elements if built in a manner that is accelerated, or has no impact to mobility
- MSE, modular block, or proprietary walls
- Geosynthetic Reinforced Soil (GRS) abutment
- Other prefabricated abutment or wall elements

#### Miscellaneous Elements

Prefabricated miscellaneous elements either eliminate various activities that are associated with conventional bridge construction or compliment the use of PBES.

Examples of Miscellaneous Elements include:

- precast approach slabs
- prefabricated parapets
- deck closure joints
- overlays
  - Includes overlays that can be placed in an accelerated manner that complements or enhances the durability and rideability of the prefabricated element
- other prefabricated miscellaneous elements

***Note:** Any cast-in-place concrete or overlay placement operation should be performed in a manner that reduces the impacts to mobility. This may require work that is performed under “Fast Track Contracting” methods with incentive/disincentive clauses, nighttime or off-peak hour timeframes, or work done entirely off line. Innovative materials may be needed to expedite placement times such as the use of rapid-set/early-strength-gain materials or ultra-high-performance concrete (UHPC) in closure pours.*

### **Systems:**

Prefabricated Systems are a category of PBES that consists of an entire superstructure, an entire superstructure and substructure, or a total bridge that is procured in a modular manner such that traffic operations can be allowed to resume after placement. Prefabricated systems are rolled, launched, slid, lifted, or otherwise transported into place, having the deck and preferably the parapets in place such that no separate construction phase is required after placement. Due to the manner in which they are installed, prefabricated systems often require innovations in planning, engineering design, high-performance materials, and “Structural Placement Methods”.

Benefits of using prefabricated systems include:

- Minimal utility relocation and right-of-way take (if any at all)
- No- to- minimal traffic detouring over an extended period of time
- Preservation of existing roadway alignment
- No use of temporary alignments
- No temporary bridge structures
- No- to- minimal traffic phasing or staging

### **Superstructure Systems:**

Superstructure systems include both the deck and primary supporting members integrated in a modular manner such that mobility disruptions occur only as a result of the system being placed. These systems can be rolled, launched, slid, lifted, or transported in place, onto existing or new substructures (abutments and/or piers) that have been built in a manner that does not impact mobility.

Examples of Superstructure Systems include:

- full-width beam span with deck
- through-girder span with deck
- truss span with deck
- arch span with deck
- other prefabricated superstructure systems

### **Superstructure/Substructure Systems:**

Prefabricated superstructure/substructure systems include either the interior piers or abutments which are integrated in a modular manner with the superstructure as described above. Superstructure/substructure systems can be slid, lifted, or transported into place onto new or existing substructures that have been built in a manner that does not impact mobility.

Examples of Superstructure/Substructure Systems include:

- rigid frames with decks and parapets
- other prefabricated superstructure/substructure systems

Total Bridge Systems:

Total bridge systems include the entire superstructure and substructures (both abutments and piers) that are integral with the superstructure that are built off-line and installed in a manner to allow traffic operations to resume after placement. This excludes projects that are built off-line and, once complete, traffic is “shifted” to the new alignment. Total bridge systems typically require innovations in designs, high-performance materials, and “Structural Placement Methods” with or without the use of “Fast Track Contracting” methods.

Examples of Total Bridge Systems include:

- total bridges of any kind rolled/launched/slid/lifted into place
- rigid frames with decks, parapets and integrated substructures
- other prefabricated total bridge systems

The following pages contain examples of the most common prefabricated bridge elements and systems:

Table 1 Deck Element Examples

Deck Elements	Examples
<p>Partial-depth precast deck panels</p>	
<p>Full-depth precast deck panels with and without longitudinal post-tensioning</p> <p>Lightweight precast deck panels</p>	 





Deck Elements	Examples
FRP deck panels	
Steel grid (open or filled with concrete)	
Orthotropic deck	

Table 2 Deck Beam Element Examples

Deck Beam Elements	Examples
Adjacent deck bulb tee beams	 <p>A 3D perspective rendering of a bridge deck structure. It shows a series of white, bulb-tee shaped beams supporting a dark grey deck surface. The beams are spaced evenly and extend across the width of the bridge. The bridge is shown above a blue body of water.</p>
Adjacent double tee beams	 <p>A 3D perspective rendering of a bridge deck structure. It shows a series of grey, double-tee shaped beams supporting a dark grey deck surface. The beams are spaced evenly and extend across the width of the bridge. The bridge is shown above a yellow background.</p>
Adjacent inverted tee beams	 <p>A photograph showing the construction of a bridge deck. It features a series of green, inverted-tee shaped beams arranged in a row. The beams are supported by wooden forms and are being prepared for concrete pouring. The surrounding area is a construction site with dirt and rebar.</p>

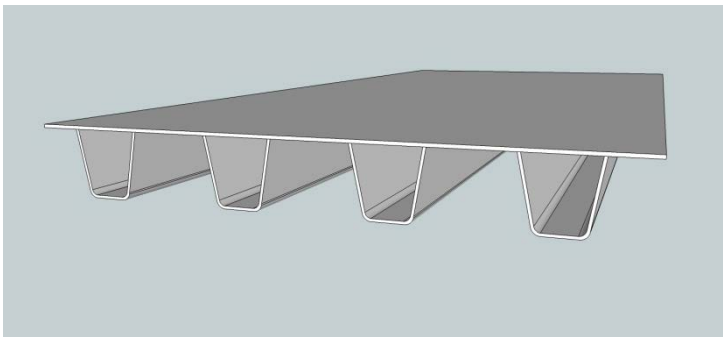
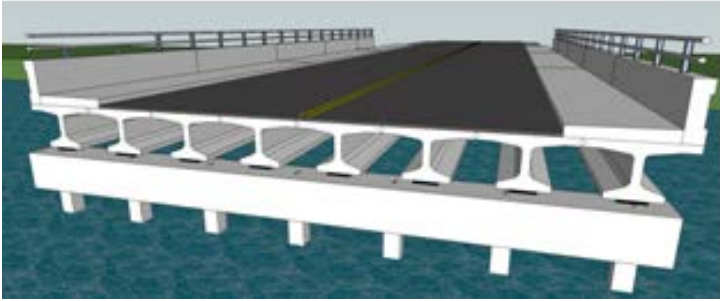
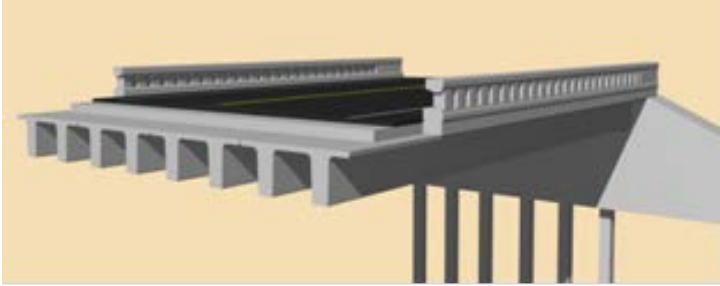

Deck Beam Elements	Examples
Adjacent box beams	 <p>A 3D perspective rendering of two adjacent box beams. The beams are shown in a light gray color with a dark interior. They are supported by several vertical columns. A yellow line runs along the top surface of the beams, and a white railing-like structure is visible on the right side.</p>
Modular beams with decks	 <p>A photograph of a construction site. Two large, modular beams with decks are being lifted into place by two orange cranes. The beams are supported by a network of steel beams and concrete pillars. Several construction workers in yellow safety vests and hard hats are visible on the site. The background shows trees and a building under a cloudy sky.</p>

Table 3 Full Width Beam Element Examples

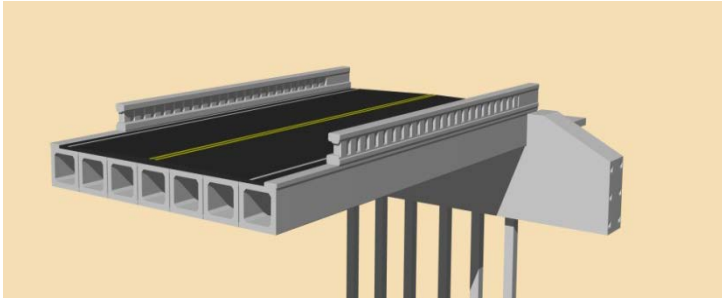

Full Width Beam Elements	Examples
Truss span without deck	
Arch span without deck	

Table 4 Pier Element Examples





Pier Elements	Examples
<p>Prefabricated caps for caisson or pile foundations</p>	
<p>Precast spread footings                      Prefabricated columns                      Prefabricated column caps</p>	

Table 5 Abutment and Wall Element Examples

Abutment and Wall Elements	Examples
<p>Prefabricated caps for caisson or pile foundations</p>	
<p>Precast footings, wing walls, or backwalls</p>	
<p>Sheet Piling (Steel Or Precast Concrete)</p>	

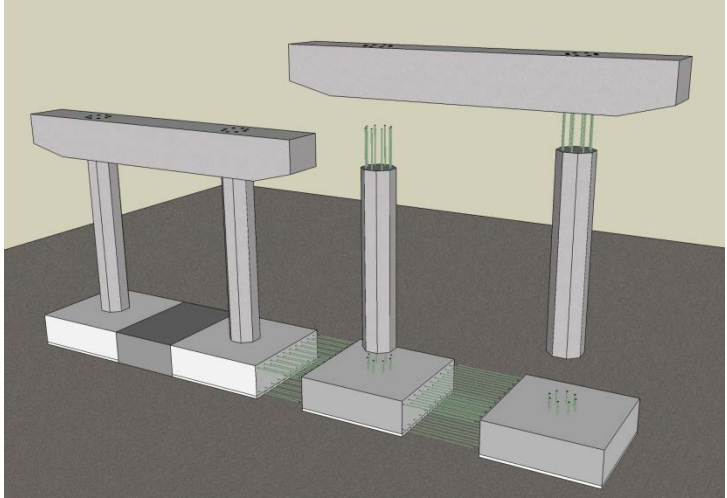

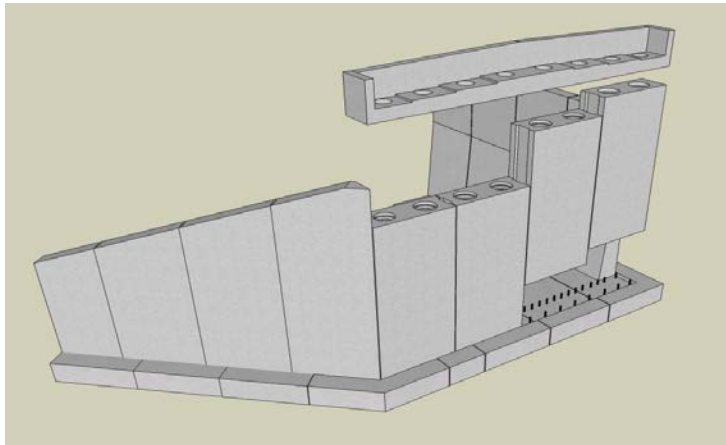

Abutment and Wall Elements	Examples
<p>Prefabricated Full Height Wall Panels Used In Front, Behind, Or Around Foundation Elements</p>	
<p>MSE, modular block, or proprietary walls</p>	
<p>Geosynthetic Reinforced Soil (GRS) abutment</p>	

Table 6 Prefabricated System Examples

System	Examples
<p>Superstructure Systems</p> <p>Full-Width Beam Span With Deck</p>	
<p>Total Bridge System</p> <p>Total bridges of any kind rolled/launched/slid/lifted into place</p>	

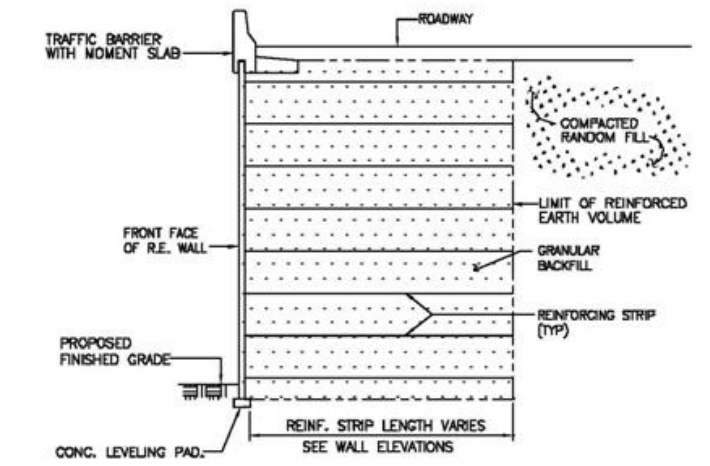
## Glossary of Terms

The following terms may be used in this document. The description of each term is written in the context of this document.

<b>Term</b>	<b>Description</b>
accelerated bridge construction	Construction methods that result in an overall decrease in construction time when compared to the historic construction methods used to build bridges
additives	Substances (typically chemical) that are added to a grout mixture to counteract the natural tendency of grouts to shrink.
air release grouts	A type of grout that does not rely on a chemical reaction to achieve expansion. The additive reacts with water to release air and cause expansion of the grout.
anchor rods	Steel rods that are used to transfer loads from the superstructure to the substructure. Often referred to as “anchor bolts”, anchor rods differ in that they do not have a hexagonal head. Anchor rods are normally specified according to ASTM F1554.
approach slabs	Structural slabs that span between the bridge abutments and the approach fill. They are used to span across the potential settlement of the approach roadway fills directly behind the abutments.
backwall	A structural wall element that retains the backfill soils directly behind the beam ends on a bridge abutment
barrier	A structural wall element that is used to contain aberrant vehicles. They can be used on the bridge (parapet), or on the approach roadway.
batching	The process of combining and mixing the materials to form concrete
bearing	A structural element that connects the bridge superstructure to the substructure, while allowing for movements such as thermal expansion and contraction.
benefit-cost analysis	The comparison of benefits over time and of costs over time for proposed projects. BCA is a tool used to aid in public investment decision making by measuring the efficiency of spending from the viewpoint of net benefit to society.

<b>Term</b>	<b>Description</b>
bleed water (grout)	Water that seeps out of the surface of a grout due to expansion of a grout in a confined or semi-confined area
blockouts	Voids that are cast in prefabricated concrete elements that are used in connecting the elements in the field
bottom up estimating	A process of construction estimating that breaks the individual tasks into discrete segments where the cost for time, equipment and materials can be determined for each segment. The total of all segments are then combined for the total construction estimate.
breastwall	A wall that is typically non-structural that covers the beam ends at the corners of the bridge abutments. Sometimes referred to as “cheekwalls” by some states.
bridge deck	A structural slab that spans between support elements (typically beams and girders) on a bridge. Bridge decks can be made of many materials, including reinforced concrete, steel, timber, fiber reinforced polymers, etc.
cable restrainers	Structural elements that are used to restrain a bridge superstructure from excessive lateral movement during seismic events. The goal being to prevent the superstructure from falling off the substructure, which is a very common form of failure during seismic events.
camber	A geometric adjustment of a bridge beam that is designed to compensate for the vertical deflection of the beam when subjected to dead loads. Camber is typically built into steel beams during fabrication. Camber is an inherent side effect of prestressed girder construction.
carbon fiber	A materials that is used in fiber reinforced polymer elements (FRP) to provide the structure performance. These fibers are oriented parallel to the direction of stress.
cast-in-place concrete	Concrete that is cast on site (as opposed to cast in a fabrication plant)
cheekwall	A wall that is typically non-structural that covers the beam ends at the corners of the bridge abutments. Sometimes referred to as “breastwalls” by some states.
cofferdam	An enclosure used to retain water and support excavation in order to create a dry work environment. Typically used for bridge substructure construction in rivers and along river banks.

<b>Term</b>	<b>Description</b>
composite beam action	The process of connecting the bridge deck to the beams or girders to form a combined structural element.
composites	The combining of multiple structural materials to form a structural element.
compressive strength	The value of uniaxial compressive stress reached when a material fails.
concrete	A construction material that consists of cement (commonly portland cement), coarse aggregates (such as gravel limestone or granite), fine aggregates (such as sand), and water. Often other materials are added to improve the structural properties such as chemical admixtures and other cementitious materials (such as fly ash and slag cement).
concrete/steel hybrid decks	A structural bridge deck system that combines structural steel elements with composite concrete to create a prefabricated deck system.
confinement steel	Reinforcing steel used to contain the concrete core of a column when subjected to plastic deformations brought on by seismic loading.
consistency	The state of a mixture of materials where the formulation is of uniform quality.
constructability	The extent to which a design of a structure provides for ease of construction yet meets the overall strength and quality requirements.
construction joints	Joints in structures that are used to facilitate the construction of a portion of the structure. Construction joints typically have reinforcing steel passing from one side of the joint to the other providing continuity of the joined elements.
construction stages	A process of building a bridge in segments in order to maintain traffic during construction.
continuity connection	A connection used to connect two longitudinal bridge element (beams) to form a continuous bridge system. Typically these connections are only designed to resist live load.
continuous spans	A structural system where the beams span across more than two supports without joints.

<b>Term</b>	<b>Description</b>
contraction joints	Joints in structures that are used to allow the concrete elements to shrink without causing excessive cracking. Contraction joints typically do not have reinforcing steel passing from one side of the joint to the other.
controlled density fill	See “flowable fill”.
conventional bridge construction	Construction methods that do not include prefabrication. Methods that employ non-adjacent butted girders that have cast-in-place (CIP) concrete deck and CIP concrete substructures.
cover concrete	The specified minimum distance between the surface of the reinforcing bars, strands, posttensioning ducts, anchorages, or other embedded items, and the surface of the concrete.
critical path	The portion of the sequence of construction activities which represents the longest overall duration. This in turn determines the shortest time possible to complete a project.
cross frame	A transverse structural element connecting adjacent longitudinal flexural element used to transfer and distribute vertical and lateral loads and to provide stability during construction. Sometimes synonymous with the term “diaphragm”.
crown	The apex of the roadway cross slope.
curing compounds	Chemical compounds that are used to prevent the rapid evaporation of water from concrete during curing.
curb	A structural element that is constructed at the edge of the bridge deck that is used to contain rain water runoff. Curbs are often combined with structural railings to retain vehicles.
debonding	The process of disconnecting prestressing strand from the surrounding concrete in a prestressed concrete element. This is done to control stresses in prestressed elements (typically at the ends of the element).
deck	The structural portion of a bridge that is directly beneath the wheels of passing vehicles.
dewatering	The process of removing water from an excavation that is below the water table or surface of adjacent water.

<b>Term</b>	<b>Description</b>
diaphragm	A transverse structural element connecting adjacent longitudinal flexural element used to transfer and distribute vertical and lateral loads and to provide stability during construction. Sometimes synonymous with the term “cross frame”.
differential camber	A variation on the camber of two adjacent beams. See “camber”.
dimensional growth	The phenomenon that results in the change in overall structure width or length when multiple elements are butted together. This is brought on by a build up of element side variations or tolerances that are a result of the fabrication process.
distribution direction	A direction that is normally parallel to the supporting members and is perpendicular to the direction of beam action in reinforced concrete slabs that are designed for one-way slab action.
drilled shafts	A deep foundation unit, wholly or partly embedded in the ground, constructed by placing fresh concrete in a drilled hole with or without steel reinforcement. Drilled shafts derive their capacity from the surrounding soil and/or from the soil or rock strata below its tip. Drilled shafts are also commonly referred to as caissons, drilled caissons, bored piles, or drilled piers.
dry pack grout	A form of grout that has very stiff consistency that is placed by packing the material into voids by hand and hand tools.
effective prestress	The stress or force remaining in the prestressing steel after all losses have occurred.
elastomeric bearing pads	A type of structural bearing that is comprised of virgin neoprene or natural rubber. Sometimes combined with internal steel plates, fiberglass sheets, or cotton duck sheets.
emulation design	A design method where a prefabricated connection is designed and detailed to act as (or emulate) a conventional concrete construction joint.
epoxy adhesive anchoring systems	A method of embedding reinforcing rods into hardened concrete to form a structural connection. The process involves a drilled hole and a chemical adhesive. Note: Epoxy adhesive anchoring systems should not be used in sustained tension applications.

<b>Term</b>	<b>Description</b>
epoxy grouts	Grout materials with chemical adhesives used in place of cementitious materials.
ettringite expansive grout	Ettringite is crystal that forms as a result of the by product of reactive chemicals that can be interground into the cement in expansive grouts to produce non-shrink grout.
exodermic bridge deck	A bridge deck system that is composed of a steel grid deck combined with a top layer of concrete to form a composite system. This system differs from filled grid decks in that the concrete is placed above the top of the grid to maximize the composite action between the steel and the concrete.
expansion joints	Joints in structures that are used to allow the concrete elements to expand and contract with temperature variation without causing excessive cracking. Expansion joints are similar to contraction joints except they are normally wider and often include a compressible material to allow for thermal expansion. They also do not have reinforcing steel passing from one side of the joint to the other.
fiber reinforced polymers (FRP)	A structural matrix of materials used to produce a structural element. FRP is commonly made reinforcing fibers that are combined with polyester, epoxy or nylon, which bind and protect the fibers from damage, and transfers the stresses between fibers. FRPs are typically organized in a laminate structure, such that each lamina (or flat layer) contains an arrangement of unidirectional fibers or woven fiber fabrics embedded within a thin layer of light polymer matrix material. The fibers, typically composed of carbon or glass, provide the strength and stiffness.
filled steel grids	A bridge deck system that is composed of a steel grid deck combined that is either fully or partially filled with concrete.
flowable fill	A material used to rapidly fill a void in embankment backfills or under structures without compaction. It normally has high flow characteristics. It is commonly made up of sand, water and a minor amount of cement. It is also referred to as "controlled density fill".
flying wingwalls	Walls used to retain embankment soils at the corners of abutments that are cantilevered from the end or rear of the abutment as opposed to being supported on a footing.

<b>Term</b>	<b>Description</b>
foam block fill	A material made with expanded polystyrene (EPS) used to rapidly fill embankments where low unit weight materials are desired. This is often used over highly compressible soils such as clays. This material is also referred to as geofoam.
full-depth precast concrete deck slabs	A bridge deck system that is composed of reinforced concrete elements that when placed, make up the full structural deck system.
gantry crane	A crane type that is characterized by two or more legs supporting an overhead beam with a traveling trolley hoist.
gas generating grout	A type of non-shrink grout that expands due to the production of gas during the curing process. The gas is generated by adding reactive materials to the mix (often aluminum) to produce the gas.
geosynthetic reinforced soil integrated bridge system	Geosynthetic Reinforced Soil (GRS) technology consists of closely spaced layers of geosynthetic reinforcement and compacted granular fill material. GRS-IBS includes a reinforced soil foundation, a GRS abutment, and a GRS integrated approach. When integrated with a bridge superstructure, the system blends the embankment with the superstructure to act as a single unit with respect to settlement.
girder-floorbeam bridges	A bridge framing system that is composed of main girders that run parallel to the centerline of the roadway combined with transverse floorbeams that support the deck. Often the system includes stringer beams that run between floorbeams (parallel to the roadway).
glue laminated wood	A structural framing material that consists of multiple layers of dimensional lumber glued together to form a large timber element.
greenfield	A construction area where a bridge or highway is being built on land that previously did not support a roadway or bridge.
grout	A material (often cementitious or epoxy) that is used to fill voids between elements.
grouted reinforcing splice couplers	A proprietary product used to join precast concrete elements by connecting reinforcing steel bars at the ends of the elements. They consist of a steel casting sleeve that is filled with grout. The reinforcing bars are inserted

Term	Description
haunch	into the ends of the casting and developed by the interaction of the grout with the sleeve.
high early strength concrete	The material between the top of a beam element and the bottom of the bridge deck that gaps the space between the two elements (also referred to as the “web gap” in some states).
integral abutment	A concrete mixture that gains strength rapidly in order to accelerate construction.
integral abutment connection	A bridge abutment type that is made integral with the bridge superstructure through a combined shear and moment connection. They are often constructed with a single row of piles that allow for thermal movement and girder rotation. Soil forces behind the abutments are resisted through the strut action of the superstructure.
integral pier connection	The connection between the superstructure and the integral abutment substructure that can resist both shear and moment.
keeper assemblies	The connection between the superstructure and the pier substructure elements that can resist both shear and moment.
leveling bolts	Devices that are placed on top of substructures to prevent lateral movement of the bridge superstructure. They are often used to resist lateral seismic forces. They can be constructed with structural steel or reinforced concrete.
life-cycle cost analysis	Bolt assemblies embedded in various prefabricated elements that are used to make grade adjustments in the field during construction.
match casting	A process for evaluating the total economic worth of a usable project segment by analyzing initial costs and discounted future costs, such as maintenance, user costs, reconstruction, rehabilitation, restoring, and resurfacing costs, over the life of the project segment.
	A process of joining two precast concrete elements with high precision. This is done by casting one element against the adjoining element in the fabrication yard, separating them, and then re-joining them in the field. The field connection is normally made with thin epoxy adhesives combined with post-tensioning.

<b>Term</b>	<b>Description</b>
mechanical splices	Devices used to connect reinforcing through mechanical means. Examples of these systems include grouted sleeves, wedge assemblies, and threaded bar ends.
mechanically stabilized earth (MSE) retaining walls	A soil-retaining system, employing either strip or grid-type, metallic, or polymeric tensile reinforcements in the soil mass, and a facing element that is either vertical or nearly vertical. In this system, the soil mass is engaged by the strips to become a gravity type retaining wall.
mild reinforcement	Steel bars or grids within concrete elements that are used to resist tension stresses. Mild reinforcement normally consists of deformed steel bars or welded wire fabric.
modular block retaining walls	A soil-retaining system employing interlocking soil-filled timber, reinforced concrete, or steel modules or bins to resist earth pressures by acting as gravity retaining walls.
near site fabrication	A process of constructing prefabricated elements near the bridge construction site in order to minimize problems with shipping of large elements.
network arch bridge	A type of tied arch that includes suspender cables that are run diagonally forming a crisscrossing pattern
non-shrink cementitious grout	A structural grout used for filling voids between elements that is formulated with cement, fine aggregates and admixtures. The admixtures are used to provide expansive properties of the material during curing. This expansion counteracts the natural tendency of cement grouts to shrink during curing.
one-way slab	A reinforced concrete slab system that primarily spans between two parallel support members. In this system, the majority of the reinforcing runs perpendicular to the support members.
open grid decks	A bridge deck system that is composed of an open steel grid spanning between supporting members.
orthotropic bridge deck	A steel bridge deck system comprised of a top deck plate supported by open or closed ribs that are welded to the top plate.
parapet	A structural element that is constructed at the edge of bridge deck that is used to contain aberrant vehicles.
partial-depth precast	A bridge deck system that consists of relatively thin

<b>Term</b>	<b>Description</b>
concrete deck panels	precast concrete panels that span between supporting members that are made composite with a thin layer of site-cast reinforced concrete. The precast panel makes up the bottom portion of the structural slab. The site cast concrete makes up the remainder of the structural slab.
pier box	A prefabricated system that includes a precast concrete box that is placed over driven piles or drilled shafts. The box becomes the form to contain site cast reinforced concrete. Often pier boxes are used in water applications to form a cofferdam for the footing concrete.
pier cap	A structural beam spanning between pier columns.
pier column	The vertical structural element in a bridge pier
pile bent pier	A bridge pier without a footing that is comprised of driven piles or drilled shafts supporting a pier cap.
pile cap footing	A footing that is supported by driven piles or drilled shafts.
plastic hinge	A method of dissipating lateral seismic forces by allowing portions of reinforced concrete pier columns to bend beyond the yield point. Stability of the structure is maintained by providing adequate confinement reinforcement.
post-tensioning ducts	A form device used to provide a path for post-tensioning tendons or bars in hardened concrete
post-tensioning (PT)	A method of prestressing in which the strands or bars are tensioned after the concrete has reached a specified strength.
precast concrete	Concrete elements that are cast in a location other than their final position on the bridge.
prefabrication	The process of building bridge elements prior to on-site construction in order to accelerate the construction of the bridge.
prefabricated bridge elements	Portions of a bridge structure that are constructed away from the final bridge site (see Definitions on page I-9)
prefabricated bridge systems	Portions of a bridge structure that are made up of several elements that are combined to form a larger portion of the bridge such as the superstructure, substructure or the

<b>Term</b>	<b>Description</b>
	entire bridge (see Definitions on page I-9)
prestressed concrete	Concrete elements in which force is introduced into the element during fabrication to produce internal stresses that are normally opposite of the anticipated stresses in the completed structure. Prestressing can be accomplished with pretensioning or post-tensioning.
pretensioning	A method of prestressing in which strands are tensioned before the concrete is placed, and released after the concrete has hardened to a specified strength.
quality assurance and quality control (QA/QC)	The process of inspection and control during fabrication to ensure that the specified quality is achieved.
reflective cracking	A crack that can form in site cast concrete that is placed over a joint between two elements below the pour.
reinforced closure pours	A method of connecting two prefabricated elements by casting a segment of reinforced concrete between two elements. The connection is often made using lap splices or mechanical reinforcing connectors.
reinforced concrete	Concrete elements with reinforcing steel cast into the concrete to form a structural element. The steel is normally used to resist tension stresses in the element.
reinforcing steel	Steel placed in concrete elements (either be mild reinforcement or prestressing steel).
return on investment	Measurement of the efficiency of spending from the viewpoint of net benefit to society. ROI analysis is essentially identical to benefit/cost analysis, incorporating benefit concepts that do not directly result in a revenue stream.
right of way	The land used for the route of a railroad or public road
road user costs	Costs that incurred by users of a highway network when they are delayed due to construction activities.
saturated surface dry (SSD) condition	A condition that is normally specified for concrete surfaces that are to be grouted. Saturated Surface Dry describes the condition of the concrete surface in which the pores are filled with water; however no excess water is on the surface. This condition minimizes the absorption of water from the grout into the surrounding concrete.

<b>Term</b>	<b>Description</b>
segregation	A condition where the distribution of coarse or fine aggregates in the concrete or grout mix become non-uniform.
self-propelled modular transporter (SPMT)	A high capacity transport trailer that can lift and move prefabricated elements with a high degree of precision and maneuverability.
shear key	A shaped joint between two prefabricated elements that can resist shear through the geometric configuration of the joint.
shear studs	Headed steel rods that are welded to elements to provide composite action between two bridge elements. Typically used between beams and the deck slab.
sheeting	A structural system used to retain earth and water and allow for excavation during the construction of a bridge substructure.
shims pack	Flat plates placed between two prefabricated elements used to provide a specified separation. Shims are also used to make vertical grade adjustments. Shims are typically made of steel or polymer sheets.
shrinkage (grout)	A property of cementitious concretes and grouts that occurs during curing where the material reduces in size.
skew angle	In most state agencies, this is defined as the angle measured between the centerline of the bridge elements (abutments, piers, joints, etc.) and a line perpendicular to the roadway alignment. (i.e. a bridge with zero skew is square bridge). This definition is used in this manual. Several states define the skew angle as the complimentary angle (i.e. a bridge with 90 degree skew is square).
spandrel wall	A wall that is constructed on the sides of earth filled arch structures that are used to retain the fill soils.
spiral reinforcement	Transverse reinforcement used in reinforced concrete columns to resist shear. Spirals are also used for confinement of the concrete core as a plastic hinge forms.
steel stay-in-place forms	Corrugated steel sheeting that is used to support the wet concrete in a bridge deck during construction, and left in place in the permanent structure.
strength direction	A direction that is normally perpendicular to the supporting

Term	Description
	members and is parallel to the direction of beam action in reinforced concrete slabs that are designed for one-way slab action.
stress laminated timber deck bridges	A timber bridge deck that is comprised of multiple layers of dimension lumber placed on edge and connected with transverse prestressing. Shear transfer between the laminations is accomplished through friction.
stringers	There are two common uses for this term. <ol style="list-style-type: none"> <li>1. Longitudinal steel beams on short span multi-beam bridges.</li> <li>2. Secondary framing members on floor beam type bridges that span from floor beam to floor beam.</li> </ol>
stub abutments	A short cantilever type abutment that is constructed near the top of the approach embankment.
substructure	The portion of the bridge that is below the beam and/or deck elements. It typically includes piers, abutments, and walls.
superstructure	The portion of the bridge that is above substructure. It typically includes bearings, beams, girders, trusses, and the bridge deck.
surface preparation (grout)	The process of preparing a concrete surface for grouting by cleaning or intentionally roughening the surface. This is done to improve the adhesion of the grout to the concrete. It typically includes sand blasting, water blasting, or hand tool cleaning.
sweep	The lateral curvature of a prefabricated element caused by fabrication form irregularities and/or internal stresses.
test pours and test mock-ups	A method of quality control whereas a contractor will build a model of a portion of the bridge structure that includes a void that requires grout placement. These are used to demonstrate proper grout placement in complex voids.
tied arch	An arch structure where the thrust forces at the supports are resisted by a continuous bottom chord that runs from end to end.
timber deck panels	Prefabricated timber panels that are made with glue laminated lumber.
tolerance	Specified allowable dimensional variations in prefabricated

Term	Description
	elements. The variations are a result of irregularities in formwork and minor deviations in measurements during fabrication.
transverse ties	Reinforcement used in reinforced concrete columns to resist shear. Ties, if properly detailed, can also used for confinement of the concrete core as a plastic hinge forms.
tremie concrete pour	Concrete that is placed underwater and within a cofferdam to resist the vertical pore pressure of the water below a footing during construction.
variable web gap	See "Haunch"
water content	The specified amount of water in a concrete or grout mix.
wearing surface	The top portion of the bridge deck that is directly below the vehicle tires. Often wearing surfaces are designed to be sacrificial and replaceable.
wet curing	Curing is the process of retaining sufficient moisture (water) in freshly placed grout/concrete to complete the hydration reaction which occurs when water is introduced to Portland cement. Wet curing leaves the freshly placed grout/concrete in an environment of 100 percent humidity
working time	The amount of time that a concrete or grout mix remains in a liquid or plastic state so it can be placed and consolidated.
yield strength	The stress at which an elastic material begins to deform in a plastic manner. Prior to yield, the material will deform elastically and will return to its original shape when the applied stress is removed. If loaded beyond yield and then unloaded, the material will not return to its original shape.

## Chapter 1 Introduction on WHY ABC?

The use of Accelerated Bridge Construction (ABC) using Prefabricated Bridge Elements and Systems (PBES) has become more commonplace over the last 20 years in the United States. The use of ABC for the most part has been driven by acute traffic control issues at specific sites. Many of these projects simply had to be built with ABC. In recent years, more states are considering ABC on more typical projects. The desire to reduce impacts to the traveling public is driving this effort.

During the last 20 years, there have been incremental advancements in the use of ABC. Early projects focused on specific prefabricated elements such as bridge decks or pier caps. For instance, bridge deck construction using full depth precast concrete deck panels have been in use for over 20 years. More recently, ABC projects that use Prefabricated Bridge Elements and Systems (PBES) have spread to all bridge elements including substructures and foundations. Some states have made or are moving toward making the use of ABC and PBES standard practice.

Several FHWA documents on the subject of PBES have been written and published including:

- *Decision-Making Framework for Prefabricated Bridge Elements and Systems (PBES)*, Publication Number FHWA-HIF-06-030, May 2006 [1]
- *Manual on the Use of Self-Propelled Modular Transporters to Remove and Replace Bridges*, Publication Number FHWA-HIF-07-022, June 2007 [2]
- *Connection Details for Prefabricated Bridge Elements and Systems*, Publication Number FHWA-IF-09-010, March 2009 [3]

All of these documents offer important information for the use of ABC with PBES; however none of these documents cover all the major aspects of an accelerated bridge construction project. Several sections in this manual cover some of the same information that is included in these other documents; therefore the subjects will be covered in less detail in this manual. This manual should be considered an overview manual on the subject of ABC with PBES.

The Transportation Research Board is in the process of a significant research effort entitled the Strategic Highway Research Program (SHRP2). This wide ranging program focuses on the idea of rapid renewal for highway infrastructure. Three objectives have been identified to achieve renewal:

1. Perform construction rapidly
2. Cause minimal disruption
3. Produce Long-Lived facilities

Most of the SHRP2 research efforts are directly applicable to ABC and this manual. The SHRP2 work is more specific and in more detail than the information included in this manual. Users of this manual should reference the SHRP2 work as they explore deeper into the field of ABC. Figure 1-1 is a table that outlines the SHRP2 planned research topics.

SHRP2 Rapid Renewal Research Activities	
Project Number	Description
R01	Encouraging Innovation in Locating and Characterizing Underground Utilities
R02	Geotechnical Solutions for Soil Improvement, Rapid Embankment Construction, and Stabilization of the Pavement Working Platform
R03	Identifying and Reducing Worker, Inspector, and Manager Fatigue in Rapid Renewal Environments
R04	Innovative Bridge Designs for Rapid Renewal
R05	Modular Pavement Technology
R06	A Plan for Developing High-Speed, Nondestructive Testing Procedures for Both Design Evaluation and Construction Inspection
R07	Performance Specifications for Rapid Highway Renewal
R09	Risk Manual for Rapid Renewal Contracts
R10	Innovative Project Management Strategies for Large, Complex Projects
R11	Strategic Approaches at the Corridor and Network Level to Minimize Disruption from the Renewal Process
R15	Strategies for Integrating Utility and Transportation Agency Priorities in Highway Renewal Projects
R16	Railroad-DOT Institutional Mitigation Strategies
R19-A	Bridges for Service Life beyond 100 Years: Innovative Systems, Subsystems, and Components
R19-B	Bridges for Service Life beyond 100 Years: Service Limit State Design
R21	Composite Pavement Systems
R23	Using Existing Pavement in Place and Achieving Long Life
R26	Preservation Approaches for High Traffic Volume Roadways

*Figure 1-1 Planned SHRP2 Research Projects*

The majority of the SHRP2 research will be completed in the near future, which will be followed by an implementation program. Bridge designers are encouraged to use this manual as a primer on ABC and then use the

SHRP2 work as a technical resource on specific issues regarding ABC and rapid renewal.

## 1.1. Purpose and Use of this Manual

This document represents the “State of the Practice” at this time with respect to most aspects of accelerated bridge construction. The intent of this manual is to fill in the gaps left following the publication of the previous manuals by presenting an overview of all aspects of the field of accelerated bridge construction, from project planning through detailing, to project delivery.

The FHWA has focused on 5 components of Accelerated Bridge Construction. They include:

- Foundation and Wall Elements
- Rapid Embankment Construction
- Prefabricated Bridge Elements and Systems
- Structural Placement Methods
- Fast Tracked Contracting

This manual will cover all of these topics in some detail. The subject of ABC is in a constant state of change. In the future, other new technologies may emerge that will be included in field Accelerated Bridge Construction. The FHWA will maintain a website for ABC that will be kept current with the latest ABC technologies.

### 1.1.1. Intended Users

#### 1.1.1.1. Decision Makers

Project decision makers can range from agency management to project planners. The benefits of ABC go far beyond the actual construction; therefore agency managers need to be aware of the short-term and long-term benefits of this method of construction.

This manual covers many aspects of the decision making process. Chapter 4 explores the ways to implement ABC technologies in a transportation agency. This covers the strategies for implementation at all levels of the agency. Success cannot be attributed to a single individual or unit within the DOT. It needs to be an organized approach that involved all members of the department, contractors, fabricators, and the consulting engineering community.

Before any project can get off the ground, a project normally goes through a planning process. Many agencies have teams devoted to project planning and preliminary design development. These teams do not normally get involved with the minutia of bridge analysis and design, but instead focus on the general approach to the project. Chapter 3 explores the ABC decision processes that can be used during project planning and scoping to ensure that

ABC is used where it is appropriate and can have a beneficial effect on the project.

The previously published FHWA Manual entitled *Decision-Making Framework for Prefabricated Bridge Elements and Systems (PBES)*, Publication Number FHWA-HIF-06-030, May 2006 [1] is an excellent source of information on the process of planning a successful ABC project. Decision makers can use the decision making framework document combined with the information in this manual to make informed decisions regarding the most appropriate uses of the ABC. Several agencies have used the FHWA manual as a basis for development of decision making processes that are specific to their agencies. The Utah DOT has developed a process with weighted factors in lieu of the yes/no decisions in the FHWA manual. The Oregon DOT is working with several other states on a more elaborate project decision process that looks at many more factors and compares different construction approaches. This study will be completed in the next year and made available to all transportation agencies.

#### 1.1.1.2. Project Managers

Once a decision has been made to implement ABC on a particular project, the project managers are called on to organize and implement the project. In some cases, project planners have already determined the approach for the project (sometimes in conjunction with assistance from FHWA). In other cases, project managers are given the broad task of accelerating construction by any feasible means.

In either case, this document can be useful to project managers in implementing specific methods or in the determination of the most appropriate forms of ABC.

Chapter 3 of this manual includes significant information for project managers who are responsible for development of ABC projects.

#### 1.1.1.3. Bridge Designers

Bridge Design engineers are asked to take the concepts that are developed in the project planning process and turn them into plans and specifications that are suitable for project bidding and construction. The previously published FHWA Manual entitled *Manual on the Use of Self-Propelled Modular Transporters to Remove and Replace Bridges*, Publication Number FHWA-HIF-07-022, June 2007 [2] and *Connection Details for Prefabricated Bridge Elements and Systems*, Publication Number FHWA-IF-09-010, June 2007

[3] are good sources of information and details that can be used in this process.

Other sources of design information can be found at a growing number of state agency websites. For instance, the Utah Department of Transportation has published design standards and manuals on the use of PBES for ABC projects. Other states such as Oregon, Washington, Texas and Massachusetts are also actively developing similar documents.

This manual can be used in conjunction with these other sources. When combined with sound engineering judgment, a successful ABC project can be developed and completed.

### 1.2. Why use Accelerated Bridge Construction?

During the development of the modern highway network, most bridge projects involved the construction of bridges for new highways. The construction work zones were typically open areas or “greenfields” with no traffic. Figure 1.2-1 shows a cast-in-place concrete bridge under construction in the 1930's. The lack of traffic management allowed the use of shored formwork. These projects also involved large scale earthwork associated with the construction of the roadway. The construction process for the bridges in this scenario was not limited by adjacent traffic and was often not on the critical path for the overall construction of the highway.

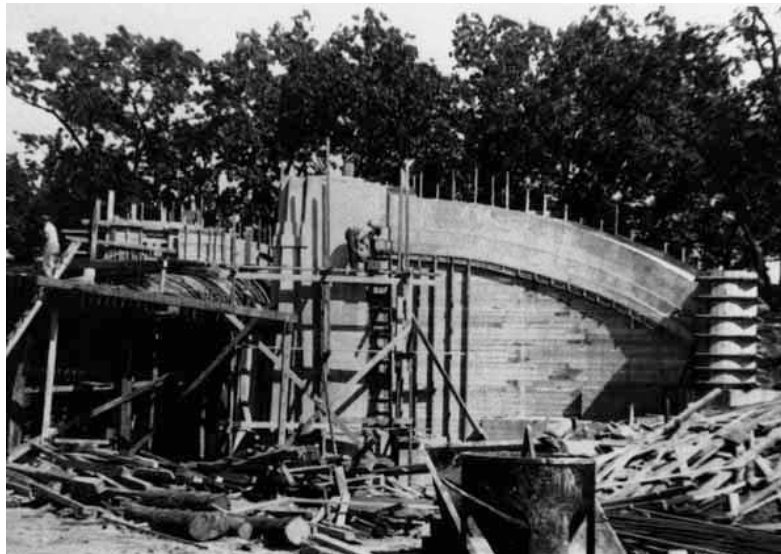

*Figure 1.2-1 Cast-In-Place Concrete Bridge Construction Techniques*

The majority of the nation's highway network is now complete. A large portion of this network has matured to the point where rehabilitation and reconstruction are necessary. Individual bridge replacement projects that

are not part of an overall highway reconstruction are becoming more commonplace. This type of project brings the construction of the bridge to the critical path of the construction process.

In most bridge replacement projects, vehicles traveling on the roadway need to be accommodated during the construction, which greatly complicates the design and construction process. This has been referred to as being analogous to replacing an engine's oil while it is still running. Bridge designers and constructors have had to change the paradigm of bridge construction in order to account for this. Control of traffic (vehicular, bicycle and pedestrian) has become a significant portion of the overall construction process. This normally results in one of the following bridge construction scenarios:

- *Relocation of traffic on a detour*

This approach can have significant impact on the roads used for the detours, especially if the duration of the detour is significant. Traffic congestion is increased and safety is often compromised as the volume of vehicles traveling the detour increases. This approach also leads to increases in vehicle emissions, increases in noise pollution and accelerated deterioration of the road used for the detours.

- *Construction of a temporary bridge and bypass roadway*

Temporary bridges are an effective means of freeing up space at the bridge site. This is often a preferred option to a detour; however it comes at a cost, both financial and physical. The construction of the temporary bridge and bypass approaches can represent a large portion of the overall project cost. This includes the cost for the installation and removal of the bypass. Temporary bridges may also require the acquisition of right-of-way and additional environmental permitting.

- *Employ Stage Construction Techniques*

This involves the construction of the bridge in portions or stages. Depending on the configuration of the bridge and the traffic volume, it may involve over-building the bridge in order to accommodate enough traffic lanes during construction. There is a cost implication to this approach; however the exact cost of construction staging is difficult to ascertain. Most bridge projects are bid on a unit cost basis or a lump sum basis. The cost of stage construction is included in the unit costs and cannot be easily separated from the actual cost of the materials. The general consensus of bridge engineers is that this cost is significant. This may partially explain the reason why bridge construction costs are higher in the northeast and north central United States where the stage construction approach is common.

All of these scenarios have negative impacts on the overall construction process either through costs, safety to workers and the traveling public, impacts to the public, or impacts to the environment. Accelerated Bridge Construction using Prefabricated Bridge Elements and Systems can be used to address this paradigm shift in bridge construction.

ABC is not the answer for all projects. The impact of ABC on individual construction projects needs to be evaluated through the use of a decision making framework. The FHWA document entitled “*Decision-Making Framework for Prefabricated Bridge Elements and Systems (PBES)*” [1] can be used to develop a consistent decision process. Other frameworks are in development and described in more detail in later sections.

The following section outlines the benefits that can be realized through the use of ABC in today’s infrastructure.

#### 1.2.1. Benefits of ABC projects using PBES

There are a number of benefits that can be realized through the use of ABC with PBES. The following sections contain some of the more common benefits that have been experienced in different agencies.

##### 1.2.1.1. Reduced Road User Impacts

Construction projects have a significant impact to highway users. Delays caused by construction congestion and detours result in loss of revenue to roadway users. Work zones are also cited as a significant risk factor contributing to roadway crashes. ABC can be used to reduce these impacts by shortening the duration of a project.

The intent of transportation systems is to support mobility, not to infringe upon it. Not recognizing the travel delay and motorist and worker safety impacts caused by construction activities, or by accepting the status quo is doing a disservice to the traveling public. The FHWA Highways for Life Pilot Program, authorized by SAFETEA-LU, has challenged this notion. Through a combination of methods, the program has strived to create a culture change in the highway community to embrace innovation in ways that will improve service to America’s drivers. ABC using PBES is a vanguard technology promoted by the program.

ABC provides a balanced approach - cost versus impacts. There are tools available for DOTs to help decide on the balance that is right for each project. This manual provides an overview of these tools and makes reference to locations where agencies can look for in-depth information.

Road users are impacted by all forms of construction. Impacts can be significant, even if lanes are not affected by the actual work. For instance, on a busy highway that is flowing near capacity, a disabled vehicle in the shoulder can cause a significant back-up on the main line. Even in low volume roads, roadside activities can distract drivers

and lead to accidents. Construction projects have a similar effect. Construction equipment working adjacent to travel lanes can have a negative effect on road users.

The definitions for ABC listed in the beginning of this manual identify the term “Mobility Impact Time”. This is any period of time the traffic flow of the transportation network is reduced due to onsite construction activities. Mobility impact time can be broken down into 5 tiers of potential impact:

- Tier 1: Traffic Impacts within 1 to 24 hours
- Tier 2: Traffic Impacts within 3 days
- Tier 3: Traffic Impacts within 2 weeks
- Tier 4: Traffic Impacts within 3 months
- Tier 5: Traffic Impacts from 3 months to years

One of the goals of any ABC project is to move a project constructed with conventional methods from one tier to at least one higher tier. For instance, if a project build with conventional methods is estimated to take 6 months to build, the goal might be to reduce the mobility impact time to within 3 months.

A reduction in mobility leads to increases in costs to society. Construction affects road users by increasing the time it takes to travel through a work zone. Road user costs are real; however they are not funds that can be applied to agency budgets. The funds used to finance construction project come from roadway users through taxes and/or tolls; therefore the impacts of roadway users should be identified and accounted for in the project planning process. Chapter 3 contains more information on how different agencies account for road user costs. Through documented case studies, the Highways for Life Pilot Program has demonstrated in several states that the cost of deploying ABC innovations is often outweighed by the cost avoidance/savings to the road users.

#### 1.2.1.2. Improved Worker and Motorist Safety

Construction of a bridge along an active highway is usually a dangerous work zone. Workers are often performing their duties directly adjacent to active traffic. Every year, construction workers are killed in work zones, which makes work zone safety a primary focus of transportation agencies.

Motorist safety is affected by the change in the existing transportation network and the distractions caused by the on-site construction activity. Work zone traffic management layouts often maximize the lane volume of

traffic through a work zone. This leads to a higher potential for slow-downs and braking within the work zone. The inevitable result is rear-end accidents brought on by slowed or stopped vehicles and driver distraction.

There are several ways to improve worker safety and motorist safety through the use of ABC. By reducing the amount of time that a project is actually in construction, the exposure of workers and motorists to potentially hazardous situations is reduced. The most significant way to improve worker safety is to remove traffic from the site via a short-term detour combined with ABC. This greatly improves worker safety since no active traffic will be on the bridge site during construction. Use of PBES can be used to minimize the amount of labor at the site. Construction of large portions of the bridge in fabrication plants or staging areas can be done in a safer environment without the impacts of traffic.

#### 1.2.1.3. Expedited Project Planning Process

The construction of a bridge project can result in significant impacts to utilities, right of way, and the environment (including air quality, water quality, noise, flora and fauna).

Today, some projects are built with limitations placed on activities that occur over environmentally sensitive areas due to potential effects on various species. For instance, spawning of fish can lead to limitations on in-water work periods such as pile driving. These types of limitations can prolong the construction time for a project. It is not uncommon to have a construction site close down for months because of these necessary environmental limitations. ABC can be used to minimize the time that a contractor is working in and around an environmentally sensitive area during allowable periods. This can reduce the duration of a project by months or even years for some projects if the work can be completed before the activity limitation period. These potential limitation timeframes should be evaluated during the project planning and scheduling process. ABC should be considered as a way to work within the limitation timeframe without have the project drag on for months or years due to inactivity at the construction site.

In some cases, new roadway alignments are used to accommodate traffic during construction. ABC can allow for construction on the same alignment with a full roadway closure and a short duration detour. This will reduce the overall impact to the environment. This also has a beneficial effect on utility and right of way impacts. These reductions can benefit the project planning process. By

reducing impacts, the project can progress more quickly through the design development and environmental impact review processes.

#### 1.2.1.4. Improved Quality

The quality of on-site work has always been held to a high standard. Quality of construction is achieved by strict specifications and quality control procedures. Even with these controls, it can be challenging to construct a bridge to a high degree of quality given the harsh environments that work crews are exposed to.

The quality of site cast concrete can be affected by temperature, humidity, rain and wind. These factors can reduce the durability of the concrete and lead to excessive cracking. Construction of steel structures can also present challenges as well. Field welding of steel in low temperatures can be very challenging and expensive.

Prefabrication can offer a number of advantages when compared to on-site construction. Many prefabrication plants include indoor fabrication areas where the work can be removed from the elements. Outdoor fabrication areas can also be tented during extreme weather conditions. Prefabrication plants also have the luxury of construction without traffic. The workers and their work activity are taken off the critical path for on-site construction. Worker's exposure to difficult and dangerous situations such as work zone traffic management and night time construction are also reduced.

A significant benefit to prefabrication of concrete elements is the lack of restraint during the concrete curing process. Restraint of concrete occurs when a concrete pour is made adjacent to and connected to a previously poured element or fabricated element. Examples of this include concrete decks cast on top of girders and concrete walls cast on top of footings. The freshly placed concrete will shrink during curing; however the adjacent concrete or girder restrains the concrete from shrinking. This leads to a build-up of internal tensile stresses in the concrete that can lead to cracking during the cure.

Prefabricated concrete elements have less potential for restraint cracking since the element is typically not cast against another element. The only restraint is the friction between the form and concrete. Historically, precast concrete elements have experienced significantly less cracking than site cast concretes. It is well known that cracking can lead to long-term deterioration; therefore,

reductions in cracking will have a positive effect on the long-term durability of the element.

Improvements to quality have an effect on the service life of the structure. Higher quality reduces the need for maintenance and extends the life span of the structure. This will lead to a reduced life cycle cost for prefabricated structures. This can be used to offset the potential increase in initial cost for ABC that is discussed in Section 1.2.1.6.

An example of improved quality through the use of ABC and PBES is a bridge built by the Connecticut DOT in 1990 using a full-depth precast concrete deck panel system. The bridge is a six span curved structure that carries ramp traffic from Interstate 84 to Connecticut Route 8. The ramp was narrow; therefore stage construction was not viable. The ramp was closed and a detour was established. ABC was used to minimize the impact of the detour to the traveling public. The result of this approach was that the deck was replaced in 42 days using a system that included longitudinal post tensioning to join the individual deck panels. A waterproofing system combined with a bituminous overlay was used to provide added protection and a smooth riding surface. Figure 1.2.1.4-1 shows the deck under construction in 1990.

The resulting structure has a crack free deck. The bridge is void of typical cracks that are found in virtually all cast-in-place concrete decks that are primarily caused by the restraint of the girders below. The deck has been in service for 20 years and it is still in excellent condition with no noticeable cracking. Based on its current condition, it is anticipated that the deck will have a service life that exceeds that of cast-in-place concrete decks. Section 2.6.1.1 has more information on precast deck panels including present day photos of this Connecticut bridge after 20 years in service.



*Figure 1.2.1.4-1 Precast Deck Construction in 1990*

#### 1.2.1.5. Improved Constructability

Prefabricated elements can improve the constructability of a bridge, especially on sites that have significant constraints. The use of prefabricated bridge deck elements can be used to minimize or eliminate the need for workers to install and remove formwork. This can be especially beneficial for bridges over railroads, rivers, and high volume highways.

The use of prefabricated substructure elements can be advantageous for substructure that are located adjacent to traffic or rails, where there are strict time and space limitations around the elements. The use of prefabricated elements can allow the contractor to get in quickly and complete the construction within a limited timeframe.

#### 1.2.1.6. Reduced Cost to Society

All infrastructure projects come at a cost to society; however the benefit of the completed project outweighs the cost for construction. The monetary costs of construction can be measured in two ways. The first is the actual construction cost of the project in tax dollars. The second is the monetary cost to society cause by delays during construction. The intent of ABC and PBES is to reduce construction time, thereby reducing the cost to society caused by delays. The ultimate goal of prefabrication is to

also reduce the construction cost through repetitive use and a shift of construction work from dangerous and congested work zones to safe and open prefabrication areas.

Agencies that have completed initial ABC/PBES projects have seen increases in construction costs in the range of 10% to 30% depending on the size and nature of the project. There is no general factor that can be applied to the costs for ABC/PBES. Some of the factors can have an impact on the overall construction costs for ABC include:

- Size of project
- Construction time limits including procurement time
- Need for specialized equipment
- Repetition of elements
- Repetition of similar projects

All of these factors can affect the construction cost for an ABC/PBES project. The following generalizations can be made for typical projects:

- For projects that are large and have significant repetition, the costs for ABC/PBES can actually be less than conventional construction.
- Moderate sized projects with some repetition can be expected to cost between 10% and 20% more than conventional construction.
- Smaller projects can be expected to cost between 20% to 30% more than conventional construction.
- Complex projects with very specialized requirements can have costs that exceed these values.

FHWA is developing a “rule of thumb” guideline for calculating ABC costs for various projects entitled “Work Zone Road User Costs”. This will be available in the near future on the FHWA ABC website.

While the unit price of prefabricated bridge elements can be higher than conventional construction, there are other ways that prefabrication can be used to reduce overall project costs. Any reduction in construction time can result in lower agency costs and lower maintenance of traffic costs. Chapter 3 has more information on how to reduce costs with ABC and PBES.

As with implementation of any new technology, initial costs can be significant. This is due to many factors, some of which include:

- Purchase of equipment or formwork
- Cost of training for staff
- Unfamiliarity of the process

- Risk

Many of these factors can be reduced simply by building a series of projects versus construction of just one prefabricated bridge. Equipment and formwork can be re-used or amortized over multiple projects. Staff will become more experienced with the process, which will lead to reduced risk.

Long-term use of any new technology has historically led to lower construction costs. The best example in the bridge construction market is the introduction and development of prestressed concrete. Early uses of prestressed concrete were undoubtedly more expensive than site cast concrete. Over time, with increased use, the cost of prestressed concrete has decreased to the point that it is significantly lower than site cast concrete in most situations.

Minor increases in construction costs associated with ABC can be justified in several ways. The increase in quality discussed in Section 1.2.1.4 can lead to lower life cycle costs. The reduction in road user costs can also be accounted for in the project development process. Road user costs are not dollars that can be spent on the project; however they are real dollars to the traveling public, who are the financial supporters of the project through their taxes.

#### 1.2.2. Positive Public Perception of ABC

The impacts of a construction project on the traveling public are significant. ABC can reduce these impacts, which results in a tremendous positive perception of the construction process and the agency. Public perception and user impacts are very important, since the public are the customers of the agency that is building the project, and they are the ones paying for product. In many locations, the public is resigned to the fact that bridge construction projects take a long time. The delays caused by the construction are a necessary burden that comes with the process. Agencies can receive intense criticism for projects that seem to go on forever. This does not need to be the case. ABC can be used to present a more positive view of bridge construction.

##### 1.2.2.1. Public Response to ABC Projects

The Utah Department of Transportation undertook an ABC initiative that was the most ambitious program in the United States. Starting with the build-up for the 2002 Olympics, they worked toward considering ABC for all bridge projects. They have developed standards, manuals and

specifications for all forms of ABC. To date, they have built hundreds of bridges using ABC techniques.

Part of this process includes the measurement of success. The department routinely measures public perception of construction projects through the use of post-construction questionnaires. Following a typical construction project, stakeholders are asked to rate their overall satisfaction with the project results. Responses to most projects break down into three roughly equal categories.

- One third of the respondents are satisfied
- One third are not satisfied
- One third are indifferent

One can surmise that the satisfied respondents are simply happy to see an improvement in the facility regardless of the time for construction. The other respondents are clearly not satisfied with the project as a whole.

A Likert 7-point polling process was done for a project that used ABC techniques. The results of this polling are depicted in Figure 1.2.2.1-1. The results of this poll are quite different from the typical construction project in Utah. Over 94 percent of the respondents rated the project with a score of 6 or 7 (out of 7), and over 97 percent of the respondents rated the project as a success. In addition, no respondents rated the project less than 3.

The overwhelmingly positive perception of ABC projects was not lost on the decision makers of the State. This data was used by the department of transportation to demonstrate the benefits of ABC to the State legislature. Even in a time of fiscal restraint, the legislature of Utah continued to fund the transportation program at a higher level than in previous years.

Other states have completed user satisfaction polling and found similar responses. The general response is satisfaction with the reduction in onsite construction time and mobility impact times.

### Stakeholder Overall Satisfaction with ABC

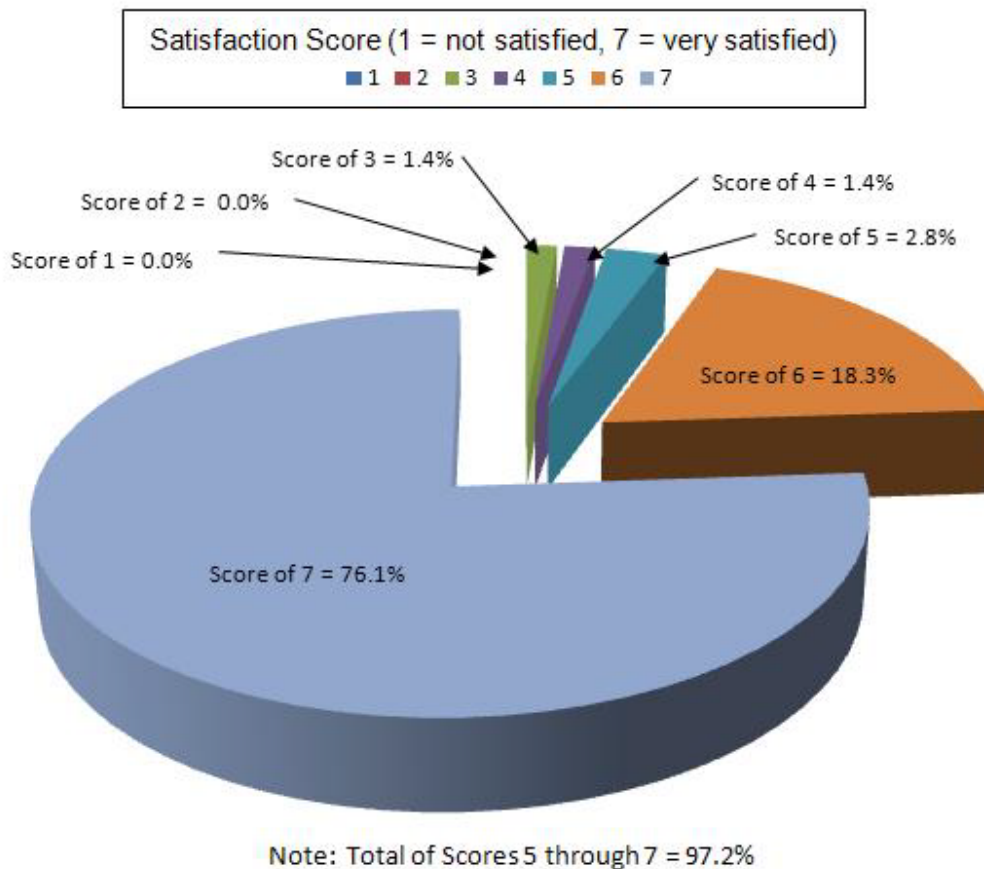

Figure 1.2.2.1-1 Sample Public Satisfaction Poll in Utah

One of the performance goals a construction project should strive to satisfy in order to be granted incentive funding from the Highways for Life program is achieving a score of 4+ on a 7-point Likert scale for user satisfaction. Several highway agencies that have been recipients of grant funding under this program have achieved these scores and intend to sustain the user satisfaction levels on future projects. Examples of notable ABC demonstration projects funded by the program that have documented user satisfaction surveys include those from Georgia, Oregon, and Utah. Project summaries from these projects can be found from the program's website:

[http://www.fhwa.dot.gov/hfl/summary/projects\\_summary.cfm](http://www.fhwa.dot.gov/hfl/summary/projects_summary.cfm).

## Chapter 2 Accelerated Bridge Construction Technologies

This chapter will focus on the various technologies that are employed for ABC projects, the processes and provisions, and how they are applicable to various types of bridge construction projects.

There is no one ABC technique in use in the United States. Instead, there is a family of ABC construction and contracting technologies that are in use that cover the majority of ABC projects. Figure 2-1 shows the most common forms of ABC technologies in use today as compiled by the Federal Highway Administration as part of the “Every Day Counts” initiative. This effort is being used to encourage innovation in construction in order to reduce impacts to the traveling public. The foundation and wall element technologies and rapid embankment construction technology are in the early stages of deployment, while others are mature and in use on a regular basis. It is notable that some of the construction practices support bridge construction, but are not strictly bridge elements. The innovative contracting techniques work synergistically with ABC, as well as other types of construction.

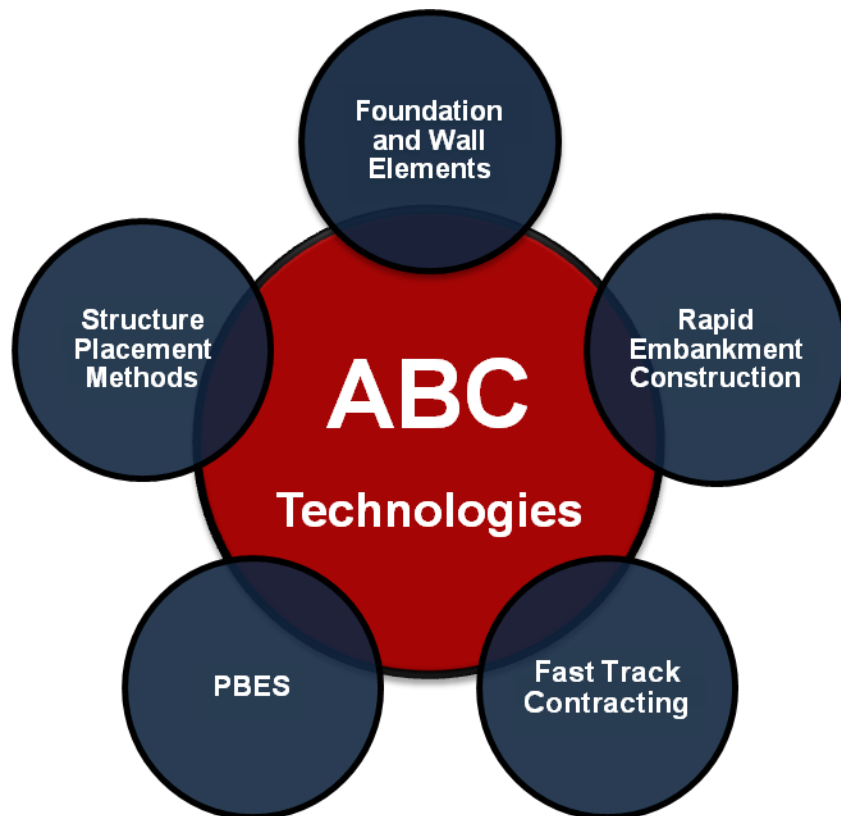

*Figure 2-1 Accelerated Bridge Construction Technologies  
source: FHWA Every Day Counts Initiative)*

## 2.1. Foundation and Wall Elements

### 2.1.1. Continuous Flight Auger Piles (CFA)

This is method of constructing a deep foundation element using a simplified continuous process. CFA piles are sometimes referred to as Augered Cast-In-Place (ACIP) piles, drilled displacement piles, and screw piles.

Normally, drill shafts require several distinct processes. First, the shaft is drilled using an auger or rock coring device. The materials within the pile bore hole are removed. Following this, reinforcement is placed in the hole and the voids are filled with concrete.

Continuous flight auger piles methods combine several of these processes into essentially one process. Figure 2.1.1-1 depicts a graphical representation of a CFA pile installation. In process “a”, a soil auger is drilled into the ground in a continuous stroke. Once the proper depth is achieved, the auger is withdrawn from the soil in the hole, while continuously injecting concrete through the hollow stem of the auger. This process is labeled “b” in the figure. Once the auger has been withdrawn from the hole, a reinforcing cage is inserted into the wet concrete to complete the installation. This process is labeled “c” in the figure.

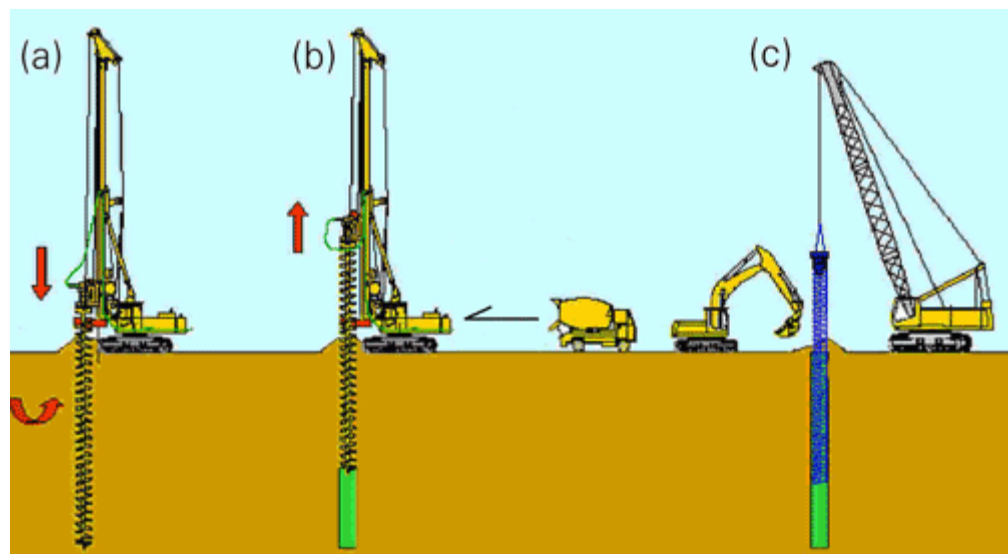
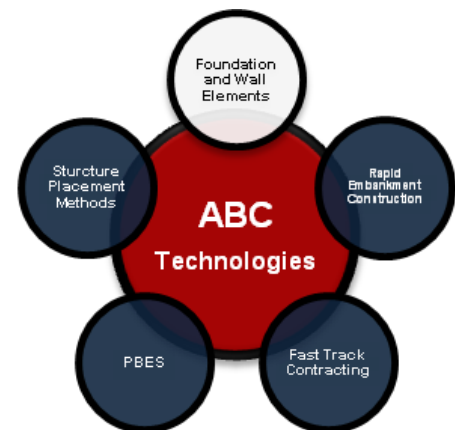

Figure 2.1.1-1 Continuous Flight Auger Pile Installation  
(source: Bauer Maschinen)

By combining these processes, the time for foundation installation can be reduced. More information on this subject can be obtained in the FHWA Geotechnical Engineering Circular (GEC) No. 8 entitled "*Design and Construction of Continuous Flight Auger Piles*" [5].

#### 2.1.2. Geosynthetic Reinforced Soil Integrated Bridge System (GRS/IBS)

This method of foundation installation involves combining the foundation, abutment and approach embankment into one composite material. The structure below the superstructure is comprised of multiple thin layers of soil and geosynthetic reinforcement. The internal soil is retained at the face of the abutment with a high quality concrete block facing. The facing is not a structural element of the system. It simply retains and prevents erosion of the soil near the face of the wall. The composite mass extends beyond the ends of the bridge superstructure and into the embankment. This integration of the abutment with the superstructure and approach allows the system to move and settle as one unit, thereby eliminating the problem with differential settlement between the abutment seat and the approach backfill. This differential settlement often leads to a bump at the end of the bridge. The integrated bridge system does not require approach slabs to span across the potential bump.

The superstructure typically sits on top of the GRS fill without bearings. The superstructure loads, rotations, and movements are carried directly by the GRS system. The system can be used with precast butted box beams, precast slabs, or with conventional stringer deck systems. With stringer bridges, a small footing combined with an integral pour is used to seat the superstructure on the GRS embankment. Figure 2.1.2-1 depicts a typical section of a GRS/IBS bridge abutment.

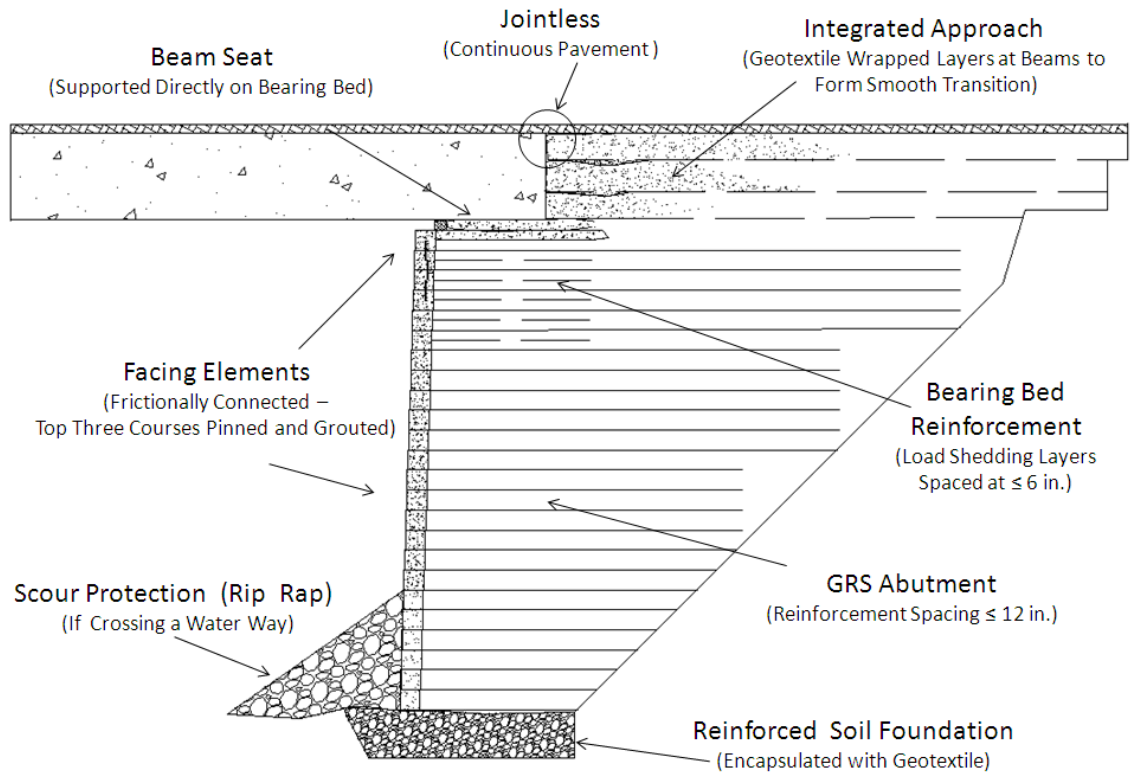

Figure 2.1.2-1 Typical Section of a GRS/IBS Bridge Abutment

The benefits of this system include:

- Low initial cost
- Low life cycle cost
- Fast construction (under 30 days for most bridges)
- Minimal installation labor and equipment
- Eliminates the need for approach slabs

The limitations of this system include:

- Span lengths are currently limited to spans less than 140 feet (until more data on longer span bridges is compiled).
- The system is not appropriate for locations where scour would prevent the use of shallow foundations.
- It is currently only recommended for single span bridges, however multi-span bridges are being considered.

Even with these limitations, the GRS/IBS system could potentially be used for a large number of the single span bridge inventory, including the large number of rural county bridges in the United States. More information on this subject can be obtained at the FHWA website: [www.fhwa.dot.gov/everydaycounts](http://www.fhwa.dot.gov/everydaycounts). A GRS/IBS implementation guide is also available at the FHWA website:

### 2.1.3. Prefabricated Pier Cofferdams

Construction of deep foundations in deep water is a daunting challenge. Several methods have been developed for cofferdams including driven steel sheeting and framing systems combined with underwater tremie concrete. The advent of large diameter piles and drilled shafts has reduced the need for deep concrete pours that were traditionally placed below the mud line. Today, it is becoming more common to perch the bottom of the pile cap footing just below the water surface.

Prefabrication can be used to facilitate the casting of the pile cap footing. Pier box forms have been developed that can be floated into position and hung from the piles or drilled shafts. In some cases, the forms can be ballasted into position using buoyancy to support the wet concrete. The pier boxes can be fabricated with steel and removed after casting, or be fabricated with precast concrete and left in place.

## 2.2. Rapid Embankment Construction

### 2.2.1. Expanded Polystyrene (EPS)

#### Geofoam

EPS Geofoam is an embankment fill system that is comprised of large blocks of expanded polystyrene. Unlike the GRS/IBS system, it is not intended to be a structural support system for the bridge abutment. The EPS blocks can be placed behind a conventional abutment or around the piles of an integral abutment.

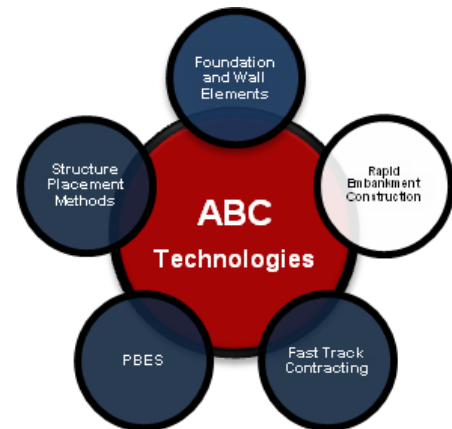

Figure 2.2.1-1 is a photograph of a typical EPS Geofoam embankment prior to placement of the roadway structure and side slopes.

The benefits of this system include:

- Fast construction
- Extremely lightweight (1-2 pounds per cubic foot)
- Eliminates or reduces pre-load settlement times

The design considerations for this system include:

- A layer of subbase is required below the pavement to distribute wheel loads.
- Protection of the foam blocks from gasoline spills.
- The system should not be used where the water table will be above the bottom of the EPC blocks, which would cause uplift forces.



*Figure 2.2.1-1 EPS Geofoam Embankment  
(source ACH Foam Technologies)*

The lightweight nature of this material makes it ideal for areas where long-term settlement potential is high. The embankment weight can be reduced by a factor of up to 100, which will greatly reduce the amount of long-term settlement and the need for embankment pre-load time. More information on this subject can be obtained at the FHWA website:

[www.fhwa.dot.gov/engineering/geotech/improvement](http://www.fhwa.dot.gov/engineering/geotech/improvement).

#### 2.2.2. Accelerated Embankment Preload Techniques

Establishment of embankments over soils that are subject to long-term settlement such as clays can lead to a long-term construction process. Often, preloads are applied to the embankments to accelerate the settlement of the sub-soils prior to roadway construction. Preload areas are often required to be left in place for many months and in some cases more than a year.

Technologies are available to accelerate the settlement of the sub-soils. The goal of a preload system is to remove water from underlying clays in order to consolidate the layers. Stone columns and wick drains have been used to accelerate the removal of the water. This approach can reduce pre-load times by a factor of four or more.

#### 2.2.3. Column Supported Embankment Techniques

Another method of constructing embankments over compressible soils is to build a soil structure over the existing compressible sub-soils. This can involve the installation of closely spaced piles or stone columns that are installed through the compressible soils.

Once in place, multiple layers of geosynthetic reinforced soils can be placed over the columns to produce a structural soil layer that can be used to support the new embankment. This method eliminates the need for time consuming pre-load of compressible soils.

## 2.3. Prefabricated Bridge Elements and Systems

### 2.3.1. Prefabricated Elements

The most common form of ABC is the use of prefabricated bridge elements. These elements can be fabricated in a controlled environment off site and assembled in place at the bridge site. This construction method can best be described as building blocks. The prefabricated elements are connected at the site to form a complete bridge.

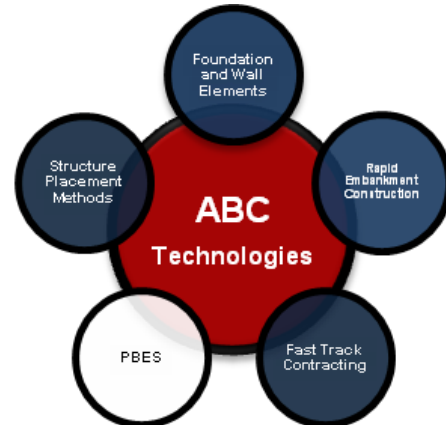

Prefabrication of beams is not a new concept. Virtually all bridges are currently built with prefabricated beams and girders. Other industries have used prefabrication to speed project delivery and lessen cost. Industries such as parking structure have taken prefabrication to the highest levels. The newer concepts that are now finding more widespread use are prefabrication of the other elements on a typical bridge, such as bridge decks and prefabricated substructure elements (including pier columns, footings, and abutment/retaining wall stems and footings). Installation of prefabricated elements is normally completed using standard cranes.

Prefabricated construction requires joints between elements. There has been concern expressed by some agencies regarding the durability and structural integrity of the joints. Connection joints between elements are not only found in prefabricated construction. Conventional cast-in-place concrete construction includes many connections and joints. Cast-in-place construction is not normally monolithic. For example, there are construction joints between footings and columns and construction joints between columns and pier caps in open frame pier bents. There are even construction joints in bridge decks on multi-span bridges. These construction joints are required in order to facilitate the forming and placement of concrete and to reduce cracking brought on by shrinkage of concrete and deflection of structures.

The approach to connecting prefabricated elements is to replace construction joints with precast connections. The term “emulation design” was applied to this approach by the American Concrete

Institute (ACI). ACI in conjunction with the American Society of Civil Engineers (ASCE) have published a report entitled “*Emulating Cast-in-place Detailing in Precast Concrete Structures*” [6]. This report recommends various connections for prefabricated elements. The connections include small closure pours, grouted tubes with reinforcing dowels, welded ties and mechanical couplers. Many of these connections have been tested for structural capacity, seismic capacity, and long-term durability in other markets. The transportation market has been slow to adopt these solutions.

The FHWA manual entitled “*Connection Details for prefabricated bridge Elements and Systems*” [3] contains significant information for various prefabricated element connections. The durability of these connections has also been proven. The FHWA manual provides many examples of durable connections. For example; precast bridge decks panels that have been in service in a northern environment for over 20 years and precast bridge piers that have been in service in a highly corrosive environment for over 15 years. There are also on-going research projects in several research institutions that are looking into the durability of prefabricated connections. Preliminary results indicate that these connections can be both structurally sound and highly durable. Chapter 8 includes more information on the durability of prefabricated elements and connections.

Examples of prefabricated substructure elements are shown in Figure 2.3.1-1 (precast concrete cantilever abutment) and Figure 2.3.1-2 (precast concrete open frame pier bent). These graphical representations are based on details developed by the PCI Northeast Bridge Technical Committee. Similar details have also been used in Florida, Georgia, Utah, and New Hampshire. In these structures, all elements are made with precast concrete.

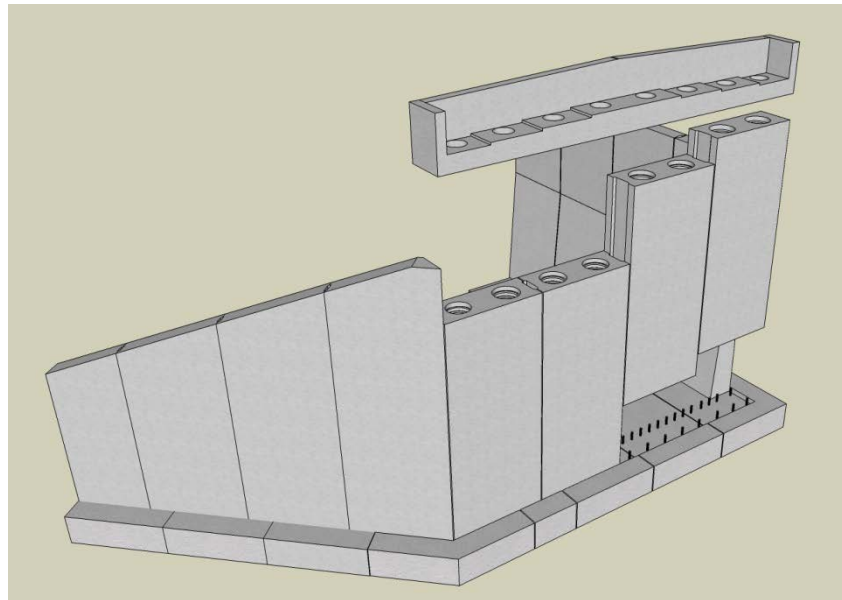

*Figure 2.3.1-1 Prefabricated Cantilever Abutment*

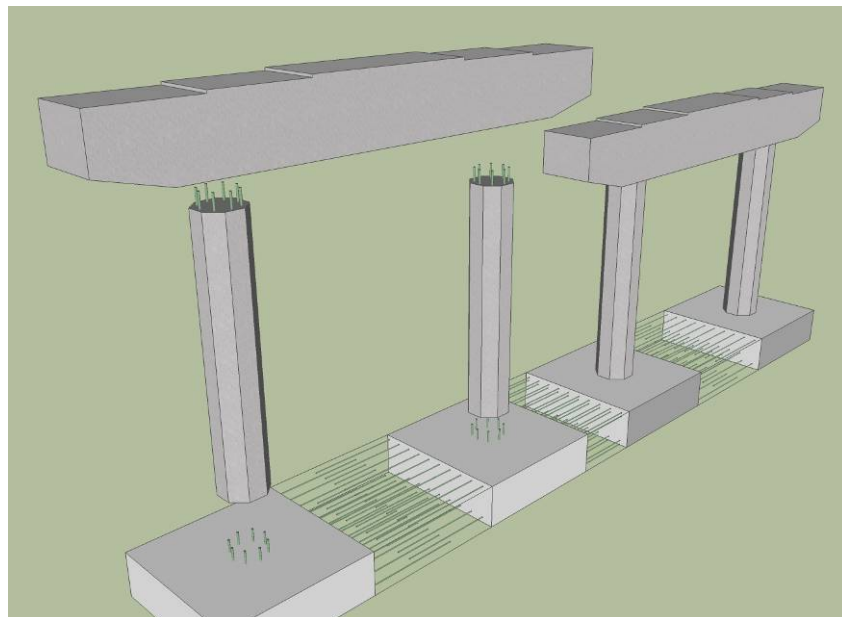

*Figure 2.3.1-2 Prefabricated Open Frame Pier Bent*

Modular bridge elements are prefabricated elements that represent a more significant portion of the finished structure. They are typically larger elements that are made up of several smaller components that are joined during prefabrication. An example of a modular element is two beams with a composite concrete deck cast in the fabrication shop or staging area. Installation of

modular elements is similar to prefabricated elements. The crane sizes can get quite large because the modular elements are typically heavier than smaller elements.

There have been several successful projects built using modular bridge technology. The most notable was the James River Bridge in Richmond Virginia. The superstructure of this viaduct bridge was replaced using only nighttime closures. The superstructure was prefabricated using multi-beam modules that were constructed with steel stringers and pre-topped concrete deck. The old bridge was removed in pieces using cranes, and new modular units were installed using the same equipment. Figure 2.3.1-3 shows a new module being installed on the project.



*Figure 2.3.1-3 Modular Steel Superstructure Element Installation  
James River Bridge, Richmond, VA*

Figure 2.3.1-4 shows a concept that was developed by the Massachusetts DOT for the replacement of bridge superstructures on Interstate 93 in Medford, Massachusetts. This project involved the replacement of 41 bridge spans in 10 weekends. The concept involved the complete closure of one side of the highway on weekends to create a 55 hour work window for the contractor to install the modules. Traffic was maintained on the opposite side of the interstate via two cross-overs that were constructed at each end of the project.



*Figure 2.3.1-4 I-93 Superstructure Replacement Concept*

Figure 2.3.1-5 shows the actual construction in progress. Up to 6 spans per weekend were replaced using this concept.



*Figure 2.3.1-5 I-93 Superstructure Replacement Construction*

These are just some examples of how prefabricated elements can be used to construct bridges using details that are similar to cast-

in-place concrete. This has been referred to as “reverse engineering the bridge”, or “emulation design”. The goal is to build bridges that are similar to proven design using precast concrete in place of cast-in-place concrete.

### 2.3.2. Prefabricated Systems

It is possible to fabricate larger portions of the bridge and move them into place at a later date. Examples of prefabricated systems include complete superstructures, superstructures with integral piers, or even complete bridges. Most work completed to date in the United States has been with prefabricated superstructures although engineers are starting to investigate work completed in Europe that also included integral prefabricated substructures. A key component to large-scale prefabrication is the methods used to move and install the elements. Typical crane installations are not normally used due to the weight of the systems. The following section describes methods used to install prefabricated systems.

## 2.4. Structural Placement Methods

### 2.4.1. Self Propelled Modular Transporters (SPMTs)

There are families of high capacity, highly maneuverable transport trailers called Self Propelled Modular Transporters (SPMTs) that are being used in the bridge industry. The term “self propelled” in the title describes the fact that these trailers do not need a tractor to push or pull them. The propulsion comes from an on-board hydraulic power pack that is connected to hydraulic drive motors on several of the axles. The term “modular” in the title describes the ability to connect the trailers longitudinally and transversely to form a larger transporter. The descriptions of various configurations are normally noted as “lines” of wheel sets. Figure 2.4.1-1 depicts a sketch of several different configurations and the corresponding descriptions. Other larger configurations are also possible.

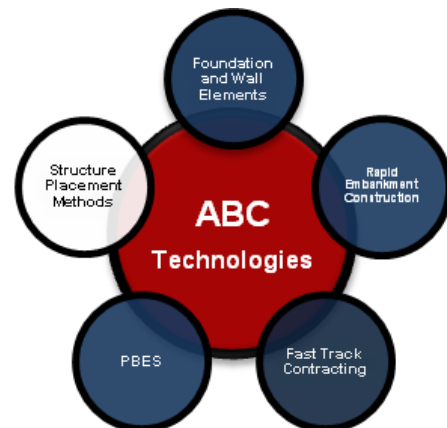

There are several manufacturers of SPMTs. All are similar but have somewhat differing capabilities. Some have 8 tires per line, and others have 4 tires per line. Some transporters have wheel sets that can rotate 360 degrees, and others have limited rotation capacity. The SPMT’s are highly maneuverable and can be moved and rotated in all three dimensional axes (vertical, transverse, and longitudinal). When the individual transporters are interconnected, they can be programmed to function as one

unit. Rotation about the vertical axis can be programmed to pivot about any point in space.

The typical load capacity for SPMTs is approximately 50,000 pounds per axle line. Some SPMTs can carry over 75,000 per axle line. When interconnected, the units can move several million pounds or more. They can also be laid out and configured to accommodate varying soil conditions if these axle loads are problematic.

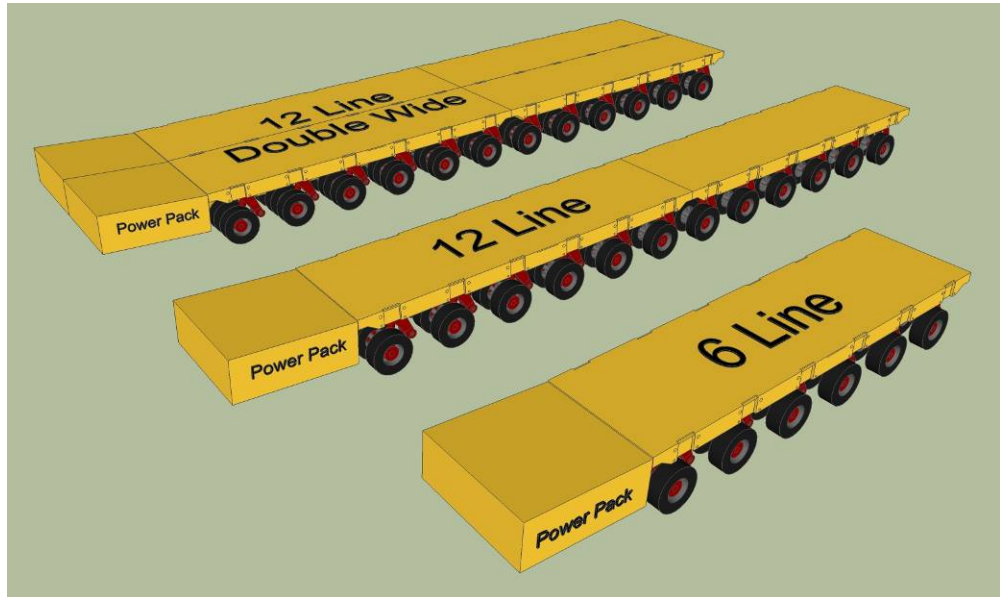

*Figure 2.4.1-1 Sample Self Propelled Modular Transporter Configurations*

SPMTs have been used for many prefabricated bridge installations. The Utah DOT installed over 20 bridges in a three year period. Installation times range from 2 hours to 8 hours depending on the complexity of the travel path and the geometry of the bridge. Figure 2.4.1-2 shows an SPMT bridge move in Utah. This bridge weighed several million pounds and was moved approximately 1 mile from a staging area to the bridge site. Figure 2.4.1-3 shows a large SPMT bridge move in Providence Rhode Island. This bridge was transported from a shipping pier onto two large barges. Once on board, the bridge was moved to the construction site that was 12 miles away. The entire installation only took several days. The Providence Bridge weighed approximately 6 million pounds.



Figure 2.4.1-2 SPMT Bridge Moves in Utah



Figure 2.4.1-3 SPMT Bridge Move in Rhode Island

The document entitled “*Manual on Use of Self-Propelled Modular Transporters to Move Bridges*” [1] is recommended for more information on these machines.

Since the publication of the FHWA SPMT Manual, the use of SPMTs has increased. To date, approximately 30 bridges in 13 states have been moved using SPMTs. The Utah DOT is considered a leader in the use of this equipment. They have published a manual entitled “*SPMT Process Manual and Design Guide*” [7]. This manual covers project scoping, the design of bridges using SPMTs, and contracting with SPMTs. Sample specifications are also included in this manual (included in

Appendix C of this manual). More information on the use of SPMTs can be found at the FHWA website:  
<http://www.fhwa.dot.gov/bridge/abc/introspmtmoves.cfm>.

Many agencies have expressed concern over the specialized nature of this work, and the ability of local contractors to use SPMTs. The increased use of SPMTs has spawned a number of specialized heavy lift companies that own and operate this equipment. On a recent project in Massachusetts, multiple firms were involved in the proposal phase of the project.

To date, at least six SPMT Heavy Lift firms are operating in the United States. The Federal highway administration maintains a listing of the ever growing number of SPMT suppliers. These firms cover the entire country; therefore this equipment is available to all state agencies. This increase in activity has also resulted in a reduction in the cost of the equipment. There is competition in the market, and costs have been significantly reduced.

Determination of the cost of an SPMT bridge move is not a simple matter. There are various factors that can affect the overall cost of the move. The following are several major factors:

- Size of the bridge being moved
  - The number of SPMT Lines required for the move
  - Size of framing required to support the bridge over the SPMTs
- Length and geometry of the travel path
  - Required turning movements
  - Transverse and longitudinal slopes requiring special leveling systems or temporary fill
- Engineering Costs
  - Requirements for lift calculations
  - Design of framing between the SPMT and the bridge
- Quality of the supporting soil on the travel path
  - Need for structural fill and/or steel plating
- Monitoring
  - Requirements for monitoring during the move
- Length of time that the equipment needs to be on site
  - Multiple stages
  - Idle time of equipment
- Number of projects in the area
  - The opportunities to use equipment on more than one project during a given timeframe

Agencies are encouraged to review the documents previously noted and to contact SPMT heavy lift contractors to explore the actual costs for a specific project. The agency should be armed with answers to at least some of the factors noted above.

The time required to complete an SPMT bridge move varies depending on the complexities of the project. Superstructures have been installed in several hours (minus the connection to the approach roadways). Utah DOT has completed two superstructure replacements, including approach roadway connections in less than 24 hours.

#### 2.4.2. Longitudinal Launching

Launching of superstructures has been used for many years for bridges over terrain that is inaccessible for cranes. Longitudinal launching involves erection of the bridge superstructure in a launching pit located behind one or both of the abutments. A lightweight launching nose is often used to minimize the deflection of the cantilevered end of the superstructure during the launching and to account for the deflection of the end of the bridge as it reaches each support. In some cases, intermediate towers are used to minimize deflections on longer spans.

Once the superstructure erection is complete in the launching pit, it is jacked horizontally out over the spans using a sliding or rolling system.

Launching has been used for both steel and concrete structures. It has also been used on curved structures. Launching can be relatively faster than other methods of construction at difficult sites; therefore it warrants consideration.

One example of an appropriate use of launching is a bridge over a deep gorge. The cost and size of cranes in a deep valley can be large. It may not even be possible to set elements in certain situations. One method that has been used is segmental construction using balanced cantilever construction, launching should be considered as another option.

Another example is the construction of a bridge over a busy navigation channel. Launching methods can eliminate the need for delivery of elements by barge that may tie up the navigation channel for periods of time. The access limitations in the channel may significantly increase the time required to construct the span. Launching can be used to eliminate the need for work within the channel and thereby expedite the construction process. More information on longitudinal launching can be found in an NCHRP report entitled "Bridge Construction Practices using Incremental Launching" [61].

Figure 2.4.2-1 shows a longitudinal launch of a bridge in Utah. The superstructure was delivered to the site using SPMTs traveling on the widened interstate roadway. Once at the bridge site, the superstructure was transferred onto a launching frame. This installation was completed in approximately 3 days.



*Figure 2.4.2-1 Longitudinal Launching of a Utah Bridge  
(source: Utah DOT)*

The time required to complete a longitudinal launch varies depending on the size of the bridge and the available room for a launching pit. The procedure can typically take between several days and several months.

#### 2.4.3. Horizontal Skidding or Sliding

Another method of moving and installing large bridge systems is called lateral sliding/skidding. This method requires that the new bridge be built in parallel to the proposed finished location. The structure is normally built on a temporary support frame that is equipped with rails. The bridge can be moved transversely using cables or hydraulic systems. Minor vertical adjustment can also be incorporated into these systems. Figure 2.4.3-1 shows a lateral slide of a single span bridge in Utah.



*Figure 2.4.3-1 Lateral Bridge Slide in Utah*

There are several approaches that can be used for this method. The first and most common, is to build the new bridge along the side the existing bridge. Once the new bridge is complete, the old bridge is demolished, the new substructures are installed (if required), and the new bridge is slid into place. Another method is to build the new substructures under the old bridge prior to the move. Once complete, the old bridge is slid out of the way, and the new bridge is installed immediately. Figure 2.4.3-2 shows a lateral slide of a multi-span bridge in Oregon that demonstrates this process. The new bridge is located on right, and the old bridge, which has already been moved out of place is on the left. This project was a FHWA Highways for LIFE demonstration project. More information on this project can be obtained at the FHWA Highways for Life website:  
[www.fhwa.dot.gov/hfl/summary/projects\\_summary.cfm](http://www.fhwa.dot.gov/hfl/summary/projects_summary.cfm).



*Figure 2.4.3-2 Lateral Bridge Slide in Oregon*

Innovative foundations can be incorporated into this process. Foundations that include drilled shafts placed outboard of the existing bridge have been combined with transverse cap beams to allow for construction of the new substructure under the existing bridge. On several bridges in Utah, the cap beam was integrated into the new bridge superstructure. This approach eliminates the need to build the substructures after the removal of the existing bridge. The use of prefabricated substructure elements can also be used to reduce the amount of time between the demolition of the existing bridge and the lateral slide-in.

One of the most dramatic examples of a lateral slide-in is a project that was completed in California on the Oakland Bay Bridge. The slide-in was required to connect the new approach structure temporarily to the existing main span, thereby making room for the construction of a portion of the new bridge in the area. Once that span is complete, another lateral slide-in will be used to make the final connection to the new main span. Figure 2.4.3-2 shows the lateral slide in progress. In the photo, the old bridge has already been moved (to the left), and sliding of the new bridge is about to commence (to the right). The bridge is a multi-level through truss. The lateral slide of this bridge occurred during a three day weekend closure.



*Figure 2.4.3-3 Lateral Bridge Slide of the Oakland Bay Bridge Approach  
(source: Mammoet)*

Another approach that has been used involves the use of the existing bridge as a temporary bridge on a temporary alignment. The existing bridge is slide laterally onto temporary supports that are adjacent to the bridge. In this scenario, the old bridge is used as a temporary bridge, while the new structure is built along the final alignment. This saves the cost of designing, erection and removal of a temporary bridge superstructure.

The time required to complete a lateral slide-in varies depending on the size and complexity of the bridge. Typical replacement of single and multiple spans have been completed during weekend closures.

#### 2.4.4. Other Heavy Lifting Equipment and Methods

Large-scale elements can also be installed using vertical lifting machinery. The most common types of equipment are strand jacks and climbing jacks. The difference between these two systems is that strand jacks pull the elements up vertically using cables and the climbing jacks push the elements using hydraulics. These systems can lift a large structure incrementally. Strand Jacks can be used to lift large structures over waterway crossings where the structure can be shipped to the site via barge.

Figure 2.4.4-1 depicts a strand jack lift of the Providence River Bridge in Rhode Island. The original design called for erection of the arch on false work over a navigation channel. The contractor

chose an alternate method of construction where the bridge would be assembled 12 miles from the construction site on a shipping pier. This allowed the construction of the superstructure to occur in parallel with the construction of the foundations and substructures. The network arch bridge was erected at ground level, where the majority of the field bolting took place. The bolting at ground level saved months of erection time when compared to higher level piece work on staging. Strand Jacks were used to lift the completed structure to its final elevation. The structure was then transferred to SPMTs, and then transferred to two large barges for final transport to the bridge site. This method of construction saved approximately 1 year in construction. Significant disruption of the river channel was limited to one day.



*Figure 2.4.4-1 Strand Jack Lifting of the Providence River Bridge  
(source: Mammoet)*

Another less common method of prefabricating and installing a bridge is pivoting. This method involved rotating the prefabricated bridge into its final position in either the vertical or transverse bridge axis. Vertical axis pivoting can be used for waterway and railroad crossings. The structure can be built alongside the feature that is to be crossed and rotated into its final position. Figure 2.4.4-2 shows transverse pivoting of a new pedestrian bridge in Meylan, France. Transverse axis pivoting has been used to erect arch bridges by installing the elements in the vertical position at the supports and rotating them into position with cables (similar to a bascule bridge closing).



*Figure 2.4.4-2 Vertical Axis Pivot Technique  
Meylan Pedestrian Bridge, France*

Other innovative erection methods have been developed to install prefabricated elements on various bridges. Gantry cranes are finding more use on ABC projects. There are several configurations that have been used. The first is a transverse gantry crane. Figure 2.4.4-3 is a sketch of a gantry crane supported on a temporary trestle. Once installed, the crane can access all portions of the bridge site. During peak traffic hours, the crane can be left in place, allowing traffic to pass beneath. This type of system has been used on long span suspension bridge, where the gantry support rails were placed on the fascia stiffening truss.

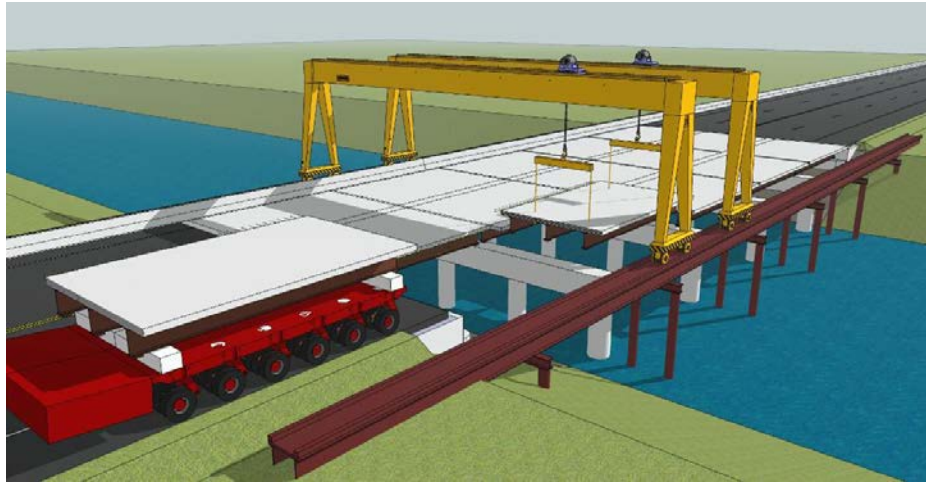

*Figure 2.4.4-3 Transverse Gantry Crane Installation Technique*

Another type of gantry systems is a longitudinal gantry frame. The Washington State DOT completed the re-decking of the Lewis and Clark Bridge using this technology. The project involved the replacement of the deck on a long-span through truss. An innovative gantry crane system combined with SPMTs was used to remove existing modules and install the new modules in one procedure. The gantry frame was designed to fit within the truss framing, and it was designed to carry both the old deck/stringers and the new module. Figure 2.4.4-4 shows the gantry system that was used on the Lewis and Clark Bridge. This system allowed the removal and replacement of deck/stringer modules in an overnight operation.



*Figure 2.4.4-4 Delivery of Modular Unit using a Gantry Frame*

Figure 2.4.4-5 is a graphical representation of how the gantry frame system could be used on bridge. The longitudinal gantry frame method of installation is limited to relatively short span bridges because the size of the frame needs to be more than twice the length of the modules being installed.

Large overhead longitudinal gantry cranes are used on segmental bridge construction to build over areas that are inaccessible to conventional construction equipment. This includes environmentally sensitive wetland, busy highways and river channels. These systems can be used to install piling, drilled shafts, segmental superstructures, and total bridge systems. Longitudinal gantry cranes can save significant time on difficult construction sites.



Delivery of New module and Removal of Portion of Bridge using the Gantry Frame



Installation of new Module using the Gantry Frame

*Figure 2.4.4-5 Longitudinal Gantry Frame Installation Technique*

#### 2.4.5. Conventional Cranes

Many prefabricated elements can be installed using conventional cranes. Cranes are an integral part of most bridge construction projects. The erection of beams and girders are the primary use for cranes. It is possible in many cases to design prefabricated elements to be approximately the same weight as the girders. In this scenario, the same cranes can potentially be used for the erection of the prefabricated elements and the girders. Figure 2.4.5-1 shows the installation of a prefabricated deck panel with a crane.



*Figure 2.4.5-1 Precast Deck Panel Installation using Cranes  
(source: Utah DOT)*

Modular systems can also be installed using cranes. The larger weight of the elements may require the use of multiple cranes at a bridge site (similar to erection of large girders). Figure 2.4.5-2 shows a scenario for the erection of modular elements using conventional cranes. Four cranes are shown. The center two cranes are used for erection of the center span. The cranes behind the abutments could work with one of the center cranes to erect the end span modules.

Modern High Capacity Hydraulic Cranes have been developed for use in heavy lift projects. These cranes are available in the United States. They can travel over the road and be set up in a short amount of time (1-2 hours). Crawler Cranes are also available for heavy lift operations. Lifts of approximately 150,000 pounds picked at a radius of 100 feet are attainable using this type of equipment. Larger loads may also be feasible with shorter pick radii. Designers should investigate the feasibility of cranes at a site by checking availability with local crane companies, establishing set-up locations, locations for delivery trucks and

capacity of underlying soils and structures to accommodate the crane loads.

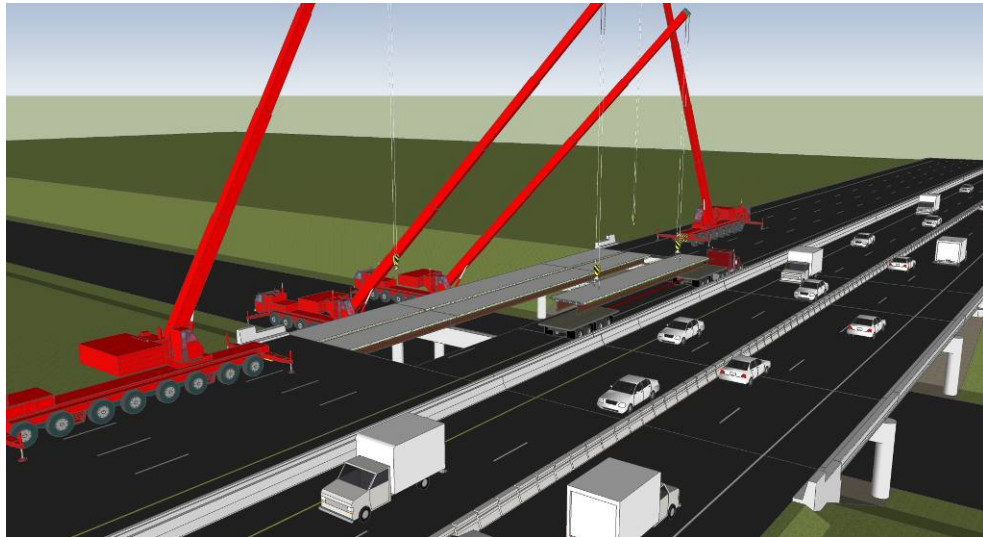

Figure 2.4.5-2 Modular Element Installation using Cranes

## 2.5. Fast Track Contracting

The previous sections focus on methods which are typically used to accelerated on-site bridge construction. This section will discuss other methods that are used to Accelerate Bridge Construction during the planning stages using Contracting Processes, and by the use of contracting language using Contracting Provisions.

There are two major forms of accelerating the construction of a bridge. The first is accelerating the actual construction of the bridge in the field. The previous sections focus on the typical methods in use. The goal is to minimize the impacts of the construction on the traveling public and surrounding communities. In many cases, the design of the project can be carefully planned and designed. In construction, the fabrication of elements can also be completed prior to roadway closures with no impact to the public. Once the fabrication is complete, the project can be completed quickly.

The second way to accelerate the construction of a project is to reduce the time required to plan, design, and bid the project. This is referred to as Accelerated Project Delivery (APD). Another key component to accelerating construction is through the use of contracting provisions that

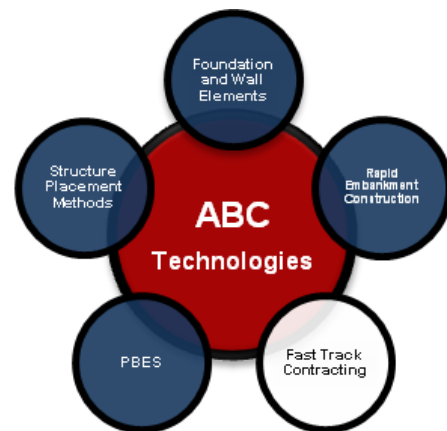

place emphasis on the need to complete the project quickly. The following sections explore these concepts in more detail.

#### 2.5.1. Accelerated Project Delivery

Accelerated Project Delivery (APD) is used to expedite projects for various reasons. An extreme situation, such as a closure of a bridge due to deterioration, would warrant an APD approach. Other scenarios would include bridges damaged by vehicle impacts, ship impacts, floods, or seismic events. The use of APD is also increasing as States feel political and economic pressures to expedite projects. Accelerated project delivery can be combined with ABC to get these critical projects open to traffic in a short period of time.

APD can take several forms, but the most commonly used forms, have consisted of methods that shorten the design and construction times in project delivery. These methods take advantage of the idea that design and construction can take place concurrently with certain types of innovative contracting. This differs from the widespread traditional practice of Design-Bid-Build (DBB), which requires design and construction to take place sequentially. Innovative contracting is characterized by early contractor involvement and input into design decisions, and by initiation of construction prior to design completion.

Innovative contracting is a natural fit for accelerated bridge construction. Often, there are multiple methods of construction that are feasible for a particular bridge site, each with its own requirements for equipment. The ability to have the construction contractor involved in the design process can be a valuable tool for innovative projects. In these situations, the contractor's input can play a significant role in the design options that are examined. The design can also be tailored to the equipment that the contractor has access to.

FHWA has established a project entitled *Special Experimental Project Number 14 (SEP-14) - Innovative Contracting*. This was developed to enable state transportation agencies the ability to test and evaluate a variety of alternative project contracting methods. The goal is to expedite highway projects in a more cost-effective manner, without jeopardizing product quality or contractor profitability.

Two common innovative contracting methods of APD that are in use on ABC projects are "Design/Build" and "Construction Manager General Contractor". The following sections describe these two processes, including their similarities and differences:

##### 2.5.1.1. Design-Build (DB)

Design-Build is a project delivery tool that combines the expertise of the design engineer with the expertise of the

contractor in one team and in one contract. With this method the owner relinquishes control of the design and construction process and decisions to the Design-Builder. In this method it is important that the owner can articulate and convey their performance expectations of the final project to the Design-Builder. Many agencies are using Design-Build to expedite project delivery. Each agency has specific approaches to this process; however there are commonalities.

The DB process combines the design and construction processes into one contract. Contractors team with design engineers to design and build a particular project. A certain amount of up-front design is normally completed by the agency prior to bidding a DB project. This often involves preliminary design, acquisition of right of way, and procurement of environmental permits. The DB process requires that the owner properly define the fundamental parameters and expected performance criteria of the project so that the bidding teams can work toward a common solution. In some cases, this solution is intentionally left somewhat open to encourage innovation on the part of the DB team. The solution is left open, but the owners expected performance criteria is clearly defined.

An example of this can be illustrated by the following: In a Design-Build contract and RFP would ask for a bridge, designed to handle a specified traffic load in year X, as opposed to an owner prescribing a certain number of lanes, with a certain type of bridge. This statement of performance versus prescription gives a Design-Builder flexibility to design and build many alternatives, and to find an owner the best solution.

On simple projects that do not involve right of way acquisition or environmental permits, a project can be awarded with less up-front design, as the consultant will be performing a large portion of the design work in parallel with construction activities. An example of this may be the replacement of a bridge damaged by an over-height truck impact. In this case, the parameters of the final product are well defined.

Figure 2.5.1.1-1 depicts a flowchart of a sample DB project. The major team members are shown in different colored boxes.

Advantages to the DB process are as follows:

- Accelerated Project Delivery - most agencies report consistently expedited project schedules.

- The design can be tailored to the contractor's expertise and equipment.
- The team can take advantage of innovative construction processes.
- DB Teams are sometimes encouraged to modify the preliminary designs to save money.
- Owners can obligate monies very quickly and with good results on meaningful capacity projects.

Disadvantages to the DB process are as follows:

- The owner needs to clearly identify and communicate the desired project outcomes.
- The DB team needs to complete a relatively detailed design process in order to bid the project. In some agencies, stipends are used to defer the cost of this process to the short-listed teams.
- The owner does not have complete control over the final design. The design team is working under the direction of the contractor, not the agency. Requests for changes to the design after the bid often result in extra costs.
- Risk is increased on the designer and contractor. However, DB allows the designer and contractor to develop solutions to minimize risk.
- Most agencies have seen little or no change in project cost. Some agencies have reported higher costs. In these cases owners generally agree that the decrease in traffic disruption has positive cost benefit. The increase costs have been more than made up in a modeling of road user costs.

Even with the listed disadvantages, the ability to deliver a project in a short time period has compelled agencies to use this method for many projects. Some states have statutory restrictions to this form of contracting. In some cases, special legislation has been used to allow the use of DB on a limited basis.

More information on the Design-Build process can be found at the FHWA website:  
[www.fhwa.dot.gov/construction/cqit/desbuild.cfm](http://www.fhwa.dot.gov/construction/cqit/desbuild.cfm).

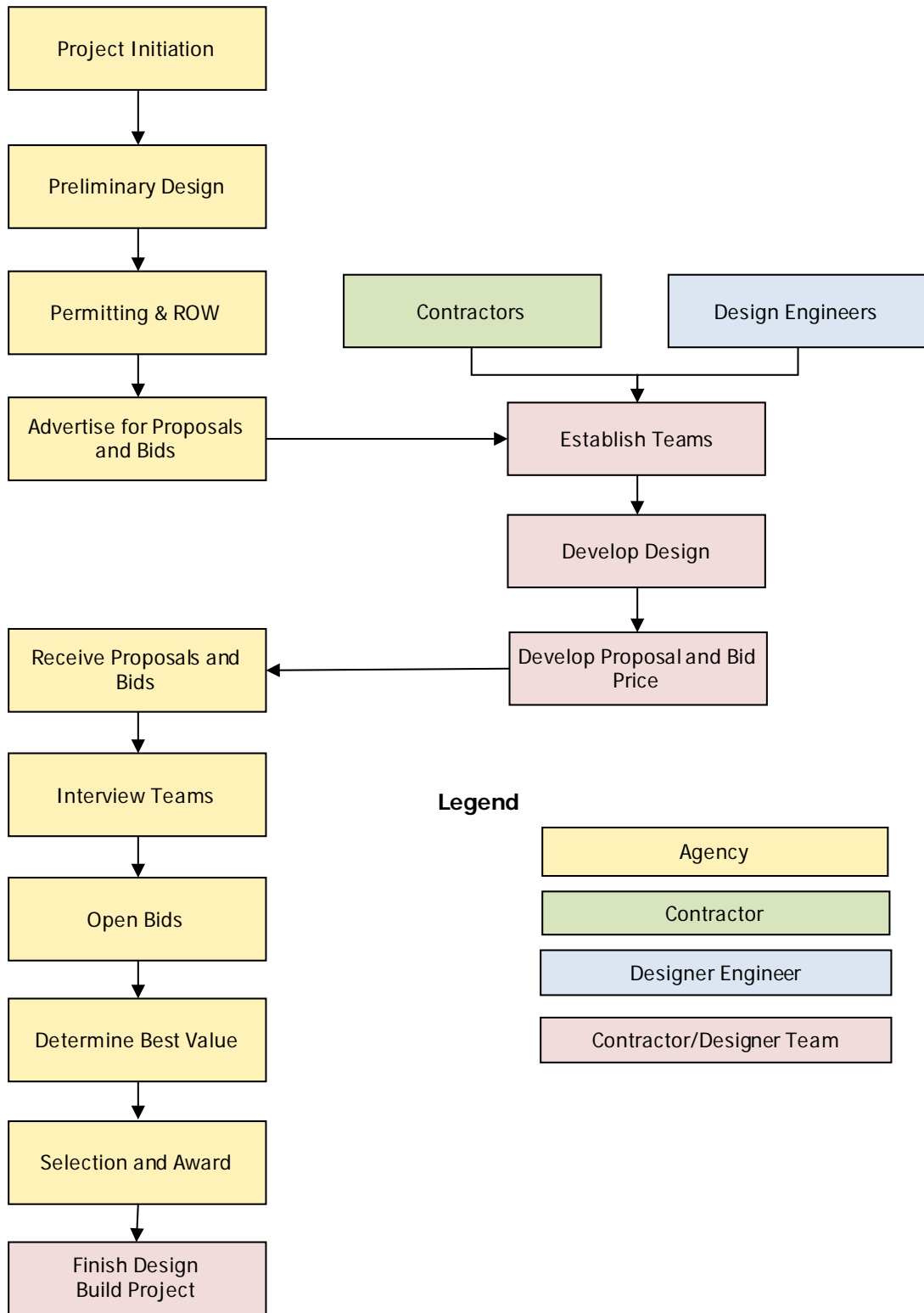

Figure 2.5.1.1-1 Sample Design-Build Process

#### 2.5.1.2. Construction Manager General Contractor (CMGC)

This method of project delivery is similar to DB in that the designer and contractor work together to complete a design; however there are some significant differences. The fundamental difference is in the contracts with the owner. In CMGC, both the designer and the contractor have contracts with the owner, and the owner is part of the design team. In CMGC the owner does not relinquish control or risk as in DB. Other attributes of CMGC include:

- A preliminary design does not need to be completed prior to selection of the designer or the contractor.
- The design engineer is selected by the agency using a standard qualifications based approach. The design engineer works under the direction of the agency, not the contractor.
- The contractor is selected by the agency using a qualifications approach.
- The selected firms (contractor and designer) form a design team along with the agency in a collaborative manner.
- The team (owner, contractor, designer) develops the design.
- Risks are identified and managed. Solutions to potential problems are resolved during the design phase.

Figure 2.5.1.2-1 depicts a flowchart of a sample CMGC project. The major team members are shown in different colored boxes.

Advantages to the CMGC process are as follows:

- Accelerated Project Delivery - most agencies report consistently expedited project schedules
- The design engineer and the contractor do not need to perform significant up-front design work prior to the bid. Stipends are not necessary.
- The design can be tailored to the contractor's expertise and equipment.
- The team can take advantage of innovative construction processes.
- The agency has complete control over the design. The design engineer is working under the direction of the agency.
- Contractor risk is identified during the design process and managed.
- Total construction costs (bid price plus change orders) can be lower than other contracting processes. This is primarily due to reduced construction change orders

and lower risk, as a result of having the contractor involved in the design process.

Disadvantages to the CMGC process are as follows:

- The agency needs to establish ways to select contractors without a design. This can be done with a qualifications based selection process or with a best value selection process, which includes a price component. Some states have required that contractors supply guaranteed unit prices for major items during the selection process. This is done to bring in an element of cost into the selection process.
- There is concern that the agency may not be getting the lowest price, since only one contractor is involved in the bid, therefore the owner should develop a method of verifying bid costs.

CMGC is particularly suited for ABC projects. By having control over the entire design process, the owner can stipulate the construction methods that will best suit the traveling public. Innovative designs can be developed by the team. Risks associated with these designs can be identified and worked out prior to construction. In some cases, the owner may be willing to accept the potential for cost overruns if a design does not work as planned. For instance, if the team identifies a risk that a certain piece of equipment could breakdown during a short duration work period, the team can assess whether or not they should pay extra to have back-up equipment available or to accept the risk that this may happen and lead to a delay in the project. If the latter option is chosen, the cost for the work will be decreased. Risk management is a process of identifying the risk, planning for it, and establishing a course of action to mitigate it.

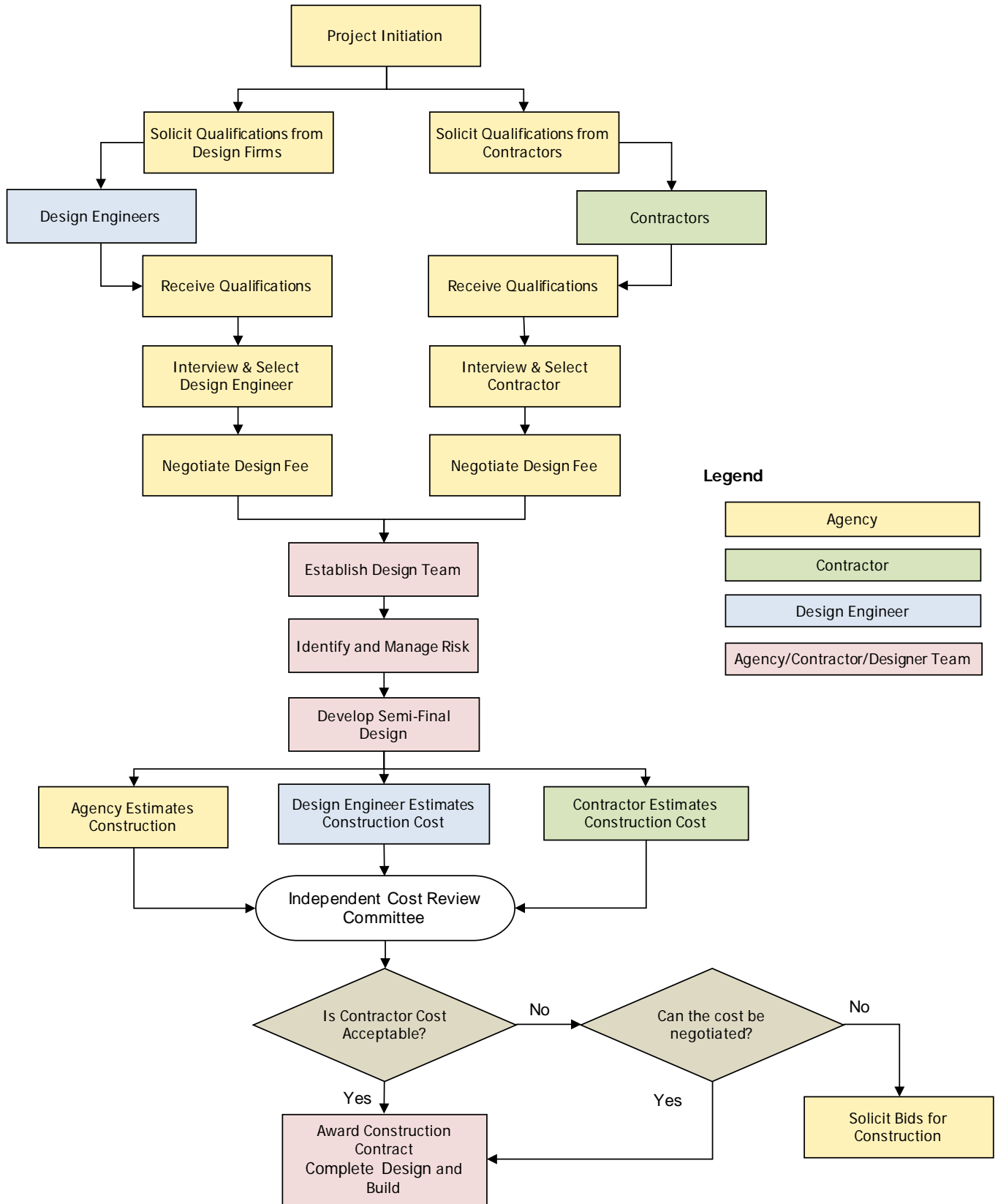

Figure 2.5.1.2-1 Sample CMGC Process

The Utah DOT has used the CMGC process for many of their ABC projects with excellent results. Many feel that the advantages of CMGC far outweigh the disadvantages. The agency can exercise total control over the design process and has the ability to select the best designer and contractor. In UDOT's experiences, the cost of projects was lower than DBB and DB. One of the reasons for this is that there are very few construction change orders. There is little or no possibility for misunderstandings with regard to details and specifications because all parties are involved in the development.

More information on the Construction Manager General Contractor process can be found at the FHWA website [www.fhwa.dot.gov/construction/cgit/cm.cfm](http://www.fhwa.dot.gov/construction/cgit/cm.cfm). Other DOTs also have information on the CMGC process on their websites including Oregon, Arizona Utah, and Nevada.

#### 2.5.2. Contracting Provisions

Regardless of the contracting process chosen, there are several contracting provisions that are commonly used on ABC projects. The application of these provisions varies greatly from agency to agency. The following sections describe the basic premise of each provision.

##### 2.5.2.1. Best Value Selection

The interstate highway system was built using the low-bid selection system for contractors. This system served the nation well; however, ABC projects often require contractors with special expertise. In these cases, low-bid contracting may lead to problems during construction if an inexperienced contractor is involved. Perhaps in the future, when ABC is more commonplace, agencies can return to a low-bid format. In the meantime, agencies are moving toward a new selection process called "Best Value" selection.

Best Value selection is the process where owners select the Design-Build team, or in CMGC where they select the designer and contractor. The process uses a technical evaluation of the contractor submitted proposal, and a bid or quote which are then combined to determine "best value". One definition of value is "to rate something according to its perceived worth, quality, or usefulness". Best value by definition includes a determination by the owner of quality of proposal at some cost.

Part of the reason for this approach is the new contracting methods described in the previous sections. In the

Design-Build contracting method, the selection process involves both the contractor and design engineer. Traditionally, in Design-Bid-Build, the selection of the design engineer is qualifications based followed by a negotiated fee process. The intent is to select a high quality designer for the project, when public monies are used. In some states, there are statutory requirements for this approach. In most states by contrast, construction projects are awarded based on low bid. By including the design team in the selection process, a different approach is warranted because the agency is looking for a quality design combined with a fair price.

The goal of best value selection is to meld the qualifications based approach to the low-bid approach. Typically, agencies will require that Design-Build teams submit both a proposal package and a separate bid package. Other agencies use a two tiered selection process. First they short-list teams based on qualifications, and then they ask those teams to submit detailed bids. The final selection can then be made by combining the qualifications of each team with the cost proposal.

The simplest way to combine technical score with price is to assign points to technical score and points to price (price points are assigned inversely proportional to bid amount). This method is sometimes called the weighted criteria method. The owner can then weight the technical score and the price score according to the importance that the owner places on the criteria. In this system the high point total wins. Owners should carefully evaluate the relative weighting of the technical score and the price score in order to ensure that the goals of the selection are met.

The range of the technical score assigned to the various teams should also be evaluated. If the spread between the high and low technical score is small, the bid will go to the low bidder in most cases. This will encourage teams to place less emphasis on quality of design and innovation. If the technical score spread is greater, then more emphasis will be placed on delivering a high quality and innovative design. The key to this evaluation is to strike a balance between innovation and cost.

According to Design-Build institute of America (DBIA), there are many methods for evaluation, but the primary ones used are the previously mentioned Weighted Criteria, a method called Fixed Price Competitive Design, and a

method called Integrated Assessment and Trade-off (federal model).

Each of these methods is characterized by a process by which the proposals are evaluated. DBIA suggests that a best practice is to have that process be known to proposers. To quote from DBIA “ Disclosure (of the process) encourages participation in the owners competition, imparts a sense of high integrity and clarity in the process, and results in proposals which respond more closely to the owners requirements and expectations.

If an agency is interested in a best value selection process, they should investigate various processes in other states to find one that fits the goals of the agency.

#### 2.5.2.2. A+B and A+B+C Bidding

The nature of Accelerated Bridge Construction projects is that a reduction in project time is desirable. The selection of the low bid can take into account the time component of the project. There are two common methods of addressing this in the bidding phase of the project.

A+B bidding is a method that assigns a value to the base bid price (the “A” component) and a value to a time component (The “B” component). The low bid is determined the sum of these two components.

- The "A" component is the dollar bid for the contract work items.
- The "B" component is the time to complete the project or a portion of the project converted to dollars, usually by using road user cost models that compute the “cost” of road user delays.

A+B+C bidding is similar to A+B bidding except a third component is added to the equation. The “C” component is normally used for specific milestone timeframes. For example, a contract may have a “B” component that is tied to final project completion, and a “C” component that is tied to the completion of a phase of construction.

The “B” and “C” components are multiplied by a dollar value that is normally tied to road user costs. The contract is awarded based on the total of the "A", "B", and “C” (if applicable) components. The contract amount after award is limited to the "A" portion of the bid. The summation of the “A”, “B”, and “C” components is used to identify the best value.

The dollar values assigned to the “B” and “C” components are open to interpretation and variation. Road user costs are somewhat subjective, difficult to calculate, and sometimes hard to justify. Agencies need to identify these costs and make rational decisions based on the needs of the project and the impacts to the traveling public.

More information on A+B+C Bidding can be found at various agency websites. A simple web search on “A+B Bidding” will uncover numerous state agency practices for this subject. Some states will refer to this type of bidding as “price plus time”.

#### 2.5.2.3. Continuity of the Construction Process

One of the most frustrating issues for the traveling public is to have a construction process start and then stop for an extended period of time. On some occasions, this is inevitable such as the need to fulfill the requirements of an environmental permit. An example might be a limitation on in-river work during spawning season.

In many cases, contractors choose to make the most efficient use of their staff and equipment. Shifting work crews from one project to another is common. It is not always possible to have the work flow match the available manpower and equipment.

Contracts can have provisions that limit the amount of down time in a construction process. It is difficult to define what an inactive worksite is; however some provisions can be incorporated into the contract. An example may be that the girders be placed within a certain number of days after final acceptance of the substructures.

This approach can reduce the overall project time by eliminating the down time periods. It is important to note that this approach may increase the overall cost of the project. Contractors may need to hire temporary workers or rent additional equipment to achieve these requirements.

#### 2.5.2.4. Incentive/Disincentive (I/D) Clauses

I/D clauses are contract provisions that are used to financially compensate or penalize the contractor for time spent on the construction of a project (or a portion of the project). Normally I/D clauses are linked to calendar days; however they can be linked to weekdays only. On ABC projects, I/D clauses have even been linked to minutes. For example, I/D payments may be applied to the time that a roadway is re-opened after weekend construction.

Disincentives are typically assessed when a work process exceeds a contract stipulated timeframe. Incentives are typically awarded when work is completed ahead of schedule. The intent of I/D clauses is not to just punish poor performance. The goal is also to reward accelerated work and minimize the loss of value of the facility through impacts to the traveling public. If the goal is to accelerate the work to something less than conventional construction, then the contract should include an incentive. Generally, the incentive rate and the disincentive rates are equal. If different two rates are used, the incentive rate should be the smaller value.

Another option is to bid a project with a very short construction timeframe, and not include an incentive clause. This is due to fact that there may be no room for significant time savings. A disincentive clause would be justified in order to reduce the risk of a loss of service on the facility. The bids for the work will generally be higher in this scenario as contractors include the costs of extra workers and extra work shifts into the contract. This avoids the need for the agency to carry incentive funds in the contract for the duration of the project. The contractor also does not need to wait until the end of the contract to capture the extra costs for the increased effort.

I/D should not be confused with Liquidated Damages. Liquidated Damages are normally linked to the agency costs associated with the delay of a project.

The dollar amounts of I/D clauses are normally based upon road user costs and inconvenience to the traveling public. Impacts to traffic safety, and traffic maintenance can also be weighed in this process. In many cases, this approach will generate excessive incentive values, which may not be justified on a cost/benefit basis. Another approach that can be used is to calculate the contractor's premium on labor due to increased work hours. A cap of 5% of the total contract amount is recommended as a maximum incentive value.

The use I/D clauses will inevitably bring about a need for careful time tracking. All parties need to be cognizant of the time spent on a project. Delays in agency approval of submittals may be grounds for time extensions, which will greatly affect the I/D values.

More information on I/D clauses can be found at various agency websites. A simple web search on "incentive disincentive clauses" will uncover numerous state agency practices for this subject. The FHWA also has technical

advisory on this subject entitled “Incentive/Disincentive (I/D) for Early Completion” (T5080.10). It can be found at: [www.fhwa.dot.gov/construction/contracts/t508010.cfm](http://www.fhwa.dot.gov/construction/contracts/t508010.cfm).

#### 2.5.2.5. Warranties

Warranties are common in the retail marketplace. Virtually every major purchase in the United States comes with some sort of warranty. The purpose of a warranty on a purchased item is to provide a level of comfort to the purchaser with regard to the quality of the product and to provide recourse if the product fails.

The construction of bridges is a different matter. The quality of bridges has always been dictated by the quality control procedures that are undertaken during design and construction. Designers follow typical procedures such as checking of calculations and independent checking of entire designs. Construction inspectors in the field and in fabrication shops ensure that the plans and specifications are followed precisely.

Until 1995 the use of warranties was not permitted on Federal-aid projects. This was based on the concern that participation in a warranty payment would constitute an indirect Federal-aid participation in maintenance costs.

The advent of innovative contracts such as Design-Build brought about new interest in warranties. In DB contracts, the agency has less control over the design and potentially the construction. The Design-Build team has much more control over the quality control procedures. For this reason, new interest in warranties arose. In 1995, FHWA began allowing the use of warranties (Title 23 C.F.R. 635.413 – Guaranty and Warranty Clauses).

Warranties are typically used for specific project items and not the entire project. Routine maintenance items such as replacement of damaged beam rail do not qualify for warranties. Some common warranty items include asphalt concrete pavements, bridge painting, traffic striping, bridge bearings, and bridge expansion joints. These items heavily depend on material performance, which justifies the use of the warranty.

The length of time for typical warranties is between 1 and 5 years. Some agencies use warranty bonds in contracts to assure that a warranted item survives the warranty period in the prescribed condition. The warranty bond can be repaid at the end of the warranty or incrementally over the life of the bond.

ABC will inevitably lead to use of more innovative products and materials. Performance warranties can be used to alleviate the agency concerns over the use of new techniques and products.

FHWA has specific rules governing the use of warranties. Agencies should coordinate with FHWA on the use of warranties on specific projects.

#### 2.5.2.6. Lane Rental

One of the goals of ABC is to minimize impacts to the traveling public. Lane closures can cause major disruption to the transportation network; however they are inevitable on many projects. Closure of lanes also has a negative impact on the public perception of construction projects. Lane closures with seemingly idle construction work can infuriate passing vehicles, especially if the closure has resulted in a travel delay.

Lane Rental is a means of reducing the impacts to road users by minimizing the amount of delays caused by construction. The contractor is charged for the amount of time that a lane is out of service. The amount of the charge may vary by time and day of the week. In previous sections of this manual, the concepts of roadway user costs were discussed. On most projects, roadway user costs are nebulous costs that are borne by society; however they cannot be applied to the actual construction of the project. The Lane Rental concept is a way of applying roadway user costs to the value of the project, since the monetary value of the lane closure is based in part on the roadway user cost impacts.

Lane Rental requires that contractors account for roadway user impacts during construction and in the bid process. The bid typically consist of a base bid for the actual construction and a secondary bid for the lane rentals, The two values are combined in the bid analysis resulting in a best value selection process.

More information on Lane Rentals can be obtained from several state departments of transportation (such as Minnesota and Washington) that have lane rental policies and specifications in place.

#### 2.6. Applicability of ABC Technologies to Different Bridge Projects

ABC is most effective for projects that require the management of traffic during construction. This section will cover how ABC can be applied to the various types of bridge projects that typical transportation agencies manage. Chapter 3 will explore how to incorporate ABC into the planning of these various bridge projects.

### 2.6.1. Rehabilitation of Existing Bridges

The national bridge inventory is aging; therefore, many of the bridges in the United States have significant deterioration. Most of this deterioration is centered on the bridge superstructure. Concrete deck replacement projects are becoming more common. Deterioration is not limited to the decks. The supporting girders also experience deterioration due to leaking bridge joints and lack of maintenance.

On many of these bridges, the substructure is in better condition when compared to the superstructure. This is especially true for single span bridges and continuous span bridge without deck joints. On many projects, rehabilitation of the substructure combined with replacement of superstructure elements is feasible. The following sections discuss how ABC can be used for the execution of bridge rehabilitation projects.

#### 2.6.1.1. Deck Replacement

Replacement of bridge decks is one of the most common uses of ABC. The installation of a bridge deck is time consuming, requiring significant manpower to form the deck, place reinforcing, cast concrete, cure the concrete, and strip the forms. This labor intensive work is difficult under the best circumstances, but in a situation where traffic management is required, it becomes even more complicated.

Three basic forms of ABC deck replacement strategies have been used in the United States. The first is stay-in-place deck forms. These forms consist of corrugated metal panels that are designed to support the reinforcing steel and the wet concrete of the deck. The benefit to this method of deck construction is that it eliminates the need to strip the forms after the concrete is cured. The disadvantage to this system is that it still requires the placement of reinforcing steel, casting of concrete and curing of concrete, which does not result in a significant time savings during construction. Also, future visual inspection of the underside of the deck is not possible.

The second ABC deck replacement strategy is the use of precast and prestressed concrete partial depth deck panels. These panels are typically cast to half the thickness of the finished deck. The remainder of the deck is made up of one layer of steel reinforcement and site cast concrete. The panels are designed to span from girder to girder with reinforcement designed to accommodate the positive deck bending moments. Negative deck bending moments are accommodated by the top layer of field placed reinforcement. The benefits and disadvantages of

this system are similar to stay-in-place deck forms except that the panel is a structural part of the deck , and is exposed for future visual inspections.

The fastest form of deck placement is through the use of full depth prefabricated deck panels. Different systems have been used in the United States including open grid steel (often partially filled with concrete), exodermic deck panels (grid panels with a composite concrete topping), fiber reinforced polymer panels, aluminum extrusion panels, and precast concrete panels.

The precast panels make up the majority of the ABC projects. There is been significant research into the use of precast concrete deck panels. The research includes the composite connections between the panel and the girders and the connections between the panels. In fact, it is reasonable to state that precast concrete deck panels are one of the most thoroughly researched ABC bridge technologies.

The AASHTO LRFD Bridge Specifications [8] includes provisions for precast concrete deck panels. The basic provisions include:

- Transverse connections using a grouted shear key
- The use of post-tensioning to join panels in areas where the deck is exposed to road salts. The level of effective post-tensioning is specified at 0.25 ksi minimum.
- The composite connection between the panel and the girder can be made via shear connectors placed in block outs that are filled with grout.

Figure 2.6.1.1-1 shows a deck replacement project involving the use of full depth precast deck panel project during construction. The longitudinal post-tensioning ducts can be seen at the edge of the panel.



*Figure 2.6.1.1-1 Full Depth Precast Concrete Deck Panels  
(source: New Hampshire DOT)*

The performance of these provisions has been verified by a number of state agencies. The Connecticut DOT has had several decks in service for almost twenty years with no leakage of the deck joints and excellent performance. Figure 2.6.1.1-2 shows the underside of one of the Connecticut Bridges after 20 years in service.



*Figure 2.6.1.1-2 Underside of Full Depth Precast Deck Panels  
(after 20 years in service)*

Research has been completed on deck panels that are connected without post-tensioning. This work was completed under NCHRP Project 12-65 (Report 584) [9]. The research focused on the following concepts:

- Develop a girder connection with a blind pocket (not protruding through the top of the deck). The idea was to minimize the amount of filled deck voids to promote the use of precast decks without overlays.
- Develop a panel to panel connection that did not require post-tensioning.
- Investigate the use of larger maximum shear connector spacing (up to 4 feet on center).

These concepts were developed and successfully tested. Both the blind pockets and the panel connections use standard structural steel tubing to produce confined spaces to develop the forces required to make the connections. The shear connector pockets are filled with non-shrink grout through small ports and the panel to panel connection is made with a grouted slot cast into the edges of the panels. Figure 2.6.1.1-3 shows the details of this system, and Figure 2.6.1.1-4 shows the construction of one of the first bridge decks using this system. The project was built by the Texas DOT.

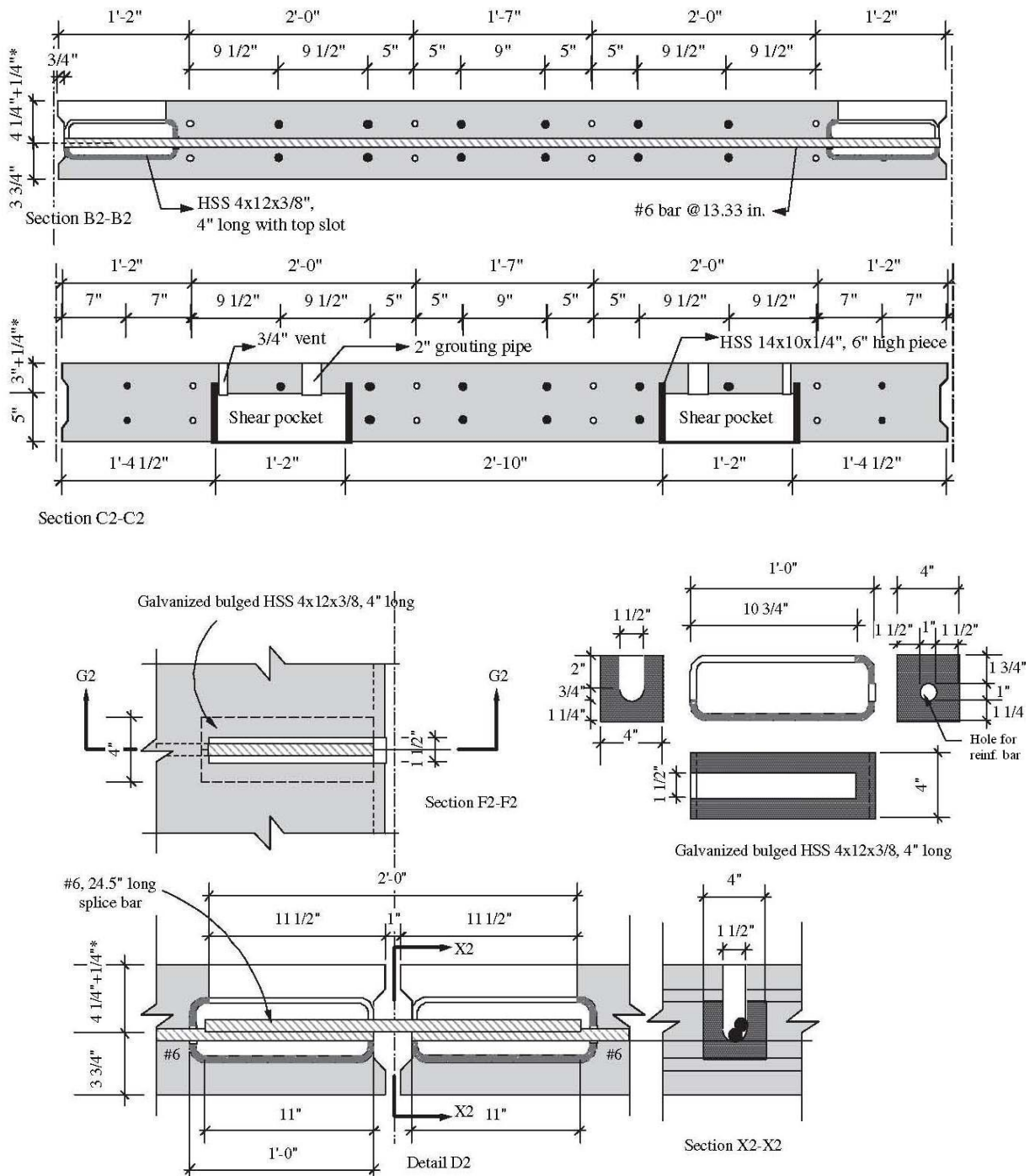

Figure 2.6.1.1-3 Blind Pocket and Bar Slot Connection Details  
(source: NCHRP Report 584 [9])



*Figure 2.6.1.1-4 Precast Deck Panel Project in Texas  
Based on NCHRP Report 584 Details  
(source: Texas DOT)*

Several agencies have developed standard details for precast full depth concrete deck panels. There are several sources of details, manuals and specifications. The Utah DOT has developed standard details that include blind pockets and longitudinal post-tensioning. They have also developed manuals and specifications for full depth deck panels. They can be found at [www.udot.utah.gov](http://www.udot.utah.gov) (search "ABC").

The Precast/Prestressed Concrete Institute has a Northeast Bridge Technical Committee that has developed typical details and a manual for full depth precast concrete deck panels. This information can be found at [www.pcine.org](http://www.pcine.org).

#### 2.6.1.2. Superstructure Replacement

The use of ABC for superstructure replacement projects is common. ABC techniques are particularly well suited for superstructure replacement projects, since the time consuming process of building foundations and substructures is not required. Several states have used several different ABC techniques to accomplish this type of work in very short order.

Several states have used SPMT technology or lateral skidding/sliding technology to remove and install entire bridge superstructure systems. The new superstructures can be built off site and moved into position in as little as a few hours. Figure 2.6.1.2-1 shows an SPMT superstructure replacement project on Interstate 80 near Salt Lake City. This project involved the replacement of four superstructure spans. The spans were replaced in 24 hour time periods on two separate weekends (2 spans per weekend). The installation was complete in a matter of hours. The remainder of time was spent completing the approach slab and barrier installation.



*Figure 2.6.1.2-1 Superstructure Installation Using SPMTs*

Another ABC method that is well suited for superstructure replacement projects is the use of modular bridge elements. Several states have constructed new superstructures using prefabricated beam/deck modules.

Sections 2.4.3, 2.4.4, and 2.4.5 discuss the methods for this type of installation.

The third method of ABC that is available is the use of prefabricated bridge elements. The construction can include new beams, combined with a prefabricated deck system. The New Hampshire DOT completed a single span superstructure replacement in 2010 using steel beams and precast concrete full depth deck panels. The bridge carries Interstate 93 over a local road in Concord, New Hampshire. The superstructure was replaced in one weekend using this method. Figure 2.6.1.2-2 shows the completed bridge.



*Figure 2.6.1.2-2 Completed Superstructure Replacement Constructed with Prefabricated Elements*

### 2.6.1.3. Substructure Replacement

On some bridges, the substructure may also be in disrepair. This can be caused by leaking deck joints and spray from vehicles passing underneath. If abutments are deteriorated, full bridge replacement or patching of the abutment may be in order. This is due to the difficulty of replacing an abutment without significant disruption to adjacent areas.

Accelerated replacement of pier columns and caps has more potential. It is possible to remove old pier columns and caps and replace them with prefabricated pier elements if the footings and foundations are in sound condition and structurally adequate. Closure pours at the base of the columns can be used to connect the old footings to the new pier elements. If an existing pier is supported on a spread footing, it is possible to build the new pier alongside the existing bridge on rails and jack it into place in a similar fashion to lateral superstructure

skidding/sliding. Once in place, the footing can be underpinned with grout to seat it on the subgrade.

#### 2.6.2. Replacement of Existing Bridges and New Bridges

Replacements of entire bridges and the construction of new bridges differs from deck replacement and superstructure replacement projects in that there is also a need to replace the substructures and foundations. This adds a level of complexity to the project; however, ABC methods are still appropriate in many cases.

Replacement of an existing bridge is different than construction of a new bridge on a new alignment. Often, traffic needs to be accommodated during construction. This either requires building the bridge in and around the traffic, or building the bridge with a traffic detour. ABC can be used to minimize impacts to traffic in both of these scenarios. The following sections describe the role that ABC can play in several different replacement strategies.

##### 2.6.2.1. Staging

On many projects, traffic needs to be maintained through the construction site if a suitable traffic detour is not available. This often involves multiple stages of construction. ABC can be used to minimize the duration of each construction stage. All forms of ABC described in Section 2.3 and 2.4 can be used for stage construction projects. In some cases, complete superstructure prefabrication may not be possible due to conflicts with the adjacent roadways; however the use of prefabricated elements is always possible in stage construction projects. Individual prefabricated elements can be used for all portions of the substructures and superstructures.

On any project where staging is being considered, the project team should investigate the potential for changing from staged construction to ABC with full closure with a detour. This approach will offer the greatest opportunity for accelerating the construction since the contractor will have full access to the site for manpower and equipment. It also offers the safest work zone for workers and inspectors.

Businesses have also expressed approval of a short duration mobility impact versus a long duration stage construction project with the coinciding mobility impacts. During one of the FHWA Accelerated Construction Technology Workshops, the technology team determined that the construction time for a staged replacement project could be reduced from two years to three months by using a full closure with a minor detour. This approach should be investigated for all projects that are scheduled for multi-stage construction.

#### 2.6.2.2. Full Closure and New Construction

On many projects, the entire construction site can be made available to a contractor for the construction of an entire bridge. This occurs on new bridges being built on new roadway alignments (sometimes referred to as “greenfields”), and on bridges that are built with traffic detours.

The previous section outlined the benefits of ABC on projects with detours. Full closure of the bridge offers significant benefits to the ABC process. The use of ABC on projects that involve detours is appropriate if the detour is long or has undesirable geometrics. ABC can be used to minimize the length of time that the detour is in place.

One might think that ABC is not appropriate for greenfield construction. In many situations, this may be the case. Often, greenfield construction involves the construction of significant portions of roadway along with the bridges. Sometimes, the construction of the bridge is not on the critical path for the overall construction of the projects; therefore, ABC may not be necessary.

There may be certain situations where ABC may still be applicable in a greenfield construction site. Significant construction limitations may be imposed by regulatory agencies for bridges that are spanning over environmentally sensitive habitats. ABC can be used to minimize the amount of time that the construction impacts the habitat. If the bridge is a new structure over an existing roadway, the impacts to the lower roadway may still warrant an ABC approach in order to minimize the impacts to the vehicles below.

All forms of ABC strategies are applicable to complete bridge construction either under a roadway closure scenario or for new greenfield construction.

#### 2.6.3. Effect of Structure Type on ABC Methods

Virtually any bridge can be built using ABC methods; however certain bridge features can have an effect on the ABC process. This section covers some of the most common features of bridges that affect the ABC process.

##### 2.6.3.1. Curved, Skewed and Flared Bridges

Most bridges built in the early 20<sup>th</sup> century were constructed without horizontal curvature or skew. Often, engineers sacrificed roadway geometry for the simplicity of design and construction of square and straight bridges.

During the development of the interstate highway system in the latter half of the 20<sup>th</sup> century, a need arose for more complex bridge geometries that could match the complexities of the high speed roadway designs, and reduce impacts to right-of-way, utilities and environmentally sensitive areas. In addition, problems with river scour led to substructure elements that were designed to minimize turbulence in flowing waters. Today, curved and skewed bridge alignments are commonplace.

The definition of skew varies in different states. The terminology used in this manual is based on the definition that most states use, which is defined as the angle measured between the centerline of the bridge elements (abutments, piers, joints, etc.) and a line perpendicular to the roadway alignment. (i.e. a bridge with zero skew is square bridge).

The curve and skew of a bridge does have an impact on the use of ABC; however it does not preclude the use of the methods described in this manual. Often, these factors simply affect the detailing and complexity of the processes.

The following are some of the issues for various ABC methods with regard to bridge skew:

- Skews greater than 25 degrees are required to have the main transverse reinforcement in the deck placed perpendicular to the girders (AASHTO LRFD Bridge Specifications [8]). This results in deck panels that are also square to the bridge girders. This will require the use of non-rectangular panels at the ends of the bridge, or large closure pours.
- Large skews can have an impact on the complexity of the lifting and moving of a bridge superstructure using SPMTs. or lateral slide-in technologies.
- The complexity of prefabricated substructure elements and connections increases with skewed designs.

The following are some of the issues for various ABC methods with regard to bridge curvature:

- Curvature requires that precast full depth deck panels be made trapezoidal to accommodate deck curvature.
- Longitudinal post-tensioning in precast full depth deck panels needs to be designed to account for the loss in post-tensioning force due to friction in the ducts if the ducts are run along the curvature of the roadway.

- Curvature can have an impact on the complexity of the lifting and moving of a bridge superstructure using SPMTs. or lateral slide-in technologies. For difficult geometries, the superstructure may need to be moved into place above the adjacent roadway and jacked vertically down to the bridge seats after they are positioned in the horizontal position. This is especially true for curved bridges with non-parallel substructures.

All of these issues can be overcome with sound engineering judgment and careful planning. Attention to detailing and geometry are critical to the success of any curved or skewed bridge design regardless of whether or not ABC methods are employed.

#### 2.6.3.2. Bridges with Transverse Floor Beams (trusses and widely spaced girder bridges)

Most bridges built in the United States are designed and constructed with multiple beams and girders that are run parallel to the roadway alignment. This method of construction, sometimes referred to as multiple stringer bridges, offers several advantages to other bridge types. Stringer bridges are often very redundant and have the ability to sustain significant damage without collapse. There have been many documented cases where girders have fractured due to fatigue, truck impacts, and ship impacts, without collapse of the bridge superstructure. Stringer bridges are also ideal for situation where future widening of the roadway is anticipated. The popularity of this bridge type is the reason why the majority of the discussion and details in this manual are based on parallel stringer bridges.

There are other instances where other framing techniques are appropriate. These primarily occur in long span bridges and older bridges that were constructed with widely spaced longitudinal main members (trusses, large girders, suspension bridges). These bridges typically have transverse floorbeams spaced at regular intervals that span from the main load carrying members.

Many of the ABC techniques described in this manual are also applicable to these bridge framing systems. In fact, some of the techniques are particularly well suited for these bridges. The repetitive nature of floorbeam system structures leads to economies of scale. It is not unusual for a bridge to have several hundred floorbeam bays with intermediate framing that is essentially the same in every bay.

The gantry crane systems described in Section 2.4.4 have been used to replace portions of bridge deck/stringer modules using overnight construction closures. The spacing between floorbeams is normally small enough to make the handling of the modular elements reasonable.

#### 2.6.3.3. Box Culverts

Some states construct culverts using CIP reinforced concrete construction. This type of construction is very slow due to water handling needs and the difficulties of forming the roofs of the culverts.

Construction of culverts is sometimes seen as ancillary part of roadway construction. This is normally true for new construction; however if there is a need to replace a culvert on an existing highway facility, the construction can be critical to the function of the highway. Deterioration of culverts has become a problem in the last 20 years. Deterioration of culvert inverts due to corrosion and stream bed abrasion has brought about a need for more replacements.

Precast four sided and three sided culverts are becoming more popular. They offer the potential to construct a culvert quickly during periods of low flow. The bottomless three sided culverts are seeing more widespread use. These structures allow for construction of the abutment footings without a temporary relocation of the channel with greatly reduced impact on the environment.

## Chapter 3 PBES for ABC – Planning and Scoping Projects

In the last decade, there have been many ABC projects in the United States using the various techniques described in Chapter 2. These techniques and projects are helpful for generating ideas; however, it can be difficult for project planners to decide how to make a certain technique fit into particular projects.

There are two major steps in the project planning and scoping process that apply to ABC. First, the agency needs to determine if ABC is appropriate at a site. This decision making process needs to include a study of several factors including but not limited to ADT, potential detours, emergency routes, road user costs (Section 3.1 will describe ways to use these factors in a decision making process). The second step involves a decision as to what ABC technology is appropriate for a site once a decision has been made to use an ABC technology. This step can be challenging since multiple ABC technologies may be appropriate at a site. This chapter will explore ways to evaluate sites and make sound decisions as to the ABC technology that is appropriate for each site.

The FHWA has completed a series of summit meetings for the “Every Day Counts” (EDC) initiative. These summits were used to encourage state and county agencies to make use of new technologies including PBES. All 50 states, Puerto Rico, the District of Columbia, and several territories were invited to these summit meetings to learn about EDC, provide comments and input, and start the process of implementing the new technologies. During the summit meetings, the following comments represent typical concerns and issues with regard to the project planning process:

- “I can’t see how ABC would work in my case”.
- “I cannot figure out which type of ABC technology is right for my site”.
- How do I get an ABC project started?

Information about the EDC Summit meetings can be found at the FHWA EDC website at [www.fhwa.dot.gov/everydaycounts/index.cfm](http://www.fhwa.dot.gov/everydaycounts/index.cfm).

The AASHTO TIG and FHWA had developed a process called Accelerated Construction Technology Transfer (ACTT). The purpose of this process was to assist agencies with the implementation of ABC on specific projects. On a typical project, a workshop is held where a group of experts brainstorm on how to build a project faster based on the site constraints of the particular project. After three days, a consensus is reached on the most appropriate ABC method for the project. In some cases, multiple methods are identified. Following the workshop, the agency explores the options and developed the final project concept. In several ACTT workshops, it was determined that the projects were too far along in the development process to incorporate a particular ABC technology. The most successful ABC projects are ones where ABC technologies are integral to the project planning and scoping process from the start; therefore it is important to consider ABC at the earliest planning stages, and in the early phases of a programmatic implementation of ABC. The ACTT workshops were a successful program that assisted agencies in the decision making process for ABC projects. The following sections outline a process that is similar to the process used in the ACTT workshops.

### 3.1. ABC Decision Making Process

Chapter 1 of this manual explored the reasons for using ABC and the benefits associated with ABC. One of the most important processes in the project planning is making the decision to use ABC on a particular project. The previously published FHWA Manual entitled Decision-Making Framework for Prefabricated Bridge Elements and Systems (PBES), Publication Number FHWA-HIF-06-030, May 2006 [1] is an excellent source of information on the process of planning a successful ABC project. It is recommended that all projects be evaluated using a decision making framework during the project planning process.

Some agencies have taken the decision making framework document and modified the framework to account their specific practices and needs. They have tailored the process to meet the goals of their specific agencies. Utah DOT has developed a new approach that involves measured responses to multiple decision measures such as ADT, detour time, evacuation route, economy of scale, applicability to standards, worker safety, environmental issues, railroad impacts, and weather limitations. The individual measures are weighted in order to be consistent with the Department policies. The weighted measures are then used to calculate an ABC rating, which is used to provide direction on the use of ABC for the project. If the project scores a high rating, ABC is used. For projects with low ratings, ABC is not used. For projects with marginal ratings, the costs of the various construction options are studied. Any potential increase in cost due to ABC is weighed against road user costs. If the Department policies and direction change in the future, the weighting factors can be adjusted to coincide with the changes. The result of this new approach is that a bridge with one significant control factor may actually rate lower than a bridge with several moderate control factors.

Oregon DOT in collaboration with 7 other states through a pooled fund study has developed another decision making process that will account for the characteristics of the project such as project size, complexity, road user characteristics, environmental requirements and construction site attributes. This tool that can assist agencies with the decision making process to compare conventional construction with ABC. The FHWA will make it available to the FHWA Division offices, State DOTs and local transportation agencies.

### 3.2. Decision Process for Selection of Appropriate ABC Methods

Once a decision is made to explore ABC on a project, the agency needs to determine which types of ABC technologies are appropriate for the project. This determination is not always obvious to the project planner, especially with the various technologies in use today. The following sections outline a basic process that can be used to determine the appropriate types of ABC methods that are feasible for the project. The basic family of ABC component listed in Chapter 2 includes:

- Foundation and Wall Elements
- Rapid Embankment Construction
- Prefabricated Bridge Elements & Systems

- Structural Placement Methods
- Fast Track Contracting

Chapter 2 describes each of these components in more detail. For the context of this section, the decision to use several of these technologies is left out of the decision process for the following reasons:

- Continuous flight auger piles: This is a technology that is linked to a particular bridge type (deep foundation), that is not necessarily tied to the ABC decision process. All bridges that are required to be supported by deep foundations should consider this technology.
- Longitudinal Launching and Pivoting: These technologies are relatively rare and only applicable to certain situations. The majority of ABC projects will not lend themselves to these technologies. Launching and pivoting should be considered for new bridges and on bridges placed on new alignments where the superstructure can be built behind the proposed abutment and moved into place.
- Fast Track Contracting: These technologies are applicable to all ABC projects.

In some cases, only one method of ABC will work for a project site. In many cases, multiple options will be feasible. In these cases, the owner will need to further investigate each option and weigh the major contributing factors in the final decision making process.

### 3.2.1. Defining the Problem

Before a decision can be made on the appropriate methods of ABC for a given project, the constraints of the project must be identified and studied. This can be used as a starting point for the ABC method selection process.

The following sections contain common controls that define the project site characteristics. These characteristics will have an impact on the planning process and the ABC technologies that are appropriate for the site.

#### 3.2.1.1. Site Constraints

In order to determine the appropriate methods for ABC, the design team needs to evaluate the project site and surrounding area. Site constraints can have a significant impact on the practicality of the various ABC techniques. These constraints also can have a significant impact on the construction time and cost.

The following sections describe the typical site constraints encountered on typical bridge projects. This list is not intended to be all-inclusive. Each site, especially sites in urban environments can contain unique challenges and must be accounted for.

### Water Crossings

Bodies of water can be a significant obstacle to ABC; however in some cases they can be a significant opportunity. One method of large scale prefabrication is delivery of the prefabricated bridge system via barges. The following constraints should be identified by the design team as a minimum:

- Is the body of water is navigable and accessible by barge?
- Is the water tidal or subject to significant elevation fluctuations?
- Is the depth of water adequate to accommodate barges?
- Are there environmental constraints for in-water construction?

Some bodies of water are not accessible by conventional barges; however it may be possible to launch a segmental barge near the bridge site. These barges are modular and can be transported to a site in pieces on trailers. Once in the water, the modules can be joined to form a larger barge. A number of configurations can be used to support large loads. Designers should investigate the depth of water in any potential travel path for a barge. The depth of the barge should be determined after completing bathymetric surveys and investigating draft depths of typical barges.

### Highway Grade Separations

Bridges that span over roadways make up a large portion of the population of bridge structures. Roadways under bridges often offer more flexibility in construction methods when compared to railroad crossings. It has been demonstrated on many occasions that entire bridge structures can be transported on normal roads using SPMT's. The wheel loads of SPMT's can be adjusted by adding axles to reduce the individual axle loads and the local effects of the tires by spreading the load out. Steel plating can also be used to spread wheel loads over shallow buried utilities. By keeping the wheel loads within acceptable parameters, it is possible to move a bridge over existing utilities, pipes and small culverts. Small bridges can also be crossed using temporary bridging plates and beam that can be installed over the roadway very quickly.

The design team needs to identify the following roadway parameters as a minimum:

- What are the required clearances for all phases of construction?
- What are available lane closures above or below the bridge?
- Are there reasonable detours available?
- Are there available work zones at the ends of the bridge?
- What is the available room adjacent to the bridge?

As with railroad crossings, it may be possible to move large-scale elements using SPMT's. Cranes located on the lower roadway may also facilitate the installation of prefabricated components. Figure 3.2.1.2-2 depicts a potential installation of modular superstructure elements using cranes located on a local road under a limited access highway.

### Railroad Crossings

Railroads also present challenges for ABC projects. As with water crossings, rail crossing can also provide opportunities. Rail transport can accommodate larger and heavier elements when compared to roadway delivery methods.

Railroad access is often limited and sometimes subject to rigid time schedules. Closure of roadway lanes can be accommodated with detours; however railroad closures often result in the shut-down of larger rail systems.

The design team needs to identify the following railroad parameters as a minimum:

- What are the required clearances for all phases of construction?
- What are the weight restrictions and clearance limitations of the rail line approaches leading to the site?
- Is there a nearby siding that can be used for storage and offloading of elements?
- What are the available track closure periods?
- Is the line electrified (catenary above the rails or a third rail on the ground)?
- Is there signal equipment and/or signal lines in the area?
- Can temporary fill be placed between and around the rails for temporary equipment placement?

With adequate track closures and temporary fills, it may be possible to move large-scale elements over tracks using SPMT's. Cranes located on the tracks during track outages may also facilitate the installation of larger modular elements, since the reach of the cranes can be reduced. The tracks can also facilitate the delivery of heavy prefabricated elements to the site. The weight and clearance limitations on element delivery will control the size of the elements that can be shipped.

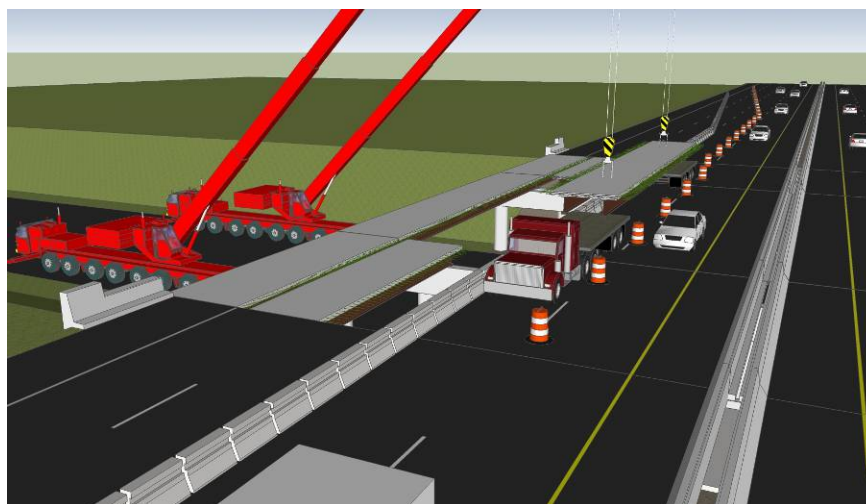

*Figure 3.2.1.2-2 Crane Access from Local Street*

### Geotechnical Constraints

Many of the ABC methods described in this manual involve the use of specialized equipment. SPMTs can effectively distribute large loads over large areas, thereby reducing the unit pressure on the supporting soils. Cranes can produce large concentrated loads in small areas. A thorough review of the existing soils below any potential work areas needs to be undertaken. This can include subsurface explorations and laboratory testing.

The duration of loading can have an impact on the capacity of the soils to resist construction loads. Long term settlement is not normally a significant concern on ABC projects due to the short duration of the applied load. If a crane is to be placed in one position for some time, the effects of settlement may need to be investigated, especially if there are subsurface utilities in the area under the crane.

Stability of the supporting soils under equipment can lead to disastrous outcomes. Often equipment is placed near the edges of the embankments near the bridge. The stability of the embankment (both local and global) should be checked to ensure that the soil will be stable during the use of the equipment.

If staging areas are proposed combined with an SPMT installation, the travel path for the SPMT should also be studied. In many cases, steel plating can be used to

better distribute the individual wheel loads on questionable soils.

#### 3.2.1.2. Staging Areas

Many methods of prefabrication can make use of staging areas. Most roadways will have shipping limitations on the size and weight of the prefabricated elements. It may be desirable to allow a contractor to prefabricate elements in a near-site staging/fabrication yard. This will greatly reduce the complexity of installing the elements and allow for larger and heavier lifts. Staging areas can also open up the potential for large-scale prefabrication and installation with SPMT's. The design team needs to investigate the following opportunities and parameters as a minimum:

- Is there room within the highway right of way to establish a staging yard?
- Is the area large enough for fabrication of the entire superstructure including room for cranes?
- Are there overhead wires near the staging area and along the travel path from the area to the bridge? If so, can they be easily relocated or removed?
- Are there any sensitive underground utilities or structures along the travel path from the area to the bridge? If so, can they be bridged?
- Are there available work zones at the ends of the bridge?
- Is there available room adjacent to the bridge?

It is reasonable to assume that large-scale prefabrication combined with an SPMT bridge move is reasonable for most roadways. It is possible to drive SPMT's over underground utility pipes and small culverts. In some cases, bridges can be driven over other bridges. Figure 3.2.1.3-1 shows a bridge being moved over a previously placed bridge in Interstate 80. The lower bridge was strengthened by the addition of intermediate temporary supports.

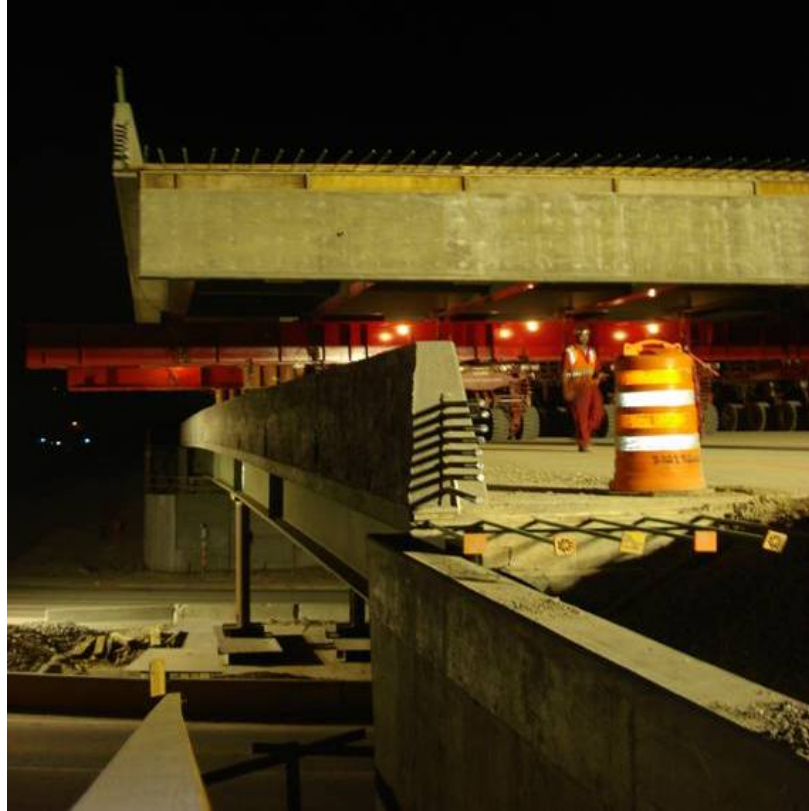

*Figure 3.2.1.3-1 SPMT Bridge Move over another Bridge  
(source: Utah DOT)*

Large-scale prefabrication can be combined with barge installations as well. It is possible to build a bridge superstructure on barges, but the costs of barge rental and the difficulties of placement of erection equipment can reduce the viability of this method.

It is possible to build the superstructure on land and then transfer it onto barges using SPMT's. There needs to be adequate draft near the water's edge to place the barge close to shore. The design team should investigate the access to the water's edge and the depth of water at the access point.

#### 3.2.1.3. Traffic Management

Maintenance of traffic can be one of the most complex parts of the replacement project. The need for traffic management often leads to multi-stage construction processes with shifting traffic. In some cases, the new bridge is overbuilt in order to accommodate lanes during one of the construction stages.

The difficulties of traffic management is a common reason for choosing ABC techniques in the first place; however accommodating the traffic can also present one of the most significant challenges. ABC methods can reduce construction time from several years to several months, or even several days. Detours are often not a desirable approach; however if the construction time can be reduced to a reasonable level, the opportunities for short term detours may be more acceptable. For these reasons, planners should consider short duration detours combined with ABC.

The following are examples of typical quantitative and qualitative measures should be identified for any potential detour:

- Length of detour and time to traverse the detour route
- Length of time that the detour will be in place
- Land use along the detour and impacts to adjacent businesses and residences
- Roadway geometry
- Traffic flow and signal timing
- Mass Transit routes
- School bus routes
- Access for emergency vehicles

#### Detours

Detours not only have a cost impact to the project, but they also have an impact on both the travelers and the surrounding communities. Residents along a detour route will not find the addition of significant traffic desirable. Businesses adjacent to the project site will be concerned with loss of revenue due to decreased traffic. This loss of revenue is measurable; however so are the effects of a long-term multi-stage construction project. Maintenance of traffic through a project site is a double edged sword for businesses. They would prefer to have steady traffic access to their establishments instead of a detour of traffic away from their site. The traffic volumes on staged construction projects without detours will typically decrease as travelers choose alternate routes to avoid the construction site. This leads to a long-term decrease in business over the entire construction process. A detour has a more acute impact to the amount of vehicles passing a particular site; however this can be mitigated by substantially reducing the time for the disruption. Many businesses have noted a preference to have a more severe short-term reduction in traffic versus a long-term moderate reduction in business.

All reasonable detours should be identified and studied. The geometry and traffic capacities of the detours needs to be determined to ensure that the peak flows can negotiate the detour without significant delay. The impacts to travelers should be studied including road user costs. The impacts to through traffic as well as local traffic along the route need to be assessed.

On projects in rural locations, there may not be many detour options. The goal should be to determine the detours that can accommodate the anticipated traffic in a safe an efficient manner.

On larger complex projects in urban locations that involve limited access highways, multiple levels of detours may be in order. For instance, one detour can be used for traffic in the immediate vicinity of the project site, and a separate detours used for long distance through travelers on the highway. Variable message signs can be used to alert interstate vehicles and offer recommended interstate detours around the project sites.

The Massachusetts DOT used this approach during the planning for a large ABC project on Interstate 93 in Medford, Massachusetts (also known as the Fast 14). I-93 carries approximately 190,000 vehicles per day on 8 lanes of highway (4 in each direction). The project involved the replacement of 14 bridge superstructures (41 spans). The time required to replace the superstructures using conventional staged construction was determined to be 4 years. The impacts to local businesses and the greater Boston metropolitan area would be significant. The DOT investigated the use of detours and ABC in order to reduce the overall timeframe for the project. Three levels of detours were investigated. The first involved shifting traffic on to the two beltways that surround Boston. Vehicles traveling through the Boston area can be diverted onto these beltways through the use of interstate variable message signs. The second level of detours involves the reduction of two travel lanes on the interstate in each direction on weekends, corresponding to a reduction in capacity of 50 percent. Median crossovers were used to detour bi-directional traffic to one side of the interstate, thereby freeing up an entire 4 lane area for construction. The third level of detours involves the use of local roads around the construction site. These will be used for spill over traffic that cannot be

accommodated on the reduced capacity interstate, and for local residents that sometimes use the interstate for short trips across town.

This approach allowed for the complete closure of one direction of I-93 for a 55 hour weekend period. Using this approach, the DOT developed an ABC approach that was able to replace up to 6 spans per weekend. This was done using prefabricated modular superstructure elements. On Monday morning, the entire interstate was re-opened to 8 lanes of traffic. The resulting construction impacts to I-93 were reduced from 4 years to 10 weekends. Construction for this project was completed during the summer of 2011.

The DOT instituted a significant public outreach effort as part of this project. Local businesses as well as the central Boston businesses agreed that the short duration severe impact would be preferable to the long-term construction option. In fact, the impacts to the greater Boston area were negligible during construction, due in part to the success of the traffic management approach and public outreach.

#### Construction Staging

In some cases, no viable detours are available. This may be due to poor capacity, poor geometry, or the overall length of the proposed detour. Bridges in rural areas often fall into this third category, where the detour lengths can be many miles. In these situations, construction staging may be the only viable option.

ABC techniques are still appropriate for these situations. ABC can be used to reduce the duration of each stage, and thereby the entire duration of the project.

Construction staging can have a significant cost effect on a project. Staged construction inevitably results in lower production rates for all aspects of construction. Removal and delivery of materials is more difficult, and additional safety features are required to provide a secure work zone. Even with these measures in place, the work zone for a staged project is much more dangerous when compared to a complete road closure. The cost of construction staging should be weighed against the potential extra cost for ABC.

#### Temporary Bridges

In some instances, the use of construction staging or detours is not viable. This can be due to factors such as project site constraints or the structure type.

The use of temporary bridges should be a last resort traffic management option. The time required to construct a temporary bridge further extends the overall project construction timeframe. Also, the cost of the temporary bridges and approaches is significant. In some cases, the temporary bridge cost can approach 50 percent of the final bridge costs. These factors should be carefully weighed against the time savings and potential extra cost for ABC.

#### 3.2.1.4. Right of Way Issues

ABC projects often necessitate temporary right of way beyond the proposed transportation facility. Staging yards on agency owned right of way are not always available. If the design team chooses a lateral skidding/sliding method, temporary right of way adjacent to the bridge may be necessary. The design team needs to identify the following right of way parameters as a minimum:

- Is there available right of way for a staging yard near the bridge site? If not, is there potential for a short term lease of land for this purpose?
- Is there available right of way for crane locations near the bridge site? If not, is there potential for short term construction easements?
- Is there available right of way adjacent to the bridge?

#### 3.2.1.5. Utilities

Utilities both above ground and underground are present on many bridge sites. These can have a significant impact on the methods of construction that are feasible for the site. The impact of the utilities on the installation of prefabricated elements and systems can be significant.

Overhead wires can obstruct crane operations; however this can sometimes be overcome through the use of gantry cranes, which require lower headroom and SPMTs that move elements at levels that are just above the level of the bridge. In most cases, it is desirable to remove overhead utilities from the site, either by temporary or permanent relocations.

Underground utilities can be left in place in many cases, as long as the utilities are not affected by excavations and foundation installations. Construction loads can be accommodated with steel plates or crane mats.

Agencies should consider relocation of utilities in a separate pre-construction contract. This will eliminate potential delays during construction caused by utility work.

#### 3.2.1.6. Local Government Constraints

It is important to open a dialog with the local governments for any construction project. The community impact of a construction project can be significant. Project planners should meet with local governments to identify any constraints that may be applicable to the project. For instance, the construction may impact the traffic access for a local festival. Detours or lane restrictions can greatly limit the success of these events. ABC can be used to complete projects, or stages of projects before community events.

School bus routes are often cited by local governments as a point of concern. Even small detours can have a significant impact on bus routes and schedules. These impacts should be identified and explored during the project planning process. In some cases, agencies have used ABC to complete entire bridge projects during summer recess in order to avoid school bus route impacts.

#### 3.2.1.7. Structure Type Options

Most bridge construction projects include a structure type study. The goal of most type studies is to find the lowest cost option with a given set of parameters. ABC project differ from this traditional approach. Different ABC methods may favor certain bridge types. This is especially true for foundations and substructures. If a reconstruction of a bridge is planned to be built on the same footprint as the existing bridge, the construction of the foundations and substructures may result in a slow construction process. In this case, building the new foundations and substructures around the existing substructures should be investigated. This will have an effect on the span layouts, foundation types, and substructure configurations.

For example, several bridges have been designed and built with large diameter drilled shafts installed outboard of the existing bridge prior to the closure of the bridge. Once the existing bridge is closed and removed, a precast cap beam can be installed between the drilled shafts. Figure 3.2.1.7-1 shows this sequence of construction.

It is also possible in some cases to install drilled shafts and micropiles under existing bridges. There is equipment that is specifically designed to work in low headroom situations. This also opens up the opportunities to install the deep foundations prior to roadway closure.

On many highway overpass bridges, the abutments are perched on top of the approach embankments. In this situation, it may be possible to construct the new abutment in front of the existing abutment prior to roadway closure using cast-in-place concrete.

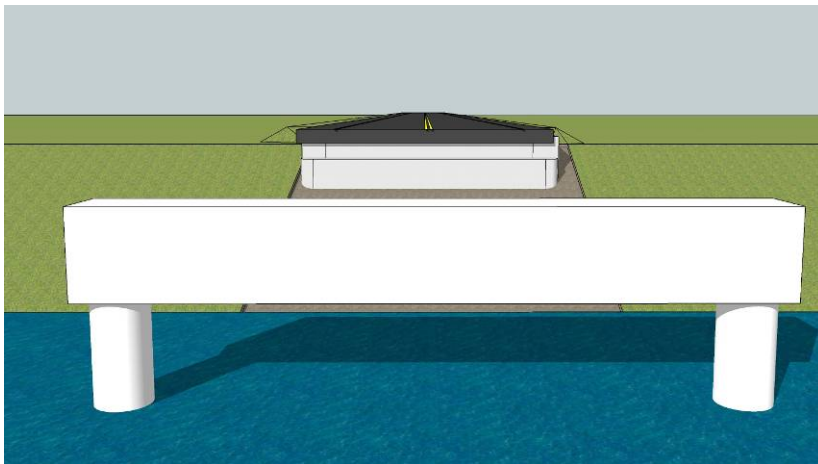
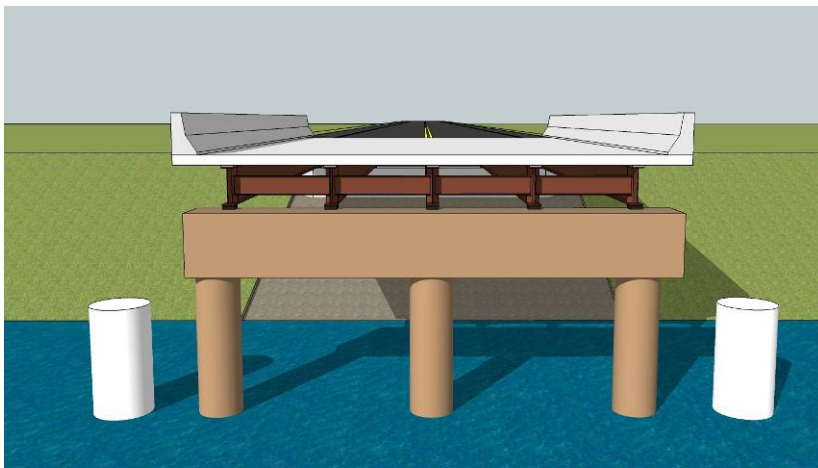
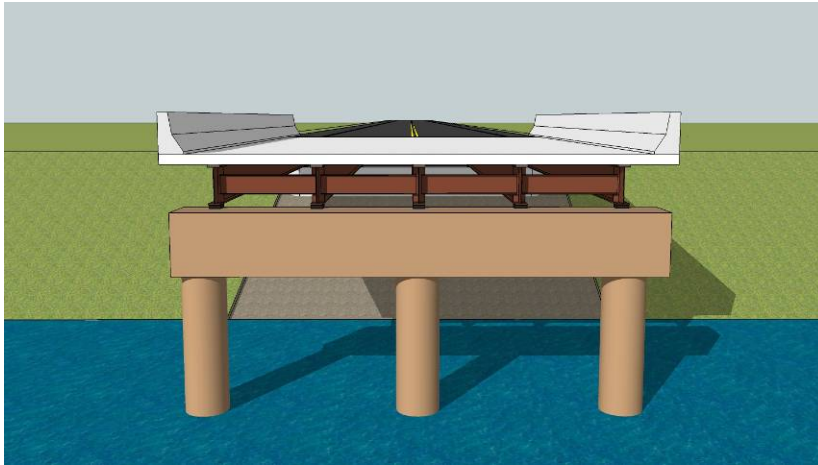

*Figure 3.2.1.7-1 Construction of Drilled Shafts  
(Prior to Removal of the Existing bridge)*

The following considerations should be made during the structure type study phase of the design:

- What is the most feasible structure type for the site?
- What other structure types are reasonable?
- For replacement projects, are there foundation and substructure types that can be installed on a different footprint prior to removal of the existing bridge?

### 3.2.2. Flowcharts for Determination of Appropriate ABC Methods

The characteristics of each bridge site identified in the previous sections will have an impact on the viable ABC methods that can be used. In many cases, multiple ABC methods will be acceptable.

The following pages contain flowcharts that have been developed to identify the most appropriate ABC method for a particular site. A project development team can run through the flow charts with the available site constraints and determine the most appropriate ABC methods.

These flowcharts, which are shown on the following pages, cover the most common bridges; however they will also be a good starting point for more complex bridges. The intent is to steer design teams in appropriate directions based on past experience.

Separate charts have been developed for the following scenarios:

Figure 3.2.2-1 Superstructure Construction over Roadway or Land

Figure 3.2.2-2 Superstructure Construction over Railroad or Transit

Figure 3.2.2-3 Superstructure Construction over Waterway or Wetland

Figure 3.2.2-4 Substructure Construction

Note: Construction with individual prefabricated elements is appropriate and should be considered for all sites. Construction time for these systems can be as fast as 3 weeks for a single span bridge and 4-5 weeks for a typical two span overpass bridge. For more complex sites, alternate ABC methods may be more appropriate. For example, if traffic management requires a replacement to take place in 2 weeks, a more complex ABC method such as an SPMT move may be more in order.

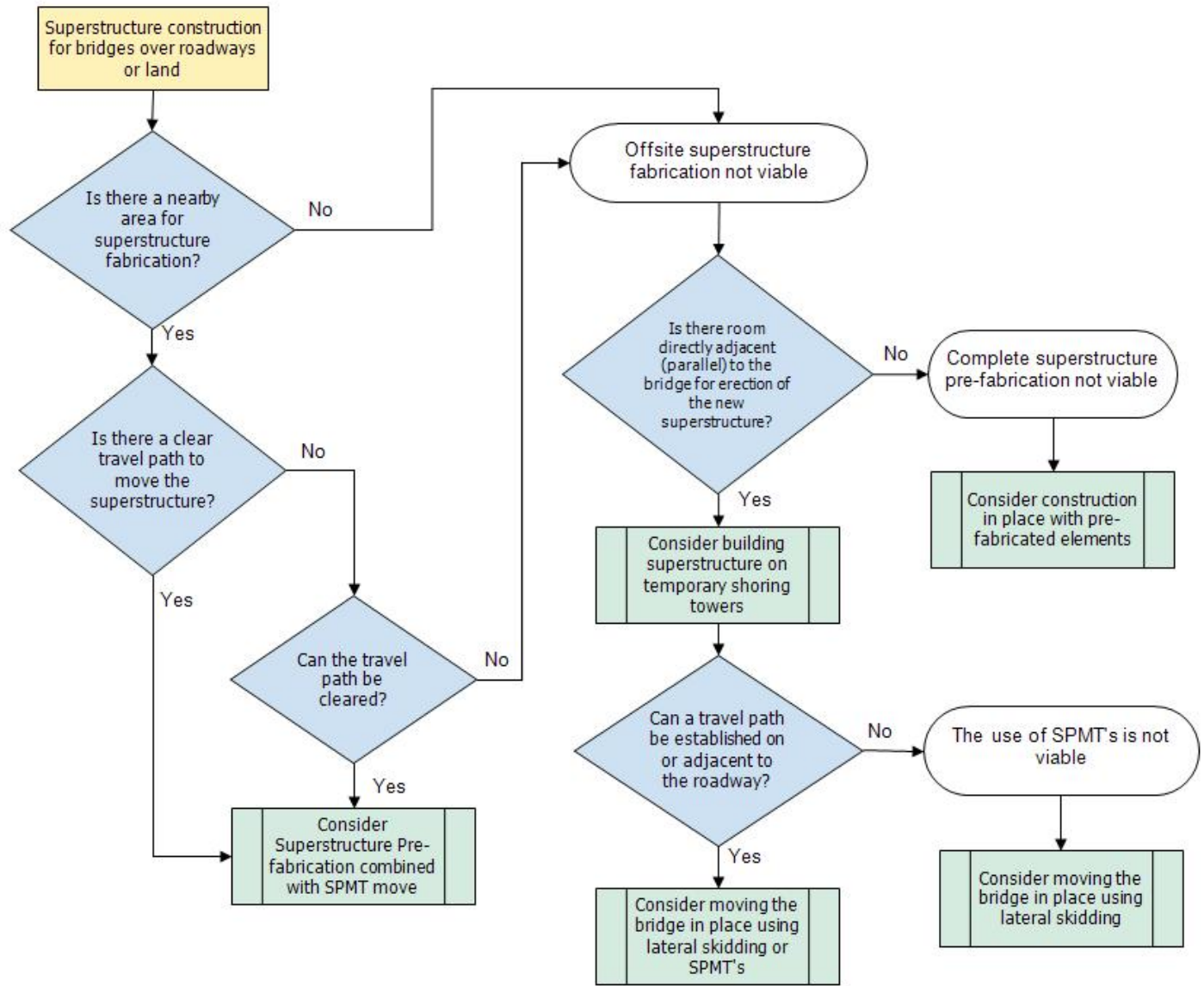

**Legend**

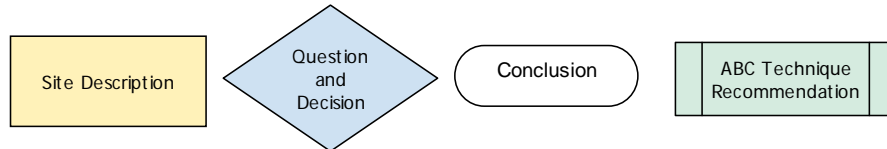
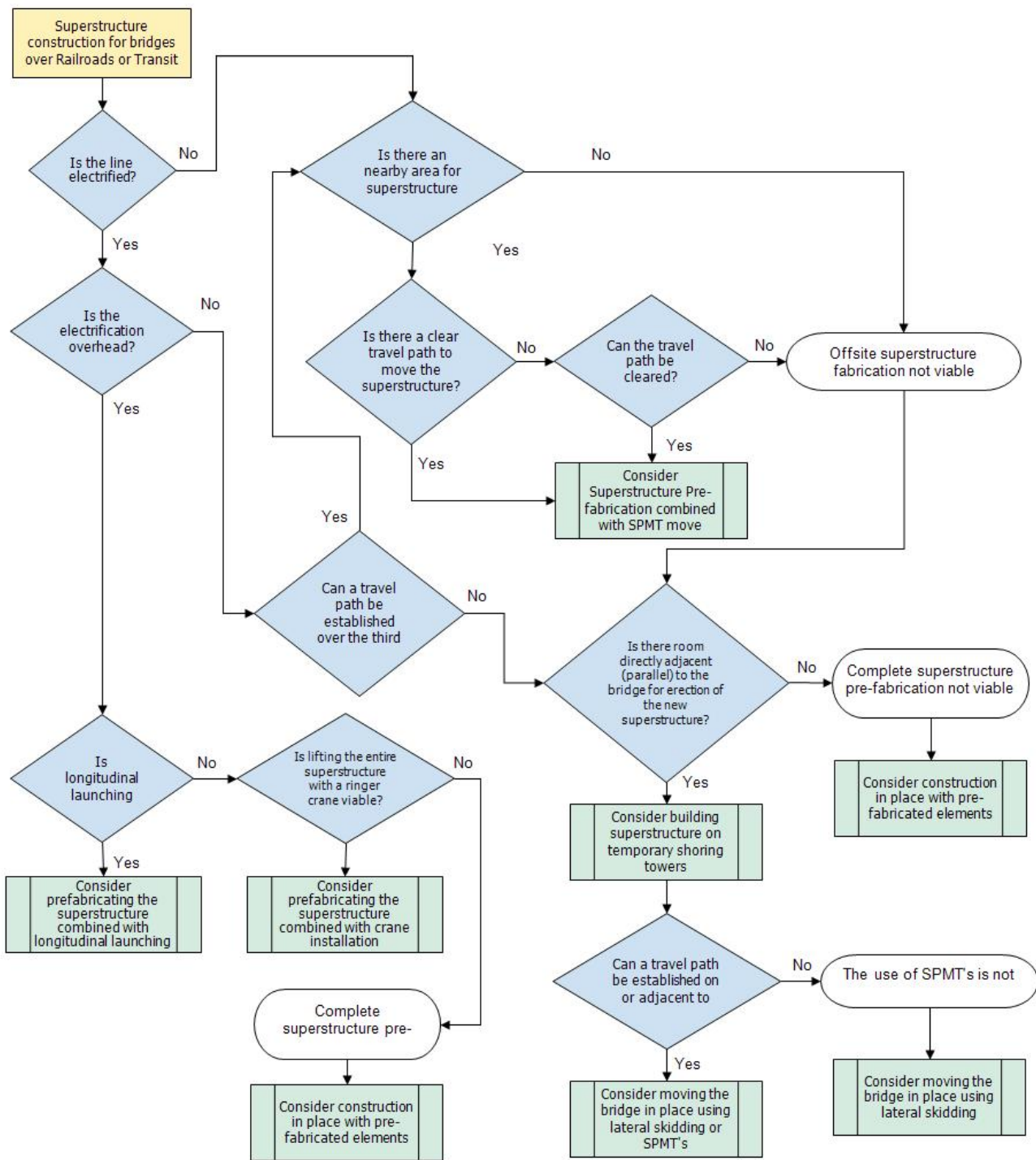

Figure 3.2.2-1: Decision Flowchart for Superstructure Construction over Roadway or Land



**Legend**

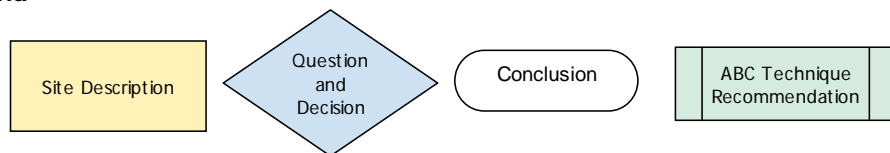
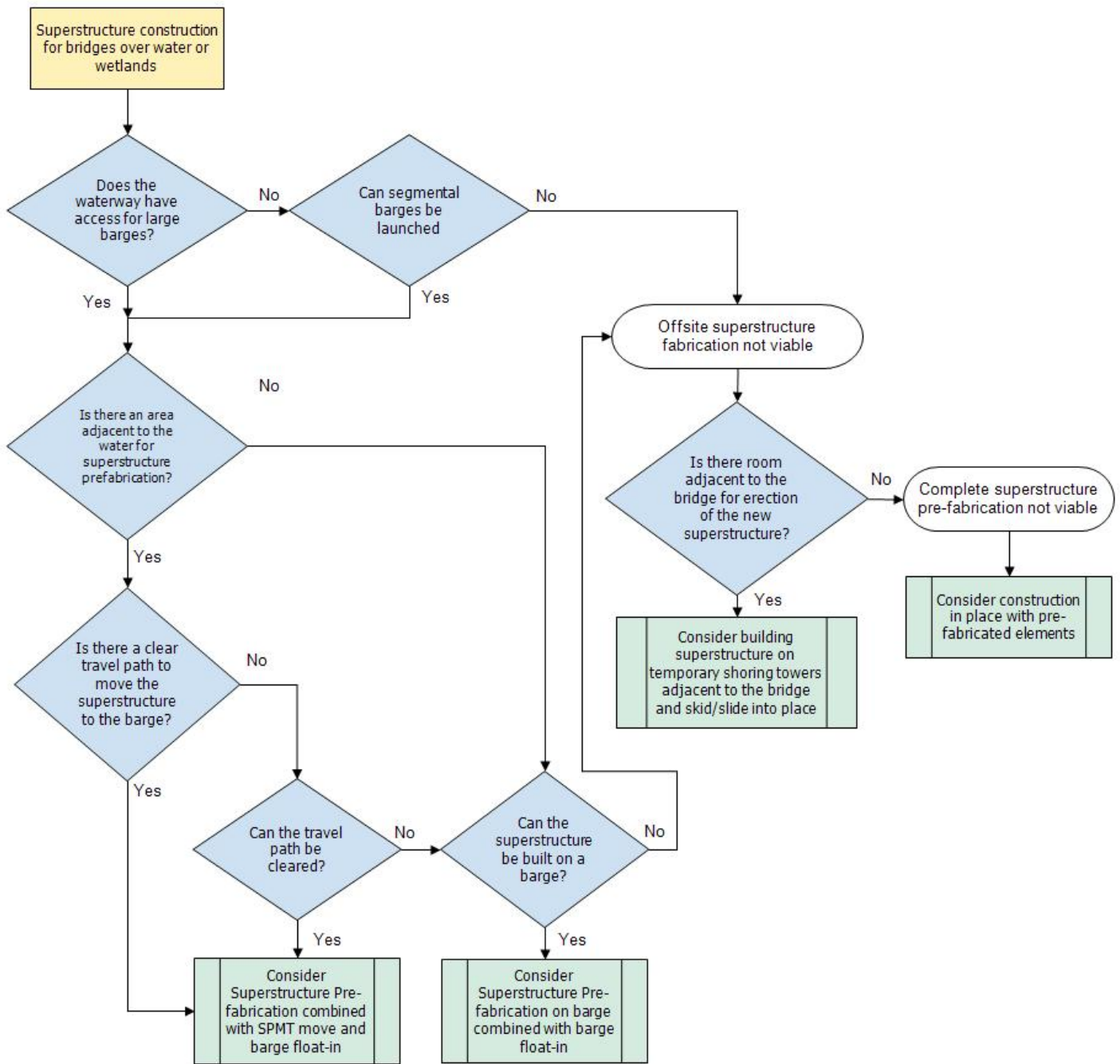

Figure 3.2.2-3: Decision Flowchart for Superstructure Construction over Railroad or Transit



**Legend**

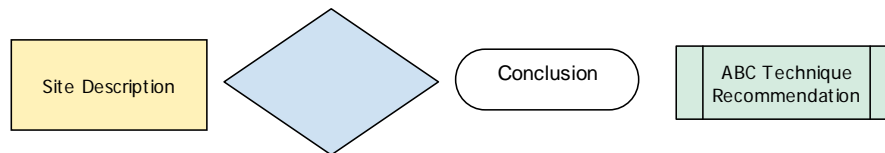
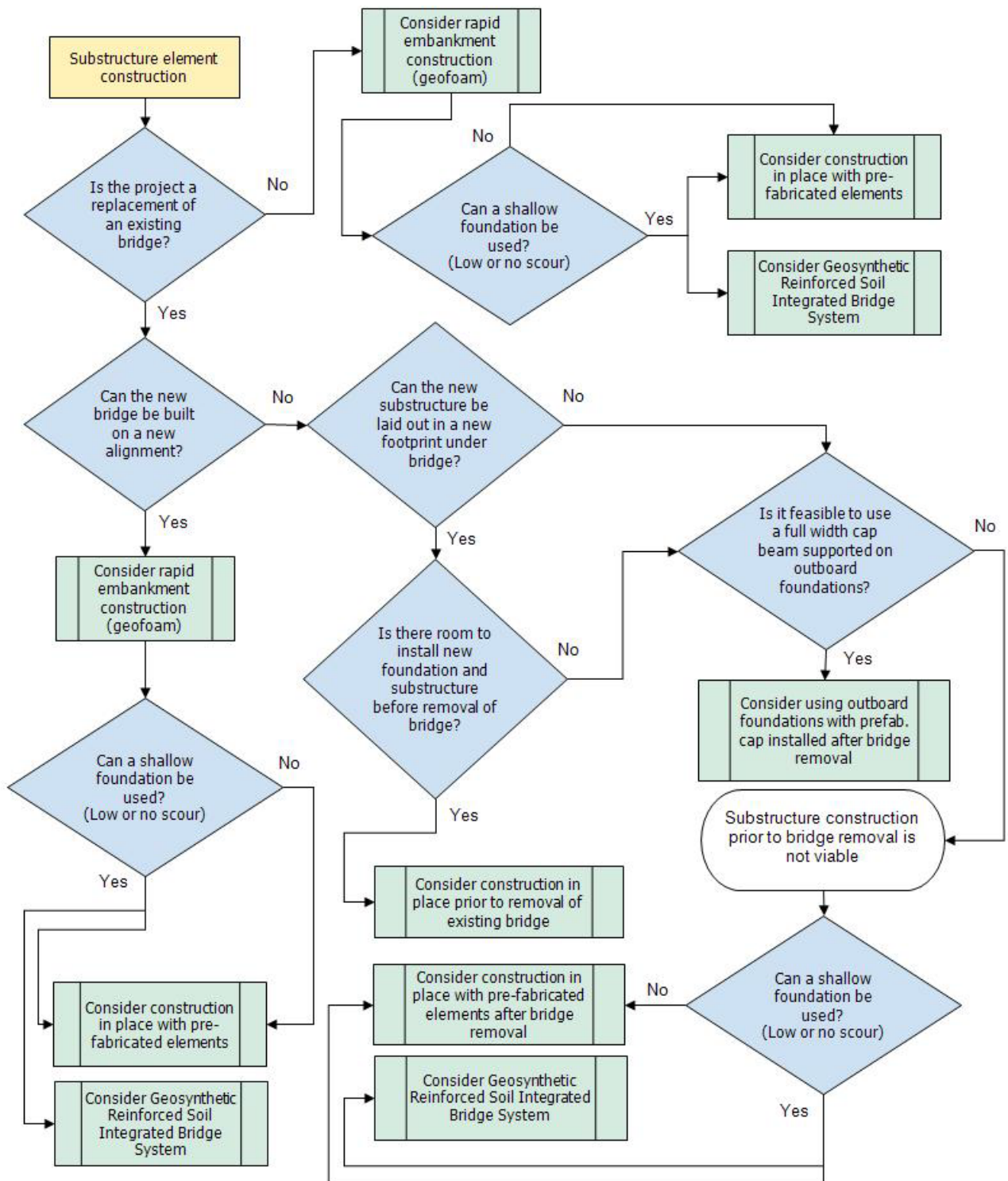

Figure 3.2.2-3: Decision Flowchart for Superstructure Construction over Water or Wetlands



**Legend**

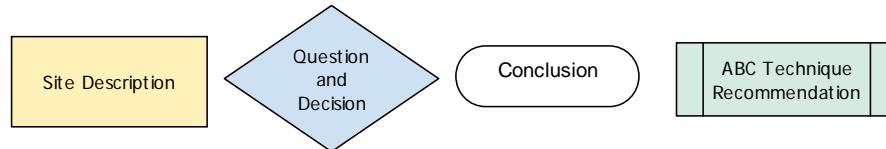

Figure 3.2.2-4: Decision Flowchart for Substructure Construction

The pooled fund study that is underway at the Oregon Department of Transportation will include similar decision processes.

### 3.2.2.1. Example Project

The following is a sample hypothetical bridge project that will be used to demonstrate the use of the flowcharts. The basis for this hypothetical project is a bridge that was part of the FHWA Accelerated Construction Technology Transfer workshop projects. The project was located in Helena, Montana. Minor details regarding the site will be modified in the hypothetical situation.

#### Project Description:

The project consists of the replacement of an existing 4 span bridge.

#### Bridge Description:

The bridge carries two lanes of a local road over an Interstate Highway. Figure 3.2.2.1-1 shows an elevation of the existing bridge. The bridge is in fair to poor condition.



*Figure 3.2.2.1-1 Existing Bridge Elevation*

#### Overpass Roadway Description:

The land surrounding the bridge site has been under development in recent years. There are several large retail stores near the bridge site. The road is a two lane road with narrow shoulder and no sidewalks. The roadway geometry is favorable; therefore, no significant geometric changes are required. The traffic volume is expected to exceed the design capacity in the near future. There is a need to widen the roadway to four lanes with two sidewalks.

#### Lower Roadway Description:

The road under the bridge is an Interstate Highway. Traffic volumes are not excessive.

#### Traffic Management:

The roadway carried by the bridge has high ADT. There is a detour; however it will have a significant impact to traffic traveling to and from the retail stores. Following several public meetings, and meetings with the local retailers it was decided that a long-term staged construction project was not desirable. A short-term detour would be acceptable if the roadway closure time was kept short.

#### Land Availability:

The land adjacent to the bridge approaches is scheduled for retail development and is not available for a staging area. The low volume of traffic on the interstate is conducive to construction over traffic during low volume hours.

#### ABC Decision Making Process

The agency used an ABC Decision Making Flowchart to determine if ABC was appropriate for the project. The traffic management requirements and the impact to the local retail stores led the agency to decide to move forward with ABC.

#### Preliminary Structure Type:

Several Structure Types were investigated. There was a desire to eliminate the two piers adjacent to the low speed lanes of the interstate. This would allow for future widening of the interstate. The structure type chosen for the replacement is a two span continuous weathering steel girder bridge with a composite concrete deck. The substructure will consist of integral abutments and an open frame pier bent supported on a spread footing.

#### Evaluation of Appropriate ABC Methods using Flowcharts

The following pages contain the previously illustrated flowcharts with the decision path outlined in red. Figure 3.2.2.1-2 shows the flowchart for the superstructure, and Figure 3.2.2.1-3 shows the flowchart for the substructure.

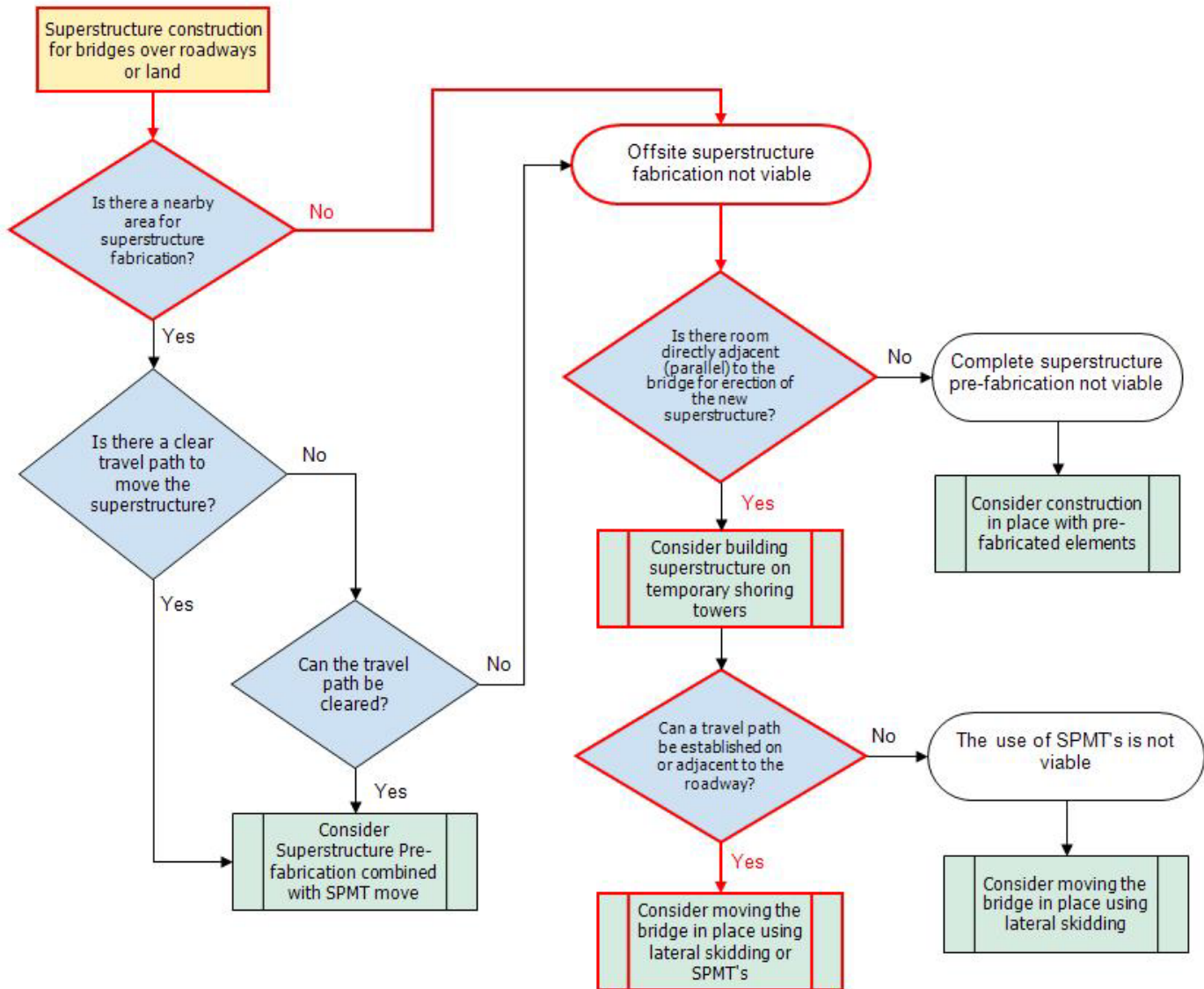

Figure 3.2.2.1-2 ABC Flowchart for Example Bridge Superstructure

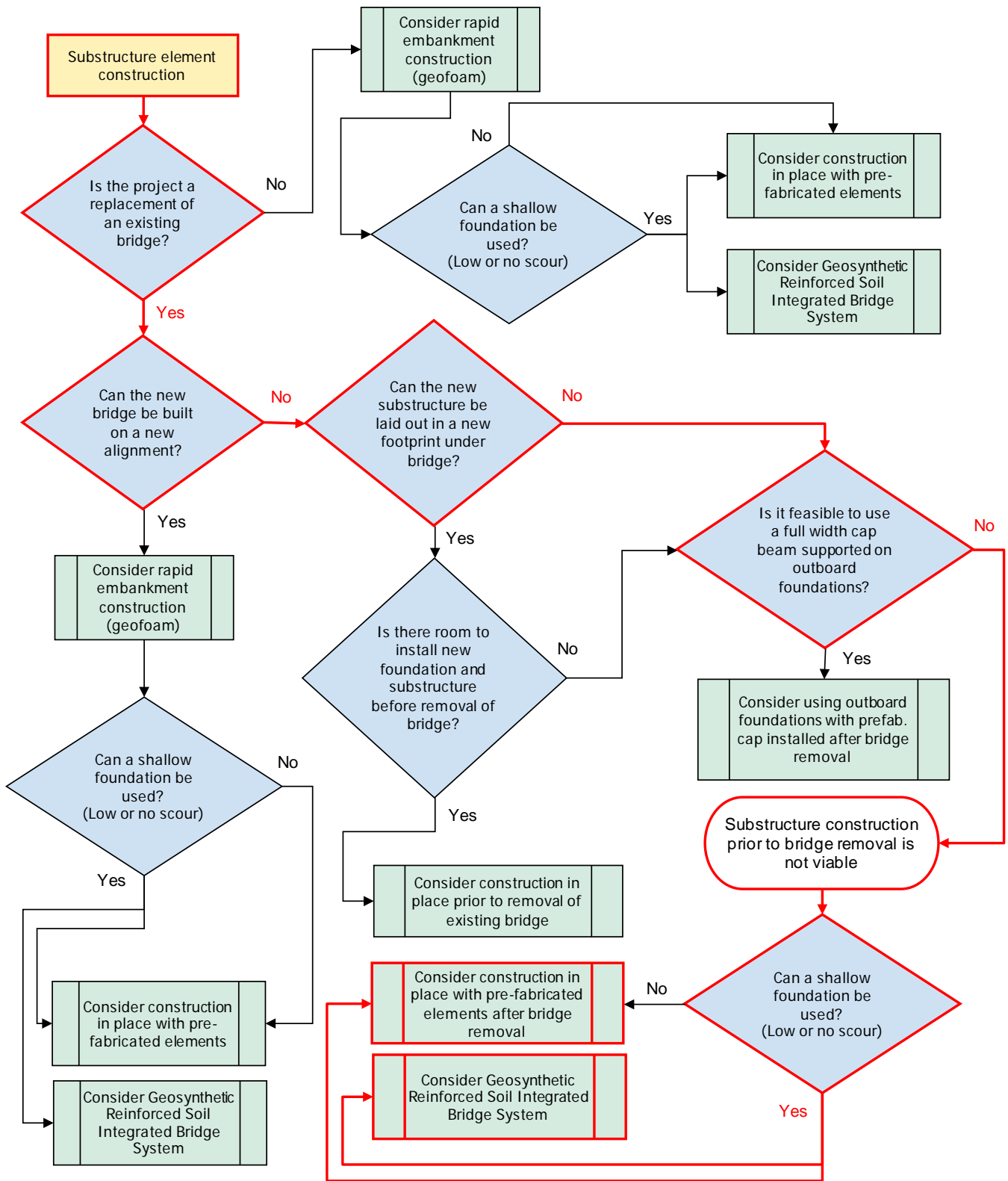

Figure 3.2.2.1-3 ABC Flowchart for Example Bridge Substructure

### Discussion on the Superstructure Flowchart Results

The superstructure flowchart shown in Figure 3.2.2.1-2 shows the decisions that were made by the design team (in red).

The first question asks if there was a nearby area for superstructure prefabrication. As previously stated, the land near the bridge is scheduled for development; therefore it could not be used for a staging area. This led to the conclusion that offsite superstructure prefabrication was not viable.

The next question asks if there was room adjacent to the bridge for superstructure prefabrication. A review of the photo in Figure 3.2.2.1-1 shows that there is ample room for prefabrication of the superstructure adjacent to the bridge. The traffic on the interstate highway is also light; therefore the erection of beams and placement of concrete should not have a significant impact on the traveler on the interstate.

The next question asks if there is a travel path between the prefabrication site and the new bridge. The design team determined that there is ample room in the median and shoulder to construct either an SPMT travel path or to construct a lateral sliding frame.

The result of the flowchart exercise is that there are three potential ABC options.

1. Construct the superstructure on false work adjacent to the existing bridge and move it into place using SPMTs
2. Construct the superstructure on false work adjacent to the existing bridge and move it into place using lateral sliding/skidding equipment.
3. Construct the superstructure in place using prefabricated elements (beams and precast deck)

The third option is always viable since it most closely replicates conventional construction. The difference is that the cast-in-place concrete pours are replaced with precast concrete elements, which reduces overall construction time.

### Discussion on the Substructure Flowchart Results

The substructure flowchart shown in Figure 3.2.2.1-3 shows the decisions that were made by the design team (in red).

The first question asks if the project involves the replacement of an existing bridge. The answer is yes in this case.

The next question asks if the bridge could be built on a new alignment. The design team determined that there was insufficient right of way adjacent to the bridge site to re-align the roadway; therefore the answer was no.

The next question asks if the new substructure could be laid out in a different footprint than the existing bridge. The proposed structure is a two span bridge. The proposed center pier will be in the same location as the existing pier. It may be possible to construct the new abutment in front of the existing; however the integral abutment stem would be too tall and pile installation would not be possible. For these reasons, the design team decided that the new substructures would at least be in partial conflict with the existing substructure. Therefore, the answer to the question was no.

The next question asks if it was feasible to use a full width cap beam supported on outboard drilled shafts. The design team decided that this was not feasible since the proposed structure would be very wide (four lanes, shoulders, and sidewalks). Therefore, substructure construction prior to removal of the existing bridge is not feasible; however other ABC methods for substructure construction are still viable.

The next question asks if a shallow foundation can be used. The answer is yes. This provides two potential solutions for the construction. The first is the use of the GRS IBS technology. The FHWA technology team has not yet recommended that this technology be used for multi-span bridges due to concerns about differential settlement; therefore this technology is not recommended. Therefore, the result of the flowchart exercise is that there is only one potential ABC option for the substructure:

Construct the substructure in place after removal of the existing bridge using prefabricated elements.

#### Final Construction Choices

The result of this exercise is that ABC is viable for the site and an acceptable solution was found. The design team chose to close the roadway over the interstate and establish a short term detour.

Construction would be accelerated by building the new superstructure on false work prior to bridge closure. This would have no disruption to the heavy traffic on the overpass roadway, and limited disruption to the traffic on the interstate highway. Once the superstructure is complete, the detour will be put in place and demolition of the existing bridge will take place. Precast concrete elements will speed up the construction of the substructure to approximately 4 weeks. Installation of the superstructure can then follow in several days. Total roadway closure time for this hypothetical project is approximately 5 weeks.

- 3.2.3. Structure Type Selection Analysis Including Overall Project Costs  
Once armed with the information outlined above, the designers and planners can now investigate the various options in order to determine the most appropriate approach for the construction of the bridge. Every agency will place different emphasis on the various aspects of the project. For this reason, hard and fast rules will not apply. The following sections contain general information on the typical aspects of the final project planning process.

#### 3.2.3.1. Cost Evaluation

In many cases, multiple options for construction will be viable. The design team needs to identify all viable options and study the cost impact of the project. Traditional project cost estimating and decision making only accounts for the cost of the construction items. Many agencies are now accounting for other non-project costs in the project planning process.

During recent FHWA summit meetings for the “Every Day Counts” initiative, one of the primary concerns expressed by agencies regarding ABC was the higher cost for construction. To date, most ABC projects have resulted in higher bid prices. The major factors that affect the cost differential are the complexity of the project and the severity of the time constraints imposed on the contractors.

Based on the cost analysis of eight bridge projects built under the Highways for Life (HfL) program, the additional cost premium for deploying ABC was found to range between 6 and 21% when compared to the cost estimates of traditional construction. In some projects, the use of ABC may result in reduced cost premium or overall cost savings by eliminating the need for certain construction requirements associated with traditional methods. For example, in the bridge replacement project of MD 28 over Washington Run, the use of ABC resulted in eliminating

the additional expenses of constructing temporary bridges to maintain traffic flow.

Some agencies that have expressed concerns over cost, indicate that they do not see a need to spend extra funds to minimize impacts to the public. In fact these agencies are already spending additional funds for this purpose. Most agencies employ phased (staged) construction in order to keep traffic flowing through a work zone. It is well known that this construction method is more expensive than construction with a full road closure. The contractors are required to work in a small work zone with adjacent traffic that impedes the work in progress. This approach can increase the cost of the construction. ABC/PBES allows owners to take reductions in traffic impacts to the next level by providing even better customer service. In some cases, it may be preferable to close the roadway, establish a detour and build the bridge quickly using ABC/PBES. The additional costs for this process may very well be offset by the elimination of phased construction costs.

As more ABC projects are built, the costs for construction are trending downward. This is due to contractor familiarity with the process, which results in lower risk. Contractors have noted that risk equates to higher cost. Consistency in design and detailing will lead to less risk to the contractors, which leads to lower construction costs.

The most applicable analogy to this is the development of prestressed concrete during the latter half of the 20<sup>th</sup> century. Initial costs for prestressed concrete beams were inevitable higher than cast-in-place concrete construction in the 1950's. The use of prestressed concrete beams required specialized fabrication techniques, and large cranes for lifting and placement of the beams. There was also a loss of revenue for the general contractors since the construction of the beams would be handled by a third party (the fabricator). As time went by, contractors become more familiar with the material and the prices came down. Today, most agencies and contractor would not consider cast-in-place concrete for concrete bridge girders.

Similar analogies can be applied to items such as color televisions, microwave ovens and personal computers. The key to reduction in costs is the consistent use of the technology with an avoidance of "one of a kind" projects. Standardization of details and the incorporation of a program of projects into an agency plan will help to reduce project costs. A program of ABC projects will send a clear

message to contractors that the investment in training and equipment is well worth the effort.

The use of ABC is very similar to the prestressed concrete analogy. Contractors are unfamiliar with the ABC process and the equipment used on many of these projects. There is also a concern by general contractors regarding the loss of revenue for field crews as they substitute precast concrete for cast-in-place concrete. There are potential solutions to this concern that are being explored by some agencies. They are considering allowing prefabrication by general contracts. The contractors are required to establish a quality control programs that mimic plant production programs. This alleviates some of the contractor concerns over ABC and puts more control over the final product with the general contractor.

Another potential scenario is that general contractors will focus their efforts more on roadway construction and apply less emphasis on bridge building. Sub-contractors or teams within general contracting companies specializing in the installation of prefabricated elements could potentially become more common. These teams could, in theory, move from project to project, thereby making the most efficient use of the equipment needed for construction of prefabricated bridges.

On ABC projects, the least expensive construction cost may not result in the lowest total construction cost. The cost for various ABC techniques needs to be factored into the total cost of the bridge. The cost for ancillary items such as railroad flagging, police details, resident engineering time, traffic control devices costs, etc. also needs to be studied. Many states calculate road user costs in order to determine the impact on travelers. This may also be a factor in deciding the most appropriate structure type. It is recommended that all reasonable structure types and the associated ABC costs be studied for each project.

The following sections contain information on different cost factors that are being used during the project planning process.

#### Time and Materials Estimating

Most state agencies use a unit price approach to estimating construction projects. This approach is easy for engineers since it combines the cost for time, equipment, manpower, and materials, general and project-specific overhead, contingency, and profit. This approach works well for conventional projects that

have similar constraints. Unusual project constraints place a higher premium on man-power and equipment. For instance, the forming and stripping of forms on a bridge over a railroad will take more hours than a bridge over a rural road. The time frames for work crew to access the formwork will be limited on the railroad crossing and virtually unrestrained on the roadway overpass.

In order to evaluate different construction strategies (including ABC), it is necessary to approach the estimating of the project through the use of cost-based estimation. This is sometimes referred to as “bottom up estimating”. This approach requires a careful examination of production rates, equipment needs, and man-power needs for each construction operation. Estimators will need to identify unit costs for equipment, as well as production rates for specific work tasks. Experienced construction management personnel should be advised for recommendations on these factors.

A cost-based estimate should be calculated for each construction option being investigated. This approach will help to identify the increased costs associated with limited access at a site and the reduced costs associated with a site that is closed to traffic. By using this type of estimating, a design team can evaluate different strategies such as staged construction versus full closure combined with a detour and ABC.

#### Road User Costs (RUC)

The New Jersey Department of Transportation defines road user costs as follows:

*“Road User Costs in the work zone are added vehicle operating costs and delay costs to highway users resulting from construction, maintenance, or rehabilitation activity. They are a function of the timing, duration, frequency, scope, and characteristics of the work zone; the volume and operating characteristics of the traffic affected; and the dollar cost rates assigned to vehicle operations and delays”*[4].

Road user costs represent the incremental cost borne by the road users and the society at large as a result of the construction of the bridge. It typically refers to monetized components of mobility, safety and environmental impacts resulting from the work zone activities. It also helps to quantify the impact of bridge construction and nearby construction projects, if any, at a corridor level.

FHWA is preparing a practitioners guide for estimating work zone road user costs. This document provides step-by-step approach to calculate key components of work zone RUC, and presents a discussion on input needs and available tools. There are several tools available to compute these costs.

Several state departments of transportation have developed spreadsheet-based tools for RUC computations. Examples include the New Jersey DOT's road user cost spreadsheets, Michigan DOT's CO3, and Maryland SHA's Loss of Public Benefit (LOPB) tool.

The 2010 Highway Capacity Manual [57] provides an analytical basis for estimating work zone traffic impacts, a key component of the road user cost model. Some agencies have not incorporated the study of road user costs during the project planning process. There is a concern that they should not spend extra money to reduce road user costs. The fact is that virtually all agencies already spend extra money on construction project in order to reduce user impacts. It is well known that the cost of a bridge construction project is lowest when there is not traffic to maintain. Typical approaches to maintenance of traffic are the use of staged construction and temporary bridges. Both of these options result in increased project costs, which is well justified by the need to keep traffic moving through a work zone. Therefore, agencies are already spending more to reduce user impacts. The goal of ABC is to take this approach to the next level. By potentially spending a little more, the impacts to roadway users can be dramatically reduced through the use of ABC technologies.

Regardless of the actual level of financial impacts to the traveling public, road user costs can be significantly reduced through the use of ABC and PBES. The value of road user costs on a particular project may be debatable; however the benefits of ABC when applied to road user costs are obvious. ABC can be used to reduce the mobility, safety and environmental impacts of work zone activities by reducing the overall duration of the project while the road user quantifies the benefits of shorter construction duration and reduced work zone exposure. The cost premium of using ABC is offset partially or fully by the gains in work zone road user costs.

Therefore, the agencies are encouraged to account for road user costs in the decisions making process for all projects to evaluate the economic efficiency of various construction options. The total project cost is the construction cost combined with the road user costs. A return-on-investment (ROI) analysis can be conducted by comparing the costs (i.e. increase in construction costs) with benefits (i.e. savings in road user costs through shorter construction time) for various construction options considered in the decision making process.

The HfL ROI analysis measures the economic efficiency of an option using its total project cost, which is the sum of construction and road user costs. The economic analysis of four HfL bridge projects showed immediate net savings of 8 to 65% in total project costs, thus justifying the use of ABC against traditional construction methods [62]. By taking this approach, the agency can provide the best value to the traveling public.

#### Maintenance of Traffic Costs

Various construction methods will require different maintenance of traffic approaches. The three most common approaches for maintenance of traffic on bridge replacement projects include, traffic control (e.g. staged construction, detours or temporary bridges), traffic control devices (e.g. signs and markings), public information campaigns (e.g. information centers and 511 traveler information), operations management (e.g. signal timing improvements and traffic restrictions), and law enforcement strategies. The maintenance of traffic strategies are selected based on the severity of work zone impacts and project significance.

All of the approaches come at a cost to the overall project. It is relatively easy to calculate the cost for items such as barriers, signs and even temporary bridges. The difficult cost to calculate is the loss of productivity for crews working adjacent to and sometime in between live traffic. Numbers higher than 50% have been discussed; however there are few published studies on the actual cost for work within an active roadway. Individual agencies can study these costs by comparing the actual cost of similar sized projects that were built with different traffic management approaches. From this, the general premium on traffic management can be determined.

When comparing the total project cost for an ABC project, the design team should factor in the cost for traffic maintenance into the overall project cost. In many cases, the extra cost for ABC can easily be mitigated through the reduction in traffic management costs and loss of production at the site.

### Safety Costs

Providing a safe work environment is always a priority. The various ABC methods described in this manual provide a different level of safety. In all cases, the reduction in construction time will inevitably reduce the exposure time and associated safety risks for both workers and motorists. Safety costs quantify the cost differential of exposure times associated with various construction options. These costs are estimated by taking into account the crash history (i.e. crash frequency and severity), exposure times (i.e. time of day when the work is performed and the number of work days), and maintenance of traffic strategies (e.g. safety features installed in the work zone). The HfL demonstration project reports illustrate the computation of work zone safety costs [63]. This cost differential should be incorporated into the final decision process.

### Agency Construction Engineering Costs

One very large cost that is not normally included in the project planning process is the cost to the agency for construction management. In most cases, the construction management costs exceed the cost for design. Typical agency costs include labor costs for inspectors and resident engineers, rental of construction offices and law enforcement costs. Most, if not all of these costs are not included in the bid results.

ABC can be used to reduce agency's construction engineering costs by reducing the overall site construction time. With the use of prefabrication, there will be more cost for plant inspections; however these costs are intermittent and normally much less than full time construction staffing.

The agency's construction engineering costs should be studied during the project development process. Any savings in agency costs should be included in the final decision making process.

### Life Cycle Costs

Life cycle cost analysis is a subject in itself that will not be covered in great detail here. The intent is to focus on

how prefabrication can be used within the context of a life cycle cost analysis. The FHWA has a website devoted to life cycle cost analysis. It can be found at: [www.fhwa.dot.gov/infrastructure/asstgmt/lcca.cfm](http://www.fhwa.dot.gov/infrastructure/asstgmt/lcca.cfm).

The quality of plant produced product is well recognized as being of higher quality when compared to field produced elements. There are several reasons for this increase in quality.

First, the quality of precast concrete can be better than site cast concrete. Prefabricated elements can be built in a controlled environment. The control of temperature and reduction in weather exposure normally result in higher quality concrete product. The quality of plant produced concrete mixes can also be controlled better since the concrete does not need to be trucked to a construction site.

The second added benefit to precast concrete is that the elements are cast in an un-restrained condition. In cast-in-place construction, concrete is often placed against previously cast concrete. As the new concrete cures and shrinks, cracking commonly occurs. Designers try to mitigate this issue with the incorporation of control joints and expansion joints; however, it is inevitable that some cracking will occur. The issue of cracking in bridge decks is widespread throughout the United States. Precast elements and precast bridge deck panels in particular are allowed to cure and shrink in an unrestrained condition, thereby reducing, and in most cases, eliminating shrinkage cracking. The reduction in cracking eliminates one avenue for water infiltration and long term deterioration of the concrete.

The increase in quality inevitably leads to an increase in service life. This leads to reduced life cycle cost for the bridge since the structure can remain in service for a longer period of time. Many agencies are starting to investigate sustainability in bridge construction. The increase in service life will reduce the need to replace bridges in the future, which is a major factor in sustainable construction.

### Inflation Costs

Inflation has a significant effect on the cost of long-term construction projects. Contractors need to account for inflation during the bid process, because the cost of materials and labor will potentially increase over time. The difficulty with long-term projects is that the

estimation of future inflation becomes more uncertain. In these cases, contractors normally use higher estimated costs in order to cover the potential of future inflation.

Some agencies build inflationary escalation factors into major bid items in order to reduce the amount of inflationary risk at the time of bid. Escalation factors can cover material cost fluctuations; however labor cost escalations are not covered. Escalation factors can lead to lower initial bid prices, but the overall project cost can still be affected by inflation.

ABC can be used to reduce the inflation effects on both the bid and inflation escalation factors. By reducing the time for construction, the potential impact of inflation is reduced. Contractors bidding on projects will have less uncertainty during development of the proposal, and inflation escalation factors will have less impact on the overall final cost of the project.

#### 3.2.4. Public Involvement

Public involvement is a part of the NEPA process for all projects. Public involvement process can take on several levels. In early project planning, public meetings may be required to help define the problem and identify issues that need to be addressed. The goal of this preliminary process is to identify the stake holders and their needs. On ABC projects, it may be necessary to include an additional public involvement process prior to and during construction.

Once a decision has been made on the preliminary structure type and construction methods, a more significant process of informing the public can take place. The agency can present all of the factors that were used to determine the project approach. This form of transparency is often well received and is mandated by many agencies.

Each agency will place a different level of emphasis on the public involvement process. More densely populated areas will require a more diverse public involvement process. The need to keep the public informed drives the level of effort. For instance, in a low population area, mailings to local residents combined with a public meeting may be adequate. In complex urban environments, the public involvement process can expand to multiple media formats, multiple public meetings, meetings with local officials, and in some cases meetings with out of state agencies. This is just a partial listing of the possible public involvement process.

Public involvement is critical to the success of an ABC project for several reasons. In many cases, an ABC project will create a

short-term acute impact to travelers, businesses, and residents. Informing these stakeholders will ensure proper public support and reduce problems during construction. It is important to be upfront and clear on the impacts of the project. For instance, if around-the-clock construction work is scheduled for a residential neighborhood, the residents should know that it will be noisy and during the night. They should also know the benefits of ABC and that the noise will be for a short duration.

The second way that public involvement can be used for ABC is to foster good will among the traveling public and local residents. Section 1.2.2 of this manual showed described how the Utah DOT gathered information on public opinion of ABC projects. UDOT places significant emphasis on the public involvement process for all ABC projects, which they cite as one reason for the success of their program.

The bridge design and construction industry has been lax about promoting our efforts and celebrating our achievements. ABC is an opportunity to show that the ABC is not business as usual and that agencies can make a reduction in impacts to travelers and local communities.

Many agencies have public involvement manuals and processes. The FHWA document entitled "*Public Involvement Techniques for Transportation Decision-making*" [10] is recommended as a source for information on the development of a successful public involvement process.

## Chapter 4      **Implementing ABC in a Transportation Agency (A Case Study from the Utah DOT)**

Many states have experimented with ABC on individual projects, and some have begun a program of ABC projects, but only one agency has implemented ABC as standard practice. During the build-up to the 2002 Winter Olympics, the Utah DOT used ABC to complete several projects within the time leading up to the event. The success and popularity of ABC encouraged the state to move toward making ABC standard practice for all bridges. In 2010, the state met that goal. Today, ABC is considered on all bridge projects and used where appropriate, with road user costs and innovation driving the decision process.

This chapter outlines the approach that was used to implement ABC in Utah. All aspects of this approach may not work in every agency; however the general approach is a good roadmap to a successful implementation of ABC.

### 4.1. General Approach: No Magic Bullet

What follows is a general approach for implementing an ABC program. It would be a simple thing to replicate the Utah Department of Transportation success in this area, if the formula for doing so was readily available. For those who wish to find the simple solution, what may they find that is contained in this chapter will be disappointing. For it is a complex matter to implement a change of such magnitude. What is required beyond the fortitude, is a multi-faceted, multilayered, complex weave of activities, some small, some large and some bold, all with the singular purpose of driving both the agency and the industry within the state to change.

What follows are some of the activities that UDOT undertook to implement ABC. In one post-implementation exercise, where UDOT staff was asked to compile all of the activities that they had undertaken to implement ABC, they brainstormed 43 separate efforts that supported implementation. What follows are some of the most important activities. What is not guaranteed is that by doing so, by practicing these activities that an ABC program will materialize. The truth is that one may do these activities and still not be successful. On the other hand, success will surely not come, unless one tries. What follows are not guarantees of success, but ideas and activities that have led to success in one state.

Figure 4.1-1 is a sample flow chart for ABC implementation in a state agency has been developed based on the text in this Chapter, the Utah experience, and the recommendations of the FHWA Every Day Counts initiative. The flow chart represents a suggested approach to this effort. It is understood that each agency functions in a different manner; therefore the approach may need to be modified for each agency. The intent is to present the major activities that will help to produce a successful ABC program.

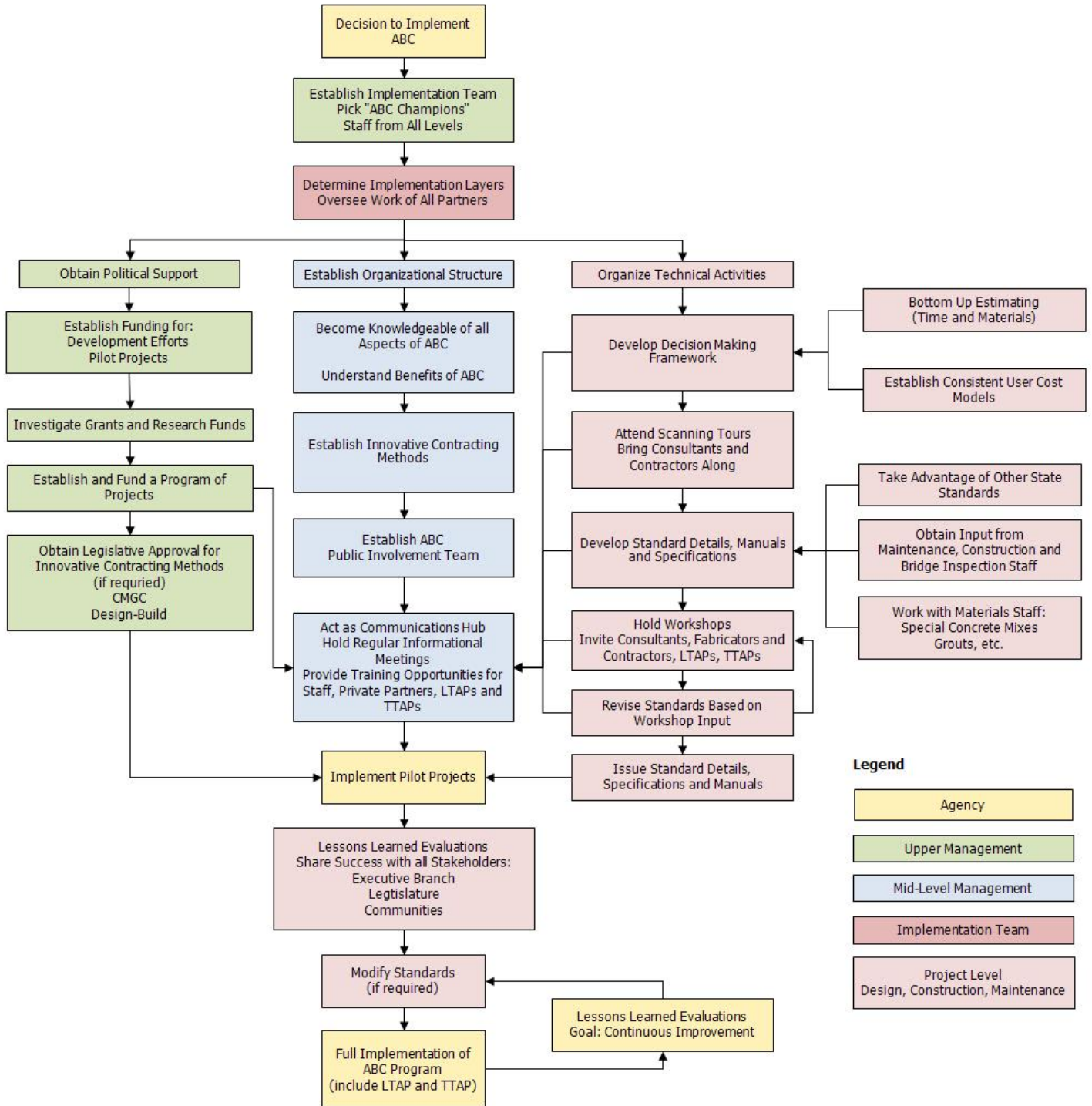

Figure 4.1-1 Sample ABC Implementation Flow Chart for a State Agency

#### 4.1.1. Strategic Layers of Implementation

As one tries to implement an ABC program, one should keep in mind the following idea. In order to be successful, one must contemplate that there are different strategic layers of implementation.

A state agency must have a plan for each component, and must have multiple sub-strategies. An organizational behavior to watch for is the blossoming of spontaneous supporting activities led by working units. The state will have planned for two dimensions, layers, and depth within layers, and their people will bring forth another dimension as implementation proceeds, and as the idea gains momentum.

#### 4.1.2. Upper Management and Politics

It is an obvious observation to state that the success of implementing ABC is dependent upon the support of upper management. There must be communication, and education to keep leadership informed and knowledgeable about the status, needs, and early successes of the program. A good strategy is to establish a regular communication pattern. It is extremely important that management be kept in the loop and has confidence in what they are being told. The time spent to inform and communicate will pay off dividends when problems and adversity occur.

The strategies that work for upper management also work for politicians. Politicians can be kept in the loop the same way as upper management. This may be a task best accomplished by upper management. An ABC champion should talk about involving and advising politicians with upper management, and they should decide how to proceed. Political and upper management support can be gained through careful and honest communication. This activity can be seen as the "air war".

#### 4.1.3. Mid-Level and Organization

There must be a plan to deal with articulating ABC to middle management and first level supervisors. The plan must include messaging, question and answer sessions, informational meetings, and expectations discussed. The plan must provide middle managers and supervisors with information about why ABC is important, and what it will bring to the organization.

*Standard messages concerning ABC are:*

- ABC decreases impacts to the traveling public: The projects may last as long, but the work zones will not impact the traveling public as long. ABC is part of the department's effort to stay out of the public's way.

- ABC increases the safety of the traveling public, and workers: It is obvious that it will be safer for the traveling public if work zones and detours are not in place as long. What is not as obvious is the safety implications to workers and employees. Construction workers and department employees will be safer and will be out of harm's way more often.
- ABC has the potential to cost less than current methods: Precast elements have the potential to cost less than cast-in-place methods. Precast girders have long been shown to be less expensive than cast-in-place girders. It is reasonable to conclude that other precast elements may be less expensive than their cast-in-place counterparts.
- ABC has the potential to deliver higher quality bridges: By using manufacturing methods, and constructing pieces in controlled environments, other industries have increased the quality of end products. It is reasonable to conclude that prefabricated elements can be manufactured to be of higher quality.

Middle management must be given the opportunity to question decisions, and in return, be given good reasons for them to support a change. They must be given the ammunition they will need to convince others. They must also understand that ABC is the direction of the future, and that they will be expected to support the agency's decision. This information, the questioning and discussions should take place in meetings separate from their employees, so that middle management may be free to openly communicate and question.

The agenda for these meetings with middle managers should include the following:

- There will be an outline of what the department is planning to change, and why they are planning to implement ABC. The presentation should include information about those that have successfully implemented ABC elsewhere.
- There should be a discussion of the messages, complete with questions and answers. Upper management should ask middle management what they see as problems with initiating the change, and answer how they plan to overcome those obstacles. Upper management should have prepared for this question-and-answer session with what they perceive to be frequently asked questions. For those obstacles that do not have an immediate answer, upper management should ask middle management how they would suggest solving that issue. If there are no obstacles presented that couldn't be answered readily, then upper management should still ask the questions:

What does middle-management intend to do to help implement this effort? What resources do they need, what organizational changes will they make, and what will the future look like with ABC implemented? This part of the meeting will help build momentum and organizational alignment.

- The last part of the meeting will be spent in discussing roll-out sessions with the rest of the organization. Upper management should ask middle management to conduct meetings whereby employees are informed and educated concerning the roll-out effort for implementing ABC.
- The last part of the meeting with middle management will set schedule and agenda for these employee roll-out meetings.

This strategic communication plan, involving middle-management, follows the principle of aligning the entire organization from top to bottom with the messages, and the reasons for the implementation of ABC. This careful communication, respectful of middle management's needs to be seen as "in the know", and as leaders, does much to build support in the organization. The messages themselves are important, but not as important as involving middle management, and giving them the tools they need to speak to front-line employees.

#### 4.1.4. Project Level

The mid-level managers and supervisors should communicate information to employees concerning ABC implementation. As stated earlier, the plan should include meetings conducted by middle management to roll-out ABC to the employees. Middle management must be given the opportunity to deliver the messages, answer the questions, and demonstrate support for accelerated bridge construction.

The agenda for the meeting is parallel to the meetings that were held between upper management and middle management. The same items are discussed. Middle management should present the agency's reasons for implementing ABC including:

- Citing successful implementations elsewhere
- Communicate why the agency is implementing ABC
- Allowance for a question-and-answer session.

Just as upper management asked middle management for ideas concerning implementation, middle management should engage employees in those same types of discussions. Middle management should ask employees for ideas concerning how to implement ABC.

A difference in these employee meetings will be that middle management will ask: What tools are required at the project level

to implement ABC? Things like training, realignment of staffing, design software, scanning tours, and other tools to help build knowledge and commitment at the working level. Middle management should carry these requests for resources back to upper management.

#### 4.1.5. Identify ABC Champions at All Levels

As ABC implementation proceeds, the agency will be able to identify ABC champions at all levels. It is important that these champions are given resources, and helped through the process. These champions that blossom are a resource to help the implementation effort. Management should identify these individuals, reward them, and give them what they need to be successful.

#### 4.2. Stakeholder Buy-in

The implementation of ABC requires participation of other important stakeholders. ABC implementation should include the following with respect to contractors, designers and industry:

- Education and training
- Roll-out meetings
- Leading to understanding and acceptance

Implementing ABC changes the way that contractors build bridge projects, and requires more industry-generated prefabricated elements. The agency should carefully think through their strategy for communications and messaging with contractors and industry.

The state should strive for the support of contractors and fabricators. They should be supplied with business reasons, an understanding of direction, and an ability to participate in the implementation. Just as with middle management and employees, the agency must ask the questions of contractors: How do we, the construction industry within this state, implement ABC? The agency can generate much support for ABC by listening to, and acting on these suggestions.

One of the common problems in implementing ABC is that of training and education. Contractors, designers and fabricators will have the same issues. It will fall to the state to provide training and workshops for contractors, designers and fabricators.

#### 4.3. Scanning Tours

One of the most useful implementation efforts is the use of scanning tours. Scanning tours are visits to construction sites where successful implementation of ABC can be observed. In Utah this took the format of visiting states that were more advanced than Utah, and construction sites where interesting ABC techniques were being deployed. Utah stakeholders visited the state of New York to view their implementation of prefabricated elements. They also visited several sites and states where SPMTs (self-propelled modular transporters) were being used to move

bridges. This activity provided the opportunity to see, and hear directly from successful implementers.

The makeup of the scanning tours included Department personnel, Department contractors, Department suppliers, and Department design consultants. Utah was able to pay for these trips by utilizing federal SPR research funds. There were several positives to the implementation effort from these tours. The most significant positive outcome was the demonstration that ABC can be done, and that it can be done in standard applications and projects.

The scanning tours can build confidence, and almost a sense of competition between agencies. One of the most revealing comments came from one of Utah's most successful ABC contractors. Upon seeing the nation's first SPMT move in Florida, the contractor commented "If they can do this in Florida, we can do this in Utah". This contractor went on to be one of the first and now one of the most successful ABC implementers in Utah.

Other benefits of the scanning tours included the establishment of a network for questions. Utah personnel met with other states, and developed a communication link with peers in those states. Those same peer-to-peer relationships occurred within the consultants, fabricators and contractors. The geographical separation between Utah and the locations of the scanning tours meant that these relationships and communications were non-threatening, and non-competitive financially. This allowed for open communication concerning challenges and rewards for implementing ABC. The scanning tours proved to be one of the most often cited, successful, and beneficial implementation strategies.

#### 4.4. Demonstration Projects

Demonstration projects should be a part of ABC implementation. The UDOT used demonstration projects to prove the worth and concept of ABC. UDOT used programs such as "Highways for LIFE", federal Innovative Bridge Research and Deployment (IBRD) funding, and federal research money to help with implementation of ABC demonstration projects. These monies in grants can help the state pay for the increased cost of first implementations. Equally as important were the efforts that led to the first projects. UDOT spent time and effort to ensure the success of these first projects, by choosing good projects, and by allocating resources to ensure that the projects went well. Demonstration projects play an important role in implementing ABC.

#### 4.5. The Role of Innovative Contracting

Innovative contracting, such as the use of Design-Build (DB) or Construction Manager General Contractor (CMGC) can help in implementation of ABC (See Section 2.5). On many of the first ABC projects, UDOT used innovative contracting methods. For instance, the first SPMT project UDOT built was also a CMGC project. The benefits of these innovative contracting methods allow for the introduction of these new techniques and technologies.

CMGC is especially adaptable to ABC with its formation of a design team that includes the owner, the designer, and the contractor. In this design team the owner can exert and ensure that new technologies are not only a part of the contract, but successful. There also seems to be much contractor support of innovation when the contractor is in control of the risk. Innovative contracting places much of the risk with the contractor but also allows him the freedom to innovate and to mitigate risk. The observation from viewing UDOT projects is that there is much synergy between innovative contracting and ABC projects.

#### 4.6. PBES Decision Making Framework

Another organizational modification that was helpful in promoting ABC was the adoption by UDOT of a decision-making framework (See Section 3.1). In UDOT's decision-making framework there was a process by which project managers were asked to consider the use of accelerated bridge construction on all projects. The decision making process was guided by an organizational theme that favored ABC. The decision-making framework implemented by UDOT was instrumental in guiding the programmatic adoption of ABC.

Another component of the decision-making process was a consideration of road user costs (See Section 3.2.3.1). Standardization of a road user cost model and the process by which road user costs are determined should be undertaken. A central unit should conduct the modeling, in a prescribed manner. Road user costs should be computed in the same way for all projects. This standardization of road user cost models also helps with the decision-making process and theme that favors ABC.

An outgrowth of the decision-making process was a realization that to implement ABC there would need to be a mechanism to recognize this early in the project development process and to plan for it within project budgets. In the early phases of implementation it was acknowledged that ABC would cost more than the traditional methods. It was a department policy decision to implement ABC by necessity, and to include these costs in early implementation projects.

#### 4.7. Establish a "Program of Projects"

A good strategy for implementing ABC is to plan for a program of projects. UDOT established a policy early on that they would not just implement demonstration projects, but would announce implementation of a program of projects. This strategy helped give contractors and industry the business reasons they might need to invest in ABC technologies, training and process. Early implementers among contractors and industry recognized that they would have a competitive advantage in subsequent projects if they were involved in the first projects. This led to great competition and great acceptance of the early projects, as contractors were jockeying for position.

The announcement of a program of projects also proved to be an incentive for UDOT personnel to make organizational changes to adapt to

the new normal. The strategy of pursuing a program of projects was a signal to UDOT and the entire industry that ABC was a method of the future. The strategy has proven to be an accelerant for implementing ABC. Another example of this programmatic implementation can be seen in Massachusetts's implementation of ABC. Massachusetts announced in 2010 its intent to consider ABC on all projects, and has begun a substantial program. This has led to a groundswell of support in their industry.

#### 4.8. Develop Specifications, Standards, and Standard Details

Another effective strategy that UDOT employed was the development of specifications, standards, and standard details for ABC. This effort should involve contractors, designers and industry. In UDOT's case, several workshops and convened working groups were conducted to help with the development of standards and specifications. UDOT worked closely with groups such as Utah Association of General Contractors (AGC), American Council of Engineering Companies (ACEC) and the Precast Prestressed Concrete Institute (PCI). This effort included widely distributing draft standards and specifications, and looking to other states for examples of details that might work in Utah. Utah also published manuals on their website, making it available for comment and use.

This strategy also demonstrated UDOT's commitment to ABC implementation. It is another demonstration that they were heading in the direction of an ABC program. This demonstration had positive effects on both the UDOT organization, and the industry in Utah.

#### 4.9. Communication

In developing the implementation plan for ABC, UDOT used professional communication staff. An implementation plan normally consists of a communication plan, a marketing plan, and an organizational plan. UDOT employed professionals trained in communications to help develop the communications and marketing plans. They found that by using careful communication developed by professional communicators, the message reached target audiences effectively.

Professional communicators are especially adept at developing messages and helping to deal with the media. If these messages are carefully crafted, they will resonate with the media and the public. An example of this was a message crafted concerning minimizing the impacts to the traveling public. The communication professionals helped develop the slogan "From Months to Days", as a way to describe that the impacts of the project would be less. It was interesting to watch as the media adopted the message and would say in describing the project that literally the process was going "From Months to Days". These types of messages and this type of media attention help to positively improve the implementation of the ABC program.

Another portion of the messages developed should be meant for helping members of the state executive branch talk about ABC. The agency should develop ways to communicate the messages and successes of

ABC programs. Things such as flyers describing the program could be distributed to the legislature and state executive branch.

Another effective outreach would be to local governments and partner agencies. The fliers containing messages and facts could be distributed widely to help in this educational effort.

There are many other examples of how professional communicators can help with the implementation of ABC. They are trained to recognize the audience and how to tailor effective communications for those audiences. Utah's ABC program benefited tremendously from the involvement of professional communications personnel during the development of the plan; and before, during and after the construction of ABC projects.

#### 4.10. Measure and Share Successes

Part of the implementation plan at UDOT was the development of measures of success. It was immediately recognized that there were certain arguments against ABC and that UDOT would need data and examples of success to negate and mitigate these concerns.

One of the first arguments against implementing ABC will typically be an objection to the cost of changing from current practice. UDOT developed a series of presentations and slides to help policymakers understand that while it may cost more to implement ABC, over time it was hoped that the costs would be less than traditional methods. During the implementation UDOT tracked this cost information and was able to show confirmation of their theory concerning first costs. They were able to show that high costs during early projects went down over time as more projects were completed and as the industry became familiar with ABC. UDOT was able to show that in some cases, costs for ABC bridges are less than traditional methods. Perhaps more importantly, they were able to show that schedules for ABC projects are faster than projects using traditional methods. It is important that agencies implementing ABC collect baseline data and that during the implementation, collect data to help explain the program and show progress. This interim data collection and sharing can be used to help sell the implementation process.

An agency can also develop information to measure public support for ABC. In Utah's case, their first projects showed overwhelming public support for the projects. The public showed support of the speed at which the projects progressed, and the innovative methods that were used. These opinions had great impact on UDOT's public support. Public support has great ramifications for legislative support and hence public funding. Measuring and sharing these statistics has positive organizational impacts. Most people like to be on a team that is recognized positively.

Another strategy that was proven to be effective was to invite legislature and local politicians to ribbon-cutting opportunities. The public opinion of ABC grew, and there was recognition that projects were open to the traveling public faster. Politicians were asked to celebrate these projects

and to be a part of ribbon cutting ceremonies. These opportunities to share in the success of the projects are valuable in helping build momentum and in ensuring political support for implementing ABC.

#### 4.11. Conclusions

There are a variety of strategic implementation efforts that can help a DOT move forward with ABC. Many foundational change management techniques were discussed in this chapter. It is easy to see that these techniques work together, and that they require much planning and preparation, as well as energy in execution. To implement ABC is a journey, not an easily completed trip.

## Chapter 5 Prefabricated Bridge Elements

There are many types of prefabricated bridge elements in use in the United States. Prefabricated elements are used for all components in a bridge. This includes superstructures and substructures. The previously published FHWA Manual entitled “*Connection Details for Prefabricated Bridge Elements and Systems*” [3] covered prefabricated bridge elements in detail. Some of the content from that manual will be re-stated in this chapter. Several concepts have advanced following the publishing of the connections manual. In these cases, the new information will also be included.

Proprietary products are normally prequalified by agencies. FHWA has specific guidelines on the use of proprietary products. These can be found at the FHWA website ([www.fhwa.dot.gov/construction/cqit/propriet.cfm](http://www.fhwa.dot.gov/construction/cqit/propriet.cfm)). Specifications for proprietary products should include, but not be limited to, provisions for the submission of engineering and load rating calculations. The requirement for submission of maintenance and inspection guidelines should also be considered by the agency.

### 5.1. Materials

This section provides an overview of the many different types of materials used in prefabrication and discusses the impact of the materials on accelerated construction processes. Most agencies have approval processes for prequalification of proprietary materials (i.e. grouts, mechanical connectors, etc.). Designers should be aware of the materials that are available for use in a particular agency prior to specifying the material.

#### 5.1.1. Structural Steel

Steel elements are well suited for prefabrication and accelerated construction. There is a high degree of control over fabrication tolerances; therefore, complex connections can be employed using structural steel. Common elements include steel beams and girders, steel grid decks (including concrete filled and exodermic grid decks), and steel railings. Other less common applications include steel pier columns, pier bents and cellular sheet piling abutments.

One advantage that steel has over precast concrete is that it typically weighs less than an equivalent concrete element. This factor can be critical when considering shipping, crane capacities, and SPMT capacities.

Steel has the ability to handle large stress reversals. SPMT bridge moves typically induce large stress reversals during lifting and transport. Pretensioned prestressed concrete beams have limited capacity for these stress events.

#### 5.1.2. Concrete (Normal Weight and Lightweight)

Concrete is a popular and versatile material for prefabrication and ABC projects. The ability to build elements off site in virtually any shape makes this material a prime choice for designers. Common

prefabricated concrete elements include beams and girders, full depth deck panels, and pier caps. Several states have built entire bridges using precast concrete elements including pier columns, abutment stems, footings, and retaining walls.

Concrete can also be used for making connections between different prefabricated bridge elements. These connections often require the use of high early strength concrete to allow for accelerated construction processes.

Durability is a major concern of bridge owners. The new generation of high performance concretes offer durability that exceeds the performance of past concretes. Plant produced precast concrete also has the advantage of being constructed in a controlled environment with higher production and curing standards than normally found in the field. This benefit of higher quality materials of accelerated construction projects is often overlooked or undervalued by designers.

One obstacle to the use of prefabricated concrete elements is the shipping and handling weight. One way to reduce the weight of the elements is to cast voids in the elements during prefabrication. Once in place, the voids can be filled with concrete. The voids can also be used to make connections between elements. A common cost effective way to make voids is to use corrugated steel pipe to form the void. The corrugations are very effective at transmitting very large forces. There have been several research projects that have been completed where the use of corrugated steel voids was studied. Two studies of note are *Development of Precast Bent Cap Systems for Seismic Regions* [11] (NCHRP Report 681), and *Precast Concrete Elements for Accelerated Bridge Construction* [12].

Figure 5.1.2-1 is a sketch of a cantilever abutment showing corrugated steel pipes used to reduce the weight of the abutment stem elements and also to make a connection to a precast concrete abutment cap. The cap connection is made with reinforcing steel dowels cast into the void. The reinforcing is not shown for clarity.

Figure 5.1.2-2 is a sketch of an integral abutment showing corrugated steel pipes used to reduce the weight of the stem elements and also to make a connection to the piling. This approach is based on research completed at Iowa State University [12].

Another way to reduce the weight of elements is through the use of lightweight concrete. The unit weight of concrete can be reduced by 20 percent or more. Lightweight concrete can have a substantial impact on the equipment needed for installation of prefabricated elements. In some cases, the cost savings on the

equipment has been found to out-weight the premium that is paid for the lightweight concrete. The reduced unit weight also reduces the internal forces and stresses on elements as they are handled. The Utah DOT has used lightweight concrete bridge decks on several bridges installed using SPMTs. Appendix C contains a sample specification from the Utah DOT for lightweight concrete. One down-side to lightweight concrete is that some states require overlays on lightweight concrete decks. This requirement can add to the overall project cost and timeframe.

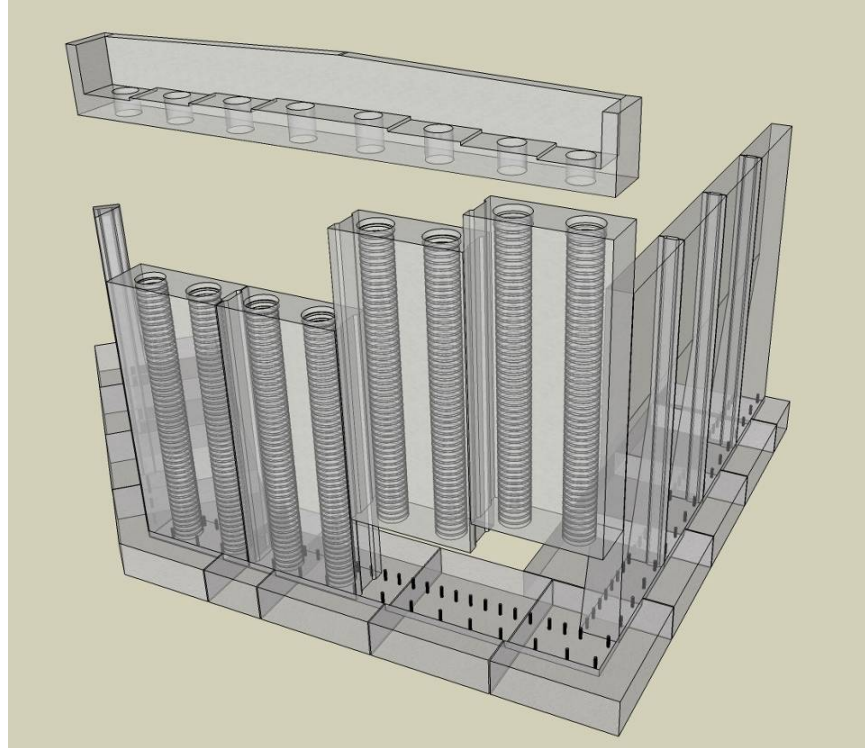

*Figure 5.1.2-1 Transparent View of a Cantilever Abutment Showing Corrugated Pipe Voids*

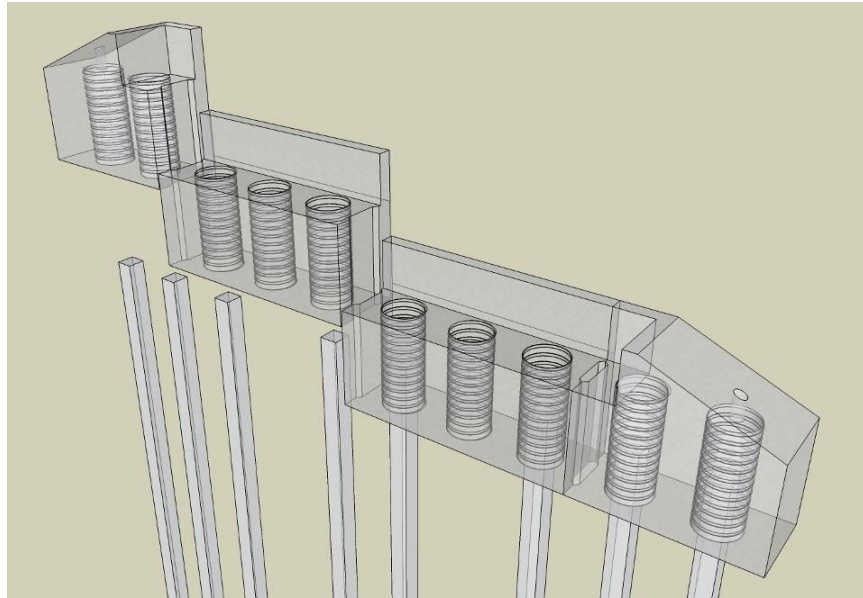

*Figure 5.1.2-2 Transparent View of an Integral Abutment Showing Corrugated Pipe Voids*

Concrete is not only used for fabrication of elements, it can be used for connections between elements. There are many ways to connect bridge elements using grouts and mechanical connectors; however it is inevitable that small closure pours will be required to complete some connections. Figure 5.1.2-3 shows a detail from the Utah DOT ABC standard details. It depicts the integral abutment connection to the bridge superstructure. Concrete is used to connect the drilled shaft to the abutment cap (via a corrugated pipe void) and to connect the superstructure to the substructure. This latter pour connects the beams, deck, backwall, abutment stem, and approach slab, all with one pour. Construction tolerances in all of these elements would not allow for a tight fit-up of all of these elements. The concrete closure pour can make up for all of the tolerances in one location. This is an example of an efficient use of cast-in-place concrete in ABC construction.

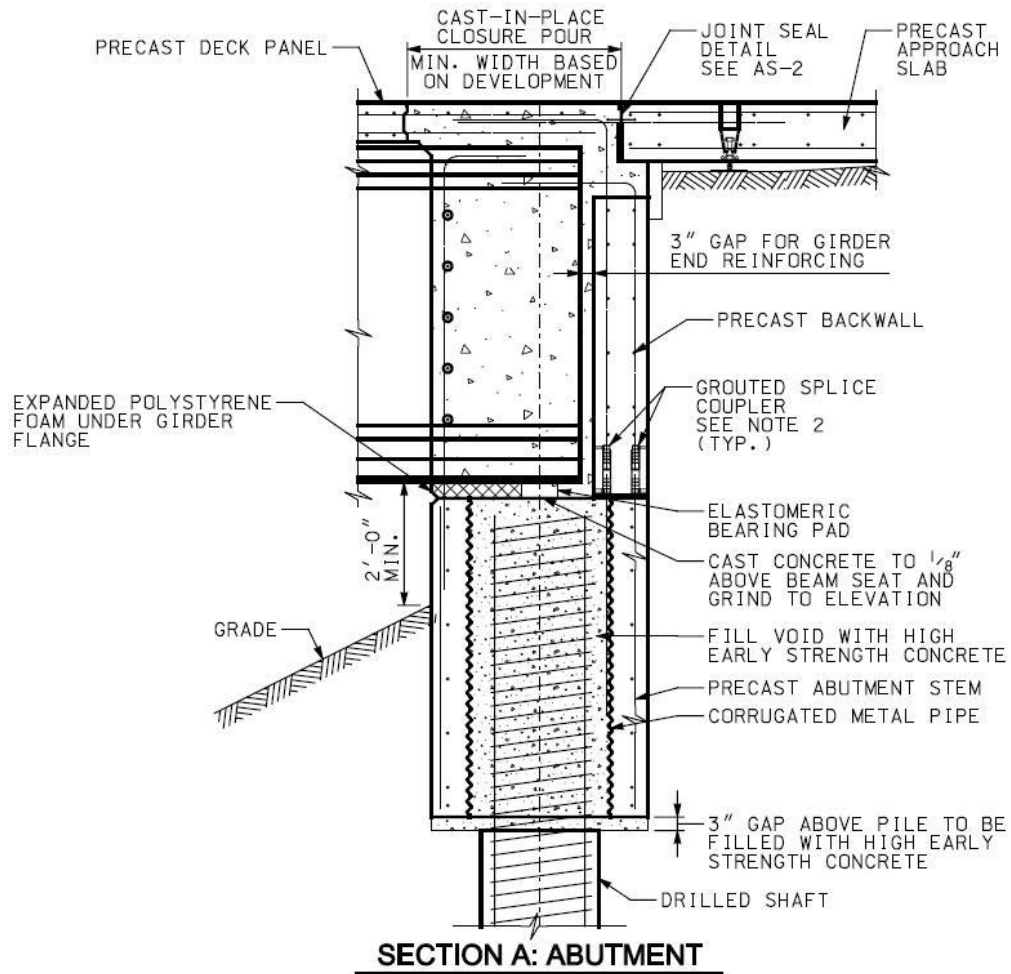

Figure 5.1.2-3 Sample Cast-in-place Closure Pour Detail  
(source: Utah DOT)

Concrete link-slab technology has also been used on ABC projects at bridge piers to make a jointless bridge without live load continuity. The concept with link slabs is to design the connection of the deck across the pier to accommodate the rotation of the beams without significant cracking. This is done by de-bonding a small portion of the deck near the pier to allow for a wider spread of the rotation strain. Information on link slabs can be found in the following papers:

- *Behavior and Design of Link Slabs for Jointless Bridge Decks* [13]
- *Combining Link Slab, Deck Sliding over Backwall, and Revising Bearings* [14]

### 5.1.3. Timber

Timber bridges were common in the 1800's; however the use of timber has waned in the last 75 years. There has been a

resurgence in the use of timber as a bridge material during the last two decades. The use of glue laminated products make the design of larger timber bridge elements more practical and cost effective. Common types of prefabricated timber bridge elements include glue laminated deck panels and glue laminated beams and stringers.

#### 5.1.4. Aluminum

Aluminum elements have been used in the past in various bridge projects. The Pennsylvania DOT has built aluminum girder bridges and used aluminum for bridge decks. Aluminum can be used for prefabricated bridge girders and bridge decks. The material can be extruded into panels that can be connected in the field. Connections can then be made to the bridge girders via grout pockets.

#### 5.1.5. Fiber-Reinforced Polymer

There has been much research into the use of fiber-reinforced polymers in recent years. Many states and universities have experimented with these materials. The development of high strength polymers has made the use of FRP materials practical for many bridge applications. Types of FRP bridge elements include beams and stringers and full-depth deck panels.

The state of New York has had FPR deck systems in place for almost a decade with excellent performance. Maine has led research on the use of fiber exoskeleton structures, pioneering both a technology called “Bridge in a Backpack” and a beam product with a concrete arch encased in a fiber-reinforced case designed by John Hillman.

#### 5.1.6. Grouts

Many of the precast concrete elements discussed in this Manual are joined with grout. The connections between precast concrete elements require the use of grout to fill the void between the adjoining elements. Nominal width joints are required for several reasons. The primary reasons are to allow for element tolerances and to make adjustments in the field. See Section 7.4.3 for more information on element tolerances.

Non-shrink cementitious grout is most often used to easily and efficiently provide a durable, structurally stable connection between precast concrete elements. Epoxy grouts can be used; however, they tend to have a low modulus of elasticity and are expensive when compared to cementitious grouts. In order to achieve desired results, careful selection and specification is required when using non-shrink grouts.

The following section contains information on different grout types. The FHWA manual entitled *Connection Details for Prefabricated*

*Bridge Elements and Systems* [3] has more information on grout placement, curing and specifications.

#### 5.1.6.1. Grout Types

There is no such thing as a generic non-shrink grout. There are several different types of grouts, each with its own advantages and disadvantages. Cementitious non-shrink grouts are inexpensive, generally easy to work with, and develop adequate strengths in reasonable time. These grouts are often pre-packaged and can be extended using small diameter stone for larger pours. Cementitious grouts are ideal for static and light dynamic loadings. This section will focus on cementitious non-shrink grouts since they are adequate for virtually all prefabricated connections. Other grout types may be acceptable for precast connections but require additional specification and suitability considerations on the part of the designer.

Ideally a non-shrink cementitious grout will not exhibit dimensional change in the plastic or hardened state. To achieve non-shrink characteristics in grout, additives are mixed into the grout to counteract the natural tendency of grouts to shrink. There are different types of additives for cementitious grouts in the market. The additives have certain advantages and disadvantages. Several common additives are as follows:

##### *Gas Generating:*

This is the most common grout type. A chemical substance is added to the grout mixture to control shrinkage. In most cases, an aluminum powder is used. A chemical reaction occurs with the aluminum powder and the alkalis in the cement during the plastic phase to form hydrogen gas. The generated gas is used to promote expansion.

However, because small amounts of aluminum powder are used, the expansion can be difficult to control under various conditions. This uncontrolled expansion can cause bleed water to form at the grout surface that can cause loss of support and bond. This has led to the development of alternative compounds that can ensure a quality grout under varying conditions.

##### *Ettringite:*

Ettringite expansive grout relies on the growth of ettringite crystals during the hardened state to counteract shrinkage.

##### *Air Release:*

Air release grouts do not rely on a chemical reaction to achieve expansion. The additive reacts with water to release air and cause expansion.

#### 5.1.7. Ultra High Performance Concrete

A new generation of high performance concrete has emerged in the ABC market. The material is referred to as Ultra High Performance Concrete (UHPC) or as Reactive Powder Concrete. This proprietary product combines high quality cement and stone products along with either steel or organic fibers. The material can achieve very high compressive strengths of 18,000 to 33,000 psi. Another key feature of the material is that it can also achieve very high flexural strengths of between 900 and 7000 psi depending on the type of fibers used. This leads to a material that is very ductile.

Recent research into the product has shown that under high tensile loading, the UHPC will develop tension cracks; however the cracks are very small and tightly spaced, as opposed to wide intermittent cracks found in normal reinforced concrete elements that are exposed to high tensile stresses. UHPC also has very low permeability, which should lead to long service life. FHWA research has shown promising results for several applications (adjacent beam elements, precast full depth deck panel connections). The work focused on creep, shrinkage, resistance to chloride ion penetration, and freeze-thaw behavior.

This high performance material comes at a cost. The unit price for the material is much higher than conventional high performance concrete; therefore replacement of high performance concrete with UHPC on major bridge elements is not financially viable at this time. UHPC has been successfully used on several bridges in the United States for girders and decks on an experimental basis.

Even with its high cost, UHPC has a high potential for use in ABC. The high compressive and tensile strength makes the product ideal for closure pour connections between adjacent elements. On-going testing at FHWA has shown that UHPC can develop reinforcing bars in very small distances. This opens up the potential to have very small closure pours that are fully reinforced. This is perhaps the best use UHPC at this time, where designers can take advantage of the extremely high strength without incurring high overall costs for the bridge. This approach is being studied under the SHRP2 Project R04 entitled "Innovative Bridge Designs for Rapid Renewal". More information on this subject will be available once this research is completed.

Figure 5.1.7-1 is a sketch of a potential flange connection for a double tee girder in use in the Northeast United States called the NEXT Beam. The goal of this connection is to achieve a full moment connection with a lap splice of approximately 5". UHPC

is being investigated for the closure pour connection. The benefit of this type of connection is that it will provide enough moment capacity to make the beams act as a unit. This will allow the use of a live load distribution factor for bridge cross section Type "e" in Table 4.6.2.2.1-1 of the AASHTO LRFD Bridge Design Specifications [8].

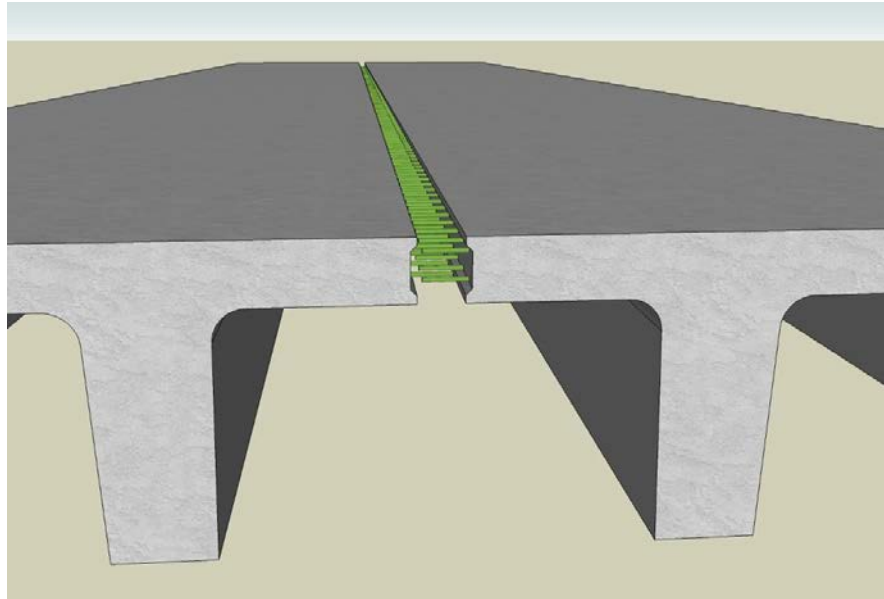

*Figure 5.1.7-1 Potential UHPC Connection for the NEXT Beam (Northeast Extreme Tee)*

#### 5.1.8. Corrosion Resistant Reinforcing Steel

The use of corrosion resistant reinforcing steel is becoming more prevalent in the United States. Corrosion resistant reinforcing offers several advantages over epoxy coated reinforcing bars when used in ABC applications. The lack of coatings on the bars allows designer to layout closure pour areas with shorter lap splice lengths. The strengths of these materials are also higher than conventional reinforcing steel; therefore the number of bars in a connections could potentially be reduced. Epoxy coated bars are in use in many states. These bars are less expensive than other corrosion resistant bar options.

##### 5.1.8.1. Stainless Steel

Stainless steel has long been known as a highly corrosion resistant material. It is a staple of the medical and food service industries because of its high resistance to corrosion. Stainless steel reinforcing bars have been in the United States Bridge Market for many years; however widespread use has not been seen. Recently, several states started specifying stainless steel in order to improve the service life of key elements in the bridge structure, such as the decks.

Specifications for stainless steel reinforcing bars can be found in *ASTM A955-10a Standard Specification for Deformed and Plain Stainless-Steel Bars for Concrete Reinforcement* [15].

#### 5.1.8.2. Low-carbon, Chromium, Steel Bars

A corrosion resistant alloy of steel has been developed for use in reinforcing steel. This material is up to five times more corrosion resistant than conventional reinforcing. It also provides higher strength. The corrosion resistance is not as high as stainless steel; however the unit cost of the material is less, which makes this an attractive alternative to conventional coated reinforcing.

More information on the use of this material can be found in NCHRP Report 679 entitled "Design of Concrete Structures using High-Strength Steel Reinforcement" [60]. Specifications for low carbon, chromium steel reinforcing bars can be found in *ASTM A1035 - 09 Standard Specification for Deformed and Plain, Low-carbon, Chromium, Steel Bars for Concrete Reinforcement* [16] and *AASHTO MP 18M/MP 18-09 Uncoated, Corrosion-Resistant, Deformed and Plain Alloy, Billet-Steel Bars for Concrete Reinforcement and Dowels* [59].

#### 5.1.8.3. Coated and Galvanized Bars

Coated reinforcing bars have been used for many years. There are two common coatings. The first is epoxy coatings. The epoxy prevents moisture from contacting the bar and thereby breaks a potential corrosion cell. Epoxy coatings are typically the most cost effective corrosion resistance option. One downside to epoxy coatings have reduced bond with the concrete; therefore they require longer lap splice lengths. This can become an issue with the size of closure pour joints.

Another coating option is hot dipped galvanizing. This coating is the application of zinc by means of dipping the bars in a molten zinc bath. The zinc coating becomes integral with the bar as opposed to a coating that can chip off. Galvanizing differs from epoxy coatings in that it does not simply prevent moisture from contacting the bar. The zinc is a sacrificial material that will form a corrosion cell before the corrosion cell can form in the steel bar. Galvanized bars do not have the same issues with bond as with epoxy coated bars.

#### 5.1.8.4. Fiber Reinforced Polymer (FRP) Bars

There are several types of fiber reinforced polymer reinforcing bars in use. The most common are glass fiber

bars and carbon fiber bars. These bars do not require coatings since the base material is non-corrosive. The most popular use of FRP bars has been in bridge decks. This is due to the high exposure of the decks to corrosive environments. FRP bars are typically more expensive than steel bars; however, they can be a reasonable choice when life cycle costs are considered. Bending of FRP bars is not possible, therefore geometries for bend bars needs to be carefully planned during the fabrication process.

## 5.2. Superstructure Elements

Superstructures are defined by AASHTO as “Structural parts of the bridge that provide the horizontal span.” For conventional bridges, the superstructure is often defined as the portion of the bridge above the bridge bearings. The following sections contain information on typical superstructure elements and systems used for ABC. These systems include decks, stringers/beams, and large modular systems.

### 5.2.1. Beams and Girders

Prefabrication of beams and girders has been an integral part of bridge construction in the United States for many years. For this reason, this subject will not be covered in any great detail in this manual. The application of these systems to ABC will be presented here instead.

#### 5.2.1.1. Steel

Welded steel girders can be configured in many ways to form a superstructure framing system. The development of high performance weathering steels (HPS) has the potential to reduce the need for painting and/or long-term maintenance over the service life of the bridge. HPS steels have higher strengths and better corrosion resistance than previous typical weathering steels. They also provide improved weldability and higher fracture toughness.

Steel beams can be combined with a pre-topped concrete deck to form modular superstructure units. These modular units have been used to allow the replacement of superstructures in hours instead of months.

#### 5.2.1.2. Precast/Prestressed Concrete

Precast prestressed concrete is one of the most common forms of prefabricated superstructure girders. High performance concrete (HPC) has been introduced into the market to improve the performance and durability of concrete girders. The use of more efficient shapes such as bulb tee girders has become more common.

Adjacent butted precast girder systems such as double tees and deck bulb tees create opportunities for ABC.

These girders function as both the beam and the deck, thereby eliminating the need for deck placement in the field.

#### 5.2.2. Stay-in-place Deck Forming

Stay-in-place deck forming can be used to reduce construction time by eliminating the need to strip forms after deck casting. Several systems have been in use in the United States for many years.

##### 5.2.2.1. Corrugated Steel

Galvanized corrugated steel deck forms can be used to support the deck reinforcing and the cast concrete. These forms span from flange tip to flange tip on adjacent girders. The forms are intended to remain in place for the life of the structure.

They can be used on both steel and concrete girders. Grade adjustment and forming of the beam haunch is normally accomplished through the use of light gage steel angles placed at the flange edges.

Light gage steel stay-in-place forms are widely used in the building industry. In some applications, the forms are used as the tension reinforcing for the deck. This approach has not been used in the bridge industry due to the high moment demand in bridge decks.

The corrugations may require an increase in the volume of concrete so that the lower corrugations can be filled. This can result in an increase in the overall dead load of the bridge. Some states have used expanded polystyrene foam in the corrugations to mitigate this issue. Other designers take advantage of the location of the corrugations to place bottom transverse bars within the lower corrugations, which reduces the overall concrete mass to the same as a conventional formed deck. This approach can only be used where the reinforcement is parallel to the corrugations.

##### 5.2.2.2. Partial-depth Precast Concrete Deck Panels

Partial-depth precast concrete deck panels are similar to steel stay-in-place deck form in that they remain in place and support cast concrete. The difference is that the panel makes up the bottom portion of the structural deck.

Partial-depth precast concrete deck panels have been used by many states, and are extensively used in some states. For example, 85 percent of all bridges built in Texas use this forming method [17]. These panels are typically 3.5 to 4 inches thick and placed on top of the

beams on interior bays. The typical details used in Texas can be found at the Texas DOT Website: [www.state.tx.us](http://www.state.tx.us). Overhangs on bridges with these panels are usually formed using conventional forming methods. The panels have not been cantilevered over the fascia beam because normally the design requires a composite connection between the beam and the deck. A continuous deck panel interferes with this connection. In the past the Texas DOT experimented with a system that used blockouts for shear connectors, but has since decided that it is easier to simply form the overhangs using conventional deck forming techniques.

Once placed, a top layer of conventional reinforcing is placed over the panels and a partial-depth concrete pour is made to finish the composite deck.

These deck panels serve two purposes:

1. They act as a form to support the wet concrete of the deck pour. The slowest portion of reinforced concrete deck construction is the installation of deck formwork. On a conventional bridge, this is accomplished using wood forms or steel stay-in-place forms. These forms need to be fitted between the beam flanges within tight tolerances. The precast concrete panels span between the beams and overlap the beam edges. They are supported temporarily on bedding strips on top of the flanges until the deck concrete flows underneath them to provide continuous support; therefore, installation is faster and requires less manufacturing tolerance.
2. The deck panels also act as the lower portion of the reinforced concrete deck. This is possible because the moment demand in a deck is primarily positive bending in the middle portion of the bay between beams, and negative bending over the beams. Having a discontinuity of bottom mat reinforcing over the beams between the panels is not an issue because the moment demand is resisted by the top reinforcing in the cast-in-place top pour.

Significant research has been completed on partial-depth deck panels. The Texas DOT has sponsored much of this research [18]. There have been laboratory studies and field verification test. Strength tests and cyclic live load tests have also been completed. The results of this research show the following:

- Decks composed of precast panels topped with cast-in-place concrete are stronger and stiffer than full-depth cast-in-place concrete decks [19].
- The panels can be considered a part of the structural deck system.
- Composite action between the panels and the topping concrete is possible without the use of horizontal shear reinforcement.
- The panels combined with the concrete topping can be used as a composite deck for the design of the beam.
- It is preferred to use prestressing as the main reinforcement in the panels.
- The amount of force and the size of the prestress strand should be kept as low as possible to minimize cracking and the development requirements of the strand.

Texas and Tennessee have had good performance on their decks where partial-depth precast concrete decks panels have been used. The key to good performance is a positive support between the panels and the top of the girders. Other States have experienced problems with the panels where fiber board was used to support the panels. The board deteriorated over time and there wasn't a positive support between the panels and the girders. Research has shown that there is a need to work the concrete under the edge of the panels to achieve this positive support

Flexibility of the superstructures should also be taken into consideration. Virginia has experienced significant reflective cracks on flexible steel structures with span lengths greater than 140 feet. These reflective cracks can affect the long-term durability of the deck, particularly where deicing chemicals are used.

### 5.2.3. Full-Depth Deck Panels

The most common form of ABC in use in the United States is the use of full-depth deck systems. The process of installing a bridge deck is one of the most labor intensive operations in bridge construction. Prefabrication of deck systems offers an opportunity to significantly reduce construction time. The following sections describe the most common forms of prefabricated decks systems in use.

#### 5.2.3.1. Precast/Prestressed Concrete

Full-depth precast concrete deck systems have been used by a number of states. A group of northeast states, working as a PCI Bridge Technical committee, has

published design and detailing standards for this type of system [20]. The Utah DOT has also published standard details for full depth precast deck panels. In general, this system is designed as a one-way slab between supporting beams using either mild reinforcement or prestressing.

Figure 5.2.3.1-1 shows a precast deck panel installation on a bridge in Iowa. The photo shows the use of longitudinal post tensioning system used to interconnect the panels and the blockouts used to connect the panels to the beams. Figure 5.2.3.1-2 shows panel leveling devices that were used on the same project. The leveling devices allow the adjustment of the deck panels to meet the prescribed grade. They also provide proper dead load distribution to the supporting beams. This is done by tightening all of the leveling devices to the same torque. This project was a FHWA Highways for LIFE demonstration project. More information on this project can be obtained at the FHWA Highways for Life website:

[www.fhwa.dot.gov/hfl/summary/projects\\_summary.cfm](http://www.fhwa.dot.gov/hfl/summary/projects_summary.cfm).



*Figure 5.2.3.1-1 Precast Full Depth Deck Installation*



*Figure 5.2.3.1-2 Precast Full Depth Deck Leveling System*

There has been significant research [21-37] involving the use of full-depth precast concrete deck panels; therefore, many of the details are thoroughly tested and the behavior of the systems is well known. Most research has focused on the connection between the deck and the supporting beams. Composite action is a prerequisite for most

designs; therefore, this connection is critical. Most of this research has been completed on steel beam connections, and several studies have been completed on precast concrete beams. More research is underway on the connection of deck slabs to concrete beams; therefore designers should keep apprised of further work in this area.

The AASHTO LRFD Bridge Specifications includes some requirements for the design of precast concrete deck slabs on girders (LRFD Section 9.7.5 [8]). This includes the need for transverse grouted shear keys combined with post-tensioning (on longitudinal girder bridges). Recent research has shown that a connection without post-tensioning is viable [9]. Other researchers are studying connections using Ultra High Performance Concrete. These studies may lead to modifications to the AASHTO provisions in the future.

Research is underway at Iowa State University for a new deck panel system that takes advantage of the high strength and quality of ultra high performance concrete. This work is being funded through a grant from the FHWA Highways for LIFE Technology Partnerships Program. The panels resemble a waffle on the bottom with longitudinal and transverse ribs containing the reinforcing bars. The top surface is smooth. This system promises to be lightweight and very durable. The research includes girder connections and fatigue testing. A trial bridge in Iowa will be built with the new system.

More information on precast deck panels can be found in the FHWA Manual entitled "*Connection Details for Prefabricated Bridge Elements and Systems*" [3].

#### 5.2.3.2. Steel Grid

There are several steel grid deck systems in use in the United States. In most cases, the steel grid provides the structure system for the deck. Some systems combine the grid with composite concrete to form a solid deck system with a smooth riding surface. All of these systems can be prefabricated for rapid installation.

One advantage to these systems is that they typically are lighter in weight when compared to concrete decks. This helps to reduce shipping and handling costs for the elements. Grid panels can also be used to increase the load capacity of older bridges that require deck replacements.

The AASHTO LRFD Bridge Design Specifications include provisions for the design of metal grid decks [8]. Designers are also encouraged to contact the Bridge Grid Flooring Manufacturers Association for assistance with details of grid decks ([www.bgfma.org](http://www.bgfma.org)).

The following sections describe the most common forms of prefabricated grid decks systems in use. More information on grid decks can also be found in the FHWA Manual entitled “*Connection Details for Prefabricated Bridge Elements and Systems*” [3].

#### *Open Grid*

Open grid decks have been used for many years. They are most common on bridges that require very lightweight decks, such as moveable bridges and suspension bridges. However, long term durability of elements below the open grid decks are a concern and should be addressed accordingly. This is due to the exposure of the framing to the elements, including road salts in northern climates.

Grid decks are essentially mini-steel framing systems. They usually consist of main rail members in one direction that span between supporting beams, and transverse cross bars in the perpendicular direction that run parallel to the supporting beams.

#### *Concrete Filled Grid*

These systems consist of decks that include a combination of concrete and steel elements. The most common systems involve the use of steel grid. There are two common options for these systems, as described below:

#### *Partially Filled Grid Decks*

These systems include a steel grid deck in which the upper portion of the deck is filled with concrete. In most cases, the concrete is filled over the top of the grid to improve performance by covering the top of the grid.

#### *Exodermic Decks<sup>TM</sup>*

An exodermic deck is a proprietary deck system that is similar to partially filled grid decks except the concrete is primarily placed above the grid. The main bars act as mini-composite steel beams in concert with the concrete over pour. These decks are lightweight and lend themselves to prefabricated operations. Figure 5.2.3.2.2-1 shows exodermic deck details and Figure

5.2.3.2.2-2 is a photograph of a prefabricated exodermic deck installation during a nighttime closure.

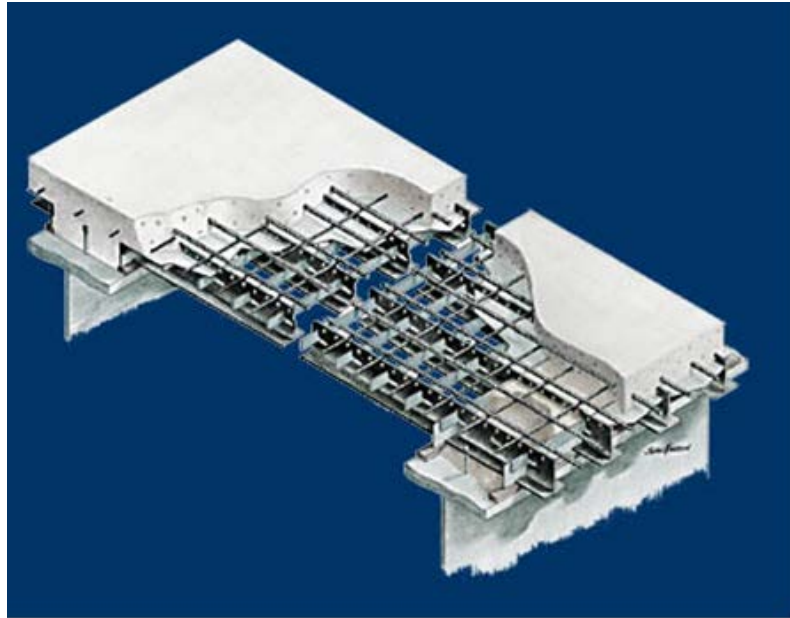

*Figure 5.2.3.2.2-1 Exodermic Deck Details  
(source: D.S. Brown Company)*

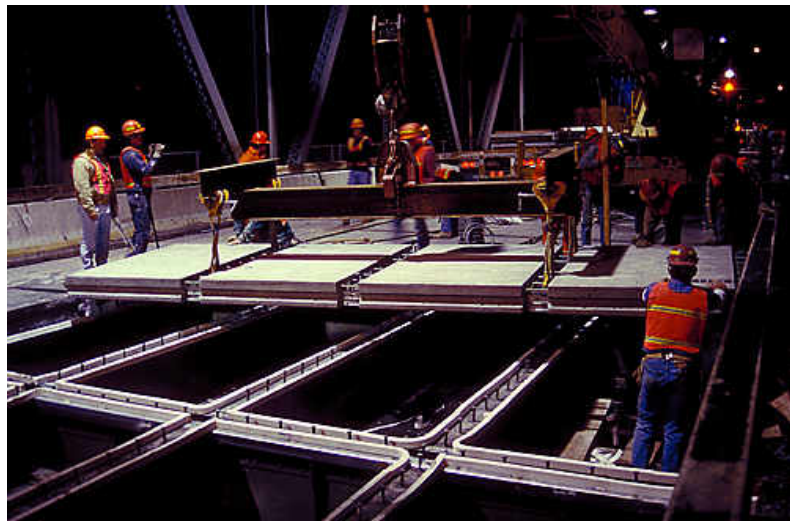

*Figure 5.2.3.2.2-2 Exodermic Deck Installation  
(source: D.S. Brown Company)*

Another similar deck system is the Effideck™ system developed by the Fort Miller Company in New York. This is a composite concrete and steel tube deck system. This deck system is a composite system that includes both steel members and precast concrete. The use of steel ribs reduces the overall weight of the deck. Figure 5.2.3.2.2-3 shows the underside of the Effideck™ system.



*Figure 5.2.3.2.2-3 Underside of the Effideck™ system  
(source: The Fort Miller Company)*

Users of the Manual are encouraged to contact the manufacturers of these systems for guidance with connections for specific bridge projects.

#### *Metal Panel Decks*

Metal panel decks have been in use for many years. Metal deck systems can provide very long service life with reduced weight when compared to traditional concrete decks. The following sections include information on the most common metal deck systems.

#### *Orthotropic Steel Decks*

An orthotropic deck system is comprised of a steel top plate that is supported by open or closed ribs that are welded to the underside of the top deck plate. This forms a system that is very durable and lightweight. Orthotropic decks are primarily used in long span bridges and moveable bridges where savings in deck weight have a significant impact on the overall design of the bridge. Figure 5.2.3.2.3-1 is a sketch of an orthotropic bridge deck panel.

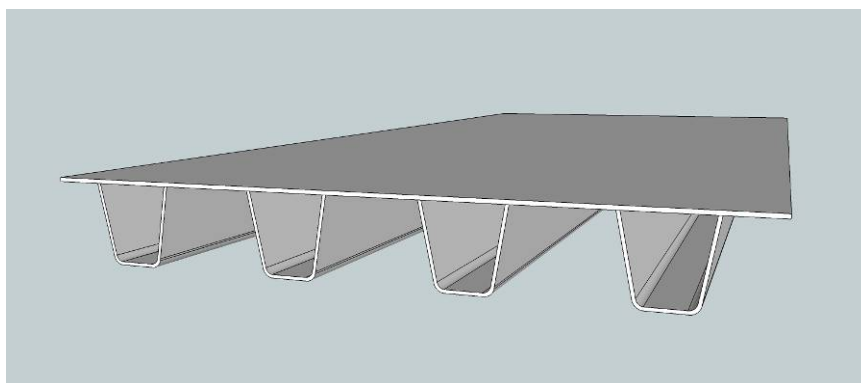

*Figure 5.2.3.3-1 Orthotropic Bridge Deck*

There have been issues with fatigue cracking in the welds in the systems used to date. Significant research has been undertaken to address these issues and improve the design methodologies. Designers are encouraged to study past research before undertaking a design of an orthotropic deck. The cost for orthotropic decks has traditionally been higher than concrete bridge decks. This is often offset by the extended service life that these systems can provide.

FHWA is currently investigating ways to reduce costs for orthotropic decks through the use of modular designs and automated shop welding technologies.

#### *Extruded Aluminum Decks*

Over the years, various forms of aluminum deck systems have been used on bridges. Aluminum is a material that lends itself to extrusion processes. Using this technology, complex shapes can be fabricated including internal closed rib systems. Aluminum also offers a significant savings in dead load, which makes it attractive for rehabilitation of bridges with load restrictions.

Aluminum bridge decks are desirable because of the high strength to weight ratio of the material. The weight savings can reduce shipping and handling costs and reduce the cost of the supporting members. It can also be used for the replacement of decks on existing load restricted bridges. Concerns over weldability of aluminum and the unit cost of aluminum has restricted the use of the material in the past; however there are new manufacturing technologies that have been developed that are improving the quality and reducing the fabrication and construction costs. Figure 5.2.3.2.3-1 shows a portion of an aluminum bridge deck extrusion.

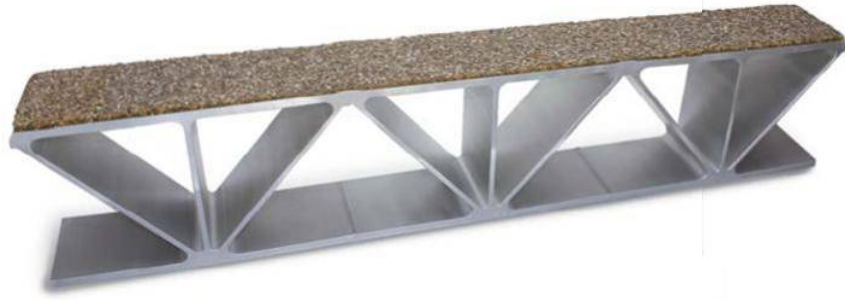

*Figure 5.2.3.3-2 Aluminum Deck Extrusion  
(source: SAPA Industrial Extrusions)*

#### *Steel Sandwich Panels*

New technologies have been brought into use to produce a steel sandwich panel system. This system is similar to the orthotropic deck system except it has a bottom plate in addition to the top deck plate, which forms a sandwich. The final product is similar to the aluminum deck panel system previously discussed.

The fabrication of a steel sandwich panel requires special welding techniques. Welding of ribs in an orthotropic panel system is accomplished in the inverted position with all welds on the underside of the top deck plate. A sandwich panel can only be built half-way in this manner. The top deck plate can be joined to the internal ribs in the inverted position; however, the connection of the bottom plate to the ribs cannot be welded using traditional welding equipment. Hybrid Laser Arc Welding (HLAW) technology is used to solve this problem. This technique can weld two thin plates (less than  $\frac{1}{4}$ " ) together that are laid on top of one another. The welding can be made through one plate and into the lower plate. This allows the bottom plate to be attached to the internal rib plates from the outside.

Laboratory research has been completed by the Maine Department of Transportation on steel sandwich panels that included a study of welding techniques and an analysis of the panels using finite elements [39]. Maine DOT is planning on installing a steel sandwich panel system on a local bridge. Figure 5.2.3.2.3-2 is a sketch of the panel that was studied in the research.

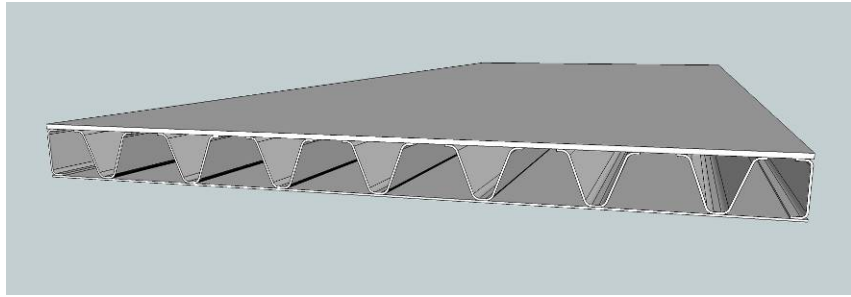

*Figure 5.2.3.3-3 Trial Steel Sandwich Panel Bridge Deck*

#### *Prefabricated Timber*

The United States Department of Agriculture Forest Products Laboratory (USDA FPL) has developed standard details for timber bridges, including details for prefabricated timber panels and beams. There is a significant amount of information on timber bridges at the USDA FPL website. At this time, most timber bridges are used on low volume roadways, but may be applicable to higher volume roads as well. The performance of timber bridges has been very good, especially in regions where the environment is dry. Users of this Manual are encouraged to visit the Forest Products Laboratory website for more information on timber bridges ([www.fpl.fs.fed.us](http://www.fpl.fs.fed.us)).

Prefabricated timber beams and panels are normally manufactured using the glue laminating process. This involves gluing nominal dimension lumber side-by-side to create a solid panel. For deck panels, the wide dimension of the laminations is typically placed vertical. Protection against rotting is controlled by the use of pressure treated wood products. The individual laminations can be pressure treated before being laminated together, or the laminated pieces can be pressure treated after fabrication. The glue used for bridge application must be water proof.

Timber deck panels have been used in two ways:

- Installed on top of beams (glue laminated wood beams or steel beams)
- Installed as adjacent-deck-slab superstructure for short span bridges

The deck panels can be connected with bolting or with post-tensioning. The post-tensioned system offers improved durability; however the tensioning process must be repeated several times during the construction process due to creep of the wood fibers, which tends to relax the post-tensioning forces.

#### 5.2.3.3. Fiber Reinforced Polymer

Fiber reinforced polymers have been used in the aerospace industry for years but have been used only recently in the bridge industry. FRP composites can be manufactured with several different types of fibers combined with polymer resins to form structural shapes. The choice of fiber affects the material properties of the finished product. The most common fibers used are glass fiber and carbon fiber. FRP can be molded into virtually any shape by using established manufacturing methods such as pultrusion and vacuum assisted resin transfer.

FRP products offer the following advantages over other structural materials:

- High tensile strength
- Lightweight
- High fatigue resistance
- Corrosion resistance

The lightweight properties have led to the use of FRP decks on bridge rehabilitation projects. The use of FRP deck panels can have a significant positive effect on the load capacity of the bridge. FRP can be molded into cellular panels that can be used as full-depth deck panels. The panels are similar to the aluminum and steel sandwich panel decks described above. FRP products to date have not been standardized. Each project has been “one of a kind,” based on the manufacturing process of the supplier.

Virginia has installed three FRP decks. West Virginia, Pennsylvania, and Delaware have also installed FRP decks. Ohio had an initiative to install an FRP deck in each of its counties.

#### 5.2.4. Modular Superstructure Systems

Modular superstructure systems are gaining popularity in the ABC market. Accelerated construction can be achieved because the pre-topped modules do not require the installation of a deck after erection. It offers benefits over prefabricated deck systems since the deck is connected to the beam or girder during fabrication. This significant connection which normally calls for grouted shear connector pockets can be a time consuming process in the field, even on ABC projects.

Construction of modular beam systems can be accomplished in less than two days. Some states have installed modular units using an overnight construction timeframe. The connection of the deck edges is the key to long term durability. The following three systems are most commonly found in use today:

- Closure pour with lapped reinforcement
- Small closure pour with Ultra High Performance Concrete (see Section 5.1.7)
- Small closure pour with headed reinforcing bars and non-shrink grout
- Grouted shear key with transverse post-tensioning
- Match cast epoxied edges with transverse post-tensioning

It is very important to use non-shrink or low shrinkage materials in closure pours. Shrinkage of the closure pour concrete can result in transverse cracking or cracking along the precast interface. This cracking is caused by the restraint brought on by the adjacent modular units. Several states are using shrinkage modifying admixtures to reduce the amount of drying shrinkage in the closure pour concrete. Section 7.8 contains more information on concretes used for closure pours.

The use of modular systems inevitably leads to the need to move and erect larger and heavier elements. There are limitations to the use of modular systems that can be controlled by dimensional and weight shipping restrictions and maximum crane capacities. Modules with spans over 100 feet have been used with weights of approximately 150,000 pounds. Lightweight concrete can be considered to offset the weight of larger modules.

The design team will need to evaluate the feasibility of shipping and erecting large modular systems. A detailed erection procedure should be investigated in order to determine the feasibility of the proposed system.

In special cases, a fabrication area near the bridge may offer the best opportunity. This will allow for the fabrication of larger modules that can be moved with specialized equipment. Chapter 2 includes several examples of specialized equipment that can be used to move larger modules. These include SPMT gantries and larger cranes.

#### 5.2.4.1. Modular Steel Systems

##### *Topped Multi-beam Units*

Steel modules offer advantages over precast double tee systems and deck bulb tee systems in some instances due to the reduced shipping weight of the modules. Several projects have been completed to date that involved modular elements that have two or three steel beams that are topped with a precast reinforced concrete deck. Figure 5.2.4.1-1 is a sketch of a modular steel bridge concept that was developed by the Massachusetts DOT.

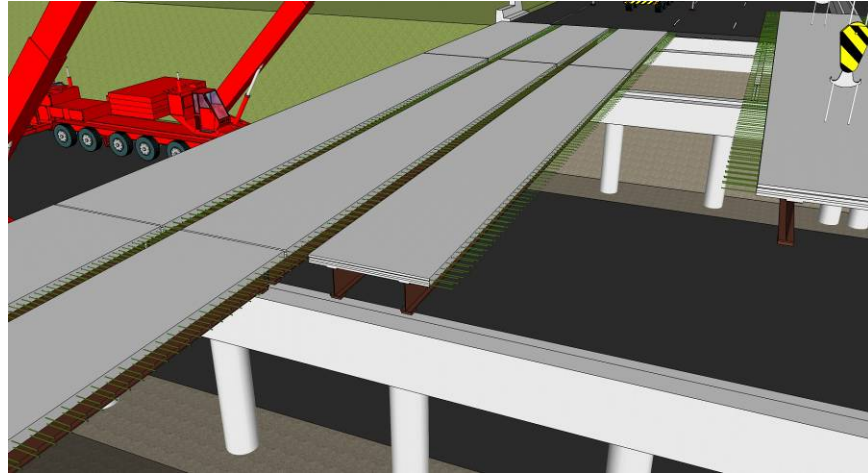

*Figure 5.2.4.1-1 Modular Steel Topped Multi-beam Units*

These modules can be transported and erected in a matter of hours. The bridges can be opened to traffic once the connections at the deck edges are completed. This approach is also being studied under the SHRP2 Project R04 entitled “Innovative Bridge Designs for Rapid Renewal”. More information on this subject will be available once this research is completed.

A modular steel folded plate girder system has also been developed by the University of Nebraska. This consists of modular steel inverted tub girder elements topped with a precast concrete deck. The beams are made of a single folded steel plate. Figure 5.2.4.1-2 shows the folded plate bridge being tested at the University of Nebraska. This system could be very useful for short span bridges. Currently the system is limited to spans under 60 feet due to limits on plate bending equipment.



*Figure 5.2.4.1-2 Folded Plate Modular Bridge Element  
(source: National Steel Bridge Alliance)*

*Design: Simple Span for DL, Continuous for LL*

Multi-span structures can be achieved by using the technology of designing the beams as simply supported for dead load and continuous for live load. This approach has been used for many years in the prestressed concrete industry. By using this technique for modular steel beam units, the time consuming process of in-span bolted field splices can be reduced or eliminated. If live load continuity is not required, link slab techniques can be used to provide a jointless deck at the piers.

The University of Nebraska has studied a cast-in-place closure pour connection for continuity at the piers [40]. They have studied steel I-girders and box girders. The conclusion was that full live load continuity can be achieved using simple connection details.

#### *Orthotropic Systems*

Another potential use of steel in ABC is through the use of modular orthotropic steel deck systems. The two systems being investigated are a single span orthotropic superstructure with the ribs running the entire span of the bridge, and an orthotropic deck T beam that combines a steel girder with a portion of an orthotropic deck. Figures 5.2.4.1-3 and 4 show the two systems being investigated.

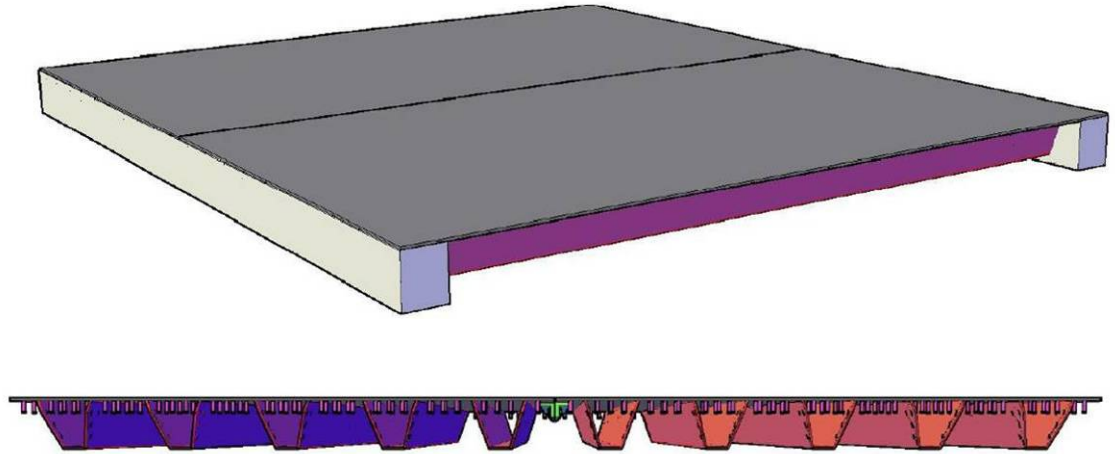

Figure 5.2.4.1-3 Modular Orthotropic Deck Span

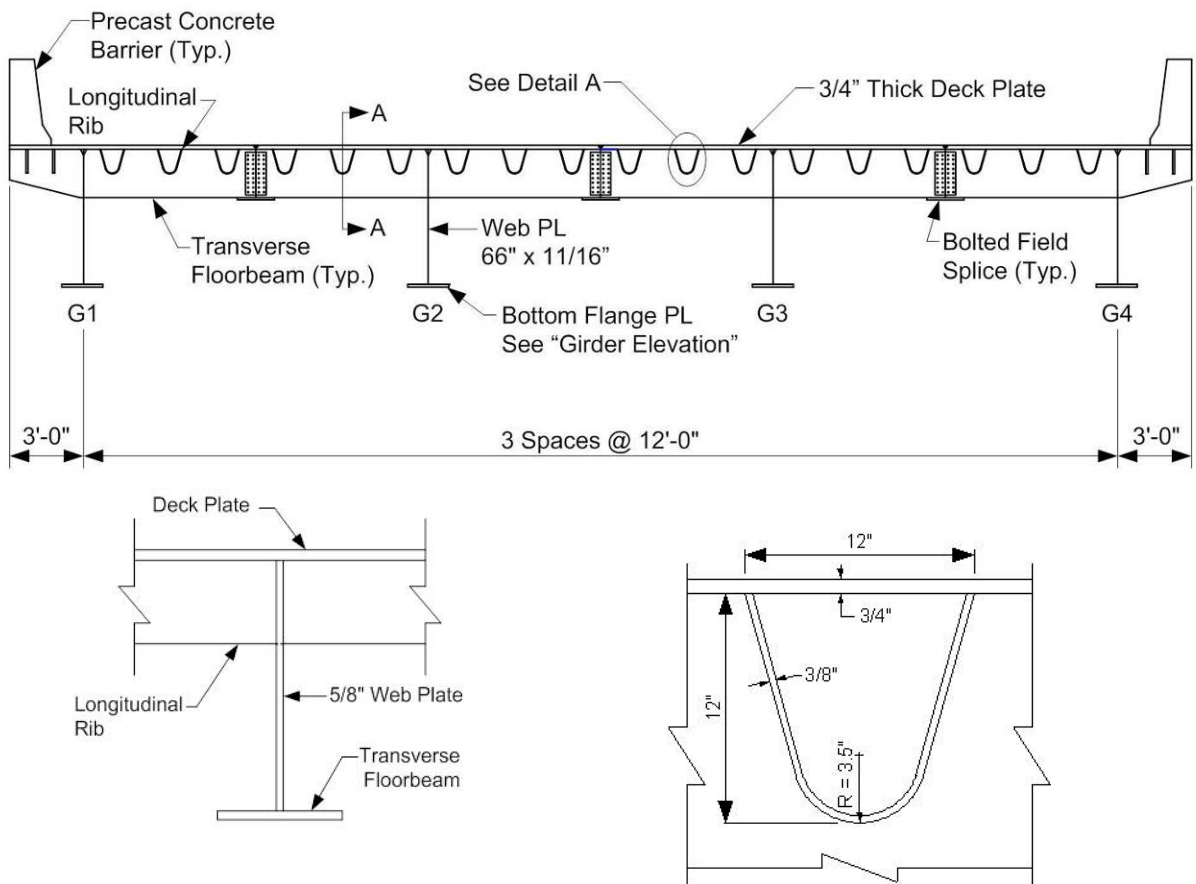

Figure 5.2.4.1-4 Modular Orthotropic T-Beam Bridge Details

As with orthotropic deck systems, the cost for fabrication can be detrimental to widespread use of these systems. FHWA is investigating ways to reduce costs by standardizing designs and through the use of innovative automated fabrication techniques.

#### 5.2.4.2. Modular Precast Concrete Superstructure Systems

Precast and prestressed concrete elements offer significant opportunities for modular superstructure systems. Any system that incorporates the bridge deck into the beam elements will normally result in an accelerated construction process. As with modular steel elements, the connections between the adjacent modules are critical to durable long-term performance (see Section 5.2.4). This approach is also being studied under the SHRP2 Project R04 entitled “Innovative Bridge Designs for Rapid Renewal”. More information on this subject will be available once this research is completed.

##### *Double Tees*

Adjacent butted precast concrete sections have been in used for many years. These structures eliminate the need to form and cast a concrete deck in the field. Traditionally, adjacent butted beam bridges consisted of precast concrete adjacent box beams or deck slabs that were connected with shear keys, bolts or transverse post-tensioning. New approaches to butted systems are evolving through the use of new decked precast sections such as deck bulb tee girders and decked double tee sections. Figure 5.2.4.2-1 is a sketch of a cross section of an adjacent precast concrete double-tee beam bridge.

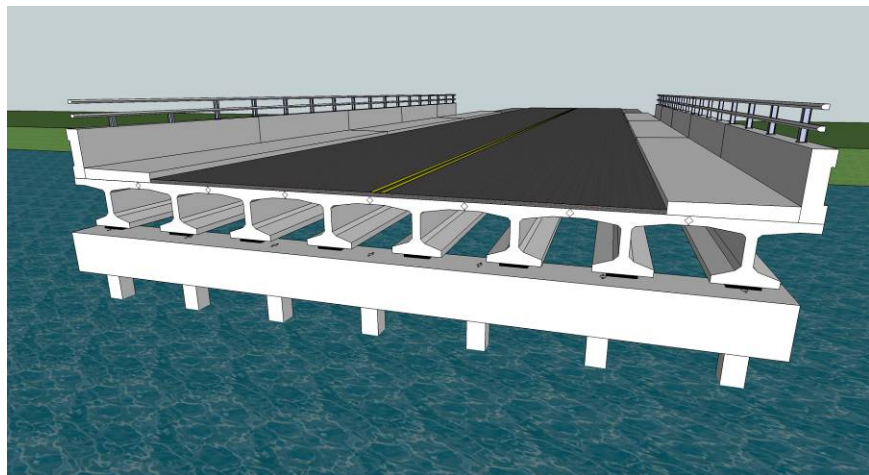

*Figure 5.2.4.2-1 Adjacent Deck Double Tee Beam Superstructure*

### *Decked Bulb Tees*

Decked bulb tee bridges are similar to the Double Tee bridges described in the previous section. These girders are typically modified bulb tee girders that are placed adjacent to one another to form the riding surface of the bridge. The modifications to the girders typically involve thickening and widening of the top flange and modifications to the flange edge to accommodate connections. Figure 5.2.4.2-2 is a sketch of a deck bulb tee bridge.

The most common connection used to date is a welded tab connection. Washington DOT has developed standard details for these girders. To date, deck bulb tee girders with welded tab connections have mostly been limited to low volume roads. This is due in part to concerns over the long-term durability of the welded tab connections. Research is currently underway at FHWA and New York DOT to investigate the use of ultra high performance concrete for the flange edge connections (similar to detail shown in figure 5.2.4.2-1). This research includes long-term fatigue testing to ensure the viability of this connection.



*Figure 5.2.4.2-1 Adjacent Deck Bulb Tee Beam Superstructure*

### *Segmental Bridges*

Segmental construction is becoming more common in the United States. Segmental construction involves the connection of numerous full-width concrete elements using post-tensioning. There are two common forms of segmental construction. The first involves cast-in-place segmental construction, where traveling forms are used to

incrementally cast portions of the bridge. The second involves match casting of precast segments that are lifted into place and post-tensioned together. This form of segmental construction can be considered an ABC method because it is faster than cast-in-place segmental construction.

Normally segmental construction involves the use of elaborate gantry cranes to lift and place the segments without the need for shoring or cranes on the ground. This is beneficial in locations where the areas under the bridge are inaccessible for cranes (i.e. environmentally sensitive areas, roadways, railroads, developed areas, etc.). For bridges over roadways or railroads, the segmental approach can reduce the impacts to the vehicles and trains under the bridge, which makes this method a desirable ABC approach. Reductions in environmental impacts are also a good reason to consider segmental construction.

#### 5.2.4.3. Modular Timber Superstructure Elements and Systems

The United States Department of Agriculture Forest Products Laboratory (USDA FPL) has developed standard details for timber bridges, including details for prefabricated timber panels and beams. There is a significant amount of information on timber bridges at the USDA FPL website. Users of this Manual are encouraged to visit the Forest Products Laboratory website for more information on timber bridges ([www.fpl.fs.fed.us](http://www.fpl.fs.fed.us)).

##### *Laminated Deck Span Systems*

Laminated deck spans are comprised of adjacent timber elements that are laid side by side to form a solid wood panel. These panels can be used to span the entire length of the bridge. The laminations can be made with sawn lumber laid on edge, or glue laminated wood panels. The connection between laminations can be made with spikes, bolts or transverse post-tensioning. The AASHTO LRFD Bridge Design Specifications include design provisions for laminated wood deck spans [8].

Prefabricated laminated deck span bridges can be built very quickly since all the elements are prefabricated, and there is no need for casting of concrete. The final riding surface is typically a bituminous concrete overlay placed over a membrane waterproofing system. Figure 5.2.4.3-1 shows construction of a laminated wood deck span. This was a superstructure replacement in Massachusetts. The connection between panels was made using transverse bar post-tensioning.



*Figure 5.2.4.3-1 Stress Laminated Timber Deck Span  
Top Photo: Panel Erection  
Bottom Photo: Final Post-tensioning  
(source: Massachusetts DOT)*

### *Laminated Girder Deck Systems*

Laminated timber decks can be installed on top of timber or steel beams. These decks are similar to the deck spans except the panels span transversely from beam to beam. Laminated wood beams have been in use for many years in the building industry. In recent years the use of laminated wood beams has become more common in bridge structures.

The design of the beams and decks are covered in the AASHTO LRFD Bridge Design Specifications [8]. The USDA Forest Products Laboratory website contains standard plans for laminated wood beams and decks ([www.fpl.fs.fed.us](http://www.fpl.fs.fed.us)).

As with laminated deck spans, the construction of laminated wood decks and beams can be accomplished very quickly, since all the elements are prefabricated, and there is no need for casting of concrete. The final riding surface is typically a bituminous concrete overlay placed over a membrane waterproofing system.

## 5.3. Substructure Elements

Substructures are defined by AASHTO as the portion of the bridge between the superstructure and the foundation. For conventional bridges, the substructure is normally defined as the portion of the bridge below the bridge bearings and above the footings. The following sections contain information on typical substructure elements and systems used for ABC. These systems include piers, abutments, wingwalls and modular culvert/arch systems.

### 5.3.1. Piers

Prefabricated pier elements have been used by many state agencies. This is due to the difficulty of forming and pouring concrete high above the ground and the fact that substructures offer opportunities for repetition. There can also be significant savings by reducing construction time for substructure work over bodies of water or near hazards such as railroads and power lines.

#### 5.3.1.1. Open Frame Bents

Construction of open frame bents using cast-in-place concrete can be challenging. The shoring and formwork systems required to cast the concrete can be a significant structure in itself. This is especially true for bent caps. Prefabrication of pier elements can save significant time during construction.

Figure 5.3.1.1-1 shows a large bridge built in Florida using precast pier caps and columns. The connections were made using grouted sleeve reinforcing bar couplers.

Figure 5.3.1.1-2 is a sketch of an open framed pier bent based on the Utah DOT and PCI Northeast standards.



*Figure 5.3.1.1-1 Precast Open Frame Pier Bent  
Top Photo: Overall Bridge  
Bottom Photo: Casting of Columns  
(source: Splice Sleeve North America Inc.)*

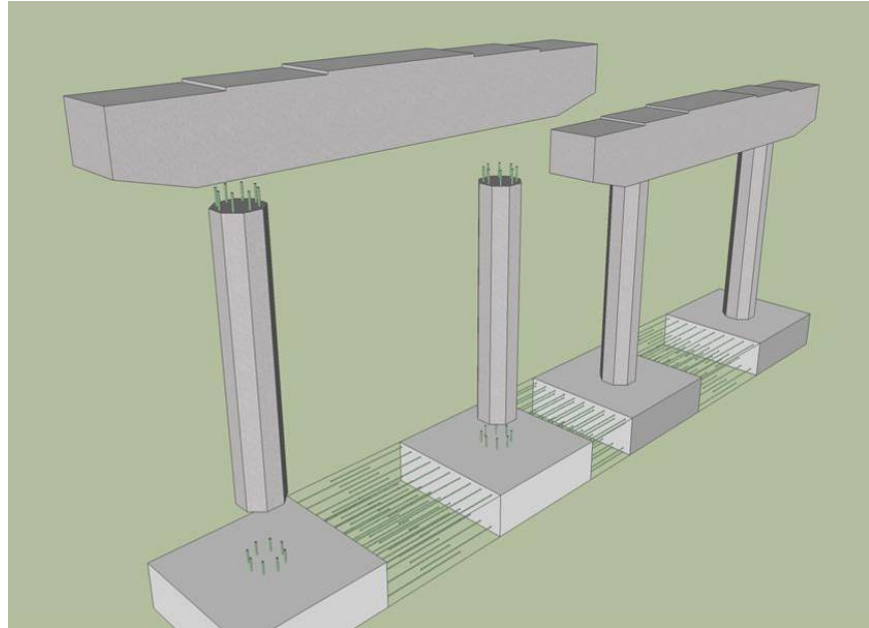

*Figure 5.3.1.1-2 Precast Open Frame Pier Bent Sketch*

Figure 5.3.1.1-3 shows the completed construction of an open frame pier bent in Georgia. The pier columns and caps were constructed using precast concrete. The foundations were cast-in-place concrete. The connections at the base and top of the columns were made using grouted sleeve reinforcing bar couplers. This project was a FHWA Highways for LIFE demonstration project. More information on this project can be obtained at the FHWA Highways for Life website:

[www.fhwa.dot.gov/hfl/summary/projects\\_summary.cfm](http://www.fhwa.dot.gov/hfl/summary/projects_summary.cfm).



*Figure 5.3.1.1-3 Precast Open Frame Pier Bent*

There are several methods of connections that are in use today. See Section 2.3.1 and the FHWA connections manual [3] for more information on the various connections that have been used. This approach is also being studied under the SHRP2 Project R04 entitled "Innovative Bridge Designs for Rapid Renewal". More information on this subject will be available once this research is completed.

The construction of precast concrete piers can be accomplished very quickly. Using precast concrete connection technology, a typical pier bent can be constructed in as little as two days once the footings are in place.

Pier elements are typically constructed with concrete elements; however there are some agencies that have incorporated steel elements into pier construction. Tubular steel pier bents that are based on off shore oil platform technology have been used in Mexico. This technology has had limited use in the United States; however some states are considering this substructure type.

#### 5.3.1.2. Wall Piers

Wall piers are used in situation where open frame bents are not desirable. Examples include piers adjacent to traffic that may be impacted by errant vehicles or river piers where flood debris can accumulate. Prefabrication of wall piers has not seen widespread use in the United States; however several agencies and the PCI Northeast Bridge Technical Committee are investigating the use of wall piers.

Figure 5.3.1.2-1 depicts a prefabricated wall pier that is under development by the Connecticut DOT. This pier will be built adjacent to an existing railroad. ABC is being used in part to reduce the costs of railroad flagging at the site during construction.

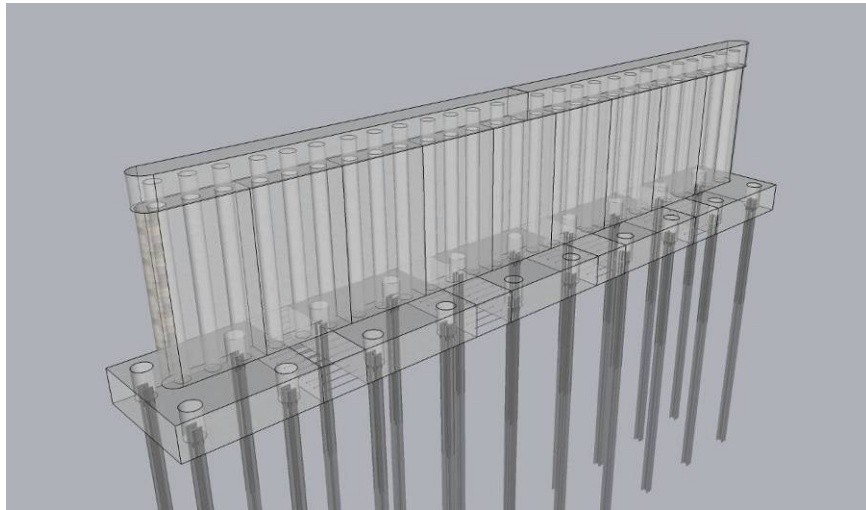

*Figure 5.3.1.2-1 Precast Wall Pier  
Top Sketch: Transparent View  
Bottom Sketch: Finished Pier*

#### 5.3.1.3. Seismic Requirements

Piers are often called upon to resist the majority of seismic forces in a bridge. Designs often account for non-linear plastic hinging in the pier columns. This places a significant demand on prefabricated elements and the connections between elements.

In the past, the design of prefabricated bridge piers for seismic events has been a challenge. There simply was very little seismic research on prefabricated elements and connections. The Utah DOT adopted standards for precast pier elements based on the use of grouted splice couplers. The performance of these connections is essentially the same as conventional cast-in-place

concrete. This connection was developed in the vertical construction industry over 30 years ago. The couplers are embedded in one element and they receive bar extensions from the adjacent element. The two elements are “plugged” together, braced in place, and the coupler is grouted with high strength grout. The popularity of this connection stems from the fact that it emulates a reinforcing bar lap splice in a typical construction joint, which makes the connector very versatile. It can be used in many different connections in a typical bridge such as abutment stems, backwalls, and wingwalls. Another added benefit is that the design of the elements is the same as conventional cast-in-place concrete.

The seismic behavior of these connections has been demonstrated through research and testing [51]. Figures 5.3.1.3-1 depicts a plastic hinge bending test of a conventional cast-in-place concrete column to cap connection. Figure 5.3.1.3-2 depicts the same test on a prefabricated connection made with grouted reinforcing splice couplers. A careful review of the data indicates that the two results are essentially identical. Both connections achieve high levels of ductility. This is an example of how a prefabricated connection can be used to emulate a cast-in-place connection.

Similar results have been found for other connections. One connection that has been studied by several states is very similar to the grouted couplers described above [54-56]. The coupler is replaced with a post-tensioning duct that is cast into one of the elements. These connections require longer dowel bar lengths than grouted couplers; however they are less expensive and allow larger casting tolerances on the dowel bars. The diameter of the duct may cause interference issues with the pier cap reinforcing on heavily reinforced sections, such as single column hammerhead pier caps. One way to solve this problem is to cap the duct just below the top mat of reinforcing in the cap beam. Small diameter grout ports can then be used to install the grout in the duct. Figure 5.3.1.3-3 is a sketch of a grouted duct pocket connection.

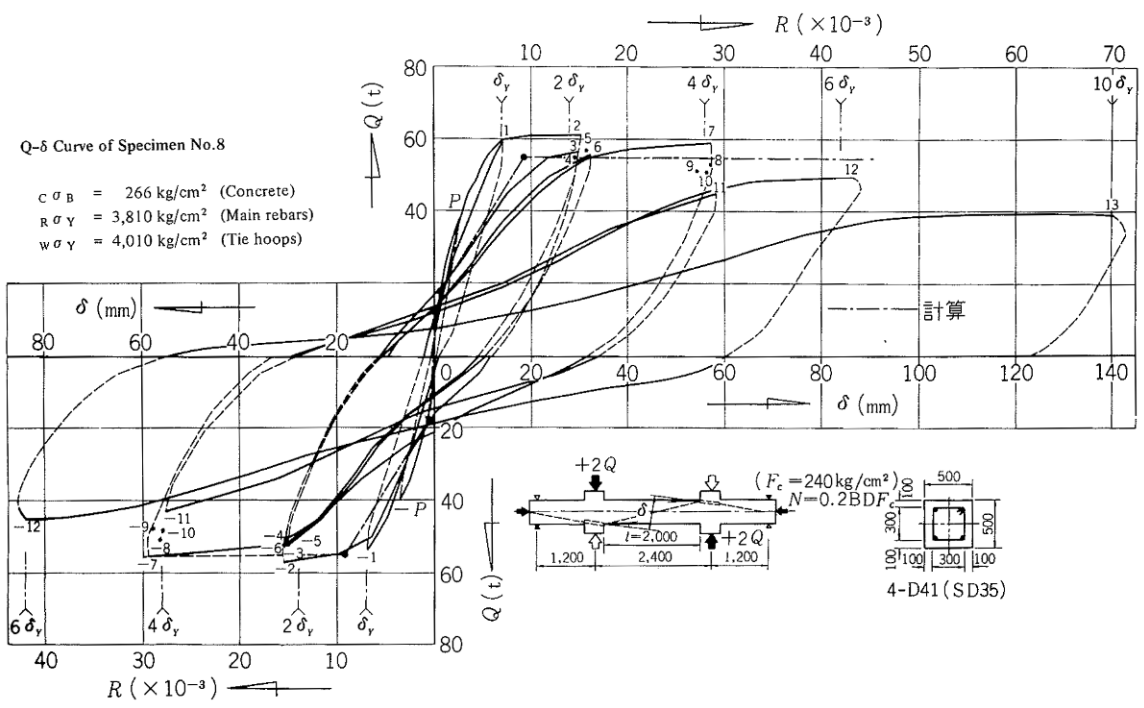

**Figure 5.3.1.3-1 Plastic Moment Connection Test  
Cast-in-place Concrete Column-to-Cap [51]  
(source: Splice Sleeve North America Inc.)**

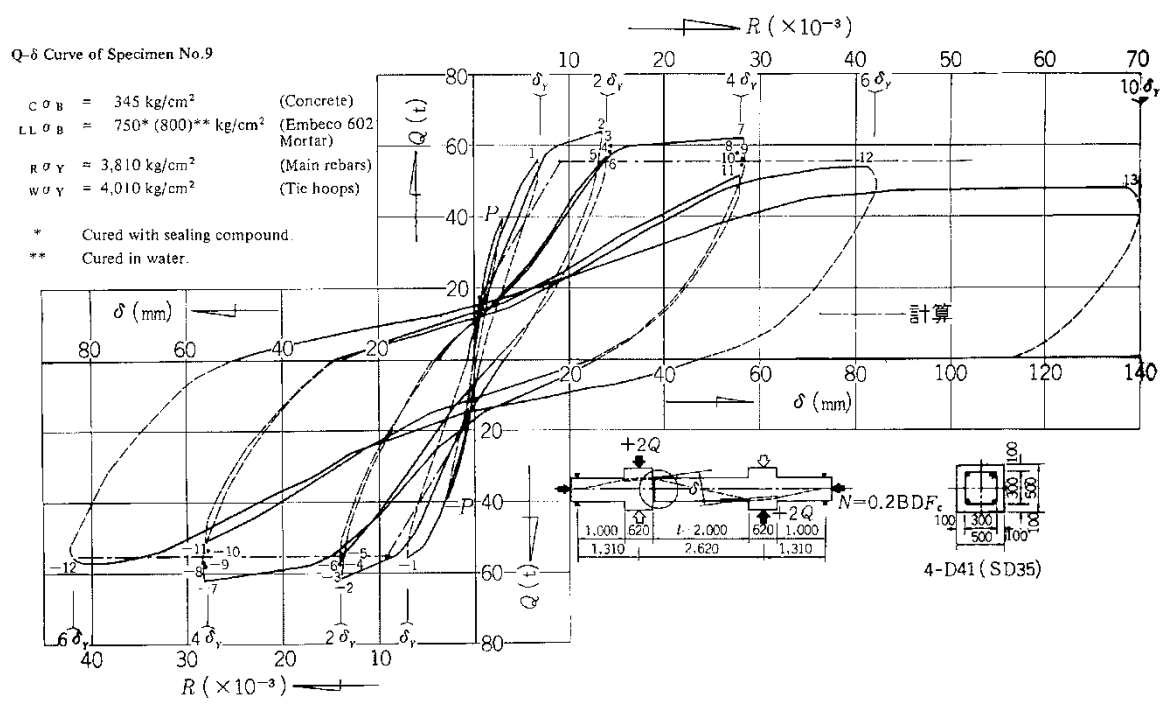

**Figure 5.3.1.3-2 Plastic Moment Connection Test  
Precast Concrete Column-to-Cap [51]  
(source: Splice Sleeve North America Inc.)**

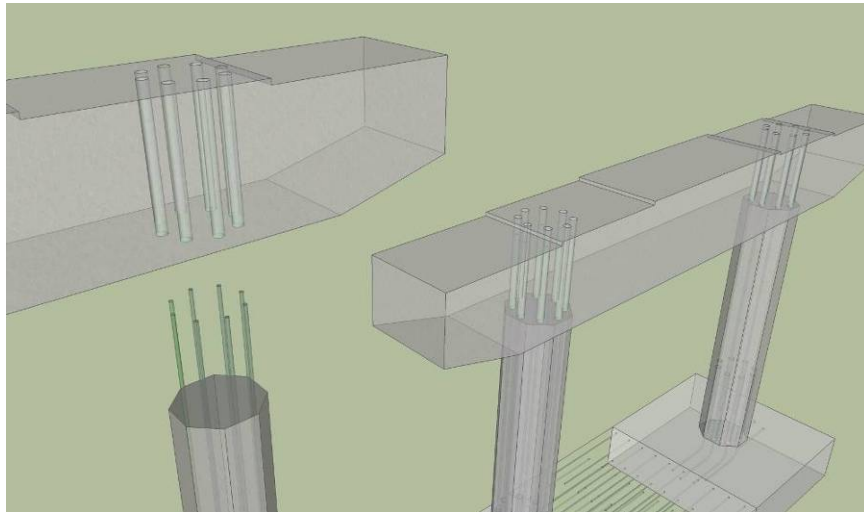
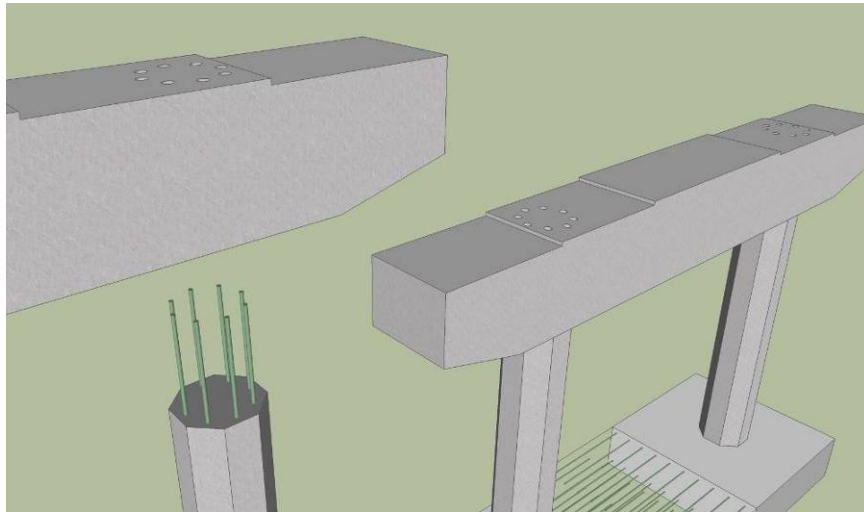

*Figure 5.3.1.3-3 Grouted Post-tensioning Duct Connection  
Top Sketch: Installation  
Bottom Sketch: Transparent View*

Other states and the NCHRP have embarked on new research to study other connections. The recently published Report entitled “*Development of Precast Bent Cap Systems for Seismic Regions*” [11] offers several options for pier cap connections. Washington State has also tested connections using grout filled post-tensioning ducts [54-56]. They are also testing corrugated precast columns ends cast into footings (research is underway). The FHWA connections manual [3] also has more information on the design of prefabricated connections for seismic loading.

### 5.3.2. Abutments

Prefabricated abutments are not as common as prefabricated superstructure elements or even prefabricated piers.

Prefabrication of abutments is feasible. There have been several very successful projects where prefabricated elements were used.

Abutment construction can be a slow process; therefore prefabrication offers an opportunity to reduce the overall project time. There are different types of abutments in use today in the United States. Integral and semi-integral abutments are gaining popularity over conventional free standing wall abutments. Both types of abutments have been built using prefabricated elements; therefore designers can detail prefabricated abutments for virtually any abutment configuration that is in use today. The following sections contain more information on various types of prefabricated abutments.

#### 5.3.2.1. Cantilever

Cantilever abutments serve two purposes. They need to retain the soils behind the ends of the bridge and they need to support the bridge superstructure. Some wall abutments are referred to as stub abutments. These abutments are made as short as possible and are installed at the top of approach embankments. Stub abutments usually only retain soils that are slightly higher than the superstructure thickness.

An example of a prefabricated cantilever abutment is depicted in Figure 5.3.2.1-1. This graphical representation is based on several details developed by the New Hampshire DOT, the Utah DOT and the PCI Northeast Bridge technical Committee. All elements are precast concrete. The footings are connected to the wall stems using grouted reinforcing splice couplers. Corrugated steel pipes are used in the abutment stems to reduce shipping weight and to facilitate the connection between the wall stems and the abutment cap. The abutment cap is connected to the wall stems using a reinforcing bar cage cast into the corrugated voids. The vertical joints are left open or filled with expansive foam. This replicates a typical expansion joint in a cast-in-place concrete abutment.

An abutment similar to this was constructed in Epping, New Hampshire in less than three (3) days once the excavation was complete. The design of the abutment is the same as a cast-in-place abutment since the connections simply emulate cast-in-place concrete construction joints with reinforcing lap splices.

The Utah DOT has developed standards for cantilever abutments. These can be found at [www.udot.utah.gov](http://www.udot.utah.gov).

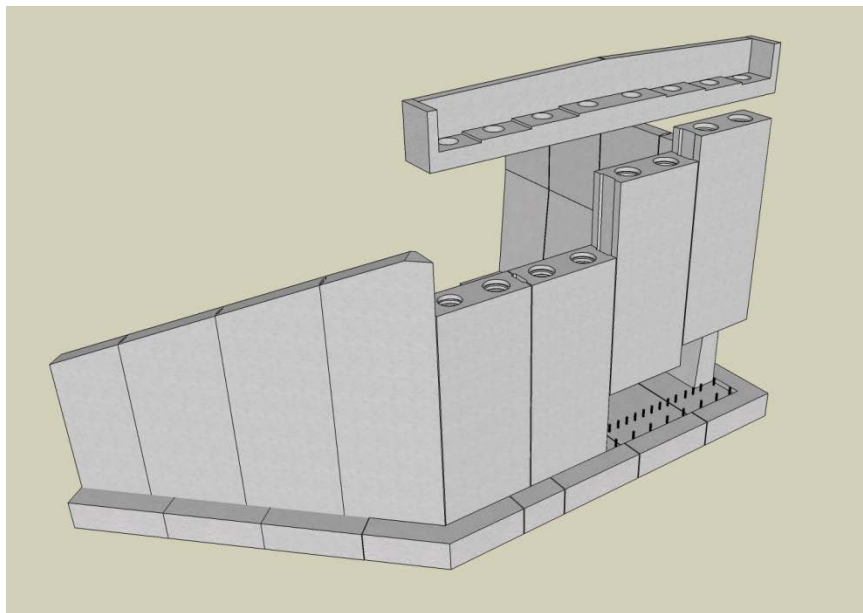

*Figure 5.3.2.1-1 Precast Concrete Cantilever Abutment*

#### 5.3.2.2. Spill-Through

The intent of spill-through abutments is to reduce the amount of soil pressure on the cantilever abutment by installing large voids in the stem. Spill-through abutments are similar to piers except the majority of the structure is below grade. Information in Section 5.3.1.1 can be used for prefabricated bridges with spill-through abutments.

#### 5.3.2.3. Integral and Semi-Integral Abutments

Integral abutments get their name because the abutment structure is made integral with the superstructure elements. There are two major advantages for the use of integral abutments:

- Integral abutments do not have deck joints. This eliminates one of the most common deterioration areas on bridges.
- Integral abutments transfer the embankment soil forces into the bridge superstructure. The superstructure has tremendous available capacity for axial load; therefore this usually has no effect on the superstructure design. Integral abutments are normally supported on a single row of piles that are designed to move with the bridge during thermal cycles and rotate with the beam end under live load. The result of this approach is that the abutment does not need a spread footing or multiple rows of piles to resist the overturning soil forces.

There are two types of integral abutments. The most common is a fully integral abutment where the connection to the superstructure is a full moment connection. The second type of integral abutment is a semi-integral abutment where the moment connection is replaced with a pinned connection that allows rotation of the superstructure with respect to the substructure.

An example of a prefabricated integral abutment is depicted in Figure 5.3.2.3-1. This graphical representation is based on several details developed by the Utah DOT and several other states. The concept is based on the use of corrugated steel pipes to form voids in the stem and complete the connection between the piles and the stem. The corrugated void connection was originally developed by the Iowa DOT and researched by Iowa State University. The results of the research are published in a report entitled "*Precast Concrete Elements for Accelerated Bridge Construction*" [12].

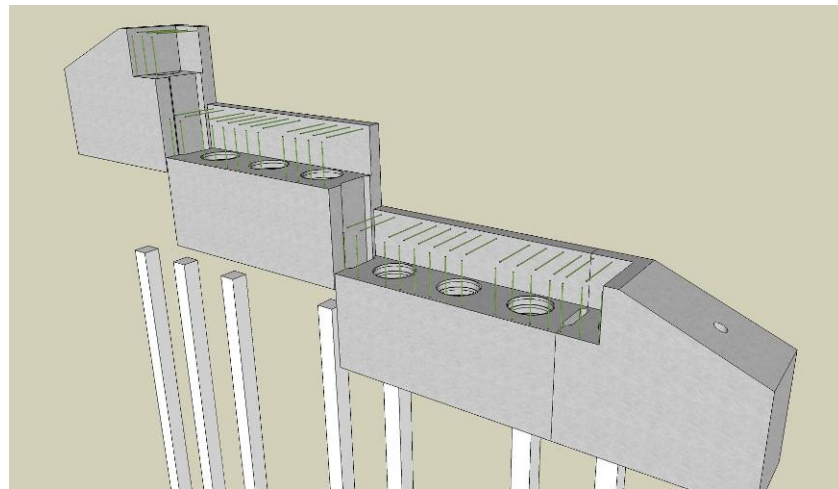

*Figure 5.3.2.3-1 Prefabricated Integral Abutment*

The connection of the superstructure to the integral abutment is normally accommodated with a cast-in-place concrete closure pour. Some states have used match casting combined with transverse post-tensioning to connect the stem elements. It is possible to design the abutment with simple grouted vertical shear keys. The vertical reinforcing is then designed to accommodate the soil and pile forces. The transverse reinforcement is used for distribution reinforcement. This approach was developed by the Utah DOT. Details for this can be found at: [www.udot.utah.gov](http://www.udot.utah.gov). Appendix A has more information on the design of precast integral abutment stems.

Semi-integral abutments are similar to integral abutment designs in that a portion of the abutment is made integral with the superstructure. The semi-integral approach includes a joint that allows for un-restrained rotation and thermal movement. Several states have built semi-integral abutments where the backwall is integral with the beams and is located at the end of the beams. The backwall is simply cantilevered and lapped behind the abutment stem. Figure 5.3.2.3-2 is a sketch of this approach. This system lends itself well to superstructure installations using large scale installation methods such as SPMTs and lateral sliding/skidding. The lack of a significant connection between the superstructure and substructure allows for tolerance adjustment during the superstructure installation. This approach is also being studied under the SHRP2 Project R04 entitled "Innovative Bridge Designs for Rapid Renewal". More information on this subject will be available once this research is completed.

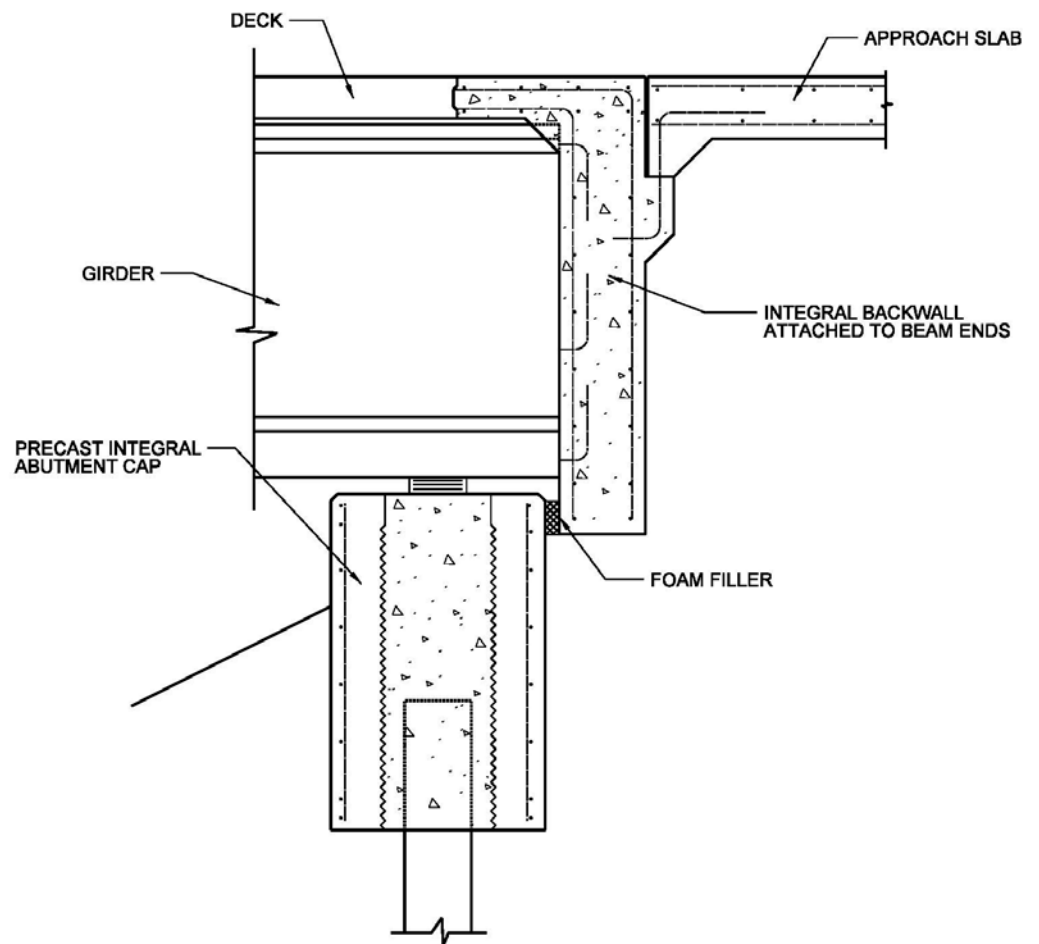

Figure 5.3.2.3-2 Semi-Integral Abutment

#### 5.3.2.4. Geosynthetic Reinforced Soil Integrated Bridge System (GRS)

The FHWA has developed a unique abutment system that integrates the approach roadway fill with the abutment to produce a system that functions as one unit. The superstructure is placed directly on top of a geosynthetic reinforced soil wall. This allows the superstructure to settle along with the approach fill, thereby eliminating the needs for approach slabs to prevent differential settlement bumps. Section 2.1.2 of this manual contains more information on GRS abutments. GRS abutments can be built in one week or less, because there is no need for placement and curing of site cast concrete. Entire bridges can be built in approximately 8 weeks. Figure 5.3.2.4-1 shows a GRS-IBS bridge that was built in Ohio.



*Figure 5.3.2.4-1 GRS-IBS Bridge Example  
Top Photo: GRS Abutment During Construction  
Bottom Photo: Completed Bridge (built in 47 days)  
(source: Defiance County Ohio)*

#### 5.3.2.5. Seismic Requirements

The design of prefabricated abutments for seismic should normally follow the same design requirements for conventional abutments. This is because most prefabricated abutments are designed and detailed to emulate conventional abutments.

The elements that make up the abutment and the connections between the abutment stem and the footing on cantilever abutment needs to be able to develop the forces that are imposed during seismic events. Spill through abutments may need to be designed and detailed in a similar fashion as piers since the construction is similar.

The design of GRS bridge abutments for seismic events is provided in the FHWA Geosynthetic Reinforced Soil Integrated Bridge System, Interim Implementation Guide. This can be found at:  
[www.fhwa.dot.gov/publications/research/infrastructure/structures/11026/index.cfm](http://www.fhwa.dot.gov/publications/research/infrastructure/structures/11026/index.cfm)

#### 5.3.3. Wing Walls and Retaining walls

Wingwalls and retaining walls are types of earth retaining systems. There are many different types of systems for constructing earth retaining walls. The most common types of walls include:

- Concrete Cantilever
- Concrete Gravity
- Mechanically Stabilized Earth
- Prefabricated Modular
- Anchored
- Cantilever Sheet piling and Soldier Pile

The AASHTO LRFD Bridge Design Specifications [8] includes design information about each one of these wall systems. This section will include information on prefabrication of retaining wall systems and how they can be used in accelerated construction projects.

Some of the systems shown in this section are proprietary; however in most cases, there are multiple manufacturers that can produce similar walls. Some states allow multiple wall systems for larger wall projects by bidding the walls as a Design-Build product, where the manufacturer designs the wall based on the constraints of the site.

##### 5.3.3.1. Precast Concrete Cantilever

Conventional cantilever walls are normally comprised of a reinforced concrete footing connected to a reinforced

concrete stem. These wall types are common for wingwalls on bridges that are relatively short in both length and height. Figure 5.3.3.1-1 depicts a sketch of a precast concrete cantilever wall, based on details developed by the New Hampshire DOT. These details were used on the Epping Bridge in New Hampshire, where the entire bridge was constructed in only eight days.

The construction time for a typical wall of this type can be accomplished in as little as two days (for a typical wingwall of reasonable length).

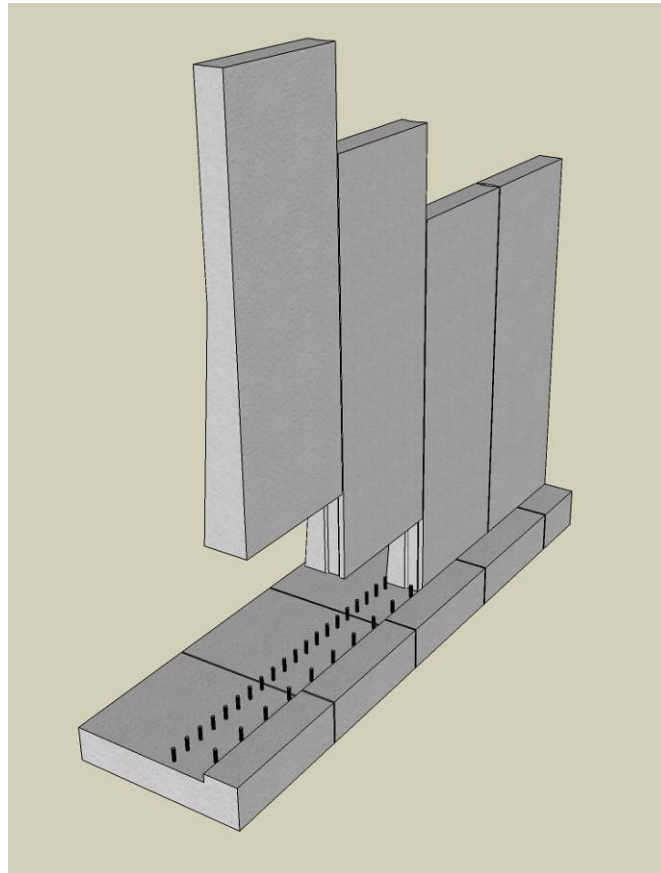

*Figure 5.3.3.1-1 Precast Concrete Cantilever Wingwall*

#### 5.3.3.2. Modular Precast

Modular precast concrete wall systems are walls that are made up of prefabricated elements that are joined in different ways to create a wall system.

There are two distinct types of prefabricated wall systems that are primarily in use today, Mechanically Stabilized Earth and Modular Block retaining walls. There are also other systems in use and more in development. All of these wall systems include prefabricated elements;

therefore they are well suited for prefabricated bridge projects.

#### *Mechanically Stabilized Earth Systems (MSE)*

MSE systems normally use prefabricated wall panels that are connected to earth reinforcing devices. These devices engage the soil mass behind the wall face to create a soil mass gravity wall. There are also wall systems that use GRS fabric, wire mesh or natural vegetation in place of the wall panel facings. The construction of these walls can progress rapidly because the system is built while the soil is being placed behind the wall; thereby combining two processes into one.

MSE walls systems may be proprietary. There are multiple manufacturers that make this type of system; therefore public bidding of these wall systems is possible. Most agencies have standard details or approved wall products; therefore individual details from each state are not presented in this manual.

Figure 5.3.3.2-1 depicts a typical wall section for a mechanically stabilized earth wall. Designers should contact each state to determine which wall systems are allowed for use.

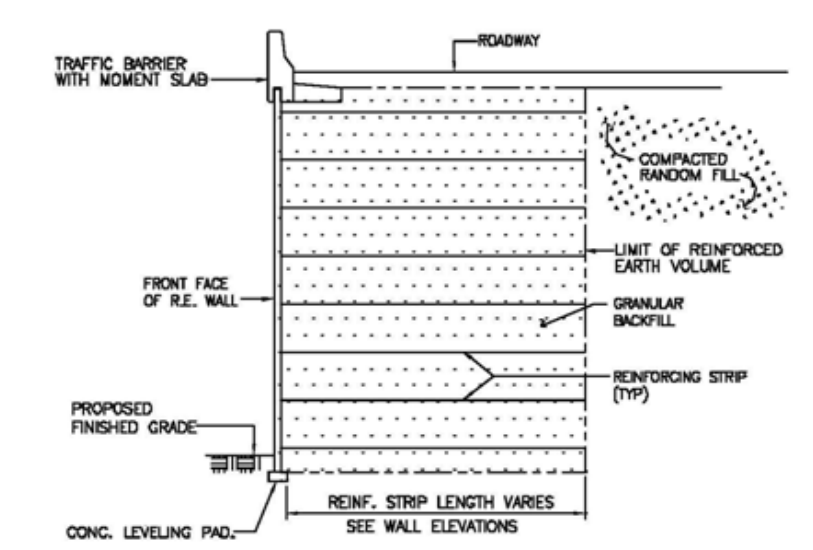

Figure 5.3.3.2-1 Typical MSE Wall Details

#### *Modular Block Systems*

Modular block retaining walls are a form of gravity retaining wall in which the cast-in-place concrete is replaced by modular reinforced concrete modules that interlock to form a wall system. The system resists soil forces by the mass

of the wall and sometimes by the mass of soil placed within voids in the blocks.

As with MSE systems, modular block walls are normally proprietary. Many states have approved product lists for these wall systems; therefore individual details from each state are not presented in this manual. Figure 5.3.3.2-1 depicts a typical wall section for a modular block wall. Designers should contact each state to determine which wall systems are allowed for use.

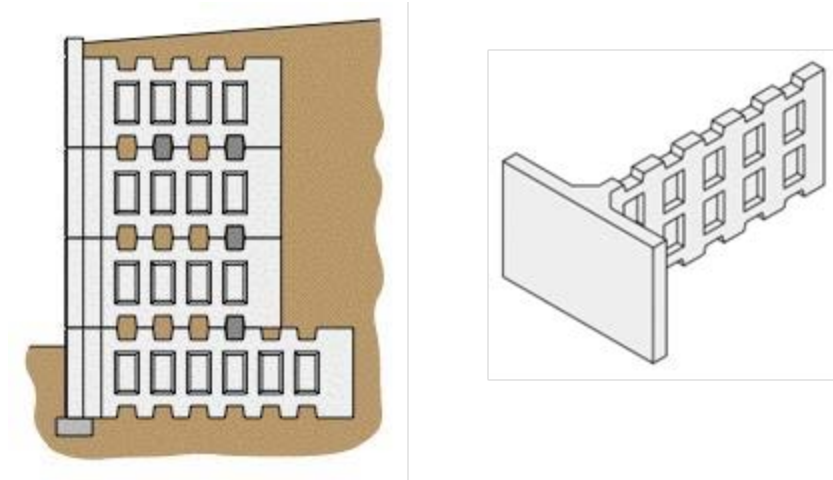

*Figure 5.3.3.2-2 Modular Block Wall Example (T-WALL®)  
(source: The Neel Company)*

#### 5.3.4. Modular Culvert/Arch Systems

Culverts represent a significant portion of the structures found on typical highways. Many states currently use prefabricated arch structures. The most common forms are precast concrete box culverts and corrugated steel arch pipes.

A new generation of modular culvert systems is gaining popularity due to the desire to provide a bottomless stream bed by regulatory agencies. These systems consist of arch structures or three sided frame structures supported on strip footings.

##### 5.3.4.1. Precast Arches and Three Sided Frames

Several manufacturers have developed precast concrete arch and three sided frame systems. These systems consist of precast strip elements placed side-by-side to create the bridge span. Most systems are filled with granular backfill placed over the precast elements to complete the structure. In some cases, these structures have been slid under existing bridges without closure of the overpass roadway. Once in place the voids between

the two structures can be quickly filled with granular fill after removal of the bridge, or filled with flowable fill without removal of the existing bridge.

Most precast systems are complete span elements that include the vertical stems. Other systems consist of two or three precast arch elements connected in the field to complete the arch. Some of these systems are developed by private companies and others have been developed by state agencies.

In most cases, the arches are designed as a two-hinge arch. The connection to the footings is designed as a pinned connection. The arch base is simply inserted into a keyway in the footing and grouted in place.

Figure 5.3.4.1-1 depicts an arch system called the Con/Span® Bridge System. This system, including the arch elements, the spandrel walls, the wingwalls and the footings, can be completely made with precast concrete elements.

Construction of a typical precast arch structure can be completed in as little as one week, since all elements (including the footings) can be made with precast concrete.

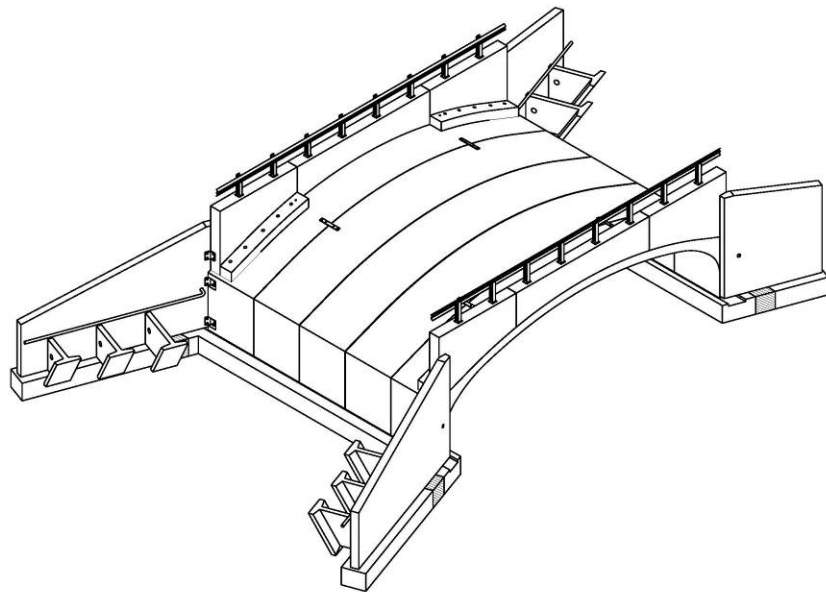

*Figure 5.3.4.1-1 Con/Span® Bridge System  
(source: Contech Construction Products, Inc.)*

#### 5.3.4.2. Steel Arches and Pipes

Corrugated steel arches and pipes have been in use for many years. Steel plate arches can span significant distances in order to span rivers, roadways or even railroads. The arches can be designed as a culvert or as a bottomless frame supported on concrete footings.

Construction of a typical steel plate arches can be accomplished in as little as one to three days depending on the water handling needs, the complexity of the shape and the number of plates required to make up the structure.

#### 5.3.4.3. Box Culverts

Many state agencies have developed standard details for precast concrete box culvert systems. The American Society of Testing and Materials (ASTM) Specification C1577 entitled "*Precast Reinforced Concrete Monolithic Box Sections for Culverts, Storm Drains, and Sewers Designed According to AASHTO LRFD*" [41] can be used to design and detail these systems. This ASTM specification is for single cell box culverts. For multi-cell box culverts, designers typically butt single-cell units side-by-side.

The use of precast concrete box culverts has become commonplace across the country; therefore, significant details are not presented in this Manual. Readers are urged to contact state highway agencies for more information on the details used in their region.

The construction time for a precast concrete box culvert can vary depending on water handling needs. For simple sites, the construction can be completed in one to three days.

### 5.4. Foundations

This section will describe in general the types of foundation elements that are commonly used on ABC projects that involve new foundations. On some ABC projects, such as superstructure replacement projects, the foundation can be re-used. In these cases the foundation capacities should be investigated. This section has been broken out into typical foundation elements that are used on most bridges. The AASHTO LRFD design specifications [8] define constructed foundations as spread footings, driven piles and drilled shafts.

#### 5.4.1. Common Deep Foundations

Most state agencies design bridges with deep foundations that are either supported on driven piles, micropiles, continuous flight auger piles, or drilled shafts. Pile foundations are normally capped with concrete footings in order to provide a stable platform to support piers, walls and abutments. For short span bridges, the

piles bents can be used (piles directly connected to the bent cap). Pile bents are cost effective and can be built quickly since there is no need for a footing. Most pile bents are constructed with precast concrete piles.

Drilled shafts are becoming more popular. Large diameter drilled shafts can be used to support individual concrete pier columns, thereby eliminating the need for a concrete footing. The Washington State DOT has developed ways to connect precast concrete pier columns to drilled shafts. The method involves the use of non-contact lap splices in a small closure pour at the base of the column. The column reinforcing is kept to a smaller diameter than the shaft reinforcing, thereby allowing the column reinforcing cage to be placed within the top of the shaft reinforcing. This connection was studied under a research project with the University of Washington [42].

#### 5.4.2. Foundation Challenges

The construction of foundations can present several significant challenges depending on the site constraints. ABC can be used to minimize the difficulty of addressing some of these challenges. The following sections contain information on some of the more common challenges.

##### 5.4.2.1. Earth Retention

Excavation for foundations can be difficult, especially if there are adjacent structures, roadways or rails. Typically the retention of earth is handled with temporary sheet piling. Once in place, the new foundations can be constructed within the temporary structures.

In some situations, prefabricated elements can be used to retain soil and be part of the finished structure. Two examples of this are as follows:

##### *Precast Concrete Sheet Piling*

The Florida DOT has developed standards for precast concrete sheet piling. The precast panels have interlocking edges that prevent differential lateral movement between panels. Once driven into place, the panels are capped to complete the structure.

##### *Cellular Steel Sheet Piling Abutments*

Several agencies have constructed bridges using cellular steel sheeting structures. There are two types of systems in use. The first is closed cell sheeting, which is comprised of steel sheeting driven in an oval or circular configuration to form a cell. Once in place, the cell is filled with compacted soil and a concrete cap to complete the abutment. Open cell sheet pile abutments are similar, except that the sheeting is placed in a "C" configuration.

The ends of the sheeting elements are anchored into the approach fill using a proprietary system.

#### 5.4.2.2. Deep Water

Construction of bridges in deep water has always been a challenge. Long-span bridge technology has in-part grown out of the need to span over deep water so that shallow water foundations can be used. Historically, deep water foundations were built using deep cofferdams and caissons. The advent of large size driven piles and large diameter drilled shafts has opened up the possibility of building deep water foundations without deep cofferdams or caissons. Prefabricated elements can be used to cap the piles or shafts well above the mud-line of the waterway. These structures can also be used as a shallow cofferdam to allow for placement of footing reinforcing and concrete. Section 5.4.3.3 includes information on precast concrete pier box cofferdams.

### 5.4.3. Prefabricated Foundation Elements

#### 5.4.3.1. Spread Footings

Precast concrete spread footings are a relatively new concept in bridge construction. The New Hampshire DOT developed a precast spread footing system for the Epping Bridge project. These footings were placed over a prepared subgrade on leveling bolts and then grouted into place. The joints between the footing elements are made with shear keys that are filled with non-shrink grout.

The Utah DOT has also developed similar standard details for this application. The Utah standards make use of flowable fill to bridge the gaps between the bottom of the footings and the subgrade. Figure 5.3.3.1-1 is a sketch of a retaining wall with a precast concrete spread footing.

The size of footings for bridge piers can get quite large, which makes transportation of precast concrete footings difficult or even impossible. Figure 5.3.1.1-2 depicts a four column pier bent. Four individual footings are shown (one for each column). If a single continuous footing was required, a single footing would be too large for shipping and handling. A continuous footing can be achieved by using precast concrete under the columns only. These smaller footings are designed to support the dead load of the bridge. Reinforcing bars can be extended from the precast footings, and a cast-in-place closure pour can then be completed during the erection of the remaining portions of the bridge. The completed continuous footing is designed to support all other loads. The same approach can be used for single column piers. Small footings can be

placed under the column and extended as the pier structure is being constructed.

#### 5.4.3.2. Pile Cap Footings

Precast concrete can be used for concrete pile caps. Several states have used grouted pockets to connect the piles to the cap. The FHWA Connections Manual [3] contains several details for pile cap connections.

Recently, new details have been developed that make use of corrugated steel pipe voids that are based on research that was completed in Iowa [12]. This research showed that a void made in a precast concrete footing with a corrugated steel pipe can provide very large punching shear resistance. Research on seismic connections has also demonstrated that these voids can develop large moment resistance as well [11].

Figure 5.4.3.2-1 is a sketch of a precast concrete footing placed on precast concrete piles. Corrugated steel pipe voids are used to make the connection between the piles and the footing.

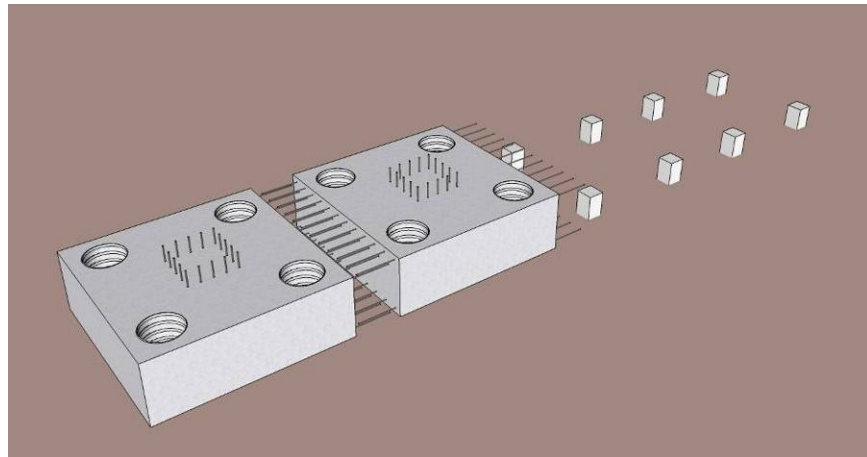

*Figure 5.4.3.2-1 Precast Pile Cap Footing  
(with corrugated steel pipe void connection)*

#### 5.4.3.3. Precast Pier Box Cofferdams

Several projects have been designed where a precast concrete pier box was used to dewater the area where the drilled shaft connects to the bridge footing. For example, the new Providence River Bridge in Providence, Rhode Island, has precast concrete pier boxes that were hung from the 8 foot diameter drilled shafts that allowed the construction of the footings in the dry. The precast box was set over the drilled shaft and sealed with a small tremie pour around the drilled shaft. These systems can

eliminate the need for complicated cofferdams and dewatering systems, especially in deep water. When built using HPC, the precast box forms can serve as an additional corrosion protection system for the new pier footing.

Figure 5.4.3.3-1 shows the construction of the Providence River Bridge. Figure 5.4.3.3-2 shows the details of the installation of the pier box. The construction started with the installation of large pipe hanger clamps that were hung from the edges of the drilled shaft casings. A steel alignment framing was then set on the clamps that were hung from the pile casing, followed by the installation of precast floor and side panels. After that, the joints were grouted and a tremie pour installed. This system gave the contractor a work space to set reinforcing and to pour the footing concrete. The use of the precast concrete pier boxes saved the contractor many months of in the construction of the foundations.



*Figure 5.4.3.3-1 Precast Concrete Pier Box Cofferdam  
Top photo: Exterior View  
Bottom Photo: Interior View  
(source: Cardi Corporation)*

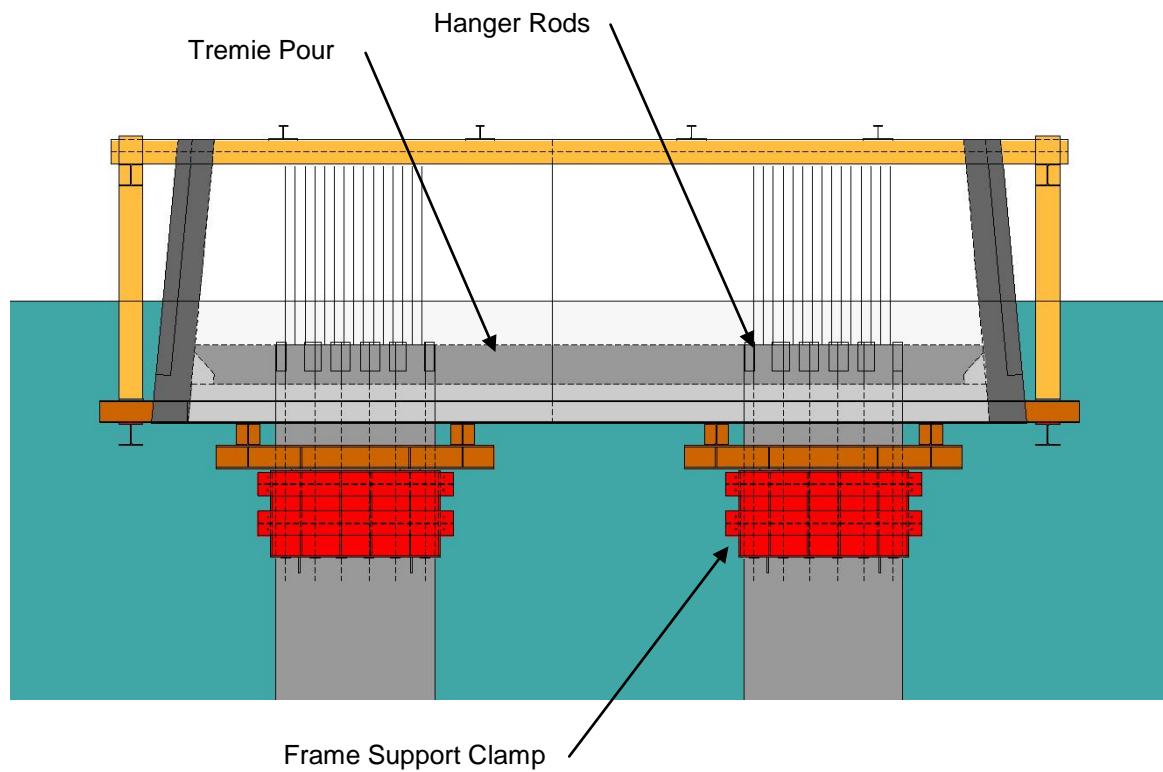
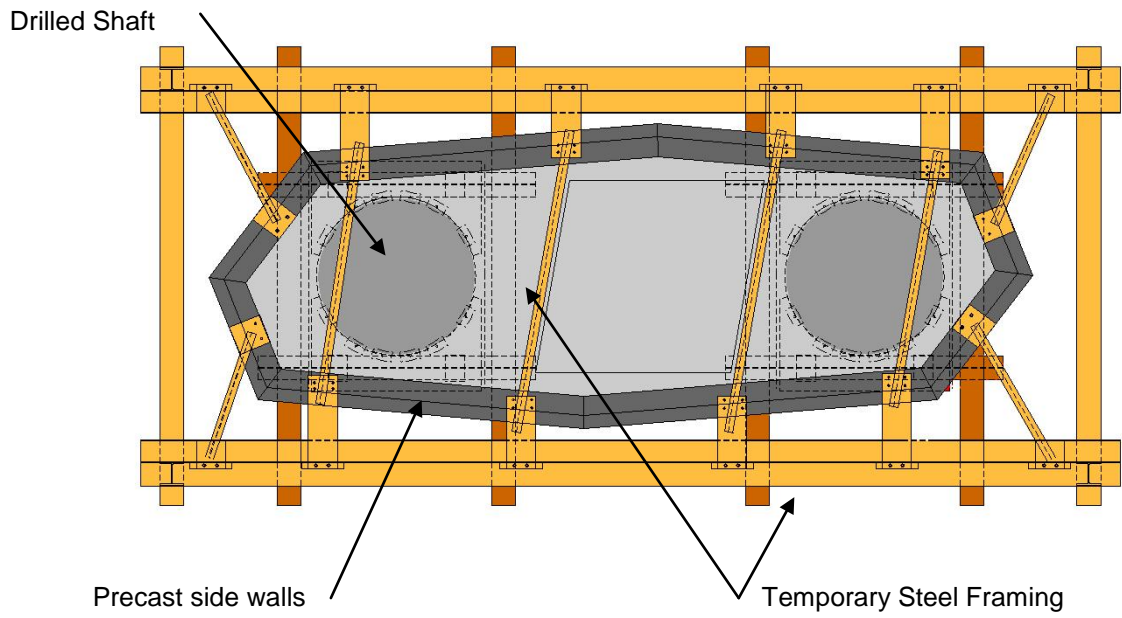

Figure 5.4.3.3-2 Precast Concrete Pier Box Cofferdam Installation  
 Top view: Plan  
 Bottom view: Section

## Chapter 6      Miscellaneous Bridge Elements

Minor bridge elements can have an impact on the construction and long-term performance of a bridges built with ABC methods. This chapter will describe the effects that these elements have on bridges built using ABC techniques.

### 6.1. Deck Overlays I Riding Surface Quality

There are two approaches to deck riding surfaces in the United States. With the advent of low permeability High Performance Concrete (HPC), many states are building bridges without supplemental wearing surfaces (bare concrete decks). This approach is most likely born out of long-term issues with bituminous concrete overlays on bridge decks. In the past, agencies placed bituminous concrete overlays on bridge decks to reduce roadway noise in urban residential environments, improve the riding surface, and to protect the deck from deterioration. The problem with this approach is that the bituminous overlay is porous and not waterproof by any means. In fact, the overlay tends to trap moisture on top of the concrete deck. This can lead to accelerated deterioration of the deck due to the infiltration of water and deicing salts.

The European approach to deck protection is to use bituminous overlays combined with high quality waterproofing membranes. This approach has yielded long lasting bridge decks that can meet the AASHTO goal of a 75 year service life. Several states have adopted this approach with similar results. Anecdotal information on bridges built with bituminous overlays and waterproofing systems in Connecticut in the 1960's indicated that they have performed very well over the last 50 years.

Certain ABC methods can lead to problems with the riding surface quality of bridge decks. The use of prefabricated bridge deck elements will inevitably require the use of joints between elements. Construction of the elements will also require reasonable fabrication and erection tolerances. These issues will lead to an un-even riding surface. Several states have used diamond grinding to smooth out the deck after installation of the elements. This required that the concrete cover in the elements be thick enough to accommodate the grinding operation. The Utah DOT has found that diamond grinding can improve the riding surface, but the finished product is not as smooth as a cast-in-place concrete deck. Diamond grinding can be problematic in that it removes the concrete fines at the surface and exposes the larger aggregate. This may cause problems in northern environments in the future as the deck is exposed to freeze thaw cycles and deicing chemicals.

Overlays can be used to eliminate the need for grinding. For states that prefer smooth concrete riding surfaces, thin concrete overlays can be used. Bituminous concrete riding surfaces can be used in states that allow their use. The application of a concrete overlay will require additional time and/or bridge closures in order to place the overlay. For very fast construction projects, this can be accomplished on subsequent

weekends after the bridge is re-opened to traffic. The Virginia DOT has developed a very-early-strength latex modified concrete overlay. Research has shown that this material can be placed and cured in as little as three hours and provide low permeability and high bond strength [43]. Thin overlays will ensure a better quality final riding surface on the bridge deck. The overlay can be thought of as the last tolerance adjustment during the construction of the prefabricated structure.

## 6.2. Bridge Deck Expansion Joints

Bridge deck expansion joints have long been the source of premature deterioration of bridge decks and supporting framing. Most states are designing bridges using integral abutments and continuous superstructures in order to eliminate expansion joints. On larger bridges, it is inevitable that deck expansion joints will be required. Bridge deck expansion joints can be placed into two categories:

- Joints placed within the deck overlay system: These consist of various asphaltic plug materials and epoxy header systems combined with glands or seals.
- Joints embedded into the deck or supported directly by the superstructure framing: These systems tend to more elaborate and can accommodate larger movement. They typically consist of armored seals, finger joints, or modular expansion joint systems.

The effect of joint systems on ABC projects depends on the category. Joints that are placed within the overlay are typically not affected by ABC methods. The joint can be installed in the same manner as with conventional construction. For embedded joint systems, it is difficult to install the joints within the prefabricated elements to the required tolerances. The best way to alleviate this issue is to install the joints system within small closure pours after the installation of the prefabricated bridge deck. Details should be developed to allow for adjustment of the joint system in the field in order to accommodate the fabrication and erection tolerances of the prefabricated elements.

## 6.3. Bridge Bearings

On conventional bridge construction, bridge bearings are set during the erection of beam elements. The design and construction of the bearings normally does not include vertical adjustment for construction tolerances. This is normally accounted for in the gap between the top of girder and the deck, which is often referred to as the deck haunch.

On certain modular prefabricated ABC projects, the deck is fabricated along with the girders prior to installation. This is applicable to full superstructure bridge moves and for modular superstructure element bridges. For these bridges, the bearings can be used to adjust the elevation of the girders and the finished riding surface. Bearing adjustments can also be used to properly seat elements that have more than three support points. A three dimensional plane can be defined by three coordinates. If an element has more than three support points, the additional points must be on the same plane in order for the element to

seat properly. Adjustments need to be made to account for the fact that the support plane will not be exact.

There are various ways to make these adjustments. Figure 6.3-1 is a sketch of an adjustable elastomeric bearing on a modular steel bridge superstructure element. The sole plate is welded to the girder in the fabrication shop (tan plate). The bearing has a top plate (grey). The white plate is a shim plate used to make up the gap between the bearing top plate and the modular unit sole plate. In this case, the contractor could fabricate extra shim plates of varying thicknesses in order to account for field tolerances.

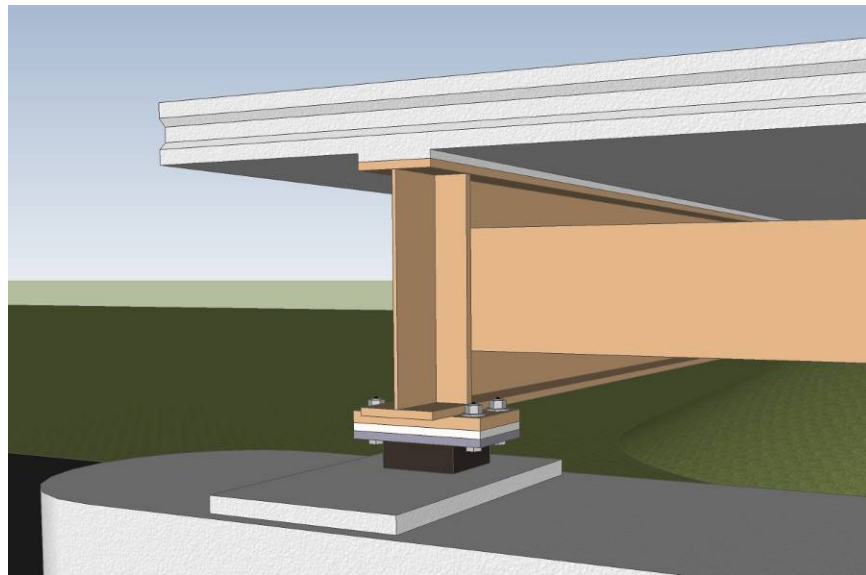

*Figure 6.3-1 Adjustable Bearing Detail*

This is just one example of how to account for field tolerances. Other methods can be used, as long as the anticipated fabrication and erection tolerances are accounted for.

#### 6.4. Drainage Assemblies

Designers typically try to detail bridges without drainage assemblies. Drainage assemblies have a tendency to clog and fail, thereby allowing roadway water to spill onto beams and substructures. On long span bridges, bridges with flat grades where run-off widths are unacceptable, or bridges built on sag vertical curbs, it may be necessary to install drainage systems. It is possible to install drainage assemblies into prefabricated deck elements. The standard details that are used for conventional bridges can normally be applied to prefabricated elements. Minor adjustment may be required in order to facilitate the fabrication process.

#### 6.5. Barriers and Railings

Barriers and railings can be a significant problem with ABC projects. The major issue is the lack of crash tested prefabricated barrier systems. The FHWA Connections Manual [3] contains more information on the issues with connecting barriers and railing to prefabricated elements. There are several ways to address barrier and railing issues that will be discussed in the following sections.

#### 6.5.1. Crash Testing Requirements

The FHWA requires that all parapets and railings on the National Highway System (NHS) be crash tested. The AASHTO LRFD Bridge Design Specifications [8] require that all barriers and railing be crash tested in accordance with the requirements outlined in NCHRP Report 350 entitled “*Recommended Procedure for the Safety Performance Evaluation of Highway Features*” [44]. This document is published by the Transportation Research Board and is available for download at the Transportation Research Board online publication website. These requirements have limited the number of prefabricated barrier systems that can be used. Some states have used non-crash tested barriers and railings designed according to the AASHTO LRFD Bridge Design Specifications [8] for non-NHS projects.

#### 6.5.2. Concrete Barriers

Difficulties can arise on bridges with concrete curbing or concrete barriers. Some states have anchored precast concrete barriers to prefabricated decks by through bolting the parapet to the deck. In this scenario, the bolt projects down below the deck and is secured with a nut and an anchor plate. This type of connection has been problematic. If the bolts are placed in pre-formed holes, water can migrate through the hole and corrode the anchor plate and the underlying framing. If this connection is used, it should be properly sealed.

The Utah DOT has designed and built several prefabricated bridge decks with the concrete barrier cast onto the deck in the fabrication shop. Figure 6.5-1 shows the erection of one of the bridges. The dead load distribution of the parapet weight needs to be addressed, since it may not be the same as a conventional cast-in-place construction. The fascia beam may end up carrying more dead load than what is normally assumed in design. The designers need to account for this in the design of the girders. It may be possible to mitigate this through the use of leveling bolts. By specifying a uniform torque on all bolts, the dead load of the barrier can be shifted to interior girders.



*Figure 6.5-1 Precast Deck Panel with Integral Barriers  
(source: Utah DOT)*

There have been issues with alignment of the barrier face when this method of construction was employed. The complexity of cross slope and tolerances for width at the gutter line and top of parapet can make fit-up of these elements difficult. This is mostly an issue with deck panels that have two barriers as shown. On bridges where a longitudinal closure pour was used, the fit-up has been much better. A longitudinal closure pour can be used to make up for casting and erection tolerances, as well as provide a location to accommodate a roadway crown angle point.

*Effect of joints in precast parapets:*

If the system shown in Figure 6.5-1 is employed, the detailing of the barrier needs to be based on a barrier end zone. The AASHTO LRFD Bridge Design Specifications [8] have requirements for barrier end zones that are different from interior span zones. This may require different reinforcing than what is used on conventional barrier designs.

**6.5.3. Metal Railings**

On ABC projects, prefabrication of metal railings is not normally an issue. Anchor rods can be installed in the deck panels in the fabrication shop. If a metal railing is to be placed on top of a concrete curb, the same issues outlined in Section 6.5.2 would apply.

**6.5.4. Barriers on MSE and Modular Walls**

Prefabricated MSE and Modular Block walls are very common. In some instances, the top of the wall is used to support a concrete

barrier. Most states have developed standard details for precast concrete barriers that are set on top of the modular wall. The resistance of the barrier to vehicular impacts is normally accommodated through the use of a simple cast-in-place moment slab.

#### 6.6. Utilities

The accommodation of utilities on ABC projects can have an impact on the design and detailing. Utilities can also have an adverse impact on the construction methods chosen. The best option for utilities is to remove and relocate them prior to the start of construction. This leaves the contractor unobstructed access to the site. In the case of a deck or superstructure replacement project, it may be possible to temporarily support the utilities and work around them during erection. Once in place, the utilities can be reattached to the new elements.

In some cases, it will not be feasible to remove or relocate utilities. This can have an impact on the construction methods that are feasible. Overhead wires can be problematic for crane operations. If overhead wires cannot be moved, designers should investigate other installation methods such as gantry cranes, lateral slide-in systems, longitudinal launching systems, or installation using SPMTs (see Section 2.4).

Underground utilities can also affect ABC methods. Placement of cranes on top of fragile underground utilities may be problematic. It is possible to span over these utilities through the use of steel plates and/or crane mats. Concern has arisen over the use of SPMTs over underground utilities. Steel plating has been used to protect utilities; however it can become impractical for longer travel paths. SPMTs have the ability to distribute the load over a large area with many wheel sets. The utility concerns can be alleviated by specifying a maximum wheel load in the project specifications that is acceptable to the utility company.

In some cases, utility companies can temporarily shut down service during short construction periods. Gas and water mains are sometimes designed with redundancy, thereby allowing short term closure without significant impact to the utility network. ABC can be used to limit the length of time of these closures.

## Chapter 7 Construction

The nature of ABC projects is that there is more emphasis on temporary works and specialized equipment. Standard construction processes and construction engineering methods need to account for these differences. This section will explore these differences and how construction processes need to change to account for ABC construction.

### 7.1. Shoring Systems and Temporary Works

AASHTO has two published documents on temporary works. The first relates to design of temporary works [45] and the second relates to construction practices [46]. These documents are based on conventional construction methods, although many of the provisions in these documents can be applied to ABC projects. Shoring systems, earth retaining systems, and temporary support systems can be designed and constructed using these provisions.

On most projects, the design of shoring and temporary works is the responsibility of the contractor. On design-build and CMGC projects this responsibility may be undertaken by the design team. The reason for this approach on design-bid-build projects is that the design team is not privy to the equipment and materials that are available to the contractor. In any case, the design and detailing of shoring and bridge temporary works should be undertaken by a professional engineer that is experienced in the design of such structures.

#### 7.1.1. Shoring for Large-scale Bridge Moves (using SPMT, lateral sliding, launching, etc.)

Large-scale prefabrication and moving of structures is not addressed by the AASHTO documents; however there are resources available to assist designers and constructors. The FHWA SPMT Manual [2] contains significant information on the process of designing and moving bridges with SPMT's. Much of this information is also applicable to bridge moves using other technologies such as lateral sliding. The Utah DOT has also developed a manual on design and construction using SPMT technology [7].

Shoring systems for large-scale bridge moves are significant structures in themselves. The design and construction of these systems needs to follow many of the same steps that a permanent structure would require. Several important aspects of the design include geotechnical investigations and design, wind loading analysis, and stability analysis. In most cases, the design of the shoring systems is left up to the contractor. It is important that the design of these systems be accomplished by a registered professional engineer with experience in the design of large-scale shoring systems.

The materials for shoring ABC bridges may also be somewhat different than conventional construction. Shoring companies often try to make use of materials that are on hand. One piece of shoring equipment has migrated from another industry. Prefabricated shipping containers have been used on several ABC projects for temporary abutments and for falsework on top of SPMTs. Figure 7.1.1-1 shows the moving of the Providence River Bridge, which weighed more than 6 million pounds. Shipping containers were extensively used for the shoring system. Shipping containers offer the following benefits:

- High load capacity: Container ratings can range from approximately 400 to 500 kips.
- High Shear Capacity: The corrugated sides of the containers can accommodate large shear forces (both horizontal and vertical).
- Adaptable: Containers are modular and designed to be stacked in groups.
- Readily Available: Shipping containers are available all over the country.
- Low Cost: These containers can be rented at reasonable rates.

Some contractors have used these containers for on-site storage when they were used for temporary abutments. The key structural feature of these containers is that the vertical loads typically need to be applied to the corners of the container. Figure 7.1.1-1 shows red spreader beams on top of the top containers. These are used to transfer the load to the corners of the containers.



*Figure 7.1.1-1 Shipping Containers Used for Shoring*

Moving of unusual structures may require temporary bracing systems. The Providence River Bridge is a network tied arch. The key features of a network arch are the diagonal hanger cables and the lack of vertical compression members. In order to move this structure, the lifting points needed to be placed 100 feet from the end supports, so that the barges could clear the bridge piers. The uncoated vertical members shown in Figure 7.1.1-1 are temporary compression members that were designed to resist the unusual support position. The entire structure needed to be analyzed with these members in place to ensure that the stresses were kept within tolerable limits.

Another important aspect of shoring for SPMT bridge moves is the stiffness and make-up of the framing below the superstructure. It is often impractical to provide one support point for each beam in a bridge cross section. Figure 7.1.1-2 shows an SPMT bridge move in Utah. In this case, a transverse carrying beam was used to transfer the load from each beam to two support points. A second transverse distribution beam was then used to transfer the load to four SPMT's



*Figure 7.1.1-2 Support Framing for SPMT Moves  
(source: Utah DOT)*

The relative stiffness of the support framing compared to the stiffness of the bridge superstructure makes the analysis of this situation a complex problem. The design of the girders is often based on relatively equal dead load to all girders. The flexibility of the support framing makes this assumption invalid. The girders directly under the support points will inevitably carry more load than the other girders. In this case, a three dimensional analysis of the entire system is required in order to determine the stresses in all the members (including the superstructure).

There are ways to ensure that the load is distributed to the girders equally. The first approach is to install a hydraulic jack system that is interconnected to a common manifold. By placing equal pressure at each jack, the support reactions can be kept equal. This approach is often used for bridge jacking systems. The second approach is to place varying height shims between the girders and the top carrying beam. The height of the shims can be calculated based on the calculated deflection of the carrying beam under uniform support loads. Once loaded, the bottom flanges of the girders will be kept in their uniform load position.

#### 7.1.2. Geotechnical Investigations

The large scale movement of bridges requires additional geotechnical investigations. Normally, bridge designers only investigate the soil directly beneath the proposed foundations. On large-scale bridge moves, additional geotechnical investigations need to be undertaken at the fabrication site and along any

proposed travel paths. It is important to note that the tire loads on most SPMTs are similar to standard truck tires; therefore pavement distress should not be an issue. SPMTs can be driven over relatively rough terrain including dirt pathways. In some cases, steel plates are used to spread the tire loads evenly to the supporting soil.

## 7.2. Acceleration of Submissions and Reviews

The use of accelerated project delivery methods can place a premium on contract management. Many states are exploring the use of electronic data submissions. On conventional construction projects, significant amounts of paper plans, specifications and reports are generated and distributed for review. With today's modern technology, the use of paper can be significantly reduced and even eliminated.

### 7.2.1. Electronic Data Transfer

There are several forms of electronic data files. The use of computer aided design (CAD) files and word processing files for data transfer is normally discouraged. This is due to the ease of modifications to these types of files, which could lead to problems. For instance, it would be easy for a reviewer to accidentally erase line work and text from a CAD file.

The availability of viewing software can also be a hindrance to the use of these files. If the reviewer did not have the particular CAD software, an electronic review would not be possible.

Other forms of electronic files are preferred since they are closer to permanent paper files, and the software for viewing the documents is readily available. The following are the most common forms of files used for construction documents:

- Tagged Image File Format (TIFF) is a bitmapped image format that contains descriptive information about the image.
- Joint Photographic Experts Group (JPEG) is a file type that is a compressed digital photographic image. The resolution can be adjusted to reduce the overall file size with minimal loss of quality.
- Portable Document Format (PDF) is a file format developed by Adobe Systems Incorporated. It has become an open standard for document exchange.

There are also other file formats in use; however the most common file standard in use today is PDF. Most major CAD software packages now have the capability of generating PDF output. It is now possible to generate entire plan sets that are indexed using CAD software and Adobe software. Many offices also use document scanners on a regular basis. Many of these scanners can generate TIFF, JPEG or PDF files from scanned images. TIFF and JPEG files can be viewed on virtually all personal computers. PDF readers are available on-line free of charge.

#### 7.2.1.1. Electronic Shop Drawing and Submittals

The use of electronic submittals can greatly reduce the time required to review and approve construction submissions. A typical submission schedule can be reduced from weeks to days. It is possible to review and mark-up plans using software; however many reviewers still prefer to mark-up drawings. This can still be done if a document scanner is available for electronic generation of marked up plans. One convenient feature of electronic submittals is that the reviewer need not print the entire set of drawings for mark-up. Some reviewers are not required to comment on all sheets. For instance, a materials engineer may only be interested in the materials specifications on one sheet. This engineer would only need to view and possibly print that sheet as opposed to the entire set.

Even if reviewers prefer to print entire submissions, they can print reduced size prints for the review. Tabloid size (11"x17") is a common paper size for plan reviews. The Utah DOT has standardized all of their contract and review drawings to tabloid size. This will save paper and eliminate the need to handle large rolls of plans. It also simplifies the scanning process. Many office copiers can now easily scan tabloid size paper.

#### 7.2.1.2. Digital Stamps and Signatures

One of the most significant issues with electronic plan submissions is the need for certified and stamped drawings. For example, many plans require professional engineering stamps and signatures, or approval stamps and initials. Some software packages can produce electronic digital signatures and approval stamps. These are password protected applications that only the certifying personnel can apply.

Some states may have statutory requirements for physical hand written signatures. This does not necessarily mean that electronic submissions cannot be used. In this case, the preliminary submissions can be reviewed electronically. Once all comments are resolved, a hard copy document can be produced with the appropriate signatures. This process is not as efficient as full electronic approvals, but it is faster than paper submissions.

#### 7.2.2. "Intent to build" Drawings

In the bridge construction industry, there is a common requirement that a shop drawing must be generated for each element that is fabricated. The idea stems from the historical practice of using

the actual drawing on the shop floor to build the element. Many modern fabrication shops have moved toward computer applications including Computer Numerical Control (CNC) equipment. This eliminates the need to have individual paper drawings for some shop applications. In addition, on many projects, there is a significant repetition of certain elements. The generation of individual plan sheets for each similar element is redundant and superfluous.

Most contracts place the responsibility for fabrication accuracy on the contractor and fabricator. This normally includes the accuracy of dimensions and materials on shop drawings. This requirement brings into question the need for detailed review of each drawing by the design engineer. Some agencies have investigated the use of "Intent to build" drawings. These drawings are intended to demonstrate the overall fabrication process without individual drawings for each element. Often one element is completely detailed and a table is generated that includes the variable for each element. On a large bridge, the total number of drawings that are submitted for review can be significantly reduced. This saves time in the generation of the drawings and the review by the designer.

### 7.3. Materials Testing on ABC Projects

On ABC projects where construction durations are reduced from months to days, the need for accelerated materials testing is critical. Curing of concretes and grouts used for connecting elements and systems is normally the critical path in an ABC project. On some projects, the strength of concretes and grouts need to be measured in increments of hours or minutes instead of days.

#### 7.3.1. Accelerated Testing Protocol

The extreme timelines on some ABC projects will require accelerated testing protocols. This will lead to the need for increased sampling levels so that tests can be run on more frequent and shorter intervals. The designers should carefully specify the amount of samples and the required testing intervals for ABC projects.

In many cases, testing laboratories are situated in centralized locations. Complications may arise if the construction site is located in a remote area. Some agencies have required that contractors supply and set-up a remote testing facility that is near the bridge site. This helps to expedite the testing process and get the approval information to the field quickly.

#### 7.3.2. Concrete Maturity Method

A maturity method has been developed to assist in the testing process for cast concrete. The maturity method equates a maturity index to the concrete strength of a mix. The concept is based on the proven assumption that concretes of equal maturity

will have equal strengths. The maturity index is a function of the age and temperature of the concrete. During mix development, multiple tests are run on samples in order to develop a strength-maturity curve. This method does not normally replace the requirement for concrete cylinder testing; however it can aid in the determination of when to test the cylinders.

In order to use this method, temperature sensors need to be embedded in the placed concrete. Temperatures need to be measured during the entire curing process. From these readings, the maturity index can be calculated and the concrete strength estimated based on the mix development curve.

#### 7.3.3. Load Indicating Washers for Steel Structures

Bolting of structural steel elements can be a time consuming process. Most states use the “turn of the nut method” or the “calibrated torque wrench” method for tightening bolts. Regardless of which method is used, the inspection of the completed connection needs to be completed. This may require marking nut positions during tightening process (turn of the nut method), or checking the final torque (calibrated torque wrench method). These inspections can slow down the installation time since the work crews have to work in concert with the inspectors or wait for inspectors to approve an installation prior to moving on to the next task.

Several companies have developed specialized washers that are manufactured with bumps. The bumps are specifically designed to crush at the specified bolt tension. These washers can expedite the installation process for bolted connections since the inspector is not required to spend significant time checking the connection. A simple visual inspection is only required after the connection is complete.

### 7.4. Fabrication

Prefabrication of materials is a major component of ABC. It has been demonstrated that prefabrication can save significant time; however there are issues that need to be addressed with certain ABC projects. This is especially true for quality and fabrication tolerances.

It is important to understand that there are lead times for prefabricated elements. This is especially true for bridges built using accelerated project delivery methods. Ample time should be given for development and review shop drawings, and element fabrication and delivery. Project schedules should account for these efforts.

#### 7.4.1. Plant Certification

The importance of fabrication plant certification cannot be stressed enough. The quality and proper fit-up of prefabricated elements is critical to the success of an ABC project. Plant certifications ensure that a level of quality control and assurance is

following for every element that is produced. Many states specify PCI certification for concrete elements and AISC certification for steel elements.

#### 7.4.2. Near-site Casting Certification

The use of certified fabrication plants for prefabricated elements can be problematic for bridges in remote locations. The cost of shipping large prefabricated elements over long distances can lead to cost increases and time delays. One way to resolve this issue is to allow the establishment of a near-site fabrication yard.

Some states are investigating the prequalification of general contractors for near-site fabrication. It may be possible to work with the certifying institutes to establish a certification process for this scenario. Another option is to allow a certified fabricator to set up a remote fabrication yard near the bridge site.

There is one potential benefit to allowing a contractor the ability to prefabricate elements. In this scenario, the contractor is required to take on the risk of proper fit-up, which can lead to better quality.

#### 7.4.3. Tolerances

Tolerances can be the source of many problems in accelerated bridge construction projects. Field fit-up is also one of the major concerns of agencies who are considering an accelerated bridge project using prefabricated elements. Designers of a prefabricated bridge project should assume that nothing is perfect and that tolerance will need to be accounted for in every detail. The Utah DOT has developed typical tolerance limit details for typical prefabricated bridge elements. These drawings can be found at: [www.udot.utah.gov](http://www.udot.utah.gov).

The following sections discuss the issues with tolerance in prefabricated bridge elements.

##### 7.4.3.1. Element Tolerances

A common misconception by designers of prefabricated bridge projects is that the elements are built to exact dimensions. In fact, all prefabricated elements are built within some tolerance. The designers should be aware of the specified construction tolerances for cambers, sweep, and overall dimensions in all elements. The locations of holes, inserts and blockouts are also very important.

Prefabrication and accelerated bridge construction projects usually do not need to be designed with elements having stricter tolerances than conventional construction. The tolerances specified by the various industries are usually

sufficient. A designer of prefabricated bridges should be familiar with the design tolerances in the state in which each project is located, and account for these tolerances in the design and details. Consideration should also be given to whether tolerances used in conventional construction can be increased for prefabricated construction to simplify fit-up in the field.

#### 7.4.3.2. Dimensional Growth

If designers do not account for element tolerances, a phenomenon called “dimensional growth” can occur. This is due to a build-up of dimensional tolerances over several or many elements. For example, if ten panels that are each ten feet wide are placed side by side, the overall length of the system will typically be greater than 100 feet. This is due to the width tolerances and the tolerances of the edges of the adjoining pieces. Match casting of concrete projects can minimize this problem, but minor dimensional growth of the structure is inevitable. To address this problem, designers should compensate for member tolerances in the joint details or allow for minor overall variation in the structure dimensions.

Another form of dimensional growth has to do with the detailing of tolerance limits for multiple protruding elements, post-tensioning ducts, and embedded attachments. It is important to specify that the location tolerance be measured from a common working point. If center-to-center spacing tolerances are used, the layout error tolerance can become additive and affect the connection of the elements.

#### 7.4.3.3. Hardware Tolerances

The location of hardware in prefabricated elements can be critical to the success of the project. Some hardware elements are more critical than others; therefore, designers need to specify the location tolerances of all hardware and attachments.

##### *Post-tensioning Systems*

Post-tensioning systems usually require the installation of strand or thread bars after the erection of the individual elements. It is important to specify the tolerance of the location of the ducts, especially at the ends of the element. Match casting is sometimes used to keep these tolerances to a minimum. If small grout keys or closure pours are used, there is a greater likelihood of post-tensioning duct offset at the joints. In this case, it is recommended that ducts be oversized to allow for minor offsets in the duct at the joints.

#### *Grouted Reinforcing Splice Couplers*

Couplers require a certain degree of tolerance that is attainable in normal precast concrete construction. The typical coupler can accommodate minor variation in bar locations. It also may be possible to use an oversized coupler to provide even greater tolerance. This approach normally provides approximately ½ inch of tolerance adjustment, which is well within normal tolerances for precast elements. Designers should contact coupler companies to determine the appropriate coupler tolerances.

Precast manufacturers can maintain the level of tolerance between pieces by using frames and jigs as templates to position and support the reinforcing steel and couplers. If a design requires the connection of a precast element to a field cast portion of the bridge, it is recommended that the precast producer provide a template jig to the general contract to ensure proper fit-up in the field during erection. The designer should clearly specify the responsible parties for this approach.

#### *Embedded Attachments*

The level of tolerance for embedded attachments is a function of the tolerance for the attaching member. If the attachment is for a utility pipe hanger that has adjustability, then the tolerance will not be as strict as it will be for other elements. Designers should clearly identify the required level of tolerance for all embedded attachments.

#### 7.4.4. Lifting/Moving Elements

Prefabricated elements are typically very heavy. Special lifting hardware may be required to safely lift elements without causing damage. The design of lifting hardware is typically the responsibility of the contractor or fabricator. For heavy elements, conventional lifting hardware such as bent reinforcing bars will most likely not be sufficient. Specialized lifting hardware with embedded reinforcing bars will most likely be required. Careful attention should be given to the location of the lifting device and the angle that the anticipated load will be applied. Some lifting devices are specifically not designed for large lateral loads. This is especially important for elements that are scheduled to be cast flat and then tilted up into a vertical position. This would apply to elements such as wall stems.

The effects of lifting on the prefabricated elements also need to be checked. This is also typically the responsibility of the fabricator, since the fabricator selects the lifting points and hardware. The PCI Design Handbook (Chapter 5) [47] contains more information on lifting and handling of precast concrete elements. This manual includes procedures for checking member stresses,

recommendations for dynamic effects during handling, and form stripping forces.

The PCI Manual also includes recommended factors of safety for handling stresses. There are two criteria specified, one for “no cracking” and another for “no discernable cracking”. Designers should specify which of these criteria is required for each element. There is a cost associated with each criteria, which should be considered by designers. It may be appropriate to use the lesser “no discernable cracking” criteria for secondary elements such as footings. Appendix A includes an example of calculating lifting stresses on a precast concrete deck panel.

#### 7.4.5. Workmanship

The most important aspect of workmanship is the fabrication of elements that are within tolerance. This does not imply that other forms of workmanship are not important. Elements that are not fabricated within tolerance simply will not fit together in the field. This can have a significant impact on the construction timeframe, especially for projects with extremely tight construction windows. Fabricators may wish to dry fit the elements in the fabrication yard in order to ensure that the elements will fit together in the field.

### 7.5. Erection Issues

Erection of bridge beams and girders are well understood by owner agencies. Erection of prefabricated bridge elements brings about different challenges. The speed of construction often precludes the opportunity to set up large cranes. Specialized equipment and/or smaller cranes are required for some projects. Tolerances and adjustments are also critical to the success of an ABC project. This section will cover the issues of erection of elements on ABC projects.

#### 7.5.1. Responsibilities

The responsibilities for erection and handling of prefabricated elements should be clearly defined in the contract documents. The most important aspect of erection procedures is to require that the erection engineer be experienced in erection calculations and a licensed professional engineer.

##### 7.5.1.1. Designer

The designer is typically not involved with the development of the erection plan and supporting calculations. This is due to the fact that the designer does not know what equipment will be used for the construction.

On complex projects, some agencies require that the designer develop an erection plan as part of a constructability study. In this case, the designer simply selects reasonable construction equipment from catalogs. From this, an erection plan can be developed including preliminary lifting calculations.

Once a project is in construction, the designer is typically responsible for the review of the erection plans and calculations. In the case of Design/Build or CMGC contracting, the designer is part of the construction team; therefore the erection plans may become the responsibility of the designer.

#### 7.5.1.2. Contractor

The contractor is typically responsible for the development of erection plans and calculations. The erection plans needs to account the following items as a minimum:

- Available equipment
- Lifting hardware
- Underground utilities
- Overhead utilities
- Adjacent wetlands
- Available right of way

It is not unusual for the contractor's erection plan to be significantly different from the erection plan envisioned by the designer. Contractors can be very resourceful in the development of an erection plan. This is controlled by the availability of equipment for the project.

#### 7.5.1.3. Fabricator

In most cases, the fabricator is not involved in the erection process. If the fabricator is also the erection contractor, then they should follow the same procedures and provisions noted above.

### 7.5.2. Large-scale Bridge Lifting

Section 2.4 describes the various methods for structure placement. In many cases, the structure is temporarily supported in locations that are not congruent with the final support locations. This type of placement method can have significant effects on the bridge structure. The FHWA SPMT Manual [2] contains some recommendations on lifting and handling stress calculations.

The Utah DOT has studied the effects of SPMT bridge moves on superstructures. During the initial group of SPMT bridge installations, the department installed numerous strain gages on the major structural elements. The goal was to monitor the internal stresses during the entire installation process. Utah State University was asked to review the data and report back on their findings. Figure 7.5.2-1 shows the results of one of the bridge moves. It was a single span steel bridge that was cast while end-supported, and lifted at a significant distance from the beam ends.

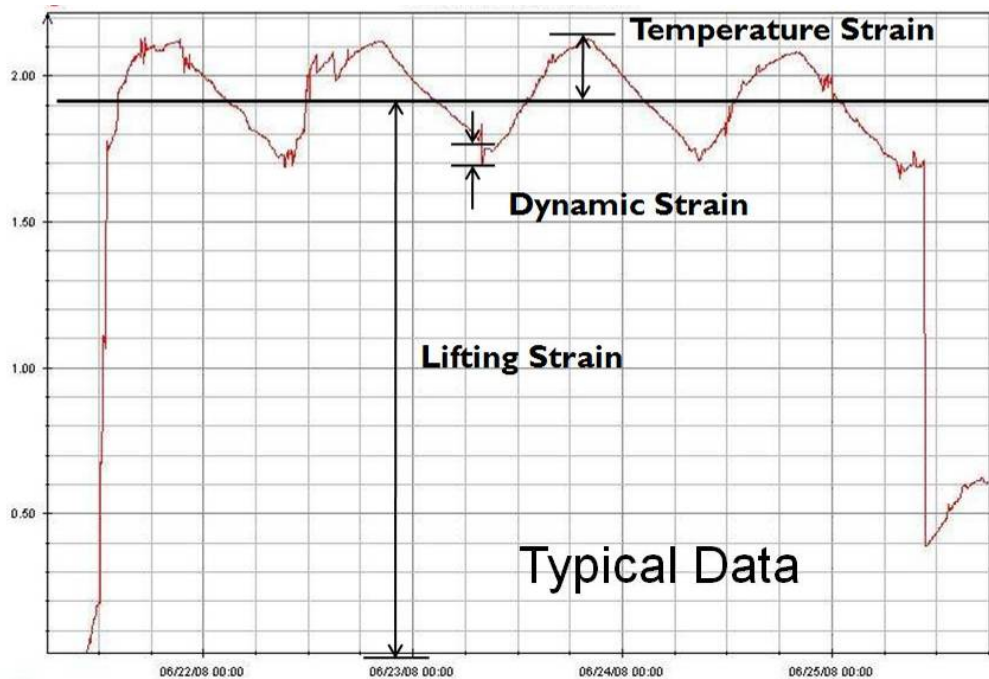

Figure 7.5.2-1 Strain Measurements During an SPMT Bridge Move  
(source: Utah DOT and Utah State University)

The gage shown was located on the steel girder near the lifting point. The gages were set to zero after the deck was cast and while the bridge was supported at the ends. The initial strain is due to the transfer of the bridge from the end supported condition to the SPMT supported condition. This represents a very large strain that equates to a steel stress of approximately 55 ksi. At first glance, this may seem excessive, but it is important to note that the strain represents a reversal. The area in question was stressed in compression when the gage was attached. The large strain represents the change from positive bending to negative bending.

The bridge was supported on SPMTs for four days. During this time two things happened. The structure was moved several times, and the temperature changed daily. The thermal strain, which is represented as semi-sinusoidal curves, is not related to an internal stress change since there was no restraint in the system. This simply represents the length change of the girder when exposed to temperature variations. The jagged portions of the curve represent the strain due to dynamic effects. The Utah State University study showed that the dynamic strains were in the range of 5% to just over 10% of the dead load strain at the lift points (points of maximum stress). Based on this study, The Utah DOT now specifies a dynamic stress allowance by specifying that the dead load of the structure be increased by 15%. It is recommended that this dynamic effect also be applied to other large scale bridge placement methods.

A secondary part of the Utah State University study was to investigate the torsional effects in the bridge during the SPMT bridge move. It was found that the torsional effects were negligible, as long as the bridge warping was kept within the specified tolerances in the UDOT SPMT Manual [7].

#### 7.5.3. The Effect of Tolerances and Adjustability

As previously stated, all prefabricated elements are built to a tolerance. The key to design and construction is to account for the tolerances in the design of the joints and the layout of the elements.

The joint width is directly affected by the element tolerance. If an element has a length tolerance of  $\pm 1/2"$ , then the nominal joint width should be designed to accommodate adjacent elements that are either both at the maximum length tolerance or both at the minimum length tolerance.

The same holds true for the horizontal joints. Minor tolerances can build up during the construction of a bridge. This can result in beams being too low, or uneven roadway profiles. In order to control this, designers should specify element erection elevation tolerances. The Utah DOT standard details for substructure element contain recommended erection tolerance limits. These can be found at: [www.udot.utah.gov](http://www.udot.utah.gov).

### 7.6. Field Inspection

ABC projects bring about a need for accelerated construction inspection. Short duration construction timeframes also require the need to have all levels of project management make decisions quickly. The key to this effort is to empower decision making at all levels of the project team. This section will explore options that designers and agencies can adopt to improve the construction management of ABC projects.

#### 7.6.1. Accelerated Decision Making

The lack of ability to make decisions can adversely affect the progress of an ABC project. On some conventional construction projects, the field personnel are given very little decision making authority. This leads to long construction processes with large amounts of downtime.

The goal on ABC projects is to accelerate the decisions making process. One way to do this is to have high level personnel on site at all times, although this may not be practical in some situations. Another tool that is available is an issue resolution ladder. Figure 7.6.1-1 shows a schematic resolution ladder. If an issue arises on a project, every attempt is made to resolve the issue at the lowest level. The process starts at the lowest level and if the two parties at that level cannot resolve the issue, it moves up the ladder until the issue is resolved. By having this

ladder clearly defined, decision making can be expedited. The key to success on an ABC project is to have experienced and competent personnel at the lowest possible levels in the ladder. The decision making authority for these personnel should be clearly identified to all parties.

Level	Contractor	Agency
6	President	Commissioner
5	Vice President	Chief Engineer
4	Regional manager	District Engineer
3	Project Manager	Construction Office Manager
2	Field Superintendent	Lead Inspector
1	Foreman	Field Inspector

*Figure 7.6.1-1 Construction Issue Resolution Ladder*

The following are typical guidelines for use of an issue resolution ladder:

1. Resolve all simple issues at the field level, whenever possible. The team should identify the level of decisions that need to move up the ladder beyond this level prior to the start of construction.
2. Escalate issues up the ladder whenever:
  - the partners cannot agree on the decision.
  - the partners do not have the authority to make the decision.
  - an issue is threatening to delay the project.
  - an issue is threatening to damage the partnering relationship.
3. Agree to disagree, and disagree without being disagreeable.
4. Escalate issues evenly up both sides of the ladder, and let go of the issue.
5. Do not skip levels or "leap-frog" up the ladder.
6. Upper level partners should insist that the ladder (chain of command) be used.
7. Avoid "swoop-downs" by partners higher up in the chain of command.

8. Keep partners at lower levels informed of progress as it develops in the resolution process.
9. Return the agreed upon decision to the field personnel as quickly as possible, once the issue is resolved.

The basis of this ladder is that the agency is responsible for the construction management of the project. Design build and CMGC projects would require a different, but similar ladder. It is important to note that the engineer of record is part of this process. Any issues that involve design aspects of the project should be coordinated with the engineer of record.

#### 7.6.2. Staff Training

ABC projects differ from conventional construction projects; therefore training of staff needs to be different as well. Two of the key differences in ABC construction are the use of grouts and post-tensioning systems.

It is helpful to have construction staff involved during the design of an ABC project. This allows the inspection staff to understand the reasons for the ABC processes, and it gives them an opportunity ask questions and receive answer before the project is bid. In many cases, the field inspection personnel can provide valuable insight into the potential problems that may occur.

ABC workshops can be held where all parties are invited to discuss a particular project or a proposed construction process. These workshops should be run by experts in ABC techniques and attended by designers, construction inspectors, fabricators, and contractors. The Utah DOT has had great success with ABC workshops, which is part of the reason for the successes that they have had with ABC projects.

The following sections contain information on these processes and the require training for field inspection personnel.

### 7.7. Grout Placement and Curing

The connection of prefabricated bridge elements often involves the use of grouts. Grouting of small voids is not routine in the bridge construction industry. Improper grouting of voids can have an impact on ABC schedules, and an even more dramatic effect on the long-term durability of the finished product. These installations are often on the critical path of construction. It is important to execute proper grouting procedures in order to keep the project moving forward. There are several approaches that can be followed to minimize the potential for grouting problems.

#### 7.7.1. Small Void Grouting

There is no one grout and no one grouting technique that is applicable to all projects. Grouts can range from dry pack grouts

that are installed by hand, to flowable grouts that are poured into intricate voids.

On some occasions, the Texas DOT has required that a contractor demonstrate proper grout placement before the actual construction starts. The contractor is required to build a full scale wood mock-up of the void that is to be grouted. The contractor then installs the grout using the proposed techniques. Once the grout has cured, the mock-up is disassembled and the grout is inspected. If voids or segregation are found, the process is repeated until a proper technique or material is found.

Field inspectors also need to be well versed in all grouting techniques including proper mixing and placement. Some grout manufacturers have published grout installation manuals, which can be a good resource for the field inspection staff. In some instances, it may be necessary to have a grout manufacturer technician come out to the field to train the inspection staff on proper installation techniques, or be present during initial grouting operations.

#### 7.7.2. Grouting of Post-tensioning Ducts

The installation and grouting of post-tensioning ducts has been problematic over the years. There have been several failures of strand and anchoring devices that were attributed to poor installation techniques and low quality materials. The FHWA has developed a manual entitled "*Post-Tensioning Tendon Installation and Grouting Manual*" [48]. This manual is a valuable resource for field personnel on projects that involve post-tensioning. The American Segmental Bridge Institute (ASBI) also publishes manuals on post-tensioning installation and grouting. Some states now require that a certified ASBI Grout Technician be present during all post-tensioning duct grouting procedures. Another approach is to specify that workers with past grouting experience be on-site during grouting operations.

#### 7.8. High Early Strength Concrete

As with grouting, it is inevitable that small closure pours will be part of many ABC projects. These pours are normally used to connect major elements and systems that require significant room for adjustment. Typical examples would include the connection of a superstructure to a substructure in an integral abutment or pier, or a closure pour near a bridge deck joint.

There have been problems with shrinkage and cracking of high early strength mixes. The Utah DOT has found moderate cracking in many closure pours. These cracks can lead to deck leakage and premature deck deterioration. Figure 7.8-1 shows a closure pour in Utah. The left side of the photo shows precast concrete deck panels. The right side shows the closure pour concrete. There are cracks spaced at approximately 2-3 feet along the edge of this pour.

The cause of the cracking is related to the need for high early strength in the mix. In order to get early strength gain, mix designers may design a mix for a much higher strength in order to achieve an early specified strength. This approach is acceptable since the contract specifications only require a minimum strength. For example, a contractor may use an 8000 psi mix for a specified 4000 psi deck in order to reach the specified strength in a short period of time. The high cement content in such a mix tends to lead to more drying shrinkage. The restraint of the adjacent precast panels causes a build-up of tension stress in the closure pour concrete. When the internal tension stress in the closure pour exceeds the tensile capacity of the concrete, a crack will form.

There are two approaches to the design of closure pours and the concrete mixes that can be followed:

- The first approach is to simply design the connection for the required final strength. The issue will force the contractor to overdesign the mix in order to attain the minimum required strength in a short period of time. This will inevitably lead to more shrinkage and cracking.
- Second, the connection can be designed for a lower strength concrete. The mix can be based on a higher strength; however the specifications could allow opening of the bridge at lower strengths. For example, the Massachusetts DOT recently designed a deck closure pour for an ABC project. The closure pour was designed with a concrete strength of 2000 psi. The concrete specifications were still set at 4000 psi minimum; however the contractor is allowed to open the bridge when the strength reached 2000 psi. Extensive mix design and testing protocols are being use to ensure that the mix will not produce significant cracks and that it will achieve the required strength after the bridge is opened to traffic.

The second approach is preferred because it will result in a concrete that has less susceptibility to cracking.



*Figure 7.8-1 Cracking in Closure Pour Concrete*

The Utah DOT has been studying the issue of cracking in high early strength concretes. They have set the following strength performance criteria for the closure pour concrete:

- Attain a 6-hour compressive strength of 2500 psi
- Attain a 7-day compressive strength of 4000 psi.
- Develop a mix that contains shrinkage compensating additives that will meet a specified department shrinkage performance test.

The shrinkage component of this mix is not intended to be “non-shrink”. The goal is to produce concrete with low shrinkage characteristics.

Typical agency prescriptive concrete mixes cannot meet these requirements. It may be possible to develop a prescriptive concrete mix; however it may be difficult to come up with one mix that can work for all suppliers. The recommended approach is to develop a performance specification. Given a set of parameters, a producer can develop a specialized mix based on the materials that are available. This approach is similar to what is typically done in precast fabrication plants. Each plant has mixes that have been developed and approved by the agency.

#### 7.8.1. Mix Design Approach

The Utah DOT and the Massachusetts DOT are using a performance specification approach for high early strength concrete. The basis of this approach is to obtain high early concrete strengths while minimizing shrinkage in concrete. This

approach is based in part on research that was completed in Washington State in a paper entitled “*Mitigation Strategies for Early-Age Shrinkage Cracking in Bridge Decks*” [49]

The following is the preliminary Utah DOT approach for mix design of high early strength concrete:

1. The mix design for high early strength concrete should be developed by each concrete producer. This is based on the fact that the aggregate source and size have an impact on the final product. The department will evaluate each mix for approval.
2. It is recommended that the water to cementitious materials ratio (w/c) be kept to 0.4 or less.
3. Use between 4 and 7 percent-entrained air.
4. The size of the aggregate should be maximized for the intended use. Mixes with coarse aggregates as large as 1½” are recommended. Multiple mixes that use different coarse aggregate sizes may be required for different pour locations.
5. Shrinkage compensating admixtures should be used.
6. The use of expansive materials such as aluminum powder and oxidizing iron aggregates is not recommended.

The Massachusetts DOT specification has similar requirements and is included in Appendix C of this manual.

As previously stated, cracking in closure pour concrete is typically a result of shrinkage of the confined concrete. The surrounding precast concrete will restrain the closure pour concrete. The key to minimizing cracking is to have the concrete gain tensile strength faster than the development of internal shrinkage stresses. Typical ASTM shrinkage tests measure the shrinkage of unconfined concrete. A simple specimen is cast and its length change is measured over time. This test method is not an appropriate measure of the potential for cracking in confined concrete.

In order to determine the susceptibility of a concrete mix to confined shrinkage cracking, a test must be used that includes confined concrete. The AASHTO construction specifications include a confined shrinkage test entitled *AASHTO T334-08 Practice for Estimating the Crack Tendency of Concrete* [50]. Figure 7.8.1-1 is a sketch of an AASHTO ring test setup. This test consists of a ring of concrete cast around a 12” diameter, ½” thick steel pipe that is 6” tall. A 3” thick concrete ring is cast around the pipe. Strain gages are installed on the steel ring to measure the build-up of stress in the ring as the concrete shrinks. When cracking occurs in the concrete, the stresses in the steel ring will drop off indicating the exact time of the crack.

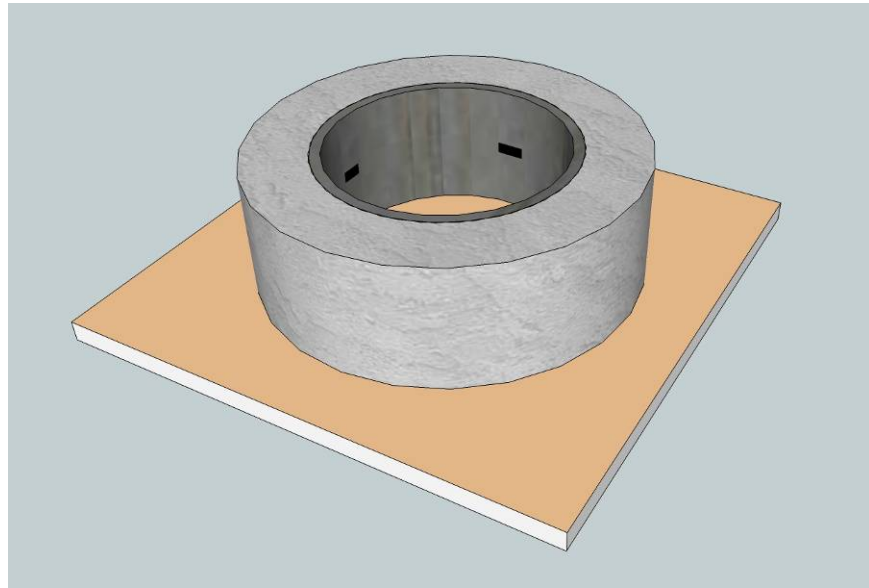

*Figure 7.8.1-1 AASHTO Ring Test for Confined Concrete Shrinkage*

It should be noted that this test will not guarantee that a confined concrete pour will not crack. It will measure the relative cracking resistance of different mixes. A goal for this test may be to develop a mix that does not crack within a specified timeframe such as 14 or 28 days. The Massachusetts specifications use the ring test to identify potential candidate mixes. The final acceptance is made after a full-scale confined closure pour is cast and cured. Cracking limits are specified for this closure pour concrete.

Minor cracking may occur in closure pours even with a low shrinkage concrete mix. The key is to minimize the amount of cracking. Many states have specification requirements for sealing and repair of cracked concrete. The most common repair procedures include the use of methacrylate crack sealers, or epoxy injection methods.

There is research that is underway at this time that is investigating different materials for grouted joints and concrete closure pours. This work is being done at the Virginia Polytechnic Institute and State University. The research includes an investigation of leakage of water through joints in precast deck elements. Agencies should investigate the results of this research once it is completed and adjust construction specifications and materials accordingly.

#### 7.8.2. Accelerated Curing

Curing methods can have a significant impact on high early strength gain. The use of applied heat during curing can be used to expedite strength gain provided that the same heat can be successfully incorporated into the field poured concrete. The precast concrete industry has been using accelerated curing methods for many years. This often involves the use of steam to increase the temperature of the mix during curing.

Portable heating units have been developed that can increase the temperature of field placed concrete. Tarpaulins and space heaters are not recommended because they do not apply uniform and consistent heat, especially during cold weather pours. These units can be used in conjunction with the concrete maturity method of measuring early strength gain (see Section 7.3.2).

If heating is proposed, the contractors should submit detailed heating procedures including the uniform application of heat to all portions of the concrete pour, and provisions for preventing overheating of the concrete.

## Chapter 8 Long Term Performance of Prefabricated Elements

There is little debate in the bridge design and construction industry over the durability of prefabricated elements. Plant produced products have been in use for many years, and have performed admirably. The concerns expressed by agencies are mostly with regard to the connections used between the elements. This section will explore the past performance of ABC projects and how ABC affects management of these bridges.

### 8.1. Inspection Preservation, and Maintenance

The inspection preservation, and maintenance of bridges built with ABC techniques differs somewhat from bridges built using conventional methods, although the differences are minor. The majority of bridges built with prefabricated elements are designed based on the technique of emulating cast-in-place concrete. In most cases, prefabricated connections mimic a construction joint in conventional construction. This means that the bridges will perform essentially the same as a cast-in-place concrete structure.

There are a few potential inspection, preservation, and maintenance activities associated with prefabricated element bridges; however based on performance to date, these activities are not seen as being more significant than those on bridges built using conventional construction techniques. . Grouted joints in substructure elements could potentially be subject to long-term deterioration. One example that is often cited is the joint at the top of a footing. These areas tend to be subjected to moisture and salt spray. The condition of the grout joint should be monitored during normal inspection cycles. If deterioration is found, the joint can be re-pointed, which involves removal of the grout to sound material and replacement with new grout. For connections in critical locations such as slat water splash zones, the designer may consider stainless steel reinforcing bars to eliminate potential corrosion problems.

If there is a concern for the long-term durability of this joint in particular, there is a solution to provide better protection. Figure 8.1-1 is a sketch of a column to footing connection that is based on a detail developed by the New Hampshire DOT. The actual connection is recessed into the footing. Once the connection is complete, the entire recess is filled with grout or concrete to provide protection that is in addition to the actual grout.

Several states have used post-tensioning for connections for prefabricated bridge elements. Many of these states also have post-tensioned structures in their inventory. The inspection, preservation, and long-term maintenance of post-tensioned prefabricated elements should be the same as normal post-tensioned structures.

Some states are concerned with the inspection and long-term preservation and maintenance of precast bridge deck panels. Experience has shown that with proper design and detailing, these panels can provide a long service life with no maintenance beyond what is done for

conventional bridge decks. Designs based on the provisions of Section 9.7.5 of the AASHTO LRFD Bridge Design Specifications have provided excellent performance. Section 8.2 will cover case studies of the long-term performance of precast concrete deck panels designed to these provisions.

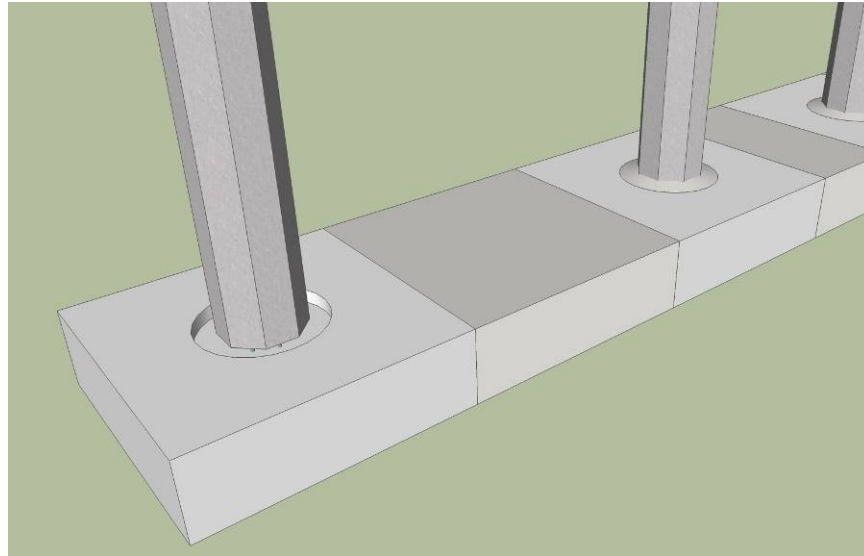

*Figure 8.1-1 Recessed and Grouted Footing Joint*

## 8.2. Durability of Modular Systems

This section will include case studies of several ABC projects that have been in service for extended periods of time. The projects contain details that are commonly used today. Projects include the Edison Bridge in Fort Meyers, Florida (15 years) and two bridge deck replacement projects in Connecticut (almost 20 years). A number of other bridges built with full-depth precast concrete decks have been in service for more than 10 years, and the performance has been excellent.

One notable bridge is the Woodrow Wilson Bridge that crosses the Potomac River near Washington, D.C. This bridge carries Interstate 95 and is one of the most heavily traveled bridges in the country. In the 1980's, the deck was replaced with full-depth precast lightweight concrete slabs [38]. The Maryland DOT has noted that the deck had performed very well under the most severe environment until it was replaced by the new Outer Loop Bridge in the summer of 2006.

One of the key features of precast concrete construction, when compared to cast-in-place construction is the lack of restraint during curing. Individual elements are allowed to cure in a relatively unrestrained condition. The only restraint is the friction between the elements and the forms. In cast-in-place concrete construction, the casting of fresh concrete against previously placed elements leads to a build-up of internal stresses during curing, which often leads to cracking in the

concrete. The most common form of this type of cracking is transverse cracking in bridge decks caused by restraint of the girders. Prefabricated concrete elements are placed after shrinkage has occurred; therefore the potential for shrinkage cracking is eliminated. This will have a significant impact on the long-term durability of the elements.

#### 8.2.1. Case Studies in Durability

To date, many bridges have been built using ABC techniques. ABC projects date back to the 1960s and 1970s. This section will showcase several ABC projects that have been in service for a number of years in order to demonstrate the long-term durability of prefabricated elements

##### 8.2.1.1. Joints in Substructure Elements

As previously stated, the concern over the durability of joints in substructure elements has focused on joints near the base of columns and wall stems. The Florida DOT constructed a high level viaduct in Fort Meyers in 1992. The bridge carries Route 41 across the Caloosahatchie River. The river is tidal in this area; therefore the structure is exposure to brackish water. The piers for this bridge were constructed with precast concrete columns and precast concrete pier caps. The connections were made with grouted reinforcing splice couplers and grouted joints. Figure 8.2.1.1-1 shows the bridge during and after construction.



*Figure 8.2.1.1-1 Edison Bridge  
Top Photo: During Construction  
Bottom Photo: Just Prior to Opening  
(source: Splice Sleeve North America Inc.)*

The environment for this bridge can be considered severe. Florida has had a history of bridges with pier column deterioration problems. A review of the bridge inspection files showed that this bridge is still in good condition, even after 15 years in service. No deficiencies in the joints were noted.

#### 8.2.1.2. Joints in Precast Concrete Deck Panels

The Connecticut DOT replaced a deck on a bridge in the Interstate 84/ Route 8 interchange in Waterbury, CT (CT Bridge 03200). The deck was replaced in 1991 using full depth precast concrete bridge deck panels. The bridge is a six span curved structure. This bridge deck was built well before the development of the AASHTO LRFD Bridge Design Specifications; however the detailing and design are essentially the same as what is currently specified in Section 9.7.5 [8]. The decks span transversely across the superstructure and are connected using grouted shear keys combined with longitudinal post-tensioning. Figure

8.2.1.2-1 shows an aerial view of the bridge. Figure 8.2.1.2-2 shows a recent photo of the underside of the bridge deck.



*Figure 8.2.1.2-1 Connecticut Bridge 03200*



*Figure 8.2.1.2-2 Underside of Bridge 03200 after 19 Years in Service*

This bridge deck was protected with a waterproofing system and a bituminous concrete overlay. A review of the photo in Figure 8.2.1.2-2 shows that the deck is essentially in pristine condition. The hint of staining in the photograph is overspray from a bridge painting project after the deck was replaced. There are no signs of leakage at the joints and the deck is virtually un-cracked. Two other bridges were built in Connecticut in the early 1990's using the same details. These bridges are also in excellent condition.

### 8.2.1.3. Large-scale Bridge Moves

The durability of bridges installed using SPMT methods has one potential drawback. Depending on the location of

the lifting points, the bridge deck and parapets can experience cracking. The early SPMT bridge moves in Utah were lifted at approximately the third points of the bridges, which resulted in large overhangs during the bridge moves. Figure 8.2.1.3-1 shows one of the Interstate 80 Westbound bridges during the installation. The large overhangs led to cracking in the decks and parapets. The reason that cracking was allowed was based on the understanding that the cracks would close after the bridge was set. This actually was the case. Upon setting, the cracks closed significantly. They are similar to shrinkage cracks in bridge decks built with cast-in-place concrete.



*Figure 8.2.1.3-1 Utah DOT I-80 Westbound Bridge Installation  
(source: Utah DOT)*

Figure 8.2.1.3-2 shows the underside of one of the bridge decks. There are a significant amount of cracks that are leaking. The cracks are small and not any different than typical shrinkage cracks in bridge decks. The leakage is most likely due to inadequate performance of the waterproofing system and wearing surface overlay. This type of leakage was found on several decks including cast-in-place structures.



*Figure 8.2.1.3-2 Typical Cracking on the I-80 Bridges  
(source: Utah DOT)*

One year after the SPMT installations, the adjacent I-80 eastbound bridges were built using conventional methods. Figure 8.2.1.3-3 shows a side-by side comparison of the two bridges. The bridge on the right was installed using SPMTs, and the bridge on the left was cast-in-place. The cracking is obviously worse on the cast-in-place deck. This does not necessarily demonstrate that concrete decks on SPMT bridges are better than decks cast on conventionally constructed bridge. It does demonstrate that deck cracking can occur on all bridge structures that employ casting of a deck on top of girders.



*Figure 8.2.1.3-3 Side-by-side Comparison  
Bridge on right installed with SPMTs  
Bridge on left built with conventional construction methods  
(source: Utah DOT)*

In order to minimize the potential for deck and parapet cracking, the Utah DOT has changed its policy regarding SPMT bridge moves. They now limit the overhangs to approximately 20 percent of the span length. Some designers limit the concrete stresses in the deck during transport to less than the modulus of rupture. Bridges built to these new criteria have had little or no discernable cracking.

## Chapter 9 Design and Analysis

### 9.1. LRFD Design

The design of most ABC elements and systems follows traditional LRFD design specifications. The individual elements are typically designed as if they were built using CIP construction techniques. The design of connections in reinforced concrete elements are typically based on the AASHTO requirements for mechanical reinforcing devices in that the device is required to resist 125% of the specified yield strength of the reinforcing bar. This chapter will cover common prefabricated elements and the design issues associated with each element type. This chapter will also address issues that are not specifically covered in the AASHTO design specifications, and recommendations to designers for these situations.

#### 9.1.1. Precast Substructure Elements

The majority of the prefabricated substructures that are being detailed in the United States are precast concrete elements that are emulating cast-in-place structures. The design of these elements should follow the applicable LRFD provisions for cast-in-place and precast concrete construction.

The following are the minor modifications to the design of a precast concrete substructure that are required when using precast elements:

##### *Design of the Grouted Splice Coupler*

The AASHTO LRFD Bridge Design Specifications require that all mechanical reinforcing splice devices develop 125% of the specified yield strength of the bar (Article 5.11.5.2.2) [8]. Several manufacturers produce grouted splice couplers that can meet and exceed this requirement. If this requirement is met, the coupler can be treated the same as a reinforcing lap splice.

The design of the elements is the same as the design of a standard reinforced concrete element with one minor change. The couplers are larger than the connecting bars; therefore in order to obtain proper cover over the coupler, the reinforcing cage needs to be moved toward the interior of the element. This may have an effect on the design of the element since the effective structural depth of the member is reduced when compared to cast-in-place concrete construction. The resulting change will be larger or more closely spaced bars.

##### *Design of the Grouted Post-tensioning Duct Connections*

The Texas DOT has completed research on the use of reinforcing dowels grouted into post-tensioning ducts for connections of pier bent caps. The research paper entitled

“*Development of a Precast Bent Cap System*” [52] contains design criteria for this type of connection. The Washington State DOT has also completed significant research on these connections [54-56]. These research papers can be used for the design of these particular connections.

#### *Design of Pile Connections for Precast Footings and Integral Abutment Bridges*

The Iowa DOT has developed details for connections of precast elements to piles. These connections have been studied by Iowa State University and have been proven on actual projects. These details involve the use of corrugated steel pipes cast into the elements to form a void. The corrugations are used to transfer substructure loads into the piles via shear friction. The elements are simply placed over the piles and the voids are filled with concrete to make the connection. The research paper entitled “*Precast Concrete Elements for Accelerated Bridge Construction*” [12] contains design criteria for this and other connections.

The corrugated pipes can also be used to reduce the shipping weight of elements. They can be filled with concrete after installation to make the element emulate a solid concrete structure.

#### *Design of Connections for Seismic Loading*

Section 5.3.1.3 of this manual includes information on the design of prefabricated connections in seismic regions.

The NCHRP report entitled “*Development of Precast Bent Cap Systems for Seismic Regions*” [11] contains design examples for seismic connections studied in the project. The Washington State DOT has also published papers on the design of connections for seismic loading [54-56].

#### 9.1.2. Deck Panel Elements

The design of the reinforcing in the deck panels should follow the applicable provisions for concrete decks in the AASHTO LRFD Bridge Design Specifications [8]. Section 9.7.5 of the AASHTO Specifications has specific provisions for precast concrete decks. This includes requirements for grouted shear keys and longitudinal post-tensioning. Appendix A of the FHWA connections manual contains information on the design of the deck panel and the longitudinal post-tensioning [3].

The design of other deck systems is also covered in Chapter 9 of the AASHTO LRFD Bridge Design Specifications [8] including steel grid decks, wood decks and orthotropic decks.

### 9.1.3. ABC Issues not Covered in the LRFD Bridge Design Specifications

#### *Mechanical Reinforcing Splices in Seismic Connections*

The current AASHTO LRFD code does not allow the use of mechanical connectors in the plastic hinge zone of columns. Mechanical splices are required to be staggered a minimum of 24" for bridges in high seismic zones. (Section 5.10.11.4.1f [8]).

The ACI Building Code Requirements for Structural Concrete [53] do allow mechanical connectors in the plastic hinge zone, provided that they can meet certain requirements. There are two levels of mechanical splice devices specified in the ACI 318 Code. Type 1 mechanical splices need to be capable of developing 125% of the specified minimum yield strength of the bar. Type 2 mechanical splices need to be capable of developing 100% of the specified minimum tensile strength of the bar (equal to 150% of specified yield for standard grade 60 Bars).

The ACI 318 code has restrictions that are similar to the AASHTO Specifications for Type 1 mechanical splices; however the use of Type 2 mechanical splices are unrestricted for special moment frames constructed with precast concrete (including the plastic hinge zone). Upon further research and testing, provisions similar to the ACI code may eventually become part of the AASHTO LRFD Code.

Another approach that can be followed in most cases is to place the mechanical couplers in the footing and pier cap as opposed to the column hinge zones. The AASHTO provisions that restrict mechanical splices are for column reinforcing. There are no specific restrictions on footing and cap reinforcement. This is due to the lower demand that is placed on reinforcing outside of the column plastic hinge zone.

#### *Innovative Full Depth Deck Panel Connections*

With regard to transverse full depth deck panel connections, the AASHTO LRFD Bridge Design Specifications only contain provisions for longitudinal post-tensioning with grouted shear keys. Research has been completed on systems that do not have post-tensioning [36], and there are other states that have used reinforced concrete closure pours, and ultra-high performance concrete joints between panels. These systems may also be acceptable provided that the details can emulate cast-in-place concrete or are supported by proper research efforts.

The AASHTO specifications should be amended to include other deck panel connections as research is completed. Designers may choose to use the research results for design at this time.

### *Grouted Post-tensioning Duct Connections and Other Seismic Connections*

Several research studies have investigated the use of corrugated metal post-tensioning duct for grouting of reinforcing bars and other seismic column connections [11, 52, and 54]. These connections are not currently covered in the AASHTO LRFD Bridge Design Specifications. The cited research reports do contain design guidance for these connections.

### *Shear capacity of Corrugated Metal Pipe Voids*

Several states have used corrugated metal pipe voids to reduce element weight and to provide a connection [11,12]. These connections are primarily used to transmit direct shear and moment between two elements. The direct shear capacity of these connections is significant. Moment resistance can be accommodated through the use of reinforcing within the corrugated pipe void, or external to the void. The AASHTO LRFD Bridge Design Specifications do not specifically cover this type of connection. The provisions for interface shear in AASHTO Article 5.8.4 are recommended for the calculation of the direct shear (shear friction) capacity of this type of connection. The provisions for “Normal concrete placed against a clean concrete surface, free of laitance, with a surface intentionally roughened to an amplitude of 0.25 in.” are recommended. The corrugations of the pipe will act as a roughened surface, which justifies the use of this provision.

### *Dynamic Effects of Large Scale Bridge Moves*

The AASHTO LRFD Bridge Design Specifications do not include provisions for the dynamic effects of large scale bridge moves. The Utah Department of Transportation has studied this by instrumenting many of the bridges that were moved. The results indicate that a conservative approximation of vertical dynamic effects is to increase the dead load of the structure by 15% for the analysis. The lateral effects of starting and stopping were not studied; however the effects on the bridge framing are thought to be negligible. The effects on the support framing are a different situation. Erection engineers should consult with heavy lift contractors regarding the level of lateral dynamic forces.

#### 9.1.4. Design of Bridges with Large-scale Lifting Methods

The design of bridges built using large-scale prefabrication is not specifically covered in the AASHTO LRFD Bridge Design Specifications; however the tools required to design the bridge are. When lifting and moving a superstructure, the location of the support points as well as the stiffness of the supporting falsework need to be identified and accounted for in the design.

### *Design-Build and CMGC Contracting Method*

In a Design-Build or CMGC scenarios, the designers and the contractor are on the same team. The design of the bridge and

the falsework are under the direction of the project team. The stiffness of the falsework should be modeled with the bridge superstructure in order to account for the potential redistribution of loads due to deflection of the falsework. Hydraulic and shim systems can also be used to minimize this effect (see Section 7.1).

#### *Design-Bid-Build*

In the Design-Bid-Build contracting method, the contractor is not available during design development. This means that the exact makeup of the falsework is not known to the design engineer. In this case, there are two options available for the design of the bridge.

- Design the bridge with rigid supports: In this scenario, the support is assumed to be equal at each beam support point. This assumption must be clearly noted on the plans and in the specifications. The notes should indicate that equal support must be provided. Alternate support conditions (flexible falsework) can be allowed; however the contractor would be required to re-analyze the bridge and possibly strengthen the members.
- Design and detail the falsework and large scale lifting machinery layout: This scenario is not common since design engineers typically are not experts in shoring design and large scale lifting systems. If this approach is taken, the designers should contact several heavy lift companies in order to determine which systems are feasible.

Based on the above discussion, it can be seen that the Design-Build or CMGC contracting method is best suited for a large-scale bridge prefabrication project.

#### *Recommended AASHTO LRFD Limit States*

The following limit states checks are recommended during the design of the superstructure:

##### *Strength Limit State:*

Analyze and design the superstructure using all applicable Strength Limit States as specified in the AASHTO LRFD Bridge Design Specifications [8]. Include dynamic effects.

##### *Service Limit State:*

Check the span for displacements and deck cracking based on

Service I Limit State. Include dynamic effects. Check tension in the prestressed concrete superstructure using the Service III Limit State. Check crack control on prestressed concrete columns using the Service IV Limit State.

## 9.2. LRFR Ratings

As with design, the rating procedures for prefabricated bridge systems typically follow traditional methods of analysis. This is due to the fact that most bridge elements built to date have followed the emulative detailing method. This means that the design and details emulate traditional design and construction.

Analysis and rating of superstructures built with precast concrete decks should account for the transverse joints between the deck panels. If longitudinal post-tensioning is used, the tendons can be accounted for in the design of the negative moment regions of the girders.

## 9.3. Design and Analysis of Temporary Works

Temporary works such as shoring, earth retaining, support and bracing systems should be properly analyzed and designed in accordance with the applicable AASHTO Specifications [45,46] and general engineering principles. Refer to Chapter 7 for more information.

## 9.4. Evaluation of Existing Structures

If prefabricated elements will be transported to construction sites using hauling vehicles, all existing bridges and structures on the transport route should be evaluated for load carrying capacity. The AASHTO Manual for Bridge Evaluation [58] should be used. Special hauling permits may be required for movement of elements that are oversize and/or overweight. Designers should consult with local and state authorities on permitting requirements.

## References

1. *Decision-Making Framework for Prefabricated Bridge Elements and Systems (PBES)*, U.S. Department of Transportation, Federal Highway Administration, Publication Number FHWA-HIF-06-030, May 2006
2. *Manual on the Use of Self-Propelled Modular Transporters to Remove and Replace Bridges*, U.S. Department of Transportation, Federal Highway Administration, Publication Number FHWA-HIF-07-022, June 2007
3. *Connection Details for Prefabricated Bridge Elements and Systems*, U.S. Department of Transportation, Federal Highway Administration, Publication Number FHWA-IF-09-010, March 2009
4. *Road User Cost Manual*, The New Jersey Department of Transportation, June 2001
5. *Geotechnical Engineering Circular (GEC) No. 8, Design and Construction Of Continuous Flight Auger Piles*, U.S. Department of Transportation, Federal Highway Administration, Publication Number FHWA-HIF-07-039, April 2007.
6. *Emulating Cast-in-Place Detailing in Precast Concrete Structures ACI-550.1 R01*, The American Concrete Institute, 2001
7. *SPMT Process Manual And Design Guide, The Utah Department of Transportation, November 2009.*
8. *AASHTO LRFD Bridge Design Specifications, American Association of State Highway and Transportation Officials, Washington, D.C., Fourth Edition 2007.*
9. Badie and Tadros “*Full Depth Precast Concrete Bridge Deck Panel Systems*” Report Number 584, National Cooperative Highway Research Program, Transportation Research Board, 2008
10. *Public Involvement Techniques for Transportation Decision-making*, U.S. Department of Transportation, Federal Highway Administration, Publication Number FHWA-PD-96-031, December 1996
11. Restrepo, Tobolski, Matsumoto, *Development of a Precast Bent Cap System for Seismic Regions* Report Number 681, National Cooperative Highway Research Program, Transportation Research Board, 2011
12. Wipf, Klaiber, and Hockerman, *Precast Concrete Elements for Accelerated Bridge Construction*, IHRB Project TR-561, Iowa Highway Research Board and the Iowa Department of Transportation, January 2009
13. Caner and Zia, *Behavior and Design of Link Slabs for Jointless Bridge Decks*, Journal of the Precast Prestressed Concrete Institute, May-June 1998
14. Aktan, Attanayake, and Ulku, *Combining Link Slab, Deck Sliding over Backwall, and Revising Bearings*, Research Report RC-1514, Western Michigan University and the Michigan Department of Transportation, 2008
15. *ASTM A955 - 10a Standard Specification for Deformed and Plain Stainless-Steel Bars for Concrete Reinforcement*, ASTM International, West Conshohocken, PA

16. ASTM A1035 - 09 Standard Specification for Deformed and Plain, Low-carbon, Chromium, Steel Bars for Concrete Reinforcement, ASTM International, West Conshohocken, PA
17. Merrill, "Texas' Use of Precast Concrete Stay-in-Place Forms for Bridge Decks", 2002 Concrete Bridge Conference,
18. Jones, Furr, "A Study of Prestressed Panels and Composite Action in Concrete bridges Made of Prestressed Beams, Prestressed Sub-Deck Panels, and Cast-in-place Deck", Research Project No. 2-5-70-145, Texas Highway Department
19. Bieschke and Klingner, "The Effects of Transverse Strand Extensions on the Behavior of Precast Prestressed Panel Bridges", Research Report 303-1F, Center for Transportation Research, The University of Texas at Austin, June 1982
20. "Full Depth Precast Concrete Deck Slabs", PCINER-02-FDPCDS, Precast Prestressed Concrete Institute, Northeast Bridge Technical Committee, June 2002.
21. Abendroth, "Nominal Strength of Composite Prestressed Concrete Bridge Deck Panels," *Journal of Structural Engineering, ASCE*, Vol. 121, No. 2, February 1995, pp. 307-318
22. Babaei, Fouladgar, and Nicholson, "Nighttime Bridge Deck Replacement with Full Depth Precast Concrete Panels at Route 7 over Route 50, Fairfax County, Virginia," Transportation Research Board, 80th Annual Meeting, January 7-11, 2001, Paper #01-0196, Washington, D.C.
23. Badie, Baishya, and Tadros, "NUDECK- An Efficient and Economical Precast Bridge Deck System", *Prestressed/Precast Concrete Institute (PCI) Journal*, September-October, Vol. 43, No. 5, 1998, pp. 56-74.
24. Badie, Baishya, and Tadros, "NUDECK- An Efficient and Economical Precast Bridge Deck System", *Prestressed/Precast Concrete Institute (PCI) Journal*, September-October, Vol. 43, No. 5, 1998, pp. 56-74.
25. Badie, Tadros, Kakish, Splittgerber, and Baishya, "Large Studs for Composite Action in Steel Bridge Girders," *American Society of Civil Engineering (ASCE), Bridge Journal*, Vol. 7, No. 3, May/June 2002, pp. 195-203.
26. Biswas, "Precast Bridge Deck Design Systems," *PCI Journal*, V. 31, No. 2, March-April 1986, pp. 40-94.
27. Culmo, "Bridge Deck Rehabilitation Using Precast Concrete Slabs," Paper Number IBC-91-55, Eighth Annual International Bridge Conference, Pittsburgh, Pennsylvania, June 10-12, 1991.
28. Issa, Idriss, Kaspar, and Khayyat, "Full Depth Precast and Precast, Prestressed Concrete Bridge Deck Panels," *PCI Journal*, Vol. 40, No. 1, January-February 1995a, pp. 59-80.
29. Issa, Yousif, Issa, Kaspar and Khayyat, "Field Performance of Full Depth Precast Panels in Bridge Deck Reconstruction," *PCI Journal*, Vol. 40, No. 3, May-June 1995d, pp. 82-108.
30. Issa, Yousif, Issa, Kaspar, and Khayyat, "Analysis of Full Depth Precast Concrete Bridge Deck Panels," *PCI Journal*, Vol. 43, No. 1, January-February 1998, pp. 74-85.

31. Issa, Anderson, Domagalski, and Khayyat, "Design Considerations of Full Depth Precast/Prestressed Concrete Bridge Deck Panels," Proceedings of the 1<sup>st</sup> annual Concrete Bridge Conference, October 6-9, 2002, p 20.
32. Issa, Patton, Thomas, Abdalla, Hiba, Yousif, Alfred, and Issa, "Composite Behavior of Shear Connections in Full-Depth Precast Concrete Bridge Deck Panels on Steel Stringers," PCI Journal, September/October 2003, vol. 48, no. 5, pp. 76-89.
33. Menkulasi and Roberts-Wollmann, "Behavior of Horizontal Shear Connections for Full-Depth Precast Concrete Bridge Decks on Prestressed I-Girders," PCI Journal, V. 50, No. 3., May/June 2005, pp. 60-73.
34. Scholz, Wallenfelsz, Cintia, Roberts-Wollmann, "Recommendations for the Connection Between Full Depth Precast Bridge Deck Panel Systems and Precast I-Beams", Final Report Number VTRC 07-CR17, Virginia Transportation Research Council, Charlottesville, VA
35. Tadros, Badie, and Kamel, "A New Connection Method for Rapid Removal of Bridge Decks," PCI Journal, May-June 2002, Vol. 47, No. 3, pp. 2-12.
36. Tadros, and Baishya, "Rapid Replacement of Bridge Decks," Final Report, 12-41, National Cooperative Highway Research Program, Transportation Research Board, July 1997.
37. Tadros, and Baishya, "Rapid Replacement of Bridge Decks," National Cooperative Highway Research Program, NCHRP Report 407, Washington, D.C., 1998.
38. Lutz and Scalia, "Deck Widening and Replacement of Woodrow Wilson Memorial Bridge" PCI Journal, V. 29, No. 3, May-June, 1984, pp. 74-93.
39. Caccese and Yorulmaz, "Laser Welded Steel Sandwich Panel Bridge Deck Development: Finite Element Analysis and Stake Weld Strength Tests", Report Number 09-09, Maine Department of Transportation Research Division, September 2009.
40. Azizinamini, Yakel, and Farimani, *Development of a Steel Bridge System – Simple for Dead Load and Continuous for Live Load*, Volumes 1 and 2, National Bridge Research Organization and the Nebraska Department of Roads, 2005
41. ASTM C1577 *Precast Reinforced Concrete Monolithic Box Sections for Culverts, Storm Drains, and Sewers Designed According to AASHTO LRFD*, ASTM International, West Conshohocken, PA
42. McLean and Smith, *Noncontact Lap Splices in Bridge Column-Shaft Connections*, Washington State Transportation Center (TRAC) and the Washington State Department of Transportation, Report Number WA-RD 417.1, July 1997
43. Sprinkel, *Very-Early-Strength Latex Modified Concrete Overlay*, Virginia Transportation Research Council, Technical Assistance Report Number TAR 99-TAR3, December 1998
44. Ross, Sickling, Zimmer, and Michie, "Recommended Procedure for the Safety Performance Evaluation of Highway Features," National Cooperative Highway Research Program, NCHRP Report 350, Washington, D.C., 1993.

45. *AASHTO Guide Specifications for Bridge Temporary Works*, American Association of State Highway and Transportation Officials, Washington, D.C., First Edition 1995 with 2008 Interim Revisions.
46. *AASHTO Construction Handbook for Bridge Temporary Works*, American Association of State Highway and Transportation Officials, Washington, D.C., First Edition 1995 with 2008 Interim Revisions.
47. *PCI Design Handbook Precast and Prestressed Concrete*, The Precast Prestressed Concrete Institute, Chicago, IL, Seventh Edition
48. *Post-Tensioning Tendon Installation and Grouting Manual*, U.S. Department of Transportation, Federal Highway Administration, May 2004
49. Qiao, McLean, and Zhuang, *Mitigation Strategies for Early-Age Shrinkage Cracking in Bridge Decks*, Report Number WA-RD 747.1, Washington State Department of Transportation and Washington State University, April 2010
50. *AASHTO T334-08 Practice for Estimating the Crack Tendency of Concrete*, AASHTO Standard Specifications for Transportation Materials and Methods of Sampling and Testing (29th Edition) and AASHTO Provisional Standards, 2009 Edition
51. *Tests on Re-Bar Splices in Reinforced Concrete Columns using NMB Splice Sleeves*, Report Number NPD-024, Splice Sleeve Japan, LTD. (available from Splice Sleeve North America, Inc.)
52. Matsumoto, Waggoner, Sumen, Kreger, Wood, and Breen, "Development of a Precast Bent Cap System", Center for Transportation Research, The University of Texas at Austin, January 2001
53. *Building Code Requirements for Structural Concrete (ACI 318-08)*, American Concrete Institute Committee 318, 2008.
54. Wacker, Hieber, Stanton, Eberhard, *Design of Precast Concrete Piers for Rapid Bridge Construction in Seismic Regions*, Washington State Transportation Center (TRAC) and the Washington State Department of Transportation, Report Number WA-RD 629.1, August 2005
55. Steuck, Pang, Stanton, Eberhard, *Anchorage of Large-Diameter Reinforcing Bars Grouted into Ducts*, Washington State Transportation Center (TRAC) and the Washington State Department of Transportation, Report Number WA-RD 684.1, November 2007
56. Pang, Steuck, Cohagen, Stanton, Eberhard, *Rapidly Constructible Large-bar Precast Bridge Bent Seismic Connection*, Washington State Transportation Center (TRAC) and the Washington State Department of Transportation, Report Number WA-RD 684.2, October 2008
57. *Highway Capacity Manual 2010*, Transportation Research Board, 2010
58. *AASHTO Manual for Bridge Evaluation*, American Association of State Highway and Transportation Officials, Washington, D.C., Second Edition 2010
59. *AASHTO Specification MP 18M/MP 18-09 Uncoated, Corrosion-Resistant, Deformed and Plain Alloy, Billet-Steel Bars for Concrete Reinforcement and Dowels*, American Association of State Highway and Transportation Officials, Washington, D.C.,

60. Shahrooz, Miller, Harries, and Russell, *Design of Concrete Structures using High-Strength Steel Reinforcement*, National Cooperative Highway Research Program, NCHRP Report 679, Washington, D.C., 2011
61. LaViolette, Wipf, Lee, Bigelow and Phares, *Bridge Construction Practices using Incremental Launching*, National Cooperative Highway Research Program, NCHRP Project 20-07, Task 229, Transportation Research, Washington, D.C., 2007
62. Mallela, Huie, Lord and Sadasivam, *Return on Investment from Deploying Project Delivery Innovations: Methodology and Findings from the Highways for Life Program*, 2<sup>nd</sup> International Conference on Transportation Construction Management, Orlando, FL, 2011
63. Littleton, Mallela and Hoffman, *Iowa Demonstration Project: Improvements to the 24th Street–I-29/80 Interchange in Council Bluffs*, HfL Demonstration Project Report, Office of Infrastructure, Federal Highway Administration, Washington, DC, 2009.

## Appendices

### Appendix A: Design Examples

As stated in Chapter 9, the design of most ABC elements and systems follows traditional AASHTO LRFD design specifications. Emulation detailing is common. The goal of emulation detailing is to mimic a cast-in-place reinforced concrete structure using precast concrete elements. Most ABC projects in the United States are based on this concept.

The following sections contain information on the most common prefabricated elements currently in use:

#### Example A1.1: Full-depth Precast Concrete Deck Panels

Figure A1.1-1 is a sketch of a typical precast concrete deck panel installation.

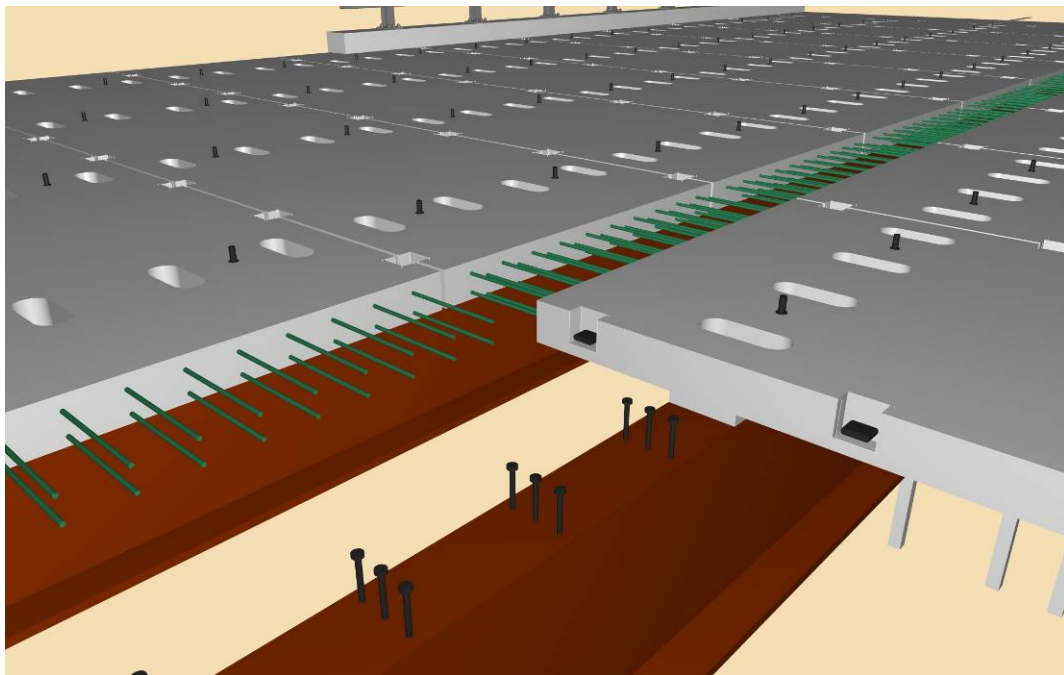

*Figure A1.1-1 Typical Precast Concrete Deck Panel Installation*

The FHWA Connections manual [3] contains design information of this type of element including an example of the design of the post-tensioning system.

### Example A1.2: Precast Concrete Piers

Emulative detailing is typically used for piers. The design of the pier elements is accomplished using the LRFD specifications. The only change with respect to ABC is the design of the connections between the elements. Again, emulation is used to obtain the desired performance.

Figure A1.2-1 shows a transparent view of a wall pier. The pier includes precast concrete footings supported on piles, precast wall stems, and precast caps. Corrugated pipe voids are used to make connections and to reduce member weight. Closure pours are used to make the footings continuous. Note that this example is similar to an open frame pier bent and a cantilever abutment or retaining wall.



*Figure A1.2-1 Precast Pier Supported on Piles*

The pile design would follow normal practice. The connection of the pile to the footings is made within a corrugated pipe void. The research entitled “*Precast Concrete Elements for Accelerated Bridge Construction*” [15] can be used to check the connection for punching shear. The AASHTO provisions for interface shear can also be used.

The design of the pier footing is based on the LRFD specifications assuming cast-in-place concrete. The spacing of the footing reinforcement needs to be adjusted to account for the size of the corrugated pipe voids. It is possible to keep uniform reinforcing spacing by running the reinforcement through the voids. This is discouraged due to the added complexity in fabrication. Continuity of the footing can be made with small closure pours between the footings. These closure pours would be completed after the placement of the wall stems.

The design of the wall stems would be based on the LRFD specifications assuming cast-in-place concrete. The connection between the wall stem and the footing can be made with mechanical splice couplers. Mechanical couplers meeting the requirements of the LRFD specifications can be used to substitute

for a lap splice. If grouted post-tensioning ducts are used, the research paper entitled "*Development of a Precast Bent Cap System*" [56] can be used to design the grouted duct connection. The joints between the wall stem elements can be treated as typical wall expansion joints, therefore a structural connection is not required. Some designers have designed these joints with a grouted shear key. Corrugated pipe voids are used to reduce the member weight and to assist with the cap connection. These voids would be filled with concrete after installation of the wall stems.

The design of the pier cap is also based on the LRFD specifications assuming cast-in-place concrete. This is a low moment demand element since there is no spacing between wall stems. The connection between the wall elements and the cap can be made within the corrugated pipe voids. Projecting reinforcement can be placed within the void pour during the installation of the wall elements. This reinforcement can be designed to resist the moment demand at the joint. Once the cap is set on top of the wall elements, the voids in the cap can be grouted or concreted through ports to complete the connection.

### Example A1.3: Precast Integral Abutments

Emulative detailing is also used for integral abutments. State bridge design manuals and specifications should be reviewed since the LRFD specifications do not cover integral abutment designs in great detail. The AASHTO LRFD specifications can be used for the design of the internal reinforcement.

Figure A1.3-1 shows a sketch of a precast concrete integral abutment prior to placement of the superstructure. Figure A1.3-2 is a typical section of a Utah DOT Integral abutment. The abutment includes precast wall stems supported on piles, precast wingwalls, and precast backwall stems. Corrugated pipe voids are used to make connections to the piles and to reduce member weight. Closure pours are used to make the integral connection to the superstructure. The Utah details show a separate precast backwall element connected with grouted splice sleeve connectors. The backwall can also be fabricated integral with the abutment cap as shown in the sketch.

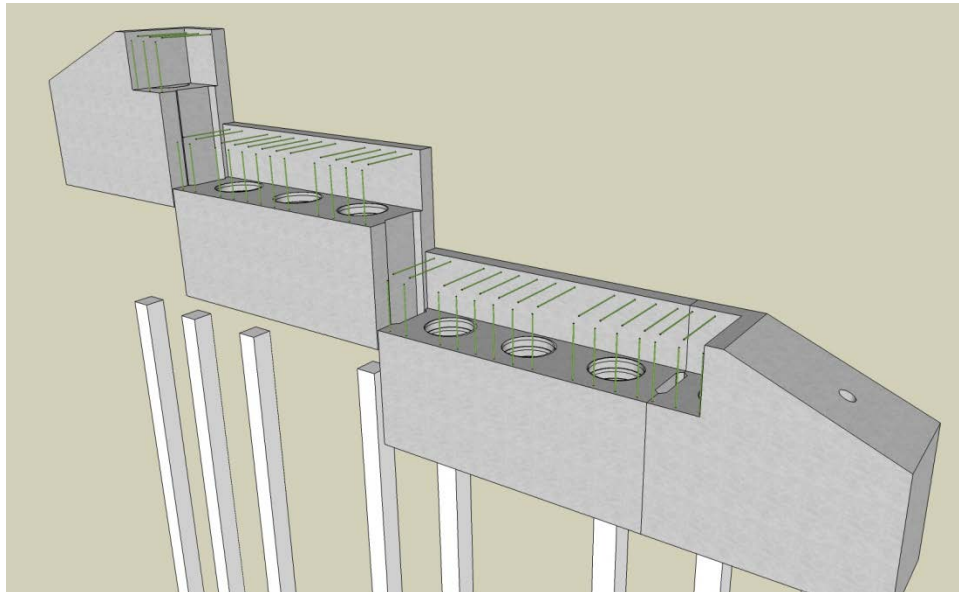

*Figure A1.3-1 Precast Integral Abutment*

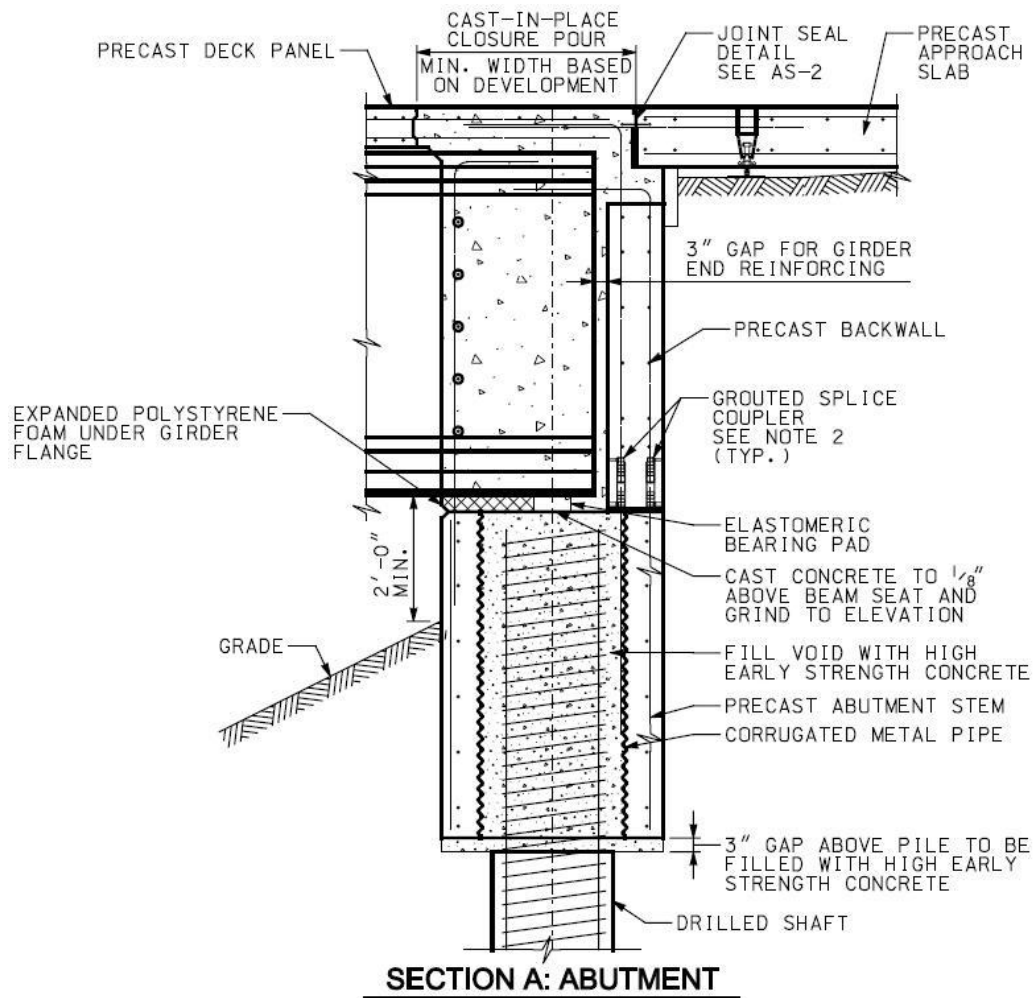

Figure A1.3-2 Typical Section Through Abutment  
(source: Utah DOT Standards)

The connection of the pile to the abutment cap is made with a corrugated pipe void. The research entitled "*Precast Concrete Elements for Accelerated Bridge Construction*" [15] can be used to check the connection for punching shear. The AASHTO provisions for interface shear can also be used.

The joints between the abutment cap elements are simple grouted shear keys. This is somewhat different than conventional cast-in-place concrete integral abutments, where the cap is cast continuous across the width of the abutment. Maine DOT used match-cast stem elements combined with transverse post-tensioning. This is a good connection, but it may be a somewhat slower construction process. The concept behind the grouted key is to design the abutment stem with one-way action. The primary reinforcement would be run vertically from the superstructure pour to the abutment stem. The transverse reinforcement would run across the pile voids and terminate at the joints. This reinforcement

would be designed assuming that the joint was a simple pin connection. The integral pour between the beams will further join the stem elements.

### Example A1.4: Erection Calculations for a Full Depth Precast Concrete Deck Panel

The goal is to lift, transport and handle the panel without causing cracking. Chapter 5 of the PCI Design Handbook [47] offers information on the design of panels for lifting and handling. Normally, this calculation would be completed by the contractor. The intent is to present a sample calculation to designers who may review calculations and contractors that may be designing for lifting. Agencies and designers may specify other more stringent handling requirements that designers and contractors should be aware of prior to designing lifting and handling systems.

This example is for a hypothetical deck panel. It will be checked for handling and shipping according to Chapter 5 of the PCI Design Handbook based on “no cracking criteria”. Article and table references in this example refer to the PCI Design Handbook.

Panel information: (refer to Figure A1.4-1 on next page for reference)

1. Panel Overall dimensions
  - a. Length:  $b = 24$  feet
  - b. Width:  $a = 8$  feet
  - c. Thickness:  $t = 8$ "
  - d. Void size:  $16$ " x  $5$ "
2. Concrete Information:
  - a. Compressive strength at removal from forms: 2000psi
  - b. Compressive strength at delivery: 4000psi
  - c. Unit weight: 150 pcf (including reinforcing)
3. Internal reinforcing (all Grade 60 mild reinforcing)
  - a. Longitudinal bars: #5@6" top and bottom
  - b. Transverse bars: #4@12" top and bottom
  - c. Top cover:  $2\frac{1}{2}$ "
  - d. Bottom Cover:  $1\frac{1}{2}$ "

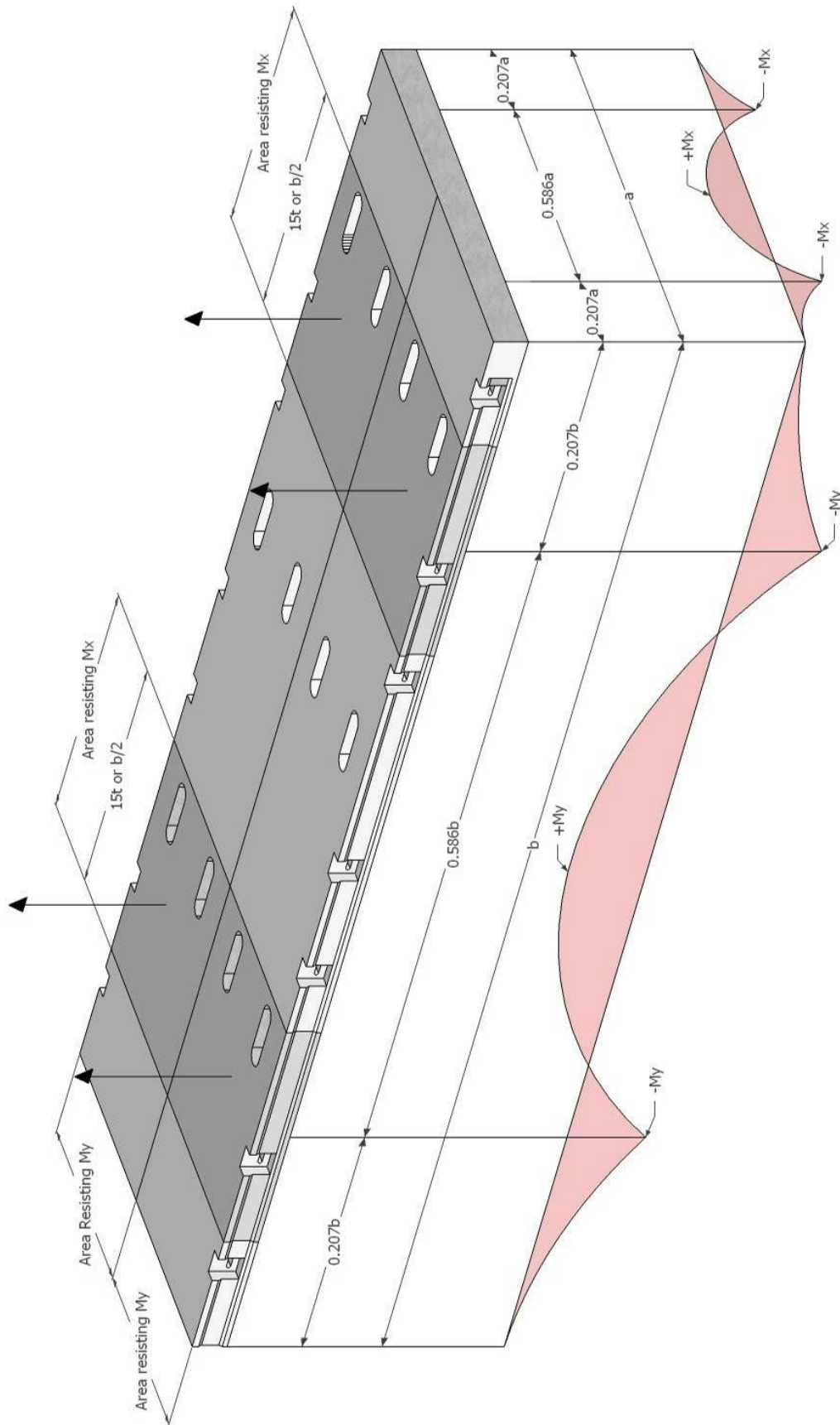

Figure A1.4-1 Example Full Depth Precast Panel Lift

### Step 1: Calculate Member weight

Volume of concrete =  $8' \times 24' \times 0.666' = 128 \text{ cf}$  (neglect voids)

Weight of panel =  $128 \text{ cf} \times 0.150 \text{ k/cf} = 19.2 \text{ kips}$

### Step 2: Calculate Allowable Stresses (Article 5.3.3.2)

For members designed for a “no cracking” approach, use an allowable stress equal to the modulus of rupture divided by a factor of safety of 1.5. It should be noted that this approach does not guarantee a crack free section. Experience has shown that decks designed to these provisions have performed well.

Allowable stress at removal from forms =  $7.5 \sqrt{f'c} / 1.5 = 5 \sqrt{2000} = 224 \text{ psi}$

Allowable stress for shipping =  $7.5 \sqrt{f'c} / 1.5 = 5 \sqrt{4000} = 316 \text{ psi}$

### Step 3: Determine Equivalent Static Load Multipliers (Table 5.3.3.1)

Form Stripping: 1.3 (smooth mold with no false joints or reveals)

Yard handling: 1.2

Travel: 1.5

### Step 4: Calculate Section Properties for Critical Sections (refer to diagram)

Section resisting  $M_x$ :

Overall Width =  $15t = 15 \times 8 = 120 \text{ in}$

or =  $b/2 = 240 / 2 = 120 \text{ in}$  ✓ control

Net Width (minus 1 void) =  $120'' - 16'' = 104''$

$S_x = w t^2 / 6 = 104 \times 8^2 / 6 = 1109 \text{ in}^3$

Section resisting  $M_y$ :

Overall Width =  $a / 2 = 96 / 2 = 48 \text{ in}$

Net Width (minus 2 voids) =  $48'' - (2 \times 5'') = 38''$

$S_y = w t^2 / 6 = 38 \times 8^2 / 6 = 405 \text{ in}^3$

### Step 5: Check Form Stripping (Figure 5.3.1.2 moments with 1.3 form stripping factor)

$+M_x = -M_x = 0.0107wa^2b \times 1.3$

$+M_y = -M_y = 0.0107wab^2 \times 1.3$

$w = \text{weight per unit area} = 0.666' \times .150 \text{ k/cf} = 0.100 \text{ ksf}$

$a = 8'$                        $b = 24'$

Transverse Bending:

$M_x = 0.0107 \times 0.100 \text{ksf} \times (8\text{ft})^2 \times 24\text{ft} \times 12(\text{in/ft}) \times 1.3 = 25.64 \text{ k-in}$

$$f_t = f_b = Mx/S_x = 25.64 / 1109 = 0.023 \text{ ksi} < 0.224 \text{ ksi allowable OK} \checkmark$$

Longitudinal Bending:

$$M_y = 0.0107 \times 0.100 \text{ksf} \times 8\text{ft} \times (24\text{ft})^2 \times 12(\text{in}/\text{ft}) \times 1.3 = 76.92 \text{ k-in}$$

$$f_t = f_b = Mx/S_x = 76.92 / 405 = 0.190 \text{ ksi} < 0.224 \text{ ksi allowable OK} \checkmark$$

Step 6: Check Shipping and Handling (Figure 5.3.1.2 moments with 1.5 travel factor)

$$+M_x = -M_x = 0.0107 w a^2 b \times 1.5$$

$$+M_y = -M_y = 0.0107 w a b^2 \times 1.5$$

$$w = \text{weight per unit area} = 0.666' \times .150 \text{ k/cf} = 0.100 \text{ ksf}$$

$$a = 8' \quad b = 24'$$

Transverse Bending:

$$M_x = 0.0107 \times 0.100 \text{ksf} \times (8\text{ft})^2 \times 24\text{ft} \times 12(\text{in}/\text{ft}) \times 1.5 = 29.58 \text{ k-in}$$

$$f_t = f_b = Mx/S_x = 29.58 / 1109 = 0.027 \text{ ksi} < 0.316 \text{ ksi allowable OK} \checkmark$$

Longitudinal Bending:

$$M_y = 0.0107 \times 0.100 \times 8 \times 24^2 \times 12 \times 1.5 = 88.75 \text{ k-in}$$

$$f_t = f_b = Mx/S_x = 88.75 / 405 = 0.219 \text{ ksi} < 0.316 \text{ ksi allowable OK} \checkmark$$

Step 7: Calculate Lifting Hardware Loads

$$\text{Load per anchor} = \text{total weight} / 4 = 19.2\text{k} / 4 = 4.8 \text{ kips}$$

$$\text{Form stripping load} = 4.8 \times 1.3 = 6.24 \text{ kips (f'ci = 2000psi)}$$

$$\text{Handling load} = 4.8 \times 1.5 = 7.2 \text{ kips (f'c = 4000psi)}$$

Design lifting inserts for the following:

Use embedded inserts and erection devices with a pullout strength at least equal to 4 times the calculated loads on the device (Article 5.3.3.2).

The calculated loads are for vertical lifting. Account for angular load vectors in the embedded insert design.

Step 8: Check Member Strength at Form Stripping

Negative bending controls due to larger top cover (smallest d)

Assume: Singly reinforced section (conservative)

Transverse Bending

$$M_x = 25.64 \text{ k-in (unfactored)}$$

$$\text{Factored } M_x = 25.64 \times 1.25 = 32.05 \text{ k-in}$$

Beam information

Width = 120 in

Reinforcing =  $10 \times 0.2 \text{ in}^2 = 2.0 \text{ in}^2$  (#4 @ 12")

$d = 8\text{in} - 2.5\text{in (cover)} - 0.625\text{in (top bar)} - 0.5\text{in}/2 \text{ (trans. bar)}$   
 $= 4.625 \text{ in}$

$f'_{ci} = 2000\text{psi}$                        $f_y = 60,000 \text{ psi}$

$\beta_1 = 0.85$  (for  $f'_{ci} = 2000 \text{ psi}$ )

$T = A_s F_y = 2.0 \text{ in}^2 \times 60 \text{ ksi} = 120 \text{ kips}$

$a = T / (0.85 \times f'_{ci} \times b) = 120\text{kips} / (0.85 \times 2\text{ksi} \times 120 \text{ in}) = 0.68 \text{ in}$

Tension control check

Distance to neutral axis =  $c = a / \beta_1 = 0.68\text{in} / 0.85 = 0.80 \text{ in}$

Steel Strain =  $0.003 \times (d-c)/c = 0.003 \times (4.625\text{in} - 0.80 \text{ in})/0.80 \text{ in}$   
 $= 0.0144$

Yield Strain =  $F_y/E_s = 60\text{ksi} / 29,000 \text{ ksi} = 0.0021$

Steel strain is greater than yield strain therefore tension controls ✓

Calculate  $\Phi$  (AASHTO LRFD Article 5.5.4.2.1)

Steel strain is greater than 0.005, therefore  $\Phi = 0.9$

$\Phi M_n = \Phi A_s F_y (d - a/2) = 0.9 \times 120 \text{ kips} (4.625\text{in} - 0.68\text{in}/2)$   
 $= 463 \text{ k-in} \gg 32.05 \text{ k-in}$                       OK✓

Longitudinal Bending:

$M_y = 76.92 \text{ k-in}$  (unfactored)

Factored  $M_x = 76.92 \times 1.25 = 96.15 \text{ k-in}$

Beam information

Width = 38 in

Reinforcing =  $9 \times 0.31 \text{ in}^2 = 2.79 \text{ in}^2$

$d = 8" - 2.5" \text{ (cover)} - 0.625"/2 \text{ (top bar)}$   
 $= 5.19 \text{ in}$

$f'_{ci} = 2000\text{psi}$                        $f_y = 60,000 \text{ psi}$

$\beta_1 = 0.85$  (for  $f'_{ci} = 2000 \text{ psi}$ )

$T = A_s F_y = 2.79 \text{ in}^2 \times 60 \text{ ksi} = 167.4 \text{ kips}$

$a = T / (0.85 \times f'_{ci} \times b) = 167.4\text{kips} / (0.85 \times 2\text{ksi} \times 38 \text{ in}) = 2.59 \text{ in}$

Tension control check

Distance to neutral axis =  $c = a / \beta_1 = 2.59\text{in} / 0.85 = 3.05 \text{ in}$

Steel Strain =  $0.003 \times (d-c)/c = 0.003 \times (5.19\text{in} - 3.05 \text{ in})/3.05 \text{ in}$   
 $= 0.0021$

$$\text{Yield Strain} = F_y/E_s = 60\text{ksi} / 29,000 \text{ ksi} = 0.0021$$

Steel strain is equal to yield strain therefore tension controls ✓

Calculate  $\Phi$  (AASHTO LRFD Article 5.5.4.2.1)

Steel strain is less than 0.005 and greater than 0.002

therefore  $\Phi = 0.65 + 0.15(d/c - 1)$  (AASHTO LRFD Fig. C5.5.4.2.1-1)

$$\Phi = 0.65 + 0.15(5.19\text{in} / 3.05\text{in} - 1) = 0.755$$

$$\Phi M_n = \Phi A_s F_y (d - a/2) = 0.755 \times 167.4 \text{ kips} (5.19\text{in} - 2.59\text{in}/2)$$

$$= 492 \text{ k-in} \gg 96.15 \text{ k-in} \quad \text{OK} \checkmark$$

By inspection, shipping moments will be OK.

### Example A1.5: Reference Documents that Include Design Information

Many of the reference documents in this manual include design information. The following is a list of the references and the design information contained in each:

*Table A1.5-1 Reference Documents that Include Design Information*

Reference Number See Pages 269-273	Reference Titles	Design Information
2	Manual on the Use of Self-Propelled Modular Transporters to Remove and Replace Bridges	Design of bridges with SPMT installation. Design of shoring systems
3	Connection Details for Prefabricated Bridge Elements and Systems	Design of connections Design of longitudinal post-tensioning in precast decks
6	Emulating Cast-in-Place Detailing in Precast Concrete Structures	Emulative detailing of precast connections
7	SPMT Process Manual and Design Guide	Design of bridges with SPMT installation. Design of shoring systems
9, 20-38	Various research reports covering full depth precast concrete deck panels	Design of Precast Deck Panels Design of Connections to girders Design of connections between panels
11	Development of Precast Bent Cap Systems for Seismic Regions	Design of column to cap connections for pier bents in seismic regions
12	Precast Concrete Elements for Accelerated Bridge Construction	Design of corrugated pipe void connections
13, 14	Behavior and Design of Link Slabs for Jointless Bridge Decks Combining Link Slab, Deck Sliding over Backwall, and Revising Bearings	Design of Link slab connections

Reference Number See Pages 269-273	Reference Titles	Design Information
17-19	<p>Use of Precast Concrete Stay-in-Place Forms for Bridge Decks</p> <p>A Study of Prestressed Panels and Composite Action in Concrete bridges Made of Prestressed Beams, Prestressed Sub-Deck Panels, and Cast-in-place Deck</p> <p>The Effects of Transverse Strand Extensions on the Behavior of Precast Prestressed Panel Bridges</p>	Design of partial depth precast deck panels
42	<i>Noncontact Lap Splices in Bridge Column-Shaft Connections</i>	Design of a connection between a large diameter drilled shaft and a precast concrete column
47	<i>PCI Design Handbook Precast and Prestressed Concrete</i>	Design of precast products for lifting and handling
48	<i>Post-Tensioning Tendon Installation and Grouting Manual</i>	Design and specifications for installation of post-tensioning systems
51	<i>Tests on Re-Bar Splices in Reinforced Concrete Columns using NMB Splice Sleeves</i>	Structural performance of grouted splice sleeve couplers
52, 54-56	<p><i>Development of a Precast Bent Cap System</i></p> <p><i>Design of Precast Concrete Piers for Rapid Bridge Construction in Seismic Regions</i></p> <p><i>Anchorage of Large-Diameter Reinforcing Bars Grouted into Ducts</i></p> <p><i>Rapidly Constructible Large-bar Precast Bridge Bent Seismic Connection</i></p>	Design of pier bent cap connections using grouted post-tensioning ducts.

## **Appendix B: Standard and Proprietary Products**

The following are products used in ABC/PBES projects that are potentially proprietary items.

### Prefabricated Superstructure Systems

- Effideck™
- BEBO® Concrete Arch System
- HY-SPAN® Bridge System

### Grouted Reinforcing Splice Couplers

- NMB Splice Sleeve
- Dayton Superior DB Grout Sleeve
- Erico Lenton Interlok Rebar Splicing System

### Proprietary Retaining Wall Systems

- Reinforced Earth® and Retained Earth™ Retaining Walls
- Doublewall Retaining Wall
- T-WALL® Retaining Wall System

### Post-tensioning Systems

- Dydiwag Systems
- VSL Post-tensioning Systems
- Williams Threadbar Systems

FHWA has rules and regulations concerning the use and specification of Proprietary Products on Federal-aid highway projects. The FHWA has a website that is devoted to this subject. It can be found at: [www.fhwa.dot.gov/construction/cqit/propriet.cfm](http://www.fhwa.dot.gov/construction/cqit/propriet.cfm)

The listing of the products above does not constitute approval for these products for usage on Federal-aid projects.

### Appendix C: Sample Construction Specifications

The FHWA Manual entitled “Connection Details for Prefabricated Bridge Elements and Systems” [3] contains sample specifications from ABC projects (Appendix C). Since the publication of the manual, Several States have developed ABC specifications.

The following is a listing of these specifications from several state agencies. These specifications are written in the format of the particular agency; therefore the formats are not similar. These specifications are presented for reference only and may become outdated as time passes. Designers can use the information contained in this appendix; however the specifications should be carefully reviewed and modified as needed.

<b>Example</b>	<b>Title</b>	<b>Page</b>
1	Utah DOT – Precast Substructure Elements	292
2	Utah DOT – Precast Concrete Deck Panel	
3	Utah DOT – Bridge Construction using Self-propelled Modular Transporters (SPMT)	312
4	Utah DOT – Structural Lightweight Concrete (used for reducing element weight)	327
5	Massachusetts DOT – High Early Strength Concrete (used for closure pours)	342

**Example Specification C1:**

Source: Utah Department of Transportation  
Title: Precast Substructure Elements  
Use: Covers precast abutments, piers, and walls

**SPECIAL PROVISION**

**PROJECT #  
PIN #**

**SECTION 03131S**

**PRECAST SUBSTRUCTURE ELEMENTS**

**Add Section 03131:**

**PART 1 GENERAL**

**1.1 SECTION INCLUDES**

- A. This work consists of furnishing, erecting, and installing all precast concrete elements for bridge substructures including all necessary materials and equipment to complete the work as shown on the plans. Substructures in general include footings, columns, pier caps, abutment stems, and wall stems. The use of cast-in-place concrete will not be considered for substitution.
- B. Procedures for installing elements
- C. Procedures for placing structural non-shrink grout.
- D. Procedures for placing flowable bedding concrete.
- E. Procedures for placing high early strength concrete at closure pours.

**1.2 RELATED SECTIONS**

- A. Section 03055: Portland Cement Concrete
- B. Section 03211: Reinforcing Steel and Welded Wire
- C. Section 03310: Structural Concrete
- D. Section 03575: Flowable Fill

### 1.3 REFERENCES

- A. AASHTO M 36: Corrugated Steel Pipe, Metallic-Coated, for Sewers and Drains
- B. AASHTO M 245: Standard Specification for Corrugated Steel Pipe, Polymer-Precoated, for Sewers and Drains
- C. AASHTO T 106: Standard Test Method for Compressive Strength of Hydraulic Cement Mortars (Using 2-in. Cube Specimens)
- D. AASHTO T 160: Standard Method of Test for Length Change of Hardened Hydraulic Cement Mortar and Concrete
- E. AASHTO T 161: Standard Method of Test for Resistance of Concrete to Rapid Freezing and Thawing
- F. AASHTO T 260: Standard Method of Test for Sampling and Testing Chloride Ion in Concrete and Concrete Raw Materials
- G. AASHTO Standard Specifications for Highway Bridges
- H. ASTM A 370: Standard Test Methods and Definitions for Mechanical Testing of Steel Products
- I. ASTM A 615: Standard Specification for Deformed and Plain Carbon-Steel Bars for Concrete Reinforcement.
- J. ASTM A 706: Standard Specification for Low-Alloy Steel Deformed and Plain Bars for Concrete Reinforcement.
- K. ASTM C 666: Standard Test Method for Resistance of Concrete to Rapid Freezing and Thawing
- L. ASTM C 882: Standard Test Method for Bond Strength of Epoxy-Resin Systems Used With Concrete By Slant Shear.
- M. ASTM D 2240: Standard Test Method for Rubber Property – Durometer Hardness
- N. PCI Design Handbook, Fifth Edition with all Interims and Errata
- O. UDOT Quality Management Plan

## 1.4 DEFINITIONS

- A. Continuous Butt Welded Hoops: Individual reinforcing steel bars that are formed into a circular shape with ends connected by a resistance butt welding process.
  - 1. The hoops are used to provide transverse column reinforcing by confining the vertical column reinforcing.
  
- B. Grouted Splice Coupler: Mechanical devices used to splice reinforcing steel within precast concrete elements.
  - 1. These couplers are proprietary devices that are comprised of a combination of a steel casting and a high strength cementitious grout.
  - 2. Some couplers combine a threaded connection for the bar that is cast into the element combined with a grouted portion that is used to make the connection in the field.
  - 3. The grout used for the coupler is part of the proprietary system and is supplied by the coupler manufacturer.

## 1.5 SUBMITTALS

- A. The submittals requiring written approval from the Engineer are as follows:
  - 1. Assembly Plan:
    - a. Submit five sets of half-size, 11 x 17 inch sheets with a 1½ inch blank margin on the left-hand edge.
    - b. Place the project designation data in the lower right-hand corner of each sheet.
    - c. Follow Chapter 5 of the PCI Design Handbook for handling and erection bracing requirements.
    - d. Comply with all requirements of applicable environmental permits.
    - e. Comply with the construction timeframes specified in the Maintenance of Traffic Specifications.
    - f. Include a work area plan, depicting items such as utilities overhead and below the work area, drainage inlet structures, and protective measures.
    - g. Include details of all equipment that will be employed for the assembly of the substructure.
    - h. Include details of all equipment to be used to lift substructure elements including cranes, excavators, lifting slings, sling hooks, and jacks. Include crane locations, operation radii, and lifting calculations.
    - i. Include a detailed sequence of construction and a timeline for all operations. Account for setting and

- cure time for grouts, grouted splice couplers, and concrete closure pours.
- j. Include methods of providing temporary support of the elements. Include methods of adjusting and securing the element after placement.
  - k. Include procedures for controlling tolerance limits both horizontal and vertical. Include details of any alignment jigs including bi-level templates for reinforcing anchor dowels.
  - l. Include a detailed installation procedure for connecting the grouted splice couplers including pre-grout and post-grout applications.
  - m. Include methods for curing grout and closure pour concrete.
  - n. Include proposed methods for installing non-shrink grout and the sequence and equipment for the grouting operation.
  - o. Include methods for placement of flowable bedding concrete for spread footings. Add grout ports in the footings to facilitate the bedding process if required.
  - p. Include methods of forming closure pours including the use of backer rods. Do not assume that the backer rods will restrain the pressure from the grout in vertical grout joints. Provide additional forming to retain the backer rod.
  - q. Include a list of personnel that will be responsible for the grouting of the reinforcing splice couplers. Include proof of completion of two successful installations within the last two years. Training of new personnel within three months of installation by a manufacturer's technical representative is an acceptable substitution for this experience. In this case, provide proof of training.
  - r. Prepare the plan under the seal of a Utah Professional Engineer.
  - s. The Engineer reserves the right to retain these drawings up to 14 calendar days without granting an increase in the number of working days on the project. This duration is reduced to 7 days when the drawings are submitted electronically. This right applies each time the drawings are submitted or re-submitted.
2. Element Shop Drawings:
- a. Submit five sets of half-size, 11 x 17 inch sheets with a 1½ inch blank margin on the left-hand edge.

- b. Place the project designation data in the lower right-hand corner of each sheet.
  - c. Prepare shop drawings and stamp by Professional Engineer licensed in Utah.
  - d. Show all lifting inserts, hardware, or devices and locations on the shop drawings for Engineer's approval.
  - e. Show locations and details of the lifting devices, including supporting calculations, type, and amount of any additional reinforcing required for lifting. Design all lifting devices based on the no cracking criteria in Chapter 5 of the PCI Design Handbook.
  - f. Show minimum compressive strength attained prior to handling the precast elements.
  - g. Show Details of vertical adjusting hardware.
  - h. Do not order materials or begin work until receiving final approval of the shop detail drawings.
  - i. The Department will reject any elements fabricated before receiving written approval, or any elements that deviate from the approved drawings. The Contractor is responsible for costs incurred due to faulty detailing or fabrication.
  - j. The Engineer reserves the right to retain these drawings up to 14 calendar days without granting an increase in the number of working days on the project. This duration is reduced to 7 days when the drawings are submitted electronically. This right applies each time the drawings are submitted or re-submitted.
3. Grouted Splice Couplers
- a. Submit five copies of an independent test report confirming the compliance of the coupler with the following requirements:
    - 1) Develop 100 percent of the specified tensile strength of the attached reinforcing bar. This equates to 90 ksi bar stress for an ASTM A 615 bar and 80 ksi bar stress for an ASTM A 706 bar.
    - 2) Determine through testing, the amount of time required to provide 100 percent of the specified minimum yield strength of the attached reinforcing bar. Use this value to develop the assembly plan timing.
  - b. Submit an independent test report that includes data for each supplied coupler size.

- c. Use the same grout in the construction that was used in the testing.
  - d. Submit the specification requirements for the grout including required strength gain to develop the specified minimum yield strength of the connected reinforcing bar.
4. Resistance Butt Welded Reinforcing Hoops
- a. Submit five copies of proof that the manufacturer is approved by the California Department of Transportation for the bar size and diameter specified. Lists of approved fabricators can be found at the California Department of Transportation website ([http://www.dot.ca.gov/hq/esc/approved\\_products\\_list/pdf/PrequalFlashWeldedHoops.pdf](http://www.dot.ca.gov/hq/esc/approved_products_list/pdf/PrequalFlashWeldedHoops.pdf)).
  - b. Submit five copies of the manufacturer's quality Control (QC) manual for the hoop fabrication. Include the following information in the manual as a minimum:
    - 1) The pre-production procedures for the qualification of material and equipment.
    - 2) The methods and frequencies for performing QC procedures during production.
    - 3) The calibration procedures and calibration frequency for all equipment.
    - 4) The welding procedure specification (WPS) for resistance welding.
    - 5) The method for identifying and tracking lots.
5. Structural Non-Shrink Grout
- a. Submit a Certificate of Compliance to Engineer.
  - b. Submit a proposed method for forming grout voids and installing the structural non-shrink grout, sequence, and equipment for grouting operation to Engineer for review for a minimum of 14 days. Obtain approval before placing grout.
- B. Concrete Requirements
- 1. Submit substitutions for self-consolidating concrete mix designs to Engineer for approval as an alternate to the structural concrete for the precast elements.
  - 2. Submit to the Engineer for approval a high early strength concrete mix or material data information that states the percentage of each component to be used depending on the closure pour concrete selected.
  - 3. Regardless of the type of high early strength concrete proposed, submit substantive data that demonstrates the ability of the material to meet the specification requirements

with the proposed mix design at least two weeks prior to its use.

- C. Defects and breakage of precast elements
  - 1. Submit proposed written repair procedures for approval.
- D. Grout substitution in the couplers
  - 1. Refer to this Section, article 2.1 paragraph E5a for additional certified test report requirements.
- E. Installation of elements
  - 1. Refer to this Section, article 3.2 paragraph A for changes warranted due to varying site conditions.

## **PART 2 PRODUCTS**

### **2.1 MATERIALS**

- A. Concrete
  - 1. Precast elements: Use Class AA (AE) concrete as specified in Section 03055 and on the plans.
  - 2. Bedding under elements: Use flowable fill conforming to the requirements of Section 03575.
  - 3. High Early Strength Concrete: Use one of the following:
    - a. A high early strength concrete mix designed as follows:
      - 1) Use air-entraining, Portland cement, fine and coarse aggregates, admixtures, water, and additives.
      - 2) Use between 4 and 7 percent-entrained air.
      - 3) Develop a mix that can attain a 6-hour compressive strength of 2500 psi, and a 7-day compressive strength of 4000 psi.
      - 4) Additionally, develop a mix that contains shrinkage compensating additives such that there will be no separation of the closure pour concrete from the adjacent precast concrete.
      - 5) Use a shrinkage-compensating additive that produces expansion in the high early strength concrete of no more than 3 percent.
    - b. A proprietary concrete mix may be used that meets the same physical requirements as those stated above.
- B. Reinforcing Steel

1. Conform to Section 03211.
  2. Use coated reinforcing steel in all elements.
  3. Use reinforcing conforming to ASTM A 706 (weldable) for vertical reinforcing in the pier columns, transverse reinforcing in the pier columns, and any bar passing from the columns into the footing or pier cap. Use reinforcing conforming to ASTM A 615 for all other substructure elements.
  4. Use continuous butt welded hoops or spiral reinforcing for transverse column reinforcing. Connect the ends of the continuous hoops by the resistance butt welding method. Hoop ends connected by lap welding will not be allowed. Other mechanically connected end devices are also not allowed.
  5. Lap splices in vertical column reinforcing bars are not allowed unless specifically noted on the plans.
- C. Non- Shrink Grout
1. Use structural non-shrink grout for joints between precast elements as shown on the plans.
    - a. Mix structural non-shrink grout just prior to use according to the manufacturer's instructions.
    - b. Use gray, non-shrink grout concrete and containing no calcium chloride or admixture containing calcium chloride or other ingredient in sufficient quantity to cause corrosion to steel reinforcement.
    - c. Follow manufacturer's recommendation for dosage of corrosion inhibitor admixture.
    - d. Use quick-setting, rapid strength gain, non-shrink, and high-bond strength grout.
    - e. Warranty the in-place structural non-shrink grout performance and workmanship for two years.
    - f. Repair or refund at the Department's option any bonding failures that occur during the warranty period.
    - g. Use structural non-shrink grout that meets a minimum compressive strength of 4,000 psi within 24 hours when tested as specified in AASHTO T 106.
    - h. Meet all the requirements of AASHTO T 160 with the exception that the Contractor-supplied cube molds will remain intact with a top firmly attached throughout the curing period.
    - i. Use structural non-shrink grout with no expansion after seven days.
    - j. Refer to Table 1 for structural non-shrink grout requirements.

Table 1

<b>Structural Non-Shrink Grout</b>			
<b>*Properties</b>	<b>Requirements</b>	<b>ASTM</b>	<b>AASHTO</b>
Accelerated Weathering	As Specified in ASTM or AASHTO	C 666	T 260
Compressive Strength	>5,000 psi @ 28 days		T 106
Accepted Bond Strengths	>1,000 psi @ 24 Hours	C 882	
Test Medium	<3% White Utah Road Salt		T 161
Accepted Weight Loss	<15% @ 300 Cycles		T 161
Length Change	No expansion after 7 days		T 160

\*Certified test results from a private AASHTO accredited testing laboratory will suffice for acceptance.

**D. Precast Concrete Elements**

1. Use a Department Certified Concrete Precaster or a pre-qualified project site caster for concrete products according to the Department Quality Management Plan: Precast-Prestressed Concrete Structures.
2. Maintain a minimum compressive strength of 500 psi prior to stripping the form. Continuously wet cure the precast elements for 7-days commencing immediately after final finishing with all exposed surfaces covered. The precast elements will have a minimum cure of 14 days prior to placement.
3. Supply test data such as slump, air voids, or unit weight for the fresh concrete and compressive strengths for the hardened concrete after 7, 14, and 28 days, if applicable.

**E. Grouted Splice Couplers**

1. Use grouted splice couplers to join precast elements as shown on the plans.
  - a. Provide couplers that use cementitious grout placed inside a steel casting.
  - b. Threaded connections may be used for the portions of the coupler that are placed within the precast element if the strength of the coupler meets or exceeds the requirements of this specification.
2. The following reinforcing splice couplers are acceptable for use provided that the requirements of this specification are met.
  - a. NMB Splice Sleeve  
Splice Sleeve North America, Inc.  
192 Technology Drive, Suite J,  
Irvine, California 92618-2409



2. Permanently mark each precast element with date of casting and supplier identification. Stamp markings in fresh concrete.
3. Prevent cracking or damage of precast elements during handling and storage.
4. Replace defects and breakage of precast elements
  - a. Members that sustain damage or surface defects during fabrication, handling, storage, hauling, or erection are subject to review or rejection.
  - b. Obtain approval before performing repairs.
  - c. Repair work must reestablish the elements' structural integrity, durability, and aesthetics to the satisfaction of the Engineer.
  - d. Determine the cause when damage occurs and take corrective action.
  - e. Failure to take corrective action, leading to similar repetitive damage, can be cause for rejection of the damaged element.
  - f. Cracks that extend to the nearest reinforcement plane and fine surface cracks that do not extend to the nearest reinforcement plane but are numerous or extensive are subject to review and rejection.
  - g. Full depth cracking and breakage greater than one foot are cause for rejection.
5. Construct precast elements to tolerances shown on the plans.
6. The plant will document all test results. The quality control file will contain at least the following information:
  - a. Element identification
  - b. Date and time of cast
  - c. Concrete cylinder test results
  - d. Quantity of used concrete and the batch printout
  - e. Form-stripping date and repairs if applicable
  - f. Location/number of blockouts and lifting inserts
  - g. Temperature and moisture of curing period
  - h. Document lifting device details, requirements, and inserts

**B. Continuous Butt Welded Hoops**

1. Provide samples for Quality Assurance testing in conformance with the provisions in these specifications.
2. Perform all production tests for all size splices (by the contractor's independent laboratory). Remove four sample splices from each lot of completed splices. Test according to ASTM A 370. The Engineer may select the sample splices for hoops either at the job site or at the fabrication facility.

- C. Grouted Splice Couplers
  - 1. The performance of grouted splice couplers is related to the embedment length of the bars and the compressive strength of the grout.
    - a. Check the length of rebar anchor dowel to make sure they meet the minimum embedment specified in the manufacturer's manual.
    - b. Monitor shim thickness between the precast elements to ensure that the reinforcing extensions are within the manufacturers recommended tolerance.
    - c. Monitor the grout mixing, water to grout ratio, mixing time, and shelf life of the grout for conformance with the manufacturers written instructions.
    - d. Monitor the grouting operation to verify that all sleeves have been filled.
    - e. Make four sets of three - two inch cube molds in heavy brass molds with cover plates for testing according to AASHTO T 106.
    - f. Verify that all sleeves are protected from any vibration, shock, or other excessive movement until temporary bracing is removed.
    - g. Check the temperature of the sleeve at the time of grouting (50 degrees F minimum) and during curing.

## **PART 3 EXECUTION**

### **3.1 FABRICATION**

- A. Do not place concrete in the forms until the Engineer has inspected and approved all the materials in the elements.
- B. Provide the Engineer a tentative casting schedule at least two weeks in advance to make inspection and testing arrangements. A similar notification is required for the shipment of precast elements to the job site.
- C. Do not place concrete in the forms until the Engineer has inspected the form and has approved the placement of all materials in the precast elements.
- D. Finish the precast elements according to Section 03310. Trowel finish the top surface of all precast concrete elements.

### **3.2 GENERAL PROCEDURE FOR ALL INSTALLATION OF ELEMENTS**

- A. Review the approved assembly plan. If changes are warranted due to varying site conditions, resubmit the plan for review and approval.
- B. Dry fit adjacent elements in the shop if noted on the plans. The fabricator may opt to dry fit elements in any case.
- C. Establish working points, working lines, and benchmark elevations prior to placement of all elements.
- D. Check the condition of the receiving bonding surface prior to connecting elements and take any necessary measures to remove items such as dust, rust, and debris to provide the satisfactory bonding required between the protruding reinforcing bars element and the grouted couplers.
- E. Place elements in the sequence and according to the methods outlined in the assembly plan. Adjust the height of each element by means of leveling devices or shims.

### **3.3 CONNECTION PROCEDURE USING GROUTED SPLICE COUPLERS**

- A. Use personnel that are familiar with installation and grouting of splice couplers that have completed at least two successful projects in the last two years.
  - 1. Training of new personnel within three months of installation by a manufacturer's technical representative is an acceptable substitution for this experience.
- B. Remove and clean all debris from the joints prior to application of non-shrink grout.
- C. Keep bonding surfaces free from laitance, dirt, dust, paint, grease oil, or any contaminants other than water.
- D. Saturate Surface DRY (SSD) all joint surfaces prior to connecting the elements.
- E. Use heaters in freezing temperatures to maintain a minimum temperature of 50 degrees F. Monitor the temperature of the covered sleeves until the temporary bracing is removed.
- F. Follow the recommendations of the manufacturer for the installation and grouting of the couplers.

- G. Install with couplers above a horizontal joint
1. Determine the thickness of shims to provide the specified elevation within tolerance.
  2. Mix the non-shrink grout according to the supplier's recommendations including preparation and application.
  3. Place non-shrink grout on the interface between the two elements being joined prior to setting the element. Crown the thickness of the grout toward the center of the joint so that the grout can be displaced outward as the element is lowered onto the joint. Take precautions to prevent the non-shrink grout from entering the coupler above (e.g. grout dams or seals).
  4. Set the element in place. Engage all couplers in the joint. Allow the non-shrink grout to seep out of the joint.
  5. Trowel off excess non-shrink grout to form a neat joint once the element is set, plumbed, and aligned. Pack grout into any voids around the joint perimeter.
  6. Flush out the coupler with clean potable water.
  7. Mix the special coupler grout according to the manufacturer's recommendations for methods and proportions of mix and water.
  8. Make four sets of three 2-inch cube specimens for testing. Cure the specimens according to AASHTO T 106. Test one set of cubes for compressive strength at a minimum of 24 hours (or to determine when to release bracing) and 28-days. Store extra sets for longer term testing, if necessary.
  9. Pump the coupler grout into the coupler that is cast into the element. Start from the lower port. Pump until the grout is flowing freely from the upper port.
  10. Cap the upper port first and then remove the nozzle to cap the lower port. Proceed to the next coupler in a defined sequence.
  11. Cure the joint according to the non-shrink grout manufacturer's recommendations.
- H. Installation with couplers below a horizontal joint
1. Determine shim thickness to provide the specified elevation within tolerance.
  2. Prior to setting the element:
    - a. Mix the special coupler grout paying strict attention to the manufacturer's recommendations for methods and proportions of mix and water.
    - b. Clean debris from the interior using compressed air. Remove any rain water using a vacuum that can remove water from the confined space in the coupler.

- c. First, pour the coupler grout into the coupler by pouring or pumping into the coupler. It is acceptable to fill the coupler to the top.
  - d. Second, place non-shrink grout on the interface between the two elements being joined. Crown the thickness of the grout toward the center of the joint so that the grout can be displaced outward as the element is lowered onto the joint.
  - e. Trowel off excess non-shrink grout to form a neat joint once the element is set, plumbed, and aligned. Pack grout into any voids around the joint perimeter.
- I. Installation of coupler in vertical joints (horizontal bar/coupler connection)
- 1. Establish a method to provide the specified alignment and spacing of the elevation within tolerance.
  - 2. Use washers or seals to prevent mixing of the non-shrink joint grout and the coupler grout.
  - 3. Set the element in place. Engage all couplers in the joint.
  - 4. Flush out the couplers with clean potable water once the element is set, plumbed, and aligned.
  - 5. Mix the special coupler grout paying strict attention to the manufacturer's recommendations for methods and proportions of mix and water.
  - 6. Pump the coupler grout into the coupler that is cast into the element. Start from the port closest to the joint. Pump until the grout is flowing freely from the other port.
  - 7. Cap the port farthest from the joint first and then remove the nozzle to cap the other port. Proceed to the next coupler in a defined sequence.
  - 8. Form the edges of the joint and place non-shrink grout into the joint.
  - 9. Cure the joint according to the non-shrink grout manufacturer's recommendations.

### **3.4 FOOTINGS**

- A. Lift footing segments as shown in the assembly plan using lifting devices as shown on the shop drawings.
- B. Set footing in the proper horizontal location. Check for proper alignment within specified tolerances.

- C. Adjust vertical leveling devices prior to full release of the element from the crane to facilitate the vertical adjustment process. This will reduce the amount of torque required to turn the bolts in the leveling devices. Check for proper grade within specified tolerances.
- D. Check the spacing of dowels or grouted splice couplers between adjacent footings that are to support common elements in future stages of construction. The use of bi-level templates and jigs is recommended. Adjust the location of the footing if required.
- E. Pour flowable bedding concrete through the ports for spread footings supported on soil or rock. Start from the center of the footing and proceed toward the outside edges. Verify that bedding concrete is filling the entire void between the footing and the subgrade.
- F. Place concrete around pile tops as shown on the plans for footings supported on drilled shafts or piles. Allow this concrete to flow partially under the footing. The entire underside of the footing need not be filled with concrete.
- G. Do not remove the installation bolts or proceed with the installation of elements above the footing until the compressive test result of the cylinders for bedding concrete or pile connection concrete has reached the specified minimum values.

### **3.5 PIER COLUMNS**

- A. Lift column element as shown in the assembly plan using lifting devices as shown on the shop drawings.
- B. Survey the elevation of the element directly below the column. Provide shims to bring the bottom of the column to the required elevation.
- C. Measure the elevation of the top of the shim stack and the top of the projecting dowels. Verify that the elevations and dowel extensions are within specified tolerances.
- D. A dry fit of the column is recommended until work crews become more familiar with the process. Set column in the proper horizontal location. Check for proper horizontal and vertical alignment within specified tolerances. Remove and adjust the shims and reset the column if the column is not within tolerance.

- E. Check the dowel spacing or grouted splice couplers between adjacent columns that will support common elements in future stages of construction. The use of bi-level templates and jigs is recommended. Adjust the location of the footing if required. Slight tilting of the column within tolerances is permitted.
- F. Set the column and install the couplers as described in this Section, article 3.3 once the connection geometry is established and checked.
- G. Install temporary bracing if specified in the assembly plan.
- H. Allow the grout in the coupler to cure until the coupler can resist 100 percent of the specified minimum yield strength of the bar prior to removal of bracing and proceeding with installation of components above the pier column. The required strength of the grout for this is based on the certified test report. Verify the strength of the grout by testing cube samples according to AASHTO T 106.

### **3.6 PIER CAPS**

- A. Lift pier cap element as shown in the assembly plan using lifting devices as shown on the shop drawings.
- B. Survey the elevation of the column directly below the cap. Provide shims to bring the bottom of the cap to the required elevation. Measure the elevation of the top of the shim stack and the top of the projecting dowels. Verify that the elevations and dowel extensions are within specified tolerances.
- C. A dry fit of the cap is recommended until work crews become more familiar with the process. Set cap in the proper horizontal location. Check for proper horizontal and vertical alignment within specified tolerances. Remove and adjust the shims and reset the cap if the cap is not within tolerance.
- D. Set the cap and install the couplers as described in this Section, article 3.3 once the connection geometry is established and checked.
- E. Install temporary bracing if specified in the assembly plan.
- F. Allow the grout in the coupler to cure until the coupler can resist 100 percent of the specified minimum yield strength of the bar prior to removal of bracing and proceeding with installation of

components above the pier cap. The required strength of the grout for this is based on the certified test report. Verify the strength of the grout by testing cube samples according to AASHTO T 106.

### 3.7 WALL PANELS

- A. Wall panels consist of the following:
  - 1. Cantilever Abutment Stems
  - 2. Wingwall stems
  - 3. Integral abutment pile cap stems
  - 4. Abutment Backwalls and Cheekwalls
  
- B. Lift wall panel element as shown in the assembly plan using lifting devices as shown on the shop drawings.
  
- C. Wall panels supported on precast concrete elements (footing or stem)
  - 1. Survey the elevation of the base directly below the panel. Provide shims to bring the bottom of the panel to the required elevation. Measure the elevation of the top of the shim stack and the top of the projecting dowels. Verify that the elevations and dowel extensions are within specified tolerances.
  - 2. A dry fit of the panel is recommended until work crews become more familiar with the process. Set panel in the proper horizontal location. Check for proper horizontal and vertical alignment within specified tolerances. Remove and adjust the shims and reset the panel if the panel is not within tolerance.
  - 3. Set the panel and install the couplers as described in this Section, article 3.3 once the connection geometry is established and checked.
  - 4. Install temporary bracing if specified in the assembly plan.
  - 5. Allow the grout in the coupler to cure until the coupler can resist 100 percent of the specified minimum yield strength of the bar prior to removal of bracing and proceeding with installation of components above the panel. The required strength of the grout for this is based on the certified test report. Verify the strength of the grout by testing cube samples according to AASHTO T 106.
  - 6. Place concrete inside the blockouts and cure if the panels contain corrugated pipe blockouts.
  
- D. Wall panels supported on piles or drilled shafts (integral abutments)
  - 1. Lift wall panel as shown in the assembly plan using lifting devices as shown on the shop drawings.

2. Set the panel in the proper horizontal location. Check for proper alignment within specified tolerances.
3. Adjust the devices prior to full release from the crane if vertical leveling devices are used. This will reduce the amount of torque required to turn the bolts in the leveling devices. Check for proper grade within specified tolerances.
4. Check the spacing of dowels or grouted splice couplers between adjacent panels that are to support common elements in future stages of construction. The use of bi-level templates and jigs is recommended. Adjust the location of the panel if required.
5. Place concrete around pile tops as shown on the plans. Allow concrete to flow partially under the panel. The entire underside of the panel need not be filled with concrete.
6. Do not remove the installation bolts (if used) or proceed with the installation of elements above the panel until the compressive test result of the cylinders for the pile connection concrete has reached the specified minimum values.

### **3.8 PRECAST BEAM SEATS**

- A. Lift the precast beam seats as shown in the assembly plan using lifting devices as shown on the shop drawings.
- B. Set beam seat in the proper horizontal location.
  1. Check for proper alignment within specified tolerances.
- C. Adjust vertical leveling devices.
  1. Check for proper grade within specified tolerances.
- D. Install temporary bracing if specified in the assembly plan.
- E. Pour or pump grout through the blockouts in the seat.
  1. Start from the center of the seat and proceed toward the outside edges.
  2. Verify that grout is filling the entire void between the seat and the substructure element below.
- F. Grind beam seat to achieve the specified seat elevation tolerance if required.
  1. Grind to a maximum depth of  $\frac{1}{8}$  inch.

END OF SECTION

**Example Specification C2:**

Source: Utah Department of Transportation  
Title: Precast Concrete Deck Panel  
Use: Precast concrete deck panels with longitudinal post-tensioning

**SPECIAL PROVISION**

**PROJECT #  
PIN #**

**SECTION 03339S**

**PRECAST CONCRETE DECK PANEL**

**Delete Section 03339 in its entirety and replace with the following:**

**PART 1 GENERAL**

**1.1 SECTION INCLUDES**

- A. This work consists of furnishing, erecting, and installing all precast concrete deck panels including all necessary materials and equipment to complete the work as shown on the plans. The use of cast-in-place concrete is not an acceptable alternative for precast panels.
- B. Procedures for preparing and installing structural non-shrink grout.
- C. Placing structural non-shrink grout into the camber strips, filling the shear stud blockouts and, all other blockouts in the bridge precast concrete deck panels to produce a finished deck.
- D. Procedures relating to preparing bridges for widening and grinding deck panels.
- E. Procedures relating to installing new shear studs on top flanges of existing steel girders and installing shear connectors to the top flanges of existing concrete or prestressed beams as shear studs.
- F. Procedures for full depth precast concrete deck panel.

**1.2 RELATED SECTIONS**

- A. Section 02982: Bridge Concrete Grinding
- B. Section 03055: Portland Cement Concrete
- C. Section 03211: Reinforcing Steel and Welded Wire

- D. Section 03251S: Post Tensioning Concrete
- E. Section 03310: Structural Concrete
- F. Section 03372: Thin Bonded Polymer Overlay
- G. Section 03412: Prestressed Concrete

### 1.3 REFERENCES

- A. AASHTO M 111: Standard Specifications for Zinc (Hot-Galvanized) Coatings on Products Fabricated From Rolled, Pressed and Forged Steel Shape Plates, Bars, and Strip
- B. AASHTO M 169: Standard Specification for Steel Bars, Carbon and Alloy, Cold-Finished
- C. AASHTO M 235: Standard Specification for Epoxy Resin Adhesives
- D. AASHTO M 270: Structural Steel for Bridges
- E. AASHTO T 106: Compressive Strength of Hydraulic Cement Mortar
- F. AASHTO T 160: Length Change of Hardened Hydraulic Cement Mortar and Concrete
- G. AASHTO T 161: Standard Method of Test for Resistance of Concrete to Rapid Freezing and Thawing
- H. AASHTO T 260: Standard Method of Test for Sampling and Testing Chloride Ion in Concrete and Concrete Raw Materials
- I. AASHTO/AWS D1.5 2008 Bridge Welding Code
- J. ASTM A 108: Standard Specification for Steel Bar, Carbon and Alloy, Cold-Finished
- K. ASTM A 109: Standard Specification for Steel Carbon Cold-rolled Strip
- L. ASTM A 500: Standard Specification for Cold-Formed Welded and Seamless Carbon Steel Structural Tubing in Rounds and Shapes

- M. ASTM A 706: Standard Specification for Low-Alloy Steel Deformed and Plain Bars for Concrete Reinforcement
- N. ASTM C 494: Standard Specification for Chemical Admixtures for Concrete
- O. ASTM C 666: Standard Test Method for Resistance of Concrete to Rapid Freezing and Thawing
- P. ASTM C 882: Standard Test Method for Bond Strength of Epoxy-Resin Systems Used With Concrete By Slant Shear
- Q. ASTM E 1512: Standard Test Methods for Testing Bond Performance of Bonded Anchors
- R. ANSI/AWS C 6.2-89: Specification for Friction Welding of Metals
- S. PCI Design Handbook, Fifth Edition with all Interims and Errata
- T. UDOT Quality Management Plan

#### **1.4 DEFINITIONS NOT USED**

#### **1.5 SUBMITTALS**

- A. Submit the following to the Engineer for written approval:
  - 1. Shop Drawings:
    - a. Submit five sets half-size, 11 x 17 inch sheets with a 1½ inch blank margin on the left-hand edge.
    - b. Place the project designation data in the lower right-hand corner of each sheet.
    - c. Prepare shop drawings stamped by a Professional Engineer licensed in Utah.
    - d. Design, show, and locate all lifting inserts, hardware or devices, and vertical adjustment hardware on the shop drawings for the Engineer's approval. Design lifting hardware according to the provisions of Chapter 5 of the PCI Design Handbook.
    - e. Show type and size of longitudinal post-tensioning anchorage assembly and ducts. Design local zone reinforcing for the anchorage assembly.
    - f. Submit a Certificate of Compliance for non-shrink grout to the Engineer for approval.
    - g. Do not order materials or begin work until receiving final approval of the shop detail drawings.

- h. Do not deviate from the approved shop drawings unless authorized in writing. Contractor is responsible for costs incurred due to faulty detailing or fabrication.
  - i. The Engineer reserves the right to retain these drawings up to 14 calendar days without granting an increase in the number of working days on the project. This duration is reduced to 7 days when the drawings are submitted electronically. This right applies each time the drawings are submitted or re-submitted. The Department will reject units fabricated before receiving written approval.
2. Erection Plans:
- a. Submit five sets half-size, 11 x 17 inch sheets with a 1½ inch blank margin on the left-hand edge.
  - b. Place the project designation data in the lower right-hand corner of each sheet.
  - c. Prepare drawings and supporting calculations stamped by a Professional Engineer licensed in Utah.
  - d. Check that all handling and erection bracing conform to Chapter 5 of the PCI Design Handbook.
  - e. Include the following at a minimum on the erection plans:
    - 1) Minimum clearances of reinforcing to panel edges.
    - 2) Locations and details of lifting devices including supporting calculations. Design all lifting devices based on the no cracking criteria in Chapter 5 of the PCI Design Handbook.
    - 3) Type and amount of any additional reinforcing required.
    - 4) Calculations showing that tensile stresses on both faces do not exceed the modulus of rupture during the handling, fabrication, shipping, and erection of the panel.
    - 5) Minimum compressive strength attained prior to handling the panels.
    - 6) Load distribution.
    - 7) Cables and lifting equipment.
    - 8) Details of vertical adjusting hardware.
  - f. Include details showing the erection and installation of the proposed deck panels in accordance with the design plans.
  - g. Submit Erection Plan drawings including the following minimum information:
    - 1) Crane and pick locations
    - 2) Crane charts

- 3) Panel erection and sequence
  - h. Submit to the Engineer for review a proposed method for forming the camber strips and installing the structural non-shrink grout, sequence, and equipment for grouting operation. Obtain approval prior to placing structural non-shrink grout begins.
  - i. Submit a method of forming closure pours at joints between precast panels.
  - j. The Engineer reserves the right to retain these drawings up to 14 calendar days without granting an increase in the number of working days on the project. This duration is reduced to 7 days when the drawings are submitted electronically. This right applies each time the drawings are submitted or re-submitted.
3. Submit substitutions for self-consolidating concrete (SCC) mix designs to the Engineer for approval as an alternate to the structural concrete for the precast deck panels.
- B. Submit for Materials. Refer to this Section, article 2.1.
- 1. Supply test data such as slump, air voids, or unit weight after 7, 14, and 28 days for fresh concrete and compressive strengths for the hardened concrete.
- C. Submit for High Early Strength Concrete. Refer to this Section, article 2.1, paragraph H.
- 1. Submit material data information that states the percentage of each component used.
  - 2. Provide substantive data at least two weeks prior to use that demonstrates the ability of the material to meet the specification requirements with the proposed mix design regardless of the type of high early strength concrete proposed.

## **PART 2 PRODUCTS**

### **2.1 MATERIALS**

- A. Mild Reinforced Panel: Use Class AA (AE) concrete for precast concrete deck panels as specified in Section 03055 and on the plans.
- B. Prestressed Panel: Use Class AA (AE) concrete according to Section 03055 except as modified by Section 03412 for Prestressed Concrete Panels. Use  $\frac{3}{4}$  inch nominal aggregate.

- C. Use coated reinforcing steel as specified in Section 03211.
- D. Use mechanical threaded couplers when specified for precast concrete deck panel reinforcing according to Section 03211.
  - 1. Do not use lap splices for mild reinforcement within the panel.
  - 2. Lap splices are acceptable in cast-in-place closure pours.
- E. Use embedded prefabricated steel pocket blockouts when shown on the plans that conform to the following:
  - 1. Use cold formed rectangular steel tubing meeting the requirements of ASTM A 500 Grade B.
  - 2. Use a steel top plate meeting the requirements of AASHTO M 270 Grade 36. Higher strength grades of steel may be substituted with prior approval from the Engineer.
  - 3. Galvanize the steel assembly after fabrication according to the requirements of AASHTO M 111.
  - 4. Use plastic pipe for grout ports and vents.
- F. Use lifting devices that meet the following criteria:
  - 1. Use devices that can support the required vertical and horizontal forces with the applicable safety factors as specified in the PCI Design Handbook, Chapter 5.
  - 2. Use a device that will have 2¾ inch top cover and 1 inch bottom cover after installation. This may require partial removal of the device after installation.
  - 3. Galvanize the leveling device after fabrication according to the requirements of AASHTO M 111.
- G. Use structural non-shrink grout for camber strips, shear stud blockouts, keyway blockouts, and other blockouts shown on the plans.
  - 1. Use a mix design according to Section 03055 if adding more than 15 lb of coarse aggregate (size No. 8) or larger per 50 lb bag of structural non-shrink grout.
  - 2. Mix structural non-shrink grout just prior to use according to the manufacturer's instructions.
  - 3. Use non-shrink, gray grout concrete containing no calcium chloride or admixture containing calcium chloride or other ingredient in sufficient quantity to cause corrosion to steel reinforcement.
  - 4. Follow manufacturer's recommendation for corrosion inhibitor admixture dosage.
  - 5. Use quick-setting, rapid strength gain, non-shrink, and high-bond strength grout.

6. Warranty the in-place structural non-shrink grout performance and workmanship for two years.
7. Repair or refund at the Department's option any bonding failures that occur during the warranty period.
8. Refer to Table 1 for structural non-shrink grout requirements.

**Table 1**

<b>Structural Non-Shrink Grout</b>			
<b>*Properties</b>	<b>Requirements</b>	<b>ASTM</b>	<b>AASHTO</b>
Accelerated Weathering	As Specified in ASTM or AASHTO	C 666	T 260
Compressive Strength	>5,000 psi @ 28 days		T 106
Accepted Bond Strengths	>1,000 psi @ 24 Hours	C 882	
Test Medium	<3% White Utah Road Salt		T 161
Accepted Weight Loss	<15% @ 300 Cycles		T 161
Length Change	No expansion after 7 days		T 160

\*Certified test results from a private AASHTO accredited testing laboratory will suffice for acceptance.

- H. High Early Strength Concrete for closure pours: Use one of the following methods:
  1. Design a high early strength concrete mix and obtain the Engineer's approval.
    - a. Use air-entraining, Portland cement, fine and coarse aggregates, admixtures, water, and additives.
    - b. Use between 4 to 7 percent-entrained air.
    - c. Develop a mix that can attain a 6-hour compressive strength of 2,500 psi and a 7-day compressive strength of 4,000 psi.
    - d. Develop a mix that contains shrinkage compensating additives such that there will be no separation of the closure pour concrete from the adjacent precast concrete.
    - e. Use a shrinkage-compensating additive that produces expansion in the high early strength concrete of no more than 3 percent.
  2. A proprietary concrete mix that meets the same physical requirements as those stated above may be used.

## **2.2 CONCRETE CORROSION INHIBITOR ADMIXTURE**

- A. The concrete corrosion inhibitor admixture will contain a minimum of 30 percent calcium nitrite by mass and formulated to meet ASTM C 494 requirements for Type C, accelerating admixture.

- B. Use a dosage rate of 4 gal/yd<sup>3</sup> unless otherwise directed by the manufacturer.
- C. Use the admixture in all new concrete and grout placed.

### **2.3 PRESTRESSING STRAND, POST TENSIONING AND SHEAR CONNECTORS**

- A. Refer to Section 03412: Prestressed Concrete for requirements.
- B. Refer to Section 03251S: Post Tensioning Concrete for bar, strand, grout and other requirements.
- C. Fabricate new shear studs from cold-drawn bars, Grades 1015, 1018 or 1020, conforming to AASHTO M 169 standard quality, and have a minimum tensile strength of 60.0 ksi.
  - 1. Use headed anchor studs for shear connectors conforming to dimensions showing on the plans.
  - 2. Use steel conforming to the requirement of AASHTO M 169.
  - 3. Automatically end weld studs in the shop or field with equipment designed for stud welding operations.
  - 4. Use equipment having capacity adequate for the size of stud welded.
- D. Use a low carbon grade suitable for welding that will conform to ASTM A 109 for the caps if steel, flux-retaining caps are used.
- E. Concrete girders:
  - 1. Use T- Headed bars consisting of deformed rebar with steel plates friction-welded to one end of the rebar. Friction welding conforms to the approved quality control manual and the Specification for Friction Welding of Metals, ANSI/AWS C6.2.
  - 2. Use deformed rebar that conforms to ASTM A 706, Grade 60.
  - 3. Cut plate heads for T-Headed bars from flats of hot-rolled steel conforming to ASTM A 108.
  - 4. Use an approved epoxy grout to develop minimum pullout strength in T-headed bar anchorage as shown on the Plan.

### **2.4 ADHESIVE DOWELED ANCHORS**

- A. Use Epoxy resin adhesive for anchors that conform to AASHTO M 235 Standard Specification for Epoxy Resin Adhesives.

## 2.5 QUALITY ASSURANCE

- A. The Department pre-qualifies pre-cast and site-cast fabricators according to the UDOT Quality Management Plan: Pre-cast/Prestressed Concrete Structures. Only fabricators pre-qualified in Category Two will be accepted.
- B. Permanently mark each precast unit with date of casting and supplier identification. Stamp markings in fresh concrete.
- C. Prevent cracking or damage during handling and storage of precast units.
- D. Defects and Breakage of Prestressed and Nonstressed Elements:
  - 1. Elements that sustain damage or surface defects during fabrication, handling, storage, hauling, or erection are subject to review and rejection.
  - 2. Write proposed repair procedures and obtain approval before performing repairs.
  - 3. Repair work must reestablish the element's structural integrity, durability, and aesthetics to the satisfaction of the Engineer.
  - 4. Determine the cause of any damage and take corrective action.
  - 5. Failure to take corrective action leading to similar repetitive damage is cause for rejection of the damaged elements.
  - 6. Cracks that extend to the nearest reinforcement plane and fine surface cracks that do not extend to the nearest reinforcement plane but are numerous or extensive are subject to review and rejection.
  - 7. Full depth cracking and breakage greater than 12 inches in length are cause for rejection.
- E. Construct panels to tolerances shown on the plans or in the specifications.

## PART 3 EXECUTION

### 3.1 FABRICATION

- A. Do not place concrete in the forms until the Engineer has inspected and approved the placement of all materials in the deck panels.
- B. Finish the precast concrete deck panels following Section 03310.

- C. Wet cure the deck panels for 14 consecutive days. This cure is to begin immediately after performing the final finish.
  - 1. Wet cure panels by covering all exposed surfaces with wet burlap, cotton mats, or both, and plastic sheets.
  - 2. Maintain a saturated condition for the burlap and cotton for the entire duration of the 14 days  $\pm 7$  days.
  - 3. A 10 percent pay incentive exists for wet cure durations of 21 consecutive days. A 10 percent pay disincentive exists for durations provided at the minimum required 7 days.
- D. Perform prestressing according to Section 03412 Prestressed Concrete.
- E. Do not strip the forms before the precast panels have obtained a minimum compressive strength of 500 psi.

### **3.2 NEW SHEAR STUDS ON EXISTING STEEL GIRDERS AND CONCRETE BEAMS**

- A. Installation of the Shear Connectors
  - 1. Install shear connectors at the locations shown on the plans.
  - 2. Weld shear studs to steel girders or plates embedded in prestressed concrete according to AWS specifications.
    - a. Adjust studs as necessary to provide clearance for bolts in existing bolted splices.
    - b. Use method and equipment recommended by the manufacturer of the studs and approved by the Engineer.
    - c. Field weld studs using friction welding. Conform to the approved quality control manual and the Specification for Friction Welding of Metals ANSI/AWS C.6.2-89.
  - 3. Field drill holes in the top flange of existing concrete and prestressed concrete beams and install shear studs according to manufacturer's recommendations.
    - a. Locate all internal beam reinforcing prior to drilling holes.
    - b. Avoid drilling through reinforcing
    - c. Use method and equipment recommended by the manufacturer of the studs, epoxy grout, as approved by the Engineer.

### **3.3 PLACING PRECAST CONCRETE DECK PANELS**

- A. Fully brace concrete beams or steel girders prior to placing panels.

- B. Place the precast concrete deck panels as shown on the plans or approved working drawings.
- C. Adjust leveling devices to bring panels to the elevations shown on the Plans. Torque all leveling devices to within 15 percent of each other to provide proper distribution of panel weight to the supporting beams.
- D. Prevent shifting of the precast concrete deck panels during the joining of all the deck panels.

### **3.4 LONGITUDINAL POST TENSIONING**

- A. Cure Precast panels 28-days before tensioning of any post-installed cables or rods.
- B. Design and show all post-tensioning hardware and blockouts if required. Manufactured designed proprietary hardware is acceptable with the Engineer's approval.
- C. Clean and remove all debris from blockouts.
- D. Set final elevations after all panels are in place.
- E. Grout shear keyway between panels.
- F. Do not begin stressing operations until the concrete reaches the strength and age designated on the plans. Stress strands within 72 hours of panel placement and transverse joint grouting.
- G. Do not post tension until the shear key grout has attained a compressive strength of 500 psi (based on manufacturer's data).
- H. Install strands as shown on the plans.
- I. Fully tension strand and grout all ducts according to Section 03251S.
- J. Visually inspect the shear stud installation and connection details. Place structural non-shrink grout in the girder camber strips and shear stud blockouts in a continuous operation complete without voids.

### **3.5 INSTALLATION OF HEADED T BARS AND ANCHORS**

- A. Adhesive doweled anchors:

1. Use items such as reinforcing, bar dowels, reinforcing bars, threaded rods, and bolts as shown in the plans and connected using adhesive dowel into concrete.
2. Weld heads on bars according to the requirements of the AASHTO/AWS D1.5 2008 Bridge Welding Code.
3. Drill, brush, clean all holes, and install all anchors according to manufacturer's published recommendations as well as all applicable specifications.
4. Inspection is required for installation of reinforcement or threaded rods.
5. Install adhesive anchors and test according to the epoxy anchor test schedule and as follows:
  - a. Testing through the blockout is at the contractor's risk. Repair damaged beams, girders, and panels as instructed by the Engineer. Panel may be rejected if not repaired as instructed.
  - b. Test 25 percent of the first 40 anchors installed and 10 percent of all anchors installed thereafter.
  - c. Test the previous ten installed anchors and the next five installed anchors if any failures occur.
  - d. Allow anchor adhesives to cure 48 hours prior to testing.
  - e. Tension test according to ASTM E 1512.
  - f. Provide minimum capacity as defined in Table 2 below.

Table 2

<b>Epoxy Anchor Test Schedule For Anchors Installed in Hard Rock Concrete (2000 psi min. Strength)</b>					
<b>Reinforcing bars (<math>f_y = 60</math> ksi)</b>			<b>Bolts or threaded rods (<math>f_y = 36</math> ksi)</b>		
Bar size	Minimum embedment	Tension test load (0.9 $f_y$ )	Anchor diameter	Minimum embedment	Tension test load*
#4	6 inches	10800#	$\frac{3}{8}$ inch	5 inches	3384#
#5	7 inches	16700#	$\frac{1}{2}$ inch	7 inches	5400#
#6	9 inches	23800#	$\frac{5}{8}$ inch	8 inches	9390#
#7	10 inches	32400#	$\frac{3}{4}$ inch	10 inches	13530#
#8	12 inches	42700#	$\frac{7}{8}$ inch	12 inches	18417#
#9	13 inches	54000#	1 inch	13 inches	24050#
#10	16 inches	68600#	1 $\frac{1}{4}$ inch	15 inches	37580#
#11	18 inches	84200#			

Notes: \* allowable loads equal 1/2 test load values

### **3.6 PREPARATION AND INSTALLATION OF STRUCTURAL NON-SHRINK GROUT**

- A. Clean and remove all debris from the camber strips and blockouts prior to placement of the structural non-shrink grout.
- B. Keep bonding surfaces free from laitance, dirt, dust, paint, grease, oil, rust, or any contaminant other than water.
- C. Form the girder camber strips as shown on the plans after installing shear studs at the locations shown on the plans.
- D. Pre-test grout material installation under field conditions in a grout pocket and camber strip mock-up prior to construction of the deck to determine grout flowability and whether subsequent cracking will occur. Include in the mock-up at least two shear connector pockets and a camber strip that is of the same configuration as the actual bridge.
  - 1. The Engineer will determine the required corrective action.
  - 2. Proceed with grouting process at the Engineer's direction.
- E. Saturate surface dry (SSD) all surfaces receiving structural non-shrink grout.
- F. Mix and place product following manufacturer's recommendations for preparation and installation.
- G. Grout the shear stud blockouts and girder camber strips using structural non-shrink grout. Place structural non-shrink grout in the girder camber strips and shear stud blockouts in a continuous operation within a panel. Do not allow voids in the grout for the girder camber strips and shear stud blockouts.
- H. Do not apply superimposed dead loads or live loads to the precast concrete deck panels until the structural non-shrink grout in the shear stud blockouts and the girder camber strips has reached a strength of 500 psi based on manufacturer's published data.
- I. Fill all surface voids with non-shrink grout including lifting device blockouts and grout ports.
- J. Cure structural non-shrink grout per manufacturer's recommendation.

1. Contact the manufacturer's representative for advice on how to reduce heat such as wet curing or adding retarding admixture if the heat of hydration is excessive.
- K. Repair or refund at the Department's option any bonding failures that occur during the warranty period.
- L. Finish grout flush or a maximum of  $\frac{1}{8}$  inch above adjacent panels.
1. Correct blockout and void profiles in excess of  $\frac{1}{8}$  inch higher than the adjacent panel through surface grinding
  2. Correct blockout and void profiles below the top of the adjacent panels through removal and replacement of the blockout or void.
  3. Pay for any corrections to the finish of the blockout or void at no cost to the Department.

### **3.7 DECK GRINDING**

- A. Profile grind the deck and approaches after all panels are in place, grouting is complete, and design strength is achieved according to Section 02982.

### **3.8 SURFACE PREPARATION**

- A. Prepare deck and approach slabs and place Polymer Overlay, Type 1. Refer to Section 03372.

END OF SECTION

**Example Specification C3:**

Source: Utah Department of Transportation  
Title: Bridge Construction using Self-Propelled Modular Transporters (SPMT)  
Use: SPMT Bridge Moves

**SPECIAL PROVISION**

**PROJECT #  
PIN #**

**SECTION 03253S**

**BRIDGE CONSTRUCTION USING SELF-PROPELLED  
MODULAR TRANSPORTERS (SPMT)**

**Add Section 03253:**

**PART 1 GENERAL**

**1.1 SECTION INCLUDES**

- A. Calculations, shop detail drawings, manuals, and engineering data addressing bridge movement
- B. Confirm structural stress
- C. Execution of bridge movement
- D. Monitoring of bridge movement
- E. Post-movement inspection and remedial action

**1.2 RELATED SECTIONS**

- A. Section 03310: Structural Concrete

**1.3 REFERENCES**

- A. AASHTO Guide Design Specifications for Bridge Temporary Works, 1<sup>st</sup> Edition, 2008 Interim Revisions
- B. AASHTO LRFD Bridge Construction Specifications, 2<sup>nd</sup> Edition, 2004, 2008 Interim Revisions
- C. UDOT Manual for the Moving of Utah Bridges with Self Propelled Modular Transporters (SPMTs)
- D. UDOT Minimum Sampling and Testing Requirements Manual

## 1.4 DEFINITIONS

- A. Change in Longitudinal Gradient Along the Girders – The change in slope experienced along the edge girders from conditions just before first lifting to any time during transportation.
- B. Change in Transverse Gradient Across the Girder Span – The change in slope experienced along the end diaphragms from conditions just before first lifting to any time during transportation.
- C. Definitions and terminology used with SPMT systems - Refer to UDOT Manual for the Moving of Utah Bridges with Self Propelled Modular Transporters (UDOT SPMT Manual).
- D. Twist – The maximum allowable upward or downward deflection of one corner relative to the plane defined concurrently by the elevations of the other three corners.

## 1.5 SUBMITTALS

- A. Submit a schedule addressing the timing and sequence of fabrication and erection of the permanent substructure and superstructure, removal or demolition of the old structure, construction of temporary abutments, connections with the roadway, road closures, and the transportation of the superstructure.
- B. Submit working drawings for Engineer approval prior to ordering materials or commencing related work.
  - 1. Engineer reserves the right to review these drawings for up to five working days without granting an increase in the number of working days for the project.
    - a. This right applies each time drawings are submitted.
  - 2. Bridge Staging Area (BSA) and Travel Path (TP).
    - a. Indicate all ground improvements, soft soil mitigation, and utility protection.
    - b. Verify clearances from above ground obstacles and provide mitigation.
  - 3. Selected movement system.
    - a. Design the movement system to lift the bridge at the pick points indicated in the project plans.
    - b. Demonstrate that the new pick points support the structure within the stress limits indicated on the project plans when lifting the bridge at pick points other than those indicated on the design.

- c. Design the lifting system to provide wheel loads equal to or less than those indicated on the project plans.
  - d. Indicate that the selected lifting system will possess adequate stroke to negotiate the TP as designed.
  - e. Indicate any additional systems required to move the structure, for example such items may include skid shoes, climbing jacks, and strand jacks.
    - 1) Demonstrate that stresses provided in the project plans are not exceeded.
  - f. Provide pre-operations checklist.
  - 4. SPMT Support Apparatus
    - a. Design SPMT Supports to meet AASHTO Guide Design Specifications for Bridge Temporary Works, 1st Edition, 2008 Interim Revisions and 2<sup>nd</sup> edition 2004 AASHTO LRFD Bridge Construction Specifications, 2008 interim revisions.
    - b. Calculate the anticipated lateral forces due to for example braking, turning, and vertical grades and provide a system to transfer loads to SPMTs.
  - 5. Temporary abutments
    - a. Refer to Section 03310.
    - b. AASHTO Guide Design Specifications for Bridge Temporary Works, 1st Edition, 2008 Interim Revisions.
  - 6. QA/QC procedures
- C. Submit elected changes to project plans in the form of shop drawings stamped by a professional engineer licensed in the State of Utah.
- 1. Submit all shop drawings to the Engineer electronically in 11 inch X 17 inch format with the Department project designation data, drawing number, and sheet number in the lower right hand corner.
  - 2. Changes to BSA and TP
    - a. Submit VE proposals for changes to BSA and TP.
    - b. Provide design of BSA and TP meeting criteria in UDOT SMPT Manual.
  - 3. Changes to Pick-Points
    - a. If elected pick points cause stresses exceeding those allowed in the project plans, redesign bridge at Contractor's expense.
    - b. Identify additional project plans affected by the redesign of the structure.
    - c. Provide a redesign of any project plans affected by the redesign of the structure.

- D. Provide MOT plan and schedule.
- E. Contingency plans.

## **1.6 ACCEPTANCE**

- A. Acceptance is in accordance with UDOT Minimum Sampling and Testing Requirements.

## **PART 2 PRODUCTS**

### **2.1 BRIDGE CONSTRUCTION USING MOVEMENT SYSTEMS**

- A. Provide all materials for the permanent features of the project in conformance with UDOT specifications.
- B. Provide all temporary features of the project suitable to sustain applied forces.
- C. Provide satisfactory replacement material at no additional expense to the Department.
- D. Contact the Engineer for qualified product information.

## **Part 3 EXECUTION**

### **3.1 PREPARATION FOR TRANSPORT OF SUPERSTRUCTURE**

- A. Follow established and submitted QC/QA procedures.
- B. Follow Pre-Operations checklist.
- C. Obtain Engineers approval for all temporary Traffic Control Plans (TCPs) and Traffic Operational procedures prior to transportation.
- D. Implement traffic control prior to transportation.
- E. Do not exceed the SPMT ground pressures for the supporting capacity of the soil, roadway construction, or any structures over which the load will travel.
- F. Follow approved working drawings for the positioning of the SPMTs.

- G. Follow specified allowable limits for loss of support by any pair of wheels or axle lines.
- H. Implement contingency plans in the event of a major breakdown of equipment to complete the installation with minimal disruption or delay to traffic.

### **3.2 LIFT, TRANSPORT, AND PLACEMENT OF SUPERSTRUCTURE**

- A. General
  - 1. Check elevations of bearing seats and tops of bearings prior to lifting bridge.
    - a. Notify the Engineer of differences between as-built and as-planned bearing elevation and submit proposals for corrective adjustments.
  - 2. Lift and transport structure in accordance with the lifting points established in the drawings.
  - 3. Deliver the structure to its final location with no damage or loss of strength, performance, or long-term durability.
- B. Monitoring
  - 1. Monitor the span for stability and integrity of the SPMT system during lifting, transport, and placement following the plans for the equipments and methods of monitoring.
  - 2. Monitor deflection and twist control during transportation.
  - 3. Obtain deflection and twist tolerances from the Engineer.
  - 4. Provide measurements to the Engineer for actual deflection and twist during lift, transport, and setting.
  - 5. Halt operations immediately if deflection or twist exceed allowable limits as designed by the Engineer, returning bridge to temporary supports if necessary.
- C. Tolerances
  - 1. Plan alignment, location, and clearances for the final condition of the span after placement.
  - 2. Do not exceed 2 inches for spans under 100 ft, and 3 inches for spans over 100 ft at each end of the span for maximum deviation from overall longitudinal alignment of an individual span after setting.
  - 3. Do not exceed 2 inches for spans under 100 ft, and 3 inches for spans over 100 ft for maximum deviation from the overall transverse location at each line of bearing.
  - 4. Do not exceed 2 inches for spans under 100 ff, and 3 inches for spans over 100 ft for maximum yaw.
  - 5. Maintain individual elements or surfaces within 2 inches for spans under 100 ft, and 3 inches for spans over 100 ft of

location with respect to similar matching surfaces at expansion joints (plane of web parapet) of adjacent spans, pier or abutment features in the absence of other constraints.

6. Provide the maximum allowable change in longitudinal gradient. along the girders.
  - a. Calculate change from differences between the elevations taken just before lifting and the elevations taken at any time during transport.
7. Provide the maximum allowable change in transverse gradient across the girder span.
  - a. Calculate change from differences between the elevations taken just before lifting and the elevations taken at any time during transport.

END OF SECTION

**Example Specification C4:**

Source: Utah Department of Transportation  
Title: Structural Concrete - Lightweight  
Use: Lightweight concrete for reducing weight of prefabricated elements

**SPECIAL PROVISION**

**PROJECT #  
PIN #**

**SECTION 03314S**

**STRUCTURAL CONCRETE - LIGHTWEIGHT**

**Add Section 03314:**

**PART 1 GENERAL**

**1.1 SECTION INCLUDES**

- A. Materials and procedures for producing Portland cement concrete using lightweight aggregate for the coarse portion of the mix.
- B. Materials and procedures for constructing structural concrete, including box culverts, diversion boxes, catch basins, cleanout boxes and other items as specified.

**1.2 RELATED SECTIONS**

- A. Section 03055: Portland Cement Concrete
- B. Section 03211: Reinforcing Steel and Welded Wire
- C. Section 03310: Structural Concrete
- D. Section 03390: Concrete Curing

**1.3 REFERENCES**

- A. AASHTO M 6: Fine Aggregate for Portland Cement Concrete
- B. AASHTO M 195: Lightweight Aggregates for Structural Concrete
- C. AASHTO T 104: Soundness of Aggregate by Use of Sodium Sulfate or Magnesium Sulfate
- D. AASHTO T 121: Density (Unit Weight), Yield, and Air Content (Gravimetric) of Concrete

- E. AASHTO T 196: Air Content of Freshly Mixed Concrete by the Volumetric Method
- F. ASTM C 567: Standard Test Method for Determining Density of Structural Lightweight Concrete
- G. UDOT Materials Manual of Instruction
- H. UDOT Minimum Sampling and Testing Requirements
- I. UDOT Quality Management Plans

#### **1.4 DEFINITIONS**

- A. Structural Concrete – Lightweight – a concrete mixture with all attributes equal to structural concrete with exception to weight. Weight is limited to a maximum of 120 lb/ft<sup>3</sup>.

#### **1.5 SUBMITTALS**

- A. Furnish to the Resident Engineer and Region Materials Engineer a mix design based on the recommendations of the lightweight aggregate manufacturer for each combination of materials to be used.
  - 1. Mix designs will be approved based on results of trial batches or on history from UDOT projects within the last year.
  - 2. Use the same components in the trial batches that are to be used in the project.
    - a) Accelerators and site-added air-entrainment can be incorporated in the trial batch but are not required.
    - b) Assume responsibility for the compatibility of all admixtures with the mix design and their potential effects on concrete properties.
  - 3. List the weight and absolute volume for each component to be used.
  - 4. Provide certified test reports showing the unit weight of fresh concrete that will result in the air-dry unit weight specified.
  - 5. Personnel performing and witnessing trial batches, and performing compressive and flexural strength testing, must be UDOT TTQP Concrete and Concrete Strength Testing qualified.
  - 6. The Department or its representative may witness the trial batch.

7. Mix concrete trial batches as specified in UDOT Materials Manual of Instruction Part 8-974: Guidelines for Portland Cement Concrete Mix Design.
  8. Compressive and flexural strength testing for verification of trial batches will be performed by an AASHTO accredited laboratory, approved through the UDOT Laboratory Qualification Program.
- B. Provide test results verifying the coarse and fine aggregate used meets this Section, article 2.3.
  - C. Provide test results for potential reactivity of fine aggregates in accordance with the requirements of the UDOT Quality Management Plan for Ready-Mix Concrete for any proposed mix design.
  - D. Provide results from appropriate testing to determine the ability of the combinations of cementitious materials and aggregates to control the reactivity when using potentially reactive aggregates in a mix design.
  - E. Submit verification that cement used is from a pre-qualified supplier. See Section 03055.
  - F. Submit verification that fly ash or other pozzolan used is from a pre-qualified supplier. See Section 03055.
  - G. Submit verification that the batch plant meets the requirements of the UDOT Quality Management Plan for Ready-Mix Concrete.
  - H. Submit cold and hot weather plans as required in Section 03055.

## **1.6 ACCEPTANCE**

- A. Refer to Section 03055.
- B. Acceptance is in accordance with UDOT Minimum Sampling and Testing Requirements with the following exception:
  1. Air content will be determined by AASHTO T 196
  2. Density of fresh concrete with each air content determination. Refer to AASHTO T 121.

## **PART 2 PRODUCTS**

### **2.1 MIX REQUIREMENTS**

- A. Class AA(AE) concrete, unless specified otherwise. Refer to Section 03055
- B. Keep the air-dry unit weight of the mix between 2950 to 3100 lb/ yd<sup>3</sup>.
  - 1. Determine the air-dry weight in accordance with ASTM C 567.
- C. Do not allow the fresh concrete to vary more than  $\pm 110$  lb/yd<sup>3</sup> from that shown on the mix design.

## **2.2 CEMENT**

- A. Refer to Section 03055.

## **2.3 AGGREGATES**

- A. Coarse Aggregate
  - 1. Use lightweight aggregates that are rotary kiln expanded shale or clay having a surface sealed by firing.
    - a. Do not crush coarse aggregate after firing except that a small amount of aggregate,  $\frac{3}{4}$  inch or smaller, may be crushed to the extent necessary to produce the required coarse aggregate grading.
    - b. Use coarse aggregate of  $\frac{3}{4}$  inch maximum.
  - 2. Meet the requirements of AASHTO M 195.
    - a. Meet Table 1, gradation band 12.5 to 4.75 mm ( $\frac{1}{2}$  inch to #4) or 19.0 to 4.75 mm ( $\frac{3}{4}$  inch to #4)
  - 3. Use lightweight aggregates that have not more than 5 percent loss, when tested for soundness using Magnesium Sulfate (5 cycles). Refer to AASHTO T 104.
- B. Fine Aggregate
  - 1. Refer to Section 03055

## **2.4 WATER**

- A. Refer to Section 03055.

## **2.5 ADMIXTURES**

- A. Refer to Section 03055.

## **2.6 POZZOLAN**

A. Refer to Section 03055.

## **2.7 REINFORCING STEEL AND WELDED WIRE**

A. Refer to Section 03311.

## **2.8 JOINTS AND SEALERS**

A. Refer to Section 03310.

## **2.9 BACKER ROD**

A. Refer to Section 03310.

## **2.10 WATERSTOPS**

A. Refer to Section 03310.

## **2.11 RIGID PLASTIC FOAM**

A. Refer to Section 03310.

## **2.12 CURING COMPOUND**

A. Refer to Section 03390.

## **2.13 FORMS**

A. Refer to Section 03310.

## **2.14 MISCELLANEOUS STEEL ITEMS**

A. Refer to Section 03310.

# **PART 3 EXECUTION**

## **3.1 PREPARATION - CONCRETE**

- A. Aggregate Stockpiles
1. Refer to Section 03055.
  2. Uniformly pre-wet or pre-saturate the aggregates in such a manner that uniform penetration of the concrete will be maintained.
    - a. Pumping of the concrete requires pre-saturation of the lightweight aggregate.

### **3.2 BATCH MATERIALS**

- A. Refer to section 03055.
- B. Batch lightweight coarse aggregate either by weight or by volume. If by volume, equip the batching equipment such that the weight of each size of aggregate in the batch can be verified.
- C. Do not allow the fresh concrete to vary more than  $\pm 110 \text{ lb/yd}^3$  from that shown submitted with the mix design.
  - 1. Verify each load using batched weights of materials.

### **3.3 MIX DESIGN**

- A. Design mixes to meet the requirements of this Section and project specific criteria.
- B. Design the cementitious system to mitigate potential alkali-aggregate reactivity.
  - 1. Use a minimum of 20 percent by weight of the total cementitious system when using fly ash.
- C. Use only concrete mixes that have been approved by the Region Materials Engineer.
- D. Obtain concurrence from the Resident Engineer for the project specific application of an approved mix

### **3.4 PREPARATION – PLACEMENT**

- A. Refer to Section 03310.

### **3.5 GIRDERS SLABS AND COLUMNS**

- A. Refer to Section 03310.

### **3.6 BOX CULVERTS**

- A. Refer to Section 03310.

### **3.7 PLACE CONCRETE**

- A. Refer to Section 03310.

### **3.8 PUMP CONCRETE**

A. Refer to Section 03310.

### **3.9 LIMITATIONS – GENERAL**

A. Refer to Section 03055.

### **3.10 LIMITATIONS – COLD WEATHER**

A. Refer to Section 03310.

### **3.11 LIMITATIONS – HOT WEATHER**

A. Refer to Section 03310.

### **3.12 CYLINDER STORAGE DEVICE**

A. Refer to Section 03055.

END OF SECTION

**Example Specification C5:**

Source: Massachusetts Department of Transportation  
Title: High Early Strength Concrete  
Use: Concrete for closure pours used in ABC

The work to be done under this item shall conform to the relevant provisions of Section 901 of the Standard Specifications and the following:

The Contractor shall develop a high early strength concrete mix design for use in the longitudinal and transverse closure pours. This high early strength concrete may also be used in the cast in place concrete work for the modifications to the approach slabs.

The high early strength concrete shall conform to the requirements of M4.00.00, M4.01. and M4.02. and the following criteria:

1. Use Portland cement conforming to AASHTO M 85 with compatible admixtures and air entraining agent.
2. Water-cementitious material ratio shall not exceed 0.4 by weight, including water in the admixture solution and based on saturated surface dry condition of aggregates.
3. Use a maximum size coarse aggregate of  $\frac{3}{4}$ ".
4. The amount of entrained air shall be 6.0 +/- 1.5%.
5. A slump test shall be developed as part of the QC plan and shall address changing environmental conditions.
6. High early strength concrete shall achieve a minimum compressive strength of 2,000 psi at 4 hours after the final set. The minimum 28-day compressive strength shall be 4000 psi.
7. A shrinkage reducing admixture shall be added to the concrete mix according to the manufacturer's recommendation such that there will be no cracks at 14 days in the sample tested in AASHTO T334 (see below). A shrinkage reducing admixture shall be tested by an approved testing lab and meet the requirements of ASTM C494-10 Type S, except that in Table 1 length change shall be measured as: Length Change (percent of control) shall be a minimum of 35% less than that of the control. Table 1 Length Change (increase over control) shall not apply. Shrinkage reducing admixtures shall not contain expansive metallic materials.
8. The maximum allowable total chloride content in concrete shall not exceed 0.1% by weight of cement.

### **Mix Design Requirements**

The concrete mix design shall be mitigated per Subsection M4.02.00. Proposed mix design (overdesign factor of 120% of the design strength) with data sheets and trial batches shall be submitted within 15 days from the date of Notice to Proceed to the Research and Materials Section for review and approval. The Engineer shall be notified at least 48 hours prior to the test batching and shall be present to witness the testing.

All tests necessary to demonstrate the adequacy of the concrete mix shall be performed by the Contractor, including, but not limited to: slump, air content, temperature, initial set and final set (AASHTO T197). Compressive strength tests shall be determined on field cured cylinders (6" X 12" cylinders) at 9 hours, 12 hours, 15 hours, 18 hours, 24 hours, 30 hours, 36 hours, 42 hours, 2 days and 3 days, and standard cured cylinders at 7 days and 28 days. Additionally, a confined shrinkage test as outlined in the AASHTO T334 - Practice for Estimating the Crack Tendency of Concrete shall be performed by an

AASHTO accredited laboratory. The results of these tests (documenting zero cracks at 14 days) shall be submitted to the Engineer.

### **Field Trial Placement**

In addition, a trial placement shall be done a minimum of (90) ninety days before the intended date of the initial closure pour placement. The Contractor will be required to demonstrate proper mix design, batching, placement, finishing and curing of the high early strength concrete. The trial placement shall simulate the actual job conditions in all respects including plant conditions, transit equipment, travel conditions, admixtures, forming, the use of bonding compounds, restraint of adjacent concrete, placement equipment, and personnel.

The details for the trial placement configuration are shown in Figure 1.

Acceptance criteria for the trial placement shall be as follows:

- The trial placement concrete shall not exhibit cracking or separation from the test panel in excess of 0.016 inches wide
- There shall be no more than one transverse crack in excess of 0.010 inches wide in the 10 foot long pour.
- The evaluation of the trial placement shall take place 14 days after placement.

If the trial placement fails these criteria, the Contractor will be required to submit a corrective action plan on how repairs of these crack sizes will be performed. The Engineer may require the Contractor to conduct more trial batches and trial placements. The costs of trial batches, trial placements and the removal of trial placement concrete from the job site is incidental to Item 904.XX. The requirement for multiple test placements shall not be cause for a time extension.

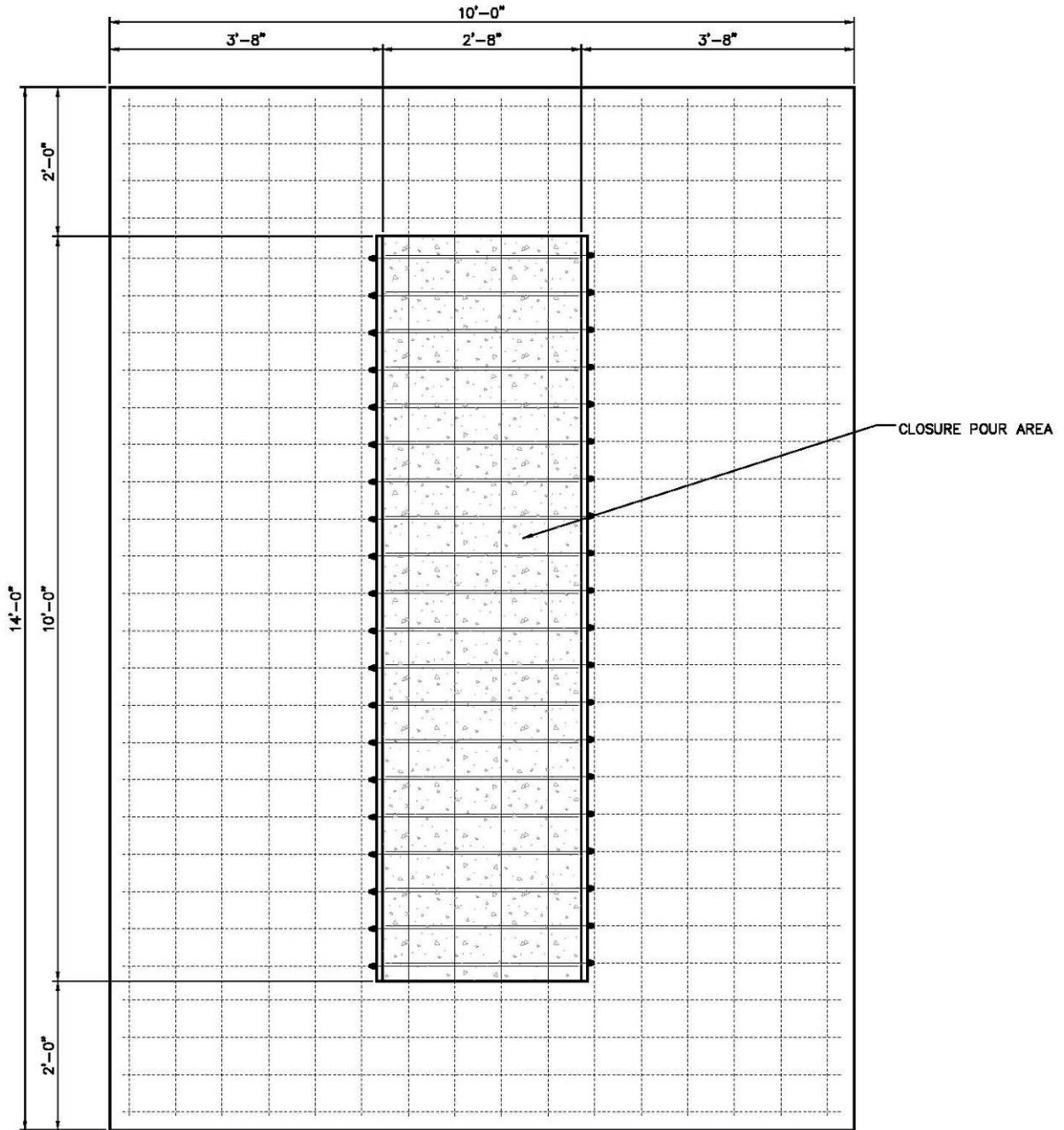

**PLAN**

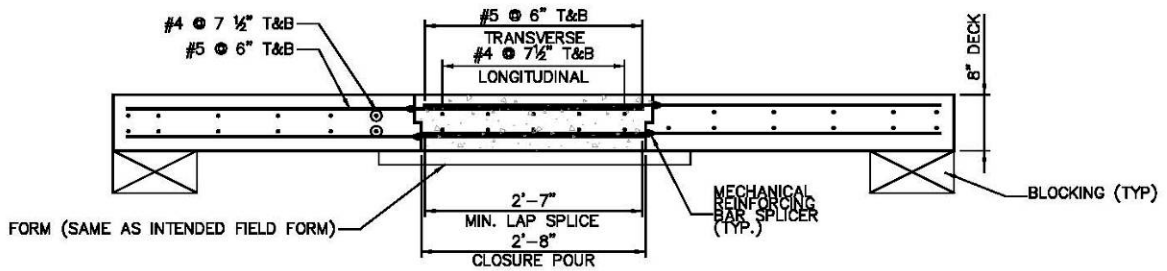

**TYPICAL SECTION**

**FIGURE 1 – TRIAL PLACEMENT TEST SET-UP**

### **Field Testing of Concrete Mix during Construction**

The Contractor shall engage an AASHTO accredited laboratory to provide on-site mobile testing facilities which are qualified laboratories under the NETTCP program to perform all Quality Control field testing. All personnel performing tests shall be qualified NETTCP Concrete Technicians and certified ACI Concrete Laboratory Technicians. Anytime the Contractor moves the laboratory, all associated equipment shall be recalibrated. The onsite laboratories should be located and calibrated at each bridge location. On weekends where more than one bridge is being constructed, additional on site laboratories shall be provided so that there is one for each bridge being constructed. This requirement is intended to minimize the movement of test cylinders.

The Contractor is required to perform initial set and final set tests (AASHTO T197) in addition to slump, air content and temperature on concrete from each concrete truck used in the placing of this High Early Strength Concrete. Field cured cylinders (6" X 12" cylinders) will be made from the first and last concrete trucks. A set of three (3) field-cured cylinders shall be made for each informational test associated with early structural loading. The Contractor is advised to fabricate adequate sets of cylinders to allow multiple tests to verify field concrete strength. The Engineer shall be allowed to witness the test and comment on all the tests performed by the Contractor. The Contractor must have a contingency plan established and approved in case compressive strength and other requirements are not met. The Contractor shall not open the roadway to traffic until all of the following conditions have been met:

- At least four hours has elapsed from the last final set time recorded for any concrete. Final set is achieved when the penetration resistance measures 4000 psi by AASHTO T197.
- Field cured cylinder breaks have achieved at least 2000 psi.
- The Engineer has directed that the roadway can be opened to traffic.

All testing and equipment shall conform to AASHTO T-22, and the making and curing of concrete cylinders shall conform to AASHTO T23. All costs associated with the on-site mobile testing facilities, personnel and field testing, equipment calibration and verification to demonstrate the field concrete strength shall be incidental to Item 904.XX.

Verification tests will be performed by MassDOT on field cured cylinders at 3 days and on standard cured cylinders at 7 days and 28 days. Cylinder breaks at 3 days and 7 days must be at least 10% above the approved trial batch results. The Contractor will be notified of any verification tests that do not meet these requirements and will be required to develop a contingency corrective action plan incase final strength is not achieved. Concrete will be accepted based on meeting the 28-day strength requirement of 4000 psi.

### **Curing Methods**

The concrete curing methods shall be developed by the Contractor as part of the QC plan. The curing methods used in the production placements shall be the same as the curing methods used for the trial placement.

### **High Early Strength Concrete Crack Inspection**

The Contractor shall inspect the finished high early strength concrete surface for cracks. Inspection of the deck for cracking shall be completed after the 14 day cure and prior to the preparation of the deck for placement of the membrane waterproofing system.

The Contractor shall document the location and frequency of cracks on the closure pours (number of cracks per square foot). Cracks greater than 0.016 inches in width shall be repaired as required by the membrane waterproofing manufacturer. The Contractor shall develop repair procedures as part of the QC plan.

The work completed under this Item will be paid for at the contract price per actual number of cubic yards of high early strength concrete that is measured complete in place. Payment under this Item includes full compensation for all testing and approval of the mix design.