

# Reinforced Concrete Design

Fourth  
Edition

W.H. Mosley  
and J.H. Bungey



# REINFORCED CONCRETE DESIGN

**Other Macmillan titles of interest to civil engineers**

Hulse/Mosley	<i>Reinforced Concrete Design by Computer</i>
Bolton	<i>Guide to Soil Mechanics</i>
Boxer	<i>Work Out Fluid Mechanics</i>
Jackson/Dhir	<i>Civil Engineering Materials</i> , 4th edition
John	<i>Work Out Engineering Materials</i>
Newton	<i>Structural Design</i>
Salter	<i>Highway Design and Construction</i> , 2nd edition
Salter	<i>Highway Traffic Analysis and Design</i> , 2nd edition
Seeley	<i>Civil Engineering Contract Administration and Control</i>
Seeley	<i>Civil Engineering Quantities</i>
Seeley	<i>Civil Engineering Specification</i>
Spencer	<i>Fundamental Structural Analysis</i>
Stone	<i>Management of Engineering Projects</i>
Uren/Price	<i>Surveying for Engineers</i> , 2nd edition
Wilson	<i>Engineering Hydrology</i> , 4th edition

# REINFORCED CONCRETE DESIGN

W. H. Mosley

*and*

J. H. Bungey

*Department of Civil Engineering  
University of Liverpool*

FOURTH EDITION

**M**  
MACMILLAN

© W. H. Mosley and J. H. Bungey 1976, 1982, 1987, 1990

All rights reserved. No reproduction, copy or transmission of this publication may be made without written permission.

No paragraph of this publication may be reproduced, copied or transmitted save with written permission or in accordance with the provisions of the Copyright, Designs and Patents Act 1988, or under the terms of any licence permitting limited copying issued by the Copyright Licensing Agency, 33–4 Alfred Place, London WC1E 7DP.

Any person who does any unauthorised act in relation to this publication may be liable to criminal prosecution and civil claims for damages.

First published 1976  
Reprinted 1977, 1978, 1980, 1981 (twice)  
Second edition 1982  
Reprinted 1983, 1984, 1985, 1986  
Third edition 1987  
Reprinted 1988, 1989  
Fourth edition 1990  
Reprinted 1991

Published by  
MACMILLAN EDUCATION LTD  
Houndmills, Basingstoke, Hampshire RG21 2XS  
and London  
Companies and representatives  
throughout the world

British Library Cataloguing in Publication Data  
Mosley, W. H. (William Henry)  
Reinforced concrete design. - 4th ed.  
1. Reinforced concrete structural components. Design  
I. Title II. Bungey, J. H. (John Henry), 1944–  
624.18341

ISBN 978-0-333-53718-3      ISBN 978-1-349-20929-3 (eBook)  
DOI 10.1007/978-1-349-20929-3

# Contents

<i>Preface to Fourth Edition</i>	viii
<i>Notation</i>	ix
<b>1 Properties of Reinforced Concrete</b>	<b>1</b>
1.1 Composite Action	1
1.2 Stress-Strain Relations	2
1.3 Shrinkage and Thermal Movement	7
1.4 Creep	11
1.5 Durability	12
1.6 Specification of Materials	12
<b>2 Limit State Design</b>	<b>15</b>
2.1 Limit States	16
2.2 Characteristic Material Strengths and Characteristic Loads	17
2.3 Partial Factors of Safety	18
2.4 Global Factor of Safety	19
<b>3 Analysis of the Structure</b>	<b>24</b>
3.1 Loads	24
3.2 Load Combinations	26
3.3 Analysis of Beams and Frames	28
3.4 Redistribution of Moments	48
<b>4 Analysis of the Section</b>	<b>53</b>
4.1 Stress-Strain Relations	53
4.2 The Distribution of Strains and Stresses across a Section	55
4.3 Bending and the Equivalent Rectangular Stress Block	57
4.4 Singly Reinforced Rectangular Section in Bending	58
4.5 Rectangular Section with Compression Reinforcement at the Ultimate Limit State	63
4.6 Flanged Section in Bending at the Ultimate Limit State	68
4.7 Moment Redistribution and the Design Equations	75

4.8	Bending Plus Axial Load at the Ultimate Limit State	79
4.9	The Rectangular-Parabolic Stress Block	88
4.10	The Triangular Stress Block	91
<b>5</b>	<b>Shear, Bond and Torsion</b>	<b>98</b>
5.1	Shear	98
5.2	Anchorage Bond	103
5.3	Laps in Reinforcement	106
5.4	Analysis of Section Subject to Torsional Moments	107
<b>6</b>	<b>Serviceability, Durability and Stability Requirements</b>	<b>112</b>
6.1	Detailing Requirements	113
6.2	Span-Effective Depth Ratios	117
6.3	Calculation of Deflections	119
6.4	Flexural Cracking	134
6.5	Thermal and Shrinkage Cracking	141
6.6	Other Serviceability Requirements	144
6.7	Stability	147
<b>7</b>	<b>Design of Reinforced Concrete Beams</b>	<b>154</b>
7.1	Preliminary Analysis and Member Sizing	156
7.2	Design for Bending	159
7.3	Design for Shear	174
7.4	Bar Spacing	180
7.5	Continuous Beams	180
7.6	Cantilever Beams	187
7.7	Design for Torsion	188
<b>8</b>	<b>Design of Reinforced Concrete Slabs</b>	<b>192</b>
8.1	Simplified Analysis	192
8.2	Shear in Slabs	193
8.3	Span-Effective Depth Ratios	198
8.4	Reinforcement Details	200
8.5	Solid Slabs Spanning in One Direction	201
8.6	Solid Slabs Spanning in Two Directions	209
8.7	Flat Slab Floors	214
8.8	Ribbed and Hollow Block Floors	222
8.9	Stair Slabs	226
8.10	Yield Line and Strip Methods	230
<b>9</b>	<b>Column Design</b>	<b>239</b>
9.1	Loading and Moments	239
9.2	Short and Slender Columns	241
9.3	Reinforcement Details	244
9.4	Design of Short Columns	246
9.5	Non-rectangular Sections	261
9.6	Design of Slender Columns	264

## CONTENTS

vii

<b>10 Foundations</b>	<b>270</b>
10.1 Pad Footings	273
10.2 Combined Footings	280
10.3 Strap Footings	284
10.4 Strip Footings	286
10.5 Raft Foundations	289
10.6 Piled Foundations	291
<b>11 Water-retaining Structures and Retaining Walls</b>	<b>296</b>
11.1 Water-retaining Structures	296
11.2 Joints in Water-retaining Structures	298
11.3 Reinforcement Details	302
11.4 Design Methods	304
11.5 Retaining Walls	318
<b>12 Prestressed Concrete</b>	<b>329</b>
12.1 Principles of Prestressing	329
12.2 Methods of Prestressing	332
12.3 Analysis of Concrete Section Under Working Loads	335
12.4 Design for the Serviceability Limit State	341
12.5 Analysis and Design at the Ultimate Limit State	367
<i>Appendix</i>	382
<i>Further Reading</i>	386
<i>Index</i>	388

# Preface to Fourth Edition

The purpose of this book is to provide a straightforward introduction to the principles and methods of design for concrete structures. It is directed primarily at students and young designers who require an understanding of the basic theory and a concise guide to design procedures. Although the detailed design methods are generally according to British Standards, much of the theory and practice is of a fundamental nature and should, therefore, be useful to engineers in other countries. Limit state concepts, as recently introduced in the new Codes of Practice, are used and the calculations are in SI units throughout.

The subject matter has been arranged so that chapters 1 to 5 deal mostly with theory and analysis while the subsequent chapters cover the design and detailing of various types of member and structure. In order to include topics that are usually in an undergraduate course, there is a chapter on earth-retaining and water-retaining structures, and also a final chapter on prestressed concrete.

Important equations that have been derived within the text are highlighted by an asterisk adjacent to the equation number.

In preparing the fourth edition of this book, the principal aim has been to incorporate new information relating to the design of water-retaining structures, as proposed by British Standard BS 8007. The remainder of the text, which relates to BS 8110, remains essentially unchanged with only very minor amendments.

It should be mentioned that standard Codes of Practice such as BS 8110 are always liable to be revised, and readers should ensure that they are using the latest edition of any relevant standard.

Extracts from the British Standards are reproduced by permission of the British Standards Institution, 2 Park Street, London W1A 2BS, from whom complete copies can be obtained.

Finally, the authors wish to thank Mrs B. Cotgreave who prepared the diagrams and Mrs F. Zimmermann who typed most of the draft and final copies of the manuscript.

# Notation

Notation is generally in accordance with BS 8110, and the principal symbols are listed below. Other symbols are defined in the text where necessary. The symbols  $\epsilon$  for strain and  $f$  for stress have been adopted throughout, with the general system of subscripts such that the first subscript refers to the material, c – concrete, s – steel, and the second subscript refers to the type of stress, c – compression, t – tension.

$A_s$	Cross-sectional area of tension reinforcement
$A_s'$	Cross-sectional area of compression reinforcement
$A_{sb}$	Cross-sectional area of shear reinforcement in the form of bent-up bars
$A_{sv}$	Cross-sectional area of shear reinforcement in the form of links
$a$	Deflection
$a_{cr}$	Distance from surface crack position to point of zero strain
$b$	Width of section
$b_v$	Breadth of web or rib of a member
$b_w$	Breadth of web or rib of a member
$d$	Effective depth of tension reinforcement
$d'$	Depth to compression reinforcement
$E_c$	Static secant modulus of elasticity of concrete
$E_s$	Modulus of elasticity of steel
$e$	Eccentricity
$F$	Ultimate load
$f_{cu}$	Characteristic concrete cube strength
$f_{pu}$	Characteristic strength of prestressing tendons
$f_s$	Service stress or steel stress
$f_y$	Characteristic strength of reinforcement
$f_{yv}$	Characteristic strength of link reinforcement
$G_k$	Characteristic dead load
$g_k$	Characteristic dead load per unit length or area
$h$	Overall depth of section in plane of bending
$h_f$	Thickness of flange
$I$	Second moment of area
$k_1$	Average compressive stress in the concrete for a rectangular-parabolic stress block

$k_2$	A factor that relates the depth to the centroid of the rectangular-parabolic stress block and the depth of the neutral axis
$l_a$	Lever-arm factor = $z/d$
$l_e$	Effective height of a column or wall
$M$	Bending moment
$M_u$	Ultimate moment of resistance
$N$	Axial load
$n$	Ultimate load per unit area
$N_{bal}$	Axial load on a column corresponding to the balanced condition
$P$	Final prestress force (chapter 12)
$Q_k$	Characteristic imposed load
$q_k$	Characteristic live load per unit length or area
$1/r_x$	Curvature of a beam at point x
$r_{crit}$	Critical steel ratio to control thermal cracks
$s$	Depth of equivalent rectangular stress block
$s_{max}$	Maximum likely crack spacing
$s_v$	Spacing of links along the member
$T$	Torsional moment
$u$	Perimeter
$V$	Shear force
$v$	Shear stress
$v_c$	Ultimate shear stress in concrete
$W_k$	Characteristic wind load
$w_{max}$	Maximum likely surface crack width
$w_u$	Ultimate load per unit length
$x$	Neutral axis depth
$z$	Lever arm
$\alpha_c$	Coefficient of thermal expansion of mature concrete
$\alpha_e$	Modular ratio
$\gamma_f$	Partial safety factor for load
$\gamma_m$	Partial safety factor for strength
$\epsilon_{sh}$	Shrinkage strain
$\mu$	Coefficient of friction
$\Phi$	Bar size
$\phi$	Creep coefficient

# 1

## Properties of Reinforced Concrete

Reinforced concrete is a strong durable building material that can be formed into many varied shapes and sizes ranging from a simple rectangular column, to a slender curved dome or shell. Its utility and versatility is achieved by combining the best features of concrete and steel. Consider some of the widely differing properties of these two materials that are listed below.

	Concrete	Steel
strength in tension	poor	good
strength in compression	good	good, but slender bars will buckle
strength in shear	fair	good
durability	good	corrodes if unprotected
fire resistance	good	poor – suffers rapid loss of strength at high temperatures

It can be seen from this list that the materials are more or less complementary. Thus, when they are combined, the steel is able to provide the tensile strength and probably some of the shear strength while the concrete, strong in compression, protects the steel to give durability and fire resistance. This chapter can present only a brief introduction to the basic properties of concrete and its steel reinforcement. For a more comprehensive study, it is recommended that reference should be made to the specialised texts listed in Further Reading at the end of the book.

### 1.1 Composite Action

The tensile strength of concrete is only about 10 per cent of the compressive strength. Because of this, nearly all reinforced concrete structures are designed on the assumption that the concrete does not resist any tensile forces. Reinforcement is designed to carry these tensile forces, which are transferred by bond between the interface of the two materials. If this bond is not adequate, the reinforcing bars

will just slip within the concrete and there will not be a composite action. Thus members should be detailed so that the concrete can be well compacted around the reinforcement during construction. In addition, some bars are ribbed or twisted so that there is an extra mechanical grip.

In the analysis and design of the composite reinforced concrete section, it is assumed that there is perfect bond, so that the strain in the reinforcement is identical to the strain in the adjacent concrete. This ensures that there is what is known as 'compatibility of strains' across the cross-section of the member.

The coefficients of thermal expansion for steel and for concrete are of the order of  $10 \times 10^{-6}$  per  $^{\circ}\text{C}$  and  $7-12 \times 10^{-6}$  per  $^{\circ}\text{C}$  respectively. These values are sufficiently close that problems with bond seldom arise from differential expansion between the two materials over normal temperature ranges.

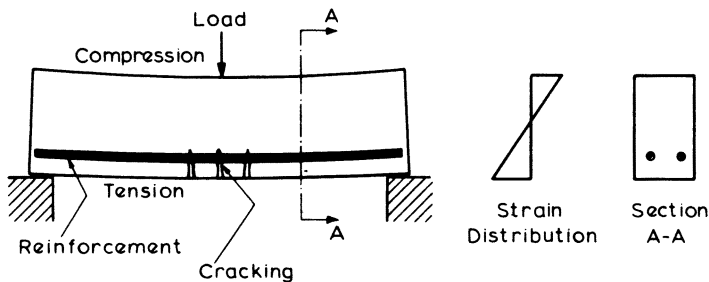

Figure 1.1 Composite action

Figure 1.1 illustrates the behaviour of a simply supported beam subjected to bending and shows the position of steel reinforcement to resist the tensile forces, while the compression forces in the top of the beam are carried by the concrete.

Wherever tension occurs it is likely that cracking of the concrete will take place. This cracking, however, does not detract from the safety of the structure provided there is good reinforcement bond to ensure that the cracks are restrained from opening so that the embedded steel continues to be protected from corrosion.

When the compressive or shearing forces exceed the strength of the concrete, then steel reinforcement must again be provided, but in these cases it is only required to supplement the load-carrying capacity of the concrete. For example, compression reinforcement is generally required in a column, where it takes the form of vertical bars spaced near the perimeter. To prevent these bars buckling, steel binders are used to assist the restraint provided by the surrounding concrete.

## 1.2 Stress-Strain Relations

The loads on a structure cause distortion of its members with resulting stresses and strains in the concrete and the steel reinforcement. To carry out the analysis and design of a member it is necessary to have a knowledge of the relationship between these stresses and strains. This knowledge is particularly important when dealing with reinforced concrete which is a composite material; for in this case the analysis

of the stresses on a cross-section of a member must consider the equilibrium of the forces in the concrete and steel, and also the compatibility of the strains across the cross-section.

**1.2.1 Concrete**

Concrete is a very variable material, having a wide range of strengths and stress-strain curves. A typical curve for concrete in compression is shown in figure 1.2. As the load is applied, the ratio between the stresses and strains is approximately linear at first and the concrete behaves almost as an elastic material with virtually a full recovery of displacement if the load is removed. Eventually, the curve is no longer linear and the concrete behaves more and more as a plastic material. If the load were removed during the plastic range the recovery would no longer be complete and a permanent deformation would remain. The ultimate strain for most structural concretes tends to be a constant value of approximately 0.0035, irrespective of the strength of the concrete. The precise shape of the curve is very dependent on the length of time the load is applied, a factor which will be further discussed in section 1.4 on creep. Figure 1.2 is typical for a short-term loading.

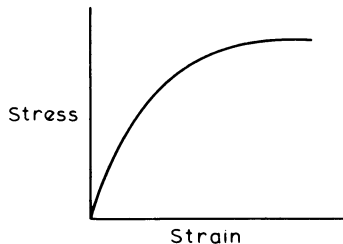

**Figure 1.2** *Stress-strain curve for concrete in compression*

Concrete generally increases its strength with age. This characteristic is illustrated by the graph in figure 1.3 which shows how the increase is rapid at first, becoming more gradual later. Some codes of practice allow the concrete strength used in design to be varied according to the age of the concrete when it supports the design load. A typical variation in strength of an adequately cured Ordinary Portland cement concrete, as suggested by BS 8110, is

7 days	1 month	2 months	3 months	6 months	1 year
20	30	33	35	36	37 N/mm <sup>2</sup>

BS 8110 does not permit the use of strengths greater than the 28-day value in calculations, but the Modulus of Elasticity may be modified to account for age as shown overleaf.

## REINFORCED CONCRETE DESIGN

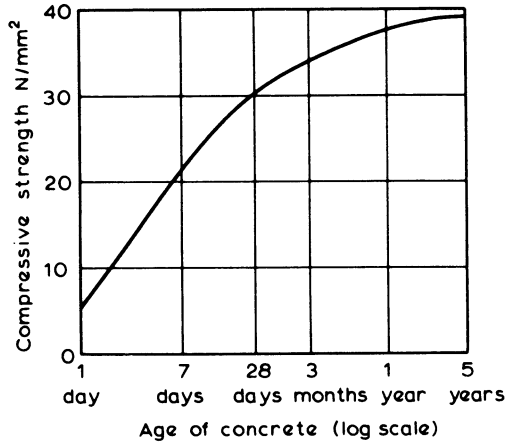

Figure 1.3 Increase of concrete strength with age. Typical curve for an Ordinary Portland cement concrete

### Modulus of Elasticity of Concrete

It is seen from the stress–strain curve for concrete that although elastic behaviour may be assumed for stresses below about one-third of the ultimate compressive strength, this relationship is not truly linear. Consequently it is necessary to define precisely what value is to be taken as the modulus of elasticity

$$E = \frac{\text{stress}}{\text{strain}}$$

A number of alternative definitions exist, but the most commonly adopted is  $E = E_c$  where  $E_c$  is known as the *secant* or *static modulus*. This is measured for a particular concrete by means of a static test in which a cylinder is loaded to just above one-third of the corresponding control cube stress and then cycled back to zero stress. This removes the effect of initial ‘bedding in’ and minor stress redistributions in the concrete under load. Load is then reapplied and the behaviour will then be almost linear; the average slope of the line up to the specified stress is taken as the value for  $E_c$ . The test is described in detail in BS 1881 and the result is generally known as the *instantaneous static modulus of elasticity*.

The *dynamic modulus of elasticity*,  $E_{cq}$ , is sometimes referred to since this is much easier to measure in the laboratory and there is a fairly well-defined relationship between  $E_c$  and  $E_{cq}$ . The standard test is based on determining the resonant frequency of a laboratory prism specimen and is also described in BS 1881. It is also possible to obtain a good estimate of  $E_{cq}$  from ultrasonic measuring techniques, which may sometimes be used on site to assess the concrete in an actual structure. The standard test for  $E_{cq}$  is on an unstressed specimen. It can be seen from figure 1.4 that the value obtained represents the slope of the tangent at zero stress and  $E_{cq}$  is therefore higher than  $E_c$ . The relationship between the two moduli is given by

$$\text{Static modulus } E_c = (1.25 E_{cq} - 19) \text{ kN/mm}^2$$

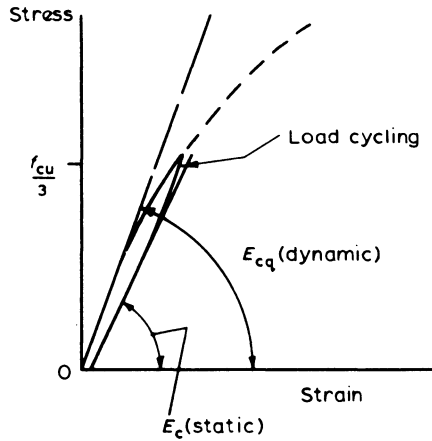

Figure 1.4 Moduli of elasticity of concrete

This equation is sufficiently accurate for normal design purposes.

The actual value of  $E$  for a concrete depends on many factors related to the mix, but a general relationship is considered to exist between the modulus of elasticity and the compressive cube strength. Ranges of  $E_c$  for various concrete grades which are suitable for design are shown in table 1.1. The magnitude of the modulus of elasticity is required when investigating the deflection and cracking of a structure. When considering short-term effects, member stiffnesses will be based on the static modulus  $E_c$ , as defined above. If long-term effects are being considered, it can be shown that the effects of creep can be represented by modifying the value of  $E_c$  and this is discussed in section 6.3.2.

Table 1.1 Short-term modulus of elasticity of concrete

28 day characteristic cube strength $f_{cu,28}$ (N/mm <sup>2</sup> )	Static modulus $E_{c,28}$ (kN/mm <sup>2</sup> )	
	Typical range	Mean
25	19-31	25
30	20-32	26
40	22-34	28
50	24-36	30
60	26-38	32

The elastic modulus at an age other than 28 days may be estimated from

$$E_{c,\tau} = E_{c,28}(0.4 + 0.6 f_{cu,\tau}/f_{cu,28})$$

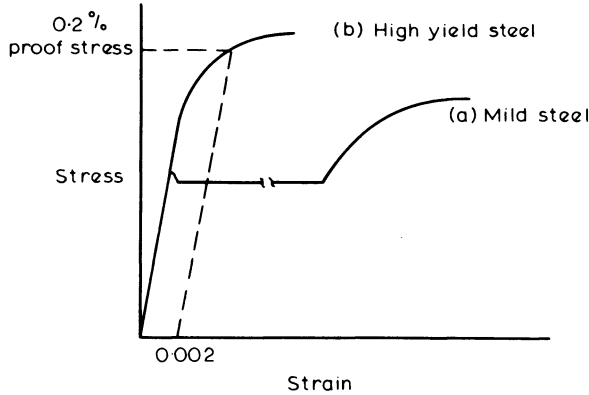

Figure 1.5 Stress-strain curves for steel

### 1.2.2 Steel

Figure 1.5 shows typical stress-strain curves for (a) mild steel, and (b) high yield steel. Mild steel behaves as an elastic material, with the strain proportional to the stress up to the yield, at which point there is a sudden increase in strain with no change in stress. After the yield point, mild steel becomes a plastic material and the strain increases rapidly up to the ultimate value. High yield steel on the other hand, does not have a definite yield point but shows a more gradual change from an elastic to a plastic behaviour.

The specified strength used in design is based on the yield stress for mild steel, whereas for high yield steel the strength is based on a specified proof stress. A 0.2 per cent proof stress is defined in figure 1.5 by the broken line drawn parallel to the linear part of the stress-strain curve.

Removal of the load within the plastic range would result in the stress-strain diagram following a line approximately parallel to the loading portion – see line BC in figure 1.6. The steel will be left with a permanent strain AC, which is known as ‘slip’. If the steel is again loaded, the stress-strain diagram will follow the unloading curve until it almost reaches the original stress at B and then it will curve in the direction of the first loading. Thus, the proportional limit for the second loading is higher than for the initial loading. This action is referred to as ‘strain hardening’ or ‘work hardening’.

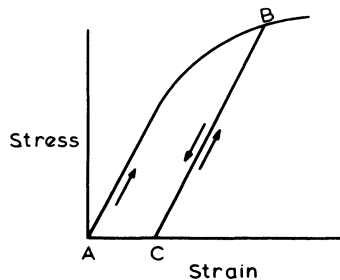

Figure 1.6 Strain hardening

The deformation of the steel is also dependent on the length of time the load is applied. Under a constant stress the strains will gradually increase – this phenomenon is known as ‘creep’ or ‘relaxation’. The amount of creep that takes place over a period of time depends on the grade of steel and the magnitude of the stress. Creep of the steel is of little significance in normal reinforced concrete work, but it is an important factor in prestressed concrete where the prestressing steel is very highly stressed.

### 1.3 Shrinkage and Thermal Movement

As concrete hardens there is a reduction in volume. This shrinkage is liable to cause cracking of the concrete, but it also has the beneficial effect of strengthening the bond between the concrete and the steel reinforcement. Shrinkage begins to take place as soon as the concrete is mixed, and is caused initially by the absorption of the water by the concrete and the aggregate. Further shrinkage is caused by evaporation of the water which rises to the concrete surface. During the setting process the hydration of the cement causes a great deal of heat to be generated, and as the concrete cools, further shrinkage takes place as a result of thermal contraction. Even after the concrete has hardened, shrinkage continues as drying out persists over many months, and any subsequent wetting and drying can also cause swelling and shrinkage. Thermal shrinkage may be reduced by restricting the temperature rise during hydration, which may be achieved by the following procedures.

- (1) Use a mix design with a low cement content.
- (2) Avoid rapid hardening and finely ground cement if possible.
- (3) Keep aggregates and mixing water cool.
- (4) Use steel shuttering and cool with a water spray.
- (5) Strike the shuttering early to allow the heat of hydration to dissipate.

A low water-cement ratio will help to reduce drying shrinkage by keeping to a minimum the volume of moisture that can be lost.

If the change in volume of the concrete is allowed to take place freely without restraint, there will be no stress change within the concrete. Restraint of the shrinkage, on the other hand, will cause tensile strains and stresses. The restraint may be caused externally by fixity with adjoining members or friction against an earth surface, and internally by the action of the steel reinforcement. For a long wall or floor slab, the restraint from adjoining concrete may be reduced by using a system of constructing successive bays instead of alternate bays. This allows the free end of every bay to contract before the next bay is cast.

Day-to-day thermal expansion of the concrete can be greater than the movements caused by shrinkage. Thermal stresses and strains may be controlled by the correct positioning of movement or expansion joints in a structure. For example, the joints should be placed at an abrupt change in cross-section and they should, in general, pass completely through the structure in one plane.

When the tensile stresses caused by shrinkage or thermal movement exceed the strength of the concrete, cracking will occur. To control the crack widths, steel reinforcement must be provided close to the concrete surface; the codes of

practice specify minimum quantities of reinforcement in a member for this purpose.

### Calculation of Stresses Induced by Shrinkage

#### (a) Shrinkage Restrained by the Reinforcement

The shrinkage stresses caused by reinforcement in an otherwise unrestrained member may be calculated quite simply. The member shown in figure 1.7 has a free shrinkage strain  $\epsilon_{sh}$  if made of plain concrete, but this overall movement is

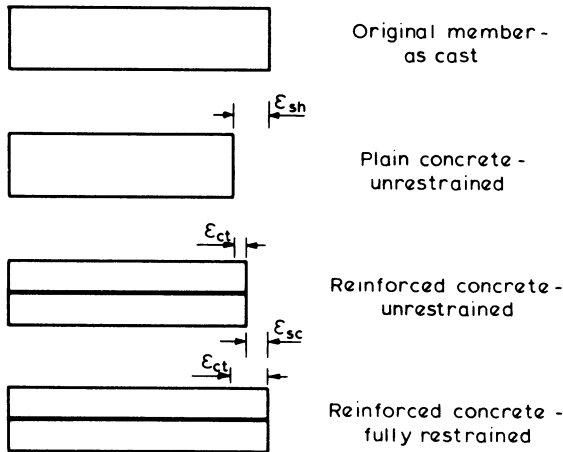

Figure 1.7 Shrinkage strains

reduced by the inclusion of reinforcement, giving a compressive strain  $\epsilon_{sc}$  in the steel and causing an effective tensile strain  $\epsilon_{ct}$  in the concrete. Thus

$$\begin{aligned}\epsilon_{sh} &= \epsilon_{ct} + \epsilon_{sc} \\ &= \frac{f_{ct}}{E_c} + \frac{f_{sc}}{E_s}\end{aligned}\quad (1.1)$$

where  $f_{ct}$  is the tensile stress in concrete area  $A_c$  and  $f_{sc}$  is the compressive stress in steel area  $A_s$ .

Equating forces in the concrete and steel for equilibrium gives

$$A_c f_{ct} = A_s f_{sc} \quad (1.2)$$

therefore

$$f_{ct} = \frac{A_s}{A_c} f_{sc}$$

Substituting for  $f_{ct}$  in equation 1.1

$$\epsilon_{sh} = f_{sc} \left( \frac{A_s}{A_c E_c} + \frac{1}{E_s} \right)$$

Thus if

$$\alpha_e = \frac{E_s}{E_c}$$

$$\epsilon_{sh} = f_{sc} \left( \frac{\alpha_e A_s}{A_c E_s} + \frac{1}{E_s} \right)$$

$$= \frac{f_{sc}}{E_s} \left( \frac{\alpha_e A_s}{A_c} + 1 \right)$$

Therefore steel stress

$$f_{sc} = \frac{\epsilon_{sh} E_s}{1 + \frac{\alpha_e A_s}{A_c}} \quad (1.3)$$

**Example 1.1 Calculation of Shrinkage Stresses in Concrete that is Restrained by Reinforcement Only**

A member contains 1.0 per cent reinforcement, and the free shrinkage strain  $\epsilon_{sh}$  of the concrete is  $200 \times 10^{-6}$ . For steel,  $E_s = 200 \text{ kN/mm}^2$  and for concrete  $E_c = 15 \text{ kN/mm}^2$ . Hence from equation 1.3:

$$\begin{aligned} \text{stress in reinforcement } f_{sc} &= \frac{\epsilon_{sh} E_s}{1 + \alpha_e \frac{A_s}{A_c}} \\ &= \frac{200 \times 10^{-6} \times 200 \times 10^3}{1 + \frac{200}{15} \times 0.01} \\ &= 35.3 \text{ N/mm}^2 \text{ compression} \\ \text{stress in concrete } f_{ct} &= \frac{A_s}{A_c} f_{sc} \\ &= 0.01 \times 35.3 \\ &= 0.35 \text{ N/mm}^2 \text{ tension} \end{aligned}$$

The stresses produced in members free from external restraint are generally small as in the above example, and can be easily withstood both by the steel and the concrete.

**(b) Shrinkage Fully Restrained**

If the member is fully restrained, then the steel cannot be in compression since  $\epsilon_{sc} = 0$  and hence  $f_{sc} = 0$  (figure 1.7). In this case the tensile strain induced in the concrete  $\epsilon_{ct}$  must be equal to the free shrinkage strain  $\epsilon_{sh}$ , and the corresponding stress will probably be high enough to cause cracking in immature concrete.

**Example 1.2 Calculation of Fully Restrained Shrinkage Stresses**

If the member in example 1.1 were fully restrained, the stress in the concrete is given by

$$f_{ct} = \epsilon_{ct} E_c$$

where

$$\epsilon_{ct} = \epsilon_{sh} = 200 \times 10^{-6}$$

then

$$\begin{aligned} f_{ct} &= 200 \times 10^{-6} \times 15 \times 10^3 \\ &= 3.0 \text{ N/mm}^2 \end{aligned}$$

When cracking occurs, the uncracked lengths of concrete try to contract so that the embedded steel between cracks is in compression while the steel across the cracks is in tension. This feature is accompanied by localised bond breakdown, adjacent to each crack. The equilibrium of the concrete and reinforcement is shown in figure 1.8 and calculations may be developed to relate crack widths and spacings to properties of the cross-section; this is examined in more detail in chapter 6, which deals with serviceability requirements.

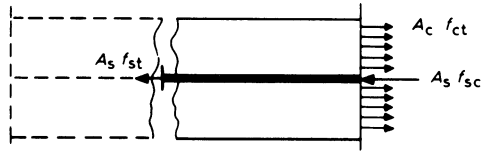

Figure 1.8 Shrinkage forces adjacent to a crack

**Thermal Movement**

As the coefficients of thermal expansion of steel and concrete ( $\alpha_s$  and  $\alpha_c$ ) are similar, differential movement between the steel and concrete will only be very small and is unlikely to cause cracking.

The differential thermal strain due to a temperature change  $T$  may be calculated as

$$T(\alpha_c - \alpha_s)$$

and should be added to the shrinkage strain  $\epsilon_{sh}$  if significant.

The overall thermal contraction of concrete is, however, frequently effective in producing the first crack in a restrained member, since the required temperature changes could easily occur overnight in a newly cast member, even with good control of the heat generated during the hydration processes.

**Example 1.3 Thermal Shrinkage**

Find the fall in temperature required to cause cracking in a restrained member if ultimate tensile strength of the concrete  $f_t = 2 \text{ N/mm}^2$ ,  $E_c = 16 \text{ kN/mm}^2$  and

$\alpha_c = \alpha_s = 10 \times 10^{-6}$  per °C. Ultimate tensile strain of concrete

$$\epsilon_{ult} = \frac{f_t}{E_c} = \frac{2}{16 \times 10^3} = 125 \times 10^{-6}$$

Minimum temperature drop to cause cracking

$$= \frac{\epsilon_{ult}}{\alpha_c} = \frac{125}{10} = 12.5 \text{ } ^\circ\text{C}$$

It should be noted that full restraint, as assumed in this example, is unlikely to occur in practice; thus the temperature change required to cause cracking is increased.

### 1.4 Creep

Creep is the continuous deformation of a member under sustained load. It is a phenomenon associated with many materials, but it is particularly evident with concrete. The precise behaviour of a particular concrete depends on the aggregates and the mix design, but the general pattern is illustrated by considering a member subjected to axial compression. For such a member, a typical variation of deformation with time is shown by the curve in figure 1.9.

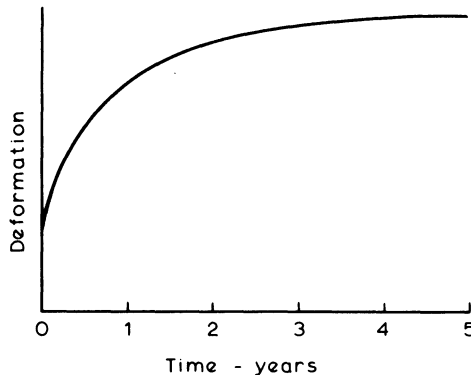

Figure 1.9 Typical increase of deformation with time for concrete

The characteristics of creep are

- (1) The final deformation of the member can be three to four times the short-term elastic deformation.
- (2) The deformation is roughly proportional to the intensity of loading and to the inverse of the concrete strength.
- (3) If the load is removed, only the instantaneous elastic deformation will recover – the plastic deformation will not.
- (4) There is a redistribution of load between the concrete and any steel present.

The redistribution of load is caused by the changes in compressive strains being transferred to the reinforcing steel. Thus the compressive stresses in the steel are increased so that the steel takes a larger proportion of the load.

The effects of creep are particularly important in beams, where the increased deflections may cause the opening of cracks, damage to finishes, and the non-alignment of mechanical equipment. Redistribution of stress between concrete and steel occurs primarily in the uncracked compressive areas and has little effect on the tension reinforcement other than reducing shrinkage stresses in some instances. The provision of reinforcement in the compressive zone of a flexural member, however, often helps to restrain the deflections due to creep.

### 1.5 Durability

Concrete structures, properly designed and constructed, are long lasting and should require little maintenance. The durability of the concrete is influenced by

- (1) the exposure conditions
- (2) the concrete quality
- (3) the cover to the reinforcement
- (4) the width of any cracks.

Concrete can be exposed to a wide range of conditions such as the soil, sea water, stored chemicals or the atmosphere. The severity of the exposure governs the type of concrete mix required and the minimum cover to the reinforcing steel. Whatever the exposure, the concrete mix should be made from impervious and chemically inert aggregates. A dense, well-compacted concrete with a low water-cement ratio is all important and for some soil conditions it is advisable to use a sulphate-resisting cement.

Adequate cover is essential to prevent corrosive agents reaching the reinforcement through cracks and pervious concrete. The thickness of cover required depends on the severity of the exposure and the quality of the concrete (as shown in table 6.1). The cover is also necessary to protect the reinforcement against a rapid rise in temperature and subsequent loss of strength during a fire. Information concerning this is given in Part 2 of BS 8110, while durability requirements with related design calculations to check and control crack widths and depths are described in chapter 6.

### 1.6 Specification of Materials

#### 1.6.1 Concrete

The selection of the type of concrete is frequently governed by the strength required, which in turn depends on the intensity of loading and the form and size of the structural members. For example, in the lower columns of a multi-storey building a higher-strength concrete may be chosen in preference to greatly increasing the size of the column section with a resultant loss in clear floor space.

The concrete strength is assessed by measuring the crushing strength of cubes or cylinders of concrete made from the mix. These are usually cured, and tested after

twenty-eight days according to standard procedures. Concrete of a given strength is identified by its 'grade' – a grade 25 concrete has a characteristic cube crushing strength of 25 N/mm<sup>2</sup>. Table 1.2 shows a list of commonly used grades and also the lowest grade appropriate for various types of construction.

Exposure conditions and durability can also affect the choice of the mix design and the grade of concrete. A structure subject to corrosive conditions in a chemical plant, for example, would require a denser and higher grade of concrete than, say, the interior members of a school or office block. Although Ordinary Portland cement would be used in most structures, other cement types can also be used to advantage. Blast-furnace or sulphate-resisting cement may be used to resist chemical attack, low-heat cements in massive sections to reduce the heat of hydration,

**Table 1.2** Grades of concrete

Grade	Lowest grade for use as specified
C7	Plain concrete
C10	
C15	Reinforced concrete with
C20	lightweight aggregate
C25	Reinforced concrete with
	dense aggregate
C30	Concrete with post-tensioned
	tendons
C40	Concrete with pre-tensioned
	tendons
C50	
C60	

or rapid-hardening cement when a high early strength is required. Generally, natural aggregates found locally are preferred; however, manufactured lightweight material may be used when self-weight is important, or a special dense aggregate when radiation shielding is required.

The concrete mix may either be classified as 'designed' or 'prescribed'. A 'designed mix' is one where the contractor is responsible for selecting the mix proportions to achieve the required strength and workability, whereas for a 'prescribed mix' the engineer specifies the mix proportions, and the contractor is responsible only for providing a properly mixed concrete containing the correct constituents in the prescribed proportions.

### 1.6.2 Reinforcing Steel

Table 1.3 lists the characteristic design strengths of several of the more common types of reinforcement. The nominal size of a bar is the diameter of an equivalent circular area.

**Table 1.3** Strength of reinforcement

Designation	Nominal sizes (mm)	Specified characteristic strength $f_y$ (N/mm <sup>2</sup> )
Hot-rolled mild steel (BS 4449)	All sizes	250
Hot-rolled high yield (BS 4449) } Cold-worked high yield (BS 4461) }	All sizes	460
Hard-drawn steel wire (BS 4482)	Up to and including 12	485

Hot-rolled mild-steel bars usually have a smooth surface so that the bond with the concrete is by adhesion only. Mild-steel bars can readily be bent, so they are often used where small radius bends are necessary, such as for links in narrow beams or columns.

High-yield bars are manufactured either with a ribbed surface or in the form of a twisted square. Ribbed bars are usually described by the British Standards as type 2 bars provided specified requirements are satisfied, and these are the bars most commonly used. Square twisted bars have inferior bond characteristics and are usually classified as type 1 bars, although these are more or less obsolete. All deformed bars have an additional mechanical bond with the concrete so that higher ultimate bond stresses may be specified as described in section 5.2. The bending of high-yield bars through a small radius is liable to cause tension cracking of the steel, and to avoid this the radius of the bend should not be less than three times the nominal bar size (see figure 5.6).

High-yield steel bars are only slightly more expensive than mild-steel bars. Therefore, because of their significant stress advantage, high-yield bars are the more economical. Nevertheless, mild-steel bars are sometimes preferred in water-retaining structures, where the maximum steel stresses are limited in order to reduce the tensile strains and cracking of the concrete.

Floor slabs, walls, shells and roads may be reinforced with a welded fabric of reinforcement, supplied in rolls and having a square or rectangular mesh. This can give large economies in the detailing of the reinforcement and also in site labour costs of handling and fixing.

The cross-sectional areas and perimeters of various sized bars, and the cross-sectional area per unit width of slabs are listed in the appendix. Reinforcing bars in a member should either be straight or bent to standard shapes. These shapes must be fully dimensioned and listed in a schedule of the reinforcement which is used on site for the bending and fixing of the bars. Standard bar shapes and a method of scheduling are specified in BS 4466. The bar types as previously described are commonly identified by the following codes: R for mild steel; Y for high yield deformed steel, type 1; T for high yield deformed steel, type 2; this notation is generally used throughout this book.

# 2

## Limit State Design

The design of an engineering structure must ensure that (1) under the worst loadings the structure is safe, and (2) during normal working conditions the deformation of the members does not detract from the appearance, durability or performance of the structure. Despite the difficulty in assessing the precise loading and variations in the strength of the concrete and steel, these requirements have to be met. Three basic methods using factors of safety to achieve safe, workable structures have been developed; they are

- (1) The permissible stress method in which ultimate strengths of the materials are divided by a factor of safety to provide design stresses which are usually within the elastic range.
- (2) The load factor method in which the working loads are multiplied by a factor of safety.
- (3) The limit state method which multiplies the working loads by partial factors of safety and also divides the materials' ultimate strengths by further partial factors of safety.

The permissible stress method has proved to be a simple and useful method but it does have some serious inconsistencies. Because it is based on an elastic stress distribution, it is not really applicable to a semi-plastic material such as concrete, nor is it suitable when the deformations are not proportional to the load, as in slender columns. It has also been found to be unsafe when dealing with the stability of structures subject to overturning forces (see example 2.2).

In the load factor method the ultimate strength of the materials should be used in the calculations. As this method does not apply factors of safety to the material stresses, it cannot directly take account of the variability of the materials, and also it cannot be used to calculate the deflections or cracking at working loads.

The limit state method of design overcomes many of the disadvantages of the previous two methods. This is done by applying partial factors of safety, both to the loads and to the material strengths, and the magnitude of the factors may be varied so that they may be used either with the plastic conditions in the ultimate state or with the more elastic stress range at working loads. This flexibility is particularly important if full benefits are to be obtained from development of improved concrete and steel properties.

## 2.1 Limit States

The purpose of design is to achieve acceptable probabilities that a structure will not become unfit for its intended use – that is, that it will not reach a limit state. Thus, any way in which a structure may cease to be fit for use will constitute a limit state and the design aim is to avoid any such condition being reached during the expected life of the structure.

The two principal types of limit state are the ultimate limit state and the serviceability limit state.

### (a) Ultimate Limit State

This requires that the structure must be able to withstand, with an adequate factor of safety against collapse, the loads for which it is designed. The possibility of buckling or overturning must also be taken into account, as must the possibility of accidental damage as caused, for example, by an internal explosion.

### (b) Serviceability Limit States

Generally the most important serviceability limit states are

- (1) Deflection – the appearance or efficiency of any part of the structure must not be adversely affected by deflections.
- (2) Cracking – local damage due to cracking and spalling must not affect the appearance, efficiency or durability of the structure.
- (3) Durability – this must be considered in terms of the proposed life of the structure and its conditions of exposure.

Other limit states that may be reached include

- (4) Excessive vibration – which may cause discomfort or alarm as well as damage.
- (5) Fatigue – must be considered if cyclic loading is likely.
- (6) Fire resistance – this must be considered in terms of resistance to collapse, flame penetration and heat transfer.
- (7) Special circumstances – any special requirements of the structure which are not covered by any of the more common limit states, such as earthquake resistance, must be taken into account.

The relative importance of each limit state will vary according to the nature of the structure. The usual procedure is to decide which is the crucial limit state for a particular structure and base the design on this, although durability and fire resistance requirements may well influence initial member sizing and concrete grade selection. Checks must also be made to ensure that all other relevant limit states are satisfied by the results produced. Except in special cases, such as water-retaining structures, the ultimate limit state is generally critical for reinforced concrete although subsequent serviceability checks may affect some of the details of the design. Prestressed concrete design, however, is generally based on serviceability conditions with checks on the ultimate limit state.

In assessing a particular limit state for a structure it is necessary to consider all the possible variable parameters such as the loads, material strengths and constructional tolerances.

## 2.2 Characteristic Material Strengths and Characteristic Loads

### 2.2.1 Characteristic Material Strengths

The strengths of materials upon which design is based are those strengths below which results are unlikely to fall. These are called 'characteristic' strengths. It is assumed that for a given material, the distribution of strength will be approximately 'normal', so that a frequency distribution curve of a large number of sample results would be of the form shown in figure 2.1. The characteristic strength is taken as that value below which it is unlikely that more than 5 per cent of the results will fall. This is given by

$$f_k = f_m - 1.64s$$

where  $f_k$  = characteristic strength,  $f_m$  = mean strength,  $s$  = standard deviation.

The relationship between characteristic and mean values accounts for variations in results of test specimens and will, therefore, reflect the method and control of manufacture, quality of constituents, and nature of the material.

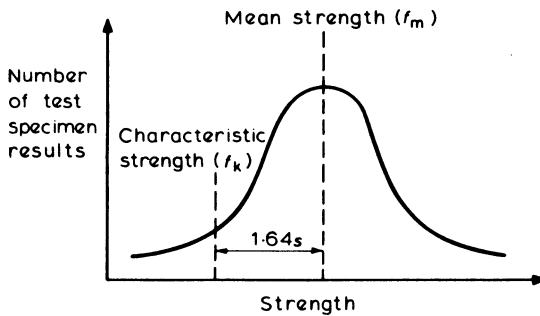

Figure 2.1 Normal frequency distribution of strengths

### 2.2.2 Characteristic Loads

Ideally it should also be possible to assess loads statistically, in which case

$$\text{characteristic load} = \text{mean load} \pm 1.64 \text{ standard deviations}$$

In most cases it is the maximum loading on a structural member that is critical and the upper, positive value given by this expression is used, but the lower, minimum value may apply when considering stability or the behaviour of continuous members.

These characteristic values represent the limits within which at least 90 per cent of values will lie in practice. It is to be expected that not more than 5 per cent of cases will exceed the upper limit and not more than 5 per cent will fall below the lower limit. They are design values which take into account the accuracy with which the loads can be predicted.

Usually, however, there is insufficient statistical data to allow loading to be treated in this way, and in this case the standard loadings, given in BS 6399 Design Loads for Buildings, Part 1: Code of Practice for dead and imposed loads, should be used as representing characteristic values.

### 2.3 Partial Factors of Safety

Other possible variations such as constructional tolerances are allowed for by partial factors of safety applied to the strength of the materials and to the loadings. It should theoretically be possible to derive values for these from a mathematical assessment of the probability of reaching each limit state. Lack of adequate data, however, makes this unrealistic and in practice the values adopted are based on experience and simplified calculations.

#### 2.3.1 Partial Factors of Safety for Materials ( $\gamma_m$ )

$$\text{Design strength} = \frac{\text{characteristic strength } (f_k)}{\text{partial factor of safety } (\gamma_m)}$$

The following factors are considered when selecting a suitable value for  $\gamma_m$

- (1) The strength of the material in an actual member. This strength will differ from that measured in a carefully prepared test specimen and it is particularly true for concrete where placing, compaction and curing are so important to the strength. Steel, on the other hand, is a relatively consistent material requiring a small partial factor of safety.
- (2) The severity of the limit state being considered. Thus, higher values are taken for the ultimate limit state than for the serviceability limit state.

Recommended values for  $\gamma_m$  are given in table 2.1 although it should be noted that for precast factory conditions it may be possible to reduce the value for concrete at the ultimate limit state.

**Table 2.1** Partial factors of safety applied to materials ( $\gamma_m$ )

Limit state	Material	
	Concrete	Steel
Ultimate		
Flexure	1.5	1.15
Shear	1.25	1.15
Bond	1.4	
Serviceability	1.0	1.0

#### 2.3.2 Partial Factors of Safety for Loads ( $\gamma_f$ )

Errors and inaccuracies may be due to a number of causes:

- (1) design assumptions and inaccuracy of calculation
- (2) possible unusual load increases
- (3) unforeseen stress redistributions
- (4) constructional inaccuracies.

These cannot be ignored, and are taken into account by applying a partial factor of safety ( $\gamma_f$ ) on the loadings, so that

$$\text{design load} = \text{characteristic load} \times \text{partial factor of safety } (\gamma_f)$$

The value of this factor should also take into account the importance of the limit state under consideration and reflect to some extent the accuracy with which different types of loading can be predicted, and the probability of particular load combinations occurring. Recommended values are given in table 2.2. It should be noted that design errors and constructional inaccuracies have similar effects and are thus sensibly grouped together. These factors will account adequately for normal conditions although gross errors in design or construction obviously cannot be catered for.

**Table 2.2** Partial factors of safety for loadings

Load combination	Ultimate				Serviceability All ( $\gamma_G, \gamma_Q, \gamma_W$ )
	Dead ( $\gamma_G$ )	Imposed ( $\gamma_Q$ )	Earth & Water ( $\gamma_Q$ )	Wind ( $\gamma_W$ )	
Dead & Imposed (+ Earth & Water)	1.4 (or 1.0)	1.6 (or 0.0)	1.4	—	1.0
Dead & Wind (+ Earth & Water)	1.4 (or 1.0)	—	1.4	1.4	1.0
Dead & Imposed & Wind (+ Earth & Water)	1.2	1.2	1.2	1.2	1.0

The lower values in brackets applied to dead or imposed loads at the Ultimate Limit State should be used when *minimum* loading is critical.

## 2.4 Global Factor of Safety

The use of partial factors of safety on materials and loads offers considerable flexibility, which may be used to allow for special conditions such as very high standards of construction and control or, at the other extreme, where structural failure would be particularly disastrous.

The global factor of safety against a particular type of failure may be obtained by multiplying the appropriate partial factors of safety. For instance, a beam failure caused by yielding of tensile reinforcement would have a factor of

$$\gamma_m \times \gamma_f = 1.15 \times 1.4 = 1.61 \quad \text{for dead loads only}$$

or

$$1.15 \times 1.6 = 1.84 \quad \text{for live loads only}$$

Thus the practical case will have a value between these, depending on the relative loading proportions, and this can be compared with the value of 1.8 which has generally been used as the overall factor in the load factor design approach.

Similarly, failure by crushing of the concrete in the compression zone has a factor of  $1.5 \times 1.6 = 2.40$  due to live loads only, which reflects the fact that such failure is generally without warning and may be very serious. Thus the basic values of partial factors chosen are such that under normal circumstances the global factor of safety is similar to that used in earlier design methods.

### Example 2.1

Determine the cross-sectional area of a mild steel cable which supports a total dead load of 3.0 kN and a live load of 2.0 kN as shown in figure 2.2.

The characteristic yield stress of the mild steel is  $250 \text{ N/mm}^2$ .

Carry out the calculations using

- (1) The load factor method with a load factor = 1.8.
- (2) A permissible stress design with a factor of safety of 1.8 on the yield stress.
- (3) A limit state design with the following factors of safety.

$\gamma_G = 1.4$  for the dead load,  $\gamma_Q = 1.6$  for the live load,  $\gamma_m = 1.15$  for the steel strength.

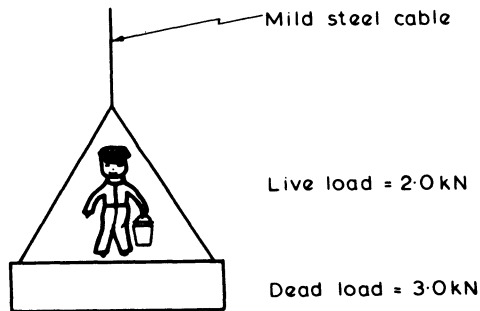

Figure 2.2

#### (a) Load Factor Method

$$\begin{aligned} \text{Design load} &= \text{load factor} (\text{dead load} + \text{live load}) \\ &= 1.8 (3.0 + 2.0) = 9.0 \text{ kN} \end{aligned}$$

$$\begin{aligned} \text{Required cross-sectional area} &= \frac{\text{design load}}{\text{yield stress}} \\ &= \frac{9.0 \times 10^3}{250} = 36 \text{ mm}^2 \end{aligned}$$

## (b) Permissible Stress Method

$$\text{Design load} = 3.0 + 2.0 = 5.0 \text{ kN}$$

$$\begin{aligned} \text{Permissible stress} &= \frac{\text{yield stress}}{\text{safety factor}} \\ &= \frac{250}{1.8} = 139 \text{ N/mm}^2 \end{aligned}$$

$$\begin{aligned} \text{Required cross-sectional area} &= \frac{\text{design load}}{\text{permissible stress}} \\ &= \frac{5.0 \times 10^3}{139} = 36 \text{ mm}^2 \end{aligned}$$

## (c) Limit State Method

$$\begin{aligned} \text{Design load} &= \gamma_G \times \text{dead load} + \gamma_Q \times \text{live load} \\ &= 1.4 \times 3.0 + 1.6 \times 2.0 = 7.4 \text{ kN} \end{aligned}$$

$$\begin{aligned} \text{Design stress} &= \frac{\text{characteristic yield stress}}{\gamma_m} \\ &= \frac{250}{1.15} = 217 \text{ N/mm}^2 \end{aligned}$$

$$\begin{aligned} \text{Required cross-sectional area} &= \frac{\text{design load}}{\text{design stress}} \\ &= \frac{7.4 \times 10^3}{217} \\ &= 34.1 \text{ mm}^2 \end{aligned}$$

These different design methods all give similar results for the cross-sectional area. Fewer calculations are required for the permissible stress and the load factor methods, so reducing the chances of an arithmetical error. The limit state method provides much better control over the factors of safety, which are applied to each of the variables. For convenience, the partial factors of safety in the example are the same as those recommended in BS 8110. Probably, in a practical design, higher factors of safety would be preferred for a single supporting cable, in view of the consequences of a failure.

**Example 2.2**

Figure 2.3 shows a beam supported on foundations at A and B. The loads supported by the beam are its own uniformly distributed dead weight of 20 kN/m

and a 170 kN live load concentrated at end C. Determine the weight of foundation required at A in order to resist uplift

- (1) by applying a factor of safety of 2.0 to the reaction calculated for the working loads
- (2) using a limit state approach with partial factors of safety of  $\gamma_G = 1.4$  or 1.0 for the dead load and  $\gamma_Q = 1.6$  for the live load.

Investigate the effect on these designs of a 7 per cent increase in the live load.

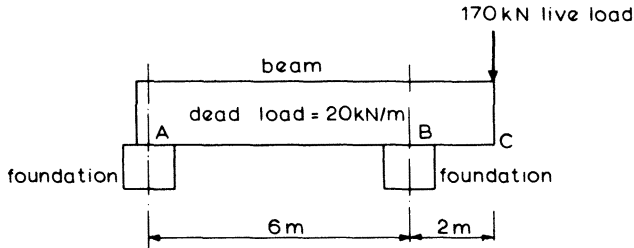

(a)

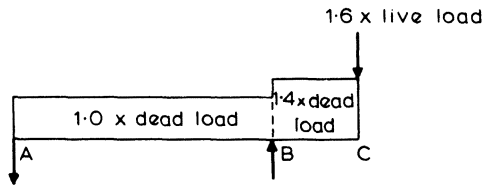

(b) Loading arrangement for uplift at A at the ultimate limit state.

Figure 2.3

(a) Factor of Safety on Uplift = 2.0

Taking moments about B

$$\text{Uplift } R_A = \frac{(170 \times 2 - 20 \times 8 \times 2)}{6.0} = 3.33 \text{ kN}$$

$$\begin{aligned} \text{Weight of foundation required} &= 3.33 \times \text{safety factor} \\ &= 3.33 \times 2.0 = 6.7 \text{ kN} \end{aligned}$$

With a 7 per cent increase in the live load

$$\text{Uplift } R_A = \frac{(1.07 \times 170 \times 2 - 20 \times 8 \times 2)}{6.0} = 7.3 \text{ kN}$$

Thus with a slight increase in the live load there is a significant increase in the uplift and the structure becomes unsafe.

**(b) Limit State Method**

The arrangement of the loads for the maximum uplift at A is shown in figure 2.3b.

$$\begin{aligned}\text{Design dead load over BC} &= \gamma_G \times 20 \times 2 \\ &= 1.4 \times 20 \times 2 = 56 \text{ kN} \\ \text{Design dead load over AB} &= \gamma_G \times 20 \times 6 \\ &= 1.0 \times 20 \times 6 = 120 \text{ kN} \\ \text{Design live load} &= \gamma_Q \times 170 \\ &= 1.6 \times 170 = 272 \text{ kN}\end{aligned}$$

Taking moments about *B* for the ultimate loads

$$\text{Uplift } R_A = \frac{(272 \times 2 + 56 \times 1 - 120 \times 3)}{6.0} = 40 \text{ kN}$$

Therefore weight of foundation required = 40 kN.

A 7 per cent increase in the live load will not endanger the structure, since the actual uplift will only be 7.3 kN as calculated previously. In fact in this case it would require an increase of 65 per cent in the live load before the uplift would exceed the weight of a 40 kN foundation.

# 3

## Analysis of the Structure

A reinforced concrete structure is a combination of beams, columns, slabs and walls, rigidly connected together to form a monolithic frame. Each individual member must be capable of resisting the forces acting on it, so that the determination of these forces is an essential part of the design process. The full analysis of a rigid concrete frame is rarely simple; but simplified calculations of adequate precision can often be made if the basic action of the structure is understood.

The analysis must begin with an evaluation of all the loads carried by the structure, including its own weight. Many of the loads are variable in magnitude and position, and all possible critical arrangements of loads must be considered. First the structure itself is rationalised into simplified forms that represent the load-carrying action of the prototype. The forces in each member can then be determined by one of the following methods.

- (1) Applying moment and shear coefficients.
- (2) Manual calculations.
- (3) Computer methods.

Tabulated coefficients are suitable for use only with simple, regular structures such as equal-span continuous beams carrying uniform loads. Manual calculations are possible for the vast majority of structures, but may be tedious for large or complicated ones. The computer can be an invaluable help in the analysis of even quite small frames, and for some calculations it is almost indispensable. However, the amount of output from a computer analysis is sometimes almost overwhelming; and then the results are most readily interpreted when they are presented diagrammatically by means of a graph plotter or other visual device.

Since the design of a reinforced concrete member is generally based on the ultimate limit state, the analysis is usually performed for loadings corresponding to that state. Prestressed concrete members, however, are normally designed for serviceability loadings, as discussed in chapter 12.

### 3.1 Loads

The loads on a structure are divided into two types: 'dead' loads, and 'live' (or imposed) loads. Dead loads are those which are normally permanent and constant

during the structure's life. Live loads, on the other hand, are transient and are variable in magnitude, as for example those due to wind or to human occupants. Recommendations for the loadings on buildings are given in the British Standards, numbers BS 6399: Part 1. Design loads for Buildings, and CP3: Chapter V: Part 2. Wind loads. Bridge loadings are specified in BS 5400: Part 2, Specification for Loads.

A table of values for some useful dead loads and imposed loads is given in the appendix.

### **3.1.1 Dead Loads**

Dead loads include the weight of the structure itself, and all architectural components such as exterior cladding, partitions and ceilings. Equipment and static machinery, when permanent fixtures, are also often considered as part of the dead load. Once the sizes of all the structural members, and the details of the architectural requirements and permanent fixtures have been established, the dead loads can be calculated quite accurately; but first of all, preliminary design calculations are generally required to estimate the probable sizes and self-weights of the structural concrete elements.

For most reinforced concretes, a typical value for the self-weight is 24 kN per cubic metre, but a higher density should be taken for heavily reinforced or dense concretes. In the case of a building, the weights of any partitions should be calculated from the architects' drawings. A minimum partition imposed loading of 1.0 kN per square metre is usually specified, but this is only adequate for light-weight partitions.

Dead loads are generally calculated on a slightly conservative basis, so that a member will not need redesigning because of a small change in its dimensions. Over-estimation, however, should be done with care, since the dead load can often actually reduce some of the forces in parts of the structure as will be seen in the case of the hogging moments in the continuous beam of figure 3.1.

### **3.1.2 Imposed Loads**

These loads are more difficult to determine accurately. For many of them, it is only possible to make conservative estimates based on standard codes of practice or past experience. Examples of imposed loads on buildings are: the weights of its occupants, furniture, or machinery; the pressures of wind, the weight of snow, and of retained earth or water; and the forces caused by thermal expansion or shrinkage of the concrete.

A large building is unlikely to be carrying its full imposed load simultaneously on all its floors. For this reason the British Standard Code of Practice allows a reduction in the total imposed floor loads when the columns, walls or foundations are designed, for a building more than two storeys high. Similarly, the imposed load may be reduced when designing a beam span which supports a floor area greater than 40 square metres.

Although the wind load is an imposed load, it is kept in a separate category when its partial factors of safety are specified, and when the load combinations on the structure are being considered.

### 3.2 Load Combinations

#### 3.2.1 Load Combinations for the Ultimate State

Various combinations of the characteristic values of dead load  $G_k$ , imposed load  $Q_k$ , wind load  $W_k$  and their partial factors of safety must be considered for the loading of the structure. The partial factors of safety specified by BS 8110 are discussed in chapter 2, and for the ultimate limit state the loading combinations to be considered are as follows.

(1) Dead and imposed load

$$1.4G_k + 1.6Q_k$$

(2) Dead and wind load

$$1.0G_k + 1.4W_k$$

(3) Dead, imposed and wind load

$$1.2G_k + 1.2Q_k + 1.2W_k$$

The imposed load can usually cover all or any part of the structure and, therefore, should be arranged to cause the most severe stresses. Load combination 1 should also be associated with a minimum design dead load of  $1.0G_k$  applied to such parts of the structure as will give the most unfavourable condition.

For load combination 1, a three-span continuous beam would have the loading arrangement shown in figure 3.1, in order to cause the maximum sagging moment in the outer spans and the maximum possible hogging moment in the centre span. A study of the deflected shape of the beam would confirm this to be the case.

Figure 3.2 shows the arrangements of vertical loading on a multi-span continuous beam to cause (i) maximum sagging moments in alternate spans and maximum possible hogging moments in adjacent spans, and (ii) maximum hogging moments at support A.

As a simplification, BS 8110 allows the ultimate design moments at the supports to be calculated from one loading condition with all spans fully covered with the ultimate load  $1.4G_k + 1.6Q_k$  as shown in part (iii) of figure 3.2.

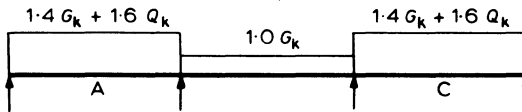

(a) Loading Arrangement for Maximum Sagging Moment at A and C



(b) Deflected Shape

Figure 3.1 Three-span beam

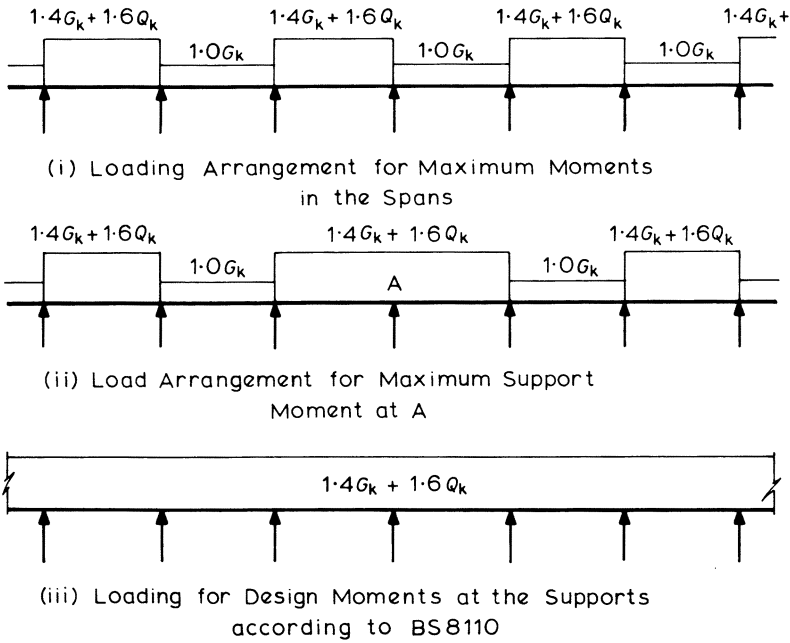

Figure 3.2 Multi-span beam loading arrangements

Under load combination 2, dead and wind load, it is possible that a critical stability condition may occur if, on certain parts of a structure, the dead load is taken as  $1.4G_k$ . An example of this is illustrated in figure 3.3, depicting how the dead load of the cantilever section increases the overturning moment about support B.

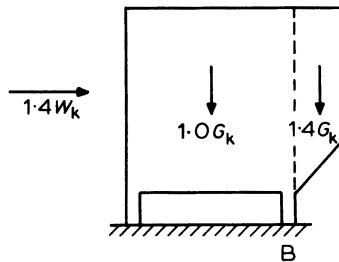

Figure 3.3 Load combination dead plus wind

### 3.2.2 Load Combinations for the Serviceability Limit State

A partial factor of safety of  $\gamma_f = 1.0$  is usually applied to all load combinations at the serviceability limit state.

In considering deflections, the imposed load should be arranged to give the worst effects. The deflections calculated from the load combinations are the immediate deflections of a structure. Deflection increases due to the creep of the concrete should be based only on the dead load plus any part of the imposed load which is permanently on the structure, this being considered fully in chapter 6, which deals with serviceability requirements.

### 3.3 Analysis of Beams and Frames

To design a structure it is necessary to know the bending moments, torsional moments, shearing forces and axial forces in each member. An elastic analysis is generally used to determine the distribution of these forces within the structure; but because – to some extent – reinforced concrete is a plastic material, a limited redistribution of the elastic moments is sometimes allowed. A plastic yield-line theory may be used to calculate the moments in concrete slabs. The properties of the materials, such as Young's modulus, which are used in the structural analysis should be those associated with their characteristic strengths. The stiffnesses of the members can be calculated on the basis of any one of the following.

- (1) The entire concrete cross-section (ignoring the reinforcement).
- (2) The concrete cross-section plus the transformed area of reinforcement based on the modular ratio.
- (3) The compression area only of the concrete cross-section, plus the transformed area of reinforcement based on the modular ratio.

The concrete cross-section described in (1) is the simpler to calculate and would normally be chosen.

A structure should be analysed for each of the critical loading conditions which produce the maximum stresses at any particular section. This procedure will be illustrated in the examples for a continuous beam and a building frame. For these structures it is conventional to draw the bending-moment diagram on the tension side of the members.

#### *Sign Conventions*

- (1) For the moment-distribution analyses anti-clockwise support moments are positive as, for example, in table 3.1 for the fixed end moments (FEM).
- (2) For subsequently calculating the moments along the span of a member, moments causing sagging are positive, while moments causing hogging are negative, as illustrated in figure 3.5.

#### **3.3.1 Non-continuous Beams**

One-span, simply supported beams or slabs are statically determinate and the analysis for bending moments and shearing forces is readily performed manually. For the ultimate limit state we need only consider the maximum load of  $1.4G_k + 1.6Q_k$  on the span.

**Example 3.1 Analysis of a Non-continuous Beam**

The one-span simply supported beam shown in figure 3.4a carries a distributed dead load including self-weight of 25 kN/m, a permanent concentrated partition load of 30 kN at mid-span, and a distributed imposed load of 10 kN/m.

Figure 3.4 shows the values of ultimate load required in the calculations of the shearing forces and bending moments.

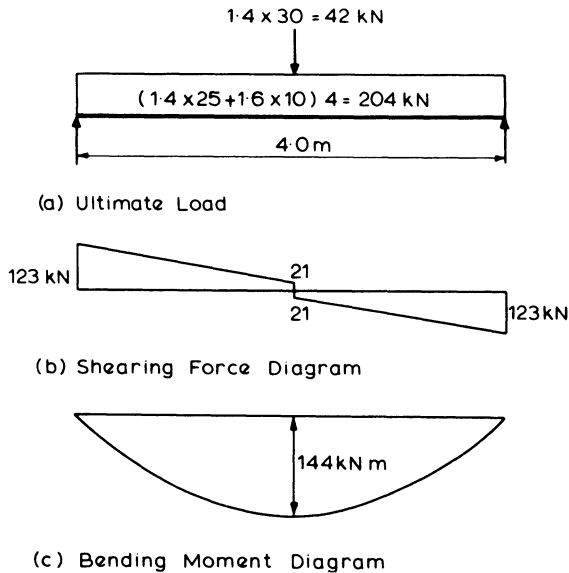

**Figure 3.4** Analysis of one-span beam

$$\text{Maximum shear force} = \frac{42}{2} + \frac{204}{2} = 123 \text{ kN}$$

$$\text{Maximum bending moment} = \frac{42 \times 4}{4} + \frac{204 \times 4}{8} = 144 \text{ kN m}$$

The analysis is completed by drawing the shearing-force and bending-moment diagrams which would later be used in the design and detailing of the shear and bending reinforcement.

**3.3.2 Continuous Beams**

The methods of analysis for continuous beams may also be applied to continuous slabs which span in one direction. A continuous beam is considered to have no fixity with the supports so that the beam is free to rotate. This assumption is not strictly true for beams framing into columns and for that type of continuous beam it is more accurate to analyse them as part of a frame, as described in section 3.3.3. A simplified method of analysis that can be applied to slabs is described in chapter 8.

A continuous beam should be analysed for the loading arrangements which give the maximum stresses at each section, as described in section 3.2.1 and illustrated

in figures 3.1 and 3.2. The analysis to calculate the bending moments can be carried out manually by moment distribution or equivalent methods, but tabulated shear and moment coefficients may be adequate for continuous beams having approximately equal spans and uniformly distributed loads.

*Continuous Beams – The General Case*

Having determined the moments at the supports by, say, moment distribution, it is necessary to calculate the moments in the spans and also the shear forces on the beam. For a uniformly distributed load, the equations for the shears and the maximum span moments can be derived from the following analysis.

Using the sign convention of figure 3.5 and taking moments about support B:

$$V_{AB}L - \frac{wL^2}{2} + M_{AB} - M_{BA} = 0$$

therefore

$$V_{AB} = \frac{wL}{2} - \frac{(M_{AB} - M_{BA})}{L} \quad (3.1)$$

and

$$V_{BA} = wL - V_{AB} \quad (3.2)$$

Maximum span moment  $M_{\max}$  occurs at zero shear, and distance to zero shear

$$a_3 = \frac{V_{AB}}{w} \quad (3.3)$$

therefore

$$M_{\max} = \frac{V_{AB}^2}{2w} + M_{AB} \quad (3.4)$$

The points of contraflexure occur at  $M = 0$ , that is

$$V_{AB}x - \frac{wx^2}{2} + M_{AB} = 0$$

where  $x$  is the distance from support A. Taking the roots of this equation gives

$$x = \frac{V_{AB} \pm \sqrt{(V_{AB}^2 + 2wM_{AB})}}{w}$$

so that

$$a_1 = \frac{V_{AB} - \sqrt{(V_{AB}^2 + 2wM_{AB})}}{w} \quad (3.5)$$

and

$$a_2 = L - \frac{V_{AB} + \sqrt{(V_{AB}^2 + 2wM_{AB})}}{w} \quad (3.6)$$

A similar analysis can be applied to beams that do not support a uniformly distributed load. In manual calculations it is usually not considered necessary to calculate the distances  $a_1$ ,  $a_2$  and  $a_3$  which locate the points of contraflexure and maximum moment – a sketch of the bending moment is often adequate – but if a computer is performing the calculations these distances may as well be determined also.

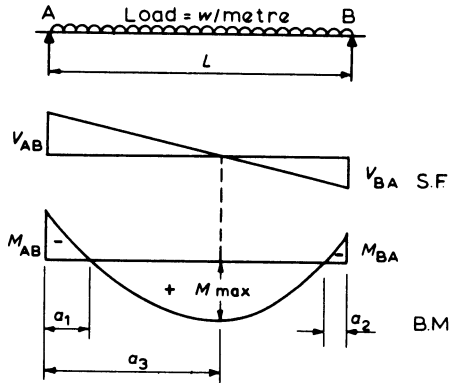

Figure 3.5 Shears and moments in a beam

**Example 3.2 Analysis of a Continuous Beam**

The continuous beam shown in figure 3.6 has a constant cross-section and supports a uniformly distributed dead load including its self-weight of  $G_k = 25$  kN/m and an imposed load  $Q_k = 10$  kN/m.

The critical loading arrangements for the ultimate limit state are shown in figure 3.6 where the heavy line indicates the region of maximum moments, sagging

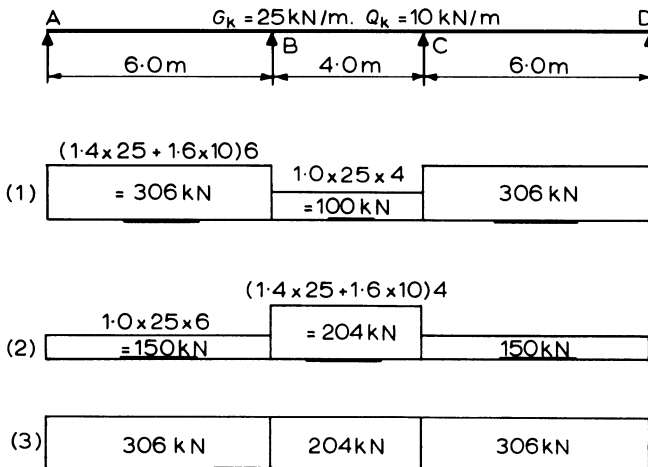

Figure 3.6 Continuous beam loading arrangements

**Table 3.1** Moment distribution for the first loading case

	A	B	C	D
Stiffness ( <i>k</i> )	$\frac{3}{4} \cdot \frac{I}{L}$	$\frac{I}{L}$	$\frac{3}{4} \cdot \frac{I}{L}$	
	$\frac{3}{4} \cdot \frac{1}{6} = 0.125$	$= \frac{1}{4} = 0.25$	$= 0.125$	
Distr. factors	$\frac{0.125}{0.125 + 0.25}$	$\frac{0.25}{0.125 + 0.25}$		
	$= 1/3$	$= 2/3$	$2/3$	$1/3$
Load (kN)	306	100		
F.E.M.	0	$\pm \frac{100 \times 4}{12}$		$\pm \frac{306 \times 6}{8}$
=	0	-229.5	+33.3	-33.3
Balance	+ 65.4	+130.8	-130.8	- 65.4
Carry over		- 65.4	+ 65.4	
Balance	+ 21.8	+ 43.6	- 43.6	- 21.8
Carry over		- 21.8	+ 21.8	
Balance	+ 7.3	+ 14.5	- 14.5	- 7.3
Carry over		- 7.3	+ 7.3	
Balance	+ 2.4	+ 4.9	- 4.9	- 2.4
Carry over		- 2.4	+ 2.4	
Balance	+ 0.8	+ 1.6	- 1.6	- 0.8
<i>M</i> (kN m)	0	-131.8	+131.8	-131.8
				+131.8
				0

or possible hogging. Table 3.1 is the moment distribution carried out for the first loading arrangement: similar calculations would be required for each of the remaining load cases. It should be noted that the reduced stiffness of  $\frac{3}{4}I/L$  has been used for the end spans.

The shearing forces, the maximum span bending moments, and their positions along the beam, can be calculated using the formulae previously derived. Thus for the first loading arrangement and span AB, using the sign convention of figure 3.5:

$$\begin{aligned} \text{Shear } V_{AB} &= \frac{\text{load}}{2} - \frac{(M_{AB} - M_{BA})}{L} \\ &= \frac{306}{2} - \frac{131.8}{6.0} = 131.0 \text{ kN} \end{aligned}$$

$$V_{BA} = \text{load} - V_{AB} = 306 - 131.0 = 175.0 \text{ kN}$$

$$\text{Maximum moment, span AB} = \frac{V_{AB}^2}{2w} + M_{AB}$$

where  $w = 306/6.0 = 51 \text{ kN/m}$ . Therefore

$$M_{\max} = \frac{131.0^2}{2 \times 51} = 168.2 \text{ kN m}$$

$$\text{Distance from A, } a_3 = \frac{V_{AB}}{w} = \frac{131.0}{51} = 2.6 \text{ m}$$

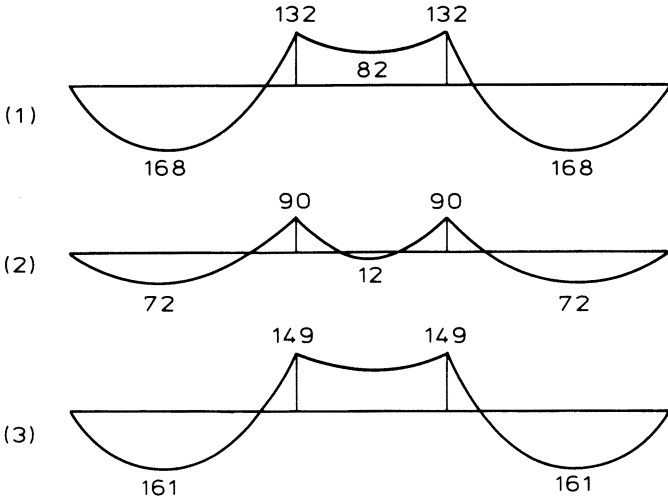

Figure 3.7 Bending-moment diagrams (kN m)

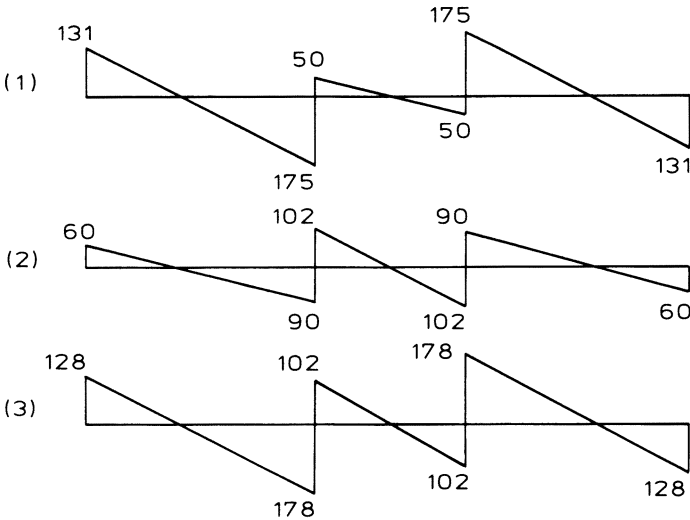

Figure 3.8 Shearing-force diagrams (kN)

The bending-moment diagrams for each of the loading arrangements are shown in figure 3.7, and the corresponding shearing-force diagrams are shown in figure 3.8. The individual bending-moment diagrams are combined in figure 3.9a to give the bending-moment design envelope. Similarly, figure 3.9b is the shearing-force design envelope. Such envelope diagrams are used in the detailed design of the beams, as described in chapter 7.

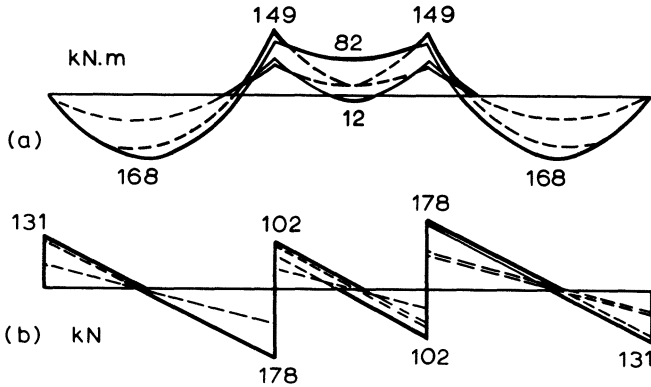
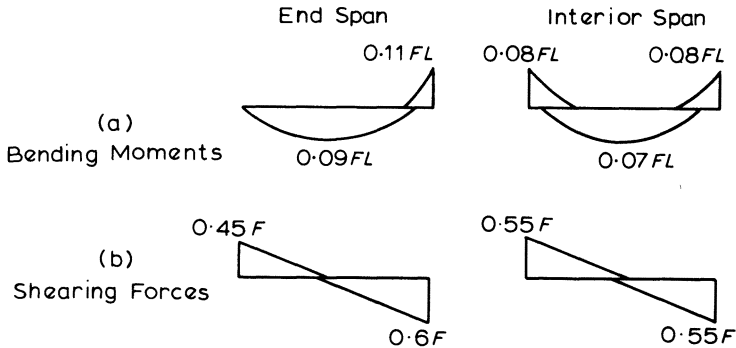

Figure 3.9 Bending-moment and shearing-force envelopes

*Continuous Beams with Approximately Equal Spans and Uniform Loading*

The ultimate bending moments and shearing forces in continuous beams of three or more approximately equal spans can be obtained from BS 8110 provided that the spans differ by no more than 15 per cent of the longest span, that the loading is uniform, and that the characteristic live load does not exceed the characteristic dead load. The values from BS 8110 are shown in diagrammatic form in figure 3.10 for beams (equivalent simplified values for slabs are given in chapter 8).

The possibility of hogging moments in any of the spans should not be ignored, even if it is not indicated by these coefficients. For example, a beam of three equal spans will have a hogging moment in the centre span if  $Q_k$  exceeds  $G_k/16$ .



$F = \text{Total ultimate load on span} = (1.4G_k + 1.6Q_k) \text{ kN}$

$L = \text{Effective span}$

Figure 3.10 Bending-moment and shearing-force coefficients for beams

### 3.3.3 Structural Frames

*In situ* reinforced concrete structures behave as rigid frames, and should be analysed as such. They can be analysed as a complete space frame or be divided into a series of plane frames. Bridge-deck types of structures can be analysed as an equivalent grillage, whilst some form of finite-element analysis can be utilised in solving complicated shear-wall buildings. All these methods lend themselves to solution by the computer, but many frames can be simplified for solution by hand calculations.

The general procedure for a building frame is to analyse the slabs as continuous members supported by the beams or structural walls. The slabs can be either one-way spanning or two-way spanning. The columns and main beams are considered as a series of rigid plane frames, which can be divided into two types: (1) braced frames supporting vertical loads only, (2) frames supporting vertical and lateral loads.

Type 1 frames are in buildings where none of the lateral loads, including wind, are transmitted to the columns and beams but are carried by shear walls or other forms of bracing. Type 2 frames are designed to carry the lateral loads, which cause bending, shearing and axial forces in the beams and columns. For both types of frame the axial forces due to the vertical loads in the columns can normally be calculated as if the beams and slabs were simply supported.

#### *Braced Frames Supporting Vertical Loads Only*

A building frame can be analysed as a complete frame, or it can be simplified into a series of substitute frames for analysis. The frame shown in figure 3.11 for example, can be divided into any of the subframes shown in figure 3.12.

The substitute frame 1 in figure 3.12 consists of one complete floor beam with its connecting columns (which are assumed rigidly fixed at their remote ends). An analysis of this frame will give the bending moments and shearing forces in the beams and columns for the floor level considered.

Substitute frame 2 is a single span combined with its connecting columns and two adjacent spans, all fixed at their remote ends. This frame may be used to

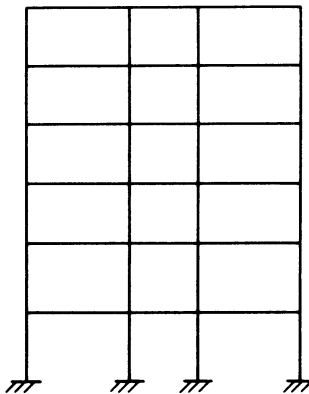

Figure 3.11 Building frame

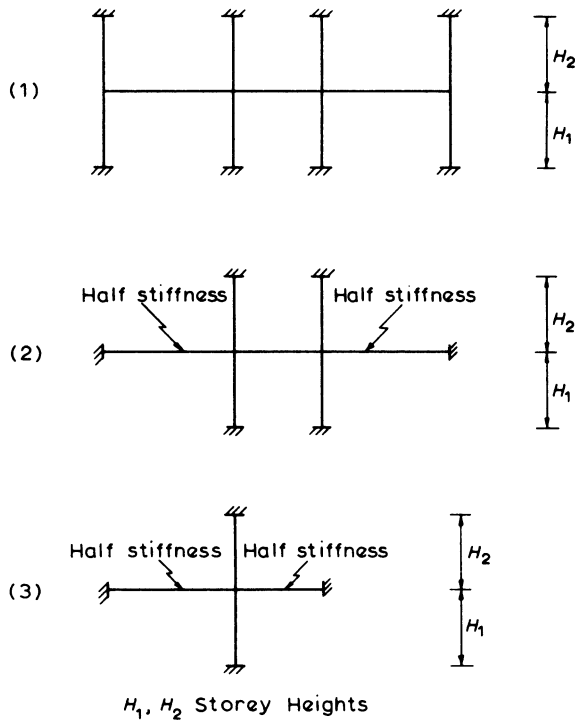

Figure 3.12 Substitute frames

determine the bending moments and shearing forces in the central beam. Provided that the central span is greater than the two adjacent spans, the bending moments in the columns can also be found with this frame.

Substitute frame 3 can be used to find the moments in the columns only. It consists of a single junction, with the remote ends of the members fixed. This type of subframe would be used when the beams have been analysed as continuous over simple supports.

In frames 2 and 3, the assumption of fixed ends to the outer beams overestimates their stiffnesses. These values are, therefore, halved to allow for the flexibility resulting from continuity.

The various critical loading arrangements to produce maximum stresses have to be considered. In general these loading arrangements for the ultimate limit state as specified by the code are:

- (1) Alternate spans loaded with total ultimate load ( $1.4G_k + 1.6Q_k$ ) and all other spans loaded with minimum dead load ( $1.0G_k$ ); this loading will give maximum span moments and maximum column moments.
- (2) All spans loaded with the total ultimate load ( $1.4G_k + 1.6Q_k$ ) to provide the design moments at the supports.

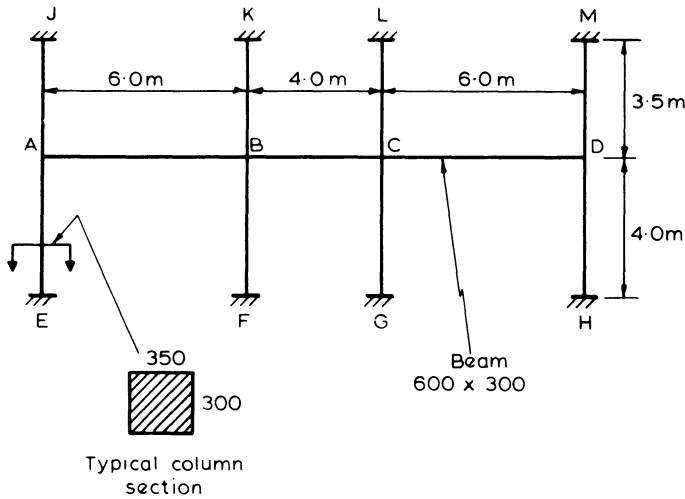

Figure 3.13 Substitute frame

When considering the critical loading arrangements for a column, it is sometimes necessary to include the case of maximum moment and minimum possible axial load, in order to investigate the possibility of tension failure caused by the bending.

### Example 3.3 Analysis of a Substitute Frame

The substitute frame shown in figure 3.13 is part of the complete frame in figure 3.11. The characteristic loads carried by the beams are dead loads (including self-weight),  $G_k = 25 \text{ kN/m}$ , and imposed load,  $Q_k = 10 \text{ kN/m}$ , uniformly distributed along the beam. The analysis of the beam will be carried out by moment distribution: thus the member stiffnesses and their relevant distribution factors are first required.

Stiffnesses,  $k$

Beam

$$I = \frac{0.3 \times 0.6^3}{12} = 5.4 \times 10^{-3} \text{ m}^4$$

Spans AB and CD

$$k_{AB} = k_{CD} = \frac{5.4 \times 10^{-3}}{6.0} = 0.9 \times 10^{-3}$$

Span BC

$$k_{BC} = \frac{5.4 \times 10^{-3}}{4.0} = 1.35 \times 10^{-3}$$

Columns

$$I = \frac{0.3 \times 0.35^3}{12} = 1.07 \times 10^{-3} \text{ m}^4$$

Upper

$$k_U = \frac{1.07 \times 10^{-3}}{3.5} = 0.31 \times 10^{-3}$$

Lower

$$k_L = \frac{1.07 \times 10^{-3}}{4.0} = 0.27 \times 10^{-3}$$

$$k_U + k_L = (0.31 + 0.27) 10^{-3} = 0.58 \times 10^{-3}$$

Distribution Factors

Joints A and D

$$\Sigma k = 0.9 + 0.58 = 1.48$$

$$\text{D.F.}_{AB} = \text{D.F.}_{DC} = \frac{0.9}{1.48} = 0.61$$

$$\text{D.F.}_{\text{cols}} = \frac{0.58}{1.48} = 0.39$$

Joints B and C

$$\Sigma k = 0.9 + 1.35 + 0.58 = 2.83$$

$$\text{D.F.}_{BA} = \text{D.F.}_{CD} = \frac{0.9}{2.83} = 0.32$$

$$\text{D.F.}_{BC} = \text{D.F.}_{CB} = \frac{1.35}{2.83} = 0.48$$

$$\text{D.F.}_{\text{cols}} = \frac{0.58}{2.83} = 0.20$$

The critical loading arrangements for the ultimate limit state are identical to those for the continuous beam in example 3.2, and they are illustrated in figure 3.6. The moment distribution for the first loading arrangement is shown in table 3.2. In the table, the distributions for each upper and lower column have been combined, since this simplifies the layout for the calculations.

The shearing forces and the maximum span moments can be calculated from the formulae of section 3.3.2. For the first loading arrangement and span AB:

$$\text{Shear } V_{AB} = \frac{\text{load}}{2} - \frac{(M_{AB} - M_{BA})}{L}$$

$$= \frac{306}{2} - \frac{(-73.4 + 136.0)}{6.0} = 143 \text{ kN}$$

$$V_{BA} = \text{load} - V_{AB} = 306 - 143 = 163 \text{ kN}$$

$$\begin{aligned} \text{Maximum moment, span AB} &= \frac{V_{AB}^2}{2w} + M_{AB} \\ &= \frac{143^2}{2 \times 51} - 73.4 = 126 \text{ kN m} \end{aligned}$$

$$\text{Distance from A, } a_3 = \frac{V_{AB}}{w} = \frac{143}{51} = 2.8 \text{ m}$$

Figure 3.14 shows the bending moments in the beams for each loading arrangement: figure 3.15 shows the shearing forces. These diagrams have been combined in figure 3.16 to give the design envelopes for bending moments and shearing forces.

A comparison of the design envelopes of figure 3.16 and figure 3.9 will emphasise the advantages of considering the concrete beam as part of a frame, not as a continuous beam as in example 3.2. Not only is the analysis of a subframe more precise, but many moments and shears in the beam are smaller in magnitude.

The moment in each column is given by

$$M_{\text{col}} = \Sigma M_{\text{col}} \times \frac{k_{\text{col}}}{\Sigma k_{\text{cols}}}$$

Thus, for the first loading arrangement and taking  $\Sigma M_{\text{col}}$  from table 3.2 gives

$$\text{column moment } M_{AJ} = 74 \times \frac{0.31}{0.58} = 40 \text{ kN m}$$

$$M_{AE} = 74 \times \frac{0.27}{0.58} = 34 \text{ kN m}$$

$$M_{BK} = 46 \times \frac{0.31}{0.58} = 25 \text{ kN m}$$

$$M_{BF} = 46 \times \frac{0.27}{0.58} = 21 \text{ kN m}$$

This loading arrangement gives the maximum column moments, as plotted in figure 3.17.



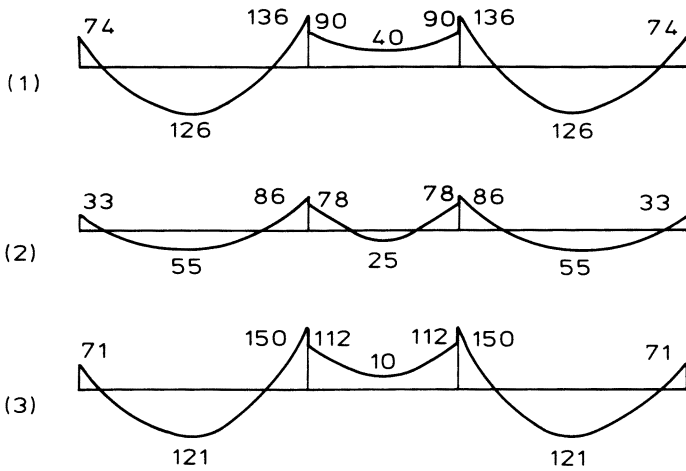

Figure 3.14 Beam bending-moment diagrams (kN m)

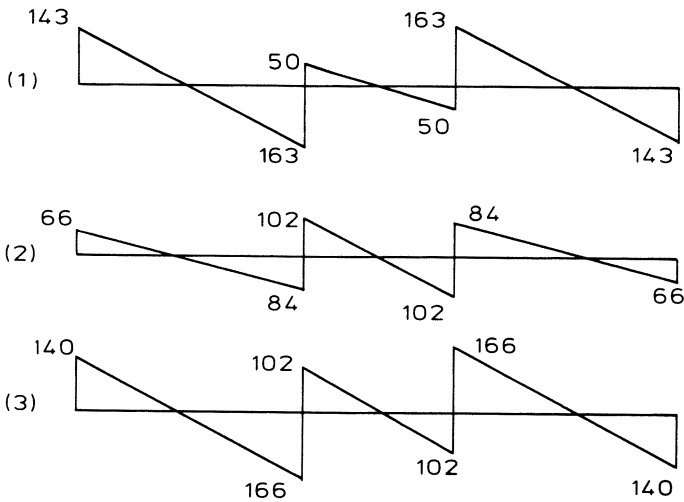

Figure 3.15 Beam shearing-force diagrams (kN)

REINFORCED CONCRETE DESIGN

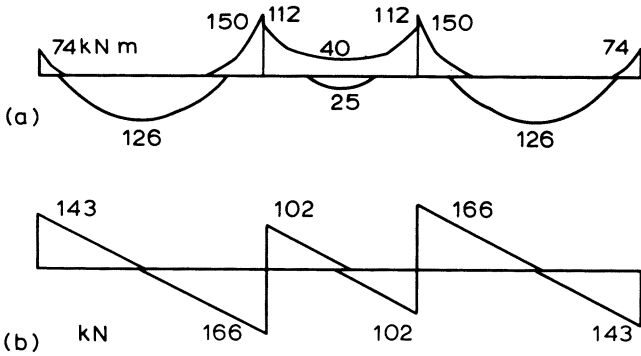

Figure 3.16 Bending-moment and shearing-force envelopes

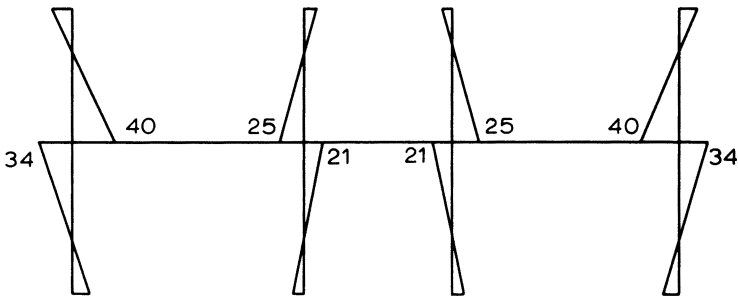

Figure 3.17 Column bending moment (kNm)

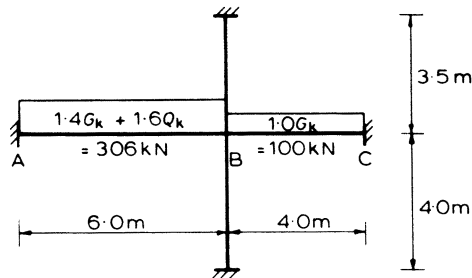

Figure 3.18 Substitute frame

**Example 3.4 Analysis of a Substitute Frame for a Column**

The substitute frame for this example, shown in figure 3.18, is taken from the building frame in figure 3.11. The loading to cause maximum column moments is shown in the figure for  $G_k = 25 \text{ kN/m}$  and  $Q_k = 10 \text{ kN/m}$ .

The stiffnesses of these members are identical to those calculated in example 3.3, except that for this type of frame the beam stiffnesses are halved. Thus

$$k_{AB} = \frac{1}{2} \times 0.9 \times 10^{-3} = 0.45 \times 10^{-3}$$

$$k_{BC} = \frac{1}{2} \times 1.35 \times 10^{-3} = 0.675 \times 10^{-3}$$

$$\text{upper column } k_U = 0.31 \times 10^{-3}$$

$$\text{lower column } k_L = 0.27 \times 10^{-3}$$

$$\begin{aligned} \Sigma k &= (0.45 + 0.675 + 0.31 + 0.27) \times 10^{-3} \\ &= 1.705 \times 10^{-3} \end{aligned}$$

$$\text{fixed-end moment } M_{BA} = 306 \times \frac{6}{12} = 153 \text{ kN m}$$

$$\text{fixed-end moment } M_{BC} = 100 \times \frac{4}{12} = 33.3 \text{ kN m}$$

Column moments are

$$\text{upper column } M_U = (153 - 33.3) \times \frac{0.31}{1.705} = 22 \text{ kN m}$$

$$\text{lower column } M_L = (153 - 33.3) \times \frac{0.27}{1.705} = 19 \text{ kN m}$$

The column moments are illustrated in figure 3.19. They should be compared with the corresponding moments for the internal column in figure 3.17.

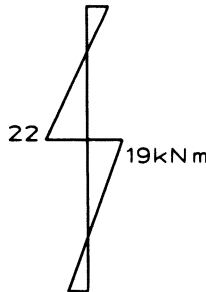

Figure 3.19 Column moments

In examples 3.3 and 3.4 the second moment of area of the beam was calculated as  $bh^3/12$  for a rectangular section for simplicity, but where an *in situ* slab forms a flange to the beam, the second moment of area may be calculated for the T-section or L-section.

*Frames Supporting Vertical and Lateral Loads*

Lateral loads on a structure may be caused by wind pressures, by retained earth, or by seismic forces. An unbraced frame subjected to wind forces, must be analysed for all the three loading combinations described in section 3.2.1. The vertical-loading analysis can be carried out by the methods described previously for braced frames (see page 35). The analysis for the lateral loads should be kept separate and the forces may be calculated by an elastic analysis or by a simplified approximate method. For preliminary design calculations, and also for medium-size regular structures, a simplified analysis may well be adequate.

BS 8110 recommends that any simplified form of analysis should assume points of contraflexure at the mid-lengths of all the columns and beams. A suitable approximate analysis is the cantilever method. It assumes that:

- (1) Points of contraflexure are located at the mid-points of all columns and beams; and
- (2) The direct axial loads in the columns are in proportion to their distances from the centre of gravity of the frame. It is also usual to assume that all the columns in a storey are of equal cross-sectional area.

Application of this method is probably best illustrated by an example, as follows.

***Example 3.5 Simplified Analysis for Lateral Loads – Cantilever Method***

Figure 3.20 shows a building frame subjected to a characteristic wind load of 3.0 kN per metre height of the frame. This load is assumed to be transferred to the frame as a concentrated load at each floor level as indicated in the figure.

By inspection, there is tension in the two columns to the left and compression in the columns to the right; and by assumption 2 the axial forces in columns are proportional to their distances from the centre line of the frame. Thus

$$\text{axial force in exterior column: axial force in interior column} = 4.0P : 1.0P$$

The analysis of the frame continues by considering a section through the top-storey columns: the removal of the frame below this section gives the remainder shown in figure 3.21a. The forces in this subframe are calculated as follows.

**(a) Axial Forces in the Columns**

Taking moments about point s,  $\Sigma M_s = 0$ , therefore

$$5.25 \times 1.75 + P \times 6.0 - P \times 10.0 - 4P \times 16.0 = 0$$

and therefore

$$P = 0.135 \text{ kN}$$

thus

$$N_1 = -N_4 = 4.0P = 0.54 \text{ kN}$$

$$N_2 = -N_3 = 1.0P = 0.135 \text{ kN}$$

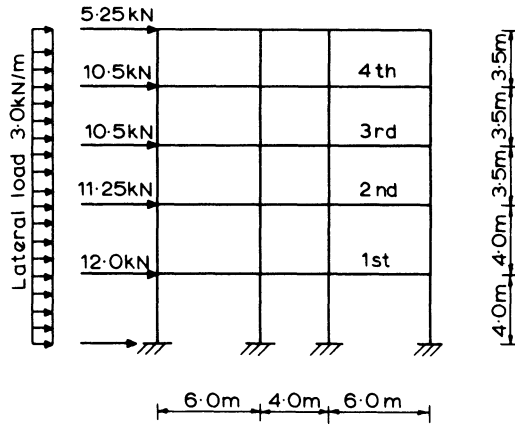

Figure 3.20 Frame with lateral load

(b) Vertical Shearing Forces  $F$  in the Beams

For each part of the subframe,  $\Sigma F = 0$ , therefore

$$F_1 = N_1 = 0.54 \text{ kN}$$

$$F_2 = N_1 + N_2 = 0.675 \text{ kN}$$

(c) Horizontal Shearing Forces  $H$  in the Columns

Taking moments about the points of contraflexure of each beam,  $\Sigma M = 0$ , therefore

$$H_1 \times 1.75 - N_1 \times 3.0 = 0$$

$$H_1 = 0.93 \text{ kN}$$

and

$$(H_1 + H_2) 1.75 - N_1 \times 8.0 - N_2 \times 2.0 = 0$$

$$H_2 = 1.70 \text{ kN}$$

The calculations of the equivalent forces for the fourth floor (figure 3.21b) follow a similar procedure as follows.

## (d) Axial Forces in the Columns

For the frame above section  $tt'$ ,  $\Sigma M_t = 0$ , therefore

$$5.25 (3 \times 1.75) + 10.5 \times 1.75 + P \times 6.0 - P \times 10.0 - 4P \times 16.0 = 0$$

$$P = 0.675 \text{ kN}$$

therefore

$$N_1 = 4.0P = 2.70 \text{ kN}$$

$$N_2 = 1.0P = 0.68 \text{ kN}$$

## REINFORCED CONCRETE DESIGN

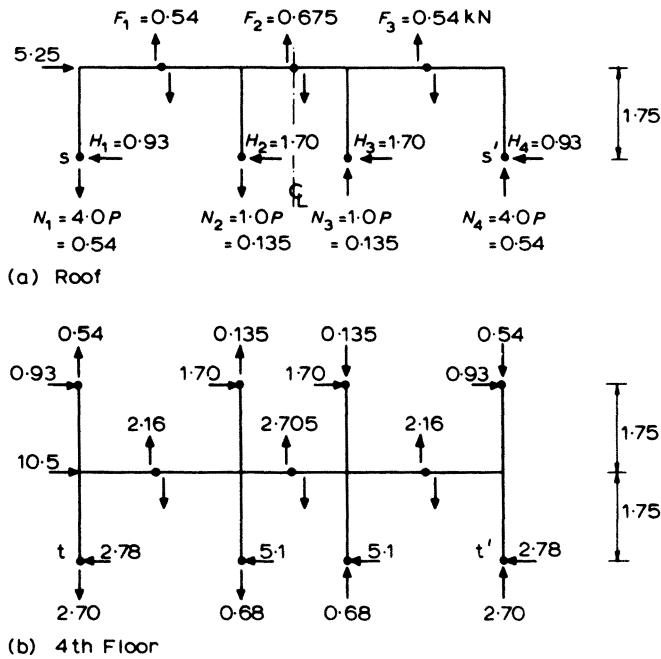

Figure 3.21 Subframes at the roof and fourth floor

## (e) Beam Shears

$$F_1 = 2.70 - 0.54 = 2.16 \text{ kN}$$

$$F_2 = 2.70 + 0.68 - 0.54 - 0.135 = 2.705 \text{ kN}$$

## (f) Column Shears

$$H_1 \times 1.75 + 0.93 \times 1.75 - (2.70 - 0.54) 3.0 = 0$$

$$H_1 = 2.78 \text{ kN}$$

$$H_2 = \frac{1}{2}(10.5 + 5.25) - 2.78 = 5.1 \text{ kN}$$

Values calculated for sections taken below the remaining floors are

$$\text{third floor } N_1 = 7.03 \text{ kN} \quad N_2 = 1.76 \text{ kN}$$

$$F_1 = 4.33 \text{ kN} \quad F_2 = 5.41 \text{ kN}$$

$$H_1 = 4.64 \text{ kN} \quad H_2 = 8.49 \text{ kN}$$

$$\text{second floor } N_1 = 14.14 \text{ kN} \quad N_2 = 3.53 \text{ kN}$$

$$F_1 = 7.11 \text{ kN} \quad F_2 = 8.88 \text{ kN}$$

$$H_1 = 6.61 \text{ kN} \quad H_2 = 12.14 \text{ kN}$$

first floor  $N_1 = 24.37 \text{ kN}$     $N_2 = 6.09 \text{ kN}$   
 $F_1 = 10.23 \text{ kN}$     $F_2 = 12.79 \text{ kN}$   
 $H_1 = 8.74 \text{ kN}$     $H_2 = 16.01 \text{ kN}$

The bending moments in the beams and columns at their connections can be calculated from these results by the following formulae

beams  $M_B = F \times \frac{1}{2} \text{ beam span}$

columns  $M_C = H \times \frac{1}{2} \text{ storey height}$

so at the roof's external connection

$$M_B = 0.54 \times \frac{1}{2} \times 6.0 = 1.6 \text{ kN m}$$

$$M_C = 0.93 \times \frac{1}{2} \times 3.5 = 1.6 \text{ kN m}$$

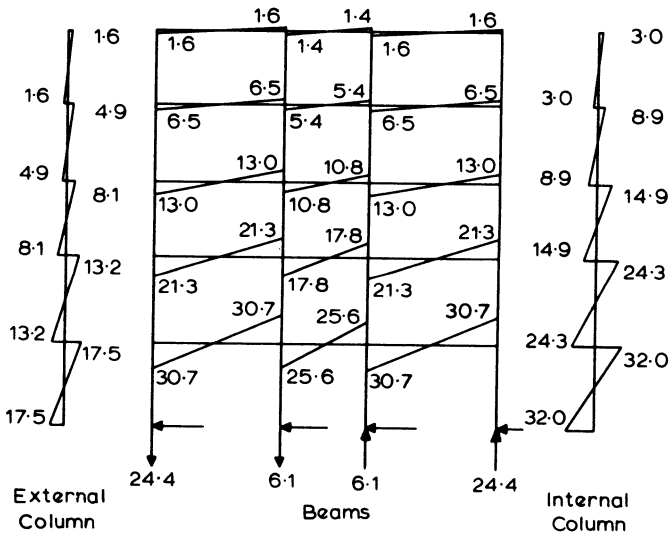

Figure 3.22 Moments (kN m) and reactions (kN)

As a check at each joint,  $\Sigma M_B = \Sigma M_C$ .

The bending moments due to characteristic wind loads in all the columns and beams of this structure are shown in figure 3.22.

### 3.4 Redistribution of Moments

Some method of elastic analysis is generally used to calculate the forces in a concrete structure, despite the fact that the structure does not behave elastically near its ultimate load. The assumption of elastic behaviour is reasonably true for low stress levels; but as a section approaches its ultimate moment of resistance, plastic deformation will occur. This is recognised in BS 8110, by allowing redistribution of the elastic moments subject to certain limitations.

Reinforced concrete behaves in a manner midway between that of steel and concrete. The stress-strain curves for the two materials (figures 1.5 and 1.2) show the elastoplastic behaviour of steel and the plastic behaviour of concrete. The latter will fail at a relatively small compressive strain. The exact behaviour of a reinforced concrete section depends on the relative quantities and the individual properties of the two materials. However, such a section may be considered virtually elastic until the steel yields; and then plastic until the concrete fails in compression. Thus the plastic behaviour is limited by the concrete failure; or more specifically, the concrete failure limits the rotation that may take place at a section in bending. A typical moment-curvature diagram for a reinforced concrete member is shown in figure 3.23.

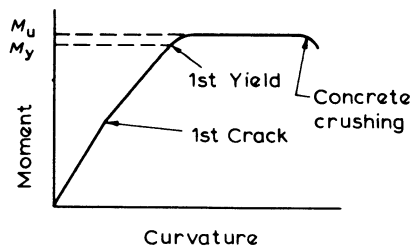

Figure 3.23 Typical moment/curvature diagram

Thus, in an indeterminate structure, once a beam section develops its ultimate moment of resistance  $M_u$ , it then behaves as a plastic hinge resisting a constant moment of that value. Further loading must be taken by other parts of the structure, with the changes in moment elsewhere being just the same as if a real hinge existed. Provided rotation of a hinge does not cause crushing of the concrete, further hinges will be formed until a mechanism is produced. This requirement is considered in more detail in chapter 4.

**Example 3.6 Moment Redistribution – Single Span Fixed-end Beam**

The beam shown in figure 3.24 is subjected to an increasing uniformly distributed load.

$$\text{Elastic support moment} = \frac{wL^2}{12}$$

$$\text{Elastic span moment} = \frac{wL^2}{24}$$

In the case where the ultimate bending strengths are equal at the span and at the supports; and where adequate rotation is possible, then the additional load  $w_a$ , which the member can sustain by plastic behaviour, can be found.

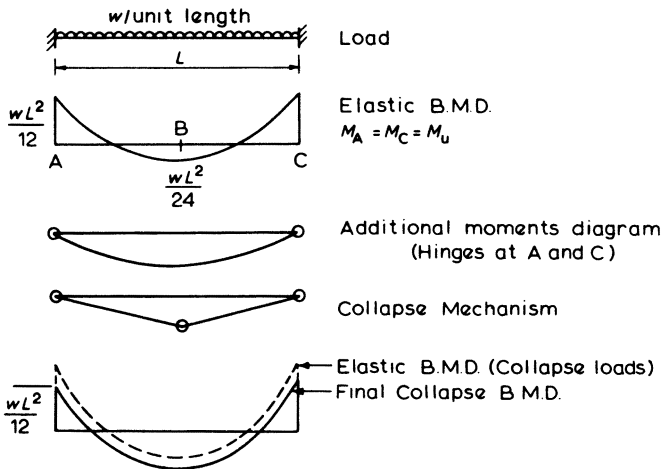

Figure 3.24 Moment redistribution – one-span beam

At collapse

$$M_u = \frac{wL^2}{12} = \frac{wL^2}{24} + \text{additional mid-span moment } m_B$$

where  $m_B = (w_a L^2)/8$  as for a simply supported beam with hinges at A and C. Thus

$$\frac{wL^2}{12} = \frac{wL^2}{24} + \frac{w_a L^2}{8}$$

Hence

$$w_a = \frac{w}{3}$$

where  $w$  is the load to cause the first plastic hinge; thus the beam may carry a load of  $1.33w$  with redistribution.

From the design point of view, the elastic bending-moment diagram can be obtained for the required ultimate loading in the ordinary way. Some of these moments may then be reduced; but this will necessitate increasing others to maintain the static equilibrium of the structure. Usually it is the maximum support moments which are reduced, so economising in reinforcing steel and also reducing congestion at the columns. The requirements for applying moment redistribution are:

- (a) Equilibrium between internal and external forces must be maintained, hence it is necessary to recalculate the span bending moments and the shear forces for the load case involved.
- (b) At sections of largest moment the depth of neutral axis,  $x$ , is limited by

$$x \leq (\beta_b - 0.4)d$$

where  $d$  = the effective depth, and

$$\beta_b = \frac{\text{moment at section after redistribution}}{\text{moment at section before redistribution}}$$

This rule effectively prevents any reduction of the moments in columns which are primarily compression members with large values of  $x$ , and this is dealt with more fully in chapter 4.

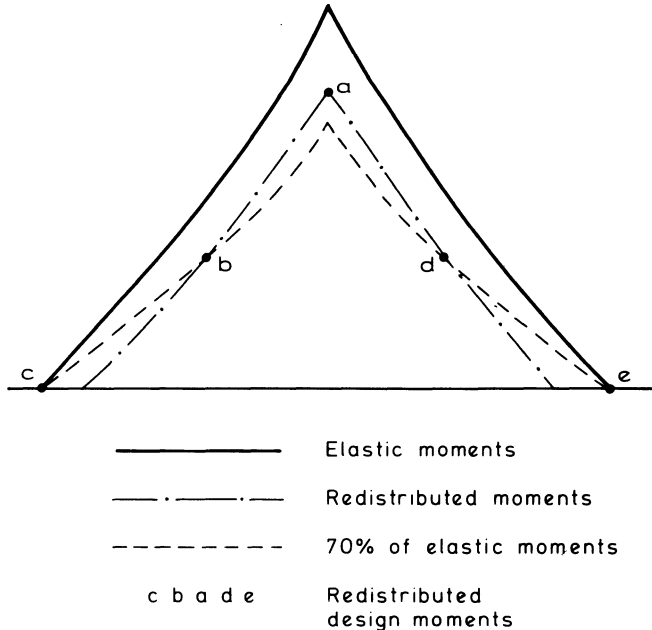

Figure 3.25 Redistribution of hogging moments

- (c) The moment of resistance of any section should be at least 70 per cent of the moment from the elastic analysis, hence allowing up to 30 per cent redistribution. This requirement ensures that there can be no movement in the position of the points of contraflexure obtained from the elastic analysis as shown by figure 3.25. It thus also ensures that a sufficient length of tension reinforcement is provided to resist cracking at the serviceability limit state.
- For unbraced structures over four storeys the redistribution is limited to 10 per cent, to prevent lateral instability.

### Example 3.7 Moment Redistribution

In example 3.3, figure 3.14 it is required to reduce the maximum support moment of  $M_{BA} = 150 \text{ kN m}$  as much as possible, but without increasing the span moment above the present maximum value of  $126 \text{ kN m}$ .

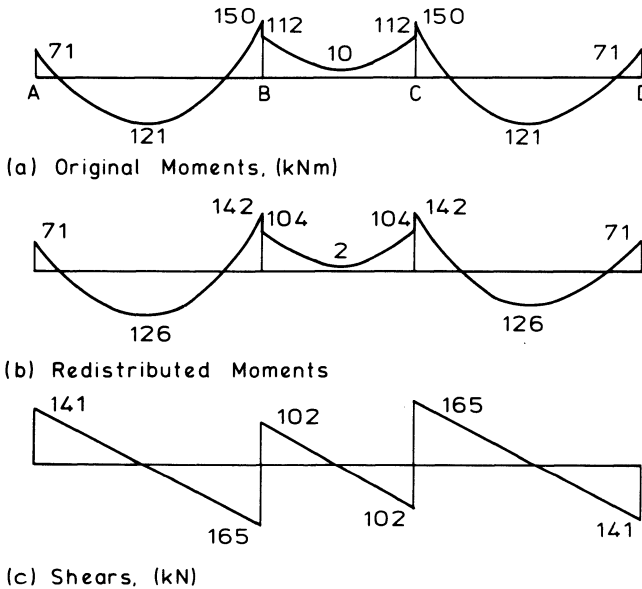

Figure 3.26 Moments and shears with redistribution

Figure 3.26a duplicates the original bending-moment diagram (part 3 of figure 3.14) of example 3.3 while figure 3.26b shows the redistributed moments, with the span moment set at  $126 \text{ kN m}$ . The moment at support B can be calculated, using a rearrangement of equations 3.4 and 3.1. Thus

$$V_{AB} = \sqrt{[(M_{\max} - M_{AB}) 2w]}$$

and

$$M_{BA} = \left( V_{AB} - \frac{wL}{2} \right) L + M_{AB}$$

For span AB,  $w = 51 \text{ kN/m}$ , therefore

$$V_{AB} = \sqrt{[(126 + 70) \times 2 \times 51]} = 141 \text{ kN}$$

$$M_{BA} = \left( 141 - \frac{51 \times 6.0}{2} \right) 6.0 - 70$$

$$= -142 \text{ kN m}$$

and

$$V_{BA} = 306 - 141$$

$$= 165 \text{ kN}$$

Reduction in  $M_{BA} = 150 - 142$

$$= 8 \text{ kN m}$$

$$= \frac{8 \times 100}{150} = 5.3 \text{ per cent}$$

In order to ensure that the moments in the columns at joint B are not changed by the distribution, moment  $M_{BC}$  must also be reduced by 8 kN m. Therefore

$$M_{BC} = 112 - 8 = 104 \text{ kN m} \quad \text{hogging}$$

Figure 3.26c shows the revised shearing-force diagram to accord with the redistributed moments.

This example illustrates how, with redistribution

- (1) the moments at a section of beam can be reduced without exceeding the maximum design moments at other sections
- (2) the values of the column moments are not affected; and
- (3) the equilibrium between external loads and internal forces is maintained.

# 4

## Analysis of the Section

A satisfactory and economic design of a concrete structure rarely depends on a complex theoretical analysis. It is achieved more by deciding on a practical overall layout of the structure, careful attention to detail and sound constructional practice. Nevertheless the total design of a structure does depend on the analysis and design of the individual member sections.

Wherever possible the analysis should be kept simple, yet it should be based on the observed and tested behaviour of reinforced concrete members. The manipulation and juggling with equations should never be allowed to obscure the fundamental principles that unite the analysis. The three most important principles are

- (1) The stresses and strains are related by the material properties, including the stress-strain curves for concrete and steel.
- (2) The distribution of strains must be compatible with the distorted shape of the cross-section.
- (3) The resultant forces developed by the section must balance the applied loads for static equilibrium.

These principles are true irrespective of how the stresses and strains are distributed, or how the member is loaded, or whatever the shape of the cross-section.

This chapter describes and analyses the action of a member section under load. It derives the basic equations used in design and also those equations required for the preparation of design charts. Emphasis has been placed mostly on the analysis associated with the ultimate limit state but the behaviour of the section within the elastic range and the serviceability limit state has also been considered.

Section 4.7 deals with the redistribution of the moments from an elastic analysis of the structure, and the effect it has on the equations derived and the design procedure.

### 4.1 Stress-Strain Relations

Short-term stress-strain curves are presented in BS 8110. These curves are in an idealised form which can be used in the analysis of member sections.

4.1.1 Concrete

The behaviour of structural concrete (figure 4.1) is represented by a parabolic stress-strain relationship, up to a strain  $\epsilon_0$ , from which point the strain increases while the stress remains constant. Strain  $\epsilon_0$  is specified as a function of the characteristic strength of the concrete ( $f_{cu}$ ), as is also the tangent modulus at the origin. The ultimate design stress is given by

$$\frac{0.67 f_{cu}}{\gamma_m} = \frac{0.67 f_{cu}}{1.5} = 0.447 f_{cu} \approx 0.45 f_{cu}$$

where the factor of 0.67 allows for the difference between the bending strength and the cube crushing strength of the concrete, and  $\gamma_m = 1.5$  is the usual partial safety factor for the strength of concrete when designing members cast *in situ*. The ultimate strain of 0.0035 is typical for all grades of concrete.

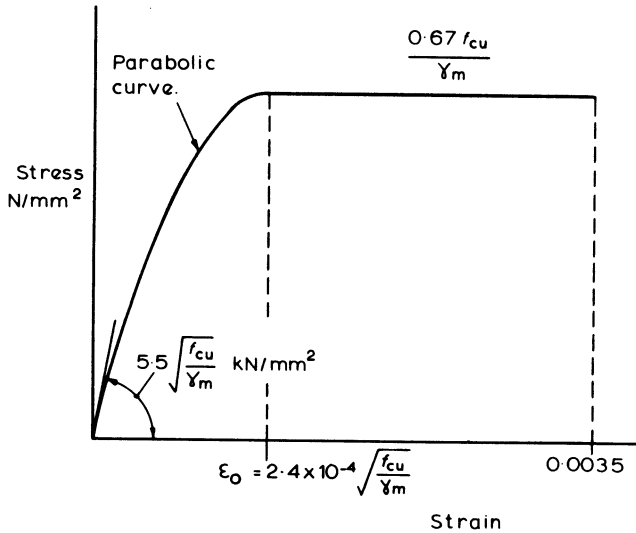

Figure 4.1 Short-term design stress-strain curve for concrete in compression

4.1.2 Reinforcing Steel

The representative short-term design stress-strain curve for reinforcement is given in figure 4.2. The behaviour of the steel is identical in tension and compression, being linear in the elastic range up to the design yield stress of  $f_y/\gamma_m$  where  $f_y$  is the characteristic yield stress and  $\gamma_m$  is the partial factor of safety.

Within the elastic range, the relationship between the stress and strain is

$$\begin{aligned} \text{stress} &= \text{elastic modulus} \times \text{strain} \\ &= E_s \times \epsilon_s \end{aligned} \tag{4.1}$$

so that the design yield strain is

$$\epsilon_y = \left( \frac{f_y}{\gamma_m} \right) / E_s$$

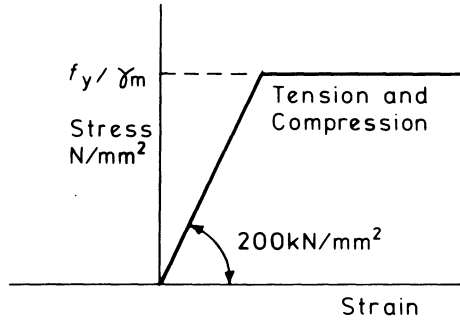

Figure 4.2 Short-term design stress-strain curve for reinforcement

At the ultimate limit for  $f_y = 460 \text{ N/mm}^2$

$$\begin{aligned} \epsilon_y &= 460 / (1.15 \times 200 \times 10^3) \\ &= 0.002 \end{aligned}$$

and for

$$\begin{aligned} f_y &= 250 \text{ N/mm}^2 \\ \epsilon_y &= 250 / (1.15 \times 200 \times 10^3) \\ &= 0.00109 \end{aligned}$$

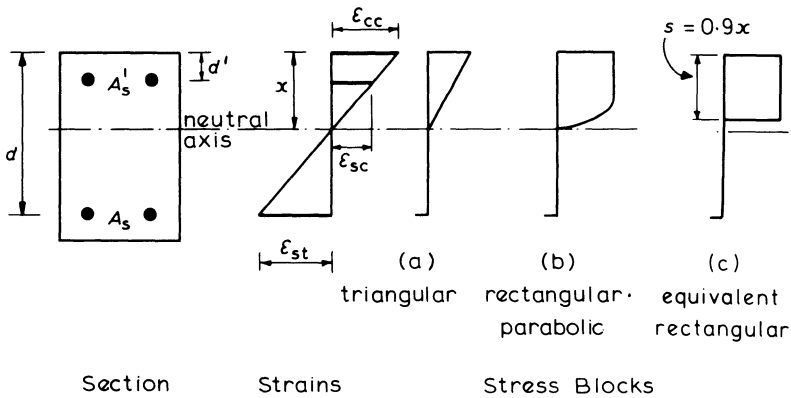

Figure 4.3 Section with strain diagram and stress blocks

#### 4.2 The Distribution of Strains and Stresses across a Section

The theory of bending for reinforced concrete assumes that the concrete will crack in the regions of tensile strains and that, after cracking, all the tension is

carried by the reinforcement. It is also assumed that plane sections of a structural member remain plane after straining, so that across the section there must be a linear distribution of strains.

Figure 4.3 shows the cross-section of a member subjected to bending, and the resultant strain diagram, together with three different types of stress distribution in the concrete.

- (1) The triangular stress distribution applies when the stresses are very nearly proportional to the strains, which generally occurs at the loading levels encountered under working conditions and is, therefore, used at the serviceability limit state.
- (2) The rectangular-parabolic stress block represents the distribution at failure when the compressive strains are within the plastic range and it is associated with the design for the ultimate limit state.
- (3) The equivalent rectangular stress block is a simplified alternative to the rectangular-parabolic distribution.

As there is compatibility of strains between the reinforcement and the adjacent concrete, the steel strains  $\epsilon_{st}$  in tension and  $\epsilon_{sc}$  in compression can be determined from the strain diagram. The relationship between the depth of neutral axis ( $x$ ) and the maximum concrete strain ( $\epsilon_{cc}$ ) and the steel strains is given by

$$\epsilon_{st} = \epsilon_{cc} \left( \frac{d - x}{x} \right) \quad (4.2)$$

and

$$\epsilon_{sc} = \epsilon_{cc} \left( \frac{x - d'}{x} \right) \quad (4.3)$$

where  $d$  is the effective depth of the beam and  $d'$  is the depth of the compression reinforcement.

Having determined the strains, we can evaluate the stresses in the reinforcement from the stress-strain curve of figure 4.2, together with the equations developed in section 4.1.2.

For analysis of a section with known steel strains, the depth of the neutral axis can be determined by rearranging equation 4.2 as

$$x = \frac{d}{1 + \frac{\epsilon_{st}}{\epsilon_{cc}}} \quad (4.4)$$

At the ultimate limit state the maximum compressive strain in the concrete is taken as

$$\epsilon_{cc} = 0.0035$$

For steel with  $f_y = 460 \text{ N/mm}^2$  the yield strain is 0.002. Inserting these values into equation 4.4:

$$x = \frac{d}{1 + \frac{0.002}{0.0035}} = 0.636 d$$

Hence, to ensure yielding of the tension steel at the ultimate limit state:

$$x \triangleright 0.636 d$$

At the ultimate limit state it is important that member sections in flexure should be ductile and that failure should occur with the gradual yielding of the tension steel and not by a sudden catastrophic compression failure of the concrete. Also, yielding of the reinforcement enables the formation of plastic hinges so that redistribution of maximum moments can occur, resulting in a safer and more economical structure. To be very certain of the tension steel yielding, the code of practice limits the depth of neutral axis so that

$$x \triangleright (\beta_b - 0.4) d$$

where

$$\beta_b = \frac{\text{moment at the section after redistribution}}{\text{moment at the section before redistribution}}$$

Thus with moment redistribution not greater than 10 per cent, and  $\beta_b \geq 0.9$ :

$$x \triangleright 0.5 d$$

This limit will normally be adopted for ultimate limit state design, but larger degrees of moment redistribution will require a smaller limit to  $x$  to ensure that plastic hinges can form, providing adequate rotation at the critical sections (see section 4.7 and table 4.1).

### 4.3 Bending and the Equivalent Rectangular Stress Block

For the design of most reinforced concrete structures it is usual to commence the design for the conditions at the ultimate limit state, which is then followed by checks to ensure that the structure is adequate for the serviceability limit state without excessive deflection or cracking of the concrete. For this reason the analysis in this chapter will first consider the simplified rectangular stress block which can be used for the design at the ultimate limit state.

The rectangular stress block as shown in figure 4.4 may be used in preference to the more rigorous rectangular-parabolic stress block. This simplified stress distribution will facilitate the analysis and provide more manageable design equations, in particular when dealing with non-rectangular cross-sections.

It can be seen from the figure that the stress block does not extend to the neutral axis of the section but has a depth  $s = 0.9 x$ . This will result in the centroid of the stress block being  $s/2 = 0.45 x$  from the top edge of the section, which is very nearly the same location as for the more precise rectangular-parabolic stress block; also the areas of the two types of stress block are approximately equal (see section 4.9). Thus the moment of resistance of the section will be similar using calculations based on either of the two stress blocks.

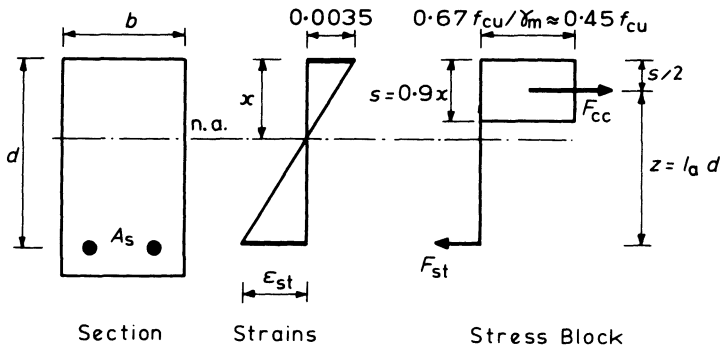

Figure 4.4 *Singly reinforced section with rectangular stress block*

The design equations derived in sections 4.4 to 4.6 are for redistribution of moments being not greater than 10 per cent. When a greater moment redistribution is applied, reference should be made to section 4.7 which describes how to modify the design equations.

#### 4.4 Singly Reinforced Rectangular Section in Bending

Bending of the section will induce a resultant tensile force  $F_{st}$  in the reinforcing steel, and a resultant compressive force in the concrete  $F_{cc}$  which acts through the centroid of the effective area of concrete in compression, as shown in figure 4.4.

For equilibrium, the ultimate design moment,  $M$  must be balanced by the moment of resistance of the section so that

$$M = F_{cc} \times z = F_{st}z \quad (4.5)$$

where  $z$  is the lever arm between the resultant forces  $F_{cc}$  and  $F_{st}$ .

$$\begin{aligned} F_{cc} &= \text{stress} \times \text{area of action} \\ &= 0.45 f_{cu} \times bs \end{aligned}$$

$$\text{and} \quad z = d - s/2 \quad (4.6)$$

So that substituting in equation 4.5

$$M = 0.45 f_{cu} bs \times z$$

and replacing  $s$  from equation 4.6

$$M = 0.9 f_{cu} b (d - z) z \quad (4.7)$$

Rearranging and substituting  $K = M/bd^2 f_{cu}$ :

$$(z/d)^2 - (z/d) + K/0.9 = 0$$

Solving this quadratic equation:

$$z = d [0.5 + \sqrt{(0.25 - K/0.9)}] \quad (4.8)^*$$

which is the equation in the code of practice BS 8110 for the lever arm,  $z$ , of a singly reinforced section.

In equation 4.5

$$F_{st} = (f_y/\gamma_m) A_s \quad \text{with } \gamma_m = 1.15$$

$$= 0.87 f_y A_s$$

Hence

$$A_s = \frac{M}{0.87 f_y \times z} \tag{4.9}^*$$

Equations 4.8 and 4.9 can be used to design the area of tension reinforcement in a concrete section to resist an ultimate moment,  $M$ .

$K = M/bd^2 f_{cu}$	0.05	0.06	0.07	0.08	0.09	0.10	0.11	0.12	0.13	0.14	0.15	0.156
$l_a = z/d$	0.941	0.928	0.915	0.901	0.887	0.873	0.857	0.842	0.825	0.807	0.789	0.775

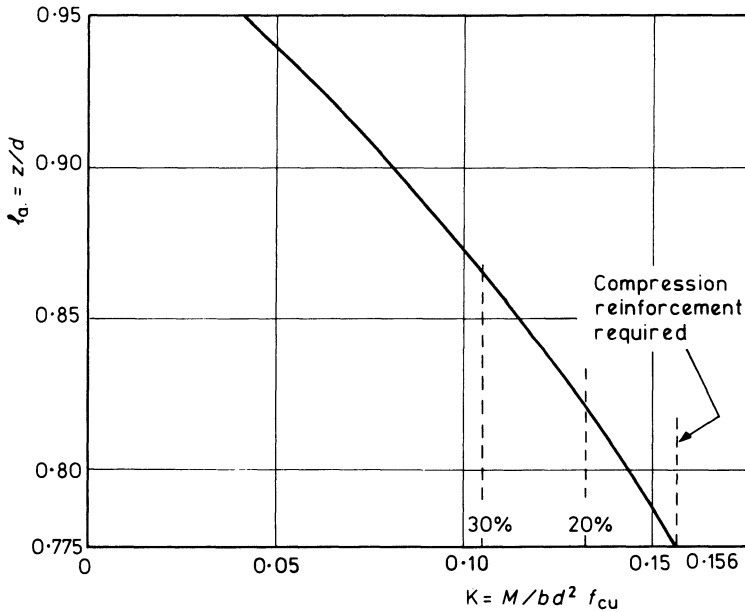

The % values on the  $K$  axis mark the limits for singly reinforced sections with moment redistribution applied (see Section 4.7)

Figure 4.5 Lever-arm curve

Equation 4.8 for the lever arm  $z$  can be used to set up a table and draw a lever-arm curve as shown in figure 4.5, and the curve may be used to determine the lever arm,  $z$ , instead of solving equation 4.8.

The upper limit of the lever-arm curve,  $z = 0.95$ , is specified by BS 8110. The lower limit of  $z = 0.775 d$  is when the depth of neutral axis  $x = d/2$ , which is the maximum value allowed by the code for a singly reinforced section in order to provide a ductile section which will have a gradual tension type failure as already described. With  $z = 0.775 d$  from equation 4.7:

$$M = 0.9 f_{cu} b (d - 0.775 d) \times 0.775 d$$

or

$$M = 0.156 f_{cu} b d^2 \quad (4.10)^*$$

as marked on the lever-arm diagram. The coefficient 0.156 has actually been calculated using the concrete stress as more precisely equal to  $0.67 f_{cu}/\gamma_m = 0.447 f_{cu}$ , instead of  $0.45 f_{cu}$ .

When

$$\frac{M}{b d^2 f_{cu}} = K > 0.156$$

compression reinforcement is also required to supplement the moment of resistance of the concrete.

#### **Example 4.1 Design of a Singly Reinforced Rectangular Section**

The ultimate design moment to be resisted by the section in figure 4.6 is 185 kN m. Determine the area of tension reinforcement ( $A_s$ ) required given the characteristic material strengths are  $f_y = 460 \text{ N/mm}^2$  and  $f_{cu} = 30 \text{ N/mm}^2$ .

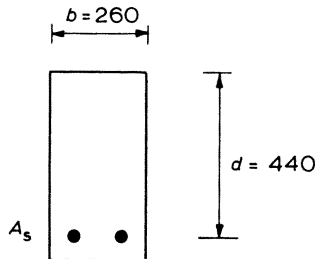

**Figure 4.6** Design example – singly reinforced section

$$\begin{aligned} K &= \frac{M}{b d^2 f_{cu}} \\ &= \frac{185 \times 10^6}{260 \times 440^2 \times 30} = 0.122 \\ &< 0.156 \end{aligned}$$

therefore compression steel is not required.

Lever arm:

$$\begin{aligned} z &= d \left\{ 0.5 + \sqrt{\left(0.25 - \frac{K}{0.9}\right)} \right\} \\ &= 440 \left\{ 0.5 + \sqrt{\left(0.25 - \frac{0.122}{0.9}\right)} \right\} \\ &= 369 \text{ mm} \end{aligned}$$

(Or alternatively, the value of  $z = l_a d$  could be obtained from the lever-arm diagram, figure 4.5.)

$$\begin{aligned} A_s &= \frac{M}{0.87 f_y z} \\ &= \frac{185 \times 10^6}{0.87 \times 460 \times 369} \\ &= 1253 \text{ mm}^2 \end{aligned}$$

#### *Analysis Equations for a Singly Reinforced Section*

The following equations may be used to calculate the moment of resistance of a given section with a known area of steel reinforcement.

For equilibrium of the compressive force in the concrete and the tensile force in the steel in figure 4.4:

$$F_{cc} = F_{st}$$

or

$$0.45 f_{cu} b \times s = 0.87 f_y A_s$$

Therefore depth of stress block is

$$s = \frac{0.87 f_y A_s}{0.45 f_{cu} b} \quad (4.11)$$

and

$$x = s/0.9$$

Therefore moment of resistance of the section is

$$\begin{aligned} M &= F_{st} \times z \\ &= 0.87 f_y A_s (d - s/2) \\ &= 0.87 f_y A_s \left( d - \frac{0.87 f_y A_s}{0.9 f_{cu} b} \right) \end{aligned} \quad (4.12)$$

These equations assume the tension reinforcement has yielded, which will be the case if  $x \geq 0.636 d$ . If this is not the case, the problem would require solving by trying successive values of  $x$  until

$$F_{cc} = F_{st}$$

with the steel strains and hence stresses being determined from equations 4.2 and 4.1, to be used in equation 4.12 instead of  $0.87 f_y$ .

**Example 4.2 Analysis of Singly Reinforced Rectangular Section in Bending**

Determine the ultimate moment of resistance of the cross-section shown in figure 4.7 given that the characteristic strengths are  $f_y = 460 \text{ N/mm}^2$  for the reinforcement and  $f_{cu} = 30 \text{ N/mm}^2$  for the concrete.

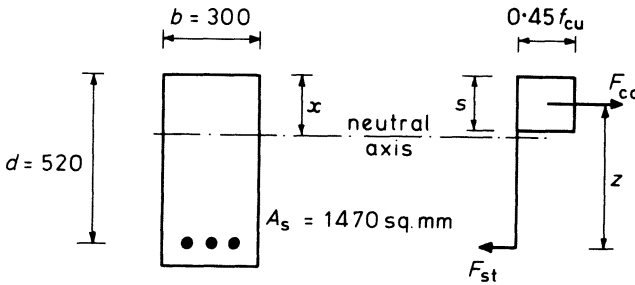

Figure 4.7 Analysis example – singly reinforced section

For equilibrium of the compressive and tensile forces on the section

$$F_{cc} = F_{st}$$

therefore

$$0.45 f_{cu} b s = 0.87 f_y A_s$$

$$0.45 \times 30 \times 300 \times s = 0.87 \times 460 \times 1470$$

therefore

$$s = 145 \text{ mm}$$

and

$$x = s/0.9 = 145/0.9 \\ = 161 \text{ mm}$$

This value of  $x$  is less than the value of  $0.636 d$  derived from section 4.2, and therefore the steel has yielded and  $f_{st} = 0.87 f_y$  as assumed.

Moment of resistance of the section is

$$M = F_{st} \times z \\ = 0.87 f_y A_s (d - s/2) \\ = 0.87 \times 460 \times 1470 (520 - 145/2) \times 10^{-6} \\ = 263 \text{ kN m}$$

**4.5 Rectangular Section with Compression Reinforcement at the Ultimate Limit State**

*(a) Derivation of Basic Equations*

It should be noted that the equations in this section have been derived for the case where the reduction in moment at a section due to moment redistribution is not greater than 10 per cent. When this is not the case, reference should be made to section 4.7 which deals with the effect of moment redistribution.

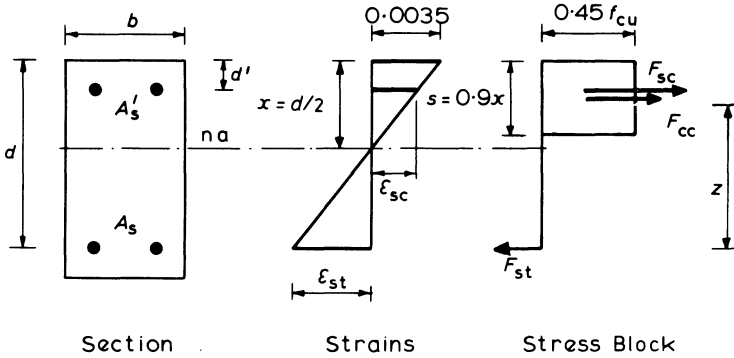

**Figure 4.8** Section with compression reinforcement

From the section dealing with the analysis of a singly reinforced section when

$$M > 0.156 f_{cu} b d^2$$

the design ultimate moment exceeds the moment of resistance of the concrete and therefore compression reinforcement is required. For this condition the depth of neutral axis,  $x > 0.5 d$ , the maximum value allowed by the code in order to ensure a tension failure with a ductile section.

Therefore

$$\begin{aligned} z &= d - s/2 = d - 0.9 x/2 \\ &= d - 0.9 \times 0.5 d/2 \\ &= 0.775 d \end{aligned}$$

For equilibrium of the section in figure 4.8

$$F_{st} = F_{cc} + F_{sc}$$

so that with the reinforcement at yield

$$0.87 f_y A_s = 0.45 f_{cu} b s + 0.87 f_y A_s'$$

or with

$$s = 0.9 \times d/2 = 0.45 d$$

$$0.87 f_y A_s = 0.201 f_{cu} b d + 0.87 f_y A_s' \tag{4.13}$$

and taking moments about the centroid of the tension steel,  $A_s$

$$\begin{aligned}
 M &= F_{cc} \times z + F_{sc} (d - d') \\
 &= 0.201 f_{cu} b d \times 0.775 d + 0.87 f_y A'_s (d - d') \\
 &= 0.156 f_{cu} b d^2 + 0.87 f_y A'_s (d - d') \quad (4.14)
 \end{aligned}$$

From equation 4.14

$$A'_s = \frac{M - 0.156 f_{cu} b d^2}{0.87 f_y (d - d')} \quad (4.15)^*$$

Multiplying both sides of equation 4.13 by  $z = 0.775 d$  and rearranging gives

$$A_s = \frac{0.156 f_{cu} b d^2}{0.87 f_y \times z} + A'_s \quad (4.16)^*$$

with  $z = 0.775 d$

Hence the areas of compression steel,  $A'_s$ , and tension steel,  $A_s$ , can be calculated from equations 4.15 and 4.16.

Substituting  $K' = 0.156$  and  $K = M/bd^2 f_{cu}$  into these equations would convert them into the same forms as in the code of practice, BS 8110, which are

$$A'_s = \frac{(K - K') f_{cu} b d^2}{0.87 f_y (d - d')} \quad (4.17)^*$$

$$A_s = \frac{K' f_{cu} b d^2}{0.87 f_y z} + A'_s \quad (4.18)^*$$

In this analysis it has been assumed that the compression steel has yielded so that the steel stress  $f_{sc} = 0.87 f_y$ . From the proportions of the strain distribution diagram:

$$\frac{\epsilon_{sc}}{x - d'} = \frac{0.0035}{x} \quad (4.19)$$

so that

$$\frac{x - d'}{x} = \frac{\epsilon_{sc}}{0.0035}$$

or

$$\frac{d'}{x} = 1 - \frac{\epsilon_{sc}}{0.0035}$$

At yield with  $f_y = 460 \text{ N/mm}^2$ , the steel strain  $\epsilon_{sc} = \epsilon_y = 0.002$ . Therefore for yielding of the compression steel

$$\frac{d'}{x} \geq 1 - \frac{0.002}{0.0035} \geq 0.43 \quad (4.20)^*$$

as specified in the code, or with  $x = d/2$

$$\frac{d'}{d} \geq 0.215 \quad (4.21)$$

The ratio of  $d'/d$  for the yielding of other grades of steel can be determined by using their yield strain in equation 4.19, but for values of  $f_y$  less than  $460 \text{ N/mm}^2$ , the application of equation 4.21 will provide an adequate safe check.

If  $d'/d > 0.215$ , then it is necessary to calculate the strain  $\epsilon_{sc}$  from equation 4.19 and then determine  $f_{sc}$  from

$$f_{sc} = E_s \times \epsilon_{sc} = 200\,000 \epsilon_{sc}$$

This value of stress for the compressive steel must then be used in the denominator of equation 4.15 in place of  $0.87 f_y$  in order to calculate the area  $A'_s$  of compression steel. The area of tension steel is calculated from a modified equation 4.16 such that

$$A_s = \frac{0.156 f_{cu} b d^2}{0.87 f_y z} + A'_s \times \frac{f_{sc}}{0.87 f_y}$$

### (b) Design Charts

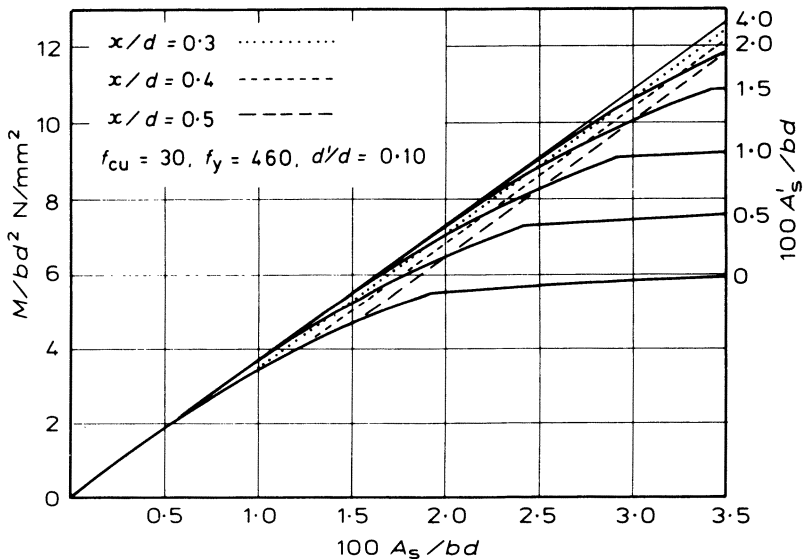

Figure 4.9 Typical design chart for doubly reinforced beams

The equations for the design charts are obtained by taking moments about the neutral axis. Thus

$$M = 0.45 f_{cu} 0.9 x (x - 0.9 x/2) + f_{sc} A'_s (x - d') + f_{st} A_s (d - x)$$

This equation and 4.13 may be written in the form

$$f_{st} \frac{A_s}{bd} = 0.201 f_{cu} \frac{x}{d} + f_{sc} \frac{A'_s}{bd}$$

$$\frac{M}{bd^2} = 0.401 f_{cu} \frac{x^2}{d^2} (1 - 0.45) + f_{sc} \frac{A'_s}{bd} \left( \frac{x}{d} - \frac{d'}{d} \right) + f_{st} \frac{A_s}{bd} \left( 1 - \frac{x}{d} \right)$$

For specified ratios of  $A'_s/bd$ ,  $x/d$  and  $d'/d$ , the two non-dimensional equations can be solved to give values for  $A_s/bd$  and  $M/bd^2$  so that a set of design charts such as the one shown in figure 4.9 may be plotted. Before the equations can be solved, the steel stresses  $f_{st}$  and  $f_{sc}$  must be calculated for each value of  $x/d$ . This is achieved by first determining the relevant strains from the strain diagram (or by applying equations 4.2 and 4.3) and then by evaluating the stresses from the stress-strain curve of figure 4.2. Values of  $x/d$  below 0.5 apply when moments are redistributed.

**Example 4.3 Design of a Rectangular Section with Compression Reinforcement (Moment Redistribution Factor  $\beta_b \geq 0.9$ )**

The section shown in figure 4.10 is to resist an ultimate design moment of 285 kN m. The characteristic material strengths are  $f_y = 460 \text{ N/mm}^2$  and  $f_{cu} = 30 \text{ N/mm}^2$ . Determine the areas of reinforcement required.

$$K = \frac{M}{bd^2 f_{cu}}$$

$$= \frac{285 \times 10^6}{260 \times 440^2 \times 30} = 0.189$$

$$> 0.156$$

therefore compression steel is required

$$d'/d = 50/440 = 0.11 < 0.2$$

as in equation 4.21 and the compression steel will have yielded.

Compression steel:

$$A'_s = \frac{(K - K') f_{cu} bd^2}{0.87 f_y (d - d')}$$

$$= \frac{(0.189 - 0.156) 30 \times 260 \times 440^2}{0.87 \times 460 (440 - 50)}$$

$$= 319 \text{ mm}^2$$

Tension steel:

$$A_s = \frac{K' f_{cu} bd^2}{0.87 f_y z} + A'_s$$

$$= \frac{0.156 \times 30 \times 260 \times 440^2}{0.87 \times 460 (0.775 \times 440)} + 319$$

$$= 1726 + 319 = 2045 \text{ mm}^2$$

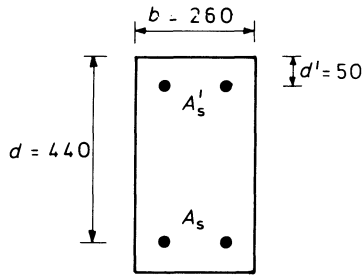

Figure 4.10 Design example with compression reinforcement,  $\beta_b > 0.9$

**Example 4.4 Analysis of a Doubly Reinforced Rectangular Section**

Determine the ultimate moment of resistance of the cross-section shown in figure 4.11 given that the characteristic strengths are  $f_y = 460 \text{ N/mm}^2$  for the reinforcement and  $f_{cu} = 30 \text{ N/mm}^2$  for the concrete.

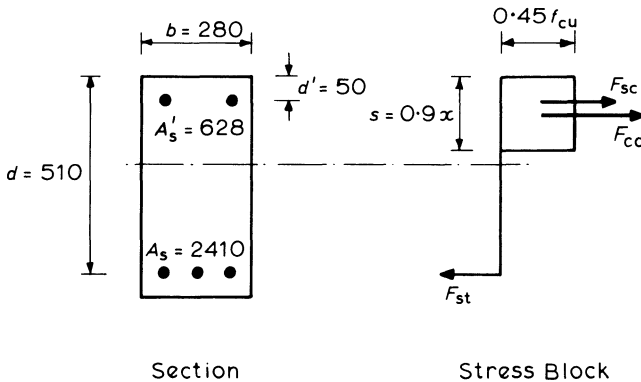

Figure 4.11 Analysis example, doubly reinforced section

For equilibrium of the tensile and compressive forces on the section:

$$F_{st} = F_{cc} + F_{sc}$$

Assuming initially that the steel stresses  $f_{st}$  and  $f_{sc}$  are the design yield values, then

$$0.87 f_y A_s = 0.45 f_{cu} b s + 0.87 f_y A'_s$$

Therefore

$$\begin{aligned} s &= \frac{0.87 f_y (A_s - A'_s)}{0.45 f_{cu} b} \\ &= \frac{0.87 \times 460 (2410 - 628)}{0.45 \times 30 \times 280} \\ &= 189 \text{ mm} \end{aligned}$$

$$x = s/0.9 = 210 \text{ mm}$$

$$x/d = 210/510 = 0.41 < 0.636$$

so the tension steel will have yielded. Also

$$d'/x = 50/210 = 0.24 < 0.43$$

so the compression steel will also have yielded, as assumed.

Taking moments about the tension steel

$$\begin{aligned} M &= F_{cc} (d - s/2) + F_{sc} (d - d') \\ &= 0.45 f_{cu} b s (d - s/2) + 0.87 f_y A_s' (d - d') \\ &= 0.45 \times 30 \times 280 \times 189 (510 - 189/2) + 0.87 \times 460 \times 620 (510 - 50) \\ &= 412 \times 10^6 \text{ N mm} \end{aligned}$$

If the depth of neutral axis was such that the compressive or tensile steel had not yielded, it would have been necessary to try successive values of  $x$  until

$$F_{st} = F_{cc} + F_{sc}$$

balances, with the steel strains and stresses being calculated from equations 4.2, 4.3 and 4.1. The steel stresses at balance would then be used to calculate the moment of resistance.

#### 4.6 Flanged Section in Bending at the Ultimate Limit State

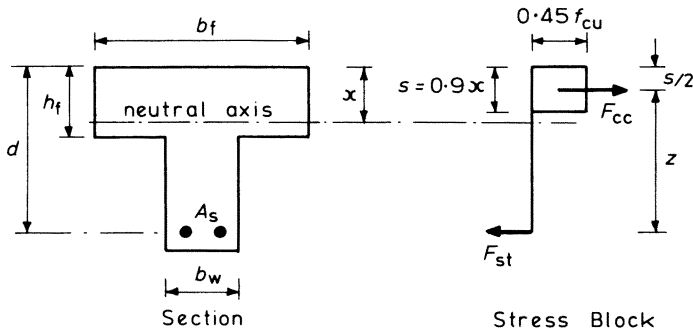

Figure 4.12 *T-section, stress block within the flange,  $s < h_f$*

T-sections and L-sections which have their flanges in compression can both be designed or analysed in a similar manner, and the equations which are derived can be applied to either type of cross-section. As the flanges generally provide a large compressive area, it is usually unnecessary to consider the case where compression steel is required; if it should be required, the design would be based on the principles derived in section 4.6.3.

For the singly reinforced section it is necessary to consider two conditions:

- (1) the stress block lies within the compression flange, and
- (2) the stress block extends below the flange.

**4.6.1 Flanged Section – the Depth of the Stress Block Lies Within the Flange,  $s < h_f$  (figure 4.12)**

For this depth of stress block, the beam can be considered as an equivalent rectangular section of breadth  $b_f$  equal to the flange width. This is because the non-rectangular section below the neutral axis is in tension and is, therefore, considered to be cracked and inactive. Thus  $K = M/b_f d^2 f_{cu}$  can be calculated and the lever arm determined from the lever-arm curve of figure 4.5 or equation 4.8. The relation between the lever arm;  $z$ , and depth,  $x$ , of the neutral axis is given by

$$z = d - 0.5s$$

or

$$s = 2(d - z)$$

If  $s$  is less than the flange thickness ( $h_f$ ), the stress block does lie within the flange as assumed and the area of reinforcement is given by

$$A_s = \frac{M}{0.87 f_y z}$$

The design of a T-section beam is described further in section 7.2.3 with a worked example.

**Example 4.5 Analysis of a Flanged Section**

Determine the ultimate moment of resistance of the T-section shown in figure 4.13. The characteristic material strengths are  $f_y = 460 \text{ N/mm}^2$  and  $f_{cu} = 30 \text{ N/mm}^2$

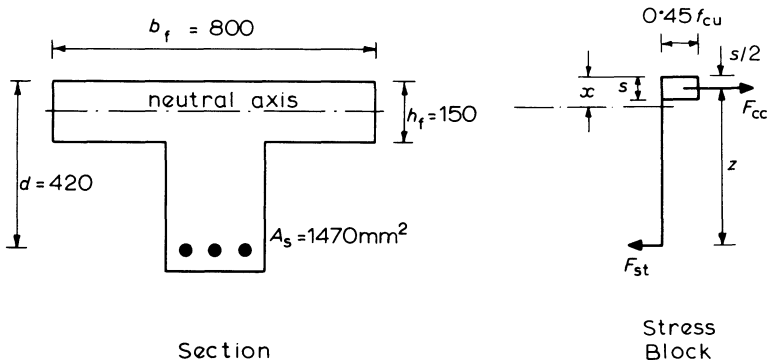

**Figure 4.13** Analysis example of a T-section,  $s < h_f$

Assume initially that the stress block depth lies within the flange and the reinforcement is strained to the yield, so that  $f_{st} = 0.87 f_y$ .

For no resultant axial force on the sections

$$F_{cc} = F_{st}$$

therefore

$$0.45 f_{cu} b_f s = 0.87 f_y A_s$$

and solving for the depth of stress block

$$s = \frac{0.87 \times 460 \times 1470}{0.45 \times 30 \times 800}$$

$$= 54 \text{ mm}$$

$$x = s/0.9 = 60 \text{ mm}$$

Hence the stress block does lie within the flange and with this depth of neutral axis the steel will have yielded as assumed.

Lever arm:

$$\begin{aligned} z &= d - s/2 \\ &= 420 - 54/2 = 393 \text{ mm} \end{aligned}$$

Taking moments about the centroid of the reinforcement the moment of resistance is

$$\begin{aligned} M &= F_{cc} \times z \\ &= 0.45 f_{cu} b_f s z \\ &= 0.45 \times 30 \times 800 \times 54 \times 393 \times 10^{-6} \\ &= 229 \text{ kN m} \end{aligned}$$

If in the analysis it had been found that  $s > h_f$ , then the procedure would then be similar to that in example 4.7.

#### 4.6.2 Flanged Section – the Depth of the Stress Block Extends Below the Flange, $s > h_f$

For the design of a flanged section, the procedure described in section 4.6.1 will check if the depth of the stress block extends below the flange. An alternative procedure is to calculate the moment of resistance,  $M_f$ , of the section with  $s = h_f$ , the depth of the flange (see equation 4.22 of example 4.6 following). Hence if the design moment,  $M$ , is such that

$$M > M_f$$

then the stress block must extend below the flange, and

$$s > h_f$$

In this case the design can be carried out by either:

- (a) using an exact method to determine the depth of the neutral axis, as in example 4.6 or

- (b) designing for the conservative condition of  $x = d/2$  as described at the end of this section.

**Example 4.6 Design of a Flanged Section with the Depth of the Stress Block Below the Flange**

The T-section beam shown in figure 4.14 is required to resist an ultimate design moment of 180 kN m. The characteristic material strengths are  $f_y = 460 \text{ N/mm}^2$  and  $f_{cu} = 30 \text{ N/mm}^2$ . Calculate the area of reinforcement required.

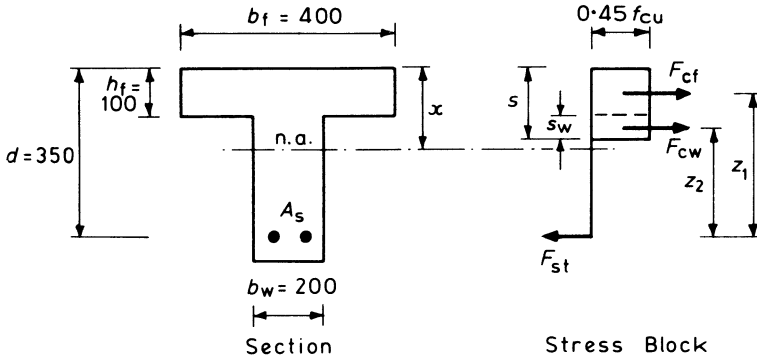

Figure 4.14 Design example, T-section with  $s > h_f$

In the figure

$F_{cf}$  is the force developed in the flange

$F_{cw}$  is the force developed in the area of web in compression

Moment of resistance,  $M_f$ , of the flange is

$$M_f = F_{cf} \times z_1$$

or

$$M_f = 0.45 f_{cu} b_f h_f (d - h_f/2) \tag{4.22}^*$$

$$= 0.45 \times 30 \times 400 \times 100 (350 - 100/2) \times 10^{-6}$$

$$= 162 \text{ kN m} < 180 \text{ kN m, the design moment}$$

Therefore, the stress block must extend below the flange.

It is now necessary to determine the depth,  $s_w$ , of the web in compression, where  $s_w = s - h_f$ .

For equilibrium:

Applied moment

$$180 = F_{cf} \times z_1 + F_{cw} \times z_2$$

$$= 162 + 0.45 f_{cu} b_w s_w \times z_2$$

$$\begin{aligned}
 &= 162 + 0.45 \times 30 \times 200 s_w (250 - s_w/2) \times 10^{-6} \\
 &= 162 + 2700 s_w (250 - s_w/2) \times 10^{-6}
 \end{aligned}$$

This equation can be rearranged into

$$s_w^2 - 500 s_w + 13.33 \times 10^3 = 0$$

Solving this quadratic equation

$$s_w = 28 \text{ mm}$$

So that the depth of neutral axis

$$\begin{aligned}
 x &= s/0.9 = (100 + 28)/0.9 \\
 &= 142 \text{ mm}
 \end{aligned}$$

As  $x < d/2$ , compression reinforcement is not required.

For the equilibrium of the section

$$F_{st} = F_{cf} + F_{cw}$$

or

$$\begin{aligned}
 0.87 f_y A_s &= 0.45 f_{cu} b_f h_f + 0.45 f_{cu} b_w s_w \\
 0.87 \times 460 \times A_s &= 0.45 \times 30 (400 \times 100 + 200 \times 28)
 \end{aligned}$$

Therefore

$$\begin{aligned}
 A_s &= \frac{616 \times 10^3}{0.87 \times 460} \\
 &= 1540 \text{ mm}^2
 \end{aligned}$$

#### **Example 4.7 Analysis of a Flanged Section**

Determine the ultimate moment of resistance of the T-beam section shown in figure 4.15, given  $f_y = 460 \text{ N/mm}^2$  and  $f_{cu} = 30 \text{ N/mm}^2$ .

The compressive force in the flange is

$$\begin{aligned}
 F_{cf} &= 0.45 f_{cu} b_f h_f \\
 &= 0.45 \times 30 \times 450 \times 150 \times 10^{-3} \\
 &= 911.2 \text{ kN}
 \end{aligned}$$

Then tensile force in the reinforcing steel, assuming it has yielded, is

$$\begin{aligned}
 F_{st} &= 0.87 f_y A_s \\
 &= 0.87 \times 460 \times 2410 \times 10^{-3} \\
 &= 964.5 \text{ kN}
 \end{aligned}$$

Therefore  $F_{st} > F_{cc}$

so that  $s > h_f$

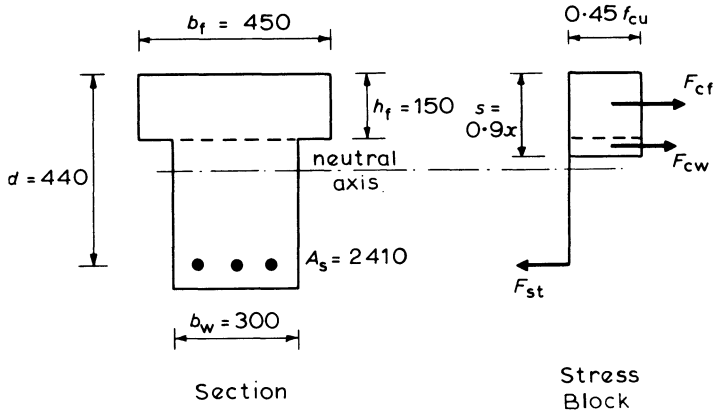

Figure 4.15 Analysis example of a T-section,  $s > h_f$

and the force in the web is

$$\begin{aligned} F_{cw} &= 0.45 f_{cu} b_w (s - h_f) \\ &= 0.45 \times 30 \times 300 (s - 150) \times 10^{-3} \\ &= 4.05 (s - 150) \end{aligned}$$

For equilibrium

$$F_{cw} = F_{st} - F_{cf}$$

$$\text{or} \quad 4.05 (s - 150) = 964.5 - 911.2$$

Hence

$$s = 163 \text{ mm}$$

$$x = s/0.9 = 181 \text{ mm}$$

With this depth of neutral axis the reinforcement has yielded, as assumed, and

$$F_{cw} = 4.05 (163 - 150) = 53 \text{ kN}$$

(If  $F_{cf} > F_{st}$ , then the stress block would not extend beyond the flange and the section would be analysed as in example 4.2 for a rectangular section of dimensions  $b_f \times d$ .)

Taking moments about the centroid of the reinforcement

$$\begin{aligned} M &= F_{cf} (d - h_f/2) + F_{cw} (d - s/2 - h_f/2) \\ &= [911.2 (440 - 150/2) + 53 (440 - 163/2 - 150/2)] \times 10^{-3} \\ &= 348 \text{ kN m} \end{aligned}$$

#### Example 4.8 Design of a Flanged Section with Depth of Neutral Axis

$x = d/2$

A safe but conservative design for a flanged section with  $s > h_f$  can be achieved by setting the depth of neutral axis to  $x = d/2$ , the maximum depth allowed in the code. Design equations can be derived for this condition as follows.

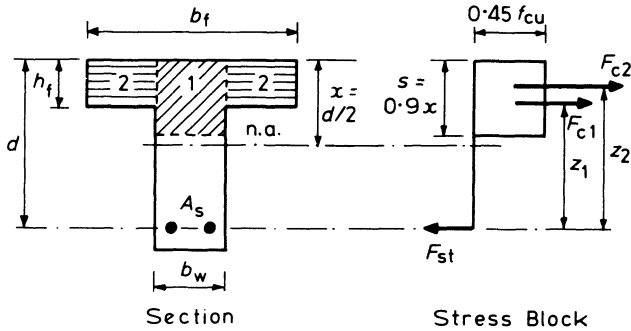

Figure 4.16 Flanged section with depth of neutral axis  $x = d/2$

Depth of stress block,  $s = 0.9 x = 0.45 d$

Divide the flanged section within the depth of the stress block into areas 1 and 2 as shown in figure 4.16, so that

$$\text{Area 1} = b_w \times s = 0.45 b_w d$$

$$\text{Area 2} = (b_f - b_w) \times h_f$$

and the compression forces developed by these areas are

$$F_{c1} = 0.45 f_{cu} \times 0.45 b_w d = 0.2 f_{cu} b_w d$$

$$F_{c2} = 0.45 f_{cu} h_f (b_f - b_w)$$

Taking moments about  $F_{c2}$  at the centroid of the flange

$$\begin{aligned} M &= F_{st} (d - h_f/2) - F_{c1} (s/2 - h_f/2) \\ &= 0.87 f_y A_s (d - h_f/2) - 0.2 f_{cu} b_w d (0.45 d - h_f)/2 \end{aligned}$$

Therefore

$$A_s = \frac{M + 0.1 f_{cu} b_w d (0.45 d - h_f)}{0.87 f_y (d - 0.5 h_f)} \quad (4.23)^*$$

This is the equation given in clause 3.4.4.5 of BS8110. It should not be used when  $h_f > 0.45 d$ .

Applying this equation to example 4.6:

$$\begin{aligned} A_s &= \frac{180 \times 10^6 + 0.1 \times 30 \times 200 \times 350 (0.45 \times 350 - 100)}{0.87 \times 460 (350 - 100/2)} \\ &= 1600 \text{ mm}^2 \text{ (compare with } 1540 \text{ mm}^2 \text{ of example 4.6)} \end{aligned}$$

Before using equation 4.23 for calculating  $A_s$ , it is necessary to confirm that compression reinforcement is not required. This is achieved by using equation 4.24 to check that the moment of resistance of the concrete,  $M_c$ , is greater than the design moment,  $M$ .

### 4.6.3 Flanged Section with Compression Reinforcement

With  $x = d/2$  in figure 4.16 and taking moments about  $A_s$ , the maximum resistance moment of the concrete is

$$\begin{aligned} M_c &= F_{c1} \times z_1 + F_{c2} \times z_2 \\ &= 0.156 f_{cu} b_w d^2 + 0.45 f_{cu} (b_f - b_w) (d - h_f/2) \end{aligned} \quad (4.24)$$

(Note that the value of 0.156 was derived previously for the rectangular section.)

Dividing through by  $f_{cu} b_f d^2$

$$\frac{M}{f_{cu} b_f d^2} = 0.156 \frac{b_w}{b_f} + 0.45 \frac{h_f}{d} \left(1 - \frac{b_w}{b_f}\right) \left(1 - \frac{h_f}{2d}\right) \quad (4.25)^*$$

which is similar to the equation given in BS 8110.

If the applied design moment,  $M > M_c$ , compression reinforcement is required. In which case the areas of steel can be calculated from

$$A'_s = \frac{M - M_c}{0.87 f_y (d - d')} \quad (4.26)$$

and considering the equilibrium of forces on the section

$$F_{st} = F_{c1} + F_{c2} + F_{sc}$$

so that

$$A_s = \frac{0.2 f_{cu} b_w d + 0.45 f_{cu} h_f (b_f - b_w)}{0.87 f_y} + A'_s \quad (4.27)$$

Again,  $d'/x \gtrsim 0.43$ , otherwise the design compressive steel stress is less than  $0.87 f_y$ .

When, because of moment redistribution,  $\beta_b < 0.9$  the limiting depth of neutral axis is less than  $d/2$  and these equations will require modification using the factors given in the table 4.1 of section 4.7 which deals with moment redistribution.

### 4.7 Moment Redistribution and the Design Equations

The plastic behaviour of reinforced concrete at the ultimate limit state affects the distribution of moments in a structure. To allow for this, the moments derived from an elastic analysis may be redistributed based on the assumption that plastic hinges have formed at the sections with the largest moments. The formation of plastic hinges requires relatively large rotations with yielding of the tension reinforcement. To ensure large strains in the tension steel, the code of practice restricts the depth of the neutral axis of a section according to the reduction of the elastic moment so that

$$x \gtrsim (\beta_b - 0.4) d \quad (4.28)^*$$

where  $d$  is the effective depth

and 
$$\beta_b = \frac{\text{moment at section after redistribution}}{\text{moment at section before redistribution}} \leq 1.0$$

So, for the design of a section with compression reinforcement after moment redistribution the depth of neutral axis  $x$  will take the maximum value from equation 4.28.

Therefore the depth of the stress block is

$$s = 0.9 (\beta_b - 0.4) d$$

and the level arm is

$$\begin{aligned} z &= d - \frac{s}{2} \\ &= d - 0.9 (\beta_b - 0.4) d/2 \end{aligned} \quad (4.29)$$

The moment of resistance of the concrete in compression is

$$\begin{aligned} M_c &= F_{cc} \times z = 0.45 f_{cu} b s \times z \\ &= 0.45 f_{cu} b \times 0.9 (\beta_b - 0.4) d \times [d - 0.9 (\beta_b - 0.4) d/2] \end{aligned}$$

Therefore

$$\begin{aligned} \frac{M_c}{bd^2 f_{cu}} &= 0.45 \times 0.9 (\beta_b - 0.4) [1 - 0.45 (\beta_b - 0.4)] \\ &= 0.402 (\beta_b - 0.4) - 0.18 (\beta_b - 0.4)^2 \end{aligned}$$

So that rearranging

$$M_c = K' b d^2 f_{cu}$$

where 
$$K' = 0.402 (\beta_b - 0.4) - 0.18 (\beta_b - 0.4)^2 \quad (4.30)^*$$

This is the equation for  $K'$  given in BS 8110.

(It should be noted that in calculating the coefficients 0.402 and 0.18, the more precise value of concrete stress  $f_{cc} = 0.67 f_{cu}/1.5$  has been used and not the value  $0.45 f_{cu}$ .)

When the ultimate design moment is such that

$$M > K' b d^2 f_{cu}$$

or 
$$K > K'$$

then compression steel is required such that

$$A'_s = \frac{(K - K') f_{cu} b d^2}{0.87 f_y (d - d')} \quad (4.31)^*$$

and

$$A_s = \frac{K' f_{cu} b d^2}{0.87 f_y z} + A'_s \quad (4.32)^*$$

where 
$$K = \frac{M}{bd^2 f_{cu}} \tag{4.33}^*$$

These equations are identical in form to those derived previously for the design of a section with compression reinforcement for  $\beta_b \geq 0.9$ .

Table 4.1 shows the various design factors associated with the moment redistribution. If the value of  $d'/d$  for the section exceeds that shown in the table, the compression steel will not have yielded and the compressive stress will be less than  $0.87 f_y$ . In such cases, the compressive stress  $f_{sc}$  will be  $E_s \epsilon_{sc}$  where the strain  $\epsilon_{sc}$  is obtained from the proportions of the strain diagram. This value of  $f_{sc}$  should replace  $0.87 f_y$  in equation 4.31, and equation 4.32 becomes

$$A_s = \frac{K' f_{cu} b d^2}{0.87 f_y z} + A'_s \times \frac{f_{sc}}{0.87 f_y}$$

**Table 4.1** Moment redistribution design factors

Redistribution (per cent)	$\beta_b$	$x/d$	$z/d$	$K'$	$d'/d$
$\leq 10$	$\geq 0.9$	0.5	0.775	0.156	0.215
15	0.85	0.45	0.797	0.144	0.193
20	0.8	0.4	0.82	0.132	0.172
25	0.75	0.35	0.842	0.199	0.150
30	0.7	0.3	0.865	0.104	0.129

It should be noted that for a singly reinforced section ( $K < K'$ ), the lever arm  $z$  is calculated from equation 4.8.

For a section requiring compression steel, the lever arm can be calculated from equation 4.29 or by using the equation

$$z = d [0.5 + \sqrt{(0.25 - K'/0.9)}] \tag{4.34}$$

as given in BS 8110, and is similar to equation 4.8 but with  $K'$  replacing  $K$ .

**Example 4.9 Design of a Section with Moment Redistribution Applied and  $\beta_b = 0.8$**

The section shown in figure 4.17 is subject to an ultimate design moment of 228 kN m. The characteristic material strengths are  $f_y = 460 \text{ N/mm}^2$  and  $f_{cu} = 30 \text{ N/mm}^2$ . Determine the areas of reinforcement required.

**(A) From First Principles**

Limiting neutral axis depth,  $x = (\beta_b - 0.4) d = (0.8 - 0.4) d$   
 $= 0.4 d = 176 \text{ mm}$

Stress block depth,  $s = 0.9x = 0.36 d$

Lever arm  $z = d - s/2 = 0.82 d$

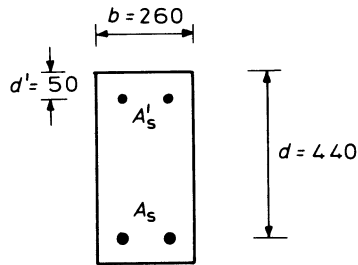

Figure 4.17 Design example with moment redistribution,  $\beta_b = 0.8$

Moment of resistance of the concrete

$$\begin{aligned} M_c &= F_{cc} \times z = 0.45 f_{cu} b s \times z \\ &= 0.45 \times 30 \times 260 \times 0.36 \times 0.82 \times 440^2 \times 10^{-6} \\ &= 201 \text{ kN m} \\ &< 228 \text{ kN m, the applied moment} \end{aligned}$$

therefore compression steel is required.

$$d'/x = 50/176 = 0.28 < 0.43$$

therefore the compression steel has yielded.

Compression steel:

$$\begin{aligned} A'_s &= \frac{M - M_c}{0.87 f_y (d - d')} \\ &= \frac{(228 - 201) \times 10^6}{0.87 \times 460 (440 - 50)} \\ &= 173 \text{ mm}^2 \end{aligned}$$

Tension steel:

$$\begin{aligned} A_s &= \frac{M_c}{0.87 f_y z} + A'_s \\ &= \frac{201 \times 10^6}{0.87 \times 460 \times 0.82 \times 440} + 173 \\ &= 1392 + 173 = 1565 \text{ mm}^2 \end{aligned}$$

(B) Alternative Solution Applying Equations from BS 8110

From equations 4.30 to 4.34:

$$\begin{aligned} K' &= 0.402 (\beta_b - 0.4) - 0.18 (\beta_b - 0.4)^2 \\ &= 0.402 (0.8 - 0.4) - 0.18 (0.8 - 0.4)^2 \\ &= 0.132 \end{aligned}$$

$$\begin{aligned}
 K &= \frac{M}{bd^2 f_{cu}} \\
 &= \frac{228 \times 10^6}{260 \times 440^2 \times 30} \\
 &= 0.151 > K'
 \end{aligned}$$

therefore compression steel is required.

Compression steel:

$$\begin{aligned}
 A'_s &= \frac{(K - K') f_{cu} b d^2}{0.87 f_y (d - d')} \\
 &= \frac{(0.151 - 0.132) 30 \times 260 \times 440^2}{0.87 \times 460 (440 - 50)} \\
 &= 184 \text{ mm}^2
 \end{aligned}$$

(The variation with the previous result is due to rounding-off errors in the arithmetic and the subtraction of two numbers of similar magnitude in the numerator.)

Tension steel:

$$\begin{aligned}
 z &= d [0.5 + \sqrt{(0.25 - K'/0.9)}] \\
 &= d [0.5 + \sqrt{(0.25 - 0.132/0.9)}] = 0.82 d \\
 A_s &= \frac{K' f_{cu} b d^2}{0.87 f_y z} + A'_s \\
 &= \frac{0.32 \times 30 \times 260 \times 440^2}{0.87 \times 460 \times 0.82 \times 440} + 184 \\
 &= 1381 + 184 = 1565 \text{ mm}^2
 \end{aligned}$$

#### 4.8 Bending Plus Axial Load at the Ultimate Limit State

The applied axial force may be tensile or compressive. In the analysis that follows, a compressive force is considered. For a tensile load the same basic principles of equilibrium, compatibility of strains, and stress-strain relationships, would apply, but it would be necessary to change the sign of the applied load ( $N$ ) when we consider the equilibrium of forces on the cross-section. (The area of concrete in compression has not been reduced to allow for the concrete displaced by the compression steel. This could be taken into account by reducing the stress  $f_{sc}$  in the compression steel by an amount equal to  $0.45 f_{cu}$ .)

Figure 4.18 represents the cross-section of a member with typical strain and stress distributions for varying positions of the neutral axis. The cross-section is subject to a moment  $M$  and an axial compressive force  $N$ , and in the figure the direction of the moment is such as to cause compression on the upper part of the section and tension on the lower part.

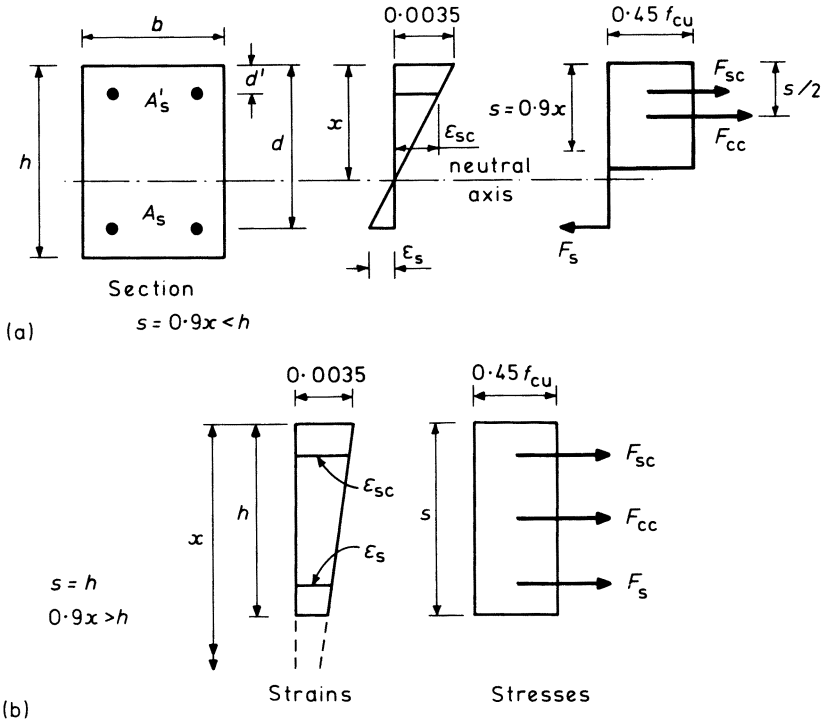

Figure 4.18 Bending plus axial load with varying positions of the neutral axis

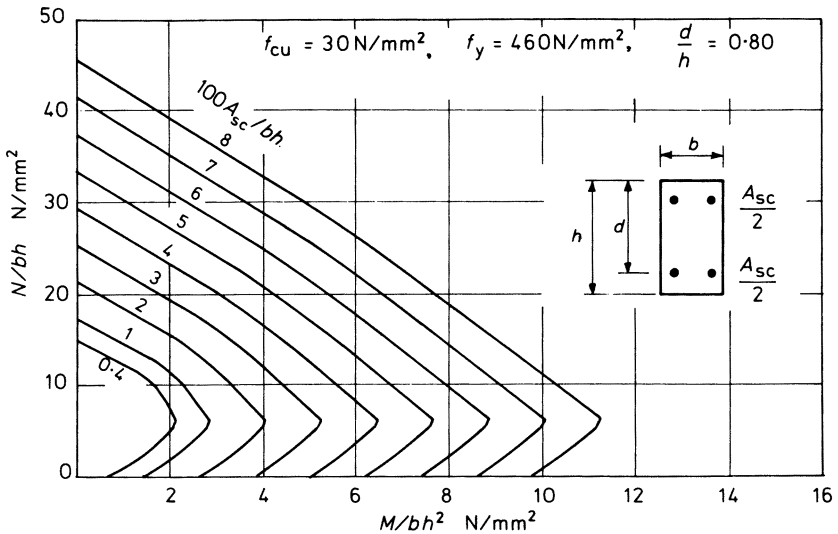

Figure 4.19 Typical column design chart

Let

$F_{cc}$  be the compressive force developed in the concrete and acting through the centroid of the stress block

$F_{sc}$  be the compressive force in the reinforcement area  $A'_s$  and acting through its centroid

$F_s$  be the tensile or compressive force in the reinforcement area  $A_s$  and acting through its centroid.

(i) *Basic Equations and Design Charts*

The applied force ( $N$ ) must be balanced by the forces developed within the cross-section, therefore

$$N = F_{cc} + F_{sc} + F_s$$

In this equation,  $F_s$  will be negative whenever the position of the neutral axis is such that the reinforcement  $A_s$  is in tension, as in figure 4.18a. Substituting into this equation the terms for the stresses and areas

$$N = 0.45 f_{cu} bs + f_{sc} A'_s + f_s A_s \quad (4.35)^*$$

where  $f_{sc}$  is the compressive stress in reinforcement  $A'_s$  and  $f_s$  is the tensile or compressive stress in reinforcement  $A_s$ .

The design moment  $M$  must be balanced by the moment of resistance of the forces developed within the cross-section. Hence, taking moments about the mid-depth of the section

$$M = F_{cc} \left( \frac{h}{2} - \frac{s}{2} \right) + F_{sc} \left( \frac{h}{2} - d' \right) + F_s \left( \frac{h}{2} - d \right)$$

or

$$M = 0.45 f_{cu} bs \left( \frac{h}{2} - \frac{s}{2} \right) + f_{sc} A'_s \left( \frac{h}{2} - d' \right) - f_s A_s \left( d - \frac{h}{2} \right) \quad (4.36)^*$$

When the depth of neutral axis is such that  $0.9 x \geq h$  as in part (b) of figure 4.18, then the whole concrete section is subject to a uniform compressive stress of  $0.45 f_{cu}$ . In this case, the concrete provides no contribution to the moment of resistance and the first term on the right side of equation 4.36 disappears.

For a symmetrical arrangement of reinforcement ( $A'_s = A_s = A_{sc}/2$  and  $d' = h - d$ ), equations 4.35 and 4.36 can be rewritten in the following form

$$\frac{N}{bh} = \frac{0.45 f_{cu} s}{h} + f_{sc} \frac{A_s}{bh} + f_s \frac{A_s}{bh} \quad (4.37)$$

$$\frac{M}{bh^2} = \frac{0.45 f_{cu} s}{h} \left( 0.5 - \frac{s}{2h} \right) + \frac{f_{sc} A_s}{bh} \left( \frac{d}{h} - 0.5 \right) - \frac{f_s A_s}{bh} \left( \frac{d}{h} - 0.5 \right) \quad (4.38)$$

In these equations the steel strains, and hence the stresses  $f_{sc}$  and  $f_s$ , vary with the depth of the neutral axis ( $x$ ). Thus  $N/bh$  and  $M/bh^2$  can be calculated for specified ratios of  $A_s/bh$  and  $x/h$  so that column design charts for a symmetrical arrangement of reinforcement such as the one shown in figure 4.19 can be plotted.

The direct solution of equations 4.37 and 4.38 for the design of column reinforcement would be very tedious and, therefore, a set of design charts for the usual case of symmetrical sections have been prepared by the British Standards Institution. Examples showing the design of column steel are given in chapter 9.

### (ii) Modes of Failure

The relative magnitude of the moment ( $M$ ) and the axial load ( $N$ ) governs whether the section will fail in tension or in compression. With large effective eccentricity ( $e = M/N$ ) a tensile failure is likely, but with a small eccentricity a compressive failure is more likely. The magnitude of the eccentricity affects the position of the neutral axis and hence the strains and stresses in the reinforcement.

Let

- $\epsilon_{sc}$  be the compressive strain in reinforcement  $A'_s$
- $\epsilon_s$  be the tensile or compressive strain in reinforcement  $A_s$
- $\epsilon_y$  be the tensile yield strain of steel as shown in the stress-strain curve of figure 4.2.

From the linear strain distribution of figure 4.18

$$\epsilon_{sc} = 0.0035 \left( \frac{x - d'}{x} \right)$$

and

$$\epsilon_s = 0.0035 \left( \frac{d - x}{x} \right)$$

(4.39)\*

The steel stresses and strains are then related according to the stress-strain curve of figure 4.2.

Consider the following modes of failure of the section as shown on the interaction diagram of figure 4.20.

#### (a) Tension Failure, $\epsilon_s > \epsilon_y$

This type of failure is associated with large eccentricities ( $e$ ) and small depths of neutral axis ( $x$ ). Failure begins with yielding of the tensile reinforcement, followed by crushing of the concrete as the tensile strains rapidly increase.

#### (b) Balanced Failure, $\epsilon_s = \epsilon_y$ , point b on figure 4.20

When failure occurs with yielding of the tension steel and crushing of the concrete at the same instant it is described as a 'balanced' failure. With  $\epsilon_s = \epsilon_y$  and from equation 4.39

$$x = x_{bal} = \frac{d}{1 + \frac{\epsilon_y}{0.0035}}$$

For example, substituting the values of  $\epsilon_y = 0.002$  for grade 460 steel

$$x_{bal} = 0.636 d$$

Equations 4.35 and 4.36 become

$$N_{bal} = F_{cc} + F_{sc} - F_s$$

$$\text{and} \quad = 0.45 f_{cu} b \times 0.9 x_{bal} + f_{sc} A'_s - 0.87 f_y A_s \quad (4.40)$$

$$M_{bal} = F_{cc} \left( \frac{h}{2} - \frac{0.9 x_{bal}}{2} \right) + F_{sc} \left( \frac{h}{2} - d' \right) + F_s \left( d - \frac{h}{2} \right)$$

where

$$f_{sc} \leq 0.87 f_y$$

At point b on the interaction diagram of figure 4.20,  $N = N_{bal}$ ,  $M = M_{bal}$  and  $f_s = -0.87 f_y$ . When the design load  $N > N_{bal}$  the section will fail in compression, whilst if  $N < N_{bal}$  there will be an initial tensile failure, with yielding of reinforcement  $A_s$ .

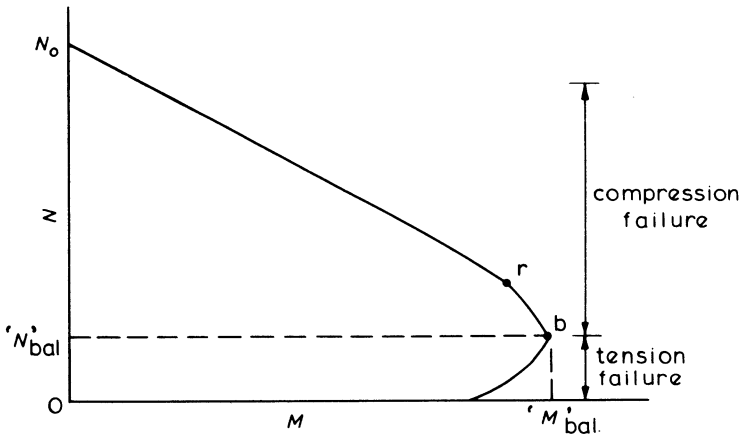

Figure 4.20 Bending, plus axial load chart with modes of failure

(c) Compression Failure

In this case  $x > x_{bal}$  and  $N > N_{bal}$ .

The change in slope at point r in figure 4.20 occurs when

$$\epsilon_{sc} = \epsilon_y$$

and from equation 4.39

$$x_r = 0.0035 d' / (0.0035 - \epsilon_y)$$

$$= 2.33 d' \text{ for grade 460 steel}$$

Point r will occur in the tension failure zone of the interaction diagram if

$$x_r < x_{bal}$$

When  $x < d$

$$f_s \leq 0.87 f_y \text{ and tensile}$$

When  $x = d$

$$f_s = 0$$

When  $x > d$

$$f_s \leq 0.87 f_y \text{ and compressive}$$

When  $x = 2.33 d$ , then from equation 4.39

$$\epsilon_s = 0.002 = \epsilon_y \text{ for grade 460 steel}$$

At this stage, both layers of steel will have yielded and there will be zero moment of resistance with a symmetrical section, so that

$$N_0 = 0.45 f_{cu} bh + 0.87 f_y (A'_s + A_s)$$

Such  $M-N$  interaction diagrams can be constructed for any shape of cross-section which has an axis of symmetry by applying the basic equilibrium and strain compatibility equations with the stress-strain relations, as demonstrated in the following examples. These diagrams can be very useful for design purposes.

**Example 4.10 M-N Interactive Diagram for an Unsymmetrical Section**

Construct the interaction diagram for the section shown in figure 4.21 with  $f_{cu} = 30 \text{ N/mm}^2$  and  $f_y = 460 \text{ N/mm}^2$ . The bending causes maximum compression on the face adjacent to the steel area  $A'_s$ .

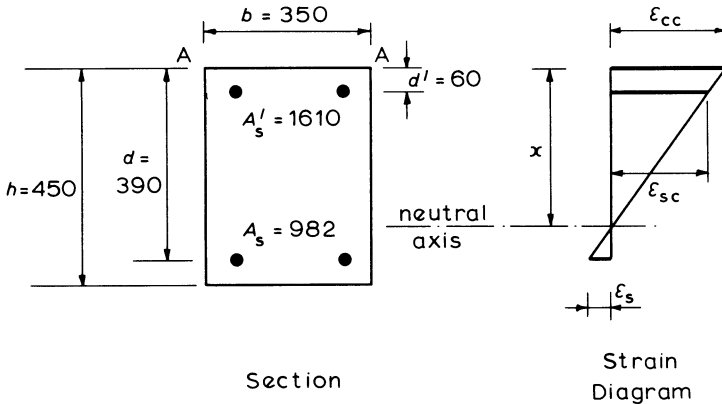

Figure 4.21 Non-symmetrical section M-N interaction example

For a symmetrical cross-section, taking moments about the centre-line of the concrete section will give  $M = 0$  with  $N = N_0$  and both areas of steel at the yield stress. This is no longer true for unsymmetrical steel areas as  $F_{sc} \neq F_s$  at yield therefore, theoretically, moments should be calculated about an axis referred to

as the 'plastic centroid'. The ultimate axial load  $N_0$  acting through the plastic centroid causes a uniform strain across the section with compression yielding of all the reinforcement, and thus there is zero moment of resistance. With uniform strain the neutral-axis depth,  $x$ , is at infinity.

The location of the plastic centroid is determined by taking moments of all the stress resultants about an arbitrary axis such as AA in figure 4.21 so that

$$\begin{aligned}\bar{x}_p &= \frac{\Sigma (F_{cc}h/2 + F_{sc}d' + F_s d)}{\Sigma (F_{cc} + F_{sc} + F_s)} \\ &= \frac{0.45 f_{cu} A_{cc} \times 450/2 + 0.87 f_y A'_s \times 60 + 0.87 f_y A_s \times 390}{0.45 f_{cu} A_{cc} + 0.87 f_y A'_s + 0.87 f_y A_s} \\ &= \frac{0.45 \times 30 \times 350 \times 450^2/2 + 0.87 \times 460 (1610 \times 60 + 982 \times 390)}{0.45 \times 30 \times 350 \times 450 + 0.87 \times 460 (1610 + 982)} \\ &= 212 \text{ mm from AA}\end{aligned}$$

The fundamental equation for calculating points on the interaction diagram with varying depths of neutral axis are

(i) Compatibility of strains (used in table 4.2, columns 2 and 3):

$$\begin{aligned}\epsilon_{sc} &= 0.0035 \left( \frac{x - d'}{x} \right) \\ \epsilon_s &= 0.0035 \left( \frac{d - x}{x} \right)\end{aligned}\tag{4.41}$$

(ii) Stress-strain relations for the steel (table 4.2, columns 4 and 5):

$$\begin{aligned}\epsilon \geq \epsilon_y &= 0.002, & f &= 0.87 f_y \\ \epsilon < \epsilon_y & & f &= E \times \epsilon\end{aligned}\tag{4.42}$$

(iii) Equilibrium (table 4.2, columns 6 and 7):

$$N = F_{cc} + F_{sc} + F_s$$

$$\text{or } 0.9 x < h \quad N = 0.45 f_{cu} b 0.9 x + f_{sc} A'_s + f_s A_s$$

$$0.9 x > h \quad N = 0.45 f_{cu} b h + f_{sc} A'_s + f_s A_s$$

Taking moments about the plastic centroid

$$0.9 x < h \quad M = F_{cc} (\bar{x}_p - 0.9 x/2) + F_{sc} (\bar{x}_p - d') - F_s (d - \bar{x}_p)$$

$$0.9 x \geq h \quad M = F_{cc} (\bar{x}_p - h/2) + F_{sc} (\bar{x}_p - d') - F_s (d - \bar{x}_p)$$

$F_s$  is negative when  $f_s$  is a tensile stress.

These equations have been applied to provide the values in table 4.2 for a range of key values of  $x$ . Then the  $M$ - $N$  interaction diagram has been plotted in figure 4.22 from the values in table 4.2 as a series of straight lines. Of course,  $N$  and  $M$  could have been calculated for intermediate values of  $x$  to provide a more accurate curve.

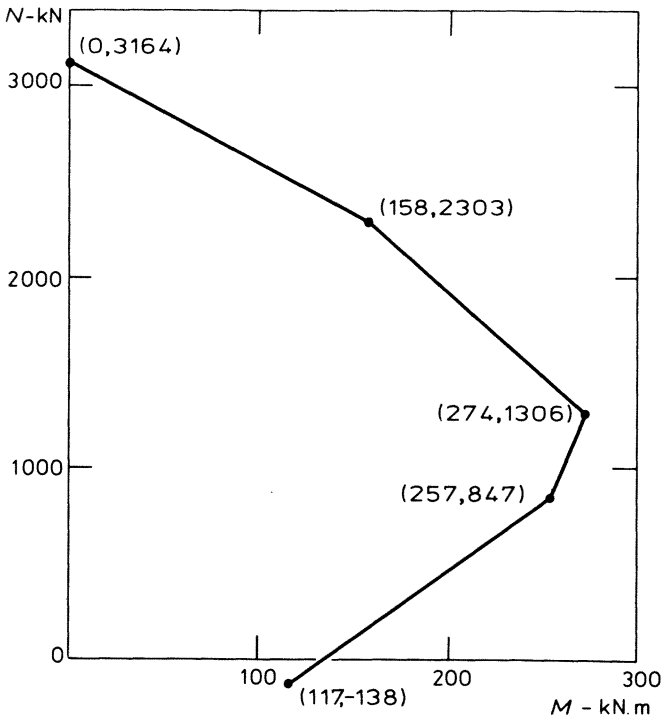

Figure 4.22 M-N interaction diagram for a non-symmetrical section

Table 4.2 M-N interaction values for example 4.9

(1) $x$	(2) $\epsilon_{sc}$	(3) $\epsilon_s$	(4) $f_{sc}$	(5) $f_s$	(6) $N$	(7) $M$
$d' = 60$	0	$> 0.002$	0	$-0.87 f_y$	- 138	117
$2.33 d' = 140$	0.002	$> 0.002$	$0.87 f_y$	$-0.87 f_y$	847	257
$x_{bal} = 0.636 d = 248$	$> 0.002$	0.002	$0.87 f_y$	$-0.87 f_y$	1306	274
$d = 390$	$> 0.002$	0	$0.87 f_y$	0	2303	158
$2.33 d = 909$	$> 0.002$	$> 0.002$	$0.87 f_y$	$0.87 f_y$	3164	0

**Example 4.11 M-N Interaction Diagram for a Non-rectangular Section**

Construct the interaction diagram for the equilateral triangular column section in figure 4.23 with  $f_{cu} = 30 \text{ N/mm}^2$  and  $f_y = 460 \text{ N/mm}^2$ . The bending is about an axis parallel to the side AA and causes maximum compression on the corner adjacent to the steel area  $A_s$ .

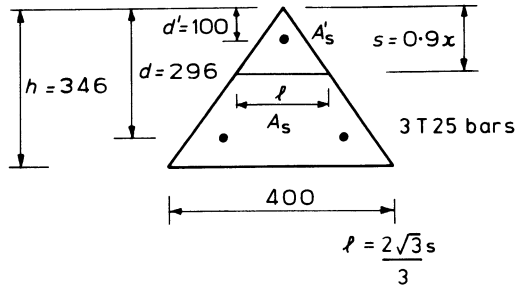

Figure 4.23 Non-rectangular section M-N interaction example

For this triangular section, the plastic centroid is at the same location as the geometric centroid, since the moment of  $F_{sc}$  equals the moment of  $F_s$  about this axis when all the bars have yielded in compression.

The fundamental equations for strain compatibility and the steel's stress-strain relations are as presented in example 4.9 and are used again in this example. The equilibrium equations for the triangular section become

$$N = F_{cc} + F_{sc} + F_s$$

or

$$\begin{aligned} 0.9x < h & \quad N = 0.45 f_{cu} sl/2 + f_{sc} A'_s + f_s A_s \\ 0.9x > h & \quad N = 0.45 f_{cu} h \times 400/2 + f_{sc} A'_s + f_s A_s \\ 0.9x < h & \quad M = F_{cc} 2(h - 0.9x)/3 + F_{sc} (2h/3 - d') - F_s (d - 2h/3) \\ 0.9x \geq h & \quad M = F_{sc} (2h/3 - d') - F_s (d - 2h/3) \end{aligned}$$

$F_s$  is negative when  $f_s$  is a tensile stress, and from the geometry of figure 4.23

$$l = \frac{2}{3} s \sqrt{3}$$

Table 4.3 has been calculated using the fundamental equations with the values of  $x$  shown. The interaction diagram is shown constructed in figure 4.24.

With a non-rectangular section, it could be advisable to construct a more accurate interaction diagram using other intermediate values of  $x$ . This would certainly be the case with, say, a flanged section where there is sudden change in breadth.

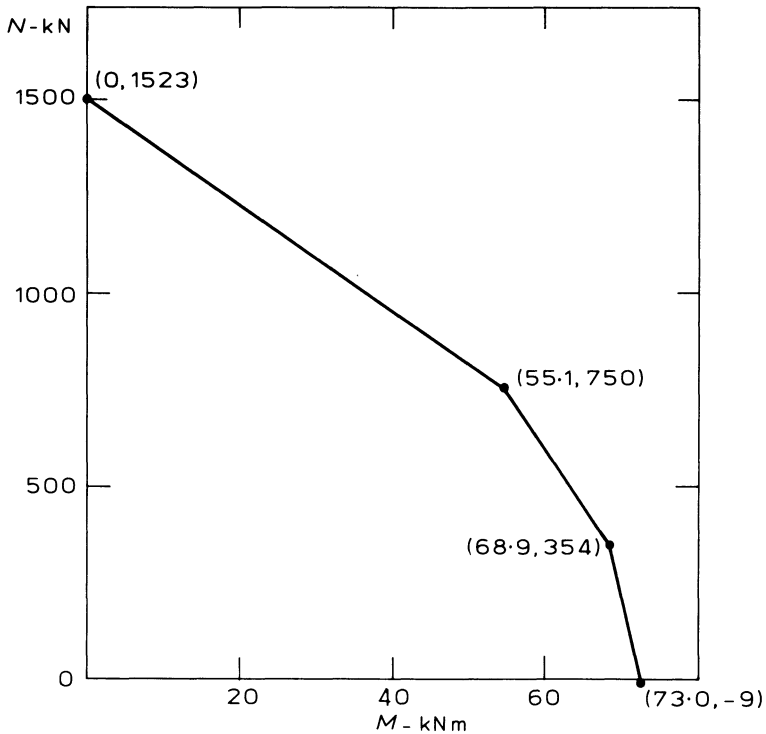

Figure 4.24 M-N interaction diagram for a non-rectangular section

Table 4.3 M-N interaction values for example 4.10

$x$	$\epsilon_{sc}$	$\epsilon_{st}$	$f_{sc}$ (N/mm <sup>2</sup> )	$f_s$ (N/mm <sup>2</sup> )	$N$ (kN)	$M$ (kN m)
$d' = 100$	0	$> 0.002$	0	$-0.87 f_y$	- 330	36.5
$x_{bal} = 0.636 d$ $= 188$	0.0016	0.002	328	$-0.87 f_y$	- 9	73.0
$2.33 d' = 233$	0.002	0.00095	$0.87 f_y$	- 189	354	68.9
$d = 296$	$> 0.002$	0	$0.87 f_y$	0	750	55.1
$2.33 d = 690$	$> 0.002$	$> 0.002$	$0.87 f_y$	$0.87 f_y$	1523	0

#### 4.9 The Rectangular-Parabolic Stress Block

A rectangular-parabolic stress block may be used to provide a more rigorous analysis of the reinforced concrete section. The stress block is similar in shape to the stress-strain curve for concrete in figure 4.1, having a maximum stress of  $0.45 f_{cu}$  at the ultimate strain of 0.0035.

In figure 4.25

- $\epsilon_0$  = the concrete strain at the end of the parabolic section
- $w$  = the distance from the neutral axis to strain  $\epsilon_0$
- $x$  = depth of the neutral axis
- $k_1$  = the mean concrete stress
- $k_2x$  = depth to the centroid of the stress block.

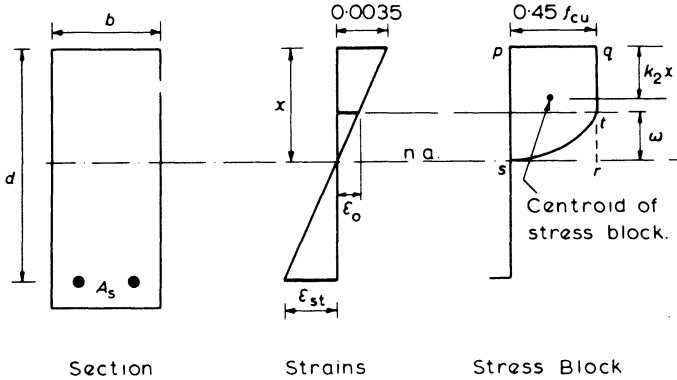

Figure 4.25 Section in bending with a rectangular-parabolic stress block

(a) To Determine the Mean Concrete Stress,  $k_1$

From the strain diagram

$$\frac{x}{0.0035} = \frac{w}{\epsilon_0}$$

therefore

$$w = \frac{x\epsilon_0}{0.0035}$$

Substituting for  $\epsilon_0 = 2.4 \times 10^{-4} \sqrt{f_{cu}/\gamma_m}$  (see figure 4.1)

$$w = \frac{x \sqrt{f_{cu}}}{17.86} \text{ with } \gamma_m = 1.5 \tag{4.43}$$

For the stress block

$$\begin{aligned} k_1 &= \frac{\text{area of stress block}}{x} \\ &= \frac{\text{area pqrs} - \text{area rst}}{x} \end{aligned}$$

Thus, using the area properties of a parabola as shown in figure 4.26, we have

$$k_1 = \frac{0.45 f_{cu}x - 0.45 f_{cu} \cdot w/3}{x}$$

Substituting for  $w$  from equation 4.43 gives

$$k_1 = \left( 0.45 - \frac{0.15 \sqrt{f_{cu}}}{17.86} \right) f_{cu} \quad (4.44)^*$$

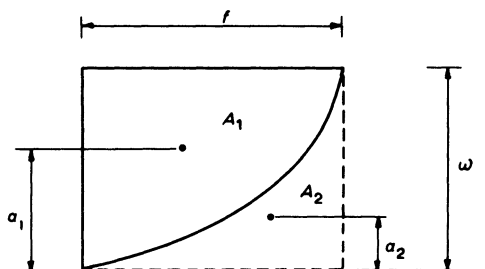

$$\text{Areas : } A_1 = \frac{2}{3} \omega f, \quad A_2 = \frac{\omega f}{3}$$

$$\text{Position of centroids : } a_1 = \frac{5}{8} \omega, \quad a_2 = \frac{\omega}{4}$$

Figure 4.26 Properties of a parabola

(b) To Determine the Depth of the Centroid  $k_2x$

$k_2$  is determined for a rectangular section by taking area moments of the stress block about the neutral axis – see figures 4.25 and 4.26. Thus

$$\begin{aligned} (x - k_2x) &= \frac{\text{area pqrs} \times x/2 - \text{area rst} \times w/4}{\text{area of stress block}} \\ &= \frac{(0.45 f_{cu}x)x/2 - (0.45 f_{cu} w/3)w/4}{k_1x} \\ &= \frac{0.45 f_{cu}(x^2/2 - w^2/12)}{k_1x} \end{aligned}$$

Substituting for  $w$  from equation 4.43

$$(x - k_2x) = \frac{0.45 f_{cu}x^2}{k_1x} \left[ 0.5 - \frac{f_{cu}}{3828} \right]$$

hence

$$k_2 = 1 - \frac{0.45 f_{cu}}{k_1} \left[ 0.5 - \frac{f_{cu}}{3828} \right] \quad (4.45)^*$$

Values of  $k_1$  and  $k_2$  for varying characteristic concrete strengths have been tabulated in table 4.4.

Once we know the properties of the stress block, the magnitude and position of the resultant compressive force in the concrete can be determined, and hence the moment of resistance of the section calculated using procedures similar to those for the rectangular stress block.

**Table 4.4** Values of  $k_1$  and  $k_2$  for different concrete grades

$f_{cu}$ (N/mm <sup>2</sup> )	$k_1$ (N/mm <sup>2</sup> )	$k_1/f_{cu}$	$k_2$	$k_1/k_2 f_{cu}$
20	8.249	0.412	0.460	0.896
25	10.200	0.408	0.456	0.895
30	12.120	0.404	0.452	0.894
40	15.875	0.397	0.445	0.892
50	19.531	0.391	0.439	0.890
60	23.097	0.385	0.434	0.887
Typical values		0.4	0.45	0.89

Using typical values from table 4.4, a comparison of the rectangular-parabolic and the rectangular stress blocks provides

(i) Stress resultant,  $F_{cc}$

$$\text{rectangular-parabolic: } k_1 bx \approx 0.4 f_{cu} bx$$

$$\text{rectangular: } 0.45 f_{cu} \times 0.9 bx \approx 0.4 f_{cu} bx$$

(ii) Lever arm,  $z$

$$\text{rectangular parabolic: } d - k_1 x \approx d - 0.45 x$$

$$\text{rectangular: } d - \frac{1}{2} \times 0.9 x = d - 0.45 x$$

So both stress blocks have almost the same moment of resistance,  $F_{cc} \times z$ , showing it is adequate to use the simpler rectangular stress block for design calculations.

#### 4.10 The Triangular Stress Block

The triangular stress block applies to elastic conditions during the serviceability limit state. In practice it is not generally used in design calculations except for liquid-retaining structures, or for the calculations of crack widths and deflections as described in chapter 6. With the triangular stress block, the cross-section can be considered as

(i) cracked in the tension zone, or

(ii) uncracked with the concrete resisting a small amount of tension.

##### 4.10.1 Cracked Section

A cracked section is shown in figure 4.27 with a stress resultant  $F_{st}$  acting through the centroid of the steel and  $F_{cc}$  acting through the centroid of the triangular stress block.

For equilibrium of the section

$$F_{cc} = F_{st}$$

$$\text{or } 0.5 bx f_{cc} = A_s f_{st} \quad (4.46)^*$$

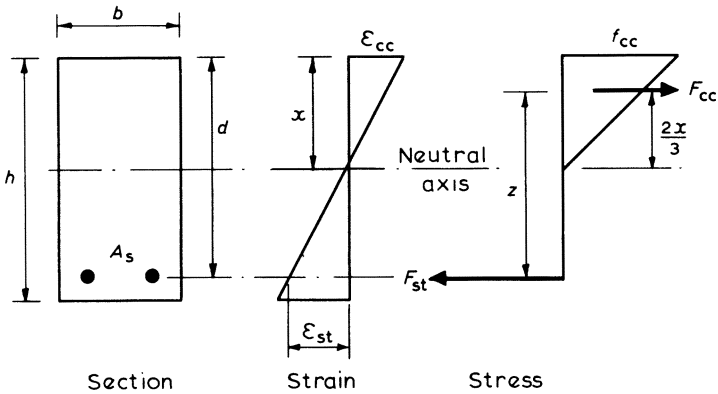

Figure 4.27 Triangular stress block – cracked section

and the moment of resistance

$$M = F_{cc} \times z = F_{st} \times z$$

or 
$$M = 0.5 b x f_{cc} (d - x/3) = A_s f_{st} (d - x/3) \tag{4.47}^*$$

(i) Analysis of a Specified Section

The depth of the neutral axis,  $x$ , can be determined by converting the section into an ‘equivalent’ area of concrete as shown in figure 4.28, where  $\alpha_e = E_s/E_c$ , the modular ratio. Taking area moments about the upper edge:

$$x = \frac{\Sigma (Ax)}{\Sigma A}$$

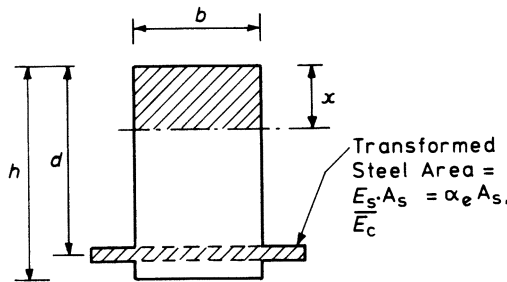

Figure 4.28 Equivalent transformed section with the concrete cracked

Therefore

$$x = \frac{bx \times x/2 + \alpha_e A_s d}{bx + \alpha_e A_s}$$

or

$$\frac{1}{2} bx^2 + \alpha_e A_s x - \alpha_e A_s d = 0$$

Solving this quadratic equation gives

$$x = \frac{-\alpha_e A_s \pm \sqrt{[(\alpha_e A_s)^2 + 2b \alpha_e A_s d]}}{b} \tag{4.48}^*$$

Equation 4.48 may be solved using a chart such as the one shown in figure 4.29.

Equations 4.46 to 4.48 can be used to analyse a specified reinforced concrete section.

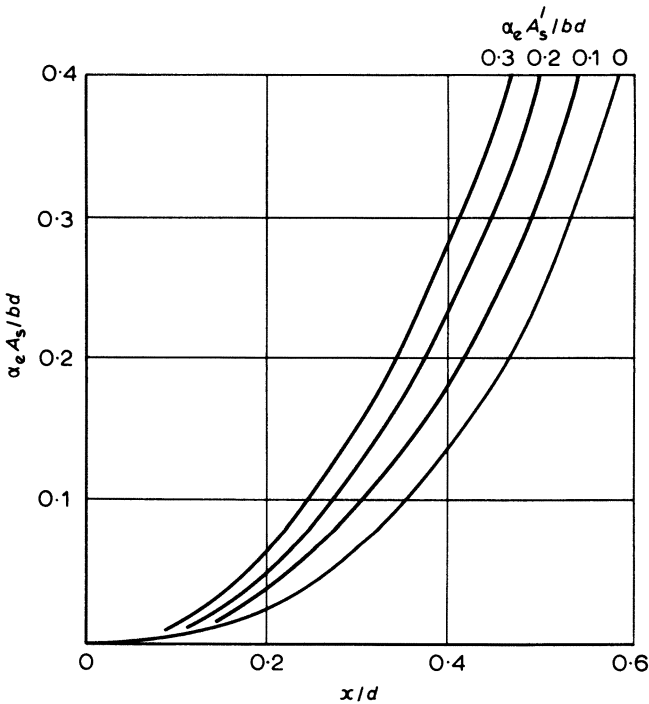

Figure 4.29 Neutral-axis depths for cracked rectangular sections – elastic behaviour

(ii) Design of Steel Area,  $A_s$ , with Stresses  $f_{st}$  and  $F_{cc}$  Specified

The depth of the neutral axis can also be expressed in terms of the strains and stresses of the concrete and steel.

From the linear strain distribution of figure 4.27:

$$\frac{x}{d} = \frac{\epsilon_{cc}}{\epsilon_{cc} + \epsilon_{st}} = \frac{f_{cc}/E_c}{f_{cc}/E_c + f_{st}/E_s}$$

Therefore

$$\frac{x}{d} = \frac{1}{1 + \frac{f_{st}}{\alpha_e f_{cc}}} \quad (4.49)^*$$

Equations 4.47 and 4.49 may be used to design the area of tension steel required, at a specified stress, in order to resist a given moment.

**Example 4.12 Analysis of a Cracked Section using a Triangular Stress Block**

For the section shown in figure 4.30, determine the concrete and steel stresses caused by a moment of 120 kN m, assuming a cracked section. Take  $E_s/E_c = \alpha_e = 15$

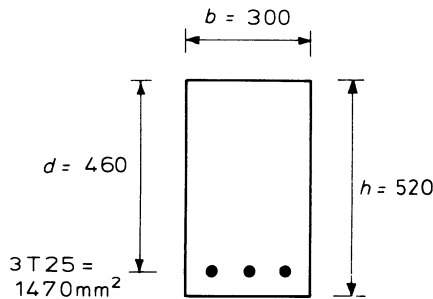

Figure 4.30 Analysis example with triangular stress block

$$\alpha_e \frac{A_s}{bd} = \frac{15 \times 1470}{300 \times 460} = 0.16$$

Using the chart of figure 4.29 or equation 4.48 gives  $x = 197$  mm.

From equation 4.47

$$M = \frac{1}{2} bx f_{cc} \left( d - \frac{x}{3} \right)$$

therefore

$$120 \times 10^6 = \frac{1}{2} \times 3000 \times 197 \times f_{cc} \left( 460 - \frac{197}{3} \right)$$

therefore

$$f_{cc} = 10.3 \text{ N/mm}^2$$

From equation 4.46

$$f_{st} A_s = \frac{1}{2} bx f_{cc}$$

therefore

$$f_{st} = 300 \times 197 \times \frac{10.3}{2} \times \frac{1}{1470} = 207 \text{ N/mm}^2$$

#### 4.10.2 Triangular Stress Block – Uncracked Section

The concrete may be considered to resist a small amount of tension. In this case a tensile stress resultant  $F_{ct}$  acts through the centroid of the triangular stress block in the tension zone as shown in figure 4.31.

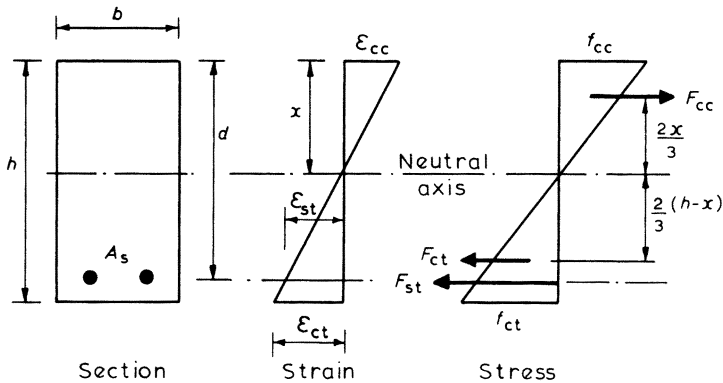

Figure 4.31 Triangular stress block – uncracked section

For equilibrium of the section

$$F_{cc} = F_{ct} + F_{st} \quad (4.50)$$

where  $F_{cc} = 0.5 bx f_{cc}$

$$F_{ct} = 0.5 b (h - x) f_{ct}$$

and  $F_{st} = A_s \times f_{st}$

Taking moments about  $F_{cc}$ , the moment of resistance of the section is given by

$$M = F_{st} \times (d - x/3) + F_{ct} \times \left( \frac{2}{3}x + \frac{2}{3}(h - x) \right) \quad (4.51)^*$$

The depth of the neutral axis,  $x$ , can be determined by taking area moments about the upper edge AA of the equivalent concrete section shown in figure 4.32, such that

$$x = \frac{\Sigma (Ax)}{\Sigma A}$$

$$\alpha_e = \frac{E_s}{E_c} \text{ is termed the modular ratio}$$

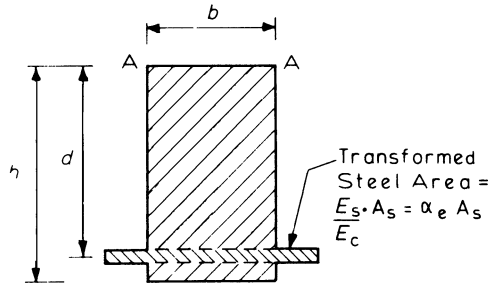

Figure 4.32 Equivalent transformed section with the concrete uncracked

Therefore

$$\begin{aligned}
 x &= \frac{bh \times h/2 + \alpha_e A_s \times d}{bh + \alpha_e A_s} \\
 &= \frac{h + 2\alpha_e r d}{2 + 2\alpha_e r} \tag{4.52}*
 \end{aligned}$$

where  $r = A_s/bh$

From the linear proportions of the strain diagram in figure 4.31:

$$\begin{aligned}
 \epsilon_{cc} &= \frac{x}{h - x} \times \epsilon_{ct} \\
 \epsilon_{st} &= \frac{d - x}{h - x} \times \epsilon_{ct} \tag{4.53}
 \end{aligned}$$

Therefore as stress =  $E \times$  strain:

$$\begin{aligned}
 f_{ct} &= E_c \epsilon_{ct} \\
 f_{cc} &= \frac{x}{h - x} \times f_{ct} \\
 f_{st} &= \frac{d - x}{h - x} \times \alpha_e f_{ct} \tag{4.54}*
 \end{aligned}$$

Hence if the maximum tensile strain or stress is specified, it is possible to calculate the corresponding concrete compressive and steel tensile stresses from equations 4.54.

The equations derived can be used to analyse a given cross-section in order to determine the moment of resistance of the uncracked section, as for liquid-retaining structures. This is illustrated further by examples in chapter 11.

**Example 4.12 Analysis of an Uncracked Section**

For the section shown in figure 4.30, calculate the serviceability moment of resistance with no cracking of the concrete, given  $f_{ct} = 3 \text{ N/mm}^2$ ,  $E_c = 30 \text{ kN/mm}^2$  and  $E_s = 200 \text{ kN/mm}^2$ .

$$r = \frac{A_s}{bh} = \frac{1470}{300 \times 520} = 0.0094$$

$$\alpha_e = \frac{E_s}{E_c} = \frac{200}{30} = 6.67$$

$$x = \frac{h + 2\alpha_e r d}{2 + \alpha_e r}$$

$$= \frac{520 + 2 \times 6.67 \times 0.0094 \times 460}{2 + 2 \times 6.67 \times 0.0094} = 272 \text{ mm}$$

$$f_{st} = \left( \frac{d - x}{h - x} \right) \alpha_e f_{ct}$$

$$= \frac{(460 - 272) 6.67 \times 3}{(520 - 272)} = 15.2 \text{ N/mm}^2$$

$$M = A_s f_{st} \left( d - \frac{x}{3} \right) + \frac{1}{2} b (h - x) f_{ct} \times \left( \frac{2}{3} x + \frac{2}{3} (h - x) \right)$$

$$= 1470 \times 15.2 \left( 460 - \frac{272}{3} \right) 10^{-6} + \frac{1}{2} \times 300 (520 - 272) \times 3$$

$$\times \left( \frac{2}{3} \times 272 + \frac{2}{3} (520 - 272) \right) 10^{-6}$$

$$= 8.3 + 38.7 = 47 \text{ kN m}$$

# 5

## Shear, Bond and Torsion

This chapter deals with the theory and derivation of the design equations for shear, bond and torsion. Some of the more practical factors governing the choice and arrangement of the reinforcement are dealt with in the chapters on member design, particularly chapter 7, which contains examples of the design and detailing of shear and torsion reinforcement in beams. Punching shear caused by concentrated loads on slabs is covered in section 8.2 of the chapter on slab design.

### 5.1 Shear

Figure 5.1 represents the distribution of principal stresses across the span of a homogeneous concrete beam. The direction of the principal compressive stresses takes the form of an arch, while the tensile stresses have the curve of a catenary or suspended chain. Towards mid-span, where the shear is low and the bending stresses are dominant, the direction of the stresses tends to be parallel to the beam axis. Near the supports, where the shearing forces are greater, the principal stresses are inclined at a steeper angle, so that the tensile stresses are liable to cause diagonal cracking. If the diagonal tension exceeds the limited tensile strength of the concrete then shear reinforcement must be provided. This reinforcement is either in the form of (1) stirrups, or (2) inclined bars (used in conjunction with stirrups).

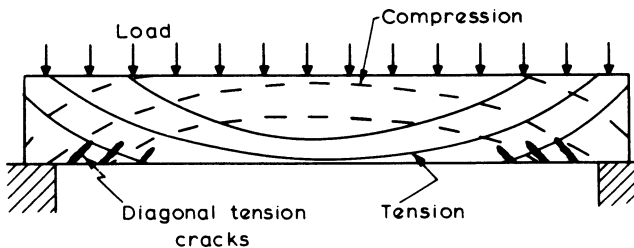

Figure 5.1 *Principal stresses in a beam*

The shear in a reinforced concrete beam without shear reinforcement is carried by a combination of three main components. These are

- (i) concrete in the compression zone
- (ii) dowelling action of tensile reinforcement
- (iii) aggregate interlock across flexural cracks.

The actual behaviour is complex, and difficult to analyse theoretically, but by applying the results from many experimental investigations, reasonable simplified procedures for analysis and design have been developed.

### 5.1.1 Stirrups

In order to derive simplified equations the action of a reinforced concrete beam in shear is represented by an analogous truss in which the longitudinal reinforcement forms the bottom chord, the stirrups are the vertical members and the concrete acts as the diagonal and top chord compression members as indicated in figure 5.2. In the truss shown, the stirrups are spaced at a distance equal to the effective depth ( $d$ ) of the beam so that the diagonal concrete compression members are at an angle of  $45^\circ$ , which more or less agrees with experimental observations of the cracking of reinforced concrete beams close to their supports.

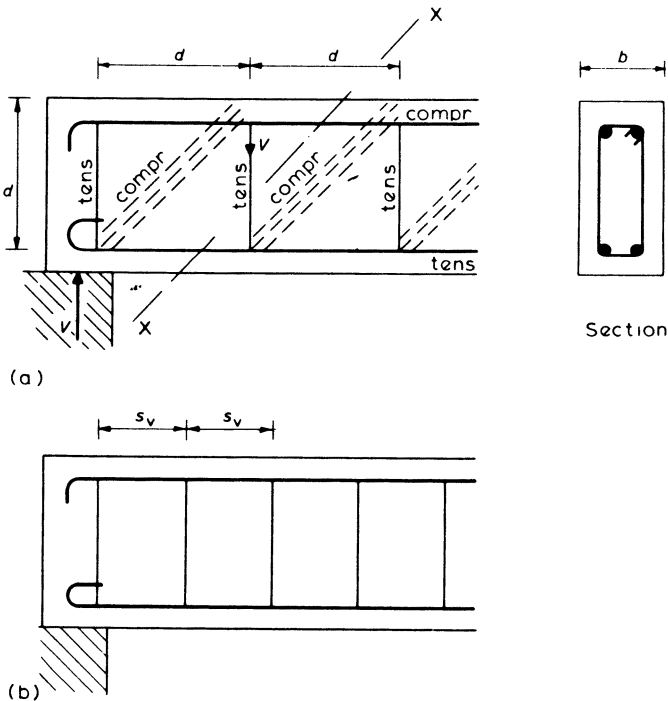

Figure 5.2 Stirrups and the analogous truss

In the analogous truss, let

$A_{sv}$  be the cross-sectional area of the two legs of the stirrup  
 $f_{yv}$  be the characteristic strength of the stirrup reinforcement  
 $V$  be the shear force due to the ultimate loads.

Using the method of sections it can be seen at section XX in the figure that at the ultimate limit state the force in the vertical stirrup member must equal the shear force  $V$ , that is

$$0.87 f_{yv} A_{sv} = V$$

or

$$0.87 f_{yv} A_{sv} = vbd \quad (5.1)$$

where  $v = V/bd$  is the average shear stress on the section.

When the stirrup spacing is less than the effective depth, a series of super-imposed equivalent trusses may be considered, so that the force to be resisted by the stirrup is reduced proportionally. Thus if  $s_v$  = the stirrup spacing, equation 5.1 becomes

$$0.87 f_{yv} A_{sv} = vbd \left( \frac{s_v}{d} \right)$$

or

$$\frac{A_{sv}}{s_v} = \frac{vb}{0.87 f_{yv}}$$

Since the concrete is also capable of resisting a limited amount of shear this equation is rewritten as

$$\frac{A_{sv}}{s_v} = \frac{b(v - v_c)}{0.87 f_{yv}} \quad (5.2)^*$$

where  $v_c$  is the ultimate shear stress that can be resisted by the concrete. Values of  $v_c$  are given in table 5.1. It can be seen from the table that  $v_c$  increases for shallow members and those with larger percentages of tensile reinforcement. The longitudinal tension bars contribute to the shear resistance by their dowelling action and they also help to prevent shear cracks from commencing at small tension cracks. To be effective, these tension bars should continue an effective depth,  $d$ , beyond the section, or at a support they should be adequately curtailed and anchored.

Close to supports, sections have an enhanced shear resistance owing in part to the induced compressive stresses from the concentrated reaction and the steeper angle of the failure plane, which would normally occur at angle of  $30^\circ$  to the horizontal for an unreinforced section. Within a distance of  $2d$  from a support or a concentrated load the design concrete shear stress  $v_c$  may be increased to  $v_c 2d/a_v$ . The distance  $a_v$  is measured from the support or concentrated load to the section being designed. This enhancement is useful when designing beams with concentrated loads near to a support, or with corbels and pile caps.

As a simplified approach for beams carrying mainly uniformly distributed loads, the critical section for design may be taken at a distance  $d$  from the face of the

**Table 5.1** Value of ultimate shear stress  $v_c$  (N/mm<sup>2</sup>) for a concrete strength of  $f_{cu} = 30$  N/mm<sup>2</sup>

$100 A_s$	Effective depth (mm)							
	$bd$	150	175	200	225	250	300	$\geq 400$
$\leq 0.15$		0.46	0.44	0.43	0.41	0.40	0.38	0.36
0.25		0.54	0.52	0.50	0.49	0.48	0.46	0.42
0.50		0.68	0.66	0.64	0.62	0.59	0.57	0.53
0.75		0.76	0.75	0.72	0.70	0.69	0.64	0.61
1.00		0.86	0.83	0.80	0.78	0.75	0.72	0.67
1.50		0.98	0.95	0.91	0.88	0.86	0.83	0.76
2.00		1.08	1.04	1.01	0.97	0.95	0.91	0.85
$\geq 3.00$		1.23	1.19	1.15	1.11	1.08	1.04	0.97

For characteristic strengths other than 30 N/mm<sup>2</sup> the values in the table may be multiplied by  $(f_{cu}/25)^{1/3}/1.06$ . The value of  $f_{cu}$  should not be greater than 40 N/mm<sup>2</sup>.

support using the value of  $v_c$  from table 5.1 in equation 5.2. The shear links required should then continue to the face of the support.

Large shearing forces are also liable to cause crushing of the concrete along the directions of the principal compressive stresses, and therefore at the face of a support the average shear stress should never exceed the lesser of  $0.8 \sqrt{f_{cu}}$  or 5 N/mm<sup>2</sup>.

The areas and spacings of the stirrups can be calculated from equation 5.2. Rearrangement of the equation gives the shearing resistance for a given stirrup size and spacing thus:

$$\text{Shear resistance} = v bd = \left( \frac{A_{sv}}{s_v} \times 0.87 f_{yv} + bv_c \right) d \quad (5.3)$$

Further information on the practical details and design examples are given in section 7.3 (Design for Shear).

### 5.1.2 Bent-up Bars

To resist the shearing forces, bars may be bent up near the supports as shown in figure 5.3. The bent-up bars and the concrete in compression are considered to act as an analogous lattice girder and the shear resistance of the bars is determined by taking a section XX through the girder.

From the geometry of part (a) of the figure, the spacing of the bent-up bars is

$$s_b = (d - d') (\cot \alpha + \cot \beta)$$

and at the section XX the shear resistance of the single bar is

$$V = 0.87 f_{yv} A_{sb} \sin \alpha \quad (5.4)$$

where  $A_{sb}$  is the cross-sectional area of the bent-up bar.

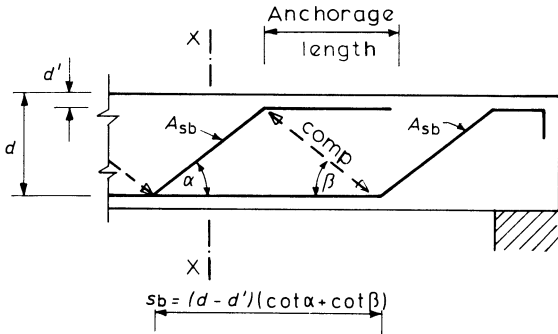

(a) Single System

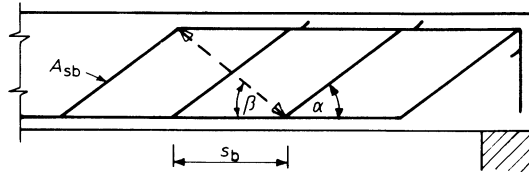

(b) Multiple System

Figure 5.3 Bent-up bars

For a multiple system of bent-up bars, as in part (b) of the figure, the shear resistance is increased proportionately to the spacing,  $s_b$ . Hence

$$V = 0.87 f_{yv} A_{sb} \sin \alpha \frac{(d - d') (\cot \alpha + \cot \beta)}{s_b} \tag{5.5}$$

The angles  $\alpha$  and  $\beta$  should both be greater than or equal to  $45^\circ$  and the code requires that the spacing  $s_b$  has a maximum value of  $1.5d$ . With  $\alpha = \beta = 45^\circ$  and  $s_b = (d - d')$ , equation 5.5 becomes

$$V = 1.23 f_{yv} A_{sb} \tag{5.6}$$

and this arrangement is commonly referred to as a double system.

**Example 5.1 Shear Resistance at a Section**

Determine the shear resistance of the beam shown in figure 5.4, which carries a uniformly distributed load. The characteristic strengths are:  $f_{yv} = 250 \text{ N/mm}^2$  for the stirrups,  $f_{yv} = 460 \text{ N/mm}^2$  for the bent-up bars and  $f_{cu} = 30 \text{ N/mm}^2$  for the concrete.

$$\frac{100 A_s}{bd} = \frac{100 \times 982}{350 \times 650} = 0.43$$

Thus, from table 5.1,  $v_c = 0.5 \text{ N/mm}^2$  by interpolation. Cross-sectional area of a size 12 bar =  $113 \text{ mm}^2$ .

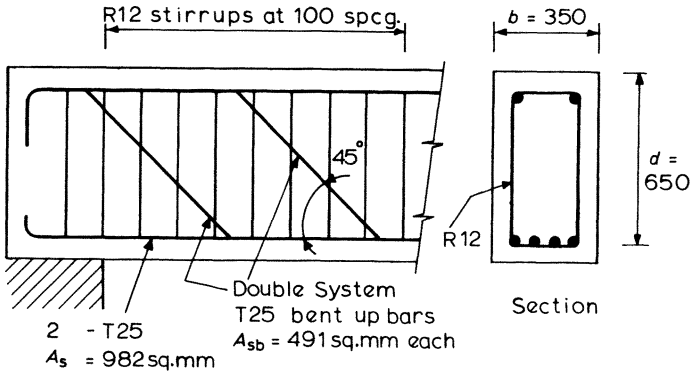

Figure 5.4 Beam with stirrups and bent-up bars

Thus, for the stirrups,  $A_{sv}/s_v = 2 \times 113/100 = 2.26$ .

The shear resistance of the stirrups plus the concrete is given by equation 5.3 as

$$\begin{aligned}
 V_s &= \frac{A_{sv}}{s_v} \times 0.87 f_{yv} d + b v_c d \\
 &= 2.26 \times 0.87 \times 250 \times 650 + 350 \times 0.5 \times 650 \\
 &= (319 + 114) \times 10^3 \text{ N} = 433 \times 10^3 \text{ N}
 \end{aligned}$$

The bent-up bars are arranged in a double system. Hence the shear resistance of the bent-up bars is

$$\begin{aligned}
 V_b &= 1.23 f_{yv} A_{sb} \\
 &= 1.23 \times 460 \times 491 \\
 &= 278 \times 10^3 \text{ N}
 \end{aligned}$$

Total shear resistance of the stirrups, concrete and bent-up bars is therefore

$$\begin{aligned}
 V &= V_s + V_b = (433 + 278) 10^3 \\
 &= 711 \times 10^3 \text{ N}
 \end{aligned}$$

It should be noted that the shear resistance of 319 kN provided by the stirrups is greater than the shear resistance of the bent-up bars, 278 kN, as required by BS 8110.

It should also be checked that at the face of the support  $V/bd$  does not exceed the lesser of  $0.8 \sqrt{f_{cu}}$  or  $5 \text{ N/mm}^2$ .

## 5.2 Anchorage Bond

The reinforcing bar subject to direct tension shown in figure 5.5 must be firmly anchored if it is not to be pulled out of the concrete. Bars subjected to forces induced by flexure must similarly be anchored to develop their design stresses. The

anchorage depends on the bond between the bar and the concrete, and the area of contact. Let

- $L$  = minimum anchorage length to prevent pull out
- $\Phi$  = bar size or nominal diameter
- $f_{bu}$  = ultimate anchorage bond stress
- $f_s$  = the direct tensile or compressive stress in the bar

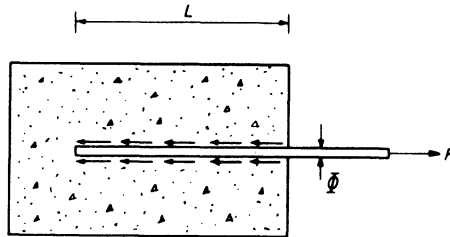

Figure 5.5 Anchorage bond

Considering the forces on the bar

tensile pull-out force = bar's cross-sectional area  $\times$  direct stress

$$= \frac{\pi \Phi^2}{4} f_s$$

anchorage force = contact area  $\times$  anchorage bond stress

$$= (L\pi\Phi) \times f_{bu}$$

therefore

$$(L\pi\Phi) f_{bu} = \frac{\pi \Phi^2}{4} \times f_s$$

hence

$$L = \frac{f_s}{4 f_{bu}} \Phi$$

and when  $f_s = 0.87 f_y$ , the ultimate tensile or compressive stress, the anchorage length is

$$L = \frac{0.87 f_y}{4 f_{bu}} \Phi \quad (5.7)^*$$

The design ultimate anchorage bond stress,  $f_{bu}$ , is obtained from the equation

$$f_{bu} = \beta \sqrt{f_{cu}} \quad (5.8)$$

The coefficient  $\beta$  depends on the bar type and whether the bar is in tension or compression. Values of  $\beta$  are given in table 5.2.

Equation 5.7 may be rewritten as

$$\text{anchorage length } L = K_A \Phi$$

**Table 5.2** Value of bond coefficient  $\beta$ 

Bar type	$\beta$	
	Bars in tension	Bars in compression
Plain bars	0.28	0.35
Type 1: deformed bars	0.40	0.50
Type 2: deformed bars	0.50	0.63
Fabric	0.65	0.81

Values of  $K_A$  corresponding to the anchorage of tension and compression bars for various grades of concrete and reinforcing bars have been tabulated in the appendix.

Anchorage may also be provided by hooks or bends in the reinforcement; their anchorage values are indicated in figure 5.6. When a bent bar or hook is used, the bearing stress on the inside of the bend should be checked as described in section 7.3.2 and example 7.8.

- (a) Anchorage value =  $4n$  but not greater than  $12\phi$

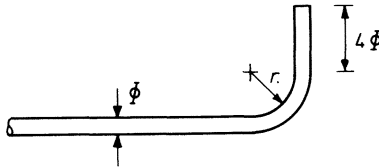

- (b) Anchorage value =  $8r$  but not greater than  $24\phi$

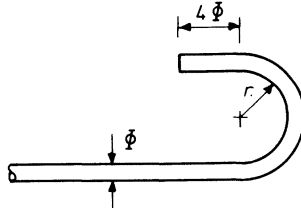

For mild steel bars minimum  $r = 2\phi$

For high yield bars minimum  $r = 3\phi$  or

$4\phi$  for sizes 25mm and above

**Figure 5.6** Anchorage values for bends and hooks

### Example 5.2 Calculation of Anchorage Length

Determine the length of tension anchorage required for the 25 mm diameter plain mild steel reinforcing bars in the cantilever of figure 5.7. The characteristic material strengths are  $f_{cu} = 30 \text{ N/mm}^2$  and  $f_y = 250 \text{ N/mm}^2$ .

The ultimate anchorage bond stress,  $f_{bu} = \beta \sqrt{f_{cu}} = 0.28 \sqrt{30} = 1.5 \text{ N/mm}^2$  (see table 5.2).

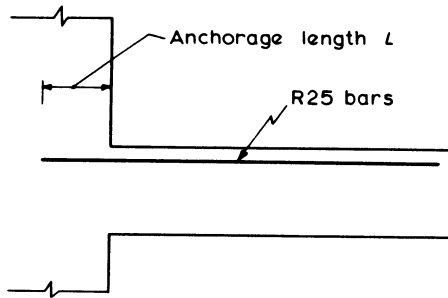

Figure 5.7 Anchorage for a cantilever beam

$$\begin{aligned} \text{Anchorage length } L &= \frac{0.87 f_y \Phi}{4 f_{bu}} \\ &= \frac{0.87 \times 250}{4 \times 1.5} \times 25 = 36.2 \times 25 \end{aligned}$$

therefore

$$L = 910 \text{ mm}$$

### 5.3 Laps in Reinforcement

Lapping of reinforcement is often necessary to transfer the forces from one bar to another. The rules for this are:

- (1) The laps should preferably be staggered and be away from sections with high stresses.
- (2) The minimum lap length should be not less than the greater of
  - 15 $\Phi$  or 300 mm for bars
  - 250 mm for fabric
- (3) Tension laps should be equal to at least the design tension anchorage length, but in certain conditions this should be increased as shown in figure 5.8, according to the following rules.
  - (a) At the top of a section and with minimum cover  $< 2\Phi$   
multiply by 1.4
  - (b) At corners where minimum cover to either face  $< 2\Phi$  or clear spacing between adjacent laps  $< 75 \text{ mm}$  or  $6\Phi$   
multiply by 1.4
  - (c) Where both (a) and (b) apply  
multiply by 2.0

The concrete at the top of a member is generally less compacted and also tends to have a greater water content, resulting in a lower concrete strength. Also, at the corners of members there is less confinement of the reinforcement. For these reasons longer lap lengths are required at these locations.

- (4) Compression laps should be at least 25 per cent greater than the compression anchorage length.
- (5) Lap lengths for unequal size bars may be based on the smaller bar.

A table of minimum lap lengths is included in the appendix.

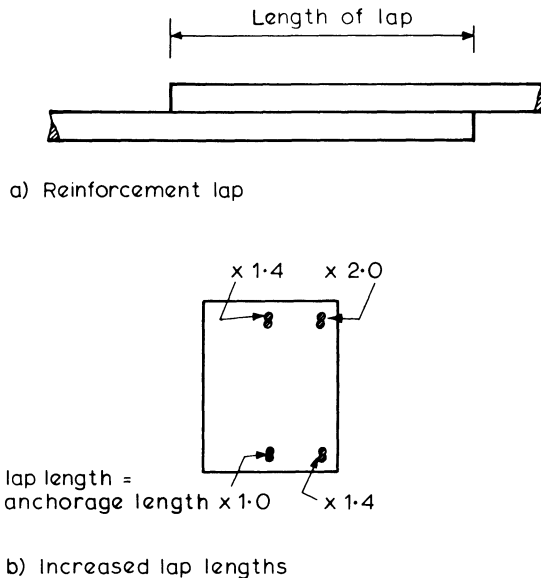

**Figure 5.8** *Lapping of reinforcing bars*

#### 5.4 Analysis of Section Subject to Torsional Moments

Torsional moments produce shear stresses which result in principal tensile stresses inclined at approximately  $45^\circ$  to the longitudinal axis of the member. Diagonal cracking occurs when these tensile stresses exceed the tensile strength of the concrete. The cracks will form a spiral around the member as in figure 5.9.

Reinforcement in the form of closed links and longitudinal bars will carry the forces from increasing torsional moment after cracking, by a truss action with reinforcement as tension members and concrete as compressive struts between links. Failure will eventually occur by reinforcement yielding, coupled with crushing of the concrete along line AA as the cracks on the other faces open up.

It is assumed that once the torsional shear stress on a section exceeds the value to cause cracking, tension reinforcement in the form of closed links must be provided to resist the full torsional moment.

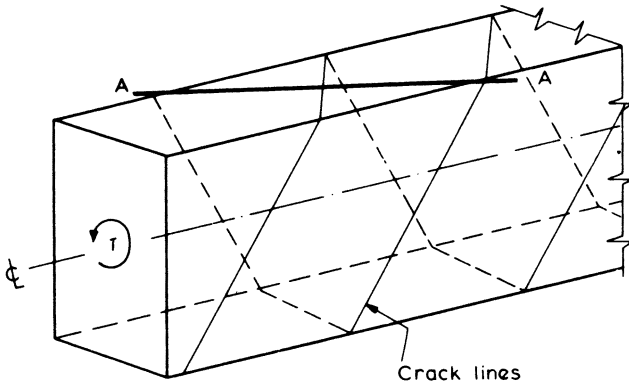

Figure 5.9 Torsional cracking

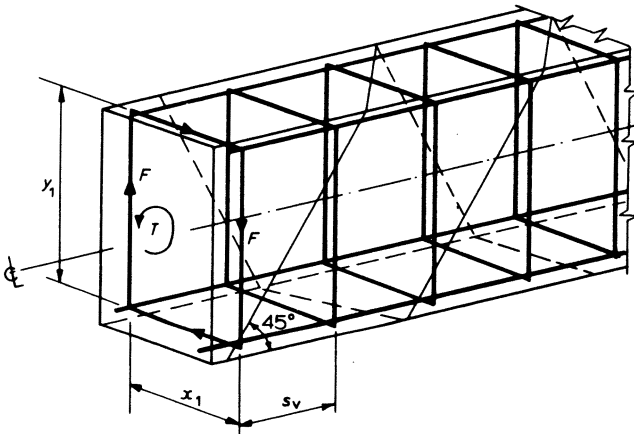

Figure 5.10 Torsional reinforcement

Tension force in link  $F = \frac{A_{sv}}{2} \times 0.87 f_{yv}$

moment of force  $F$  about centre line =  $F \frac{x_1}{2}$  for vertical leg

and

$$= F \frac{y_1}{2} \text{ for horizontal leg}$$

where  $A_{sv}$  = cross-sectional area of the two legs of a link. The total torsional moment provided by one closed link is, therefore, given by the sum of the moments due to each leg of the link about the centre line of the section, that is

$$T = F \frac{x_1}{2} \times 2 + F \frac{y_1}{2} \times 2$$

Where links are provided at a distance  $s_v$  apart, the torsional resistance of the system of links is obtained by multiplying the moments due to each leg in the above expressions by the number of legs crossing each crack. This number is given by  $y_1/s_v$  for vertical legs and  $x_1/s_v$  for horizontal legs if it is assumed that all cracks are approximately at  $45^\circ$ .

The total torsional resistance then becomes

$$T = \frac{A_{sv}}{2} (0.87 f_{yv}) \frac{y_1}{s_v} \frac{x_1}{2} \times 2 + \frac{A_{sv}}{2} (0.87 f_{yv}) \frac{x_1}{s_v} \frac{y_1}{2} \times 2$$

Hence

$$T = \frac{A_{sv}}{s_v} x_1 y_1 (0.87 f_{yv}) \times 0.8$$

The efficiency factor of 0.8 is included to allow for errors in assumptions made about the truss behaviour.

Hence closed links must be provided such that

$$\frac{A_{sv}}{s_v} \geq \frac{T}{0.8 x_1 y_1 (0.87 f_{yv})}$$

To ensure the proper action of these links, longitudinal bars evenly distributed round the inside perimeter of the links must be provided. This reinforcement which resists the longitudinal component of the diagonal tension forces should be such that the total quantity is equal to the same volume as the steel in the links, suitably adjusted to allow for differing strengths. This is given by

$$A_s \geq \frac{A_{sv}}{s_v} \frac{f_{yv}}{f_y} (x_1 + y_1)$$

where  $f_y$  is the characteristic yield strength of longitudinal reinforcement.

The calculated amounts of torsional reinforcement must be provided in addition to the full bending and shear reinforcement requirements for the ultimate load combination corresponding to the torsional moment considered. Where longitudinal bending reinforcement is required, the additional torsional steel area may either be provided by increasing the size of bars provided, or by additional bars. A member which is designed for torsion plus bending or shear will require to be heavily reinforced.

The clear distance between longitudinal torsion bars must not exceed 300 mm, and a minimum of four bars must be used in each link. All torsion steel must also extend a distance at least equal to the largest member dimension past the point at which it is not required to resist torsion, to ensure that all possible cracks are adequately protected.

The torsional shear stress on a section can be determined by a variety of methods. BS 8110 recommends a plastic analysis such that, for a rectangular section

$$v_t = \frac{2T}{h_{\min}^2 (h_{\max} - h_{\min}/3)}$$

where  $h_{\min}$  is the smaller dimension of the section,  $h_{\max}$  is the larger dimension of the section, or

$$v_t = \frac{T}{2Ah_t} \quad \text{for a thin hollow section}$$

where  $h_t$  is the wall thickness and  $A$  is the area enclosed by the centre-line of the walls.

If the sum of wall thicknesses of a hollow section exceeds one-quarter of the overall dimension, this should be treated as solid.

A section having a T-, L- or I-shape should be divided into component rectangles to maximise the function  $\Sigma(h_{\min}^3 h_{\max})$ . The torsion shear stress on each rectangle should then be calculated by considering the rectangle as carrying a torsional moment of

$$T \times \left( \frac{h_{\min}^3 h_{\max}}{\Sigma(h_{\min}^3 h_{\max})} \right)$$

Torsion reinforcement will be required if the torsional shear stress  $v_t$  exceeds the capacity of the concrete section. It has been found experimentally that this value is related approximately to the square root of the characteristic concrete cube strength, and the limiting value recommended by BS 8110 is

$$v_{t \min} = 0.067 \sqrt{f_{cu}} \quad \text{but not more than } 0.4 \text{ N/mm}^2$$

#### *Torsion Combined with Bending and Shear Stress*

Torsion is seldom present alone, and in most practical situations will be combined with shear and bending stresses.

#### (a) Shear Stresses

Diagonal cracking starts on the side of a member where torsional and shear stresses are additive. The shear force has a negligible effect on ultimate torsional strength when  $V < v_c bd$ , the shear strength of the concrete section, but once diagonal cracks form, the torsional stiffness is reduced considerably.

To ensure that crushing of the concrete does not occur (figure 5.9) the sum of the shear and torsion stresses on a section should not be excessive so that

$$(v + v_t) \not\geq v_{tu}$$

where

$$v_{tu} = 0.8 \sqrt{f_{cu}} \quad \text{or } 5 \text{ N mm}^2$$

Additionally in the case of small sections where  $y_1$  is less than 550 mm

$$v_t \not\geq v_{tu} \frac{y_1}{550}$$

must be satisfied to prevent spalling of the corners.

The recommendations for reinforcement to resist a combination of shear and torsion are given in table 7.3.

**(b) Bending Stresses**

When a bending moment is present, diagonal cracks will usually develop from the top of the flexural cracks. The flexural cracks themselves only slightly reduce the torsional stiffness, provided that the diagonal cracks do not develop. The final mode of failure will depend on the distribution and quantity of reinforcement present.

Figure 5.11 shows a typical ultimate moment and ultimate torsion interaction curve for a section. As can be seen, for moments up to approximately  $0.8M_u$  the section can also resist the full ultimate torsion  $T_u$ . Hence no calculations for torsion are generally necessary for the ultimate limit state of reinforced concrete unless torsion has been included in the original analysis or is required for equilibrium.

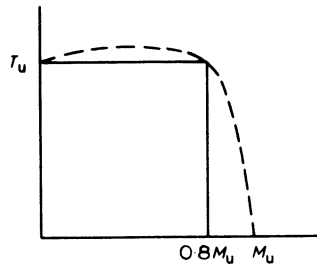

**Figure 5.11** *Combined bending and torsion*

# 6

## Serviceability, Durability and Stability Requirements

The concept of serviceability limit states has been introduced in chapter 2, and for reinforced concrete structures these states are often satisfied by observing empirical rules which affect the detailing only. In some circumstances, however, it may be desired to estimate the behaviour of a member under working conditions, and mathematical methods of estimating deformations and cracking must be used. The design of water-retaining structures, and prestressed concrete, are both based primarily on the avoidance or limitation of cracking and these are considered separately in other chapters.

Where the foundations of a structure are in contact with the ground, the pressures developed will influence the amount of settlement that is likely to occur. To ensure that these movements are limited to acceptable values and are similar throughout a structure, the sizes of foundations necessary are based on the service loads for the structure.

Durability is necessary to ensure that a structure remains serviceable throughout its lifetime. This requirement will involve aspects of design, such as concrete mix selection and determination of cover to reinforcing bars, as well as selection of suitable materials for the exposure conditions which are expected. Good construction procedures including adequate curing are also essential if reinforced concrete is to be durable.

Simplified rules governing the selection of cover, member dimensions, and reinforcement detailing are given in section 6.1 and 6.2, while more rigorous procedures for calculation of actual deflections and crack widths are described in sections 6.3 to 6.5. Durability and fire resistance are discussed in section 6.6.

The stability of a structure under accidental loadings, although an ultimate limit state analysis, will usually take the form of a check to ensure that empirical rules designed to give a reasonable minimum resistance against misuse or accident are satisfied. Like serviceability checks, this will often merely involve detailing of reinforcement and not affect the total quantity provided. Stability requirements are described in section 6.7.

## 6.1 Detailing Requirements

These are to ensure that a structure has satisfactory durability and serviceability performance under normal circumstances. BS 8110 recommends simple rules concerning the concrete mix and cover to reinforcement, minimum member dimensions, and limits to reinforcement quantities and spacings which must be taken into account at the member sizing and reinforcement detailing stages. Reinforcement detailing may also be affected by stability considerations as described in section 6.7, as well as rules concerning anchorage and lapping of bars which have been discussed in sections 5.2 and 5.3.

### 6.1.1 Minimum Concrete Mix and Cover (Exposure Conditions)

These requirements are interrelated, and BS 8110 specifies minimum combinations of thickness of cover and mix characteristics for various exposure conditions. The mixes are expressed in terms of minimum cement content, maximum water/cement ratio and corresponding minimum strength grade. These basic requirements are given in table 6.1.

The nominal cover is that to all steel, and allows for a maximum fixing tolerance of  $\pm 5$  mm. Adjustments must be made to cement contents if different aggregate sizes are used, and details of these and other possible modifications are given in BS 8110.

### 6.1.2 Minimum Member Dimensions and Cover (Fire Resistance)

BS 8110 also provides tabulated values of minimum dimensions and nominal covers for various types of concrete member which are necessary to permit the member to withstand fire for a specified period of time. These are summarised in tables 6.2 and 6.3.

### 6.1.3 Maximum Spacing of Reinforcement

The maximum clear spacings given in table 6.4 apply to bars in tension in beams when a maximum likely crack width of 0.3 mm is acceptable and the cover to reinforcement does not exceed 50 mm.

It can be seen that the spacing is restricted according to the amount of moment redistribution applied. Any bar of diameter less than 0.45 times that of the largest bar in a section must be ignored when applying these spacings. Bars adjacent to corners of beams must not be more than one-half of the clear distance given in table 6.4 from the corner.

Rules for slabs permit greater spacings under specified conditions as follows:

- (a) If  $h \leq 200$  mm with high yield steel ( $f_y = 460$  N/mm<sup>2</sup>)
- or (b) If  $h \leq 250$  mm with Mild steel ( $f_y = 250$  N/mm<sup>2</sup>)
- or (c) If  $100 A_s/bd \leq 0.3$  per cent

then the maximum clear spacing between bars should not exceed 750 mm or  $3d$ , whichever is smaller.

**Table 6.1** Nominal cover and mix requirements for normal weight 20 mm maximum size aggregate concrete

Environment classification	Nominal cover to all reinforcement (mm)				
<i>Mild</i> : for example, protected against weather or aggressive conditions	25	20	20	20	20
<i>Moderate</i> : for example, sheltered from severe rain and freezing while wet; subject to condensation or continuously under water; in contact with non-aggressive soil	—	35	30	25	20
<i>Severe</i> : for example, exposed to severe rain; alternate wetting and drying; occasional freezing or severe condensation	—	—	40	30	25
<i>Very Severe</i> : for example, exposed to sea water spray, de-icing salts, corrosive fumes or severe wet freezing	—	—	50*	40*	30
<i>Extreme</i> : for example, exposed to abrasive action (sea water and solids, flowing acid water, machinery or vehicles)	—	—	—	60*	50
Maximum free water/cement ratio	0.65	0.60	0.55	0.50	0.45
Minimum cement content (kg/m <sup>3</sup> )	275	300	325	350	400
Lowest concrete grade	C30	C35	C40	C45	C50

\*Entrained air required for wet freezing.

**Table 6.2** Nominal cover for fire resistance

Fire resistance (hours)	Nominal cover to all reinforcement (mm)						
	Beams		Floors		Ribs		Columns
	s.s.	cont.	s.s.	cont.	s.s.	cont.	
0.5	20	20	20	20	20	20	20
1.0	20	20	20	20	20	20	20
1.5	20	20	25	20	35	20	20
2.0	40	30	35	25	45*	35	25
3.0	60*	40	45*	35	55*	45*	25
4.0	70*	50*	55*	45*	65*	55*	25

\*Additional measures necessary to reduce risk of spalling.

**Table 6.3** Minimum dimensions of RC members for fire resistance  
(nominal cover requirements satisfied)

Fire resistance (hours)	Minimum dimensions (mm)					
	Beam width	Rib width	Floor thickness	Exposed column width	Wall thicknesses	
					$\frac{A_s}{A_c} < 0.4\%$	$> 1.0\%$
0.5	200	125	75	150	150	75
1.0	200	125	95	200	150	75
1.5	200	125	110	250	175	100
2.0	200	125	125	300		100
3.0	240	150	150	400		150
4.0	280	175	170	500		180

**Table 6.4** Maximum clear spacings (mm) for tension bars in beams

$f_y$	% Moment redistribution						
	-30	-20	10	0	+10	+20	+30
250	210	240	270	300	300	300	300
460	115	130	145	160	180	195	210

If none of these apply, the maximum spacing should be taken as that given in table 6.4, except that if the ratio  $100A_s/bd$  is less than 1.0, the values from table 6.4 should be divided by that ratio. If the amount of moment redistribution is unknown when using table 6.4 for slabs, zero should be assumed for span moments and -15 per cent for support moments.

**6.1.4 Minimum Spacing of Reinforcement**

To permit concrete flow around reinforcement during construction the minimum clear gap between bars, or groups of bars, should exceed  $(h_{agg} + 5 \text{ mm})$  horizontally and  $(2h_{agg}/3)$  vertically, where  $h_{agg}$  is the maximum size of the coarse aggregate. The gap must also exceed the bar diameter, or in the case of ‘bundled bars’ the diameter of a bar of equivalent total cross-sectional area.

**6.1.5 Minimum Areas of Reinforcement**

For most purposes, thermal and shrinkage cracking may be controlled within acceptable limits by the use of minimum reinforcement quantities specified by BS 8110, although requirements of water-retaining structures will be more stringent (see chapter 11). The principal requirements are summarised in table 6.5, although other requirements include 0.15 per cent transverse reinforcement in the top surfaces of flanges in flanged beams and 0.25 per cent (High yield) or 0.30 per cent (Mild steel) anti-crack steel in plain walls (bar diameter  $\nless 6 \text{ mm}$  or

one-quarter diameter of vertical compressive bars). Requirements for shear links and column binders are given in sections 7.3 and 9.3 respectively.

**Table 6.5** Minimum reinforcement areas

		Mild steel ( $f_y = 250$ N/mm <sup>2</sup> )	High yield steel ( $f_y = 460$ N/mm <sup>2</sup> )
<i>Tension reinforcement</i>			
(1) Pure tension	$100A_s/A_c$	= 0.8%	0.45%
(2) Flexure			
(a) rectangular section (both ways in solid slabs)	$100A_s/A_c$	} = 0.24%	0.13%
(b) flanged – web in tension			
$b_w/b \geq 0.4$	$100A_s/b_w h$	= 0.32%	0.18%
$b_w/b < 0.4$	$100A_s/b_w h$		
– flange in tension			
T-beam	$100A_s/b_w h$	= 0.48%	0.26%
L-beam	$100A_s/b_w h$	= 0.36%	0.20%
<i>Compression reinforcement</i>			
(1) General	$100A_{sc}/A_{cc}$	} = 0.4%	0.4%
(2) Rect. column or wall	$100A_{sc}/A_c$		
(3) Flanged beam			
flange in compression	$100A_{sc}/bh_f$	} = 0.2%	0.2%
web in compression	$100A_{sc}/b_w h$		
(4) Rectangular beam	$100A_{sc}/A_c$		

### 6.1.6 Maximum Areas of Reinforcement

These are determined largely from the practical need to achieve adequate compaction of the concrete around reinforcement. The limits specified by BS 8110 are as follows.

- (a) For a Slab or Beam, Longitudinal Steel

$$\frac{100A_s}{bh} \quad \text{or} \quad \frac{100A_{sc}}{bh} \quad \text{not greater than 4 per cent each}$$

Where bars are lapped, the sum of the bar sizes in a layer must not be greater than 40 per cent of the section breadth.

- (b) For a Column

$$\frac{100A_s}{bh} \quad \text{not greater than 6 per cent if cast vertically}$$

not greater than 8 per cent if cast horizontally  
not greater than 10 per cent at laps in either case

**6.1.7 Side Face Reinforcement in Beams**

Where beams exceed 750 mm in depth, longitudinal bars should be provided near side faces at a spacing  $\geq 250$  mm over a distance  $2h/3$  from the tension face. These bars, which may be used in calculating the moment of resistance, must have a diameter  $> \sqrt{(s_b b / f_y)}$  where  $s_b$  is the bar spacing and  $b$  the breadth of the section (or 500 mm if less), as indicated in figure 6.1.

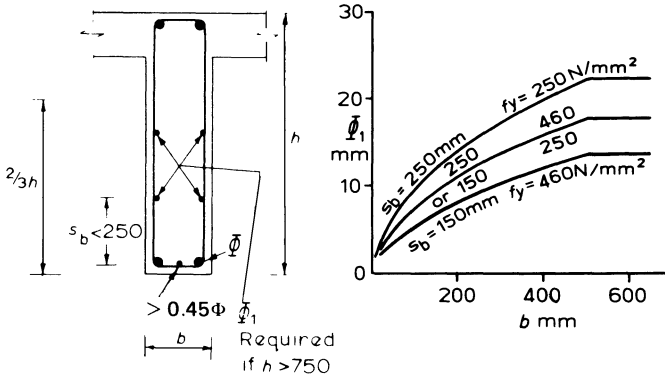

**Figure 6.1** Side face reinforcement in beams

**6.2 Span-Effective Depth Ratios**

BS 8110 specifies a set of basic span-effective depth ratios to control deflections which are given in table 6.6 for rectangular sections and for flanged beams with spans less than 10 m. Where the web width of a flanged beam  $b_w > 0.3b$ , linear interpolation should be used between the values for a flanged beam and a rectangular section. Ratios for spans  $> 10$  m are factored as in example 6.1.

**Table 6.6** Basic span-effective depth ratios

	Rectangular section	Flanged ( $b_w \leq 0.3b$ )
Cantilever	7	5.6
Simply supported	20	16.0
Continuous	26	20.8

The basic ratios given in table 6.6 are modified in particular cases according to

- (a) The service stress in the tension steel and the value of  $M/bd^2$ , as shown in table 6.7, which is also presented in the form of a chart in figure 8.4.
- (b) The area of compression steel as in table 6.8.

The area of tension reinforcement provided is related to the value of  $M/bd^2$ , thus lower values of service stress and  $M/bd^2$  will result in smaller depths of neutral axis  $x$ . This effect will reduce deflections due to creep, as there will be less of the

section subject to compressive stresses. Compression reinforcement restrains creep deflections in a similar manner and also reduces the effects of shrinkage.

**Table 6.7** Tension reinforcement modification factors

Reinforcement service stress	(N/mm <sup>2</sup> )	$M/bd^2$									
		0.50	0.75	1.0	1.5	2.0	3.0	4.0	5.0	6.0	
$(f_y = 250)$	100	2.0	2.0	2.0	1.86	1.63	1.36	1.19	1.08	1.01	
	156	2.0	2.0	1.96	1.66	1.47	1.24	1.10	1.00	0.94	
	200	2.0	1.95	1.76	1.51	1.35	1.14	1.02	0.94	0.88	
$(f_y = 460)$	288	1.68	1.50	1.38	1.21	1.09	0.95	0.87	0.82	0.78	

The service stress in the reinforcement  $f_s$  is usually a function of the yield stress  $f_y$ , as indicated in the table. The reinforcement areas  $A_s$  and  $A'_s$  are measured at the centre of span, or at the support for a cantilever, and the value of  $A'_s$  used with table 6.8 should include all bars located in the compression zone.

**Table 6.8** Compression reinforcement modification factors

$\frac{100A'_{s,prov}}{bd}$	Factor
0.00	1.00
0.15	1.05
0.25	1.08
0.35	1.10
0.50	1.14
0.75	1.20
1.0	1.25
1.5	1.33
2.0	1.40
2.5	1.45
$\geq 3.0$	1.50

The use of these factors is illustrated by example 6.1. It should be noted that the basic ratios given in table 6.6 are for uniformly distributed loadings, and procedures for making adjustments to the basic ratios to allow for other loading patterns are given in section 6.3.4 and illustrated by example 6.3.

**Example 6.1 Span-Effective Depth Ratio Check**

A rectangular continuous beam spans 12 m with a mid-span ultimate moment of 400 kN m. If the breadth is 300 mm, check the acceptability of an effective depth of 600 mm when high yield reinforcement  $f_y = 460 \text{ N/mm}^2$  is used. Two 16 mm bars are located within the compressive zone.

Basic span-effective depth ratio (table 6.6) = 26.

To avoid damage to finishes, modified ratio =  $26 \times \frac{10}{12} = 21.7$ .

Tensile reinforcement modification factor:

$$\frac{M}{bd^2} = \frac{400 \times 10^6}{300 \times 600^2} = 3.7$$

thus, from table 6.7 for  $f_y = 460 \text{ N/mm}^2$ , modification factor = 0.89.

Compression reinforcement modification factor:

$$\frac{100A'_s}{bd} = \frac{100 \times 402}{300 \times 600} = 0.22$$

thus from table 6.8, modification factor = 1.07.

Hence, modified span-effective depth ratio is equal to

$$21.7 \times 0.89 \times 1.07 = 20.7$$

Span-effective depth ratio provided =  $\frac{12 \times 10^3}{600} = 20$

which is less than the allowable upper limit, thus deflection requirements are likely to be satisfied.

### 6.3 Calculation of Deflections

The general requirement is that neither the efficiency nor appearance of a structure is harmed by the deflections which will occur during its life. Deflections must thus be considered at various stages. The limitations necessary to satisfy the requirements will vary considerably according to the nature of the structure and its loadings, but for reinforced concrete the following may be regarded as reasonable guides.

- (1) The final deflection of horizontal members below the level of casting should not exceed span/250.
- (2) The deflection taking place after fixing of partitions or application of finishes should not exceed the lesser of 20 mm or span/500 to avoid damage.

Lateral deflections must not be ignored, especially on tall slender structures, and limitations in these cases must be judged by the engineer. It is important to realise that there are many factors which may have significant effects on deflections, and are difficult to allow for, thus any calculated value must be regarded as an estimate only. The most important of these effects are as follows.

- (1) Support restraints must be estimated on the basis of simplified assumptions, which will have varying degrees of accuracy.

- (2) The precise loading and duration cannot be predicted and errors in dead loading may have significant effect.
- (3) A cracked member will behave differently to one that is uncracked – this may be a problem in lightly reinforced members where the working load may be close to the cracking limits.
- (4) The effects of floor screeds, finishes and partitions are very difficult to assess. Frequently these are neglected despite their ‘stiffening’ effect.

It may sometimes be possible to allow for these factors by averaging maximum and minimum estimated effects, and provided that this is done there are a number of calculation methods available which will give reasonable results. The method adopted by BS 8110 is very comprehensive, and is based on the calculation of curvatures of sections subjected to the appropriate moments, with allowance for creep and shrinkage effects where necessary. Deflections are then calculated from these curvatures.

The procedure for estimating deflections is rather lengthy and complex, involving the following stages which are illustrated in example 6.2.

- (1) Calculate the short-term curvature under total load;  $C_{s,tot}$ .
- (2) Calculate the short-term deflection from (1), and if the long-term deflection is required:
- (3) Calculate the short-term curvature due to permanent loads,  $C_{s,perm}$ .
- (4) Calculate the long-term curvature due to permanent loads,  $C_{l,perm}$ .
- (5) Calculate the curvature due to shrinkage,  $C_{shr}$ .
- (6) Estimate the total long-term curvature  $C_l$  as

$$C_l = C_{s,tot} - C_{s,perm} + C_{l,perm} + C_{shr}$$

- (7) Calculate the long-term deflection using the value from (6).

The curvatures in (1), (3) and (4) are taken as the larger value from considering the section as

- (a) cracked
- (b) uncracked.

As the concrete may have cracked under the total load, the additional short-term curvature  $C_{s,temp}$  due to the temporary loading is obtained from

$$C_{s,temp} = C_{s,tot} - C_{s,perm}$$

in part (6) of the procedure and is not calculated directly.

If deflections are assumed to be small, elastic bending theory is based on the expression

$$M_x = EI \frac{d^2y}{dx^2} \quad (6.1)$$

where  $M_x$  is the bending moment at a section distance  $x$  from the origin as shown in figure 6.2.

For small deflections the term  $d^2y/dx^2$  approximately equals the curvature, which is the reciprocal of the radius of curvature; thus

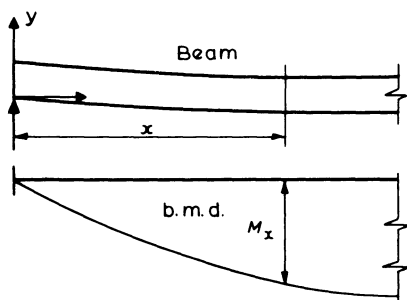

Figure 6.2 Curvature of a beam

$$M_x = EI \frac{1}{r_x} \tag{6.2}$$

where  $1/r_x$  is the curvature at  $x$ .

Integrating expression 6.1 twice will yield values of displacements  $y$  of the member, thus if curvatures of a member are known, displacements can be deduced.

The analysis of deflections will use the partial factors of safety from tables 2.1 and 2.2, which effectively mean that materials properties are taken as the characteristic values, and that loadings are true working loads.

### 6.3.1 Calculation of Curvatures – Short Term

The curvature of any section should be taken as the larger value obtained from considering the section to be either uncracked or cracked.

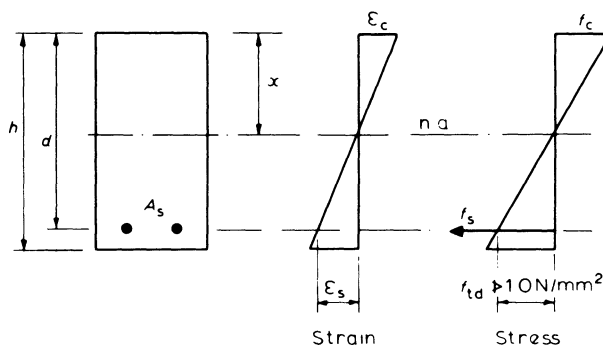

Figure 6.3 Uncracked section – strain and stress distribution

#### Uncracked Section

The assumed elastic strain and stress distributions are shown in figure 6.3, and the upper limit to concrete stress at the level of tension reinforcement should be noted.

From equation 6.2

$$\text{curvature } \frac{1}{r} = \frac{M}{E_c I}$$

From the theory of bending

$$f_c = \frac{Mx}{I}$$

hence

$$\frac{1}{r} = \frac{f_c}{E_c} \frac{1}{x}$$

where  $M$  = applied moment at section considered

$E_c$  = instantaneous static modulus of elasticity of concrete (for short-term deflections)

$I$  = second moment of area of section

$f_c$  = maximum compressive stress in the concrete

$x$  = depth of neutral axis.

The above expression gives the instantaneous curvature of the uncracked section. If this is found to be greater than for a cracked section, the tensile stress  $f_{td}$  of the concrete at the level of tension reinforcement must be checked.

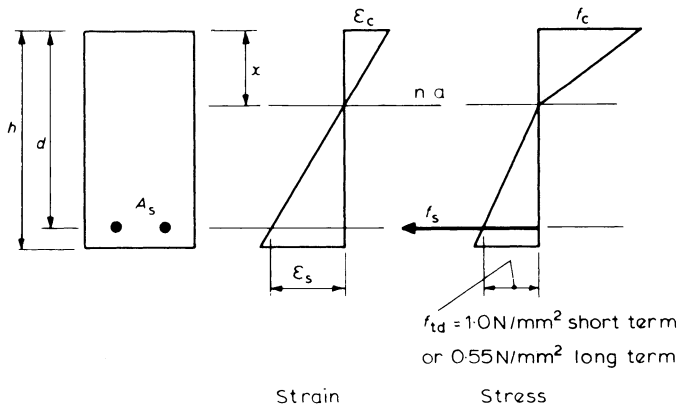

Figure 6.4 Cracked section – strain and stress distribution

### Cracked Section

The recommended stress and strain distribution are given in figure 6.4 where the stiffening effect of the cracked concrete is taken into account by the tensile stress block shown.

$$\text{Curvature } \frac{1}{r} = \frac{f_c}{xE_c} = \frac{f_s}{(d-x)E_s}$$

Hence it is necessary to analyse the section subjected to its applied moment  $M$  to obtain values of  $x$  and either  $f_c$  or  $f_s$ . This calculation is ideally suited to computer application, but if required to be solved manually must be performed on a trial and error basis.

Considering the section equilibrium by taking moments about the centre of compression

$$M = A_s f_s \left( d - \frac{x}{3} \right) + \frac{1}{3} b h f_{ct} (h - x) \quad (6.3)$$

and from the strain distribution

$$f_c = \frac{x}{(d - x)} \frac{E_c}{E_s} f_s \quad (6.4)$$

and equating tension and compression forces

$$\frac{1}{2} b x f_c = f_s A_s + \frac{1}{2} b (h - x) f_{ct} \quad (6.5)$$

where  $f_{ct}$  = maximum tensile stress allowed in the concrete

$$= \left( \frac{h - x}{d - x} \right) f_{td}$$

$$E_s = 200 \text{ kN/mm}^2$$

$$E_c = \text{instantaneous static modulus of elasticity of concrete (for short-term deflection)}$$

The most convenient method of solving these expressions is to assume a neutral axis position; for this value of  $x$  evaluate  $f_s$  from equation 6.3 and using this value obtain two values of  $f_c$  from equations 6.4 and 6.5. This should be repeated for two further trial values of  $x$ , and a plot of  $f_c$  from each expression is made against  $x$ . The intersection of the two curves will yield values of  $x$  and  $f_c$  with sufficient accuracy to permit the curvature to be calculated. This method is demonstrated in example 6.2.

### 6.3.2 Calculation of Curvatures – Long Term

In calculating long-term curvatures it is necessary to take into account the effects of creep and shrinkage in addition to the reduced tensile resistance of the cracked concrete as indicated in figure 6.4.

#### Creep

This is allowed for by reducing the effective modulus of elasticity of the concrete to  $E_{\text{eff}} = E_c / (1 + \phi)$  where  $\phi$  is a creep coefficient, equal to the ratio of creep strain to initial elastic strain.

The value of  $\phi$ , while being affected by aggregate properties, mix design and curing conditions, is governed also by the age at first loading, the duration of the load and the section dimensions. Figure 6.5 gives long-term values of  $\phi$ , as suggested by BS 8110, and it may be assumed that about 40 per cent, 60 per cent and 80 per cent of this will occur within 1 month, 6 months and 30 months under load

respectively for constant relative humidity. The effective section thickness is taken as twice the cross-sectional area divided by the exposed perimeter, but is taken as 600 mm if drying is prevented by sealing or immersion of the concrete in water.

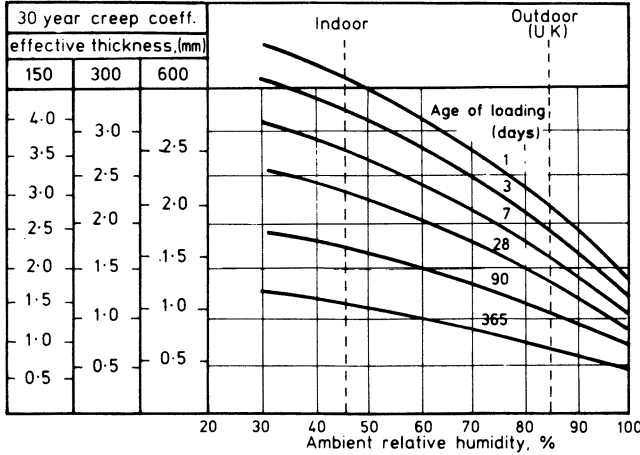

Figure 6.5 Creep coefficients

*Shrinkage*

Curvature due to shrinkage must be estimated and added to that due to applied moments, such that

$$\frac{1}{r_{cs}} = \frac{\epsilon_{cs} \alpha_e S_s}{I}$$

where  $\epsilon_{cs}$  is the free shrinkage strain,  $\alpha_e$  is the modular ratio  $E_s/E_{eff}$ , and  $S_s$  is the first moment of area of the reinforcement about the centroid of the cracked or gross cross-section as appropriate.

Shrinkage is influenced by many features of the mix and construction procedures, but for most circumstances where aggregates do not have high shrinkage characteristics, values of  $\epsilon_{cs}$  may be obtained from figure 6.6 which is based on BS 8110.

The total long-term curvature of a section subjected to a combination of permanent and non-permanent loads should be compounded as follows.

$$\begin{aligned} \text{Total long-term curvature} = & \text{long-term curvature due to permanent loads} \\ & + \text{short-term curvature due to non-permanent} \\ & \text{loads} + \text{shrinkage curvature} \end{aligned}$$

In this expression the short-term curvature due to the non-permanent loads is calculated as the curvature due to the total loads minus that due to the permanent loads. This is because the total loads may cause a cracked section and a larger curvature.

The net result is that the long-term curvature of a reinforced concrete member may be considerably greater than the instantaneous value, as illustrated in example 6.2.

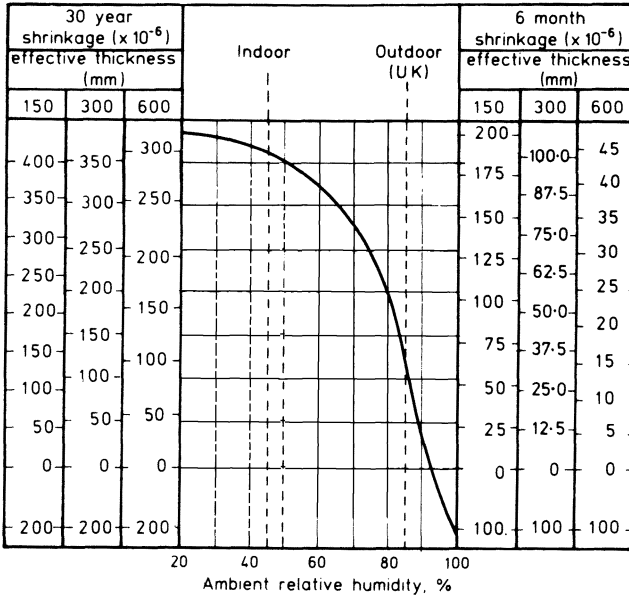

Figure 6.6 Drying shrinkage

6.3.3 Calculation of Deflections from Curvatures

Double integration of the expression 6.1

$$EI \frac{d^2y}{dx^2} = M_x$$

will yield an expression for the deflection. This may be illustrated by considering the case of a pin-ended beam subjected to constant moment  $M$  throughout its length, so that  $M_x = M$ .

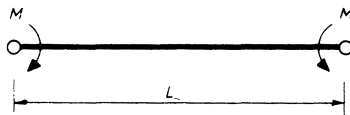

Figure 6.7 Pin-ended beam subjected to constant moment  $M$

$$EI \frac{d^2y}{dx^2} = M \tag{6.6}$$

therefore

$$EI \frac{dy}{dx} = Mx + C$$

but if the slope is zero at mid-span where  $x = L/2$ , then

$$C = -\frac{ML}{2}$$

and

$$EI \frac{dy}{dx} = Mx - \frac{ML}{2}$$

Integrating again gives

$$EIy = \frac{Mx^2}{2} - \frac{MLx}{2} + D$$

but at support A when  $x = 0$ ,  $y = 0$ . Hence

$$D = 0$$

thus

$$y = \frac{M}{EI} \left( \frac{x^2}{2} - \frac{Lx}{2} \right) \quad \text{at any section} \quad (6.7)$$

The maximum deflection in this case will occur at mid-span, where  $x = L/2$ , in which case

$$y_{\max} = -\frac{M}{EI} \frac{L^2}{8} \quad (6.8)$$

but since at any uncracked section

$$\frac{M}{EI} = \frac{1}{r}$$

the maximum deflection may be expressed as

$$y_{\max} = -\frac{1}{8} L^2 \frac{1}{r}$$

In general, the bending-moment distribution along a member will not be constant, but will be a function of  $x$ . The basic form of the result will however be the same, and the deflection may be expressed as

$$\text{maximum deflection } a = KL^2 \frac{1}{r_b} \quad (6.9)^*$$

where

$K$  = a constant, the value of which depends on the distribution of bending moments in the member

$L$  = the effective span

$\frac{1}{r_b}$  = the mid-span curvature for beams, or the support curvature for cantilevers

Typical values of  $K$  are given in table 6.9 for various common shapes of bending-moment diagrams. If the loading is complex, then a value of  $K$  must be estimated for the complete load since summing deflections of simpler components will yield incorrect results.

Although the derivation has been on the basis of an uncracked section, the final expression is in a form that will deal with a cracked section simply by the substitution of the appropriate curvature.

Since the expression involves the square of the span, it is important that the true effective span as defined in chapter 7 is used, particularly in the case of cantilevers. Deflections of cantilevers may also be increased by rotation of the supporting member, and this must be taken into account when the supporting structure is fairly flexible.

**Table 6.9** Typical deflection coefficients

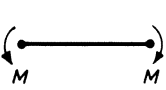
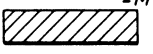
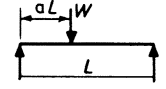
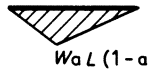
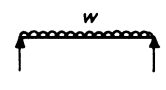
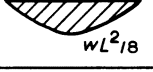
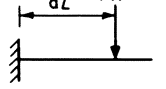
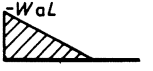
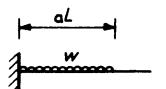
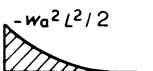
Loading	B.M. Diagram	$K$
		0.125
		$\frac{4a^2 - 8a + 1}{48a}$ [if $a = 1/2$ then $K = 0.083$ ]
		0.104
		End Deflection $\frac{a(3-a)}{6}$ [if $a = 1$ then $K = 0.33$ ]
		End Deflection $\frac{a(4-a)}{12}$ [if $a = 1$ then $K = 0.25$ ]

**Example 6.2 Calculation of a Deflection**

Estimate short-term and long-term deflections for the simply supported beam shown in figure 6.8, which is assumed to be made of normal aggregates and props removed at twenty-eight days.

- Concrete grade: 30
- Instantaneous static modulus of elasticity = 26 kN/mm<sup>2</sup>
- Reinforcement: Hot-rolled high yield  $f_y = 460$  N/mm<sup>2</sup>
- Loading: Dead (permanent) = 10 kN/m u.d.l.
- Live (transitory) = 5 kN/m u.d.l.

(a) Calculate Design Moments at Mid-span

From table 2.1

$$\gamma_m = 1.0 \text{ for steel and concrete}$$

From table 2.2

$$\gamma_f = 1.0 \text{ for dead and live loads}$$

$$\text{Design moments} - \text{total} = \frac{15 \times 12^2}{8} = 270 \text{ kN m}$$

$$\text{Permanent} = \frac{10 \times 12^2}{8} = 180 \text{ kN m}$$

$$\text{Live} = \frac{5 \times 12^2}{8} = 90 \text{ kN m}$$

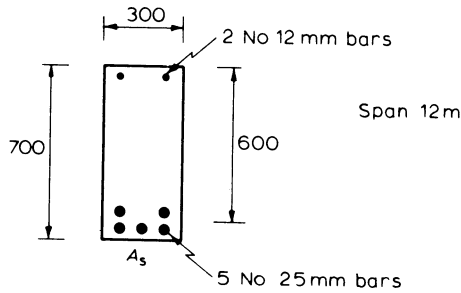

Figure 6.8

(b) Calculate Short-term Curvature – Uncracked Section – Total Load

$$\begin{aligned} \frac{1}{r_b} &= \frac{M}{E_c I} \\ &= \frac{270 \times 10^6}{26 \times 10^3 \times 300 \times 700^3 / 12} = 1.2 \times 10^{-6} / \text{mm} \end{aligned}$$

(c) Calculate Short-term Curvature – Cracked Section – Total Load

Consider equations 6.3, 6.4 and 6.5. Assume  $x = 100$  and substitute in equation 6.3, that is

$$M = A_s f_s \left( d - \frac{x}{3} \right) + \frac{1}{3} b h f_{ct} (h - x)$$

with

$$\begin{aligned} f_{ct} &= \left( \frac{h - x}{d - x} \right) \times 1.0 = \frac{700 - 100}{600 - 100} \\ &= 1.2 \text{ N/mm}^2 \end{aligned}$$

and

$$A_s = 2450 \text{ mm}^2$$

thus

$$f_s = \left( 270 \times 10^6 - \frac{300 \times 700 \times 600 \times 1.2}{3} \right) \times \frac{1}{567 \times 2450} = 158 \text{ N/mm}^2$$

From equation 6.4

$$f_c = f_{c1} = \frac{x}{(d - x)} \frac{E_c}{E_s} f_s = \frac{100}{500} \times \frac{26}{200} \times 158 = 4.1 \text{ N/mm}^2$$

But  $f_c$  is also given by equation 6.5 as

$$f_c = f_{c2} = \frac{f_s A_s + \frac{1}{2} b (h - x) f_{ct}}{\frac{1}{2} b x} = \frac{158 \times 2450 + 0.5 \times 300 \times 600 \times 1.2}{150 \times 100} = 33.0 \text{ N/mm}^2$$

These values of  $f_c$  do not agree, therefore further depths of the neutral axis are tried giving the following results.

$x$	$f_{c1}$	$f_{c2}$
100	4.1	33.0
210	12.2	16.5
300	24.7	12.1

These values are plotted in figure 6.9a from which it is seen that  $f_{c1} = f_{c2} = f_c = 15 \text{ N/mm}^2$  approximately, at  $x = 230 \text{ mm}$ . Hence

$$\frac{1}{r_b} = \frac{f_c}{x E_c} = \frac{15}{230 \times 26 \times 10^3} = 2.5 \times 10^{-6} / \text{mm}$$

Since this curvature is greater than the uncracked value, it is not necessary to check the concrete tensile stress for that case, the cracked value of  $2.5 \times 10^{-6} / \text{mm}$  being used to determine the deflection.

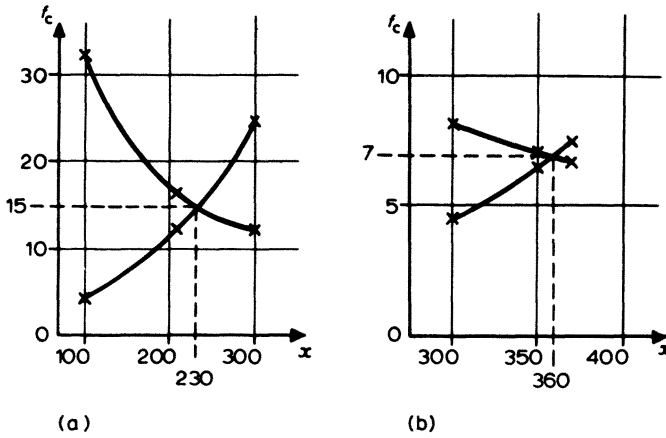

Figure 6.9

(d) Calculate Short-term Deflection – Total Load

$$a = KL^2 \frac{1}{r_b}$$

where

$$\frac{1}{r_b} = 2.5 \times 10^{-6} / \text{mm}$$

$$L = 12 \text{ m}$$

$$K = 0.104 \text{ for u.d.l. from table 6.9}$$

Hence mid-span short-term deflection

$$\begin{aligned} a &= 0.104 \times 12^2 \times 10^6 \times 2.5 \times 10^{-6} \\ &= 37 \text{ mm approximately} \end{aligned}$$

(e) Calculate Short-term Curvature due to Permanent Loads

$$\text{Permanent moment} = 180 \text{ kN m}$$

Thus, if section uncracked

$$\frac{1}{r_b} = \frac{180 \times 10^6}{26 \times 10^3 \times 300 \times 700^3 / 12} = 0.8 \times 10^{-6} / \text{mm}$$

and if cracked, an approach similar to that used in (c) above gives  $f_c = 9.7 \text{ N/mm}^2$  at  $x = 245 \text{ mm}$ . Hence

$$\frac{1}{r_b} = \frac{9.7}{245 \times 26 \times 10^3} = 1.5 \times 10^{-6} / \text{mm}$$

(f) Calculate Long-term Curvature due to Permanent Loads

In this case, analysis is based on a reduced concrete tensile stress of  $0.55 \text{ N/mm}^2$  at the level of reinforcement, thus

$$f_{ct} = \left( \frac{h - x}{d - x} \right) \times 0.55$$

and a reduced

$$E_{\text{eff}} = \frac{26}{1 + \phi}$$

The effective section thickness equals

$$\frac{\text{twice cross-sectional area}}{\text{perimeter}} = \frac{2 \times 700 \times 300}{2(700 + 300)} = 210 \text{ mm}$$

thus the value of  $\phi$  from figure 6.5 for loading at twenty-eight days with indoor exposure is approximately 2.75. Hence

$$E_{\text{eff}} = \frac{26}{1 + 2.75} = 6.93 \text{ kN/mm}^2$$

Thus, using the same approach as previously for the cracked analysis, it is found that

$$\text{when } x = 300 \text{ mm then } f_{c1} = 4.5 \text{ N/mm}^2, f_{c2} = 8.1 \text{ N/mm}^2$$

$$x = 350 \text{ mm} \quad f_{c1} = 6.6 \text{ N/mm}^2, f_{c2} = 7.1 \text{ N/mm}^2$$

$$x = 370 \text{ mm} \quad f_{c1} = 7.7 \text{ N/mm}^2, f_{c2} = 6.8 \text{ N/mm}^2$$

Thus as can be seen from figure 6.9b, the solution lies at  $x = 360 \text{ mm}$  when  $f_c = 7.0 \text{ N/mm}^2$ . Therefore

$$\frac{1}{r_b} = \frac{7.0}{360 \times 6.93 \times 10^3} = 2.8 \times 10^{-6} / \text{mm}$$

In this instance it is not necessary to evaluate the uncracked case since in part (e) it has been established that the permanent loads yield the higher instantaneous curvature when the section is cracked.

(g) Calculate Shrinkage Curvature

$$\frac{1}{r_{cs}} = \frac{\epsilon_{cs} \alpha_e S_s}{I}$$

where  $\alpha_e = \frac{E_s}{E_{\text{eff}}} = \frac{200}{6.93} = 28.9$

And for a transformed cracked section (see figure 4.28)

$$I = \frac{bx^3}{12} + bx \left( \frac{x}{2} \right)^2 + \alpha_e A_s (d - x)^2$$

therefore with  $x = 360$  mm from part (f)

$$\begin{aligned} I &= (1.17 + 3.50 + 4.08) \times 10^9 \\ &= 8.75 \times 10^9 \text{ mm}^4 \end{aligned}$$

and

$$\begin{aligned} S_s &= A_s (d - x) \\ &= 2450 \times 240 \\ &= 588 \times 10^3 \text{ mm}^3 \end{aligned}$$

From figure 6.6 for indoor exposure, the long-term value

$$\epsilon_{cs} \approx 390 \times 10^{-6}$$

Thus

$$\begin{aligned} \frac{1}{r_{cs}} &= \frac{390 \times 10^{-6} \times 28.9 \times 588 \times 10^3}{8.75 \times 10^9} \\ &\approx 0.8 \times 10^{-6} / \text{mm} \end{aligned}$$

(h) Calculate Total Long-term Deflection

Short-term curvature, non-permanent loads = Short-term curvature, total loads  
– Short-term curvature, permanent loads

$$\begin{aligned} &= 2.5 \times 10^{-6} - 1.5 \times 10^{-6} \\ &= 1.0 \times 10^{-6} / \text{mm} \end{aligned}$$

Long-term curvature, permanent loads =  $2.8 \times 10^{-6} / \text{mm}$

Shrinkage curvature =  $0.8 \times 10^{-6} / \text{mm}$

Therefore

$$\text{Total long-term curvature} \quad \frac{1}{r_b} = 4.6 \times 10^{-6} / \text{mm}$$

hence

$$\begin{aligned} \text{estimated total} \\ \text{long-term deflection} &= \frac{KL^2}{r_b} \\ &= 0.104 \times 12^2 \times 10^6 \times 4.6 \times 10^{-6} \\ &= 69 \text{ mm} \end{aligned}$$

### 6.3.4 Basis of Span-Effective Depth Ratios

The calculation of deflections has been shown to be a tedious operation, however, for general use rules based on limiting the span-effective depth ratio of a member are adequate to ensure that the deflections are not excessive. The application of this method is described in section 6.2.

The relationship between the deflection and the span-effective depth ratio of a member can be derived from equation 6.9; thus

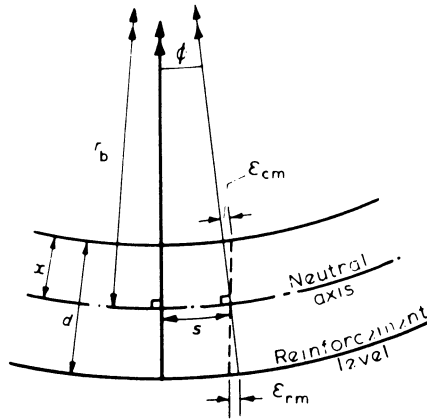

Figure 6.10 Curvature and strain distribution

$$\text{deflection } a = K \frac{1}{r_b} L^2$$

and for small deflections it can be seen from figure 6.10 that for unit length,  $s$

$$\phi = \frac{1}{r_b} = \frac{\epsilon_{cm} + \epsilon_{rm}}{d}$$

where

$\epsilon_{cm}$  = maximum compressive strain in the concrete

$\epsilon_{rm}$  = tensile strain in the reinforcement

$K$  = a factor which depends on the pattern of loading

Therefore

$$\frac{\text{span}}{\text{effective depth}} = \frac{L}{d} = \frac{a}{L} \frac{1}{K} \frac{1}{(\epsilon_{cm} + \epsilon_{rm})}$$

The strains in the concrete and tensile reinforcement depend on the areas of reinforcement provided and their stresses. Thus for a particular member section and a pattern of loading, it is possible to determine a span-effective depth ratio to satisfy a particular  $a/L$  or deflection/span limitation.

The modified span-effective depth ratios obtained in section 6.2 are based on limiting the total deflection to span/250 for a uniformly distributed loading. For spans of less than 10 m this should also ensure that the limits of span/500 or 20 mm after application of finishes are met but, for spans over 10 m where avoidance of damage to finishes may be important, the basic ratios of table 6.6 should be factored by 10/span.

For loading patterns other than uniformly distributed a revised ratio is given by changing the basic ratio in proportion to the relative values of  $K$ , as shown in example 6.3. Similarly, for limiting the deflection to span/ $\beta$

$$\text{revised ratio} = \text{basic ratio} \times \frac{250}{\beta}$$

In cases where the basic ratio has been modified for spans greater than 10 m, maximum deflections are unlikely to exceed 20 mm after construction of partitions and finishes.

When another deflection limit is required, the ratios given should be multiplied by  $\alpha/20$  where  $\alpha$  is the proposed maximum deflection.

### Example 6.3 Adjustment of Basic Span to Effective Depth Ratio

Determine the appropriate basic ratio for a cantilever beam supporting a uniform load and a concentrated point load at its tip as shown in figure 6.11.

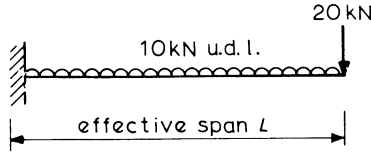

Figure 6.11 Point load on cantilever example

Basic ratio from table 6.6 = 7 for a u.d.l.

From table 6.9:

$K$  for cantilever with u.d.l. over full length = 0.25

$K$  for cantilever with point load at tip = 0.33

Thus, for the point load only, adjusted basic ratio equals

$$7 \times \frac{0.25}{0.33} = 5.3$$

An adjusted basic ratio to account for both loads can be obtained by factoring the moment due to the point load by the ratio of the  $K$  values as follows

$$M_{\text{udl}} = 10 \times L/2 = 5L$$

$$M_{\text{point}} = 20L$$

$$\begin{aligned} \text{Adjusted basic ratio} &= \text{Basic ratio} \left( \frac{M_{\text{udl}} + M_{\text{point}} \times K_{\text{udl}}/K_{\text{point}}}{M_{\text{udl}} + M_{\text{point}}} \right) \\ &= 7 \left( \frac{5 + 20 \times 0.25/0.33}{5 + 20} \right) \\ &= 5.6 \end{aligned}$$

## 6.4 Flexural Cracking

Members subjected to bending generally exhibit a series of distributed flexural cracks, even at working load. These cracks are unobtrusive and harmless unless the widths become excessive, in which case appearance and durability suffer as the reinforcement is exposed to corrosion.

The actual width of cracks in a reinforced concrete structure will vary between wide limits, and cannot be precisely estimated, thus the limiting requirement to be satisfied is that the probability of the maximum width exceeding a satisfactory value is small. The maximum acceptable value suggested by BS 8110 is 0.3 mm at any position on the surface of the concrete in normal environments, although some other codes of practice recommend lower values for important members. Requirements for specialised cases such as water-retaining structures may be more stringent and these are given in chapter 11.

If calculations to estimate maximum crack widths are performed, they are based on 'working' loads with  $\gamma_f = 1.0$  and material partial factors of safety of  $\gamma_m = 1.0$  for steel and concrete. BS 8110 recommends that the effective modulus of elasticity of the concrete should be taken as half the instantaneous value as given in table 1.1, to allow for creep effects.

Prestressed concrete members are designed primarily on the basis of satisfying limitations which are different from those for reinforced concrete.

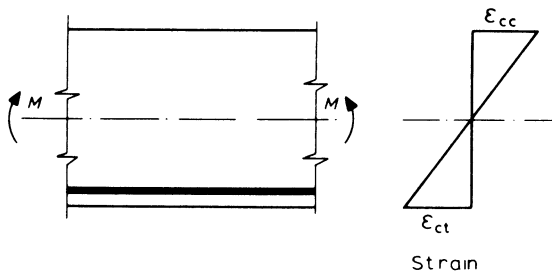

Figure 6.12 Bending of a length of beam

#### 6.4.1 Mechanism of Flexural Cracking

This can be illustrated by considering the behaviour of a member subjected to a uniform moment.

A length of beam as shown in figure 6.12 will initially behave elastically throughout, as the applied uniform moment  $M$  is increased. When the limiting tensile strain for the concrete is reached a crack will form, and the adjacent tensile zone will no longer be acted upon by direct tension forces. The curvature of the beam, however, causes further direct tension stresses to develop at some distance from the original crack to maintain internal equilibrium. This in turn causes further cracks to form, and the process continues until the distance between cracks does not permit sufficient tensile stresses to develop to cause further cracking. These initial cracks are called 'primary cracks', and the average spacing in a region of constant moment has been shown experimentally to be approximately  $1.67(h - x)$  and will be largely independent of reinforcement detailing.

As the applied moment is increased beyond this point, the development of cracks is governed to a large extent by the reinforcement. Tensile stresses in the concrete surrounding reinforcing bars are caused by bond as the strain in the reinforcement increases. These stresses increase with distance from the primary cracks and may eventually cause further cracks to form approximately midway between the primary cracks. This action may continue with increasing moment until the

bond between concrete and steel is incapable of developing sufficient tension in the concrete to cause further cracking in the length between existing cracks. Since the development of the tensile stresses is caused directly by the presence of the reinforcing bars, the spacing of cracks will be influenced by the spacings of the reinforcement. If bars are sufficiently close for their 'zones of influence' to overlap then secondary cracks will join up across the member, while otherwise they will form only adjacent to the individual bars. It has been confirmed experimentally that the average spacing of cracks along a line parallel to, and at a distance  $a_{cr}$  from, a main reinforcing bar depends on the efficiency of bond, and may be taken as  $1.67a_{cr}$  for deformed bars, or  $2.0a_{cr}$  for plain round bars.

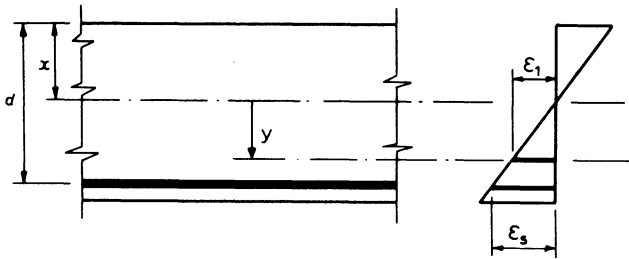

Figure 6.13 Bending strains

#### 6.4.2 Estimation of Crack Widths

If the behaviour of the member in figure 6.13 is examined, it can be seen that the overall extension per unit length at depth  $y$  below the neutral axis is given by

$$\epsilon_1 = \frac{y}{(d-x)} \epsilon_s$$

where  $\epsilon_s$  is the average strain in the main reinforcement over the length considered, and may be assumed to be equal to  $f_s/E_s$  where  $f_s$  is the steel stress at the cracked sections. Hence assuming any tensile strain of concrete between cracks as small, since full bond is never developed

$$\epsilon_1 = \frac{y}{(d-x)} \frac{f_s}{E_s} = \Sigma w$$

where  $\Sigma w$  = sum of crack widths per unit length at level  $y$ .

The actual width of individual cracks will depend on the number of cracks in this unit length, the average number being given by length/average spacing where average spacing,  $s_{av} = 1.67a_{cr}$  for deformed bars; also  $s_{av} \leq 1.67(h-x)$ , the spacing of primary cracks. Thus

$$\text{average crack width } w_{av} = \frac{\Sigma w}{\text{av. number of cracks}} = \epsilon_1 s_{av}$$

The designer is concerned however with the maximum crack width, and it has been shown experimentally that if this is taken as twice the average value, the chance of this being exceeded is about 1 in 100, hence for deformed reinforcing

bars, the maximum likely crack width  $w_{\max}$  at any level defined by  $y$  in a member will thus be given by

$$\begin{aligned} w_{\max} &= \epsilon_1 2s_{av} \\ &= \epsilon_1 3.33a_{cr} \end{aligned}$$

provided that the limit of  $w_{\max} = \epsilon_1 3.33(h - x)$  based on the primary cracks is not exceeded.

The positions on a member where the surface crack widths will be greatest, depend on the relative values of strain ( $\epsilon_1$ ) and the distance to a point of zero strain ( $a_{cr}$ ). Despite the effects of bond slip adjacent to cracks, and the steel strain across cracks, the crack width at the surface of a reinforcing bar is very small and may be assumed to be zero. This may therefore be taken as a point of zero strain for the purposes of measuring  $a_{cr}$ . The neutral axis of the beam will also have zero strain, and hence  $a_{cr}$  may also relate to this if appropriate.

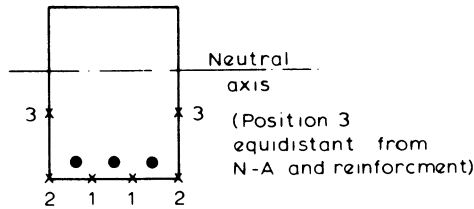

Figure 6.14 Critical crack positions

Critical positions for maximum crack width will on a beam generally occur at the positions indicated in figure 6.14. These occur when the distance to points of zero strain, that is, reinforcement surface or neutral axis, are as large as possible. Positions 1 and 2 will have a maximum value of strain, while at position 3, although the strain is smaller,  $a_{cr}$  is considerably larger. The expression for  $w_{\max}$  at any point may thus be expressed in the general form

maximum surface crack width at a point = constant  $\times$  distance to the surface of the nearest reinforcing bar or neutral axis  $\times$  apparent tensile strain in the concrete at the level considered

The expression for maximum surface crack width given in BS 8110 is basically of this form, with the constant based on a probability of the calculated value being exceeded of somewhat greater than 1 in 100. The expression is given as

$$w_{\max} = \frac{3a_{cr}\epsilon_m}{1 + 2\left(\frac{a_{cr} - c_{\min}}{h - x}\right)} \tag{6.10}^*$$

where  $c_{\min}$  is the minimum cover to the main reinforcement and  $\epsilon_m$  is the average concrete strain and is based on  $\epsilon_1$  but allows for the stiffening effect of the cracked concrete in the tension zone  $\epsilon_2$ . The value of  $\epsilon_2$  is given by an empirical expression

$$\epsilon_2 = \frac{b_t (h - x) (a' - x)}{3 E_s A_s (d - x)} \tag{6.11}^*$$

and

$$\epsilon_m = \epsilon_1 - \epsilon_2$$

where  $b_t$  is the width of section at centroid of tensile steel and  $a'$  the distance from compressive face to the point at which crack is calculated. This expression allows for variations of steel stress between cracks, and results in correspondingly reduced maximum crack width estimates. A negative value of  $\epsilon_m$  indicates that the section is uncracked.

**6.4.3 Analysis of Section to Determine Crack Width**

Whatever formula is used, it is necessary to consider the apparent concrete strain at the appropriate position. This must be done by elastic analysis of the cracked section using half the instantaneous value of  $E_c$  to allow for creep effects as discussed in section 6.4.

The methods discussed in section 4.10.1 should be used to find the neutral axis position  $x$  and hence  $f_s$  the stress in the tensile reinforcement. Then

$$\epsilon_1 = \frac{y}{(d - x)} \frac{f_s}{E_s}$$

hence  $\epsilon_m$  may be obtained.

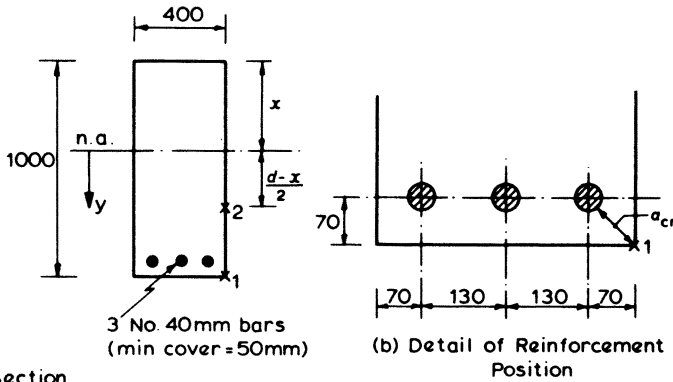

Figure 6.15

**Example 6.4 Calculation of Flexural Crack Widths**

Estimate the maximum flexural crack widths for the beam section shown in figure 6.15a when subjected to a moment of 650 kN m.

- Characteristic strengths of concrete  $f_{cu} = 30 \text{ N/mm}^2$
- of steel  $f_y = 460 \text{ N/mm}^2$
- Modulus of elasticity of steel  $E_s = 200 \text{ kN/mm}^2$

Calculate Neutral Axis Position and Steel Stress

From table 1.1, instantaneous modulus of elasticity = 26 kN/mm<sup>2</sup>, therefore

$$E_c = \frac{26}{2} = 13 \text{ kN/mm}^2$$

Then from section 4.10.1 the neutral axis position is given by

$$\frac{1}{2} bx^2 + \frac{E_s}{E_c} A_s x - \frac{E_s}{E_c} A_s d = 0$$

In this case  $A_s$  = area of three no. 40 mm bars = 3770 mm<sup>2</sup>

$$d = 1000 - (20 + 50) = 930 \text{ mm}$$

thus

$$\frac{1}{2} \times 400 \times x^2 + \frac{200}{13} \times 3770 \times x - \frac{200}{13} \times 3770 \times 930 = 0$$

therefore

$$x = - \frac{290 \pm \sqrt{(290)^2 + 4 \times 269\,700}}{2}$$

$$= 394 \text{ mm}$$

(Alternatively charts may be used, as in figure 4.29 in which case

$$\alpha_e \frac{A_s}{bd} = \frac{200}{13} \frac{3770}{400 \times 930} = 0.156$$

taking  $A'_s = 0$ ,  $x/d = 0.42$  from charts and hence  $x = 391$  mm.)

The stress in the reinforcement

$$f_s = \frac{M}{(d - x/3) A_s} = \frac{650 \times 10^6}{798 \times 3770}$$

$$= 216 \text{ N/mm}^2$$

thus

$$\epsilon_1 = \frac{y}{536} \times \frac{216}{200 \times 10^3} = y \times 2.04 \times 10^{-6}$$

and using equation 6.11

$$\epsilon_m = \epsilon_1 - \frac{b_t (h - x) (a' - x)}{3 E_s A_s (d - x)}$$

The maximum crack width will occur either at position 1 or 2 indicated on figure 6.15; thus

Position	$y$	$a_{cr}$	$a'$	$\epsilon_1 \times 10^{-3}$
1	606	$\sqrt{(70^2 + 70^2)} - 20 = 79$	1000	1.24
2	$\frac{536}{2} = 268$	$\sqrt{(70^2 + 268^2)} - 20 = 257$	662	0.55

Minimum cover,  $c_{min} = 50$  mm; thus at position 1

$$\begin{aligned}\epsilon_m &= \left( 1.24 - \frac{400(1000 - 394)(1000 - 394)}{3 \times 200 \times 3770(930 - 394)} \right) \times 10^{-3} \\ &= 1.12 \times 10^{-3}\end{aligned}$$

and equation 6.10 gives

$$\begin{aligned}w_{max} &= \frac{3a_{cr}\epsilon_m}{1 + 2\left(\frac{a_{cr} - c_{min}}{h - x}\right)} \\ &= \frac{3 \times 79 \times 1.12 \times 10^{-3}}{1 + 2\left(\frac{79 - 50}{1000 - 394}\right)} = 0.24 \text{ mm}\end{aligned}$$

and similarly at position 2

$$\begin{aligned}\epsilon_m &= \left[ 0.55 - \frac{400(1000 - 394)(662 - 394)}{3 \times 200 \times 3770(930 - 394)} \right] \times 10^{-3} \\ &= 0.50 \times 10^{-3}\end{aligned}$$

thus

$$w_{max} = \frac{3 \times 257 \times 0.50 \times 10^{-3}}{1 + 2\left(\frac{257 - 50}{606}\right)} = 0.23 \text{ mm}$$

The maximum crack width of 0.24 mm is therefore likely to occur at the bottom corners of the member, and the cracks are likely to be at an average spacing of  $1.67a_{cr} = 1.67 \times 79 \approx 130$  mm at these positions. Cracks of similar width may occur on side faces at a spacing of approximately  $1.67 \times 257 \approx 430$  mm.

#### 6.4.4 Control of Crack Widths

It is apparent from the expressions derived above that there are two fundamental ways in which surface crack widths may be reduced.

- (1) Reduce the stress in the reinforcement ( $f_s$ ).
- (2) Reduce the distance to the nearest bar ( $a_{cr}$ ).

The use of steel at reduced stresses is generally uneconomical, and although this approach is used in the design of water-retaining structures where cracking must often be avoided altogether, it is generally easier to limit the bar cover and spacing

and hence  $a_{cr}$ . Durability requirements limit the minimum value of cover; however bars should be as close to the concrete surface as is allowed. Reinforcement spacing may be reduced by keeping bar diameters as small as is reasonably possible.

Since the side face of a beam is often a critical crack-width position it is good practice to consider the provision of longitudinal steel in the side faces of beams of moderate depth. Recommendations regarding this, and spacing of main reinforcement, are given by BS 8110 and are discussed in section 6.1. If these recommendations are followed, it is not necessary to calculate crack widths except in unusual circumstances. Reinforcement detailing however, has been shown to have a large effect on flexural cracking, and must in practice be a compromise between the requirements of cracking, durability and constructional ease and costs.

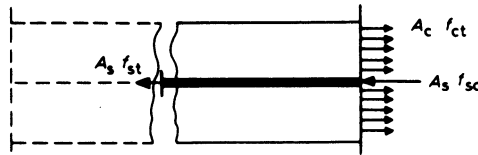

Figure 6.16 Forces adjacent to a crack

### 6.5 Thermal and Shrinkage Cracking

Thermal and shrinkage effects, and the stresses developed prior to cracking of the concrete were discussed in chapter 1. After cracking, the equilibrium of concrete adjacent to a crack is illustrated in figure 6.16.

Equating tension and compression forces

$$A_s f_{st} = A_c f_{ct} - A_s f_{sc}$$

or

$$f_{ct} = \frac{A_s}{A_c} (f_{st} + f_{sc})$$

if the condition is considered when steel and concrete simultaneously reach their limiting values in tension, that is,  $f_{st} = f_y$  and  $f_{ct} = f_t =$  tensile strength of concrete at appropriate age – usually taken as three days. Then

$$r = \frac{A_s}{A_c} = \frac{f_t}{f_y + f_{sc}}$$

where  $r$  is the steel ratio.

The value of  $f_{sc}$  can be calculated but is generally very small and may be taken as zero without introducing undue inaccuracy; hence the critical value of steel ratio

$$r_{crit} = \frac{A_s}{A_c} = \frac{f_t}{f_y} \text{ approximately} \quad (6.12)^*$$

If the steel ratio is less than this value, the steel will yield in tension resulting in a few wide cracks; however if it is greater then more cracks will be formed when the

tensile stress caused by bond between the steel and concrete exceeds the concrete tensile strength, that is

$$f_b s \Sigma u_s \geq f_t A_c$$

where  $f_b$  = average bond stress

$s$  = development length along a bar

$\Sigma u_s$  = sum of perimeters of reinforcement.

For a round bar

$$\frac{u_s}{A} = \frac{4\pi\Phi}{\pi\Phi^2} = \frac{4}{\Phi}$$

Hence, since

$$\Sigma u_s = \frac{A_s}{A} u_s \quad \text{for similar bars}$$

then

$$\Sigma u_s = \frac{4rA_c}{\Phi}$$

and thus

$$s \geq \frac{f_t \Phi}{4rf_b}$$

The maximum crack spacing is twice this value immediately prior to the formation of a new crack, when the development length on both sides is  $s_{\min}$ , that is

$$s_{\max} = \frac{f_t \Phi}{2rf_b} \quad (6.13)^*$$

Crack spacing and hence width, therefore, is governed both by the reinforcement size and quantity for ratios above the critical value, which should be taken as a minimum requirement for controlled cracking. Empirical values for general use are given in section 6.1.

### 6.5.1 Crack Width Calculation

The expressions for crack spacing assume that the total thermal and shrinkage strains are sufficient to cause cracking, although in practice it is found that predicted cracks may not always occur. It is possible to estimate however the maximum crack width likely to occur by considering total concrete contraction in conjunction with the maximum likely crack spacing. For steel ratios greater than the critical value, and when the total contraction exceeds the ultimate tensile strain for the concrete ( $\epsilon_{ult}$ ), the tensile stress in the concrete increases from zero at a crack to a maximum value at mid-distance between cracks. Hence the mean tensile strain in the uncracked length is  $\epsilon_{ult}/2$  when a new crack is just about to form. The crack width is thus given by crack width = (total unit movement –

concrete strain)  $\times$  crack spacing with the maximum width corresponding to the maximum spacing of  $s_{\max}$

$$w_{\max} = (\epsilon_{\text{sh}} + T\alpha_c - \frac{1}{2}\epsilon_{\text{ult}}) s_{\max} \quad (6.14)$$

where  $\epsilon_{\text{sh}}$  = shrinkage strain

$T$  = fall in temperature from hydration peak

$\alpha_c$  = coefficient of thermal expansion of concrete – taken as 0.5  $\times$  the value for mature concrete, to allow for creep effects

In practice, variations in restraints cause large variations within members and between otherwise similar members, with ‘full’ restraint seldom occurring. The behaviour depends considerably on this and temperatures at the time of casting. Guidance concerning possible ‘restraint factors’ is given in Part 2 of BS 8110.

**Example 6.5 Calculation of Shrinkage and Thermal Crack Widths**

A fully restrained section of reinforced concrete wall is 150 mm thick, and drying shrinkage strain of 50 microstrain ( $\epsilon_{\text{sh}}$ ) is anticipated together with a temperature drop ( $T$ ) of 20°C after setting. Determine the minimum horizontal reinforcement to control cracking and estimate maximum crack widths and average spacing for a suitable reinforcement arrangement.

Three-day ultimate tensile strength of concrete ( $f_t$ ) = ultimate average bond stress ( $f_b$ ) = 1.5 N/mm<sup>2</sup>

Modulus of elasticity of concrete ( $E_c$ ) = 10 kN/mm<sup>2</sup>

Coefficient of thermal expansion for mature concrete ( $\alpha_c$ ) = 12 microstrain/°C

Characteristic yield strength of reinforcement ( $f_y$ ) = 460 N/mm<sup>2</sup>

Modulus of elasticity of reinforcement ( $E_s$ ) = 200 kN/mm<sup>2</sup>

$$\begin{aligned} \text{Critical steel ratio } r_{\text{crit}} &= \frac{f_t}{f_y} = \frac{1.5}{460} = 0.33 \text{ per cent from equation 6.12} \\ &= \frac{0.33}{100} \times 150 \times 1000 \\ &= 495 \text{ mm}^2/\text{m} \end{aligned}$$

This could be conveniently provided as 10 mm bars at 300 mm centres in each face of the member (524 mm<sup>2</sup>/m).

For this reinforcement, the maximum crack spacing is given by equation 6.13 as

$$\begin{aligned} s_{\max} &= \frac{f_t \Phi}{2 \frac{A_s}{A_c} f_b} = \frac{1.5 \times 10}{2 \times \frac{524 \times 1.5}{150\,000}} \\ &= 1430 \text{ mm} \end{aligned}$$

Since the minimum spacing is given by one-half of this value, the average spacing will be  $s_{av} = 0.75 \times 1430 = 1072$  mm.

The maximum crack width corresponds to  $s_{max}$  and is given by

$$w_{max} = s_{max} \left( \epsilon_{sh} + T \frac{\alpha_c}{2} - \frac{1}{2} \epsilon_{ult} \right)$$

as given in equation 6.14 where ultimate tensile strain for the concrete

$$\begin{aligned} \epsilon_{ult} &= \frac{f_t}{E_c} \\ &= \frac{1.5}{10 \times 10^3} = 150 \text{ microstrain} \end{aligned}$$

therefore

$$\begin{aligned} w_{max} &= 1430 \left( 50 + \frac{20 \times 12}{2} - \frac{150}{2} \right) \times 10^{-6} \\ &= 0.14 \text{ mm} \end{aligned}$$

## 6.6 Other Serviceability Requirements

The two principal other serviceability considerations are those of durability and resistance to fire, although occasionally a situation arises in which some other factor may be of importance to ensure the proper performance of a structural member in service. This may include fatigue due to moving loads or machinery, or specific thermal and sound insulation properties. The methods of dealing with such requirements may range from the use of reduced working stresses in the materials, to the use of special concretes, for example lightweight aggregates for good thermal resistance.

### 6.6.1 Durability

Deterioration will generally be associated with water permeating the concrete, and the opportunities for this to occur should be minimised as far as possible by providing good architectural details with adequate drainage and protection to the concrete surface.

Permeability is the principal characteristic of the concrete which affects durability, although in some situations it is necessary to consider also physical and chemical effects which may cause the concrete to decay.

For reinforced concrete, a further important aspect of durability is the degree of protection which is given to the reinforcement. Carbonation by the atmosphere will, in time, destroy the alkalinity of the surface zone concrete, and if this reaches the level of the reinforcement will render the steel vulnerable to corrosion in the presence of moisture and oxygen.

If a concrete is made with a sound inert aggregate, deterioration will not occur in the absence of an external influence. Since concrete is a highly alkaline material,

its resistance to other alkalis is good, but it is however very susceptible to attack by acids or substances which easily decompose to produce acids. Concrete made with Portland cement is thus not suitable for use in situations where it comes into contact with such materials, which include beer, milk and fats. Some neutral salts may also attack concrete, the two most notable being calcium chloride and soluble sulphates. These react with a minor constituent of the hydration products in different ways. The chloride must be in concentrated solution, when it has a solvent effect on the concrete in addition to corroding the reinforcement, while sulphates need only be present in much smaller quantities to cause internal expansion of the concrete with consequent cracking and strength loss. Sulphates present the most commonly met chemical-attack problem for concrete since they may occur in groundwater and sewage. In such cases cements containing reduced proportions of the vulnerable tricalcium aluminate, such as Sulphate Resisting Portland Cement or Super Sulphated Cement, should be used. The addition of Pulverised Fuel Ash (Pfa) or ground granulated blast furnace slag (ggbfs) may also be beneficial. Table 6.10 indicates minimum concrete mix requirements for use in situations where sulphates are present. Both chlorides and sulphates are present in sea water, and because of this the chemical actions are different, resulting in reduced sulphate damage, although if the concrete is of poor quality, serious damage may occur from reactions of soluble magnesium salts with the hydrated compounds. Well-constructed Ordinary Portland cement structures have nevertheless been found to endure for many years in sea water.

**Table 6.10** Concrete exposed to sulphate attack

Class	Concentration of sulphates (SO <sub>3</sub> )		Cement type	Min. total cement content (kg/m <sup>3</sup> )	Max. free water/cement
	In soil (total SO <sub>3</sub> )	In groundwater (g/l)			
1	< 0.2%	< 0.3	Any	—	—
2	0.2 to 0.5%	0.3 to 1.2	Any	330	0.50
			OPC/RHPC+ 25-40% Pfa	310	0.55
			or 70-90% ggbfs SRPC or SSC	280	0.55
3	0.5 to 1.0%	1.2 to 2.5	OPC/RHPC+ 25-40% Pfa or	380	0.45
			70-90% ggbfs	330	0.50
			SRPC or SSC	370	0.45
4	1.0 to 2.0%	2.5 to 5.0	SRPC or SSC	370	0.45
5	> 2.0%	> 5.0	SRPC or SSC + protection	370	0.45

*Note:* These values relate to dense concrete with 20 mm max. aggregate size.

Physical attack of the concrete must also be considered. This may come from abrasion or attrition as may be caused by sand or shingle, and by alternate wetting and drying. The latter effect is particularly important in the case of marine structures near the water surface, and causes stresses to develop if the movements produced are restrained. It is also possible for crystal growth to occur from drying out of sea water in cracks and pores, and this may cause further internal stresses, leading to cracking. Alternate freezing and thawing is another major cause of physical damage, particularly in road and runway slabs and other situations where water in pores and cracks can freeze and expand thus leading to spalling. It has been found that the entrainment of a small percentage of air in the concrete in the form of small discrete bubbles offers the most effective protection against this form of attack. Although this reduces the strength of the concrete, it is recommended that  $4.5 \pm 1.5$  per cent by volume of entrained air should be included in concrete subjected to regular wetting and drying combined with severe frost.

All these forms of attack may be minimised by the production of a dense, well-compacted concrete with low permeability, thus restricting damage to the surface zone of the member. Aggregates which are likely to react with the alkali matrix should be avoided, as must those which exhibit unusually high shrinkage characteristics. If this is done, then permeability, and hence durability, is affected by

- (1) aggregate type and density
- (2) water-cement ratio
- (3) degree of hydration of cement
- (4) degree of compaction.

A low water-cement ratio is necessary to limit the voids due to hydration, which must be well advanced with the assistance of good curing techniques. Coupled with this is the need for non-porous aggregates which are hard enough to resist any attrition, and for thorough compaction. It is essential that the mix is designed to have adequate workability for the situation in which it is to be used, thus the cement content of the mix must be reasonably high.

BS 8110 specifies minimum cement contents for various exposure conditions, as well as minimum strength and maximum water cement ratio, related to minimum cover requirements as described in section 6.1.1.

The consequences of thermal effects on durability must not be overlooked, and very high cement contents should only be used in conjunction with a detailed cracking assessment. BS 8110 suggests that  $550 \text{ kg/m}^3$  cement content should be regarded as an upper limit for general use.

Provided that such measures are taken, and that adequate cover of sound concrete is given to the reinforcement, deterioration of reinforced concrete is unlikely. Thus although the surface concrete may be affected, the reinforcing steel will remain protected by an alkaline concrete matrix which has not been carbonated by the atmosphere. Once this cover breaks down and water and possibly chemicals can reach the steel, rusting and consequent expansion lead rapidly to cracking and spalling of the cover concrete and severe damage — visually and sometimes structurally.

### 6.6.2 Fire Resistance

Depending on the type of structure under consideration, it may be necessary to consider the fire resistance of the individual concrete members. Three conditions must be examined

- |                                    |   |  |
|------------------------------------|---|--|
| (1) effects on structural strength | } | in the case of dividing members<br>such as walls and slabs |
| (2) flame penetration resistance   |   |  |
| (3) heat transmission properties   |   |  |

Concrete and steel in the form of reinforcement or prestressing tendons exhibit reduced strength after being subjected to high temperatures. Although concrete has low thermal conductivity, and thus good resistance to temperature rise, the strength begins to drop significantly at temperatures above 300°C and it has a tendency to spall at high temperatures. The extent of this spalling is governed by the type of aggregate, with siliceous materials being particularly susceptible while calcareous and light-weight aggregate concretes suffer very little. Reinforcement will retain about 50 per cent of its normal strength after reaching about 550°C, while for prestressing tendons the corresponding temperature is only 400°C.

Thus as the temperature rises the heat is transferred to the interior of a concrete member, with a thermal gradient established in the concrete. This gradient will be affected by the area and mass of the member in addition to the thermal properties of the concrete, and may lead to expansion and loss of strength. Dependent on the thickness and nature of cover, the steel will rise in temperature and lose strength, this leading to deflections and eventual structural failure of the member if the steel temperature becomes excessive. Design must therefore be aimed at providing and maintaining sound cover of concrete as a protection, thus delaying the temperature rise in the steel. The presence of plaster, screeds and other non-combustible finishes assists the cover in protecting the reinforcement and may thus be allowed for in the design.

BS 8110 gives tabulated values of minimum dimensions and nominal covers for various types of concrete member which are necessary to permit the member to withstand fire for a specified period of time. Although these values, which have been summarised in tables 6.2 and 6.3, do not take into account the influence of aggregate type, they may be considered adequate for most normal purposes. More detailed information concerning design for fire resistance is given in Part 2 of BS 8110 including concrete type, member type and details of finishes. The period that a member is required to survive, both in respect of strength in relation to working loads and the containment of fire, will depend upon the type and usage of the structure – and minimum requirements are generally specified by building regulations. Prestressed concrete beams must be considered separately in view of the increased vulnerability of the prestressing steel.

### 6.7 Stability

While it would be unreasonable to expect a structure to withstand extremes of accidental loading as may be caused by collision, explosion or similar happening, it is important that resulting damage should not be disproportionate to the cause. It follows therefore that a major structural collapse must not be allowed to be

caused by a relatively minor mishap which may have a reasonably high probability of happening in the anticipated lifetime of the structure.

The possibilities of a structure buckling or overturning under the 'design' loads will have been considered as part of the ultimate limit state analysis. However, in some instances a structure will not have an adequate lateral strength even though it has been designed to resist the specified combinations of wind load and vertical load. This could be the case if there is an explosion or a slight earth tremor, since then the lateral loads are proportional to the mass of the structure. Therefore it is recommended that a structure should always be capable of resisting a lateral force not less than 1.5 per cent of the total characteristic load acting through the centroid of the structure above any level considered.

Damage and possible instability should also be guarded against wherever possible, for example vulnerable load-bearing members should be protected from collision by protective features such as banks or barriers.

### 6.7.1 Ties

In addition to these precautions, the general stability and robustness of a building structure can be increased by providing reinforcement acting as ties. These ties should act both vertically between roof and foundations, and horizontally around and across each floor, and all external vertical load-bearing members should be anchored to the floors and beams.

#### *Vertical Ties*

Vertical ties are not generally necessary in structures of less than five storeys, but in higher buildings should be provided by reinforcement, effectively continuous from roof to foundation by means of proper laps, running through all vertical load-bearing members. This steel should be capable of resisting a tensile force equal to the maximum design ultimate load carried by the column or wall from any one storey or the roof. In *in situ* concrete, this requirement is almost invariably satisfied by a normal design, but joint detailing may be affected in precast work.

#### *Horizontal Ties*

Horizontal ties should be provided for all buildings, irrespective of height, in three ways

- (1) peripheral ties
- (2) internal ties
- (3) column and wall ties.

The resistance of these ties when stressed to their characteristic strength is given in terms of a force  $F_t$ , where  $F_t = 60 \text{ kN}$  or  $(20 + 4 \times \text{number of storeys in structure}) \text{ kN}$ , whichever is less. This expression takes into account the increased risk of an accident in a large building and the seriousness of the collapse of a tall structure.

#### (a) Peripheral Ties

The peripheral tie must be provided, by reinforcement which is effectively continuous, around the perimeter of the building at each floor and roof level. This

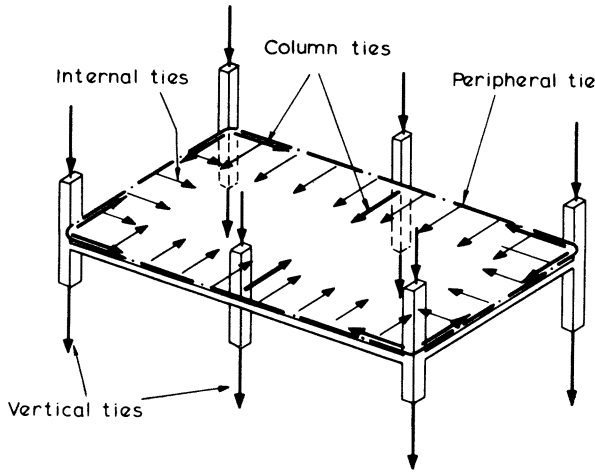

Figure 6.17 Tie forces

reinforcement must lie within 1.2 m from the outer edge and at its characteristic stress be capable of resisting a force of at least  $F_t$ .

#### (b) Internal Ties

Internal ties should also be provided at each floor in two perpendicular directions and be anchored at each end either to the peripheral tie or to the continuous column or wall ties.

These ties must be effectively continuous and they may either be spread evenly across a floor, or grouped at beams or walls as convenient. Where walls are used, the tie reinforcement must be concentrated in the bottom 0.5 m.

The resistance required is related to the span and loading. Internal ties must be capable of resisting a force of  $F_t$  kN per metre width or  $[F_t(g_k + q_k)/7.5] L/5$  kN per metre width, if this is greater. In this expression,  $L$  is the greatest horizontal distance in the direction of the tie between the centres of vertical load-bearing members, or if smaller,  $5 \times$  the clear storey height measured to underside of the beams. The loading  $(g_k + q_k)$  kN/m<sup>2</sup> is the average characteristic load on unit area of the floor considered. Internal ties parallel to cross-walls occurring in one direction only, on plan, need only resist the force  $F_t$  kN per metre width.

#### (c) Column and Wall Ties

Column and wall ties must be able to resist a force of at least 3 per cent of the total vertical ultimate load for which the member has been designed. Additionally, the resistance provided must not be less than the smaller of  $2F_t$  or  $F_t l_0/2.5$  kN where  $l_0$  is the floor to ceiling height in metres. Wall ties are assessed on the basis of the above forces acting per metre length of the wall, while column ties are concentrated within 1 m either side of the column centre line. Particular care should be taken with corner columns to ensure they are tied in two perpendicular directions.

In considering the structure subjected to accidental loading it is assumed that no other forces are acting, thus reinforcement provided for other purposes may also act as ties. Indeed, peripheral and internal ties may also be considered to be acting as column or wall ties.

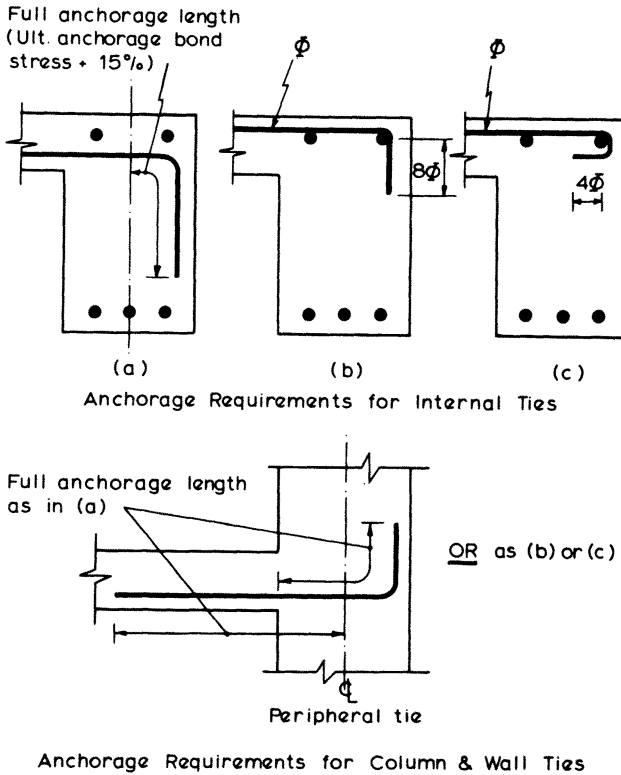

Figure 6.18 Anchorage of ties

As with vertical ties, the provision of horizontal ties for *in situ* construction will seldom affect the amount of reinforcement provided. Detailing of the reinforcement may however be affected, and particular attention must be paid to the manner in which internal ties are anchored to peripheral ties. The requirements for the full anchorage of ties are illustrated in figure 6.18. If these are not met, then the assumed stresses in the ties must be reduced appropriately.

Precast concrete construction however presents a more serious problem since the requirements of tie forces and simple easily constructed joints are not always compatible. Unless the required tie forces can be provided with the bars anchored by hooks and bends in the case of column and wall ties, an analysis of the structure must be performed to assess the remaining stability after a specified degree of structural damage.

**Example 6.6 Stability Ties**

Calculate the stability ties required in an eight-storey building of plan area shown in figure 6.19

Clear storey height under beams = 2.9 m

Floor to ceiling height ( $l_0$ ) = 3.4 m

Characteristic dead load ( $g_k$ ) = 6 kN/m<sup>2</sup>

Characteristic live load ( $q_k$ ) = 3 kN/m<sup>2</sup>

Characteristic steel strength ( $f_y$ ) = 460 N/mm<sup>2</sup>

$$F_t = (20 + 4 \times \text{number of storeys})$$

$$= 20 + 4 \times 8 = 52 \text{ kN} < 60 \text{ kN}$$

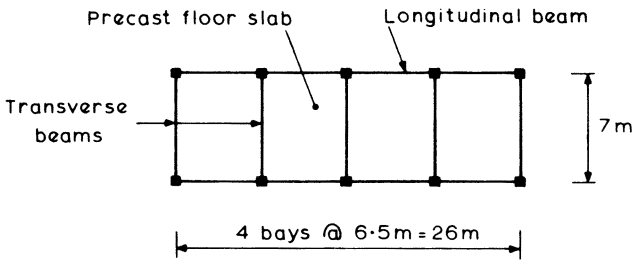

Figure 6.19

(a) *Peripheral ties*

$$\text{Force to be resisted} = F_t = 52 \text{ kN}$$

$$\text{Bar area required} = \frac{52 \times 10^3}{460} = 113 \text{ mm}^2$$

This could be provided by one T12 bar.

(b) *Internal ties*

$$\text{Force to be resisted} = \frac{F_t(g_k + q_k)}{7.5} \times \frac{L}{5} \text{ kN per metre}$$

(1) *Transverse direction*

$$\text{Force} = \frac{52(6 + 3)}{7.5} \times \frac{7}{5} = 87.4 \text{ kN/m} > F_t$$

$$\text{Force per bay} = 87.4 \times 6.5$$

$$= 568.1 \text{ kN}$$

Therefore, bar area required in each transverse interior beam is

$$\frac{568.1 \times 10^3}{460} = 1235 \text{ mm}^2$$

This could be provided by 4T20 bars.

(2) *Longitudinal direction*

$$\text{Force} = \frac{52(6+3)}{7.5} \times \frac{6.5}{5} = 81.1 \text{ kN/m} > F_t$$

Therefore force along length of building =  $81.1 \times 7 = 567.7 \text{ kN}$ , hence bar area required in each longitudinal beam is

$$\frac{567.7 \times 10^3}{2 \times 460} = 617 \text{ mm}^2$$

This could be provided by 2T20 bars.

(3) *Column ties*

Force to be designed for is

$$\left(\frac{l_0}{2.5}\right) F_t = \left(\frac{3.4}{2.5}\right) 52 = 70.7 \text{ kN} < 2F_t$$

or 3 per cent of ultimate floor load on a column is

$$8 \left[ \frac{3}{100} (1.4 \times 6 + 1.6 \times 3) \times 6.5 \times \frac{7}{2} \right] = 72 \text{ kN at ground level}$$

To allow for 3 per cent of column self-weight, take design force to be 75 kN, say, at each floor level.

$$\text{Area of ties required} = \frac{75 \times 10^3}{460} = 163 \text{ mm}^2$$

This would be provided by 1T20 and incorporated with the internal ties.

(c) *Vertical ties*

Maximum column load from one storey is approximately equal to

$$(1.6 \times 3 + 1.4 \times 6) \times 3.5 \times 6.5 = 300.3 \text{ kN}$$

Therefore bar area required throughout each column is equal to

$$\frac{300.3 \times 10^3}{460} = 653 \text{ mm}^2$$

This would be provided by 4T16 bars.

### 6.7.2 Analysis of 'Damaged' Structure

This must be undertaken when a structure has five or more storeys and does not comply with the vertical-tie requirements, or when every precast floor or roof unit does not have sufficient anchorage to resist a force equal to  $F_t$  kN per metre width acting in the direction of the span. The analysis must show that each key load-bearing member, its connections, and the horizontal members which provide lateral support, are able to withstand a specified loading from any direction. If this cannot be satisfied, then the analysis must demonstrate that the removal of any single vertical load-bearing element, other than key members, at each storey in turn will not result in collapse of a significant part of the structure.

The minimum loading that may act from any direction on a key member is recommended as  $34 \text{ kN/m}^2$  in BS 8110. The decision as to what loads should be considered acting is left to the engineer, but will generally be on the basis of permanent and realistic live-loading estimates, depending on the building usage. This method is attempting therefore to assess quantitatively the effects of exceptional loading such as explosion. The design 'pressure' must thus be regarded as a somewhat arbitrary value.

The 'pressure' method will generally be suitable for application to columns in precast framed structures; however, where precast load-bearing panel construction is being used an approach incorporating the removal of individual elements may be more appropriate. In this case, vertical loadings should be assessed as described, and the structure investigated to determine whether it is able to remain standing by a different structural action. This action may include parts of the damaged structure behaving as a cantilever or a catenary, and it may also be necessary to consider the strength of non-load-bearing partitions or cladding.

Whichever approach is adopted, such analyses are tedious, and the provision of effective tie forces within the structure should be regarded as the preferred solution both from the point of view of design and performance.

Continuity reinforcement and good detailing will greatly enhance the overall fire resistance of a structure with respect to collapse. A fire-damaged structure with reduced member strength may even be likened to a structure subjected to accidental overload, and analysed accordingly.

# 7

## Design of Reinforced Concrete Beams

Reinforced concrete beam design consists primarily of producing member details which will adequately resist the ultimate bending moments, shear forces and torsional moments. At the same time serviceability requirements must be considered to ensure that the member will behave satisfactorily under working loads. It is difficult to separate these two criteria, hence the design procedure consists of a series of interrelated steps and checks. These steps are shown in detail in the flow chart in figure 7.1, but may be condensed into three basic design stages

- (1) preliminary analysis and member sizing
- (2) detailed analysis and design of reinforcement
- (3) serviceability calculations.

Much of the material in this chapter depends on the theory and design specifications from the previous chapters. The loading and calculation of moments and shear forces should be carried out using the methods described in chapter 3. The equations used for calculating the areas of reinforcement have been derived in chapters 4 and 5.

Full details of serviceability requirements and calculations are given in chapter 6, but it is normal practice to make use of simple rules which are specified in the Code of Practice and are quite adequate for most situations. Typical of these are the span-effective depth ratios to ensure acceptable deflections, and the rules for maximum bar spacings and minimum quantities of reinforcement, which are to limit cracking, as described in chapter 6.

Design and detailing of the bending reinforcement must allow for factors such as anchorage bond between the steel and concrete. The area of the tensile bending reinforcement also affects the subsequent design of the shear and torsion reinforcement. Arrangement of reinforcement is constrained both by the requirements of the codes of practice for concrete structures and by practical considerations such as construction tolerances, clearance between bars and available bar sizes and lengths. Many of the requirements for correct detailing are illustrated in the examples which deal with the design of typical beams.

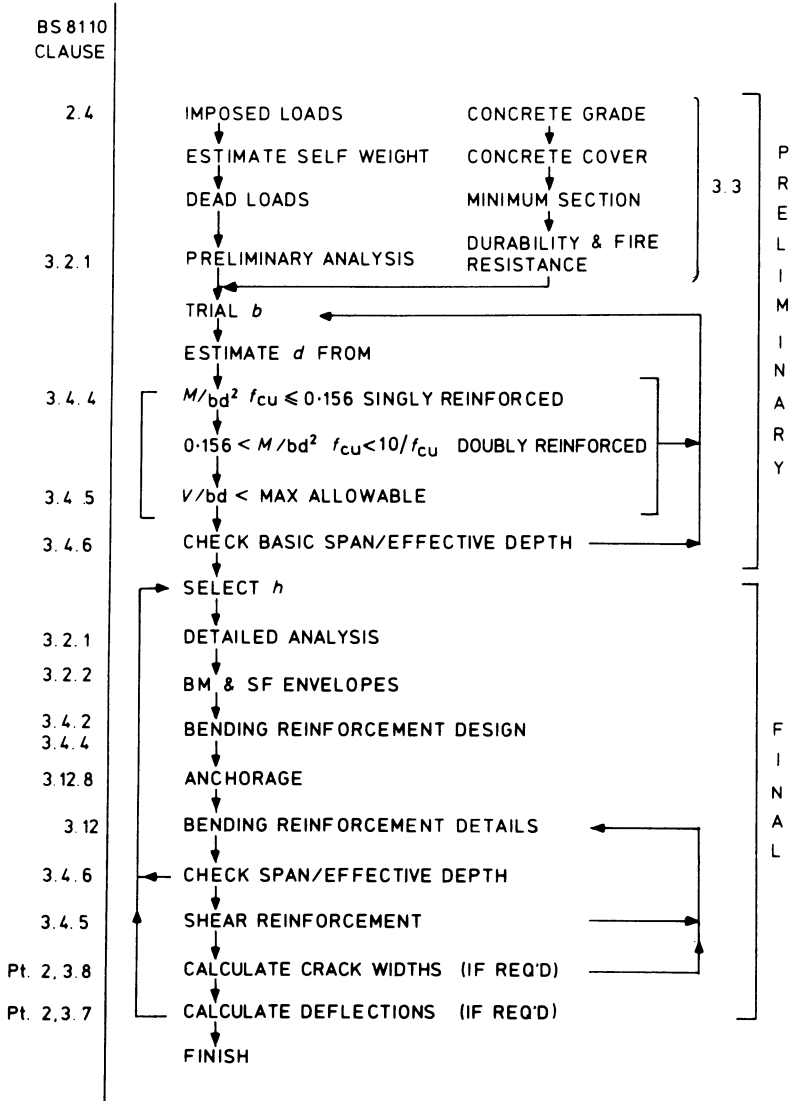

Figure 7.1 Beam design flow chart

All calculations should be based on the effective span of a beam which is given as follows.

- (1) A simply supported beam – the smaller of the distances between the centres of bearings, or the clear distance between supports plus the effective depth.
- (2) A continuous beam – the distance between centres of supports.
- (3) A cantilever beam – the length to the face of the support plus half the effective depth, or the distance to the centre of the support if the beam is continuous.

### 7.1 Preliminary Analysis and Member Sizing

The layout and size of members are very often controlled by architectural details, and clearances for machinery and equipment. The engineer must either check that the beam sizes are adequate to carry the loading, or alternatively, decide on sizes that are adequate. The preliminary analysis need only provide the maximum moments and shears in order to ascertain reasonable dimensions. Beam dimensions required are

- (1) cover to the reinforcement
- (2) breadth ( $b$ )
- (3) effective depth ( $d$ )
- (4) overall depth ( $h$ ).

Adequate concrete cover is required to protect the reinforcement from corrosion and damage. The necessary cover depends on the grade of concrete, the exposure of the beam, and the required fire resistance. Table 6.1 gives the nominal cover which should be provided to all reinforcement, including links. This cover should additionally never be less than the bar size, and it may also need to be increased to meet the fire resistance requirements of the Code of Practice.

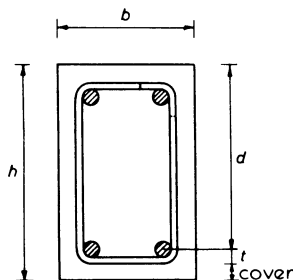

Figure 7.2 *Beam dimensions*

The strength of a beam is affected considerably more by its depth than its breadth. A suitable breadth may be a third to half of the depth; but it may be much less for a deep beam and at other times wide shallow beams are used to conserve headroom. The beam should not be too narrow; if it is much less than 200 mm wide there may be difficulty in providing adequate side cover and space for the reinforcing bars.

Suitable dimensions for  $b$  and  $d$  can be decided by a few trial calculations as follows.

- (1) For no compression reinforcement

$$M/bd^2f_{cu} \leq 0.156$$

With compression reinforcement it can be shown that

$$M/bd^2f_{cu} < 10/f_{cu}$$

if the area of bending reinforcement is not to be excessive.

(2) Shear stress  $v = V/bd$  and  $v$  should never exceed  $0.8\sqrt{f_{cu}}$  or  $5 \text{ N/mm}^2$ , whichever is the lesser. To avoid congested shear reinforcement,  $v$  should preferably be somewhat closer to half (or less) of the maximum allowed.

(3) The span-effective depth ratio for spans not exceeding 10 m should be within the basic values given below

Cantilever beam	7
Simply supported beam	20
Continuous beam	26

which are modified according to  $M/bd^2$  and the service stress in the tension reinforcement as described in chapter 6. For spans greater than 10 m, the basic ratios are multiplied by 10/span.

- (4) The overall depth of the beam is given by

$$h = d + \text{Cover} + t$$

where  $t$  = estimated distance from the outside of the link to the centre of the tension bars (see figure 7.2). For example, with nominal sized 12 mm links and one layer of 32 mm tension bars,  $t = 28$  mm approximately. It will, in fact, be slightly larger than this with deformed bars as they have a larger overall dimension than the nominal bar size.

### Example 7.1 Beam Sizing

A concrete lintel with an effective span of 4.0 m supports a 230 mm brick wall as shown in figure 7.3. The loads on the lintel are  $G_k = 100 \text{ kN}$  and  $Q_k = 40 \text{ kN}$ . Determine suitable dimensions for the lintel if grade 30 concrete is used.

The beam breadth  $b$  will match the wall thickness so that

$$b = 230 \text{ mm}$$

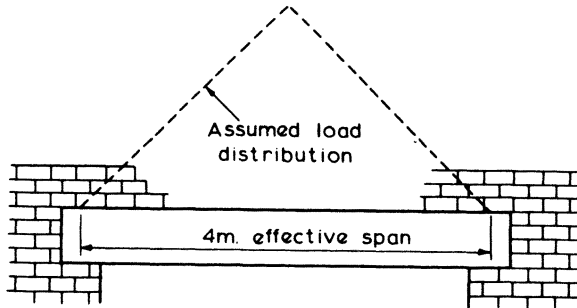

Figure 7.3

Allowing, say, 14 kN for the weight of the beam, gives the ultimate load

$$\begin{aligned} F &= 1.4 \times 114 + 1.6 \times 40 \\ &= 224 \text{ kN} \end{aligned}$$

Therefore maximum shear

$$V = 112 \text{ kN}$$

Assuming a triangular load distribution for the preliminary analysis, we have

$$\begin{aligned} M &= \frac{F \times \text{span}}{6} = \frac{224 \times 4.0}{6} \\ &= 149 \text{ kN m} \end{aligned}$$

For such a relatively minor beam the case with no compression steel should be considered

$$\frac{M}{bd^2 f_{cu}} < 0.156$$

therefore

$$\begin{aligned} \frac{149 \times 10^6}{230 \times d^2 \times 30} &< 0.156 \\ d &> 372 \text{ mm} \end{aligned}$$

For mild conditions of exposure the cover = 25 mm (table 6.1). So for 10 mm links and, say, 32 mm bars

$$\begin{aligned} \text{overall depth } h &= d + 25 + 10 + 32/2 \\ &= d + 51 \end{aligned}$$

Therefore make  $h = 525$  mm as an integer number of brick courses. So that

$$d = 525 - 51 = 474 \text{ mm}$$

$$\begin{aligned} \text{shear stress } \nu &= \frac{V}{bd} = \frac{112 \times 10^3}{230 \times 474} \\ &= 1.03 \text{ N/mm}^2 \end{aligned}$$

For grade 30 concrete, maximum  $\nu$  allowed  $= 0.8 \sqrt{30} = 4.38 \text{ N/mm}^2$ . Therefore

$$\nu < \frac{4.38}{2}$$

$$\text{Basic span-effective depth} = \frac{4000}{474} = 8.4 < 20$$

A beam size of 230 mm by 525 mm deep would be suitable.

$$\begin{aligned} \text{Weight of beam} &= 0.23 \times 0.525 \times 4.0 \times 24 \\ &= 11.6 \text{ kN} \end{aligned}$$

which is sufficiently close to the assumed value.

## 7.2 Design for Bending

The calculation of main bending reinforcement is performed using the equations and charts derived in chapter 4. In the case of rectangular sections which require only tension steel, the lever-arm curve method is probably the simplest. Where compression steel is required, either design charts or a manual approach with the simplified design formulae may be used. When design charts are not applicable, as in the case of non-rectangular sections, the formulae based on the equivalent rectangular stress block will simplify calculations considerably.

The type of reinforcing steel to be used must be decided initially since this, in conjunction with the chosen concrete grade, will affect the areas required and also influence bond calculations. In most circumstances one of the available types of high-yield bars will be used unless cracking is critical, as for example in water-retaining structures, when mild steel may be preferred. Areas of reinforcement are calculated at the sections with maximum moments, and suitable bar sizes selected. (Tables of bar areas are given in the appendix.) This permits anchorage calculations to be performed and details of bar arrangement to be produced, taking into account the guidance given by the codes of practice.

An excessive amount of reinforcement usually indicates that a member is under-sized and it may also cause difficulty in fixing the bars and pouring the concrete. Therefore the code stipulates  $A_s/bh$  should not exceed 4.0 per cent. On the other hand too little reinforcement is also undesirable therefore  $A_s/bh$  should not be less than 0.24 per cent for mild steel or 0.13 per cent for high-yield steel.

To avoid excessive deflections it is also necessary to check the span to effective depth ratio as outlined in chapter 6.

### 7.2.1 Singly Reinforced Rectangular Section

A beam section needs reinforcement only in the tensile zone when  $M/bd^2f_{cu}$  is not greater than 0.156. This is not true if the moments at a section have been reduced by more than 10 per cent as a result of a redistribution of the elastic moments, and in this case reference should be made to equations 7.2 and 7.6 in order to decide whether or not compression steel is necessary.

The singly reinforced section considered is shown in figure 7.4 and it is subjected to a sagging moment  $M$  at the ultimate limit state. Using the lever-arm curve, the design calculations for the longitudinal steel can be summarised as follows.

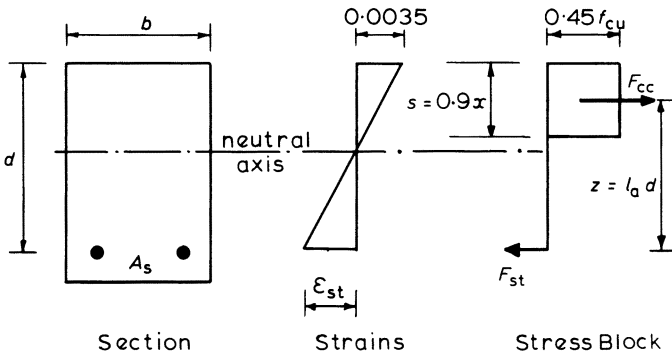

Figure 7.4 Singly reinforced section

- (1) Calculate  $K = M/bd^2f_{cu}$
- (2) Determine the lever-arm,  $z$ , from the curve of figure 7.5 or from the equation

$$z = d [0.5 + \sqrt{(0.25 - K/0.9)}] \quad (7.1)$$

- (3) The area of tension steel is given by

$$A_s = \frac{M}{z0.87f_y}$$

- (4) Select suitable bar sizes.
- (5) Check that the area of steel actually provided is within the limits required by the code, that is

$$100 \frac{A_s}{bh} \leq 4.0$$

and

$$100 \frac{A_s}{bh} \geq 0.13 \text{ for high-yield or } 0.24 \text{ for mild steel}$$

$K = M/bd^2 f_{cu}$	0.05	0.06	0.07	0.08	0.09	0.10	0.11	0.12	0.13	0.14	0.15	0.156
$f_a = z/d$	0.941	0.928	0.915	0.901	0.887	0.873	0.857	0.842	0.825	0.807	0.789	0.775

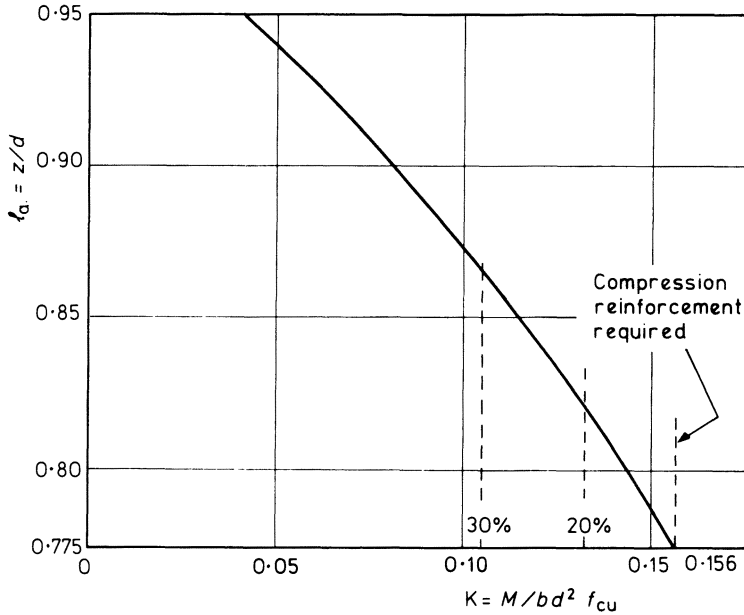

The % values on the K axis mark the limits for singly reinforced sections with moment redistribution applied (see Section 4.7)

Figure 7.5 Lever-arm curve

**Example 7.2 Design of Tension Reinforcement for a Rectangular Section**

The beam section shown in figure 7.6 has characteristic material strengths of  $f_{cu} = 30 \text{ N/mm}^2$  for the concrete and  $f_y = 460 \text{ N/mm}^2$  for the steel. The design moment at the ultimate limit state is 165 kN m which causes sagging of the beam

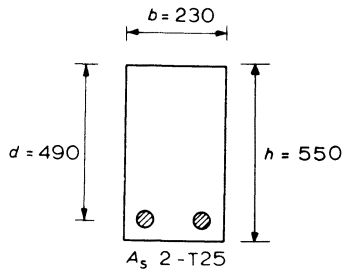

Figure 7.6

$$K = \frac{M}{bd^2 f_{cu}} = \frac{165 \times 10^6}{230 \times 490^2 \times 30} = 0.1$$

This is less than 0.156 therefore compression steel is not required.

From the lever-arm curve of figure 7.5  $l_a = 0.87$ , therefore

$$\text{lever arm } z = l_a d = 0.87 \times 490 = 426 \text{ mm}$$

and

$$A_s = \frac{M}{0.87 f_y z} = \frac{165 \times 10^6}{0.87 \times 460 \times 426} = 968 \text{ mm}^2$$

Provide two T25 bars, area = 982 mm<sup>2</sup>. For the steel provided

$$\frac{100A_s}{bh} = \frac{100 \times 982}{230 \times 550} = 0.78$$

and

$$0.13 < \frac{100A_s}{bh} < 4.0$$

therefore the steel percentage is within the limits specified by the code.

### 7.2.2 Rectangular Section with Compression Reinforcement

Compression steel is required whenever the concrete in compression is unable, by itself, to develop the necessary moment of resistance. Design charts such as the one in figure 4.9 may be used to determine the steel areas but the simplified equations based on the equivalent rectangular stress block are quick to apply.

The maximum moment of resistance that can be developed by the concrete occurs with the neutral axis at the maximum depth allowed by the code of practice. This limiting depth is given as

$$x = (\beta_b - 0.4) d \geq 0.5d \quad (7.2)$$

$$\text{where } \beta_b = \frac{\text{moment at the section after redistribution}}{\text{moment at the section before redistribution}}$$

This reduction is due to the designer redistributing the moments from an elastic analysis of the structure, as described in sections 3.4 and 4.7.

With  $x$  less than  $d/2$  the stress in the compression steel may be considerably less than the yield, therefore, the design procedure is somewhat different if  $\beta_b$  is less than 0.9.

It should also be noted that, in order to maintain the limitation on the depth of neutral axis as specified in equation 7.2, the areas of reinforcement required and provided should meet the following requirement

$$(A'_{s,\text{prov}} - A'_{s,\text{req}}) \geq (A_{s,\text{prov}} - A_{s,\text{req}}) \quad (7.3)$$

This is to ensure a gradual tension type failure with yielding of the tension reinforcement as explained in chapter 4.

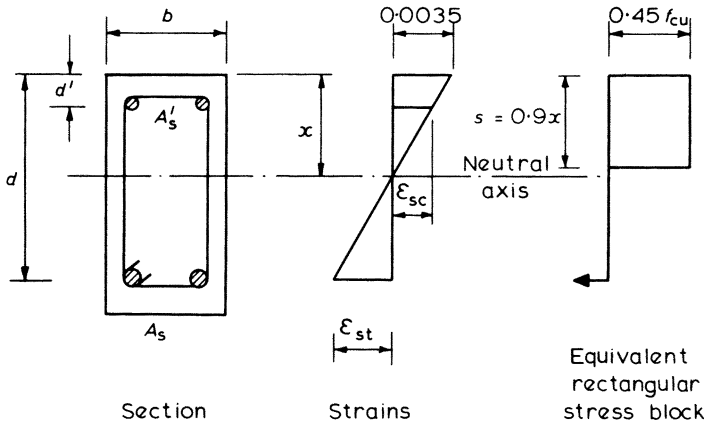

Figure 7.7 Beam doubly reinforced to resist a sagging moment

*Moment Redistribution Factor*  $\beta_b \geq 0.9$  and  $d'/d \geq 0.2$

If  $d'/d$  is not greater than 0.2, as is usually the case, the proportions of the strain diagram will ensure that the compression steel will have yielded.

Compression reinforcement is required if

$$M > 0.156 f_{cu} b d^2$$

and the design equations as given in section 4.5 are

(1) Area of compression steel

$$A'_s = \frac{(M - 0.156 f_{cu} b d^2)}{0.87 f_y (d - d')} \quad (7.4)$$

(2) Area of tension steel

$$A_s = \frac{0.156 f_{cu} b d^2}{0.87 f_y z} + A'_s \quad (7.5)$$

with lever arm  $z = 0.775 d$

If  $d'/d$  is greater than 0.2 the stress in the compression steel should be determined as outlined in part (2) of example 7.4.

*Moment Redistribution Factor*  $\beta_b < 0.9$

The limiting depth of the neutral axis can be calculated from equation 7.2 and compression steel is required if

$$M > 0.45 f_{cu} b s \left( d - \frac{s}{2} \right) \quad (7.6)$$

where  $s$  = depth of stress block =  $0.9x$ .

The design procedure is

- (1) Calculate  $K = M/bd^2 f_{cu}$ .
- (2) Calculate  $K' = 0.402 (\beta_b - 0.4) - 0.18 (\beta_b - 0.4)^2$ .  
If  $K < K'$ , compression steel is not required so proceed as for a singly reinforced section as in example 7.2.  
If  $K > K'$ , compression steel is required.
- (3) Calculate  $x = (\beta_b - 0.4) d$ .  
If  $d'/x < 0.43$ , the compression steel has yielded and  $f_{sc} = 0.87 f_y$ .  
If  $d'/x > 0.43$ , calculate the steel compressive strain  $\epsilon_{sc}$  and hence the stress  $f_{sc}$  as in example 7.4.
- (4) Calculate the area of compression steel from

$$A'_s = \frac{(K - K') f_{cu} b d^2}{0.87 f_y (d - d')} \quad (7.7)$$

- (5) Calculate the area of tension steel from

$$A_s = \frac{K' f_{cu} b d^2}{0.87 f_y z} + A'_s \frac{f_{sc}}{0.87 f_y} \quad (7.8)$$

where  $z = d - 0.9x/2$ .

Links should be provided to give lateral restraint to the outer layer of compression steel according to the following rules.

- (1) The links should pass round the corner bars and each alternate bar.
- (2) The link size should be at least one-quarter the size of the largest compression bar.
- (3) The spacing of the links should not be greater than twelve times the size of the smallest compression bar.
- (4) No compression bar should be more than 150 mm from a restrained bar.

### **Example 7.3 Design of Tension and Compression Reinforcement, $\beta_b > 0.9$**

The beam section shown in figure 7.8 has characteristic material strengths of  $f_{cu} = 30 \text{ N/mm}^2$  and  $f_y = 460 \text{ N/mm}^2$ . The ultimate moment is 165 kN m, causing hogging of the beam.

$$\begin{aligned} \frac{M}{bd^2 f_{cu}} &= \frac{165 \times 10^6}{230 \times 330^2 \times 30} \\ &= 0.22 > 0.156 \end{aligned}$$

so that compression steel is required, and

$$d'/d = 50/330 = 0.15 < 0.2$$

therefore

$$f_{sc} = 0.87 f_y$$

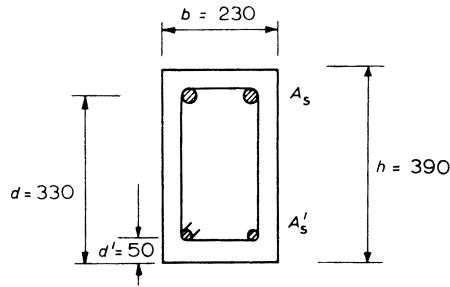

Figure 7.8 Beam doubly reinforced to resist a hogging moment

From equation 7.4

$$\begin{aligned} \text{Compression steel } A'_s &= \frac{(M - 0.156 f_{cu} b d^2)}{0.87 f_y (d - d')} \\ &= \frac{(165 \times 10^6 - 0.156 \times 30 \times 230 \times 330^2)}{0.87 \times 460 (330 - 50)} \\ &= 427 \text{ mm}^2 \end{aligned}$$

And from equation 7.5

$$\begin{aligned} \text{tension steel } A_s &= \frac{0.156 f_{cu} b d^2}{0.87 f_y z} + A'_s \\ &= \frac{0.156 \times 30 \times 230 \times 330^2}{0.87 \times 460 \times 0.775 \times 330} + 427 \\ &= 1572 \text{ mm}^2 \end{aligned}$$

Provide two T20 bars for  $A'_s$ , area = 628 mm<sup>2</sup> and two T32 bars for  $A_s$ , area = 1610 mm<sup>2</sup>, so that for the areas of steel required and provided in equation 7.3

$$628 - 427 > 1610 - 1572$$

Also

$$\begin{aligned} \frac{100A'_s}{bh} &= \frac{100 \times 628}{230 \times 390} = 0.70 \\ \frac{100A_s}{bh} &= \frac{100 \times 1610}{230 \times 390} = 1.79 \end{aligned}$$

therefore the bar areas are within the limits specified by the code.

The minimum link size =  $20/4 = 5$  mm, say 8 mm links, and the maximum link spacing =  $12 \times 20 = 240$  mm, centres. The link size and spacing may be governed by the shear calculations. Figure 7.8 shows the arrangement of the reinforcement to resist a hogging moment.

**Example 7.4 Design of Tension and Compression Reinforcement,  $\beta_b = 0.7$** 

The beam section shown in figure 7.9 has characteristic material strengths of  $f_{cu} = 30 \text{ N/mm}^2$  and  $f_y = 460 \text{ N/mm}^2$ . The ultimate moment is 370 kN m, causing hogging of the beam.

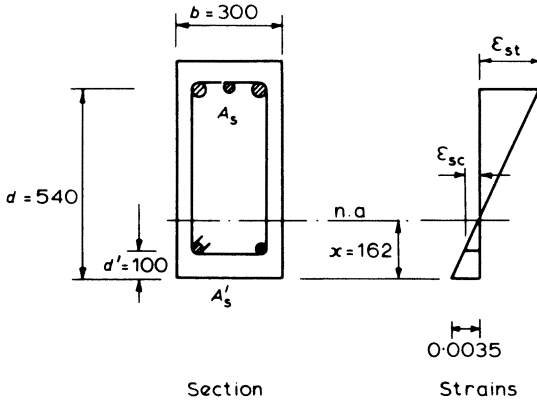

Figure 7.9 Beam doubly reinforced to resist a hogging moment

As the moment reduction factor  $\beta_b = 0.7$ , the limiting depth of the neutral axis is

$$\begin{aligned}
 x &= (\beta_b - 0.4) d \\
 &= (0.7 - 0.4) 540 = 162 \text{ mm} \\
 K &= M/bd^2 f_{cu} = 370 \times 10^6 / (300 \times 540^2 \times 30) \\
 &= 0.141 \\
 K' &= 0.402 (\beta_b - 0.4) - 0.18 (\beta_b - 0.4)^2 \\
 &= 0.104
 \end{aligned}$$

$K > K'$  therefore compression steel is required

$$d'/x = 100/162 = 0.62 > 0.43$$

therefore  $f_{sc} < 0.87 f_y$

(1)

$$\begin{aligned}
 \text{Steel compressive strain } \epsilon_{sc} &= \frac{0.0035 (x - d')}{x} \\
 &= \frac{0.0035 (162 - 100)}{162} = 0.00134
 \end{aligned}$$

(2) From the relevant equation of section 4.1.2

$$\begin{aligned}\text{Steel compressive stress} &= E_s \epsilon_{sc} \\ &= 200\,000 \times 0.00134 \\ &= 268 \text{ N/mm}^2\end{aligned}$$

(3)

$$\begin{aligned}\text{Compression steel } A'_s &= \frac{(K - K') f_{cu} b d^2}{f_{sc} (d - d')} \\ &= \frac{(0.141 - 0.104) 30 \times 300 \times 540^2}{268 (540 - 100)} \\ &= 823 \text{ mm}^2\end{aligned}$$

(4)

$$\begin{aligned}\text{Tension steel } A_s &= \frac{K' f_{cu} b d^2}{0.87 f_y z} + A'_s \frac{f_{sc}}{0.87 f_y} \\ &= \frac{0.104 \times 30 \times 300 \times 540^2}{0.87 \times 460 (540 - 0.9 \times 162/2)} + 823 \times \frac{268}{0.87 \times 460} \\ &= 2011 \text{ mm}^2\end{aligned}$$

Provide two T25 bars for  $A'_s$ , area = 982 mm<sup>2</sup> and two T32 plus one T25 bars for  $A_s$ , area = 2101 mm<sup>2</sup>, which also meet the requirements of equation 7.3.

These areas lie within the maximum and minimum limits specified by the code. To restrain the compression steel, at least 8 mm links at 300 mm centres should be provided.

### 7.2.3 T-beams

Figure 7.10 shows sections through a T-beam and an L-beam which may form part of a concrete beam and slab floor. When the beams are resisting sagging moments, part of the slab acts as a compression flange and the members may be designed as T- or L-beams. With hogging moments the slab will be in tension and assumed to be cracked, therefore the beam must then be designed as a rectangular section of width  $b_w$  and overall depth  $h$ .

When the slab does act as the flange its effective width is defined by empirical rules which are specified in BS 8110 as follows.

- (1) T-section – the lesser of the actual flange width, or the width of the web plus one-fifth of the distance between zero moments.
- (2) L-section – the lesser of the actual flange width or the width of the web plus one-tenth of the distance between zero moments.

As a simple rule, the distance between the points of zero moment may be taken as 0.7 times the effective span for a continuous beam.

Since the slab acts as a large compression area, the stress block for the T- or L-section usually falls within the slab thickness. For this position of the stress

## REINFORCED CONCRETE DESIGN

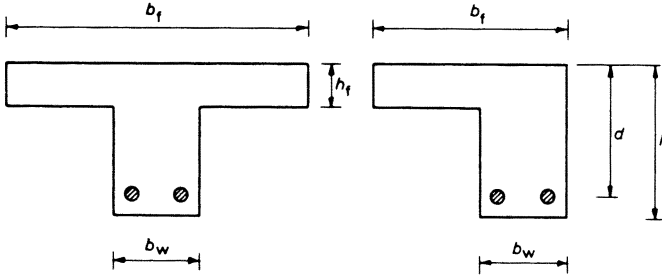
Figure 7.10 *T-beam and L-beam*

block, the section may be designed as an equivalent rectangular section of breadth  $b_f$ .

Transverse reinforcement should be placed across the top of the flange to prevent cracking. The area of this reinforcement should not be less than 0.15 per cent of the longitudinal cross-section of the flange.

*Design Procedure*

- (1) Calculate  $M/b_f d^2 f_{cu}$  and determine  $l_a$  from the lever-arm curve of figure 7.5

$$\text{Lever arm } z = l_a d \quad \text{or from equation 7.1}$$

- (2) If  $d - z < h_f/2$  the stress block falls within the flange depth, and the design may proceed as for a rectangular section, breadth  $b_f$ .
- (3) Provide transverse steel in the top of the flange

$$\text{Area} = 0.15 h_f \times 1000/100 = 1.5 h_f \text{ mm}^2 \text{ per metre length of the beam}$$

On the very few occasions that the neutral axis does fall below the flange, reference should be made to the methods described in section 4.6.2 for a full analysis.

*Example 7.5 Design of Reinforcement for a T-section*

The beam section shown in figure 7.11 has characteristic material strengths of  $f_{cu} = 30 \text{ N/mm}^2$  and  $f_y = 460 \text{ N/mm}^2$ . The design moment at the ultimate limit state is 190 kN m, causing sagging.

$$\frac{M}{b_f d^2 f_{cu}} = \frac{190 \times 10^6}{600 \times 530^2 \times 30} = 0.038$$

From the lever-arm curve, figure 7.5,  $l_a = 0.95$ , therefore

$$\text{lever arm } z = l_a d = 0.95 \times 530 = 503 \text{ mm}$$

$$d - z = 530 - 503$$

$$= 27 \text{ mm} < h_f/2$$

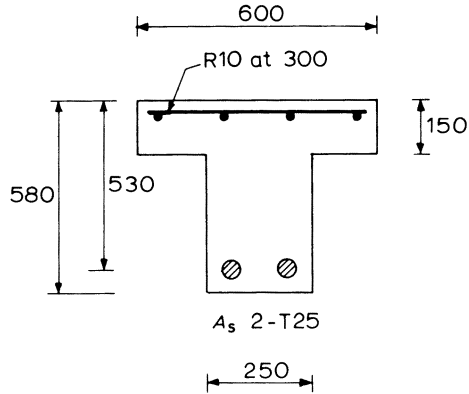

Figure 7.11 T-beam

Thus the stress block lies within the flange

$$A_s = \frac{M}{0.87 f_y z} = \frac{190 \times 10^6}{0.87 \times 460 \times 503} \\ = 943 \text{ mm}^2$$

Provide two T25 bars, area = 982 mm<sup>2</sup>. For these bars

$$\frac{100A_s}{b_w h} = \frac{100 \times 982}{250 \times 580} = 0.68 \text{ per cent}$$

Thus the steel percentage is greater than the minimum specified by the code.

$$\text{Transverse steel in the flange} = 1.5 h_f = 1.5 \times 150 \\ = 225 \text{ mm}^2/\text{m}$$

Provide R10 bars at 300 mm centres = 262 mm<sup>2</sup>/m.

#### 7.2.4 Anchorage Bond

From section 5.2 the anchorage bond stress,  $f_{bu}$ , for a reinforcing bar is given by the following equation:

$$f_{bu} = \frac{f_s}{4L} \Phi$$

where  $f_s$  = the direct tensile or compressive stress in the bar  
 $L$  = the length of embedment beyond the section considered  
 $\Phi$  = the bar size.

This stress should not exceed the ultimate anchorage bond stress given by

$$f_{bu} = \beta \sqrt{f_{cu}}$$

where the coefficient  $\beta$  is given in table 5.2.

The required anchorage length should be measured from the point at which the bar is assumed to be stressed.

The appendix lists the anchorage lengths appropriate to the ultimate stress,  $0.87f_v$ , for various grades of concrete and steel. The effective anchorage lengths for hooks and bends in reinforcing bars are detailed in figure 5.6.

The anchorage of a bar is more effective in a compression zone of a member than in a tension zone and this should be considered when detailing the reinforcement. Anchorage requirements are also important when detailing the curtailment of bars as described in the following section.

**7.2.5 Curtailment of Bars**

As the magnitude of the bending moment on a beam decreases along its length, so may the area of bending reinforcement be reduced by curtailing bars as they are no longer required. Figure 7.12 illustrates the curtailment of bars in the span and at an internal support of a continuous beam. The bending-moment envelope diagram is divided into sections as shown, in proportion to the area and effective depth of each bar.

Each curtailed bar should extend beyond the point at which it is no longer needed so that it is well anchored into the concrete. The rules for curtailing such bars, other than at a simple end support, are as follows.

- (1) The curtailment anchorage should not be less than twelve times the bar size or the effective depth of the beam, whichever is the greater.

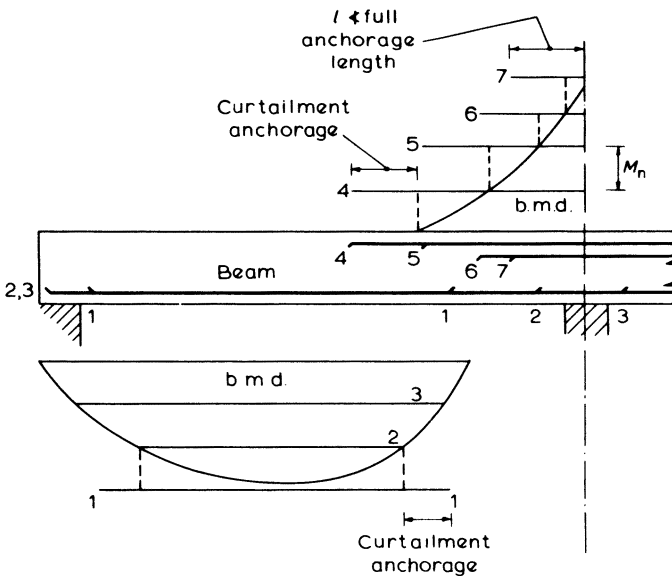

Figure 7.12 Curtailment of reinforcement

- (2) A bar should not be stopped in a tension zone unless
- (i) the shear capacity is twice the actual shear present
  - (ii) the continuing bars have twice the area required to resist the moment at that section, or
  - (iii) the curtailment anchorage is increased to a full anchorage bond length based on a stress of  $0.87f_y$ .

Thus in figure 7.12, bar 4 is curtailed in a compression zone and the curtailment anchorage would be the greater of twelve bar diameters or the effective depth. Bars 1 and 5, though, are curtailed in a tension zone and a full anchorage bond length would be required, unless the conditions of rules 2(i) or 2(ii) apply, in which case the curtailment anchorage would be twelve bar diameters or the effective depth.

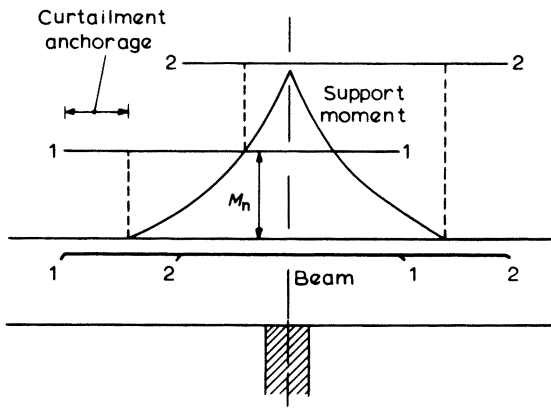

Figure 7.13 Staggering the curtailment of bars

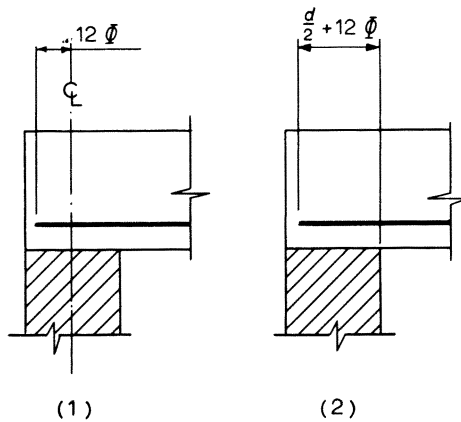

Figure 7.14 Alternative anchorage lengths at a simple support

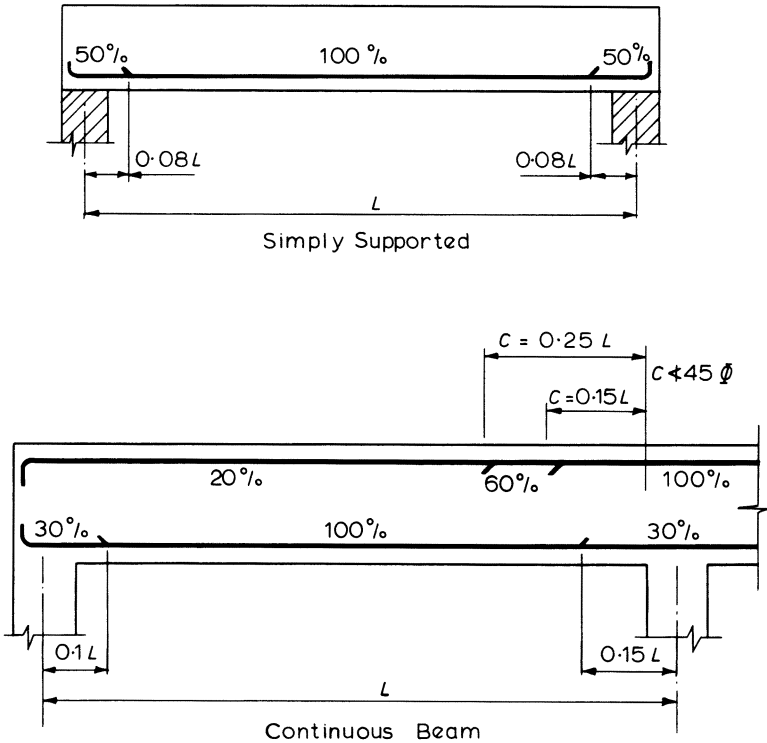

Figure 7.15 Simplified rules for curtailment of bars in beams

It is most important that all bars should have at least a full anchorage bond length beyond the section of maximum moment. This is relevant to bars such as no. 7 in figure 7.12 and also to bars in a cantilever or at an end support framing into a column. The anchorage length should be based on the design stress of a bar as described in sections 5.2 and 7.2.4.

The curtailment of bars should be staggered wherever possible in order to avoid sudden changes in cross-section with resulting stress concentrations and possible cracking. This curtailment can often be achieved whilst using bars of equal length, as illustrated in figure 7.13.

At a simply supported end of a member, the reinforcing bars should extend over the supports so that the beam is sure to be reinforced in this region of high shears and bearing stresses. Therefore, each tension bar should be anchored according to one of the two rules shown diagrammatically in figure 7.14. No bend or hook should begin before the centre of the support for rule 1 nor before  $d/2$  from the face of the support for rule 2.

Where the loads on a beam are substantially uniformly distributed, simplified rules for curtailment may be used. These rules only apply to continuous beams if the characteristic imposed load does not exceed the characteristic dead load and the spans are equal. Figure 7.15 shows the rules in a diagrammatic form.

### 7.2.6 Span-Effective Depth Ratios

As already described in section 7.1, it is necessary to check the span-effective depth ratios to ensure that the deflections are not excessive. This is unlikely to be a problem with beams except perhaps for cantilevers or long span beams. These requirements are fully described and explained in chapter 6, dealing with Serviceability.

### 7.2.7 Bending-reinforcement Example

The following example describes the calculations for designing the bending reinforcement for a simply supported beam. It brings together many of the items from the previous sections. The shear reinforcement for this beam is designed later in example 7.7.

#### Example 7.6 Design of a Beam – Bending Reinforcement

The beam shown in figure 7.16 supports the following uniformly distributed loads

$$\begin{aligned} \text{dead load } g_k &= 40 \text{ kN/m, including self-weight} \\ \text{imposed load } q_k &= 12 \text{ kN/m} \end{aligned}$$

The characteristic material strengths are  $f_{cu} = 30 \text{ N/mm}^2$  and  $f_y = 460 \text{ N/mm}^2$ . Effective depth,  $d = 550 \text{ mm}$  and breadth,  $b = 300 \text{ mm}$ .

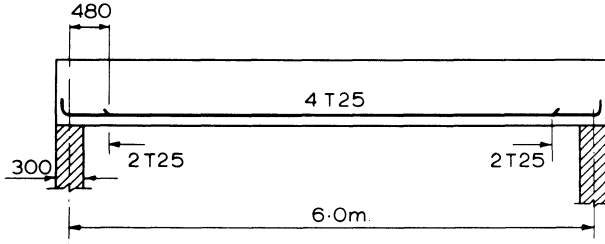

Figure 7.16 One-span beam-bending reinforcement

(a) Analysis

$$\begin{aligned} \text{Ultimate load } w_u &= (1.4g_k + 1.6q_k) \text{ kN/metre} \\ &= (1.4 \times 40 + 1.6 \times 12) = 75.2 \text{ kN/metre} \end{aligned}$$

therefore

$$\text{maximum design moment } M = \frac{w_u L^2}{8} = \frac{75.2 \times 6.0^2}{8} = 338 \text{ kN m}$$

(b) Bending Reinforcement

$$K = \frac{M}{bd^2 f_{cu}} = \frac{338 \times 10^6}{300 \times 550^2 \times 30} = 0.124$$

From the lever-arm curve, figure 7.5,  $l_a = 0.83$ . Therefore

$$\text{effective depth } z = l_a d = 0.83 \times 550 = 456 \text{ mm}$$

$$A_s = \frac{M}{0.87 f_y z} = \frac{338 \times 10^6}{0.87 \times 460 \times 456} = 1852 \text{ mm}^2$$

Provide four T25 bars, area = 1960 mm<sup>2</sup>

(c) Curtailment at Support

A 90° bend with radius  $4\Phi$  beyond the support centre-line will provide an equivalent anchorage, length  $16\Phi$  which meets the requirements of the code.

(d) Span-Effective Depth Ratio

$$M/bd^2 = 338 \times 10^6 / (300 \times 550^2) = 3.72$$

Basic ratio = 20. From table 6.7, modification factor = 0.89 by interpolation. Therefore

$$\text{maximum } \frac{\text{span}}{d} = 20 \times 0.89 = 17.8$$

$$\text{actual } \frac{\text{span}}{d} = \frac{6000}{550} = 10.9$$

### 7.3 Design for Shear

The distribution of shear along a beam is given by the shear-force envelope diagram. If  $V$  is the shear force at a section, then the shear stress  $v$  is given by

$$v = V/bd$$

The shear stress must never exceed the lesser of  $0.8\sqrt{f_{cu}}$  or  $5 \text{ N/mm}^2$ .

Shear reinforcement will take the form of vertical stirrups or a combination of stirrups and bent-up bars.

#### 7.3.1 Vertical Stirrups

The usual form of stirrup is a closed link. This helps to make a rigid cage of the beam reinforcement and is essential if there is any compression steel present. An alternative is the open link as shown in figure 7.17; this may have a closing piece if lateral support is required, and offers advantages for *in situ* steel fixing.

All of the tension reinforcement must be enclosed by links, and if compression steel is not present, hanger bars are required to anchor the links in the compression zone (see figure 7.18). The minimum spacing of links is determined by the requirements of placing and compacting the concrete, and should not normally be less than about 80 mm. Maximum spacing of links longitudinally along the span should

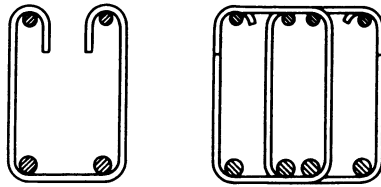

Figure 7.17 Open and multiple links

not exceed  $0.75d$ . At right angles to the span the spacing of the vertical legs should not exceed  $d$ , and all tension bars should be within 150 mm of a vertical leg. Because of these requirements (or if there are large shears), it may often be convenient to provide multiple links as illustrated in figure 7.17.

The choice of steel type is often governed by the fact that mild steel may be bent to a smaller radius than high-yield steel. This is particularly important in narrow members to allow correct positioning of tension reinforcement as shown in figure 7.18.

The advantages of mild steel links are further increased by the need to provide anchorage for the vertical leg of a stirrup within the compression zone. Although high-yield reinforcement has better bond characteristics, anchorage lengths are greater than for mild steel bars of comparable size if the steel is to act at its full design stress. This factor is of particular importance if 'open' links are to be used.

The size and spacing of the stirrups, according to the equations derived in section 5.1.1 should be such that

$$\frac{A_{sv}}{s_v} \geq \frac{b(v - v_c)}{0.87 f_{yv}}$$

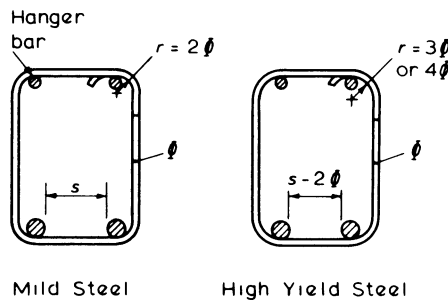

Figure 7.18 Bending of links

where  $A_{sv}$  = cross-sectional area of the legs of a stirrup

$s_v$  = spacing of the stirrups

$b$  = breadth of the beam

$v$  =  $V/bd$

$v_c$  = the ultimate shear stress from table 5.1

$f_{yv}$  = characteristic strength of the link reinforcement.

Values of  $A_{sv}/s_v$  for various stirrup sizes and spacings are tabulated in the appendix. The calculation for  $A_{sv}/s_v$  is carried out at the critical section, usually distance  $d$  from the face of the support. Since the shear force diminishes along the beam, similar calculations can be repeated so that a greater spacing or a smaller stirrup size may be used.

If  $v$  is less than  $v_c$  nominal links must still be provided unless the beam is a very minor one and  $v < v_c/2$ . The nominal links should be provided such that

$$A_{sv}/s_v = 0.4b/0.87f_{yv}$$

Even when shear steel is required, there is a section at which the shear resistance of the concrete plus the nominal stirrups equals the shear force from the envelope diagram. At this section the stirrups necessary to resist shear can stop and be replaced by the nominal stirrups. The shear resistance  $V_n$  of the concrete plus the nominal stirrups is given by

$$V_n = (0.4 + v_c) bd$$

or

$$V_n = \left( \frac{A_{sv}}{s_v} 0.87f_{yv} + bv_c \right) d$$

for the link spacing provided (see equation 5.3). Once this value of  $V_n$  has been calculated it may be marked on the shear-force envelope to show the limits for the shear reinforcement, as shown in figure 7.19.

### ***Example 7.7 Design of Shear Reinforcement for a Beam***

Shear reinforcement is to be designed for the one-span beam of example 7.6, as shown in figures 7.16 and 7.19. The characteristic strength of the mild steel links is  $f_{yv} = 250 \text{ N/mm}^2$ .

(a) Check maximum shear stress

$$\begin{aligned} \text{Total load on span, } F &= w_u \times \text{span} = 75.2 \times 6.0 \\ &= 451 \text{ kN} \end{aligned}$$

At face of support

$$\begin{aligned} \text{shear } V_s &= F/2 - w_u \times \text{support width}/2 \\ &= 451/2 - 75.2 \times 0.15 = 214 \text{ kN} \end{aligned}$$

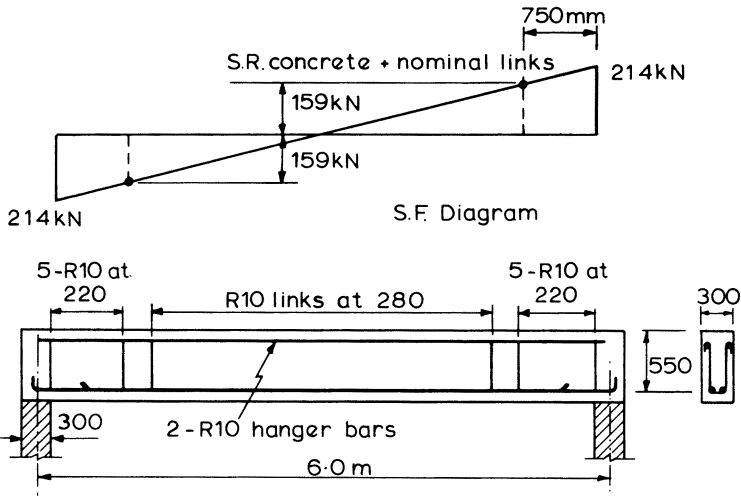

Figure 7.19 Non-continuous beam-shear reinforcement

$$\begin{aligned} \text{shear stress, } v &= \frac{V_s}{bd} = \frac{214 \times 10^3}{300 \times 550} \\ &= 1.3 \text{ N/mm}^2 < 0.8 \sqrt{f_{cu}} \end{aligned}$$

(b) Shear links

Distance  $d$  from face of support

$$\begin{aligned} \text{shear } V_d &= V_s - w_u d \\ &= 214 - 75.2 \times 0.55 = 173 \text{ kN} \end{aligned}$$

$$\text{Shear stress } v = \frac{173 \times 10^3}{300 \times 550} = 1.05 \text{ N/mm}^2$$

Only two 25 mm bars extend a distance  $d$  past the critical section. Therefore for determining  $v_c$

$$\frac{100A_s}{bd} = \frac{100 \times 982}{300 \times 550} = 0.59$$

From table, 5.1,  $v_c = 0.56 \text{ N/mm}^2$

$$\frac{A_{sv}}{s_v} = \frac{b(v - v_c)}{0.87 f_{yv}} = \frac{300(1.05 - 0.56)}{0.87 \times 250} = 0.68$$

Provide R10 links at 220 mm centres

$$\frac{A_{sv}}{s_v} = \frac{2 \times 78.5}{220} = 0.71$$

(c) Nominal links

For mild steel links

$$\frac{A_{sv}}{s_v} = \frac{0.4 b}{0.87 f_{yv}} = \frac{0.4 \times 300}{0.87 \times 250} = 0.55$$

Provide R10 links at 280 mm centres

$$\frac{A_{sv}}{s_v} = \frac{2 \times 78.5}{280} = 0.56$$

(d) Extent of shear links

Shear resistance of nominal links + concrete is

$$\begin{aligned} V_n &= \left( \frac{A_{sv}}{s_v} 0.87 f_{yv} + b v_c \right) d \\ &= (0.56 \times 0.87 \times 250 + 300 \times 0.56) 550 \\ &= 159 \text{ kN} \end{aligned}$$

Shear reinforcement is required over a distance  $s$  given by

$$\begin{aligned} s &= \frac{V_s - V_n}{w_u} = \frac{214 - 159}{75.2} \\ &= 0.73 \text{ metres from the face of the support} \end{aligned}$$

Number of R10 links at 220 mm required at each end of the beam is

$$1 + (s/220) = 1 + (730/220) = 5$$

### 7.3.2 Bent-up Bars

In regions of high shear forces it may be found that the use of links to carry the full force will cause steel congestion and lead to constructional problems. In these situations, consideration should be given to 'bending up' main reinforcement which is no longer required to resist bending forces. At least 50 per cent of the shear resistance provided by the steel should be in the form of links.

For a 'double system' of bent-up bars at  $45^\circ$  and spaced  $(d - d')$  apart, as described in section 5.1.2, the shear resistance is

$$V = 2 \times 1.23 f_y A_{sb}$$

where  $A_{sb}$  is the cross-sectional area of a bent-up bar.

Bent-up bars must be fully anchored past the point at which they are acting as tension members, as indicated in figure 5.3. To guard against possible crushing of

**Table 7.1** Shear resistance in kN of bent-up bars, 'double system'

$f_y$ (N/mm <sup>2</sup> )	Bar size $\Phi$					
	12	16	20	25	32	40
250	35	62	96	151	247	387
460	64	114	177	278	455	713

the concrete it may also be necessary to check the bearing stress inside the bends of a bar. This stress is given by

$$\text{Bearing stress} = \frac{F_{bt}}{r \Phi}$$

where  $F_{bt}$  is the tensile force in the bar,  $r$  is the internal radius of the bend, and  $\Phi$  is the bar size. This stress should not exceed

$$\frac{2 f_{cu}}{1 + 2 \Phi/a_b}$$

where  $a_b$  is the centre to centre distance between bars perpendicular to the plane of the bend, but for a bar adjacent to the face of a member

$$a_b = \Phi + \text{side cover}$$

### **Example 7.8 Bearing Stresses inside a Bend**

Determine the inside radius required for the 25 mm bent-up bar shown in figure 7.20, so that the ultimate bending stress is not exceeded. The bar has a side cover of 50 mm. Assume the bar is at the ultimate tensile stress of  $0.87 f_y$  and the characteristic material strengths are  $f_y = 460 \text{ N/mm}^2$  and  $f_{cu} = 30 \text{ N/mm}^2$ .

$$a_b = \Phi + \text{cover} = 25 + 50 = 75 \text{ mm}$$

therefore

$$\begin{aligned} \frac{2 f_{cu}}{1 + 2 \Phi/a_b} &= \frac{2 \times 30}{1 + 2 \times 25/75} = 36 \text{ N/mm}^2 \\ \frac{F_{bt}}{r \Phi} &= \frac{0.87 \times 460 \times A_s}{r \times 25} = \frac{0.87 \times 460 \times 491}{25 r} \\ &= \frac{7860}{r} \end{aligned}$$

thus

$$\frac{7860}{r} \leq 36$$

or

$$r \geq \frac{7860}{36} = 219 \text{ mm or } 9 \Phi$$

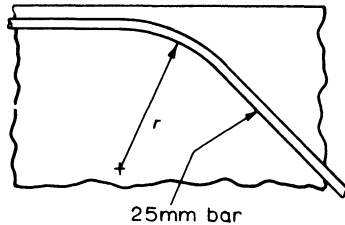

Figure 7.20 Radius of bend for a bent-up bar

#### 7.4 Bar Spacing

There are limitations on the minimum and maximum spacing of the reinforcing bars. In the case of minimum values this is governed by constructional requirements to allow for the access of poker vibrators and the flow of concrete to obtain a well-compacted and dense concrete. The maximum limitations on spacings are to prevent excessive cracking caused by shrinkage of the concrete and thermal expansion and contraction of the member. These serviceability requirements are dealt with in chapter 6.

#### 7.5 Continuous Beams

Beams, slabs and columns of a cast *in situ* structure all act together to form a continuous load-bearing structure. The reinforcement in a continuous beam must be designed and detailed to maintain this continuity by connecting adjacent spans and tying together the beam and its supporting columns. There must also be transverse reinforcement to unite the slab and the beam.

The bending-moment envelope is generally a series of sagging moments in the spans and hogging moments at the supports as in figure 7.21, but occasionally the hogging moments may extend completely over the span. Where the sagging moments occur the beam and slab act together, and the beam can be designed as a T-section. At the supports, the beam must be designed as a rectangular section – this is because the hogging moments cause tension in the slab.

The moment of resistance of the concrete T-beam section is somewhat greater than that of the rectangular concrete section at the supports. Hence it is often advantageous to redistribute the support moments as described in chapter 3. By this means the design support moments can be reduced and the design span moments possibly increased.

Design of the beam follows the procedures and rules set out in the previous sections. Other factors which have to be considered in the detailed design are as follows.

- (1) At an exterior column the beam reinforcing bars which resist the design moments must have an anchorage bond length within the column.
- (2) A minimum area of transverse reinforcement must be placed in the top of the slab, across the effective flange width as described in section 7.2.3.
- (3) Reinforcement in the top of the slab must pass over the beam steel and still have the necessary cover. This must be considered when detailing the beam reinforcement and when deciding the effective depth of the beam at the support sections.
- (4) The column and beam reinforcement must be carefully detailed so that the bars can pass through the junctions without interference.

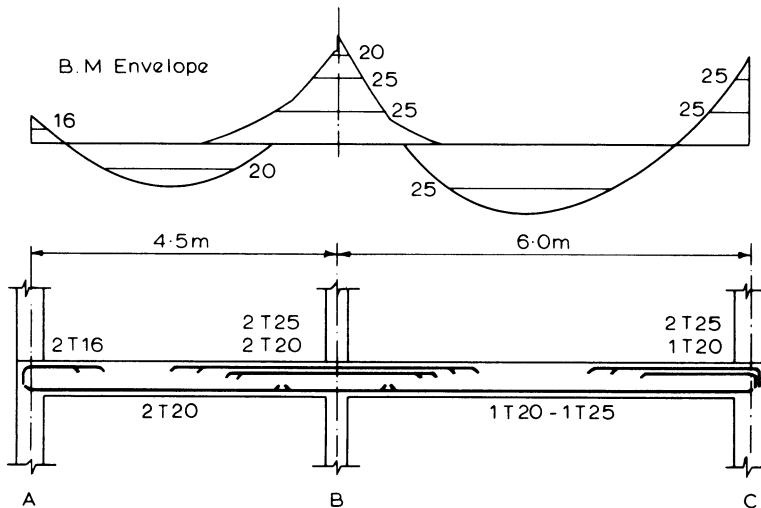

**Figure 7.21** Arrangement of bending reinforcement

Figure 7.21 illustrates a typical arrangement of the bending reinforcement for a two-span continuous beam. The reinforcement has been arranged with reference to the bending-moment envelope and in accordance with the rules for anchorage and curtailment described in sections 7.2.4 and 7.2.5. The bending-moment envelope has been divided into sectors equivalent to the moment of resistance of each reinforcing bar. This establishes the cut-off points beyond which the bars must extend at least a curtailment anchorage length. It should be noted that at the external columns the reinforcement has been bent down to give a full anchorage bond length.

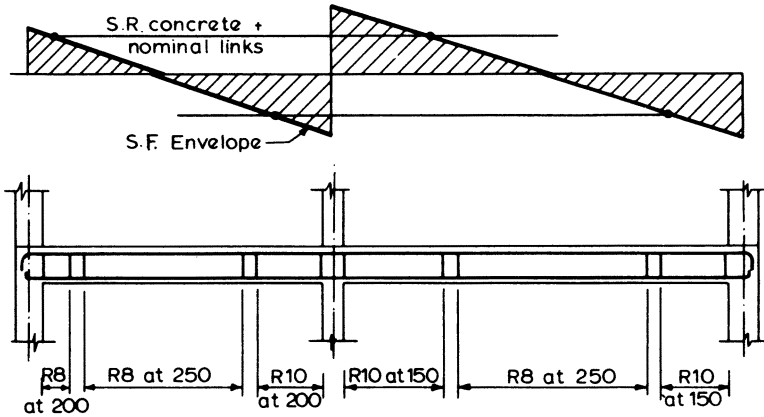

Figure 7.22 Arrangement of shear reinforcement

The shear-force envelope and the arrangement of the shear reinforcement for the same continuous beam is shown in figure 7.22. On the shear-force envelope the resistance of the concrete plus the nominal stirrups has been marked and this shows the lengths of the beam which need shear reinforcement. When designing the shear reinforcement, reference should be made to the arrangement of bending reinforcement to ensure that the longitudinal tension bars used to establish  $v_c$  extend at least an effective depth beyond the section being considered.

### Example 7.9 Design of a Continuous Beam

The beam is 300 mm wide by 660 mm deep with three equal 5.0 m spans. In the transverse direction, the beams are at 4.0 m centres with a 180 mm thick slab, as shown in figure 7.24.

The live load  $q_k$  on the beam is 50 kN/m and the dead load  $g_k$ , including self-weight, is 85 kN/m.

Characteristic material strengths are  $f_{cu} = 30 \text{ N/mm}^2$ ,  $f_y = 460 \text{ N/mm}^2$  for the longitudinal steel and  $f_{yv} = 250 \text{ N/mm}^2$  for the links. For a mild exposure the minimum concrete cover is to be 25 mm.

For each span

$$\text{ultimate load } w_u = (1.4g_k + 1.6q_k) \text{ kN/metre}$$

$$(1.4 \times 85 + 1.6 \times 50) = 199 \text{ kN/metre}$$

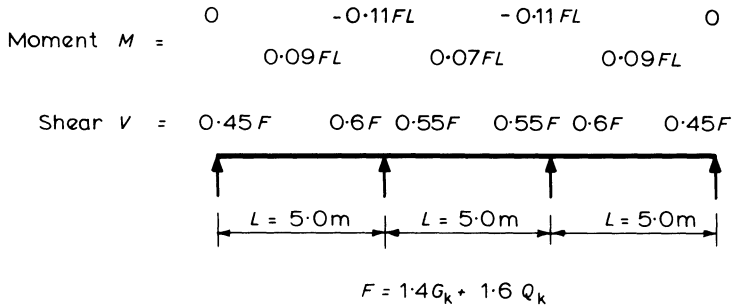

**Figure 7.23** Continuous beam with ultimate bending moment and shear-force coefficients

Total ultimate load on a span is

$$F = 199 \times 5.0 = 995 \text{ kN}$$

As the loading is uniformly distributed,  $q_k \gg g_k$ , and the spans are equal, the coefficients shown in figure 7.23 have been used to calculate the design moment and shears.

### Bending

(a) Mid-span of 1st and 3rd Spans – Design as a T-section

$$\text{Moment } M = 0.09 FL = 0.09 \times 995 \times 5 = 448 \text{ kN m}$$

$$\text{Effective width of flange} = b_w + 0.7L/5$$

$$= 300 + \frac{0.7 \times 5000}{5} = 1000 \text{ mm}$$

therefore

$$\frac{M}{bd^2f_{cu}} = \frac{448 \times 10^6}{1000 \times 600^2 \times 30} = 0.041$$

From the lever-arm curve,  $l_a = 0.95$ , therefore

$$z = 0.95 \times 600 = 570 \text{ mm}$$

and

$$d - z = 600 - 570 = 30 < h_f/2$$

so that the stress block must lie within the 180 mm thick flange. Therefore

$$A_s = \frac{M}{0.87f_y z} = \frac{448 \times 10^6}{0.87 \times 460 \times 570} = 1964 \text{ mm}^2$$

Provide two T32 plus one T25 bar, area = 2101 mm<sup>2</sup> (bottom steel).

## (b) Interior Supports – Design as a Rectangular Section

$$M = 0.11 FL = 0.11 \times 995 \times 5 = 547 \text{ kN m hogging}$$

$$\frac{M}{bd^2 f_{cu}} = \frac{547 \times 10^6}{300 \times 580^2 \times 30} = 0.18 > 0.156$$

Thus, compression steel is required.

$$\begin{aligned} A'_s &= \frac{M - 0.156 f_{cu} b d^2}{0.87 f_y (d - d')} \\ &= \frac{547 \times 10^6 - 0.156 \times 30 \times 300 \times 580^2}{0.87 \times 460 (580 - 50)} = 352 \text{ mm}^2 \end{aligned}$$

This area of steel will be provided by extending the span reinforcement beyond the supports.

$$\begin{aligned} A_s &= \frac{0.156 f_{cu} b d^2}{0.87 f_y z} + A'_s \\ &= \frac{0.156 \times 30 \times 300 \times 580^2}{0.87 \times 460 \times 0.775 \times 580} + 352 = 2977 \text{ mm}^2 \end{aligned}$$

Provide two T32 plus three T25 bars, area = 3080 mm<sup>2</sup> (top steel).

## (c) Mid-span of 2nd Span – Design as a T-section

$$M = 0.07 FL = 0.07 \times 995 \times 5 = 348 \text{ kN m}$$

Using the lever-arm curve, it is found that  $l_a = 0.95$

$$A_s = \frac{M}{0.87 f_y z} = \frac{348 \times 10^6}{0.87 \times 460 (0.95 \times 600)} = 1525 \text{ mm}^2$$

Provide one T32 plus two T25 bars, area = 1786 mm<sup>2</sup> (bottom steel).

*Shear*

## (a) Check maximum shear stress

Maximum shear at face of support is

$$\begin{aligned} V_s &= 0.6F - w_u \times \text{support width}/2 \\ &= 0.6 \times 995 - 199 \times 0.15 = 567 \text{ kN} \end{aligned}$$

$$\begin{aligned} v &= \frac{V_s}{bd} = \frac{567 \times 10^3}{300 \times 580} \\ &= 3.26 \text{ N/mm}^2 < 0.8 \sqrt{f_{cu}} \end{aligned}$$

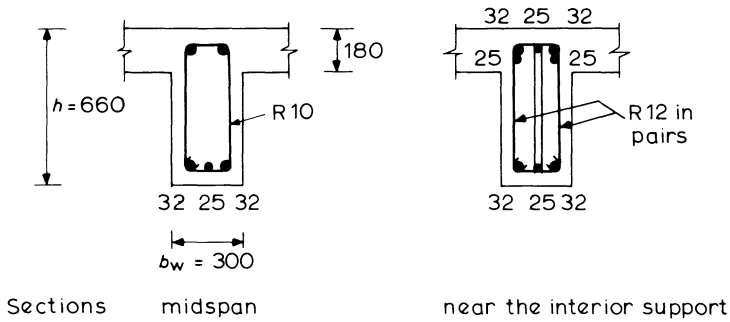
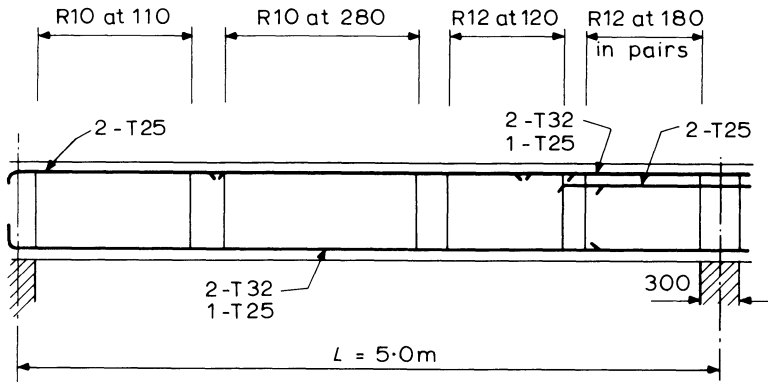

Figure 7.24 End-span reinforcement details

(b) Nominal links

$$\frac{A_{sv}}{s_v} = \frac{0.4b}{0.87f_{yv}} = \frac{0.4 \times 300}{0.87 \times 250} = 0.55$$

Provide R10 links at 280 mm centres,  $A_{sv}/s_v = 0.56$

(c) End supports

Shear distance,  $d$  from support face is

$$\begin{aligned} V_d &= 0.45F - w_u(d + \text{support width}/2) \\ &= 0.45 \times 995 - 199(0.6 + 0.15) \\ &= 299 \text{ kN} \end{aligned}$$

$$v = \frac{V_d}{bd} = \frac{299 \times 10^3}{300 \times 600} = 1.66 \text{ N/mm}^2$$

$$\frac{100A_s}{bd} = \frac{100 \times 2101}{300 \times 600} = 1.17$$

Therefore from table 5.1

$$v_c = 0.70 \text{ N/mm}^2$$

$$\frac{A_{sv}}{s_v} = \frac{b(v - v_c)}{0.87f_{yv}} = \frac{300(1.66 - 0.7)}{0.87 \times 250} = 1.32$$

Provide R10 links at 110 mm centres,  $A_{sv}/s_v = 1.41$ .

Shear resistance of nominal links + concrete is

$$V_n = \left( \frac{A_{sv}}{s_v} 0.87f_{yv} + bv_c \right) d$$

$$= (0.56 \times 0.87 \times 250 + 300 \times 0.7) 600 = 199 \text{ kN}$$

Shear reinforcement other than the nominal is required over a distance

$$s = \frac{V_d - V_n}{w_u} + d$$

$$= \frac{299 - 199}{199} + 0.6 = 1.1 \text{ m}$$

from the face of the support.

(d) First and third spans interior supports

Distance  $d$  from support face

$$V_d = 0.6 \times 995 - 199(0.58 + 0.15)$$

$$= 452 \text{ kN}$$

$$v = \frac{452 \times 10^3}{300 \times 580} = 2.60 \text{ N/mm}^2$$

$$\frac{100A_s}{bd} = \frac{100 \times 3080}{300 \times 580} = 1.77$$

therefore from table 5.1

$$v_c = 0.81$$

$$\frac{A_{sv}}{s_v} = \frac{300(2.6 - 0.81)}{0.87 \times 250} = 2.47$$

Provide R12 links in pairs at 180 mm centres,  $A_{sv}/s_v = 2.51$ . Using  $V_n$  from part (c) as a conservative value, shear links are required over a distance

$$s = \frac{V_d - V_n}{w_u} + d = \frac{452 - 199}{199} + 0.58 = 1.85 \text{ m}$$

A similar calculation would show that single R12 links at 120 mm centres would be adequate 1.0 m from the support face.

(e) Second span

Distance  $d$  from support face

$$V_d = 0.55 \times 995 - 199 (0.58 + 0.15) = 402 \text{ kN}$$

Calculations would show that R10 links in pairs at 150 mm centres would be adequate.

**7.6 Cantilever Beams**

The moments, shears and deflections for a cantilever beam are substantially greater than those for an equivalently loaded span that is supported at both its ends. Also the moments in a cantilever can never be redistributed to other parts of the structure – the beam must always be capable of resisting the full static moment. Because of these factors and the problems that often occur with increased deflections due to creep, the design and detailing of a cantilever beam should be done with care.

When the loads are uniformly distributed the reinforcement may be arranged as shown in figure 7.25. The provision of additional steel in the compressive zone of the beam can help to restrain the increased deflections caused by creep. Horizon-

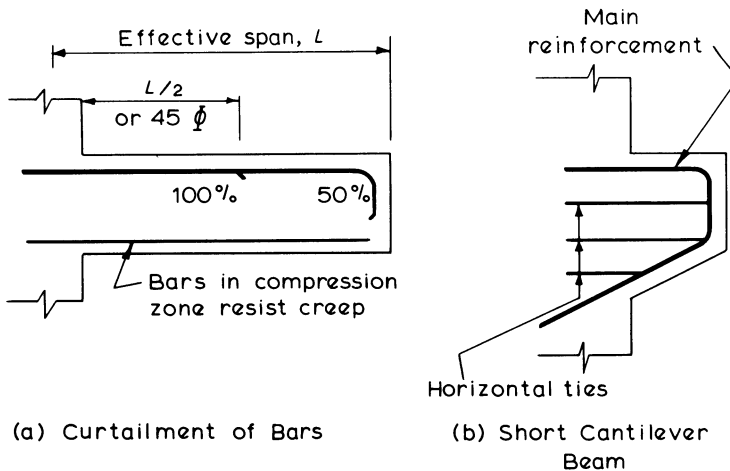

**Figure 7.25** Cantilever reinforcement details

tal links should be provided as in figure 7.25b when the cantilever has a short span or when there is a concentrated load near to the support. These horizontal links should have a full anchorage length within the support.

### 7.7 Design for Torsion

The method for designing a beam to resist torsion is described in the Code of Practice. It consists of calculations to determine an additional area of longitudinal and link reinforcement required to resist the torsional shear forces. The requirements for torsion have also been described in section 5.4. The procedure for a rectangular section is as follows.

- (1) Determine  $A_s$  and  $A_{sv}$  to resist the bending moments and shear forces by the usual procedures.
- (2) Calculate the torsional shear stress

$$v_t = \frac{2T}{h_{\min}^2 (h_{\max} - h_{\min}/3)}$$

where  $T$  = torsional moment due to the ultimate loads

$h_{\min}$  = the smaller dimension of the beam section

$h_{\max}$  = the larger dimension of the beam section

- (3) If  $v_t > v_{t\min}$  in table 7.2, then torsional reinforcement is required. Refer to table 7.3 for the reinforcement requirements with a combination of torsion and shear stress  $v$ .
- (4)  $v + v_t$  must not be greater than  $v_{tu}$  in table 7.2 where  $v$  is the shear stress due to the shear force. Also for sections with  $y_1 < 550$  mm

$$v_t \not> \frac{v_{tu} y_1}{550}$$

where  $y_1$  is the larger centre-to-centre dimension of a link.

- (5) Calculate the additional shear reinforcement required from

$$\frac{A_{sv}}{s_v} = \frac{T}{0.8 x_1 y_1 (0.87 f_{yv})}$$

where  $x_1$  is the smaller centre-to-centre dimension of the link. This value of  $A_{sv}/s_v$  is added to the value from step 1, and a suitable link size and spacing is chosen, but

$$s_v < 200 \text{ mm or } x_1$$

The links should be of the closed type shown in figure 7.26.

- (6) Calculate the additional area of longitudinal steel

$$A_s = \frac{A_{sv}}{s_v} \left( \frac{f_{yv}}{f_y} \right) (x_1 + y_1)$$

where  $A_{sv}/s_v$  is the value from step 5 and  $f_y$  is the characteristic strength of the longitudinal steel.  $A_s$  should be distributed evenly around the inside perimeter of the links. At least four corner bars should be used and the clear distance between bars should not exceed 300 mm.

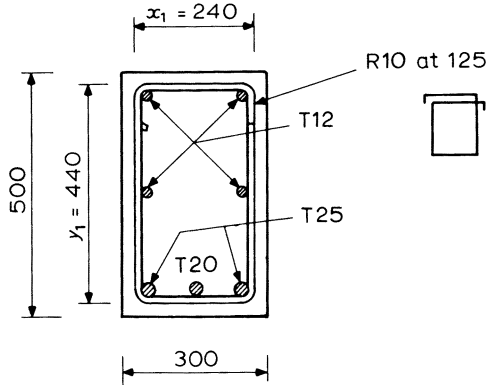

Figure 7.26 Torsion example

Table 7.2 Ultimate torsion shear stresses (N/mm<sup>2</sup>)

	Concrete grade		
	25	30	40 or more
$v_t \text{ min}$	0.33	0.37	0.40
$v_{tu}$	4.00	4.38	5.00

Table 7.3 Reinforcement for shear and torsion

	$v_t \leq v_{t. \text{min}}$	$v_t > v_{t. \text{min}}$
$v \leq v_c + 0.4$	Nominal shear reinforcement, no torsion reinforcement	Designed torsion reinforcement only, but not less than nominal shear reinforcement
$v > v_c + 0.4$	Designed shear reinforcement, no torsion reinforcement	Designed shear and torsion reinforcement

**Example 7.10 Design of Torsional Reinforcement**

The rectangular section of figure 7.26 resists a bending moment of 170 kN m, a shear of 160 kN and a torsional moment of 10 kN m. The characteristic material strengths are  $f_{cu} = 30 \text{ N/mm}^2$ ,  $f_y = 460 \text{ N/mm}^2$  and  $f_{yv} = 250 \text{ N/mm}^2$ .

- (1) Calculations for bending and shear would give

$$A_s = 1100 \text{ mm}^2$$

and

$$\frac{A_{sv}}{s_v} = 0.79$$

- (2) Torsional shear stress

$$\begin{aligned} v_t &= \frac{2T}{h_{\min}^2 (h_{\max} - h_{\min}/3)} \\ &= \frac{2 \times 10 \times 10^6}{300^2 (500 - 300/3)} = 0.56 \text{ N/mm}^2 \end{aligned}$$

- (3)
- $0.56 > 0.37$
- from table 7.2. Therefore torsional reinforcement is required.

- (4)

$$v = \frac{V}{bd} = \frac{160 \times 10^3}{300 \times 450} = 1.19 \text{ N/mm}^2$$

therefore

$$v + v_t = 1.19 + 0.56 = 1.75 \text{ N/mm}^2$$

 $v_{tu}$  from table 7.2 =  $4.38 \text{ N/mm}^2$ , therefore

$$\frac{v_{tu} y_1}{550} = \frac{4.38 \times 440}{550} = 3.5$$

so that  $v_t < v_{tu} y_1 / 550$  as required.

- (5)

$$\begin{aligned} \text{Additional } \frac{A_{sv}}{s_v} &= \frac{T}{0.8 x_1 y_1 (0.87 f_{yv})} \\ &= \frac{10.0 \times 10^6}{0.8 \times 240 \times 440 \times 0.87 \times 250} \\ &= 0.55 \end{aligned}$$

therefore

$$\text{Total } \frac{A_{sv}}{s_v} = 0.79 + 0.55 = 1.34$$

Provide R10 links at 100 mm centres

$$\frac{A_{sv}}{s_v} = 1.57$$

The links are of the closed type with their ends fully anchored.

(6) Additional longitudinal steel

$$\begin{aligned} A_s &= \left( \frac{A_{sv}}{s_v} \right) \left( \frac{f_{yv}}{f_y} \right) (x_1 + y_1) \\ &= 0.55 \times \frac{250}{460} (240 + 440) = 203 \text{ mm}^2 \end{aligned}$$

therefore

$$\text{total steel area} = 1100 + 203 = 1303 \text{ mm}^2$$

Provide the longitudinal steel shown in figure 7.26.

(7) The torsional reinforcement should extend at least  $h_{\max}$  beyond where it is required to resist the torsion.

# 8

## Design of Reinforced Concrete Slabs

Reinforced concrete slabs are used in floors, roofs and walls of buildings and as the decks of bridges. The floor system of a structure can take many forms such as *in situ* solid slabs, ribbed slabs or precast units. Slabs may span in one direction or in two directions and they may be supported on monolithic concrete beams, steel beams, walls or directly by the structure's columns.

Continuous slabs should in principle be designed to withstand the most unfavourable arrangements of loads, in the same manner as beams. Because there are greater opportunities for redistribution of loads in slabs, analysis may however often be simplified by the use of a single load case, provided that certain conditions are met as described in section 8.1. Bending moment coefficients based on this simplified method are provided for slabs which span in one direction with approximately equal spans, and also for flat slabs.

The moments in slabs spanning in two directions can also be determined using coefficients tabulated in the code of practice. Slabs which are not rectangular in plan or which support an irregular loading arrangement may be analysed by techniques such as the yield line method or the Hilleborg strip method, as described in section 8.10.

Concrete slabs behave primarily as flexural members and the design is similar to that for beams, although in general it is somewhat simpler because

- (1) the breadth of the slab is already fixed and a unit breadth of 1 m is used in the calculations
- (2) the shear stresses are usually low in a slab except when there are heavy concentrated loads, and
- (3) compression reinforcement is seldom required.

### 8.1 Simplified Analysis

BS 8110 permits the use of a simplified load arrangement for all slabs of maximum ultimate design load throughout all spans or panels provided that the following conditions are met:

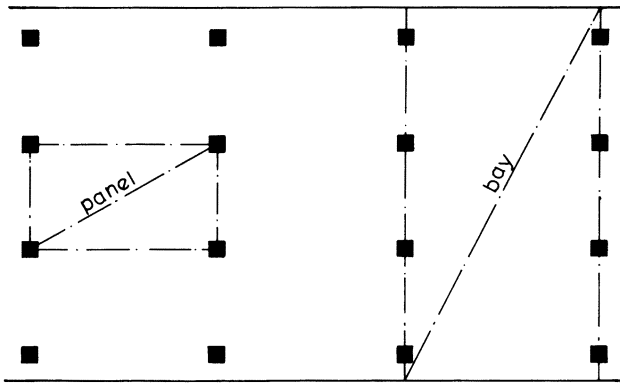

Figure 8.1 Slab definitions

- (a) In a one-way slab, the area of each bay  $\leq 30 \text{ m}^2$  (see figure 8.1).
- (b) Live load  $q_k \geq 1.25$  Dead load  $g_k$
- (c) Live load  $q_k \geq 5 \text{ kN/m}^2$  excluding partitions.

If analysis is based on this single load case, all support moments (except at a cantilever) should be reduced by 20 per cent and span moments increased accordingly. No further redistribution is then permitted, but special attention must be given to cases where a cantilever is adjacent to a span which is less than three times that of the cantilever. In this situation the condition where the cantilever is fully loaded and the span unloaded must be examined to determine possible hogging moments in the span.

Tabulated bending moment and shear force coefficients for use with approximately equal spans and when these conditions are satisfied are given in section 8.5.2 for one-way spanning slabs and in section 8.7 for flat slabs.

## 8.2 Shear in Slabs

The shear resistance of a solid slab may be calculated by the procedures given in chapter 5. Experimental work has indicated that, compared with beams, shallow slabs fail at slightly higher shear stresses and this is incorporated into the values of design ultimate shear stress  $v_c$  given in table 5.1.

The shear stress at a section in a solid slab is given by

$$v = \frac{V}{bd}$$

where  $V$  is the shear force due to the ultimate load,  $d$  is the effective depth of the slab and  $b$  is the width of section considered. Calculations are usually based on a strip of slab 1 m wide.

The code requires that for a solid slab

- (1)  $v \nlessgtr$  the lesser of  $0.8 \sqrt{f_{cu}}$  or  $5 \text{ N/mm}^2$ .
- (2)  $v \nlessgtr v_c$  for a slab thickness less than 200 mm.
- (3) If  $v > v_c$ , shear reinforcement must be provided in slabs more than 200 mm thick.

If shear reinforcement is required, then nominal steel, as for beams, should be provided when  $v < (v_c + 0.4)$  and 'designed' reinforcement provided for higher values of  $v$ . Since shear stresses in slabs due to distributed loads are generally small, shear reinforcement will seldom be required for such loads. Localised 'punching' actions due to heavy concentrated loads may, however, cause more critical conditions as shown in the following sections. Practical difficulties concerned with bending and fixing of shear reinforcement lead to the recommendation that it should not be used in slabs which are less than 200 mm deep.

### 8.2.1 Punching Shear – Analysis

A concentrated load ( $N$ ) on a slab causes shearing stresses on a section around the load; this effect is referred to as punching shear. The initial critical section for shear is shown in figure 8.2 and the shearing stress is given by

$$v = \frac{N}{\text{Perimeter of the section} \times d} = \frac{N}{(2a + 2b + 12d)d}$$

where  $a$  and  $b$  are the plan dimensions of the concentrated load. No shear reinforcement is required if the punching shear stress,  $v < v_c$ . The value of  $v_c$  in table 5.1 depends on the percentage of reinforcement  $100A_s/bd$  which should be calculated as an average of the area of tensile reinforcement in the two directions

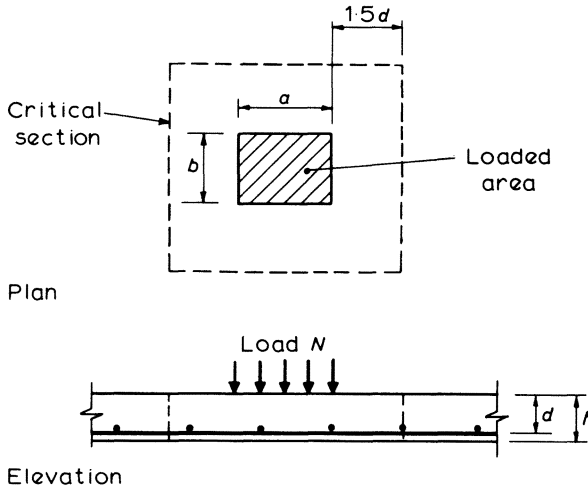

Figure 8.2 Punching shear

and should include all the reinforcement crossing the critical section and extending a further distance equal to at least  $d$  or 12 bar diameters on either side.

Checks must also be undertaken to ensure that the stress  $v$  calculated for the perimeter at the face of the loaded area is less than the smaller of  $0.8\sqrt{f_{cu}}$  or  $5 \text{ N/mm}^2$ .

### **Example 8.1 Punching Shear**

A slab 175 mm thick,  $d = 145 \text{ mm}$ , is constructed with grade 30 concrete and is reinforced with 12 mm bars at 150 mm centres one way and 10 mm bars at 200 mm centres in the other direction. Determine the maximum load that can be carried on an area,  $300 \times 400 \text{ mm}$ , without exceeding the ultimate shear stress.

For 12 mm bars at 150 mm centres

$$\frac{100A_s}{bd} = \frac{100 \times 754}{1000 \times 145} = 0.52$$

and for 10 mm bars at 200 mm centres

$$\frac{100A_s}{bd} = \frac{100 \times 393}{1000 \times 145} = 0.27$$

Average  $\frac{100A_s}{bd} = 0.395$

From table 5.1,  $v_c = 0.62 \text{ N/mm}^2$  for grade 30 concrete

$$\begin{aligned} \text{Punching shear perimeter} &= (2a + 2b + 12d) \\ &= 600 + 800 + 12 \times 145 = 3140 \text{ mm} \end{aligned}$$

$$\begin{aligned} \text{Maximum load} &= v_c \times \text{perimeter} \times d \\ &= 0.62 \times 3140 \times 145 \\ &= 282 \times 10^3 \text{ N} \end{aligned}$$

At the face of the loaded area, the shear stress

$$\begin{aligned} v &= \frac{N}{(2a + 2b) d} \\ &= \frac{282 \times 10^3}{(600 + 800) 145} \\ &= 1.39 \text{ N/mm}^2 \end{aligned}$$

which is less than  $0.8\sqrt{f_{cu}}$  and  $5 \text{ N/mm}^2$ .

### **8.2.2 Punching Shear – Reinforcement Design**

If reinforcement is required for the initial critical section shown in figure 8.2, this steel should be located within the failure zone lying between the face of the loaded area and the perimeter checked. The amount of reinforcement required is given by

$$\Sigma A_{sv} \sin \alpha \geq \frac{(v - v_c) ud}{0.87 f_{yv}}$$

where  $\alpha$  = angle between shear reinforcement and the plane of the slab

$u$  = length of the outer perimeter of the zone

and  $(v - v_c)$  should not be taken as less than  $0.4 \text{ N/mm}^2$ .

The reinforcement should be distributed evenly around the zone on at least two perimeters not greater than  $1.5d$  apart as illustrated in example 8.2. It will then be necessary to check a second perimeter taken a distance  $0.75d$  further away from the face of the load than the initial critical section, as shown in figure 8.3. The failure zone associated with this perimeter is  $1.5d$  wide and shear reinforcement within the zone which has been provided to reinforce previous zones may be included when designing reinforcement for the zone. This design procedure continues by checking successive zones until a perimeter is obtained which does not require reinforcing.

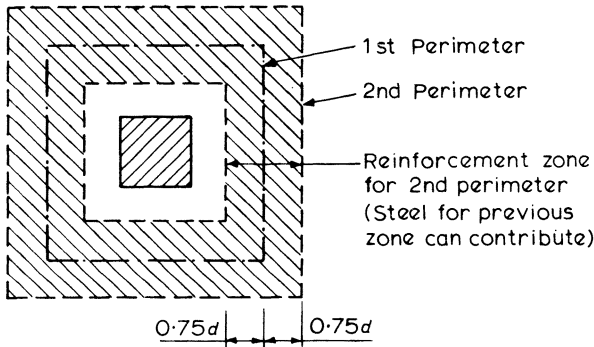

Figure 8.3 *Punching shear reinforcement zones*

Similar procedures must be applied to the regions of flat slabs which are close to supporting columns, but allowances must be made for the effects of moment transfer from the columns as described in section 8.7.

### **Example 8.2 Design of Punching Shear Reinforcement**

A 260 mm thick slab of grade 30 concrete is reinforced by 12 mm High yield bars at 200 mm centres in each direction. The slab is subject to a mild environment and must be able to support a localised concentrated load of 650 kN over a square area of 300 mm side. Determine the shear reinforcement required for  $f_{yv} = 250 \text{ N/mm}^2$ .

For mild exposure, nominal cover required by grade 30 concrete is 25 mm, thus average effective depth allowing for 8 mm links is equal to

$$260 - (25 + 8 + 12) = 215 \text{ mm}$$

(a) Check shear stress at face of loaded area

$$\text{Perimeter } u = 4 \times 300 = 1200 \text{ mm}$$

$$\text{thus } v = \frac{V}{ud} = \frac{650 \times 10^3}{1200 \times 215} = 2.52 \text{ N/mm}^2$$

which is less than  $0.8\sqrt{f_{cu}}$  and  $5 \text{ N/mm}^2$ .

(b) Check first critical perimeter at  $1.5d$  from load face

$$\text{Perimeter side} = 300 + 2 \times 1.5 \times 215 = 945 \text{ mm}$$

$$\text{and perimeter } u = 4 \times 945 = 3780 \text{ mm.}$$

$$\text{Shear stress } v = \frac{V}{ud} = \frac{650 \times 10^3}{3780 \times 215} = 0.80 \text{ N/mm}^2$$

$$\frac{100A_s}{bd} = \frac{100 \times 566}{1000 \times 215} = 0.26$$

From table 5.1,  $v_c = 0.50$  for grade 30 concrete, and thus  $v > v_c$  and shear reinforcement is required.

For vertical links

$$A_{sv} = \frac{(v - v_c) ud}{0.87 f_{yv}}$$

$(v - v_c) = 0.3 \text{ N/mm}^2$  is less than the minimum  $0.4 \text{ N/mm}^2$  required, thus take  $(v - v_c) = 0.4$  and

$$\begin{aligned} A_{sv} &= \frac{0.4 \times 3780 \times 215}{0.87 \times 250} \\ &= 1495 \text{ mm}^2 \end{aligned}$$

$$\begin{aligned} \text{Total number of 8 mm links required} &= \frac{A_{sv}}{2\pi\Phi^2/4} = \frac{1495}{2 \times 50.3} \\ &= 15 \end{aligned}$$

The links must be distributed evenly between two perimeters within the failure zone. The spacing between the legs of the links must not be greater than  $1.5d = 1.5 \times 215 \approx 320 \text{ mm}$ .

Position the links on two perimeters 150 mm and 300 mm from the face of the load. The lengths of these perimeters are

$$u_1 = 4 \times 600 = 2400 \text{ mm}$$

$$\text{and } u_2 = 4 \times 900 = 3600 \text{ mm}$$

$$\text{Number of links on perimeter, } u_1 = 15 \times \frac{2400}{(2400 + 3600)} = 6$$

$$\text{Number of links on perimeter, } u_2 = 15 - 6 = 9$$

$$\begin{aligned} \text{Spacing of legs of the links} &= (2400 + 3600)/(2 \times 15) \\ &= 200 \text{ mm} < 320 \text{ mm} \end{aligned}$$

(c) Check second perimeter at  $(1.5 + 0.75)d$  from load face

$$\text{Perimeter side} = 300 + 2 \times 2.25 \times 215 = 1268 \text{ mm}$$

$$\text{and perimeter } u = 4 \times 1268 = 5072 \text{ mm.}$$

$$\text{Thus } v = \frac{V}{ud} = \frac{650 \times 10^3}{5072 \times 215} = 0.60 \text{ N/mm}^2$$

As  $v > v_c$ , nominal reinforcement is still required within the failure zone associated with the second perimeter.

$$A_{sv} = \frac{0.4 \times 5072 \times 215}{0.87 \times 250} = 2006 \text{ mm}^2$$

$$\text{for 8 mm links } \frac{2006}{2 \times 50.3} = 20 \text{ are required}$$

In part (b), on the perimeter at 300 mm from the load face 9 links are already provided, thus at least 11 further links are required. These could be provided at 450 mm from the load face by similar links at approximately 400 mm centres.

(d) Check third perimeter at  $(1.5 + 1.5)d$  from the load face

$$\text{Perimeter side} = 300 + 2 \times 3 \times 215 = 1590 \text{ mm}$$

$$\text{and perimeter } u = 4 \times 1590 = 6360 \text{ mm.}$$

$$\text{Thus } v = \frac{V}{ud} = \frac{650 \times 10^3}{6360 \times 215} = 0.48 \text{ N/mm}^2$$

As this is less than  $v_c$  no further reinforcement is required. It should be noted, however, that wherever links are required, top steel must also be provided in the slab at 200 mm centres to ensure proper fixing and anchorage of the shear links.

### 8.3 Span-Effective Depth Ratios

Excessive deflections of slabs will cause damage to the ceiling, floor finishes and other architectural details. To avoid this, limits are set on the span-depth ratios. These limits are exactly the same as those for beams as described in section 6.2. As a slab is usually a slender member the restrictions on the span-depth ratio

become more important and this can often control the depth of slab required. In terms of the span-effective depth ratio the depth of the slab is given by

$$\text{minimum effective depth} = \frac{\text{span}}{\text{basic ratio} \times \text{modification factors}}$$

The modification factor is based on the area of tension steel in the shorter span when a slab is singly reinforced at mid-span but if a slab has both top and bottom steel at mid-span the modification factors for the areas of tension and compression steel, as given in tables 6.7 and 6.8 are used. For convenience, the factors for tension steel have been plotted in the form of a graph in figure 8.4.

It can be seen from the figure that a lower service stress gives a higher modification factor and hence a smaller depth of slab would be required. The service stress may be reduced by providing an area of tension reinforcement greater than that required to resist the design moment, or alternatively mild steel reinforcement with its lower service stress may be used.

The span-depth ratios may be checked using the service stress appropriate to the characteristic stress of the reinforcement, as given in table 6.7. Thus a service stress of  $288 \text{ N/mm}^2$  would be used when  $f_y$  is  $460 \text{ N/mm}^2$ . However, if a more accurate assessment of the limiting span-depth ratio is required the service stress  $f_s$  can be calculated from

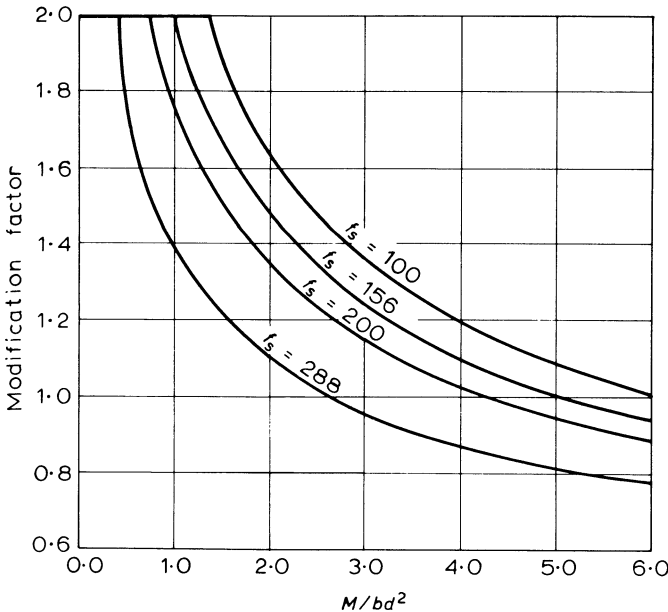

Figure 8.4 Modification factors for span-effective depth ratio

$$f_s = \frac{5}{8} f_y \frac{A_{s \text{ req}}}{A_{s \text{ prov}}} \times \frac{1}{\beta_b}$$

where  $A_{s \text{ req}}$  = the area of reinforcement required at mid-span  
 $A_{s \text{ prov}}$  = the area of reinforcement provided at mid-span  
 $\beta_b$  = the ratio of the mid-span moments after and before any redistribution

The second part of example 8.3 illustrates the calculations to determine the service stress, and how the provision of extra reinforcement reduces the depth of slab required.

#### 8.4 Reinforcement Details

To resist cracking of the concrete, codes of practice specify details such as the minimum area of reinforcement required in a section and limits to the maximum and minimum spacing of bars. Some of these rules are as follows:

##### (a) Minimum Areas of Reinforcement

$$\text{minimum area} = \frac{0.13 bh}{100} \text{ for high-yield steel}$$

$$\text{or} \quad = \frac{0.24 bh}{100} \text{ for mild steel}$$

in both directions.

##### (b) Maximum Spacing of the Bars

These requirements are described in detail in section 6.1.3 and are similar to beams except that for thin slabs, or if the tensile steel percentage is small, spacings may be increased from those given in table 6.4 to a maximum of  $3d$ .

##### (c) Reinforcement in the Flange of a T- or L-beam

When the slab forms the flange of a T- or L-beam the area of reinforcement in the flange and at right angles to the beam should not be less than 0.15 per cent of the longitudinal cross-section of the flange.

##### (d) Curtailment and Anchorage of Reinforcement

The general rules for curtailment of bars in a flexural member were discussed in section 7.2.5. Simplified rules for curtailment in different types of slabs are illustrated in the subsequent sections of this chapter. At a simply supported end the bars should be anchored as specified in figure 7.14 or figure 8.5.

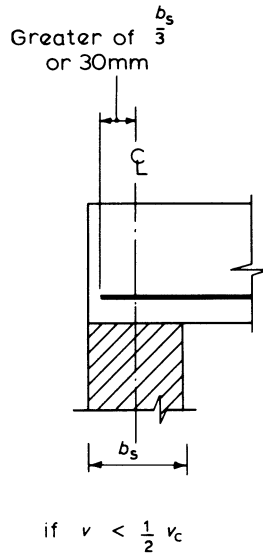

Figure 8.5 Anchorage at simple support for a slab

### 8.5 Solid Slabs Spanning in One Direction

The slabs are designed as if they consist of a series of beams of 1 m breadth. The main steel is in the direction of the span and secondary or distribution steel is required in the transverse direction. The main steel should form the outer layer of reinforcement to give it the maximum lever arm.

The calculations for bending reinforcement follow a similar procedure to that used in beam design. The lever-arm curve of figure 7.5 is used to determine the lever arm ( $z$ ) and the area of tension reinforcement is then given by

$$A_s = \frac{M_u}{0.87 f_y z}$$

For solid slabs spanning one way the simplified rules for curtailing bars as shown in figure 8.6 may be used provided the loads are substantially uniformly distributed. With a continuous slab it is also necessary that the spans are approximately equal and the simplified single load case analysis has been used.

#### 8.5.1 Single-span Solid Slab

The effective span of the slab is taken as the lesser of: (a) the centre-to-centre distance of the bearings, or (b) the clear distance between supports plus the effective depth of the slab. The basic span-effective depth ratio for this type of slab is 20:1.

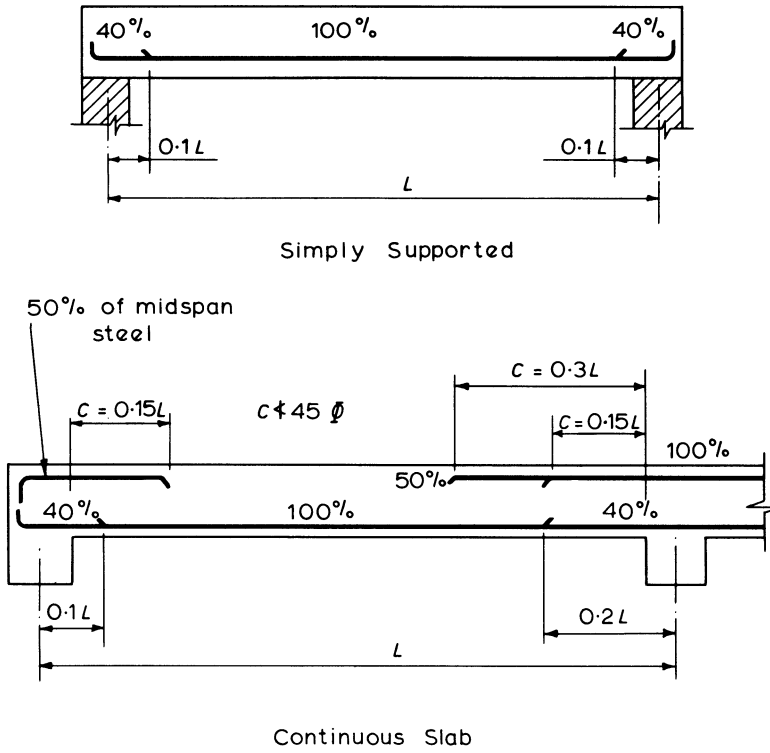

Figure 8.6 Simplified rules for curtailment of bars in slab spanning in one direction

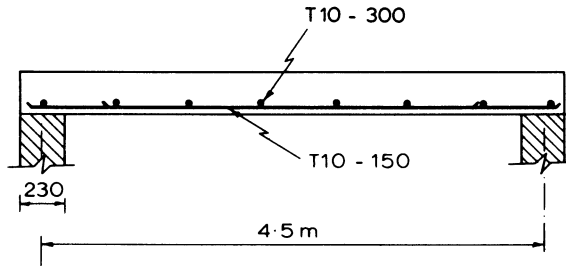

Figure 8.7

**Example 8.3 Design of a Simply Supported Slab**

The slab shown in figure 8.7 is to be designed to carry a live load of  $3.0 \text{ kN/m}^2$ , plus floor finishes and ceiling loads of  $1.0 \text{ kN/m}^2$ . The characteristic material strengths are  $f_{cu} = 30 \text{ N/mm}^2$  and  $f_y = 460 \text{ N/mm}^2$ . Basic span-effective depth ratio = 20

$$\begin{aligned} \text{therefore minimum effective depth } d &= \frac{\text{span}}{20 \times \text{modification factor m.f.}} \\ &= \frac{4500}{20 \times \text{m.f.}} = \frac{225}{\text{m.f.}} \end{aligned}$$

- (1) Estimating the modification factor to be of the order of 1.3 for a lightly reinforced slab. Try effective depth  $d = 170 \text{ mm}$ . For a mild exposure the cover = 25 mm. Allowing, say, 5 mm as half the diameter of the reinforcing bar

$$\begin{aligned} \text{overall depth of slab } h &= 170 + 25 + 5 = 200 \text{ mm} \\ \text{self-weight of slab} &= 200 \times 24 \times 10^{-3} = 4.8 \text{ kN/m}^2 \\ \text{total dead load} &= 1.0 + 4.8 = 5.8 \text{ kN/m}^2 \end{aligned}$$

For a 1 m width of slab

$$\begin{aligned} \text{ultimate load} &= (1.4g_k + 1.6q_k) 4.5 \\ &= (1.4 \times 5.8 + 1.6 \times 3.0) 4.5 = 58.1 \text{ kN} \\ M &= 58.1 \times 4.5/8 = 32.7 \text{ kN m} \end{aligned}$$

**Span-Effective Depth Ratio**

$$\frac{M}{bd^2} = \frac{32.7 \times 10^6}{1000 \times 170^2} = 1.13$$

From table 6.7, for  $f_s = 288 \text{ N/mm}^2$  the span-effective depth modification factor = 1.34. Therefore

$$\begin{aligned} \text{limiting } \frac{\text{span}}{\text{effective depth}} &= 20 \times 1.34 = 26.8 \\ \text{actual } \frac{\text{span}}{\text{effective depth}} &= \frac{4500}{170} = 26.5 \end{aligned}$$

Thus  $d = 170 \text{ mm}$  is adequate.

**Bending Reinforcement**

$$\frac{M}{bd^2 f_{cu}} = \frac{32.7 \times 10^6}{1000 \times 170^2 \times 30} = 0.038$$

From the lever arm curve of figure 7.5,  $l_a = 0.95$ . Therefore

$$\text{lever arm } z = l_a d = 0.95 \times 170 = 161 \text{ mm}$$

$$A_s = \frac{M}{0.87f_y z} = \frac{32.7 \times 10^6}{0.87 \times 460 \times 161} \\ = 508 \text{ mm}^2/\text{m}$$

Provide T10 bars at 150 mm centres,  $A_s = 523 \text{ mm}^2/\text{m}$ .

### Shear

At the face of the support

$$\text{Shear } V = \frac{58.1}{2} \left( \frac{2.25 - 0.5 \times 0.23}{2.25} \right) = 27.6 \text{ kN}$$

$$\text{Shear stress, } \nu = \frac{V}{bd} = \frac{27.6 \times 10^3}{1000 \times 170} = 0.16 \text{ N/mm}^2 < 0.8 \sqrt{f_{cu}}$$

$$\frac{100A_s}{bd} = \frac{100 \times 523}{1000 \times 170} = 0.31$$

from table 5.1,  $\nu_c = 0.55 \text{ N/mm}^2$  and since  $\nu < \nu_c$  no further shear checks or reinforcement are required

### End Anchorage (figure 8.5)

$$\nu = 0.16 < \nu_c/2$$

therefore

$$\text{anchorage length} \geq 30 \text{ mm} \quad \text{or} \quad \frac{\text{end bearing}}{3}$$

$$\text{end bearing} = 230 \text{ mm}$$

therefore

$$\text{anchorage length} = \frac{230}{3} \\ = 77 \text{ mm}$$

beyond the centre line of the support.

### Distribution Steel

$$\text{Area of transverse high-yield reinforcement} = \frac{0.13bh}{100} \\ = \frac{0.13 \times 1000 \times 200}{100} \\ = 260 \text{ mm}^2/\text{m}$$

Provide T10 at 300 mm centres.

(2) The second part of this example illustrates how a smaller depth of slab is adequate provided it is reinforced so that there is a low service stress in the steel and therefore a high modification factor for the span-effective depth ratio. Try a thickness of slab,  $h = 170$  mm and  $d = 140$  mm.

$$\text{Self-weight of slab} = 0.17 \times 24 = 4.08 \text{ kN/m}^2$$

$$\text{total dead load} = 5.08 \text{ kN/m}^2$$

$$\text{ultimate load} = (1.4g_k + 1.6q_k) 4.5$$

$$= (1.4 \times 5.08 + 1.6 \times 3.0) 4.5 = 53.6 \text{ kN}$$

### *Bending*

$$M = 53.6 \times \frac{4.5}{8} = 30.2 \text{ kN m}$$

$$\frac{M}{bd^2 f_{cu}} = \frac{30.2 \times 10^6}{1000 \times 140^2 \times 30} = 0.051$$

From the lever-arm curve, figure 7.5,  $l_a = 0.94$

Therefore using mild steel bars

$$A_s = \frac{M}{0.87 f_y z} = \frac{30.2 \times 10^6}{0.87 \times 250 \times 0.94 \times 140}$$

$$= 1055 \text{ mm}^2/\text{m}$$

Provide R12 at 100 mm centres,  $A_s = 1130 \text{ mm}^2/\text{m}$ .

### *Span-Effective Depth Ratio*

$$\frac{M}{bd^2} = \frac{30.2 \times 10^6}{1000 \times 140^2}$$

$$= 1.54$$

Service stress  $f_s$  is given by the equation of section 8.3 as

$$f_s = \frac{5}{8} f_y \times \frac{A_{s \text{ reg}}}{A_{s \text{ prov}}} \times \frac{1}{\beta_b}$$

$$= \frac{5}{8} \times 250 \times \frac{1055}{1130} \times 1 = 146 \text{ N/mm}^2$$

From figure 8.4, for  $M/bd^2 = 1.54$ , span-effective depth modification factor = 1.7. Therefore

$$\text{limiting } \frac{\text{span}}{\text{effective depth}} = 20 \times 1.7 = 34.0$$

$$\text{actual } \frac{\text{span}}{\text{effective depth}} = \frac{4500}{140} = 32.1$$

Therefore  $d = 140$  mm is adequate.

### 8.5.2 Continuous Solid Slab Spanning in One Direction

For a continuous slab, bottom reinforcement is required within the span and top reinforcement over the supports. The effective span is the distance between the centre lines of supports and the basic span-effective depth ratio is 26:1.

If the conditions of section 8.1 are met for the single load case analysis, bending moment and shear force coefficients as shown in table 8.1 may be used.

**Table 8.1** Ultimate bending moment and shear force coefficients in one-way spanning slabs

	Outer support	Middle of end span	First interior support	Middle of interior span	Interior supports
Moment	0	0.086 $FL$	-0.086 $FL$	0.063 $FL$	-0.063 $FL$
Shear	0.4 $F$	—	0.6 $F$	—	0.5 $F$

*Note:*  $F$  is the total design ultimate load on the span, and  $L$  is the effective span.

### Example 8.4 Design of a Continuous Solid Slab

The four-span slab shown in figure 8.8 supports a live load of  $3.0 \text{ kN/m}^2$ , plus floor finishes and a ceiling load of  $1.0 \text{ kN/m}^2$ . The characteristic material strengths are  $f_{cu} = 30 \text{ N/mm}^2$  and  $f_y = 460 \text{ N/mm}^2$ .

Basic span-effective depth ratio = 26

$$\frac{\text{span}}{26} = \frac{4500}{26} = 173 \text{ mm}$$

Try effective depth  $d = 140$  mm, and with a mild exposure overall depth,  $h = 170$  mm.

$$\text{self-weight of slab} = 170 \times 24 \times 10^{-3} = 4.08 \text{ kN/m}^2$$

$$\text{total dead weight} = 1.0 + 4.08 = 5.08 \text{ kN/m}^2$$

$$\text{ultimate load } F \text{ per span} = (1.4g_k + 1.6q_k) 4.5$$

$$= (1.4 \times 5.08 + 1.6 \times 3.0) 4.5$$

$$= 53.6 \text{ kN per metre width}$$

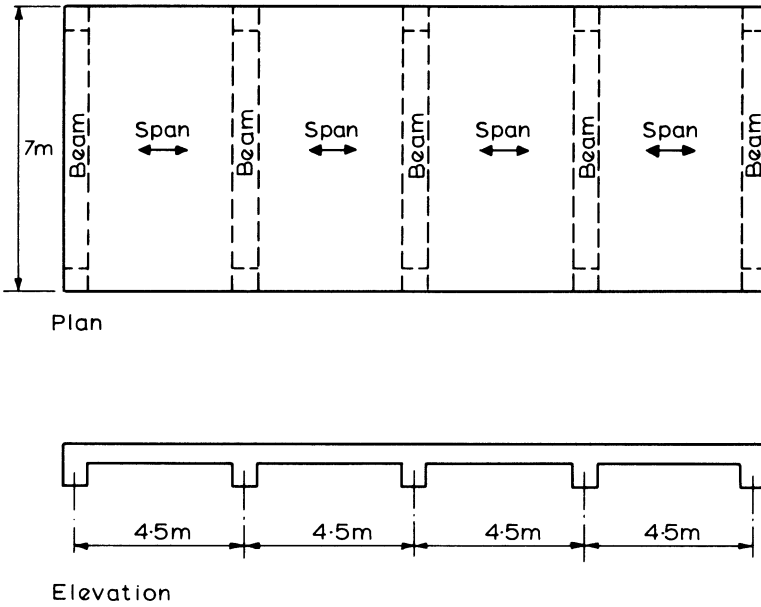

Figure 8.8 Continuous slab

**Bending**

Since the bay size  $> 30 \text{ m}^2$ , the spans are equal and  $q_k \geq 1.25 g_k$  the moment coefficients shown in table 8.1 may be used. Thus for the first span

$$M = 0.086 FL = 0.086 \times 53.6 \times 4.5 = 20.8 \text{ kN m}$$

**Span-Effective Depth Ratio**

$$\frac{M}{bd^2} = \frac{20.8 \times 10^6}{1000 \times 140^2} = 1.06$$

From table 6.7, span-depth modification factor = 1.36. Therefore

$$\text{limiting } \frac{\text{span}}{\text{effective depth}} = 26 \times 1.36 = 35.3$$

$$\text{actual } \frac{\text{span}}{\text{effective depth}} = \frac{4500}{140} = 32.1$$

Thus  $d = 140$  mm is adequate.

*Bending Reinforcement*

$$\frac{M}{bd^2 f_{cu}} = \frac{20.8 \times 10^6}{1000 \times 140^2 \times 30} = 0.035$$

From the lever-arm curve, figure 7.5,  $l_a = 0.95$ . Therefore

$$\text{lever arm } z = l_a d = 0.95 \times 140 = 133 \text{ mm}$$

$$A_s = \frac{M}{0.87 f_y z} = \frac{20.8 \times 10^6}{0.87 \times 460 \times 133} \\ = 391 \text{ mm}^2 \text{ per metre}$$

Provide T10 at 200 mm centres,  $A_s = 393 \text{ mm}^2/\text{m}$ .

Similar calculations for the supports and the interior span give the steel areas shown in figure 8.9.

Over the interior support beams  $100A_s/bh_f > 0.15$  for the reinforcement provided and therefore extra steel is not required for the flange of the T-beam.

At the end supports there is a monolithic connection between the slab and the beam, therefore top steel should be provided to resist any negative moment. The area of this steel should not be less than half the area of steel at mid-span. In fact to provide the 0.15 per cent of steel for the flange of the L-beam, T10 bars at 300 mm centres have been specified.

The layout of the reinforcement in figure 8.9 is according to the simplified rules for the curtailment of bars in slabs as illustrated in figure 8.6

$$\text{Transverse reinforcement} = \frac{0.13 bh}{100} \\ = \frac{0.13 \times 1000 \times 170}{100} = 221 \text{ mm}^2/\text{m}$$

Provide T10 at 350 mm centres top and bottom, wherever there is main reinforcement.

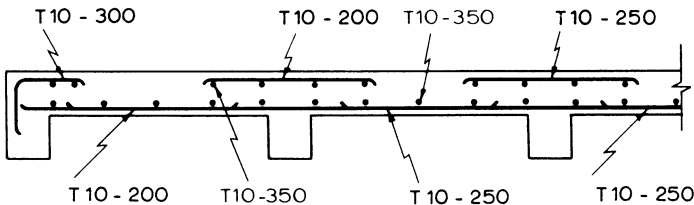

Figure 8.9

### 8.6 Solid Slabs Spanning in Two Directions

When a slab is supported on all four of its sides it effectively spans in both directions, and it is sometimes more economical to design the slab on this basis. The amount of bending in each direction will depend on the ratio of the two spans and the conditions of restraint at each support.

If the slab is square and the restraints are similar along the four sides then the load will span equally in both directions. If the slab is rectangular then more than one-half of the load will be carried in the stiffer, shorter direction and less in the longer direction. If one span is much longer than the other, a large proportion of the load will be carried in the short direction and the slab may as well be designed as spanning in only one direction.

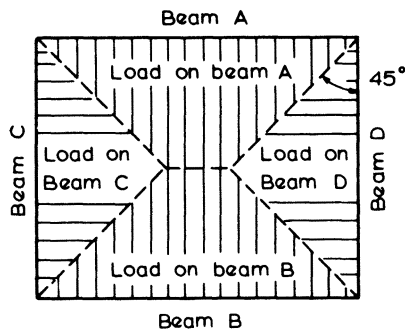

Figure 8.10 Loads carried by supporting beams

Moments in each direction of span are generally calculated using coefficients which are tabulated in the codes of practice. Areas of reinforcement to resist the moments are determined independently for each direction of span. The slab is reinforced with bars in both directions parallel to the spans with the steel for the shorter span placed furthest from the neutral axis to give it the greater effective depth.

The span-effective depth ratios are based on the shorter span and the percentage of reinforcement in that direction.

With a uniformly distributed load the loads on the supporting beams may generally be apportioned as shown in figure 8.10.

#### 8.6.1 Simply Supported Slab Spanning in Two Directions

A slab simply supported on its four sides will deflect about both axes under load and the corners will tend to lift and curl up from the supports, causing torsional moments. When no provision has been made to prevent this lifting or to resist the torsion then the moment coefficients of table 8.2 may be used and the maximum moments are given by

$$M_{sx} = \alpha_{sx} n l_x^2 \quad \text{in direction of span } l_x$$

and

$$M_{sy} = \alpha_{sy} n l_x^2 \quad \text{in direction of span } l_y$$

where  $M_{sx}$  and  $M_{sy}$  are the moments at mid-span on strips of unit width with spans  $l_x$  and  $l_y$  respectively, and

$n = (1.4g_k + 1.6q_k)$ , that is the total ultimate load per unit area

$l_y$  = the length of the longer side

$l_x$  = the length of the shorter side

and  $\alpha_{sx}$  and  $\alpha_{sy}$  are the moment coefficients from table 8.2.

The area of reinforcement in directions  $l_x$  and  $l_y$  respectively are

$$A_{sx} = \frac{M_{sx}}{0.87 f_y z} \quad \text{per metre width}$$

and

$$A_{sy} = \frac{M_{sy}}{0.87 f_y z} \quad \text{per metre width}$$

The slab should be reinforced uniformly across the full width, in each direction.

The effective depth  $d$  used in calculating  $A_{sy}$  should be less than that for  $A_{sx}$  because of the different depths of the two layers of reinforcement.

At least 40 per cent of the mid-span reinforcement should extend to the supports and the remaining 60 per cent should extend to within  $0.1l_x$  or  $0.1l_y$  of the appropriate support.

**Table 8.2** Bending-moment coefficients for slabs spanning in two directions at right angles, simply supported on four sides

$l_y/l_x$	1.0	1.1	1.2	1.3	1.4	1.5	1.75	2.0
$\alpha_{sx}$	0.062	0.074	0.084	0.093	0.099	0.104	0.113	0.118
$\alpha_{sy}$	0.062	0.061	0.059	0.055	0.051	0.046	0.037	0.029

**Example 8.5** Design the Reinforcement for a Simply Supported Slab 220 mm Thick and Spanning in Two Directions

The effective span in each direction is 4.5 m and 6.3 m and the slab supports a live load of  $10 \text{ kN/m}^2$ . The characteristic material strengths are  $f_{cu} = 30 \text{ N/mm}^2$  and  $f_y = 460 \text{ N/mm}^2$ .

$$l_y/l_x = 6.3/4.5 = 1.4$$

From table 8.2,  $\alpha_{sx} = 0.099$  and  $\alpha_{sy} = 0.051$ .

$$\text{Self-weight of slab} = 220 \times 24 \times 10^{-3} = 5.3 \text{ kN/m}^2$$

$$\begin{aligned} \text{ultimate load } n &= 1.4g_k + 1.6q_k \\ &= 1.4 \times 5.3 + 1.6 \times 10.0 = 23.4 \text{ kN/m}^2 \end{aligned}$$

### *Bending – Short Span*

With mild exposure conditions take  $d = 185$  mm.

$$\begin{aligned} M_{sx} &= \alpha_{sx} n l_x^2 = 0.099 \times 23.4 \times 4.5^2 \\ &= 46.9 \text{ kN m} \end{aligned}$$

$$\frac{M_{sx}}{bd^2 f_{cu}} = \frac{46.9 \times 10^6}{1000 \times 185^2 \times 30} = 0.046$$

From the lever-arm curve, figure 7.5,  $l_a = 0.95$ . Therefore

$$\text{lever arm } z = 0.95 \times 185 = 176 \text{ mm}$$

and

$$\begin{aligned} A_s &= \frac{M_{sx}}{0.87 f_y z} = \frac{46.9 \times 10^6}{0.87 \times 460 \times 176} \\ &= 666 \text{ mm}^2/\text{m} \end{aligned}$$

Provide T12 at 150 mm centres,  $A_s = 754 \text{ mm}^2/\text{m}$

### *Span-Effective Depth Ratio*

$$\frac{M_{sx}}{bd^2} = \frac{46.9 \times 10^6}{1000 \times 185^2} = 1.37$$

From table 6.7, for  $f_s = 288 \text{ N/mm}^2$  the span-effective depth modification factor = 1.25.

$$\text{limiting } \frac{\text{span}}{\text{effective depth}} = 20 \times 1.25 = 25.0$$

$$\text{actual } \frac{\text{span}}{\text{effective depth}} = \frac{4500}{185} = 24.3$$

Thus  $d = 185$  mm is adequate.

### *Bending – Long Span*

$$\begin{aligned} M_{sy} &= \alpha_{sy} n l_x^2 = 0.051 \times 23.4 \times 4.5^2 \\ &= 24.2 \text{ kN m} \end{aligned}$$

Since the reinforcement for this span will have a reduced effective depth, take  $z = 176 - 12 = 164$  mm. Therefore

$$A_s = \frac{M_{sy}}{0.87 f_y z} = \frac{24.2 \times 10^6}{0.87 \times 460 \times 164} = 369 \text{ mm}^2/\text{m}$$

Provide T10 at 200 mm centres,  $A_s = 393 \text{ mm}^2/\text{m}$

$$\frac{100A_s}{bh} = \frac{100 \times 393}{1000 \times 220} = 0.18$$

which is greater than 0.13, the minimum for transverse steel.

The arrangement of the reinforcement is shown in figure 8.11.

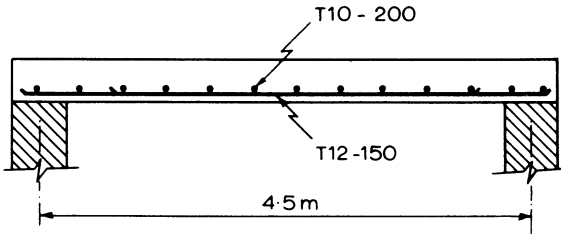

Figure 8.11 Simply supported slab spanning in two directions

### 8.6.2 Restrained Slab Spanning in Two Directions

When the slabs have fixity at the supports and reinforcement is added to resist torsion and to prevent the corners of the slab from lifting then the maximum moments per unit width are given by

$$M_{sx} = \beta_{sx} n l_x^2 \text{ in direction of span } l_x$$

and

$$M_{sy} = \beta_{sy} n l_x^2 \text{ in direction of span } l_y$$

where  $\beta_{sx}$  and  $\beta_{sy}$  are the moment coefficients given in table 3.15 of BS 8110 for the specified end conditions, and  $n = (1.4g_k + 1.6q_k)$ , the total ultimate load per unit area.

The slab is divided into middle and edge strips as shown in figure 8.12 and reinforcement is required in the middle strips to resist  $M_{sx}$  and  $M_{sy}$ . The arrangement this reinforcement should take is illustrated in figure 8.6. In the edge strips only nominal reinforcement is necessary, such that  $100A_s/bh = 0.13$  for high yield steel or 0.24 for mild steel.

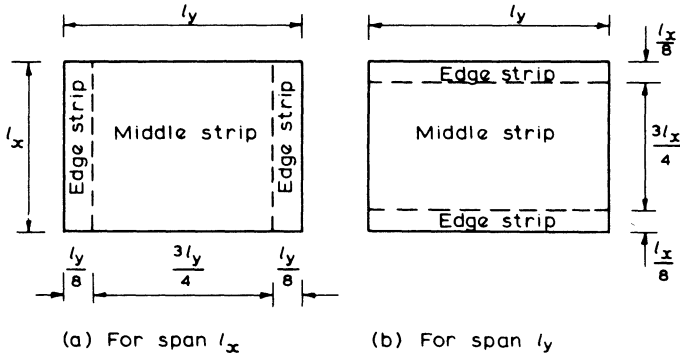

Figure 8.12 Division of slab into middle and edge strips

In addition, torsion reinforcement is provided at discontinuous corners and it should

- (1) consist of top and bottom mats, each having bars in both directions of span
- (2) extend from the edges a minimum distance  $l_x/5$
- (3) at a corner where the slab is discontinuous in both directions have an area of steel in each of the four layers equal to three-quarters of the area required for the maximum mid-span moment.
- (4) at a corner where the slab is discontinuous in one direction only, have an area of torsion reinforcement only half of that specified in rule 3.

Torsion reinforcement is not, however, necessary at any corner where the slab is continuous in both directions.

Where  $l_y/l_x > 2$ , the slabs should be designed as spanning in one direction only.

Shear force coefficients are also given in BS 8110 for cases where torsion corner reinforcement is provided, and these are based on a simplified distribution of load to supporting beams which may be used in preference to the distribution shown in figure 8.10.

**Example 8.6 Moments in a Continuous Two-way Slab**

The panel considered is an edge panel, as shown in figure 8.13 and the uniformly distributed load,  $n = (1.4g_k + 1.6q_k) = 10 \text{ kN/m}^2$ .

The moment coefficients are taken from case 3 of table 3.15 of BS 8110.

$$\frac{l_y}{l_x} = \frac{6.0}{5.0} = 1.2$$

Positive moments at mid-span

$$M_{sx} = \beta_{sx} n l_x^2 = 0.042 \times 10 \times 5^2 = 10.5 \text{ kN m in direction } l_x$$

$$M_{sy} = \beta_{sy} n l_x^2 = 0.028 \times 10 \times 5^2$$

$$= 7.0 \text{ kN m in direction } l_y$$

Negative moments

$$\text{Support ad, } M_x = 0.056 \times 10 \times 5^2 = 14 \text{ kN m}$$

$$\text{Supports ab and dc, } M_y = 0.037 \times 10 \times 5^2 = 9.3 \text{ kN m}$$

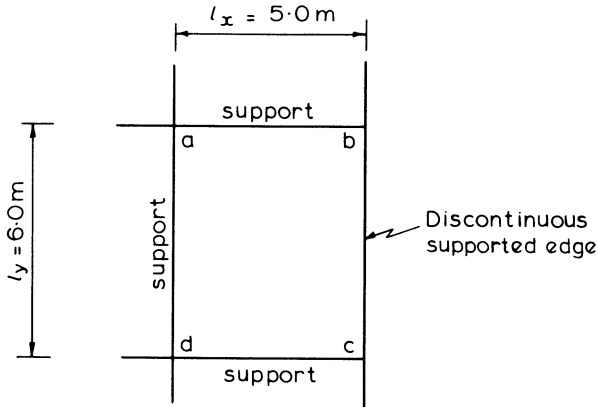

Figure 8.13 Continuous panel spanning in two directions

The moments calculated are for a metre width of slab.

The design of reinforcement to resist these moments would follow the usual procedure. Torsion reinforcement, according to rule 4 is required at corners b and c. A check would also be required on the span-effective depth ratio of the slab.

### 8.7 Flat Slab Floors

A flat slab floor is a reinforced concrete slab supported directly by concrete columns without the use of intermediary beams. The slab may be of constant thickness throughout or in the area of the column it may be thickened as a drop panel. The column may also be of constant section or it may be flared to form a column head or capital. These various forms of construction are illustrated in figure 8.14.

The drop panels are effective in reducing the shearing stresses where the column is liable to punch through the slab, and they also provide an increased moment of resistance where the negative moments are greatest. They are generally used with live loads in excess of  $7 \text{ kN/m}^2$ , or thereabouts.

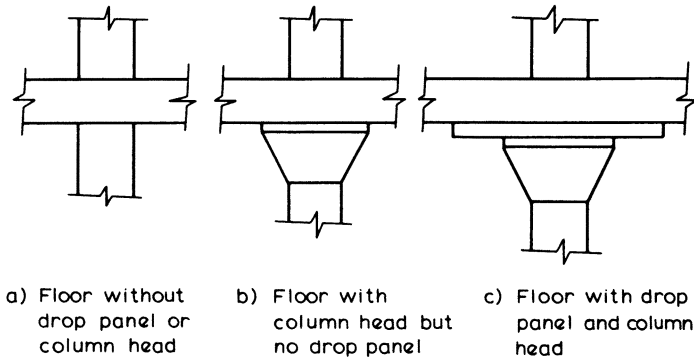

Figure 8.14 Drop panels and column heads

The flat slab floor has many advantages over the beam and slab floor. The simplified formwork and the reduced storey heights make it more economical. Windows can extend up to the underside of the slab, and there are no beams to obstruct the light and the circulation of air. The absence of sharp corners gives greater fire resistance as there is less danger of the concrete spalling and exposing the reinforcement. Deflection requirements will generally govern slab thicknesses which should not be less than 125 mm.

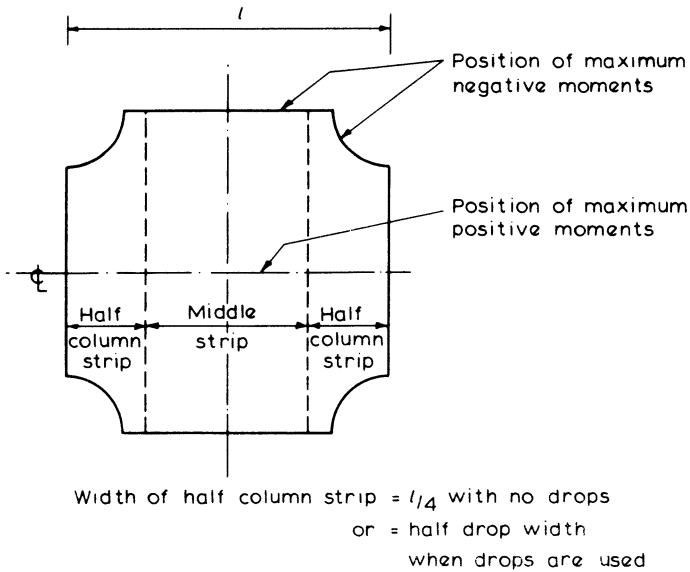

Figure 8.15 Flat slab divided into strips

The analysis of a flat slab structure may be carried out by dividing the structure into a series of equivalent frames. The moments in these frames may be determined by

- (a) a method of frame analysis such as moment distribution, or the stiffness method on a computer
- or (b) a simplified method using the moment and shear coefficients of table 8.3 subject to the following requirements:
- (i) the lateral stability is not dependent on the slab-column connections
  - (ii) the conditions for using the single load case described in section 8.1 are satisfied
  - (iii) there are at least three rows of panels of approximately equal span in the direction being considered.

**Table 8.3** Simplified moment and shear coefficients for flat slabs

	Outer support		First span	First interior support	Interior span	Interior support
	Col.	Wall				
Moment	$-0.04FL^*$	$-0.02FL$	$+0.083FL^*$	$-0.063FL$	$+0.071FL$	$-0.055FL$
Shear	$0.45F$	$0.4F$	—	$0.6F$	—	$0.5F$
Column mom.	$0.04FL$	—	—	$0.022FL$	—	$0.022FL$

\*Check column moment transfer capacity (see BS 8110).

In this calculation  $L$  is the effective span and  $F$  is the total ultimate load on the slab strip between columns. The effective span is the distance between column centre lines  $- 2h_c/3$  where  $h_c$  is the effective diameter of the column or column heads.

Interior panels of the flat slab should be divided as shown in figure 8.15 into column and middle strips. Drop panels should be ignored if their smaller dimension is less than the  $1/3$  of the smaller panel dimension  $l_x$ . If a panel is not square, strip widths in both directions are based on  $l_x$ .

Moments determined from a structural analysis or the coefficients of table 8.3 are distributed between the strips as shown in table 8.4.

Reinforcement designed to resist these slab moments may be detailed according to the simplified rules for slabs, and satisfying normal spacing limits. This should be spread across the respective strip, but steel to resist negative moments in column strips should have two-thirds of the area located in the central  $1/2$  strip width. If the column strip is narrower because of drops, the moments resisted by the column and middle strips should be adjusted proportionally as illustrated in example 8.7.

**Table 8.4** Division of moments between strips

	Column strip	Middle strip
Negative moment	75%	25%
Positive moment	55%	45%

Column moments can be calculated using the coefficients from table 8.3, but reference should also be made to BS 8110 regarding the moment transfer capacity at the outer columns. The moments calculated should be divided between the column lengths above and below the floor in proportion to their stiffnesses.

Particular care is needed over the transfer of moments to edge columns. This is to ensure that there is adequate moment capacity within the slab adjacent to the column since moments will only be able to be transferred to the edge column by a strip of slab considerably narrower than the normal internal panel column strip width.

The reinforcement for a flat slab should generally be arranged according to the rules illustrated in figure 8.6.

An important feature in the design of the slabs are the calculations for punching shear at the head of the columns and at the change in depth of the slab, if drop panels are used. The design for shear should take the procedure described in the previous section on punching shear except that BS 8110 requires that the design shear force be increased above the calculated value by 15 per cent for internal columns and up to 40 per cent for edge columns to allow for the effects of moment transfer. If spans are not approximately equal, reference should be made to BS 8110. In this respect it can be advantageous to use mild steel in the design, as the resulting higher percentages of reinforcement will allow a correspondingly higher ultimate concrete shear stress.

The usual span-effective depth ratios may be used if the slabs have drop panels of widths at least equal to one-third of the respective span, otherwise the ratios should be multiplied by a factor of 0.9.

Reference should be made to codes of practice for further detailed information describing the requirements for the analysis and design of flat slabs.

### **Example 8.7 Design of a Flat Slab**

The columns are at 6.5 m centres in each direction and the slab supports a live load of 5 kN/m<sup>2</sup>. The characteristic material strengths are  $f_{cu} = 30$  N/mm<sup>2</sup> and  $f_y = 250$  N/mm<sup>2</sup> for mild steel reinforcement.

It is decided to use a floor slab as shown in figure 8.16 with 200 mm overall depth of slab, and drop panels 2.5 m square by 100 mm deep. The column heads are to be made 1.4 m diameter.

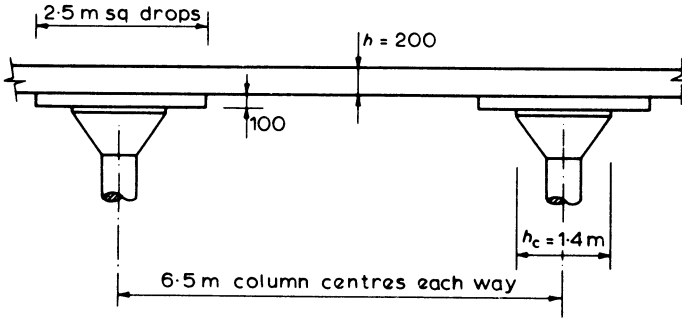

Figure 8.16

**Dead load**

$$\text{Weight of slab} = 0.2 \times 24 \times 6.5^2 = 203 \text{ kN}$$

$$\text{Weight of drop} = 0.1 \times 24 \times 2.5^2 = 15 \text{ kN}$$

$$\text{Total} = 218 \text{ kN}$$

**Live load**

$$\text{Total} = 5 \times 6.5^2 = 212 \text{ kN}$$

Therefore ultimate load on the floor  $F = 1.4 \times 218 + 1.6 \times 212$

$$= 645 \text{ kN per panel}$$

and equivalent distributed load  $n = \frac{645}{6.5^2} = 15.3 \text{ kN/m}^2$ .

The effective span  $L = \text{clear span} - \frac{2h_c}{3}$

$$= 6.5 - \frac{2 \times 1.4}{3} = 5.6 \text{ m}$$

A concrete cover of 25 mm has been allowed, and where there are two equal layers of reinforcement the effective depth has been taken as the mean depth of the two layers in calculating the reinforcement areas.

The drop dimension is greater than one-third of the panel dimension, therefore the column strip is taken as the width of the drop panel (2.5 m).

Since the live load is less than  $1.25 \times$  the dead load, and is not greater than  $5 \text{ kN/m}^2$ , the single load case may be used. From tables 8.3 and 8.4:

**Bending Reinforcement****(1) Centre of interior span**

$$\text{Positive moment} = 0.071 FL$$

$$= 0.071 \times 645 \times 5.6 = 257 \text{ kN m}$$

The width of the middle strip is  $(6.5 - 2.5) = 4$  m which is greater than half the panel dimension, therefore the proportion of this moment taken by the middle strip is given by

$$0.45 \times \frac{4}{6.5/2} = 0.55$$

Thus middle strip positive moment =  $0.55 \times 257 = 142$  kN m

The column strip positive moment =  $(1 - 0.55) \times 257 = 116$  kN m

(a) For the middle strip

$$\frac{M}{bd^2 f_{cu}} = \frac{142 \times 10^6}{4000 \times 155^2 \times 30} = 0.049$$

From the lever-arm curve, figure 7.5,  $l_a = 0.94$ , therefore

$$A_s = \frac{M}{0.87 f_y l_a d} = \frac{142 \times 10^6}{0.87 \times 250 \times 0.94 \times 155} = 4481 \text{ mm}^2, \text{ bottom steel}$$

Thus provide twenty-three R16 bars each way in the span, distributed evenly across the 4 m width of the middle strip.

(b) The column strip moment will require  $3622 \text{ mm}^2$  bottom steel which can be provided as nineteen R16 bars in the span distributed evenly across the 2.5 m width of the column strip.

(2) Interior support

Negative moment =  $-0.055 FL$

$$= -0.055 \times 645 \times 5.6 = 199 \text{ kN m}$$

and this is also divided to

$$\text{middle strip} = 0.25 \times \frac{4 \times 199}{6.5/2} = 0.31 \times 199 = 62 \text{ kN m}$$

and column strip  $\approx 0.69 \times 199 = 138 \text{ kN m}$

(a) For the middle strip

$$\frac{M}{bd^2 f_{cu}} = \frac{62 \times 10^6}{4000 \times 155^2 \times 30} = 0.02$$

From the lever-arm curve  $l_a = 0.95$ , therefore

$$A_s = \frac{62 \times 10^6}{0.87 \times 250 \times 0.95 \times 155} = 1936 \text{ mm}^2$$

Provide eighteen evenly spaced R12 bars as top steel.

(b) For the column strip

$$\frac{M}{bd^2 f_{cu}} = \frac{138 \times 10^6}{2500 \times 255^2 \times 30} = 0.029$$

From lever-arm curve  $l_a = 0.95$ , therefore

$$A_s = \frac{138 \times 10^6}{0.87 \times 250 \times 0.95 \times 255} = 2619 \text{ mm}^2$$

Provide fourteen R16 bars as top steel, ten of these bars should be placed at approximately 125 mm centres within the central half of the column strip.

The bending reinforcement requirements are summarised in figure 8.17.

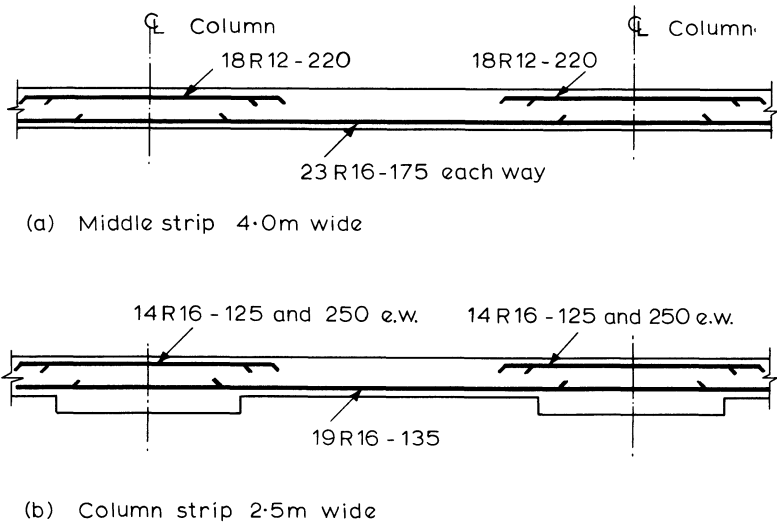

Figure 8.17 Details of bending reinforcement

### Punching Shear

(1) At the column head:

$$\begin{aligned} \text{perimeter } u &= \pi \times \text{diameter of column head} \\ &= \pi \times 1400 = 4398 \text{ mm} \end{aligned}$$

$$\begin{aligned} \text{Shear force } V &= F - \frac{\pi}{4} 1.4^2 n = 645 - \frac{\pi \times 1.4^2}{4} \times 15.3 \\ &= 621.5 \text{ kN} \end{aligned}$$

To allow for the effects of moment transfer,  $V$  is increased by 15 per cent, thus

$$v = \frac{1.15 V}{ud} = \frac{1.15 \times 621.5 \times 10^3}{4398 \times 255} = 0.64 \text{ N/mm}^2$$

which is less than  $0.8 \sqrt{f_{cu}}$  and  $5 \text{ N/mm}^2$ .

(2) First critical perimeter is  $1.5 d = 1.5 \times 255 \text{ mm}$   
 $= 383 \text{ mm}$  from the column face  
 thus the length of perimeter  $u = 4(1400 + 2 \times 383)$   
 $= 8664 \text{ mm}$

Ultimate shear force

$$= 645 - (1.4 + 2 \times 0.383)^2 \times 15.3$$

$$= 574 \text{ kN}$$

thus shear stress  $v = \frac{1.15 \times 574 \times 10^3}{8664 \times 255} = 0.30 \text{ N/mm}^2$

By inspection from table 5.1  $v < v_c$ , therefore the section is adequate in punching shear.

(3) At the dropped panel, critical section is  $2.5 + 2 \times 1.5 \times 0.155 = 2.965 \text{ m}$  square and perimeter  $u = 4 \times 2965 = 11\,860 \text{ mm}$ .

Calculated shear  $V = 645 - 2.965^2 \times 15.3 = 511 \text{ kN}$

thus shear stress  $v = \frac{1.15 \times 511 \times 10^3}{11\,860 \times 155} = 0.32 \text{ N/mm}^2$

which is also less than  $v_c$ , thus the section is adequate.

#### *Span-Effective Depth Ratios*

(This calculation could usefully be performed as part of step (1) but has been presented here for clarity.)

At the centre of span

$$\frac{M}{bd^2} = \frac{142 \times 10^6}{4000 \times 155^2} = 1.48$$

From table 6.7, for a service stress  $f_s = 156 \text{ N/mm}^2$  the modification factor is 1.67.

Therefore

$$\text{limiting } \frac{\text{span}}{\text{effective depth}} = 26 \times 1.67 = 43.4$$

$$\text{actual } \frac{\text{span}}{\text{effective depth}} = \frac{6500}{155} = 41.9$$

(To take care of stability requirements, extra reinforcement may be necessary in the column strips to act as a tie between each pair of columns — see section 6.7.)

### 8.8 Ribbed and Hollow Block Floors

Cross-sections through a ribbed and hollow block floor slab are shown in figure 8.18. The ribbed floor is formed using temporary or permanent shuttering while the hollow block floor is generally constructed with blocks made of clay tile or with concrete containing a light-weight aggregate. If the blocks are suitably manufactured and have an adequate strength they can be considered to contribute to the strength of the slab in the design calculations, but in many designs no such allowance is made.

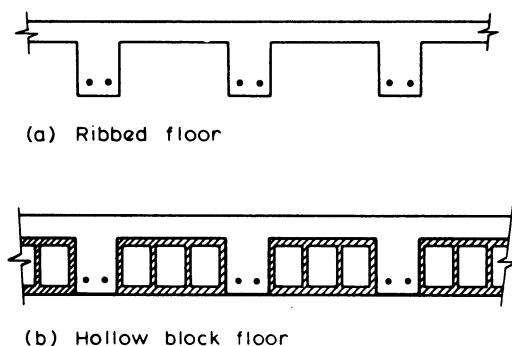

Figure 8.18 Sections through ribbed and hollow block floors

The principal advantage of these floors is the reduction in weight achieved by removing part of the concrete below the neutral axis and, in the case of the hollow block floor, replacing it with a lighter form of construction. Ribbed and hollow block floors are economical for buildings where there are long spans, over about 5 m, and light or moderate live loads, such as in hospital wards or apartment buildings. They would not be suitable for structures having a heavy loading, such as warehouses and garages.

Near to the supports the hollow blocks are stopped off and the slab is made solid. This is done to achieve a greater shear strength, and if the slab is supported by a monolithic concrete beam the solid section acts as the flange of a T-section. The ribs should be checked for shear at their junction with the solid slab. It is good practice to stagger the joints of the hollow blocks in adjacent rows so that, as they are stopped off, there is no abrupt change in cross-section extending across the slab. The slabs are usually made solid under partitions and concentrated loads.

During construction the hollow tiles should be well soaked in water prior to placing the concrete, otherwise shrinkage cracking of the top concrete flange is liable to occur.

The thickness of the concrete flange or topping should not be less than

- (1) 30 mm for slabs with permanent blocks which are capable of contributing to the structural strength as specified in BS 8110, and where there is a clear distance between ribs of not more than 500 mm

- (2) 25 mm when the blocks described in (1) are jointed with a cement-sand mortar
- (3) 40 mm or one-tenth of the clear distance between ribs, whichever is the greater, for all other slabs with permanent blocks
- (4) 50 mm or one-tenth of the clear distance between ribs, whichever is the greater, for slabs without permanent blocks.

The rib width will be governed by cover, bar spacing and fire resistance (section 6.1).

With *in situ* construction, the ribs should be spaced no further apart than 1.5 m and their depth below the flange should not be greater than four times their width.

The shear stress is calculated as

$$v = \frac{V}{b_w d}$$

where  $b_w$  is the breadth of the rib. If hollow blocks are used this breadth may be increased by the wall thickness of the block on one side of the rib. When  $v$  exceeds  $v_c$  shear reinforcement is required, and  $v$  must be less than  $0.8 \sqrt{f_{cu}}$  and  $5 \text{ N/mm}^2$ . Links are also needed in ribs with more than one longitudinal bar if  $v > v_c/2$ .

Span-effective depth ratios are limited to the values for a flanged beam based on the shorter span but the web width used in determining the ratio from table 6.6 may include the thickness of the two adjacent block-walls.

At least 50 per cent of the total tensile reinforcement in the span should continue to the supports and be anchored. In some instances the slabs are supported by steel beams and are designed as simply supported even though the topping may be continuous. Reinforcement should be provided over the supports to prevent cracking in these cases. It is recommended that the area of this top steel should not be less than one-quarter of the area of steel required in the middle of the span and it should extend at least 0.15 of the clear span into the adjoining spans.

A light reinforcing mesh in the topping flange can give added strength and durability to the slab, particularly if there are concentrated or moving loads, or if cracking due to shrinkage or thermal movements is likely. An area of 0.12 per cent of the topping flange is recommended.

### **Example 8.8 Design of a Ribbed Floor**

The ribbed floor is constructed with permanent fibreglass moulds; it is continuous over several equal spans of 5.0 m. The characteristic material strengths are  $f_{cu} = 30 \text{ N/mm}^2$  and  $f_y = 250 \text{ N/mm}^2$ .

An effective section as shown in figure 8.19 is to be tried. The characteristic dead load including self-weight and finishes is  $4.5 \text{ kN/m}^2$  and the characteristic live load is  $2.5 \text{ kN/m}^2$ .

The calculations are for an interior span for which the moments and shears can be determined by using the coefficients in table 8.1.

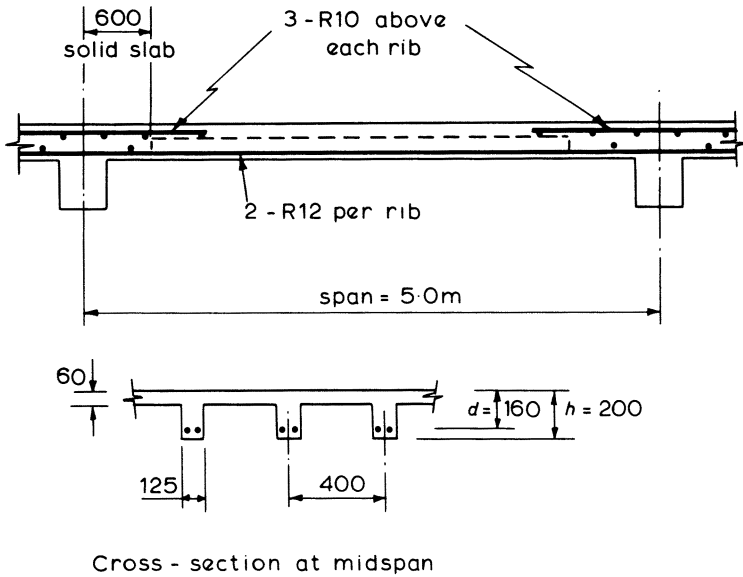

Figure 8.19

Considering a 0.4 m width of floor as supported by each rib

$$\begin{aligned}\text{Ultimate load} &= 0.4 (1.4g_k + 1.6q_k) \\ &= 0.4 (1.4 \times 4.5 + 1.6 \times 2.5) \\ &= 4.12 \text{ kN/m}\end{aligned}$$

$$\text{ultimate load on the span } F = 4.12 \times 5.0 = 20.6 \text{ kN}$$

### Bending

- (1) At mid-span: design as a T-section

$$M = 0.063 FL = 0.063 \times 20.6 \times 5.0 = 6.49 \text{ kN m}$$

$$\frac{M}{bd^2f_{cu}} = \frac{6.49 \times 10^6}{400 \times 160^2 \times 30} = 0.021$$

From the lever-arm curve, figure 7.5,  $l_a = 0.95$ . Thus the neutral axis lies within the flange and

$$\begin{aligned}A_s &= \frac{M}{0.87f_y z} = \frac{6.49 \times 10^6}{0.87 \times 250 \times 0.95 \times 160} \\ &= 197 \text{ mm}^2\end{aligned}$$

Provide two R12 bars in the ribs,  $A_s = 226 \text{ mm}^2$ .

- (2) At a support: design as a rectangular section for the solid slab

$$M = 0.063 FL = 0.063 \times 20.6 \times 5.0 = 6.49 \text{ kN m as in (1)}$$

and

$$A_s = 197 \text{ mm}^2 \text{ as at mid-span}$$

Provide three R10 bars in each 0.4 m width of slab,  $A_s = 236 \text{ mm}^2$ .

- (3) At the section where the ribs terminate: this occurs 0.6 m from the centre line of the support and the moment may be hogging so that the 125 mm ribs must provide the concrete area required to develop the design moment. The maximum moment of resistance of the concrete ribs is

$$\begin{aligned} M_u &= 0.156 f_{cu} b d^2 = 0.156 \times 30 \times 125 \times 160^2 \times 10^{-6} \\ &= 15.0 \text{ kN m} \end{aligned}$$

which must be greater than the moment at this section, therefore compression steel is not required.

#### *Span-Effective Depth Ratio*

$$\text{At mid-span } M/bd^2 = \frac{6.49 \times 10^6}{400 \times 160^2} = 0.63$$

From table 6.7, with  $f_s = 156 \text{ N/mm}^2$ , the modification factor = 2.0. For a T-section with web width 0.31  $\times$  flange width the basic ratio is 20.8 from table 6.6.

$$\text{limiting } \frac{\text{span}}{\text{effective depth}} = 20.8 \times 2.0 = 41.6$$

$$\text{actual } \frac{\text{span}}{\text{effective depth}} = \frac{5000}{160} = 31.3$$

Thus  $d = 160 \text{ mm}$  is adequate.

#### *Shear*

Maximum shear in the rib 0.6 m from the support centre line

$$= 0.5F - 0.6 \times 4.12 = 0.5 \times 20.6 - 2.5 = 7.8 \text{ kN}$$

Therefore

$$\text{shear stress} = \frac{V}{bd} = \frac{7800}{125 \times 160} = 0.39 \text{ N/mm}^2$$

$$\frac{100A_s}{bd} = \frac{100 \times 226}{125 \times 160} = 1.13$$

From table 5.1,  $v_c = 0.87 \text{ N/mm}^2$ ; therefore the section is adequate in shear, and since  $v < v_c/2$  no links are required provided that the bars in the ribs are securely located during construction.

### 8.9 Stair Slabs

The usual form of stairs can be classified into two types: (1) Those spanning horizontally in the transverse direction, and (2) Those spanning longitudinally.

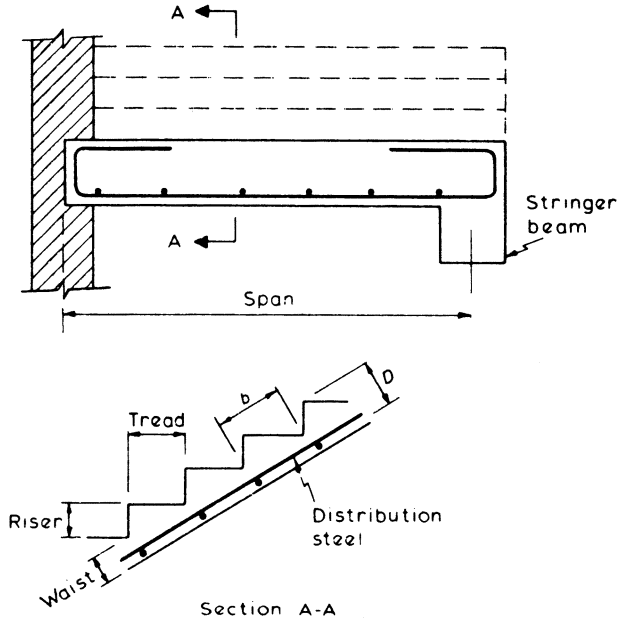

Figure 8.20 Stairs spanning horizontally

#### 8.9.1 Stairs Spanning Horizontally

Stairs of this type may be supported on both sides or they may be cantilevered from a supporting wall.

Figure 8.20 shows a stair supported on one side by a wall and on the other by a stringer beam. Each step is usually designed as having a breadth  $b$  and an effective depth of  $d = D/2$  as shown in the figure; a more rigorous analysis of the section is rarely justified. Distribution steel in the longitudinal direction is placed above the main reinforcement.

Details of a cantilevered stair are shown in figure 8.21. The effective depth of the member is taken as the mean effective depth of the section and the main reinforcement must be placed in the top of the stairs and anchored into the support. A light mesh of reinforcement is placed in the bottom face to resist shrinkage cracking.

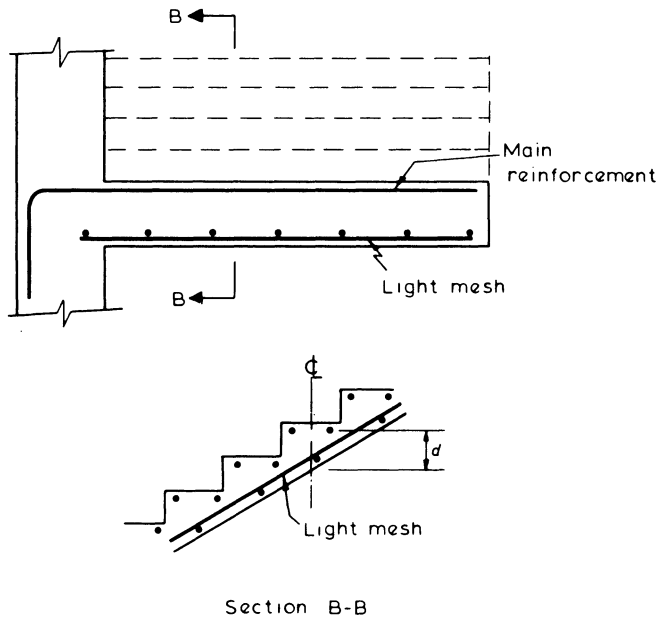

Figure 8.21 Cantilevered stairs

### 8.9.2 Stair Slab Spanning Longitudinally

The stair slab may span into landings which span at right angles to the stairs as in figure 8.22 or it may span between supporting beams as in figure 8.23 of the example.

The dead load is calculated along the slope length of the stairs but the live load is based on the plan area. Loads common to two spans which intersect at right angles and surround an open well may be assumed to be divided equally between the spans. The effective span ( $l$ ) is measured horizontally between the centres of the supports and the thickness of the waist ( $h$ ) is taken as the slab thickness. Span-effective depth ratios may be increased by fifteen per cent provided that the stair flight occupies at least 60 per cent of the span.

Stair slabs which are continuous and constructed monolithically with their supporting slabs or beams can be designed for a bending moment of say  $F/10$ , where  $F$  is the total ultimate load. But in many instances the stairs are precast or constructed after the main structure, pockets with dowels being left in the supporting beams to receive the stairs, and with no appreciable end restraint the design moment should be  $F/8$ .

#### Example 8.9 Design of a Stair Slab

The stairs are of the type shown in figure 8.23 spanning longitudinally and set into pockets in the two supporting beams. The effective span is 3 m and the rise of the

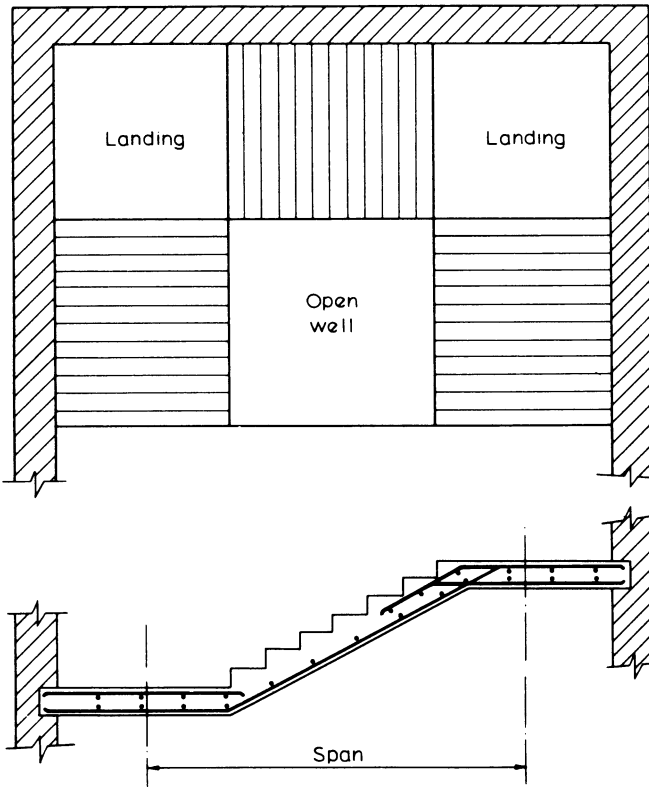

Figure 8.22 Stairs spanning into landings

stairs is 1.5 m, with 260 mm treads and 150 mm risers. The live load is  $3.0 \text{ kN/m}^2$ , and the characteristic material strengths are  $f_{cu} = 30 \text{ N/mm}^2$  and  $f_y = 250 \text{ N/mm}^2$ . Try a 125 mm thick waist, effective depth,  $d = 90 \text{ mm}$ .

$$\text{Slope length of stairs} = \sqrt{(3^2 + 1.5^2)} = 3.35 \text{ m}$$

Considering a 1 m width of stairs

$$\begin{aligned} \text{weight of waist plus steps} &= (0.125 \times 3.35 + 0.26 \times 1.5/2) 24 \\ &= 14.7 \text{ kN} \end{aligned}$$

$$\text{Live load} = 3.0 \times 3 = 9.0 \text{ kN}$$

$$\text{Ultimate load } F = 1.4 \times 14.7 + 1.6 \times 9.0 = 35.0 \text{ kN}$$

With no effective end restraint

$$M = \frac{Fl}{8} = \frac{35.0 \times 3.0}{8}$$

$$= 13.1 \text{ kN m}$$

Check span to effective depth ratio:

$$\frac{M}{bd^2} = \frac{13.1 \times 10^6}{1000 \times 90^2} = 1.62$$

for simply supported span, basic ratio from table 6.6 = 20 and modification factor from table 6.7 for a service stress of 156 N/mm<sup>2</sup> is 1.61.

Since the stair flight occupies more than 60 per cent of the span, a further increase of 15 per cent is permitted, thus

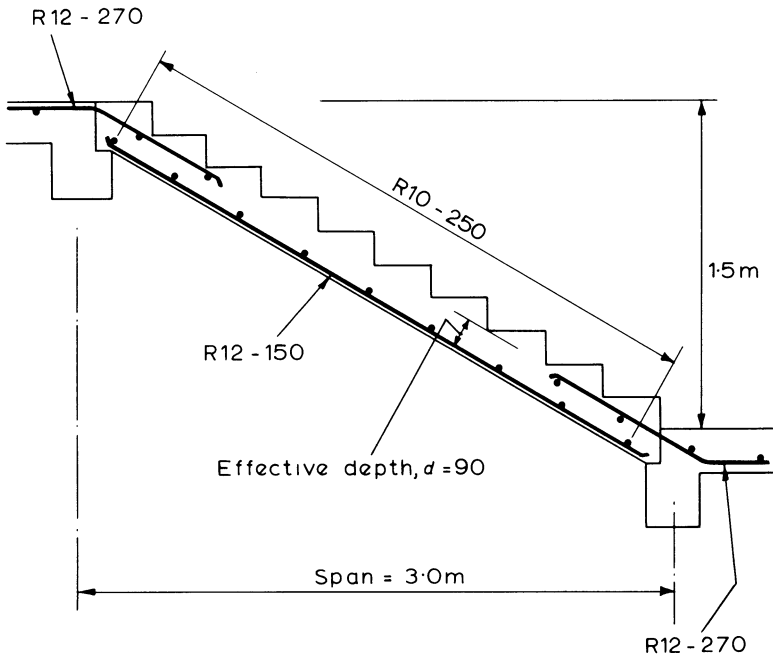

Figure 8.23 Stairs supported by beams

$$\text{limiting } \frac{\text{span}}{\text{effective depth}} = 20 \times 1.61 \times 1.15 = 37.0$$

$$\text{actual } \frac{\text{span}}{\text{effective depth}} = \frac{3000}{90} = 33.3$$

$$\frac{M}{bd^2 f_{cu}} = \frac{13.1 \times 10^6}{1000 \times 90^2 \times 30} = 0.054$$

Therefore from the lever-arm curve of figure 7.5,  $l_a = 0.93$

$$\begin{aligned} A_s &= \frac{M}{0.87 f_y l_a d} \\ &= \frac{13.1 \times 10^6}{0.87 \times 250 \times 0.93 \times 90} \\ &= 720 \text{ mm}^2/\text{m} \end{aligned}$$

Provide R12 bars at 150 mm centres, area = 754 mm<sup>2</sup>/m.

$$\begin{aligned} \text{Transverse distribution steel} &= \frac{0.24 bh}{100} = \frac{0.24 \times 1000 \times 125}{100} \\ &= 300 \text{ mm}^2/\text{m} \end{aligned}$$

Provide R10 bars at 250 mm centres, area = 314 mm<sup>2</sup>/m.

Continuity bars at the top and bottom of the span should be provided and about 50 per cent of the main steel would be reasonable, while satisfying maximum spacing limits of  $3d = 270$  mm.

## 8.10 Yield Line and Strip Methods

For cases which are more complex as a result of shape, support conditions, the presence of openings, or loading conditions it may be worth while adopting an ultimate analysis method. The two principal approaches are the yield line method, which is particularly suitable for slabs with a complex shape or concentrated loading, and the strip method which is valuable where the slab contains openings.

These methods have been the subject of research in recent years, and are well documented although they are of a relatively specialised nature. A brief introduction is included here to illustrate the general principles and features of the methods, which are particularly valuable in assisting an understanding of failure mechanisms.

### 8.10.1 Yield Line Method

The capacity of reinforced concrete to sustain plastic deformation has been described in section 3.4. For an under-reinforced section the capacity to develop curvatures between the first yield of reinforcement and failure due to crushing of concrete is considerable. For a slab which is subjected to increasing load, cracking and reinforcement yield will first occur in the most highly stressed zone. This will then act as a plastic hinge as subsequent loads are distributed to other regions of the slab. Cracks will develop to form a pattern of 'yield lines' until a mechanism is formed and collapse is indicated by increasing deflections under constant load.

It is assumed that a pattern of yield lines can be superimposed on the slab, which will cause a collapse mechanism, and that the regions between yield lines remain rigid and uncracked. Figure 8.24 shows the yield line mechanism which will occur for the simple case of a fixed ended slab spanning in one direction with a uniform load. Rotation along the yield lines will occur at a constant moment equal to the ultimate moment of resistance of the section, and will absorb

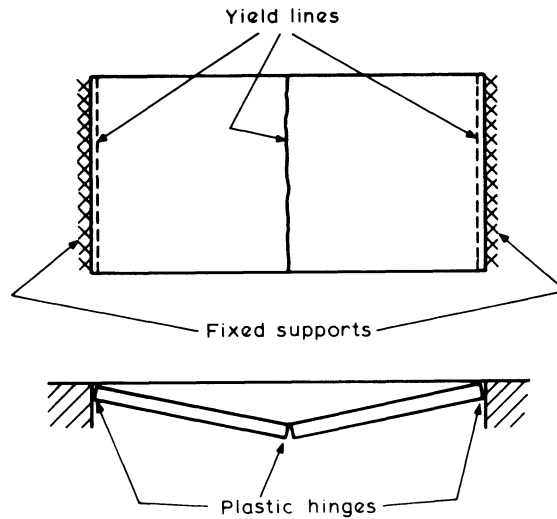

Figure 8.24

energy. This can be equated to the energy expended by the applied load undergoing a compatible displacement and is known as the virtual work method.

Considerable care must be taken over the selection of likely yield line patterns, since the method will give an 'upper bound' solution, that is, either a correct or unsafe solution. Yield lines will form at right angles to bending moments which have reached the ultimate moment of resistance of the slab, and the following rules may be helpful.

- (1) Yield lines are usually straight and end at a slab boundary.
- (2) Yield lines will lie along axes of rotation, or pass through their points of intersection.
- (3) Axes of rotation lie along supported edges, pass over columns or cut unsupported edges.

In simple cases the alternative patterns to be considered will be readily determined on the basis of common sense, while for more complex cases differential calculus may be used. The danger of missing the critical layout of yield lines, and thus obtaining an incorrect solution, means that the method can only be used with confidence by experienced designers.

A number of typical patterns are shown in figure 8.25.

A yield line caused by a sagging moment is generally referred to as a 'positive' yield line and represented by a full line, while a hogging moment causing cracking on the top surface of the slab causes a 'negative' yield line shown by a broken line.

The basic approach of the method is illustrated for the simple case of a one-way spanning slab in example 8.10.

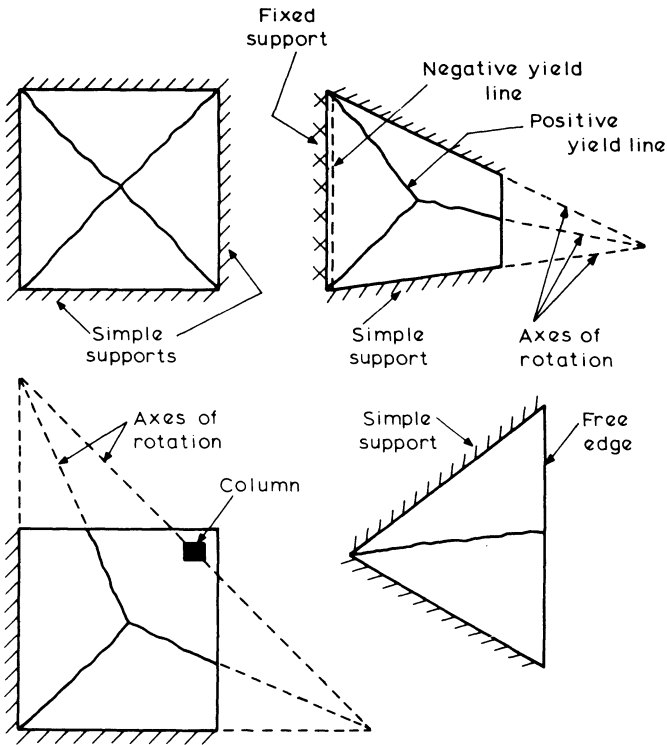

Figure 8.25

**Example 8.10 Simply Supported, One-way Spanning Rectangular Slab**

The slab shown in figure 8.26 is subjected to a uniformly distributed load  $w$  per unit area. Longitudinal reinforcement is provided as indicated giving a uniform ultimate moment of resistance  $m$  per unit width.

The maximum moment will occur at midspan and a positive yield line can thus be superimposed as shown. If this is considered to be subject to a small displacement  $\Delta$ , then

external work done = area  $\times$  load  $\times$  average distance moved for each rigid half of the slab

$$= \left( \alpha L \times \frac{L}{2} \right) \times w \times \frac{\Delta}{2}$$

therefore

$$\text{total} = \frac{1}{2} \alpha L^2 w \Delta$$

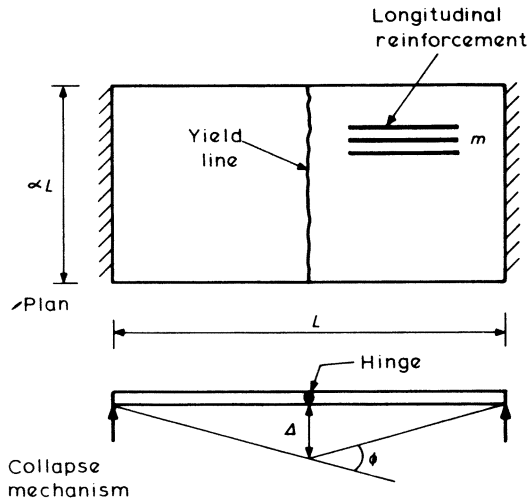

Figure 8.26

Internal energy absorbed by rotation along the yield line is

$$\text{moment} \times \text{rotation} \times \text{length} = m\phi\alpha L$$

where

$$\phi \approx 2 \left( \frac{\Delta}{0.5L} \right) = \frac{4\Delta}{L}$$

hence

$$\text{internal energy} = 4m\alpha\Delta$$

Thus equating internal energy absorbed with external work done

$$4m\alpha\Delta = \frac{1}{2} \alpha L^2 w \Delta$$

or

$$m = \frac{wL^2}{8} \text{ as anticipated}$$

Since the displacement  $\Delta$  is eliminated, this will generally be set to unity in calculations of this type.

In the simple case of example 8.10, the yield line crossed the reinforcement at right angles and transverse steel was not involved in bending calculations. Generally, a yield line will lie at an angle  $\theta$  to the orthogonal to the main reinforcement and will thus also cross transverse steel. The ultimate moment of resistance developed is not easy to define, but Johansen's stepped yield criteria is the most popular approach. This assumes that an inclined yield line consists of a number of steps, each orthogonal to a reinforcing bar as shown in figure 8.27.

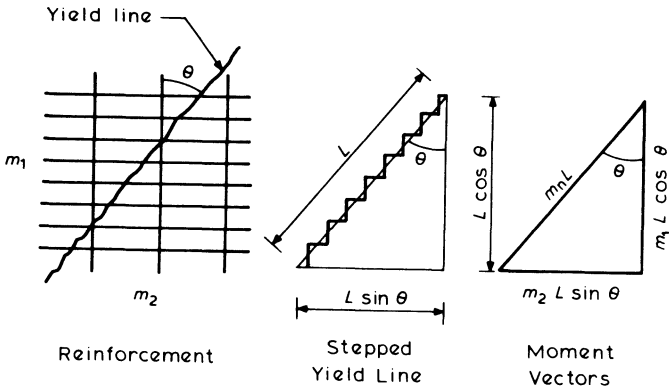

Figure 8.27

If the ultimate moments of resistance provided by main and transverse steel are  $m_1$  and  $m_2$  per unit width, it follows that for equilibrium of the vectors shown, the ultimate moment of resistance normal to the yield line  $m_n$  per unit length is given by

$$m_n L = m_1 L \cos \theta \times \cos \theta + m_2 L \sin \theta \times \sin \theta$$

hence 
$$m_n = m_1 \cos^2 \theta + m_2 \sin^2 \theta$$

In the extreme cases of  $\theta = 0$ , this reduces to  $m_n = m_1$ , and when  $m_1 = m_2 = m$ , then  $m_n = m$  for any value of  $\theta$ . This latter case of an orthotropically reinforced slab (reinforcement mutually perpendicular) with equal moments of resistance is said to be isotropically reinforced.

When applying this approach to complex situations it is often difficult to calculate the lengths and rotations of the yield lines, and a simple vector notation can be used. The total moment component  $m_n$  can be resolved vectorially in the  $x$  and  $y$  directions and since internal energy dissipation along a yield line is given by moment  $\times$  rotation  $\times$  length it follows that the energy dissipated by rotation of yield lines bounding any rigid area is given by

$$m_x l_x \phi_x + m_y l_y \phi_y$$

where  $m_x$  and  $m_y$  are yield moments in directions  $x$  and  $y$ ,  $l_x$  and  $l_y$  are projections of yield lines along each axis, and  $\phi_x$  and  $\phi_y$  are rotations about the axes. This is illustrated in example 8.11.

**Example 8.11 Slab Simply Supported on Three Sides**

The slab shown in figure 8.28 supports a uniformly distributed load of  $w$  per unit area.

*Internal energy absorbed (E) for unit displacement at points X and Y*

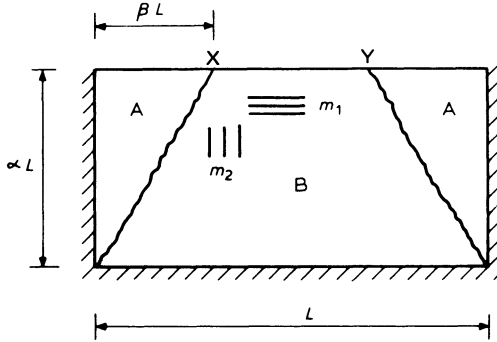

Figure 8.28

Area A

$$E_A = m_x l_x \phi_x + m_y l_y \phi_y$$

where  $\phi_x = 0$ ; hence

$$E_A = m_1 \alpha L \times \frac{1}{\beta L} = m_1 \frac{\alpha}{\beta}$$

Area B

$$E_B = m_x l_x \phi_x + m_y l_y \phi_y$$

where  $\phi_y = 0$ ; hence

$$E_B = 2m_2 \beta L \times \frac{1}{\alpha L} = 2m_2 \frac{\beta}{\alpha}$$

hence total for all rigid areas is

$$2E_A + E_B = \frac{2}{\alpha\beta} (m_1 \alpha^2 + m_2 \beta^2)$$

External work done can also be calculated for each region separately

$$W_A = \frac{1}{2} (\alpha L \times \beta L) w \times \frac{1}{3} = \frac{1}{6} w \alpha \beta L^2$$

$$W_B = \left[ \frac{1}{6} w \alpha \beta L^2 + \alpha L \left( \frac{L}{2} - \beta L \right) w \times \frac{1}{2} \right] \times 2$$

therefore total =  $2W_A + W_B$

$$= \frac{1}{6} \alpha (3 - 2\beta) L^2 w$$

Hence equating internal and external work, the maximum u.d.l. that the slab can sustain is given by

$$w_{\max} = \frac{2}{\alpha\beta} (m_1\alpha^2 + m_2\beta^2) \times \frac{6}{\alpha(3 - 2\beta)L^2}$$

$$= \frac{12(m_1\alpha^2 + m_2\beta^2)}{\alpha^2 L^2 (3\beta - 2\beta^2)}$$

It is clear that the result will vary according to the value of  $\beta$ . The maximum value of  $w$  may be obtained by trial and error using several values of  $\beta$ , or alternatively, by differentiation, let  $m_2 = \mu m_1$ , then

$$w = \frac{12m_1(\alpha^2 + \mu\beta^2)}{\alpha^2 L^2 (3\beta - 2\beta^2)}$$

and

$$\frac{d(m_1/w)}{d\beta} = 0 \text{ will give the critical value of } \beta$$

hence

$$3\mu\beta^2 + 4\alpha^2\beta - 3\alpha^2 = 0$$

and

$$\beta = \frac{\alpha^2}{\mu} \left[ \pm \sqrt{\left(\frac{4}{9} + \frac{\mu}{\alpha^2}\right) - \frac{2}{3}} \right]$$

A negative value is impossible, hence the critical value of  $\beta$  for use in the analysis is given by the positive root.

### 8.10.2 Hillerborg Strip Method

This is based on the 'lower bound' concept of plastic theory which suggests that if a stress distribution throughout a structure can be found which satisfies all equilibrium conditions without violating yield criteria, then the structure is safe for the corresponding system of external loads. Although safe, the structure will not necessarily be serviceable or economic, hence considerable skill is required on the part of the engineer in selecting a suitable distribution of bending moments on which the design can be based. Detailed analysis of a slab designed on this basis is not necessary, but the designer's structural sense and 'feel' for the way loads are transmitted to the supports are of prime importance.

Although this method for design of slabs was proposed by Hillerborg in the 1950s, developments by Wood and Armer in the 1960s have produced its currently used form. The method can be applied to slabs of any shape, and assumes that at failure the load will be carried by bending in either the  $x$  or  $y$  direction separately with no twisting action. Hence the title of 'strip method'.

Considering a rectangular slab simply supported on four sides and carrying a uniformly distributed load, the load may be expected to be distributed to the supports in the manner shown in figure 8.29.

Judgement will be required to determine the angle  $\alpha$ , but it can be seen that if  $\alpha = 90^\circ$  the slab will be assumed to be one-way spanning and, although safe, is

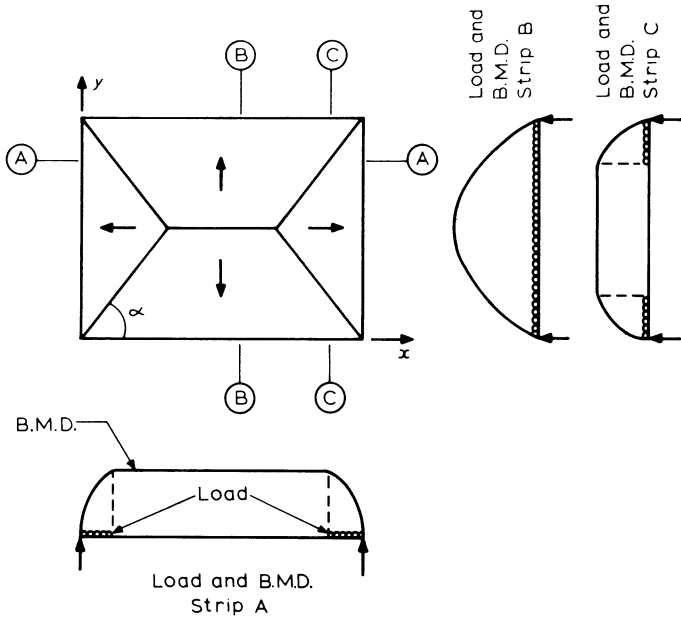

Figure 8.29

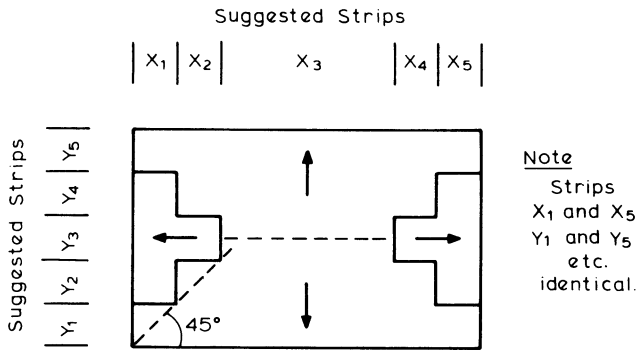

Figure 8.30

unlikely to be serviceable because of cracking near the supports along the  $y$  axis. Hillerborg suggests that for such a slab,  $\alpha$  should be  $45^\circ$ . The load diagram causing bending moments along typical strips spanning each direction are also shown. It will be seen that the alternative pattern, suggested by Wood and Armer in figure 8.30 will simplify the design, and in this case five strips in each direction may be conveniently used as shown. Each of these will be designed in bending for its particular loading, as if it were one-way spanning using the methods of section 8.5. Reinforcement will be arranged uniformly across each strip, to produce an overall pattern of reinforcement bands in two directions. Support reactions can also be obtained very simply from each strip.

The approach is particularly suitable for slabs with openings, in which case strengthened bands can be provided round the openings with the remainder of the slab divided into strips as appropriate. A typical pattern of this type is shown in figure 8.31.

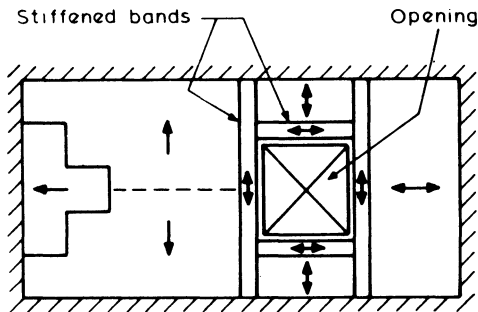

Figure 8.31

# 9

## Column Design

The columns in a structure carry the loads from the beams and slabs down to the foundations, and therefore they are primarily compression members, although they may also have to resist bending forces due to the continuity of the structure. The analysis of a section subjected to an axial load plus bending is dealt with in chapter 4, where it is noted that a direct solution of the equations which determine the areas of reinforcement can be very laborious and impractical. Therefore, design charts or some form of electronic computer are often employed to facilitate the routine design of column sections.

Design of columns is governed by the ultimate limit state; deflections and cracking during service conditions are not usually a problem, but nevertheless correct detailing of the reinforcement and adequate cover are important.

Many of the principles used in this chapter for the design of a column can also be applied in a similar manner to other types of members which also resist an axial load plus a bending moment.

### 9.1 Loading and Moments

The loading arrangements and the analysis of a structural frame have been described with examples in chapter 3. In the analysis it was necessary to classify the column into one of the following types

- (1) a braced column – where the lateral loads are resisted by walls or some other form of bracing, and
- (2) an unbraced column – where the lateral loads are resisted by the bending action of the columns.

With a braced column the axial forces and moments are caused by the dead and imposed load only, whereas with an unbraced column the loading arrangements which include the effects of the lateral loads must also be considered.

For a braced column the critical arrangement of the ultimate load is usually that which causes the largest moment in the column, together with a large axial load. As an example, figure 9.1 shows a building frame with the critical loading arrangement for the design of its centre column at the first-floor level and also the

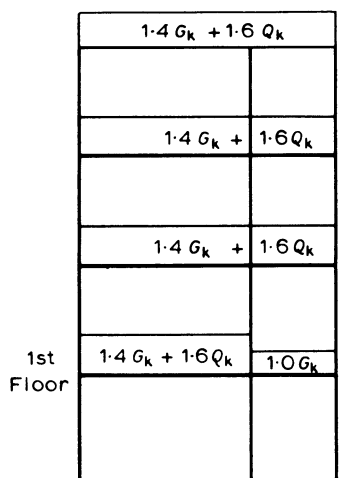

Figure 9.1 A critical loading arrangement

left-hand column at all floor levels. When the moments in columns are large and particularly with unbraced columns, it may also be necessary to check the case of maximum moment combined with the minimum axial load.

The axial forces due to the vertical loading may be calculated as though the beams and slabs are simply supported. In some structures it is unlikely that all the floors of a building will carry the full imposed load at the same instant, therefore, a reduction is usually allowed in the total imposed load when designing columns and foundations in buildings which are two or more storeys high, as shown by table 9.1.

**Table 9.1** Reduction of total imposed floor loads on columns, walls and foundations

No. of floors carried by member	Reduction of imposed load on all floors above the member
1	0 per cent
2	10
3	20
4	30
5 to 10	40
over 10	50

**9.2 Short and Slender Columns**

A column is classified as short if both  $l_{ex}/h$  and  $l_{ey}/b$  are:

less than 15 for a braced column

less than 10 for an unbraced column

The effective lengths  $l_{ex}$  and  $l_{ey}$  are relative to the XX and YY axis,  $h$  is the overall depth of the section in the plane of bending about the XX axis, that is  $h$  is the dimension perpendicular to the XX axis. The effective lengths are specified as

$$l_e = \beta l_0$$

$l_0$  is the clear distance between the column end restraints  
and  $\beta$  is a coefficient which depends on the degree of end restraints as specified in table 9.2.

The application of these coefficients is illustrated for the braced column shown in figure 9.2.

**Table 9.2**

$\beta$ for braced columns				$\beta$ for unbraced columns			
End condition at top	End condition at bottom			End condition at top	End condition at bottom		
	1	2	3		1	2	3
1	0.75	0.80	0.90	1	1.2	1.3	1.6
2	0.80	0.85	0.95	2	1.3	1.5	1.8
3	0.90	0.95	1.00	3	1.6	1.8	—
				4	2.2	—	—

End conditions. The four end conditions are as follows:

- (a) *Condition 1.* The end of the column is connected monolithically to beams on either side which are at least as deep as the overall dimension of the column in the plane considered. Where the column is connected to a foundation structure, this should be of a form specifically designed to carry moment.
- (b) *Condition 2.* The end of the column is connected monolithically to beams or slabs on either side which are shallower than the overall dimension of the column in the plane considered.
- (c) *Condition 3.* The end of the column is connected to members which, while not specifically designed to provide restraint to rotation of the column will, nevertheless, provide some nominal restraint.
- (d) *Condition 4.* The end of the column is unrestrained against both lateral movement and rotation (for example, the free end of a cantilever column in an unbraced structure).

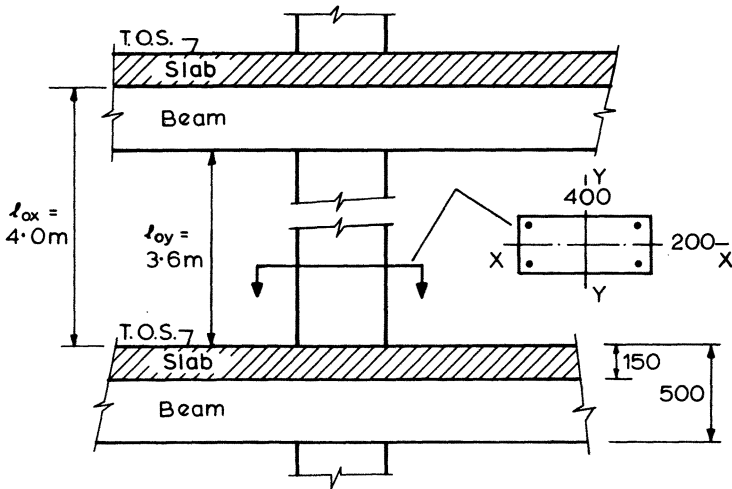

For end condition 1 of Table 9.2, top and bottom

$$\frac{l_{ey}}{b} = \frac{\beta_y l_{oy}}{b} = 0.75 \times \frac{3600}{400} = 6.75 < 15$$

For end condition 2, top and bottom

$$\frac{l_{ex}}{h} = \frac{\beta_x l_{ox}}{h} = 0.85 \times \frac{4000}{200} = 17 > 15$$

Therefore: Column is slender about the X X axis.

Figure 9.2 Braced column slenderness ratios

Short columns usually fail by crushing but a slender column is liable to fail by buckling. The end moments on a slender column cause it to deflect sideways and thus bring into play an additional moment  $Ne_{add}$  as illustrated in figure 9.3. The moment  $Ne_{add}$  causes a further lateral deflection and if the axial load ( $N$ ) exceeds a critical value this deflection, and the additional moment become self-propagating until the column buckles. Euler derived the critical load for a pin-ended strut as

$$N_{crit} = \frac{\pi^2 EI}{l^2}$$

The crushing load  $N_{uz}$  of a truly axially loaded column may be taken as

$$N_{uz} = 0.45 f_{cu} A_c + 0.87 A_{sc} f_y$$

where  $A_c$  is the area of the concrete and  $A_{sc}$  is the area of the longitudinal steel.

Values of  $N_{crit}/N_{uz}$  and  $l/h$  have been calculated and plotted in figure 9.4 for a typical column cross-section.

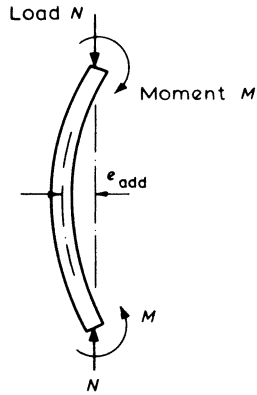

Figure 9.3 Slender column with lateral deflection

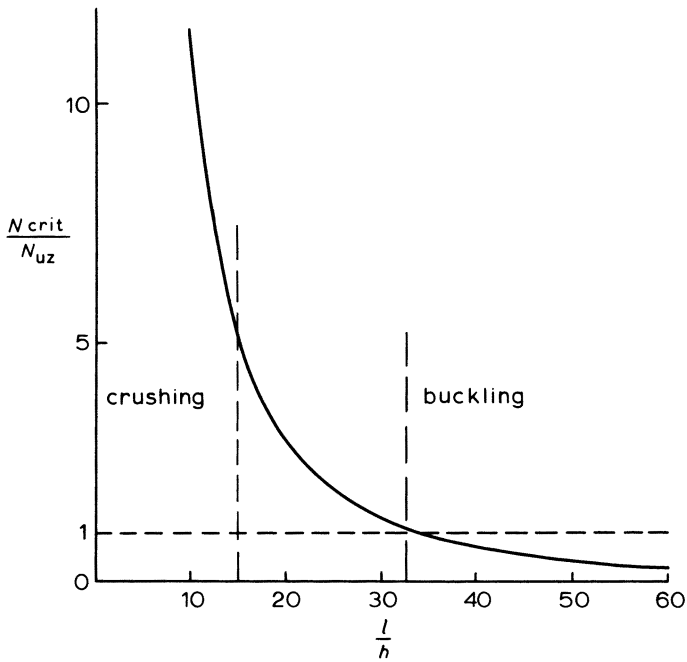

Figure 9.4 Column failure modes

The ratio of  $N_{\text{crit}}/N_{\text{uz}}$  in the figure determines the type of failure of the column. With  $l/h$  less than, say, 15 the load will probably cause crushing,  $N_{\text{uz}}$  is much less than  $N_{\text{crit}}$ , the load that causes buckling – and therefore a buckling failure will not occur. This is not true with higher values of  $l/h$  and so a buckling failure is possible, depending on such factors as the initial curvature of the column and the actual eccentricity of the load. When  $l/h$  is greater than 32 then  $N_{\text{crit}}$  is less than  $N_{\text{uz}}$  and in this case a buckling failure will occur for the column considered.

The mode of failure of a column can be one of the following.

- (1) Material failure with negligible lateral deflection, which usually occurs with short columns but can also occur when there are large end moments on a column with an intermediate slenderness ratio.
- (2) Material failure intensified by the lateral deflection and the additional moment. This type of failure is typical of intermediate columns.
- (3) Instability failure which occurs with slender columns and is liable to be preceded by excessive deflections.

### 9.3 Reinforcement Details

The rules governing the minimum and maximum amounts of reinforcement in a load bearing column are as follows.

#### Longitudinal Steel

- (1) A minimum of four bars is required in a rectangular column and six bars in a circular column.
- (2)

$$\frac{100A_s}{A_{\text{col}}} \leq 0.4$$

- (3)

$$\frac{100A_s}{A_{\text{col}}} \geq 6.0 \text{ in a vertically cast column}$$

or

$$\frac{100A_s}{A_{\text{col}}} \geq 8.0 \text{ in a horizontally cast column}$$

but at laps

$$\frac{100A_s}{A_{\text{col}}} \geq 10.0 \text{ for both types of columns}$$

where  $A_s$  is the total area of longitudinal steel and  $A_{\text{col}}$  is the cross-sectional area of the column.

Links

- (1) Minimum size =  $1/4 \times$  size of the largest compression bar but not less than 6 mm.
- (2) Maximum spacing =  $12 \times$  size of the smallest compression bar.
- (3) The links should be arranged so that every corner bar and alternate bar or group in an outer layer of longitudinal steel is supported by a link passing round the bar and having an included angle not greater than  $135^\circ$ .
- (4) All other bars or groups not restrained by a link should be within 150 mm of a restrained bar.
- (5) In circular columns a circular link passing around a circular arrangement of longitudinal bars is adequate.

No provision is made in BS 8110 for calculating the strength of a column which has helical reinforcement in place of links. This form of spiral reinforcement is widely used in the USA and their codes take account of the added strength it gives to a column and its resistance to seismic forces.

Figure 9.5 shows possible arrangements of reinforcing bars at the junction of two columns and a floor. In figure 9.5a the reinforcement in the lower column is cranked so that it will fit within the smaller column above. The crank in the reinforcement should, if possible, commence above the soffit of the beam so that the

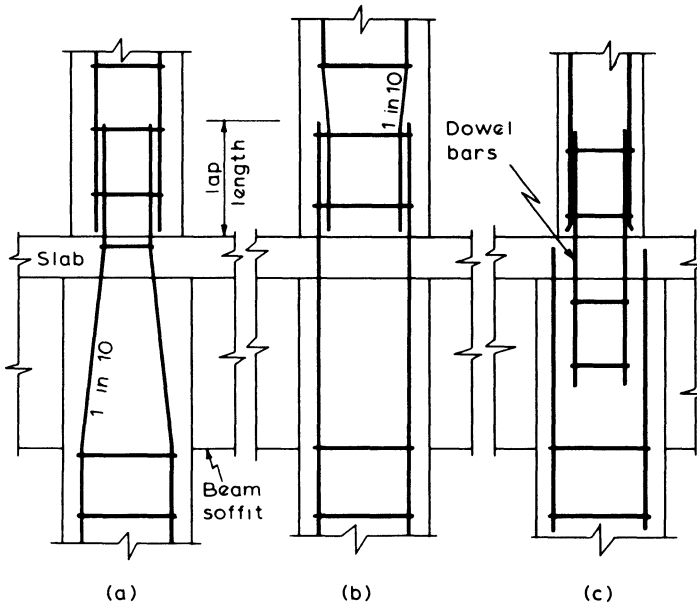

Figure 9.5 Details of splices in column reinforcement

moment of resistance of the column is not reduced. For the same reason, the bars in the upper column should be the ones cranked when both columns are of the same size as in figure 9.5b. Links should be provided at the points where the bars are cranked in order to resist buckling due to horizontal components of force in the inclined lengths of bar. Separate dowel bars as in figure 9.5c may also be used to provide continuity between the two lengths of column. The column-beam junction should be detailed so that there is adequate space for both the column steel and the beam steel. Careful attention to detail on this point will greatly assist the fixing of the steel during construction.

## 9.4 Design of Short Columns

Short columns are divided into three categories according to the degree of eccentricity of the loading as described in the following sections.

### 9.4.1 Short Braced Axially Loaded Columns

This type of column can occur in precast concrete construction when there is no continuity between the members. Also it can be considered to occur when the columns support a symmetrical and very rigid structure.

When the load is perfectly axial the ultimate axial resistance is

$$N = 0.45 f_{cu} A_c + 0.87 f_y A_{sc}$$

where  $A_c$  is the net area of the concrete and  $A_{sc}$  is the area of the longitudinal reinforcement.

Perfect conditions never exist and to allow for a small eccentricity the ultimate load should be calculated from

$$N = 0.4 f_{cu} A_c + 0.75 f_y A_{sc} \quad (9.1)^*$$

For a rectangular column and to allow for the area of concrete displaced by the longitudinal reinforcement this equation may be modified to

$$N = 0.4 f_{cu} bh + A_{sc}(0.75 f_y - 0.4 f_{cu}) \quad (9.2)$$

#### Example 9.1 Axially Loaded Column

Design the longitudinal reinforcement for a 300 mm square column which supports an axial load of 1700 kN at the ultimate limit state. The characteristic material strengths are  $f_y = 460 \text{ N/mm}^2$  for the reinforcement and  $f_{cu} = 30 \text{ N/mm}^2$  for the concrete.

From equation 9.2

$$1700 \times 10^3 = 0.4 \times 30 \times 300^2 + A_{sc}(0.75 \times 460 - 0.4 \times 30)$$

therefore

$$A_{sc} = \frac{(1700 - 1080) 10^3}{333} = 1862 \text{ mm}^2$$

Provide four T25 bars, area = 1960 mm<sup>2</sup>.

**9.4.2 Short Braced Columns Supporting an Approximately Symmetrical Arrangement of Beams**

The moments on these columns will be small and due primarily to unsymmetrical arrangements of the live load. Provided the beam spans do not differ by more than 15 per cent of the longer, and the loading on the beams is uniformly distributed, the column may be designed to support the axial load only. The ultimate load that can be supported should then be taken as

$$N = 0.35 f_{cu} A_c + 0.67 f_y A_{sc} \quad (9.3)^*$$

To take account of the area of concrete displaced by the reinforcement the equation for a rectangular section may be written as

$$N = 0.35 f_{cu} bh + (0.67 f_y - 0.35 f_{cu}) A_{sc}$$

**9.4.3 Short Columns Resisting Moments and Axial Forces**

The area of longitudinal steel for these columns is determined by:

- (1) using design charts or constructing *M-N* interaction diagrams as in section 4
- (2) a solution of the basic design equations, or
- (3) an approximate method.

Design charts are usually used for columns having a rectangular or circular cross-section and a symmetrical arrangement of reinforcement, but interaction diagrams can be constructed for any arrangement of cross-section as illustrated in examples 4.9 and 4.10. The basic equations or the approximate method can be used when an unsymmetrical arrangement of reinforcement is required, or when the cross-section is non-rectangular as described in section 9.5.

Whichever design method is used, a column should not be designed for a moment less than  $N \times e_{min}$ , where  $e_{min}$  has the lesser value of  $h/20$  or 20 mm. This is to allow for tolerances in construction. The dimension  $h$  is the overall size of the column cross-section in the plane of bending.

*(i) Design Charts and Interaction Diagrams*

The design of a section subjected to bending plus axial load should be in accordance with the principles described in section 4.8, which deals with the analysis of the cross-section. The basic equations derived for a rectangular section as shown in figure 9.6 and with a rectangular stress block are

$$N = F_{cc} + F_{sc} + F_s \quad (9.4)$$

$$= 0.45 f_{cu} bs + f_{sc} A'_s + f_s A_s$$

$$M = F_{cc} \left( \frac{h}{2} - \frac{s}{2} \right) + F_{sc} \left( \frac{h}{2} - d' \right) - F_s \left( d - \frac{h}{2} \right) \quad (9.5)$$

- $s$  = the depth of the stress block =  $0.9x$
- $A'_s$  = the area of longitudinal reinforcement in the more highly compressed face
- $A_s$  = the area of reinforcement in the other face
- $f_{sc}$  = the stress in reinforcement  $A'_s$

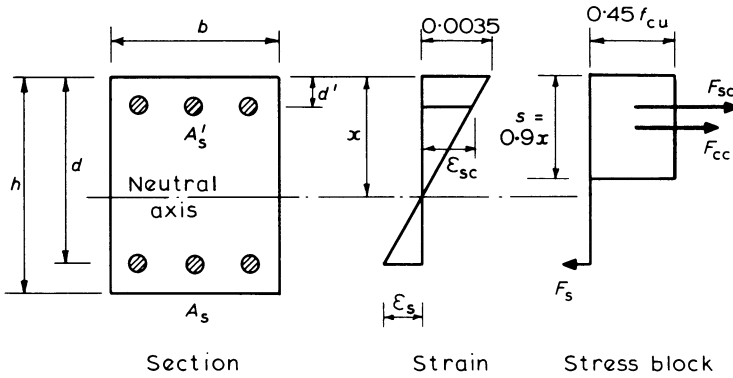

Figure 9.6 Column section

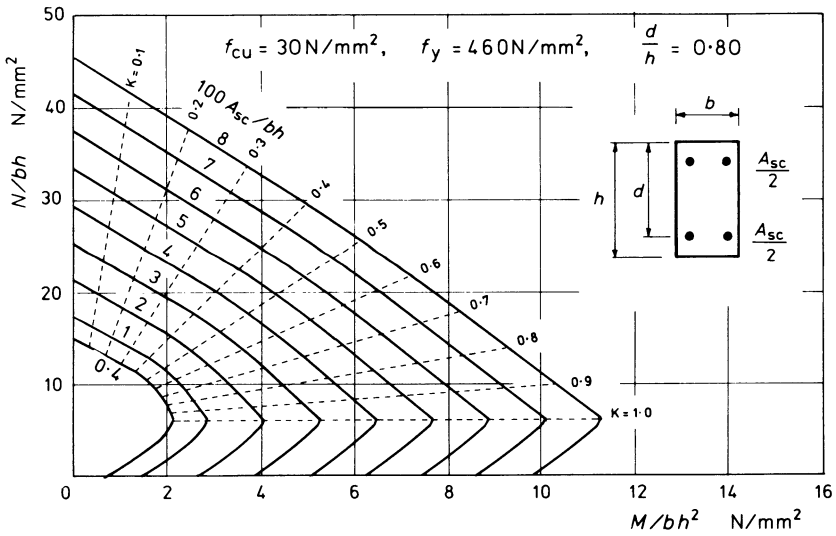

Figure 9.7 Column design chart

$f_s$  = the stress in reinforcement  $A_s$ , negative when tensile

These equations are not suitable for direct solution and the design of a column with symmetrical reinforcement in each face is best carried out using design charts similar to those published in Part 3 of BS 8110. An example of one of these charts is shown in figure 9.7.

**Example 9.2 Column Design Using Design Charts**

Figure 9.8 shows a frame of a heavily loaded industrial structure for which the centre columns along line PQ are to be designed in this example. The frames at 4 m centres, are braced against lateral forces, and support the following floor loads:

dead load  $g_k = 10 \text{ kN/m}^2$

live load  $q_k = 15 \text{ kN/m}^2$

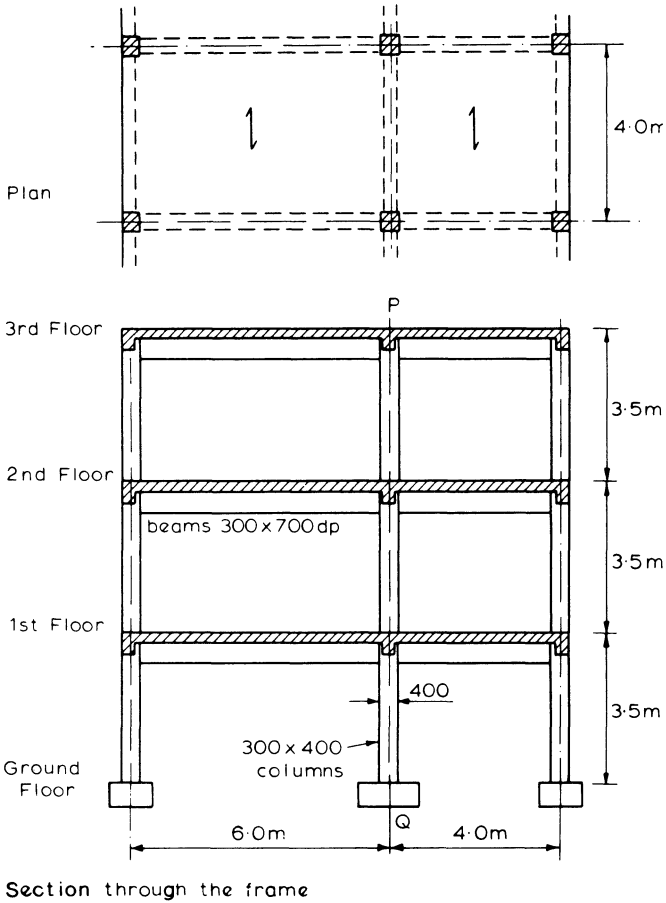

**Figure 9.8** Columns in an industrial structure

Characteristic material strengths are  $f_{cu} = 30 \text{ N/mm}^2$  for the concrete and  $f_y = 460 \text{ N/mm}^2$  for the steel.

$$\begin{aligned} \text{Maximum ultimate load at each floor} &= 4.0(1.4g_k + 1.6q_k) \text{ per metre} \\ &\quad \text{length of beam} \\ &= 4(1.4 \times 10 + 1.6 \times 15) \\ &= 152 \text{ kN/m} \end{aligned}$$

$$\begin{aligned} \text{Minimum ultimate load at each floor} &= 4.0 \times 1.0g_k \\ &= 4.0 \times 10 = 40 \text{ kN per metre} \\ &\quad \text{length of beam} \end{aligned}$$

Consider first the design of the centre column at the underside (u.s.) of the first floor. The critical arrangement of load which will cause the maximum moment in the column is shown in figure 9.9a.

Column loads

$$\begin{aligned} \text{second and third floors} &= 2 \times 152 \times 10/2 &&= 1520 \text{ kN} \\ \text{first floor} &= 152 \times 6/2 + 40 \times 4/2 &&= 536 \\ \text{Column self-weight, say } 2 \times 14 &&&\frac{28}{N = 2084 \text{ kN}} \end{aligned}$$

Similar arrangements of load will give the axial load in the column at the underside (u.s.) and top side (t.s.) of each floor level and these values of  $N$  are shown in table 9.3.

The moments on the column are not large and therefore equation 9.3 may be used for a preliminary sizing. Trying a  $300 \times 400$  column

$$\begin{aligned} N &= 0.35 f_{cu} bh + 0.67 f_y A_{sc} \\ 2084 \times 10^3 &= 0.35 \times 30 \times 300 \times 400 + 0.67 \times 460 \times A_{sc} \end{aligned}$$

from which

$$A_{sc} = 2674 \text{ mm}^2 \text{ and } 100 A_{sc}/bh = 2.23$$

This provides an adequate cross-section and a  $300 \times 400$  column is to be used.

Column Moments

The loading arrangement and the substitute frame for determining the column moments at the first and second floors are shown in figure 9.9b. Member stiffnesses are

$$\begin{aligned} \frac{k_{AB}}{2} &= \frac{1}{2} \frac{bh^3}{12L_{AB}} = \frac{1}{2} \times \frac{0.3 \times 0.7^3}{12 \times 6} = 0.71 \times 10^{-3} \\ \frac{k_{BC}}{2} &= \frac{1}{2} \times \frac{0.3 \times 0.7^3}{12 \times 4} = 1.07 \times 10^{-3} \\ k_{col} &= \frac{0.3 \times 0.4^3}{12 \times 3.5} = 0.46 \times 10^{-3} \end{aligned}$$

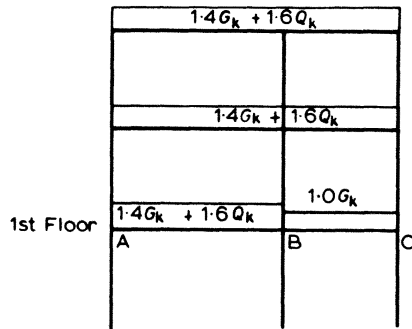

(a) Critical loading arrangement for centre columns at 1st floor

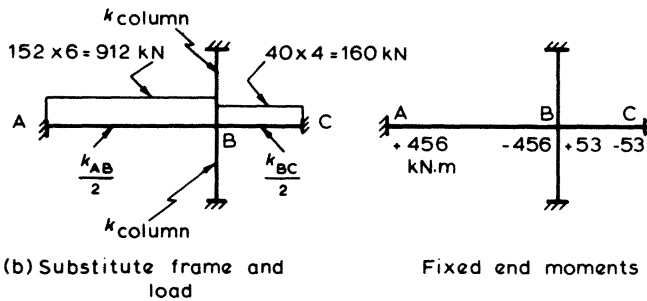

Figure 9.9

therefore

$$\Sigma k = (0.71 + 1.07 + 2 \times 0.46) 10^{-3} = 2.70 \times 10^{-3}$$

and

$$\text{distribution factor for the column} = \frac{k_{col}}{\Sigma k} = \frac{0.46}{2.70} = 0.17$$

Fixed end moments at B are

$$F.E.M_{BA} = \frac{152 \times 6^2}{12} = 456 \text{ kN m}$$

$$F.E.M_{BC} = \frac{40 \times 4^2}{12} = 53 \text{ kN m}$$

Thus

$$\text{column moment } M = 0.17(456 - 53) = 69 \text{ kN m}$$

At the 3rd floor

$$\begin{aligned}\Sigma k &= (0.71 + 1.07 + 0.46) 10^{-3} \\ &= 2.24 \times 10^{-3}\end{aligned}$$

and

$$\text{column moment } M = \frac{0.46}{2.24} (456 - 53) = 83 \text{ kN m}$$

The areas of reinforcement in table 9.3 are determined by using the design chart of figure 9.7. Sections through the column are shown in figure 9.10.

Cover for the reinforcement is taken as 50 mm and  $d/h = 320/400 = 0.8$ . The minimum area of reinforcement allowed in the section is given by

$$A_{sc} = 0.004 bh = 0.004 \times 300 \times 400 = 480 \text{ mm}^2$$

and the maximum area is

$$A_{sc} = 0.06 \times 300 \times 400 = 7200 \text{ mm}^2$$

or at laps

$$A_{sc} = 0.1 \times 300 \times 400 = 12000 \text{ mm}^2$$

and the reinforcement provided is within these limits.

**Table 9.3**

Floor	$N$ (kN)	$M$ (kN m)	$\frac{N}{bh}$	$\frac{M}{bh^2}$	$\frac{100A_{sc}}{bh}$	$A_{sc}$ (mm <sup>2</sup> )
3rd u.s.	536	83.0	4.47	1.73	0.4	480
2nd t.s.	774	69.0	6.45	1.44	0.4	480
	<u>+536</u>					
2nd u.s.	1310	69.0	10.92	1.44	0.4	480
1st t.s.	1548	69.0	12.9	1.44	0.9	1080
	<u>+536</u>					
1st u.s.	2084	69.0	17.37	1.44	2.1	2520
Foundation	2098	34.5	17.48	0.72	1.6	1920

A smaller column section could have been used above the first floor but this would have involved changes in formwork and also increased areas of reinforcement. For simplicity in this example no reduction was taken in the total live load although this is permitted with some structures, as shown by table 9.1.

*(ii) Design Equations*

The symmetrical arrangement of the reinforcement with  $A'_s = A_s$  is justifiable for



$$N \left( e + \frac{h}{2} - d_2 \right) = 0.45 f_{cu} b s (d - s/2) + f_{sc} A'_s (d - d')$$

where  $s = 0.9x$  (9.6)

This equation can be solved to give a value for  $A'_s$ .

(5)  $A_s$  is then determined from the equilibrium of the axial forces, that is

$$N = 0.45 f_{cu} b s + f_{sc} A'_s + f_s A_s$$
 (9.7)

(6) Further values of  $x$  may be selected and steps 1 to 5 repeated until a minimum value for  $A'_s + A_s$  is obtained.

The term  $f_{sc}$  in the equations may be modified to  $(f_{sc} - 0.45 f_{cu})$  to allow for the area of concrete displaced by the reinforcement  $A'_s$ . Stress  $f_s$  has a negative sign whenever it is tensile.

**Example 9.3 Column Section with an Unsymmetrical Arrangement of Reinforcement.**

The column section shown in figure 9.12 resists an axial load of 1100 kN and a moment of 230 kN m at the ultimate limit state. Determine the areas of reinforcement required if the characteristic material strengths are  $f_y = 460 \text{ N/mm}^2$  and  $f_{cu} = 30 \text{ N/mm}^2$ .

- (1) Select a depth of neutral axis,  $x = 190 \text{ mm}$ .
- (2) From the strain diagram

$$\begin{aligned} \text{steel strain } \epsilon_{sc} &= \frac{0.0035}{x} (x - d') \\ &= \frac{0.0035}{190} (190 - 80) = 0.00203 \end{aligned}$$

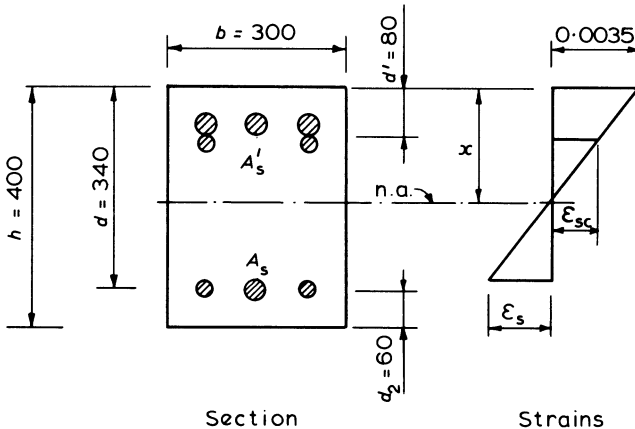

Figure 9.12 Unsymmetrical column design example

and

$$\begin{aligned} \text{steel strain } \epsilon_s &= \frac{0.0035}{x} (d - x) \\ &= \frac{0.0035}{190} (340 - 190) = 0.00276 \end{aligned}$$

- (3) From the stress-strain curve and the relevant equations of section 4.1.2  
yield strain,  $\epsilon_y = 0.002$  for grade 460 steel

Both  $\epsilon_{sc}$  and  $\epsilon_s > 0.002$

therefore  $f_{sc} = 460/1.15 = 400 \text{ N/mm}^2$

and  $f_s = 400 \text{ N/mm}^2$ , tension.

- (4) In equation 9.6

$$N \left( e + \frac{h}{2} - d_2 \right) = 0.45 f_{cu} b s (d - s/2) + f_{sc} A'_s (d - d')$$

$$e = \frac{M}{N} = \frac{230 \times 10^6}{1100 \times 10^3} = 209 \text{ mm}$$

$$\begin{aligned} s &= 0.9x = 0.9 \times 190 \\ &= 171 \text{ mm} \end{aligned}$$

To allow for the area of concrete displaced

$$f_{sc} \text{ becomes } 400 - 0.45 f_{cu} = 400 - 0.45 \times 30 = 386 \text{ N/mm}^2$$

and from equation 9.6

$$\begin{aligned} A'_s &= \frac{1100 \times 10^3 (209 + 140) - 0.45 \times 30 \times 300 \times 171 (340 - 171/2)}{386 (340 - 80)} \\ &= 2069 \text{ mm}^2 \end{aligned}$$

- (5) From equation 9.7

$$N = 0.45 f_{cu} b s + f_{sc} A'_s + f_s A_s$$

$$A_s = \frac{(0.45 \times 30 \times 300 \times 171) + (386 \times 2069) - (1100 \times 10^3)}{400}$$

$$= 978 \text{ mm}^2$$

Thus

$$A'_s + A_s = 3047 \text{ mm}^2 \text{ for } x = 190 \text{ mm}$$

- (6) Values of  $A'_s + A_s$  calculated for other depths of neutral axis,  $x$  are plotted in figure 9.13. From this figure the minimum area of reinforcement required occurs with  $x \approx 210 \text{ mm}$ . Using this depth of neutral axis, steps 2 to 5 are repeated giving

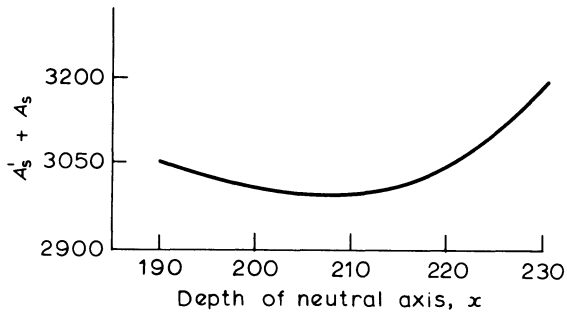

Figure 9.13 Design chart for unsymmetrical column example

$$\epsilon_{sc} = \epsilon_s = 0.00217 > 0.002$$

$$f_{sc} = f_y/\gamma_m = 400 \text{ N/mm}^2 \text{ and } f_s = 400 \text{ N/mm}^2 \text{ tension}$$

so that

$$A'_s = 1950 \text{ mm}^2 \text{ and } A_s = 1049 \text{ mm}^2$$

(Alternatively separate values of  $A'_s$  and  $A_s$  as calculated for each value of  $x$  could also have been plotted against  $x$  and their values read from the graph at  $x = 210$  mm.) This area would be provided with

$$A'_s = \text{three T25 plus two T20 bars} = 2098 \text{ mm}^2$$

and

$$A_s = \text{one T25 plus two T20 bars} = 1119 \text{ mm}^2$$

With a symmetrical arrangement of reinforcement the area from the design chart of figure 9.7 would be  $A'_s + A_s = 3200 \text{ mm}^2$  or 7 per cent greater than the area with an unsymmetrical arrangement, and including no allowance for the area of concrete displaced by the steel.

These types of iterative calculations are readily programmed for solution by a small microcomputer, which could find the optimum steel areas without the necessity of plotting a graph.

### (iii) Simplified Design Method

As an alternative to the previous rigorous method of design an approximate method may be used when the eccentricity of loading,  $e$  is not less than  $(h/2 - d_2)$ .

The moment  $M$  and the axial force  $N$  are replaced by an increased moment  $M_a$  where

$$M_a = M + N \left( \frac{h}{2} - d_2 \right) \quad (9.8)$$

plus a compressive force  $N$  acting through the tensile steel  $A_s$  as shown in figure 9.14. Hence the design of the reinforcement is carried out in two parts.

- (1) The member is designed as a doubly reinforced section to resist  $M_a$  acting by itself. The equations for calculating the areas of reinforcement to resist  $M_a$  are given in section 4.5 as

$$M_a = 0.156 f_{cu} b d^2 + 0.87 f_y A'_s (d - d') \tag{9.9}$$

$$0.87 f_y A_s = 0.201 f_{cu} b d + 0.87 f_y A'_s \tag{9.10}$$

- (2) The area of  $A_s$  calculated in the first part is reduced by the amount  $N/0.87 f_y$ .

This preliminary design method is probably most useful for non-rectangular column sections as shown in example 9.6, but the procedure is first demonstrated with a rectangular cross-section in the following example.

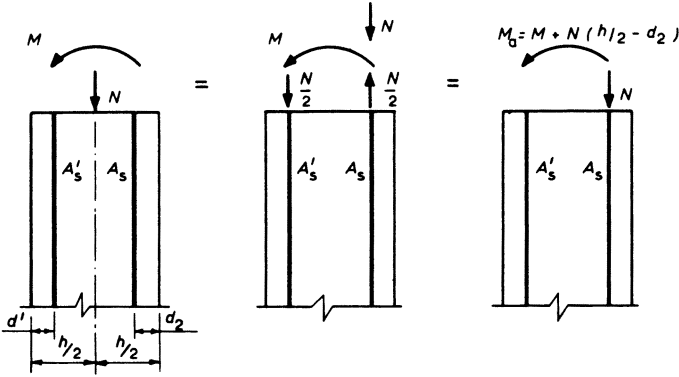

Figure 9.14 Simplified design method

**Example 9.4 Column Design by the Simplified Method**

Calculate the area of steel required in the  $300 \times 400$  column of figure 9.12.  $N = 1100$  kN,  $M = 230$  kN m,  $f_{cu} = 30$  N/mm<sup>2</sup> and  $f_y = 460$  N/mm<sup>2</sup>.

$$\text{Eccentricity } e = \frac{230 \times 10^6}{1100 \times 10^3} = 209 \text{ mm} > \left( \frac{h}{2} - d_2 \right)$$

- (1) Increased moment

$$M_a = M + N \left( \frac{h}{2} - d_2 \right)$$

$$= 230 + 1100 (200 - 60) 10^{-3} = 384 \text{ kN m}$$

The area of steel to resist this moment can be calculated using the

formulae 9.9 and 9.10 for the design of a beam with compressive reinforcement, that is

$$M_a = 0.156 f_{cu} b d^2 + 0.87 f_y A'_s (d - d')$$

and

$$0.87 f_y A_s = 0.201 f_{cu} b d + 0.87 f_y A'_s$$

therefore

$$384 \times 10^6 = 0.156 \times 30 \times 300 \times 340^2 + 0.87 \times 460 A'_s (340 - 80)$$

so that

$$A'_s = 2130 \text{ mm}^2$$

and

$$0.87 \times 460 A_s = 0.201 \times 30 \times 300 \times 340 + 0.87 \times 460 \times 2130$$

$$A_s = 3667 \text{ mm}^2$$

(2) Reducing this area by  $N/0.87 f_y$

$$\begin{aligned} A_s &= 3667 - \frac{1100 \times 10^3}{0.87 \times 460} \\ &= 919 \text{ mm}^2 \end{aligned}$$

This compares with  $A'_s = 1950 \text{ mm}^2$  and  $A_s = 1049 \text{ mm}^2$  with the design method of example 9.3. (To give a truer comparison the stress in the compressive reinforcement should have been modified to allow for the area of concrete displaced, as was done in example 9.3.)

#### 9.4.4 Biaxial Bending of Short Columns

For most columns, biaxial bending will not govern the design. The loading patterns necessary to cause biaxial bending in a building's internal and edge columns will not usually cause large moments in both directions. Corner columns may have to resist significant bending about both axes, but the axial loads are usually small and a design similar to the adjacent edge columns is generally adequate.

A design for biaxial bending based on a rigorous analysis of the cross-section and the strain and stress distributions would be according to the fundamental principles of chapter 4, otherwise a simplified method as described in BS 8110 may be used.

This method specifies that a column subjected to an ultimate load  $N$  and moments  $M_x$  and  $M_y$  about the  $xx$  and  $yy$  axes respectively may be designed for single axis bending but with an increased moment and subject to the following conditions:

$$(a) \text{ if } \frac{M_x}{h'} \geq \frac{M_y}{b'}$$

then increased single axis design moment is

$$M'_x = M_x + \beta \frac{h'}{b'} \times M_y$$

(b) if  $\frac{M_x}{h'} < \frac{M_y}{b'}$

then increased single axis design moment is

$$M'_y = M_y + \beta \frac{b'}{h'} \times M_x$$

The dimensions  $h'$  and  $b'$  are defined in figure 9.15 and the coefficient  $\beta$  is specified in table 9.4.

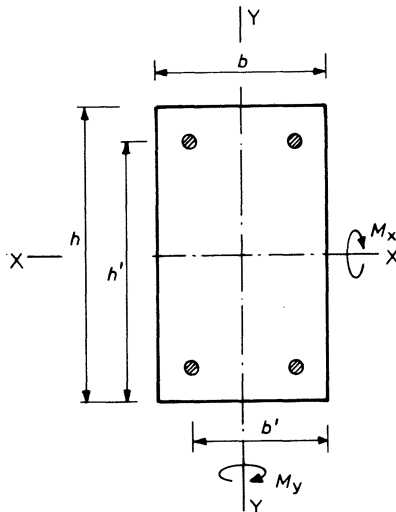

Figure 9.15 Section with biaxial bending

Table 9.4 Values of coefficient  $\beta$  for biaxial bending

$\frac{N}{bhf_{cu}}$	0	0.1	0.2	0.3	0.4	0.5	$\geq 0.6$
$\beta$	1.00	0.88	0.77	0.65	0.53	0.42	0.30

**Example 9.5 Design of a Column for Biaxial Bending**

The column section shown in figure 9.16 is to be designed to resist an ultimate axial load of 1200 kN plus moments of  $M_{xx} = 75$  kN m and  $M_{yy} = 80$  kN m. The characteristic material strengths are  $f_{cu} = 30$  N/mm<sup>2</sup> and  $f_y = 460$  N/mm<sup>2</sup>.

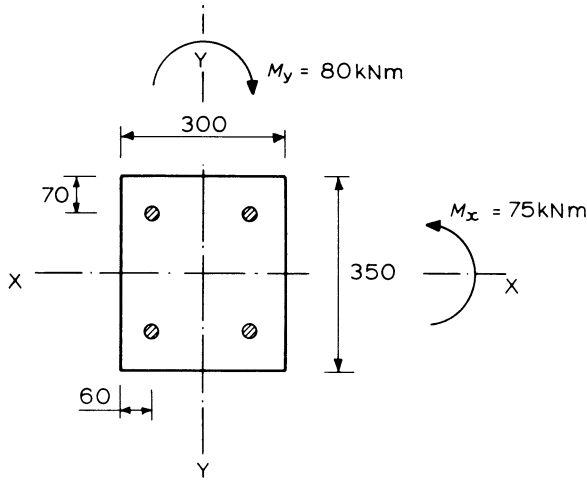

Figure 9.16 Biaxial bending example

$$\frac{M_x}{h'} = \frac{75}{(350 - 70)} = 0.268$$

$$\frac{M_y}{b'} = \frac{80}{(300 - 60)} = 0.333$$

$$M_x/h' < M_y/b'$$

therefore increased single axis design moment is

$$M'_y = M_y + \beta \frac{b'}{h'} \times M_x$$

$$N/bhf_{cu} = 1200 \times 10^3 / (300 \times 350 \times 30) = 0.38$$

From table 9.4,  $\beta = 0.55$

$$M'_y = 80 + 0.55 \times \frac{240}{280} \times 75 = 115.4 \text{ kN m}$$

$$'N/bh' = 1200 \times 10^3 / (350 \times 300) = 11.4$$

$$'M/bh^2' = 115.4 \times 10^6 / (350 \times 300^2) = 3.66$$

From the design chart of figure 9.7

$$100A_{sc}/bh = 2.6$$

Therefore required  $A_{sc} = 2730 \text{ mm}^2$ .

Provide four T32 bars.

### 9.5 Non-rectangular Sections

Design charts are not usually available for columns of other than a rectangular or a circular cross-section. Therefore the design of a non-rectangular section entails either (1) an iterative solution of design equations, (2) a simplified form of design, or (3) construction of  $M-N$  interaction diagrams.

#### (i) Design Equations

For a non-rectangular section it is much simpler to consider the equivalent rectangular stress-block. Determination of the reinforcement areas follows the same procedure as described for a rectangular column in section 9.4.3(ii), namely

- (1) Select a depth of neutral axis.
- (2) Determine the corresponding steel strains.
- (3) Determine the steel stresses.
- (4) Take moments about  $A_s$  so that with reference to figure 9.17.

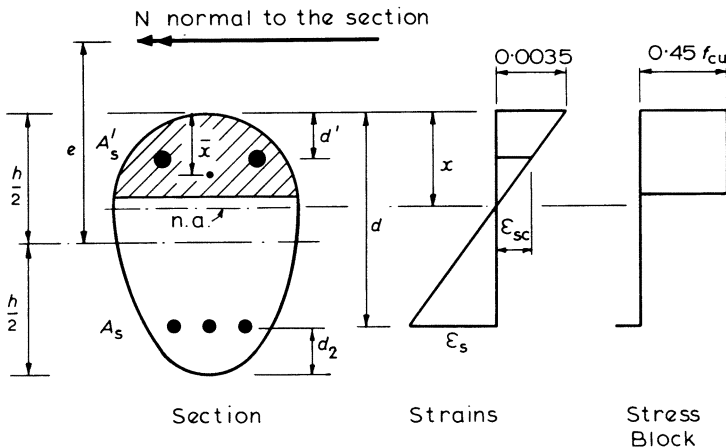

Figure 9.17 Non-rectangular column section

$$N \left( e + \frac{h}{2} - d_2 \right) = 0.45 f_{cu} A_{cc} (d - \bar{x}) + f_{sc} A'_s (d - d')$$

Solve this equation to give  $A'_s$

- (5) For no resultant force on the section

$$N = 0.45 f_{cu} A_{cc} + f_{sc} A'_s + f_s A_s$$

Solve this equation to give  $A_s$ .

- (6) Repeat the previous steps for different values of  $x$  to find a minimum ( $A'_s + A_s$ ).

In steps 4 and 5

$A_{cc}$  is the area of concrete in compression shown shaded

$\bar{x}$  is the distance from the centroid of  $A_{cc}$  to the extreme fibre in compression

$f_s$  the stress in reinforcement  $A_s$  is negative if tensile

The calculation for a particular cross-section would be very similar to that described in example 9.3 except when using the design equations it would be necessary to determine  $A_{cc}$  and  $\bar{x}$  for each position of the neutral axis.

### (ii) Simplified Preliminary Design Method

The procedure is similar to that described for a column with a rectangular section as described in section 9.4.3(iii) and figure 9.14.

The column is designed to resist a moment  $M_a$  only, where

$$M_a = M + N \left( \frac{h}{2} - d_2 \right) \quad (9.11)$$

The steel area required to resist this moment can be calculated from

$$M_a = 0.45 f_{cu} A_{cc} (d - \bar{x}) + 0.87 f_y A'_s (d - d') \quad (9.12)$$

and

$$0.87 f_y A_s = 0.45 f_{cu} A_{cc} + 0.87 f_y A'_s \quad (9.13)$$

where  $A_{cc}$  is the area of concrete in compression with  $x = d/2$ , and  $\bar{x}$  is the distance from the centroid of  $A_{cc}$  to the extreme fibre in compression.

The area of tension reinforcement,  $A_s$  as given by equation 9.13 is then reduced by an amount equal to  $N/0.87 f_y$ .

This method should not be used if the eccentricity,  $e$  is less than  $(h/2 - d_2)$ .

### (iii) M-N Interaction Diagram

These diagrams can be constructed using the method described in section 4.8 with examples 4.9 and 4.10. They are particularly useful for a column in a multi-storey building where the moments and associated axial forces change at each storey.

The diagrams can be constructed after carrying out the approximate design procedure in (ii) to obtain suitable arrangements of reinforcing bars.

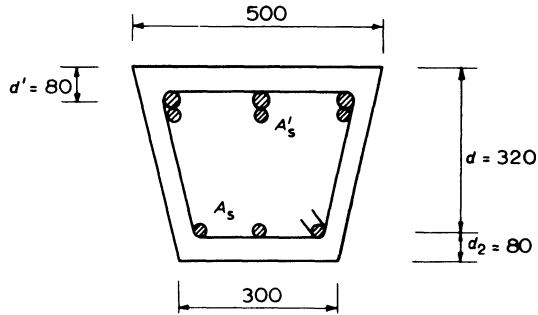

Figure 9.18

**Example 9.6 Design of a Non-rectangular Column Section**

Design the reinforcement for the non-rectangular section shown in figure 9.18 given  $M = 320 \text{ kN m}$ ,  $N = 1200 \text{ kN}$  at the ultimate limit state and the characteristic material strengths are  $f_{cu} = 30 \text{ N/mm}^2$  and  $f_y = 460 \text{ N/mm}^2$ .

$$e = \frac{M}{N} = \frac{320 \times 10^6}{1200 \times 10^3} = 267 \text{ mm} > \left( \frac{h}{2} - d_2 \right)$$

$$\begin{aligned} \text{Increased moment } M_a &= M + N \left( \frac{h}{2} - d_2 \right) \\ &= 320 + 1200(200 - 80) 10^{-3} \\ &= 464 \text{ kN m} \end{aligned}$$

With  $x = d/2 = 160 \text{ mm}$ ,  $s = 0.9x = 144 \text{ mm}$  and the width ( $b_1$ ) of the section at the limit of the stress block

$$\begin{aligned} b_1 &= 300 + \frac{200(400 - 144)}{400} = 428 \text{ mm} \\ A_{cc} &= \frac{x(b + b_1)}{2} \\ &= \frac{144(500 + 428)}{2} = 66816 \text{ mm}^2 \end{aligned}$$

The depth of the centroid of the trapezium is given by

$$\begin{aligned} \bar{x} &= \frac{s(b + 2b_1)}{3(b + b_1)} \\ &= 144 \frac{(500 + 2 \times 428)}{3(500 + 428)} = 70.1 \text{ mm} \end{aligned}$$

Therefore substituting in equation 9.12

$$464 \times 10^6 = 0.45 \times 30 \times 66\,816 (320 - 70.1) + 0.87 \times 460 A'_s (320 - 80)$$

hence

$$A'_s = 2484 \text{ mm}^2$$

Provide three T32 plus two T16 bars, area = 2812 mm<sup>2</sup>.

From equation 9.13

$$0.87 f_y A_s = 0.45 \times 30 \times 66\,816 + 0.87 \times 460 \times 2484$$

therefore

$$A_s = 4738 \text{ mm}^2$$

Reducing  $A_s$  by  $N/0.87 f_y$  gives

$$\begin{aligned} A_s &= 4738 - \frac{1200 \times 10^3}{0.87 \times 460} \\ &= 1740 \text{ mm}^2 \end{aligned}$$

Provide one T16 plus two T32 bars, area = 1811 mm<sup>2</sup>

The total area of reinforcement provided = 4623 mm<sup>2</sup> which is less than the 6 per cent allowed.

An  $M-N$  interaction diagram could now be constructed for this steel arrangement, as in section 4.8, to provide a more rigorous design.

### 9.6 Design of Slender Columns

As specified in section 9.2, a column is classified as slender if the slenderness ratio about either axis is

$$> 15 \text{ for a braced column}$$

or  $> 10$  for an unbraced column

There is a general restriction on the maximum slenderness of

$$l_0 \geq 60b'$$

and for an unbraced column

$$l_0 \geq 100 \frac{b'^2}{h'}$$

where  $l_0$  is the clear distance between end restraints and

$b'$  and  $h'$  are respectively the smaller and larger dimensions of the column section

A slender column must be designed for an additional moment caused by its curvature at ultimate conditions. The expressions given in BS 8110 for the addi-

tional moments were derived by studying the moments' curvature behaviour for a member subject to bending plus axial load. The equations for calculating the design moments are only applicable to columns of a rectangular or circular section and with symmetrical reinforcement.

A slender column should be designed for an ultimate axial load ( $N$ ) plus an increased moment given by

$$\begin{aligned} M_t &= M_i + M_{\text{add}} \\ &= M_i + N a_u \end{aligned} \tag{9.14}$$

where  $M_i$  is the initial moment in the column

$M_{\text{add}}$  is the moment caused by the deflection of the column

$a_u$  is the deflection of the column.

The deflection of a rectangular or circular column is given by

$$a_u = \beta_a K h \tag{9.15}$$

The coefficient  $\beta_a$  is calculated from the equation

$$\beta_a = \frac{1}{2000} \left( \frac{l_e}{b'} \right)^2 \tag{9.16}$$

with  $b'$  being generally the smaller dimension of the column section except when biaxial bending is considered.

In equation 9.15 the coefficient  $K$  is a reduction factor to allow for the fact that the deflection must be less when there is a large proportion of the column section in compression. The value for  $K$  is given by the equation

$$K = \frac{N_{\text{uz}} - N}{N_{\text{uz}} - N_{\text{bal}}} \leq 1.0 \tag{9.17}$$

where  $N_{\text{uz}}$  is the ultimate axial load such that

$$N_{\text{uz}} = 0.45 f_{\text{cu}} A_c + 0.87 f_y A_{\text{sc}}$$

and  $N_{\text{bal}}$  is the axial load at balanced failure defined in section 4.8 and may be taken as

$$N_{\text{bal}} = 0.25 f_{\text{cu}} A_c$$

In order to calculate  $K$ , the area  $A_{\text{sc}}$  of the columns reinforcement must be known and hence a trial and error approach is necessary, taking an initial conservative value of  $K = 1.0$ . Values of  $K$  are also marked on the column design charts as shown in figure 9.7.

### 9.6.1 Braced Slender Column

Typical bending moment diagrams for a braced column are shown in figure 9.19. The maximum additional moment  $M_{\text{add}}$  occurs near the mid-height of the column and at this location the initial moment is taken as

$$M_i = 0.4 M_1 + 0.6 M_2 \geq 0.4 M_2 \tag{9.18}$$

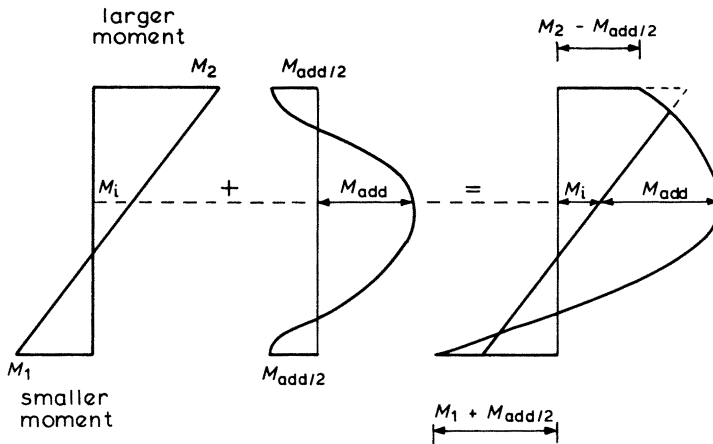

Figure 9.19 Braced slender column design moments

where  $M_1$  is the smaller initial end moment due to the design ultimate loads and  $M_2$  is the corresponding larger initial end moment.

For the usual case with double curvature of a braced column,  $M_1$  should be taken as negative and  $M_2$  as positive. From figure 9.19, the final design moment should never be taken as less than

$$\begin{aligned} &M_2 \\ &M_1 + M_{\text{add}} \\ &M_1 + M_{\text{add}}/2 \end{aligned}$$

or  $N \times e_{\text{min}}$  with  $e_{\text{min}} \geq h/20$  or 20 mm

Equations 9.14 to 9.18 can be used to calculate the additional moment and combined with the appropriate initial moment to design a slender column with single axis bending about either axis, provided that the ratio of the lengths of the sides is always less than 3 and the slenderness ratio  $l_e/h$  for a column bent about its major axis does not exceed 20. Where these conditions do not apply and the column is bent about its major axis, the effect of biaxial bending should be considered with zero initial moment about the minor axis and additional moments about both axes.

### Example 9.7 Design of a Slender Column

A braced column of  $300 \times 450$  cross-section resists at the ultimate limit state an axial load of 1700 kN and end moments of 70 kN m and 10 kN m causing double curvature about the minor axis XX as shown in figure 9.20. The column's effective heights are  $l_{\text{ex}} = 6.75$  m and  $l_{\text{ey}} = 8.0$  m and the characteristic material strengths  $f_{\text{cu}} = 30$  N/mm<sup>2</sup> and  $f_y = 460$  N/mm<sup>2</sup>.

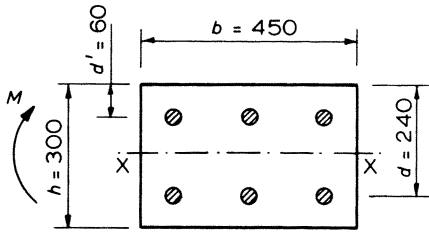

(a) Section

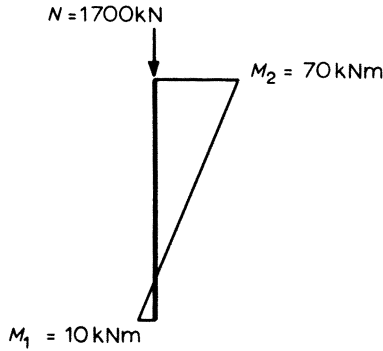

(b) Axial load and initial moments

**Figure 9.20** Slender column example

Slenderness ratios are

$$l_{ex}/h = 6.75/0.3 = 22.5 > 15$$

$$l_{ey}/b = 8.0/0.45 = 17.8 > 15$$

Therefore the column is slender.

As the column is bent in double curvature

$$M_1 = -10 \text{ kN m}$$

and

$$M_i = 0.4 M_1 + 0.6 M_2$$

$$= 0.4 \times -10 + 0.6 \times 70 = 38 \text{ kN m}$$

and  $M_i$  is therefore greater than  $0.4 M_2$ .

The additional moment induced by deflection of the column is

$$\begin{aligned}
 M_{\text{add}} &= \frac{Nh}{2000} \left( \frac{l_e}{b'} \right)^2 K \\
 &= \frac{1700 \times 300}{2000} \left( \frac{6750}{300} \right)^2 \times 1.0 \times 10^3 \\
 &= 129 \text{ kN m}
 \end{aligned}$$

with  $K = 1.0$  for the initial value.

For the first iteration the total moment is

$$\begin{aligned}
 M_t &= M_i + M_{\text{add}} \\
 &= 38 + 129 = 167 \text{ kN m} \\
 N/bh &= \frac{1700 \times 10^3}{450 \times 300} = 12.6 \\
 M/bh^2 &= \frac{167 \times 10^6}{450 \times 300^2} = 4.12
 \end{aligned}$$

From the design chart of figure 9.7

$$100A_{\text{sc}}/bh = 3.2$$

and

$$K = 0.65$$

This new value for  $K$  is used to recalculate  $M_{\text{add}}$  and hence  $M_t$  for the second iteration. The design chart is again used to determine  $100A_{\text{sc}}/bh$  and a new  $K$  is shown in table 9.5. The iterations are continued until the value of  $K$  in columns (1) and (5) of the table are in reasonable agreement, which in this design occurs after two iterations. So that the steel area required is

$$\begin{aligned}
 A_{\text{sc}} &= 2.2 bh/100 \\
 &= 2.2 \times 450 \times 300/100 = 2970 \text{ mm}^2
 \end{aligned}$$

As a check on the final value of  $K$  interpolated from the design chart:

$$\begin{aligned}
 N_{\text{bal}} &= 0.25 f_{\text{cu}} bd \\
 &= 0.25 \times 30 \times 450 \times 240 \times 10^{-3} \\
 &= 810 \text{ kN} \\
 N_{\text{uz}} &= 0.45 f_{\text{cu}} bh + 0.87 f_y A_{\text{sc}} \\
 &= (0.45 \times 30 \times 450 \times 300 + 0.87 \times 460 \times 2970) 10^{-3} \\
 &= 3011 \text{ kN} \\
 K &= \frac{N_{\text{uz}} - N}{N_{\text{uz}} - N_{\text{bal}}} \\
 &= \frac{3011 - 1700}{3011 - 810} \\
 &= 0.6
 \end{aligned}$$

which agrees with the final value in column 5 of the table.

**Table 9.5**

(1) $K$	(2) $M_t$	(3) $M/bh^2$	(4) $100A_{sc}/bh$	(5) $K$
1.0	167	4.12	3.2	0.65
0.65	122	3.0	2.2	0.6

**9.6.2 Unbraced Slender Columns**

The sway of an unbraced structure causes larger additional moments in the columns. Figure 9.21 shows how these additional moments are added to the initial moments at the ends of the columns. The additional moment calculated from equations 9.14 to 9.17 is added to the initial moment in the column at the end with the stiffer joint. At the other end of the column the additional moment may be reduced in proportion to the ratio of the stiffnesses of the two joints.

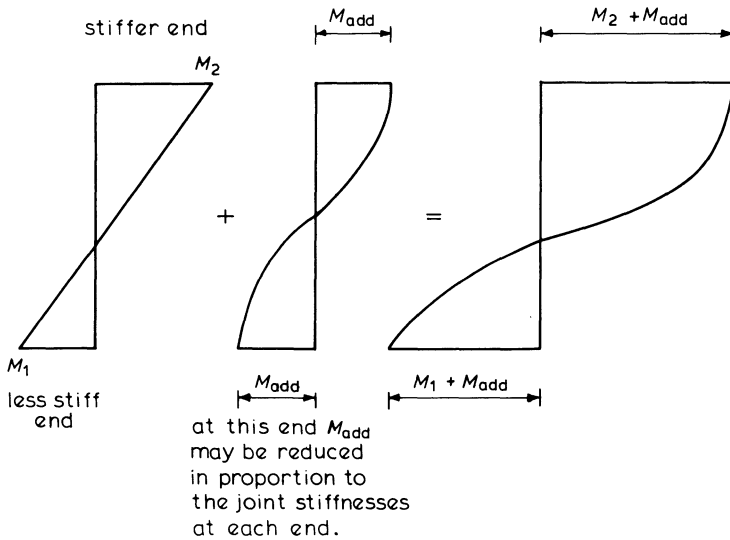

**Figure 9.21** Unbraced slender column design moments

# 10

## Foundations

A building is generally composed of a superstructure above the ground and a substructure which forms the foundations below ground. The foundations transfer and spread the loads from a structure's columns and walls into the ground. The safe bearing capacity of the soil must not be exceeded otherwise excessive settlement may occur, resulting in damage to the building and its service facilities, such as the water or gas mains. Foundation failure can also affect the overall stability of a structure so that it is liable to slide, to lift vertically or even overturn.

The earth under the foundations is the most variable of all the materials that are considered in the design and construction of an engineering structure. Under one small building the soil may vary from a soft clay to a dense rock. Also the nature and properties of the soil will change with the seasons and the weather. For example Keuper Marl, a relatively common soil, is hard like a rock when dry but when wet it can change into an almost liquid state.

It is important to have an engineering survey made of the soil under a proposed structure so that variations in the strata and the soil properties can be determined. Drill holes or trial pits should be sunk, *in situ* tests such as the penetration test performed and samples of the soil taken to be tested in the laboratory. From the information gained it is possible to recommend safe earth bearing pressures and, if necessary, calculate possible settlements of the structure. Representative values of the safe bearing pressures for typical soils are listed in table 10.1.

In the design of foundations, the areas of the bases in contact with the ground should be such that the safe bearing pressures will not be exceeded. Settlement takes place during the working life of the structure, therefore the design loading to be considered when calculating the base areas should be those that apply to the serviceability limit state, and typical values that can be taken are

- |                                      |                              |
|--------------------------------------|------------------------------|
| (1) dead plus imposed load           | $= 1.0G_k + 1.0Q_k$          |
| (2) dead plus wind load              | $= 1.0G_k + 1.0W_k$          |
| (3) dead plus imposed plus wind load | $= 1.0G_k + 0.8Q_k + 0.8W_k$ |

These partial factors of safety are suggested as it is highly unlikely that the maximum imposed load and the worst wind load will occur simultaneously.

**Table 10.1** Typical allowable bearing values

Rock or soil	Typical bearing value (kN/m <sup>2</sup> )
Massive igneous bedrock	10 000
Sandstone	2000 to 4000
Shales and mudstone	600 to 2000
Gravel, sand and gravel, compact	600
Medium dense sand	100 to 300
Loose fine sand	less than 100
Hard clay	300 to 600
Medium clay	100 to 300
Soft clay	less than 75

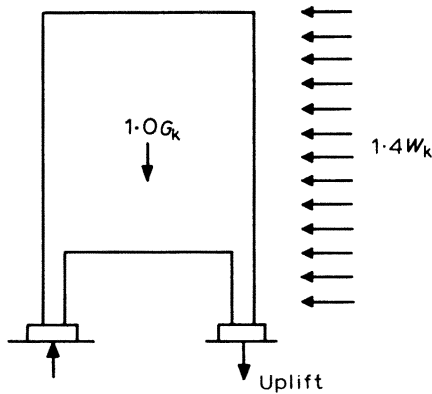

**Figure 10.1** Uplift on footing

Where the foundations are subject to a vertical and a horizontal load the following rule can be applied.

$$\frac{V}{P_v} + \frac{H}{P_h} < 1.0$$

- where  $V$  = the vertical load
- $H$  = the horizontal load
- $P_v$  = the allowable vertical load
- $P_h$  = the allowable horizontal load

The allowable horizontal load would take account of the passive resistance of the ground in contact with the vertical face of the foundation plus the friction and cohesion along the base.

The calculations to determine the structural strength of the foundations, that is the thickness of the bases and the areas of reinforcement, should be based on the loadings and the resultant ground pressures corresponding to the ultimate limit state.

With some structures, such as the type shown in figure 10.1, it may be necessary to check the possibility of uplift on the foundations and the stability of the structure when it is subjected to lateral loads. To ensure adequate safety, the stability calculations should also be for the loading arrangements associated with the ultimate limit state. The critical loading arrangement is usually the combination of maximum lateral load with minimum dead load and no live load, that is  $1.4W_k + 1.0G_k$ . Minimum dead load can sometimes occur during erection when many of the interior finishes and fixtures may not have been installed.

For most designs a linear distribution of soil pressure across the base of the footing is assumed as shown in figure 10.2a. This assumption must be based on the soil acting as an elastic material and the footing having infinite rigidity. In fact, not only do most soils exhibit some plastic behaviour and all footings have a finite stiffness, but also the distribution of soil pressure varies with time. The actual distribution of bearing pressure at any moment may take the form shown in figure 10.2b or c, depending on the type of soil and the stiffness of the base and the structure. But as the behaviour of foundations involves many uncertainties regarding the action of the ground and the loading, it is usually unrealistic to consider an analysis which is too sophisticated.

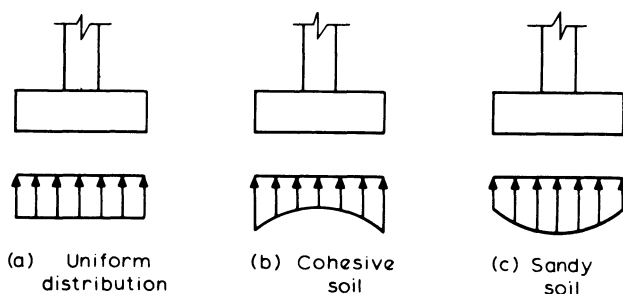

Figure 10.2 Pressure distributions under footings

Foundations should be constructed so that the underside of the bases are below frost level. As the concrete is subjected to more severe exposure conditions a larger nominal cover to the reinforcement is required. It is recommended that the minimum cover should be not less than 75 mm when the concrete is cast against the ground, or less than 50 mm when the concrete is cast against a layer of blinding concrete. A concrete grade of at least  $f_{cu} = 35 \text{ N/mm}^2$  is required to meet the serviceability requirements of BS 8110; see table 6.1.

10.1 Pad Footings

The footing for a single column may be made square in plan, but where there is a large moment acting about one axis it may be more economical to have a rectangular base.

Assuming there is a linear distribution the bearing pressures across the base will take one of the three forms shown in figure 10.3, according to the relative magnitudes of the axial load  $N$  and the moment  $M$  acting on the base.

- (1) In figure 10.3a there is no moment and the pressure is uniform

$$p = \frac{N}{BD} \tag{10.1}^*$$

- (2) With a moment  $M$  acting as shown, the pressures are given by the equation for axial load plus bending. This is provided there is positive contact between the

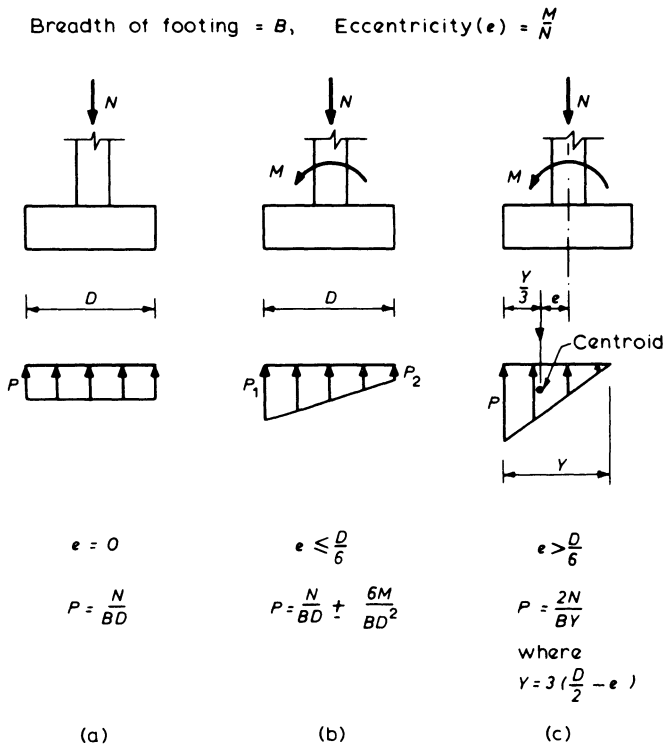

Figure 10.3 Pad footing – pressure distributions

base and the ground along the complete length  $D$  of the footing, as in figure 10.3b so that

$$p = \frac{N}{BD} \pm \frac{My}{I}$$

where  $I$  is the second moment of area of the base about the axis of bending and  $y$  is the distance from the axis to where the pressure is being calculated. Substituting for  $I = BD^3/12$  and  $y = D/2$ , the maximum pressure is

$$p_1 = \frac{N}{BD} + \frac{6M}{BD^2} \quad (10.2)^*$$

and the minimum pressure is

$$p_2 = \frac{N}{BD} - \frac{6M}{BD^2} \quad (10.3)^*$$

There is positive contact along the base if  $p_2$  from equation 10.3 is positive. When pressure  $p_2$  just equals zero

$$\frac{N}{BD} - \frac{6M}{BD^2} = 0$$

or

$$\frac{M}{N} = \frac{D}{6}$$

So that for  $p_2$  to always be positive,  $M/N$  – or the effective eccentricity,  $e$  – must never be greater than  $D/6$ . In these cases the eccentricity of loading is said to lie within the ‘middle third’ of the base.

- (3) When the eccentricity,  $e$  is greater than  $D/6$  there is no longer a positive pressure along the length  $D$  and the pressure diagram is triangular as shown in figure 10.3c. Balancing the downward load and the upward pressures.

$$\frac{1}{2} pBY = N$$

therefore

$$\text{maximum pressure } p = \frac{2N}{BY}$$

where  $Y$  is the length of positive contact. The centroid of the pressure diagram must coincide with the eccentricity of loading in order for the load and reaction to be equal and opposite. Thus

$$\frac{Y}{3} = \frac{D}{2} - e$$

or

$$Y = 3 \left( \frac{D}{2} - e \right)$$

therefore in this case of  $e > D/6$

$$\text{maximum pressure } p = \frac{2N}{3B(D/2 - e)} \quad (10.4)^*$$

A typical arrangement of the reinforcement in a pad footing is shown in figure 10.4. With a square base the reinforcement to resist bending should be distributed uniformly across the full width of the footing. For a rectangular base the reinforcement in the short direction should be distributed with a closer spacing in the region under and near the column, to allow for the fact that the transverse moments must be greater nearer the column. If the footing should be subjected to a large overturning moment so that there is only partial bearing, or if there is a resultant uplift force, then reinforcement may also be required in the top face.

Dowels or starter bars should extend from the footing into the column in order to provide continuity to the reinforcement. These dowels should be embedded into the footing and extend into the columns a full lap length. Sometimes a 75 mm length of the column is constructed in the same concrete pour as the footing so as to form a 'kicker' or support for the column shutters. In these cases the dowel lap length should be measured from the top of the kicker.

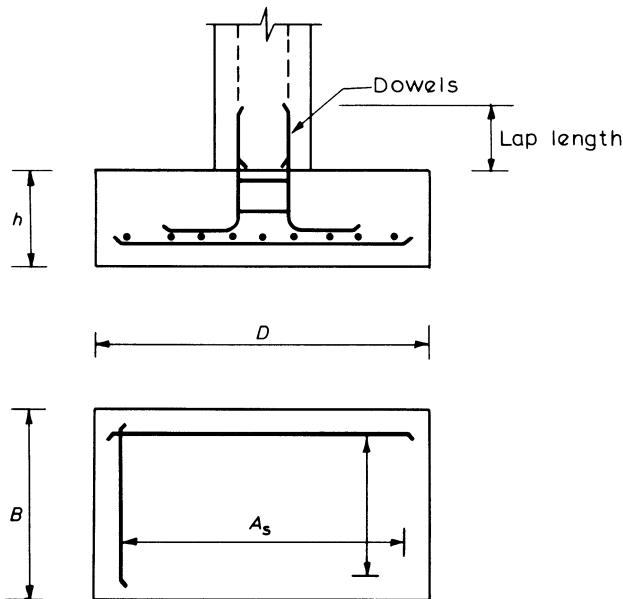

Figure 10.4 Pad footing reinforcement details

The critical sections through the base for checking shear, punching shear, bending and local bond are shown in figure 10.5. The shearing force and bending moments are caused by the ultimate loads from the column and the weight of the base should not be included in these calculations.

The thickness of the base is often governed by the requirements for shear resistance.

The principal steps in the design calculations are as follows.

- (1) Calculate the plan size of the footing using the permissible bearing pressure and the critical loading arrangement for the serviceability limit state.
- (2) Calculate the bearing pressures associated with the critical loading arrangement at the ultimate limit state.
- (3) Assume a suitable value for the thickness ( $h$ ) and effective depth ( $d$ ). Check that the shear stress at the column face is less than  $5 \text{ N/mm}^2$  or  $0.8 \sqrt{f_{cu}}$ , whichever is the smaller.
- (4) Check the thickness for punching shear, assuming a probable value for the ultimate shear stress,  $v_c$ , from table 5.1.
- (5) Determine the reinforcement required to resist bending.
- (6) Make a final check of the punching shear, having established  $v_c$  precisely.
- (7) Check the shear stress at the critical sections.
- (8) Where applicable, foundations and structure should be checked for overall stability at the ultimate limit state.

Reinforcement to resist bending in the bottom of the base should extend at least a full tension anchorage length beyond the critical section for bending.

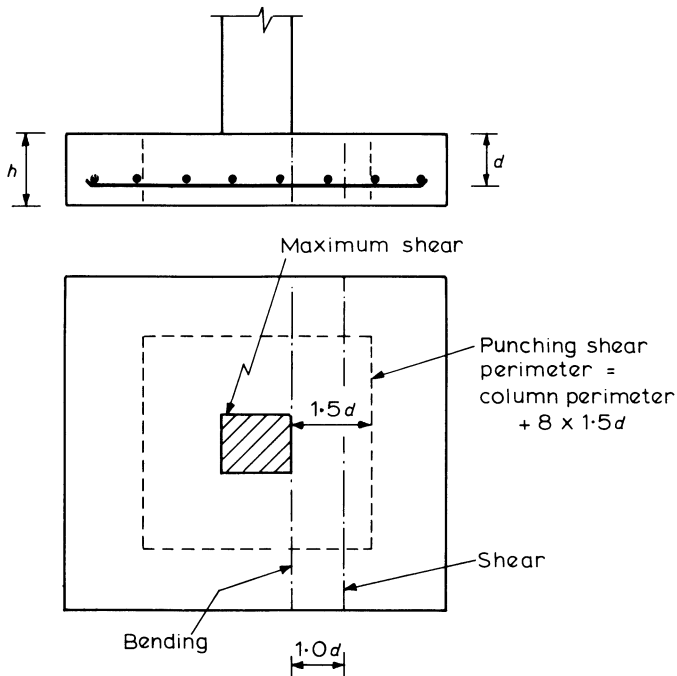

Figure 10.5 Critical sections for design

**Example 10.1 Design of a Pad Footing**

The footing is required to resist characteristic axial loads of 1000 kN dead and 350 kN imposed from a 400 mm square column. The safe bearing pressure on the soil is 200 kN/m<sup>2</sup> and the characteristic material strengths are  $f_{cu} = 35 \text{ N/mm}^2$  and  $f_y = 460 \text{ N/mm}^2$ .

Assume a footing weight of 150 kN so that the total dead load is 1150 kN.

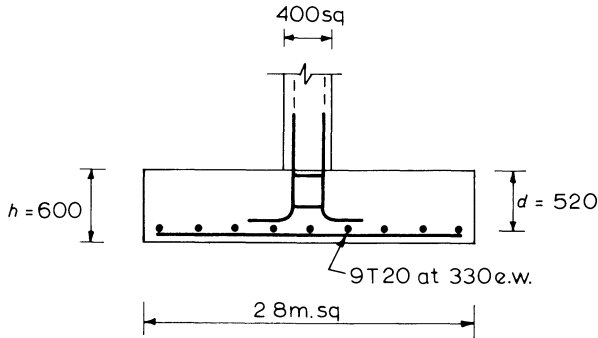

Figure 10.6 Pad footing example

(a) For the Serviceability Limit State

$$\begin{aligned} \text{Total design axial load} &= 1.0G_k + 1.0Q_k \\ &= 1150 + 350 = 1500 \text{ kN} \end{aligned}$$

$$\text{required base area} = \frac{1500}{200} = 7.5 \text{ m}^2$$

Provide a base 2.8 m square, area = 7.8 m<sup>2</sup>.

(b) For the Ultimate Limit State

$$\begin{aligned} \text{Column design axial load} &= 1.4G_k + 1.6Q_k \\ &= 1.4 \times 1000 + 1.6 \times 350 = 1960 \text{ kN} \end{aligned}$$

$$\text{earth pressure} = \frac{1960}{2.8^2} = 250 \text{ kN/m}^2$$

(c) Assume a 600 mm thick footing and with the footing constructed on a blinding layer of concrete the minimum cover is taken as 50 mm. Therefore take mean effective depth  $d = 520$  mm.

At the column face

$$\begin{aligned}\text{shear stress, } \nu_c &= N/(\text{column perimeter} \times d) \\ &= 1960 \times 10^3 / (1600 \times 520) \\ &= 2.36 \text{ N/mm}^2 < 0.8 \sqrt{f_{cu}}\end{aligned}$$

(d) Punching Shear – see figure 10.5

$$\begin{aligned}\text{critical perimeter} &= \text{column perimeter} + 8 \times 1.5d \\ &= 4 \times 400 + 12 \times 520 = 7840 \text{ mm} \\ \text{area within perimeter} &= (400 + 3d)^2 \\ &= (400 + 1560)^2 \\ &= 3.84 \times 10^6 \text{ mm}^2\end{aligned}$$

therefore

$$\begin{aligned}\text{punching shear force } V &= 250 (2.8^2 - 3.84) \\ &= 1000 \text{ kN}\end{aligned}$$

$$\begin{aligned}\text{punching shear stress } \nu &= \frac{V}{\text{Perimeter} \times d} \\ &= \frac{1000 \times 10^3}{7840 \times 520} = 0.25 \text{ N/mm}^2\end{aligned}$$

From table 5.1 this ultimate shear stress is not excessive, therefore  $h = 600$  mm will be suitable.

(e) Bending Reinforcement – see figure 10.7a

At the column face which is the critical section

$$\begin{aligned}M &= (250 \times 2.8 \times 1.2) \times \frac{1.2}{2} \\ &= 504 \text{ kN m}\end{aligned}$$

for the concrete

$$\begin{aligned}M_u &= 0.156 f_{cu} b d^2 \\ &= 0.156 \times 35 \times 2800 \times 520^2 \times 10^{-6} \\ &= 4133 \text{ kN m} > 504\end{aligned}$$

$$A_s = \frac{M}{0.87 f_y z}$$

From the lever-arm curve, figure 7.5,  $l_a = 0.95$ . Therefore

$$A_s = \frac{504 \times 10^6}{0.87 \times 460 (0.95 \times 520)}$$

$$= 2550 \text{ mm}^2$$

Provide nine T20 bars at 330 mm centres,  $A_s = 2830 \text{ mm}^2$ . Therefore

$$\frac{100A_s}{bh} = \frac{100 \times 2830}{2800 \times 600} = 0.17 > 0.13 \text{ as required}$$

Maximum spacing = 750 mm. Therefore the reinforcement provided meets the requirements specified by the code for minimum area and maximum bar spacing in a slab.

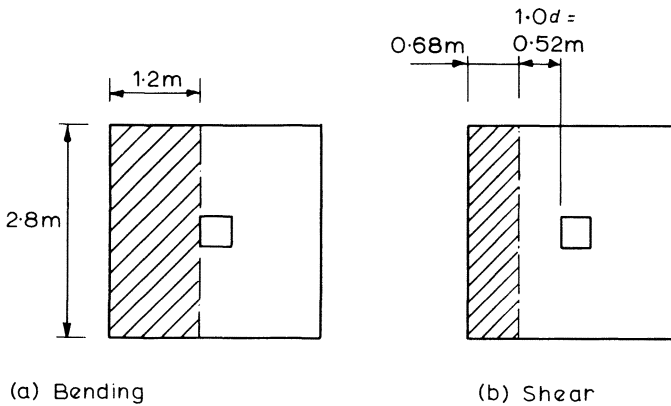

Figure 10.7 Critical sections

(f) Final Check of Punching Shear

From table 5.1, for  $f_{cu} = 35$  and  $100A_s/bd = 0.19$

$$\text{ultimate shear stress, } v_c = 0.4 \text{ N/mm}^2$$

punching shear stress was  $0.25 \text{ N/mm}^2$ , therefore a 600 mm thick pad is adequate.

(g) Shear Stress – see figure 10.7b

At the critical section for shear,  $1.0d$  from the column face

$$V = 250 \times 2.8 \times 0.68$$

$$= 476 \text{ kN}$$

$$v = \frac{V}{bd} = \frac{476 \times 10^3}{2800 \times 520}$$

$$= 0.33 \text{ N/mm}^2 < 0.4$$

Therefore the section is adequate in shear.

### 10.2 Combined Footings

Where two columns are close together it is sometimes necessary or convenient to combine their footings to form a continuous base. The dimensions of the footing should be chosen so that the resultant load passes through the centroid of the base area. This may be assumed to give a uniform bearing pressure under the footing and help to prevent differential settlement. For most structures the ratios of dead and imposed loads carried by each column are similar so that if the resultant passes through the centroid for the serviceability limit state then this will also be true – or very nearly – at the ultimate limit state, and hence in these cases a uniform pressure distribution may be considered for both limit states.

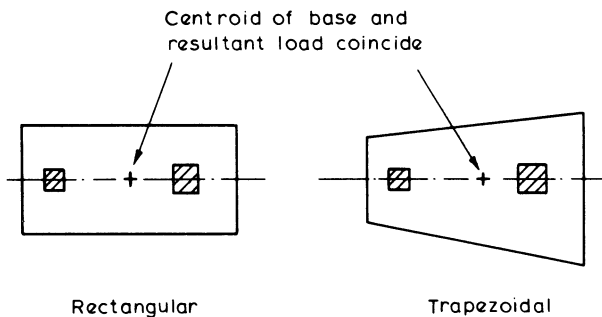

Figure 10.8 Combined bases

The shape of the footing may be rectangular or trapezoidal as shown in figure 10.8. The trapezoidal base has the disadvantage of detailing and cutting varying lengths of reinforcing bars; it is used where there is a large variation in the loads carried by the two columns and there are limitations on the length of the footing. Sometimes in order to strengthen the base and economise on concrete a beam is incorporated between the two columns so that the base is designed as an inverted T-section.

The proportions of the footing depend on many factors. If it is too long, there will be large longitudinal moments on the lengths projecting beyond the columns, whereas a short base will have a larger span moment between the columns and the greater width will cause large transverse moments. The thickness of the footing must be such that the shear stresses are not excessive.

#### Example 10.2 Design of a Combined Footing

The footing supports two columns 300 mm square and 400 mm square with characteristic dead and imposed loads as shown in figure 10.9. The safe bearing pressure is  $300 \text{ kN/m}^2$  and the characteristic material strengths are  $f_{cu} = 35 \text{ N/mm}^2$  and  $f_y = 460 \text{ N/mm}^2$

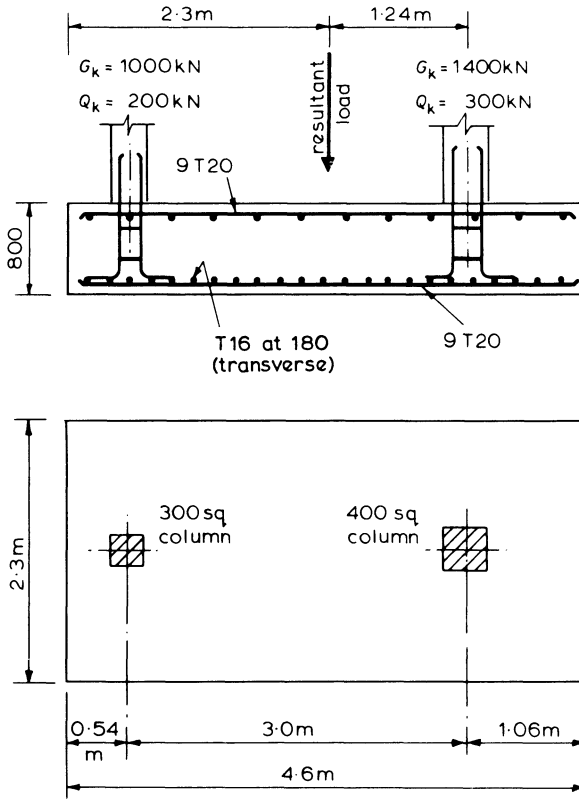

Figure 10.9 Combined footing example

- (1) Base area: allow, say, 250 kN for the self-weight of the footing. At the serviceability limit state

$$\text{total load} = 250 + 1000 + 200 + 1400 + 300 = 3150 \text{ kN}$$

$$\text{area of base required} = \frac{3150}{300} = 10.5 \text{ m}^2$$

provide a rectangular base, 4.6 m × 2.3 m, area = 10.58 m<sup>2</sup>.

- (2) Resultant of column loads and centroid of base: taking moments about the centre line of the 400 mm square column

$$\bar{x} = \frac{1200 \times 3}{1200 + 1700} = 1.24 \text{ m}$$

The base is centred on this position of the resultant of the column loads as shown in figure 10.9.

- (3) Bearing pressure at the ultimate limit state: at the ultimate limit state

$$\begin{aligned} \text{column loads} &= 1.4 \times 1000 + 1.6 \times 200 + 1.4 \times 1400 + 1.6 \times 300 \\ &= 1720 + 2440 = 4160 \text{ kN} \end{aligned}$$

therefore

$$\text{earth pressure} = \frac{4160}{4.6 \times 2.3} = 393 \text{ kN/m}^2$$

- (4) Assuming an 800 mm thick base with
- $d = 740$
- mm for the longitudinal bars and with a mean
- $d = 730$
- mm for punching shear calculations:

At the column face

$$\text{shear stress, } v_c = N / \text{column perimeter} \times d$$

For 300 mm square column

$$\begin{aligned} v_c &= 1720 \times 10^3 / (1200 \times 730) \\ &= 1.47 \text{ N/mm}^2 < 0.8 \sqrt{f_{cu}} \end{aligned}$$

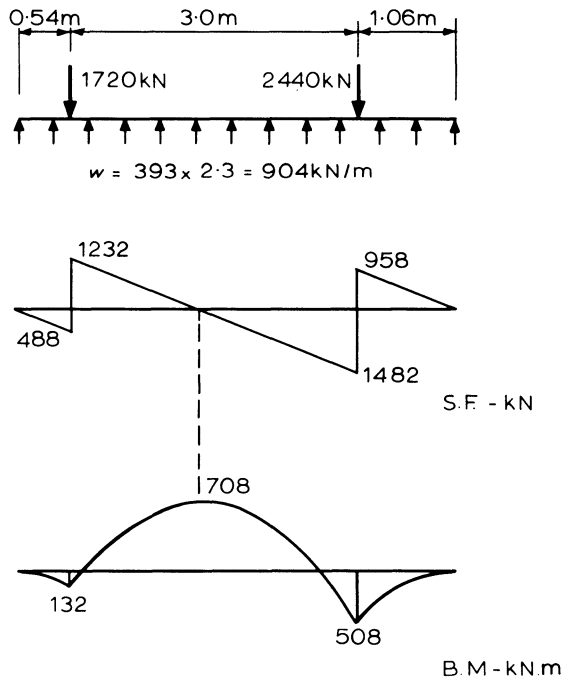

Figure 10.10 Shear-force and bending-moment diagrams

For 400 mm square column

$$\begin{aligned} v_c &= 2440 \times 10^3 / (1600 \times 730) \\ &= 2.09 \text{ N/mm}^2 < 0.8 \sqrt{f_{cu}} \end{aligned}$$

- (5) Longitudinal moments and shear forces: the shear-force and bending-moment diagrams at the ultimate limit state and for a net upward pressure of  $393 \text{ kN/m}^2$  are shown in figure 10.10.
- (6) Shear: punching shear cannot be checked, since the critical perimeter  $1.5d$  from the column face lies outside the base area. The critical section for shear is taken  $1.0d$  from the column face. Therefore with  $d = 730 \text{ mm}$

$$\begin{aligned} V &= 1482 - 393 \times 2.3 (0.74 + 0.2) \\ &= 632 \text{ kN} \end{aligned}$$

thus

$$\begin{aligned} \text{shear stress } v &= \frac{V}{bd} = \frac{632 \times 10^3}{2300 \times 730} \\ &= 0.38 \text{ N/mm}^2 \text{ which from table 5.1 is just} \\ &\text{satisfactory for grade 35 concrete} \end{aligned}$$

- (7) Longitudinal bending

(i) Mid-span between the columns

$$\begin{aligned} A_s &= \frac{M}{0.87 f_y z} = \frac{708 \times 10^6}{0.87 \times 460 \times 0.95 \times 740} \\ &= 2517 \text{ mm}^2 \end{aligned}$$

Provide nine T20 at 270 mm centres, area =  $2830 \text{ mm}^2$ , top.

(ii) At the face of the 400 mm square column

$$\begin{aligned} M &= 393 \times 2.3 \times \frac{(1.06 - 0.2)^2}{2} \\ &= 334 \text{ kN m} \\ A_s &= \frac{M}{0.87 f_y z} = \frac{334 \times 10^6}{0.87 \times 460 \times 0.95 \times 740} \\ &= 1188 \text{ mm}^2 \end{aligned}$$

but

$$\begin{aligned} \text{minimum } A_s &= \frac{0.13bh}{100} = \frac{0.13 \times 2300 \times 800}{100} \\ &= 2392 \text{ mm}^2 \end{aligned}$$

Provide nine T20 at 270 mm centres,  $A_s = 2830 \text{ mm}^2$ , bottom.

(8) Transverse bending

$$M = 393 \times \frac{1.15^2}{2} = 260 \text{ kN m/m}$$

$$A_s = \frac{M}{0.87 f_y z} = \frac{260 \times 10^6}{0.87 \times 460 \times 0.95 \times 720}$$

$$= 950 \text{ mm}^2/\text{m}$$

But

$$\text{minimum } A_s = \frac{0.13 bh}{100} = \frac{0.13 \times 1000 \times 800}{100}$$

$$= 1040 \text{ mm}^2/\text{m}$$

Provide T16 bars at 180 mm centres, area = 1117 mm<sup>2</sup> per metre.

The transverse reinforcement should be placed at closer centres under the columns to allow for greater moments in those regions.

### 10.3 Strap Footings

Strap footings, as shown in figure 10.11, are used where the base for an exterior column must not project beyond the property line. A strap beam is constructed between the exterior footing and the adjacent interior footing – the purpose of the strap is to restrain the overturning force due to the eccentric load on the exterior footing.

The base areas of the footings are proportioned so that the bearing pressures are uniform and equal under both bases. Thus it is necessary that the resultant of the loads on the two footings should pass through the centroid of the areas of the two bases. The strap beam between the footings should not bear against the soil, hence the ground directly under the beam should be loosened and left uncompacted.

To achieve suitable sizes for the footings several trial designs may be necessary. With reference to figure 10.11 the principal steps in the design are as follows.

- (1) Choose a trial width  $D$  for the rectangular outer footing and assume weights  $W_1$  and  $W_2$  for the footings and  $W_s$  for the strap beam.
- (2) Take moments about the centre line of the inner column in order to determine the reaction  $R_1$  under the outer footing. The loadings should be those required for the serviceability limit state. Thus

$$(R_1 - W_1) \left( L + f - \frac{D}{2} \right) - N_1 L - W_s \frac{L}{2} = 0 \quad (10.5)$$

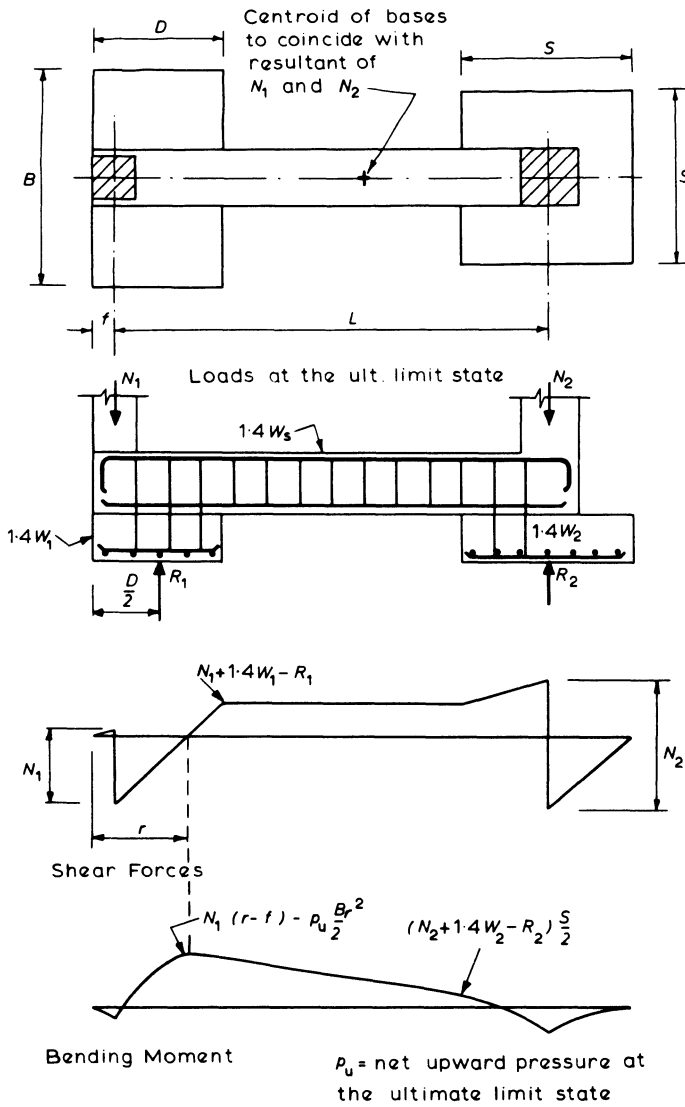

Figure 10.11 Strap footing with shearing force and bending moments for the strap beam

and solve for  $R_1$ . The width  $B$  of the outer footing is then given by

$$B = \frac{R_1}{pD}$$

where  $p$  is the safe bearing pressure.

- (3) Equate the vertical loads and reactions to determine the reaction  $R_2$  under the inner footing. Thus

$$R_1 + R_2 - (N_1 + N_2 + W_1 + W_2 + W_s) = 0 \quad (10.6)$$

and solve for  $R_2$ . The size  $S$  of the square inner footing is then given by

$$S = \sqrt{\frac{R_2}{p}}$$

- (4) Check that the resultant of all the loads on the footings passes through the centroid of the areas of the two bases. If the resultant is too far away from the centroid then steps 1 to 4 must be repeated until there is adequate agreement.
- (5) Apply the loading associated with the ultimate limit state. Accordingly, revise equations 10.5 and 10.6 to determine the new values for  $R_1$  and  $R_2$ . Hence calculate the bearing pressure  $p_u$  for this limit state. It may be assumed that the bearing pressures for this case are also equal and uniform, provided the ratios of dead load to imposed load are similar for both columns.
- (6) Design the inner footing as a square base with bending in both directions.
- (7) Design the outer footing as a base with bending in one direction and supported by the strap beam.
- (8) Design the strap beam. The maximum bending moment on the beam occurs at the point of zero shear as shown in figure 10.11. The shear on the beam is virtually constant, the slight decrease being caused by the beam's self-weight. The stirrups should be placed at a constant spacing but they should extend into the footings over the supports so as to give a monolithic foundation. The main tension steel is required at the top of the beam but reinforcement should also be provided in the bottom of the beam so as to cater for any differential settlement or downward loads on the beam.

#### 10.4 Strip Footings

Strip footings are used under walls or under a line of closely-spaced columns. Even were it possible to have individual bases, it is often simpler and more economic to excavate and construct the formwork for a continuous base.

On a sloping site the foundations should be constructed on a horizontal bearing and stepped where necessary. At the steps the footings should be lapped as shown in figure 10.12.

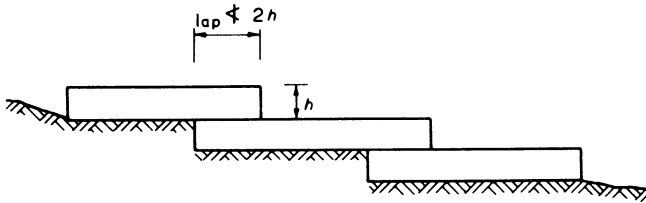

Figure 10.12 Stepped footing on a sloping site

The footings are analysed and designed as an inverted continuous beam subjected to the ground bearing pressures. With a thick rigid footing and a firm soil, a linear distribution of bearing pressure is considered. If the columns are equally spaced and equally loaded the pressure is uniformly distributed but if the loading is not symmetrical then the base is subjected to an eccentric load and the bearing pressure varies as shown in figure 10.13.

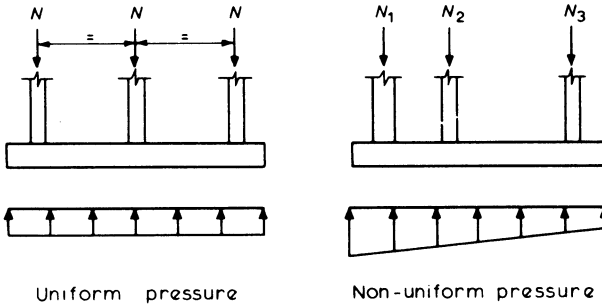

Figure 10.13 Linear pressure distribution under a rigid strip footing

The bearing pressures will not be linear when the footing is not very rigid and the soil is soft and compressible. In these cases the bending-moment diagram would be quite unlike that for a continuous beam with firmly held supports and the moments could be quite large, particularly if the loading is unsymmetrical. For a large foundation it may be necessary to have a more detailed investigation of the soil pressures under the base in order to determine the bending moments and shearing forces.

Reinforcement is required in the bottom of the base to resist the transverse bending moments in addition to the reinforcement required for the longitudinal bending. Footings which support heavily loaded columns often require stirrups and bent-up bars to resist the shearing forces.

**Example 10.3 Design of a Strip Footing**

Design a strip footing to carry 400 mm square columns equally spaced at 3.5 m centres. On each column the characteristic loads are 1000 kN dead and 350 kN

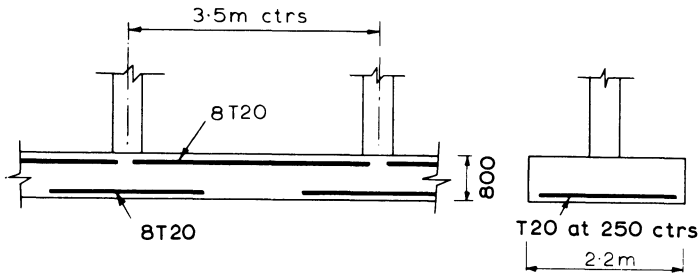

Figure 10.14 Strip footing with bending reinforcement

imposed. The safe bearing pressure is  $200 \text{ kN/m}^2$  and the characteristic material strengths are  $f_{cu} = 35 \text{ N/mm}^2$  and  $f_y = 460 \text{ N/mm}^2$ .

- (1) Try a thickness of footing = 800 with  $d = 740 \text{ mm}$  for the longitudinal reinforcement. Assume a footing self-weight =  $45 \text{ kN/m}$ .

$$\text{Width of footing required} = \frac{1000 + 350 + (45 \times 3.5)}{200 \times 3.5} = 2.15 \text{ m}$$

Provide a strip footing 2.2 m wide.

At the ultimate limit state

$$\text{column load} = 1.4 \times 1000 + 1.6 \times 350 = 1960 \text{ kN}$$

$$\begin{aligned} \text{bearing pressure} &= \frac{1960}{2.2 \times 3.5} \\ &= 255 \text{ kN/m}^2 \end{aligned}$$

- (2) *Punching shear* at column face

$$\begin{aligned} v_c &= N / \text{column perimeter} \times d \\ &= 1960 \times 10^3 / 1600 \times 740 \\ &= 1.7 \text{ N/mm}^2 < 0.8 \sqrt{f_{cu}} \end{aligned}$$

By inspection, the normal shear on a section at the column face will be significantly less severe.

- (3) *Longitudinal Reinforcement*

Using the moment and shear coefficients for an equal-span continuous beam (figure 3.10), for an interior span

$$\begin{aligned} \text{moment at the columns} &= 255 \times 2.2 \times 3.5^2 \times 0.08 \\ &= 550 \text{ kN m} \end{aligned}$$

therefore

$$A_s = \frac{550 \times 10^6}{0.87 \times 460 \times 0.95 \times 740} = 1955 \text{ mm}^2$$

$$\text{Minimum } A_s = \frac{0.13bh}{100} = 0.13 \times 2200 \times \frac{800}{100} = 2288 \text{ mm}^2$$

Provide eight T20 at 300 mm centres, area = 2510 mm<sup>2</sup>, bottom steel.  
In the span

$$M = 255 \times 2.2 \times 3.5^2 \times 0.07 \\ = 481 \text{ kN m}$$

therefore

$$A_s = \frac{481 \times 10^6}{0.87 \times 460 \times 0.95 \times 740} = 1710 \text{ mm}^2$$

Provide eight T20 bars at 300 mm centres, area = 2510 mm<sup>2</sup>, top steel.

(4) *Transverse Reinforcement*

$$M = 255 \times \frac{1.1^2}{2} = 155 \text{ kN m/m}$$

$$A_s = \frac{155 \times 10^6}{0.87 \times 460 \times 0.95 \times 720} = 566 \text{ mm}^2/\text{m}$$

$$\text{Minimum } A_s = \frac{0.13bh}{100} = 0.13 \times 1000 \times \frac{800}{100} = 1040 \text{ mm}^2$$

Provide T20 bars at 250 mm centres, area = 1260 mm<sup>2</sup>/m, bottom steel.

(5) *Normal Shear* will govern as the punching shear perimeter is outside the footing.

1.0d from column face

$$V = 255 \times 2.2 (3.5 \times 0.55 - 0.74 - 0.2) = 553 \text{ kN}$$

(The coefficient of 0.55 is from figure 3.10.)

$$\text{Shear stress } \nu = \frac{553 \times 10^3}{2200 \times 740} = 0.34 \text{ N/mm}^2$$

Allowable ultimate shear stress = 0.38 N/mm<sup>2</sup>, from table 5.1 for  $f_{cu} = 35 \text{ N/mm}^2$ .

## 10.5 Raft Foundations

A raft foundation transmits the loads to the ground by means of a reinforced concrete slab that is continuous over the base of the structure. The raft is able to span over any areas of weaker soil and it spreads the loads over a wide area. Heavily loaded structures are often provided with one continuous base in preference to many closely spaced, separate footings. Also where settlement is a problem, because of mining subsidence, it is common practice to use a raft foundation in conjunction with a more flexible superstructure.

The simplest type of raft is a flat slab of uniform thickness supporting the columns. Where punching shears are large the columns may be provided with a

pedestal at their base as shown in figure 10.15. The pedestal serves a similar function to the drop panel in a flat slab floor. Other, more heavily loaded rafts require the foundation to be strengthened by beams to form a ribbed construction. The beams may be downstanding, projecting below the slab or they may be upstanding as shown in the figure. Downstanding beams have the disadvantage of disturbing the ground below the slab and the excavated trenches are often a nuisance during construction, while upstanding beams interrupt the clear floor area above the slab. To overcome this a second slab is sometimes cast on top of the beams, so forming a cellular raft.

Rafts having a uniform slab, and without strengthening beams, are generally analysed and designed as an inverted flat slab floor subjected to the earth bearing pressures. With regular column spacing and equal column loading, the coefficients tabulated in section 8.7 for flat slab floors are used to calculate the bending moments in the raft. The slab must be checked for punching shear around the columns and around pedestals, if they are used.

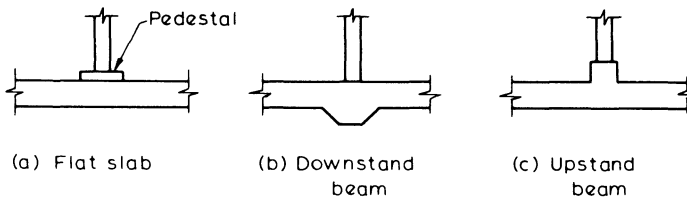

Figure 10.15 Raft foundations

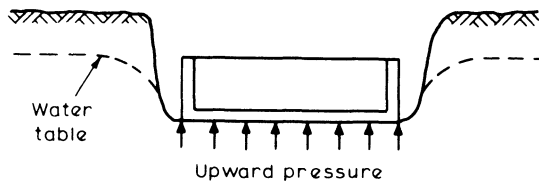

Figure 10.16 Raft foundation subject to uplift

A raft with strengthening beams is designed as an inverted beam and slab floor. The slab is designed to span in two directions where there are supporting beams on all four sides. The beams are often subjected to high shearing forces which need to be resisted by a combination of stirrups and bent-up bars.

Raft foundations which are below the level of the water table as in figure 10.16 should be checked to ensure that they are able to resist the uplift forces due to the hydrostatic pressure. This may be critical during construction before the weight of

the superstructure is in place, and it may be necessary to provide extra weight to the raft and lower the water table by pumping. An alternative method is to anchor the slab down with short tension piles.

### 10.6 Piled Foundations

Piles are used where the soil conditions are poor and it is uneconomical, or not possible, to provide adequate spread foundations. The piles must extend down to firm soil so that the load is carried by either (1) end bearing, (2) friction, or (3) a combination of both end bearing and friction. Concrete piles may be precast and driven into the ground, or they may be the cast *in situ* type which are bored or excavated.

A soils survey of a proposed site should be carried out to determine the depth to firm soil and the properties of the soil. This information will provide a guide to the lengths of pile required and the probable safe load capacity of the piles. On a large contract the safe loads are often determined from full-scale load tests on typical piles or groups of piles. With driven piles the safe load can be calculated from equations which relate the resistance of the pile to the measured set per blow and the driving force.

The load-carrying capacity of a group of piles is not necessarily a multiple of that for a single pile — it is often considerably less. For a large group of closely spaced friction piles the reduction can be of the order of one-third. In contrast, the load capacity of a group of end bearing piles on a thick stratum of rock or compact sand or gravel is substantially the sum total of the resistance of each individual pile. Figure 10.17 shows the bulbs of pressure under piles and illustrates why the settlement of a group of piles is dependent on the soil properties at a greater depth.

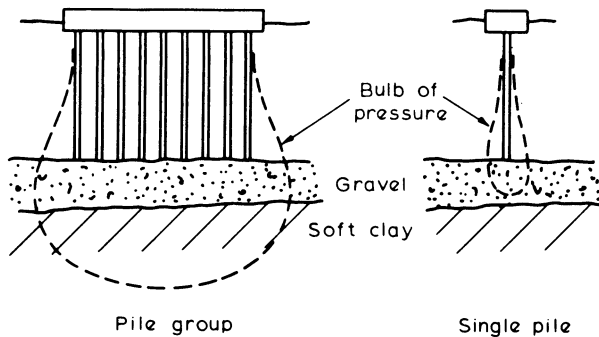

Figure 10.17 *Bulbs of pressure*

The minimum spacing of piles, centre to centre, should not be less than (1) the pile perimeter – for friction piles, or (2) twice the least width of the pile – for end bearing piles. Bored piles are sometimes enlarged at their base so that they have a larger bearing area or a greater resistance to uplift.

A pile is designed as a short column unless it is slender and the surrounding soil is too weak to provide restraint. Precast piles must also be designed to resist the bending moments caused by lifting and stacking, and the head of the pile must be reinforced to withstand the impact of the driving hammer.

It is very difficult if not impossible to determine the true distribution of load of a pile group, therefore, in general, it is more realistic to use methods that are simple but logical. A vertical load on a group of vertical piles with an axis of symmetry is considered to be distributed according to the following equation, which is similar in form to that for an eccentric load on a pad foundation:

$$P_n = \frac{N}{n} \pm \frac{Ne_{xx}}{I_{xx}} y_n \pm \frac{Ne_{yy}}{I_{yy}} x_n$$

where  $P_n$  is the axial load on an individual pile

$N$  is the vertical load on the pile group

$n$  is the number of piles

$e_{xx}$  and  $e_{yy}$  are the eccentricities of the load  $N$  about the centroidal axes  $XX$  and  $YY$  of the pile group

$I_{xx}$  and  $I_{yy}$  are the second moments of area of the pile group about axes  $XX$  and  $YY$

$x_n$  and  $y_n$  are the distances of the individual pile from axes  $YY$  and  $XX$ , respectively.

#### **Example 10.4 Loads in a Pile Group**

Determine the distribution between the individual piles of a 1000 kN vertical load acting at position A of the group of vertical piles shown in figure 10.18. Centroid of the pile group: taking moments about line TT

$$\bar{y} = \frac{\Sigma y}{n} = \frac{2.0 + 2.0 + 3.0 + 3.0}{6} = 1.67 \text{ m}$$

where  $n$  is the number of piles. Therefore the eccentricities of the load about the  $XX$  and  $YY$  centroidal axis are

$$e_{xx} = 2.0 - 1.67 = 0.33 \text{ m}$$

and

$$e_{yy} = 0.2 \text{ m}$$

$$I_{xx} = \Sigma y_n^2 \text{ with respect to the centroidal axis } XX \\ = 2 \times 1.67^2 + 2 \times 0.33^2 + 2 \times 1.33^2 = 9.33$$

similarly

$$I_{yy} = \Sigma x_n^2 = 3 \times 1.0^2 + 3 \times 1.0^2 = 6.0$$

Therefore

$$\begin{aligned}
 P_n &= \frac{N}{n} \pm \frac{Ne_{xx}}{I_{xx}} y_n \pm \frac{Ne_{yy}}{I_{yy}} x_n \\
 &= \frac{1000}{6} \pm \frac{1000 \times 0.33}{9.33} y_n \pm \frac{1000 \times 0.2}{6.0} x_n \\
 &= 166.7 \pm 35.4 y_n \pm 33.3 x_n
 \end{aligned}$$

Therefore, substituting for  $y_n$  and  $x_n$

$$P_1 = 166.7 - 35.4 \times 1.67 + 33.3 \times 1.0 = 140.9 \text{ kN}$$

$$P_2 = 166.7 - 35.4 \times 1.67 - 33.3 \times 1.0 = 74.3 \text{ kN}$$

$$P_3 = 166.7 + 35.4 \times 0.33 + 33.3 \times 1.0 = 211.7 \text{ kN}$$

$$P_4 = 166.7 + 35.4 \times 0.33 - 33.3 \times 1.0 = 145.1 \text{ kN}$$

$$P_5 = 166.7 + 35.4 \times 1.33 + 33.3 \times 1.0 = 247.1 \text{ kN}$$

$$P_6 = 166.7 + 35.4 \times 1.33 - 33.3 \times 1.0 = 180.5 \text{ kN}$$

$$\text{Total} \quad \underline{999.6 \approx 1000 \text{ kN}}$$

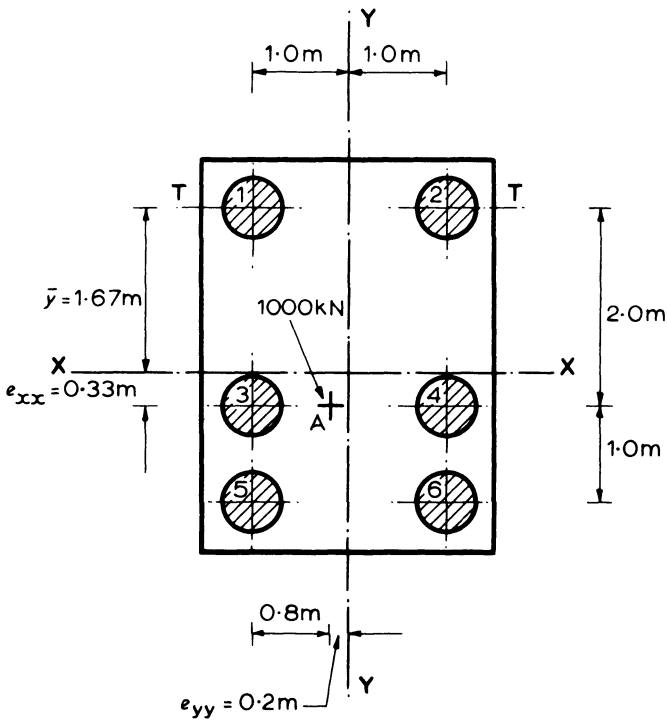

Figure 10.18

When a pile group is unsymmetrical about both co-ordinate axes it is necessary to consider the theory of bending about the principal axes which is dealt with in most textbooks on strength of materials. In this case the formulae for the pile loads are

$$P_n = \frac{N}{n} \pm Ay_n \pm Bx_n$$

where

$$A = \frac{N(e_{xx}\Sigma x_n^2 - e_{yy}\Sigma x_n y_n)}{\Sigma x_n^2 \Sigma y_n^2 - (\Sigma x_n y_n)^2}$$

and

$$B = \frac{N(e_{yy}\Sigma y_n^2 - e_{xx}\Sigma x_n y_n)}{\Sigma x_n^2 \Sigma y_n^2 - (\Sigma x_n y_n)^2}$$

Note that  $e_{xx}$  is the eccentricity about the  $XX$  axis, while  $e_{yy}$  is the eccentricity about the  $YY$  axis, as in figure 10.18.

Piled foundations are sometimes required to resist horizontal forces in addition to the vertical loads. If the horizontal forces are small they can often be resisted by the passive pressure of the soil against vertical piles, otherwise if the forces are not small then raking piles must be provided as shown in figure 10.19a.

To determine the load in each pile either a static method or an elastic method is available. The static method is simply a graphical analysis using Bow's notation as illustrated in figure 10.19b. This method assumes that the piles are pinned at their ends so that the induced loads are axial. The elastic method takes into account the

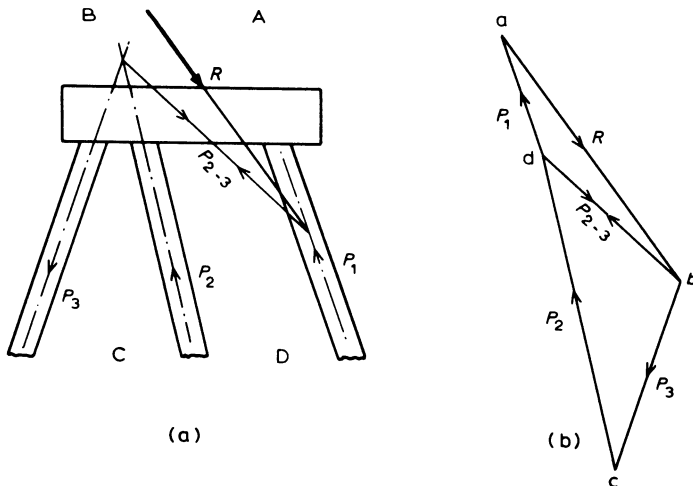

Figure 10.19 Forces in raking piles

displacements and rotations of the piles which may be considered pinned or fixed at their ends. The pile foundation is analysed in a similar manner to a plane frame or space frame and available computer programs are commonly used.

The pile cap must be rigid and capable of transferring the column loads to the piles. It should have sufficient thickness for anchorage of the column dowels and the pile reinforcement, and it must be checked for punching shear, diagonal shear, bending and local bond. Piles are rarely positioned at the exact locations shown on the drawings, therefore this must be allowed for when designing and detailing the pile cap.

# 11

## Water-retaining Structures and Retaining Walls

The design of both of these types of structure is based on fundamental principles and analysis techniques which have been discussed in previous chapters. Because of their specialised nature, however, design is often governed by factors which may be regarded as secondary in normal reinforced concrete work. Such structures are relatively common, in one form or another, and hence justify coverage in some detail.

### 11.1 Water-retaining Structures

This category includes those which are required to contain, or exclude, any non-aggressive aqueous liquid. Since water is that most commonly involved, however, the rather loose title is frequently used to describe such structures. Common structures of this type include water towers and reservoirs, storage tanks including sewage disposal and treatment systems, and floors and walls of basements and other underground constructions where it is necessary to prevent ingress of groundwater.

As it is important to restrain cracking so that leakages do not take place the design is generally governed by the requirements of the serviceability limit state, but stability considerations are particularly important and design must take careful account of the construction methods to be used. British Standard Code of Practice BS 8007 offers guidance on the design and construction of this category of structure, and is based on a limit state philosophy as embodied in BS 8110.

Elastic design methods have traditionally been used, and these are also summarised in this chapter although not included in BS 8007.

Code of Practice BS 8007 recommends modifications to the detailed Limit State design requirements of BS 8110, with the principal features being:

- (a) Use of  $\gamma_f = 1.4$  for liquid loads.
- (b) Use of concrete grade C35A (this has a maximum water/cement ratio of

0.55 and minimum cement content of  $325 \text{ kg/m}^3$  – that is, durability performance comparable to grade C40).

- (c) Exposure classification of internal members and both faces of members exposed to liquid on at least one face is severe, giving minimum cover of 40 mm. If a more severe exposure condition exists, BS 8110 durability requirements may dominate.
- (d) Maximum crack width limited to 0.2 mm unless the aesthetic appearance is critical, when 0.1 mm is required to avoid staining of the concrete.
- (e) Maximum bar spacing of 300 mm.
- (f) Anchorage bond stresses for straight horizontal bars in sections subjected to direct tension must be reduced to 70 per cent of the usual values.
- (g) At least 75 mm blinding concrete is required below ground slabs.

Design procedures are aimed primarily at providing appropriate combinations of movement joints and reinforcement to limit crack widths to the required values.

### *11.1.1 Design and Construction Problems*

To ensure a watertight structure the concrete must be adequately reinforced in sections where tension may occur. For this reason it is important to be able to envisage the deflected shape of the structure and its individual elements. Tensile stresses due to any direct tensile forces as well as those due to bending must be included in the design calculations.

Continuity reinforcement to prevent cracking must be provided at corners and at member junctions. This reinforcement must extend well beyond where it is required to resist the tensile stresses, particularly when these stresses occur on the face in contact with the liquid.

The design should consider the cases where the structure is full of liquid (allowing for blocked outlets) and also when it is empty. The structure when empty must have the strength to withstand the active pressure of any retained earth. Since the passive resistance of the earth is never certain to be acting, it should generally be ignored when designing for the structure full.

Cracking may occur not only from flexure and shrinkage, but also from subsidence and in some areas earthquakes. Careful attention must thus be given to geological aspects of a proposed site and in particular to the possibilities of differential settlement. It may sometimes be necessary to provide movement joints to cater for this, in addition to expansion and contraction joints required to allow for thermal and shrinkage movements. Flexural cracking can be controlled by careful design and detailing and is discussed in chapter 6, while shrinkage and thermal effects can be reduced considerably by careful attention to the construction factors listed in section 1.3.

With a thick section, the heat generated by hydration cannot readily be dissipated, and the resulting temperature rise in the body of the concrete may be considerable. In addition to the normal precautions, it may be necessary to use low-heat cements and to restrict the size of pours, for example. Experimental work has shown that in walls and slabs greater than 500 mm in thickness, the outer 250 mm on each face may be regarded as the surface zone and the remainder as core. Minimum reinforcement quantities to control thermal and shrinkage cracking should thus be based on a maximum member thickness of 500 mm.

The bottom surface zone for ground slabs should be only 100 mm. Temperature rises due to hydration must be averaged to allow for the core temperature.

The importance of good curing cannot be overemphasised, but it is important to remember that good compaction on site is just as vital, if not more critical, in producing an impermeable concrete. It is essential, therefore, that the concrete mix used is sufficiently workable to enable easy handling during construction, with no tendency to segregation. An increased water content combined with a higher cement content will help to achieve this, while a longer mixing time, and the use of natural aggregates in preference to crushed stone are also helpful. Wall thicknesses of at least 200 mm are recommended to assist compaction.

Formwork must also be carefully constructed to avoid grout leakage at joints and consequent areas of concrete vulnerable to water penetration. Particular care must also be given to the use of formwork ties. Through ties should not be used, as these offer a potential leakage path. The choice of surface finish should take account of possible staining of exposed surfaces.

Flotation, particularly during construction, is a major problem in many underground tanks and basements. To overcome this it may be necessary to dewater the site, increase the dead weight of the structure, use anchor piles or provide for temporary flooding of the structure. In any case, the construction sequence must be carefully studied, and specified at the design stage to ensure a minimum factor of safety of 1.1 against flotation.

When filling a tank or reservoir for the first time, this should be done slowly. This permits stress redistributions to occur, and this, coupled with creep effects, will greatly reduce the extent of cracking. An initial watertightness test is likely to be specified, and a recommended procedure is given by BS 8007. Access provision will be required for inspection, cleaning and testing and this must take account of safety and ventilation requirements.

## 11.2 Joints in Water-retaining Structures

All concrete structures must inevitably contain construction joints, although the need for joints to accommodate movement in water-retaining structures is governed by the likelihood of, and need to restrict, unacceptable cracking principally due to shrinkage and thermal movements. Frequently it may be possible to combine the two categories of joint.

The principal characteristics of joints are that they must be watertight, and in the case of movement joints must also permit the repeated required movements to take place as freely as possible. Waterbars will generally be incorporated, either the surface type in slabs, or commonly the centre bulb type in walls. These must be effectively held in position during concreting, while allowing good compaction of the concrete to be still possible. Such waterbars must furthermore be able to accommodate anticipated movement without tearing, and withstand considerable water pressures.

All movement joints must be sealed with a flexible compound which effectively is watertight and also prevents dust and grit from entering and thus blocking the joint. Jointing materials must be durable under the conditions of exposure to which they may be subjected, but routine replacement is likely to be necessary.

**11.2.1 Construction Joints**

Construction joints cannot be avoided, and the aim must be to ensure reinforcement continuity with good bonding between the new concrete and old. Such requirements, of course, apply to any reinforced concrete construction but especial care must be taken in this instance if leakage is to be avoided. Laitance must always be removed to expose coarse aggregate and a sound irregular concrete surface. The new concrete is then poured either directly against this surface, or alternatively a thin layer of grout may be applied before casting. If well constructed, such joints should be completely watertight. Waterstops are not usually necessary; however, it is sometimes preferred to seal the joint on the water-retaining surface as an additional precaution.

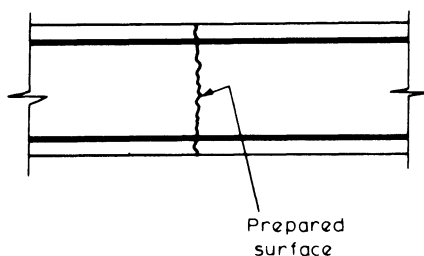

**Figure 11.1** Construction joint

Wherever possible the construction should be arranged so that the joints are either all horizontal or all vertical. In some instances long lengths of walls or slab are constructed in alternate lengths as shown in figure 11.2, so that when the intermediate pours are made later the older concrete in the earlier pours will have

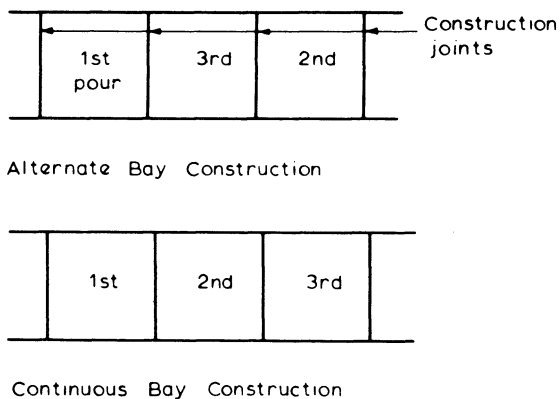

**Figure 11.2** Construction procedure for walls

already taken up some of the shrinkage movement. But on the other hand some engineers prefer to construct successive lengths, arguing that this will mean there is only one restrained edge and the other edge of the slab is free to contract without cracking.

### 11.2.2 Movement Joints

Movement joints are provided to reduce the likelihood of unwanted thermal or shrinkage stress concentrations. They ensure there is only a partially restrained condition during contraction of the immature concrete.

Joints to accommodate contraction may be of two types, 'partial' or 'complete', depending upon the extent of contraction anticipated and the degree of restraint that can be tolerated. 'Partial' contraction joints are the simplest to provide, and consist of a deliberate discontinuity of the concrete, but without an initial gap, as shown in figure 11.3. Care must be taken to prevent excessive adhesion of the concrete surfaces when the second slab is cast against the first, and a waterbar may be desirable as a precaution in addition to the joint sealer. Reinforcement is continuous across the joint to provide some shear transfer, but at the same time this reduces the effective freedom of movement of the adjacent concrete sections. Such joints thus provide only limited relief from constraint and they must always be separated by at least one movement joint with complete discontinuity of concrete and steel.

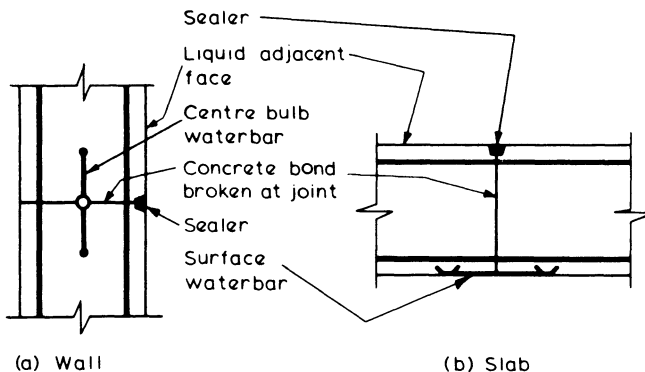

Figure 11.3 *Partial contraction joint*

An example of a 'complete' contraction joint which fulfils this requirement is shown in figure 11.4a. In this case both steel and concrete are discontinuous, but if any shear must be transferred then a shear key is required, as shown. In this type of joint a waterbar is considered to be essential, although there is no initial gap between the concrete surfaces.

Where expansion of the concrete is considered possible, joints must be provided which permit this to take place freely without the development of compressive stresses in the concrete. Expansion joints must, therefore, not only provide complete discontinuity of concrete and steel reinforcement, but also must have an initial gap to accommodate such movement. Contraction can also of course be

catered for by this type of joint. Figure 11.4b shows a common expansion joint detail, where in addition to a sealer and special waterstop, the joint is filled with a non-absorbent compressible filler. Shear can obviously not be transmitted by this joint, but if it is essential that provision for shear transfer be made, a special joint involving sliding concrete surfaces must be designed. Water pressure on the joint materials may also cause problems if the gap is wide, and this must be considered.

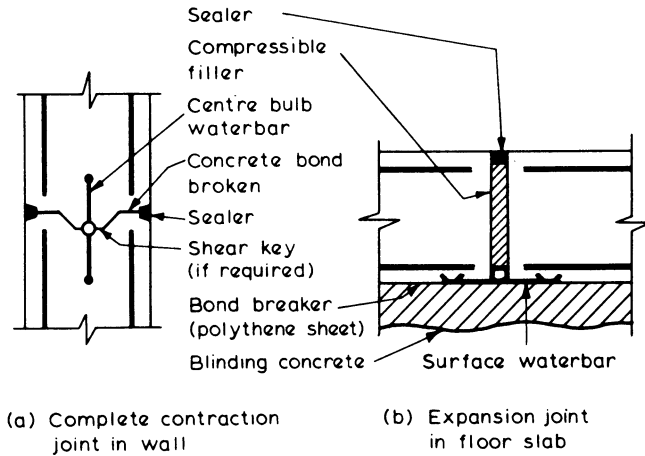

Figure 11.4 Complete movement joints

Occasionally, a structure may be designed on the basis that one part is to be free to move relative to another, for example in a circular tank on a flat base, the walls may be designed as independent of the base. In such cases special sliding joints are sometimes used. The essential requirement is that the two concrete surfaces are absolutely plane and smooth and that bond is broken between the surfaces such as by painting or the use of building paper, or that a suitable flexible rubber pad is used. Figure 11.5 shows a typical detail for such a joint, which must always be effectively sealed.

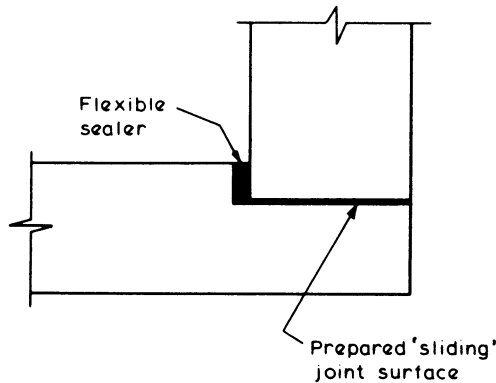

Figure 11.5 Typical sliding joint between slab and wall

*Provision of Movement Joints*

The need for movement joints will depend to a considerable extent on the nature of the structure and the usage to which it is put. For instance an elevated structure may be subjected to few restraints, while an underground structure may be massive and restrained. On the other hand, temperature and moisture variations may be greater in exposed structures than those which are buried. If warm liquids are involved, then this must be reflected in the provision of adequate joints.

The type of member, and construction sequence, will also be an important consideration. Floor slabs will generally be cast on a separating layer of polythene or some similar material laid on the blinding concrete, and in this case joints should be complete contraction or expansion joints. Alternatively, the slab may be cast directly on to the blinding and reinforced to limit cracking on the basis of full restraint as described in chapter 1.

Walls may similarly be designed as fully restrained, or alternatively contraction joints provided at spacings indicated by table 11.1.

Expansion joints must be provided if necessary. In some instances roofs may be separated from the walls by sliding joints. If the roof is to be designed as unrestrained then great care must be taken to minimise the restraints to thermal movement during construction. If significant restraints cannot be avoided, reinforcement must be designed to limit the likely cracking. Where roof and wall are monolithic, joints in the roof should correspond to those in the wall, which in turn may be related to those in the floor slab.

If design of a member is based on the fully restrained condition, it is assumed that cracking will be controlled by the reinforcement; therefore the critical steel ratio  $r_{crit}$  which is discussed in section 6.5 must be exceeded. The reinforcement is then detailed to limit the maximum likely crack width to the required value, using appropriate values of likely temperature change and concrete properties recommended by the code of practice. In this instance greatest benefit is obtained from closely spaced small diameter bars.

Alternatively, if proper movement joints are provided so that cracks are concentrated at the joints, reinforcement may be designed on the basis of only partial restraint as indicated in table 11.1, but bar spacing should not exceed 300 mm, or the section thickness.

**11.3 Reinforcement Details**

Reinforcement should normally be placed near the surface of the concrete but with a minimum cover of 40 mm. Minimum steel areas in each of two directions at right angles depend on the joint arrangement as discussed above, but these will frequently need to be exceeded to limit thermal crack widths.

The critical steel ratio,  $r_{crit}$ , is given by  $f_{ct}/f_y$  as in equation 6.12 of section 6.5, and typically has the following values for grade C35A concrete:

High-yield bars ( $f_y = 460 \text{ N/mm}^2$ ),  $r_{crit} = 0.0035$

Mild steel bars ( $f_y = 250 \text{ N/mm}^2$ ),  $r_{crit} = 0.0064$

Table 11.1 Design options for control of thermal contraction and restrained shrinkage

Option	Type of construction and method of control	Movement joint spacing	Steel ratio (see note)	Comments
1	Continuous: for full restraint	No joints, but expansion joints at wide spacings may be desirable in walls and roofs that are not protected from solar heat gain or where the contained liquid is subjected to a substantial temperature range	Minimum of $r_{crit}$	Use small size bars at close spacing to avoid high steel ratios well in excess of $r_{crit}$
2	Semicontinuous: for partial restraint	(a) Complete contraction joints, $\leq 15$ m (b) Alternate partial and complete contraction joints (by interpolating), $\leq 11.25$ m (c) Partial joints, $\leq 7.5$ m	Minimum of $r_{crit}$	Use small size bars but less steel than in option 1
3	Close movement joint spacing: for freedom of movement	(a) Complete joints, in metres $\leq 4.8 + \frac{w}{\epsilon}$ (b) Alternate partial and complete joints, in metres $\leq 0.5 s_{max} + 2.4 + \frac{w}{\epsilon}$ (c) Partial joints $\leq s_{max} + \frac{w}{\epsilon}$	Minimum of $2/3 r_{crit}$	Restrict the joint spacing for options 3(b) and 3(c)  In these expressions $s_{max}$ = maximum likely crack spacing (metres) $w$ = allowable crack width (mm) $\epsilon$ = strain in concrete

Note: In options 1 and 2 the steel ratio will generally exceed  $r_{crit}$  to restrict the crack widths to acceptable values. In option 3 the steel ratio of  $2/3 r_{crit}$  will be adequate. Evaluation of joint spacings for option 3 is illustrated in example 11.1.

In walls less than 200 mm thick or ground slabs less than 300 mm thick steel areas should be provided in one layer, but in thicker members two equal layers should be provided. Spacing should not exceed 300 mm or the section thickness.

Limitation of crack widths means that under service conditions the reinforcement is likely to be acting at stresses below those normally existing in reinforced concrete members. This reduces the advantages of increased strengths usually associated with high-yield steels. It will be noted however that minimum thermal crack control quantities are considerably reduced if deformed bars are used, because of their improved bond characteristics. The choice between high-yield and mild steel is, therefore, not well-defined and is often a matter of personal preference of the engineer.

### 11.4 Design Methods

The design of water-retaining structures may be carried out using either

- (1) a limit state design, as recommended by BS 8007, or
- (2) an elastic design, which is not now covered by the British Code of Practice.

A limit state design is based on both the ultimate and serviceability limit states, using the methods described in the previous chapters. As the restraint of cracking is of prime importance with these structures, the simplified rules for minimum steel areas and maximum spacing are no longer adequate. It is necessary to check the concrete strains and crack widths, using the methods described in chapters 1 and 6. The calculations tend to be lengthy and depend on factors such as the degree of restraint, shrinkage and creep which are difficult to assess accurately.

Elastic design is the traditional method which will possibly continue to be used for many structures. It is relatively simple and easy to apply. It could be used in conjunction with limit state methods when there are special circumstances, such as when stability calculations are necessary, or when the structure has an irregular layout, so that the critical loading patterns for the ultimate limit state should be considered. Even though a structure has been designed by the elastic method it may still be necessary to calculate the possible movement and crack widths.

#### 11.4.1 Limit State Design

The application of limit state techniques to water-retaining structures is relatively new and the recommendations of BS 8110 are used subject to modifications contained in BS 8007. The principal steps for the limit state design of a reinforced concrete structure are:

1. Ultimate limit state design calculations
2. Serviceability limit state design calculations with either
  - (a) Calculation of crack widths
  - or (b) 'Deemed to satisfy' requirements for applied loading effects on the mature concrete. These are based on maximum service stresses in the reinforcement and analysis involves the triangular stress block of section 4.10.

If a water-retaining structure is to be constructed in prestressed concrete, the category of prestressed member to be adopted as described in chapter 12 will be determined on the basis of the exposure conditions. Once the appropriate category has been established, each member will be designed in the way described in chapter 12. Special provisions for cylindrical structures which are prestressed vertically and circumferentially are given in BS 8007.

For the ultimate limit state the procedures followed are exactly the same as for any other reinforced concrete structure. The partial factor of safety on imposed loading due to contained liquid should be taken as 1.4 for strength calculations to reflect the degree of accuracy with which hydrostatic loading may be predicted. Calculations for the analysis of the structure subject to the most severe load combinations will then proceed in the usual way.

Serviceability design will involve the classification of each member according to its crack-width category as described in section 11.1. External members not in contact with the liquid can be designed using the criteria discussed in other chapters for normal reinforced concrete work.

The maximum likely crack widths may be calculated using the methods given in section 1.3 and chapter 6 and then checked for compliance with the allowable values. Alternatively, reinforcement stresses due to bending or direct tension may be calculated and checked for compliance with the demand to satisfy limits as illustrated in example 11.1.

Serviceability calculations will be required to consider three specific cases:

- (1) *Flexural tension in mature concrete.* This may result from both dead and imposed loads.
- (2) *Direct tension in mature concrete.* This may be caused by hydrostatic loadings.
- (3) *Direct tension in immature concrete.* This is caused by restrained thermal and shrinkage movement.

*Flexural Tension in Mature Concrete*

The design surface crack width may be calculated from equation 6.10 in section 6.4.2 such that

$$w_{\max} = \frac{3a_{\text{cr}} \epsilon_{\text{m}}}{1 + 2 \left( \frac{a - c_{\text{min}}}{h - x} \right)} \tag{6.10}^*$$

where  $a_{\text{cr}}$  is the distance from the point at which the crack width is being calculated to a point of zero concrete strain (which is commonly taken as the surface of the nearest longitudinal reinforcing bar) as illustrated in figure 11.6.  $c_{\text{min}}$  is the minimum cover to main reinforcement,  $\epsilon_{\text{m}}$  is the average concrete strain and is based on  $\epsilon_1$ , the apparent strain, but allows for the stiffening effect of the cracked concrete in the tension zone by the relationship  $\epsilon_{\text{m}} = \epsilon_1 - \epsilon_2$ . The value of  $\epsilon_2$  is given by an empirical expression such that

$$\epsilon_2 = \frac{b_{\text{t}} (h - x) (a' - x)}{3 E_{\text{s}} A_{\text{s}} (d - x)}$$

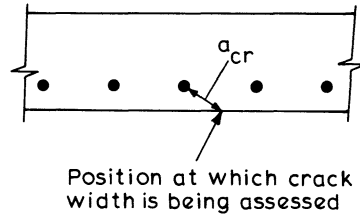

Figure 11.6 Position of calculated crack width

for a limiting design surface crack width of 0.2 mm, as in equation 6.11

or

$$\epsilon_2 = \frac{1.5 b_t (h - x) (a' - x)}{3 E_s A_s (d - x)} \quad (11.1)'$$

for a limiting design surface crack width of 0.1 mm. In these expressions  $b_t$  is the width of the section at the centroid of the tensile steel and  $a'$  is the distance from the compressive face to the point at which the crack is calculated. A negative value of  $\epsilon_m$  indicates that the section is uncracked.

As an alternative to such calculations of crack widths, table 11.2 offers maximum service stresses for the reinforcement and if these values can be shown to be satisfied it may be assumed that maximum likely crack widths in the mature concrete will be below the limiting values. This requires an elastic analysis of the member under working conditions using the equations for the triangular stress block as derived in section 4.10 and illustrated in example 11.1.

Table 11.2 Allowable steel stresses in direct or flexural tension for serviceability limit states

Design crack width (mm)	Allowable stress	
	Plain bars ( $f_y = 250 \text{ N/mm}^2$ ) (N/mm <sup>2</sup> )	Deformed bars ( $f_y = 460 \text{ N/mm}^2$ ) (N/mm <sup>2</sup> )
0.1	85	100
0.2	115	130

#### Direct Tension in Mature Concrete

The maximum likely surface crack width due to direct tension may be calculated from

$$w_{\max} = 3a_{\text{cr}} \epsilon_m \quad (11.2)*$$

where  $a_{\text{cr}}$  is the distance to the surface of the nearest reinforcing bar and the average concrete strain  $\epsilon_m$  is given by  $\epsilon_m = \epsilon_1 - \epsilon_2$

where  $\epsilon_2 = \frac{2 b_t h}{3 E_s A_s}$  for a 0.2 mm design surface crack width limit (11.3)\*

or  $\epsilon_2 = \frac{b_t h}{E_s A_s}$  for a 0.1 mm design surface crack width limit (11.4)\*

In these expressions  $\epsilon_1$  is the apparent concrete tensile strain and  $b_t$  is the width of the section at the centroid of the tensile steel. This is illustrated in example 11.2.

Service stresses in the reinforcement may alternatively be calculated for comparison with the ‘deemed to satisfy’ stresses given in table 11.2.

*Combined Flexural and Direct Tension in Mature Concrete*

Where flexural tension and direct tension are combined, the strains due to each must be added together in calculating crack widths in the mature concrete. Usually one of these will dominate as illustrated in example 11.3.

*Direct Tension in Immature Concrete*

Calculations of crack widths are based on the procedures described in section 6.5 with some simplifications often used. Provided the critical steel ratio  $r_{crit}$  is exceeded, thermal cracking is taken to have a maximum spacing

$$s_{max} = \frac{f_{ct}}{f_b} \times \frac{\Phi}{2r} \tag{6.13}*$$

where  $r$  = steel ratio  $A_s/A_c$

$\Phi$  = bar diameter

$f_{ct}$  = 3 day tensile strength – taken as 1.6 N/mm<sup>2</sup> for grade C35A concrete

$f_b$  = average bond strength between concrete and steel – taken as 1.6 N/mm<sup>2</sup> for plain round bars, or 2.4 N/mm<sup>2</sup> for deformed type 2 bars, with grade C35A concrete.

The critical steel ratio  $r_{crit}$  will have a value of 0.0035 when  $f_y = 460$  N/mm<sup>2</sup>, or 0.0064 when  $f_y = 250$  N/mm<sup>2</sup> as described in section 11.3.

The width of a fully developed crack may be taken generally as

$$w_{max} = s_{max} \left( \epsilon_{sh} + T \frac{\alpha_c}{2} - (100 \times 10^{-6}) \right)$$

$$= s_{max} \epsilon_{th}$$

based on equation 6.14 where  $\epsilon_{sh}$  is the drying shrinkage strain and  $\alpha_c$  is the coefficient of thermal expansion of the mature concrete. In practice the drying shrinkage strain may be of the order of  $100 \times 10^{-6}$   $\mu s$ , hence a simplified expression

$$w_{max} = s_{max} T \frac{\alpha_c}{2} \tag{11.5}*$$

is suggested as adequate, where  $T^{\circ}C$  is the relevant temperature change.

Temperature rises due to hydration of the concrete ( $T_1$  °C) in walls may be expected to be of the order of 20°C in winter and 30°C in summer but should be increased for high cement contents, rapid hardening cement, thick members or timber shutters in summer. Values for ground floor slabs may be about 5°C less as illustrated in table 11.3.

**Table 11.3** Typical design values of  $T_1$  for O.P.C. concrete in U.K.

Section thickness (mm)	Walls and slabs with steel formwork			Walls with 18 mm plywood formwork			Slabs on ground or plywood formwork		
	Cement content (kg/m <sup>3</sup> )			Cement content (kg/m <sup>3</sup> )			Cement content (kg/m <sup>3</sup> )		
	325	350	400	325	350	400	325	350	400
	°C	°C	°C	°C	°C	°C	°C	°C	°C
300	20*	20*	20*	23	25	31	15	17	21
500	20	22	27	32	35	43	25	28	34
700	28	32	39	38	42	49	—	—	—
1000	38	42	49	42	47	56	—	—	—

\*15°C for slabs.

Note: These values assume a placing temperature of 20°C with a mean daily temperature of 15°C, and the formwork is not removed until the temperature peak has passed. No allowance has been made for solar gain in slabs.

Additional seasonal temperature falls may also be directly substituted into the above expression since the effects of concrete maturity are offset by a smaller ratio of tensile to bond strength and other effects. These should be included as  $T_2$  °C in calculations for continuous construction so that  $T = T_1 + T_2$ .

The final details of reinforcement to be provided must be co-ordinated with the joint spacing arrangement. This is a complicated procedure since a wide range of possibilities exists, but some alternative combinations based on control of thermal and shrinkage effects are suggested in table 11.1 and are illustrated in example 11.1. Particular care must be taken to ensure that joints do not interfere with intended structural actions. Reinforcement provided to resist thermal and shrinkage cracking in the immature concrete may form part or the whole of the reinforcement required to resist direct or flexural cracking in the mature concrete.

It will be seen that small-sized, closely spaced bars are best when joint spacing is large; however, since crack spacing is related to bar diameter, large bars should be used when closer joints are combined with less steel. Although table 11.1 offers a general guide, flexural effects may dominate and it is recommended that the engineer consults specialist literature when undertaking a major design on this basis.

#### **Example 11.1** Limit State Design of a Water-retaining Section

The wall section shown in figure 11.7 is subject to a moment of 14.6 kN m under working loads which may be considered as purely hydrostatic. The moment acts so that there is tension in the face adjacent to the liquid. A grade C35A concrete

with mild steel bars are specified and appearance is not critical. 18 mm plywood formwork is to be used.

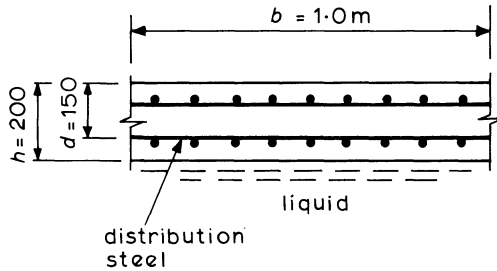

Figure 11.7 Wall section

Minimum cover = 40 mm, therefore assume  $d = 150$  mm.

(a) *Ultimate Limit State*

Ultimate moment  $M = 14.6 \times 1.4 = 20.44$  kN m

$$\frac{M}{bd^2 f_{cu}} = \frac{20.44 \times 10^6}{1000 \times 150^2 \times 35} = 0.026$$

therefore lever-arm factor  $l_a = 0.95$ , hence

$$A_{st} = \frac{20.44 \times 10^6}{0.87 \times 250 \times 0.95 \times 150} = 659 \text{ mm}^2/\text{m}$$

This requires 12 mm bars at 150 mm centres, area =  $754 \text{ mm}^2/\text{m}$ .

(b) *Serviceability Limit State*

*Flexural Tension in Mature Concrete*

Using the ‘deemed to satisfy’ conditions, check the service stress in the reinforcement assuming a cracked section and an estimated  $E_c = 27 \text{ kN/mm}^2$ .

Modular ratio  $\alpha_e = \frac{E_s}{E_c/2} = \frac{200}{27/2} = 14.8$  (includes allowance for creep)

therefore

$$\alpha_e \frac{A_s}{bd} = \frac{14.8 \times 754}{1000 \times 150} = 0.074$$

and from figure 4.29,  $x \approx 0.31d = 0.31 \times 150 = 46$  mm, therefore the reinforcement tensile stress is given by equation 4.47 as

$$f_s = \frac{M}{A_s \left( d - \frac{x}{3} \right)} = \frac{14.6 \times 10^6}{754 \left( 150 - \frac{46}{3} \right)} = 144 \text{ N/mm}^2$$

This is greater than the 115 N/mm<sup>2</sup> allowable from table 11.2 and the steel area must be increased if 'deemed to satisfy' requirements are to be met.

$$\text{Minimum } A_s = \frac{144}{115} \times 754 = 944 \text{ mm}^2/\text{m}$$

which may be provided as 12 mm bars at 110 mm centres, area 1028 mm<sup>2</sup>/m, and exceeds the ultimate limit state requirement.

### *Direct Tension in Immature Concrete*

To control thermal and shrinkage cracking, the critical steel ratio  $r_{\text{crit}} = 0.0064$  from section 11.3 for plain bars and grade C35A concrete. Thus

$$\begin{aligned} \text{minimum steel area to control cracking} &= A_s = 0.0064 A_c \\ &= 0.0064 \times 1000 \times 200 = 1280 \text{ mm}^2/\text{m} \end{aligned}$$

and maximum crack spacing  $s_{\text{max}} = \frac{f_{\text{ct}}}{f_b} \times \frac{\Phi}{2r}$  from equation 6.13.

For grade C35A concrete and plain bars,  $f_{\text{ct}} = 1.6 \text{ N/mm}^2$  and  $f_b = 1.6 \text{ N/mm}^2$ , thus for 12 mm bars

$$s_{\text{max}} = \frac{1.6 \times 12}{1.6 \times 2 \times \frac{1280}{200 \times 1000}} = 937 \text{ mm}$$

The temperature fall from the hydration peak  $T_1$ , assuming summer concreting (ambient temperature 15°C), is taken as 23°C from table 11.3. Assuming a typical value of  $\alpha_c = 10 \times 10^{-6}/^\circ\text{C}$

$$w_{\text{max}} = s_{\text{max}} \frac{\alpha_c}{2} T_1 = 937 \times \frac{10 \times 10^{-6}}{2} \times 23 = 0.11 \text{ mm}$$

from equation 11.5. This satisfies the 0.2 mm limit.

### *Reinforcement and Joint Detailing*

Since the wall is 200 mm thick, reinforcement must be provided in two layers with at least  $1/2 r_{\text{crit}} = 640 \text{ mm}^2/\text{m}$  in each face. (12 mm bars at 175 mm centres, area = 646 mm<sup>2</sup>/m.) Thermal effects may thus be considered adequately covered if 12 mm bars are provided at 110 mm centres in the liquid adjacent face as required by flexural requirements, and at 175 mm centres in the other face. Alternatively 10 mm bars also at 110 mm centres (area = 722 mm<sup>2</sup>/m) may be more convenient in the liquid remote face.

Continuous construction will be required in the direction subject to the bending moment. Thus seasonal temperature effects on thermal crack widths should be checked.

For the proposed reinforcement arrangement,

$$s_{\max} = \frac{1.6 \times 12}{1.6 \times \frac{2 \times (1028 + 646)}{200 \times 1000}} = 717 \text{ mm}$$

and assuming  $T_2 = 25^\circ\text{C}$ , equation 11.5 gives

$$w_{\max} = s_{\max} \frac{\alpha_c}{2} (T_1 + T_2) = 717 \times \frac{10}{2} \times 10^{-6} (23 + 25) = 0.17 \text{ mm}$$

which still satisfies the 0.2 mm limit.

**Transverse reinforcement** requirements will depend on jointing arrangements. If there are no structural actions in that direction, options as defined in table 11.1 range from continuous construction to close joint spacings with steel reduced to  $2/3 r_{\text{crit}}$  which is the equivalent of 10 mm bars at 185 mm centres in each face ( $853 \text{ mm}^2/\text{m}$  total).

If continuous construction is to be used, crack widths including seasonal temperature changes should be checked and it will be found that a total steel area of at least  $1440 \text{ mm}^2/\text{m}$  is required to satisfy the 0.2 mm limit.

If option 3 of table 11.1 is adopted, the alternatives are:

- (a) Complete joints at  $4.8 + \frac{w}{\epsilon}$  metres

where  $w$  = allowable crack width =  $0.2 \times 10^{-3}$  m

and  $\epsilon$  = thermal strain =  $\frac{\alpha_c}{2} T_1 = \frac{10}{2} \times 10^{-6} \times 23 = 115 \times 10^{-6}$  m

thus spacing must be less than  $4.8 + \frac{0.2 \times 10^{-3}}{115 \times 10^{-6}}$   
 $= 4.8 + 1.74 = 6.54$  m centres.

- (b) Alternate partial and complete joints at  $\leq 0.5s_{\max} + 2.4 + \frac{w}{\epsilon}$  metres

In this calculation  $s_{\max}$  should correspond to a steel area of  $853 \text{ mm}^2/\text{m}$  and 10 mm bars and will thus be

$$= 937 \times \frac{1280}{853} \times \frac{10}{12} \times 10^{-3} = 1.173 \text{ m}$$

thus spacing must be less than  $\frac{1.173}{2} + 2.4 + 1.74 = 4.73$  m centres.

- (c) Partial joints at  $\leq s_{\max} + \frac{w}{\epsilon}$

thus spacing must be less than  $1.173 + 1.74 = 2.91$  m centres.

**Example 11.2 Limit State Design of Section Subject to Direct Tension Only**

A wall is subject only to a direct tensile working force of 265 kN/m due to hydrostatic loads. Determine a suitable thickness and reinforcement arrangement using high-yield bars,  $f_y = 460 \text{ N/mm}^2$ , and grade C35A concrete for a 0.1 mm maximum crack width.

**(a) Ultimate limit state**

Ultimate tensile force =  $265 \times 1.4 = 371 \text{ kN/m}$

thus 
$$A_s = \frac{371 \times 10^3}{0.87 \times 460} = 927 \text{ mm}^2/\text{m}$$

**(b) Serviceability limit state**

Critical steel ratio to control thermal cracking from equation 6.12

$$r_{\text{crit}} = \frac{f_{\text{ct}}}{f_y} = \frac{1.6}{460} = 0.0035 \text{ as in section 11.3}$$

thus for continuous construction, maximum allowable section thickness for this steel area is given by

$$\frac{927}{1000h} = 0.0035$$

hence maximum  $h = 265 \text{ mm}$ .

Try  $h = 150$  (note that this is less than the 200 mm generally recommended but is used to illustrate procedures).

**Direct Tension in Mature Concrete**

Maximum crack width =  $0.1 \text{ mm} = 3 a_{\text{cr}} \epsilon_m$

thus for a 150 mm thick section, with 16 mm bars at 100 mm centres in one layer

$$A_s = 2010 \text{ mm}^2/\text{m} \text{ and strain } \epsilon_1 = \frac{\text{tension force}}{E_s A_s} = \frac{265 \times 10^3}{200 \times 10^3 \times 2010} = 0.00066$$

and from equation 11.4 
$$\epsilon_2 = \frac{b_t h}{E_s A_s} = \frac{1000 \times 150}{200 \times 10^3 \times 2010} = 0.00037$$

hence

$$\epsilon_m = \epsilon_1 - \epsilon_2 = 0.00066 - 0.00037 = 0.00029$$

Since from equation 11.2  $w_{\text{max}} = 3 a_{\text{cr}} \epsilon_m$

$$\text{maximum allowable } a_{\text{cr}} = \frac{0.1}{3 \times 0.00029} = 115 \text{ mm}$$

For 16 mm bars in one layer at 100 mm centres

$$a_{cr} = \sqrt{\left\{\left(\frac{100}{2}\right)^2 + \left(\frac{150}{2}\right)^2\right\}} - 8 = 82 \text{ mm which is less than } 115 \text{ mm (see example 6.4)}$$

∴ Crack width is less than 0.1 mm as required.

### *Direct Tension in Immature Concrete*

To control thermal and shrinkage cracking

$$\text{steel ratio } r = \frac{A_s}{bh} = \frac{2010}{1000 \times 150} = 0.013 (> r_{crit})$$

thus from equation 6.13  $s_{max} = \frac{f_{ct} \Phi}{f_b 2r}$  where  $f_{ct}/f_b = 0.67$  for high-yield bars

$$= \frac{0.67 \times 16}{2 \times 0.013} = 412 \text{ mm}$$

Thus for continuous construction with  $T_1 = 20^\circ\text{C}$ ,  $T_2 = 20^\circ\text{C}$  and  $\alpha_c = 10 \times 10^{-6}/^\circ\text{C}$ , equation 11.5 gives

$$w_{max} = s_{max} \frac{\alpha_c}{2} (T_1 + T_2) = 412 \times \frac{10 \times 10^{-6}}{2} (20 + 20) = 0.08 \text{ mm } (< 0.1 \text{ mm})$$

hence a 150 mm thick section with 16 mm bars at 100 mm centres in one central layer is acceptable.

Note: If a thicker section is used, thermal cracking will probably dominate since  $\epsilon_m$  in the direct tension calculation decreases while  $s_{max}$  increases. If the thickness exceeds 200 mm, steel should be provided in two equal layers.

### ***Example 11.3 Design of a Water-retaining Structure by the Limit State Method***

A cross-section of a long rectangular tank which is to be designed is shown in figure 11.8. The floor slab spans on to supporting beams at B and C. A grade C35A concrete and plain mild steel bars are to be used (1 m<sup>3</sup> of water weighs 9.81 kN). Aesthetic appearance is critical hence maximum crack width is 0.1 mm. It may be assumed that  $\alpha_c = 10 \mu\text{s}/^\circ\text{C}$  and  $E_s = 27 \text{ kN}/\text{mm}^2$ .

For the walls:  $h = 200 \text{ mm}$  and  $d = 150 \text{ mm}$  with  $T_1 = 20^\circ\text{C}$  and  $T_2 = 20^\circ\text{C}$

For the slab:  $h = 300 \text{ mm}$  and  $d = 250 \text{ mm}$  with  $T_1 = 15^\circ\text{C}$  and  $T_2 = 15^\circ\text{C}$

The design of the floor slab in this example illustrates the calculation of crack widths in the mature concrete.

#### **(i) Walls**

Maximum water pressure at base of wall =  $9.81 \times 2.0 = 19.62 \text{ kN}/\text{m}^2$ . For the effective span of the cantilever and considering a 1 m length of wall, the serviceability moment

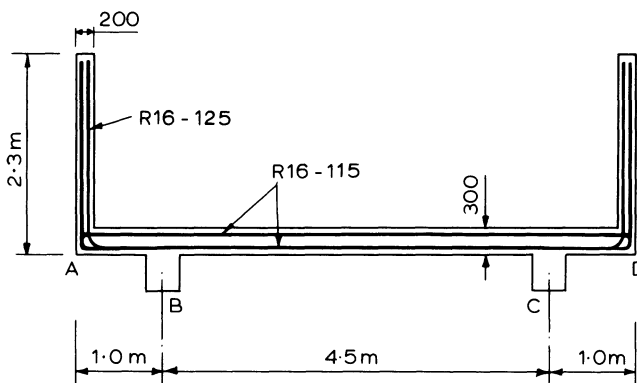

Figure 11.8 Water tank showing location of main reinforcement

$$M = \frac{1}{2} \times 19.62 \times 2.0 \left( \frac{2.0}{3} + \frac{0.15}{2} \right) = 14.6 \text{ kN m}$$

(a) *Ultimate Limit State*

This has been considered in example 11.1 giving a minimum requirement of  $659 \text{ mm}^2/\text{m}$ . (12 mm bars at 150 mm centres gives area =  $754 \text{ mm}^2/\text{m}$ .)

(b) *Serviceability Limit State*

*Flexural Tension in Mature Concrete*

Check the service stress in the reinforcement as in example 11.1 giving  $144 \text{ N/mm}^2$ . For 0.1 mm crack width limit this stress must be limited to  $85 \text{ N/mm}^2$  as in table 11.2.

Thus

$$\text{minimum } A_s = \frac{144}{85} \times 754 = 1277 \text{ mm}^2/\text{m}$$

Try 16 mm bars at 150 mm centres, area =  $1340 \text{ mm}^2/\text{m}$  which exceeds ultimate limit state requirements.

*Direct Tension in Immature Concrete*

To control thermal and shrinkage cracking, equation 6.12 gives

$$\text{critical steel ratio } r_{\text{crit}} = \frac{f_{\text{ct}}}{f_y} = \frac{1.6}{250} = 0.0064$$

thus

$$\text{minimum steel area} = 0.0064 bh = 0.0064 \times 1000 \times 200 = 1280 \text{ mm}^2/\text{m}$$

If 16 mm bars at 150 mm centres are provided in each face

$$r = \frac{2 \times 1340}{1000 \times 200} = 0.0134 \text{ and for plain bars } f_{ct} = f_b$$

then

$$s_{\max} = \frac{f_{ct}}{f_b} \times \frac{\Phi}{2r} = \frac{1.0 \times 16}{2 \times 0.0134} = 597 \text{ mm from equation 6.13}$$

giving a maximum crack width of  $w_{\max} = s_{\max} \frac{\alpha_c}{2} (T_1 + T_2)$  from equation 11.5

$$= 597 \times \frac{10 \times 10^{-6}}{2} (20 + 20) = 0.12 \text{ mm}$$

Since this exceeds the 0.1 mm allowable, close 16 mm steel to 125 mm centres in each face giving  $w_{\max} = 0.10 \text{ mm}$  which is just acceptable. Continuous construction is required vertically. Similar steel should be provided transversely assuming continuous construction along the length of the tank, or alternatively joints should be provided as illustrated in example 11.1.

(ii) Floors

The serviceability bending moment diagram is shown drawn on the tension side of the structure in figure 11.9.

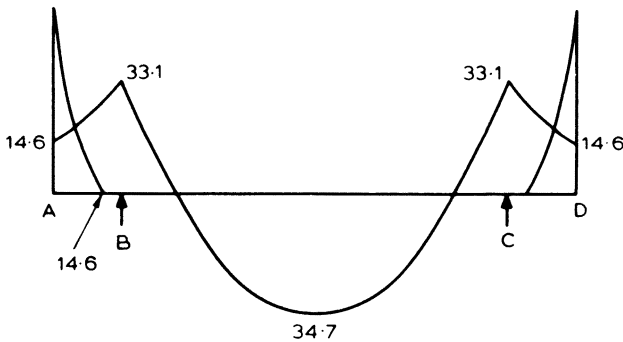

Figure 11.9 Bending-moment diagram (kN m)

Weight of slab + water =  $0.3 \times 24 + 9.81 \times 2 = 26.8 \text{ kN/m}^2$

Weight of wall =  $2.3 \times 0.2 \times 24 = 11.0 \text{ kN/m}$

Considering 1 m breadth of slab; at the supporting beam

$$M = 14.6 + 11.0 (1.0 - 0.1) + 26.8 \times 0.8^2 / 2 = 33.1 \text{ kN m hogging}$$

and at mid-span between B and C

$$M = 26.8 \times 4.5^2 / 8 - 33.1 = 34.7 \text{ kN m sagging}$$

The slab will also carry a direct tension force of

$$\frac{1}{2} \times 19.62 \times 2.0 = 19.62 \text{ kN/m}$$

which must be allowed for in the design. The critical section for bending is at mid-span.

(a) *Ultimate Limit State*

$$\text{Ultimate moment} = 1.4 \times 34.7 = 48.6 \text{ kN m/m}$$

$$\frac{M}{bd^2 f_{cu}} = \frac{48.6 \times 10^6}{1000 \times 250^2 \times 35} = 0.022, \text{ thus } l_a = 0.95$$

$$\text{and } A_s = \frac{48.6 \times 10^6}{0.87 \times 250 \times 0.95 \times 250} = 941 \text{ mm}^2/\text{m}$$

(b) *Serviceability Limit State*

*Flexural and Direct Tension in Mature Concrete*

Try 16 mm bars at 125 mm centres, area = 1610 mm<sup>2</sup>/m, as for walls then

$$a_{cr} = \sqrt{\left\{ \left( \frac{125}{2} \right)^2 + 50^2 \right\}} - 8 = 72 \text{ mm}$$

$$\text{and } \frac{\alpha_e A_s}{bd} = \frac{14.7 \times 1610}{1000 \times 250} = 0.095$$

hence  $\frac{x}{d} = 0.34$  from figure 4.29 and  $x = 85$  mm, thus equation 4.47 gives the bending stress in steel

$$f_s = \frac{M}{\left( d - \frac{x}{3} \right) A_s} = \frac{34.7 \times 10^6}{\left( 250 - \frac{85}{3} \right) 1610}$$

thus  $f_s = 97.2 \text{ N/mm}^2$

$$\text{and flexural strain} = \frac{(h-x)}{(d-x)} \frac{f_s}{E_s} = \frac{215}{165} \times \frac{97.2}{200 \times 10^3} = 0.63 \times 10^{-3}.$$

$$\text{Direct tensile strain} = \frac{\text{tension force}}{A_s E_s} = \frac{19.62 \times 10^3}{1610 \times 2 \times 200 \times 10^3} = 0.03 \times 10^{-3}.$$

Thus it is clear that flexural strain dominates, and total strain

$$\epsilon_1 = (0.63 + 0.03) \times 10^{-3} = 0.66 \times 10^{-3}$$

For 0.1 mm crack width limit

$$\epsilon_m = (\epsilon_1 - \epsilon_2) \text{ where } \epsilon_2 = \frac{1.5 b_t (h - x) (a' - x)}{3 E_s A_s (d - x)} \text{ according to equation 11.1}$$

$$\text{then } \epsilon_2 = \frac{1.5 \times 1000 (300 - 85) (300 - 85)}{3 \times 200 \times 10^3 \times 1610 (250 - 85)} = 0.43 \times 10^{-3}$$

$$\text{thus } \epsilon_m = (0.66 - 0.43) \times 10^{-3} = 0.23 \times 10^{-3}$$

and equation 6.10 gives

$$w_{\max} = \frac{3 a_{\text{cr}} \epsilon_m}{1 + 2 \left( \frac{a_{\text{cr}} - c_{\min}}{h - x} \right)} = \frac{3 \times 72 \times 0.23 \times 10^{-3}}{1 + 2 \left( \frac{72 - 40}{300 - 85} \right)}$$

$$= 0.038 \text{ mm}$$

which is acceptable.

#### *Direct Tension in Immature Concrete*

To control thermal and shrinkage cracking the critical steel ratio  $r_{\text{crit}} = 0.0064$ , thus minimum  $A_s = 0.0064 A_c$ .

$$\therefore A_s = 0.0064 \times 1000 \times 300 = 1920 \text{ mm}^2/\text{m}$$

thus proposed 16 mm at 125 mm centres in each face, area = 3220 mm<sup>2</sup>/m, satisfies this requirement.

$$r = \frac{A_s}{A_c} = \frac{3220}{1000 \times 300} = 0.0107$$

$$\text{then } s_{\max} = \frac{f_{\text{ct}}}{f_b} \times \frac{\Phi}{2r} = \frac{1.0 \times 16}{2 \times 0.0107} = 748 \text{ mm from equation 6.13}$$

with equation 11.5 giving a maximum crack width

$$w_{\max} = s_{\max} \frac{\alpha}{2} (T_1 + T_2)$$

$$= 748 \times \frac{10}{2} \times 10^{-6} (15 + 15)$$

$$= 0.11 \text{ mm}$$

This just exceeds the allowable limit, and since continuous construction is required in the direction of the span 16 mm bar spacing should be reduced to 115 mm centres in both faces, area = 3500 mm<sup>2</sup>/m. The design of the slab is thus governed by thermal cracking requirements, and hogging moments at A and B are adequately covered. Similar reinforcement will be required transversely unless closely spaced joints are provided according to table 11.1.

#### **11.4.2 Elastic Design**

This method is based on working loads, and permissible stresses in the concrete and steel which are considered to be acting within the elastic range. Hence the

design assumes a triangular stress block as analysed in section 4.10. The ratio ( $\alpha_e$ ) of the modulus of elasticity of steel to that of concrete is taken as 15.

Calculations are performed on the basis of two criteria: strength, and resistance to cracking, with exposure class related to allowable crack widths.

Strength calculations assume a cracked section. Low permissible steel stresses are specified in order to limit the width of cracks and thus reduce the chance of leakage and corrosion of the reinforcement.

The analysis for resistance to cracking assumes a limiting tensile stress in the concrete and is based on an uncracked concrete section. The governing factor in such an analysis is inevitably the permissible tensile stress in the concrete, with the steel and concrete stresses being related by the compatibility of strains across the section.

Reference should be made to previous editions of this book for a more detailed treatment of this design approach.

## 11.5 Retaining Walls

Such walls are usually required to resist a combination of earth and hydrostatic loadings. The fundamental requirement is that the wall is capable of holding the retained material in place without undue movement arising from deflection, overturning or sliding.

### 11.5.1 Types of Retaining Wall

Concrete retaining walls may be considered in terms of three basic categories: (1) gravity, (2) counterfort, and (3) cantilever. Within these groups many common variations exist, for example cantilever walls may have additional supporting ties into the retained material.

The structural action of each type is fundamentally different, but the techniques used in analysis, design and detailing are those normally used for concrete structures.

#### (i) Gravity Walls

These are usually constructed of mass concrete, with reinforcement included in the faces to restrict thermal and shrinkage cracking. As illustrated in figure 11.10, reliance is placed on self-weight to satisfy stability requirements, both in respect of overturning and sliding.

It is generally taken as a requirement that under working conditions the resultant of the self-weight and overturning forces must lie within the middle third at the interface of the base and soil. This ensures that uplift is avoided at this interface, as described in section 10.1. Friction effects which resist sliding are thus maintained across the entire base.

Bending, shear, and deflections of such walls are usually insignificant in view of the large effective depth of the section. Distribution steel to control thermal crack-

ing is necessary, however, and great care must be taken to reduce hydration temperatures by mix design, construction procedure and curing techniques.

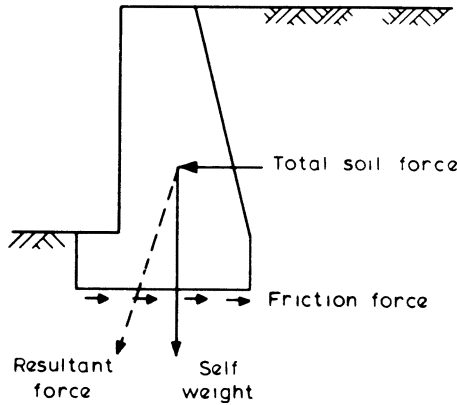

Figure 11.10 Gravity wall

*(ii) Counterfort Walls*

This type of construction will probably be used where the overall height of wall is too large to be constructed economically either in mass concrete or as a cantilever.

The basis of design of counterfort walls is that the earth pressures act on a thin wall which spans horizontally between the massive counterforts (figure 11.11). These must be sufficiently large to provide the necessary dead load for stability requirements, possibly with the aid of the weight of backfill on an enlarged base. The counterforts must be designed with reinforcement to act as cantilevers to resist the considerable bending moments that are concentrated at these points.

The spacing of counterforts will be governed by the above factors, coupled with the need to maintain a satisfactory span-depth ratio on the wall slab, which must be designed for bending as a continuous slab. The advantage of this form of construction is that the volume of concrete involved is considerably reduced, thereby removing many of the problems of large pours, and reducing the quantities of excavation. Balanced against this must be considered the generally increased shuttering complication and the probable need for increased reinforcement.

*(iii) Cantilever Walls*

These are designed as vertical cantilevers spanning from a large rigid base which often relies on the weight of backfill on the base to provide stability. Two forms of this construction are illustrated in figure 11.12. In both cases, stability calculations follow similar procedures to those for gravity walls to ensure that the resultant force lies within the middle third of the base and that overturning and sliding requirements are met.

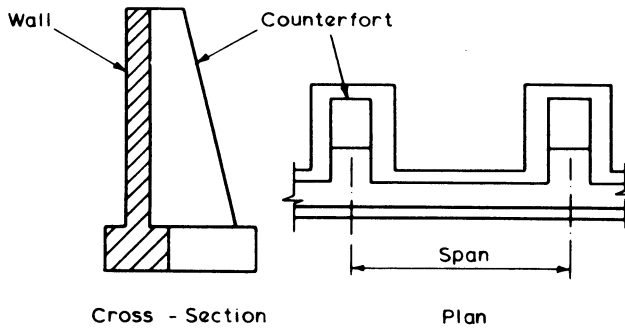

Figure 11.11 Counterfort wall

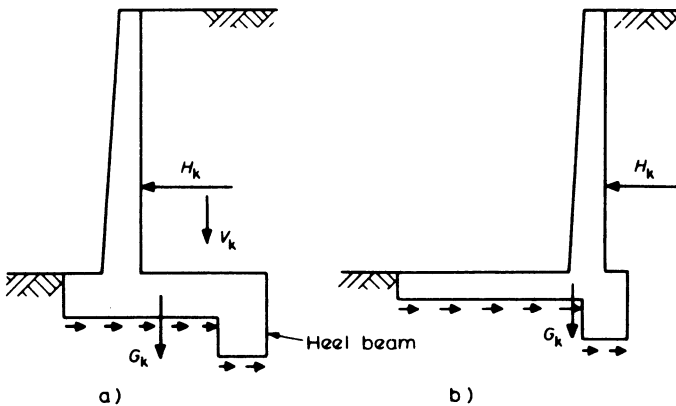

Figure 11.12 Cantilever walls

### 11.5.2 Analysis and Design

The design of retaining walls may be split into three fundamental stages: (1) Stability analysis – ultimate limit state, (2) Bearing pressure analysis – serviceability limit state, and (3) Member design and detailing – ultimate and serviceability limit states.

#### (i) Stability Analysis

Under the action of the loads corresponding to the ultimate limit state, a retaining wall must be stable in terms of resistance to overturning and sliding. This is demonstrated by the simple case of a gravity wall as shown in figure 11.13.

The critical conditions for stability are when a maximum horizontal force acts with a minimum vertical load. To guard against a stability failure, it is usual to

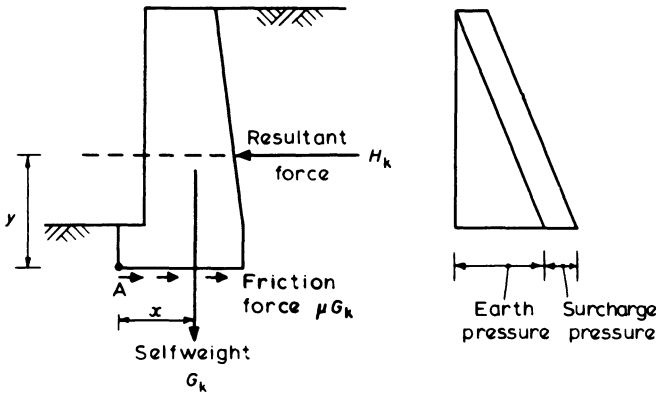

Figure 11.13 Forces and pressures on a gravity wall

apply conservative factors of safety to the force and loads. The values given in table 2.2 are appropriate to strength calculations but a value of  $\gamma_f = 1.6$  or higher should be used for stability calculations.

If this force is predominantly hydrostatic and well defined, a factor of 1.4 may be used. A partial factor of safety of  $\gamma_f = 1.0$  is usually applied to the dead load  $G_k$ .

For resistance to overturning, moments would normally be taken about the toe of the base, point A on figure 11.13, thus the requirement is that

$$1.0G_k x \geq \gamma_f H_k y \tag{11.6}$$

Resistance to sliding is provided by friction between the underside of the base and the ground, and thus is also related to total self-weight  $G_k$ . Resistance provided by the passive earth pressure on the front face of the base may make some contribution, but since this material is often backfilled against the face, this resistance cannot be guaranteed and is usually ignored. Thus, if the coefficient of friction between base and soil is  $\mu$ , the total friction force will be given by  $\mu G_k$  for the length of wall of weight  $G_k$ ; and the requirement is that

$$1.0\mu G_k \geq \gamma_f H_k \tag{11.7}$$

where  $H_k$  is the horizontal force on this length of wall.

If this criterion is not met, a heel beam may be used, and the force due to the passive earth pressure over the face area of the heel may be included in resisting the sliding force. The partial load factor  $\gamma_f$  on the heel beam force should be taken as 1.0 to give the worst condition. To ensure the proper action of a heel beam, the front face must be cast directly against sound, undisturbed material, and it is important that this is not overlooked during construction.

In considering cantilever walls, a considerable amount of backfill is often placed on top of the base, and this is taken into account in the stability analysis. The forces acting in this case are shown in figure 11.14. In addition to  $G_k$  and  $H_k$  there is an additional vertical load  $V_k$  due to the material above the base acting a

distance  $q$  from the toe. The worst condition for stability will be when this is at a minimum; therefore a partial load factor  $\gamma_f = 1.0$  is appropriate. The stability requirements then become

$$1.0G_k x + 1.0V_k q \geq \gamma_f H_k y \quad \text{for overturning} \quad (11.8)$$

$$\mu(1.0G_k + 1.0V_k) \geq \gamma_f H_k \quad \text{for sliding} \quad (11.9)$$

When a heel beam is provided the additional passive resistance of the earth must be included in equation 11.9.

Stability analysis, as described here, will normally suffice. However, if there is doubt about the foundation material in the region of the wall or the reliability of loading values, it may be necessary to perform a full slip-circle analysis, using techniques common to soil mechanics, or to use increased factors of safety.

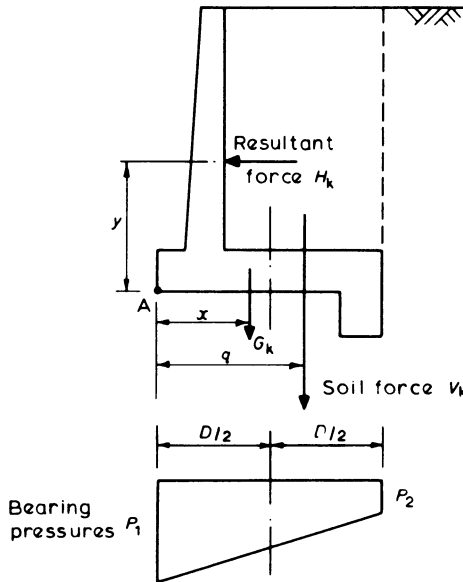

Figure 11.14 Forces on a cantilever wall

(ii) Bearing Pressure Analysis

As with foundations, the bearing pressures underneath retaining walls are assessed on the basis of the serviceability limit state when determining the size of base that is required. The analysis will be similar to that discussed in section 10.1 with the foundation being subject to the combined effects of an eccentric vertical load, coupled with an overturning moment.

Considering a unit length of the cantilever wall (figure 11.14) the resultant moment about the centroidal axis of the base is

$$M = \gamma_{f1} H_k y + \gamma_{f2} G_k (D/2 - x) + \gamma_{f3} V_k (D/2 - q) \quad (11.10)$$

and the vertical load is

$$N = \gamma_{f2} G_k + \gamma_{f3} V_k \quad (11.11)$$

where in this case for the serviceability limit state the partial factors of safety are

$$\gamma_{f1} = \gamma_{f2} = \gamma_{f3} = 1.0$$

The distribution of bearing pressures will be as shown in the figure, provided the effective eccentricity lies within the 'middle third' of the base, that is

$$\frac{M}{N} \leq \frac{D}{6}$$

The maximum bearing pressure is then given by

$$p_1 = \frac{N}{D} + \frac{M}{I} \times \frac{D}{2}$$

where  $I = D^3/12$ . Therefore

$$p_1 = \frac{N}{D} + \frac{6M}{D^2} \quad (11.12)$$

and

$$p_2 = \frac{N}{D} - \frac{6M}{D^2} \quad (11.13)$$

### (iii) Member Design and Detailing

As with foundations, the design of bending and shear reinforcement is based on an analysis of the loads for the ultimate limit state, with the corresponding bearing pressures. Gravity walls will seldom require bending or shear steel, while the walls in counterfort and cantilever construction will be designed as slabs. The design of counterforts will generally be similar to that of a cantilever beam unless they are massive.

With a cantilever-type retaining wall the stem is designed to resist the moment caused by the force  $\gamma_f H_f$ , with  $\gamma_f = 1.4$  or larger, depending on how accurately the load may be predicted. For preliminary sizing, the thickness of the wall may be taken as 80 mm per metre depth of backfill.

The thickness of the base is usually of the same order as that of the stem. The heel and toe must be designed to resist the moments due to the upward earth bearing pressures and the downward weight of the soil and base. The soil bearing pressures are calculated from equations 11.10 to 11.13, provided the resultant of the horizontal and vertical forces lies within the 'middle third'. Should the resultant lie outside the 'middle third', then the bearing pressures should be calculated using equation 10.4. The partial factors of safety  $\gamma_{f1}$ ,  $\gamma_{f2}$  and  $\gamma_{f3}$  should be taken to provide a combination which gives the critical design condition.

Reinforcement detailing must follow the general rules for slabs and beams as appropriate. Particular care must be given to the detailing of reinforcement to

limit shrinkage and thermal cracking. Gravity walls are particularly vulnerable because of the large concrete pours that are generally involved, and these should be treated in the manner described in section 11.1 for thick sections.

Restraints to thermal and shrinkage movement should be reduced to a minimum; however, this is counteracted in the construction of bases by the need for good friction between the base and soil; thus a sliding layer is not possible. Reinforcement in the bases must thus be adequate to control the cracking caused by a high degree of restraint. Long walls restrained by the rigid bases are particularly susceptible to cracking during thermal movement due to loss of hydration heat, and detailing must attempt to distribute these cracks to ensure acceptable widths. Complete vertical movement joints must be provided, and the methods used for the design of joints for water-retaining structures can be used. These joints will often incorporate a shear key to prevent differential movement of adjacent sections of wall, and waterbars and sealers should be used as shown in figure 11.4a.

The back faces of retaining walls will usually be subject to hydrostatic forces from groundwater. This may be reduced by the provision of a drainage path at the face of the wall. It is usual practice to provide such a drain by a layer of rubble or porous blocks as shown in figure 11.15, with pipes to remove the water, often through to the front of the wall. In addition to reducing the hydrostatic pressure on the wall, the likelihood of leakage through the wall is reduced, and water is also less likely to reach and damage the soil beneath the foundations of the wall.

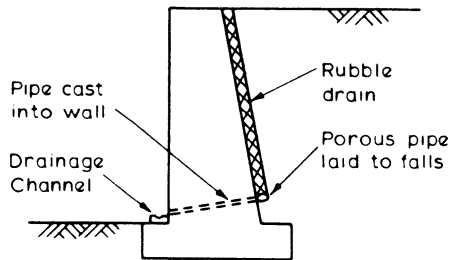

Figure 11.15 *Drainage layer*

#### **Example 11.4 Design of a Retaining Wall**

The cantilever retaining wall shown in figure 11.16 supports a granular material of saturated density  $2000 \text{ kg/m}^3$ , and the allowable bearing pressure is  $110 \text{ kN/m}^2$ . It is required to

- (1) check the stability of the wall
- (2) determine the actual bearing pressures, and
- (3) design the bending reinforcement using high-yield steel,  $f_y = 460 \text{ N/mm}^2$  and grade 35 concrete.

(a) Stability

Horizontal force: it is assumed that the coefficient of active pressure  $K_a = 0.33$ , which is a typical value for a granular material. So the earth pressure is given by

$$p = K_a \rho g h$$

where  $\rho$  is the density of the backfill and  $h$  is the depth considered. Thus, at the base

$$\begin{aligned} p &= 0.33 \times 2000 \times 10^{-3} \times 9.81 \times 4.9 \\ &= 31.7 \text{ kN/m}^2 \end{aligned}$$

Therefore horizontal force on 1 m length of wall is

$$H_k = 0.5 p h = 0.5 \times 31.7 \times 4.9 = 77.7 \text{ kN}$$

Vertical loads

$$\begin{aligned} \text{wall} &= \frac{1}{2}(0.4 + 0.3) \times 4.5 \times 24 &= 37.8 \text{ kN} \\ \text{base} &= 0.4 \times 3.4 \times 24 &= 32.6 \\ \text{earth} &= 2.2 \times 4.5 \times 2000 \times 10^{-3} \times 9.81 = \underline{194.2} \\ \text{Total} &= 264.6 \text{ kN} \end{aligned}$$

For stability calculations a partial factor of safety of 1.6 is used for the lateral loadings, while 1.4 will be used for strength calculations.

(i) Sliding: from equation 11.9 it is necessary that

$$\mu(1.0G_k + 1.0V_k) \geq \gamma_f H_k \text{ for no heel beam}$$

Assuming a value of coefficient of friction  $\mu = 0.45$

$$\text{frictional resisting force} = 0.45 \times 1.0 \times 264.6 = 119.1 \text{ kN}$$

$$\text{sliding force} = 1.6 \times 77.7 = 124.3 \text{ kN}$$

Since the sliding force exceeds the frictional force, resistance must also be provided by the passive earth pressure acting against the heel beam and this force is given by

$$H_p = \gamma_f \times 0.5 K_p \rho g a^2$$

where  $K_p$  is the coefficient of passive pressure, assumed to be 3.0 for this granular material and  $a$  is the depth of the heel. Therefore

$$\begin{aligned} H_p &= 1.0 \times 0.5 \times 3.0 \times 2000 \times 10^{-3} \times 9.81 \times 0.6^2 \\ &= 10.6 \text{ kN} \end{aligned}$$

Therefore total resisting force is

$$119.1 + 10.6 = 129.7 \text{ kN}$$

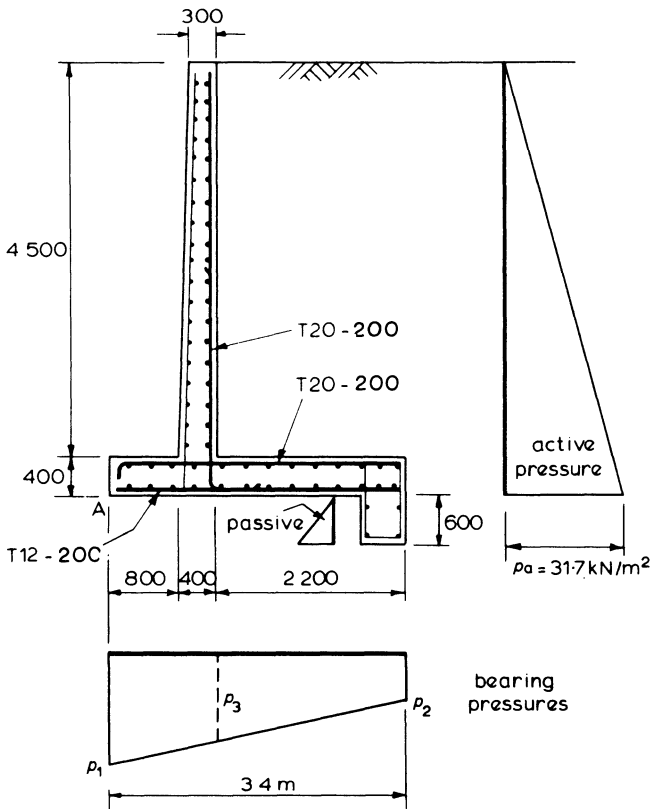

Figure 11.16

which exceeds the sliding force.

(ii) Overturning: taking moments about point A at the edge of the toe, at the ultimate limit state

$$\begin{aligned} \text{overturning moment} &= \gamma_f H_k h / 3 = 1.6 \times 77.7 \times 4.9 / 3 \\ &= 203 \text{ kN m} \end{aligned}$$

$$\begin{aligned} \text{restraining moment} &= 1.0 (37.8 \times 1.0 + 32.6 \times 1.7 \\ &\quad + 194.2 \times 2.3) \\ &= 540 \text{ kN m} \end{aligned}$$

Thus the criterion for overturning is satisfied.

(b) Bearing Pressures

From equations 11.12 and 11.13 the bearing pressures are given by

$$p = \frac{N}{D} \pm \frac{6M}{D^2}$$

where  $M$  is the moment about the base centre-line. Therefore

$$\begin{aligned} M &= 77.7 \times 4.9/3 + 37.8(1.7 - 1.0) + 194.2(1.7 - 2.3) \\ &= 126.9 + 26.5 - 116.5 = 36.9 \text{ kN m} \end{aligned}$$

Therefore

$$\begin{aligned} \text{maximum bearing pressure } p_1 &= \frac{264.6}{3.4} + \frac{6 \times 36.9}{3.4^2} \\ &= 77.8 + 19.2 = 97 \text{ kN/m}^2 \end{aligned}$$

which is less than the allowable.

(c) Bending Reinforcement

(i) Wall

$$\begin{aligned} \text{Horizontal force} &= \gamma_f 0.5 K_a \rho g h^2 \\ &= 1.4 \times 0.5 \times 0.33 \times 2000 \times 10^{-3} \times 9.81 \times 4.5^2 \\ &= 91.8 \text{ kN} \end{aligned}$$

considering the effective span, the maximum moment is

$$\begin{aligned} M &= 91.8(0.2 + 4.5/3) = 156 \text{ kN m} \\ \frac{M}{bd^2 f_{cu}} &= \frac{156 \times 10^6}{1000 \times 330^2 \times 35} = 0.04 \end{aligned}$$

for which  $l_a = 0.95$  (figure 7.5). Therefore

$$A_s = \frac{156 \times 10^6}{0.95 \times 330 \times 0.87 \times 460} = 1243 \text{ mm}^2/\text{m}$$

Provide T20 bars at 200 mm centres.

(ii) Base: the bearing pressures are obtained from equations 11.10 to 11.13. The critical partial factors of safety are

$$\gamma_{f1} = 1.4 \text{ and } \gamma_{f2} = \gamma_{f3} = 1.0$$

Using the figures from part (b) of this example, the moment about the base centre-line is

$$M = \gamma_{f1} \times 126.9 + \gamma_{f2} \times 26.5 - \gamma_{f3} \times 116.5 = 87.7 \text{ kN m}$$

and

$$N = \gamma_{f2}(37.8 + 32.6) + \gamma_{f3} \times 194.2 = 264.6 \text{ kN}$$

Therefore

$$\text{pressure } p_1 = \frac{264.6}{3.4} + \frac{6 \times 87.7}{3.4^2} = 78 + 45 = 123 \text{ kN/m}^2$$

$$p_2 = 78 - 45 = 33 \text{ kN/m}^2$$

and in figure 11.16

$$p_3 = 33 + (123 - 33) 2.2/3.4 = 91 \text{ kN/m}^2$$

Heel: taking moments about the stem centre-line for the vertical loads and the bearing pressures

$$\begin{aligned} M &= \gamma_{f2} \times 32.6 \times 1.3 \times \frac{2.2}{3.4} + \gamma_{f3} \times 194.2 \times 1.3 - 33 \\ &\quad \times 2.2 \times 1.3 - (91 - 33) \times \frac{2.2}{2} \times 0.93 = 126 \text{ kN m} \end{aligned}$$

therefore

$$A_s = \frac{126 \times 10^6}{0.87 \times 460 \times 0.95 \times 330} = 1004 \text{ mm}^2/\text{m}$$

Provide T20 bars at 200 mm centres, top steel

Toe: taking moments about the stem centre-line

$$\begin{aligned} M &\approx \gamma_{f2} \times 32.6 \times 0.6 \times \frac{0.8}{3.4} - \gamma_{f3} \times 123 \times 0.8 \times 0.6 \\ &= 55 \text{ kN m} \end{aligned}$$

(In fact for this wall the design moment for the toe would be marginally higher with  $\gamma_{f2} = 1.4$  and  $\gamma_{f3} = 1.4$  throughout.)

$$A_s = \frac{55 \times 10^6}{0.87 \times 460 \times 0.95 \times 330} = 438 \text{ mm}^2/\text{m}$$

The minimum area for this, and for longitudinal distribution steel which is also required in the wall and the base is

$$A_s = 0.13 \times 1000 \times 400 = 520 \text{ mm}^2/\text{m}$$

Thus, provide T12 bars at 200 mm centres, bottom and distribution steel.

Also steel should be provided in the compression face of the wall in order to prevent cracking – say, T10 bars at 200 mm centres each way.

Bending reinforcement is required in the heel beam to resist the moment due to the passive earth pressure. This reinforcement would probably be in the form of closed links.

# 12

## Prestressed Concrete

The analysis and design of prestressed concrete is a specialised field which cannot possibly be covered comprehensively in one chapter. This chapter concentrates therefore on the basic principles of prestressing, and the analysis and design of statically determinate members in bending for the serviceability and ultimate limit states.

A fundamental aim of prestressed concrete is to limit tensile stresses, and hence flexural cracking, in the concrete under working conditions. Design is therefore based initially on the requirements of the serviceability limit state. Subsequently considered are ultimate limit state criteria for bending and shear. In addition to the concrete stresses under working loads, deflections must be checked, and attention must also be paid to the construction stage when the prestress force is first applied to the immature concrete. This stage is known as the *transfer condition*.

Design of prestressed concrete may therefore be summarised as

- (1) design for serviceability – cracking
- (2) check stresses at transfer
- (3) check deflections
- (4) check ultimate limit state – bending
- (5) design shear reinforcement for ultimate limit state.

The stages are illustrated by the flow chart in figure 12.1.

When considering the basic design of a concrete section subject to prestress, the stress distribution due to the prestress must be combined with the stresses from the loading conditions to ensure that permissible stress limits are satisfied. Many analytical approaches have been developed to deal with this problem; however, it is considered that the method presented offers many advantages of simplicity and ease of manipulation in design.

### 12.1 Principles of Prestressing

In the design of a reinforced concrete beam subjected to bending it is accepted that the concrete in the tensile zone is cracked, and that all the tensile resistance is

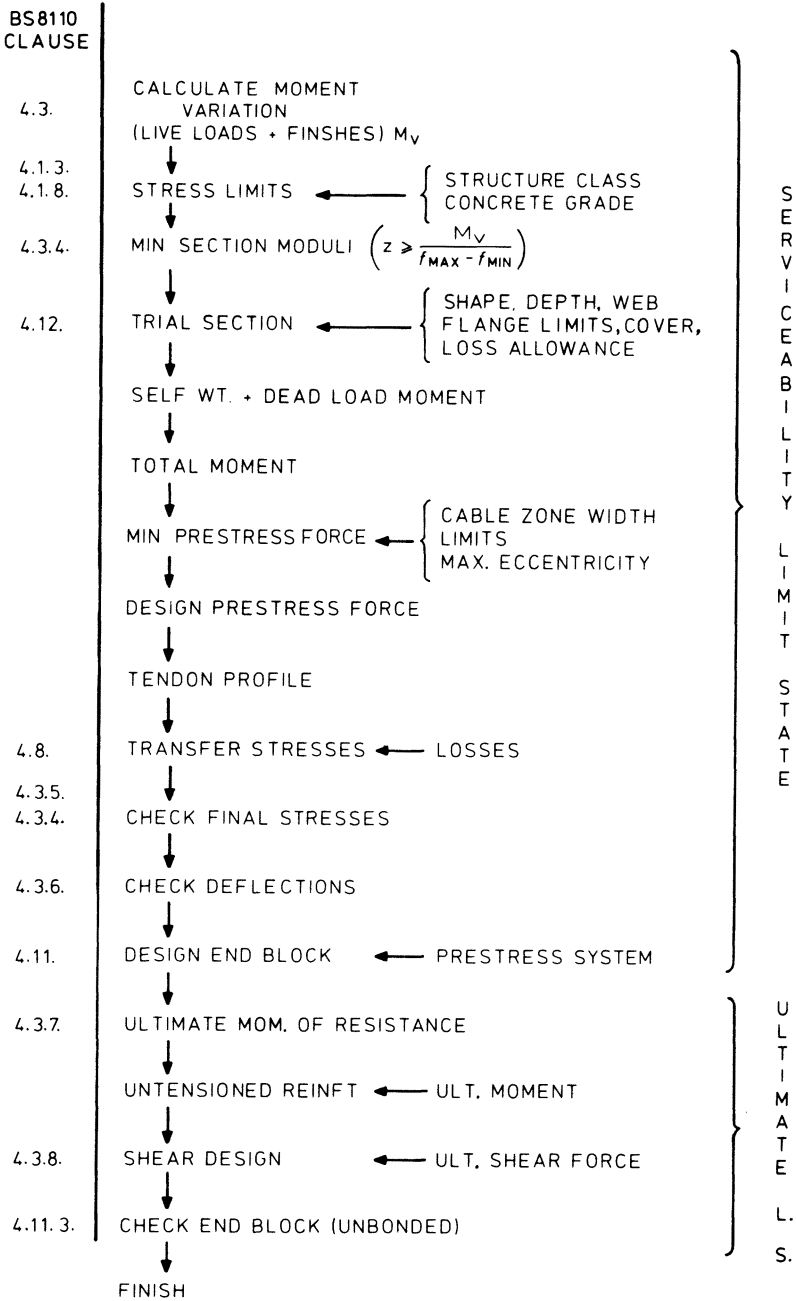

Figure 12.1 Prestressed concrete design flow chart

provided by the reinforcement. The stress that may be permitted in the reinforcement is limited by the need to keep the cracks in the concrete to acceptable widths under working conditions, thus there is no advantage to be gained from the use of very high strength steels which are available. The design is therefore uneconomic in two respects: (1) dead weight includes 'useless' concrete in tensile zone, and (2) economic use of steel resources is not possible.

'Prestressing' means the artificial creation of stresses in a structure before loading, so that the stresses which then exist under load are more favourable than would otherwise be the case. Since concrete is strong in compression the material in a beam will be used most efficiently if it can be maintained in a state of compression throughout. Provision of a longitudinal compressive force acting on a concrete beam may therefore overcome both of the disadvantages of reinforced concrete cited above. Not only is the concrete fully utilised, but also the need for conventional tension reinforcement is removed. The compressive force is usually provided by tensioned steel wires or strands which are anchored against the concrete and, since the stress in this steel is not an important factor in the behaviour of the beam but merely a means of applying the force, full advantage may be taken of very high strength steels.

The way in which the stresses due to bending and an applied compressive force may be combined are demonstrated in figure 12.2 for the case of an axially applied force acting over the length of a beam. The stress distribution at any section will equal the sum of the compression and bending stresses if it is assumed that the concrete behaves elastically. Thus it is possible to determine the applied force so that the combined stresses are always compressive.

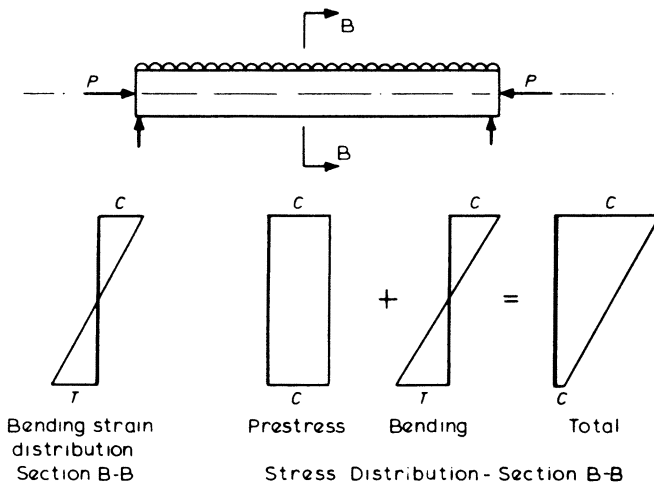

Figure 12.2 Effects of axial prestress

By applying the compressive force eccentrically on the concrete cross-section, a further stress distribution, due to the bending effects of the couple thus created, is added to those shown in figure 12.2. This effect is illustrated in figure 12.3 and offers further advantages when attempting to produce working stresses within required limits.

Early attempts to achieve this effect were hampered both by the limited steel strengths available and by shrinkage and creep of the concrete under sustained compression, coupled with relaxation of the steel. These meant that the steel lost a large part of its initial pretension and as a result residual stresses were so small as to be useless. It is now possible, however, to produce stronger concretes which have good creep properties, and very high strength steels which can be stressed up to a high percentage of their 0.2 per cent proof stress are also available. For example, hard-drawn wires may carry stresses up to about six times those possible in mild steel. This not only results in savings of steel quantity, but also the effects of shrinkage and creep become relatively smaller and may typically amount to the loss of only about 25 per cent of the initial applied force. Thus, modern materials mean that the prestressing of concrete is a practical proposition, with the forces being provided by steel passing through the beam and anchored at each end while under high tensile load.

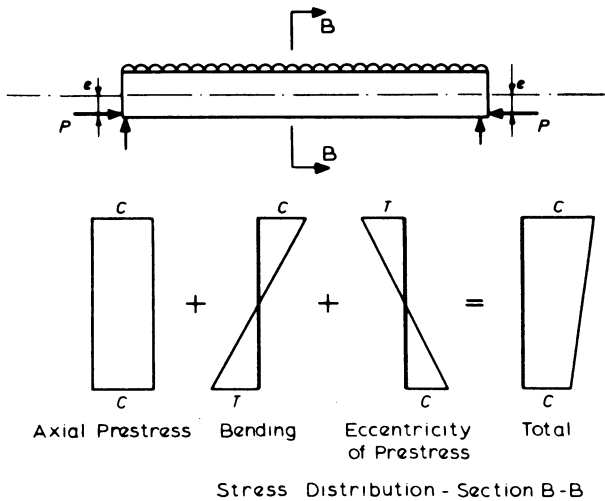

Figure 12.3 Effects of eccentric prestress

## 12.2 Methods of Prestressing

Two basic techniques are commonly employed in the construction of prestressed concrete, their chief difference being whether the steel tensioning process is performed before or after the hardening of the concrete. The choice of method will be governed largely by the type and size of member coupled with the need for precast or *in situ* construction.

**12.2.1 Pretensioning**

In this method the steel wires or strands are stretched to the required tension and anchored to the ends of the moulds for the concrete. The concrete is cast around the tensioned steel, and when it has reached sufficient strength, the anchors are released and the force in the steel is transferred to the concrete by bond. In addition to long-term losses due to creep, shrinkage and relaxation, an immediate drop in prestress force occurs due to elastic shortening of the concrete. These features are illustrated in figure 12.4.

Because of the dependence on bond, the tendons for this form of construction generally consist of small diameter wires or small strands which have good bond characteristics. Anchorage near the ends of these wires is often enhanced by the provision of small indentations in the surface of the wire.

The method is ideally suited for factory production where large numbers of identical units can be economically made under controlled conditions, a development of this being the 'long-line' system where several units can be cast at once – end to end – and the tendons merely cut between each unit after release of the anchorages. An advantage of factory production of prestressed units is that specialised curing techniques such as steam curing can be employed to increase the rate of hardening of the concrete and to enable earlier 'transfer' of the stress to the concrete. This is particularly important where re-use of moulds is required, but it is essential that under no circumstances must calcium chloride be used as an

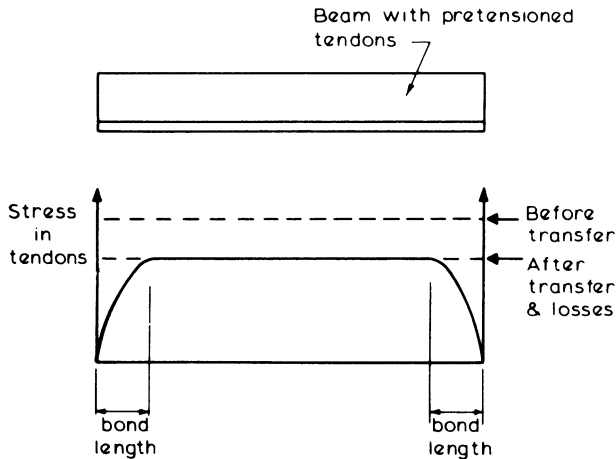

**Figure 12.4** *Tendon stresses – pretensioning*

accelerator because of its severe corrosion action on small diameter steel wires.

One major limitation of this approach is that tendons must be straight, which may cause difficulties when attempting to produce acceptable final stress levels throughout the length of a member. It may therefore be necessary to reduce either the prestress force or eccentricity of force near the ends of a member, in which case tendons must either be 'debonded' or 'deflected'.

- (1) Debonding consists of applying a wrapping or coating to the steel to prevent bond developing with the surrounding concrete. Treating some of the wires in this way over part of their length allows the magnitude of effective prestress force to be varied along the length of a member.
- (2) Deflecting tendons is a more complex operation and is usually restricted to large members, such as bridge beams, where the individual members may be required to form part of a continuous structure in conjunction with *in situ* concrete slabs and sill beams. A typical arrangement for deflecting tendons is shown in figure 12.5, but it must be appreciated that substantial ancillary equipment is required to provide the necessary reactions.

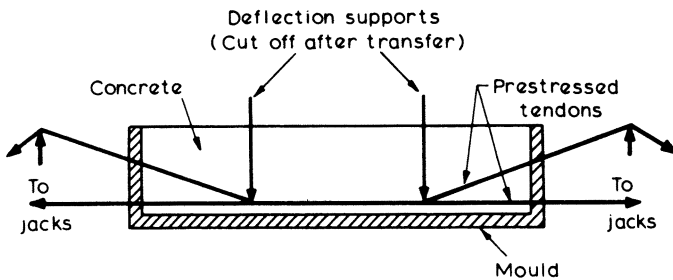

Figure 12.5 Tendon deflection

### 12.2.2 Post-tensioning

This method, which is the most suitable for *in situ* construction, involves the stressing against the hardened concrete of tendons or steel bars which are not bonded to the concrete. The tendons are passed through a flexible sheathing, which is cast into the concrete in the correct position. They are tensioned by jacking against the concrete, and anchored mechanically by means of steel thrust

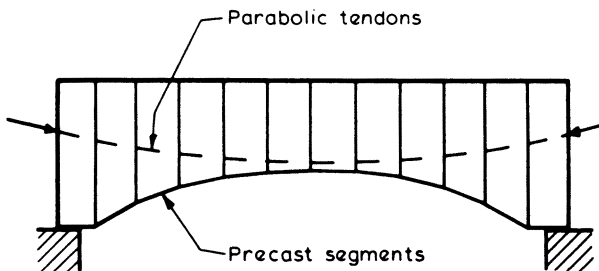

Figure 12.6 Post-tensioned segmental construction

plates or anchorage blocks at each end of the member. Alternatively, steel bars threaded at their ends may be tensioned against bearing plates by means of tightening nuts. It is of course usually necessary to wait a considerable time between casting and stressing to permit the concrete to gain sufficient strength under *in situ* conditions.

The use of tendons consisting of a number of strands passing through flexible sheathing offers considerable advantages in that curved tendon profiles may be obtained. A post-tensioned structural member may be constructed from an assembly of separate pre-cast units which are constrained to act together by means of tensioned cables which are often curved as illustrated in figure 12.6. Alternatively, the member may be cast as one unit in the normal way but a light cage of untensioned reinforcing steel is necessary to hold the ducts in their correct position during concreting.

After stressing, the remaining space in the ducts may be left empty ('unbonded' construction), or more usually will be filled with grout under high pressure ('bonded' construction). Although this grout assists in transmitting forces between the steel and concrete under live loads, and improves the ultimate strength of the member, the principal use is to protect the highly stressed strands from corrosion. The bonding of the highly stressed steel with the surrounding concrete beam also greatly assists demolition, since the beam may then safely be 'chopped-up' into small lengths without releasing the energy stored in the steel.

### 12.3 Analysis of Concrete Section under Working Loads

Since the object of prestressing is to maintain favourable stress conditions in a concrete member under load, the 'working load' for the member must be considered in terms of both maximum and minimum values. Thus at any section, the stresses produced by the prestress force must be considered in conjunction with the stresses caused by maximum and minimum values of applied moment.

Unlike reinforced concrete, the primary analysis of prestressed concrete is based on service conditions, and on the assumption that stresses in the concrete are limited to values which will correspond to elastic behaviour. In this section, the following assumptions are made in analysis.

- (1) Plane sections remain plane.
- (2) Stress-strain relationships are linear.
- (3) Bending occurs about a principal axis.
- (4) The prestressing force is the value remaining after all losses have occurred.
- (5) Changes in tendon stress due to applied loads on the member have negligible effect on the behaviour of the member.
- (6) Section properties are generally based on the gross concrete cross-section.

The stress in the steel is unimportant in the analysis of the concrete section under working conditions, it being the force provided by the steel that is considered in the analysis.

The sign conventions and notations used for the analysis are indicated in figure 12.7.

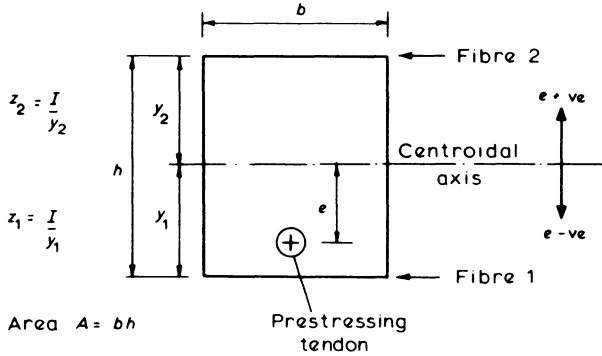

Figure 12.7 Sign convention and notation

For direct and bending stresses, compression is taken as positive – and a positive moment is defined as one which causes a numerically greater stress to occur in fibre 2 than in fibre 1, that is  $f_2$  greater than  $f_1$  corresponds to a positive moment, hence sagging is positive. To fit this convention, the eccentricity of the prestress force from the centroidal axis must thus be taken as having a negative value if below the axis and positive if above.

12.3.1 Member Subjected to Axial Prestress Force

If section BB of the member shown in figure 12.8 is subjected to moments ranging between  $M_{max}$  and  $M_{min}$ , the net stresses at the outer fibres of the beam are given by

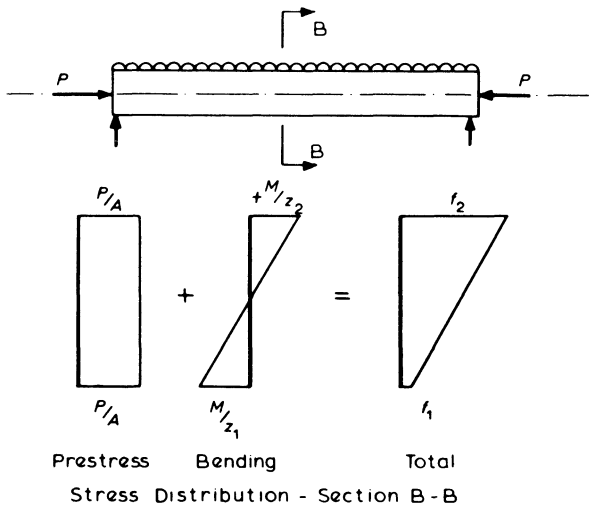

Figure 12.8 Stresses in member with axial prestress force

$$\text{under } M_{\max} \left\{ \begin{array}{l} f_2 = \frac{P}{A} + \frac{M_{\max}}{z_2} \quad \text{at the top} \end{array} \right. \quad (12.1)$$

$$\left\{ \begin{array}{l} f_1 = \frac{P}{A} - \frac{M_{\max}}{z_1} \quad \text{at the bottom} \end{array} \right. \quad (12.2)$$

$$\text{under } M_{\min} \left\{ \begin{array}{l} f_2 = \frac{P}{A} + \frac{M_{\min}}{z_2} \quad \text{at the top} \end{array} \right. \quad (12.3)$$

$$\left\{ \begin{array}{l} f_1 = \frac{P}{A} - \frac{M_{\min}}{z_1} \quad \text{at the bottom} \end{array} \right. \quad (12.4)$$

where  $z_1$  and  $z_2$  are the elastic section moduli and  $P$  is the final prestress force.

The critical condition for tension in the beam is given by equation 12.2 which for no tension, that is  $f_1 = 0$ , becomes

$$\frac{P}{A} = \frac{M_{\max}}{z_1}$$

or

$$P = \frac{M_{\max} A}{z_1} = \text{minimum prestress force required}$$

For this value of prestress force, substitution in the other equations will yield the stresses in the beam under maximum load and also under minimum load. Similarly the stresses immediately after prestressing, before losses have occurred, may be calculated if the value of losses is known.

For example, the maximum stress in the top of the member is given by equation 12.1

$$f_2 = \frac{P}{A} + \frac{M_{\max}}{z_2}$$

where

$$P = \frac{M_{\max} A}{z_1}$$

therefore

$$f_2 = \frac{P}{A} + \frac{P}{A} \frac{z_1}{z_2} = \frac{P}{A} \frac{(z_1 + z_2)}{z_2}$$

It can be seen from the stress distributions in figure 12.8 that the top fibre is generally in considerable compression, while the bottom fibre is generally at lower stresses. Much better use of the concrete could be made if the stresses at both top and bottom can be caused to vary over the full range of permissible stresses for the two extreme loading conditions. This may be achieved by providing the force at an eccentricity  $e$  from the centroid.

**12.3.2 Member Subjected to Eccentric Prestress Force**

The stress distributions will be similar to those in section 12.3.1 but with the addition of the term  $\pm Pe/z$  due to the eccentricity  $e$  of the prestressing force. For the position shown in figure 12.9,  $e$  will have a negative value. So that

$$\text{under } M_{\max} \left\{ \begin{aligned} f_2 &= \frac{P}{A} + \frac{M_{\max}}{z_2} + \frac{Pe}{z_2} && \text{at the top} && (12.5) \\ f_1 &= \frac{P}{A} - \frac{M_{\max}}{z_1} - \frac{Pe}{z_1} && \text{at the bottom} && (12.6) \end{aligned} \right.$$

$$\text{under } M_{\min} \left\{ \begin{aligned} f_2 &= \frac{P}{A} + \frac{M_{\min}}{z_1} + \frac{Pe}{z_2} && \text{at the top} && (12.7) \\ f_1 &= \frac{P}{A} - \frac{M_{\min}}{z_1} - \frac{Pe}{z_1} && \text{at the bottom} && (12.8) \end{aligned} \right.$$

The critical condition for no tension in the bottom of the beam is again given by equation 12.6, which becomes

$$\frac{P}{A} - \frac{M_{\max}}{z_1} - \frac{Pe}{z_1} = 0$$

or

$$P = \frac{M_{\max}}{\left(\frac{z_1}{A} - e\right)} = \text{minimum prestress force required for no tension in bottom fibre}$$

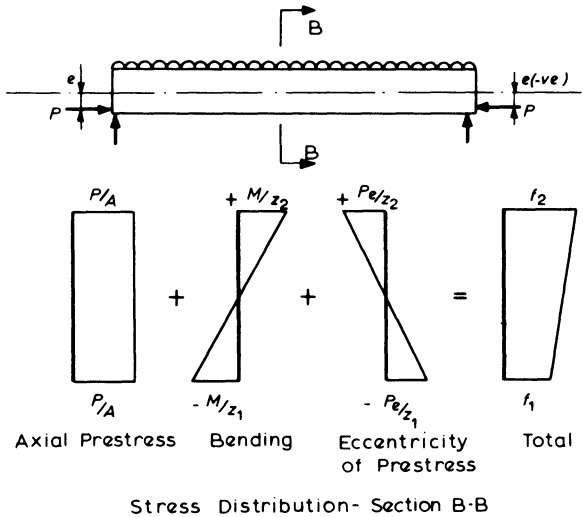

Figure 12.9 Stresses in member with eccentric prestress force

Thus for a given value of prestress force  $P$ , the beam may carry a maximum moment of

$$M_{\max} = P \left( \frac{z_1}{A} - e \right)$$

When compared with  $M_{\max} = Pz_1/A$  for an axial prestress force it indicates an increase in moment carrying capacity of  $Pe$  when  $e$  is negative.

The maximum stress in the top of the beam is given by equation 12.5 as

$$f_2 = \frac{P}{A} + \frac{M_{\max}}{z_2} + \frac{Pe}{z_2}$$

where

$$M_{\max} = \frac{Pz_1}{A} - Pe$$

thus

$$\begin{aligned} f_2 &= \frac{P}{A} + \frac{Pz_1}{Az_2} - \frac{Pe}{z_2} + \frac{Pe}{z_2} \\ &= \frac{P}{A} \left( \frac{z_1 + z_2}{z_2} \right) \end{aligned}$$

which is the same as that obtained in section 12.3.1 for an axially prestressed member. Thus the advantages of an eccentric prestress force with respect to the maximum moment-carrying capacity of a beam are apparent.

If the stress distributions of figure 12.9 are further examined, it can be seen that the differences in the net stress diagrams for the extreme loading cases are solely due to the differences between the applied moment terms  $M_{\max}$  and  $M_{\min}$ . It follows that by increasing the range of the stresses by the use of an eccentric prestress force the range of applied moments that the beam can carry is also increased. The minimum moment  $M_{\min}$  that can be resisted is generally governed by the need to avoid tension in the top of the beam, as indicated by equation 12.7.

In the design of prestressed beams it is important that the minimum moment condition is not overlooked, especially when straight tendons are employed, as stresses near the ends of beams where moments are small may often exceed those at sections nearer mid-span. This feature is illustrated by the results obtained in example 12.1.

**Example 12.1 Calculation of Prestress Force and Stresses**

A rectangular beam 300 × 150 mm is simply supported over a 4 m span, and supports a live load of 10 kN/m. If a straight tendon is provided at an eccentricity of 65 mm below the centroid of the section, find the minimum prestress force necessary for no tension under live load at mid-span. Calculate the corresponding stresses under self-weight only at mid-span and at the ends of the member.

## (a) Beam Properties

$$\text{Self-weight} = 0.15 \times 0.3 \times 24 = 1.08 \text{ kN/m}$$

$$\text{Area} = 45 \times 10^3 \text{ mm}^2$$

$$\text{Section moduli } z_1 = z_2 = z = \frac{bh^2}{6} = \frac{150 \times 300^2}{6} = 2.25 \times 10^6 \text{ mm}^3$$

## (b) Loadings (Mid-span)

$$M_{\max} = \frac{(10 + 1.08) \times 4^2}{8} = 22.2 \text{ kN m}$$

$$M_{\min} = \frac{1.08 \times 4^2}{8} = 2.2 \text{ kN m}$$

## (c) Calculate Minimum Prestress Force

For no tension at the bottom under  $M_{\max}$

$$\frac{P}{A} - \frac{M_{\max}}{z} - \frac{Pe}{z} = 0$$

where

$$e = -65 \text{ mm}$$

hence

$$\begin{aligned} P &= \frac{M_{\max}}{\left(\frac{z}{A} - e\right)} = \frac{22.2 \times 10^6 \times 10^{-3}}{\frac{2.25 \times 10^6}{45 \times 10^3} + 65} \\ &= 193 \text{ kN} \end{aligned}$$

(d) Calculate Stresses at Mid-span under  $M_{\min}$ 

$$\text{Stress at top } f_2 = \frac{P}{A} + \frac{M_{\min}}{z} + \frac{Pe}{z}$$

where

$$\begin{aligned} \frac{P}{A} &= \frac{193 \times 10^3}{45 \times 10^3} = 4.3 \text{ N/mm}^2 \\ \frac{M_{\min}}{z} &= \frac{2.2 \times 10^6}{2.25 \times 10^6} = 1.0 \text{ N/mm}^2 \\ \frac{Pe}{z} &= \frac{-193 \times 10^3 \times 65}{2.25 \times 10^6} = -5.6 \text{ N/mm}^2 \end{aligned}$$

Hence

$$f_2 = 4.3 + 1.0 - 5.6 = -0.3 \text{ N/mm}^2$$

and

$$\begin{aligned} \text{stress at bottom } f_1 &= \frac{P}{A} - \frac{M_{\min}}{z} - \frac{Pe}{z} \\ &= 4.30 - 1.0 + 5.6 = +8.9 \text{ N/mm}^2 \end{aligned}$$

(e) Calculate Stresses at Ends

In this situation  $M = 0$ . Hence

$$f_2 = \frac{P}{A} + \frac{Pe}{z} = 4.3 - 5.6 = -1.3 \text{ N/mm}^2$$

and

$$f_1 = \frac{P}{A} - \frac{Pe}{z} = 4.3 + 5.6 = 9.9 \text{ N/mm}^2$$

## 12.4 Design for the Serviceability Limit State

The design of a prestressed concrete member is based on maintaining the concrete stresses within specified limits at all stages in the life of the member. Hence the primary design is based on the serviceability limit state, with the concrete stress limits based on the acceptable degree of flexural cracking.

A prestressed member may be categorised into one of three basic groups depending on the allowable concrete tensile stress.

Class 1 – no tension permitted under working conditions.

Class 2 – tensile stresses are permitted, but these are limited to avoid flexural cracking.

Class 3 – cracking permitted, but tensile stresses limited on the basis of maximum permissible flexural crack widths.

Guidance regarding suitable tensile stress limits for class 2 and 3 members is given in BS 8110, but the maximum allowable concrete compressive stress in bending is generally the same for all three classes at one-third of the characteristic compressive cube strength, this value being determined by the dual requirements of avoidance of spalling in the compression zone, and the prevention of excessive loss in the prestress force due to creep.

At initial transfer to the concrete, the prestress force will be considerably higher than the 'long-term' value as a result of subsequent losses which are due to a number of causes including elastic shortening, creep and shrinkage of the concrete member. Estimation of losses is described in section 12.4.6. Since these losses commence immediately, the conditions at transfer represent a transitory stage in the life of the member and maximum permissible concrete stresses are related to the actual cube strength at transfer, usually by a factor of one-half. Concrete

tensile stress limits may be increased where they are due to prestress alone, and for a class 1 structure 1.0 N/mm<sup>2</sup> is permitted.

The choice of class for a structure will depend upon a number of factors which include conditions of exposure and the nature of loading. If a member consists of precast segments with mortar joints, or if it is essential that cracking should not occur then design must be as a class 1 member, but otherwise class 2 would generally be used. This offers the most efficient use of materials, while still avoiding flexural cracking under normal circumstances. The design procedure for class 1 and class 2 members will be similar, with the basic cross-section and prestress force details being determined by the above serviceability requirements. Subsequent checks for adequacy at the ultimate limit state will generally be satisfied, although a class 2 member may sometimes require a small amount of additional reinforcing steel (see section 12.5.2).

Class 3, which is often known as partial prestressing, represents a form of construction which is intermediate between reinforced and prestressed concrete. While not offering the full advantages of prestressing, this technique allows high strength steels to be used in situations where crack avoidance is not essential, and the otherwise excessive deflections are controlled by the prestressing. This form of construction is governed by the requirements of the ultimate limit state, thus the design procedure should consider this first, followed by the design of prestressing.

The design of prestressing requirements is based on the manipulation of the four basic expressions given in section 12.3.2 describing the stress distributions across the concrete section. These are used in conjunction with the permissible stresses appropriate to the class of member, coupled with the final prestress force after losses and the maximum and minimum loadings on the member. These loadings must encompass the full range that the member will encounter during its life, and the minimum value will thus be governed by the construction techniques to be used. The partial factors of safety applied to these loads will be those for the serviceability limit state, that is 1.0 for both dead and live loads.

The basic equations from section 12.3.2 are expressed in the following form

$$\text{at the top} \left\{ \begin{array}{l} \frac{P}{A} + \frac{Pe}{z_2} + \frac{M_{\max}}{z_2} \leq f_{\max} \end{array} \right. \quad (12.9)*$$

$$\left\{ \begin{array}{l} \frac{P}{A} + \frac{Pe}{z_2} + \frac{M_{\min}}{z_2} \geq f_{\min} \end{array} \right. \quad (12.10)*$$

$$\text{at the bottom} \left\{ \begin{array}{l} \frac{P}{A} - \frac{Pe}{z_1} - \frac{M_{\max}}{z_1} \geq f_{\min} \end{array} \right. \quad (12.11)*$$

$$\left\{ \begin{array}{l} \frac{P}{A} - \frac{Pe}{z_1} - \frac{M_{\min}}{z_1} \leq f_{\max} \end{array} \right. \quad (12.12)*$$

where  $f_{\max}$  and  $f_{\min}$  are the appropriate permissible stresses.

**12.4.1 Determination of Minimum Section Properties**

The two pairs of expressions can be combined as follows.  
12.9 and 12.10

$$(M_{\max} - M_{\min}) \leq (f_{\max} - f_{\min}) z_2 \quad (12.13)$$

12.11 and 12.12

$$(M_{\max} - M_{\min}) \leq (f_{\max} - f_{\min}) z_1 \quad (12.14)$$

Hence, if  $(M_{\max} - M_{\min})$  is written as  $M_v$ , the moment variation

$$z_2 \geq \frac{M_v}{(f_{\max} - f_{\min})} \quad (12.15)^*$$

and

$$z_1 \geq \frac{M_v}{(f_{\max} - f_{\min})} \quad (12.16)^*$$

These minimum values of section moduli must be satisfied by the chosen section in order that a prestress force and eccentricity exist which will permit the stress limits to be met. Stresses at transfer are discussed in 12.4.3, and to avoid overstressing in that condition the chosen section must have a margin above the minimum values of section moduli calculated above. Detailed calculations may be based on loss estimates, but it will usually be adequate at this stage to provide a section with moduli exceeding the calculated minima by 20 per cent for post-tensioned and 35 per cent for pre-tensioned construction. The maximum moment on the section has not directly been included in these figures, thus it is possible that the resulting prestress force may not be economic or practicable. However, it is found in the majority of cases that if a section is chosen which satisfies these minimum requirements, coupled with any other specified requirements regarding the shape of the section, then a satisfactory design is usually possible. The ratio of acceptable span-depth for a prestressed beam cannot be categorised on the basis of deflections as easily as for reinforced concrete. In the absence of any other criteria, the following formulae may be used as a guide and will generally produce reasonably conservative designs for post-tensioned members.

$$\text{span} \leq 36 \text{ m} \quad h = \frac{\text{span}}{25} + 0.1 \text{ m}$$

$$\text{span} \geq 36 \text{ m} \quad h = \frac{\text{span}}{20} \text{ m}$$

In the case of short-span members it may be possible to use very much greater span-depth ratios quite satisfactorily, although the resulting prestress forces may become very high.

Other factors which must be considered at this stage include the slenderness ratio of beams, where the same criteria apply as for reinforced concrete, and the possibility of web and flange splitting in flanged members.

### **Example 12.2 Selection of Cross-section**

Select a rectangular section for a post-tensioned beam to carry, in addition to its self-weight, a uniformly distributed load of 3 kN/m over a simply supported span

of 10 m. The member is to be designed as class 1 with grade 40 concrete, without lateral support.

Class 1 member, thus

$$f_{\max} = \frac{40}{3} = 13.3 \text{ N/mm}^2$$

$$f_{\min} = 0 \text{ N/mm}^2$$

$$\begin{aligned} \text{'Live load'} \\ \text{moment at} \\ \text{mid-span } M_v \end{aligned} = \frac{3 \times 10^2}{8} = 37.5 \text{ kN m}$$

thus

$$z = z_1 = z_2 = \frac{M_v}{(f_{\max} - f_{\min})} = \frac{37.5 \times 10^6}{13.3} = 2.82 \times 10^6 \text{ mm}^3 \text{ (minimum)}$$

This should be increased by 20 per cent to allow for transfer case. Therefore

$$\begin{aligned} z &= 1.2 \times 2.82 \times 10^6 \text{ mm}^3 \\ &= 3.38 \times 10^6 \text{ mm}^3 \end{aligned}$$

To prevent lateral buckling, BS 8110 specifies maximum permissible span/breadth = 60, that is

$$\text{minimum } b = \frac{10 \times 10^3}{60} = 167 \text{ mm}$$

thus if  $b = 170 \text{ mm}$

$$z = \frac{bh^2}{6} = \frac{170h^2}{6}$$

hence

$$\begin{aligned} \text{minimum } h &= \sqrt{\left(\frac{6 \times 3.38}{170} \times 10^6\right)} \\ &= 345 \text{ mm} \end{aligned}$$

This represents a span-depth ratio =  $10 \times 10^3 / 345 = 29.0$  which may prove to be excessive when deflections are checked (see example 12.7) but as a first trial a section  $350 \times 170$  is adopted ( $z_1 = z_2 = z = 3.47 \times 10^6 \text{ mm}^3$ ) and this is used in subsequent examples.

#### 12.4.2 Design of Prestress Force

The inequalities of equations 12.9 and 12.12, and 12.10 and 12.11 may also be combined to yield expressions involving the moment variation  $M_v$ , thus

12.9 and 12.12

$$M_v = (M_{\max} - M_{\min}) \leq \left( \frac{z_1 + z_2}{A} \right) (Af_{\max} - P) \tag{12.17}$$

12.10 and 12.11

$$M_v = (M_{\max} - M_{\min}) \leq \left( \frac{z_1 + z_2}{A} \right) (P - Af_{\min}) \tag{12.18}$$

thus if  $M_v$  and  $P$  are treated as variables, these are both of the general form  $M_v \leq \alpha P + \beta$  where  $\alpha$  and  $\beta$  are constants. These two expressions therefore represent linear limits, and since the signs of  $P$  are opposite, one represents an upper limit to  $P$  and the other a lower limit as shown in figure 12.10. The upper limits to  $M_v$  for the section moduli chosen, as given by equations 12.13 and 12.14 are also shown and since these are independent of the value of  $P$ , these are parallel 'horizontal lines'. If the section is symmetrical, lines 12.13 and 12.14 coincide, and it can be shown that this passes through the intersection of 12.17 and 12.18.

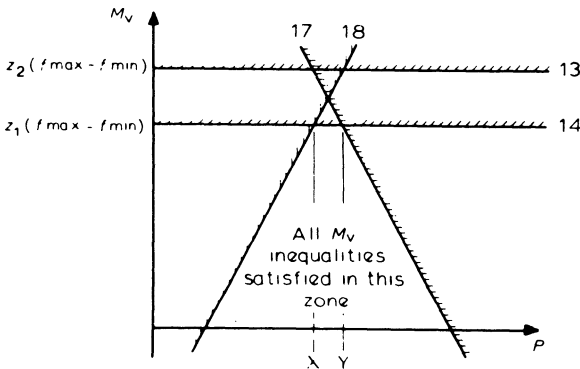

Figure 12.10 Moment variation and prestress force relationships

It is necessary to choose a value of prestress force which lies between these limits for the appropriate value of moment variation to be carried by the member. It can be seen that no advantage in moment variation capacity is to be gained by providing a prestress force in excess of the value  $X$  shown in figure 12.10.

In the case illustrated in figure 12.10, where  $z_2 > z_1$ , the value of  $X$  is given by the intersection of equations 12.14 and 12.18, that is

$$X = \frac{f_{\max}z_1 + f_{\min}z_2}{\left( \frac{z_1 + z_2}{A} \right)} \tag{12.19}$$

and  $Y$  is similarly given by

$$Y = \frac{f_{\max}z_2 + f_{\min}z_1}{\left(\frac{z_1 + z_2}{A}\right)} \quad (12.20)$$

If  $z_1 > z_2$  then 12.13 lies below 12.14 and the values of  $X$  and  $Y$  are interchanged.

The minimum prestress force for a given moment variation is therefore given by equation 12.18 which is based on satisfying the minimum stress requirements.

This may be rewritten in the form

$$P \geq \frac{M_v}{\left(\frac{z_1 + z_2}{A}\right)} + Af_{\min}$$

that is

$$P \geq \frac{M_v + f_{\min}(z_1 + z_2)}{\left(\frac{z_1 + z_2}{A}\right)} \quad (12.21)^*$$

Although a range of values of permissible prestress force can be found, this makes no allowance for the fact that the corresponding eccentricity must lie within the beam. It is necessary therefore to consider the effect of limiting the eccentricity to a maximum practical value for the section under consideration. The effect of this limitation will be most severe when considering the maximum moment acting on the section, that is, the inequalities of equations 12.9 and 12.11.

If the limiting value for maximum eccentricity,  $e_{\max}$  depends on cover requirements; equation 12.9 becomes

$$M_{\max} \leq f_{\max}z_2 - P\left(\frac{z_2}{A} + e_{\max}\right) \quad (12.22)$$

and equation 12.11 becomes

$$M_{\max} \leq P\left(\frac{z_1}{A} - e_{\max}\right) - f_{\min}z_1 \quad (12.23)$$

Thus these represent linear relationships between  $M_{\max}$  and  $P$ . For the case of a beam subjected to sagging moments,  $e_{\max}$  will generally be negative in value, thus equation 12.23 is of positive slope and represents a lower limit to  $P$ . It can be shown also that for most practical cases  $[(z_2/A) + e_{\max}] < 0$ , thus equation 12.22 is similarly a lower limit of positive, though smaller, slope.

Figure 12.11 represents the general form of these expressions, and it can be seen clearly that providing a prestress force in excess of  $Y'$  produces only small benefits of additional maximum moment capacity. The value of  $Y'$  is given by the intersection of these two expressions, when

$$P\left(\frac{z_1}{A} - e_{\max}\right) - f_{\min}z_1 = f_{\max}z_2 - P\left(\frac{z_2}{A} + e_{\max}\right)$$

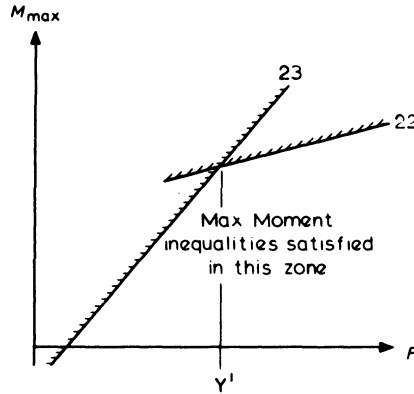

Figure 12.11 Maximum moment and prestress force relationship

thus

$$P = \frac{f_{\max} z_2 + f_{\min} z_1}{\left( \frac{z_1 + z_2}{A} \right)} = Y' \tag{12.24}^*$$

It should be noted that this corresponds to the value of  $P = Y$  in equation 12.20, thus the value of prestress force  $P = Y = Y'$  may be conveniently considered as a maximum economic value. Equation 12.23 provides a second lower limit to  $P$  such that

$$P \geq \frac{M_{\max} + f_{\min} z_1}{\left( \frac{z_1}{A} - e_{\max} \right)} \tag{12.25}^*$$

Practically therefore, the prestress force must be selected to satisfy two lower limits, based on

- (1) the moment variation,  $M_{\max} - M_{\min}$  from equation 12.21
- (2) the maximum permissible eccentricity and maximum moment  $M_{\max}$  from equation 12.25
- (3) the prestress force should be less than the economic maximum given by equation 12.24.

In the case of a simply supported beam, the design prestress force will generally be based on the minimum value which satisfies these criteria at the critical section for bending in the member. If the governing criterion is that of moment variation, the member is said to be 'below the critical span', and if maximum moment governs, it is 'above the critical span' – the latter case generally applies only to long-span beams.

Although this treatment relates only to the commonly occurring case where  $M_{\max}$  and  $M_{\min}$  are both sagging, the approach can be extended quite easily to deal with other situations which may occur.

**Example 12.3 Calculation of Prestress Force**

Calculate the minimum prestress force for the beam in example 12.2. (From example 12.2,  $b = 170$ ,  $h = 350$ ,  $z_1 = z_2 = 3.47 \times 10^6 \text{ mm}^3$ ,  $M_v = 37.5 \text{ kN m}$ ,  $f_{\min} = 0$ ,  $f_{\max} = 13.3 \text{ N/mm}^2$ .)

(a) Based on Moment Variation

Lower limit to  $P$  from equation 12.21

$$\begin{aligned} P &\geq \frac{M_v + f_{\min}(z_1 + z_2)}{\left(\frac{z_1 + z_2}{A}\right)} \\ &\geq \frac{37.5 \times 10^6 + 0}{\frac{2 \times 3.47 \times 10^6}{350 \times 170}} \times 10^{-3} \\ &\geq 322 \text{ kN} \end{aligned}$$

(b) Based on Maximum Eccentricity and Maximum Moment

$$\text{Self-weight of beam} = 350 \times 170 \times 10^{-6} \times 24 = 1.43 \text{ kN/m}$$

thus

$$M_{\min} = \frac{1.43 \times 10^2}{8} = 17.9 \text{ kN m}$$

and

$$M_{\max} = M_{\min} + M_v = 17.9 + 37.5 = 55.4 \text{ kN m}$$

Thus lower limit to  $P$  from maximum moment is given by equation 12.25 as

$$P \geq \frac{M_{\max} + f_{\min} z_1}{\left(\frac{z_1}{A} - e_{\max}\right)}$$

where  $e_{\max}$  is given by  $-(h/2) - \text{cover}$ . Thus if minimum cover = 50 mm,

$$\begin{aligned} e_{\max} &= -(175 - 50) \\ &= -125 \text{ mm} \end{aligned}$$

hence

$$P \geq \frac{55.4 \times 10^6 + 0}{\frac{3.47 \times 10^6}{350 \times 170} + 125} \times 10^{-3}$$

$$\geq 302 \text{ kN}$$

Thus the critical minimum value is given by moment variation requirements and the member is below the critical span. Provision of a prestress force of 322 kN will therefore produce an acceptable eccentricity at mid-span.

(c) Check the Upper Limit to Prestress Force

From equation 12.24

$$P \leq \frac{f_{\max} z_2 + f_{\min} z_1}{\frac{z_1 + z_2}{A}} = \frac{13.3 z A}{2z}$$

$$\leq 6.65 A$$

$$\leq 6.65 \times 350 \times 170 \times 10^{-3}$$

$$\leq 395 \text{ kN}$$

Since this is above the value of 322 kN to be provided, the design will be considered as acceptable at this stage.

### 12.4.3 Transfer Stresses

Stresses existing in the concrete at transfer must always be checked, since these will generally be higher than those occurring in the design based on final prestress force. This is due to the combined effects of a higher prestress force, and an applied moment which is frequently lower than  $M_{\min}$  considered in the basic design. In addition to the increased stresses, the concrete is usually relatively immature and not at full strength. These factors combine to make transfer a critical stage which must always be examined carefully, even though allowance may have been made when determining section size.

Since this condition is transitory with losses commencing immediately, it is usually permitted that stresses may reach higher values than normal relative to the concrete strength. This has been discussed in section 12.4 and transfer-stress calculations will often govern the minimum permissible concrete cube strength at the time of transfer.

#### *Example 12.4 Transfer Stresses*

For the previous examples, check transfer stresses at mid-span. Assume losses = 25 per cent and prestress force constant throughout span. Assume also that  $M = M_{\min} = 17.9 \text{ kN m}$  and  $e = -100 \text{ mm}$ .

$$\text{Prestress force at transfer } P_t = \frac{322}{0.75} = 430 \text{ kN}$$

Then minimum stress at top fibre, from equation 12.10 is

$$\begin{aligned} f_{\min} &= \frac{P_t}{A} + \frac{P_t e}{z_2} + \frac{M_{\min}}{z_2} = \frac{430 \times 10^3}{170 \times 350} - \frac{430 \times 10^3 \times 100}{3.47 \times 10^6} + \frac{17.9 \times 10^6}{3.47 \times 10^6} \\ &= 7.2 - 12.4 + 5.2 \\ &= 0 \end{aligned}$$

and maximum stress at bottom fibre from equation 12.12 is

$$\begin{aligned} f_{\max} &= \frac{P_t}{A} - \frac{P_t e}{z_1} - \frac{M_{\min}}{z_1} \\ &= 7.2 + 12.4 - 5.2 \\ &= 14.4 \text{ N/mm}^2 \end{aligned}$$

If it is assumed that the compressive stress at transfer may reach 50 per cent of the cube strength at that time, the minimum permissible concrete strength at transfer is given by  $2 \times 14.4 \approx 30 \text{ N/mm}^2$ . The minimum stress is within the limit permitted in a class 1 structure.

Near the ends of the member,  $M_{\min}$  becomes very small and the resultant stresses will be even more severe than those calculated at mid-span. This demonstrates the common situation where it is necessary to reduce either the prestress force or its eccentricity near supports as discussed in sections 12.2.1 and 12.4.4.

#### 12.4.4 Design of Tendon Profiles

Having obtained a value of prestress force which will permit all stress conditions to be satisfied at the critical section, it is necessary to determine the eccentricity at which this force must be provided, both at the critical section and throughout the length of the member.

At any section along the member,  $e$  is the only unknown term in the four expressions 12.9 to 12.12 and these will yield two upper and two lower limits which must all be simultaneously satisfied. This requirement must be met at all sections throughout the member and will reflect both variations of moment, prestress force, and section properties along the member.

The design expressions can be rewritten as

$$e \leq \left[ \frac{f_{\max} z_2}{P} - \frac{z_2}{A} \right] - \frac{M_{\max}}{P} \quad (12.26)$$

$$e \geq \left[ \frac{f_{\min} z_2}{P} - \frac{z_2}{A} \right] - \frac{M_{\min}}{P} \quad (12.27)$$

$$e \leq \left[ \frac{z_1}{A} - \frac{f_{\min} z_1}{P} \right] - \frac{M_{\max}}{P} \quad (12.28)$$

$$e \geq \left[ \frac{z_1}{A} - \frac{f_{\max} z_1}{P} \right] - \frac{M_{\min}}{P} \tag{12.29}$$

Although it is relatively simple to evaluate all four expressions, it can be shown that expressions 12.27 or 12.29 and 12.28 govern when  $M_{\max}$  and  $M_{\min}$  are both positive, although this does not apply in other situations. The moments  $M_{\max}$  and  $M_{\min}$  are those relating to the section being considered.

For a member of constant cross-section, if minor changes in prestress force along the length are neglected, the terms in brackets in the above expressions are constants. Therefore the zone within which the centroid of prestress force must lie is governed by the shape of the bending-moment envelopes, as shown in figure 12.12. In the case of uniform loading, these are parabolic, hence the usual practice is to provide parabolic tendon profiles if a straight profile will not fit within this zone.

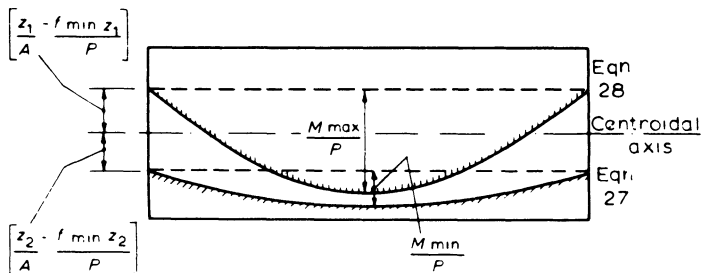

Figure 12.12 Cable zone limits

At the critical section, the zone is generally narrow and reduces to zero if the value of prestress force is taken as the minimum value from moment variation requirements. At sections away from the critical section, the zone becomes increasingly wide as the moments reduce and the prestress force provided is increasingly greater than the minimum required.

**Example 12.5 Calculation of Cable Zone**

Determine the cable zone limits at mid-span and ends of the member designed in examples 12.2 and 12.3 for a constant prestress force of 322 kN.

(a) Ends of Beam

Limits to cable eccentricity are given by

equation 12.27

$$e \geq \left[ \frac{f_{\min} z_2}{P} - \frac{z_2}{A} \right] - \frac{M_{\min}}{P}$$

and equation 12.28

$$e \leq \left[ \frac{z_1}{A} - \frac{f_{\min} z_1}{P} \right] - \frac{M_{\max}}{P}$$

equation 12.27 becomes

$$e \geq \left[ 0 - \frac{3.47 \times 10^6}{350 \times 170} \right] - 0$$

$$\geq -58.3 \text{ mm}$$

Similarly equation 12.28 becomes

$$e \leq \left[ \frac{3.47 \times 10^6}{350 \times 170} - 0 \right] - 0$$

$$\leq +58.3 \text{ mm}$$

Thus at the ends of the member, the tendons must lie at a practical eccentricity in the range  $\pm 58$  mm.

(b) Mid-span

Equation 12.27 gives

$$e \geq \left[ 0 - \frac{3.47 \times 10^6}{350 \times 170} \right] - \frac{17.9 \times 10^6}{322 \times 10^3}$$

$$\geq -58.3 - 55.6$$

$$\geq -113.9 \text{ mm}$$

and equation 12.28 gives

$$e \leq \left[ \frac{3.47 \times 10^6}{350 \times 170} - 0 \right] - \frac{55.4 \times 10^6}{322 \times 10^3}$$

$$\leq 58.3 - 172$$

$$\leq -113.7 \text{ mm}$$

Hence at mid-span the tendon must theoretically lie at an eccentricity of  $-113.8$  mm and the practical width of cable zone is zero for this prestress force.

#### 12.4.5 Width of Cable Zone

The widths ( $s_x$ ) of the permissible cable zone at any section  $x$  may be obtained by subtracting equations 12.28 and 12.27 for a simply supported beam, thus

$$s_x = \frac{z_1}{A} - \frac{f_{\min} z_1}{P} - \frac{M_{\max}}{P} - \frac{f_{\min} z_2}{P} + \frac{z_2}{A} + \frac{M_{\min}}{P}$$

therefore

$$s_x = \frac{(z_1 + z_2)}{A} - f_{\min} \frac{(z_1 + z_2)}{P} - \frac{(M_{\max} - M_{\min})}{P}$$

where the values of moment, prestress and section properties are those relating to section  $x$ . The design expression for minimum prestress force based on moment variation (equation 12.21) may be rewritten so that

$$\frac{M_v}{P} = \left( \frac{z_1 + z_2}{A} \right) - f_{\min} \left( \frac{z_1 + z_2}{P} \right)$$

where  $M_v$  = design moment variation at critical section. Hence

$$\begin{aligned} s_x &= \frac{M_v}{P} - \left( \frac{M_{\max} - M_{\min}}{P} \right) \\ &= \frac{M_v - (M_{\max} - M_{\min})}{P} \end{aligned}$$

When section  $x$  coincides with the critical section,  $(M_{\max} - M_{\min})$  corresponds to  $M_v$  and hence  $s_x = 0$ , unless the value of  $M_v$  used in the design calculations for prestress force is increased to provide for a positive zone width, in which case the value of  $M_v$  used in the design must be obtained from the above expression, so that

$$M_v = (M_{\max} - M_{\min}) + Ps_x$$

where  $s_x$  is the minimum required zone width at section  $x$ . Hence the expression for minimum prestress force corresponding to equation 12.21 becomes

$$P \geq \frac{(M_{\max} - M_{\min}) + Ps_x + f_{\min}(z_1 + z_2)}{\left( \frac{z_1 + z_2}{A} \right)}$$

or

$$P \geq \frac{(M_{\max} - M_{\min}) + f_{\min}(z_1 + z_2)}{\left( \frac{z_1 + z_2}{A} - s_x \right)} \quad (12.30)^*$$

**Example 12.6 Calculation of Prestress Force for Minimum Cable Zone Width**

Find the minimum prestress force necessary for the beam in examples 12.2 and 12.3 if the minimum cable zone width is to be  $\pm 10$  mm and minimum cover remains at 50 mm.

(a) Based on Moment Variation from Equation 12.30

At mid-span section

$$P \geq \frac{(M_{\max} - M_{\min}) + f_{\min}(z_1 + z_2)}{\left(\frac{z_1 + z_2}{A} - s_x\right)}$$

where  $s_x = 20$  mm. Hence

$$P \geq \frac{37.5 \times 10^6 + 0}{\frac{2 \times 3.47 \times 10^6}{350 \times 170} - 20} \times 10^{-3}$$

$$\geq 388 \text{ kN}$$

(b) Based on Limits of Eccentricity from Equation 12.25

Now for maximum tolerance,  $e_{\max}$  may be reduced to  $-[(h/2 - \text{Cover}) + 20]$ , thus

$$e_{\max} = -(175 - 50) + 20 = -105 \text{ mm}$$

hence

$$P \geq \frac{M_{\max} + f_{\min}z_1}{\left(\frac{z_1}{A} - e_{\max}\right)}$$

$$\geq \frac{55.4 \times 10^6 + 0}{\frac{3.47 \times 10^6}{350 \times 170} + 105} \times 10^{-3}$$

$$\geq 339 \text{ kN}$$

Thus, moment variation still governs.

It will be noted immediately that the minimum prestress force is increased considerably by this requirement, and approaches the maximum economic value of 395 kN for the section chosen, as determined in example 12.3. This demonstrates clearly the need for precision of construction in prestressed concrete members, particularly with reference to tendon fixing. The importance in selecting section properties which exceed the minimum values by a reasonable margin is also emphasised and confirmed by example 12.4 in order that transfer conditions may be met.

#### 12.4.6 Prestress Losses

From the moment that the prestressing force is first applied to the concrete member, losses of this force will take place because of the following causes

- (1) Elastic shortening of the concrete.
- (2) Creep of the concrete under sustained compression.
- (3) Relaxation of the prestressing steel under sustained tension.
- (4) Shrinkage of the concrete.

These losses will occur whichever form of construction is used, although the effects of elastic shortening will generally be much reduced when post-tensioning is used. This is because stressing is a sequential procedure, and not instantaneous as with pre-tensioning. Creep and shrinkage losses depend to a large extent on the properties of the concrete with particular reference to the maturity at the time of stressing. In pre-tensioning, where the concrete is usually relatively immature at transfer, these losses may therefore be expected to be higher than in post-tensioning.

In addition to losses from these causes, which will generally total between 20 to 30 per cent of the initial prestress force at transfer, further losses occur in post-tensioned concrete during the stressing procedure. These are due to friction between the strands and the duct, especially where curved profiles are used, and to mechanical anchorage slip during the stressing operation. Both these factors depend on the actual system of ducts, anchorages and stressing equipment that are used.

Thus although the basic losses are generally highest in pre-tensioned members, in some instances overall losses in post-tensioned members may be of similar magnitude.

### *Elastic Shortening*

The concrete will immediately shorten elastically when subjected to compression, and the steel will generally shorten by a similar amount (as in pre-tensioning) with a corresponding loss of prestress force. To calculate this it is necessary to obtain the compressive strain at the level of the steel.

If the transfer force is  $P_t$ , and the force after elastic losses is  $P'$  then

$$P' = P_t - \text{loss in force}$$

and the corresponding stress in the concrete at the level of the tendon

$$f_c = \frac{P'}{A} + \frac{(P'e) \times e}{I} + f(w_d)$$

where  $f(w_d)$  is the stress due to self weight which will be relatively small when averaged over the length of the member and may thus be neglected. Hence

$$f_c = \frac{P'}{A} \left( 1 + \frac{e^2 A}{I} \right)$$

and concrete strain =  $f_c/E_c$ , thus reduction in steel strain =  $f_c/E_c$  and

$$\text{reduction in steel stress} = \left( \frac{f_c}{E_c} \right) E_s = \alpha_e f_c$$

thus

$$\text{loss in prestress force} = \alpha_e f_c A_{st}$$

where  $A_{st}$  = area of tendons

$$= \alpha_e \frac{A_{st}}{A} P' \left( 1 + \frac{e^2 A}{I} \right)$$

hence

$$P' = P_t - \alpha_e \frac{A_{st}}{A} P' \left( 1 + \frac{e^2 A}{I} \right)$$

so that

$$\text{remaining prestress force } P' = \frac{P_t}{1 + \alpha_e \frac{A_{st}}{A} \left( 1 + \frac{e^2 A}{I} \right)}$$

In pre-tensioned construction this full loss will be present; however when post-tensioning the effect will only apply to previously tensioned cables and although a detailed calculation could be undertaken it is normally adequate to assume 50 per cent of the above losses. In this case the remaining prestress force is

$$P' = \frac{P_t}{1 + 0.5\alpha_e \frac{A_{st}}{A} \left( 1 + \frac{e^2 A}{I} \right)}$$

and it is this value which applies to subsequent loss calculations.

#### *Creep of Concrete*

The sustained compressive stress on the concrete will also cause a long-term shortening due to creep, which will similarly reduce the prestress force. As above, it is the stress in the concrete at the level of the steel which is important, that is

$$f_c = \frac{P'}{A} \left( 1 + \frac{e^2 A}{I} \right)$$

and

$$\text{loss of steel stress} = E_s f_c \times \text{specific creep strain}$$

then

$$\text{loss of prestress force} = E_s \frac{A_{st}}{A} P' \left( 1 + \frac{e^2 A}{I} \right) \times \text{specific creep strain}$$

The value of specific creep used in this calculation will be influenced by the factors discussed in section 6.3.2, and may be obtained from the values of creep coefficient  $\phi$  given in figure 6.5 using the relationship

$$\text{specific creep strain} = \frac{\phi}{E_c} / \text{N/mm}^2$$

For most outdoor exposure purposes in the UK it will be adequate to use values of creep coefficient between 1.8 for transfer within 3 days and 1.4 for transfer after 28 days.

*Relaxation of Steel*

Despite developments in prestressing steel manufacture which have taken place in recent years, relaxation of the wire or strand under sustained tension may still be expected to be a significant factor. The precise value will depend upon whether pre-tensioning or post-tensioning is used and the characteristics of the steel type defined in BS 5896. Factors allowing for method of construction are given in BS 8110 which should be applied to 1000 hour relaxation values provided by the manufacturer. The amount of relaxation will also depend upon the initial tendon load relative to its breaking load. In most practical situations the transfer steel stress is about 70 per cent of the characteristic strength and relaxation losses are likely to be approximately 8–10 per cent of the tendon load remaining after transfer. This loss decreases linearly to zero for a transfer stress of about 40 per cent characteristic.

*Shrinkage of Concrete*

This is based on empirical figures for shrinkage/unit length of concrete ( $\epsilon_{sh}$ ) for particular curing conditions and transfer maturity as discussed in chapter 6. Typical values for pre-tensioned concrete (stressed at 3 to 5 days) range from  $100 \times 10^{-6}$  for UK outdoor exposure to  $300 \times 10^{-6}$  for indoor exposure. Corresponding values for post-tensioning (stressed at 7 to 14 days) are reduced to  $70 \times 10^{-6}$  and  $200 \times 10^{-6}$ . More detailed guidance in unusual circumstances may be obtained from section 6.3.2.

The loss in steel stress is thus given by  $\epsilon_{sh}E_s$ , hence

$$\text{loss in prestress force} = \epsilon_{sh}E_sA_{st}$$

*Friction in Ducts (Post-tensioning only)*

When a post-tensioned cable is stressed, it will move relative to the duct and other cables within the duct and friction will tend to resist this movement hence reducing the effective prestress force at positions remote from the jacking point. This effect may be divided into unintentional profile variations, and those due to designed curvature of ducts.

- (a) ‘Wobble’ effects in straight ducts will usually be present. If  $P_o$  = jack force, and  $P_x$  = cable force at distance  $x$  from jack then it is generally estimated that

$$P_x = P_o e^{-kx}$$

where  $e$  = base of napierian logs (2.718) and  $k$  = constant, depending on duct characteristics and construction procedures, generally taken as  $< 33 \times 10^{-4}$  but reducing to  $17 \times 10^{-4}$  in special cases.

- (b) Duct curvature will generally cause greater prestress force losses, and is given by

$$P_x = P_o e^{-\mu x/r_{ps}}$$

where  $\mu$  = coefficient of friction (typically 0.55 steel on concrete, 0.3 steel on steel, 0.12 greased strand on plastic) and  $r_{ps}$  = radius of curva-

ture of duct. If  $r_{ps}$  is not constant, the profile must be subdivided into sections, each assumed to have constant  $r_{ps}$ , in which case  $P_o$  is taken as the force at the jacking end of the section and  $x$  the length of the segment.  $P_x$ , the force at the end remote from the jack then becomes  $P_o$  for the next section and so on.

The above effects may be combined to produce an effective prestress force diagram for a member. If friction losses are high, it may be worth while to jack simultaneously from both ends, in which case the two diagrams may be superimposed, maintaining symmetry of prestress force relative to the length of the member.

### Example 12.7 Estimation of Prestress Losses

A rectangular  $250 \times 150$  mm pre-tensioned beam is stressed by wires of total area  $200 \text{ mm}^2$  with a total characteristic strength of  $370 \text{ kN}$  at an eccentricity of  $-50 \text{ mm}$ .

If the transfer prestress force is  $250 \text{ kN}$ , estimate the final value after losses. Assume:  $E_c$  (transfer) =  $28 \text{ kN/mm}^2$ ;  $E_s = 205 \text{ kN/mm}^2$ ; shrinkage/unit length ( $\epsilon_{sh}$ ) =  $300 \times 10^{-6}$ ; specific creep =  $48 \times 10^{-6} / \text{N/mm}^2$ .

#### (1) Elastic Shortening

$$P' = \frac{P_t}{1 + \alpha_e \frac{A_{st}}{A} \left( 1 + \frac{e^2 A}{I} \right)}$$

where  $A = 37500 \text{ mm}^2$

$$I = \frac{bh^3}{12} = 195 \times 10^6 \text{ mm}^4$$

therefore

$$\begin{aligned} P' &= \frac{250}{1 + \frac{205}{28} \times \frac{200}{37500} \left( 1 + \frac{50^2 \times 37500}{195 \times 10^6} \right)} \\ &= 236.3 \text{ kN} \left( \text{that is, loss} = \frac{13.7}{250} = 5.5\% \right) \end{aligned}$$

#### (2) Creep

$$\begin{aligned} \text{Loss in force} &= \text{specific creep} \times E_s \times \frac{P'}{A} \left( 1 + \frac{e^2 A}{I} \right) A_{st} \\ &= 48 \times 10^{-6} \times 205 \times 10^3 \times \frac{236}{37500} \times \\ &\quad \left( 1 + \frac{50^2 \times 37500}{195 \times 10^6} \right) \times 200 \end{aligned}$$

$$= 18.3 \text{ kN} \left( \text{that is, loss} = \frac{18.3}{250} = 7.3\% \right)$$

(3) *Relaxation*

$$\text{Transfer force} = \frac{250}{370} \times 100 = 67.5 \text{ per cent characteristic}$$

therefore assuming that a loss of about 8 per cent corresponds to a stress of 70 per cent characteristic,

$$\text{relaxation loss} \approx 8 \times \frac{(67.5 - 40)}{30} = 7.3 \text{ per cent}$$

therefore

$$\text{loss in force} \approx \frac{7.3}{100} \times 236.3 = 17.3 \text{ kN}$$

(4) *Shrinkage*

$$\begin{aligned} \text{Loss in force} &= \epsilon_{\text{sh}} E_s A_{\text{st}} = 300 \times 10^{-6} \times 205 \times 200 \\ &= 12.3 \text{ kN} \end{aligned}$$

Thus

$$\begin{aligned} \text{final prestress force} &= 236.3 - 18.3 - 17.3 - 12.3 \\ &= 188 \text{ kN} \end{aligned}$$

and

$$\text{total estimated loss of force is } \frac{62}{250} = 25 \text{ per cent}$$

#### 12.4.7 Calculation of Deflections

The anticipated deflections of a prestressed member must always be checked since specific span-effective depth ratios are not met in the design procedure. The deflection due to the eccentric prestress force must be evaluated and added to that from the normal dead and applied loading on the member. In the case of class 1 and 2 structures, the member is designed to be uncracked, and a similar procedure is followed to that described in chapter 6. Although class 3 members are designed as cracked under full load, when evaluating deflections due to non-prestress loadings it has been found that little error is introduced if the uncracked case is again considered, thus simplifying calculations considerably. BS 8110 recommends that for class 3 members such an assumption may be made if the permanent load is no more than 25 per cent of the total design load. If this is not satisfied then the member deflections must be evaluated as cracked unless the basic span-effective depth ratios (section 6.2) are satisfied, in which case the deflections of the member may be assumed to be not excessive.

The basic requirements which should generally be satisfied in respect of deflections are similar to those for a reinforced beam (section 6.3), which are

- (1) Final deflection  $\nabla$  span/250 measured below the level of supports.
- (2) 20 mm or span/500 maximum movement after finishes applied.

Additionally in prestressed concrete

- (3) Total upward deflection  $\nabla$  span/350 or 20 mm where finishes are applied, unless uniformity of camber between adjacent units can be ensured.

The evaluation of deflections due to prestress loading can be obtained by double integration of the expression

$$M_x = Pe_x = \frac{EI d^2 y}{dx^2}$$

over the length of the member, although this calculation can prove tedious for complex tendon profiles.

The simple case of straight tendons in a uniform member however, yields  $M = Pe =$  a constant, which is the situation evaluated in section 6.3.3 to yield a maximum mid-span deflection of  $-ML^2/8EI = -PeL^2/8EI$ . If the cables lie below the centroidal axis,  $e$  is negative, and the deflection due to prestress is then positive, that is upwards.

Another common case of a symmetrical parabolic tendon profile in a beam of constant section can also be evaluated quite simply by considering the bending-moment distribution in terms of an equivalent uniformly distributed load.

For the beam in figure 12.13 the moment due to prestress loading at any section is  $M_x = Pe_x$  but since  $e_x$  is parabolic, the prestress loading may be likened to a uniformly distributed load  $w_e$  on a simply supported beam; then mid-span moment

$$M = \frac{w_e L^2}{8} = Pe_c$$

thus

$$w_e = \frac{8Pe_c}{L^2}$$

But since the mid-span deflection due to a uniformly distributed load  $w$  over a span  $L$  is given by

$$y = -\frac{5}{384} \frac{wL^4}{EI}$$

the deflection due to  $w_e$  is

$$y = -\frac{5}{48} \frac{(Pe_c)L^2}{EI}$$

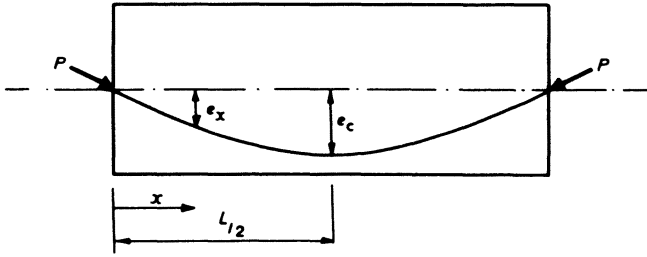

Figure 12.13 Parabolic tendon profile

If the prestress force does not lie at the centroid of the section at the ends of the beam, but at an eccentricity  $e_0$  as shown in figure 12.14, the expression for deflection must be modified. It can be shown that the deflection is the same as that caused by a force  $P$  acting at a constant eccentricity  $e_0$  throughout the length of the member, plus a force  $P$  following a parabolic profile with mid-span eccentricity  $e'_c$  as shown in figure 12.14.

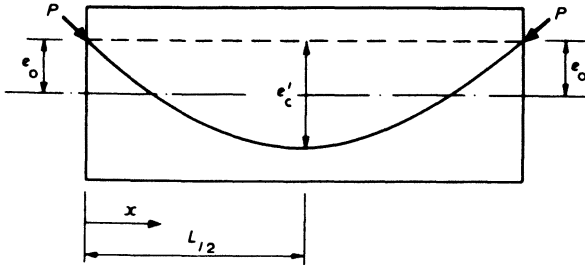

Figure 12.14 Parabolic tendon profile eccentric at ends of beam

The mid-span deflection thus becomes

$$y = -\frac{(Pe_0)L^2}{8EI} - \frac{5}{48} \frac{(Pe'_c)L^2}{EI}$$

Deflections due to more complex tendon profiles are most conveniently estimated on the basis of coefficients which can be evaluated for commonly occurring arrangements. These are on the basis  $y = (KL^2)/EI$  where  $K$  incorporates the variations of curvature due to prestress along the member length.

There are three principal stages in the life of a prestressed member at which deflections may be critical and may require to be assessed.

- (1) At transfer – a check of actual deflection at transfer for comparison with estimated values is a useful guide that a prestressed beam has been correctly constructed.
- (2) Under dead load, before application of finishes – deflections must be evaluated to permit subsequent movement and possible damage to be estimated.
- (3) Long term under full load – deflections are required, both to determine the subsequent movement and also to assess the appearance of the final structure.

Short-term deflections will be based on materials properties associated with characteristic strengths ( $\gamma_m = 1$ ) and with actual loading ( $\gamma_f = 1$ ). Long-term assessment however must not only take into account loss in prestress force, but also the effects of creep both on the applied loading and the prestress loading components of the deflection. Creep is allowed for by using an effective modulus of elasticity for the concrete, as discussed in section 6.3.2.

Thus if  $E_c$  is the instantaneous value, the effective value after creep is given by

$$E_{\text{eff}} = \frac{E_c}{1 + \phi}$$

where the value of  $\phi$ , the creep coefficient can be obtained from figure 6.5.

It can be shown in some instances that when net upward deflections occur, these often increase because of creep, thus the most critical downward deflection may well be before creep losses occur, while the most critical upward deflection may be long term. This further complicates a procedure which already has many uncertainties as discussed in chapter 6; thus deflections must always be regarded as estimates only.

### *Example 12.8 Calculation of Deflections*

Estimate transfer and long-term deflections for the 350 × 170 mm beam of 10 m span in examples 12.2 to 12.4 if it is assumed that the mid-span eccentricity = – 100 mm and the end eccentricity = 0. Assume that prestress losses amount to 25 per cent and that the creep coefficient = 2.0. The prestress force may be assumed constant throughout the member. (From the previous examples, final prestress force  $P = 322$  kN, minimum loading  $w_{\text{min}} = 1.43$  kN/m and maximum loading  $w_{\text{max}} = 4.43$  kN/m.)

(a) At Transfer

$$P_t = \frac{322}{0.75} = 430 \text{ kN}$$

take  $E_c = 31 \text{ kN/mm}^2$  as typical for a grade 40 concrete. Thus

$$\text{deflection due to self-weight} = - \frac{5}{384} \frac{w_{\text{min}} L^4}{E_c I}$$

$$\text{deflection due to prestress} = - \frac{5}{48} \frac{(P_t e_c) L^2}{E_c I}$$

But

$$I = \frac{bh^3}{12} = \frac{170 \times 350^3}{12} = 607 \times 10^6 \text{ mm}^4$$

Thus

$$\begin{aligned} \text{deflection } y &= \frac{-5 \times 1.43 \times 10^4 \times 10^{12}}{384 \times 31 \times 10^3 \times 607 \times 10^6} \\ &\quad - \frac{5}{48} \times \frac{430 \times 10^3 \times (-100) \times 10^2 \times 10^6}{31 \times 10^3 \times 607 \times 10^6} \\ &= -9.9 + 24 \\ &= +14 \text{ mm (upward)} \end{aligned}$$

(b) At Application of Finishes

If the dead load due to finishes = 2.0 kN/m, the instantaneous deflection due to finishes

$$\begin{aligned} y &= \frac{-5 \times 2.0 \times 10^4 \times 10^{12}}{384 \times 31 \times 10^3 \times 607 \times 10^6} \\ &= -14 \text{ mm (downward)} \end{aligned}$$

Assuming that only a small proportion of prestress losses have occurred at this stage, the total deflection will be given by

$$y = +14 - 14 = 0$$

(c) In the Long Term

$$E_{\text{eff}} = \frac{E_c}{1 + \phi} = \frac{31}{1 + 2} = 10.3 \text{ kN/mm}^2$$

Thus deflection under sustained minimum loading of dead load plus finishes becomes

$$\begin{aligned} y &= -\frac{5 \times (1.43 + 2.0) \times 10^4 \times 10^{12}}{384 \times 10.3 \times 10^3 \times 607 \times 10^6} - \frac{5 \times 322 \times 10^3 \times (-100) \times 10^2 \times 10^6}{48 \times 10.3 \times 10^3 \times 607 \times 10^6} \\ &= -71 + 53 = -18 \text{ mm (downward)} \end{aligned}$$

The deflection under sustained maximum loading is given by

$$\begin{aligned} y &= -71 \times \frac{4.43}{3.43} + 53 \\ &= -92 + 53 \\ &= -39 \text{ mm (downward)} \end{aligned}$$

The criteria that should be satisfied are

- (1) Maximum downward deflection =  $\text{span}/250 = 10\,000/250 = 40$  mm.  
This is just satisfied.
- (2) Maximum upward deflection =  $\text{span}/350 = 29$  mm or 20 mm. This is satisfied.
- (3) Maximum movement after finishes =  $\text{span}/500 = 20$  mm.

The actual value is given by

$$\begin{aligned} &\text{Maximum long-term deflection} - \text{instantaneous deflection} \\ &\text{after application of finishes} \\ &= -39 - 0 = -39 \text{ mm} \end{aligned}$$

Hence this requirement is not satisfied, and special consideration must be given to the importance attached to this criterion in this particular instance.

#### 12.4.8 End Blocks

In pre-tensioned members, the prestress force is transferred to the concrete by bond over a definite length at each end of the member. The transfer of stress to the concrete is thus gradual. In post-tensioned members however, the force is concentrated over a small area at the end faces of the member, and this leads to high tensile forces at right angles to the direction of the compression force. This effect will extend some distance from the end of the member until the compression has distributed itself across the full concrete cross-section. This region is known as the 'end block' and must be heavily reinforced by steel to resist the bursting tension forces. End block reinforcement will generally consist of closed links which surround the anchorages, and the quantities provided are usually obtained from empirical methods.

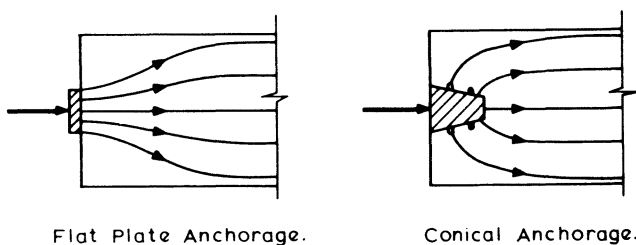

Figure 12.15

Typical 'flow lines' of compressive stress are shown in figure 12.15, from which it can be seen that whatever type of anchorage is used, the required distribution can be expected to have been attained at a distance from the loaded face equal to the lateral dimension of the member. This is relatively independent of the anchorage type, and the distribution of bursting tensile stress is generally as shown in figure 12.16.

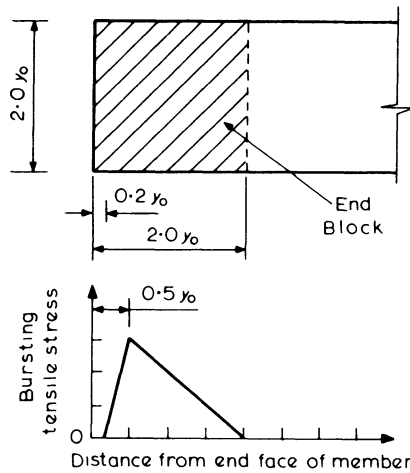

Figure 12.16

The magnitude of these stresses depends on the ratio of the dimensions of the loaded area to the dimensions of the end block. It will normally be necessary to establish the end-block dimensions both horizontally and vertically based on the size of the end face of the beam and the layout of the anchorages. The end block for each individual anchorage will be symmetrical about the centre line of the anchorage and its total width ( $2y_o$ ) will be limited by the distance ( $y_o$ ) to an edge of the concrete member or half the distance to an adjacent anchorage. Values of bursting tensile force ( $F_{bst}$ ) are given in table 12.1 related to the jacking force ( $P_o$ ) for a square end block of side  $2y_o$  loaded through a square anchorage of side  $2y_{po}$ . If a circular anchorage is used, then  $2y_{po}$  is taken as the side of a square of equivalent area, and if the end block is not square, then separate values of  $F_{bst}$  must be evaluated for both vertical and horizontal planes based on the largest symmetrical end block.

Once  $F_{bst}$  has been obtained, reinforcement is provided to act at a stress of  $200 \text{ N/mm}^2$  and is usually distributed evenly over the length of the end block. The calculation is thus based on serviceability conditions and will be adequate for

Table 12.1 Bursting forces in end blocks

$\frac{2y_{po}}{2y_o}$	0.3	0.4	0.5	0.6	0.7
$\frac{F_{bst}}{P_o}$	0.23	0.20	0.17	0.14	0.11

bonded tendons. If tendons are unbonded, an ultimate limit state check with  $F_{bst}$  based on the tendon characteristic load and with reinforcement acting at its design strength of  $0.87f_y$  will be necessary.

High local stresses should also be controlled by limiting the maximum compressive bearing stress to  $0.6 \times$  transfer cube strength, and extra helical reinforcement is often incorporated into 'wedge' type anchorages.

In situations where there is more than one anchorage, each should be treated individually and then combined as indicated in example 12.9.

**Example 12.9 Design of End Block Reinforcement (Bonded)**

The beam end in figure 12.17 is stressed by four identical 100 mm conical anchorages located as shown, with a jacking force of 400 kN applied to each.

The area may be subdivided into four equal end zones of side  $200 \times 150$  mm (figure 12.17a), that is

$$\begin{aligned} 2y_o &= 200 \text{ mm vertically} \\ &= 150 \text{ mm horizontally} \end{aligned}$$

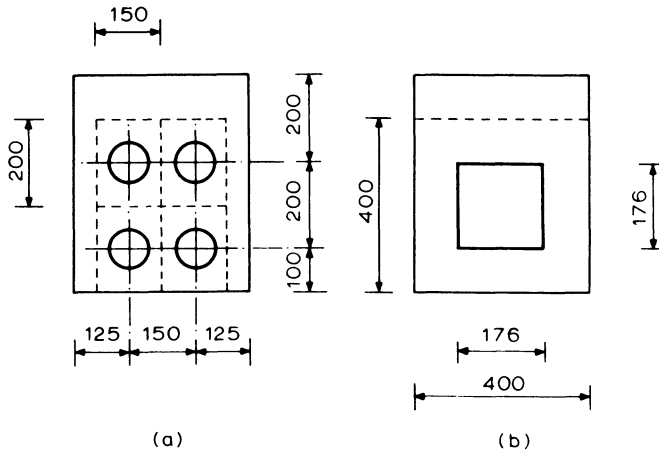

Figure 12.17

Equivalent square anchorage has side  $2y_{po} = \sqrt{(\pi \times 100^2/4)} = 88$  mm. Thus *vertically*

$$\frac{2y_{po}}{2y_o} = \frac{88}{200} = 0.44$$

hence from table 12.1

$$F_{bst} = 400 \times 0.188 = 75.2 \text{ kN}$$

to be resisted by horizontal steel within 200 mm of end face; and *horizontally*

$$\frac{2y_{po}}{2y_o} = \frac{88}{150} = 0.59$$

hence from table 12.1

$$F_{bst} = 400 \times 0.143 = 57.2 \text{ kN}$$

to be resisted by vertical steel within 150 mm of end face.

Then using High-yield steel with  $f_y = 460 \text{ N/mm}^2$  for bonded tendons  
allowable stress =  $200 \text{ N/mm}^2$

hence force of 75.2 kN requires

$$\frac{75.2 \times 10^3}{200} = 376 \text{ mm}^2$$

that is, three 10 mm closed links ( $471 \text{ mm}^2$ ) adequate, at say 50, 100 and 150 mm from end face

*Check horizontal plane:* two links lie within 150 mm of end face, thus requirement satisfied.

*Consider combined effects of anchorages,*  $P_k = 4 \times 400 = 1600 \text{ kN}$

side of end block = 400 mm each way (figure 12.17b)

side of equivalent anchorage =  $\sqrt{(88^2 \times 4)} = 176 \text{ mm}$

hence

$$\frac{2y_{po}}{2y_o} = \frac{176}{400} = 0.44$$

and

$$F_{bst} = 1600 \times 0.188 = 301 \text{ kN}$$

to be resisted by horizontal and vertical steel over 400 mm from end face needing

$$\frac{301}{200} \times 10^3 = 1505 \text{ mm}^2$$

provide as seven 12 mm links ( $1584 \text{ mm}^2$ ) at 50 mm centres commencing 50 mm from end face of the beam.

## 12.5 Analysis and Design at the Ultimate Limit State

After a prestressed member has been designed to satisfy serviceability requirements, a check must be carried out to ensure that the ultimate moment of resistance and shear resistance are adequate to satisfy the requirements of the ultimate limit state. The partial factors of safety on loads and materials for this analysis are the normal values for the ultimate limit state which are given in chapter 2.

### 12.5.1 Analysis of the Section

As the loads on a prestressed member increase above the working values, cracking occurs and the prestressing steel begins to behave as conventional reinforcement. The behaviour of the member at ultimate is exactly the same as that of an ordinary reinforced concrete member except that the initial strain in the steel must be taken into account in the calculations. The section may easily be analysed by the use of the equivalent rectangular stress block described in chapter 4. BS 8110 contains tables to permit the stress in the prestressing steel at ultimate, and the corresponding neutral axis position to be obtained for rectangular sections. These are based on empirical results but alternatively the simplified method illustrated in example 12.10 may be adopted for bonded members.

Although illustrated by a simple example this method may be applied to a cross-section of any shape which may have any arrangement of prestressing wires or tendons. Use is made of the stress-strain curve for the prestressing steel as shown in figure 12.18, to calculate tension forces in each layer of steel. The total steel strain is that due to bending added to the initial strain in the steel resulting from prestress. For a series of assumed neutral axis positions, the total tension capacity is compared with the compressive force developed by a uniform stress of  $0.45 f_{cu}$ , and when reasonable agreement is obtained, the moment of resistance can be evaluated.

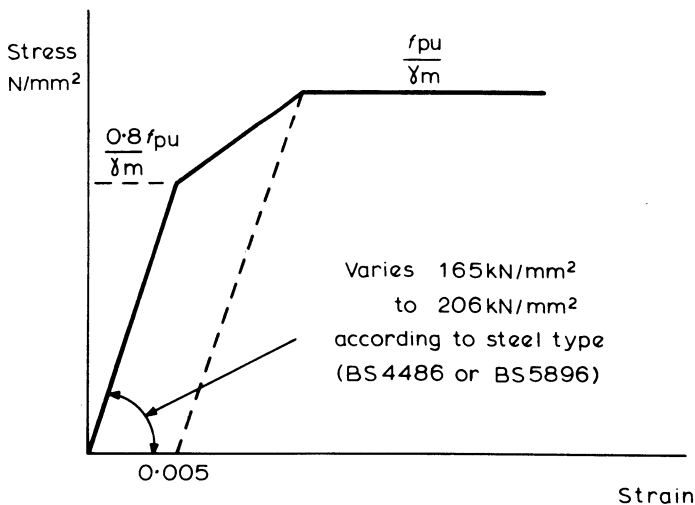

Figure 12.18 Stress-strain curve for prestressing steel

#### Example 12.10 Calculation of Ultimate Moment of Resistance

The section of a pretensioned beam shown in figure 12.19 is stressed by ten 5 mm wires of characteristic strength  $f_{pu} = 1470 \text{ N/mm}^2$ . If these wires are

initially stressed to  $1000 \text{ N/mm}^2$  and 30 per cent losses are anticipated, estimate the ultimate moment of resistance of the section if grade 40 concrete is used. The stress-strain curve for the prestressing wire is shown in figure 12.20.

$$\text{Area of 5 mm wire} = \pi \times 5^2 / 4 = 19.6 \text{ mm}^2$$

$$\text{Stress in steel after losses} = 1000 \times 0.7 = 700 \text{ N/mm}^2$$

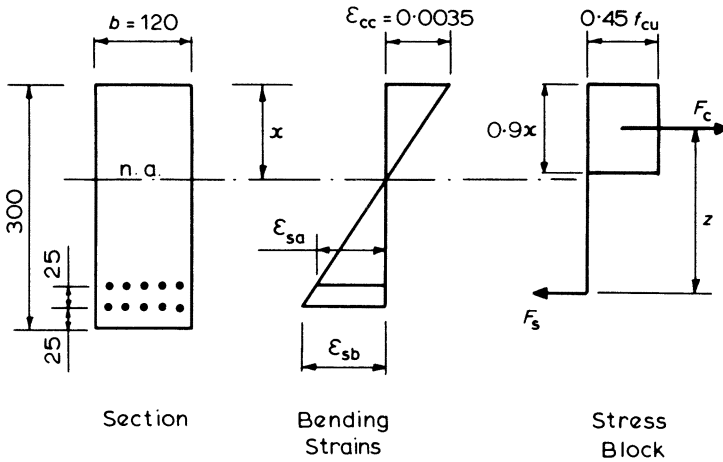

Figure 12.19

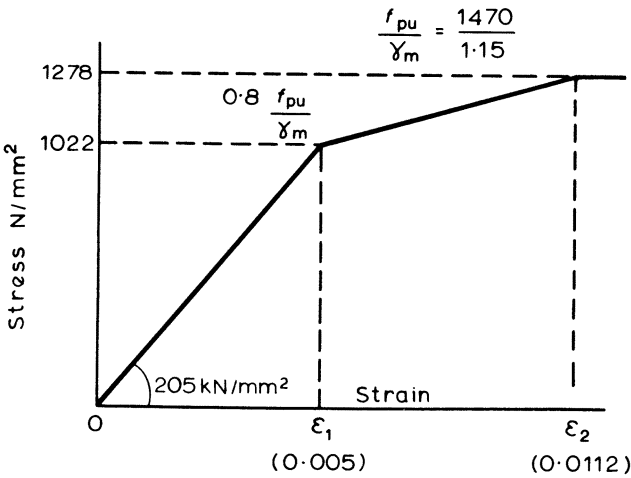

Figure 12.20 Stress-strain curve for wire

therefore

$$\text{strain in steel after losses} = \frac{f_s}{E_s} = \frac{700}{205 \times 10^3} = 0.0034$$

which is less than  $\epsilon_1$ , the lower yield strain.

A depth  $x$  of neutral axis must be found for which the compressive force  $F_c$  in the concrete is balanced by the tensile force  $F_s$  in the steel. Then the ultimate moment of resistance is given by

$$M_u = F_c z = F_s z \quad (12.31)$$

where  $z$  is the lever arm between  $F_c$  and  $F_s$ .

As a first attempt try  $x = 130$  mm, approximately equal to  $0.5d$ .

#### (a) Steel Strains

Final steel strain  $\epsilon_s = \text{prestress strain} + \text{bending strain}, \epsilon'_s$

(In calculating  $\epsilon'_s$ , the initial concrete strain due to prestress can be ignored without undue error.)

Top layer

$$\epsilon_{sa} = 0.0034 + \epsilon'_{sa}$$

$$\text{therefore } \epsilon_{sa} = 0.0034 + \frac{(250 - x)}{x} \epsilon_{cc} \quad (12.32)$$

$$= 0.0034 + \frac{(250 - 130)}{130} 0.0035$$

$$= 0.0066$$

Bottom layer

$$\epsilon_{sb} = 0.0034 + \epsilon'_{sb}$$

$$= 0.0034 + \frac{(275 - x)}{x} \epsilon_{cc} \quad (12.33)$$

$$= 0.0034 + \frac{(275 - 130)}{130} 0.0035$$

$$= 0.0073$$

#### (b) Steel Stresses

From the stress-strain curve the corresponding steel stresses are

Top layer

$$f_{sa} = 1022 + \frac{(1278 - 1022)}{(0.0112 - 0.005)} (\epsilon_{sa} - 0.005) \quad (12.34)$$

$$= 1022 + 41\,290(0.0066 - 0.005)$$

$$= 1088 \text{ N/mm}^2$$

and

$$f_{sb} = 1022 + 41\,290(\epsilon_{sb} - 0.005) \tag{12.35}$$

$$= 1022 + 41\,290(0.0073 - 0.005)$$

$$= 1117 \text{ N/mm}^2$$

(c) Forces in Steel and Concrete

$$\text{Steel tensile force } F_s = \Sigma f_s A_s = (f_{sa} + f_{sb}) 5 \times 19.6 \tag{12.36}$$

$$= (1088 + 1117) 98$$

$$= 216 \times 10^3 \text{ N}$$

With a rectangular stress block

$$\text{concrete compressive force } F_c = 0.45 f_{cu} b \times 0.9x \tag{12.37}$$

$$= 0.45 \times 40 \times 120 \times 130 \times 0.9$$

$$= 253 \times 10^3 \text{ N}$$

The force  $F_c$  in the concrete is larger than the force  $F_s$  in the steel, therefore a smaller depth of neutral axis must be tried.

Table 12.2 shows the results of calculations for further trial depths of neutral axis. For  $x = 110$ ,  $F_c$  became smaller than  $F_s$ , therefore  $x = 120$  and 116 were tried and it was then found that  $F_s = F_c$ .

**Table 12.2**

$x$ (mm)	Strains		Stresses		Forces	
	$\epsilon_{sa}$ ( $\times 10^3$ )	$\epsilon_{sb}$	$f_{sa}$ (N/mm <sup>2</sup> )	$f_{sb}$	$F_s$ (kN)	$F_c$
130	6.6	7.3	1088	1117	216	253
110	7.8	8.6	1138	1171	226	214
120	7.2	7.9	1113	1142	221	233
116	7.4	8.2	1121	1154	223	225

In terms of the tensile force in the steel, the ultimate moment of resistance of the section is given by

$$M_u = F_s z = \Sigma [f_s A_s (d - 0.45x)] \tag{12.38}$$

$$= 5 \times 19.6 [1121(250 - 0.45 \times 116) + 1154(275 - 0.45 \times 116)]$$

$$= 46.9 \times 10^6 \text{ N mm}$$

If  $x$  had been incorrectly chosen as 130 mm then using equation 12.38  $M_u$  would equal 44.1 kN m, or in terms of the concrete

$$\begin{aligned} M_u &= 0.45 f_{cu} b \times 0.9xz \\ &\approx 0.45 \times 40 \times 120 \times 0.9 \times 130 (262.5 - 0.45 \times 130) \times 10^{-6} \\ &\approx 51 \text{ kN m} \end{aligned}$$

Comparing the average of these two values of  $M_u$  ( $= 47.5$  kN m) with the correct answer, it can be seen that a slight error in the position of the neutral axis does not have any significant effect on the calculated moment of resistance.

### 12.5.2 Design of Additional Reinforcement

If it is found, as may be the case with class 2 or 3 members, that the ultimate limit state requirements are not met, additional untensioned or partially tensioned steel may be added to increase the ultimate moment of resistance.

#### Example 12.11 Design of Untensioned Reinforcement

Design untensioned high yield reinforcement ( $f_y = 460$  N/mm<sup>2</sup>) for the rectangular beam section shown in figure 12.21 which is stressed by five 5 mm wires, if the ultimate moment of resistance is to exceed 40 kN m for grade 50 concrete. The characteristic strength of tensioned steel,  $f_{pu} = 1470$  N/mm<sup>2</sup>.

(a) Check Ultimate Moment of Resistance

$$\begin{aligned} \text{Maximum tensile force if} \\ \text{prestressing steel yielded} \end{aligned} = 5 \times 19.6 \times \frac{1470}{1.15} \times 10^{-3} = 125 \text{ kN}$$

$$\begin{aligned} \text{Concrete compressive} \\ \text{area to balance} \end{aligned} = \frac{125 \times 10^3}{0.45 \times 50} = 0.9 \times 120x$$

thus, neutral axis depth  $x = 51$  mm.

Assuming prestrain as calculated in example 12.10

$$\begin{aligned} \text{total steel strain} &= \text{prestrain} + \text{bending strain} \\ &= 0.0034 + \frac{(d-x)}{x} \times 0.0035 \\ &= 0.0034 + \frac{224}{51} \times 0.0035 = 0.0187 (> \text{yield}) \end{aligned}$$

$$\text{Lever arm} = 275 - 0.45 \times 51 = 252 \text{ mm}$$

Hence

$$\text{ultimate moment of resistance} = 252 \times 125 \times 10^{-3} = 31.5 \text{ kN m}$$

Untensioned steel is therefore required to permit the beam to support an ultimate moment of 40 kN m.

Additional moment of capacity to be provided =  $40 - 31.5 = 8.5 \text{ kN m}$

Effective depth of additional steel =  $245 \text{ mm}$

then

lever arm to additional steel  $\approx 210 \text{ mm}$

then

$$\text{additional tension force required} = \frac{8500}{210} = 40.5 \text{ kN}$$

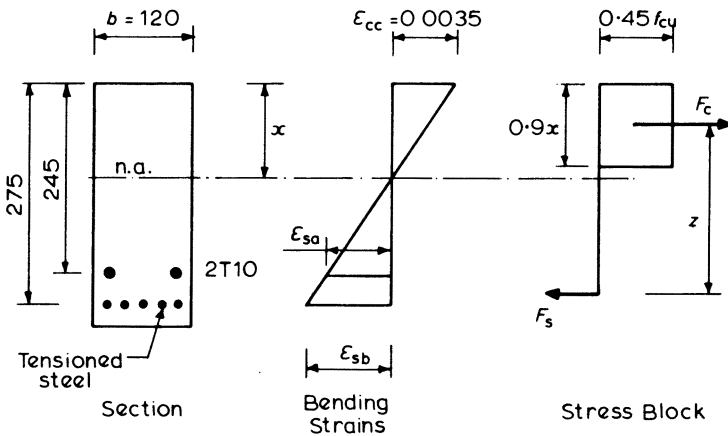

Figure 12.21

thus

$$\text{estimated area of untensioned steel required at its yield stress} = \frac{40500}{460 \times 0.87} = 102 \text{ mm}^2$$

Try two 10 mm diameter bars ( $157 \text{ mm}^2$ ).

(b) Check Steel Strain

If additional steel has yielded, force in two T10 bars =  $157 \times 460 \times 10^{-3} / 1.15 = 62.8 \text{ kN}$ , therefore

$$\begin{aligned} \text{total tensile force if all the steel has yielded} &= 125 + 62.8 \\ &= 187.8 \text{ kN} \end{aligned}$$

Thus

$$\begin{aligned} \text{depth of neutral axis at ultimate} &= \frac{187.8 \times 10^3}{0.45 \times 50 \times 120 \times 0.9} \\ &= 77 \text{ mm} \end{aligned}$$

Therefore

$$\begin{aligned}\text{prestressing steel strain } \epsilon_{sb} &= \frac{198}{77} \times 0.0035 + 0.0034 \\ &= 0.0124 (> \text{yield})\end{aligned}$$

and

$$\begin{aligned}\text{untensioned steel strain } \epsilon_{sa} &= \frac{245 - 77}{77} \times 0.0035 \\ &= 0.0076\end{aligned}$$

This value is greater than the yield strain of 0.002 from section 4.1.2.

### (c) Check Ultimate Moment of Resistance

Taking moments about the centre of compression

$$\begin{aligned}M_u &= 125(275 - 0.45x) + 62.8(245 - 0.45x) \\ &= [125(275 - 0.45 \times 77) + 62.8(245 - 0.45 \times 77)] 10^{-3} \\ &= 43.2 \text{ kN m}\end{aligned}$$

If it had been found in (b) that either the prestressing steel or untensioned steel had not yielded, then a trial and error approach similar to example 12.10 would have been necessary.

### 12.5.3 Shear

Shear in prestressed concrete is considered at the ultimate limit state. Design for shear therefore involves the most severe loading conditions, with the usual partial factors of safety on loading for the ultimate limit state being incorporated.

The action of a member in resisting shear is similar to that for reinforced concrete, but with the additional effects of the compression due to the prestress force. This will increase the shear resistance considerably, since design is based on limiting the diagonal principal tensile stresses in the concrete.

Although most prestressed concrete members will be uncracked under working loads, when carrying the loads for the ultimate limit state they may well be cracked over part of their span. This will reduce the shear capacity, but fortunately the regions of cracking in simply supported members will generally be the centre part of the span where shear forces are relatively small.

#### Uncracked Section

At an uncracked section, a Mohr's circle analysis of a beam element shown in figure 12.22 which is subjected to a longitudinal compressive stress  $f_c$  and a shear stress  $v_{co}$ , gives the principal tensile stress as

$$f_t = \sqrt{\left[\left(\frac{f_c}{2}\right)^2 + v_{co}^2\right]} - \left(\frac{f_c}{2}\right)$$

This can be rearranged to give the shear stress

$$v_{co} = \sqrt{(f_t^2 + f_c f_t)}$$

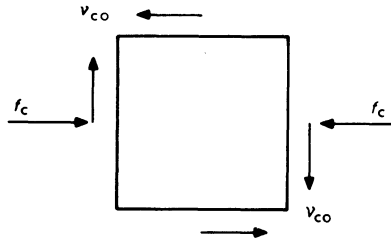

Figure 12.22

The actual shear stress at any level of a beam subjected to a shear force,  $V$ , can be shown to be

$$v = \frac{V(A\bar{y})}{bI}$$

where  $(A\bar{y})$  is the first moment of area of the part of the section above the level considered about the centroidal axis of the beam, as shown in figure 12.23,  $b$  is the breadth of the section at the level considered and  $I$  is the second moment of area of the whole section about its centroidal axis.

Hence if  $f_t$  is the limiting value of principal tensile force, the ultimate shear resistance  $V_{co}$  of an uncracked section becomes

$$V_{co} = \frac{bI}{(A\bar{y})} \sqrt{(f_t^2 + f_c f_t)}$$

For a rectangular section the maximum shear stress occurs at the centroid, thus  $A = bh/2$ ,  $I = bh^3/12$ ,  $\bar{y} = h/4$ ; then

$$\frac{Ib}{(A\bar{y})} = 0.67bh$$

and

$$v_{co} = \frac{3}{2} \frac{V_{co}}{bh}$$

giving

$$V_{co} = 0.67bh \sqrt{(f_t^2 + f_c f_t)}$$

This equation forms the basis of the design expression given in BS 8110. A partial factor of safety of 0.8 is applied to the centroidal compressive stress due to prestress  $f_{cp}$ , hence  $f_c = 0.8f_{cp}$ .  $f_t$  is taken as positive and is given a limiting value

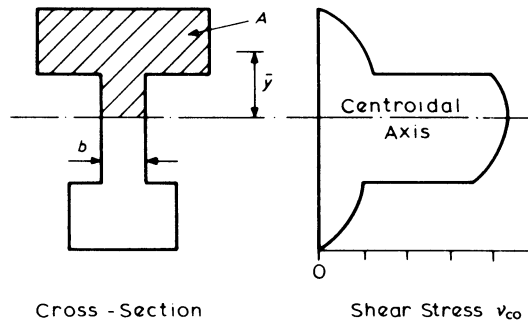

Figure 12.23

of  $0.24 \sqrt{f_{cu}}$  which may be regarded as being equivalent to  $0.3 \sqrt{(f_{cu}/\gamma_m)}$  with  $\gamma_m = 1.5$ .

The resulting expression

$$V_{co} = 0.67bh \sqrt{(f_t^2 + 0.8f_{cp}f_t)}$$

may also be applied to I- and T-sections with sufficient accuracy for practical purposes, although the maximum principal tensile stress may not coincide with the centroid. If the centroid of the section lies within the flange however, the expression should be evaluated for the flange/web junction with  $b$  taken as the web width and  $f_{cp}$  being the compression due to prestress at that level.

If a duct lies in the web, then the value of  $b$  used in calculations should be reduced by the duct diameter if the tendons are unbonded or two-thirds of the diameter if bonded.

Additional shear resistance will be provided by the vertical component of the prestress force where curved cables are used, provided the section is uncracked. Near the ends of beams where shear forces are highest, and cable slopes generally greatest, a considerable increase in resistance can be obtained from this, and shear strength contribution should be a consideration when detailing tendon profiles.

The total shear resistance of an uncracked section may then be taken as  $V_c = V_{co} + P \sin \beta$  where  $\beta$  is the cable slope.

### Cracked Section

BS 8110 gives an empirical expression for the calculation of shear resistance of a section which is cracked in flexure

$$V_{cr} = \left(1 - 0.55 \frac{f_{pe}}{f_{pu}}\right) v_c bd + \frac{M_0}{M} V \leq 0.1 bd \sqrt{f_{cu}}$$

- where  $f_{pe}$  = prestressing steel stress after losses  
 $d$  = effective depth to centroid of tendons  
 $b$  = width of web for flanged beam  
 $v_c$  = allowable ultimate shear stress (as for reinforced concrete)  
 $V$  = ultimate shear force acting on section

- $M$  = ultimate moment acting on section
- $M_0 = 0.8 f_{pt} I/y$  is the moment necessary to produce zero stress at the extreme tensile fibre which is a distance  $y$  from the centroid of the section, where  $f_{pt}$  is the concrete compressive stress at this level due to prestress and a factor of safety of 0.8 is applied to this value.

Thus if  $M < M_0$  it follows that  $V_{cr}$  will always be greater than the applied ultimate shear force, and a check on cracking is thus incorporated. The vertical component of prestressing force should not be added to the value of  $V_{cr}$  obtained from this expression.

*Upper Limit to Shear Force*

A further upper limit to shear force must be imposed to avoid web crushing and this is achieved by limiting the value of shear stress so that  $V/bd < v_{max}$  in the same way as for reinforced concrete.  $v_{max}$  is the maximum allowable ultimate shear stress with a value which may be calculated as the lesser of  $0.8 \sqrt{f_{cu}}$  or  $5 \text{ N/mm}^2$ .

*Design Procedure*

The usual design procedure consists of calculating the shear resistance of the cracked and uncracked sections at intervals along the length of the member for comparison with the applied ultimate shear force  $V$ . The lower of the two values obtained from the analyses must be taken as shear resistance at the point concerned. Thus

$$\text{ultimate shear resistance } V_c = \text{lesser of } V_{cr} \text{ or } V_{co} + P \sin \beta$$

If  $V$  is less than  $0.5 V_c$  no shear reinforcement is required, but for values between  $0.5 V_c$  and  $V_c + 0.4 bd$  nominal links should be provided such that

$$\frac{A_{sv}}{s_v} \geq \frac{0.4b}{0.87 f_{yv}}$$

and where  $V > V_c + 0.4 bd$  designed steel is needed such that for links

$$\frac{A_{sv}}{s_v} \geq \frac{V - V_c}{0.87 f_{yv} d_t}$$

In this expression  $d_t$  is the greater of the depth to the centroid of the tendons or the corner longitudinal bars anchoring links.

As for reinforced concrete the usual design procedure will be to evaluate the shear resistances of the sections plus nominal steel to identify areas which require more detailed attention, as illustrated in example 12.12.

**Example 12.12 Design of Shear Reinforcement**

The beam cross-section in figure 12.24 is constant over a 30 m span with a parabolic tendon profile and an eccentricity varying between  $-300 \text{ mm}$  at the ends to  $-750 \text{ mm}$  at mid-span. The beam supports an ultimate uniformly distributed load of  $43 \text{ kN/m}$  and is of grade 40 concrete.

$$P = 2590 \text{ kN}$$

$$I = 145\,106 \times 10^6 \text{ mm}^4$$

$$A = 500 \times 10^3 \text{ mm}^2$$

(a) Upper limit to shear force

$$\frac{V}{bd} = \frac{43 \times 15 \times 1000}{150 \times 950} = 4.5 \text{ N/mm}^2$$

$$< 0.8 \sqrt{f_{cu}} (= 5.1 \text{ N/mm}^2) \text{ and } < 5 \text{ N/mm}^2 \text{ at end of beam}$$

(b) Uncracked resistance: since centroid lies within web

$$V_{co} = 0.67 bh \sqrt{(f_t^2 + 0.8 f_{cp} f_t)}$$

where  $f_t = 0.24 \sqrt{f_{cu}} = 0.24 \sqrt{40} = 1.51 \text{ N/mm}^2$  and

$$f_{cp} = \frac{P}{A} = \frac{2590 \times 10^3}{500 \times 10^3} = 5.18 \text{ N/mm}^2$$

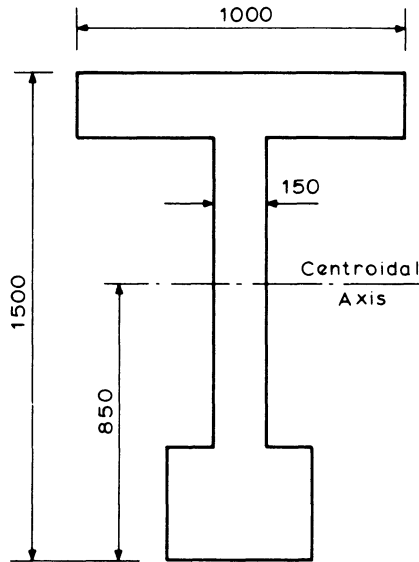

Figure 12.24

hence

$$\begin{aligned} V_{co} &= 0.67 \times 150 \times 1500 \sqrt{(1.51^2 + 0.8 \times 5.18 \times 1.51)} \times 10^{-3} \\ &= 440.4 \text{ kN} \end{aligned}$$

The vertical component of prestress force is  $P \sin \beta$ , where  $\beta$  = tendon slope.

Tendon profile is  $y = Kx^2 + C$ , and if origin is at mid-span  $x = 0$ ,  $y = 0$  and  $C = 0$  hence at  $x = 15\ 000$ ,  $y = 750 - 300 = 450$  and

$$450 = K \times 15\ 000^2$$

$$K = 2.0 \times 10^{-6}$$

therefore tendon profile is  $y = 2.0 \times 10^{-6}x^2$ , therefore

$$\text{tendon slope} = \frac{dy}{dx} = 2Kx$$

$$\text{at end } \frac{dy}{dx} = 2 \times 2.0 \times 10^{-6} \times 15\ 000 = 0.060 = \tan \beta$$

hence  $\beta = 3.43^\circ$  and  $\sin \beta \approx \tan \beta = 0.06$ . Therefore

$$\text{vertical component of prestress force at end of beam} = 2590 \times 0.06 = 155 \text{ kN}$$

Hence

$$\begin{aligned} \text{maximum uncracked resistance} &= 440 + 155 \\ &= 595 \text{ kN} \end{aligned}$$

This value will decrease away from the end of the beam

$$\text{at } 2 \text{ m from support} = 440 + 134 = 574 \text{ kN}$$

$$5 \text{ m from support} = 440 + 103 = 543 \text{ kN}$$

$$10 \text{ m from support} = 440 + 51 = 491 \text{ kN}$$

(c) Cracked resistance

$$V_{cr} = \left(1 - 0.55 \frac{f_{pe}}{f_{pu}}\right) v_c bd + M_0 \frac{V}{M}$$

This will vary along beam. At mid-span  $V = 0$ ,  $d = 1400$  mm. If tendons stressed to 70 per cent characteristic strength at transfer and then subject to 30 per cent losses

$$\frac{f_{pe}}{f_{pu}} = 0.7 \times 0.7 = 0.49$$

If total area of tendons =  $3450 \text{ mm}^2$ , then

$$\frac{100A_s}{bd} = \frac{100 \times 3450}{150 \times 1400} = 1.64$$

therefore from table 5.1,  $v_c = 0.86 \text{ N/mm}^2$  for grade 40 concrete

$$\begin{aligned} V_{cr} &= (1 - 0.55 \times 0.49) 0.86 \times 150 \times 1400 \times 10^{-3} \\ &= 132 \text{ kN} \end{aligned}$$

Also check minimum

$$\begin{aligned} V_{cr} &\leq 0.1 bd \sqrt{f_{cu}} \\ &\leq 0.1 \times 150 \times 1400 \times \sqrt{40} \times 10^{-3} \\ &= 133 \text{ kN} \end{aligned}$$

At section 10 m from supports,  $d = 1400 - 2.0 \times 10^{-6} \times 5000^2 = 1350$  mm, therefore

$$\frac{100A_s}{bd} = 1.70 \text{ and hence } \nu_c = 0.87$$

$$V = 43 \times 5 = 215 \text{ kN}$$

$$M = 15 \times 43 \times 10 - 10 \times 43 \times 5 = 4300 \text{ kN m}$$

$$M_o = 0.8 f_{pt} \frac{I}{y}$$

where  $y = y_1 = 850$  mm, and

$$\begin{aligned} f_{pt} &= \frac{P}{A} - \frac{Pey_1}{I} \\ &= 5.18 - \frac{2590 \times (-700) \times 850 \times 10^3}{145\,106 \times 10^6} \\ &= 15.8 \text{ N/mm}^2 \end{aligned}$$

hence

$$M_o = \frac{0.8 \times 15.8 \times 145\,106}{850} = 2158 \text{ kN m}$$

and

$$\begin{aligned} V_{cr} &= (1 - 0.55 \times 0.49) 0.87 \times 150 \times 1350 + \frac{2158 \times 215 \times 10^3}{4300} \\ &= (128.7 + 107.9) \times 10^3 \text{ N} \\ &= 236.6 \text{ kN} \end{aligned}$$

This calculation may be repeated for other sections to give the resistance diagram shown in figure 12.25.

From this diagram it can be seen that at all points except for about 3 m at midspan  $V > \frac{1}{2} V_c$  and hence nominal reinforcement is required such that

$$\frac{A_{sv}}{s_v} = \frac{0.4b}{0.87f_{yv}}$$

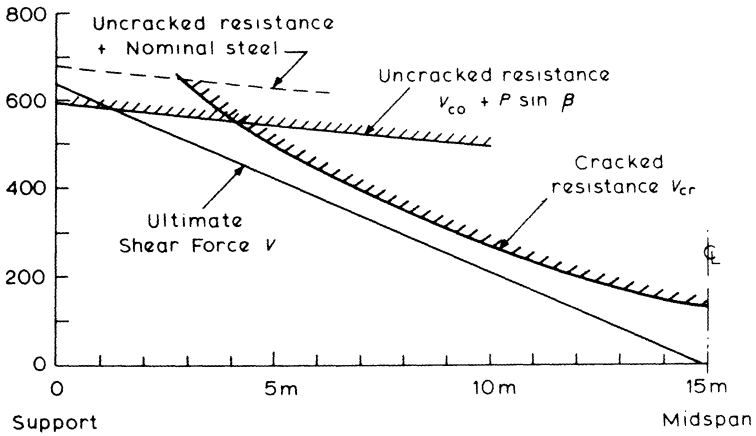

Figure 12.25

therefore with mild-steel links  $f_{yv} = 250 \text{ N/mm}^2$ , hence

$$\frac{A_{sv}}{s_v} = \frac{0.4 \times 150}{0.87 \times 250} = 0.276$$

which could be provided by 8 mm stirrups at 350 mm centres ( $A_{sv}/s_v = 0.287$ ).

$$\begin{aligned} \text{Shear resistance provided by these links} &= 0.87 f_{yv} d_t \left( \frac{A_{sv}}{s_v} \right) \\ &= 0.87 \times 250 \times 1400 \\ &\quad \times 0.287 \times 10^{-3} \\ &= 87.4 \text{ kN} \end{aligned}$$

hence at the ends of the beam

$$\begin{aligned} \text{total shear resistance of section + nominal steel} &= 595 + 87.4 \\ &= 682.4 \text{ kN} \end{aligned}$$

Since this is greater than the ultimate shear force of 645 kN, no additional reinforcement is required. Thus provide 8 mm mild-steel links at 350 mm centres throughout.

# Appendix

## Typical Weights and Live Loads

$$\begin{aligned}1 \text{ lb} &= 0.454 \text{ kg} && = 4.448 \text{ N force} \\1 \text{ lb/ft}^2 &= 4.88 \text{ kg/m}^2 && = 47.9 \text{ N/m}^2 \\1 \text{ lb/ft}^3 &= 16.02 \text{ kg/m}^3 && = 157 \text{ N/m}^3\end{aligned}$$

### *Weights*

	kN/m <sup>3</sup>
Aluminium, cast	26
Asphalt paving	23
Bricks, common	19
Bricks, pressed	22
Clay, dry	19–22
Clay, wet	21–25
Concrete, reinforced	24
Glass, plate	27
Lead	112
Oak	9.5
Pine, white	5
Sand, dry	16–19
Sand, wet	18–21
Steel	77
Water	9.81

	kN/m <sup>2</sup>
Brick wall, 115 mm thick	2.6
Gypsum plaster, 25 mm thick	0.5
Glazing, single	0.3

**Floor and Roof Loads**

	kN/m <sup>2</sup>
Classrooms	3.0
Dance halls	5.0
Flats and houses	1.5
Garages, passenger cars	2.5
Gymnasiums	5.0
Hospital wards	2.0
Hotel bedrooms	2.0
Offices for general use	2.5
Flat roofs, with access	1.5
Flat roofs, no access	0.75

**Bar Areas and Perimeters**Sectional areas of groups of bars (mm<sup>2</sup>)

Bar size (mm)	Number of bars									
	1	2	3	4	5	6	7	8	9	10
6	28.3	56.6	84.9	113	142	170	198	226	255	283
8	50.3	101	151	201	252	302	352	402	453	503
10	78.5	157	236	314	393	471	550	628	707	785
12	113	226	339	452	566	679	792	905	1020	1130
16	201	402	603	804	1010	1210	1410	1610	1810	2010
20	314	628	943	1260	1570	1890	2200	2510	2830	3140
25	491	982	1470	1960	2450	2950	3440	3930	4420	4910
32	804	1610	2410	3220	4020	4830	5630	6430	7240	8040
40	1260	2510	3770	5030	6280	7540	8800	10100	11300	12600

## Perimeters and weights of bars

Bar size (mm)	6	8	10	12	16	20	25	32	40
Perimeter (mm)	18.85	25.1	31.4	37.7	50.2	62.8	78.5	100.5	125.6
Weight (kg/m)	0.222	0.395	0.616	0.888	1.579	2.466	3.854	6.313	9.864

Bar weights based on a density of 7850 kg/m<sup>3</sup>.

Sectional areas per metre width for various bar spacings (mm<sup>2</sup>)

Bar size (mm)	Spacing of bars								
	50	75	100	125	150	175	200	250	300
6	566	377	283	226	189	162	142	113	94.3
8	1010	671	503	402	335	287	252	201	168
10	1570	1050	785	628	523	449	393	314	262
12	2260	1510	1130	905	754	646	566	452	377
16	4020	2680	2010	1610	1340	1150	1010	804	670
20	6280	4190	3140	2510	2090	1800	1570	1260	1050
25	9820	6550	4910	3930	3270	2810	2450	1960	1640
32	16100	10700	8040	6430	5360	4600	4020	3220	2680
40	25100	16800	12600	10100	8380	7180	6280	5030	4190

**Shear Reinforcement** $A_{sv}/s_v$  for varying stirrup diameter and spacing

Stirrup diameter (mm)	Stirrup spacing (mm)										
	85	90	100	125	150	175	200	225	250	275	300
8	1.183	1.118	1.006	0.805	0.671	0.575	0.503	0.447	0.402	0.366	0.335
10	1.847	1.744	1.57	1.256	1.047	0.897	0.785	0.698	0.628	0.571	0.523
12	2.659	2.511	2.26	1.808	1.507	1.291	1.13	1.004	0.904	0.822	0.753
16	4.729	4.467	4.02	3.216	2.68	2.297	2.01	1.787	1.608	1.462	1.34

**Anchorage and Lap Requirements**Anchorage lengths (anchorage length  $L = K_A \times \text{bar size}$ )

	$K_A$			
	$f_{cu} = 25$	30	35	40 or more
<b>Plain (250)</b>				
Tension	39	36	33	31
Compression	32	29	27	25
<b>Deformed Type 1 (460)</b>				
Tension	51	46	43	40
Compression	41	37	34	32
<b>Deformed Type 2 (460)</b>				
Tension	41	37	34	32
Compression	32	29	27	26

Basic lap lengths in tension and compression (lap length =  $K_L \times \text{bar size}$ )

	$K_L$			
	$f_{cu} = 25$	30	35	40 or more
<b>Plain (250)</b>	39	36	33	31
<b>Deformed Type 1 (460)</b>	51	46	43	40
<b>Deformed Type 2 (460)</b>	41	37	34	32

Minimum lap lengths :  $15 \times \text{bar size}$  or 300 mm.

Refer to figure 5.8 for increased lap lengths at certain locations in a member section.

Type 1 and 2 bars are described in section 1.6.2.

# Further Reading

## (a) British Standards

- BS 1881 Methods of testing concrete*
- BS 4449 Specification for hot rolled steel bars for the reinforcement of concrete*
- BS 4461 Specification for cold worked steel bars for the reinforcement of concrete*
- BS 4466 Specification for bending dimensions and scheduling of reinforcement for concrete*
- BS 4482 Hard drawn mild steel wire for the reinforcement of concrete*
- BS 4483 Steel fabric for the reinforcement of concrete*
- BS 5075 Concrete admixtures*
- BS 5896 Specification for high tensile steel wire strand for the prestressing of concrete*
- BS 6399 Design loading for buildings*
- BS 8007 Code of practice for the design of concrete structures for retaining aqueous liquids*
- BS 8110 Structural use of concrete, Parts 1, 2 and 3*
- CP 3 Code of basic data for the design of buildings*
  - Chapter V Loading
  - Part 2 Wind loads
- CP 8004 Foundations*

## (b) Textbooks and Other Publications

- R. D. Anchor, *Design of Liquid Retaining Structures* (Blackie)
- J. H. Bungey, *The Testing of Concrete in Structures* (Surrey University Press)
- R. J. Cope and L. A. Clark, *Concrete Slabs: Analysis and Design* (Elsevier Applied Science)
- B. P. Hughes, *Limit State Theory for Reinforced Concrete* (Pitman)
- R. Hulse and W. H. Mosley, *Reinforced Concrete Design by Computer* (Macmillan)
- R. Hulse and W. H. Mosley, *Prestressed Concrete Design by Computer* (Macmillan)
- M. K. Hurst, *Prestressed Concrete Design* (Chapman and Hall)
- L. L. Jones and R. H. Wood, *Yield Line Analysis of Slabs* (Chatto and Windus)

- F. K. Kong and R. H. Evans, *Reinforced and Prestressed Concrete* (Nelson)  
K. Leet, *Reinforced Concrete Design* (McGraw-Hill)  
T. Y. Lin and N. H. Burns, *Design of Prestressed Concrete Structures* (Wiley)  
T. J. MacGinley, *Reinforced Concrete* (Spon)  
S. Mindess and J. F. Young, *Concrete* (Prentice-Hall)  
A. M. Neville, *Properties of Concrete* (Pitman)  
R. Park and W. L. Gamble, *Reinforced Concrete Slabs* (Wiley)  
R. Park and R. Paulay, *Reinforced Concrete Structures* (Wiley)  
C. E. Reynolds and J. C. Steedman, *Reinforced Concrete Designers Handbook*  
(Viewpoint Publications)  
F. Sawko (ed.), *Developments in Prestressed Concrete, Vols 1 and 2* (Applied  
Science)  
*Handbook on BS 8110: 1986* (Viewpoint Publications)

# Index

- Age factors 3
- Analysis of structures
  - beams 26–33
  - column moment 39, 42–3, 239, 249–52
  - damaged structure 153
  - frames 35–47, 249
  - lateral loads 44–7
  - retaining walls 318–28
- Analysis of the section
  - bending 57, 61, 67
  - elastic 91–7
  - flanged 68–75
  - uncracked 95–7
  - with axial load 79–88
- Anchorage bond 103–6
- Anchorage bond lengths 105, 297, 385
- Areas of bars 383–4
  
- Balanced failure 82–3
- Bars *see* Reinforcement
- Bases *see* Footings
- Beams
  - analysis of moments and shears 26–33
  - analysis of sections 57, 61, 67
  - cantilever 187
  - continuous 26–33, 180–7
  - deflections 119–32, 359–64
  - design 154–91
  - design charts 59, 65–6, 161
  - doubly reinforced 63–8, 162–7
  - effective spans 156
  - one span 29, 157–8, 173, 177
  - prestressed 329–81
  - reinforcement details 113–17, 164, 170–2, 175
  - singly reinforced 58–62, 160–2
  - sizing 156–7
- Bearing pressures 271–5, 322
- Bearing stresses at a bend 179
- Bending moments
  - coefficients 34, 183, 206
  - envelopes 34, 42, 170, 181
  - redistribution 48–52, 75–9, 180
- Bending with axial load 79–88, 239
- Bends and hooks 105, 179
- Bent-up bars 101–2, 178
- Biaxial bending 258–61
- Bond, anchorage 103–6
- Bond lengths 385
- Braced columns 35, 239, 246–7
- Bundled bars 115
  
- Cantilever beams 187–8
- Cantilever retaining walls 319–28
- Characteristic loads 17, 24, 382–3
- Characteristic material strengths 13, 17
- Circumference of bars 383
- Coefficients of bending moments and shears 34, 183, 206
- Columns
  - analysis of section 79–88
  - axially loaded 246
  - biaxial bending 258–61
  - braced 35, 239, 246–7
  - design 239–69
  - design charts 80–8, 248
  - effective height 241–2

- loading arrangements 36, 42
  - 240, 251
- moments 36, 42, 240, 251,
  - 266, 269
- non-rectangular section 86-8,
  - 261-4
- reinforcement details 244-6
  - short 241-4, 246-7
  - simplified design 246-7, 262-4
  - slender 241-4, 264-9
  - substitute frame 36, 42, 251
  - unsymmetrically reinforced
    - 253-8
- Combined footings 280-4
- Compression reinforcement 63-8,
  - 162-7
- Concrete
  - age factor 3
  - characteristic strength 13, 17
  - cover 12, 113-14, 146, 272, 297,
    - 302
  - cracking 7, 134-44, 297, 304-8
  - creep 11, 124, 356, 362
  - durability 12, 144-6, 297
  - elastic modulus 4-5, 123, 362
  - shrinkage 7-11, 124, 141-4,
    - 297, 307, 357
  - stress-strain curve 3, 5, 54
  - thermal expansion 2, 7, 10,
    - 141-4, 298-302
- Continuous beams
  - analysis 29-34
  - curtailment of bars 170-2
  - design 182-7
  - envelopes 34, 181
  - loading arrangements 26-7, 31
  - moment and shear coefficients
    - 34, 183
- Counterfort retaining walls 319
- Cover to reinforcement 12, 113-14,
  - 146, 272, 297, 302
- Cracking
  - control 7, 140-1, 297-308
  - flexural 134-41
  - thermal and shrinkage 7-11,
    - 141-4
- Creep 11, 124, 356, 362
- Creep coefficients 124, 356
- Critical section 194, 276
- Critical span 347
- Critical steel ratio 141, 302, 307,
  - 310
- Curtailment of bars 170-2
- Curvatures 125-6
- Dead loads 19, 25, 382
- Deflections 119-32, 198, 359-64
- Design charts
  - beams 59, 65-6, 161
  - columns 80-8, 248
- Diagonal tension 98, 197, 374
- Distribution steel 117, 200
- Doubly reinforced beams 63-8,
  - 162-7
- Dowels 245, 275
- Durability 12, 144-6
- Earth-bearing pressures 271-5,
  - 322-3
- Effective depth 56, 156
- Effective flange width 167
- Effective height of a column 241-2
- Effective span 156, 201, 206
- Elastic analysis of a section 91-7,
  - 317-18
- Elastic modulus
  - concrete 4-5, 123, 362
  - steel 54-5
- End blocks 364-7
- Envelopes, bending moment and
  - shear force 34, 42, 170, 181
- Equivalent rectangular stress block
  - 55-7
- Factors of safety
  - global 19-20
  - partial 18-19, 270, 296, 298,
    - 321
- Fire resistance 16, 113-15, 147
- Flanged section *see* T-beams
- Flat slab 214-21
- Floors *see* Slabs
- Footings
  - allowable soil pressures 271
  - combined 280-4
  - horizontal loads 271, 294
  - pad 273-9
  - piled 291-5
  - raft 289-91
  - strap 284-6
  - strip 286-9
- Foundations *see* Footings
- Frames
  - analysis 35-47
  - braced 35-43
  - laterally loaded 44-7
  - loading arrangements 26-8, 36,
    - 239-40
  - unbraced 35, 44-7, 239

- Gravity retaining walls 318–19, 321
- Hooks and bends 105, 175, 179
- Joints  
   construction 299–300  
   contraction and expansion 299–302, 303, 324
- Lap lengths 106–7, 385
- Laps 106–7, 385
- L-beams *see* T-beams
- Lever arm 58–9, 77, 161
- Lever arm curve 59, 161
- Limit state design 15–23, 304–17
- Limit states  
   serviceability 16, 112–44, 270  
   ultimate 16
- Links 99–101, 108–9, 164, 174–8, 188, 245, 377
- Load combinations 26–8
- Loading arrangements 26–7, 36, 240, 271, 321–22
- Loads  
   characteristic 17  
   dead 25  
   imposed or live 25, 305, 321  
   typical values 382–3
- Long-term deflection 119–20, 123–7, 359, 362
- Loss of prestress 354–9
- Material properties 1–14, 54
- Maximum bar spacing 113–15, 117, 164, 175, 180, 200, 245, 297, 302
- Maximum steel areas 116, 159, 244–5
- Minimum bar spacing 115, 174
- Minimum steel areas 115–17, 159, 176, 194, 200, 213, 244–5, 303, 309
- Modular ratio 92, 318
- Modulus of elasticity *see* Elastic modulus
- Moment coefficients 34, 206, 210, 216
- Moment envelopes 34, 41, 170, 181
- Moment redistribution 48–52, 57, 75–9, 162, 193
- Moments in columns 36, 39–47, 239–44, 247–64
- Neutral-axis depth 56–7, 59, 69
- Nominal reinforcement 115–17, 159, 176, 194, 200, 213, 244–5, 308
- Non-rectangular section 86–8, 261–4
- Overturning 22, 27, 273, 320–2
- Pad footings 273–9
- Parabola, properties of 89–90
- Partial safety factors 18–19, 296, 298, 305, 321
- Permissible bearing pressures 271
- Permissible stresses 21, 306, 318, 341
- Piled foundations 291–5
- Prestressed concrete  
   analysis and design 329–81  
   cable zone 351–4  
   deflections 359–64  
   end block 364–7  
   losses 354–9  
   post-tensioning 334–5, 343  
   pretensioning 333–4, 343  
   shear 374–81  
   transfer stress 349–50  
   ultimate strength 367–81
- Punching shear 194–8, 217, 220–1, 276
- Raft foundations 289–91
- Rectangular stress block 55–9
- Rectangular-parabolic stress block 54, 89–91
- Redistribution of moments 48–52, 57, 75–9, 162, 193
- Reinforcement  
   areas 383–4  
   bond lengths 385  
   characteristic strengths 14, 17  
   circumference 383  
   lap lengths 106, 385  
   maximum and minimum areas 115–17, 159, 176, 194, 200, 213, 244–5, 303, 308  
   properties 6, 13–14, 54–5  
   spacing 113–15, 117, 164, 174–5, 180, 200, 245  
   torsion 107–11, 188–91  
   untensioned 372–4

- Retaining walls
  - analysis and design 318–28
  - cantilever 319–20, 322, 324–8
  - counterfort 319
  - gravity 318–19, 321
- Serviceability limit state
  - cracking 134–44, 304–8, 317–18
  - deflections 119–34, 359–64
  - durability 12, 112, 144–6
  - factors of safety 18–19
  - fire resistance 114–15, 147
- Shear
  - beams 30, 98–103, 174–9
  - concrete stresses 101, 174
  - footings 276, 278–9
  - prestressed beams 374–81
  - punching 194–8, 217, 220–1, 276
  - reinforcement 99–103, 174–9, 377–81
  - slabs 193–8, 220–1
  - torsion 107–10, 188–91
- Short columns 241–4, 246–7
- Shrinkage 7–11, 124–5, 131–2, 141–4, 307, 357
- Slabs
  - continuous, spanning one direction 206–8
  - flat 214–21
  - hollow block 222–3
  - one span, spanning one direction 201–6
  - ribbed 222–5
  - spanning two directions 209–14
  - stair 226–30
  - strip method 236–8
- Slender column 241–4, 264–9
- Spacing of reinforcement 113–15, 117, 164, 174–5, 180, 200, 245, 297, 302, 308
- Span-effective depth ratios 117–19, 132–4, 198–200, 217
- Stability 147–53, 271, 320–2
- Stairs 226–30
- Steel
  - characteristic stresses 14, 17
  - stress-strain curve 5–6, 54–5, 368–9
  - yield strains 55
- Stirrups *see* Links
- Strap footings 284–6
- Stress blocks 54–5, 89–92, 95
- Stresses
  - anchorage 103–6, 297, 307
  - bond 103–5, 297, 307
  - concrete, characteristic 13, 17
  - permissible 21, 306, 317–18, 341
  - shear 102–3, 374–7
  - steel, characteristic 14, 17
- Stress-strain curves 3–6, 54–7, 368
- Strip footings 286–9
- Strip method 236–8
- Substitute frame
  - braced 35–43
  - column 36, 42–3
  - continuous beam 29–37
- Tanks 296–318
- T-beams
  - analysis 68–75
  - design 167–9, 183
  - flange reinforcement 115, 168
  - flange width 167
  - second moments of area 43
  - span-effective depth ratio 117
- Tendons 331–5
- Thermal cracking 10, 141–4, 306–8
- Thermal movement 7, 10–11, 299
- Tie forces 148–52
- Torsion
  - analysis 107–11
  - design 188–91
- Transfer stresses 332, 341–43, 349–50
- Transmission length 333
- Triangular stress block 91–7, 121–3, 318
- Ultimate limit state
  - factors of safety 18, 19, 297, 304, 321
  - loading arrangements 26–7, 193, 240, 320–3
  - prestressed concrete 367–81
  - stability 27, 271, 320–2
- Uncracked section 95–7, 121–2
- Untensioned steel in prestressed concrete 372–4

- Water-retaining structures
  - elastic analysis 91–7
  - elastic design 317–18
  - joints 298–302, 303
  - limit state design 304–17
  - reinforcement details 302, 304
- Weights of materials 382
- Wind loading 19, 25, 44–7, 271
- Yield lines 230–6
- Yield strains 55
- Young's modulus *see* Elastic modulus