

THIRD EDITION

# Fundamental Electrical and Electronic Principles

Christopher R Robertson



# Fundamental Electrical and Electronic Principles

This page intentionally left blank

# Fundamental Electrical and Electronic Principles

Third Edition

**Christopher R Robertson**



AMSTERDAM • BOSTON • HEIDELBERG • LONDON • NEW YORK • OXFORD  
PARIS • SAN DIEGO • SAN FRANCISCO • SINGAPORE • SYDNEY • TOKYO

Newnes is an imprint of Elsevier



Newnes is an imprint of Elsevier  
Linacre House, Jordan Hill, Oxford OX2 8DP, UK  
30 Corporate Drive, Suite 400, Burlington, MA 01803, USA

First published 1993 as *Electrical and Electronic Principles 1* by Edward Arnold  
Second edition 2001  
Third edition 2008

Copyright © C. R. Robertson 1993, 2001  
Copyright © 2008 Elsevier Ltd. All rights reserved

The right of Christopher R. Robertson to be identified as the author of this work has been asserted in accordance with the Copyright, Designs and Patents Act 1988

No part of this publication may be reproduced, stored in a retrieval system or transmitted in any form or by any means electronic, mechanical, photocopying, recording or otherwise without the prior written permission of the publisher

Permissions may be sought directly from Elsevier's Science & Technology Rights Department in Oxford, UK: phone (+44) (0) 1865 843830; fax (+44) (0) 1865 853333; email: [permissions@elsevier.com](mailto:permissions@elsevier.com). Alternatively you can submit your request online by visiting the Elsevier web site at <http://elsevier.com/locate/permissions>, and selecting *Obtaining permission to use Elsevier material*

#### Notice

No responsibility is assumed by the publisher for any injury and/or damage to persons or property as a matter of products liability, negligence or otherwise, or from any use or operation of any methods, products, instructions or ideas contained in the material herein.

#### British Library Cataloguing in Publication Data

A catalogue record for this book is available from the British Library

#### Library of Congress Cataloguing in Publication Data

A catalogue record for this book is available from the Library of Congress

ISBN: 978-0-7506-8737-9

For information on all Newnes publications visit our web site at <http://books.elsevier.com>

Typeset by Charon Tec Ltd., A Macmillan Company.  
([www.macmillansolutions.com](http://www.macmillansolutions.com))

Printed and bound in Slovenia

08 09 10 11 12 10 9 8 7 6 5 4 3 2 1

Working together to grow  
libraries in developing countries

[www.elsevier.com](http://www.elsevier.com) | [www.bookaid.org](http://www.bookaid.org) | [www.sabre.org](http://www.sabre.org)

ELSEVIER BOOK AID International Sabre Foundation

# Contents

Preface.....	ix
Introduction.....	xi
<b>1 Fundamentals.....</b>	<b>1</b>
1.1 Units.....	1
1.2 Standard Form Notation.....	2
1.3 'Scientific' Notation.....	2
1.4 Conversion of Areas and Volumes.....	4
1.5 Graphs.....	5
1.6 Basic Electrical Concepts.....	7
1.7 Communication.....	26
Summary of Equations.....	29
Assignment Questions.....	30
<b>2 D.C. Circuits.....</b>	<b>31</b>
2.1 Resistors in Series.....	31
2.2 Resistors in Parallel.....	35
2.3 Potential Divider.....	40
2.4 Current Divider.....	41
2.5 Series/Parallel Combinations.....	43
2.6 Kirchhoff's Current Law.....	48
2.7 Kirchhoff's Voltage Law.....	49
2.8 The Wheatstone Bridge Network.....	55
2.9 The Wheatstone Bridge Instrument.....	63
2.10 The Slidewire Potentiometer.....	65
Summary of Equations.....	68
Assignment Questions.....	69
Suggested Practical Assignments.....	72
<b>3 Electric Fields and Capacitors.....</b>	<b>75</b>
3.1 Coulomb's Law.....	75
3.2 Electric Fields.....	76
3.3 Electric Field Strength (E).....	78
3.4 Electric Flux ( $\psi$ ) and Flux Density (D).....	79
3.5 The Charging Process and Potential Gradient.....	80
3.6 Capacitance (C).....	83
3.7 Capacitors.....	84
3.8 Permittivity of Free Space ( $\epsilon_0$ ).....	84
3.9 Relative Permittivity ( $\epsilon_r$ ).....	84
3.10 Absolute Permittivity ( $\epsilon$ ).....	85

3.11	Calculating Capacitor Values.....	85
3.12	Capacitors in Parallel.....	87
3.13	Capacitors in Series.....	89
3.14	Series/Parallel Combinations.....	92
3.15	Multiplate Capacitors.....	95
3.16	Energy Stored.....	97
3.17	Dielectric Strength and Working Voltage.....	101
3.18	Capacitor Types.....	102
	Summary of Equations.....	105
	Assignment Questions.....	107
	Suggested Practical Assignment.....	110
<b>4</b>	<b>Magnetic Fields and Circuits.....</b>	<b>111</b>
4.1	Magnetic Materials.....	111
4.2	Magnetic Fields.....	111
4.3	The Magnetic Circuit.....	114
4.4	Magnetic Flux and Flux Density.....	115
4.5	Magnetomotive Force (mmf).....	116
4.6	Magnetic Field Strength.....	117
4.7	Permeability of Free Space ( $\mu_0$ ).....	118
4.8	Relative Permeability ( $\mu_r$ ).....	119
4.9	Absolute Permeability ( $\mu$ ).....	119
4.10	Magnetisation ( $B/H$ ) Curve.....	122
4.11	Composite Series Magnetic Circuits.....	126
4.12	Reluctance ( $S$ ).....	128
4.13	Comparison of Electrical, Magnetic and Electrostatic Quantities.....	131
4.14	Magnetic Hysteresis.....	132
4.15	Parallel Magnetic Circuits.....	134
	Summary of Equations.....	135
	Assignment Questions.....	136
	Suggested Practical Assignments.....	138
<b>5</b>	<b>Electromagnetism.....</b>	<b>141</b>
5.1	Faraday's Law of Electromagnetic Induction.....	141
5.2	Lenz's Law.....	144
5.3	Fleming's Righthand Rule.....	144
5.4	EMF Induced in a Single Straight Conductor.....	147
5.5	Force on a Current-Carrying Conductor.....	151
5.6	The Motor Principle.....	153
5.7	Force between Parallel Conductors.....	156
5.8	The Moving Coil Meter.....	158
5.9	Shunts and Multipliers.....	162
5.10	Shunts.....	162
5.11	Multipliers.....	163

5.12	Figure of Merit and Loading Effect .....	166
5.13	The Ohmmeter .....	170
5.14	Wattmeter.....	171
5.15	Eddy Currents.....	172
5.16	Self and Mutual Inductance.....	174
5.17	Self-Inductance.....	175
5.18	Self-Inductance and Flux Linkages.....	176
5.19	Factors Affecting Inductance.....	179
5.20	Mutual Inductance.....	180
5.21	Relationship between Self- and Mutual-Inductance.....	182
5.22	Energy Stored.....	184
5.23	The Transformer Principle .....	186
5.24	Transformer Voltage and Current Ratios.....	188
	Summary of Equations.....	191
	Assignment Questions.....	192
	Suggested Practical Assignments.....	195
<b>6</b>	<b>Alternating Quantities .....</b>	<b>197</b>
6.1	Production of an Alternating Waveform.....	197
6.2	Angular Velocity and Frequency .....	200
6.3	Standard Expression for an Alternating Quantity.....	200
6.4	Average Value.....	203
6.5	r.m.s. Value.....	205
6.6	Peak Factor.....	206
6.7	Form Factor.....	207
6.8	Rectifiers.....	208
6.9	Half-wave Rectifier .....	209
6.10	Full-wave Bridge Rectifier.....	210
6.11	Rectifier Moving Coil Meter.....	212
6.12	Phase and Phase Angle.....	213
6.13	Phasor Representation.....	216
6.14	Addition of Alternating Quantities.....	219
6.15	The Cathode Ray Oscilloscope.....	224
6.16	Operation of the Oscilloscope.....	226
6.17	Dual Beam Oscilloscopes.....	228
	Summary of Equations.....	229
	Assignment Questions.....	230
	Suggested Practical Assignments.....	232
<b>7</b>	<b>D.C. Machines.....</b>	<b>233</b>
7.1	Motor/Generator Duality.....	233
7.2	The Generation of d.c. Voltage.....	235
7.3	Construction of d.c. Machines.....	238
7.4	Classification of Generators.....	238

7.5	Separately Excited Generator.....	239
7.6	Shunt Generator.....	240
7.7	Series Generator.....	242
7.8	D. C. Motors.....	244
7.9	Shunt Motor.....	244
7.10	Series Motor.....	245
	Summary of Equations.....	247
	Assignment Questions.....	248
<b>8</b>	<b>D.C. Transients.....</b>	<b>249</b>
8.1	Capacitor-Resistor Series Circuit (Charging).....	249
8.2	Capacitor-Resistor Series Circuit (Discharging).....	253
8.3	Inductor-Resistor Series Circuit (Connection to Supply).....	256
8.4	Inductor-Resistor Series Circuit (Disconnection).....	259
	Summary of Equations.....	260
	Assignment Questions.....	261
	Suggested Practical Assignments.....	262
<b>9</b>	<b>Semiconductor Theory and Devices.....</b>	<b>263</b>
9.1	Atomic Structure.....	263
9.2	Intrinsic (Pure) Semiconductors.....	264
9.3	Electron-Hole Pair Generation and Recombination.....	266
9.4	Conduction in Intrinsic Semiconductors.....	267
9.5	Extrinsic (Impure) Semiconductors.....	268
9.6	n-type Semiconductor.....	268
9.7	p-type Semiconductor.....	270
9.8	The p-n Junction.....	271
9.9	The p-n Junction Diode.....	272
9.10	Forward-biased Diode.....	273
9.11	Reverse-biased Diode.....	273
9.12	Diode Characteristics.....	274
9.13	The Zener Diode.....	276
	Assignment Questions.....	281
	Suggested Practical Assignments.....	282
	Appendix A: SI Units and Quantities.....	283
	Answers to Assignment Questions.....	285
	Index.....	289

# Preface

This Textbook supersedes the second edition of *Fundamental Electrical and Electronic Principles*. In response to comments from colleges requesting that the contents more closely match the objectives of the BTEC unit Electrical and Electronic Principles, some chapters have been removed and some exchanged with the companion book *Further Electrical and Electronic Principles*, ISBN 9780750687478. Also, in order to encourage students to use other reference sources, those chapters that have been totally removed may be accessed on the website address <http://books.elsevier.com/companions/9780750687379>. The previous edition included Supplementary Worked Examples at the end of each chapter. The majority of these have now been included within each chapter as Worked Examples, and those that have been removed may be accessed on the above website.

This book continues with the philosophy of the previous editions in that it may be used as a complete set of course notes for students undertaking the study of Electrical and Electronic Principles in the first year of a BTEC National Diploma/Certificate course. It also provides coverage for some other courses, including foundation/bridging courses which require the study of Electrical and Electronic Engineering.

*Fundamental Electrical and Electronic Principles* contains 349 illustrations, 112 worked examples, 26 suggested practical assignments and 234 assignment questions. The answers to the latter are to be found towards the end of the book.

The order of the chapters does not necessarily follow the order set out in any syllabus, but rather follows a logical step-by-step sequence through the subject matter. Some topic areas may extend beyond current syllabus requirements, but do so both for the sake of completeness and to encourage those students wishing to extend their knowledge.

Coverage of the second year BTEC National Diploma/Certificate unit, Further Electrical Principles, is found in the third edition of the companion book *Further Electrical and Electronic Principles*.

C. Robertson  
Tonbridge  
March 2008

This page intentionally left blank

# Introduction

The chapters follow a sequence that I consider to be a logical progression through the subject matter, and in the main, follow the order of objectives stated in the BTEC unit of Electrical and Electronic Principles. The major exception to this is that the topics of instrumentation and measurements do not appear in a specific chapter of that title. Instead, the various instruments and measurement methods are integrated within those chapters where the relevant theory is covered.

Occasionally a word or phrase will appear in **bold blue type**, and close by will be a box with a blue background. These emphasised words or phrases may be ones that are not familiar to students, and within the box will be an explanation of the words used in the text.

Throughout the book, Worked Examples appear as **Q questions in bold type**, followed by **A answers**. In all chapters, Assignment Questions are provided for students to solve.

The first chapter deals with the basic concepts of electricity; the use of standard form and its adaptation to scientific notation; SI and derived units; and the plotting of graphs. This chapter is intended to provide a means of ensuring that all students on a given course start with the same background knowledge. Also included in this chapter are notes regarding communication. In particular, emphasis is placed on logical and thorough presentation of information, etc. in the solution of Assignment Questions and Practical Assignment reports.

This page intentionally left blank

# Fundamentals

## 1.1 Units

Wherever measurements are performed there is a need for a coherent and practical system of units. In science and engineering the International System of units (SI units) form the basis of all units used. There are seven ‘base’ units from which all the other units are derived, called derived units.

**Table 1.1** The SI base units

Quantity	Unit	Unit symbol
Mass	kilogram	kg
Length	metre	m
Time	second	s
Electric current	ampere	A
Temperature	kelvin	K
Luminous intensity	candela	cd
Amount of substance	mole	mol

A few examples of derived units are shown in Table 1.2, and it is worth noting that different symbols are used to represent the quantity and its associated unit in each case.

**Table 1.2** Some SI derived units

Quantity		Unit	
Name	Symbol	Name	Symbol
Force	$F$	Newton	N
Power	$P$	Watt	W
Energy	$W$	Joule	J
Resistance	$R$	Ohm	$\Omega$

For a more comprehensive list of SI units see Appendix A at the back of the book.

## 1.2 Standard Form Notation

Standard form is a method of writing large and small numbers in a form that is more convenient than writing a large number of trailing or leading zeroes.

For example the speed of light is approximately 300 000 000 m/s. When written in standard form this figure would appear as

$$3.0 \times 10^8 \text{ m/s, where } 10^8 \text{ represents } 100\,000\,000$$

Similarly, if the wavelength of 'red' light is approximately 0.000 000 767 m, it is more convenient to write it in standard form as

$$7.67 \times 10^{-7} \text{ m, where } 10^{-7} = 1/10\,000\,000$$

It should be noted that whenever a 'multiplying' factor is required, the base 10 is raised to a positive power. When a 'dividing' factor is required, a negative power is used. This is illustrated below:

$$\begin{array}{l} 10 = 10^1 \quad 1/10 = 0.1 = 10^{-1} \\ 100 = 10^2 \quad 1/100 = 0.01 = 10^{-2} \\ 1000 = 10^3 \quad 1/1000 = 0.001 = 10^{-3} \\ \text{etc.} \qquad \qquad \text{etc.} \end{array}$$

One restriction that is applied when using standard form is that only the first non-zero digit must appear before the decimal point.

Thus, 46 500 is written as

$$4.65 \times 10^4 \text{ and not as } 46.5 \times 10^3$$

Similarly, 0.002 69 is written as

$$2.69 \times 10^{-3} \text{ and not as } 26.9 \times 10^{-4} \text{ or } 269 \times 10^{-5}$$

## 1.3 'Scientific' Notation

This notation has the advantage of using the base 10 raised to a power but it is not restricted to the placement of the decimal point. It has the added advantage that the base 10 raised to certain powers have unique symbols assigned.

For example if a body has a mass  $m = 500\,000$  g.

In standard form this would be written as

$$m = 5.0 \times 10^5 \text{ g.}$$

Using scientific notation it would appear as

$$m = 500 \text{ kg (500 kilogram)}$$

where the 'k' in front of the g for gram represents  $10^3$ .

Not only is the latter notation much neater but it gives a better 'feel' to the meaning and relevance of the quantity.

See Table 1.3 for the symbols (prefixes) used to represent the various powers of 10. It should be noted that these prefixes are arranged in multiples of  $10^3$ . It is also a general rule that the positive powers of 10 are represented by capital letters, with the negative powers being represented by lower case (small) letters. The exception to this rule is the 'k' used for kilo.

**Table 1.3** Unit prefixes used in 'scientific' notation

Multiplying factor	Prefix name	Symbol
$10^{12}$	tera	T
$10^9$	giga	G
$10^6$	mega	M
$10^3$	kilo	k
$10^{-3}$	milli	m
$10^{-6}$	micro	$\mu$
$10^{-9}$	nano	n
$10^{-12}$	pico	p

### Worked Example 1.1

**Q** Write the following quantities in a concise form using (a) standard form, and (b) scientific notation  
(i) 0.000 018 A (ii) 15 000V (iii) 250 000 000 W

**A**

- (a) (i)  $0.000\ 018\ \text{A} = 1.8 \times 10^{-5}\ \text{A}$   
(ii)  $15\ 000\ \text{V} = 1.5 \times 10^4\ \text{V}$   
(iii)  $250\ 000\ 000\ \text{W} = 2.5 \times 10^8\ \text{W}$
- (b) (i)  $0.000\ 018\ \text{A} = 18\ \mu\text{A}$   
(ii)  $15\ 000\ \text{V} = 15\ \text{kV}$   
(iii)  $250\ 000\ 000\ \text{W} = 250\ \text{MW}$  **Ans**

The above example illustrates the neatness and convenience of the scientific or engineering notation.

### Worked Example 1.2

**Q** Write the following quantities in scientific (engineering) notation. (a)  $25 \times 10^{-5}\ \text{A}$ , (b)  $3 \times 10^4\ \text{W}$ , (c) 850 000 J, (d) 0.0016V.

**A**

- (a) 
$$25 \times 10^{-5} = 25 \times 10 \times 10^{-6}$$

$$= 250 \times 10^{-6}$$
and since  $10^{-6}$  is represented by  $\mu$  (micro)

$$\text{then } 25 \times 10^{-5} \text{ A} = 250 \mu\text{A} \text{ Ans}$$

$$\begin{aligned} \text{Alternatively, } 25 \times 10^{-5} &= 25 \times 10^{-2} \times 10^{-3} \\ &= 0.25 \times 10^{-3} \end{aligned}$$

$$\text{so } 25 \times 10^{-5} \text{ A} = 0.25 \text{ mA} \text{ Ans}$$

$$\text{(b) } 3 \times 10^{-4} = 3 \times 10^{-1} \times 10^{-3} \text{ or } 300 \times 10^{-6}$$

$$\text{so } 3 \times 10^{-4} \text{ W} = 0.3 \text{ mW or } 300 \mu\text{W} \text{ Ans}$$

$$\text{(c) } 850\,000 = 850 \times 10^3 \text{ or } 0.85 \times 10^6$$

$$\text{so } 850\,000 \text{ J} = 850 \text{ kJ or } 0.85 \text{ MJ} \text{ Ans}$$

$$\text{(d) } 0.0016 = 1.6 \times 10^{-3}$$

$$\text{so } 0.0016 \text{ V} = 1.6 \text{ mV} \text{ Ans}$$

## 1.4 Conversion of Areas and Volumes

Consider a square having sides of 1 m as shown in Fig. 1.1. In this case each side can also be said to be 100 cm or 1000 mm. Hence the area  $A$  enclosed could be stated as:

$$A = 1 \times 1 = 1 \text{ m}^2$$

$$\text{or } A = 100 \times 100 = 10^2 \times 10^2 = 10^4 \text{ cm}^2$$

$$\text{or } A = 1000 \times 1000 = 10^3 \times 10^3 = 10^6 \text{ mm}^2.$$

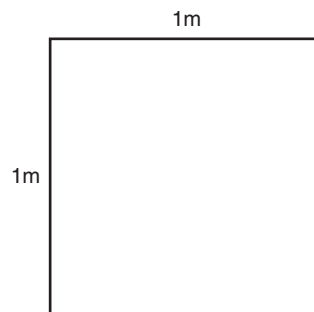

Fig. 1.1

From the above it may be seen that

$$1 \text{ m}^2 = 10^4 \text{ cm}^2$$

$$\text{and that } 1 \text{ m}^2 = 10^6 \text{ mm}^2.$$

Similarly, if the square had sides of 1 cm the area would be

$$A = 1 \text{ cm}^2 = 10^{-2} \times 10^{-2} = 10^{-4} \text{ m}^2.$$

Again if the sides were of length 1 mm the area would be

$$A = 1 \text{ mm}^2 = 10^{-3} \times 10^{-3} = 10^{-6} \text{ m}^2.$$

Thus  $1 \text{ cm}^2 = 10^{-4} \text{ m}^2$  and  $1 \text{ mm}^2 = 10^{-6} \text{ m}^2$ .

Since the basic unit for area is  $\text{m}^2$ , then areas quoted in other units should firstly be converted into square metres before calculations proceed. This procedure applies to all the derived units, and it is good practice to convert all quantities into their 'basic' units before proceeding with calculations.

It is left to the reader to confirm that the following conversions for volumes are correct:

$$\begin{aligned}1 \text{ mm}^3 &= 10^{-9} \text{ m}^3 \\1 \text{ cm}^3 &= 10^{-6} \text{ m}^3.\end{aligned}$$

### Worked Example 1.3

**Q** A mass  $m$  of 750 g is acted upon by a force  $F$  of 2 N. Calculate the resulting acceleration given that the three quantities are related by the equation

$$F = ma \text{ newton}$$

**A**

$$m = 750 \text{ g} = 0.75 \text{ kg}; F = 2 \text{ N}$$

Since  $F = ma$  newton, then

$$\begin{aligned}a &= \frac{F}{m} \text{ metre/second}^2 \\&= \frac{2}{0.75}\end{aligned}$$

$$\text{so } a = 2.667 \text{ m/s}^2 \text{ Ans}$$

## 1.5 Graphs

A graph is simply a pictorial representation of how one quantity or variable relates to another. One of these is known as the dependent variable and the other as the independent variable. It is general practice to plot the dependent variable along the vertical axis and the independent variable along the horizontal axis of the graph. To illustrate the difference between these two types of variable consider the case of a vehicle that is travelling between two points. If a graph of the distance travelled versus the time elapsed is plotted, then the distance travelled would be the dependent variable. This is because the distance travelled depends on the time that has elapsed. But the time is independent of the distance travelled, since the time will continue to increase regardless of whether the vehicle is moving or not.

Such a graph is shown in Fig. 1.2, from which it can be seen that over the first three hours the distance travelled was 30 km. Over the next two hours a further 10 km was travelled, and subsequently no further distance was travelled. Since distance travelled divided by the time

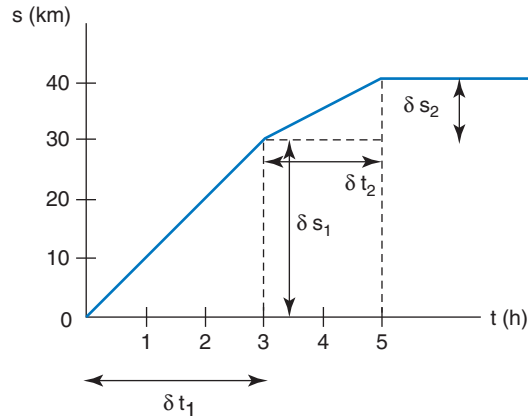

Fig. 1.2

taken is velocity, then the graph may be used to determine the speed of the vehicle at any time. Another point to note about this graph is that it consists of straight lines. This tells us that the vehicle was travelling at different but constant velocities at different times. It should be apparent that the steepest part of the graph occurs when the vehicle was travelling fastest. To be more precise, we refer to the slope or gradient of the graph. In order to calculate the velocity over the first three hours, the slope can be determined as follows:

Change in time,  $\delta t_1 = 3 - 0 = 3 \text{ h}$

change in distance  $\delta s_1 = 30 - 0 = 30 \text{ km}$

slope or gradient  $\equiv$  velocity  $v = \frac{\delta s_1}{\delta t_1} = \frac{30}{3} = 10 \text{ km/h}$

Similarly, for the second section of the graph:

$$v = \frac{\delta s_2}{\delta t_2} = \frac{(40 - 30)}{(5 - 3)} = 5 \text{ km/h}$$

Considering the final section of the graph, it can be seen that there is no change in distance (the vehicle is stationary). This is confirmed, since if  $\delta s$  is zero then the velocity must be zero.

In some ways this last example is a special case, since it involved a straight line graph. In this case we can say that the distance is directly proportional to time. In many cases a non-linear graph is produced, but the technique for determining the slope at any given point is similar. Such a graph is shown in Fig. 1.3, which represents the displacement of a mass when subjected to simple harmonic motion. The resulting graph is a sinewave. To determine the slope at any given instant in time we would have to determine the slope of the tangent to the curve at that point on the graph. If this is done then the figure obtained in each case would be the velocity of the mass at that instant. Notice that the slope is steepest at the instants that the curve passes through the zero displacement axis (maximum velocity). It is zero at the 'peaks' of the graph (zero velocity). Also note that if the graph is sloping upwards

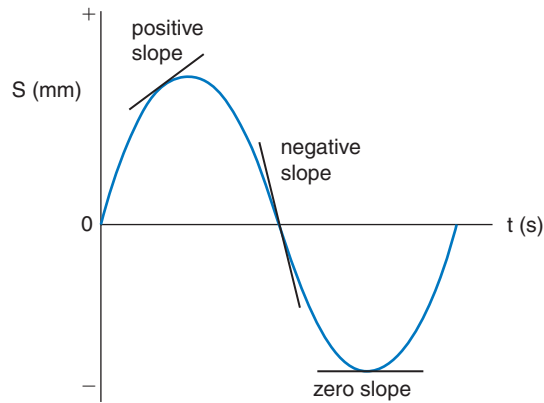

Fig. 1.3

as you trace its path from left to right it is called a positive slope. If it slopes downwards it is called a negative slope.

## 1.6 Basic Electrical Concepts

All matter is made up of atoms, and there are a number of ‘models’ used to explain physical effects that have been both predicted and subsequently observed. One of the oldest and simplest of these is the Bohr model. This describes the atom as consisting of a central nucleus containing minute particles called protons and neutrons. Surrounding the nucleus are a number of electrons in various orbits. This model is illustrated in Fig. 1.4. The possible presence of neutrons in the nucleus has been ignored, since these particles play no part in the electrical concepts to be described. It should be noted that this atomic model is greatly over-simplified. It is this very simplicity that makes it ideal for the beginner to achieve an understanding of what electricity is and how many electrical devices operate.

The model shown in Fig. 1.4 is not drawn to scale since a proton is approximately 2000 times more massive than an electron. Due to this *relatively* large mass the proton does not play an active part in electrical current flow. It is the behaviour of the electrons that is more important. However, protons and electrons do share one thing in

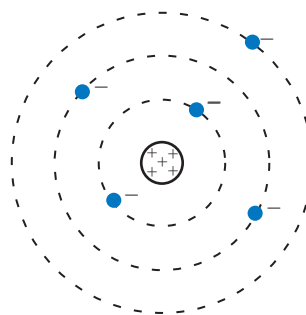

Fig. 1.4

common; they both possess a property known as electric charge. The unit of charge is called the coulomb ( $C$ ). Since charge is considered as the *quantity* of electricity it is given the symbol  $Q$ . An electron and proton have exactly the same amount of charge. The electron has a negative charge, whereas the proton has a positive charge. Any atom in its 'normal' state is electrically neutral (has no net charge). So, in this state the atom must possess as many orbiting electrons as there are protons in its nucleus. If one or more of the orbiting electrons can somehow be persuaded to leave the parent atom then this charge balance is upset. In this case the atom acquires a net positive charge, and is then known as a positive ion. On the other hand, if 'extra' electrons can be made to orbit the nucleus then the atom acquires a net negative charge. It then becomes a negative ion.

An **analogy** is a technique where the **behaviour** of one system is compared to the **behaviour** of another system. The system chosen for this comparison will be one that is more familiar and so more easily understood. HOWEVER, it must be borne in mind that an analogy should not be extended too far. Since the two systems are usually very different physically there will come a point where comparisons are no longer valid

You may now be wondering why the electrons remain in orbit around the nucleus anyway. This can best be explained by considering an **analogy**. Thus, an electron orbiting the nucleus may be compared to a satellite orbiting the Earth. The satellite remains in orbit due to a balance of forces. The gravitational force of attraction towards the Earth is balanced by the centrifugal force on the satellite due to its high velocity. This high velocity means that the satellite has high kinetic energy. If the satellite is required to move into a higher orbit, then its motor must be fired to speed it up. This will increase its energy. Indeed, if its velocity is increased sufficiently, it can be made to leave Earth orbit and travel out into space. In the case of the electron there is also a balance of forces involved. Since both electrons and protons have mass, there will be a gravitational force of attraction between them. However the masses involved are so minute that the gravitational force is negligible. So, what force of attraction does apply here? Remember that electrons and protons are oppositely charged particles, and oppositely charged bodies experience a force of attraction. Compare this to two simple magnets, whereby opposite polarities attract and like (the same) polarities repel each other. The same rule applies to charged bodies. Thus it is the balance between this force of electrostatic attraction and the kinetic energy of the electron that maintains the orbit. It may now occur to you to wonder why the nucleus remains intact, since the protons within it are all positively charged particles! It is beyond the scope of this book (and of the course of study on which you are now embarked) to give a comprehensive answer. Suffice to say that there is a force within the nucleus far stronger than the electrostatic repulsion between the protons that binds the nucleus together.

All materials may be classified into one of three major groups—conductors, insulators and semiconductors. In simple terms, the group into which a material falls depends on how many ‘free’ electrons it has. The term ‘free’ refers to those electrons that have acquired sufficient energy to leave their orbits around their parent atoms. In general we can say that conductors have many free electrons which will be drifting in a *random* manner within the material. Insulators have very few free electrons (ideally none), and semiconductors fall somewhere between these two extremes.

**Electric current** This is the rate at which free electrons can be made to drift through a material *in a particular direction*. In other words, it is the rate at which charge is moved around a circuit. Since charge is measured in coulombs and time in seconds then logically the unit for electric current would be the coulomb/second. In fact, the amount of current flowing through a circuit may be calculated by dividing the amount of charge passing a given point by the time taken. The unit however is given a special name, the ampere (often abbreviated to amp). This is fairly common practice with SI units, whereby the names chosen are those of famous scientists whose pioneering work is thus commemorated. The relationship between current, charge and time can be expressed as a mathematical equation as follows:

$$I = \frac{Q}{t} \text{ amp, or } Q = It \text{ coulomb} \quad (1.1)$$

### Worked Example 1.4

**Q** A charge of 35 mC is transferred between two points in a circuit in a time of 20 ms. Calculate the value of current flowing.

**A**

$$Q = 35 \times 10^{-3} \text{ C}; t = 20 \times 10^{-3} \text{ s}$$

$$\begin{aligned} I &= \frac{Q}{t} \text{ amp} \\ &= \frac{35 \times 10^{-3}}{20 \times 10^{-3}} \\ I &= 1.75 \text{ A Ans} \end{aligned}$$

### Worked Example 1.5

**Q** If a current of 120  $\mu\text{A}$  flows for a time of 15 s, determine the amount of charge transferred.

**A**

$$\begin{aligned} I &= 120 \times 10^{-6} \text{ A}; t = 15 \text{ s} \\ Q &= It \text{ coulomb} \\ &= 120 \times 10^{-6} \times 15 \\ Q &= 1.8 \text{ mC Ans} \end{aligned}$$

**Worked Example 1.6**

**Q** 80 coulombs of charge was transferred by a current of 0.5 A. Calculate the time for which the current flowed.

**A**

$$Q = 80 \text{ C}; I = 0.5 \text{ A}$$

$$\begin{aligned} t &= \frac{Q}{I} \text{ seconds} \\ &= \frac{80}{0.5} \\ t &= 160 \text{ s} \text{ Ans} \end{aligned}$$

**Electromotive Force (emf)** The *random* movement of electrons within a material does not constitute an electrical current. This is because it does not result in a drift in one particular direction. In order to cause the ‘free’ electrons to drift in a given direction an electromotive force must be applied. Thus the emf is the ‘driving’ force in an electrical circuit. The symbol for emf is  $E$  and the unit of measurement is the volt (V). Typical sources of emf are cells, batteries and generators.

The amount of current that will flow through a circuit is directly proportional to the size of the emf applied to it. The circuit diagram symbols for a cell and a battery are shown in Figs. 1.5(a) and (b) respectively. Note that the positively charged plate (the long line) usually does not have a plus sign written alongside it. Neither does the negative plate normally have a minus sign written by it. These signs have been included here merely to indicate (for the first time) the symbol used for each plate.

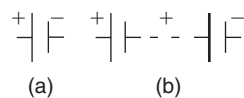

**Fig. 1.5**

**Resistance (R)** Although the amount of electrical current that will flow through a circuit is directly proportional to the applied emf, the other property of the circuit (or material) that determines the resulting current is the opposition offered to the flow. This opposition is known as the electrical resistance, which is measured in ohms ( $\Omega$ ). Thus conductors, which have many ‘free’ electrons available for current carrying, have a low value of resistance. On the other hand, since insulators have very few ‘free’ charge carriers then insulators have a very high resistance. Pure semiconductors tend to behave more like insulators in this respect. However, in practice, semiconductors tend to be used in an impure form, where the added impurities improve the conductivity of the material. An electrical device that is designed to have a specified value of resistance is called a resistor. The circuit diagram symbol for a resistor is shown in Fig. 1.6.

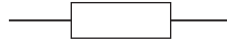

Fig. 1.6

**Potential Difference (p.d.)** Whenever current flows through a resistor there will be a p.d. developed across it. The p.d. is measured in volts, and is quite literally the difference in voltage levels between two points in a circuit. Although both p.d. and emf are measured in volts they are not the same quantity. Essentially, emf (being the driving force) causes current to flow; whilst a p.d. is the result of current flowing through a resistor. Thus emf is a *cause* and p.d. is an *effect*. It is a general rule that the symbol for a quantity is different to the symbol used for the unit in which it is measured. One of the few exceptions to this rule is that the quantity symbol for p.d. happens to be the same as its unit symbol, namely  $V$ . In order to explain the difference between emf and p.d. we shall consider another analogy.

Figure 1.7 represents a simple hydraulic system consisting of a pump, the connecting pipework and two restrictors in the pipe. The latter will have the effect of limiting the rate at which the water flows around the circuit. Also included is a tap that can be used to interrupt the flow completely. Figure 1.8 shows the equivalent electrical circuit, comprising a battery, the connecting conductors (cables or leads) and two resistors. The latter will limit the amount of current flow. Also included is a switch that can be used to ‘break’ the circuit and so prevent any current flow. As far as each of the two systems is concerned we are going to make some assumptions.

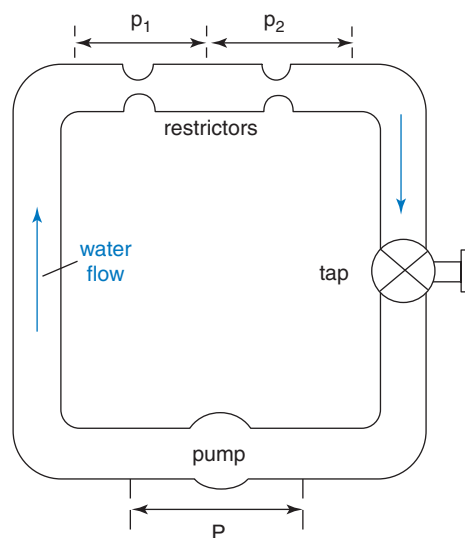

Fig. 1.7

For the water system we will assume that the connecting pipework has no slowing down effect on the flow, and so will not cause any pressure

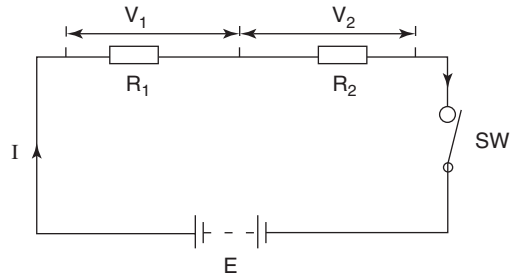

Fig. 1.8

drop. Provided that the pipework is relatively short then this is a reasonable assumption. The similar assumption in the electrical circuit is that the connecting wires have such a low resistance that they will cause no p.d. If anything, this is probably a more legitimate assumption to make. Considering the water system, the pump will provide the total system pressure ( $P$ ) that circulates the water through it. Using some form of pressure measuring device it would be possible to measure this pressure together with the pressure drops ( $p_1$  and  $p_2$ ) that would occur across the two restrictors. Having noted these pressure readings it would be found that the total system pressure is equal to the sum of the two pressure drops. Using a similar technique for the electrical circuit, it would be found that the sum of the two p.d.s ( $V_1$  and  $V_2$ ) is equal to the total applied emf  $E$  volts. These relationships may be expressed in mathematical form as:

$$P = p_1 + p_2 \text{ pascal}$$

and

$$E = V_1 + V_2 \text{ volt} \quad (1.2)$$

When the potential at some point in a circuit is quoted as having a particular value (say 10 V) then this implies that it is 10 V above some reference level or datum. Compare this with altitudes. If a mountain is said to be 5000 m high it does not necessarily mean that it rises 5000 m from its base to its peak. The figure of 5000 m refers to the height of its peak above mean sea level. Thus, mean sea level is the reference point or datum from which altitudes are measured. In the case of electrical potentials the datum is taken to be the potential of the Earth which is 0 V. Similarly,  $-10$  V means 10 V below or less than 0 V.

**Conventional current and electron flow** You will notice in Fig. 1.8 that the arrows used to show the direction of current flow indicate that this is from the positive plate of the battery, through the circuit, returning to the negative battery plate. This is called conventional current flow. However, since electrons are negatively charged particles, then these must be moving in the opposite direction. The latter is called electron

flow. Now, this poses the problem of which one to use. It so happens that before science was sufficiently advanced to have knowledge of the electron, it was assumed that the positive plate represented the ‘high’ potential and the negative the ‘low’ potential. So the convention was adopted that the current flowed around the circuit from the high potential to the low potential. This compares with water which can naturally only flow from a high level to a lower level. Thus the concept of conventional current flow was adopted. All the subsequent ‘rules’ and conventions were based on this direction of current flow. On the discovery of the nature of the electron, it was decided to retain the concept of conventional current flow. Had this not been the case then all the other rules and conventions would have needed to be changed! Hence, true electron flow is used only when it is necessary to explain certain effects (as in semiconductor devices such as diodes and transistors). Whenever we are considering basic electrical circuits and devices we shall use *conventional current flow* i.e. current flowing around the circuit *from* the *positive* terminal of the source of emf *to* the *negative* terminal.

**Ohm’s Law** This states that the p.d. developed between the two ends of a resistor is directly proportional to the value of current flowing through it, provided that all other factors (e.g. temperature) remain constant. Writing this in mathematical form we have:

$$V \propto I$$

However, this expression is of limited use since we need an equation. This can only be achieved by introducing a constant of proportionality; in this case the resistance value of the resistor.

$$\text{Thus } V = IR \text{ volt} \quad (1.3)$$

$$\text{or } I = \frac{V}{R} \text{ amp} \quad (1.4)$$

$$\text{and } R = \frac{V}{I} \text{ ohm} \quad (1.5)$$

### Worked Example 1.7

**Q** A current of 5.5 mA flows through a 33 kΩ resistor. Calculate the p.d. thus developed across it.

**A**

$$I = 5.5 \times 10^{-3} \text{ A}; \quad R = 33 \times 10^3 \Omega$$

$$V = IR \text{ volt}$$

$$= 5.5 \times 10^{-3} \times 33 \times 10^3$$

$$V = 181.5 \text{ V Ans}$$

### Worked Example 1.8

**Q** If a p.d. of 24V exists across a 15Ω resistor then what must be the current flowing through it?

**A**

$$V = 24\text{V}; R = 15\Omega$$

$$I = \frac{V}{R} \text{ amp}$$

$$= \frac{24}{15}$$

$$I = 1.6 \text{ A Ans}$$

**Internal Resistance ( $r$ )** So far we have considered that the emf  $E$  volts of a source is available at its terminals when supplying current to a circuit. If this were so then we would have an ideal source of emf. Unfortunately this is not the case in practice. This is due to the internal resistance of the source. As an example consider a typical 12V car battery. This consists of a number of oppositely charged plates, appropriately interconnected to the terminals, immersed in an **electrolyte**. The plates themselves, the internal connections and the electrolyte all combine to produce a small but **finite** resistance, and it is this that forms the battery internal resistance.

An **electrolyte** is the chemical 'cocktail' in which the plates are immersed. In the case of a car battery, this is an acid/water mixture.

In this context, **finite** simply means measurable.

Figure 1.9 shows such a battery with its terminals on open circuit (no external circuit connected). Since the circuit is incomplete no current can flow. Thus there will be no p.d. developed across the battery's internal resistance  $r$ . Since the term p.d. quite literally means a difference in potential between the two ends of  $r$ , then the terminal A must be at a potential of 12V, and terminal B must be at a potential of 0V. Hence, under these conditions, the full emf 12V is available at the battery terminals.

Figure 1.10 shows an external circuit, in the form of a 2Ω resistor, connected across the terminals. Since we now have a complete circuit

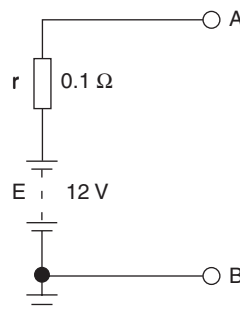

Fig. 1.9

then current  $I$  will flow as shown. The value of this current will be 5.71 A (the method of calculating this current will be dealt with early in the next chapter). This current will cause a p.d. across  $r$  and also a p.d. across  $R$ . These calculations and the consequences for the complete circuit now follow:

$$\begin{aligned} \text{p.d. across } r &= Ir \text{ volt (Ohm's law applied)} \\ &= 5.71 \times 0.1 \\ &= 0.571 \text{ V} \end{aligned}$$

$$\begin{aligned} \text{p.d. across } R &= IR \text{ volt} \\ &= 5.71 \times 2 \\ &= 11.42 \text{ V} \end{aligned}$$

**Note:**  $0.571 + 11.42 = 11.991 \text{ V}$  but this figure *should* be 12 V. The very small difference is simply due to 'rounding' the figures obtained from the calculator.

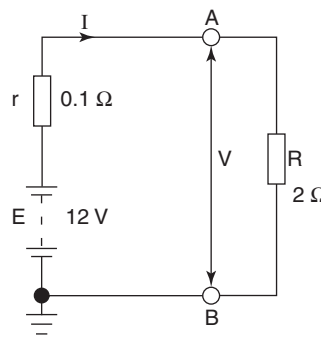

Fig. 1.10

The p.d. across  $R$  is the battery terminal p.d.  $V$ . Thus it may be seen that when a source is supplying current, the terminal p.d. will always be less than its emf. To emphasise this point let us assume that the external resistor is changed to one of  $1.5 \Omega$  resistance. The current now drawn from the battery will be 7.5 A. Hence:

$$\begin{aligned} \text{p.d. across } r &= 7.5 \times 0.1 = 0.75 \text{ V} \\ \text{and p.d. across } R &= 7.5 \times 1.5 = 11.25 \text{ V} \end{aligned}$$

Note that  $11.25 + 0.75 = 12 \text{ V}$  (rounding error not involved). Hence, the battery terminal p.d. has fallen still further as the current drawn has increased. This example brings out the following points.

- 1 Assuming that the battery's charge is maintained, then its emf remains constant. But its terminal p.d. varies as the current drawn is varied, such that

$$V = E - Ir \text{ volt} \quad (1.6)$$

- 2 Rather than having to write the words 'p.d. across  $R$ ' it is more convenient to write this as  $V_{AB}$ , which translated, means the potential difference between points A and B.

- 3 In future, if no mention is made of the internal resistance of a source, then for calculation purposes you may assume that it is zero, i.e. an ideal source.

### Worked Example 1.9

- Q** A battery of emf 6V has an internal resistance of 0.15 Ω. Calculate its terminal p.d. when delivering a current of (a) 0.5 A, (b) 2 A, and (c) 10 A.

**A**

$$E = 6\text{V}; r = 0.15\ \Omega$$

(a)  $V = E - Ir$  volt  
 $= 6 - (0.5 \times 0.15) = 6 - 0.075$

so,  $V = 5.925\text{V}$  **Ans**

(b)  $V = 6 - (2 \times 0.15) = 6 - 0.3$   
 so,  $V = 5.7\text{V}$  **Ans**

(c)  $V = 6 - (10 \times 0.15) = 6 - 1.5$   
 so,  $V = 4.5\text{V}$  **Ans**

**Note:** This example verifies that the terminal p.d. of a source of emf decreases as the load on it (the current drawn from it) is increased.

### Worked Example 1.10

- Q** A battery of emf 12V supplies a circuit with a current of 5 A. If, under these conditions, the terminal p.d. is 11.5V, determine (a) the battery internal resistance, (b) the resistance of the external circuit.

**A**

$$E = 12\text{V}; I = 5\ \text{A}; V = 11.5\text{V}$$

As with the vast majority of electrical problems, a simple sketch of the circuit diagram will help you to visualise the problem. For the above problem the circuit diagram would be as shown in Fig. 1.11.

(a)  $E = V + Ir$  volt  
 $E - V = Ir$  volt  
 so,  $r = \frac{E - V}{I}$  ohm  
 $= \frac{12 - 11.5}{5}$

hence,  $r = 0.1\ \Omega$  **Ans**

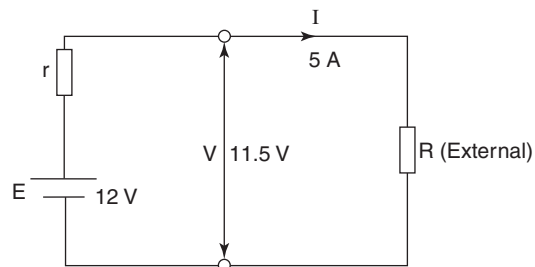

Fig. 1.11

$$\begin{aligned}
 \text{(b)} \quad R &= \frac{V}{I} \text{ ohm} \\
 &= \frac{11.5}{5} \\
 \text{so, } R &= 2.3 \, \Omega \text{ Ans}
 \end{aligned}$$

**Energy ( $W$ )** This is the property of a system that enables it to do work. Whenever work is done energy is transferred from that system to another one. The most common form into which energy is transformed is heat. Thus one of the effects of an electric current is to produce heat (e.g. an electric kettle). J. P. Joule carried out an investigation into this effect. He reached the conclusion that the amount of heat so produced was proportional to the value of the square of the current flowing and the time for which it flowed. Once more a constant of proportionality is required, and again it is the resistance of the circuit that is used. Thus the heat produced (or energy dissipated) is given by the equation

$$W = I^2 R t \text{ joule} \quad (1.7)$$

and applying Ohm's law as shown in equations (1.3) to (1.5)

$$W = \frac{V^2 t}{R} \text{ joule} \quad (1.8)$$

or

$$W = V I t \text{ joule} \quad (1.9)$$

### Worked Example 1.11

**Q** A current of 200 mA flows through a resistance of  $750 \, \Omega$  for a time of 5 minutes. Calculate (a) the p.d. developed, and (b) the energy dissipated.

**A**

$$I = 200 \text{ mA} = 0.2 \text{ A}; t = 5 \times 60 = 300 \text{ s}; R = 750 \, \Omega$$

$$\begin{aligned}
 \text{(a)} \quad V &= IR \text{ volt} \\
 &= 0.2 \times 750 \\
 V &= 150 \text{ V Ans}
 \end{aligned}$$

$$\begin{aligned}
 \text{(b)} \quad W &= I^2 R t \text{ joule} \\
 &= 0.2 \times 750 \times 300 \\
 W &= 9000 \text{ J or } 9 \text{ kJ Ans}
 \end{aligned}$$

**Note:** It would have been possible to use either equation (1.8) or (1.9) to calculate  $W$ . However, this would have involved using the calculated value for  $V$ . If this value had been miscalculated, then the answers to both parts of the question would have been incorrect. So, whenever possible, make use of data that are given in the question in preference to values that you have calculated. Please also note that the time has been converted to its basic unit, the second.

**Power ( $P$ )** This is the rate at which work is done, or at which energy is dissipated. The unit in which power is measured is the watt (W).

**Warning:** Do not confuse this unit symbol with the quantity symbol for energy. In general terms we can say that power is energy divided by time.

$$\text{i.e. } P = \frac{W}{t} \text{ watt}$$

Thus, by dividing each of equations (1.7), (1.8) and (1.9), in turn, by  $t$ , the following equations for power result:

$$P = I^2R \text{ watt} \quad (1.10)$$

$$P = \frac{V^2}{R} \text{ watt} \quad (1.11)$$

$$\text{or } P = VI \text{ watt} \quad (1.12)$$

### Worked Example 1.12

**Q** A resistor of  $680\Omega$ , when connected in a circuit, dissipates a power of  $85\text{ mW}$ . Calculate (a) the p.d. developed across it, and (b) the current flowing through it.

**A**

$$R = 680\Omega; P = 85 \times 10^{-3}\text{W}$$

$$(a) \quad P = \frac{V^2}{R} \text{ watt}$$

$$\text{so, } V^2 = PR$$

$$\text{and } V = \sqrt{PR} \text{ volt}$$

$$= \sqrt{85 \times 10^{-3} \times 680} = \sqrt{57.8}$$

$$\text{so, } V = 7.6\text{ V Ans}$$

$$(b) \quad P = I^2R \text{ watt}$$

$$\text{so, } I^2 = \frac{P}{R}$$

$$\text{and } I = \sqrt{\frac{P}{R}} \text{ amp}$$

$$= \sqrt{\frac{85 \times 10^{-3}}{680}} = \sqrt{1.25 \times 10^{-4}}$$

$$\text{so, } I = 11.18 \text{ mA Ans}$$

**Note:** Since  $P = VI$  watt, the calculations may be checked as follows

$$P = 7.6 \times 11.18 \times 10^{-3}$$

so,  $P = 84.97$  mW, which when rounded up to one decimal place gives 85.0 mW — the value given in the question.

### Worked Example 1.13

**Q** A current of 1.4 A when flowing through a circuit for 15 minutes dissipates 200 KJ of energy. Calculate (a) the p.d., (b) power dissipated, and (c) the resistance of the circuit.

**A**

$$I = 1.4 \text{ A}; t = 15 \times 60 \text{ s}; W = 2 \times 10^5 \text{ J}$$

(a)  $W = VIt$  joule

$$\begin{aligned} \text{so } V &= \frac{W}{It} \text{ volt} \\ &= \frac{2 \times 10^5}{1.4 \times 15 \times 60} \\ V &= 158.7 \text{ V } \mathbf{Ans} \end{aligned}$$

(b)  $P = VI$  watt

$$\begin{aligned} &= 158.7 \times 1.4 \\ P &= 222.2 \text{ W } \mathbf{Ans} \end{aligned}$$

(c)  $R = \frac{V}{I}$  ohm

$$\begin{aligned} &= \frac{158.7}{1.4} \\ R &= 113.4 \Omega \mathbf{Ans} \end{aligned}$$

**The Commercial Unit of Energy (kWh)** Although the joule is the SI unit of energy, it is too small a unit for some practical uses, e.g. where large amounts of power are used over long periods of time. The electricity meter in your home actually measures the energy consumption. So, if a 3 kW heater was in use for 12 hours the amount of energy used would be 129.6 MJ. In order to record this the meter would require at least ten dials to indicate this very large number. In addition to which, many of them would have to rotate at an impossible rate. Hence the commercial unit of energy is the kilowatt-hour (kWh). Kilowatt-hours are the ‘units’ that appear on electricity bills. The number of units consumed can be calculated by multiplying the power (in kW) by the time interval (in hours). So, for the heater mentioned above, the number of ‘units’ consumed would be written as 36 kWh. It should be apparent from this that to record this particular figure, fewer dials are required, and their speed of rotation is perfectly acceptable.

---

**Worked Example 1.14**

**Q** Calculate the cost of operating a 12.5 kW machine continuously for a period of 8.5 h if the cost per unit is 7.902 p.

**A**

$$\begin{aligned} W &= 12.5 \times 8.5 \text{ kWh} \\ \text{so } W &= 106.25 \text{ kWh} \\ \text{and cost} &= 106.25 \times 7.902 \\ &= \text{£}8.40 \text{ Ans} \end{aligned}$$

---

*Note:* When calculating energy in kWh the power must be expressed in kW, and the time in hours respectively, rather than in their basic units of watts and seconds respectively.

---

**Worked Example 1.15**

**Q** An electricity bill totalled £78.75, which included a standing charge of £15.00. The number of units charged for was 750. Calculate (a) the charge per unit, and (b) the total bill if the charge/unit had been 9p, and the standing charge remained unchanged.

**A**

Total bill = £78.75; standing charge = £15.00; units used = 750 = 750 kWh

(a) Cost of the energy (units) used = total – standing charge  
 $= \text{£}78.75 - \text{£}15.00 = \text{£}63.75$

$$\text{Cost/unit} = \frac{\text{£}63.75}{750} = \text{£}0.085$$

so, cost/unit = 8.5 p **Ans**

(b) If the cost/unit is raised to 9p, then  
 cost of energy used =  $\text{£}0.09 \times 750 = \text{£}67.50$   
 total bill = cost of units used + standing charge =  $\text{£}67.50 + \text{£}15.00$   
 so, total bill = **£82.50 Ans**

---

**Alternating and Direct Quantities** The sources of emf and resulting current flow so far considered are called d.c. quantities. This is because a battery or cell once connected to a circuit is capable of driving current around the circuit in one direction only. If it is required to reverse the current it is necessary to reverse the battery connections. The term d.c., strictly speaking, means ‘direct current’. However, it is also used to describe unidirectional voltages. Thus a d.c. voltage refers to a unidirectional voltage that may only be reversed as stated above.

However, the other commonly used form of electrical supply is that obtained from the electrical mains. This is the supply that is generated

and distributed by the power companies. This is an alternating or a.c. supply in which the current flows alternately in opposite directions around a circuit. Again, the term strictly means ‘alternating current’, but the emfs and p.d.s associated with this system are referred to as a.c. voltages. Thus, an a.c. generator (or alternator) produces an alternating voltage. Most a.c. supplies provide a sinusoidal waveform (a sinewave shape). Both d.c. and a.c. waveforms are illustrated in Fig. 1.12. The treatment of a.c. quantities and circuits is dealt with in Chapters 6, and need not concern you any further at this stage.

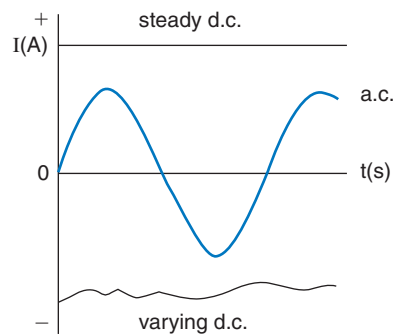

Fig. 1.12

**Factors affecting Resistance** The resistance of a sample of material depends upon four factors

- (i) its length
- (ii) its cross-sectional area (csa)
- (iii) the actual material used
- (iv) its temperature

Simple experiments can show that the resistance is directly proportional to the length and inversely proportional to the csa. Combining these two statements we can write:

$$R \propto \frac{\ell}{A} \quad \text{where } \ell = \text{length (in metres) and } A = \text{csa (in square metres)}$$

The constant of proportionality in this case concerns the third factor listed above, and is known as the resistivity of the material. This is defined as the resistance that exists between the opposite faces of a 1 m cube of that material, measured at a defined temperature. The symbol for resistivity is  $\rho$ . The unit of measurement is the ohm-metre ( $\Omega\text{m}$ ). Thus the equation for resistance using the above factor is

$$R = \rho \frac{\ell}{A} \text{ ohm} \quad (1.13)$$

**Worked Example 1.16**

**Q** A coil of copper wire 200 m long and of csa  $0.8 \text{ mm}^2$  has a resistivity of  $0.02 \mu\Omega\text{m}$  at normal working temperature. Calculate the resistance of the coil.

**A**

$$\ell = 200 \text{ m}; \rho = 2 \times 10^{-8} \Omega\text{m}; A = 8 \times 10^{-7} \text{ m}^2$$

$$\begin{aligned} R &= \frac{\rho \ell}{A} \text{ ohm} \\ &= \frac{2 \times 10^{-8} \times 200}{8 \times 10^{-7}} \\ R &= 5 \Omega \text{ Ans} \end{aligned}$$

**Worked Example 1.17**

**Q** A wire-wound resistor is made from a 250 metre length of copper wire having a circular cross-section of diameter 0.5 mm. Given that the wire has a resistivity of  $0.018 \mu\Omega\text{m}$ , calculate its resistance value.

**A**

$$\ell = 250 \text{ m}; d = 5 \times 10^{-4} \text{ m}; \rho = 1.8 \times 10^{-8} \Omega\text{m}$$

$$R = \frac{\rho \ell}{A} \text{ ohm, where cross-sectional area, } A = \frac{\pi d^2}{4} \text{ metre}^2$$

$$\text{hence, } A = \frac{\pi \times (5 \times 10^{-4})^2}{4} = 1.9635 \times 10^{-7} \text{ m}^2$$

$$\text{hence, } R = \frac{1.8 \times 10^{-8} \times 250}{1.9635 \times 10^{-7}}$$

$$\text{so, } R = 22.92 \Omega \text{ Ans}$$

The resistance of a material also depends on its temperature and has a property known as its temperature coefficient of resistance. The resistance of all pure metals increases with increase of temperature. The resistance of carbon, insulators, semiconductors and electrolytes decreases with increase of temperature. For these reasons, conductors (metals) are said to have a positive temperature coefficient of resistance. Insulators etc. are said to have a negative temperature coefficient of resistance. Apart from this there is another major difference. Over a moderate range of temperature, the change of resistance for conductors is relatively small and is a very close approximation to a straight line. Semiconductors on the other hand tend to have very much larger changes of resistance over the same range of temperatures, and follow an exponential law. These differences are illustrated in Fig. 1.13.

Temperature coefficient of resistance is defined as the ratio of the change of resistance per degree change of temperature, to the resistance at some specified temperature. The quantity symbol is  $\alpha$  and the unit of

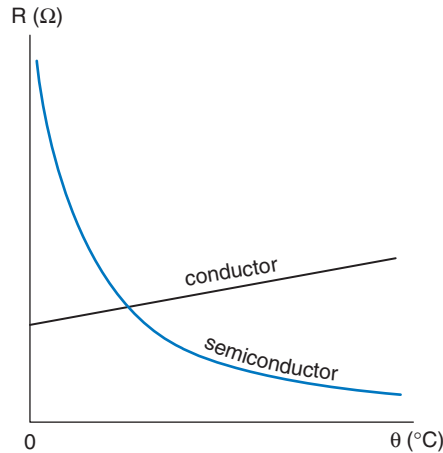

Fig. 1.13

measurement is per degree, e.g. /°C. The reference temperature usually quoted is 0°C, and the resistance at this temperature is referred to as  $R_0$ . Thus the resistance at some other temperature  $\theta_1$ °C can be obtained from:

$$R_1 = R_0(1 + \alpha\theta_1) \text{ ohm} \quad (1.14)$$

In general, if a material having a resistance  $R_0$  at 0°C has a resistance  $R_1$  at  $\theta_1$ °C and  $R_2$  at  $\theta_2$ °C, and if  $\alpha$  is the temperature coefficient at 0°C, then

$$R_1 = R_0(1 + \alpha\theta_1) \text{ and } R_2 = R_0(1 + \alpha\theta_2)$$

$$\text{so } \frac{R_1}{R_2} = \frac{1 + \alpha\theta_1}{1 + \alpha\theta_2} \quad (1.15)$$

### Worked Example 1.18

**Q** The field coil of an electric motor has a resistance of 250Ω at 15°C. Calculate the resistance if the motor attains a temperature of 45°C when running. Assume that  $\alpha = 0.00428/^\circ\text{C}$  referred to 0°C.

**A**

$$R_1 = 250\Omega; \theta_1 = 15^\circ\text{C}; \theta_2 = 45^\circ\text{C}; \alpha = 4.28 \times 10^{-3}$$

Using equation (1.15):

$$\frac{250}{R_2} = \frac{1 + (4.28 \times 10^{-3} \times 15)}{1 + (4.28 \times 10^{-3} \times 45)}$$

$$\frac{250}{R_2} = 0.8923$$

$$R_2 = 280.2\Omega \text{ Ans}$$

**Worked Example 1.19**

**Q** A coil of wire has a resistance value of  $350\ \Omega$  when its temperature is  $0^\circ\text{C}$ . Given that the temperature coefficient of resistance of the wire is  $4.26 \times 10^{-3}/^\circ\text{C}$  referred to  $0^\circ\text{C}$ , calculate its resistance at a temperature of  $60^\circ\text{C}$ .

**A**

$$R_0 = 350\ \Omega; \alpha = 4.26 \times 10^{-3}/^\circ\text{C}; \theta_1 = 60^\circ\text{C}$$

$$\begin{aligned} R_1 &= R_0(1 + \alpha\theta_1)\ \text{ohm; where } R_1 \text{ is the resistance at } 60^\circ\text{C} \\ &= 350 \{1 + (4.26 \times 10^{-3} \times 60)\} \\ &= 350 \{1 + 0.22556\} \\ &= 350 \times 1.2556 \end{aligned}$$

$$\text{so, } R_1 = 439.6\ \Omega \text{ Ans}$$

**Worked Example 1.20**

**Q** A carbon resistor has a resistance value of  $120\ \Omega$  at a room temperature of  $16^\circ\text{C}$ . When it is connected as part of a circuit, with current flowing through it, its temperature rises to  $32^\circ\text{C}$ . If the temperature coefficient of resistance of carbon is  $-0.000\ 48/^\circ\text{C}$  referred to  $0^\circ\text{C}$ , calculate its resistance under these operating conditions.

**A**

$$\theta_1 = 16^\circ\text{C}; \theta_2 = 32^\circ\text{C}; R_1 = 120\ \Omega; \alpha = -0.000\ 48/^\circ\text{C}$$

$$\frac{R_1}{R_2} = \frac{1 + \alpha\theta_1}{1 + \alpha\theta_2}$$

$$\frac{120}{R_2} = \frac{1 + (-0.000\ 48 \times 16)}{1 + (-0.000\ 48 \times 32)}$$

$$\frac{120}{R_2} = 1.0078$$

$$R_2 = \frac{120}{1.0078}$$

$$\text{so, } R_2 = 119.1\ \Omega \text{ Ans}$$

**Use of meters** The measurement of electrical quantities is an essential part of engineering, so you need to be proficient in the use of the various types of measuring instrument. In this chapter we will consider only the use of the basic current and voltage measuring instruments, namely the ammeter and voltmeter respectively.

An ammeter is a current measuring instrument. It has to be connected into the circuit in such a way that the current to be measured is forced to flow through it. If you need to measure the current flowing in a section of a circuit that is already connected together, you will need to ‘break’ the circuit at the appropriate point and connect the ammeter in the ‘break’. If you are connecting a circuit (as you will frequently have to do when carrying out practical assignments), then insert the ammeter as the circuit connections are being made. Most ammeters will have their terminals colour coded: red for the positive and black for the negative.

PLEASE NOTE that these polarities refer to *conventional current flow*, so the current should enter the meter at the red terminal and leave via the black terminal. The ammeter circuit symbol is shown in Fig. 1.14.



Fig. 1.14

As you would expect, a voltmeter is used for measuring voltages; in particular, p.d.s. Since a p.d. is a voltage between two points in a circuit, then this meter is NOT connected into the circuit in the same way as an ammeter. In this sense it is a simpler instrument to use, since it need only be connected across (between the two ends of) the component whose p.d. is to be measured. The terminals will usually be colour coded in the same way as an ammeter, so the red terminal should be connected to the more positive end of the component, i.e. follow the same principle as with the ammeter. The voltmeter symbol is shown in Fig. 1.15.



Fig. 1.15

It is most probable that you will have to make use of meters that are capable of combining the functions of an ammeter, a voltmeter and an ohmmeter. These instruments are known as multimeters. One of the most common examples is the AVO. This meter is an example of the type known as analogue instruments, whereby the 'readings' are indicated by the position of a pointer along a graduated scale. The other type of multimeter is of the digital type (often referred to as a DMM). In this case, the 'readings' are in the form of a numerical display, using either light emitting diodes or a liquid crystal, as on calculator displays. Although the digital instruments are easier to read, it does not necessarily mean that they give more accurate results. The choice of the type of meter to use involves many considerations. At this stage it is better to rely on advice from your teacher as to which ones to use for a particular measurement.

All multimeters have switches, either rotary or pushbutton, that are used to select between a.c. or d.c. measurements. There is also a facility for selecting a number of current and voltage ranges. To gain a proper understanding of the use of these meters you really need to have the instrument in front of you. This is a practical exercise that your teacher will carry out with you. I will conclude this section by outlining some important general points that you should observe when carrying out practical measurements.

All measuring instruments are quite fragile, not only mechanically (please handle them carefully) but even more so electrically. If an instrument becomes damaged it is very inconvenient, but more

importantly, it is expensive to repair and/or replace. So whenever you use them please observe the following rules:

- 1 Do not switch on (or connect) the power supply to a circuit until your connections have been checked by the teacher or laboratory technician.
- 2 Starting with all meters switched to the OFF position, select the highest possible range, and then carefully select lower ranges until a suitable deflection (analogue instrument) or figure is displayed (DMM).
- 3 When taking a series of readings try to select a range that will accommodate the whole series. This is not always possible. However, if the range(s) *are* changed and the results are used to plot a graph, then a sudden unexpected gap or 'jump' in the plotted curve may well occur.
- 4 When finished, turn off and disconnect all power supplies, and turn all meters to their OFF position.

## 1.7 Communication

It is most important that an engineer is a good communicator. He or she must be capable of transmitting information orally, by the written word and by means of sketches and drawings. He or she must also be able to receive and translate information in all of these forms. Most of these skills can be perfected only with guidance and practice. Thus, an engineering student should at every opportunity strive to improve these skills. The art of good communication is a specialised area, and this book does not pretend to be authoritative on the subject. However, there are a number of points, given below, regarding the presentation of written work, that may assist you.

The assignment questions at the end of each chapter are intended to fulfil three main functions. To reinforce your knowledge of the subject matter by repeated application of the underlying principles. To give you the opportunity to develop a logical and methodical approach to the solution of problems. To use these same skills in the presentation of technical information. Therefore when you complete each assignment, treat it as a vehicle for demonstrating your understanding of the subject. This means that your method and presentation of the solution, are more important than always obtaining the 'correct' numerical answer. To help you to achieve this use the following procedures:

- 1 Read the question carefully from beginning to end in order to ensure that you understand fully what is required.
- 2 Extract the numerical data from the question and list this at the top of the page, using the relevant quantity symbols and units. This is particularly important when values are given for a number of quantities. In this case, if you try to extract the data in the midst of calculations, it is all too easy to pick out the wrong figure amongst all the words. At the same time, convert all values into their basic

units. Another advantage of using this technique is that the resulting list, with the quantity symbols, is likely to jog your memory as to the appropriate equation(s) that will be required.

- 3 Whenever appropriate, sketch the relevant circuit diagram, clearly identifying all components, currents, p.d.s etc. If the circuit is one in which there are a number of junctions then labelling as shown in Fig. 1.16 makes the presentation of your solution very much simpler. For example

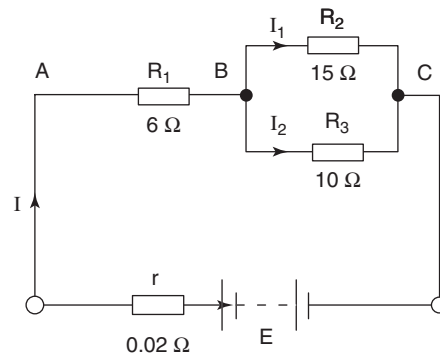

Fig. 1.16

If the diagram had not been labelled, and you wished to refer to the effective resistance between points B and C, then you would have to write out ‘the effective resistance of  $R_2$  and  $R_3$  in parallel = ...’. However, with the diagram labelled you need simply write ‘ $R_{BC} = \dots$ ’. Similarly, instead of having to write ‘the current through the  $15\ \Omega$  resistor = ...’, all that is required is ‘ $I_1 = \dots$ ’.

- 4 Before writing down any figures quote the equation being used, together with the appropriate unit of measurement. This serves to indicate your method of solution. Also note that the units should be written in words. The unit symbols should only be used when preceded by a number thus. Thus,  $V = IR$  volt for equation, and  $24\ \text{V}$  for actual value.
- 5 Avoid the temptation to save space by having numerous ‘=’ signs along one line. If the line is particularly short then a maximum of two equals signs per line is acceptable.
- 6 Show ALL figures used in the calculations including any sub-answers obtained.
- 7 Clearly identify your answer(s) by either underlining or by writing ‘Ans’ alongside.

You will notice that the above procedures have been followed in all of the worked examples throughout this book.

In addition to written assignments you will be required to undertake others. Although these may not entail using exactly the same procedures as outlined above, they will still require a logical and

methodical approach to the presentation. Practical assignments will also be a major feature of your course of study. These will normally involve the use of equipment and measuring instruments in order that you may discover certain technical facts or to verify your theories, etc. This form of exercise also needs to be well documented so that, if necessary, another person can repeat your procedure to confirm (or refute!) your findings. In these cases a more formalised form of written report is required, and the following format is generally acceptable:

*'Title'*

- Objective:* This needs to be a concise and clear statement as to what it is that you are trying to achieve.
- Apparatus:* This will be a list of all equipment and instruments used, quoting serial numbers where appropriate.
- Diagram(s):* The circuit diagram, clearly labelled.
- Method:* This should consist of a series of numbered paragraphs that describe each step of the procedure carried out. This section of the report (as with the rest) should be impersonal and in the past tense. Words such as 'I', 'we', 'they', 'us' should not be used. Thus, instead of writing a phrase such as 'We set the voltage to 0 V and I adjusted it in 0.1 V steps ...' you should write 'The voltage was set to 0 V and then adjusted in 0.1 V steps ...'
- Results:* All measurements and settings should be neatly tabulated. To avoid writing unit symbols alongside figures in the body of the table the appropriate units need to be stated at the top of each column. If there is more than one table of results then each one should be clearly identified. These points are illustrated below:

**Table 1**

p.d. (V)	$I$ (mA)	$R$ (k $\Omega$ )
0.0	0.00	—
1.0	1.25	0.80
2.0	1.75	1.14
	etc.	

*Calculations:* This section may not always be required, but if you have carried out any calculations using the measured data then these should be shown here.

*Graphs:* In most cases the tabulated results form the basis for a graph or graphs which must be carefully plotted on

approved graph paper. Simple lined or squared paper is NOT adequate. Try to use as much of the page as possible, but at the same time choose sensible scales. For example let the graduations on the graph paper represent increments such as 0.1, 0.2, 0.5, 10 000, etc. and not 0.3, 0.4, 0.6, 0.7, 0.8, 0.9 etc. By doing this you will make it much simpler to plot the graph in the first place, and more importantly, very much easier to take readings from it subsequently.

*Conclusions:* Having gone through the above procedure you need to complete the assignment by drawing some conclusions based on all the data gathered. Any such conclusions must be justified. For example, you may have taken measurements of some variable  $y$  for corresponding values of a second variable  $x$ . If your plotted graph happens to be a straight line that passes through the origin then your conclusion would be as follows:

‘Since the graph of  $y$  versus  $x$  is a straight line passing through the origin then it can be concluded that  $y$  is directly proportional to  $x$ ’.

### Summary of Equations

**Charge:**  $Q = It$  coulomb

**Ohm’s law:**  $V = IR$  volt

**Terminal p.d.:**  $V = E - Ir$  volt

**Energy:**  $W = VIt = I^2Rt = \frac{V^2t}{R}$  joule

**Power:**  $P = \frac{W}{t} = VI = I^2R = \frac{V^2}{R}$  watt

**Resistance:**  $R = \frac{\rho\ell}{A}$  ohm

**Resistance at specified temp.:**  $R_1 = R_0(1 + \alpha\theta)$  ohm

$$\text{or } \frac{R_1}{R_2} = \frac{1 + \alpha\theta_1}{1 + \alpha\theta_2}$$

## Assignment Questions

- 1 Convert the following into standard form.  
(a) 456.3 (b) 902 344 (c) 0.000 285 (d) 8000  
(e) 0.047 12 (f) 180  $\mu\text{A}$  (g) 38 mV (h) 80 GN  
(i) 2000  $\mu\text{F}$
- 2 Write the following quantities in scientific notation.  
(a) 1500  $\Omega$  (b) 0.0033  $\Omega$  (c) 0.000 025 A  
(d) 750V (e) 800 000V (f) 0.000 000 047 F
- 3 Calculate the charge transferred in 25 minutes by a current of 500 mA.
- 4 A current of 3.6 A transfers a charge of 375 mC. How long would this take?
- 5 Determine the value of charging current required to transfer a charge of 0.55 mC in a time of 600  $\mu\text{s}$ .
- 6 Calculate the p.d. developed across a 750  $\Omega$  resistor when the current flowing through it is (a) 3 A, (b) 25 mA.
- 7 An emf of 50V is applied in turn to the following resistors: (a) 22  $\Omega$ , (b) 820  $\Omega$ , (c) 2.7 M $\Omega$ , (d) 330 k $\Omega$ . Calculate the current flow in each case.
- 8 The current flowing through a 470  $\Omega$  resistance is 4 A. Determine the energy dissipated in a time of 2 h. Express your answer in both joules and in commercial units.
- 9 A small business operates three pieces of equipment for nine hours continuously per day for six days a week. If the three equipments consume 10 kW, 2.5 kW and 600W respectively, calculate the weekly cost if the charge per unit is 7.9 pence.
- 10 A charge of 500  $\mu\text{C}$  is passed through a 560  $\Omega$  resistor in a time of 1 ms. Under these conditions determine (a) the current flowing, (b) the p.d. developed, (c) the power dissipated, and (d) the energy consumed in 5 min.
- 11 A battery of emf 50V and internal resistance 0.2  $\Omega$  supplies a current of 1.8 A to an external load. Under these conditions determine (a) the terminal p.d. and (b) the resistance of the external load.
- 12 The terminal p.d. of a d.c. source is 22.5V when supplying a load current of 10 A. If the emf is 24V calculate (a) the internal resistance and (b) the resistance of the external load.
- 13 For the circuit arrangement specified in Q12 above determine the power and energy dissipated by the external load resistor in 5 minutes.
- 14 A circuit of resistance 4  $\Omega$  dissipates a power of 16W. Calculate (a) the current flowing through it, (b) the p.d. developed across it, and (c) the charge displaced in a time of 20 minutes.
- 15 In a test the velocity of a body was measured over a period of time, yielding the results shown in the table below. Plot the corresponding graph and use it to determine the acceleration of the body at times  $t = 0$ ,  $t = 5$  s and  $t = 9$  s. You may assume that the graph consists of a series of straight lines.
 

$v(\text{m/s})$	0.0	3.0	6.0	10.0	14.0	15.0	16.0
$t(\text{s})$	0.0	1.5	3.0	4.5	6.0	8.0	10.0
- 16 The insulation resistance between a conductor and earth is 30 M $\Omega$ . Calculate the leakage current if the supply voltage is 240V.
- 17 A 3 kW immersion heater is designed to operate from a 240V supply. Determine its resistance and the current drawn from the supply.
- 18 A 110V d.c. generator supplies a lighting load of forty 100W bulbs, a heating load of 10 kW and other loads which consume a current of 15 A. Calculate the power output of the generator under these conditions.
- 19 The field winding of a d.c. motor is connected to a 110V supply. At a temperature of 18°C, the current drawn is 0.575 A. After running the machine for some time the current has fallen to 0.475 A, the voltage remaining unchanged. Calculate the temperature of the winding under the new conditions, assuming that the temperature coefficient of resistance of copper is 0.004 26/°C at 0°C.
- 20 A coil consists of 1500 turns of aluminium wire having a cross-sectional area of 0.75 mm<sup>2</sup>. The mean length per turn is 60 cm and the resistivity of aluminium at the working temperature is 0.028  $\mu\Omega\text{m}$ . Calculate the resistance of the coil.

## D.C. Circuits

### Learning Outcomes

This chapter explains how to apply circuit theory to the solution of simple circuits and networks by the application of Ohm's law and Kirchhoff's laws, and the concepts of potential and current dividers.

This means that on completion of this chapter you should be able to:

- 1 Calculate current flows, potential differences, power and energy dissipations for circuit components and simple circuits, by applying Ohm's law.
- 2 Carry out the above calculations for more complex networks using Kirchhoff's Laws.
- 3 Calculate circuit p.d.s using the potential divider technique, and branch currents using the current divider technique.
- 4 Understand the principles and use of a Wheatstone Bridge.
- 5 Understand the principles and use of a slidewire potentiometer.

### 2.1 Resistors in Series

Resistors **cascaded** or connected **in series**

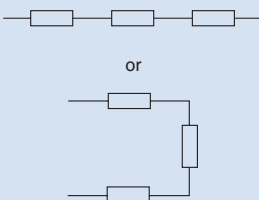

When resistors are connected 'end-to-end' so that the same current flows through them all they are said to be **cascaded** or **connected in series**. Such a circuit is shown in Fig. 2.1. Note that, for the sake of simplicity, an ideal source of emf has been used (no internal resistance).

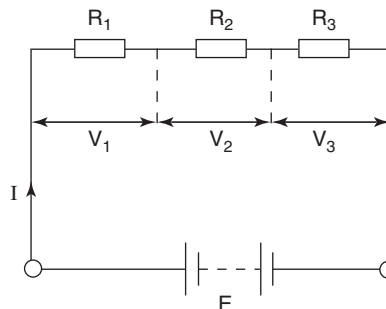

Fig. 2.1

From the previous chapter we know that the current flowing through the resistors will result in p.d.s being developed across them. We also know that the sum of these p.d.s must equal the value of the applied emf. Thus

$$V_1 = IR_1 \text{ volt; } V_2 = IR_2 \text{ volt; and } V_3 = IR_3 \text{ volt}$$

However, the circuit current  $I$  depends ultimately on the applied emf  $E$  and the total resistance  $R$  offered by the circuit. Hence

$$E = IR \text{ volt.}$$

Also,  $E = V_1 + V_2 + V_3 \text{ volt}$

and substituting for  $E$ ,  $V_1$ ,  $V_2$  and  $V_3$  in this last equation

$$\text{we have } IR = IR_1 + IR_2 + IR_3 \text{ volt}$$

and dividing this last equation by the common factor  $I$

$$R = R_1 + R_2 + R_3 \text{ ohm} \quad (2.1)$$

where  $R$  is the total circuit resistance. From this result it may be seen that when resistors are connected in series the total resistance is found simply by adding together the resistor values.

### Worked Example 2.1

**Q** For the circuit shown in Fig. 2.2 calculate (a) the circuit resistance, (b) the circuit current, (c) the p.d. developed across each resistor, and (d) the power dissipated by the complete circuit.

**A**

$$E = 24\text{V}; R_1 = 330\ \Omega; R_2 = 1500\ \Omega; R_3 = 470\ \Omega$$

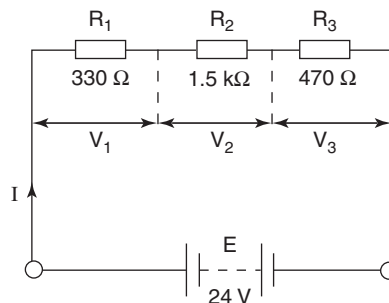

Fig. 2.2

$$\begin{aligned} \text{(a)} \quad R &= R_1 + R_2 + R_3 \text{ ohm} \\ &= 330 + 1500 + 470 \\ R &= 2300 \Omega \text{ or } 2.3 \text{ k}\Omega \text{ Ans} \end{aligned}$$

$$\begin{aligned} \text{(b)} \quad I &= \frac{E}{R} \text{ amp} \\ &= \frac{24}{2300} \\ I &= 10.43 \text{ mA Ans} \end{aligned}$$

$$\begin{aligned} \text{(c)} \quad V_1 &= IR_1 \text{ volt} \\ &= 10.43 \times 10^{-3} \times 330 \\ V_1 &= 3.44 \text{ V Ans} \end{aligned}$$

$$\begin{aligned} V_2 &= IR_2 \text{ volt} \\ &= 10.43 \times 10^{-3} \times 1500 \\ V_2 &= 15.65 \text{ volts Ans} \end{aligned}$$

$$\begin{aligned} V_3 &= IR_3 \text{ volt} \\ &= 10.43 \times 10^{-3} \times 470 \\ V_3 &= 4.90 \text{ V Ans} \end{aligned}$$

**Note:** The sum of the above p.d.s is 23.99V instead of 24V due to the rounding errors in the calculation. It should also be noted that the value quoted for the current was 10.43 mA whereas the calculator answer is 10.4347 mA. This latter value was then stored in the calculator memory and used in the calculations for part (c), thus reducing the rounding errors to an acceptable minimum.

$$\begin{aligned} \text{(d)} \quad P &= EI \text{ watt} \\ &= 24 \times 10.43 \times 10^{-3} \\ P &= 0.25 \text{ W or } 250 \text{ mW Ans} \end{aligned}$$

It should be noted that the power is dissipated by the three resistors in the circuit. Hence, the circuit power could have been determined by calculating the power dissipated by each of these and adding these values to give the total. This is shown below, and serves, as a check for the last answer.

$$\begin{aligned} P_1 &= I^2 R_1 \text{ watt} \\ &= (10.43 \times 10^{-3})^2 \times 330 \\ P_1 &= 35.93 \text{ mW} \\ P_2 &= (10.43 \times 10^{-3})^2 \times 1500 \\ &= 163.33 \text{ mW} \\ P_3 &= (10.43 \times 10^{-3})^2 \times 470 \\ &= 51.18 \text{ mW} \end{aligned}$$

$$\begin{aligned} \text{total power: } P &= P_1 + P_2 + P_3 \text{ watt} \\ \text{so } P &= 250.44 \text{ mw} \end{aligned}$$

(Note the worsening effect of continuous rounding error)

### Worked Example 2.2

- Q** Two resistors are connected in series across a battery of emf 12 V. If one of the resistors has a value of  $16\ \Omega$  and it dissipates a power of 4 W, then calculate (a) the circuit current, and (b) the value of the other resistor.

**A**

Since the only two pieces of data that are directly related to each other concern the  $16\ \Omega$  resistor and the power that it dissipates, then this information must form the starting point for the solution of the problem. Using these data we can determine either the current through or the p.d. across the  $16\ \Omega$  resistor (and it is not important which of these is calculated first). To illustrate this point both methods will be demonstrated. The appropriate circuit diagram, which forms an integral part of the solution, is shown in Fig. 2.3.

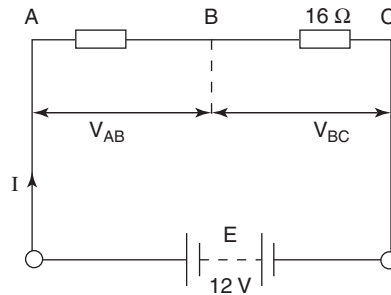

Fig. 2.3

$$E = 12\text{ V}; R_{BC} = 16\ \Omega; P_{BC} = 4\text{ W}$$

(a)  $I^2 R_{BC} = P_{BC}$  watt

$$\begin{aligned} I^2 &= \frac{P_{BC}}{R_{BC}} \\ &= \frac{4}{16} = 0.25 \end{aligned}$$

so  $I = 0.5\ \text{A}$  **Ans**

(b) total resistance,  $R = \frac{E}{I}$  ohm

$$= \frac{12}{0.5} = 24\ \Omega$$

$$R_{AB} = R - R_{BC}$$

$$= 24 - 16$$

so  $R_{AB} = 8\ \Omega$  **Ans**

Alternatively, the problem can be solved thus:

(a)  $\frac{V_{BC}^2}{R_{BC}} = P_{BC}$  watt

$$\begin{aligned} V_{BC}^2 &= P_{BC} \times R_{BC} = 4 \times 16 \\ &= 64 \end{aligned}$$

$$\text{so } V_{BC} = 8\text{V}$$

$$I = \frac{V_{BC}}{R_{BC}} \text{ amp}$$

$$= \frac{8}{16}$$

$$\text{so } I = 0.5 \text{ A Ans}$$

$$\text{(b) } V_{AB} = E - V_{BC} \text{ volt}$$

$$= 12 - 8$$

$$V_{AB} = 4\text{V}$$

$$R_{AB} = \frac{V_{AB}}{I}$$

$$= \frac{4}{0.5}$$

$$\text{so } R_{AB} = 8\Omega \text{ Ans}$$

## 2.2 Resistors in Parallel

When resistors are joined ‘side-by-side’ so that their corresponding ends are connected together they are said to be connected in **parallel**. Using this form of connection means that there will be a number of paths through which the current can flow. Such a circuit consisting of three resistors is shown in Fig. 2.4, and the circuit may be analysed as follows:

### Resistors in Parallel

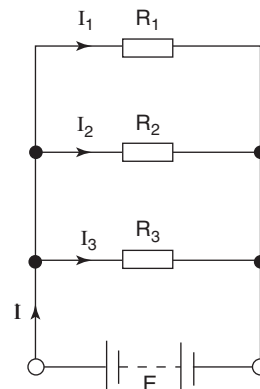
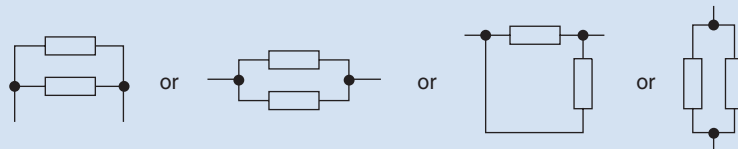

Fig. 2.4

Since all three resistors are connected directly across the battery terminals then they all have the same voltage developed across them. In other words the voltage is the common factor in this arrangement of resistors. Now, each resistor will allow a certain value of current to flow through it, depending upon its resistance value. Thus

$$I_1 = \frac{E}{R_1} \text{ amp}; I_2 = \frac{E}{R_2} \text{ amp}; \text{ and } I_3 = \frac{E}{R_3} \text{ amp}$$

The total circuit current  $I$  is determined by the applied emf and the total circuit resistance  $R$ ,

$$\text{so } I = \frac{E}{R} \text{ amp}$$

Also, since all three branch currents originate from the battery, then the total circuit current must be the sum of the three branch currents

$$\text{so } I = I_1 + I_2 + I_3$$

and substituting the above expression for the currents:

$$\frac{E}{R} = \frac{E}{R_1} + \frac{E}{R_2} + \frac{E}{R_3}$$

and dividing the above equation by the common factor  $E$ :

$$\frac{1}{R} = \frac{1}{R_1} + \frac{1}{R_2} + \frac{1}{R_3} \text{ siemen} \quad (2.2)$$

**Note:** The above equation does NOT give the total resistance of the circuit, but does give the total circuit **conductance** ( $G$ ) which is measured in Siemens (S). Thus, conductance is the reciprocal of resistance, so to obtain the circuit resistance you must then take the reciprocal of the answer obtained from an equation of the form of equation (2.2).

**Conductance** is a measure of the 'willingness' of a material or circuit to allow current to flow through it

$$\text{That is } \frac{1}{R} = G \text{ siemen; and } \frac{1}{G} = R \text{ ohm} \quad (2.3)$$

However, when only two resistors are in parallel the combined resistance may be obtained directly by using the following equation:

$$R = \frac{R_1 \times R_2}{R_1 + R_2} \text{ ohm} \quad (2.4)$$

In this context, the word **identical** means having the same value of resistance

If there are '**x**' **identical** resistors in parallel the total resistance is simply  $R/x$  ohms.

### Worked Example 2.3

- Q** Considering the circuit of Fig. 2.5, calculate (a) the total resistance of the circuit, (b) the three branch current, and (c) the current drawn from the battery.

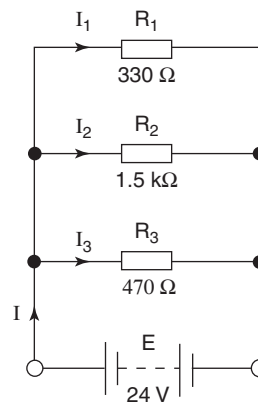

Fig. 2.5

**A**

$$E = 24\text{V}; R_1 = 330\Omega; R_2 = 1500\Omega; R_3 = 470\Omega$$

$$(a) \quad \frac{1}{R} = \frac{1}{R_1} + \frac{1}{R_2} + \frac{1}{R_3} \text{ siemen}$$

$$= \frac{1}{330} + \frac{1}{1500} + \frac{1}{470}$$

$$= 0.00303 + 0.000667 + 0.00213$$

$$= 0.005825 \text{ S}$$

$$\text{so } R = 171.68\Omega \text{ Ans (reciprocal of 0.005825)}$$

$$(b) \quad I_1 = \frac{E}{R_1} \text{ amp}$$

$$= \frac{24}{330}$$

$$I_1 = 72.73 \text{ mA Ans}$$

$$I_2 = \frac{E}{R_2} \text{ amp}$$

$$= \frac{24}{1500}$$

$$I_2 = 16 \text{ mA Ans}$$

$$I_3 = \frac{E}{R_3} \text{ amp}$$

$$= \frac{24}{470}$$

$$I_3 = 51.06 \text{ mA Ans}$$

(c)  $I = I_1 + I_2 + I_3 \text{ amp}$   
 $= 72.73 + 16 + 51.06 \text{ mA}$   
 so  $I = 139.8 \text{ mA Ans}$

Alternatively, the circuit current could have been determined by using the values for  $E$  and  $R$  as follows

$$I = \frac{E}{R} \text{ amp}$$

$$= \frac{24}{171.68}$$

$$I = 139.8 \text{ mA Ans}$$

Compare this example with worked example 2.1 (the same values for the resistors and the emf have been used). From this it should be obvious that when resistors are connected in parallel the total resistance of the circuit is reduced. This results in a corresponding increase of current drawn from the source. This is simply because the parallel arrangement provides more paths for current flow.

### Worked Example 2.4

**Q** Two resistors, one of  $6\ \Omega$  and the other of  $3\ \Omega$  resistance, are connected in parallel across a source of emf of  $12\text{ V}$ . Determine (a) the effective resistance of the combination, (b) the current drawn from the source, and (c) the current through each resistor.

**A**

The corresponding circuit diagram, suitably labelled is shown in Fig. 2.6.

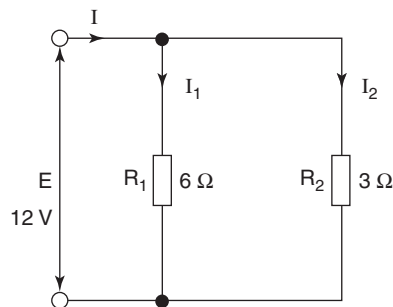

Fig. 2.6

$$E = 12\text{V}; R_1 = 6\Omega; R_2 = 3\Omega$$

$$\begin{aligned} \text{(a)} \quad R &= \frac{R_1 R_2}{R_1 + R_2} \text{ ohm} \\ &= \frac{6 \times 3}{6 + 3} = \frac{18}{9} \end{aligned}$$

so  $R = 2\Omega$  **Ans**

$$\begin{aligned} \text{(b)} \quad I &= \frac{E}{R} \text{ amp} \\ &= \frac{12}{2} \end{aligned}$$

so  $I = 6\text{ A}$  **Ans**

$$\begin{aligned} \text{(c)} \quad I_1 &= \frac{E}{R_1} \text{ amp} \\ &= \frac{12}{6} \end{aligned}$$

$I_1 = 2\text{ A}$  **Ans**

$$\begin{aligned} I_2 &= \frac{E}{R_2} \\ &= \frac{12}{3} \end{aligned}$$

$I_2 = 4\text{ A}$  **Ans**

### Worked Example 2.5

**Q** A  $10\Omega$  resistor, a  $20\Omega$  resistor and a  $30\Omega$  resistor are connected (a) in series, and then (b) in parallel with each other. Calculate the total resistance for each of the two connections.

**A**

$$R_1 = 10\Omega; R_2 = 20\Omega; R_3 = 30\Omega$$

$$\begin{aligned} \text{(a)} \quad R &= R_1 + R_2 + R_3 \text{ ohm} \\ &= 10 + 20 + 30 \end{aligned}$$

so,  $R = 60\Omega$  **Ans**

$$\begin{aligned} \text{(b)} \quad \frac{1}{R} &= \frac{1}{R_1} + \frac{1}{R_2} + \frac{1}{R_3} \text{ siemen} \\ &= \frac{1}{10} + \frac{1}{20} + \frac{1}{30} = 0.1 + 0.05 + 0.033 \end{aligned}$$

$$\text{so, } R = \frac{1}{0.183} = 5.46\Omega \text{ **Ans**}$$

Alternatively,

$$\begin{aligned}\frac{1}{R} &= \frac{1}{10} + \frac{1}{20} + \frac{1}{30} = \frac{6+3+2}{60} \\ &= \frac{11}{60} \text{ S} \\ \text{so, } R &= \frac{60}{11} = 5.46 \Omega \text{ Ans}\end{aligned}$$

## 2.3 Potential Divider

When resistors are connected in series the p.d. developed across each resistor will be in direct proportion to its resistance value. This is a useful fact to bear in mind, since it means it is possible to calculate the p.d.s without first having to determine the circuit current. Consider two resistors connected across a 50 V supply as shown in Fig. 2.7. In order to demonstrate the potential divider effect we will in this case firstly calculate circuit current and hence the two p.d.s by applying Ohm's law:

$$R = R_1 + R_2 \text{ ohm}$$

$$R = 75 + 25 = 100 \Omega$$

$$I = \frac{E}{R} \text{ amp}$$

$$I = \frac{50}{100} = 0.5 \text{ A}$$

$$V_1 = IR_1 \text{ volt}$$

$$= 0.5 \times 75$$

$$V_1 = 37.5 \text{ V Ans}$$

$$V_2 = IR_2 \text{ volt}$$

$$= 0.5 \times 25$$

$$V_2 = 12.5 \text{ V Ans}$$

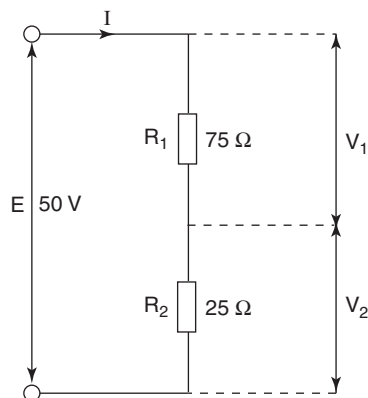

Fig. 2.7

Applying the potential divider technique, the two p.d.s may be obtained by using the fact that the p.d. across a resistor is given by the ratio of its resistance value to the total resistance of the circuit, expressed as a proportion of the applied voltage. Although this sounds complicated it is very simple to put into practice. Expressed in the form of an equation it means

$$V_1 = \frac{R_1}{R_1 + R_2} \times E \text{ volt} \quad (2.5)$$

and

$$V_2 = \frac{R_2}{R_1 + R_2} \times E \text{ volt} \quad (2.6)$$

and using the above equations the p.d.s can more simply be calculated as follows:

$$V_1 = \frac{75}{100} \times 50 = 37.5 \text{ V Ans}$$

$$\text{and } V_2 = \frac{25}{100} \times 50 = 12.5 \text{ V Ans}$$

This technique is not restricted to only two resistors in series, but may be applied to any number. For example, if there were three resistors in series, then the p.d. across each may be found from

$$V_1 = \frac{R_1}{R_1 + R_2 + R_3} \times E$$

$$V_2 = \frac{R_2}{R_1 + R_2 + R_3} \times E$$

$$\text{and } V_3 = \frac{R_3}{R_1 + R_2 + R_3} \times E \text{ volt}$$

## 2.4 Current Divider

It has been shown that when resistors are connected in parallel the total circuit current divides between the alternative paths available. So far we have determined the branch currents by calculating the common p.d. across a parallel branch and dividing this by the respective resistance values. However, these currents can be found directly, without the need to calculate the branch p.d., by using the current divider theory. Consider two resistors connected in parallel across a source of emf 48 V as shown in Fig. 2.8. Using the p.d. method we can calculate the two currents as follows:

$$I_1 = \frac{E}{R_1} \quad \text{and} \quad I_2 = \frac{E}{R_2} \text{ amp}$$

$$= \frac{48}{12} \quad \quad \quad = \frac{48}{24}$$

$$I_1 = 4 \text{ A} \quad \text{and} \quad I_2 = 2 \text{ A}$$

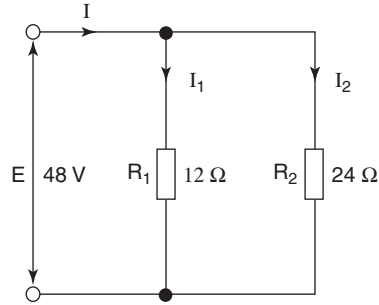

Fig. 2.8

It is now worth noting the values of the resistors and the corresponding currents. It is clear that  $R_1$  is half the value of  $R_2$ . So, from the calculation we obtain the quite logical result that  $I_1$  is twice the value of  $I_2$ . That is, a ratio of 2:1 applies in each case. Thus, the smaller resistor carries the greater proportion of the total current. By stating the ratio as 2:1 we can say that the current is split into three equal 'parts'. Two 'parts' are flowing through one resistor and the remaining 'part' through the other resistor.

Thus  $\frac{2}{3} \times I$  flows through  $R_1$

and  $\frac{1}{3} \times I$  flows through  $R_2$

Since  $I = 6 \text{ A}$  then

$$I_1 = \frac{2}{3} \times 6 = 4 \text{ A}$$

$$I_2 = \frac{1}{3} \times 6 = 2 \text{ A}$$

In general we can say that

$$I_1 = \frac{R_2}{R_1 + R_2} \times I \quad (2.7)$$

and

$$I_2 = \frac{R_1}{R_1 + R_2} \times I \quad (2.8)$$

**Note:** This is NOT the same ratio as for the potential divider. If you compare (2.5) with (2.7) you will find that the numerator in (2.5) is  $R_1$  whereas in (2.7) the numerator is  $R_2$ . There is a similar 'cross-over' when (2.6) and (2.8) are compared.

Again, the current divider theory is not limited to only two resistors in parallel. Any number can be accommodated. However, with three or

more parallel resistors the current division method can be cumbersome to use, and it is much easier for mistakes to be made. For this reason it is recommended that where more than two resistors exist in parallel the 'p.d. method' is used. This will be illustrated in the next section, but for completeness the application to three resistors is shown below.

Consider the arrangement shown in Fig. 2.9:

$$\frac{1}{R} = \frac{1}{R_1} + \frac{1}{R_2} + \frac{1}{R_3} = \frac{1}{3} + \frac{1}{4} + \frac{1}{6} = \frac{4 + 3 + 2}{12}$$

and examining the numerator, we have  $4 + 3 + 2 = 9$  'parts'.

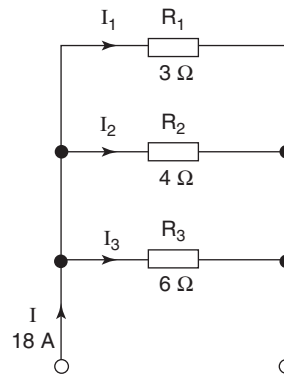

Fig. 2.9

Thus, the current ratios will be  $4/9$ ,  $3/9$  and  $2/9$  respectively for the three resistors.

$$\text{So, } I_1 = \frac{4}{9} \times 18 = 8\text{ A}; I_2 = \frac{3}{9} \times 18 = 6\text{ A}; I_3 = \frac{2}{9} \times 18 = 4\text{ A}$$

## 2.5 Series/Parallel Combinations

Most practical circuits consist of resistors which are interconnected in both series and parallel forms. The simplest method of solving such a circuit is to reduce the parallel branches to their equivalent resistance values and hence reduce the circuit to a simple series arrangement. This is best illustrated by means of a worked example.

### Worked Example 2.6

**Q** For the circuit shown in Fig. 2.10, calculate (a) the current drawn from the supply, (b) the current through the  $6\ \Omega$  resistor, and (c) the power dissipated by the  $5.6\ \Omega$  resistor.

**A**

The first step in the solution is to sketch and label the circuit diagram, clearly showing all currents flowing and identifying each part of the circuit as shown in

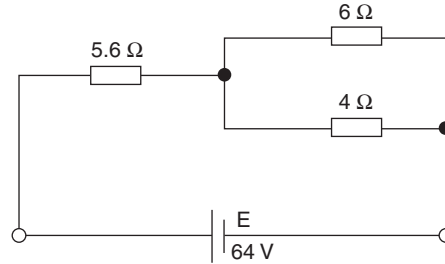

Fig. 2.10

Fig. 2.11. Also note that since there is no mention of internal resistance it may be assumed that the source of emf is ideal.

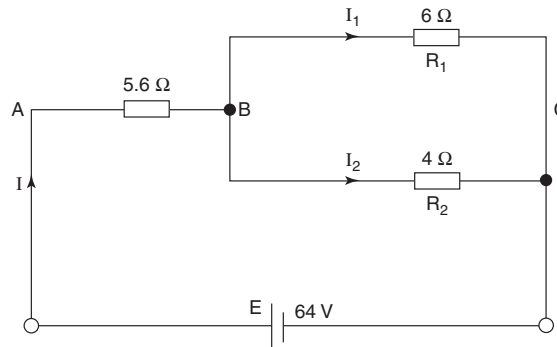

Fig. 2.11

- (a) To determine the current  $I$  drawn from the battery we need to know the total resistance  $R_{AC}$  of the circuit.

$$R_{BC} = \frac{6 \times 4}{6 + 4} \text{ (using } \frac{\text{product}}{\text{sum}} \text{ for two resistors in parallel)}$$

$$= \frac{24}{10}$$

$$\text{so } R_{BC} = 2.4\Omega$$

The original circuit may now be redrawn as in Fig 2.12.

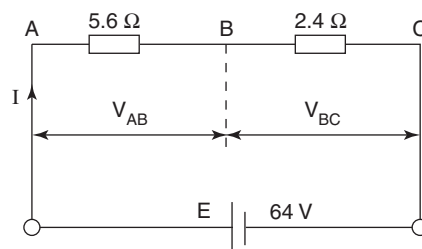

Fig. 2.12

$$R_{AC} = R_{AB} + R_{BC} \text{ ohm (resistors in series)}$$

$$= 5.6 + 2.4$$

$$\text{so } R_{AC} = 8\Omega$$

$$I = \frac{E}{R_{AC}} \text{ amp} = \frac{64}{8}$$

$$\text{so } I = 8 \text{ A Ans}$$

- (b) To find the current  $I_1$  through the  $6\Omega$  resistor we may use either of two methods. Both of these are now demonstrated.

*p.d. method:*

$$V_{BC} = IR_{BC} \text{ volt (Fig. 2.12)}$$

$$= 8 \times 2.4$$

$$\text{so, } V_{BC} = 19.2\text{V}$$

$$I_1 = \frac{V_{BC}}{R_1} \text{ amp (Fig. 2.11)}$$

$$= \frac{19.2}{6}$$

$$\text{so, } I_1 = 3.2 \text{ A Ans}$$

This answer may be checked as follows:

$$I_1 = \frac{V_{BC}}{R_2} \text{ amp}$$

$$= \frac{19.2}{4} = 4.8 \text{ A}$$

and since  $I = I_1 + I_2 = 3.2 + 4.8 = 8 \text{ A}$   
which agrees with the value found in (a).

*current division method:*

Considering Fig. 2.11, the current  $I$  splits into the components  $I_1$  and  $I_2$  according to the ratio of the resistor values. *However*, you must bear in mind that the *larger* resistor carries the *smaller* proportion of the total current.

$$I_1 = \frac{R_2}{R_1 + R_2} \times I \text{ amp}$$

$$= \frac{4}{6 + 4} \times 8$$

$$\text{so, } I_1 = 3.2 \text{ A Ans}$$

(c)  $P_{AB} = I^2 R_{AB} \text{ watt}$

$$= 8^2 \times 5.6$$

$$\text{so, } P_{AB} = 358.4\text{W Ans}$$

Alternatively,  $P_{AB} = V_{AB} I \text{ watt}$

where  $V_{AB} = E - V_{BC} \text{ volt} = 64 - 19.2 = 44.8\text{V}$

$$P_{AB} = 44.8 \times 8$$

$$\text{so, } P_{AB} = 358.4\text{W Ans}$$

### Worked Example 2.7

- Q** For the circuit of Fig. 2.13 calculate (a) the current drawn from the source, (b) the p.d. across each resistor, (c) the current through each resistor, and (d) the power dissipated by the  $5\Omega$  resistor.

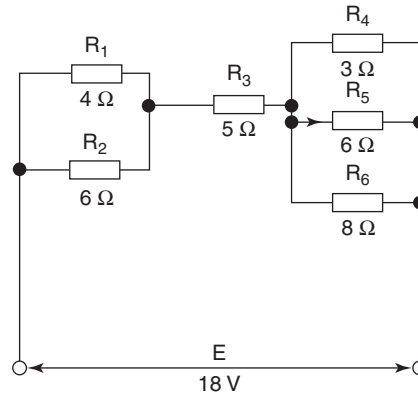

Fig. 2.13

### A

The first step in the solution is to label the diagram clearly with letters at the junctions and identifying p.d.s and branch currents. This shown in Fig. 2.14.

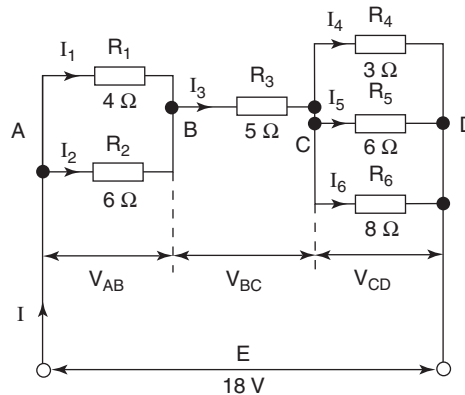

Fig. 2.14

$$(a) \quad R_{AB} = \frac{R_1 R_2}{R_1 + R_2} \text{ ohm} = \frac{4 \times 6}{4 + 6} = 2.4 \Omega$$

$$R_{BC} = 5 \Omega$$

$$\begin{aligned} \frac{1}{R_{CD}} &= \frac{1}{R_4} + \frac{1}{R_5} + \frac{1}{R_6} = \frac{1}{3} + \frac{1}{6} + \frac{1}{8} \\ &= \frac{8 + 4 + 3}{24} = \frac{15}{24} \text{ S} \end{aligned}$$

$$R_{CD} = \frac{24}{15} = 1.6 \Omega$$

$$R = R_{AB} + R_{BC} + R_{CD} \text{ ohm}$$

$$R = 2.4 + 5 + 1.6 = 9 \Omega$$

$$I = \frac{E}{R} \text{ amp} = \frac{18}{9}$$

$$I = 2 \text{ A Ans}$$

- (b) The circuit has been reduced to its series equivalent as shown in Fig. 2.15. Using this equivalent circuit it is now a simple matter to calculate the p.d. across each section of the circuit.

$$V_{AB} = IR_{AB} \text{ volt} = 2 \times 2.4$$

$$V_{AB} = 4.8 \text{ V Ans}$$

(this p.d. is common to both  $R_1$  and  $R_2$ )

$$V_{BC} = IR_{BC} \text{ volt} = 2 \times 5$$

$$V_{BC} = 10 \text{ V Ans}$$

$$V_{CD} = IR_{CD} \text{ volt} = 2 \times 1.6$$

$$V_{CD} = 3.2 \text{ V Ans}$$

(this p.d. is common to  $R_4$ ,  $R_5$  and  $R_6$ )

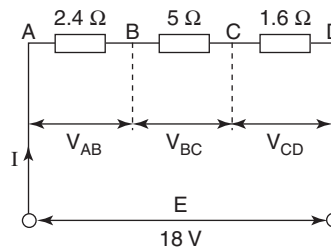

Fig. 2.15

$$(c) \quad I_1 = \frac{V_{AB}}{R_1} = \frac{4.8}{4} \text{ or} \quad I_1 = \frac{R_2}{R_1 + R_2} \times I = \frac{6}{10} \times 2$$

$$I_1 = 1.2 \text{ A Ans}$$

$$I_1 = 1.2 \text{ A Ans}$$

$$I_2 = \frac{V_{AB}}{R_2} = \frac{4.8}{6} \text{ or}$$

$$I_2 = \frac{R_1}{R_1 + R_2} \times I = \frac{4}{10} \times 2$$

$$I_2 = 0.8 \text{ A Ans}$$

$$I_2 = 0.8 \text{ A Ans}$$

$$I_3 = I = 2 \text{ A Ans}$$

$$I_4 = \frac{V_{CD}}{R_4} = \frac{3.2}{3} \text{ or}$$

$$\frac{1}{R_{CD}} = \frac{1}{R_4} + \frac{1}{R_5} + \frac{1}{R_6}$$

$$I_4 = 1.067 \text{ A Ans}$$

$$= \frac{1}{3} + \frac{1}{6} + \frac{1}{8}$$

$$I_5 = \frac{V_{CD}}{R_5} = \frac{3.2}{6}$$

$$= \frac{8 + 4 + 3}{24} = \frac{15}{24}$$

$$I_5 = 0.533 \text{ A Ans}$$

$$\text{so } I_4 = \frac{8}{15} \times 2$$

$$I_6 = \frac{V_{CD}}{R_6} = \frac{3.2}{8}$$

$$I_4 = 1.067 \text{ A Ans}$$

$$I_6 = 0.4 \text{ A Ans}$$

$$I_5 = \frac{4}{15} \times 2$$

$$I_5 = 0.533 \text{ A Ans}$$

$$I_6 = \frac{3}{15} \times 2$$

$$I_6 = 0.4 \text{ A Ans}$$

Notice that the p.d. method is an easier and less cumbersome than current division when more than two resistors are connected in parallel.

$$(d) P_3 = I_3^2 R_3 \text{ watt or } V_{BC} I_3 \text{ watt}$$

$$\text{or } \frac{V_{BC}^2}{R_3} \text{ watt}$$

and using the first of these alternative equation:

$$P_3 = 2^2 \times 5$$

$$P_3 = 20\text{W Ans}$$

It is left to the reader to confirm that the other two power equations above yield the same answer.

## 2.6 Kirchhoff's Current Law

We have already put this law into practice, though without stating it explicitly. The law states that the algebraic sum of the currents at any junction of a circuit is zero. Another, and perhaps simpler, way of stating this is to say that the sum of the currents arriving at a junction is equal to the sum of the currents leaving that junction. Thus we have applied the law with parallel circuits, where the assumption has been made that the sum of the branch currents equals the current drawn from the source. Expressing the law in the form of an equation we have:

$$\Sigma I = 0 \quad (2.9)$$

where the symbol  $\Sigma$  means 'the sum of'.

Figure 2.16 illustrates a junction within a circuit with a number of currents arriving and leaving the junction. Applying Kirchhoff's current law yields:

$$I_1 - I_2 + I_3 + I_4 - I_5 = 0$$

where '+' signs have been used to denote currents arriving and '-' signs for currents leaving the junction. This equation can be transposed to comply with the alternative statement for the law, thus:

$$I_1 + I_3 + I_4 = I_2 + I_5$$

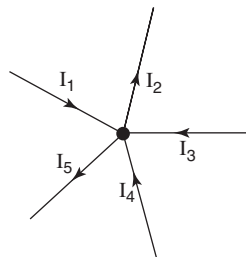

Fig. 2.16

### Worked Example 2.8

**Q** For the network shown in Fig. 2.17 calculate the values of the marked currents.

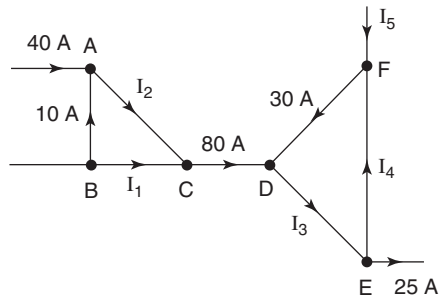

Fig. 2.17

**A**

$$\text{Junction A: } I_2 = 40 + 10 = 50 \text{ A Ans}$$

$$\text{Junction C: } I_1 + I_2 = 80$$

$$I_1 + 50 = 80$$

$$\text{so } I_1 = 30 \text{ A Ans}$$

$$\text{Junction D: } I_3 = 80 + 30 = 110 \text{ A Ans}$$

$$\text{Junction E: } I_4 + 25 = I_3$$

$$I_4 = 110 - 25$$

$$\text{so } I_4 = 85 \text{ A Ans}$$

$$\text{Junction F: } I_5 + I_4 = 30$$

$$I_5 + 85 = 30$$

$$I_5 = 30 - 85$$

$$\text{so } I_5 = -55 \text{ A Ans}$$

**Note:** The minus sign in the last answer tells us that the current  $I_5$  is actually flowing away from the junction rather than towards it as shown.

## 2.7 Kirchhoff's Voltage Law

This law also has already been used — in the explanation of p.d. and in the series and series/parallel circuits. This law states that in any closed network the algebraic sum of the emfs is equal to the algebraic sum of the p.d.s taken in order about the network. Once again, the law sounds very complicated, but it is really only common sense, and is simple to apply. So far, it has been applied only to very simple circuits, such as resistors connected in series across a source of emf. In this case we have said that the sum of the p.d.s is equal to the applied emf (e.g.  $V_1 + V_2 = E$ ). However, these simple circuits have had only one source

of emf, and could be solved using simple Ohm's law techniques.

When more than one source of emf is involved, or the network is more complex, then a network analysis method must be used. Kirchhoff's is one of these methods.

Expressing the law in mathematical form:

$$\Sigma E = \Sigma IR \quad (2.10)$$

A generalised circuit requiring the application of Kirchhoff's laws is shown in Fig. 2.18. Note the following:

- 1 The circuit has been labelled with letters so that it is easy to refer to a particular loop and the direction around the loop that is being considered. Thus, if the left-hand loop is considered, and you wish to trace a path around it in a clockwise direction, this would be referred to as ABEFA. If a counterclockwise path was required, it would be referred to as FEBAF or AFEBA.

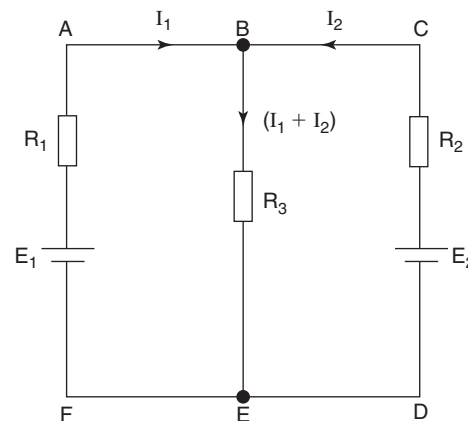

Fig. 2.18

- 2 Current directions have been assumed and marked on the diagram. As was found in the previous worked example (2.8), it may well turn out that one or more of these currents actually flows in the opposite direction to that marked. This result would be indicated by a negative value obtained from the calculation. However, to ensure consistency, make the initial assumption that all sources of emf are discharging current into the circuit; i.e. current leaves the positive terminal of each battery and enters at its negative terminal. The current law is also applied at this stage, which is why the current flowing through  $R_3$  is marked as  $(I_1 + I_2)$  and not as  $I_3$ . This is an important point since the solution involves the use of simultaneous equations, and the fewer the number of 'unknowns' the simpler the solution. Thus marking the third-branch current in this way means

that there are only two ‘unknowns’ to find, namely  $I_1$  and  $I_2$ . The value for the third branch current,  $I_3$ , is then simply found by using the values obtained for  $I_1$  and  $I_2$ .

- 3 If a negative value is obtained for a current then the minus sign MUST be retained in any subsequent calculations. However, when you quote the answer for such a current, make a note to the effect that it is flowing in the opposite direction to that marked, e.g. from C to D.
- 4 When tracing the path around a loop, concentrate solely on that loop and ignore the remainder of the circuit. Also note that if you are following the marked direction of current then the resulting p.d.(s) are assigned positive values. If the direction of ‘travel’ is opposite to the current arrow then the p.d. is assigned a negative value.

Let us now apply these techniques to the circuit of Fig. 2.18.

Consider first the left-hand loop in a clockwise direction. Tracing around the loop it can be seen that there is only one source of emf within it (namely  $E_1$ ). Thus the sum of the emfs is simply  $E_1$  volt. Also, within the loop there are only two resistors ( $R_1$  and  $R_2$ ) which will result in two p.d.s,  $I_1R_1$  and  $(I_1 + I_2)R_3$  volt. The resulting loop equation will therefore be:

$$\underline{\text{ABEFA}}: E_1 = I_1R_1 + (I_1 + I_2)R_3 \quad [1]$$

Now taking the right-hand loop in a counterclockwise direction it can be seen that again there is only one source of emf and two resistors. This results in the following loop equation:

$$\underline{\text{CBEDC}}: E_2 = I_2R_2 + (I_1 + I_2)R_3 \quad [2]$$

Finally, let us consider the loop around the edges of the diagram in a clockwise direction. This follows the ‘normal’ direction for  $E_1$  but is opposite to that for  $E_2$ , so the sum of the emfs is  $E_1 - E_2$  volt. The loop equation is therefore

$$\underline{\text{ABCDEF A}}: E_1 - E_2 = I_1R_1 - I_2R_2 \quad [3]$$

Since there are only two unknowns then only two simultaneous equations are required, and three have been written. However it is a useful practice to do this as the ‘extra’ equation may contain more convenient numerical values for the coefficients of the ‘unknown’ currents.

The complete technique for the applications of Kirchhoff’s laws becomes clearer by the consideration of a worked example containing numerical values.

**Worked Example 2.9**

**Q** For the circuit of Fig. 2.19 determine the value and direction of the current in each branch, and the p.d. across the 10Ω resistor.

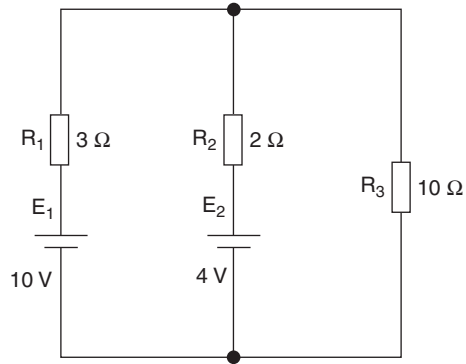

Fig. 2.19

**A**

The circuit is first labelled and current flows identified and marked by applying the current law. This is shown in Fig. 2.20.

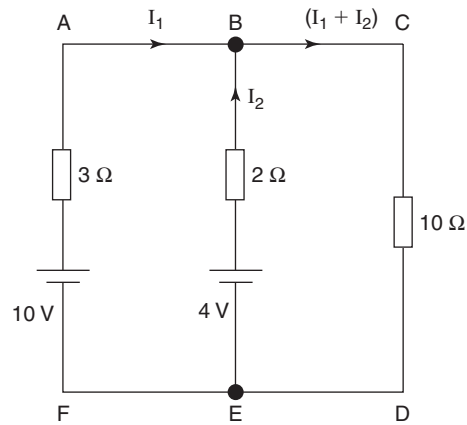

Fig. 2.20

ABEFA:

$$10 - 4 = 3I_1 - 2I_2$$

$$\text{so } 6 = 3I_1 - 2I_2 \dots\dots\dots [1]$$

ABCDEFA:

$$10 = 3I_2 + 10(I_1 + I_2)$$

$$= 3I_2 + 10I_1 + 10I_2$$

$$\text{so } 10 = 13I_1 + 10I_2 \dots\dots\dots [2]$$

BCDEB:

$$\begin{aligned} 4 &= 2I_2 + 10(I_1 + I_2) \\ &= 2I_2 + 10I_1 + 10I_2 \\ \text{so } 4 &= 10I_1 + 12I_2 \dots\dots\dots [3] \end{aligned}$$

Inspection of equations [1] and [2] shows that if equation [1] is multiplied by 5 then the coefficient of  $I_2$  will be the same in both equations. Thus, if the two are now added then the term containing  $I_2$  will be eliminated, and hence a value can be obtained for  $I_1$ .

$$\begin{aligned} 30 &= 15I_1 - 10I_2 \dots\dots\dots [1] \times 5 \\ 10 &= 13I_1 + 10I_2 \dots\dots\dots [2] \\ \hline 40 &= 28I_1 \\ \text{so } I_1 &= \frac{40}{28} = 1.429 \text{ A } \mathbf{Ans} \end{aligned}$$

Substituting this value for  $I_1$  into equation [3] yields;

$$\begin{aligned} 4 &= 14.29 + 12I_2 \\ 12I_2 &= 4 - 14.29 \\ \text{so } I_2 &= \frac{-10.29}{12} = -0.857 \text{ A (charge) } \mathbf{Ans} \end{aligned}$$

$$\begin{aligned} (I_1 + I_2) &= 1.429 - 0.857 = 0.572 \text{ A } \mathbf{Ans} \\ V_{CD} &= (I_1 + I_2) \cdot R_{CD} \text{ volt} \\ &= 0.572 \times 10 \\ \text{so } V_{CD} &= 5.72 \text{ V } \mathbf{Ans} \end{aligned}$$

### Worked Example 2.10

**Q** For the circuit shown in Fig 2.21, use Kirchhoff's Laws to calculate (a) the current flowing in each branch of the circuit, and (b) the p.d. across the  $5\ \Omega$  resistor.

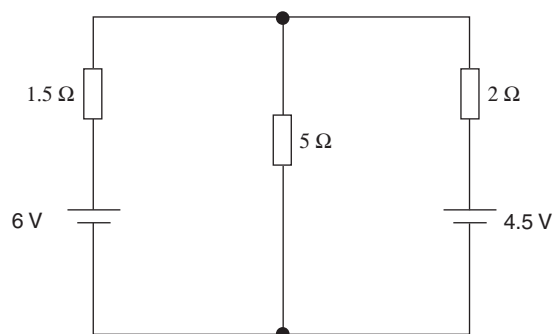
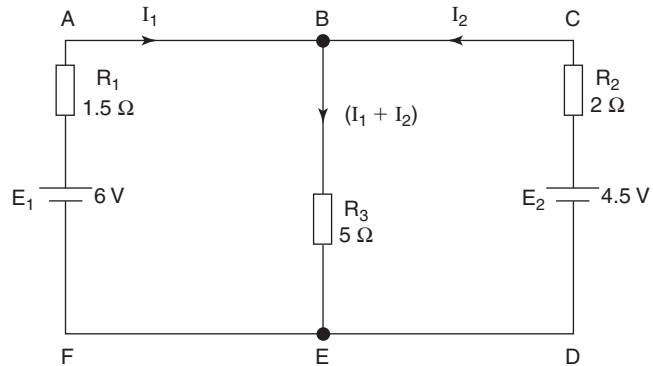

Fig. 2.21

**A**

Firstly the circuit is sketched and labelled and currents identified using Kirchhoff's current law. This is shown in Fig. 2.22.



**Fig. 2.22**

- (a) We can now consider three loops in the circuit and write down the corresponding equations using Kirchhoff's voltage law:

**ABEFA:**

$$E_1 = I_1 R_1 + (I_1 + I_2) R_3 \text{ volt}$$

$$6 = 1.5 I_1 + 5(I_1 + I_2) = 1.5 I_1 + 5 I_1 + 5 I_2$$

so,  $6 = 6.5 I_1 + 5 I_2 \dots\dots\dots [1]$

**CBEDC:**

$$E_2 = I_2 R_2 + (I_1 + I_2) R_3 \text{ volt}$$

$$4.5 = 2 I_2 + 5(I_1 + I_2) = 2 I_2 + 5 I_1 + 5 I_2$$

so,  $4.5 = 5 I_1 + 7 I_2 \dots\dots\dots [2]$

**ABCDEFA:**

$$E_1 - E_2 = I_1 R_1 - I_2 R_2 \text{ volt}$$

$$6 - 4.5 = 1.5 I_1 - 2 I_2$$

so,  $1.5 = 1.5 I_1 - 2 I_2 \dots\dots\dots [3]$

Now, any pair of these three equations may be used to solve the problem, using the technique of simultaneous equations. We shall use equations [1] and [3] to eliminate the unknown current  $I_2$ , and hence obtain a value for current  $I_1$ . To do this we can multiply [1] by 2 and [3] by 5, and then add the two modified equations together, thus:

$$12 = 13 I_1 + 10 I_2 \dots\dots\dots [1] \times 2$$

$$7.5 = 7.5 I_1 - 10 I_2 \dots\dots\dots [3] \times 5$$

$$\hline 19.5 = 20.5 I_1$$

hence,  $I_1 = \frac{19.5}{20.5} = 0.951 \text{ A Ans}$

Substituting this value for  $I_1$  into equation [3] gives:

$$1.5 = (1.5 \times 0.951) - 2I_2$$

$$1.5 = 1.427 - 2I_2$$

$$\text{hence, } 2I_2 = 1.427 - 1.5 = -0.0732$$

$$\text{and } I_2 = -0.0366 \text{ A Ans}$$

**Note:** The minus sign in the answer for  $I_2$  indicates that this current is actually flowing in the opposite direction to that marked in Fig. 2.22. This means that battery  $E_1$  is both supplying current to the  $5\ \Omega$  resistor and charging battery  $E_2$ .

$$\text{Current through } 5\ \Omega \text{ resistor} = I_1 + I_2 \text{ amp} = 0.951 + (-0.0366)$$

$$\text{so current through } 5\ \Omega \text{ resistor} = 0.951 - 0.0366 = 0.914 \text{ A Ans}$$

- (b) To obtain the p.d. across the  $5\ \Omega$  resistor we can either subtract the p.d. (voltage drop) across  $R_1$  from the emf  $E_1$  or add the p.d. across  $R_2$  to emf  $E_2$ , because  $E_2$  is being charged. A third alternative is to multiply  $R_3$  by the current flowing through it. All three methods will be shown here, and, provided that the same answer is obtained each time, the correctness of the answers obtained in part (a) will be confirmed.

$$V_{BE} = E_1 - I_1 R_1 \text{ volt} = 6 - (0.951 \times 1.5)$$

$$= 6 - 1.4265$$

$$\text{so, } V_{BE} = 4.574 \text{ V Ans}$$

OR:

$$V_{BE} = E_2 + I_2 R_2 \text{ volt} = 4.5 + (0.0366 \times 2)$$

$$= 4.5 + 0.0732$$

$$\text{so, } V_{BE} = 4.573 \text{ V Ans}$$

OR:

$$V_{BE} = (I_1 + I_2) R_3 \text{ volt} = 0.914 \times 5$$

$$\text{so, } V_{BE} = 4.57 \text{ V Ans}$$

The very small differences between these three answers is due simply to rounding errors, and so the answers to part (a) are verified as correct.

## 2.8 The Wheatstone Bridge Network

This is a network of interconnected resistors or other components, depending on the application. Although the circuit contains only one source of emf, it requires the application of a network theorem such as the Kirchhoff's method for its solution. A typical network, suitably labelled and with current flows identified is shown in Fig. 2.23.

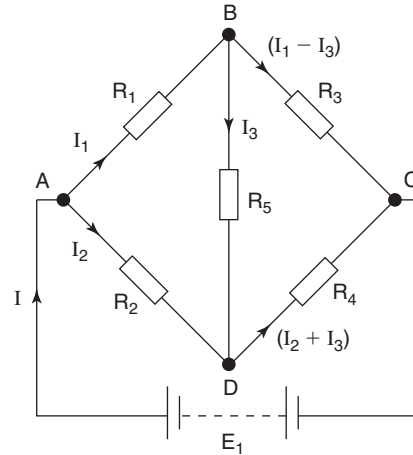

Fig. 2.23

Notice that although there are five resistors, the current law has been applied so as to minimise the number of 'unknown' currents to three. Thus only three simultaneous equations will be required for the solution, though there are seven possible loops to choose from. These seven loops are:

ABCD; ADCA; ABDCA; ADBCA; ABDA; BCDB; and ABCDA

If you trace around these loops you will find that the last three do not include the source of emf, so for each of these loops the sum of the emfs will be ZERO! Up to a point it doesn't matter which three loops are chosen provided that at least one of them includes the source. If you chose to use only the last three 'zero emf' loops you would succeed only in proving that zero equals zero!

The present level of study does not require you to solve simultaneous equations containing three unknowns. It is nevertheless good practice in the use of Kirchhoff's laws, and the seven equations for the above loops are listed below. In order for you to gain this practice it is suggested that you attempt this exercise before reading further, and compare your results with those shown below.

$$\underline{ABCA:} \quad E_1 = I_1 R_1 + (I_1 - I_3) R_3$$

$$\underline{ADCA:} \quad E_1 = I_2 R_2 + (I_2 + I_3) R_4$$

$$\underline{ABDCA:} \quad E_1 = I_1 R_1 + I_3 R_5 + (I_2 + I_3) R_4$$

$$\underline{ADBCA:} \quad E_1 = I_2 R_2 - I_3 R_5 + (I_1 - I_3) R_3$$

$$\underline{ABDA:} \quad 0 = I_1 R_1 + I_3 R_5 - I_2 R_2$$

$$\underline{BCDB:} \quad 0 = (I_1 - I_3) R_3 - (I_2 + I_3) R_4 - I_3 R_5$$

$$\underline{ABCDA:} \quad 0 = I_1 R_1 + (I_1 - I_3) R_3 - (I_2 + I_3) R_4 - I_2 R_2$$

As a check that the current law has been correctly applied, consider junctions B and C:

$$\begin{aligned} \text{current arriving at B} &= I \\ \text{total current leaving} &= I_1 + I_2 \\ \text{so } I &= I_1 + I_2 \\ \text{current arriving at C} &= (I_1 - I_3) + (I_2 + I_3) \\ &= I_1 - I_3 + I_2 + I_3 \\ &= I_1 + I_2 \\ &= I \end{aligned}$$

Hence, current leaving battery = current returning to battery.

### Worked Example 2.11

**Q** For the bridge network shown in Fig. 2.24 calculate the current through each resistor, and the current drawn from the supply.

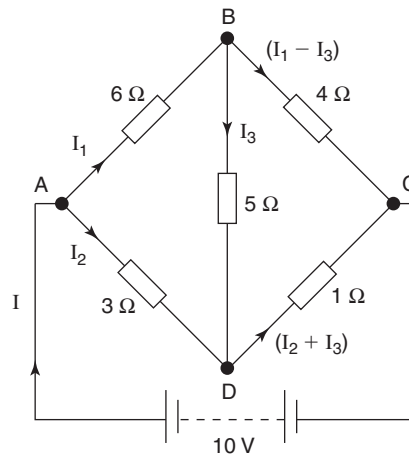

Fig. 2.24

**A**

The circuit is first labelled and the currents identified using the current law as shown in Fig. 2.24.

ABDA:

$$\begin{aligned} 0 &= 6I_1 + 5I_3 - 3I_2 \\ 0 &= 6I_1 - 3I_2 + 5I_3 \dots\dots\dots [1] \end{aligned}$$

BDCB:

$$\begin{aligned} 0 &= 5I_3 + 1(I_2 + I_3) - 4(I_1 - I_3) \\ &= 5I_3 + I_2 + I_3 - 4I_1 + 4I_3 \\ 0 &= -4I_1 + I_2 + 10I_3 \dots\dots\dots [2] \end{aligned}$$

ADCA:

$$\begin{aligned} 10 &= 3I_2 + 1(I_2 + I_3) \\ &= 3I_2 + I_2 + I_3 \\ 10 &= 4I_2 + I_3 \dots\dots\dots[3] \end{aligned}$$

Multiplying equation [1] by 2, equation [2] by 3 and then adding them

$$\begin{aligned} 0 &= 12I_1 - 6I_2 + 10I_3 \dots\dots\dots[1] \times 2 \\ 0 &= -12I_1 + 3I_2 + 30I_3 \dots\dots\dots[2] \times 3 \\ \hline 0 &= \quad \quad - 3I_2 + 40I_3 \dots\dots\dots[4] \end{aligned}$$

Multiplying equation [3] by 3, equation [4] by 4 and then adding them

$$\begin{aligned} 30 &= 12I_2 + 3I_3 \dots\dots\dots[3] \times 3 \\ 0 &= -12I_2 + 160I_3 \dots\dots\dots[4] \times 4 \\ \hline 30 &= \quad \quad \quad 163I_3 \\ I_3 &= \frac{30}{163} = 0.184 \text{ A } \mathbf{Ans} \end{aligned}$$

Substituting for  $I_3$  in equation [3]

$$\begin{aligned} 10 &= 4I_2 + 0.184 \\ 4I_2 &= 9.816 \\ I_2 &= \frac{9.816}{4} = 2.454 \text{ A } \mathbf{Ans} \end{aligned}$$

Substituting for  $I_3$  and  $I_2$  in equation [2]

$$\begin{aligned} 0 &= -4I_1 + 2.454 + 1.84 \\ 4I_1 &= 4.294 \\ I_1 &= \frac{4.294}{4} = 1.074 \text{ A } \mathbf{Ans} \end{aligned}$$

$$\begin{aligned} I &= I_1 + I_2 \\ &= 1.074 + 2.454 \\ I &= 3.529 \text{ A } \mathbf{Ans} \end{aligned}$$

Since all of the answers obtained are positive values then the currents will flow in the directions marked on the circuit diagram.

### Worked Example 2.12

**Q** If the circuit of Fig. 2.24 is now amended by simply changing the value of  $R_{DC}$  from  $1\ \Omega$  to  $2\ \Omega$ , calculate the current flowing through the  $5\ \Omega$  resistor in the central limb.

**A**

The amended circuit diagram is shown in Fig. 2.25.

ABDA:

$$\begin{aligned} 0 &= 6I_1 + 5I_3 - 3I_2 \\ 0 &= 6I_1 - 3I_2 + 5I_3 \dots\dots\dots[1] \end{aligned}$$

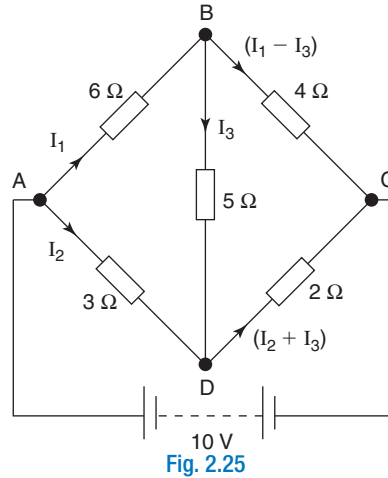

Fig. 2.25

BDCB:

$$\begin{aligned}
 0 &= 5I_3 + 2(I_2 + I_3) - 4(I_1 - I_3) \\
 &= 5I_3 + 2I_2 + 2I_3 - 4I_1 + 4I_3 \\
 0 &= -4I_1 + 2I_2 + 11I_3 \dots\dots\dots [2]
 \end{aligned}$$

Multiplying equation [1] by 2, equation [2] by 3 and adding them

$$\begin{aligned}
 0 &= 12I_1 - 6I_2 + 10I_3 \dots\dots\dots [1] \times 2 \\
 0 &= -12I_1 + 6I_2 + 33I_3 \dots\dots\dots [2] \times 3 \\
 \hline
 0 &= \qquad \qquad \qquad 43I_3
 \end{aligned}$$

so  $I_3 = 0$  A **Ans**

At first sight this would seem to be a very odd result. Here we have a resistor in the middle of a circuit with current being drawn from the source, yet no current flows through this particular resistor! Now, in any circuit, current will flow between two points only if there is a difference of potential between the two points. So we must conclude that the potentials at junctions B and D must be the same. Since junction A is a common point for both the  $6\Omega$  and  $3\Omega$  resistors, then the p.d. across the  $6\Omega$  must be the same as that across the  $3\Omega$  resistor. Similarly, since point C is common to the  $4\Omega$  and  $2\Omega$  resistors, then the p.d. across each of these must also be equal. This may be verified as follows.

Since  $I_3$  is zero then the  $5\Omega$  resistor plays no part in the circuit. In this case we can ignore its presence and re-draw the circuit as in Fig. 2.26.

Thus the circuit is reduced to a simple series/parallel arrangement that can be analysed using simple Ohm's law techniques.

$$\begin{aligned}
 R_{ABC} &= R_1 + R_3 \text{ ohm} = 6 + 4 \\
 \text{so } R_{ABC} &= 10 \Omega \\
 I_1 &= \frac{E}{R_{ABC}} \text{ amp} \\
 \text{so } I_1 &= \frac{10}{10} = 1 \text{ A} \\
 V_{AB} &= I_1 R_1 \text{ volt} = 1 \times 6 = 6 \text{ V}
 \end{aligned}$$

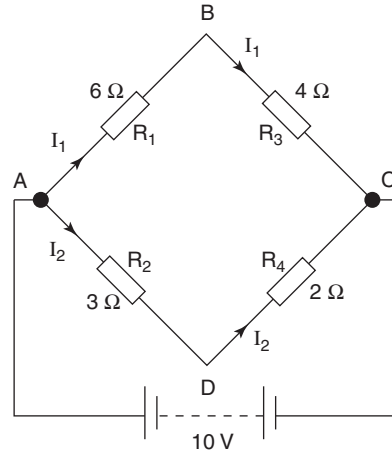

Fig. 2.26

Similarly,  $R_{ADC} = 3 + 2 = 5 \Omega$

$$I_2 = \frac{10}{5} = 2A$$

and  $V_{AD} = 2 \times 3 = 6 V$

**Balance condition** refers to that condition when zero current flows through the central arm of the bridge circuit, due to a particular combination of resistor values in the four 'outer' arms of the bridge

Thus  $V_{AB} = V_{AD} = 6 V$ , so the potentials at B and D are equal. In this last example, the values of  $R_1, R_2, R_3$  and  $R_4$  are such to produce what is known as the **balance condition** for the bridge. Being able to produce this condition is what makes the bridge circuit such a useful one for many applications in measurement systems. The value of resistance in the central limb has no effect on the balance conditions. This is because, at balance, zero current flows through it. In addition, the value of the emf also has no effect on the balance conditions, but will of course affect the values for  $I_1$  and  $I_2$ . Consider the general case of a bridge circuit as shown in Fig. 2.27, where the values of resistors  $R_1$  to  $R_4$  are adjusted so that  $I_3$  is zero.

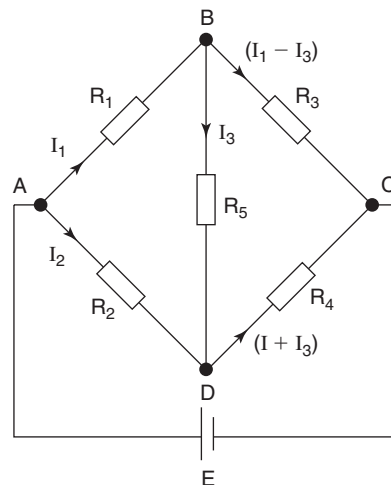

Fig. 2.27

$$V_{AB} = I_1 R_1 \text{ and } V_{AD} = I_2 R_2$$

but under the balance condition  $V_{AB} = V_{AD}$

$$\text{so } I_1 R_1 = I_2 R_2 \dots \dots \dots [1]$$

Similarly,  $V_{BC} = V_{DC}$

$$\text{so } (I_1 - I_3) \cdot R_3 = (I_2 + I_3) R_4$$

but,  $I_3 = 0$ , so current through  $R_3 = I_1$

and current through  $R_4 = I_2$ , therefore

$$I_1 R_3 = I_2 R_4 \dots \dots \dots [2]$$

Dividing equation [1] by equation [2]:

$$\frac{I_1 R_1}{I_1 R_3} = \frac{I_2 R_2}{I_2 R_4}$$

$$\text{so } \frac{R_1}{R_3} = \frac{R_2}{R_4}$$

This last equation may be verified by considering the values used in the previous example where  $R_1 = 6\Omega$ ,  $R_2 = 3\Omega$ ,  $R_3 = 4\Omega$  and  $R_4 = 2\Omega$ .

$$\text{i.e. } \frac{6}{3} = \frac{4}{2}$$

So for balance, the ratio of the two resistors on the left-hand side of the bridge equals the ratio of the two on the right-hand side.

However, a better way to express the balance condition in terms of the resistor values is as follows. If the product of two diagonally opposite resistors equals the product of the other pair of diagonally opposite resistors, then the bridge is balanced, and zero current flows through the central limb

$$\text{i.e. } R_1 R_4 = R_2 R_3 \quad (2.11)$$

and transposing equation (2.11) to make  $R_4$  the subject we have

$$R_4 = \frac{R_2}{R_1} R_3 \quad (2.12)$$

Thus if resistors  $R_1$ ,  $R_2$  and  $R_3$  can be set to known values, and adjusted until a sensitive current measuring device inserted in the central limb indicates zero current, then we have the basis for a sensitive resistance measuring device.

**Worked Example 2.13**

- Q** A Wheatstone Bridge type circuit is shown in Fig. 2.28. Determine (a) the p.d. between terminals B and D, and (b) the value to which  $R_4$  must be adjusted in order to reduce the current through  $R_3$  to zero (balance the bridge).

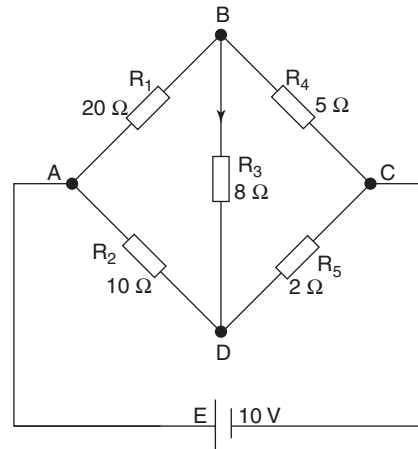

Fig. 2.28

**A**

The circuit is sketched and currents marked, applying Kirchhoff's current law, as shown in Fig. 2.29.

Kirchhoff's voltage law is now applied to any three loops. Note that as in this case there are three unknowns ( $I_1$ ,  $I_2$ , and  $I_3$ ) then we must have at least three equations in order to solve the problem.

ABDA:

$$0 = 20I_1 + 8I_3 - 10I_2$$

$$\text{so, } 0 = 20I_1 - 10I_2 + 8I_3 \dots\dots\dots[1]$$

BDCB:

$$0 = 8I_3 + 2(I_2 + I_3) - 5(I_1 - I_3)$$

$$= 8I_3 + 2I_2 + 2I_3 - 5I_1 + 5I_3$$

$$\text{so, } 0 = -5I_1 + 2I_2 + 15I_3 \dots\dots\dots[2]$$

ADCA:

$$10 = 10I_2 + 2(I_2 + I_3)$$

$$= 10I_2 + 2I_2 + 2I_3$$

$$\text{so, } 10 = 12I_2 + 2I_3 \dots\dots\dots[3]$$

Using equations [1] and [2] to eliminate  $I_1$  we have:

$$0 = 20I_1 - 10I_2 + 8I_3 \dots\dots\dots[1]$$

$$0 = -20I_1 + 8I_2 + 60I_3 \dots\dots\dots[2] \times 4$$

$$\text{and adding, } 0 = -2I_2 + 68I_3 \dots\dots\dots[4]$$

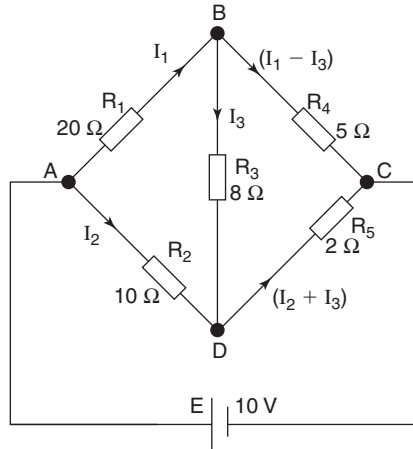

Fig. 2.29

and now using equations [3] and [4] we can eliminate  $I_2$  as follows:

$$\begin{aligned} 10 &= 12I_2 + 2I_3 \dots\dots\dots [3] \\ 0 &= -12I_2 + 408I_3 \dots\dots\dots [4] \times 6 \\ \hline 10 &= 410I_3 \end{aligned}$$

$$\text{and } I_3 = \frac{10}{410} = 0.0244 \text{ A}$$

$$\begin{aligned} V_{BD} &= I_3 R_3 \text{ volt} \\ &= 0.0244 \times 8 \end{aligned}$$

$$\text{so, } V_{BD} = 0.195 \text{ V Ans}$$

(b) For balance conditions

$$R_2 R_4 = R_1 R_5$$

$$R_4 = \frac{R_1 R_5}{R_2} \text{ ohm}$$

$$= \frac{20 \times 2}{10}$$

$$\text{so, } R_4 = 4 \Omega \text{ Ans}$$

## 2.9 The Wheatstone Bridge Instrument

This is an instrument used for the accurate measurement of resistance over a wide range of resistance values. It comprises three arms, the resistances of which can be adjusted to known values. A fourth arm contains the 'unknown' resistance, and a central limb contains a sensitive microammeter (a galvanometer or 'galvo'). The general arrangement is shown in Fig. 2.30. Comparing this circuit with that of Fig. 2.27 and using equation (2.12), the value of the resistance to be measured ( $R_x$ ) is given by

$$R_x = \frac{R_m}{R_d} R_v \text{ ohm}$$

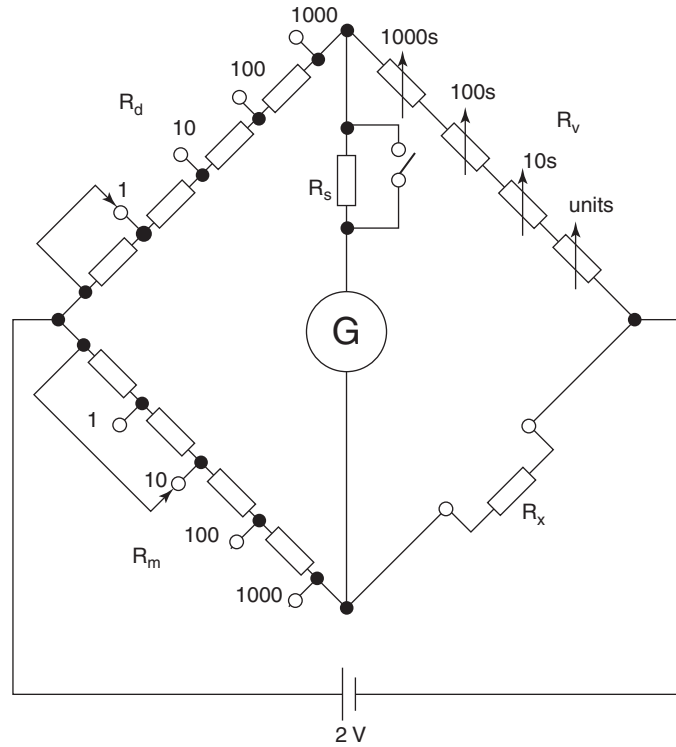

Fig. 2.30

$R_m$  and  $R_d$  are known collectively as the ratio arms, where  $R_m$  is the multiplier and  $R_d$  is the divider arm. Both of these arms are variable in decade steps (i.e. 1, 10, 100, 1000). This does not mean that these figures represent actual resistance values, but they indicate the appropriate ratio between these two arms. Thus, if  $R_d$  is set to 10 whilst  $R_m$  is set to 1000, then the resistance value selected by the variable arm  $R_v$  is 'multiplied' by the ratio  $1000/10 = 100$ .

### Worked Example 2.14

**Q** Two resistors were measured using a Wheatstone Bridge, and the following results were obtained.

(a)  $R_m = 1000$ ;  $R_d = 1$ ;  $R_v = 3502 \Omega$

(b)  $R_m = 1$ ;  $R_d = 1000$ ;  $R_v = 296 \Omega$

For each case determine the value of the resistance being measured.

**A**

(a)  $R_x = \frac{1000}{1} \times 3502 = 3.502 \text{ M}\Omega$  **Ans**

(b)  $R_x = \frac{1}{1000} \times 296 = 0.296 \Omega$  **Ans**

From the above example it may be appreciated that due to the ratio arms, the Wheatstone Bridge is capable of measuring a very wide range of resistance values. The instrument is also very **accurate** because it is what is known as a null method of measurement. This term is used because no settings on the three arms are used to determine the value of  $R_x$  until the galvo (G) in the central limb indicates zero (null reading). Since the galvo is a very sensitive microammeter it is capable of indicating fractions of a microamp. Hence, the slightest imbalance of the bridge can be detected. Also, since the bridge is adjusted until the galvo indicates zero, then this condition can be obtained with maximum accuracy. The reason for this accuracy is that before any measurements are made (no current through the galvo) it is a simple matter to ensure that the galvo pointer indicates zero. Thus, only the sensitivity of the galvo is utilised, and its accuracy over the remainder of its scale is unimportant. Included in the central limb are a resistor and a switch. These are used to limit the galvo current to a value that will not cause damage to the galvo when the bridge is well off balance. When the ratio arms and the variable arm have been adjusted to give only a small deflection of the galvo pointer, the switch is then closed to bypass the swamp resistor  $R_s$ . This will revert the galvo to its maximum sensitivity for the final balancing using  $R_v$ . The bridge supply is normally provided by a 2 V cell as shown.

Do not confuse **accuracy** with sensitivity. For an instrument to be accurate it must also be sensitive. However, a sensitive instrument is not necessarily accurate. Sensitivity is the ability to react to small changes of the quantity being measured. Accuracy is to do with the closeness of the indicated value to the true value

## 2.10 The Slidewire Potentiometer

This instrument is used for the accurate measurement of small voltages. Like the Wheatstone Bridge, it is a null method of measurement since it also utilises the fact that no current can flow between points of equal potential. In its simplest form it comprises a metre length of wire held between two brass or copper blocks on a base board, with a graduated metre scale beneath the wire. Connected to one end of the wire is a contact, the other end of which can be placed at any point along the wire. A 2 V cell causes current to flow along the wire. This arrangement, including a voltmeter, is shown in Fig. 2.31. The wire between the blocks A and B must be of uniform cross-section and resistivity throughout its length, so that each millimetre of its length has the same resistance as the next. Thus it may be considered as a number of equal resistors connected in series between points A and B. In other words it is a continuous potential divider.

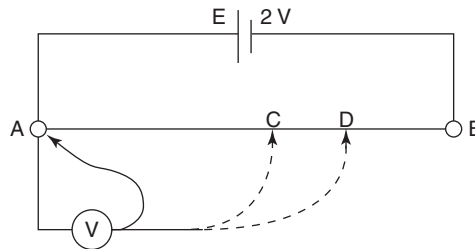

Fig. 2.31

Let us now conduct an imaginary experiment. If the movable contact is placed at point A then both terminals of the voltmeter will be at the same potential, and it will indicate zero volts. If the contact is now moved to point B then the voltmeter will indicate 2 V. Consider now the contact placed at point C which is midway between A and B. In this case it is exactly halfway along our 'potential divider', so it will indicate 1 V. Finally, placing the contact at a point D (say 70 cm from A), the voltmeter will indicate 1.4 V. These results can be summarised by the statement that there is a uniform potential gradient along the wire. Therefore, the p.d. 'tapped off' by the moving contact, is in direct proportion to the distance travelled along the wire from point A. Since the source has an emf of 2 V and the wire is of 1 metre length, then the potential gradient must be 2 V/m. In general we can say that

$$V_{AC} = \frac{AC}{AB} E \text{ volt} \quad (2.13)$$

where AC = distance travelled along wire  
 AB = total length of the wire  
 and  $E$  = the source voltage

Utilising these facts the simple circuit can be modified to become a measuring instrument, as shown in Fig. 2.32. In this case the voltmeter

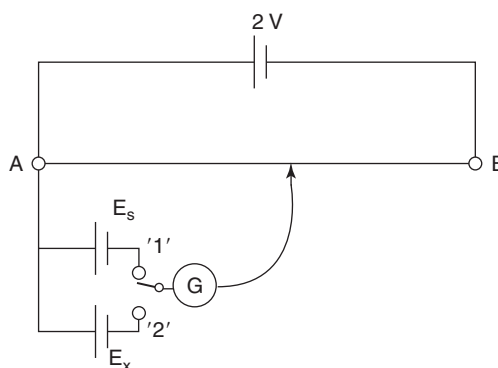

Fig. 2.32

has been replaced by a galvo. The movable contact can be connected either to the cell to be measured or the standard cell, via a switch. Using this system the procedure would be as follows:

- 1 The switch is moved to position '1' and the slider moved along the wire until the galvo indicates zero current. The position of the slider on the scale beneath the wire is then noted. This distance from A represents the emf  $E_s$  of the standard cell.
- 2 With the switch in position '2', the above procedure is repeated, whereby distance along the scale represents the emf  $E_x$  of the cell to be measured.
- 3 The value of  $E_x$  may now be calculated from

$$E_x = \frac{AD}{AC} \times E_s$$

where AC represents the scale reading obtained for the standard cell and AD the scale reading for the unknown cell.

It should be noted that this instrument will measure the true emf of the cell since the readings are taken when the galvo carries zero current (i.e. no current is being drawn from the cell under test), hence there will be no p.d. due to its internal resistance.

### Worked Example 2.15

**Q** A slidewire potentiometer when used to measure the emfs of two cells provided balance conditions at scale settings of (a) 600 mm and (b) 745 mm. If the standard cell has an emf of 1.0186 V and a scale reading of 509.3 mm then determine the values for the two cell emfs.

**A**

Let  $E_s$ ,  $\ell_1$  and  $\ell_2$  represent the scale readings for the standard cell and cells 1 and 2 respectively. Hence:

$$\ell_s = 509.3 \text{ mm } \ell_1 = 600 \text{ mm}; \ell_2 = 745 \text{ mm}; E_s = 1.0186 \text{ V}$$

$$\begin{aligned} E_1 &= \frac{\ell_1}{\ell_s} \times E_s \text{ volt} \\ &= \frac{600}{509.3} \times 1.0186 \\ E_1 &= 1.2 \text{ V Ans} \end{aligned}$$

$$\begin{aligned} E_2 &= \frac{\ell_2}{\ell_s} \times E_s \text{ volt} \\ &= \frac{745}{509.3} \times 1.0186 \\ E_2 &= 1.49 \text{ V Ans} \end{aligned}$$

It is obviously inconvenient to have an instrument that needs to be one metre in length and requires the measurements of lengths along a scale.

In the commercial version of the instrument the long wire is replaced by a series of precision resistors plus a small section of wire with a movable contact. The standard cell and galvo would also be built-in features. Also, to avoid the necessity for separate calculations, there would be provision for standardising the potentiometer. This means that the emf values can be read directly from dials on the front of the instrument.

### Summary of Equations

**Resistors in series:**  $R = R_1 + R_2 + R_3 + \dots$  ohm

**Resistors in parallel:**  $\frac{1}{R} = \frac{1}{R_1} + \frac{1}{R_2} + \frac{1}{R_3} + \dots$  siemen

and for ONLY two resistors in parallel,  $R = \frac{R_1 R_2}{R_1 + R_2}$  ohm  $\left( \frac{\text{product}}{\text{sum}} \right)$

**Potential divider:**  $V_1 = \frac{R_1}{R_1 + R_2} \times E$  volt

**Current divider:**  $I_1 = \frac{R_2}{R_1 + R_2} \times I$  amp

**Kirchhoff's laws:**  $\Sigma I = 0$  (sum of the currents at a junction = 0)

$\Sigma E = \Sigma IR$  (sum of the emfs = sum of the p.d.s, in order)

**Wheatstone Bridge:** Balance condition when current through centre limb = 0 or  $R_1 R_4 = R_2 R_3$  (multiply diagonally across bridge circuit)

**Slidewire potentiometer:**  $V_{AC} = \frac{AC}{AB} \times E$  volt

## Assignment Questions

- 1 Two  $560\ \Omega$  resistors are placed in series across a  $400\text{V}$  supply. Calculate the current drawn.
- 2 When four identical hotplates on a cooker are all in use, the current drawn from a  $240\text{V}$  supply is  $33\text{ A}$ . Calculate (a) the resistance of each hotplate, (b) the current drawn when only three plates are switched on. The hotplates are connected in parallel.
- 3 Calculate the total current when six  $120\ \Omega$  torch bulbs are connected in parallel across a  $9\text{V}$  supply.
- 4 Two  $20\ \Omega$  resistors are connected in parallel and this group is connected in series with a  $4\ \Omega$  resistor. What is the total resistance of the circuit?
- 5 A  $12\ \Omega$  resistor is connected in parallel with a  $15\ \Omega$  resistor and the combination is connected in series with a  $9\ \Omega$  resistor. If this circuit is supplied at  $12\text{V}$ , calculate (a) the total resistance, (b) the current through the  $9\ \Omega$  resistor and (c) the current through the  $12\ \Omega$  resistor.
- 6 For the circuit shown in Fig. 2.33 calculate the values for (a) the current through each resistor, (b) the p.d. across each resistor and (c) the power dissipated by the  $20\ \Omega$  resistor.

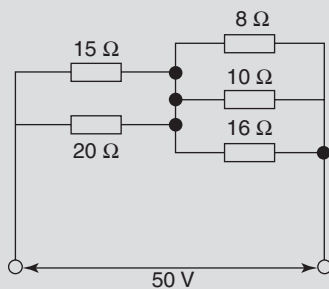

Fig. 2.33

- 7 Determine the p.d. between terminals E and F of the circuit in Fig. 2.34.

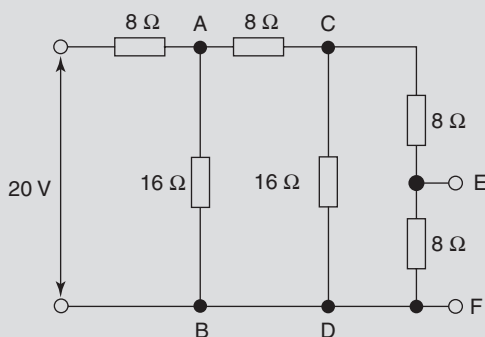

Fig. 2.34

- 8 For the circuit of Fig. 2.35 calculate (a) the p.d. across the  $8\ \Omega$  resistor, (b) the current through the  $10\ \Omega$  resistor and (c) the current through the  $12\ \Omega$  resistor.



Fig. 2.35

- 9 Three resistors of  $5\ \Omega$ ,  $6\ \Omega$  and  $7\ \Omega$  respectively are connected in parallel. This combination is connected in series with another parallel combination of  $3\ \Omega$  and  $4\ \Omega$ . If the complete circuit is supplied from a  $20\text{V}$  source, calculate (a) the total resistance, (b) the total current, (c) the p.d. across the  $3\ \Omega$  resistor and (d) the current through the  $4\ \Omega$  resistor.
- 10 Two resistors of  $18\ \Omega$  and  $12\ \Omega$  are connected in parallel and this combination is connected in series with an unknown resistor  $R_x$ . Determine the value of  $R_x$  if the complete circuit draws a current of  $0.6\text{ A}$  from a  $12\text{V}$  supply.
- 11 Three loads, of  $24\text{ A}$ ,  $8\text{ A}$ , and  $12\text{ A}$  are supplied from a  $200\text{V}$  source. If a motor of resistance  $2.4\ \Omega$  is also connected across the supply, calculate (a) the total resistance and (b) the total current drawn from the supply.
- 12 Two resistors of  $15\ \Omega$  and  $5\ \Omega$  connected in series with a resistor  $R_x$  and the combination is supplied from a  $240\text{V}$  source. If the p.d. across the  $5\ \Omega$  resistor is  $20\text{V}$  calculate the value of  $R_x$ .
- 13 A  $200\text{V}$ ,  $0.5\text{ A}$  lamp is to be connected in series with a resistor across a  $240\text{V}$  supply. Determine the resistor value required for the lamp to operate at its correct voltage.
- 14 A  $12\ \Omega$  and a  $6\ \Omega$  resistor are connected in parallel across the terminals of a battery of emf  $6\text{V}$  and internal resistance  $0.6\ \Omega$ . Sketch the circuit diagram and calculate (a) the current drawn from the battery, (b) the terminal p.d. and (c) the current through the  $6\ \Omega$  resistor.

## Assignment Questions

- 15** An electric cooker element consists of two parts, each having a resistance of  $18\Omega$ , which can be connected (a) in series, (b) in parallel, or (c) using one part only. Calculate the current drawn from a  $240\text{V}$  supply for each connection.
- 16** A cell of emf  $2\text{V}$  has an internal resistance  $0.1\Omega$ . Calculate the terminal p.d. when (a) there is no load connected and (b) a  $2.9\Omega$  resistor is connected across the terminals. Explain why these two answers are different.
- 17** A battery has a terminal voltage of  $1.8\text{V}$  when supplying a current of  $9\text{A}$ . This voltage rises to  $2.02\text{V}$  when the load is removed. Calculate the internal resistance.
- 18** Four resistors of values  $10\Omega$ ,  $20\Omega$ ,  $40\Omega$ , and  $40\Omega$  are connected in parallel across the terminals of a generator having an emf of  $48\text{V}$  and internal resistance  $0.5\Omega$ . Sketch the circuit diagram and calculate (a) the current drawn from the generator, (b) the p.d. across each resistor and (c) the current flowing through each resistor.
- 19** Calculate the p.d. across the  $3\Omega$  resistor shown in Fig. 2.36 given that  $V_{AB}$  is  $11\text{V}$ .

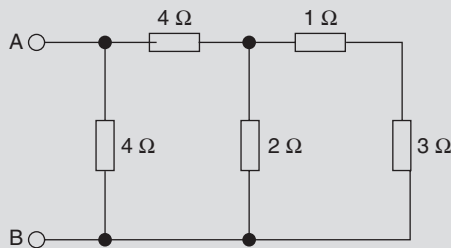

Fig. 2.36

- 20** Calculate the p.d.  $V_{AB}$  in Fig. 2.37.

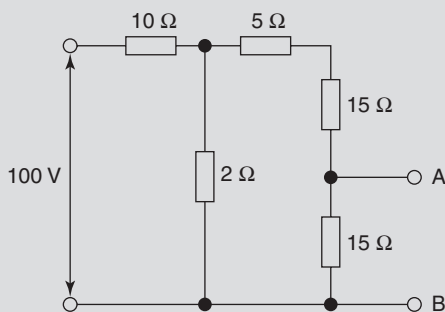

Fig. 2.37

- 21** For the network shown in Fig. 2.38, calculate (a) the total circuit resistance, (b) the supply current, (c) the p.d. across the  $12\Omega$  resistor, (d) the total power dissipated in the whole circuit and (e) the power dissipated by the  $12\Omega$  resistor.

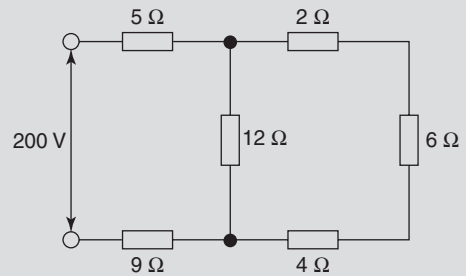

Fig. 2.38

- 22** A circuit consists of a  $15\Omega$  and a  $30\Omega$  resistor connected in parallel across a battery of internal resistance  $2\Omega$ . If  $60\text{W}$  is dissipated by the  $15\Omega$  resistor, calculate (a) the current in the  $30\Omega$  resistor, (b) the terminal p.d. and emf of the battery, (c) the total energy dissipated in the external circuit in one minute and (d) the quantity of electricity through the battery in one minute.
- 23** Use Kirchhoff's laws to determine the three branch currents and the p.d. across the  $5\Omega$  resistor in the network of Fig. 2.39.

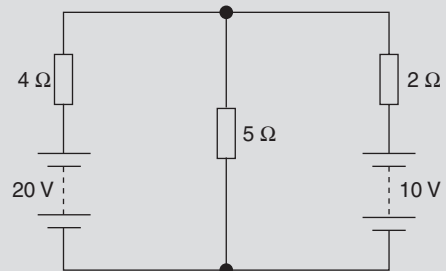

Fig. 2.39

- 24** Determine the value and direction of current in each branch of the network of Fig. 2.40, and the power dissipated by the  $4\Omega$  load resistor.

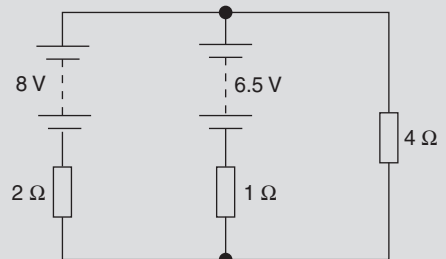

Fig. 2.40

- 25** Two batteries A and B are connected in parallel (positive to positive) with each other and this combination is connected in parallel with a battery C; this is in series with a  $25\Omega$  resistor, the negative terminal of C being connected to

## Assignment Questions

the positive terminals of A and B. Battery A has an emf of 108V and internal resistance  $3\Omega$ , and the corresponding values for B are 120V and  $2\Omega$ . Battery C has an emf of 30V and negligible internal resistance. Sketch the circuit and calculate (a) the value and direction of current in each battery and (b) the terminal p.d. of A.

- 26** For the circuit of Fig. 2.41 determine (a) the current supplied by each battery, (b) the current through the  $15\Omega$  resistor and (c) the p.d. across the  $10\Omega$  resistor.

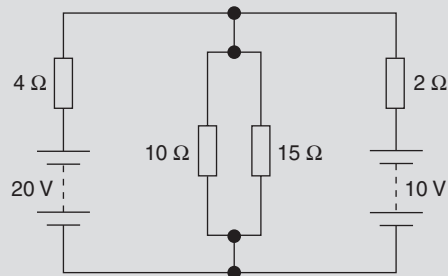

Fig. 2.41

- 27** For the network of Fig. 2.42, calculate the value and direction of all the branch currents and the p.d. across the  $80\Omega$  load resistor.

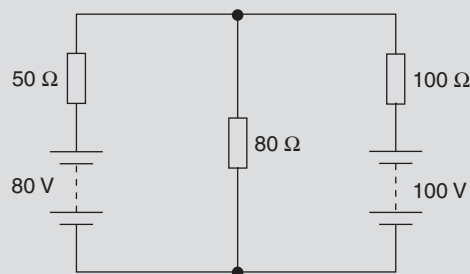

Fig. 2.42

- 28** Figure 2.43 shows a Wheatstone Bridge network, (a) For this network, write down (but

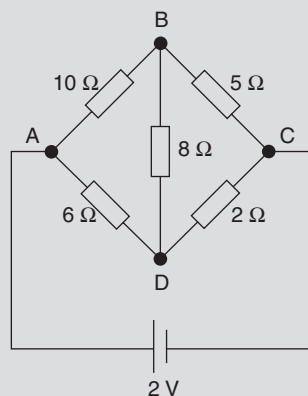

Fig. 2.43

do not solve) the loop equations for loops ABDA, ABCDA, ADCA, and CBDC, (b) to what value must the  $2\Omega$  resistor be changed to ensure zero current through the  $8\Omega$  resistor? (c) Under this condition, calculate the currents through and p.d.s across the other four resistors.

- 29** Three resistances were measured using a commercial Wheatstone Bridge, yielding the following results for the settings on the multiplying, dividing and variable arms. Determine the resistance value in each case.

$R_d$	1000	10	100
$R_m$	10	100	100
$R_v (\Omega)$	349.8	1685	22.5

- 30** The slidewire potentiometer instrument shown in Fig. 2.44 when used to measure the emf of cell  $E_x$  yielded the following results:

- (a) galvo current was zero when connected to the standard cell and the movable contact was 552 mm from A;  
 (b) galvo current was zero when connected to  $E_s$  and the movable contact was 647 mm from A.

Calculate the value of  $E_x$ , given  $E_s = 1.0183\text{V}$ .

It was found initially that  $E_x$  was connected the opposite way round and a balance could not be obtained. Explain this result.

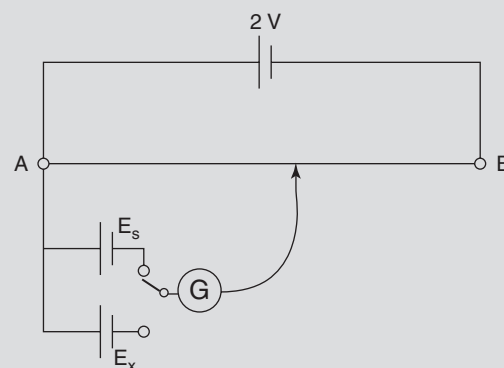

Fig. 2.44

## Suggested Practical Assignments

**Note:** Component values and specific items of equipment when quoted here are only suggestions. Those used in practice will of course depend upon availability within a given institution.

### Assignment 1

To investigate Ohm's law and Kirchhoff's laws as applied to series and parallel circuits.

#### Apparatus:

Three resistors of different values  
 1 × variable d.c. power supply unit (psu)  
 1 × ammeter  
 1 × voltmeter (DMM)

#### Method:

- 1 Connect the three resistors in series across the terminals of the psu with the ammeter connected in the same circuit. Adjust the current (as measured with the ammeter) to a suitable value. Measure the applied voltage and the p.d. across each resistor. Note these values and compare the p.d.s to the theoretical (calculated) values.
- 2 Reconnect your circuit so that the resistors are now connected in parallel across the psu. Adjust the psu to a suitable voltage and measure, in turn, the current drawn from the psu and the three resistor currents. Note these values and compare to the theoretical values.
- 3 Write an assignment report and in your conclusions justify whether the assignment confirms Ohm's law and Kirchhoff's laws, allowing for experimental error and resistor tolerances.

### Assignment 2

To investigate the application of Kirchhoff's laws to a network containing more than one source of emf.

#### Apparatus:

2 × variable d.c. psu  
 3 × different value resistors  
 1 × ammeter  
 1 × voltmeter (DMM)

#### Method:

- 1 Connect the circuit as shown in Fig. 2.45. Set psu 1 to 2V and psu 2 to 4V. Measure, in turn, the current in each limb of the circuit, and the p.d. across each resistor. For each of the three possible loops in the circuit compare the sum of the p.d.s measured with the sum of the emfs. Carry out a similar exercise regarding the three currents.

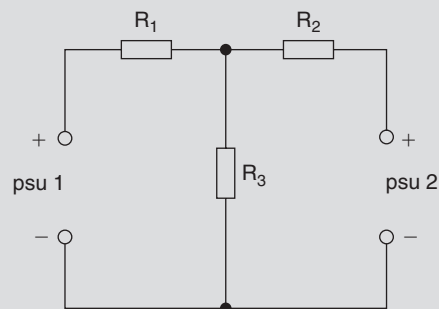

Fig. 2.45

- 2 Reverse the polarity of psu 2 and repeat the above.
- 3 Write the assignment report and in your conclusions justify whether or not Kirchhoff's laws have been verified for the network.

### Assignment 3

To investigate potential and current dividers.

#### Apparatus:

- 2 × decade resistance boxes
- 1 × ammeter
- 1 × voltmeter (DMM)
- 1 × d.c. psu

#### Method:

- 1 Connect the resistance boxes in series across the psu. Adjust one of them ( $R_1$ ) to  $3\text{ k}\Omega$  and the other ( $R_2$ ) to  $7\text{ k}\Omega$ . Set the psu to  $10\text{V}$  and measure the p.d. across each resistor. Compare the measured values with those predicted by the voltage divider theory.
- 2 Reset both  $R_1$  and  $R_2$  to two or more different values and repeat the above procedure.
- 3 Reconnect the two resistance boxes in parallel across the psu and adjust the current drawn from the psu to  $10\text{ mA}$ . Measure the current flowing through each resistance and compare to those values predicted by the current division theory.
- 4 Repeat the procedure of 3 above for two more settings of  $R_1$  and  $R_2$ , but let one of these settings be such that  $R_1 = R_2$ .

### Assignment 4

To make resistance measurements using a Wheatstone Bridge.

#### Apparatus:

- 1 × commercial form of Wheatstone Bridge
- 3 × decade resistance boxes
- $10\Omega$ ,  $6.8\text{ k}\Omega$ , and  $470\text{ k}\Omega$  resistors
- 1 × centre-zero galvo
- 1 × d. c. psu

#### Method:

- 1 Using the decade boxes, galvo and psu (set to  $2\text{V}$ ) connect your own Wheatstone Bridge circuit and measure the three resistor values.
- 2 Use the commercial bridge to re-measure the resistors and compare the results obtained from both methods.

### Assignment 5

Use a slidewire potentiometer to measure the emf of a number of primary cells (nominal emf no more than  $1.5\text{V}$ ).

This page intentionally left blank

# Electric Fields and Capacitors

## Learning Outcomes

This chapter deals with the laws and properties of electric fields and their application to electric components known as capacitors.

On completion of this chapter you should be able to:

- 1 Understand the properties of electric fields and insulating materials.
- 2 Carry out simple calculations involving these properties.
- 3 Carry out simple calculations concerning capacitors, and capacitors connected in series, parallel and series/parallel combinations.
- 4 Describe the construction and electrical properties of the different types of capacitor.
- 5 Understand the concept of energy storage in an electric field, and perform simple related calculations.

## 3.1 Coulomb's Law

A force exists between charged bodies. A force of attraction exists between opposite charges and a force of repulsion between like polarity charges. Coulomb's law states that the force is directly proportional to the product of the charges and is inversely proportional to the square of the distance between their centres. So for the two bodies shown in Fig. 3.1, this would be expressed as

$$F \propto \frac{Q_1 Q_2}{d^2}$$

In order to obtain a value for the force, a constant of proportionality must be introduced. In this case it is the permittivity of free space,  $\epsilon_0$ . This concept of permittivity is dealt with later in this chapter, and need not concern you for the time being. The expression for the force in newtons becomes

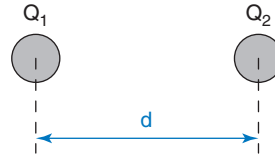

Fig. 3.1

$$F = \frac{Q_1 Q_2}{\epsilon_0 d^2} \text{ newton} \quad (3.1)$$

This type of relationship is said to follow an inverse square law because  $F \propto 1/d^2$ . The consequence of this is that if the distance of separation is doubled then the force will be reduced by a factor of four times. If the distance is increased by a factor of four times, the force will be reduced by a factor of sixteen times, etc. The practical consequence is that although the force can never be reduced to zero, it diminishes very rapidly as the distance of separation is increased. This will continue until a point is reached where the force is negligible relative to other forces acting within the system.

## 3.2 Electric Fields

You are probably more familiar with the concepts and effects of magnetic and gravitational fields. For example, you have probably conducted simple experiments using bar magnets and iron filings to discover the shape of magnetic fields, and you are aware that forces exist between magnetised bodies. You also experience the effects of gravitational forces constantly, even though you probably do not consciously think about them.

Both of these fields are simply a means of transmitting the forces involved, from one body to another. However, the fields themselves cannot be detected by the human senses, since you cannot see, touch, hear or smell them. This tends to make it more difficult to understand their nature. An electric field behaves in the same way as these other two examples, except that it is the method by which forces are transmitted between charged bodies. In all three cases we can represent the appropriate field by means of arrowed lines. These lines are usually referred to as the lines of force.

To illustrate these points, consider Fig. 3.2 which shows two oppositely charged spheres with a small positively charged particle placed on the surface of  $Q_1$ . Since like charges repel and unlike charges attract each other, then the small charged particle will experience a force of repulsion from  $Q_1$  and one of attraction from  $Q_2$ .

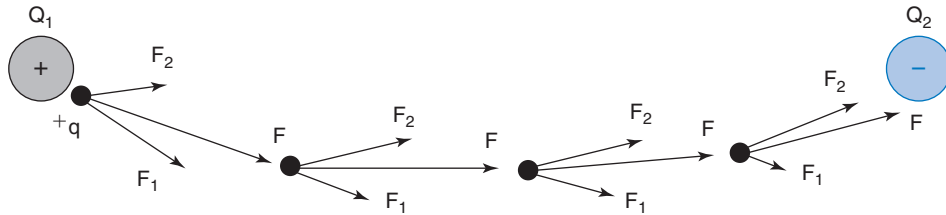

Fig. 3.2

The force of repulsion from  $Q_1$  will be very much stronger than the force of attraction from  $Q_2$  because of the relative distance involved. The other feature of the forces is that they will act so as to be at right angles to the charged surfaces. Hence there will be a resultant force acting on the particle. Assuming that it is free to move, then it will start to move in the direction of this resultant force. For the sake of clarity, the distance moved in this direction is greatly exaggerated in the diagram. However, when the particle moves to the new position, force  $F_1$  will have decreased and  $F_2$  will have increased. In addition, the direction of action of each force will have changed. Thus the direction of action of the resultant will have changed, but its magnitude will have remained constant. The particle will now respond to the new resultant force  $F$ . This is a continuous process and the particle will trace out a curved path until it reaches the surface of  $Q_2$ . If this 'experiment' was carried out for a number of starting points at the surface of  $Q_1$ , the paths taken by the particle would be as shown in Fig. 3.3.

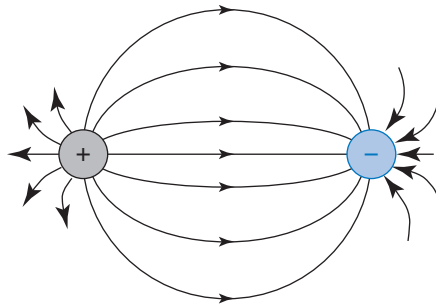

Fig. 3.3

The following points should be noted:

- 1 The lines shown represent the possible paths taken by the positively charged particle in response to the force acting on it. Thus they are called the lines of electric force. They may also be referred to as the lines of electric flux,  $\psi$ .
- 2 The total electric flux makes up the whole electric field existing between and around the two charged bodies.
- 3 The lines themselves are imaginary and the field is three dimensional. The whole of the space surrounding the charged

bodies is occupied by the electric flux, so there are no 'gaps' in which a charged particle would not be affected.

- 4 The lines of force (flux) radiate outwards from the surface of a positive charge and terminate at the surface of a negative charge.
- 5 The lines always leave (or terminate) at right angles to a charged surface.
- 6 Although the lines drawn on a diagram do not actually exist as such, they are a very convenient way to represent the existence of the electric field. They therefore aid the understanding of its properties and effects.
- 7 Since force is a vector quantity any line representing it must be arrowed. The convention used here is that the arrows point from the positive to the negative charge.

It is evident from Fig. 3.3 that the spacing between the lines of flux varies depending upon which part of the field you consider. This means that the field shown is non-uniform. A uniform electric field may be obtained between two parallel charged plates as shown in Fig. 3.4.

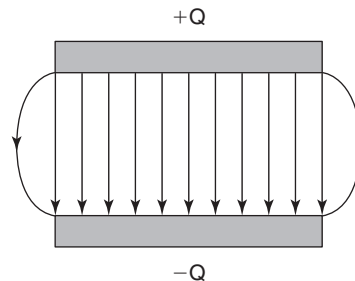

Fig. 3.4

Note that the electric field will exist in *all* of the space surrounding the two plates, but the uniform section exists only in the space between them. Some non-uniformity is shown by the curved lines at the edges (fringing effect). At this stage we are concerned only with the uniform field between the plates. If a positively charged particle was placed between the plates it would experience a force that would cause it to move from the positive to the negative plate. The value of force acting on the particle depends upon what is known as the electric field strength.

### 3.3 Electric Field Strength (E)

This is defined as the force per unit charge exerted on a test charge placed inside the electric field. (An outdated name for this property is 'electric force').

Hence, field strength =  $\frac{\text{force}}{\text{charge}}$

$$\text{So, } \mathbf{E} = \frac{F}{q} \text{ newton/coulomb} \quad (3.2)$$

$$\text{or, } F = \mathbf{E}q \text{ newton} \quad (3.3)$$

where  $q$  is the charge on the *particle*, and not the plates.

### 3.4 Electric Flux ( $\psi$ ) and Flux Density ( $D$ )

In the SI system one ‘line’ of flux is assumed to radiate from the surface of a positive charge of one coulomb and terminate at the surface of a negative charge of one coulomb. Hence the electric flux has the same numerical value as the charge that produces it. Therefore the coulomb is used as the unit of electric flux. In addition, the Greek letter psi is usually replaced by the symbol for charge, namely  $Q$ .

The electric flux density  $D$  is defined as the amount of flux per square metre of the electric field. This area is measured at right angles to the lines of force. This gives the following equation

$$D = \frac{\psi}{A}$$

$$\text{or, } D = \frac{Q}{A} \text{ coulomb/metre}^2 \quad (3.4)$$

#### Worked Example 3.1

**Q** Two parallel plates of dimensions 30 mm by 20 mm are oppositely charged to a value of 50 mC. Calculate the density of the electric field existing between them.

**A**

$$Q = 50 \times 10^{-3} \text{ C}; A = 30 \times 20 \times 10^{-6} \text{ m}^2$$

$$\begin{aligned} D &= \frac{Q}{A} \text{ coulomb/metre}^2 \\ &= \frac{50 \times 10^{-3}}{600 \times 10^{-6}} \end{aligned}$$

$$\text{so } D = 83.3 \text{ C/m}^2 \text{ Ans}$$

### Worked Example 3.2

**Q** Two parallel metal plates, each having a csa of  $400 \text{ mm}^2$ , are charged from a constant current source of  $50 \mu\text{A}$  for a time of 3 seconds. Calculate (a) the charge on the plates, and (b) the density of the electric field between them.

**A**

$$A = 400 \times 10^{-6} \text{ m}^2; I = 50 \times 10^{-6} \text{ A}; t = 3 \text{ s}$$

$$(a) \quad Q = It \text{ coulomb} = 50 \times 10^{-6} \times 3$$

$$\text{so, } Q = 150 \mu\text{C} \text{ Ans}$$

$$(b) \quad D = \frac{Q}{A} \text{ coulomb/metre}^2$$

$$= \frac{50 \times 10^{-6}}{400 \times 10^{-6}}$$

$$\text{so, } D = 0.125 \text{ C/m}^2 \text{ Ans}$$

## 3.5 The Charging Process and Potential Gradient

We have already met the concept of a potential gradient when considering a uniform conductor (wire) carrying a current. This concept formed the basis of the slidewire potentiometer discussed in Chapter 2. However, we are now dealing with static charges that have been induced on to plates (the branch of science known as electrostatics). Current flow is only applicable during the charging process. The material between the plates is some form of insulator (a dielectric) which could be vacuum, air, rubber, glass, mica, pvc, etc. So under ideal conditions there will be no current flow from one plate to the other via the dielectric. Nonetheless there will be a potential gradient throughout the dielectric.

Consider a pair of parallel plates (initially uncharged) that can be connected to a battery via a switch, as shown in Fig. 3.5. Note that the number of electrons and protons shown for each plate are in no way

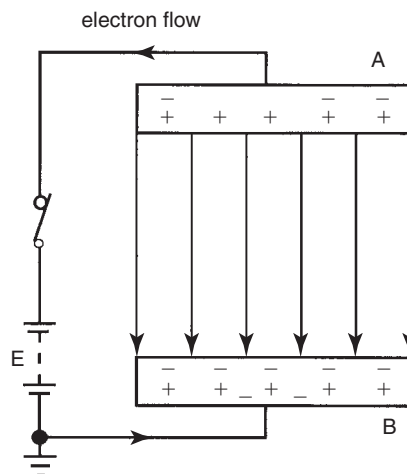

Fig. 3.5

representative of the actual numbers involved. They are shown to aid the explanation of the charging process that will take place when the switch is closed. On closing the switch, some electrons from plate A will be attracted to the positive terminal of the battery. In this case, since plate A has lost electrons it will acquire a positive charge. This results in an electric field radiating out from plate A. The effect of this field is to induce a negative charge on the top surface of plate B, by attracting electrons in the plate towards this surface. Consequently, the lower surface of plate B must have a positive charge. This in turn will attract electrons from the negative terminal of the battery. Thus for every electron that is removed from plate A one is transferred to plate B. The two plates will therefore become equally but oppositely charged.

This charging process will not carry on indefinitely (in fact it will last for only a very short space of time). This is because as the charge on the plates increases so too does the voltage developed between them. Thus the charging process continues only until the p.d. between the plates,  $V$  is equal to the emf,  $E$  of the battery. The charging current at this time will become zero because plates A and B are positive and negative respectively. Thus, this circuit is equivalent to two batteries of equal emf connected in parallel as shown in Fig. 3.6. In this case each battery would be trying to drive an equal value of current around the circuit, but in opposite directions. Hence the two batteries 'balance out' each other, and no current will flow.

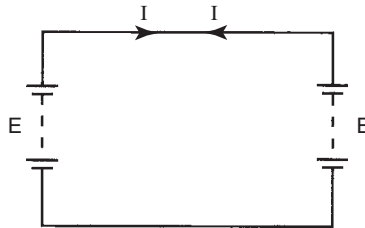

Fig. 3.6

With suitable instrumentation it would be possible to measure the p.d. between plate B and any point in the dielectric. If this was done, then a graph of the voltage versus distance from B would look like that in Fig. 3.7. The slope of this graph is uniform and has units of volts/metre i.e. the units of potential gradient

$$\text{so potential gradient} = \frac{V}{d} \text{ volt/metre} \quad (3.5)$$

$$\text{Now, energy} = VIt \text{ joule, and } I = \frac{Q}{t} \text{ amp}$$

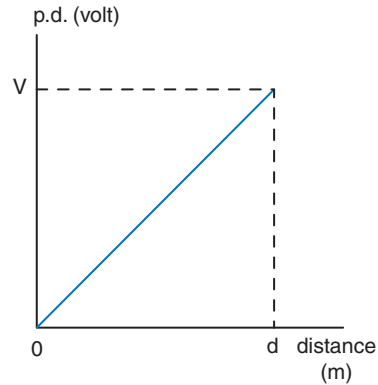

Fig. 3.7

therefore energy =  $\frac{VQt}{t} = VQ$  joule, and transposing this

$$V = \frac{\text{energy}}{Q} \text{ joule/coulomb}$$

$$\text{i.e. } 1 \text{ volt} = 1 \frac{\text{J}}{\text{C}} \dots\dots\dots [1]$$

but the joule is the unit used for work done, and work is force  $\times$  distance, i.e. newton metre,

$$\text{so } 1 \text{ J} = 1 \text{ Nm} \dots\dots\dots [2]$$

Substituting [2] into [1]:

$$1 \text{ volt} = 1 \text{ Nm/C or } V \equiv \frac{\text{Nm}}{\text{C}} \dots\dots\dots [3]$$

Dividing both sides of [3] by distance of separation  $d$ :

$$\frac{V}{d} \equiv \frac{\text{Nm}}{\text{Cm}} = \frac{\text{N}}{\text{C}}$$

Referring back to equation (3.2), we know that electric field strength  $\mathbf{E}$  is measured in  $\text{N/C}$ . So potential gradient and electric field strength must be one and the same thing. Now, electric field strength is defined in terms of the ratio of the force exerted on a charge to the value of the charge. This is actually an extremely difficult thing to measure. However, it is a very simple matter to measure the p.d. and distance between the charged plates. Hence, for practical purposes, electric field strength is always quoted in the units volt/metre

$$\text{i.e. } \mathbf{E} = \frac{V}{d} \text{ volt/metre} \quad (3.6)$$

Notice that the symbol  $\mathbf{E}$  has been used for electric field strength. This is in order to avoid confusion with the symbol  $E$  used for emf.

### Worked Example 3.3

**Q** Two parallel plates separated by a dielectric of thickness 3 mm acquire a charge of 35 mC when connected to a 150V source. If the effective csa of the field between the plates is 144 mm<sup>2</sup>, calculate (a) the electric field strength and (b) the flux density.

**A**

$$d = 3 \times 10^{-3} \text{ m}; Q = 35 \times 10^{-3} \text{ C}; V = 150 \text{ V}; A = 144 \times 10^{-6} \text{ m}^2$$

$$(a) \quad E = \frac{V}{d} \text{ volt/metre} = \frac{150}{3 \times 10^{-6}}$$

so  $E = 50 \text{ kV/m}$  **Ans**

$$(b) \quad D = \frac{Q}{A} \text{ coulomb/metre}^2 = \frac{35 \times 10^{-3}}{144 \times 10^{-6}}$$

so  $D = 243.1 \text{ C/m}^2$  **Ans**

## 3.6 Capacitance (C)

We have seen that in order for one plate to be at a different potential to the other one there is a need for a charge. This requirement is known as the capacity of the system. For a given system the ratio of the charge required to achieve a given p.d. is a constant for that system. This is called the *capacitance* ( $C$ ) of the system

$$\text{i.e. } C = \frac{Q}{V} \text{ farad} \quad (3.7)$$

$$\text{or } Q = VC \text{ coulomb} \quad (3.8)$$

From equation (3.7) it may be seen that the unit for capacitance is the farad (F). This is defined as the capacitance of a system that requires a charge of one coulomb in order to raise its potential by one volt.

The farad is a very large unit, so in practice it is more usual to express capacitance values in microfarads ( $\mu\text{F}$ ), nanofarads (nF), or picofarads (pF).

### Worked Example 3.4

**Q** Two parallel plates, separated by an air space of 4 mm, receive a charge of 0.2 mC when connected to a 125V source. Calculate (a) the electric field strength between the plates, (b) the csa of the field between the plates if the flux density is 15 C/m<sup>2</sup>, and (c) the capacitance of the plates.

**A**

$$d = 4 \times 10^{-3} \text{ m}; Q = 2 \times 10^{-4} \text{ C}; V = 125 \text{ V}; D = 15 \text{ C/m}^2$$

$$(a) \quad \mathbf{E} = \frac{V}{d} \text{ volt/metre} = \frac{125}{4 \times 10^{-3}}$$

so,  $\mathbf{E} = 31.25 \text{ kV/m Ans}$

$$(b) \quad D = \frac{Q}{A} \text{ coulomb/metre}^2$$

$$\text{so, } A = \frac{Q}{D} \text{ metre}^2 = \frac{2 \times 10^{-4}}{15}$$

thus,  $A = 13.3 \times 10^{-6} \text{ m}^2$  or  $13.3 \text{ mm}^2 \text{ Ans}$

$$(c) \quad Q = CV \text{ coulomb}$$

$$\text{so, } C = \frac{Q}{V} \text{ farad} = \frac{2 \times 10^{-4}}{125}$$

thus,  $C = 1.6 \text{ } \mu\text{F Ans}$

## 3.7 Capacitors

A capacitor is an electrical component that is designed to have a specified value of capacitance. In its simplest form it consists of two parallel plates separated by a dielectric; i.e. exactly the system we have been dealing with so far.

In order to be able to design a capacitor we need to know what dimensions are required for the plates, the thickness of the dielectric (the distance of separation  $d$ ), and the other properties of the dielectric material chosen. Let us consider first the properties associated with the dielectric.

## 3.8 Permittivity of Free Space ( $\epsilon_0$ )

When an electric field exists in a vacuum then the ratio of the electric flux density to the electric field strength is a constant, known as the permittivity of free space.

$$\text{The value for } \epsilon_0 = 8.854 \times 10^{-12} \text{ F/m.}$$

Since a vacuum is a well defined condition, the permittivity of free space is chosen as the reference or datum value from which the permittivity of all other dielectrics are measured. This is a similar principle to using Earth potential as the datum for measuring voltages.

## 3.9 Relative Permittivity ( $\epsilon_r$ )

The capacitance of two plates will be increased if, instead of a vacuum between the plates, some other dielectric is used. This difference in capacitance for different dielectrics is accounted for by the relative

permittivity of each dielectric. Thus relative permittivity is defined as the ratio of the capacitance with that dielectric to the capacitance with a vacuum dielectric

$$\text{i.e. } \epsilon_r = \frac{C_2}{C_1} \quad (3.9)$$

where  $C_1$  is with a vacuum and  $C_2$  is with the other dielectric.

**Note:** Dry air has the same effect as a vacuum so the relative permittivity for air dielectrics = 1.

### 3.10 Absolute Permittivity ( $\epsilon$ )

For a given system the ratio of the electric flux density to the electric field strength is a constant, known as the absolute permittivity of the dielectric being used.

$$\text{so } \epsilon = \frac{D}{E} \text{ farad/metre} \quad (3.10)$$

but we have just seen that a dielectric (other than air) is more effective than a vacuum by a factor of  $\epsilon_r$  times, so the absolute permittivity is given by:

$$\epsilon = \epsilon_0 \epsilon_r \text{ farad/metre} \quad (3.11)$$

### 3.11 Calculating Capacitor Values

From the equation (3.10):

$$\epsilon = \frac{D}{E}$$

but  $D = Q/A$  and  $E = V/d$

$$\text{so } \epsilon = \frac{Qd}{VA}$$

also,  $Q/V = \text{capacitance } C$

$$\text{therefore } \epsilon = C \frac{d}{A}$$

and transposing this for  $C$  we have

$$C = \frac{\epsilon A}{d} = \frac{\epsilon_0 \epsilon_r A}{d} \text{ farad} \quad (3.12)$$

**Worked Example 3.5**

- Q** A capacitor is made from two parallel plates of dimensions 3 cm by 2 cm, separated by a sheet of mica 0.5 mm thick and of relative permittivity 5.8. Calculate (a) the capacitance and (b) the electric field strength if the capacitor is charged to a p.d. of 200 V.

**A**

$$A = 3 \times 2 \times 10^{-4} \text{ m}^2; d = 5 \times 10^{-4} \text{ m}; \epsilon_r = 5.8; V = 200 \text{ V}$$

$$\begin{aligned} \text{(a)} \quad C &= \frac{\epsilon_0 \epsilon_r A}{d} \text{ farad} \\ &= \frac{8.854 \times 10^{-12} \times 5.8 \times 6 \times 10^{-4}}{5 \times 10^{-4}} \end{aligned}$$

$$\text{so } C = 61.62 \text{ pF } \mathbf{Ans}$$

$$\begin{aligned} \text{(b)} \quad E &= \frac{V}{d} \text{ volt/metre} \\ &= \frac{200}{5 \times 10^{-4}} \end{aligned}$$

$$\text{so } E = 400 \text{ kV/m } \mathbf{Ans}$$

**Worked Example 3.6**

- Q** A capacitor of value 0.224 nF is to be made from two plates each 75 mm by 75 mm, using a waxed paper dielectric of relative permittivity 2.5. Determine the thickness of paper required.

**A**

$$C = 0.224 \times 10^{-9} \text{ F}; A = 75 \times 75 \times 10^{-6} \text{ m}^2; \epsilon_r = 2.5$$

$$C = \frac{\epsilon_0 \epsilon_r A}{d} \text{ farad}$$

$$\text{so } d = \frac{\epsilon_0 \epsilon_r A}{C} \text{ metre} = \frac{8.854 \times 10^{-12} \times 2.5 \times 75 \times 75 \times 10^{-6}}{0.224 \times 10^{-9}}$$

$$\text{so } d = 5.6 \times 10^{-4} \text{ m} = 0.56 \text{ mm } \mathbf{Ans}$$

**Worked Example 3.7**

- Q** A capacitor of value 47 nF is made from two plates having an effective csa of 4 cm<sup>2</sup> and separated by a ceramic dielectric 0.1 mm thick. Calculate the relative permittivity.

**A**

$$C = 47 \times 10^{-9} \text{ F}; A = 4 \times 10^{-4} \text{ m}^2; d = 1 \times 10^{-4} \text{ m}$$

$$C = \frac{\epsilon_0 \epsilon_r A}{d} \text{ farad}$$

$$\text{so } \epsilon_r = \frac{Cd}{\epsilon_0 A} = \frac{47 \times 10^{-9} \times 10^{-4}}{8.854 \times 10^{-12} \times 4 \times 10^{-4}}$$

$$\text{so } \epsilon_r = 1327 \mathbf{Ans}$$

### Worked Example 3.8

**Q** A p.d. of 180V creates an electric field in a dielectric of relative permittivity 3.5, thickness 3 mm and of effective csa  $4.2 \text{ cm}^2$ . Calculate the flux and flux density thus produced.

**A**

$$V = 180 \text{ V}; d = 3 \times 10^{-3} \text{ m}; \epsilon_r = 3.5; A = 4.2 \times 10^{-4} \text{ m}^2$$

There are two possible methods of solving this problem; either determine the capacitance and the use  $Q = VC$  or determine the electric field strength and use  $D = \epsilon_0 \epsilon_r \mathbf{E}$ . Both solutions will be shown.

$$C = \frac{\epsilon_0 \epsilon_r A}{d} \text{ farad} = \frac{8.854 \times 10^{-12} \times 3.5 \times 4.2 \times 10^{-4}}{3 \times 10^{-3}}$$

so  $C = 4.34 \text{ pF}$  and since  $Q = VC$  coulomb then

$$Q = 180 \times 4.34 \times 10^{-12}$$

hence,  $Q = 0.78 \text{ nC}$  **Ans**

$$D = \frac{Q}{A} \text{ coulomb/metre}^2 = \frac{7.8 \times 10^{-10}}{4.2 \times 10^{-4}}$$

so  $D = 1.86 \mu\text{C/m}^2$  **Ans**

Alternatively:

$$\mathbf{E} = \frac{V}{d} \text{ volt/metre} = \frac{180}{3 \times 10^{-3}}$$

so  $\mathbf{E} = 60 \text{ kV/m}$  and using  $D = \epsilon_0 \epsilon_r \mathbf{E}$  coulomb/metre<sup>2</sup>

$$D = 8.854 \times 10^{-12} \times 3.5 \times 60 \times 10^3$$

so  $D = 1.86 \mu\text{C/m}^2$  **Ans**

$$Q = DA \text{ coulomb} = 1.86 \times 10^{-6} \times 4.2 \times 10^{-4}$$

so  $Q = 0.78 \text{ nC}$  **Ans**

## 3.12 Capacitors in Parallel

Consider two capacitors that are identical in every way (same plate dimensions, same dielectric material and same distance of separation between plates) as shown in Fig. 3.8. Let them now be moved vertically until the top and bottom edges respectively of their plates make contact. We will now effectively have a single capacitor of twice the csa of one of the original capacitors, but all other properties will remain unchanged.

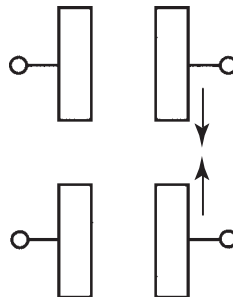

Fig. 3.8

Since  $C = \epsilon A/d$  farad, then the 'new' capacitor so formed will have twice the capacitance of one of the original capacitors. The same effect could have been achieved if we had simply connected the appropriate plates together by means of a simple electrical connection. In other words connect them in parallel with each other. Both of the original capacitors have the same capacitance, and this figure is doubled when they are connected in parallel. Thus we can draw the conclusion that with this connection the total capacitance of the combination is given simply by adding the capacitance values. However, this might be considered as a special case. Let us verify this conclusion by considering the general case of three different value capacitors connected in parallel to a d.c. supply of  $V$  volts as in Fig. 3.9.

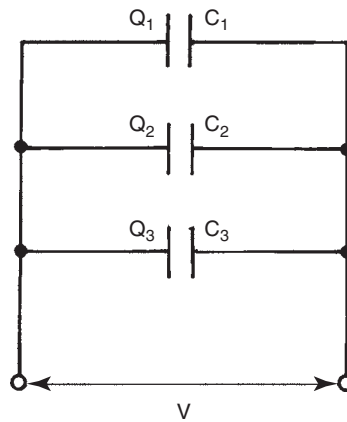

Fig. 3.9

Each capacitor will take a charge from the supply according to its capacitance:

$$Q_1 = VC_1; Q_2 = VC_2; Q_3 = VC_3 \text{ coulomb}$$

but the total charge drawn from the supply must be:

$$Q = Q_1 + Q_2 + Q_3$$

$$\text{also, total charge, } Q = VC$$

where  $C$  is the total circuit capacitance.

Thus,  $VC = VC_1 + VC_2 + VC_3$ , and dividing through by  $V$

$$C = C_1 + C_2 + C_3 \text{ farad} \quad (3.13)$$

**Note:** This result is exactly the *opposite in form* to that for *resistors* in parallel.

### Worked Example 3.9

**Q** Three capacitors of value  $4.7 \mu\text{F}$ ,  $3.9 \mu\text{F}$  and  $2.2 \mu\text{F}$  are connected in parallel. Calculate the resulting capacitance of this combination.

**A**

In this case, since all of the capacitor values are in  $\mu\text{F}$  then it is not necessary to show the  $10^{-6}$  multiplier in each case, since the answer is best quoted in  $\mu\text{F}$ . However it must be made clear that this is what has been done.

$$C = C_1 + C_2 + C_3 \text{ microfarad}$$

$$C = 4.7 + 3.9 + 2.2$$

$$\text{so } C = 10.8 \mu\text{F} \text{ Ans}$$

## 3.13 Capacitors in Series

Three parallel plate capacitors are shown connected in series in Fig. 3.10. Each capacitor will receive a charge. However, you may wonder how capacitor  $C_2$  can receive any charging current since it is sandwiched between the other two, and of course the charging current cannot flow through the dielectrics of these. The answer lies in the explanation of the charging process described in section 3.6 earlier. To assist the explanation, the plates of capacitors  $C_1$  to  $C_3$  have been labelled with letters.

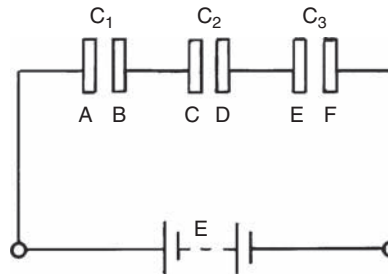

Fig. 3.10

Plate A will lose electrons to the positive terminal of the supply, and so acquires a positive charge. This creates an electric field in the dielectric of  $C_1$  which will cause plate B to attract electrons from plate C of  $C_2$ . The resulting electric field in  $C_2$  in turn causes plate D to attract electrons from plate E. Finally, plate F attracts electrons from the negative terminal of the supply. Thus all three capacitors become charged to the same value.

Having established that all three capacitors will receive the same amount of charge, let us now determine the total capacitance of the arrangement. Since the capacitors are of different values then each will acquire a different p.d. between its plates. This is illustrated in Fig. 3.11.

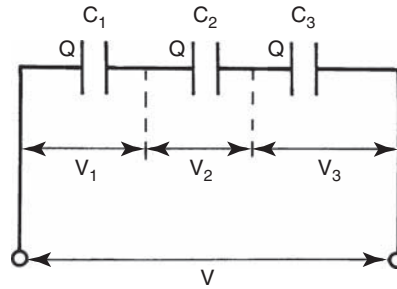

Fig. 3.11

$$V_1 = \frac{Q}{C_1}; V_2 = \frac{Q}{C_2}; V_3 = \frac{Q}{C_3} \text{ volt}$$

and  $V = V_1 + V_2 + V_3$  (Kirchhoff's voltage law)

also,  $V = \frac{Q}{C}$  volt, where  $C$  is the total circuit capacitance.

Hence,  $\frac{Q}{C} = \frac{Q}{C_1} + \frac{Q}{C_2} + \frac{Q}{C_3}$ , and dividing by  $Q$ :

$$\frac{1}{C} = \frac{1}{C_1} + \frac{1}{C_2} + \frac{1}{C_3} \quad (3.14)$$

**Note:** The above equation does not give the total capacitance directly. To obtain the value for  $C$  the reciprocal of the answer obtained from equation (3.14) must be found. However, if ONLY TWO capacitors are connected in series the total capacitance may be obtained directly by using the 'product/sum' form

$$\text{i.e. } C = \frac{C_1 C_2}{C_1 + C_2} \text{ farad} \quad (3.15)$$

### Worked Example 3.10

**Q** A  $6 \mu\text{F}$  and a  $4 \mu\text{F}$  capacitor are connected in series across a  $150\text{V}$  supply. Calculate (a) the total capacitance, (b) the charge on each capacitor and (c) the p.d. developed across each.

**A**

Figure 3.12 shows the appropriate circuit diagram.

$$C_1 = 6 \mu\text{F}; C_2 = 4 \mu\text{F}; V = 150\text{V}$$

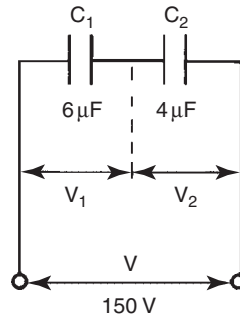

Fig. 3.12

$$\begin{aligned} \text{(a)} \quad C &= \frac{C_1 C_2}{C_1 + C_2} \text{ farad} \\ &= \frac{6 \times 4}{6 + 4} \text{ microfarad} = \frac{24}{10} \end{aligned}$$

so  $C = 2.4 \mu\text{F}$  **Ans**

$$\text{(b)} \quad Q = VC \text{ coulomb} = 150 \times 2.4 \times 10^{-6}$$

so  $Q = 360 \mu\text{C}$  **Ans**

(same charge on both)

Since capacitors in series all receive the same value of charge, then this must be the total charge drawn from the supply,

$$Q = VC$$

This is equivalent to a series resistor circuit where the current drawn from the supply is common to all the resistors

$$\text{(c)} \quad V_1 = \frac{Q}{C_1} \text{ volt} = \frac{360 \times 10^{-6}}{6 \times 10^{-6}}$$

so  $V_1 = 60 \text{ V}$  **Ans**

$$\text{Similarly, } V_2 = \frac{Q}{C_2} \text{ volt} = \frac{360 \times 10^{-6}}{4 \times 10^{-6}}$$

so  $V_2 = 90 \text{ V}$  **Ans**

Note that  $V_1 + V_2 = 150 \text{ V} = V$

### Worked Example 3.11

**Q** Capacitors of  $3 \mu\text{F}$ ,  $6 \mu\text{F}$  and  $12 \mu\text{F}$  are connected in series across a  $400 \text{ V}$  supply. Determine the p.d. across each capacitor.

**A**

Figure 3.13 shows the relevant circuit diagram.

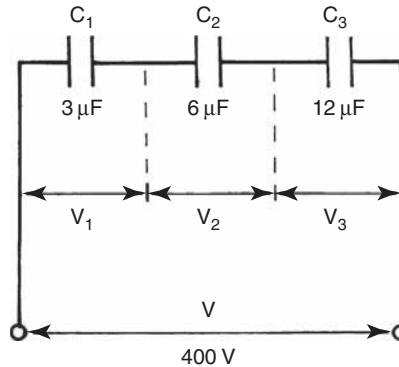

Fig. 3.13

$$C_1 = 3 \mu\text{F}; C_2 = 6 \mu\text{F}; C_3 = 12 \mu\text{F}; V = 400 \text{ V}$$

$$\begin{aligned} \frac{1}{C} &= \frac{1}{C_1} + \frac{1}{C_2} + \frac{1}{C_3} = \frac{1}{3} + \frac{1}{6} + \frac{1}{12} \\ &= \frac{4 + 2 + 1}{12} = \frac{7}{12} \end{aligned}$$

$$\text{so } C = \frac{12}{7} = 1.714 \mu\text{F}$$

$$Q = VC \text{ coulomb} = 400 \times 1.714 \times 10^{-6}$$

$$Q = 685.7 \mu\text{C}$$

$$V_1 = \frac{Q}{C_1} \text{ volt} = \frac{685.7 \times 10^{-6}}{3 \times 10^{-6}}$$

$$\text{so } V_1 = 228.6 \text{ V Ans}$$

$$\text{Similarly, } V_2 = \frac{685.7 \times 10^{-6}}{6 \times 10^{-6}} = 114.3 \text{ V Ans}$$

$$\text{and } V_3 = \frac{685.7 \times 10^{-6}}{12 \times 10^{-6}} = 57.1 \text{ V Ans}$$

### 3.14 Series/Parallel Combinations

The techniques required for the solution of this type of circuit are again best demonstrated by means of a worked example.

#### Worked Example 3.12

- Q** For the circuit shown in Fig. 3.14, determine (a) the charge drawn from the supply, (b) the charge on the \$8 \mu\text{F}\$ capacitor, (c) the p.d. across the \$4 \mu\text{F}\$ capacitor, and (d) the p.d. across the \$3 \mu\text{F}\$ capacitor.

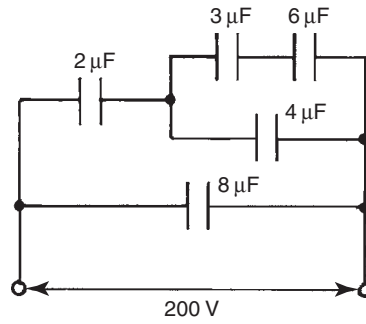

Fig. 3.14

**A**

The first task is to label the diagram as shown in Fig. 3.15.

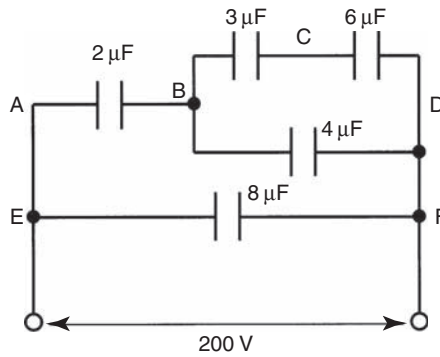

Fig. 3.15

(a)  $C_{BCD} = \frac{3 \times 6}{3 + 6} = 2 \mu\text{F}$  (see Fig. 3.16)

$C_{BD} = 2 + 4 = 6 \mu\text{F}$  (see Fig. 3.17)

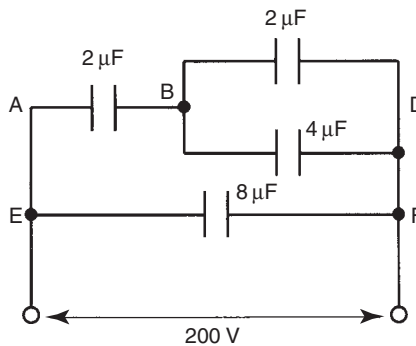

Fig. 3.16

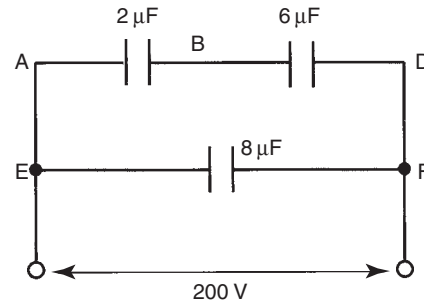

Fig. 3.17

$$C_{AD} = \frac{6 \times 2}{6 + 2} = 1.5 \mu\text{F} \text{ (see Fig. 3.18)}$$

$$C = C_{AD} + C_{EF} = 1.5 + 8$$

$$\text{so } C = 9.5 \mu\text{F}$$

$$Q = VC \text{ coulomb} = 200 \times 9.5 \times 10^{-6}$$

hence,  $Q = 1.9 \text{ mC}$  **Ans**

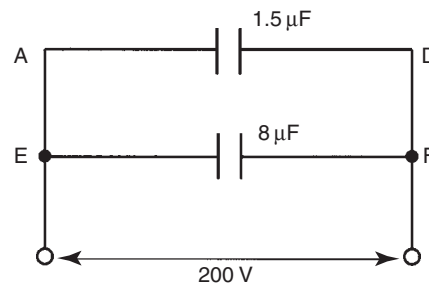

Fig. 3.18

(b)  $Q_{EF} = VC_{EF} \text{ coulomb} = 200 \times 8 \times 10^{-6}$   
so  $Q_{EF} = 1.6 \text{ mC}$  **Ans**

(c) Total charge  $Q = 1.9 \text{ mC}$  and  $Q_{EF} = 1.6 \text{ mC}$

so  $Q_{AD} = 1.9 - 1.6 = 0.3 \text{ mC}$  (see Fig. 3.18).

and referring to Fig. 3.17, this will be the charge on both the capacitors shown, i.e.

$$Q_{AB} = Q_{BD} = 0.3 \text{ mC.}$$

Thus,  $V_{BD}$  = p.d. across  $4 \mu\text{F}$  capacitor (see Fig. 3.16)

$$\begin{aligned} V_{BD} &= \frac{Q_{BD}}{C_{BD}} \\ &= \frac{0.3 \times 10^{-3}}{6 \times 10^{-6}} \text{ volt} \end{aligned}$$

so  $V_{BD} = 50 \text{ V}$  **Ans**

$$\begin{aligned}
 \text{(d) } Q_{BCD} &= V_{BD} C_{BCD} \quad (\text{see Figs 3.16 and 3.15}) \\
 &= 50 \times 2 \times 10^{-6} \\
 &= 100 \mu\text{C}
 \end{aligned}$$

and this will be the charge on both the  $3 \mu\text{F}$  and  $6 \mu\text{F}$  capacitors, i.e.

$$\begin{aligned}
 Q_{BC} &= Q_{CD} = 100 \mu\text{C} \\
 \text{Thus } V_{BC} &= \frac{Q_{BC}}{C_{BC}} \text{ volt} \\
 &= \frac{1 \times 10^{-4}}{3 \times 10^{-6}} \\
 \text{so } V_{BC} &= 33.33 \text{ V Ans}
 \end{aligned}$$

### 3.15 Multiplate Capacitors

Most practical capacitors consist of more than one pair of parallel plates, and in these cases they are referred to as multiplate capacitors. The sets of plates are often interleaved as shown in Fig. 3.19. The example illustrated has a total of five plates. It may be seen that this effectively forms four identical capacitors, in which the three inner plates are common to the two 'inner' capacitors. Since all the positive plates are joined together, and so too are the negative plates, then this arrangement is equivalent to four identical capacitors connected in parallel, as shown in Fig. 3.20. The total capacitance of four identical capacitors connected in parallel is simply four times the capacitance of one of them. Thus, this value will be the effective capacitance of the complete capacitor.

The capacitance between one adjacent pair of plates will be

$$C_1 = \frac{\epsilon_0 \epsilon_r A}{d} \text{ farad}$$

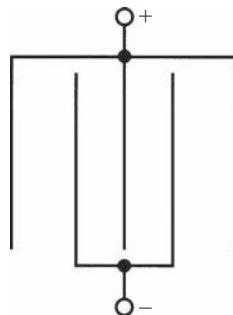

Fig. 3.19

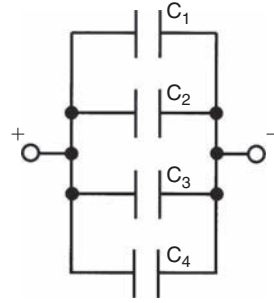

Fig. 3.20

so, the total for the complete arrangement =  $C_1 \times 4$ , but we can express 4 as  $(5 - 1)$  so the total capacitance is

$$C_1 = \frac{\epsilon_0 \epsilon_r A (5 - 1)}{d} \text{ farad}$$

In general therefore, if a capacitor has  $N$  plates, the capacitance is given by the expression:

$$C_1 = \frac{\epsilon_0 \epsilon_r A (N - 1)}{d} \text{ farad} \quad (3.16)$$

Since the above equation applies generally, then it must also apply to capacitors having just one pair of plates as previously considered. This is correct, since if  $N = 2$  then  $(N - 1) = 1$ , and the above equation becomes identical to equation (3.12) previously used.

### Worked Example 3.13

**Q** A capacitor is made from 20 interleaved plates each 80 mm by 80 mm separated by mica sheets 1.5 mm thick. If the relative permittivity for mica is 6.4, calculate the capacitance.

**A**

$$N = 20; A = 80 \times 80 \times 10^{-6} \text{ m}^2; d = 1.5 \times 10^{-3} \text{ m}; \epsilon_r = 6.4$$

$$\begin{aligned} C_1 &= \frac{\epsilon_0 \epsilon_r A (N - 1)}{d} \text{ farad} \\ &= \frac{8.854 \times 10^{-12} \times 6.4 \times 6400 \times 10^{-6} \times 19}{1.5 \times 10^{-3}} \end{aligned}$$

so  $C = 4.6 \text{ nF}$  **Ans**

### Worked Example 3.14

**Q** A 300 pF capacitor has nine parallel plates, each 40 mm by 30 mm, separated by mica of relative permittivity 5. Determine the thickness of the mica.

**A**

$$N = 9; C = 3 \times 10^{-10} \text{F}; A = 40 \times 30 \times 10^{-6} \text{m}^2; \epsilon_r = 5$$

$$C = \frac{\epsilon_0 \epsilon_r A (N - 1)}{d} \text{ farad}$$

$$d = \frac{\epsilon_0 \epsilon_r A (N - 1)}{C} \text{ metre}$$

$$= \frac{8.854 \times 10^{-12} \times 5 \times 1200 \times 10^{-6} \times 8}{3 \times 10^{-10}}$$

so  $d = 1.42 \text{mm}$  **Ans**

### Worked Example 3.15

**Q** A parallel plate capacitor consists of 11 circular plates, each of radius 25 mm, with an air gap of 0.5 mm between each pair of plates. Calculate the value of the capacitor.

**A**

$$N = 11; r = 25 \times 10^{-3} \text{m}; d = 5 \times 10^{-4} \text{m}; \epsilon_r = 1(\text{air})$$

$$A = \pi r^2 \text{ metre}^2 = \pi \times (25 \times 10^{-3})^2$$

$$\text{so, } A = 1.9635 \times 10^{-3} \text{m}^2$$

$$C = \frac{\epsilon_0 \epsilon_r A (n - 1)}{d} \text{ farad}$$

$$= \frac{8.854 \times 10^{-12} \times 1.9635 \times 10^{-3} \times 10}{5 \times 10^{-4}}$$

thus,  $C = 3.48 \times 10^{-10} \text{ F}$  or 348 pF **Ans**

## 3.16 Energy Stored

When a capacitor is connected to a voltage source of  $V$  volts we have seen that it will charge up until the p.d. between the plates is also  $V$  volts. If the capacitor is now disconnected from the supply, the charge and p.d. between its plates will be retained.

Consider such a charged capacitor, as shown in Fig. 3.21, which now has a resistor connected across its terminals. In this case the capacitor will behave as if it were a source of emf. It will therefore drive current through the resistor. In this way the stored charge will be dissipated as the excess electrons on its negative plate are returned to the positive plate. This discharge process will continue until the capacitor becomes completely discharged (both plates electrically neutral). Note that the discharge current marked on the diagram indicates *conventional* current flow.

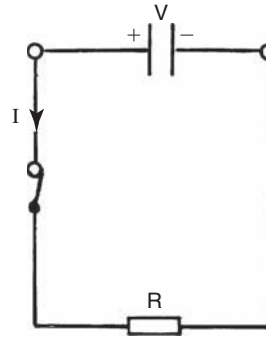

Fig. 3.21

However, if a discharge current flows then work must be done (energy is being dissipated). The only possible source of this energy in these circumstances must be the capacitor itself. Thus the charged capacitor must store energy.

If a graph is plotted of capacitor p.d. to the charge it receives, the area under the graph represents the energy stored. Assuming a constant charging current, the graph will be as shown in Fig. 3.22.

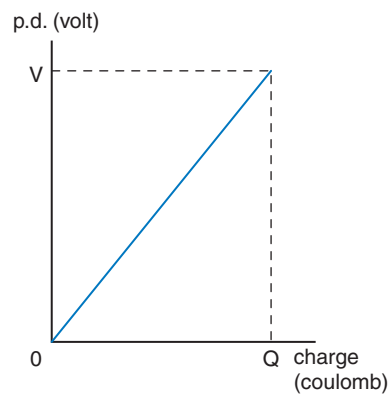

Fig. 3.22

$$\text{The area under the graph} = \frac{1}{2} QV$$

$$\text{but } Q = CV \text{ coulomb}$$

$$\text{so energy stored, } W = \frac{1}{2} CV^2 \text{ joule}$$

(3.17)

### Worked Example 3.16

**Q** A  $3\ \mu\text{F}$  capacitor is charged from a  $250\ \text{V}$  d.c. supply. Calculate the charge and energy stored. The charged capacitor is now removed from the supply and connected across an uncharged  $6\ \mu\text{F}$  capacitor. Calculate the p.d. between the plates and the energy now stored by the combination.

**A**

$$C_1 = 3\ \mu\text{F}; V_1 = 250\ \text{V}; C_2 = 6\ \mu\text{F}$$

$$Q = V_1 C_1 \text{ coulomb} = 250 \times 3 \times 10^{-6}$$

$$\text{so } Q = 0.75 \text{ mC } \mathbf{Ans}$$

$$W = \frac{1}{2} C_1 V_1^2 \text{ joule} = \frac{1}{2} \times 3 \times 10^{-6} \times 250^2$$

$$\text{so } W = 93.75 \text{ mJ } \mathbf{Ans}$$

When the two capacitors are connected in parallel the  $3\ \mu\text{F}$  will share its charge with  $6\ \mu\text{F}$  capacitor. Thus the total charge in the system will remain unchanged, but the total capacitance will now be different:

$$\text{Total capacitance, } C = C_1 + C_2 \text{ farad} = 3 + 6$$

$$\text{so } C = 9\ \mu\text{F}$$

$$V = \frac{Q}{C} \text{ volt} = \frac{7.5 \times 10^{-4}}{9 \times 10^{-6}}$$

$$\text{so } V = 83.33 \text{ V } \mathbf{Ans}$$

$$\text{total energy stored, } W = \frac{1}{2} C V^2 \text{ joule} = \frac{1}{2} \times 9 \times 10^{-6} \times 83.33^2$$

$$\text{so } W = 31.25 \text{ mJ } \mathbf{Ans}$$

*Note:* The above example illustrates the law of conservation of charge, since the charge placed on the first capacitor is simply redistributed between the two capacitors when connected in parallel. The total charge therefore remains the same. However, the p.d. now existing between the plates has fallen, and so too has the total energy stored. But there is also a law of conservation of energy, so what has happened to the ‘lost’ energy? Well, in order for the  $3\ \mu\text{F}$  capacitor to share its charge with the  $6\ \mu\text{F}$  capacitor a charging current had to flow from one to the other. Thus this ‘lost’ energy was used in the charging process.

### Worked Example 3.17

**Q** Consider the circuit of Fig. 3.23, where initially all three capacitors are fully discharged, with the switch in position ‘1’.

- If the switch is now moved to position ‘2’, calculate the charge and energy stored by  $C_1$ .
- Once  $C_1$  is fully charged, the switch is returned to position ‘1’. Calculate the p.d. now existing across  $C_1$  and the amount of energy used in charging  $C_2$  and  $C_3$  from  $C_1$ .

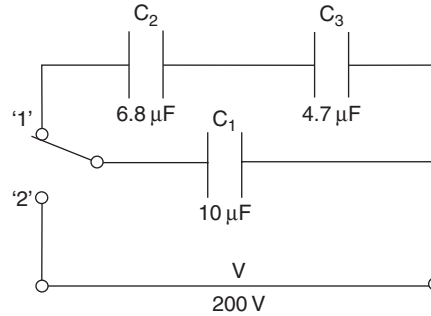

Fig. 3.23

**A**

$$(a) \quad Q_1 = VC_1 \text{ coulomb} = 200 \times 10 \times 10^{-6}$$

so,  $Q_1 = 2 \text{ mC}$  **Ans**

$$W_1 = \frac{1}{2} C_1 V^2 \text{ joule} = 0.5 \times 10^{-5} \times 200^2$$

so,  $W_1 = 0.2 \text{ J}$  **Ans**

$$(b) \quad C_2 \text{ and } C_3 \text{ in series is equivalent to } C_4 = \frac{C_2 C_3}{C_2 + C_3} \text{ microfarad}$$

$$\text{so, } C_4 = \frac{6.8 \times 4.7}{6.8 + 4.7} = 2.78 \mu\text{F}$$

and total capacitance of the whole circuit,

$$C = C_1 + C_4 \text{ microfarad} \\ = 10 + 2.78$$

hence,  $C = 12.78 \mu\text{F}$

Now, the charge received by the circuit remains constant, although the total capacitance has increased.

$$\text{Thus, } V = \frac{Q}{C} \text{ volt} = \frac{2 \times 10^{-3}}{12.78 \times 10^{-6}}$$

and  $V = 156.5 \text{ V}$  **Ans**

$$\text{Total energy remaining in the circuit, } W = \frac{1}{2} CV^2 \text{ joule}$$

$$= 0.5 \times 12.78 \times 10^{-6} \times 156.5^2$$

and  $W = 0.156 \text{ J}$

the energy used up must be the difference between the energy first stored by  $C_1$  and the final energy stored in the system, hence

Energy used =  $0.2 - 0.156 = 44 \text{ mJ}$  **Ans**

### 3.17 Dielectric Strength and Working Voltage

There is a maximum potential gradient that any insulating material can withstand before **dielectric breakdown** occurs.

There are of course some applications where dielectric breakdown is deliberately produced e.g. a sparking plug in a car engine, which produces an arc between its electrodes when subjected to a p.d. of several kilovolts. This then ignites the air/fuel mixture. However, it is obviously not a condition that is desirable in a capacitor, since it results in its destruction.

Capacitors normally have marked on them a maximum working voltage. When in use you must ensure that the voltage applied between its terminals does not exceed this value, otherwise dielectric breakdown will occur.

Dielectric breakdown is the effect produced in an insulating material when the voltage applied across it is more than it can withstand. The result is that the material is forced to conduct. However when this happens, the sudden surge of current through it will cause it to burn, melt, vaporise or be permanently damaged in some other way

Another way of referring to this maximum working voltage is to quote the dielectric strength. This is the maximum voltage gradient that the dielectric can withstand, quoted in kV/m or in V/mm.

#### Worked Example 3.18

**Q** A capacitor is designed to be operated from a 400V supply, and uses a dielectric which (allowing for a factor of safety), has a dielectric strength of 0.5 MV/m. Calculate the minimum thickness of dielectric required.

**A**

$$V = 400\text{V}; E = 0.5 \times 10^6 \text{ V/m}$$

$$E = \frac{V}{d} \text{ volt/metre}$$

$$\text{so } d = \frac{V}{E} \text{ metre} = \frac{400}{0.5 \times 10^6}$$

$$d = 0.8 \text{ mm } \mathbf{Ans}$$

#### Worked Example 3.19

**Q** A 270pF capacitor is to be made from two metallic foil sheets, each of length 20 cm and width 3 cm, separated by a sheet of Teflon having a relative permittivity of 2.1. Determine (a) the thickness of Teflon sheet required, and (b) the maximum possible working voltage for the capacitor if the Teflon has a dielectric strength of 350 kV/m.

**A**

$$C = 270 \times 10^{-12} \text{ F}; A = 20 \times 3 \times 10^{-4} \text{ m}^2; \epsilon_r = 2.1; E = 350 \times 10^3 \text{ V/m}$$

$$(a) \quad C = \frac{\epsilon_0 \epsilon_r A}{d} \text{ farad}$$

$$\text{so, } d = \frac{\epsilon_0 \epsilon_r A}{C} \text{ metre}$$

$$= \frac{8.854 \times 10^{-12} \times 2.1 \times 60 \times 10^{-4}}{270 \times 10^{-12}}$$

$$\text{thus, } d = 0.413 \text{ mm } \mathbf{Ans}$$

(b) Dielectric strength is the same thing as electric field strength, expressed in volt/metre, so

$$E = \frac{V}{d} \text{ volt/metre}$$

$$\text{and } V = Ed \text{ volt} = 350 \times 10^3 \times 0.413 \times 10^{-3}$$

$$\text{so, } V = 144.6 \text{ V } \mathbf{Ans}$$

**Note:** This figure is the voltage at which the dielectric will start to break down, so, for practical purposes, the maximum working voltage would be specified at a lower value. For example, if a factor of safety of 20% was required, then the maximum working voltage in this case would be specified as 115V.

### 3.18 Capacitor Types

The main difference between capacitor types is in the dielectric used. There are a number of factors that will influence the choice of capacitor type for a given application. Amongst these are the capacitance value, the working voltage, the **tolerance**, the stability, the leakage resistance, the size and the price.

**Tolerance** is the deviation from the nominal value. This is normally expressed as a percentage. Thus a capacitor of nominal value  $2 \mu\text{F}$  and a tolerance of  $\pm 10\%$ , should have an actual value of between  $1.8$  and  $2.2 \mu\text{F}$

Since  $C = \epsilon A/d$ , then any or all of these factors can be varied to suit particular requirements. Thus, if a large value of capacitance is required, a large csa and/or a small distance of separation will be necessary, together with a dielectric of high relative permittivity. However, if the area is to be large, then this can result in a device that is unacceptably large. Additionally, the dielectric cannot be made too thin lest its dielectric strength is exceeded. The various capacitor types overcome these problems in a number of ways.

**Paper** This is the simplest form of capacitor. It utilises two strips of aluminium foil separated by sheets of waxed paper. The whole assembly is rolled up into the form of a cylinder (like a Swiss roll). Metal end caps make the electrical connections to the foils, and the whole assembly is then encapsulated in a case. By rolling up the foil and paper a comparatively large csa can be produced with reasonably compact dimensions. This type is illustrated in Fig. 3.24.

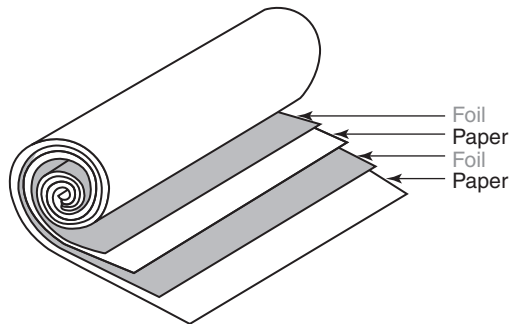

Fig. 3.24

**Air** Air dielectric capacitors are the most common form of variable capacitor. The construction is shown in Fig. 3.25. One set of plates is fixed, and the other set can be rotated to provide either more or less overlap between the two. This causes variation of the effective csa and hence variation of capacitance. This is the type of device connected to the station tuning control of a radio.

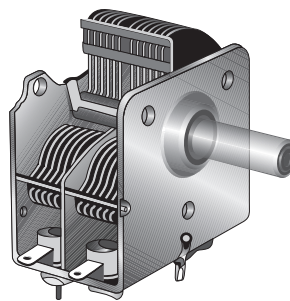

Fig. 3.25

**'Plastic'** With these capacitors the dielectric can be of polyester, polystyrene, polycarbonate or polypropylene. Each material has slightly different electrical characteristics which can be used to advantage, depending upon the proposed application. The construction takes much the same form as that for paper capacitors. Examples of these types are shown in Fig. 3.26, and their different characteristics are listed in Table 3.1.

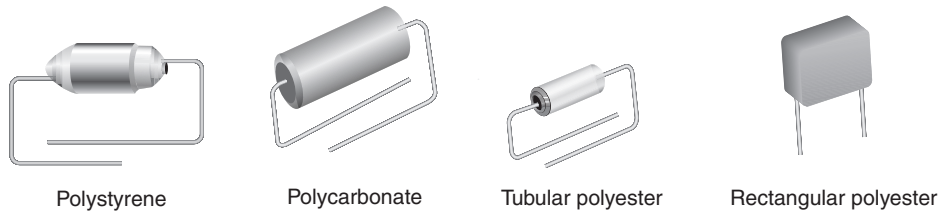

Fig. 3.26

Table 3.1 Capacitor characteristics

Type	Capacitance	Tolerance (%)	Other characteristics
Paper	1 nF–40 $\mu$ F	$\pm 2$	Cheap. Poor stability
Air	5 pF–1 nF	$\pm 1$	Variable. Good stability
Polycarbonate	100 pF–10 $\mu$ F	$\pm 10$	Low loss. High temperature
Polyester	1 nF–2 $\mu$ F	$\pm 20$	Cheap. Low frequency
Polypropylene	100 pF–10 nF	$\pm 5$	Low loss. High frequency
Polystyrene	10 pF–10 nF	$\pm 2$	Low loss. High frequency
Mixed	1 nF–1 $\mu$ F	$\pm 20$	General purpose
Silvered mica	10 pF–10 nF	$\pm 1$	High stability. Low loss
Electrolytic (aluminium)	1–100 000 $\mu$ F	–20 to +80	High loss. High leakage. d.c. circuits only
Electrolytic (tantalum)	0.1–150 $\mu$ F	$\pm 20$	As for aluminium above
Ceramic	2 pF–100 nF	$\pm 10$	Low temperature coefficient. High frequency

**Silvered mica** These are the most accurate and reliable of the capacitor types, having a low tolerance figure. These features are usually reflected in their cost. They consist of a disc or hollow cylinder of ceramic material which is coated with a silver compound. Electrical connections are affixed to the silver coatings and the whole assembly is placed into a casing or (more usually) the assembly is encased in a waxy substance.

**Mixed dielectric** This dielectric consists of paper impregnated with polyester which separates two aluminium foil sheets as in the paper capacitor. This type makes a good general-purpose capacitor, and an example is shown in Fig. 3.27.



Fig. 3.27

**Electrolytic** This is the form of construction used for the largest value capacitors. However, they also have the disadvantages of reduced working voltage, high leakage current, and the requirement to be **polarised**. Their terminals are marked + and –, and these polarities must be observed when the device is connected into a circuit. Capacitance values up to 100 000  $\mu\text{F}$  are possible.

A **polarised** capacitor is one in which the dielectric is formed by passing a d.c. current through it. The polarity of the d.c. supply used for this purpose must be subsequently observed in any circuit in which the capacitor is then used. Thus, they should be used only in d.c. circuits

The dielectric consists of either an aluminium oxide or tantalum oxide film that is just a few micrometres thick. It is this fact that allows such high capacitance values, but at the same time reduces the possible maximum working voltage. Tantalum capacitors are usually very much smaller than the aluminium types. They therefore cannot obtain the very high values of capacitance possible with the aluminium type. The latter consist of two sheets of aluminium separated by paper impregnated with an electrolyte. These are then rolled up like a simple paper capacitor. This assembly is then placed in a hermetically sealed aluminium cannister. The oxide layer is formed by passing a charging current through the device, and it is the polarity of this charging process that determines the resulting terminal polarity that must be subsequently observed. If the opposite polarity is applied to the capacitor the oxide layer is destroyed. Examples of electrolytic capacitors are shown in Fig. 3.28.

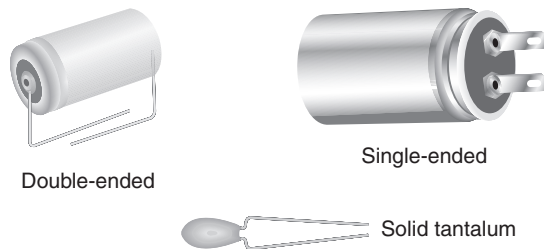

Fig. 3.28

### Summary of Equations

**Force between charges:**  $F = \frac{Q_1 Q_2}{\epsilon_0 d^2}$  newton

**Electric field strength:**  $E = \frac{F}{q}$  newton/coulomb =  $\frac{V}{d}$  volt/metre

**Electric flux density:**  $D = \frac{Q}{A} = \epsilon_0 \epsilon_r \mathbf{E}$  coulomb/metre<sup>2</sup>

**Permittivity:**  $\epsilon = \epsilon_0 \epsilon_r \frac{D}{\mathbf{E}}$  farad/metre

**Capacitance:**  $C = \frac{Q}{V}$  farad =  $\frac{\epsilon_0 \epsilon_r A(N-1)}{d}$  farad

**Capacitors in parallel:**  $C = C_1 + C_2 + C_3 + \dots$  farad

**Capacitors in series:**  $\frac{1}{C} = \frac{1}{C_1} + \frac{1}{C_2} + \frac{1}{C_3} + \dots$  farad<sup>-1</sup>

For ONLY two in series:  $C = \frac{C_1 C_2}{C_1 + C_2}$  farad  $\left( \frac{\text{product}}{\text{sum}} \right)$

**Energy stored:**  $W = 0.5 QV = 0.5 CV^2$  joule

## Assignment Questions

- 1 Two parallel plates 25 cm by 35 cm receive a charge of  $0.2 \mu\text{C}$  from a 250V supply. Calculate (a) the electric flux and (b) the electric flux density.
- 2 The flux density between two plates separated by a dielectric of relative permittivity 8 is  $1.2 \mu\text{C}/\text{m}^2$ . Determine the potential gradient between them.
- 3 Calculate the electrical field strength between a pair of plates spaced 10 mm apart when a p.d. of 0.5 kV exists between them.
- 4 Two plates have a charge of  $30 \mu\text{C}$ . If the effective area of the plates is  $5 \text{ cm}^2$ , calculate the flux density.
- 5 A capacitor has a dielectric 0.4 mm thick and operates at 50V. Determine the electric field strength.
- 6 A  $100 \mu\text{F}$  capacitor has a p.d. of 400V across it. Calculate the charge that it has received.
- 7 A  $47 \mu\text{F}$  capacitor stores a charge of 7.8 mC when connected to a d.c. supply. Calculate the supply voltage.
- 8 Determine the p.d. between the plates of a 470 nF capacitor if it stores a charge of 0.141 mC.
- 9 Calculate the capacitance of a pair of plates having a p.d. of 600V when charged to  $0.3 \mu\text{C}$ .
- 10 The capacitance of a pair of plates is 40 pF when the dielectric between them is air. If a sheet of glass is placed between the plates (so that it completely fills the space between them), calculate the capacitance of the new arrangement if the relative permittivity of the glass is 6.
- 11 A dielectric 2.5 mm thick has a p.d. of 440V developed across it. If the resulting flux density is  $4.7 \mu\text{C}/\text{m}^2$  determine the relative permittivity of the dielectric.
- 12 State the factors that affect the capacitance of a parallel plate capacitor, and explain how the variation of each of these factors affects the capacitance.  
  
Calculate the value of a two plate capacitor with a mica dielectric of relative permittivity 5 and thickness 0.2 mm. The effective area of the plates is  $250 \text{ cm}^2$ .
- 13 A capacitor consists of two plates, each of effective area  $500 \text{ cm}^2$ , spaced 1 mm apart in air. If the capacitor is connected to a 400V supply, determine (a) the capacitance, (b) the charge stored and (c) the potential gradient.
- 14 A paper dielectric capacitor has two plates, each of effective csa  $0.2 \text{ m}^2$ . If the capacitance is 50 nF calculate the thickness of the paper, given that its relative permittivity is 2.5.
- 15 A two plate capacitor has a value of 47 nF. If the plate area was doubled and the thickness of the dielectric was halved, what then would be the capacitance?
- 16 A parallel plate capacitor has 20 plates, each 50 mm by 35 mm, separated by a dielectric 0.4 mm thick. If the capacitance is 1000 pF determine the relative permittivity of the dielectric.
- 17 Calculate the number of plates used in a 0.5 nF capacitor if each plate is 40 mm square, separated by dielectric of relative permittivity 6 and thickness 0.102 mm.
- 18 A capacitor is to be designed to have a capacitance of 4.7 pF and to operate with a p.d. of 120V across its terminals. The dielectric is to be teflon ( $\epsilon_r = 2.1$ ) which, after allowing for a safety factor has a dielectric strength of 25 kV/m. Calculate (a) the thickness of teflon required and (b) the area of a plate.
- 19 Capacitors of  $4 \mu\text{F}$  and  $10 \mu\text{F}$  are connected (a) in parallel and (b) in series. Calculate the equivalent capacitance in each case.
- 20 Determine the equivalent capacitance when the following capacitors are connected (a) in series and (b) in parallel
  - (i)  $3 \mu\text{F}$ ,  $4 \mu\text{F}$  and  $10 \mu\text{F}$
  - (ii)  $0.02 \mu\text{F}$ ,  $0.05 \mu\text{F}$  and  $0.22 \mu\text{F}$
  - (iii) 20 pF and 470 pF
  - (iv)  $0.01 \mu\text{F}$  and 220 pF.
- 21 Determine the value of capacitor which when connected in series with a 2 nF capacitor produces a total capacitance of 1.6 nF.
- 22 Three  $15 \mu\text{F}$  capacitors are connected in series across a 600V supply. Calculate (a) the total capacitance, (b) the p.d. across each and (c) the charge on each.
- 23 Three capacitors, of  $6 \mu\text{F}$ ,  $8 \mu\text{F}$  and  $10 \mu\text{F}$  respectively are connected in parallel across a 60V supply. Calculate (a) the total capacitance,

**Assignment Questions**

(b) the charge stored in the  $8 \mu\text{F}$  capacitor and  
 (c) the total charge taken from the supply.

- 24 For the circuit of Fig. 3.29 calculate (a) the p.d. across each capacitor and (b) the charge stored in the  $3 \text{ nF}$ .

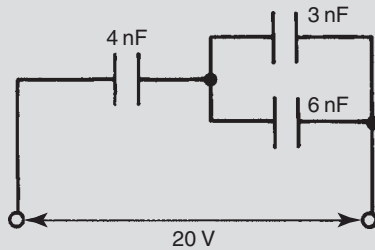

Fig. 3.29

- 25 Calculate the values of  $C_2$  and  $C_3$  shown in Fig. 3.30.

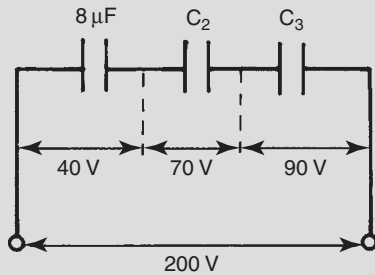

Fig. 3.30

- 26 Calculate the p.d. across, and charge stored in, each of the capacitors shown in Fig. 3.31.

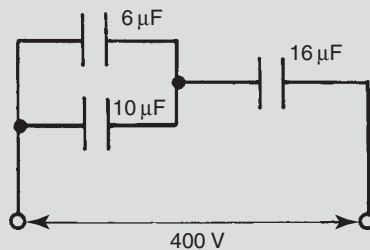

Fig. 3.31

- 27 A capacitor circuit is shown in Fig. 3.32. With the switch in the open position, calculate the p.d.s across capacitors  $C_1$  and  $C_2$ . When the switch is closed, the p.d. across  $C_2$  becomes  $400\text{V}$ . Calculate the value of  $C_3$ .
- 28 In the circuit of Fig. 3.33 the variable capacitor is set to  $60 \mu\text{F}$ . Determine the p.d. across this capacitor if the supply voltage between terminals AB is  $500\text{V}$ .

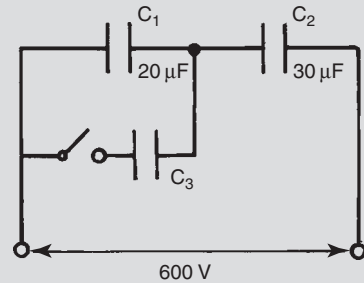

Fig. 3.32

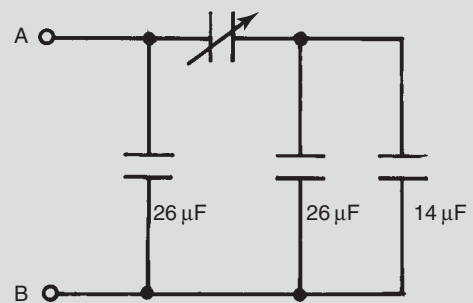

Fig. 3.33

- 29 A  $50 \text{ pF}$  capacitor is made up of two plates separated by a dielectric  $2 \text{ mm}$  thick and of relative permittivity  $1.4$ . Calculate the effective plate area.
- 30 For the circuit shown in Fig. 3.34 the total capacitance is  $16 \text{ pF}$ . Calculate (a) the value of the unmarked capacitor, (b) the charge on the  $10 \text{ pF}$  capacitor and (c) the p.d. across the  $40 \text{ pF}$  capacitor.

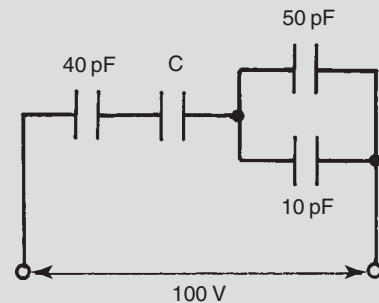

Fig. 3.34

- 31 A  $20 \mu\text{F}$  capacitor is charged to a p.d. of  $250\text{V}$ . Calculate the energy stored.
- 32 The energy stored by a  $400 \text{ pF}$  capacitor is  $8 \mu\text{J}$ . Calculate the p.d. between its plates.
- 33 Determine the capacitance of a capacitor that stores  $4 \text{ mJ}$  of energy when charged to a p.d. of  $40\text{V}$ .

## Assignment Questions

- 34** When a capacitor is connected across a 200V supply it takes a charge of  $8\mu\text{C}$ . Calculate (a) its capacitance, (b) the energy stored and (c) the electric field strength if the plates are 0.5 mm apart.
- 35** A  $4\mu\text{F}$  capacitor is charged to a p.d. of 400V and then connected across an uncharged  $2\mu\text{F}$  capacitor. Calculate (a) the original charge and energy stored in the  $4\mu\text{F}$ , (b) the p.d. across, and energy stored in, the parallel combination.
- 36** Two capacitors, of  $4\mu\text{F}$  and  $6\mu\text{F}$  are connected in series across a 250V supply. (a) Calculate the charge and p.d. across each. (b) The capacitors are now disconnected from the supply and reconnected in parallel with each other, with terminals of similar polarity being joined together. Calculate the p.d. and charge for each.
- 37** A ceramic capacitor is to be made so that it has a capacitance of  $100\text{pF}$  and is to be operated from a 750V supply. Allowing for a safety factor, the dielectric has a strength of 500 kV/m. Determine (a) the thickness of the ceramic, (b) the plate area if the relative permittivity of the ceramic is 3.2, (c) the charge and energy stored when the capacitor is connected to its rated supply voltage, and (d) the flux density under these conditions.
- 38** A large electrolytic capacitor of value  $100\mu\text{F}$  has an effective plate area of  $0.942\text{m}^2$ . If the aluminium oxide film dielectric has a relative permittivity of 6, calculate its thickness.

## Suggested Practical Assignment

### Assignment 1

To determine the total capacitance of capacitors, when connected in series, and in parallel.

#### Apparatus:

Various capacitors, of known values  
1 × capacitance meter, or capacitance bridge

#### Method:

- 1 Using either the meter or bridge, measure the actual value of each capacitor.
- 2 Connect different combinations of capacitors in parallel, and measure the total capacitance of each combination.
- 3 Repeat the above procedure, for various series combinations.
- 4 Calculate the total capacitance for each combination, and compare these values to those previously measured.
- 5 Account for any difference between the actual and nominal values, for the individual capacitors.

# Magnetic Fields and Circuits

## Learning Outcomes

This chapter introduces the concepts and laws associated with magnetic fields and their application to magnetic circuits and materials.

On completion of this chapter you should be able to:

- 1 Describe the forces of attraction and repulsion between magnetised bodies.
- 2 Understand the various magnetic properties and quantities, and use them to solve simple series magnetic circuit problems.
- 3 Appreciate the effect of magnetic hysteresis, and the properties of different types of magnetic material.

## 4.1 Magnetic Materials

All materials may be broadly classified as being in one of two groups. They may be magnetic or non-magnetic, depending upon the degree to which they exhibit magnetic effects. The vast majority of materials fall into the latter group, which may be further classified into diamagnetic and paramagnetic materials. The magnetic properties of these materials are very slight, and extremely difficult even to detect. Thus, for practical purposes, we can say that they are totally non-magnetic. The magnetic materials (based on iron, cobalt and ferrites) are the ferromagnetic materials, all of which exhibit very strong magnetic effects. It is with these materials that we will be principally concerned.

## 4.2 Magnetic Fields

Magnetic fields are produced by permanent magnets and by electric current flowing through a conductor. Like the electric field, a magnetic field may be considered as being the medium by which forces are

transmitted. In this case, the forces between magnetised materials. A magnetic field is also represented by lines of force or magnetic flux. These are attributed with certain characteristics, listed below:

- 1 They always form complete closed loops. Unlike lines of electric flux, which radiate from and terminate at the charged surfaces, lines of magnetic flux also exist all the way through the magnet.
- 2 They behave as if they are elastic. That is, when distorted they try to return to their natural shape and spacing.
- 3 In the space surrounding a magnet, the lines of force radiate from the north (N) pole to the south (S) pole.
- 4 They never intersect (cross).
- 5 Like poles repel and unlike poles attract each other.

Characteristics (1) and (3) are illustrated in Fig. 4.1 which shows the magnetic field pattern produced by a bar magnet.

Characteristics (2) and (4) are used to explain characteristic (5), as illustrated in Figs. 4.2 and 4.3.

In the case of the arrangement of Fig. 4.2, since the lines behave as if they are elastic, then those lines linking the two magnets try to shorten themselves. This tends to bring the two magnets together.

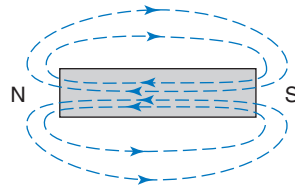

Fig. 4.1

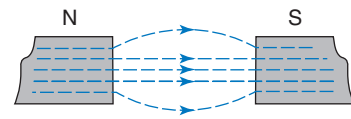

Fig. 4.2

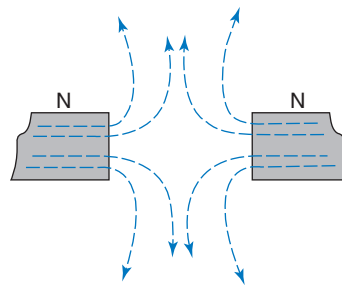

Fig. 4.3

The force of repulsion shown in Fig. 4.3 is a result of the unnatural compression of the lines between the two magnets. Once more, acting as if they are elastic, these lines will expand to their normal shape. This will tend to push the magnets apart.

Permanent magnets have the advantage that no electrical supply is required to produce the magnetic field. However, they also have several

disadvantages. They are relatively bulky. The strength of the field cannot be varied. Over a period of time they tend to lose some of their magnetism (especially if subjected to physical shock or vibration). For many practical applications these disadvantages are unacceptable. Therefore a more convenient method of producing a magnetic field is required.

In addition to the heating effect, an electric current also produces a magnetic field. The strength of this field is directly proportional to the value of the current. Thus a magnetic field produced in this way may be turned on and off, reversed, and varied in strength very simply. A magnetic field is a vector quantity, as indicated by the arrows in the previous diagrams. The field pattern produced by a current flowing through a straight conductor is illustrated in Figs. 4.4(a) and (b). Note that *conventional* current flow is considered. The convention adopted to represent conventional current flowing away from the observer is a cross, and current towards the observer is marked by a dot. The direction of the arrows on the flux lines can easily be determined by considering the X as the head of a cross-head screw. In order to drive the screw away from you, the screw would be rotated *clockwise*. On the other hand, if you were to observe the point of the screw coming out towards you, it would be rotating *anticlockwise*. This convention is called the screw rule, and assumes a normal right-hand thread.

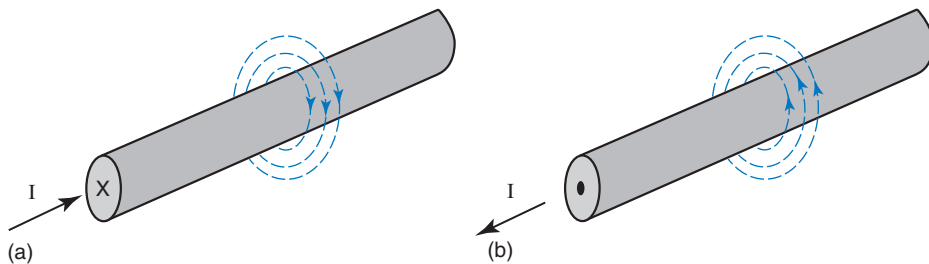

Fig. 4.4

It should be noted that the magnetic flux actually extends the whole length of the conductor, in the same way that the insulation on a cable covers the whole length. In addition, the flux pattern extends outwards in concentric circles to infinity. However, as with electric and gravitational fields, the force associated with the field follows an inverse square law. It therefore diminishes very rapidly with distance.

The flux pattern produced by a straight conductor can be adapted to provide a field pattern like a bar magnet. This is achieved by winding the conductor in the form of a coil. This arrangement is known as a solenoid. The principle is illustrated in Figs. 4.5(a) and (b), which show a cross-section of a solenoid. Figure 4.5(a) shows the flux patterns produced by two adjacent turns of the coil. However, since lines of flux will not intersect, the flux distorts to form complete loops around the whole coil as shown in Fig. 4.5(b).

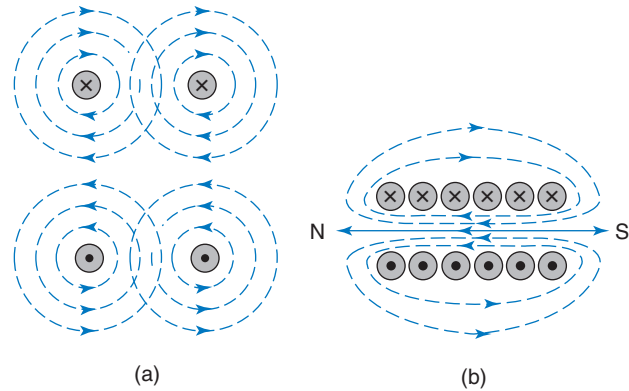

Fig. 4.5

### 4.3 The Magnetic Circuit

A magnetic circuit is all of the space occupied by the magnetic flux. Figure 4.6 shows an iron-cored solenoid, supplied with direct current, and the resulting flux pattern. This is what is known as a composite magnetic circuit, since the flux exists both in the iron core and in the surrounding air space. In addition, it can be seen that the spacing of the lines within the iron core is uniform, whereas it varies in the air space. Thus there is a uniform magnetic field in the core and a non-uniform field in the rest of the magnetic circuit. In order to make the design and analysis of a magnetic circuit easier, it is more convenient

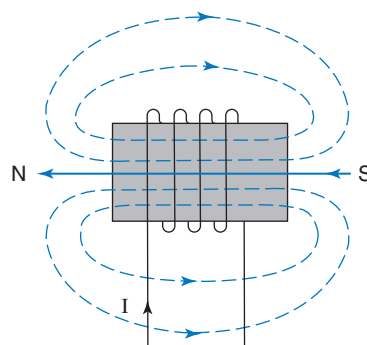

Fig. 4.6

if a uniform field can be produced. This may be achieved by the use of a completely enclosed magnetic circuit. One form of such a circuit is an iron toroid, that has a current carrying coil wound round it. A toroid is a 'doughnut' shape having either a circular or a rectangular cross-section. Such an arrangement is shown in Fig. 4.7, and from this it can

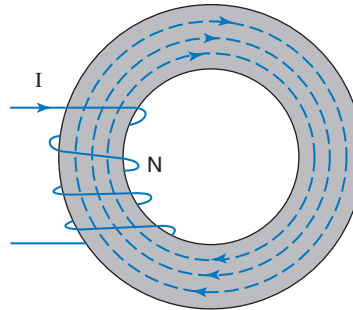

Fig. 4.7

be seen that only the toroid itself forms the magnetic circuit. Provided that it has a uniform cross-section then the field contained within it will be uniform.

## 4.4 Magnetic Flux and Flux Density

The magnetic flux is what causes the observable magnetic effects such as attraction, repulsion etc. The unit of magnetic flux is the weber (Wb). This was the name of a German scientist so it is pronounced as ‘vayber’.

The number of webers of flux per square metre of cross-section of the field is defined as the magnetic flux density ( $B$ ), which is measured in tesla (T). This sometimes causes some confusion at first, since the logical unit would appear to be weber/metre<sup>2</sup>. Indeed, this is the way in which it is calculated: the value of flux must be divided by the appropriate area. Tesla was the name of another scientist, whose name is thus commemorated. On reflection, it should not be particularly confusing, since the logical unit for electrical current would be coulomb/second; but it seems quite natural to use the term ampere.

The quantity symbols for magnetic flux and flux density are  $\Phi$  and  $B$  respectively. Hence, flux density is given by the equation:

$$B = \frac{\Phi}{A} \text{ tesla} \quad (4.1)$$

**Note:** references have been made to iron as a core material and as the material used for toroids etc. This does not necessarily mean that pure iron is used. It could be mild steel, cast iron, silicon iron, or ferrite etc. The term ‘iron circuit’, when used in this context, is merely a simple way in which to refer to that part of the circuit that consists of a magnetic material. It is used when some parts of the circuit may be formed from non-magnetic materials.

**Worked Example 4.1**

**Q** The pole face of a magnet is 3 cm by 2 cm and it produces a flux of  $30 \mu\text{Wb}$ . Calculate the flux density at the pole face.

**A**

$$A = 3 \times 2 \times 10^{-4} \text{ m}^2; \Phi = 30 \times 10^{-6} \text{ Wb}$$

$$B = \frac{\Phi}{A} \text{ tesla}$$

$$= \frac{30 \times 10^{-6}}{6 \times 10^{-4}}$$

$$\text{so } B = 50 \text{ mT } \mathbf{Ans}$$

**Worked Example 4.2**

**Q** A magnetic field of density 0.6 T has an effective csa of  $45 \times 10^{-6} \text{ m}^2$ . Determine the flux.

**A**

$$B = 0.6 \text{ T}; A = 45 \times 10^{-6} \text{ m}^2$$

$$\text{Since } B = \frac{\Phi}{A} \text{ tesla, then } \Phi = BA \text{ weber}$$

$$\text{so } \Phi = 0.6 \times 45 \times 10^{-6} = 27 \mu\text{Wb } \mathbf{Ans}$$

## 4.5 Magnetomotive Force (mmf)

In an electric circuit, any current that flows is due to the existence of an emf. Similarly, in a magnetic circuit, the magnetic flux is due to the existence of an mmf. The concept of an mmf for permanent magnets is a difficult one. Fortunately it is simple when we consider the flux being produced by current flowing through a coil. This is the case for most practical magnetic circuits.

In section 4.2 we saw that each turn of the coil made a contribution to the total flux produced, so the flux must be directly proportional to the number of turns on the coil. The flux is also directly proportional to the value of current passed through the coil.

Putting these two facts together we can say that the mmf is the product of the current and the number of turns. The quantity symbol for mmf is  $F$  (the same as for mechanical force). The number of turns is just a number and therefore dimensionless. The SI unit for mmf is therefore simply ampere. However, this tends to cause considerable confusion to students new to the subject. For this reason, throughout *this book*, the unit will be quoted as ampere turns (At).

$$\text{Thus mmf, } F = NI \text{ ampere turn} \quad (4.2)$$

### Worked Example 4.3

**Q** A 1500 turn coil is uniformly wound around an iron toroid of uniform csa  $5 \text{ cm}^2$ . Calculate the mmf and flux density produced if the resulting flux is  $0.2 \text{ mWb}$  when the coil current is  $0.75 \text{ A}$ .

**A**

$$N = 1500; A = 5 \times 10^{-4} \text{ m}^2; \Phi = 0.2 \times 10^{-3} \text{ Wb}; I = 0.75 \text{ A}$$

$$F = NI \text{ ampere turn} = 1500 \times 0.75$$

so  $F = 1125 \text{ At}$  **Ans**

$$B = \frac{\Phi}{A} \text{ tesla} = \frac{0.2 \times 10^{-3}}{5 \times 10^{-4}}$$

so  $B = 0.4 \text{ T}$  **Ans**

### Worked Example 4.4

**Q** Calculate the excitation current required in a 600 turn coil in order to produce an mmf of  $1500 \text{ At}$ .

**A**

$$N = 600; F = 1500 \text{ At}$$

since  $F = NI$  ampere turn, then  $I = \frac{F}{N}$  ampere

$$\text{so } I = \frac{1500}{600} = 2.5 \text{ A} \text{ **Ans**}$$

## 4.6 Magnetic Field Strength

This is the magnetic equivalent to electric field strength in electrostatics. It was found that electric field strength is the same as potential gradient, and is measured in volt/metre. Now, the volt is the unit of emf, and we have just seen that mmf and emf are comparable quantities, i.e. mmf can be considered as the magnetic circuit equivalent of electric potential. Hence magnetic field strength is defined as the mmf per metre length of the magnetic circuit. The quantity symbol for magnetic field strength is  $H$ , the unit of measurement being ampere turn/metre.

$$H = \frac{F}{\ell} = \frac{NI}{\ell} \text{ ampere turn/metre} \quad (4.3)$$

where  $\ell$  is the *mean* or average length of the magnetic circuit. Thus, if the circuit consists of a circular toroid, then the mean length is the mean circumference. This point is illustrated in Figs. 4.8(a) and (b).

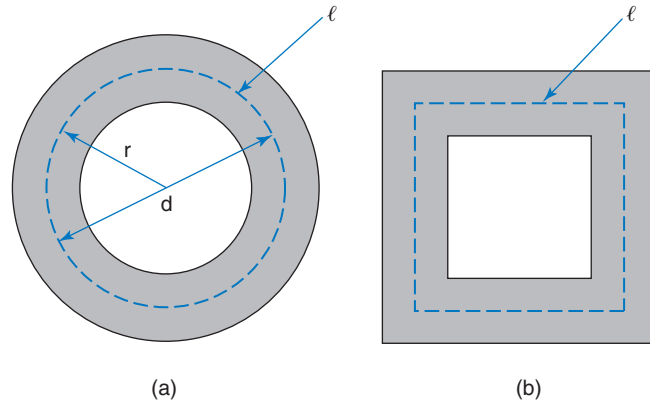

Fig. 4.8

### Worked Example 4.5

**Q** A current of 400 mA is passed through a 550 turn coil wound on a toroid of mean diameter 8 cm. Calculate the magnetic field strength.

**A**

$$I = 0.4 \text{ A}; N = 550; d = 8 \times 10^{-2} \text{ m}$$

$$\ell = \pi d \text{ metre} = \pi \times 8 \times 10^{-2} = 0.251 \text{ m}$$

$$H = \frac{NI}{\ell} \text{ ampere turn/metre} = \frac{550 \times 0.4}{0.251}$$

$$\text{so } H = 875.35 \text{ At/m } \mathbf{Ans}$$

## 4.7 Permeability of Free Space ( $\mu_0$ )

We have seen in electrostatics that the permittivity of the dielectric is a measure of the 'willingness' of the dielectric to allow an electric field to exist in it. In magnetic circuits the corresponding quantity is the permeability of the material.

If the magnetic field exists in a vacuum, then the ratio of the flux density to the magnetic field strength is a constant, called the permeability of free space.

$$\mu_0 = \frac{B}{H} \text{ henry/metre} \quad (4.4)$$

compare this to  $\epsilon_0 = \frac{D}{E}$  farad/metre

The value for  $\mu_0 = 4\pi \times 10^{-7}$  henry/metre

$\mu_0$  is used as the reference or datum level from which the permeabilities of all other materials are measured.

## 4.8 Relative Permeability ( $\mu_r$ )

Consider an air-cored solenoid with a fixed value of current flowing in it. The mmf will produce a certain flux density in this air core. If an iron core was now inserted, it would be found that the flux density would be very much increased. To account for these different results for different core materials, a quantity known as the relative permeability is used. This is defined as the ratio of the flux density produced in the iron, to that produced in the air, for the same applied mmf.

$$\text{i.e. } \mu_r = \frac{B_2}{B_1} \quad (4.5)$$

where  $B_2$  is the flux density produced in the iron and  $B_1$  is the flux density produced in the air.

Compare this to the equation  $\varepsilon_r = \frac{C_2}{C_1}$  used in electrostatics.

As with  $\varepsilon_r$ ,  $\mu_r$  has no units, since it is simply a ratio.

**Note:** For air or any other NON-MAGNETIC material,  $\mu_r = 1$ . In other words, all non-magnetic materials have the same magnetic properties as a vacuum.

## 4.9 Absolute Permeability ( $\mu$ )

The absolute permeability of a material is the ratio of the flux density to magnetic field strength, for a given mmf.

$$\text{Thus, } \mu = \frac{B}{H} \text{ henry/metre} \quad (4.6)$$

but since  $\mu_0$  is the reference value, then  $\mu = \mu_0\mu_r$ .

compare this to the equation  $\varepsilon = \varepsilon_0\varepsilon_r$

$$\text{Therefore, } \mu_0\mu_r = \frac{B}{H} \text{ so, } B = \mu_0\mu_r H \text{ tesla} \quad (4.7)$$

This equation compares directly with  $D = \varepsilon_0\varepsilon_r\mathbf{E}$  coulomb/m<sup>2</sup>.

### Worked Example 4.6

**Q** A solenoid with a core of csa of 15 cm<sup>2</sup> and relative permeability 65, produces a flux of 200  $\mu$ Wb. If the core material is changed to one of relative permeability 800 what will be the new flux and flux density?

**A**

$$A = 15 \times 10^{-4} \text{ m}^2; \mu_{r1} = 65; \Phi_1 = 2 \times 10^{-4} \text{ Wb}; \mu_{r2} = 800$$

$$B_1 = \frac{\Phi_1}{A} \text{ tesla} = \frac{2 \times 10^{-4}}{15 \times 10^{-4}}$$

$$\text{so } B_1 = 0.133 \text{ T}$$

Now, the original core is 65 times more effective than air. The second core is 800 times more effective than air. Therefore, we can say that the second core will produce a greater flux density. The ratio of the two flux densities will be  $800/65 = 12.31:1$ . Thus the second core will result in a flux density 12.31 times greater than produced by the first core

$$\text{Thus } B_2 = 12.31 B_1 = 12.31 \times 0.133$$

$$\text{so } B_2 = 1.641 \text{ T Ans}$$

$$\text{and } \Phi_2 = B_2 A \text{ weber} = 1.641 \times 15 \times 10^{-4}$$

$$\text{so } \Phi_2 = 2.462 \text{ mWb Ans}$$

### Worked Example 4.7

- Q** A toroid of mean radius 40 mm, effective csa  $3 \text{ cm}^2$ , and relative permeability 150, is wound with a 900 turn coil that carries a current of 1.5 A. Calculate (a) the mmf, (b) the magnetic field strength and (c) the flux and flux density.

**A**

$$r = 0.04 \text{ m}; A = 3 \times 10^{-4} \text{ m}^2; \mu_r = 150; N = 900; I = 1.5 \text{ A}$$

**(a)**  $F = NI$  ampere turn =  $900 \times 1.5$

$$\text{so } F = 1350 \text{ At Ans}$$

**(b)**  $H = \frac{F}{\ell}$  ampere turn/metre, where  $\ell = 2\pi r$  metre

$$= \frac{1350}{2\pi \times 0.04}$$

$$\text{so, } H = 5371.5 \text{ At/m Ans}$$

**(c)**  $B = \mu_0 \mu_r H$  tesla =  $4\pi \times 10^{-7} \times 150 \times 5371.5$

$$\text{so } B = 1.0125 \text{ T Ans}$$

$$\Phi = BA \text{ weber} = 1.0125 \times 3 \times 10^{-4}$$

$$\text{so } \Phi = 303.75 \mu\text{Wb Ans}$$

### Worked Example 4.8

- Q** A steel toroid of the dimensions shown in Fig. 4.9 is wound with a 500 turn coil of wire. What value of current needs to be passed through this coil in order to produce a flux of  $250 \mu\text{Wb}$  in the toroid, if under these conditions the relative permeability of the toroid is 300.

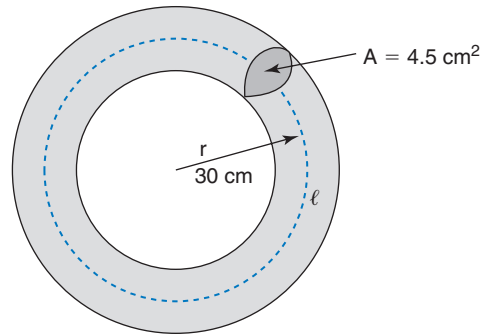

Fig. 4.9

**A**

$r = 3 \times 10^{-2} \text{ m}$ ;  $A = 4.5 \times 10^{-4} \text{ m}^2$ ;  $N = 500$ ;  $\Phi = 250 \times 10^{-6} \text{ Wb}$ ;  $\mu_r = 300$   
 Effective length of the toroid,  $\ell = 2\pi r$  metre  $= 2\pi \times 3 \times 10^{-2} \text{ m} = 0.188 \text{ m}$

$$B = \frac{\Phi}{A} \text{ tesla} = \frac{250 \times 10^{-6}}{4.5 \times 10^{-4}}$$

$$\text{so, } B = 0.556 \text{ T}$$

Now,  $B = \mu_0 \mu_r H$  tesla

$$\text{and, } H = \frac{B}{\mu_0 \mu_r} \text{ ampere turns/weber}$$

$$= \frac{0.556}{4\pi \times 10^{-7} \times 300}$$

$$\text{so, } H = 1474 \text{ At/m}$$

$$F = H\ell \text{ ampere turns}$$

$$= 1474 \times 0.188$$

$$\text{thus, } F = 277 \text{ At}$$

$$\text{and, } I = \frac{F}{N} \text{ amp} = \frac{277}{500}$$

$$\text{so, } I = 0.55 \text{ A Ans}$$

### Worked Example 4.9

**Q** A coil is made by winding a single layer of 0.5 mm diameter wire onto a cylindrical wooden dowel, which is 5 cm long and of csa  $7 \text{ cm}^2$ . When a current of 0.2 A is passed through the coil, calculate (a) the mmf produced, (b) the flux density, and (c) the flux produced.

**A**

(a)  $I = 0.2 \text{ A}$ ;  $\ell = 5 \times 10^{-2} \text{ m}$ ;  $A = 7 \times 10^{-4} \text{ m}^2$ ;  $d = 0.5 \times 10^{-3}$ ;  $\mu_r = 1$  (wood)

Since  $F = NI$  ampere turn, we first need to calculate the number of turns of wire on the coil. Consider Fig. 4.10 which represents the coil wound onto the dowel.

From Fig. 4.10 it may be seen that the number of turns may be obtained by dividing the length of the dowel by the diameter (thickness) of the wire.

$$\text{Thus, } N = \frac{\ell}{d} = \frac{50}{0.5}$$

$$\text{so, } N = 100$$

$$\text{Thus, } F = 100 \times 0.2 = 20 \text{ At Ans}$$

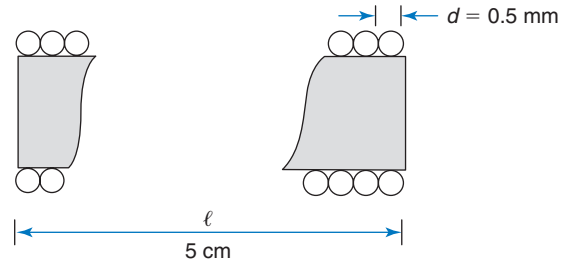

Fig. 4.10

$$(b) \quad B = \frac{\Phi}{A} \text{ tesla, or } B = \mu_0 \mu_r H \text{ tesla}$$

but since we do not yet know the value for the flux, but can calculate the value for  $H$ , then the second equation needs to be used.

$$H = \frac{F}{\ell} \text{ ampere turn/metre} = \frac{20}{5 \times 10^{-2}}$$

$$\text{so, } H = 400 \text{ At/m}$$

$$\text{and, } B = 4\pi \times 10^{-7} \times 1 \times 400 = 5.026 \times 10^{-4}$$

$$\text{so, } B = 503 \mu\text{T} \text{ Ans}$$

$$(c) \quad \Phi = BA \text{ weber} = 503 \times 10^{-6} \times 7 \times 10^{-4}$$

$$\text{thus, } \Phi = 0.352 \mu\text{Wb} \text{ Ans}$$

## 4.10 Magnetisation ( $B/H$ ) Curve

A magnetisation curve is a graph of the flux density produced in a magnetic circuit as the magnetic field strength is varied. Since  $H = NI/\ell$ , then for a given magnetic circuit, the field strength may be varied by varying the current through the coil.

If the magnetic circuit consists entirely of air, or any other non-magnetic material then, the resulting graph will be a straight line passing through the origin. The reason for this is that since  $\mu_r = 1$  for all non-magnetic materials, then the ratio  $B/H$  remains constant. Unfortunately, the relative permeability of magnetic materials does not remain constant for all values of applied field strength, which results in a curved graph.

This non-linearity is due to an effect known as magnetic saturation. The complete explanation of this effect is beyond the scope of this book, but a much simplified version of this afforded by Ewing's molecular theory. This states that each molecule in a magnetic material may be considered as a minute magnet in its own right. When the material is unmagnetised, these molecular magnets are orientated in a completely random fashion. Thus, the material has no overall magnetic polarisation. This is similar to a conductor in which the free electrons are drifting in a random manner. Thus, when no emf is applied, no current flows. This random orientation of the molecular magnets is illustrated in Fig. 4.11 where the arrows represent the north poles.

However, as the coil magnetisation current is slowly increased, so the molecular magnets start to rotate towards a particular orientation. This results in a certain degree of polarisation of the material, as shown in Fig. 4.12. As the coil current continues to be increased, so the molecular magnets continue to become more aligned. Eventually, the coil current will be sufficient to produce complete alignment. This means that the flux will have reached its maximum possible value. Further increase of the current will produce no further increase of flux. The material is then said to have reached magnetic saturation, as illustrated in Fig. 4.13.

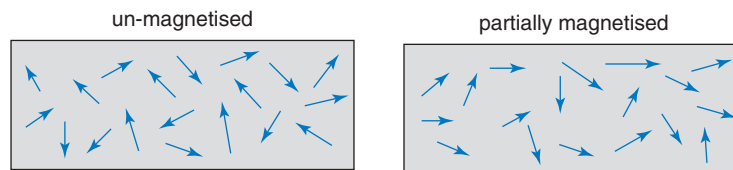

Fig. 4.11

Fig. 4.12

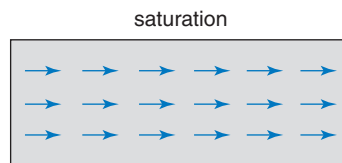

Fig. 4.13

Typical magnetisation curves for air and a magnetic material are shown in Fig. 4.14. Note that the flux density produced for a given value of  $H$  is very much greater in the magnetic material. The slope of the graph is  $B/H = \mu_0\mu_r$ , and this slope varies. Since  $\mu_0$  is a constant, then the value of  $\mu_r$  for the magnetic material must vary as the slope of the graph varies.

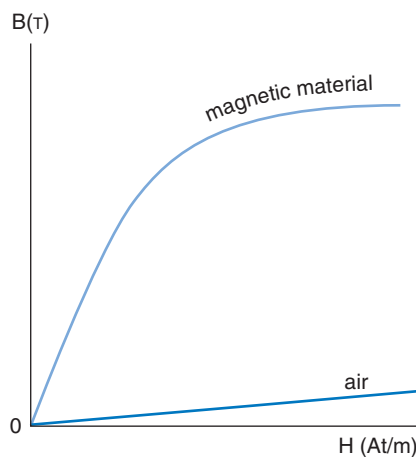

Fig. 4.14

The variation of  $\mu_r$  with variation of  $H$  may be obtained from the  $B/H$  curve, and the resulting  $\mu_r/H$  graph is shown in Fig. 4.15. The magnetisation curves for a range of magnetic materials is given in Fig. 4.16.

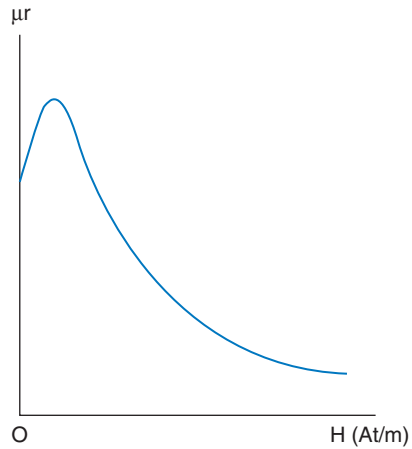

Fig. 4.15

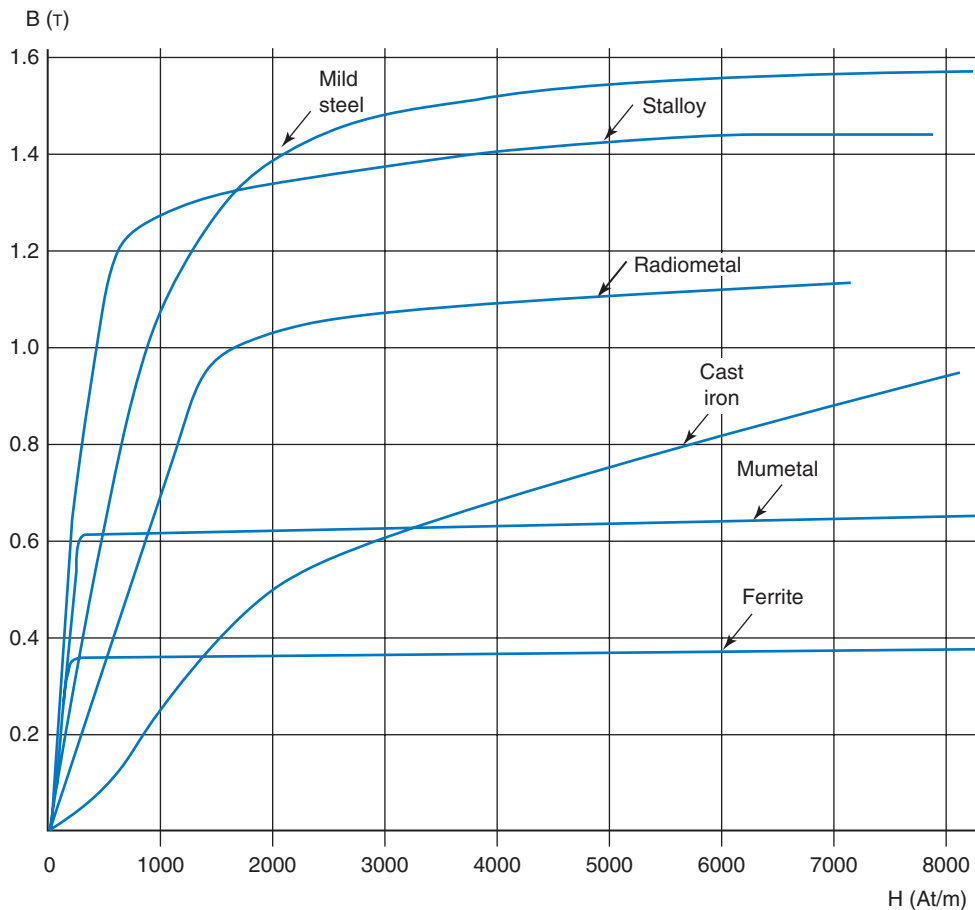

Fig. 4.16

For a practical magnetic circuit, a single value for  $\mu_r$  cannot be specified unless it is quoted for a specified value of  $B$  or  $H$ . Thus  $B/H$  data must be available. These may be presented either in the form of a graph as in Fig. 4.14, or in the form of tabulated data, from which the relevant section of the  $B/H$  curve may be plotted.

### Worked Example 4.10

**Q** An iron toroid having a mean radius of 0.1 m and csa of  $\pi \text{ cm}^2$  is wound with a 1000 turn coil. The coil current results in a flux of 0.1775 mWb in the toroid. Using the following data, determine (a) the coil current and (b) the relative permeability of the toroid under these conditions.

$H(\text{At/m})$	80	85	90	95	100
$B(\text{T})$	0.50	0.55	0.58	0.59	0.6

#### A

The first step in the solution of the problem is to plot the section of  $B/H$  graph from the given data.

**Note:** This *must* be plotted as accurately as possible on *graph* paper. The values used in this example have been obtained from such a graph.

$$B = \frac{\Phi}{A} \text{ tesla} = \frac{0.1775 \times 10^{-3}}{\pi \times 10^{-4}}$$

so  $B = 0.565 \text{ T}$

and from the plotted graph, when  $B = 0.565 \text{ T}$ ,  $H = 88 \text{ At/m}$ .

(a) Now, the length of the toroid,  $\ell = 2\pi r \text{ metre} = 0.27 \pi \text{ m}$

$$\text{and } H = \frac{NI}{\ell} \text{ ampere turn/metre}$$

$$\text{so } I = \frac{H\ell}{N} \text{ amp} = \frac{88 \times 0.2\pi}{1000}$$

hence  $I = 55.3 \text{ mA}$  **Ans**

(b)  $B = \mu_0 \mu_r H$  tesla

$$\text{so } \mu_r = \frac{B}{\mu_0 H} = \frac{0.565}{4\pi \times 10^{-7} \times 88}$$

hence  $\mu_r = 5109$  **Ans**

### Worked Example 4.11

**Q** A cast iron toroid of mean length 15 cm is wound with a 2500 turn coil, through which a magnetising current of 0.3 A is passed. Calculate the resulting flux density and relative permeability of the toroid under these conditions.

#### A

Since  $B/H$  data are necessary for the solution, but none have been quoted, then the  $B/H$  curve for cast iron shown in Fig. 4.16 will be used.

$$\ell = 0.15 \text{ m}; N = 2500; I = 0.3 \text{ A}$$

$$H = \frac{NI}{\ell} \text{ ampere turn/metre} = \frac{2500 \times 0.3}{0.15}$$

$$\text{so } H = 5000 \text{ At/m}$$

and from the graph for cast iron in Fig. 4.16, the corresponding flux density is

$$B = 0.75 \text{ T Ans}$$

$$\text{But, } B = \mu_0 \mu_r H \text{ tesla}$$

$$\text{so } \mu_r = \frac{B}{\mu_0 H} = \frac{0.75}{4\pi \times 10^{-7} \times 5000}$$

$$\mu_r = 119.4 \text{ Ans}$$

## 4.11 Composite Series Magnetic Circuits

Most practical magnetic circuits consist of more than one material in series. This may be deliberate, as in the case of an electric motor or generator, where there have to be air gaps between the stationary and rotating parts. Sometimes an air gap may not be required, but the method of construction results in small but unavoidable gaps.

In other circumstances it may be a requirement that two or more different magnetic materials form a single magnetic circuit.

Let us consider the case where an air gap is deliberately introduced into a magnetic circuit. For example, making a sawcut through a toroid, at right angles to the flux path.

### Worked Example 4.12

- Q** A mild steel toroid of mean length 18.75 cm and csa  $0.8 \text{ cm}^2$  is wound with a 750 turn coil. (a) Calculate the coil current required to produce a flux of  $112 \mu\text{Wb}$  in the toroid. (b) If a 0.5 mm sawcut is now made across the toroid, calculate the coil current required to maintain the flux at its original value.

**A**

$$l = 0.1875 \text{ m}; A = 8 \times 10^{-5} \text{ m}^2; N = 750; \Phi = 112 \times 10^{-6} \text{ Wb}; \ell_{\text{gap}} = 0.5 \times 10^{-3} \text{ m}$$

$$\text{(a) } B = \frac{\Phi}{A} \text{ tesla} = \frac{112 \times 10^{-6}}{8 \times 10^{-5}}$$

So  $B = 1.4 \text{ T}$ , and from the graph for mild steel in Fig. 4.16, the corresponding value for  $H$  is  $2000 \text{ At/m}$

$$F_{\text{Fe}} = H\ell \text{ ampere turn} = 2000 \times 0.1875$$

$$\text{so } F_{\text{Fe}} = 375 \text{ At}$$

**Fe** is the chemical symbol for iron. In Worked Example 4.12 the mmf required to produce the flux in the 'iron' part of the circuit has been referred to as  $F_{\text{Fe}}$ . This will distinguish it from the mmf required for the air gap which is shown as  $F_{\text{gap}}$

$$I = \frac{F_{\text{Fe}}}{N} \text{ amp} = \frac{375}{750}$$

so  $I = 0.5 \text{ A}$  **Ans**

- (b) When the air gap is introduced into the steel the effective length of the steel circuit changes by only 0.27%. This is a negligible amount, so the values obtained in part (a) above for  $H$  and  $F_{\text{Fe}}$  remain unchanged. However, the introduction of the air gap will produce a considerable reduction of the circuit flux. Thus we need to calculate the extra mmf, and hence current, required to restore the flux to its original value.

Since the relative permeability for air is a constant ( $=1$ ), then a  $B/H$  graph is not required. The csa of the gap is the same as that for the steel, and the same flux exists in it. Thus, the flux density in the gap must also be the same as that calculated in part (a) above. Hence the value of  $H$  required to maintain this flux density in the gap can be calculated from:

$$B = \mu_0 H_{\text{gap}}$$

$$\text{so } H_{\text{gap}} = \frac{B}{\mu_0} \text{ ampere turn/metre} = \frac{1.4}{4\pi \times 10^{-7}}$$

$$\text{and } H_{\text{gap}} = 1.11 \times 10^6 \text{ At/m}$$

$$\text{also, since } F_{\text{gap}} = H_{\text{gap}} \ell_{\text{gap}}$$

$$\text{then } F_{\text{gap}} = 1.11 \times 10^6 \times 0.5 \times 10^{-3} = 557 \text{ At}$$

$$\text{Total circuit mmf, } F = F_{\text{Fe}} + F_{\text{gap}} = 375 + 557$$

$$\text{so, } F = 932 \text{ At}$$

$$I = \frac{F}{N} = \frac{932}{750}$$

so  $I = 1.243 \text{ A}$  **Ans**

### Worked Example 4.13

- Q** A magnetic circuit consists of two stalloy sections A and B as shown in Fig. 4.17. The mean length and csa for A are 25 cm and  $11.5 \text{ cm}^2$ , whilst the corresponding values for B are 15 cm and  $12 \text{ cm}^2$  respectively. A 1000 turn coil wound on section A produces a circuit flux of 1.5 mWb. Calculate the coil current required.

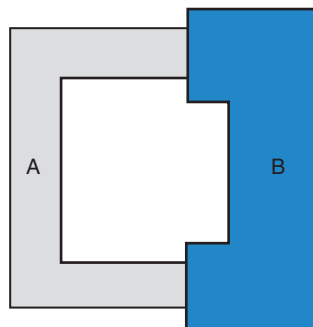

Fig. 4.17

**A**

$$\ell_A = 0.25 \text{ m}; A_A = 11.5 \times 10^{-4} \text{ m}^2; \ell_B = 0.15 \text{ m}$$

$$A_B = 12 \times 10^{-4} \text{ m}^2; \Phi = 1.5 \times 10^{-3} \text{ Wb}; N = 1000$$

$$B_A = \frac{\Phi}{A_A} \text{ tesla} \quad \text{and} \quad B_B = \frac{\Phi}{A_B} \text{ tesla}$$

$$= \frac{1.5 \times 10^{-3}}{11.5 \times 10^{-4}} \quad = \frac{1.5 \times 10^{-3}}{12 \times 10^{-4}}$$

$$\text{so } B_A = 1.3 \text{ T} \quad \text{and} \quad B_B = 1.25 \text{ T}$$

From the  $B/H$  curve for stalloy in Fig. 4.16, the corresponding  $H$  values are:

$$H_A = 1470 \text{ At/m} \quad \text{and} \quad H_B = 845 \text{ At/m}$$

$$F_A = H_A I_A \text{ ampere turn/metre, and } F_B = H_B I_B \text{ ampere turn/metre}$$

$$= 1470 \times 0.25 \quad = 845 \times 0.15$$

$$F_A = 367.5 \text{ At} \quad F_B = 126.75 \text{ At}$$

$$\text{total circuit mmf, } F = F_A + F_B$$

$$\text{so, } F = 494.25 \text{ At}$$

$$\text{and } I = \frac{F}{N} = \frac{494.25}{1000}$$

$$\text{so } I = 0.494 \text{ A } \mathbf{Ans}$$

From the last two examples it should now be apparent that in a series magnetic circuit the only quantity that is common to both (all) sections is the magnetic flux  $\Phi$ . This common flux is produced by the current flowing through the coil, i.e. the total circuit mmf  $F$ . Also, if the lengths, csa and/or the materials are different for the sections, then their flux densities and  $H$  values must be different. For these reasons it is not legitimate to add together the individual  $H$  values. It *is* correct, however, to add together the individual mmfs to obtain the total circuit mmf  $F$ . This technique is equivalent to adding together the p.d.s across resistors connected in series in an electrical circuit. The sum of these p.d.s then gives the value of emf required to maintain a certain current through the circuit.

For example, if a current of 4 A is to be maintained through two resistors of  $10 \Omega$  and  $20 \Omega$  connected in series, then the p.d.s would be 40 V and 80 V respectively. Thus, the emf required would be 120 V.

## 4.12 Reluctance ( $S$ )

Comparisons have already been made between the electric circuit and the magnetic circuit. We have compared mmf to emf; **current** to **flux**; and potential gradient to magnetic field strength. A further comparison may be made, as follows.

The resistance of an electric circuit limits the current that can flow for a given applied emf. Similarly, in a magnetic circuit, the flux produced by a given mmf is limited by the reluctance of the circuit. Thus,

the reluctance of a magnetic circuit is the opposition it offers to the existence of a magnetic flux within it.

**Current** is a movement of electrons around an electric circuit. A magnetic **flux** merely *exists* in a magnetic circuit; it does not involve a flow of particles. However, both current and flux are the direct result of some form of applied force

In an electric circuit,  $\text{current} = \frac{\text{emf}}{\text{resistance}}$

so in a magnetic circuit,  $\text{flux} = \frac{\text{mmf}}{\text{reluctance}}$

Thus,  $\Phi = \frac{F}{S} = \frac{NI}{S}$  weber

$$\text{So reluctance, } S = \frac{F}{\Phi} = \frac{NI}{\Phi} \text{ amp turn/weber} \quad (4.8)$$

$$\text{but } NI = H\ell$$

$$\text{so } S = \frac{H\ell}{\Phi}$$

$$\text{also, } \Phi = BA$$

$$\text{so } S = \frac{H\ell}{BA}$$

$$\text{and since } \frac{H}{B} = \frac{1}{\mu} = \frac{1}{\mu_0\mu_r}$$

$$\text{then } S = \frac{\ell}{\mu_0\mu_r A} \text{ amp turn/metre} \quad (4.9)$$

Let us continue the comparison between series electrical circuits and series magnetic circuits. We know that the total resistance in the electrical circuit is obtained simply by adding together the resistor values. The same technique may be used in magnetic circuits, such that the total reluctance of a series magnetic circuit,  $S$  is given by

$$S = S_1 + S_2 + S_3 + \dots \quad (4.10)$$

Assume that the physical dimensions of the sections, and the relative permeabilities (for the given operating conditions) of each section are known. In this case, equations (4.9), (4.10) and (4.8) enable an alternative form of solution.

### Worked Example 4.14

- Q** An iron ring of csa  $8 \text{ cm}^2$  and mean diameter  $24 \text{ cm}$ , contains an air gap  $3 \text{ mm}$  wide. It is required to produce a flux of  $1.2 \text{ mWb}$  in the air gap. Calculate the mmf required, given that the relative permeability of the iron is  $1200$  under these operating conditions.

**A**

$$A_{\text{Fe}} = A_{\text{gap}} = 8 \times 10^{-4} \text{ m}^2; \Phi = 1.2 \times 10^{-3}; \mu_r = 1200; \ell_{\text{gap}} = 3 \times 10^{-3} \text{ m};$$

$$\ell_{\text{Fe}} = 0.24 \times \pi \text{ m}$$

$$\text{For the iron circuit: } S_{\text{Fe}} = \frac{\ell_{\text{Fe}}}{\mu_0 \mu_r A} \text{ ampere turn/Wb}$$

$$= \frac{0.24 \times \pi}{4\pi \times 10^{-7} \times 1200 \times 8 \times 10^{-4}}$$

$$\text{so } S_{\text{Fe}} = 6.25 \times 10^5 \text{ At/Wb}$$

$$\text{For the air gap: } S_{\text{gap}} = \frac{\ell_{\text{gap}}}{\mu_0 \mu_r A}$$

$$= \frac{3 \times 10^{-3}}{4\pi \times 10^{-7} \times 1 \times 8 \times 10^{-4}}$$

$$\text{so } S_{\text{gap}} = 2.984 \times 10^6 \text{ At/Wb}$$

$$\text{Total circuit reluctance, } S = S_{\text{Fe}} + S_{\text{gap}}$$

$$= 6.25 \times 10^5 + 2.984 \times 10^6$$

$$\text{so } S = 3.61 \times 10^6 \text{ At}$$

$$\text{Since } \Phi = \frac{F}{S} \text{ weber}$$

$$\text{then } F = \Phi S \text{ ampere turn (compare to } V = IR \text{ volt)}$$

$$\text{so } F = 4331 \text{ At } \mathbf{Ans}$$

The above example illustrates the quite dramatic increase of circuit reluctance produced by even a very small air gap. In this example, the air gap length is only 0.4% of the total circuit length. Yet its reluctance is almost five times greater than that of the iron section. For this reason, the design of a magnetic circuit should be such as to try to minimise any unavoidable air gaps.

**Worked Example 4.15**

**Q** A magnetic circuit consists of three sections, the data for which is given below. Calculate (a) the circuit reluctance and (b) the current required in a 500 turn coil, wound onto section 1, to produce a flux of 2 mWb.

Section	length (cm)	csa (cm <sup>2</sup> )	$\mu_r$
1	85	10	600
2	65	15	950
3	0.1	12.5	1

**A**

$$\text{(a) } S_1 = \frac{\ell_1}{\mu_0 \mu_r A_1} \text{ ampere turn/weber}$$

$$= \frac{0.85}{4 \times 10^{-7} \times \pi \times 600 \times 10^{-3}}$$

$$\text{so } S_1 = 1.127 \times 10^6 \text{ At/Wb}$$

$$S_2 = \frac{\ell_2}{\mu_0 \mu_r A_2}$$

$$= \frac{0.65}{4 \times 10^{-7} \times \pi \times 950 \times 15 \times 10^{-4}}$$

so  $S_2 = 3.63 \times 10^5 \text{ At/Wb}$

$$S_3 = \frac{\ell_3}{\mu_0 \mu_r A_3}$$

$$= \frac{10^{-3}}{4 \times 10^{-7} \times \pi \times 1 \times 12.5 \times 10^{-4}}$$

so  $S_3 = 6.37 \times 10^5 \text{ At/Wb}$

Total reluctance,  $S = S_1 + S_2 + S_3$

$$= 1.27 \times 10^6 + 3.63 \times 10^5 + 6.37 \times 10^5$$

so  $S = 2.13 \times 10^6 \text{ At/Wb Ans}$

(b)  $F = \Phi S \text{ ampere turn} = 2 \times 10^{-3} \times 2.13 \times 10^6$

so  $F = 4254 \text{ At}$

and  $I = \frac{F}{N} \text{ amp} = \frac{4254}{500}$

so  $I = 8.51 \text{ A Ans}$

Magnetic flux, like most other things in nature tends to take the easiest path available. For flux this means the lowest reluctance path. This is illustrated in Fig. 4.18. The reluctance of the soft iron bar is very much less than the surrounding air. For this reason, the flux will opt to distort from its normal pattern, and make use of this lower reluctance path.

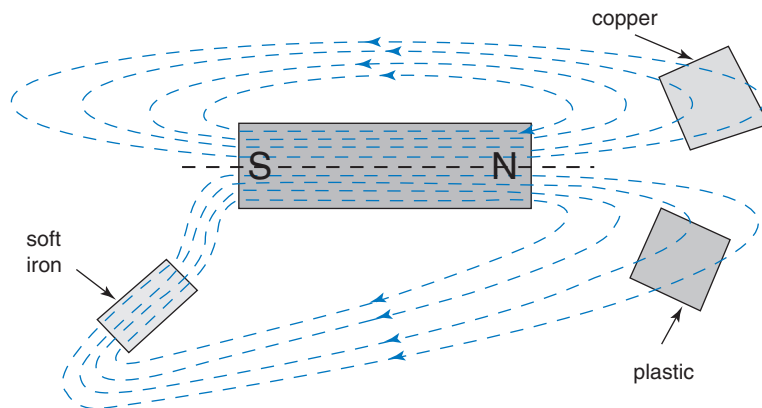

Fig. 4.18

## 4.13 Comparison of Electrical, Magnetic and Electrostatic Quantities

Although a number of comparisons have already been made in the text, it is useful to list these comparisons on one page. This helps to put the three systems into context, and Table 4.1 serves this purpose.

**Table 4.1** Comparison of Quantities

Electrical			Magnetic			Electrostatic		
Quantity	Symbol	Unit	Quantity	Symbol	Unit	Quantity	Symbol	Unit
emf	$E$	V	mmf	$F$	At	emf	$E$	V
current	$I$	A	flux	$\Phi$	Wb	flux	$Q$	C
resistance	$R$	$\Omega$	reluctance	$S$	At/Wb	resistance	$R$	$\Omega$
resistivity	$\rho$	$\Omega\text{m}$	permeability	$\mu$	H/m	permittivity	$\epsilon$	F/m
potential gradient	—	V/m	field strength	$H$	At/m	field strength	$E$	V/m
current density	$J$	A/m <sup>2</sup>	flux density	$B$	T	flux density	$D$	C/m <sup>2</sup>

Also listed below are some comparable equations

$$E = IR \text{ volt}; F = \Phi S \text{ ampere turn}$$

$$J = \frac{I}{A} \text{ amp/metre}^2; B = \frac{\Phi}{A} \text{ tesla}; D = \frac{Q}{A} \text{ coulomb/metre}^2$$

$$R = R_1 + R_2 + \dots \text{ ohm}; S = S_1 + S_2 + \dots \text{ ampere turn/weber}$$

$$\text{potential gradient} = \frac{E}{d} \text{ volt/metre}; H = \frac{F}{\ell} \text{ ampere turn/metre};$$

$$E = \frac{V}{d} \text{ volt/metre}$$

$$B = \mu_0 \mu_r H \text{ tesla}; D = \epsilon_0 \epsilon_r E \text{ coulomb/metre}^2$$

$$\mu_r = \frac{B_2}{B_1}; \epsilon_r = \frac{D_2}{D_1} \text{ or } \frac{C_2}{C_1}$$

$$\mu_r = 1 \text{ for all non-magnetic materials}; \epsilon_r = 1 \text{ air only}$$

$$\mu_0 = 4\pi \times 10^{-7} \text{ henry/metre}; \epsilon_0 = 8.854 \times 10^{-12} \text{ farad/metre}$$

**Note:** Although the concept of current density has not been covered previously, it may be seen from Table 4.1 that it is simply the value of current flowing through a conductor divided by the csa of the conductor.

## 4.14 Magnetic Hysteresis

Hysteresis comes from a Greek word meaning ‘to lag behind’. It is found that when the magnetic field strength in a magnetic material is varied, the resulting flux density displays a lagging effect.

Consider such a specimen of magnetic material that initially is completely unmagnetised. If no current flows through the magnetising coil then both  $H$  and  $B$  will initially be zero. The value of  $H$  is now increased by increasing the coil current in discrete steps. The corresponding flux density is then noted at each step. If these values

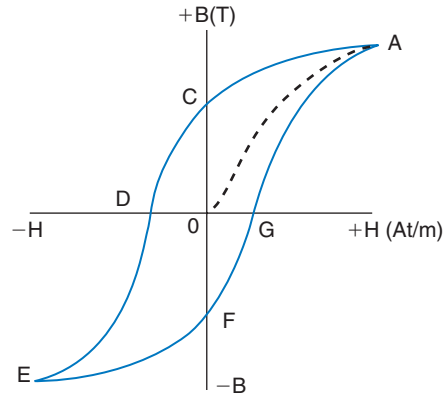

Fig. 4.19

are plotted on a graph until magnetic saturation is achieved, the dotted curve (the initial magnetisation curve) shown in Fig. 4.19 results.

Let the current now be reduced (in steps) to zero, and the corresponding values for  $B$  again noted and plotted. This would result in the section of graph from  $A$  to  $C$ . This shows that when the current is zero once more (so  $H = 0$ ), the flux density has not reduced to zero. The flux density remaining is called the remanent flux density (OC). This property of a magnetic material, to retain some flux after the magnetising current is removed, is known as the remanance or retentivity of the material.

Let the current now be reversed, and increased in the opposite direction. This will have the effect of opposing the residual flux. Hence, the latter will be reduced until at some value of  $-H$  it reaches zero (point  $D$  on the graph). The amount of reverse magnetic field strength required to reduce the residual flux to zero is known as the coercive force. This property of a material is called its coercivity.

If we now continue to increase the current in this reverse direction, the material will once more reach saturation (at point  $E$ ). In this case it will be of the opposite polarity to that achieved at point  $A$  on the graph.

Once again, the current may be reduced to zero, reversed, and then increased in the original direction. This will take the graph from point  $E$  back to  $A$ , passing through points  $F$  and  $G$  on the way. Note that residual flux density shown as  $OC$  has the same value, but opposite polarity, to that shown as  $OF$ . Similarly, coercive force  $OD = OG$ .

In taking the specimen through the loop  $ACDEFGA$  we have taken it through one complete magnetisation cycle. The loop is referred to as the hysteresis loop. The degree to which a material is magnetised depends upon the extent to which the 'molecular magnets' have been aligned. Thus, in taking the specimen through a magnetisation cycle, energy must be expended. This energy is proportional to the area enclosed by the loop, and the rate (frequency) at which the cycle is repeated.

Magnetic materials may be subdivided into what are known as 'hard' and 'soft' magnetic materials. A hard magnetic material is one which possesses a large remanance and coercivity. It is therefore one which retains most of its magnetism, when the magnetising current is removed. It is also difficult to demagnetise. These are the materials used to form permanent magnets, and they will have a very 'fat' loop as illustrated in Fig. 4.20(a).

A soft magnetic material, such as soft iron and mild steel, retains very little of the induced magnetism. It will therefore have a relatively 'thin' hysteresis loop, as shown in Fig. 4.20(b). The soft magnetic materials are the ones used most often for engineering applications. Examples are the magnetic circuits for rotating electric machines (motors and generators), relays, and the cores for inductors and transformers.

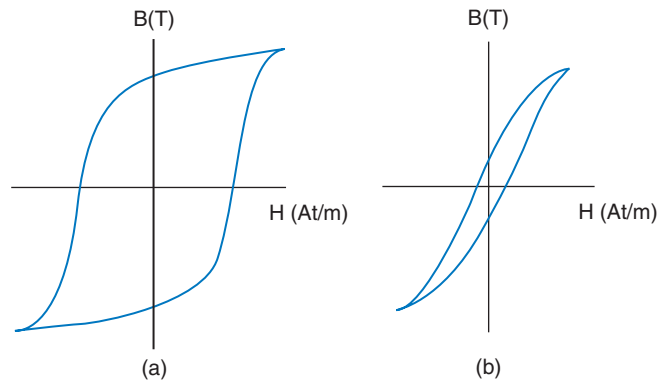

Fig. 4.20

When a magnetic circuit is subjected to continuous cycling through the loop a considerable amount of energy is dissipated. This energy appears as heat in the material. Since this is normally an undesirable effect, the energy thus dissipated is called the hysteresis loss. Thus, the thinner the loop, the less wasted energy. This is why 'soft' magnetic materials are used for the applications listed above.

## 4.15 Parallel Magnetic Circuits

The BTEC syllabus at this level does not require the treatment of parallel magnetic circuits, but since many practical circuits take this form, a brief coverage now follows.

We have seen that the magnetic circuit may be treated in much the same manner as its electrical circuit equivalent. The same is true for parallel circuits in the two systems.

Two equivalent circuits are shown in Fig. 4.21, and from this the following points emerge:

- 1 In the electrical circuit, the current supplied by the source of emf splits between the two outer branches according to the resistances

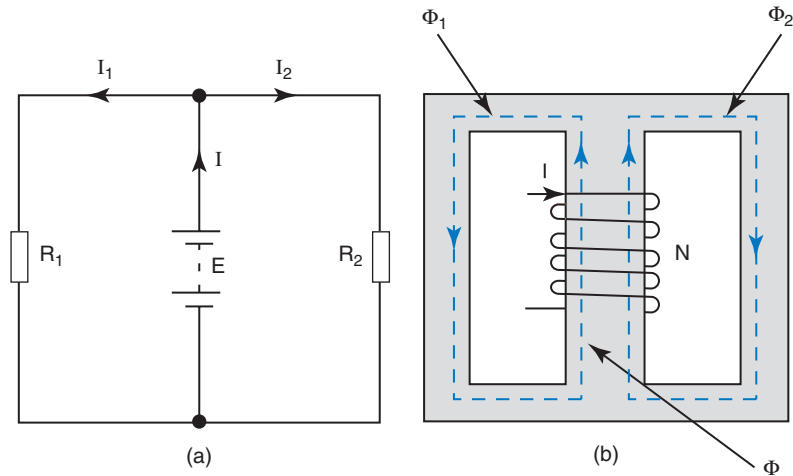

Fig. 4.21

offered. In the magnetic circuit, the flux produced by the mmf splits between the outer limbs according to the reluctances offered.

- 2 If the two resistors in the outer branches are identical, the current splits equally. Similarly, if the reluctances of the outer limbs are the same then the flux splits equally between them.

However, a note of caution. In the electric circuit it has been assumed that the source of emf is ideal (no internal resistance) and that the connecting wires have no resistance. The latter assumption cannot be applied to the magnetic circuit. All three limbs will have a value of reluctance that *must* be taken into account when calculating the total circuit reluctance.

### Summary of Equations

**Magnetic flux density:**  $B = \frac{\Phi}{A} = \mu_0 \mu_r H$  tesla

**Magnetomotive force (mmf):**  $F = NI = \Phi S$  ampere turn

**Magnetic field strength:**  $H = \frac{F}{\ell} = \frac{NI}{\ell}$  ampere turn/metre

**Permeability:**  $\mu = \mu_0 \mu_r \frac{B}{H}$  henry/metre

**Reluctance:**  $S = \frac{\ell}{\mu_0 \mu_r A} = \frac{NI}{\Phi} = \frac{F}{\Phi}$  ampere turn/weber

**Series magnetic circuit:**  $S = S_1 + S_2 + S_3 + \dots$  ampere turn/weber

## Assignment Questions

- 1 The pole faces of a magnet are  $4\text{ cm} \times 3\text{ cm}$  and produce a flux of  $0.5\text{ mWb}$ . Calculate the flux density.
- 2 A flux density of  $1.8\text{ T}$  exists in an air gap of effective csa  $11\text{ cm}^2$ . Calculate the value of the flux.
- 3 If a flux of  $5\text{ mWb}$  has a density of  $1.25\text{ T}$ , determine the csa of the field.
- 4 A magnetising coil of 850 turns carries a current of  $25\text{ mA}$ . Determine the resulting mmf.
- 5 It is required to produce an mmf of  $1200\text{ At}$  from a 1500 turn coil. What will be the required current?
- 6 A current of  $2.5\text{ A}$  when flowing through a coil produces an mmf of  $675\text{ At}$ . Calculate the number of turns on the coil.
- 7 A toroid has an mmf of  $845\text{ At}$  applied to it. If the mean length of the toroid is  $15\text{ cm}$ , determine the resulting magnetic field strength.
- 8 A magnetic field strength of  $2500\text{ At/m}$  exists in a magnetic circuit of mean length  $45\text{ mm}$ . Calculate the value of the applied mmf.
- 9 Calculate the current required in a 500 turn coil to produce an electric field strength of  $4000\text{ At/m}$  in an iron circuit of mean length  $25\text{ cm}$ .
- 10 A 400 turn coil is wound onto an iron toroid of mean length  $18\text{ cm}$  and uniform csa  $4.5\text{ cm}^2$ . If a coil current of  $2.25\text{ A}$  results in a flux of  $0.5\text{ mWb}$ , determine (a) the mmf, (b) the flux density, (c) the magnetic field strength.
- 11 An air-cored coil contains a flux density of  $25\text{ mT}$ . When an iron core is inserted the flux density is increased to  $1.6\text{ T}$ . Calculate the relative permeability of the iron under these conditions.
- 12 A magnetic circuit of mean diameter  $12\text{ cm}$  has an applied mmf of  $275\text{ At}$ . If the resulting flux density is  $0.8\text{ T}$ , calculate the relative permeability of the circuit under these conditions.
- 13 A toroid of mean radius  $35\text{ mm}$ , effective csa  $4\text{ cm}^2$  and relative permeability 200, is wound with a 1000 turn coil that carries a current of  $1.2\text{ A}$ . Calculate (a) the mmf, (b) the magnetic field strength, (c) the flux density and (d) the flux in the toroid.
- 14 A magnetic circuit of square cross-section  $1.5 \times 1.5\text{ cm}$  and mean length  $20\text{ cm}$  is wound with a 500 turn coil. Given the  $B/H$  data below, determine (a) the coil current required to produce a flux of  $258.8\text{ }\mu\text{Wb}$  and (b) the relative permeability of the circuit under these conditions.
 

$B(\text{T})$	0.9	1.1	1.2	1.3
$H(\text{At/m})$	250	450	600	825
- 15 For the circuit of Question 14 above, a  $1.5\text{ mm}$  sawcut is made through it. Calculate the current now required to maintain the flux at its original value.
- 16 A cast steel toroid has the following  $B/H$  data. Complete the data table for the corresponding values of  $\mu_r$  and hence plot the  $\mu_r/H$  graph, and (a) from your graph determine the values of magnetic field strength at which the relative permeability of the steel is 520, and (b) the value of relative permeability when  $H = 1200\text{ At/m}$ .
 

$B(\text{T})$	0.15	0.35	0.74	1.05	1.25	1.39
$H(\text{At/m})$	250	500	1000	1500	2000	2500
$\mu_r$						
- 17 A magnetic circuit made of radiometal is subjected to a magnetic field strength of  $5000\text{ At/m}$ . Using the data given in Fig. 4.16, determine the relative permeability under this condition.
- 18 A magnetic circuit consists of two sections as shown in Fig. 4.22. Section 1 is made of mild steel and is wound with a 100 turn coil. Section 2 is made from cast iron. Calculate the coil current required to produce a flux of  $0.72\text{ mWb}$  in the circuit. Use the  $B/H$  data given in Fig. 4.16.

## Assignment Questions

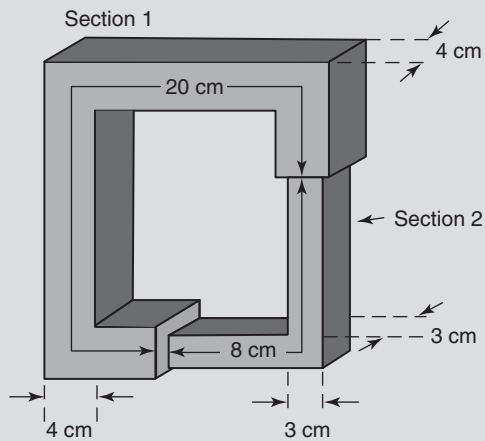

Fig. 4.22

- 19** A circular toroid of mean diameter 25 cm and csa  $4 \text{ cm}^2$  has a 1.5 mm air gap in it. The toroid is wound with a 1200 turn coil and carries a flux of 0.48 mWb. If, under these conditions, the relative permeability of the toroid is 800, calculate the coil current required.
- 20** A closed magnetic circuit made from silicon steel consists of two sections, connected in series. One is of effective length 42 mm and csa  $85 \text{ mm}^2$ , and the other of length 17 mm and csa  $65 \text{ mm}^2$ . A 50 turn coil is wound on to the second section and carries a current of 0.4 A. Determine the flux density in the 17 mm length section if the relative permeability of the silicon iron under this condition is 3000.
- 21** A magnetic circuit of csa  $0.45 \text{ cm}^2$  consists of one part 4 cm long and  $\mu_r$  of 1200; and a second part 3 cm long and  $\mu_r$  of 750. A 100 turn coil is wound onto the first part and a current of 1.5 A is passed through it. Calculate the flux produced in the circuit.

## Suggested Practical Assignments

**Note:** These assignments are qualitative in nature.

### Assignment 1

To compare the effectiveness of different magnetic core materials.

#### Apparatus:

- 1 × coil of wire of known number of turns
- 1 × d.c. psu
- 1 × ammeter
- 1 × set of laboratory weights
- 1 × set of different ferromagnetic cores, suitable for the coil used.

#### Method:

- 1 Connect the circuit as shown in Fig. 4.23.
- 2 Adjust the coil current carefully until the magnetic core *just* holds the smallest weight in place. Note the value of current and weight.
- 3 Using larger weights, in turn, increase the coil current until each weight is just held by the core. Record all values of weight and corresponding current.
- 4 Repeat the above procedure for the other core materials.
- 5 Tabulate all results. Calculate and tabulate the force of attraction and mmf in each case.
- 6 Write an assignment report, commenting on your findings, and comparing the relative effectiveness of the different core materials.

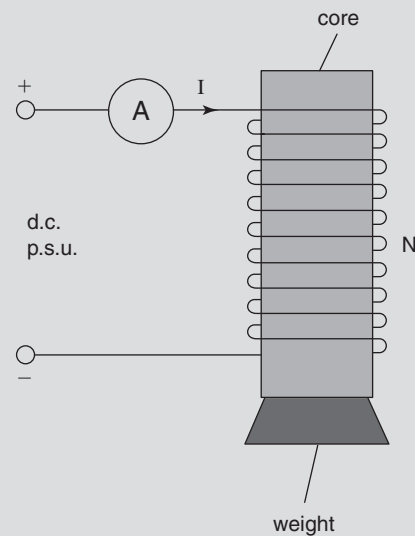

Fig. 4.23

### Assignment 2

To plot a magnetisation curve, and initial section of a hysteresis loop, for a magnetic circuit.

#### Apparatus:

- 1 × magnetic circuit of known length, and containing a coil(s) of known number of turns
- 1 × variable d.c. psu
- 1 × Hall Effect probe
- 1 × ammeter
- 1 × DVM

**Method:**

- 1 Ensure that the core is completely demagnetised before starting.
- 2 Zero the Hall probe, monitoring its output with the DVM.
- 3 Connect the circuit as in Fig. 4.24.
- 4 Increase the coil current in 0.1 A steps, up to 2 A. Record the DVM reading at each step.  
**Note:** If you 'overshoot' a desired current setting. DO NOT then reduce the current back to that setting. Record the value actually set, together with the corresponding DVM reading.
- 5 Reduce the current from 2 A to zero, in 0.1 A steps. Once more, if you overshoot a desired current setting, DO NOT attempt to correct it.
- 6 Reverse the connections to the psu, and increase the reversed current in small steps until the DVM indicates zero.  
**Note:** The Hall effect probe output (as measured by the DVM) *represents* the flux density in the core. The magnetic field strength,  $H$ , may be calculated from  $NI/\ell$ .

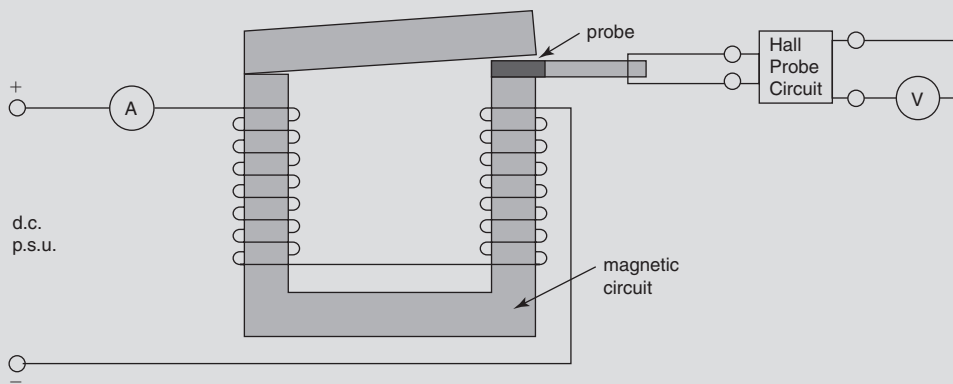

Fig. 4.24

- 7 Plot a graph of DVM readings ( $B$ ) versus  $H$ .
- 8 Submit a full assignment report.

This page intentionally left blank

# Electromagnetism

## Learning Outcomes

This chapter concerns the principles and laws governing electromagnetic induction and the concepts of self and mutual inductance.

On completion of this chapter you should be able to use these principles to:

- 1 Understand the basic operating principles of motors and generators.
- 2 Carry out simple calculations involving the generation of voltage, and the production of force and torque.
- 3 Appreciate the significance of eddy current loss.
- 4 Determine the value of inductors, and apply the concepts of self and mutual inductance to the operating principles of transformers.
- 5 Calculate the energy stored in a magnetic field.
- 6 Explain the principle of the moving coil meter, and carry out simple calculations for the instrument.
- 7 Describe the operation of a wattmeter and simple ohmmeter.

## 5.1 Faraday's Law of Electromagnetic Induction

It is mainly due to the pioneering work of Michael Faraday, in the nineteenth century, that the modern technological world exists as we know it. Without the development of the generation of electrical power, such advances would have been impossible. Thus, although the concepts involved with electromagnetic induction are very simple, they have far-reaching influence. Faraday's law is best considered in two interrelated parts:

- 1 The value of emf induced in a circuit or conductor is directly proportional to the rate of change of magnetic flux linking with it.
- 2 The polarity of such an emf, induced by an increasing flux, is opposite to that induced by a decreasing flux.

The key to electromagnetic induction is contained in part one of the law quoted above. Here, the words 'rate of change' are used. If there is no change in flux, or the way in which this flux links with a conductor, then no emf will be induced. The proof of the law can be very simply demonstrated. Consider a coil of wire, a permanent bar magnet and a galvanometer as illustrated in Figs. 5.1 and 5.2.

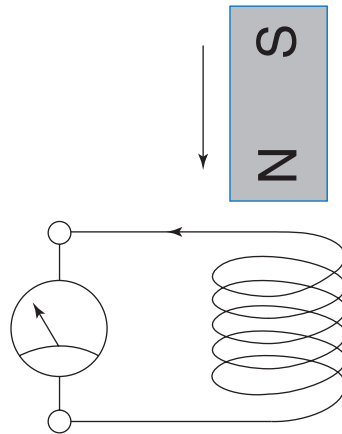

Fig. 5.1

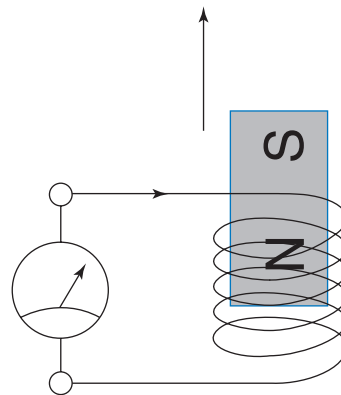

Fig. 5.2

Consider the magnet being moved so that it enters the centre of the coil. When this is done it will be seen that the pointer of the galvo deflects in one direction. This deflection of the pointer is only momentary, since it only occurs whilst the magnet is moving. The galvo is of course a current measuring device. However, any current flowing through it must be due to a voltage between its terminals. Since there is no other source of emf in the circuit, then it must be concluded that an emf has been induced or created in the coil itself. The resulting current indicated by the galvo depends on the value of this emf. It will also be observed that when the magnet is stationary (either inside or outside the coil) the galvo does not deflect. Hence, emf is induced into the coil only when the magnet is in motion.

When the magnet is withdrawn from the coil, the galvo will again be seen to deflect momentarily. This time, the deflection will be in the opposite direction. Provided that the magnet is removed at the same rate as it was inserted, then the magnitudes of the deflections will be the same. The polarities of the induced emfs will be opposite to each other, since the current flow is reversed. Thus far, we have confirmation that an emf is induced in the coil when a magnetic flux is moving relative to it. We also have confirmation of part two of the law.

In order to deduce the relationship between the value of induced emf and the rate of change of flux, the magnet needs to be moved at different speeds into and out of the coil. When this is done, and the resulting magnitudes of the galvo deflection noted, it will be found that the faster the movement, the greater the induced emf.

This simple experiment can be further extended in three ways. If the magnet is replaced by a more powerful one, it will be found that for the same speed of movement, the corresponding emf will be greater. Similarly, if the coil is replaced with one having more turns, then for a given magnet and speed of movement, the value of the emf will again be found to be greater. Finally, if the magnet is held stationary within the coil, and the coil is then moved away, it will be found that an emf is once more induced in the coil. In this last case, it will also be found the emf has the same polarity as obtained when the magnet was first inserted into the stationary coil. This last effect illustrates the point that it is the *relative movement* between the coil and the flux that induces the emf.

The experimental procedure described above is purely qualitative. However, if it was refined and performed under controlled conditions, then it would yield the following results:

The magnitude of the induced emf is directly proportional to the value of magnetic flux, the rate at which this flux links with the coil, and the number of turns on the coil. Expressed as an equation we have:

$$e = \frac{-Nd\Phi}{dt} \text{ volt} \quad (5.1)$$

#### Notes:

- 1 The symbol for the induced emf is shown as a lower-case letter  $e$ . This is because it is only present for the short interval of time during which there is relative movement taking place, and so has only a momentary value.
- 2 The term  $d\Phi/dt$  is simply a mathematical means of stating 'the rate of change of flux with time'. The combination  $Nd\Phi/dt$  is often referred to as the 'rate of change of flux linkages'.
- 3 The minus sign is a reminder that Lenz's law applies. This law is described in the next section.

- 4 Equation (5.1) forms the basis for the definition of the unit of magnetic flux, the weber, thus:

The weber is that magnetic flux which, linking a circuit of one turn, induces in it an emf of one volt when the flux is reduced to zero at a uniform rate in one second.

In other words, 1 volt = 1 weber/second or 1 weber = 1 volt second.

## 5.2 Lenz's Law

This law states that the polarity of an induced emf is always such that it opposes the change which produced it. This is similar to the statement in mechanics, that for every force there is an opposite reaction.

## 5.3 Fleming's Righthand Rule

This is a convenient means of determining the polarity of an induced emf in a conductor. Also, provided that the conductor forms part of a complete circuit, it will indicate the direction of the resulting current flow.

The first finger, the second finger and the thumb of the *right* hand are held out mutually at right angles to each other (like the three edges of a cube as shown in Fig. 5.3). The *F*irst finger indicates the direction of the *F*lux, the *th*uMb the direction of *M*otion of the conductor relative to the flux, and the *sE*Cond finger indicates the polarity of the induced *E*mf, and direction of *C*urrent flow. This process is illustrated in Fig. 5.4, which shows the cross-section of a conductor being

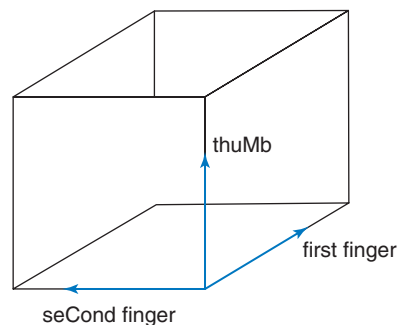

Fig. 5.3

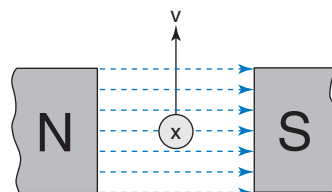

Fig. 5.4

moved vertically upwards at a constant velocity through the magnetic field.

**Note:** The thumb indicates the direction of motion of the *conductor relative to the flux*. Thus, the same result would be obtained from the arrangement of Fig. 5.4 if the conductor was kept stationary and the magnetic field was moved down.

### Worked Example 5.1

**Q** The flux linking a 100 turn coil changes from 5 mWb to 15 mWb in a time of 2 ms. Calculate the average emf induced in the coil; see Fig. 5.5.

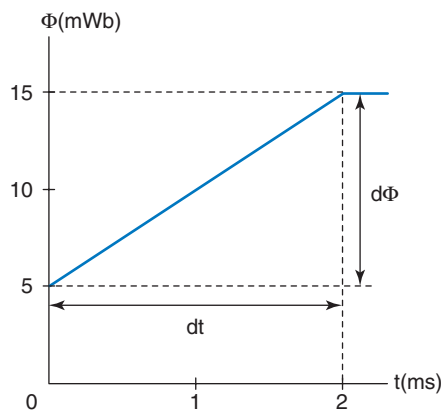

Fig. 5.5

**A**

$$N = 100; d\Phi = (15 - 5) \times 10^{-3} \text{ Wb}; dt = 2 \times 10^{-3} \text{ s}$$

$$\begin{aligned} e &= \frac{-Nd\Phi}{dt} \text{ volt} = \frac{-100 \times (15 - 5) \times 10^{-3}}{2 \times 10^{-3}} \\ &= \frac{-100 \times 10 \times 10^{-3}}{2 \times 10^{-3}} \end{aligned}$$

$$\text{so } e = -500 \text{ V Ans}$$

Note that if the flux was *reduced* from 15 mWb to 5 mWb, then the term shown in brackets above would be  $-10$ . The resulting emf would be  $+500$  V. When quoting equation (5.1), the minus sign should always be included. However, since it is often the magnitude of the induced emf that is more important, it is normal practice to ignore the minus sign in the subsequent calculation. One of the major exceptions to this practice arises when considering the principles of operation of the transformer.

**Worked Example 5.2**

**Q** A 250 turn coil is linked by a magnetic flux that varies as follows: an increase from zero to 20 mWb in a time of 0.05 s; constant at this value for 0.02 s; followed by a decrease to 4 mWb in a time of 0.01 s. Assuming that these changes are uniform, draw a sketch graph (i.e. not to an accurate scale) of the variation of the flux and the corresponding emf induced in the coil, showing all principal values.

**A**

Firstly, the values of induced emf must be calculated for those periods when the flux changes.

$$d\Phi_1 = (20 - 0) \times 10^{-3} \text{ Wb}; dt_1 = 0.05 \text{ s}$$

$$d\Phi_2 = (4 - 20) \times 10^{-3} \text{ Wb}; dt_2 = 0.01 \text{ s}$$

$$e_1 = \frac{-Nd\Phi_1}{dt_1} \text{ volt} \quad \text{and} \quad e_2 = \frac{-Nd\Phi_2}{dt_2} \text{ volt}$$

$$= \frac{-250 \times 20 \times 10^{-3}}{0.05} \quad = \frac{-250 \times (-16) \times 10^{-3}}{0.01}$$

$$\text{so } e_1 = -100 \text{ V} \quad \text{and} \quad e_2 = 400 \text{ V}$$

The resulting sketch graph is shown in Fig. 5.6.

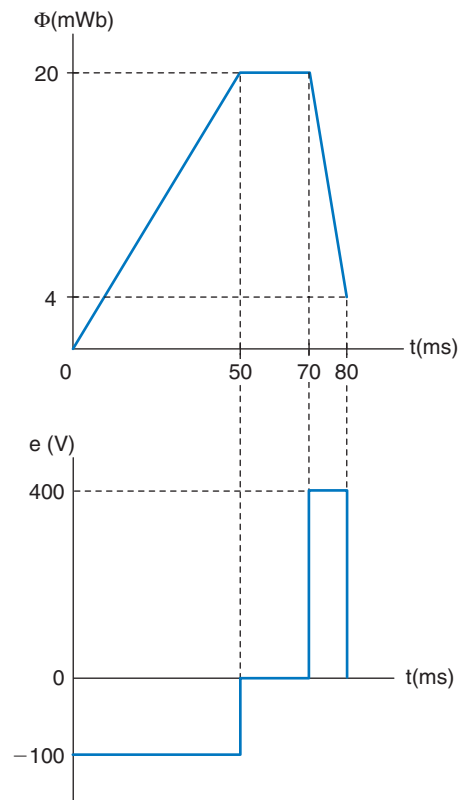

**Fig. 5.6**

### Worked Example 5.3

**Q** A coil when linked by a flux which changes at the rate of 0.1 Wb/s, has induced in it an emf of 100V. Determine the number of turns on the coil.

**A**

$$e = 100 \text{ V}; \frac{d\Phi}{dt} = 0.1 \text{ Wb/s}$$

$$e = \frac{-Nd\Phi}{dt} \text{ volt}$$

$$\text{so } N = \frac{e}{d\Phi/dt} \text{ turns} = \frac{100}{0.1}$$

$$N = 1000 \text{ Ans}$$

Note that the minus sign has been ignored in the calculation. A negative value for number of turns makes no sense.

## 5.4 EMF Induced in a Single Straight Conductor

Consider a conductor moving at a constant velocity  $v$  metre per second at right angles to a magnetic field having the dimensions shown in Fig. 5.7. The direction of the induced emf may be obtained using Fleming's righthand rule, and is shown in the diagram. Equation (5.1) is applicable, and in this case, the value for  $N$  is 1.

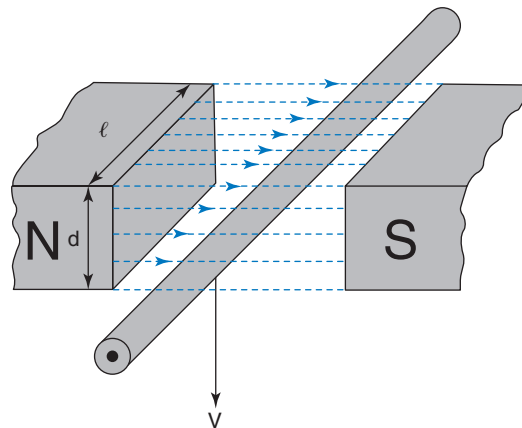

Fig. 5.7

Thus,  $e = \frac{d\Phi}{dt}$  volt, and since  $\Phi$  is constant

$$\text{then } e = \frac{\Phi}{t} \text{ volt}$$

but  $\Phi = BA$  weber

$$\text{so } e = \frac{BA}{t}$$

also, the csa of the field,  $A = \ell \times d$  metre<sup>2</sup>

so  $e = \frac{B\ell d}{t}$  and since  $\frac{d}{t} = \text{velocity } v$ , then

$$e = B\ell v \text{ volt} \quad (5.2)$$

The above equation is only true for the case when the conductor is moving at right angles to the magnetic field. If the conductor moves through the field at some angle less than  $90^\circ$ , then the ‘cutting’ action between the conductor and the flux is reduced. This results in a consequent reduction in the induced emf. Thus, if the conductor is moved horizontally through the field, the ‘cutting’ action is zero, and so no emf is induced. To be more precise, we can say that *only the component of the velocity at  $90^\circ$  to the flux* is responsible for the induced emf. In general therefore, the induced emf is given by:

$$e = B\ell v \sin \theta \text{ volt} \quad (5.3)$$

where  $v \sin \theta$  is the component of velocity at  $90^\circ$  to the field, as illustrated in Fig. 5.8.

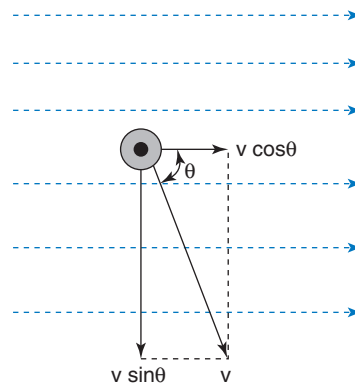

Fig. 5.8

This equation is simply confirmed by considering the previous two extremes; i.e. when conductor moves parallel to the flux,  $\theta = 0^\circ$ ;  $\sin \theta = 0$ ; so  $e = 0$ . When it moves at right angles to the flux,  $\theta = 90^\circ$ ;  $\sin \theta = 1$ ; so we are back to equation (5.2).

**Note:**  $\ell$  is known as the *effective* length of the conductor, since it is that portion of the conductor that actually links with the flux. The total length of the conductor may be considerably greater than this, but those portions that may extend beyond the field at either end will not have any emf induced.

### Worked Example 5.4

- Q** A conductor is moved at a velocity of 5 m/s at an angle of  $60^\circ$  to a uniform magnetic field of 1.6 mWb. The field is produced by a pair of pole pieces, the faces of which measure 10 cm by 4 cm. If the conductor length is parallel to the longer side of the field, calculate the emf induced; see Fig. 5.9.

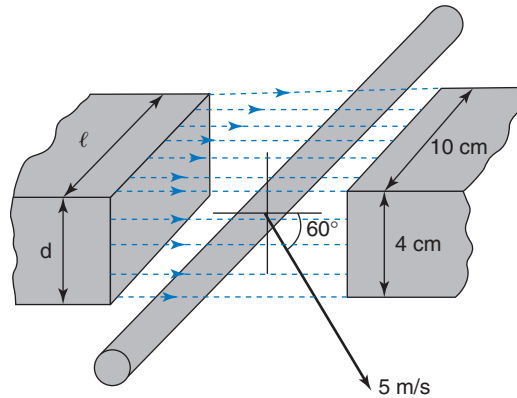

Fig. 5.9

**A**

$$v = 5 \text{ m/s}; \theta = 60^\circ; \Phi = 1.6 \times 10^{-3} \text{ Wb}; \ell = 0.1 \text{ m}; d = 0.04 \text{ m (see Fig. 5.9)}$$

$$B = \frac{\Phi}{A} \text{ tesla} = \frac{1.6 \times 10^{-3}}{0.1 \times 0.04} = 0.4 \text{ T}$$

$$e = B\ell v \sin \theta \text{ volt} = 0.4 \times 0.1 \times 5 \times \sin 60^\circ$$

$$\text{so } e = 0.173 \text{ V Ans}$$

### Worked Example 5.5

- Q** A conductor of effective length 15 cm, when moved at a velocity of 8 m/s at an angle of  $55^\circ$  to a uniform magnetic field, generates an emf of 2.5 V. Determine the density of the field.

**A**

$$\ell = 0.15 \text{ m}; v = 8 \text{ m/s}; \theta = 55^\circ; e = 2.5 \text{ V}$$

$$e = B\ell v \sin \theta \text{ volt, so } B = \frac{e}{\ell v \sin \theta} \text{ tesla}$$

$$\text{hence, } B = \frac{2.5}{0.15 \times 8 \times \sin 55^\circ}$$

$$B = 2.543 \text{ T Ans}$$

### Worked Example 5.6

- Q** The axle of a lorry is 2.2 m long, and the vertical component of the Earth's magnetic field density, through which the lorry is travelling, is  $38 \mu\text{T}$ . If the speed of the lorry is 80 km/h, then calculate the emf induced in the axle.

**A**

$$\ell = 2.2 \text{ m}; v = \frac{80 \times 10^3}{60 \times 60} \text{ m/s}; B = 38 \times 10^{-6} \text{ T}; \sin \theta = 1, \text{ since } \theta = 90^\circ$$

$$e = B\ell v \sin \theta \text{ volt}$$

$$= \frac{38 \times 10^{-6} \times 2.2 \times 80 \times 10^3}{3600}$$

so,  $e = 1.86 \text{ mV}$  **Ans**

This section, covering the induction or generation of an emf in a conductor moving through a magnetic field, forms the basis of the generator principle. However, most electrical generators are rotating machines, and we have so far considered only linear motion of the conductor.

Consider the conductor now formed into the shape of a rectangular loop, mounted on to an axle. This arrangement is then rotated between the poles of a permanent magnet. We now have the basis of a simple generator as illustrated in Fig. 5.10.

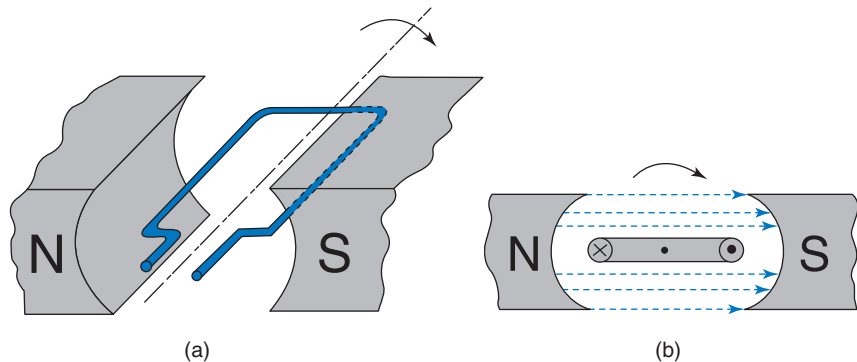

**Fig. 5.10**

The two sides of the loop that are parallel to the pole faces will each have an effective length  $\ell$  metre. At any instant of time, these sides are passing through the field in opposite directions. Applying the righthand rule at the instant shown in Fig. 5.10, the directions of the induced emfs will be as marked, i.e. of opposite polarities. However, if we trace the path around the loop, it will be seen that both emfs are causing current to flow in the same direction around the loop. This is equivalent to two cells connected in series as shown in Fig. 5.11.

The situation shown in Fig. 5.10 applies only to one instant in one revolution of the loop (it is equivalent to a 'snapshot' at that instant).

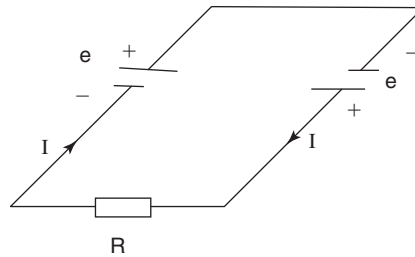

Fig. 5.11

If we were to plot a graph of the total emf generated in the loop, for one complete revolution, it would be found to be one cycle of a sine wave, i.e. an alternating voltage. This result should not come as any surprise though, since the equation for the emf generated in each side of the loop is  $e = Blv \sin\theta$  volt. This very simple arrangement therefore is the basis of a simple form of a.c. generator or alternator. Exactly the same principles apply to a d.c. generator, but the way in which the inherent a.c. voltage is converted into d.c. automatically by the machine is dealt with in detail in *Further Electrical and Electronic Principles*.

**Note:** the ‘ends’ of the loop attached to the axle do not have emf induced in them, since they do not ‘cut’ the flux. Additionally, current can only flow around the loop provided that it forms part of a closed circuit.

## 5.5 Force on a Current-Carrying Conductor

Figure 5.12(a) shows the field patterns produced by two pole pieces, and the current flowing through the conductor. Since the lines of flux obey the rule that they will not intersect, then the flux pattern from the poles will be distorted as illustrated in Fig. 5.12(b). Also, since the lines of flux tend to act as if elastic, then they will try to straighten themselves. This results in a force being exerted on the conductor, in the direction shown.

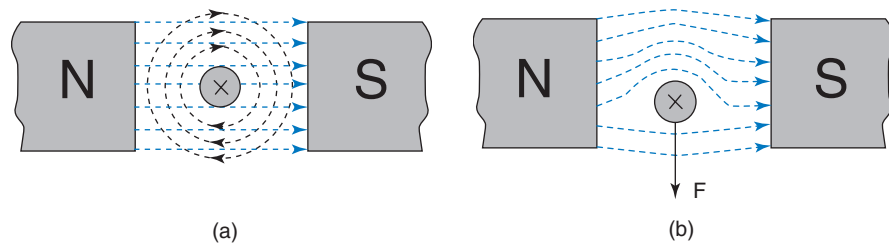

Fig. 5.12

The direction of this force may be more simply obtained by applying Fleming’s *lefthand* rule. This rule is similar to the righthand rule. The major difference is of course that the fingers and thumb of the left hand

are now used. In this case, the *F*irst finger indicates the direction of the main *F*lux (from the poles). The *se*Cond finger indicates the direction of *C*urrent flow. The *thu*Mb shows the direction of the resulting force and hence consequent *M*otion. This is shown in Fig. 5.13.

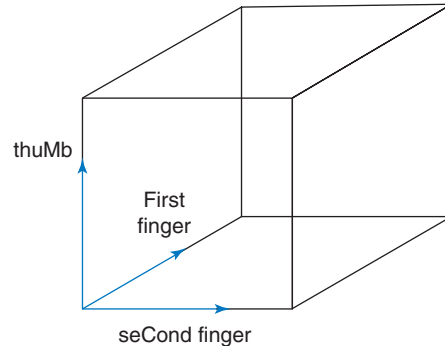

Fig. 5.13

Simple experiments can be used to confirm that the force exerted on the conductor is directly proportional to the flux density produced by the pole pieces, the value of current flowing through the conductor, and the length of conductor lying inside the field. This yields the following equation:

$$\text{Force, } F = BI\ell \text{ newton} \quad (5.4)$$

The determination of the effective length  $\ell$  of the conductor is exactly the same as that for the generator principle previously considered. So any conductor extending beyond the main field does not contribute to the force exerted.

Equation (5.4) also only applies to the condition when the conductor is perpendicular to the main flux. If it lies at some angle less than  $90^\circ$ , then the force exerted on it will be reduced. Thus, in general, the force exerted is given by

$$F = BI\ell \sin \theta \text{ newton} \quad (5.5)$$

### Worked Example 5.7

**Q** A conductor of effective length 22 cm lies at right angles to a magnetic field of density 0.35 T. Calculate the force exerted on the conductor when carrying a current of 3 A.

**A**

$$\ell = 0.22 \text{ m}; B = 0.35 \text{ T}; I = 3 \text{ A}; \theta = 90^\circ$$

$$F = BI\ell \sin \theta \text{ newton} = 0.35 \times 3 \times 0.22 \times 1$$

$$\text{so, } F = 0.231 \text{ N Ans}$$

### Worked Example 5.8

**Q** A pair of pole pieces 5 cm by 3 cm produce a flux of 2.5 mWb. A conductor is placed in this field with its length parallel to the longer dimension of the poles. When a current is passed through the conductor, a force of 1.25 N is exerted on it. Determine the value of the current.

**If the conductor was placed at 45° to the field, what then would be the force exerted?**

**A**

$$\Phi = 2.5 \times 10^{-3} \text{ Wb}; \ell = 0.05 \text{ m}; d = 0.03 \text{ m}; F = 1.25 \text{ N}$$

$$\text{csa of the field, } A = 0.05 \times 0.03 = 1.5 \times 10^{-3} \text{ m}^2$$

$$\text{flux density, } B = \frac{\Phi}{A} \text{ tesla} = \frac{2.5 \times 10^{-3}}{1.5 \times 10^{-3}} = 1.667 \text{ T}$$

$$\text{and since } \theta = 90^\circ, \text{ then } \sin \theta = 1$$

$$F = B I \ell \sin \theta \text{ newton, so } I = \frac{F}{B \ell} \text{ amp}$$

$$\text{therefore } I = \frac{1.25}{1.667 \times 0.05} = 15 \text{ A } \mathbf{Ans}$$

$$F = B I \ell \sin \theta \text{ newton, where } \theta = 45^\circ$$

$$\text{so } F = 1.667 \times 15 \times 0.05 \times 0.707$$

$$\text{hence, } F = 0.884 \text{ N } \mathbf{Ans}$$

The principle of a force exerted on a current carrying conductor as described above forms the basis of operation of a linear motor. However, since most electric motors are rotating machines, the above system must be modified.

## 5.6 The Motor Principle

Once more, consider the conductor formed into the shape of a rectangular loop, placed between two poles, and current passed through it. A cross-sectional view of this arrangement, together with the flux patterns produced is shown in Fig. 5.14.

The flux patterns for the two sides of the loop will be in opposite directions because of the direction of current flow through it. The result is that the main flux from the poles is twisted as shown in Fig. 5.15. This produces forces on the two sides of the loop in opposite directions. Thus there will be a turning moment exerted on the loop, in a counterclockwise direction. The distance from the axle (the pivotal point) is  $r$  metre, so the torque exerted on each side of the loop is given by

$$T = F r \text{ newton metre}$$

$$\text{but } F = B I \ell \sin \theta \text{ newton, and } \sin \theta = 1$$

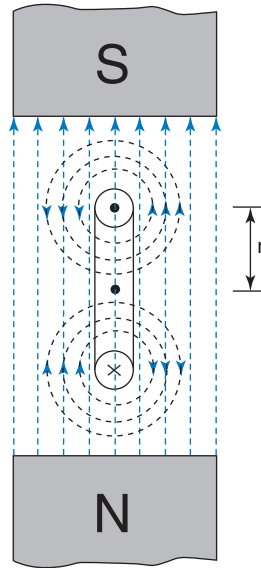

Fig. 5.14

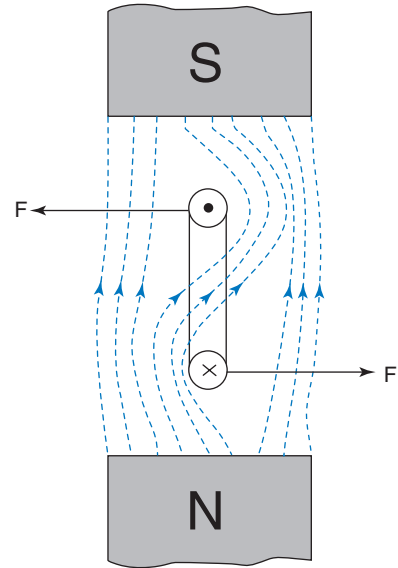

Fig. 5.15

so torque on each side =  $BI\ell r$ . Since the torque on each side is exerting a counterclockwise turning effect then the total torque exerted on the loop will be

$$T = 2BI\ell r \text{ newton metre} \quad (5.6)$$

### Worked Example 5.9

**Q** A rectangular single-turn loop coil 1.5 cm by 0.6 cm is mounted between two poles, which produce a flux density of 1.2 T, such that the longer sides of the coil are parallel to the pole faces. Determine the torque exerted on the coil when a current of 10 mA is passed through it.

**A**

$$\ell = 0.015 \text{ m}; B = 1.2 \text{ T}; I = 10^{-2} \text{ A}$$

$$\text{radius of rotation, } r = 0.006/2 = 0.003 \text{ m}$$

$$T = 2BI\ell r \text{ newton metre}$$

$$= 2 \times 1.2 \times 10^{-2} \times 0.015 \times 0.003$$

$$\text{so } T = 1.08 \mu\text{Nm} \text{ Ans}$$

From the above example it may be seen that a single-turn loop produces a very small amount of torque. It is acknowledged that the dimensions of the coil specified, and the current flowing through it, are also small. However, even if the coil dimensions were increased by a factor of ten times, and the current increased by a factor of a thousand times (to 10 A), the torque would still be only a very modest 0.108 Nm.

The practical solution to this problem is to use a multi-turn coil, as illustrated in Fig. 5.16. If the coil now has  $N$  turns, then each side has

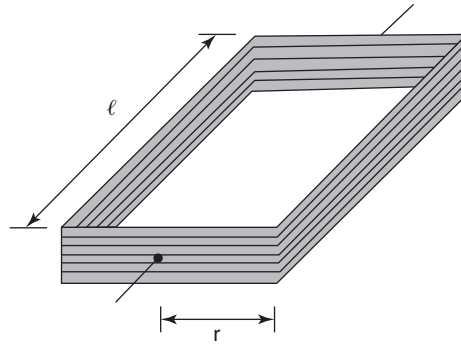

Fig. 5.16

an effective length of  $N \times \ell$ . The resulting torque will be increased by the same factor. So, for a multi-turn coil the torque is given by

$$T = 2NB\ell r \text{ newton metre}$$

The term  $2\ell r$  in the above expression is equal to the area 'enclosed' by the coil dimensions, so this is the effective csa  $A$ , of the field affecting the coil.

Thus,  $2\ell r = A \text{ metre}^2$ , and the above equation may be written

$$T = BAN\ell r \text{ newton metre} \quad (5.7)$$

The principle of using a multi-turn current-carrying coil in a magnetic field is therefore used for rotary electric motors. However, the same principles apply to the operation of analogue instruments known as moving coil meters. The classic example of such an instrument is the AVO meter, mentioned earlier, in Chapter 1.

### Worked Example 5.10

**Q** The coil of a moving coil meter consists of 80 turns of wire wound on a former of length 2 cm and radius 1.2 cm. When a current of  $45 \mu\text{A}$  is passed through the coil the movement comes to rest when the springs exert a restoring torque of  $1.4 \mu\text{Nm}$ . Calculate the flux density produced by the pole pieces.

**A**

$$N = 80; \ell = 0.02 \text{ m}; r = 0.012 \text{ m}; I = 45 \times 10^{-6}; T = 1.4 \times 10^{-6} \text{ Nm}$$

The meter movement comes to rest when the deflecting torque exerted on the coil is balanced by the restoring torque of the springs.

$$T = BAN\ell r \text{ newton metre}$$

$$\text{so, } B = \frac{T}{ANI} \text{ tesla}$$

$$= \frac{1.4 \times 10^{-6}}{0.02 \times 2 \times 0.012 \times 80 \times 45 \times 10^{-6}}$$

$$\text{so, } B = 0.81 \text{ T Ans}$$

## 5.7 Force between Parallel Conductors

When two parallel conductors are both carrying current their magnetic fields will interact to produce a force of attraction or repulsion between them. This is illustrated in Fig. 5.17.

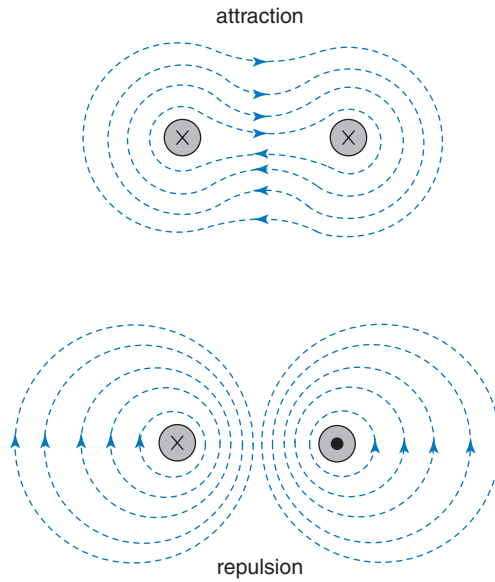

Fig. 5.17

In order to determine the value of such a force, consider first a single conductor carrying a current of  $I$  ampere. The magnetic field produced at some distance  $d$  from its centre is shown in Fig. 5.18.

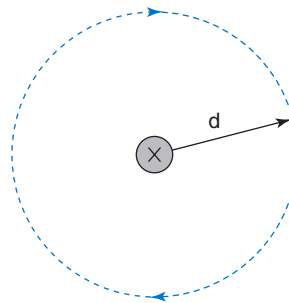

Fig. 5.18

In general,  $H = \frac{NI}{\ell}$  ampere turn/metre

but in this case,  $N = 1$  (one conductor) and  $\ell = 2\pi d$  metre (the circumference of the dotted circle), so

$$H = \frac{NI}{2\pi d}$$

Now, flux density  $B = \mu_0\mu_r H$  tesla, and as the field exists in air, then  $\mu_r = 1$ . Thus, the flux density at distance  $d$  from the centre is given by

$$B = \frac{I\mu_0}{2\pi d} \text{ tesla} \dots\dots\dots [1]$$

Consider now two conductors Y and Z carrying currents  $I_1$  and  $I_2$  respectively, at a distance of  $d$  metres between their centres as in Fig. 5.19.

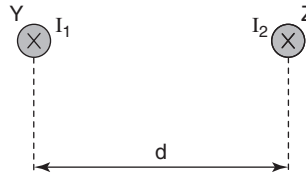

Fig. 5.19

Using equation [1] we can say that the flux density acting on Z due to current  $I_1$  flowing in Y is:

$$B_1 = \frac{I_1\mu_0}{2\pi d} \text{ tesla}$$

and the force exerted on  $Z = B_1 I_2 \ell$  newton, or  $B_1 I_2$  newton per metre length of Z.

Hence, force/metre length acting on Z

$$\begin{aligned} &= \frac{\mu_0 I_1 I_2}{2\pi d} \text{ newton} \\ &= \frac{4\pi \times 10^{-7} \times I_1 I_2}{2\pi d} \end{aligned}$$

so force/metre length acting on Z

$$= \frac{2 \times 10^{-7} \times I_1 I_2}{d} \text{ newton} \tag{5.8}$$

Now, the current  $I_2$  flowing in Z also produces a magnetic field which will exert a force on Y. Using the same reasoning as above, it can be shown that:

force/metre length acting on Y

$$= \frac{2 \times 10^{-7}}{d} I_1 I_2 \text{ newton}$$

so if  $I_1 = I_2 = 1$  A, and  $d = 1$  m, then

force exerted on *each* conductor =  $2 \times 10^{-7}$  newton

This value of force forms the basis for the definition of the ampere, namely: that current, which when maintained in each of two infinitely long parallel conductors situated *in vacuo*, and separated one metre between centres, produces a force of  $2 \times 10^{-7}$  newton per metre length on each conductor.

### Worked Example 5.11

**Q** Two long parallel conductors are spaced 35 mm between centres. Calculate the force exerted between them when the currents carried are 50 A and 40 A respectively.

**A**

$$d = 0.035 \text{ m}; I_1 = 50 \text{ A}; I_2 = 40 \text{ A}$$

$$F = \frac{2 \times 10^{-7} I_1 I_2}{d} \text{ newton} = \frac{2 \times 10^{-7} \times 50 \times 40}{0.035}$$

$$\text{so } F = 11.4 \text{ mN Ans}$$

### Worked Example 5.12

**Q** Calculate the flux density at a distance of 2 m from the centre of a conductor carrying a current of 1000 A. If the centre of a second conductor, carrying 300 A, was placed at this same distance, what would be the force exerted?

**A**

$$d = 2 \text{ m}; I_1 = 1000 \text{ A}; I_2 = 300 \text{ A}$$

$$B = \frac{\mu_0 I_1}{d} \text{ tesla} = \frac{4\pi \times 10^{-7} \times 1000}{2}$$

$$\text{so, } B = 0.628 \text{ mT Ans}$$

$$F = \frac{2 \times 10^{-7} I_1 I_2}{d} \text{ newton} = \frac{2 \times 10^{-7} \times 300 \times 1000}{2}$$

$$\text{so } F = 30 \text{ mN Ans}$$

## 5.8 The Moving Coil Meter

Most analogue (pointer-on-scale) instruments rely on three factors for their operation: a *deflecting* torque; a *restoring* torque; and a *damping* torque.

**Deflecting Torque** Essentially, a moving coil meter is a current measuring device. The current to be measured is passed through a multi-turn coil suspended between the poles of a permanent magnet. The coil is made from fine copper wire which is wound on to a light aluminium **former**. Thus the motor effect, described in section 5.6, is utilised. Since the wire is of small diameter, and the aluminium former

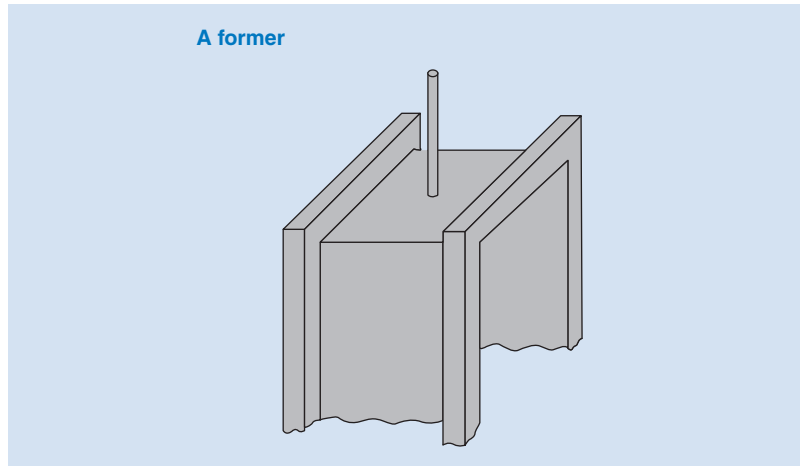

is also very light, then this assembly has very little inertia. This is an essential requirement, to ensure that the instrument is sufficiently sensitive. This means that it can respond to very small deflecting torques. To illustrate this point, refer back to Worked Example 5.9, in which the torque exerted on a small coil with a current of 10 mA was found to be only  $1.08 \mu\text{Nm}$ . In order to improve the sensitivity further, the friction of the coil pivots must be minimised. This is achieved by the use of jewelled bearings as shown in Fig. 5.20.

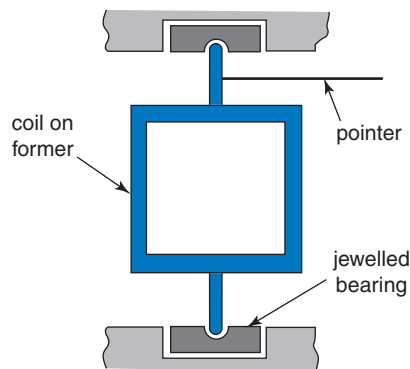

Fig. 5.20

When a current is passed through the coil it will rotate under the influence of the deflecting torque. However, if the ‘starting’ position of the coil is as shown in Fig. 5.21, then it will finally settle in the vertical position, regardless of the actual value of the current. The reason is that the effective perpendicular distance from the pivot point (the term  $r \sin \theta$  in the expression  $F = 2NB\ell r \sin \theta$ ) decreases to zero at this position. Another way to explain this is to consider the forces acting on each side of the coil. These will always act at right angles to the main flux. Thus, when the coil reaches the vertical position, these forces are no longer producing a turning effect. This means that the instrument is capable of indicating only the presence of a current, but not the actual

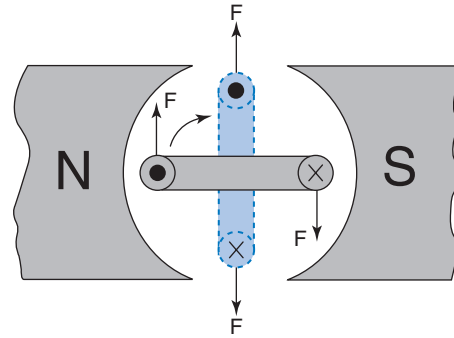

Fig. 5.21

value. Hence, the deflecting torque (which is dependent upon the value of the coil current) needs to be counter-balanced by another torque.

**Restoring Torque** This is the counter-balancing torque mentioned above. It is provided by two **contrawound** spiral springs, one end of each being connected to the top and bottom respectively, of the spindle that carries the coil former. The greater the current passed through the coil, the greater will be the deflecting torque. The restoring torque provided by the springs will increase in direct proportion to the deflection applied to them. The pointer, carried by the coil spindle will therefore move to a point at which the deflecting and restoring torques balance each other. The springs also serve as the means of passing the current to and from the coil. This avoids the problem of the coil having to drag around a pair of trailing leads.

The word **contrawound** means 'wound in opposite directions'. The reason for winding them in this way is to prevent the pointer position from being affected by temperature changes. If the temperature increases, then both springs tend to expand, by the same amount. Since one spring is acting to push the pointer spindle in one direction, and the other one in the opposite direction, then the effects cancel out

We now have a system in which the deflection obtained depends upon the value of the coil current. There are still other problems to overcome though. One of these is that the deflecting torque, due to a given value of current, will vary with the coil position. This would have the effect of non-linear deflections for linear increments of current. If we could ensure that the coil always lies at right angles to the field, regardless of its rotary position, then this problem would be resolved. The way in which this is achieved is by the inclusion of a soft iron cylinder inside the coil former. This cylinder does not touch the former, but causes a radial flux pattern in the air gap in which the coil rotates. This pattern results from the fact that the lines of flux will take the path(s) of least reluctance, and so cross the gaps between the pole faces and iron cylinder by the shortest possible path, i.e. at  $90^\circ$  to the surfaces. This effect is illustrated in Fig. 5.22.

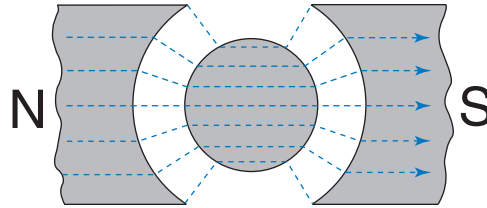

Fig. 5.22

**Damping Torque** When current is passed through the coil, the deflecting torque accelerates the pointer away from the zero position. Now, although the coil and pointer assembly is very light, it will still have sufficient inertia to ‘overshoot’ its final position on the graduated scale. It is also likely to under- and overshoot several times before settling. To prevent this from happening, the movement needs to be slowed down, or damped. This effect is achieved automatically by the generation of eddy currents in the aluminium coil former as it rotates in the magnetic field. The full description of eddy currents is dealt with later in this chapter. However, being induced currents means they are subject to Lenz’s law. They will therefore flow in the coil former in such a direction as to oppose the change that produced them; that is the rapid deflection of the coil. If the dimensions of the former are correctly chosen, then the result will be either one very small overshoot, or the overshoots are *just* prevented from occurring. In the latter case the instrument is said to be critically damped, or ‘dead beat’.

The main advantages of the moving coil instrument are:

- 1 Good sensitivity: this is due to the low inertia of the coil and pointer assembly. Typically, a current of  $50\ \mu\text{A}$  through the coil is sufficient to move the pointer to the extreme end of the scale (full-scale deflection or fsd).
- 2 Linear scale: from equation (5.7) we know that  $T = BANlI$ . For a given instrument,  $B, A,$  and  $N$  are fixed values, so  $T \propto I$ . Thus the deflecting torque is *directly* proportional to the coil current.

The main disadvantage is the fact that the basic meter movement so far described can be used only for d.c. measurements. If a.c. was applied to the coil, the pointer would try to deflect in opposite directions alternately. Thus, if only a moderate frequency such as 50 Hz is applied, the pointer cannot respond quickly enough. In this case only a very small vibration of the pointer, about the zero position, might be observed.

The complete arrangement for a moving coil meter is illustrated in Fig. 5.23.

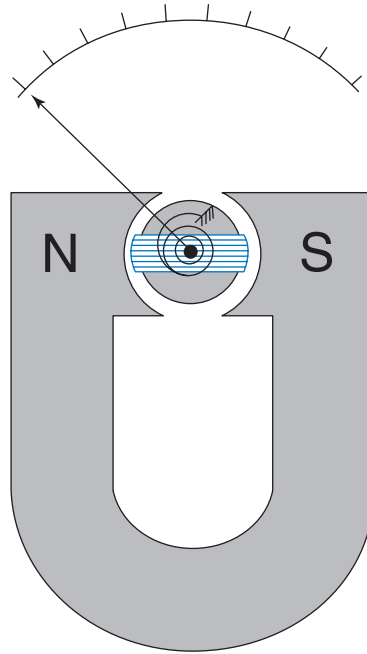

Fig. 5.23

## 5.9 Shunts and Multipliers

The basic instrument so far described is capable of measuring only small d.c. currents (up to  $50\ \mu\text{A}$  typically). This obviously severely limits its usefulness. The figure of  $50\ \mu\text{A}$  quoted is the value of coil full-scale deflection current ( $I_{fsd}$ ) for an AVO meter. As you will now be aware, this meter is in fact capable of measuring up to 10 A, by using the current range switch. This is achieved by means of what are known as shunts. Similarly, this type of meter is also capable of measuring a range of voltages. This is achieved by means of multipliers. Both shunts and multipliers are incorporated into the instrument when it is assembled.

## 5.10 Shunts

A shunt is a device connected in parallel with the meter's moving coil, in order to extend the current reading range of the instrument. It consists of a very low resistance element, often made from a small strip of copper or aluminium. Being connected in parallel with the coil, it forms an alternative path for current flow. It can therefore divert excessive current from the coil itself. In this instance, 'excessive current' means current in excess of that required to produce full-scale deflection of the pointer. The latter is known as the full-scale deflection current, which is normally abbreviated to  $I_{fsd}$ .

The application for a shunt is best illustrated by a worked example.

**Worked Example 5.13**

**Q** A moving coil meter has a coil resistance of  $40\ \Omega$ , and requires a current of  $0.5\ \text{mA}$  to produce f.s.d. Determine the value of shunt required to extend the current reading range to  $3\ \text{A}$ .

**A**

A sketch of the appropriate circuit should be made, and such a diagram is shown in Fig. 5.24.

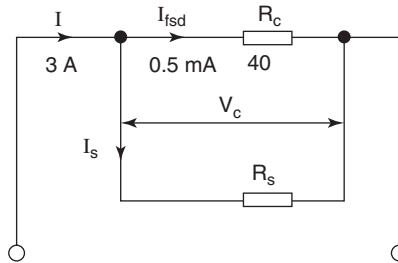

Fig. 5.24

$$R_C = 40\ \Omega; I_{fsd} = 5 \times 10^{-4}\ \text{A}; I = 3\ \text{A}$$

$$V_C = I_{fsd} R_C\ \text{volt} = 5 \times 10^{-4} \times 40$$

$$\text{so } V_C = 0.02\ \text{V}$$

$$I_s = I - I_{fsd}\ \text{amp} = 3 - (5 \times 10^{-4})$$

$$\text{so } I_s = 2.995\ \text{A}$$

$$R_s = \frac{V_C}{I_s}\ \text{ohm} = \frac{0.02}{2.995}$$

therefore,  $R_s = 6.67\ \text{m}\Omega$  **Ans**

## 5.11 Multipliers

From the previous worked example, it may be seen that the p.d. across the coil ( $V_C$ ) when  $I_{fsd}$  flows through it is only  $20\ \text{mV}$ . This is therefore the maximum voltage that may be applied to the coil. It also represents the maximum voltage measurement that can be made.

In order to extend the voltage reading range, a multiplier must be employed. This is a high value resistance, connected in series with the meter coil. Thus, when a voltage in excess of  $V_C$  is applied to the meter terminals, the multiplier will limit the current to  $I_{fsd}$ .

**Worked Example 5.14**

**Q** Considering the same meter movement specified in Worked Example 5.13, determine the multiplier required to extend the voltage reading range to  $10\ \text{V}$ .

**A**

$$R_C = 40\ \Omega; I_{fsd} = 5 \times 10^{-4}\ \text{A}; V = 10\ \text{V}$$

From worked Example 5.13, we know that the p.d. across the coil with  $I_{fsd}$  flowing is  $V_c = 0.02\text{ V}$ . The circuit diagram is shown in Fig. 5.25.

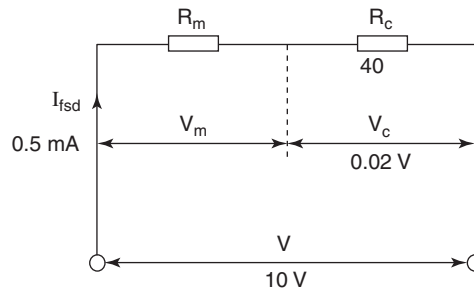

Fig. 5.25

$$\text{Total resistance, } R = \frac{V}{I_{fsd}} \text{ volt} = \frac{10}{5 \times 10^{-4}}$$

$$\text{so } R = 20\text{ k}\Omega$$

$$\text{but } R = R_m + R_c \text{ ohm}$$

$$\text{so } R_m = R - R_c = 20\,000 - 40$$

$$\text{therefore, } R_m = 19.96\text{ k}\Omega \text{ Ans}$$

This problem may also be solved by the following method:

$$V_m = V - V_c \text{ volt} = 10 - 0.02$$

$$\text{so } V_m = 9.98\text{ V}$$

$$R_m = \frac{V_m}{I_{fsd}} \text{ ohm} = \frac{9.98}{5 \times 10^{-4}}$$

$$\text{therefore, } R_m = 19.96\text{ k}\Omega \text{ Ans}$$

### Worked Example 5.15

- Q** The coil of a moving coil multimeter has a resistance of  $1.5\text{ k}\Omega$ , and it requires a current of  $75\text{ }\mu\text{A}$  through it in order to produce full-scale deflection. Calculate (a) the value of shunt required to enable the meter to indicate current up to the value of  $5\text{ A}$ , and (b) the value of multiplier required to enable it to indicate voltage up to  $10\text{ V}$ .

**A**

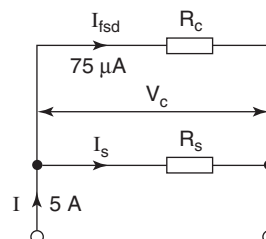

Fig. 5.26

Coil resistance,  $R_C = 1500\ \Omega$ ;  $I_{fsd} = 75 \times 10^{-6}\ \text{A}$ ; (a)  $I = 5\ \text{A}$ ; (b)  $V = 10\ \text{V}$

$$(a) \quad V_C = I_{fsd} R_C \text{ volt} = 75 \times 10^{-6} \times 1500$$

$$\text{so, } V_C = 0.1125\ \text{V}$$

$$I_S = I - I_{fsd} \text{ amp} = 5 - (75 \times 10^{-6})$$

$$\text{and, } I_S = 4.999\ 925\ \text{A}$$

$$R_S = \frac{V_C}{I_S} \text{ ohm}$$

$$= \frac{0.1125}{4.999\ 925}$$

$$\text{and, } R_S = 22.5\ \text{m}\Omega \text{ Ans}$$

**Note:** Since the value of  $R_S$  will be very small, all the digits obtained for  $I_S$  are retained in the calculation in order to minimise any rounding error.

(b) From part (a),  $V_C = 0.1125\ \text{V}$ , and the circuit is now equivalent to that shown in Fig. 5.27.

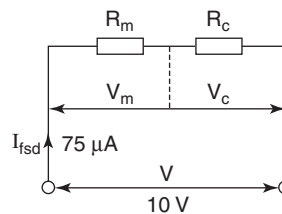

Fig. 5.27

$$\text{Thus, } V_m = V - V_C = 10 - 0.1125$$

$$\text{so, } V_m = 9.8875\ \text{V}$$

$$R_m = \frac{V_m}{I_{fsd}} \text{ ohm} = \frac{9.8875}{75 \times 10^{-6}}$$

$$\text{so, } R_m = 131.83\ \text{k}\Omega \text{ Ans}$$

Alternatively, total resistance,  $R = R_m + R_C$  ohm

$$\text{and also, } R = \frac{V}{I_{fsd}} \text{ ohm} = \frac{10}{75 \times 10^{-6}}$$

$$\text{so, } R = 133.33\ \text{k}\Omega$$

$$\text{and, } R_m = R - R_C = (133.33 - 1.5) \times 10^3$$

$$\text{thus, } R_m = 131.83\ \text{k}\Omega \text{ Ans}$$

When the voltage range switch on an AVO is rotated, it simply connects the appropriate value of multiplier in series with the moving coil. Similarly, when the current range switch is operated, it connects the appropriate value shunt in parallel with the coil. In order to protect the instrument from an electrical overload, you must always start the measurement from the highest available range. Progressively lower range settings can then be selected, until a suitable deflection is obtained.

**Note:** The range setting marked on any instrument indicates the value of applied voltage or current that will cause full-scale deflection on that range.

## 5.12 Figure of Merit and Loading Effect

When a moving coil meter is used as a voltmeter, the total resistance between its terminals will depend upon the value of multiplier connected. This will of course vary with the range selected. This total resistance is called the input resistance of the instrument ( $R_{in}$ ). An ideal voltmeter would draw zero current from the circuit to which it is connected. Thus, for a practical instrument, the higher the value of  $R_{in}$ , the closer it approaches the ideal.

Since  $R_{in}$  changes as the voltage ranges are changed, some other means of indicating the 'quality' of the instrument is required. This is the figure of merit, which is quoted in ohms/volt.

$$R_{in} = \frac{V}{I_{fsd}} \text{ ohm; where}$$

$V$  is the voltage range selected

$$\text{So, } \frac{1}{I_{fsd}} = \frac{R_{in}}{V} \text{ ohms/volt;}$$

$$\text{and } \frac{1}{I_{fsd}} \text{ is the figure of merit}$$

Thus, the reciprocal of the full-scale deflection current gives the figure of merit for a moving coil instrument, when used as a voltmeter.

The lowest current range on an AVO is  $50 \mu\text{A}$ , which happens to be its  $I_{fsd}$ . Hence, its figure of merit

$$= \frac{1}{50 \times 10^{-6}} = 20 \text{ k}\Omega/\text{V}$$

Since  $R_{in} = \text{figure of merit} \times V$ , then on the  $0.3 \text{ V}$  range,  $R_{in} = 20000 \times 0.3 = 6 \text{ k}\Omega$ . The figures for other voltage ranges will therefore be:

$$1 \text{ V range, } R_{in} = 20 \text{ k}\Omega; 100 \text{ V range, } R_{in} = 2 \text{ M}\Omega; \text{ etc}$$

It may therefore be seen that the higher the voltage range selected, the closer  $R_{in}$  approaches the ideal of infinity. In order to illustrate the practical significance of this, let us consider another example.

### Worked Example 5.16

**Q** A simple potential divider circuit is shown in Fig. 5.28. The p.d.  $V_2$  is to be measured by an AVO, using the 10V range. Calculate the p.d. indicated by this meter, and the percentage error in this reading.

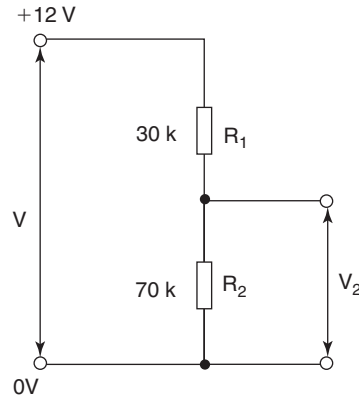

Fig. 5.28

**A**

Firstly, we can calculate the p.d. developed across  $R_2$  by applying the potential divider theory, thus

$$V_2 = \frac{R_2}{R_1 + R_2} V \text{ volt} = \frac{7}{10} \times 12$$

so, the true value of  $V_2 = 8.4 \text{ V}$

However, when the voltmeter is connected across  $R_2$ , the circuit is effectively modified to that shown in Fig. 5.29. (Since it is an AVO, switched to the 10V range, then the value for  $R_{in}$  is  $200 \text{ k}\Omega$ .)

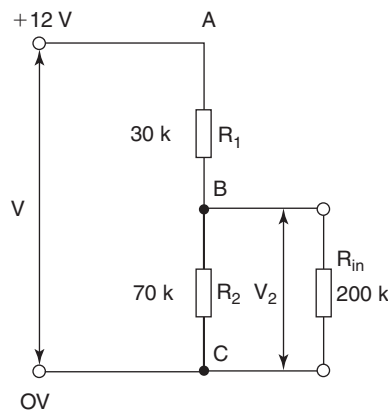

Fig. 5.29

$$R_{BC} = \frac{R_2 R_{in}}{R_2 + R_{in}} \text{ ohm} = \frac{70 \times 200}{270} \text{ k}\Omega$$

so  $R_{BC} = 51.85 \text{ k}\Omega$

and using the potential divider technique:

$$V_2 = \frac{51.85}{51.85 + 70} \times 12 = 7.6 \text{ V};$$

this is the p.d. that will be indicated by the voltmeter.

$$\text{so, } V_2 = 7.6 \text{ V Ans}$$

The percentage error in the reading is defined as:

$$\text{error} = \frac{\text{indicated value} - \text{true value}}{\text{true value}} \times 100\%$$

$$\text{so, error} = \frac{7.6 - 8.4}{8.4} \times 100\% = -9.52\% \text{ Ans}$$

Hence, it can be seen that the meter does not indicate the true p.d. across  $R_2$ , since it indicates a lower value. This is known as the loading effect. The reason for this effect is that, in order to operate, the meter has to draw current from the circuit. The original circuit conditions have therefore been altered, as shown in Fig. 5.29.

The loading effect does not depend entirely on the value of  $R_{in}$ . The value of  $R_{in}$ , relative to the resistance of the component whose p.d. is being measured, is equally important. It is left to the reader to verify that, if resistors  $R_1$  and  $R_2$  in Fig. 5.28 were  $300\ \Omega$  and  $700\ \Omega$  respectively, the loading error would be only 0.004%.

Digital multimeters have an input resistance of 10 to 20 M $\Omega$ . This figure remains sensibly constant regardless of the voltage range selected. The loading effect is therefore much less than for an AVO, especially when using the lower voltage ranges. Also, as the indicated values are easier to read, they tend to be used more often than moving coil meters. However, there are other factors that need to be considered when selecting a meter for a given measurement. These are covered in *Further Electrical and Electronic Principles*.

### Worked Example 5.17

**Q** Two resistors, of 10 k $\Omega$  and 47 k $\Omega$  respectively, are connected in series across a 10V d.c. supply. The p.d. developed across each resistor is measured with a moving coil multimeter having a figure of merit of 20 k $\Omega$ /V, and switched to its 10V range. For each measurement calculate (a) the p.d. indicated by the meter, and (b) the loading error involved in each case.

**A**

With a figure of merit of 20 k $\Omega$ /V the meter internal resistance,  $R_{in}$  will be  
 $R_{in} = 20 \text{ k}\Omega \times 10 = 200 \text{ k}\Omega$

Without the meter connected, the circuit will be as shown in Fig. 5.30, and the actual p.d. across each resistor will be  $V_1$  and  $V_2$  respectively.

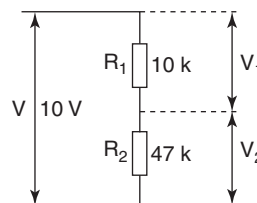

Fig. 5.30

$$V_1 = \frac{R_1}{R_1 + R_2} \times V \text{ volt} = \frac{10 \times 10}{10 + 47}$$

$$\text{so, } V_1 = 1.754 \text{ V}$$

$$V_2 = \frac{R_2}{R_1 + R_2} \times V \text{ volt} = \frac{47 \times 10}{10 + 47}$$

$$\text{and, } V_2 = 8.246 \text{ V}$$

- (a) With the meter connected across  $R_1$ , the meter will indicate  $V_{AB}$  volt as shown in Fig. 5.31.

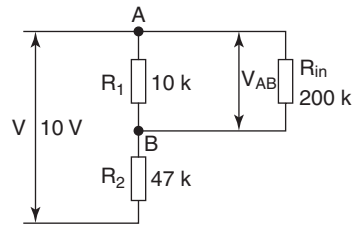

Fig. 5.31

$$R_{AB} = \frac{R_{in} R_1}{R_{in} + R_1} \text{ ohm} = \frac{200 \times 10}{210} \text{ k}\Omega$$

$$\text{so, } R_{AB} = 9.524 \text{ k}\Omega$$

$$V_{AB} = \frac{R_{AB}}{R_{AB} + R_2} \times V \text{ volt} = \frac{9.524 \times 10}{9.524 + 47}$$

$$\text{and, } V_{AB} = 1.69 \text{ V Ans}$$

In this case the voltmeter reading has been rounded up because it would not be practical to read the scale to two decimal places. Indeed, the indication would *probably* be read as 1.7V.

With the meter now connected across  $R_2$ , the circuit is now modified to that as shown in Fig. 5.32.

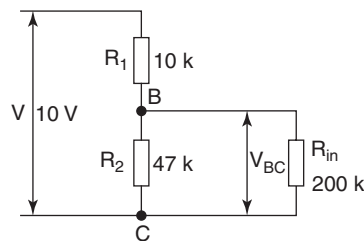

Fig. 5.32

$$R_{BC} = \frac{R_2 R_{in}}{R_2 + R_{in}} \text{ ohm} = \frac{47 \times 200}{247} \text{ k}\Omega$$

$$\text{so, } R_{BC} = 38.057 \text{ k}\Omega$$

$$V_{BC} = \frac{R_{BC}}{R_{BC} + R_1} \times V \text{ volt} = \frac{38.057 \times 10}{48.057}$$

$$\text{and, } V_{BC} = 7.92 \text{ V Ans}$$

$$(b) \text{ error} = \frac{\text{indicated value} - \text{true value}}{\text{true value}} \times 100\%$$

$$\text{so, error for } V_1 \text{ measurement} = \frac{1.69 - 1.754}{1.754} \times 100\%$$

$$\text{hence, error} = -3.65\% \text{ Ans}$$

$$\text{error for } V_2 \text{ measurement} = \frac{7.92 - 8.246}{8.246} \times 100\%$$

$$\text{and, error} = -3.95\% \text{ Ans}$$

**Note:** Although the two error figures are fairly close to each other in value, the percentage error in the second measurement is about 10% greater than that for the first. This illustrates the fact that the higher the meter internal resistance, compared with the resistance across which it is placed, the smaller the loading effect, and hence higher accuracy is obtained. Since the internal resistance of DVMs is usually in the order of megohms, in many cases they are used in preference to the traditional moving coil instrument.

## 5.13 The Ohmmeter

As the name implies, this instrument is used for the measurement of resistance. This feature is normally included in multimeters. In the case of the AVO, the moving coil movement is also utilised for this purpose. The theory is based simply on Ohm's law. If a known emf is applied to a resistor, the resulting current flow is inversely proportional to the resistance value. The basic arrangement is shown in Fig. 5.33. The battery is incorporated into the instrument, as is the variable resistance, R.

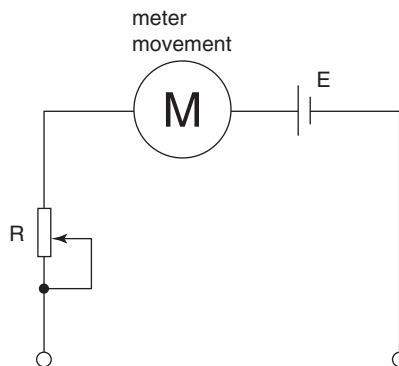

Fig. 5.33

To use the instrument in this mode, the terminals are first 'shorted' together, using the instrument leads. The resistor R is then adjusted so that the pointer indicates zero on the ohms scale. Note that the zero position on this scale is at the *righthand* extreme of the scale. Having

'zeroed' the meter, the 'short' is removed. Finally, the resistance to be measured is connected between the terminals. The resistance value will then be indicated by the position of the pointer on the ohms scale.

It is not recommended that resistance values be measured using this technique! The scale is extremely cramped over the higher resistance range, and is extremely non-linear. This makes accurate measurement of resistance virtually impossible. However, the use of this facility for continuity checking is useful.

If you wish to measure a resistance value fairly accurately, then use this facility on a digital multimeter. The same basic principle, of applying a known emf and measuring the resulting current, may still be employed. The internal electronic circuitry then converts this into a display of resistance value. By definition, the scale cannot be cramped, and is easy to read. If a resistance has to be measured with a high degree of accuracy, then a Wheatstone Bridge must be used.

## 5.14 Wattmeter

This instrument is used to measure electrical power. In its traditional form it is called a dynamometer wattmeter. It is also available in a purely electronic form. The dynamometer type utilises the motor principle. The meter consists of two sets of coils. One set is fixed, and is made in two identical parts. This is the current coil, and is made from heavy gauge copper wire. The resistance of this coil is therefore low. The voltage coil is wound from fine gauge wire, and therefore has a relatively high resistance. The voltage coil is mounted on a circular former, situated between the two parts of the current coil. The basic arrangement is illustrated in Fig. 5.34.

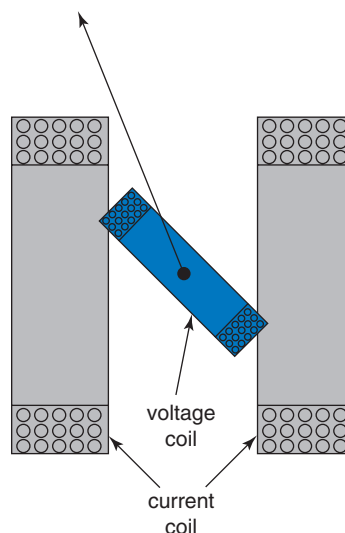

Fig. 5.34

The current coil is connected to a circuit so as to allow the circuit current to flow through it. The voltage coil is connected in parallel with the load, in the same way as a voltmeter. Both coils produce magnetic fields, which interact to produce a deflecting torque on the voltage coil. Restoring torque is provided by contrawound spiral springs, as in the moving coil meter. The interacting fields are proportional to the circuit current and voltage respectively. The deflecting torque is therefore proportional to the product of these two quantities; i.e.  $VI$  which is the circuit power.

The voltage coil may be connected either on the supply side or the load side of the current coil. The choice of connection depends on other factors concerning the load. This aspect is dealt with in *Further Electrical and Electronic Principles*. The manner of connecting the wattmeter into a circuit is shown in Fig. 5.35.

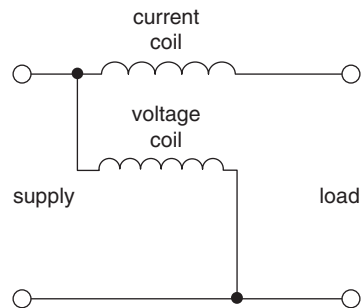

Fig. 5.35

For d.c. circuits, a wattmeter is not strictly necessary. Since power  $P = VI$  watt, then  $V$  and  $I$  may be measured separately by a multimeter. The power can then be calculated simply by multiplying together these two meter readings. However, in an a.c. circuit, this simple technique does not yield the correct value for the true power. Thus a wattmeter is required for the measurement of power in a.c. circuits.

## 5.15 Eddy Currents

Consider an iron-cored solenoid, as shown in cross-section in Fig. 5.36. Let the coil be connected to a source of emf via a switch. When the switch is closed, the coil current will increase rapidly to some steady value. This steady value will depend upon the resistance of the coil. The coil current will, in turn, produce a magnetic field. Thus, this flux pattern will increase from zero to some steady value. This changing flux therefore expands outwards from the centre of the iron core. This movement of the flux pattern is shown by the arrowed lines pointing outwards from the core.

Since there is a changing flux linking with the core, then an emf will be induced in the core. As the core is a conductor of electricity, then

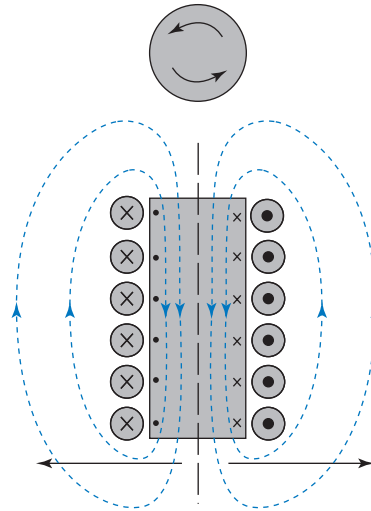

Fig. 5.36

the induced emf will cause a current to be circulated around it. This is known as an eddy current, since it traces out a circular path similar to the pattern created by an eddy of water. The direction of the induced emf and eddy current will be as shown in Fig. 5.36. This has been determined by applying Fleming's righthand rule. Please note, that to apply this rule, we need to consider the movement of the *conductor relative to the flux*. Thus, the *effective* movements of the left and right halves of the core are *opposite* to the arrows showing the expansion of the flux pattern.

As the eddy current circulates in the core, it will produce a heating effect. This is normally an undesirable effect. The energy thus dissipated is therefore referred to as the eddy current loss. If the solenoid forms part of a d.c. circuit, this loss is negligible. This is because the eddy current will flow only momentarily—when the circuit is first connected, and again when it is disconnected. However, if an a.c. supply is connected to the coil, the eddy current will be flowing continuously, in alternate directions. Under these conditions, the core is also being taken through repeated magnetisation cycles. This will result in a hysteresis loss also.

In order to minimise the eddy current loss, the resistance of the core needs to be increased. On the other hand, the low reluctance needs to be retained. It would therefore be pointless to use an insulator for the core material, since we might just as well use an air core! The technique used for devices such as transformers, used at mains frequency, is to make the core from laminations of iron. This means that the core is made up of thin sheets (laminations) of steel, each lamination being insulated from the next. This is illustrated in Fig. 5.37. Each lamination, being thin, will have a relatively high resistance. Each lamination will have an eddy current, the circulation of which is confined to that lamination. If

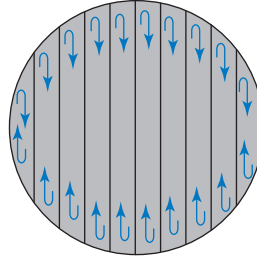

Fig. 5.37

the values of these individual eddy currents are added together, it will be found to be less than that for the solid core.

The hysteresis loss is proportional to the frequency  $f$  of the a.c. supply. The eddy current loss is proportional to  $f^2$ . Thus, at higher frequencies (e.g. radio frequencies), the eddy current loss is predominant. Under these conditions, the use of laminations is not adequate, and the eddy current loss can be unacceptably high. For this type of application, iron dust cores or ferrite cores are used. With this type of material, the eddy currents are confined to individual 'grains', so the eddy current loss is considerably reduced.

## 5.16 Self and Mutual Inductance

The effects of self and mutual inductance can be demonstrated by another simple experiment. Consider two coils, as shown in Fig. 5.38. Coil 1 can be connected to a battery via a switch. Coil 2 is placed close to coil 1, but is not electrically connected to it. Coil 2 has a galvo connected to its terminals.

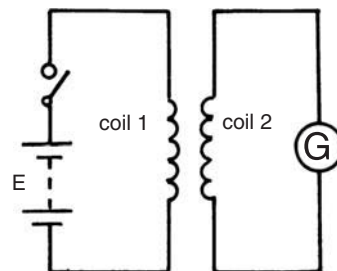

Fig. 5.38

When the switch is closed, the current in coil 1 will rapidly increase from zero to some steady value. Hence, the flux produced by coil 1 will also increase from zero to a steady value. This changing flux links with the turns of coil 2, and therefore induces an emf into it. This will be indicated by a momentary deflection of the galvo pointer.

Similarly, when the switch is subsequently opened, the flux produced by coil 1 will collapse to zero. The galvo will again indicate that a momentary emf is induced in coil 2, but of the opposite polarity to the first case. Thus, an emf has been induced into coil 2, by a changing current (and flux) in coil 1. This is known as a mutually induced emf.

If the changing flux can link with coil 2, then it must also link with the turns of coil 1. Thus, there must also be a momentary emf induced in this coil. This is known as a self-induced emf. Any induced emf obeys Lenz's law. This self-induced emf must therefore be of the opposite polarity to the battery emf. For this reason, it is also referred to as a back emf. Unfortunately, it is extremely difficult to demonstrate the existence of this back emf. If a voltmeter was connected across coil 1, it would merely indicate the terminal voltage of the battery.

## 5.17 Self-Inductance

Self-inductance is that property of a circuit or component which causes a self-induced emf to be produced, when the current through it changes. The unit of self-inductance is the henry, which is defined as follows:

A circuit has a self-inductance of one henry (1 H) if an emf of one volt is induced in it, when the circuit current changes at the rate of one ampere per second (1 A/s).

The quantity symbol for self-inductance is  $L$ . From the above definition, we can state the following equation

$$L = \frac{-e}{di/dt} \text{ henry}$$

$$\text{or, self-induced emf, } e = \frac{-Ldi}{dt} \text{ volt} \quad (5.9)$$

### Notes:

- 1 The minus sign again indicates that Lenz's law applies.
- 2 The emf symbol is  $e$ , because it is only a momentary emf.
- 3 The current symbol is  $i$ , because it is the *change* of current that is important.
- 4 The term  $di/dt$  is the rate of change of current.

**Worked Example 5.18**

**Q** A coil has a self-inductance of 0.25 H. Calculate the value of emf induced, if the current through it changes from 100 mA to 350 mA, in a time of 25 ms.

**A**

$$L = 0.25 \text{ H}; di = (350 - 100) \times 10^{-3} \text{ A}; dt = 25 \times 10^{-3} \text{ s}$$

$$e = \frac{-Ldi}{dt} \text{ volt} = \frac{0.25 \times 250 \times 10^{-3}}{25 \times 10^{-3}}$$

$$\text{so } e = 2.5 \text{ V } \mathbf{Ans}$$

**Worked Example 5.19**

**Q** Calculate the inductance of a circuit in which an emf of 30V is induced, when the circuit current changes at the rate of 200 A/s.

**A**

$$e = 30 \text{ V}; \frac{di}{dt} = 200 \text{ A/S}$$

$$e = \frac{-Ldi}{dt} \text{ volt}$$

$$\text{so, } L = \frac{e}{di/dt} \text{ henry} = \frac{30}{200}$$

$$\text{therefore, } L = 0.15 \text{ H } \mathbf{Ans}$$

**Worked Example 5.20**

**Q** A circuit of self-inductance 50 mH has an emf of 8V induced into it. Calculate the rate of change of the circuit current that induced this emf.

**A**

$$L = 50 \times 10^{-3} \text{ H}; e = 8 \text{ V}$$

$$e = \frac{-Ldi}{dt} \text{ volt}$$

$$\text{So, } \frac{di}{dt} = \frac{e}{L} \text{ amp/s} = \frac{8}{50 \times 10^{-3}}$$

$$\text{hence } = \frac{di}{dt} = 160 \text{ A/s } \mathbf{Ans}$$

## 5.18 Self-Inductance and Flux Linkages

Consider a coil of  $N$  turns, carrying a current of  $I$  amp. Let us assume that this current produces a flux of  $\Phi$  weber. If the current now changes at a uniform rate of  $di/dt$  ampere per second, it will cause a corresponding change of flux of  $d\phi/dt$  weber per second. Let us also assume that the coil has a self-inductance of  $L$  henry.

The self-induced emf may be determined from equation (5.9):

$$e = \frac{-Ldi}{dt} \text{ volt} \dots\dots\dots [1]$$

However, the induced emf is basically due to the rate of change of flux linkages. Thus, the emf may also be calculated by using equation (5.1), namely:

$$e = \frac{-Nd\phi}{dt} \text{ volt} \dots\dots\dots [2]$$

Since both equations [1] and [2] represent the same induced emf, then [1] must be equal to [2]. Thus

$$\frac{Ldi}{dt} = \frac{Nd\phi}{dt} \text{ (the minus signs cancel out)}$$

$$\text{so, } L = \frac{Nd\phi}{di} \text{ henry} \quad (5.10)$$

A coil which is designed to have a specific value of self-inductance is known as an inductor. An inductor is the third of the main **passive** electrical components. The other two are the resistor and the capacitor.

A **passive** component is one which (a) requires an external source of emf in order to serve a useful function, and (b) does not provide any amplification of current or voltage

Now, a resistor will have a specific value of resistance, regardless of whether it is in a circuit or not. Similarly, an inductor will have some value of self-inductance, even when the current through it is constant. In other words, an inductor does not have to have an emf induced in it, in order to possess the property of self-inductance. For this reason, equation (5.10) may be slightly modified as follows.

If the current  $I$  through an  $N$  turn coil produces a flux of  $\Phi$  weber, then its self-inductance is given by the equation

$$L = \frac{N\phi}{I} \text{ henry} \quad (5.11)$$

In other words, although no *change* of current and flux is specified, the coil will still have some value of inductance. Strictly speaking, equation (5.11) applies only to an inductor with a non-magnetic core. The reason is that, in this case, the flux produced is directly proportional to the coil current. However, it is a very close approximation to the true value of inductance for an iron-cored inductor which contains an air gap in it.

### Worked Example 5.21

**Q** A coil of 150 turns carries a current of 10 A. This current produces a magnetic flux of 0.01 Wb. Calculate (a) the inductance of the coil, and (b) the emf induced when the current is uniformly reversed in a time of 0.1 s.

**A**

$$N = 150; I = 10 \text{ A}; \Phi = 0.01 \text{ Wb}; dt = 0.1 \text{ s}$$

$$(a) \quad L = \frac{N\Phi}{I} \text{ henry} = \frac{150 \times 0.10}{10}$$

$$\text{so, } L = 1.5 \text{ H Ans}$$

(b) Since current is reversed then it will change from 10 A to  $-10$  A, i.e. a change of  $10 - (-10)$ . So,  $dI = 20$  A.

$$e = \frac{-Ldi}{dt} \text{ volt} = \frac{1.5 \times 20}{0.1}$$

$$\text{therefore, } e = 300 \text{ V Ans}$$

### Worked Example 5.22

**Q** A current of 8 A, when flowing through a 3000 turn coil, produces a flux of 4 mWb. If the current is reduced to 2 A in a time of 100 ms, calculate the emf thus induced in the coil. Assume that the flux is directly proportional to the current.

**A**

$$I_1 = 8 \text{ A}; N = 3000; \Phi_1 = 4 \times 10^{-3} \text{ Wb}; I_2 = 2 \text{ A}; dt = 0.1 \text{ s}$$

This problem may be solved in either of two ways. Both methods will be demonstrated.

$$e = \frac{-Ldi}{dt} \text{ volt, where } L = \frac{N\Phi_1}{I_1} \text{ henry}$$

$$\text{so, } L = \frac{3000 \times 4 \times 10^{-3}}{8} = 1.5 \text{ H}; di = 8 - 2 = 6 \text{ A}$$

$$\text{therefore, } e = \frac{1.5 \times 6}{0.1} = 90 \text{ V Ans}$$

Alternatively,  $\Phi \propto I$  so  $\Phi_1 \propto I_1$  and  $\Phi_2 \propto I_2$

$$\text{therefore, } \frac{\Phi_2}{\Phi_1} = \frac{I_2}{I_1} \text{ and } \Phi_2 = \frac{\Phi_1 I_2}{I_1}$$

$$\text{hence, } \Phi_2 = \frac{2 \times 4 \times 10^{-3}}{8} = 1 \times 10^{-3} \text{ Wb};$$

$$\text{and } d\phi = (4 - 1) \times 10^{-3} \text{ Wb}$$

$$e = \frac{-Nd\phi}{dt} \text{ volt} = \frac{3000 \times 3 \times 10^{-3}}{0.1}$$

$$\text{so, } e = 90 \text{ V Ans}$$

## 5.19 Factors Affecting Inductance

Consider a coil of  $N$  turns wound on to a non-magnetic core, of uniform csa  $A$  metre<sup>2</sup> and mean length  $\ell$  metre. The coil carries a current of  $I$  amp, which produces a flux of  $\Phi$  weber. From equation (5.11), we know that the inductance will be

$$L = \frac{N\Phi}{I} \text{ henry, but } \Phi = BA \text{ weber}$$

therefore,  $L = \frac{NBA}{I}$  henry ..... [1]

Also, magnetic field strength,  $H = \frac{NI}{\ell}$  ; so  $I = \frac{H\ell}{N}$

and substituting this expression for  $I$  into equation [1]

$$L = \frac{NBA}{H\ell/N} = \frac{BAN^2}{H\ell} \text{ ..... [2]}$$

Now, equation [2] contains the term  $\frac{B}{H}$ , which equals  $\mu_0\mu_r$

$$\text{therefore, } L = \frac{\mu_0\mu_r N^2 A}{\ell} \text{ henry} \tag{5.12}$$

We also know that  $\frac{\ell}{\mu_0\mu_r A} = \text{reluctance, } S$

$$\text{hence } L = \frac{N^2}{S} \text{ henry} \tag{5.13}$$

**Notes:**

- 1 Equation (5.12) compares with  $C = \frac{\epsilon_0\epsilon_r A(N-1)}{d}$  farad for a capacitor.
- 2 If the number of turns is doubled, then the inductance is quadrupled, i.e.  $L \propto N^2$ .
- 3 The terms  $A$  and  $\ell$  in equation (5.12) refer to the dimensions of the core, and NOT the coil.

### Worked Example 5.23

- Q** A 600 turn coil is wound on to a non-magnetic core of effective length 45 mm and csa 4 cm<sup>2</sup>.  
 (a) Calculate the inductance, (b) The number of turns is increased to 900. Calculate the inductance value now produced. (c) The core of the 900 turn coil is now replaced by an iron core having a relative permeability of 75, and of the same dimensions as the original. Calculate the inductance in this case.

**A**

$$N_1 = 600; \ell = 45 \times 10^{-3} \text{ m}; A = 4 \times 10^{-4} \text{ m}^2; \mu_{r1} = 1$$

$$N_2 = 900; \mu_{r2} = 1; N_3 = 900; \mu_{r3} = 75$$

$$\begin{aligned} \text{(a)} \quad L_1 &= \frac{\mu_0 \mu_{r1} N_1^2 A}{\ell} \text{ henry} \\ &= \frac{4\pi \times 10^{-7} \times 1 \times 600^2 \times 4 \times 10^{-4}}{45 \times 10^{-3}} \end{aligned}$$

$$\text{so, } L_1 = 4.02 \text{ mH Ans}$$

**(b)** Since  $L_1 \propto N_1^2$ , and  $L_2 \propto N_2^2$ , then

$$\begin{aligned} \frac{L_2}{L_1} &= \frac{N_2^2}{N_1^2} \\ \text{so, } L_2 &= \frac{L_1 N_2^2}{N_1^2} = \frac{4.02 \times 10^{-3} \times 900^2}{600^2} \end{aligned}$$

$$\text{therefore, } L_2 = 9.045 \text{ mH Ans}$$

**(c)** Since  $\mu_{r3} = 75 \times \mu_{r2}$ , and there are no other changes, then  $L_3 = 75 \times L_2$   
therefore,  $L_3 = 0.678 \text{ H Ans}$ 

## 5.20 Mutual Inductance

When a changing current in one circuit induces an emf in another separate circuit, then the two circuits are said to possess mutual inductance. The unit of mutual inductance is the henry, and is defined as follows.

Two circuits have a mutual inductance of one henry, if the emf induced in one circuit is one volt, when the current in the other is changing at the rate of one ampere per second.

The quantity symbol for mutual inductance is  $M$ , and expressing the above definition as an equation we have

$$\begin{aligned} M &= \frac{\text{induced emf in coil 2}}{\text{rate of change of current in coil 1}} \\ &= \frac{-e_2}{di_1/dt} \text{ henry} \end{aligned}$$

and transposing this equation for emf  $e_2$

$$e_2 = \frac{-M di_1}{dt} \text{ volt} \quad (5.14)$$

This emf may also be expressed in terms of the flux linking coil 2. If *all* of the flux from coil 1 links with coil 2, then we have what is called 100% flux linkage. In practice, it is more usual for only a proportion of the flux from coil 1 to link with coil 2. Thus the flux linkage is usually less than 100%. This is indicated by a factor, known as the coupling factor,  $k$ . 100% coupling is indicated by  $k = 1$ . If there is no flux linkage with coil 2, then  $k$  will have a value of zero. So if zero emf is induced in coil 2, the mutual inductance will also be zero. Thus, the possible values for the coupling factor  $k$ , lie between zero and 1. Expressed mathematically, this is written as

$$0 \leq k \leq 1$$

Consider two coils possessing mutual inductance, and with a coupling factor  $< 1$ . Let a change of current  $di_1/dt$  amp/s in coil 1 produce a change of flux  $d\phi_1/dt$  weber/s. The proportion of this flux change linking coil 2 will be  $d\phi_2/dt$  weber/s. If the number of turns on coil 2 is  $N_2$ , then

$$e_2 = \frac{-N_2 d\phi_2}{dt} \text{ volt} \quad (5.15)$$

However, equations (5.14) and (5.15) both refer to the same induced emf. Therefore we can equate the two expressions

$$\frac{M di_1}{dt} = \frac{N_2 d\phi_2}{dt}$$

and transposing for  $M$ , we have

$$M = \frac{N_2 d\phi_2}{di_1} \text{ henry} \quad (5.16)$$

As with self-inductance for a single coil, mutual inductance is a property of a pair of coils. They therefore retain this property, regardless of whether or not an emf is induced. Hence, equation (5.16) may be modified to

$$M = \frac{N_2 \Phi_2}{I_1} \text{ henry} \quad (5.17)$$

**Worked Example 5.24**

**Q** Two coils, A and B, have 2000 turns and 1500 turns respectively. A current of 0.5 A, flowing in A, produces a flux of  $60 \mu\text{Wb}$ . The flux linking with B is 83% of this value. Determine (a) the self-inductance of coil A, and (b) the mutual inductance of the two coils.

**A**

$$N_A = 2000; N_B = 1500; I_A = 0.5 \text{ A}; \Phi_A = 60 \times 10^{-6} \text{ Wb}$$

$$(a) \quad L_A = \frac{N_A \Phi_A}{I_A} \text{ henry} = \frac{2000 \times 60 \times 10^{-6}}{0.5}$$

$$\text{so, } L_A = 0.24 \text{ H Ans}$$

$$(b) \quad M = \frac{N_B \Phi_B}{I_A} \text{ henry} = \frac{1500 \times 0.83 \times 60 \times 10^{-6}}{0.5}$$

$$\text{so, } M = 0.149 \text{ H Ans}$$

**5.21 Relationship between Self- and Mutual-Inductance**

Consider two coils of  $N_1$  and  $N_2$  turns respectively, wound on to a common non-magnetic core. If the reluctance of the core is  $S$  ampere turns/weber, and the coupling coefficient is unity, then

$$L_1 = \frac{N_1^2}{S} \quad \text{and} \quad L_2 = \frac{N_2^2}{S}$$

therefore,

$$L_1 L_2 = \frac{N_1^2 N_2^2}{S^2} \dots\dots\dots [1]$$

$$M = \frac{N_2 \Phi}{I_1} \text{ henry, and multiplying by } \frac{N_1}{N_1}$$

$$M = \frac{N_1 N_2 \Phi}{N_1 I_1}$$

The above expression contains the term

$$\frac{\Phi}{N_1 I_1} = \frac{1}{S}$$

$$\text{so, } M = \frac{N_1 N_2}{S}$$

$$\text{therefore, } M^2 = \frac{N_1^2 N_2^2}{S^2} \dots\dots\dots [2]$$

and comparing equations [1] and [2]

$$M^2 = L_1 L_2$$

$$\text{therefore, } M = \sqrt{L_1 L_2} \text{ henry} \quad (5.18)$$

the above equation is correct only provided that there is 100% coupling between the coils; i.e.  $k = 1$ . If  $k < 1$ , then the general form of the equation, shown below, applies.

$$M = k\sqrt{L_1L_2} \text{ henry} \quad (5.19)$$

### Worked Example 5.25

**Q** A 400 turn coil is wound onto a cast steel toroid having an effective length of 25 cm and csa  $4.5 \text{ cm}^2$ . If the steel has a relative permeability of 180 under the operating conditions, calculate the self-inductance of the coil.

**A**

$$N = 400; \ell = 0.25 \text{ m}; A = 4.5 \times 10^{-4} \text{ m}^2; \mu_r = 180$$

$$L = \frac{\mu_0\mu_r N^2 A}{\ell} \text{ henry} = \frac{4\pi \times 10^{-7} \times 180 \times 400^2 \times 4.5 \times 10^{-4}}{0.25}$$

so,  $L = 65 \text{ mH}$  **Ans**

### Worked Example 5.26

**Q** Considering Example 5.25, a second coil of 650 turns is wound over the first, and the current through coil 1 is changed from 2 A to 0.5 A in a time of 3 ms. If 95% of the flux thus produced links with coil 2, then calculate (a) the self-inductance of coil 2, (b) the value of mutual inductance, (c) the self-induced emf in coil 1, and (d) the mutually induced emf in coil 2.

**A**

$$L_1 = 65 \times 10^{-3} \text{ H}; dI_1 = 2 - 0.5 = 1.5 \text{ A}; dt = 3 \times 10^{-3} \text{ s}; k = 0.95$$

(a) From the equation for inductance we know that  $L \propto N^2$ , and since all other factors for the two coils are the same, then

$$\frac{L_2}{L_1} = \frac{N_2^2}{N_1^2}$$

$$\begin{aligned} \text{so, } L_2 &= \frac{N_2^2 L_1}{N_1^2} \text{ henry} \\ &= \frac{650^2 \times 65}{400^2} \text{ mH} \end{aligned}$$

and,  $L_2 = 172 \text{ mH}$  **Ans**

It is left to the student to confirm this answer by using the equation

$$L = \frac{\mu_0\mu_r N^2 A}{\ell}$$

(b)  $M = k\sqrt{L_1L_2} \text{ henry} = 0.95\sqrt{65 \times 172} \text{ mH}$   
thus,  $M = 100 \text{ mH}$  **Ans**

$$(c) \quad e_1 = -L_1 \frac{di}{dt} \text{ volt} = \frac{65 \times 10^{-3} \times 1.5}{3 \times 10^{-3}}$$

so,  $e_1 = 32.5 \text{ V Ans}$

$$(d) \quad e_2 = -M \frac{di_1}{dt} \text{ volt} = \frac{100 \times 1.5}{3 \times 10^{-3}}$$

and,  $e_2 = 50 \text{ V Ans}$

## 5.22 Energy Stored

As with an electric field, a magnetic field also stores energy. When the current through an inductive circuit is interrupted, by opening a switch, this energy is released. This is the reason why a spark or arc occurs between the contacts of the switch, when it is opened.

Consider an inductor connected in a circuit, in which the current increases uniformly, to some steady value  $I$  amp. This current change is illustrated in Fig. 5.39. The magnitude of the emf induced by this change of current is given by

$$e = \frac{LI}{t} \text{ volt}$$

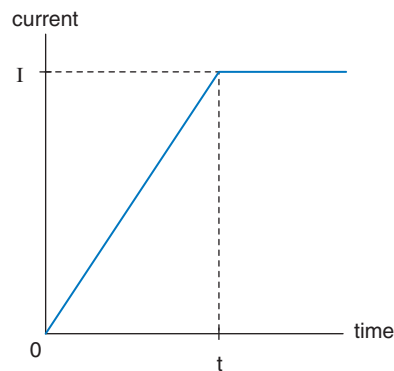

Fig. 5.39

The average power input to the coil during this time is:

$$\text{average power} = e \times \text{average current}$$

From the graph, it may be seen that the average current over this time is  $I/2$  amp.

Therefore,

$$\text{average power} = \frac{1}{2} eI = \frac{LI}{2t} = \frac{LI^2}{2t} \text{ watt}$$

but, energy stored = average power  $\times$  time

$$\text{power} = \frac{LI^2 t}{2t} \text{ joule}$$

$$\text{thus, energy stored, } W = \frac{1}{2} LI^2 \text{ joule} \quad (5.20)$$

Equation 5.20 applies to a single inductor. When two coils possess mutual inductance, and are connected in series, both will store energy. In this situation, the total energy stored is given by the equation

$$W = \frac{1}{2} L_1 I_1^2 + \frac{1}{2} L_2 I_2^2 \pm M I_1 I_2 \text{ joule} \quad (5.21)$$

### Worked Example 5.27

**Q** Calculate the energy stored in a 50 mH inductor when it is carrying a current of 0.75 A.

**A**

$$L = 50 \times 10^{-3} \text{ H}; I = 0.75 \text{ A}$$

$$W = \frac{1}{2} LI^2 \text{ joule} = \frac{50 \times 10^{-3} \times 0.75^2}{2}$$

therefore,  $W = 14.1 \text{ mJ}$  **Ans**

### Worked Example 5.28

**Q** Two inductors, of inductance 25 mH and 40 mH respectively, are wound on a common ferromagnetic core, and are connected in series with each other. The coupling coefficient,  $k$ , between them is 0.8. When the current flowing through the two coils is 0.25 A, calculate (a) the energy stored in each, (b) the total energy stored when the coils are connected (i) in series aiding, and (ii) in series opposition.

**A**

$$L_1 = 25 \times 10^{-3} \text{ H}; L_2 = 40 \times 10^{-3} \text{ H}; I_1 = I_2 = 0.25 \text{ A}; k = 0.8$$

$$(a) \quad W_1 = \frac{1}{2} L_1 I_1^2 \text{ joule} = 0.5 \times 25 \times 10^{-3} \times 0.25^2$$

so,  $W_1 = 0.78 \text{ mJ}$  **Ans**

$$W_2 = \frac{1}{2} L_2 I_2^2 \text{ joule} = 0.5 \times 40 \times 10^{-3} \times 0.25^2$$

so,  $W_2 = 1.25 \text{ mJ}$  **Ans**

(b) The general equation for the energy stored by two inductors with flux linkage between them is:

$$W = \frac{1}{2} L_1 I_1^2 + \frac{1}{2} L_2 I_2^2 \pm M I_1 I_2 \text{ joule}$$

When the coils are connected in series such that the two fluxes produced act in the same direction, the total flux is increased and the coils are said to be connected in series aiding. In this case the total energy stored in the system will be increased, so the last term in the above equation is added, i.e. the + sign applies. If, however, the connections to one of the coils are reversed, then the two fluxes will oppose each other, the total flux will be reduced, and the coils are said to be in series opposition. In this case the – sign is used. These two connections are shown in Fig. 5.40.

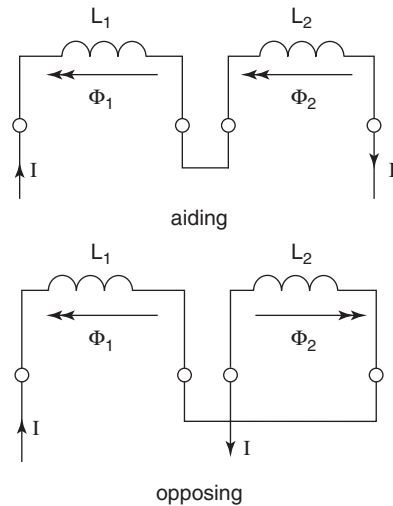

Fig. 5.40

$$M = k\sqrt{L_1L_2} \text{ henry} = 0.8\sqrt{25 \times 40} \text{ mH}$$

so,  $M = 25.3 \text{ mH}$

The values for  $\frac{1}{2}L_1I_1^2$  and  $\frac{1}{2}L_2I_2^2$  have been calculated in part (a) and

$$MI_1I_2 = 25.3 \times 10^{-3} \times 0.25^2 = 1.58 \text{ mJ}$$

(i) For series aiding:

$$W = 0.78 + 1.25 + 1.58 \text{ mJ}$$

so,  $W = 3.6 \text{ mJ}$  **Ans**

(ii) For series opposition:

$$W = 0.78 + 1.25 - 1.58 \text{ mJ}$$

so,  $W = 0.45 \text{ mJ}$  **Ans**

## 5.23 The Transformer Principle

A transformer is an **a.c.** machine, which utilises the mutual inductance between two coils, or windings. The two windings are wound on to

a common iron core, but are not electrically connected to each other. The purpose of the iron core is to reduce the reluctance of the magnetic circuit. This ensures that the flux linkage between the coils is almost 100%.

**a.c.** means alternating current, i.e. one which flows alternately, first in one direction, then in the opposite direction. It is normally a sine wave

Since it is an a.c. machine, an alternating flux is produced in the core. The core is therefore laminated, to minimise the eddy current loss. Indeed, the transformer is probably the most efficient of all machines. Efficiencies of 98% to 99% are typical. This high efficiency is due mainly to the fact that there are no moving parts.

The general arrangement is shown in Fig. 5.41. One winding, called the primary, is connected to an a.c. supply. The other winding, the secondary, is connected to a **load**. The primary will draw an alternating current  $I_1$  from the supply. The flux,  $\Phi$ , produced by this winding, will therefore

A **load** is any device or circuit connected to some source of emf. Thus, a load will draw current from the source. The term load is also loosely used to refer to the actual current drawn from a source

also be alternating; i.e. it will be continuously changing. Assuming 100% flux linkage, then this flux is the only common factor linking the two windings. Thus, a mutually induced emf,  $E_2$ , will be developed across the secondary. Also, there will be a back emf,  $E_1$ , induced across

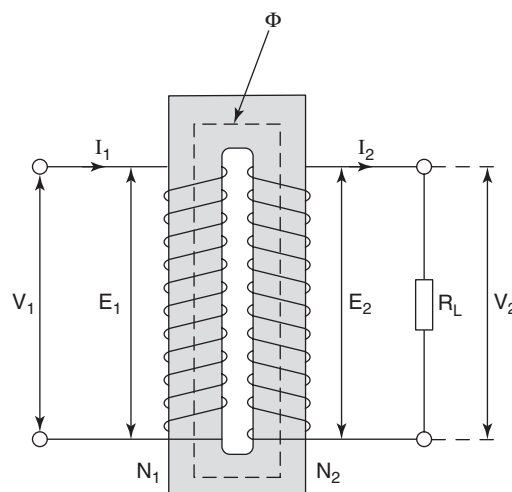

Fig. 5.41

the primary. If the secondary is connected to a load, then it will cause the secondary current  $I_2$  to flow. This results in a secondary terminal voltage,  $V_2$ . Figure 5.42 shows the circuit symbol for a transformer.

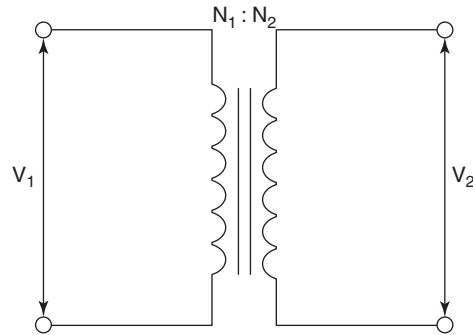

Fig. 5.42

## 5.24 Transformer Voltage and Current Ratios

Let us consider an ideal transformer. This means that the resistance of the windings is negligible, and there are no core losses due to hysteresis and eddy currents. Also, let the secondary be connected to a purely resistive load, as shown in Fig. 5.43.

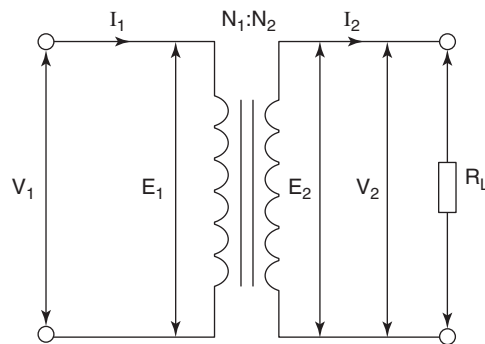

Fig. 5.43

Under these conditions, the primary back emf,  $E_1$ , will be of the same magnitude as the primary applied voltage,  $V_1$ . The secondary terminal voltage,  $V_2$ , will be of the same magnitude as the secondary induced emf,  $E_2$ . Finally, the output power will be the same as the input power.

The two emfs are given by

$$E_1 = \frac{-N_1 d\Phi}{dt} \text{ volt, and } E_2 = \frac{-N_2 d\Phi}{dt} \text{ volt so,}$$

$$\frac{d\Phi}{dt} = \frac{E_1}{N_1} \dots\dots\dots [1]$$

$$\text{and } \frac{d\Phi}{dt} = \frac{E_2}{N_2} \dots\dots\dots [2]$$

Since both equations [1] and [2] refer to the same rate of change of flux in the core, then [1] = [2]:

$$\frac{E_1}{N_1} = \frac{E_2}{N_2}$$

$$\text{hence, } \frac{E_1}{E_2} = \frac{N_1}{N_2}$$

and since  $E_1 = V_1$ , and  $E_2 = V_2$ , then

$$\frac{V_1}{V_2} = \frac{N_1}{N_2} \quad (5.22)$$

From this equation, it may be seen that the voltage ratio is the same as the turns ratio. This is perfectly logical, since the same flux links both windings, and each induced emf is directly proportional to its respective number of turns. This is the main purpose of the transformer. It can therefore be used to 'step up' or 'step down' a.c. voltages, depending upon the turns ratio selected.

### Worked Example 5.29

**Q** A transformer is to be used to provide a 60V output from a 240V a.c. supply. Calculate (a) the turns ratio required, and (b) the number of primary turns, if the secondary is wound with 500 turns.

**A**

$$V_2 = 60\text{V}; V_1 = 240\text{V}; N_2 = 500$$

$$(a) \quad \frac{V_1}{V_2} = \frac{N_1}{N_2} = \frac{240}{60}$$

$$\text{so, turns ratio, } \frac{N_1}{N_2} = \frac{4}{1} \text{ or } 4:1 \text{ Ans}$$

$$(b) \quad \frac{N_1}{500} = \frac{4}{1}$$

$$\text{therefore, } N_1 = 2000 \text{ Ans}$$

Since the load is purely resistive, then the output power,  $P_2$ , is given by

$$P_2 = V_2 I_2 \text{ watt}$$

$$\text{and the input power, } P_1 = V_1 I_1 \text{ watt}$$

Also since the transformer has been considered to be 100% efficient (no losses), then

$$P_2 = P_1$$

therefore,  $V_2 I_2 = V_1 I_1$

$$\frac{I_1}{I_2} = \frac{V_2}{V_1} \text{ but } \frac{V_2}{V_1} = \frac{N_2}{N_1}$$

$$\text{hence, } \frac{I_1}{I_2} = \frac{N_2}{N_1} \quad (5.23)$$

i.e. The current ratio is the *inverse* of the turns ratio.

This result is also logical. For example, if the voltage was ‘stepped up’ by the ratio  $N_2/N_1$ , then the current must be ‘stepped down’ by the same ratio. If this was not the case, then we would get more power out than was put in! Although this result would be very welcome, it is a physical impossibility. It would require the machine to be *more* than 100% efficient.

### Worked Example 5.30

**Q** A  $15\ \Omega$  resistive load is connected to the secondary of a transformer. The terminal p.d. at the secondary is 240V. If the primary is connected to a 600V a.c. supply, calculate (a) the transformer turns ratio, (b) the current and power drawn by the load, and (c) the current drawn from the supply. Assume an ideal transformer.

**A**

$$R_L = 15\ \Omega; V_2 = 240\text{V}; V_1 = 600\text{V}$$

The appropriate circuit diagram is shown in Fig. 5.43.

$$(a) \quad \frac{N_1}{N_2} = \frac{V_1}{V_2} = \frac{600}{240}$$

so, turns ratio,  $N_1/N_2 = 2.5:1$  **Ans**

$$(b) \quad I_2 = \frac{V_2}{R_L} \text{ ohm} = \frac{240}{15}$$

so,  $I_2 = 16\text{ A}$  **Ans**

$$P_2 = V_2 I_2 \text{ watt} = 240 \times 16$$

therefore,  $P_2 = 3.84\text{ kW}$  **Ans**

$$(c) \quad P_1 = P_2 = 3.84\text{ kW}$$

and,  $P_1 = V_1 I_1$  watt

$$\text{therefore, } I_1 = \frac{P_1}{V_1} \text{ amp} = \frac{3840}{600}$$

hence,  $I_1 = 6.4\text{ A}$  **Ans**

Alternatively, using the inverse of the turns ratio:

$$I_1 = I_2 \times \frac{N_2}{N_1} = \frac{16}{2.5}$$

so,  $I_1 = 6.4 \text{ A}$  **Ans**

## Summary of Equations

**Self-induced emf:**  $e = -N \frac{d\phi}{dt}$  volt

**Emf in a straight conductor:**  $e = B\ell v \sin \phi$  volt

**Force on a current carrying conductor:**  $F = BI\ell \sin \phi$  volt

**Motor principle:**  $T = BANl$  newton metre

**Force between current carrying conductors:**  $F = \frac{2 \times 10^{-7} I_1 I_2}{d}$  newton

**Voltmeter figure of merit:**  $\frac{1}{I_{fsd}}$  ohm/volt

**Self-inductance:** Self-induced emf,  $e = -L \frac{di}{dt}$  volt

$$L = N \frac{d\phi}{di} = \frac{N\Phi}{I} \text{ henry}$$

$$L = \frac{N^2}{S} = \frac{\mu_0 \mu_r N^2 A}{\ell} \text{ henry}$$

**Energy stored:**  $W = 0.5LI^2$  joule

**Mutual inductance:** Mutually induced emf,  $e_2 = -M \frac{di_1}{dt}$  volt

$$M = N_2 \frac{d\phi_2}{di_1} = \frac{N_2 \Phi_2}{I_1} \text{ henry}$$

$$M = k\sqrt{L_1 L_2} \text{ henry}$$

**Energy stored:**  $W = 0.5L_1 I_1^2 + 0.5L_2 I_2^2 \pm MI_1 I_2$  joule

**Transformer:** Voltage ratio,  $\frac{V_2}{V_1} = \frac{N_2}{N_1}$

Current ratio,  $\frac{I_2}{I_1} = \frac{N_1}{N_2}$

## Assignment Questions

- 1 The flux linking a 600 turn coil changes uniformly from 100 mWb to 50 mWb in a time of 85 ms. Calculate the average emf induced in the coil.
- 2 An average emf of 350V is induced in a 1000 turn coil when the flux linking it changes by 200  $\mu$ Wb. Determine the time taken for the flux to change.
- 3 A flux of 1.5 mWb, linking with a 250 turn coil, is uniformly reversed in a time of 0.02 s. Calculate the value of the emf so induced.
- 4 A coil of 2000 turns is linked by a magnetic flux of 400  $\mu$ Wb. Determine the emf induced in the coil when (a) this flux is reversed in 0.05 s, and (b) the flux is reduced to zero in 0.15 s.
- 5 When a magnetic flux linking a coil changes, an emf is induced in the coil. Explain the factors that determine (a) the magnitude of the emf, and (b) the direction of the emf.
- 6 State Lenz's law, and hence explain the term 'back emf'.
- 7 A coil of 15 000 turns is required to produce an emf of 15 kV. Determine the rate of change of flux that must link with the coil in order to provide this emf.
- 8 A straight conductor, 8 cm long, is moved with a constant velocity at right angles to a magnetic field. If the emf induced in the conductor is 40 mV, and its velocity is 10 m/s, calculate the flux density of the field.
- 9 A conductor of effective length 0.25 m is moved at a constant velocity of 5 m/s, through a magnetic field of density 0.4T. Calculate the emf induced when the direction of movement relative to the magnetic field is (a) 90°, (b) 60°, and (c) 45°.
- 10 Figure 5.44 represents two of the **armature** conductors of a d.c. generator, rotating in a clockwise direction. Copy this diagram and hence:
  - (a) Indicate the direction of the field pattern of the magnetic poles.

An **armature** is the rotating part of a d.c. machine. If the machine is used as a generator, it contains the coils into which the emf is induced. In the case of a motor, it contains the coils through which current must be passed, to produce the torque

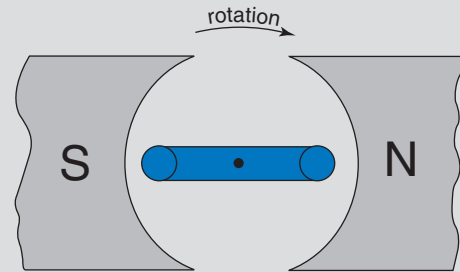

Fig. 5.44

- (b) Indicate the direction of induced emf in each side of the coil.
  - (c) If this arrangement was to be used as a motor, with the direction of rotation as shown, indicate the direction of current flow required through the coil.
- 11 A conductor of effective length 0.5 m is placed at right angles to a magnetic field of density 0.45T. Calculate the force exerted on the conductor if it carries a current of 5 A.
  - 12 A conductor of effective length 1.2 m is placed inside a magnetic field of density 250 mT. Determine the value of current flowing through the conductor, if a force of 0.75 N is exerted on the conductor.
  - 13 A conductor, when placed at right angles to a magnetic field of density 700 mT, experiences a force of 20 mN, when carrying a current of 200 mA. Calculate the effective length of the conductor.
  - 14 A conductor, 0.4 m long, lies between two pole pieces, with its length parallel to the pole faces. Determine the force exerted on the conductor, if it carries a current of 30 A, and the flux density is 0.25T.
  - 15 The coil of a moving coil meter is wound with 75 turns, on a former of effective length 2.5 cm, and diameter 2 cm. The former rotates at right angles to the field, which has a flux density of 0.5T. Determine the deflecting torque when the coil current is 50  $\mu$ A.
  - 16 A moving coil meter has a coil of 60 turns wound on to a former of effective length 22.5 mm and diameter 15 mm. If the flux density in the air gap is 0.2T, and the coil current is 0.1 mA. Calculate (a) the force acting on each side of the coil, and (b) the restoring torque exerted by the springs for the resulting deflection of the coil.

## Assignment Questions

- 17** Two long parallel conductors, are spaced 12 cm between centres. If they carry 100 A and 75 A respectively, calculate the force per metre length acting on them. If the currents are flowing in opposite directions, will this be a force of attraction or repulsion? Justify your answer by means of a sketch of the magnetic field pattern produced.
- 18** The magnetic flux density at a distance of 1.4 m from the centre of a current carrying conductor is 0.25 mT. Determine the value of the current.
- 19** A moving coil meter has a coil resistance of  $25\ \Omega$ , and requires a current of 0.25 mA to produce full-scale deflection. Determine the values of shunts required to extend its current reading range to (a) 10 mA, and (b) 1 A. Sketch the relevant circuit diagram.
- 20** For the meter movement described in question 19 above, show how it may be adapted to serve as a voltmeter, with voltage ranges of 3V and 10V. Calculate the values for, and name, any additional components required to achieve this. Sketch the relevant circuit diagram.
- 21** Explain what is meant by the term 'loading effect'.
- 22** A voltmeter, having a figure of merit of  $15\ \text{k}\Omega/\text{volt}$ , has voltage ranges of 0.1V, 1V, 3V and 10V. If the resistance of the moving coil is  $30\ \Omega$ , determine the multiplier values required for each range. Sketch a circuit diagram, showing how the four ranges could be selected.
- 23** Figure 5.45 shows a circuit in which the p.d. across resistor  $R_2$  is to be measured. The voltmeter available for this measurement has a figure of merit of  $20\ \text{k}\Omega/\text{V}$ , and has voltage ranges of 1V, 10V and 100V. Determine the percentage error in the voltmeter reading, when used to measure this p.d.

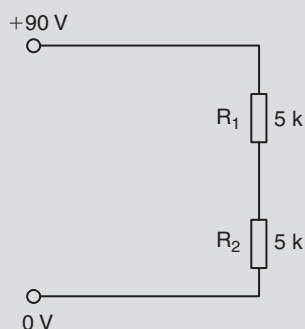

Fig. 5.45

- 24** Calculate the self-inductance of a 700 turn coil, if a current of 5 A flowing through it produces a flux of 8 mWb.
- 25** A coil of 500 turns has an inductance of 2.5 H. What value of current must flow through it in order to produce a flux of 20 mWb?
- 26** When a current of 2.5 A flows through a 0.5 H inductor, the flux produced is  $80\ \mu\text{Wb}$ . Determine the number of turns.
- 27** A 1000 turn coil has a flux of 20 mWb linking it when carrying a current of 4 A. Calculate the coil inductance, and the emf induced when the current is reduced to zero in a time of 25 ms.
- 28** A coil has 300 turns and an inductance of 5 mH. How many turns would be required to produce an inductance of 0.8 mH, if the same core material were used?
- 29** If an emf of 4.5V is induced in a coil having an inductance of 200 mH, calculate the rate of change of current.
- 30** An iron ring having a mean diameter of 300 mm and cross-sectional area of  $500\ \text{mm}^2$  is wound with a 150 turn coil. Calculate the inductance, if the relative permeability of the ring is 50.
- 31** An iron ring of mean length 50 cm and csa  $0.8\ \text{cm}^2$  is wound with a coil of 350 turns. A current of 0.5 A through the coil produces a flux density of 0.6T in the ring. Calculate (a) the relative permeability of the ring, (b) the inductance of the coil, and (c) the value of the induced emf if the current decays to 20% of its original value in 0.01 s, when the current is switched off.
- 32** When the current in a coil changes from 2 A to 12 A in a time of 150 ms, the emf induced into an adjacent coil is 8V. Calculate the mutual inductance between the two coils.
- 33** The mutual inductance between two coils is 0.15 H. Determine the emf induced in one coil when the current in the other decreases uniformly from 5 A to 3 A, in a time of 10 ms.
- 34** A coil of 5000 turns is wound on to a non-magnetic toroid of csa  $100\ \text{cm}^2$ , and mean circumference 0.5 m. A second coil of 1000 turns is wound over the first coil. If a current of 10 A flows through the first coil, determine (a) the self-inductance of the first coil, (b) the mutual inductance, assuming a coupling factor of 0.45, and (c) the average emf induced in the second coil if interruption of the current causes the flux to decay to zero in 0.05 s.

### Assignment Questions

- 35** Two air-cored coils, A and B, are wound with 100 and 500 turns respectively. A current of 5 A in A produces a flux of  $15 \mu\text{Wb}$ . Calculate (a) the self-inductance of coil A, (b) the mutual inductance, if 75% of the flux links with B, and (c) the emf induced in each of the coils, when the current in A is reversed in a time of 10 ms.
- 36** Two coils, of self-inductance 50 mH and 85 mH respectively, are placed parallel to each other. If the coupling coefficient is 0.9, calculate their mutual inductance.
- 37** The mutual inductance between two coils is 250 mH. If the current in one coil changes from 14 A to 5 A in 15 ms, calculate (a) the emf induced in the other coil, and (b) the change of flux linked with this coil if it is wound with 400 turns.
- 38** The mutual inductance between the two windings of a car ignition coil is 5 H. Calculate the average emf induced in the high tension winding, when a current of 2.5 A, in the low tension winding, is reduced to zero in 1 ms. You may assume 100% flux linkage between the two windings.
- 39** Sketch the circuit symbol for a transformer, and explain its principle of operation. Why is the core made from laminations? Is the core material a 'hard' or a 'soft' magnetic material? Give the reason for this.
- 40** A transformer with a turns ratio of 20:1 has 240V applied to its primary. Calculate the secondary voltage.
- 41** A 4:1 voltage 'step-down' transformer is connected to a 110 V a.c. supply. If the current drawn from this supply is 100 mA, calculate the secondary voltage, current and power.
- 42** A transformer has 450 primary turns and 80 secondary turns. It is connected to a 240V a.c. supply. Calculate (a) the secondary voltage, and (b) the primary current when the transformer is supplying a 20 A load.
- 43** A coil of self-inductance 0.04 H has a resistance of  $15 \Omega$ . Calculate the energy stored when it is connected to a 24V d.c. supply.
- 44** The energy stored in the magnetic field of an inductor is 68 mJ, when it carries a current of 1.5 A. Calculate the value of self-inductance.
- 45** What value of current must flow through a 20 H inductor, if the energy stored in its magnetic field, under this condition, is 60 J?

## Suggested Practical Assignments

**Note:** The majority of these assignments are only qualitative in nature.

### Assignment 1

To investigate Faraday's laws of electromagnetic induction.

**Apparatus:**

Several coils, having different numbers of turns  
 2 × permanent bar magnets  
 1 × galvanometer

**Method:**

- 1 Carry out the procedures outlined in section 5.1 at the beginning of this chapter.
- 2 Write an assignment report, explaining the procedures carried out, and stating the conclusions that you could draw from the observed results.

### Assignment 2

Force on a current carrying conductor.

**Apparatus:**

1 × current balance  
 1 × variable d.c. psu  
 1 × ammeter

**Method:**

- 1 Assemble the current balance apparatus.
- 2 Adjust the balance weight to obtain the balanced condition, prior to connecting the psu.
- 3 With maximum length of conductor, and all the magnets in place, vary the conductor current in steps. For each current setting, re-balance the apparatus, and note the setting of the balance weight.
- 4 Repeat the balancing procedure with a constant current, and maximum magnets, but varying the effective length of the conductor.
- 5 Repeat once more, this time varying the number of magnets. The current must be maintained constant, as must the conductor length.
- 6 Tabulate all results obtained, and plot the three resulting graphs.
- 7 Write an assignment report. This should include a description of the procedures carried out, and conclusions drawn, regarding the relationships between the force produced and  $I$ ,  $\ell$ , and  $B$ .

### Assignment 3

To investigate the loading effect of a moving coil meter.

**Apparatus:**

1 × 10 k $\Omega$  rotary potentiometer, complete with circular scale  
 1 × d.c. psu  
 1 × Heavy Duty AVO  
 1 × DVM (digital voltmeter)

**Method:**

- 1 Connect the circuit as shown in Fig. 5.46, with the psu set to 10V d.c.
- 2 Start with the potentiometer moving contact at the 'zero' end. Measure the p.d. indicated, in turn, by both the DVM and the AVO, for every 30° rotation of the moving contact.

**Note:** Do NOT connect both meters at the same time; connect them IN TURN.

## Suggested Practical Assignments

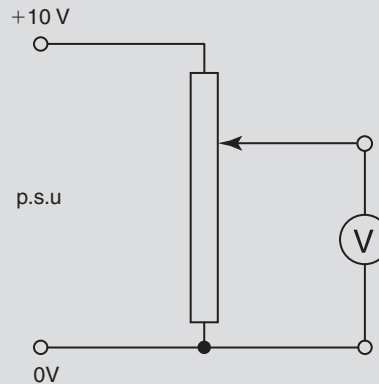

Fig. 5.46

- 3 Tabulate both voltmeter readings. Plot graphs (on the same axes) for the voltage readings versus angular displacement.
- 4 Determine the percentage loading error of the AVO, for displacements of  $0^\circ$ ,  $180^\circ$ , and  $270^\circ$ . Write an assignment report, and include comment regarding the variation of loading error found.

### Assignment 4

To demonstrate mutual inductance and coupling coefficient.

#### Apparatus:

Several coils, having different numbers of turns.  
 Ferromagnet core  
 1  $\times$  galvo  
 1  $\times$  d.c. psu

#### Method:

- 1 Place the two coils as close together as possible. Connect the galvo to one coil, and connect the other coil to the psu via a switch.
- 2 Close the switch, and note the deflection obtained on the galvo.
- 3 Repeat this procedure for increasing distances of separation, and for different coils.
- 4 Mount two of the coils on a common magnetic core, and repeat the procedure.
- 5 Write an assignment report, explaining the results observed.

### Assignment 5

To determine the relationship between turns ratio and voltage ratio for a simple transformer.

#### Apparatus:

*Either* 1  $\times$  single-phase transformer with tapings on both windings;  
*or* Several different coils with a ferromagnetic core.  
*Either* a low voltage a.c. supply;  
*or* 1  $\times$  a.c. signal generator.  
 1  $\times$  DVM (a.c. voltage ranges)

#### Method:

- 1 Connect the primary to the a.c. source.
- 2 Measure both primary and secondary voltages, and note the corresponding number of turns on each winding.
- 3 Vary the number of turns on each winding, and note the corresponding values of the primary and secondary voltages.
- 4 Tabulate all results. Write a brief report, explaining your findings.

# Alternating Quantities

## Learning Outcomes

This chapter deals with the concepts, terms and definitions associated with alternating quantities. The term alternating quantities refers to any quantity (current, voltage, flux, etc.), whose polarity is reversed alternately with time. For convenience, they are commonly referred to as a.c. quantities. Although an a.c. can have any waveshape, the most common waveform is a sinewave. For this reason, unless specified otherwise, you may assume that sinusoidal waveforms are implied.

On completion of this chapter you should be able to:

- 1 Explain the method of producing an a.c. waveform.
- 2 Define all of the terms relevant to a.c. waveforms.
- 3 Obtain values for an a.c., both from graphical information and when expressed in mathematical form.
- 4 Understand and use the concept of phase angle.
- 5 Use both graphical and phasor techniques to determine the sum of alternating quantities.

## 6.1 Production of an Alternating Waveform

From electromagnetic induction theory, we know that the average emf induced in a conductor, moving through a magnetic field, is given by

$$e = B\ell v \sin\theta \text{ volt} \dots\dots\dots[1]$$

Where  $B$  is the flux density of the field (in tesla)

$\ell$  is the effective length of conductor (in metre)

$v$  is the velocity of the conductor (in metre/s)

$\theta$  is the angle at which the conductor ‘cuts’ the lines of magnetic flux (in degrees or radians)

i.e.  $v \sin \theta$  is the component of velocity at right angles to the flux.

Consider a single-turn coil, rotated between a pair of poles, as illustrated in Figs. 6.1(a) and (b). Figure (a) shows the general arrangement. Figure (b) shows a cross-section at one instant in time, such that the coil is moving at an angle of  $\theta^\circ$  to the flux.

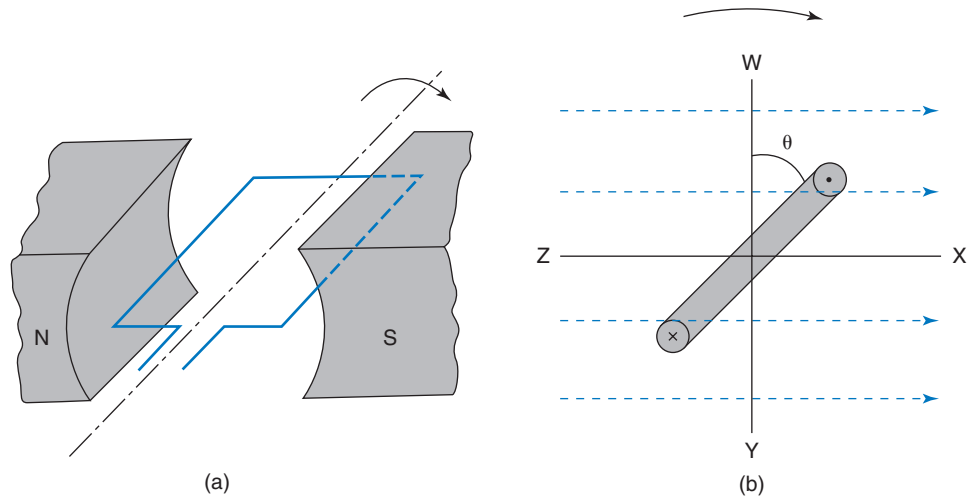

Fig. 6.1

Considering Fig. 6.1(b), each side of the coil will have the same value of emf induced, as given by equation [1] above. The polarities of these emfs will be as shown (Fleming’s righthand rule). Although these emfs are of opposite polarities, they both tend to cause current to flow in the same direction around the coil. Thus, the total emf generated is given by:

$$e = 2 \times B\ell v \sin\theta \text{ volt} \dots\dots\dots[2]$$

Still considering Fig. 6.1(b), at the instant the coil is in the plane W–Y, angle  $\theta = 0^\circ$ . Thus the emf induced is zero. At the instant that it is in the plane X–Z,  $\theta = 90^\circ$ . Thus, the emf is at its maximum possible value, given by:

$$e = 2 \times B\ell v \text{ volt} \dots\dots\dots[3]$$

Let us consider just one side of the coil, starting at position W. After  $90^\circ$  rotation (to position X), the emf will have increased from zero to its maximum value. During the next  $90^\circ$  of rotation (to position Y), the emf falls back to zero. During the next  $180^\circ$  rotation (from Y to Z to W), the emf will again increase to its maximum, and reduce once more to zero. However, during this half revolution, the polarity of the emf is reversed.

If the instantaneous emf induced in the coil is plotted, for one complete revolution, the sinewave shown in Fig. 6.2 will be produced. For convenience, it has been assumed that the maximum value of the coil emf is 1 V, and that the plot starts with the coil in position W.

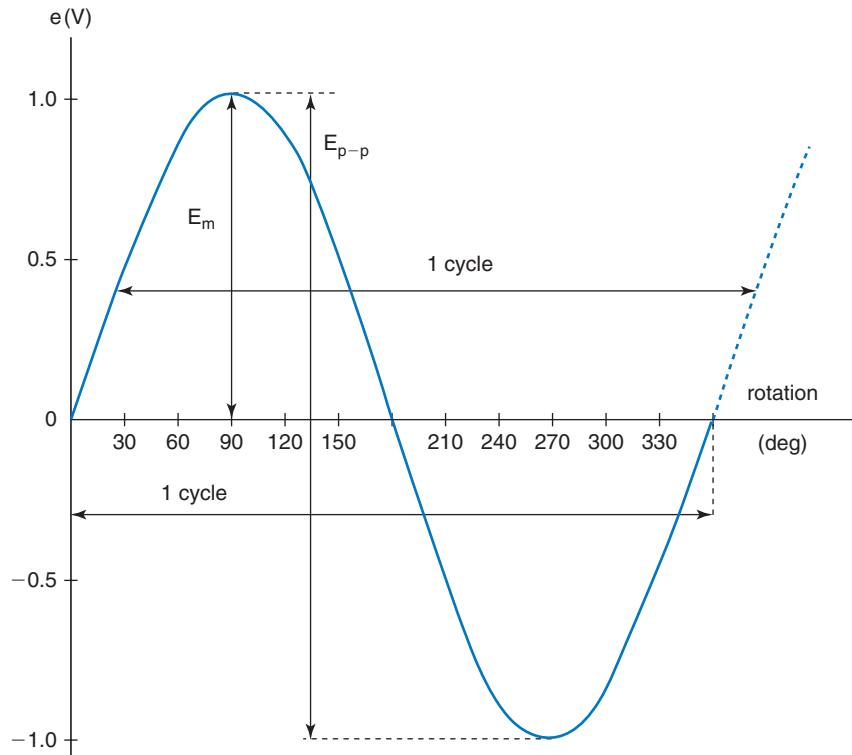

Fig. 6.2

When the coil passes through one complete revolution, the waveform returns to its original starting point. The waveform is then said to have completed one cycle. Note that one cycle is the interval between any two *corresponding* points on the waveform. The number of cycles generated per second is called the *frequency*,  $f$ , of the waveform. The unit for frequency is the hertz (Hz). Thus, one cycle per second is equal to 1 Hz.

For the simple two-pole arrangement considered, one cycle of emf is generated in one revolution. The frequency of the waveform is therefore the same as the speed of rotation, measured in revolution per second (rev/s). This yields the following equation

$$f = np \text{ hertz} \quad (6.1)$$

where  $p$  = the number of pole *pairs*

Therefore, if the coil is rotated at 50 rev/s, the frequency will be

$$f = 50 \times 1 \text{ Hz (one pair of poles)} = 50 \text{ Hz}$$

The time taken for the waveform to complete one cycle is called the *periodic time*,  $T$ . Thus, if 50 cycles are generated in one second, then one cycle must be generated in  $1/50$  of a second. The relationship between frequency and period is therefore

$$T = \frac{1}{f} \text{ second, or } f = \frac{1}{T} \text{ hertz} \quad (6.2)$$

The maximum value of the emf in one cycle is shown by the peaks of the waveform. This value is called, either the maximum or peak value, or the *amplitude* of the waveform. The quantity symbol used may be either  $\hat{E}$ , or  $E_m$ .

The voltage measured between the positive and negative peaks is called the peak-to-peak value. This has the quantity symbol  $E_{pk-pk}$ , or  $E_{p-p}$ .

## 6.2 Angular Velocity and Frequency

In SI units, angles are measured in **radians**, rather than degrees. Similarly, angular velocity is measured in radian per second, rather than revolutions per second. The quantity symbol for angular velocity is  $\omega$  (lower case Greek omega).

A **radian** is the angle subtended at the centre of a circle, by an arc on the circumference, which has length equal to the radius of the circle. Since the circumference =  $2\pi r$ , then there must be  $2\pi$  such arcs in the circumference. Hence there are  $2\pi$  radians in one complete circle; i.e.  $2\pi \text{ rad} = 360^\circ$

If the coil is rotating at  $n$  rev/s, then it is rotating at  $360 \times n$  degrees/second. Since there are  $2\pi$  radians in  $360^\circ$ , then the coil must be rotating at  $2\pi n$  radian per second.

Thus, angular velocity,  $\omega = 2\pi n$  rad/s

but for a 2-pole system,  $n = \text{frequency, } f$  hertz,

$$\text{therefore, } \omega = 2\pi f \text{ rad/s} \quad (6.3)$$

$$\text{and, } f = \frac{\omega}{2\pi} \text{ hertz} \quad (6.4)$$

If the coil is rotating at  $\omega$  rad/s, then in a time of  $t$  seconds, it will rotate through an angle of  $\omega t$  radian. Hence the waveform diagram may be plotted to a base of degrees, radians, or time. In the latter case, the time interval for one cycle is, of course, the periodic time,  $T$ . These are shown in Fig. 6.3.

## 6.3 Standard Expression for an Alternating Quantity

All the information regarding an a.c. can be presented in the form of a graph. The information referred to here is the amplitude,

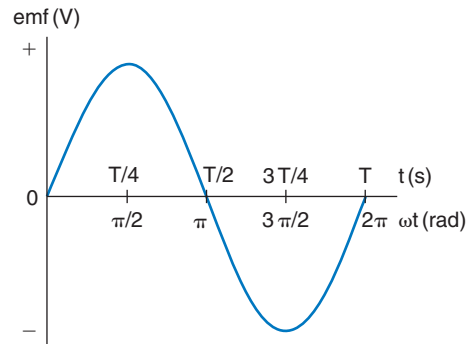

Fig. 6.3

frequency, period, and value at any instant. The last is normally called the instantaneous value. However, presenting the information in this way is not always very convenient. Firstly, the graph has to be plotted accurately, on graph paper. This in itself is a time-consuming procedure. In addition, obtaining precise information from the graph is difficult. The degree of accuracy depends on the suitability of the scales chosen, and the individual's interpretation. For example, if several people are asked to obtain a particular value from the graph, their answers are likely to differ slightly from one another. To overcome these difficulties, the a.c. needs to be expressed in a more convenient form. This results in an equation, sometimes referred to as the algebraic form of the a.c. More correctly, it should be called the trigonometric form. Since many students are put off by these terms, we shall refer to it simply as the standard expression for a waveform.

The emf for an  $N$ -turn coil is:

$$e = 2 \times NB\ell v \sin\theta \text{ volt, where } \theta \text{ is in degrees}$$

$$\text{or, } e = 2 \times NB\ell v \sin(\omega t) \text{ volt, where } \omega t \text{ is in radians}$$

and the emf is at its maximum value when  $\sin(\omega t)$ , or  $\sin\theta$  is equal to 1. Therefore,  $E_m = 2 \times NB\ell v$  volt, so the expression becomes:

$$e = E_m \sin\theta \text{ volt} \quad (6.5)$$

$$\text{or, } e = E_m \sin(\omega t) \text{ volt} \quad (6.6)$$

$$\text{or, } e = E_m \sin(2\pi ft) \text{ volt} \quad (6.7)$$

All three of the above equations are the so-called standard expressions for this a.c. voltage. Equations (6.6), and (6.7) in particular, are those most commonly used. Using these, all the relevant information concerning the waveform is contained in a neat mathematical expression. There is also no chance of ambiguity.

### Worked Example 6.1

**Q** An alternating voltage is represented by the expression  $v = 35 \sin(314.2t)$  volt. Determine, (a) the maximum value, (b) the frequency, (c) the period of the waveform, and (d) the value 3.5 ms after it passes through zero, going positive.

**A**

(a)  $v = 35 \sin(314.2t)$  volt

and comparing this to the standard,

$$v = V_m \sin(2\pi ft) \text{ volt we can see that:}$$

$$V_m = 35 \text{ V Ans}$$

(b) Again, comparing the two expressions:

$$2\pi f = 314.2$$

$$\text{so, } f = \frac{314.2}{2\pi} = 50 \text{ Hz Ans}$$

(c)  $T = \frac{1}{f} = \frac{1}{50}$  second

$$\text{so, } T = 20 \text{ ms Ans}$$

(d) When  $t = 3.5$  ms; then:

$$v = 35 \sin(2\pi \times 50 \times 3.5 \times 10^{-3}) \text{ volt}$$

$$= 35 \sin(1.099)^*$$

$$= 35 \times 0.891$$

$$\text{therefore, } v = 31.19 \text{ V Ans}$$

\*The term inside the brackets is an angle in RADIAN. You must therefore remember to switch your calculator into the RADIAN MODE.

So far, we have dealt only with an alternating voltage. However, all of the terms and definitions covered are equally applicable to any alternating quantity. Thus, exactly the same techniques apply to a.c. currents, fluxes, etc. The same applies to mechanical alternating quantities involving oscillations, vibrations, etc.

### Worked Example 6.2

**Q** For a current,  $i = 75 \sin(200\pi t)$  milliamp, determine (a) the frequency, and (b) the time taken for it to reach 35 mA, for the first time, after passing through zero.

**A**

(a)  $i = 75 \sin(200\pi t)$  milliamp

$$i = I_m \sin(2\pi ft) \text{ amp}$$

$$\text{so, } 2\pi f = 200\pi$$

$$\text{and } f = \frac{200\pi}{2\pi} = 100 \text{ Hz Ans}$$

(b)  $35 = 75 \sin(200\pi t)$  milliamp

$$\frac{35}{75} = \sin(200\pi t) = 0.4667$$

$$\begin{aligned} \text{therefore, } 200\pi t &= \sin^{-1} 0.4667^* \\ &= 0.4855 \text{ rad} \end{aligned}$$

$$\text{so, } t = \frac{0.4855}{200\pi} = 0.773 \text{ ms Ans}$$

\*Remember, use RADIAN mode on your calculator.

## 6.4 Average Value

Figure 6.4 shows one cycle of a sinusoidal current.

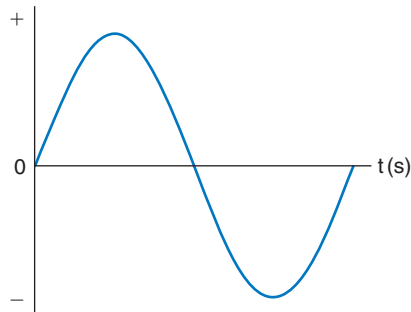

Fig. 6.4

From this it is apparent that the area under the curve in the positive half is exactly the same as that for the negative half. Thus, the average value over one complete cycle must be zero. For this reason, the average value is taken to be the average over one half cycle. This average may be obtained in a number of ways. These include, the mid-ordinate rule, the trapezoidal rule, Simpson's rule, and integral calculus. The simplest of these is the mid-ordinate rule, and this will be used here to illustrate average value; see Fig. 6.5.

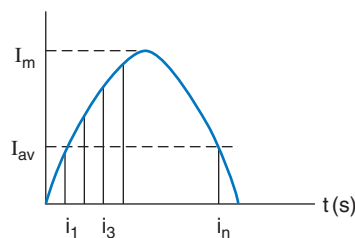

Fig. 6.5

A number of equally spaced intervals are selected, along the time axis of the graph. At each of these intervals, the instantaneous value is determined.

This results in values for a number of ordinates,  $i_1, i_2, \dots, i_n$ , where  $n$  is the number of ordinates chosen. The larger the number of ordinates chosen, the more accurate will be the final average value obtained. The average is simply found by adding together all the ordinate values, and then dividing this figure by the number of ordinates chosen, thus

$$I_{av} = \frac{i_1 + i_2 + i_3 + \dots + i_n}{n}$$

The average value will of course depend upon the shape of the waveform, and *for a sinewave only* it is

$$I_{av} = \frac{2}{\pi} I_m = 0.637 I_m \quad (6.8)$$

### Worked Example 6.3

**Q** A sinusoidal alternating voltage has an average value of 3.5 V and a period of 6.67 ms. Write down the standard (trigonometrical) expression for this voltage.

**A**

$$V_{av} = 3.5 \text{ V}; T = 6.67 \times 10^{-3} \text{ s}$$

The standard expression is of the form  $v = V_m \sin(2\pi ft)$  volt

$$V_{av} = 0.637 V_m \text{ volt}$$

$$\text{so, } V_m = \frac{V_{av}}{0.637} \text{ volt} = \frac{3.5}{0.637}$$

$$V_m = 5.5 \text{ V}$$

$$f = \frac{1}{T} \text{ hertz} = \frac{1}{6.67 \times 10^{-3}} \text{ Hz}$$

$$\text{and, } f = 150 \text{ Hz}$$

$$v = 5.5 \sin(2\pi \times 150 \times t) \text{ volt}$$

$$\text{so, } v = 5.5 \sin(300\pi t) \text{ volt } \mathbf{Ans}$$

### Worked Example 6.4

**Q** For the waveform specified in Example 6.3 above, after the waveform passes through zero, going positive, determine its instantaneous value (a) 0.5 ms later, (b) 4.5 ms later, and (c) the time taken for the voltage to reach 3 V for the first time.

**A**

$$(a) \quad t = 0.5 \times 10^{-3} \text{ s}; \quad (b) \quad t = 4.5 \times 10^{-3} \text{ s}; \quad (c) \quad v = 3 \text{ V}$$

$$\begin{aligned} (a) \quad v &= V_m \sin(300\pi \times 0.5 \times 10^{-3}) \text{ volt} \\ &= 5.5 \sin 0.4712 \\ &= 5.5 \times 0.454 \end{aligned}$$

$$\text{thus, } v = 2.5 \text{ V } \mathbf{Ans}$$

$$\begin{aligned}
 \text{(b)} \quad v &= 5.5 \sin (300\pi \times 4.5 \times 10^{-3}) \text{ volt} \\
 &= 5.5 \sin 4.241 \\
 &= 5.5 \times (-0.891) \\
 \text{and, } v &= -4.9 \text{ V Ans}
 \end{aligned}$$

**Note:** Remember that the expression inside the brackets is an angle in RADIANS.

$$\begin{aligned}
 \text{(c)} \quad 3 &= 5.5 \sin (300\pi t) \text{ volt} \\
 \text{so, } \sin (300\pi t) &= \frac{3}{5.5} = 0.5455 \\
 300\pi t &= \sin^{-1} 0.5455 = 0.5769 \text{ rad} \\
 t &= \frac{0.5769}{300\pi} = 6.12 \times 10^{-4} \\
 \text{and, } t &= 0.612 \text{ ms Ans}
 \end{aligned}$$

A sketch graph illustrating these answers is shown in Fig. 6.6.

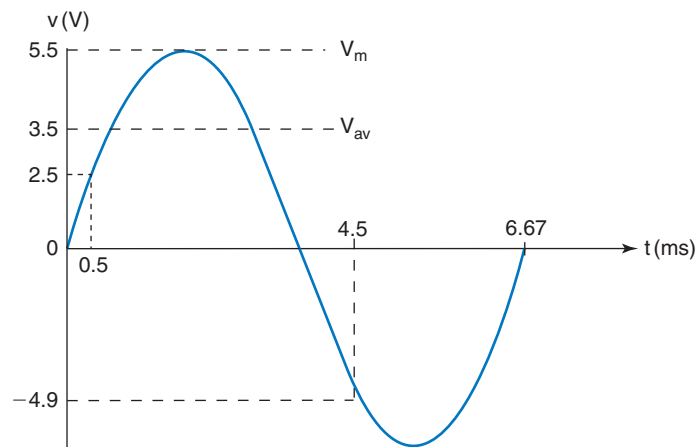

Fig. 6.6

## 6.5 r.m.s. Value

The r.m.s. value of an alternating current is equivalent to that value of direct current, which when passed through an identical circuit, will dissipate exactly the same amount of power. The r.m.s. value of an a.c. thus provides a means of making a comparison between a.c. and d.c. systems.

The term r.m.s. is an abbreviation of the square Root of the Means Squared. The technique for finding the r.m.s. value may be based on the same ways as were used to find the average value. However, the r.m.s. value applies to the complete cycle of the waveform. For simplicity, we will again consider the use of the mid-ordinate rule technique.

Considering Fig. 6.5, the ordinates would be selected and measured in the same way as before. The value of each ordinate is then squared. The resulting values are then summed, and the average found. Finally, the square root of this average (or mean) value is determined. This is illustrated below:

$$I_{rms} = \sqrt{\frac{i_1^2 + i_2^2 + i_3^2 + \dots + i_n^2}{n}}$$

$$\text{and, for a sinewave only, } I_{rms} = \frac{1}{\sqrt{2}} I_m = 0.707 I_m \quad (6.9)$$

Other waveforms will have a different ratio between r.m.s. and peak values.

**Note:** The r.m.s. value of an a.c. is the value normally used and quoted. For example, if reference is made to a 240 V a.c. supply, then 240 V is the r.m.s. value. In general therefore, if an unqualified value for an a.c. is given, then the assumption is made that this is the r.m.s. value. Since r.m.s. values are those commonly used, the subscript letters r.m.s. are not normally included.  $I_{rms}$  has been used above, simply for emphasis. The following convention is used:

$i, v, e$ , represent instantaneous values  
 $I_{av}, V_{av}, E_{av}$ , represent average values  
 $I_m, V_m, E_m$ , represent maximum or peak values, or *amplitude*  
 $I, V, E$ , represent r.m.s. values

## 6.6 Peak Factor

This is defined as the ratio of the peak or maximum value, to the r.m.s. value, of a waveform. Thus, *for a sinewave only*

$$\begin{aligned} \text{peak factor} &= \frac{\text{maximum value}}{\text{r.m.s. value}} \\ &= \frac{V_m}{0.707 V_m} = \sqrt{2} \text{ or } 1.414 \end{aligned}$$

### Worked Example 6.5

**Q** Calculate the amplitude of the household 240V supply.

**A**

Since this supply is sinusoidal, then the peak factor will be  $\sqrt{2}$ , so

$$V_m = \sqrt{2} \times V \text{ volt} = \sqrt{2} \times 240$$

so,  $V_m = 339.4 \text{ V}$  **Ans**

### Worked Example 6.6

**Q** A non-sinusoidal waveform has a peak factor of 2.5, and an r.m.s. value of 240V. It is proposed to use a capacitor in a circuit connected to this supply. Determine the minimum safe working voltage rating required for the capacitor.

**A**

$$\text{peak factor} = 2.5; V = 240 \text{ V}$$

$$V_m = 2.5 \times V \text{ volt} = 2.5 \times 240$$

$$\text{so, } V_m = 600 \text{ V}$$

Thus the absolute minimum working voltage must be 600V **Ans**

In practice, a capacitor having a higher working voltage would be selected. This would then allow a factor of safety.

## 6.7 Form Factor

As the name implies, this factor gives an indication of the form or shape of the waveform. It is defined as the ratio of the r.m.s. value to the average value.

Thus, *for a sine wave*,

$$\text{form factor} = \frac{\text{r.m.s. value}}{\text{average value}} = \frac{0.707}{0.637}$$

$$\text{so, form factor} = 1.11$$

For a rectangular waveform (a squarewave), form factor = 1, since the r.m.s. value, the peak value, and the average value are all the same.

### Worked Example 6.7

**Q** A rectangular coil, measuring 25 cm by 20 cm, has 80 turns. The coil is rotated, about an axis parallel with its longer sides, in a magnetic field of density 75 mT. If the speed of rotation is 3000 rev/min, calculate, from first principles, (a) the amplitude, r.m.s. and average values of the emf, (b) the frequency and period of the generated waveform, (c) the instantaneous value, 2 ms after it is zero.

**A**

$$\ell = 0.25 \text{ m}; d = 0.2 \text{ m}; N = 80; B = 0.075 \text{ T}$$

$$n = \frac{3000}{60} \text{ rev/s}; t = 2 \times 10^{-3} \text{ s}$$

**(a)**  $e = 2 \times NB\ell v \sin(2\pi ft)$  volt

Now, we know the rotational speed  $n$ , but the above equation requires the tangential velocity,  $v$ , in metre per second. This may be found as follows.

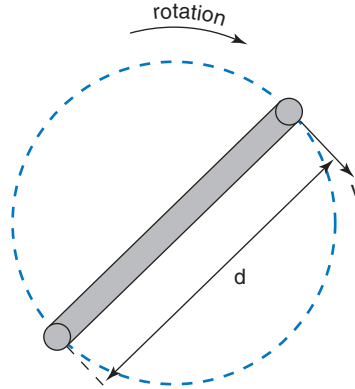

Fig. 6.7

Consider Fig. 6.7,

which shows the path travelled by the coil sides.

The circumference of rotation =  $\pi d$  metre =  $0.2\pi$  metre.

The coil sides travel this distance in one revolution.

The rotational speed  $n = 3000/60 = 50$  rev/s.

Hence the coil sides have a velocity,  $v = 50 \times 0.2\pi$  m/s.

Therefore,  $e = 2 \times 80 \times 0.075 \times 0.25 \times 50 \times 0.27\pi \sin(2\pi ft)$  volt  
and emf is a maximum value when  $\sin(2\pi ft) = 1$

$$\text{so, } E_m = 2 \times 80 \times 0.075 \times 0.25 \times 50 \times 0.2\pi$$

$$E_m = 94.25 \text{ V Ans}$$

Assuming a sinusoidal waveform:

$$E = 0.707 E_m = 0.707 \times 94.25$$

$$\text{so, } E = 66.64 \text{ V Ans}$$

$$E_{av} = 0.637 E_m = 0.637 \times 94.25$$

$$\text{so, } E_{av} = 60.04 \text{ V Ans}$$

Assuming a 2-pole field system, then  $f = n$  therefore  $f = 50$  Hz **Ans**

$$(b) \quad T = \frac{1}{f} = \frac{1}{50} \text{ s}$$

so  $T = 20$  ms **Ans**

$$(c) \quad e = E_m \sin(2\pi ft) \text{ volt}$$

$$= 94.25 \sin(2\pi \times 50 \times 2 \times 10^{-3})$$

$$= 94.25 \times 0.5878$$

so,  $e = 55.4$  V **Ans**

## 6.8 Rectifiers

A rectifier is a circuit which converts a.c. to d.c. The essential component of any rectifier circuit is a diode. This is a semiconductor device, which allows current to flow through it in one direction only.



Fig. 6.8

It is the electronic equivalent of a mechanical valve, for example the valve in a car tyre. This device allows air to be pumped into the tyre, but prevents the air from escaping.

The circuit symbol for a diode is shown in Fig. 6.8. The ‘arrow head’ part of the symbol is known as the anode. This indicates the direction in which *conventional* current can flow through it. The ‘plate’ part of the symbol is the cathode, and indicates that conventional current is prevented from entering at this terminal. Thus, provided that the anode is more positive than the cathode, the diode will conduct. This is known as the forward bias condition. If the cathode is more positive than the anode, the diode is in its blocking mode, and does not conduct. This is known as reverse bias.

**Note:** The potentials at anode and cathode do not have to be positive and negative. Provided that the anode is *more* positive than the cathode, the diode will conduct. So if the anode potential is (say) +10 V, and the cathode potential is +8 V, then the diode will conduct. Similarly, if these potentials are reversed, the diode will not conduct.

## 6.9 Half-wave Rectifier

This is the simplest form of rectifier circuit. It consists of a single diode, placed between an a.c. supply and the load, for which d.c. is required. The arrangement is shown in Fig. 6.9, where the resistor  $R$  represents the load.

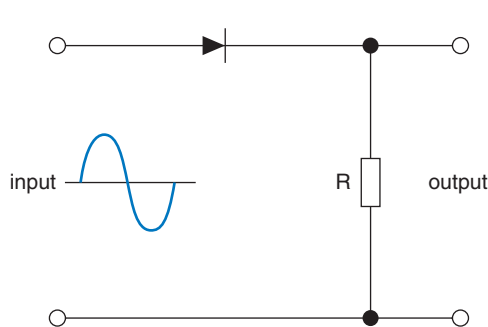

Fig. 6.9

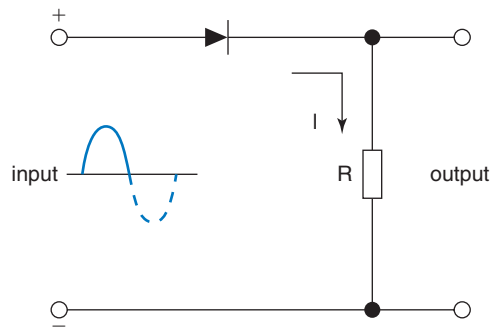

Fig. 6.10

Let us assume that, in the first half cycle of the applied voltage, the instantaneous polarities at the input terminals are as shown in Fig. 6.10. Under this condition, the diode is forward biased. A half sinewave of current will therefore flow through the load resistor, in the direction shown.

In the next half cycle of the input waveform, the instantaneous polarities will be reversed. The diode is therefore reverse biased, and no current will flow. This is illustrated in Fig. 6.11.

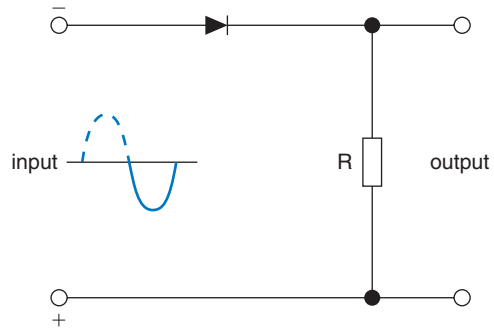

Fig. 6.11

The graphs of the applied a.c. voltage, and the corresponding load current, are shown in Fig. 6.12. The load p.d. will be of exactly the same waveshape as the load current. Both of these quantities are unidirectional, and so by definition, are d.c. quantities. The 'quality' of the d.c. so produced is very poor, since it exists only in pulses of current. The average value of this current is determined over the time period, 0 to  $t_2$ . The average value from 0 to time  $t_1$  will be  $0.637I_m$ . From  $t_1$  to  $t_2$  it will be zero. The average value of the d.c. will therefore be,  $I_{av} = 0.318I_m$ .

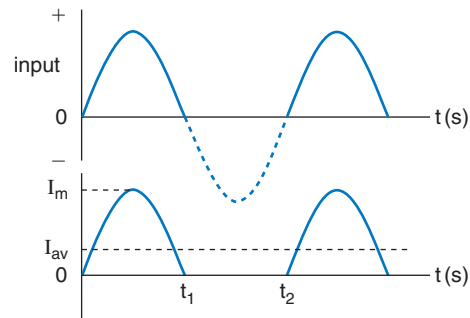

Fig. 6.12

## 6.10 Full-wave Bridge Rectifier

Both the 'quality' and average value of the d.c. need to be improved. This may be achieved by utilising the other half cycle of the a.c. supply. The circuit consists of four diodes, connected in a 'bridge' configuration, as shown in Fig. 6.13.

We will again assume the instantaneous polarities for the first half cycle as shown. In this case, diodes  $D_1$  and  $D_4$  will be forward biased. Diodes  $D_2$  and  $D_3$  will be reverse biased. Thus,  $D_1$  and  $D_4$  allow current to flow, as shown. In the next half cycle, the polarities are reversed. Hence,  $D_2$  and  $D_3$  will conduct, whilst  $D_1$  and  $D_4$  are reverse biased. Current will therefore flow as shown in Fig. 6.14. Notice that

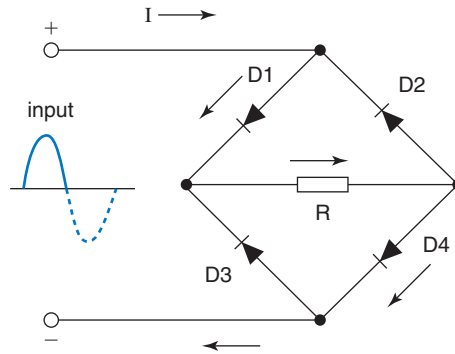

Fig. 6.13

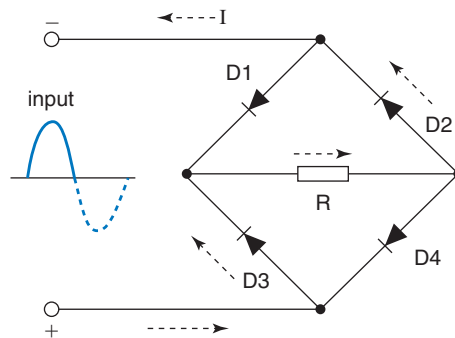

Fig. 6.14

the current through the load resistor is in the same direction, for the whole cycle of the a.c. supply.

The relevant waveforms are shown in Fig. 6.15. It should be apparent that the average value of the a.c. will now be twice that in the previous circuit. That is  $I_{av} = 0.637I_m$ .

It is this type of rectifier circuit that is incorporated in multimeters. This enables the measurement of a.c. voltages and currents.

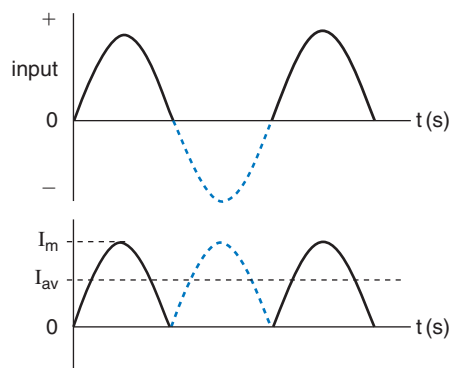

Fig. 6.15

## 6.11 Rectifier Moving Coil Meter

The circuit arrangement for such a meter is illustrated in Fig. 6.16. The symbol, with the letter M in it, represents the moving coil movement. The current through the coil will therefore be a series of half-sinewave pulses, as in Fig. 6.15.

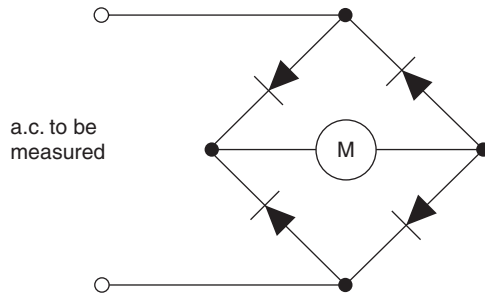

Fig. 6.16

Due to the inertia of the meter movement, the coil will respond to the average value of this current. Thus, the pointer would indicate the *average* value of the a.c. waveform being measured. However, the normal requirement is for the meter to indicate the *r.m.s.* value. Thus, some form of 'correction factor' is required.

The majority of a.c. quantities to be measured are sinewaves. For this reason, the meter is calibrated to indicate the r.m.s. values of sinewaves. Now, the ratio between r.m.s. and average values is the form factor. For the sinewave, the form factor has a value of 1.11. The values chosen for shunts and multipliers, used on the a.c. ranges, are therefore modified by this factor. Thus, although the pointer position corresponds to the average value, the scale indication will be the r.m.s. value.

### Worked Example 6.8

**Q** A moving coil meter has a figure of merit of  $10\text{ k}\Omega/\text{V}$ . The coil has a resistance of  $50\ \Omega$ . Calculate the value of multiplier required for (a) the  $10\text{ V}$  d.c. range, (b) the  $10\text{ V}$  a.c. range.

**A**

$$R_c = 50\ \Omega; \text{ figure of merit} = 10\text{ k}\Omega/\text{V}; V = 10\text{ V}$$

$$\text{(a) } I_{fsd} = 1/10\ 000 = 100\ \mu\text{A}$$

$$\text{total meter resistance, } R = \frac{V}{I_{fsd}} \text{ ohm} = \frac{10}{10^{-4}}$$

so,  $R = 100\ \text{k}\Omega$ ; and since  $R = R_m + R_c$ , then:

$$R_m = 100\ 000 - 50 = 99.95\ \text{k}\Omega \text{ Ans}$$

$$(b) I_{fsd} = 100 \mu\text{A} = I_{av}$$

therefore, r.m.s. value,

$$I = 1.11 \times 100 = 111 \mu\text{A}$$

$$\text{so, } R = \frac{10}{111 \times 10^{-6}} = 90.09 \text{ k}\Omega$$

$$\text{therefore, } R_m = 90\,090 - 50$$

$$= 90.04 \text{ k}\Omega \text{ Ans}$$

The meter is therefore calibrated for the measurement of sinewaves. If any other waveform is measured, the meter reading will be in error, because the waveform will have a different form factor. Provided that the form factor is known, then the true r.m.s. value can be calculated.

### Worked Example 6.9

**Q** A moving coil meter is used to measure both a squarewave and a triangular wave voltage. The meter reading is 5V in each case. Calculate the true r.m.s. values.

**A**

- (a) The form factor for a squarewave is 1. The meter, however, has been calibrated for a form factor of 1.11. Thus the indicated reading will be too high by a factor of 1.11:1

$$\begin{aligned} \text{Therefore the true value} &= 5 \times \frac{1}{1.11} \\ &= 4.504 \text{ V Ans} \end{aligned}$$

- (b) If the form factor for the triangular wave is 1.15, then the meter reading will be too low, by a factor of 1.15:1.11.

$$\begin{aligned} \text{Therefore the true value} &= 5 \times \frac{1.15}{1.11} \\ &= 5.18 \text{ V Ans} \end{aligned}$$

A further complication arises when the meter is used to measure small a.c. voltages. When conducting, each diode will have a small p.d. developed across it. This forward voltage drop will be in the order of 0.6 to 0.7 V. At any instant, two diodes are conducting. Thus, there will be a total forward voltage drop of 1.2 to 1.4 V across the diodes. This voltage drop is 'lost' as far as the meter coil is concerned. This effect also must be taken into account when determining the values of multipliers, for the lower a.c. voltage ranges.

## 6.12 Phase and Phase Angle

Consider two a.c. voltages, of the same frequency, as shown in Fig. 6.17. Both voltages pass through the zero on the horizontal axis at the same time. They also reach their positive and negative peaks at the

same time. Thus, the two voltages are exactly synchronised, and are said to be *in phase* with each other.

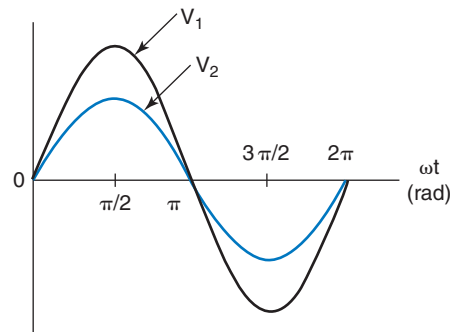

Fig. 6.17

Figure 6.18 shows the same two voltages, but in this case let  $v_2$  reach its maximum value  $\pi/2$  radian ( $90^\circ$ ) after  $v_1$ . It is necessary to consider one of the waveforms as the *reference* waveform. It is normal practice to consider the waveform that passes through zero, going positive, at the beginning of the cycle, as the reference waveform. So, for the two waveforms shown,  $v_1$  is taken as the reference. In this case,  $v_2$  is said to *lag*  $v_1$  by  $\pi/2$  radian or  $90^\circ$ . The standard expressions for the two voltages would therefore be written as follows:

$$v_1 = V_{m1} \sin(2\pi ft), \text{ or } V_{m1} \sin \theta \text{ volt}$$

$$v_2 = V_{m2} \sin(2\pi ft - \pi/2), \text{ or } V_{m2}(\sin \theta - 90^\circ) \text{ volt}$$

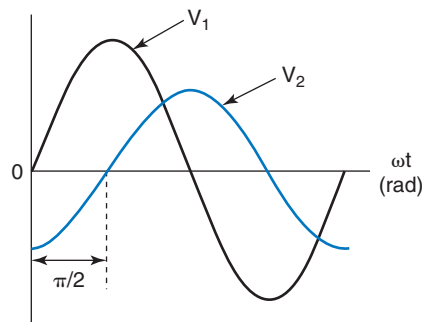

Fig. 6.18

The minus signs, in the brackets of the above expressions, indicate that  $v_2$  lags the reference by the angle quoted. This angle is known as the *phase angle*, or *phase difference*, between the two waveforms.

In general, the standard expression for an a.c. voltage is:

$$v = V_m \sin(2\pi ft \pm \phi) \text{ volt,} \quad (6.10)$$

$$\text{or } v = V_m \sin(\omega t \pm \phi) \text{ volt}$$

Although it would be usual to take  $v_1$  as the reference in the above example, it is not mandatory. Thus, if for some good reason  $v_2$  was chosen as the reference, the expressions would be written as:

$$v_2 = V_{m2} \sin(\omega t), \text{ or } V_{m2} \sin \theta \text{ volt}$$

$$v_1 = V_{m1} \sin(\omega t + \pi/2), \text{ or } V_{m1} \sin(\theta + 90^\circ) \text{ volt}$$

**Note:** when the relevant phase angle,  $\phi$ , is quoted in the standard expression, do *not* mix degrees with radians. Thus, if the initial angular data is in radian ( $\omega t$  or  $2\pi ft$ ), then  $\phi$  must also be expressed in radian. Similarly, if the angular data is initially in degrees ( $\theta$ ), the  $\phi$  must also be quoted in degrees.

### Worked Example 6.10

**Q** Three alternating currents are specified below. Determine the frequency, and for each current, determine its phase angle, and amplitude.

$$i_1 = 5 \sin(80\pi t + \pi/6) \text{ amp}$$

$$i_2 = 3 \sin 80\pi t \text{ amp}$$

$$i_3 = 6 \sin(80\pi t - \pi/4) \text{ amp}$$

**A**

All three waveforms have the same value of  $\omega$ , namely  $80\pi$  rad/s. Thus all three have the same frequency:

$$\omega = 2\pi f = 80\pi \text{ rad/s}$$

$$\text{therefore, } f = \frac{80\pi}{2\pi} = 40 \text{ Hz } \mathbf{Ans}$$

Since zero phase angle is quoted for  $i_2$ , then this is the reference waveform, of amplitude 3 A **Ans**

$$I_{m1} = 5 \text{ A, and leads } i_2 \text{ by } \pi/6 \text{ rad } (30^\circ) \mathbf{Ans}$$

$$I_{m3} = 6 \text{ A, and lags } i_2 \text{ by } \pi/4 \text{ rad } (45^\circ) \mathbf{Ans}$$

The majority of people can appreciate the relative magnitudes of angles, when they are expressed in degrees. Angles expressed in radians are more difficult to appreciate. Some of the principal angles encountered are listed below. This should help you to gain a better ‘feel’ for radian measure.

degrees	radians	radians	degrees
360	$2\pi \approx 6.28$	0.1	5.73
270	$3\pi/2 \approx 4.71$	0.2	11.46
180	$\pi \approx 3.14$	0.3	17.19
120	$2\pi/3 \approx 2.09$	0.4	22.92
90	$\pi/2 \approx 1.57$	0.5	28.65
60	$\pi/3 \approx 1.05$	1.0	57.30
45	$\pi/4 \approx 0.79$	1.5	85.94
30	$\pi/6 \approx 0.52$	2.0	114.60

## 6.13 Phasor Representation

A phasor is a rotating vector. Apart from the fact that a phasor rotates at a constant velocity, it has exactly the same properties as any other vector. Thus its length corresponds to the magnitude of a quantity. It has one end arrowed, to show the direction of action of the quantity.

Consider two such rotating vectors,  $v_1$  and  $v_2$ , rotating at the same angular velocity,  $\omega$  rad/s. Let them rotate in a counterclockwise direction, with  $v_2$  lagging behind  $v_1$  by  $\pi/6$  radian ( $30^\circ$ ). This situation is illustrated in Fig. 6.19.

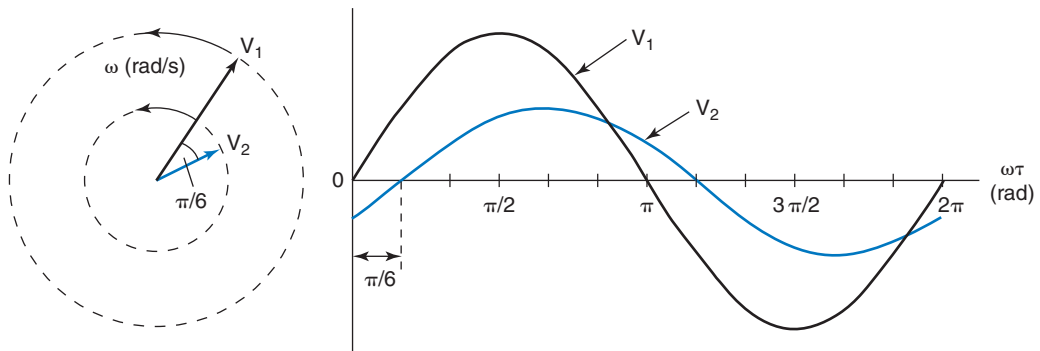

Fig. 6.19

The instantaneous vertical height of each vector is then plotted for one complete revolution. The result will be the two sinewaves shown.

Notice that the angular difference between  $v_1$  and  $v_2$  is also maintained throughout the waveform diagram. Also note that the peaks of the two waveforms correspond to the magnitudes, or amplitudes, of the two vectors. In this case, these two waveforms could equally well represent either two a.c. voltages, or currents. If this were the case, then the two a.c. quantities would be of the *same frequency*. This is because the value of  $\omega$  is the same for both. The angular difference, of  $\pi/6$  radian, would then be described as the phase difference between them.

We can therefore, represent an alternating quantity by means of a phasor. The length of the phasor represents the amplitude. Its angle, with respect to some reference axis, will represent its phase angle. Considering the two waveforms in Fig. 6.19, the plot has been started with  $V_1$  in the horizontal position (vertical component of  $V_1 = 0$ ). This horizontal axis is therefore taken as being the reference axis. Thus, if these waveforms represent two voltages,  $v_1$  and  $v_2$ , then the standard expressions would be:

$$v_1 = V_{m1} \sin(\omega t) \text{ volt}$$

$$\text{and } v_2 = V_{m2} \sin(\omega t - \pi/6) \text{ volt}$$

The inconvenience of representing a.c. quantities in graphical form was pointed out earlier, in section 6.3. This section introduced the concept

of using a standard mathematical expression for an a.c. However, a visual representation is also desirable. We now have a much simpler means of providing a visual representation. It is called a phasor diagram. Thus the two voltages we have been considering above may be represented as in Fig. 6.20.

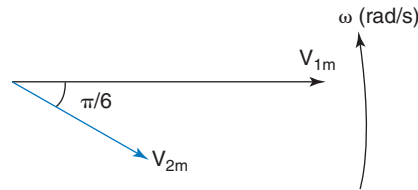

Fig. 6.20

Notice that  $v_1$  has been chosen as the reference phasor. This is because the standard expression for this voltage has a phase angle of zero (there is no  $\pm\phi$  term in the bracket). Also, since the phasors are rotating counterclockwise, and  $v_2$  is lagging  $v_1$  by  $\pi/6$  radian, then  $v_2$  is shown at this angle *below* the reference axis.

### Notes

- 1 Any a.c. quantity can be represented by a phasor, *provided that it is a sinewave.*
- 2 Any number of a.c. voltages and/or currents may be shown on the same phasor diagram, *provided that they are all of the same frequency.*
- 3 Figure 6.20 shows a *counterclockwise* arrow, with  $\omega$  rad/s. This has been shown here to emphasise the point that phasors *must* rotate in this direction only. It is normal practice to omit this from the diagram.
- 4 When dealing with a.c. circuits, r.m.s. values are used almost exclusively. In this case, it is normal to draw the phasors to lengths that correspond to r.m.s. values.

## Worked Example 6.11

**Q** Four currents are as shown below. Draw to scale the corresponding phasor diagram.

$$i_1 = 2.5 \sin(\omega t + \pi/4) \text{ amp}; \quad i_2 = 4 \sin(\omega t - \pi/3) \text{ amp};$$

$$i_3 = 6 \sin \omega t \text{ amp}; \quad i_4 = 3 \cos \omega t \text{ amp}$$

### A

Before the diagram is drawn, we need to select a reference waveform (if one exists). The currents  $i_1$  and  $i_2$  do not meet this criterion, since they both have an associated phase angle.

This leaves the other two currents. Neither of these has a phase angle shown. However,  $i_3$  is a sinewave, whilst  $i_4$  is a *cosine* waveform. Now, a cosine wave *leads* a sinewave by  $90^\circ$ , or  $\pi/2$  radian.

Therefore,  $i_4$  may also be expressed as  $i_4 = 3 \sin(\omega t + \pi/2)$  amp. Thus  $i_3$  is chosen as the reference waveform, and will therefore be drawn along the horizontal axis.

The resulting phasor diagram is shown in Fig. 6.21.

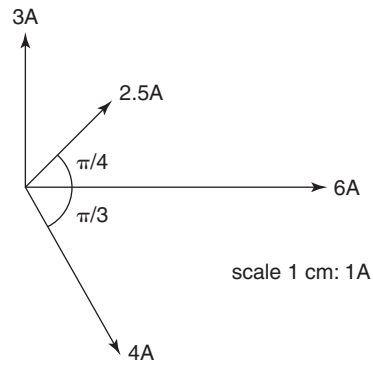

Fig. 6.21

### Worked Example 6.12

**Q** The phasor diagram representing four alternating currents is shown in Fig. 6.22, where the length of each phasor represents the amplitude of that waveform. Write down the standard expression for each waveform.

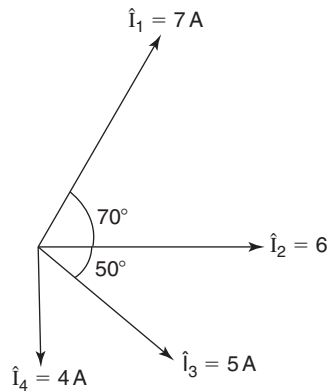

Fig. 6.22

**A**

$$I_{m1} = 7 \text{ A}; \phi_1 = +70^\circ = \frac{70\pi}{180} = 1.22 \text{ rad}$$

$$I_{m2} = 6 \text{ A}; \phi_2 = 0^\circ = 0 \text{ rad}$$

$$I_{m3} = 5 \text{ A}; \phi_3 = -50^\circ = \frac{-50\pi}{180} = -0.873 \text{ rad}$$

$$I_{m4} = 4 \text{ A}; \phi_4 = -90^\circ = \frac{-90\pi}{180} = -1.571 \text{ rad}$$

hence,

$$i_1 = 7 \sin(\omega t + 1.22) \text{ amp Ans}$$

$$i_2 = 6 \sin \omega t \text{ amp Ans}$$

$$i_3 = 5 \sin(\omega t - 0.873) \text{ amp Ans}$$

$$i_4 = 4 \sin(\omega t - 1.571) \text{ amp Ans}$$

## 6.14 Addition of Alternating Quantities

Consider two alternating currents,  $i_1 = I_{m1} \sin \omega t$  amp and  $i_2 = I_{m2} \sin (\omega t - \pi/4)$  amp, that are to be added together. There are three methods of doing this, as listed below.

- (a) Plotting them on graph paper. Their ordinates are then added together, and the resultant waveform plotted. This is illustrated in Fig. 6.23. The amplitude,  $I_m$ , and the phase angle,  $\phi$ , of the resultant current are then measured from the two axes.

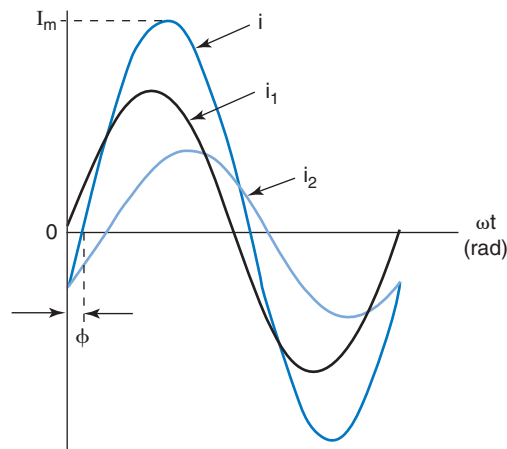

Fig. 6.23

Thus,  $i = I_m \sin(\omega t - \phi)$  amp

**Note:** Although  $i = i_1 + i_2$ , the AMPLITUDE of the resultant is NOT  $I_{m1} + I_{m2}$  amp. This would only be the case if  $i_1$  and  $i_2$  were in phase with each other.

- (b) Drawing a scaled phasor diagram, as illustrated in Fig. 6.24. The resultant is found by completing the parallelogram of vectors. The amplitude and phase angle are then measured on the diagram.
- (c) Resolving the two currents, into horizontal and vertical components, and applying Pythagoras' theorem. This method involves using a *sketch* of the phasor diagram, followed by a purely mathematical process. This phasor diagram, including the identification of the horizontal and vertical components, is shown in Fig. 6.25.

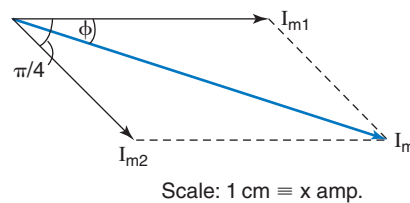

Fig. 6.24

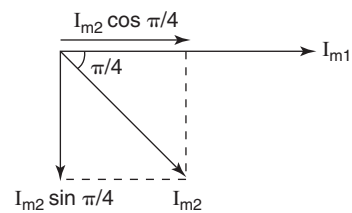

Fig. 6.25

*Horizontal Component (H.C.):*

$$\begin{aligned} \text{H.C.} &= I_{m1} \cos 0 + I_{m2} \cos \pi/4 \\ \text{so, H.C.} &= I_{m1} + (0.707 \times I_{m2}) \text{ amp} \end{aligned}$$

*Vertical Component (V.C.):*

$$\begin{aligned} \text{V.C.} &= I_{m1} \sin 0 + I_{m2} \sin \pi/4 \\ \text{so, V.C.} &= 0 + (0.707 \times I_{m2}) \text{ amp} \end{aligned}$$

The triangle of H.C., V.C., and the resultant current, is shown in Fig. 6.26. From this, we can apply Pythagoras' theorem to determine the amplitude and phase angle, thus:

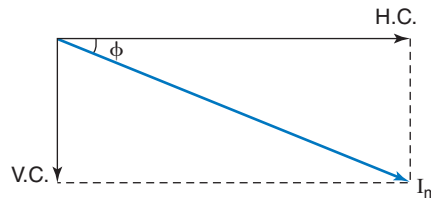

Fig. 6.26

$$\begin{aligned} I_m &= \sqrt{\text{H.C.}^2 + \text{V.C.}^2} \text{ amp} \\ \text{and } \tan \phi &= \frac{\text{V.C.}}{\text{H.C.}}, \text{ so } \phi = \tan^{-1} \frac{\text{V.C.}}{\text{H.C.}} \end{aligned}$$

The final answer, regardless of the method used, would then be expressed in the form  $i = I_m \sin(\omega t \pm \phi)$  amp.

Let us now compare the three methods, for speed, convenience, and accuracy.

The graphical technique is very time-consuming (even for the addition of only two quantities). The accuracy also leaves much to be desired; in particular, determining the exact point for the maximum value of the resultant. The determination of the precise phase angle is also very difficult. This method is therefore not recommended.

A phasor diagram, drawn to scale, can be the quickest method of solution. However, it does require considerable care, in order to ensure a reasonable degree of accuracy. Even so, the precision with which the length—and (even more so) the angle—can be measured, leaves a lot to be desired. This is particularly true when three or more phasors are involved. This method is therefore recommended only for a rapid estimate of the answer.

The use of the resolution of phasors is, with practice, a rapid technique, and yields a high degree of accuracy. Unless specified otherwise it is the technique you should use. Although, at first acquaintance, it may seem to be rather a complicated method, this is not the case. With a little practice, the technique will be found to be relatively simple and quick. Two worked examples now follow.

**Worked Example 6.13**

**Q** Determine the phasor sum of the two voltages specified below.

$$v_1 = 25 \sin(314t + \pi/3), \text{ and } v_2 = 15 \sin(314t - \pi/6) \text{ volt}$$

**A**

Figure 6.27 shows the sketch of the phasor diagram.

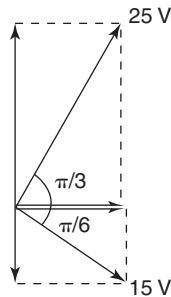

**Fig. 6.27**

**Note:** Always sketch a phasor diagram.

$$\begin{aligned} \text{H.C.} &= 25 \cos \pi/3 + 15 \cos(-\pi/6) \\ &= (25 \times 0.5) + (15 \times 0.866) \\ &= 12.5 + 12.99 \end{aligned}$$

so, H.C. = 25.49 V

$$\begin{aligned} \text{V.C.} &= 25 \sin \pi/3 + 15 \sin(-\pi/6) \\ &= (25 \times 0.866) + (15 \times (-0.5)) \\ &= 21.65 - 7.5 \end{aligned}$$

so, V.C. = 14.15 V

Figure 6.28 shows the phasor diagram for H.C., V.C. and  $V_m$ .

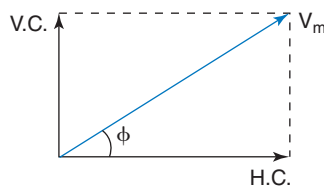

**Fig. 6.28**

$$V_m = \sqrt{\text{H.C.}^2 + \text{V.C.}^2} = \sqrt{25.49^2 + 14.15^2}$$

so,  $V_m = 29.15 \text{ V}$

$$\tan \phi = \frac{\text{V.C.}}{\text{H.C.}} = \frac{14.15}{25.49} = 0.555^*$$

so,  $\phi = \tan^{-1} 0.555 = 0.507 \text{ rad}$

therefore,  $v = 29.15 \sin(314t + 0.507) \text{ volt}$  **Ans**

\*radian mode required

**Worked Example 6.14**

**Q** Calculate the phasor sum of the three currents listed below.

$$i_1 = 6 \sin \omega t \text{ amp}$$

$$i_2 = 8 \sin(\omega t - \pi/2) \text{ amp}$$

$$i_3 = 4 \sin(\omega t + \pi/6) \text{ amp}$$

**A**

The relevant phasor diagrams are shown in Figs. 6.29 and 6.30.

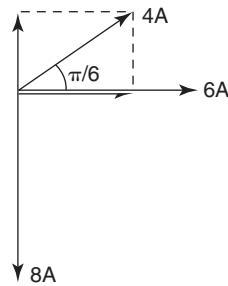

Fig. 6.29

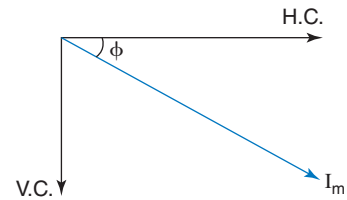

Fig. 6.30

$$\begin{aligned} \text{H.C.} &= 6 \cos 0 + 8 \cos(-\pi/2) + 4 \cos \pi/6 \\ &= (6 \times 1) + (8 \times 0) + (4 \times 0.866) \\ &= 6 + 3.46 \end{aligned}$$

$$\text{so, H.C.} = 9.46 \text{ A}$$

$$\begin{aligned} \text{V.C.} &= 6 \sin 0 + 8 \sin(-\pi/2) + 4 \sin \pi/6 \\ &= (6 \times 0) + (8 \times [-1]) + (4 \times 0.5) \\ &= -8 + 2 \end{aligned}$$

$$\text{so, V.C.} = -6 \text{ A}$$

$$I_m = \sqrt{\text{H.C.}^2 + \text{V.C.}^2} = \sqrt{9.46^2 + (-6)^2}$$

$$\text{so, } I_m = 11.2 \text{ A}$$

$$\phi = \tan^{-1} \frac{\text{V.C.}}{\text{H.C.}} = \tan^{-1} \frac{-6}{9.46} = \tan^{-1} -0.6342$$

$$\text{so, } \phi = -0.565 \text{ rad}$$

$$\text{therefore, } i = 11.2 \sin(\omega t - 0.565) \text{ amp Ans}$$

**Worked Example 6.15**

**Q** Three alternating voltages and one current are as specified in the expressions below.

$$v_1 = 10 \sin(628t - \pi/6) \text{ volt}$$

$$v_2 = 8 \sin(628t + \pi/3) \text{ volt}$$

$$v_3 = 12 \sin(628t + \pi/4) \text{ volt}$$

$$i = 6 \sin(628t) \text{ amp}$$

- For each voltage determine the frequency, phase angle and amplitude.
- Determine the phasor sum of the three voltages.

**A**

- (a) All four waveforms have the same value of  $\omega = 628 \text{ rad/s}$ , so they are all of the same frequency, hence

$$\omega = 2\pi f = 628$$

$$\text{so, } f = \frac{628}{2\pi} \text{ Hz}$$

$$\text{and, } f = 100 \text{ Hz Ans}$$

for  $v_1$ ,  $\phi_1 = -\pi/6 \text{ rad}$  or  $-30^\circ$ ; and  $V_m = 10 \text{ V Ans}$

for  $v_2$ ,  $\phi_2 = +\pi/3 \text{ rad}$  or  $+60^\circ$ ; and  $V_m = 8 \text{ V Ans}$

for  $v_3$ ,  $\phi_3 = +\pi/4 \text{ rad}$  or  $+45^\circ$ ; and  $V_m = 12 \text{ V Ans}$

- (b) Firstly the phasor diagram (Fig. 6.31) is sketched, very roughly to scale. In order to do this a reference waveform needs to be selected, and since the current has a zero phase angle, this is chosen as the reference. However, if the current waveform had not been specified, the horizontal axis would still be taken as the reference from which all phase angles are measured. Since  $v_2$  and  $v_3$  have positive phase angles, and phasors rotate anticlockwise, then these two phasors will appear above the reference axis. The voltage  $v_1$ , having a negative phase angle will appear below the reference axis. Also shown on the phasor diagram are the horizontal and vertical components of each voltage.

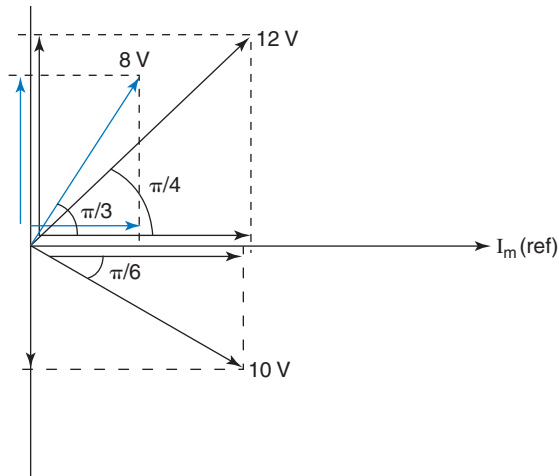

**Fig. 6.31**

$$\begin{aligned} \text{H.C.} &= 12 \cos \pi/4 + 8 \cos \pi/3 + 10 \cos \pi/6 \\ &= (12 \times 0.707) + (8 \times 0.5) + (10 \times 0.866) \\ &= 8.48 + 4 + 8.66 \end{aligned}$$

$$\text{so, H.C.} = 21.44 \text{ V}$$

$$\begin{aligned} \text{V.C.} &= 12 \sin \pi/4 + 8 \sin \pi/3 - 10 \sin \pi/6 \\ &= (12 \times 0.707) + (8 \times 0.866) - (10 \times 0.5) \\ &= 8.48 + 6.928 - 5 \end{aligned}$$

$$\text{and V.C.} = 10.412 \text{ V}$$

The phasor diagram for H.C. and V.C., and the resultant phasor sum is Fig. 6.32.

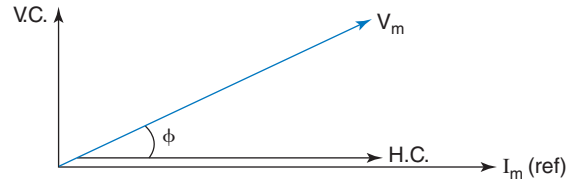

Fig. 6.32

$$V_m = \sqrt{\text{H.C.}^2 + \text{V.C.}^2} = \sqrt{21.44^2 + 10.412^2}$$

$$\text{so, } V_m = 23.83 \text{ V}$$

$$\phi = \tan^{-1} \frac{\text{V.C.}}{\text{H.C.}} = \tan^{-1} \frac{10.412}{21.44} = \tan^{-1} 0.4856$$

$$\text{and, } \phi = 0.452 \text{ rad}$$

Hence, the phasor sum,  $v = 23.83 \sin(628t + 0.452)$  volt **Ans**

## 6.15 The Cathode Ray Oscilloscope

The name of this instrument is more often abbreviated to the oscilloscope, the 'scope, or CRO. It is a very versatile instrument, that may be used to measure both a.c. and d.c. voltages. For d.c. measurements, a voltmeter is usually more convenient to use. The principal advantages of the oscilloscope when used to measure a.c. quantities are:

- 1 A visual indication of the waveform is produced.
- 2 The frequency, period and phase angle of the waveform(s) can be determined.
- 3 It can be used to measure very high frequency waveforms.
- 4 Any waveshape can be displayed, and measured with equal accuracy.
- 5 The input resistance (impedance) is of the same order as a digital voltmeter. It therefore applies minimal loading effect to a circuit to which it is connected.
- 6 Some oscilloscopes can display two or more waveforms simultaneously.

**Cathode Ray Tube** The basic arrangement of a crt is shown in Fig. 6.33. The main components are contained within an evacuated

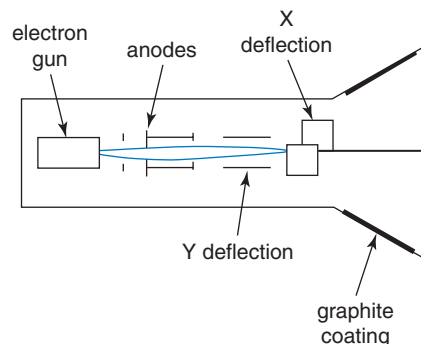

Fig. 6.33

glass tube. These components are: the electron gun; a focusing system; a beam deflection system; and a screen. Each of these will be very briefly described.

**Electron gun assembly** This component produces a beam of electrons. This beam can then be accelerated, down the axis of the tube, by a series of high potential anodes.

**Focusing system** The beam consists entirely of electrons. Since they are all negatively charged, then they will tend to repel each other. The beam will therefore tend to spread out, and this would result in a very fuzzy display. The focusing system consists of a series of high potential anodes. These also provide the acceleration for the electron beam. Each successive anode along the tube, towards the screen, is at a higher potential than the previous one. The electric fields, between these anodes, will be of the same shape as a double convex optical lens. This is referred to as an electron lens, and causes the beam to converge to a small spot by the time it reaches the screen.

**Deflection system** Two sets of parallel plates are situated after the last anode. One set is mounted in the horizontal, and the other set in the vertical plane. These are the X-plates and the Y-plates. When a p.d. is developed between a pair of plates, an electric field will exist between them. This electric field will cause the electrons in the beam to be deflected, towards the more positive of the two plates. Thus, the beam can be made to deflect in both planes. This effect is illustrated in Fig. 6.34.

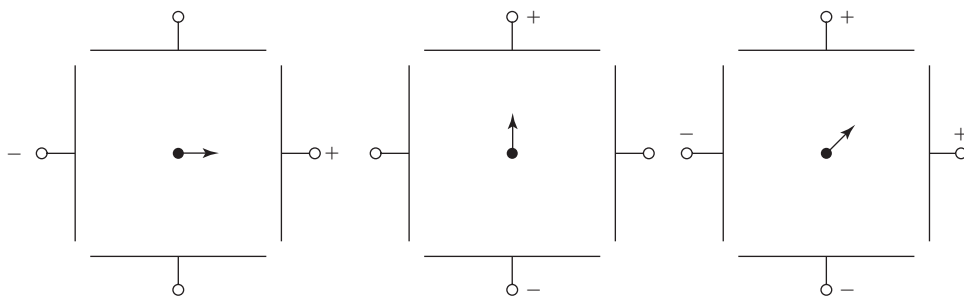

Fig. 6.34

**The screen** The inner surface of the screen is coated with a phosphor. Wherever the electron beam strikes the phosphor, it will glow very briefly. This is because the kinetic energy of the bombarding electrons is converted into 'light' energy. On the inside of the 'bell' shape of the tube is a graphite coating. This provides a conducting path to return the electrons to the internal power supply, and hence complete the circuit back to the electron gun.

In order for a waveform to be displayed on the screen, the beam must be swept at a constant speed across the screen. At the same time, the beam has to be deflected up and down. You can demonstrate this for

yourself, as follows. Take a pencil and a sheet of paper. At the left-hand edge of the paper, move the pencil up and down, at as constant a rate as possible. Maintaining this up-and-down rhythm, now move the pencil across the page, again at as constant a rate as possible. The pattern traced on to the paper should now resemble a sinewave.

The electron beam in the crt is subjected to similar forces, exerted by the deflecting plates, when displaying a sinusoidal waveform. The X-plates cause the beam to be swept across the screen at a constant rate. The Y-plates cause the beam to deflect up and down, in sympathy with the voltage being displayed.

## 6.16 Operation of the Oscilloscope

In addition to the crt, the other main components in the oscilloscope enable the user to adjust the display, by means of controls on the front panel. A simplified block diagram of the oscilloscope is shown in Fig. 6.35.

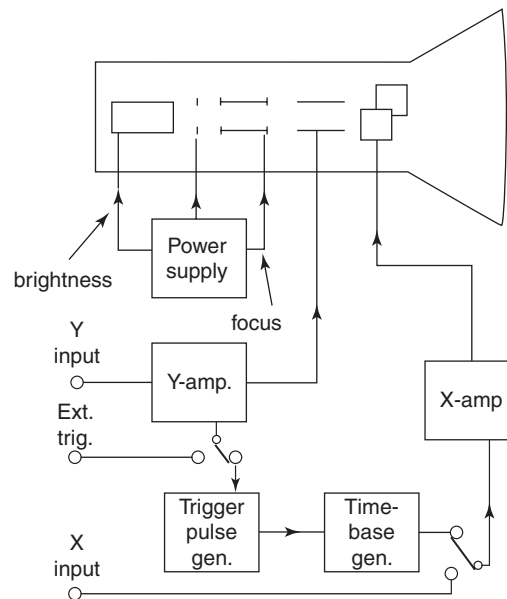

Fig. 6.35

**The Power Supply** This provides the high potentials required for the anodes. It also provides the d.c. supplies for the amplifiers, the electron gun, the timebase and trigger pulse generators.

**The Focus Control** This control allows the potentials applied to the anodes to be varied. This allows the shape of the electron lens to be altered, and hence achieve a sharp clear trace on the screen.

**The Brightness Control** This varies the potentials applied to the electron gun. The number of electrons forming the beam are thus controlled, which determines the brightness of the display.

**The Timebase Control** This controls the speed at which the beam is swept across the screen, from left to right. It does this by setting the 'sweep' time of the Timebase generator.

This generator produces a sawtooth voltage, as illustrated in Fig. 6.36. This waveform is applied to the X-plates. During the sweep time, the beam is steadily deflected across the screen. During the 'flyback' time, the beam is rapidly returned to the left-hand side of the screen, ready for the next sweep. The steepness of the sweep section of this waveform determines the speed of the sweep.

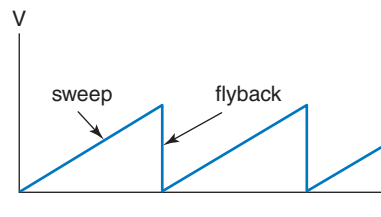

Fig. 6.36

At the front of the screen is a graticule, marked out in centimetre squares. The timebase control is marked in units of time/cm. Thus, if this control is set to (say) 10 ms/cm, then each centimetre graduation across the graticule represents a time interval of 10 ms. This facility enables the measurement of the periodic time (and hence frequency), of the displayed waveform.

**Trigger Control** This enables the user to obtain a single stationary image of the trace on the screen. If this control is incorrectly set, then the trace will scroll continuously across the screen. Alternatively, multiple overlapping traces are displayed, which may also be scrolling. In either case, measurement of the periodic time is impossible. This control determines the point in time at which the sweep cycle of the sawtooth waveform commences. If required an external trigger input may be used.

**X-Amplifier** This amplifies the sawtooth waveform. This ensures that the voltage applied to the X-plates is sufficiently large to deflect the beam across the full width of the screen. There is also provision for the application of an external timebase signal.

**Y-Amplifier** The waveform to be displayed is applied to this amplifier. Thus, small amplitude signals can be amplified to give a convenient height of the trace. The gain or amplification of this amplifier is determined by the user. The control on the front panel is marked in units of volt/cm. Thus, if this control was set to (say) 100 mV/cm, then each vertical graduation on the screen graticule represents a voltage of 100 mV. This enables the measurement of the amplitude of the displayed waveform.

**X and Y Shift Controls** These controls enable the trace position on the screen to be adjusted. This makes the measurement of period and amplitude easier.

## 6.17 Dual Beam Oscilloscopes

These instruments are widely used, and are more versatile than the single beam type described. They have the advantage that two waveforms can be displayed simultaneously. This enables waveforms to be compared, in terms of their amplitudes, shape, phase angle or frequency.

The principles of operation are exactly the same as for the single beam instrument. They contain two electron gun assemblies, which have common brightness and focusing controls. The timebase generator is also common to both channels. There will be two separate Y-amplifiers, each controlling its own set of vertical deflection plates. The inputs to these two amplifiers are usually marked as channel 1 and channel 2, or as channels A and B.

### Worked Example 6.16

**Q** The traces obtained on a double beam oscilloscope are shown in Fig. 6.37. The graticule is marked in 1 cm squares. The channel 1 input is displayed by the upper trace. If settings of the controls for the two channels are as follows, determine the amplitude, r.m.s. value, and frequency of each input.

*Channel 1:* timebase of 0.1 ms/cm; Y-amp setting of 5 V/cm

*Channel 2:* timebase of 10  $\mu$ s/cm; Y-amp setting of 0.5 V/cm

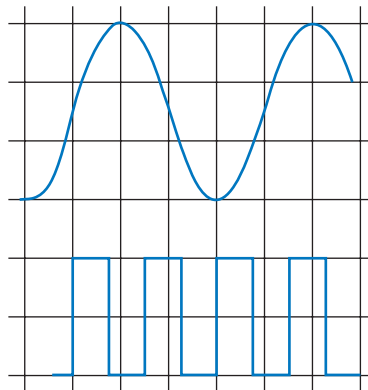

Fig. 6.37

**A**

*Channel 1:* peak to peak occupies 3 cm, so

$$V_{p-p} = 3 \times 5 = 15 \text{ V}$$

$$\text{the amplitude} = \frac{V_{p-p}}{2} = \frac{15}{2}$$

$$\text{therefore, } V_m = 7.5 \text{ V Ans}$$

As the waveform is a sinewave, then r.m.s. value  $V = V_m I \sqrt{2}$

$$\text{therefore, } V = \frac{7.5}{\sqrt{2}} = 5.3 \text{ V Ans}$$

1 cycle occupies 4 cm, so  $T = 4 \times 0.1 = 0.4 \text{ ms}$

$$f = \frac{1}{T} \text{ Hz} = \frac{1}{0.4 \times 10^{-3}}$$

so,  $f = 2.5 \text{ kHz Ans}$

Channel 2: peak to peak occupies 2 cm, so

$$V_{p-p} = 2 \times 0.5 = 1 \text{ V, and } V_m = 0.5 \text{ V Ans}$$

Since it is a squarewave, then r.m.s. value = amplitude,

$$\text{hence } V = 0.5 \text{ V Ans}$$

2 cycles occur in 3 cm, so 1 cycle occurs in  $2/3 \text{ cm}$

therefore,  $T = 0.6667 \times 10 = 6.667 \mu\text{s}$

$$f = \frac{1}{T} \text{ Hz} = \frac{1}{6.667 \times 10^{-6}}$$

so,  $f = 150 \text{ kHz Ans}$

## Summary of Equations

**Frequency generated:**  $f = np$  hertz

**Periodic time:**  $T = \frac{1}{f}$  second

**Angular velocity:**  $\omega = 2\pi f$  rad/second

**Standard expression for a sinewave:**  $e = E_m \sin(\theta \pm \phi) = E_m \sin(\omega t \pm \phi)$   
 $= E_m \sin(2\pi f t \pm \phi)$  volt

**Average value for a sinewave:**  $I_{ave} = \frac{2I_m}{\pi} = 0.637I_m$

**R.m.s. value for a sinewave:**  $I = \frac{I_m}{\sqrt{2}} = 0.707I_m$

**Peak factor for a sinewave:**  $\frac{\text{max. value}}{\text{r.m.s. value}} = 1.414$

**Form factor for a sinewave:**  $\frac{\text{r.m.s. value}}{\text{ave value}} = 1.11$

## Assignment Questions

- 1 A coil is rotated between a pair of poles. Calculate the frequency of the generated emf if the rotational speed is (a) 150 rev/s, (b) 900 rev/minute, (c) 200 rad/s.
- 2 An alternator has 8 poles. If the motor winding is rotated at 1500 rev/minute, determine (a) the frequency of the generated emf, and (b) the speed of rotation required to produce frequency of 50 Hz.
- 3 A frequency of 240 Hz is to be generated by a coil, rotating at 1200 rev/min. Calculate the number of poles required.
- 4 A sinewave is shown in Fig. 6.38. Determine its amplitude, periodic time and frequency.

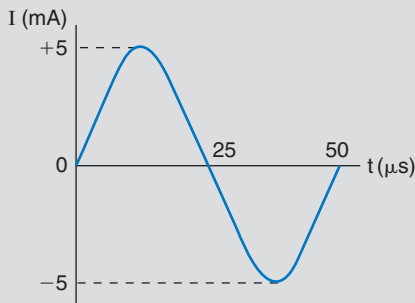

Fig. 6.38

- 5 A sinusoidal current has a peak-to-peak value of 15 mA and a frequency of 100 Hz. (a) Plot this waveform, to a base of time, and (b) write down the standard expression for the waveform.
- 6 A sinusoidal voltage is generated by an 85 turn coil, of dimensions 20 cm by 16 cm. The coil is rotated at 3000 rev/min, with its longer sides parallel to the faces of a pair of poles. If the flux density produced by the poles is 0.5 T, calculate (a) the amplitude of the generated emf, (b) the frequency, (c) the r.m.s. and average values.
- 7 Write down the standard expression for a voltage, of r.m.s. value 45 V, and frequency 1.5 kHz. Hence, calculate the instantaneous value, 38 μs after the waveform passes through its zero value.
- 8 For each of the following alternating quantities, determine (a) the amplitude and r.m.s. value, and (b) the frequency and period.
  - (i)  $e = 250 \sin 50\pi t$  volt
  - (ii)  $i = 75 \sin 628.3t$  milliamp

(iii)  $\phi = 20 \sin 100\pi t$  milliwber

(iv)  $v = 6.8 \sin (9424.8t + \phi)$  volt.

- 9 For a current of r.m.s. value 5 A, and frequency 2 kHz, write down the standard expression. Hence, calculate (a) the instantaneous value 150 μs after it passes through zero, and (b) the time taken for it to reach 4 A, after passing through zero for the first time.
- 10 Calculate the peak and average values for a 250V sinusoidal supply.
- 11 A sinusoidal current has an average value of 3.8 mA. Calculate its r.m.s. and peak values.
- 12 An alternating voltage has an amplitude of 500V, and an r.m.s. value of 350V. Calculate the peak factor.
- 13 A waveform has a form factor of 1.6, and an average value of 10V. Calculate its r.m.s. value.
- 14 A moving coil voltmeter, calibrated for sinewaves, is used to measure a voltage waveform having a form factor of 1.25. Determine the true r.m.s. value of this voltage, if the meter indicates 25V. Explain why the meter does not indicate the true value.
- 15 Explain why only sinusoidal waveforms can be represented by phasors.
- 16 Sketch the phasor diagram for the two waveforms shown in Fig. 6.39.

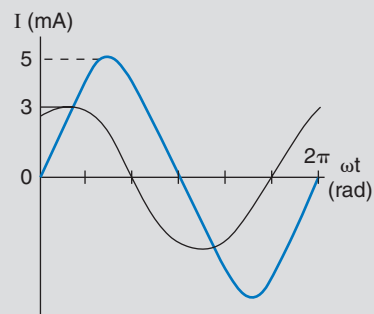

Fig. 6.39

- 17 Sketch the phasor diagram for the two voltages represented by the following expressions:
 
$$v_1 = 12 \sin 314t \text{ volt,}$$

$$v_2 = 8 \sin(314t + \pi/3) \text{ volt.}$$

## Assignment Questions

- 18** Determine the phasor sum of the two voltages specified in Question 17 above.
- 19** Three currents, in an a.c. circuit, meet at a junction. Calculate the phasor sum, if the currents are:
- $$i_1 = 10 \sin \omega t \text{ amp}$$
- $$i_2 = 5 \sin(\omega t + \pi/4) \text{ amp}$$
- $$i_3 = 14 \sin(\omega t - \pi/3) \text{ amp.}$$

- 20** Determine the phasor sum of the following voltages, all of which are sinewaves of the same frequency:
- $v_1$  has an amplitude of 25 volt, and a phase angle of zero.
- $v_2$  has an amplitude of 13.5 volt, and lags  $v_1$  by  $25^\circ$ .
- $v_3$  has an amplitude of 7.6 volt, and leads  $v_2$  by  $40^\circ$ .
- 21** By means of a phasor diagram, drawn to scale, check your answer to Question 19 above.
- 22** Plot, on the same axes, the graphs of the following two voltages. By adding ordinates, determine the sum of these voltages. Express the result in the form

$$v = V_m \sin(\omega t \pm \phi)$$

$$v_1 = 12 \sin t, \text{ and } v_2 = 8 \sin(\omega t - \pi/6) \text{ volt.}$$

- 23** The waveform displayed on an oscilloscope is as shown in Fig. 6.40. The timebase is set to  $100 \mu\text{s/cm}$ , and the Y-amp is set to  $2\text{V/cm}$ . Determine the amplitude, r.m.s. value, periodic time and frequency of this waveform.

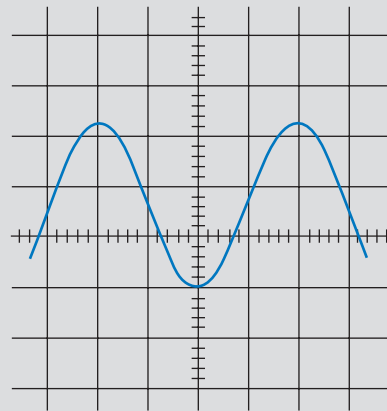

Fig. 6.40

### *Suggested Practical Assignments*

The principal practical exercise relating to this chapter is the usage of the oscilloscope. The actual exercises carried out are left to the discretion of your teacher. Using an oscilloscope is not difficult, but does require some practice; particularly in obtaining a clear, stationary trace, from which measurements can be made.

## D.C. Machines

### Learning Outcomes

This chapter covers the operating principles of d.c. generators and motors, their characteristics and applications. On completion you should be able to:

- 1 Understand and explain generator/motor duality.
- 2 Appreciate the need for a commutator.
- 3 Identify the different types of d.c. generator, and describe their characteristics. Carry out practical tests to compare the practical and theoretical characteristics.

### 7.1 Motor/Generator Duality

An electric motor is a rotating machine which converts an electrical input power into a mechanical power output. A generator converts a mechanical power input into an electrical power output. Since one process is the converse of the other, a motor may be made to operate as a generator, and vice versa. This duality of function is not confined to d.c. machines. An alternator can be made to operate as a synchronous a.c. motor, and vice versa.

To demonstrate the conversion process involved, let us reconsider two simple cases that were met when dealing with electromagnetic induction.

Consider a conductor being moved at constant velocity, through a magnetic field of density  $B$  tesla, by some externally applied force  $F$  newton. This situation is illustrated in Fig. 7.1.

Work done in moving the conductor,

$$W = Fd \text{ newton metre}$$

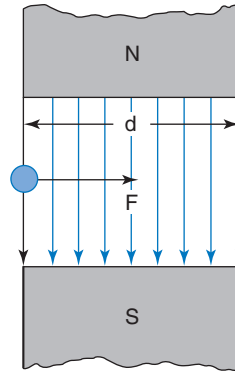

Fig. 7.1

mechanical power input,  $P_1 = \frac{W}{t}$  watt

$$\text{so, } P_1 = \frac{Fd}{t} \text{ watt}$$

and since  $d/t$  is the velocity,  $v$  at which the conductor is moved, then

$$P_1 = Fv \text{ watt.....[1]}$$

However, when the conductor is moved, an emf will be induced into it. Provided that the conductor forms part of a closed circuit, then the resulting current flow will be as shown in Fig. 7.2. This induced current,  $i$ , produces its own magnetic field, which reacts with the main field, producing a reaction force,  $F_r$ , in direct opposition to the applied force,  $F$ .

$$\text{Now, } F_r = Bil \text{ newton}$$

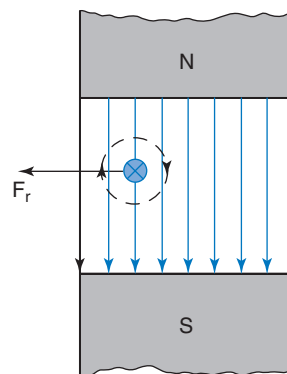

Fig. 7.2

Assuming no frictional or other losses, then the applied force has only to overcome the reaction force, such that:

$$F = F_r = B i l \text{ newton}$$

$$\text{so eqn [1] becomes } P_1 = B i l v \text{ watt.....[2]}$$

$$\text{Also, induced emf, } e = B l v \text{ volt}$$

$$\text{so generated power, } P_2 = e i \text{ watt}$$

$$\text{therefore, } P_2 = B i l v \text{ watt.....[3]}$$

Since [3] = [2], then the electrical power generated is equal to the mechanical power input (assuming no losses). Now consider the conductor returned to its original starting position. Let an external source of emf,  $e$  volt pass a current of  $i$  ampere through the conductor. Provided that the direction of this current is opposite to that shown in Fig. 7.2, then the conductor will experience a force that will propel it across the field. In this case, the same basic arrangement exhibits the motor effect, since the electrical input power is converted into mechanical power.

Although the above examples involve linear movement of the conductor, exactly the same principles apply to a rotating machine.

## 7.2 The Generation of d.c. Voltage

We have seen in Chapter 6 already that, if a single-loop coil is rotated between a pair of magnetic poles, then an *alternating* emf is induced into it. This is the principle of a simple form of alternator. Of course, this a.c. output could be converted to d.c. by employing a rectifier circuit. Indeed, that is exactly what is done with vehicle electrical systems. However, in order to have a truly d.c. machine, this rectification process needs to be automatically accomplished within the machine itself. This process is achieved by means of a commutator, the principle and action of which will now be described.

Consider a simple loop coil the two ends of which are connected to a single 'split' slip-ring, as illustrated in Fig. 7.3. Each half of this slip-ring is insulated from the other half, and also from the shaft on which it is mounted. This arrangement forms a simple commutator, where the connections to the external circuit are via a pair of carbon brushes. The rectifying action is demonstrated in the series of diagrams of Fig. 7.4. In these diagrams, one side of the coil and its associated commutator segment are identified by a **thickened line edge**. For the sake of clarity, the physical connection of each end of the coil, to its associated commutator segment, is not shown. Figure 7.4(a) shows the instant when maximum emf is induced in the coil. The current directions have been determined by applying Fleming's right-hand rule. At this

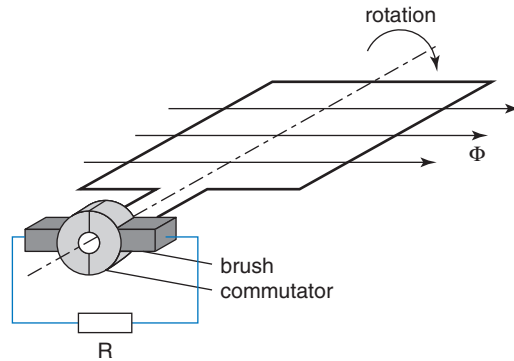

Fig. 7.3

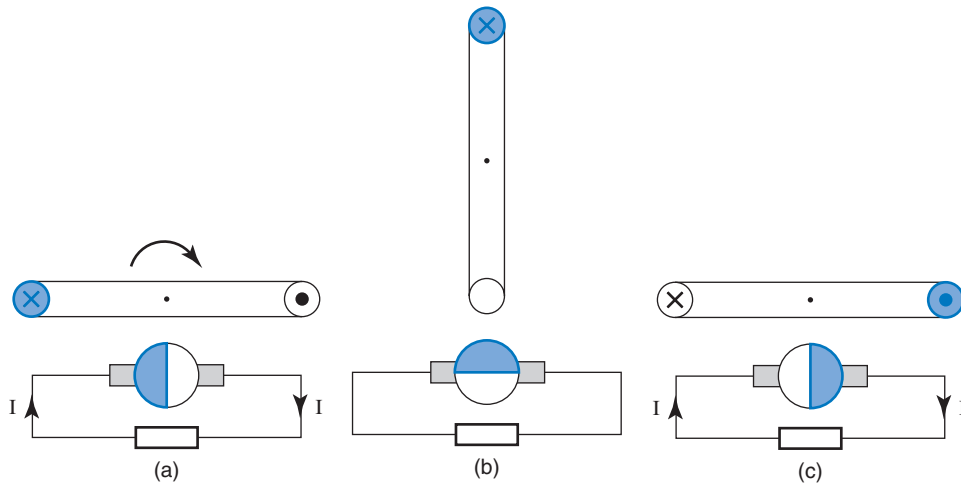

Fig. 7.4

instant current will be fed out from the coil, through the external circuit from right to left, and back into the other side of the coil. As the coil continues to rotate from this position, the value of induced emf and current will decrease. Figure 7.4(b) shows the instant when the brushes short-circuit the two commutator segments. However, the induced emf is also zero at this instant, so no current flows through the external circuit. Further rotation of the coil results in an increasing emf, but of the opposite polarity to that induced before. Figure 7.4(c) shows the instant when the emf has reached its next maximum. Although the generated emf is now reversed, the current through the external circuit will be in the same direction as before. The load current will therefore be a series of half-sinewave pulses, of the same polarity. Thus the commutator is providing a d.c. output to the load, whereas the armature generated emf is alternating.

A single-turn coil will generate only a very small emf. An increased amplitude of the emf may be achieved by using a multi-turn coil.

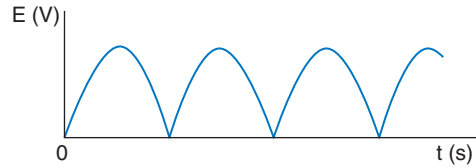

Fig. 7.5

The resulting output voltage waveform is shown in Fig. 7.5. Although this emf is unidirectional, and may have a satisfactory amplitude, it is not a satisfactory d.c. waveform. The problem is that we have a concentrated winding. In a practical machine the armature has a number of multi-turn coils. These are distributed evenly in slots around the periphery of a laminated steel core. Each multi-turn coil has its own pair of slots, and the two ends are connected to its own pair of commutator segments. Figure 7.6 shows the armature construction (before the coils have been inserted). The riser is the section of the

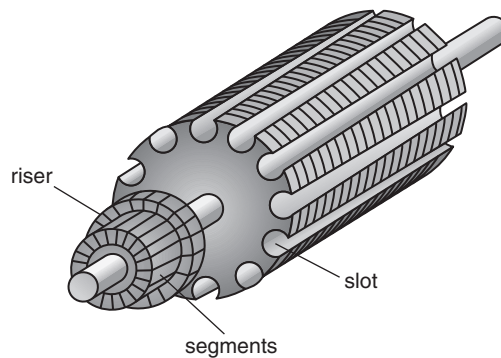

Fig. 7.6

commutator to which the ends of the coils are soldered. Due to the distribution of the coils around the armature, their maximum induced emfs will occur one after the other, i.e. they will be out of phase with each other. Figure 7.7 illustrates this, but for simplicity, only three coils have been considered.

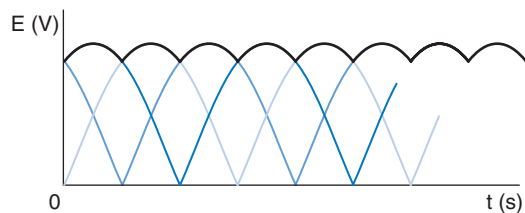

Fig. 7.7

Nevertheless, the effect on the resultant machine output voltage is apparent, and is shown by the thick line along the peaks of the waveform.

With a large number of armature coils the ripple on the resultant waveform will be negligible, and a smooth d.c. output is produced.

### 7.3 Construction of d.c. Machines

The various parts of a small d.c. machine are shown separately in Fig. 7.8, with the exception that neither the field nor armature windings have been included. The frame shell (bottom left) contains the pole pieces, around which the field winding would be wound. One end frame (top left) would simply contain a bearing for the armature shaft.

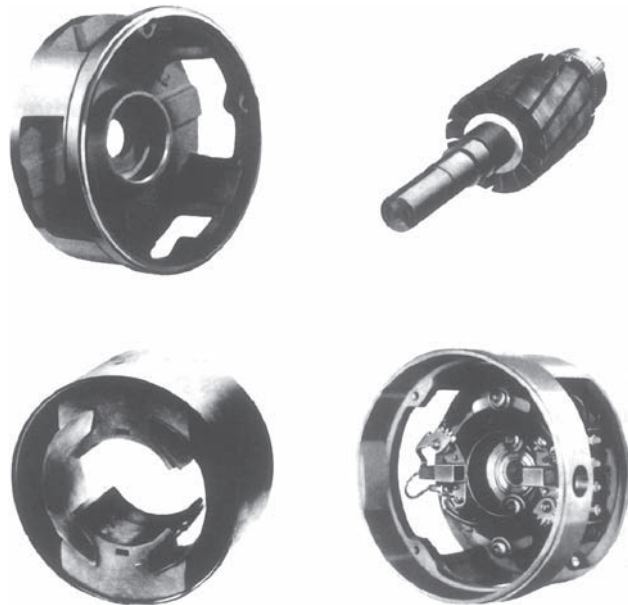

Fig. 7.8

The other end frame (bottom right) contains the brushgear assembly in addition to the other armature shaft bearing. The armature (top right) construction has already been described. The slots are skewed to provide a smooth starting and slow-speed torque.

### 7.4 Classification of Generators

D.C. generators are classified according to whether the field winding is electrically connected to the armature winding, and if it is, whether it is connected in parallel with or in series with the armature. The field current may also be referred to as the excitation current. If this current is supplied internally, by the armature, the machine is said to be self-excited. When the field current is supplied from an external d.c. source, the machine is said to be separately excited. The circuit symbol used

for the field winding of a d.c. machine is simply the same as that used to represent any other form of winding. The armature is represented by a circle and two 'brushes'. The armature conductors, as such, are not shown.

## 7.5 Separately Excited Generator

The circuit diagram of a separately excited generator is shown in Fig. 7.9. The rheostat,  $R_1$ , is included so that the field excitation current,  $I_f$ , can be varied. This diagram also shows the armature being driven at constant speed by some primemover. Since the armature of any generator must be driven, this drive is not normally shown. The load,  $R_L$ , being supplied by the generator may be connected or disconnected by switch  $S_2$ . The resistance of the armature circuit is represented by  $R_a$ .

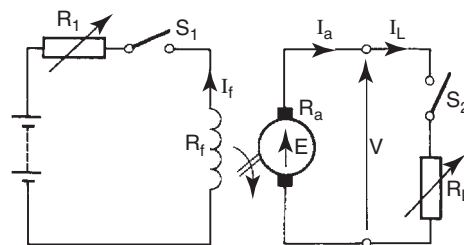

Fig. 7.9

Consider the generator being driven, with switches  $S_1$  and  $S_2$  both open. Despite the fact that there will be zero field current, a small emf would be measured. This emf is due to the small amount of residual magnetism retained in the poles. With switch  $S_1$  now closed, the field current may be increased in discrete steps, and the corresponding values of generated emf noted. A graph of generated emf versus field current will be as shown in Fig. 7.10, and is known as the open-circuit characteristic of the machine.

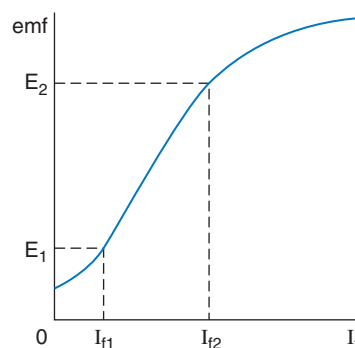

Fig. 7.10

It will be seen that the shape of this graph is similar to the magnetization curve for a magnetic material. This is to be expected, since the emf will be directly proportional to the pole flux. The 'flattening' of the emf graph indicates the onset of saturation of the machine's magnetic circuit. When the machine is used in practice, the field current would normally be set to some value within the range indicated by  $I_{f1}$  and  $I_{f2}$  on the graph. This means that the facility exists to vary the emf between the limits  $E_1$  and  $E_2$  volts, simply by adjusting rheostat  $R_1$ .

Let the emf be set to some value  $E$  volt, within the range specified above. If the load is now varied, the corresponding values of terminal voltage,  $V$  and load current  $I_L$  may be measured. Note that with this machine the armature current is the same as the load current. The graph of  $V$  versus  $I_L$  is known as the output characteristic of the generator, and is shown in Fig. 7.11. The terminal p.d. of the machine will be less than the generated emf, by the amount of internal voltage drop due to  $R_a$ , such that:

$$V = E - I_a R_a \text{ volt} \quad (7.1)$$

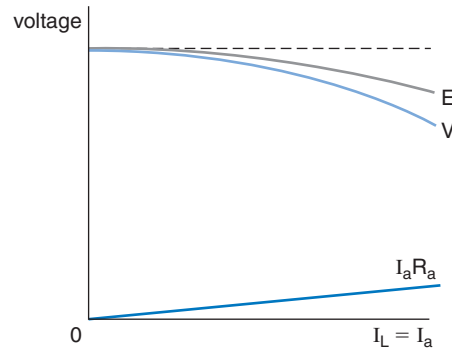

Fig. 7.11

Ideally, the graph of  $E$  versus  $I_L$  would be a horizontal line. However, an effect known as armature reaction causes this graph to 'droop' at the higher values of current. The main advantage of this type of generator is that there is some scope for increasing the generated emf in order to offset the internal voltage drop,  $I_a R_a$ , as the load is increased. The big disadvantage is the necessity for a separate d.c. supply for the field excitation.

## 7.6 Shunt Generator

This is a self-excited machine, where the field winding is connected in parallel (shunt) with the armature winding. The circuit diagram is

shown in Fig. 7.12, and from this it may be seen that the armature has to supply current to both the load and the field, such that:

$$I_a = I_L + I_f \text{ amp} \quad (7.2)$$

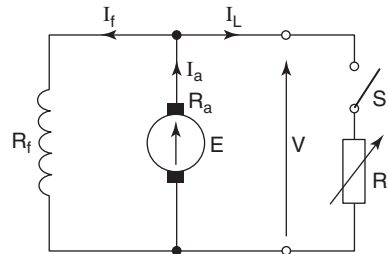

Fig. 7.12

This self-excitation process can take place only if there is some residual flux in the poles, and if the resistance of the field circuit is less than some critical value. The open-circuit characteristic is illustrated in Fig. 7.13.

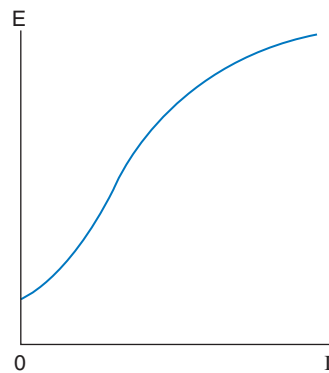

Fig. 7.13

The resistance of the field winding,  $R_f$ , is constant and of a relatively high value compared with  $R_a$ . Typically,  $I_f$  will be in the order of 1A to 10A, and will remain reasonably constant. The shunt machine is therefore considered to be a constant-flux machine. When switch  $S$  is closed, the armature current will increase in order to supply the demanded load current,  $I_L$ . Thus  $I_a \propto I_L$ , and as the load current is increased, so the terminal voltage will fall, according to the equation,  $V = E - I_a R_a$  volt. The output characteristic will therefore follow much the same shape as that for the separately excited generator and is shown in Fig. 7.14. This condition applies until the machine is providing its rated full-load output. If the load should now demand even more current, i.e. the machine is overloaded, the result is that the generator simply stops generating. This effect is shown by the dotted lines in the output characteristics.

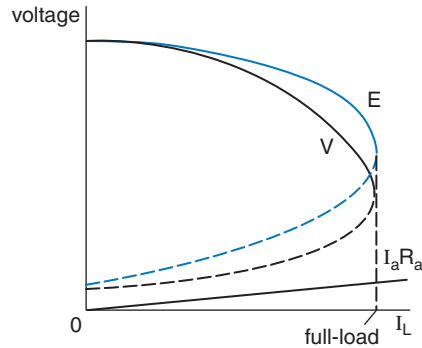

Fig. 7.14

The shunt generator is the most commonly used d.c. generator, since it provides a reasonably constant output voltage over its normal operating range. Its other obvious advantage is the fact that it is self-exciting, and therefore requires only some mechanical means of driving the armature.

## 7.7 Series Generator

In this machine the field winding is connected in series with the armature winding and the load, as shown in Fig. 7.15. In this case,  $I_L = I_a = I_f$ , so this is a variable-flux machine. Since the field winding must be capable of carrying the full-load current (which could be in hundreds of amps for a large machine), it is usually made from a few turns of heavy gauge wire or even copper strip. This also has the advantage of offering a very low resistance. This generator is a self-excited machine, provided that it is connected to a load when started. Note that a *shunt* generator will self-excite only when *disconnected* from its load.

When the load on a series generator is increased, the flux produced will increase, in almost direct proportion. The generated emf will therefore

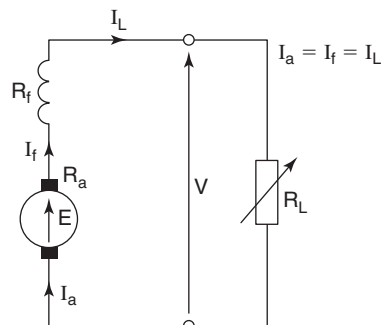

Fig. 7.15

increase with the demanded load. The increase of flux, and hence voltage, will continue until the onset of magnetic saturation, as shown in the output characteristic of Fig. 7.16. The terminal voltage is related to the emf by the equation:

$$V = E - I_a(R_a + R_f) \text{ volt} \quad (7.3)$$

The variation of terminal voltage with load is not normally a requirement for a generator, so this form of machine is seldom used. However, the rising voltage characteristic of a series-connected field winding is put to good use in the compound machine, which is described in *Further Electrical and Electronic Principles*.

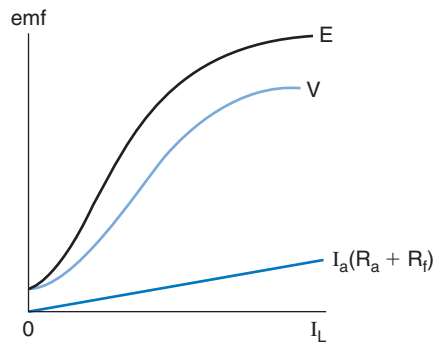

Fig. 7.16

### Worked Example 7.1

**Q** The resistance of the field winding of a shunt generator is  $200\ \Omega$ . When the machine is delivering  $80\ \text{kW}$  the generated emf and terminal voltage are  $475\ \text{V}$  and  $450\ \text{V}$  respectively. Calculate (a) the armature resistance, and (b) the value of generated emf when the output is  $50\ \text{kW}$ , the terminal voltage then being  $460\ \text{V}$ .

**A**

$$R_f = 200\ \Omega; P_o = 80 \times 10^3 \text{ watt}; V = 450\ \text{V}; E = 475\ \text{V}$$

The circuit diagram is shown in Fig. 7.17. It is always good practice to sketch the appropriate circuit diagram when solving machine problems.

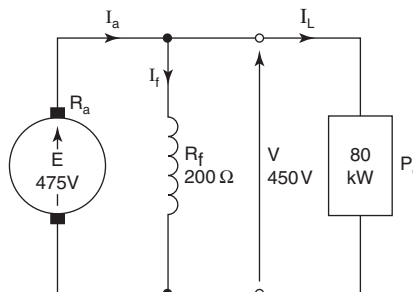

Fig. 7.17

$$\begin{aligned}
 \text{(a)} \quad P_o &= VI_L \text{ watt; so } I_L = \frac{P_o}{V} \text{ amp} \\
 \text{therefore } I_L &= \frac{80 \times 10^3}{450} = 177.8 \text{ A} \\
 I_f &= \frac{V}{R_f} \text{ amp} = \frac{450}{200} = 2.25 \text{ A} \\
 I_a &= I_L + I_f \text{ amp} = 180.05 \text{ A} \\
 I_a R_a &= E - V \text{ volt} = 475 - 450 = 25 \text{ V} \\
 \text{therefore } R_a &= \frac{25}{180.05} \text{ ohm} = 0.139 \Omega \text{ Ans}
 \end{aligned}$$

$$\begin{aligned}
 \text{(b)} \quad \text{When } P_o &= 50 \times 10^3 \text{ W, } V = 460 \text{ V} \\
 \text{thus } I_L &= \frac{50 \times 10^3}{460} = 108.7 \text{ A} \\
 I_f &= \frac{V}{R_f} = \frac{460}{200} = 2.3 \text{ A} \\
 \text{hence, } I_a &= 108.7 + 2.3 = 111 \text{ A} \\
 E &= V + I_a R_a \text{ volt} = 460 + (111 \times 0.139) \\
 \text{therefore } E &= 475.4 \text{ V Ans}
 \end{aligned}$$

**Note:** Although the load had changed by about 60%, the field current has changed by only about 2.2%. This justifies the statement that a shunt generator is considered to be a constant-flux machine.

## 7.8 D.C. Motors

All of the d.c. generators so far described could be operated as motors, provided that they were connected to an appropriate d.c. supply. When the machine is used as a motor, the armature generated emf is referred to as the back-emf,  $E_b$ , which is directly proportional to the speed of rotation. However, the speed is *inversely* proportional to the field flux  $\Phi$ .

In addition, the torque produced by the machine is proportional to both the flux and the armature current. Bearing these points in mind, we can say that:

$$\text{Speed, } \omega \propto \frac{E_b}{\Phi} \quad (7.4)$$

$$\text{and torque, } T \propto \Phi I_a \quad (7.5)$$

## 7.9 Shunt Motor

When the machine reaches its normal operating temperature,  $R_f$  will remain constant. Since the field winding is connected directly to a

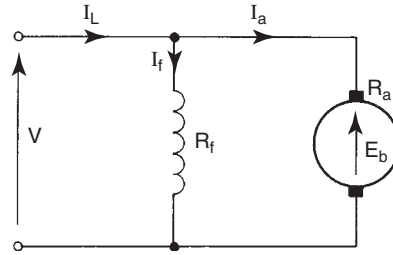

Fig. 7.18

fixed supply voltage,  $V$  volt, then  $I_f$  will be fixed. Thus, the shunt motor (Fig. 7.18) is a constant-flux machine.

As the back-emf will have the same shape graph as that for the generator emf, and using (7.4) and (7.5) the graphs of speed and torque versus current will be as in Fig. 7.19. Note that when the machine is used as a motor, the supply current is identified as  $I_L$ . In this case, the subscript 'L' represents the word 'line'. Thus  $I_L$  identifies the line current drawn from the supply, and  $I_a$  is directly proportional to  $I_L$ .

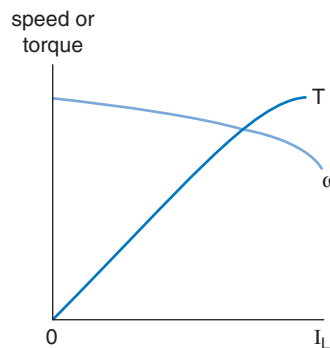

Fig. 7.19

Shunt motors are used for applications where a reasonably constant speed is required, between no-load and full-load conditions.

## 7.10 Series Motor

Like the series generator, this machine is a variable-flux machine. Despite this, the back-emf of this motor remains almost constant, from light-load to full-load conditions. This fact is best illustrated by considering the circuit diagram (Fig. 7.20), with some typical values.

$$E_b = V - I_a(R_a + R_f) \text{ volt} \quad (7.6)$$

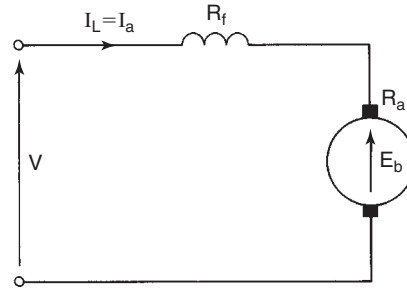

Fig. 7.20

Let us assume the following:  $V = 200\text{ V}$ ;  $R_a = 0.15\ \Omega$ ;  $R_f = 0.03\ \Omega$ ;  
 $I_a = 5\text{ A}$  on light-load;  $I_a = 50\text{ A}$  on full-load

Light-load:  $E_b = 200 - 5(0.15 + 0.03) = 199.1\text{ V}$

Full-load:  $E_b = 200 - 50(0.15 + 0.03) = 191\text{ V}$

From the above figures, it may be seen that although the armature current has increased tenfold, the back-emf has decreased by only 4%. Hence,  $E_b$  remains sensibly constant.

Since  $\omega \propto E_b/\Phi$ , and  $E_b$  is constant, then:

$$\omega \propto \frac{1}{\Phi} \dots\dots\dots [1]$$

Similarly,  $T \propto \Phi I_a$ , and since  $\Phi \propto I_a$  until the onset of magnetic saturation,

then  $T \propto I_a^2 \dots\dots\dots [2]$

and after saturation,  $T \propto I_a \dots\dots\dots [3]$

Using [1] to [3] above, the speed and torque characteristics shown in Fig. 7.21 may be deduced.

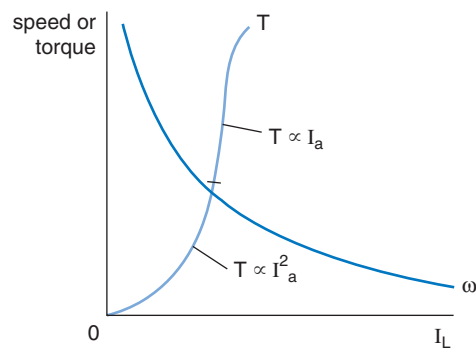

Fig. 7.21

*Note:* From the speed characteristic it is clear that, on very light loads, the motor speed would be excessive. *Theoretically*, the no-load speed

would be infinite! For this reason a series motor must NEVER be started unless it is connected to a mechanical load sufficient to prevent a dangerously high speed. Similarly, a series motor must not be used to operate belt-driven machinery, lifting cranes etc., due to the possibility of the load being suddenly disconnected. If a series motor is allowed to run on a very light load, its speed builds up very quickly. The probable outcome of this is the disintegration of the machine, with the consequent dangers to personnel and plant.

The series motor has a high starting torque due to the 'square-law' response of the torque characteristic. For this reason, it tends to be used mainly for traction purposes. For example, an electric train engine requires a very large starting torque in order to overcome the massive inertia of a stationary train.

### Summary of Equations

#### *Generators:*

**Shunt generator:**  $I_a = I_L + I_f$  amp

$$V = E - I_a R_a \text{ volt}$$

**Series generator:**  $I_a = I_L = I_f$  amp

$$V = E - I_a (R_a + R_f) \text{ volt}$$

#### *Motors:*

**Shunt motor:**  $E_b = V - I_a R_a$  volt

**Series motor:**  $E_b = V - I_a (R_a + R_f)$  volt

**Speed equation:**  $n \propto \frac{E_b}{\Phi}$  rev/second; or  $\omega \propto \frac{E_b}{\Phi}$  rad/second

**Torque equation:**  $T \propto \Phi I_a$  newton metre

### Assignment Questions

- 1 A shunt generator supplies a current of 85 A at a terminal p.d. of 380V. Calculate the generated emf if the armature and field resistances are  $0.4\Omega$  and  $95\Omega$  respectively.
- 2 A generator produces an armature current of 50 A when generating an emf of 400V. If the terminal p.d. is 390V, calculate (a) the value of the armature resistance, and (b) the power loss in the armature circuit.
- 3 A d.c. shunt generator supplies a 50 kW load at a terminal voltage of 250V. The armature and field circuit resistances are  $0.15\Omega$  and  $50\Omega$  respectively. Calculate the generated emf.

## D.C. Transients

### Learning Outcomes

This chapter explains the response of capacitor-resistor, and inductor-resistor circuits, when they are connected to and disconnected from, a d.c. supply.

On completion of this chapter you should be able to:

- 1 Show how the current and capacitor voltage in a series  $C$ - $R$  circuit varies with time, when connected to/disconnected from a d.c. supply.
- 2 Show how the current through, and p.d. across an inductor in a series  $L$ - $R$  circuit varies with time, when connected to/disconnected from a d.c. supply.
- 3 Define the term time constant for both types of above circuits.

### 8.1 Capacitor-Resistor Series Circuit (Charging)

Before dealing with the charging process for a  $C$ - $R$  circuit, let us firstly consider an analogous situation. Imagine that you need to inflate a 'flat' tyre with a foot pump. Initially it is fairly easy to pump air into the tyre. However, as the air pressure inside the tyre builds up, it becomes progressively more difficult to force more air in. Also, as the internal pressure builds up, the rate at which air can be pumped in decreases. Comparing the two situations, the capacitor (which is to be charged) is analogous to the tyre; the d.c. supply behaves like the pump; the charging current compares to the air flow rate; and the p.d. developed between the plates of the capacitor has the same effect as the tyre pressure. From these comparisons we can conclude that as the capacitor voltage builds up, it reacts against the emf of the supply, so slowing down the charging rate. Thus, the capacitor will charge at a non-uniform rate, and will continue to charge until the p.d. between its plates is equal to the supply emf. This last point would also apply to tyre inflation, when the tyre pressure reaches the maximum pressure available from the pump. At this point the air flow into the tyre would

cease. Similarly, when the capacitor has been fully charged, the charging current will cease.

Let us now consider the  $C$ - $R$  charging circuit in more detail. Such a circuit is shown in Fig. 8.1. Let us assume that the capacitor is initially fully discharged, i.e. the p.d. between its plates ( $v_C$ ) is zero, as will be the charge,  $q$ . Note that the lowercase letters  $v$  and  $q$  are used because, during the charging sequence, they will have continuously changing values, as will the p.d. across the resistor ( $v_R$ ) and the charging current,  $i$ . Thus these quantities are said to have *transient* values.

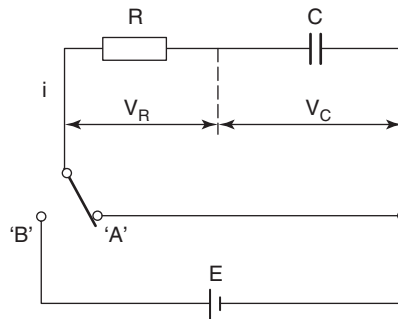

Fig. 8.1

At some time  $t = 0$ , let the switch be moved from position 'A' to position 'B'. At this instant the charging current will start to flow. Since there will be no opposition offered by capacitor p.d. ( $v_C = 0$ ), then only the resistor,  $R$ , will offer any opposition. Consequently, the initial charging current ( $I_0$ ) will have the maximum possible value for the circuit. This initial charging current is therefore given by:

$$I_0 = \frac{E}{R} \text{ amp} \quad (8.1)$$

Since we are dealing with a series d.c. circuit, then the following equation must apply *at all times*:

$$E = v_R + v_C \text{ volt} \dots \dots \dots [1]$$

thus, at time  $t = 0$

$$E = v_R + 0$$

i.e. the full emf of  $E$  volt is developed across the resistor at the instant the supply is connected to the circuit. Since  $v_R = iR$ , and at time  $t = 0$ ,  $i = I_0$ , this confirms equation (8.1) above.

Let us now consider the situation when the capacitor has reached its fully-charged state. In this case, it will have a p.d. of  $E$  volt, a charge of  $Q$  coulomb, and the charging current,  $i = 0$ . If there is no current flow then the p.d. across the resistor,  $v_R = 0$ , and eqn [1] is:

$$E = 0 + v_C$$

Having confirmed the initial and final values for the transients, we now need to consider how they vary, with time, between these limits. It has already been stated that the variations will be non-linear (i.e. not a straight line graph). In fact the variations follow an *exponential* law.

Any quantity that varies in an exponential fashion will have a graph like that shown in Fig. 8.2(a) if it increases with time, and as in Fig. 8.2(b) for a decreasing function.

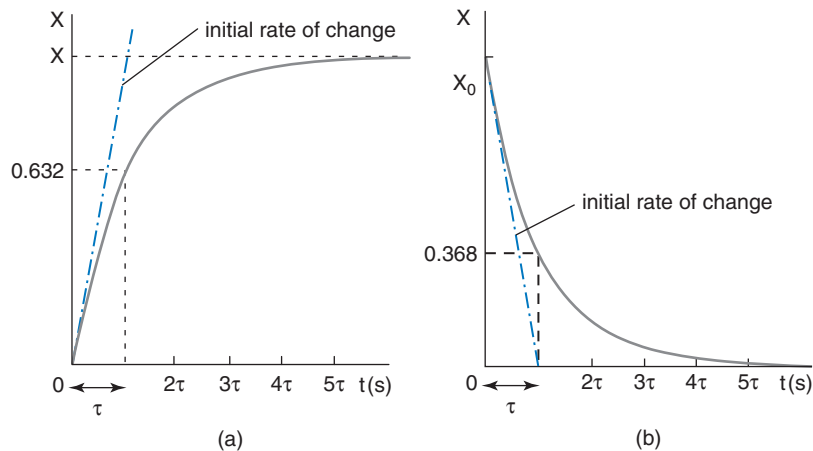

Fig. 8.2

In Fig. 8.2(a),  $X$  represents the final steady state value of the variable  $x$ , and in Fig. 8.2(b),  $X_0$  represents the initial value of  $x$ . In each case the straight line (tangent to the curve at time  $t = 0$ ) indicates the initial rate of change of  $x$ . The time interval shown as  $\tau$  shown on both graphs is known as the time constant, which is defined as follows:

The time constant is the time that it would take the variable to reach its final steady state if it continued to change at its initial rate.

From the above Figures it can be seen that for an increasing exponential function, the variable will reach 63.2% of its final value after one time constant, and for a decreasing function it will fall to 36.8% of its initial value after  $\tau$  seconds.

**Note:** Considering *any* point on the graph, it would take one time constant for the variable to reach its final steady value if it continued to change at the same rate as at that point. Thus an exponential graph may be considered as being formed from an infinite number of tangents, each of which represents the slope at a particular instant in time. This is illustrated in Fig. 8.3.

Also, *theoretically*, an exponential function can never actually reach its final steady state. However, for *practical* purposes it is assumed that the final steady state is achieved after 5 time constants. This is justifiable since the variable will be within 0.67% of the final value after  $5\tau$  seconds. So for Fig. 8.2(a), after  $5\tau$  seconds,  $x = 0.9973 X$ .

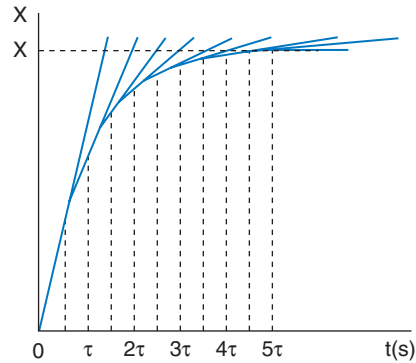

Fig. 8.3

Considering the circuit of Fig. 8.1, assuming that the capacitor is fully discharged, let the switch be moved to position 'B'. The capacitor will now charge via resistor  $R$  until the p.d. between its plates,  $v_C = E$  volts. Once fully charged, the circuit current will be zero. The variations of capacitor voltage and charge, p.d. across the resistance and charging current are shown in Figs. 8.4 to 8.7.

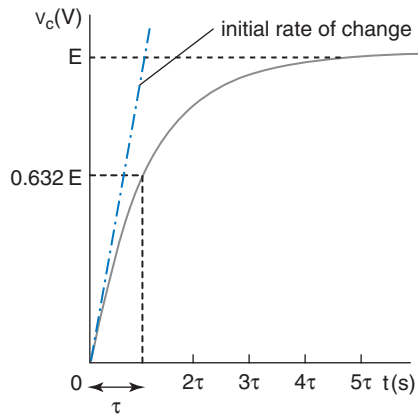

Fig. 8.4

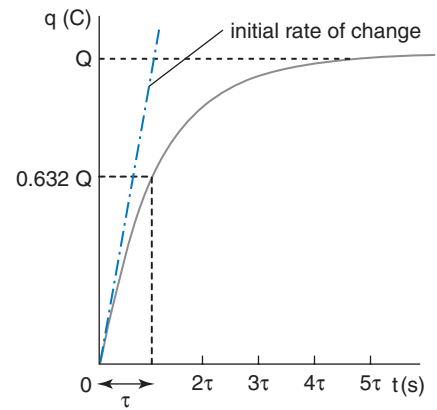

Fig. 8.5

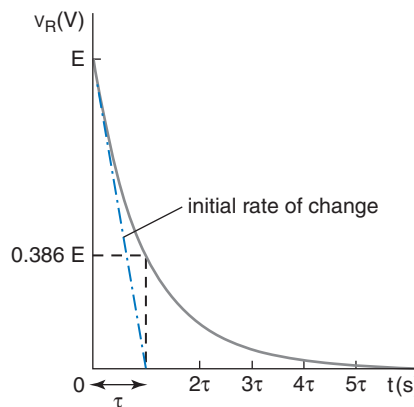

Fig. 8.6

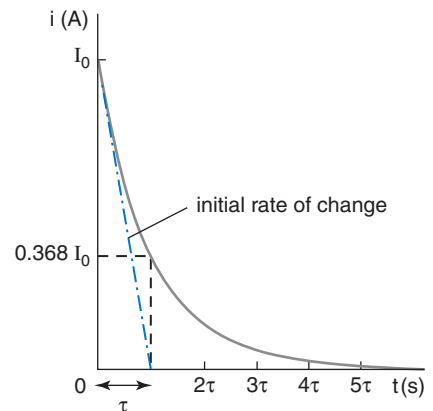

Fig. 8.7

For such a  $CR$  circuit the time constant,  $\tau$  (Greek letter tau), is  $CR$  seconds. It may appear strange that the product of capacitance and resistance yields a result having units of time. This may be justified by considering a simple dimensional analysis, as follows.

$$C = \frac{Q}{V} = \frac{It}{V} \quad \text{and} \quad R = \frac{V}{I}$$

$$\text{so, } CR = \frac{It}{V} \times \frac{V}{I} = t \text{ seconds}$$

$$\text{Hence, } \tau = CR \text{ seconds} \quad (8.2)$$

### Worked Example 8.1

**Q** An  $8 \mu\text{F}$  capacitor is connected in series with a  $0.5 \text{ M}\Omega$  resistor, across a  $200 \text{ V}$  d.c. supply. Calculate (a) the circuit time constant, (b) the initial charging current, (c) the p.d.s across the capacitor and resistor 4 seconds after the supply is connected. You may assume that the capacitor is initially fully discharged.

**A**

$$C = 8 \times 10^{-6} \text{ F}; R = 0.5 \times 10^6 \Omega; E = 200 \text{ V}$$

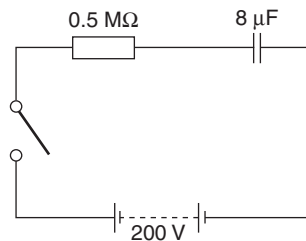

Fig. 8.8

(a)  $\tau = CR \text{ second} = 8 \times 10^{-6} \times 0.5 \times 10^6$

so  $\tau = 4 \text{ s}$  **Ans**

(b)  $I_0 = \frac{E}{R} \text{ amp} = \frac{200}{0.5 \times 10^6}$

therefore  $I_0 = 400 \mu\text{A}$  **Ans**

(c) After  $\tau$  seconds,  $v_C = 0.632 E \text{ volt} = 0.632 \times 200$

$$v_C = 126.4 \text{ V} \text{ **Ans**}$$

$$v_R = E - v_C \text{ volt}$$

$$= 200 - 126.4$$

$$\text{so } v_R = 73.6 \text{ V} \text{ **Ans**}$$

## 8.2 Capacitor-Resistor Series Circuit (Discharging)

Consider the circuit of Fig. 8.1, where the switch has been in position 'B' for sufficient time to allow the charging process to be completed.

Thus the charging current will be zero, the p.d. across the resistor will be zero, the p.d. across the capacitor will be  $E$  volt, and it will have stored a charge of  $Q$  coulomb.

At some time  $t = 0$ , let the switch be moved back to position 'A'. The capacitor will now be able to discharge through resistor  $R$ . The general equation for the voltages in the circuit will still apply.

$$\text{In other words } E = v_R + v_C$$

but, at the instant the switch is moved to position 'A', the source of emf is removed. Applying this condition to the general equation above yields:

$$\begin{aligned} 0 &= v_R + v_C; \quad \text{where } v_C = E \text{ and } v_R = I_0 R \\ \text{so } 0 &= I_0 R + E \end{aligned}$$

$$\text{hence } I_0 = -\frac{E}{R} \text{ amp} \quad (8.3)$$

This means that the initial discharge current has the same value as the initial charging current, but (as you would expect) it flows in the opposite direction.

Since the capacitor is discharging, then its voltage will decay from  $E$  volt to zero; its charge will decay from  $Q$  coulomb to zero; and the discharge current will also decay from  $I_0$  to zero. The circuit time constant will be the same as before i.e.  $\tau = CR$  seconds.

The graphs for  $v_C$  and  $i$  are shown in Fig. 8.9.

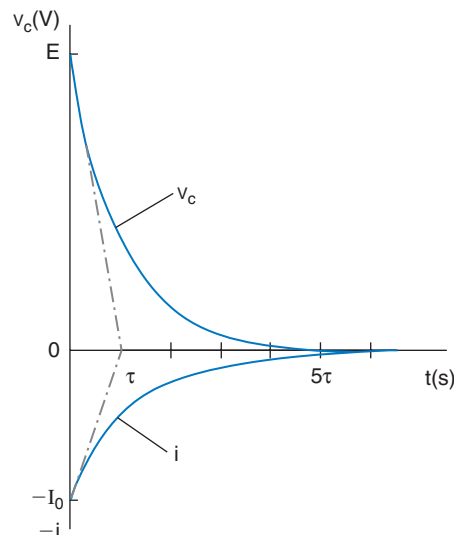

Fig. 8.9

**Note:** The time constant for the  $C$ - $R$  circuit was defined previously in terms of the capacitor charging. However, a time constant also applies to the discharge conditions. It is therefore better to define the time constant in a more general manner, as follows:

The time constant of a circuit is the time that it would have taken for any transient variable to change, from one steady state to a new steady state, if it had maintained its rate of change existing at the time of the first steady state.

### Worked Example 8.2

**Q** A  $C$ - $R$  charge/discharge circuit is shown in Fig. 8.10. The switch has been in position '1' for a sufficient time to allow the capacitor to become fully discharged.

- (a) If the switch is now moved to position '2', calculate the time constant and initial charging current.  
 (b) After the capacitor has completely charged the switch is moved back to position '2'. Calculate the time constant and the p.d across  $R_2$  at this time.

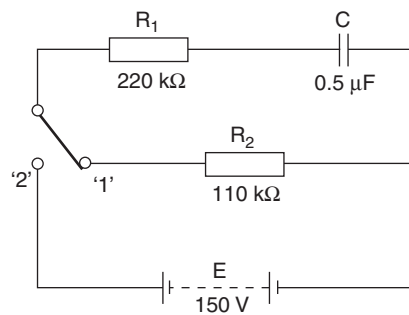

Fig. 8.10

**A**

$$C = 0.5 \mu\text{F}; R_1 = 220 \text{ k}\Omega; R_2 = 110 \text{ k}\Omega; E = 150 \text{ V}$$

- (a) When charging, only resistor  $R_1$  is connected in series with the capacitor, so  $R_2$  may be ignored.

$$\tau = CR_1 \text{ seconds} = 0.5 \times 10^{-6} \times 220 \times 10^3$$

$$\text{so } \tau = 0.11 \text{ s Ans}$$

$$I_0 = \frac{E}{R} \text{ amp}$$

$$= \frac{150}{220 \times 10^3}$$

$$I_0 = 682 \mu\text{A Ans}$$

- (b) When discharging, both  $R_1$  and  $R_2$  are connected in series with the capacitor, so their combined resistance  $R = R_1 + R_2$ , will determine the discharge time constant.

$$\tau = CR \text{ seconds} = 0.5 \times 10^{-6} \times 330 \times 10^3$$

$$\text{so, } \tau = 0.16 \text{ s Ans}$$

After one time constant the discharge current will have fallen to  $0.368 I_0$

$$I_0 = \frac{E}{R} \text{ amp} = \frac{150}{330 \times 10^3}$$

$$I_0 = 454.5 \mu\text{A}$$

$$i = 0.368 \times 454 \times 10^{-6}$$

$$i = 167.26 \mu\text{A}$$

$$v_{R2} = iR_2 \text{ volt} = 167.26 \times 10^{-6} \times 110 \times 10^3$$

$$v_{R2} = 18.4 \text{ V Ans}$$

### 8.3 Inductor-Resistor Series Circuit (Connection to Supply)

Consider the circuit of Fig. 8.11. At some time  $t = 0$ , the switch is moved from position 'A' to position 'B'. The connection to the supply is now complete, and current will start to flow, increasing towards its final

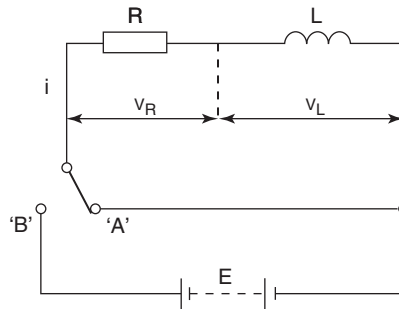

Fig. 8.11

steady value. However, whilst the current is *changing* it will induce a back-emf across the inductor, of  $e$  volt. From electromagnetic induction theory we know that this induced emf will have a value given by:

$$e = -L \frac{di}{dt} \text{ volt}$$

Being a simple series circuit, Kirchhoff's voltage law will apply, such that the sum of the p.d.s equals the applied emf. Also, since we are considering a perfect inductor (the resistor shown may be considered as the coil's resistance), the p.d. across the inductor will be exactly equal but opposite in polarity to the induced emf.

Therefore,  $v_L = -e = L \frac{di}{dt}$  volt

hence,  $E = v_R + v_L$  volt

or,  $E = iR + L \frac{di}{dt}$  volt .....[1]

Comparing this equation with that for the *C-R* circuit, it may be seen that they are both of the same form. Using the analogy technique, we

can conclude that both systems will respond in a similar manner. In the case of the  $L$ - $R$  circuit, the *current* will increase from zero to its final steady value, following an exponential law.

At the instant that the switch is moved from 'A' to 'B' ( $t = 0$ ), the current will have an instantaneous value of zero, but it *will* have a certain rate of change,  $di/dt$  amp/s. From eqn [1] above, this initial rate of change can be obtained, thus:

$$E = 0 + L \frac{di}{dt}$$

$$\text{so, initial } \frac{di}{dt} = \frac{E}{L} \text{ amp/s} \quad (8.4)$$

When the current reaches its final steady value, there will be no back-emf across the inductor, and hence no p.d. across it. Thus the only limiting factor on the current will then be the resistance of the circuit. The final steady current is therefore given by:

$$I = \frac{E}{R} \text{ amp} \quad (8.5)$$

The time constant of the circuit is obtained by dividing the inductance by the resistance.

$$\text{Thus } \tau = \frac{L}{R} \text{ seconds} \quad (8.6)$$

The above equation may be confirmed by using a simple form of dimensional analysis, as follows.

$$\begin{aligned} \text{In general, } V &= \frac{LI}{t}; \quad \text{so } L = \frac{Vt}{I} \\ \text{and } R &= \frac{V}{I} \\ \text{therefore, } \frac{L}{R} &= \frac{Vt}{I} \times \frac{I}{V} = t \text{ seconds} \end{aligned}$$

The time constant of the circuit may be defined in the general terms given in the 'Note', in the previous section, dealing with the  $C$ - $R$  circuit.

The rate of change of current will be at its maximum value at time  $t = 0$ , so the p.d. across the inductor will be at its maximum value at this time. This p.d. therefore decays exponentially from  $E$  volt to zero. The graphs for  $i$ ,  $v_R$ , and  $v_L$  are shown in Figs. 8.12 to 8.14 respectively.

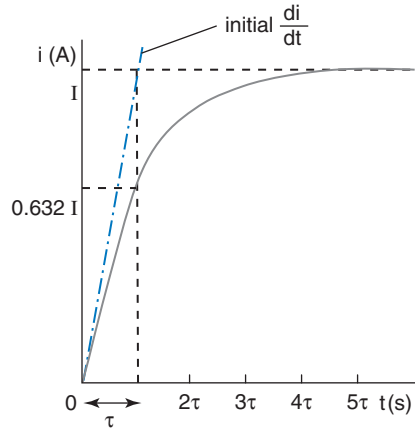

Fig. 8.12

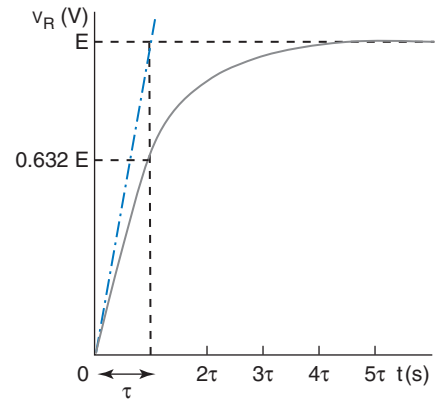

Fig. 8.13

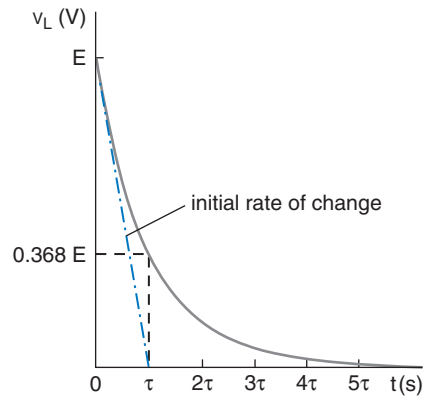

Fig. 8.14

**Worked Example 8.3**

**Q** The field winding of a 110 V, d.c. motor has an inductance of 1.5 H, and a resistance of 220 Ω. From the instant that the machine is connected to a 110V supply, calculate (a) the initial rate of change of current, (b) the final steady current, and (c) the time taken for the current to reach its final steady value.

**A**

$$E = 110\text{V}; \quad L = 1.5 \text{ H}; \quad R = 220 \Omega$$

The circuit diagram is shown in Fig. 8.15.

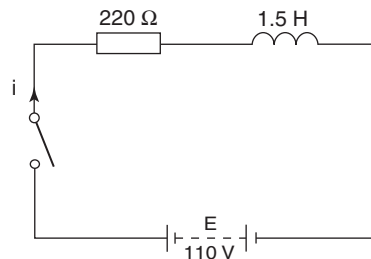

Fig. 8.15

$$(a) \quad \text{initial } \frac{di}{dt} = \frac{E}{L} \text{ amp/s} = \frac{110}{1.5}$$

$$\text{so, initial } \frac{di}{dt} = 73.33 \text{ A/s } \mathbf{Ans}$$

$$(b) \quad \text{final current, } I = \frac{E}{R} \text{ amp} = \frac{110}{220}$$

$$\text{therefore, } I = 0.5 \text{ A } \mathbf{Ans}$$

$$(c) \quad \tau = \frac{L}{R} \text{ second} = \frac{1.5}{220}$$

$$\text{hence, } \tau = 6.82 \text{ ms}$$

Since the system takes approximately  $5\tau$  seconds to reach its new steady state, then the current will reach its final steady value in a time:

$$t = 5 \times 6.82 \text{ ms} = 34.1 \text{ ms } \mathbf{Ans}$$

## 8.4 Inductor-Resistor Series Circuit (Disconnection)

Figure 8.16 shows such a circuit, connected to a d.c. supply. Assume that the current has reached its final steady value of  $I$  amps. Let the switch now be returned to position 'A' (at time  $t = 0$ ). The current will now decay to zero in an exponential manner. However, the decaying current will induce a back-emf across the coil. This emf must oppose the change of current. Therefore, the decaying current will flow *in the same direction* as the original steady current. In other words, the back-emf will try to maintain the original current flow. The graph of the decaying current, with respect to time, will therefore be as shown in Fig. 8.17. The time constant of the circuit will, of course, still be  $L/R$  second, and the current will decay from a value of  $I = E/R$  amp. The initial rate of decay will also be  $E/L$  amp/s.

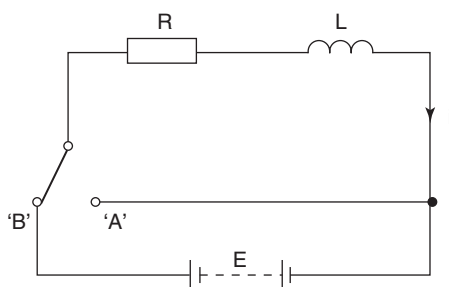

Fig. 8.16

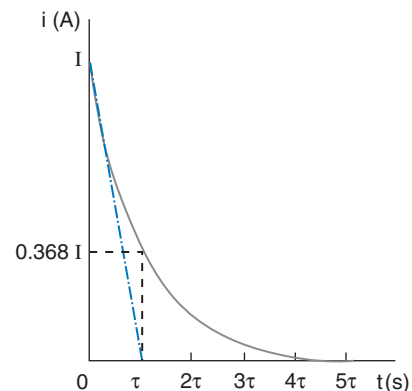

Fig. 8.17

### Summary of Equations

#### ***C-R circuit:***

Time constant,  $\tau = CR$  second

Initial current,  $I_0 = \frac{E}{R}$  amp

steady-state conditions after approx.  $5\tau$  second

after,  $\tau$  second,  $v_C = 0.632E$  volt; and  $i = 0.368I_0$  amp

#### ***L-R circuit:***

Time constant,  $\tau = \frac{L}{R}$  second

Initial rate of change of current,  $\frac{di}{dt} = \frac{E}{L}$  amp/second

final current flowing,  $I = \frac{E}{R}$  amp

steady-state conditions after approx.  $5\tau$  second

after  $\tau$  second,  $V_L = 0.368E$  volt; and  $i = 0.632I$  amp

## Assignment Questions

- 1 A  $47\ \mu\text{F}$  capacitor is connected in series with a  $39\ \text{k}\Omega$  resistor, across a  $24\ \text{V}$  d.c. supply. Calculate (a) the circuit time constant, (b) the values for initial and final charging current, and (c) the time taken for the capacitor to become fully charged.
- 2 A  $150\ \text{mH}$  inductor of resistance  $50\ \Omega$  is connected to a  $50\ \text{V}$  d.c. supply. Determine (a) the initial rate of change of current, (b) the final steady current, and (c) the time taken for the current to change from zero to its final steady value.
- 3 An inductor of negligible resistance and of inductance  $0.25\ \text{H}$ , is connected in series with a  $1.5\ \text{k}\Omega$  resistor, across a  $24\ \text{V}$  d.c. supply. Calculate the current flowing after one time constant.
- 4 A  $5\ \text{H}$  inductor has a resistance  $R$  ohm. This inductor is connected in series with a  $10\ \Omega$  resistor, across a  $140\ \text{V}$  d.c. supply. If the resulting circuit time constant is  $0.4\ \text{s}$ , determine (a) the value of the coil resistance, and (b) the final steady current.
- 5 Define the *time constant* of a capacitor-resistor series circuit.  
  
Such a circuit comprises a  $50\ \mu\text{F}$  capacitor and a resistor, connected to a  $100\ \text{V}$  d.c. supply via a switch. If the circuit time constant is to be  $5\ \text{s}$ , determine (a) the resistor value, (b) the initial charging current.
- 6 The dielectric of a  $20\ \mu\text{F}$  capacitor has a resistance of  $65\ \text{M}\Omega$ . This capacitor is fully charged from a  $120\ \text{V}$  d.c. supply. Calculate the time taken, after disconnection from the supply, for the capacitor to become fully discharged.

## Suggested Practical Assignments

### Assignment 1

To investigate the variation of capacitor voltage and current during charge and discharge cycles.

#### Apparatus:

- 1 × 10  $\mu$ F capacitor
- 1 × 10 M $\Omega$  resistor
- 1 × 2-pole switch
- 1 × d.c. power supply
- 1 × ammeter (microammeter)
- 1 × DVM (with highest possible input resistance)
- 1 × stopwatch

#### Method:

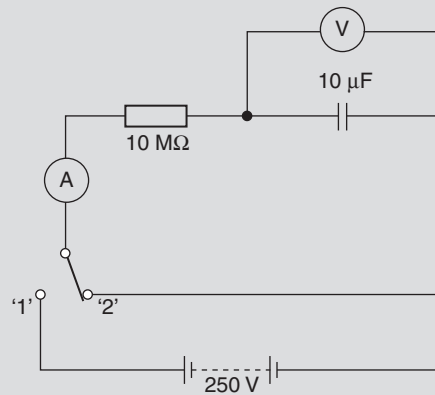

Fig. 8.18

- 1 Connect the circuit of Fig. 8.18, and adjust the psu output to 250V.
- 2 Simultaneously move the switch to position '1' and start the stopwatch.
- 3 Record the circuit current and capacitor p.d. at 10 s intervals, for the first 60 s.
- 4 Continue recording the current and voltage readings, at 20 s intervals, for a further 4 minutes. Reset the stopwatch to zero. Reverse the connections to the ammeter.
- 5 Move the switch back to position '2', and repeat the procedures of paragraphs (3) and (4) above.
- 6 Plot graphs of current and capacitor p.d., versus time, for both the charging and discharging cycles.
- 7 Submit a complete assignment report, which should include the following:
  - (i) The comparison of the actual time constant (determined from the plotted graphs) to the theoretical value. Explain any discrepancy found.
  - (ii) Explain why both the charging and discharging currents tend to 'level off' at some small value, rather than continuing to decrease to zero.

# Semiconductor Theory and Devices

## Learning Outcomes

This chapter explains the behaviour of semiconductors and the way in which they are employed in diodes.

On completion of this chapter you should be able to:

- 1 Understand the way in which conduction takes place in semiconductor materials.
- 2 Understand how these materials are employed to form devices such as diodes.
- 3 Understand the action of a zener diode and perform basic calculations involving a simple regulator circuit.

## 9.1 Atomic Structure

In Chapter 1 it was stated that an atom consists of a central nucleus containing positively charged protons, and neutrons, the latter being electrically neutral, surrounded by negatively charged electrons orbiting in layers or shells. Electrons in the inner orbits or shells have the least energy and are tightly bound into their orbits due to the electrostatic force of attraction between them and the nucleus. Electrons in the outermost shell experience a much weaker binding force, and are known as valence electrons.

In conductors it is these valence electrons that can gain sufficient energy to break free from their parent atoms. They thus become 'free' electrons which are available to drift through the material under the influence of an emf and hence are mobile charge carriers which produce current flow.

The shells are identified by letters of the alphabet, beginning with the letter K for the innermost shell, L for the next and so on. Each shell represents a certain energy level, and each shell can contain only up to a

certain maximum number of electrons. This maximum possible number of electrons contained in a given shell is governed by the relationship  $2n^2$ , where  $n$  is the number of the shell. Thus the *maximum* number of electrons in the first four shells will be as shown in Table 9.1.

**Table 9.1**

Shell	n	Max. No. of electrons
K	1	$2 \times 1^2 = 2$
L	2	$2 \times 2^2 = 8$
M	3	$2 \times 3^2 = 18$
N	4	$2 \times 4^2 = 32$

All things in nature tend to stabilise at their lowest possible energy level, and atoms and electrons are no exception. This results in the lowest energy levels (shells) being filled first until all the electrons belonging to that atom are accommodated. Another feature of the system is that if the outermost shell of an atom is completely full (contains its maximum permitted number of electrons) then the binding force on these valence electrons is very strong and the atom is very stable. To illustrate this consider the inert gas neon. The term inert is used because it is very difficult to make it react to external influences. A neon atom has a total of 10 electrons, two of which are in the K shell and the remaining eight completely fill the L shell. Having a full valence shell is the reason why neon, krypton and xenon are inert gases. In contrast, a hydrogen atom has only one electron, so its valence shell is almost empty and it is a highly reactive element. One further point to bear in mind is that the electrons in the shells (from L onwards) may exist at slightly different energy levels known as subshells. These subshells may also contain only up to a certain maximum number of electrons. This is shown, for the L, M and N shells, in Table 9.2.

**Table 9.2**

Shell	L		M			N			
Subshell	2s	2p	3s	3p	3d	4s	4p	4d	4f
Max. No.	2	6	2	6	10	2	6	10	14
Total	8		18			32			

## 9.2 Intrinsic (Pure) Semiconductors

Semiconductors are group 4 elements, which means they have four valence electrons. For this reason they are also known as tetravalent

elements. Among this group of elements are carbon (C), silicon (Si), germanium (Ge) and tin (Sn). Of these only silicon and germanium are used as intrinsic semiconductors, with silicon being the most commonly used. Carbon is not normally considered as a semiconductor because it can exist in many different forms, from diamond to graphite. Similarly, tin is not used because at normal ambient temperatures it acts as a good conductor. The following descriptions of the behaviour of semiconductor materials will be confined to silicon although the general properties and behaviour of germanium are the same. The arrangement of electrons in the shells and subshells of silicon are shown in Table 9.3.

**Table 9.3**

K	L		M		
1s	2s	2p	3s	3p	3d
2	2	6	2	2	—

From Table 9.3 it may be seen that the four valence electrons are contained in the M shell, where the 3s subshell is full but the 3p subshell contains only two electrons. However, from Table 9.2 it can be seen that a 3p subshell is capable of containing up to a maximum of six electrons before it is full, so in the silicon atom there is space for a further four electrons to be accommodated in this outermost shell.

Silicon has an atomic bonding system known as covalent bonding whereby each of the valence electrons orbits not only its 'parent' atom, but also orbits its closest neighbouring atom. This effect is illustrated in Fig. 9.1, where the five large circles represent the nucleus and shells K and L of five adjacent atoms (identified as A, B, C, D and E) and the small circles represent their valence electrons, where the letters a, b, c etc. identify their 'parent' atoms.

Concentrating on the immediate space surrounding atom A, it may be seen that there are actually eight valence electrons orbiting this atom; four of its own plus one from each of its four nearest neighbours. This figure is only two-dimensional and is centred on atom A. However, the same arrangement would be found if the picture was centred on any given atom in the crystal lattice. In addition, the actual lattice is of course three-dimensional. In this case imagine atom A being located at the centre of an imaginary cube with the other four neighbouring atoms being at four of the corners of the cube. Each of these 'corner' atoms is in turn at the centre of another imaginary cube, and so on throughout the whole crystal lattice. The result is what is known as the diamond crystal lattice.

From the above description it may be seen that each silicon atom has an *apparent* valency of 8, which is the same as for the inert gases

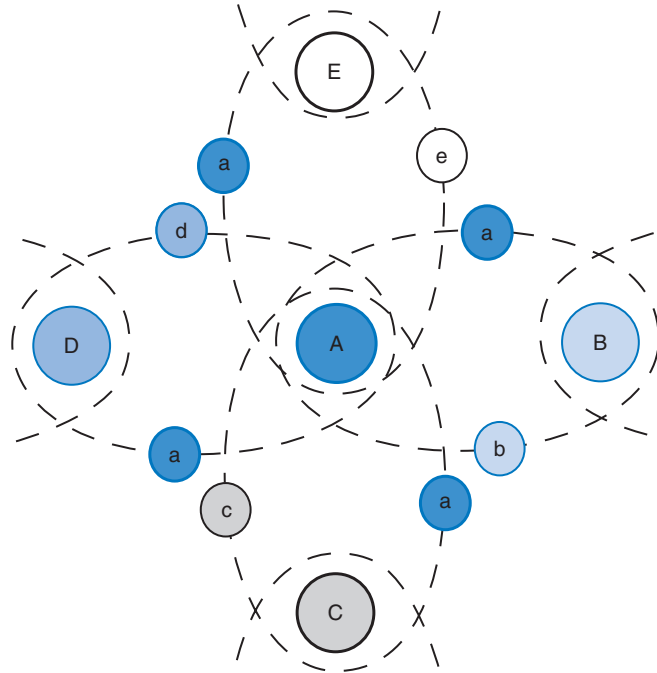

Fig. 9.1

such as neon. The covalent bonding system is a very strong one so the valence electrons are quite tightly bound into it. It is for this reason that intrinsic silicon is a relatively poor conductor of electrical current, and is called a semiconductor.

### 9.3 Electron-Hole Pair Generation and Recombination

Although the covalent bond is strong, it is not perfect. Thus, when a sample of silicon is at normal ambient temperature, a few valence electrons will gain sufficient energy to break free from the bond and so become free electrons available as mobile charge carriers. Whenever such an electron breaks free and drifts away from its parent atom it leaves behind a space in the covalent bond, and this space is referred to as a hole. Thus, whenever a bond is broken an electron-hole pair is generated. This effect is illustrated in Fig. 9.2, where the short straight lines represent electrons and the small circle represents a corresponding hole. The large circles again represent the silicon atoms complete with their inner shells of electrons.

The atom which now has a hole in its valence band is effectively a positive ion because it has lost an electron which would normally occupy that space. On the atomic scale, the ion is very massive, is locked into the crystal lattice, and so cannot move. However, electron-hole pair generation will be taking place in a random manner throughout the crystal lattice, and a generated free electron will at

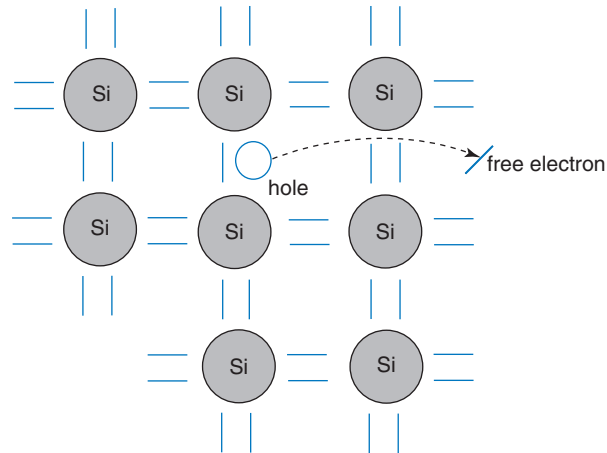

Fig. 9.2

some stage drift into the vicinity of one of these positive ions, and be captured, i.e. the hole will once more be filled by an electron. This process is known as recombination, and when it occurs the normal charge balance of that atom is restored.

The hole-pair generation and recombination processes occur continuously, and since heat is a form of energy, will increase as the temperature increases. This results in more mobile charge carriers being available, and accounts for the fact that semiconductors have a negative temperature coefficient of resistance, i.e. as they get hotter they conduct more easily. It must be borne in mind that although these thermally generated mobile charge carriers are being produced, the sample of material *as a whole* still remains electrically neutral. In other words, if a 'head count' of all the positive and negative charged particles could be made, there would still be a balance between positive and negative, i.e. for every free electron there will be a corresponding hole.

The concept of the drift of free electrons through the material may be readily understood, but the concept of hole mobility is more difficult to appreciate. In fact the holes themselves cannot move — they are merely generated and filled. However, when a bond breaks down the electron that drifts away will at some point fill a hole elsewhere in the lattice. Thus the hole that has been filled is replaced elsewhere by the newly generated hole, and will *appear* to have drifted to a new location. In order to simplify the description of conduction in a semiconductor, the holes are considered to be mobile positive charge carriers whilst the free electrons are of course mobile negative charge carriers.

## 9.4 Conduction in Intrinsic Semiconductors

Figure. 9.3 illustrates the effect when a source of emf is connected across a sample of pure silicon. The electric field produced by

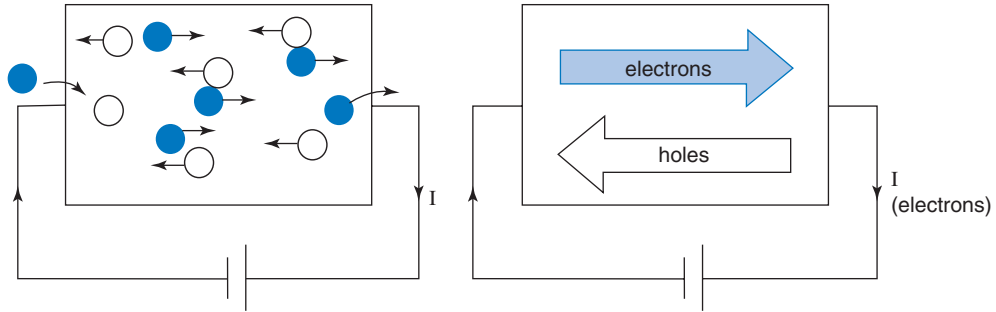

Fig. 9.3

the battery will attract free electrons towards the positive plate and the corresponding holes towards the negative plate. Since the external circuit is completed by conductors, and holes exist only in semiconductors, then how does current actually flow around the circuit without producing an excess of positive charge (the holes) at the left-hand end of the silicon? The answer is quite simple. For every electron that leaves the right-hand end and travels to the positive plate of the battery, another is released from the negative plate and enters the silicon at the left-hand end, where a recombination can occur. This recombination will be balanced by fresh electron-hole pair generation. Thus, within the silicon there will be a continuous drift of electrons in one direction with a drift of a corresponding number of holes in the opposite direction. In the external circuit the current flow is of course due only to the drift of electrons.

## 9.5 Extrinsic (Impure) Semiconductors

Although pure silicon and germanium will conduct, as explained in the previous section, their characteristics are still closer to insulators than to conductors. In order to improve their conduction very small quantities (in the order of 1 part in  $10^8$ ) of certain other elements are added. This process is known as doping. The impurity elements that are added are either pentavalent (have five valence electrons) or are trivalent (have three valence electrons) atoms. Depending upon which type is used in the doping process determines which one of the two types of extrinsic semiconductor is produced.

## 9.6 n-type Semiconductor

To produce this type of semiconductor, pentavalent impurities are employed. The most commonly used are arsenic (As), phosphorus (P), and antimony (Sb). When atoms of such an element are added to the silicon a bonding process takes place such that each impurity atom joins the covalent bonding system of the silicon. However, since each impurity atom has five valence electrons, one of these cannot find a place in a covalent bond. These 'extra' electrons then tend to drift

away from their parent atoms and become additional free electrons in the lattice. Since these impurities donate an extra free electron to the material they are also known as donor impurities.

As a consequence of each donor atom losing one of its valence electrons, they become positive ions locked into the crystal lattice. Note that free electrons introduced by this process *do not* leave a corresponding hole, although thermally generated electron-hole pairs will still be created in the silicon. The effect of the doping process is illustrated in Fig. 9.4.

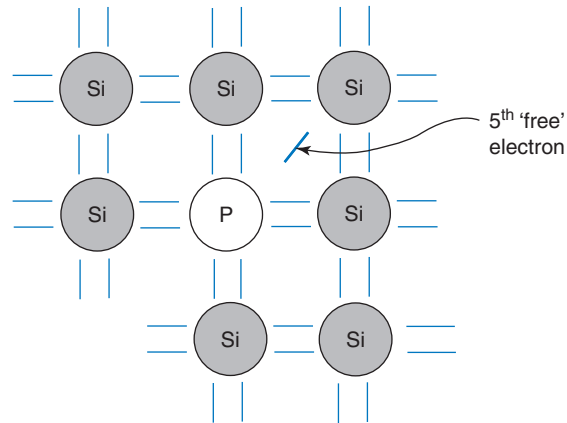

Fig. 9.4

Since the extra charge carriers introduced by the impurity atom are negatively charged electrons, and these will be in addition to the electron-hole pairs, then there will be more mobile negative charge carriers than positive, which is why the material is known as n-type semiconductor. In this case the electrons are the majority charge carriers and the holes are the minority charge carriers. It should again be noted that the material as a whole still remains electrically neutral since for every extra donated free electron there will be a fixed positive ion in the lattice. Thus a sample of n-type semiconductor may be represented as consisting of a number of fixed positive ions with a corresponding number of free electrons, in addition to the thermally generated electron-hole pairs. This is shown in Fig. 9.5.

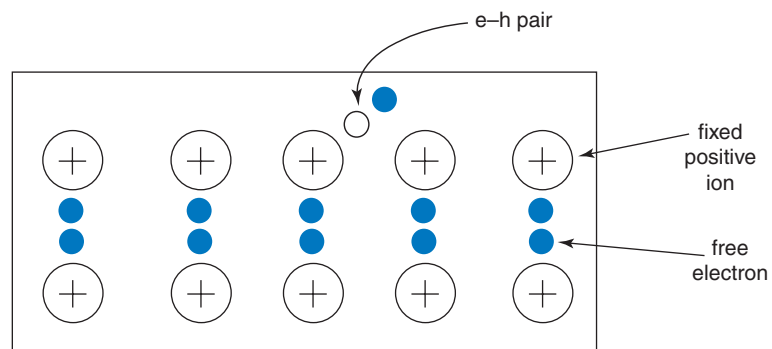

Fig. 9.5

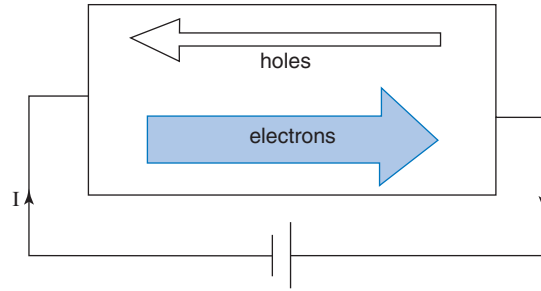

Fig. 9.6

The circuit action when a battery is connected across the material is illustrated in Fig. 9.6. Once more, only electrons flow around the external circuit, whilst within the semiconductor there will be movement of majority carriers in one direction and minority carriers in the opposite direction.

## 9.7 p-type Semiconductor

In this case a trivalent impurity such as aluminium (Al), gallium (Ga), or indium (In) is introduced. These impurity atoms also join the covalent bonding system, but since they have only three valence electrons there will be a gap or hole in the bond where an electron would normally be required. Due to electron-hole pair generation in the lattice, this hole will soon become filled, and hence the hole will have effectively drifted off elsewhere in the lattice. Since each impurity atom will have accepted an extra electron into its valence band they are known as acceptor impurities, and become fixed negative ions. The result of the doping process is illustrated in Fig. 9.7.

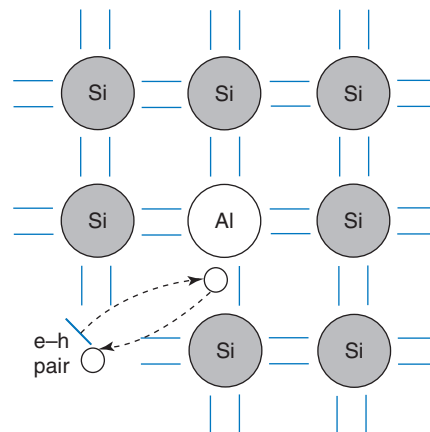

Fig. 9.7

We now have the situation whereby there will be more mobile holes than there are free electrons. Since holes are positive charge carriers, and they will be in the majority, the doped material is called p-type semiconductor, and it may be considered as consisting of a number of fixed negative ions and a corresponding number of mobile holes as shown in Fig. 9.8.

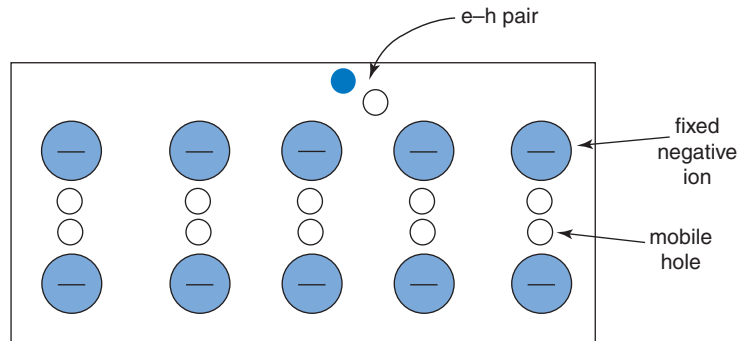

Fig. 9.8

The circuit action when a battery is connected across the material is shown in Fig. 9.9. As the holes approach the left-hand end they are filled by incoming electrons from the battery. At the same time, fresh electron-hole pairs are generated; the electrons being swept to and out of the right-hand end, and the holes drift to the left-hand end to be filled. Once more, the current flow in the semiconductor is due to the movement of holes and electrons in opposite directions, and only electrons in the external circuit. As with the n-type material, p-type is also electrically neutral.

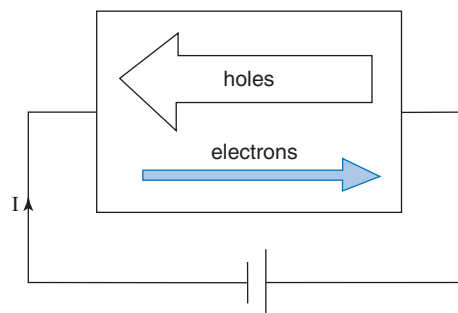

Fig. 9.9

## 9.8 The p-n Junction

When a sample of silicon is doped with both donor and acceptor impurities so as to form a region of p-type and a second region of n-type material in the *same crystal lattice*, the boundary where the two regions meet is called a p-n junction. This is illustrated in Fig. 9.10.

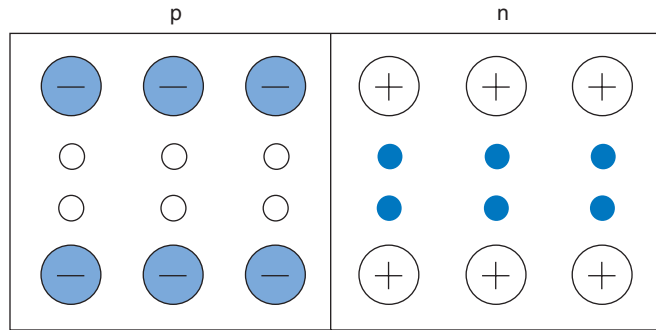

Fig. 9.10

Due to their random movement some of the electrons will diffuse across the junction into the p-type, and similarly some of the holes will diffuse across into the n-type. This effect is illustrated in Fig. 9.11, and from this figure it may be seen that region x acquires a net negative charge whilst region y acquires an equal but positive net charge.

The region between the dotted lines is only about  $1\ \mu\text{m}$  wide, and the negative charge on x prevents further diffusion of electrons from the n-type. Similarly the positive charge on y prevents further diffusion of holes from the p-type. This redistribution of charge results in a potential barrier across the junction. In the case of silicon this barrier potential will be in the order of 0.6 to 0.7 V, and for germanium about 0.2 to 0.3 V. Once again note that although there has been some redistribution of charge, the sample of material *as a whole* is still electrically neutral (count up the numbers of positive and negative charges shown in Fig. 9.11).

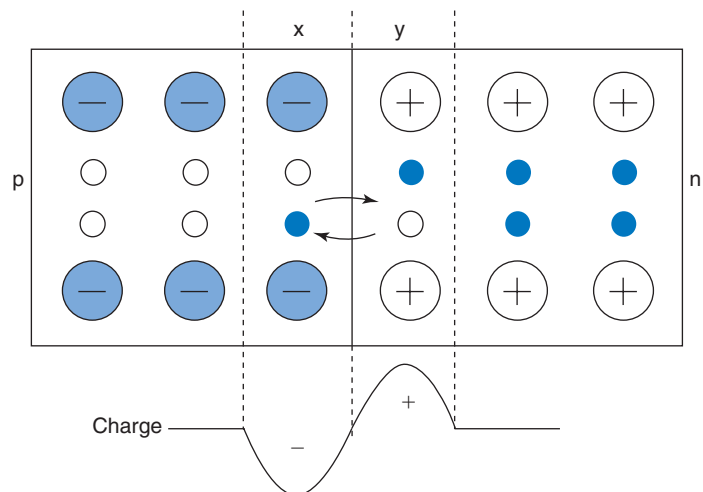

Fig. 9.11

## 9.9 The p-n Junction Diode

A diode is so called because it has two terminals: the anode, which is the positive terminal, and the cathode, which is the negative

terminal. In the case of a p-n junction diode the anode is the p-type and the cathode is the n-type. In Chapter 6 it was stated that a diode will conduct in one direction but not in the other. This behaviour is explained as follows.

## 9.10 Forward-biased Diode

Figure 9.12 shows a battery connected across a diode such that the positive terminal is connected to the anode and the negative terminal to the cathode.

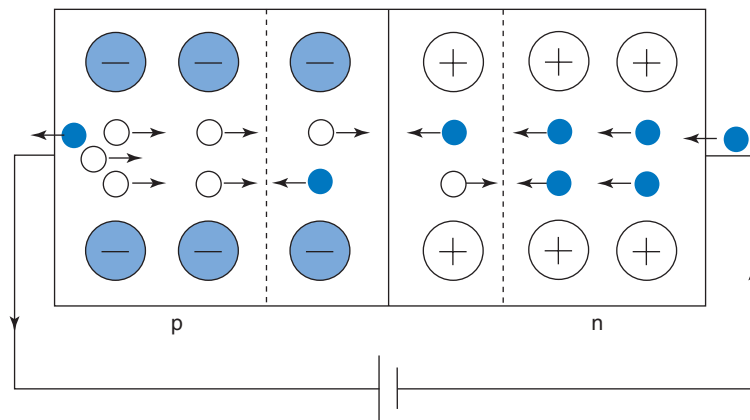

Fig. 9.12

The electric field produced by the battery will cause holes and electrons to be swept toward the junction, where recombinations will take place. For each of these an electron from the battery will enter the cathode. This would have the effect of disturbing the charge balance within the semiconductor, so to counterbalance this a fresh electron-hole pair will be created in the p-type. This newly freed electron will then be attracted to the positive plate of the battery, whilst the hole will be swept towards the junction. Thus the circuit is complete, with electrons moving through the external circuit, and a movement of holes and electrons in the semiconductor. Hence, when the anode of the diode is made positive with respect to the cathode it will conduct, and it is said to be forward biased.

## 9.11 Reverse-biased Diode

Consider what now happens when the battery connections are reversed (Fig. 9.13). The electric field of the battery will now sweep all the mobile holes into the p-type and all the free electrons into the n-type. This leaves a region on either side of the junction which has been depleted of all of its mobile charge carriers. This layer thus acts

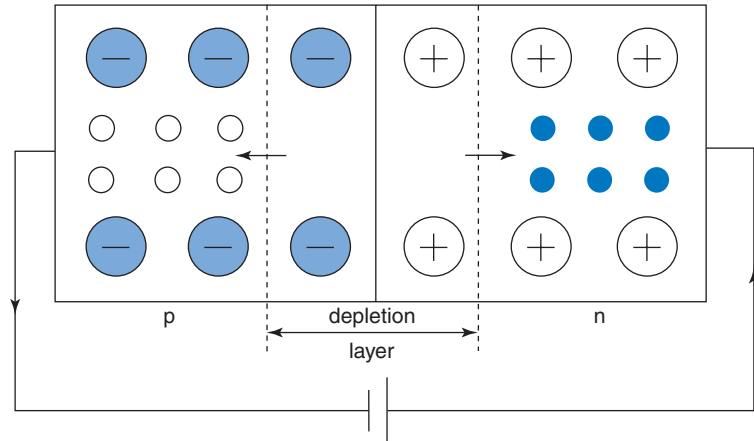

Fig. 9.13

as an insulator, and is called the depletion layer. There has been a redistribution of charge within the semiconductor, but since the circuit has an insulating layer in it, current cannot flow. The diode is said to be in its blocking mode.

However, there is no such thing as a perfect insulator, and the depletion layer is no exception. Although all the mobile charge carriers provided by the doping process have been swept to opposite ends of the semiconductor, there will still be some thermally generated electron-hole pairs. If such a pair is generated in the p-type region, the electron will be swept across the junction by the electric field of the battery. Similarly, if the pair is generated in the n-type, the hole will be swept across the junction. Thus a very small reverse current (in the order of microamps) will flow, and is known as the reverse leakage current. Since this leakage current is the result of thermally generated electron-hole pairs, then as the temperature is increased so too will the leakage current.

## 9.12 Diode Characteristics

The characteristics of a device such as a diode can be best illustrated by means of a graph (or graphs) of the current flow through it versus applied voltage. Circuits for determining both the forward and reverse characteristics are shown in Fig. 9.14.

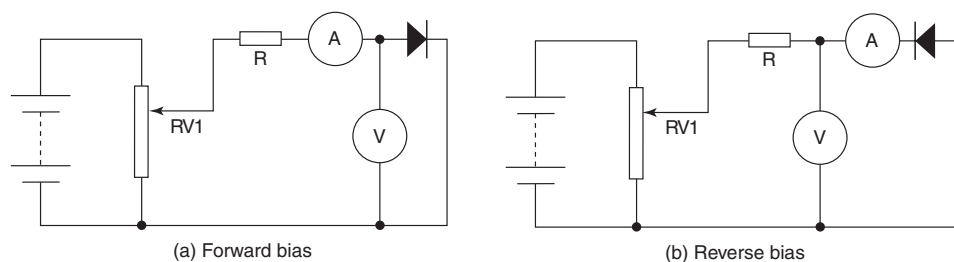

Fig. 9.14

Note the change of position of the voltmeter for the two different tests. In (a) the voltmeter measures only the small p.d. across the diode itself, and not any p.d. across the ammeter. In (b) the ammeter measures only the leakage current of the diode, and does not include any current drawn by the voltmeter. Ideally the voltmeter should not draw any current at all, so it is recommended that a DVM is used rather than a moving coil instrument such as an AVOMeter. The procedure in each case is to vary the applied voltage, in steps, by means of RV1 and record the corresponding current values. When these results are plotted, for both silicon and germanium diodes, the graphs will typically be as shown in Fig. 9.15. The very different scales for both current and voltage for the forward and reverse bias conditions should be noted. Also, the actual values shown for the forward current scale and the reverse voltage scale can vary considerably from those shown, depending upon the type of diode being tested, i.e. whether it be a small signal diode or a power rectifying diode. In the case of the latter, the forward current would usually be in amperes rather than milliamps.

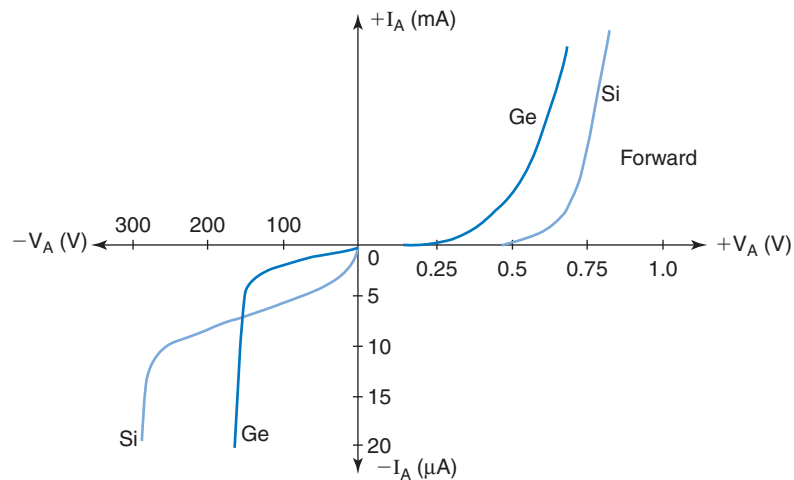

Fig. 9.15

The sudden increase in reverse current occurs at a reverse voltage known as the reverse breakdown voltage. The effect occurs because the intensity of the applied electric field causes an increase in electron-hole pair generation. These electron-hole pairs are not due to temperature, but the result of electrons being torn from bonds by the electric field. This same field will rapidly accelerate the resulting charge carriers and as they cross the junction they will collide with atoms. These collisions will free more charge carriers, and the whole process builds up very rapidly. For this reason the effect is known as avalanche breakdown, and will usually result in the destruction of the diode.

When the impurity doping of the semiconductor is heavier than 'normal', the depletion layer produced is much thinner. In this case, when breakdown occurs, the charge carriers can pass through the depletion

with very little chance of collisions taking place. This type of breakdown is known as zener breakdown and such diodes are called zener diodes.

### 9.13 The Zener Diode

The main feature of the zener diode is its ability to operate in the reverse breakdown mode without sustaining permanent damage. In addition, during manufacture, the precise breakdown voltage (zener voltage) for a given diode can be predetermined. For this reason they are also known as voltage reference diodes. The major application for these devices is to limit or stabilise a voltage between two points in a circuit. Diodes are available with zener voltages from 2.6 V to about 200 V. The circuit symbol for a zener diode is shown in Fig. 9.16.

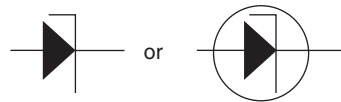

Fig. 9.16

The forward characteristic for a zener diode will be the same as for any other p-n junction diode, and also, since the device is always used in its reverse bias mode, only its reverse characteristic need be considered. Such a characteristic is shown in Fig. 9.17.

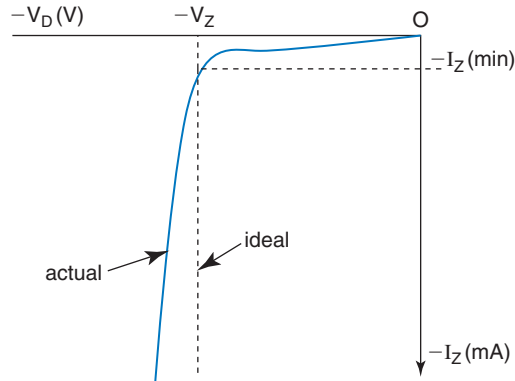

Fig. 9.17

In Fig. 9.17,  $V_Z$  represents the zener breakdown voltage, and if it were an ideal device, this p.d. across it would remain constant, regardless of the value of current,  $I_Z$ , flowing through it. In practice the graph will have a fairly steep slope as shown. The inverse of the slope of the graph is defined as the diode slope resistance,  $r_Z$ , as follows

$$r_Z = \frac{\delta V_D}{\delta I_Z} \text{ ohm} \quad (9.1)$$

Typical values for  $r_z$  range from  $0.5\ \Omega$  to about  $150\ \Omega$ . For satisfactory operation the current through the diode must be at least equal to  $I_{Z(min)}$ . Due to the diode slope resistance, the p.d. across the diode will vary by a small amount from the ideal of  $V_Z$  volt as the diode current changes. For example, if  $r_z = 1\ \Omega$  and  $V_Z = -15\ \text{V}$ , a change in diode current of  $30\ \text{mA}$  would cause only a  $0.02\%$  change in the diode p.d. This figure may be verified by applying equation (9.1).

The value of current that may be allowed to flow through the device must be limited so as not to exceed the diode power rating. This power rating is always quoted by the manufacturer, and zener diodes are available with power ratings up to about  $75\ \text{W}$ .

Consider now the application of a zener diode to provide simple voltage stabilisation to a load. A circuit is shown in Fig. 9.18.

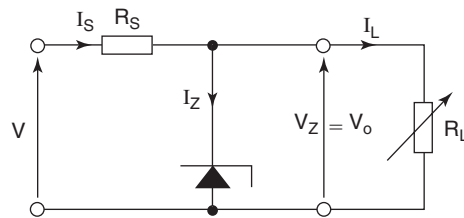

Fig. 9.18

In order for satisfactory operation the supply voltage,  $V_S$ , needs to be considerably greater than the voltage required at the load. The purpose of the series resistor  $R_S$  is to limit the maximum diode current to a safe value, bearing in mind the diode's power rating. Considering Fig. 9.18, the diode current will be at its maximum when the load is disconnected, because under this condition all of the current from the supply will flow through the diode, i.e.  $I_Z = I_S$ . When the load is connected it will draw a current  $I_L$ , and since  $I_Z = I_S - I_L$ , then under this condition the diode current will decrease, since it must divert current to the load. The output voltage, however, will remain virtually unchanged. Knowing the diode power rating a suitable value for  $R_S$  may be calculated as shown in the following worked example. This example also demonstrates the stabilising action of the circuit.

### Worked Example 9.1

**Q** A  $9.1\ \text{V}$ ,  $500\ \text{mW}$  zener diode is used in the circuit of Fig. 9.18 to supply a  $2.5\ \text{k}\Omega$  load. The diode has a slope resistance of  $1.5\ \Omega$ , and the input supply has a nominal value of  $12\ \text{V}$ .

- Calculate a suitable value for the series resistor  $R_S$ .
- Calculate the value of diode current when the load resistor is connected to the circuit.
- If the input supply voltage decreases by  $10\%$ , calculate the percentage change in the p.d. across the load.

**A**

$$V_Z = 9.1 \text{ V}; P_Z = 0.5 \text{ W}; r_Z = 1.5 \Omega; V = 12 \text{ V}; R_L = 2500 \Omega$$

$$(a) \quad P_Z = V_Z I_Z \text{ watt}$$

$$I_Z = \frac{P_Z}{V_Z} \text{ amp} = \frac{0.5}{9.1}$$

$$\text{so, } I_Z = I_S = 54.95 \text{ mA}$$

( $I_S = I_Z$  because for this condition the load is disconnected)

$$V_S = V - V_Z \text{ volt} = 12 - 9.1$$

$$V_S = 2.9 \text{ V}$$

$$R_S = \frac{V_S}{I_S} \text{ ohm} = \frac{2.9}{54.95 \times 10^{-3}}$$

$$R_S = 52.78 \Omega$$

A resistor of this precise value would not be readily available, so the nearest preferred value resistor would be chosen. However, to ensure that the diode power rating cannot be exceeded, the nearest preferred value *greater than*  $52.78 \Omega$  would be chosen. Thus a  $56 \Omega$  resistor would be chosen.

In order to protect the resistor, its own power rating must be taken into account. In this circuit, the maximum power dissipated by  $R_S$  is:

$$P_{max} = I_S^2 R_S \text{ watt} = (54.95 \times 10^{-3})^2 \times 56$$

$$P_{max} = 0.169 \text{ W}, \text{ so a } 0.25 \text{ W resistor would be chosen,}$$

and the complete answer to part (a) is:

$$R_S \text{ should be a } 56 \Omega, 0.25 \text{ W resistor } \mathbf{Ans}$$

$$(b) \quad \text{With } R_L = 2500 \Omega \text{ and } V_o = 9.1 \text{ V}$$

$$I_L = \frac{V_o}{R_L} \text{ amp} = \frac{9.1}{2.5 \times 10^3}$$

$$I_L = 3.64 \text{ mA}$$

$$I_Z = I_S - I_L \text{ amp} = (55 - 3.64) \text{ mA}$$

$$I_Z = 51.36 \text{ mA } \mathbf{Ans}$$

$$(c) \quad \text{When } V \text{ falls by } 10\% \text{ from its nominal value, then}$$

$$V = 12 - (0.1 \times 12) = 12 - 1.2$$

$$\text{hence, } V = 10.8 \text{ V}$$

$$I_S = \frac{V - V_Z}{R_S} \text{ amp} = \frac{10.8 - 9.1}{56}$$

$$I_S = 30.36 \text{ mA}$$

The current for the load must still be diverted from the diode, so

$$I_Z = I_S - I_L \text{ amp} = (30.36 - 3.64) \text{ mA} = 26.72 \text{ mA}$$

therefore,  $\delta I_Z = (51.36 - 26.72) \text{ mA} = 24.64 \text{ mA}$ , and from equation (10.1):

$$\delta V_Z = \delta I_Z r_Z \text{ volt} = 24.64 \times 10^{-3} \times 1.5$$

$$\delta V_Z = 0.037 \text{ V}$$

Thus the voltage applied to the load changes by 0.037V, which expressed as a percentage change is:

$$\text{change} = \frac{0.037}{9.1} \times 100$$

$$\text{change} = 0.41\% \text{ Ans (compared with a 10\% change in supply)}$$

### Worked Example 9.2

**Q** A d.c. voltage of  $15\text{V} \pm 5\%$  is required to be supplied from a 24V unregulated source. This is to be achieved by the simple regulator circuit of Fig. 9.19.

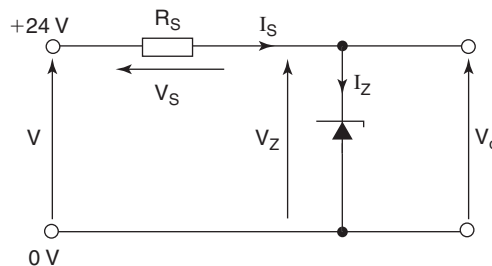

Fig. 9.19

The available diodes and resistors are listed below.

- For each diode listed determine the appropriate resistor required and hence determine the total unit cost for each circuit.
- In order to satisfy the specified output voltage tolerance of  $\pm 5\%$ , determine which of the three circuits will meet the specification at lowest cost.

Diode No.	$V_Z$ (V)	Slope resistance ( $\Omega$ )	Max power (W)	Unit cost (£)
1	15	30	0.5	0.07
2	15	15	1.3	0.20
3	15	2.5	5.0	0.67

Resistors are available in the following values and unit costs

18, 27, 56, 100, 120, 150, 220, 270, and 330  $\Omega$

0.25W	£0.026
0.5W	£0.038
1.0W	£0.055
2.5W	£0.260
7.5W	£0.280

**A****(a)** For all three diodes:

$$V_S = (V - V_Z) \text{ volt} = 24 - 15 = 9\text{V}$$

Diode 1:

$$I_Z = \frac{P_Z}{V_Z} \text{ amp} = \frac{0.5}{15}$$

$$I_Z = 33.3 \text{ mA}$$

$$R_S = \frac{V_S}{I_Z} \text{ ohm} = \frac{9}{33.3 \times 10^{-3}}$$

$$R_S = 270 \Omega$$

$$P_S = \frac{V_S^2}{R_S} \text{ watt} = \frac{81}{270}$$

$$P_S = 0.3 \text{ W}$$

and,  $R_S = 270 \Omega$ , 0.5 W **Ans**

$$\text{total unit cost} = \pounds(0.07 + 0.038) = \pounds 0.045 \text{ Ans}$$

Diode 2:

$$I_Z = \frac{1.3}{15} \text{ amp} = 86.7 \text{ mA}$$

$$R_S = \frac{9}{86.7 \times 10^{-3}} = 103.85 \Omega, \text{ so choose the } 120 \Omega \text{ resistor}$$

$$P_S = \frac{81}{120} = 0.675 \text{ W, so choose } 1.0 \text{ W rating}$$

hence,  $R_S = 120 \Omega$ , 1.0 W **Ans**

$$\text{total unit cost} = \pounds(0.20 + 0.055) = \pounds 0.26 \text{ Ans}$$

Diode 3:

$$I_Z = \frac{5}{15} = 333.3 \text{ mA}$$

$$R_S = \frac{9}{333.3 \times 10^{-3}} = 27 \Omega$$

$$P_S = \frac{81}{27} = 3 \text{ W so choose } 7.5 \text{ W resistor}$$

hence,  $R_S = 27 \Omega$ , 7.5 W **Ans**

$$\text{total unit cost} = \pounds(0.67 + 0.28) = \pounds 0.95 \text{ Ans}$$

$$\text{(b) Allowable } \delta V_Z = \frac{5 \times 15}{100} - 0.75 \text{ V}$$

Diode 1:  $\delta V_Z = \delta I_{Zrz} \text{ volt} = 30 \times 10^{-3} \times 30 = 0.9 \text{ V}$ , which is unacceptableDiode 2:  $\delta V_Z = 30 \times 10^{-3} \times 15 = 0.45 \text{ V}$ , which is acceptableDiode 3:  $\delta V_Z = 30 \times 10^{-3} \times 2.5 = 0.075 \text{ V}$ , which is acceptableThus to meet the specification at lowest cost, circuit 2 would be adopted **Ans**

## Assignment Questions

- 1 A simple voltage stabiliser circuit is shown in Fig. 9.20. The zener diode is a 7.5V, 500 mW device and the supply voltage is 12V. Calculate (a) a suitable value for  $R_S$  and (b) the value of zener current when  $R_L = 470\ \Omega$ .
- 2 Using the circuit of Fig. 9.20 with a 10V, 1.3W zener diode having a slope resistance of  $2.5\ \Omega$ , and a supply voltage of 24V, calculate (a) a suitable value for  $R_S$ , (b) the value of zener current when on no-load, and (c) the variation of zener voltage when  $R_L$  is changed from  $500\ \Omega$  to  $200\ \Omega$ .

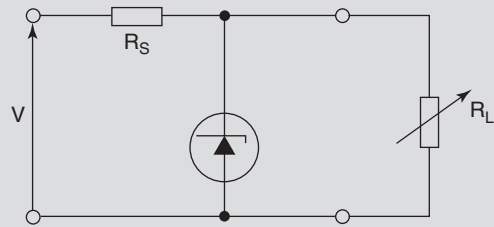

Fig. 9.20

## Suggested Practical Assignments

### Assignment 1

To obtain the forward and reverse characteristics for silicon and germanium p-n junction diodes. An investigation into the effects of increased temperature on the reverse leakage current could also be undertaken.

### Assignment 2

To investigate the operation of the zener diode.

#### Apparatus:

- 1 × 5.6 V, 400 mW zener diode
- 1 × 9.1 V, 400 mW zener diode
- 1 × 470 Ω resistor
- 1 × variable d.c. power supply unit (psu)
- 1 × voltmeter (DVM)
- 1 × ammeter

#### Method:

- 1 Connect the circuit of Fig. 9.21 using the 5.6 V diode.
- 2 Vary the input voltage in 1 V steps from 0 V to +15 V, and note the corresponding values of  $V_Z$  and  $I$ .
- 3 Tabulate your results and plot the reverse characteristic for the diode.

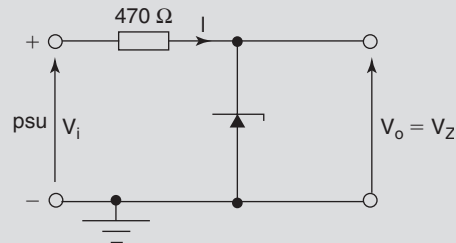

Fig. 9.21

- 4 Repeat steps 1 to 3 above for the 9.1 V diode.
- 5 From the plotted characteristics, determine the diode slope resistance in each case.

# Appendix A

## Physical Quantities with SI and other preferred units

<b>General quantities</b>	<b>Symbol</b>	<b>Units</b>
Acceleration, linear	$a$	$\text{m/s}^2$ (metre/second/second)
Area	$A$	$\text{m}^2$ (square metre)
Energy or work	$W$	J (joule)
Force	$F$	N (newton)
Length	$l$	m (metre)
Mass	$m$	kg (kilogram)
Power	$P$	W (watt)
Pressure	$p$	Pa (pascal)
Temperature value	$\theta$	K or °C (Kelvin or degree Celsius)
Time	$t$	s (second)
Torque	$T$	Nm (newton metre)
Velocity, angular	$\omega$	rad/s (radian/second)
Velocity, linear	$v$ or $u$	m/s (metre/second)
Volume	$V$	$\text{m}^3$ (cubic metre)
Wavelength	$\lambda$	m metre

<b>Electrical quantities</b>	<b>Symbol</b>	<b>Units</b>
Admittance	$Y$	$\Omega$ (ohm)
Charge (quantity)	$Q$	C (coulomb)
Conductance	$G$	S (siemen)
Current	$I$	A (ampere)
Current density	$J$	$\text{A/m}^2$ (ampere/square metre)
Electromotive force (emf)	$E$	V (volts)
Frequency	$f$	Hz (hertz)
Impedance	$Z$	$\Omega$ (ohm)
Period	$T$	s (second)
Potential difference (p.d.)	$V$	V (volt)
Power, active	$P$	W (watt)
Power, apparent	$S$	VA (volt ampere)
Power, reactive	$Q$	VA <sub>r</sub> (volt ampere reactive)
Reactance	$X$	$\Omega$ (ohm)
Resistance	$R$	$\Omega$ (ohm)
Resistivity	$\rho$	$\Omega\text{m}$ (ohm metre)
Time constant	$\tau$	s (second)

<b>Electrostatic quantities</b>	<b>Symbol</b>	<b>Unit</b>
Capacitance	$C$	F (farad)
Field strength	$E$	V/m (volt/metre)
Flux	$\psi$	C (coulomb)
Flux density	$D$	C/m <sup>2</sup> (coulomb/square metre)
Permittivity, absolute	$\epsilon$	F/m (farad/metre)
<b>General quantities</b>	<b>Symbol</b>	<b>Unit</b>
Permittivity, relative	$\epsilon_r$	no units
Permittivity, of free space	$\epsilon_0$	F/m (farad/metre)
<b>Electromagnetic quantities</b>	<b>Symbol</b>	<b>Unit</b>
Field strength	$H$	A/m (ampere/metre) <sup>(1)</sup>
Flux	$\Phi$	Wb (weber)
Flux density	$B$	T (tesla)
Inductance, mutual	$M$	H (henry)
Inductance, self	$L$	H (henry)
Magnetomotive force (mmf)	$F$	A (ampere) <sup>(2)</sup>
Permeability, absolute	$\mu$	H/m (henry/metre)
Permeability, relative	$\mu_r$	no units
Permeability, of free space	$\mu_0$	H/m (henry/metre)
Reluctance	$S$	A/Wb (ampere/weber) <sup>(3)</sup>

(1) At/m (ampere turn/metre) in this book

(2) (ampere turn) in this book

(3) At/Wb (ampere turn/weber) in this book

## Answers to Assignment Questions

### Chapter 1

- 1.1** (a)  $4.563 \times 10^2$   
(b)  $9.023 \times 10^5$   
(c)  $2.85 \times 10^{-4}$   
(d)  $8 \times 10^3$   
(e)  $4.712 \times 10^{-2}$   
(f)  $1.8 \times 10^{-4}$  A  
(g)  $3.8 \times 10^{-2}$  V  
(h)  $8 \times 10^{10}$  N  
(i)  $2 \times 10^{-3}$  F
- 1.2** (a) 1.5 k $\Omega$   
(b) 3.3 m $\Omega$   
(c) 25  $\mu$ A  
(d) 750 V or 0.75 kV  
(e) 800 kV  
(f) 47 nF
- 1.3** 750 C
- 1.4** 0.104 s
- 1.5** 0.917 A
- 1.6** (a) 2.25 kV  
(b) 18.75 V
- 1.7** (a) 2.273 A  
(b) 61 mA  
(c) 18.52  $\mu$ A  
(d) 0.512 mA
- 1.8** 54.14 MJ or 15.04 kWh
- 1.9** £55.88
- 1.10** (a) 0.5 A  
(b) 280 V  
(c) 140 W  
(d) 42 kJ
- 1.11** (a) 49.64 V  
(b) 27.58  $\Omega$
- 1.12** (a) 0.15  $\Omega$   
(b) 2.25  $\Omega$
- 1.13** 225 W; 67.5 kJ
- 1.14** (a) 2 A  
(b) 8 V  
(c) 2.4 kC
- 1.15** 2 m/s<sup>2</sup>; 2.67 m/s<sup>2</sup> 0.5 m/s<sup>2</sup>

- 1.16** 8  $\mu$ A
- 1.17** 19.2  $\Omega$ ; 12.5 A
- 1.18** 15.65 kW
- 1.19** 71.72°C
- 1.20** 33.6  $\Omega$

### Chapter 2

- 2.1** 0.375 A
- 2.2** (a) 29.1  $\Omega$   
(b) 24.75 A
- 2.3** 0.45 A
- 2.4** 14  $\Omega$
- 2.5** (a) 15.67  $\Omega$   
(b) 0.766 A  
(c) 0.426 A
- 2.6** (a) 2.371 A; 1.779 A; 1.804 A; 1.443 A; 0.902 A  
(b) 35.37 V (15  $\Omega$  and 20  $\Omega$ ); 14.43 V (8  $\Omega$ , 10  $\Omega$ , 16  $\Omega$ )  
(c) 63.26 W
- 2.7** 2.5 V
- 2.8** (a) 12.63 V  
(b) 2.4 A  
(c) 0.947 A
- 2.9** (a) 3.68  $\Omega$   
(b) 5.44 A  
(c) 9.32 V  
(d) 2.33 A
- 2.10** 12.8  $\Omega$
- 2.11** (a) 1.57  $\Omega$   
(b) 127.33  $\Omega$
- 2.12** 40  $\Omega$
- 2.13** 80  $\Omega$
- 2.14** (a) 1.304 A  
(b) 5.217 V  
(c) 0.87 A
- 2.15** (a) 6.67 A  
(b) 26.67 A  
(c) 13.33 A
- 2.16** (a) 2 V  
(b) 1.933 V

- 2.17**  $0.024\ \Omega$
- 2.18** (a) 9.6 A  
(b) 43.2 V  
(c) 4.32 A; 2.16 A; 1.08 A
- 2.19** 3.094 V
- 2.20** 6.82 V
- 2.21** (a)  $20\ \Omega$   
(b) 10 A  
(c) 60 V  
(d) 2 kW  
(e) 300 W
- 2.22** (a) 1 A  
(b) 30 V; 36 V  
(c) 54 kJ  
(d) 180 C
- 2.23** 2.368 A;  $-0.263\ \text{A}$ ; 2.105 A; 10.526 V
- 2.24** 1 A (discharge); 0.5 A (discharge); 1.5 A; 9 W
- 2.25** (a)  $-0.183\ \text{A}$  (charge); 5.725 A (discharge);  
5.542 A (discharge)  
(b) 108.55 V
- 2.26** (a) 2.273 A (discharge);  $-0.455\ \text{A}$  (charge);  
(b) 1.32 A  
(c) 11.363 V
- 2.27** 0.376 A; 0.388 A; 0.764 A; 61.14 V
- 2.28** (b)  $3\ \Omega$   
(c) 0.133 A ( $10\ \Omega$  and  $5\ \Omega$ ); 0.222 A ( $6\ \Omega$  and  $3\ \Omega$ );  
1.33 V ( $10\ \Omega$  and  $6\ \Omega$ ); 0.67 V ( $5\ \Omega$  and  $3\ \Omega$ )
- 2.29**  $3.498\ \Omega$ ; 16.85 k $\Omega$ ; 22.5  $\Omega$
- 2.30** 1.194 V
- Chapter 3**
- 3.1** (a)  $0.2\ \mu\text{C}$   
(b)  $2.29\ \mu\text{C}/\text{m}^2$
- 3.2** 16.94 kV/m
- 3.3** 50 kV/m
- 3.4** 60 mC/m<sup>2</sup>
- 3.5** 125 kV/m
- 3.6** 40 mC
- 3.7** 165.96 V
- 3.8** 300 V
- 3.9** 500 pF or 0.5 nF
- 3.10** 240 pF or 0.24 nF
- 3.11** 3
- 3.12** 5.53 nF
- 3.13** (a) 442.7 pF  
(b)  $0.177\ \mu\text{C}$   
(c) 400 kV/m
- 3.14** 0.089 mm
- 3.15** 188 nF
- 3.16** 1.36
- 3.17** 25
- 3.18** (a) 4.8 mm  
(b)  $1.213 \times 10^{-3}\ \text{m}^2$
- 3.19** (a)  $14\ \mu\text{F}$   
(b)  $2.86\ \mu\text{F}$
- 3.20** (i)  $1.463\ \mu\text{F}$ ;  $17\ \mu\text{F}$   
(ii)  $0.013\ \mu\text{F}$ ;  $0.29\ \mu\text{F}$   
(iii) 19.18 pF; 490 pF  
(iv) 215 pF; 10.2 nF
- 3.21** 8 nF
- 3.22** (a)  $5\ \mu\text{F}$   
(b) 200 V  
(c) 3 mC
- 3.23** (a)  $24\ \mu\text{F}$   
(b) 480  $\mu\text{C}$   
(c) 1.44 mC
- 3.24** (a) 13.85 V (4 nF); 6.15 V  
(b) 18.46 nC
- 3.25**  $C_2 = 4.57\ \mu\text{F}$ ;  $C_3 = 3.56\ \mu\text{F}$
- 3.26** 200 V; 200 V; 1.2 mC; 2 mC; 3.2 mC
- 3.27**  $V_1 = 360\ \text{V}$ ;  $V_2 = 240\ \text{V}$ ;  $C_3 = 40\ \mu\text{F}$
- 3.28** 200 V
- 3.29**  $80.67\ \text{cm}^2$
- 3.30** (a) 48 pF  
(b) 267 pC  
(c) 40 V
- 3.31** 625 mJ
- 3.32** 200 V
- 3.33**  $5\ \mu\text{F}$
- 3.34** (a) 40 nF  
(b) 0.8 mJ  
(c) 400 kV/m
- 3.35** (a) 1.6 mC; 0.32 J  
(b) 266.7 V; 0.213 J
- 3.36** (a) 0.6 mC; 150 V; 100 V  
(b) 120 V; 0.48 mC; 0.72 mC
- 3.37** (a) 1.5 mm  
(b)  $52.94\ \text{cm}^2$

- (c) 75 nC; 28  $\mu$ J  
 (d) 14.2  $\mu$ C/m<sup>2</sup>

**3.38** 0.5  $\mu$ m

## Chapter 4

- 4.1** 0.417 T  
**4.2** 1.98 mWb  
**4.3** 40 cm<sup>2</sup>  
**4.4** 21.25 At  
**4.5** 0.8 A  
**4.6** 270  
**4.7** 5633 At/m  
**4.8** 112.5 At  
**4.9** 2A  
**4.10** (a) 900 At  
 (b) 1.11 T  
 (c) 5000 At/m  
**4.11** 64  
**4.12** 278  
**4.13** (a) 1200 At  
 (b) 5457 At/m  
 (c) 1.37 T  
 (d) 549  $\mu$ Wb  
**4.14** (a) 0.206 A  
 (b) 1777  
**4.15** 2.95 A  
**4.16** (a) 360 At/m; 1830 At/m  
 (b) 582  
**4.17** 176.7  
**4.18** 5.14 A  
**4.19** 1.975 A  
**4.20** 1.54 T  
**4.21** 11.57  $\mu$ Wb

## Chapter 5

- 5.1** 352.9V  
**5.2** 0.571 ms  
**5.3** 37.5V  
**5.4** (a) 32V  
 (b) 5.33V  
**5.7** 1 Wb/s  
**5.8** 0.05 T  
**5.9** (a) 0.5V

- (b) 0.433V  
 (c) 0.354V

- 5.11** 1.125 N  
**5.12** 2.5 A  
**5.13** 0.143 m  
**5.14** 3 N  
**5.15** 0.94  $\mu$ Nm  
**5.16** (a) 27  $\mu$ N  
 (b) 0.405  $\mu$ Nm  
**5.17** 12.5 mN  
**5.18** 1750 A  
**5.19** (a) 0.641  $\Omega$   
 (b) 6.25 m $\Omega$   
**5.20** 11.975 k $\Omega$ ; 39.975 k $\Omega$   
**5.22** 1.47 k $\Omega$ ; 14.97 k $\Omega$ ; 44.97 k $\Omega$ ; 149.97 k $\Omega$   
**5.23** -0.125%  
**5.24** 1.12 H  
**5.25** 4 A  
**5.26** 15 625  
**5.27** 5H; 800V  
**5.28** 120  
**5.29** 22.5 A/s  
**5.30** 0.75 mH  
**5.31** (a) 1364  
 (b) 33.6 mH  
 (c) 1.344V  
**5.32** 0.12 H  
**5.33** 30V  
**5.34** (a) 628.3 mH  
 (b) 56.5 mH  
 (c) 5.09V  
**5.35** (a) 0.3 mH  
 (b) 1.125 mH  
 (c) 0.3V; 1.125V  
**5.36** 58.67 mH  
**5.37** (a) 150V  
 (b) 5.625 mWb  
**5.38** 12.5 kV  
**5.40** 12V  
**5.41** 27.5V; 400 mA; 11 W  
**5.42** (a) 42.67V  
 (b) 3.56 A

**5.43** 51.2 mJ

**5.44** 60.4 mH

**5.45** 2.45 A

### Chapter 6

- 6.1** (a) 150 Hz  
(b) 15 Hz  
(c) 31.83 Hz

- 6.2** (a) 100 Hz  
(b) 12.5 rev/s

**6.3** 24

**6.4** 5 mA; 50  $\mu$ s; 20 kHz

**6.5** (b)  $i = 7.5 \sin(200\pi t)$  milliamp

- 6.6** (a) 427.3 V  
(b) 50 Hz  
(c) 302 V; 272.2 V

**6.7**  $v = 63.64 \sin(3000\pi t)$  volt; 22.31 V

- 6.8** (a) 250 V; 176.8 V; 75 mA; 53 mA; 20 mWb;  
14.14 mWb; 6.8 V; 4.81 V  
(b) 25 Hz; 100 Hz; 50 Hz; 1.5 kHz

- 6.9**  $i = 7.07 \sin(4000\pi t)$  amp  
(a) 6.724 A  
(b) 47.86  $\mu$ s

**6.10** 353.6 V; 159.25 V

**6.11** 4.22 mA; 5.97 mA

**6.12** 1.429

**6.13** 16 V

**6.14** 22.2 V

**6.18**  $v = 17.44 \sin(314t + 0.409)$  volt

**6.19**  $i = 22.26 \sin(\omega t - 0.396)$  amp

**6.20**  $v = 43.06 \sin(\omega t - 0.019)$  volt

**6.23** 3.2 V; 2.26 V; 400  $\mu$ s; 2.5 kHz

### Chapter 7

**7.1** 415.6 V

- 7.2** (a) 0.2  $\Omega$   
(b) 500 W

**7.3** 280.75 V

### Chapter 8

- 8.1** (a) 0.183 s  
(b) 6.15 mA; 0 A  
(c) 0.915 s

- 8.2** (a) 333.3 A/s  
(b) 1 A  
(c) 15 ms

**8.3** (a) 10.1 mA

**8.4** (a) 2.5  $\Omega$

- 8.5** (a) 100  $\Omega$   
(b) 1 mA

**8.6** 1.8 h

### Chapter 9

- 9.1** (a) 67.5  $\Omega$  [NPV 68  $\Omega$ , 0.5 W]  
(b) 50.7 mA

- 9.2** (a) 108  $\Omega$  [NPV 120  $\Omega$ , 2 W]  
(b) 117 mA  
(c) 12 mV

- Absolute permeability, 119
- Absolute permittivity, 85
- Acceptor impurity, 270
- Alternating quantities, 21, 192
  - angular velocity of, 200
  - addition of, 218
  - amplitude of, 200
  - average value of, 203
  - expression for, 201, 214
  - form factor of, 207
  - frequency of, 199
  - maximum value of, 200
  - peak factor of, 206
  - periodic time of, 199
  - phase angle of, 214
  - phasor representation of, 216
  - production of, 197
  - rms value of, 205
- Alternator, 151
- Ammeter, 22
  - moving coil, 159
  - rectifier moving coil, 212
- Ampere, 9
- Atom, 7
  - acceptor, 270
  - Bohr model, 7
  - donor, 269
  - shell structure, 263
- Back-emf, 244
- Battery, 10
- $B/H$  curve, 133
- Bridge rectifier, 210
- Capacitance, 83
- Capacitors, 84
  - dielectric strength, 101
  - energy stored in, 97
  - in parallel, 87
  - in series, 89
  - in series/parallel, 92
  - multiplate, 95
  - types of, 102
- Cathode ray oscilloscope (CRO), 224
- Cathode ray tube (CRT), 224
- Cell, 10
- Charge ( $Q$ ), 8
- Coercive force, 133
- Coercivity, 133
- Commercial unit of energy (kWh), 19
- Commutator, 235
- Coulomb, 8
- Coulomb's law, 75
- Coupling factor, 181
- Covalent bond, 265
- Current, 9
  - divider, 41
  - ratio, 190
- Cycle, 199
- D.C., 21
- D.C. circuits, 31
  - parallel, 35
  - series, 31
  - series/parallel, 43
- D.C. generators, 235
  - armature, 235
  - commutator, 235
  - construction, 238
  - self excitation, 241
  - separately excited, 239
  - series, 242
  - shunt, 240
- D.C. transients, 249
  - $C-R$  series circuits, 249
  - $L-R$  series circuits, 256
  - time constant, 251, 255, 257
- Diode, 272
  - characteristics, 274
  - p-n junction, 272
  - zener, 276
- Eddy currents, 172
- Electric
  - charge, 8
  - current, 9
  - field, 76
  - field strength, 78
  - flux, 79
  - flux density, 79

- Electromagnetic induction, 141, 147
- Electromotive force (emf), 10
- Electron-hole pair, 266
- Energy, 17
  - dissipated by resistance, 17
  - stored in a capacitor, 97
  - stored in an inductor, 184
- Extrinsic semiconductor, 268
  
- Farad, 83
- Faraday's laws, 141
- Ferrite, 174
- Ferromagnetic material, 111
- Field
  - electric, 76
  - magnetic, 111
- Field strength
  - electric, 78
  - magnetic, 111
- Figure of merit, 166
- Fleming's lefthand rule, 152
- Fleming's righthand rule, 144
- Flux
  - electric, 79
  - magnetic, 111
- Flux density
  - electric, 79
  - magnetic, 115
- Force between charged bodies, 75
- Force between conductors, 156
- Form factor, 207
- Frequency, 199
- Fringing, 78
- Full-wave rectifier, 210
  
- Galvanometer (galvo), 63
- Generation of emf, 147, 150, 235
  
- Half-wave rectifier, 209
- Henry, 175
- Hysteresis, 132
  - loop, 133
  - loss, 134
  
- Induced emf, 142
- Inductance, 175
  - mutual, 180
  - self, 175
- Inductor, 177
  - energy storage, 184
- Internal resistance, 14
  
- Instantaneous value, 198, 206
- Intrinsic semiconductor, 264
- Ion
  - negative, 7, 270
  - positive, 7, 266, 269
- Iron circuit, 115
- Iron dust core, 174
  
- Kilowatt-hour (kWh), 19
- Kirchhoff's laws, 48, 49
  
- Laminations, 173
- Lenz's law, 144
- Loading effect on voltmeter, 166
  
- Magnetic circuits, 114
  - comparison with other circuits, 132
  - composite, 126
  - parallel, 134
  - series, 126
- Magnetic
  - field, 111
  - field strength ( $H$ ), 117
  - flux, 115
  - flux density, 115
  - hysteresis, 132
  - reluctance, 128
  - saturation, 123
- Magnetisation curve ( $B/H$ ), 122
- Magnetomotive force (mmf), 116
- Meter
  - damping torque, 161
  - deflecting torque, 159
  - full-scale deflection (fsd), 161
  - multiplier, 163
  - ohmmeter, 170
  - restoring torque, 160
  - shunt, 162
  - wattmeter, 171
- Motor principle, 153
- Motors, 244
  - series, 245
  - shunt, 244
- Motor/generator duality, 233
- Moving coil meter, 159
  
- n-type semiconductor, 268
  
- Ohm, 10
- Ohmmeter, 170
- Ohm's law, 13

- Peak factor, 206
- Peak value, 200
- Periodic time, 199
- Permeability, 118
  - absolute, 119
  - of free space, 118
  - relative, 119
- Permittivity, 84
  - absolute, 85
  - of free space, 84
  - relative, 84
- Phase and phase angle, 214
- Phasor, 216
- Phasor diagram, 217
- p-n junction, 271
- p-n junction diode, 272
  - forward characteristics, 273
  - reverse characteristics, 273
- Potential difference (pd), 11
- Potential divider, 40
- Potential gradient, 80
- Potentiometer, 65
- Power, 18
- Proton, 7
- p-type semiconductor, 270
  
- Recombination, 266
- Rectifier, 208
  - bridge, 210
  - full-wave, 210
  - half-wave, 209
  - instrument, 212
- Relative permeability, 119
- Relative permittivity, 84
- Reluctance, 128
- Remanance, 133
- Remanent flux density, 133
- Resistance, 10
  - internal, 14
- Resistivity, 21
- Resistors, 10
  - in parallel, 35
  - in series, 31
  - in series/parallel, 43
- Root of the means
  - squared (rms) value, 205
  
- Saturation, 123
- Sawtooth waveform, 227
- Scientific notation, 2
- Self-excitation, 244
- Self-inductance, 175
- Semiconductors, 23, 263
- Separately-excited generator, 239
- Series generator, 242
- Series motor, 245
- Shunt generator, 240
- Shunt motor, 244
- Sinusoidal waveform, 21
- Slidewire potentiometer, 65
- Solenoid, 113
- Standard form notation, 2
  
- Temperature coefficient of resistance, 22
- Time constant, 251, 255, 257
- Transient response, 250
- Transformer, 186
  - current ratio, 190
  - principle, 186
  - turns ratio, 189
  - voltage ratio, 189
  
- Units, 1, Appendix A
  
- Valence shell, 264
- Volt, 10
- Voltage drop (pd), 11
- Voltmeter, 25
  - analogue, 25
  - digital (DVM or DMM), 25
  - figure of merit, 166
  - loading effect, 166
  - multiplier, 163
  
- Watt, 18
- Wattmeter, 171
- Weber, 115
- Wheatstone bridge, 55
  - balance conditions, 60, 61
  - circuit, 56
  - instrument, 63
  
- Zener diode, 276