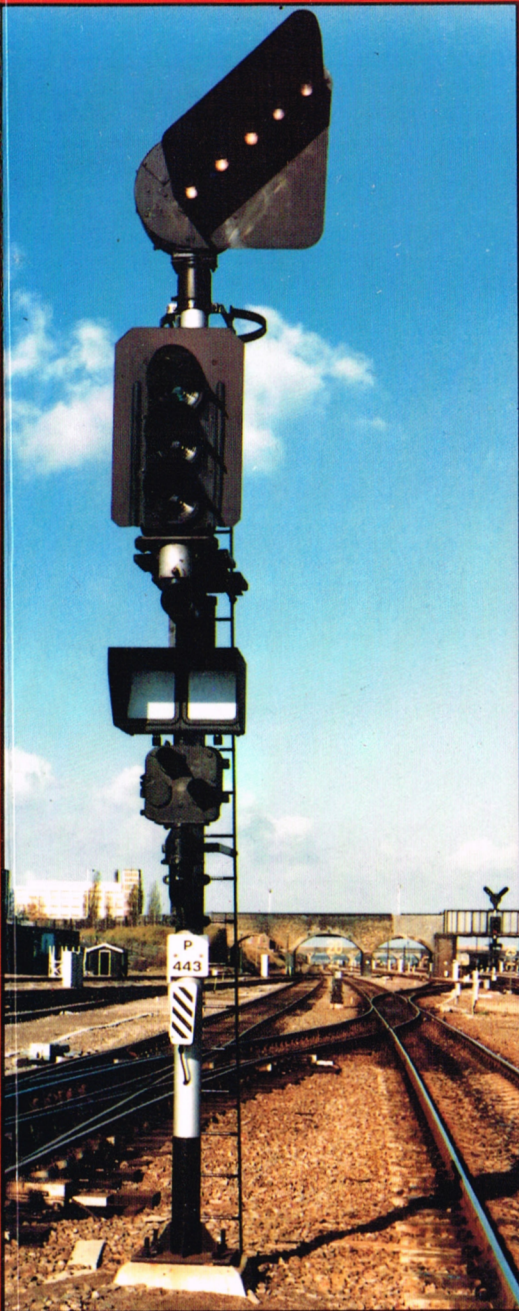


# RAILWAY CONTROL SYSTEMS



*a sequel to Railway Signalling*

# Railway Signalling

BR  
8/2/90

## Editorial Committee

\*O. S. NOCK, A.C.G.I., B.Sc., D.I.C., C.Eng., F.I.C.E., F.I.Mech.E.,  
F.I.R.S.E. *Chairman*

J. H. FEWS, C.Eng., F.I.R.S.E., F.I.E.E.

R. A. POPE, M.A., C.Eng., F.I.R.S.E., M.I.E.E.

\*L. H. F. TUFF, C.Eng., F.I.R.S.E., F.I.E.E.

\*J. F. H. TYLER, B.Sc., C.Eng., F.I.R.S.E., F.I.E.E., F.C.I.T.

\*D. C. WEBB, C.Eng., F.I.R.S.E., F.I.E.E.

\*Past-Presidents of the I.R.S.E.

The Committee must express their appreciation of the contributions made by the following: Messrs B. G. Buckler, A. D. Fleet, D. J. Glyde, J. V. Goldsbrough, B. H. Grose, D. A. Hotchkiss, R. T. Hutt, P. C. James, C. Law, C. A. Porter, A. J. R. Rowbotham, G. C. Smith, D. H. Stratton and R. B. Woodhead.

The circuit diagrams and signalling plans were prepared by D. A. Wood.

First published 1980

Paperback edition 1985

Reprinted 1988, 1989

A & C Black (Publishers) Limited

35 Bedford Row, London WC1R 4JH

© 1980 Institution of Railway Signal Engineers

All rights reserved. No part of this publication may be reproduced, stored in a retrieval system, or transmitted, in any form or by any means, electronic, photocopying, recording or otherwise, without the prior permission in writing of A & C Black (Publishers) Limited

### British Library Cataloguing in Publication Data

Railway signalling: a treatise on the recent practice of British Railways.

I. Railroads—Great Britain—Signal

I. Institution of Railway Signal Engineers

II. Nock, Oswald Stevens

625.1'65'0941

TF615

ISBN 0-7136-2724-7

Typeset by Santype International Limited, Salisbury, Wilts.

Printed in Great Britain by Antony Rowe Limited, Chippenham

# Railway Signalling

**A treatise on the recent practice of  
British Railways**

*Prepared under the direction of a  
Committee of the Institution of  
Railway Signal Engineers under the  
general editorship*

*of*

**O. S. NOCK**

*Honorary Fellow and Past President  
of the Institution*



A & C Black · London

# Contents and Illustrations

<b>Foreword</b>	<b>vii</b>
<b>Preface</b>	<b>viii</b>
<b>1 The Philosophy of Railway Signalling</b>	<b>1</b>
1:1 British Railways' multiple-aspect signalling system	2
<b>2 Layout of Signals and Track Circuits</b>	<b>4</b>
2:1 2-aspect signalling: (A) Rapid Transit (B) British Railways	7
2:2 3- and 4-aspect signalling	9
2:3 2-Yellow headway in 4-aspect area	11
2:4 British Railways' standard braking 'W' curve	12
2:5 British Railways' standard composite braking curve	13
2:6 Optimum headway and line capacity and effect of running at a speed less than that for which the line is signalled	19
2:7 Theoretical and practical braking technique	21
2:8 Stopping headway at an intermediate station	22
2:9 3-aspect stopping headway calculations for an intermediate station	23
2:10 4-aspect stopping headway calculations for an intermediate station	25
2:11 Effect of train speed on headway	27
2:12 Signalling at an intermediate station with loop platform	29
2:13 Layout of signals at a converging junction	30
2:14 Layout of signals at a double junction	31
2:15 Layout of signals at a left-hand double running junction	33
2:16 Double running junctions on high speed lines	34
2:17 Track circuiting at a divergence of two tracks	35
2:18 Track circuiting at a crossover between parallel running lines	35
2:19 Track circuiting at a left-hand double junction	36
2:20 Track circuiting at a left-hand double running junction	37
2:21 Subsidiary signal at entrance to siding or yard	38
2:22 Subsidiary signal at entrance to occupied platform (simple case)	39
2:23 Subsidiary signal as draw-ahead for setting back into siding	39
2:24 Shunting signals and associated track circuiting	41
2:25 Signalling and track circuiting at a terminal station	43
2:26 3-aspect junction signalling	46
2:27 4-aspect junction signalling	47
<b>3 The Principles of Interlocking and Controls</b>	<b>50</b>
3:1 Main features of signalling control panel	51
3:2 Main signal controls	54
3:3 Main signal and point controls at a right-hand running junction	57
3:4 Main signal and point controls at a left-hand running junction	58
3:5 Facing points in overlap	61
3:6 Route locking between signals and points	63
3:7 Opposing signal route locking	64
3:8 Point to point interlocking	65
3:9 Double junction on high speed line	66
3:10 Reciprocal and non-reciprocal locking	67
3:11 Conditional and counter-conditional locking	69
3:12 Head and tail movements at a station	71
3:13 Layout relating to examples of control tables	73
3:14 Example of signal and route control table	75
3:15 Example of point control table	76
3:16 Example of route and approach locking table	77
<b>4 Equipment: Relays, Signals and Point Machines</b>	<b>78</b>
4:1 BR 930 series relay	79
4:2 Multi-unit colour light signal: optical system	81
4:3 Multi-unit colour light signal: typical beam intensity and range	83
4:4 4-aspect multi-unit signal: lighting and main filament lamp indication circuit	84
4:5 Main signal on/off indication circuit	85
4:6 Searchlight signal: optical system	87
4:7 4-aspect searchlight signal: lighting and main filament lamp indication circuit	88
4:8 Position light junction indicator and optical system	89
4:9 Junction indicator: lighting circuit	91
4:10 Multi-lamp route indicator	93
4:11 Position light shunting signal and optical system	94
4:12 Shunting signal: control, lighting and indication circuit	95
4:13 Position light subsidiary signal: control, lighting and indication circuit	97
4:14 Point machine drive and lock movement: 'straight through'	99
4:15 Point machine drive and lock movement: 'in and out'	101
4:16 Split field point machine: 4-wire operating circuit	102

4:17 Split field point machine: operating circuit sequence	103	6:3 Multiple system of route identification	155
4:18 Permanent magnet point machine: operating circuit	104	6:4 Typical layout of relay sets: System A	157
4:19 Electric point machine: detection circuit	105	6:5 System A: push button circuits: entrance registration	161
4:20 Point machine control circuit	107	6:6 System A: exit registration	162
4:21 Rail clamp lock: principle of operation and detection	109	6:7 System A: selection and locking levels	164
4:22 Electro-hydraulic point machine (clamp lock type): control and drive circuit	110	6:8 System A: selection and locking levels: relay operating sequence	165
4:23 Electro-hydraulic point machine (clamp lock type): detection circuit	111	6:9 System A: point setting circuit	167
4:24 Electro-hydraulic point machine (clamp lock type): hydraulic operation	112	6:10 System A: aspect level	169
4:25 Layout for typical 'free-wired' circuit example	113	6:11 System B: typical layout of relay sets	171
4:26 Push button circuitry	115	6:12 System B: push button circuits	173
4:27 Control panel indication circuits	116	6:13 System B: route priming calling and locking circuits	175
4:28 Route LR circuits	117	6:14 System B: signal control and route releasing	177
4:29 Point setting circuits	118	6:15 System B: point setting circuit	179
4:30 Sectional release route locking circuits	119	6:16 System B: route priming calling and locking: relay operating sequence	180
4:31 Point proving circuits	120	6:17 System B: route priming: circuit operation	181
4:32 Aspect control and swinging overlap circuits	121		
4:33 Approach locking and auto working circuits	123		
Tables: B 930 series Relays	125-7		
<b>5 Signalling Control Panel</b>	<b>128</b>	<b>7 Track Circuit Principles and Equipment</b>	<b>182</b>
5:1 Mosaic diagram: part of a control panel and including an interlocking that is remotely controlled	129	7:1 Basic track circuit: occupied	183
5:2 Signalling control panel: combined type	130	7:2 Basic track circuit: clear	183
5:3 Signalling control panel with separate operating console	131	7:3 Example of track circuit calculation	186
5:4 Cross-section of combined type control panel	132	7:4 Insulated rail joint failure: equivalent circuits	187
5:5 Combined type of control panel: diagram showing constructional features	133	7:5 Typical bonding of track circuits	188
5:6 Portion of a mosaic diagram including CCTV monitor screen and controls for level crossing	138	7:6 Typical series bonding of track circuits	189
5:7 Signaller's telephone concentrator	141	7:7 Track circuit interrupter assembly	190
5:8 Part of a desk shelf with train description interpose and interrogate facilities	142	7:8 Typical examples of track circuit interrupters at trap points	191
5:9 Detail of mosaic panel, top unit, spring base and plug coupler assembly	145	7:9 Typical circuits for track circuit interrupters	193
		7:10 Magnetic circuits: DC ordinary and AC-immune relays	194
		7:11 Cross bonding and loss of broken rail protection	195
		7:12 AC-immune DC track circuit	196
		7:13 Double-element vane relay: details	199
		7:14 Double-element vane relay: resonated control winding	201
		7:15 Single rail AC track circuit in DC traction area	202
		7:16 Double rail AC track circuit in DC traction area	203
		7:17 Double rail AC track circuit with resonated impedance bonds	205
		7:18 Double rail AC track circuit with auto-coupled impedance bonds	207
		7:19 Double rail AC track circuit with inductance feed	209
		7:20 Impedance bond: typical saturation curve	211
<b>6 Geographical Circuitry</b>	<b>147</b>		
6:1 Track layout and geographical unit representation	150		
6:2 Track layout and geographical equivalents	151		

## CONTENTS

7:21	Double rail to double rail: impedance bond layout	212	9:9	Stepping table: example 3	268
7:22	Reed filter	213	9:10	Stepping table: example 4	269
7:23	Reed track circuit	214	9:11	Stepping table: example 5	270
7:24	Principles of jointless track circuits	217	9:12	Control Centre panel operator's train description panel layout	272
7:25	Jointless track circuit: voltage-operated type	219	9:13	Fringe box signalman's train description panel layout	273
7:26	Alsthom current-operated jointless track circuit	220	9:14	Train berth describer: sequence of panel operator's actions	275
7:27	Reed jointless track circuit: typical applications	221	9:15	Cathode-ray tube as used for train description display	277
7:28	Reed jointless track circuit: details	222	9:16	Cathode-ray tube: formation of characters	277
7:29	Jeumont impulse track circuit	224	9:17	Cathode-ray tube: display store	279
7:30	Jeumont impulse track circuit: impulse waveform	225	9:18	Basic train describer functions	281
7:31	Lucas impulse track circuit: impulse waveform	225	9:19	Main components of the computer	281
<b>8</b>	<b>Remote Control Systems</b>	<b>226</b>	9:20	Main components of the computer-based train describer	285
8:1	Comprehensive remote control scheme	229	9:21	Dual computer train describer	287
8:2	Remote control system with individual returns	230	9:22	Computer-based train describer: input multiplexer	289
8:3	Remote control system with common return	231	9:23	Anti-noise precautions	290
8:4	Typical micro-core cable section	232	9:24	Display system module	291
8:5	Basic FDM system	234	9:25	Train reporting system as installed on British Railways (L.M. Region)	295
8:6	FDM remote control system: twin reed filter	236	9:26	Comprehensive scheme for the automatic compilation of timetables and the provision of other ancillary services using train describers currently being installed by British Railways (Southern Region)	297
8:7	FDM remote control system: part of a fail-safe system	239			
8:8	Fail-safe reed transmitter: circuit diagram	240	<b>10</b>	<b>The British Railways' Automatic Warning System</b>	<b>299</b>
8:9	Fail-safe reed receiver: circuit diagram	241	10:1	AWS: principle of operation	300
8:10	FDM remote control: part of a non-vital system	243	10:2	AWS: magnets in track	301
8:11	FDM fail-safe system: tokenless block	244	10:3	AWS: cab indicator face plate	302
8:12	TDM system: input multiplexing	247	10:4	AWS: cab circuits—normal conditions	303
8:13	TDM system: make-up of transmitted messages	249	10:5	AWS: cab circuits—condition immediately after receiver has passed over permanent magnet	304
8:14	TDM system: binary methods of carrier modulation	250	10:6	AWS: cab circuits—condition after receiver has passed over energised electro-magnet	305
8:15	TDM system: output multiplexing	251	10:7	AWS: cab circuits—condition after receiver has passed over de-energised electro-magnet	306
8:16	TDM system: high density traffic scheme (uni-directional)	252	10:8	AWS: cab circuits—condition after driver has acknowledged a caution signal	307
8:17	TDM system: high density single station traffic scheme (bi-directional)	253	10:9	Location of AWS magnets	308
8:18	TDM system: low density multi-station traffic scheme (bi-directional)	255	<b>11</b>	<b>The Future</b>	<b>309</b>
<b>9</b>	<b>Train Description</b>	<b>258</b>		<b>Index</b>	<b>311</b>
9:1	Train description by block bell	259			
9:2	Magazine train describer	259			
9:3	Magazine train describer: displayed and 'blind' storage	260			
9:4	Train berth describer: train description display	261			
9:5	Symbols and abbreviations used in train describer systems	264			
9:6	Typical block schematic	265			
9:7	Stepping table: example 1	266			
9:8	Stepping table: example 2	267			

## Foreword

The railways throughout the world have changed considerably since the last comprehensive book on signal engineering was published in Britain forty years ago. From being a relatively small branch of railway engineering, it has become a senior profession employing the most modern technology in the fields of engineering control and communications.

Signalling and communication systems and techniques are now an essential ingredient of every activity of railway business and operations. This book, with all the authority of the Institution, deals in depth with the modern signalling technology of British Railways, which is unquestionably one of the busiest and most varied in the world. The varied traffic requirements of British Railways and hence the associated signalling practices described in the book make it eminently suitable as an international treatise for general reference and advanced studies. I am sure that members of the profession and students of the rather special art of railway signal engineering will find it invaluable.

K. E. HODGSON, C.Eng., F.I.R.S.E., F.I.E.E., M.C.I.T.  
President, Institution of Railway Signal Engineers  
March 1980

## Preface

This book is the result of several years' work by senior members of the Institution of Railway Signal Engineers. It describes the more recent practices of British Railways, historically the first railway network in the world, and today one of the most modern, fastest, busiest, and most finely equipped. The book has been prepared to be of interest to a wide variety of readers in many parts of the world, but primarily for professional signal engineers.

It is particularly directed towards younger men studying to obtain a wider and more complete knowledge of the subject. The total number of men employed in the signalling industry is small, but while the most advanced electronic, electrical and mechanical engineering systems are employed, and require a high proportion of men having Chartered Engineer status, the numbers represent a very small percentage of the railway engineering profession as a whole and it is impracticable to provide training in the expertise of signalling in Universities and Colleges of Further Education. Experience must be obtained within the industry, and the Institution sets and maintains the qualifying standards by the examination needed to be passed to obtain corporate membership. It is hoped that this book will help those making the necessary studies.

Additionally, the members of the committee charged by the Council of the Institution with the preparation of this book hope it will

be of interest and value to engineers and operating men on railways in many parts of the world on which developing traffics require the introduction of improved signalling, to increase line capacity and accelerate service. Equally, it is hoped that the book will be of interest to railwaymen in the 'advanced countries', in which the philosophies of operation and signalling may not necessarily be the same as on British Railways, but who may like to make comparisons of ideas, just as British based members of the Institution of Railway Signal Engineers are so happy to do with their fellow members overseas on various technical and social occasions.

In presenting this work, however, it is important to emphasise that as always, throughout the hundred years and more of its history, the technology and practice of railway signalling is in a constant state of evolution, and the book can be said to be up to date only up to the time of final editing, before going to press.

The Committee wishes to thank the Chief Signal and Telecommunications Engineer of the British Railways Board, and Messrs GEC-General Signal and the Westinghouse Brake and Signal Company for their assistance in producing the book and for the valuable suggestions they have made.

Finally, a word of special thanks is due to Mr. P. C. Harris who, on behalf of Messrs. A. & C. Black, has done a mammoth job in preparing the layout of the book and in getting all the illustrations into the right places!

O. S. NOCK  
Chairman,  
(Past-President)

## The Philosophy of Railway Signalling

The essential purposes of a railway signalling system are:

- (a) to maintain a safe distance between following trains on the same track;
- (b) to safeguard the movement of trains at junctions, and when crossing a path which could be taken by another;
- (c) to regulate the passage of trains according to the service density and speed required.

It is also a fundamental requirement that in the event of equipment failure the safety of trains must be ensured.

There are many systems of signalling in use in various parts of the world which satisfy these criteria, but the system used in Great Britain is known as multiple aspect colour light signalling (MAS.). It was adopted in 1923, following a report by a committee of the Institution of Railway Signal Engineers, and has changed little since. It is a very simple system so far as the driver is concerned, and has been found capable of coping successfully with the wide range of speeds, varying braking rates, and headway between following trains on British Railways. Fig. 1:1 shows the elements of the system, which may be 2-, 3- or 4-aspect according to traffic needs.

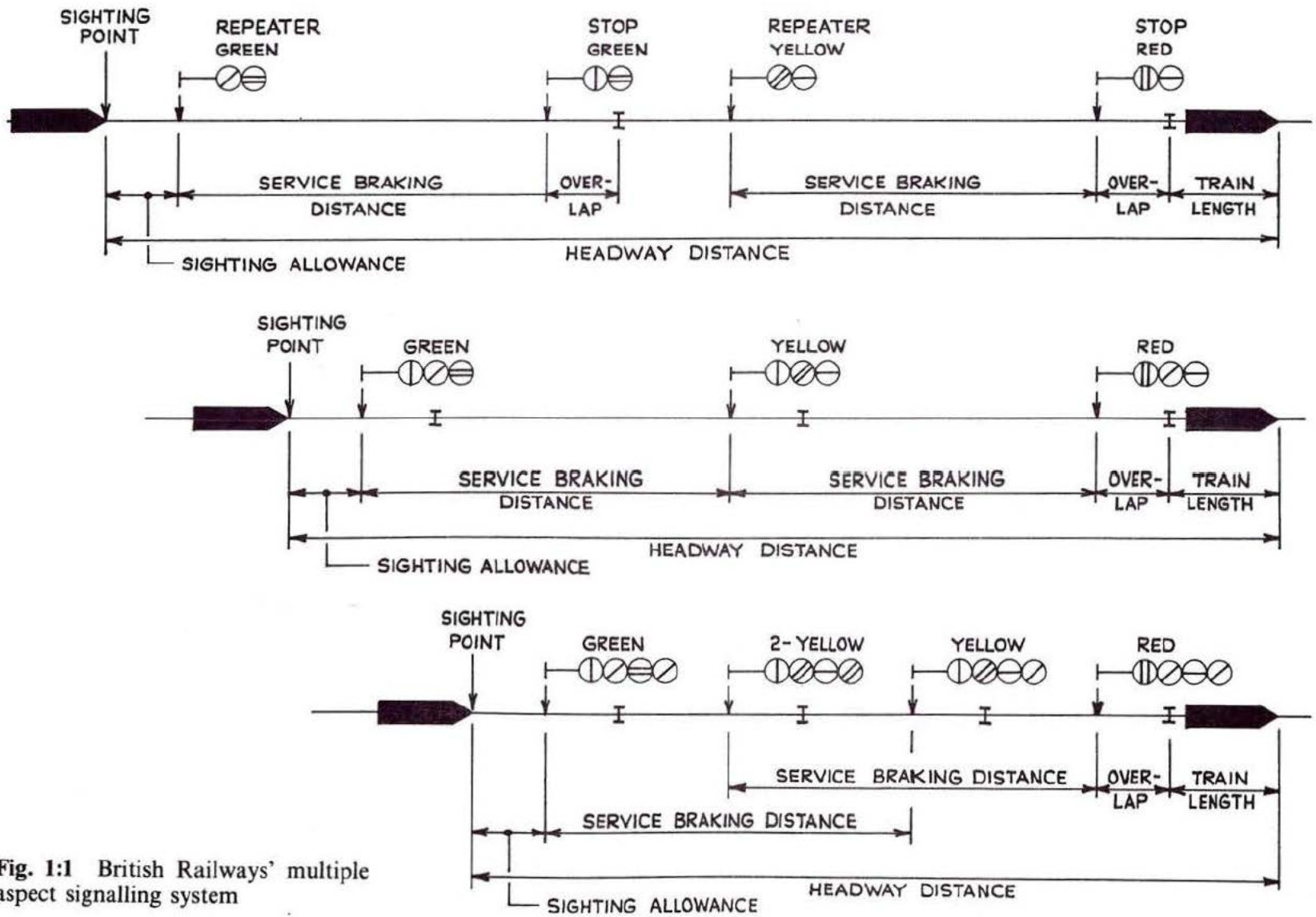
This book describes the current state of signal engineering on British Railways and shows how it is linked to developing techniques in traction systems, permanent way, and the increasing speed of trains. The lineside signals are operated by the signalman, or where possible automatically, and the signalman is protected from errors on his part by the interlocking and controls applied to the signals. Such protection is complete, barring failure of equipment, as discussed later. The driver acts on the authority of the aspects displayed by

the lineside signals, but to protect him against error on his part is more difficult.

In practice a compromise is accepted by British Railways by use of an automatic warning system (AWS.). This warns the driver of the need to make a brake application such that the train may be brought to a stand at a signal displaying a Red aspect. Should this warning be ignored the brakes are applied automatically, and will bring the train to rest before the signal is reached. For practical reasons, it is necessary that the driver should have the ability to release and to re-apply the brakes after an automatic application. Because of this the protection offered to the driver cannot be considered as complete and, on British Railways, he still therefore carries responsibility for controlling his train safely, although much has been done to make his tasks easier. Full automation on British Railways is quite feasible, but having regard to the mixed nature of the traffic, its density, and the size of the system, it is currently uneconomic. It should, however, be noted that British signal engineers have led in the development of fully automated systems of train control coupled with advanced techniques in signalling.

While the British Railways signalling system has been developed to provide for the safe movement of mixed types of train in conditions of high traffic density and increasing speed, equipment failure can still arise occasionally. On these fortunately rare occasions the signalman or the driver may be stripped of the protection provided by the system, and reliance has to be placed on the sense of responsibility of the men concerned, and upon their knowledge of the British Railways Rules and Regulations, and other relevant instructions, which remain as important today as they were in the days of simple semaphore signalling.

On British Railways the signalman is provided with all the means necessary to operate the points and signals, generally as a complete route, and he is also provided with continuous indications showing the state of the line, the position of all trains in his area of control, and the position of all points and the state of all signals. Much of the important equipment operates automatically, and further sec-



**Fig. 1:1** British Railways' multiple aspect signalling system

tions of the line may be caused to work automatically at the signalman's discretion. In such instances his physical workload may be considerably reduced. There is now no technical limit to the area which can be controlled from one central point. The limits have been extended considerably in recent years by agreement between the operator and the signal engineer, as the advantages of central control became apparent. The size of the controlled area depends upon geography, the type and density of the traffic, and the boundaries of traffic divisions of the line, or of its sub-divisions.

The signal engineer must be for ever vigilant towards the effects of human error, whether by the driver, the signalman or the maintenance technician. He must ensure that the effects of any such error are reduced to the absolute minimum. The chief elements of the signalling system that guard against the results of human failure are:

- (a) TRACK CIRCUITING, which ensures that a train on a running line cannot remain undetected, unobserved (by indication from a remote location) or unprotected;
- (b) INTERLOCKING, and route holding, which ensures the safe passage of trains from one signal to the next;
- (c) MULTIPLE-ASPECT COLOUR LIGHT SIGNALS to give simple and clear indications to the drivers in all weather conditions;
- (d) an AUDIBLE WARNING SYSTEM, which warns the driver to make a brake application which will bring his train to rest at a signal displaying a Red aspect, and to enforce such application automatically if the audible warning is ignored.

The importance of displaying simple and clear signal aspects to the driver cannot be over-stressed, because in an emergency his reaction must be immediate and without question. Experience has shown that the system of signal aspects in British Railways is second to none in this respect.

Lastly, it is essential in the design of signalling equipment and circuitry that it should be fail-safe. This means that no failure shall result in an unsafe situation, such as a less restrictive aspect being displayed by a signal, or in points moving when they should be locked. A track circuit should show itself to be occupied under failure conditions. Such failures are classified as 'right side', and while they cause delay to traffic they do not create unsafe conditions. If, however, a failure should not comply with these conditions it is classified as 'wrong side'. Fortunately, cases of the latter are rare.

Careful attention to design, and long experience, has given signalling equipment a low failure record. Of the railway signal engineer's responsibilities the most important is to maintain the equipment in such a state that it may be relied upon to function correctly at all times. All railway signal engineers keep detailed statistics and reports of all failures to check for weaknesses in design. The result is robust, reliable equipment which has a long working life.

Such is the philosophy of the railway signal engineer who, perforce, acquires a deep sense of responsibility for safety which remains with him throughout his career.

## Layout of Signals and Track Circuits

This chapter deals with the principles and development of multiple-aspect colour light signalling and its application to various types of traffic, first on plain line and then at junctions and intermediate and terminal stations. All types of layout cannot be dealt with, but it is hoped that the principles laid down will enable the reader to find the solution to other examples that he meets in practice. Also, the purpose and location of subsidiary and shunting signals are discussed, with examples, including the signalling necessary for entry to, and exit from sidings and yards. As an essential part of a modern system the track circuiting necessary is shown in each illustration. At this stage the type of track circuit is of no concern. These are dealt with comprehensively in a later chapter.

### Symbols and Definitions

The symbols used in this book for signalling problems are:

- $D$  = Service braking distance in metres
- $d$  = Distance between consecutive stop signals in metres
- $O$  = Overlap in metres
- $L$  = Train length in metres
- $SP$  = Sighting point
- $S$  = Sighting allowance in metres
- $CP$  = Clearance point
- $H$  = Headway distance in metres
- $T$  = Headway time in seconds
- $V$  = Maximum permissible speed of line (or line speed) in kilometres per hour
- $v$  = Train speed (if not at line speed) in kilometres per hour
- $C$  = Line capacity, in trains per hour

SERVICE BRAKING DISTANCE ( $D$ ) is the distance to stop a train, travelling at the maximum permissible speed of the line, at such a rate of deceleration that the passengers do not suffer discomfort or alarm. The British Railways standard braking curve, which is applicable to vacuum or air braked stock, is known as the 'W' curve and is reproduced in Fig. 2:4. As an example this curve shows that a train travelling at 160 km/h (100 miles/h) requires a stopping distance of 2039 metres (6690 ft). This corresponds to an overall uniform braking rate of 0.484 m/sec<sup>2</sup> (1.6 ft/sec<sup>2</sup>). When line speed is low certain classes of train require longer braking distances than are given by the 'W' curve. For such cases British Railways use a composite set of braking curves, see Fig. 2:5. Rapid transit multiple unit stock has a braking rate of about 0.9 m/sec<sup>2</sup> (2.94 ft/sec<sup>2</sup>).

SIGHTING POINT ( $SP$ ) is the point at which the driver would commence a brake application in order to stop at a signal ahead displaying a Red aspect. The British Railways standard is a point 10 seconds at train speed (about 450 metres at 160 km/h) on the approach side of the first signal displaying a warning aspect (2 Yellows for 4-aspect, or single Yellow for 3- and 2-aspect signalling). For rapid transit lines, where the signalling does not provide for a warning signal at service braking distance from the Red aspect, it is usual to consider it as a point service braking distance plus a margin (about 30 per cent) from the Red aspect.

SIGHTING ALLOWANCE ( $S$ ) is the distance from the sighting point to the first warning signal.

OVERLAP ( $O$ ) is the distance ahead of a stop signal that must be unoccupied before a train may approach that signal from the rear. On British Railways it is a nominal distance which may be regarded as a protection for the driver against overrunning in foggy weather or when the rails are slippery, assuming of course that a brake application had been made at or before the train passed the first warning signal. Statistics show that overrunning seldom exceeds 90

metres (about 300ft). In 1978 British Railways reviewed the matter and decided that, in future, all overlaps should be 183 metres (600ft) except where the line speed is 97 km/h (60 miles/h) or less when the length may be progressively reduced. In this book, all overlaps are shown as 183 metres.

For rapid transit lines, where stop signals are provided with train stops, overlaps are calculated from the following formula:—

$$O = \frac{0.51 V^2}{n \pm G}$$

where  $n$  = ratio of train weight/braking force (usually taken as 10)

$G$  = percentage gradient (i.e. 1 in 100 is  $\frac{G}{100}$ )

HEADWAY TIME ( $T$ ) is the time between two following trains on the same line passing a given point. The minimum, or optimum headway for non-stop trains would require both trains to travel at the speed for which the line is signalled, which is usually the line speed. For stopping trains the optimum headway would include a braking period, a station stop (usually taken as 30 seconds) and an accelerating period, discussed later.

HEADWAY DISTANCE ( $H$ ) corresponds to headway time,  $T$ .

LINE SPEED ( $V$ ) is the maximum permissible speed on the line. This is laid down for each section of line by the Chief Civil Engineer, according to physical considerations. It is usually not more than 160 km/h for design purposes, although trains which have a maximum speed of 200 km/h (125 miles/h), such as the HST of British Railways, have improved braking characteristics which enable them to stop in the same distance as that required by the conventional 160 km/h train.

## LAYOUT OF SIGNALS AND TRACK CIRCUITS

LINE CAPACITY ( $C$ ) in its simplest form is the maximum number of trains per hour permitted by the signalling system, and is inversely proportional to the headway time; but on a railway carrying a variety of traffic, and at varying speeds, such as British Railways, definite values of line capacity can be quoted only in relation to the traffic pattern at the particular time of day.

TRAIN LENGTH ( $L$ ) in the following discussions is that for which the service is designed. In this, consideration may have to be given to the fact that many freight trains are not only much longer than passenger trains, but are limited to considerably lower maximum speeds, and so take longer to clear the signal sections.

Concluding these introductory matters, it must be pointed out that the distance between consecutive stop signals ( $d$ ) is not related to service braking distance in the case of 2-aspect signalling, but is a factor in the headway equation. As will be shown later, it must not be less than 1.5  $D$ . Headway is usually related to individual signals. It could, for example, be stated that the Green headway on signal 'XY22' is 136 seconds, or that the 2-Yellow headway on 'GH45' is 192 seconds. It is however very important to appreciate at the outset that as in practice signals cannot always be spaced precisely, because of physical features of the line, the resultant headways will vary from the theoretical position. There may well be difficult cases, but the result must always be equal to, or less than the operating requirements. It must always be remembered that the longest headway on a stretch of line will govern the line capacity. One cannot average headways.

### 2-Aspect Signalling

There are two forms of 2-aspect signalling currently in use in Great Britain, namely that for rapid transit and underground railways, and that used by British Railways. While this book is concerned only with the latter so far as in-depth treatment is concerned a few notes on rapid transit signalling will help towards an understanding of the principles of multiple aspect signalling.

Colour light signalling in Great Britain originated on the lines of the London Underground Railways where speeds are relatively slow, braking rates are high and sighting conditions ideal, except where curvature intervenes. The signalling consists simply of 2-aspect Red/Green stop signals, each with a train stop in line, and having a calculated overlap. If the stop signal cannot be seen at the sighting point a Yellow/Green repeating signal is provided to give the driver, in effect, a continuous sight of the stop signal from the sighting point. In some cases more than one repeater signal is needed; but the effect of this practice is to enable the driver to take immediate advantage of the stop signal clearing, before he can actually see it. This may be necessary if timetable headway is to be maintained. It is important to appreciate that in this case the position of the repeater signal, or signals, is not related to service braking distance from the stop signal. The arrangement is shown in Fig. 2:1(A). The minimum practical headway for this form of signalling, in conditions where trains stop at all stations, is about 90 seconds. It should also be noted that with train stops giving an irrevocable brake application and calculated overlaps, the driver is fully protected.

### 2-Aspect Main Line Signalling

On the main lines where speeds are much higher it is necessary to provide warning signals. The British Railways 2-aspect signalling system is shown in Fig. 2:1(B). Such signalling would be appropriate to a line with a limited service, albeit including trains travelling at high speed (140 km/h, or more). The signal spacing might not

be governed so much by the service to be run as by certain fixed points on the line, such as stations or siding connections where signals are required for other reasons. It would equally be suitable for a single line.

Referring to Fig. 2:1(B) the sighting allowance of 10 seconds may not be applicable when the speed is low and the service sparse. There is an understandable tendency among drivers to make a brake application earlier than is necessary, and therefore the signal engineer is well advised to be generous in his headway calculations. It would be quite usual, for example, to signal the line for a 5 minute service when the timetable requirement is 8-10 minutes, or to provide for a 2 minute headway, when only 2½ minutes is called for. This is done not only to allow for early braking, but to provide a usable margin for late, or out-of-course running. It will be seen from Fig. 2:1(B) that the service braking distance is from post to post, and that sighting allowance is additional. Even though adequate braking distance is thus provided there is a further margin of safety available, in that if necessary an emergency application could be made. This requires a distance of about 10 per cent less than service braking. Lastly there is the overlap.

The sighting allowance of 10 seconds is more suited to an intensive suburban service than to an Inter-City express train travelling at 160 km/h. On the latter a preliminary brake application would probably be made as soon as the first warning signal is sighted by the driver. For an intensive suburban service (say 2½ to 3 minute interval) the point at which the brake application is made is more important. Drivers soon get to know that unless it is left until just before the AWS inductors are reached, the service interval cannot be maintained. The standard braking distance should not be exceeded by more than 50%, otherwise unnecessary checks will result, with consequent loss of headway. While much of the foregoing is unlikely to arise on lines where only 2-aspect signalling is required the principles are important, and help towards an appreciation of the need for more elaborate signalling. In the 2-aspect case it is more likely to be a question of determining what the headway will be if signals

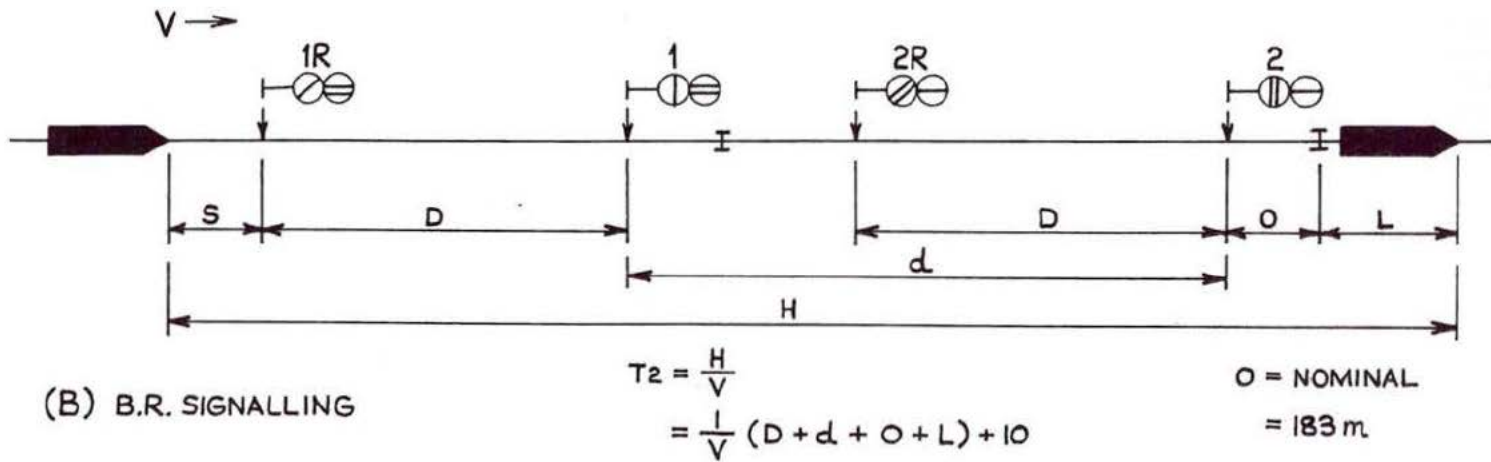
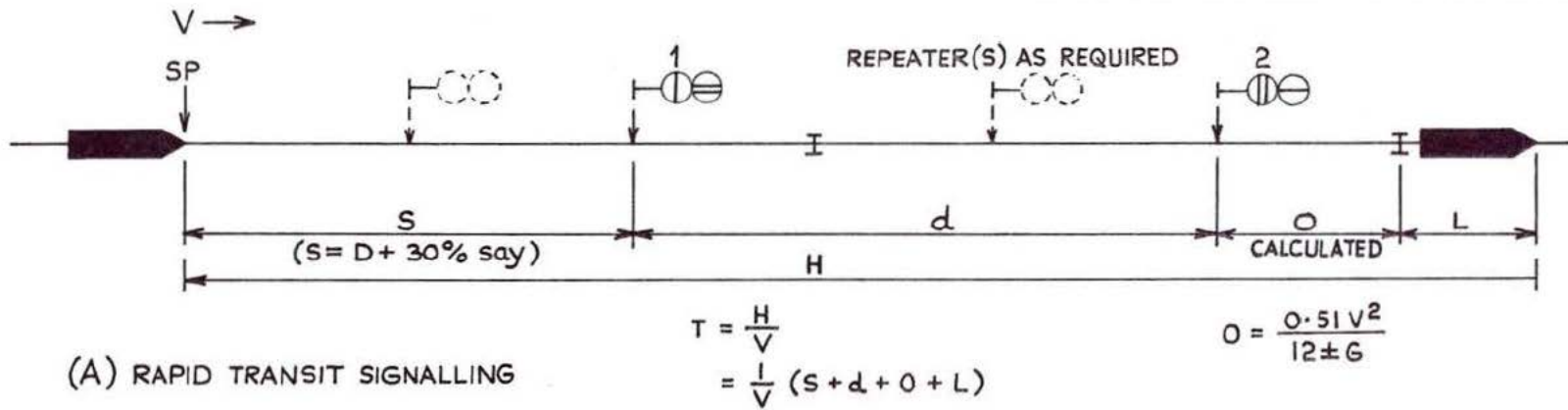


Fig. 2:1 2-aspect signalling: (A) Rapid Transit (B) British Railways

## LAYOUT OF SIGNALS AND TRACK CIRCUITS

have to be located at specific points, rather than the reverse process of determining the signal spacing for a specified headway requirement.

For example, to check the headway on a line where certain of the fixed points (station to station) are 10 km (6.2 miles) apart:

$$\begin{aligned}\text{Assume } V &= 130 \text{ km/h (80 miles/h)} \\ D &= 1189 \text{ metres on level (from the BR braking curve)} \\ O &= 183 \text{ metres} \\ L &= 350 \text{ metres} \\ d &= 10 \text{ km}\end{aligned}$$

$$\begin{aligned}H\left(\begin{array}{l} \text{headway} \\ \text{distance} \end{array}\right) &= D + d + O + L + S \\ &= 1189 + 10,000 + 183 + 350 + S \\ &= 11722 + S\end{aligned}$$

$$\begin{aligned}T\left(\begin{array}{l} \text{headway} \\ \text{time} \end{array}\right) &= \frac{11722}{V} + 10 \\ &= \frac{11722 \times 3600}{130 \times 1000} + 10 \text{ (sighting allowance)} \\ &= 325 + 10, \text{ or } 5 \text{ min. } 35 \text{ sec.}\end{aligned}$$

This would be adequate for a timetable interval of about 7 minutes.

In practice, signal spacing is generally determined from time-distance graphs of the line concerned, but a simple calculation as the foregoing enables the spacing to be roughly assessed. Even so, after the calculations have been made it may be found that the theoretical position for a signal is not a good one on the site, because of curvature or some obstruction to sighting, such as an overbridge. The effect on headway must then be checked, because it might involve the re-location of other signals.

The service braking distance is also affected by the gradients of the line. The effects of these can be studied from Fig. 2:4, but the data provided must be considered not only in relation to the variations of gradient that occur, sometimes from mile to mile,

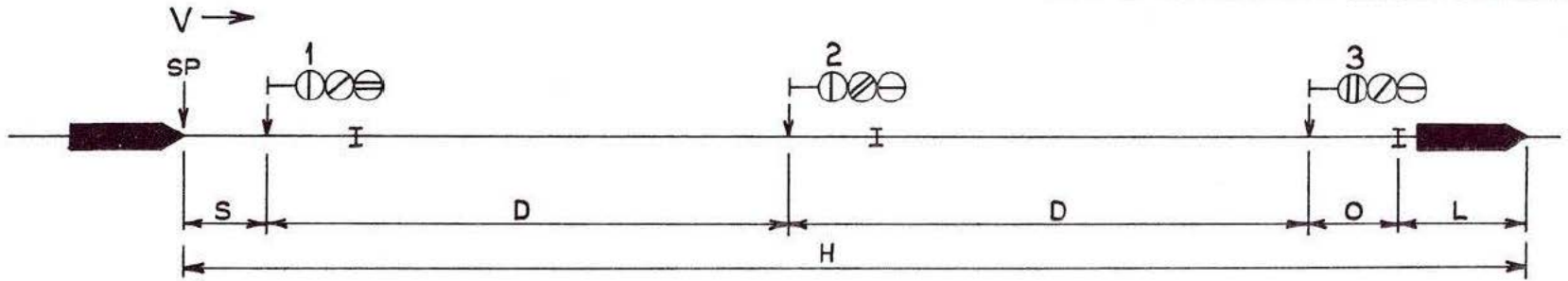
but also in relation to the variations in train speed due to the gradients.

Generally, passenger trains travelling at the maximum permissible speed will require longer braking distances than other types of train, but occasionally freight trains travelling at lower speeds, but having less brake power, may require longer distances than passenger trains. British Railways have therefore prepared a composite graph for multi-traffic lines, which shows the maximum braking distance required at various maximum line speeds. This is shown in Fig. 2:5.

### 3-Aspect Signalling

When the line capacity given by the 2-aspect system shown in Fig. 2:1(B) becomes inadequate and more trains per hour are to be run, the headway must be shorter and the stop signals brought closer together. As the headway gets shorter, repeater signal 2R gets closer to stop signal 1 until eventually their positions coincide as in the 3-aspect system shown in Fig. 2:2(A). An increase in the maximum permissible speed would contribute to this same result, because the distance between the repeaters and their associated stop signals would become greater.

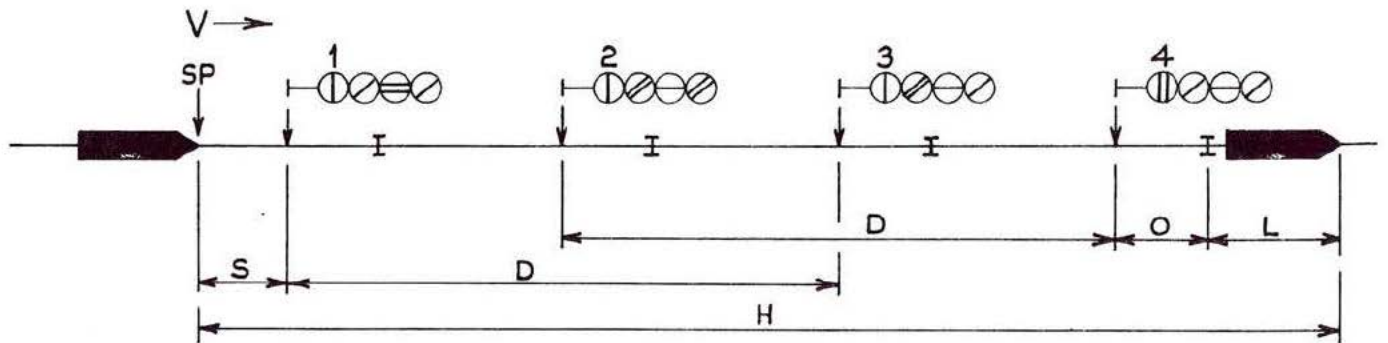
Before their positions do coincide however, there would be a situation when each repeater signal would only be a short distance ahead of the stop signal in rear and be clearly visible from it. The danger of 'reading through' now arises. If 2R is at Green and 1 is at Red (because there is a train between them) it is possible, particularly at night, that the driver might tend to ignore stop signal 1 and proceed irregularly with the inevitable result. To protect the driver in these circumstances, the practice of British Railways is to combine the signals as a 3-aspect when the distance between signals 1 and 2 is  $1.5 \times D$  or less. This may seem contrary to a statement made earlier that excessive braking distances may cause unnecessary checks and loss of headway. This will not be so, provided the application of the  $1.5 \times D$  rule satisfies the headway requirements



(A)

$$T_3 = \frac{H}{V}$$

$$= \frac{1}{V} (2D + O + L) + 10$$



(B)

$$T_4 = \frac{H}{V}$$

$$= \frac{1}{V} (1.5D + O + L) + 10$$

Fig. 2:2 3- and 4-aspect signalling

## LAYOUT OF SIGNALS AND TRACK CIRCUITS

after all allowances have been made. If the headway requirements are not satisfied, an additional signal section is required, or a 4-aspect system is needed.

The effect of mixed traffic on signal spacing can now be examined with the aid of an example.

### PROBLEM

An Inter-City service at 160 km/h has to run over the same track as a suburban service running at 97 km/h (60 miles/h). What is the practical headway for the suburban service assuming 3-aspect signalling?

### SOLUTION

For the Inter-City service,  $D = 2039$  m, which settles the signal spacing at 2039 m.

Let  $O = 183$  m,  $L = 350$  m and  $S = 10$  sec at  $V = 97$  km/h. Then for the suburban service the optimum headway is,

$$\begin{aligned} T_3 &= \frac{1}{V} (2D + O + L) + 10 \\ &= \frac{3600}{97 \times 10^3} (2 \times 2039 + 183 + 350) + 10 \\ &= 181 \text{ seconds} \end{aligned}$$

This means that a  $3\frac{1}{2}$  to 4 minute suburban service could be run non-stop, but at this stage it should be pointed out however that if the train is to stop at stations on the same track, the stopping headway will be greater. An example is given later. In the same conditions the Inter-City headway is 114 seconds.

The opinion is sometimes expressed that at 160 km/h, the signals are too far apart, and the driver should be given 4-aspect signalling because he will not have so far to travel before being given an indication of the state of the line ahead. This must remain a matter of opinion, but at 160 km/h a signal is passed every 46 seconds.

Even on a falling gradient of 1 in 200, where  $D$  would increase to 3281 m, the interval between passing signals is no more than 75 seconds. However, it is important to look to the future even if the current signalling requirements can be met with 3-aspect signalling; because in the event of a traffic increase demanding a 4-aspect system, it is not only an expensive matter to make the change, but the resultant disruption may cost as much in traffic receipts, and loss of goodwill through delays.

It will, by now, be apparent that, so far as the driver is concerned, there is no difference between 2- and 3-aspect systems in that the aspects he sees do not depart from Red, single Yellow, and Green.

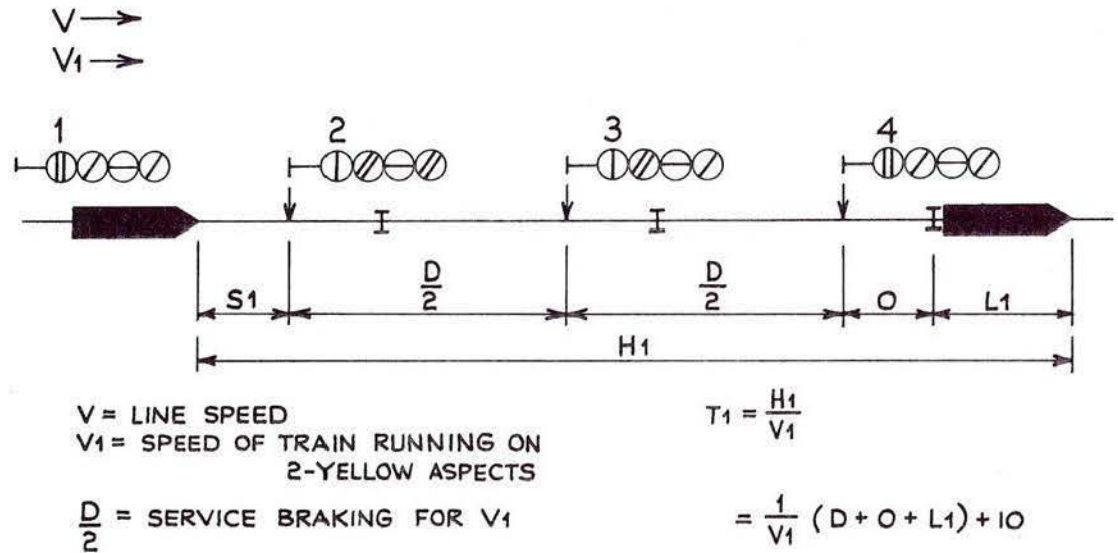
### 4-Aspect Signalling

The need for shorter headways than could be obtained under 3-aspect signalling was first realised when the South-East London suburban lines were resignalled and electrified in the mid-1920's. The recommendations of the 1923 I.R.S.E. Committee to add a 'double-yellow' to the existing 3-aspect system were then adopted for the first time. The aspect sequence is shown in Fig. 2:2(B) and the resulting shorter headway is clearly seen.

It might be thought to be disadvantageous to have two different caution or warning aspects at service braking distance from the Red aspect but in practice it has worked very well. The reason is that 3- and 4-aspect areas are kept distinctive, and there is no intermingling which could cause confusion amongst the drivers. In other words, a situation must never be allowed to arise where a driver is led to mistake a single Yellow aspect in 4-aspect territory for the same aspect in 3-aspect territory.

At this point, it would be helpful to note the very careful wording in the *British Railways Rule Book* which sets out the meaning to the driver of each of the aspects in multiple-aspect signalling. On page 11 is an extract from Section C—'Fixed Signals' of the *Rule Book*.

Fig. 2:3 2-Yellow headway in 4-aspect area



From the Rule Book

3.1. Colour Light signals

3.1.1. Main aspects

(a) The day and night aspects of colour light signals are given by means of lights only, as follows:

Aspect	Meaning
Red light	Danger (Stop)
One Yellow light	Caution—be prepared to stop at next signal
Two Yellow lights (vertically displayed)	Preliminary caution—be prepared to find next signal exhibiting one yellow light
Green light	Clear—next signal exhibiting a Proceed aspect

} Proceed Aspects

It will be seen that the wording is such that it is equally applicable to 2-, 3- or 4-aspect signalling. There is no mention of braking distance, but what has been said so far follows logically from the wording.

The application of 4-aspect signalling to the previously mentioned suburban lines in the London area soon showed that, at the lower speeds, the 2-Yellow aspect could be treated as a clear aspect and the single Yellow as a caution aspect in a similar manner to a 3-aspect system. Theoretically, in such a case, the distance between the Yellow and Red aspects must not be less than service braking distance for the train speed at the Yellow aspect. Fig. 2:3 shows this situation. It is assumed that signals are equally spaced.

An illustration of the possibilities of 4-aspect signalling is given in the example on page 14.

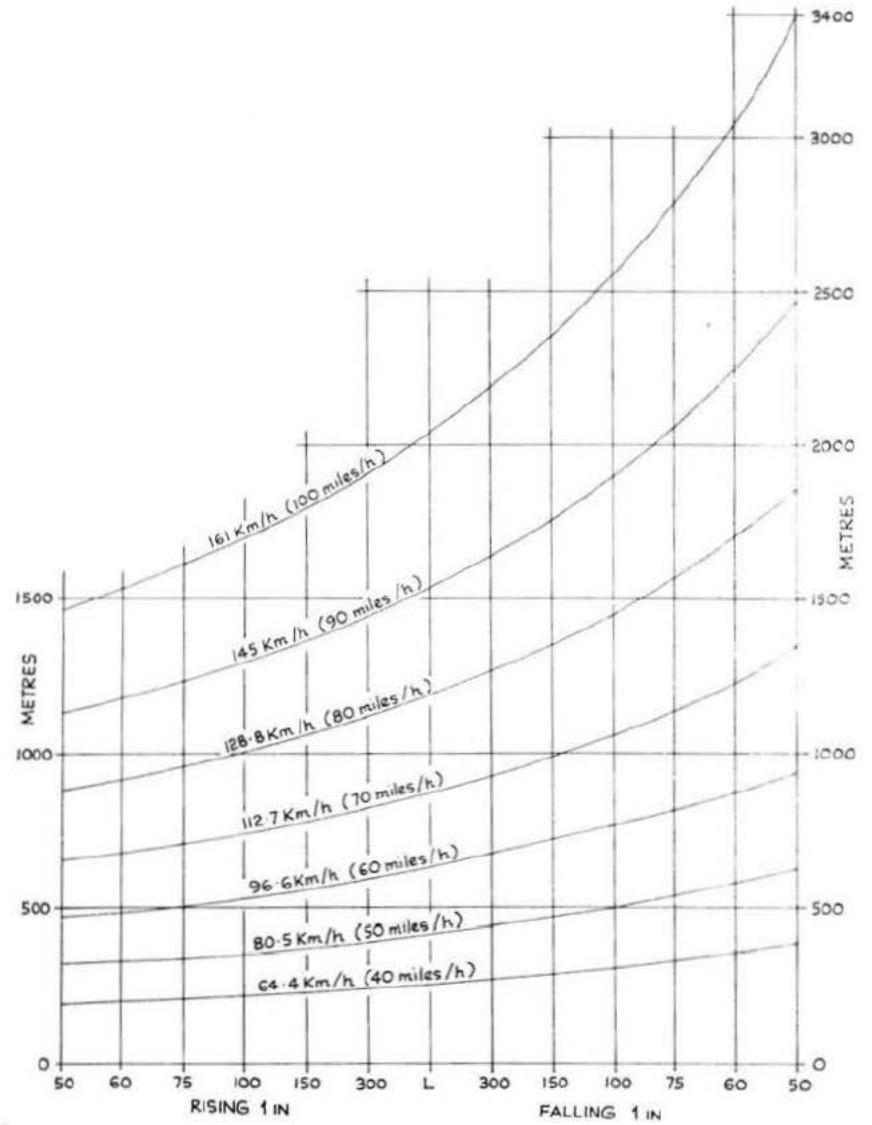


Fig. 2:4 British Railways' standard braking 'W' curve

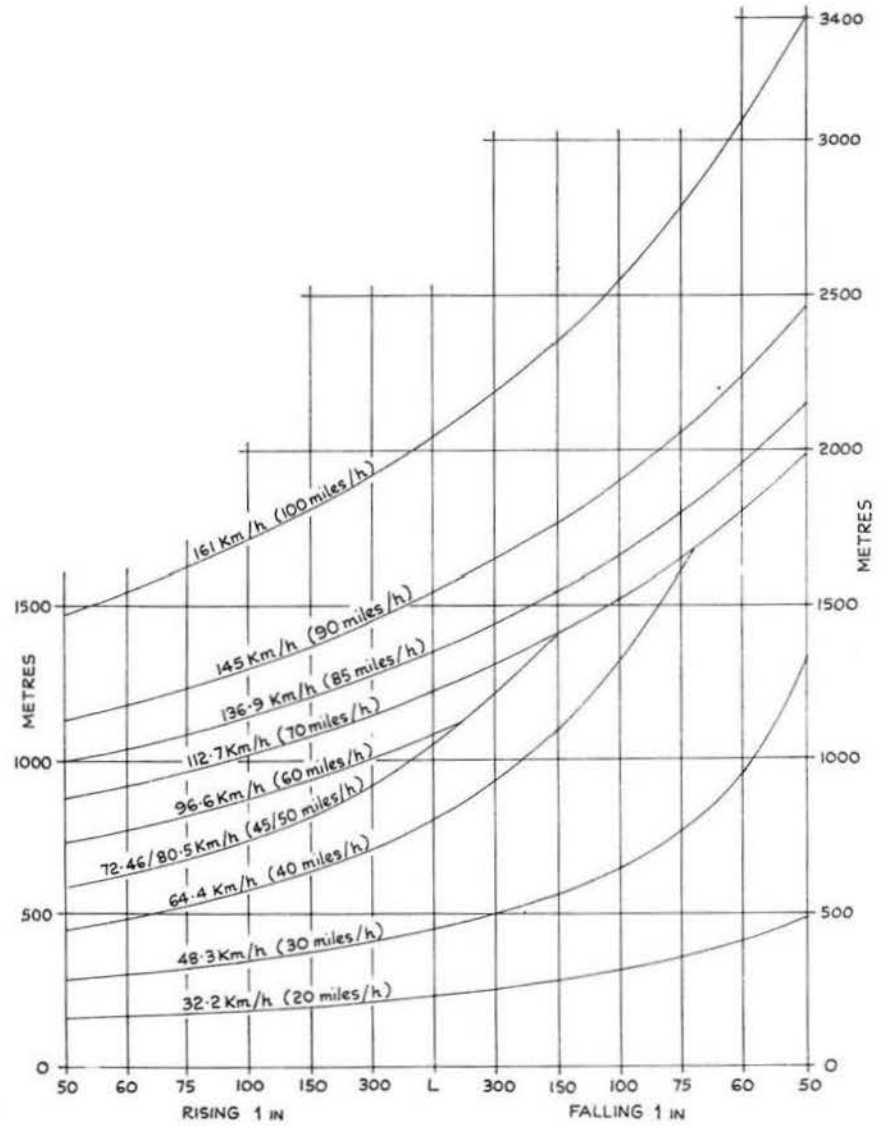


Fig. 2:5 British Railways' standard composite braking curve

## LAYOUT OF SIGNALS AND TRACK CIRCUITS

### PROBLEM

On a mixed traffic line, Inter-City trains travel at 160 km/h, suburban trains at 130 km/h and freight trains at 97 km/h (100, 80 and 60 miles/h respectively).

The line is signalled to capacity and the lengths of the trains are 350 m, 250 m, and 300 m respectively.

Calculate

- the minimum headways in each case
- the speed at which the suburban train can safely run on 2-Yellow aspects.

### SOLUTION

From standard braking curve

$D = 2039$  m for the Inter-City train

$D = 1189$  m for the suburban train

$D = 622$  m for the freight train

Fig. 2:2(B) shows the Green headway situation

Fig. 2:3 shows the 2-Yellow headway situation

The braking distance required for the Inter-City train settles the signal spacing at 1020 m.

For the Inter-City train,

$$T_4 = \frac{3600}{160 \times 10^3} (1.5 \times 2039 + 183 + 350) + 10$$
$$= 91 \text{ seconds}$$

For the suburban train,

$$T_4 = \frac{3600}{130 \times 10^3} (1.5 \times 2039 + 183 + 250) + 10$$
$$= 107 \text{ seconds}$$

For the freight train,

$$T_4 = \frac{3600}{97 \times 10^3} (1.5 \times 2039 + 183 + 300) + 10$$
$$= 141 \text{ seconds}$$

For the suburban train travelling on 2-Yellow aspects,

$$\frac{D}{2} = \frac{2039}{2} = 1020 \text{ m.}$$

From the braking curve, 1020 m is the braking distance for 121 km/h. Hence

$$T_1 = \frac{3600}{121 \times 10^3} (2040 + 183 + 250) + 10$$
$$= 84 \text{ seconds.}$$

The driver, using his judgment, will not run at the theoretical maximum speed of 121 km/h, but at some lower speed, say 100 km/h. At this speed, the headway would be 99 seconds.

The interesting conclusion to be drawn from this example is that, owing to the long distance between signals required for the Inter-City train, it is quite safe for the suburban train to run at 100 km/h on 2-Yellow aspects—and more advantageous. Nevertheless, as mentioned earlier, the suburban timetable service will be governed by the headway through the stations at which it stops.

One other problem which needs to be mentioned is that of signal spacing on lines running parallel with one another. It is a requirement that the signals must be opposite, so that a driver on either line will always see the signals in pairs as he approaches. If signals were staggered because of one line being signalled for a higher speed than the other, there would be a danger that a driver might ignore a caution, or even a Red signal, thinking that it did not

$$\frac{5000}{4} = 1250 \text{ m.}$$

apply to the line on which he was running—or at least not realise it until too late. With mixed traffic, this positioning of the signals in pairs can cause difficulties, particularly if an intensive suburban service is to be run on one line and a high speed Inter-City service on the other; sometimes the result is a limited headway on the slower line.

In the previous example, it was shown that the minimum headway for a suburban train with a maximum speed of 130 km/h, is 107 seconds. This could correspond to a timetable service of 2–2½ minutes, and there is no difficulty. However, it is during the braking and accelerating periods at stations that the suburban train needs more signals. There is one concession which is helpful. At stations, the location of which is known to the drivers of both trains (station lights can be seen etc.) an additional signal is permitted on the suburban line because it is associated with the station and is easily recognised. Signal 2 in Fig. 2:12 is an example. Nevertheless, this solution should not be used if it can be avoided.

The following example will enable the problem of signalling on parallel running lines to be fully appreciated.

#### PROBLEM

On a 4-line section of track, the two outer lines are to be reserved for a suburban service with a maximum attainable speed between stations of 97 km/h (60 miles/h). The inner lines are to be reserved for an Inter-City service having a maximum speed of 160 km/h.

The distance between stations is 5 km and the length of the trains will be 250 m (suburban) and 350 m (Inter-City).

Calculate the signal spacing and headways on each line.

#### SOLUTION

From standard braking curve

$$D = 622 \text{ m for } 97 \text{ km/h}$$

$$D = 2039 \text{ m for } 160 \text{ km/h}$$

As there will be a starting signal at each station, the signal spacing for the 160 km/h lines will be

This assumes that the Inter-City lines will be 4-aspect. The headway will then be

$$\begin{aligned} T_4 &= \frac{3600}{160 \times 10^3} (1.5 \times 2500 + 183 + 350) + 10 \\ &= 106 \text{ seconds} \end{aligned}$$

If the suburban line signalling is 3-aspect the headway would be

$$\begin{aligned} T_3 &= \frac{3600}{97 \times 10^3} (2 \times 1250 + 183 + 250) + 10 \\ &= 119 \text{ seconds} \end{aligned}$$

If the suburban line signalling was 4-aspect the headway would be

$$T_4 = 165 \text{ seconds}$$

Clearly, 3-aspect signalling is the solution for the suburban lines, but as the distance between signals is 1250 m it is in excess of the  $1.5 \times D$  rule if 97 km/h is considered to be the maximum permissible speed. In fact the maximum permissible speed is that for which 1250 m is the braking distance, which by reference to the standard curve is 133 km/h.

The rule for excessive braking distance only applies when the distance is that for the maximum speed of the line.

A workable headway is about 25 per cent greater than the calculated figure. The suburban line timetable headway should therefore be 147.5 seconds or say 2½ minutes. This figure still remains to be checked against the station stopping headway.

**Optimum Headway and Line Capacity at Various Line Speeds**

The general equation for a 3-aspect system is

$$T = \frac{1}{V}(2D + O + L) + 10$$

If it is assumed that  $L = 350$  m;  $O = 183$  m and the maximum permissible (or line) speed is 161 km/h

$$\begin{aligned} T &= \frac{3600}{161 \times 10^3} (2 \times 2039 + 183 + 350) + 10 \\ &= 0.0224 \times 4611 + 10 \\ &= 113 \text{ seconds} \end{aligned}$$

As the train is running at the speed for which the line is signalled, this is the optimum (or best) headway.

If however the train runs at some lower speed  $v$  km/h the equation becomes

$$T = \frac{1}{v} \times 4611 + 10$$

At 100 km/h

$$\begin{aligned} T &= \frac{3600}{v \times 10^3} \times 4611 + 10 \\ &= 176 \text{ seconds} \end{aligned}$$

Similarly at 80 km/h

$$T = 217 \text{ seconds}$$

Note the considerable increase in headway when trains run at less than the speed for which the line is signalled.

For a 4-aspect system

$$T = \frac{1}{V} (1.5D + O + L) + 10$$

Assuming the same constants

$$\begin{aligned} T &= \frac{3600}{161 \times 10^3} (1.5 \times 2039 + 183 + 350) + 10 \\ &= 0.0224 \times 3592 + 10 \\ &= 90 \text{ seconds} \end{aligned}$$

At 100 km/h

$$\begin{aligned} T &= \frac{1}{v} \times 3592 + 10 \\ &= 139 \text{ seconds} \end{aligned}$$

At 80 km/h

$$T = 172 \text{ seconds}$$

The 2-Yellow headway in a 4-aspect system has a maximum speed imposed on it by the speed for which the line is signalled because the Yellow to Red braking distance is  $0.5 \times D$ .

If the 4-aspect signalling is for a maximum speed of 161 km/h,  $D = 2039$  and the Yellow to Red distance will be 1020 m which corresponds to a speed of 121 km/h. This is the maximum speed for running on 2-Yellow headways.

Admittedly, this is theoretical, but it is important to see first what the theoretical possibilities are and then to make allowances for what happens in practice.

The 2-Yellow headway is given by

$$T = \frac{1}{v} (D + O + L) + 10$$

With the same constants as before, the optimum 2-Yellow headway is

$$\begin{aligned} T &= \frac{3600}{121 \times 10^3} (2039 + 183 + 350) + 10 \\ &= 0.03 \times 2572 + 10 \\ &= 87 \text{ seconds} \end{aligned}$$

At 80 km/h

$$\begin{aligned} T &= 0.045 \times 2572 + 10 \\ &= 126 \text{ seconds} \end{aligned}$$

At 60 km/h

$$\begin{aligned} T &= 0.06 \times 2572 + 10 \\ &= 164 \text{ seconds} \end{aligned}$$

## LAYOUT OF SIGNALS AND TRACK CIRCUITS

These results are shown on the curves shown in Fig. 2:6. This figure shows in full line the optimum capabilities of 3- and 4-aspect signalling over a range of line speeds from 50 to 160 km/h.

It also shows in dotted lines the headways which result when trains run at less than the speed for which the line is signalled. They are related to lines which are signalled for maximum speeds of 97, 129 and 161 km/h.

Two important characteristics of the optimum headway curves (full line) will be noticed:

- (a) the increase in headway and corresponding reduction in line capacity at the higher speeds resulting from the variation in the braking distance approximately with the square of the speed; and
- (b) the minimum headways which occur in the region of 50 to 80 km/h—thereafter as the line speed becomes less, the headways increase.

There is little disadvantage in (a) because high speed trains are not operated on the same short headways as suburban services and also because there are fewer intermediate stops; and where they do occur, there is generally a platform loop so that the headway of following trains is not unduly affected. There is an advantage in (b) in a rapid transit system because the speeds at which the trains run is of the same order as the speed at which minimum headway occurs, albeit on 2-aspect signalling. At these lower speeds, therefore, more people can be transported in a given time and the comparatively longer time taken is of little consequence in an area fed by a rapid transit system. Station stops are not included in

the calculations but have the obvious result of increasing the headways, although the effect is relative. It will be clear from the above that a rapid transit system or a main line suburban system requires a separate line with signalling for the appropriate headway. Note also the maximum speed which is imposed on trains which run on 2-Yellow headways in 4-aspect areas.

It will now be apparent that the parallel location of signals on adjacent lines imposes limitations on the signalling system or on the train service. Either the suburban service, on its own separate track, is restricted in headway by the signal spacing for the faster service running on a parallel track, or the latter must have a speed restriction imposed to enable it to run safely when signal spacing is governed by the suburban service. These are the limitations of multiple-aspect signalling which are, fortunately, not often reached.

One obvious solution is physically to separate the suburban lines in such a manner that the signals on one line cannot be seen from the other, but this is not practicable on British Railways. There is just not enough space available in the densely populated areas where the problem exists. On the other hand, the multiple-aspect system has enabled very fast Inter-City services to be run on nearly all Regions of British Railways to the extent that on the London-Manchester run for example, the majority of the air traffic has been captured. The gradual increase in speed on British Railways led to much consideration of the signalling system which was to form the standard for the future but nothing better has emerged than multiple-aspect which, by comparison with all other systems, has fewer limitations. Furthermore, it has the great, almost overwhelming, advantage of being simple.

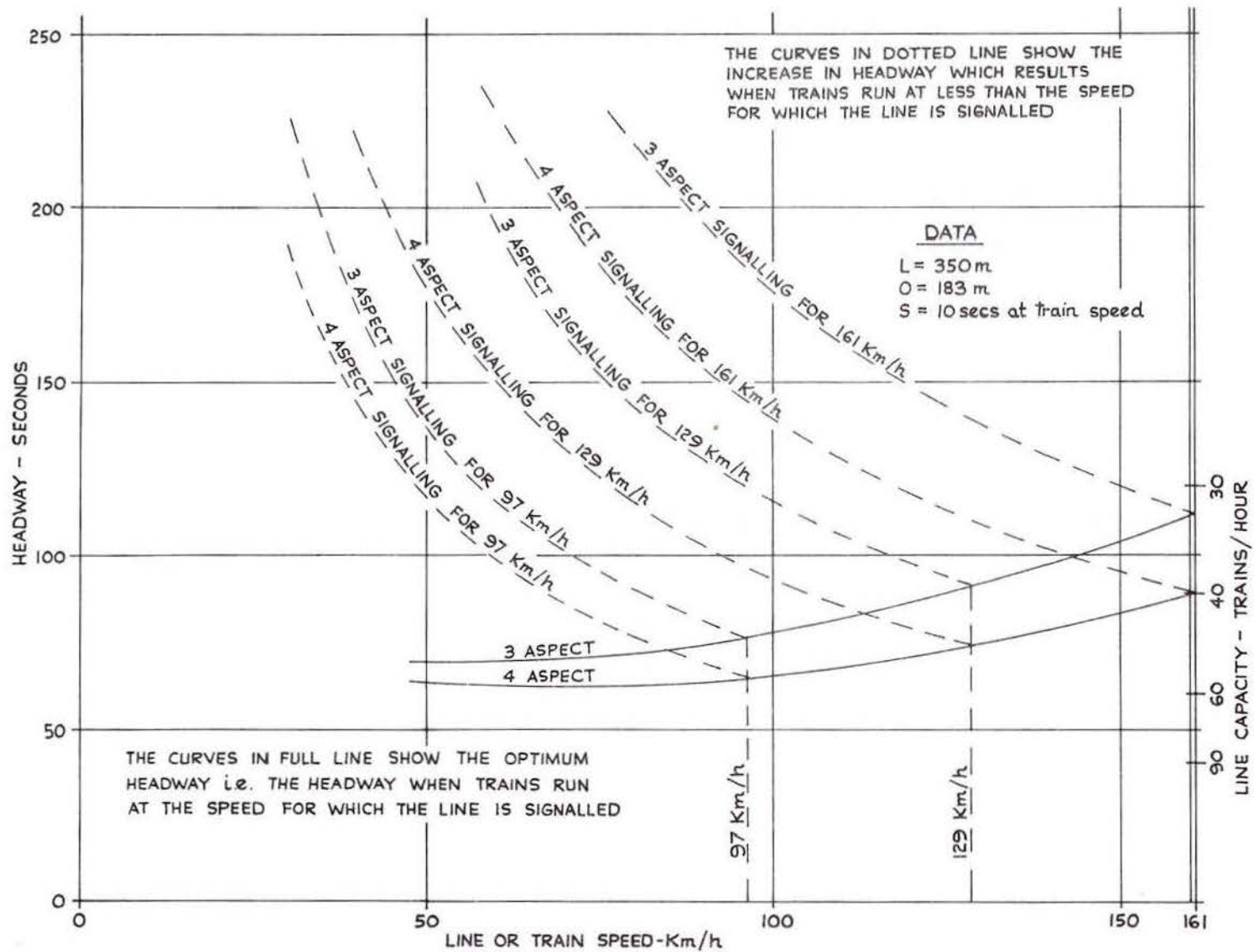


Fig. 2:6 Optimum headway and line capacity and effect of running at a speed less than that for which the line is signalled

## LAYOUT OF SIGNALS AND TRACK CIRCUITS

### Braking Technique

Signalling calculations assume that a brake application is uniform from the point of application at the sighting point to the train coming to rest at the signal. This is probably only strictly correct for suburban or 'rapid transit' services where repeated station stops are made. In other cases, particularly where the train is travelling at high speed, the driver tends to brake in two stages (or more) in the manner shown in Fig. 2:7. First he makes a limited application well on the approach side of the sighting point (the somewhat incorrect expression 'bringing his train under control' is often used); then when the train speed has been reduced to roughly half its original value, he eases the application; and finally he makes a heavier one to bring the train to a stand at the signal. The time taken to bring the train to rest is about the same as it would be with a uniform application—perhaps a little more—so that calculations based on an even deceleration can be considered as sufficiently accurate for headway purposes.

### Signalling at Intermediate Stations

There are many ways of arranging the signalling at an intermediate station depending on the type of traffic which is to pass: whether there is a preponderance of stopping or non-stopping trains, and whether there is a parallel track. The problems and their solution are best illustrated by a series of worked examples commencing with one dealing with a simple 3-aspect case where there is a preponderance of non-stop traffic.

#### PROBLEM 1

It is required to run a stopping service over a line having a maximum permissible speed of 160 km/h on which the signalling is 3-aspect with signals spaced uniformly at  $1.5 \times D$ . The platform is so sited that one of the existing signals will become a platform starter. The stopping service will have a maximum speed of 130 km/h. The following may be assumed.

Station stop = 30 seconds

$S = 10$  seconds at train speed

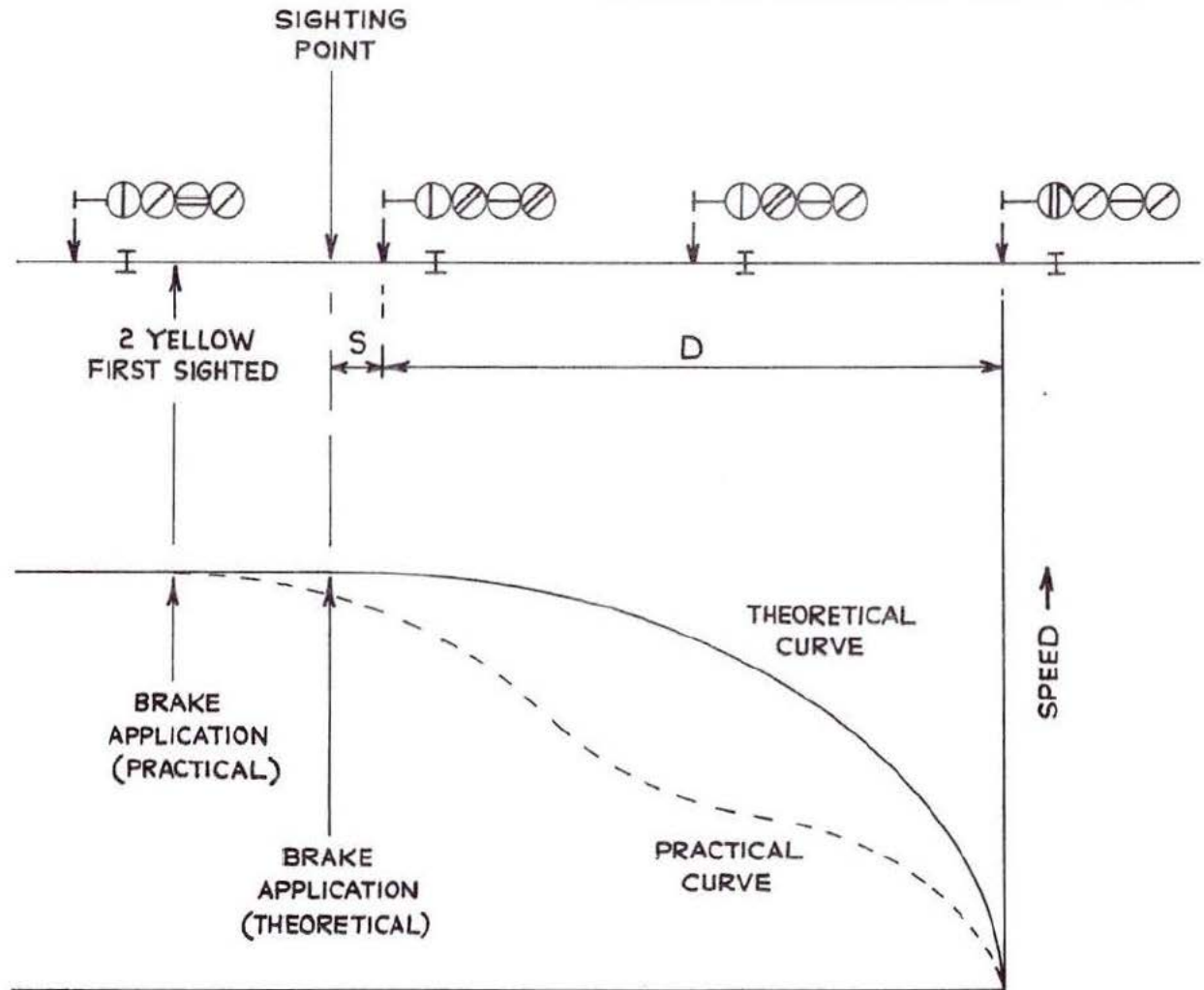
Acceleration =  $0.6 \text{ m/sec}^2$

$L = 250 \text{ m}$  (stopping train)

$O = 183 \text{ m}$

What would be a practical timetable headway?

Fig. 2:7 Theoretical and practical braking technique



## LAYOUT OF SIGNALS AND TRACK CIRCUITS

### SOLUTION

Fig. 2.8 shows the signalling in the vicinity of the station and the time-distance graph of the stopping train. (For clarity this graph is not to scale). Note that in determining the headways through the station, it is often only necessary to plot the front of the train on the approach side and the rear on the leaving side.

Signal spacing is  $1.5 D$  (the maximum distance) =  $1.5 \times 2039 = 3079$  m.

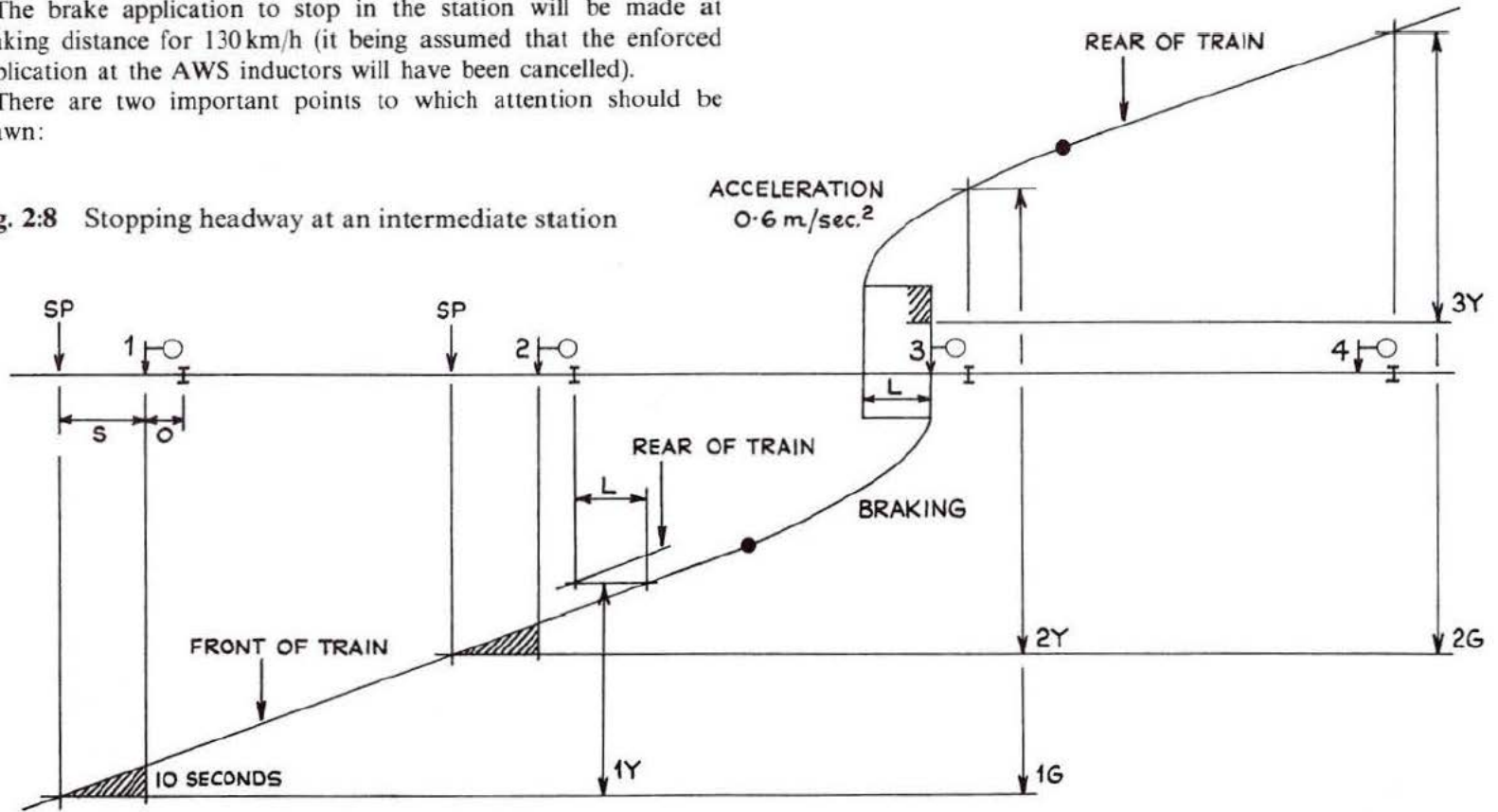
The approach speed is  $130 \text{ km/h} = 36 \text{ m/sec}$

The brake application to stop in the station will be made at braking distance for  $130 \text{ km/h}$  (it being assumed that the enforced application at the AWS inductors will have been cancelled).

There are two important points to which attention should be drawn:

- There is no objection to the stopping train entering the station on a Yellow aspect.
- The starting signal should preferably display a Green aspect before the train leaves. If it does not, there will be a tendency for drivers to 'crawl' away from the station (particularly in foggy weather) with resultant loss of headway.

Fig. 2.8 Stopping headway at an intermediate station

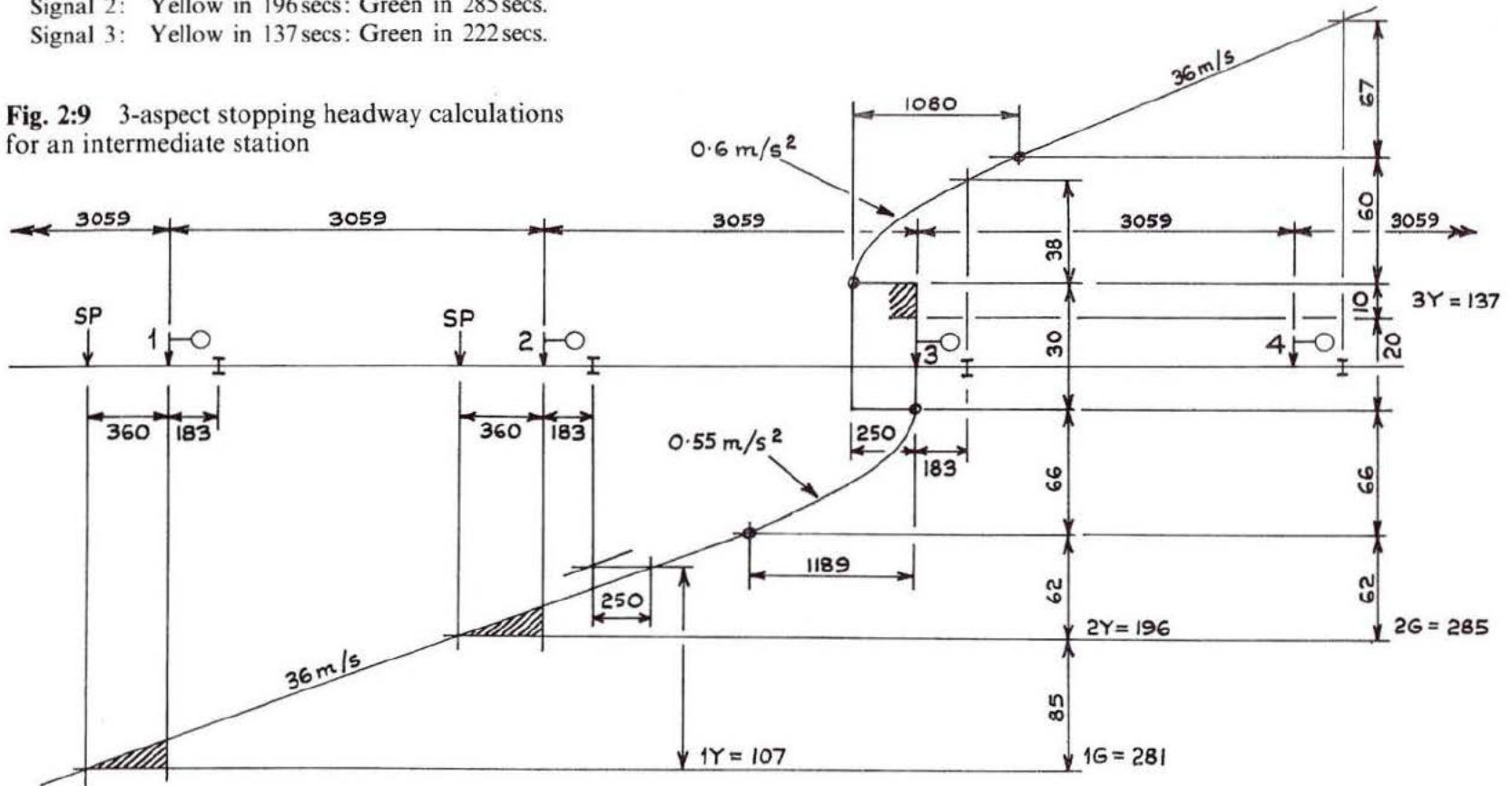


At this stage it should be decided whether the graph is to be drawn to scale or the headways calculated. The former method is usual because the effect of re-locating signals is more easily seen; but in this case it is more instructive to calculate the headways and plot the results on Fig. 2.9. The calculations need no comment but the results are interesting. They show that unless the signals are respaced the headways are as follows:

- Signal 1: Yellow in 107secs; Green in 281secs.
- Signal 2: Yellow in 196secs; Green in 285secs.
- Signal 3: Yellow in 137secs; Green in 222secs.

This means that a practical timetable headway should not be less than  $1.25 \times 281 = 351$  seconds or say 6 minutes. The Green headway on signal 1 governs the service because, although the Green headway on signal 2 is greater, trains will enter the station on a Yellow aspect. Note that signal 3 clears to Green in 222 seconds which means that trains will leave on a Green aspect, even if the

Fig. 2.9 3-aspect stopping headway calculations for an intermediate station



## LAYOUT OF SIGNALS AND TRACK CIRCUITS

headway, due to out of course running, reduces to 281 seconds. If it is less, trains will pass signal 1 on a Yellow aspect and may make a brake application unless signal 2 can be seen at Yellow. Obviously, it could not be seen in fog, or if it is located on a curve.

The answer to the problem is therefore 6 minutes.

Consider now the case where the stopping service needs to be as intensive as practicable, but non-stop trains at line speed must also be able to run.

### PROBLEM 2

It is required to resignal a line, having a maximum permissible speed of 160 km/h, to enable the most intensive practicable stopping service to be run. The maximum speed of the stopping service will be 130 km/h but non-stop trains at maximum line speed will also run.

Determine the minimum headways on all signal aspects through a typical station. What would be a practicable timetable stopping service? Calculate also the non-stop headway.

The following may be assumed.

$S = 10$  seconds at line speed

$L = 250$  m for stopping train

$O = 183$  m

$L = 350$  m for non-stop train

Acceleration =  $0.6 \text{ m/sec}^2$  for stopping train

Station stop = 30 seconds

### SOLUTION

It is obvious that the signalling should be 4-aspect. Fig. 2:10 shows the minimum signal spacing which will be  $0.5 \times D = 1020$  m from the standard braking curve.

For 130 km/h the standard braking curve also gives  $D = 1189$  m. Stopping trains may enter the station on a Green—2-Yellow—Yellow aspect sequence if necessary for minimum headway, but for trains

leaving the station, the platform starting signal should be at 2-Yellow or Green, preferably the latter.

For stopping train, the run-in speed will be 130 km/h (36 m/sec) to a point 1189 m from the platform starting signal at which point a brake application will be made. The train may run up to the starting signal at Red, but 10 seconds before the train is due to leave (for minimum practical headway) the signal must be at 2-Yellow or Green.

The headways for Yellow, 2-Yellow and Green aspects have been calculated and are shown on Fig. 2:10 but it would be interesting for the reader to attempt to determine them graphically for himself.

The headways may be tabulated as follows.

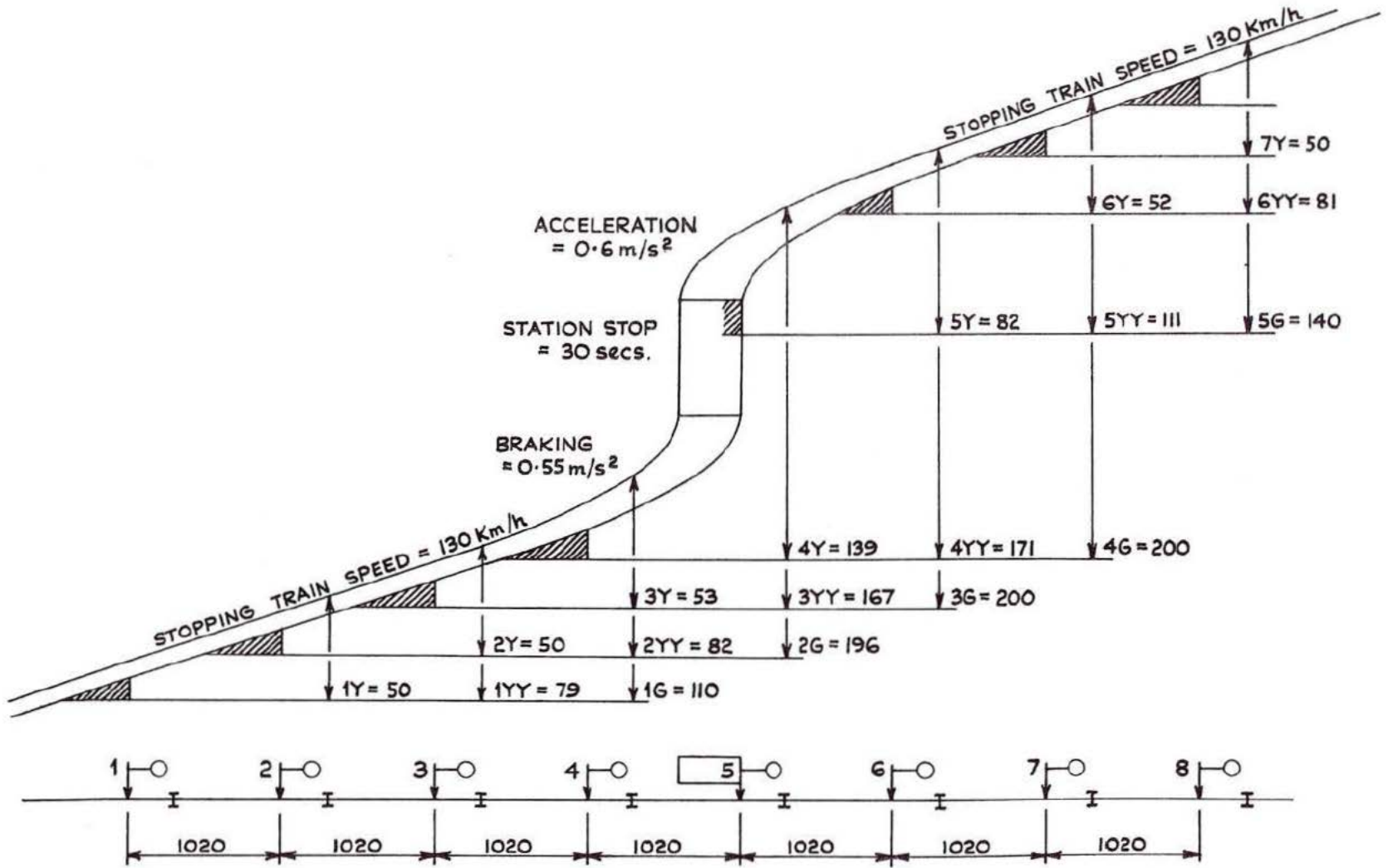
<i>Headways in seconds</i>			
Signal	Yellow	2-Yellow	Green
1	50	79	110
2	50	82	196
3	53	167	(200)
4	139	(171)	(200)
5	82	111	140
6	52	81	
7	50		

These are the best headways which could be achieved given the conditions laid down in the problem. Headway times shown in parentheses are those which may be ignored as the stopping train is entering the station with signal 2 at Green, signal 3 at 2-Yellow and signal 4 at Yellow.

The longest relevant headway is therefore the Green headway on signal 2 which is 196 seconds.

The timetable service could therefore be  $1.25 \times 196 = 245$  seconds or  $4\frac{1}{2}$  to 5 minutes.

Fig. 2:10 4-aspect stopping train headway calculations for an intermediate station



## LAYOUT OF SIGNALS AND TRACK CIRCUITS

Trains at 160 km/h could run on a headway of

$$T = \frac{1}{V}(1.5D + O + L) + 10 = 91 \text{ seconds}$$

A headway of 91 seconds for trains travelling at 160 km/h is unlikely to be needed. It is possible but unlikely that such a headway could be maintained because few drivers at that speed would wait to reach the 10-second sighting point before making a brake application. If the train data is correct, the limit has been reached if a non-stop service of 160 km/h is to be run. The limiting headway for the stopping service is the Green headway on signal 2. The only improvement which can be made is to bring it closer to the station; but doing so would reduce the non-stop braking distance, which means reducing the maximum speed of the non-stop train. There is no other reasonable alternative. If, for instance, the line speed were reduced to 130 km/h with 4-aspect signalling, the signal spacing would be  $0.5 \times 1189 = 595$  m which would effect a considerable improvement for the stopping train. There is, understandably, a reluctance on the part of the operating officers to agree to this course because it prevents the running of a high-speed prestige service at 160 km/h or 200 km/h; but in commuter areas a compromise is the only solution and on at least two Regions of British Railways the maximum speed has been reduced in the inner-London area.

Further consideration of Figs. 2:9 and 2:10 show that, for maximum line capacity for stopping trains at an intermediate station, after paying due regard to the braking distance value, the following principles apply to the location of signals.

- (a) Those signals on the approach side of the station, having an aspect, the headway on which includes a braking period (or part thereof), should be located as close as possible to the station. (This applies to signals 1 and 2 in Fig. 2:9 and signals 1, 2, 3 and 4 in Fig. 2:10)

- (b) There should always be a platform starting signal so that the innermost 'home' signal clears to Yellow as quickly as possible.
- (c) Other signals ahead of the station, the location of which control the headways of signals on the approach side, should be sited as short a distance ahead as possible. (This applies to signal 4 in Fig. 2:9 and signals 6 and 7 in Fig. 2:10)

Thus, subject to the braking distance rules, for maximum line capacity, appropriate signals should be grouped each side of the station. The efficient spacing of signals at stations through which trains also run non-stop can provide the greatest problems to the signal engineer. This section has been concerned with the signalling problems associated with a stopping service on a high-speed line. If, however, the stopping service is infrequent and does not cause problems with the non-stop service, the signal spacing need not be interrupted by the provision of a platform starting signal.

As has already been seen, trains running at different speeds provide most of the problems for the signal engineer; and the wider the speed range, the greater will be the problem. Currently, traffic on British Railways varies in speed from loose-coupled freights running at 64 km/h (40 miles/h) to high speed Inter-City services at 200 km/h (125 miles/h). Fig. 2:11 illustrates the problem when the speed difference is only about 30 km/h. It shows that if two 130 km/h trains are separated by one with a maximum speed of 97 km/h, the faster trains must be separated in time by 26 minutes on a run of 100 km instead of the minimum 4 minutes which would be within the capability of the signalling. This is obviously wasteful use of line capacity.

For more efficient working, high speed trains are often scheduled to run in 'flights' at 4-5 minutes timetable intervals. Long distance high-speed services to and from certain London termini are timed in this manner. Sooner or later, however, the problem will arise of providing closer headway for both classes of traffic, and this can be done either by providing loops at strategically sited inter-

mediate stations, or by the provision of a separate line over which freight or passenger trains may run whilst being passed by the faster trains.

There is no one solution to the problem. Each case must be judged on its merits.

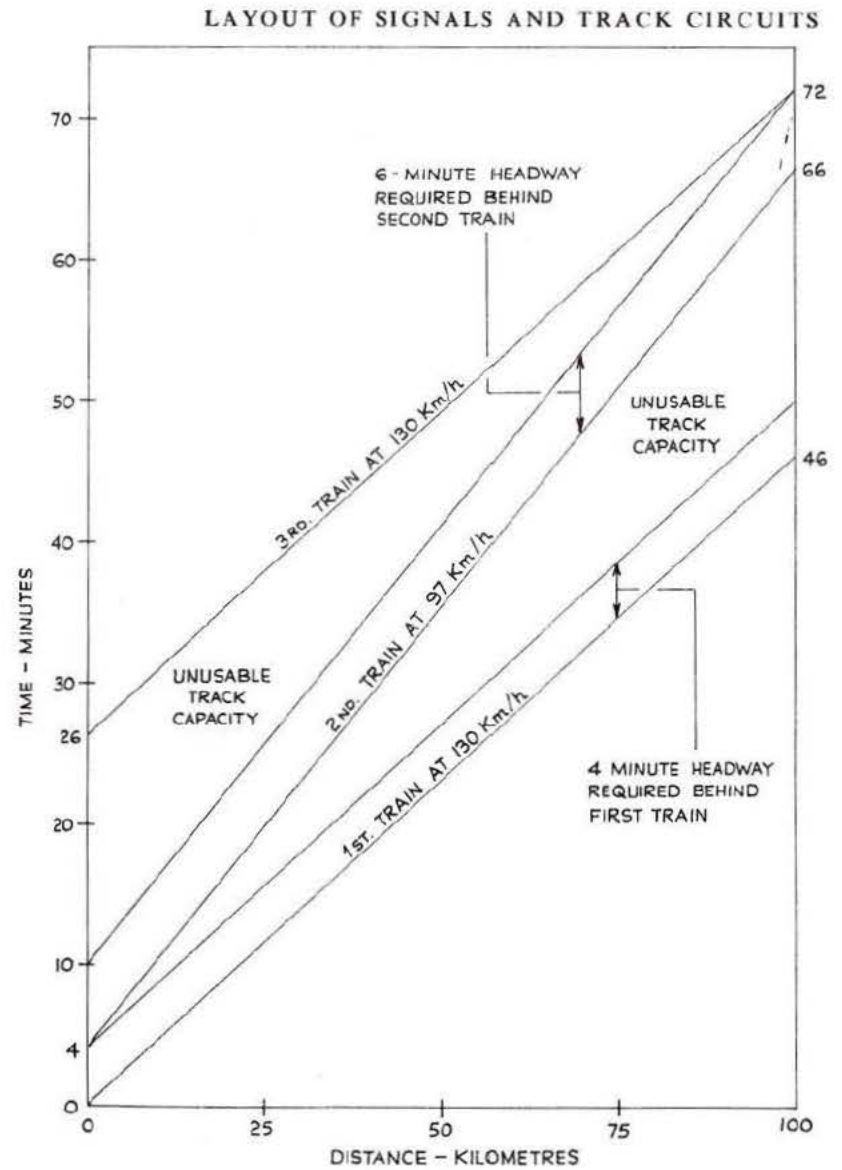


Fig. 2:11 Effect of train speed on headway

### Further Intermediate Station Signalling

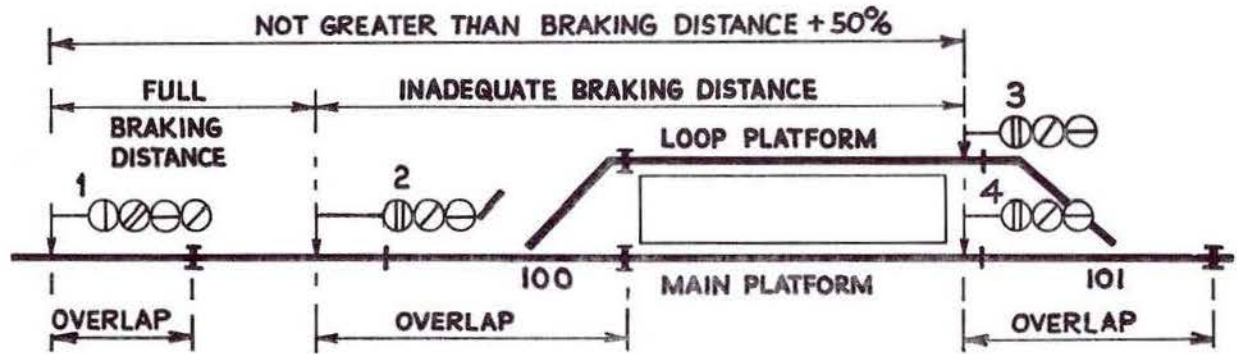
Fig. 2:12 shows an intermediate station with a loop platform in a 3-aspect area. The signal spacing on the main line is assumed to be  $1.5D$ , and the situation is as follows.

To avoid excessive headway in the signals in rear the loop should be entered as quickly as possible, though the loop entry signal must be approach released to enforce a speed reduction before passing over the points. Approach release, or approach control as it is sometimes called, will be discussed in detail later; it involves controlling the loop entry signal so that it does not clear until a suitable time interval has elapsed after the occupation of the approach track circuit. Thus the train passes a Yellow aspect at signal 1 and approaches signal 2 at Red. When the train is nearly at a stand, signal 2 clears to Yellow (the loop entry points having previously

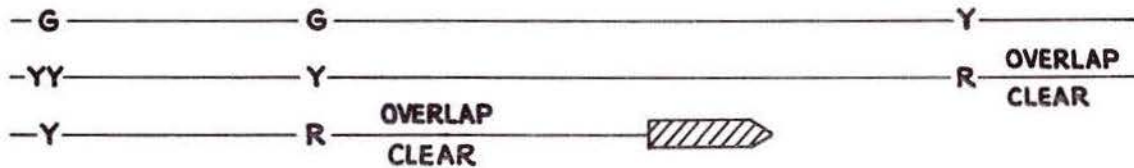
been reversed when the route was set up) and the train enters the loop at reduced speed. Clearly, the loop entry signal should be as close as possible to the entry points to limit the duration of the slow speed running and clear the main line as quickly as possible.

The normal signal spacing on the main line is from signal 1 to 4, both being 3-aspect. But with the necessary approach release on signal 1 the train would be slowed almost to a stand some distance in rear of the entry points, and the actual entry to the loop platform very slow. The insertion of an extra signal 2, at overlap distance from the fouling point, enables a more rapid approach to be made, but because signal 2 will be at less braking distance from signal 4, it is necessary for the signal in rear to be converted to 4-aspect. This solution is shown in Fig. 2:12.

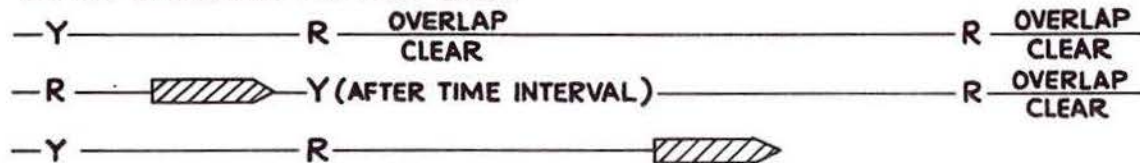
Fig. 2:12 Signalling at an intermediate station with loop platform



ASPECT SEQUENCES FOR MAIN LINE :-



ASPECT SEQUENCES FOR LOOP LINE :-



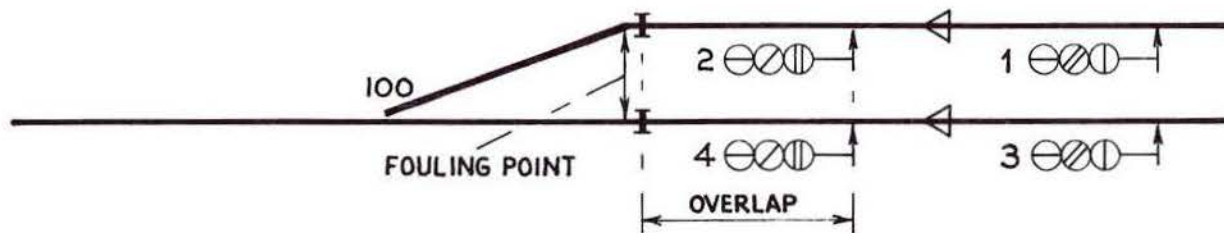
**Layout of Signals at a Simple Trailing Junction**

Fig. 2:13 shows two possible arrangements of signals at a converging junction. The approach may be from two parallel adjacent lines as shown or widely separated lines which converge on the junction. Ideally, the innermost signals 2 and 4 should be located overlap distance from the fouling point as shown in (A) because there is then freedom to make movements simultaneously from signals 1 to 2 and from signals 3 to 4.

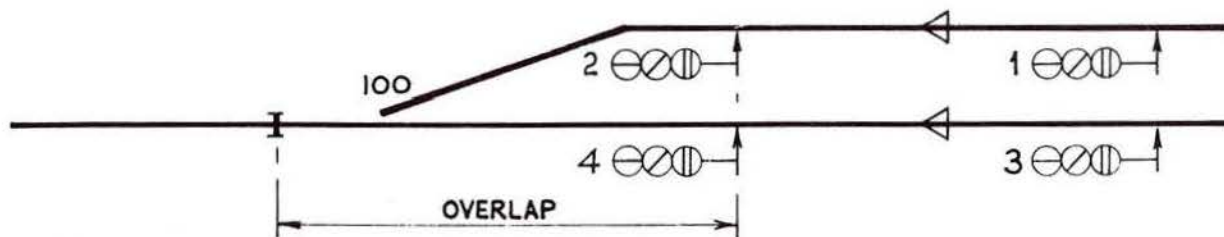
Although this arrangement also enables the junction to be cleared as quickly as possible for a following movement from the opposite

line, it may be better not to interfere with uniform signal spacing by locating Nos. 2 and 4 signals further in rear.

The arrangement at (B) is a type of control which is frequently used in a congested layout where headways are tight and must not be degraded by forcing a train to stand a long distance in rear until its overlap control is cleared by the completion of a conflicting movement. The principle to be observed in all such cases is that if a driver has been given a non-delayed Yellow aspect implying that the overlap is clear, such overrun protection must not be subsequently removed. It has often to be used at stations when two platform lines converge.



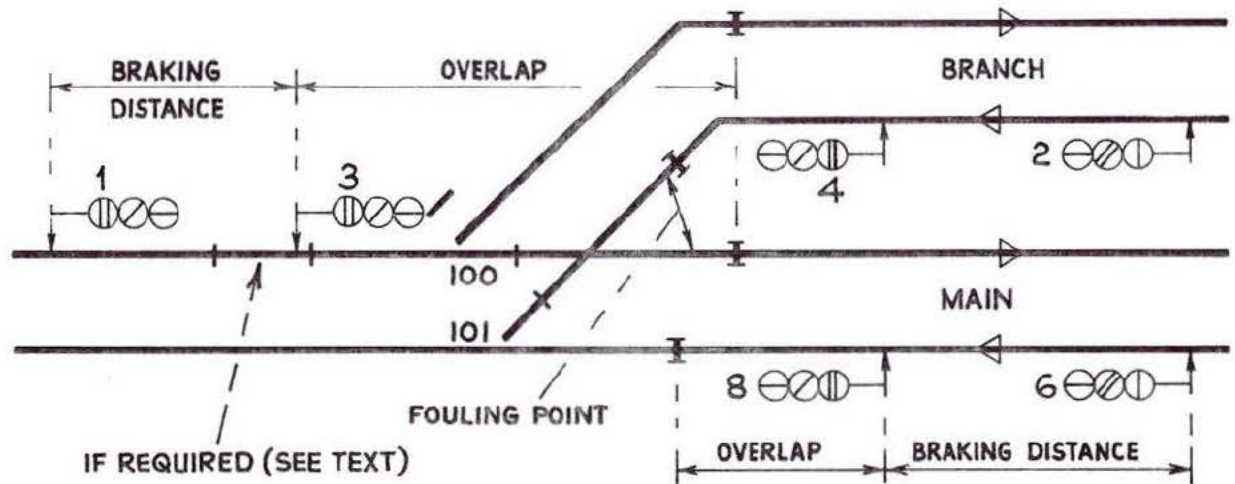
(A) PREFERRED ARRANGEMENT



(B) NON - PREFERRED ARRANGEMENT

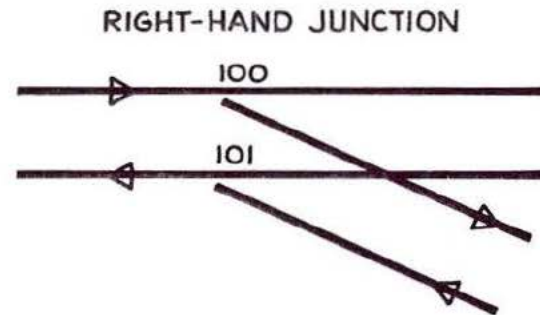
**Fig. 2:13** Layout of signals at a converging junction

**Fig. 2:14** Layout of signals at a double junction



### Layout of Signals at a Double Junction

Fig. 2:14 shows a typical layout of signals at a left-hand double junction. An important difference between left-hand and right-hand double junctions should be noted. In the layout shown, it is usual practice for movements from the branch to the main line to be protected against an overrun past signal 3 by requiring 100 points to be in the reverse position, so that the overrun is 'trapped' by being diverted to the branch line. In the right-hand junction (see inset in Fig. 2:14) such protection is not possible unless separate trap points (and a sand drag) are provided ahead of signal 8. At this stage it should be mentioned that, to save unnecessary wear and tear on point machines, it is the usual practice in a route installation for points to remain in the position to which they were last operated until required again. The terms 'Normal' and 'Reverse' are therefore reference positions only.



## LAYOUT OF SIGNALS AND TRACK CIRCUITS

Consider Fig. 2:14: signal 1 cannot be cleared unless the overlap ahead of signal 3 is clear. This overlap may be extended along the main line or the branch according to the position of 100 points. Assuming that signal 1 has been cleared with the points normal, that is, for the main line, and another movement is required to be made from the branch line with signals 2 and 4, there is no problem in clearing signal 2 and in fact it could be automatically operated. When the route for signal 4 is operated, and before 101 points are reversed, 100 must be reversed to provide the trap mentioned earlier. After that 101 will reverse and signal 4 will clear.

In the meantime, the first train may be proceeding along the main line between signals 1 and 3 so that 100 points may be operating to reverse whilst the train is approaching signal 3. If this signal is too close to 100, it might be possible for the points to be moving if the train overruns the signal. The result would be damage to the point machine and the point switches, although the movement from the branch would not start, because the 100 points would not have been detected in the reverse position. Nevertheless, the junction may be some distance from the Control Centre and repairs could take considerable time to effect. To avoid damage of this kind and a possible derailment it is usual to provide sufficient distance between signal 3 and the points to ensure that the point movement is completed before an overrunning train can strike the point switches. It must be understood that as soon as the track circuit ahead of the signal is occupied by the train, no movement of the points is possible, although having started it would continue.

As the points will take 3–5 seconds to throw, there must be sufficient distance between the track circuit joint and the tip of the switches to ensure that the points will have sufficient time to move from full normal to full reverse before the train arrives. This distance is determined according to the estimated speed of the train, but is of the order of 100 m. If there is insufficient distance available, either signal 3 must be located further to the rear, or a separate track circuit must be provided on the approach side of the signal to make up the total distance to 100 m. This separate track circuit

must then lock the points, with a time release to ensure that the points may be moved after the train has come to a stand at the signal. The 100 m distance is known as the 'track locking distance' of the points.

After the movement from the branch is clear of the trailing points (101), the route from signal 3 along the main line may be operated, 100 points will return to normal, followed by 101, after which signal 3 will clear.

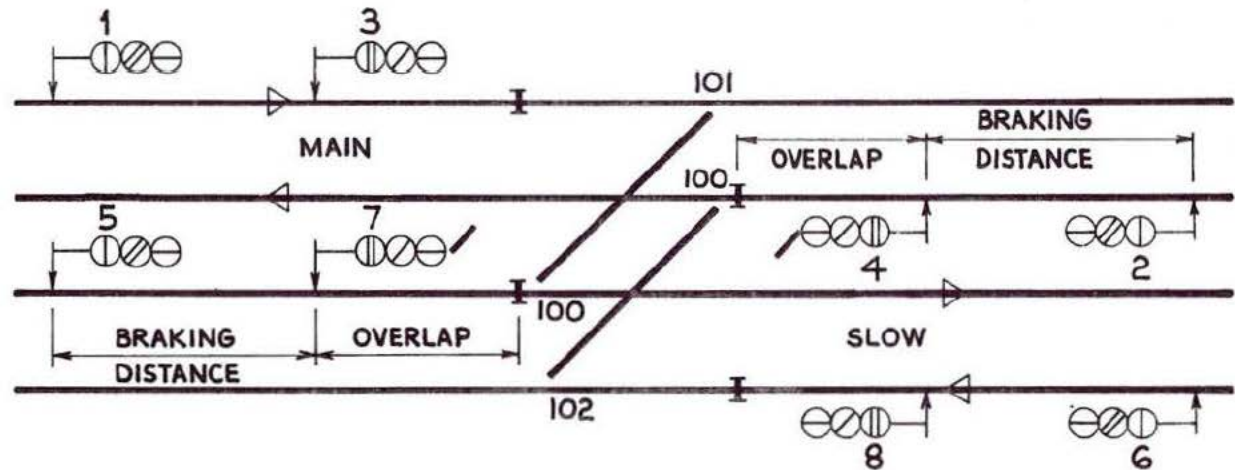
In route installations, with few exceptions, facing points within the overlap are not operated by the signal immediately in rear—in this case signal 1. The interlocking and controls must therefore be such that the facing points may be either normal or reverse when the outer route—signal 1 in this case—is operated. This will be discussed in detail later, but it should be noted that it is a fundamental difference between mechanical locking and interlocking for a route installation.

It would be less complicated if signal 3 was further to the rear, so that the junction itself was clear of the overlap; but as junction points must generally be run over in the reverse position at less than line speed, it is important that the junction should be cleared as quickly as possible to avoid retarding the headway for following trains. If practicable therefore, signal 3 should be in the position shown.

### Layout of Signals at a Left-hand Double Running Junction

Fig. 2:15 shows the layout of signals at a left-hand double running crossover junction, and much of what has been said for the simple double junction applies to this case. The ideal position of the 'splitting' signals Nos. 4 and 7 is however further to the rear than shown in Fig. 2:14 to avoid conflicting movements fouling the overlaps. This is not always possible in a congested layout and the overlaps may then have to be terminated at the trailing ends of 101 and 102 points. This results in shared overlaps when the junction points

**Fig. 2:15** Layout of signals at a left-hand double running junction



are reversed. Simultaneous moves with Nos. 2 and 6 with 100 reversed, and Nos. 5 and 1, are then no longer possible unless the delayed Y approach facility is used. Shared overlap controls are dealt with later.

Note the trapping. When signal 7 is routed to the main line with 100 points reversed, the other end of 100 points is reversed

at the same time to form the trap. This applies also when signal 4 is routed to the slow line. Trapping is therefore automatic, but trapping is not practicable in the case of a right-hand running junction. With the overlaps as shown in Fig. 2:15 there would be no objection to signals 1, 2, 5 and 6 being automatically operated.

## LAYOUT OF SIGNALS AND TRACK CIRCUITS

### Double Running Junctions on High-Speed Lines

The exceptionally high standard of permanent way needed for the very high-speed trains now common on British Railways, has demanded the elimination of as many diamond crossings as is practicable and also single and double slip connections. Instead, single crossovers suitable for speeds of up to 113 km/h (70 miles/h) are now used in place of conventional running junctions. This has brought new problems, and additional cost to the signal engineer.

Fig. 2:16 shows the layout. The two long crossovers are replaced by three single crossovers. It should be noted that:

(a) The overall length of the crossing is greater, and this makes the location of signals more difficult if uniform spacing is to be maintained. On such a line the signalling is likely to be 4-aspect.

- (b) The running junction does not permit parallel movements.
- (c) The trapping feature on left-hand junctions is not possible unless an additional crossover for parallel movements were to be provided.
- (d) It is likely that 'swing nose' crossings will eventually become part of the layout, making the rails on the running lines continuous. These will require to be power operated as part of the crossover.
- (e) It provides a convenient point at which to commence or terminate wrong line working which is a facility which is increasingly required for the maintenance of high-speed track.

There is little doubt that this type of crossing will be a feature of all high-speed lines, and allowance will have to be made for them in signalling schemes.

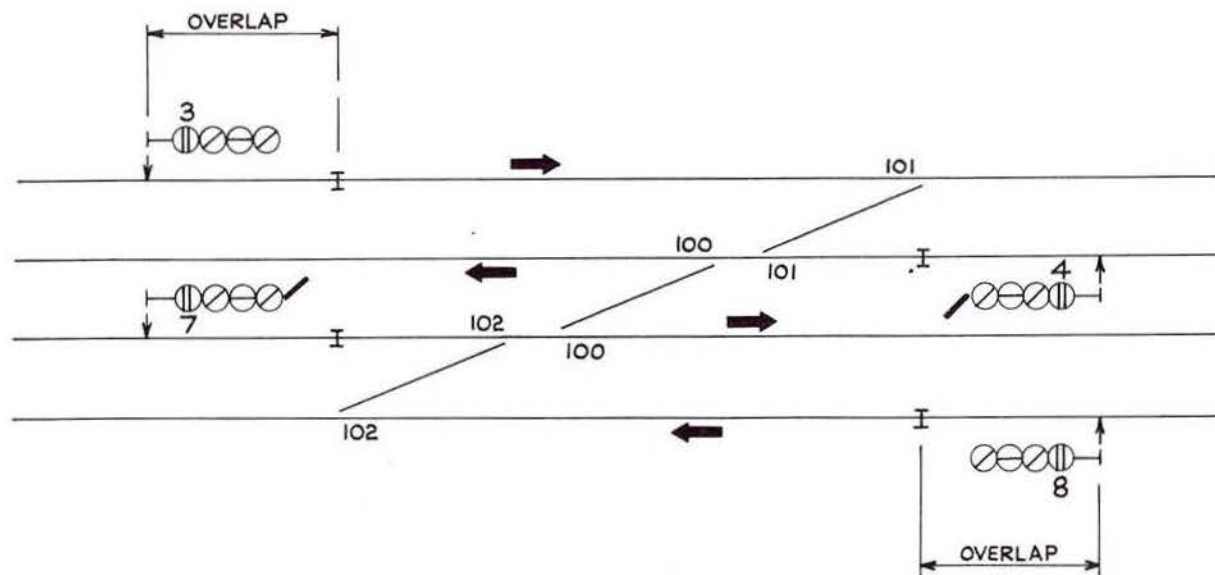


Fig. 2:16 Double running junctions on high speed lines

### Track Circuiting

In Chapter 4, some of the many types of track circuit are described, but at this stage the manner in which track circuiting is laid out to fulfil its functions for detecting the presence of trains is discussed and the usual arrangement of track circuiting is shown for various typical layouts.

Track circuiting must be so arranged that

- it detects that the route, over which the train is to pass, is clear of all vehicles;
- it detects that no vehicle is standing foul of the route;
- it permits 'parallel' movements of other trains when it is safe to do so;
- it permits the route to be released for the safe passage of other trains as soon as practicable;
- it determines the extent of the overlap at running signals;
- it enables the position of the front or rear of the train to be detected.

In the examples which follow, 3-aspect signalling is shown, but they apply equally to 4-aspect cases.

Fig. 2:17 shows how it is ensured that no vehicle is standing foul of the route along which a train is to pass. The track circuit joints are placed at the clearance (or fouling) points between the

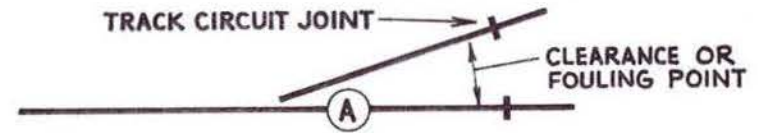


Fig. 2:17 Track circuiting at a divergence of two tracks

diverging lines. These are commonly known as 'six-foot' points but the overhang of certain types of vehicles over their wheels makes it necessary for the track circuit joints to be placed further out than the 'six-foot' clearance points. It is also necessary to make a similar allowance on sharp curves where the end of a vehicle may swing foul of the other track. Rules exist which take these two factors into account and lay out the precise position for the track circuit joints. In laying out track circuiting it is always assumed that the last vehicle has stopped immediately ahead of the track circuit joint. If the standing room ahead of the joint is tight, allowance may have to be made for the train 'easing back', particularly on a rising gradient.

Fig. 2:18 shows the arrangements at a crossover between two parallel running lines. Signal 10 when routed along the slow line will be controlled by track circuits A, B, C, and D 'clear'. Similarly signal 12 will be controlled by E, F, G, and H. When signal 10 is routed to the main line, it will be controlled by track circuits

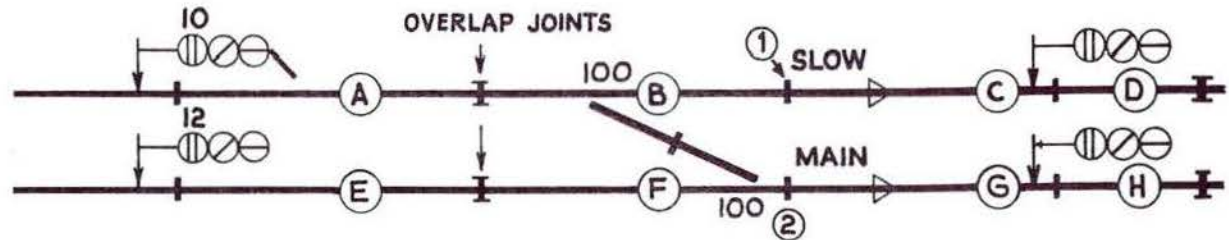


Fig. 2:18 Track circuiting at a crossover between parallel running lines

## LAYOUT OF SIGNALS AND TRACK CIRCUITS

A, B, E, F, G, and H. It is controlled by E so that in the event of an overrun past 12, signal 10 would be replaced to Red and a possible collision avoided. This control is known as 'flank protection'.

B and F exist as separate track circuits to permit replacement of points 100 (which they both control) for a following movement. Track circuit joints 1 and 2 exist for this purpose and enable the points to be moved from normal to reverse and *vice versa* immediately a train has passed, provided both track circuits are clear. There is no question of track locking distance in these cases as the points are overlap distance ahead of the signal.

Fig. 2:19 shows the complete track circuiting at a double junction. It has been discussed to a limited extent already (see Fig. 2:14 and text) but in this example, the junction splitting signal 8 is overlap distance from facing points 100. There is therefore no question of track locking distance for these points as previously mentioned. Track circuit A forms the overlap and if signal 8 had to be even further to the rear, A would move bodily with it. Track circuit B exists not only to control signal 8 but also to lock 100 points. It is terminated at joint 1, which is positioned at the clearance

point with the main line to allow following movements along the main line as soon as the train to the branch is clear.

On the main line B joins D which covers the diamond crossing. D must be a separate track circuit to permit simultaneous movements to and from the branch. It is terminated at joint 3, which also proves clearance for a movement from the branch after a train has passed along the main line. Joints 2 and 4 define the end of the overlap at signals 13 and 11 respectively. They could also be further to the rear if headway or braking distance required the signals to be moved back. Signal 8, when routed to the branch, will be controlled by (or will 'require') A, B and C clear, but in addition will require D to prove that the previous train along the main line is clear; but as D will be occupied during a movement, this control must be conditioned on 101 being normal.

Signal 13 will require F, D, G, H and J clear. It will not require B clear, because it also requires 100 reversed to form the trap against overruns. B is proved clear at this time, and movements are trapped thereafter. Flank protection is not therefore required from signal 8, but the requirement that G should be clear provides the flank protection from signal 11.

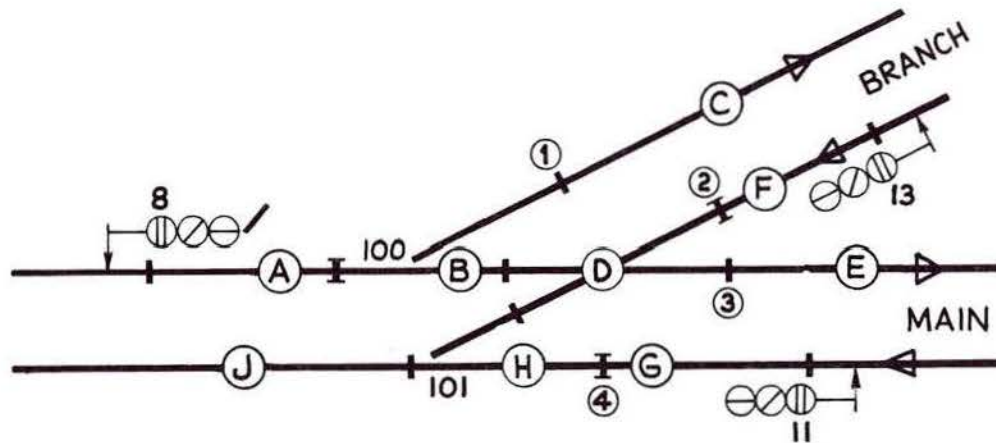


Fig. 2:19 Track circuiting at a left-hand double junction

Fig. 2:20 Track circuiting at a left-hand double running junction

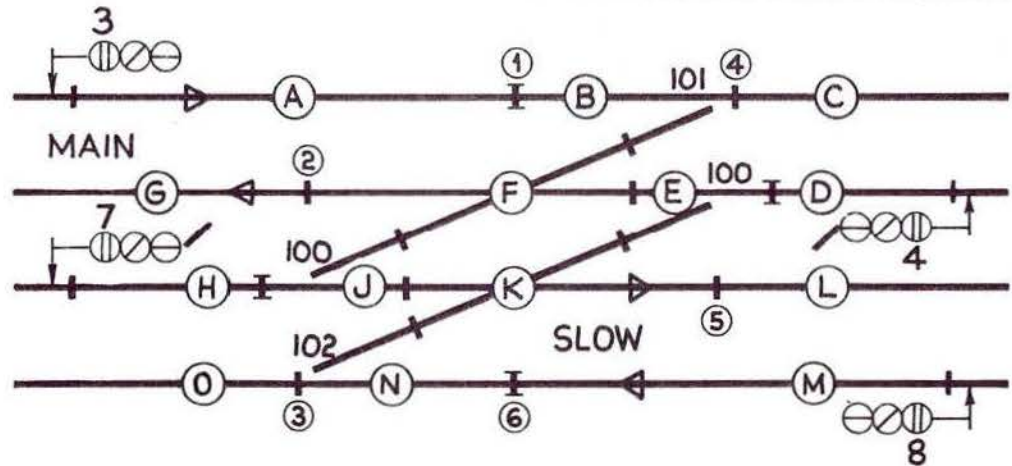


Fig. 2:20 shows the track circuiting at a left-hand double running junction.

As discussed on Fig. 2:15, the trapping on a left-hand double running junction is achieved by operating two sets of points together (in this case 100). Consequently, signal 7, when routed over 100 R, will require track circuits H, J, F, A, B and C clear. Track circuits E and K, which prove clearance, are proved during the reversal of 100 points. The controls on signal 4 will be similar.

When it is a matter of proving clearance, reliance is often placed on the movements of points requiring the particular track circuits clear. For instance, if, in Fig. 2:20, the previous movement along the slow line (with 100 normal) had resulted in part of the train remaining on track circuit K, the requirement to reverse 100 for a following movement from slow to main could not be met because, to operate 100 points, requires K clear.

**Subsidiary Signals and Associated Track Circuiting**

A subsidiary signal, which is mounted on the same post as, and below, a multiple-aspect signal authorises the driver to pass the Red aspect and draw ahead prepared to stop short of any obstructions. Unlike the multiple-aspect signal, which can display up to four aspects differentiated by colour, the subsidiary signal has only an OFF aspect which is differentiated by position. It is described (like the shunting signal) as a position-light signal. The OFF aspect consists of two White lights in the left-hand upper quadrant. There is no ON aspect because the instruction to stop is provided by the Red aspect in the main signal.

Three conditions govern the provision of subsidiary signals, namely:

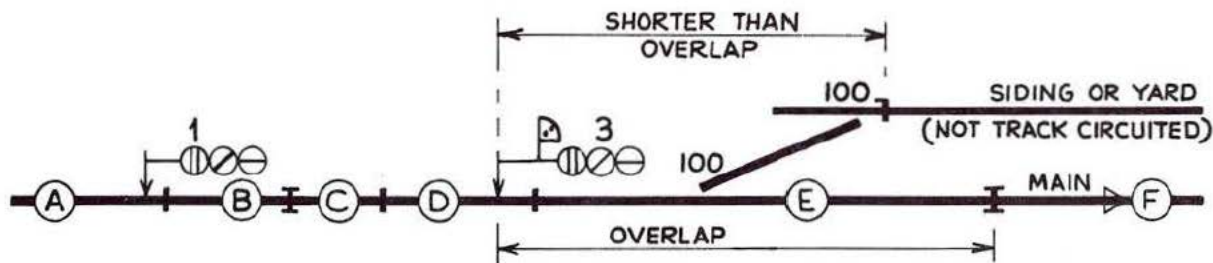
- (a) For direct entry to a siding or yard from a running line. Normally, no route indication is provided, but such may be needed in difficult cases.
- (b) For entry to an occupied platform. A route indicator exhibiting the platform number is provided.
- (c) For shunting purposes when, for instance, it is necessary to move a short distance ahead of the main signal to clear points in rear prior to setting back. No route indicator is provided in this case.

Subsidiary signals are approach released, by the occupation of the

approach track circuit until a calculated time interval has elapsed.

Fig. 2:21 shows typical signalling arrangements for routing a train from the main line direct into a siding or yard. In the case shown, the entry signal, 3, is closer than overlap distance from the clearance point at the far end of the siding connection. Thus, whilst a full overlap exists on the main line, it does not exist when 100 points are reversed for the movement to the siding.

Assume that a train is approaching signal 1 and 100 points are reversed, either from a previous movement or because the route to the siding has been set. A delayed Yellow approach is needed because only a short overlap exists ahead of signal 3. Thus, the train will be checked at signal 1 until it is at, or nearly at, a stand. Signal 1 will then clear and the train will proceed towards signal 3 where it must be checked again because the siding entry points must be passed over at low speed. A 'timed-out' occupation of track circuit D must then elapse before subsidiary signal 3 clears, thus causing the driver to reduce speed. The train then proceeds into the siding where it will come under the control of a shunter. There is always a risk that, so long as 100 points remain in the reverse position, vehicles in the siding may be accidentally propelled on to the main line and therefore the signalman should always normalise the points by the use of the individual point key as soon as the train is in the siding clear of the points. There is however no compulsion on him to do this. In special local conditions (e.g. gradient) the points would be restored to normal automatically.



**Fig. 2:21** Subsidiary signal at entrance to siding or yard

**Fig. 2:22** Subsidiary signal at entrance to occupied platform (simple case)

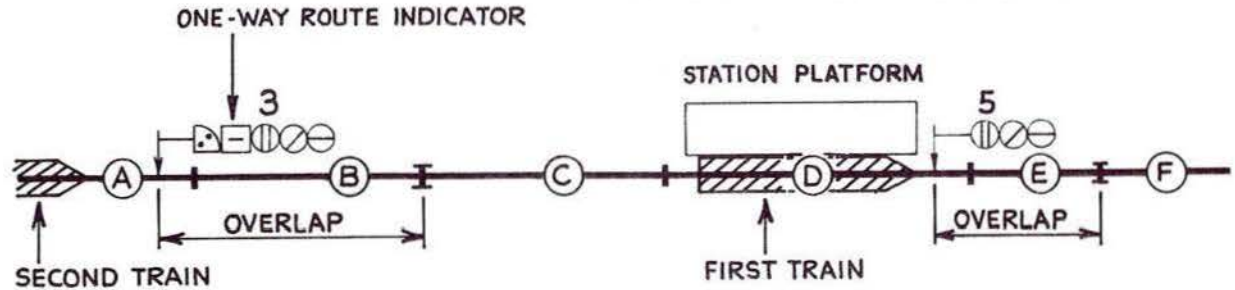
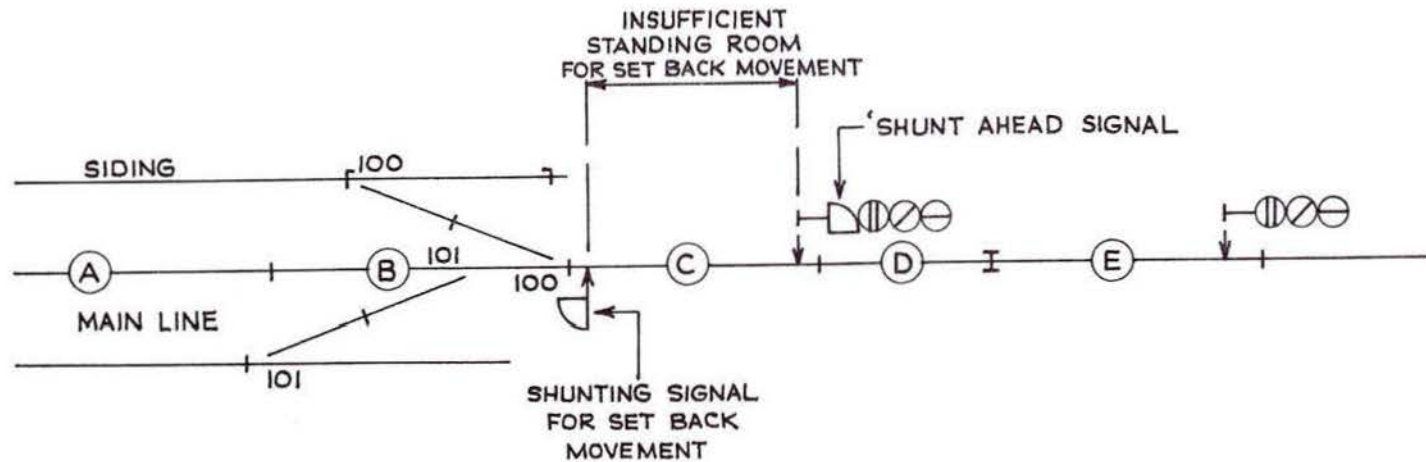


Fig. 2:22 shows a simple case of the use of a subsidiary signal for routing a train into an occupied platform at an intermediate station. The subsidiary signal requires track circuit D occupied and a timed-out approach control on track circuit A. In this case, a route indicator is required purely to differentiate it from the case where 'shunt ahead' conditions apply.

Fig. 2:23 shows the case where a subsidiary signal, without route indicator, is used to indicate to the driver that he must draw ahead sufficiently to enable the train to set back over a trailing connection. Where such movements are rare a subsidiary signal is sometimes not provided, on the assumption that the driver is aware of the move he has to make.



**Fig. 2:23** Subsidiary signal as draw-ahead for setting back into siding

## LAYOUT OF SIGNALS AND TRACK CIRCUITS

### Shunting Signals and Associated Track Circuiting

The practice of British Railways is to provide signals for all shunting movements so that hand signalling is confined to abnormal situations and emergencies. Shunting signals are of the position-light type. The ON aspect consists of one Red or Yellow light and one White light horizontally displaced. The OFF aspect is identical with that of the subsidiary signal, that is, two White lights at 45° in the left-hand upper quadrant; the lower White light being common with the ON aspect.

Shunting signals are provided in the following circumstances:

- (a) for setting back from the running line into sidings over trailing connections;
- (b) for movements from one running line to another over trailing crossovers;
- (c) for exit movements from sidings;
- (d) for movements in the facing direction where the provision of a signal would reduce the length of a shunting movement.

Shunting signals are not normally fitted with route indicators because they apply only as far as the line is clear, and because the driver is aware of the movements which are to be made, either by instruction from the signalman (probably by telephone) or a shunter.

The track circuiting is arranged on the assumption that, during shunting operations, trains or motive power units will always move to the approach side of another shunting signal or a main signal.

The pattern of traffic on British Railways has changed in recent years. There is now a preponderance of multiple unit stock or, like the HST, the motive power unit forms part of the train and is permanently coupled to it. Push-pull working is also used on certain Regions. The use of 'block' freight trains, such as the freightliner, is now common. This has reduced the movement of single motive power units considerably, and with it has greatly lessened the need for engine lay-by sidings. The movements of isolated freight

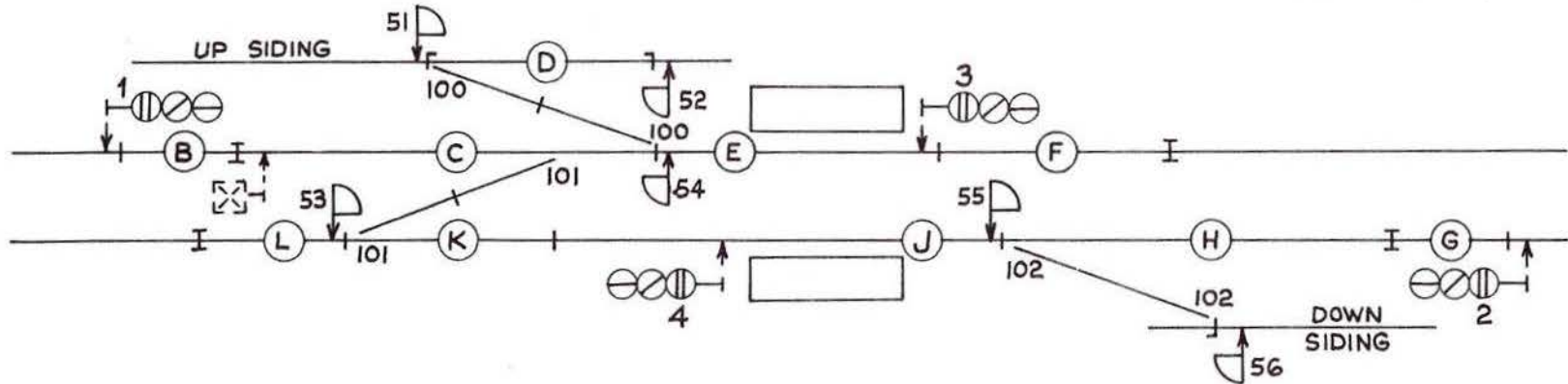
wagons has also been reduced, although at certain stations it is still necessary to make provision for vehicles to be attached to the head or tail of a train standing in a platform. All this has resulted in the simplification of permanent way layouts, and in a general reduction in shunting movements. In general, however, the provision of shunting signals is linked to the layout rather than to the shunting movements made.

Fig. 2:24 shows a number of typical cases of the provision of shunting signals at an intermediate station layout. The table on Fig. 2:24 shows the routes over which the shunting (or shunt) signals apply.

Note that 54 may be routed to either the down line or to the up siding, but not to the up line. If this latter movement were required, a 'limit of shunt' sign would be provided at a suitable distance along the line as shown dotted. A 'limit of shunt' consists of a framed square of frosted glass bearing those words, and it is illuminated from behind at night.

It should be noted also that shunt signal 53 applies to the up line, or to the down line up to 55. Sometimes, according to the regular movements at the layout, 53 also requires 55 to be OFF to ensure that there is no possibility of an overrun along the down line in the wrong direction. If the up line end of points 100 and 101 were more than say 125m apart, a separate shunt signal would often be located at 101 to reduce the length of a movement (and reduce the time taken) along the up line to reverse over 101 and proceed to the down line.

A further point to consider is the position of the joint between track circuits J and K. If there is sufficient standing room at 55, this joint might be left in its usual position about 20m ahead of signal 4. If, however, there is not sufficient room, or there is any doubt, it would be placed at the fouling point of 101 as shown. In this connection, it will now be appreciated that a train standing at 55, waiting to enter the down siding, could, if long enough, also occupy track circuit K and 101 could not be reversed for another movement. It should also be noted that in the position



shown, signal 4 will not be replaced to Red until the train reaches the fouling point of 101 points.

If shunting within the up sidings results in vehicles having constantly to occupy track circuit D, passing signals 51 and 52 in the process, consideration should be given to making 51 applicable through 100 points normal (this is shown in the table), and relinquishing the usual locking between 51 and 52, this allowing both signals to be OFF at the same time. This has the advantage that the driver of the shunting engine is not continually having to pass the signals at Red. Such movements would be under the control of a shunter; this man would be responsible for seeing that the siding is clear for incoming trains, having previously been advised on the telephone by the signalman at the Control Centre. If there is insufficient standing room between 3 and 54 signals, a subsidiary would be added to signal 3.

Shunt signals, which when ON display a Yellow light, are generally situated at siding outlets where there is a short overrun. They may be passed, when ON, for movements in the direction (for example towards the overrun) for which the signal when cleared does not apply.

ROUTE	REQUIRES POINTS
51	A 100N.
	B 100R. 101N.
52	100N.
53	A 101R. 100N.
	B 101N.
54	A 100N. 101R.
	B 100R. 101N.
55	102R.
56	102R.

Fig. 2:24 Shunting signals and associated track circuiting

### Signalling and Track Circuiting at a Terminal Station

There are two important factors which must be taken into account when designing the signalling at a terminal station, namely:

- (a) The line capacity in the station area must be at least twice the line capacity on the tracks approaching and leaving the station.
- (b) The approach and departure speeds may be restricted to less than the maximum permissible speed of the track by the signalling requirements of the local suburban service.

The location of signals in the neighbourhood of a city terminal is often hampered by local siding and depot connections, intersections with other lines, tunnels and so on. In the result, what may appear to be a relatively simple problem may prove less easy than was thought. The platform entry signal should be located as close to the platform as the overlap and layout will permit. In view of the restricted and reducing train speed approaching the terminal, a limited overlap may be acceptable although with all overlaps at 183 m (600 ft) there is now less difficulty in siting these signals.

In the departure direction, the signals next ahead of the platform starting signals should be at minimum distance having regard to standing room. This will ensure that there will be the greatest possibility of the platform signal displaying a Green aspect for departing trains, and thus avoiding slow running in fog. Braking distance need not be considered as the train is starting from rest.

At the platform entry signal, the aspects displayed are Red and Yellow; the latter when the platform is clear to the buffer stops where there is a Red 'stop' lamp which is not proved to be alight before the main signal can be cleared, thus maintaining the correct aspect sequence of Yellow to Red. There are some existing installations where the entry signal displays a Green aspect when the platform is clear and a Yellow aspect when the section nearer the buffer stops only is occupied. These arrangements will disappear in the course of time. A subsidiary signal is therefore necessary in such

cases as the entry signal for draw-ahead movements into occupied platforms, together with a multi-lamp route indicator which is common to both signals.

It will be appreciated that if the signalman should route a train into an occupied platform where there is insufficient room for it, serious traffic delay could result since both incoming and outgoing traffic may be blocked until the train is moved; an operation which may involve hand signalmen for both the trains concerned and possibly for a following incoming train.

To assist the signalman, the platform track circuit is divided in all but the shortest platforms, thus giving some indication of the room available for further vehicles. For normal length platforms two track circuits are provided.

The track circuit nearer to the buffer stops is as short as practicable but of sufficient length to accommodate the maximum number of vehicles which may in normal working be in the platform when it is necessary for further vehicles, exceeding two, to enter.

In a short platform, only one track circuit is necessary if no more than two further vehicles will be required to enter.

The significance of 'two vehicles' is that it corresponds to the length of two locomotives, allowing for double heading. A short track circuit, equivalent in length to two locomotives (or two vehicles) is provided at the entry signal to measure the length of the incoming vehicles after both platform track circuits are occupied, thus ensuring that even if the platform is completely full, a mistake is confined to no more than two vehicles.

Fig. 2:25 shows typical signalling at a terminal station and the table shows the track circuit controls for entry to platforms 4 and 6. These are typical. The method of working multiple unit stock is as follows. Normally the shorter off-peak trains will occupy the track circuit nearer to the buffer stops. When it is necessary to lengthen trains for the peak service, the additional units are coupled in the platform after entering with the draw ahead signal, and thereafter the whole train works as a single unit in and out of the platform with the main signals.

LAYOUT OF SIGNALS AND TRACK CIRCUITS

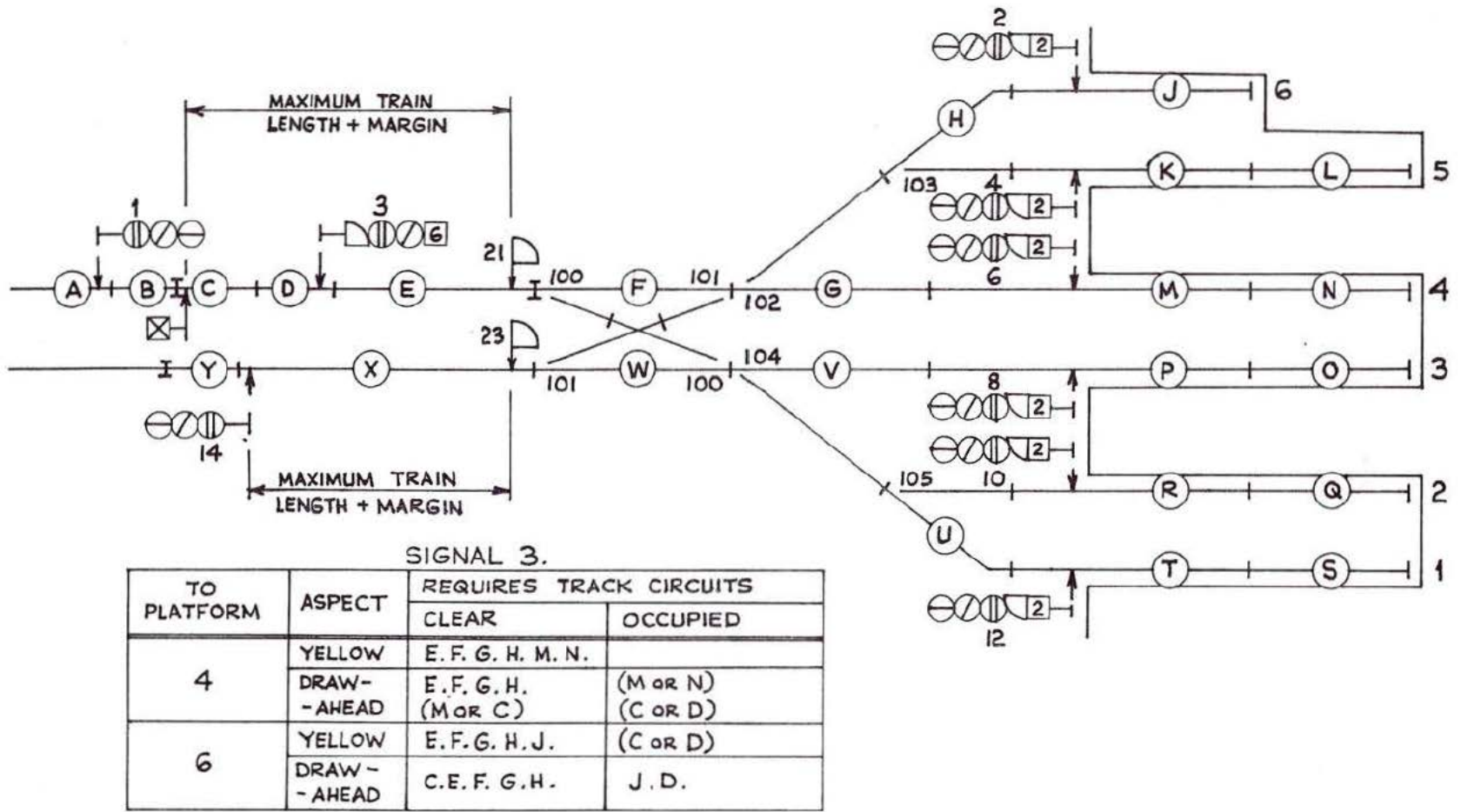


Fig. 2:25 Signalling and track circuiting at a terminal station

## LAYOUT OF SIGNALS AND TRACK CIRCUITS

Locomotive-hauled stock will be drawn into the platform and the yard locomotive will be uncoupled. Such trains will usually occupy most of the platform, leaving room for the train locomotive(s) at the starting signal end.

When this arrives at the entry signal, it will be 'measured' by the draw-ahead signal requiring track circuit C clear and D occupied before it will clear. If, however, it becomes necessary to signal more vehicles than two into the platform, the signalman has an override button on his control panel which, when pulled, allows the route to be set and the draw-ahead signal to be cleared under shunting conditions, that is, without route indications, for one movement only. The draw-ahead signal is always approach released, but main signal is normally free to clear when the route is set, unless it is set to a short platform (such as platform 6 in Fig. 2:25) or there is a particularly sharp curve.

In the outgoing direction, the 3-aspect platform starting signals have only one route—to the outgoing line up to signal 14. Draw-ahead signals must, however, be provided under each main starting signal, for any shunting movements needed for moving rolling stock, or locomotives, from one platform to another, or for movements directly to a motive power depot or carriage sidings. These movements may involve a preliminary movement on to the wrong (i.e. incoming) line. A 'limit of shunt' signal must therefore be provided on this line as shown. To avoid such movements being shunted further than necessary, a facing shunting signal (21) is provided on the incoming line. Another shunting signal (23) is also necessary for setting back into the platforms from the outgoing line.

So far as track circuiting is concerned, it will be noted that in the 'switching' area of the layout, track circuits have been so arranged that points are cleared as quickly as possible to enable other movements to be made with the minimum of delay. As stated earlier, it is important that line capacity should be as high as practicable in this area.

The 'limit of shunt' shown in Fig. 2:25 allows standing room from the entry signal. It is not strictly necessary to locate it so

far out, because normal shunting movements to the wrong line would stop when the last vehicle is just on the approach side of the set-back shunting signal (21). There is no disadvantage in the increasing standing room, provided there is at least 46 m (150 ft) overrun to the overlap at signal 1. For example, if the speed at signal 1 were only 97 km/h (60 miles/h), the braking distance from the braking curve would be 622 m. The margin available with a 350 m train would be  $622 - 350 - 183 - 46 = 43$  m, which is ample, bearing in mind that it is a slow speed movement.

The margin on the outgoing line between signal 14 and shunting signal 23 should be greater, because the speed will be higher. A reasonable allowance would be 100 m, which would make the overall standing room  $350 + 100 = 450$  m.

### Junction Signalling

This subject has been mentioned earlier in considering the layout and spacing of signals, but it needs to be discussed in detail. The route indication at running junctions having a turnout speed in excess of 64 km/h (40 miles/h) is the 5-light junction indicator which does not normally display an indication for the high-speed route, irrespective of whether or not this is regarded as the main route.

Each route indication consists of a line of five lunar-White lights inclined at  $45^\circ$ ,  $90^\circ$  or  $135^\circ$  from the vertical to the left or right for the first, second and third routes respectively as required. The construction is described in Chapter 4. Where there is no difference in maximum speed between the routes at a junction, and none can be designated as the 'straight' route, a junction indication is provided for each route.

The use of the junction indicator simplifies the signal aspects displayed at a junction, because there is only one multiple-aspect signal; and for the high-speed route, with the exception mentioned in the preceding paragraph, there is no difference between the splitting signal and any other. Since the junction indication is not displayed for the high-speed route, it will be appreciated that it must be

proved alight before the multiple-aspect signal can clear for a move over the junction. At least 3 of the 5 lamps must be alight before the signal clears.

Formerly, it was considered that the distance at which the junction indication could be clearly discerned was 366 m (1200 ft), but a new type now being introduced by British Railways has a range of 732 m (2400 ft) and, in what follows, it is assumed that this type is in use.

Originally the semaphore signalling practice of separate signals for each route at a junction was adopted in multiple-aspect signalling. The signal for the turnout was, however, approach released to avoid the complication of splitting distant signals to which the drivers had become accustomed in semaphore signalling. It needs little imagination to visualise the complication that would have resulted if the practice of using splitting distant signals had been perpetuated in 4-aspect signalling, although from time to time attempts were made to solve particular problems in that way. Fortunately this is now history, and British Railways have stated unequivocally that splitting distant signals are no part of the modern multiple-aspect signalling system.

In effect, approach releasing is a form of speed signalling, in that it enforces a speed reduction by controlling the signal aspects by track circuit occupation. Speed measurement is no part of the system, and the approach releasing is the same for all types of train passing over the junction. In practice, however, the driver knows that the braking distance between the first caution and the Red aspects is suitable for the highest permissible speed at that point, and knowing the route, and knowing his own speed, he is able to make a sensible judgment of the point at which a brake application should be made. He is backed up by the Automatic Warning System, discussed in detail later, which makes an automatic but cancellable brake application at every caution aspect.

It was about the year 1935 that the junction indicator was introduced, and since then 'geographical' signals at junctions have been gradually abolished.

Figs. 2:26(A) and 2:27(A) show one form of aspect sequences and approach releasing which is standard practice under certain conditions on British Railways.

Reference may now be made to Fig. 2:26(A) assuming that a train is approaching signal 1, which is displaying a Green aspect. It is assumed also that the route over the junction has been set. The junction splitting signal will be at Red, because it is approach released when the points are reversed. The driver will therefore initiate a brake application as he approaches signal 3, which is displaying a Yellow aspect, on the assumption that he is required to stop at signal 5. After passing signal 3, the timing-out of the approach release will commence on the occupation of the approach track circuit to signal 5 (the overlap track circuit may be included, depending on the distances involved) and at about 700 m from the signal, it will then clear to Yellow with a junction indication (45° to the left in this case). It is important that, at this point, the driver should be able to see the junction indicator as well as the Yellow aspect, since reliance is placed on the driver's knowledge of the maximum permissible speed over the junction. If he cannot see it, the approach release must be further delayed until he can. Finally, after having received the audible warning from the AWS equipment as he passes over the inductors, the junction signal may change to a Green aspect subject to conditions ahead, if it is operationally justified. The distance between the AWS inductors and the junction signal is so short, however (less than 183 m), that little if any operational advantage can derive from stepping up the aspect at this point. Much depends on the speed and the alertness of the driver. From the signal engineer's point of view there is little objection. During the time the junction signal is at Red or Yellow, the signal ahead is maintained at Red to avoid the possibility of the driver 'reading through' the junction signal aspect.

Fig. 2:27(A) shows a similar set of conditions in a 4-aspect area. In this case, when the junction signal is approach released from Red (after timing-out) it is permissible (unless the junction speed is low) to allow the aspect to step up to 2-Yellow and, after receipt



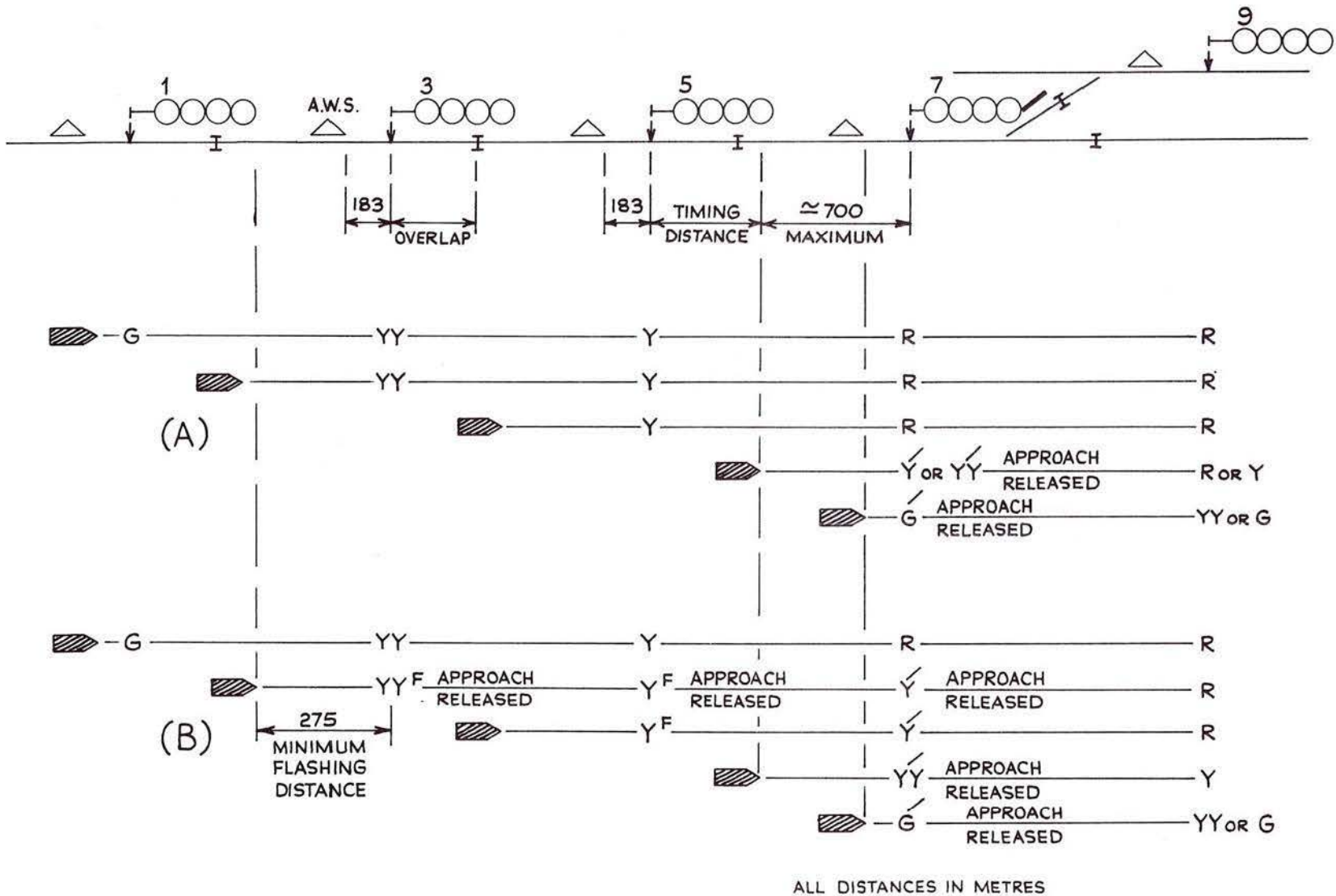


Fig. 2:27 4-aspect junction signalling

## LAYOUT OF SIGNALS AND TRACK CIRCUITS

of the AWS caution indication, to Green if conditions ahead permit.

The introduction of high-speed trains with better braking characteristics has shown that approach releasing as described above results in time being lost, because speed may be reduced by too much and too quickly after sighting the Yellow or 2-Yellow aspects. Furthermore, an unnecessary speed reduction by this type of train is costly in fuel and brake block wear. It was apparent that a scheme of aspects and approach release needed to be devised which would advise the driver that the junction route was set, and that his speed reduction was not required to be lower than the maximum speed over the junction points.

An operational improvement might have been possible in 4-aspect areas by approach releasing the signal ahead of the junction so that, when the route was set, the junction signal immediately displayed a Yellow aspect with junction indication. The signal next in rear would then display a 2-Yellow aspect, at which point the driver would make a brake application with the object of stopping at the signal ahead of the junction, although at that time he would not know that the train was to be diverted from the straight route. However, the brake application would so reduce the speed that only a comparatively small adjustment of speed after sighting the junction indication would be required to pass over the junction points at or below the maximum permitted speed.

This method is unfortunately unacceptable for high-speed trains because the high braking performance might mean little, if any, speed reduction between the 2-Yellow and Yellow aspects. Then when the Yellow aspect and junction indication were sighted the distance remaining would be too short to enable a sufficient speed reduction to be made for the junction to be negotiated safely.

In 3-aspect areas, the train would be too close to the junction before the junction indication was sighted by the driver to allow the speed reduction to be made, even in clear weather. In fog, the situation would be much worse as the Yellow aspect and junction indication would only be seen by the driver just before the signal was passed.

In both cases, if the points were some distance ahead of the signal, the speed reduction might be sufficient, but it is generally accepted that the junction indication would be seen too late for comfort and would be disliked by the drivers.

British Railways decided that if the speed reduction over the junction was not greater than about 60 per cent of the maximum speed on the straight route, a system of flashing Yellow aspects should be added to the basic aspects to give this information to the driver in time to prevent an unnecessary speed reduction.

It was decided that if the permissible speed over the junction points is not less than

- (a) 80 km/h (50 miles/h) irrespective of the straight route speed; or
- (b) 64 km/h (40 miles/h) where the straight route speed is less than 161 km/h (100 miles/h); or
- (c) 48 km/h (30 miles/h) where the straight route speed is less than 129 km/h (80 miles/h),

the junction signal could display an unrestricted Yellow aspect (with junction indication) and the signal next in rear could then display a flashing Yellow aspect. In a 4-aspect system, the signal in rear of the flashing Yellow could display a flashing 2-Yellow aspect. Furthermore, the junction signal in 4-aspect signalling could be approach released (by timing out) to 2-Yellow after passing the signal in rear.

These principles are illustrated in Figs. 2:26(B) and 2:27(B) for 3- and 4-aspect signalling respectively. For reference purposes in this book, the system has been termed the Basic/Flashing Yellow aspect sequence to distinguish it from the basic aspect sequence.

Referring now to Fig. 2:26(B) and assuming the train to be approaching signal 1, which is at Green, and the route has been set, signal 5 will be at Red and signal 3 at Yellow. After the train has passed signal 1 and occupied the approach track circuit to signal 3, the junction signal will clear to Yellow with the junction indication

and signal 3 will commence to flash. The driver now knows from the flashing aspect displayed by signal 3 that the route has been set, and the junction signal is clear, and he adjusts his speed accordingly. No further aspect change occurs until the front of the train passes over the AWS inductor at the junction signal, when the aspect may change to Green as previously described.

The reason for not displaying the flashing Yellow at signal 3 until the train is approaching it is to limit the period of flashing and thus conserve lamp life. This however is not mandatory, as lamp life is also conserved by not reducing the lamp current to zero during flashing. Where there are two or more diversions at a junction, the diversion having the highest permissible speed is the only one to which flashing aspects are applied. If two or more diversions have equal (and the highest) diversionary speeds, flashing aspects are provided.

If the junction is not set, until the train is approaching signal 3, the flashing must be displayed at a minimum distance of 275 m (900 ft). If the distance is less, it is inhibited because it is possible that the signal aspect may not flash for a sufficiently long period to be noticed by the driver. In these circumstances, the junction signal remains at Red. If the flashing of the Yellow aspect at signal 3 fails and the aspect remains steady, the junction signal returns to Red and is again approach released from that aspect. This avoids the aspect sequence becoming Yellow-Yellow-Red. In these circumstances it will be appreciated that the junction signal will be approach released from Red.

Fig. 2:27(B) shows the 4-aspect case. There is no difference in principle between this and the 3-aspect case. The flashing 2-Yellow aspect, however, is not proved and if the flashing fails at that signal, aspects in other signals do not return to their original state. Consideration will show that the aspect sequence would be acceptable.

There are some layouts where two or more junctions in succession may require variation in the aspects to be displayed by the signal at the first junction, and beyond; but if the principles described above are applied it will be found that a satisfactory system of

aspects can be devised. It may be found that, in certain cases, the use of a junction indicator is not possible, due to local constructional limitations, or because the number of routes to one side or the other exceeds the capacity of the junction indicator. In such cases, provided that the maximum speed over the straight route exceeds 64 km/h (40 miles/h), a multi-lamp ('theatre') type may be used subject to:

- (a) no indication being given with the main aspect for the straight route;
- (b) the route indication being proved to be displayed before the signal can be cleared for a route for which an indication is required; and
- (c) the maximum speed over any of the turnouts to which the route indicator applies not exceeding 64 km/h.

If all routes at a junction are subject to speed restrictions of 64 km/h or less, including the straight route, a multi-lamp route indicator displaying an indication for every route may be used. It is not necessary, in these circumstances, to prove that the route indication is alight before permitting the signal to clear. Where a multi-lamp route indicator is used, it is important that precautions should be taken to ensure that a mutilated indication cannot be exhibited, which could be misread for another route.

### Conclusion

In this chapter the reasoning which lies behind the various elements of a signalling scheme have been made clear. At the same time it is important to appreciate that a complete signalling scheme for a particular locality in Great Britain cannot be prepared without access to, and full understanding of the *British Railways Rule Book*, and the Block Telegraph Regulations, while close attention would have to be paid to various Appendices to the working timetable which applies to the locality involved.

## The Principles of Interlocking and Controls

The words 'interlocking' and 'controls' are traditional. They derive from semaphore signalling where there was a mechanical interlocking lever frame to which electrical lever locks were added. These were electrically controlled by track circuits and the block telegraph. In a modern route installation with a signalling control panel from which the signalling system is operated, 'interlocking' in a sense could be called 'control'. The words 'locked by' and 'controlled by' are now almost synonymous and both will be replaced by the word 'requires'. In this chapter the principles adopted by British Railways for the control of functions are set out. It will be found that these are identical, except in some details, with the signalling principles of any other railway administration. The differences will be found to lie mainly in the methods of achievement.

### Panel Operation

British Railways have standardised on an entrance-exit system of route operation for its signalling control panel. The reasons which lay behind this decision were:

- (a) to reduce the physical work load of the signaller and thus enable him to control a greater area;
- (b) to enable the signaller to concentrate more on the movement and regulation of trains;
- (c) to minimise the size of the signalling control panel in view of the greatly increased area to be operated from one central point.

The train berth type of train describer was an essential feature of the greater area of control but tended to lengthen the panel, and so a smaller (but still clear) type of diagram had to be adopted at the same time.

There were several route operating systems already in existence on British Railways from which a selection could be made. It was, however, considered to be an essential feature of route operation that the signaller should not have to remember the number or identification of each route but, in setting up a route, go straight to the panel and operate it. The push-push type of entrance-exit working best fulfilled this requirement and had the advantage that a minimum of panel area was required.

Fig. 3:1 shows the main operating features of this control panel and the method of displaying the essential indications. Route setting is effected by pushing a button adjacent to the signal symbol at the entrance to the route required followed by the pushing of a similar button at the exit end, generally also adjacent to a signal symbol. These buttons are spring-loaded and return to the central (or normal) position whether they are pushed or pulled.

When an entrance button is pushed, all exit buttons in an associated network cease to be effective as entrance buttons until one of them has been operated as an exit button for the entrance button already pushed. The remainder are then again available as entrance or exit buttons for other routes.

The entrance button, when first operated, flashes White to indicate that it is waiting for an appropriate exit button to be pushed. The light becomes steady when a suitable exit button is pushed. It remains so until it is pulled and released to release the route.

After the entrance and exit buttons have been pushed the route will be set up. This will be apparent to the signaller by the appearance of the route lights (along the route) and (unless approach released) by a Green indication in the signal symbol which had previously been Red.

The route which has been set will remain locked and can only be released when the approach locking conditions have been fulfilled.

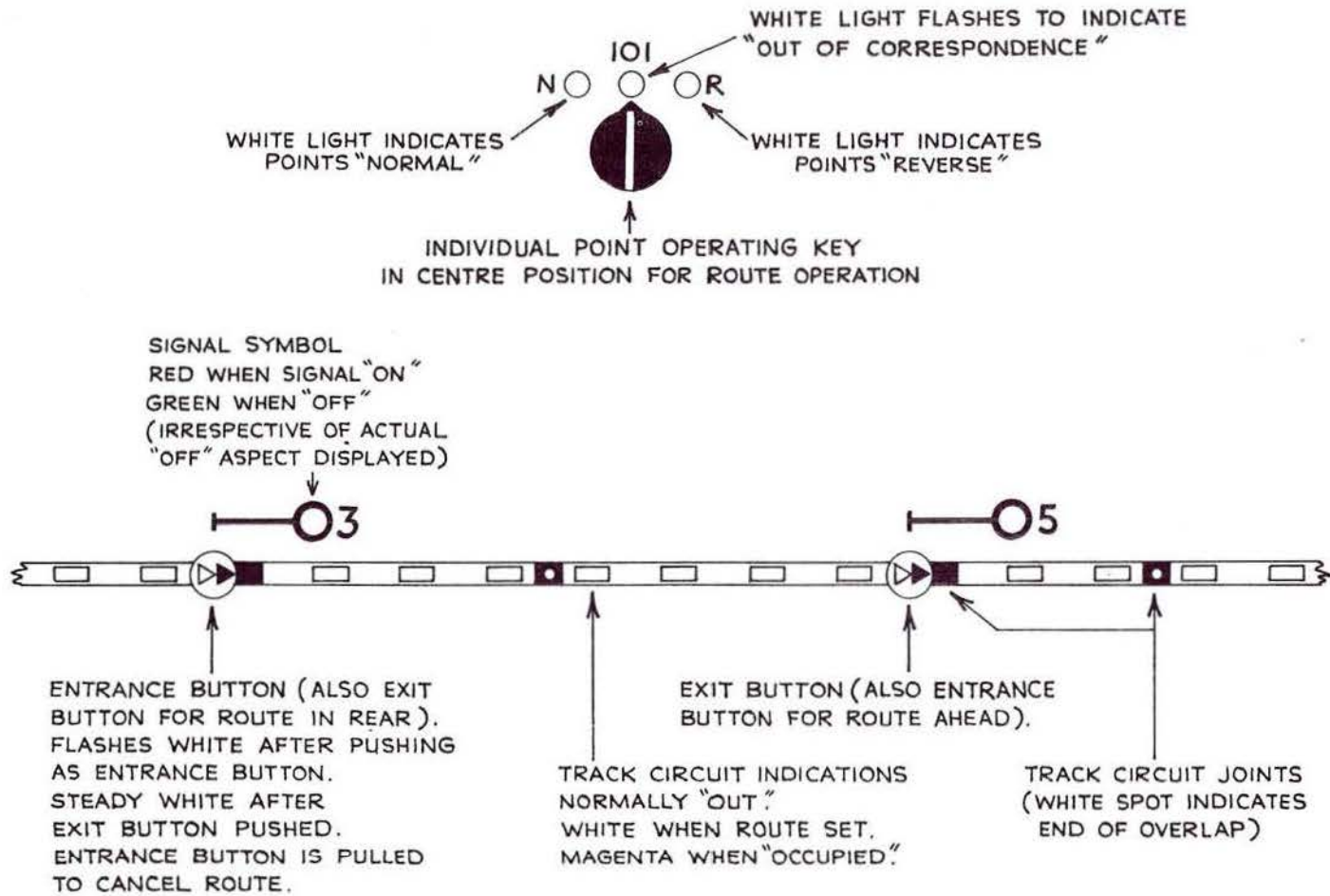


Fig. 3:1 Main features of signalling control panel

## THE PRINCIPLES OF INTERLOCKING AND CONTROLS

If the signal did not clear because it was approach released or because of circuit or other failure, the route may be released immediately by pulling and releasing the entrance button.

The purpose of approach locking is to prevent release of the route which would permit the setting of another when the approaching train is so close to the signal that the driver is unable to prevent an overrun. This means that the train must be at least braking distance on the approach side of the signal. Approach locking may be 'comprehensive', that is, by the occupation of track circuits from braking distance in rear, or by time. In the latter case, provided the signal clears, approach locking is effective for a specified time after the entrance button has been pulled, generally 2 minutes for a main signal or 1 minute for shunting signals.

Once the train has passed the signal which has returned to Red, the route may be released by pulling the entrance button, but the points ahead in the route will remain held either by direct track circuit locking or by route locking, as described later, and no conflicting route may be set until the train has cleared the points concerned.

There are other facilities on the panel for the assistance of the signalman which will be described later; notably the ability to be able, by operating a button adjacent to some signal symbols, to cause the signal concerned to work automatically.

### Numbering of Signals, Points and Routes

None of the careful consideration necessary in the numbering up of a mechanical interlocking lever frame applies to the layout on a signalling control panel, but if a little care is taken, wiring and cabling in the relay room may be minimised. It is helpful if each type of function is numbered in a distinctive series, so that the number gives a clue not only to the type of function but also to its geographical location.

It is usual to number signals with odd numbers in one direction and even numbers in the other. Main signals, including subsidiaries, would be numbered in one series, say 1 to 100, and shunting signals

in another, say 201 to 300. Points would be numbered in another series, say, 501 to 600.

Within each series, blocks of numbers will be reserved for remotely controlled installations so that they, too, may be easily recognisable.

Each signal will therefore bear a single number but the routes to which it applies will be lettered, beginning with A for the left-hand route and continuing in a clockwise direction. A main signal, carrying a subsidiary, will be designated 1(M)A, 1(M)B etc. and the subsidiary 1(S)A, 1(S)B etc. If either signal does not apply to a particular route, it is left out, but the same route letters apply. A main signal without subsidiary does not carry the designation (M).

### Main Signal Controls

Considering the controls in more detail, the following conditions must be met before a main signal is permitted to display a clear aspect.

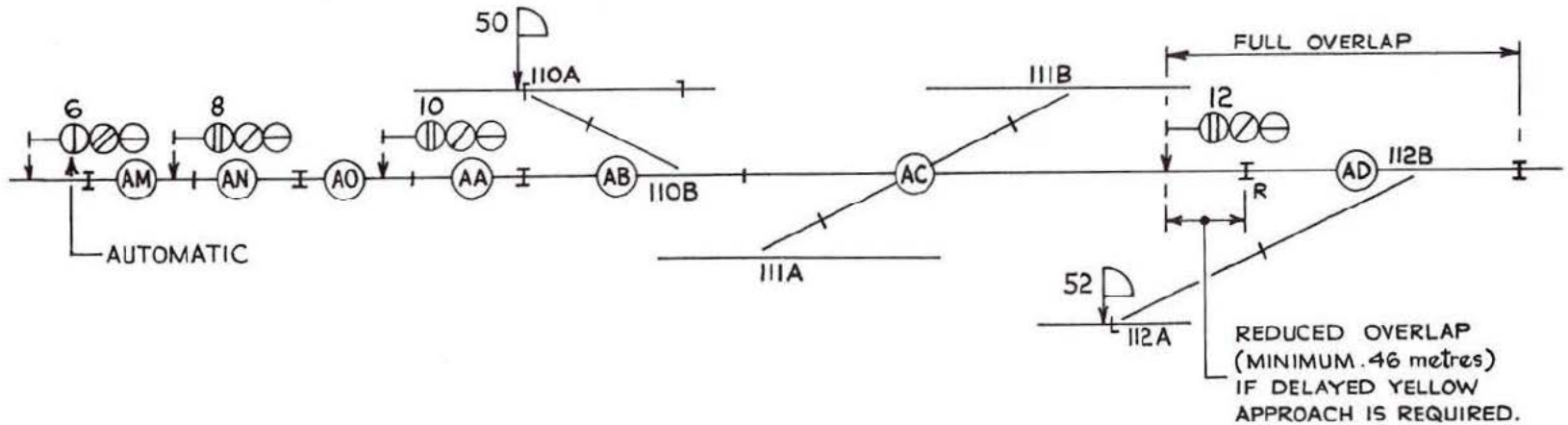
- (a) All track circuits must be clear between the main (entrance) signal and the main (exit) signal next ahead.
- (b) Track circuits in the overlap immediately ahead of the exit signal must be clear unless delayed Yellow aspect conditions apply.  
(In the case of automatic signals a separate overlap track circuit may not be provided.)
- (c) Track circuits forming flank protection against overruns past the entrance signal of conflicting routes must be clear.
- (d) Track circuits on which vehicles could stand foul of the route must be clear.
- (e) All points in the route between entrance and exit signals must be set, locked and detected in the correct position.
- (f) Trailing points in the overlap at the exit signal must be set, locked and detected normal unless delayed Yellow aspect conditions obtain.

- (g) Points which trap conflicting movements or overruns or otherwise give flank protection to the route must be set locked and detected in the correct position.
- (h) Facing points in the overlap at the exit signal must be detected normal or reverse, but if delayed Yellow aspect conditions obtain such detection must be bridged out during a movement of the facing points.
- (i) Facing shunt signals, if any, in the route must be proved to be OFF. (Such signals will not require to be separately operated for a main route.)

#### THE PRINCIPLES OF INTERLOCKING AND CONTROLS

- (j) The exit signal must be proved to be alight.
- (k) The entrance signals of directly opposing routes must be proved to be at Red.
- (l) Approach release track circuits, where applicable, must be proved occupied or the associated timing-out feature to have operated.
- (m) The approach locking must be proved to be in operation.

THE PRINCIPLES OF INTERLOCKING AND CONTROLS



ROUTE	REQUIRES TRACK CIRCUITS		REQUIRES POINTS		REQUIRES SIGNAL ALIGHT
	CLEAR	OCCUPIED	NORMAL	REVERSE	
10	AA. AB. AC. AD.		110. 111. 112.		12.

ALTERNATIVE IF DELAYED YELLOW APPROACH IS REQUIRED

10	AA. AB. AC. (AD OR 112R).	(AO [ATR] OR 112N)	110. 111.		12.
----	------------------------------	-----------------------	-----------	--	-----

Consider the application of the above to signal 10 in Fig. 3:2. Note first the suffix A or B to the point numbers. The convention is that the A end is nearer to the Control Centre or local relay room than the B end. It is not usual to add the suffixes on signalling diagrams but in this example it is useful to be able to refer to each point end separately.

The track circuit controls need little comment. If, however, movements over 112 points (with shunt signal 52) take place frequently and, as a result, trains are detained at signal 10 (possibly up to 2500m in rear of 12) waiting for AD track circuit to clear, consideration would have to be given to the provision of a delayed Yellow approach to 12.

Normally, route 10 would require route 52A to be normal and *vice versa*. If a delayed Yellow approach is to be provided, clearly 10 cannot require 52A to be normal although if 52A is set first it must require 10 to be normal because, if 10 has cleared to Yellow with a full length overlap (that is, AD clear and 112 normal), this overlap must not be destroyed by a movement over 112 points reverse. This is known as non-reciprocal locking.

Fig. 3:2 Main signal controls

Under delayed Yellow conditions, which means only a limited overlap of 46m ahead of 12, it is necessary to ensure that the speed of the train has been reduced and hence signal 10 must be approach released after track circuit AO has been occupied for a time which forces the driver to brake until the train is at, or nearly at, a stand.

These two conditions of track circuit control of signal 10 are shown separately in the two tables on Fig. 3:2.

It will now be clear that the term 'requires points normal' or 'requires points reverse' includes all ends of a set of points, but it is worth noting that each end may be required to be detected for a different purpose. For instance, the B end of 110 points is required to be normal because it forms part of the route over which the train is to travel, but the A end is required normal to form a trap to protect the same movement from a overrun past signal 50.

The only other requirement to note is that signal 10 requires 12 to be alight. Whether the auxiliary filament is in use or not is immaterial to the driver since a main filament failure is automatically indicated to the signalman.

It is assumed in this example that signal 6 in rear of 8, is an automatic and does not have a separate overlap track circuit.

The layout shown in Fig. 3:2 is relatively simple and further layouts will be given later which illustrate other conditions enumerated earlier. Before proceeding further, however, consider how the route from 10 to 12 is maintained locked as the train approaches.

Once the train is within braking distance of 10, the driver may no longer be able to stop it without the risk of overrunning signal 10. If therefore this signal is returned to Red after the train has passed the braking point, the route must remain locked in case the signalman should attempt to restore the route and set up a conflicting one. Theoretically, it would be sufficient to 'hold the road' from the sighting point of the first caution aspect when 10 is at Red, that is, the point from which headways are calculated, but the replacement of a signal in these circumstances is unexpected

and might not be observed immediately by the driver. It is therefore safer to provide a margin for error, and for this reason the approach locking is taken back to the next signal in rear or at least to the overlap thereat.

This is the theory of approach locking and, as stated earlier, it may be either comprehensive (that is by track circuit occupation as described) or by time release, in which case the signal is said to be 'approach locked when operated'. In both cases, it is not effective unless the signal has cleared. The principle here is that having given the driver the authority to proceed on the understanding that the route ahead is held, the route must not be destroyed.

The advantage of comprehensive approach locking is that, if the approach track circuits are clear, the route may be freed immediately and another set up. This is useful if there is a possibility that the signalman may have set up the wrong route for the train (due perhaps to an incorrect train description being received) or perhaps after the signal has been working automatically and he has left it too late for a time release to operate without delaying the train. Comprehensive approach locking can be complex, particularly in a 4-aspect area where there are facing points between the Green and Red aspects. Time release approach locking is relatively simple and adequate in many cases.

Assuming the comprehensive type applies to signal 10, it must be approach locked by track circuits AM, AN and AO. Bearing in mind that the purpose of comprehensive approach locking is to enable the route to be restored immediately if no train is approaching within braking distance of the signal concerned, the locking on 10 should strictly be AO, AN, (AM or 8N): 8N denoting 8 route normal. This would ensure that, if AN and AO were clear, the route could be restored without delay, even if a train were standing at 8. It is often not considered necessary to apply conditional approach locking in such a simple layout as that shown and 10 would be locked generally by AM, AN and AO directly. If, however, the layout in rear of 8 were such that AM could be occupied by a crossing or diverging movement which is not approaching 8, condi-

## THE PRINCIPLES OF INTERLOCKING AND CONTROLS

tional approach locking must be applied. The conditional locking involved may then be quite complex, particularly if the signalling is 4-aspect involving three signal section in rear of 10.

After the train has passed signal 10, the approach locking must be released to enable the route to be restored as quickly as possible to enable other routes to be set up with the minimum of delay. The proof that the train has passed the signal is by the occupation of a convenient track circuit ahead; for example AA. A single track circuit, however, is not sufficient proof since a momentary insulated rail joint failure could cause a premature release. It is therefore the practice to require two consecutive track circuits to be occupied simultaneously followed by the first track circuit clear. In the case of 10, the release could be by AO and AA occupied followed by AO clear. If it were required to split trains at 10, which means that AO would remain occupied after the first portion had proceeded, the approach locking would have to be released by AA and AB occupied followed by AA clear. Layouts differ and much depends on the track circuiting arrangements and the movements which are made. The principle, however, applies.

After the approach locking has been released and the entrance button pulled and released, the route remains held by the direct track circuit locking or the route locking on the points. Although the route button has been restored, conflicting routes remain locked because, except for directly opposing routes, all such routes require one or more points in a contrary position to that required by route 10. In the case of directly opposing routes, signal to signal route locking ensures that they remain locked.

In the case shown in Fig. 3:2, points 110 will be directly locked by the occupation of AA and AB and as the approach locking is not released until AA is occupied, the points remain held until AB becomes clear.

Points 111 will be directly locked by AC, but for quick release during set back shunting movements over 110 reversed, they cannot be locked directly by AB. Hence 111 must be route locked by AA and AB after 10 operated. This is a directional lock. Points

111 would be similarly locked by any other route applying in the same direction, for example 50 (route B) applying over 110 reversed.

Lastly, points 112 in the overlap at 12 will be directly locked by AD but must be route locked by AA, AB and AC after 10 operated. The route locking in this case is necessary to maintain the overlap during movements up to 12, but as 112 must be capable of being reversed after the train has been brought to a stand at 12, this locking must be time released. As the fouling point of 112 is more than 46m ahead of 12, route locking by any shunting signal leading up to 12 will not be necessary.

It will be appreciated that, with few exceptions, after points are set and locked when the routes are set up, they remain in the position to which they were last operated until required in the opposite position.

It should be stressed that all signals can be replaced to Red at any time by pulling and releasing the entrance button. If this is done whilst the route is approach locked, a time release will commence to operate which on the expiry of the time interval will restore the route. This applies whether the approach locking is comprehensive or by time release (that is 'when operated').

During the operation of the time release mechanism, it is usual for the Red indication in the signal symbol on the panel to flash to advise the signaller that it is operating and the route will eventually be released. In the absence of this feature, the signaller would only be aware of a failure of the timing mechanism after the time interval had elapsed, which could involve unnecessary delay in sending for the technician.

The usual time interval for the release of an approach locked main signal is 2 minutes. If the brake application is made over a distance of, say, 2500m and the speed when the application was made was 150km/h, the train would arrive at the signal at the same time as the route was released, assuming uniform deceleration. If the initial speed was slower, the release would have been effective before the arrival of the train. It might seem that, in these circumstances, the time release should be of longer duration but the 2-minute

delay in releasing the route obliges the signalman to think what he is doing. It is safe to assume that he will take care before he resets the route; particularly as the Red indication has been flashing for all to see. He may possibly wait for the driver to telephone him from the signal to enquire the reason for the replacement of the signal. A further precaution which could always be taken is to install counters and oblige the signalman to record the reason for replacing the signal on each occasion.

Another precaution taken where there are very long distances between stop signals is to increase the time interval to 4 minutes.

In all cases, before approach locking is released or timing-out can start, the signal is proved to be at Red.

Fig. 3:3 shows a right-hand double junction and demonstrates some of the other enumerated control conditions not met in Fig. 3:2.

Assume signal 10 to be routed from the main to the slow line via points 101 reversed. It will require 101 points to be set, locked and detected reversed. It will also require tracks circuits AA, AB, BC, CE and CF in the line of route to be clear. In addition, it will require track circuits BB and CC clear to give flank protection

against an overrun at 11 and 12 respectively. It will also require CD or 102 reversed for the latter because CD will be occupied by movements over 102 points reversed.

Fouling protection is given by the inclusion of BD or 102 reversed. This ensures that no vehicles or the tail of a train remains standing foul after a previous movement with 11.

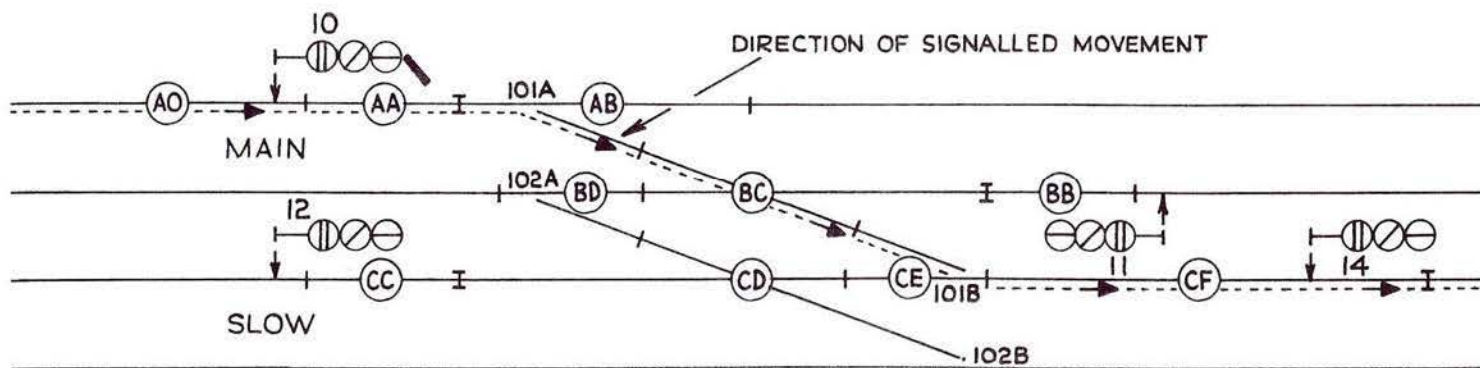
The full track circuit control for this route, that is, 10B, will therefore be:

AA, AB, BB, BC, CC, CE, CF (BD, CD or 102R)

Signal 10 for the B route will not clear until the junction indicator has been proved to be alight as described in the section on junction signalling.

Fig. 3:3 Main signal and point controls at a right-hand running junction

ROUTE	REQUIRES TRACK CIRCUITS		REQUIRES POINTS		REQUIRES SIGNAL ALIGHT
	CLEAR	OCCUPIED	NORMAL	REVERSE	
10B	AA. AB. BC. BB. CC. CE. CF. (BD. CD. w 102N)	A0 (ATR)		101.	14.



## THE PRINCIPLES OF INTERLOCKING AND CONTROLS

Points 101 will be locked by the following track circuits occupied or, put another way, will require them to be clear before the points can be operated to either normal or reverse:

AA, AB, BB, BC, CC, CE (BD, CD or 102R)

Points 102 will require to be locked in a similar manner.

This is the direct track circuit locking and as it goes back to the signals on all four tracks it will link with the approach locking and no route locking is necessary.

Note that AB and BD are terminated at the fouling points at the leaving ends, thus providing the quickest possible release for a following movement and the maximum standing room at the signal ahead.

The reason why fouling and flank protection track circuits are included in the point controls when they are also included in the signal controls, and not needed for route holding, is to provide some protection for emergency movements either by hand signals or under telephone authorisation from the signalman.

Fig. 3:4 shows a left-hand double running junction. As seen earlier, a left-hand junction permits some inherent flank protection by trapping.

In the layout shown, route 12A (from slow to main) will require the following track circuits clear:

CC, CD, BD, AA, AB, AC

but will require to set, lock and detect 101 and 102 reverse.

Points 101 will require BB, BC, CC, CD (BD or 102R) (CE or 103R) clear.

Points 102 will require AA, AB, BD, CC, CD clear.

Points 103 will require BB, BC, CE, DD, DE clear.

Route 11A will require similar controls to 12A.

The value of trapping at left-hand double junctions has sometimes been questioned for two reasons, namely:

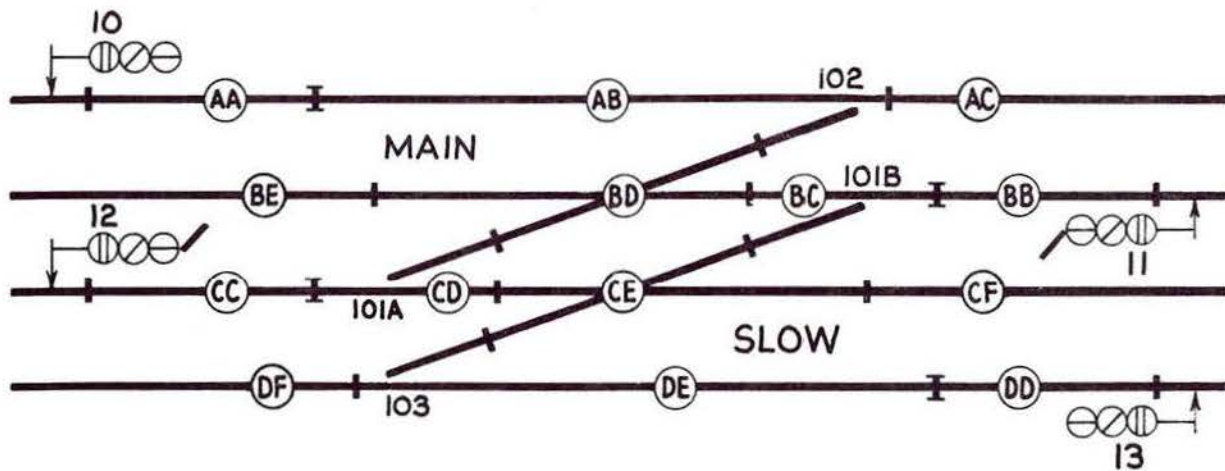


Fig. 3:4 Main signal and point controls at a left-hand running junction

## THE PRINCIPLES OF INTERLOCKING AND CONTROLS

- (a) One route is trapped at the expense of another, for example, 12A is trapped but 13 is thereby untrapped.
- (b) The overlap is reckoned to be able to contain overruns.

The answer to (a) is that an overrun past signal 11 could cause a facing collision with a train routed over the junction with 12, whereas a collision with a train routed with 13 would not only be a trailing collision but the distance from 11 would also be somewhat longer.

The answer to (b) is that whilst an overlap statistically will contain overruns, it will not necessarily contain a run by. A run by could be the result of a lamp failure at 11 after the train had passed the signal in rear (which would have been at Yellow) although the location of the signal would be indicated to the driver by the AWS warning and brake application. The circumstances are rare but none the less possible.

At a double running junction such as shown in Fig. 3:4 it is therefore considered that, on balance, it is better to provide the trapping.

It is admittedly not practicable to follow the principle at all layouts but a double running junction is often designed for fairly high speeds and they generally exist on high-speed lines.

Figs. 3:3 and 3:4 illustrate a small convention in the preparation of signalling plans and control tables. Letters are generally used for track circuit identification and double letters must often be used. By commencing each series by AA, BB, CC, etc. there is no possibility of mistaking AB for BA etc. If possible this practice should be followed although there may often be too many track circuits in a particular interlocking area for it to be done. It is also easier to follow controls on signals if they are listed in the direction of running and not alphabetically or numerically.

## THE PRINCIPLES OF INTERLOCKING AND CONTROLS

### Facing Points in the Overlap

In semaphore signalling, the lever of the signal in rear of a junction signal is always preceded by the point lock lever of facing points ahead of the junction signal so that in the event of an overrun the points are held in one position or the other. Thus, to give the train an unrestricted run, the facing points must be set and locked before the signal in rear of the junction is pulled OFF. If the required route at the junction cannot be set to the required route, the train must be checked at the signal in rear (in accordance with the *Rule Book*) before allowing it to proceed up to the junction signal. When the junction becomes free, the signal in rear must be replaced before the junction can be set correctly and the signal pulled OFF. This procedure can cause considerable delay.

In a route operated system, this delay is avoided by permitting the facing points to be moved (with safeguards) whilst the train is moving up to the signal in rear without it having to be replaced, thus also maintaining the principle of operating routes consecutively in the direction of travel.

Fig. 3:5 shows a typical layout with facing points in the overlap. For an unrestricted Yellow aspect at 12 it is obviously necessary that there should be a clear overlap at 14, although this does not have to be the overlap over which the train will eventually travel.

Assume that the train is to travel over the main lines but track circuit FL is temporarily occupied but EG is clear. Before clearing 12 route, the signalman therefore reverses 104 points by using the individual point key. In some installations, separate overlap buttons are provided for this purpose but generally the use of the individual point key is simpler and minimises the number of buttons on the control panel.

Signal 12 having been cleared, assume that the train is approaching it when the route ahead on the main line becomes free. The signalman now operates route 14B, 104 points return to normal and the signal clears.

It is obviously important that the facing points should not be permitted to 'swing' to an occupied overlap and replace 12 to Red. Accordingly, as shown in Fig. 3:5, once 12 has been operated, 104 points require FL to be clear before they can move from reverse to normal and EG to be clear before they can be moved from normal to reverse.

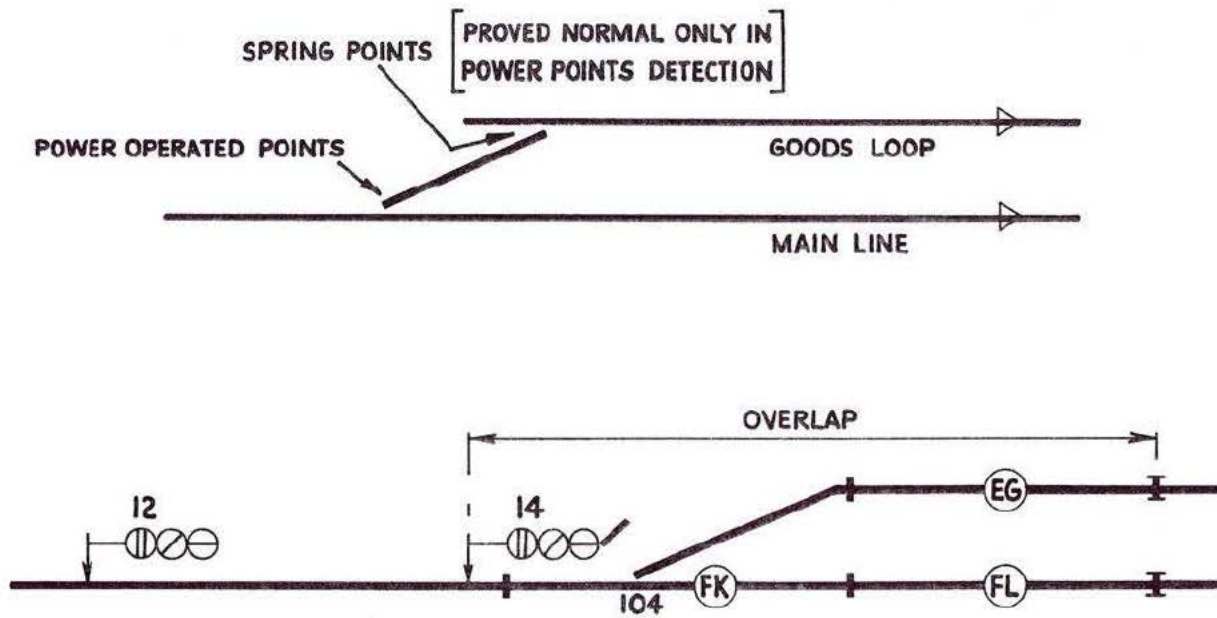
If, on frequent occasions, both overlaps are occupied at the same time, consideration would be given to providing a delayed Yellow approach on signal 12, provided a short overlap of not less than 46m is available.

If there are trailing points in the overlap which would have been normalised by the operation of 12 if the overlap had been free, they must be normalised before the facing points are swung towards the overlap of which they form a part.

Subject, therefore, to 12 having been operated, the movement of the facing points must be inhibited until the trailing points have been normalised. If this were not done, and the trailing points were in fact reversed, signal 12 would revert to Red as the train was approaching it and then again display a Yellow aspect after the points had normalised.

The operation of the facing point key therefore first causes the normalising of the trailing points after which the facing points are operated.

If separate overlap buttons were provided they would have the same effect.



SIGNAL 12 REQUIRES FK.(EG OR IO4N).(FL OR IO4R) CLEAR ;

THUS IO4N→R IS LOCKED WHEN EG occ. & 12 OPERATED,  
& IO4R→N IS LOCKED WHEN FL occ. & 12 OPERATED.

SIGNAL 12 DETECTS IO4 NORMAL OR REVERSE, BUT IF IO4 POINTS  
ARE MOVED, A TIME DELAY OF 7-9 SECONDS BRIDGES OUT  
DETECTION DURING POINT MACHINE OPERATION.

Fig. 3:5 Facing points in overlap

### Route Locking

This subject has already been introduced in discussing signal controls for the layout shown in Fig. 3:2, but a more detailed study is necessary.

Route locking may be defined as a method of maintaining the locking between functions by track circuit occupation in one direction only, thus permitting the early release of functions when the locking is no longer required.

Although on occasions it is necessary for opposing signals to route lock one another, the majority of route locking is between signals and points for the purpose of 'holding the road'. For this reason, it is known as 'sectional release' route locking. In the U.S.A. the term is 'directional sticks' although this is related to the circuitry employed.

Fig. 3:6 shows a typical example of where route locking between signals and points would be needed in part of a congested layout.

In determining the extent of the route locking, the first task is to note the point at which the approach locking on the signal concerned is released and the direct track circuit locking on each set of points. In the case of opposing signals, the route locking would extend from the release point of the approach locking in each case. Next, any interlocking between points should be noted as this may minimise the extent of route locking in favourable circumstances.

In Fig. 3:6, consider a movement from signal 10 to signal 12, that is, route 10(M)B. As the train passes the signal it occupies track circuit B which directly locks points 101 and no route locking on these points is necessary. The occupation of B (after 10 operated) initiates the route locking on 102, 103 and 104. The time release for 104 also commences to operate.

When the train clears C, the entrance button having been pulled and released, 101 points become free and, if required, a movement could be made with 55. When the train clears E, 102 points become free so far as 10 is concerned and if also free otherwise could be used for another movement. Likewise, when the train has cleared G, 103 also becomes free and 53 shunt signal could be used.

If 12 is at Red and the train draws to a stand, the time release eventually operates and 104 points also become free of route locking by 10 so that a shunt ahead and set back movement could be made using signal 12 and 51 shunt. As soon as H is clear, whether or not the time release for 104 has operated, all route locking is released.

In the down direction, 51A will set and lock 104, 103 and 102 normal. The direct track circuit locking on 104 meets 51 approach locking and no route locking on these points is necessary, but 103 will be route locked by J and H after 51A operated until the train clears H when this locking will be released and the points held on the direct lock until G is cleared. Points 102 will be similarly held until the train clears E.

Points 101 will not be route locked after 51A operated owing to the presence of 55 shunt. If the shunt signal shown dotted existed, there would be no need to route lock 102 in the down direction.

In addition to the route locking shown in Fig. 3:6, 52 would require to route lock 102 when D was occupied, but not 103. In the absence of the shunt shown dotted, 53 would route lock 102 when F was occupied.

Signal 10 will require the facing shunt signal 54 to be OFF before it will clear but a separate entrance-exit button operation is not necessary. However, when 10 returns to Red on the occupation of B, 54 must remain OFF until G is occupied.

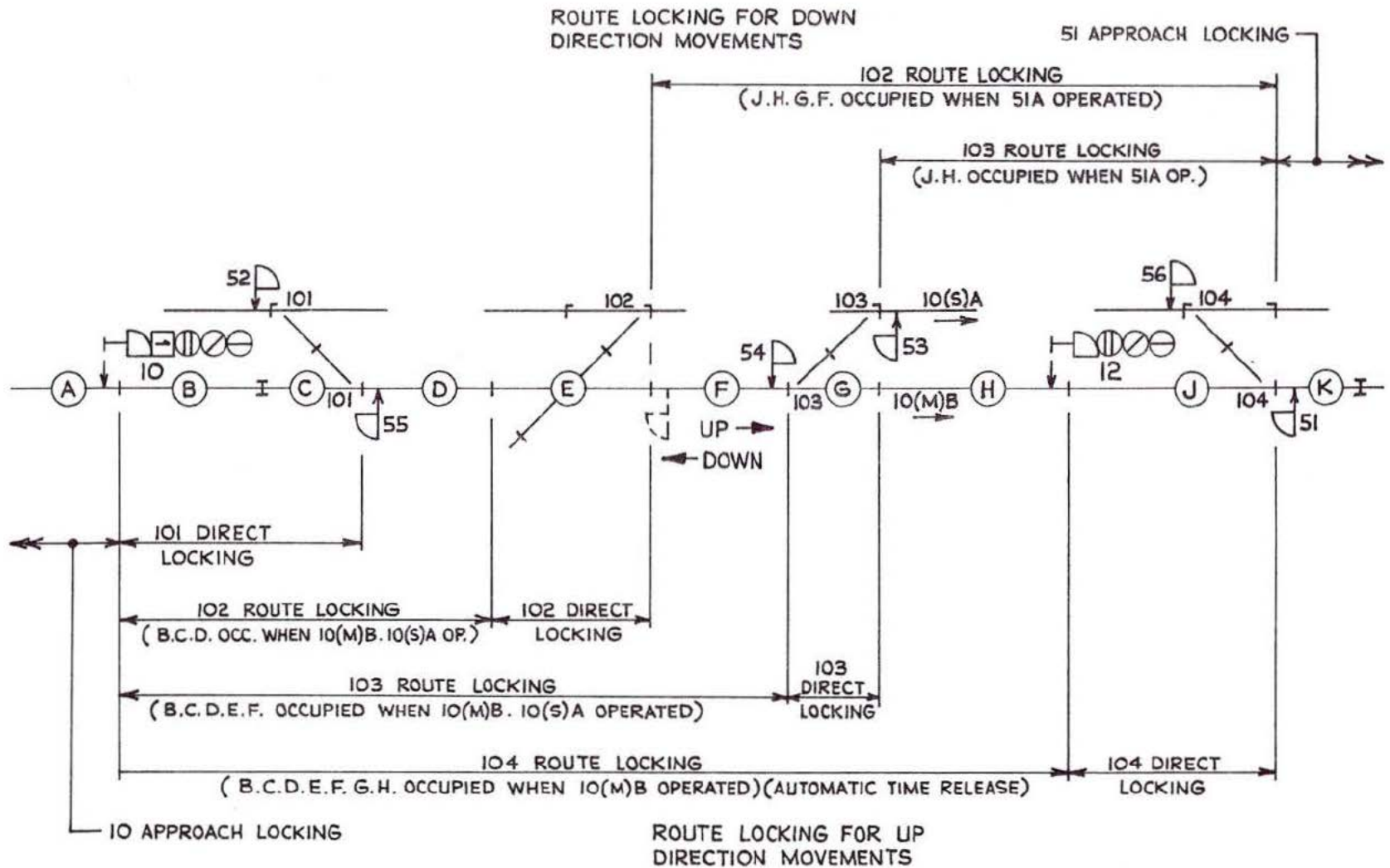


Fig. 3:6 Route locking between signals and points

## THE PRINCIPLES OF INTERLOCKING AND CONTROLS

If two opposing signals, either two main signals or a main and a shunt signal or two shunt signals take identically the same route, the locking between them must be maintained by route locking.

Fig. 3:7(A) shows two opposing main signals, 10 and 23. If 10 is cleared and the route button replaced on the occupation of AA, 23 could be cleared before the train occupied AB if route locking did not exist. The second train could then start and meet the first head on.

As both signals are fully controlled by track circuits, all that is necessary is for each to route lock the other to the overlap joint immediately ahead, that is, 23 must be route locked when AA occu-

ped after 10 has been operated. Similarly, 10 must be route locked when AE occupied after 23 has been operated.

If, for reasons of layout, standing room etc., each signal were located at the overlap joint of the other, no route locking would be necessary because the direct locking could not be released until the first train was occupying the track circuit control of the second.

Fig. 3:7(B) shows another case. Shunt signal 53 which is not track circuit controlled, is sited at the overlap joint of the opposing main signal 10. The route locking is therefore required in one direction only as shown.

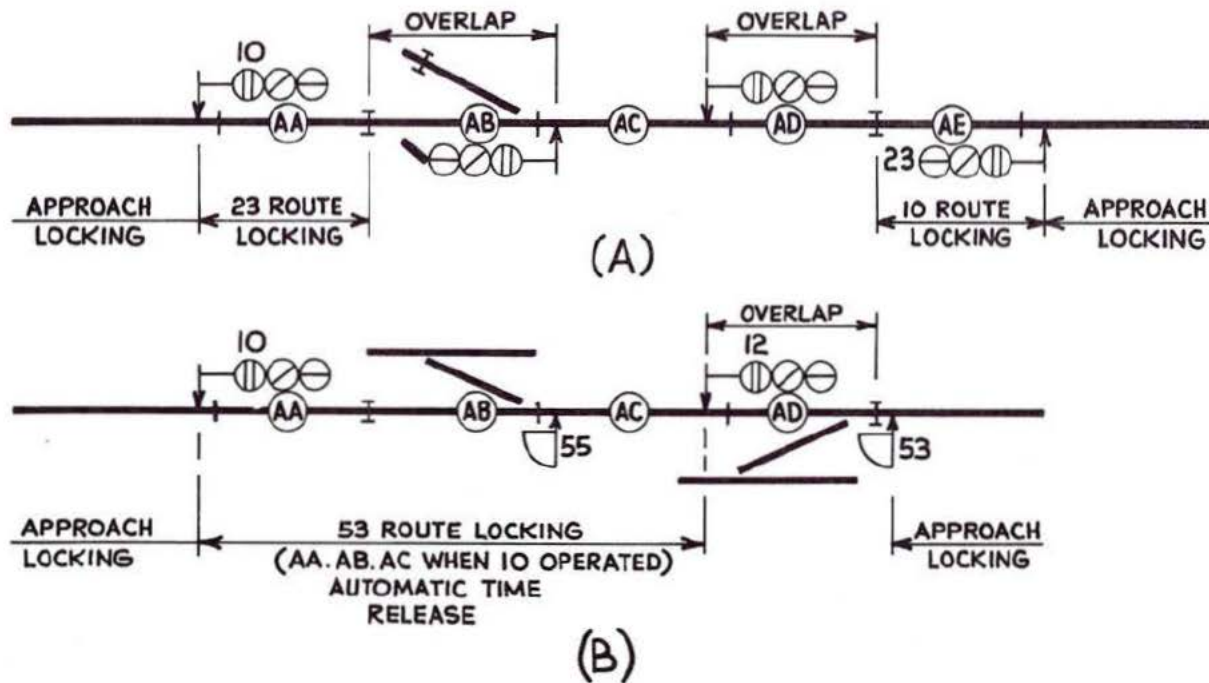
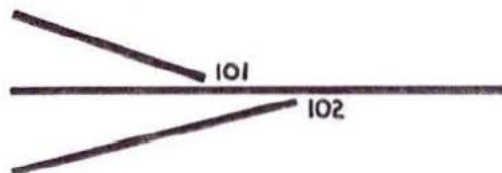


Fig. 3:7 Opposing signal route locking

**Fig. 3:8** Point to point interlocking



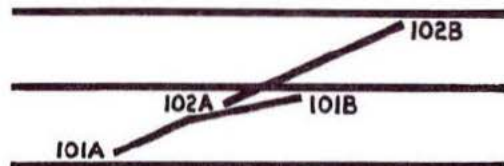
POINTS 101N→R REQUIRE 102N  
POINTS 102N→R REQUIRE 101N

(A) CONFLICTING MOVEMENTS WITHIN A TRACK CIRCUIT



POINTS 110R→N REQUIRE 111N  
POINTS 111N→R REQUIRE 110R

(B) JUNCTION INTERLOCKING



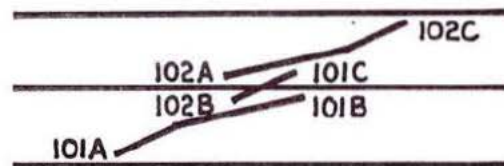
POINTS 102N→R REQUIRE 101R  
POINTS 101R→N REQUIRE 102N

(C) SINGLE COMPOUND POINTS



POINTS 104N→R REQUIRE 103R & 105R  
POINTS 103R→N } REQUIRE 104N  
POINTS 105R→N }

(D) DOUBLE COMPOUND POINTS WITH INDEPENDENT SLIPS



(E) ALTERNATIVE NUMBERING OF DOUBLE COMPOUND POINTS  
(POINT-TO-POINT INTERLOCKING NOT REQUIRED)

### Interlocking between Points

In semaphore signalling installations, in the absence of track circuits for point locking, it was the practice to provide point to point locking on an extensive scale for the purpose of holding the road and, where possible, for protecting hand signalled movements.

In modern power signalling, there is a minimum of point to point locking because track circuits provide the means of holding the road and enabling points to be released quickly for other movements. Another reason is that point to point locking can result in delay

in setting up routes since such locking obliges the points to operate in sequence instead of simultaneously.

In a route setting system, point to point locking is not generally provided except in the following circumstances.

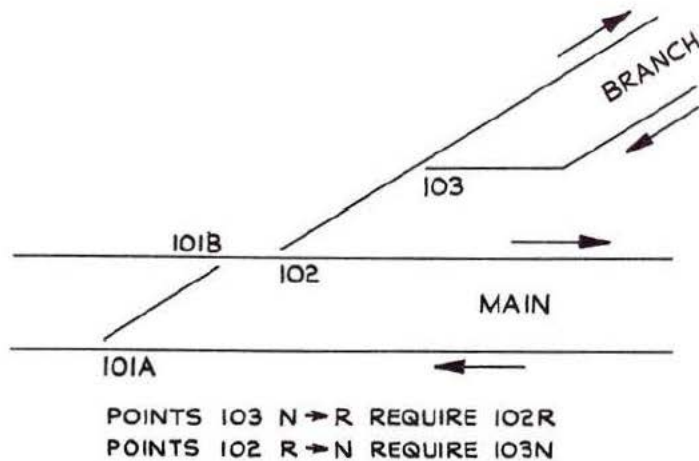
- (a) Where two or more point ends lie on the same track circuit (Fig. 3:8(A)).

## THE PRINCIPLES OF INTERLOCKING AND CONTROLS

- (b) For trapping at a left-hand junction (Fig. 3:8(B)).
- (c) At single slip points (also known as single compound points) where the slip points are released by the crossover points (Fig. 3:8(C)). This locking is frequently omitted.
- (d) In the case of double slips where the intermediate slip ends are operated separately (Fig. 3:8(D)).
- (e) It is more usual to operate double slips as shown in Fig. 3:8(E), thus eliminating two point operating machines and the point to point interlocking.

Slip points are gradually being removed on high-speed lines and replaced by single crossovers but in terminal areas where, in any case, speeds are low, layouts are often so congested that there is no alternative.

Double junctions, which involve diamond crossings, are also being replaced by single leads either as shown in Fig. 2:16 or as shown in Fig. 3:9.



**Fig. 3:9** Double junction on high speed line

## Dead Locking, Conditional Locking and Counter-Conditional Locking

If one function requires another to be in a certain state before it can be operated, it generally follows that after the first function has been operated, the second function must not be capable of changing its state and destroying the original requirement. This is reciprocal locking and in mechanical lever locking it is inherent in the system, but in electrical locking, whether lever or relay, the lock and counter lock must each be provided separately and hence there is an opportunity to provide non-reciprocal locking where it is advantageous to do so. Non-reciprocal locking is particularly useful where a delayed Yellow release is required for restricted overlap conditions.

'Dead' locking is the term applied to unconditional locking, that is, locking which is always required.

Conditional locking is locking which is dependant on the condition or state of other functions.

Counter-conditional locking is required where the condition (or function which forms the condition) would otherwise be free to be operated after the locking is effective. It is not required if one or other of the functions which lock one another under the conditions also lock it.

Fig. 3:10 illustrates the difference between reciprocal and non-reciprocal locking. The former needs no comment but the layout depicting the latter has already been briefly discussed when dealing with signalling layouts. It shows the locking associated with a delayed Yellow release. If 102 points are reversed the overlap is fouled and route 10 when operated is approach released so that the signal clears after the elapse of a suitable time interval. If 102 points are not normalised, the train eventually draws to a stand at signal 12 and waits for the line ahead to clear.

If, however, 102 became free and the overlap track circuits became clear, 102 could be normalised and 10 would exhibit an unrestricted Yellow aspect. Points 102 must now be locked and must not be

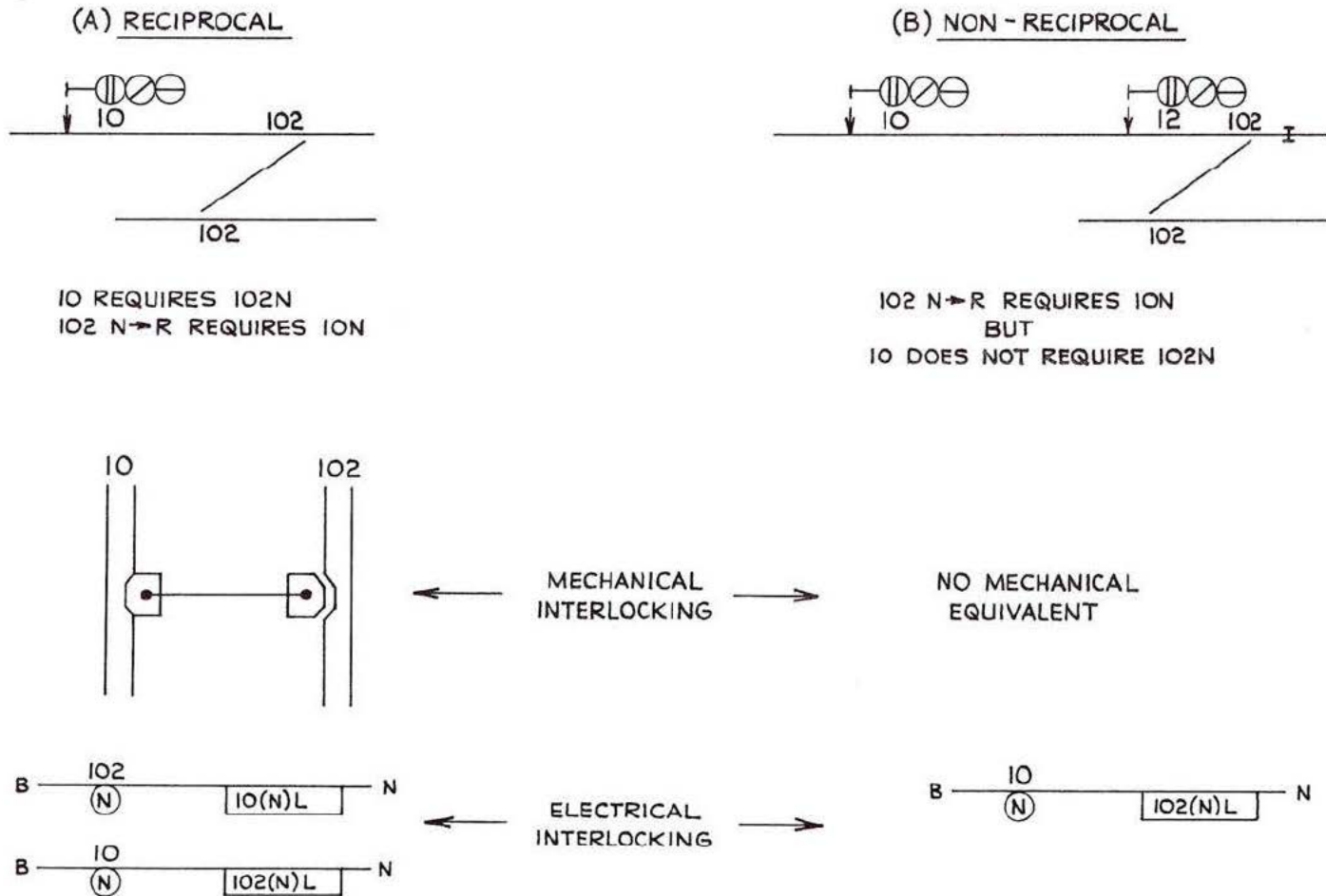


Fig. 3:10 Reciprocal and non-reciprocal locking

## THE PRINCIPLES OF INTERLOCKING AND CONTROLS

reversed again until the route locking holding the points has been timed-out. This is important since, having given the driver an unrestricted Yellow aspect, the protection of the overlap must not be taken away.

Fig. 3:11 shows conditional locking and the associated counter-conditional locking.

Counter-conditional locking can sometime be confusing but can be easily understood by comparing mechanical locking (where it does not have to be provided) with electrical locking (where it does).

Assume 107 to be reversed, 16 and 108 remain free to be operated. If 16 is then cleared to Yellow, the signalman can only swing the overlap (that is, normalise 107) if 108 is normal, but if it has been reversed in the meantime for another movement, 107 must remain locked in the reverse position. Note 107 reverse electric lever lock. To swing the overlap therefore 108 must be normal, which enables a clear overlap to be maintained.

If the train has already passed signal 16 and the route button has been replaced, the locking is maintained by the route locking until the elapse of the time release, by which time the train is standing at the junction signal and it is safe to normalise 107 points, even if 108 is still reversed.

In route operation all interlocking is by relay circuitry, which is the equivalent of the electric lever locking shown.

### Subsidiary (or Draw-Ahead) Signal Controls

In Chapter 2, it was shown that there are three types of draw-ahead signal, all of which are mounted on a main signal and exhibit an OFF aspect only.

In most cases, draw-ahead signals are approach-released and there are no overlap controls ahead of the next signal except for shunt-ahead signals where there are propelling movements. Otherwise, except as indicated below, the controls and interlocking follow the same principles as for main signals.

For direct entry to a siding or yard, track circuit controls can obviously only be provided up to the end of the track circuited area although there may also be a release from a signalbox or ground frame within the yard.

For entry into an occupied platform, the appropriate track circuits must be proved to be occupied as shown in the control table extract on Fig. 2:25. There is also no need to prove the buffer stop lamp alight in the draw-ahead signal controls.

For the shunt-ahead condition, there is generally no track circuit 'clear' controls although sometimes the first track circuit ahead of the signal is included in order to replace the signal, and if propelling movements are frequent, the overlap track circuit ahead of the next signal would be included as stated earlier.

### Shunting Signal Controls

Formerly, shunting signals were only controlled by track circuit when applying into the block section between two signalboxes or, if there were no track circuits, by the block instrument at 'line clear'.

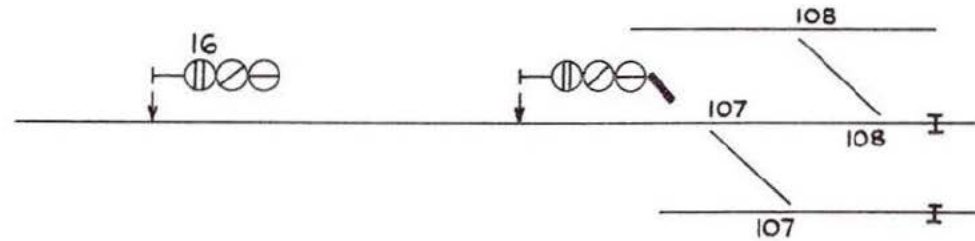
Nowadays, with less 'wagon load' traffic and few 'pick-up' freight trains, it has become possible to control shunt signals by track circuit to a greater extent than was formerly possible.

Track circuit controls on shunt signals are now in accordance with the following principles:

- (a) When leading to running lines other than permissive lines or where station yard working is in force, shunt signals are controlled by track circuits clear in the route ahead up to the next main running signal.

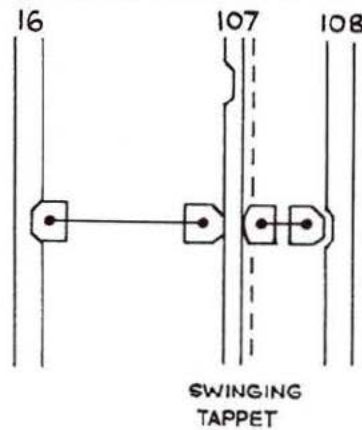
Should it be necessary to make shunting movements for attaching or detaching with track circuits ahead occupied, a special button may be provided on the panel to override the (normal) track circuit control. Pulling the button after the route has been set will then cut out the track circuit

**Fig. 3:11** Conditional and counter-conditional locking

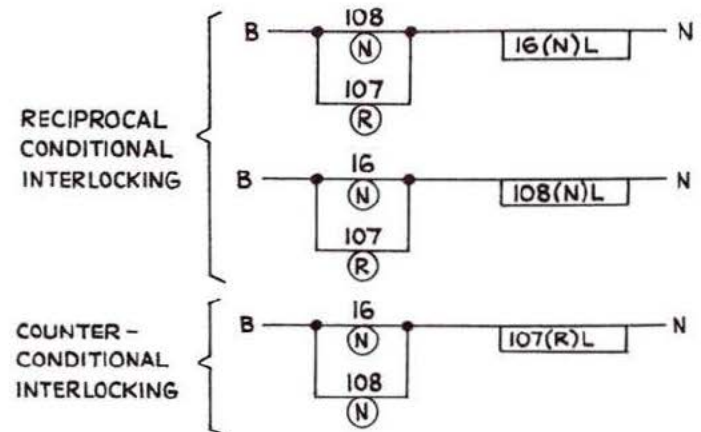


16 REQUIRES 108N OR 107R  
 CONVERSELY  
 107 R→N REQUIRES 108N WHEN 16 HAS BEEN OPERATED

MECHANICAL INTERLOCKING



ELECTRICAL INTERLOCKING



## THE PRINCIPLES OF INTERLOCKING AND CONTROLS

control for a single movement. Provisions of such buttons must be kept to a minimum and only after the necessity has been established by the operators.

- (b) Shunting signals are normally to be replaced to the ON position by the occupation of an appropriate track circuit, for one movement only. The replacement feature may be omitted where it is required to allow repeated shunting movements to take place without the intervention of the signalman.
- (c) Fouling and flank protection track circuits must also be proved clear.
- (d) Wherever practicable overlaps shall be 46 m in length although a separate track circuit is not necessary.

Applying these rules to Fig. 2:24, route 53A would be controlled by track circuits K, B, C, E, and F clear; route 53B would not be track controlled but 55 would be controlled by H and G, and route 54A would require C, B, K, L and track circuits beyond to the end of the overlap at the next signal.

There must necessarily be variations according to the layout and traffic which is to be dealt with.—

Overlaps of not less than 46 m (150 ft) are provided at shunt signals for the locking of points but where a shunt signal applies up to a main signal, the overlap at the signal is included.

With these exceptions, controls on shunt signals are as enumerated earlier for main signals.

### Head and Tail Movements

When a train is standing in a platform it is sometimes necessary to attach and/or detach vehicles or motive power units to the front and rear of the train. To save time, it is desirable that such movements should be carried out simultaneously.

The opposing locking between the signals authorising such movements would normally prevent them from being simultaneous.

Fig. 3:12 shows a typical case. Coaches would be attached to the tail of the train using 53 shunt and the locomotive would be attached to the head of the train using 52 shunt. Normally these two shunt signals would interlock when 107 points are normal but this locking would be released after A track circuit had been occupied for a specified time interval, say 30 seconds, if A was not much longer than the train length, to ensure that the train is at a stand.

### The Automatic Operation of Signals

There are three reasons why British Railways' signalling practice favours the automatic operation of signals wherever it is practicable to do so, namely:

- (a) It lessens the signalman's mental and physical work load.
- (b) It is not subject to human error.
- (c) It is less costly than operation from the signalling control panel.

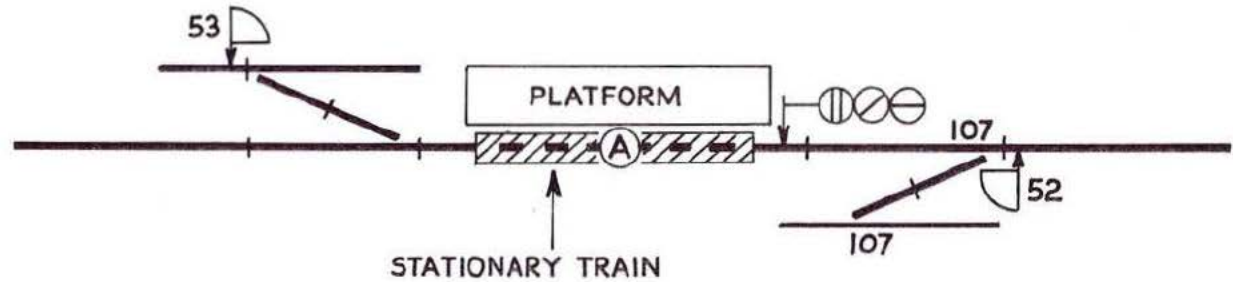
These three reasons apply equally to other items of equipment and it could be said to be British Railways' policy to automate as much equipment operation as is practicable and economic.

A multiple-aspect signal may be operated automatically at all times by the passage of trains provided that:

- (a) There are no points in the route to the next signal;
- (b) there are no points in the overlap;
- (c) there is a unique overlap (that is, not shared);
- (d) there are no directly opposing routes.

It is not current practice to provide separate overlap track circuits for automatic signals. This has been a controversial issue in the past but it is now accepted that such track circuits serve only to replace the signal to Red immediately the train has passed the signal. They do not protect against overruns or flank protection and it

Fig. 3:12 Head and tail movements at a station



52 REQUIRES 53N OR 107R OR A OCCUPIED (A.T.R.)

53 REQUIRES 52N OR 107R OR A OCCUPIED (A.T.R.)

is uneconomic to provide protection for situations which do not exist. In this connection, it is worth noting that most trains are longer than the standard overlap of 183 metres.

Automatic signals have the disadvantage that, in the event of a mishap ahead, maybe on another line but foul of the line concerned, there is no means of stopping trains. Cases have occurred where, not only from the safety aspect but also for operating reasons, it is necessary to hold trains back from the site of the mishap.

Buttons are therefore provided on the panel for the purpose of replacing selected automatic signals to Red, together with a positive indication that the button operation has been effective. Automatic operation is restored by pulling and releasing the button.

Such buttons are provided on the following scale.

- (a) At signals protecting level crossings equipped with automatically operated barriers.
- (b) At signals controlling a section of line in which a long tunnel or a viaduct exists.

(c) In a series of 3- and 4-aspect automatic signals on the basis of one signal in five in combination with (a) and (b) and subject to local circumstances. In 2-aspect signalled areas, on a comparative basis, for example, at distances of 9 or 10 km.

(d) For automatic signals approaching barrow crossings.

In cases where controlled signals are rarely used or where a series of successive trains use the through route and divergences are infrequent, auto buttons are provided on the control panel adjacent to the signal symbols concerned.

When pushed, the button causes the signal to work automatically (following the usual route set up procedure) and a White light within the button indicates that it has been effective. To cancel automatic operation, the button is pulled although the signal remains OFF until the next train has passed. If the signal is replaced at any time, the approach locking remains effective.

### Control Tables

Having designed the signalling scheme in accordance with the operating requirements for the traffic to be dealt with, the signal engineer's next task is the preparation of the control tables, which are required not only to enable the circuits to be prepared but also to give the operating officers an opportunity to check the movements and routeing which are proposed.

Control tables at one time were relatively simple to prepare but nowadays need considerable experience and a knowledge of the circuitry.

As stated earlier, there are a number of different types of control tables in use; each the speciality of a different Region but with the same object in view, which is to so arrange the column headings so that the designer is reminded of all the controls which must be applied to the signals, routes and points.

Originally, the interlocking between routes and the controls applied to them were independent and no reliance was placed on the controls to reduce the interlocking between routes.

Now there is no distinction and if one route requires to set and lock a set of points reverse and another conflicting route requires the same points to be set and locked normal, it is accepted that interlocking between the two routes is unnecessary. In effect this is a return to the philosophy of mechanical lever interlocking.

It might be thought that, with the coming of geographical circuitry, the preparation of control tables would have been eliminated as

it has been in those countries where geographical circuitry was first adopted. But British interlocking practice, particularly in regard to overlaps, coupled with the circuitry employed by British Railways, has shown that control tables must continue to be prepared.

In this chapter, the reader has so far been shown the various elements which make up the control and interlocking. Before proceeding to the circuitry, however, it is necessary that he should study this application with a typical layout and associated control table.

Figs. 3:13, 3:14, 3:15 and 3:16 show a portion of the layout and extracts from the control tables for a large installation which was completed in November 1976 and could be said to represent the latest British Railways' practice at the time of writing (1978). This is a good example of a modern installation and the remainder of this section discusses the controls shown in the extracts and the signalling facilities which are provided.

It is not possible to exemplify every feature of a route setting installation in a small part of a large layout but the reader will get nearer to the practical experience of preparing control tables by studying this example in detail.

Consider signal 508. Routes 508A, 508B and 508C apply up to signals 500, 498 and 496 respectively. These latter are platform entry signals and therefore exhibit Red or Yellow aspects only but each has an associated draw-ahead subsidiary signal for entry when the platform tracks are partially or fully occupied as shown in Fig. 2:25.

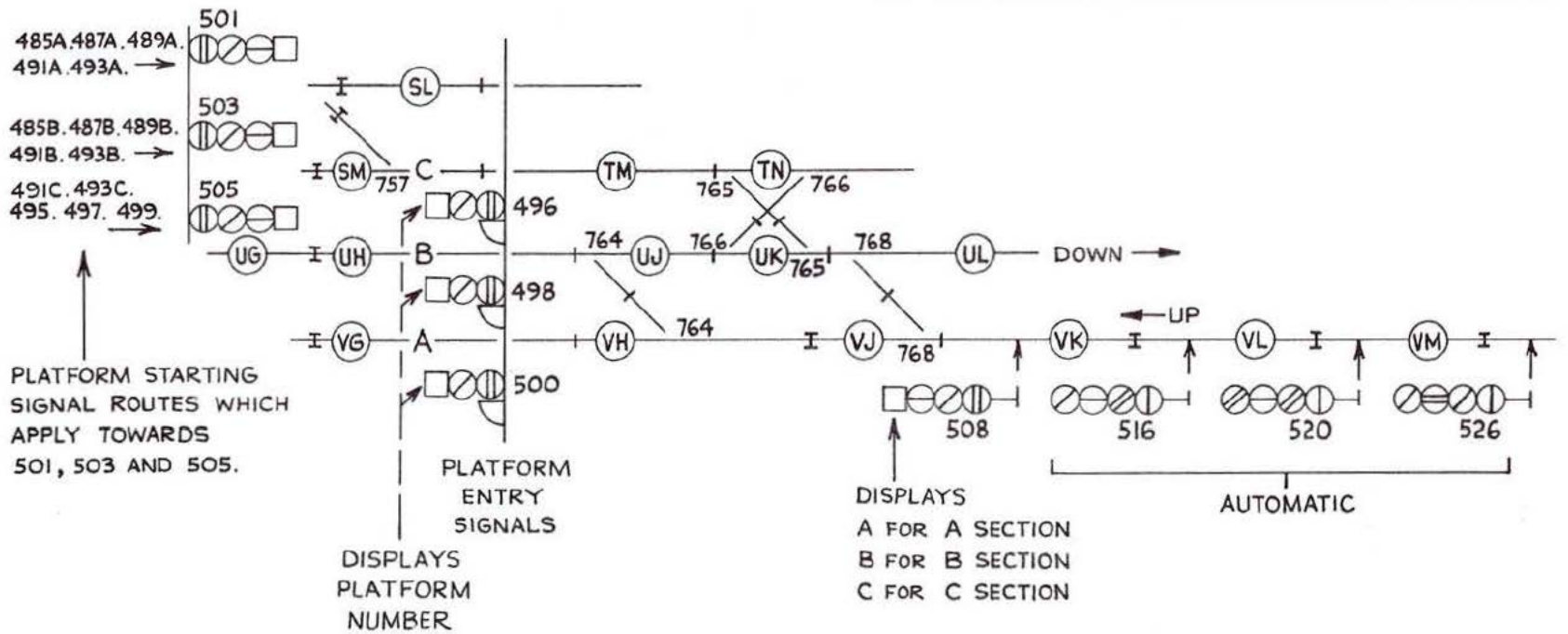


Fig. 3:13 Layout relating to examples of control tables

## THE PRINCIPLES OF INTERLOCKING AND CONTROLS

Take route 508A first. When the entrance button is pushed, it will flash until the correct exit button (500 in this case) is also pushed, but until that is done no other button in that area (or network) of the panel may be used as an entrance button. This is not restrictive as the exit button will be pushed almost immediately after the entrance button, after which the remaining buttons become free again.

Route 508A requires points 768 and 764 to be normal. If they are not and they are free to be operated, they will now be set and locked normal and if VJ, VH and VG track circuits are clear and the points are detected normal the route lights will show when the route has been set and 508 signal will clear to Yellow. The route indicator will also display 'A', indicating to the driver that the route has been set to A Section. The terms A Section, B Section etc. at this installation simply imply reference to particular sections of the layout and have no other significance.

The signal ahead (500) is assumed to be at Red. It applies to a number of platforms and if it is similarly routed to one of them, assuming the platform to be empty, signal 500 will clear to Yellow, and the route indicator will display the platform number. Signal 508 will then clear to Green, indicating to the driver that he has a clear road into one of the platforms. In this case, 500 main signal is not approach-released because the speed is low.

If the platform had been partially occupied, 500 main signal would have remained at Red and its associated draw-ahead signal would be approach released on the occupation of VH. Signal 508 would then have remained at Yellow.

At this stage, the reader should look through the controls and check that he understands the reason for each entry relating to 508A.

Route 508B is an example of an alternative route between the entrance and exit. The train may be routed from 508 to 498 either via 764 points reversed or via 768 reversed. The former (508B-1) is the preferred route and would normally be set by the usual operation of the entrance and exit buttons. It is the preferred route

because a down train might be proceeding to the down line either from B section or via points 765 reversed. The non-preferred route (508B-2) via 768 points reversed is useful if a train is standing at 500 waiting entry to a platform. In this case 764 may be locked. To select a non-preferred route there are three methods available, namely, it could be automatically selected if the preferred route is locked or an intermediate push button might be fitted on the panel (a suitable place would be between 768 and 765 points) or the individual point key could be used to set 768 reversed. Which method is used is generally decided in consultation with the operating officers and the decision made according to the frequency with which the alternative route is likely to be used. In the case of 508B, it has been left to the signaller to use the individual point key. This is the most convenient method for the signal engineer as it is less complex from the circuit point of view.

Assuming the non-preferred route is to be used, 768 point key will first be used to reverse 768 points after which the entrance and exit buttons will be pushed and 508 signal will clear as before, providing the directly opposing routes up to 505 are normal (see signal route locking table). Note that 765 and 766 will be route locked by track circuits VJ and UL after 508B-2 has been operated, thus covering the gap between the approach locking release and the direct track circuit locking on the points. Likewise, 764 will be route locked by VJ, UL and UK although this is not shown in the extract in Fig. 3:16.

Route 508C has facing points 757 in its overlap control ahead of 496. These points are detected both normal and reverse in the controls of 508C. This is to ensure that if the points should fail in midstroke as the train is approaching 508, the signal will return to Red and the consequences of an overrun at 496 and possible derailment will be avoided. The reader should note however that this protection exists only if the train is on the approach side of 508. This is considered a fair risk to take as it is extremely unlikely that an overrun will occur at the same time as a point failure. During the movement of the points the detection is obviously not

ROUTE No.	EXIT	JUNCTION OR ROUTE INDICATION ASPECT		REQUIRES SIGNAL AHEAD	APPROACH RELEASE		REQUIRES				APPROACH LOCKED WHEN SIGNAL CLEARED		REMARKS	ROUTE No.	
					TRACK OCCUPIED	SECONDS	ROUTES NORMAL	TRACKS	POINTS NORMAL	POINTS REVERSE	AND TRACKS OCCUPIED	UNTIL			SIGNAL ON
508 A	500	A	Y	500 AT R				VJ. VH. VG.	764. 768.			SEE APPROACH LOCKING TABLE  VK AFTER VK. VJ. OCCUPIED OR 2 MINUTES 508 VJ.		508 A	
			G	500 AT Y											
508 B-1	498	B	Y	498 AT R			491C. 493C. 495. 497. 499.	VJ. VH. UJ. UH. (UK w 765N OR 766R).	768.	764.					508 B-1
			G	498 AT Y											
508 B-2	498	B	Y	498 AT R			491C. 493C. 495. 497. 499.	VJ. UL. UK. UJ. UH.	764. 765. 766.	768.				508 B-2	
			G	498 AT Y											
508 C	496	C	Y	496 AT R			483(M)C. 485B. 487B. 489B. 491B. 493B.	VJ. UL. UK. TN. TM. SM. (SL. w 757R).	766.	765. 768.				508 C	
			G	496 AT Y											
									NOR. OR REV.						
									757*1						

\*1 7- SECOND TIME DELAY ON DETECTION DURING  
MOVEMENT OF POINTS WHEN 508C OPERATED.

Fig. 3:14 Example of signal and route control table

POINTS No.	SET AND LOCKED NORMAL BY ROUTES	SET AND LOCKED REVERSE BY ROUTES	CONDITIONAL SETTING				REQUIRES TRACKS		REMARKS	POINTS No.
			POSITION	POINTS SET OR FREE TO SET	TRACKS	OR ROUTES NORMAL	N to R	R to N		
764	505A. 505B. 506A. 508A. 508B-2.	508B-1.					UK w 765N OR 766R.	UJ. VH.		764
765	481(M)C. 503A. 505B. 506B. 508B-2.	481(M)D. 503B. 508C.						TN. UK.		765

Fig. 3:15 Example of point control table

maintained and to prevent the signal returning to Red the detection is bridged out during a 7-second time lag to avoid a disconnection during the operation of the point machine.

The signals in rear of 508 are automatic and will clear in sequence after the passage of a train. Hence there is no need for approach locking track circuits VM and VL to be conditional on 520 and 516 being OFF. The approach locking is released by VK clear after VK and VJ have been occupied; in effect this amounts to a 'last-wheel' release as the train clears VK. This combination of occupied and clear track circuits prevents a false release of the approach locking by a 'bobbing' track circuit or an insulated block joint failure (which would cause two track circuits to fail).

Other points to note are the absence of separate overlap track

circuits at the automatic signals 516, 520 and 526 and similarly at the controlled signals 498 and 500. At the last two signals, the speeds are low and the overlaps are so short that separate track circuits would not be warranted for flank protection alone.

In Fig. 3:16 there is an example of short track locking distance. Points 757 are situated only a short distance from signal 496 and in consequence must be locked by TM with a time release. This is shown in the point route locking table as TM clear or TM occupied with a 10-second release. A further point to note concerns the signal route locking. All track circuits which effect this route locking are situated between the end of the overlap at signal 498 (that is, at the joint between UH and UG) and the platform starting signals. They are not shown in the diagram (except for UG). The purpose

POINT ROUTE LOCKING

POINTS No.	TRACKS	SECONDS	AFTER SIGNAL OPERATED
757	TM OR TM OCCUPIED.	10	508C.
764	VJ.		508A. 508B-1.
766	VJ. UL.		508B-2. 508C.

SIGNAL ROUTE LOCKING

ROUTE No.	TRACKS	SECONDS	AFTER SIGNAL OPERATED
508 B-1	TJ. UB. UC. UF. UG.		491C.
	UB. UC. UF. UG.		493C.
	UE. UF. UG.		495.
	VB. VE. UF. UG.		497.
	VE. VC. UF. UG.		499.

APPROACH LOCKING

SIGNAL No.	TRACKS	AFTER SIGNAL OPERATED	TRACKS	AFTER SIGNAL OPERATED	TRACKS	AFTER SIGNAL OPERATED
508	VK. VL. VM.					

Fig. 3:16 Example of route and approach locking table

of this locking is to ensure that a movement is not made up to 505 signal whilst a movement is being made with 508B-1 or 508B-2 up to 498. Only a portion of this locking is shown in the table.

The installation from which Fig. 3:13 is taken is the first in which the route is released automatically. This feature is known as TORR or Train Operated Route Release. The purpose is to cause the route to be released immediately each train passes the signal unless it is in the automatically operated condition. This not only reduces

the signalman's physical work load but by releasing the route immediately enables the signalman to concentrate on the next move or another signalman to be free to make a move for which he has been waiting.

Such a feature as this and the flashing of the Red signal indication during timing-out of approach locking will not be apparent from the control table but nevertheless should be considered at this stage.

## Equipment: Relays, Signals and Point Machines

The type of operating, or signalling control, panel, the various forms of track circuit and systems of remote control are dealt with elsewhere. In this chapter, relays, signals and point operating machines, together with their operating characteristics and circuits, are described and discussed.

Development of the British Railways' signalling system has been a long and arduous process. The many and differing Regional standards were of long standing, with much to commend them; the long working life of signalling equipment making early replacement uneconomic, and the financial policy of the Government of the day towards the railways, all had an important bearing on the progress which could be made towards standardisation of practice. Taken all round it has been an immense task. It has to be remembered also that, before nationalisation in 1948, each of the four 'grouped' railways had been through a similar phase with the constituent companies after the Railways Act of 1921, which involved large scale amalgamation, and many important projects had been carried out in the intervening years.

The visits paid to various signalling installations in Europe during the Annual Conventions of the Institution of Railway Signal Engineers and contacts with European Signal Engineers at meetings of the Union Internationale des Chemins de Fer (U.I.C.) and discussions with signalling equipment manufacturers in the U.K., in Europe and in the U.S.A. all contributed to the shaping of a standard system for British Railways. At the time of writing (1978) it could be said that considerable progress has been made. The aim is absolute standardisation of signalling principles so far as the driver and the traffic operator are concerned and complete interchangeability of individual items of equipment from whatever source, subject to com-

pliance with a British Railways performance specification. Standardisation to any greater extent would restrict progress in the adoption of new techniques.

### BR 930 Series Relays

The most commonly used item of equipment in a modern signalling installation is the DC tractive armature relay. In 1958, the British Railways Board set up a working party composed of representatives of the Institution of Railway Signal Engineers, the major signalling equipment manufacturers and the Board itself, to compile a series of relay specifications which would result in a miniature, low-cost plug-in type of relay, interchangeable irrespective of manufacturer and suitable for use in the quantities required for large geographical circuitry installations. The result was the BR 930 series of specifications with which DC relays used by all signalling contractors for works carried out for British Railways must comply.

The only AC safety relays now used are those for track circuits in DC electrification areas which are now almost wholly confined to the Southern Region of British Railways. These are vane relays which cannot be miniaturised within the overall dimensions specified for the BR 930 series, and are consequently not covered by these specifications. They are covered by older British Standard specifications but are now also of the plug-in type.

The BR 930 series is rigid in regard to performance, materials, interchangeability and overall dimensions. Within these constraints, each manufacturer is permitted his own mechanical and electrical design.

The safety aspect of signalling relays is all-important and, in particular, the ability of the relay to release without fail after de-energisation, is a matter to which special attention must be given by the designer. The design must be fail-safe and reliable. It must guard against any possibility of obstruction in the mechanism, or defective linkage between the armature and the contact assembly, or contact welding, which might retain the relay in the energised position.

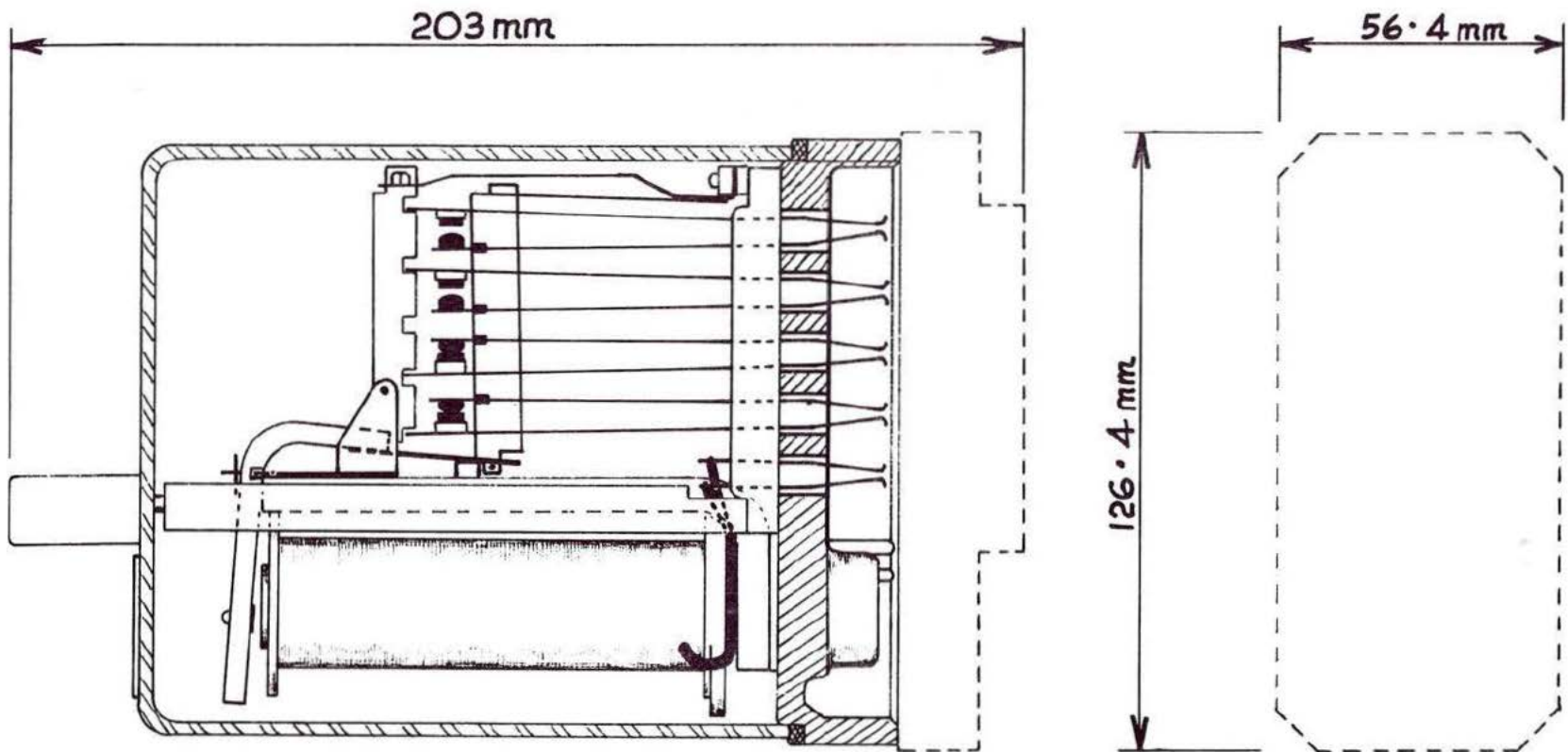


Fig. 4:1 BR 930 series relay

Space does not permit the BR 930 series of specifications to be included in this book but the tables printed on pages 125–7 list most of the available types with typical operating characteristics and available contact assemblies.

The introduction of AC electrification at industrial frequency required a range of AC-immune relays which are also included. All types of BR 930 relays have registration pins to prevent an

incorrect relay change being made. British Railways hold a master list of codes, and a manufacturer designing a new type of relay must apply for a code.

Fig. 4:1 shows the overall dimensions of the relay and its plugboard. It has been found to be sufficiently compact and low in weight to be used in all geographical relay sets, thus enabling individual relays to be changed without changing the relay set.

## EQUIPMENT: RELAYS, SIGNALS AND POINT MACHINES

The relays used in vital circuits are fitted with non-weldable front contacts (for example, silver-impregnated carbon to silver) because British circuitry practice, unlike Continental, does not generally prove relay operation. These relays are designed to have a working life of  $10^6$  cycles of operation at the rate of 250 per day. Independent contacts are used throughout.

In addition to the relay types listed in the table the following time-element relays are available:

- (a) The thermal type (BR 962) in which a bi-metal strip is caused to go through a complete heating and cooling cycle before it operates. The operating delay may be up to 2 minutes.
- (b) The impulse type in which a ratchet stepping relay with contacts operated by preset cams receives a pulsed input from an external pulse generator. The operating delay may be up to 3 minutes.
- (c) The motor-operated type (BR 947) which is capable of an operating delay of more than 2 minutes.
- (d) The electronically-operated type which is capable of an operating delay of up to 4 minutes.

Each type drives a standard BR 930 series relay on completion of the selected time cycle.

### Main Signals

There are two types of multiple-aspect signal in use, namely, the multi-unit and the searchlight. The former has a separate lens system for each of the aspects which can be displayed while the latter has a single lens system for the Red, Yellow and Green aspects and an additional unit for the second Yellow aspect when a 4-aspect signal is required. The searchlight signal is now rarely used.

Colour light signals must have a low wattage light source to minimise power supply losses on long lines, and also to enable the same intensity of light to be displayed at signals on branch lines fed from trickle-charged batteries. The optical systems must

therefore have a high efficiency and, to this end, the light source must be as small as practicable. The ideal would be a point. By this means the light is concentrated in a narrow intensive beam with a very small angle of spread.

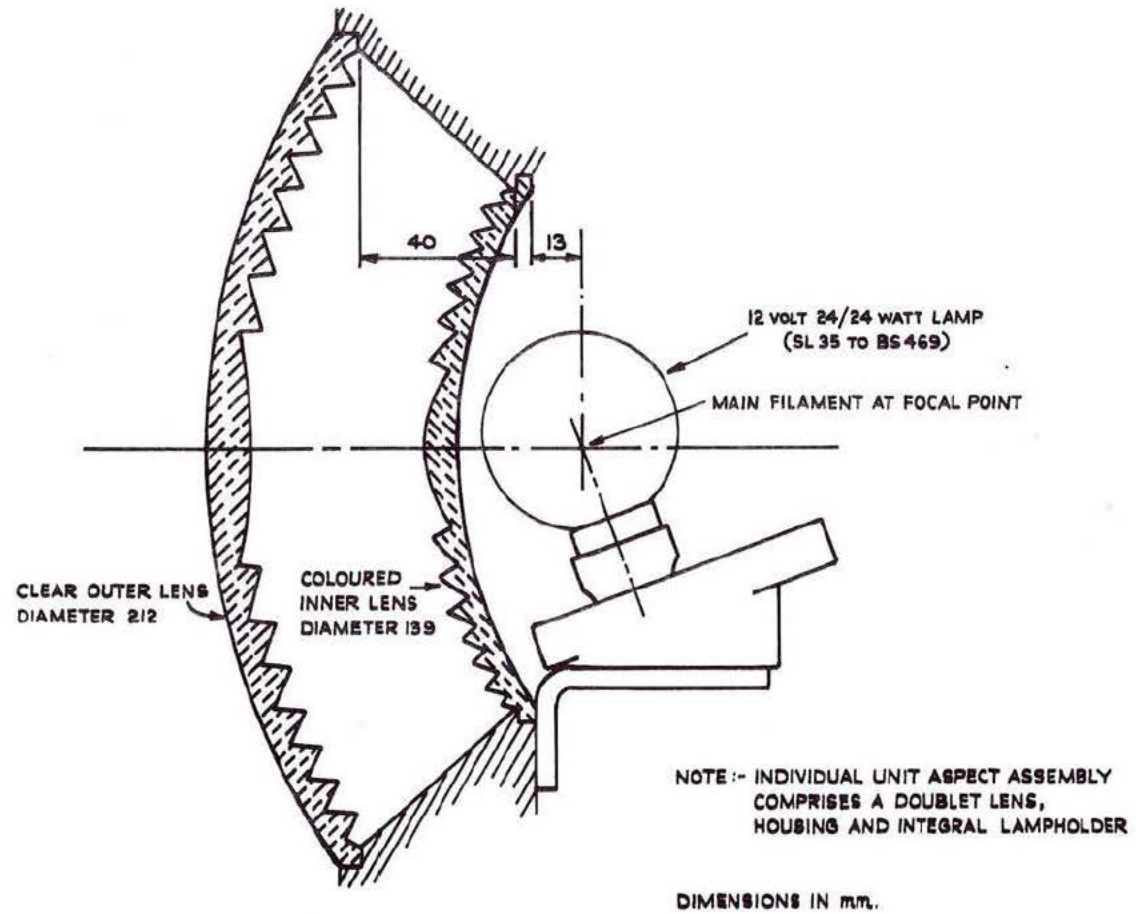
Fig. 4:2 shows the optical system used for multi-unit signals. It consists of two convex step lenses in a 'doublet' combination which enables the inner lens to have a short focal length and gather the maximum amount of light from the lamp. A step lens system has the advantage, as compared with the equivalent plano-convex system, of lenses with nearly uniform thickness, so that the light loss is minimal and uniform. It also facilitates the manufacture of the inner coloured lens to the very rigid B.S. specification for colour. This specification attaches great importance to a clear distinction between Red and Yellow to avoid misreading, particularly in fog. The outer lens, of clear glass, usually has, moulded into it, a prism section which directs a portion of the beam towards the driver of a train standing at the signal. On curves, where necessary, a special outer lens may be used to spread the beam horizontally.

The sighting of signals on the track is a subject in itself, which can only be learnt by experience. Essentially, the beam must be at a constant height above the track with the Red aspect at driver's eye level. This is about 3.66 m (12 ft) above rail level. The vertical spacing of the aspects is standardised at 279 mm (11 in.), but the vertical spread of the beam, though small, is sufficient to enable all aspects to be clearly seen until the driver arrives at the signal, when the prism section provides a close-up indication.

Because of the necessity to provide clear long-range sighting of multiple aspect colour light signals the lamps are of specialised design, with short coiled tungsten filaments, manufactured to a far greater degree of precision, with closer tolerances than ordinary commercial lamps, to ensure correct relationship to the focal point of the optical system.

It is obviously of great importance also that the displayed aspect should remain alight, and hence all signal lamps have a main and standby, or auxiliary filament. On early installations, a lamp (type

**Fig. 4:2** Multi-unit colour light signal: optical system



#### EQUIPMENT: RELAYS, SIGNALS AND POINT MACHINES

5L 17) was used which had both filaments connected in parallel. The auxiliary filament was considerably underrun until the main filament burnt out, when the voltage regulation caused the lamp voltage to rise to the rated value for the auxiliary filament. This type was suitable only for installations where the controlled signals were fed directly from the Control Centre with series indication, and for automatic signals which were subject to regular lamp inspection. The stop-and-proceed rule was also operative in some early installations. This type of lamp is not suitable for the modern large areas of control where most signals are fed locally. It is now the practice of British Railways to use only lamps with independent main and auxiliary filaments. This type of lamp enables an indication to be given to the Control Centre when any main filament fails and permits the signal in rear to be held at Red in the event of both filaments failing. Standard lamps for installations on British Railways are rated at 12 volts (nominal) but to prolong lamp life, the lamp voltage is reduced to about 11.5. Lamps for multi-unit signals are 24/24 watt (5L 35 type) and when, in rare instances, searchlight signals are used, the lamps are 12/16 watts (5L 32 type).

The main filament, which is horizontal, is located at the focal point of the lens system. Although it is short, each end of the filament is out of focus and in consequence the beam has a small spread of about 5°. The auxiliary filament, which is a nominal 3 mm behind the main filament, is vertical but being wholly out of focus

cannot produce the same beam intensity as the main filament. The spread is also much greater and mainly in the vertical plane.

Figure 4.3 shows a typical horizontal beam intensity curve and the corresponding nominal range. The range is calculated from the empirical formula:

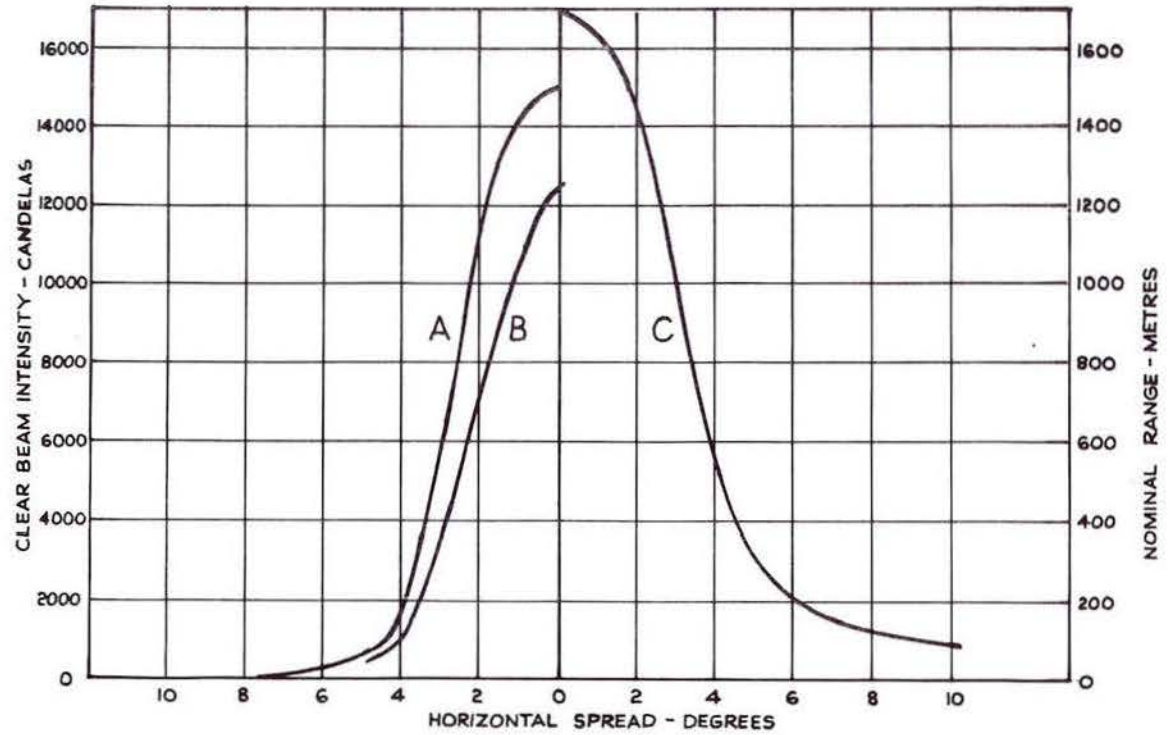
$$\text{Range (metres)} = 13.63 \sqrt{\text{BCP}}$$

Where BCP = Beam intensity in Candelas

The interior of all multi-unit signals is painted matt black to prevent reflection and minimise the possibility of 'phantom' aspects which may sometimes, but rarely, be seen.

A 'phantom' aspect results from the reflection of sunlight from the (unlighted) lamp surface and/or filaments. It can only occur when there is a critical relationship between the observer, the sun and the lamp in the signal. Although a 'phantom' aspect may be seen by an observer on the ground, it would not be seen at the same time by the driver whose eye level is some 3.7 m above rail level. Furthermore, the provision of long hoods on each aspect limits the possibility to the times of day when the sun is low and in the critical position. Even if a 'phantom' aspect did occur, the correct (lighted) aspect would be more intensive and draw attention to the phenomenon. It is not a serious problem. It obviously cannot occur in a searchlight signal.

**Fig. 4:3** Multi-unit colour light signal: typical beam intensity and range



A:- MAIN FILAMENT

B:- AUXILIARY FILAMENT

C:- RED BEAM RANGE, MAIN FILAMENT

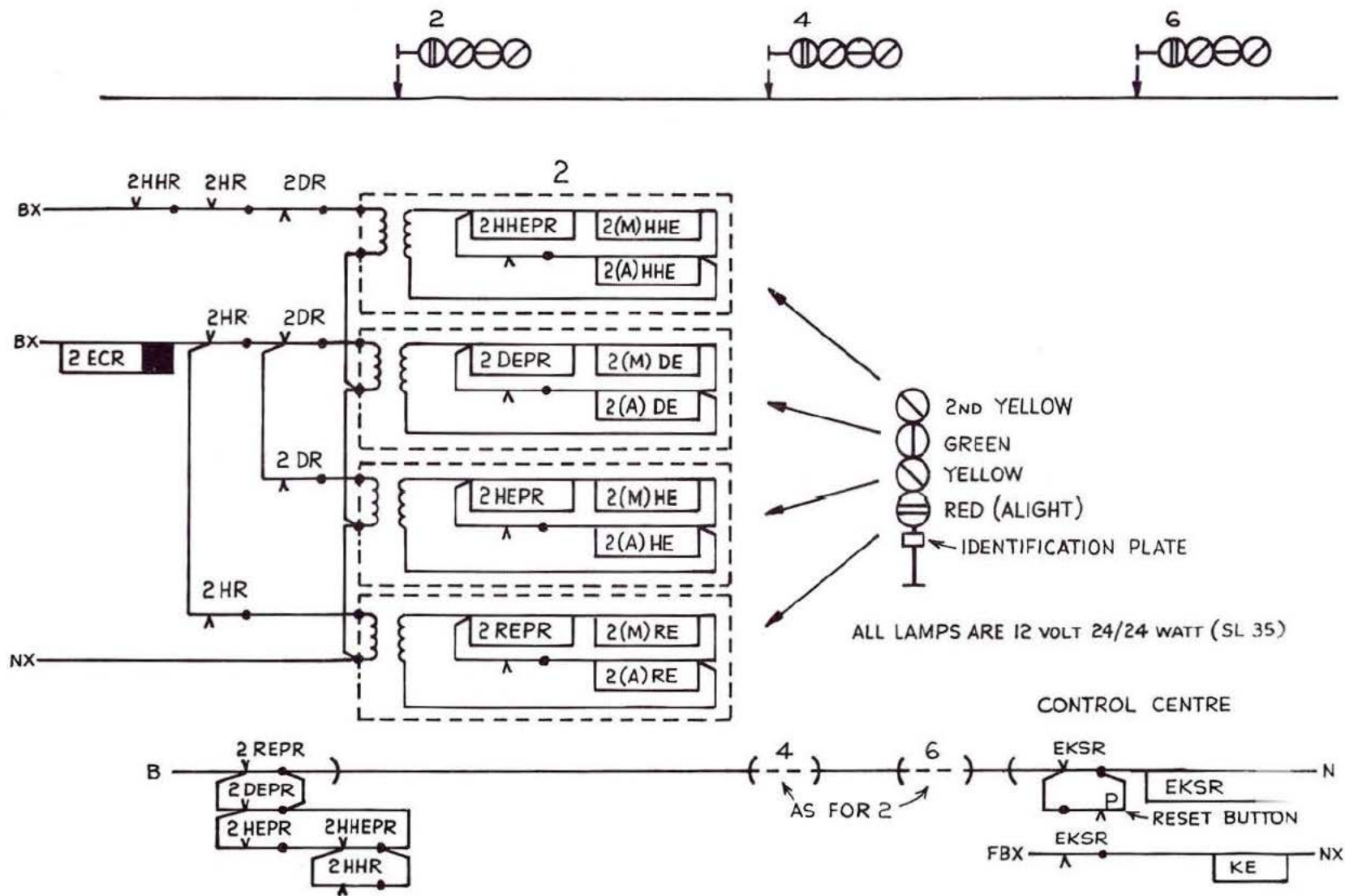


Fig. 4:4 4-aspect multi-unit signal: lighting and main filament lamp indication circuit

Fig. 4:4 shows the signal lighting and lamp indication circuits for a 4-aspect multi-unit signal. The changeover relay (EPR) in each lamp circuit cuts in the auxiliary filament if the main filament fails. The group indication circuit to the Control Centre is then disconnected and a flashing indication appears on the signalling panel to advise the signaller, who reports the failure to the maintenance technician.

The flashing indication is maintained on the panel until the reset button is pushed because a change of aspect in the signal concerned would otherwise restore the group indication circuit. These circuits are so arranged that the technician can see, from his own indications in the relay room, in which direction and on which line the failure has occurred. By resetting the circuit and observing the passage of a train on the panel he can ascertain the signal involved. In the event of the auxiliary filament also failing before a lamp replacement has been made, the lamp proving relay (ECR) will release and the signal in rear will be maintained at or restored to Red. A change of aspect to one with a sound lamp will, however, restore normal conditions temporarily.

Fig. 4:4 shows the local control circuit. Relays HR, HHR and DR are subject respectively to the controls for signal 2 being clear, the signal ahead being at Yellow and the signal ahead of that being at 2-Yellow or Green. Relay 2 ECR is slow release, because during a change of aspect it is momentarily disconnected and, if replaced to Red by the signaller or by the passage of a train, would otherwise reproduce 'lamp out' conditions during the short interval when either the HR or DR contacts are changing over. The lamp proving feature would then momentarily replace the signal in rear to Red, which is obviously undesirable. This part of the circuit is not shown in Fig. 4:4. Relay ECSR is also slow release for similar reasons but in this case as it is a 'stick' relay it would remain disconnected until the reset button is pushed.

Fig. 4:5 shows the ON/OFF indication for signal 2 in Fig. 4:4. Note the inclusion of the ECR, which extinguishes the control panel indication should both filaments of the displayed aspects fail. A change of aspect will restore the ECR and the panel indication and the failed lamp may have to be checked by the passage of a train, as stated earlier in connection with main filament failure.

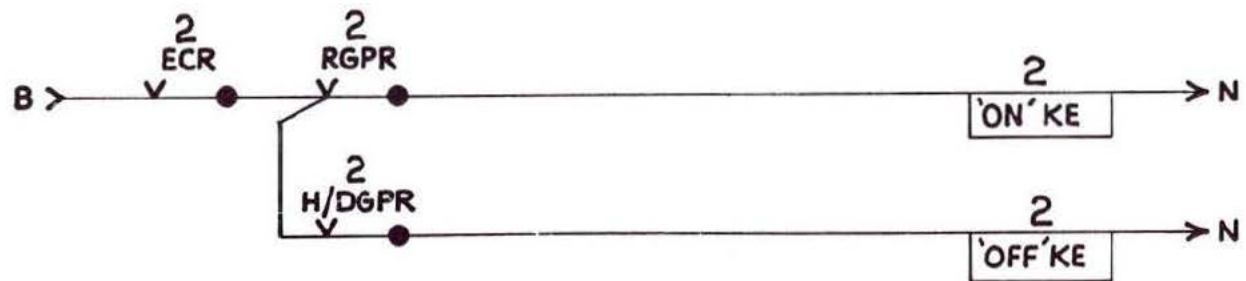


Fig. 4:5 Main signal on/off indication circuit

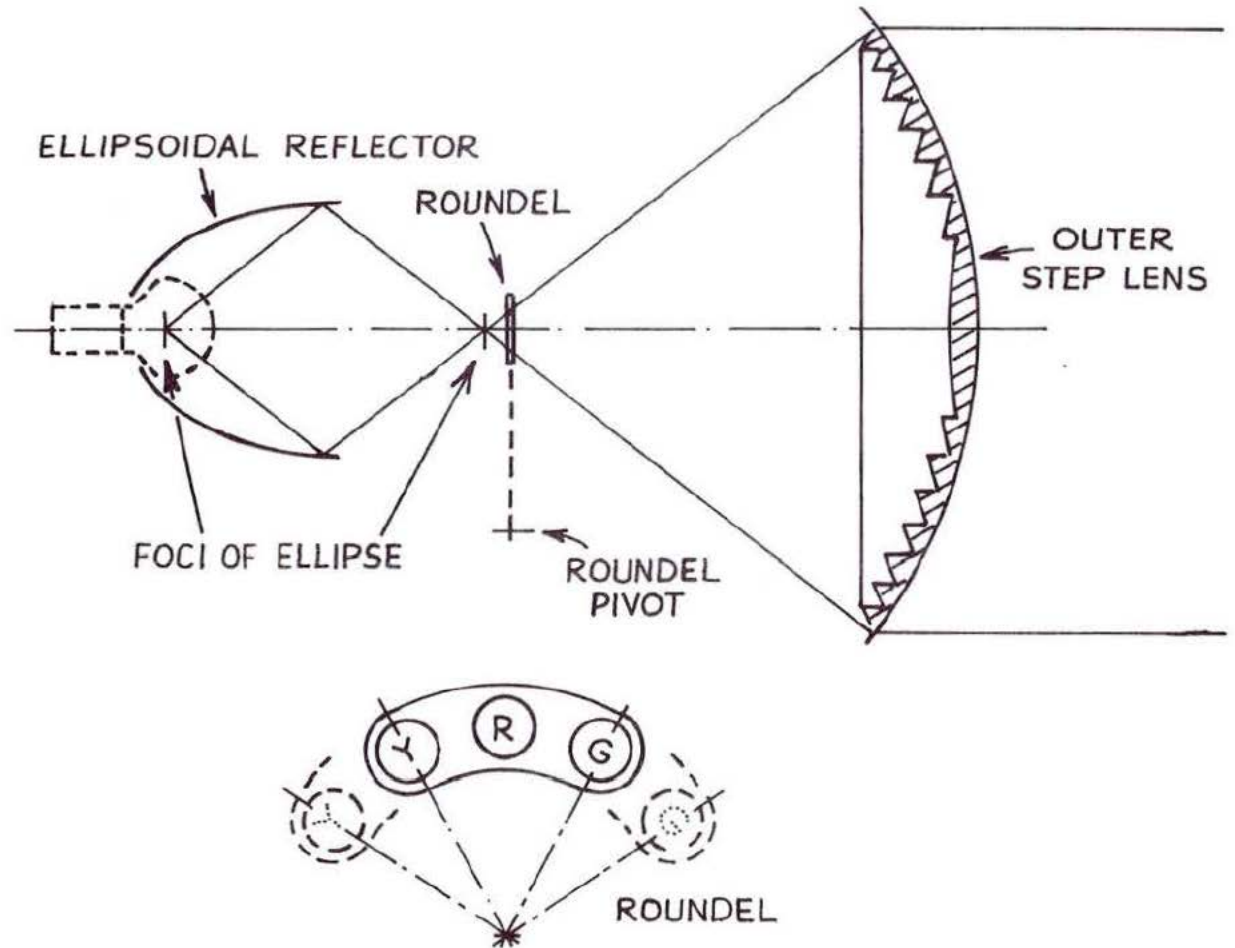
SEE ALSO FIGURE 4:4

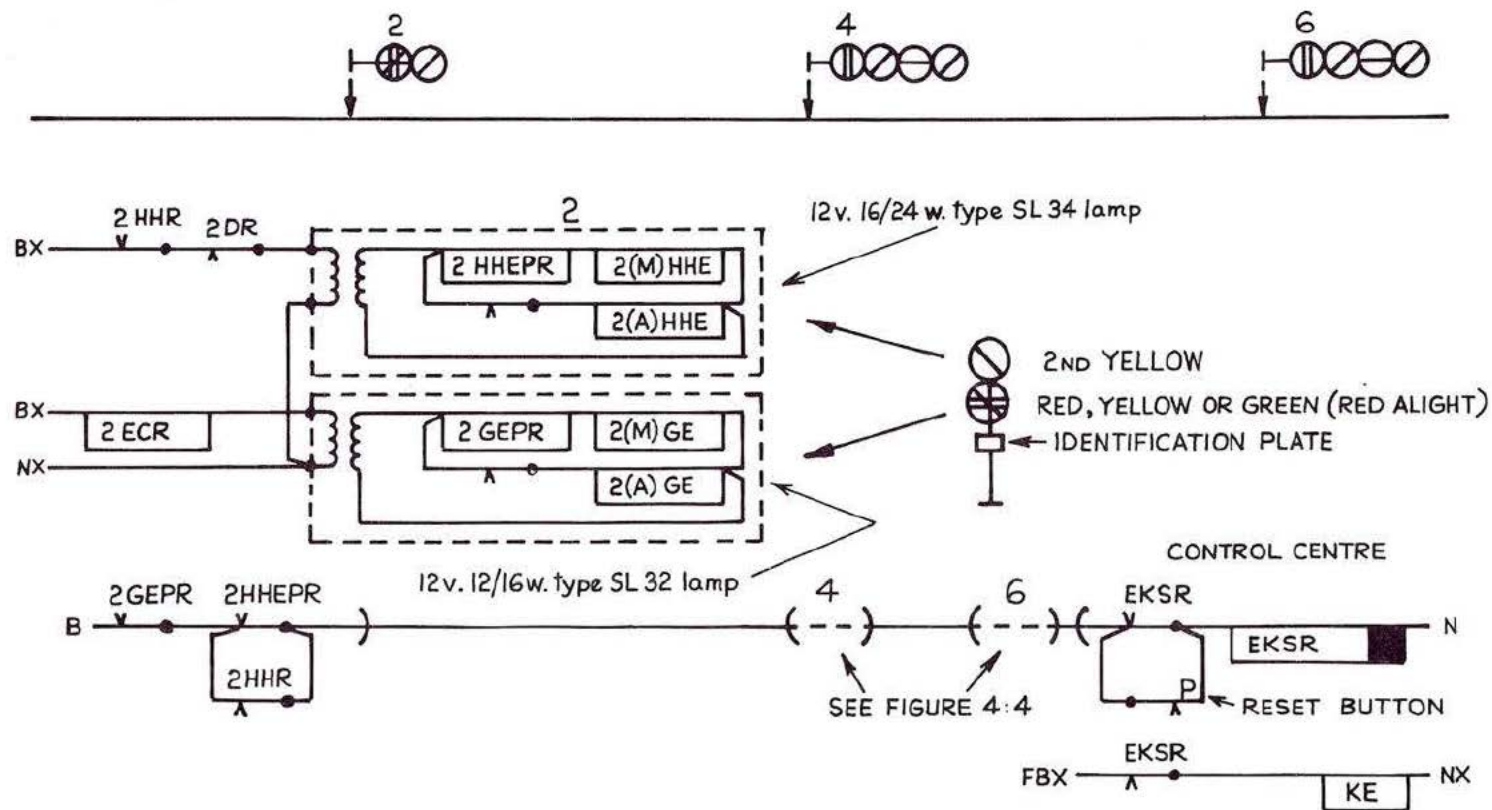
#### EQUIPMENT: RELAYS, SIGNALS AND POINT MACHINES

Fig. 4:6 shows the optical system used for searchlight signals. The design is based on the properties of an ellipse which has two focal points. If a mirror is ellipsoidal and a source of light is placed at the inner focal point, where the mirror will embrace most of the light from the lamp, all reflected light will pass through the outer focal point. Thus a small circular coloured roundel, placed near (but not at) the outer focal point will cause the reflected light to be similarly coloured. As shown in Fig. 4:6, by using this principle and passing the coloured light through an optical system, the output beam is coloured and if the roundel is changed by a relay type mechanism successively from Red to Yellow and Green, the result is a 3-aspect signal.

The searchlight signal has three advantages over the multi-lens signal. The optical system directs more light from the lamp into the beam and thus a lower wattage lamp may be used for the same beam intensity; it avoids the use of coloured lenses which are difficult to manufacture within the rigid limits required, and 'phantom' indications are not possible. The overwhelming disadvantage is that the roundel operating mechanism must be housed in the signal head itself, which is not a good environment for what must necessarily be somewhat delicate equipment. The operating circuit is also less straightforward than for a multi-unit signal. These reasons have led British Railways to restrict the use of searchlight signals to locations where site restrictions preclude the use of the multi-unit signal.

**Fig. 4:6** Searchlight signal:  
optical system

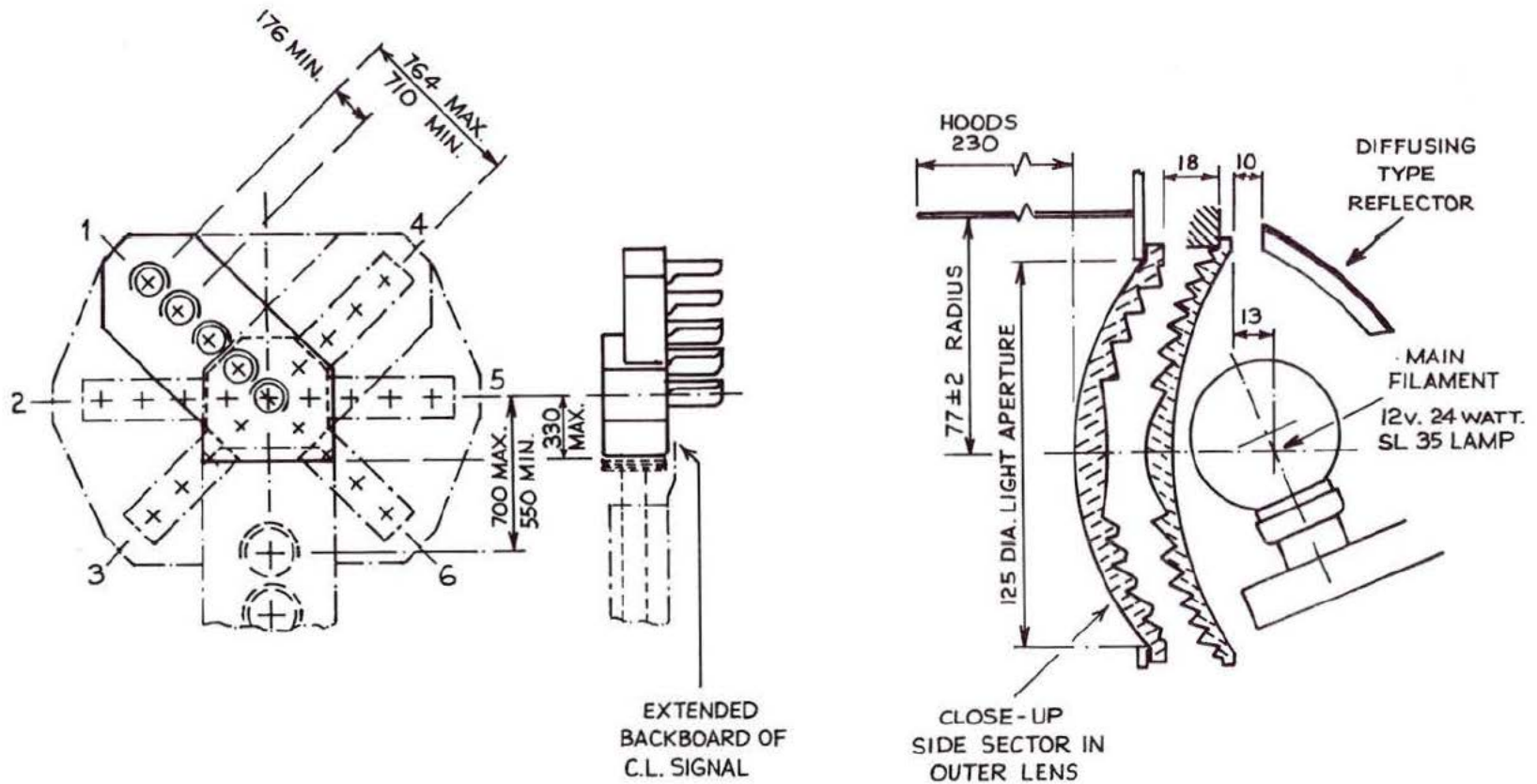




**Fig. 4:7** 4-aspect searchlight signal: lighting and main filament lamp indication circuit

Fig 4:7 shows the lighting and lamp indication for a 4-aspect searchlight signal. As the searchlight signal lamp is continuously alight, the ECR need not be slow release. Note the reduced wattage of the searchlight signal lamp due to the more efficient optical system.

The second Yellow unit uses a 12 volt 16/24 watt (5L 34) lamp which matches the 12 volt 12/16 watt (5L 32) lamp used in the searchlight unit.



**Fig. 4:8** Position light junction indicator and optical system

### Position Light Junction Indicator

The Position Light Junction Indicator, which is a British innovation, is the alternative, in multiple-aspect signalling, to geographical (or splitting) junction signals used in semaphore signalling and early

multiple-aspect signalling installations. It has already been briefly described earlier in connection with signalling at junctions. Fig. 4:8 shows the type now being introduced by British Railways,

The aim is simplicity. It ensures that the driver does not have

## EQUIPMENT: RELAYS, SIGNALS AND POINT MACHINES

to pass a Red aspect unless it is qualified by a subsidiary signal. The junction indicator does not apply to the 'straight' route, except, as previously seen, where the speed over the divergence is equal, or nearly so, to the speed on the straight route. Therefore, with this exception, when the train is not being diverted, the aspect displayed at the junction signal is the same as at any other signal.

Early junction indicators were of the 3-lamp type and the main signal was permitted to clear with only two lamps alight. The 5-lamp type not only gives a better aspect to the driver but a good indication is still provided if two lamps are out. As the junction indicator does not apply to the straight route, it is necessary that it should be proved alight before the main signal clears for a divergence. At least three lamps must be alight before the signal clears.

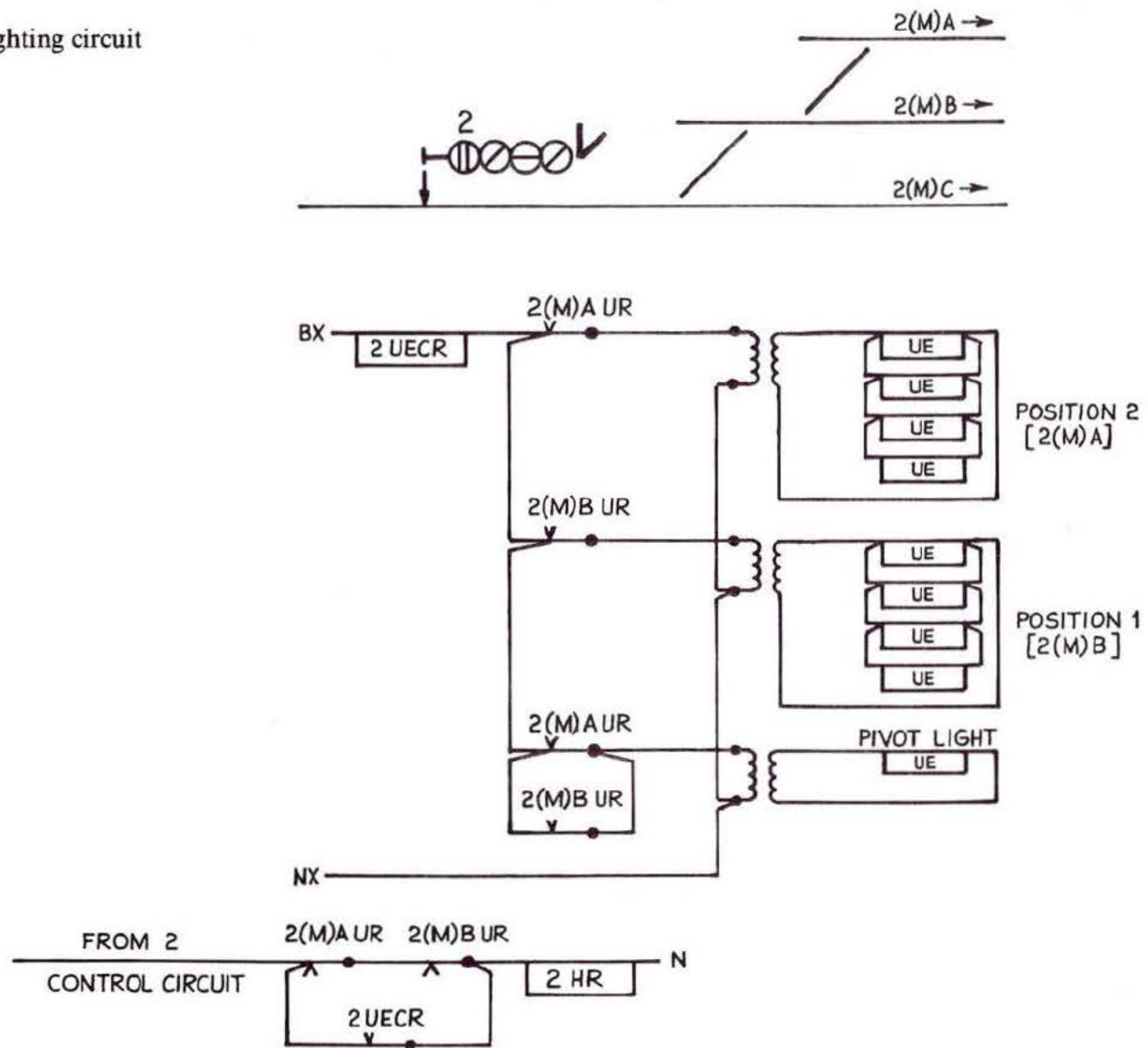
The high speeds, now common on British Railways and in particular the HST, which has a maximum speed of 200 km/h, has led to a review of junction signalling and the need for a junction indicator with a longer range than hitherto became apparent. The lamps previously used were the 110 volt 25 watt 5L 33 type. To increase the range it has been necessary to improve the optical system and use

a lamp with a shorter filament to concentrate more of the light output in the beam.

Fig. 4:8 shows the improved optical system which now consists of a doublet lens combination with, it will be noted, a small spherical reflector, and a 12 volt 24/24 watt 5L 35 type lamp. The outer lens also has a moulded prism for close-up indication. The main filament only is used because with the 'three out of five' rule, it is concluded that lamp burn-outs are adequately catered for. As the lamp is the same as that used in the multi-unit signal it assists emergency lamp replacements.

Fig. 4:9 shows the lamp circuit. It will be seen that the pivot light is common to all indications and has its own transformer except when only a single arm is used. Junction indicator lamps are not indicated separately into the Control Centre because they are necessarily included in main signal lamp circuit. Junction indicator lamps have a longer life than signal lamps because they are not in use for every train and they are generally approach released. In clear weather, the range at which the junction indicator aspect is recognisable is now reckoned to be 732 m (2400 ft).

Fig. 4:9 Junction indicator: lighting circuit



**Multi-Lamp Route Indicator**

This type of route indicator, which is also known as the theatre type, displays route indications in the form of number or letters formed by a lamp display. It is necessarily short range, and is used for slow speed movements made under the authority of main or subsidiary signals. With certain exceptions, the route indications are displayed for all divergencies and also for the straight route. The exceptions are the subsidiary signal acting as a shunt-ahead, and on high-speed routes where a junction indicator would be inappropriate, such as into platform lines, all of which are divergent from the straight high-speed route. In the former case, it is not displayed, and in the latter, the route indicator precedes the clearance of the main signal in the same manner as a junction indicator.

Fig. 4:10 shows the  $7 \times 7$  arrangement of lamps in a single unit. The character to be displayed is generally formed on a  $5 \times 7$  matrix as shown. Thus numbers 0 to 19 may be displayed on a single unit. For numbers 10 to 19, the figure 1 would occupy the extreme left-hand vertical column, the next column would be left blank and the units 0 to 9 would occupy the right-hand  $5 \times 7$  area. For numbers greater than 19 and where two letters are required, a second unit is mounted alongside the first. Letters M, N, W, X, Y and Z occupy the full  $7 \times 7$  matrix.

The indicator has a lunar-White front cover glass. In some cases, double-sided route indicators are provided; for instance, where a train, too long for the platform, has to stand with the forward part ahead of the starting signal. In such a case, the backward-facing indicator has an amber coloured cover glass to draw the driver's attention, and avoid any possibility of misunderstanding by drivers of incoming trains or men working on the track. The lamps are wired in parallel and brought into circuit by the UKR relays, one of which is provided for each route.

Care has to be taken to ensure that lamp burn-outs do not result in a mutilated indication which could be taken for another divergence, and cause the junction to be taken at too high a speed. This presents

a difficulty in circuit design, because the number of lamps required by the various indications varies considerably. For instance, the figure 1 requires only 7 lamps to be alight but the letter R requires 18.

An increment circuit as used in the junction indicator is not therefore practicable. However, the probability of a lamp burn-out causing an unfortunate mutilation of the intended indication is low. Nevertheless it remains important to replace failed lamps as quickly as possible.

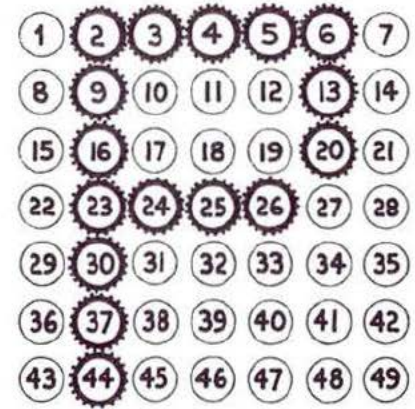
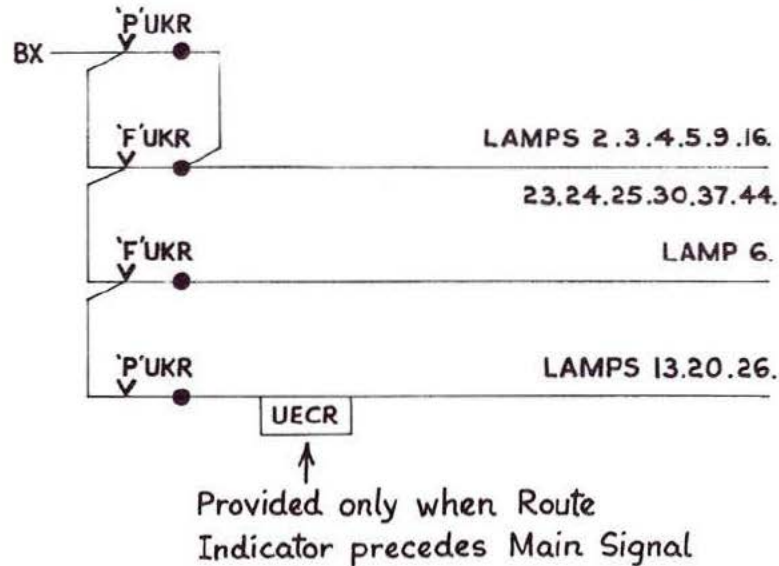
In cases where a lamp proving relay must be provided to prove the route indicator display before the main signal clears, it is considered sufficient that only a distinctive part of the display is proved. Each case must be judged on its merits. Lamps are 110 volt 15 watts morse tubular type. Where a route indicator applies to both main and subsidiary signals it is mounted above the main signal, but if it only applies to the subsidiary it is mounted immediately above it or alongside.

**Position Light Shunting Signal**

Shunting signals in early multiple-aspect signalling schemes were miniature ground colour light signals displaying Red/Green or Yellow/Green. This was abandoned in favour of the flood-lighted ground disc signal so that the many electro-mechanical installations then being carried out could comply with the power signalling standard by the addition of a flood-light unit to the existing shunt signals. Success abroad with the position (White) light signal led ultimately to its adoption in Great Britain for power installations. It had four advantages:

- (a) There were no moving parts.
- (b) The circuitry was simple.
- (c) It maintained the principle of displaying a shunting aspect by position and not by colour.
- (d) It was not necessary to clear facing shunt signals in the line of route as there was no Red aspect.

Fig. 4:10 Multi-lamp route indicator

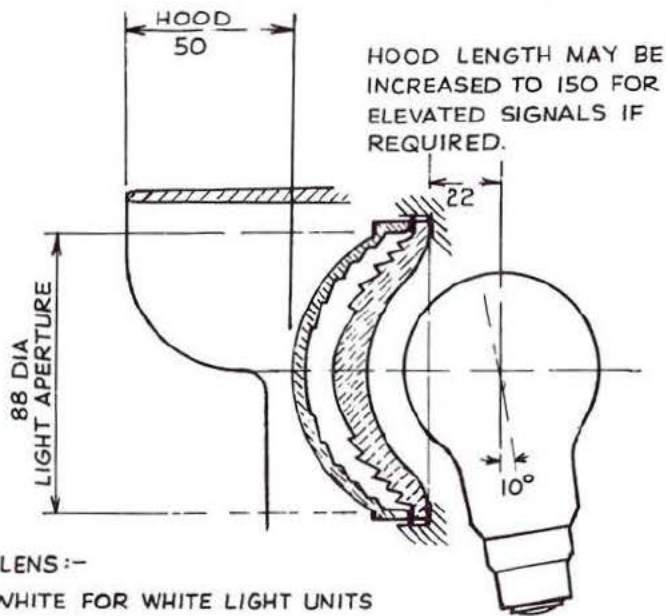


NOTE :- Lamps shown lighted are those required for 'P' and 'F'.

The last was of doubtful value because the clearance of facing shunts could in fact reduce the circuitry on the main signal and did not necessarily require separate action by the signalman in power installations.

Ultimately, however, British Railways decided that more 'stopping

power' was required and Red (or Yellow) lights were included in the ON aspect. The ON aspect is therefore horizontal Red (or Yellow) and lunar-White lights and the OFF aspect is two lunar-White lights at 45° in the upper left-hand quadrant.



OUTER LENS:-

LUNAR WHITE FOR WHITE LIGHT UNITS

CLEAR FOR RED OR YELLOW LIGHT UNITS

INNER LENS:-

CLEAR FOR WHITE LIGHT UNITS

RED OR YELLOW FOR COLOURED LIGHT UNITS

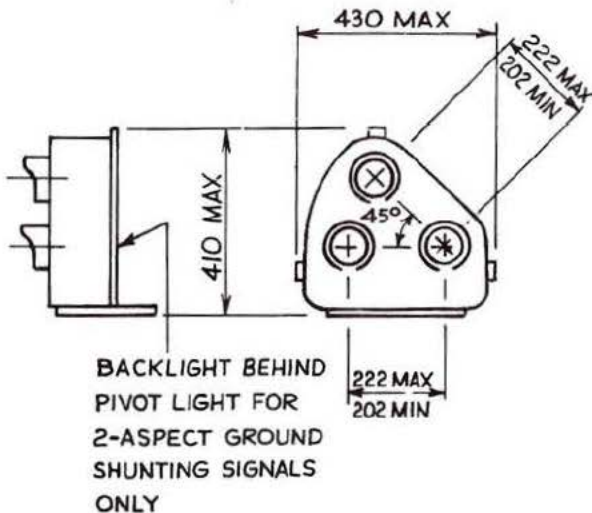


Fig. 4:11 shows the general appearance of a ground shunt signal and its optical system. Fig. 4:12 shows the control, lighting and indication circuits. Lamps are 110volts 35watts with a rated life of 4000 hours. The pivot lamp, which is permanently alight, also illuminates a backlight. The sole purpose of the backlight is to enable the signal to be located when approached from the rear at night.

Shunt signals are rarely fitted with route indicators, but where required, it is usual to use the stencil type mounted above the signal. In the stencil, each route indication has a separate compartment illuminated by two 110volt 60watt general service lamps mounted behind a screen backed by a stencil of the indication to be displayed. The Red lamp of the shunt signal is proved intact when it is acting as a limit of shunt in the opposite direction to the normal traffic flow, by all signals which lead up to it. Where propelling movements are frequent and there are sighting difficulties, shunt signals may be elevated to the driver's eye level. The backlight is then blanked out.

Referring to Fig. 4:12, it will be noted that in addition to the UCR 'operating' contacts (proving the route to be set and locked), de-energised contacts of ALSR prove that the approach locking will be operative after the signal has cleared. The reader should also study the ON indication (RGKE) circuit which is the same for all signals with minor variations. It will be remembered that provision has to be made for flashing this indication on the panel when the approach locking is being timed-out. The RGKE therefore has a steady supply for normal conditions and a flashing supply for the timing-out period.

Fig. 4:11 Position light shunting signal and optical system

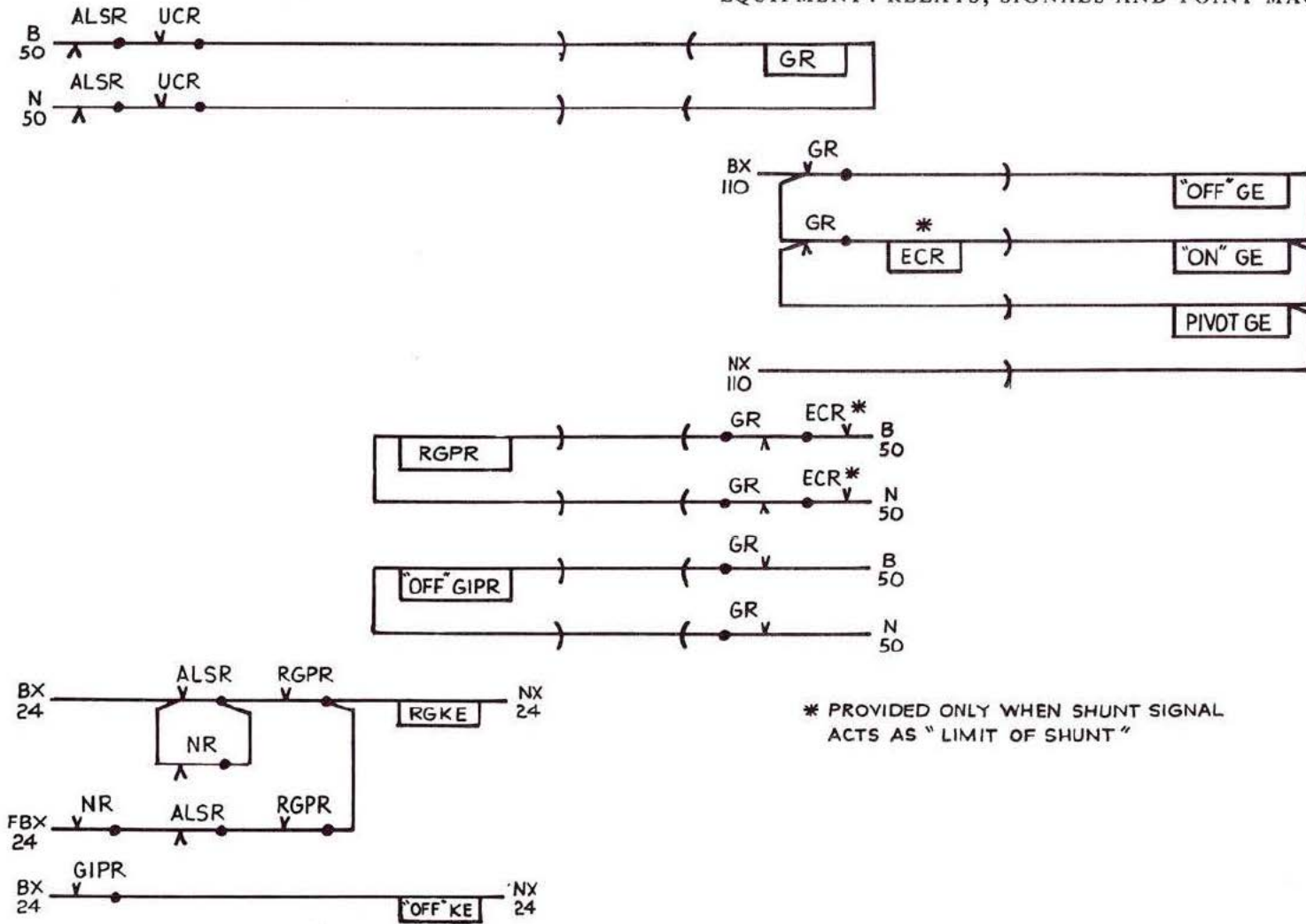


Fig. 4:12 Shunting signal: control, lighting and indication circuit

## EQUIPMENT: RELAYS, SIGNALS AND POINT MACHINES

It will also be remembered that, while the signal is replaced to Red on the occupation of the first track circuit ahead, the approach locking is not released until the berth track circuit is also clear or other similar conditions apply. The ALSR is down when the route is approach locked and up when it is free, but owing to the gap, this relay cannot be used by itself to differentiate between a steady and a flashing supply circuit to RGKE. To overcome this difficulty, in the steady supply circuit to RGKE, the energised contact of ALSR is bridged by a de-energised contact of NR, which is the relay which initiates route cancellation when the entrance button is pulled or the ALSR picks up.

If the signal is replaced to Red by the entrance button but the route is still approach locked, ALSR will be de-energised but NR will be up. This results in the flashing supply being applied to RGKE until the time interval has elapsed, after which ALSR picks up to connect the steady supply. This advises the signalman that the timing out of the approach locking has been completed. If the entrance button should be pulled immediately after the signal has been replaced to Red, but before the berth track circuit is clear, the RGKE will flash until the approach locking is released.

### Position Light Subsidiary Signal

This signal is always associated with a main signal, and is mounted below it on the same post or alongside it if on a bracket or gantry. It is identical in construction with the shunting signal except that it has no ON aspect, this being provided by the Red aspect in the main signal, thus maintaining the principle that a driver making a 'running' movement should not have to pass a Red aspect except in the case of failure. As the Red aspect of the main signal is at driver's eye level, the subsidiary signal must be mounted well below and it is therefore usually tilted slightly upwards.

Fig. 4:13 shows typical control, lighting and indication circuits. The subsidiary signal may have draw-ahead and shunt-ahead functions, and each is provided with a separate GR; the control circuit

is meshed with the main signal circuit. In certain circumstances, it may be necessary to prove the route indicator alight before the subsidiary or the main signal clears. A proving relay UECR is then provided locally as shown. Where a route indicator is provided for the main signal, it is of the multi-lamp type mounted above and it applies also to the subsidiary signal. If it is only the subsidiary signal that requires a route indicator, this is usually of the stencil type as previously described; it is then mounted below the main signal in association with the subsidiary signal. Lamps are 110 volt 35 watts as for the shunting signal. No backlight is fitted.

### Electric Power Point Operation

When points are power-operated, there is nowadays no distinction between facing and trailing points and all points are treated as facing so far as equipment is concerned. Points have been operated by electric or electro-pneumatic point machines since the inception of power operation. These conventional methods rely for their success on the maintenance of the gauge by the permanent way engineer. If the track should spread and as a result the switch rail does not fit tightly up to the stock rail, the point detection circuit will not be completed and the signal will not clear. This is a common failure experienced by the signal engineers until new permanent way has settled down. This has led to the introduction of the clamp lock by British Railways in which the switch rail on the closed side is clamped to the stock rail. If the gauge now spreads, the switch rail and stock rail move together and no failure occurs. No question of safety is involved as the gauge could spread by as much as 20 mm without danger.

Electro-pneumatic operation requires two sources of power, namely electric and air. The latter involves the provision of compressors, storage tanks and pipe runs together with standby facilities. While it remains a solution which is available, British Railways have now standardised on all-electric operation, with a current tendency to introduce the clamp lock instead of the electric point machine as experience grows.

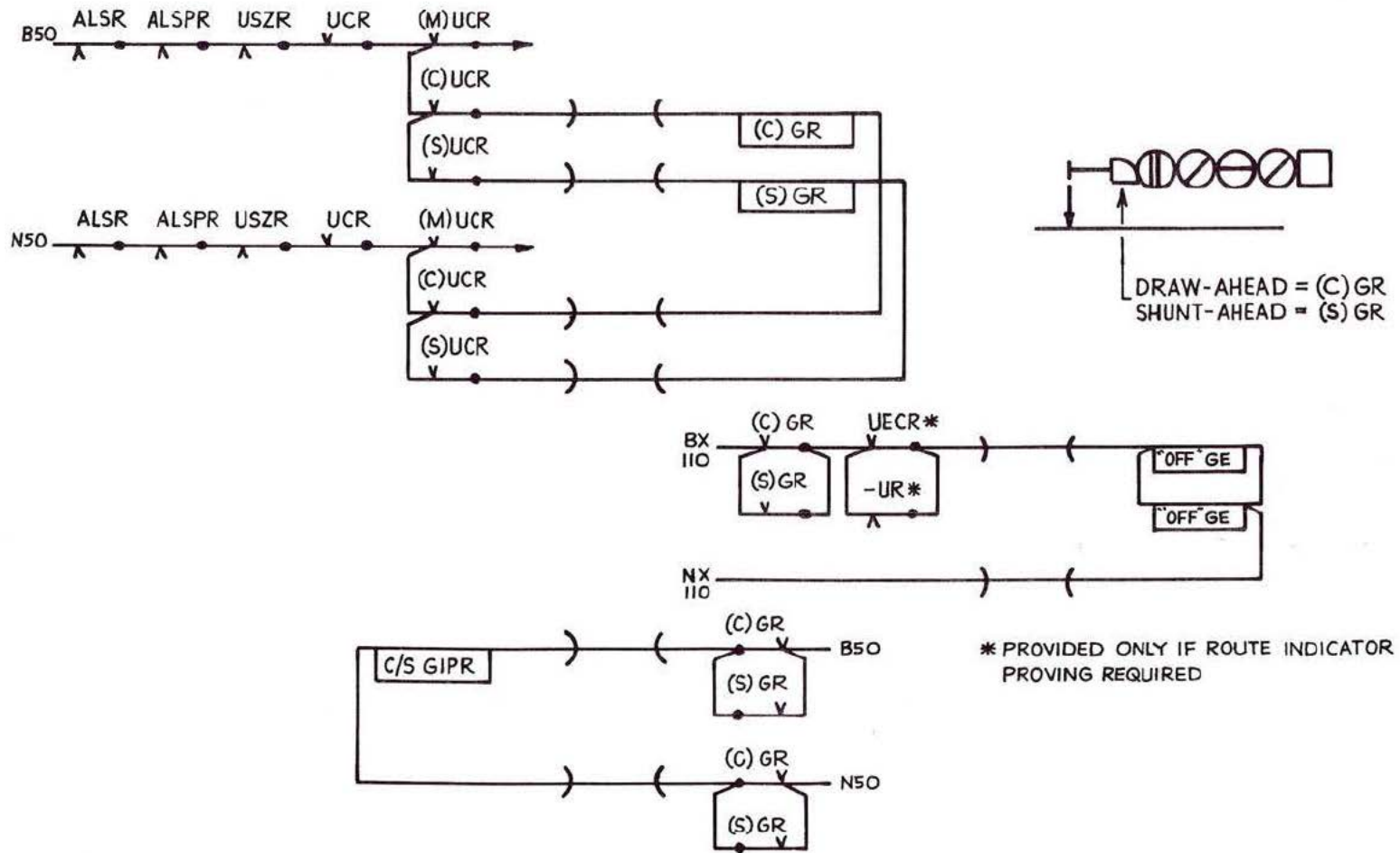


Fig. 4:13 Position light subsidiary signal : control, lighting and indication circuit

## EQUIPMENT: RELAYS, SIGNALS AND POINT MACHINES

As in mechanical signalling, it is a requirement that a separate stretcher bar shall be fitted between the switch rails, as near to the tips of the switches as is practicable for locking facing points in position during the passage of a train. In power signalling today a facing point lock in the 'four-foot', with a locking plunger engaging directly with this stretcher bar, is rarely used. The lock stretcher is now extended into the point machine, where locking takes place. In addition, it is required that both switch blades shall be continuously detected.

The sequence of operations in power working is therefore:

- (a) Unlock the points, by withdrawal of the lock plunger from the stretcher bar, noting that immediately the lock plunger begins to move the point and lock detection circuit is disconnected.
- (b) The points are driven across from normal to reverse, or *vice versa*.
- (c) The points are re-locked in their new position, the last movement of the locking plunger completing the detection circuit in the new position.

### Point Drive Equipment

Within the point machine, the rotation of the motor must be converted to two separate linear movements at right-angles to unlock, throw and re-lock the points. This requires some form of escapement mechanism. Fig. 4:14 shows one type. In this arrangement, the motor drives a ballscrew actuator through a gear train. The actuator moves the drive slides steadily from fully normal to the fully reverse position (or *vice versa*). The first movement withdraws the normal lock dog from the normal notch in the lock blades. Then a roller on the drive slide engages with the escapement to drive the throwbar and move the points, after which the drive slide inserts the reverse lock dog into the reverse notch in the lock blades. This is known as a 'straight through' movement.

Fig. 4:15 shows another arrangement. In this, the gear train has a final bevel wheel carrying a roller which engages with the escapement. The first movement of the roller drives the locking bar, which withdraws the lock dog from the lock blades. It then engages with the escapement (part of the throwbar) and drives the points. Finally, it returns the locking bar to its original position thus inserting the lock dog into the reverse notch in the lock blades. This is known as an 'in and out' mechanism.

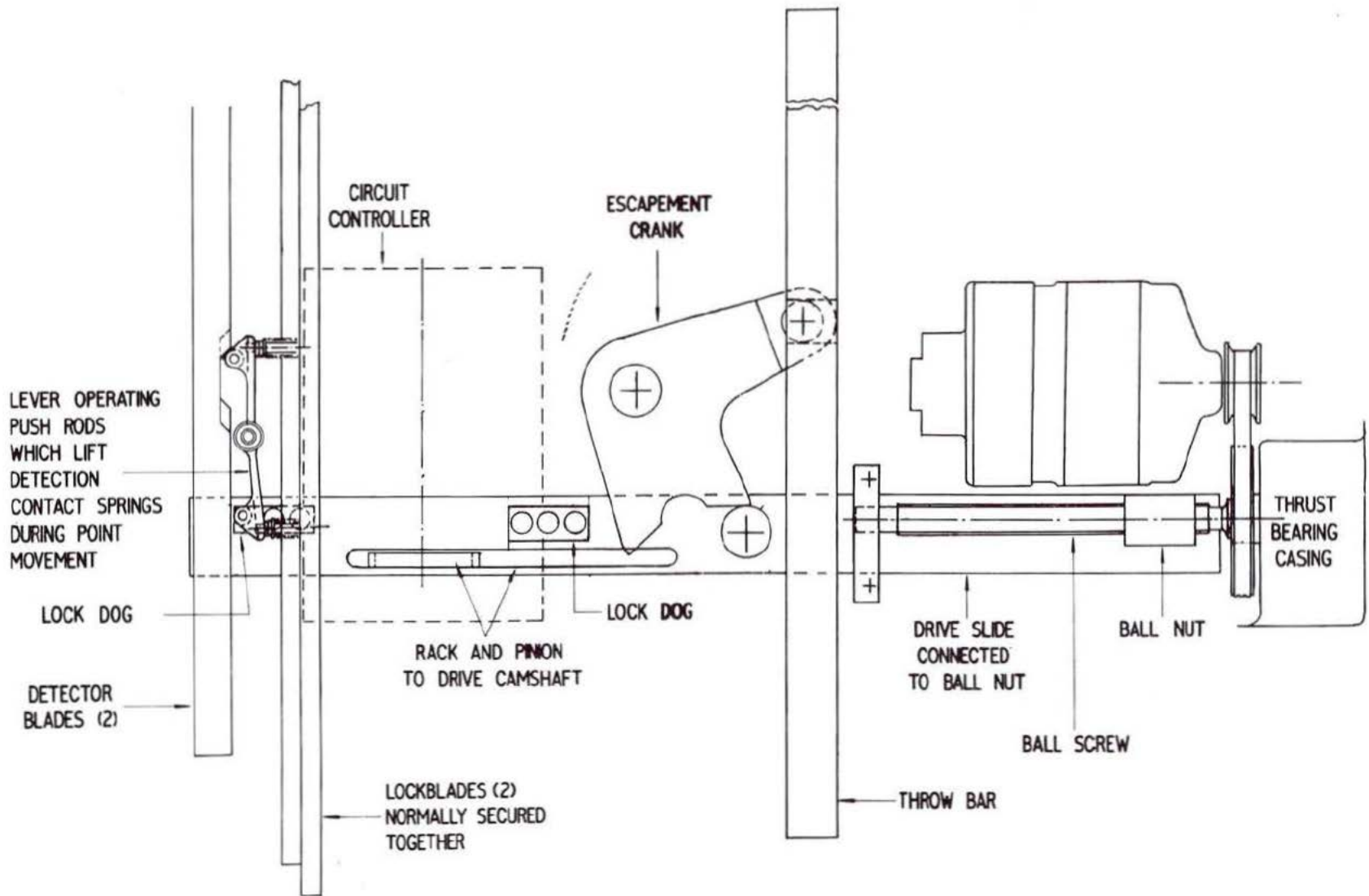


Fig. 4:14 Point machine drive and lock movement: 'straight through'

## EQUIPMENT: RELAYS, SIGNALS AND POINT MACHINES

Other essential parts of an electric point machine are:

- (a) a spring clutch having friction discs to avoid overloading the motor if the movement of the points should be held by an obstruction;
- (b) a 'snubbing' device, which may be electrical (e.g. a low resistance shunt) or magnetic, to bring the motor to rest without damage at the end of the movement;
- (c) motor contacts which reverse the connections and enable the direction of movement to be reversed at any time during the point movement;
- (d) contacts which detect the correct position of each switch rail and the lock bar when the movement has been completed;
- (e) a means of hand cranking the machine in emergency, incorporating contacts which isolate the motor electrically when the hand crank is in use.

The methods by which (c) and (d) are achieved vary with the manufacturer.

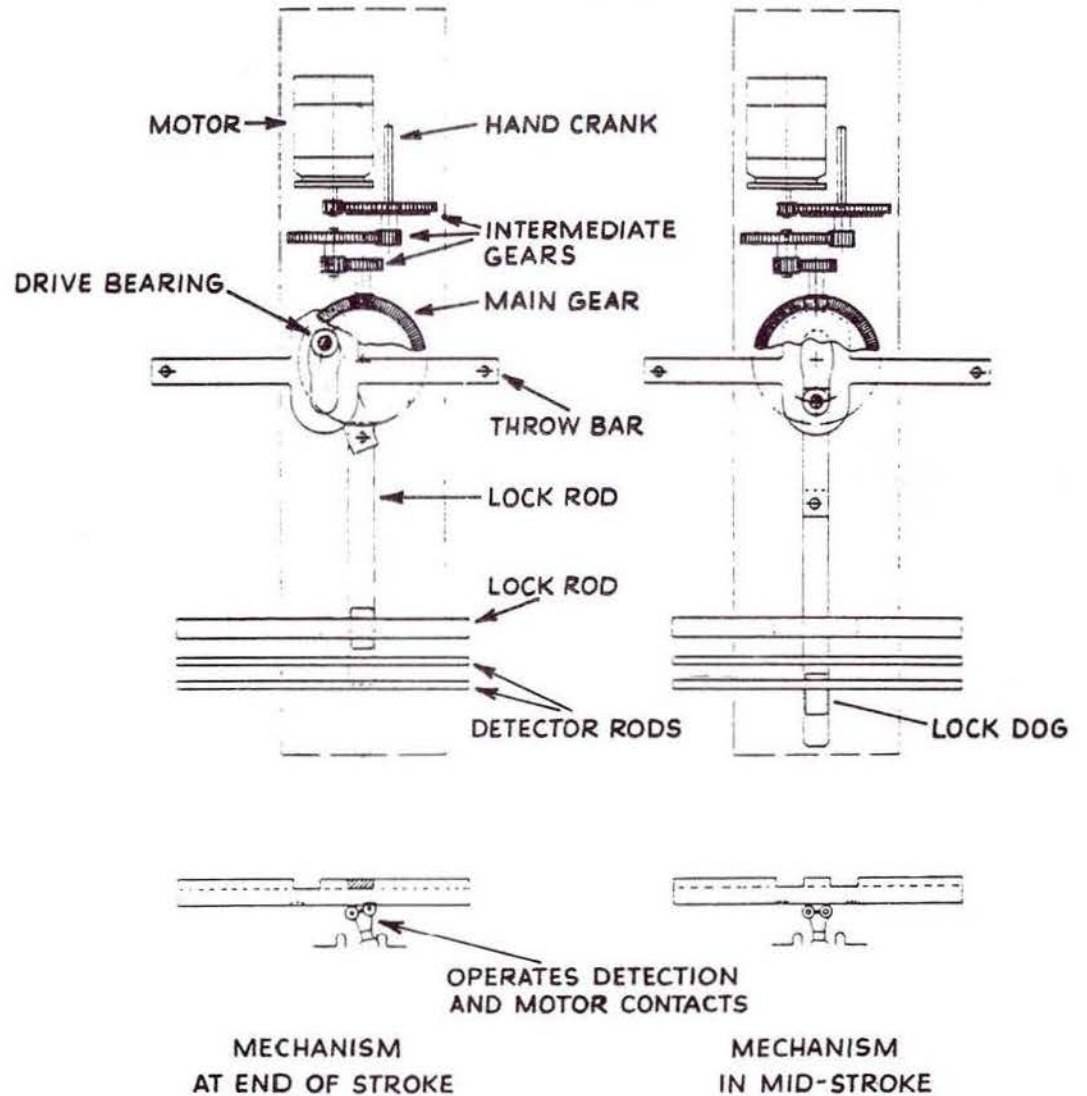
In the 'straight through' mechanism shown in Fig. 4:14, a contact camshaft is driven by a rack and pinion. When the lock slide moves, the camshaft rotates and causes the detection contacts to lift and break the detection circuit. When the points begin to move, rollers in contact with the detector blades maintain the detection contacts

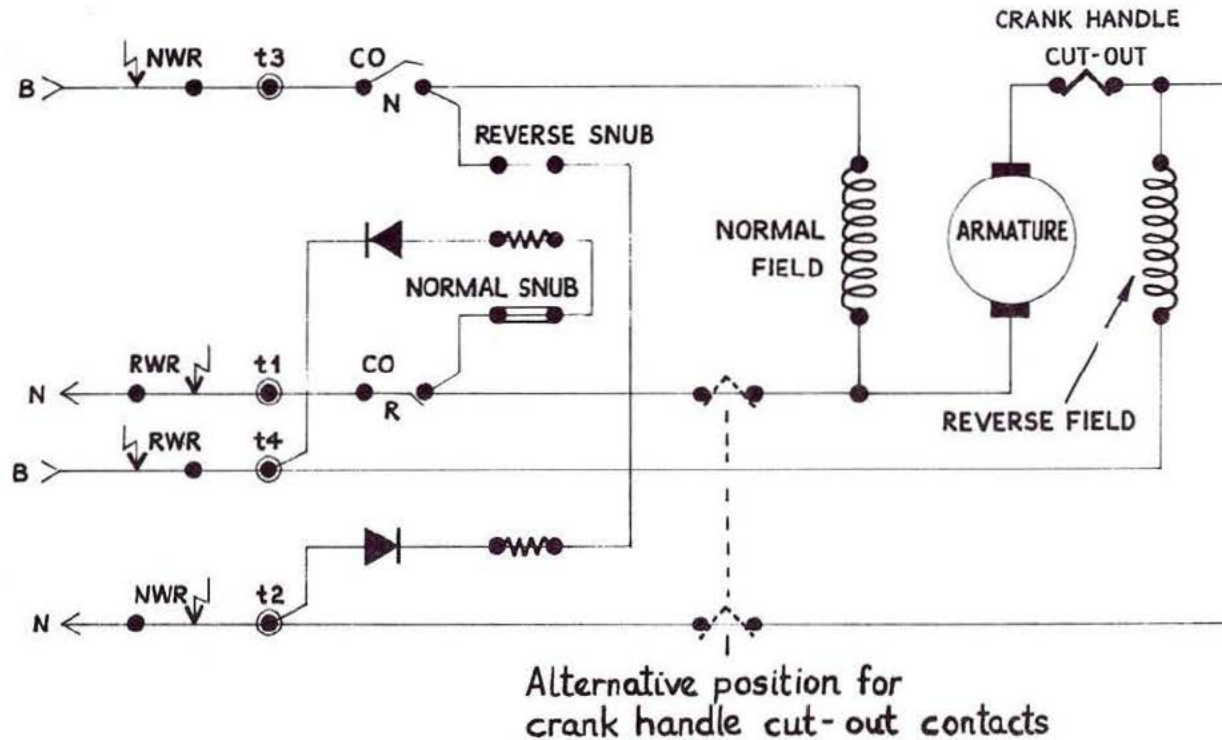
(i.e. the moving springs) in the raised position until the end of the point movement, and then the 'opposite' contacts will make, provided each switch rail is in the correct position and the points have been locked, the latter having been proved by the rotation of the camshaft. Thus a single pair of contacts prove not only that the switch rails are correctly in position but also that the points are locked.

In the 'in and out' mechanism shown in Fig. 4:15, the moving detection contacts are carried on a rocker assembly which is operated by rollers. These engage in notches in the upper edge of the detector and lock rods, both of which must be in the correct position for the detection contacts to make. The first movement of the lock bar disconnects the detection circuit.

The point machine motor, which starts on load, is ideally a series field machine because high starting torque is needed; but in AC electrified areas where protection is needed against stray traction current, it is now British Railways' practice to use a machine with a permanent magnet field which is an effective protective measure against false operation. The permanent magnet machine is, in effect, a shunt field machine which does not have the inherent high starting torque of the series machine. The armature is therefore designed to take more current. Fortunately, a point machine has a short light load period at starting (i.e. during unlocking).

**Fig. 4:15** Point machine drive and lock movement: 'in and out'





**Fig. 4:16** Split field point machine: 4-wire operating circuit

There are therefore two types of machine in use and several varieties of each according to the particular manufacturer. Taking first the series wound machine, the operating circuit must provide reversal facilities and cut-off contacts, so that when the points have been thrown and the lock re-engaged, the circuit is ready for the points to be driven back to their original position. The machine must also be capable of reversal in mid-stroke in case an obstruction prevents the movement being completed. Fig. 4:16 shows the British

Railways' standard 4-wire circuit for the operation of points by the series field machine. There are two field windings: one for operation in each direction. This simplifies the operating circuit considerably. The alternative is a 'pole-changing' type of circuit which is now rarely used. Relays NWR and RWR have heavy duty contacts with magnetic blow-outs to take the heavy motor current. The cut-off and snub contacts are operated by the machine itself.

EQUIPMENT: RELAYS, SIGNALS AND POINT MACHINES

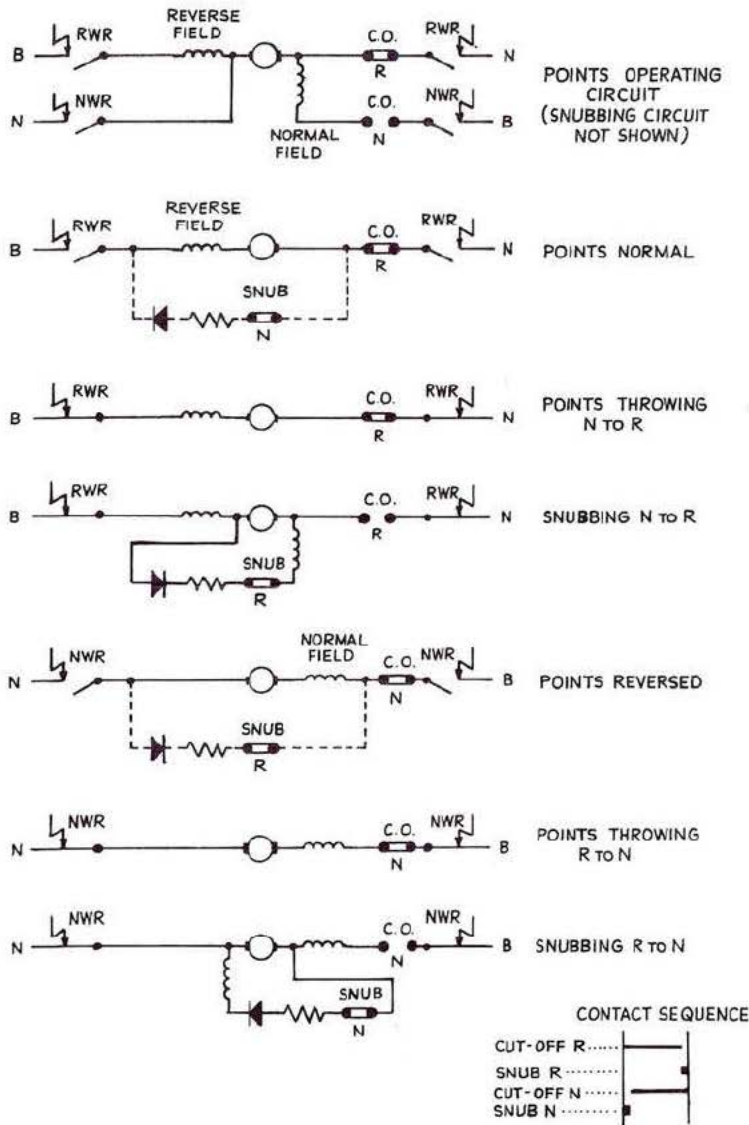


Fig. 4:17 shows the sequence of making and breaking the machine-operated contacts and the general circuit operation. If the points are normal, contact CO-R is closed so that when RWR operates the motor will operate via the reverse field winding. Near the end of the stroke, CO-R breaks and the snub-R contact makes to connect a resistance across the motor to form a dynamic brake and absorb the energy in the motor. This is important since the motor, during the re-engagement of the lock, is on light load and must be braked before the escapement reaches the end of its movement. The CO-N contact having been made soon after the machine started, the circuit is now ready for a movement from reverse to normal. In fact, as soon as both CO contacts are made during the initial movement the machine may be reversed. The rectifiers in the snubbing circuit avoid the provision of special contacts to disconnect it after the motor has been brought to rest. It should be noted that the snubbing circuit uses the opposite field winding to that used when the machine was acting as a motor. The 4-wire circuit has considerably simplified the design and reduced the number of machine-operated contacts required.

Point machines operate in an 'earthy' environment and the operating circuit needs to be protected against contact with any extraneous source of supply. Many methods have been used but the simplest and most effective is to double-cut the operating circuit and provide an efficient earth leakage detector which will give a warning immediately if either side of the point machine supply develops a low resistance to earth.

The following data on point machine operation, which must be regarded as typical, will be of interest:

Fig. 4:17 Split field point machine: operating circuit sequence

EQUIPMENT: RELAYS, SIGNALS AND POINT MACHINES

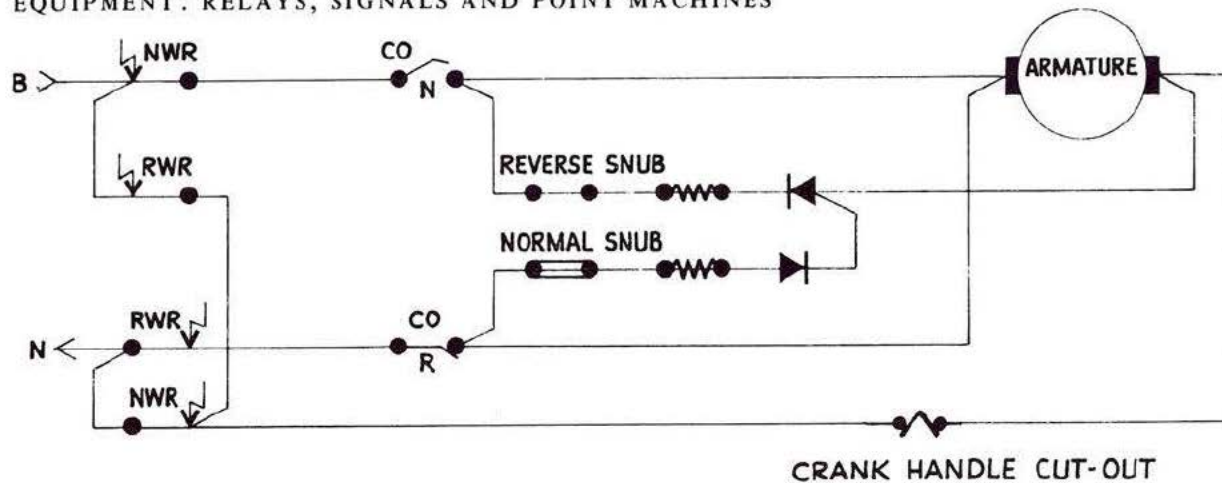


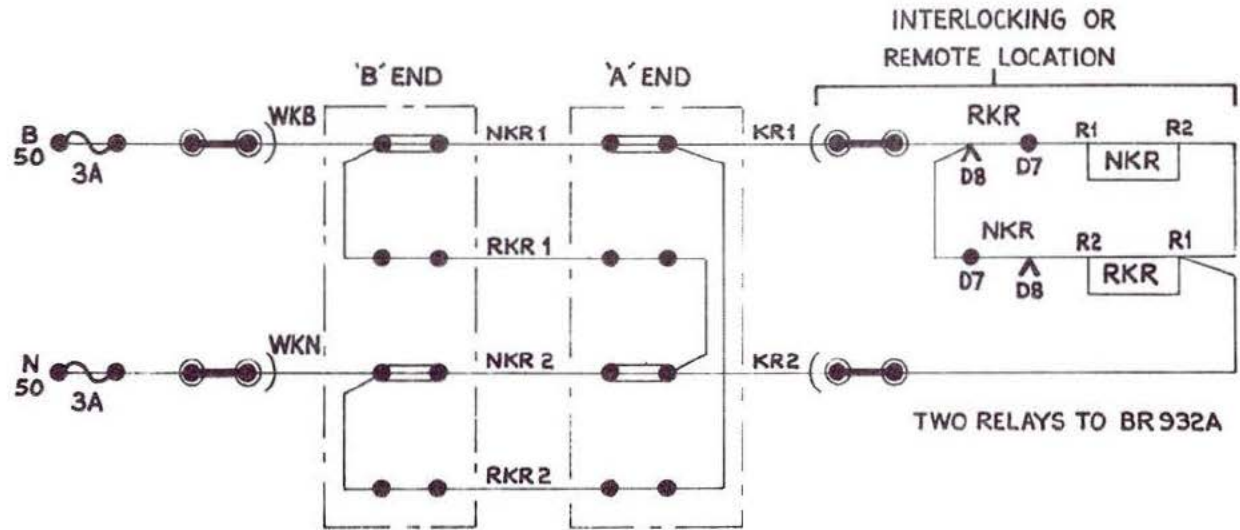
Fig. 4:18 Permanent magnet point machine: operating circuit

Supply voltage (nominal):	110DC
Starting current surge:	20 amps (Series field machine) 40 amps (Permanent magnet machine)
Running current:	3-7 amps (Series field machine) 4-12 amps (Permanent magnet machine)
Snubbing current	About 15 amps maximum
Load imposed by F.B. switches in typical adjustment:	275 kg (600 lbs)
Point switch opening:	108 mm (4.25 in.)
Point machine drive stroke:	127-152 mm (5-6 in.) according to type of machine.
(The difference of 19-44 mm ( $\frac{3}{4}$ - $1\frac{3}{4}$ in.) is taken up by a 'lost motion' coupling to the drive stretcher.)	
Point machine lock plunger stroke:	102 mm (4 in.) for 'straight through' lock 157 mm (6 in.) for 'in and out' lock

The load on the point machine when moving a set of switches is dependent on their adjustment. The normal or static position of a pair of switches connected by stretchers is at mid-stroke. Therefore, in closing the switch rail against the stock rail, the load on the point machine increases, but in moving from the closed position, the natural spring in the switches assists the machine. These are, however, ideal conditions and generally a greater load is imposed on one side than on the other.

Fig. 4:18 shows the operating circuit of the permanent magnet point machine. The direction of movement is determined by the direction of current through the armature. The cut-off and snubbing contacts operate in a similar manner to those in the split field machine.

**Fig. 4:19** Electric point machine: detection circuit



### Electric Point Machine Detection

All forms of point and lock detection are mechanical. In the purely mechanical detector, the signal slide cannot be pulled through the detector unless the position of both switch blade and the lock blade indicates that the points are correctly in position and locked. In the electrical detector, the same mechanical test must be passed, in a different form, before the electrical contacts can be permitted to close. The tight limits set by British Railways for the adjustment of detectors preclude the use of direct-acting contacts, because part

of the movement must be used to build up pressure on the contact springs. The contacts must therefore be operated by some intermediate mechanism by which, having passed the test, the contact springs are moved independently of point travel. Fig. 4:19 shows the detection circuit for a double-ended set of points. It should be noted that for each end there must be two normal and two reverse contacts: one pair for each end. The contact-operating mechanism ensures that the contacts cannot be closed until the points are locked in position.

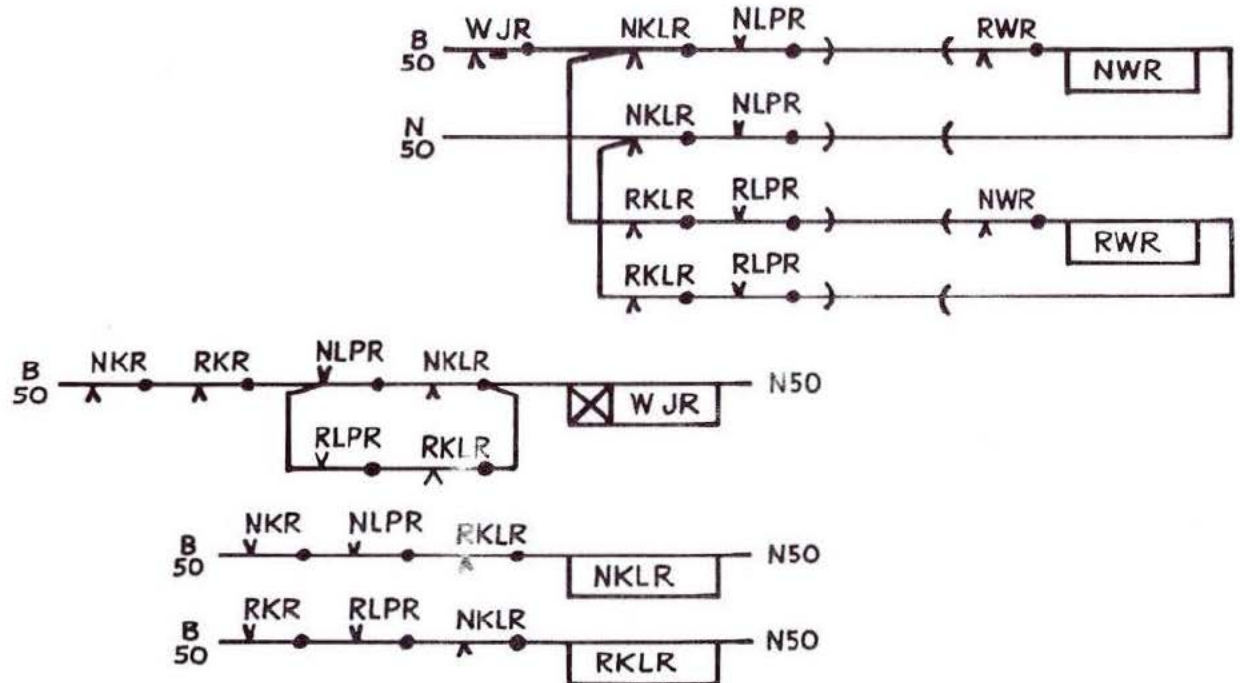
**Point Control Circuit**

Fig. 4:20 shows a point machine control circuit which applies to any type of machine. When it is desired to move the points, the appropriate NLR or RLR relay is energised, either as a result of setting the route by the entrance and exit buttons or by the use of the individual point key. Assuming that the points are free and it is required to move them to the reverse position, both contactor relays NWR and RWR will be de-energised. When relay RLPR is energised, RWR will pick up via WJR down, RKLR down, RLPR up, and NWR down. Relay RKLR is a repeat of RKR and RLPR (itself a repeat of RLR) and NKLR and NLPR are the same in the opposite sense. The energisation of RWR will move the points to the reverse position as has already been seen. On the energisation of RLPR, WJR will be energised via RLPR up, RKLR down but will not operate for 7-9 seconds.

Normally, during this time, the point machine would complete

its movement before WJR picked up; but in the event of an obstruction, the motor would continue to run on the clutch, which is obviously undesirable. In a route setting installation, this might not be noticed by the signaller immediately and WJR is provided for the purpose of disconnecting the contactor relay and cutting off the supply to the point machine. If the signaller, seeing that the route has not been set up, then uses the individual point key to restore the points to the normal position, RLPR drops away and releases WJR before NLPR picks up. The energisation of NLPR again energises WJR and the process begins again. Strictly, this circuit would operate satisfactorily if the RWR were energised by RLPR alone; but in geographical circuitry, a certain amount of vital relay proving is considered desirable, and hence in this circuit the KLR, NKR and WR relays are proved to have released. If the points reverse in the normal manner, RKR picks up and RKLR releases RWR to leave the point operating circuit 'double-cut'.

Fig. 4:20 Point machine control circuit



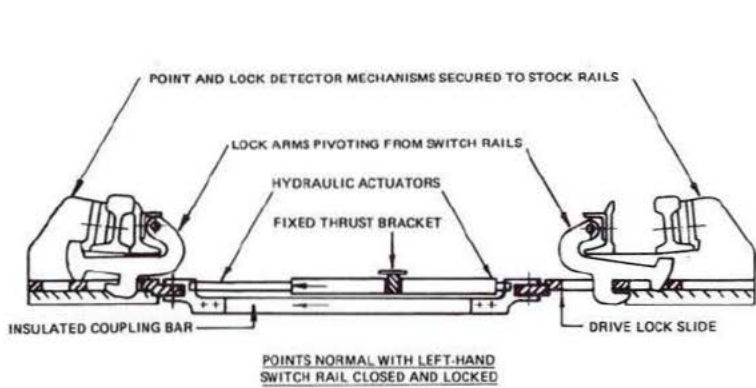
**Electro-Hydraulic Point Machine, with Rail Clamp Locks**

The advantages claimed for the clamp lock over conventional methods of operating and locking points have already been discussed. When the clamp lock was first introduced by British Railways it was associated with a hydraulic drive mechanism, but with simple modifications it could be used with electric, electro-pneumatic or even mechanical operation. It is also capable of being used as a trailable machine. So far, however, there has been no demand for anything other than electro-hydraulic non-trailable operation. Fig. 4:21 shows the general principle of operation. The layout consists of two clamp locks, an insulated drive coupling bar and two single-acting hydraulic actuators attached to a centre mounted thrust bracket, which is attached to the insulated sole plate. Each clamp lock comprises a lock body attached to the stock rail incorporating a drive-lock slide and electric detection; attached to the switch rail is a bracket carrying a lock arm and a point detection blade. The drive-lock slide, supported by the lock body unit and working below sleeper level, is driven against a hook-shaped lock arm which is pivoted from the switch rail to swing vertically and arranged to pass under the associated stock rail. When the switch rail is fully closed, the lock arm lifts behind the stock rail to clamp and lock the two rails firmly together. The coupling bar connecting the two drive-lock slides pulls on the opposite side to release its lock and retain its switch rail open.

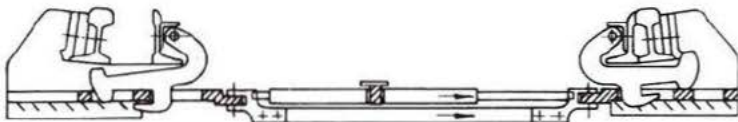
For each clamp lock, electrical detection of its switch rail and drive-lock slide is effected by double-pole high grade commercial sealed limit switches. The 'points closed' contacts can only make when the two linear cams, one on the point detection blade and

the other on the drive-lock slide, are in their correct positions. The 'points open' contacts can make only when the cam on the point detector blades has moved to a position corresponding to the minimum point opening. The left-hand limit switch in each clamp lock detects 'points closed' and the right-hand switch detects the 'points open'. The electrical detection circuit is shown in Fig. 4:23. The equipment is designed for use on BR standard track, although adaptor plates permit its use on other rail sections and track fastenings, having switch rails coupled with stretcher bars. However, it would function on points on which the switch rails are not so coupled and, in these circumstances, the mechanism would unlock, should the points be trailed.

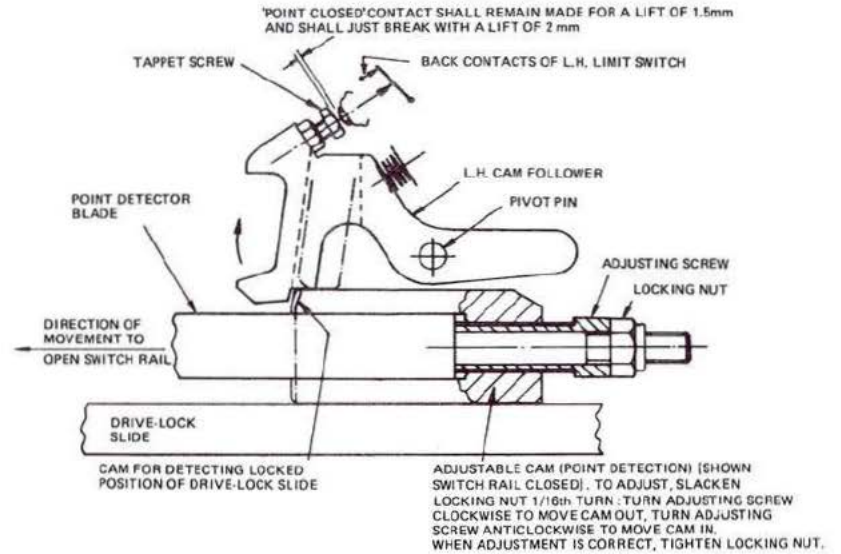
The hydraulic actuators are single-acting thrusters with spigot location at each end having retaining cotter pins. They have a maximum stroke of 213 mm ( $8\frac{3}{8}$  in.), but the equipment is adjusted for a working stroke of 210 mm ( $8\frac{1}{4}$  in.) which gives a nominal point opening of 108 mm ( $4\frac{1}{4}$  in.). The power pack is mounted on a concrete base situated at a convenient position close to the switches. It consists basically of a reservoir, a motor-driven pump and normal and reverse control valves arranged as shown in Fig. 4:24. An interlocked cut-out switch isolates the electrical control to enable a hand pump to be used in emergency. In the event of the points being obstructed during movement, a pressure relief valve returns the hydraulic fluid to the reservoir. The actuator in use (i.e. on the closed switch side) is under pressure but when the points are being moved, the hydraulic fluid is returned to the reservoir when hydraulic pressure is applied to the other actuator. Fig. 4:22 shows the control circuit, which is similar to that for the electric point machine.



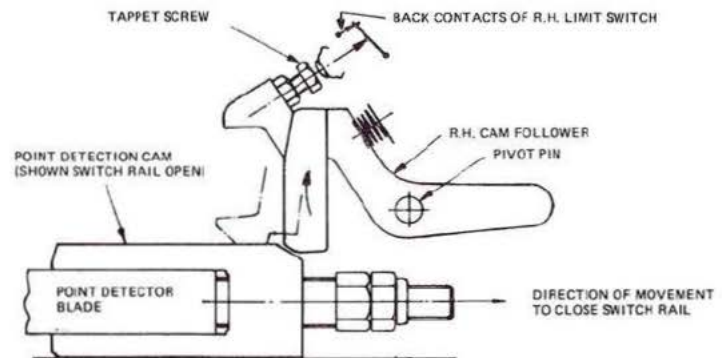
INITIAL MOVEMENT FROM LEFT TO RIGHT HAS UNLOCKED POINTS AND CONTINUED MOVEMENT WILL THROW POINTS REVERSE



POINTS REVERSED, COMPLETE MOVEMENT FROM LEFT TO RIGHT HAS CLOSED AND LOCKED THE RIGHT-HAND SWITCH RAIL



'POINT CLOSED AND LOCKED' DETECTION



'POINT OPEN' DETECTION

Fig. 4:21 Rail clamp lock : principle of operation and detection

EQUIPMENT: RELAYS, SIGNALS AND POINT MACHINES

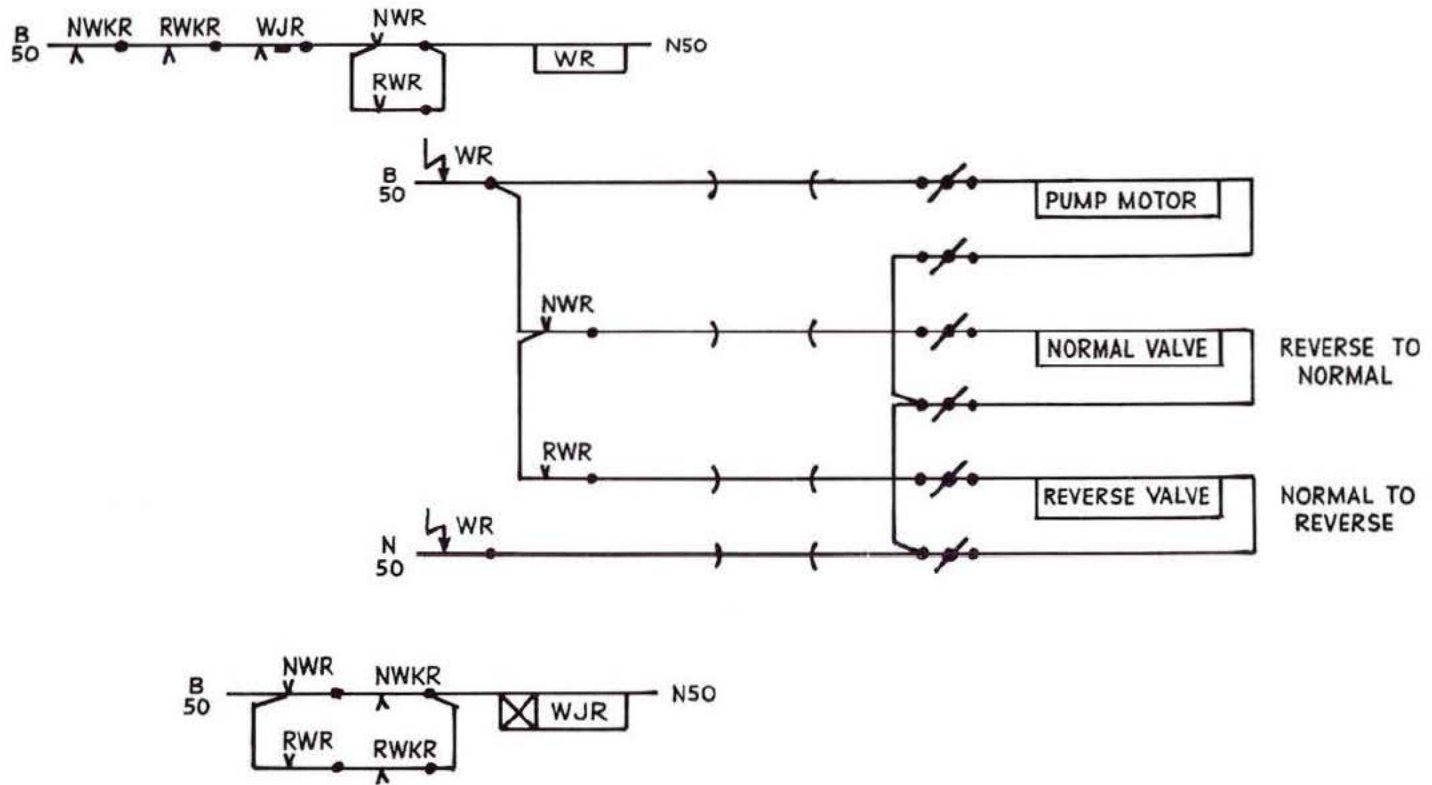


Fig. 4:22 Electro-hydraulic point machine (clamp lock type): control and drive circuit

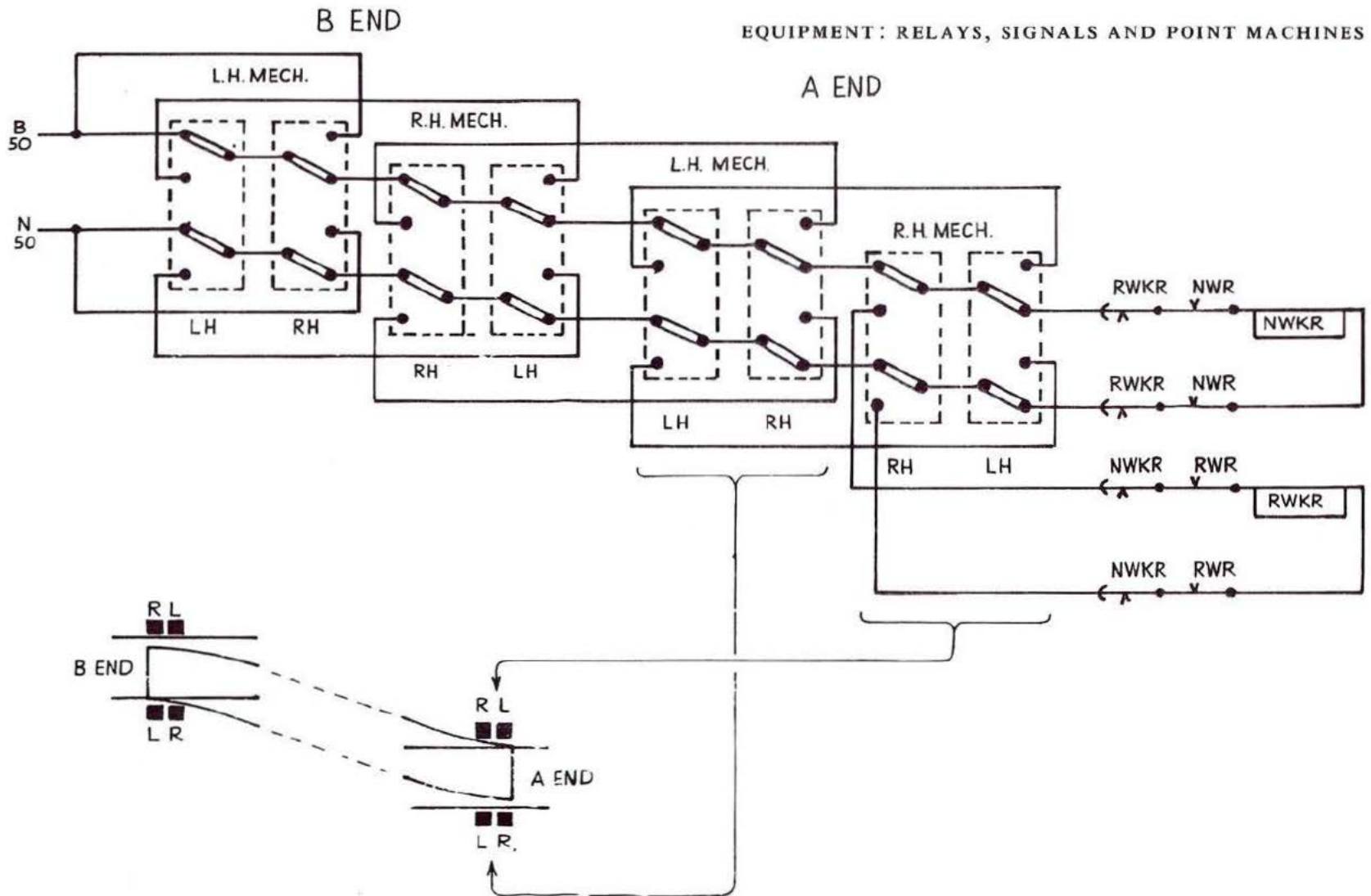


Fig. 4:23 Electro-hydraulic point machine (clamp lock type): detection circuit

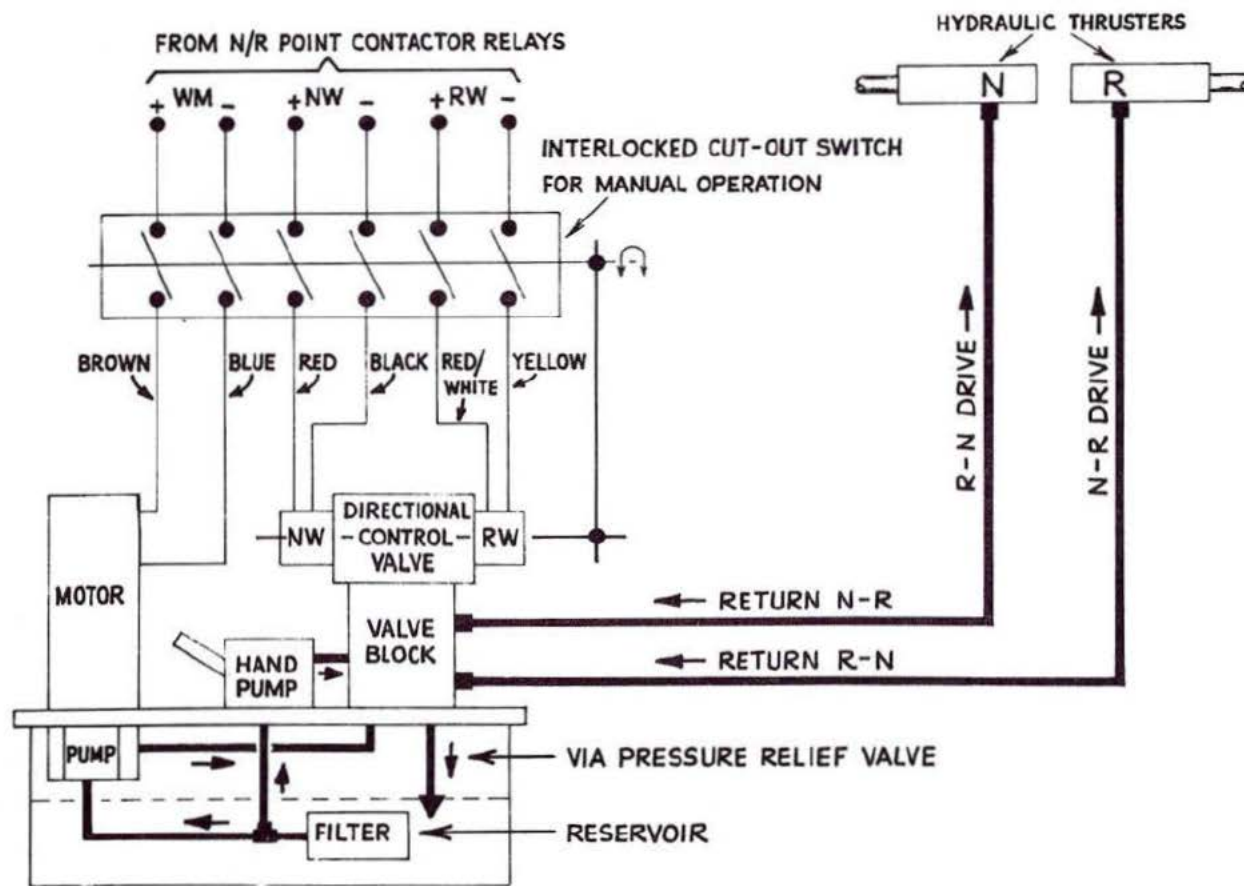


Fig. 4:24 Electro-hydraulic point machine (clamp lock type): hydraulic operation

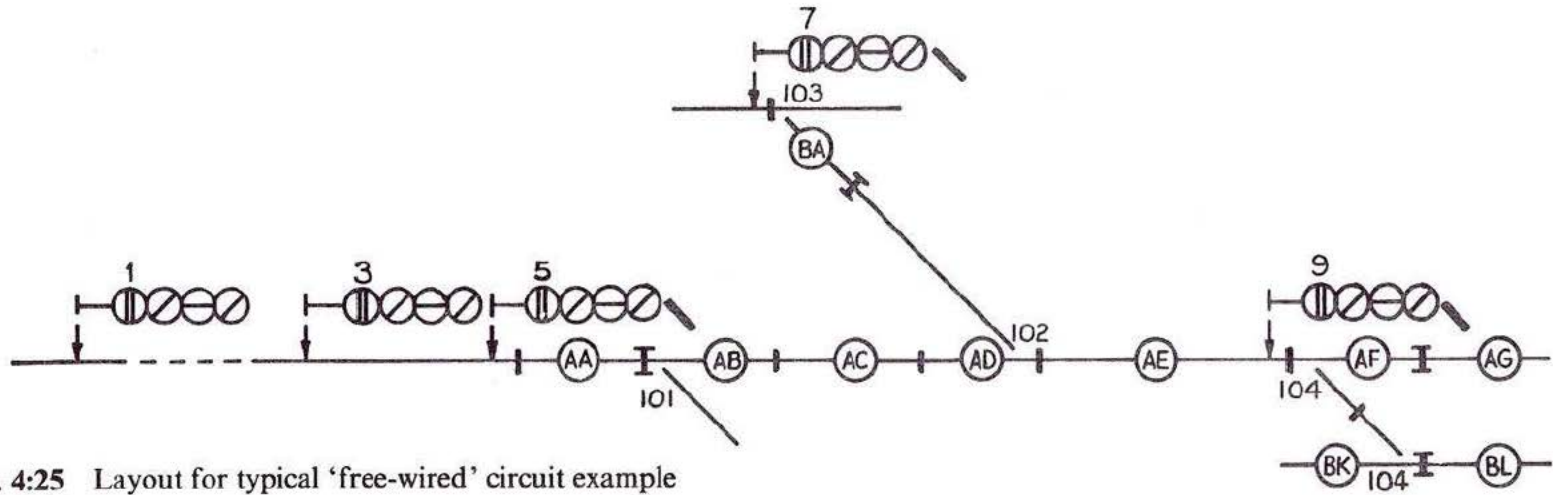


Fig. 4:25 Layout for typical 'free-wired' circuit example

### Circuit Hierarchy

Before proceeding to a discussion of individual circuits the relationship of the various groups of circuits to one another must be appreciated. In route setting systems, and in signalling circuitry generally, the pattern is a chain of self-contained circuits operating in cascade, each performing a function and passing the result to the next in the chain. This principle applies whether the system is completely 'free-wired' or partly 'free-wired' as in a geographical circuit installation. It must be emphasised that there is no basic difference between systems, although as explained later the geographical system necessarily has an amount of in-built redundancy which gives the circuits an unfamiliar look when compared with a free-wired installation. There are also a number of different methods of designing the circuits to produce the same result. In this book, space does not allow examples of more than one method to be provided; but booklets published by the Institution of Railway Signal Engineers will be found to be of considerable assistance.

Route setting circuitry may be divided broadly into the following groups, which operate roughly in the order given:

- |                     |                      |
|---------------------|----------------------|
| (a) Push button     | (g) Point detection  |
| (b) Route calling   | (h) Point indication |
| (c) Route locking   | (i) Signal control   |
| (d) Point setting   | (j) Approach locking |
| (e) Point control   | (k) Signal lighting  |
| (f) Point operation | (l) Panel indication |

In this chapter, groups (e), (f), (g), (h) and (l) have already been discussed with examples. The remaining groups are dealt with in the following sections. In all cases, for the sake of simplicity it is assumed that the installation is 'free-wired'. In the circuit descriptions which follow, the layout extract shown in Fig. 4:25 has been used throughout.

### Setting up a Route

Assuming that it is required to set up route 5A in the layout shown in Fig. 4:25, route 5A applies up to signal 9. Referring now to the push button circuits shown in Fig. 4:26, the normal state of the relays is that PBCR, DJR and DCR are energised, and the remainder de-energised. The entrance button at signal 5 is first pushed, which picks up 5(F)R. This picks up PBPR which picks the start relay 5(S)R which holds to DJR up. Relay 5(S)R picks up (ENT)R and prepares the circuit for the release of 5ANLR. On the panel, the entrance button begins to flash. The entrance button is then released, which releases PBPR and picks up PBCR, which picks up TFR via (ENT)R.

The exit button is now pushed, and PBPR again picks up. This picks up 9(D)R which holds via DJR up. Relay 9(D)R completes the circuit for the release of 5ANLR which picks up 5ARLR which holds to the route controls. Relay (D)PR releases DCR which de-energises DJR which holds for one second. When DJR releases, it releases 5(S)R and 9(D)R which respectively release (ENT)R and (D)PR. Relay DCR now picks up via (D)PR down and DJR also picks up. Relay (ENT)R releases TFR.

On the panel, the release of 5(S)R causes a steady light to be shown in the entrance button. The exit button is released as soon as the entrance button light is steady; then PBPR releases and PBCR picks up.

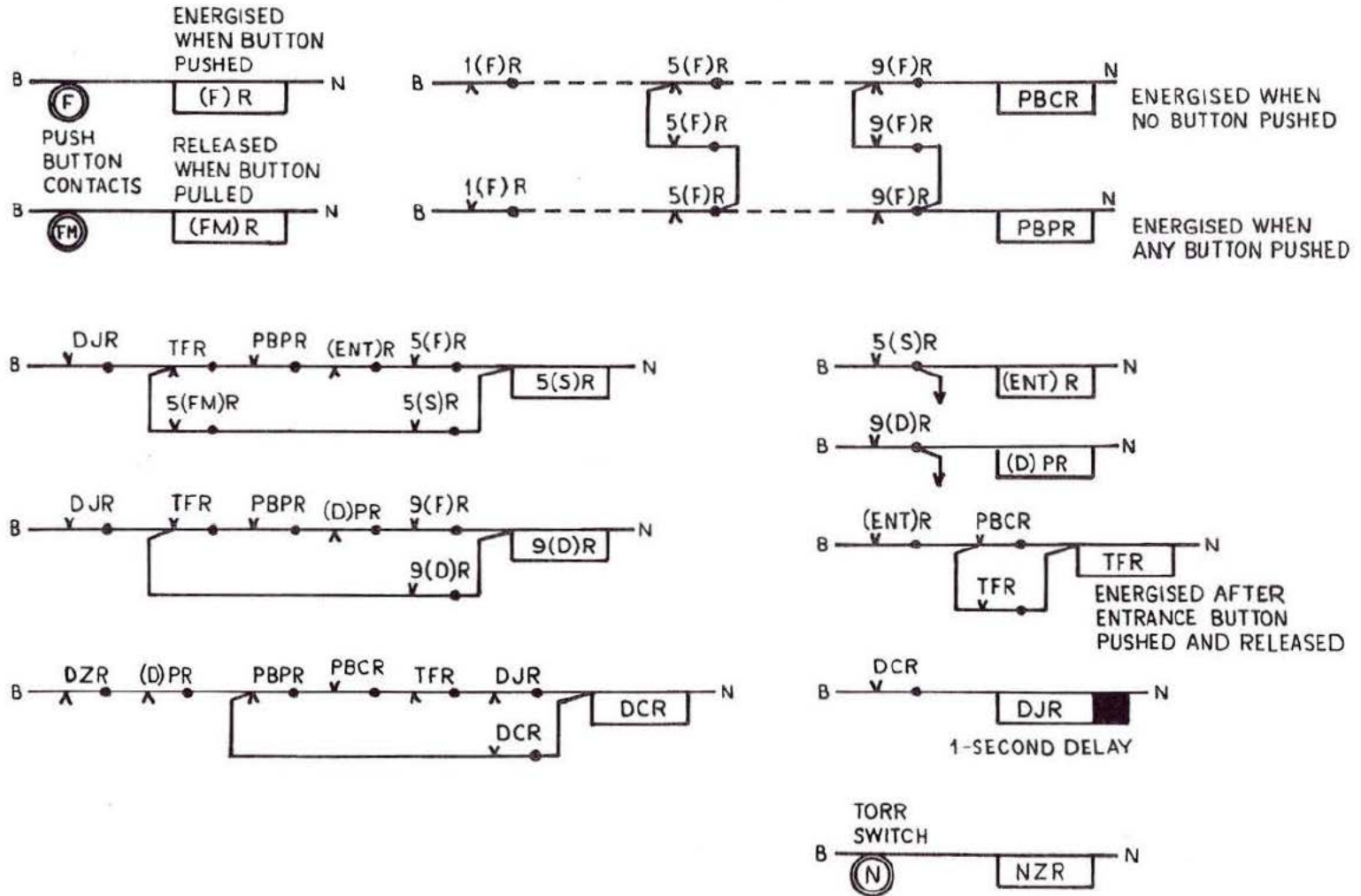
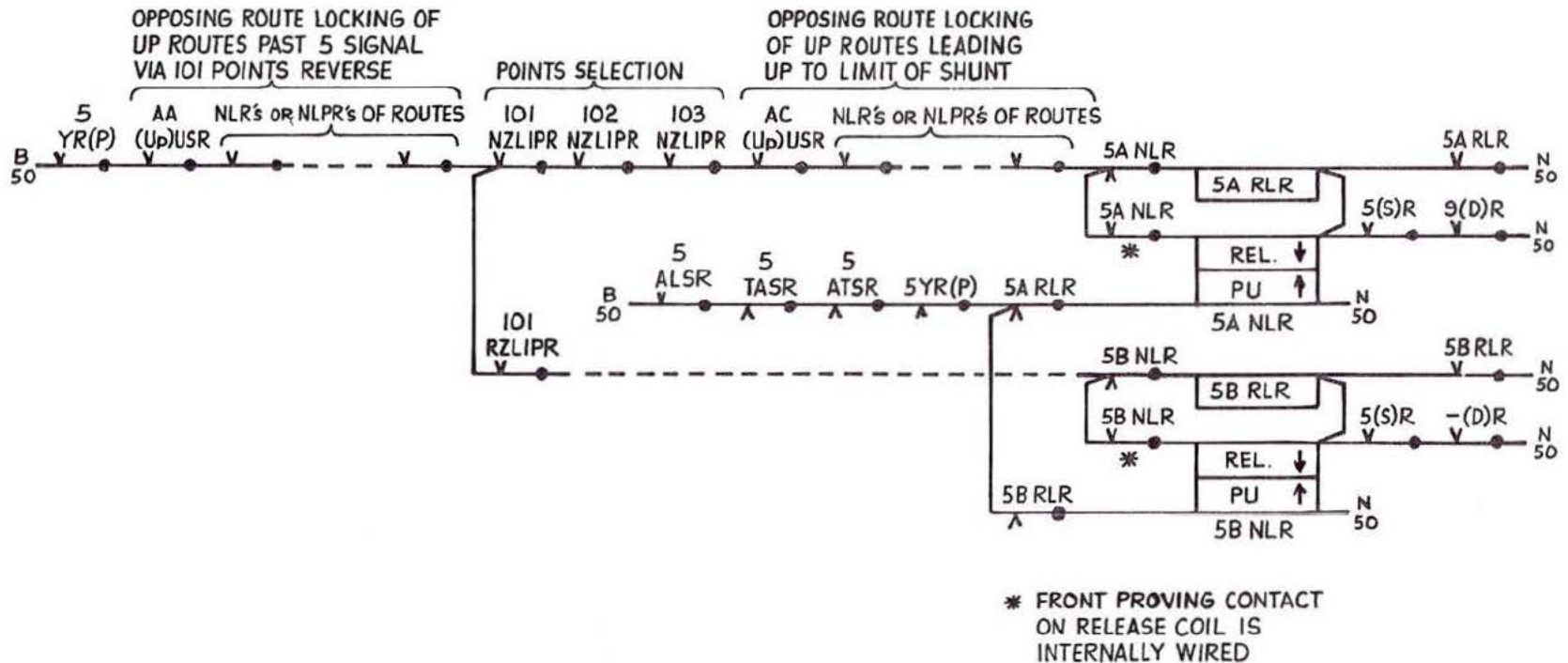


Fig. 4:26 Push button circuitry





**Fig. 4:28** Route LR circuits

The push button circuits are now normal again. To restore the route, assuming it is not approach locked, the entrance button is pulled, which releases (FM)R, which releases 5(YR)P, which releases 5ARLR, and picks up 5ALSRL to pick up 5ANLR. In the event

of the route being approach locked, (FM)R only releases 5ARLR which returns the signal to Red but leaves 5ANLR de-energised until the approach locking is free, as is shown in Fig. 4:28.

EQUIPMENT : RELAYS, SIGNALS AND POINT MACHINES

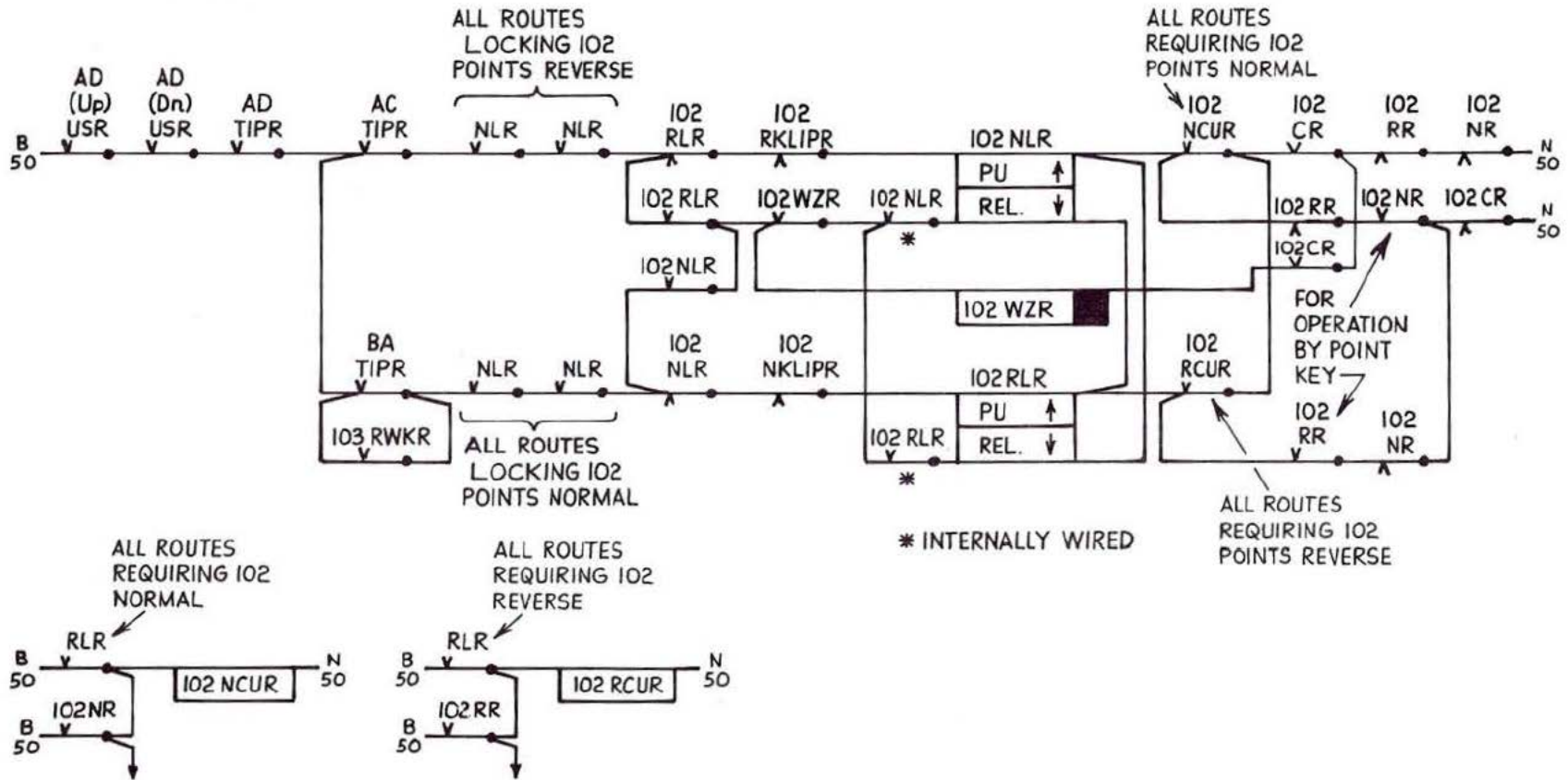


Fig. 4:29 Point setting circuits

Fig. 4:29 shows the setting circuit for 102 points. The point lock relays, NLR and RLR are separate relays. They are electrically interlocked and magnetically latched after each operation. Each relay has two coils; one to be operated and fulfil the circuit requirements

and the other to release the magnetic latch via its own energised contact which is internally wired. (In the route lock relays e.g. 5A, the NLR only is latched and the RLR has only a single coil.)

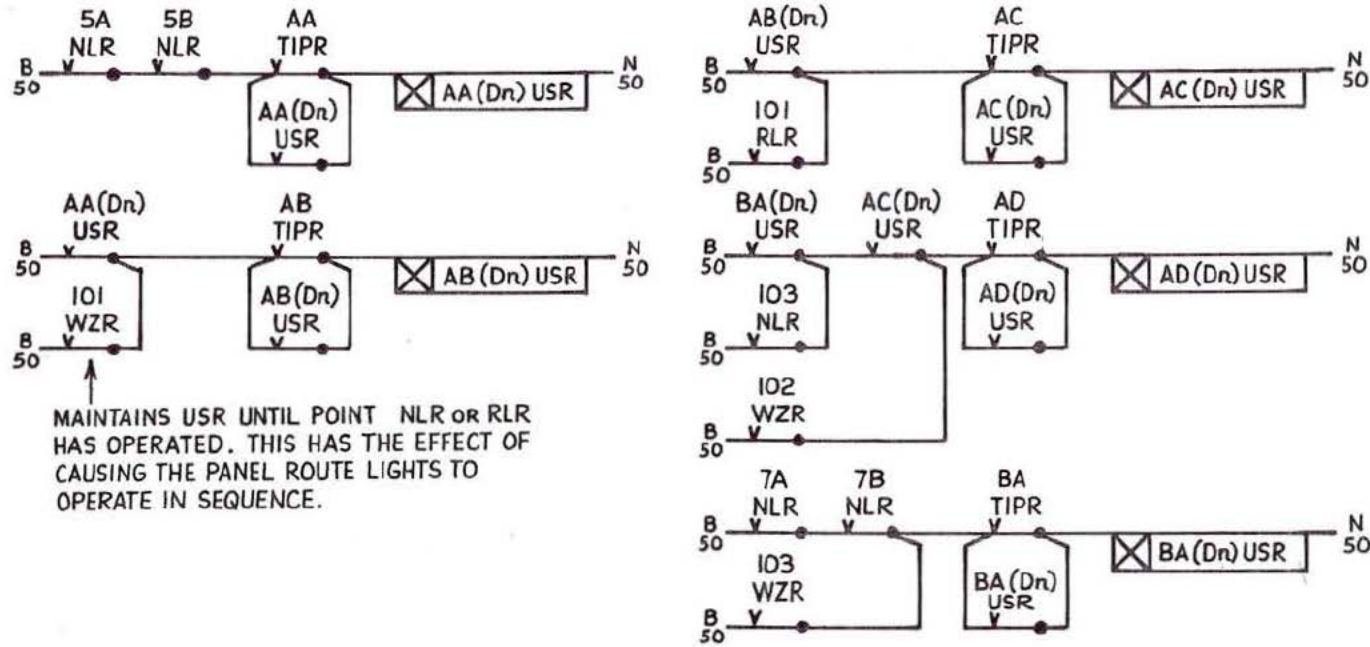


Fig. 4:30 Sectional release route locking circuits

Assume 102 points stand reversed and are required normal (as for route 5A). The point calling relay 102NCUR is picked up by 5ARLR which then unlatches 102RLR and operates 102NLR. This in turn operates 102NWR which drives the points to the normal position. On completion of the point movement, 102NWKR picks up to prove that the points are now correctly normal. In the meantime,

on its release, 5ANLR has disconnected the cascaded sectional release route locking (see Fig. 4:30) and any others for opposing route locking. The route locking relays (USRs) are slow to operate (to provide a safeguard against 'bobbing' track circuits) but are also inherently slow to release, which gives 102NLR time to operate before the USRs release.



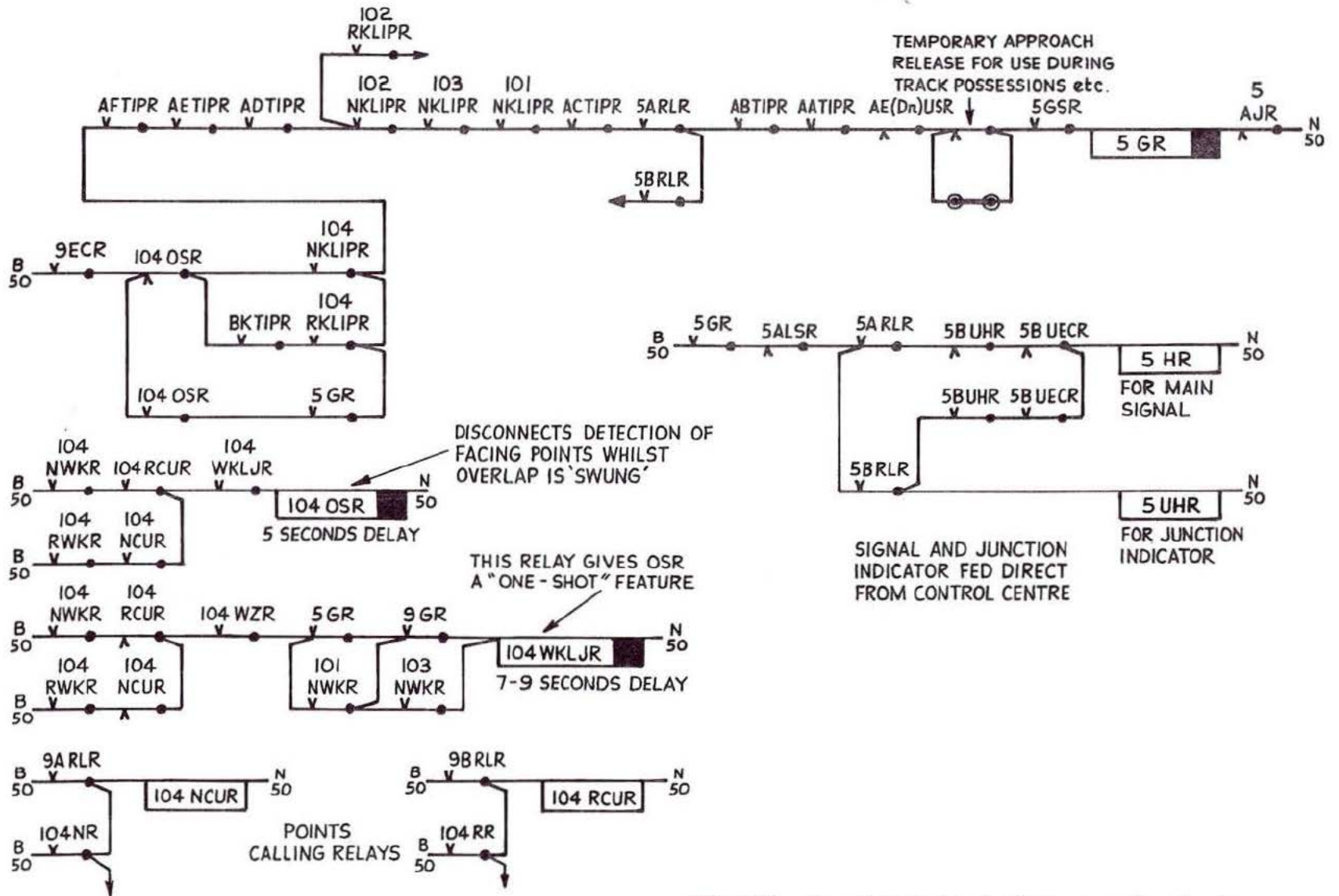


Fig. 4:32 Aspect control and swinging overlap circuits

## EQUIPMENT: RELAYS, SIGNALS AND POINT MACHINES

104 points. The individual point key, moved to its reverse position, or the appropriate route RLR, will energise 104RCUR which will cause overlap relay 104OSR to pick up and disconnect the detection part of the overlap controls in 5GR circuit, which will then be maintained over its own contact whilst the points are moving. (5GR is slow to release to cover this changeover.) If the points are free (i.e. 104WZR up), 104RLR will pick up, 104RWR will drive the points reverse and 104RWKR will pick up. This will release 104OSR and restore the detection. Relay 104WKLJR is de-energised whilst 104 points are moving and releases after 7–9 seconds if the points fail to complete their movement. This disconnects 104OSR and restores the detection to 5GR and, as the points are now not correctly in one position or the other, will release 5GR and replace signal 5 to Red. It must be stressed that these circuits are typical, and variations will be found although the principles remain the same. Differences in relay nomenclature may also be found.

### Releasing a Route

It has already been shown that it is necessary to approach-lock all routes after the signal has cleared. The approach locking may be by time interval that is 'approach locked when operated' with automatic time release, or it may be by the occupation of the approach track circuits, in which case it is known as 'comprehensive' approach locking. Fig. 4:33 shows the circuitry necessary to apply comprehensive approach locking to signal 9 in the example. Assuming 4-aspect signalling, the approach locking must come into action as soon as the train occupies the approach track circuits to signal 1 assuming this and the other intervening signals 3 and 5 are all OFF. Until these tracks are occupied, the approach locking is not effective, and the route may be restored immediately if desired.

With all signals OFF and all track circuits clear, the state of the relays is 9ALSR down, 9ATSR up, 9TAR up (stick fed), 9TASR down, 9GSR up (stick fed) and 9YR(P) up. To release the approach locking, it is necessary to re-energise 9ALSR, pull the entrance button,

and pick up (and latch) 9A (or B) NLR (see Fig. 4:28 for a similar circuit on 5). Relay 9ATSR detects the arrival of the train on the approach tracks to signal 1 when 1TAR releases. The approach locking is now effective because, at this stage, 9ALSR can pick up only if the timer is brought into circuit by pulling the entrance button and releasing 9YR(P). This state continues until the train passes signal 5 and occupies AA track when 9TAR releases.

As the train passes each signal (and clears the berth track circuit) its route may be restored. For example, after clearing the berth track to 5, that route may be restored leaving the approach locking on 9 maintained by 9TAR. On the train occupying AF track, 9GSR releases and puts the signal to Red. The 'train arrived' relay 9TASR picks up at this stage and prepares the pick up circuit for 9ALSR which is completed when AE clears. 9ALSR now picks up via AETIPR up and 9TASR up. If the entrance button is now pulled 9YR(P) releases, and completes the pick up circuit for 9A (or B) NLR which picks up and latches. The route is then restored.

Note that 9ALSR does not pick up until AE has cleared after AE and AF have been simultaneously occupied. The purpose of this is to prevent premature release by the intermittent failure of an insulated joint (i.e. between AE and AF) or by a momentary power failure.

### Automatic Working

Provision is made for most running signals to work automatically. The route is first set up in the normal manner. A separate auto-button, identical with a route button, is mounted adjacent to the route entrance button. This button is pushed to institute auto-working. Pushing the auto-button energises 9(Auto)SR, as shown in Fig. 4:33, via 9(Auto)(F)R. This cuts out the stick feature on 9GSR leaving signal 9 to work automatically until either the auto-button or the entrance button is pulled.



### **Train Operated Route Release (TORR)**

At busy Control Centres, it is of considerable assistance to the panel operator if the route is released automatically as the train passes the signal. This has been Continental practice since the introduction of geographical circuitry.

The British signal engineer has always been apprehensive of automatic release of the route while light vehicles exist in the fleet. There is also the possibility of a momentary failure of an insulated rail joint which would cause two adjacent track circuits to 'bob'. The acceptance of TORR therefore required special measures to be taken to ensure that a premature release would not result from a momentary insulated joint failure.

Fig. 4:33 shows typical 'free-wired' circuitry for TORR. Relay 9NR is provided for this condition. This relay provides a 'third

track' release (that is AG or BK occupied) in addition to the normal approach locking release. Thus, the TORR requires not only AE and AF both occupied followed by AE clear, but also AG or BK occupied according to the route set ahead of 9. The purpose is to avoid a relay cutting in during a momentary IBJ failure when AE and AF might pick up in the correct order and cause a premature release. Relay NZR is normally energised. It can only be released to cut out the TORR by the use of a key in the relay room under the procedures laid down. The system then reverts to manual release. The energisation of 9NR under TORR conditions releases 9YR(P) which picks up 9A (or B) NLR to restore the route. Relay (PO)JIPR provides a time interval after a power supply failure to ensure that slow release relays drop away before the supply is restored to them.

**BR 930 Series Relays**  
*Typical operating characteristics and contact equipment*

BR Spec.	Relay Type	Rated Volts	Coil Res. Ohms	Max. Full Operate Volts	Min. Full Release	Operate Time mS	Release Time mS	Contact Equipment Available	AC immunity
930	Neutral Line	50	835	40	7.5 v	—	—	8F 4B 8F 8B 12F 4B	—
931	Neutral Line AC Immune	50	835	40	7.5 v	—	—	8F 4B 8F 8B 12F 4B	1000 volts r.m.s.
932	Biased Neutral Line AC Immune	50	835	40	7.5 v	—	—	8F 4B 8F 8B 12F 4B	1000 volts r.m.s.
933	Slow pick-up Neutral AC Immune	50	625	40	7.5 v	450 min.	100 max.	8F 4B	1000 volts r.m.s.
934	Slow release Neutral AC Immune	50	835	40	7.5 v	—	250 min.	8F 4B	1000 volts r.m.s.
935	Magnetically Latched	50	625	40 max 20 min	—	—	—	11F 4B	—
936	Polar Magnetic Stick	50	625	40	20 v	—	—	8N 8R 12N 4R	—
938	Track Relay	0.5	4	—	68%	—	—	2F	—
939	Track Relay AC Immune	2.0	20	—	68%	—	—	2F	75 volts at 50 Hz

**BR 930 Series Relays (continued)**

BR Spec.	Relay Type	Rated Volts	Coil Res. Ohms	Max. Full Operate Volts	Min. Full Release	Operate Time mS	Release Time mS	Contact Equipment Available	AC Immunity
943	Biased Contactor AC Immune	50	835	40	7.5 v	—	—	2HF 4B	1000 volts r.m.s.
960	Neutral Line Twin double wound	50	835	40	7.5 v	—	—	4F 3B 4F 3B 6F 1B 6F 1B	—
961	Biased Neutral Line Twin AC Immune	50	835	40	7.5 v	—	—	4F 4B 4F 4B 6F 2B 6F 2B	1000 volts r.m.s.
966F2	Neutral Track AC Immune	1.4	9	—	68%	—	—	2F	75 volts at 50 Hz
968	Neutral Track	17.0	250	—	0.048 A	—	—	2F	—
966F1	Contactor for use with AC/DC converter	50	1800	40	14 v	—	—	2HF 4B	—

**BR 930 Series Relays (continued)**

BR Spec.	Relay Type	Rated Current	Coil Res. Ohms	Nominal operate Current	Minimum release	Operate Time mS	Release Time mS	Contact Equipment Available	AC Immunity
940	Lamp Proving DC slow acting (for signals)	2.2 A DC	0.85	0.8 A	0.2 A	—	200 at 2.0 A	4F	—
941	Lamp Proving AC Slow acting with internal rectifier (for signals)	0.4 A AC	18.6	0.18 A r.m.s. 50 Hz	0.11 A r.m.s.	—	200 at 0.25 A	4F	—
942	Lamp Proving AC Ord. acting with internal rectifier (for Junction Indicators)	1.4 A AC	0.69	0.78 A r.m.s. 50 Hz	0.59 A max 0.52 A min r.m.s.	—	—	2F 2B	
945	Lamp Proving DC Slow acting (for flashing signals)	4.0 A DC	0.18	1.0 A	0.2 A	—	100 at 1.5 A		

## Signalling Control Panel

The information required by the signalman to control the traffic and for the controller to supervise his movements must be displayed clearly and concisely on the signalling control panel. In Chapter 3, reasons were given for the adoption of a miniature type of control panel and for the 'push-push' method of operation which is now standard on British Railways. Fig. 3:1 also showed the main features of the panel which are necessary for understanding the basic circuitry. In this chapter, the general construction, method of operation and indications displayed are described in detail.

The British Railways' signalling control philosophy is to enable the main signalling centre to supervise and control, directly, all running and shunting movements over very wide areas—except those train movements that are made, completely off the main running lines, and which do not affect the operating of the main railway systems. Local control arrangements are provided for this secondary purpose. These may take the form of a very simple panel to control one set of points or a cross-over road, or a small collection of points and signals, or the original (or new) mechanical lever frame used for the purpose.

Local control may also be provided at remotely-controlled installations for main line traffic for use in emergency or for maintenance purposes. In such cases, a release, or releases, must also be obtained from the signalling Control Centre. For remotely controlled installations, when the emergency control panel is in use, the monitoring equipment, for example signal lamp filament indications, which is normally shown on the main panel, would be shown locally. When the emergency panel is not in use, no indications are shown although it is usual to arrange for the indications to be switched into circuit before local control is introduced.

Fig. 5:1 shows the type of control panel provided at a remotely-controlled installation. The design of the layout of each control panel

and the area each section should cover, and the merits of separate or combined panel and track diagrams are considered for each signalling project, taking into account the ergonomic and cybernetic factors. The Control Centre is required to deal with many trains simultaneously, and rapid decision making and operation are vital. The control panel must show, at all times, the current overall traffic situation to the operating staff and all signalling and communications systems must be provided in the operating room in such a manner that the staff concerned may make decisions, and execute them efficiently, with as little mental or physical stress as possible.

The normal mode is for traffic in those large control areas to be dealt with on strategical and tactical bases. The strategy is dictated by the working timetable and only altered in an emergency or during breakdown periods. Other strategies have to be decided for other activities, which are not covered by the timetable, as they arise. The man in charge of the whole Control Centre strategy supervises the panel operators and ensures that the most suitable tactical/operating modes are adopted for the whole area—and in relation to adjacent areas. The panel operator interprets the working timetable into minute-by-minute tactical modes of operation without needing detailed instructions from his supervisor. His function is to operate routes, and to observe the passage of trains and note the indications on the panel throughout his area of responsibility.

### General Description

The signalling control panel may take one of two forms depending on the layout and traffic density. The most commonly used form has the controls and indications mounted on a near vertical panel. The layout and traffic must be such that the signalmen, each of whom is allocated a longitudinal portion of the layout, do not overlap one another in carrying out their duties. Consideration shows that there is a relationship between the length of panel controlled by each signalman, the number of running lines and the traffic density. Clearly, for a given traffic density, the greater the number

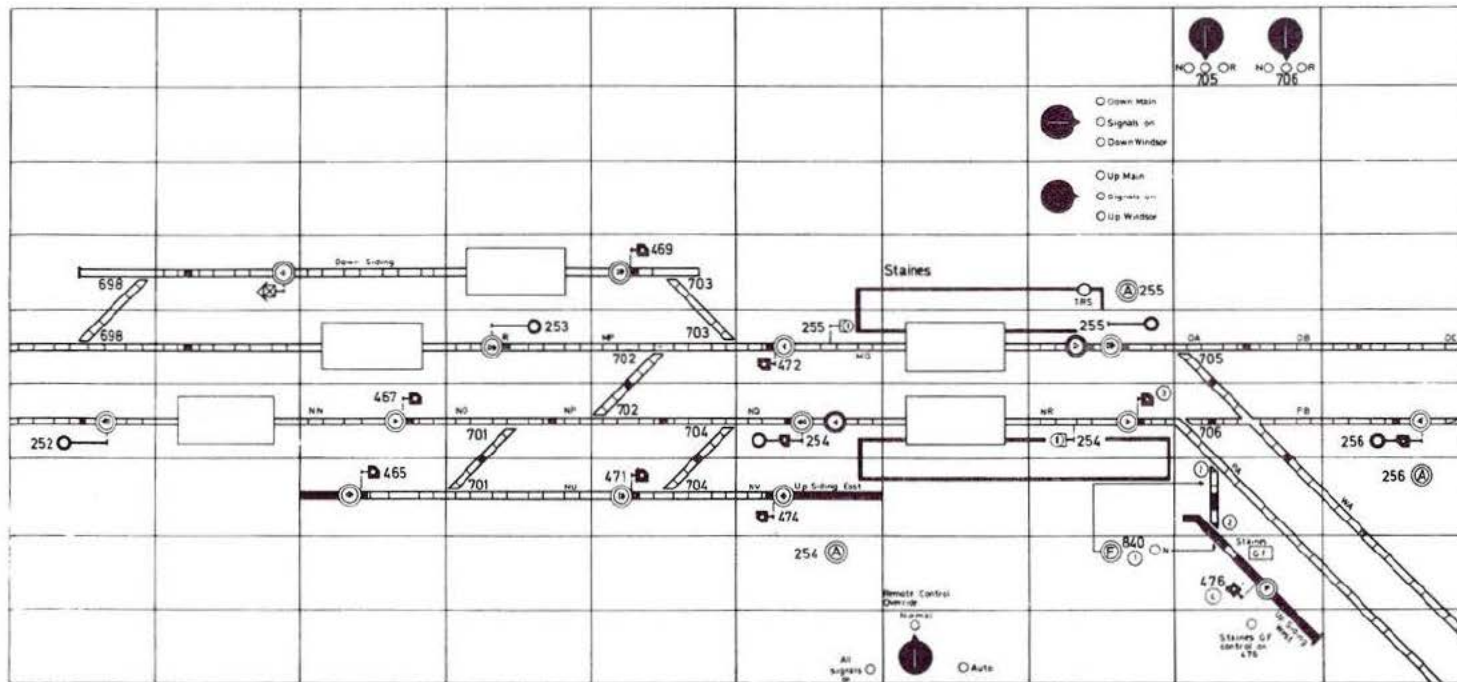


Fig. 5:1 Mosaic diagram: part of a control panel and including an interlocking that is remotely controlled

SIGNALLING CONTROL PANEL



**Fig. 5:2** Signalling control panel: combined type

**Fig. 5:3** Signalling control panel with separate operating console



of lines, the shorter will be the length of panel which can be allocated to each signalman and therefore the greater the number of signalmen who will handle a train on its passage through the layout.

This has led to the development of the second form of construction for use at large intensive traffic layouts. In this form, each signalman has a separate operating console on which the controls are mounted geographically on a miniature diagram of his control area. The button and individual point keys, and the associated indications only are included on the operating console. The comprehensive dia-

gram of the layout remains as before, but the separate console enables the signalmen's control areas to be divided longitudinally so that they may cover as many signal sections as necessary according to the work load it is considered each man should have. Furthermore, the diagram on the console, being smaller, enables the signalmen to be seated for most of the time.

Fig. 5:2 shows the combined type and Fig. 5:3 depicts the separate operating console type.

## SIGNALLING CONTROL PANEL

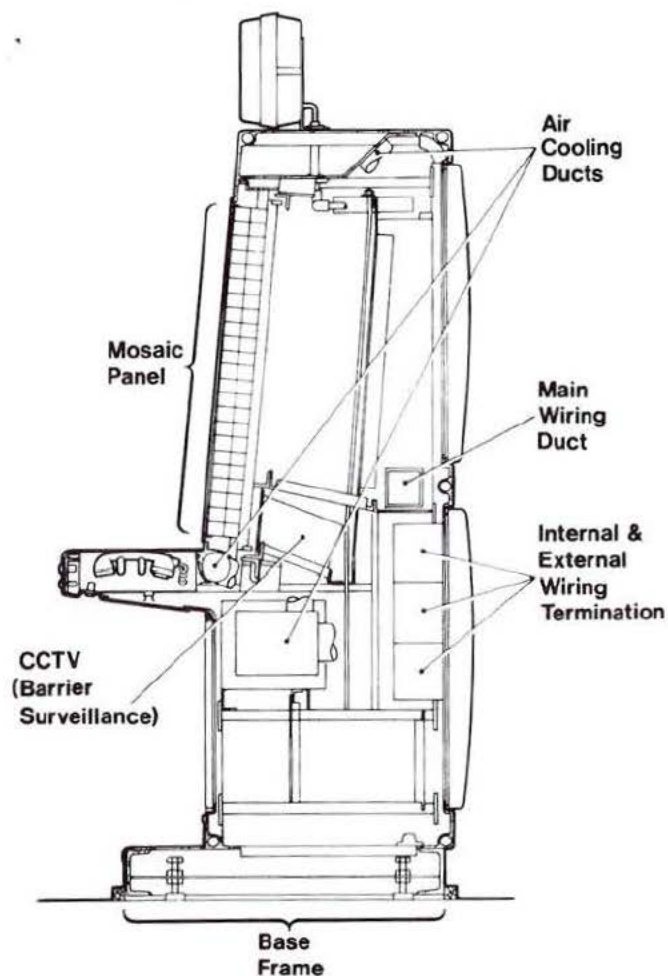


Fig. 5:4 Cross-section of combined type control panel

The separate type is obviously more expensive and is currently adopted by British Railways only after a work-study exercise has shown that more efficient operation of the layout would result. A typical work-load for a panel signaller during an 8-hour shift would be to set up and subsequently release some 700–800 routes and deal with about 80 telephone calls. From figures such as these, and a consideration of the layout and the type of traffic to be dealt with, an estimate may be made of the signaller's total work-load and a decision made on the type of control panel to be used. Each signaller should have each train under his control for at least 5 signal sections, and junction working needs to be taken into consideration so that as far as practicable, a single signaller completes the operation.

In its combined form, the layout of signalling controls and indications is based on a diagrammatic representation of the track layout. The various ancillary equipments, such as those associated with telephones and train describers, are disposed suitably on the panel within easy reach of the operator. The height and forward rake of the front panel and the shelf below are carefully arranged so that any operator can reach the various controls without undue effort or strain. The illumination of the many indicators is arranged so that operators may see those on adjacent parts of a layout without having to stand back from the panel, and all sections of the panel must be within viewing range of the supervisors, who usually sit behind the signallers. Not only has the method of control been standardised, but the way in which the track layout and its various indications are arranged also conforms to a regular pattern. The track lines are arranged at 40 mm (1.57 in.) centres with all crossovers and turn-outs being shown at 45° to normal.

The indications, push buttons and keys are mounted on a grid either 40 × 40 mm or 40 × 80 mm, depending on the manufacturer, and the surface of the panel consists of 'mosaic' tiles of the same dimensions.

Figs. 5:4 and 5:5 show the general construction.

The use of a mounting grid and tiles enables the panel to be mass-produced. Alterations may be readily made, and the small-size tile enables the apertures for track and route-set indications to be rectangular in shape, thus improving the appearance to the operator, and making a clear distinction between signal aspect and other indications (which are circular) and the track indications.

The background colour of the panel is usually pastel grey or other neutral colour, which is not only restful to the eyes but enables the tracks to stand out clearly. The track circuit sections are coloured yellow, blue, green or brown for easy identification. The buttons used for route setting and other controls, such as local releases, are of the 3-position type spring-loaded into the mid-position. The plungers are of transparent material so that a light indication may be projected from behind the panel. For the control of points and some ancillary functions, partially rotating switches are used. These are mounted in positions clear of the track layout. Fig. 5:1 shows a portion of the 'mosaic' panel.

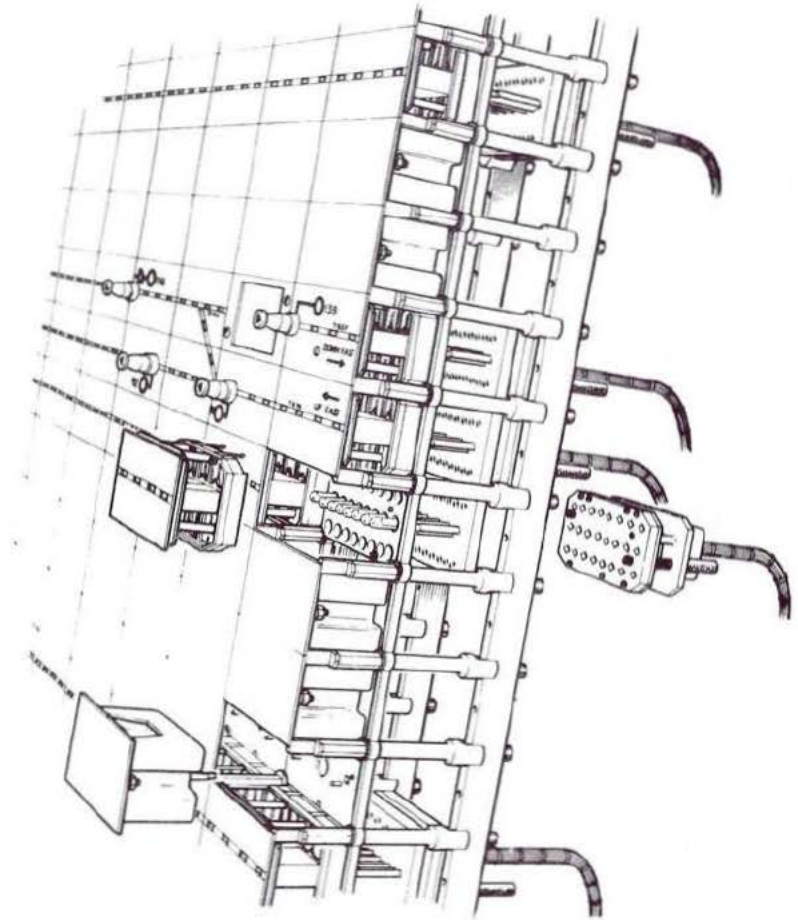
### Route Setting

Route buttons are provided at each point on the panel which defines the start or finish of a signalled route. They normally occur at signal positions, but may be provided at buffer stops and other geographical locations where no signal occurs. The top surface of each button carries an identifying symbol as follows:

- Full arrowhead indicating direction—entrance to route.
- Open arrowhead indicating direction—exit of route.
- Letter 'O'—overlap section.
- Letter 'A'—auto working.

It should be noted that two arrowheads can appear on one button and these may point in the same direction or in opposite directions.

Route buttons have coloured escutcheons as follows:



**Fig. 5:5** Combined type of control panel: diagram showing constructional features

## SIGNALLING CONTROL PANEL

- Main signal—Red
- Subsidiary or shunt signal—Yellow
- Signal slot—Green
- Auto button—Light Blue
- Overlap selection—Black

Route setting is effected by pushing a button adjacent to the signal at the entrance to a route followed by the pushing of a button at the end of a route. These buttons will be spring returned to the central position, electrical storage being used to record their operation. Once an entrance button has been pushed no other button can be used as an entrance button on a prescribed section of the panel, and a second button pushed will always act as an exit. Once the second button has been pressed all other potential exit buttons will again become available as entrance buttons. When a button has been operated as an entrance it will show a flashing White light until an associated exit button has been operated. If the two buttons operated properly identify a route, and that route is free to be set, the entrance button light will become steady to indicate that the route has been 'called'. The appearance of the White 'route set' lights will confirm that the route has been locked. Any route that has been set will remain locked and will thus show the White 'route set' lights until released by the pulling of the button, or until automatic normalisation conditions have been implemented, assuming that the appropriate approach locking and route holding release conditions have been fulfilled. A button operated as an entrance button can be reset immediately by pulling it, provided that no effective exit button has been operated.

Should the entrance button be pulled whilst the route is approach locked the signal will be replaced to 'danger' but the route lights will remain to show that the route is locked. The Red signal indication will flash until such time as the route normalises or the signal is re-cleared. Whilst this situation exists the signal can be re-cleared by pressing the entrance button only.

From the above, together with consideration of the route-setting

circuits in Chapter 4, it will be apparent that the setting of a route may be prevented by any one contact in the circuitry not being in the operated state. In these circumstances the operator could continue to hold the exit button pressed until such time as the inhibiting contact is 'made', and allowed the route to set. During the waiting period the route setting operation is said to be in a state of 'pre-selection'. If the contact preventing the route from setting were detecting an occupied track circuit, there is a slight chance that adverse circumstances, such as a combination of rusty rails and a light vehicle, could cause the track circuit to 'bob' momentarily and allow the route to set. This is an unacceptable situation (unless other special precautions are taken) and to counter it 'anti-preselection' circuitry is usually included. This is effected by making the setting operation a pulse, so that if the circuit is not intact at the instant the exit button is depressed, holding it in is ineffective and the setting operation has to be recommenced.

When alternative routes are available between the entrance and exit buttons, one of the following methods is employed to make the selection:

- (a) A preferred route, determined at the design stage, will automatically be set if it is available; if not, the alternative route will be set. Where more than one alternative is available an order of preference must be established.
- (b) Intermediate push buttons can be provided at appropriate positions along the track and one of these is operated sequentially after the entrance button.
- (c) By the use of the individual point key to set one or more sets of points to identify the alternative required before pushing the entrance and exit buttons.

A route when set and locked is indicated by an evenly spaced row of White lights, not more than 38 mm apart, between entrance and exit buttons, and to the extent of the overlap where this exists. Route lights associated with points will not show unless the points

are detected in the required position. Route lights will remain alight whilst all track circuits are unoccupied, and whilst the route concerned is still locked. It is permissible to omit certain route lights when train describer displays are incorporated in the track line.

### **Alternative Overlaps**

Facing points in the overlap at the signal next ahead are generally free to be set according to the overlap required. If the desired overlap is occupied, or about to be, or is otherwise blocked, the signalman has the facility to set another (clear) overlap and allow the train to proceed without restriction; resetting the overlap to that required as soon as it is free. The panel operator may either use the individual key for the facing points or use special buttons for the purpose, if provided, or he may be able to set the route ahead by using the entrance and exit buttons for the route ahead in the normal manner.

The controls have already been discussed in Chapter 3, but it must be borne in mind that the operator cannot 'swing' the overlap to another unless it is clear, and during the movement of the facing points, the detection in the control of the signal in rear is bridged out to avoid putting that signal to Red if the train should be approaching it.

### **Individual Point Operation**

Individual point keys are of the 3-position rotary type with knobs coloured black. The point key is normally left in the centre position, the points then being controlled by the route setting. The left-hand and right-hand position of the switch are for setting, and/or holding the points in the normal and reverse positions respectively. White 'normal' and 'reverse' lights are mounted adjacent to the point switches and are designated 'N' and 'R'. A third White light placed centrally between the others is flashed to show an 'out of correspondence' condition. To operate the points independently the switch

may be moved to the left or to the right as required. The points will respond if they are free to be moved, that is, they are not locked by a route already set, by a track circuit occupied or by point to point locking. Once the switch has been moved into an operating position, and the points set, the points are effectively locked in that position by the switch. The switches are normally only used when points cannot be set due to a failure of the route setting system, for testing points during maintenance or to change overlaps.

### **Restricted Overlap Buttons**

It is sometimes necessary to restrict the overlap so that one train may follow another although, at the time, the full overlap is not available. For this purpose, a standard route button with exit arrowhead is mounted adjacent to the normal exit button which is not then used.

### **Signal Indications**

Signal indications are displayed through the centre of the symbol representing the signal. For main signals Red and Green lights are used to show ON and OFF conditions. Subsidiary signals show a single White light when in the OFF position (the ON aspect being that of the main signal). Ground shunts show Red or White and distant signals Yellow or Green. Automatic signals with replacement buttons have a Red indication only, showing that the signal has been replaced by use of the button.

### **Duplicated Lamp Indications**

The following essential indications must consist of at least two lamps operating in parallel and when these show through a common aperture the optical arrangement must be such that the failure of either is apparent:

## SIGNALLING CONTROL PANEL

- (a) Track circuits
- (b) Block instrument indications
- (c) Failure warning lights

### Track Circuit Indications

Magenta lights are used to indicate that a track circuit is occupied. Where such track circuit which forms part of a set route becomes occupied, the White 'route set' lights are extinguished and replaced by the Magenta lights showing through the same apertures. Track circuits over points in a route will only show the 'track occupied' lights along the line of the route selected, but should such a track circuit become occupied when no route has been set, then the Magenta lights on all arms of the points will be illuminated, thus showing the full extent of the track circuit.

### Automatic Working of Normally-Controlled Signals

Provision may be made for normally controlled signals to be changed to automatic working by depression of a button marked 'A' after the main route has been set by conventional means. The 'A' button will then be illuminated to indicate that the auto feature is in use. While this is so the route will remain set and the signal will clear after the passage of each train. Cancellation of the automatic feature can be achieved by pulling either the 'A' button or the start button for the route. An 'A' button may be seen at signal 255 in Fig. 5:1.

### Emergency Replacement of Automatic Signals

In Chapter 3, it was explained that selected automatic signals were provided with a button for replacement to Red in an emergency. Replacement is achieved by pulling the button provided. Reminder of the operation is given by illumination of a Red indication in

the symbol representing the signal. The signal is restored to normal working by depression of the button, the Red indication then being extinguished. The button is mounted adjacent to the symbol which, for an automatic signal, includes a representation of the identification plate. This is a White oblong with a Black horizontal stripe.

### Signal Slots

In some cases, the area may be covered by overlap on two Control Centres and slotting is necessary. For reasons of interlocking a slot is given by the forward Control Centre to release signals controlling trains approaching from the rear. In the forward Control Centre, this is normally controlled by the operation of standard entrance and exit buttons. The exit button escutcheon plate is coloured Green. In the Control Centre in rear, the indication to the panel operator that a slot has been 'given' is a White light mounted on the panel adjacent to the exit button of the route controlling the slotted signal.

### Block Instrument Working

In the few instances where conventional block control is provided, and is in normal use, control is carried out by push buttons set into the line of track to which the block applies. If such block working is only used occasionally then the push buttons will be mounted off-set from the appropriate track line. The push buttons provided are designated 'line blocked', 'line clear' and 'train-on-line' and the identifying colour is Black in each case. When in use, each button exhibits a White light. The normal condition is 'line blocked'. At the signal box in rear similar indications are provided in association with the block controls and are mounted in the line of track to which they apply.

### Emergency Block Bells

Emergency block bells are provided for communication to adjacent

signalling Control Centres in the event of a complete failure of the 'train describer (or equivalent)' system. These are buttons of the standard type and are mounted clear of the other working buttons on the panel. A White light is provided adjacent to each block bell control button to indicate to the operator which bell is being used. This indicator incorporates a delay which allows the lamp to remain alight for several seconds after the last stroke of the bell.

### Level Crossing Control

Location of level crossings which are operated or released from the signalling Control Centre are indicated on the panel and also the location of any automatic half barrier crossings from which communication can, in an emergency, be established with the signalmen. Symbols similar to those used in BS376 Part 1, are used to show the type and location of the crossing. Where a level crossing is controlled from a local signal box, but released from the signalling Control Centre, arrangements are provided similar to those for ground frame release, that is, push button or rotary switch. The operation of such controls will be as described for ground frames. Where the level crossing is controlled directly from the main box with direct visual contact, the switches used to operate the barriers or gates are mounted in a position such that full view of the level crossing is obtained. Before such switches may be used, however, a release must be given from the main panel.

Level crossings which are remote from the main Control Centre, but operated therefrom with the aid of closed circuit television, have comprehensive control facilities mounted on the panel adjacent to the television monitor screen and conveniently near to the representation of the crossing on the track diagram. The main controls

consist of the television monitor ON/OFF button and 'up' and 'down' buttons for the barriers. Having switched on the monitor screen by depressing the 'picture' button the operator can watch the level crossing to check that it is safe to commence the barrier lowering sequence. Operation of the 'barriers down' button will start the road signal flashing sequence followed by the lowering of the barriers. Indication that the road signals are functioning is shown on the panel to supplement the operator's view on the monitor. The 'down' button must be held depressed until the barriers are fully down and locked, this being indicated by a separate indication on the panel. Having checked that all is well the operator will press the 'clear' button provided to release the signals applying to the crossing. Operation of the 'clear' button also switches off the monitor screen. Release of the 'down' button at any time before completion of the lowering sequence will result in the barriers being automatically raised.

During normal working the passage of the train over the crossing will release the barriers which will then rise automatically. Manual control of the raise operation when necessary is by use of a separate push button, this being selected by a two-position switch on the panel. A separate 'up' indication is also provided. In addition to the indications already mentioned there are alarm indications for 'power off' and 'barrier failed' conditions, each with an acknowledge button. Switches are also provided for selection of camera 1 or 2, monitor standby and floodlighting for night-time use. This latter switch also automatically adjusts the camera sensitivity for night viewing. Fig. 5:6 shows the controls and a typical position for the monitor screen on the panel. Duplicate monitor screens are provided but a single monitor may be provided as standby for all installations at a Control Centre. It is then mounted on a trolley and plugged in as required.

SIGNALLING CONTROL PANEL

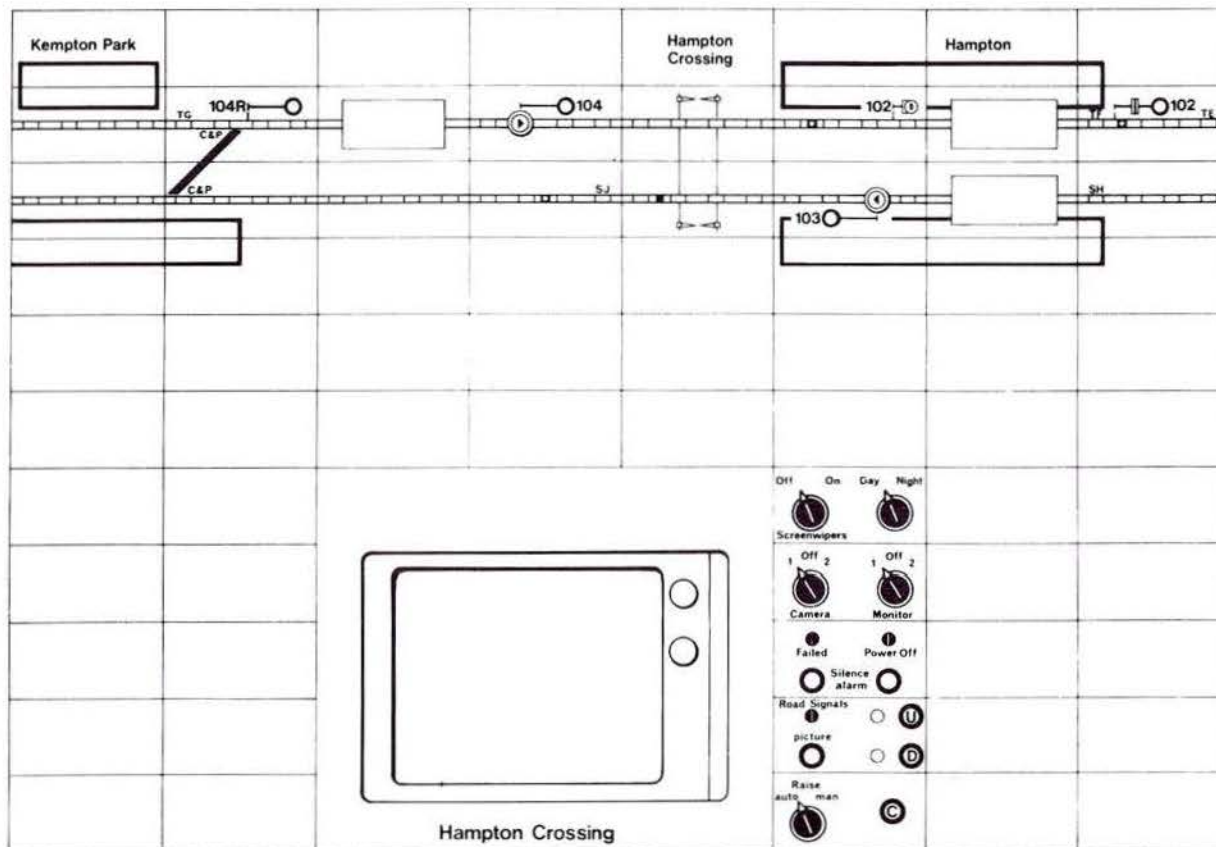


Fig. 5:6 Portion of a mosaic diagram including CCTV monitor screen and controls for level crossing

### Ground Frame Releases

These will usually be of the push button type, as used for route setting, and will carry the letter 'F'. Alternatively they may be of the 2-position rotary switch type. The identifying colour in both cases is Brown. If the release is provided with a button, this will be pushed to effect the release which will be indicated by illumination of the button. Restoration is achieved by pulling the button, a separate 'N' indication being lit only when the whole of the ground frame functions are normal. In cases where a switch is provided, release is given by turning the switch to the right; the independent release indication will then be used. The release indication will only be displayed when the release has actually been given. Should the state of the interlocking at the time of operating the controls be such as to inhibit the release, no indication will be given.

### Hot Axle Box Detectors

The introduction of modern signalling Control Centres has greatly reduced the visual observation of passing trains. To compensate for this loss of supervision, equipments known as 'hot axle box detectors' are located at selected points between the signalling Control Centres. The points at which the detectors are located are related to the position of suitable loops where a defective train may be stabled. The detectors must also be located at points which allow the train to run a sufficient distance from its last stopping point to permit a faulty axle box to heat up and operate the equipment.

The equipment detects hot journals by directing a beam of infra-red rays at each axle box as it passes. Any axle box having a temperature above a prescribed level activates the equipment which transmits information to the signalling Control Centre. The main display apparatus of hot axle box detectors may be built into a desk arranged in the centre area of the operating floor. This information supplements the alarm given on the track diagram and enables particular axles

on particular trains to be identified by the signaller in order that appropriate action may be taken. The location of hot axle box detectors is shown on the track diagram by a solid black triangle with a standard push button mounted at its centre. The push button is illuminated when a hot axle box warning is given.

### Directional Indications

Apart from single lines which are not often encountered in an area controlled by a route setting panel, bi-directional lines are often found approaching terminals where one direction is in use for the morning peak traffic and the other during the evening peak. Arrows pointing in the appropriate direction are illuminated by White lights and are mounted adjacent to the track to which they apply. These are only provided on sections of track which are bi-directional.

### Train-Ready-to-Start Indications

These are provided, mainly at terminal stations, in case a train is not ready to start at the appointed time. Otherwise, if the route is set up, other trains may be delayed while the approach locking is released. The panel operator does not therefore set up the route until he receives the Train-Ready-to-Start indication, given by the platform supervisor. A Yellow flashing light is mounted adjacent to the track to which it applies and in the vicinity of the appropriate platform starting signal.

### Remote Control Override

To keep traffic moving in the event of a failure of electronic remote control equipment, it is usual to provide for the automatic operation of certain routes. The override control is brought into use in another cable. The override arrangement involves the provision of a 3-position rotary switch which has the following positions.

## SIGNALLING CONTROL PANEL

- |                                     |   |
|-------------------------------------|---|
| (a) Position—'Normal'               | Remote control equipment connected and satellite interlocking working normally.   |
| (b) Position—'Signals on'           | Remote control equipment disconnected. All signals put to ON position and the satellite interlocking normalised subject to usual approach locking and other conditions. |
| (c) Position—'Signals working auto' | Remote control equipment disconnected. Selected signals for main routes set to work automatically subject to normal signalling controls at the satellite interlocking.  |

In certain cases, at very busy junctions, a remote control equipment override arrangement is provided in which individual buttons, for each route controlled by the junction signals, become operative when a simple two-way override rotary switch is operated. This override switch has a 'normal' position and an 'override' position. In this 'override' position the junction signal routes are cleared individually for each train.

### Alarm Buttons

Alarms associated with various monitoring circuits provided at interlockings are displayed on the control panel. Each has a push button associated with it for the suppression of the audible warning when this is provided in association with the visual. When the fault has been rectified, it is usual to give another audible warning to remind the signalman to reset the push button.

### Lighting Controls

It is usual to provide controls to enable the panel lights to be

made bright or dim according to the prevailing conditions. In this case a dimmer switch is provided, but the function can be controlled by push buttons. Similarly, shunt signal lights may need to be switched for day or night conditions.

### Reminder Devices

To enable a temporary restriction to be placed on the operation of push buttons or rotary switches due to engineering works or other contingency, reminder collars of cylindrical form are provided. These are designed to fit over the button or switch and usually incorporate small permanent magnets to hold them in position. The end of the collar may carry a suitable legend. Where the operation of a button is limited to emergency use (for example, release of emergency crossover) a sealed collar may be provided. This device is attached to the front panel and engages with the plunger so as to prevent operation without first breaking a paper seal.

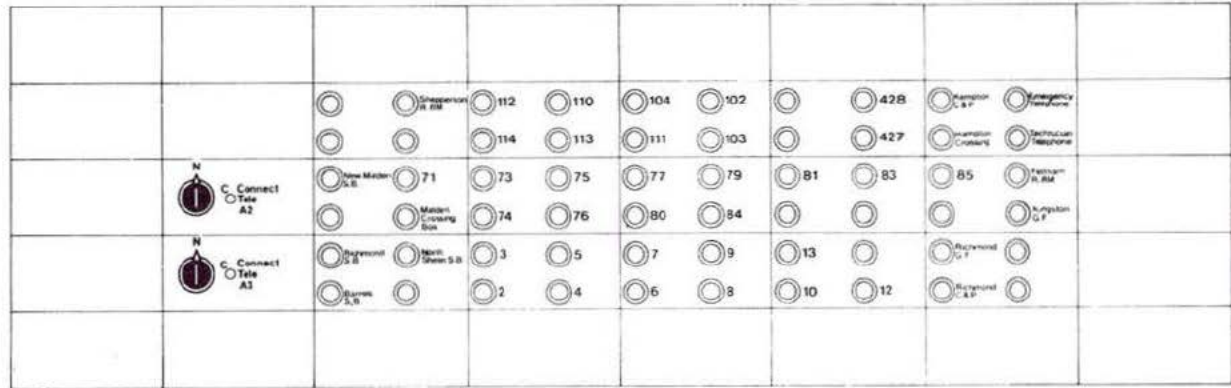
### Alarm Indications

Indications are provided for all alarm circuits. Typically these include the following:

- Signal lamps
- Remote control systems
- Power supply
- Train describer
- Telephone cable pressure
- Control panel cooling
- Level crossing barriers
- Earth leakage detectors

All alarms are provided with warning lights, which are associated with audible devices if they are primary warnings and continuously flashed if they are secondary warnings.

**Fig. 5:7** Signalman's telephone concentrator



**Telephone Concentrators**

A telephone concentrator with handset is provided in association with each section of the panel, as convenient. In the case of the combined panel the concentrators are mounted either in a clear section of the panel or in the front shelf. Where separate control consoles and diagrams are in use the telephone concentrators will normally be mounted immediately above the control panel on the console. The buttons may be of the 'push/pull' or 'push and latch' type and will be illuminated from the rear. A separate button is provided for each telephone circuit on that section of panel. These would include signal post telephones and others used for traffic purposes.

Incoming calls will be indicated by an audible signal accompanied by flashing of the appropriate push button or separate indication. Reception of such calls is obtained by pressing the button whereby the signalman's handset is connected to the calling circuit. Restoration of the line after use is achieved either by a second depression of the button or by some comparable operation depending upon the particular system in use. Outgoing calls may be made by lifting

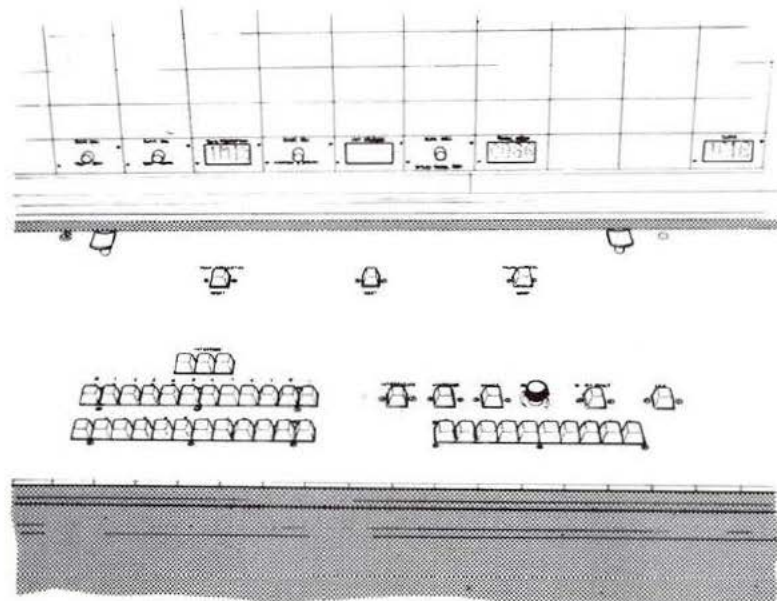
the handset and pressing the appropriate button on the concentrator.

In the case of signal post telephones a secondary indication may also be provided adjacent to the signal to which it refers. Indications connected with emergency telephones (for example, automatic half barriers) may be coloured Red to make them more distinctive. It may also be appropriate on large panels to provide a group indication for each concentrator to enable an incoming call to be more easily identified. A typical telephone concentrator is shown in Fig. 5:7.

**Train Running Information**

Teleprinter terminals may also be provided giving access to the nation-wide teleprinter service in operation throughout British Railways. They may also be used for automatic train reporting in conjunction with a computer-based train describer system. Such systems may be used to output information regarding trains passing certain points on the railway or may be used to communicate discrepancies in the running times of trains or in various other ways according to the program built into the computer system.

## SIGNALLING CONTROL PANEL



**Fig. 5:8** Part of a desk shelf with train description interpose and interrogate facilities

### Train Describers

Train describers are dealt with in a later chapter, but the following notes explain briefly their relationship with the other equipment on the signalling control panel. The modern signalling Control Centre embraces such a large area that train describers are an essential requirement for the traffic operator. Train describer equipment requires facilities for the set up, interpose and cancelling of descriptions to be provided on the panel. In the case of the combined panel these may be mounted in the panel or in the front shelf, whilst in the case of the separate control console these will be mounted above the route operating panel. Push button controls with alpha-numeric keys are provided to enable train description codes to be interposed into any display position on the panel. A display panel is associated with the interpose buttons to enable the operator to check the description he has set up before interposing is carried out. The signal berth in which the new code is required is identified by keying the signal number. Interposing takes place only when the special 'interpose' button is pressed. Manual controls may also be used to cancel a description in a similar manner.

Fig. 5:8 shows train describer push buttons mounted on the first shelf of the console, and display panels for set up, interpose etc. mounted on the lower part of the panel itself.

If the train describer system in use is of the computer-based type, which is now usual, an additional facility is normally available on the interpose keyboard. This is an interrogate feature which enables the train description associated with a particular signal (or the converse) to be obtained from the equipment by depression of an 'interrogate' button after identification of the information required. A 'not-described' alarm is also associated with the train describer controls. This is initiated by the presence of a train within the area covered without a corresponding description being displayed. The operator having acknowledged the alarm can then rectify the omission by interposing a suitable description.

### General Layout of the Operating Floor

The operating floor of a modern signalling Control Centre bears little resemblance to that of a mechanical signal box for obvious reasons. Apart from the facilities provided for the control of signalling throughout the area it is usual to provide additional facilities to enable traffic controllers and others to take full advantage of the information being made available on the signalling control panel. A typical layout is one in which the main signalling control panel is arranged on an arc of a circle in such a way that the best view of all sections is obtained from the centre. Within the arc would normally be situated the desks provided for traffic controllers, power controllers, public address operators and others associated with traffic control. Each of these desks is custom-built to incorporate the particular equipment to enable the user to carry out his prescribed duties. This, in most cases, will include a telephone concentrator which, as well as duplicating some of the circuits provided for the panel operators, will also have direct interconnection facilities to other points on the railway system, as well as dialling facilities into the national network. Traffic controllers will also have train describer interpose facilities, if this is appropriate, and also the interrogate facilities, if these are available. Visual display units (VDU) may also be provided in connection with computer-based train describer systems to enable the supervisors to obtain more detailed information regarding the traffic in the area, and these may also have facilities for interconnection with other computer-based systems in other areas of the railway network.

Architecturally, one of the main differences between the design of new signalling Control Centres and the old signal boxes is the provision of window space. The modern Control Centre, with its sophisticated communication system, does not require the operators to observe the passing of trains, and therefore the provision of windows is usually kept to an absolute minimum. Consequently ambient light conditions on modern operating floors are generally low and artificial light is used almost continuously. The design and

positioning of such lighting is therefore very important and due consideration is given to this in the early design stages. Also, in order that working conditions for the operators are as good as possible, air conditioning is usually provided and this may even be extended to include the equipment rooms in certain cases. The heat generated by modern equipment is quite considerable and this has to be taken into account when air-conditioning systems are designed. The control panel itself consumes a large amount of power, much of which is converted to heat on the operating floor, and great care has to be taken to ensure that not only does the ambient temperature within the room remain acceptable but that the working surface of panels does not reach an unacceptably high temperature. On many of the large control panels currently in use on British Railways, forced cooling systems have to be employed to remove the excess heat from within the control panel case.

### Design of the Building

Within easy access of the operating floor, messing and other facilities have to be provided for the use of the operating staff. Similar facilities for the use of maintenance staff will usually be provided in the same building. Conventionally, the operating floor occupies the upper storey of a two- or three-storey building in which is also housed the interlocking relay room, telephone equipment room and train describer equipment room, together with various maintenance facilities such as workshops, stores, and so on. Separate rooms are provided for batteries.

### Internal Cabling

The interconnecting cables between the various equipment rooms and the operating floor are accommodated in some form of ducting included within the structure of the building. In order to accommodate the very large number of cable connections required on the control panel, terminating equipment is usually provided along the whole

## SIGNALLING CONTROL PANEL

length of the panel case. This may be in the form of soldered tag blocks or multiway plug couplers, as specified. To facilitate the running of the many cables it is common to provide a computer-room type suspended floor in the operating room. This allows complete freedom of routing the cables from the ducting to the apertures in the bottom of the panel case. The panel itself is supported on a suitable framework standing directly on the load bearing structure, the false floor being fitted after the panel is in place.

### Constructional Requirements

Due to the large size of modern control panels, suitable access has to be provided to enable the sections of the panel to be installed. This usually involves leaving a special temporary access hole in the structure or in providing permanent doors for the purpose. Special consideration also has to be given at the design stage to the availability of crane access to the site, because the equipment usually has to be lifted directly from a road vehicle up to the operating floor level. The available access will also have to be taken into account when the control panel is designed to ensure that none of the sections are too large to go through the access provided. The panel is usually manufactured in sections approximately 3 m (10ft.) in length, each being equipped with temporary wheeled jacks. A lifting frame is also provided to accommodate the largest section. Each section in turn is jacked, wheeled into the frame, lifted into position and then wheeled through the access hole. The jacks are kept in position until all sections of the panel are *in situ* and lined up in the correct position.

### Control Panel Construction

Although there are constructional differences between the control panels produced by the manufacturers, the appearance, operating modes and apparatus have been standardised by British Railways. Combined switch and indication panels are usually mounted in a

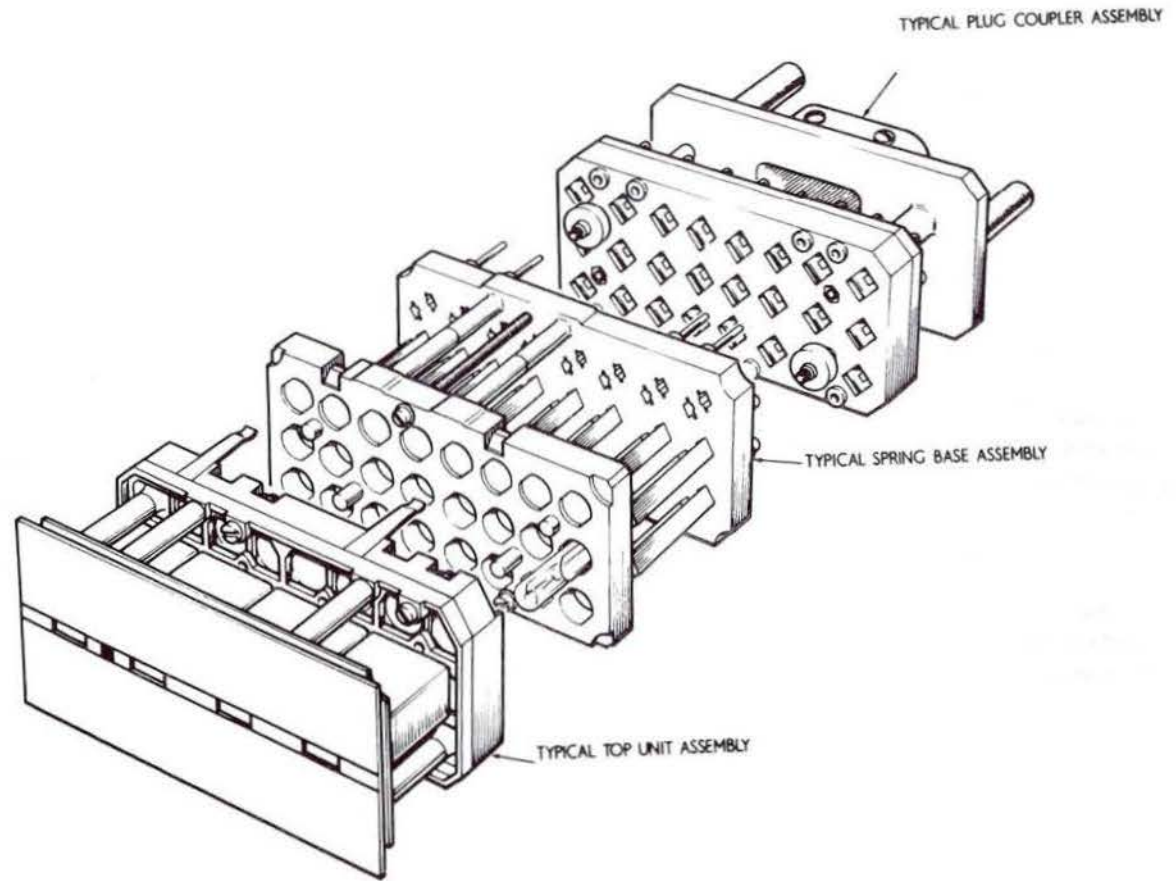
near vertical position. Where separate control console and illuminated diagram are provided the control surface is usually mounted in a near horizontal position with the diagram vertical. The front panel, whether or not this includes the illuminated track diagram, on which all switches and indications are mounted is of the mosaic type. A primary advantage of this form of construction is the ease of access to the lamps and switches for maintenance purposes, all normal maintenance being performed from the front of the panel. The tiles which make up the front surfaces of the mosaic unit are either 40 mm square or 40 mm high by 80 mm wide, the geometry of the track layout being the same in both cases. Each of the tiles carries an appropriate portion of the overall layout, such that when combined into a complete matrix the effect is one of a continuous panel. Blank tiles with no equipment are used to fill up the area between the working tiles.

The use of the mosaic principle also makes subsequent changes easier to accommodate. As shown in Fig. 5:9 each tile of a mosaic panel is carried by a plug-in top unit containing the light filters and diffusers for the indications and working parts of the rotary switches and push buttons. When in position the tile is supported at each corner by a pillar which forms part of the support framework of the panel and is adjustable to give the accurate positioning required to maintain the smooth surface of the finished panel. By making the tile of steel a small permanent magnet may be used to remove the top units from the panel.

Removal of the top units gives access to the lamp holders and switch connections which are carried by a lower mosaic unit clamped firmly in position on the support framework. Lamps may be of the Post Office, side contact type or of the bayonet type and are generally rated at approximately 1.25 watts at 24 volts. Connections for the lamps and switches are made at the rear of the lower unit and these may be made using plug couplers or by direct soldering onto the tags. Where plug couplers are used these will be identified by interlocking pins so that wrong connections cannot be made by the inadvertent transposition of two or more plugs.

SIGNALLING CONTROL PANEL

Fig. 5:9 Detail of mosaic panel, top unit, spring base and plug coupler assembly



## SIGNALLING CONTROL PANEL

Special units must be provided for any other equipment which may be mounted on the front panel and these will all be supported within the same framework. In particular, special arrangements may have to be made for train describer display devices, telephone concentrators and CCTV units. The panel support frame for each section of the control desk or illuminated diagram is itself supported within the casing of the section so as to hold it firmly in the correct position and relative to the adjoining section, thereby presenting a continuous surface. All sections are fixed together to form a continuous unit.

The outer casing of the desk and diagram can be made of sheet steel or glass-reinforced plastic (GRP) as preferred. Whilst steel has the advantage of being more easily formed and joined, GRP is lighter and being self-coloured requires no special finishing or protection. With either material it is usual to support the complete units on a base frame to give rigidity. Access for the interconnecting cables is provided in the bottom of each section, and soldered tag block or plug couplers mounted in easily accessible positions towards the rear of the case allow for the termination of these. Block bells, audible alarms and other small items of equipment are fixed inside the case in suitable positions. Removable rear doors are provided.

Equipment required for the operation of train describer displays and other ancillary equipments may also be mounted inside the case and this is usually arranged in the lower portion. Front access to this equipment may also be required in some cases.

Where the size and complexity of the control panel make the use of forced cooling necessary, suitable ducts or manifolds are provided. In cases made from GRP these are moulded integrally to the outer shell, a series of outlet holes being positioned along the top and bottom edges of the panel so as to direct cooled air through the area immediately behind the tiles. Flexible ducting is used to connect these manifolds to the piping from the cooling unit. The air cooling ducts may be seen in Fig. 5:9.

## High Voltage Power Supply Emergency Switching

On desks where television or train describer displays use high voltages for cathode-ray tubes, a prominent button or buttons must be provided on the outside of the case to allow the high tension supply to be cut off quickly in case of emergency. Special socket outlets may also be provided to meet local requirements.

## Conclusion

The mosaic type of signalling control panel is expensive, although it is doubtful whether the cost is greatly in excess of the equivalent 'tailor-made' control panel. It must be remembered however that it is the interface between the operator and the signalling system, and it provides the means whereby the state of the traffic in the whole of the control area may be seen at a glance—which has so far been considered an essential by British Railways operators. The cost of the control panel compared with the overall cost of the installation is relatively small.

Nevertheless, in a computer age with computer interlocking being given consideration by signal engineers all over the world, it is understandable that consideration should also be given to the Visual Display Unit (VDU) as an alternative to the conventional control panel. In Great Britain the London Transport Executive has already introduced the VDU as a means of display, but conditions are very different from those on British Railways. The layouts are smaller and can readily be shown on a large cathode-ray tube.

In the U.S.A., in Sweden and on the Victorian Railways in Australia, there are installations using VDU's as the sole means of display. The computer-controlled VDU is very flexible. The scale of the layout and the information shown thereon may be changed immediately by the operator and, furthermore, the computer may be programmed to draw the attention of the operator to developing traffic situations which require his attention. The use of the VDU may possibly be a development which British Railways may take up in the future, but there are many problems yet to be solved.

## Geographical Circuitry

It was soon clear that the much larger areas of control envisaged by British Railways in the early 1960s for the various modernisation and electrification projects, for which authority was anticipated, would bring problems of staff capability to design and implement schemes in a reasonable time, if the then conventional route relay interlocking practice was to continue. The need was to relieve the design staff of the mass of individual circuit design and testing, and to reduce the work of the installation staff in the individual wiring of circuits in the relay rooms.

The solution lay in the adoption of geographical circuitry which, at the price of some redundancy, would enable the layout to be broken down into basic units, each of which would have a standard factory-wired relay set connected by cable to its neighbours. With factory assembly and wiring, on mass production lines, factory testing by computer would become possible, and relay sets arriving on site would no longer require the meticulous testing needed for individually wired circuitry. Although there were ready-made systems of geographical circuitry existing, and in considerable use on the continent of Europe, none suited British Railways' interlocking practice, particular in regard to overlaps. After some years of development, two British systems emerged from the manufacturers, and one or other is now used for all but the smallest installations.

In this chapter, both systems will be described but the subject is too great to be dealt with exhaustively. Nevertheless, it is hoped that from the text and the figures, the reader will be able to grasp the principles which lie behind each system and the reasons for the practices adopted.

The description of each system is related to a simple layout consisting of a controlled signal, applying up to an automatic signal, over a trailing crossover. In both cases, for reasons of space, little more than the relevant wiring can be shown.

The systems may be adapted (or 'programmed') for bi-directional working, and both are specifically designed to cope with the variations in the controls of main signals, draw-ahead, shunt ahead subsidiary signals, and shunting signals. British interlocking practice and the variations and exceptions thereto does, however, result in a fair amount of 'free-wiring'.

### Principle of Operation

In contrast to the conventional route relay interlocking, where for example a pair of points is set by a contact of each route relay which uses them, the geographical system requires that the points in a route are dealt with in the same sequence in which they occur between the route entrance and exit. Thus, in geographical circuitry, any route which is physically possible on the layout is automatically built into the system, but in a route relay interlocking each route is specifically defined. Conversely, if a geographical route is possible on the layout, but not permissible from an operating standpoint, it has to be deliberately suppressed in the circuits.

Route setting in the system is initiated by energising a cable circuit at the entrance signal unit by operation of a control panel push button. As with all push button systems, this conditions other buttons to operate as route exits.

One of two systems of selection then takes place, either:

- (a) The energised circuit traverses all possible routes from the entrance, examining the availability of each set of points in the route, putting a claim on them and continuing if they are free, thus arriving and registering at each exit to which a route is proved available. Further action then awaits operation of the selected exit button, after which all other possible exits are released. Or
- (b) a circuit similar to (a) is energised at the entrance and performs only an exploratory process, no route action taking place until the selected exit button is operated.

## GEOGRAPHICAL CIRCUITRY

These two processes may appear to be almost identical, but (a) involves a succession of small completed operations in stages, whilst (b) can be likened to a series circuit which is not completed until the exit button is pressed.

Having established that the selected route is available the circuit then proceeds to set and lock the points in the route in geographical order, and proving circuits are completed to enable the entrance signal to display a proceed aspect.

### **The Advantages of Geographical Circuit Systems**

When examining the economics of geographical systems, it is difficult to find a fair and reliable basis for cost comparison with conventional systems. The significant factor is that a reduction in the overall time taken to complete a scheme can be achieved by the use of geographical systems, thus enabling the economic benefits derived from the scheme to be realised earlier. The larger the interlocking the more economical a geographical system becomes by reason of quantity production and time saving in circuit design; but it is the lower limit which is more difficult to define. Even with small interlockings, say up to 20 routes, whilst an individual geographical example could not by itself be classified to be as cheap as a tailored route system, a number of small geographical interlockings linked to a Control Centre in an overall scheme should show to advantage as a common system. It is also desirable for maintenance purposes to use a uniform system throughout a particular control area.

The advantages may be summarised as follows.

#### *Uniformity*

With packaged circuits the treatment of interlocking and control circuits is uniform and reduces human error in individual circuit design. However, the design and operation of the packaged circuits must not only be reliable and comprehensive, but must also include facilities for meeting all control table requirements in each unit. The uniformity of a geographical system can show up inconsistencies

which sometimes arise in control tables, particularly in respect of flank protection referred to below.

#### *Circuit Preparation*

Office geographical circuit work is usually centred on drawings of pre-prepared groups of circuit units which require detailed interconnection with other units in standard form, programming connections for the operation of the particular unit, and connections to the control panel, remote control systems and train describer.

Much of this work can be classified as semi-skilled and can release skilled staff to concentrate on circuits relating to overlaps, flank protection and so on, as will be described. With standard groups of circuits there is a considerable saving in the time required for checking.

#### *Installation and Testing*

Because of the machine testing of pre-wired units in the factory, a large proportion of the total wiring arrives on site already tested. Although there is more wiring involved within the units than in a conventional installation, the actual site wiring work is reduced, giving with it a reduction in setting-up time and in testing. The use of multicore cables between geographical units also contributes to savings in the time required for relay room wiring, but the particular system and the manner in which the cabling is used are important factors. Factory wired plug couplers can also play a part in these savings.

#### *Layout Alterations*

Relay room circuit alterations necessary in connection with track layout modifications may sometimes, but not always, be more quickly effected. Much depends on the nature of the modifications to the layout, the signalling alterations involved and the space available in the relay room. The internal wiring of the relay sets is never altered.

At worst, it could be said that alterations to the circuits are numerous but individually small.

As compared with conventional free-wired systems it must be accepted that in order to achieve flexibility, each geographical unit must incorporate circuits and relays or relay positions which are not needed in every application of the unit, but which must be present if the unit is to be of a standard type. This leads to a degree of redundancy.

It must also be accepted that fault-finding is not as straightforward as it is with a conventional system. For this reason, it is the practice to incorporate comprehensive monitoring in a form which indicates the state of the circuits in use or the progress made in setting up a route. Monitoring of this nature, in a circuit system where safety is paramount, is not easily achieved, because great care must be taken to ensure that the monitoring circuits cannot themselves introduce false feeds or by-pass vital circuits.

Pure geographical principles can only take in signalling functions situated in the direct line between the entrance and the exit of a route. Signalling principles demand that account must be taken of conditions obtaining on the approach side of an entrance signal, on the flanks of its route and in the overlap beyond the exit of the route. These conditions must accordingly be provided for in the system and may be built-in or free-wired.

#### *Approach Locking*

The type of approach locking for any particular signal will depend on the operating requirements which may allow the locking to be applied immediately the signal clears, or alternatively, only when the signal has cleared and there is a train approaching. The latter case requires the track circuits back to the sighting point for the first cautionary signal to be proved clear, and in a large interlocking such circuits can become complex. The economics of providing these circuits within a geographical system will vary with each interlocking. In some cases the approach locking condition is provided in the

'free circuitry' section. A compromise is provided in one system in which the track circuits, only back to the first signal in the rear, are built into the packaged units with other track circuits further back in the approach locking section, included in 'free wiring'. The release of approach locking is achieved by the sequential operation of track circuits after the train passes the signal, with an alternative automatic time release operative after the signal has been manually replaced to danger. The time release facility is usually built-in, but practices vary between systems for the track circuit release.

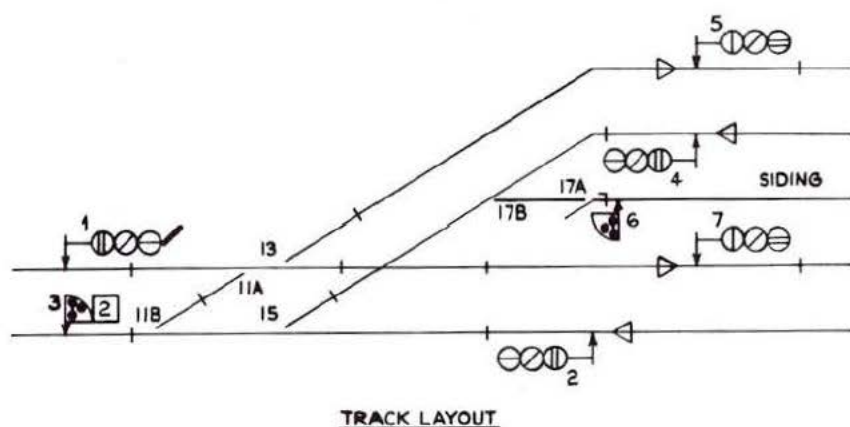
#### *Flank Protection*

This term embraces the setting of points and proving of clear track circuits, not actually in the line of route, for the purpose of protecting the route from irregular flank movements. Such protection has always been included as a matter of course in interlocking and control tables but it has been given a specific name in geographical systems, probably for the reason that it is strictly non-geographical and therefore requires special treatment.

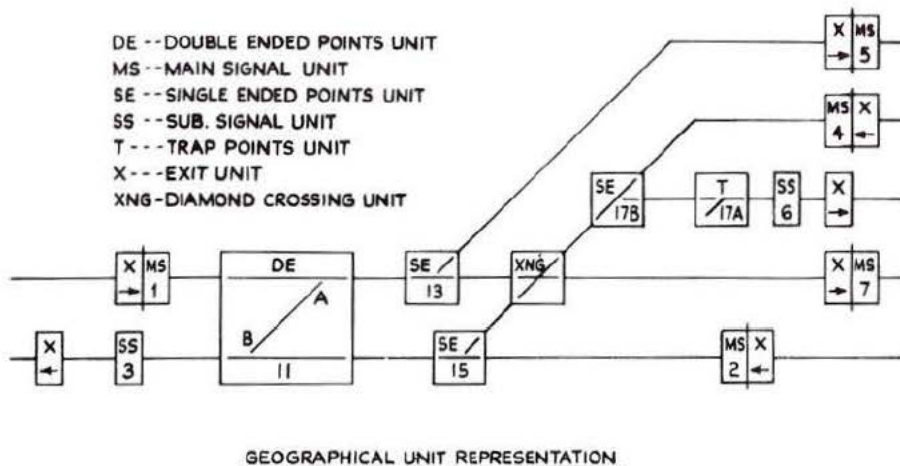
The simplest example of flank protection by point setting is at a left-hand double junction where the controls demand that the inner turnout must be reversed for a route through the outer. This will prevent a possible collision at the intersection of the main and turnout lines in the event of an overrun at the junction splitting signal.

The same principle may be applied to a left-hand double running junction in four-track layouts, provided the points are located clear of the overlap at the protecting signals on each line. If the points lie within the overlap, flank protection must be provided, and it may be included in the geographical unit or free-wired. If it is built-in, there may be redundancy in some layouts but no special design work is necessary to implement the protection when required. A compromise is possible by providing two types of point unit, with or without flank protection as required.

## GEOGRAPHICAL CIRCUITRY



**TRACK LAYOUT**



**GEOGRAPHICAL UNIT REPRESENTATION**

**Fig. 6:1** Track layout and geographical unit representation

## Overlaps

These raise the same problem as flank protection regarding incorporated facilities, but there is also a fundamental geographical problem. Overlaps are located beyond the inner, protecting, signal, but they are also concerned with the control imposed by the outer signal. Facilities are required to allow a valid alternative overlap to be selected after the outer signal route has been set, and the signal cleared, and also for an overlap to be held by the outer signal even though the inner signal has been replaced.

In built-in systems of overlaps (other than of simple track circuits) it is necessary to introduce additional cable circuits extending from the exit of the outer route (that is, the inner signal) to the limits of the allotted overlaps. These circuits must perform the overlap setting and proving, and impose additional restrictions on the movement of the overlap points. They are necessarily complicated, but do avoid the repeated individual overlap problems and produce a consistent result. The facility for changing the overlap to an alternative to give freedom for otherwise conflicting traffic movements is catered for in geographical systems; it may be built-in or free-wired.

## Unit Layout in Relation to Track Layout

The simple, but not necessarily practical, track layout shown in Fig. 6:1 has been chosen solely to illustrate a number of features in a small space. It consists of a double junction with a siding joining the branch line, and below is shown a geographical representation of the layout in functional unit form. It does not represent the layout of the units (or relay sets) of either of the systems to be described, and is intended to serve as an introduction to unit geographical circuitry.

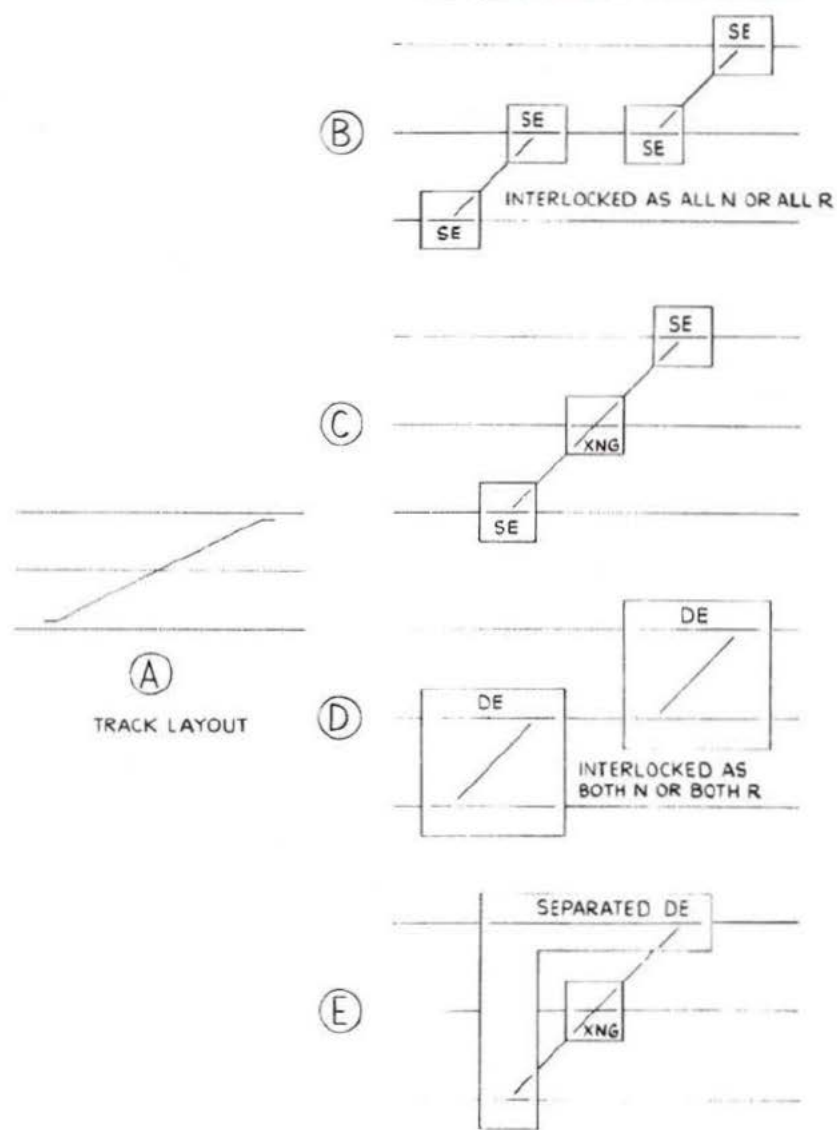
Each signal has an associated entrance and exit. These may be combined in the same unit. Each section of geographical cabling must commence at an entrance signal and terminate at a route exit; the exit is accordingly the electrical separation point between adjacent route-setting cable sections. Movements take place in only

one direction past signals 1, 2, 4, 5 and 7, but at signals 3 and 6 two directions are possible. This is significant because it means that these signal units must incorporate locking against opposing movements. The exit shown at signal 3 would normally be located at the next signal unit to the left, because movements from signals 2 and 6 would extend to that point.

Examples of point setting for flank protection also occur on this layout. If trap points 17 are not self-restored they would be set normal (and detected) in a route from 1 to 7 as protection against irregular movement of vehicles from the siding. The usual double junction point trapping would also apply for 13 to be set reverse, when on the flank of a route through 15 reversed. A track circuit interrupter would also protect the same route against vehicles derailed at the traps.

It is possible, but not necessarily economical, to represent all types of point layouts by only one geographical unit, that is a single turnout. A diamond crossing can be simulated by two turnouts, provided that both units are interlocked to allow, only, both normal or both reversed. Fig. 6:2 illustrates some representative examples of point units to suit the track layout shown at (A). (B) shows four single-end units interlocked as above, whilst (D) is a similar arrangement using interlocked double-end units. If a diamond crossing unit is used it will match with two single ends, as in (C) or a special double end unit with 'a hole in the middle' as in (E). Such a unit is useful for the formation of slip layouts. The choice of method rests solely on equipment redundancy. If a crossover with both ends worked together is represented by two single turnout units there will be a duplication of relays fulfilling the same purpose in the two units, and it is easily shown that a double-end unit is therefore more economical. For the same reason arrangement (D) is more economical than (B), and (E) more than (C). The final choice will depend on the degree of flank protection required and on the particular geographical system being used.

### GEOGRAPHICAL CIRCUITRY



**Fig. 6:2** Track layout and geographical equivalents

## GEOGRAPHICAL CIRCUITRY

### Physical Features of the Systems

The two geographical systems currently (1978) being installed by British Railways have the following general forms of unit construction.

**System A** There are two sizes of relay set, one for 6 BR 930A plug-in relays and the other for 12 relays. The relay set chassis are plugged into relay rack mountings. Wiring outlets from the relay sets are terminated in 50-way plugs mating with sockets on the relay racks to which connections are made by means of standard crimped relay connector spades.

**System B** Relay sets are based on three chassis sizes, capable of accommodating 15, 30 or 40 BR 930A plug-in relays. Plug coupler sockets are mounted on the units and 50-way plugs connect the cables and free wiring direct to the units.

All forms of unit which share the same types of plug coupler or jack in connection for different unit types have precautions in the form of pin codes or similar devices to guard against replacement of a unit by the wrong type. Similarly, a form of sealing after factory testing is provided to ensure that irregular site modifications to unit circuits do not result in units of apparently the same type ultimately having different circuits. In addition, each type of relay in use has the usual pin code identification to ensure safety when relays are changed.

#### *Sizes of Units*

The differing sizes of the relay sets in the two systems followed an independent consideration by each manufacturer on the following lines.

If it were possible to rationalise and standardise signalling principles completely it would be possible also to produce only one type of unit for signals and one type for points, and merely to connect them together in geographical sequence to produce 'instant' signalling

installations. Even with variations as they stand this would still be partly possible if a large measure of redundancy could be tolerated. Then however, each unit would have to be programmed in great detail, and more office and site-wiring time would be involved, thus defeating the main object of geographical circuitry. There is no ideal solution to this situation, because the matter is concerned with a compromise between large units, with considerable redundancy elements, and small units, with insufficient capacity to cover the majority of applications.

A simple example of unit size is for a signal with a route indicator. If there is to be only one type of signal unit, it should be able to accommodate relays or plugboards to cover the maximum number of routes. Signals with many route indications are in a minority, and if, say, 15 had been chosen as the maximum, most signal units would have had many redundant relays or plugboards. This would not have been economical, and the answer was to separate the route function from the signal and free-wire it or make it an auxiliary unit. Other examples similar to this are flank protection, overlaps and opposing locking.

#### *Vital and Non-Vital Relays*

Some of the relays incorporated in geographical units can be classified as having a non-vital function, for example panel key or button-repeat relays. Because such a relay can be of a cheaper design than a vital signalling relay it was questioned whether it might be worthwhile to use them in the units. It was decided however to design all units with all relays to vital signalling standards, to achieve both manufacturing and application benefits.

#### *Rack Mounting*

The layout of function units on the relay room racks could also be in geographical form, to assist the rapid location of a function unit. While this is possible for a small layout, with not more than 2 or 3 parallel lines, it is not so in the case of a large interlocking. Adjacent track functions are usually close together in the relay rack

layout, and no difficulties in their location are experienced. In addition to the geographical units there is always a number of individual relays, such as incoming track repeats, to be accommodated. A relay rack capable of mounting both units and individual relays is useful, but it is generally more convenient to mount the separate relays in groups together, or in units as a group, to assist location.

### Locking and Control Principles

#### *Interlocking and Control Tables*

Geographical systems do need interlocking and control tables, because all locking is not built-in. Fundamental locking is built-in, but exceptions must be specified and catered for. In respect of controls, which are governed by layout characteristics, permanent speed limitations and gradients, these will always need detailed treatment, and tables in some form are essential, particularly for functional testing. Those for any one particular geographical system are simpler than conventional ones, needing only to specify locking exceptions, flank protection, overlaps and special controls.

#### *Sectional Route Release*

This is a natural geographical feature whereby each set of points is released, in order, behind the train as it proceeds through the route and after the approach lock is released. Such a process is simpler than the detailed tailor-made route stick relays necessary in conventional route systems, and is a geographical advantage.

#### *Opposing Locking*

Most of the circuits contained in the geographical connecting cables are directional, that is, circuits for both directions of travel along the same tracks are catered for. Hence it is simple, having set a route in one direction, to open and prove the circuits for the opposing direction, and thereby to achieve built-in opposing locking. To remove such locking when necessary is not so simple, and it will usually involve special circuits, which may be built-in or free-wired.

#### *Alternative Routes*

Selection of alternative signalled routes in geographical systems is achieved by inhibiting a route selection sequence along the track path not required, thus allowing the alternative to be selected. Such selection may be made by alternative intermediate route selection buttons on the control panel, but arrangements can be made for preferred or directionally selected paths to be set automatically. In simple cases, it can be left to the panel operator to select the route required by using the individual point keys. As for opposing locking, this is a natural process because selection is carried in the geographical cables linking the route functions.

#### *Track Circuits*

Repeat relays of track circuits related to each function may be contained within its geographical unit, that is berth and first route track circuit of a signal, and locking track circuits of points or ground frames. Track circuits in an interlocking area which are not thus directly related may have a separate unit, because the geographical linking cables must pass through it to include the track circuits in aspect control circuits, and to register the panel route indications when a route is set through it. Since a number of relays in such a unit is small, composite units may be used for two or more track circuits.

#### *Route Identification*

Route identification is strictly a non-geographical feature, despite the fact that it is clearly related to the geography of the layout. In the geographical system however, it will be noted that in a fan of routes from an entrance, the first connecting cable is between the entrance signal and the first set of points. Over this one cable must be sent the instructions for setting and locking any available route, and the receipt of proof that the selected route has been set and is clear. Its identity can be established only by directly relating the entrance and particular route exit, and it cannot therefore

## GEOGRAPHICAL CIRCUITRY

be established from the common linking circuitry in the geographical cables. The question of redundancy arises again as seen when considering the size of units. The problem may be dealt with in three ways:

- (a) To provide a free-wired route identification network between entrances and exits so as to enable each signalled route to have a specific route identifying relay. This method provides a 'fan' type network initially controlled by the signal class relays within the geographical signal unit. Routeing contacts are usually available either from free-wiring contacts already provided in the units or from spare contacts on the interface relays which may be necessary between internal and external equipment, for example point detection relays.
- (b) To use a frequency identification method, whereby the signal control circuit has a superimposed voice frequency identified with each route exit. This introduces equipment not associated with normal interlocking circuits, and unless it is in the form of a safe-side-failure system, for example reed (where the cost and space required would be difficult to justify), it would have to use electronic circuits. In the latter equipment there is the risk of a change in frequency occurring due to component deterioration.
- (c) Another solution is to use the fact that in a button interlocking it is possible for only one route to be selected at a time. This allows a group, or 'multiple' of common wires, to be used; one wire of the group is energised or 'marked' by the selected exit unit at the time of route setting. The entrance unit momentarily inspects all wires so that only the route relay connected to the marked wire operates. Immediately the route is set the multiple is de-energised at the exit ready for the next route setting, and the selected route relay holds to the entrance signal locking circuit.

The number of wires in the multiple is limited to the highest number of indicated routes on any one signal in the interlock-

ing, and on average rarely exceeds six. Fig. 6:3 shows the general arrangement for a multiple of three wires.

### *Aspect Class Selection*

If a signal is capable of displaying aspects to cover all 4 classes (main, 'warning' (delayed Yellow), draw-ahead subsidiary, and shunt subsidiary), then single entrance and exit buttons on the control panel cannot effect selection between them, and supplementary buttons are therefore necessary. It is possible to select main, or draw-ahead subsidiary aspects automatically by track circuit occupation, but there are often operational advantages in the ability to select shunting and warning aspects by direct button selection. Such manual selection can be made only by additional buttons and this enforces the establishment of a relationship between entrance and exit which is similarly non-geographical to route identification.

Geographical aspect controls between entrance and exit can be accommodated on six wires, that is four aspect classes, plus HHR and DR; it is usual for these circuits to be reversible, that is, to apply as required for each direction of travel. However, it will be appreciated that each of the six wires will need routeing, and will also include track circuits clear or occupied as appropriate to the aspect class. This limits the availability of relay contacts for other requirements.

Alternatively, a method similar to that used for route identification selection can be used, that is a common bus-bar connection briefly linking entrances and exits during route setting. This reduces the aspect circuits to four wires; Main including all track circuits and overlap controls; shunt subsidiary, excluding track circuits where appropriate; and HHR and DR controls; the class identification, that is, Main/Warning or Draw-ahead subsidiary, being established at the instant of route setting.

In many instances HHR and DR controls may be provided in the external location to location circuits, and are therefore not then required in the relay room geographical circuits.

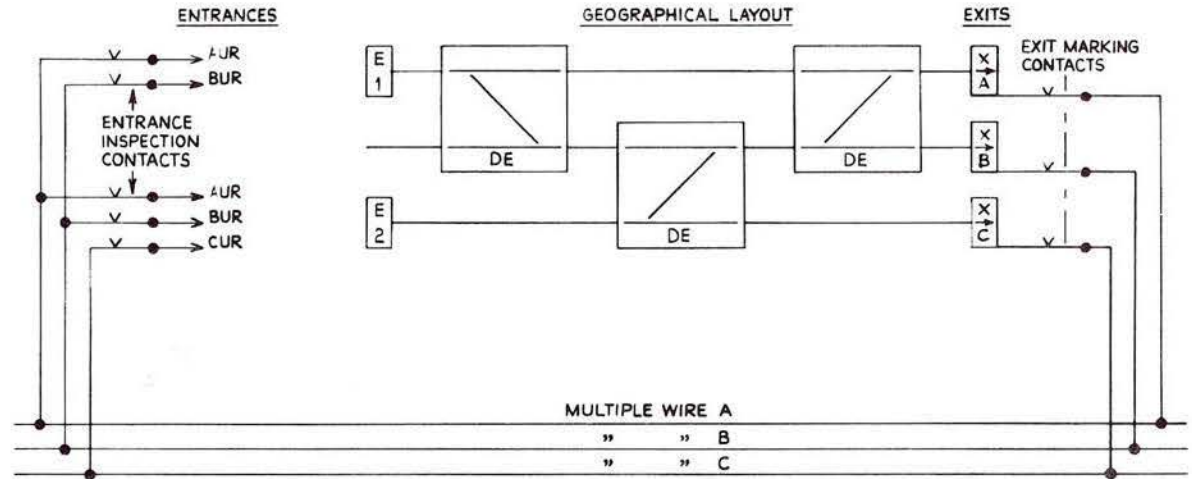
*Machine Testing after Manufacture*

Machine testing of geographical unit circuits is an essential feature if the full economies of the system are to be achieved. An ideal compromise needs to be reached in the fundamental design of the system. The more circuitry that can be accommodated in the units and the less free-wiring on site, the greater is the proportion of factory to site testing and the easier it is to set up the interlocking for functional testing. Testing on well-designed equipment can be completely free of error provided that full precautions are taken in the overall testing routine. The equipment must also be capable of testing itself regularly, for its own integrity, before it is used to test production items. The design of such a machine is simplified if the geographical units use plug-in relays; then the testing becomes merely a process of verifying a 'box of circuits' and its outlet terminals and connections to the relay plugboards. It also needs to be observed that the larger the geographical unit, the more complicated the test

equipment becomes, and there may accordingly be an economy achieved by the use of small units.

The basis of the test is usually a punched tape which lists in coded form the group of electrically interconnected points in the unit under test. The equipment reads the tape and verifies that there is connection between the listed points and with no others. The latter test, and one for insulation to earth are obviously vital from the safety angle.

A very important factor of the test is that it should run successfully from start to finish without interruption, and it must not be possible to stop the machine if a fault is detected, remove the unit, correct the wiring fault, replace the unit and continue with the test to an apparently successful conclusion. This is to guard against a second wiring fault being inadvertently introduced during the correction of the first. This could escape undetected because it may involve a test group already successfully traversed in the sequence.



**Fig. 6:3** Multiple system of route identification

#### GEOGRAPHICAL CIRCUITRY

Immediately after the test is correctly completed it is usual to affix one or more lead seals to ensure detection of any subsequent irregular modification, because each unit of the same type must be identical, and always remain so to allow interchangeability.

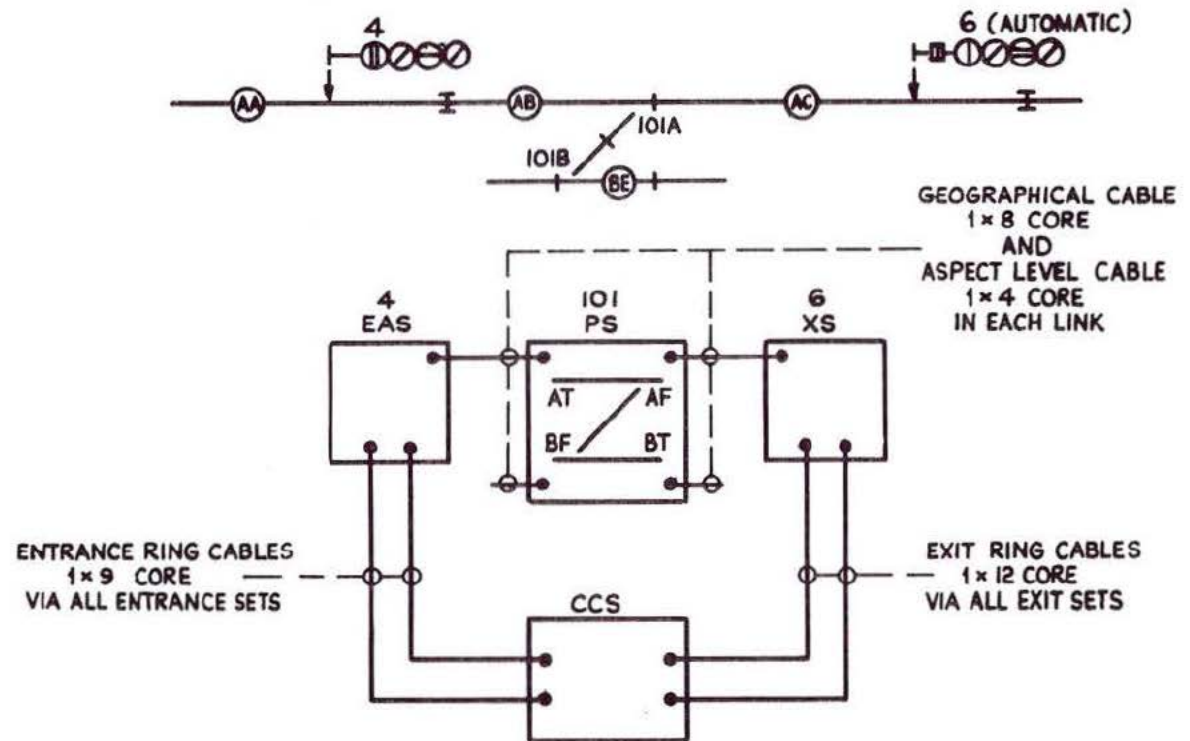
Test machines are obviously purpose-built, but the introduction of small low cost general purpose computers simplified the process and enabled the computer to be used for other tasks when not

required for testing. The appropriate choice of computer language could allow the same programme to be used on different types of computer, and reduce the inconvenience caused by failure or non-availability of a particular computer. The interface between the geographical units and the computer itself will, of course, be of special design.

## SYSTEM A

This system employs units accommodating either 6 or 12 BR 930A type plug-in relays and an 8-core geographical cable connected between functional units, four cores being used in each direction. Supplementary multicore cables are used for push button interlocking, class and aspect controls, flank protection and overlaps. The cable circuits are termed 'Levels'; each level has a defined function in

the processes of route availability examination, setting, locking and proving. The Selection Level (SL) examines availability and selects point positions required in the route; the Lock Level (LL) sets the route and locks the points, and the Aspect Levels (AL) include the track circuits and detection required in the signal aspect circuits. The Aspect Levels are accommodated in a separate 4-core cable



**Fig. 6:4** Typical layout of relay sets: System A

## GEOGRAPHICAL CIRCUITRY

and their circuits are reversible, allowing them to be used for either direction of travel through the track layout.

Latched relays are used extensively in the system to ensure retained registration of locking conditions in the event of power supply interruption, and the general principle is to unlatch the relay to register the locked condition, and to re-operate it for release. Separate Level Release circuits are provided in the 8-core cable to control re-operation of the latched relays by the Selection Level Release (SLR) and the Lock Level Release (LLR). The point units have conventional NLR and RLR relays which are operated and latched to control the point position.

Fig. 6:4 shows a simple layout of relay sets and cabling and the circuit diagrams described later relate to the track layout shown. A unique feature of System A is the 'Common Control Set' (CCS) the functions of which are:

- (a) to distinguish push button operations as entrances or exits of the route which is being set up;
- (b) to monitor the route setting to ensure correct sequence of button operation and to reject route initiation when routes are not free, not permitted or non-existent;
- (c) to determine the aspect class from both the entrance and exit sets either by button operation, non-availability of overlap, or as required by track conditions, and to pass this information to the route entrance to select the signal aspect to be displayed;
- (d) to provide lamp indications to show the stages reached in route setting and the aspect class selected; and
- (e) on completion of the above operations to release itself for further route setting.

These functions dictate that only one route may be set at a time and it is usual practice on large installations to provide a sufficient

number of such sets to avoid one panel operator interfering with another's operations.

The CCS is linked by cable rings as shown in Fig. 6:4 to all signal sets for the operation and registration of all push button operations.

### Types of Relay Set

There are three main groups of relay set, namely Signal, Point, and Overlap. They are further sub-divided as follows:

#### *Signal Sets*

##### (a) Entrance/Aspect Sets (EAS)

These are provided at all signals but different versions are available for main and shunt signals.

##### (b) Auxiliary Aspect Sets (AAS)

These sets are added when a signal has Call-on or Shunt aspects in addition to the Main aspect or Warner, in order to provide registration of the route class selected.

##### (c) Exit Sets (XS)

These sets are for use in conjunction with the EASs but they are also used alone at shunt limits or at the extremity of an interlocking. There are two types, namely 2-class and 4-class, according to the class of the routes leading up to the exit and the various overlap conditions.

##### (d) Countermove and UR Sets (CUS)

These sets are for use at a signal to provide interlocking between traffic movements in opposing directions on the same line. They provide controls for up to three routes from the signal. If the countermove facility is not required, a set for five routes is alternatively available.

*Point Sets**(a) Point Interlocking Sets (PIS)*

Various types are available for single- or double-end layouts and crossings.

*(b) Point Control Sets (PCS)*

These sets are used in conjunction with the PIS for various grades of flank protection and aspect control. For simplicity, in the descriptions and diagrams which follow, no differentiation has been made between the two types of point set and all are designated PS.

*Overlap Sets*

For simple overlaps where track circuits only are involved, an additional set is not necessary, but where points are involved, extra Overlap Point Sets (OPS) are associated with the point sets to regulate their operation in the overlap. Trailing and facing overlap sets are used as appropriate.

In this system, the breakdown of a signalling function into a number of small sets has for its object flexibility, and reduction in circuit redundancy.

## GEOGRAPHICAL CIRCUITRY

### Entrance Registration

Fig. 6:5 shows the registration of the operation of an entrance button.

The normal state of the circuit is that relays AP1, AP2, E1CR, E2CR, MXR and SXR are up and ENR, NR, NSR, ULCR, SLR, MER and SER are down. As a result, there is a negative on the Normal Proving Ring (Entrance Section) at CCS108 and a positive on the Common Entrance Ring at CCS109. When the entrance button (4) is pushed, NR in 4EAS is energised, followed by NSR which holds to the push button 'not pulled' contact (FM). Relay ENR is energised from the positive at EAS109 and the negative at EAS78. Note that the operation of NR and ENR effectively

locks out the operation of any other ENR and, by disconnecting the Common Entrance and Normal Proving Rings, releases E2CR and E1CR respectively.

The Main Entrance Registered Relay (MER) is now energised via ENR up, CCS106 and E1CR down. If for some reason MER does not pick up, the release of E1CR will release AP2 after time lag and de-energise the Common Entrance Ring. This will release ENR and restore the CCS to normal to permit further attempts at route setting.

The entrance button is now released, which releases NR, but ENR remains held and hence NSR also remains energised.



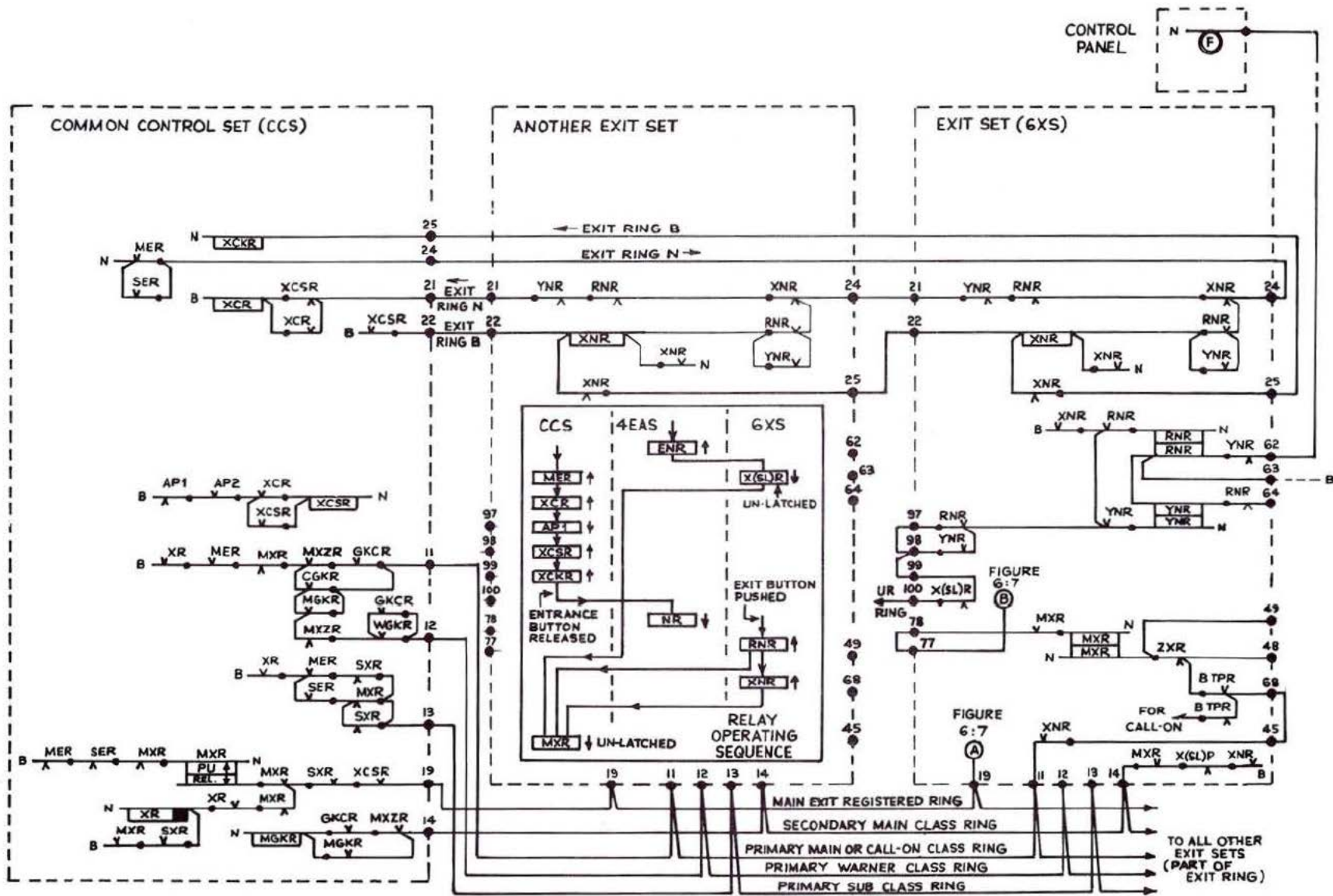


Fig. 6:6 System A: exit registration

### Exit Registration

Fig. 6:6 shows how the exit is registered. After MER has picked up, following operation of the entrance button, it puts a negative on the Exit Ring N which passes through all Exit sets (two only are shown) in series (proving that no exit button is being pushed) and energises XCR in the Common Control Set. Relay AP1 (Fig. 6:5) now releases and picks up XCSR followed by XCKR over Exit Ring B. At this stage, the state of the circuit is that relays AP2, MER, XCR, XCSR and XCKR are up and E1CR, E2CR and AP1 are down. The Exit Registration circuit is now ready for the exit button to be pushed.

When the exit button (6) is pushed, RNR in 6XS picks up. The RNR in the Exit set associated with Entrance set 4EAS did in fact pick up when the entrance button (4) was pushed, but without further effect as the Exit Rings would not be operative at that stage. Likewise, if an Entrance set had been associated with 6XS, the NR would have picked up when the exit button (6) was operated, but again without effect as AP1 has released. As 6 is an automatic signal, however, no Entrance set is necessary. Relay RNR picks up XNR via Exit Rings B and N and this relay holds to XCSR at CCS22. Note that the operation of RNR and XNR effectively locks out any other XNR in the ring. It will thus be seen that ENR and XNR perform similar functions at the entrance and exit respectively.

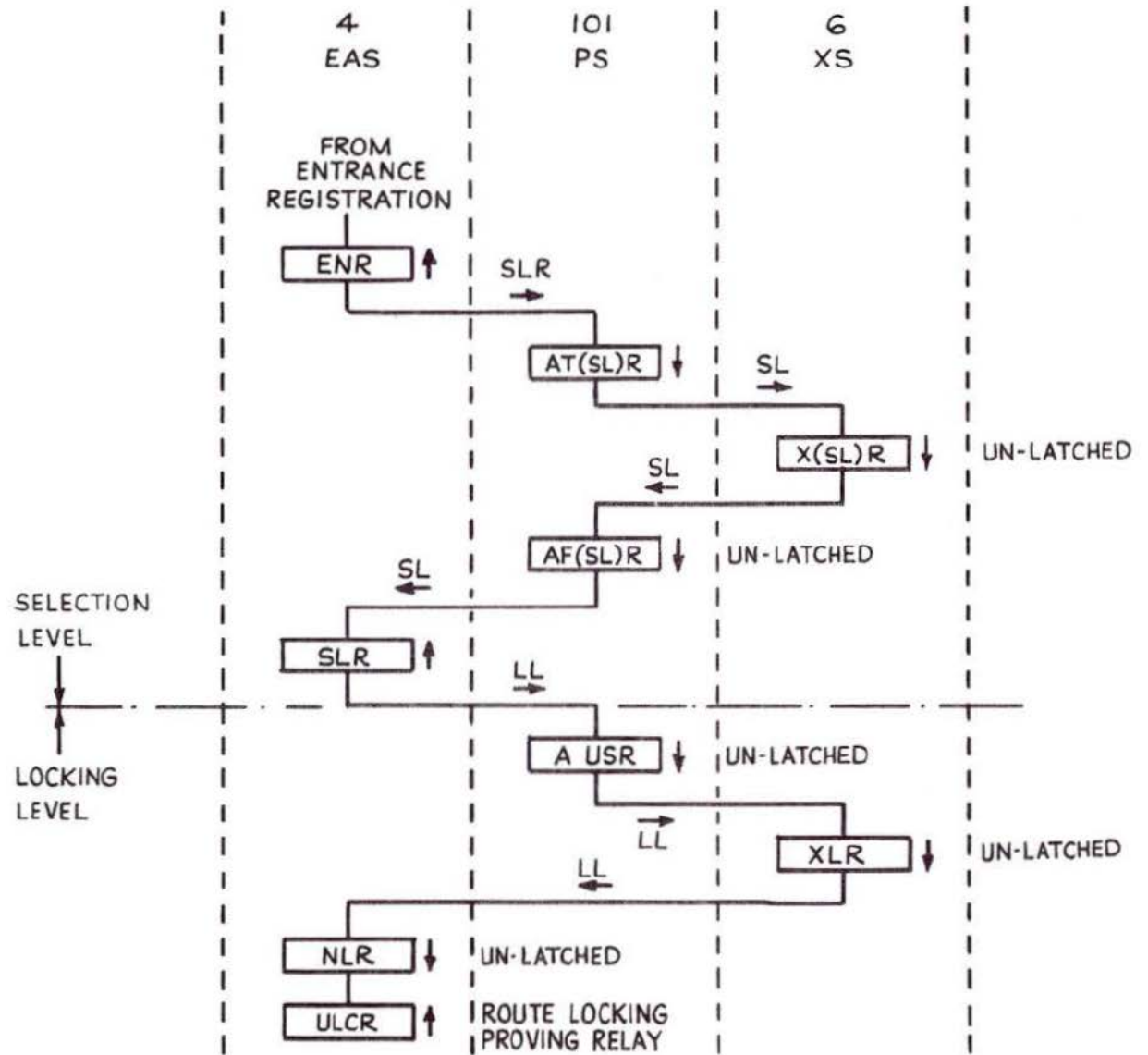
### Selection Level (Figs. 6:7 and 6:8)

When ENR picked up in the EAS, following the operation of the entrance button, a search voltage was sent out over the Selection Level (SL) to explore all possible routes from the entrance. At the same time, the complementary Selection Level Release (SLR) was de-energised. Fig. 6:7 shows relevant extracts from the Selection and Locking Level Circuits. The search voltage proceeds through the Point Set over contacts of NSAR (for normal paths) or RSAR (for reverse paths). These relays prove the availability of the points to assume that position. If, for example, 101 points were locked reverse on the point key, then the NSAR would be down and the search voltage in the example would be blocked. In this way, the search voltage will reach only available exits where from XS8 the X(SL)R will unlatch.

On the operation of exit button 6, XNR and RNR will be energised as previously described and only if the exit is a valid one, that is X(SL)R down, will a Main exit be registered in the CCS via X(SL)R down, XNR and RNR up, XS19 and CCS19 to MXR which is unlatched and released. The release of MXR connects XR (normally operated) to the Main Exit Registered Ring to monitor the Selection Level. In the event of a significant interruption, XR will release and restore the CCS to normal.



**Fig. 6:8** System A:  
selection and locking levels:  
relay operating sequence



## GEOGRAPHICAL CIRCUITRY

### Class Selection (Figs. 6:6 and 6:7)

With release of MXR, the CCS now has the information on which the entrance and exit buttons were operated and is able to determine the route class required. This information must now be sent to the route exit so that the controls which automatically select the aspect class may be included before the route aspect is determined. It is sent from the CCS to the XS over the appropriate wire in the 3-wire Primary Class Rings. These are termed Main (or Call-on), Warner and Subsidiary and leave the CCS on terminals 11, 12 and 13. In a 2-class Exit set, as required by this example, the Warner class is not included.

In the example, a Main aspect in signal 4 is all that is required. In general, however, relays MER and SER in the CCS and relays MXR and ZXR in a 2-class Exit set or relays MXR, CXR, WXR and SXR in a 4-class Exit set are used in combination to select the route class required. In Figs. 6:6 and 6:7, for simplicity, only the relays relevant to the example are shown. For a Main aspect in 4, MER in the CCS picks up MXR in 6XS via CCS11, XS11, XNR and B (i.e. AC) TPR up. Relay MXR then holds to the locking level at XS6. As this selection has been carried out in the Exit set, the CCS needs confirmation. This is given by MGKR, which is picked up via XNR and MXR up in the Exit set, XS14, CCS14 and holds to CCS14. This information is registered in 4EAS by the operation of MAR to enable the correct aspect to be displayed in the entrance signal (4). The registration of the Main exit (MXR operated in the XS) also enables the incoming SL at XS8 to be returned to the entrance via X(SL)R down, MXR up, XS1 to 101PS where AF(SL)R is unlatched and released. It is then passed back to 4EAS from PS11 to EAS8 to operate SLR. The route has now been fully selected and registered but has yet to be locked.

### Lock Level (Figs. 6:7 and 6:8)

So far as the Common Control Set is concerned, route setting is

complete (although in fact the points have not yet been set). The route aspect information must be held both at the entrance and the exit and the holding is therefore transferred to the Lock Level. The operation of SLR energises the Lock Level (LL) at EAS3 (and de-energises Lock Level Release (LLR) at EAS4) from where it passes to PS16 to unlatch AUSR. It is then passed on to the XS from PS3 to unlatch XLR. From here LL returns to the Entrance via the Point Set, proving that the points are locked (AUSR down), and finally unlatches and releases NLR and energises ULCR.

### Restoration of the Common Control Set to Normal (Fig. 6:5)

When ULCR operates, it removes the original marking of the Main Entrance Registered Ring at EAS 111. This releases MER and, as GKCR is now released, the delay unit on AP2 is disconnected and this relay releases. The release of AP2 de-energises the Common Entrance Ring at CCS109 and ENR releases in the Entrance Set. Relay XCSR is also released when AP2 releases. Relay AP1 re-operates when MER releases as XCR has already released. Relay MXR is also picked up and relatched when MER releases. Relay X(SL)R is picked up and latched by AP2 down via CCS69. Relays AP2 and XCSR down operate E1CR which then re-operates AP2 and the Common Entrance Ring is restored to prove all ENR relays down and to pick up E2CR. The CCS is now restored to normal.

### Point Setting

Fig. 6:9 shows the point setting circuit. Assume that 101 points are standing in the reverse position when it is required to set up the route from signal 4 to signal 6. With 101 reversed, 101RLR will be latched up and 101NLR will be down. To normalise the points it is necessary to unlatch and release 101RLR and then pick up and latch 101NLR. It has been shown that the operation of the Entrance and Exit resulted in the release of AT(SL)R and the

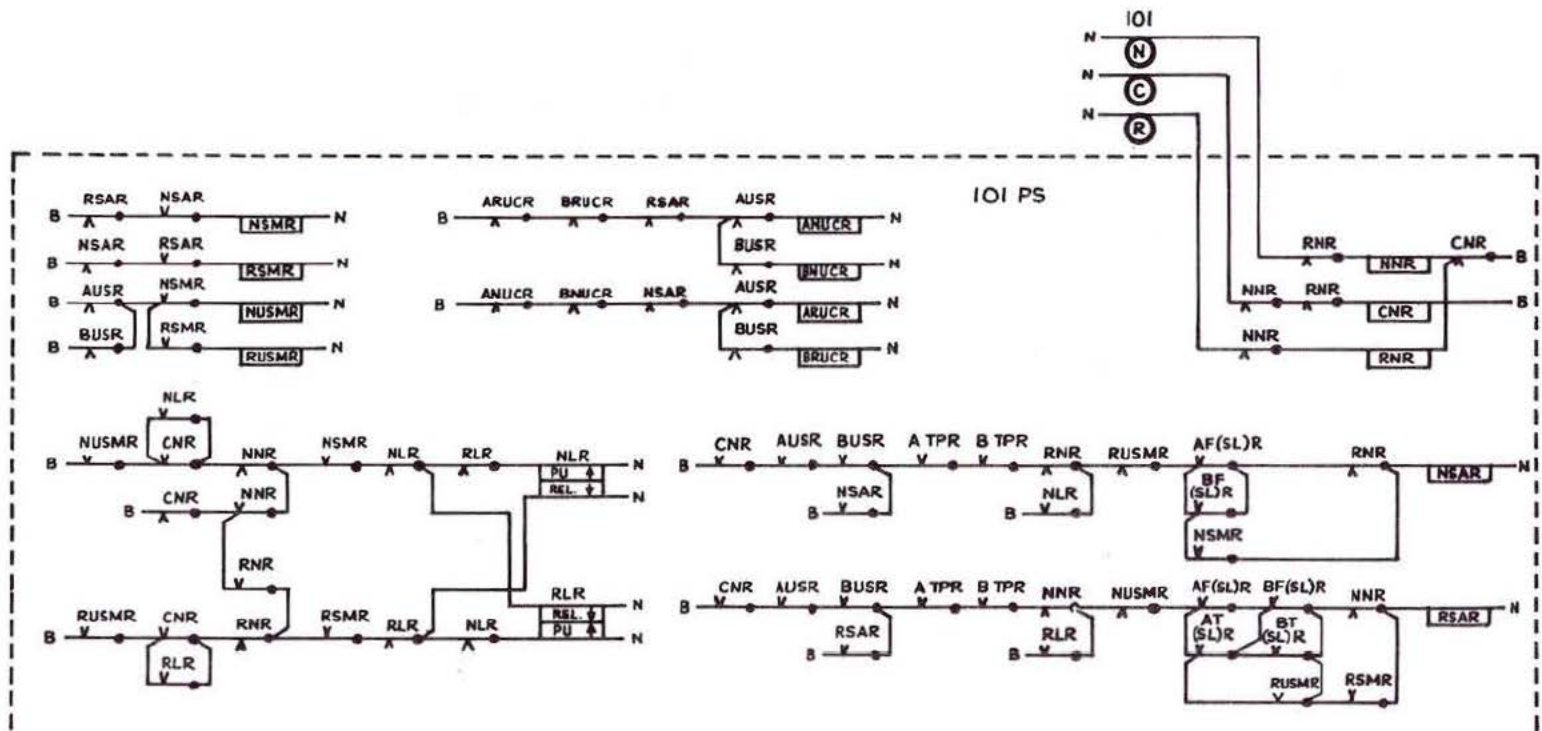
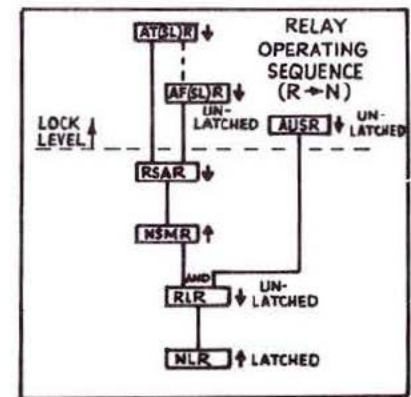
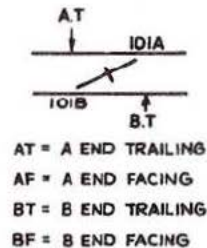


Fig. 6:9 System A: point setting circuit

unlatching and release of AF(SL)R and AUSR. At this stage in the circuit operation NSAR and RSAR are energised and in consequence NSMR, RSMR, NUSMR and RUSMR are down. Thus when AT(SL)R and AF(SL)R release, RSAR is de-energised. This picks up NSMR which completes the circuit to unlatch and release RLR and then to pick up and latch NLR. The conventional point operating circuit then drives the points from reverse to normal and the NWKR picks up.



## GEOGRAPHICAL CIRCUITRY

### Signal Aspect Level

Fig. 6:10 shows the signals controls. The 4-core aspect level cables follow similar geographical paths to the geographical level cables. The signal aspect levels are energised at the route exit and pass through the various relay sets in the route, including point and track sets, and are terminated in the Entrance/Aspect set where they are allotted to the signal aspect controls according to the route class selected. In the example, 4GR which is included in 4EAS would normally be fed from the Entrance set associated with the signal ahead but, in this case, 6 is an automatic signal and hence is fed by free wiring. The latter commences with the ECPR (proving a lamp alight in signal 6) and enters the Exit set at XS70 and proceeds via MXR, BTPR (i.e. AC) PS51, ATPR (i.e. AB), NWCR (101A and B ends detected normal), ANUCR (101 points set and locked normal), EAS51, MAR (Main Aspect Class selected), SR (Signal Stick relay), ULCR (proving that the route is locked) to 4GR. The HHR and DR relays are similarly fed from the signal ahead over the aspect level cables.

### Route Releasing

Fig. 6:10 also shows the route releasing circuit. The arrangements shown are for 'approach locked when operated' conditions, but comprehensive approach locking may also be used if required. When the route has been set and GR has picked up, the signal itself does not clear until POCR picked up as a contact on this relay is included in the circuit which energises the signal HR. Relay ALSR is normally energised and ALZR is normally de-energised. When GR picks up ALSR releases and energises POCR over GR up. Relay POCR completes the circuit to the HR (not shown). The signal now clears

and the route is approach locked. If an attempt is made to restore the route and release the locking, it is necessary to wait the operation of time relay ALJR as follows.

When the entrance button is pulled, GR will release immediately via ULCR which will release when ENR releases. The signal is now at Red and RGPR is up. The time relay ALJR now commences to operate via MAR, NSR, ULCR, all of which will be released when the entrance button is pulled. In due course, ALJR will pick up and energise ALSR to restore the route. If however, the train passes through the route, the occupation of the berth track circuit AA and the subsequent occupation of AB will pick up ALZR which will hold on its second coil to GR and NLR down. When the berth track circuit AA clears ALSR will pick up via ALZR up, EAS 127/126 and the relay will hold over its own contact until NLR picks up. The function of relay POCR is to guard the approach locking against premature release during an interruption or a power supply failure which might reproduce release conditions. When operated, POCR proves the release of ALSR and stays operated until approach lock release conditions are satisfied by the operation of ALZR.

When the approach locking is released and the entrance button has been pulled, NLR operates via ALSR up and NSR down. NSR down releases ENR which releases SLR. This completes a circuit via NLR up SLR down (see Fig. 6:7) to pick up and latch AUSR on the clearance of AB TPR (A TPR in 101 PS).

The operation of AUSR releases NUSMR and RSAR operates to release NSMR.

The route is now free for further operation.

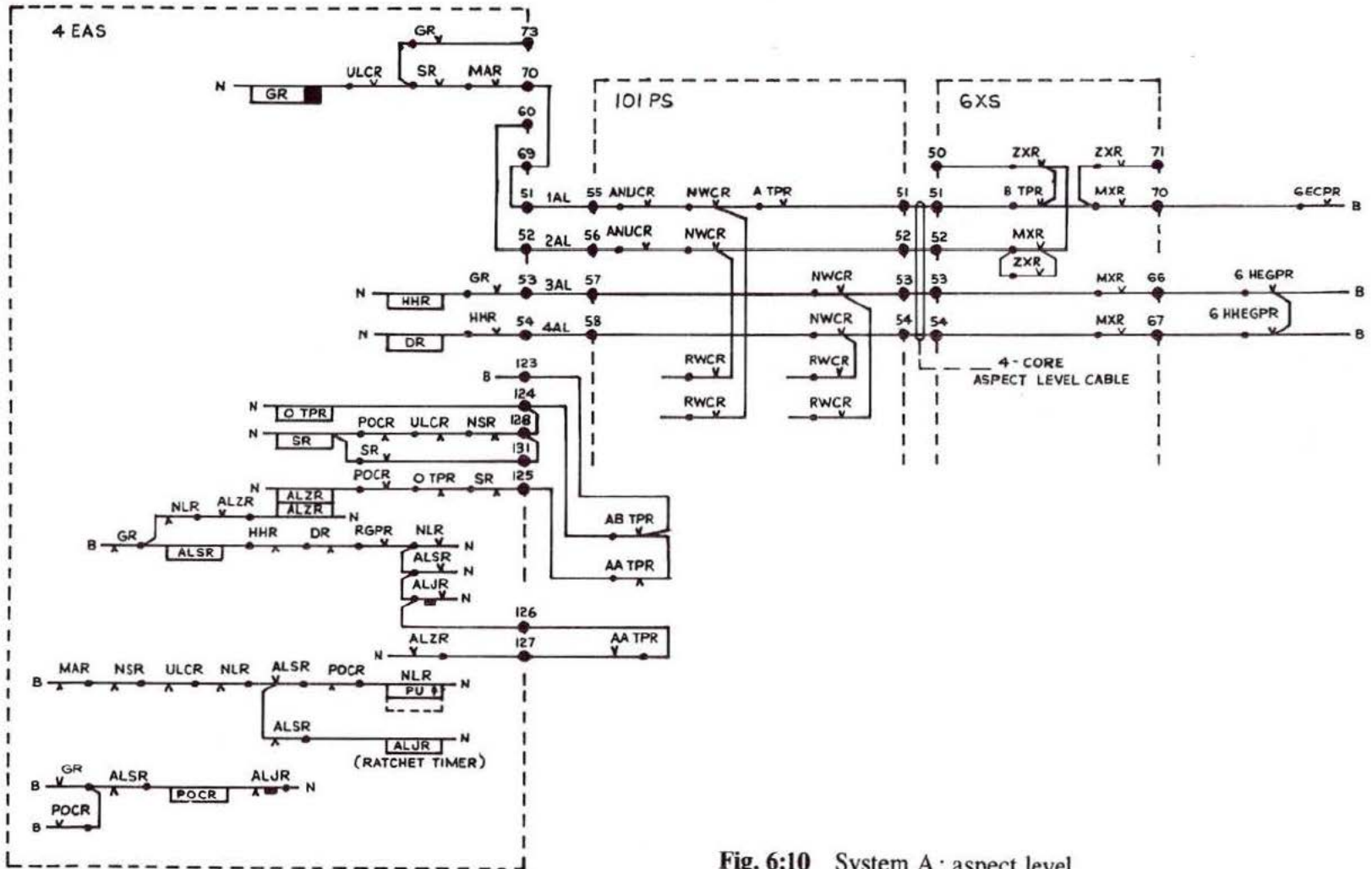


Fig. 6:10 System A: aspect level

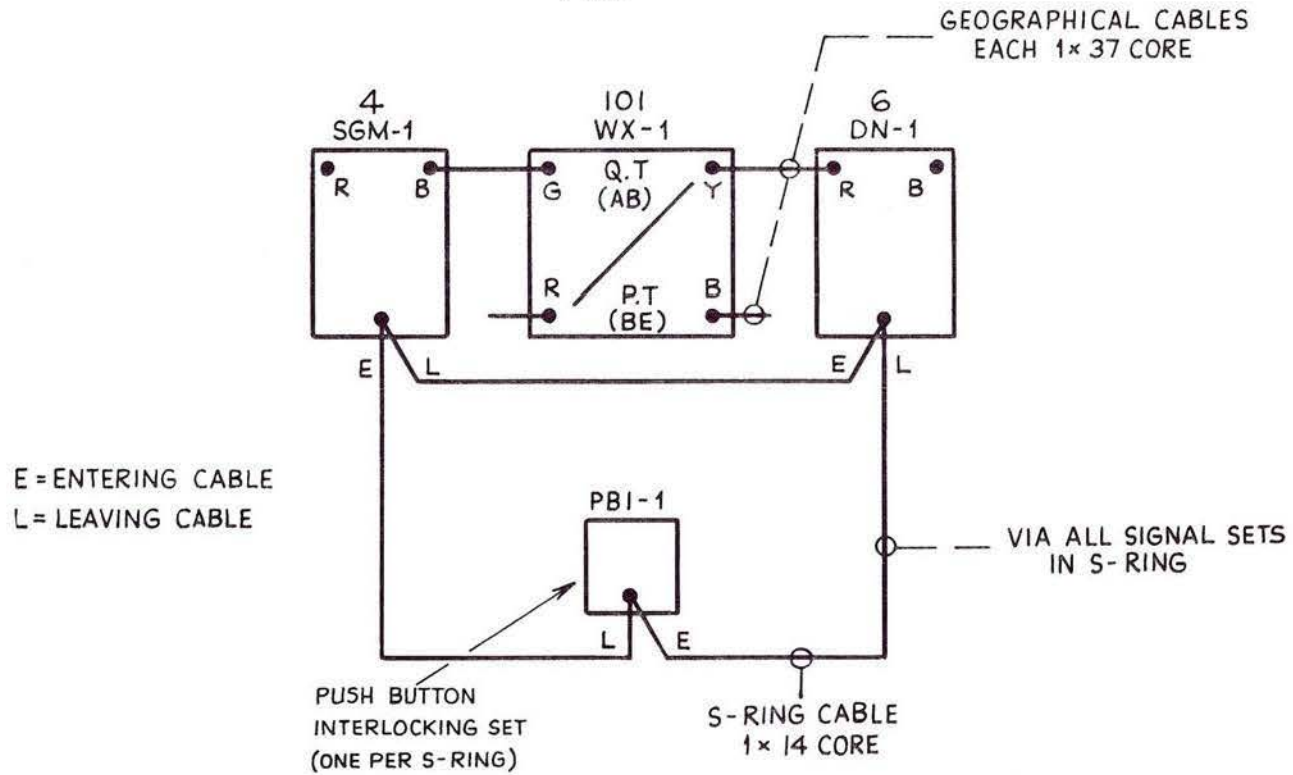
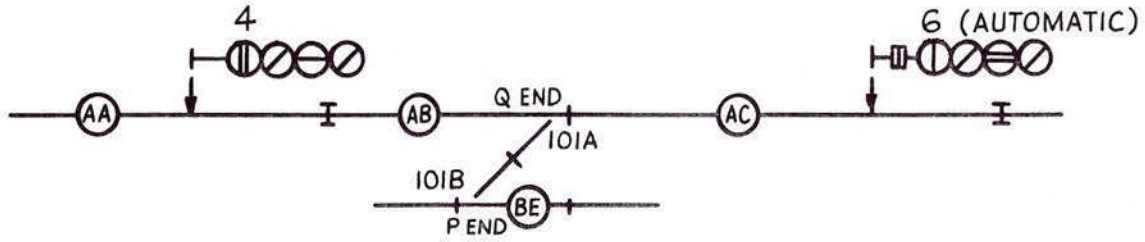
## SYSTEM B

System B consists of geographical units accommodating either 15, 30 or 40, BR 930A type relays, one unit representing a signal or point function. The units include the relays for route setting, locking and proving, signal controls and repeaters for tracks, signals and points. Circuits for control panel indications are also provided by the units. The units are joined together in a geographical manner by a 37-core cable which contains all the functions for the control and proving of the system. Some pairs of wires are cross connected between plug couplers to orientate correctly the networks concerned, and thus retain compatibility between units. A supplementary 14-core cable is provided for the push button control and proving rings which connects all signal type units to the push button interlocking unit.

The system is based on a series of circuit groups or networks

which pass in succession from unit to unit. Fig. 6:11 shows a simple layout of relay sets and cabling and the circuit diagrams which follow are based on the track layout shown. There are two groups of relay set, namely 'signal' units which represent the different classes of signal, and 'track' units which represent items on the track including track circuits located in plain track. The 37-core geographical cable connects all units in a geographical pattern in accordance with the layout. One end of the cable is termed the 'straight' end and the other the 'crossed' end. The 14-core S-Ring cable connects all 'signal' type units in series with the push button interlocking unit. Two 14-core cables are terminated in a single plug coupler; one cable being termed the 'Entering' cable and the other the 'Leaving' cable (see E and L in Fig. 6:11).

Fig. 6:11 System B: typical layout of relay sets



**Push Button Operation**

Fig. 6:12 shows the basic push button circuits and the initial relay operating sequence. The push button interlocking ring circuit connects all signal units in the S-Ring in series with the Push Button Interlocking Unit (PBI-1). As far as is practicable, each S-Ring is arranged to cover the control panel area allocated to one panel operator. This avoids one panel operator interfering with another's operations since only one route can be set at one time within the S-Ring. Two relays are directly associated with each route button, viz. the (F)SR and the (FM)R. The (F)SR is energised when the button is pushed and the (FM)R is de-energised when the button is pulled.

Assume that it is required to set the route from 4 to 6 in the layout shown in Fig. 6:11. When the entrance button at 4 is pushed, (F)SR is energised in relay set 4SGM-1. Contacts on (F)SR disconnect (F)CR ('no button pushed' relay) in PBI-1 and energise (F)PR in 4SGM-1. Contacts on (F)PR energise SR (start relay) which holds to (FM)R and DJR. Relay (M)ER ('Entrance registered') is now energised. The entrance button is now released. This releases (F)SR

and (F)PR and re-energises (F)CR. Relay SR however remains energised over its stick circuit via (M) or (S)ER.

At this time the entrance button begins to flash, indicating that an exit button is required to be pushed. The operation may be cancelled at any time by pulling the entrance button which would release (FM)R and thence SR and (M)ER. Relay DJR is, however, disconnected at (M)ER but retained on its capacitor which puts a time limit on the period between operating the entrance and exit buttons. The exit button at 6 is now pushed (SR and (M)ER being energised) and its (F)SR (in signal unit DN1) and the associated (F)PR energise. This energises DR (destination relay) which disconnects DCR, which releases and completes the hold circuit for DR. Relay DR up maintains (F)SR and (F)PR, thus locking out any other push button operation. The release of DCR disconnects its slow release repeat relay DCPR and also DJR (route setting time delay relay). During the delay period of DJR the route is called.

The exit button may now be released.



## GEOGRAPHICAL CIRCUITRY

### **Route Availability (Fig. 6:13)**

When a route is initiated by the panel operator, it is defined by SR and DR. Relay SR operates latched relay UER which marks the entrance to the route subject to no directly opposing route having been called (this is proved by NUPR and CURCR energised). Relays SR and UER (actually UEPR) energise the destination availability network which now explores the system for possible destinations. In this example, if 101 points had been set reversed for a conflicting route, RCLCSR would be de-energised and a destination would not be available. However, if no conflicting route has been operated (or called), (M)DAR will pick up via DR and (M)ER up and DCR down. The DAR network passes through all points between the entrance and all possible exits, diverging at each facing point.

### **Route Priming, Calling and Locking (Fig. 6:13)**

In the general case, a B 50 feed would be provided at Aa6 in Signal Set SGM-1 which would normally maintain QNUZR energised via QNCUPR, RCUPR and UER de-energised. In this particular case, as will be seen, such a feed is not necessary because the working is unidirectional. There are CUR relays for each path through each point unit which means that in the case of a crossover unit as

shown there would be three CURs, viz. QNCUR, PNCUR and RCUR.

The operation of relays UZR, CUR and LUR is a feature of System B which needs to be thoroughly understood. For further study the reader should refer to Figs. 6:16 and 6:17 which relate to more complicated layouts than that of Fig. 6:11.

The operation of UER therefore (normally) releases QNUZR which removes the bridge from QNCUR which picks up and latches via (M)DAR. Relay QNCUPR is now energised and removes the feed from the next section of the UZR network, thus releasing the next UZR and removing the bridge from the corresponding CUR. This CUR cannot, however, operate until the first CUR has been rebridged. This is done when QNLUR is unlatched via QNCUR. When all CURs in the networks have been operated in this manner and rebridged, full voltage is applied to FKR in the Entrance relay set via the 'route finish' latched relay UFR. Relay FKR operates UFKPR which disconnects the capacitor across DJR (not shown) and this relay now releases to disconnect SR and DR in the Entrance and Exit relay sets respectively. It also releases (F)SR and (F)PR and energises DCR. Finally (F)CR picks up. The entrance push button now has a steady White light via SR down and UER up. The route will now be set by the point setting circuit as described below.



## GEOGRAPHICAL CIRCUITRY

### Signal Aspect Controls (Fig. 6:14)

A separate network is provided for each of the three signal aspect classes, viz. Main (M), Draw-ahead (C) and Shunt (S), thus enabling the varying controls associated with each class to be achieved in a simple manner. These networks feed the route checking relay (UCR), the return for which is provided in a fourth network which proves correspondence between the route calling and locking and the point operation and detection relays. The UCR circuit in the example shown comprises only two track circuits clear (AB and AC), the detection of a single set of points (101 normal) and the lamp proving of the automatic signal ahead (6 ECPR).

Within the relay sets, the associated track circuits have their own nomenclature. For example, Q in relay set WX-1 corresponds to the track circuit at the Q end of 101 points, which in fact is AB track circuit. In relay set SGM-1, F corresponds to the first track past the signal which, as it happens in this example, is also AB. In a larger layout, these would be separate track circuits, but in this simple example there is redundancy in the signal controls since each relay set must be self-contained. The energisation of UCR proves that the route has been set and locked correctly and that all the controls are as required. In the example there is only one route and hence contacts on UCR would control the signal HR directly, but where the signal has more than one route, the signal HR circuit must be split ahead for route indicating purposes.

### Route Releasing (Fig. 6:14)

As shown above, when a set of points has been operated and locked, the calling relay (CUR) is latched in the energised position and

the route locking relay (LUR) is in the de-energised position. Each section of the track, whether or not it includes a set of points, is provided with UZR, CUR and LUR relays in its relay set. The UZR relays are wired in a network which embraces all relay sets in the route (see Fig. 6:17), but the CUR release coils and the LUR pick up coils are each wired in cascade so that the route is released section by section as the train passes over the route. It thus provides the equivalent of the sectional release route locking relays seen in the free-wired circuitry.

To free the route in each section, it is necessary to release the CUR and pick up the LUR. Assume that a train has approached, the entrance button has been pulled, and the train is passing over the route. On the clearance of the last approach track circuit, F track circuit in the Entrance signal set will be occupied and ALSR will pick up. When Q track in the next relay set (for example WX-1 in Fig. 6:14) is occupied (F and Q may be the same track circuit), the CUR will be released. A de-energised contact of the CUR will then prepare the CUR release circuit in the unit ahead via the d8/d7 connection and another will energise CURCR via the b4/b4 connection (Fig. 6:13) in the Entrance signal unit which will free the unit for further route setting.

In the meantime, the points remain locked by Q track occupied in the point setting circuit. On the clearance of Q, the LUR will pick up and energise the CLCR and CLCSR relays and complete the point setting circuit. In the event of there being no train approaching or it having passed through the route before the entrance button is pulled, the track circuits will all be clear. Hence when the entrance button is pulled, the LUR will pick up, followed by the release of the CUR.

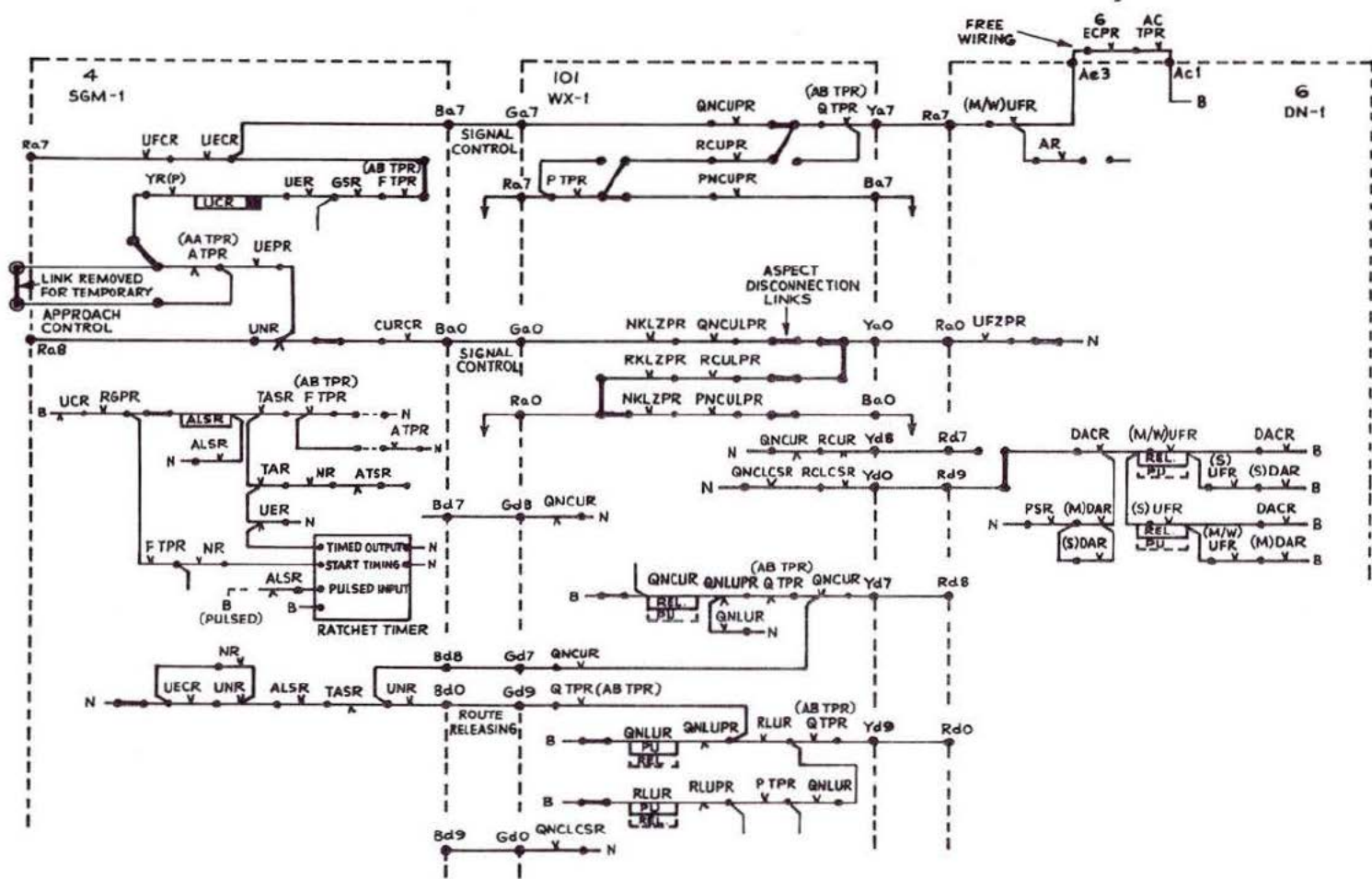


Fig. 6:14 System B: signal control and route releasing

## GEOGRAPHICAL CIRCUITRY

### Point Setting and Locking

Fig. 6:15 shows the point setting circuit which is similar to that discussed earlier for the free wiring example. Assume that 101 points are to be moved from reverse to normal to enable signal 4 to be cleared. The entrance and exit buttons will operate QNCUR as described above and QNLUR will have unlatched. As the points are not held in the reverse position, the 'no route set' relay RCLCSR will be energised. This relay, as shown in Fig. 6:15, requires RLUR energised proving that the route is not locked. If the route over 101 points reversed had been set up, RLUR would have been released and would have been prevented from picking up again by a similar network to that shown for QNLUR in Fig. 6:14. Consideration shows that QNLUR route locks the points in the normal position. Furthermore, if WZR and RLR are energised, the points are free to be moved normal. Relay QNCUR, which in the route calling network is operated by all routes passing over the Q end of the points normal, is therefore the basic operating contact for the NLR circuit. Thus if the points are not held by direct track locking, route locking or by another route, the operation of the route buttons at 4 and 6 will energise the NLR via QNCULPR (energised by QNCUR) and the points will be moved normal by the WR contactor relays as previously seen.

### Panel Key Operation

For route setting of the points the three position individual point key must be in its centre position, relay CR indicating this to the unit. An energised contact of CR controls relay WZR which, as stated earlier, is required energised to operate the lock relays NLR and RLR. Relay WZR is a slow-to-release type relay; therefore when the individual point key is turned to either normal or reverse the WZR's will remain operated a sufficient time to allow the latch release of the opposing LR to function. The required LR will then energise when the down proving of opposing repeaters is established. Because relay WZR proves the availability of the point interlocking and will be de-energised if any route or track locking is present, the moving of the individual point key away from the centre position during this time will preclude any subsequent point movement after the interlocking is cleared, thereby providing the point key 'non-pre-setting' facility.

### Conclusion

The foregoing description of the two geographical systems, can, for reasons of space, be no more than an outline of the circuit principles, and the reader who wishes to know more must study the circuits of an actual installation. While it may be found that personal preferences exist for one system or the other, experience has shown that both are equally successful.

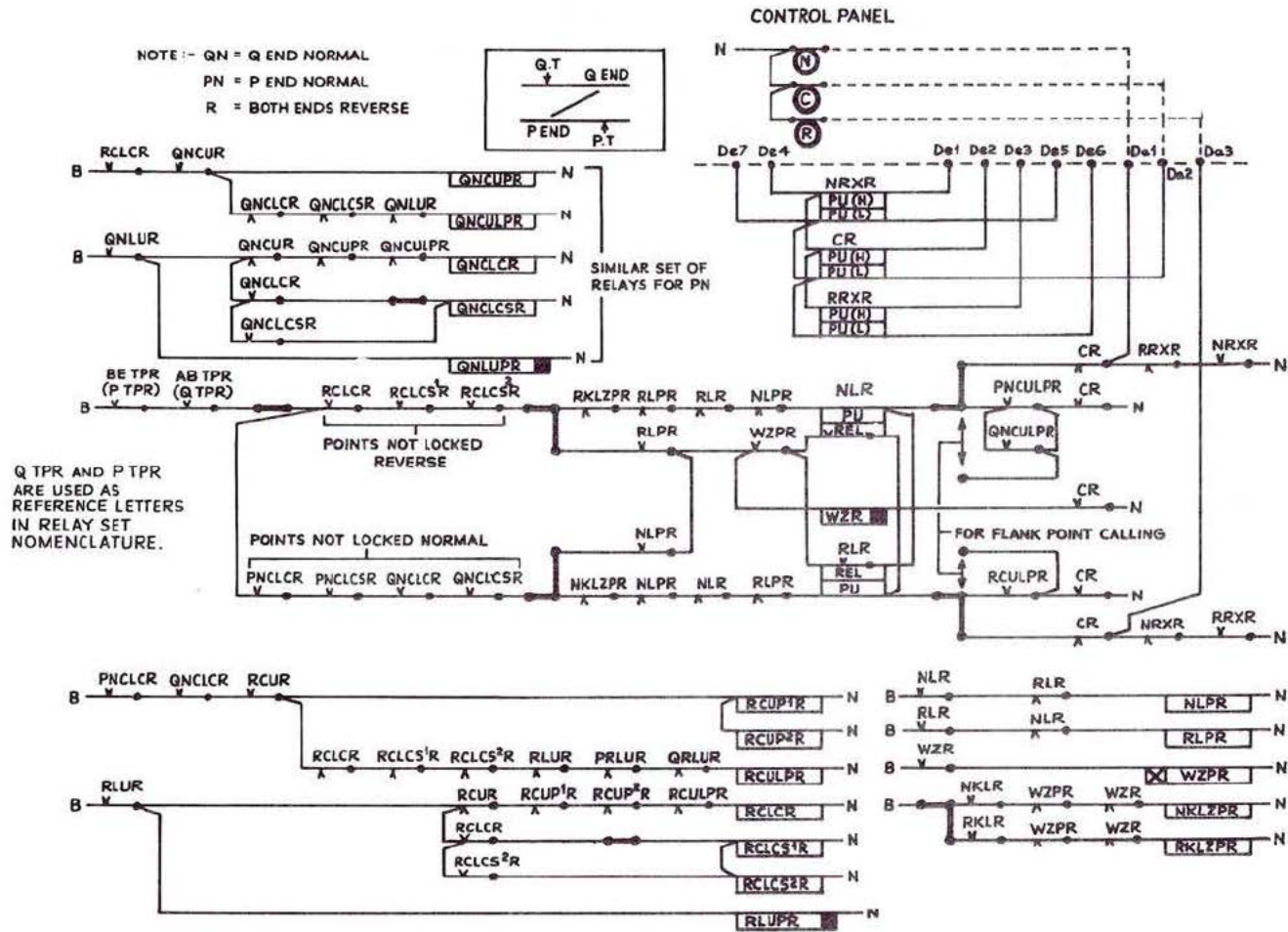
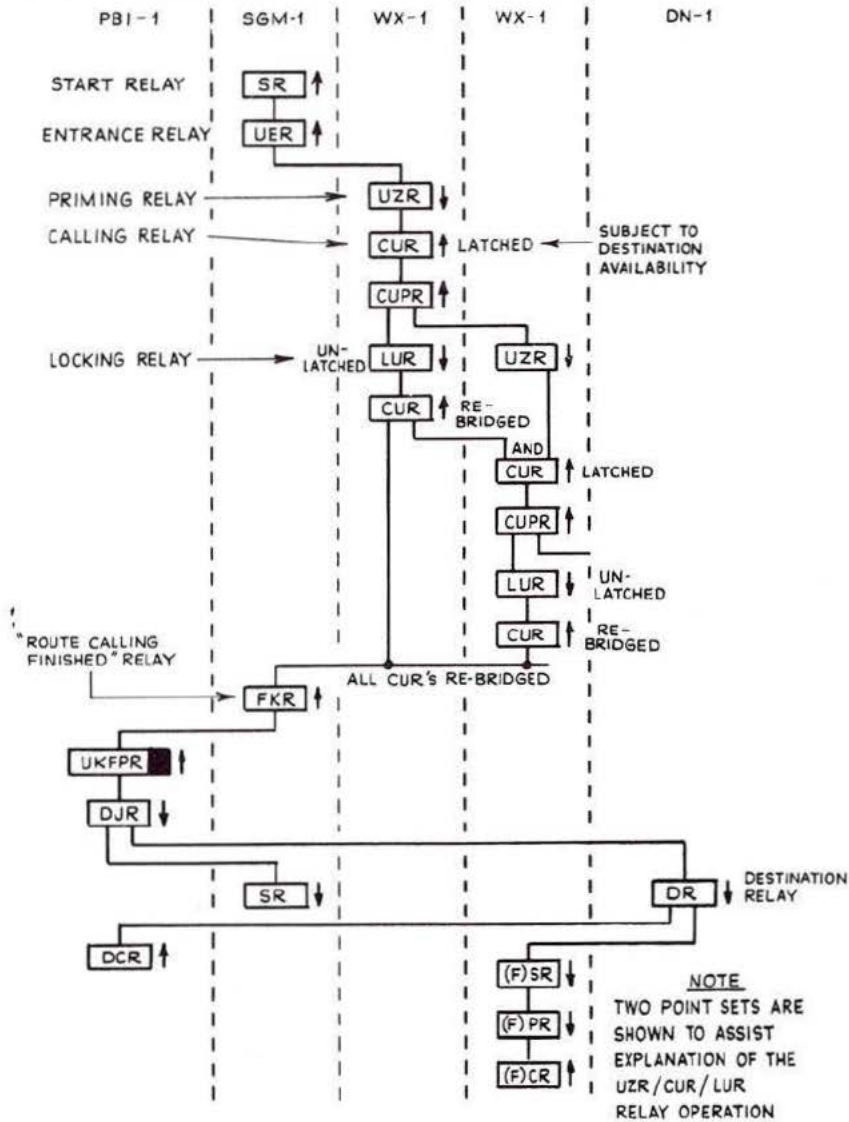


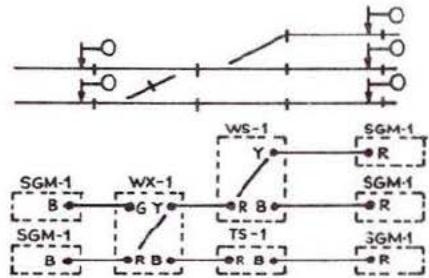
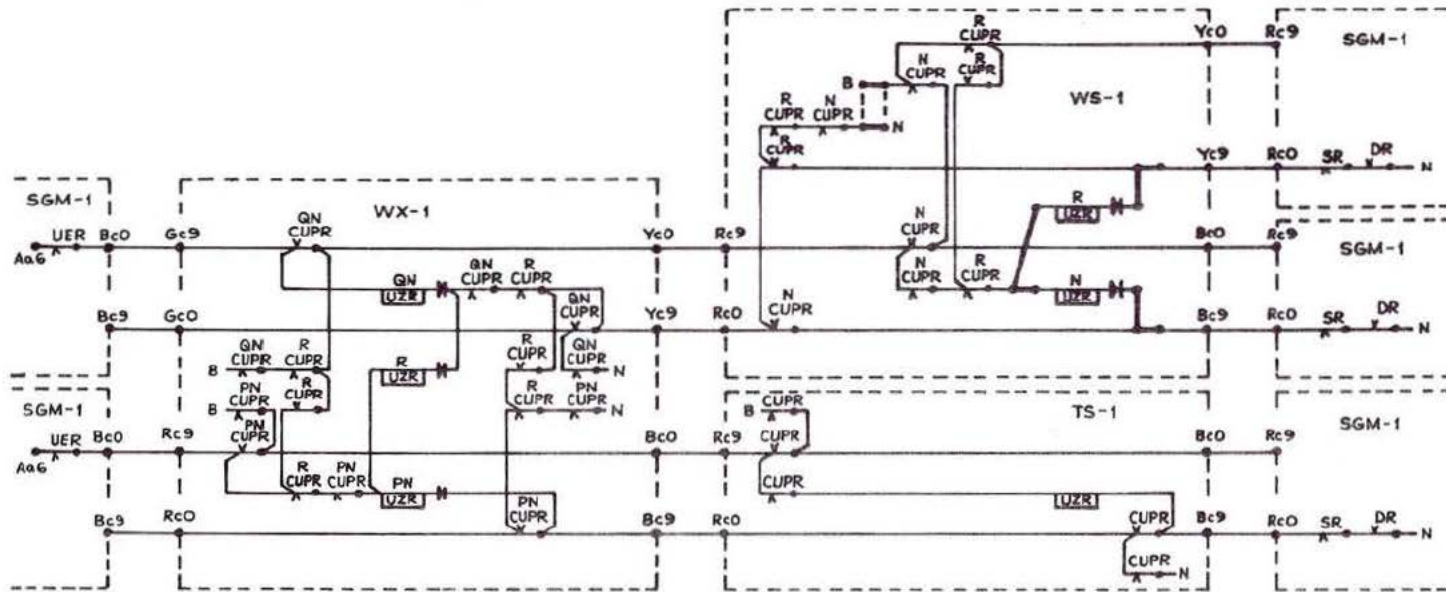
Fig. 6:15 System B: point setting circuit

# GEOGRAPHICAL CIRCUITRY



**Fig. 6:16** System B: route priming calling and locking: relay operating sequence

Fig. 6:17 System B: route priming: circuit operation



NOTE :- THIS FIGURE DOES NOT RELATE TO THE LAYOUT SHOWN IN FIGURE 6:11 BUT IS INTENDED TO ASSIST THE EXPLANATION OF THE LZR OPERATION

## Track Circuit Principles and Equipment

The track circuit is the basis of modern signalling. Its first purpose is to prove that a section of track is clear of all vehicles. That being done, points may be operated and signals then cleared for trains to move with the assurance that it is safe for the movement to be made.

The second purpose of a track circuit is to detect the presence of a train and to lock the route ahead of it and so ensure its safe transit.

The track circuit also provides the indications on the signalling control panel which advises the operator of the whereabouts of all vehicles on his section of the line and enables the train describer to keep in step with train movements.

### Principle of Operation

The running rails are used as conductors connecting a source of electrical energy at one end of the track circuit to a relay at the other; the section of line being electrically isolated by either insulated rail joints or by electrical means in the case of jointless track circuits. Fig. 7:1 illustrates the principle of operation. The track circuit is shown in the clear condition.

At one end of the section, the source of electrical energy is connected across the rails via an adjustable device for regulating the current. At the other end is connected the coil of a relay. It will be seen that with the whole section clear of vehicles, a circuit exists from the source, along one rail, through the relay coil returning via the other rail. An armature is attracted to the iron circuit forming the core of the energised relay coil thereby closing contacts which are used for control and indication purposes. As shown in Fig.

7:2, the presence of a vehicle anywhere along the section causes the track circuit current to by-pass the relay coil via the wheels and axles. The coil, now receiving insufficient electrical energy, allows the armature to release, so causing the contacts to open. It will be seen that a disconnection of any kind in the battery, regulating resistor or relay coil, or a discontinuity in the path through the rails for any reason (for example, a broken rail), will cause the relay to become de-energised, thus simulating the presence of a train. This is the more restrictive condition and the track circuit can therefore be said to be fail-safe.

The track circuit is limited in its workable length by two factors. The first is the leakage of current from one rail to the other, through the rail fixings and the sleepers and ballast (in parallel). The second is the resistance of the rails themselves and the rail bonds. The latter are not required for welded track and the resistance is then that of the rails alone.

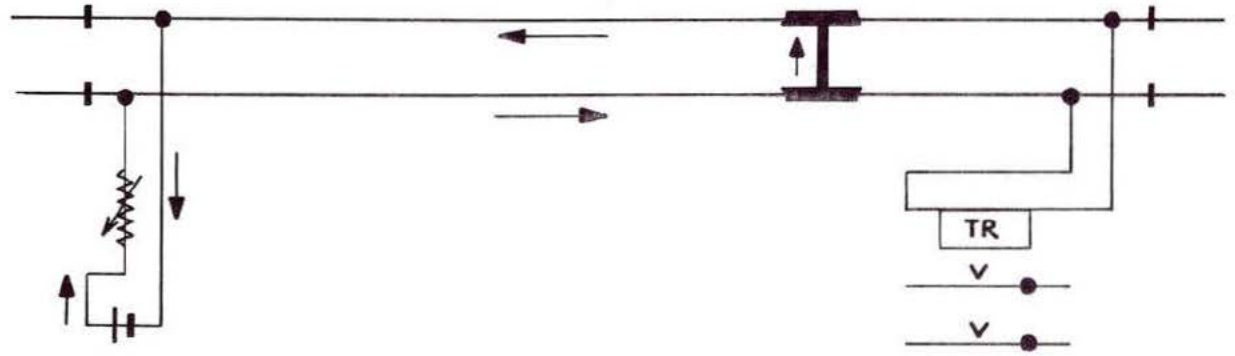
The rail to rail resistance, or 'ballast resistance', may vary from 50 ohms per 305 m (1000 ft) for well ballasted dry track with insulated rail fixings (as for flat bottom track) to as low as 0.5 ohm per 305 m in wet conditions, or when the ballast is dirty. It will be appreciated that the ballast resistance is constantly varying with the weather conditions, and therefore the adjustment of the regulating resistance must take into account the highest and lowest value of the ballast resistance for the track circuit.

The rail resistance is constant for a given track circuit but varies for different types and weight of rail and the type of bonding used. For DC track circuits only, for 95 lb bull head rails with two No. 8 galvanised non bonds it is about 0.075 ohm per 305 m (1000 ft) for each rail. For 113 lb flat bottom rail with all joints welded it will be as low as 0.01 ohm per 305 m for each rail. These figures show that for all practical purposes, rail resistance may be ignored in DC track circuit calculations. These figures must not be used in calculating the rail impedance for AC track circuits.

Although the rail resistance in a DC track circuit may be neglected, the theory of the track circuit is not so simple. If, as in the case

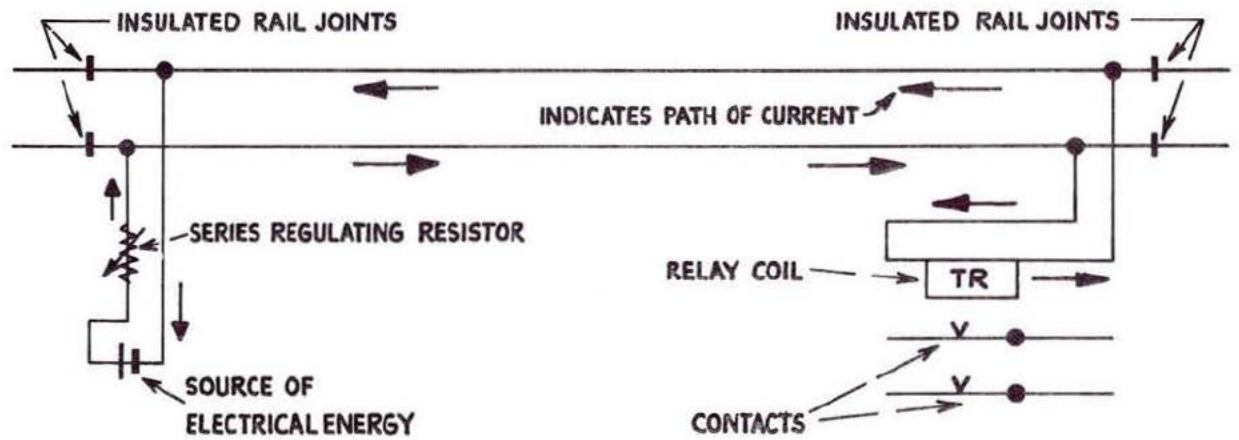
TRACK CIRCUIT PRINCIPLES AND EQUIPMENT

Fig. 7:1 Basic track circuit:  
occupied



RELAY DE-ENERGISED (CONTACTS BROKEN)  
INDICATING PRESENCE OF VEHICLE

Fig. 7:2 Basic track circuit:  
clear



RELAY ENERGISED INDICATING  
TRACK CLEAR OF VEHICLES

## TRACK CIRCUIT PRINCIPLES AND EQUIPMENT

of AC track circuits, the rail impedance must be taken into account, consideration shows that at the feed end, the rail to rail voltage will be higher than at the relay end. The ballast resistance must therefore be considered as distributed throughout the length of the track circuit, which leads to complex calculations involving hyperbolic functions.

The other important characteristic of a track circuit is the train shunt. When a train enters the track circuit it is equivalent to a resistance being connected between the rails. This is called the 'train shunt' resistance. In the case of a heavy train in normal running condition the resistance through the wheels and the contact with the rails is very low, and amounts practically to a short circuit across the rails. But in the case of a vehicle with wheels which may be rusty through standing idle the resistance may be much higher. It is of vital importance that such a vehicle shall operate the track circuit as surely as one in good condition. Contamination of the rail head increases the contact resistance, and to cover both the effects of rusty wheels and contaminated rails it is usual to specify a minimum train shunt resistance at which the track circuit will operate reliably. It must not be thought advisable to obtain as high a train shunt resistance as possible, because this would make the track circuits undesirably susceptible to the effects of rain storms. It is usual to specify a minimum train shunt resistance of 0.5 ohm, but where the rail surface is always in good condition and particularly in electrified territory where the traction current assists the shunting condition and impedance bonds stabilise the ballast resistance, a lower figure of 0.3 or even 0.2 ohm is acceptable. Many railways elsewhere in the world do not require such a high train shunt figure as British Railways. For example, in the U.S.A. the figure is 0.06 ohm. The reason is that British Railways still have many 4-wheel freight wagons in the fleet, which are not only light in weight when empty but also are not continuously braked and, in consequence, the wheels may not be so clean and do not make good contact with the rails.

It will now be seen that there are two parameters within which all track circuits must operate, namely, a failing point at minimum

ballast resistance, and a minimum train shunt at maximum ballast resistance. The regulating resistance must be adjusted such that the track circuit satisfies both conditions. For calculation, the maximum value is taken as infinite resistance.

### Simple DC Track Circuit Calculation

Having established the two most important parameters of a simple track circuit it is now necessary to consider details of the equipment which must be provided to work under the stipulated conditions. There is a large choice of relay operating characteristics and supply voltages, but the first factor to be taken into consideration is the minimum ballast resistance which is likely to be encountered. From a knowledge of this the resistance of the relay may be determined, since for maximum power economy the relay resistance should approximately equal the minimum ballast resistance. This arises from the maximum power transfer theorem. Next, from a knowledge of what available relays can do, it is possible to establish the operating characteristics of the relay. From this the necessary feed arrangements may be determined. The following calculation illustrates the point.

#### *Example 1*

Assume a minimum ballast resistance of 4 ohms, a relay resistance of 4 ohms, and a battery of 2 volts emf.

A typical 4 ohm relay has the following characteristics:

$$\begin{aligned}\text{Pick-up} &= 0.110 \text{ amp} \\ \text{Drop-away} &= 0.080 \text{ amp}\end{aligned}$$

For the relay to pick-up at minimum ballast resistance, a rail to rail voltage of 0.440 is required, but 25 per cent should be added to this as a margin to ensure satisfactory operation at minimum ballast resistance.

Assuming negligible voltage drop in the rails the regulating resistor will be adjusted to:

$$\frac{\text{Battery voltage} - \text{Rail voltage}}{\text{Battery current}} = \frac{2 - 0.55}{\frac{0.55}{2}} = 5.28 \text{ ohms}$$

The minimum train shunt resistance will occur with a dry track (which gives infinite ballast resistance), and it will be that resistance which, when connected to the rails, just reduces the relay voltage to its drop-away value.

$$\begin{aligned} \text{Battery current at drop-away} &= \frac{\text{Battery voltage} - \text{Drop-away voltage}}{\text{Regulating resistance}} \\ &= \frac{2 - 0.32}{5.28} \\ &= 0.32 \text{ amp} \end{aligned}$$

Of this current the relay will draw 0.080 amp leaving 0.24 amp to flow through the train shunt. The value of the latter will be

$$\frac{0.32}{0.24} = 1.33 \text{ ohms}$$

Thus with a regulating resistance of 5.28 ohms the train shunt will always exceed 0.5 ohm and the track circuit will operate reliably at a ballast resistance ranging from 4 ohms to infinity. To further illustrate track circuit behaviour it is of interest to recalculate the value of regulating resistance assuming a minimum ballast resistance of 2 ohms.

*Example 2*

Rail to rail voltage at pick-up = 0.55 as before

$$\text{Current through ballast} = \frac{0.55}{2} = 0.275 \text{ amp}$$

$$\text{Relay current} = \frac{0.55}{4} = 0.1375 \text{ amp as before}$$

$$\text{Battery current} = 0.1375 + 0.275 = 0.4125 \text{ amp}$$

$$\text{Whence regulating resistance} = \frac{2 - 0.55}{0.4125} = 3.52 \text{ ohms}$$

$$\text{Battery current at drop-away} = \frac{2 - 0.32}{3.52} = 0.477 \text{ amp}$$

$$\text{Current through train shunt} = 0.477 - 0.08 = 0.397 \text{ amp}$$

$$\text{Train shunt} = \frac{0.32}{0.397} = 0.805 \text{ ohm}$$

Thus, with a regulating resistance of 3.52 ohms, the train shunt will still exceed 0.5 ohm and the track circuit will operate with a minimum ballast resistance of only 2 ohms, which is obviously an advantage.

TRACK CIRCUIT PRINCIPLES AND EQUIPMENT

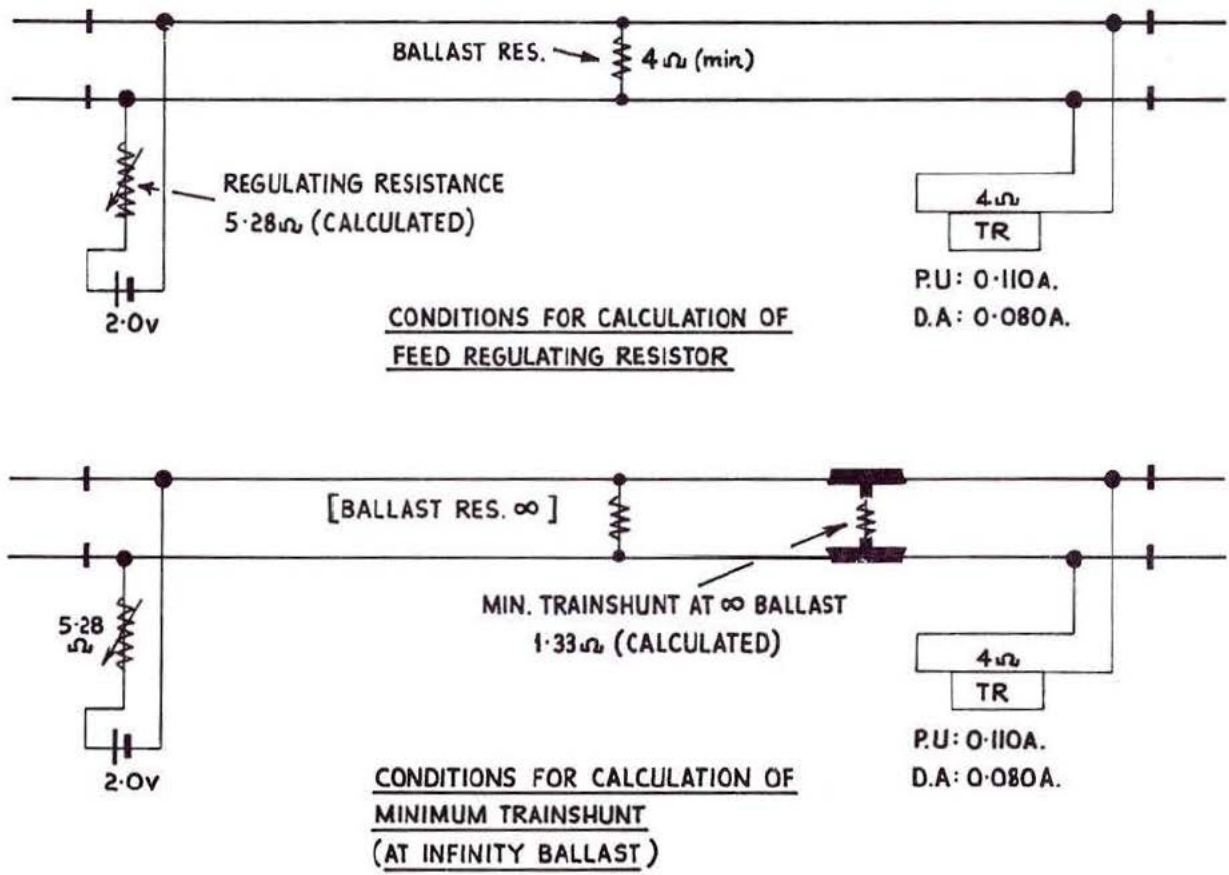


Fig. 7:3 Example of track circuit calculation

Fig. 7:3 shows the track circuit with the figures calculated in Example 1 inserted for the failing condition (minimum ballast resistance) and minimum train shunt condition (infinity ballast resistance).

## LAYOUT OF TRACK CIRCUITS

### Insulated Rail Joints

An insulated rail joint consists of two assemblies:

- an insulated (fibre or nylon) 'end post' shaped to the rail profile, and
- a pair of fishplates which must support the rail ends as do normal fishplates, but also maintain electrical isolation, usually by means of insulated ferrules and washers.

Track circuits must be so arranged that, as far as practicable, polarities on each side of every insulated rail joint are opposing. Consideration shows that if both insulated joints between two consecutive track circuits fail (i.e. become conductive), the supply voltages will then oppose one another and both relays will release. By this means the failure of an insulated rail joint is detected.

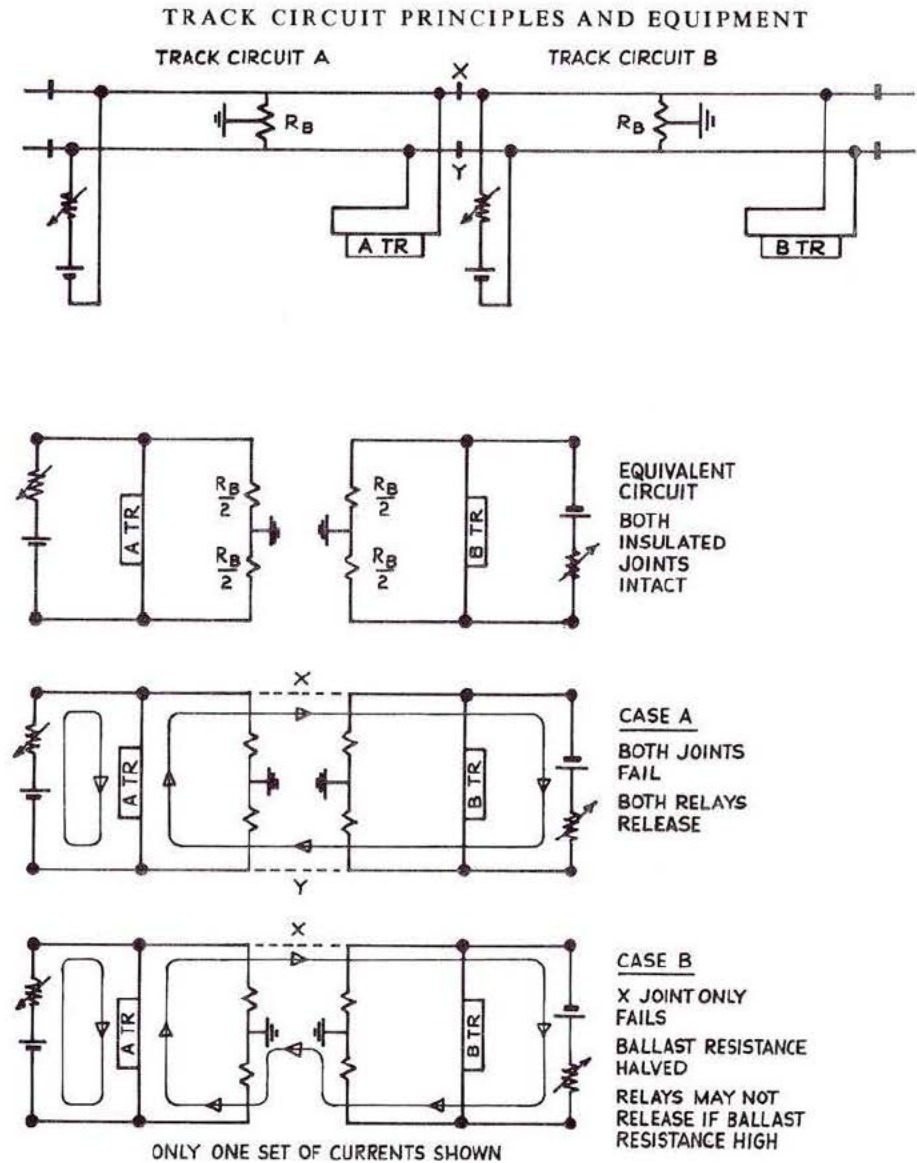
Fig. 7:4 shows the equivalent circuits under failure conditions.

If, however, only one joint fails, the effect is to convert both track circuits to single rail and halve the ballast resistance.

A single rail track circuit, with inherently lower ballast resistance, would be adjusted to suit.

The advent of continuous welded rail has enabled all rail joints except those required for signalling purposes to be eliminated. In order to strengthen the latter, 'glued' insulated rail joints are coming into use in increasing numbers. The joint is formed in a short length of rail at the permanent way pre-assembly depot. A pair of glued insulated rail joints thus formed is then welded *in situ* to complete a length of continuous welded track.

Fig. 7:4 Insulated rail joint failure: equivalent circuits



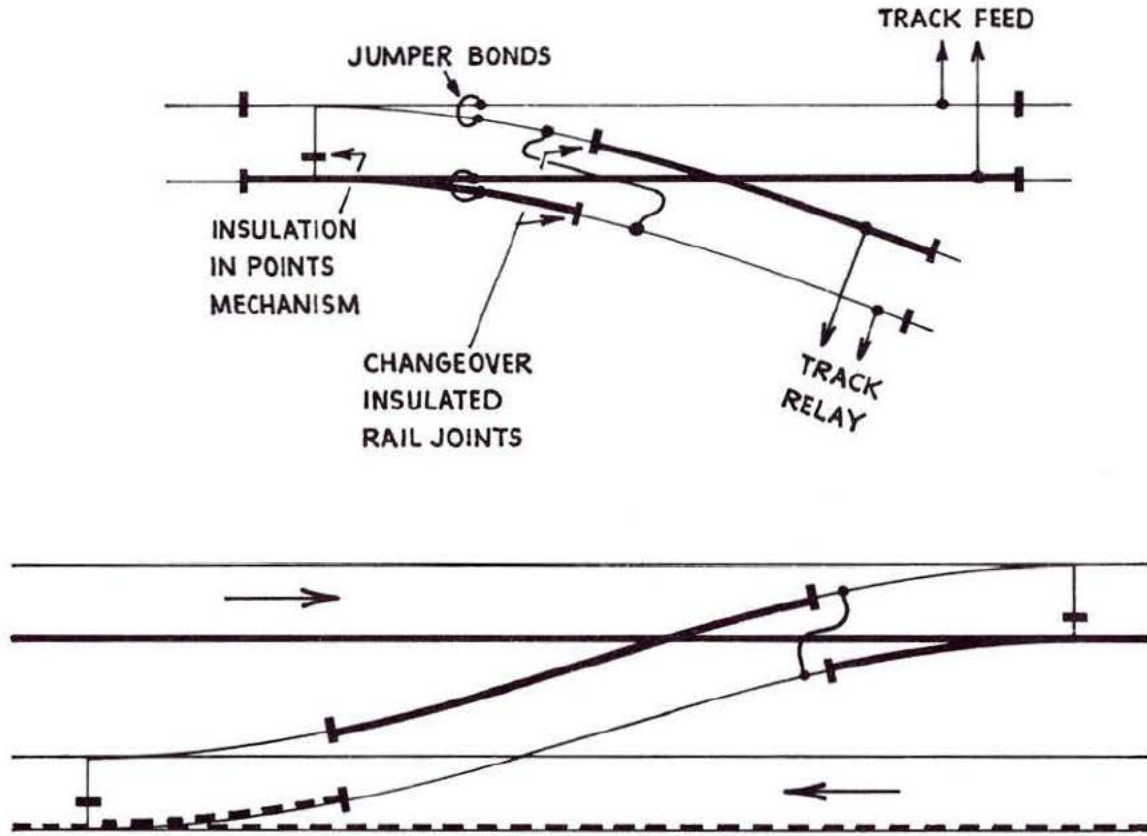


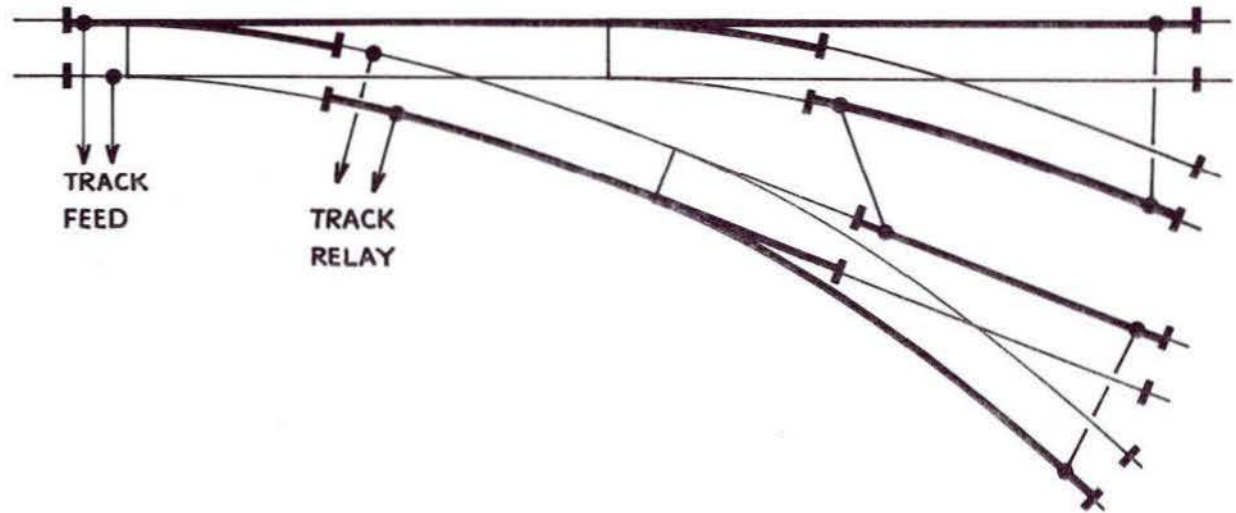
Fig. 7:5 Typical bonding of track circuits

**Track Circuits over Points**

Where points and crossings occur, intermediate insulated rail joints are provided to maintain effective continuity of polarity of each rail. These intermediate joints are usually located in the turnout

rather than in the main running line in order to limit the rate of wear. Fig. 7:5 shows typical bonding plans for two common layouts. The insulated joints are located in positions which enable point locking to be released at the earliest opportunity.

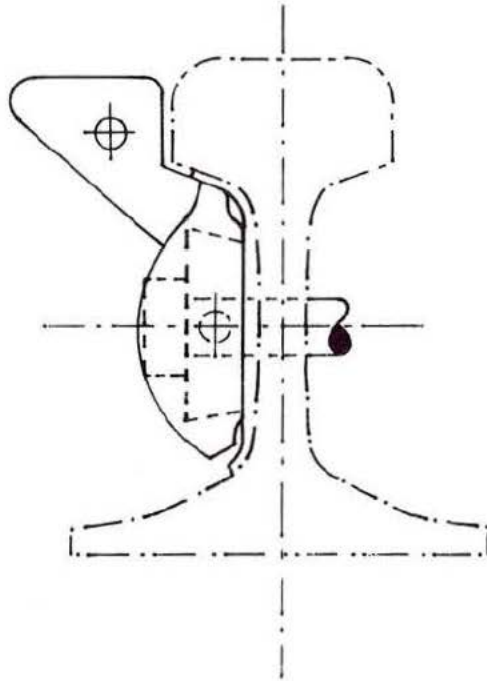
**Fig. 7:6** Typical series bonding of track circuits



### Series and Parallel Bonding

Inadvertent disconnection of any bond between adjacent components of a track circuit must result in the latter 'failing safe', that is, showing 'track occupied'. This is achieved by bonding all parts of the track circuit in series wherever possible. However, in cases

of complicated point and crossing layouts and on certain electrified lines, single rail type track circuits are employed and in such cases it is not possible to have series bonding of 'common' or traction return rail. It must be emphasised that the track circuit rail must be completely series bonded throughout. Fig. 7:6 shows a typical case of series bonding.



**Fig. 7:7** Track circuit interrupter assembly

### **Track Circuit Interrupters**

With run back catch points and trap points, there is always a possibility that a short train or single vehicle such as a locomotive could be completely derailed and permit the track circuit to be re-energised. This is overcome by the use of the track circuit interrupter which is broken by the leading wheel in the act of derailment, and opens the circuit until it is replaced. **Fig. 7:7** shows the construction and position in relation to the rail. A track circuit interrupter consists of an iron casting bolted to, but suitably insulated from, the stock rail of a set of catch points or trap points. It is positioned in the flangeway so that the leading wheel of a vehicle will break the casting, causing the track circuit to be de-energised irrespective of whether any of the vehicles are actually shunting the track.

**Fig. 7:8** Typical examples of track circuit interrupters at trap points

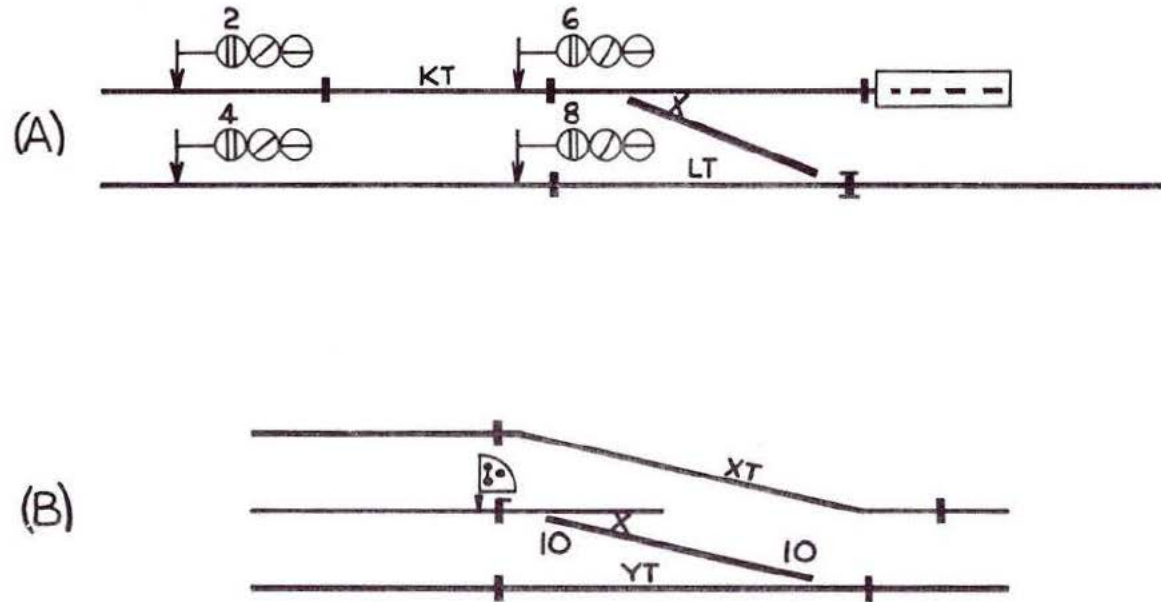


Fig. 7:8 shows typical cases of trap points where track circuit interrupters are fitted. In Fig. 7:8(B), the interrupter detecting a derailment at No. 10 points and disconnecting track circuit Y would also disconnect X in case the derailed vehicles should be foul at

that time. When a track circuit interrupter is fixed at trap points, as shown in Fig. 7:8, it is at the end of the track circuit, or may be made so by series bonding, and is wired directly in series with the feed or relay end of the track circuit.

## TRACK CIRCUIT PRINCIPLES AND EQUIPMENT

Run back catch points, however, are rarely located at the extremity of the track circuit and can only be wired in series with the track circuit by the addition of an insulated joint. If this joint failed, the interrupter would be short-circuited and hence it is necessary to provide two joints to 'stagger' the track circuit as shown in Fig. 7:9(A) so that both the interrupter and the insulated rail joints are detected to be intact when the track circuit is clear.

In electrified areas, where the rails are carrying traction current, the rails must not be open-circuited and it is necessary for the interrupter to be isolated from the track circuit. In this case, when broken by a derailment it either disconnects the track circuit TPR or the local winding of the AC track relay, according to circumstances, as shown in Fig. 7:9(B).

If the interrupter is more than 50 m from the end of the track circuit it releases a separate relay to disconnect the DC track relay or the local winding of the AC track relay as the case may be. Fig. 7:9(C) shows this arrangement.

In continuously welded track, track circuit interrupters are always dealt with as shown in Fig. 7:9(B) or (C) to avoid the provision of insulated rail joints in the main line.

### Limitations of the Simple DC Track Circuit

It will be apparent that the simple DC track circuit as described cannot be used with safety in the presence or vicinity of DC traction, since return currents of many thousands of amperes flow in the running rails and would completely swamp the track circuit current. Even where 'fourth rail' traction systems are in use an earth fault on a train, or other leakage, could result in traction currents flowing in the running rails. Track circuits for use in DC traction areas are described later in this chapter.

Simple DC track circuits cannot be used in AC (50 Hz) traction territory either, because the DC tractive armature relay can be operated by alternating current unless special precautions are taken. The 'immunisation' of DC track circuits against AC traction currents

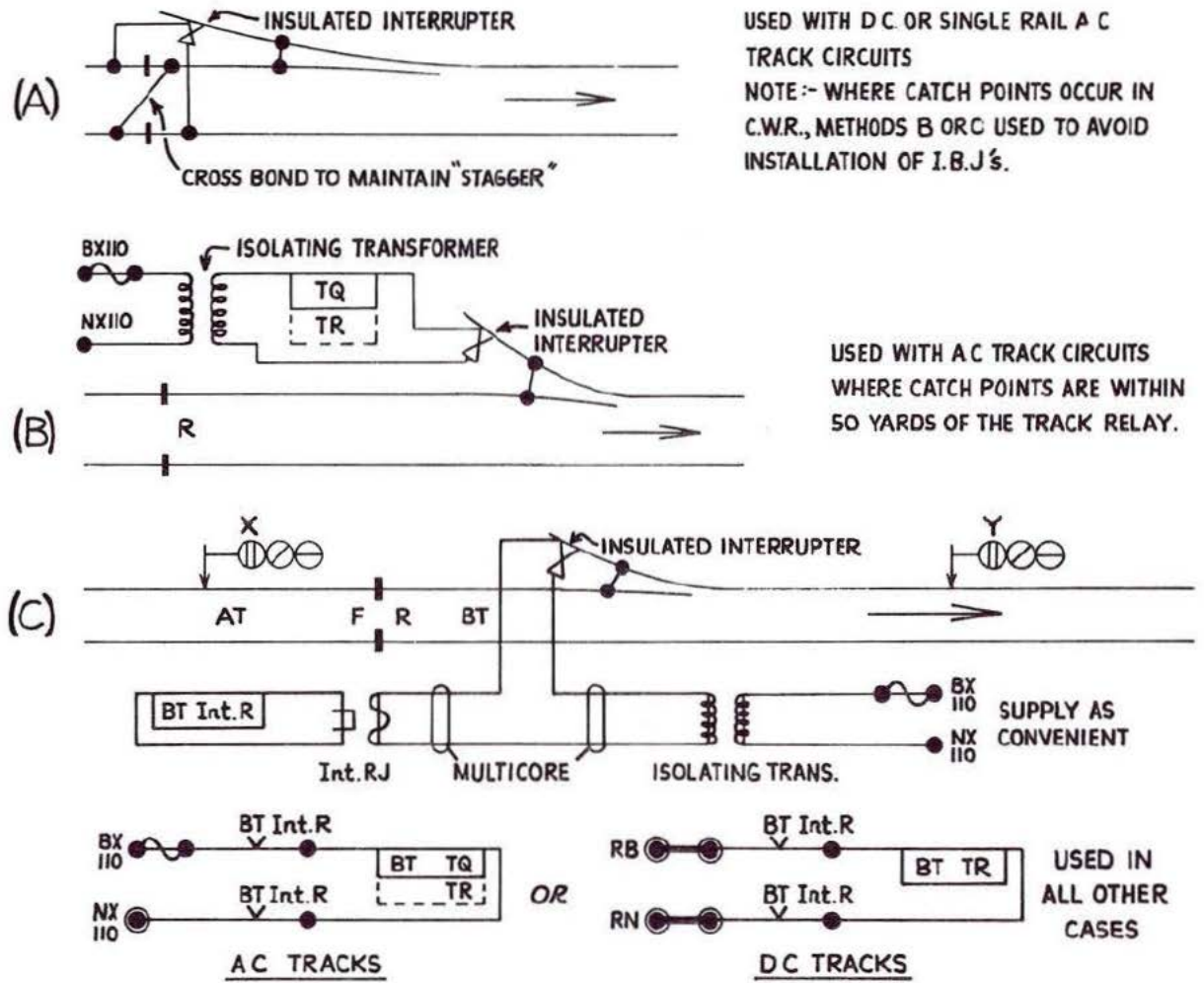
is also described later. Even in the absence of any form of electric traction, precautions are necessary to avoid interference from pipeline cathodic protection systems and other forms of stray DC. Certain types of subsoil, particularly in coastal areas, generate a potential difference which is sufficient to hold up and in some cases to energise a simple track relay. It is the practice, wherever possible, to locate the track relay at the running-on end of a track circuit, so as to obtain the maximum short circuit effect of the train immediately. It would be possible to double the length of any track circuit by feeding twice the power from a battery located at its centre, with the relay at each end. This arrangement would, however, be expensive because, in addition to another track relay, it would also be necessary to link the contacts of the two relays in a lineside circuit so that the release of either would show occupancy of the whole section.

### An Important Feature in the Design of DC Track Relays

The non-immunised DC track relay consists basically of an iron circuit upon which is wound the coil. Part of the iron circuit is movable (the armature to be attracted towards the core). This movement is transmitted to the moving contacts by a suitable linkage. The 'fixed' contacts are usually silver-impregnated graphite while the moving contacts are of fine silver. This combination gives a relatively low contact resistance (0.2 ohm maximum is allowed), and a virtually complete freedom from the risk of contacts welding together. It will be apparent that the reluctance of the magnetic circuit is less in the 'energised' condition, that is with the armature attracted, than it is with the armature in the de-energised position. It therefore follows that the flux, and therefore the current required to hold up the armature, is less than that required for pick up. The 'percentage release' is defined as:

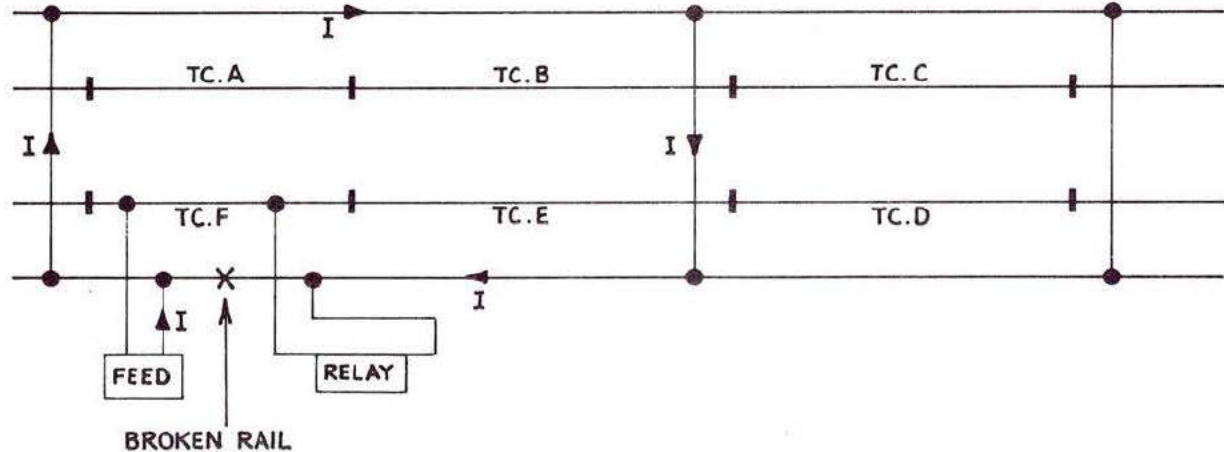
$$\frac{\text{Current at which the armature is just released}}{\text{Current at which the armature just picks up}} \times 100$$

Fig. 7:9 Typical circuits for track circuit interrupters





**Fig. 7:11** Cross bonding and loss of broken rail protection



rail, since the other rail must be continuous to provide a return path for traction currents. It is not possible to provide insulated joints in both rails and then return the traction current by means of impedance bonds, since the DC resistance of the latter would effectively shunt the rails together, thus rendering operation of the track circuit impossible. It is essential to render the track circuit immune to wrong-side failures due to traction current, and to prevent, so far as it is reasonably possible, right-side failures due to the same cause. It will be appreciated that wrong-side failures cannot be tolerated in a signalling system. Right-side failures prevent efficient operation of a railway and they too must be avoided wherever possible.

It is possible by suitable design to provide a track relay which will not respond to alternating currents at the traction supply frequency, and which ultimately will be destroyed before its front contacts can close. However, it is by no means as certain that a relay will keep its front contacts closed when energised simultaneously

by the track circuit current and alternating current arising from the traction supply. Fortunately, by suitable design it is possible to provide a reasonable degree of immunity against right-side failures arising from this cause. Cross-bonding and structure to rail bonding in electric traction areas as well as single rail track circuits with common rail bonding in point and crossing layouts, militate against broken rail detection by the track circuit current as shown in Fig. 7:11.

A DC track relay can be made immune to alternating current. Fig. 7:10 shows the principles involved, (A) showing a normal iron circuit, while in (B) the standard iron circuit has been modified to make the relay AC immune. Two copper slugs are fitted over the cores near the pole pieces and a magnetic shunt is fitted between the cores above the copper slugs. When direct current is applied to the winding the flux produced attracts the armature as normal, but some flux will be diverted through the magnetic shunt. In consequence, the operating power required will be increased. When an

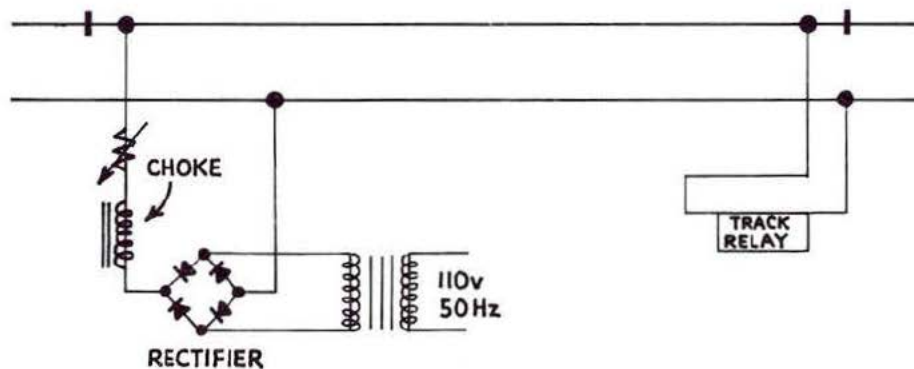


Fig. 7:12 AC-immune DC track circuit

alternating current flows in the coil, circulating currents in each slug oppose the alternating flux. The alternating flux consequently finds difficulty in establishing itself across the air gap and is largely diverted through the magnetic shunt. The alternating current flux therefore has very little effect on the armature.

Although the foregoing method provides AC immunity, the relay may release if an alternating current is superimposed on the normal direct current energisation. Alternatively, it may 'chatter'. This effect may be controlled by suitably proportioning the components of the iron circuit. For a 9ohm track relay immunity up to about 75 volts, 50Hz, can be conveniently attained. If this is insufficient the level of immunity against right-side failures may be raised by connecting a choke in series with the relay coils.

A complete AC immune DC track circuit is shown in Fig. 7:12. The similarity between this track circuit and the non-immune example given earlier will be seen at once. The differences lie in the use of an AC immune track relay and the provision of a choke in

series with the feed arrangement. The object of this is two-fold. It is possible that a voltage exists between the rails due to traction return voltage drop. This voltage could be rectified by the feed rectifier, and if of sufficient magnitude would increase the energisation of the track relay. This would have the obvious effect of reducing the sensitivity of the track circuit to the presence of a train. The insertion of the choke, because of its high impedance to alternating current at traction frequency, raises the voltage at which this would occur to a value in excess of any likely voltage to be encountered. The second effect arising from the use of the choke would be that if a train made poor contact with the rails, then the enhanced alternating voltage between the rails due to the presence of the choke would assist in breaking down any rail film and thus help to re-establish a good train shunt. Regarding right-side failures it will be appreciated that if the choke were not included, then any rail to rail voltage would be applied to the rectifier—and if of sufficient magnitude would destroy it.

## AC TRACK CIRCUITS

In the previous section of this chapter, it was shown that the simple DC track circuit, which is normally used in non-electrified areas, could be immunised and used in AC traction areas.

There are, however, other conditions which must be met and the following types of track circuit, basically AC operated, are in general use on British Railways:

- (a) Conventional AC track circuits using double-element vane relays. This type operates at 50 Hz in DC traction areas or at  $83\frac{1}{3}$  Hz in AC traction areas. The latter is used where there is a possibility of interference from a DC source in the same area (for example, DC traction).
- (b) Tuned reed track circuits which are used in similar circumstances to (a) and also when long track circuits are required in non-electrified areas. These track circuits operate in the frequency range 363 Hz to 378 Hz.
- (c) Jointless track circuits of either the voltage or current-operated type which are used on plain line in continuously welded rail (CWR) areas. This type is not yet in use in electrified areas, although at the time of writing (1978) trials of specially designed equipment are in hand.
- (d) Special purpose track circuits, for example pulsing types (designed to break down a rust film on the rail surfaces) and overlay track circuits, which are designed to detect the arrival of a train at a given point within a longer track circuit.

If the reason for using AC track circuits is the presence or proximity of a DC traction system, then the track circuit must be immunised, not only to DC itself but also to any AC frequencies which might be present as by-products of the generation, transformation or use of the traction current. The generated waveform is usually reasonably pure, but rectification can produce 6th, 12th and other harmonics

according to the type of rectifier and loading, while series-wound DC traction motors produce commutation and slot ripple, frequencies of which are proportional to the instantaneous speed of each motor.

Requirements for immunisation are even more onerous in territory electrified at both 50 Hz (25 kV or 6.25 kV) and DC (750 volts or 1500 volts) since immunity to both odd and even harmonics of the 50 Hz traction frequency is necessary. The even harmonics are not present if fullwave rectification is in use on all traction units, and some signalling systems in present use take advantage of this; but all harmonics must be expected when any traction unit is operating in the half-wave mode (for example, due to an equipment failure) or any form of phase selection by means of thyristor devices is in operation. Also, transient phenomena, such as arcs or short circuits, can generate interference anywhere in the spectrum.

It will be apparent that the frequency employed for AC track circuits in any particular scheme must be chosen with the following objectives in mind:

- (a) It must be easily generated, either centrally, to be distributed as a separate signalling main, or locally at each track feed point.
- (b) An adequate separation from all the frequencies likely to be generated by the traction systems must be ensured under all conditions of supply. Thus, if either the traction or the signalling is derived from the National Grid a tolerance of about  $\pm 3$  per cent on the fundamental frequency must be allowed. The spectrum free for signalling use therefore diminishes rapidly if odd and even harmonics are taken into account, vanishing altogether above 800 Hz.

It should be noted that the traction system on the London Transport Executive, which is often adjacent to lines of British Railways, is 600 volts DC. The trains are comparatively light and it is a 'fourth-rail' system; but train faults can result in traction current returning via the running rails. On the Southern Region, the 'third-rail' traction system is 650–750 volts DC, but the trains are heavy and starting

## TRACK CIRCUIT PRINCIPLES AND EQUIPMENT

currents may approach 10 000 amps. In AC traction areas, the system is basically 25 kV 50 Hz but in early schemes the voltage was reduced to 6.25 kV in areas approaching terminals where clearances generally were reduced. This latter, however, no longer applies. Where a 6.25 kV system exists, trains are dual-voltage and the changeover is effected by a permanent magnet situated just outside the track.

### Methods of Achieving Immunity from Electric Traction Systems

There are two principal methods of immunising AC track circuits from the effects of stray currents from electric traction systems.

- (a) **BY THE USE OF A DOUBLE ELEMENT RELAY** Double element relays of the vane type require two supplies, called 'local' and 'control', which must produce fluxes having components at right-angles in order to produce a positive torque to operate the relay vane. If the supplies are not at the same frequency the net torque will alternate to beat frequency and the relay will not operate. The relay will therefore only respond correctly to 'control' current of the same frequency as the 'local' current.

Special precautions are necessary in 50 Hz traction areas to prevent the supply to the local coil of the relay becoming contaminated with 50 Hz current. The 'local' supply for relays can be confined to specified relay rooms or may be screened by use of earth leakage detection equipment or 50 Hz detection equipment can be used.

- (b) **BY THE USE OF SUITABLE FILTERS** This technique involves an oscillator and amplifier at the feed end producing a given frequency which is passed through a relay end filter before being amplified and used to operate the track relay, which is usually of the DC tractive armature type. Enhanced security is afforded if adjacent and parallel tracks use different frequencies. Either electrically or mechanically tuned filters can be employed; the latter have the advantage of a high 'Q'. However, relay end amplifiers are required, since the energy remaining

after the rail current has been filtered is insufficient to operate the relay on its own.

The electro-magnetic amplifying action of the vane relay is both elegant and fail-safe. Electronic amplifiers for other types of track circuits must also be designed in a fail-safe manner and comply with the following:

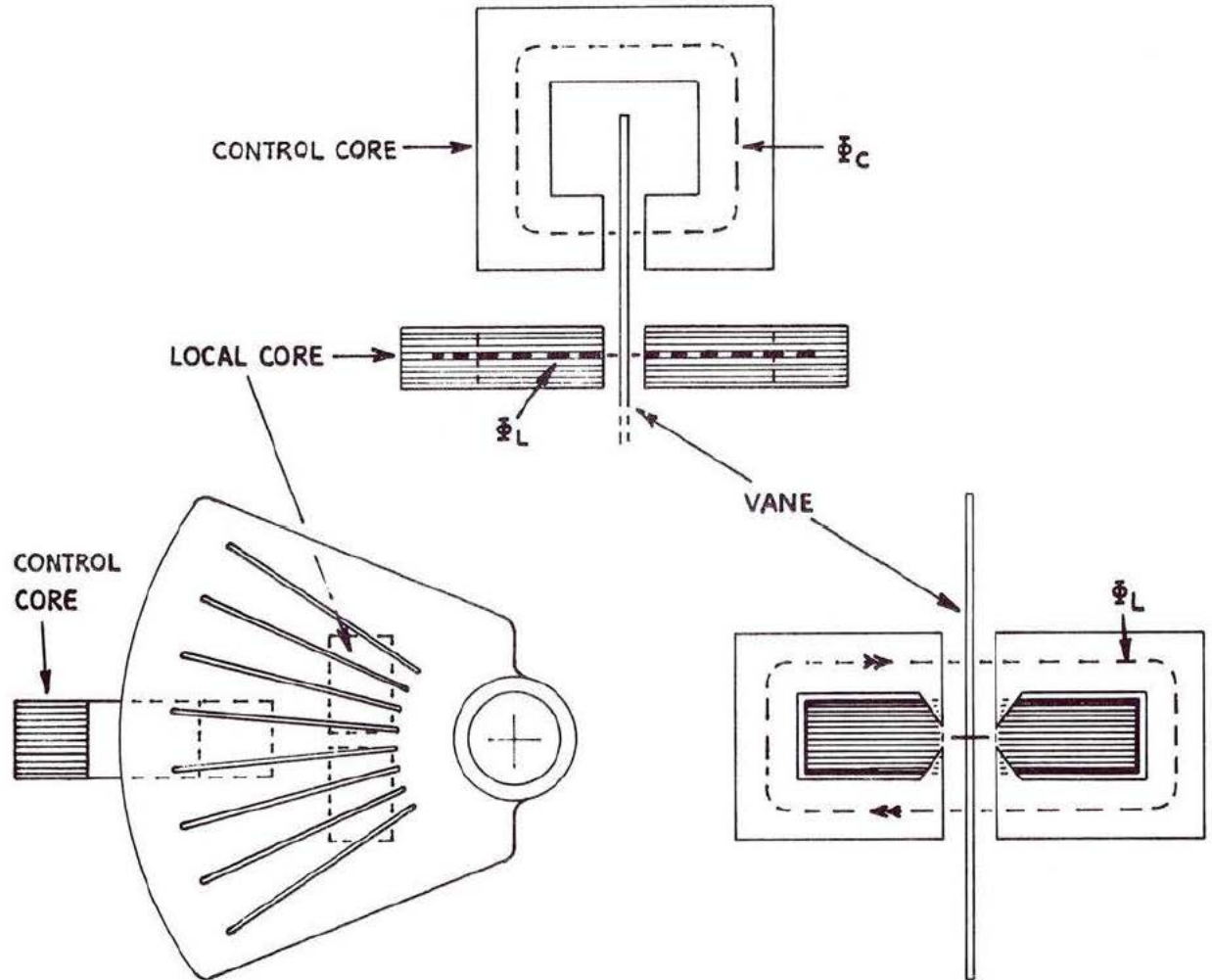
- (a) Components must be chosen to avoid any possibility of self-oscillation.
- (b) All transistors must be continually switching and failure, whether on short circuit or open circuit, must cause the relay to drop. This requires the input signal to be AC.
- (c) The DC 'HT' supply must be wired so that the smoothing capacitors cannot become accidentally disconnected (i.e. four terminal capacitors must be used).
- (d) The track relay may be a DC tractive armature type but must be isolated from the DC 'HT' supply by a transformer. If a step-up transformer is used it can be arranged so that the 'HT' is insufficient to operate the relay should the transformer become accidentally short-circuited.

One type of AC track circuit which does not require a relay-end amplifier is that used in non-electrified areas in preference to the rectifier fed DC track circuit. Transposition of the rectifier to the relay end in this type brings advantages in better shunting characteristics and faster drop away, but has the disadvantage of not being able to use a secondary cell as a stand-by supply.

### Double-Element Vane Relay

Fig. 7:13 shows the construction of the double-element vane track relay. It consists of two coils designated 'local' and 'control' each with its own iron circuit, located on either side of a sector shaped vane that is free to rotate in a vertical plane, and is connected

**Fig. 7:13** Double-element vane relay: details



## TRACK CIRCUIT PRINCIPLES AND EQUIPMENT

via a linkage to the contact operating mechanism. The local coil is fed at 110volts continuously from the signalling supply while the control coil is fed from the rails at approximately 1 volt. The currents flowing in the two coils each produce a flux; the two fluxes each produce eddy currents in the vane. The design is such that the vectorial sum of the forces produced by the local flux acting on the control current, and the control flux acting on the local current (due to the 'left-hand rule') is at a maximum when the local and control currents are in quadrature. It will be apparent that the de-energisation of either coil will result in zero force on the vane, while reversal of either current will result in a force in the opposite direction. The vane is slotted radially to improve the interaction between the eddy currents and the fluxes.

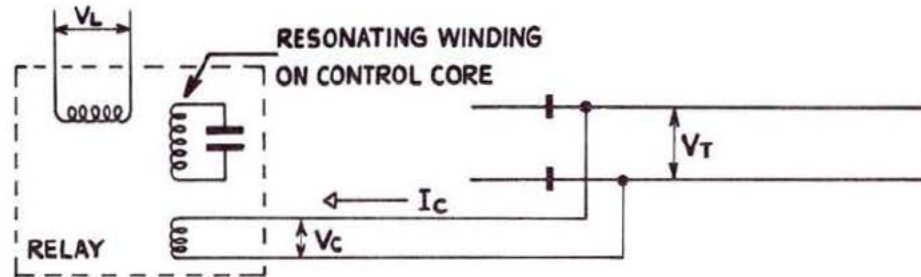
Double-element vane relays may be located at considerable distances from the relay end of the track circuit. A distance of 400m would be possible, and in order to reduce the voltage drop in the relay leads some types of relay have a resonated control winding. This is done by connecting a capacitor in parallel with a secondary

step-up winding wound on the control iron circuit. The step-up ratio is calculated to suit a capacitor of 2 mfd which is a convenient size. The terminals of the control winding then appear resistive though it is still the original magnetising current which produces the flux. Fig. 7:14 shows vector diagrams of this arrangement.

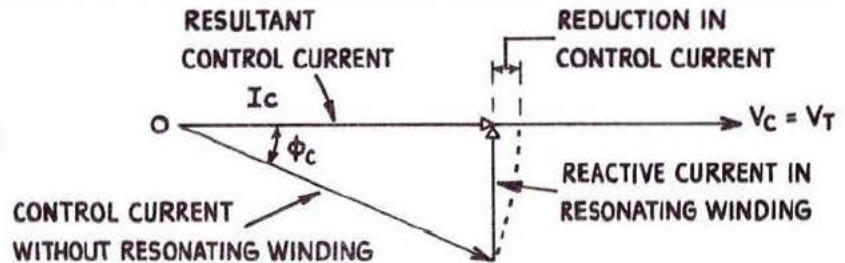
### **Rail Impedance**

The rail impedance of an AC track circuit is an important factor which needs to be taken into account in all calculations. The track circuit rail current sets up a magnetic flux within the steel rail which causes the current to flow round the outer edge of the rail, thus considerably increasing its longitudinal resistance. As a result the rail develops inductance and the impedance to the 50 Hz track circuit rail current is about 0.2ohm per rail per 305 m (1000ft) at a power factor of about 0.3. In any calculations, therefore, the ballast resistance must be considered as distributed throughout the length of the track circuit.

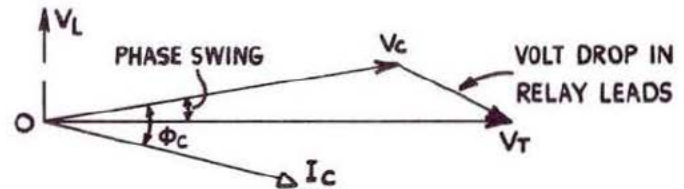
**Fig. 7:14** Double-element vane relay: resonated control winding



(a) EFFECT OF ADDING RESONATING WINDING (RELAY LEAD RESISTANCE NEGLIGIBLE)



(b) PHASE SWING DUE TO RELAY LEAD RESISTANCE (UNRESONATED CONTROL WINDING)



(c) VOLTAGE DROP IN RELAY LEADS WITH RESONATED CONTROL WINDING

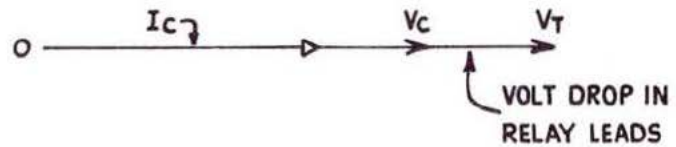
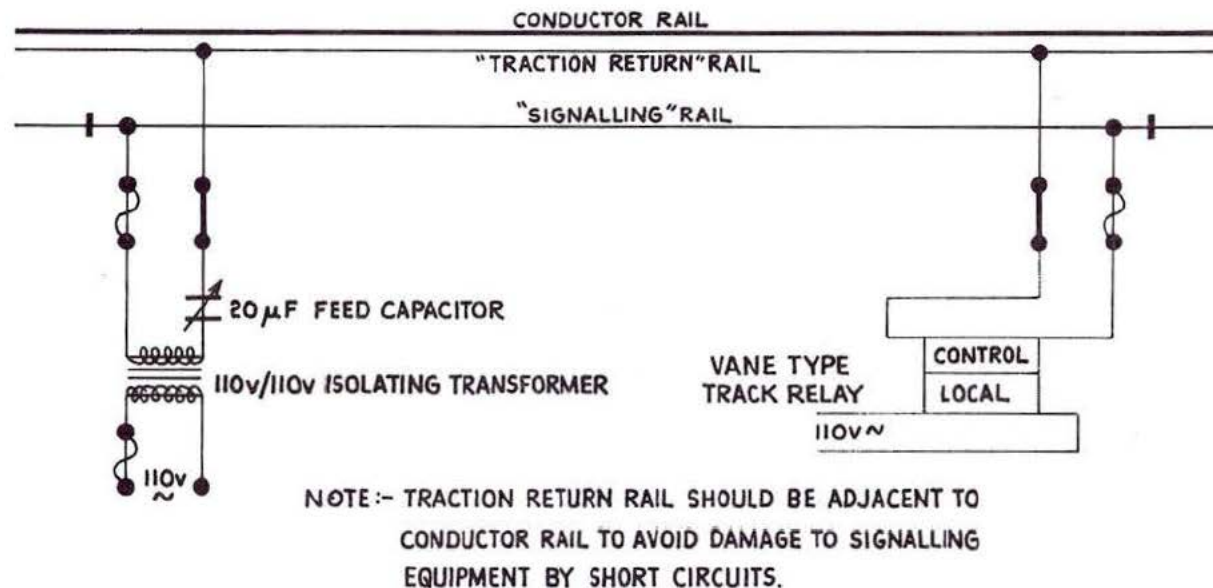


Fig. 7:15 Single rail AC track circuit in DC traction area



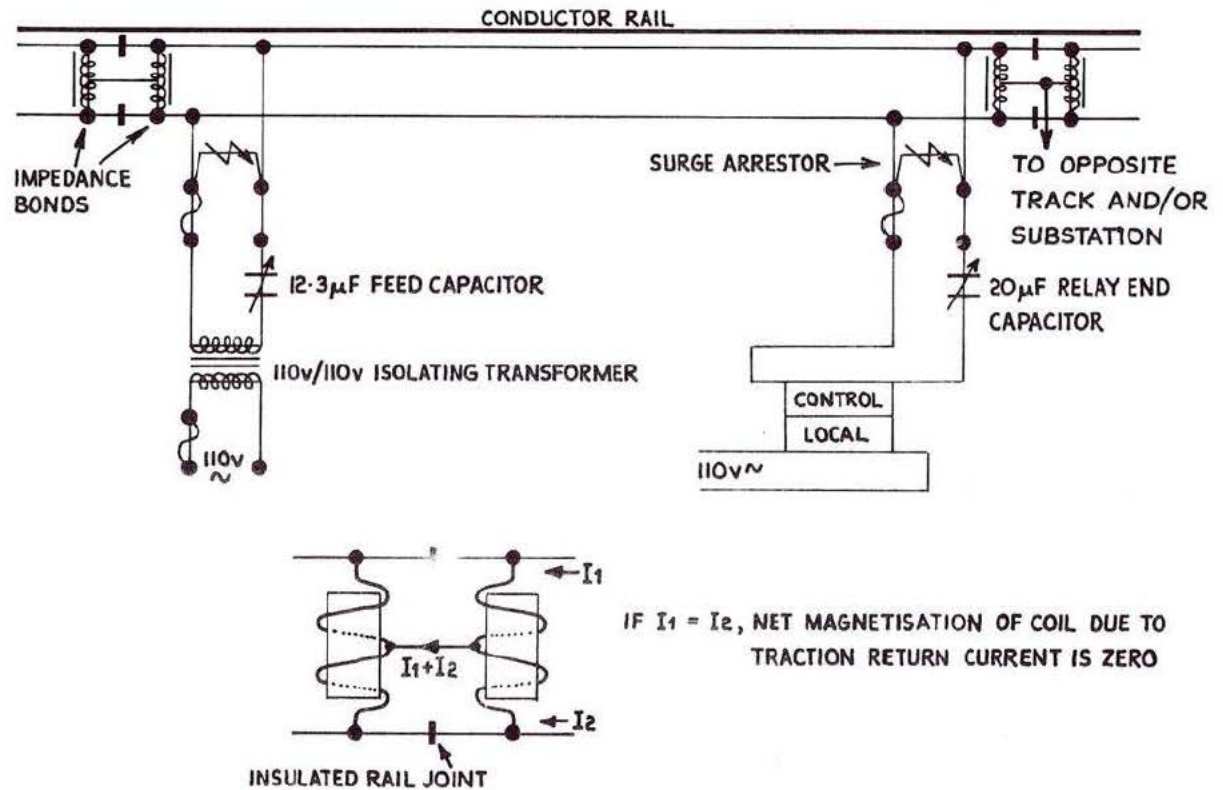
### Single and Double Rail AC Track Circuits

Before considering the design of AC track circuits as a whole, it is necessary to consider the arrangements for returning the traction current to the substation. Where separate conductor rails are provided for both positive and negative traction current (for example on London Transport Executive lines), no special arrangements are necessary since no traction current normally flows in either of the running rails. One running rail is bonded throughout the system and can be used both as an earth continuity conductor and as a means of detecting earth faults on trains, whilst the other is insulated as required to form track circuit sections.

If the traffic is light and the traction current is low it is often possible to return the traction current to the substation through one running rail in each track, in which case the other rail is used exclusively for track circuit purposes as shown in Fig. 7:15. However, where traction currents are high or distances between substations are long, the traction voltage drop in one rail only becomes prohibitively large, and it then becomes necessary to utilise both running rails to carry the traction return current.

Where the latter applies, the track circuits are double rail and it is essential to provide a path for the traction return current round every insulated rail joint back to the substation while making the track circuit sections appear electrically separate to the signalling

**Fig. 7:16** Double rail AC track circuit in DC traction area



frequency current. This is achieved by an impedance bond which consists of a heavy iron core on which are wound two coils of heavy gauge copper. These coils are wired in series across the rails, the centre point being connected as required, in like manner, to the rails of the next track circuit or to the substation bus bars as shown in Fig. 7:16. On the basis that the running rails carry approximately equal amounts of traction return current, the net flux in the iron circuit due to traction current will be zero, and

the impedance to DC will be very small (typically 0.0004 ohm). However, the AC track circuit current will tend to flow from one rail to the other; this will induce flux, which will in turn produce a back emf that results in a small but finite impedance (typically 0.4 ohm at 50 Hz) being presented to the AC signal. A double rail or impedance bond track circuit is therefore always under the handicap of a low shunt/impedance, in addition to the ballast resistance, and therefore relies on an amplifier at the relay end as described

## TRACK CIRCUIT PRINCIPLES AND EQUIPMENT

earlier—in this case a double-element vane relay. Nevertheless it also carries the corresponding advantage that the effect of variation in the ballast resistance is minimal.

Both types of track circuit can be operated adjacent to each other. The usual practice is to use double rail track circuits for long sections, and to revert to single rail track circuits through points and crossings, or in areas of modest traction return current, such as branch lines where only short trains are run, or in terminal platform lines.

The disadvantages of the simple impedance bond, as described above, is the resultant low drop away shunt resistance of the track relay. It is therefore no longer used. Impedance bonds having a higher rail to rail impedance are described in the next section.

### Impedance Bond Design

If due to imperfect bonding the traction current is unequally divided between the running rails when it arrives at the impedance bond, there will be a net flux due to the difference in ampere-turns between the two halves of the winding. If sufficiently high, this flux will cause the iron circuit to saturate and the bond will become a dead short to track circuit current, causing a right-side failure. Some measure of control can be achieved by inserting an 'air gap' in the iron circuit (typically 1.27 mm (0.05 in.) for 50 Hz track circuits). Impedance bonds are normally designed not to saturate at less than 20 per cent traction current unbalance.

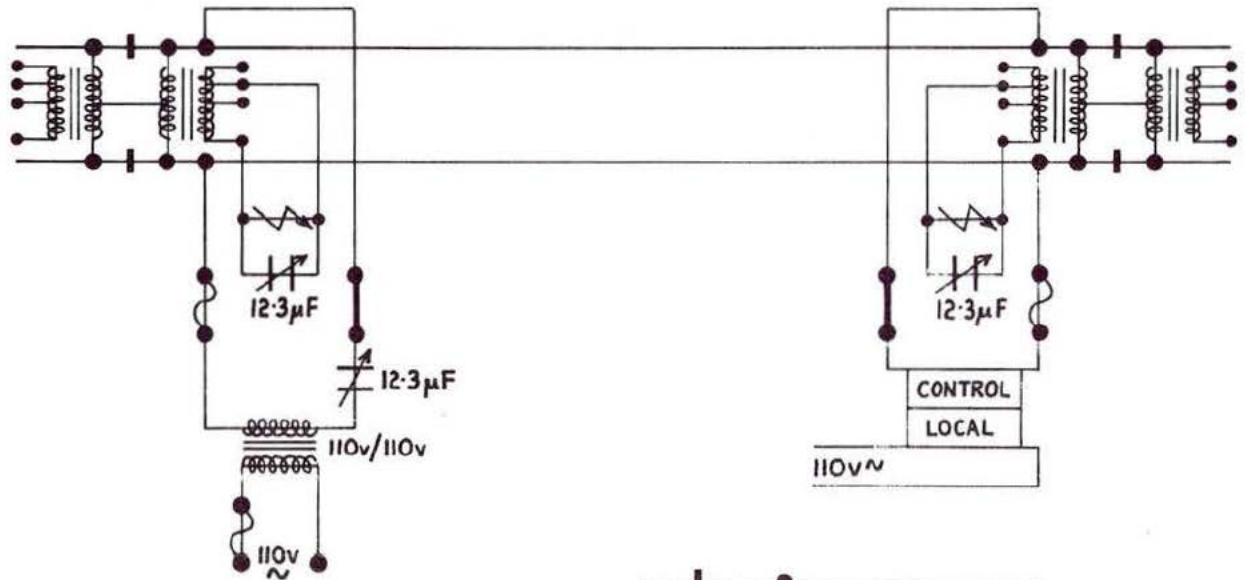
An impedance bond thus designed is satisfactory for DC traction, having a rating of 1000 amps each side (i.e. 'per rail'), but its performance from a signalling point of view can be improved by resonating

the traction coil. This is done by connecting a capacitor in parallel, that is across the rails as shown in Fig. 7:17. In fact, the resonating capacity is connected across a step-up secondary winding to enable its size to be reduced to a practical value. The turns-ratio varies between types of bond but is typically 50:1. A resonated bond therefore appears resistive across the rails at the resonant (signalling) frequency; its impedance at that frequency can be raised to the order of 2.0 ohms, which enables longer track circuits to be employed. A further development is to re-arrange the connections of the resonating winding so that it carries the signalling current to and from the track-side equipment. The bond is then said to be 'auto-coupled'.

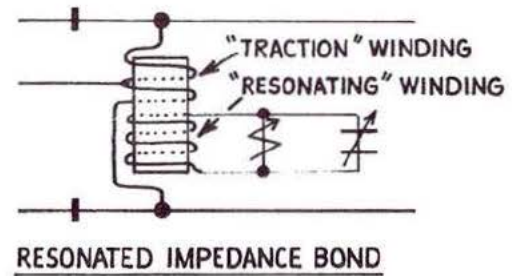
Fig. 7:18 shows the arrangement.

It will be apparent that additional advantages occur since the feed and relay circuits can operate at approximately 50 times the voltage between the rails, because of the transformer action of the bond. When changing over from DC to AC traction, there is nothing to prevent existing impedance bonds remaining in use, since they can be resonated to the new signalling frequency by altering the associated capacitances. However, since the traction current is now 50 Hz a large unbalanced return current, as might occur due to a disconnection or removal of one side lead, can induce a high voltage in the signalling coil, if auto-coupled, due to the step-up ratio of the order of 1:50. This voltage, which might be up to 1 kV, would then appear across the feed or relay end equipment. The bonds of converted AC track circuits are therefore re-connected as resonated bonds, the high voltage being thereby confined to the resonating capacitor.

**Fig. 7:17** Double rail AC track circuit with resonated impedance bonds



NOTE:- TRACK MAY ALSO BE  
INDUCTANCE OR RESISTANCE  
FED (SEE SECTION 5.6.7).



## TRACK CIRCUIT PRINCIPLES AND EQUIPMENT

In bonds designed specifically for AC traction, the air gap has been omitted, since no DC is present; this, together with the reduced traction return currents to be catered for which are typically 200 amps per rail, allow a much smaller iron and copper section to be used which in turn yields a higher impedance. Typical values are 0.0013 ohm DC and 5 ohms at 1.5 volts  $83\frac{1}{3}$  Hz. Since there is no air gap, the bond will saturate at 10 to 20 volts, permitting an auto-connected winding to be used; the ratio of this is of the order of 3 : 1.

In heavy current DC traction current areas it is necessary that the return traction current should be shared by all rails, on all tracks, as far as possible, thus reducing voltage drop between the train and the feeding substation. This is necessary to avoid electrolysis in water mains and the like which are buried adjacent to the line. It also assists in maintaining an adequate traction voltage for the train. Intermediate resonated impedance bonds are therefore provided, as shown in Fig. 7:18, between the ends of each double rail track circuit to enable traction 'cross' bonds to be connected between the tracks. The maximum allowable distance between cross bonds, including those at the impedance bonds at the ends of the track circuit, is 900 m. Only two intermediate impedance bonds can be permitted in a track circuit, for reason of the train shunt, and hence the maximum length of a double rail track circuit is fixed at 2700 m.

### AC Track Circuit Feed Arrangements

In an AC track circuit having a double-element vane relay, the feed set must incorporate some form of phase shift which will enable the current in the relay control winding to approach a quadrature relationship with the current in the local winding. Any feed to a

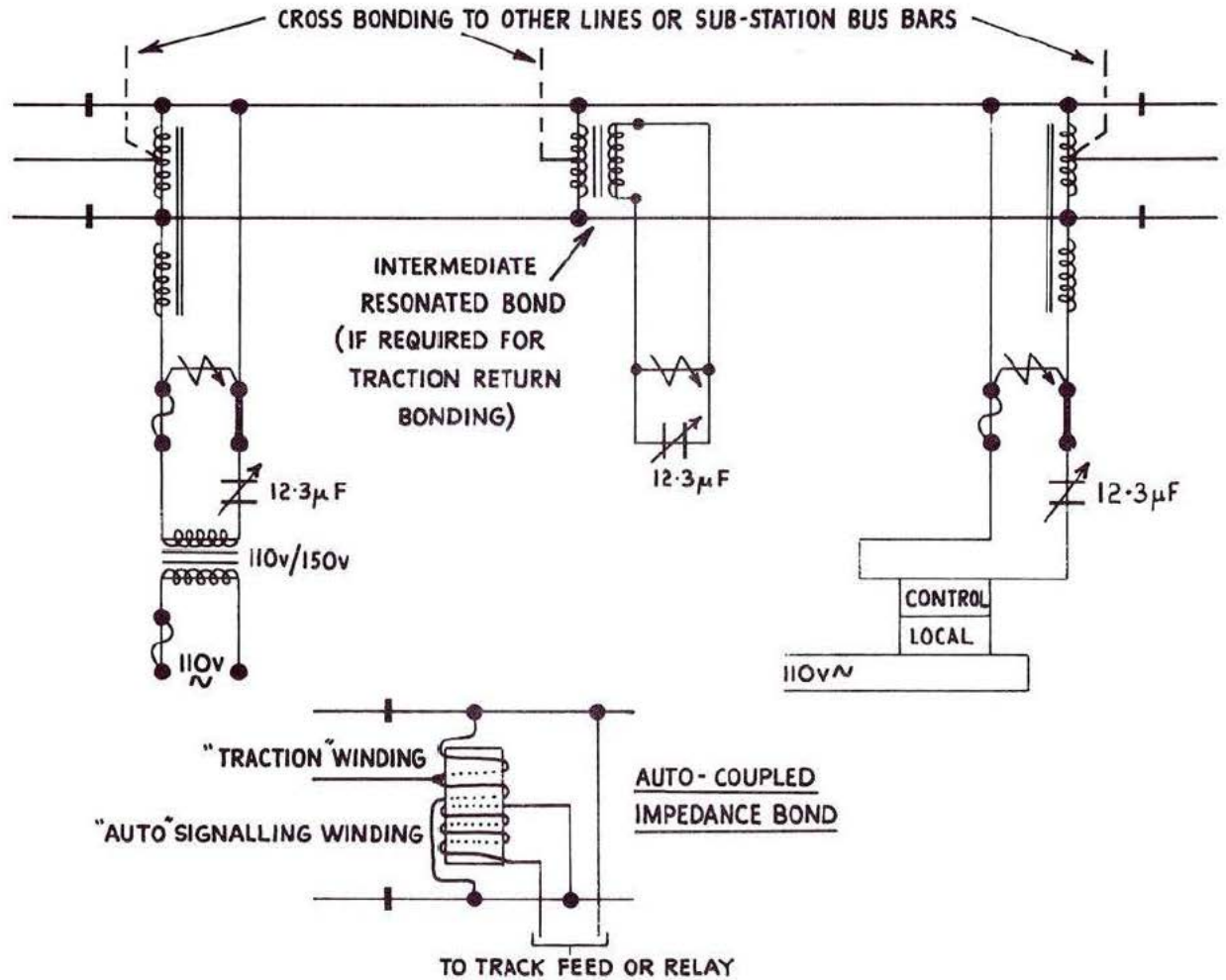
track circuit will inevitably have a low resistance to earth and it is therefore also necessary in all cases to interpose an isolating transformer to avoid multiple earths on the signalling supply. Taps on the primary and secondary windings can be provided to adjust the current fed to the track.

### *Capacitance Feed*

In the previous sections a capacitance feed has been assumed, since it is now the normal method for track circuits in DC electrified areas. It combines the following features:

- (a) Traction current is prevented from flowing in the track feed circuit.
- (b) A variable capacitor is simple to adjust and can provide feed voltage variation without loss of power. Alternatively, a tapped secondary on the feed transformer can be used instead of, or in conjunction with, a variable capacitor.
- (c) The capacitor when used, introduces a phase shift, necessary for the operation of the vane relay.
- (d) It is usually an advantage to have a steady load taking current at a leading power factor, when most other signalling equipment operates at a unity or lagging power factor. The outlay in providing rather expensive capacitors can therefore be offset by the economies of a smaller overall rating of the signalling system. However, any capacitor introduced into a track circuit must be capable of withstanding at least the DC traction voltage, plus the peak signalling frequency voltage, across its terminals.

**Fig. 7:18** Double rail AC track circuit with auto-coupled impedance bonds



## TRACK CIRCUIT PRINCIPLES AND EQUIPMENT

### *Inductance Feed*

This arrangement which is shown in Fig. 7:19 has been used in some types of feed for AC traction systems. While taking little power in introducing phase shift, it cannot serve to block extraneous traction currents. Again, a fixed inductor can be used in conjunction with a tapped feed transformer secondary.

### *Resistance Feed*

In some applications, a resistance may be used instead of an inductance, but this is rarely encountered in British practise. It would only be used where the phase relationships preclude the use of a reactive feed.

### *Phase Sensitivity of Double-Element Vane Track Circuits*

It will be apparent that in order to energise a double-element vane relay track circuit falsely by an extraneous feed, the latter must bear a certain phase relationship to the local in addition to being of the same frequency. This feature is not shared by any other type of track circuit since it stems from the design of the vane relay.

### *Single Rail Track Circuits*

The phase angle obtained is usually of the order  $40^{\circ}$ – $60^{\circ}$  so that the control coil voltage must be maintained at a value somewhat in excess of the rated voltage so as to give a torque approximating to that which would be obtained with the rated voltage at  $90^{\circ}$  phase angle. Typically, a 1.0 volt rated relay may be energised at about 1.5 volts with a phase angle of  $50^{\circ}$  to give a train shunt of 1.0 to 2.0 ohms.

### *Double Rail Track Circuits*

The phase angle of a double rail track circuit is affected by the following parameters:

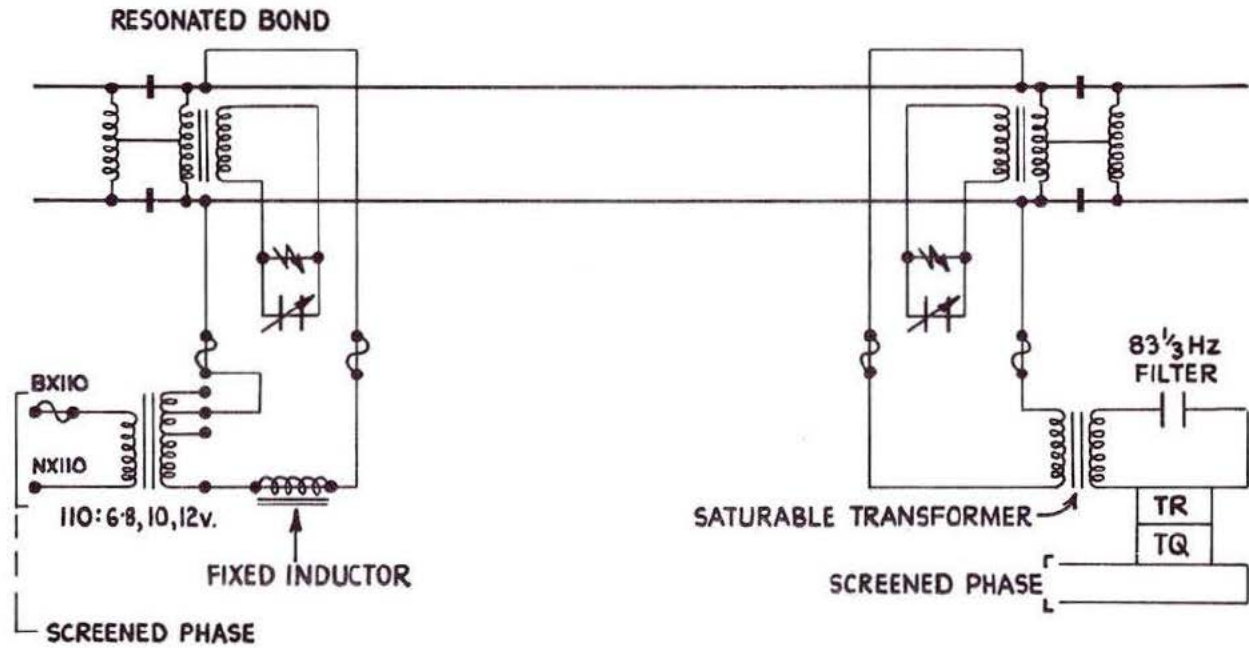
- (a) Feed capacitance.
- (b) Feed-end bond inductance.
- (c) Rail inductance.
- (d) Intermediate resonated bonds (if present).
- (e) Relay end bond conductance.
- (f) Relay end capacitance.
- (g) Resistance across the control coil of the relay (if present).

Of these, the phase shift due to rail conductance will vary in proportion to the length of the track circuit, while the intermediate resonated bonds, if properly resonated, will appear resistive across the rails. It is normal setting-up procedure to resonate the relay end bond by suitably adjusting the relay end capacitor. The resistance across the control coil is provided in some cases to enable a higher phase angle to be obtained. It is usually possible to achieve a phase angle of  $60^{\circ}$ – $80^{\circ}$  so that a control coil voltage of 1.1 to 1.3 is sufficient to give a torque which is equivalent to 1.0 volt at  $90^{\circ}$ . A train shunt of 0.3–0.5 ohm is usually obtained.

It is theoretically possible to set up auto-bond track circuits so that, when shunted, the control coil voltage is not merely reduced but also altered in phase so as to apply negative torque to the vane, which is forced into the de-energised position.

In order to maintain 'stagger' between adjacent track circuits a change of polarity is introduced into alternate feeds. However, the phase shifts introduced by the various parameters listed above are subject to variation from track circuit to track circuit. It is therefore necessary to determine the stagger of each pair of track circuits by a practical test which consists of short-circuiting one of the insulated rail joints and observing the behaviour of the relays.

**Fig. 7:19** Double rail AC track circuit with inductance feed



## TRACK CIRCUIT PRINCIPLES AND EQUIPMENT

### Effects of Unbalanced Traction Current in the Rails

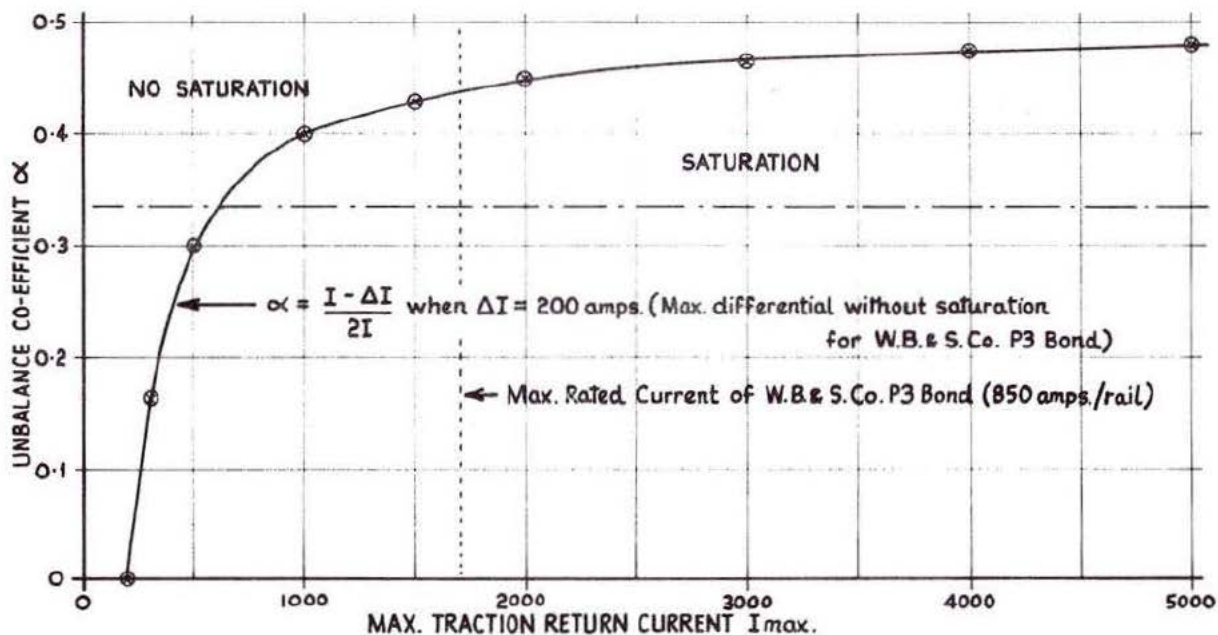
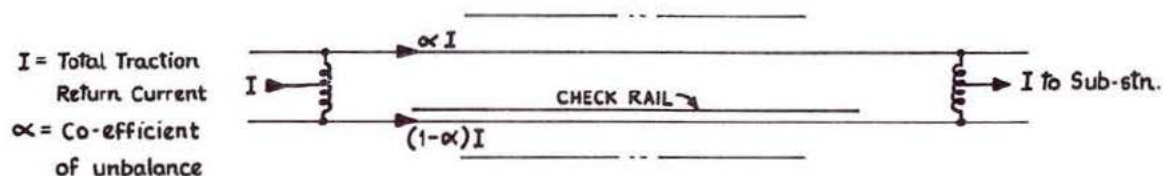
It was noted earlier that saturation of the iron circuit of an impedance bond can occur if the traction current unbalance exceeds 20 per cent. The effect of such saturation is to destroy the bond impedance to signalling frequency current, thus shunting the track circuit (see Fig. 7:20). It can be avoided by:

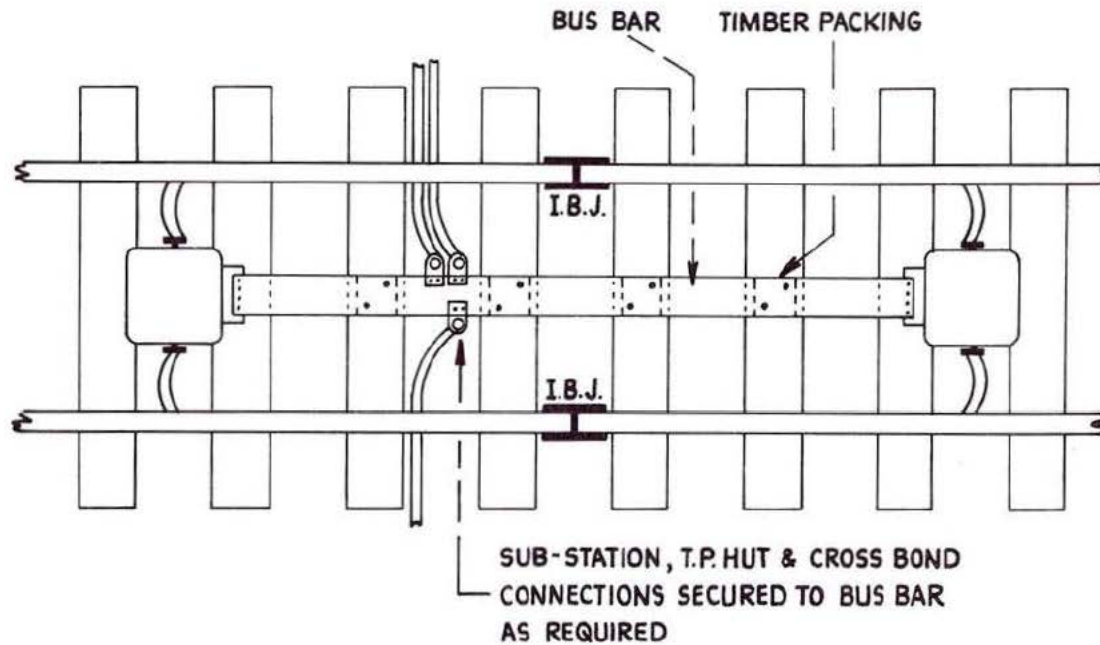
- (a) Adequate cross bonding between impedance bonds in parallel tracks.
- (b) Bond leads of adequate cross section (typically duplicated 37/2-36 mm (37/0-093 in.) cables in a 750 volt DC system).
- (c) Care in installation to avoid high resistance connections. Rail lugs must be driven immediately after the rail has been drilled.
- (d) Regular inspection and reporting of defective bond connections.
- (e) Adequately designed current carrying capacity.

A particular problem arises when a check rail is provided for the inner rail of a long curve since the reduction in resistance for the combined running and check rails can cause appreciable unbalance, particularly if located in the vicinity of a substation. One solution is to insert insulated rail joints in an appropriate position and cross over the two return paths electrically, thus equalising the rail resistance. If the DC rail resistance is known (typically it is 0.01 ohm per 305 m (1000 ft) for 113 lb F.B. rail), together with the prospective maximum traction current, a simple calculation based on less than 20 per cent unbalance will determine whether a crossover is required.

Fig. 7:20 Impedance bond:  
typical saturation curve

1. Calculate " $\alpha$ ".
2. Ascertain from C.M.E.E. the Maximum Return Traction Current ( $I_{max}$ ).
3. Plot " $\alpha$ " and  $I_{max}$ . on graph below to determine whether saturation will occur.





**Fig. 7:21** Double rail to double rail: impedance bond layout

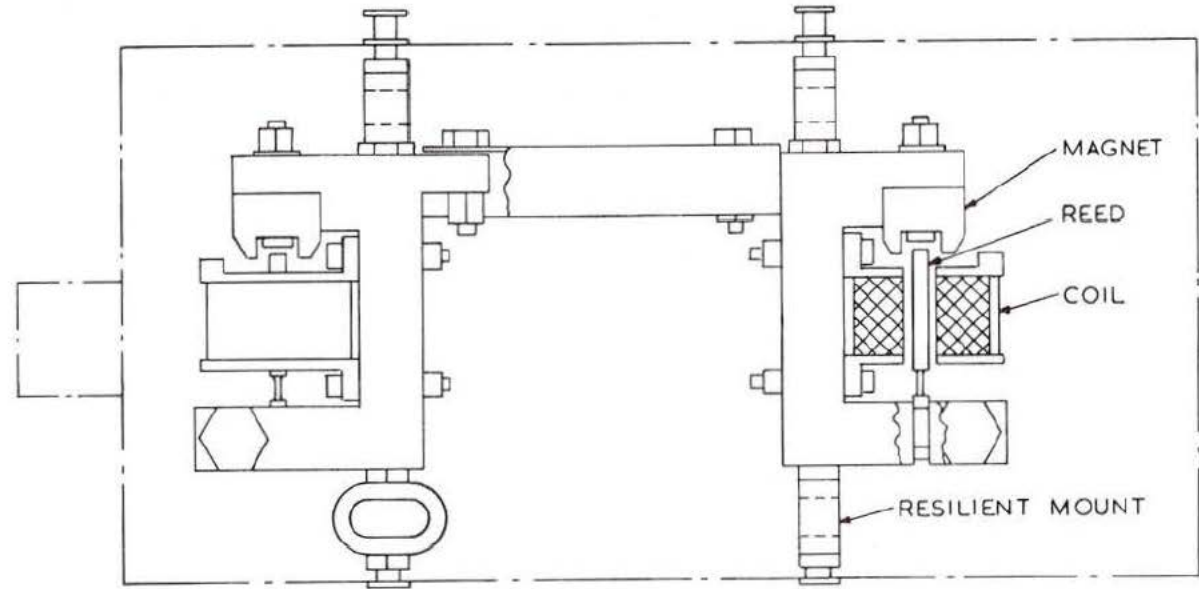
### Impedance Bond Layouts

Fig. 7:21 shows an impedance bond layout with a cross-bond to the opposite track and connections to a substation or track paralleling (TP) hut. Note that the impedance bonds are located in the third sleeper bay from the rail joint to reduce vibration. The bus bar between the impedance bonds is aluminium plate  $152 \times 6$  mm ( $6 \text{ in.} \times \frac{1}{2} \text{ in.}$ ). The side connections to the rails are  $37/2-36$  mm ( $37/0-093 \text{ in.}$ ) cables in duplicate. In each case the connection to the rail is made by drilling a hole in the web and immediately inserting the rail lug, with the cable already attached. A drift pin

is then driven through the hole in the lug, expanding it into pressure contact with the rail web.

It is important to take separate connections from the rail to the track circuit coil of the bond, and thence via the feed or relay equipment returning direct to the rail web. If this were not done, and the track circuit lead were internally connected to the bond coil, disconnection of a side head could isolate one rail from the bond and the track relay might still receive enough energy to operate the adjacent track circuit via the opposite side lead and the centre tap of the bond. As a result the presence of a train on the track circuit would not be detected.

Fig. 7:22 Reed filter



### Reed Track Circuits

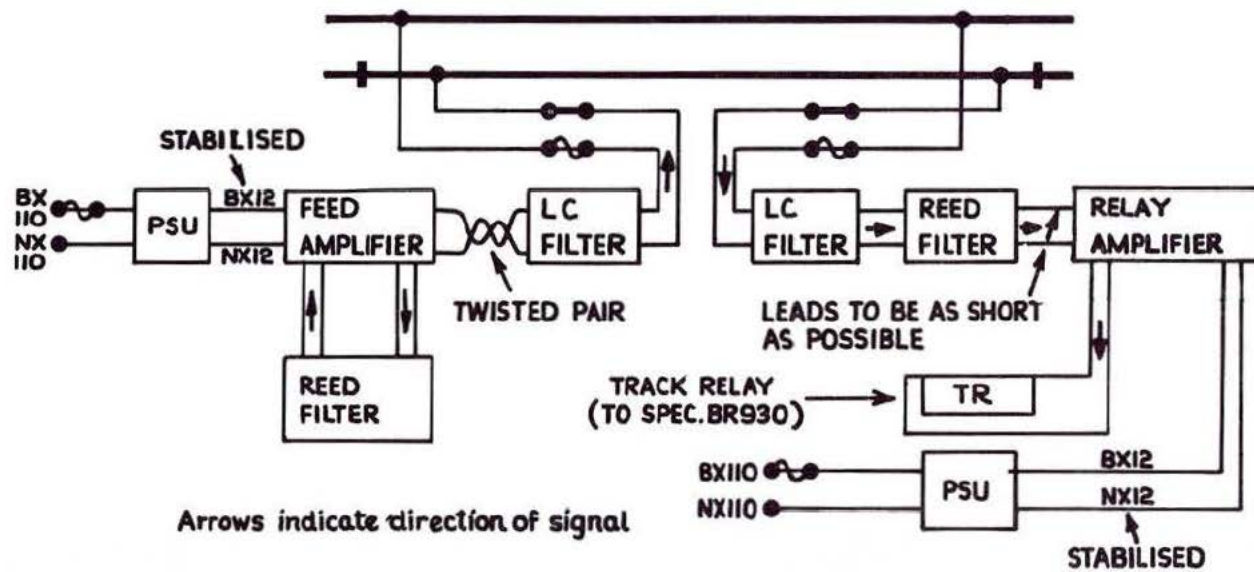
Reed track circuits may be used in areas where interference from both DC and AC traction is present and in non-electrical areas where long track circuits (such as in tunnels) are required. Their salient feature is a pair of mechanically coupled reed filters at either end; the pair at the feed end ensure that energy only at the desired frequency is fed to the rail, while the relay and filters respond only to the same frequency. The reeds can be tuned with considerable precision and possess a high  $Q$  such that frequencies in common use are pitched only 3 Hz apart—for example 363, 366, 369, 372, 375 and 378 Hz. The use of different frequencies for adjacent and

parallel track gives freedom from faulty operation, due to insulated joint failure. More detail of reed filters is to be found in Chapter 8 (Remote Control Systems).

Fig. 7:23 is a block diagram of a reed track circuit; Fig. 7:22 shows the reed filter. The feed end equipment consists of a transmitter-oscillator and amplifier governed by the reed filter in the feed back loop. The output is taken by a twisted pair to an LC filter and fixed feed resistor and thence to the rails via the usual fuse/link arrangement. The purpose of the LC filter is to prevent traction surges and other interferences from back feeding into the transmitter and causing saturation or damage.

The relay end equipment comprises first a fixed resistor and single

Fig. 7:23 Reed track circuit



LC filter (acting as a buffer) then the reed filter, the output of which is amplified and used to operate a DC relay. The relay end amplifier is designed using 'fail safe' principles. Both feed and relay equipments are fed from a stabilised 12 volt AC supply. In order to avoid any possibility of crosstalk between feed and relay equipments in the same apparatus case, wiring carrying the reed frequency signal (especially between the relay and filter amplifier) is kept as short as possible, and certain rules are laid down for the relative positioning of the various units. No adjustment is normally provided; the equipment is capable of giving a 0.5 ohm minimum train shunt on track circuits up to 609 m (2000 ft) long with ballast resistances of between 6 ohms per 305 m (1000 ft) and infinity. For longer track circuits, for example through tunnels, or for poor ballast conditions, special adjustments can be made.

### **Principles of Jointless Track Circuits**

#### *Necessity for a Jointless Track Circuit*

When continuously welded rail is used it is obviously undesirable to have to cut this specially for the insertion of insulated joints

required by conventional track circuits, such as those which have been described earlier. Equipment has therefore been designed which permits the line to be divided into independent sections electrically, without requiring any mechanical isolation in the rails themselves.

Such track circuits are in use on British Railways on non-electrified lines. Up to the time of preparing this book, the acceptability of jointless track circuits on AC electrified lines was open to question. New designs had been developed and proving trials were nearing completion.

#### *Types of Jointless Track Circuit*

There are two distinct types of jointless track circuit; these may be termed voltage-operated, and current-operated. The distinction between the two types is that those which are voltage-operated detect the voltage existing between the rails at the extremity of the track circuit to give a clear indication, while those which are current-operated detect the presence of a current flowing past the extremity of the track circuit which may be accompanied by an insignificant voltage from rail to rail.

## TRACK CIRCUIT PRINCIPLES AND EQUIPMENT

### *Voltage-Operated Track Circuits*

Fig. 7:24(A) shows how the extremity of a voltage-operated track circuit is defined. In a conventional track circuit an insulated gap in one or both rails prevents current from one track circuit from intruding into its neighbour; the same effect can be secured by short-circuiting the rails together at the extremity of the track circuit. Clearly if the short-circuit is of sufficiently low impedance then the current in the left-hand track circuit cannot produce sufficient voltage between points A and B to influence the right-hand track circuit.

The short-circuit does not shunt the relay and feed sets owing to the rail impedance between the points at which they are connected to the rail and the point of short-circuit. At the operating frequency of 1.5–3.0 kHz the rail impedance is very much higher than the figure quoted for 50 Hz.

### *Current-Operated Track Circuits*

Fig. 7:24(B) shows that at the extremity of a track circuit a coil is located adjacent to each rail which is inductively coupled to the rail itself. In consequence any current which flows in the rail will induce a voltage in the coil.

Thus with a train standing to the right of the coils, current would be shunted away from the coils and occupation of the track circuit would be detected. With a train standing to the left of the coils, current would flow through the wheels and axles of the train and the track circuit would show clear. Obviously, a path must be provided for current from the feed set when no train is present. This path

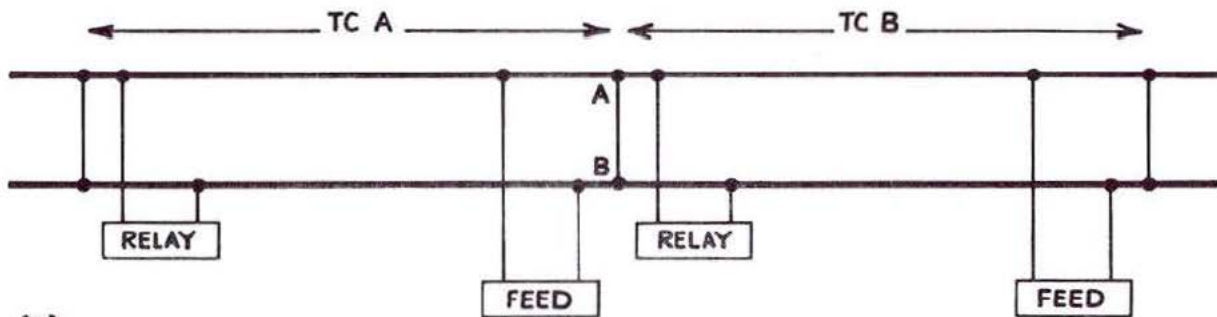
is provided by the feed set of the adjacent track circuit (i.e. to the left of the coils) supplemented by conduction current through the ballast resistance of this track circuit. It will be appreciated that when a train stands just clear of the track circuit then current will flow past each coil but the voltage between the rails will be insignificantly small. Nevertheless, the track circuit will correctly show clear.

### *Comparison Between the Two Types of Jointless Track Circuit*

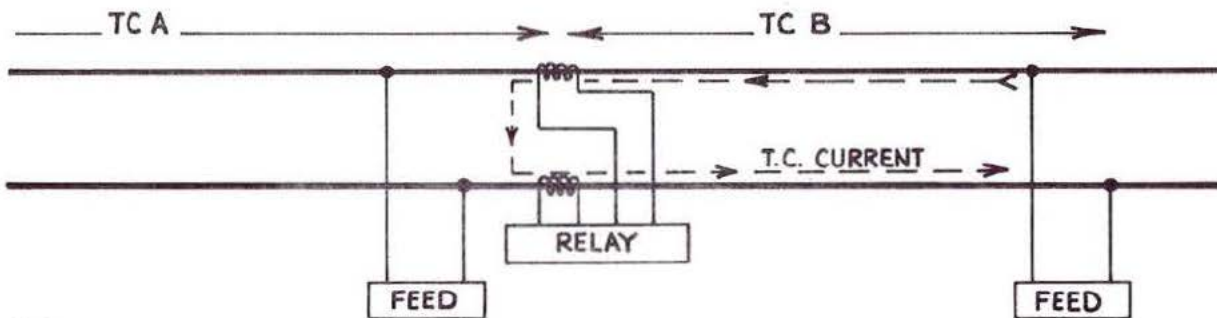
It will be seen from Fig. 7:24(A) that the extremity of a voltage-operated track circuit will have a very low impedance. This means that the shunting sensitivity, expressed as a conventional train shunt, would be unacceptably low and therefore measures are taken to raise the impedance at the end of the track circuit. These will be described later. This objection does not apply to the current-operated track circuit shown in Fig. 7:24(B). Here shunting will be maintained up to the moment when the train passes out of the track circuit, and there will be no point at which an unacceptably low train shunt will be measured.

There is however one particular case which should be noted. If there is a train on each of two successive track circuits and the train ahead has a higher shunt resistance than the one in rear, the rail current from the feed set ahead, not being fully shunted, will be increased by the lower shunt resistance of the train in rear, and will tend to cause the relay of the track circuit ahead to pick up.

Fig. 7:24 Principles of jointless track circuits



(A)  
VOLTAGE OPERATED TYPE



(B)  
CURRENT OPERATED TYPE

## EQUIPMENT

**The Aster '1-Watt' Jointless Track Circuit**

This is a voltage-operated type and of French origin. It was the first type of jointless track circuit to be used by British Railways and a considerable number have been installed.

The general arrangement is as shown in Fig. 7:25(A). The extremities of the track circuit are each defined by a Z-shaped bond laid between the rails which forms two inductive loops; being inductive, each loop can be tuned by a capacitor to resonate at a particular frequency.

To keep down the size of the loops and to use capacitors of economical size, the frequency of operation is chosen to be as high as possible without introducing excessive attenuation due to rail impedance. The latter would be disadvantageous because it would demand high levels of track circuit energy. Practical experiments have shown that the range 1.5 to 3.0 kHz is suitable. In this range frequencies are chosen so that no adjacent track circuits ever work at the same frequency. Therefore 3 frequencies are used for each line thus requiring a total of 6 frequencies for two lines: where more than two lines are in use alternate lines use the same frequencies. No cross connections are permitted between lines with this system, therefore it is safe to use the same frequencies on alternate lines.

Associated with the Z-bonds are electronic units which generate the necessary audio frequency energy for the track circuit, and detect its presence when the track circuit is clear. The energy when detected is used to operate a standard signalling relay which is quite conventional in its design.

A feature of the Z-bond is that the end of one track circuit and the beginning of its neighbour overlap so that even a theoretical single-axled vehicle cannot be lost. By this means the objection to the simple short-circuit discussed above is overcome as there is nowhere where one track circuit or the other is not adequately shunted. However, the Z-bond, which is some 30 m in length is

by no means a dead short-circuit. Therefore, there is some coupling between the track circuits; each must accept to a limited extent current arriving from its neighbour. This is easily overcome by using different frequencies for adjacent track circuits as has been stated above.

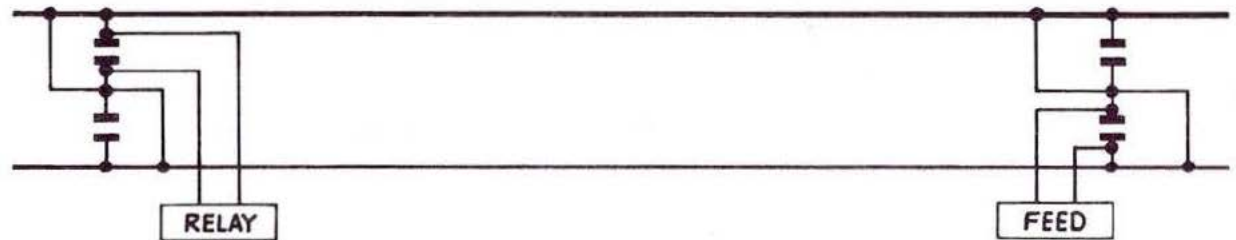
The Aster equipment adopted by British Railways will function over distances up to 880 m, with a minimum ballast resistance of 2 ohms per km. The track circuit energy is a continuous wave current, that is to say, it is not modulated in any way.

**The Aster 'Type U' Jointless Track Circuit**

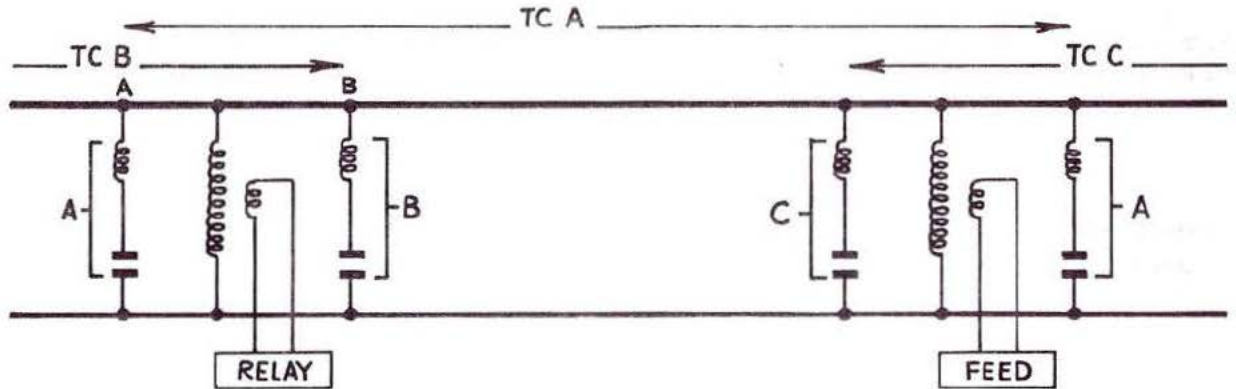
This is also a voltage-operated type and of the same origin as the Aster '1 watt' equipment. The system is similar in principle to the '1 watt' Aster system but defines the track circuit extremities in a different way. This is shown by Fig. 7:25(B) in which it will be seen that a transformer is located at the junction between adjacent track circuits. To this transformer is connected the electronic units which generate and detect track circuit energy. Definition of the ends of the track circuit is accomplished by means of series resonant tuned circuits A and B which, at the frequency of the track circuit with which they are concerned, act as short-circuits. Thus track circuit A extends to the right from point A and track circuit B extends to the left from point B. As has been stated, the train shunt for track circuit A would be very low in the vicinity of point A, similarly the shunting sensitivity of track circuit B would be unacceptably low in the neighbourhood of point B. This objection is overcome by overlapping successive track circuits as shown. Thus when track circuit A is no longer shunting satisfactorily then track circuit B will have taken over the task. The converse is equally true. Thus despite the fact that the rails are short-circuited at a particular frequency there is no point at which satisfactory shunting of a track circuit does not exist.

The Type 'U' system is employed on British Railways for track circuits of length up to 2 km, and minimum ballast 2 ohms per

Fig. 7:25 Jointless track circuit: voltage-operated type



(A) ASTER '1-WATT' TYPE



(B) ASTER 'TYPE U'

km. Like the '1 watt' system it is a continuous wave system, employing frequencies in the 1700 to 2600 kHz band. Because each track circuit is terminated by a short-circuit it is necessary only to use two frequencies per track, and again the same frequencies are used for

alternate tracks where there are more than two tracks on a route. For track circuits between 1 and 2 km in length, the transmitter is located at the centre of the track circuit and a separate track relay set is provided at each end.

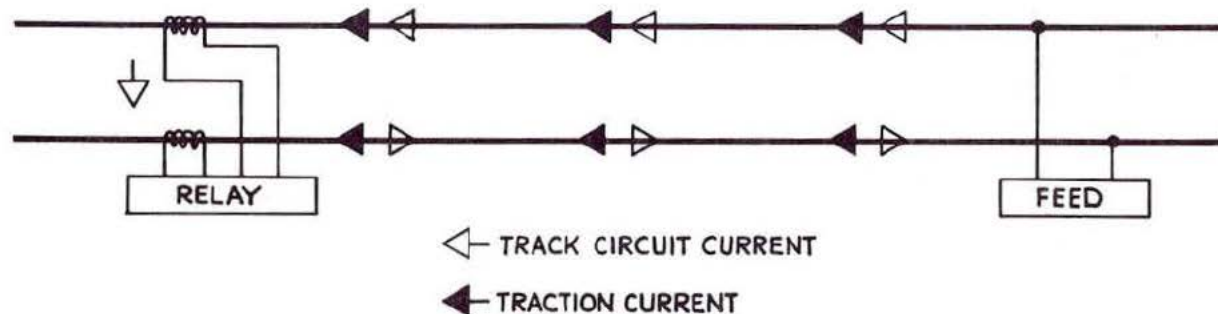


Fig. 7:26 Alsthom current-operated jointless track circuit

### The 'Alsthom' Jointless Track Circuit

This type of jointless track circuit, also of French origin, has been designed specifically for use on electrified lines.

It is current-operated and, as shown in Fig. 7:24(B), employs two coils each of which is inductively coupled to one rail. The voltages induced in the two coils are separately amplified and then combined to operate a conventional track relay. Fig. 7:26 shows the relative directions of traction and track circuit current in the rails. As will be seen from the diagram the signalling currents flow in opposite directions past the two coils whereas traction current flows either in both rails in the same direction or in one rail only. This gives a clear distinction between wanted and unwanted currents since the track circuit will give a clear indication only if there is a current in opposite directions in each rail. This system uses frequencies in a range extending from a few hundred Hz up to 10 kHz and will operate over lengths of up to 2 km with a minimum ballast resistance of 2 ohms per km.

### Reed Jointless Track Circuit

This type of current-operated jointless track circuit has been developed by GEC-GS for use in both electrified and non-electrified areas and is currently (1978) undergoing trials on British Railways.

It is a centre-fed track circuit which uses receiver loops to define the ends of the track circuit section. The feed equipment is the same as that used in the reed jointed track circuit, but at the receiver ends the track circuit current is detected by means of a rectangular pick-up loop formed from a 37-core cable which is clipped to the webs of the rails. All but one of the cores in the cables are connected in series to form a multi-turn coil and the remaining core is connected between the rails via a resonant shunt (adjusted to suit the reed frequency in use) which defines precisely the end of the track circuit. The voltage induced in the multi-turn coil is applied to the reed receiver via an attenuator filter which provides an adjustment for overall sensitivity.

Figs. 7:27 and 7:28 show respectively the principle of operation, a typical application and the circuit details.

TRACK CIRCUIT PRINCIPLES AND EQUIPMENT

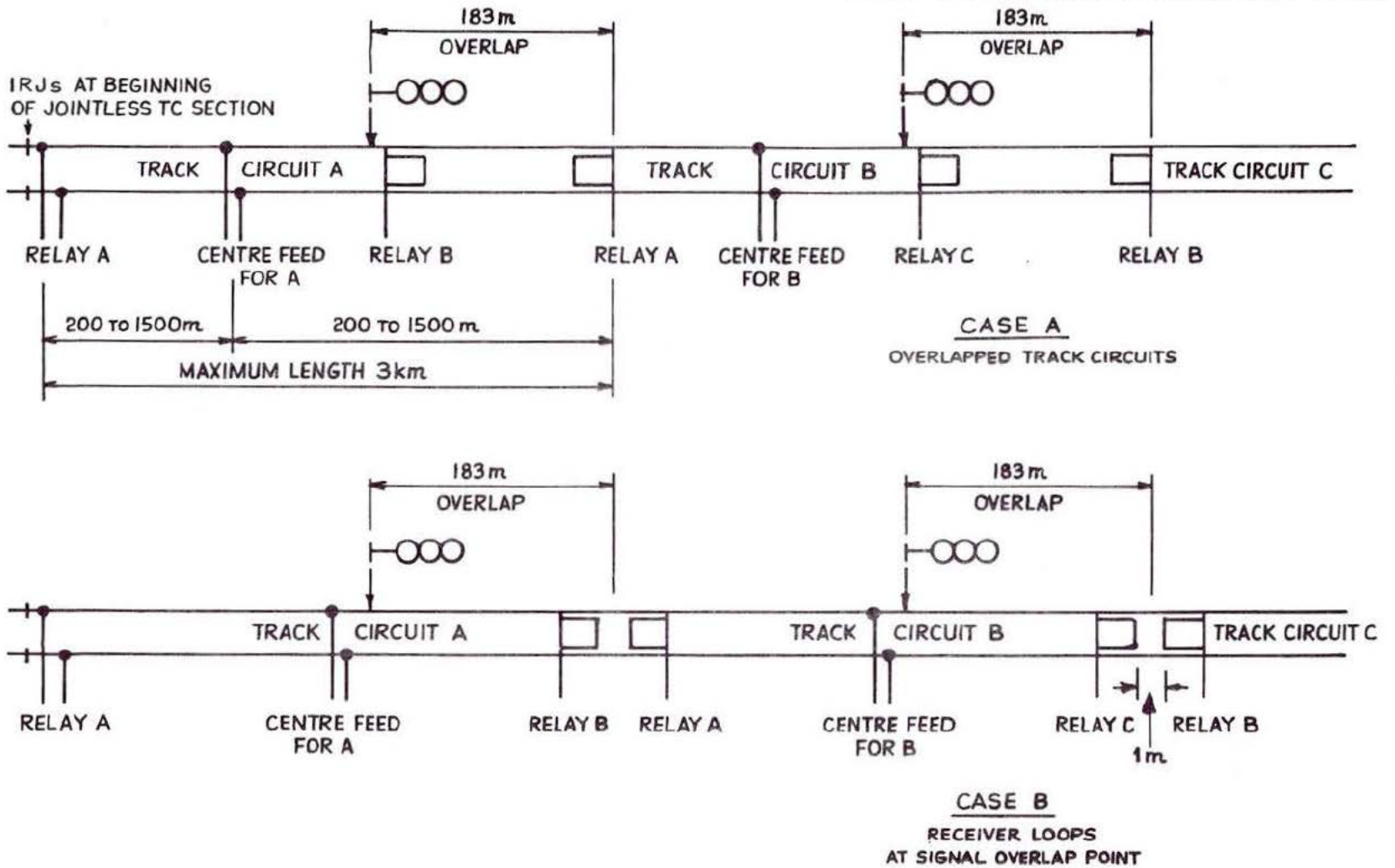


Fig. 7:27 Reed jointless track circuit: typical applications

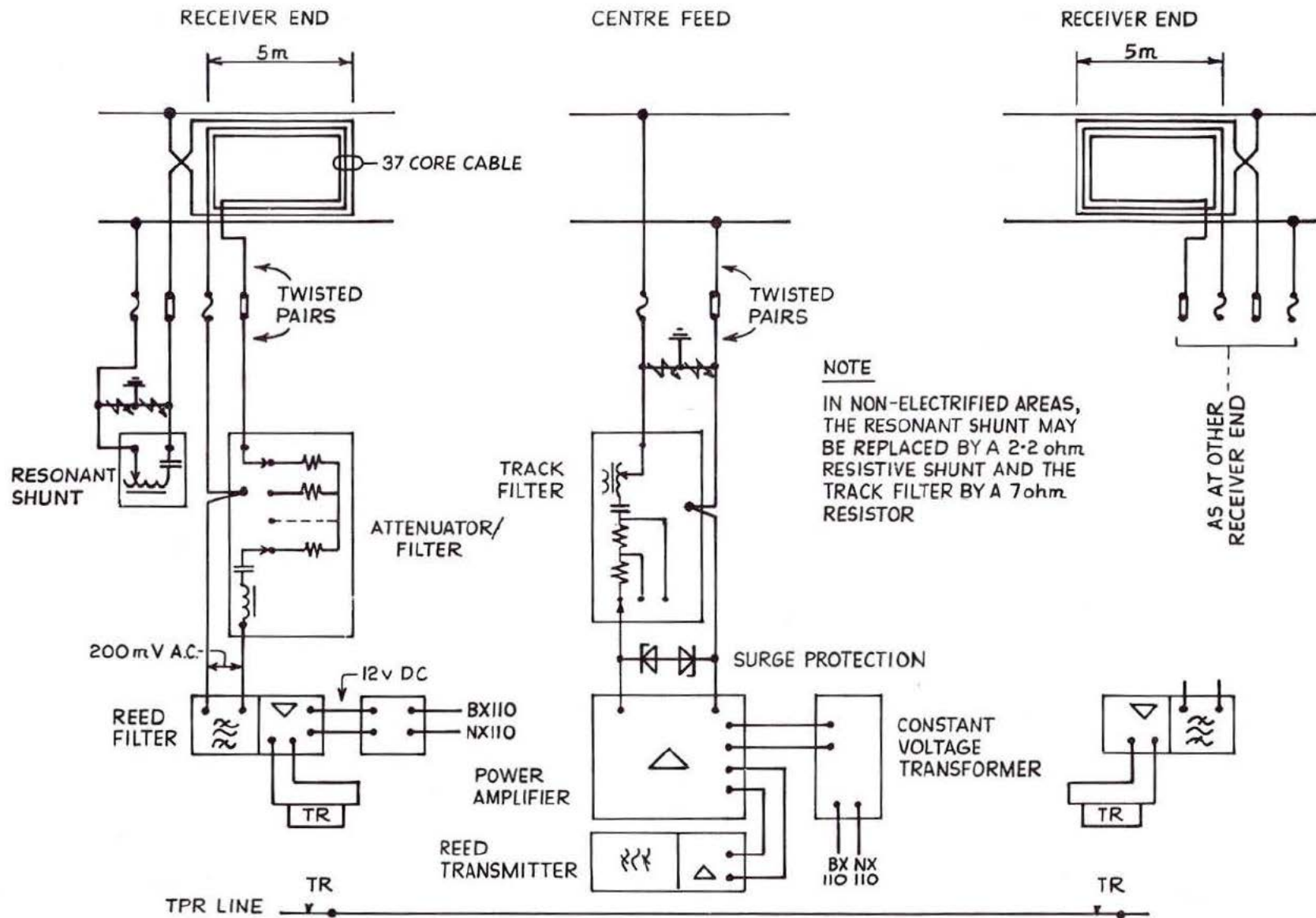


Fig. 7:28 Reed jointless track circuit: details

The ends of adjacent track circuits are overlapped so that both track circuits are occupied as the train passes over the common section. This has the same effect as the provision of a separate overlap track circuit at a signal without the additional expense.

It is claimed that, at its maximum length of 3 km, the track circuit will have a minimum shunt resistance of 0.5 ohm over a ballast resistance range of 1.6 ohms to 70 ohms per km.

For non-electrified lines, the track filter at the feed end may be replaced by a 7 ohms resistor and at the relay ends a 2.2 ohms resistive shunt may be used instead of the resonant shunt.

In AC electrified areas where the traction return current may exceed 1000 amps, a high-power version of the feed set may be used. This enables the number of turns in the receiver loops to be reduced, which maintains the signal-to-noise ratio in the presence of a high level of interference.

As previously mentioned, reed track circuits may be operated safely with a frequency spacing of only 3 Hz. It is however, necessary to avoid using operating frequencies which are odd or even harmonics of the industrial frequency in AC traction areas and rectifier ripple frequencies in DC traction areas. It is also advisable to allow for the deviation in the supply frequency which sometimes occurs when the national system becomes heavily overloaded in any emergency or breakdown. In such cases, the fundamental frequency of 50 Hz may be allowed to fall to 48.5 Hz before shut-down, after which the frequency will be increased to 51 Hz for a period in order to correct electric clocks and other frequency-controlled equipment.

The standard frequencies chosen for reed track circuits lie between the 7th and 8th and between the 8th and 9th harmonics.

In non-electrified areas the following frequencies are available: 363, 366, 369, 372, 375, 378, 381, 384 and 408 Hz.

Having regard to the foregoing and allowing 3 Hz from a possible interference frequency in electrified areas, reed track circuits should not use operating frequencies in the following bands, 336.5–360 Hz and 385–411 Hz. This leaves all frequencies available in AC and DC electrified areas except 408 Hz.

For jointless track circuits, four channels are required for each track and to give the widest possible spacing on a double track the following should be used.

Up line—363, 369, 375 and 381 in rotation.

Down line—366, 372, 378 and 384 in rotation.

### Impulse Track Circuits

This type of track circuit has been developed for bad shunting conditions where the rails have been little used or where vehicles have been standing for a considerable time. Basically, these track circuits apply high voltage pulses to the rails to break down the rust film.

There are two types of impulse track circuit which are used by British Railways, namely, the Jeumont and the Lucas types.

#### *Jeumont Type*

The Jeumont type has been designed for use on non-electrified and track electrified by AC or DC.

Fig. 7:29 shows the feed and relay end circuits and Fig. 7:30 shows the waveform applied to the rails.

At the feed end, the transmitter consists of an oscillator which outputs 80 volt 3 ms impulses at the rate of 3 per second. These are detected at the relay end by a special relay having a ring iron circuit which responds only to energy of the waveform developed by the transmitter.

The waveform consists of a well damped positive pulse of brief duration followed by a negative pulse of lower amplitude; the integrals of both pulses being equal. The result is that a symmetrical waveform cannot operate the relay and thus wrong-side failures due to the fundamental or harmonics of the traction supply cannot occur.

The ring iron circuit of the relay also guards against failures in the pulse rectification circuit.

The Jeumont track circuit will operate track circuits of up to 2 km long although on British Railways only short track circuits

## TRACK CIRCUIT PRINCIPLES AND EQUIPMENT

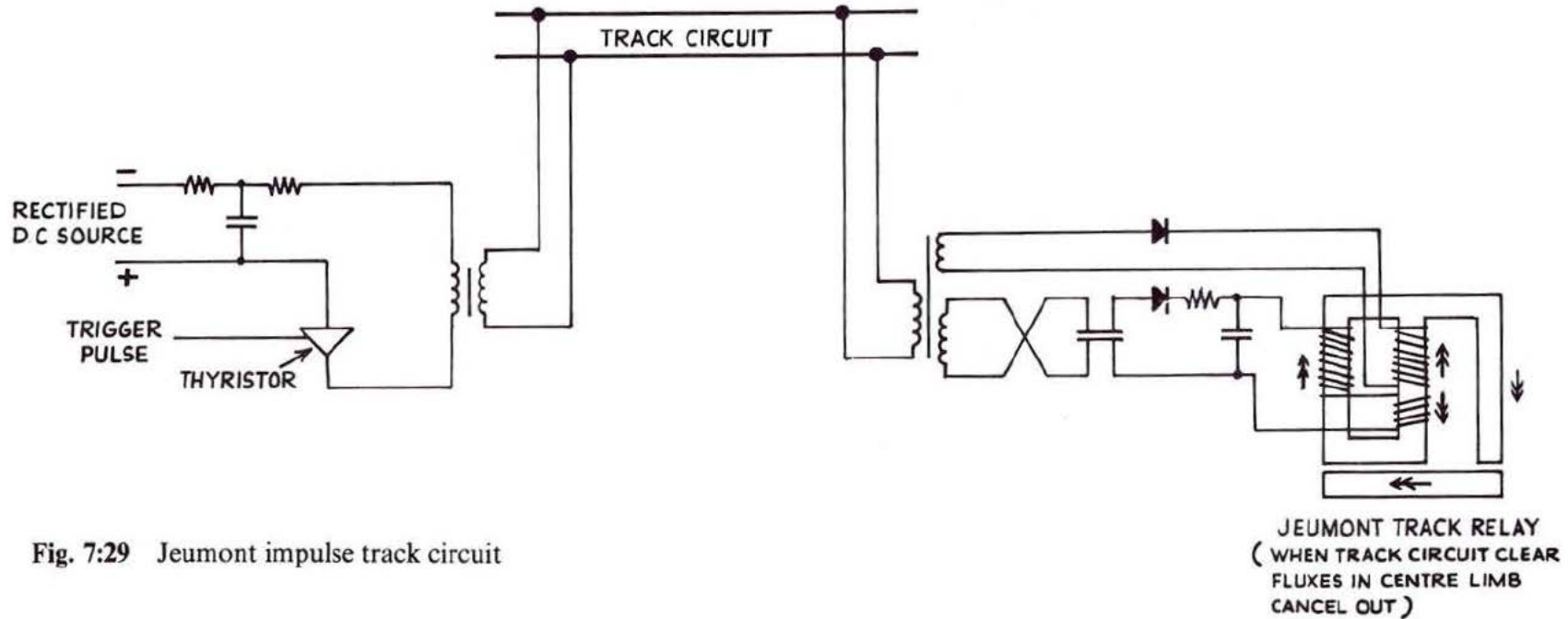


Fig. 7:29 Jeumont impulse track circuit

have been used. It operates with a minimum ballast resistance of 2 ohms/km.

### Lucas Type

The Lucas type has been designed to operate from a 4-volt DC supply and may therefore be used with a trickle-charged battery supply.

There are two versions, one outputting 20 volt pulses and the other 40 volt pulses.

The feed set includes an inverter and an oscillator and at the relay end a standard DC neutral relay is energised by a transformer/half-wave rectifier combination.

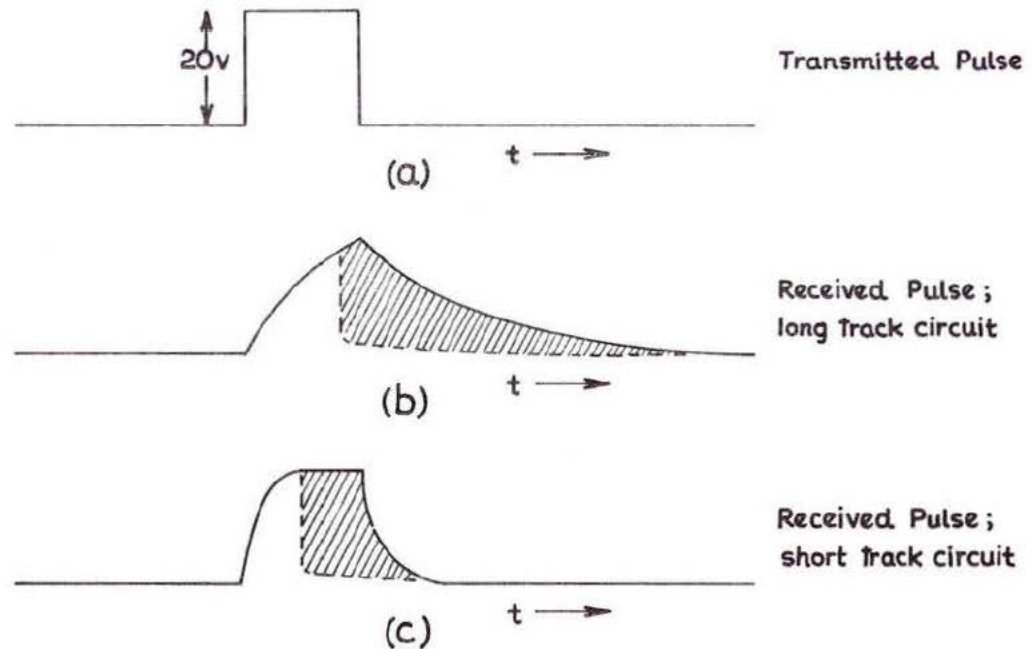
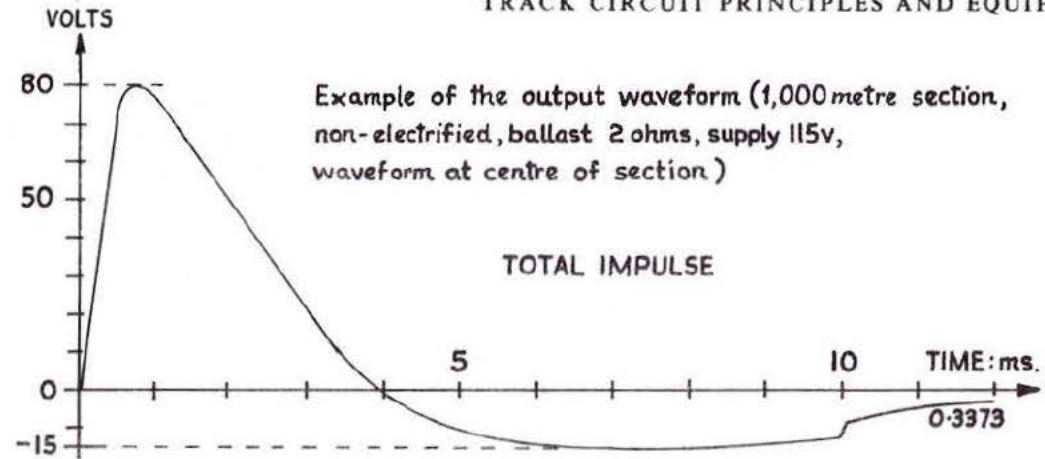
Fig. 7:31 shows a typical waveform.

The Lucas type is not suitable for electrified areas or for long track circuits, as the minimum ballast resistance for satisfactory operation is 10 ohms.

### Coded Track Circuits

Although coded track circuits have been used on British Railways and there have been successful trials with cab signals, they are no part of the current signalling system but would provide an acceptable solution for suitable problems if they should arise.

**Fig. 7:30** Jeumont impulse track circuit: impulse waveform



**Fig. 7:31** Lucas impulse track circuit: impulse waveform

## Remote Control Systems

Remote control systems may be used in situations where interlockings or lineside apparatus are beyond the normal maximum distances from the location which controls them. Although the maximum distance may be extended by the use of repeater circuits, there comes a stage where it is more economical to use one or other form of remote control system rather than extend a multicore cable for a further distance.

The majority of remote control systems are used as non-vital links between a signalman's control and indication console and remote interlockings, but a version of the frequency-division multiplex system is also used for the control and indication of vital lineside equipment from an interlocking. This latter usage is fully described later in the section of this chapter dealing with FDM systems.

The various versions of non-vital systems are used only between a signalman's console and an interlocking, or for the non-vital control and indication of lineside equipment in areas away from an interlocking such as auto-sections, ground frame releases, barrier crossings, and so on.

### Types and Usage of Remote Control Systems

There are three categories (later described in detail) into which remote control systems fall, each being suitable for a particular set of circumstances. These are:

#### *Direct Wire*

This system consists of a non-vital multicore cable either of the telecommunications type or of the micro-core type. Its normal usage is for the control and indication of an interlocking beyond the normal range from a signalman's control point, but less than the

range where a Time Division Multiplex (TDM) system would be more economical.

Direct wire systems are occasionally used beyond their economical range where it is considered that the inherently greater reliability of such a system outweighs the economic advantages of a TDM system.

#### *Frequency-Division Multiplex (FDM)*

Each control or indication function in this type of system is represented by a tone of a discrete frequency, and many such tones may be superimposed on one pair of line wires.

Each tone is generated by a transmitter unit and detected by a receiver unit, and these units may be situated at any location along the line pair.

This facility makes an FDM system in its non-vital form suitable for use where functions to be controlled and indicated are distributed individually or in small groups along a length of line such as a series of auto-sections between interlockings. Safety functions such as track circuit controls for signals and aspect sequencing are still carried in normal line circuits between locations, but the indication to the signalman of functions such as track circuits and signal aspects, being non-vital functions, can be multiplexed onto a non-vital FDM system.

An FDM system is the only type of remote control suitable for the remote control and indication of vital functions. In this form it may be used to extend the range of an interlocking, thereby making possible a reduction in the number of interlockings. In its vital form, FDM may also be used as one method of reversible working in a block section, and for block control in tokenless block systems for single line sections.

#### *Time-Division Multiplex (TDM)*

Each function in this type of system is allocated a short time slot in a series data sequence consisting of many such time slots. It

is thus possible to pass a large quantity of data in a relatively short time period and by repeating this sequence continuously the state of all functions is up-dated rapidly.

The arrangement of a TDM system enables large quantities of data to be available at only a few locations and thus makes such a system unsuitable for small quantities of distributed data. Its main use is therefore for the control and indication of remote interlockings where relatively large amounts of data are concentrated in one relay room. A TDM system may serve one interlocking only, referred to as single station operation, or more than one interlocking, known as multi-station. The latter is normally used in areas of low traffic density or simple operating pattern. Single station systems are favoured in high traffic density and complex operating pattern conditions, where failure of one system will minimise the inconvenience to traffic movement.

To further minimise the effect of a TDM system failure many installations are now equipped with separate systems for controls and indications. They are also equipped with TDM 'override' facilities which allow certain predetermined through routes to set and operate automatically.

#### *Composite Systems*

In many instances non-vital FDM systems are brought directly to and from the signalling Control Centre, and operate independently of systems controlling interlockings. In other cases it is more economical to bring FDM systems into the nearest remote interlocking and transfer the functions onto the TDM system serving that interlocking.

#### **Terminology**

Many terms are used, which are a result of usage over many years in railway engineering, and which may not necessarily be the same as those used in other modern electronic and computer fields.

Such terms used in the railway signalling industry are:—

*Bit* A single item of information from several of which a TDM word is formed. Bits are similar in their format, but their function is defined by their relative positions within the word.

Hence—data bit  
control bit  
indication bit  
address bit  
parity bit, and so on.

*Channel* A frequency band over which information may be transmitted. A TDM system may utilise a small number of relatively wide frequency band carrier channels each carrying many bits, whereas an FDM system uses many narrow band-width channels each of which is used to convey one bit of information.

*Baud rate* The number of changes of state per second that a carrier channel is designed to convey. The baud rate is largely dependent upon the frequency band-width of the carrier channel used.

In a Frequency Shift Keying (FSK) system the maximum number of bits per second is equal to the baud rate. In a Phase Shift Keying (PSK) system the maximum number of bits per second may exceed the baud rate.

*Office* The location at which the master equipment of a system together with the control and indication panels and their operators are housed. An office is also referred to as a Control Centre, Signalling Centre, Control Point, and so on.

*Field* A location remotely controlled from an Office. This term is normally applied to an outlying relay room on a Direct Wire or TDM system, and is alternatively referred to as a Field Station, Outstation, Satellite, Remote Location, and so on.

## REMOTE CONTROL SYSTEMS

### Typical Installation

The majority of modern signalling schemes on British Railways incorporate some or all types of remote control systems. A typical example is shown in Fig. 8:1, which illustrates the use of each form of system already discussed. In this example a signalling Control Centre operates five separate interlockings, together with several stretches of automatic signals and a section of single line. The local interlocking is directly controlled from the Control Centre and does not involve remote control of any type.

Remote interlocking A, whilst being beyond the range for local control, is not at sufficient distance for the use of a TDM system, and is therefore controlled by direct wire. Interlocking B is at sufficient distance to be economically operated by TDM and since it is an important junction in the scheme a single station system is used. Interlockings C and D are small enough and with a traffic density low enough to enable a multi-station TDM to be used, thus presenting a saving in line pairs down this length of line. The crossing at E, whilst frequently being used, is not large enough to warrant a separate interlocking. Its interlocking is therefore housed along with interlocking B and since it lies beyond the normal range of this interlocking, the vital functions associated with this crossing are controlled and indicated by vital FDM systems. The single line section between E and F is controlled by a block system using vital FDM.

The various auto-sections between interlockings are supervised by non-vital FDM systems. Those between C and D, and B and E use systems emanating from the nearest interlockings where the control and indication functions are transferred to and from the appropriate TDM system. The auto-sections between interlockings

B and C are an example of taking a non-vital FDM system directly to and from the Control Centre, and are independent of any interlocking or other remote control system. A signalling scheme in practice would incorporate one or other of these methods of usage of non-vital FDM throughout and would not use a mixture.

### Direct Wire System

In considering a direct wire system of remote control, a comparison may be made with direct operation which is achieved by using signalling type cable, signalling type relays and taking the usual circuit precautions such as double cutting as necessary. For instance, signal lighting circuits are generally locally fed and contactor relays feed point machines from local rectifiers.

In a direct wire system of remote control, the interlocking and controls are in a local relay room and hence a cheaper form of cable may be used; relays may be of the non-vital type and circuit precautions are unnecessary.

Cables may be of the telecommunications type, in which case separate returns may be used for each circuit as shown in Fig. 8:2, or the cable may be of the 'micro-core' type when a common return shared between all controls and indications is used as shown in Fig. 8:3.

Latterly, the use of micro-core cable has become common. A typical micro-core cable consists of 360 H.D. tinned copper conductors each 0.4 mm dia. PVC insulated, laid in 9 layers round a 56/0.3 mm dia. enamelled copper conductor which forms the common return. The cable is sheathed with aluminium/polythene interleaved tapes to form a water barrier, followed by a brass tape for protection against rodents and a final overall polythene sheath.

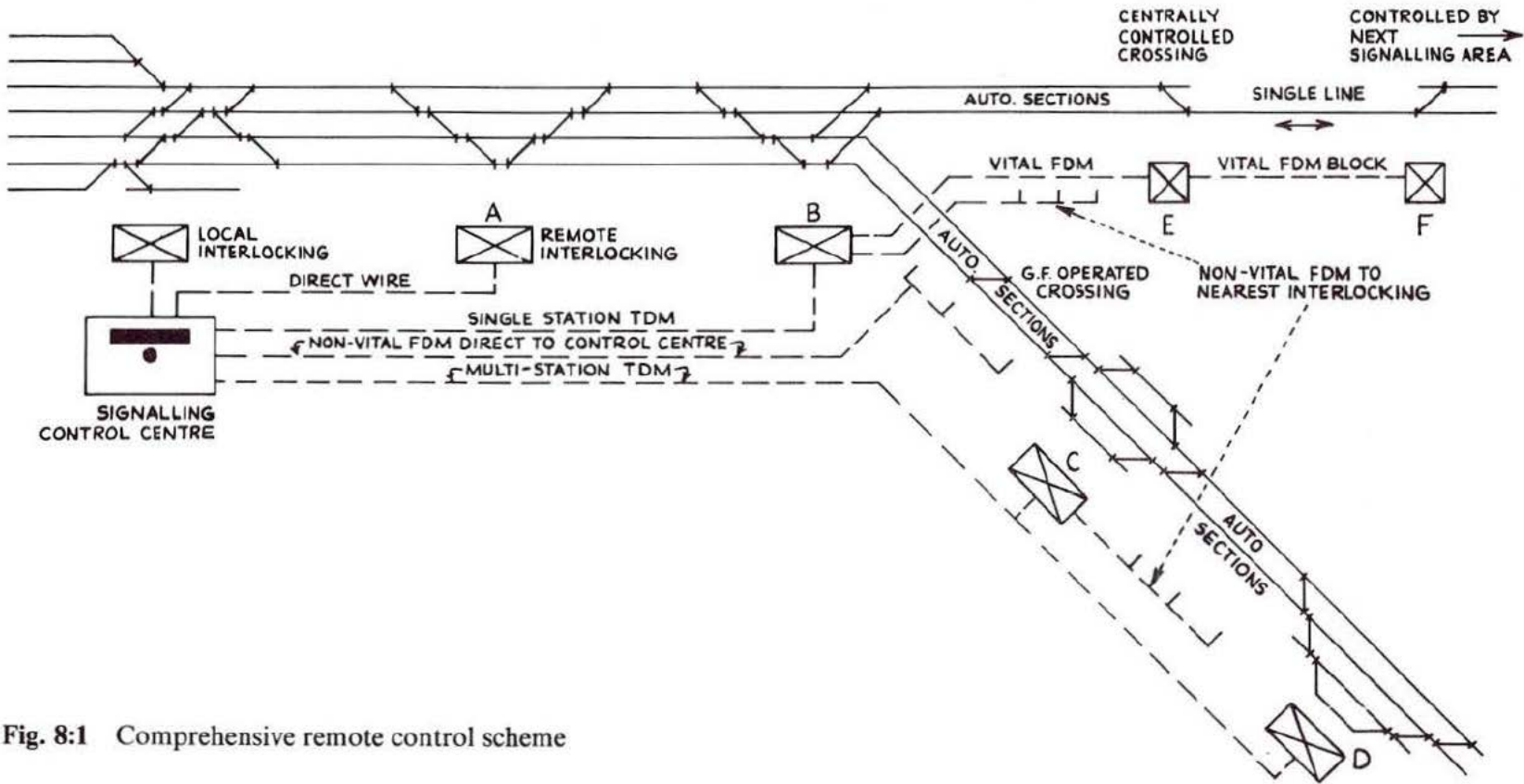


Fig. 8:1 Comprehensive remote control scheme

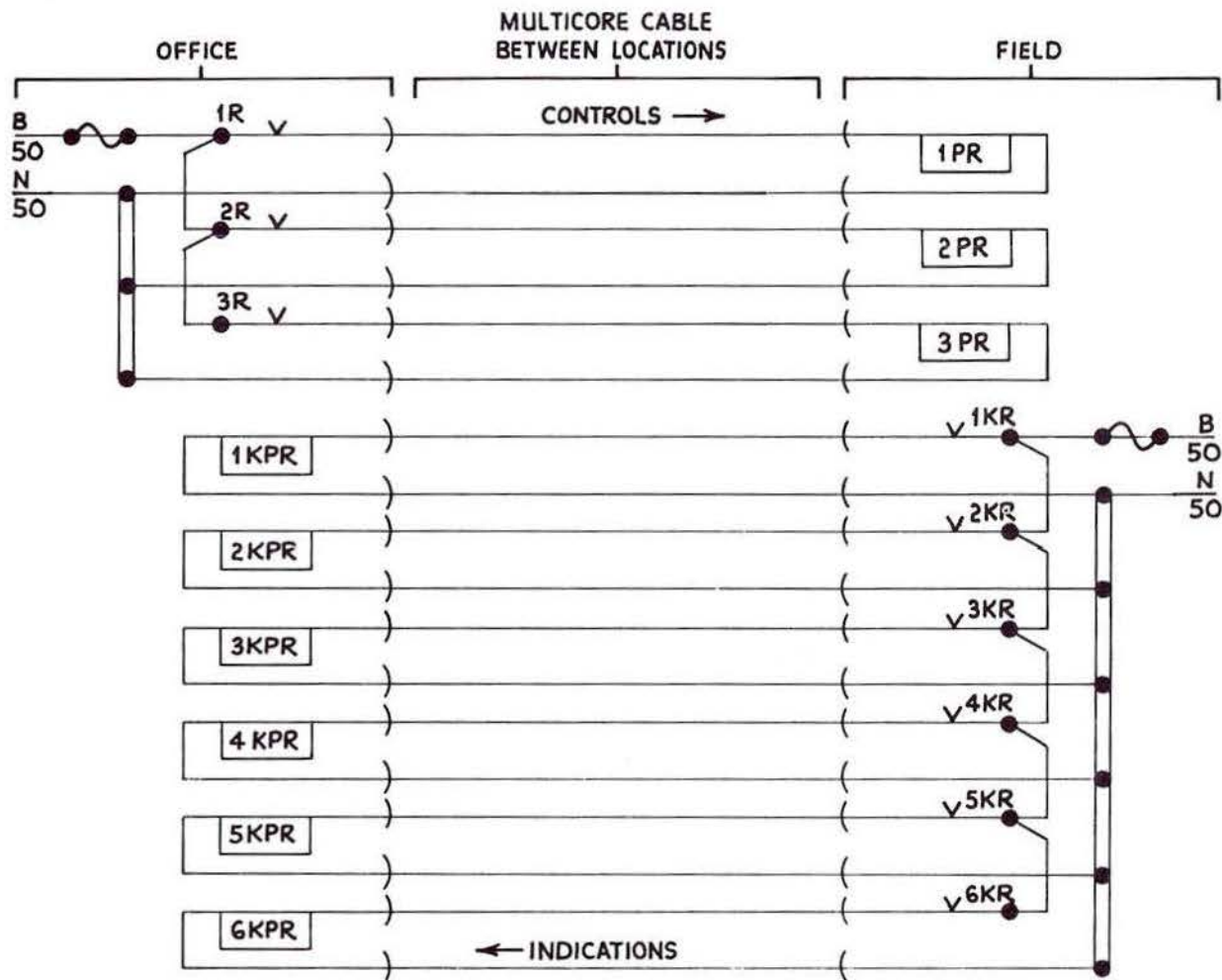
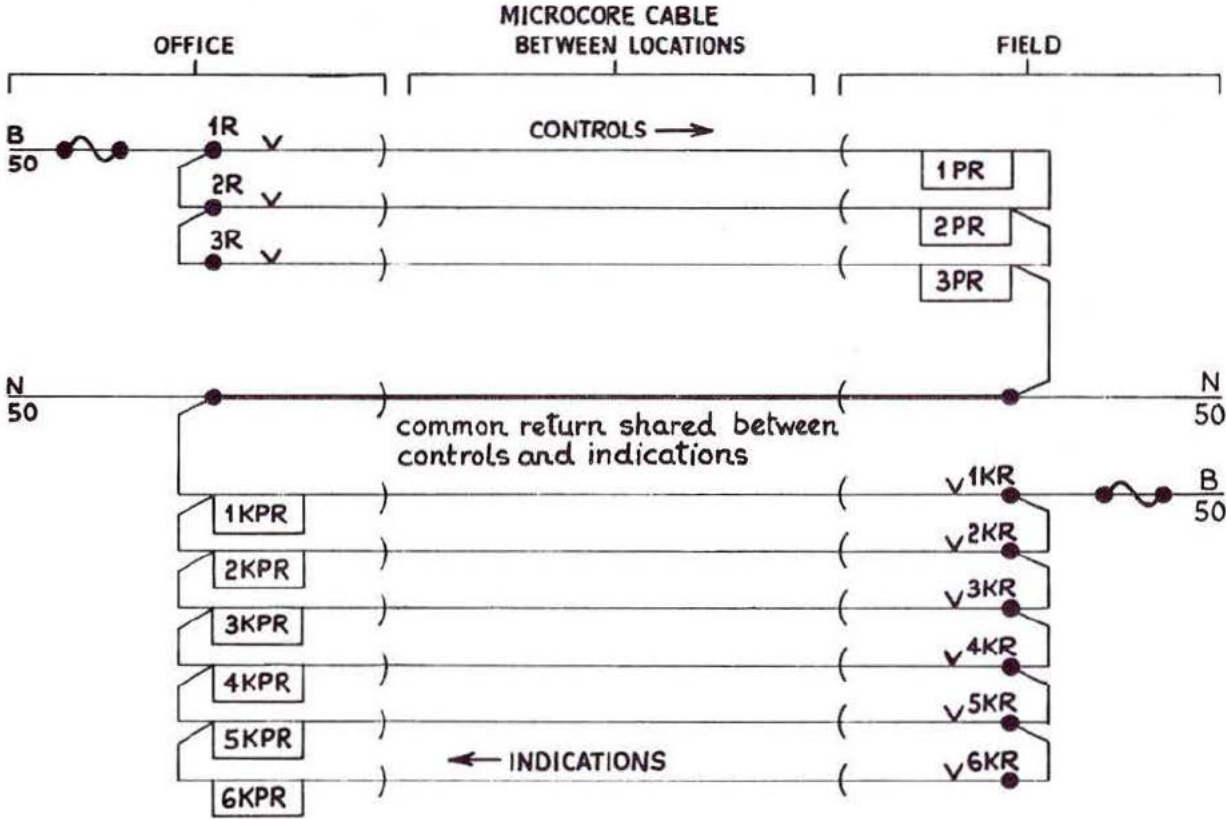
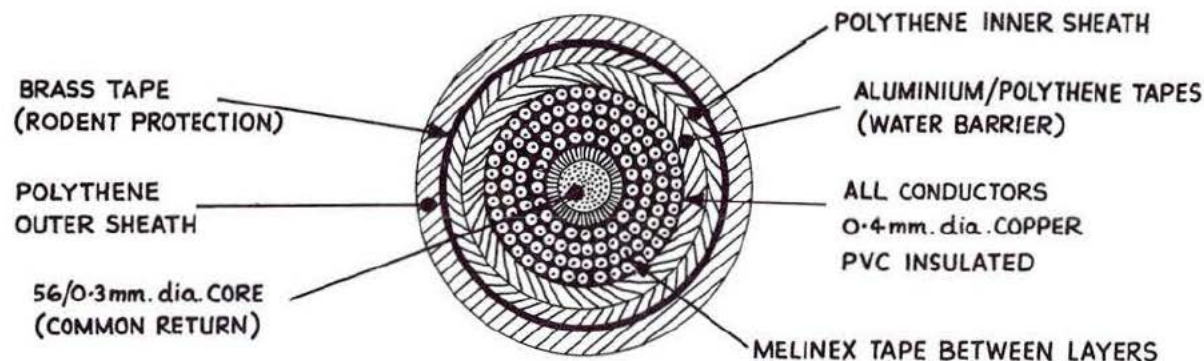


Fig. 8:2 Remote control system with individual returns

Fig. 8:3 Remote control system with common return





TYPICAL SIZE :- 360-CORE IN 9 LAYERS (ONLY 4 SHOWN)

Fig. 8:4 Typical micro-core cable section

Fig. 8:4 shows a cross section of a typical micro-core cable. The type shown would not be suitable for use in AC electrified traction areas. In these circumstances, steel armouring would need to be added to immunise the cable against the effect of induced voltage. The rodent barrier could then be dispensed with.

There can be no hard and fast rule for the economic limit to the use of direct wire control as it depends on both distance and the number of functions.

The relay resistance needs to be high to reduce voltage drop, but not so high as to render the relay too sensitive. In a typical application on a DC electrified line, 6000 ohm P.O. 'Relay' telephone types were employed to operate functions at a distance of about 10km. A simple calculation shows that voltage drop is negligible in these circumstances.

The relay should also be of the slow-operate type (about 30ms)

to avoid operation on short induced pulses which may occur on long lines when other channels are operated, due to inter-core capacitance. For local operation, the relay may be provided with a second winding fed from the local supply.

In AC electrified traction areas, the circuit length is limited to about 6km, to comply with CCITT recommendations, namely, that the longitudinal induced voltage should not exceed 430 volts RMS under fault conditions or 110 RMS on full traction load. For greater circuit lengths the circuits must be repeated to reduce the length of parallelism with the traction system. These measures of immunisation obviously affect the economics of direct wire for remote control. As a result of these constraints, there is now a tendency to use TDM systems and for tuned-reed FDM systems as an alternative to direct wire control as described later.

## FREQUENCY-DIVISION MULTIPLEX (FDM)

In a frequency-division multiplex system, each function is allocated a specific frequency. A tone of this frequency can be transmitted along a common circuit and switched to represent the state of the function, in the presence of a number of tones of other frequencies. At the far end of the circuit, a receiver is provided which responds only to tone of the specified frequency and it typically energises a relay if a tone of that frequency is present, so that the relay reproduces the state of the function. By this means, many functions can be transmitted along a common circuit independently of each other.

The path thus established for one function by frequency-division multiplex will be referred to as a 'channel'. The group of channels on one physical circuit, that is, on one pair of wires (or a derived circuit such as a micro-wave or radio link), will be referred to as a 'system'.

For each channel there must be a specific means of switching the allocated frequency to the line circuit at the transmitting end. This may take the form of an individual oscillator which is switched on and off by the controlling function, or it may simply be a switched driver amplifier fed with the required frequency from some master source. In either case, the equipment provided for the individual channel will be referred to as the transmitter for that channel. There will also be a receiver which responds only to the required frequency, and which drives an output relay or provides some equivalent output. As with all forms of multiplexing, each relay or output behaves as though it were connected directly to the corresponding input, and is quite unaffected by the other channels.

One of the principal advantages of frequency-division multiplex systems is their potential flexibility in application. For the greatest flexibility, both the transmitters and the receivers for the various channels are usually constructed as physically separate units. The equipment is then designed so that transmitters and receivers for

individual channels can be connected to the line not only at its ends, but also at any intermediate point. For example, receivers can be designed to have an input impedance high compared with the characteristic impedance of the line, so that one or more may be connected between the two line wires at any point without affecting the onward transmission. Similarly, transmitters can be designed with low output impedance, and each can be connected in parallel with a low impedance connected in one of the line wires.

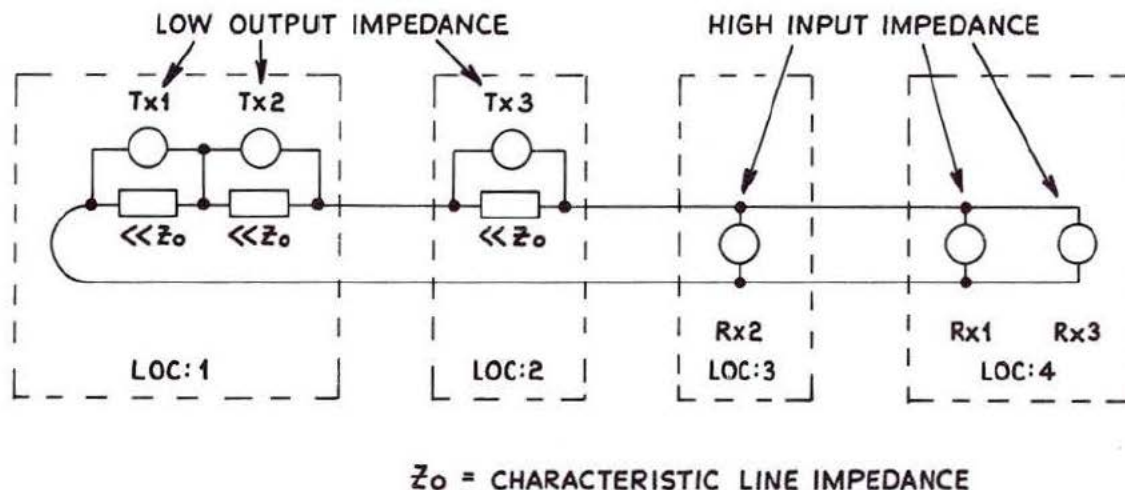
Fig. 8.5 shows a typical system constructed on this principle. In this system, three separate functions are carried between a total of four locations on a single pair of wires. It should be noted that the basic design of the system assists maintenance, for in the event of a fault in a unit belonging to one channel, that unit may be removed and replaced without interrupting the operation of the other two channels.

Practical systems can carry tens or even hundreds of channels on one pair of wires, and may work over distances of tens of kilometres. Almost any configuration can be catered for, including branched systems, two-directional working, and any other features as required. Moreover, fail-safe FDM systems, for the transmission of vital signalling functions are possible.

### The Basis of FDM Equipment

It will be seen that frequency-division multiplex equipment depends upon the use of a transmitter of stable frequency, and a receiver both stable and selective. A typical receiver consists of a filter tuned to pass only the desired frequency, which drives an amplifier whose output is rectified in order to energise a relay. The spacing of frequencies in the system must be such that the immediately adjacent frequencies are attenuated strongly by the filter, in order to avoid false

Fig. 8:5 Basic FDM system



operation of receivers by the incorrect transmitters. Thus the bandwidth of the filter determines the minimum spacing between tone frequencies in a practical system, hence the number of channels that can be accommodated in a given overall band-width. Economic factors make it desirable to have a large number of channels in the system, and so filters having narrow band-widths, and therefore high  $Q$  factors, are the basis of practical equipment.

The time taken for the filter to respond when the tone is switched depends upon the value of  $Q$ , and increases as  $Q$  increases. Hence there is a delay between the tone being switched at the transmitter and the response of the relay, which can be significant in practical equipment using high  $Q$  filters—of the order of 300 ms in some cases. A balance has to be struck in practical equipment between the requirements for large system capacities and for fast response times.

### Practical Systems

A number of different types of frequency-division multiplex equipment are in service at the present day. The frequency band employed is almost invariably in the range from 200 to 2000 Hz, since tones of such frequency can easily be transmitted along pairs in ordinary signalling cable; the fact that special cables do not have to be provided is an important feature. In most cases the necessity for making the equipment immune to interference, particularly to harmonics of the mains frequency originating from electric traction systems and other sources, restricts operation to the lower end of this band.

A simple type of FDM equipment uses straightforward, purely electronic oscillators in the transmitters, and filters using inductors and capacitors in the receivers. Stability considerations limit the

value of  $Q$  to about 50 for such filters, which limits the number of channels in a system to about twenty. However, because of the basic simplicity of the design, the cost of this form of equipment is low, and it can be used in situations where small groups of functions are required to be transmitted to or from a central point; for example, for bringing track circuit indications from individual location cases into a relay room on an automatically-signalled line.

For higher values of  $Q$ , and hence larger systems, the required combination of narrow band-width and high frequency stability is obtained by the use of electro-mechanical resonators, devices whose resonant properties are determined primarily by mechanical parameters. There are three practical forms: quartz crystals, tuning forks, and reeds. Quartz crystals are bulky and expensive at the audio frequencies required, and so have not been used in practical systems. Tuning fork filters typically yield  $Q$  values in the range 100 to 300. A small tuning fork driven by piezo-electric crystals is suitable for this application.

A reed is a metal rod clamped at one end and free to vibrate under electromagnetic (or other) excitation; filters incorporating reeds yield the highest  $Q$  values that have been used in practice, being of the order of 1000, with adequate stability. Reed systems are in service with up to sixty-five channels in a band-width of little more than one octave (typically, from 400 to 900 Hz).

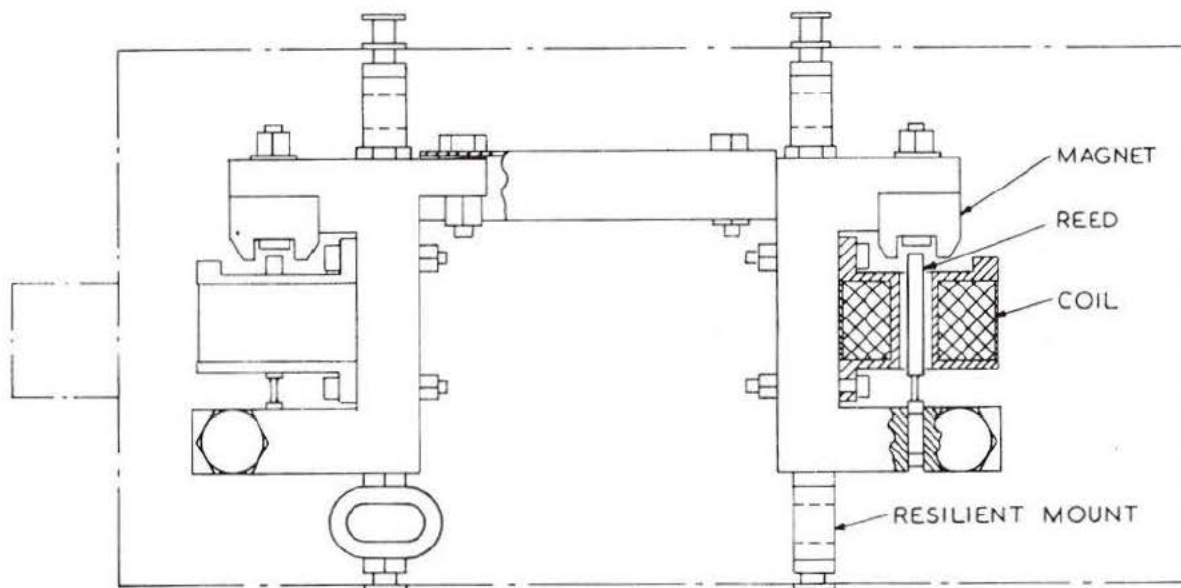
Successful systems have been developed using both methods but the reed system is generally in current use (1978) by British Railways when an FDM system is required for remote control.

The basis of practical reed equipment is the twin-reed filter with electromagnetic excitation, for this combines the high  $Q$  value with good rejection of frequencies outside the pass band. In the form usually encountered, each reed is clamped in a large brass block, on which there are also mounted a permanent magnet, between whose poles the free end of the reed vibrates, and a coil arranged so that its axis coincides with the longitudinal axis of the reed. The brass blocks are joined by a massive base, and the whole assembly is mounted resiliently so that it is acoustically isolated.

The general construction is shown in Fig. 8.6. This is identical with the reed filter used for track circuits. In each block the reed, which has a narrow neck near the clamping point which acts as a hinge, is free and moves between the poles of the magnet, and it lies along the axis of the coil. The blocks are joined by the base, and the whole is mounted on resilient supports.

If a current flows in the coil, the reed is magnetised by it, and the interaction between its magnetism and that of the permanent magnet causes it to be deflected. If the current alternates, the reed will vibrate, and if the frequency is the same as the frequency of free vibration of the reed it will resonate, the vibration building up to a large amplitude. The vibration of the one reed will be coupled through the massive base to the other assembly, and will cause the other reed to vibrate in sympathy. If the second reed is tuned to the same frequency as the first, it too will resonate and vibrate with large amplitude. The vibration of the second reed between the poles of its magnet causes an alternating voltage to appear at the terminals of its coil. Only if the two reeds are tuned to the same frequency, and the excitation of the transmitting reed is the same frequency, is this output obtained, and hence the device acts as a pass-band filter. The reed filter is in fact superior to the quartz filter in its stability and  $Q$  factor.

In the receiver, one of the coils can be connected directly between the line wires; in order to satisfy the requirements already discussed the coils must be constructed so as to have a high impedance. The output from the other coil then drives an amplifier the output of which controls a relay or electronic switch. A sub-miniature relay having several change-over contacts is usually provided, except in fail-safe equipment, in which case the output relay is a standard signalling safety relay with a coil designed to match the FDM receiver. As in the tuning-fork case, a stable transmitter can be constructed using the twin-reed filter as the frequency determining element in a feedback oscillator. However, in order to reduce costs, a simple arrangement employing only a single reed may be used in the transmitter; the same assembly of reed, coil and magnet is employed typically



**Fig. 8:6** FDM remote control system: twin reed filter

in a circuit that takes advantage of the changes in the impedance of the coil at frequencies near the resonant frequency of the reed in order to determine the frequency of the output signal. Because of the high  $Q$  values of the reed filters, switching times to the order of 100 to 300 ms are obtained with this type of equipment.

Because of the complexity of the reed filter assemblies the cost per channel of using reeds is generally more than for purely electronic systems. However, in big installations the large number of channels per system enables the greatest savings in cable costs to be made with reed equipment, and reed systems have been widely used for many years.

In order to construct, by conventional means, systems having

significantly more than sixty-five channels it would be necessary to employ filters having much better  $Q$  factors and stability than those already discussed. No such practical filter exists at the present time and even if one were available, an FDM channel using it would have an excessively long response time. However, larger capacities can be obtained instead by multiplexing complete FDM systems on to a single circuit by putting each system on to a high-frequency carrier and transmitting a number of such carriers of differing frequencies on the one circuit. Using this technique, systems with many hundreds of channels on one circuit are possible and projects now incorporate this principle for non-vital purposes.

### Line Transmission and Line Equipment

The signal present on a line carrying a frequency-division multiplex system resembles speech in that it is a broad-band audio frequency signal, but it differs from speech in that it occupies a narrower overall band-width, and has a wider dynamic range. The problems encountered in handling it are therefore similar to those encountered in telecommunications. Since the tones are put on the line additively, without any mixing taking place, the resultant composite signal is contained entirely within the band-width defined by the lowest and highest tone frequencies. However, unless the line equipment is able to handle the maximum instantaneous voltage that can occur, which is the sum of all the peak levels of the individual channels, without clipping, intermodulation will take place, and sum and difference frequencies  $f_i \pm f_j$  will be produced. In a system which depends upon frequency discrimination for its operation such effects must clearly be minimised in the interests of reliability, and the design of line equipment must take this factor into account.

The most commonly required item of line equipment is a line amplifier to counteract the attenuation of the line, and also to counteract the attenuation that may be caused by large groups of transmitters or receivers at intermediate points, or at the ends of systems. The positioning of line amplifiers depends upon the type of equipment and upon the parameters of the line. Generally speaking, on long systems the signal is not allowed to fall to a low level, and amplifiers are therefore provided fairly frequently, in order to preserve a good signal-to-noise ratio. There is no practical limit to the range of FDM systems provided the line and line equipment are of high quality. There are systems in service today working over distances of many tens of kilometres in ordinary signalling multicore cable.

In telecommunications practice, the power on the line is limited by convention to some level, typically 1 mW, in order to control crosstalk and noise in the circuit, and where there are many channels on one line, the total power in all the channels must not exceed this limit. As already mentioned, the majority of FDM systems

in service on the railway operate over line pairs in signalling multicore cables; if it is required to operate over line pairs in multicore cables or on pole routes that also carry telecommunications circuits the large number of channels in the FDM system may cause the limit to be exceeded, in which case either the transmission level for each channel, or the total number of channels in the system, must be reduced.

### Choice of Frequencies

Careful choice of frequencies is essential for reliable operation of frequency-division multiplex equipment. The following factors must be taken into account.

- (a) **MINIMUM SPACING:** As already indicated, there will always be minimum acceptable spacing between frequencies, which is determined by the band-width of the receiver filter. It will be a multiple of this band-width—of the order of five times.
- (b) **INTERFERENCE:** It is essential to consider to what interference the line is susceptible. For example, there will usually be interference at harmonics of the local mains supply frequency and especially if there is electric traction, either AC or DC. If interference can be present at any frequencies within the normal working band-width of the system at levels which approach the operating levels of the equipment, then those frequencies must be avoided in the choice of tones.
- (c) **INTERMODULATION:** In any practical line there are residual non-linearities. If two frequencies  $f_1$  and  $f_2$  are present on the line, then small components at  $f_1 \pm f_2$  are produced thereby. This is not troublesome, but in a large system with many frequencies there may be many combinations giving rise to one particular product frequency, so that the level of this product becomes large. Frequencies must be chosen so as to avoid adverse consequences of this effect.

## REMOTE CONTROL SYSTEMS

It should be noted that the effects of both interference and non-linearities become greater as the distance of transmission increases. The maximum distance over which a given type of equipment will operate satisfactorily will depend upon the extent to which these effects have been overcome.

- (d) **HARMONICS:** Frequencies must normally be chosen so that harmonics of others on the same system are avoided. In practice it is found that the number of frequencies that can be used outside a range of one octave (that is, a range of 2:1) is as a result limited on all but small systems.

### Fail-Safe Systems

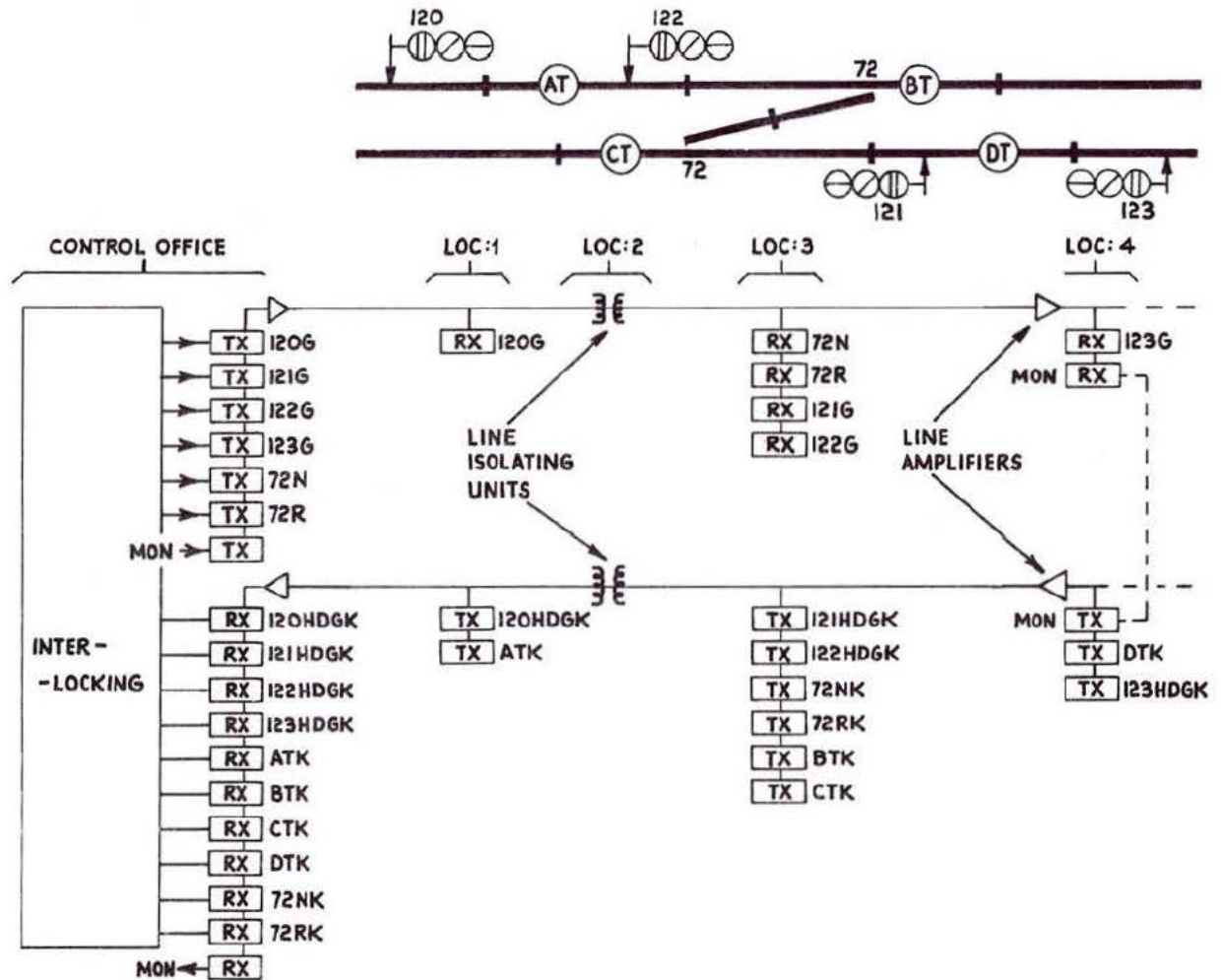
The usual application of remote control on the railway is supervisory; the interlocking circuits for an area such as a station or junction are collected together in a local relay room, which is controlled from the central signalbox by means which are not required to be fail-safe. Controls from the signalbox are only acted on if the interlocking in the local relay room permits. However, it is possible to make FDM systems which are fail-safe to the standards required for railway signalling purposes.

A typical fail-safe FDM system uses twin-reed filters of the type already described, with two tuned reeds coupled acoustically, which only pass signals of the frequency to which the two reeds are tuned, and is employed both to determine the frequency of the transmitter and to admit only the desired tone to the receiver. The frequency of free vibration of a reed is determined by its physical characteristics; in particular, by its thickness near the clamping point, and by the properties of the material used. Faults which cause the frequency of a reed to alter, while allowing it to continue vibrating, can thus only arise as a result of mechanical damage, and are extremely rare. However, if one reed in a filter were so affected, the two reeds would then have different resonant frequencies, and the input would no longer be coupled to the output. Only if the frequencies

of both reeds shifted by exactly the same amount could the filter respond to a frequency other than that to which it was originally tuned, and the probability of this occurring is so small as to be negligible. Hence the twin-reed filter is considered to be a fail-safe device that, under any reasonable fault conditions, will not respond to a frequency other than that to which it was originally tuned. Faults which do occur cause decreases in, or loss of, the output signal level.

In vital systems not only the filters but all the other parts of the equipment also must be designed so as to avoid wrong-side failures. For example, both the output level from the transmitter and the sensitivity of the receiver must be incapable of being increased as a result of any reasonable combination of failures of components of those units. Particular attention must be paid to the line wires, and to the electrical environment. Line amplifiers must be incapable of increasing their gain, or of oscillating at audio frequencies, as a result of component failures. The possibility of earth faults on any line must be accepted, and moreover, since earth faults may go undetected, the system must be safe in the presence of several simultaneous earth faults. The equipment must therefore be able to operate normally in the presence of high levels of interference, particularly from the mains supply. Where there is electric traction, considerable interference must be anticipated from the traction supply, especially under line fault conditions. If there is AC traction, the choice of frequencies which can be employed safely is limited to the bands between successive harmonics of the traction supply frequency in most cases. Because such bands are only wide enough to be useful below about 1 kHz, practical equipment has always operated in the frequency range below this figure. In some cases where there are audio-frequency track circuits, the frequencies which they use also have to be avoided. If there are several vital FDM systems in one cable, or on one overhead line, crosstalk must be minimised. This is achieved by careful allocation of the cores or wires to the various systems, and also by means of a suitable scheme of core transpositions, so that crosstalk voltages in successive sections

Fig. 8:7 FDM remote control system: part of a fail-safe system



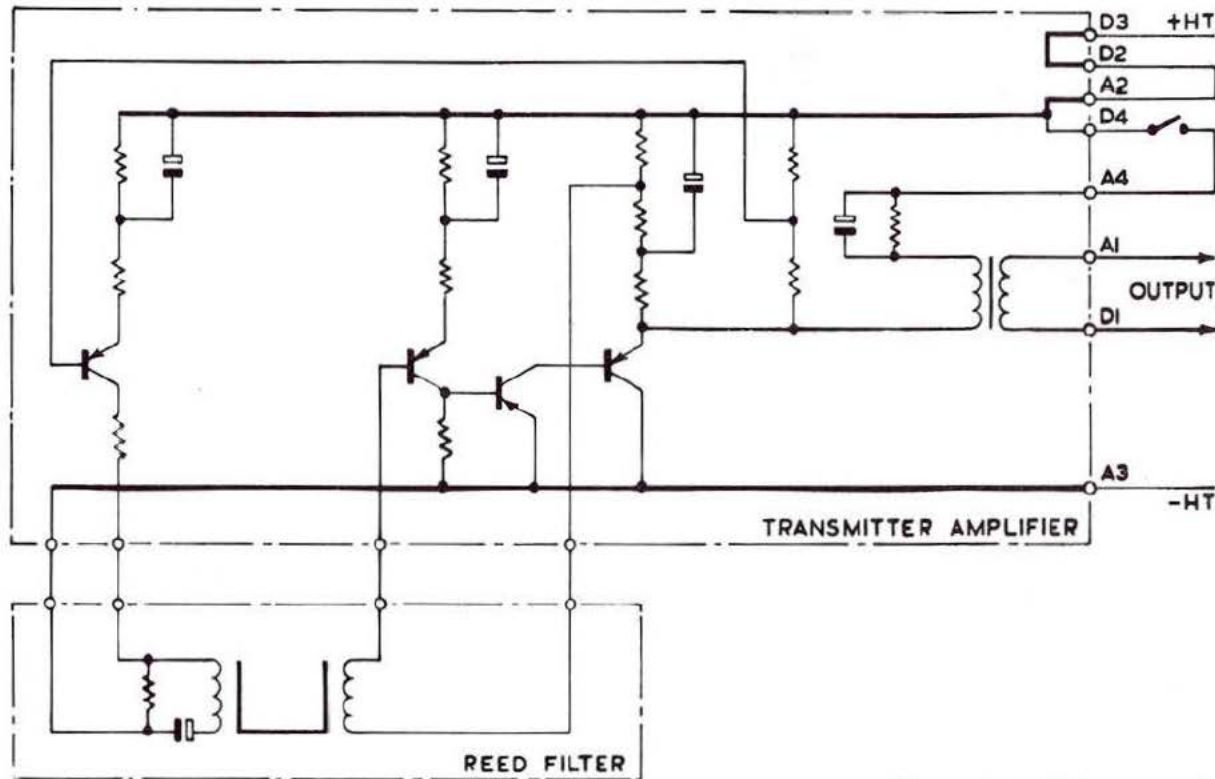


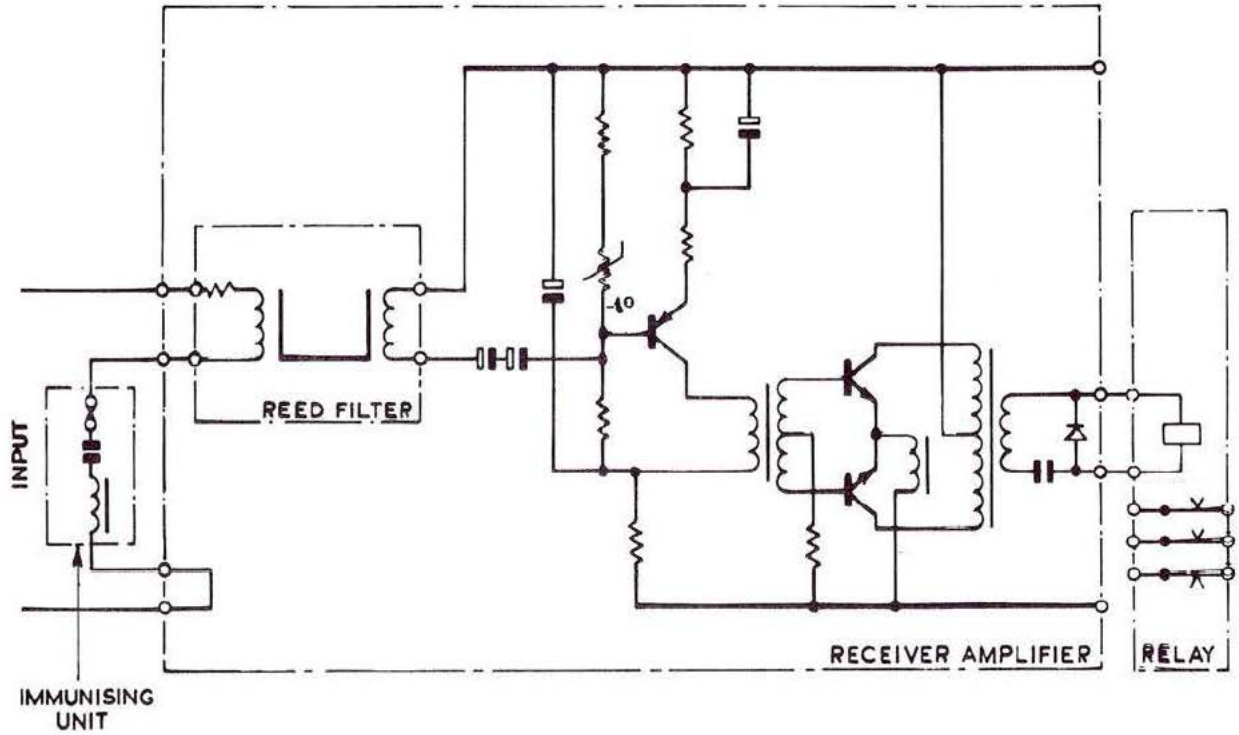
Fig. 8:8 Fail-safe reed transmitter: circuit diagram

of line are opposite in phase, and therefore tend to cancel out, or by the use of twisted line pairs, which give a similar effect.

Within these limitations, it has been found possible to design vital FDM systems which work over line pairs in ordinary signalling cables, and moreover to have several such systems sharing a multicore cable with DC line circuits without adverse effects. A number of such systems are in service at the present time, on electrified as well as non-electrified lines.

In an electrified area a fail-safe reed FDM system on a single line pair uses only up to 16 of the frequencies in the range in current manufacture to ensure freedom from interference from the traction supply system over the possible frequency variation between 48.5 and 50.5 Hz, intermodulation and harmonics. Other systems may be used on other suitable pairs as required, and as all signalling installations require multicore signalling cable and multipair telecommunications cable, the limitation is not as serious as it might at first appear. By introducing additional frequencies not at present in the standard range it would be possible to increase the number of channels in a fail-safe system.

Fig. 8:9 Fail-safe reed receiver: circuit diagram



### **Supervisory Applications of FDM Equipment**

The wide range of types of frequency-division multiplex equipment covers many of the possible applications of remote control on the modern railway. FDM equipment has the advantage of being very flexible in application; as already described, the transmitters and receivers are usually separate units for each channel, and are designed so that they can be connected to the line at any point. Hence FDM equipment is suited to applications in which it is required to control or monitor small groups of functions at each of a number of locations along a route. An example is track circuit indications on stretches of line with automatic signalling, as has already been seen. The interlocking between signals and track circuit is carried out at the lineside, but purely supervisory indications of the states of all track circuits are required at the signalbox for display to the signalman. FDM equipment is commonly used to collect these indications on a single pair of wires, as an alternative to providing a separate pair for every track circuit. The cost of the FDM equipment is offset against the saving in multicore cables which it makes possible; since individual systems may carry fifty or more channels over distances of many kilometres, as already seen, the saving may be considerable.

The essentially unit construction of FDM equipment gives rise to another fundamental advantage, namely ease of maintenance. FDM systems are usually easily understood by maintenance technicians, who may have many different types of complex apparatus in their care in a modern signalling installation, and who may therefore spend only a small proportion of their time with the remote control equipment.

Furthermore, removal for maintenance of a unit pertaining to one channel does not affect the operation of the other channels in the same system, so that, while one channel is being repaired, the others can be used normally, and large-scale disruption of traffic does not result. This does not apply to items of equipment which are common to all the channels in the system such as line

amplifiers—or indeed to the line itself. Such items must therefore be designed for maximum reliability, and the quantity of common equipment must be minimised.

In a typical large signalling installation in an area of dense traffic, a number of local interlockings are linked by supervisory remote control to a central signalbox. FDM systems may be employed in such an installation for bringing indications into the local interlockings as described above; in practice these may include signal indications, signal lamp proving, road-crossing barrier and ground-frame release indications, as well as track circuits. In addition, FDM systems are sometimes used for emergency override control of local interlockings in the event of a failure of the main remote control link. The override system provides the absolute minimum number of functions necessary to keep trains moving through stations and junctions on at least the most important routes during a remote control failure, and can make the difference between delays to traffic and complete stoppage.

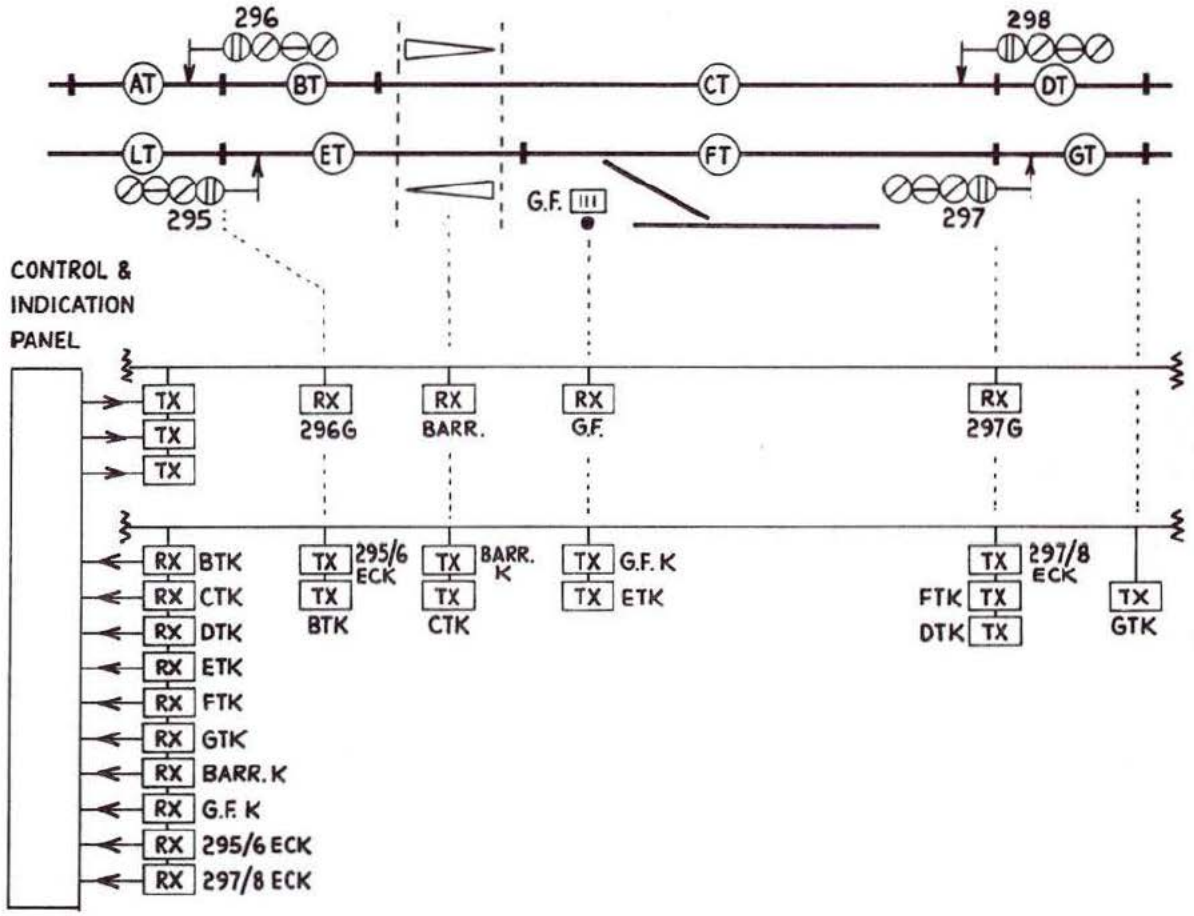
### **Applications of Fail-Safe FDM Equipment**

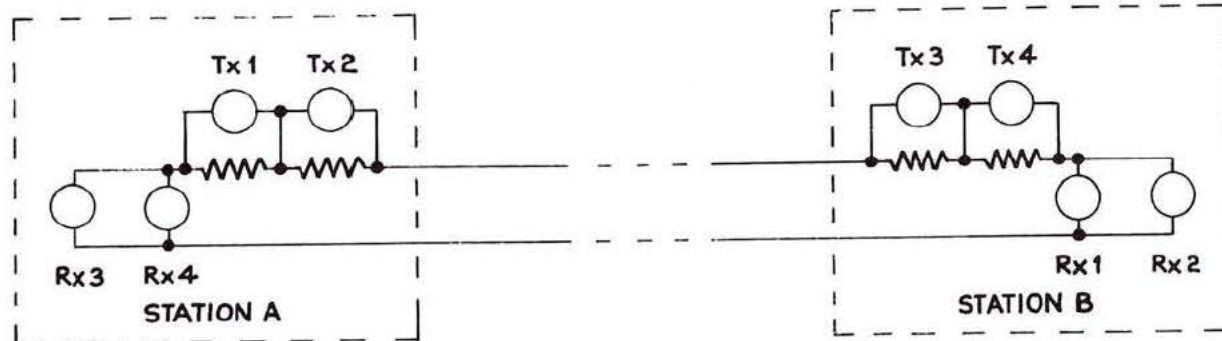
The fail-safe FDM system may often be shown to have economic advantages over local operation. The cost savings need, however, to be carefully balanced since consideration shows that all power signalling installations require lineside multicore signalling cables and telecommunication cables. The saving is not therefore in cables in but in cable cores. Relay rooms may sometimes be eliminated, reduced in size or replaced by apparatus cases.

Furthermore, many signalling installations are projected for electrified areas or for areas where it is prudent to allow for future electrification and the number of channels then available per pair of wires is therefore limited.

Even allowing for these possibilities it may still be economic to avoid local interlockings at some junction and station layouts and operate functions direct from the Control Centre. It is not practicable to generalise and each case must be looked at on its merits.

Fig. 8:10 FDM remote control: part of a non-vital system





**Fig. 8:11** FDM fail-safe system: tokenless block

There are innumerable possibilities for small-scale applications of fail-safe FDM equipment. Wherever several vital functions are transmitted side by side over conventional line circuits for any distance, the possibility exists of carrying them all on one pair of wires by this means, with a consequent reduction in the cable required. The cost of the FDM equipment, which is fixed for a given number of channels, is set against the saving in cable costs, which is proportional to the distance covered; hence, in any particular case, the use of FDM only becomes justifiable economically when the distance is greater than a certain minimum. In practice this is usually of the order of a few kilometres.

A typical practical example is the British Railways tokenless block system for single lines. The standard equipment requires two controls to be sent in each direction, and all four are usually transmitted over a single fail-safe FDM system, arranged as shown in Fig. 8:11.

In remote areas, the fact that only one pair of wires is required,

as opposed to four, can effect a worthwhile saving, especially on long sections. In practice, tokenless block equipment is often installed as a replacement for an older single line block system, and a pair of wires is already available through the section; the use of FDM means that no extra cable has to be provided. Note that this FDM system is duplex in operation; that is, functions are transmitted in both directions on one pair of wires. Larger duplex systems are also possible, and have been used to a certain extent. Provision of intermediate line amplifiers is difficult in duplex systems, so that their range tends to be limited.

Fail-safe FDM systems (or sometimes individual FDM channels) have been used for dual-immune line circuits, that is, where immunity is required to interference from both AC and DC traction supplies. The application is exactly the same as that of 83 $\frac{1}{3}$  Hz line circuits; the FDM equipment being used as a convenient local means of generating and detecting one or more frequencies immune to effects from the various traction supplies.

## TIME-DIVISION MULTIPLEX (TDM)

Whereas there are only a small number of FDM systems suitable for railway signalling applications, there are a considerable number and variety of TDM systems which have been or are in current use for the remote control and indication of remote interlockings.

Before the advent of transistors, systems were constructed of specialised relays arranged to transmit messages of various forms, but always in a 'single-shot' mode. This meant that information was only transmitted when a change of state occurred, which involved forms of 'queuing' when simultaneous changes occurred at different field stations. Even with the use of high-speed relays, transmission speeds were relatively slow, and delays of several seconds could be experienced before a control function was executed at a field or an indication from a field was displayed to the operator.

The introduction of the transistor enabled higher transmission rates to be achieved and with them a corresponding reduction in response time. It also enabled the 'single-shot' mode to be replaced by systems operating in the 'continuous scanning' mode. This mode enabled large quantities of data to be up-dated in a much shorter time, to the extent that nowadays operation over modern TDM systems is almost indistinguishable from the control of a local interlocking.

Whether controlled by relays or electronics, all TDM systems operate on the basic principle of allocating to each function a short time slot within a transmitted message. Each message, besides conveying a certain amount of data, also contained information defining the precise destination of the data, together with means of ensuring the synchronism and security of the message.

Many forms of performing this function in electronics were installed in the early and mid 1960s, but from the latter part of that decade to the present day the majority of systems follow a particular pattern, and it is this pattern with some of the minor variations that will be described.

### Principle of Operation

The basic operation of all modern TDM systems used in railway signalling, divested of various refinements, takes place basically in six stages. Three of these are concerned with taking the input information in parallel form and converting into serial messages suitable for transmission on the bearer circuit. The remaining three stages are essentially the reverse of the first stage and convert the received material message into parallel outputs.

### Input Multiplexing

Input multiplexing is split up into these three stages, the first being the division of the data into groups. These groups are put onto a data highway, and further signals are generated carrying information to identify the particular group of inputs which are on the data highway at a particular time. The second stage of multiplexing is to convert the data groups together with their identifying information from parallel to serial form. At this stage additional information may be added to the serial message to increase the security of the information and to provide a means of synchronising the message at the receiving end. The third stage consists of making the serial message suitable for transmission to line by modulating it on to a carrier signal.

These three stages are shown in block diagrams in Fig. 8:12. The three stages are each now described in detail together with some of the various methods by which each stage is achieved.

### Multiplexing onto Highways

The individual data bits are fed to data input modules in groups, the size of which varies according to the type of system.

## REMOTE CONTROL SYSTEMS

Data bits are linked to the TDM system by one of several means. The most common is by a B50 feed or by short-circuiting the input to the TDM common supply by a voltage-free contact. In some cases inputs are DC isolated from the TDM circuitry by reed relays or by opto-isolators, but in other cases no isolation is provided.

The most common group sizes are in multiples of eight, that is 8, 16 or 32, although some systems use 7, 25 or 55. The size of the group determines the number of lines on the data highway. A data input module may handle more than one group.

Data groups are selected in a sequence for placing onto the data highway by a form of addressing. The sequence of selection is controlled by the timing and address generator module. The output from this module normally takes one of two forms. The first form is an address highway as shown in Fig. 8:12. This highway carries an address code usually in binary coded form. This address code is decoded for each group of data input modules, each group being allocated a different code. For a particular address code only one decoder will be enabled and its corresponding group of inputs put on the data highway. The next address will select the next group of inputs and the address sequence is continued until all inputs have been serviced. The address generator then returns to the beginning and repeats its sequence, thus creating the mode known as continuous scanning.

The second normal method of placing groups of inputs onto the data highway is known as matrixing. The principle is similar to the highway method, except that each input group is selected by

an individual line from the timing and address generator module. This method does not require individual address decoders on the input modules.

Input information is now available to the next stage of multiplexing in the form of a data highway, together with a means of group identification, either as an address or a number of select lines.

### Parallel to Serial Conversion

The second stage of multiplexing consists of taking the groups of input data in parallel form from the data highway and converting them into a serial form suitable for transmission.

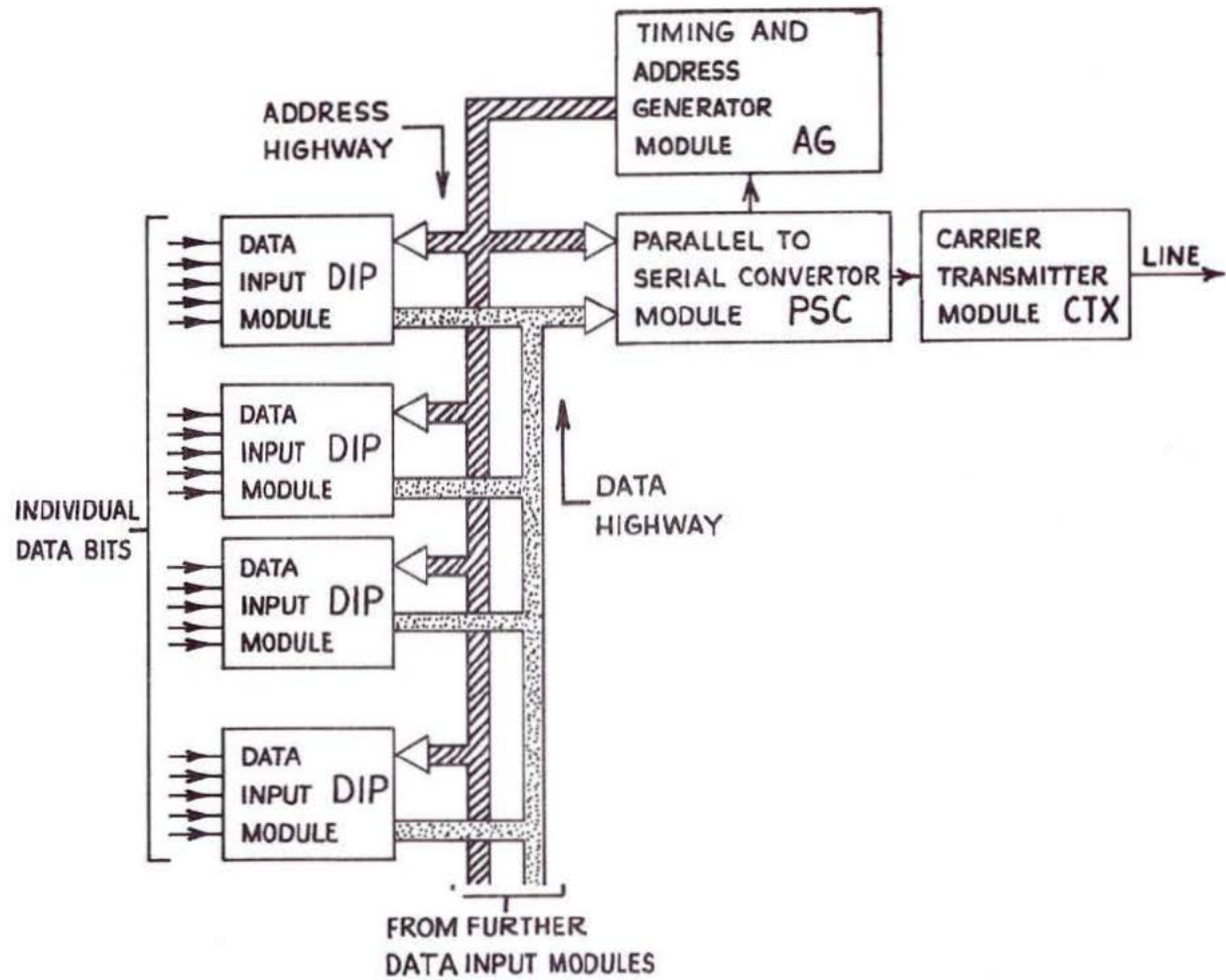
Three methods are in common use for achieving this. There are, firstly, a stepping chain in which a series of bistables are operated in a timed sequence, each step interrogating and transmitting a particular input data bit from the data highway.

The second method involves the use of a parallel-in-serial-out shift register, in which all data on the highway is interrogated at the same time.

The third and most modern method is to use a combination of microcomputer and Universal Synchronous/Asynchronous Receiver/Transmitter (USART) to undertake the conversion function. More versatility for refinements is available by this method, particularly in the field of monitoring and fault diagnosis.

All methods are under the control of the timing module and the precise message format varies according to the type of system.

**Fig. 8:12** TDM system:  
input multiplexing



## REMOTE CONTROL SYSTEMS

### Message Format

The format of the transmitted message falls into two main categories, synchronous and asynchronous. The former is suitable for single and small multi-station systems and is usually used on systems with a fixed maximum capacity. Asynchronous transmission is more suitable for large multi-station systems and those where the used system capacity is adjustable to suit the needs of a particular installation.

Typical message structures are shown in Fig. 8:13. The synchronous message consists of a string of words, each consisting of a number of information bits followed by a single parity bit. In the example shown, three such words indicate the beginning of a scan and these are followed by the number of data groups required for the system. The end of the scan is marked by two scan-stop words, followed immediately by the start of the next scan. Data is identified by the position of the word in which it is contained relative to the scan-start words.

The asynchronous message required that the data within it be positively identified and therefore identification in the form of an address code precedes the data. Security is provided after the data as parity varying from one to five bits according to the system. Beginning and end of scan signals are required to provide a synchronism signal to the receiving equipment.

It will be noted that the synchronous message is inherently more efficient, that is, it has a greater percentage of externally useful data bits compared with the asynchronous message. However, the latter provides greater versatility in a multi-station system, in that synchronism can be achieved at the start of each word, rather than only at the beginning of a complete scan.

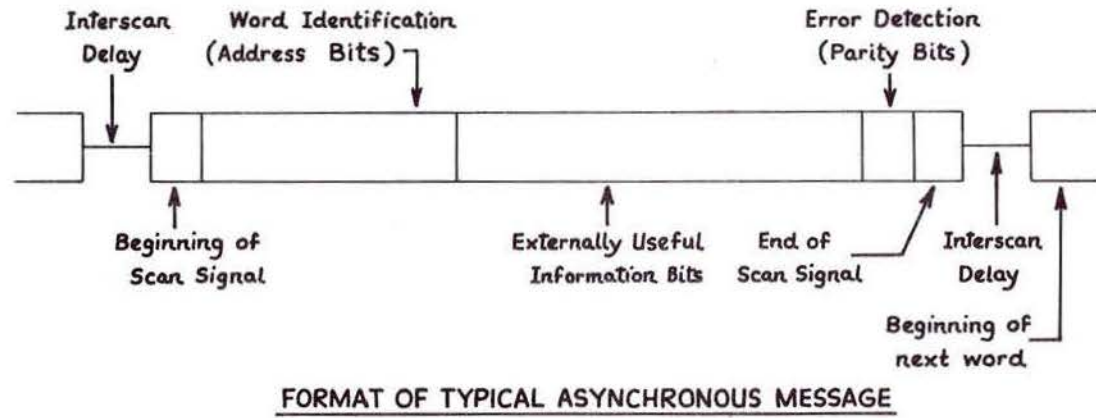
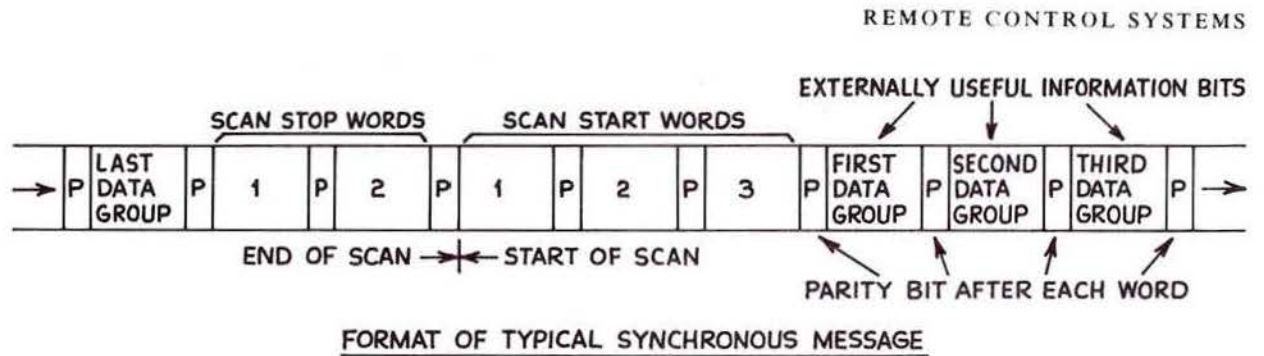
### Modulation onto Carrier

This serial message, whether synchronous or asynchronous, at this stage is still in the form of a DC signal. It is not transmittable in this form since it will be open to corruption by external noise and interference. It is therefore used to modulate a carrier signal as the third stage of multiplexing.

The carrier signal may be either in the VF range or more normally in the range of 6 to 40 kHz. Transmission rates in the VF range are usually 600 or 1200 bauds, but a restriction to VF means that systems must work either in half-duplex mode or on separate pairs for each direction. It is also considered that carrier in the VF range is more susceptible to the type of noise generated in a railway environment and is disfavoured for this reason. It does however, have the advantage that considerable distances can be achieved without amplifiers, especially if the line pairs are loaded. Additionally, operation is possible over derived VF channels such as carrier telephone links or radio.

Carrier within the 6 to 40 kHz band has the advantage that it is less susceptible to external noise, and the disadvantage that amplifiers are needed much closer together in order to extend its range. It is possible, however, to accommodate up to eight separate carrier channels at 4 kHz spacing within this frequency spectrum and thus systems with extremely high capacity and short response times are achievable on one pair of line wires.

**Fig. 8:13** TDM system:  
make-up of transmitted  
messages



REMOTE CONTROL SYSTEMS

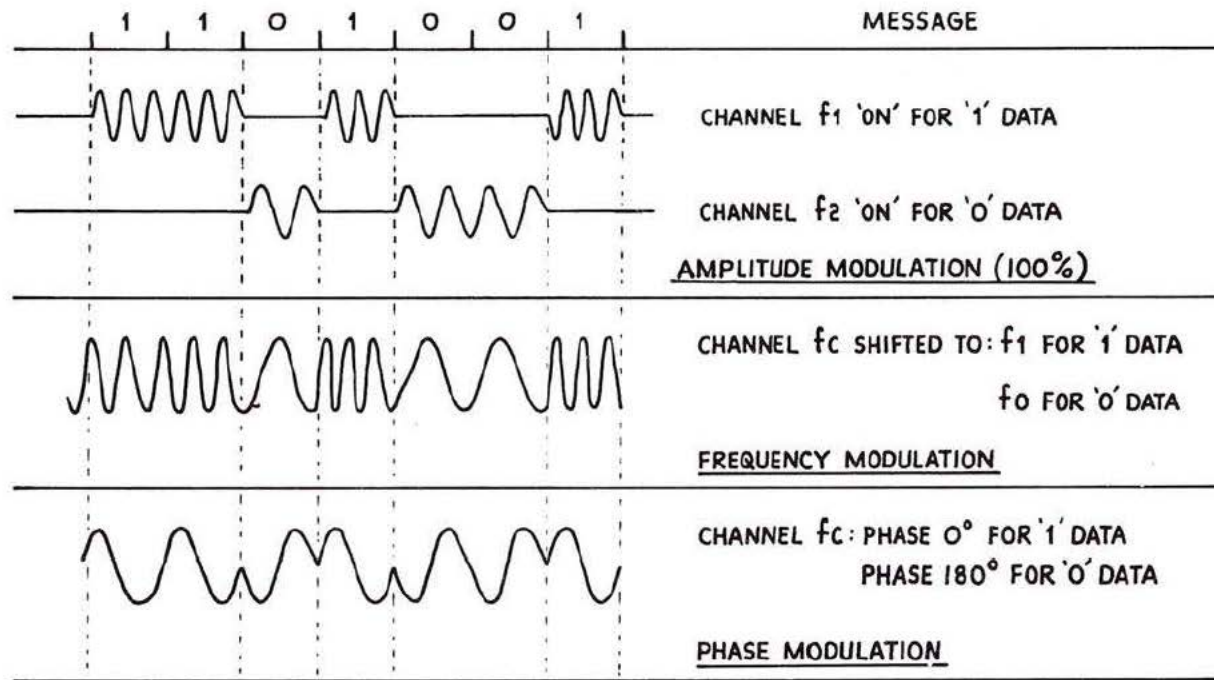


Fig. 8:14 TDM system : binary methods of carrier modulation

The type of modulation varies according to the type of system. Earlier systems used amplitude modulation, but nearly all present day systems use frequency modulation. A few systems now use phase modulation; particularly when VF modems are used.

Many systems still use tertiary modulation, that is, a three-state carrier, but the trend is now towards binary carrier. The three types of binary modulation are shown in Fig. 8:14.

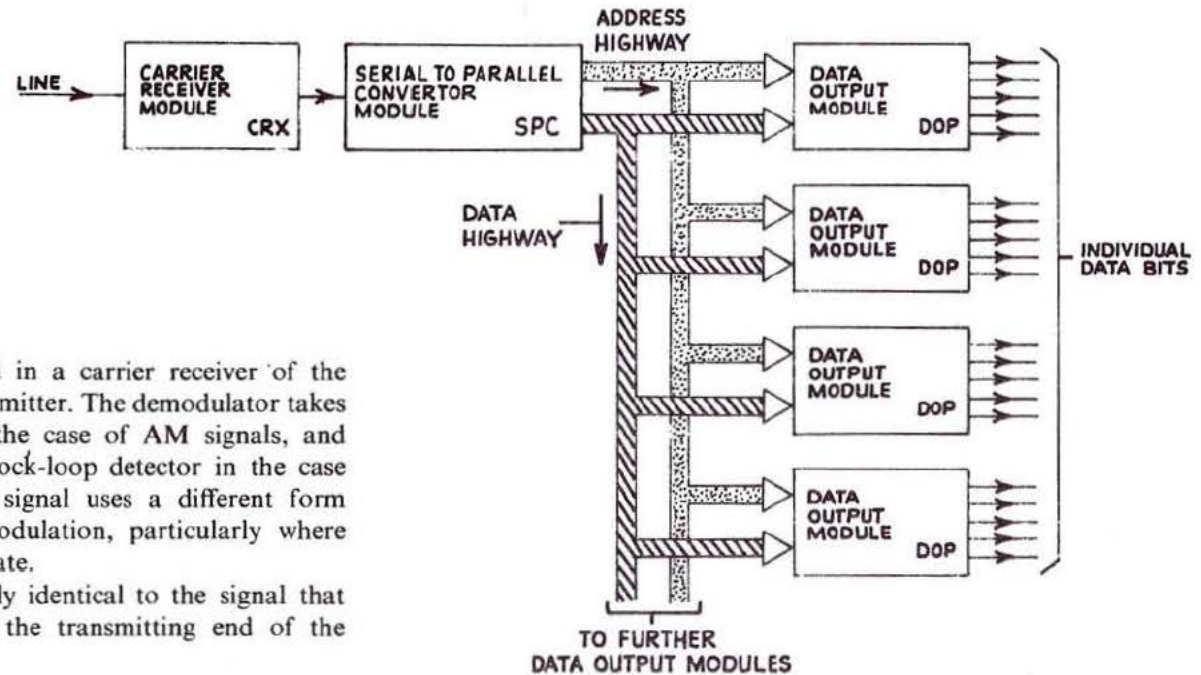
The use of more than one carrier channel on one line pair is

a further stage of multiplexing, similar in some respects to FDM.

**Message Demultiplexing**

The receipt of a carrier-borne message at a field station is subject to similar stages, but in reverse, to those for multiplexing the inputs at the office. A block schematic of this part of the system is shown in Fig. 8:15.

**Fig. 8:15** TDM system:  
output multiplexing



### Carrier Demodulation

The received message is demodulated in a carrier receiver of the same frequency as the originating transmitter. The demodulator takes the form of amplitude detectors in the case of AM signals, and of either a discriminator or a phase-lock-loop detector in the case of FM signals. A phase modulated signal uses a different form of phase-lock-loop detector for demodulation, particularly where the bits per second exceed the baud rate.

The DC signal produced is normally identical to the signal that modulated the carrier transmitter at the transmitting end of the system.

### Serial to Parallel Conversion

The second stage of demodulation is carried out in the serial to parallel converter module. In this module the synchronism of the received message is checked and re-established if necessary. The parity bit or bits for each word are checked and if found to be incorrect the complete word is rejected.

The method of conversion uses similar hardware to that at the transmitting end, but with the sense of the logic reversed. The output of the converter consists of a data highway of the same size as that at the transmitting end, together with a similar means of data group identification. This identification will be either on address highway or a number of select lines.

### Demultiplexing from Highways

The output data highway, together with the address highway or select lines are applied to a number of data output modules. If an address highway is used each module will contain an address decoder for the particular groups of data. If select lines are used the output takes the form of a matrix.

In both cases the data received is stored in bistables or latches on the data output module and the processes of demultiplexing are then complete.

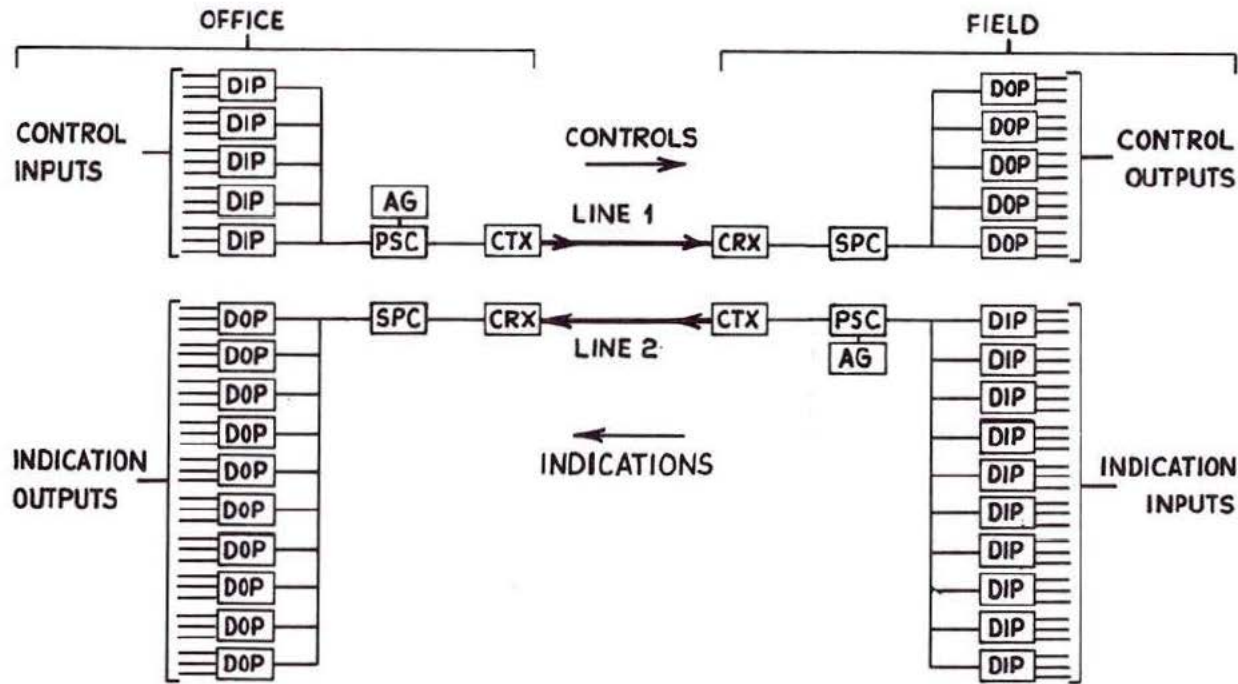


Fig. 8:16 TDM system : high density traffic scheme (uni-directional)

The data output from these modules takes one or more of several forms. Earlier forms use an output relay which provides DC isolation from the external circuits, and opto-isolation is provided in some forms of electronic output for the same purpose. Other forms of electronic output do not have such isolation.

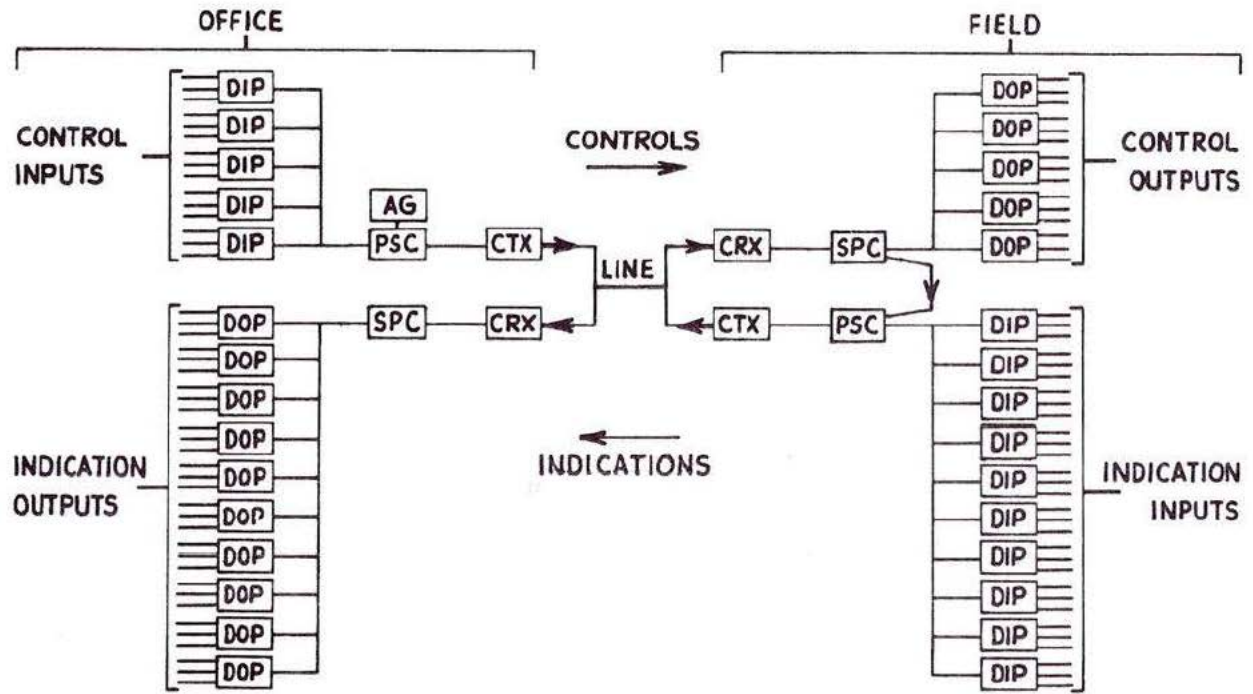
Electronic outputs take the form of an open collector transistor which switches the load to the N50 supply. Suitable protection against the back emf of the driven relay is provided. An alternative type of output is a triac which is capable of directly driving an AC load such as indicator lamps on an illuminated diagram.

**Uni-Directional Systems (Fig. 8:16)**

The system formed by the principles just described is a uni-directional link which will operate equally well for both controls and indications. Two separate and identical systems except in their capacity may serve as a complete system for high traffic density schemes. Failure of either system will not affect the other and thus the effects of a system failure are kept to a minimum.

Such arrangements of TDM systems are used widely throughout British Railways in areas of dense traffic and places of strategic importance.

**Fig. 8:17** TDM system :  
high density single station  
traffic scheme  
(bi-directional)



**Bi-Directional Single Station Systems**

Where traffic conditions are less onerous but the effects of a system failure are still required to be kept to a reasonable minimum, bi-directional single station systems may be used. The control direction of a bi-direction system operates in the manner previously described, but the indication direction differs in some aspects.

The transmission of indications from the field is controlled, not from the timing and address generation module as at the office, but from the controls reception. The address highway or select lines, together with timing from the controls reception serial-to-parallel

converter are used to select the appropriate group of indication inputs and place it on the indication data highway. Thereafter this operation is identical to control transmission from the office. If the carrier system is VF then the system will operate in full or half duplex. If carrier channels in the 6 to 40 kHz range are used it will be normal to use different channels for controls and indications and these may operate in full duplex mode. Reception of indications at the office works identically to reception of controls at the field. A block diagram of a single station bi-directional system is shown in Fig. 8:17.

### Bi-Directional Multi-Station Systems

In a multi-station system, the office control transmission circuits are similar and often identical to those for a single station system.

In the example shown in Fig. 8:18, the data input modules are grouped according to the field station they are to serve. In the example, one group of controls is required for field A at which there is one equivalent data output module. For field B two groups are required and for field C again one group is required.

A field recognises which groups of controls are destined for it by one of two methods according to the type of transmission protocol. If synchronous transmission is employed, the data groups are identified by their position in the overall message. With synchronous transmission, a data group is identified by the address code which precedes an individual word with the total message structure.

In the example, the number of indication groups to be transmitted from a field station is two to three times the number of control groups. This is a normal ratio for the majority of railway signalling applications. Hence field A is required to transmit three groups, field B five groups and field C two groups. Under the continuous scanning arrangement each field is required to transmit in groups of indications in sequence and when called to do so.

Under synchronous transmission protocol, field A would transmit its indications as the first three data groups within the message. It would receive instruction to do so from the controls reception serial-to-parallel converter at the appropriate time. Field B would then receive similar instructions to transmit its indications as data groups 4 to 8 in the overall message. Similarly field C would be instructed to use data groups 9 and 10.

In asynchronous systems, each field station would be informed when to transmit its indications by the address code at the beginning of each word. Field A would thus respond to addresses 1, 2 and 3; field B to addresses 4 to 8, and field C to addresses 9 and 10. The instruction to transmit would be derived from the controls reception address highway, which is extended to serve as the indication

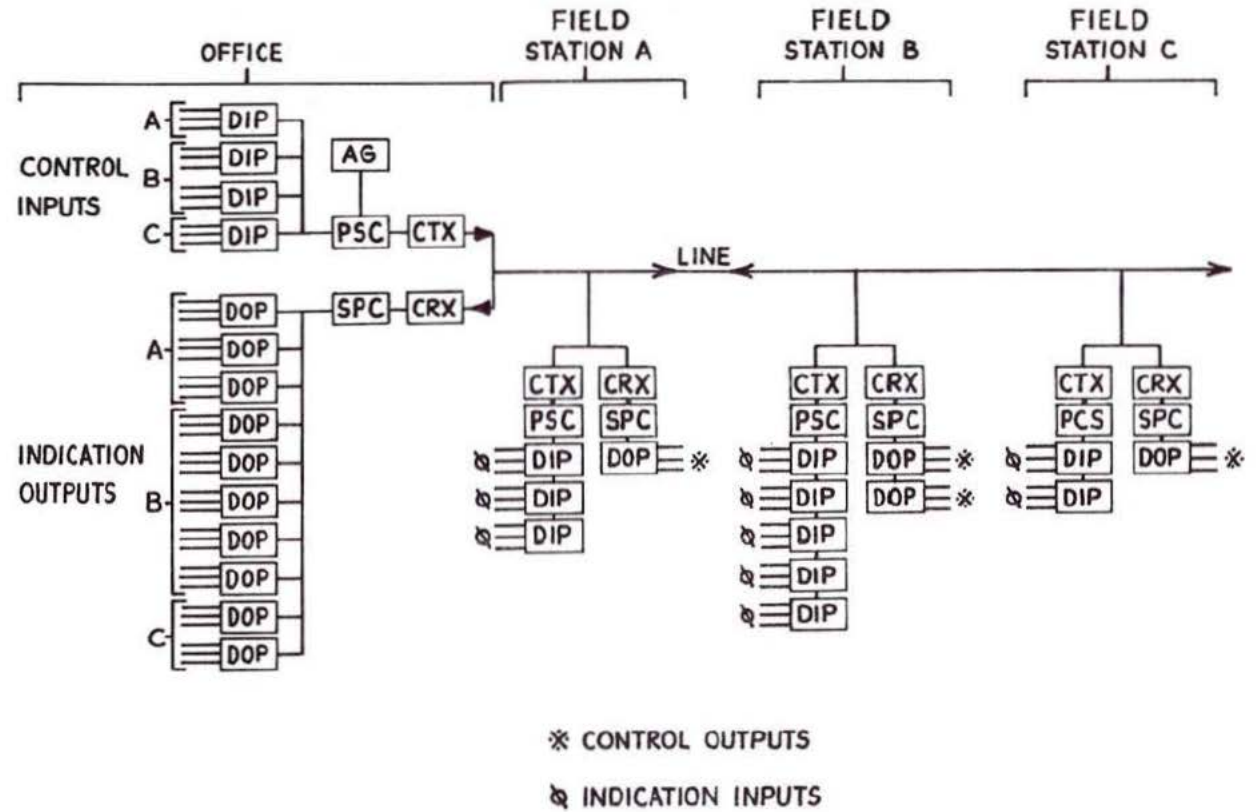
transmission address highway as well.

In either case, it is essential that the carrier transmitter at a particular field only transmits when called upon to do so, and transmits nothing, not even unmodulated carrier, to line whilst another field is transmitting. Logic to control this is derived from the group identification, together with signals from the parallel-to-serial converter. If transmitters from two or more fields were to transmit at the same time, the carrier signal received at the office would be corrupt, and the receipt of indications rejected.

It will be noted that, whereas provision must be made for the receipt of ten groups of indication data, only four groups of control data are required to be transmitted. The quantity of indication groups therefore dictates the overall length of the message, either ten data groups within a synchronous message, or ten addressed words within an asynchronous system. In order to call in the required number of indication groups, the control transmission message from the office must also cater for ten data groups, although only four are actually required for the transmission of control data. The remaining six groups would then not contain data, but would transmit a series of 'O' bits in each unwanted group. The four control data groups may be allocated to the first four available groups in the message. Alternatively it is more normal to allocate the control groups to coincide with the groups allocated for each field for indication purposes. Thus controls for field A would be allocated to group or address 1; for field B groups or addresses 4 and 5, and for field C group or address 9. Flexibility of groups or address allocation is usually available to best suit the needs of a particular installation.

Since the ratio of the number of indications to controls almost always lies between two or three to one, a reduction in overall scan time may be achieved by using two or three carrier channels for indications to each control carrier channel. This may be achieved in the VF range by the use of additional line pairs or derived channels. In the 6-40kHz range additional frequency channels on the same line pair may be used to achieve the same result. Failure of one field will not affect the operation of other fields, and a

**Fig. 8:18** TDM system:  
low density multi-station  
traffic scheme  
(bi-directional)



## REMOTE CONTROL SYSTEMS

field may be taken off line without upsetting the functioning of the remainder of the system.

### Immediate Access

Under normal continuous scanning operation a control function is taken into the system only when the appropriate data group is being interrogated. If the overall scan time is not extremely short, the effect will be that panel circuit controllers which are directly connected to the TDM system, will have to be pushed or pulled for a time long enough to ensure transmission. If this time is too long, control panel operation can be uncomfortable.

To overcome this, the majority of modern systems are provided with an 'immediate access' facility. This has the effect of causing transmission of the state of a circuit controller during the normal time that it is pushed or pulled. Operation then appears similar to control of a local interlocking.

To achieve immediate access, a system modifies its normal scanning pattern, in one of two normal methods. Upon receipt of the detection of the change of state of a control input, the normal scanning action is interrupted and, under the protection of the appropriate protocol, the data group containing the required input is sent in place of the normal group. If further changes of state of inputs have occurred involving other data groups, these groups are also sent under immediate access protocol. On completion of transmission of immediate access data sequences, the system reverts to normal scanning in one of two ways, according to the type of system.

The first method is to continue the scan from the point at which it was interrupted. This ensures that functions not affected by the immediate access interruption are serviced as soon as possible. Thus if the scan was in the process of transmitting group or address 7 when a change of state occurred in group 2, the scanning sequence of data groups would be 7, 2, 8, 9, etc.

The second method is to continue the scan from the last group or address that was transmitted under immediate access conditions.

Thus, under the same conditions as given as an example in the first method the scanning sequence would be 7, 2, 3, 4, etc. This method has advantages in multi-station operation of reducing the overall response time of system, that is, the time from the initiation of a control to the display of a resulting indication.

Immediate access cannot normally be applied to indications. Only in the case of independent simplex systems can changes of state of indications be transmitted under immediate access mode.

### Alarms and Monitoring

In all systems, the scanning action is continuously monitored and is alarmed upon failure. These alarms consist primarily of the following functions.

- Scan failure
- Synchronism failure
- Parity check error

Such failures constitute partial or total system failures and can be either intermittent or continuous in their nature. Corruption due to external electrical noise or mutilation of the transmitted carrier signal can cause such intermittent failures, usually lasting a short time, and which are generally corrected during the next scan. Continuous failures are caused by component failures, bad connections, loss of power supply, line circuit failures, etc.

In many systems, such failures are indicated to a technician observing the equipment as they occur. However, an alarm is not given to the control panel operator until it is reasonably certain that the failure is continuous. This is achieved by delaying the alarm until the time for at least three full scans has elapsed, such that intermittent failures caused by external influences are not brought to the operator's attention.

With independent single station control and indication systems, separate alarms are given to the operator for each system.

Individual bit failure cannot be alarmed economically and means

of monitoring only is normally provided. This may take the form of light-emitting diodes fitted to the actual data input and output modules, or by monitoring test units fitted in parallel with the inputs and outputs. In systems using microcomputers, bit monitoring may be achieved by interrogation of the microcomputer memory.

The failure to handle groups of data may be alarmed. The interrogation of inputs and the delivery to store of outputs may be added to the system alarms to give the operator alarm.

With multi-station systems, alarms are given to the operator for each field station in the system. These are derived from the individual system alarms and the appropriate data groups handling alarms for the fields concerned.

### **Line Circuits and Line Amplifiers**

On British Railways virtually all TDM systems operate over pairs in a telecommunication cable. These pairs would be loaded for VF operation and unloaded when using the 6–40 kHz band.

The normal maximum transmission level to line is 0 dBm, although some systems are higher or lower than this. Most systems operate reliably down to  $-30$  or  $-35$  dBm, below which the signal to noise ratio may be insufficient for satisfactory operation.

If the line attenuation at the operating frequencies is more than can be tolerated, line amplifiers are installed at suitable intervals to boost the carrier signals up to the normal maximum level.

## Train Description

When block instrument working is in force between two signalboxes, a train is described by bell codes, initiated by the signalman in rear and acknowledged by the signalman ahead. This exchange takes place before the train is accepted. The description of the train is not comprehensive and where a diverging junction exists, the signalman must route trains in accordance with the timetable and/or special bell codes which define the route. In addition, all movements of trains between signalboxes are recorded in train registers by each signalman with the times at which the train was accepted and cleared out of the section. The train register is thus a constant reminder to the signalman of the state of the line and provides a record for future study or for vital information in the event of an accident.

In the larger areas covered by multiple-aspect signalling, where traffic is generally denser, the signalman may have many trains under his control and would have to rely either on his memory for the description of each train, or constantly refer to the train register, which would be time-consuming and impractical. He therefore needs a visual reminder, or train describer.

All train describers, of whatever form, effect the basic purpose illustrated in Fig. 9:1, that is, to provide the signalmen with the best possible information about the type and destination of trains, the location of trains and train movements. As the extent and complexity of signalboxes and the size of the controlled areas increased, the requirements from a system capable of aiding signalmen in regulating and controlling traffic increased correspondingly.

Although train describers are not concerned with the control of traffic in the signalling sense—and therefore do not affect safety—they are indispensable in any large Control Centre.

### Early Forms of Train Describer

One of the earliest forms of train describer was the clock-face type Walker instrument, in which a rotating arrow pointed to a descriptive label as determined by a similar (transmitter) instrument at the sending end. This type did no more than replace the bell codes with a visual reminder; it had no storage and could therefore only deal with one train. It originated on the old South Eastern Railway where it was used in the London Bridge area in conjunction with semaphore signalling.

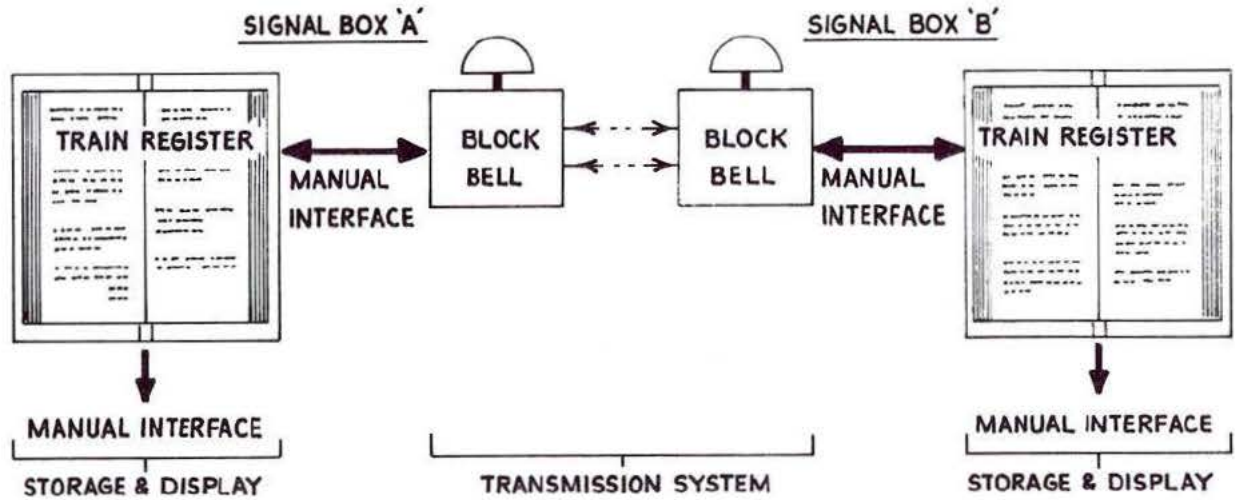
The limitations of the Walker type led to the development of the magazine type, the receiver of which has storage for six approaching trains and displayed the first three in the order received. Fig. 9:2 shows a transmitter and receiver unit for this type of describer. By using a double-width unit the transmitter may be extended to provide up to 24 codes and the receiver may have additional stores displayed or not displayed (blind), to cater for more than three approaching trains.

Operation of the relevant transmit button transmits the description in the form of a series of DC pulses, to the first available store in the receiver at the forward signalbox.

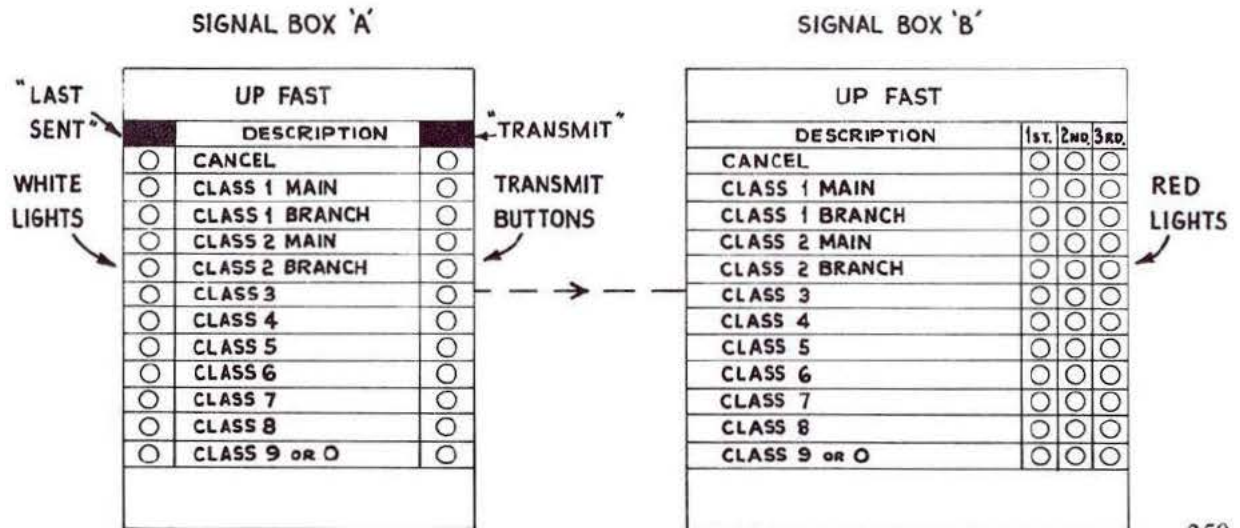
The receiver storage equipment comprises storage facilities to provide for the maximum number of trains which could be in the section between the two signalboxes. The incoming description, in pulsed code form, is decoded before being held in the first unoccupied store and routed to the correct approach display, i.e. 'first approaching', 'second approaching', etc. When the first train passes the signalbox or a specified clear-out point, the 'first approaching' display is cleared and the second, third, etc. displays move up. Thus, the 'second approaching' moves up to become the 'first approaching' display and so on, the last display being updated from the store, as shown in Fig. 9:3.

Other facilities include automatic re-transmission to the next signalbox and a 'last train sent' display recording the last transmitted train description.

**Fig. 9:1** Train description by block bell



**Fig. 9:2** Magazine train describer



## TRAIN DESCRIPTION

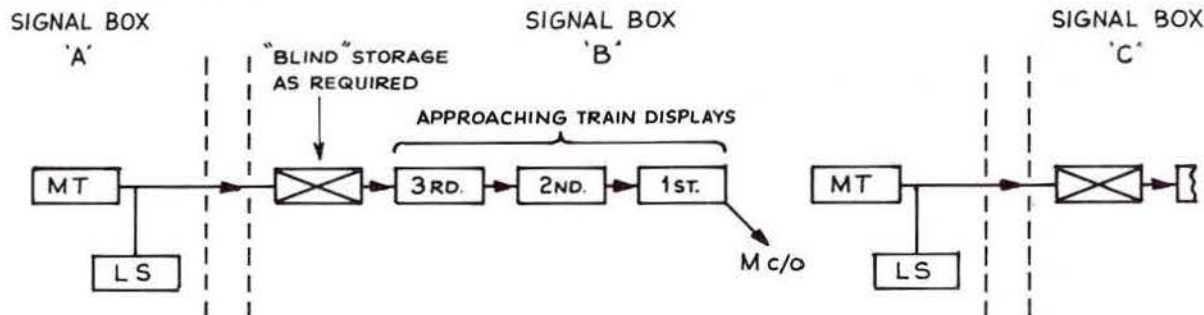


Fig. 9:3 Magazine train describer: displayed and 'blind' storage

### BERTH-TO-BERTH STEPPING TRAIN DESCRIBER

The early train describers recorded only incoming and outgoing descriptions so that between clearing out the 'approaching train' description and re-transmitting it to the signalbox ahead, reliance had to be placed on the signalman's memory, with reference to the train register if in doubt.

When the interlocking units included only a few signal sections—say about six—little difficulty was experienced, but as the area of control increased, reliance on the signalman's memory of the descriptions of three or more trains on each line made his control become impractical. A train describer which showed the descriptions of the trains at each signal berth therefore became necessary.

Up to this point, descriptions had been in words as shown in Fig. 9:2, which was clearly impracticable for a berth-to-berth train describer and it became necessary to evolve a code for each train description.

Originally, the proposal was for a 4-digit numerical code which would have allowed for 10000 unique codes, but after discussion with the traffic operators, an alpha-numerical code was adopted as follows.

- First character      Number or asterisk to represent the train classification.
- Second character    Letter representing the destination code.
- Third and fourth characters    Numbers representing the individual train number in the day's timetable.

	2	A	56
Example:—	Train	Destination	Working
	Class	Code	Timetable
	Code	Code	Reference

The adoption of a 4-character code enabled the train description to be displayed on the signalling control panel within the train berth on the diagram in characters large enough to be visible not only to the signalman (now called a panel operator) but also to the regulators and controllers seated behind him.

Fig. 9:4 shows typical train description displays on the standard British Railways type of signalling control panel.

The requirements of a berth-to-berth train describer may be summarised as follows. It should:



### Operation of the Berth Train Describer

After an initial development period of several years, commencing in the 1950s, during which electro-mechanical display and storage systems were at first used, the design turned to electronics and ultimately computer-controlled systems emerged which are now used by British Railways for all but the smallest installations.

With some exceptions when it is automatic, the full train description is inserted into the train describer manually at the point where the train first enters an area fitted with train describer equipment or at the point where a train commences its journey, for example a bay platform. Once the train description has been inserted into the train describer it proceeds through the displays in step with the passage of the train. Stepping is initiated by logic signals derived from the signalling system. When the description arrives in the last berth shown on the display panel for a particular track, or earlier if necessary, the transmitter is triggered and a code, representing the stored description, is automatically transmitted to the next signalbox. When the train passes the last signal in the control area the description steps to the 'last sent' indication.

When the description has been inserted into the train describer, it is stored electronically. With one electronic system the description is stored at any convenient place in the store, but is prefixed by an address which represents the number of the signal berth associated with a particular store. Another electronic system employs unique stores for each berth. When the train moves from the initial signal berth its change of location is detected by the signal controls, point detection, and track circuits. This information is sent to the train describer and causes the description to step into the berth relevant to the signal which the train is approaching. Thus the description displayed to the signalman moves along the illuminated track diagram in correspondence with the track circuit occupancy.

When the train passes the last signal in the control area or a signal initiating an early transmission, the description steps from the last signal berth into a store associated with the transmitter

for the track concerned, the purpose of which is to hold the description until it can be prepared for the particular transmission method used. The information, transferred to the transmitter in parallel form, is subsequently serialised and transmitted, as a chain of DC pulses, or other form, to the receiver for decoding. If the received information is correct a check back is sent to the transmitter, causing the description to step into the 'last sent' display.

When the train description arrives at the train describer at the receiving Control Centre a short warning is given and the description is displayed at the first berth on the line from the transmitting signalbox.

An early transmission takes place where a junction or station exists close to the limits of the next signalbox ahead; the step into the transmitter berth being initiated before the train passes the last signal. This facility provides the signalman at the forward signalbox with sufficient warning of the approach of a train before it passes the last signal of the signalbox in rear, to enable him to set the route and ensure clear signals, where possible, for the train. The point at which early transmission stepping into the transmitter takes place is determined by knowledge of local operating conditions. The step takes place in parallel with the normal step. However, it is undesirable for a train description to be transmitted to a signalbox for a train which will not proceed to that box. To ensure that the description entering the transmission berth is for a train which will proceed to the next signalbox, the step must only take place if the route between the train and the next signalbox is set. Equipment must also be provided to initiate an automatic cancel of the last train description sent if the route is changed. By way of explanation, early transmission can be implemented two or three signals back into the rear signalbox territory—if all the intervening signals are at 'proceed'. If the signal controls are not at 'proceed', the transmission point will be delayed until they are, and the transmission of the train describer information may, in that event, not take place until the last signal in the rear signalbox area has been passed by the train.

### General Design Considerations

The first stage in the design of a berth-to-berth train describer is a formulation of policy regarding the lines to be equipped with a train describer system. Superficially it would appear that all lines should be equipped. Such a general solution, however, is impractical since some lines used only by freight trains are worked on the 'permissive' block system which allows more than one train to be in a signal section. Consequently, full coverage of such lines is virtually impossible. The extension of train describers into sidings and shunting areas is also an indeterminable factor and, in general terms, decisions particular to each signalbox scheme are necessary.

Once the parameters and limits have been established, a block schematic for the train describer may be constructed. This is a diagram showing the berths to be provided, the connections between the berths, the transmission and reception systems and any other facilities required. It has roughly the same relationship to the train describer as the signalling plan has to the signalling. The symbols and abbreviations used in train describer systems occasionally differ from those contained in BS 376 for various functions. These differences are detailed in Fig. 9:5.

The construction of a block schematic is carried out as follows:

- (a) The extent of the system is determined and the signal berths to be included are defined.
- (b) The berth is shown on the block schematic either as displayed or non-displayed berth storage or combination of displayed stores.
- (c) The berth stores are labelled with the addresses of the berths (usually the signal number shown on the signalling plan).
- (d) The stepping pattern for each berth is indicated. In implementing this the berth stores are connected to each other by path lines signifying the possible movements of trains between the berths. The lines are arrowed to show the direction of movement. A single line denotes a step controlled by the signalling

conditions, whereas a double line denotes a step controlled solely by the train describer.

- (e) Transmission and reception facilities are determined.
- (f) The number of berths (displayed and non-displayed) and paths of stepping at fringe signalboxes are shown.
- (g) Berths requiring additional store and display facilities for items such as banking engines are shown.
- (h) Berths stepping into various parallel transmission berths (early transmission) are shown.
- (i) Additional facilities to be provided on signal berths, such as automatic clear out, automatic print out of information and so on, are added.

A typical block schematic is shown in Fig. 9:6.

### The Stepping Table

After the block schematic has been completed, the stepping tables are prepared. These tables list the signalling functions which initiate the stepping of the train code from one berth to another and also the method by which it is ultimately cleared out.

In general, a train code is stepped from one berth to another as the train passes the signal to which the first berth applies. It is usual for the train code to step ahead on the occupation of the first track circuit ahead of the signal provided the route has been set. It is not usual to require the signal itself to be clear because, economically, it is desirable to minimise the use of signalling functions in the train describer. For an incorrect step to occur, it would require the track circuit to fail after the route had been set, which is considered to be a fair risk to take. It would soon be apparent to the panel operator that the train had not passed the signal, and he has the facility of restoring the correct description by cancelling and interposing.

TRAIN DESCRIPTION

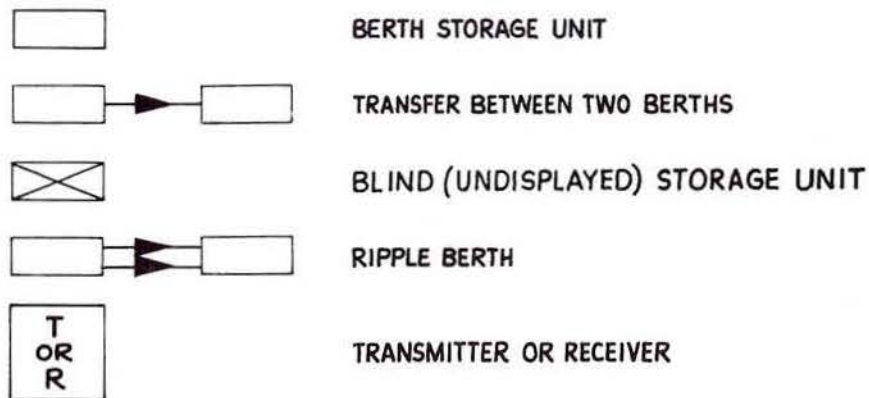
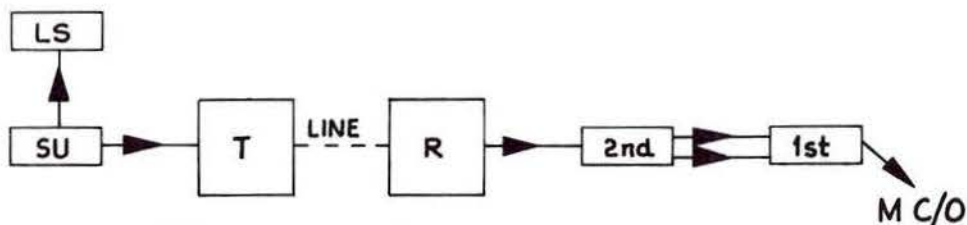
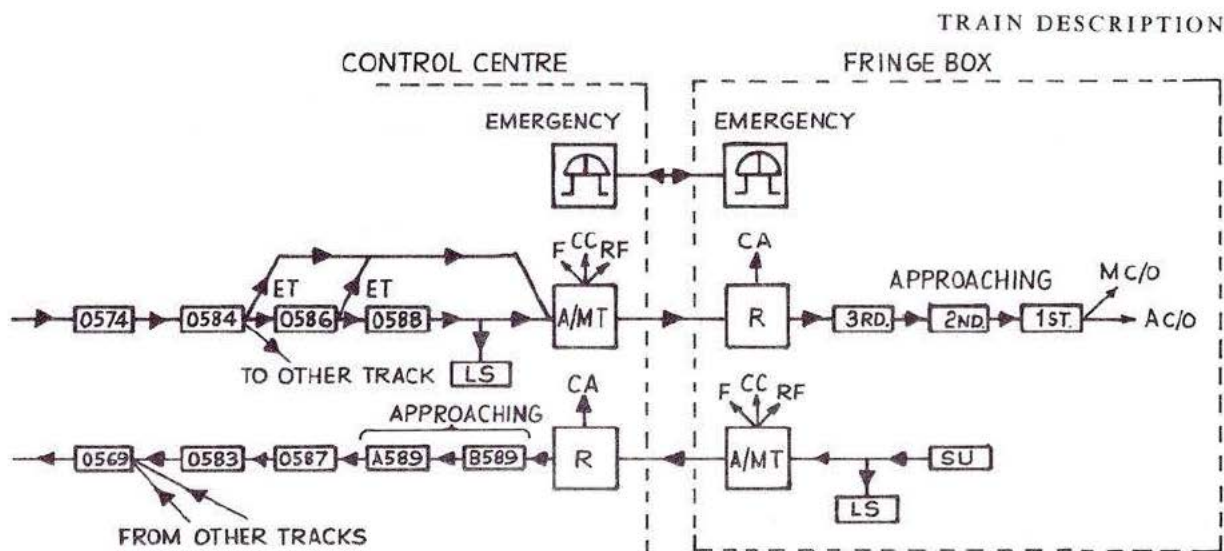


Fig. 9:5 Symbols and abbreviations used in train describer systems

LAST SENT (LS), SET UP (SU), MANUAL CLEAR-OUT (M C/O), AUTO CLEAR-OUT (A C/O).



**Fig. 9:6** Typical block schematic



- C/O..... CLEAR OUT
- ET..... EARLY TRANSMISSION
- ..... DIRECTION OF STEPPING
- LS..... LAST SENT
- SU..... SET UP
- CC..... CO-OPERATIVE CANCEL
- CA..... CANCEL ACKNOWLEDGE
- RF..... RECEIVER FULL
- F..... FAULT

TRAIN DESCRIPTION

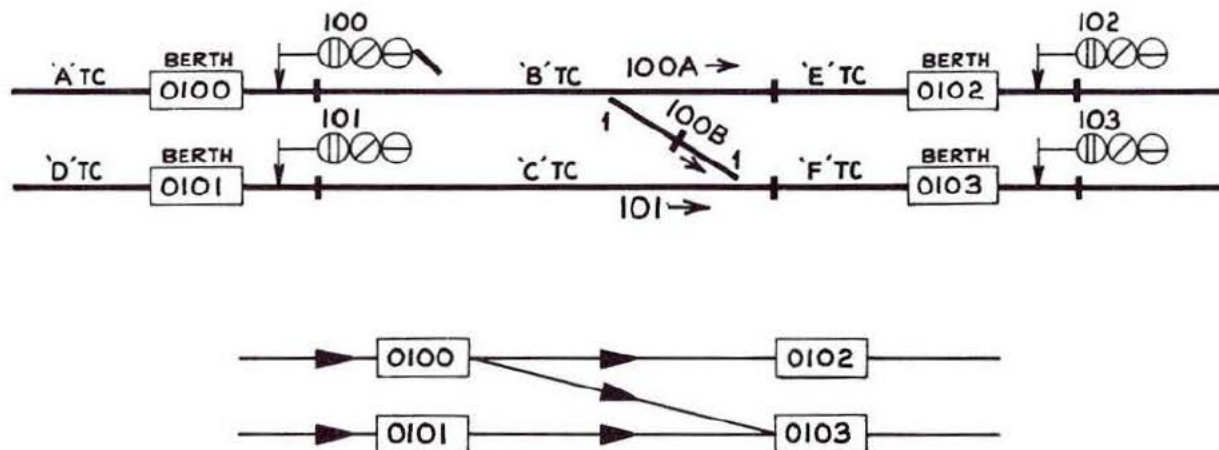


Fig. 9:7 Stepping table: example 1

STEPPING TABLE				
FROM ADDRESS	TO ADDRESS	STEP CONTROLS		
		TRACK CIRCUIT	ROUTE SET	SIGNAL OFF
0100	0102	'B' OCC.	100A	
0100	0103	'B' OCC.	100B	
0101	0103	'C' OCC.	101	

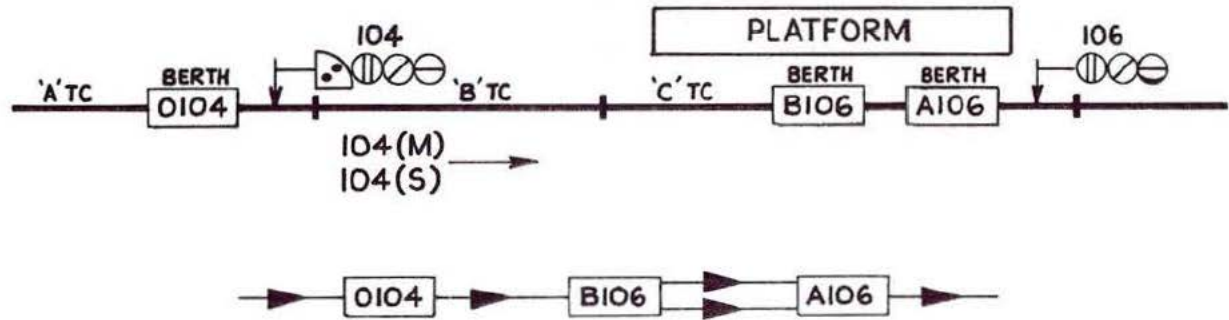
An exception arises when more than one train berth exists between two signals or several trains may be shown to be approaching a Control Centre or fringe box. In such cases, the train code may 'ripple' from one berth to another automatically.

The following examples illustrate the basic rules for the preparation of stepping tables.

Example 1 (Fig. 9:7)

This is a simple example including stepping from one line to another.

Fig. 9:8 Stepping table:  
example 2



Example 2 (Fig. 9:8)

This is an example of a platform entry signal with a draw-ahead subsidiary signal.

If the platform is clear, the occupation of track circuit 'B' steps the train code from berth 0104 to berth B106, from which it immediately 'ripples' to berth A106.

If the platform is occupied, a train code will be present in berth A106. In consequence, when the second train passes subsidiary signal 104, its code is stepped to berth B106 where it remains displayed.

When the train standing at signal 106 moves off, its code will step ahead into the next section. When that happens the second train code in berth B106 will 'ripple' into A106.

STEPPING TABLE				
FROM ADDRESS	TO ADDRESS	STEP CONTROLS		
		TRACK CIRCUIT	ROUTE	SIGNAL OFF
0104	B106	'B' OCC.	104(M) OR 104(S)	
B106	A106	WHEN A106 BERTH CLEAR		

TRAIN DESCRIPTION

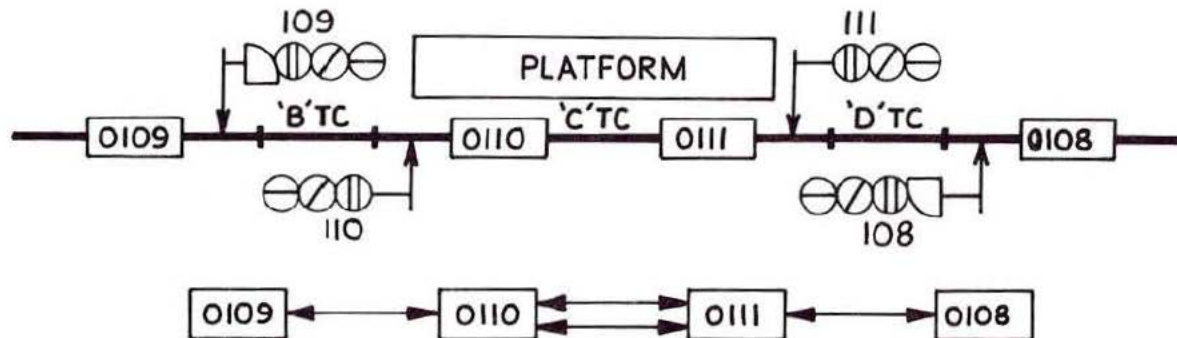


Fig. 9:9 Stepping table: example 3

STEPPING TABLE				
FROM ADDRESS	TO ADDRESS	STEP CONTROLS		
		TRACK CIRCUIT	ROUTE	SIGNAL 'OFF'
0109	0110	'B' OCC.	109(M) OR 109(S)	
0110	0111	(BERTH 0110 BUSY AND BERTH 0111 CLEAR) AND (ROUTE 109(M) SET OR SIGNAL 111 'OFF')		
0108	0111	'D' OCC.	108(M) OR 108(S)	
0111	0110	(BERTH 0111 BUSY AND BERTH 0110 CLEAR) AND (ROUTE 108(M) SET OR SIGNAL 110 'OFF')		

Note: The above controls assume that trains can neither enter nor leave the platform.

Example 3 (Fig. 9:9)

This is an example of a both-way platform with a starting signal at each end. Assuming that there are no trains in the platform and berths 0110 and 0111 are both clear: assume then that a route from signal 109 has been set to the platform. On the occupation of track circuit 'B', the train code will step from berth 0109 to 0110.

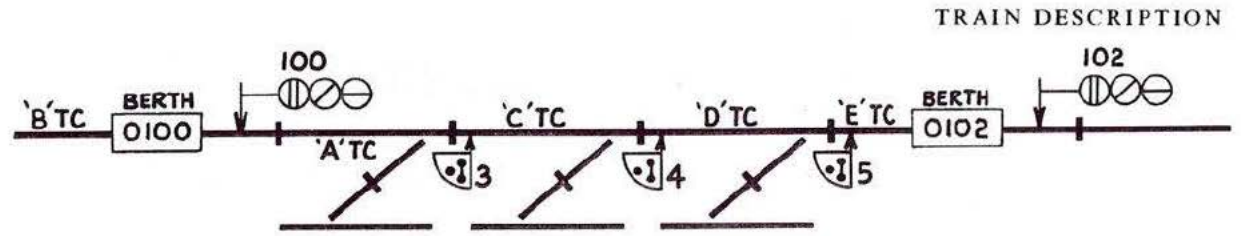
When the train code has stepped to berth 0110, it will immediately step to 0111 because the train describer has registered that berth 0111 is empty.

If route 111 is now set, the code will move onward from 0111 on the occupation of track circuit 'D'.

If however the train were to reverse in the platform, route 110 would be set after the restoration of 109. The train describer would then register the clearance of signal 110 and step the train code back from berth 0111 to 0110. It would subsequently step onwards on the occupation of track circuit 'B'.

The draw-ahead subsidiary signals, 108(S) and 109(S), cause the train codes to step in the manner described for Example 2.

**Fig. 9:10** Stepping table:  
example 4



*Example 4* (Fig. 9:10)

This is an example of automatic clear out when the train shunts back into one of the sidings and clears the track circuits between signals 100 and 102.

STEPPING TABLE				
FROM ADDRESS	TO ADDRESS	STEP CONTROLS		
		TRACK CIRCUIT	ROUTE	SIGNAL OFF
0100	0102	'A' OCC.	100	
0102	CLEAR OUT	A, C, D & E CLEAR	3, 4 OR 5	

TRAIN DESCRIPTION

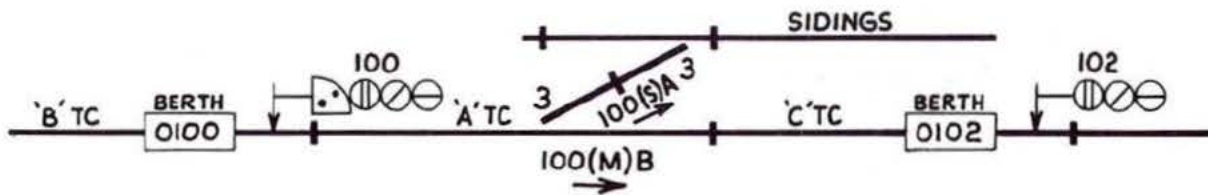


Fig. 9:11 Stepping table: example 5

STEPPING TABLE				
FROM ADDRESS	TO ADDRESS	STEP CONTROLS		
		TRACK CIRCUIT	ROUTE	SIGNAL OFF
0100	0102	'A' OCC.	100(M)	
0100	CLEAR OUT	'A' OCC.	100(S)	

Example 5 (Fig. 9:11)

This is another example of automatic clear out. In this case as the movement is in the running direction, the clear out takes place on the occupation of track circuit 'A', that is, as the train passes the signal.

**Operator Interface with the Train Describer**

There are three areas of interface between the signalling personnel in the Control Centre and the train describer. These are:

- (a) The visual display of the information stored by the train describer, for example, berth display and so on.
- (b) The facility for interposing, modification and interrogation of train descriptions.
- (c) The visual and/or audible alarms which warn the operators of events taking place associated with the train describer.

*Operator's Control Unit*

The operator's control unit is used to carry out the following functions in the train describer:

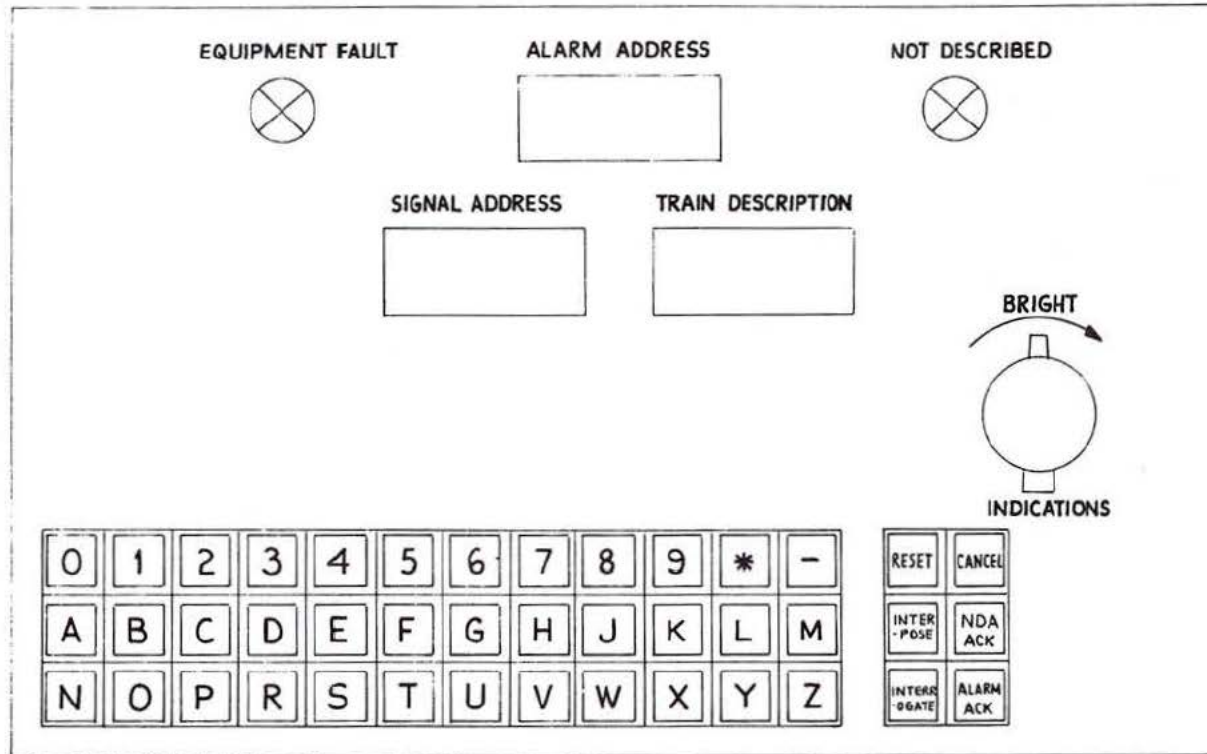
- (a) Cancel or clear-out a train description held in any berth store.
- (b) Interrogate the contents of any berth store.
- (c) Set up a new description into a temporary store and transfer (interpose) it into any berth store.
- (d) Interrogate the berth store address (location) of any train description.

(In implementing the above it is necessary for the appropriate berth store address to be set up initially. In the case of interrogation to ascertain the location of a particular train, a dummy berth address is used. This is necessary because the computer accepts the first four digits as an address and the remaining four as a train code.)

- (e) Acknowledgement of alarms.
- (f) Manual transmission.

A typical face plate layout of a Control Centre panel operator's control unit is shown in Fig. 9:12.

## TRAIN DESCRIPTION



**Fig. 9:12** Control Centre panel operator's train description panel layout

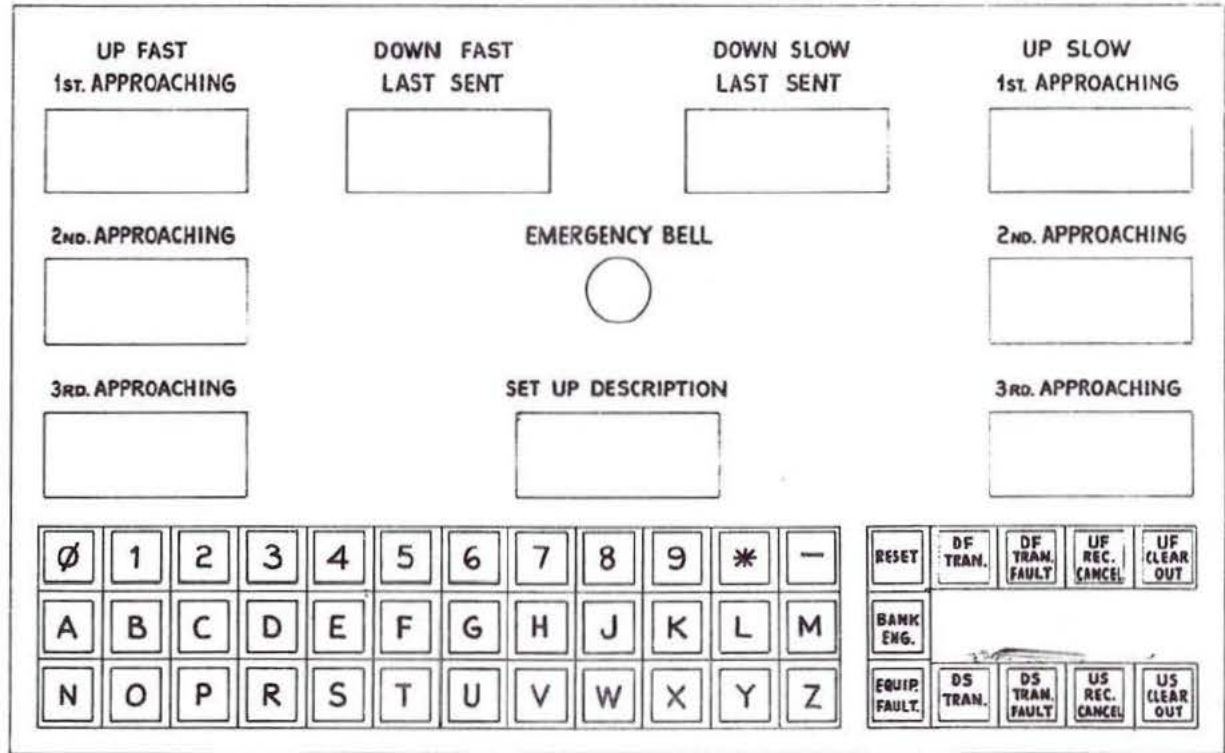
The keys in the lower half of the units are the address and train description set-up keys. The displays labelled 'Signal Address', and 'Train Description' show the contents of the temporary berth address and train description stores. These displays are capable of showing incomplete train descriptions or addresses and are up-dated at every push of the operator's control unit key. In this way they provide a visual check for each individual action and show how far the operation has proceeded. They also show that no information has been left in the operator's control unit store from a previous action.

The other display labelled 'Alarm Address' displays the address of the berth in which the alarm has been initiated.

The other keys and lights of the operator's control unit provide the signalman with:

- (a) warnings of malfunctions;
- (b) facilities to silence audible alarm warnings;
- (c) brilliance control of the displays;
- (d) block bell key.

**Fig. 9:13** Fringe box signalman's train description panel layout



*Fringe Signalboxes*

Fig. 9:13 shows a typical face plate layout for a fringe signalbox. The train descriptions in respect of trains approaching from adjacent signalboxes are displayed in the order of approach and automatically clear-out from the train describer as they pass the signalbox or other selected point. Following trains automatically step up in order of approach. The display also includes the description of the train last transmitted to the main signalbox. Although the set-up facilities

are similar to the main signalbox unit there are essential differences in the display. For example, there is no necessity for signal address display nor for the carrying out of the addressing procedure, since a train description at a fringe signalbox can only be inserted into specific berths for transmission to the Control Centre. The 'Not Described Alarm' facility and 'Alarm Address' display are also not required due to the comparatively small area under the signalman's control.

## TRAIN DESCRIPTION

### *Setting up a Description*

Normally, the first action of the operator, when using the control unit to interrogate a berth store, is to set-up the address of the berth on which he wishes to operate. The address is generally a four-character code consisting, in part, of the signal number. This is inserted, one character at a time, with a visual check after each operation. Operation of the 'Reset' key at any time during the procedure clears the 'Signal Address' part of the store.

If the operator wishes to erase a description from a berth, that is to clear out a train description, operation of the 'Cancel' button causes the erasure of all information held in the addressed store. The successful completion of the cancel function restores the operator's control unit to normal. The other operation carried out, when only the 'Signal Address' berth of the operator's control unit has been filled, is the 'Interrogate Train Describer'. This facility is used during display failures or when the person interrogating the train describer does not have clear access to the normal display system. Upon pressing the 'Interrogate' key the train description held in the addressed store is displayed on the operator's control unit 'Description' berth.

The operator's control unit is cleared by operating the 'Reset' key once to erase the train description and a second time, if required, to erase the address. Resetting does not affect the berth store information. This operation may, however, be achieved by a single operation of the 'Reset' key if desired.

If the operator should wish to interpose a new train description, he must first set up the appropriate berth address and then the new description. Both are set up and displayed after each key operation. With a valid address and a full train description in the operator's control unit store, the operation of the 'Interpose' key initiates a transfer from the operator's control unit store into the addressed store, removing any information already held there. The successful conclusion of this transfer clears down the operator's control unit to normal.

If the signal address is XXXX and a train description has been

set up, operation of the 'Interrogate' key causes a search to be carried out in the train describer store for an identical train description. When it is located, the address of the store holding that description automatically replaces the XXXX. Thus the operator has the facility to locate a given train throughout the whole of his train describer area, or, if the facility has been extended to adjacent signal-boxes, in the train describers adjacent, without resorting to a slow scan of all train descriptions or the passing of telephone messages. Fig. 9:14 summarises the panel operator's actions in carrying out the first four of the six functions listed earlier.

### *Alarms*

The alarms generally provided are:

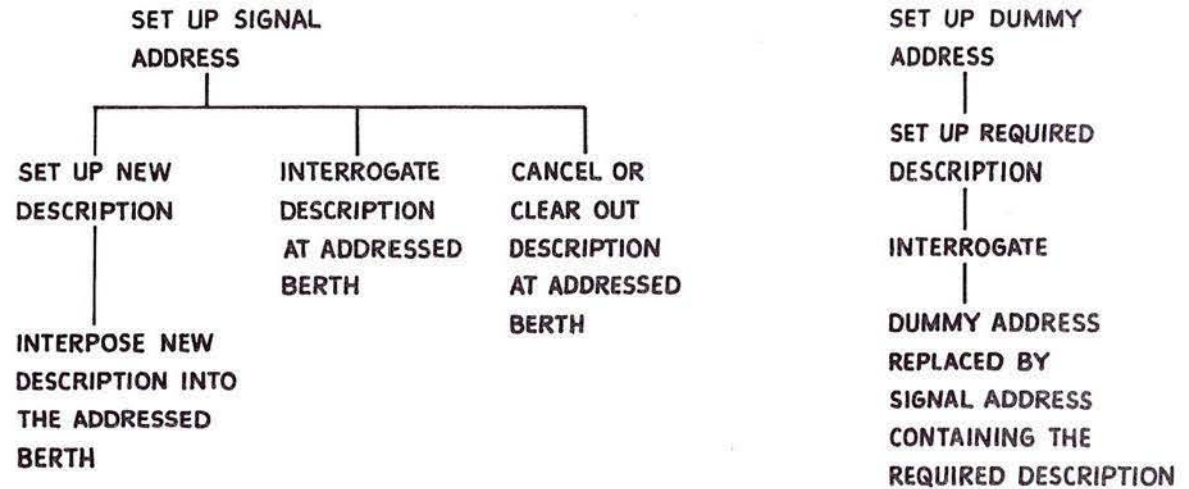
(a) Not described

Should a train generate a step in the train describer area without first having been described, a 'not described' alarm is provided to warn the signalman. This alarm is in the form of a short audible warning, a flashing red light and the display of the address of the berth which is occupied by the train not having a valid description. The alarm is shown in the 'Alarm Address' display and is acknowledged and cancelled by operation of the 'Not Described Alarm' key. The operator corrects the train describer by interposing a valid description into the correct place.

(b) Equipment failure

This alarm operates in the event of a failure of the train describer equipment. The alarm consists of a continuous audible and flashing visual warning. The audible warning is acknowledged and the flashing visual warning steadied by the operation of the 'Equipment Fault Acknowledge' key. The visual warning is automatically cancelled when the technician corrects the fault.

**Fig. 9:14** Train berth describer: sequence of panel operator's actions



(c) **Transmission fault**

The transmission fault alarm is individual to each transmitter system. It gives an audible and flashing visual warning if a train passes the last point of automatic transmission to the next signalbox without a valid transmission of the train description having been effected. Operation of the 'Transmitter Fault' key silences the audible warning and steadies the visual warning until the following train passes the last transmission point. If the following train also fails to transmit, the flashing visual warning is re-instituted until acknowledged. The steady visual alarm is cancelled by correction of the fault and successful transmission of a train description.

*Manual Transmission*

Other facilities also provided on the operator's control unit are

manual transmission of a description to adjacent signalboxes, using the set-up procedure given previously and acknowledgment of changes in incoming data from other signalboxes.

**Train Describer Display System**

The main function of a train describer is to display information to the signalman clearly and explicitly, at a viewing angle and distance adequate for the type of Control Centre or fringe signalbox in which it is installed. Significant developments have taken place in solid-state display technology such as light-emitting diodes and liquid-crystal devices. Displays based on such devices are likely to be used in future train describers and offer the advantage of elimination of the high-voltage supplies required for cathode-ray tubes.

## TRAIN DESCRIPTION

### *Cathode-Ray Tubes (Fig. 9:15)*

After a period of development during which various devices were tried as a means of display, the cathode-ray tube was adopted because it resulted in a compact high-density display with a wide viewing angle and simplified connections.

The panel space for a four-character display is  $38 \times 38$  mm for 9 mm high characters and  $76 \times 38$  mm for 19 mm high characters. The basic principle on which the display operates is that when the cathode is heated to a temperature at which it will emit electrons, these are attracted away from the cathode by a main anode. A small proportion of the electrons pass through a central pinhole in the anode to permit a beam of electrons to be projected down the tube. The focussing anode, usually cylindrical, acts as an electron lens to converge the beam and focus the stream of electrons within a small spot on the screen. A coating of fluorescent material on the inner face of the tube lights up where electrons impinge on it. The beam current, and hence the light obtained from the screen, is adjusted by the potential applied to the grid. Deflection of the electron beam from its path is achieved by applying a voltage between a pair of deflection plates. Two pairs, mutually perpendicular, permit horizontal and vertical deflections to be made.

### *Display Make-up (Fig. 9:16)*

Characters are formed on the face of the cathode-ray tube from a matrix of dots. A character is formed by brightening only the relevant dots. The matrix is formed by deflecting the electron beam in the horizontal and vertical planes in such a way that the beam steps sequentially from one dot to the next in a set fashion. The beam is also controlled so that the flow of electrons is inhibited for dot positions not required to produce the character being displayed. The control of the beam and of the deflection are synchronised to ensure the correct positioning of the dots with respect to the matrix.

### *Deflection Waveforms*

The control of the horizontal and vertical positioning of the electron

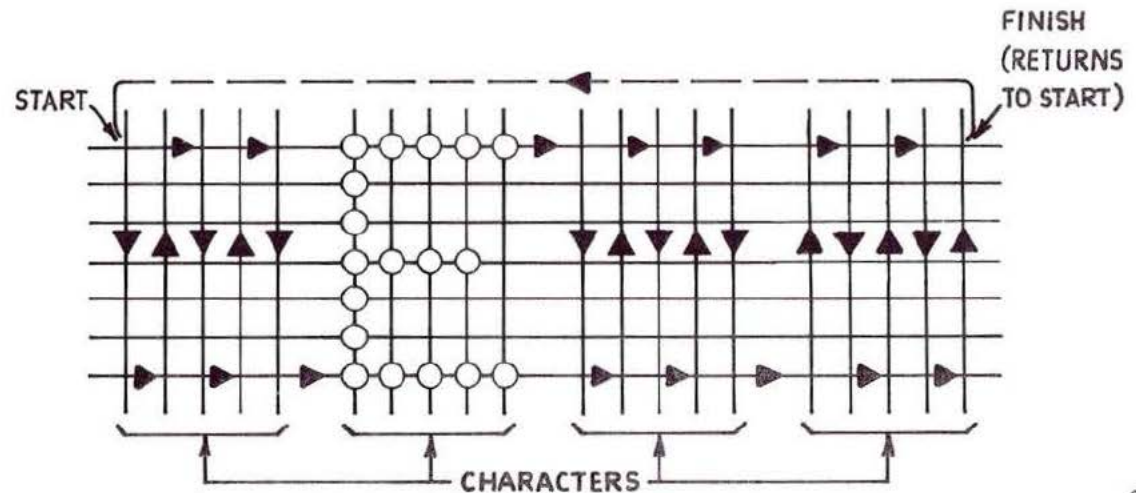
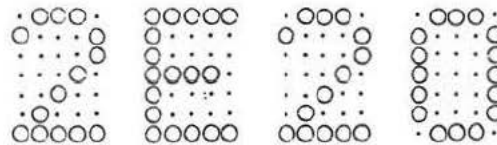
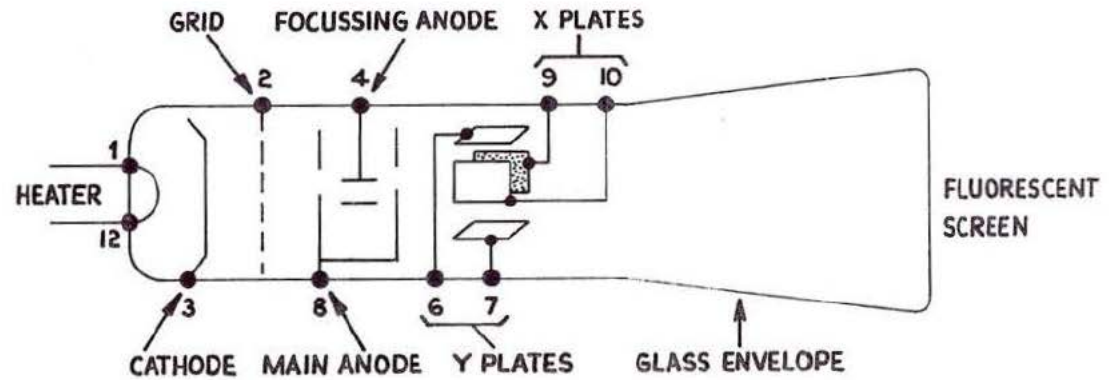
beam to produce the required matrix and pattern form is achieved by supplying separate waveforms to the X (horizontal) and Y (vertical) deflection plates. The make-up of the characters is such that there are several possible methods of scanning (pattern formation) the face of the display. The same basic principles apply to all these methods and for the purpose of this book, only the form illustrated in Fig. 9:16 will be considered.

This pattern form comprises twenty vertical columns each containing seven dot positions. In the initial column the beam is deflected downwards in increments until the seventh dot position is reached. The beam is then deflected horizontally to the lowest dot position of the second column and subsequently deflected upwards in increments until the second has been covered. Scanning continues in this way until the complete pattern has been formed and then the beam is returned in four further steps (fly-back) to start position. In order to ensure adequate separations between characters, the horizontal deflection following the fifth, tenth and fifteenth columns is made approximately double that between other columns. The total time for one complete scan, including fly-back, is 10 ms so that the display is refreshed 100 times per second. This rate is chosen to give a steady image free from flicker and is synchronised with the mains frequency to minimise the effect of electro-magnetic interference. During each scan the beam has to be deflected to 140 dot positions (made up of the four  $5 \times 7$  dot matrices) and four fly-back positions. Deflection timing is controlled by a master clock which must, therefore, run at the rate of 14.4 kHz and the time interval between the commencement of deflection from successive positions is 69.6 microseconds.

### **Display Storage**

As previously stated, to obtain a steady and continuous image the digital information for the display must be presented to a cathode-ray tube frequently, say a hundred times per second. If the train describer

**Fig. 9:15** Cathode-ray tube as used for train description display



**Fig. 9:16** Cathode-ray tube: formation of characters

## TRAIN DESCRIPTION

processing logic is called upon to generate the information at this rate, it will have little or no time available for other functions and the need for storage of the information actually displayed at any instant is apparent. This store will have to be continuously accessed by the display control circuits in order to generate the required displays and its contents modified by the processing logic when a change in the displayed information is required following an external demand on the system. An improvement in the integrity of the system can be achieved by using spare time available to the processing logic to rewrite the contents of the store, thereby limiting the length of time for which any corrupted information within the store is displayed. Whilst various methods may be used to affect the display storage, for example ferrite core, delay line and so on, only semi-conductor storage will be described in detail.

In this system advantage is taken of integrated circuit technology. Bright-up information is stored in shift registers which input and output serially bit by bit under the control of pulses from a clock pulse generator. A register is needed for each CRT display and the register outputs, as well as being routed to the CRT, are returned to the input of the register, so that the bright-up information is continually available to maintain the display. A typical arrangement is shown in Fig. 9:17. The mode select circuit permits the selection, by an 'input select' signal, of two alternative modes of operation. In the 'recirculate' mode, inputs fed back from the register output are accepted. In the 'new data' mode, the register inputs new data and recirculation is inhibited.

The register is serially loaded with 144 bits of new data, of which 140 bits represent the bright-up pattern and four cover the fly-back period. Any data already held in the register is output and lost during the load cycle. When the register holds the new data, the recirculate mode is re-established and the data is clocked out of the register and re-input at the same rate. Output data is routed to the associated CRT via a 'Nand' gate which inhibits the data when in receipt of a 'blank-off' pulse timed to blank off the CRT spot while it is moving between dot positions. Until fresh data

is again ready to be input, the recirculation mode is maintained and the complete bright-up data is presented to the CRT during each scan.

The essential synchronisation of the timing of all interrelated functions of the display system is dependent upon the clock pulse generator. Not only does this generate the register clocking pulses but, in addition, produces horizontal and vertical deflection waveforms for the cathode-ray tubes, the blank-off signal referred to above and an end-of-scan pulse. The latter has several functions but in the present context it controls the initiation of the input of new data to the display store register, synchronising the transfer with the CRT scan. The clock pulse generator is itself synchronised to the frequency of the mains power supply.

### *Light-Emitting Diodes*

The cathode-ray tube type of display was extensively used in train describer installations in the era (from c.1960) when the concept of Control Centres covering large areas had been generally accepted.

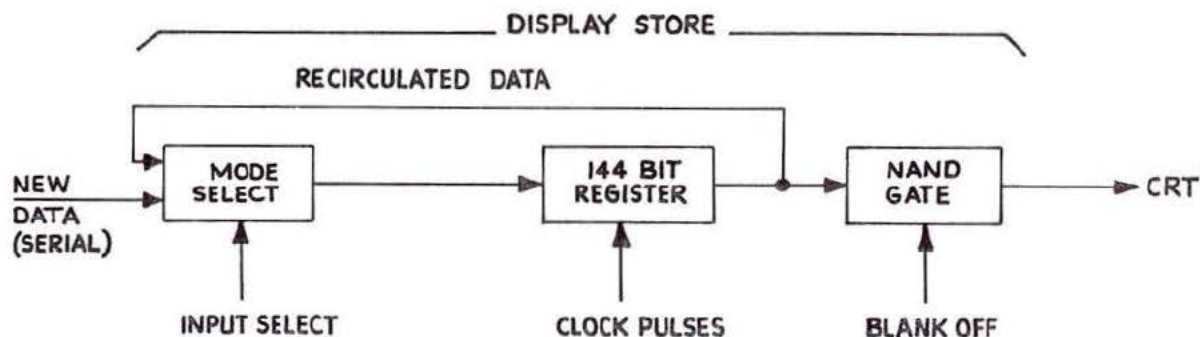
The feasibility afforded by the CRT display represented a significant step forward and brought advantages to the operators, but they had certain technical disadvantages such as:

- (a) the quality of the displays on the signalling panel due to the tubes ageing in varying degree;
- (b) continuous dissipation of heat from the tube heaters;
- (c) the problems of mounting the CRTs on signalling control panels;
- (d) the necessity for having high voltages to generate the displays;
- (e) the generation of scanning waveforms.

These disadvantages are largely overcome by the use of light-emitting diodes, which have become commercially available since the mid 1970s.

In a display employing light-emitting diodes, the 4 times  $7 \times 5$  matrix of spots, described previously, is perpetuated—although each

**Fig. 9:17** Cathode-ray tube: display store



of the spots now takes the form of an individual diode. The light is generated within the gallium arsenide crystals by the transition of the electrons from a high to low energy level. This transition takes place when the diode 'P.N.' junction is biased into forward conduction mode. If the crystals are 'doped' by the use of additives, different emission frequencies and hence different colours can be produced.

The packaging of the diodes may be as individual characters, display positions, or half display positions. The design concept does not vary a great deal with any of these alternatives; it is the single character packaging that is now considered. Each package contains the 35 diodes potted in a  $7 \times 5$  matrix, together with a 36-bit shift register—in which the character generation is stored in a serial mode—and a reference device to set the brightness of the display. Units are designed to allow the four 17mm-high character units to fit into the standard  $40\text{ mm} \times 40\text{ mm}$  or  $40\text{ mm} \times 80\text{ mm}$  domino panel without the modification which is necessary to accommodate cathode-ray tube displays.

The operation of a display using light-emitting diodes is essentially much simpler than that of a display employing cathode-ray tubes, since it is not complicated by the necessity for continually scanning the waveforms. Each LED unit has a 7-way input connection for the following controls:

Clock	(Synchronising pulse)
Select	(Display address)
Data	(Display information in bright-up code)
Brightness	(Control of the bias and hence the brightness of display)
0 v	} Power supplies
-12 v	
+5 v	

When it is required to display a train description the relevant data is prepared in the display control micro-processor for transmission on to the display data line. A separate 'display address' (or 'select') line registers a display to be accessed, and the data is then transmitted on to the display line in synchronism with the master clock pulse. Hence it is absorbed and stored in the data display shift register associated with each character. Four separate character modules are used and information on the incoming display module is rippled through from first, to second, to third and to fourth until the master clock reaches a count of 140 at which time the 'select' signal is removed and the display register contains all relevant information. The display register on each module causes the 35 light-emitting diodes to be biased in the correct direction so as to be illuminated, or to remain dark, as required.

### ELECTRONIC TRAIN DESCRIBERS

Since the late 1960s the train describers installed in British Railways major signalboxes have been electronic systems, although different forms of implementation and approach to system design can be found. Some were designed as hard-wired logic systems, with solid-state circuits performing the functions previously realised by electro-mechanical methods. There were variants of this type of system; some used delay line techniques for storage, whereas others used computer-type ferrite core stores. Further development of this type of system led to the computer-assisted systems, where the prime train describer functions were performed by hard-wired logic with overall supervision by computer; in such systems, the computer was also used for the control of transmissions to adjacent installations and fringe boxes, including code conversions where necessary.

The next significant milestone in train describer development was the introduction of the computer-based system. The ever-increasing size and complexity of modern signalling centres, and the need for very high operational availability of the train describer, led to the introduction of dual computers in both the computer-assisted and the computer-based system. Currently (1978) British Railways use one or other of these two systems.

#### Computers for use in Train Describers

The basic functions of a train describer may be divided into three groups as shown in Fig. 9:18. First a train describer must be continually aware of the state of all the relevant signalling controls and monitoring information, including the track, signal, point and route relays connected to it and it must take notice of instructions received from operators. The scanning and recording of all forms of inputs can be broadly termed 'data collection'.

Secondly, a train describer must determine the information to be output to the various display devices, printers or transmission lines as a result of information gathered from the data collection

activity. The general process of generating output data from input data can be termed 'data manipulation'.

Lastly, it is required to generate appropriate output data and make this available to the individual display devices, printers or transmission lines. This function can be collectively termed 'data display'.

A computer-based train describer can be defined as one in which all data manipulation is carried out within a central processor. For this purpose, the small general-purpose, programmable, digital computer is a very satisfactory tool, combining fundamental simplicity, absolute consistency and extremely high speed. Such computers employ a word length typically of 16 binary bits, and store data and instruction words in magnetic core or semi-conductor memories. Train describer storage requirements depend on the size and complexity of the system, usually between 8 and 32 thousand words are required, although the design of modern computers allows expansion to well above these figures by simply fitting additional storage units. Magnetic cores provide a non-volatile storage system in which stored information is retained if the power is turned off, or is lost accidentally. Automatic restart facilities in the central processor enable re-starting in an organised fashion when power returns.

A computer has the ability to accept a large number of items of information and to process them, in conjunction with fixed facts held in its memory, in accordance with a predetermined program of operations. The processing function may be to determine the logical relationship between inputs and the stored data, and on this basis generate appropriate outputs. In a train describer application, the fixed data stored in the computer will include geographical facts about the berths in the system and the conditions which contribute to the stepping of train descriptions from one berth to another. The descriptions and positions of trains within or approaching the signalling area will be temporarily stored.

Since operations are performed serially by a computer, only one task can be undertaken at a time. Thus each input transfer consists of one word of say 16 bits representing 16 input indications. A

**Fig. 9:18** Basic train describer functions

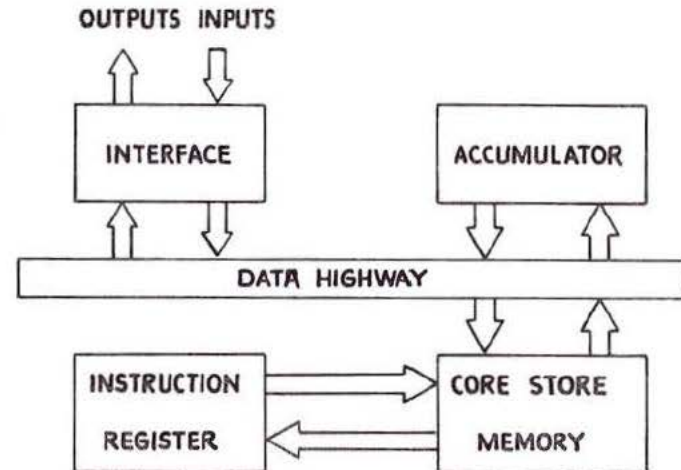


train describer system has very many input indications, typically 1000 to 2000, making it necessary to use some form of input multiplexer which will divide the inputs into groups of the required word length. Allocating an identity code (address) to each group, enables the computer to select one group at a time and accept its word of information. Similar considerations apply to the output system, but here the output information, generated one word at a time, has to be routed to the appropriate output display, printer or other device. To ensure advance warning of approaching trains, communication is required between train describers operating in adjacent signalling control areas. There may also be a need for an automatic train reporting network linking the Regional Control Office and local dissemination centres with the train describer. Telegraph links are usually used, and a number of these can be serviced simultaneously when connected to telegraph multiplexers fitted in the computer.

**Basic Computer Operation**

A digital computer is capable of storing information, performing calculations, making decisions based on results and arriving at final solutions to given problems. The computer cannot, however, perform these tasks without direction. Each operation which the computer is to carry out for a given activity must first be worked out and

placed in a program of instructions, and the instructions stored in the computer's memory. In essence, the computer consists of four major functional components interconnected as shown in Fig. 9:19.



**Fig. 9:19** Main components of the computer

## TRAIN DESCRIPTION

The bulk of a computer's central processing unit comprises a storage medium in which data can be held and manipulated. Usually storage consists of magnetic cores, each of which can store one binary bit, and several hundreds of thousands of magnetic cores are needed, although in more modern machines semi-conductor storage is used. These memory cells are divided into groups known as locations or registers, each storing one computer word; and to enable any particular word to be found, every location must be identified and therefore addressable. Both instructions and data are held in this store from which they can be read out as required and temporarily transferred for use—instructions to the instruction register and data to the accumulator. Variable input data reaches the central processing unit via an input/output interface, and the computer's internal distribution highway. It is in the accumulator that the logical combination of data and arithmetic processes are performed as directed by the instruction currently held in the instruction register.

Computer operations are controlled by a series of equally spaced timing pulses from a master clock oscillator. Distributed to all parts of the computer system, these pulses synchronise the timing of the multitude of actions which take place and form the basic time scale of the computer. The time of one cycle of the clock waveform may be regarded as the smallest unit of time in which a single action can be performed, appreciating also that the execution of many instructions will span several cycles. Present day general-purpose computers have cycle times less than one microsecond and average execution times under 5 microseconds.

A computer functions by taking each instruction in turn, analysing it and then obeying it, repeating this sequence continually with each subsequent instruction. In operation, instruction words constituting a complete program are taken, one at a time, from the core store and held in the instruction register. Each instruction remains in the register for the time required to execute it and is then replaced by the next one. The actions generated by program instructions are basically simple ones and are of four types:

- (a) Transfer instructions—used to transfer data and instruction words within the central processor. For example, they may transfer a data word to the accumulator or transfer a result back to storage.
- (b) Input/output instructions—used to transfer the state of the input lines into the accumulator or the contents of the accumulator on to the output lines.
- (c) Arithmetic instructions—used to tell the computer to merge the contents of a specified core store location with the contents of the accumulator by addition, subtraction or logical combination.
- (d) Branch instructions—which enable the contents of the accumulator to determine the next progress instruction to be executed.

Some modern computers have the facility of autonomous input/output instructions. This means that a single instruction results in a group of information being input directly to an output from the store. This facility is particularly advantageous when large amounts of data are being handled since it leaves the accumulator free for (a), (c) and (d).

## Software

The word 'software' is a generic term rather like engineering, and encompasses all functions involved in producing computer programs, that is, understanding and analysing the problem, deciding on the program strategy, writing the programs, 'debugging' and proving that the programs operate correctly, and, concurrent with all these stages, producing proper documentation. All the above are essential stages in producing satisfactory programs. Understanding and analysing the problem is perhaps the key and it is also vital that the requirements are accurately and fully specified by the user, otherwise the resultant programs will not perform the expected task. Documentation is time-consuming, but a most important part of software,

since without it the only person who will be able to understand the program is the person who wrote it, which obviously is not satisfactory. The whole process of programming is nevertheless a highly specialised business, and in referring to it there is difficulty in avoiding, to some extent, the phraseology of the specialist.

Programs for train describers are generally written in a code known as low level language, referred to also as assembler language, where each line of the program represents one detailed instruction to the computer. The number of program instructions for a small simple train describer may be about 5000, while a large train describer which provides many facilities may require up to 20 000 instructions. The following is an example of a short program, the object of which is to count the number of destination 'A' trains in a table. The table consists of groups of 4 characters in the usual British Railways' train description format, that is numeric, alpha, numeric, numeric, for example 5 D 62. The alpha component, a letter, represents the destination code of the train and in this example there are 20 trains in the table. This is presented in computer specialist language in the next column.

It is important to appreciate that to produce software requires a large amount of human effort and specialised skills, and the cost can represent a significant part of the total cost of the installation. One estimate puts the product of a man-year of software effort at around 1000 fully tested and documented assembler program instructions. Thus a small simple train describer may require up to five man-years of software effort.

Because producing software is so time-consuming, high-level programming languages have become available, for instance 'Coral 66', 'RTL2' and 'Pascal'. Such languages enable the program to be written with a smaller number of more generalised program instructions. The high-level program is then translated into the instructions for the computer by a special program known as a compiler. However, because the high-level language employs generalised statements the number of instructions for the computer will be greater than a directly written assembler program. Typically, a 20 000 word directly

*Low level language  
fed to computer*

CLA  
STA COUNT  
LDB TABLE  
INB  
  
LDA = D-20  
STA X  
LABO LBT  
  
CPA = B101  
  
JMP LAB2  
  
LAB1 ADB = B3  
  
ISZ X  
  
JMP LAB0  
  
HLT  
  
LAB2 ISZ COUNT  
JMP LAB1  
END

*Explanation*

Clear processor register A  
Store zero in 'count' to set up count  
Load the table address into processor register B  
Increment the B register to point to the alpha entry of the first T.D.  
Set processor register A to minus 20  
Store A register in location X to set count  
Load into the A register the character that is addressed by the B register and increment the B register by 1  
Compare the A register with the octal code for the alpha character 'A'.  
Skip an instruction if they are not equal  
If they are equal transfer control to location LAB2  
Add 3 to the address in the B register. Note that the instruction LBT also adds one to the B register so that this makes a total of four so as to point to the next alpha  
Increment the location X. If it reaches zero miss out the next instruction  
If the count has not terminated transfer control to the location LAB0  
Halt the processor with the number of alphas equal to 'A' in the location count  
Increment the count of locations equal to 'A'  
Continue at location LAB1

## TRAIN DESCRIPTION

written assembler program, if written in a high-level language, might require 4000 instructions, which when 'compiled' into instructions for the computer might be 30000 instructions. Thus the use of a high-level language saves programmers' time, but requires a faster computer and more computer storage. Unfortunately, the use of high-level language only reduces the time spent in writing the programs, debugging and proving that they operate correctly. It does not affect the time spent in understanding and analysing the problem. The overall saving is probably 20-25 per cent.

The program example given above for counting the number of destination 'A' trains if written in RTL2 would be as follows:

<i>Program</i>	<i>Comments</i>
PROC NUM (REF ARRAY BYTE TABLE) INT COUNT = 0	Preamble Set counter to zero
FOR X = 2 BY 4 TO 19*4 + 2	Loop on the alpha character for 20 entries
IF TABLE (X) = 'A' THEN COUNT = COUNT + 1      END	Increment count if this entry has an 'A' destina- tion code
REP RETURN (COUNT) ENDPROC	Return result

### Program Organisation

Reference was made earlier to the fundamental limitation of a general purpose computer in that it can perform only one task at a time. This limitation is incompatible with the requirements of a train describer installation where many activities must be carried out con-

currently. Activities such as stepping train descriptions on the track diagram, servicing operators' control units, transmitting information to fringe boxes, dealing with a dozen or more bi-directional telegraph links and monitoring the performance of the system may all require simultaneous attention. This conflict is by no means peculiar to computers used in train describers and exists to varying extent in all forms of industrial on-line computer control. The use of a real time operating system is the solution generally adopted in industry and an adaptation of this principle is suitable for train describers.

In principle, a separate application program is written for each of the tasks that has to be performed. In order that the train describer should appear, to a team of operators, to perform a multitude of tasks simultaneously, the computer's time is divided between the various tasks. The central processor switches rapidly from one application program to another, spending a fraction of a millisecond performing only that small part of each task that can be dealt with immediately. Control of this complex situation is undertaken by a monitoring program called the 'Real Time Executive'.

To simplify the scheduling of the work-load in a situation of constantly changing priorities, time is divided into periods of say 20ms and the application programs split into the following two groups:

#### *The Base Load*

which comprises those application programs which control the tasks performed at fixed intervals of time regardless of external stimuli. Actions such as scanning signalling inputs, refreshing fringe box displays, keeping track of elapsed time, all form part of this base load.

#### *The Variable Load*

which comprises those application programs which control the tasks performed as a result of some external influence on the train describer. The transmission and reception of information or the operation

of set up panel push-buttons or printer keyboards all demand responses from the computer but only at the time they occur.

The computer undertakes all tasks in a carefully predetermined order of priority, commencing at the beginning of each 20ms period with the highest priority task which is outstanding. Tasks may be outstanding because they were not completed in the previous period; fixed interval ones have become due, or new ones have been generated since the previous period began. At the end of each 20ms period, the program currently running is interrupted and the priority sequence recommences for the next period. Thus, in some periods work will be left outstanding and in others there will be spare time which can be usefully employed by running system self-checking programs.

#### Data Area

The fixed data which must be placed in the core store of the computer is individual to each train describer installation. This part of the storage is known as the data area and consists of all the geographical facts associated with the particular installation, encoded in such a way that they can be manipulated by the instruction programs. Train describers typically need between 5000 and 8000 words of fixed data and every one of the bits of each word has to be individually set in order to describe the schematic diagram exactly, stepping

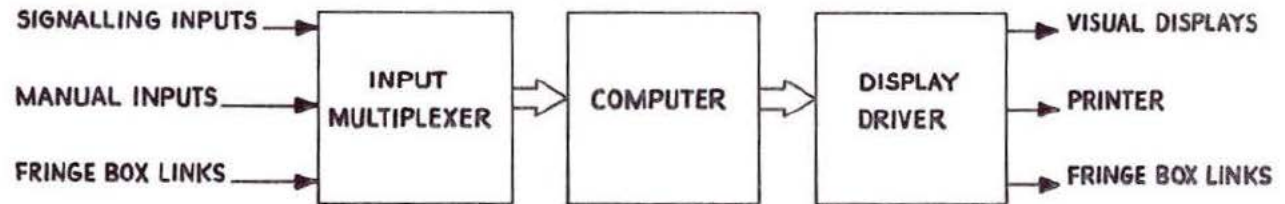
tables, number and configuration of fringe boxes, early transmission facilities, train report message routing and so on.

The task of deciding the state of each of these many thousands of bits is a formidable one. Fortunately it is possible to employ techniques which enable the data area to be generated by a computer with considerable benefits in the form of time-saving and minimising the chance of errors. This package processes stepping tables and other local information to produce in a few hours, a data file that would take several men years to compile manually.

#### Simple Computer-Based Train Describer

It has now been seen that the functions of a train describer can be achieved by the three basic parts in the configuration: shown in Fig. 9.20.

A system based on this arrangement would perform a basic step from one display berth to another in the following manner. The input multiplexer would register the track circuit input, indicating that the train had passed the signal, and present this fact to the computer. The computer would determine from its store of geographical facts the step associated with the particular track input and the berth numbers concerned. It would also examine its binary record of the description stored in the berth from which the step is to be made and translate this into the bright-up pattern required to



**Fig. 9:20** Main components of the computer-based train describer

## TRAIN DESCRIPTION

enable a four-character description to be displayed on a cathode-ray tube. This pattern, with the number of the berth in which it is to be displayed, would be passed to the display driver and followed by a command to delete the contents of the previous berth. The bright-up pattern, held in store by the display driver, would be used repeatedly to refresh the image on the screen of the cathode-ray tube. Should this simple step require a printed train report, the computer would translate the description into the appropriate printer drive code, and output a further message to the display driver giving the printer number and a complete train report.

### Dual Computer-Based Train Describer

While the simple train describer arrangement considered above would be satisfactory for smaller installations it has the limitation that the failure of any one of the three items of hardware could lead to the complete loss of all train describer facilities. In situations where, for operational reasons, the total loss of the train describer is unacceptable, a more complex configuration of the hardware modules has to be adopted. A suitable arrangement has proved to be one in which reconfiguration of the hardware modules can take place automatically when a failure occurs. Self-healing configurations of this type, which normally provide uninterrupted operation in the event of major hardware failure, inevitably involve some duplication of equipment including computers. Such systems are referred to as dual computer train describers and Fig. 9:21 illustrates a typical configuration. A description of this system follows and may be regarded as typical of modern installations currently in service.

### Duplication Philosophy

Each of the computers is large enough and fast enough to perform the complete train describer task and has its own input multiplexer, from which it determines independently the state of the inputs. The

output system shown is divided into two sections which can be connected independently to either computer. In normal operation, although both machines are running and performing all of the functions of the train describer, one machine is connected to all sections of the output system while the other machine is on 'standby'.

In the event of a fault affecting the 'on-load' computer, or its multiplexer, all of the load will be switched automatically to the standby computer. Automatic switching is performed under the control of a 'watch-dog timer'. Each of the computers is required to report to the watch-dog timer at intervals of a few seconds and they do so provided the systems they are controlling are fault free. Should the on-line computer fail to report, and provided the standby system has not failed also, control of the train describer is switched to the standby computer.

### Input System

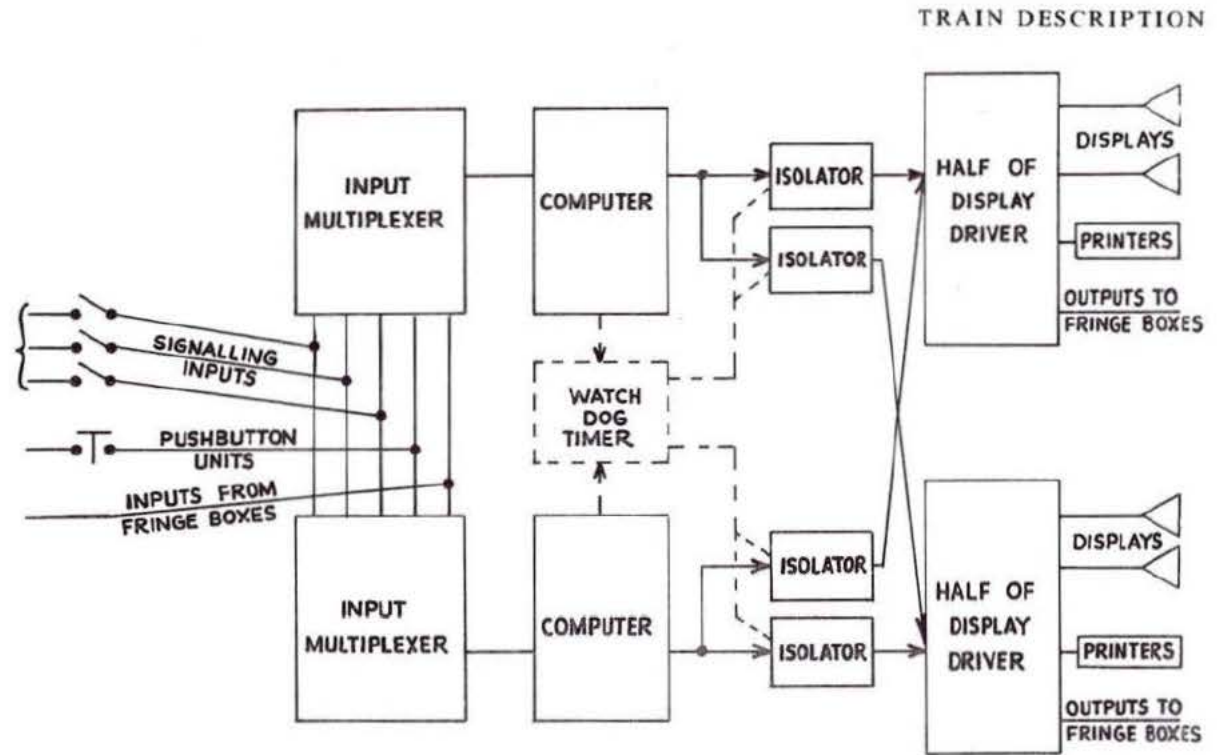
Inputs associated solely with the basic train describer functions are train descriptions and signalling inputs. Train descriptions are injected into the system in four ways:

- (a) manually by an operator at the main signalbox;
- (b) manually by a fringe box operator;
- (c) automatically by an adjacent train describer; and
- (d) automatically on completion of certain train movements, for example at a terminal when the train reverses for a programmed movement.

Signalling inputs indicate the states of all track, signal, point and route conditions relevant to the train describer function. They are used to initiate the stepping of displayed train descriptions from berth to berth on the track diagram in accordance with train movements.

With the exception of train description inputs from adjacent train describers, which are described separately, signalling and train de-

**Fig. 9:21** Dual computer train describer



## TRAIN DESCRIPTION

scriber inputs are connected to an input multiplexer. This is a scanning device consisting of a large number of printed circuit cards connected in parallel to address and data highways as shown in Fig. 9:22. Each card monitors a number of input indications. The computer outputs the address of each card in turn on to the address highway. As a card recognises its address, it responds by gating the state of its inputs on to the data highway and informing the computer that it has done so. The 16-bit data word so produced is stored by the computer for subsequent processing. All signalling inputs are scanned in this manner at intervals of approximately half a second, which is short enough to be sure of seeing a light locomotive passing over a short track circuit, and long enough to avoid possible confusion arising from the bouncing of relay contacts.

The Control Centre operator is provided with a control unit described earlier. Operation of any push-button generates an input, and the multiplexer registers that this input has changed state. At intervals of approximately 20 milliseconds the computer scans the change of state signals and subsequently addresses the push-button input card which has new information. The system is thus able to give what appears to the operator to be immediate response to any one of a large number of push-buttons. Inputs from fringe

boxes are also read by the computer at approximately 20 millisecond intervals. However, the connection to the main box equipment is made over a transmission link which combines input and output facilities and is described in the paragraph headed 'Fringe signalboxes' on page 292.

Since the input multiplexer has the task of conveying information from a signalling system where electrical noise abounds, to a fast digital computer where the maintenance of an exceedingly low level of noise is vital, noise filtering is a very significant aspect of this part of the system. Noise in a signalling system originates from two sources—first from a high voltage AC traction system which induces noise into lineside cables running into the signalbox, and secondly from the interlocking itself. Traction noise only becomes significant under certain traction fault conditions and is rather less of a threat to integrated circuit logic than the ever-present hazard of relay noise. Attenuation of unwanted frequencies, which may be as high as 1000 MHz, cannot be provided by circuit design alone, and considerable attention must be paid to the mechanical arrangement of the equipment. Fig. 9:23 illustrates the general principles of the many precautions which are taken to avoid noise contamination.

Fig. 9:22 Computer-based train describer: input multiplexer

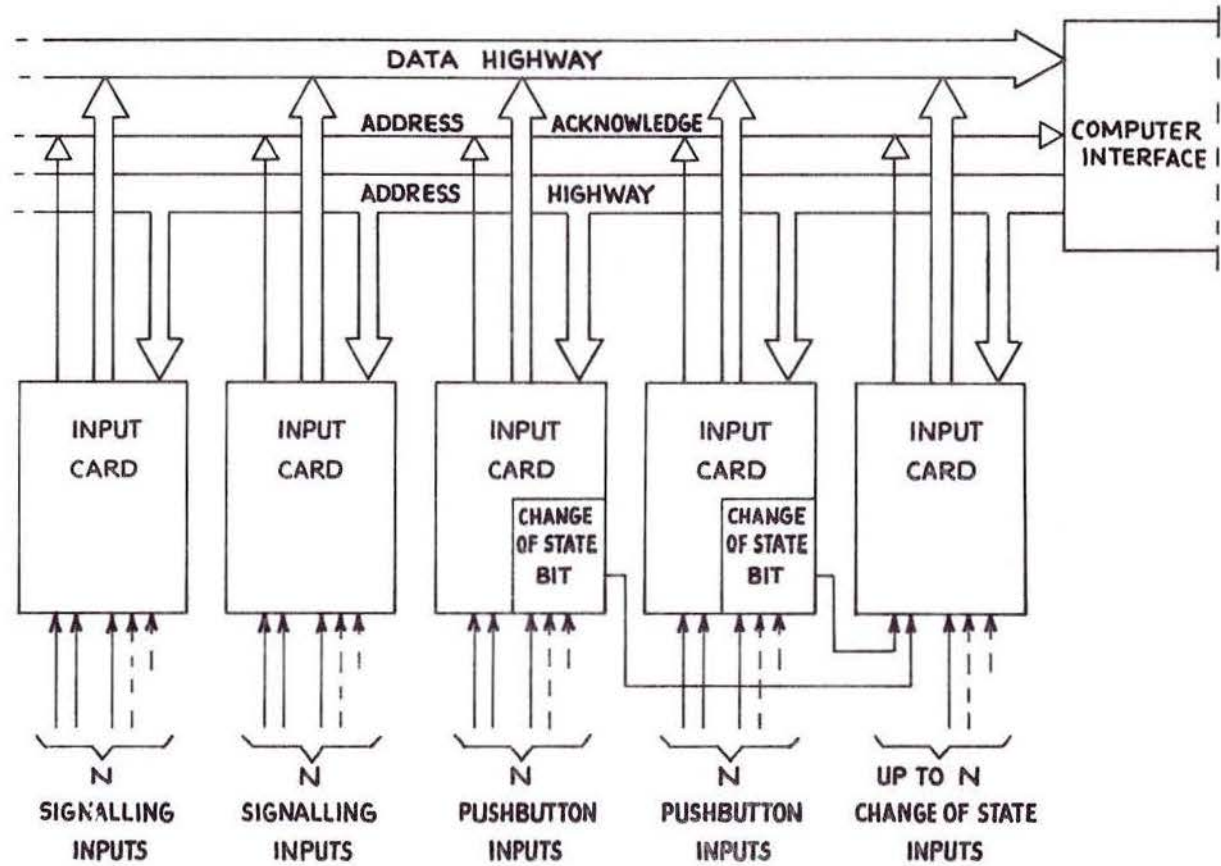
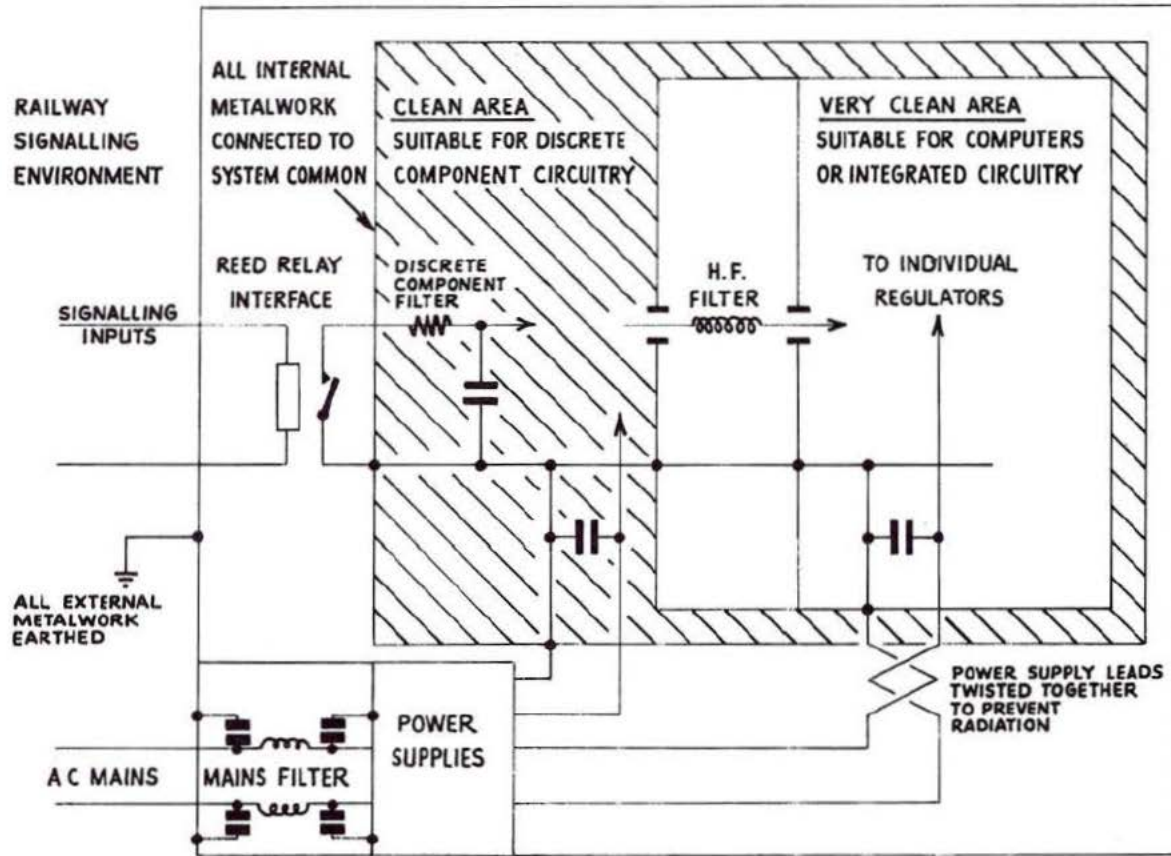


Fig. 9:23 Anti-noise precautions



### Display System

In most modern installations, several hundred cathode-ray tube displays will be incorporated in the track diagram at the Control Centre. To reduce the possibility of a single fault leading to the loss of all displays they are divided into independent groups. Even the effects of the loss of one of these groups can be alleviated by feeding adjacent displays on the track diagram from different group modules. Video signals to the cathode of a CRT control the bright-up or blank-off of each dot. The state of each dot must be defined as the beam reaches that dot position, and thus the video signal (bright-up pattern) consists of 140 bits for the description and four blank-off bits for fly-back, fed to the CRT in synchronism with the dot deflection. The system module for the control of a group of up to 56 CRT's is shown in Fig. 9:24 in which the display storage block represents 56 display stores, one for each CRT. The Control Logic generates the scanning waveforms that deflect the CRT beams and also synchronises the timing of the various functions of the display system.

Train descriptions are stored within the computer in coded form.

Whenever the displayed information is to be modified or refreshed, the computer converts the stored code to a bright-up pattern of 140 bits. The pattern is presented to the Display System Access as output words, which are registered, checked for parity, and collected together in a 144-bit shift register for temporary storage. Additional information from the computer identifying the CRT which is to display the description, enables the Display System Access to transfer the pattern data serially to the appropriate display store under the control of the Control Logic. Any pattern held in that display store is replaced by the new pattern, which is then output serially to the associated CRT. The display stores are of the recirculating type. When the train describer input conditions demand a step from one berth to another, the computer regenerates the bright-up pattern for the train description and inserts it into the display store associated with the train's new berth position. Thus, mutilated descriptions cannot be carried forward from berth to berth. Nor can mutilated displays be prolonged since each CRT is frequently refreshed with regenerated bright-up data.

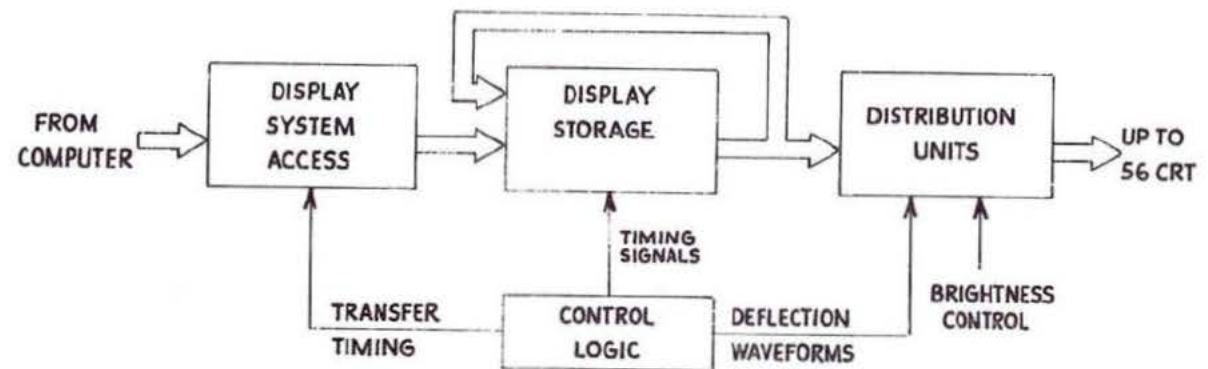


Fig. 9:24 Display system module

## TRAIN DESCRIPTION

### Fringe Signalboxes

Fringe signalboxes on the perimeter of the control area of the main signalbox are usually provided with simple train describer equipment to enable descriptions of trains approaching the fringe box to be displayed and to enable descriptions of trains entering the main box control area to be set-up and transmitted to the Control Centre train describer. In general, there are two different approaches to the design of fringe box equipments. These are:

- (a) 'Stand-alone' equipment, that is capable of operation independently of the main box, with local stepping, and with data transmission links to the main box.
- (b) Satellite equipment, with display and stepping data generated by the main box equipment and transmitted via data links to the fringe box.

Each type of system has advantages and disadvantages and the choice will be determined by the requirements for particular installations. In some installations the requirements are confined to the display of the descriptions of just the first and second trains approaching, and the satellite type is very suitable. In other cases there can be a requirement for several display berths, perhaps up to sixteen or more, with local stepping between berths, and the stand-alone type may be a more suitable method. By way of example, one implementation of the satellite type is described.

The fringe box unit (satellite type) forms an extension of the main box equipment, in that it is controlled by the computer, and almost all of the displayed information at the fringe box is derived from data held in the computer storage. Each fringe box unit is connected to the main box by two data transmission links, one operating from the main box to the fringe box and the other in the opposite direction. The links employ time-division multiplex techniques with a frequency shift carrier system. The transmission rate is 2000 baud and the carrier frequency is 16 kHz. Synchronising signals

generated by the computer every 60ms control the timing of all transmissions.

When a set-up button is operated, this fact is transmitted to the main box and input to the computer. A reply, generated by the computer, is transmitted back to the fringe box, and lights the appropriate character in the first character position of the set-up display. The whole process takes less than 100ms and appears to the operator to be instantaneous. When all four characters of the description have been set up, the transmit button is operated, indicating, by a further data transmission, that the fringe box operator requires the description to be displayed on the main box panel. In addition to initiating this action, the computer sends a message to the fringe box to reset the set-up display and up-date a last-sent display as a reminder to the fringe box signman. Transmissions from the main box indicating the approach of a train towards a fringe box are initiated by the computer, and the information is displayed at the fringe box. They do not involve reply transmissions from the fringe box. Similarly, if an alarm condition affecting the fringe box link is detected by the computer, a transmission is initiated to operate appropriate visual and/or alarm devices. Such alarm conditions are also displayed at the main box.

### Communications with Adjacent Train Describers

Adjacent major signalling installations may be equipped with train describer systems of differing types. The form of data transmission between the signalboxes depends upon the type of train describers involved. Adjacent train describers of different and non-compatible kinds (for example, a computer-based describer linking with a relay type describer) demand specially designed interface equipment to convert messages from one train describer to a form acceptable by the other.

Two train describers of the type being described here communicate via duplex modem data transmission links. The links utilise transmit/receive modems and transmit data bits serially. They interface

with the computer through a telecommunications multiplexer fitted within the computer main frame. The dual philosophy also applies to this input/output system in that incoming messages are routed to both computers whereas only the on-load computer provides outputs to the transmission lines. The outputs are switched between computers when fault conditions make changeover necessary.

### System Monitoring

The presence of a computer in a train describer installation obviously adds an additional maintenance problem which can be partially offset by using the computer as the basis of a comprehensive monitoring and fault reporting system. Dual computer train describers incorporate such a system, which features a detailed print-out of fault occurrences. For this purpose, each computer is equipped with a 10 characters per second printer. The following are examples of various types of monitoring which may be provided:

- (a) **Implicit monitoring:** Many of the cards within the input multiplexer or display controller are addressed by the computer as part of a normal input or output data transfer. If a card is faulty so that it fails to answer its address, a report of this failure will be made on the computer's fault printer, giving sufficient detail for a technician to locate the card.
- (b) **Power supply monitoring:** All power supply units at the main box provide inputs to the input multiplexer which are scanned in much the same way as signalling inputs. If a power supply fails, the appropriate input changes state and causes the computer to initiate a fault printout.
- (c) **Background monitoring:** At regular intervals the computer outputs check patterns on to the various system highways and checks that these patterns are received correctly at the remote ends of the highways. These checks detect both short circuit and open circuit failures of the highway and generate an appropriate fault printout.

- (d) **Computer monitoring:** At frequent intervals the computer executes a program which checks its own basic operational facilities and, in some systems, also checks that the area of store containing the fixed geographical data has not been corrupted. Again a fault printout will be generated if errors are found.

At regular intervals each computer outputs to the system alarm or watch-dog timer; this output indicates that the computer and the system it is controlling are clear of faults. Whenever a computer detects a fault that could be confined to itself or its input system, it stops outputting to the watch-dog timer. If it is the on-line machine the result will be an attempt to force a changeover of control to the other machine.

### Printers and Tape Punches

Information from the vast fund of facts which the computer is able to accumulate and store can be selected and recorded so that it can be visually read by operators and supervisory staff. Details of system faults that are recorded by a printer have been described. When a train describer incorporates automatic train reporting facilities, similar printers are installed at the main signalbox and at remote locations for reporting train positions and movements. Printers may incorporate keyboards which allow messages to be keyed into the computers. At some printer terminals, tape punches duplicate the printouts in a more permanent and retained form.

Thermal type printers are often used to provide virtually silent operation. The image is produced on heat sensitive paper by heating elements mounted on a monolithic solid-state printhead, which moves across the page printing up to 80 characters per line. On this head, 35 separate electronically controlled heating elements are arranged to form a  $7 \times 5$  dot matrix. Each input data character is decoded and the appropriate pattern of heating elements is energised to create a visible image of the character on the paper. Interface logic in the printer assembly performs serial to parallel conversion of input data. Automatic train reporting printers are connected via telegraph

## TRAIN DESCRIPTION

line multiplexers within the computers, and communication with remote printer terminals is over modem transmission links. At the remote end of the links the complete bi-directional terminal including the modem is housed within the printer assembly. Keyboards form part of this assembly where supervisory staff need to interrogate the computer or key in messages.

A tape punch can be connected to a printer to produce a record on punched tape of messages recorded by the printer. This provides a convenient way of logging messages over an extended period in a compact form and can be used for check-back purposes or statistical analysis at a later time. A typical tape punch consists of three parts; the punching and feeding units, the tape supply and take-up unit and the electronic control circuits. The punching and feeding unit includes a motor for incremental feed of the tape, by means of a capstan and a punching mechanism with solenoid operated punching pins. For tape handling a tape dispense reel and motor driven take-up reel are provided. An alarm is given if the tape tightens or breaks, and a tape-low lamp indicates that the tape on the supply reel has reached the point where a fresh reel is required. Built-in logic circuits synchronise tape feed and punching operations and control the gating in of data. The data path consists of input gates, a register for storing one character (one row of punched holes) and output gates to the punching solenoids. Features usually included are automatic inhibition of punching if the mains supply falls below a certain level, and reverse movement of the tape permitting the possibility of a correction to be made.

### Optional Facilities

It has been shown that a train describer contains, in processible form, a great deal of information on traffic and signalling conditions in its area and, in addition, the computer has access to information from adjacent areas. This information can be processed for dissemination to locations at any distance from the Control Centre giving advanced information on train running, or data which can control

various pieces of equipment, such as automatic train reporting, speed measurement, passenger information devices and route setting.

## AUTOMATIC TRAIN REPORTING

The full potential of automatic train reporting systems has not yet been realised. Present day ideas and possibilities can perhaps best be illustrated by a brief description of the London Midland Region network which embraces train describers at Warrington, Preston and Carlisle Control Centres. This complex, shown in Fig. 9:25, is part of a more extensive network based on a regional control office at Crewe, and links with other automatic train reporting systems installed at Glasgow and Motherwell. The computer at Crewe is solely concerned with overall supervision of the train reporting network.

Train reports within the network originate either automatically from selected signal berths within the area covered by one of the three computer-based train describers, or manually from remote terminals positioned at strategic points on the lines running into these areas. Reports are routed automatically within the network to appropriate destinations. The routing depends upon the point of origin of the message, the train classification and the train destination. Hundreds of different combinations of routing conditions are stored in the computer. In general, reports of trains approaching a Control Centre are printed on the regulating printer, while those generated automatically from within the area covered by the Control Centre are printed on the register printer. Reports frequently have more than one destination, and both manually generated and automatically generated reports may be transmitted to terminals at dissemination centres, to adjacent Control Centres or to Crewe Regional Control.

Remote terminal operators are provided with interrogate facilities similar in principle to those provided for a signaller. This facility enables operators to establish the identity or whereabouts of any train within the area covered by the Control Centre to which they

with the computer through a telecommunications multiplexer fitted within the computer main frame. The dual philosophy also applies to this input/output system in that incoming messages are routed to both computers whereas only the on-load computer provides outputs to the transmission lines. The outputs are switched between computers when fault conditions make changeover necessary.

### System Monitoring

The presence of a computer in a train describer installation obviously adds an additional maintenance problem which can be partially offset by using the computer as the basis of a comprehensive monitoring and fault reporting system. Dual computer train describers incorporate such a system, which features a detailed print-out of fault occurrences. For this purpose, each computer is equipped with a 10 characters per second printer. The following are examples of various types of monitoring which may be provided:

- (a) **Implicit monitoring:** Many of the cards within the input multiplexer or display controller are addressed by the computer as part of a normal input or output data transfer. If a card is faulty so that it fails to answer its address, a report of this failure will be made on the computer's fault printer, giving sufficient detail for a technician to locate the card.
- (b) **Power supply monitoring:** All power supply units at the main box provide inputs to the input multiplexer which are scanned in much the same way as signalling inputs. If a power supply fails, the appropriate input changes state and causes the computer to initiate a fault printout.
- (c) **Background monitoring:** At regular intervals the computer outputs check patterns on to the various system highways and checks that these patterns are received correctly at the remote ends of the highways. These checks detect both short circuit and open circuit failures of the highway and generate an appropriate fault printout.

- (d) **Computer monitoring:** At frequent intervals the computer executes a program which checks its own basic operational facilities and, in some systems, also checks that the area of store containing the fixed geographical data has not been corrupted. Again a fault printout will be generated if errors are found.

At regular intervals each computer outputs to the system alarm or watch-dog timer; this output indicates that the computer and the system it is controlling are clear of faults. Whenever a computer detects a fault that could be confined to itself or its input system, it stops outputting to the watch-dog timer. If it is the on-line machine the result will be an attempt to force a changeover of control to the other machine.

### Printers and Tape Punches

Information from the vast fund of facts which the computer is able to accumulate and store can be selected and recorded so that it can be visually read by operators and supervisory staff. Details of system faults that are recorded by a printer have been described. When a train describer incorporates automatic train reporting facilities, similar printers are installed at the main signalbox and at remote locations for reporting train positions and movements. Printers may incorporate keyboards which allow messages to be keyed into the computers. At some printer terminals, tape punches duplicate the printouts in a more permanent and retained form.

Thermal type printers are often used to provide virtually silent operation. The image is produced on heat sensitive paper by heating elements mounted on a monolithic solid-state printhead, which moves across the page printing up to 80 characters per line. On this head, 35 separate electronically controlled heating elements are arranged to form a  $7 \times 5$  dot matrix. Each input data character is decoded and the appropriate pattern of heating elements is energised to create a visible image of the character on the paper. Interface logic in the printer assembly performs serial to parallel conversion of input data. Automatic train reporting printers are connected via telegraph

## TRAIN DESCRIPTION

line multiplexers within the computers, and communication with remote printer terminals is over modem transmission links. At the remote end of the links the complete bi-directional terminal including the modem is housed within the printer assembly. Keyboards form part of this assembly where supervisory staff need to interrogate the computer or key in messages.

A tape punch can be connected to a printer to produce a record on punched tape of messages recorded by the printer. This provides a convenient way of logging messages over an extended period in a compact form and can be used for check-back purposes or statistical analysis at a later time. A typical tape punch consists of three parts; the punching and feeding units, the tape supply and take-up unit and the electronic control circuits. The punching and feeding unit includes a motor for incremental feed of the tape, by means of a capstan and a punching mechanism with solenoid operated punching pins. For tape handling a tape dispense reel and motor driven take-up reel are provided. An alarm is given if the tape tightens or breaks, and a tape-low lamp indicates that the tape on the supply reel has reached the point where a fresh reel is required. Built-in logic circuits synchronise tape feed and punching operations and control the gating in of data. The data path consists of input gates, a register for storing one character (one row of punched holes) and output gates to the punching solenoids. Features usually included are automatic inhibition of punching if the mains supply falls below a certain level, and reverse movement of the tape permitting the possibility of a correction to be made.

### Optional Facilities

It has been shown that a train describer contains, in processible form, a great deal of information on traffic and signalling conditions in its area and, in addition, the computer has access to information from adjacent areas. This information can be processed for dissemination to locations at any distance from the Control Centre giving advanced information on train running, or data which can control

various pieces of equipment, such as automatic train reporting, speed measurement, passenger information devices and route setting.

## AUTOMATIC TRAIN REPORTING

The full potential of automatic train reporting systems has not yet been realised. Present day ideas and possibilities can perhaps best be illustrated by a brief description of the London Midland Region network which embraces train describers at Warrington, Preston and Carlisle Control Centres. This complex, shown in Fig. 9:25, is part of a more extensive network based on a regional control office at Crewe, and links with other automatic train reporting systems installed at Glasgow and Motherwell. The computer at Crewe is solely concerned with overall supervision of the train reporting network.

Train reports within the network originate either automatically from selected signal berths within the area covered by one of the three computer-based train describers, or manually from remote terminals positioned at strategic points on the lines running into these areas. Reports are routed automatically within the network to appropriate destinations. The routing depends upon the point of origin of the message, the train classification and the train destination. Hundreds of different combinations of routing conditions are stored in the computer. In general, reports of trains approaching a Control Centre are printed on the regulating printer, while those generated automatically from within the area covered by the Control Centre are printed on the register printer. Reports frequently have more than one destination, and both manually generated and automatically generated reports may be transmitted to terminals at dissemination centres, to adjacent Control Centres or to Crewe Regional Control.

Remote terminal operators are provided with interrogate facilities similar in principle to those provided for a signaller. This facility enables operators to establish the identity or whereabouts of any train within the area covered by the Control Centre to which they

form a satellite. The train reporting printers provided for the use of supervisors at the Control Centres have the same interrogate facilities, and in addition the supervisor may, with a single command, generate a complete list of the position and identity of all trains within his area. The Control Centre supervisor also has at his disposal a speed reporting facility which measures and records the speed of all trains passing through certain sections. Up to six such speed reporting sections are available in each area, and are selectively energised by commands typed in on the supervisor's printer.

Two train reporting printers are installed at Crewe Regional Control, one for up trains and one for down trains. The facilities available on these printers differ slightly from those available on the signalbox printers, in that complete interrogation is extended to cover all three signalling control areas but there are no speed recording facilities. Validity checks are carried out on all reports or commands typed into train reporting printers, and unreasonable or incomplete messages are rejected. In each case the computer outputs an error code on the printer concerned to indicate the reason for rejection.

In a dense suburban area, an automatic train reporting system would produce a considerable amount of unnecessary, even useless, information when trains are running on time. This has led to a system of reporting by exception, that is trains are only reported when they are, say, more than two minutes late. Facilities are provided to alter this time margin. It will be appreciated that such a system requires that the timetable must be stored in the computer for the comparison with actual running time to be made, and having regard to the frequent alterations to the timetable, it is usual to provide a separate computer for the purpose.

### Information to Passengers

The information contained in the train describer computer has been used in the inner London area of the Southern Region of British Railways to drive arrival and departure train indicators, not only at main terminals but also at many intermediate stations where

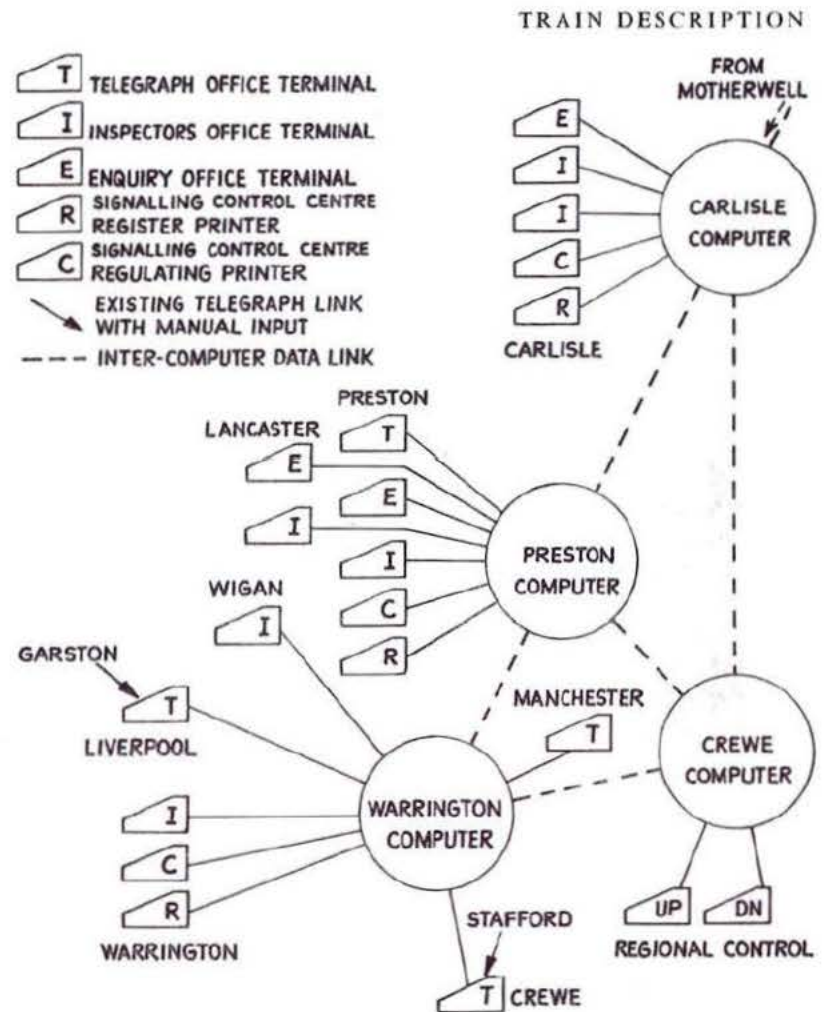


Fig. 9:25 Train reporting system as installed on British Railways (L.M. Region)

## TRAIN DESCRIPTION

formerly the work was performed manually. Some 60 stations are currently (1978) provided and some 250 are planned.

Recorded announcements may also be operated, not only to back up the platform indicators, but also to instruct passengers to keep clear of the platform edge when high-speed non-stopping trains are approaching.

### Visual Display Units (VDUs)

In the larger Control Centres where the train regulators and controllers may have difficulty in reading the train descriptions on the signalling control panel, interrogate facilities are provided. Latterly, these facilities have taken the form of VDUs which have the facility to display any portion of the layout, as required, together with the description code of all trains in that area. If required by the traffic operators, such a facility may be provided at any given office or station within the control area. The panel operators, at a large control panel, may also be provided with similar VDUs to give them advance information of trains approaching their area of control.

### Automatic Route Setting

In principle, the train describer computer is capable of setting routes for trains in accordance with the train description (or train code) provided this is unique. In a number of instances, this has already been done at simple junctions. Signal engineers generally have been somewhat reluctant to introduce automatic route setting by train describer; because, to justify the additional cost, there must be a staff economy and in the event of failure of the link, the panel operators would be required immediately to handle the traffic. Nevertheless, there is little doubt that the facility will be a feature of future signalling schemes.

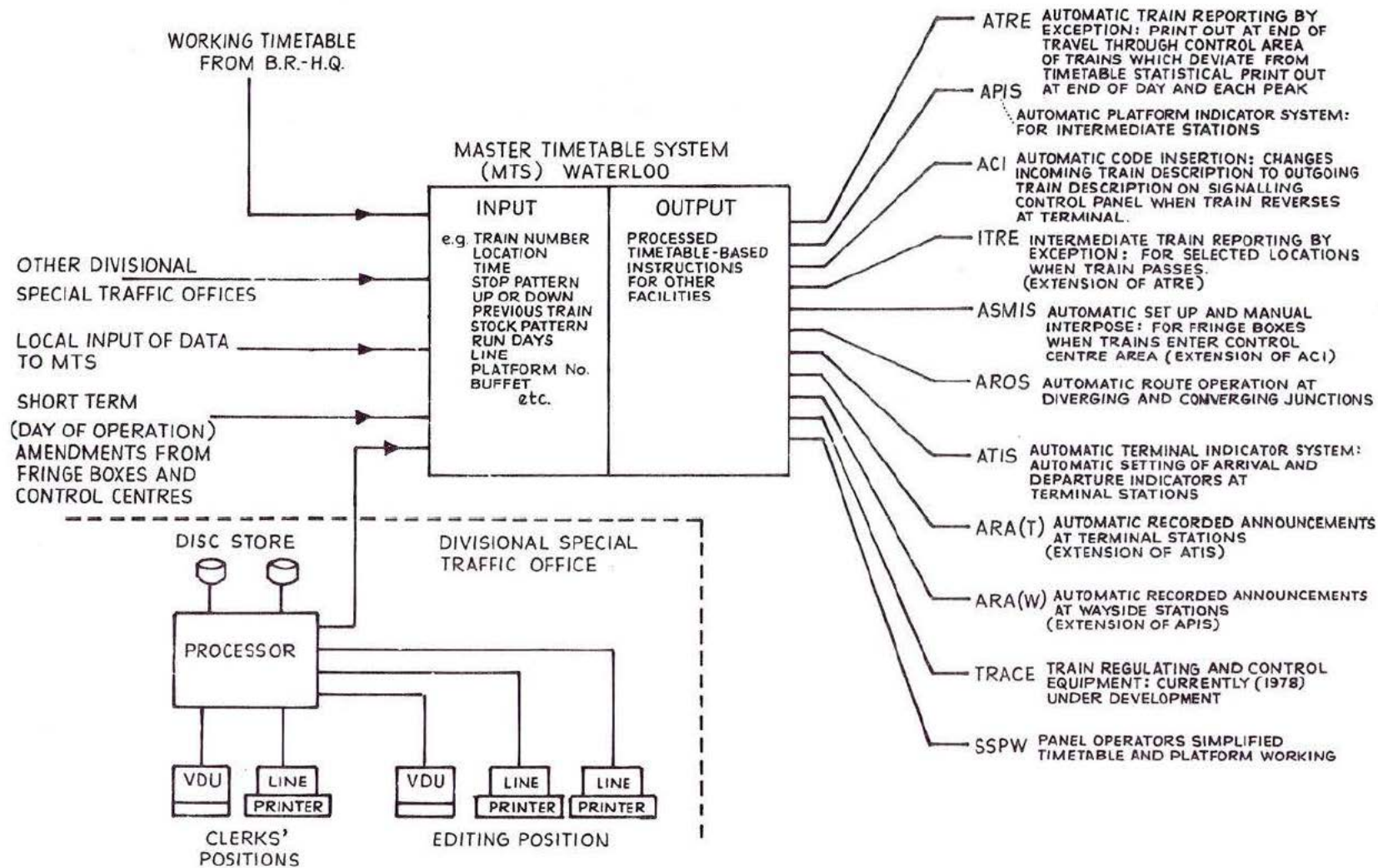
The British Railways standard train description code is not by itself sufficiently comprehensive to enable full automatic working to be achieved and it may be necessary to add 'blind' routeing

digits to each description, which would increase the capacity required in the computer. Automatic route setting does not necessarily have to be associated with the train describer in every case, and in several instances on the Southern Region some terminal station layouts are operated directly from the signalling equipment. In one interesting case at Charing Cross, which is 6-platform satellite terminal interlocking normally operated from London Bridge, automatic route setting has been provided in connection with override facilities. In the event of failure of the link to the Control Centre, the whole layout may either operate automatically or be operated from a local (emergency) control panel. The purpose of automatic operation is to avoid the delay to traffic whilst signalmen are being sent to site. When in automatic operation, up trains are signalled into the first available platform. This arrangement works quite satisfactorily provided trains arrive in the correct order but automatic platform allocation can create difficulties if they do not. In the down direction, trains are signalled to the outgoing track on the operation of the 'train-ready-to-start' plungers on the platform.

Consideration will show that to link the train describer to the signalling for route setting locally introduces another cable link which would be just as vulnerable as the signalling link. Much additional local equipment would also be required. In practice therefore, whenever Charing Cross is in local operation, whether automatically or from the local panel, the train descriptions are passed to and from London Bridge by telephone, leaving the panel operator there to clear out or interpose manually. For these reasons, route setting by train description, although feasible, is not a viable proposition when a layout is in local operation.

### Automation of Timetable Compilation

The advent of the computer-based train describer has led to a comprehensive examination of the ancillary functions which may now be operated from the data contained in the computer store. The train



**Fig. 9:26** Comprehensive scheme for the automatic compilation of timetables and the provision of other ancillary services using train descriptors currently being installed by British Railways (Southern Region)

## TRAIN DESCRIPTION

describer computer now has so much data contained in its store, which is constantly being up-dated, that the full automatic control of many functions is now feasible. While full automation is unlikely to be realised for some time, there is little doubt that, with continuing development, and the close relationship between the traffic operator and the signal engineer, much of the work at present performed manually by the panel operator will be automated in the not too distant future.

Fig. 9:26 shows the outlines of a comprehensive scheme for the automatic compilation of timetables, and the linkage of the operating and signalling function at a modern Control Centre. Parts of such a scheme have already been implemented in the London Bridge area of the Southern Region, but Fig. 9:26 shows a number of other items which are extensions of what has already been achieved. Such a scheme will no doubt be introduced gradually as each item is independent and could be switched in and out of service as desired, with a reversion to full manual operation (in the modern sense) in the event of catastrophic failure of the automation equipment.

No question of safety is involved, because this will remain in the interlocking and controls as they exist at present, each item being no more than an adjunct to the safety equipment.

## Conclusion

The computer-controlled train describer has added a new dimension to the signalling system and needs to be fully exploited. Looking to the future, the function of the panel operator may, in the course of time, merge with those of the train regulator and traffic controller. His physical work will be considerably reduced in the event of the full implementation of a scheme such as is shown Fig. 9:26. He will be left to supervise the automatic working; although in an emergency he will have to resume the present functions of a panel operator. Even on this basis, however, it is not unreasonable to anticipate a considerable reduction in the staff required for the operation of a large signalling control panel.

## The British Railways' Automatic Warning System

Previous chapters in this book have been concerned with the signalling system in use on British Railways. It has been shown that, barring failure of equipment which itself has built-in protection, the signalman is fully protected against errors on his part. It has also been shown that the equivalent protection for the driver on high-speed main line railways has practical and economic difficulties.

For a high-speed railway, a train stop system which operates in the event of a train overrunning the Red aspect, as on rapid transit railways, is not practicable from an operating point of view because the length of the overlap required for full protection would need to be the equivalent of emergency braking distance at line speed and would thus be so great that the track capacity would be reduced to an unacceptable extent. Furthermore, British Railways has such a wide variety of trains from low-speed freight at 64 km/h (40 miles/h) to high-speed passenger trains travelling at up to 200 km/h (125 miles/h) that a single train stop system for all types of train would reduce track capacity even further.

It follows therefore, that for main line railways, an automatic train control system must enforce a brake application on the approach to the first caution aspect (Y or YY). In effect, this brings the full braking distance 'overlap' to the approach side of the Red aspect, thus permitting the overlap ahead of the signal to be treated as a nominal distance which provides a margin for error.

This principle must be observed whether the system is a cancellable warning type or a comprehensive type which does not require the intervention of the driver.

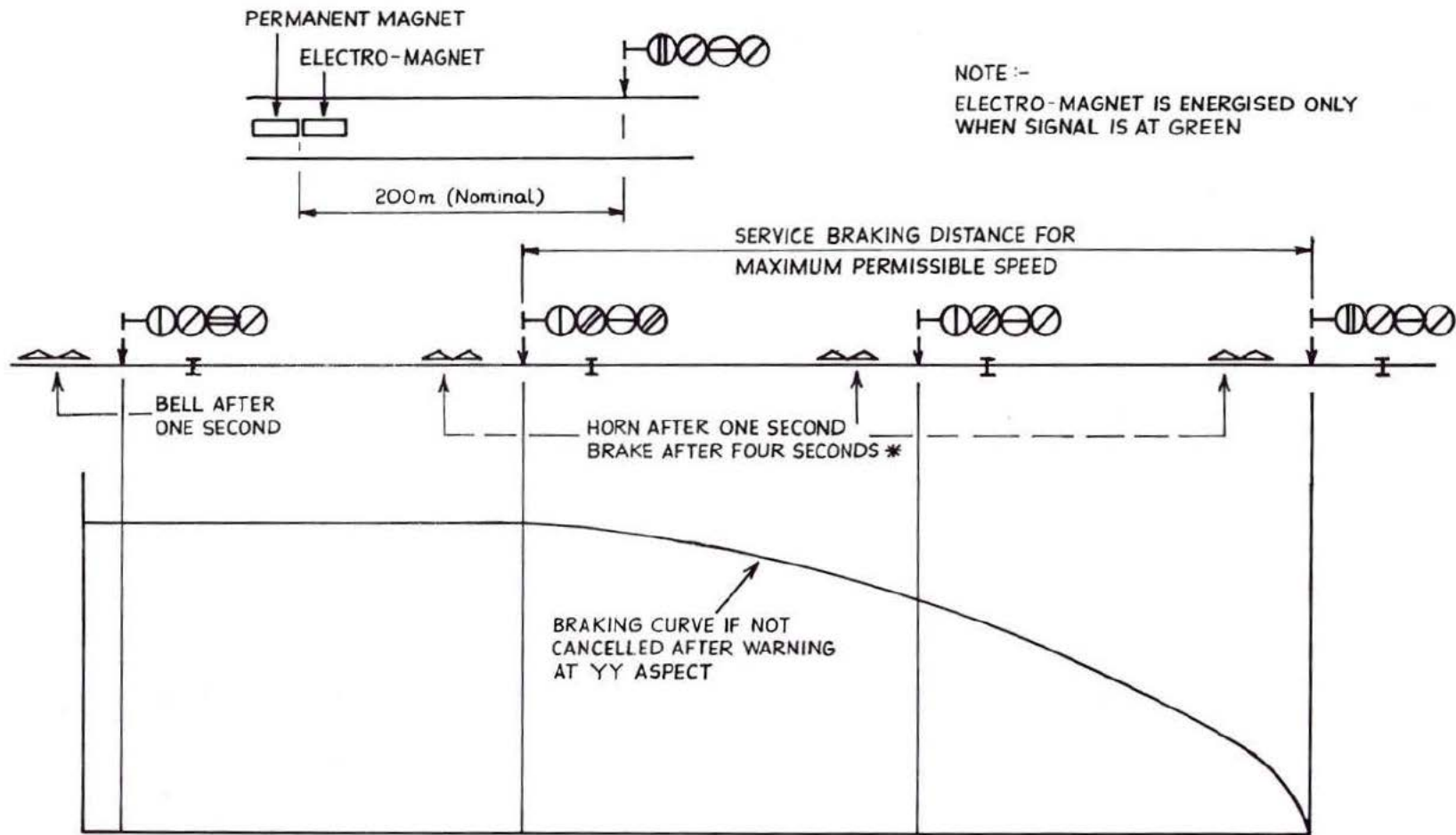
As the brake application must be enforced at full braking distance from the Red aspect, it is necessary that the driver should have the power (in a warning system) to acknowledge the warning and

avoid the automatic application. This enables him to take control so that advantage may be taken if the signal aspect ahead should become less restrictive.

Systems exist, both intermittent and continuous, which oblige the driver to keep within a reducing envelope of maximum speed approaching the Red aspect and institute a further and more severe application if the envelope speed should be exceeded. Such a system was considered by British Railways initially but rejected on the grounds of complication in complex layouts and cost.

British Railways, after nationalisation, standardised on an intermittent automatic warning system (AWS) which supervises the driver's reaction to caution aspects and indicates to him the passing of a clear aspect. It is advisory and leaves the regulation of the train speed in the hands of the driver for the most part, but causes a brake application to be made automatically if he fails to react when approaching a restrictive aspect. Fig. 10:1 shows the principle of operation.

The system operates by magnetic induction between static equipment fixed in the track and a receiver mounted on the motive power unit. It is provided in association with main signals which are capable of displaying a warning aspect i.e. double Yellow, or Yellow. (An exception is made to this rule when a Red/Green 2-aspect signal is located in between a succession of 3- or 4-aspect signals. AWS is then fitted at the 2-aspect signal if it is considered that its absence could confuse drivers.) The caution indication, that is when the signal is displaying any aspect other than Green, is given by a continuous note from a horn, and a clear (Green aspect) by a one second ring on a trembler bell. If a driver fails to acknowledge a caution indication a progressive brake application is initiated—which can be cancelled by the driver. If the driver acknowledges the caution indication—and so cancels the brake application—a visual indication is presented to him as a reminder that he has taken control of the train. This visual indication will remain until the train passes over another AWS installation, that is until the AWS is again operative.



\* MANUAL BRAKE APPLICATION MAY  
ALREADY BE IN FORCE, BUT HORN  
WILL SOUND UNTIL CANCELLED

Fig. 10:1 AWS: principle of operation



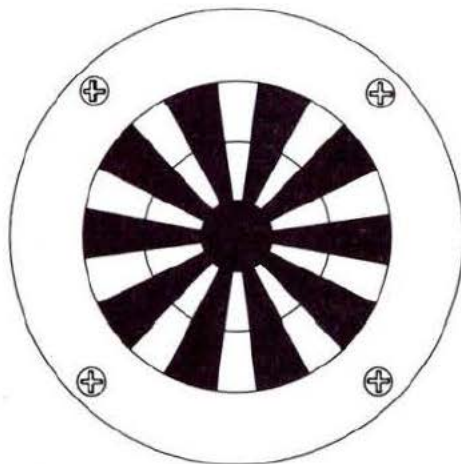
## THE BRITISH RAILWAYS' AUTOMATIC WARNING SYSTEM

unit driving cabs consists of an acknowledgement/resetting plunger conveniently mounted on the driving console, and an indicator also on the console where it can be clearly seen by the driver. The circular face of the indicator is Black and has ten radial tapering slots. Behind the face-plate is a disc which is divided into twenty segments coloured alternately Yellow and Black. This disc can be rotated magnetically through 18°. When the equipment is in the running position an all-Black appearance is presented to the driver. If the disc has been rotated the all-Black indication changes to a striking pattern of alternate Yellow and Black segments.

Fig. 10:3 shows the indicator face-plate.

### *Normal*

If the last signal passed was displaying a clear aspect, the AWS indicator will be all-Black.



**Fig. 10:3** AWS: cab indicator face plate

### *Approaching a Clear Signal*

In this situation the electro-magnet will be energised during the period that the Green aspect is displayed. The train equipment will be activated as the receiver passes over the permanent magnet. The receiver will return to its normal position when it passes through the field created by the electro-magnet. As a result the bell will sound for one second, after which the equipment will again be quiescent.

### *Approaching a Signal Displaying any Aspect other than Green*

The permanent magnet will again activate the equipment on the train but due to the absence of any field from the electro-magnet, the receiver will not be restored and the horn will sound continuously—until some action is taken by the driver. If the driver takes no action, a slow-to-release relay in the apparatus case will de-energise and institute a brake application via an electro-magnetic valve in the air/vacuum system. The degree to which the brakes are applied is pre-set so as to bring the train to a stand before it reaches the next signal displaying a stop aspect.

If after hearing the horn, the driver presses his resetting plunger, the brake application will be cancelled and the indicator will change to the Black-Yellow pattern. The driver now has the full responsibility for controlling his train as required by the signal aspects presented to him. When the next signal is reached the permanent magnet will restore the AWS indicator to all-Black and a bell indicator will be given if the signal is at Green. If the signal is at caution, a horn indication will be given and the indication will revert to Black-Yellow on acknowledgement.

### **Track Equipment Circuitry**

The electro-magnets are fed from a 12 or 24 volt DC supply which is controlled by a double cut circuit through the contacts of the DR (or equivalent) relay and ECR of the associated signal. Links are provided in the housing of the electro-magnet which will enable the

coils to be connected in series or parallel so that either feed voltage may be used. Due to the size of the coil required to produce the necessary flux with economy of current the bottom of the housing projects downwards into a lined cavity in the ballast between adjacent sleepers. The substantial magnet housings are each attached to the sleepers by three bolts, two at one end and one at the other. This arrangement avoids breakage of the holding down lugs caused by movement of the track.

*Normal Condition*

Fig. 10:4 shows the state of the circuitry of the train-borne equipment when running between signals. It should be noted that the indicator may be either Black or Black-Yellow depending on the action taken by the driver at the previous signal. In this condition a 12-volt feed from the receiver armature passes via contacts on EPR up and SR down and maintains the EPR relay in the operated position. Contact EPR2 operated (as shown in the diagram) holds the EP valve in the closed position. (When the latter valve is released a brake application ensues.)

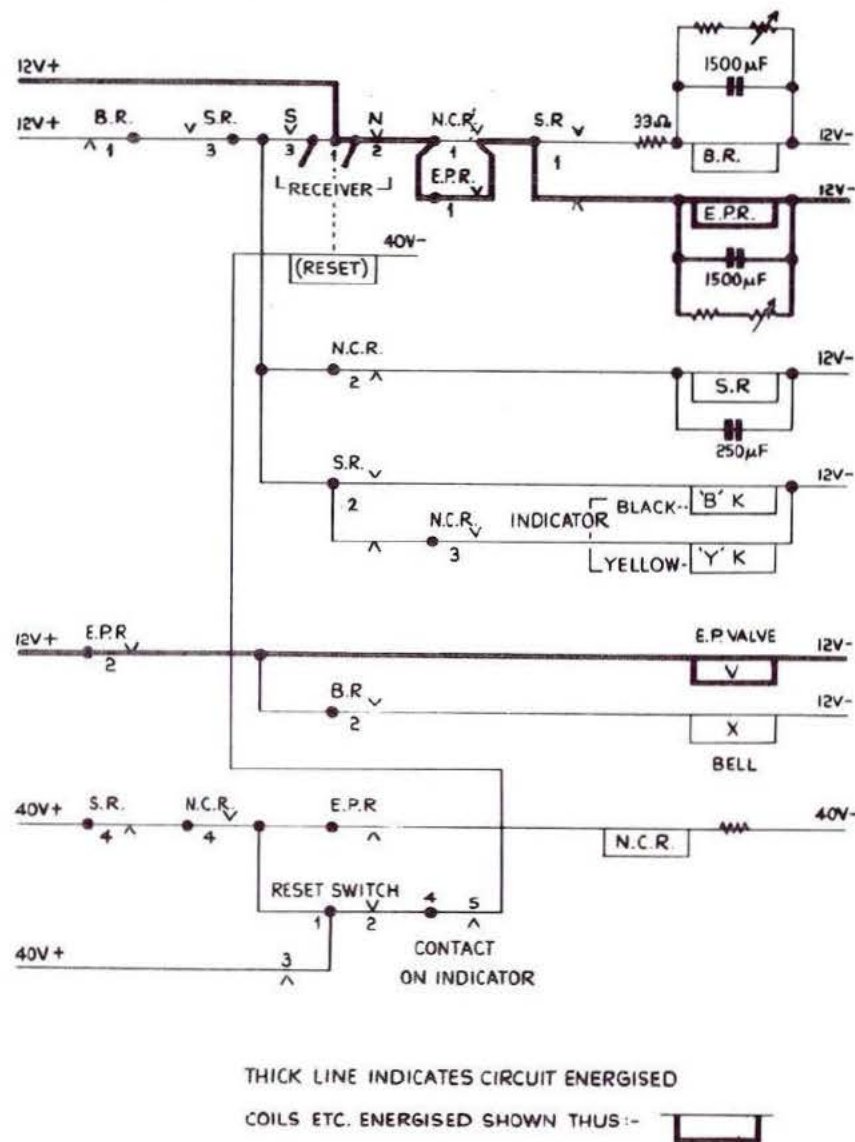
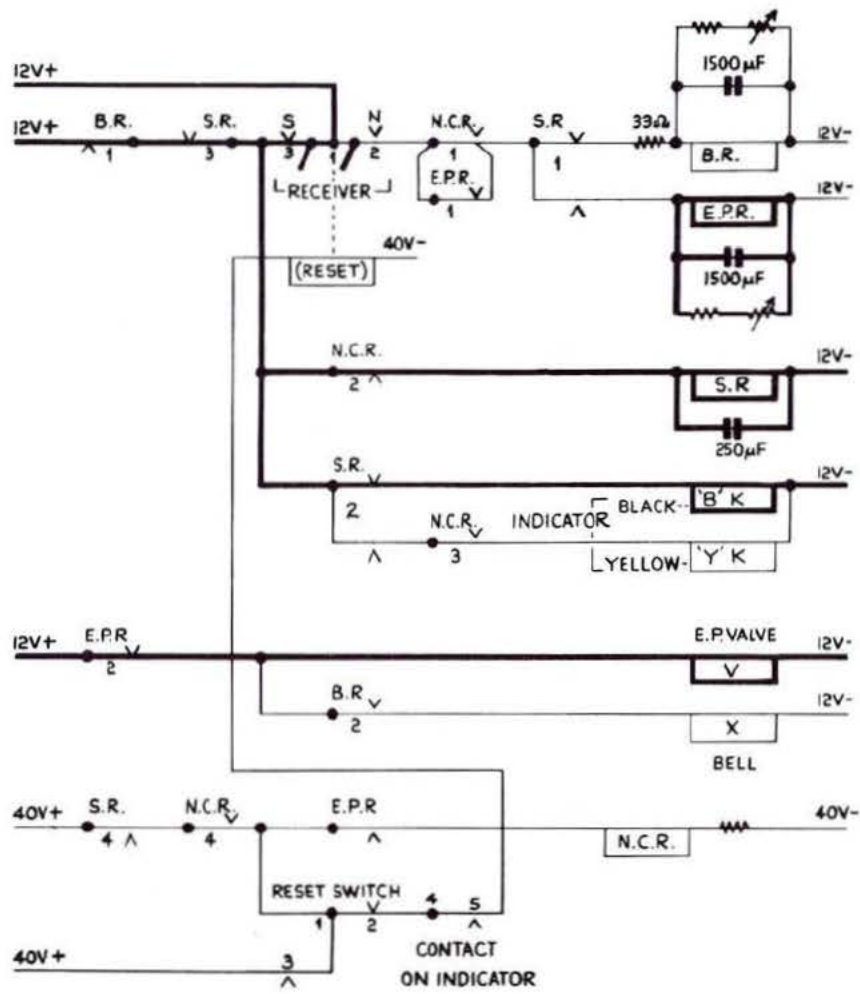


Fig. 10:4 AWS: cab circuits—normal conditions



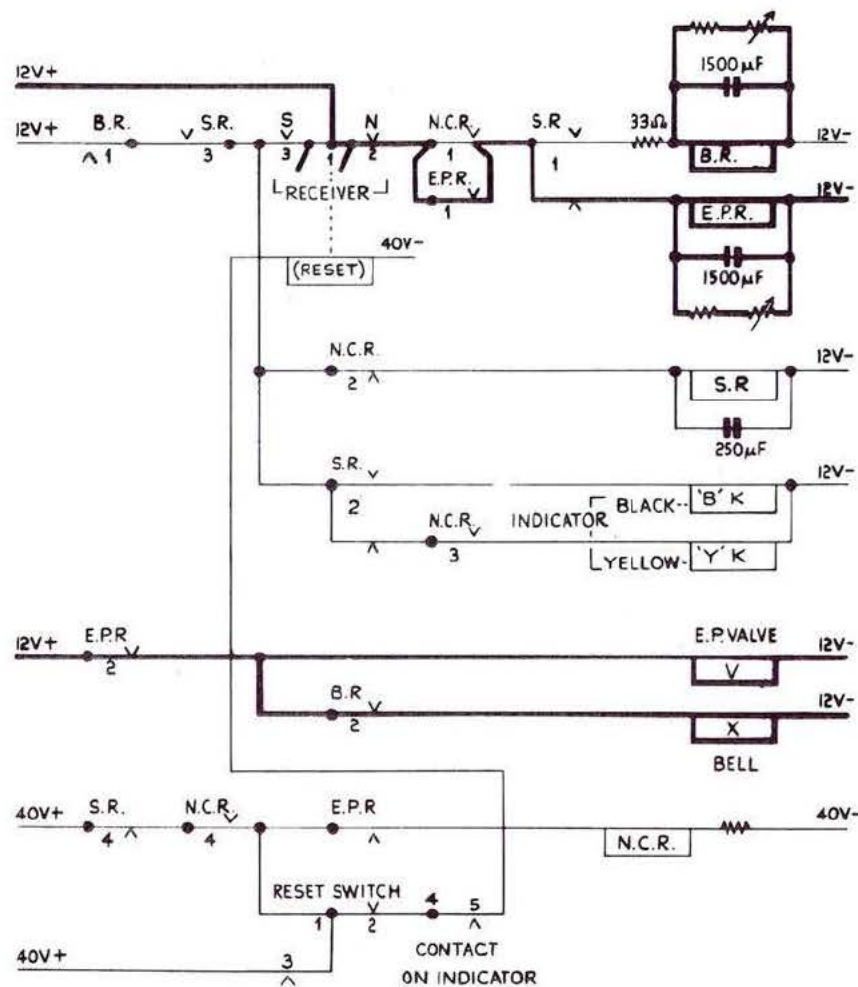
THICK LINE INDICATES CIRCUIT ENERGISED  
 COILS ETC. ENERGISED SHOWN THUS:

Condition when the Receiver has passed over the South Pole of a Permanent Magnet  
 Fig. 10:5 shows this condition. As the receiver passes over the permanent magnet the armature reverses so making contact S and breaking contact N. The circuit to relay EPR is opened but the release of the relay is delayed by the 1500 mid capacitor across its coil. S contact on the receiver extends a positive feed to operate SR. SR operated and BR released cause the Black coil of the indicator to be energised thus turning the indicator to, or maintaining it at, Black.

Fig. 10:5 AWS: cab circuits—condition immediately after receiver has passed over permanent magnet

*Condition when the Track Electro-Magnet is Energised*

This is the situation when the signal is clear (Fig. 10:6). The field from the electro-magnet restores the receiver armature to its original position. The feed to SR is removed when the BR (the bell relay) is operated. SR then releases and BR is maintained in the energised position by the capacitor across its coil for one second during which time the bell rings. The release of SR re-establishes the circuit for relay EPR—before its release time has expired—and so cancels the impending brake application. The equipment now reverts to the situation depicted in Fig. 10:4.

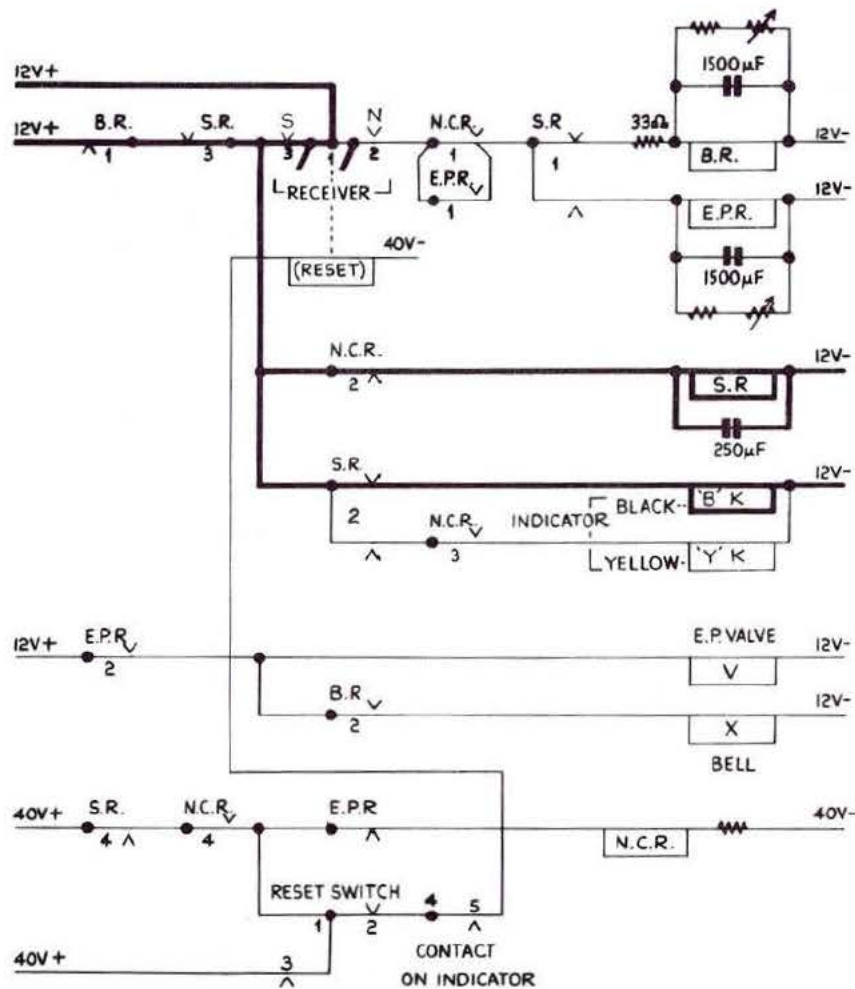


THICK LINE INDICATES CIRCUIT ENERGISED

COILS ETC. ENERGISED SHOWN THUS:-



**Fig. 10:6** AWS: cab circuits—condition after receiver has passed over energised electro-magnet



THICK LINE INDICATES CIRCUIT ENERGISED

COILS ETC. ENERGISED SHOWN THUS:- 

### Condition when the Signal is not Displaying a Green Aspect

In this case (Fig. 10:7) the receiver remains in the condition shown in Fig. 10:6. As the feed to EPR is not restored the relay will release in about one second, i.e. when the capacitor across its coil is exhausted.

The EP valve will then release, the horn will sound—and if no action is taken the brake application will commence after a further three seconds. In the case of a train travelling at 160 km/h (100 miles/h) braking will start as the front of the train reaches the signal.

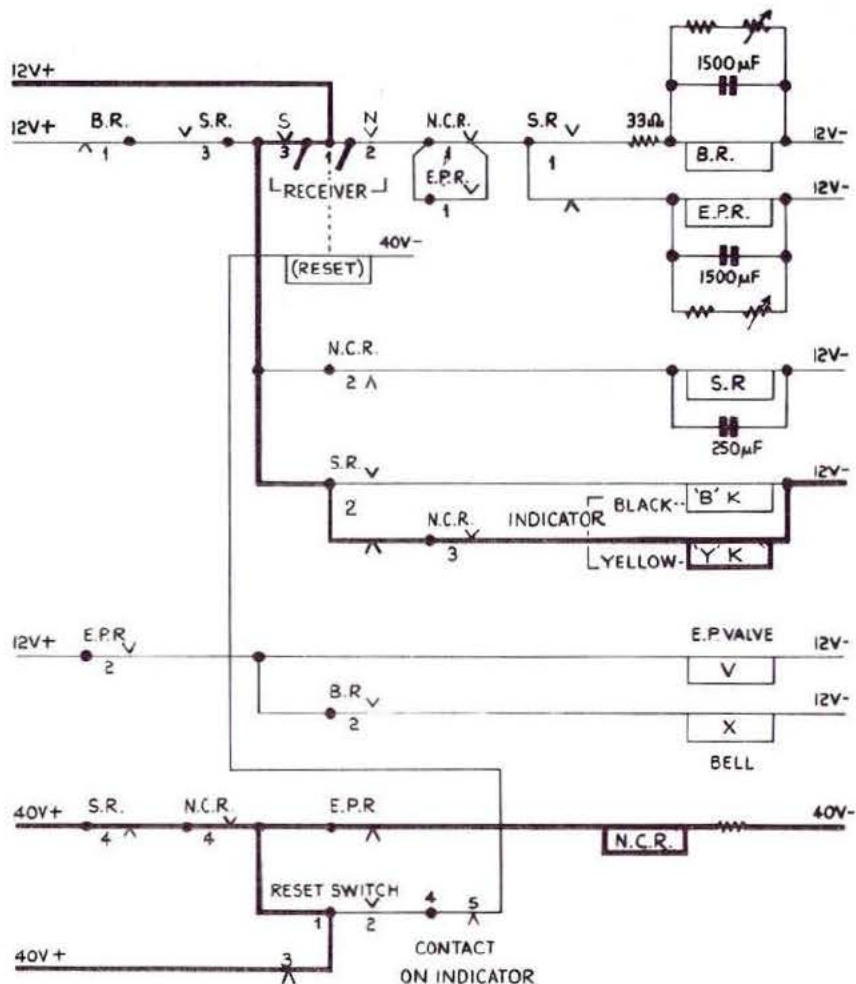
**Fig. 10:7** AWS: cab circuits—condition after receiver has passed over de-energised electro-magnet

### Driver Acknowledges a Caution (Horn) Signal

As stated earlier, after the horn has commenced to sound, the driver can acknowledge the warning, silence the horn and prevent the brake application by operating the resetting plunger (Fig. 10:8). Operation of this plunger following a caution indication directs a 40-volt positive supply—via a de-energised contact of EPR—to the coil of relay NCR. Operation of NCR interrupts the circuit to the coil of SR which now, via contact no. 2, operates the 'Y' indicator coil, so turning the display from Black to the Black-Yellow condition. This situation remains until the receiver passes over a South pole, i.e. a permanent magnet.

### AWS on Bi-Directional Track

It is implicit that the system so far described is uni-directional. In all cases where an AWS fitted line is used in both directions as normal practice, steps must be taken to suppress the permanent magnets which may run over in the wrong direction. This is effected by using special permanent magnets known as suppressors. These units contain an inductance in addition to the normal permanent magnet. An appropriately controlled feed to the inductance is switched on only when a wrong-road movement has been signalled over the AWS track equipment. A magnetic field is produced within the suppressor unit which is equal and opposite to the permanent magnet field. Thus, when AWS fitted vehicles pass over the energised suppressor they will be unaffected.



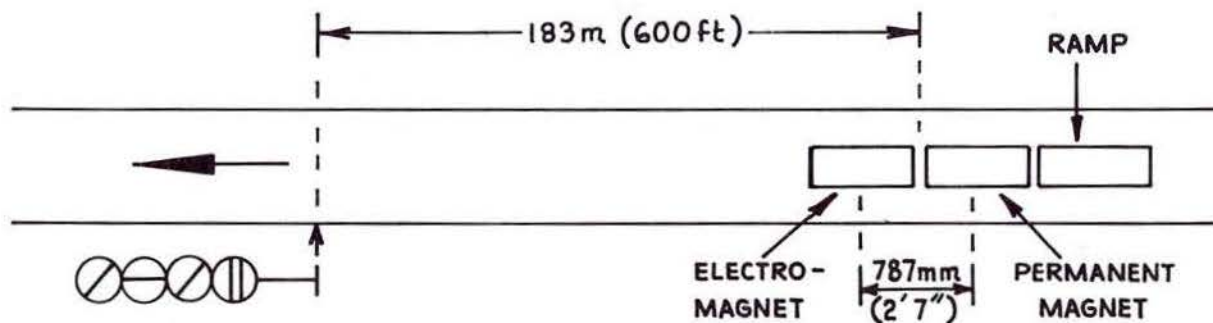
THICK LINE INDICATES CIRCUIT ENERGISED

COILS ETC. ENERGISED SHOWN THUS:-



**Fig. 10:8** AWS: cab circuits—condition after driver has acknowledged a caution signal

Fig. 10:9 Location of AWS magnets



### Audible Cab Signals

The bell and horn signals were adopted for the British Railways' Automatic Warning System at a time when the driver had no other audible signals in his cab. In a modern motive power unit there must necessarily be many other audible signals such as fire warnings and starting signals and inter-com. signals between guard and driver. In the cab of the Advanced Passenger Train, there are also audible signals for the speed restrictions which are only applicable to that unit.

As a result, there is likely to be a rationalisation of audible cab signals and the somewhat crude bell and horn will be replaced by electronically-operated signals.

### AWS in DC Electrified Areas (750 volt, 3rd rail)

On other than DC electric multiple-units and locomotives the AWS receiver is mounted on the leading bogie so that its distance above the track magnets remains practically constant. When AWS is fitted on DC electric multiple or locomotives, the heavy DC currents taken by the traction motors set up a magnetic field which may cause false operation of the AWS receiver. To overcome this it has been found necessary to fit the receiver well clear of the collector shoes and cables thereto. It is usual for it to be mounted under the centre of the leading coach of a multiple-unit set or between the bogies of a DC locomotive. In this position, the receiver is subject to greater vehicle movement due to the springing and loading of the vehicle.

It must therefore be mounted at a greater distance above the track magnets which must have a higher degree of magnetisation than those fitted in non-electrified or AC-electrified areas.

## The Future

There appear to be endless possibilities for the adoption of modern system control technology to railway signalling systems. Much has already been done by British Railways in this direction but the signal engineer is inhibited by a number of constraints.

First, the technology must be unquestionably fail-safe and reliable in performance. Many electronic methods of control would not be acceptable to the signal engineer for use in interlocking or control circuiting.

Secondly, any change in practice must either be self-financing or bring such advantages to the system that the additional cost is justified. Most signalling equipment has a working life of at least twenty-five years and represents considerable investment. It is often uneconomic to discard existing apparatus until it nears the end of its working life.

Thirdly, the lineside signalling system must be uniform throughout the network so far as the driver is concerned, or made so as quickly as possible after a change in practice has been accepted.

Fourthly, it is desirable that the circuiting and engineering practice, which forms the basis of the signalling system, should have a high degree of standardisation to facilitate maintenance and enable new projects to be designed and executed as speedily as possible.

This does not mean that the signal engineer should eschew change as a matter of principle. Far from it: but most railway administrations are engaged in fierce competition with other forms of transport, and disturbances to the system involving delays to traffic must be avoided or at least minimised.

So far as British Railways are concerned, it can be accepted that the lineside signalling is now adequate for all the traffic likely to be offered at speeds for which the line is signalled up to a maximum 200 km/h. Nevertheless, it is claimed that any sensible reduction

in journey time will result in increased revenue and, to this end, the Advanced Passenger Train (APT) has been designed. This not only has a very high speed potential (250 km/h and higher) but its tilting coaches will enable it to run at a higher speed over many sections of line where permanent speed restrictions exist for conventional trains. Thus, even if the APT is running on existing lineside signalling at speeds up to 200 km/h, the driver will require to be warned of the location of speed restrictions which are applicable to the train. Transponders in the track will be used for this purpose.

If, however, the APT is required to run at more than 200 km/h, another problem will be posed because one or more signal sections must be added to the service braking distance with some form of cab signalling for the driver. The British Railways' Chief Signal and Telecommunications Engineer and the Research Department are currently and jointly developing a system for automatic train operation (ATO) superimposed on the lineside signalling system, and it is probable that an intermittent cab signalling system will be incorporated with speed supervision and regulatory control. This may provide the basis of the solution for the higher speeds and for improved running of conventional trains.

Changes in system engineering are likely to be directed towards a greater degree of automation for two reasons. First, because as wages increase, many labour-saving devices, hitherto uneconomic, may become self-financing and, secondly, because automatic operation is generally more efficient than manual operation.

It is therefore likely that the capabilities of the computer-based train describer will be exploited as a continuation of the progress which has already been made. In this connection, British Railways will, no doubt, be giving serious consideration to a purely numerical train code which will enable each train route to be uniquely and completely identified, and provide greater scope for ancillary tasks than the current alpha-numerical code. The aim will almost certainly be towards the automation of the duties of the panel operator and the regulator. Full automation of the display of information to the public is also probable.

## THE FUTURE

There is considerable interest in the use of the Visual Display Unit (VDU) as an alternative to the mosaic type of signalling control panel, although it is difficult to visualise a successful application as an alternative, having regard to the large layouts and areas of control now common on British Railways. For small individual layouts, there is little doubt that the VDU could be used, but few, if any, small layouts will exist in isolation in the future British Railways control network.

On the transmission side, for long cable to remotely controlled interlockings and for high capacity telecommunication cables, cables using optical fibre techniques have a promising future. Attenuation would be reduced, crosstalk eliminated and repeater spacing increased. Furthermore, such cables have the great advantage of being completely immune to magnetic induction and thus, in AC electrified areas, the immunisation of signal and telecommunication circuits would no longer be needed.

In DC electrified areas, the elimination of the impedance bond track circuit in all its forms may be expected. It will be replaced by a jointless track circuit of the audio-frequency type, of which the reed type is currently being installed by British Railways. Other types, however, are being evaluated. The impedance bonds themselves will still be required in electrified areas for traction cross bonding, although redesigned to suit the new form of track circuit and the traction system.

There is also interest in computer interlocking and a system is in the development stage, although it has yet to be proved by the Chief Signal and Telecommunications Engineer for safety and reliability. It has also to be ascertained whether it will have practical and economic advantages over relay (geographical) circuiting. There seems little doubt that, in due course, a system will emerge with all the fail-safe features and flexibility of relay interlocking. If the development is successful, the elimination of the majority of relays in relay rooms and in lineside apparatus cases can be envisaged.

These are only a few of the major items of development which are currently in hand. British Railways and the manufacturers have many more. Individual items of equipment and methods of construction are constantly being improved without affecting the lineside signalling. It is a continuing process and, in consequence, complete standardisation of the system engineering will never be achieved. Nevertheless, it remains important that standard practice should be established and maintained. Progress and standardisation are contradictory, and the only way in which they can be reconciled is by a regular review of standards at which those items which have proved to be satisfactory since the previous review should be considered for general adoption. It is clear that current major development interest lies in the increased application of computers to the system engineering.

# Chapter-by-chapter index

## 1 Philosophy 1 et seq

The Elements:

- Track circuits 3
- Interlocking 3
- Multiple Aspect Signalling 3
- Automatic Warning System 3

## 2 Layout of Signals and Track Circuits 4 et seq

Symbols 4

Definitions:

- Service Braking Distance 4
- Sighting Point 4
- Sighting Allowance 4
- Overlap 4
- Headway Distance 5
- Line Capacity 5
- Train Length 5

2-aspect signalling 6

2-aspect main line signalling 6

3-aspect main line signalling 9

4-aspect main line signalling 10

Optimum Headway 16

Braking Technique 20

Signalling at Intermediate stations  
20, 28

Layout at Simple Trailing Junction  
30

Layout at Double Junction 31

Layout at L.H. Double Running  
-Junction 32

Layout at Double Running Junc. on  
High Speed line 34

Track Circuits (Layout) 35

Subsidiary Signal: assoc. track  
circuits 38

Shunt Signal: assoc. track circuits  
40

Signalling and track circuits at a  
terminal station 42

Junction signalling 44

## 3 Principles of Interlocking Controls 50 et seq

Panel Operation 50

Numbering of Signals, Points and  
Routes 52

Main signal controls 52

Facing points in the overlap 60

Route locking 62

Interlocking between points 65

Dead locking, conditional locking  
66

Subsidiary signal control 68

Shunting signal control 68

Head and tail movements 70

Automatic operation of signals 70

Control Tables 72

## 4 Equipment: 78 et seq

BR 930 Series Relays 78

Main signals 80

Position Light Junction Indicator  
89

Multiple Lamp Route Indicator  
92

Position light shunt signal 92

Position light subsidiary signal 96

Electric point operation 96

Point Drive Equipment 98

Electric point machine detection  
105

Point Control Circuits 106

Electro-hydraulic point machine  
108

Rail clamp locks 109

Circuit hierarchy 113

Setting up a route 114

Swinging the overlap 120

Releasing a route 122

Automatic Working 122

Train operated route release 124

Characteristics of BR 930 series  
relays 125-7

## 5 Signalling Control Panels 128 et seq

General description 128

Route setting 133

Alternative overlaps 135

Individual point operation 135

Restricted Overlap Buttons 135

Signal indications 135

Duplicated Lamp Indications 135

Track Circuit Indications 136

Auto. working of normally  
controlled signals 136

Emergency replacement of  
automatic signals 136

Signal Slots 136

Block Instrument Working 136

Emergency block bells 136

Level Crossing Control 137

Ground frame release 139

Hot axle box detectors 139

Directional Indicators 139

Train ready to start indicators 139

Remote control override 139

Alarm buttons 140

Lighting control 140

Reminder devices 140

Alarm indications 140

Telephone concentrators 141

Train running information 141

Train describers 142

Layout of operating floor 143

Design of building 143

Internal cabling 143

Constructional requirements 144

Control panel construction 144

High voltage power supply  
emergency switching 146

## 6 Geographical Circuitry 147 et seq

Principles 147

Advantages 148

Uniformity 148

Circuit preparation 148

Installation and Testing 148

Layout alterations 148

Approach locking 148

Flank protection 148

Overlaps 150

Unit layout in relation to track  
layout 150

Physical features 152

Locking and control principles  
153

System "A" 157 et seq

Types of relay sets 158

Entrance registration 160

Exit registration 163

Signal Aspect level 168

Route releasing 168

System "B" 170 et seq

Push button operation 172

Route Priming 174

Signal Aspect Controls 176

Route Releasing 176

Point setting and locking 178

Panel Key operation 178

## INDEX

### 7 Track Circuit Principles and Equipment 182 et seq

- Principle of operation 182
- D.C. Track Circuit Calculations 184
- Insulated rail joints 187
- Track circuits over points 188
- Series and parallel bonding 189
- Track circuit interrupters 190
- Limitations of the simple D.C. Track Circuit 192
- Important feature in design 192
- A.C. Immunised D.C. Track Circuits 194
- A.C. Track Circuits (General) 197
- Methods of achieving immunity from Electric Traction systems 198
- Double-element Vane Relay 198
- Rail Impedance 200
- Single and double rail A.C. Track Circuits 202
- Impedance bond design 204
- A.C. Track circuit feed arrangements 206
- Unbalanced traction current in the rails 210
- Impedance bond layouts 212
- Reed track circuits 213
- Jointless track circuits, principles 215
- Aster '1-Watt' jointless track circuit 218
- Aster 'Type U' jointless track circuit 218
- Alsthom jointless track circuit 220
- Reed jointless track circuit 220
- Impulse Track circuits 223

Coded track circuits 224

### 8 Remote Control Systems 226 et seq

- Types and usage 226
- Direct Wire System 226
- Frequency Division Multiplex (FDM) 226
- Time Division Multiplex (TDM) 226
- Terminology 227
- Typical Installation 228
- Direct Wire System 228
- FDM 233 et seq
  - Basis 233
  - Practical Systems 234
  - Line Transmission and Equipment 237
  - Choice of Frequency 237
  - Fail safe systems 238
  - Supervisory applications 242
  - Applications of Fail safe FDM 242
- TDM 245 et seq
  - Principle of operation 245
  - Input multiplexing 245
  - Multiplexing onto Highways 245
  - Parallel to serial conversion 246
  - Message format 248
  - Modulation on to Carrier 248
  - Message de-multiplexing 250
  - Carrier demodulation 251
  - Serial to parallel conversion 251
  - De-multiplexing from highways 251
  - Uni-directional systems 252

- Bi-directional single station systems 253
- Bi-directional multi-station systems 254
- Immediate access 256
- Alarms and monitoring 256
- Line circuits and line amplifiers 257

### 9 Train Description 258 et seq

- Early forms 258
- Berth to berth stepping 260
- Operation of the berth describer 262
- General design considerations 263
- Stepping Table 263
- Operator interface 271
  - Control unit 271
  - Fringe signal boxes 273
  - Setting up 274
  - Alarms 274
  - Manual Transmission 275
- Display Systems 275
  - Cathode Ray Tubes 276
  - Display make up 276
  - Deflection waveforms 276
  - Display Storage 276
    - Light emitting diodes 278
  - Electronic Describers 280 et seq
    - Computers, for use in, 280
    - Basic Computer operation 281
    - Software 282
    - Programme Organisation 284
      - The Base Load 284
      - The Variable Load 284
  - Data area 285
  - Simple computer-based describer 285

- Dual computer-based describer 286
- Duplication philosophy 286
- Input System 286
- Display System 291
- Fringe signalboxes 292
- Communication with Adjacent describers 292
- System monitoring 293
- Printing and tape punches 293
- Automatic train reporting 294
- Information to passengers 295
- Visual Display Units 296
- Automatic Route Setting 296
- Automation of timetables compilation 296

### 10 The BR Automatic Warning System 299 et seq

- Equipment in the track 301
- Equipment on motive power units 301
- Track equipment circuitry 302
- AWS on bi-directional track 307
- Audible cab signals 308
- AWS in D.C. Electrified Areas 308

### 11 The Future 309

- Cab signalling for Advanced Passenger train 309
- VDU instead of mosaic panels 310
- Computer interlocking 310

# RAILWAY CONTROL SYSTEMS

compiled by a Project Group  
of the Institution of Railway Signal Engineers  
under the general editorship of Maurice Leach

Technology has developed considerably since 1980 when *Railway Signalling* was published. In this book particular attention is given to Solid State Interlocking (SSI) which is now replacing earlier relay-based safety systems on British Rail.

Also covered are: modern methods of single line operation, level crossing control and train detection, and the immunisation of safety systems against electrical interference. Information on signalling principles and practice, and in equipment and apparatus design is updated.

There are chapters on automatic train protection and passenger information systems, with a final chapter on trends in signalling techniques and philosophy.

Cover photographs: *control room*, photo by courtesy of the British Railways Board;  
*outdoor signal*, photo by courtesy of GEC-Alsthom

A&C Black · London

£29.99 net

ISBN 0-7136-3420-0



9 780713 634204

