





# Southwire™

## **SOUTHWIRE THE COMPANY**

Since 1950, Southwire has grown into North America's largest wire and cable producer and supplier by offering the broadest line of the highest-quality products.

## **SOUTHWIRE THE PEOPLE**

More than 5,400 people at sales offices, customer service centers and manufacturing facilities throughout North America are dedicated to developing the highest-quality products backed by quality service.

## **SOUTHWIRE THE PRODUCTS**

Southwire offers a full line of products for a wide range of applications. Now you can get it all from one supplier.

## **SOUTHWIRE TOOLS & ACCESSORIES**

A complete line of hand tools, meters and contractor equipment that offers premium quality, innovation and reliability to the electrical industry.

## **SOUTHWIRE THE SERVICE**

With customer service centers located throughout North America, Southwire provides all of your wire and cable needs in one delivery, saving you time and money.

## **SOUTHWIRE THE INNOVATION**

Dedicated to technological innovation and backed by experience means Southwire is always one step ahead, expanding its product lines and services to meet the needs of customers.



# TABLE OF CONTENTS

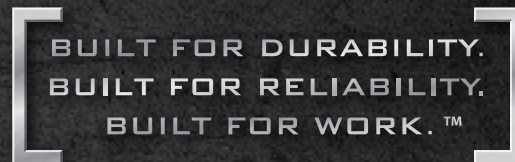

For over 60 years, Southwire® has provided high quality electrical wire and cable to the commercial and industrial construction industries. Now, the name you trust provides durable, cutting-edge professional grade tools, designed with safety and productivity in mind. Look to Southwire® for all of your tool needs, from electrician's hand tools to contractor equipment, including the Maxis® product line.

## HAND TOOLS 4

Pliers, Stripping & Cutting, Drivers, Levels & Measuring, Saws & Cutters, Kits & Accessories

## TEST & MEASUREMENT TOOLS 34

Multimeters, Clamp Meters, Voltage Detectors & Testers, Circuit Testers, IR Thermometers, Imaging, Accessories

## CABLE PULLING TOOLS 64

Cable Pullers, Fishing, Rope, Accessories

## CONDUIT BENDING TOOLS 80

Benders, Accessories

## HOLE MAKING TOOLS 84

Knockouts, Accessories

## MATERIAL HANDLING TOOLS 94

Reel Jacks, Wire Carts, Wire Wagons

## INDEX / WARRANTIES 103



**Southwire™**

# HAND TOOLS

Your hands are your most important tools, the ones you need for every job. Equip them with high-quality, durable hand tools from Southwire™. With a strong yet comfortable design and lifetime warranty\*, you can rely on these tools to make your life easier and last through years of hard work.

- Pliers
- Stripping & Cutting
- Drivers
- Levels & Measuring
- Saws & Cutters
- Kits & Accessories



[SOUTHWIRETOOLS.COM](http://SOUTHWIRETOOLS.COM)

\*Limited warranty available on most tools. See warranty for details.

[www.EngineeringBooksPDF.com](http://www.EngineeringBooksPDF.com)

## HIGH LEVERAGE DIAGONAL CUTTING PLIERS

### DCP8



The high leverage design of these 8" diagonal cutting pliers provides greater cutting power while the hot riveted joint ensures smooth action with no handle wobble.

- Induction hardened cutting blades ensure efficient and lasting cutting surfaces
- Drop forged CRV steel for durability
- High leverage design provides maximum cutting power
- Hot riveted pivot joint provides smooth action and no wobble
- Effectively cuts most hardened wire, ACSR, bolts, screws, and nails
- Available in dual molded comfort grips and plastic dipped handles

### DCPA8



### DCP8D



### DCPA8D



## SPECIFICATIONS

### COMFORT GRIP

MODEL #	STOCK #	DESCRIPTION		
DCP8	582772	8" High Leverage Diagonal Cutting Pliers		
DCPA8	582771	8" High Leverage Diagonal Cutting Pliers w/ Angled Head		
	HEIGHT	WIDTH	DEPTH	WEIGHT
DCP8	8.25"	2.25"	0.75"	11.6 oz
DCPA8	8.25"	2.25"	0.75"	11.6 oz

### DIPPED GRIP

MODEL #	STOCK #	DESCRIPTION		
DCP8D	582894	8" High Leverage Diagonal Cutting Pliers w/ Dipped Handle		
DCPA8D	582895	8" High Leverage Diagonal Cutting Pliers w/ Angled Head and Dipped Handle		
	HEIGHT	WIDTH	DEPTH	WEIGHT
DCP8D	8"	2"	0.63"	9.8 oz
DCPA8D	8"	2"	0.63"	9.8 oz

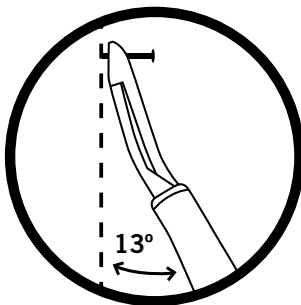

\*DCPA8 and DCPA8D

## HIGH LEVERAGE SIDE CUTTING PLIERS

### SCP9TPC



### SCP9C



### SCP9TP



### SCP9



### SCP9D



Our high leverage side cutting pliers offer streamlined design with sure-gripping, cross-hatched knurled jaws.

- Induction hardened cutting blades ensure efficient and lasting cutting surfaces for hard and soft wire
- Drop forged CRV steel for durability
- File teeth on jaws help remove burrs in conduit
- Curved ergonomic handle for comfortable use

## SPECIFICATIONS

### COMFORT GRIP

MODEL #	STOCK #	DESCRIPTION		
SCP9TPC	582769	High Leverage Side Cutting Pliers w/ Fish Tape Puller & Crimper		
SCP9C	582768	High Leverage Side Cutting Pliers w/ Crimper		
SCP9TP	582766	High Leverage Side Cutting Pliers w/ Fish Tape Puller		
SCP9	582765	High Leverage Side Cutting Pliers		
	HEIGHT	WIDTH	DEPTH	WEIGHT
SCP9TPC	9.5"	2.25"	0.88"	19 oz
SCP9C	9.5"	2.25"	0.88"	19 oz
SCP9TP	9.5"	2.25"	0.88"	19 oz
SCP9	9.5"	2.25"	0.88"	19 oz

### DIPPED GRIP

MODEL #	STOCK #	DESCRIPTION		
SCP9D	582898	High Leverage Diagonal Cutting Pliers w/ Dipped Handle		
	HEIGHT	WIDTH	DEPTH	WEIGHT
SCP9D	9.5"	2.13"	0.75"	19 oz

## LONG NOSE PLIERS

### LNP8S



Southwire™ long nose pliers provide a better grip without sacrificing tool strength or durability.

- Knurled jaws for sure gripping
- High leverage, hot rivet design for smooth action and no handle wobble
- Drop forged CRV Steel for durability
- Long nose design for forming and looping wire and handling small parts
- Precision induction-hardened cutting knives
- 12 AWG solid wire stripping feature on LNP8S and LNP8SD models

### LNP7



### LNP6



### LNP8SD



### LNP6D



## SPECIFICATIONS

### COMFORT GRIP

MODEL #	STOCK #	DESCRIPTION		
LNP8S	582763	8" Heavy Duty Long Nose Pliers w/ Side Cutting Stripper		
LNP7	582762	7" Long Nose Pliers w/ Side Cutter		
LNP6	582761	6" Long Nose Pliers w/ Side Cutter		
	HEIGHT	WIDTH	DEPTH	WEIGHT
LNP8S	8.5"	2.13"	0.88"	10.3 oz
LNP7	7.13"	2.25"	0.75"	5.7 oz
LNP6	7"	2.25"	0.75"	5.5 oz

### DIPPED GRIP

MODEL #	STOCK #	DESCRIPTION		
LNP8SD	582897	8" Heavy Duty Long Nose Pliers w/ Side Cutting Stripper Dipped Handle		
LNP6D	582896	6" Long Nose Pliers w/ Side Cut Dipped Handle		
	HEIGHT	WIDTH	DEPTH	WEIGHT
LNP8SD	8.38"	2.13"	0.63"	10.3 oz
LNP6D	6.88"	2.25"	0.56"	5 oz

## PUMP PLIERS



Our tongue and groove design provides a firm and secure grip in a wide range of versatile jaw positions.

- V-jaw design allows for greater holding force and better surface contact
- Undercut tongue and groove design resists slipping
- Smoothly adjusts between seven machined tongue and groove jaw positions
- Right angle, laser heat-treated teeth grip better and last longer
- High-carbon, CRV polished steel
- Molded comfort grip for comfortable use

### SPECIFICATIONS

MODEL #	STOCK #	DESCRIPTION			
PP10	582790	10" Pump Pliers			
PP6	582792	6 1/2" Pump Pliers			
	HEIGHT	WIDTH	DEPTH	WEIGHT	
PP10	10.5"	2.5"	0.44"	15.5 oz	
PP6	7"	2"	0.5"	7.6 oz	

## 5-IN-1 MULTI TOOL PLIERS



This versatile pair of spring action pliers performs multi-functions.

- Multi-functional pliers: grips, strips, crimps, reams, and cuts
- Narrow knurled jaw allows access to tight spaces
- Easily strips 10-14 AWG solid wire
- Crimps common size wire ferrules
- Reams and smooths thin-wall conduit ends
- Cuts small gauge copper wire and communication cables
- Durable forged construction for lasting performance
- Comfortable grips minimize hand wear and fatigue

### SPECIFICATIONS

MODEL #	STOCK #	DESCRIPTION			
S5N1	582881	5-IN-1 Multi Tool Pliers w/ Comfort Grip			
	HEIGHT	WIDTH	DEPTH	WEIGHT	
S5N1	8.25"	2.5"	0.63"	5.6 oz	

## CRIMPING/CUTTING PLIERS - INSULATED AND NON-INSULATED CONNECTORS



These high leverage crimping pliers have two die positions that permit the tool to crimp insulated and non-insulated terminals and ferrules.

- Tapered nose for working in confined spaces
- Crimp 10-22 AWG solderless terminals and connectors
- Specially-hardened wire cutter in nose
- Curved handle and ergonomic molded grip for comfortable use
- Crimps insulated and non-insulated terminals and connectors
- Curved handle and ergonomic dipped grip for comfortable use

### SPECIFICATIONS

MODEL #	STOCK #	DESCRIPTION		
TCC9D	582899	Terminal Crimper Cutter w/ Dipped Handle		
TCC9	582778	Terminal Crimper Cutter		
	HEIGHT	WIDTH	DEPTH	WEIGHT
TCC9D	9.75"	2.38"	0.63"	12.7 oz
TCC9	9.38"	1.88"	0.75"	13.7 oz

## WIRE STRIPPERS & CUTTERS

### S1018SOL



Made of stainless steel, these wire strippers have precision ground stripping holes and are fitted with comfortable double-dipped plastic grips.

- Stainless steel construction is durable and rust-proof
- Serrated nose grasps the cable for easy twisting and pulling
- Specially designed cutting blades provide fast and clean wire stripping and cutting
- Spring loaded for self-opening action
- Double dipped grip provides comfortable feel

### S1018STR



### S612STR



### S1626STR



## SPECIFICATIONS

MODEL #	STOCK #	DESCRIPTION		
S1018SOL	582780	Wire Stripper Cutter 10-18SOL;12-20 Stranded Ergonomic Handle		
S1018STR	582781	Compact Stripper Cutter 10-18 AWG Soild		
S612STR	582779	Wire Stripper Cutter 6-12 AWG Stranded Ergonomic Handle		
S1626STR	582782	Compact Stripper Cutter 16-26 AWG Stranded		
	HEIGHT	WIDTH	DEPTH	WEIGHT
S1018SOL	7.63"	8.38"	0.69"	5.3 oz
S1018STR	6.25"	2.38"	0.69"	4.6 oz
S612STR	7.38"	2.5"	0.63"	5.6 oz
S1626STR	6.25"	2"	0.69"	4.5 oz

## WIRE STRIPPERS & CUTTERS (CONTINUED)

### SNM1012



Made of stainless steel, these wire strippers have precision ground stripping holes and are fitted with comfortable double-dipped plastic grips.

- Stainless steel construction is durable and rust-proof
- Serrated nose grasps the cable for easy twisting and pulling
- Specially designed cutting blades provide fast and clean wire stripping and cutting
- Spring loaded for self-opening action (on models SNM1012, SNM1214, SVN)
- Double dipped grip provides comfortable fit

### SNM1214



### MP61



### MPLN



### SVN



## SPECIFICATIONS

MODEL #	STOCK #	DESCRIPTION		
SNM1012	582784	NM Cable Stripper Cutter 10-12 AWG Ergonomic Handle		
SNM1214	582785	NM Cable Stripper Cutter 12-14 AWG Ergonomic Handle		
MP61	582789	6-IN-1 Multipurpose Stripper		
MPLN	582788	Long Nose Multipurpose Tool		
SVN	582787	Wire Stripper V-Notch		
	HEIGHT	WIDTH	DEPTH	WEIGHT
SNM1012	8.13"	2.19"	0.69"	6 oz
SNM1214	7.88"	2.19"	0.69"	5.8 oz
MP61	9"	2.38"	0.69"	6.8 oz
MPLN	8.5"	2.38"	0.75"	5.8 oz
SVN	5.25"	2.31"	0.44"	2.3 oz

## CABLE CUTTING PLIERS

### CCP9



Shear type hook jaws grab and hold cable while shear cutting action makes clean cuts.

- Heat treated, precision ground blades ensure clean cuts
- Comfortable cushion grips reduce hand fatigue
- Beveled tips for positive mating
- Hing bolt with pin-set nut for proper blade tension (CCP350)
- Forged steel with black-oxide finish for long life

### CCP6



### CCP350



### CCP9D



## SPECIFICATIONS

### COMFORT GRIP

MODEL #	STOCK #	DESCRIPTION	HEIGHT	WIDTH	DEPTH	WEIGHT
CCP9	582774	9" High Leverage Cable Cutters				
CCP6	582773	6 3/4" Cable Cutting Shears				
CCP350	582776	16" Utility Cable Cutters 350 Cu				
CCP9			9.38"	2.13"	0.63"	15 oz
CCP6			6.75"	2"	0.75"	8.6 oz
CCP350			17"	5"	0.75"	2.8 oz

### DIPPED GRIP

MODEL #	STOCK #	DESCRIPTION	HEIGHT	WIDTH	DEPTH	WEIGHT
CCP9D	582932	9" High Leverage Cable Cutters w/ Dipped Handle				
CCP9D			9.38"	2.25"	0.63"	15.4 oz

## RATCHETING CABLE CUTTER



The hardened steel blades on this heavy duty cutter ensure consistent cuts and long-term durability, while the rounded blade design minimizes cable distortion during cutting.

- Replaceable hardened steel blades provide long lasting cutting of copper and aluminum cables
- Cuts up to 750 kcmil copper and 1000 kcmil aluminum cables
- Two-step ratcheting mechanism for fewer strokes per cut
- Quick-release lever opens blade at any time during operation
- Molded grip for comfort, stability and leverage when making cuts

### SPECIFICATIONS

MODEL #	STOCK #	DESCRIPTION			
CCPR400	582777	Ratcheting Cable Cutter			
		HEIGHT	WIDTH	DEPTH	WEIGHT
CCPR400		10.25"	5.5"	1.25"	31 oz
*MAXIMUM CUTTING POWER (COPPER)			*MAXIMUM CUTTING POWER (ALUMINUM)		
750 kcmil(MCM)			1000 kcmil(MCM)		

\*Note: Maximum cutting capacity is for single conductor wires

## CABLE RIPPING TOOL



This NM-B cable ripper makes cable jacket removal quick and easy. It slits the cable jacket with one easy stroke. Includes convenient wire gauging holes in the handle.

- Makes end or mid-run slits to expose insulated wires
- Easily slits the outer jacket on NM-B cable
- Accurate wire measuring gauge holes - 6 to 14 AWG solid wire

### SPECIFICATIONS

MODEL #	STOCK #	DESCRIPTION
CRT	582933	Cable Ripper Tool

## BOOT KNIFE



Our tough boot knife cuts electronic wire, telephone cables and skin cable jackets.

- Tough forged steel blade
- Use to cut electronic wire, telephone cables, & skin cable jackets
- Ergonomic handle for snug, solid grip
- Comes with protective storage cap

### SPECIFICATIONS

MODEL #	STOCK #	DESCRIPTION			
BN01	582884	Boot Knife			
		HEIGHT	WIDTH	DEPTH	WEIGHT
BN01		6.38"	1"	0.5"	2 oz

## ELECTRICIAN'S SCISSORS



Unlike regular scissors or shears, the serrated blades keep wire from slipping out of the jaws, so that cutting through hardware cloth, cable, wire netting, and other difficult-to-cut materials becomes an easy task.

- Durable nickel-plated steel for resistance from rust and corrosion
- Strips 19 AWG & 23 AWG
- Scraper and file on outside of both blades
- Cuts up to 16 AWG solid and 12 AWG stranded wire

### SPECIFICATIONS

MODEL #	STOCK #	DESCRIPTION		
ES001	582835	Electricians Scissors		
	HEIGHT	WIDTH	DEPTH	WEIGHT
ES001	5.38"	2.19"	0.38"	3 oz

## ELECTRICIAN'S MULTI TOOL



Meets the needs of electricians and maintenance professionals with features that come in handy on any job.

- Specially designed for electricians
- Stainless steel construction
- Strips 10-20 AWG, cuts, pulls, screws, saws, tightens and files

### SPECIFICATIONS

MODEL #	STOCK #	DESCRIPTION		
MT001	582834	Multi Tool		
	HEIGHT	WIDTH	DEPTH	WEIGHT
MT001	4"	1.75"	1"	10.8 oz

## 6-IN-1 UTILITY KNIFE



A multi-purpose tool that helps with most of those "around-the-job" needs. A must-have pocket tool for every electrician.

- Six tools in one:
  - Quick change utility blade
  - #2 phillips screwdriver
  - Sanding rasp to trim excess or rough edges
  - Keyhole saw
  - Nail and tack puller and holder
  - Hammer butt end

### SPECIFICATIONS

MODEL #	STOCK #	DESCRIPTION		
UTIL61	582885	6-IN-1 Utility Knife		
	HEIGHT	WIDTH	DEPTH	WEIGHT
UTIL61	5"	1.25"	0.88"	10.9 oz

## AUTOMATIC WIRE STRIPPER



With this wire stripper, insert a wire, squeeze the handles, and you're finished.

- Strips 8-22 AWG wire quickly and easily
- Strip wire with easy, one-handed motion
- Removes up to 1" of jacket layer with single step
- Spring design returns wire to ready position after stripping

### SPECIFICATIONS

MODEL #	STOCK #	DESCRIPTION
SA822	582786	Wire Stripper Automatic 8-22 AWG
	HEIGHT	WIDTH DEPTH WEIGHT
SA822	7"	3.38" 1.13" 13 oz

## ELECTRICIAN'S HACK SAW



An essential tool for plumbers, electricians and HVAC professionals.

- Cushioned ergonomic grip for performance and comfort
- Extra blade storage in frame
- Blades can be adjusted to 55 degree angle for flush cutting
- Forward handle can be removed and used as jab saw

### SPECIFICATIONS

MODEL #	STOCK #	DESCRIPTION
HSAW	582827	Electrician's Hack Saw
	HEIGHT	WIDTH DEPTH WEIGHT
HSAW	17"	6" 1" 2.1 oz

## DRYWALL JAB SAW



Our Drywall Jab Saw is designed with a triple cut blade for a fast and efficient cut. The sharp tip excels at plunge cutting, and its aggressive tooth design cuts fast.

- Hardened and tempered steel blade for long lasting durability and strength
- Sharp cross-ground teeth cut through drywall, wood, or plastic
- Overmolded cushion handle for comfort and firm grip
- 7" blade with cross-grained teeth cuts drywall in both directions

### SPECIFICATIONS

MODEL #	STOCK #	DESCRIPTION
DESAW	582824	Drywall Jab Saw
	HEIGHT	WIDTH DEPTH WEIGHT
DESAW	12"	1.63" 1.13" 4.7 oz

## TRIFOLD DRYWALL SAW



Ideal for flush cutting applications or when a hacksaw is not available.

- Ergonomic handle for greater comfort
- Blade locks in three positions for safer operation
- Includes three blades 5"x18 TPI, 5"x6 TPI, 5"x9 TPI; accepts standard reciprocating

## CONDUIT SCORER AND CUTTER



Cut copper, aluminum and brass tubing and galvanized thin wall conduit in a few revolutions.

- Scores and cuts EMT conduit
- Cutting wheel can be changed quickly and easily

## PLASTIC PIPE CUTTER



Our plastic pipe and tubing cutter has non-slip grips and a strong stainless steel blade that makes cutting plastic tubing easy.

- Easily performs flush cuts on ridged plastic tubing
- Durable design for rugged use
- Locking latch allows easy one-handed operation
- Cuts up to 3/4" PVC and 1-5/8" flexible tubing

## ROTARY CABLE CUTTER



Easily handles all common MC, BX, and flex cables. Securely holds cable in place and releases quickly.

- Quickly splits the armored jacket on #10, #12 and #14 armored cables and 3/8" flexible conduit with a few turns of the handle
- Adjustable cutting depth for standard and reduced diameter BX/MC cables
- Stores up to 6 extra blades in handle knob
- Durable die cast epoxy enameled construction

## SPECIFICATIONS

MODEL #	STOCK #	DESCRIPTION	HEIGHT	WIDTH	DEPTH	WEIGHT
FDWSAW	582826	Trifold Drywall Saw	7"	1.5"	1.13"	11 oz
CONCUT	582820	Conduit Cutter Scorer	5.25"	2"	1.5"	15.4 oz
PLACUT	582821	Plastic Pipe Cutter	8.75"	1.83"	1.17"	5.6 oz
MCCUT	582822	BX MC Rotary Cutter w/Lever	7.5"	1.75"	3.5"	19 oz
MCBLADE	582823	BX MC Replacement Blade (1 blade/pack)	1"	1"	0.06"	0.1 oz

## PHILLIPS TIP SCREWDRIVERS

### SD2P6HD



### SD2P4HD



### SD1P3



### SD2P1-1/2



### SDI2P4



Southwire's screwdrivers are designed for the professional with durability, quality and comfort in mind.

- Comfortable cushioned grip allows firm grasp and greater torque
- Integral flanges provide a solid, twist-resistant blade anchor
- Handle end is marked for easy identification of tip type and size
- Chrome-plated, steel shaft for maximum torque with less shaft twisting
- Precision-machined, black phosphate coated tip reduces slipping

## SPECIFICATIONS

MODEL #	STOCK #	DESCRIPTION			
SD2P6HD	582851	#2 PHILLIPS 6" HEAVY DUTY ROUND SHANK			
SD2P4HD	582847	#2 PHILLIPS SCREWDRIVER 4" ROUND SHANK			
SD1P3	582849	#1 PHILLIPS SCREWDRIVER 3" ROUND SHANK			
SD2P1-1/2	582861	#2 STUBBY SCREWDRIVER W/ 1-1/2" SHANK			
SDI2P4	582843	#2 PHILLIPS SCREWDRIVER 4" INSULATED			
		HEIGHT	WIDTH	DEPTH	WEIGHT
SD2P6HD		10.25"	1.25"	1.25"	7 oz
SD2P4HD		6.5"	1.25"	1.25"	4.2 oz
SD1P3		6.5"	1.13"	1.13"	2.4 oz
SD2P1-1/2		3.75"	1.25"	1.25"	1.8 oz
SDI2P4		8.5"	1"	1"	3.9 oz
		SHANK TYPE		SHANK LENGTH	
SD2P6HD		HEAVY-DUTY		6"	
SD2P4HD		HEAVY-DUTY		4"	
SD1P3		ROUND		3"	
SD2P1-1/2		ROUND		1 1/2"	
SDI2P4		INSULATED		4"	

## KEYSTONE TIP SCREWDRIVERS

### SD5/16K6HD



### SD1/4K4HD



### SD1/4K1-1/2



### SDI1/4K4



Southwire's screwdrivers are designed for the professional with durability, quality and comfort in mind.

- Integral flanges provide a solid, twist-resistant blade anchor
- Comfortable cushioned grip allows firm grip and greater torque
- Heavy duty models include bolster on shaft to provide additional torque
- Handle end is marked for easy identification of tip type and size
- Chrome-plated, steel shaft for application of maximum torque with less shaft twisting

## SPECIFICATIONS

MODEL #	STOCK #	DESCRIPTION			
SD5/16K6HD	582846	5/16" KEYSTONE TIP SCREWDRIVER 6" HEAVY DUTY SQUARE SHANK			
SD1/4K4HD	582854	1/4" KEYSTONE TIP SCREWDRIVER W/ 4" HEAVY DUTY SHANK			
SD1/4K1-1/2	582860	1/4" KEYSTONE TIP STUBBY SCREWDRIVER			
SDI1/4K4	582844	1/4" KEYSTONE TIP SCREWDRIVER W/ 4" INSULATED SHANK			
		HEIGHT	WIDTH	DEPTH	WEIGHT
SD5/16K6HD		11"	1.25"	1.25"	6.5 oz
SD1/4K4HD		8.38"	1.25"	1.25"	3.2 oz
SD1/4K1-1/2		3.73"	1.25"	1.25"	2.4 oz
SDI1/4K4		8.38"	1.25"	1.25"	3.9 oz
		HEAD CLASS		SHANK TYPE	SHANK LENGTH
SD5/16K6HD		KEYSTONE		HD SQUARE	6"
SD1/4K4HD		KEYSTONE		HD SQUARE	4"
SD1/4K1-1/2		KEYSTONE		ROUND	1 1/2"
SDI1/4K4		KEYSTONE		ROUND	4"

## CABINET TIP SCREWDRIVERS

### SD1/4C6



- Integral flanges provide a solid, twist-resistant blade anchor
- Comfortable cushioned grip allows firm grip and greater torque
- Heavy duty models include bolster on shaft to provide additional torque
- Precision-machined, black phosphate coated tip reduces slipping
- Handle end is marked for easy identification of tip type and size
- Chrome-plated, steel shaft for application of maximum torque with less shaft twisting

### SD1/4C4



### SD3/16C6



### SD3/16C4



## SPECIFICATIONS

MODEL #	STOCK #	DESCRIPTION			
SD1/4C6	582853	1/4" CABINET TIP SCREWDRIVER W/ 6" ROUND SHANK			
SD1/4C4	582937	1/4" CABINET TIP SCREWDRIVER W/ 4" ROUND SHANK			
SD3/16C6	582850	3/16" CABINET-TIP SCREWDRIVER 6" ROUND SHANK			
SD3/16C4	582852	3/16" CABINET TIP SCREWDRIVER 4" ROUND SHANK			
		HEIGHT	WIDTH	DEPTH	WEIGHT
SD1/4C6		10.25"	1.25"	1.25"	3.9 oz
SD1/4C4		8.38"	1.25"	1.25"	3.9 oz
SD3/16C6		9.63"	1.13"	1.13"	7 oz
SD3/16C4		6.5"	1.13"	1.13"	3.2 oz
		HEAD CLASS	SHANK TYPE	SHANK LENGTH	
SD1/4C6		CABINET	ROUND	6"	
SD1/4C4		CABINET	ROUND	4"	
SD3/16C6		CABINET	ROUND	6"	
SD3/16C4		CABINET	ROUND	4"	

SQUARE TIP SCREWDRIVERS

SDQ2P1-1/2



SDQ2P4



Southwire's screwdrivers are designed for the professional with durability, quality and comfort in mind.

- Chrome-plated, steel shaft for maximum torque with less shaft twisting
- Precision-machined, black phosphate coated tip reduces slipping
- Comfortable cushioned grip allows firm grip and greater torque
- Integral flanges provide a solid, twist-resistant blade anchor
- Handle end is marked for easy identification of tip type and size

SPECIFICATIONS

MODEL #	STOCK #	DESCRIPTION			
SDQ2P1-1/2	582842	#2 SQUARE RECESSED TIP SCREWDRIVER 1-1/2" SHANK			
SDQ2P4	582862	#2 SQUARE RECESSED TIP SCREWDRIVER 4" SHANK			
		HEIGHT	WIDTH	DEPTH	WEIGHT
SDQ2P1-1/2		3.75"	1.25"	1.25"	1.8 oz
SDQ2P4		8.5"	1.25"	1.25"	3.8 oz
		HEAD CLASS	SHANK TYPE	SHANK LENGTH	
SDQ2P1-1/2		SQUARE	ROUND	1-1/2"	
SDQ2P4		SQUARE	ROUND	4"	

CUSHION-GRIP SCRATCH AWL



Our heavy-duty, hard-pointed awl, perfect for scribing metal, starting screw holes, and a variety of other piercing and punching jobs.

- Scribes metal, starts screw holes, starts a variety of piercing and punching jobs
- Heavy duty chrome plated steel shaft
- Cushion grip handles for comfort and use

SPECIFICATIONS

MODEL #	STOCK #	DESCRIPTION			
AWL001	582836	SCRATCH AWL			
		HEIGHT	WIDTH	DEPTH	WEIGHT
AWL001		6.75"	1.13"	1.13"	3 oz



## 5-IN-1 MULTI-BIT LIGHTED SCREWDRIVER



Convenient multi-bit screwdriver, 5 tools in one.

- Three LEDs illuminate work surface for better visibility
- Two double-sided quick change bits: #1 phillips, #2 phillips, 3/16" slotted and 1/4" slotted

## 9-IN-1 MULTI TOOL SCREWDRIVER



Convenient multi-bit screwdriver, 9 tools in one.

- Three double sided quick change bits and three hex head nut drivers:  
Includes 3/16", 1/4" slotted, #1 & #2 phillips, #1 & #2 square tips, 1/4", 5/16", 3/8" hex drivers
- Cushion grip handle for comfort and maximum corrosion resistance
- Meets ASME/ANSI specifications

## SCREWDRIVER WITH INTEGRATED WIRE STRIPPER



Driver with integrated wire stripper provides 2 applications in 1 tool.

- Integrated 10-20 AWG wire stripper in handle
- Four double sided bits: #1 & #2 phillips, 3/16" & 1/4" slotted
- Comfortable cushioned grip allows firm grip and greater torque
- Constructed of durable, heavy duty materials
- Requires 2 AA batteries (not included)

## SPECIFICATIONS

MODEL #	STOCK #	DESCRIPTION	HEIGHT	WIDTH	DEPTH	WEIGHT	INCLUDES
SD5N1LITE	582939	5-IN-1 MULTI BIT LIGHTED SCREWDRIVER	8"	1.38"	1.238"	4 oz	SLOTTED TIPS: 3/16", 1/4" PHILLIPS TIPS: #1, #2
SD9N1	582856	9-IN-1 MULTI TOOL SCREWDRIVER	8.25"	1.25"	1.25"	9 oz	SLOTTED TIPS: 3/16", 1/4" PHILLIPS TIPS: #1, #2 HEX TIPS: 1/4", 5/16", 3/8" SQUARE TIPS: #1, #2
SDWS	582864	SCREWDRIVER WITH WIRE STRIPPER	8.5"	1.5"	1.5"	4.9 oz	10-20 AWG SOLID WIRE STRIPPER SLOTTED TIPS: 3/16", 1/4" PHILLIPS TIPS: #1, #2

## ROTARY SCREWDRIVERS



Rotary action screwdrivers facilitate fast and easy screw installation and removal.

- Chrome-plated, steel shaft spins to permit faster one-handed screwing than conventional screwdrivers
- Precision-machined tips reduce slipping
- Comfortable cushioned grip allows firm grip and greater torque
- Handle end is marked for easy identification of tip type and size

### SPECIFICATIONS

MODEL #	STOCK #	DESCRIPTION		
SD3/16CRD	582855	3/16" CABINET TIP CRANK SCREWDRIVER		
SDC2P	582848	#2 PHILLIPS SCREWDRIVER CRANK		
	HEIGHT	WIDTH	DEPTH	WEIGHT
SD3/16CRD	10.5"	2"	1"	4.2 oz
SDC2P	10.5"	2"	1"	4.2 oz

## SCREW HOLDING SCREWDRIVERS



These specialty screwdrivers are designed for the professional with durability, quality and comfort in mind.

- Protective sheath holds screws in place to allow one-handed operation
- Precision-machined, black phosphate coated tip reduces slipping
- Comfortable cushioned grip allows firm grip and greater torque
- Integral flanges provide a solid, twist-resistant blade anchor
- Handle end is marked for easy identification of tip type and size

### SPECIFICATIONS

MODEL #	STOCK #	DESCRIPTION			
SDSH1/4	582840	1/4" SLOTTED SCREWHOLDING SCREWDRIVER			
SDSH2P6	582839	#2 PHILLIPS SCREWHOLDING SCREWDRIVER			
	HEIGHT	WIDTH	DEPTH	WEIGHT	HEAD SIZE
SDSH1/4	11.25"	1.25"	1.25"	4.9 oz	1/4"
SDSH2P6	11.25"	1.25"	1.25"	4.9 oz	#2
	HEAD CLASS		SHANK TYPE		SHANK LENGTH
SDSH1/4	SLOTTED		SCREWHOLDING		6"
SDSH2P6	PHILLIPS		SCREWHOLDING		6"

## 4-PIECE MINI SCREWDRIVER SET



Versatile mini drivers for precise applications.

- Cushion grip handles for comfort and use
- Precision tips for an exact fit
- Includes 1/16", 3/32", and 1/8" slotted and #0 phillips tipped screwdrivers
- Handles marked for easy identification

## 8-PIECE CUSHION GRIP SCREWDRIVER SET



All-purpose assortment of frequently used screwdrivers.

- Cushion grip handles for comfort and use
- Precision tips for an exact fit
- Handles marked for easy identification
- Includes 8 pieces: 3/16"x4", 3/16"x6" and 1/4"x4" slotted tip, 1/4"x4" and 5/16"x6" keystone tip, and #1x3", #2x4", phillips tip & #2x4" square tipped screwdrivers

## 2-PIECE STUBBY SCREWDRIVER SET



Drivers for accurate fits in tight spaces.

- Cushion grip handles for comfort and use
- Precision tips for an exact fit
- Handles marked for easy identification
- #2 phillips and 1/4" keystone
- 1-1/2" shank

## SPECIFICATIONS

MODEL #	STOCK #	DESCRIPTION	HEIGHT	WIDTH	DEPTH	WEIGHT	INCLUDES
SDSET4MINI	582857	4 PIECE MINI SCREWDRIVERS	5.5"	0.75"	0.75"	3.5 oz	SLOTTED: 1/16 X 2-1/2", 3/32 X 3", 1/8 X 3" PHILLIPS: #0 X 3"
SDSET8	582845	8 PIECE CUSHION GRIP SCREWDRIVER SET	11"	1.25"	1.25"	2.3 oz	SD3/16C4, SD3/16C6, SD1/4K4HD, SD1/4C4, SD5/16K6HD, SD1P3, SD2P4HD, SDQ2P4
SDSET2-3	582859	2 PIECE STUBBY SCREWDRIVER SET	3.75"	1.25"	1.25"	3.6 oz	SD1/4K41-1/2, SD2P1-1/2

## NUT DRIVERS

ND1/2-3



ND7/16-3



ND3/8-3



ND5/16-3



ND1/4-3



Get to those hard to reach nuts/bolts with our hex head nut driver. The hollow shaft fits over long bolts and studs for most applications.

- Comfortable cushioned grips allow firm grip and greater torque
- Internal flanges provide solid, twist-resistant shaft anchor
- Chrome plated shanks are corrosion resistant
- Hollow 3" shafts for additional screw clearance

### SPECIFICATIONS

MODEL #	STOCK #	DESCRIPTION	HEIGHT	WIDTH	DEPTH	WEIGHT	SHANK LENGTH
ND1/2-3	582870	1/2" NUT DRIVER WITH 3" SHANK	7.5"	1.25"	1.25"	4.2 oz	3"
ND7/16-3	582868	7/16" NUT DRIVER WITH 3" SHANK	7.5"	1.28"	1.25"	4.2 oz	3"
ND3/8-3	582871	3/8" NUT DRIVER WITH 3" SHANK	6.75"	0.38"	0.13"	4.2 oz	3"
ND5/16-3	582869	5/16" NUT DRIVER WITH 3" SHANK	6.75"	0.38"	0.13"	2.8 oz	3"
ND1/4-3	582872	1/4" NUT DRIVER WITH 3" SHANK	6.75"	0.38"	0.13"	2.8 oz	3"

## 7-PIECE NUT DRIVER SET



The 7-piece stubby nut driver set has a compact design and is ideal for use in tight spaces and hard-to-reach fasteners.

- Hollow shafts for screw clearance
- Cushion grip handles for comfort and improved torque
- Seven nutdriver sizes for all applications
- Internal flanges provide solid, twist-resistant shaft anchor

### SPECIFICATIONS

MODEL #	STOCK #	DESCRIPTION				
NDSET7	582873	7-PIECE NUT DRIVER SET				
		HEIGHT	WIDTH	DEPTH	WEIGHT	SET INCLUDES
NDSET7	7.5"	1.25"	1.25"	32 oz	3/16", 1/4", 5/16", 11/32", 3/8", 7/16" and 1/2" Nutdrivers w/ 3" Shanks	

## 2-PIECE NUT DRIVER SET



Assures greater convenience, comfort and efficiency in use, plus exceptional strength and durability.

- Includes 1/4" and 5/16" nutdrivers with 6" shanks
- Cushion grip handles for added comfort and improved torque
- Precision tips for an exact fit
- Handles marked for easy identification
- Hollow shaft for screw clearance

### SPECIFICATIONS

MODEL #	STOCK #	DESCRIPTION				
NDSET2-6	582867	2-PIECE 6" NUT DRIVER SET				
		HEIGHT	WIDTH	DEPTH	WEIGHT	SET INCLUDES
NDSET2-6	10"	1.25"	1.25"	9 oz	1/4" AND 5/16" NUTDRIVERS WITH 6" SHANKS	

## 2-PIECE STUBBY NUT DRIVER SET



The 2-piece stubby nut driver set is made for 1/4" and 5/16" hex nut and hex screw sizes. Their compact designs are ideal for use in tight spaces and hard-to-reach fasteners.

- Hollow 1-1/2" shaft for screw clearance
- Handles marked for easy identification
- Cushion grip handles for added comfort and improved torque

### SPECIFICATIONS

MODEL #	STOCK #	DESCRIPTION			
NDSET2-1-1/2	582865	2-PIECE STUBBY NUT DRIVER SET			
	HEIGHT	WIDTH	DEPTH	WEIGHT	SHANK LENGTH
NDSET2-1-1/2	3.75"	1.25"	1.25"	3.6 oz	1/4" AND 5/16" NUTDRIVERS WITH 1-1/2" SHANKS

## T-HANDLE HEX KEYS



Designed to efficiently tighten and loosen hex screws.

- T-handle design permits application of more torque
- Hex key blade - long and short for flexible use
- Forged heavy duty steel blade for durable usage
- Overmolded grip for comfortable feel

### SPECIFICATIONS

MODEL #	STOCK #	DESCRIPTION				
THEX6-1/2	582878	1/2" HEX T-HANDLE 8" SHANK				
THEX6-3/8	582877	3/8" HEX T-HANDLE 6" SHANK				
	HEIGHT	WIDTH	DEPTH	WEIGHT	SHANK LENGTH	
THEX6-1/2	9.75"	4.75"	1"	14.5 oz	8"	
THEX6-3/8	7.25"	4.75"	1"	8.2 oz	6"	

## FOLDING HEX KEY SETS



Convenient and reliable, these folding hex key sets will help you get the job done quickly and easily.

- Precision made hex keys reduce slipping and stripping
- Set easily stores in metal case to reduce lost keys and damage
- Strong durable body doubles as a handle

### SPECIFICATIONS

MODEL #	STOCK #	DESCRIPTION				
HEX-5	582875	5-PIECE FOLDING HEX KEY SET				
HEX-8	582876	8-PIECE FOLDING HEX KEY SET				
	HEIGHT	WIDTH	DEPTH	WEIGHT	KEY SIZES	
HEX-5	5.25"	1.5"	0.75"	14.3 oz	3/16", 7/32", 1/4", 5/16", & 3/8"	
HEX-8	5.25"	1.5"	0.75"	10.8 oz	3/32", 7/64", 1/8", 9/64", 5/32", 3/16", 7/32", & 1/4"	

## CONDUIT BENDING LEVEL



High visibility vials are easy to read and set for measurements at 0°, 30°, 45° and 90°.

- Set screw secures level to conduit
- Four leveling vials set at 0°, 35°, 45°, and 90°
- Three powerful magnets for hands free operation
- Easy to read high impact acrylic bubble vials
- V-grooved edge helps hold the level in place on pipe or conduit
- Lightweight and durable aluminum construction

### SPECIFICATIONS

MODEL #	STOCK #	DESCRIPTION			
MCBLEVEL	582816	6" CONDUIT BENDING LEVEL			
	HEIGHT	WIDTH	DEPTH	WEIGHT	INCLUDES
MCBLEVEL	6.31"	1.88"	0.63"	4.9 oz	Magnets, thumb screw for attaching to conduit, and lighted vials

HAND TOOLS | Measuring & Levels

## TORPEDO LEVEL



Professional grade hands free level - perfect for pipe and conduit work.

- Integrated light illuminates vials for better visibility
- Three leveling vials set at 0°, 45°, and 90°
- Lightweight and durable aluminum construction
- Easy to read high impact acrylic bubble vials
- V-grooved edge helps hold the level in place on pipe or conduit
- Four powerful magnets for hands free operation

### SPECIFICATIONS

MODEL #	STOCK #	DESCRIPTION			
LVLTOR9	582818	9" TORPEDO LEVEL			
	HEIGHT	WIDTH	DEPTH	WEIGHT	INCLUDES
LVLTOR9	9"	1.5"	0.75"	8.7 oz	Magnets and lighted vials

## 25' TAPE MEASURE W/ CONDUIT HOOK



Great for measuring pipe, conduit, sheet metal, siding, drywall and much more!

- Tough, impact resistant case
- Printed scale on the front and back sides of the blade for easier measurements
- Double-sided end hook allows for easier measuring
- Extra-wide, high-visibility blade with oversized scale printed on the front and back
- Nylon coating on blade provides improved durability and corrosion resistance
- Exclusive V-notched bottom allows tape measure to balance on curved surfaces
- Heat-treated spring provides for long life and smooth blade recoil
- Impact-resistant, rubberized case protects end hook and button

### SPECIFICATIONS

MODEL #	STOCK #	DESCRIPTION			
ETAPE	582883	25' TAPE MEASURE W/ CONDUIT HOOK			
	HEIGHT	WIDTH	DEPTH	WEIGHT	LENGTH
ETAPE	3.13"	3.38"	1.63"	14.7 oz	25'

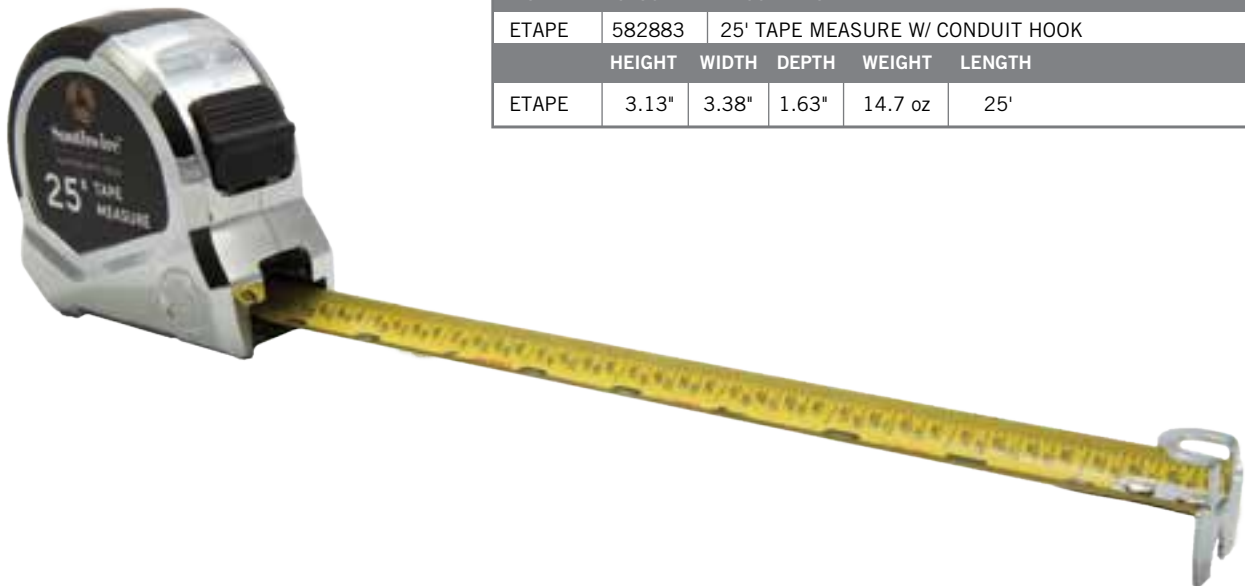

## CARBIDE TIP HOLE CUTTERS



Faster and easier to use than most standard hole saws.

- Heavy duty spring kick out for easy slug removal
- Durable cutting design specifically for sheet metal & stainless steel
- Precision ground carbide teeth for fast cutting of clean, round holes
- Split tip, double helix grooves for faster starts
- Grooved edge design to prevent extended penetration
- Easier and faster to use than most standard hole saws

### SPECIFICATIONS

MODEL #	STOCK#	DESCRIPTION
CTHC10	58133401	Complete Set
CTHC11	58143501	Small Set
INCLUDES		
CTHC10	(6) Carbide tipped hole cutters 7/8" through 2 1/2", (7) pilot drill bits, (1) 3 mm allen wrench, heavy duty carrying case	
CTHC11	(3) Carbide tipped hole cutters 7/8" through 1 3/8", (4) pilot drill bits, (1) 3 mm allen wrench, heavy duty carrying case	



## BI-METAL HOLE SAW SET



For heavy-duty cutting steel, aluminum, brass, wood and plastic.

- Easy slug ejection
- Unique tooth configuration
- Quick, easy attach and detach of saws
- Heavy duty carrying case
- Easier and faster to use than most standard hole saws
- Six (6) bi-metal hole saws (7/8", 1-1/8", 1-3/8", 1-3/4", 2", 2-1/2")
- One (1) 3/8" hex shank mandrel
- One (1) 3/8" quick change mandrel
- Two (2) pilot drills in a heavy-duty case

### SPECIFICATIONS

MODEL #	STOCK#	DESCRIPTION
BMHS10	57178501	SIX BI-METAL HOLE SAWS (7/8"-2-1/2")

## STEP DRILL BIT



Drills through steel.

- Made from high speed steel and cobalt alloy
- Cuts steel, wood, plastic, aluminum, fiberglass and laminates
- Drill multiple size holes with one bit
- Split tip provides increased drill speed
- No pilot hole needed - ultra sharp, hardened steel cuts into the material with ease
- 3/8" Hex shank
- Max. material thickness: 1/8"
- Double helix grooves improves cutting performance

### SPECIFICATIONS

MODEL #	STOCK#	DESCRIPTION
MPSB01	56826201	3/16" - 7/8"
MPSB02	57177301	3/16" - 1/2"
MPSB03	57177401	3/16" - 1 1/8"
MPSB04	57259001	3 PACK

## 4-PIECE ELECTRICIAN'S TOOL KIT



Complete with 10-20 AWG wire stripper, 9-in-1 multi-bit screwdriver, high leverage side cutting pliers and nylon carrying pouch.

### 10-20 AWG Wire Stripper - Model # S1018STR

- Strips and cuts 10-18 AWG solid and 12-20 AWG stranded wire
- Stainless steel construction is durable and corrosion resistant
- Double dipped grip provides comfortable fit
- Specially designed stainless steel cutting blades provide fast and clean wire stripping
- Serrated nose grasps the cable for easy twisting and pulling
- Spring loaded for self-opening action
- Not intended for cutting bolts or steel cable

### High Leverage Side Cutting Pliers - Model # SCP9

- Induction hardened cutting blades ensure efficient and lasting cutting surfaces for hard and soft wire
- File teeth on jaws help remove burrs in conduit
- Cuts ACSR, screws, nails, and most hardened wire
- Curved handle and ergonomic molded grip for comfortable use
- Drop forged CRV steel for durability

### 9-in-1 Multi-Bit Screwdriver - Model # SD9N1

- Includes 6 bits and 3 nut drivers for multi-purpose use
- Cushion grip handle for comfortable use and application of maximum torque

## SPECIFICATIONS

MODEL #	STOCK #	DESCRIPTION			
EKIT-4	582830	ELECTRICIAN WIRE TOOL KIT			
	HEIGHT	WIDTH	DEPTH	WEIGHT	
EKIT-4	4.25"	9.75"	2.25"	2.5 oz	S1018SOL, SCP9, and SD9N1

## CANVAS ZIPPER BAG



Our canvas zipper bag is a very convenient storage place for pliers, wrenches and other tools that you use daily.

- Durable, heavy-duty cotton canvas bag
- Sturdy plastic resin zipper
- Perfect for storing pliers, screwdrivers, small tools, or electrical connectors

### SPECIFICATIONS

MODEL #	STOCK #	DESCRIPTION			
BAG12	582828	12" CANVAS ZIPPER BAG			
	HEIGHT	WIDTH	DEPTH	WEIGHT	
BAG12	12"	7"	0.25"	2 oz	

## FLEXIBLE LED FLASHLIGHT



A flexible, compact light, designed to illuminate hard to reach places.

- Designed to illuminate hard to reach places
- 9" flexible cable will bend and hold desired position
- Heavy-duty LED light
- On/Off button on cap
- Strong aluminum housing

### SPECIFICATIONS

MODEL #	STOCK #	DESCRIPTION			
FLITE1	582829	FLEXIBLE LED LIGHT			
	HEIGHT	WIDTH	DEPTH	WEIGHT	
FLITE1	14.5"	3.25"	3.25"	3.9 oz	*Batteries not included



Southwire™

# TEST/MEASUREMENT

When there's no room for error, depend on our reliable test and measurement tools to get the job done. Backed by a two-year warranty, these tools withstand the elements and provide accurate, versatile, and professional results that every electrician can count on.

- Multimeters
- Clamp Meters
- Voltage Detectors & Testers
- Circuit Testers
- IR Thermometers
- Imaging
- Kits & Accessories



## TEST/MEASUREMENT COMPARISON CHARTS

MULTIMETERS	12070T	11060S	11050N	10040N	10030S	10020N
TRUE RMS	•	-	-	-	-	-
IP67 (WATER/DUST PROOF)	•	•	-	-	-	-
AUTORANGING	•	•	•	•	-	•
AC VOLTAGE	1000V	1000V	600V	600V	600V	600V
MAXIMUM RESOLUTION	0.1mV	0.1mV	1mV	1mV	0.1V	0.001V
BASIC ACCURACY	±1%	±1%	±1.5%	±1.5%	±1.2%	±1%
DC VOLTAGE	1000V	1000V	600V	600V	600V	600V
MAXIMUM RESOLUTION	0.1mV	0.1mV	0.1mV	0.1mV	0.1mV	0.1mV
BASIC ACCURACY	±0.5%	±0.5%	±0.5%	±0.5%	±0.8%	±0.8%
AC CURRENT	10A	10A	10A	10A	-	200mA
MAXIMUM RESOLUTION	0.1µA	0.1µA	1mA	0.1µA	-	0.1µA
BASIC ACCURACY	±1%	±1%	±3%	±1.8%	-	±2.5%
DC CURRENT	10A	10A	10A	10A	10A	200mA
MAXIMUM RESOLUTION	0.1µA	0.1µA	1mA	0.1µA	1µA	0.1µA
BASIC ACCURACY	±0.8%	±0.8%	±2.5%	±1.5%	±1.2%	±2%
RESISTANCE	40MΩ	40MΩ	60MΩ	40MΩ	2000kΩ	40MΩ
MAXIMUM RESOLUTION	0.1Ω	0.1Ω	0.1Ω	0.1Ω	0.1Ω	0.1Ω
BASIC ACCURACY	±0.8%	±0.8%	±1.2%	±1.2%	±0.8%	±1.2%
CONTINUITY	•	•	•	•	•	•
DIODE TEST	•	•	•	•	•	•
NCV (NON-CONTACT AC VOLTAGE)	-	-	100 TO 600V	100 TO 600V	-	100 TO 600V
CAPACITANCE	40mF	100µF	1000µF	100µF	-	100µF
MAXIMUM RESOLUTION	10pF	10pF	10pF	10pF	-	0.001nF
FREQUENCY	10MHz	5MHz	10MHz	10MHz	-	10MHz
MAXIMUM RESOLUTION	0.001Hz	0.001Hz	0.001Hz	0.001Hz	-	0.001Hz
DUTY CYCLE	-	99.0%	99.9%	99.9%	-	99%
MAXIMUM RESOLUTION	-	0.1%	0.1%	0.1%	-	0.5%
TEMPERATURE	-4 TO 1400°F -20 TO 760°C	-4 TO 1400°F -20 TO 760°C	-4 TO 1400°F -20 TO 760°C	-4 TO 1400°F -20 TO 760°C	-	-
DISPLAY COUNT	4000	4000	6000	4000	2000	4000
BACKLIT DISPLAY	•	•	•	•	•	-
AUTO POWER OFF	•	•	•	•	-	•
CATEGORY SAFETY RATING	CAT IV 600V CAT III 1000V	CAT IV 600V CAT III 1000V	CAT III 600V	CAT III 600V	CAT III 600V	CAT IV 600V
DIMENSIONS	6.70 X 3.11 X 1.97"	6.70 X 3.11 X 1.97"	5.91 X 2.76 X 1.89"	5.44 X 2.60 X 1.50"	5.44 X 2.60 X 1.50"	4.73 X 2.17 X 1.58"
WEIGHT	1.50LB	1.48LB	1.15LB	0.82LB	0.82LB	0.82LB

## TEST/MEASUREMENT COMPARISON CHARTS

CLAMP METERS	22070T	21050T	21030T	21010N
TRUE RMS	•	•	•	-
AC CURRENT	1000A	400A	400A	400A
MAXIMUM RESOLUTION	0.1A	0.01A	0.01A	0.01A
BASIC ACCURACY	±2.8%	±2.5%	±2.5%	±2.5%
DC CURRENT	1000A	400A	-	-
MAXIMUM RESOLUTION	0.1A	0.01A	-	-
BASIC ACCURACY	±2.8%	±2.5%	-	-
JAW OPENING	1.57" (40MM)	1.2" (30MM)	1.2" (30MM)	1.2" (30MM)
AC VOLTAGE	600V	600V	600V	600V
MAXIMUM RESOLUTION	0.001V	0.001V	0.001V	0.001V
BASIC ACCURACY	±1.8%	±1.5%	±1.8%	±1.8%
DC VOLTAGE	600V	600V	600V	600V
MAXIMUM RESOLUTION	0.1mV	0.1mV	0.1mV	0.1mV
BASIC ACCURACY	±0.8%	±0.8%	±0.8%	±0.8%
RESISTANCE	60MΩ	40MΩ	40MΩ	40MΩ
MAXIMUM RESOLUTION	0.1Ω	0.1Ω	0.1Ω	0.1Ω
BASIC ACCURACY	±1.5%	±1.5%	±1.5%	±1.5%
CONTINUITY	•	•	•	•
DIODE TEST	•	•	•	•
NCV (NON-CONTACT AC VOLTAGE)	100 TO 600V	100 TO 600V	100 TO 600V	100 TO 600V
CAPACITANCE	4000μF	100μF	100μF	100μF
MAXIMUM RESOLUTION	0.01nF	0.01nF	0.01nF	0.01nF
FREQUENCY	10kHz	10kHz	10kHz	10kHz
MAXIMUM RESOLUTION	10Hz	10Hz	10Hz	10Hz
DUTY CYCLE	99%	99%	99%	99%
MAXIMUM RESOLUTION	0.5%	0.5%	0.5%	0.5%
TEMPERATURE	-4 TO 1400°F -20 TO 760°C	-4 TO 1400°F -20 TO 760°C	-4 TO 1400°F -20 TO 760°C	-4 TO 1400°F -20 TO 760°C
RELATIVE ZERO	•	•	•	•
MIN/MAX RECORD	•	-	-	-
DISPLAY COUNT	6000	4000	4000	4000
BACKLIT DISPLAY	•	•	•	-
AUTO POWER OFF	•	•	•	•
CATEGORY SAFETY RATING	CAT III 600V	CAT III 600V	CAT III 600V	CAT III 600V
DIMENSIONS	9.06 X 2.99 X 1.58"	7.80 X 2.60 X 1.42"	7.80 X 2.60 X 1.42"	7.80 X 2.60 X 1.42"
WEIGHT	1.34LB	1.11LB	1.11LB	1.11LB

## TEST/MEASUREMENT COMPARISON CHARTS

IR THERMOMETERS	31040S	31030S	30020S	30010S
TEMPERATURE RANGE	-58° TO 1500°F -50° TO 815°C	-58° TO 1000°F -50° TO 537°C	-58° TO 900°F -50° TO 482°C	-22° TO 700°F -30 TO 371°C
RESOLUTION	0.1°F/°C <1000° 1°F/°C >1000°	0.1°F/°C <1000° 1°F/°C >1000°	0.1°F/°C	0.1°F/°C
BASIC ACCURACY	±1% ±1.8% (±1°C)	±1% ±1.8% (±1°C)	±2% OF READING OR ±4°F/±2°C, WHICHEVER IS GREATER	±2% OF READING OR ±4°F/±2°C, WHICHEVER IS GREATER
DISTANCE TO SPOT RATIO	20:1 (AT 20" MEASURES 1" SPOT)	12:1 (AT 12" MEASURES 1" SPOT)	10:1 (AT 10" MEASURES 1" SPOT)	8:1 (AT 8" MEASURES 1" SPOT)
RESPONSE TIME	150MS	150MS	<1 SEC	<1 SEC
EMISSIVITY	ADJUSTABLE 0.10 TO 1.0	ADJUSTABLE 0.10 TO 1.0	FIXED AT 0.95	FIXED AT 0.95
LASER POINTER	DUAL LASERS	DUAL LASERS	SINGLE LASER	SINGLE LASER
MAX HOLD	•	•	-	-
HIGH/LOW ALARMS	•	•	-	-
MIN/MAX RECORD	-	-	•	•
LOCK ON MODE	•	•	-	-
BACKLIT DISPLAY	•	•	•	•
DIMENSIONS	5.75 X 4.10 X 1.69"	5.75 X 4.10 X 1.69"	5.16 X 3.78 X 1.38"	5.16 X 3.78 X 1.38"
WEIGHT	0.58LB	0.58LB	0.44LB	0.44LB

NON-CONTACT VOLTAGE	40130N	40120N	40110N
AC DETECTION RANGE	50 TO 1000V	24 TO 1000V 100 TO 1000V	100 TO 1000V
CATEGORY SAFETY RATING	CAT IV 600V CAT III 1000V	CAT IV 600V CAT III 1000V	CAT IV 600V CAT III 1000V
DIMENSIONS	6.23 X 0.83 X 0.99 INCHES		

VOLTAGE TESTERS	41170S	41160S	41150S
AC VOLTAGE INDICATION	24, 48, 120, 208, 240, 277, 480, 600V	24, 120, 208, 240, 277, 480, 600V	6, 12, 24, 48, 120, 208, 240V
DC VOLTAGE INDICATION	6, 12, 24, 36, 48, 110, 220, 400V	6, 12, 24, 36, 48, 110, 220V	6, 12, 24, 48, 120, 208, 240V
TOLERANCES	-30% TO 0% OF INDICATION	-30% TO 0% OF INDICATION	-30% TO 0% OF INDICATION
AC OPERATING FREQUENCY	50/60HZ	50/60HZ	50/60HZ
ONE PROBE VOLTAGE CHECK	100 TO 480V AC	-	-
ROTARY FIELD INDICATION	100 TO 400V AC	-	-
CONTINUITY	•	•	-
CATEGORY SAFETY RATING	CAT III 600V	CAT III 600V	CAT II 300V
DIMENSIONS	9.46 X 3.07 X 1.5"	5.32 X 2.03 X 1.5"	9.46 X 3.07 X 1.58"
WEIGHT	0.89LB	0.89LB	0.51LB

12070T TRUE RMS AUTORANGING MULTIMETER



This True RMS multimeter provides the durability, accuracy and performance needed for the professional user. Features include a rugged IP67 waterproof and dust proof housing, CAT IV safety rating and 1000 volt input protection.

- 10 Functions including: Capacitance, Frequency, and Temperature functions
- True RMS for accurate measurements of non-linear loads
- Easy to read backlit, 4,000-count digital display with bar graph
- Impact resistant double molded housing also provides comfortable grip
- CAT IV 600V, CAT III 1,000V safety rating
- IP67, dustproof and waterproof
- Includes:
  - Test leads
  - 9 volt battery
  - Type K temperature probe with banana plug adapter
  - Magnetic hanging strap
  - Storage case

SPECIFICATIONS

MODEL #	STOCK #	DESCRIPTION
12070T	582904	TRUE RMS AUTORANGING MULTIMETER
	Range	Max. Resolution
AC Voltage:	1000V	0.1mV
DC Voltage:	1000V	0.1mV
AC Current:	10A	0.1µA
DC Current:	10A	0.1µA
Resistance:	40MΩ	0.1Ω
Capacitance:	40mF	10pF
Frequency:	10MHz	0.001Hz
Temperature:	-4 to 1400°F	0.1 °F
	-20 to 760°C	0.1°C
Continuity:	Audible threshold: Approximately 30Ω	
Diode Test:	Yes	
Dimensions:	6.70 x 3.11 x 1.97 in.	
Weight:	1.50 lbs.	



## 11060S AUTORANGING MULTIMETER



Rugged industrial grade multimeter offers 1000 volt input protection, IP67 waterproof and dust proof housing, and a CAT IV safety rating.

- 11 Functions including: Capacitance, Frequency, Duty Cycle, and Temperature
- IP67 Dust Proof and Waterproof for demanding environments
- Easy to read backlit, 4,000-count digital display
- Impact resistant double molded housing also provides comfortable grip
- CAT IV 600V, CAT III 1,000V safety rating
- UL Listed
- Includes:
  - 9 volt battery
  - Type K temperature probe with banana plug adapter
  - Magnetic hanging strap
  - Storage case

### SPECIFICATIONS

MODEL #	STOCK #	DESCRIPTION
10060S	582905	AUTORANGING MULTIMETER IP67 CAT IV
	Range	Max. Resolution Basic Accuracy (% reading)
AC Voltage:	1000V	0.1mV ±1.0%
DC Voltage:	1000V	0.1mV ±0.5%
AC Current:	10A	0.1µA ±1.0%
DC Current:	10A	0.1µA ±0.8%
Resistance:	40MΩ	0.1Ω ±0.8%
Capacitance:	100µF	10pF ±3.0%
Frequency:	5MHz	0.001Hz ±1.0%
Duty Cycle:	99.0%	0.1% ±1.2%
Temperature:	-4 to 1400°F -20 to 760°C	0.1°F ±3.0% 0.1°C ±3.0%
Continuity:	Audible threshold: Approximately 30Ω	
Diode Test:	Yes	
Dimensions:	6.70 x 3.11 x 1.97 in.	
Weight:	1.48 lbs.	



11050N AUTORANGING MULTIMETER



Compact multimeter with rugged double molded housing and Cat III safety rating which provides many features including max/min, backlit, 6,000 count display and 12 functions.

- 12 Functions including: Capacitance, Frequency, Duty Cycle, and Temperature functions
- Easy to read backlit, 6,000-count display with bargraph
- Max/Min captures voltage fluctuations
- Built-in AC NCV Detector
- Includes:
  - Test leads
  - 9 volt battery
  - Type K temperature probe with banana plug adapter

SPECIFICATIONS

MODEL #	STOCK #	DESCRIPTION
11050N	582906	AUTORANGE MULTIMETER
	Range	Max. Resolution
AC Voltage:	600V	1.0mV
DC Voltage:	600V	0.1mV
NCV (non-contact AC Voltage)	100 to 600V	-
AC Current:	10A	1.0mA
DC Current:	10A	1.0mA
Resistance:	60MΩ	0.1Ω
Capacitance:	1000μF	10pF
Frequency:	10MHz	0.001Hz
Duty Cycle:	99.9%	0.1%
Temperature:	-4 to 1400°F	1°F
	-20 to 760°C	1°C
Continuity:	Audible threshold: Approximately 30Ω	
Diode Test:	Yes	
Dimensions:	5.91 x 2.76 x 1.89 in.	
Weight:	1.15 lbs.	



## 10040N AUTORANGING MULTIMETER



Intertek



This compact multimeter is the perfect fit for the crowded tool bag. Features include a CAT III safety rating, built-in non-contact AC voltage tester, and Capacitance and Temperature functions.

- 12 Functions including: Capacitance, Frequency, Duty Cycle, and Temperature
- Built in AC NCV detector
- Easy to read backlit 4,000 count digital display
- Impact resistant double molded housing also provides comfortable grip
- Includes:
  - Test leads
  - 9 volt battery
  - Type K temperature probe with banana plug adapter

## SPECIFICATIONS

MODEL #	STOCK #	DESCRIPTION
10040N	582910	AUTORANGING MULTIMETER CAT III
	Range	Max. Resolution
AC Voltage:	600V	1.0mV
DC Voltage:	600V	0.1mV
NCV (non-contact AC Voltage)	100 to 600V	-
AC Current:	10A	0.1μA
DC Current:	10A	0.1μA
Resistance:	40MΩ	0.1Ω
Capacitance:	100μF	10pF
Frequency:	10MHz	0.001Hz
Duty Cycle:	99.9%	0.1%
Temperature:	-4 to 1400°F	1°F
	-20 to 760°C	1°C
Continuity:	Audible threshold: Approximately 30Ω	
Diode Test:	Yes	
Dimensions:	5.44 x 2.60 x 1.50 in.	
Weight:	0.82 lbs.	



10030S MANUAL RANGING MULTIMETER



This general purpose multimeter features a CAT III safety rating, rugged double molded housing, and a backlit display.

- 7 functions with 20 ranges. Functions are: AC Voltage, DC Voltage, DC Current, Resistance, Battery Test, Continuity and Diode Test
- Tests AAA, AA, C, D, 1.5 volt, button cell, and 9 volt batteries
- Impact resistant double molded housing also provides comfortable grip
- Easy to read backlit digital display
- 2,000 count display
- Includes:
  - Test leads
  - 9 volt battery

SPECIFICATIONS

MODEL #	STOCK #	DESCRIPTION
10030S	582908	MANUAL RANGING MULTIMETER
	Range	Max. Resolution
AC Voltage:	600V	0.1V
DC Voltage:	600V	0.1mV
DC Current:	10A	1µA
Resistance:	2000kΩ	0.1Ω
Battery Test:	1.5V, 9V / 10mV	
Continuity:	Audible threshold: Approximately 30Ω	
Diode Test:	Yes	
Dimensions:	5.44 x 2.60 x 1.50 in.	
Weight:	0.82 lbs.	



Test in low-light areas



## 10020N POCKET MULTIMETER



The pocket multimeter offers the convenience of a built-in flashlight and non-contact AC voltage detector. The rugged double molded housing and CAT IV safety rating make this the ideal compact meter for the professional electrician.

- 12 functions including: AC Voltage, DC Voltage, AC Current, DC Current, Resistance, Continuity, Capacitance, Frequency and Duty Cycle
- Easy to read display with large 0.6" digits
- LED Flashlight Built-in
- Impact resistant double molded housing provides comfortable grip
- Automatically selects the best range
- Integrated test leads
- Built-in non-contact voltage detector
- Resettable fuse eliminates replacing fuses
- 4,000 count display
- Includes:
  - Test leads
  - 2 AAA batteries

### SPECIFICATIONS

MODEL #	STOCK #	DESCRIPTION
10020N	582911	POCKET MULTIMETER
	Range	Max. Resolution
AC Voltage:	600V	0.001V
DC Voltage:	600V	0.1mV
NCV (non-contact AC Voltage)	100 to 600V	-
AC Current:	200mA	0.1µA
DC Current:	200mA	0.1µA
Resistance:	40MΩ	0.1Ω
Capacitance:	100µF	0.001nF
Frequency:	10MHz	0.001Hz
Duty Cycle:	99%	0.5%
Continuity:	Audible threshold: Approximately 30Ω	
Diode Test:	Yes	
Dimensions:	4.73 x 2.17 x 1.58 in.	
Weight:	0.82 lbs.	



## ANALOG MULTIMETER



Economical, simple to use analog multimeter is ideal for basic electrical testing.

- 5 functions with 16 measuring ranges including: AC Voltage, DC Voltage, DC Current, Resistance and Battery Test
- Tests AAA, AA, C, D, 1.5 volt, button cell, and 9 volt batteries
- Includes:
  - 10010S Multimeter
  - Test leads
  - One AA battery

## SPECIFICATIONS

MODEL #	STOCK #	DESCRIPTION
10010S	582924	ANALOG MULTIMETER
	Range	Basic Accuracy (% of FULL SCALE)
AC Voltage:	10V, 50V, 250V, 500V	±4.5%
DC Voltage:	2.5V, 10V, 50V, 250V, 500V	±3.5%
DC Current:	500µA, 10mA, 250mA	±3.5%
Resistance:	2kΩ, 200kΩ	±3.5%
Battery Test:	1.5V, 9V	-
Dimensions:	3.88 x 2.52 x 1.18 in.	
Weight:	0.40 lbs.	



## 22070T 1000A AC/DC TRUE RMS CLAMP METER



1000A AC/DC clamp meter combines the features needed for the professional electrician including True RMS readings, a built-in non-contact AC voltage detector, and Multimeter, Capacitance and Temperature functions.

- 12 Functions including: AC current, DC current, Capacitance, Frequency, Duty Cycle, and Temperature functions
- True RMS for accurate measurements of non-linear loads such as motor drives, fluorescent lights, and lamp dimmers
- Measures both AC and DC currents
- Non-contact built-in AC voltage detector
- Easy to read backlit 6,000-count digital display with bar graph
- Impact resistant double molded housing provides comfortable grip
- Max/Min function captures voltage and current fluctuations
- Includes:
  - Test leads
  - Carrying case
  - Type K temperature probe with banana plug adapter
  - 9 volt battery

### SPECIFICATIONS

MODEL #	STOCK #	DESCRIPTION		
22070T	582903	1000A AC/DC TRUE RMS CLAMP METER		
		Range	Max. Resolution	Basic Accuracy (% of reading)
AC Current:		1000A	0.1A	±2.8%
DC Current:		1000A	0.1A	±2.8%
Jaw Opening:		1.57" (40mm)		
AC Voltage:		600V	0.001V	±1.8%
DC Voltage:		600V	0.1mV	±0.8%
NCV: (non-contact AC voltage)		100 to 600V	-	-
Resistance:		60MΩ	0.1Ω	±1.5%
Capacitance:		4000μF	0.01nF	±3.0%
Frequency:		10kHz	10Hz	±1.5%
Duty Cycle:		99%	0.5%	±1.2%
Temperature:		-4 to 1400°F -20 to 760°C	0.1°F 0.1°C	±3.0% ±3.0%
Continuity:	Audible threshold: Approximately 30Ω			
Diode Test:	Yes			
Dimensions:	9.06 x 2.99 x 1.58 in.			
Weight:	1.34 lbs.			



Clamp Meters | TEST & MEASUREMENT

## 21050T 400A AC/DC TRUE RMS CLAMP METER



400A AC/DC clamp meter combines the features needed for the professional electrician including True RMS readings, a built-in non-contact AC voltage detector, and Multimeter, Capacitance and Temperature functions.

- 12 Functions including: AC current, DC current, Frequency, Duty Cycle, and Temperature functions
- True RMS for accurate measurements of non-linear loads
- Measures both AC and DC currents
- Non-contact built-in AC voltage detector
- Easy to read backlit, 4,000-count digital display
- Impact resistant double molded housing provides comfortable grip
- Great for motors and battery backups
- Includes:
  - Test leads
  - Carrying case
  - Type K temperature probe with banana plug adapter
  - Two AAA batteries

### SPECIFICATIONS

MODEL #	STOCK #	DESCRIPTION
21050T	582902	400A AC/DC TRUE RMS CLAMP METER
	Range	Max. Resolution
AC Current:	400A	0.01A
DC Current: (21050 Only)	400A	0.01A
Jaw Opening:	1.2" (30mm)	
AC Voltage:	600V	0.001V
DC Voltage:	600V	0.1mV
NCV: (non-contact AC voltage)	100 to 600V	-
Resistance:	40MΩ	0.1Ω
Capacitance:	100μF	0.01nF
Frequency:	10kHz	10Hz
Duty Cycle:	99%	0.5%
Temperature:	-4 to 1400°F	0.1°F
	-20 to 760°C	0.1°C
Continuity:	Audible threshold: Approximately 30Ω	
Diode Test:	Yes	
Dimensions:	7.80 x 2.60 x 1.42 in.	
Weight:	1.11 lbs.	



## 21030T 400A AC TRUE RMS CLAMP METER



The 21030T 400A AC clamp meter combines the features needed for the professional electrician including True RMS readings, a built-in non-contact AC voltage detector, and Multimeter, Capacitance and Temperature functions.

- 11 Functions including: AC current, Capacitance, Frequency, Duty Cycle, and Temperature functions
- True RMS for accurate measurements of non-linear loads such as motor drives, fluorescent lights, and lamp dimmers
- Non-contact built-in AC NCV detector
- Easy to read backlit, 4,000-count digital display
- Impact resistant double molded housing also provides comfortable grip
- Includes:
  - Test leads
  - Carrying case
  - Type K temperature probe with banana plug adapter
  - Two AAA batteries

### SPECIFICATIONS

MODEL #	STOCK #	DESCRIPTION	
21030T	582901	400A AC TRUE RMS CLAMP METER	
	Range	Max. Resolution	
AC Current:	400A	0.01A	
Jaw Opening:	1.2" (30mm)		
		Basic Accuracy (% of reading)	
AC Voltage:	600V	0.001V	±1.8%
DC Voltage:	600V	0.1mV	±0.8%
NCV: (non-contact AC voltage)	100 to 600V	-	-
Resistance:	40MΩ	0.1Ω	±1.5%
Capacitance:	100μF	0.01nF	±3.0%
Frequency:	10kHz	10Hz	±1.5%
Duty Cycle:	99%	0.5%	±1.2%
Temperature:	-4 to 1400°F	0.1°F	±3.0%
	-20 to 760°C	0.1°C	±3.0%
Continuity:	Audible threshold: Approximately 30Ω		
Diode Test:	Yes		
Dimensions:	7.80 x 2.60 x 1.42 in.		
Weight:	1.11 lbs.		



## 21010N 400A AC CLAMP METER



This 400A AC clamp meter combines the features needed for the professional electrician including a built-in non-contact AC Voltage Detector, and Multimeter with Capacitance and Temperature functions.

- 11 Functions including: AC current, Capacitance, Frequency, Duty Cycle, and Temperature functions
- Impact resistant double molded housing also provides comfortable grip
- Easy to read 4,000-count digital display
- Includes:
  - Test leads
  - Carrying case
  - Type K temperature probe with banana plug adapter
  - Two AAA batteries

## SPECIFICATIONS

MODEL #	STOCK #	DESCRIPTION	
21010N	582900	400A AC CLAMP METER	
	Range	Max. Resolution	
AC Current:	400A	0.01A	
Jaw Opening:	1.2" (30mm)		
		Basic Accuracy (% of reading)	
AC Voltage:	600V	0.001V	±1.8%
DC Voltage:	600V	0.1mV	±0.8%
NCV: (non-contact AC voltage)	100 to 600V	-	-
Resistance:	40MΩ	0.1Ω	±1.5%
Capacitance:	100μF	0.01nF	±3.0%
Frequency:	10kHz	10Hz	±1.5%
Duty Cycle:	99%	0.5%	±1.2%
Temperature:	-4 to 1400°F	0.1°F	±3.0%
	-20 to 760°C	0.1°C	±3.0%
Continuity:	Audible threshold: Approximately 30Ω		
Diode Test:	Yes		
Dimensions:	7.80 x 2.60 x 1.42 in.		
Weight:	1.11 lbs.		



## NON-CONTACT AC VOLTAGE DETECTORS



Southwire's non-contact AC voltage detectors quickly check for the presence of live voltage on outlets, wiring, circuit breakers, lighting fixtures and switches. All three feature a built-in flashlight for user convenience.

- Detects the presence of AC voltage without contact
- Audible and visual indication of AC voltage
- Built-in LED flashlight
- Uses readily available AAA batteries
- Impact resistant double molded housing provides comfortable grip
- Includes pocket clip for easy storage
- Batteries included
- 40130N - beep rate increases as voltage is approached

### SPECIFICATIONS

MODEL #	STOCK #	DESCRIPTION
40130N	582919	50 to 1000V AC
40120N	582918	24 to 1000V AC, 100 to 1000V AC
40110N	582920	100 to 1000V AC
Height	Width	Depth
6.23 in.	0.83 in.	0.99 in.



40130N    40120N    40110N



Voltage Present



## 41170S VOLTAGE/CONTINUITY/PHASE ROTATION TESTER



This versatile tester features a built-in flashlight, single probe AC voltage check, phase rotation on three phase circuits, and automatic indication of continuity and AC and DC voltage up to 600 volts in 8 steps.

- LED indication of AC voltage from 24 to 600V and DC voltage from 6 to 400V in 8 steps
- One-probe live voltage check
- Indicates phase rotation on three phase circuits
- Audible and visual continuity test
- Built-in LED flashlight
- Includes 41170S Tester with integrated test leads & two AA batteries

### SPECIFICATIONS

MODEL #	STOCK #	DESCRIPTION
41170S	582935	VOLTAGE/CONTINUITY/PHASE ROTATION TESTER
AC Voltage Indication:	24, 48, 120, 208, 240, 277, 480, 600V AC	
DC Voltage Indication:	6, 12, 24, 36, 48, 110, 220, 400V DC	
Tolerances:	-30% to 0% of reading	
Single Pole Voltage Test:	100 to 480V AC	
Rotary Field Indication:	100 to 400V AC	
AC Operating Frequency:	50/60Hz	
Continuity Test:	Beeper will sound if the resistance is under 300kΩ	
Overload Protection:	600VAC/DC	
Dimensions:	9.46 x 3.07 x 1.58 in.	
Weight:	0.89 lbs.	



## 41160S VOLTAGE/CONTINUITY TESTER



Simple to use tester automatically indicates polarity and live AC and DC voltage up to 600 volts in 7 steps.

- Check continuity of wires, light bulbs and fuses
- Automatic selection: AC, DC, or continuity
- Indicates polarity and seven levels of AC/DC voltage
- Automatically turns on and off
- UL listed, CAT III 600V
- AA batteries included
- Includes 41160S Tester with integrated test leads

### SPECIFICATIONS

MODEL #	STOCK #	DESCRIPTION
41160S	582916	VOLTAGE/CONTINUITY TESTER
AC Voltage Indication:	24, 120, 208, 240, 277, 480, 600V	
DC Voltage Indication:	6, 12, 24, 36, 48, 110, 220V	
Tolerances:	-30% to 0% of indication	
AC Operating Frequency:	50/60Hz	
Continuity Test:	Beeper will sound if the resistance is under 85kΩ	
Maximum Input:	600V AC/DC	
Dimensions:	5.32 x 2.03 x 1.52 in.	
Weight:	0.89 lbs.	



## 41150S AC/DC VOLTAGE TESTER



Simple to use tester automatically indicates live AC and DC voltage up to 240 volts in 7 steps.

- Indicates polarity and voltage up to 240 V in 7 steps
- No batteries required, simple automatic operation
- GFCI - verifies operation of GFCI protected outlets
- CAT II 300V and UL listed
- Includes 41150S Tester with integrated test leads
- No batteries required

### SPECIFICATIONS

MODEL #	STOCK #	DESCRIPTION
41150S	582917	AC/DC VOLTAGE TESTER
AC/DC Voltage Indication:	6, 12, 24, 48, 120, 208, 240V	
Tolerances:	-30% to 0% of indication	
AC Operating Frequency:	50/60Hz	
Overload Protection:	250V AC/DC	
Dimensions:	9.46 x 3.07 x 1.58 in.	
Weight:	0.51 lbs.	



## 40140S 4-WAY VOLTAGE TESTER



Handy pocket size tester checks live AC voltage from 120 to 480 volts in four steps.

- Indicates live voltage from AC 120 to 480V and DC 160 to 600V
- Works on AC or DC voltage
- Compact design
- Probes spaced to fit standard AC outlets
- CAT III 600V and ETL listed
- Compact size with pocket clip and durable double molded enclosure
- Includes:
  - 40140S Voltage tester
  - Built-in test leads



### SPECIFICATIONS

MODEL #	STOCK #	DESCRIPTION
40140S	582927	4-WAY VOLTAGE TESTER
AC Voltage Indication:	120V, 240V, 277V, 480V	
AC Operating Frequency:	60Hz	
DC Voltage Indication:	160V, 330V, 380V, 600V	
Dimensions:	5.79 x 1.30 x 1.02 in.	
Weight:	0.23 lbs.	



Test leads in storage position

## 31040S 1500 DEGREE FAHRENHEIT 20:1 THERMOMETER WITH COLOR ALERT



The 31040S features 20:1 distance-to-spot ratio and a broad temperature range; this device truly stands out because of its fast response, high/low alarms and dual laser pointer. It is used by maintenance professionals to quickly locate worn machinery, hot spots in electrical panels and defective HVAC equipment.

- Dual lasers pinpoint target area
- 20:1 distance to spot size ratio allows measurements at greater distance
- High/low temperature alarms and color alert
- Fast 150 milli-second response time
- Backlit display
- Adjustable emissivity for use on reflective surfaces
- Max hold captures highest reading
- Lock-on feature for continuous measurement

### SPECIFICATIONS

MODEL #	STOCK #	DESCRIPTION
31040S	582915	1500-DEG-F INFRARED THERMOMETER WITH DUAL LASERS AND COLOR ALERT
Range:	-58° to 1500°F (-50° to 815°C)	
Resolution:	0.1°F/°C <1000°    1°F/°C >1000°	
Basic Accuracy:	±1% ±1.8°F (1°C)	
Response Time:	150ms	
Emissivity:	Adjustable from 0.10 to 1.0	
Distance to Spot Ratio:	20:1 (at 20" distance measures 1" spot)	
Dimensions:	5.75 x 4.10 x 1.69 in.	
Weight:	0.58 lbs.	



## 31030S 1000 DEGREE FAHRENHEIT 12:1 THERMOMETER



Includes features, such as fast response, high and low alarms and a dual laser pointer that can help the maintenance professional quickly locate problems in electrical panels, motors, bearings, machinery and HVAC equipment.

- Dual lasers pinpoint target area
- 12:1 distance to spot size ratio allows measurements at greater distance
- High/low temperature alarms
- Backlit display
- Adjustable emissivity for use on reflective surfaces
- Max hold captures highest reading
- Fast 150 milli-second response time
- Lock-on feature for continuous measurement

### SPECIFICATIONS

MODEL #	STOCK #	DESCRIPTION
31030S	582934	1000-DEG-F INFRARED THERMOMETER WITH DUAL LASERS
Range:	-58° to 1000°F (-50° to 537°C)	
Resolution:	0.1°F/°C <1000°    1°F/°C >1000°	
Basic Accuracy:	±1% ±1.8°F (1°C)	
Response Time:	150ms	
Emissivity:	Adjustable from 0.10 to 1.0	
Distance to Spot Ratio:	12:1 (at 12" distance measures 1" spot)	
Dimensions:	5.75 x 4.10 x 1.69 in.	
Weight:	0.58 lbs	



## 30020S 900 DEGREE FAHRENHEIT 10:1 THERMOMETER



With 10:1 distance to spot, back-lit display and a temperature range of -58 to 900°F, the 30020S is a versatile addition to any toolbox.

- Laser pointer quickly identifies target
- 10:1 distance to spot size ratio allows measurements at greater distance
- Backlit display shows highest and lowest readings
- Displays highest and lowest readings

### SPECIFICATIONS

MODEL #	STOCK #	DESCRIPTION
30020S	582914	900°F 10-TO-1 INFRARED THERMOMETER
Range:	-58° to 900°F (-50° to 482°C)	
Resolution:	0.1°F/°C <1000°/1°F/°C >1000°	
Basic Accuracy:	±2% of reading or ±4°F/±2°C, whichever is greater	
Response Time:	< 1 sec	
Emissivity:	Fixed at 0.95	
Distance to Spot Ratio:	10:1 (at 10" distance measures 1" spot)	
Dimensions:	5.16 x 3.78 x 1.38 in.	
Weight:	0.44 lbs.	



## 30010S 700 DEGREE FAHRENHEIT 8:1 INFRARED THERMOMETER



Provides quick surface temperature measurements without contact. The ideal service tool for HVAC, mechanical and electrical maintenance.

- 8 to 1 distance to spot ratio
- Displays highest and lowest readings
- Laser pointer identifies target
- Backlit display
- Simple operation

### SPECIFICATIONS

MODEL #	STOCK #	DESCRIPTION
30010S	582913	700 DEGREE FAHRENHEIT INFRARED THERMOMETER
Range:	-22°F to 700°F (-30° to 371°C)	
Resolution:	0.1°F/°C	
Basic Accuracy:	± 2% of reading or ±4°F/± 2°C, whichever is greater	
Response Time:	Less than 1 second	
Emissivity:	Fixed at 0.95	
Distance to Spot Ratio:	8:1 (at 8" distance measures 1" spot)	
Dimensions:	5.16 x 3.78 x 1.38 in.	
Weight:	0.44 lbs.	



## 51010S BORESCOPE INSPECTION CAMERA



Borescope inspection camera with 1 meter-long flexible gooseneck allows the user to probe behind walls, inside ventilation ducts and difficult to reach areas that are not otherwise accessible.

- Great tool for maintenance and repair
- High resolution color display
- Four powerful and adjustable LED lights illuminate dark spaces
- Flexible gooseneck can be configured for best viewing
- Up to 2X digital zoom
- Auto Power-Off
- Includes (3) accessories that clip on to camera head
  - mirror
  - hook
  - magnet

### SPECIFICATIONS

MODEL #	STOCK #	DESCRIPTION
51010S	582923	BORESCOPE INSPECTION CAMERA
<b>Camera</b>		
Maximum Resolution:	640 x 480	
Maximum Frame Rate:	30 frames per second	
Depth of Field:	0.4" (10mm) to infinity	
Gooseneck Length:	39" (1m)	
Camera Diameter:	0.66" (17mm)	
<b>TFT-LCD Display</b>		
LCD Size:	2.4" (61mm)	
Display Resolution:	480 (W) x 234 (H)	
Power Supply:	(4) "AA" Batteries (Included)	
Dimensions:	9.46 x 6.30 x 3.94 in.	



## 41210S CIRCUIT BREAKER FINDER WITH GFCI



The circuit breaker finder pinpoints the specific breaker powering the circuit being worked on. Eliminates guessing and unwanted power outages caused by tripping the wrong breaker.

- Advanced design quickly and reliably pinpoints single breaker without service interruption
- Tests GFCI outlets
- For use on energized circuits
- Includes:
  - 41210S Transmitter and Receiver
  - 3-prong to 2-prong adapter
  - 9 volt battery
- Available accessory: 60030S Adapter Kit

### SPECIFICATIONS

MODEL #	STOCK #	DESCRIPTION
41210S	582921	CIRCUIT BREAKER FINDER
Height:	7.56 in.	
Width:	2.52 in.	
Depth:	1.65 in.	



## RECEPTACLE TESTERS



Quickly identifies the most common wiring faults in standard 3-wire outlets.

- Easy to use, simply plug into a live outlet
- Easy to read indicator LED's and wiring legend quickly identify fault
- Identifies wiring errors in standard 3-wire receptacles
- Tests 120V AC outlets
- ETL listed
- GFCI testing (40020S only) - verifies operation of GFCI protected outlets
- Includes 40010S Receptacle Tester & 40020S GFCI Receptacle Tester

## SPECIFICATIONS

MODEL #	STOCK #	DESCRIPTION
40010S, 40020S	582925, 582926	RECEPTACLE TESTERS
<b>RECEPTACLE TESTERS (40010S AND 40020S)</b>		
Height:	3.43 in.	
Width:	1.73 in.	
Length:	0.95 in.	
<b>INDICATOR LIGHT GUIDE (40010S AND 40020S)</b>		
LED Indicator	Fault	Reason for wiring fault
○ ○ ○	Open Ground	Ground terminal is not connected
○ ○ ●	Open Neutral	Neutral terminal is not connected
○ ○ ○	Open Hot	Hot terminal is not connected
● ○ ●	Reversed Hot Ground	Hot and neutral connections interchanges
● ● ○	Reversed Hot Neutral	Hot and neutral connections interchanges
○ ● ●	Correct	Receptacle is wired correctly



## 40030S CONTINUITY TESTER



A simple to use tester that checks continuity on switches, fuses, wires and cables. Not for use on live circuits.

- Tests continuity of wires and cables
- Check for blown fuses
- Check on/off switches
- Requires one AAA battery, not included

### SPECIFICATIONS

MODEL #	STOCK #	DESCRIPTION
40030S	582928	CONTINUITY TESTER
HEIGHT	WIDTH	DEPTH
5.79 in.	1.30 in.	1.02 in.

## 40005S BATTERY TESTER



A simple to use tester that checks the condition of 1.5 volt, AAA, AA, C, D, button cell and 9 volt batteries.

- Tests 1.5 volt, AAA, AA, C, D, button cell and 9 volt batteries
- Analog scale quickly identifies battery charge level
- Measures a battery under load and indicates its condition

### SPECIFICATIONS

MODEL #	STOCK #	DESCRIPTION
40005S	582936	BATTERY TESTER
HEIGHT	WIDTH	DEPTH
1.65 in.	1.42 in.	0.99 in.



## 10035K ELECTRICAL TEST KIT



Combines the 3 most commonly used electrical testers in one convenient kit. Ideal for household repairs and electrical troubleshooting.

- Manual ranging multimeter features CAT III 600V safety rating, double molded housing and includes battery testing function
- Non-contact AC voltage detector checks for live voltages 100 - 1000V AC with built in flashlight
- Receptacle tester quickly checks for miswired outlets
- Kit includes:
  - 10030S Manual Ranging Multimeter with test leads
  - 40110N Non-Contact AC Voltage Detector
  - 40010S Receptacle Tester
  - One 9 volt and two AAA batteries

### SPECIFICATIONS

MODEL #	STOCK #	DESCRIPTION
10030S	582908	MANUAL RANGING MULTIMETER
	Range	Max. Resolution
AC Voltage:	600V	0.1V
DC Voltage:	600V	0.1mV
DC Current:	10A	1μA
Resistance:	2000kΩ	0.1Ω
Battery Test:	1.5V, 9V	10mV
Continuity:	Audible threshold: Approximately 30Ω	
Diode Test:	Yes	
Dimensions:	5.44 x 2.60 x 1.50 in.	
Weight:	0.82 lbs.	
		Basic Accuracy (% of reading)
		±1.2%
		±0.8%
		±1.2%
		±0.8%
		±1.0%

MODEL #	STOCK #	DESCRIPTION
40110N	582920	NON-CONTACT AC VOLTAGE DETECTOR
	Voltage Detection Rate	Frequency Range
	100V AC to 1000V AC	50/60Hz
		Dimensions
		6.23 x 0.83 x 0.99 in.
		Weight
		0.23 lbs.

MODEL #	STOCK #	DESCRIPTION
40010S	582925	RECEPTACLE TESTER
	Height	Width
	3.43 in.	1.73 in.
	Depth	Identifies
	0.95 in.	Open Ground, Open Neutral, Open Hot, Reversed Hot Ground, Reversed Hot Neutral, Correct Wiring



## 60020S PIPE CLAMP TEMPERATURE PROBE



The 60020S Pipe Clamp Temperature Probe allows quick maintenance checks on heating and air-conditioning systems. It's the perfect accessory for clamp meters and multimeters with a temperature function.

- For Multimeters, Clamp Meters and Thermometers that accept a Type K temperature probe
- Spring-loaded jaw clamps around heating/cooling pipes up to 1.5" in diameter
- Temperature range: -4° to 200°F (-20° to 93°C)

## 60010S REPLACEMENT TEST LEADS



Southwire's 60010S Replacement Test Leads are universal replacement leads for all Southwire meters except the 10010S Analog Multimeter. UL-listed CAT IV 600V, CAT III 1000V. Also includes alligator clip attachments (CAT III 600V).

## 60030S ADAPTER KIT FOR CIRCUIT BREAKER FINDER



This adapter kit includes a light socket adapter allowing for rapid location of circuit breakers connected to lighting fixtures. Also includes alligator clips allowing transmitter to be connected to unterminated branch circuit wiring.

- For use with 41210S Circuit Breaker Finder



Southwire™

# CABLE PULLING

Southwire™ Contractor cable pulling equipment sets the industry standard. We've revolutionized these tools to make them faster, safer, and smarter than ever before. With Southwire™ Contractor cable pulling equipment on your jobsite, you can see an increase in safety, efficiency, and profitability.

- Pullers
- Pulling Grips
- Fishing
- Rope
- Accessories



[SOUTHWIRETOOLS.COM](http://SOUTHWIRETOOLS.COM)

## MAXIS® 10K CABLE PULLER

A 10,000 pound cable puller that can set up in less than 2 minutes.



- Self contained - ready to pull
- Quickly change from overhead to underground or to side pulls
- Pulls out 9 ft. of extra wire (without extending boom)
- Counter-weighted for easy set up
- No anchoring required
- Easy to transport
- Pulls at 2 speeds, 9 FPM on low and 25 FPM on high (no load)
- Telescoping front end
- Easily maneuvers into tight spaces
- 10,000 lbs. peak pulling force
- Easily extend boom with 3" rigid conduit
- Pivoting arm for easy rope access on overhead applications
- Collapsible down to 36"H x 26"W x 53"L
- 7 conduit adapter sizes. 2"-4" are included, 5" and 6" adapters sold separately
- Milwaukee® 4004 power motor, 2 speed, 20 amp, with 5 year factory warranty
- Includes: Maxis® Triggers® (dual remote foot switches)

### SPECIFICATIONS

MODEL #	STOCK #	DESCRIPTION		
M10K	57143201	M10K MAXIS 10K PULLER INCLUDES MOTOR, TRO1, CONDUIT ADAPTERS 2"-4"		
P6-208-55A-E	56833401	CONDUIT ADAPTERS 2"-4" (also sold individually)		
LENGTH	WIDTH	DEPTH	WEIGHT	
M10K	53"	26"	36"	365 lbs



## MAXIS® 6K CABLE PULLER



A 6,000 pound cable puller that sets up in less than 2 minutes.

- One person, 2 minute setup and operate
- 2 Pulling speeds: 12 fpm on low (at no load) and 44 fpm on high (at no load)
- Quickly adapts from underground to overhead pulls
- No need to bolt to the ground on most pulls
- 6,000 lbs. peak pulling force
- Versatile, can adapt to virtually any wire pull
- Can be anchored to most trucks' standard 2" receiver hitch
- Able to pull up to 9 ft. of wire out of the conduit
- Includes 5 conduit adapters 2" through 4", 5" and 6" sold separately
- Includes Puller Cart with tool bag (total weight 35 lbs.)
- Milwaukee® Super Hawg™ (included): 1/2" Super Hawg™, two speed drill, 450/1,750 RPM, 120 volt 13 Amp, 14.7 lbs. Model 1680-20 Recommended for this puller



### SPECIFICATIONS

MODEL #	STOCK #	DESCRIPTION		
M6K-M	57648501	M6K MAXIS 6K CABLE PULLER - INCLUDES PC100		
P6-208-55A-E	56833401	CONDUIT ADAPTERS 2"-4" (also sold individually)		
PC100	56829601	PULLER CART		
	LENGTH	WIDTH	DEPTH	WEIGHT
M6K-M	45"	21"	20"	194.5 lbs
PC100	50"(height)	21"	17.5"	40 lbs

## MAXIS® 3K CABLE PULLER



A high speed, lightweight 3,000 pound cable puller.

- One person, 2 minute set up and operate
- 2 Pulling speeds: 25 fpm on low (at no load) and 100 fpm on high (at no load)
- Quickly adapts from underground to overhead pulls
- No need to bolt to the ground on most pulls
- Able to pull up to 8 ft. of wire out of the conduit
- 3,000 lbs. peak pulling force
- Versatile, can adapt to virtually any wire pull
- Can be anchored to most trucks' standard 2" receiver hitch
- Includes 5 conduit adapters: sizes 2" through 4" (total weight 20 lbs.)
- Puller Cart with tool bag
- Milwaukee® Super Hawg™ (included): 1/2" Super Hawg™, two speed drill, 450/1,750 RPM, 120 volt 13 Amp, 14.7 lbs. Model 1680-20



## SPECIFICATIONS

MODEL #	STOCK #	DESCRIPTION		
M3K-M	57648401	M3K MAXIS 3K HIGH SPEED CABLE PULLER-PC100		
P3-208-55A-H	56831201	CONDUIT ADAPTERS 1"-4" (also sold individually)		
PC100	56829601	PULLER CART		
	LENGTH	WIDTH	DEPTH	WEIGHT
M3K-M	45"	20"	20"	148.5 lbs
PC100	50"(height)	21"	17.5"	40 lbs

**MAXIS® FEEDER**



**A revolutionary new way to feed wire quickly and efficiently.**

- Designed and built specifically to accommodate Southwire® SIMpull® wire
- Quick 1 person set-up and operate
- Forward and reverse, variable speed, feeds up to 30 fpm
- May be used with Maxis® Triggers® remote foot switches for simultaneous feeder/puller control
- Easily adjust wire tension, even during operation
- Fast 2 minute setup, wire sizes from 3/0 - 3 1/2" cable
- Solid rubber tires and swivel casters for easy jobsite maneuverability and will never go flat
- Digital footage meter allows easy monitoring of approximate conductor length being fed
- Uses grooved roller design with increased surface area for greater traction force (no pneumatic tires)
- Dual anchoring mechanism
- Maximum traction force: single conductor 800 lbs, 4 SIMpull THHN 500 MCM Conductors 1,600 lb capacity
- Cable capacity: 8 x 250 MCM, 6 x 500 MCM, 5 x 750 MCM

**SPECIFICATIONS**

MODEL #	STOCK#	DESCRIPTION			
MCF01	58133301	FEEDER			
	LENGTH	WIDTH	DEPTH	WEIGHT	
MCF01	35"	26"	44"	366 lbs	



## MAXIS® GRIPS™ PULLING HEADS



Increased efficiency with 2 minute head preparation.

- Dual lock pulling system using both a cam lock head and a double braided wire to quickly secure cable to rope without the fear of losing a conductor
- Each double lock Maxis® Grips™ head rated at 4000 lbs.
- Holds securely to NO-LUBE® wire
- Disconnect wire from pulling heads in 2 minutes without cutting the wire
- No cutting, stripping or weaving of wire to make pulling head
- Easily moves through conduit and around 90° bends
- Staggered lengths for easier movement
- Keeps pulling head tight for easier movement through conduit

## SPECIFICATIONS

MODEL #	STOCK #	MAXIS GRIPS	GRIPS	WIRE	PULLING JACKET		ROPE SWIVEL		CARRYING BAG
					Med.	Lrg.	Lrg.	Sml.	
GP110	56822701	Complete Set	Complete Set	1/0 - 750MCM	X	X	X	X	X
GP00AA	56822801	Group AA	4 Grips	1/0 - 4/0					
GP101A	56822901	Group A	4 Grips	3/0 - 4/0				X	X
GP102B	56823001	Group B	4 Grips	250 - 350MCM	X			X	X
GP103C	56823101	Group C	4 Grips	400 - 500MCM		X	X		X
GP104D	56823201	Group D	4 Grips	600 - 750MCM		X	X		X



## SIMpull GRIPit™ CIRCUIT SIZED PULLING HEAD

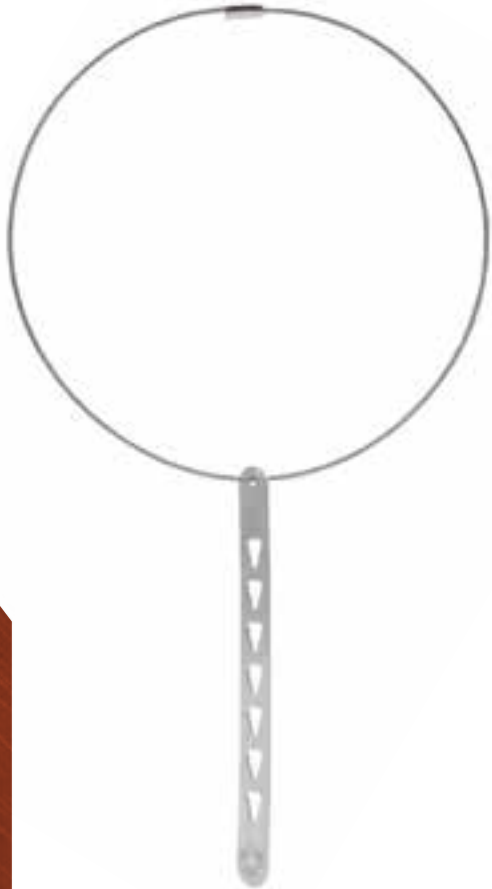

The SIMpull GRIPit™ Circuit Management System can help make every branch circuit and home run pull safer, easier and more productive.

- Easily connects to fish tape, string or rope
- 14 AWG - 10 AWG solid or stranded conductors
- Reusable pulling head for circuit wire
- Easily attach up to 7 wires per SIMpull™ pulling head
- No cutting, stripping or weaving of wire to make pulling head
- Easily connects to fish tape, string or rope
- No need to strip or tape the wire
- Saves time making pulling heads

### SPECIFICATIONS

MODEL #	STOCK#	DESCRIPTION			
CSPH1	582811	SIMpull GRIPit™ W/ 18" LEADER			
	HEIGHT	WIDTH	DEPTH	WEIGHT	DETAILS
CSPH1	13"	1.5"	0.06"	1.3 oz	Up to 7 wires of 10-14 AWG Solid or Stranded

## FIBERGLASS FISH TAPE



**Non-conductive fiberglass tape with low-friction coating for faster and easier fishing.**

- 50' and 100' non-conductive, fiberglass fish tape for safer use in occupied conduit
- 3/16" wide fish tape unwinds and rewinds easily
- High impact, durable case for lasting durability and use

### SPECIFICATIONS

MODEL #	STOCK #	DESCRIPTION			
FTFG3/16-100	582803	3/16" FISH TAPE 100' FIBERGLASS			
FTFG3/16-50	582804	3/16" FISH TAPE 50' FIBERGLASS			
	HEIGHT	WIDTH	DEPTH	WEIGHT	TAPE LENGTH
FTFG3/16-100	16.5"	12.75"	1.63"	2.9 oz	100'
FTFG3/16-50	17"	13"	1.75"	2.3 oz	50'

## STEEL FISH TAPE



**Southwire's steel fish tape reaches easily above ceilings, under carpets, and through walls to install wire. The fish tape is available in multiple lengths.**

- Available in the following lengths: 25', 50', 65', 125' and 240'
- Laser etched footage markings to help identify length of pull
- High impact, durable case for long lasting performance and use
- Specially treated steel fish tape for longer life and easier pulling

### SPECIFICATIONS

MODEL #	STOCK #	DESCRIPTION			
FTS1/8-240	582798	1/8" FISH TAPE STEEL 240'			
FTS1/8-125	582799	1/8" FISH TAPE STEEL 125'			
FTS1/8-65	582800	1/8" FISH TAPE STEEL 65'			
FTS1/8-50	582801	1/8" FISH TAPE STEEL 50'			
FTS1/8-25	582802	1/8" FISH TAPE STEEL 25'			
FTS1/4-25	582797	1/4" FLAT FISH TAPE 25'			
	HEIGHT	WIDTH	DEPTH	WEIGHT	
FTS1/8-240	8.5"	7"	1.13"	4.3 oz	
FTS1/8-125	16.5"	12.75"	1.63"	4.3 oz	
FTS1/8-65	11.5"	8.75"	1.13"	32 oz	
FTS1/8-50	11.5"	8.75"	1.13"	32 oz	
FTS1/8-25	11.5"	8.75"	1.13"	36 oz	
FTS1/4-25	8.5"	7"	1.63"	16 oz	

## FISH TAPE LEADER



Flexible leader guides steel tapes through conduit and helps reduce the challenge of pulling and pushing.

- Flexible 13" leader easily attaches to 1/8" steel fish tapes
- Assists in guiding steel fish tapes through conduit turns and bends

### SPECIFICATIONS

MODEL #	STOCK #	DESCRIPTION					
FTFL13	582807	FISH TAPE LEADER 13"					
		HEIGHT	WIDTH	DEPTH	WEIGHT	DIA.	EYELET CAPACITY
FTFL13		14.25"	0.38"	0.25"	2 oz	3/16"	5 X 12 AWG UNSTRIPPED, 7 X 10 AWG BARE

## GLOW-IN-THE-DARK FISH STICK



Make fishing through walls or over ceilings easier with our Glow-in-the-Dark Fish Sticks.

- Luminescent fiberglass rods glow in the dark and recharges in most available light sources
- 3/16" flexible rods resist splintering and cracking
- Includes bullet nose with eyelet and hook attachments
- Individual sections easily screw together to form single rod

### SPECIFICATIONS

MODEL #	STOCK #	DESCRIPTION				
FS15	582793	FISH STICK GLOW IN DARK 15'				
FS12	582794	FISH STICK GLOW IN DARK 12'				
FS8	582795	FISH STICK GLOW IN DARK 8'				
		HEIGHT	WIDTH	DEPTH	WEIGHT	DETAILS
FS15		62"	0.19"	0.19"	13.3 oz	3x5' Pieces
FS12		51"	0.19"	0.19"	13.9 oz	3x4' Pieces
FS8		26"	0.19"	0.19"	8 oz	4x2' Pieces

## PULLING GRIPS



Confidently pull wire and cable with these wire mesh pulling grips. Wire mesh basket securely holds cable, while swivel head minimizes cable twisting.

- Used to pull wire and cable through walls and conduit
- Swivel design minimizes cable twisting
- Mesh design holds wire or cable securely during pull
- Capacity: 100 lbs. pulling force
- Two separate grips available to meet your pulling requirements for 1/2" and 3/4" diameter wire and cable

### SPECIFICATIONS

MODEL #	STOCK #	DESCRIPTION	HEIGHT	WIDTH	DEPTH	WEIGHT	SIZE	PULLING FORCE
WPG3/4	582808	3/4" PULLING GRIP						
WPG1/2	582810	1/2" PULLING GRIP						
WPG3/4			9.5"	0.5"	0.5"	1.5 oz	3/4"	100 lbs.
WPG1/2			8.5"	0.5"	0.5"	1 oz	1/2"	100 lbs.

## HIGH TENSILE STRENGTH POLY LINE



Tangle resistant poly line for light duty cable or rope pulling applications.

- Ready to use storage containers quickly dispenses a tangle free line
- Line is resistant to rot and mildew
- Use to pull electrical and communication wire
- 210 lb tensile strength
- Made in the USA

### SPECIFICATIONS

MODEL #	STOCK #	DESCRIPTION	HEIGHT	WIDTH	DEPTH	WEIGHT	LINE LENGTH
PL6500	582805	POLY LINE 6500' 210 TENSILE STRENGTH					
PL500	582806	POLY LINE 500' 210 TENSILE STRENGTH					
PL6500			13"	11"	11"	11 oz	6,500'
PL500			8"	3"	3"	9 oz	500'

## PULLING ROPE



**Cable pulling rope designed for high breaking strength with low stretch.**

- High strength, low stretch
- Excellent resistance to UV rays, chemicals and abrasions
- Excellent balance
- Factory spliced pulling eye at each end
- Polyester double braid
- 9/16" diameter rope recommended for use with the M3K cable puller
- 5/8" diameter rope recommended for use with the M6K cable puller
- 7/8" diameter rope recommended for use with the M10K cable puller

## SPECIFICATIONS

MODEL #	STOCK #	DIA. (IN)	BREAKING STRENGTH	LENGTH
P-963	56823501	9/16"	16,000	300
P-966	56823601	9/16"	16,000	600
P-583	56823701	5/8"	18,000	300
P-586	56823901	5/8"	18,000	600
P-589	57791201	5/8"	18,000	900
P-786	56824001	7/8"	31,000	600
P-789	57991301	7/8"	31,000	900
P-7812	56824101	7/8"	31,000	1200

## QWIKROPE™



An innovative new high performance pulling rope that is UV resistant, lightweight and ultra low stretch for all of your feeder and circuit wire solutions.

- High performance pulling rope made from ultra high molecular weight polyethylene fibers
- 12 Strand single braided 9/16" pulling rope with a breaking strength of 32,000 lbs., pound for pound stronger than steel
- 2 Sizes for all your circuit wire pulls: 1/8" pulling rope with 1,100 lbs. of breaking strength, and 1/4" pulling rope with 7,500 lbs. of breaking strength
- Ultra low stretch, UV resistant, lightweight pulling rope
- 24% reduction in the coefficient of friction, as compared to traditional pulling ropes
- Dual factory installed pulling eyes
- Does not absorb water, no rope rot
- Need only one size rope (9/16") for feeder conductor, pulls up to 10,000 lbs.
- 1/8" QWIKrope™ can easily be vacuumed into any conduit run up to 290 ft.
- 9/16" QWIKrope™ recommended for use with all Maxis® cable pullers

### SPECIFICATIONS

#### QWIKrope™ for use in feeder conductor pulls

MODEL #	STOCK#	DIA. (IN)	CIRC. (IN)	LENGTH
SPR9612	58305901	9/16"	1 3/4"	1,200 ft.
SPR969	58305801	9/16"	1 3/4"	900 ft.
SPR966	58305701	9/16"	1 3/4"	600 ft.
SPR963	58305601	9/16"	1 3/4"	300 ft.
AVG BREAKING STRENGTH (LBS)				TOTAL WEIGHT
SPR9612		32,000		103 lbs.
SPR969		32,000		77 lbs.
SPR966		32,000		52 lbs.
SPR963		32,000		26 lbs.

#### QWIKrope™ for use in circuit wire pulls

MODEL #	STOCK#	DIA. (IN)	CIRC. (IN)	LENGTH
SPR183	58387401	1/8"	3/8"	300 ft.
SPR143	58387501	1/4"	3/4"	300 ft.
SPR146	58526301	1/4"	3/4"	600 ft.
AVG BREAKING STRENGTH (LBS)				TOTAL WEIGHT
SPR183		1,100		2.5 lbs.
SPR143		7,500		6.5 lbs.
SPR146		7,500		11 lbs.

**MAXIS® TRIGGERS®**



**Dual remote foot switches**

**Dual Power Control**

- Each pedal has the ability to control the puller's power source
- Works with any Maxis® cable puller and most other pullers
- Saves time by avoiding unnecessary stops and restarts
- Helps reduce the risk of wire feeding mishaps

**Visual Communication**

- LED lights on each footswitch indicate the cable pullers status
- Amp type force gauge- monitors pull tension based on the number of amps the motor is drawing. Useful when superior accuracy is not required (accuracy is +/- 20%). Amp usage is then translated into a tension reading shown on the display.

**Safety**

- Stop the cable pull from either end immediately
- No more audio miscommunication
- Increases safety by reducing issues associated with feeding wire

**Range**

- Will communicate up to 1500' between walls and up to 1.5 miles line of sight. 100' Antenna extension available for added strength to your Triggers® communication

**SPECIFICATIONS**

MODEL #	STOCK #	DESCRIPTION			
TR01	56824401	DUAL REMOTE FOOT SWITCH			
		HEIGHT	WIDTH	LENGTH	WEIGHT
TR01		6.5"	16.5"	23.5"	21 lbs



## SWIVEL AND CLEVIS



Connects pulling head and pulling rope to eliminate winding and tangling of rope and wire during cable pulls.

### 6,000 lb. Swivel

- Swivel diameter 1 1/4"
- Maximum rope size: 5/8"
- Designed to pass over sheaves, pulleys and rollers
- Pin roller design added for larger diameter rope and for added strength by evenly spreading load pressure

### 10,000 lb. Swivel

- Swivel diameter 1 5/8"
- Maximum rope size: 1"
- Designed to pass over sheaves, pulleys and rollers
- Pin roller design added for larger diameter rope and for added strength by evenly spreading load pressure

### 6,000 lb. Clevis

- Clevis diameter 1 1/4"
- Maximum rope size: 5/8"
- Connects to cable grip and pulling rope
- Designed to pass over sheaves, pulleys and rollers

### 10,000 lb. Clevis

- Clevis diameter 1 5/8"
- Maximum rope size: 1"
- Connects to cable grip and pulling rope
- Designed to pass over sheaves, pulleys and rollers

## SPECIFICATIONS

MODEL #	STOCK #	DESCRIPTION
RC114	56830601	6,000 LB. ROPE CLEVIS
RC158	56830701	10,000 LB. ROPE CLEVIS
MS114	57178101	6,000 LB. PULLING SWIVEL
MS158	57178001	10,000 LB. PULLING SWIVEL



TRIPODS



M3K and M6K Tripods attach to Maxis® cable pullers to make underground wire pulls simple and easy.

- Easily attach to the M3K or M6K cable puller
- Helps when pulling from transformer pads, vaults and meter bases
- Set-up in two minutes
- Helps to pull out extra wire

SPECIFICATIONS

MODEL #	STOCK #	DESCRIPTION
P3T01	56822201	P3T01 Maxis® 3K Tripod Accessory
SIZES		WEIGHT
Adjustable height: 3ft - 6ft		Adjustable leg width: 13in - 50in
		43 lbs

MODEL #	STOCK #	DESCRIPTION
P6T02	56829401	P6T02 Maxis® 6K Tripod Accessory
SIZES		WEIGHT
Adjustable height: 3ft - 6ft		Adjustable leg width: 13in - 50in
		45 lbs



## GUIDE *it*™ CIRCUIT ROUTER



**A wire router for circuit panel and junction boxes.**

- Universal adapter for hands free circuit wire feeding
- Routes circuit wire in enclosures up to 18 inches
- Helps to prevent any damage to wire during installation
- Reduces the need to route circuit wire into a raceway or conduit

### SPECIFICATIONS

MODEL #	STOCK #	DESCRIPTION		
WG01	58387301	CIRCUIT ROUTER		
	HEIGHT	WIDTH	LENGTH	WEIGHT
WG01	2.5"	7.5"	23"	2 LBS.



# CONDUIT BENDING

---

We don't just help you bend conduit—we change the way you do it. In addition to offering traditional conduit bending tools, Southwire™ has designed a bending station that allows you to bend 3/4" and 1" EMT conduit more efficiently, helping you do more work faster and stay fresh longer.

- BENDstation™ PRO
- Hand Benders
- Conduit Level

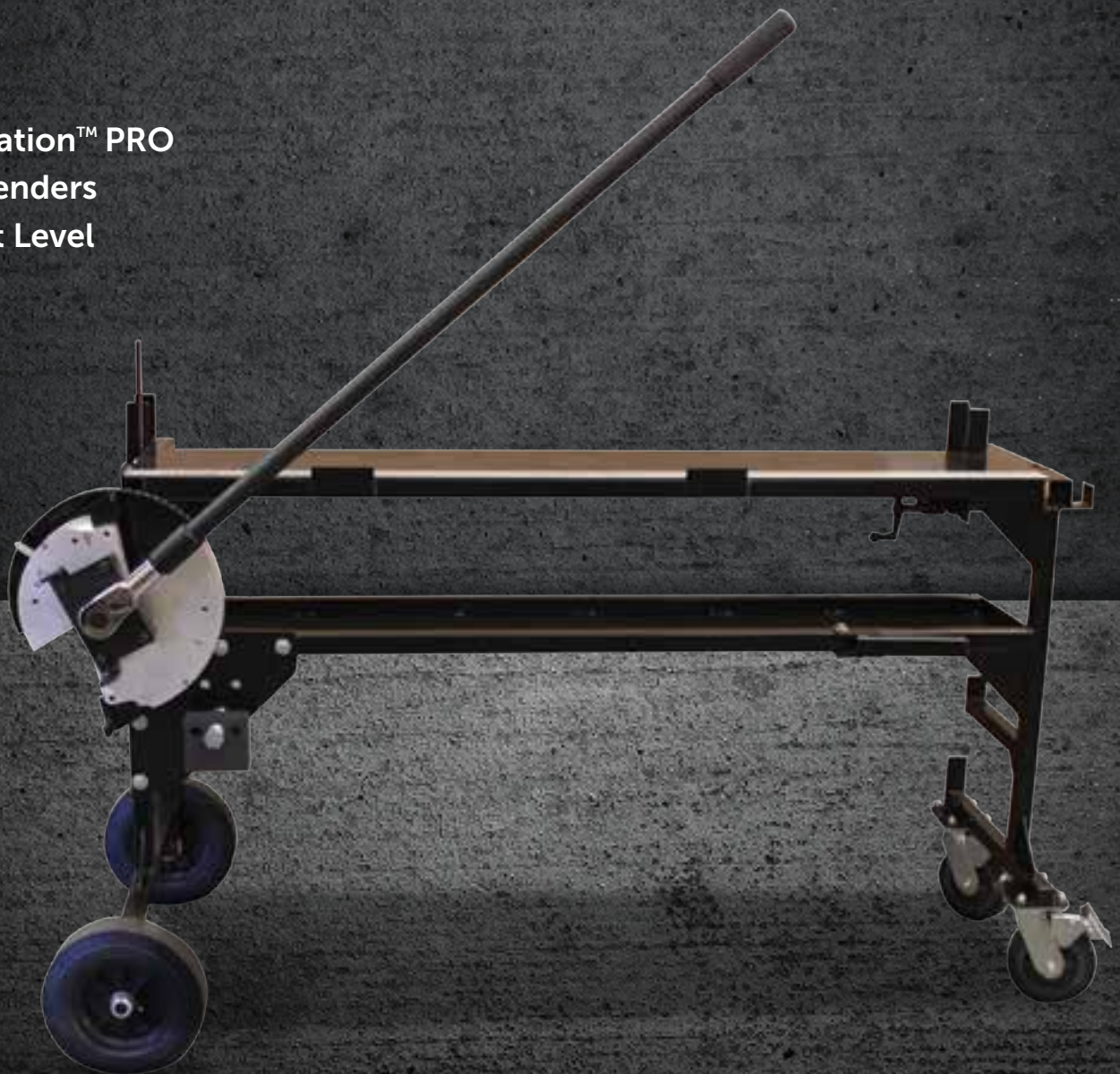

## BEND station™ PRO

A comprehensive conduit bending workstation for 1/2" & 3/4" EMT.



- Speeds up the entire bending process up to 30%
- More accurate measurements, bends, and cuts
- Built-in protractor for quick and accurate bends
- Comfortable work table height at 36"
- The ability to store up to 900 feet of conduit
- Extra shelf for storage of tools and materials
- Heavy duty casters for easy transportation and mobility
- Eliminates the need to bend over to "eye-ball" hand bends
- Less labor fatigue; work standing up and not constantly bending over
- Unique dual bending shoe, designed for both 3/4" & 1" EMT
- Ratchet system designed to make bending 1" EMT safer, easier, and more accurate
- A 60" ruler is incorporated on the working surface for quick and accurate marking
- Unique speed vice designed specifically to hold conduit and unistrut, makes cutting quicker and safer



### SPECIFICATIONS

MODEL #	STOCK #	DETAILS			
MB1000	58724401	BENDstation PRO™ FOR 3/4" AND 1" EMT			
		LENGTH	WIDTH	HEIGHT	WEIGHT
MB1000		69"	29"	38.5"	150 lbs

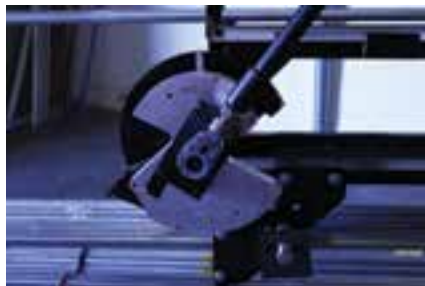

## CONDUIT BENDERS



Reliably and repeatedly perform common bends, such as stub-ups, offsets, back-to-back and saddle bends. Available in 1-1/4", 1", 1/2" and 3/4" sizes.

- Durable cast metal heads
- Swaged steel handle permits insertion of conduit to correct overbends
- Raised and highly visible bender markings are cast on both sides of the bender head
- Large serrated step provides greater control and helps prevent slippage when applying force

### SPECIFICATIONS

MODEL #	STOCK #	DETAILS		
MCB1-1/4	582943	1-1/4" STEEL CONDUIT BENDER W/ HANDLE		
MCB1	582814	1" STEEL CONDUIT BENDER W/ HANDLE		
MCB3/4	582812	3/4" AL CONDUIT BENDER W/ HANDLE		
MCB1/2	582813	1/2" AL CONDUIT BENDER W/ HANDLE		
	DEPTH	WIDTH	HEIGHT	WEIGHT
MCB1-1/4	2"	14"	45"	27 lbs.
MCB1	1.75"	12"	45"	13 lbs.
MCB3/4	1.25"	9"	39"	9 lbs.
MCB1/2	1.25"	8"	39"	7 lbs.

## CONDUIT FITTING REAMING SCREWDRIVER



Removable conduit reaming screwdriver deburs thin wall conduit with speed and ease.

- Reams and smooths 1/2", 3/4" and 1" thin-wall conduit ends to protect wire and permit correct installation of fittings
- Reams inside and outside of conduit simultaneously
- Cushion grip handles for comfort and use
- Replacement blade available - Part # SDCFRB

### SPECIFICATIONS

MODEL #	STOCK #	DESCRIPTION		
SDCFR	582837	CONDUIT FITTING REAMING SCREWDRIVER		
	HEIGHT	WIDTH	DEPTH	WEIGHT
SDCFR	7.5"	1.25"	1.25"	9.5 oz

## SPEEDSET™ CONDUIT LEVEL



A four-in-one conduit tool that works great in any situation and will help in all your conduit and gear installations.

- Four-in-one conduit tool: conduit spacer, torpedo level, dog-leg preventor, and a bending tool
- Equipped with strong magnets for easy leveling
- Create perfect bends every time
- Will easily attach to any 3/4", 1", and 1-1/4" bender head
- Multiple conduit bends exactly the same, every time without comparing them to each other

### SPECIFICATIONS

MODEL #	STOCK #	DETAILS			
SS01	582815	SPEEDSET™ CONDUIT LEVEL			
		DEPTH	WIDTH	HEIGHT	WEIGHT
SS01		0.5"	2.38"	2"	3.2 oz





**Southwire™**

# HOLE MAKING

---

Southwire™ has developed industry leading tools for electrical contractors, including a comprehensive line of hole making solutions. With tools ranging from cutting dies to the original drill-powered knockout punch, you can make quick, accurate holes every time without the muscle or mess.

- Knockouts
- Accessories



[MAXIS-TOOLS.COM](http://MAXIS-TOOLS.COM)  
[SOUTHWIRETOOLS.COM](http://SOUTHWIRETOOLS.COM)

## MAX PUNCH® 360 HYDRAULIC KNOCKOUT TOOL

A lightweight hydraulic knockout tool that can easily operate in most tight space applications.

- Lightweight aluminum head
- Full 360 degree articulating head
- Compact pump
- No awkward hoses or foot pumps required
- Includes:
  - Max Punch® 360 Hydraulic Punch
  - 7/16" Drawstud
  - 3/4" Drawstud
  - 1/2"-2" Cups and cutters
  - 1/2" Die spacer
  - Southwire™ Marksman® conduit layout tool
  - Heavy Duty carrying case



### SPECIFICATIONS

MODEL #	STOCK #	DETAILS		
M360HP-01	57578401	360 HYDRAULIC PUNCH ONLY (no case)		
M360HP	57401601	360 HYDRAULIC PUNCH SET: 1/2"-2" DIES W/ MARKSMAN CONDUIT LAYOUT TOOL		
	LENGTH	WIDTH	DEPTH	HEIGHT / WEIGHT
UNBOXED	15.5"	5.25"	3.75"	4.5"
BOXED	18"	12"	5"	16 LBS
HYDRAULIC FLUID NEEDED: 3 OZ				



## MAX PUNCH® PRO KNOCKOUT TOOL



Heavy duty knockout punch driver for mild and stainless steel.

- An advanced knockout tool used with a cordless drill to draw punch dies together for quick accurate knockouts
- No hydraulics, no ratcheting, no mess
- Thread-in / thread-out removable drawstuds (universal to fit most common KO dies)
- Rated to cut 10 gauge mild and stainless steel up to 4"
- Minimum drill recommendations: 18v cordless, equivalent of 550 in. lbs. torque rating

### SPECIFICATIONS

MODEL #	STOCK #	DETAILS			
MP-01PRO	57177501	MAX PUNCH® PRO: drive unit only (no case)			
		LENGTH	WIDTH	DEPTH	HEIGHT
BOXED		11.5"	5"	4.25"	5.5"



## MAX PUNCH® PRO STAINLESS STEEL SETS



### MP-01CSPRO

Includes:

- Max Punch PRO drive unit
- 1/2" – 4" Cutting dies (rated for stainless steel)
- 2 Drawstuds sizes 3/4" & 7/16"
- Marksman® conduit layout tool
- Step drill bit (3/16" – 7/8", 2 nut drivers) (3/8")
- 2 Heavy duty carrying cases

### MP-01SDPRO

Includes:

- Max Punch PRO drive unit
- 1/2" – 2" Max Punch PRO cutting dies (rated for stainless steel)
- 2 Drawstuds sizes 3/4" & 7/16"
- Marksman® conduit layout tool
- Step drill bit (3/16" – 7/8"), 2 nut drivers (3/8")
- Heavy duty carrying case

## SPECIFICATIONS

MODEL #	STOCK #	DETAILS	LENGTH	WIDTH	DEPTH	WEIGHT
MP-01CSPRO	57177601	MAX PUNCH® PRO STAINLESS STEEL 1/2" - 4" SET	16.5"	13"	11"	37 LBS.
MP-01SDPRO	57177701	MAX PUNCH® PRO STAINLESS STEEL 1/2" - 2" SET	16.5"	13"	8.5"	14.5 LBS

## MAX PUNCH® PRO MILD STEEL SETS



### MP-01CS

Includes:

- Max Punch PRO drive unit
- 1/2" – 4" Cutting dies (rated for mild steel)
- 2 drawstuds sizes 3/4" & 7/16"
- Marksman® conduit layout tool
- Step drill bit (3/16" – 7/8" 2 nut drivers) (3/8")
- 2 Heavy duty carrying cases

### MP-01SD

Includes:

- Max Punch PRO drive unit
- 1/2" – 2" Max Punch PRO cutting dies (rated for mild steel)
- 2 Drawstuds sizes 3/4" & 7/16"
- Marksman® conduit layout tool
- Step drill bit (3/16" – 7/8"), 2 nut drivers (3/8")
- Heavy duty carrying case

## SPECIFICATIONS

MODEL #	STOCK #	DETAILS	LENGTH	WIDTH	DEPTH	WEIGHT
MP-01CS	56830801	MAX PUNCH® MILD STEEL 1/2" - 4" SET	16.5"	13"	11"	37 LBS.
MP-01SD	56830901	MAX PUNCH® MILD STEEL 1/2" - 2" SET	16.5"	13"	8.5"	14.5 LBS

## STUD PUNCH



### 2 Tools in 1

- Sizes include - 7/8" (22.5mm) & 1-11/32" (34.1mm)
- Stud Punch is intended to punch round holes in 20 gauge steel studs
- Lock to keep handle in place when not in use
- Lightweight punch makes accurate location of holes easier
- Cushioned handle gives more leverage and makes it easier to punch in tight spaces, meaning less operator fatigue and more comfortable handling

### SPECIFICATIONS

MODEL #	STOCK #	DETAILS		
MSP01	57576201	STUD PUNCH		
MODEL #	HEIGHT	WIDTH	LENGTH	WEIGHT
MSP01	2.25"	8.55"	18.5"	7.5 lbs

## MAX PUNCH® RATCHET SET WITH 1/2"-2" CUTTING DIES



### Flex head ratchet wrench allows for easy maneuverability around obstacles

- Unique 3-point cup cutting surface provides a clean, quick and easy cut for 1" thru 2" dies
- Cuts through 10 gauge mild steel as well as aluminum, fiberglass, and plastics
- Cup design creates crimping effect on slug for easy removal for 1" thru 2" dies
- Ball bearing draw stud for reduced friction
- Includes Southwire™ Marksman® (Model # MM01) conduit layout tool

### SPECIFICATIONS

MODEL #	STOCK #	DETAILS		
MPR-01SD	582892	MAX PUNCH RATCHET SET W/ 1/2"-2" DIES		
MPR-03	57798901	MAX PUNCH RATCHET W/ 3/4" BEARING DRAWSTUD		
MODEL #	HEIGHT	WIDTH	LENGTH	WEIGHT
MPR-01SD	14.17"	10.43"	2.76"	11.57 lbs.

## MAX PUNCH® MILD STEEL CUPS & CUTTERS



### Cleaner, Quicker Steel Punch Dies

- Unique 3 point cutting surface provides a cleaner, quicker and easier cut for 1" thru 4" dies
- Cuts 10 gauge steel (3.5mm) as well as aluminum, fiberglass and plastics
- Will not bow panel or leave jagged edges
- Quicker smoother cut
- Cup creates crimping effect on slug for easy removal
- Works with MaxPunch® Punches (up to 4"), Maxis 360 Hydraulic Punch (up to 2"), and other popular knockout tools

## SPECIFICATIONS

CUPS & CUTTERS		CONDUIT & PIPE SIZE	HOLE SIZE ACTUAL "	MM	CAPACITY S.S. GA
MPK050	56826301	1/2" conduit size cutter	1/2"	.89	10
MPC50	56827301	1/2" conduit size cup	1/2"	.89	10
MPK075	56826401	3/4" conduit size cutter	3/4"	1.12	10
MPC75	56827401	3/4" conduit size cup	3/4"	.12	10
MPK100	56826501	1" conduit size cutter	1"	1.36	10
MPC100	56827501	1" conduit size cup	1"	1.36	10
MPK125	56826601	1 1/4" conduit size cutter	1 1/4"	1.70	10
MPC125	56827601	1 1/4" conduit size cup	1 1/4"	1.70	10
MPK150	56826701	1 1/2" conduit size cutter	1 1/2"	1.95	10
MPC150	56827701	1 1/2" conduit size cup	1 1/2"	1.95	10
MPK200	56826801	2" conduit cutter	2"	2.42	10
MPC200	56827801	2" conduit cup	2"	2.42	10
MPK250	56826901	2 1/2" conduit cutter	2 1/2"	2.92	10
MPC250	56828001	2 1/2" conduit cup	2 1/2"	2.92	10
MPK300	56827001	3" conduit cutter	3"	3.55	10
MPC300	56828101	3" conduit cup	3"	3.55	10
MPK350	56827101	3 1/2" conduit cutter	3 1/2"	4.04	10
MPC350	56828201	3 1/2" conduit cup	3 1/2"	4.04	10
MPK400	56827201	4" conduit cutter	4"	4.54	10
MPC400	56828301	4" conduit cup	4"	4.54	10
MP02	56825701	Small Die Set 1/2"-2" in case*	1/2"-2"	.89-2.42	10
MP03	56825801	Large Die Set 2 1/2"-4" in case*	2 1/2" - 4"	2.92-4.54	10

\*(drive unit not included)

## MAX PUNCH® STAINLESS STEEL CUPS & CUTTERS



Cleaner, quicker stainless steel punch dies.

- Unique 3 point cutting surface provides a cleaner, quicker and easier cut for 1" thru 4" dies
- Rated for 10 gauge stainless steel (3.5mm) as well as mild steel, aluminum, fiberglass and plastics
- Will not bow panel or leave jagged edges
- Crimping effect on slug for easy removal

### SPECIFICATIONS

MODEL #	STOCK #	DESCRIPTION	CONDUIT & PIPE SIZE	HOLE SIZE ACTUAL "	MM	CAPACITY S.S. GA
MPK050PRO	57174601	Max Punch® Cutter for Stainless Steel 1/2"	1/2"	.89	23	10 reg
MPC50PRO	57176101	Max Punch® Cup for Stainless Steel 1/2"	1/2"	.89	23	10 reg
MPK075PRO	57174701	Max Punch® Cutter for Stainless Steel 3/4"	3/4"	1.12	28	10 reg
MPC75PRO	57176201	Max Punch® Cup for Stainless Steel 3/4"	3/4"	1.12	28	10 reg
MPK100PRO	57174801	Max Punch® Cutter for Stainless Steel 1"	1"	1.36	35	10 reg
MPC100PRO	57176301	Max Punch® Cup for Stainless Steel 1"	1"	1.36	35	10 reg
MPK125PRO	57174901	Max Punch® Cutter for Stainless Steel 1 1/4"	1 1/4"	1.70	43	10 reg
MPC125PRO	57176401	Max Punch® Cup for Stainless Steel 1 1/4"	1 1/4"	1.70	43	10 reg
MPK150PRO	57175001	Max Punch® Cutter for Stainless Steel 1 1/2"	1 1/2"	1.95	50	10 reg
MPC150PRO	57176501	Max Punch® Cup for Stainless Steel 1 1/2"	1 1/2"	1.95	50	10 reg
MPK200PRO	57175101	Max Punch® Cutter for Stainless Steel 2"	2"	2.42	62	10 reg
MPC200PRO	57176601	Max Punch® Cup for Stainless Steel 2"	2"	2.42	62	10 reg
MPK250PRO	57175301	Max Punch® Cutter for Stainless Steel 2 1/2"	2 1/2"	2.92	74	10 reg
MPC250PRO	57176701	Max Punch® Cup for Stainless Steel 2-1/2"	2 1/2"	2.92	74	10 reg
MPK300PRO	57175401	Max Punch® Cutter for Stainless Steel 3"	3"	3.55	90	10 reg
MPC300PRO	57176801	Max Punch® Cup for Stainless Steel 3"	3"	3.55	90	10 reg
MPK350PRO	57175501	Max Punch® Cutter for Stainless Steel 3 1/2"	3 1/2"	4.04	103	10 reg
MPC350PRO	57176901	Max Punch® Cup for Stainless Steel 3 1/2"	3 1/2"	4.04	103	10 reg
MPK400PRO	57175601	Max Punch® Cutter for Stainless Steel 4"	4"	4.54	115	10 reg
MPC400PRO	57177001	Max Punch® Cup for Stainless Steel 4"	4"	4.54	115	10 reg
MPO2PRO	57177101	Small Die Set 1/2"-2" in case (drive unit not included)	1/2"-2"	.89-2.42	23-62	10 reg
MPO3PRO	57177201	Large Die Set 2 1/2"- 4" in case (drive unit not included)	2 1/2" - 4"	2.92-4.54	74-115	10 reg

## OILTIGHT PUNCHES WITH NOTCHES



### Special application punches

- Model #MPOP78, Stock #58142201, 7/8" (22.5mm) Oiltight punch with notches
- Model #MPOP1732, Stock #58142301, 1 7/32" (30.5mm) Oiltight punch with notches
- Punch, die, draw stud and nut

### SPECIFICATIONS

MODEL #	STOCK #	DETAILS		
MPOP78	58142201	7/8" OILTIGHT PUNCH		
MPOP1732	58142301	1 7/32" OILTIGHT PUNCH		
HOLE SIZE	INCH	A	B	C
MPOP78		.875	.125	1.000
MPOP1732		1.210	.190	1.380
HOLE SIZE	MM	A	B	C
MPOP78		22.5	3.2	25.4
MPOP1732		30.5	4.8	36.0
MAXIMUM CAPACITY MILD STEEL			GA	MM
MPOP78			14	2.0
MPOP1732			10	3.5

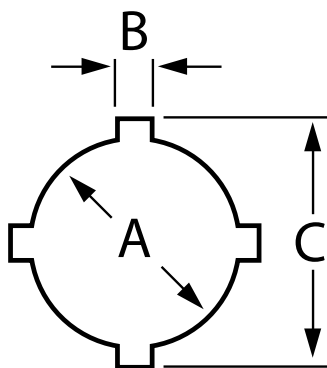

**DRAW STUDS FOR MAX PUNCH® DRIVE UNITS**



**MAX PUNCH® PRO DRAW STUDS**

- 3/4" - Main Draw Stud - Stock #57717701 Model #PRDS34
- 7/16" - Medium Draw Stud - Stock #57717901 Model #PRDS716
- 1 1/8" - Large Draw Stud (for 2 1/2" – 4" Max Punch® and Max Punch® PRO Dies) Stock #58306101 Model #PRDS118 (BLK/SI)

**MAX PUNCH® DRAW STUDS**

- 3/4" - Main Draw Stud - Stock #56825901 Model #MPDS12
- 7/16" - Medium Draw Stud - Stock #57717801 Model #MPDS716
- 3/8" - Small Draw Stud (for standard Max Punch and Max Punch Pro) - Stock #56826001 Model #MPDS38

**MAX PUNCH® 360 DRAW STUDS**

- 3/4" - Main Draw Stud - Stock #57578101 Model #HPDS34
- 7/16" - Small Draw Stud - Stock #57717601 Model #HPDS716

**SPECIFICATIONS**

MODEL #	STOCK#	DESCRIPTION	LENGTH	WEIGHT	DIAMETER
PRDS34	57717701	3/4" MAIN DRAW STUD MAX PUNCH PRO	5"	8.7 OZ	3/4"
PRDS716	57717901	7/16" MEDIUM DRAW STUD - MAX PUNCH PRO	4.25"	4.6 OZ	7/16" - 3/4"
PRDS118	58306101	LARGE DRAW STUD - 1 1/8" (FOR MILD STEEL OR STAINLESS STEEL LARGE DIES)	4.4375"	15.6 OZ	1 1/8"
MPDS38	56826001	3/8" SMALL DRAW STUD - MAX PUNCH	3"	1.2 OZ	3/8"
MPDS716	57717801	7/16" MEDIUM DRAW STUD - MAX PUNCH	3"	1.5 OZ	7/16"
MPDS12	56825901	1/2" MAIN DRAW STUD - MAX PUNCH	11.5"	4.4 OZ	15/16"
HPDS716	57717601	7/16" MEDIUM DRAW STUD - MAX PUNCH 360	4.25"	4.6 OZ	7/16" - 3/4"
HPDS34	57578101	3/4" MAIN DRAW STUD - MAX PUNCH 360	5"	8.7 OZ	3/4"

## MARKSMAN® CONDUIT LAYOUT TOOL



**STEP 1**

MARK STRUT LINE

A conduit layout tool that will pinpoint a center knockout in seconds. The Marksman layout tool also features a panel schedule showing the branch circuit number and its corresponding phase.

- 60 times faster than a tape measure
- Easy to use
- No math
- For KO sizes 1/2" to 4"
- Underground and overhead
- Features a panel schedule showing the branch circuit number to its corresponding color
- The Southwire™ Marksman® conduit layout tool is constructed of tough durable anodized aluminum
- Markings are etched for maximum durability

### SPECIFICATIONS

MODEL #	STOCK #	DETAILS				
MM01	582819	MARKSMAN CONDUIT LAYOUT TOOL				
		HEIGHT	WIDTH	DEPTH	WEIGHT	Knockout Sizes
MM01		6.5"	2"	0.25"	2.5 oz	1/2" - 4"

**STEP 2**

MARK CONDUIT COMBINATION

**STEP 3**

MARK CENTER KNOCKOUT AND DRILL





**Southwire™**

# MATERIAL HANDLING

As one of the most innovative tool lines in the industry, Southwire's Maxis® Contractor Equipment has provided material handling solutions that move material quickly, easily, and safely. With useful products like reel jacks, SIMpull CoilPAK™ carts, and Wire Wagon® carts, you can complete the job better than ever before, while saving time and energy.

- Reel Stands
- SIMpull™ Wire Carts
- Wire Wagon® Carts



[SOUTHWIRETOOLS.COM](http://SOUTHWIRETOOLS.COM)

## MAXIS® PRO-JAX™ REEL STANDS



A 6,000 lb. capacity portable reel stand.

- One person can easily transport through most jobsite environments
- Pro-Jax stands can lift up to 6000 lbs.
- Uses an 18V cordless drill to lift wire reels
- Easy adjustment for uneven surfaces on jobsite
- Axle rests on steel rollers for easy wire pay off
- Axle safety guard ensures that reel will not fall off of jack stands
- Can be used with any axle from 1 1/4" - 3 1/2" OD
- Maximum reel height: up to a 72" reel
- Minimum drill recommendations: 18V cordless, equivalent of 550 in.lbs. torque rated, for reels 3,000 - 6,000 lbs

### SPECIFICATIONS

MODEL #	STOCK #	DETAILS		
MPJ01 (single)	58133201	PRO JAX		
MPJ02 (pair)	58526401	PRO JAX SET		
	LENGTH	WIDTH	HEIGHT	WEIGHT
MPJ01 (single)	41"	17"	43"	118 lbs.



## MAXISJAX® REEL STANDS



A unique reel stand that will quickly set up and lift wire reels safely and efficiently without the hassle of conventional stands.

- Easy to store and transport
- Breaks down into a compact storable tool
- Jaw clamps onto axle so that wire reels won't come off or fall over
- Multiple steel rollers make it easy for one person to roll off heavy wire
- Max lever allows one person to lift wire reels off the ground with minimal effort
- Each pair lifts wire reels up to 3,000 lbs.
- Uses either a 1-1/2" to 2" rigid pipe for an axle. Works on reels up to 48" tall

### SPECIFICATIONS

MODEL #	STOCK #	DETAILS		
MJ707	56824501	MAXISJAX - 3,000 LBS. REEL STANDS (pair)		
	HEIGHT	WIDTH	LENGTH	WEIGHT
MJ707	37"	7"	9.5"	54 LBS



## SIMpull™ COILPAK™ CART



The best material handling solution for SIMpull® CoilPAK™ Payoffs.

- Rugged transport system for (8) SIMpull® CoilPAK™ Payoffs with an integrated pay off system
- Allows CoilPAK Payoffs to be added or changed easily without impacting other CoilPAK Payoffs
- Innovative staging springs allow you to secure and organize up to 8 wires
- Best for scenarios where conductors are frequently changing, adding or dropping
- Individual wire feeds similar to a wire cart
- Easy to use in hallways and fits through standard doors
- Cart includes (4) 8" Eco Rubber tires that increase mobility in jobsite environments

### SPECIFICATIONS

MODEL #	STOCK #	DETAILS			
CK01	58386901	SIMPULL COILPAK CART			
		LENGTH	WIDTH	HEIGHT	WEIGHT
CK01		52"	24"	90"	60.5 lbs

## SIMpull™ COILPAK™ UTILITY CART



Multipurpose cart designed for rugged use on nearly any construction.

- Can hold and transport a variety of materials, tools, supplies, and SIMpull® CoilPAK™ payoffs
- Ability to hold up to 8 SIMpull® CoilPAK™ payoffs
- Incorporated low payoff height for easy circuit wire pulling at any angle
- Compact cart design for easy storage and transport
- Durable 8" Eco rubber casters and ergonomic handles for easy mobility on the jobsite

### SPECIFICATIONS

MODEL #	STOCK #	DETAILS			
UC100	58617201	HEAVY DUTY 2 SHELF UTILITY CART			
		LENGTH	WIDTH	HEIGHT	WEIGHT
CK01		46"	24"	45"	107 lbs

**SIMpull™ COILPAK™ HAND TRUCK**



Specifically designed to hold up to 5 stacked SIMpull® CoilPAK™ Payoffs as part of the SIMpull® Circuit Wire Management System.

- Space saving design - great for service trucks and vans
- Transport SIMpull® CoilPAK™ Payoffs with ease
- Incorporates a payoff guide that allows you to pull at any angle, helps to straighten wire, reduces wire memory
- Heavy duty rubber solid wheels - no flats

**SPECIFICATIONS**

MODEL #	STOCK #	DETAILS		
CT01	58387001	SIMPULL COILPAK HAND TRUCK		
		LENGTH	WIDTH	HEIGHT
CT01		22"	14.5"	53.25"
		WEIGHT		
CT01		32 lbs		

**SIMpull™ COILPAK™ DOLLY**



Specifically designed to hold 5 stacked SIMpull® CoilPAK™ Payoffs as part of the SIMpull® Circuit Wire Management System

- Simple economical design allows for safer jobsite transport of SIMpull® CoilPAK™ Payoffs for improved wire installation
- Incorporates a payoff guide that allows you to pull at any angle, helps to straighten wire, reduces wire memory

**SPECIFICATIONS**

MODEL #	STOCK #	DETAILS		
SPD01	58450101	SIMPULL COILPAK DOLLY		
		LENGTH	WIDTH	HEIGHT
SPD01		24.25"	20.5"	55.5"
		WEIGHT		
SPD01		28 lbs		

MATERIAL HANDLING | Wire Carts

## SIMpull BARREL™ HAND TRUCK



The SIMpull BARREL™ Hand Truck makes it easy to handle and transport your SIMpull BARREL™ Drum.

- The SIMpull BARREL™ Hand Truck, when used with the SIMpull BARREL™ package, replaces the old wire cart and reels and the issues associated with them
- The hand truck includes a wire payoff feature, and is designed to transport the SIMpull BARREL™ package anywhere on the jobsite - through narrow electrical room doors, over cords on the floor or construction gravel
- Solid rubber tires for no-flat jobsite peace of mind
- Rugged steel frame with unique design

### SPECIFICATIONS

MODEL #	STOCK #	DETAILS			
SBT01	58133001	SIMPULL BARREL HAND TRUCK			
	LENGTH	WIDTH	HEIGHT	WEIGHT	
SBT01	27"	24.5"	61"	145 lbs	

## SIMpull BARREL™ TRIPOD



The SIMpull BARREL™ Tripod is a circuit wire payoff accessory to be used in conjunction with your new SIMpull BARREL™.

- The SIMpull BARREL™ Tripod is a circuit wire guide that mounts easily on the rim of the SIMpull BARREL™
- This wire guide system provides a unique means for guiding the paralleled conductors out of the barrel when it is not on the SIMpull Barrel™ hand truck.

### SPECIFICATIONS

MODEL #	STOCK #	DETAILS				
SBT02	58133101	SIMPULL WIREBARREL TRIPOD				
	LENGTH	WIDTH	HEIGHT	WEIGHT	TAP OUTSIDE DIAMETER	
SBT02	36.5"	6.25"	6.25'	5.5 lbs.	4.98"	

## WIRE WAGON® 550

### Mobile Print Table and Work Station

- No wasting time looking around the jobsite for something to use as a print table
- No wasting time back and forth to a stationary print table
- Move your plans and materials right to the work area
- 1000 lb. capacity
- Includes:
  - Mobile print table
  - Material shelf
  - Conduit rack
  - Portable work bench

### SPECIFICATIONS

MODEL #	STOCK #	DETAILS		
WW550	56825501	WIRE WAGON 550		
	LENGTH	WIDTH	HEIGHT	WEIGHT
WW550	54"	32"	42"	180 lbs

## WIRE WAGON® 510

### XL Conduit and Wire Cart

- Holds up to 14 - 2500' spools or a combination of 2500' and 500' spools
- Holds several hundred feet of conduit as well as all the additional materials and tools needed for your entire work day
- Designed with a full 24"x60" metal top shelf for storage and assembly
- 2,000 lb. capacity

### SPECIFICATIONS

MODEL #	STOCK #	DETAILS		
WW510	56824801	WIRE WAGON 510		
	LENGTH	WIDTH	HEIGHT	WEIGHT
WW510	60.5"	29.5"	46.25"	191 lbs



## WIRE WAGON® 520



### MC Cable Cart

- Holds 4 spools of 1000' MC cable
- Allows for different sizes and colors on one rack
- Comes standard with two sets of axles for wider than normal spools
- Eliminate spool jacks and the unnecessary set up and tear down time between pulls
- 2,000 lb. capacity



### SPECIFICATIONS

MODEL #	STOCK #	DETAILS		
WW520	56825001	WIRE WAGON 520		
	LENGTH	WIDTH	HEIGHT	WEIGHT
WW520	60"	52"	13"	125 lbs

## WIRE WAGON® 538



### Service Cart

- Holds up to 12 – 500' spools of 12 AWG and 14 AWG
- Constructed with 5/8" solid steel bar to support almost any combination of wire spools
- Easy movement around the jobsite
- Folds flat in seconds for minimal storage
- Great for service trucks or vans

### SPECIFICATIONS

MODEL #	STOCK #	DETAILS		
WW538	56825401	WIRE WAGON 538		
	LENGTH	WIDTH	HEIGHT	WEIGHT
WW538	32.5"	26.5"	36.5"	25.5 lbs

## WIRE WAGON® 530



### Large Spool Cart

- Holds 8 spools up to 16 inches in diameter
- Storage for extra tools, spools and materials
- Easy to load and unload
- Equipped with “T” handle and 4 casters for easy movement around the job site
- 1,000 lb. capacity

### SPECIFICATIONS

MODEL #	STOCK #	DETAILS		
WW530	56825101	WIRE WAGON 530		
	LENGTH	WIDTH	HEIGHT	WEIGHT
WW530	50"	29.5"	42"	155 lbs

## WIRE WAGON® 535



### Large Capacity Wire Cart

- Holds up to 20 – 500' spools of 12 AWG and 14 AWG or 6 -2500' spools of 12 AWG and 14 AWG
- Will hold up to 9 boxes of data cable or 6 - 1000' spools
- Extra storage shelf for tools, spools and materials
- Easy to load and unload, there are no axles or pins to remove
- Equipped with “T” handle - 4 casters for easy movement around the job site
- 1,000 lb. capacity

### SPECIFICATIONS

MODEL #	STOCK #	DETAILS		
WW535	56825201	WIRE WAGON 535		
	LENGTH	WIDTH	HEIGHT	WEIGHT
WW535	50"	29.5"	42"	142 lbs

## CABLE PULLING

CSPH1	70
CSPH2	70
FS12	72
FS15	72
FS8	72
FTFG3/16-100	71
FTFG3/16-50	71
FTFL13	72
FTS1/4-25	71
FTS1/8-125	71
FTS1/8-240	71
FTS1/8-25	71
FTS1/8-50	71
FTS1/8-65	71
GP110	69
GPO0AA	69
GP101A	69
GP102B	69
GP103C	69
GP104D	69
M10K	65
M3K-M	67
M6K-M	66
MCF-01	68
MS114	77
MS158	77
P-583	74
P-586	74
P-589	74
P-7812	74
P-786	74
P-789	74
P-963	74
P-966	74
P3-T01	78
P6-T02	78
PC100	80
PL500	73
PL6500	73
RC114	77
RC158	77
SPR-143	75
SPR-146	75
SPR-183	75
SPR-9612	75
SPR-963	75
SPR-966	75
SPR-969	75
TR01	76
WG-01	79
WPG1/2	73
WPG3/4	73

## CONDUIT BENDING

MB750	81
MCB1-1/4	82
MCB1	82
MCB1/2	82
MCB3/4	82
SDCFR	82
SS01	83

## HAND TOOLS

AWL001	20
BAG12	33
BN01	13

CCP350	12
CCP6	12
CCP9	12
CCP9D	12
CCPR400	13
CONCUT	16
CTHC10	30
CTHC11	30
CRT	13
DCP8	5
DCP8D	5
DCPA8	5
DCPA8D	5
DESAW	15
EKIT-4	32
ES001	14
ETAPE	29
FDWSAW	16
FLITE1	33
HEX-5	27
HEX-8	27
HSAW	15
LNP6	7
LNP6D	7
LNP7	7
LNP8S	7
LNP8SD	7
LVLTOR9	28
MCBLADE	16
MCBLEVEL	28
MCCUT	16
MND38	26
MP61	11
MPLN	11
MPSB01	31
MPSB02	31
MPSB03	31
MPSB01	31
MTO01	14
ND1/2-3	24
ND1/4-3	24
ND3/8-3	24
ND5/16-3	24
ND7/16-3	24
NDSET2-1-1/2	26
NDSET2-6	25
NDSET7	25
PLACUT	16
PP10	8
PP6	8
S1018SOL	10
S1018STR	10
S1626STR	10
S5N1	8
S612STR	10
SA822	15
SCP9	6
SCP9C	6
SCP9D	6
SCP9TP	6
SCP9TPC	6
SD1/4C4	19
SD1/4C6	19
SD1/4K1-1/2	18
SD1/4K4HD	18
SD1P3	17
SD2P1-1/2	17
SD2P4HD	17
SD2P6HD	17
SD3/16C4	19

SD3/16C6	19
SD3/16CRD	22
SD5/16K6HD	18
SD5N1LITE	21
SD9N1	21
SDC2P	22
SDI1/4K4	18
SDI2P4	17
SDQ2P1-1/2	20
SDQ2P4	20
SDSET2-3	23
SDSET4MINI	23
SDSET8	23
SDSH1/4	22
SDSH2P6	22
SDWS	21
SNM1012	11
SNM1214	11
SVN	11
TCC9	9
TCC9D	9
THEX6-1/2	27
THEX6-3/8	27
UTIL61	14

## HOLE MAKING

HPDS34	92
HPDS716	92
M360HP-01	85
MM01	93
MP-01CS	87
MP-01CSPRO	87
MP-01PRO	86
MP-01SD	87
MP-01SDPRO	87
MP-OPN1732	91
MP-OPN78	91
MPO2	89
MPO3	89
MPO2PRO	90
MPO3PRO	90
MPC100	89
MPC100PRO	90
MPC125	89
MPC125PRO	90
MPC150	89
MPC150PRO	90
MPC200	89
MPC200PRO	90
MPC250	89
MPC250PRO	90
MPC300	89
MPC300PRO	90
MPC350	89
MPC350PRO	90
MPC400	89
MPC400PRO	90
MPC50	89
MPC50PRO	90
MPC75	89
MPC75PRO	90
MPDS12	92
MPDS38	92
MPDS716	92
MPK0250PRO	90
MPK0400PRO	90
MPK0100	89
MPK0100PRO	90
MPK0125	89

MPK0125PRO	90
MPK0150	89
MPK0150PRO	90
MPK0200	89
MPK0200PRO	90
MPK0250	89
MPK0300	89
MPK0300PRO	90
MPK0350	89
MPK0350PRO	90
MPK0400	89
MPK050	89
MPK050PRO	90
MPK075	89
MPK075PRO	90
MPR-01SD	88
MSP01	88
PRDS118	92
PRDS34	92
PRDS716	92

## MATERIAL HANDLING

CK-01	97
CT-01	98
MJ-707	96
MPJ-01	95
SBT-01	99
SBT-02	99
SPD-01	98
WW-510	100
WW-520	101
WW-530	102
WW-535	102
WW-538	101
WW-550	100

## TESTS & MEASURE

10010S	44
10020N	43
10030S	42
10035K	62
10040N	41
11050N	40
11060S	39
12070T	38
21010N	48
21030T	47
21050T	46
22070T	45
30010S	57
30020S	56
31030S	55
31040S	54
40005S	61
40010S	60
40020S	60
40030S	61
40110N	49
40120N	49
40130N	49
40140S	53
41150S	52
41160S	51
41170S	50
41210S	59
51010S	58
60010S	63
60020S	63
60030S	63

**CABLE PULLING TOOLS**

Clevis .....77  
 Fiberglass Fish Tape .....71  
 Fish Tape Leader .....72  
 Glow-in-Dark Fish Stick .....72  
 Maxis® 10K Cable Puller .....65  
 Maxis® 3K-M Cable Puller .....67  
 Maxis® 6K-M Cable Puller .....66  
 Maxis® Cable Feeder .....68  
 Maxis® Grips Pulling Heads .....69  
 Maxis® Tripods .....78  
 Poly Line .....73  
 Puller Carts .....80  
 Pulling Grips .....73  
 Rope .....74  
 Maxis® QWIKrope .....75  
 SIMpull™ GRIP*it*™ .....70  
 SIMpull™ GUIDE*it*™ Wire Router .....79  
 Steel Fish Tape .....71  
 Swivel .....77  
 Triggers .....76

**CONDUIT BENDING TOOLS**

Conduit Benders .....82  
 Conduit Fitting Reaming Screwdriver .....82  
 EMT Bend STATION .....81  
 SPEEDSET Conduit Level .....83

**HAND TOOLS**

Bi-Metal Hole Saws .....31  
 Boot Knife .....13  
 Cable Ripping Tool .....13  
 Canvas Zipper Bag .....33  
 Carbide Tip Hole Cutters .....30  
 Conduit Scorer/Cutter .....16  
 Drywall Jab Saw .....15  
 Drywall Jab Saw, Trifold .....16  
 Electrician's Hack Saw .....15  
 Electrician's Scissors .....14  
 Electrician's Tool Kit, 4 pc. ....32  
 Flashlight, Flexible LED .....33  
 Hex Key Sets .....27  
 T-Handle Hex Keys .....27  
 Levels  
 Conduit Bending Level .....28  
 Torpedo Level .....28  
 Multi-Tool, 11-in-1 Folding .....14  
 Nut Drivers .....24  
 Nut Driver Sets  
 Nut Driver Set, 2 pc .....25  
 Nut Driver Set, 7 pc .....25  
 Stubby Nut Driver Set 2-pc. ....26  
 Nut Driver for drill .....26  
 Plastic Pipe Cutter .....16  
 Pliers  
 Cable Cutting Pliers .....12

Crimping/Cutting Pliers .....9  
 Diagonal Cutting Pliers .....5  
 Long-Nose Pliers .....7  
 Long-Nose Multi-Tool 5-in-1 .....8  
 Pump Pliers .....8  
 Side Cutting Pliers .....6  
 Ratcheting Cable Cutter .....13  
 Rotary Cutter, BX/MC .....16  
 Rotary Cutter Replacement Blades, BX/MC .....16  
 Scratch AWL .....20  
 Screwdrivers  
 Cabinet Tip .....19  
 Insulated Screwdrivers .....18-19  
 Phillips Tip Screwdrivers .....17  
 Keystone Tip Screwdrivers .....18  
 Square Tip Screwdrivers .....20  
 5-in-1 Multi-Bit Lighted Screwdriver .....21  
 Multi-bit Screwdriver w/ Wire Stripper .....21  
 9-in-1 Multi-Bit Screwdriver .....21  
 Screwholding Screwdrivers .....22  
 Rotary Screwdrivers .....22  
 Screwdriver Sets  
 Mini Screwdriver Set, 4-pc .....23  
 Screwdriver Set, 8-pc .....23  
 Stubby Screwdriver Set, 2-pc. ....23  
 Step Drill Bit .....31  
 Tape Measure w/ Conduit Hook 25' .....29  
 Utility Knife, 6-in-1 .....14  
 Wire Strippers & Cutters .....10-11,15

**HOLE MAKING TOOLS**

Draw Studs .....92  
 Marksman® Conduit Layout Tool .....93  
 Max Punch® Cup/Cutter for Mild Steel .....89  
 Max Punch® Cup/Cutter for Stainless Steel .....90  
 Max Punch® PRO .....86  
 Max Punch® PRO Kits .....87  
 Max Punch® Ratchet Set .....99  
 Maxis® 360 Hydraulic Punch set .....85  
 Maxis® Stud Punch .....88  
 Oiltight Punch .....91

**MATERIAL HANDLING TOOLS**

Maxis PRO-JAX™ .....95  
 Maxisjax® .....96  
 SIMpull™ CoilPAK™ Cart .....97  
 SIMpull™ CoilPAK™ Dolly .....98  
 SIMpull™ CoilPAK™ Hand Truck .....98  
 SIMpull BARREL™ Hand Truck .....99  
 SIMpull BARREL™ Tripod .....99  
 Wire Wagon® Carts .....100-102

**TESTS & MEASUREMENT TOOLS**

Adapter Kit for Circuit Breaker Finder .....63  
 Borescope Inspection Camera .....58  
 Circuit Testers  
 Battery Tester .....61  
 Circuit Breaker Finder with GFCI .....59  
 Continuity Tester .....61  
 Clamp Meters  
 True RMS AC/DC Clamp Meters .....45-46  
 True RMS AC Clamp Meter .....47  
 AC Clamp Meter .....48  
 Electrical Test Kit .....62  
 Infrared Thermometers .....54-57  
 Multimeters  
 Auto Ranging .....38-41  
 Manual Ranging .....42  
 Pocket .....43  
 Analog .....44  
 Test Lead Kit .....63  
 Pipe Clamp Temperature Probe .....63  
 Voltage Testers  
 Non-Contact Voltage Detector .....49  
 Receptacle Tester .....60  
 Voltage Tester, 4-way .....53  
 Voltage Tester, AC/DC .....52  
 Voltage/Continuity Tester .....51  
 Voltage/Continuity/Phase Rotation Tester .....50

### WARRANTY ON ALL SOUTHWIRE ELECTRICIAN'S TOOLS – HAND TOOLS

Southwire Company warrants this product to be free from defects in materials and workmanship for the life of the product. This warranty does not cover normal wear and tear resulting from product use, nor does this warranty cover damage arising out of misuse, abuse, modification, and/or improper maintenance of the product. If the product breaches this warranty, Southwire will replace the product free of charge. If Southwire no longer manufactures the product, then it will, at its option, replace the defective product with a substantially similar Southwire product or refund the purchase price. If the product does not conform to this warranty, simply return the defective product, along with your sales receipt, to the place of purchase. SOUTHWIRE MAKES NO WARRANTY THAT THE PRODUCT WILL BE MERCHANTABILITY OR FIT FOR ANY PARTICULAR PURPOSE. SOUTHWIRE MAKES NO OTHER WARRANTY, EXPRESSED OR IMPLIED, OTHER THAN THE WARRANTY SPECIFICALLY SET FORTH IN THIS PARAGRAPH. SOUTHWIRE WILL NOT BE LIABLE FOR ANY INCIDENTAL, CONSEQUENTIAL, INDIRECT, SPECIAL, OR PUNITIVE DAMAGES FOR ANY BREACH OF THIS WARRANTY. This warranty is void if this product is used for rental purposes.

### METERS AND TESTERS

#### LIMITED WARRANTY AND LIMITATION OF LIABILITY

Southwire Company warrants this product to be free from defects in material and workmanship for two years from the date of purchase. This warranty does not cover fuses, disposable batteries, or damage arising from an accident, neglect, misapplication, contamination, modification, improper maintenance or repair, operation outside of specifications, or abnormal handling of the product. Southwire's sole liability, and the purchaser's exclusive remedy, for any breach of this warranty is expressly limited to Southwire's repair or replacement of the product. Whether Southwire repairs or replaces the product will be a determination that Southwire makes at its sole discretion. SOUTHWIRE MAKES NO WARRANTY THAT THE PRODUCT WILL BE MERCHANTABILITY OR FIT FOR ANY PARTICULAR PURPOSE. SOUTHWIRE MAKES NO OTHER WARRANTY, EXPRESSED OR IMPLIED, OTHER THAN THE WARRANTY SPECIFICALLY SET FORTH IN THIS PARAGRAPH. SOUTHWIRE WILL NOT BE LIABLE FOR ANY INCIDENTAL, CONSEQUENTIAL, INDIRECT, SPECIAL, OR PUNITIVE DAMAGES FOR ANY BREACH OF THIS WARRANTY. No product reseller is authorized to extend any other warranty on Southwire's behalf relating to this product, and no such reseller warranty will be binding on Southwire. If you have a warranty claim, or if the product needs to be serviced during or after the warranty period set forth above, please contact the Customer Service Department at 855-SWTOOLS (855-798-6657) or visit [www.southwiretools.com](http://www.southwiretools.com) to obtain a product Return Authorization (RA) (on the website, click on "Service Department" to request an RA number). You must obtain an RA number from Southwire before Southwire will process any warranty claim or perform any product service. The sender is responsible for all shipping, freight, insurance, and packaging costs associated with sending a product to Southwire. Southwire will not be responsible for lost or damaged products returned pursuant to this warranty. All products returned to Southwire under this warranty should be mailed to:

Southwire Company, [Attention: Tool Warranty Return], One Southwire Drive, Carrollton, GA 30119

### MAXIS CONTRACTOR EQUIPMENT

#### LIMITED WARRANTY

Southwire's Maxis Contractor Equipment, (hereinafter Maxis Contractor Equipment) warrants all new Maxis Contractor Equipment Tools/Products covered by this agreement, when properly used, to be free from defects in material and workmanship under normal use and service for which it is intended for a period of one year from date of delivery by the dealer. Date of delivery shall be the date product is placed in possession of the user. NORMAL WEAR FROM USE IS NOT A PART OF THIS WARRANTY.

This Limited Warranty is extended to the original user only and is not transferable to, nor enforceable by, any other person. Maxis Contractor Equipment will replace free of charge any part(s) of the product found to be defective when such part(s) is returned to Maxis Contractor Equipment at the address shown below. Maxis Contractor Equipment will not be responsible for more than replacement of any defective part(s) and standard freight charges (parcel post or UPS Ground Rate) of any part(s) found to be defective. This is the exclusive remedy. Maxis Contractor Equipment shall not be responsible or liable for any incidental or consequential damages resulting from any defects covered by this warranty or any implied warranty applicable to the product including, but not limited to, property damage, loss of use of Product, loss of time, loss of profits, inconvenience, commercial loss, labor costs, service trips and mileage. Some states do not allow the exclusion or limitation of incidental or consequential damages, so the above limitation or exclusion may not apply to you. This warranty shall not apply to any product or part of any product which has been altered elsewhere than at the place of manufacture. Any implied warranties applicable to the product, including implied warranties or merchantability and fitness for a particular purpose, are expressly limited in duration to the term of the warranty (one year from date of delivery). Some states do not allow limitation on how long an implied warranty lasts, so the above limitation may not apply to you.

#### DEALER/DISTRIBUTOR WARRANTY CLAIM PROCEDURE

1. All warranty claims must be pre-approved by the Maxis Contractor Equipment Warranty Department PRIOR to starting any warranty work. Warranty work performed without prior approval will not be considered. 2. All claims must be handled through dealer/distributor. 3. Warrantee items will be repaired or replaced, DISTRIBUTOR CREDIT WILL NOT BE ISSUED. 4. Written approval must be received from Maxis Contractor Equipment before return of merchandise. A Return Authorization is to be returned with the merchandise which is sent back. 5. All parts must be returned to Maxis Contractor Equipment at the address shown below. 6. The serial number of the product and the date of delivery must accompany the parts being returned. 7. If the part is found to have failed because of defect in material or workmanship, replacement will be made on a no-charge basis and the part returned, freight prepaid. 8. All parts found to be defective shall be retained by and shall become the property of Maxis Contractor Equipment.

This warranty gives you specific legal rights, and you may also have other rights which vary from state to state.

CUSTOMER SERVICE Maxis Contractor Equipment, 4838 East Baseline Road Ste. 131, Mesa, Arizona 85206, 888-266-2947

This publication is a collection of items of general information related to the subject of Tools and Equipment products. It is not intended to be nor should it be used as authority for design, construction and use. The design, construction and use of Tools and Equipment products should only be undertaken by competent professionals in light of currently accepted design and engineering practices. Product users should handle and use the products only in accordance with directions, instructions and specifications furnished along with the product.

While great care has been employed to ensure that the applications, tables, standards and references and other information contained herein are free of errors, absolutely no warranties, either expressed or implied, are made as to the accuracy or completeness of any such tables and formulas contained herein.

SOUTHWIRE AND THOSE PREPARING AND/OR CONTRIBUTING TO THE PUBLICATION SPECIFICALLY DISCLAIM ANY WARRANTY OF ANY KIND, EITHER EXPRESSED OR IMPLIED. THE WARRANTIES OF MERCHANTABILITY AND FITNESS FOR A PARTICULAR PURPOSE ARE HEREBY SPECIFICALLY DISCLAIMED BY SOUTHWIRE AND ALL OTHER PARTIES INVOLVED IN THE CREATION, PRODUCTION, OR DELIVERY OF THIS PUBLICATION.

Neither Southwire nor anyone else who has been involved in the creation, production or delivery of this publication shall be liable for any direct, indirect, consequential, or incidental damages arising out of the use, the results of the use, or inability to use such publication, even if Southwire has been advised of the possibility of such damages or claim. Some states do not allow the exclusion or limitation for consequential incidental damages, so the above limitation may not apply to you.







**Southwire™**

**BUILT FOR DURABILITY.  
BUILT FOR RELIABILITY.  
BUILT FOR WORK.™**

**TO ORDER  
PLEASE CALL OR VISIT US ONLINE:**

**1-855-SWT00LS**  
**www.southwiretools.com**