

Electrical Construction and Maintenance Workers Safety Manual



IHSA.ca

Work Safe for Life

11th Edition



Electrical Construction and Maintenance Workers

Safety Manual

Infrastructure Health & Safety Association

5110 Creekbank Road
Mississauga, Ontario L4W 0A1
905-625-0100
Fax: (905) 625-8998

ihsa.ca

Developed by the ECAO/IBEW Electrical Labour-Management Health and Safety Committee, this manual is fully a document of accord between labour and management authorities.

In the past, members of the public have used printed information that was outdated by subsequent improvements in knowledge and technology. We therefore make the following statement for their protection in future.

The information presented here was, to the best of our knowledge, current at time of printing and is intended for general application. This publication is not a definitive guide to government regulations or to practices and procedures wholly applicable under every circumstance. The appropriate regulations and statutes should be consulted. Although the Electrical Contractors' Association of Ontario (ECAO), the International Brotherhood of Electrical Workers (IBEW), and the Infrastructure Health and Safety Association (IHSA) cannot guarantee the accuracy of, nor assume liability for, the information presented here, we are pleased to answer individual requests for counselling and advice.

© **Infrastructure Health and Safety Association, 1983**
978-0-919465-15-2

Previous revised editions:
1984, 1986, 1988, 1990, 1992, 1997, 1999, 2001,
2008.

Eleventh revised edition, September 2016

Labour-Management

IHSA thanks the ECAO/IBEW Electrical Labour-Management Health and Safety Committee for their valued and significant contribution in preparing the original manual and subsequent editions.

First Edition (1983)

WILLIAM ARNEZEDER
Business Manager
International Brotherhood of
Electrical Workers
Local 120, London

HUGH CARROLL
Electrical Contractors
Association of Ontario,
Toronto

GUENTHER CASPARY
Construction Safety
Association of Ontario,
Toronto

ALEX GLEN
International Brotherhood of
Electrical Workers,
Local 303, St. Catharines

JOHN HYMSON
Construction Safety
Association of Ontario,
Toronto

BERT LINDGREN
(Chairman)
B.A. Lindgren Electric Ltd.
Thunder Bay

RICHARD MAULE
State Contractors Inc.
Toronto

ROBERT RYNYK
Assistant Business Manager
International Brotherhood of
Electrical Workers
Local 353, Toronto

RALPH TERSIGNI
Secretary
International Brotherhood
of Electrical Workers—
Construction Council of
Ontario

FRANK TOPA
Canal Contractors—
A Division of Upper Lakes
Shipping Ltd.
St. Catharines

LLOYD WARNER
(Co-Chairman)
Business Manager
International Brotherhood of
Electrical Workers
Local 1739, Barrie



Eleventh Edition (2015)

SUSAN BOORMAN
Electrical Contractors
Association of Ontario, Toronto

ED BRAITHWAITE
C & C Enterprises Electrical
Construction Limited, Sarnia

TIM BUTLER
International Brotherhood of
Electrical Workers Local 1687
Sudbury

MARK CHERNEY
International Brotherhood of
Electrical Workers, Local 303
Niagara Falls

GLEN DREWES
International Brotherhood of
Electrical Workers - Local 402
Thunder Bay

GLEN HICKS
Alltrade Industrial Contractors
Ayr

RAY HOPKINS
Infrastructure Health & Safety
Association, Mississauga

ERIC HUEGLIN
Joint Apprenticeship Council
(IBEW Local Union 353)
Richmond Hill

MARK LAWLOR
International Brotherhood of
Electrical Workers Local 353
Toronto

BRUCE MCNAMARA
International Brotherhood of
Electrical Workers – 1st District
Chelmsford

MICHAEL MULGREW
Hart-Well Electrical Comp. Ltd.
Scarborough

ELLIE NASSIF
Ontario Ministry of Labour
Toronto

IAN REECE
Infrastructure Health & Safety
Association, Mississauga

ED RYAN
Guild Electric, Toronto

BRIAN SALE
Guild Electric, Toronto

Foreword

This manual has been written for electrical workers. It is a useful tool that apprentices, journeypersons, supervisors, and management can use to help keep safety in mind when planning work.

This publication reflects the requirements of Ontario's *Occupational Health and Safety Act*, Canadian electrical safety standard CSA Z462, the Regulation for Construction Projects (213/91), and the *Ontario Electrical Code*. Depending on the type of work or project type, different regulations may need to be consulted for a best practice— industrial or mining regulations for example. For a more complete study of workplace safety, this manual should be used with IHSA's *Construction Health and Safety Manual* (M029).

Although service and maintenance is generally an industrial activity, use the more stringent of the industrial or construction regulation for effective worker safety when applicable. For example, if an issue is not covered in the industrial regulations but is covered in the construction regulation, look to the guidance provided in the construction regulation to perform the activity safely.

With cooperation among workers, supervisors, constructor management, and industry clients, health and safety can be continually improved in the electrical construction and maintenance industries. This manual was created as an aid for implementing good jobsite health and safety practices, with the goal of preventing accidents, reducing injuries, and providing a healthy work environment.

Contents

1. INJURIES IN THE ELECTRICAL TRADE	1
Electrical Worker Lost-time Injuries	1
Hearing Damage	4
Contact with Electrical Energy	6
2. PREVENTION	7
Health Issues	7
• WHMIS	8
• Specific hazardous substances	11
> PCBs	11
> Asbestos	12
> Mould	14
> Dusts, gases, and fumes	16
> Heater emissions	16
• Hot and cold environments	19
PPE and Control Measures	22
• Clothing	22
• Head protection	23
• Foot protection	23
• Eye protection	24
• Hearing protection	25
• Back care	29
3. WORKPLACE OVERSIGHT	33
Workplace Responsibilities	33
• Constructor	33
• Employer	34
• Supervisor	35
• Worker	36
• Health and safety representative	37
• Joint Health and Safety Committee (JHSC)	39
• Worker Trades Committee	40
• Ministry of Labour inspectors	40
Reporting Accidents/Incidents	41
• Critical injury or fatality	41
• Notice of accident, explosion, or fire causing injury	42
• Notice of occupational illness	43
• Reporting of incidents where no injury occurs	43
• Reporting a serious electrical incident to the ESA	44
• Contact with an overhead powerline	45

Jobsite Orientation for New Workers	46
First Aid	46
• First aid requirements.....	46
• Service vehicles.....	47
• Kit components.....	48
Safety Standards	50
4. SPECIFIC TOPICS	51
Confined Spaces	51
Authorized Personnel in a Manhole, Vault, or Switchroom	53
Trenches and Excavations	53
• Protection against cave-ins.....	54
• Soil type.....	55
• Sloping.....	56
• Trench boxes.....	57
• Shoring.....	58
• Entry and exit.....	59
• Additional requirements for excavations and trenches	60
Lockout and Tagging	60
• Background and introduction.....	60
• Forms of energy.....	62
• Procedure	64
➤ Individual lockout	65
➤ Group lockout	68
➤ Complex group lockout	69
➤ Planning steps.....	72
• Return to service.....	73
• Service contractor personnel.....	74
• Discontinued use	75
Working on or near Energized Equipment	75
• Tools and equipment for working on or near energized electrical equipment.....	78
• Checklist for Electrical Hazards.....	80
Flash Hazard (Arc Flash) Protection	88
• Flame-resistant or arc-rated clothing.....	90
• Controlling arc flash.....	92
Multimeters	96
• Understanding overvoltage installation categories....	97
• Safe use of multimeters.....	98

Fishing and Pulling Wire	102
Illumination	102
• Fixed temporary wiring for illumination on construction projects.....	103
Temporary Wiring and Power	104
Portable Tools and Extension Cords	107
Fall Protection (Working at Heights)	110
• Safety harnesses and lanyards.....	113
• Lifelines.....	115
• Rope grab devices.....	116
Portable Ladders	116
• Hazard risk assessment for ladder use.....	119
• Sample 1: HRA	124
• Sample 2: Portable Ladder Risk Checklist	126
• Sample 3: Portable Ladder Risk Checklist	128
Scaffolding	130
Elevating Work Platforms and Vehicle-mounted Aerial Devices	132
Housekeeping, Storage, and Tool Maintenance	136
Fire Extinguishers	136
Service Vehicles	138
• Legislation.....	138
• Maintenance.....	144
• Trip inspections.....	144
• Vehicle layout.....	145
Working Alone	147
• Hazard awareness.....	148
5. MISCELLANEOUS INFORMATION	151
Metric Conversion Factors	151
Pipe Bending Charts	152
Cosecants for Offset Bending	154
Copper Wire Gauges and Dimensions	155

1. INJURIES IN THE ELECTRICAL TRADE

Electrical Worker Lost-time Injuries (WSIB rate group 704 LTIs)

An analysis on the lost-time injuries (LTIs) that occurred on construction projects from 1997 through to 1999 and from 2010 through to 2014 show similar patterns, demonstrating that workers are being injured in much the same ways.

In analyzing current data, the top three categories of injuries are described as:

- (1) overexertion or musculoskeletal disorders (MSDs)
- (2) being struck by an object
- (3) falls.

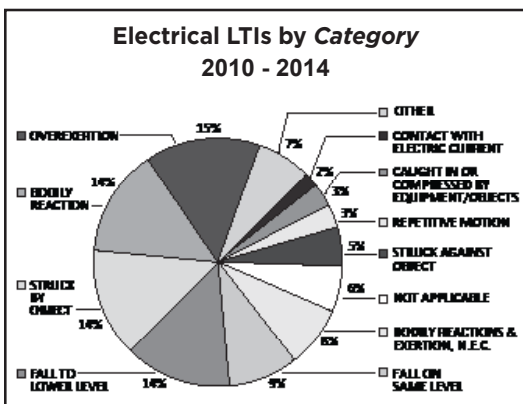

The most common overexertion injury is unclassified (42%). However, the next two categories clearly show that lifting (36%) and pulling or pushing (18%) are major activities that lead to MSDs.

Activities that involve, or expose the back to injury and involve lifting, pushing or pulling should therefore be given more attention in planning safe work habits.

The back/spine was recorded as the most common part of the body that was injured.

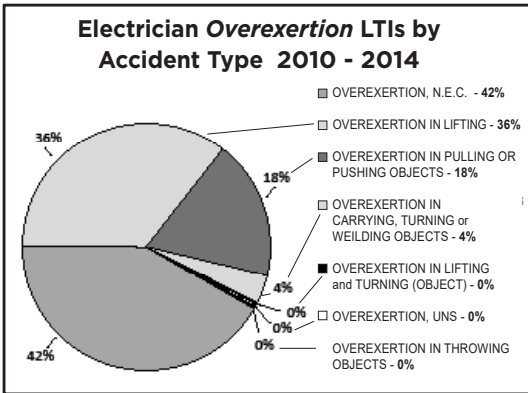

The most common **struck-by object** injuries are unclassified (22%) or related to balance (22%). However, the next three categories show that a majority of injuries are the result of being struck by falling object (19%), struck against stationary object (16%), and struck by slipping, handheld object (13%).

Injuries related to **falls** are much easier to analyze. When an electrician falls to a

Electrician *Struck-by Object* LTIs Top Six 2010 - 2014

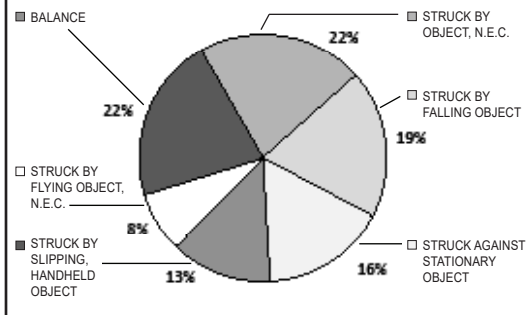

lower level, the majority of the time the fall is from a ladder. This may seem obvious given the relatively large amount of time electricians are working from a ladder. However, falls from a ladder can be prevented by working smarter. IHSA has produced a document called *Ladder Use in Construction Guideline* to assist workplace parties in understanding their obligations under the *Occupational Health and Safety Act* (OHSA) and its regulations. It is available for viewing at ihsa.ca. Employers and supervisors should review this document when determining policies for ladder use.

The guideline refers to a hazard risk assessment. IHSA has also produced a document called *Hazard Risk Assessment for Ladder Use* to help employers and supervisors meet the intent of the guideline. This document has been included under the title *Portable Ladders* in this booklet.

By far, the part of the body that was injured most often by electricians was the back (52%).

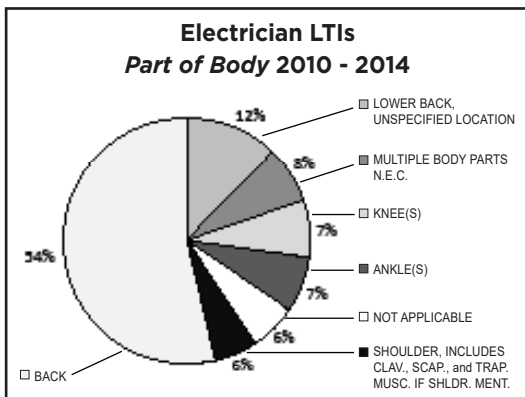

Hearing Damage

Exposure to excessive noise leads to hearing damage such as hearing loss and tinnitus. Each year in Ontario there are about 300 new compensation claims for noise-induced hearing loss (NIHL) in the industry.

Hearing damage can happen quickly, but it usually develops slowly over a person's working career. Unfortunately, once a worker begins to notice hearing damage, the damage is irreversible and will likely worsen with time.

Because the hearing loss is usually gradual, impairment often isn't noticed until a substantial degree of hearing loss has already occurred. The occupational and personal consequences are significant.

Noise Levels of Common Tools

Exposures measured in decibels (dB) at an operator's ear, except where otherwise indicated.

Tool	Noise level will probably exceed...
Chopsaw	92
Drill	87
Drywall drill	98
Electric grinder	98
Generator	72 (at 15 metres)
Impact wrench	115
Portable band saw	83
Reciprocating saw	105
Torch cutting	87

- Workers with NIHL may not hear audible warnings and safety signals.
- Hearing impairment jeopardizes the safety of not only the affected employees but also others who work with them.
- The increased effort to listen and understand may lead to fatigue, anxiety, and stress.
- NIHL may interfere with daily life, especially during social activities in noisy settings.
- Those affected may feel increasingly isolated from family and friends.

Some people with NIHL also suffer from tinnitus, causing them to continually hear ringing, buzzing, rushing, whistling, or hissing when there are in fact no such sounds to be heard.

Noise can be measured using a decibel scale: dB(A). A noise level of 85 dB(A) over an 8-hour workday is potentially damaging. The louder the noise, the faster the damage. Sound intensity doubles every 3 dB. So for each 3 dB increase in sound level, potential damage to the ear doubles. Noise exposure must be controlled accordingly.

Contact with Electrical Energy

Making contact with an electrical hazard represents a relatively small portion of the electricians' experience. Lost-time injuries from contact with electrical current decreased from 7.7% in 1997-1999 to 2% in 2010-2014. (See Electrical LTIs by Category on page 1.). Still, the number of electrical contact incidents should be much lower.

Any work on or near energized equipment must only be done as a last resort and only when measures are in place to provide protection from electric shock and burn. With appropriate safety measures in place, shock and burn injuries are preventable.

2. PREVENTION

Health Issues

Previously, the construction industry was exempt from Regulation 833—Control of Exposure to Biological or Chemical Agents. On July 1, 2016, this exemption was revoked. Below are some of the key changes.

1. Codes of Practice relating to controlling the exposure of workers to biological or chemical agents that are on Ontario's Ministry of Labour (MOL) website should be applied to construction workplaces where applicable.
2. Employers must take all measures reasonably necessary in the circumstances to protect workers from exposure to hazardous biological or chemical agents.
3. The measures to be taken must include the provision and use of:
 - Engineering controls
 - Work practices
 - Hygiene facilities and practices
 - Personal protective equipment where applicable.

For added worker protection, maintain your own personal medical record. Include known exposures to hazardous substances.

WHMIS

WHMIS (Workplace Hazardous Materials Information System) is a Canada-wide system designed to protect the health and safety of workers by providing information about hazardous materials used on the job.

In February 2015, the Government of Canada made changes to the WHMIS 1988 system to make Canada's chemical hazard communication system similar to other countries. This new system is called WHMIS 2015.

A three-year transition period will give provinces and territories time to modify their regulations and give suppliers and employers time to change their systems and train their workers.

Employers must complete the transition to WHMIS 2015 by December 2018. Until then, they must ensure that workers who may be exposed to hazardous materials receive training on both WHMIS 1988 and WHMIS 2015.

The key changes for WHMIS 2015 are new hazard classes, new pictograms used to communicate the hazards (see page 11), new required elements on labels, and new format of Material Safety Data Sheets (now called Safety Data Sheets).

For more information, visit the national website for WHMIS 2015: www.whmis.org

Right to know

WHMIS gives every worker the right to know about hazardous materials they work with and ensures workers have access to that information by using:

- (1) supplier or workplace labels
- (2) material safety data sheets (MSDSs) or safety data sheets (SDSs)
- (3) worker training and education.

Before using any caulking, solvent, or glue, read the MSDS or SDS to ensure that you have taken the required precautions with the specific products you're using.

Suppliers must label their hazardous products and provide a current MSDS or SDS with their product. MSDS information must not be more than 3 years old. SDS information must be updated within 90 days of the supplier becoming aware of "significant new data". Workers should receive refresher training on WHMIS every year.

Labels

All hazardous products must come with a supplier label. In some cases, a workplace label is required. For example,

- when the supplier label has become illegible or has been removed
- when the product has been transferred to a container for use by more than one worker or at more than one time.

A workplace label must contain the following information:

1. The identity of the product
2. Information for safe handling of the product
3. A statement that a (M)SDS is available.

Hazard classes

WHMIS 2015 divides hazardous materials into nine classes:



Flame
(fire hazards)



Exploding Bomb
(explosion or reactivity hazards)



Flame Over Circle
(oxidizing hazards)



Health Hazard
(serious health effects)



Exclamation Mark
(less serious effects)



Corrosion
(metals, skin, eyes)



Gas Cylinder
(can explode if heated)



Skull & Crossbones
(death or toxicity)



Biohazardous Infectious Materials

WHMIS 1988 divides hazardous materials into six classes (A, B, C, D, E, and F):



CLASS A:
Compressed gas



CLASS B:
Flammable and
combustible material



CLASS C:
Oxidizing material



CLASS D:
Poisonous and
infectious material



CLASS D:
2. Materials causing
other toxic effects



CLASS D:
3. Biohazardous
infectious material



CLASS E:
Corrosive material



CLASS F:
Dangerously
reactive material

Specific hazardous substances

PCBs

Older transformers, capacitors, lighting fixture ballasts, and high-voltage equipment may contain polychlorinated biphenyls (PCBs). A common trade name for PCB is Askarel.

Transformers containing PCB or Askarel can be identified by the letter "L" on the nameplate. Look for LFAF, LFAN, LFWN, LNAF, LNP, LNS, LNWN and LNWN. Transformers containing mineral oil bear the letter "O" on the nameplate, such as ONAN.

Workers must be extremely careful when handling or cleaning up spills of Askarel and other PCBs. All work should be carried out in accordance with the guidelines issued by the Ontario Ministry of Environment. See Regulation 362 made under the *Environmental Protection Act*, R.S.O. 1990, c. E.19 or contact the Ministry for further information.

Smoking or eating must not be allowed in or near PCB operations. Workers should wash their hands and face with soap and water immediately after any contact with PCBs and before eating, smoking, or going to the toilet.

Asbestos

Asbestos is a naturally occurring material once used widely in the construction industry. Its strength, ability to withstand high temperatures, and resistance to many chemicals made it useful in hundreds of applications. But asbestos can also kill. When inhaled, asbestos has been shown to cause the following diseases:

- asbestosis
- lung cancer
- mesothelioma (cancer of the lining of the chest and/or abdomen).

The early widespread use of asbestos has left a potentially dangerous legacy. The improper handling of asbestos-containing products can release harmful amounts of fibre.

Protective measures must be taken to protect yourself and coworkers from

ASBESTOS PRODUCTS IN CONSTRUCTION			
Product	Residential	Commercial/ Institutional	Industrial
Sprayed-On Fireproofing		XX*	
Pipe and Boiler Insulation	X	X	XX
Loose Fill Insulation	X**		X
Vermiculite Insulation	X**		
Asbestos Cement Products	X	X	X
Acoustical Plaster	X	X	
Acoustical Tiles	X	XX	
Vinyl Asbestos Tiles	X	X	
Gaskets		X	XX
Roofing Felts	X	X	X
Asphalt/Asbestos Limpet Spray			X
Drywall Joint-Filling Compound	X	X	
Coatings and Mastics	X	X	X
Cable Insulation	X	X	X

*Denotes extensive use. **Vermiculite insulation. XX – May contain vermiculite.

asbestos. Improper handling has also lead to workers tracking asbestos home on clothing and exposing family members.

Most structures built between 1930 and 1975 will contain products having substantial amounts of asbestos. See the chart above.

If you have any concerns about material that you think may be asbestos, have it checked **before** work is started.

The legal requirements for handling, working with, removing, and disposing of asbestos and asbestos-containing products are described in ***Asbestos on Construction Projects and in Buildings and Repair Operations (Ontario Regulation 278/05)***. Read the regulation to get a full description of your legal duties. Order a copy from IHSA or read it online at **ihsa.ca**.

In addition, IHSA publishes ***Asbestos: Controls for Construction, Renovation, and Demolition*** (DS037). This book contains more information than what's in this chapter, and it tells you how to protect yourself. It can also help you understand the asbestos regulation. You can order a copy from IHSA or download it free from **ihsa.ca**.

Mould

Electrical workers can be exposed to moulds almost anywhere outdoors and indoors. Indoor moulds usually originate from outside sources such as soil and vegetation. Moulds love dark, moist environments and can grow at room temperature on various construction materials including wallpaper, particleboard, ceiling tiles, drywall, and plywood. Construction workers can be exposed to toxic spores when working on buildings with water damage from flooding, plumbing leaks, or leaks in the structure itself.

Mould colonies are usually visible as colourful, woolly growths. They can be virtually any colour: red, blue, brown, green, white, or black. Moulds are microorganisms that produce thousands of tiny particles called spores. The mould sends out spores when it is disturbed, as part of its reproductive cycle. Spraying bleach or other compounds on the mould can also cause sporulation. Mould spores feed off dirt and moisture, both of which are present in HVAC/R systems.

Air movement and the handling of contaminated material can release toxic

spores into the atmosphere. These spores can cause adverse health effects. Not all exposed workers, however, will develop symptoms. Once released, toxic spores must contact the skin or be inhaled before symptoms can develop. Exposure to toxic moulds may irritate the skin, eyes, nose, and throat, resulting in allergy-like symptoms such as difficulty in breathing, runny nose, and watery eyes. Other symptoms such as fatigue and headache have also been reported. Workers who are allergic to moulds could experience asthmatic attacks upon exposure. People with weakened immune systems are particularly susceptible to mould-related illness and should not work in mould-contaminated areas.

Workers should know how to protect themselves against sporulation. Although there are no Ontario regulations specifically addressing moulds, an employer must, under the *Occupational Health and Safety Act*, take every precaution reasonable in the circumstances for the protection of a worker. Health Canada has published a guide for work practices titled *Fungal Contamination of Public Buildings: A Guide to Recognition and Management*.

Employers have a duty to instruct workers in the safe removal or handling of mould-contaminated material. Workers in turn have the duty to follow these instructions. Where mould is observed, it should be left undisturbed if possible. Where the growth is extreme or must be disturbed, contact the employer for instruction. As a minimum, workers should wear a NIOSH approved

respirator. Depending on the extent of contamination, a higher level of protection may be required; however, a minimum of N99 respirator is required for low level, low risk work. Also, workers must be test-fitted prior to using any type of NIOSH approved respirator to ensure it fits properly.

Dusts, gases, and fumes

A work area does not have to be designated a confined space for a hazardous atmosphere to develop. All work areas must have adequate ventilation.

In places where a hazardous atmosphere could develop, measures must be taken to prevent workers from harm. Measures may include redesigning the work procedure or using ventilation to reduce hazards. Atmospheric testing may be undertaken on its own or in conjunction with other controls to ensure levels do not reach hazardous concentrations. Where ventilation or monitoring is not practical, workers must be provided with personal protective equipment such as respirators that are appropriate to the hazard, and be trained to use and maintain the respirators properly.

Heater emissions

During the winter, direct-fired heaters are used across Ontario to keep construction workers warm. The heaters also make concrete placement, bricklaying, plastering, drywalling, and painting possible under cold conditions.

Direct-fired heaters release combustion emissions directly into the air where people work. Although carbon monoxide (CO) is the main concern, carbon dioxide (CO₂) may also be a problem.

Both CO and CO₂ can asphyxiate a worker. CO₂ displaces oxygen in the air, but you need relatively high concentrations of CO₂ for that to happen. By contrast, CO is a chemical asphyxiant. It acts in the bloodstream to reduce oxygen availability. CO affects a worker's health at lower concentrations and therefore causes greater concern.

When heated construction sites are well ventilated, concentrations of emissions tend to be low. Large buildings and tarped sites record the lowest levels of emission products. CO levels are higher at ceiling level.

Buildings such as houses at the drywall stage with windows and doors in place are considered "tight." Emission gases accumulate in these buildings when ventilation openings are closed or restricted. Tight buildings lead to higher ambient readings of CO and CO₂ and lower levels of oxygen.

Electricians can begin protecting themselves by understanding the key issues with direct-fired construction heaters. The following are recommendations for safe operation of construction heaters:

- Ensure that heaters are adequately ventilated. Ventilation disperses CO and CO₂, and provides O₂ for combustion.

Ask suppliers to label heaters regarding CO hazards and ventilation.

- Vary work at ceiling level with work at lower levels to reduce exposure to CO.
- Make sure that heaters are maintained according to manufacturers' instructions. Visual inspection alone may not accurately indicate whether a heater is functioning properly. Check when the heater was last serviced and tested (test at least every 12 months).

Adequate ventilation must be provided and maintained. Workers must not block or close openings such as windows and doors. When the temperature in a heated area is too cold, workers should request more or bigger heaters.



Do not restrict ventilation of combustion gases by blocking openings

Training is essential in alerting employees to heater hazards.

- Describe the symptoms of CO exposure.
- Provide an electronic carbon monoxide detector. A CO home alarm is not an acceptable detector.
- Explain emergency response procedures in the event of a CO incident.
- Remind workers that CO levels are higher at ceiling level.
- Warn workers to keep their distance from direct-fired heaters because high temperatures extend beyond the visible flames.

Hot and cold environments

Exposure to excessive heat can cause your body's cooling system to break down and your body temperature to increase, resulting in heat stress. Heat stress related illnesses include:

- heat rash from plugged sweat glands
- heat cramps from excessive sweating
- heat exhaustion
- heat stroke (very serious—you can die).

Heat exhaustion occurs when blood flow to your vital organs can't keep up with demand from the heat. Symptoms include

- weakness, feeling faint
- headache

- breathlessness
- nausea or vomiting
- difficulty continuing work.

Heat stroke may occur when your body has used up all its water and cannot cool itself. Heat stroke is a medical emergency and if not treated immediately death can occur. Some of the symptoms of heat stroke include:

- confusion and irrational behaviour
- convulsions
- unconsciousness
- no sweating—hot, dry skin
- high body temperature—40°C or more.

Identifying the heat hazards and putting in measures to keep cool is the key to preventing heat stress. Some of the following measures can help prevent heat stress:

- Wear light, loose clothing that allows sweat to evaporate. Light-coloured garments absorb less heat from the sun.
- Drink small amounts of water (8 oz) every half hour. Don't wait until you're thirsty.
- Avoid coffee, tea, beer, or other drinks that make you go to the bathroom frequently.
- Avoid eating hot or heavy meals that increase your body temperature.
- Remember that your physical condition can reduce your ability to deal with the heat. Age, weight, fitness, health conditions (heart

disease or high blood pressure), recent illness, or medications can all affect your ability to withstand high temperatures.

When your body cools, blood vessels in your skin, arms, and legs constrict. This causes the blood flow to your extremities to decrease. The redirection of blood helps your vital organs stay warm but places your extremities at risk of frostbite.

A good way to determine the risk of cold stress symptoms is to consult the “wind chill”. This is usually reported by a meteorologist and is a single number that tells you how cold it actually feels.

Fingers and toes exposed to cold temperatures may develop frostbite causing the flesh to freeze and potentially lead to gangrene. Additionally, when your body temperature decreases you are at risk of hypothermia.

Symptoms from hypothermia include:

- shivering
- blue lips and fingers
- slow breathing and heart rate
- disorientation and confusion
- poor coordination.

In severe cases of hypothermia, unconsciousness, reduced heart rate and breathing, lack of shivering, and even death may occur. However, if the casualty seems dead, you should assume they are alive.

Some simple ways to prevent cold stress symptoms include the following are found on the next page.

- Wear several layers of clothing rather than one thick layer to capture air as an insulator.
- Wear synthetic fabrics next to the skin to “wick” away sweat.
- If conditions require, wear a waterproof or wind-resistant outer layer.
- Wear warm gloves.
- Wear hats and hoods. You may need a balaclava.
- Tight-fitting footwear restricts blood flow. You should be able to wear either one thick or two thin pairs of socks.
- If your clothing gets wet at 2°C or less, change into dry clothes immediately and get checked for hypothermia.
- If you get hot while working, open your jacket but keep your hat and gloves on.
- Take warm, high-calorie drinks and food.

PPE and Control Measures

Information on appropriate and required personal protective equipment can be found in the Regulation for Construction Projects (213/91). The following information provides guidance.

If there is the potential for an arc flash, **all** PPE should be chosen so that the worker will be protected from it.

Clothing

When there is the potential for an arc flash, workers must wear clothing that offers flame resistance properties. For

more specific guidance, see “Arc Flash Protection” under the heading “Working on or Near Energized Equipment” in this manual.

Head protection

The following hard hats comply with the Regulation for Construction Projects (213/91)

- CSA Z94.1-1992 Class E
- ANSI Z89.1-1997 Type II Class E
- ANSI Z89.1-1997 Type I Class E.

Note that under the latest ANSI standard, there are two types of Class E hardhats: Type I and Type II. Type I hats are exactly the same as the old CSA Class B hardhats, which provide limited lateral impact protection. The Type II hats have enhanced lateral protection, like the CSA Class E. Don't assume that an ANSI Class E is equivalent to the CSA Class E. That's only true if it's Type II. In fact, there are very few ANSI Type II Class E hardhats on the market. Those few are clearly labeled “Type II.” If your hardhat just says “ANSI Class E,” assume it's Type I.

There are no prescribed expiry dates for hard hats. Ensure your hard hat meets current classifications as outlined above and follow the manufacturer's recommendations when replacing a worn hard hat.

Foot protection

Construction workers require Grade 1 toe protection with sole protection in

accordance with Canadian Standards Association standard CSA Z195-02. Protective footwear which complies with the regulation is identified by a green triangular patch on the tongue or ankle of the boot or shoe.

Electrical workers continually face the potential for receiving an electric shock due to the presence of energized equipment in their work environment. Whether on a construction project or service call, appropriate personal protective equipment must be worn to protect against inadvertent electrical contact. Footwear tested to provide additional shock protection for the worker is identified by a white rectangular label with the CSA trademark and the Greek letter omega in orange.



Eye protection

Canadian Standards Association (CSA) standard CAN/CSA Z94.3-99 *Industrial Eye and Face Protectors* can assist you in classifying hazards and recommending protectors. Appropriate protection according to this standard meets with the intent of the Regulation for Construction Projects requirements for eye protection. In any case, eye protection should be industrial quality. It can be in the form of safety glasses incorporating side-shields or a wrap-around style. Cover goggles

and face shields provide extra protection and are recommended for workers drilling overhead or into concrete, masonry, and drywall, or performing any other task involving the potential for flying debris. Arc flash protection requires a face shield that is rated for arc flash, with eyeglasses underneath.

It is essential that regular plastic face shields are not used to provide arc flash protection. They can burn and melt in an arc flash incident. Use a face shield that is designed and rated for arc flash protection.

Hearing protection

Hearing damage is preventable. There are simple and feasible measures that can be addressed in job planning to reduce noise exposure in construction:

- Position loud equipment away from workers or enclose it.
- Use equipment with lower noise levels.
- Change work procedures.

When levels still remain high, use hearing protection. It's available in three general types:

- 1. Disposable earplugs.** They are made of pliable material. They should be used only once. Hearing protection comes in different sizes and it is key that workers wear properly fitted hearing protection.

2. Permanent custom-fit earplugs.

They are available to provide protection for specific frequencies of noise – e.g. block out machinery noise but let conversation through. They provide a good seal and can be washed and reused.

3. Earmuffs. They need to fit properly to provide maximum protection.

The noise reduction rate (NRR) for a particular device is identified on its packaging. To attain the maximum rated protection, devices must be worn according to the manufacturers' instructions.

For exposure levels over 105 dB(A), double protection may be required (i.e., both earmuffs and earplugs). It's also important to avoid overprotection. Using more protection than is necessary can prevent workers from hearing noises that they need to hear, such as backup signals. Take care to select protectors with sufficient, but not excessive, attenuation to keep noise below the safe limit of 85 dB(A).

On July 1, 2016, Noise Regulation 381 under the OSHA came into effect. It requires employers to do the following:

- Limit noise exposure to a maximum time-weighted average of 85 dBA over an 8-hour work shift.
- Put measures in place to reduce noise exposure based on the “hierarchy of controls” (i.e., at the source, along the path, and at the worker).

- Provide adequate training and instruction on hearing protection devices if they are being used.

Where practicable, a clearly visible warning sign must be posted at every approach to an area in the workplace where the sound level regularly exceeds 85 dBA.

NOTE: If you must shout for someone at arm's-length to hear you, the noise level likely exceeds 85 dBA.

Maximum permitted daily duration in hours	Decibels (dB) (increasing in units of 3)
8	85
4	88
2	91
1	94
½	97
¼	100

Individuals exposed to noise in excess of 85 dB(A) averaged over an 8-hour shift should undergo periodic audiometric testing to determine whether they are developing noise-induced hearing loss (NIHL). Anyone showing a significant deterioration in hearing compared to previous tests should have a thorough medical examination.

The following indicators provide an estimate as to whether the workplace sound levels around you and the duration of your exposure pose a risk of gradual, noise-induced hearing loss:

- If someone standing a metre away from you has to shout to be understood, the sound levels around you probably exceed 85 dBA. You face a significant risk of permanent hearing loss if you are exposed to these sound levels for eight hours or more per day.
- If someone standing 30 cm away has to shout to be understood, the levels probably exceed 95 dBA. This means a significant risk of permanent hearing loss if you are exposed for about 45 minutes or more per day.
- If someone has to shout into your ear to be understood, the sound levels around you probably exceed 105 dBA. This poses a significant risk of permanent hearing loss if you are exposed for just five minutes per day.
- If you experience a temporary hearing loss after a loud sound has stopped. For example, you may notice that other sounds seem muffled, quieter, or less clear.
- If you experience tinnitus after a loud sound has stopped. This is a ringing, buzzing, roaring, or rushing sound in the ear.

(Source: *Hearing Loss and Leisure Noise*. Consumer and Clinical Radiation Bureau, Health Canada, 2005)

Back care

The back/spine is the body part most frequently involved in a lost-time injury to an electrician. These injuries can last a lifetime and have a significant negative impact on the quality of life of the injured worker. See “Injuries in the Electrical Trade” in this manual. Both young and old workers are at risk of back/spine injuries.

Regardless of the circumstances, workers can do something to reduce their risk of injury. Before attempting to do a physically demanding task, workers can do some stretching and warm up exercises. Also, in many circumstances, you can do the following:

Maintain good posture

Correct posture is not an exaggerated military pose. It means maintaining the naturally occurring curves in your spine. You have two inward curves—at the neck and low back—and one outward curve at the upper back.

Keeping your spine aligned in this way reduces everyday stresses on your back and minimizes the effects of the normal aging process on the spine.

When working in a crouched, bent, or stooping position for a prolonged period, take regular breaks by standing up and bending backwards three times. Maintain good posture to reduce back strain. Kneel on a pad or sit on a box to work near ground level.



Whenever possible, avoid awkward postures such as this.



Better work posture for short duration.

When working overhead in an arched position for prolonged periods, take regular breaks by returning to stable footing and bending forward three times.

If possible, avoid working on ladders. Use scaffolds or an elevating work platform instead, especially for long-duration tasks or for jobs where you must handle heavy materials.



For bench work, the right height is vital.

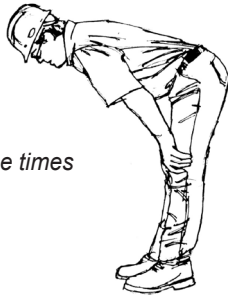

Work Overhead

Bend forward three times

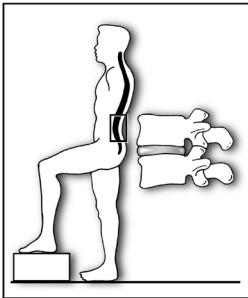

Normal Posture

Prolonged standing often causes an increased curve in your back. Elevating one foot on a stool or any other object (a phone book or brick will do) will take stress off the lower spine.

Proper lifting

► **Plan your move.**

- Size up the load and make sure the pathway is clear.
- Use a mechanical device if necessary or get help.

► **To lift:**

- Use a wide-balanced stance with one foot slightly ahead of the other.
- Get as close to the load as possible.
- Tighten your stomach muscles as the lift begins.

- When lifting, keep your lower back in its normal arched position and use your legs to lift.
- ▶ **To turn,** don't twist your back. Pick up your feet and pivot.
- ▶ **To lower,** lower the load slowly, maintaining the curve in your lower back.

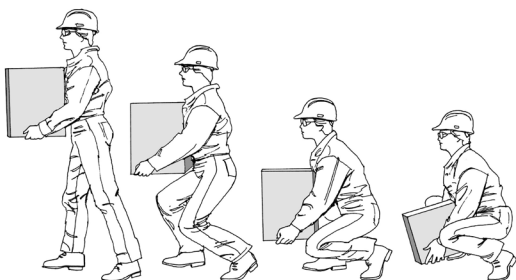

Your back can manage most lifts—if you lift correctly. Avoid lifting above shoulder height. This causes the back to arch, placing heavy stress on the small joints of the spine.

Cable pulling

Implement measures to reduce chances for overexertion. Reduce your risk of injury by asking for help, using mechanical devices, and taking a few moments for stretching and warming up exercises before pulling.

3. WORKPLACE OVERSIGHT

Information in this chapter has been taken from Ontario's *Occupational Health and Safety Act* (OHSA) and the Regulation for Construction Projects (213/91). The following is a generalized summary of the duties required of personnel on jobsites.

Workplace Responsibilities

Constructor

*“**Constructor**” means a person who undertakes a project for an owner, and includes an owner who undertakes all or part of a project by himself or by more than one employer.*

—OHSA

The constructor must ensure that

1. the measures and procedures required by the current *Occupational Health and Safety Act and Regulations for Construction Projects* are carried out on the project;
2. employers and workers on the project comply with the Act and Regulations;
3. the health and safety of workers on the project are protected.

Employer

***“Employer”** means a person who employs one or more workers or contracts for the services of one or more workers and includes a contractor or subcontractor who performs work or supplies services and a contractor or subcontractor who undertakes with an owner, constructor, contractor or subcontractor to perform work or supply services.*

—OHSA

The employer must ensure that

1. the equipment, materials, and protective devices that are prescribed are provided;
2. the equipment, materials, and protective devices provided are maintained in good condition and used as prescribed;
3. the measures and procedures required by law are carried out in the workplace;
4. information, instruction, and supervision are provided to protect the health and safety of workers;
5. the appointed supervisor is a competent person (see next page);
6. every precaution reasonable in the circumstances for the protection of the worker has been taken;
7. additional duties imposed upon the employer in the Act under section 25 and 26 are also followed.

“Competent person” means a person who,

- (a) is qualified because of knowledge, training and experience to organize the work and its performance,
- (b) is familiar with this Act and the regulations that apply to the work, and
- (c) has knowledge of any potential or actual danger to health or safety in the workplace.

—OHSА

Supervisor

“Supervisor” means a person who has charge of a workplace or authority over a worker.

—OHSА

The supervisor must ensure that workers

1. work in the manner and with the protective devices, measures, and procedures required by the Act and Regulations;
2. use or wear the equipment, protective devices, or clothing that the employer requires to be used or worn;
3. are advised of any potential or actual danger to their health or safety;
4. are given written instruction for their protection, where written instruction is prescribed;
5. have been afforded every precaution reasonable in the circumstances.

Worker

“Worker” means a person who performs work or supplies services for monetary compensation. In 2014, however, the definition of “worker” was amended to include unpaid interns, co-op students, etc., who are participating in a work placement program (OHSA, s. 1(1))

“Competent Worker” in relation to specific work, means a worker who,

- (a) is qualified because of knowledge, training and experience to perform the work,
- (b) is familiar with the Occupational Health and Safety Act and with the provisions of the regulations that apply to the work, and
- (c) has knowledge of all potential or actual danger to health or safety in the work.

—Construction Projects
(213/91)

The worker must do the following:

1. Work in compliance with the provisions of the OHSA and the Regulations.
2. Use or wear the equipment, protective devices or clothing that the employer requires to be used or worn.
3. Report any problem with equipment that may endanger workers to the employer or supervisor.

4. Report any contravention of the OHSA or Regs and any hazard on the project to the employer or supervisor.
5. Never work in a manner that may endanger themselves or others.
6. Never engage in any prank, contest, feat of strength, unnecessary running or rough and boisterous conduct on the project.

Health and safety representative

For details about the selection of health and safety representatives and their duties, consult section 8 of the OHSA.

General duties

The health and safety representative performs site inspections, helps to mediate disputes over unsafe conditions, assists in investigating serious accidents, and confers with supervisors, workers, and MOL inspectors whenever necessary. A health and safety representative will be effective only when they have the full cooperation and respect of management and the workforce.

Requirements

1. At a project or other workplace where no committee is required under the *Occupational Health and Safety Act* and where the number of workers regularly exceeds five, the constructor or employer must cause the workers to select at least one health and safety representative from among the workers

at the workplace who do not exercise managerial functions.

2. The selection must be made by workers or by the trade union or unions when represented by them.
3. The employer and workers must provide the health and safety representative with any information and assistance necessary to carry out inspections on the project.

Right to Refuse Work where Health or Safety in Danger (Occupational Health and Safety Act, Part V)

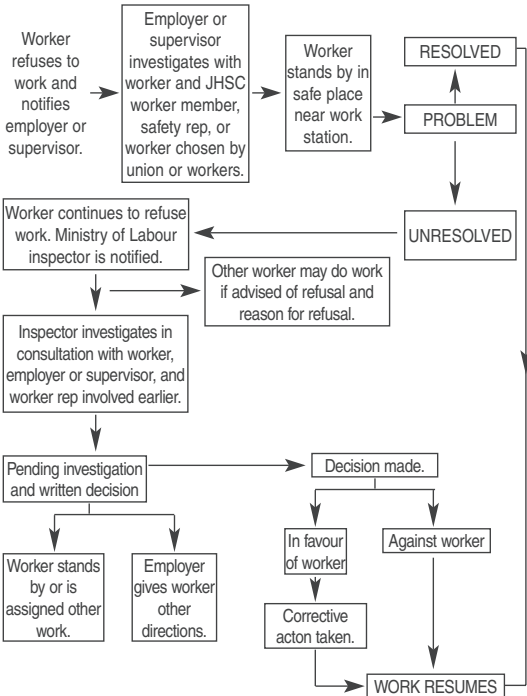

Guidelines

1. The health and safety representative should have current first aid and cardiopulmonary resuscitation (CPR) certificates. This training is part of the Accident Prevention Educational Program for Electrical Construction and Maintenance Workers.
2. The representative must be familiar with requirements of the current *Occupational Health and Safety Act and Regulations for Construction Projects*.
3. The representative should be familiar with the procedures involved in a refusal to work where health and safety is in danger.

Joint Health and Safety Committee (JHSC)

A JHSC is required

- at a workplace where 20 or more workers are regularly employed and work is expected to last three months or more
- at a workplace, other than a construction project, where a designated substances regulation applies
- at a workplace where an order dealing with toxic substances has been issued
- at a workplace where the MOL orders one.

For more info, consult the OHSA, section 9.

NOTE: On March 1, 2016, new training requirements for certified members of a JHSC came into effect. Visit the MOL website for more information:
labour.gov.on.ca/english/hs/pubs/jhsc

Worker Trades Committee (WTC)

The JHSC must establish a WTC consisting of workers employed in each of the trades at the workplace, to assist it on all projects employing more than 49 workers and lasting more than three months. Members of the WTC must be employed on the project.

The purpose of the WTC is to

- identify health and safety problems affecting individual trades
- notify the site supervisor and the JHSC of their findings
- make written recommendations to the JHSC
- meet as often as required by the JHSC
- assist the JHSC, when requested, in addressing health and safety problems relating to trade work or to trade technology.

Refer to section 10 of the *Occupational Health and Safety Act*.

Ministry of Labour inspectors

A Ministry of Labour inspector can exercise fairly broad powers to inspect, ask questions, and give orders. If the inspector approaches a worker directly, the worker should answer questions and cooperate. The supervisor must be informed of any orders given or recommendations made.

Reporting Accidents/ Incidents

Report all accidents, regardless of severity, promptly to your supervisor. A record should be kept at the jobsite. When a serious or fatal injury involves a union member, the union office and steward must be notified immediately. Labour and management should cooperate fully in conducting an investigation.

Both the *Occupational Health and Safety Act* and the *Ontario Electrical Safety Code* contain legislated requirements for reporting certain types of accidents to the Ministry of Labour (MOL) and the Electrical Safety Authority (ESA) as specified in following sections. In the event of an accident which requires reporting and investigation, care should be taken not to disturb the accident scene. No equipment or tools involved in the accident should be removed.

Critical injury or fatality

In the event of a critical injury or fatality, the constructor and employer must immediately notify an MOL inspector, the joint health and safety committee, the health and safety representative, and the trade union (if applicable).

The employer must send a written report to the MOL within 48 hours.

The following requirements are taken directly from Regulation 834: Critical Injury - Defined under the *Occupational Health and Safety Act*:

For the purpose of the Act and the Regulations, **“critically injured”** means an injury of a serious nature that,

- places life in jeopardy;
- produces unconsciousness;
- results in substantial loss of blood;
- involves the fracture of a leg or arm but not a finger or toe;
- involves the amputation of a leg, arm, hand, or foot but not a finger or toe;
- consists of burns to a major portion of the body; or,
- causes the loss of sight in an eye.

Note:

Ontario Regulation 834 and the *Ontario Electrical Safety Code* (OESC) (26th edition, 2015) use identical wording for the definition of “critical injury”.

Notice of accident, explosion, or fire causing injury

If a person is disabled from performing his or her usual work or requires medical attention because of an accident, explosion, or fire at a workplace but no person dies or is critically injured because of that occurrence, the employer shall, within four days of the occurrence, give written notice of the occurrence containing the prescribed information and particulars to the following:

1. The [Joint Health and Safety] Committee, the health and safety representative, and the trade union if any.
2. The [Ministry of Labour] Director, if an inspector requires notification of the Director.

Notice of occupational illness

If an employer is advised by or on behalf of a worker that the worker has an occupational illness or that a claim in respect of an occupational illness has been filed with the Workplace Safety and Insurance Board by or on behalf of the worker, the employer shall give notice in writing, within four days of being so advised, to a [Ministry of Labour] Director, to the [joint health and safety] committee or a health and safety representative, and to the trade union, if any, containing such information and particulars as are prescribed. This applies with all necessary modifications if an employer is advised by or on behalf of a former worker that the worker has or had an occupational illness or that a claim in respect of an occupational illness has been filed with the Workplace Safety and Insurance Board by or on behalf of the worker.

Reporting of incidents where no injury occurs

Where a notice or report is not required under section 51 or 52 and an accident, premature or unexpected explosion, fire, flood or inrush of water, failure of any equipment, machine, device, article or thing, cave-in, subsidence, rockburst,

or other prescribed incident occurs at a project site, mine, or mining plant, the constructor of the project or owner of the mine or mining plant shall give notice in writing of the occurrence to a [Ministry of Labour] Director and to the [joint health and safety] committee, health and safety representative and trade union, if any, within two days of the occurrence containing such information and particulars as are prescribed.

—OHSA Section 53

For the purpose of section 53 of the Act, a **prescribed incident** (as mentioned in the previous paragraph) includes:

- Accidental contact by a worker or by a worker's tool or equipment with energized electrical equipment, installations or conductors.
- Accidental contact by a crane, similar hoisting device, backhoe, power shovel or other vehicle or equipment or its load with an energized electrical conductor rated at more than 750 volts.

—See O. Reg. 213/91, s. 11(1) for the complete list of prescribed incidents.

Reporting a serious electrical incident to the Electrical Safety Authority (ESA)

“An owner, contractor, or operator of a facility shall report to the inspection department any serious electrical incident of which it is aware within 48 hours after the occurrence.” (ESA Rule 2-007(1))

“Serious electrical incident” means,

- a) Any electrical contact that causes death or critical injury* to a person;
- b) Any fire, explosion, or condition suspected of being electrical in origin that might have caused a fire, explosion, loss of life, critical injury* to a person, or damage to property;
- c) Any electrical contact with electrical equipment operating at over 750 volts; or
- d) Any explosion or fire of electrical equipment operating at over 750 volts.

—*Ontario Electrical Safety Code, 2015*

* See definition of “critical injury” on page 40.

To report an incident call 1-877-372-7233 (1-877-ESA-SAFE).

Contact with an overhead powerline

Contact with an overhead powerline must be reported to multiple parties. If accidental contact occurs with an energized powerline carrying 750 V or more, report the contact to the inspection department of the Electrical Safety Authority (ESA), and provide written notice to the Ministry of Labour and to the joint health and safety committee, health and safety representative, and trade union.

Jobsite Orientation for New Workers

New workers on the job must be given an orientation to the jobsite. Include the following points in the orientation:

- emergency procedures
- location of facilities such as first aid station, fire extinguishers, exits, and toilets
- possible hazards, both electrical hazards and those related to the work of other trades
- the need to be familiar with the content of this manual
- the names of:
 - the health and safety representative on the project
 - the representative on the worker trades committee
 - the representatives on the joint health and safety committee
 - the jobsite first-aiders.

First Aid

First aid requirements

Prompt and correct treatment of injuries not only reduces pain and suffering but also saves lives. A valid St.

John Ambulance Emergency First Aid certificate or its equivalent provides the training for personnel to respond quickly in an emergency. First Aid requirements for the workplace are described in Regulation 1101 under the *Workplace Safety and Insurance Act*.

Service vehicles

Of special interest to electrical workers are first aid stations in service vehicles. In general, each service vehicle must be equipped with a fully stocked first aid station and a current St. John Ambulance first aid manual. The person in charge of the station must hold a valid St. John Ambulance emergency first aid certificate or equivalent. A first aid station *in a service vehicle* must contain as a minimum:

- first aid kit
- valid first aid certificates of trained workers on duty
- inspection card for recording the date of the most recent kit inspection and the inspector's signature. Employers are responsible for ensuring that the kit is inspected at least four times per year.

The first aid station must be the responsibility of a worker who works in the immediate vicinity. Stations must be easily accessible for the prompt treatment of personnel at all times while work is in progress.

Note: The requirements above apply to service vehicles only. At permanent sites, the first aid station must contain additional items to be complete.

Kit components

Every employer employing not more than five workers in any one shift at a worksite must provide and maintain a first aid station with a first aid kit containing as a minimum:

- current edition of a standard St. John Ambulance first aid manual
- 1 card of safety pins
- dressings consisting of
 - 12 adhesive dressings individually wrapped
 - 4 sterile gauze pads, 3 inches square
 - 2 rolls of gauze bandage, 2 inches wide
 - 2 field dressings, 4 inches square, or 2 four-inch sterile bandage compresses
 - 1 triangular bandage.

—First Aid Regulation 1101, s. 8(1)

In addition, workers should have clean water available to rinse skin or eyes, and other additional first aid components that would be required to address specific hazards that can be expected on the jobsite.

Every employer employing more than five workers and not more than fifteen workers in any one shift at a worksite must provide and maintain a first aid station with a first aid box containing as a minimum:

- current edition of a standard St. John Ambulance first aid manual
- 1 card of safety pins
- dressings consisting of
 - 24 adhesive dressings individually wrapped
 - 12 sterile gauze pads, 3 inches square
 - 4 rolls of gauze bandage, 2 inches wide
 - 4 rolls of gauze bandage, 4 inches wide
 - 4 sterile surgical pads suitable for pressure dressings, individually wrapped
 - 6 triangular bandages
 - 2 rolls of splint padding
 - 1 roll-up splint.

—First Aid Regulation 1101, s. 9(1)

In addition, workers should have clean water available to rinse skin or eyes, and other additional first aid components that would be required to address specific hazards that can be expected on the jobsite.

Safety Standards

CSA Z462 – Workplace Electrical Safety

is an in-depth resource for additional information dealing with electrical safety concerns. It addresses topics such as establishing an electrical safe work area and determining the required personal protective equipment to protect against electrical shock and burn (whether the person is working directly on energized components or is otherwise exposed to an electrical hazard).

An important aspect of electrical work involves isolating electrical energy using a lockout procedure. A reference for detailed information on lockout and control of hazardous energy is the Canadian standard ***CSA Z460-05—Control of Hazardous Energy—Lockout and Other Methods.***

4. SPECIFIC TOPICS

Confined Spaces

“**Confined space**” means a fully or partially enclosed space,

- That is not both designed and constructed for continuous human occupancy, and
- In which atmospheric hazards may occur because of its construction, location or contents or because of the work that is done in it.

—Confined Spaces Regulation (632/05)

Before work begins in any confined area such as a manhole or vault, assess whether a hazard exists and determine if the area is a confined space. If the work area is a confined space, work must be performed under the confined space regulation. ***A documented program is required before entry into any confined space.*** This program is developed on behalf of the employer. Procedures must be tailored for each entry. As a minimum, comply with Confined Spaces Regulation (632/05) where a confined space is defined.

Even a space that does not meet the definition above, can pose confined space hazards. If the work being undertaken or the work of others on the job may create a hazardous atmosphere, consider applying safety measures that provide safeguards equivalent to those required of a confined space.

“Atmospheric hazards” means,

- a) the accumulation of flammable, combustible or explosive agents,
 - b) an oxygen content in the atmosphere that is less than 19.5 per cent or more than 23 per cent by volume, or
 - c) the accumulation of atmospheric contaminants, including gases, vapours, fumes, dusts or mists, that could,
 - i. result in acute health effects that pose an immediate threat to life, or
 - ii. interfere with a person’s ability to escape unaided from a confined space
- Confined Spaces Regulation (632/05)

“Acceptable atmospheric levels” means,

- a) the atmospheric concentration of any explosive or flammable gas or vapour is less than,
 - I. 25 per cent of its lower explosive limit, if paragraph 1 of subsection 19(4) applies,
 - II. 10 per cent of its lower explosive limit, if paragraph 2 of subsection 19 (4) applies,
 - III. 5 per cent of its lower explosive limit, if paragraph 3 of subsection 19(4) applies,
- b) the oxygen content of the atmosphere is at least 19.5 per cent but not more than 23 per cent by volume,
- c) in the case of a workplace that is not a project, the exposure to atmospheric

contaminants does not exceed any applicable limit set out in Regulation 833 of the Revised Regulations of Ontario, 10990 (Control of Exposure to Biological or Chemical Agents) made under the Act or Ontario Regulation 490/09 (Designated Substances) made under the Act, and

- d) in the case of a workplace that is a project, the exposure to atmospheric contaminants does not exceed any applicable limit set out in Regulation 833 of the Revised Regulations of Ontario, 1990 (Control of Exposure to Biological or Chemical Agents) made under the Act.

—Confined Spaces Regulation (632/05)

Authorized Personnel in a Manhole, Vault, or Switchroom

In accordance with Sections 44(4) and 184 of the Regulation for Construction Projects, only authorized personnel are permitted access to a room or other enclosure containing exposed energized electrical parts.

Trenches and Excavations

“Excavation” means a hole left in the ground as the result of removing material.

“Trench” means an excavation in which the depth exceeds the width (Figure 1).

—Regulation for Construction Projects (213/91)

Before starting any excavation, ensure all utilities are located. Call the local utility companies or use the Ontario One Call system at 1-800-400-2255.

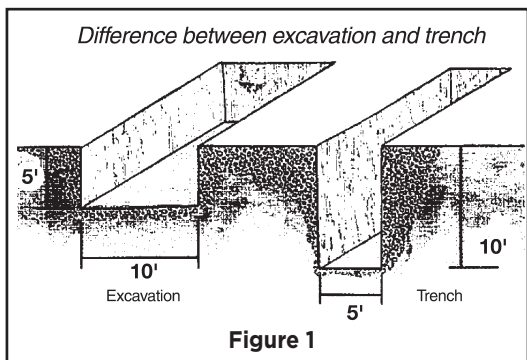

Protection against cave-ins

There are three basic methods of protecting workers against trench cave-ins:

- Sloping
- Trench boxes
- Shoring.

Most fatal cave-ins occur on small jobs of short duration such as service connections and excavations for drains and wells. Too often, people think that these jobs are not hazardous enough to require safeguards against collapse.

Unless the walls are solid rock, never enter a trench deeper than 1.2 metres (4 feet) unless it is properly sloped, shored, or protected by a trench box.

Soil type

The type of soil determines the strength and stability of trench walls. Identifying soil types requires knowledge, skill, and experience. Even hard soil may contain faults in seams or layers that make it unstable when excavated.

The foreperson or supervisor must be knowledgeable about soil types found on a project and plan protection accordingly. This knowledge must include an awareness that soil types and conditions can change over very short distances. It is not unusual for soil to change completely within 50 metres, or for soil to become saturated with moisture over even smaller distances. The Construction Regulation sets out four soil types:

- **Type 1** It is hard to drive a pick into Type 1 soil. Hence, it is often described as “hard ground to dig”. In fact, the material is so hard, it is close to rock.
- **Type 2** A pick can be driven into Type 2 soil relatively easily. It can easily be excavated by a backhoe or hand excavated with some difficulty.
- **Type 3** Much of the Type 3 soil encountered in construction is previously excavated material. Type 3 soil can be excavated by hand.
- **Type 4** Type 4 soil can be excavated with no difficulty using a hydraulic backhoe. The material will flow very easily and must be supported and contained to be excavated to any significant depth.

Sloping

One way to ensure that a trench will not collapse is to slope the walls. Where space and other requirements permit sloping, the angle of slope depends on soil conditions (Figures 2, 3 and 4).

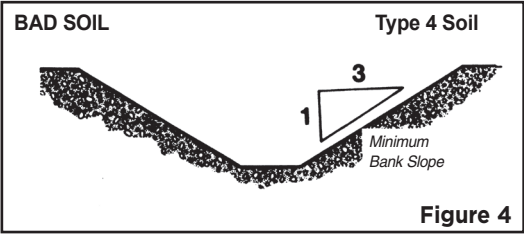
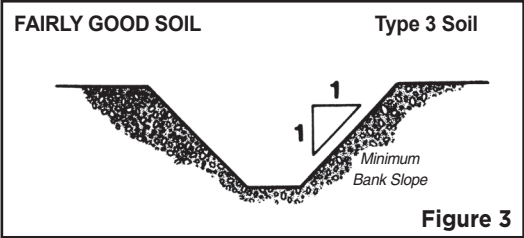
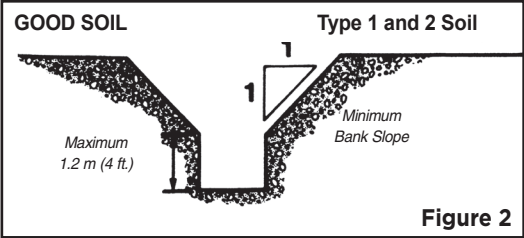

For Type 1 and 2 soils, cut trench walls back at an angle of 1 to 1 (45 degrees). That's one metre back for each metre up. Walls should be sloped to within 1.2 metres (4 feet) of the trench bottom (Figure 2).

For Type 3 soil, cut walls back at a gradient of 1 to 1 from the trench bottom (Figure 3).

For Type 4 soil, slope the walls at 1 to 3. That's 3 metres back for every 1 metre up from the trench bottom (Figure 4). Although sloping can reduce the risk of cave-in, the angle must be sufficient to prevent spoil not only from sliding back but also from exerting too much pressure on the trench wall.

Sloping is commonly used with shoring or trench boxes to cut back any soil above the protected zone. It is also good practice to cut a bench (a landing or shoulder) at the top of the shoring or trench.

Trench boxes

Trench boxes are not usually intended to shore up or otherwise support trench walls. They are meant to protect workers in case of a cave-in. If sloping is to be used above a trench box, the top portion of the cut should first be sloped according to the soil type (see above). Then the box should be lowered into the trench (Figure 5).

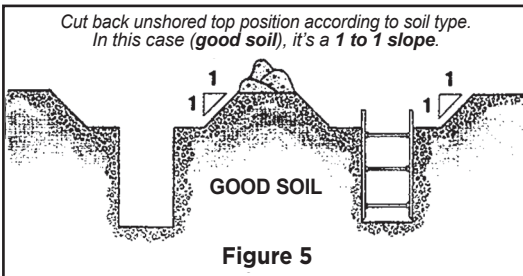

Shoring

Shoring is a system that “shores” up or supports trench walls to prevent movement of soil, underground utilities, roadways, and foundations.

Shoring should not be confused with trench boxes. A trench box provides worker safety but gives little or no support to trench walls or existing structures such as foundations and manholes holes.

The two types of shoring most commonly used are timber and hydraulic. Both consist of posts, wales, struts and sheathing. Figure 6 identifies components for timber shoring in some typical trenches.

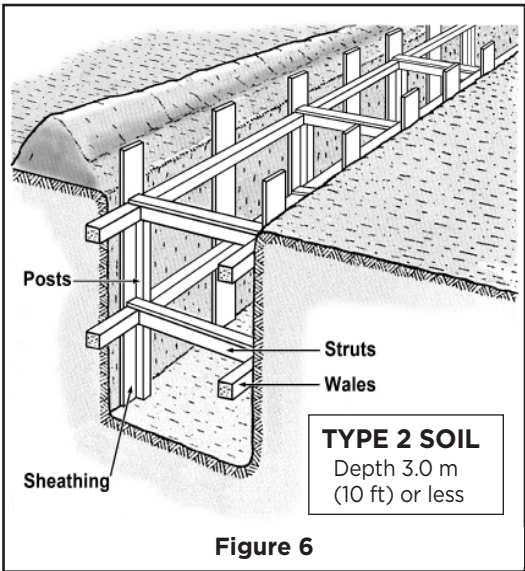

Entry and exit

Whether protected by sloping, boxes, or shoring, trenches must be provided with ladders so that workers can enter and exit safely (Figure 7). Ladders must

- be placed within the area protected by the shoring or trench box
- be securely tied off at the top
- extend above the shoring or box by at least 1 metre (3 feet)
- be inspected regularly for damage.

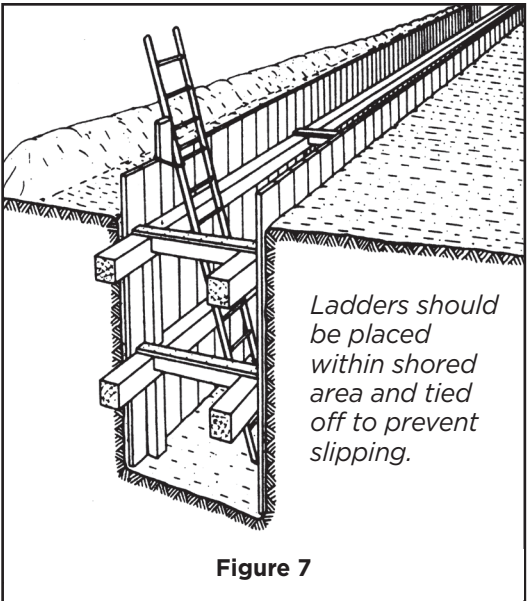

Figure 7

Additional requirements for excavations and trenches

- Working alone is not permitted in a trench. Work may only be performed in the trench when another worker is working above ground in close proximity to the trench or to the means of access to it.
- Excavations which workers are required to enter should be kept reasonably free of water.
- Equipment, construction material, and excavated soil must be kept at least one metre (3 feet) from the edge of an excavation or trench.
- No person shall operate or locate a vehicle or other machine in such a way as to affect the stability of a wall of an excavation.

Lockout and Tagging

Background and introduction

Lockout is the primary means of preventing the unplanned release of hazardous energy. For electrical workers, it often involves workers using a padlock to keep a switch in the “off” position. It may also be necessary to isolate the energy of moving parts, chemical reactions, falling counterweights, and other actions that can endanger lives. Lockout is a physical way to ensure

that the energy source is de-energized, deactivated, or otherwise inoperable.

Lockout involves:

- a. identifying all energy sources that may affect the work and work area
- b. redirecting or stopping the energy from doing what it is normally intended to do
- c. physically preventing the accidental reenergizing of the system, and
- d. verifying zero energy state.

It is important to control all energy systems involved in the work. For example, a piece of equipment may have an electrically operated component but a hydraulic or pneumatic primary power source. Failure to control each energy system could jeopardize the safety of workers involved. In addition, gravity, momentum, and stored energy can present unexpected hazards.

Tagging is an important part of a lockout. After attaching a personal lock, the worker attaches a tag to the lock. Tags are a means of communication. They are used to inform others that the device is locked out, who has locked it out, and why. Tagged devices and systems must not be re-energized without the authority of those named on the tag.

It is absolutely essential for an employer to have an effective lockout and tagging policy in place and to ensure it is diligently practiced without exception.

A reference for detailed information on lockout and control of hazardous energy is the CSA Standard Z460-05 - *Control of Hazardous Energy—Lockout and Other Methods*.

Forms of energy

When most people think of uncontrolled hazardous energy, they think of electricity. But electricians overseeing a lockout procedure need to consider a variety of energy sources. Here are the main types of energy.

- Electrical (electrical panels, generators, lighting systems, storage batteries, etc.)
- Mechanical—the energy of moving parts (flywheels, blades, fans, conveyor belts, etc.)
- Potential—stored energy that can be released during work. Examples of systems having potential energy include suspended loads, compressed air, electrical capacitors, accumulated bulk goods, coiled springs, chemical reactions, changing states (solid—liquid—gas), etc.
- Hydraulic (presses, rams, cylinders, cranes, forklifts, etc.)
- Pneumatic (lines, compression tanks, etc.)
- Thermal (steam, hot water, fire, etc.)
- Chemical (flammable materials, corrosive substances, vapours, etc.)

Some equipment may involve more than one type of energy and pose unexpected hazards. For example, a machine may have an electrically operated component but a hydraulic or pneumatic primary power source, or it may become activated on a timed schedule. With some equipment, gravity and momentum can present unexpected hazards.

Switches, power sources, controls, interlocks, pneumatics, hydraulics, computer-controlled sources, gravity-operated sources—all of these must be locked out by each worker involved and appropriately tagged. Recognize and control the energy associated with them.

Section 190 of the Regulation for Construction Projects (213/91) lists the requirements for **locking out** electrical equipment, including the requirement that the employer must “establish and implement written measures and procedures” to adequately protect workers from “electrical shock and burn.”

Section 191 of Regulation 213/91 states the **circumstances** under which work on energized equipment is permitted, as well as the **requirements** for working on or near energized equipment.

(See also “Working on or Near Energized Equipment” on page 75.)

Procedure

Employers must have a lockout policy as part of their overall health and safety policy and program. Under the lockout policy, there should be a procedure which provides guidance for how the lockout is carried out and to ensure site-specific hazards are addressed. Both the Industrial Establishments regulation (O. Reg 851, s. 42(7)) and the Construction Projects regulation (O. Reg 213/91, s. 190(2)(a)) requires written procedures to address electrical hazards. (See “Working On or Near Energized Equipment” on page 75.)

When working in plants or industrial establishments, there may be specific in-house procedures for lockout and tagging at that location. This makes sense because the in-plant workforce will have proven its procedures through use on the particular system or the machine in question. If in-plant procedures are followed, it is important to verify that these procedures (which may have been designed solely for maintenance type work) have isolated **all energy sources**. The contractor’s work activity may vary from routine plant maintenance, creating additional hazards. The shutdown of machines, equipment, or processes may be carried out by plant personnel. In other cases, plant representatives may issue a work permit to allow work on their equipment and/or a lockout permit to ensure that lockout procedures are followed before work begins.

There are typically three recommended methods of locking out equipment.

Individual lockout

This is the basic and most preferred approach to lockout. It requires each worker to be authorized to perform lockout. The authorized individual knows the hazards associated with the machine, equipment, or process to be isolated and knows the method of isolation required to protect workers. Each individual involved in the work is accountable to themselves for ensuring that before work begins, the required energy isolating devices are

- in place to isolate and control hazardous energy
- locked in place with their own personal locks
- tagged.

The machine, equipment, or process is then verified to be de-energized.



Image courtesy of Len Cicero, arcflash.ca

If several workers or trades are working on the circuit, use a lockout bar to provide space for additional locks. This arrangement can accommodate any number of locks by placing another lockout bar in the last hole of the previous bar.



Image courtesy of Len Cicero, arcflash.ca

Locks must be uniquely identified. Identify a lock by applying the worker's name directly to the lock. You could also use some other means of identifying the owner of the lock, such as a colour, a tag, or some other marking applied directly to the lock. You must also have a means of determining the date and reason for lockout. This information can be written on a tag attached to the lock, or the lock can be marked with a symbol that you can use to look up the required information. The application of a lockout device must not itself create a hazard. You must recognize that, even though the disconnect switch may already be locked,

you are not protected until you attach your own personal lock.

The individual applying the lock must be able to rely on it remaining in place until they remove the lock personally. For this reason, it is strongly recommended that no lock have a copy made of its key. Removal of a lock by any person other than the one who applied it, can only be done by following a procedure. (See “Lockout and tag removal when authorized person is absent” on page 73.)

A **tag** is required on the power supply lockout device. The tag must identify the name of the person who disconnected the equipment and their employer, the date and time of lockout, and the reason for the lockout. A tag alone should not be relied on as proof that a machine or system is locked out. The tag provides information about the lockout but does not guarantee that the energy has been isolated. Tags may also be used to identify the owner of the lock.

Use signs placed on the system to indicate that it is not to be energized or operated and that guards, locks, temporary ground cables, chains, tags, and other safeguards are not to be tampered with or removed. If more than one worker is involved, information must be posted, or otherwise communicated, to show the purpose and status of the lockout. The Regulation for Construction Projects (213/91) specifies rules for tagging in section 190(6).

Group lockout

Group lockout simplifies the lockout process when there are many devices to lock out and many authorized workers. The group lockout process still provides individual authorized workers to control hazardous energy with their own locks. Here are typical steps for group lockout:

1. The primary authorized individual is assigned responsibility for controlling all energy sources by applying any required energy-isolating devices and placing a lock and tag on each.
2. The key for each lock applied to lockout devices is placed in a lockable container such as a lock box. The lock box is then in turn locked by the primary authorized individual and a tag is applied.
3. Zero energy is then verified to ensure that the lockout is effective. Ideally, the verification is done in the presence of the work crew.
4. Before work begins, each worker assesses the lockout procedure and its adequacy to achieve zero energy relative to the work each worker will do. Once satisfied, each worker applies his or her own identifiable lock (and tag if used) to the lock box. Each crew member would ideally have been present when zero energy was verified. Otherwise, each worker must satisfy themselves that the lockout is effective.

- As each worker completes his or her work and has removed all non-essential items from the work site, their own personal lock (and tag if used) is removed from the lock box.
- Once all crew members have removed their personal locks and tags from the lock box, the primary authorized individual assigned responsibility for the lockout inspects the work site to check that all tools and workers are clear. Then, each lock and isolating device is removed.



Complex group lockout

A workplace can use complex group lockout when it's not practicable to use an individual lockout or group lockout approach due to any of the following:

- The physical extent of the equipment and/or process being serviced
- Inaccessibility of the energy-isolating devices

3. The number of energy-isolating devices
4. The length of time the equipment or processes will be isolated
5. The number of authorized individuals involved
6. The interdependence and interrelationship of the components in the system or between different systems.

Implementation of a complex group lockout must provide the equivalent level of personal protection for each member of the work crew as is afforded by individual lockout. Complex group lockout uses control measures such as work permits, administrative control measures, and control boards.

After all energy sources are isolated and locked out, work crew members verify the isolation and the effectiveness of the energy isolation for the work they are performing. For very large processes such as a nuclear plant shut down, verification may be achieved by understanding and having confidence in the process for the shut down and lockout. Individual crew members do not apply personal locks on each isolation device, but rather rely on process and controls put in place to assure reliability of the lockout.

Although electricians need to consider all possible forms of energy, most work may simply require the lockout of a single electrical device. After shutting down the



Images courtesy of Len Cicero, arcflash.ca

equipment, applying the lockout device, applying a personal lock, and attaching a tag, the isolation needs to be verified. Typically this will involve testing for power using a potential test indicator. Ensure the testing is done using adequate arc flash protection and the correct multimeter and leads for the available power, and apply safe operating procedures. (See “Safe Use of Multimeters” on page 98.)

Planning Steps

Specific lockout procedure will vary, depending on the work and the processes that must be shut down. The following chart can help you develop specific procedures.

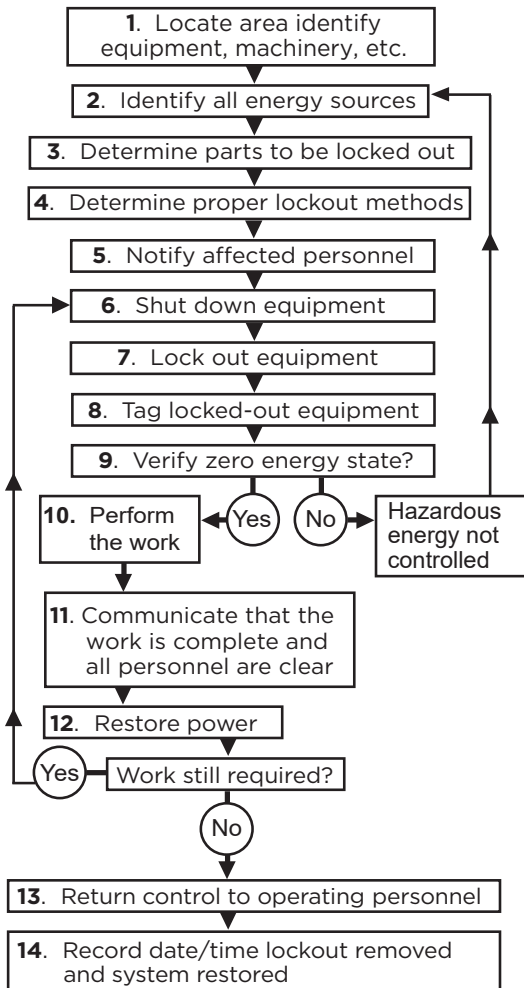

Return to service

The primary authorized individual assigned to de-energize and lock out equipment typically will be the one to return the equipment to service. Before lockout devices and locks are removed, the work area is inspected to check that all crew members associated with the lockout have been cleared from any hazardous areas and that all are accounted for. In addition, this person checks that all nonessential items have been removed and that the machine, equipment, or process is operationally intact.

Personnel who could be affected by re-energization and equipment start-up must be notified by the person assigned to return the equipment to service.

Once satisfied that the machine, equipment, or process is in a ready state, the primary authorized person removes any required locks, energy isolating devices, and tags. After lockout devices have been removed a formal startup procedure would be implemented, if applicable. If the equipment is to sit idle for a period of time, then a separate pre-start-up process should address the notification requirements.

Lockout and tag removal when authorized person is absent

Occasionally a worker leaves the jobsite and leaves a lock in place intentionally or accidentally and may not be present when the equipment needs to be re-energized. Removing the lock may

expose that worker and possibly others to danger. There must be a written procedure about how to remove lockout devices and tags safely. The procedure must cover locating the absent worker and obtaining permission to remove their lock. It must also cover how, if the worker cannot be found, to validate if it is safe to cut the lock from the lockout device and re-energize the system.

The person removing the lock should be identified in the lockout documentation.

Service contractor personnel

Communication is a key element of a hazardous energy control program. The plant and contractor should each designate a representative responsible for determining their relationship, as well as their individual responsibilities and obligations regarding hazardous energy control. To eliminate confusion on contractor-controlled lockouts, it may be useful for the plant to provide locks and tags that are recognisable by plant personnel.

The designated plant representative must advise the contractor of any special or unique hazards—to which the outside service contractor personnel could be exposed—related to the machinery, equipment, or process at the facility.

The contractor's own lockout program must be either replaced with the plant's program or coordinated with the plant hazardous energy control

program. The hazardous energy control program implemented must be mutually understood, agreed upon, and communicated between the parties.

Discontinued use

Equipment, installations, and conductors that will not be used for the purpose for which they were designed must be

- removed, or
- left in an electrically non-hazardous condition by being
 - disconnected, and
 - de-energized, and
 - tagged, and
 - grounded (if a powerline), or
 - locked out (if electrical equipment).

Working on or near Energized Equipment

For the purpose of this manual, an **“electrical hazard”** means

- a dangerous condition where a worker could make electrical contact with energized equipment or a conductor and from which the person may sustain an injury from shock, or
- a situation where there is potential for the worker to receive an arc flash burn, thermal burn, or blast injury.

Note:

An electrical hazard is considered to be removed when protective measures are put in place at the source (remove hazard or de-energize), or along the path (place electrical insulation between the worker and the electrical hazard). If personal protective equipment is the method of worker protection, the electrical hazard itself hasn't gone away. It is still necessary to address safety requirements for other workers in the area.

Where an electrical hazard exists and work must be done on an energized electrical component, or near enough to the hazard that the worker can make electrical contact or be exposed to injury from arc flash, work is permitted while the system is energized. However, this is **only if:**

- it is not reasonably possible to disconnect the equipment, installation, or conductor from the power supply
- the equipment is rated at a nominal voltage of 600 volts or less, and disconnecting the equipment would create a greater hazard to workers than proceeding without disconnecting it, or
- the work consists only of diagnostic testing.

Testing with a meter **is** live work and requires appropriate personal protective equipment.

The constructor must ensure that written procedures for work on or near live equipment are established and implemented to protect workers from electrical shock and burn. (See “Flash Hazard (ARC Flash) Protection” on page 88.) The constructor must have copies of the procedures available for employers on the project.

The employer must provide, and explain, the written procedures to workers before they start work on or near live equipment.

The constructor and the employer both have a general duty to ensure that the health and safety of workers is protected.

Unless the work consists only of diagnostic testing or involves a nominal voltage under 300 volts, an adequately equipped competent worker who can perform rescue operations, including cardiopulmonary resuscitation (CPR), must be stationed where he or she can see the workers performing the live work.

Live work on equipment nominally rated greater than 400 amperes and greater than 200 volts, or greater than 200 amperes and greater than 300 volts, can be done only if

1. the owner of the equipment provides the employer and the constructor with a record showing that it has been maintained according to the manufacturer’s specifications
2. a copy of the maintenance record is readily available at the project

3. the employer has determined from the maintenance record that work on the equipment can be performed safely without disconnecting it, and
4. before beginning live work, the worker has verified that points 1, 2, and 3 have been done.

Repair or permanently disconnect defective equipment

Section 2-300 (1) of the *Ontario Electrical Safety Code 2015* requires all operating electrical equipment to be kept in safe and proper working condition.

Tools and equipment for working on or near energized electrical equipment

Workers exposed to an electrical hazard must use mats, gloves, shields, flame-resistant clothing, and any other protective equipment required to protect themselves from electric shock and burn. Electrical workers should

- a. remove watches, rings, neck chains, or other current-conducting jewelry
- b. wear electric-shock-resistant footwear
- c. determine what category of flame-resistant (FR) arc-rated clothing, with protective equipment, is appropriate to the hazard level.
- d. wear a CSA-approved Class E hard hat or equivalent, and
- e. wear safety glasses with side shields.

Tools, devices, and equipment, including personal protective equipment, used for live work must be designed, tested, maintained, and used in ways that provide adequate protection for workers.

Rubber gloves and leather protectors must be adequate to protect the worker from electrical shock or burn. The rubber gloves must have been tested and certified for working live.

All rubber gloves, no matter what the class, must be air-tested and visually inspected for damage and adequacy immediately before use. If the requirements of IHSA's *Electrical Utility Safety Rules* ("IHSA Rule Book") are being followed, all classes of rubber gloves are required to be dielectrically tested every 90 days. If the requirements of the Construction Projects regulation (213/91) are being followed, Class 1 to Class 4 rubber gloves are required to be dielectrically tested at least once every three months if they are in service, or every six months if not in service. Refer to manufacturer's instruction when setting timeline for re-certification.

Workers must be trained in the proper use, care, and storage of rubber gloves and leather protectors.

For further information, refer to the *Checklist for Electrical Hazards* on pages 80 to 87. These are hazards that an MOL inspector may be looking for at a project.

Checklist for Electrical Hazards

Description/Concern	Regulation Section
<p>Work done on or near electrical equipment or an electrical installation or conductor</p> <ul style="list-style-type: none"> <input type="checkbox"/> Has the employer and/or constructor established and implemented written measures and procedures for protecting workers from electrical shock and burn? <input type="checkbox"/> Has the employer and/or constructor made a copy of the written measures and procedures available to every worker and employer on the project? <input type="checkbox"/> Has every reasonable precaution been taken to prevent hazards to workers from energized electrical equipment, installations, and conductors? <input type="checkbox"/> Have electrical hazards and arc flash hazards been evaluated to recognized industry standards? <input type="checkbox"/> Does the arc flash, flame resistant clothing and approved protective equipment selected provide an adequate level of protection to the worker? <input type="checkbox"/> Has the arc flash, flame resistant clothing, foul-weather clothing, and protective equipment been manufactured, tested, and maintained to current recognized industry standards? 	<p>O. Reg. 213/91 S.190 (2) or S.191 (4)</p> <p>O. Reg. 213/91 S.183 and S.191</p>
<p>Work done near high-voltage wires</p> <ul style="list-style-type: none"> <input type="checkbox"/> Has the constructor addressed high-voltage wires on the project and in close proximity to the work? <input type="checkbox"/> Were voltages determined ahead of time? <input type="checkbox"/> Is equipment or machinery encroaching on minimum distances? 	<p>O. Reg. 213/91 S.188</p> <p>O. Reg. 213/91 S.188(8)</p>

Notes

- Section 191 applies instead of section 190 if the equipment, installation, or conductor is not disconnected from the power supply before work begins.

Note: It is safer to work on de-energized “dead” circuits rather than live ones. Even if measures and procedures are in place to protect workers working live, there are very few good reasons for keeping the power on, especially in construction work.

- Reasonable precautions should include required PPE such as face shields, rubber gloves, and arc flash protection.

Note: PPE should be of an appropriate size for the individual.

- Electrical and arc flash hazards should be evaluated using a standard such as CSA Z462. Calculations can be difficult to work out and it is expected that the constructor or employer can show the various arc flash levels for affected panels.

The main feed (for a plant) is the point where measures are going to be taken to be in compliance with S. 191 (4). Arc flash calculations for the main panel as well as sub panels may be requested.

Note: Live work includes diagnostic testing on energized equipment.

- Arc flash clothing must be rated for arc flash and be chosen according to the calculated arc flash hazard.

Note: Flame resistant (FR) clothing is not equivalent to arc flash rated.

- Generally for 750V to 150,000V, maintain 10-foot clearances.
- Under 750V, S. 188 does not apply. However, S. 187 and other electrical sections may be applied for under 750V.
- A “competent worker” designated as a signaller shall warn the operator each time any part of the vehicle or equipment or its load may approach the minimum distances to overhead powerlines.

Checklist for Electrical Hazards

Description/Concern	Regulation Section
<ul style="list-style-type: none"> <input type="checkbox"/> Have measures and procedures been written and implemented by the constructor? <input type="checkbox"/> Have these measures and procedures been communicated and made available to workers and employers on the project? <input type="checkbox"/> Is there signage for overhead wires? <input type="checkbox"/> Is there a supervisor in charge? 	<p>O. Reg. 213/91 S.44 (3)</p> <p>O. Reg. 213/91 S.188 (8)</p> <p>OHSA S.1</p>
<p>Work done near underground utilities</p> <ul style="list-style-type: none"> <input type="checkbox"/> Before the excavation begins, has gas, electrical, and other services in and near the area to be excavated been located and marked? <input type="checkbox"/> Are pipes, conduits, and cables for gas, electrical, and other services in the excavation being supported to prevent failure or breakage? 	<p>O. Reg. 213/91 S.228</p>
<p>Protective devices and equipment for work under the authority of the owner of the electrical conductor</p> <ul style="list-style-type: none"> <input type="checkbox"/> Has the owner of the electrical utility installed protective devices and equipment and established and implemented written measures and procedures to protect workers from electrical shock and burn? <input type="checkbox"/> Are the workers involved in the work using the protective devices and equipment, including personal protective equipment, and following the written measures and procedures? 	<p>O. Reg. 213/91 S. 189</p>

	Notes
	<ul style="list-style-type: none"> • A signaller shall not perform other work while acting as a signaller. • A “DANGER” sign shall be posted where there is a potential hazard from an energized overhead electrical conductor at more than 750 volts. • A supervisor must be a “competent person”, which means a person who: <ul style="list-style-type: none"> (a) is qualified because of knowledge, training and experience to organize the work and its performance (b) is familiar with this Act and the regulations that apply to the work (c) has knowledge of any potential or actual danger to health or safety in the workplace.
	<ul style="list-style-type: none"> • If a service may pose a hazard, it shall be shut off and disconnected. • If it cannot be shut off or disconnected, the owner of the service shall be requested to supervise the excavation.
	<p>S.188 of the Regulation for Construction Projects (213/91) does not apply if the requirements of S.189 have been met.</p>

Checklist for Electrical Hazards

Description/Concern	Regulation Section
<p>Temporary wiring installations</p> <p><input type="checkbox"/> Are the temporary wiring installations and the electrical equipment, installations, conductors, and insulating materials on the project in compliance with the <i>Ontario Electrical Safety Code</i>?</p> <p><input type="checkbox"/> Have the installations been inspected by the Electrical Safety Authority (ESA)?</p>	<p>O. Reg. 213/91 S.185 (2)</p>
<p>Rubber gloves and leather protectors</p> <p><input type="checkbox"/> Have electrical workers been trained in the proper use, care, and storage of rubber gloves and leather protectors?</p> <p><input type="checkbox"/> Do electrical workers understand how to test their rubber gloves?</p> <p><input type="checkbox"/> Have gloves rated for use above 5,000 volts been tested?</p> <p><input type="checkbox"/> Are leather protectors clean?</p>	<p>O. Reg. 213/91 S.192 and 193</p>
<p>Electrical contractors</p> <p><input type="checkbox"/> Do electrical contractors have lock-out procedures in place?</p> <p><input type="checkbox"/> Do these lock-out procedures match up with the constructor's program for work on conductor installations or equipment?</p> <p><input type="checkbox"/> Do contractors have rubber gloves with leather protectors available to protect workers from electrical shock and burn?</p>	<p>O. Reg. 213/91 S.190 or 191 S.192 and S.193</p>
<p>Qualified workers</p> <p><input type="checkbox"/> Are workers qualified to do electrical work?</p>	<p>O. Reg. 213/91 S.182</p>

	Notes
	<ul style="list-style-type: none"> • Electrical inspections should be carried out under rule 2-004 of the <i>Ontario Electrical Safety Code</i>. • The Electrical Safety Authority (ESA) may be contacted to identify the inspector. • Equipment such as tower cranes are also subject to electrical inspection.
	<ul style="list-style-type: none"> • Leather protectors shall be inspected for damage before each use. Damaged rubber gloves or leather protectors shall not be used. • Rubber gloves shall not be worn inside out. • Rubber gloves rated for use with voltages above 5,000 volts AC shall be tested and certified to ensure that they can withstand the voltages for which they are rated, <ul style="list-style-type: none"> a) at least once every three months, if they are in service b) at least once every six months, if they are not in service. • Gloves rated under 5,000 volts should be tested according to manufacturer's instruction (typically every six months). • The date on the glove is the expiry date, not the testing date.
	<ul style="list-style-type: none"> • Constructors may use the expertise of electrical contractors to develop lock-out procedures rather than developing themselves. • Workers should have a set of rubber gloves with leather protectors since, at some point, there will be live testing.
	<p>Workers who connect, maintain, or modify electrical equipment or installations must meet the qualification requirements in the Regulation for Construction Projects (213/91).</p>

Checklist for Electrical Hazards

Description/Concern	Regulation Section
<p>Switches and panel boards</p> <ul style="list-style-type: none"> <input type="checkbox"/> Is the switch and panel board securely mounted on a soundly constructed vertical surface with a cover over uninsulated parts carrying current? <input type="checkbox"/> Is the location easily accessible to workers and within easy reach? <input type="checkbox"/> Is the location clear of obstructions and in an area where water will not accumulate? <input type="checkbox"/> Is the switch housed in an enclosure that can be locked and has a locking device? <input type="checkbox"/> Are any panels or switches locked in the on (i.e., energized) position? 	<p>O. Reg. 213/91 S.194</p>
<p>Electrical tools and equipment</p> <ul style="list-style-type: none"> <input type="checkbox"/> Do all electrical extension cords have a grounding conductor and at least two other conductors <input type="checkbox"/> Are all electrical extension cords in good working order? <input type="checkbox"/> Is the casing adequately grounded or double insulated? <input type="checkbox"/> Is the double insulated casing free of cracks or damage? <input type="checkbox"/> Are Class A GFCIs used to protect workers outdoors and in wet locations? <input type="checkbox"/> Are defective tools or equipment used on the site? <input type="checkbox"/> Are tools or equipment that is capable of conducting electricity stored in close proximity to energized electrical equipment, conductors, or installations? <input type="checkbox"/> Have any unused electrical equipment, installations, and conductors been removed or left in an electrically non-hazardous condition? <input type="checkbox"/> Are light bulbs used in temporary lighting systems enclosed by a mechanical protection device? 	<p>O. Reg. 213/91 S.195</p> <p>O. Reg. 213/91 S.195.3 and 93</p> <p>O. Reg. 213/91 S.187 and 188</p> <p>O. Reg. 213/91 S.186</p> <p>O. Reg. 213/91 S.45</p>
<p>Electrical rooms and enclosures</p> <ul style="list-style-type: none"> <input type="checkbox"/> Are there exposed conductors in the electrical room or enclosure? <input type="checkbox"/> Is there a sign on the entrance to the electrical room prohibiting entry by unauthorized persons? <input type="checkbox"/> Are any electrical rooms accessible or open? 	<p>O. Reg. 213/91 S.183 and 184</p>

Notes

- This section applies to a switch and panel board that controls a service entrance, service feeder, or branch circuit.

Note: Just because an enclosure has the ability to be locked does not mean it has to be locked.

- All cord connections to electrical equipment or tools shall be polarized.
- Check for damage to insulation and that the grounding pin has not broken off.
- If the power source is an ungrounded portable generator with a maximum output of 1.8 kilowatts or less, a Class A ground fault circuit interrupter (GFCI) shall be located in the cord feeding the tool, as close to the tool as possible. In all other cases, the tool shall be plugged into a receptacle protected by a Class A GFCI.
- Defective tools and equipment should be disconnected, removed from service, and tagged as defective.
- Equipment that is capable of conducting electricity includes scaffolding, aluminum ladders, and pipes.
- Electrical equipment and powerlines are in an electrically non-hazardous condition if they are disconnected, de-energized, or tagged. Also if the equipment is locked out or the powerlines are grounded.
- The means of access to and egress from those areas where workers are present shall be adequately lit.

- In electrical rooms, energized panels must remain covered.
- Authorized persons should have training and PPE to protect from the hazards they are exposed.
- Precautionary measures for entry into the room should be established.

Flash Hazard (Arc Flash) Protection

An arc flash is a release of energy caused by an electric arc. The flash causes an explosive expansion of air and metal. The blast produces such dangers as:

- Pressure wave
- Sound wave
- Shrapnel
- Extreme heat
- Extreme light



Arc flash

These dangers can result in blast injuries, lung injuries, ruptured eardrums, shrapnel wounds, severe burns, and blindness. Arc flash injuries can also result in death.

2012 ELECTRICAL INJURIES

Type	Electrical Injuries	Percent	Arc Flash Burns	Percent
Critical	8	53%	7	47%
Non-critical	64	96%	3	4%

Source: Ontario Ministry of Labour

Tasks with potential for arc flash:

- Operating a switch or circuit breaker
- Inserting or removing a circuit breaker
- Opening an enclosure door
- Removing a cover (bolted or hinged)
- Testing for voltage.

Warning labels are required on equipment that pose shock and flash hazards.

 WARNING	
Arc Flash & Shock Hazard	
ARC FLASH PROTECTION	SHOCK PROTECTION
Working Distance	18 inches
Incident Energy	5.0 cal/cm ²
Arc Flash Boundary	43 inches
<i>Refer to CSA Z462 and company's Electrical Safety Program for PPE requirements.</i>	
Facility: <Name>	
Equipment: Line Side of MCC #1 Main Breaker	01/26/2012

Arc Flash warning label

Electrical equipment shall be field marked to warn persons of potential electric shock and arc flash hazards

—*Ontario Electrical Safety Code 2015 (Rule 2-306 (1) Shock and arc flash protection)*

Adding the information from the results of an arc flash calculation and for electric shock gives workers the knowledge to protect themselves and makes the labels more useful.

The nature of an electrical worker's job can place the worker in close proximity to energized electrical equipment. As a result, electricians can be exposed to the hazard of arc flash during the course of a normal workday, even if the potential source of the arc flash is not being worked on. It is therefore advisable for electrical workers who are potentially exposed to arc flash to always wear clothing that provides for a basic level of arc flash protection.

Clothing made of synthetic fibres can be readily ignited by electrical arc flash and melt to the workers skin. Cotton or wool fabrics are more flame-retardant and therefore recommended as outerwear and inner-wear work clothes for electrical workers. Clothing that is flame-resistant (FR) protects a worker from receiving severe burns to the body if the worker is exposed to a flame. FR clothing is self-extinguishing when the source of the flame is removed.

Flame-resistant or arc-rated clothing



Arc-flash-resistant clothing

Photo compliments of Salisbury Electrical Safety L.L.C.

Flame-resistant (FR) clothing can protect against the increased levels of energy

generated from the intense flash flame of an arc flash. CSA Z462 requires the use of FR clothing to limit the incident energy level of the arc flash to 1.2 cal/cm^2 against the worker's chest. A second-degree burn occurs when skin is exposed to 1.2 cal/cm^2 for more than 0.1 second or 1.5 cal/cm^2 for 0.1 seconds or less.

FR clothing that additionally provides arc flash protection **will** meet ASTM F-1506, and bear a label stating 1506 approval and the arc rating of the garment. Ensure **all** materials used in manufacturing FR garments are FR-rated (e.g., thread, buttons, insulation, and zippers).

Not all PPE is FR tested to ANSI 1506. When purchasing PPE, advise the supplier that arc flash protection and FR-rated clothing is required. When PPE is not made with this specific certification, the PPE must still offer resistance to flame, ignition, and melting.

Hard hats, safety glasses, leather work boots, and leather gloves, for example, may either be inherently flame-resistant or designed to another standard that provides some protection.

The material used in manufacturing makes a difference. Generally, ear canal inserts made of PVC are more flame-resistant than inserts made from polyurethane. Non-rated clothing, and other PPE that can melt or catch fire, exposes the worker to serious burn injury. Even though the

arc-rated clothing easily survives an arc flash, workers are often severely injured by non-rated apparel that either burns or melts on the worker's skin. The result is extremely painful and lengthy hospitalization and rehabilitation, and permanent changes to their quality of life.

In some cases, it may be possible to “design out” the electrical hazard by using equipment designed to offer flash protection. For example, the plug in the picture below is designed for flash protection and can be used as a disconnect switch.

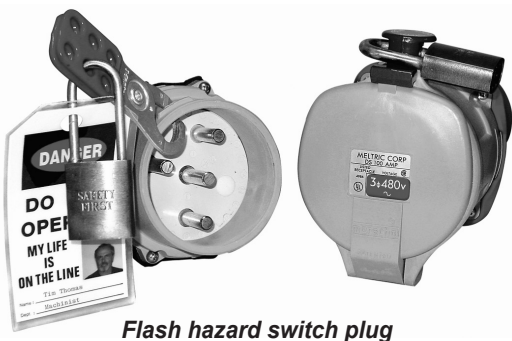

Flash hazard switch plug

Controlling arc flash

At the source

- Reduce the fault-clearing time.
- Reduce the short-circuit current.
- Improve maintenance and methods employed.
- Use flash-resistant equipment.



Flash protection is designed into this disconnect switch/plug

Photos courtesy of Meltric Corporation

Along the path

- Increase the working distance.
- Reduce the energy exposure.
- Use hinged doors instead of bolted doors to eliminate the risk of bolts falling into the panel.
- Work de-energized.

At the worker

- Energized electrical work permit
- Barriers
- Distance
- Training and skills
- Job briefings
- PPE
- Tools.



**Flash hazard helmet
with arc-rated face
shield**



**PPE protection:
arc-rated
welding gloves**

*Photo compliments of
Salisbury Electrical Safety L.L.C.*



*Photo courtesy of
EGS Electrical Group
Canada Ltd.*

**In-line Class A
GFCI**



*Photo
compliments
of Salisbury
Electrical Safety
L.L.C.*

**PPE protection:
High calorie-rated
arc-flash welding suit**



Photo compliments of
Salisbury Electrical
Safety L.L.C.

Insulated tools

Protection from an arc flash is afforded by employing protective clothing and equipment such as

- flame-resistant clothing
- safety glasses (FR face shield or flash hood is often required as well)
- hand protection
- hearing protection.

CSA Z462 *Workplace Electrical Safety* is currently the resource for Canadian arc flash and electrical safety best practices. The American standard NFPA 70E is technically aligned with CSA Z462, except that it contains unique American specific requirements.

Multimeters

In the process of troubleshooting, electrical workers face the risk of injury from improper multimeter selection or use. When used properly, multimeters that are designed to meet the International Electrotechnical Commission (IEC) 1010 standard (Overvoltage Category) offer the electrician an acceptable level of protection that is recognized by the electrical industry.

Why use overvoltage category-rated multimeters?

Momentary high-voltage transients or spikes can travel through a multimeter at any time and without warning. Motors, capacitors, lightning, and power conversion equipment, such as variable speed drives, are all possible sources of spikes.

The IEC 1010 standard defines categories I through IV that are abbreviated as CAT I, CAT II, etc. The higher-numbered categories represent an electrical environment that is susceptible to higher-energy spikes. For example, multimeters designed to the CAT IV standard provide the worker more protection from high-transient voltage spikes than do CAT III, CAT II, or CAT I designs. See the accompanying diagram and table for an explanation of each category.

Be sure the multimeter model has been tested. Simply being designed to CAT III, for example, does not mean the multimeter was also tested to that

standard. Look for proof of independent testing by an organization accredited by the Standards Council of Canada—such as the logo of CSA (Canadian Standards Association) International—along with the appropriate category rating on the equipment.

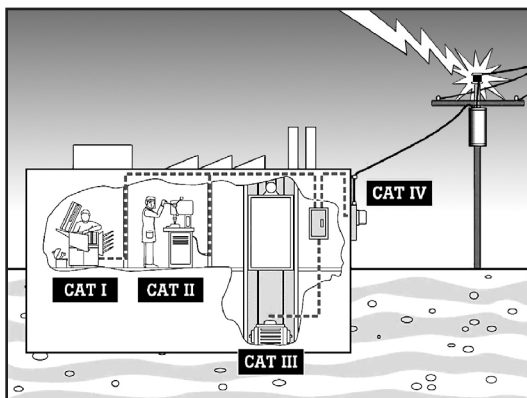

Understanding overvoltage installation categories

The division of a power distribution system into categories is based on the fact that a dangerous high-energy transient such as a lightning strike will be attenuated or dampened as it travels through the impedance (AC resistance) of the system. A higher CAT number refers to an electrical environment with higher power available and higher-energy transients. Thus a multimeter designed and tested to a CAT III standard is resistant to much higher-energy transients than one designed to CAT II standards.



Test leads should be fused and rated at the same or greater voltage than the multimeter

Safe use of multimeters

- Use only multimeters that display both the CSA logo (or equivalent) and the CAT (I, II, III, or IV) designation. Categories I through IV apply to low-voltage (less than 1000V) test equipment.
- Check and ensure that the meter's voltage rating is appropriate for the work being done. Beware of multimeters with maximum voltage ratings typical of other countries (550V for example).
- Use personal protective equipment such as eye protection, flame-resistant clothing, long-sleeved shirts, dielectric safety boots, rubber gloves with leather protectors, mats, blankets, and shields. Do not wear synthetic inner-wear or outerwear that can melt if an arc flash occurs.
- Moisture and cold may affect the performance of your meter. Check the owner's manual for special precautions.

- Wipe the multimeter and test leads clean to remove any surface contamination before use.
- Ensure that test leads are in the correct input jacks.
- Use fused test leads. Ensure fused leads and internal probe fuse are rated as high as or higher than the equipment you are going to work on. A minimum of 30kA (200kA desirable).
- When the values to be measured are uncertain, start testing with high ranges of the multimeter, then move to the lower ranges.
- Connect to ground first, and disconnect from ground last.
- Test the multimeter on a known power source to verify the meter's proper function before and after testing the suspect circuit, using the same power function for all three tests.

Testing for power with a meter

Set the meter to the power function to be used for validating the lockout. Ensure the meter is functioning correctly by testing on a known power source, then test the locked-out circuit to verify the power has been effectively isolated, and finally re-test on the same known power supply to verify the meter's fuse has not blown and the meter is still functioning correctly on that power setting.

OVERVOLTAGE CATEGORY	IN BRIEF
CAT IV	Three-phase at utility connection, any outdoors conductors
CAT III	Three-phase distribution, including single-phase commercial lighting
CAT II	Single-phase receptacle connected loads
CAT I	Electronic

*Parts of this table are reprinted with permission
from Fluke Electronics Canada Inc.*

EXAMPLES

- Refers to the “origin of installation”, i.e., where low-voltage connection is made to utility power.
- Electricity meters, primary overcurrent protection equipment.
- Outside and service entrance, service drop from pole to building, run between meter and panel.
- Overhead line to detached building, underground line to well pump.

- Equipment in fixed installations, such as switchgear and polyphase motors.
- Bus and feeder in industrial plants.
- Feeders and short branch circuits, distribution panel devices.
- Lighting systems in larger buildings.
- Appliance outlets with short connections to service entrance.

- Appliance, portable tools, and other household and similar loads.
- Outlet and long branch circuits.
 - Outlets at more than 10 meters (30 feet) from CAT III source.
 - Outlets at more than 20 meters (60 feet) from CAT III source.

- Protected electronic equipment.
- Equipment connected to (source) circuits in which measures are taken to limit transient overvoltages to an appropriately low level.
- Any high-voltage, low-energy source derived from high-winding resistance transformer such as the high-voltage section of a copier.

Fishing and Pulling Wire

Conduit may provide a path along which noxious, toxic, or flammable fumes and gases can travel. If using gases, glues, solvents, or other chemicals that could produce a hazardous gas or fume, check locations where the gas or fume can exit the conduit. Ensure other workers are not exposed to the fume or gas, or that a hazardous condition is not created as a result of the fume or gas building up in another room.

Pulling in confined spaces is particularly difficult. Workers should use care and caution under such conditions. Get help when necessary and use mechanical means if possible.

When pulling heavy runs of steel cable, wear gloves for protection from sharp strands.

When using jet lines, ensure that there is sufficient cross-ventilation to disperse carbon dioxide gas (CO_2). Jet lines must not be used in manholes unless forced ventilation is provided at each end of the run.

Illumination

All areas where workers must work or pass through must be adequately illuminated. Missing protective covers and burnt-out bulbs must be replaced.

Suggested lighting level is a minimum of 55 lux (5 foot candles).

There are many ways to achieve the requirement of 55 lux. For example, 150-watt lightbulbs suspended:

- 2.4 metres (8 feet) high and 7.5 metres (25 feet) apart; or,
- 3 metres (10 feet) high and 6 metres (20 feet) apart.

With lower wattage lighting, reduce the space between bulbs.

Fixed temporary wiring for illumination on construction projects

Lighting branch circuits shall be kept entirely separate from power branch circuits. (*OESC 2015*, Rule 76-012(2)).

Minimum temporary lighting requirements do not include provisions for portable hand-held lamps used by various trades to illuminate their immediate work area.

- Lamps should be installed in suitable locations to illuminate the entire area and they must be protected by a mechanical device such as a cage. Where necessary, additional lights should be installed over and above the minimum requirements.

- The constructor should be responsible for regularly inspecting all temporary lighting and should promptly have a competent worker replace any burned-out or missing lamps. The constructor should require relocation of any lights that become obstructed by new work such as ceilings, ducts, piping, equipment, and partitions.
- All lamp holders should be hard-usage type, medium-base sockets.
- NMW cable should be secured to the structure by an approved fastening device on both sides of each light. The intervals between supports should not be more than 1.4 m (4 ft, 6 in).
- Each lighting branch circuit shall be protected by a circuit breaker set in accordance with Rule 30-104 and the connected load shall not exceed 80% of the circuit breaker rating. (*OESC 2015*, Rule 76-012(4)).
- Lighting stringers should not be plugged into a receptacle, but hard-wired directly into a distribution panel by a worker qualified as per section 182 of O. Reg. 213/91.

Temporary Wiring and Power

1. **Temporary wiring** for construction or demolition projects must be installed in accordance with the *OESC 2015, 26th edition* (available from www.shop.csa.ca).

- 2. Temporary wiring** must be inspected and approved when initially installed and should be checked regularly. (*OESC 2015*, Rules 2-004, 2-014, 2-016)
- 3. Temporary installations** shall be constructed as separate installations and shall not be interconnected with any of the circuits of the permanent installations except by special permission. (*OESC 2015*, Rule 76-014)
- 4. Feeders** supplying fixed distribution centers shall be installed in armoured cable or the equivalent. A feeder supplying a portable distribution center is permitted to be flexible cord or power cable of the outdoor type suitable for extra-hard usage. Feeders shall be protected at all times from mechanical damage. (*OESC 2015*, Rule 76-010).
- 5. A switch and panel board,**
 - a. must be securely mounted on a soundly constructed vertical surface
 - b. must have a cover over uninsulated parts carrying current
 - c. must be located in an area where water will not accumulate and be within easy reach of workers and readily accessible to them
 - d. must be kept clear of obstructions in the area in front of the panel board. (O. Reg. 213/91, s. 194)

6. The switch that controls a service entrance, service feeder, or branch circuit providing temporary power,

- a. must not be locked in the energized position
- b. must be housed in an enclosure that can be locked and is provided with a locking device.

(O. Reg. 213/91, s. 194)

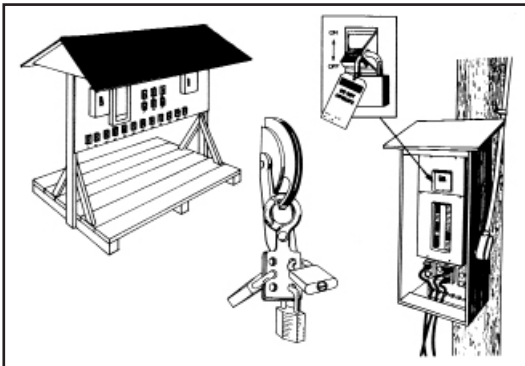

Shelter and lockout for temporary panel

- 7. Portable generators** with no connection between the neutral and the case cannot be used as a stand-alone electrical supply for the operation of portable electrical equipment. Typically, generators with no connection between the neutral and the case are intended to be connected through a transfer switch to a distribution system for use as a standby back-up system in a residential home, in case of power outage.

“Generators supplied by equipment rental stores for use as a stand-alone supply to portable electrical devices shall be a generator with the neutral bonded to the case to facilitate the operation of the overcurrent protection device(s)” (Electrical Safety Authority Flash notice 03-03-FL).

Labeling on newer portable generators must indicate the status of the neutral conductor and shall be marked on each machine as follows: NEUTRAL FLOATING or NEUTRAL BONDED TO FRAME.

- 8. Electric tools used outdoors or in wet locations** must be protected by a Class A ground fault circuit interrupter (GFCI). (O. Reg. 213/91, s. 195.2)

Portable Tools and Extension Cords

1. Unless double-insulated, power tools must have:
 - a. the casing grounded
 - b. a polarized plug connection.
2. Extension cords must be of the outdoor type, rated for not less than 300 volts, and have an insulated grounding conductor.
3. Defective cords must not be used. They should either be destroyed or be tagged and removed from the jobsite until repaired.

4. Extension cords should be protected during use to prevent damage.
5. Extension cords should be plugged into a Class A ground fault circuit interrupter (GFCI). When built-in GFCI receptacles are not available, protection can be attained with an in-line GFCI plugged directly into the receptacle.



Plug-in safely

Protection at the **SOURCE**:

- ▶ Plug into type “A” ground fault circuit interrupter (GFCI)

Protection at the **PATH**:

- ▶ Use grade A(1) heavy duty cords
- ▶ Heavier gauge wire for longer runs or bigger tools
- ▶ Check condition for ground pin, bad repairs, broken insulation
- ▶ Protect cord from: water, pedestrian and vehicle traffic, and closing doors and windows

Plug-in SAFELY

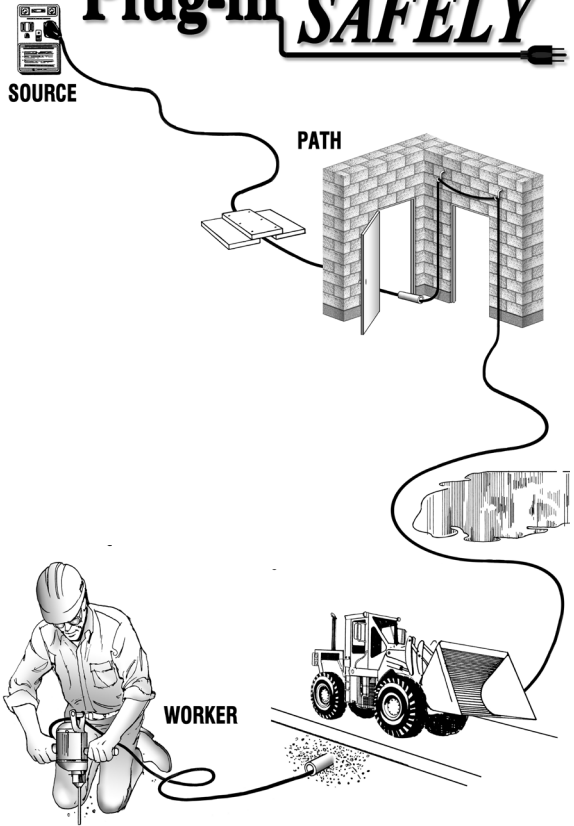

Protection at the **WORKER**:

- ▶ Test GFCI
- ▶ Keep out of water
- ▶ Check tool ground pin. On double-insulated tools, ensure that casing is not cracked.

Fall Protection (Working at Heights)

Before using fall protection, workers must complete MOL-approved working at heights training delivered by an MOL-approved training provider. This training must then be followed by site-specific training so that the worker is aware of the specific hazards and equipment used at the jobsite.

A means of fall protection must be used wherever workers may be exposed to the hazard of falling:

- more than 3 metres (10 feet)
- more than 1.2 metres (4 feet) if the work area is used as a path for a wheelbarrow or similar equipment
- into operating machinery
- into water or another liquid
- into a hazardous substance or object
- through an opening in a work surface.

A guardrail is the preferred method of fall protection. If that is not possible, use the highest ranked system that is practicable (see the list below):

1. Travel restraint
2. Fall restricting
3. Fall arrest
4. Safety net

Other areas to be protected by guardrails include:

- openings in floors, roofs, and other working surfaces not otherwise covered or protected
- edges of slab formwork for floors and roofs.

Basic requirements for wooden guardrails:

- top rail, mid-rail, and toeboard secured to vertical supports
- top rail between 90 cm (3 ft) and 110 cm (3 ft 6 in) high
- toeboard at least 89 mm (3.5 in) high —if made of wood—and installed flush with the surface
- posts at least 38 mm (1.5 in) by 89 mm (3.5 in) and no more than 2.4 metres (8 feet) apart.

When guardrails or opening covers are temporarily removed, workers in the area must be protected by a safety harness with the lanyard tied off to a suitable anchor. Barricades, guardrails, and covers must be replaced immediately after work is completed.

Regardless of type, every component of a fall protection system in Ontario construction must meet the requirements of the *Occupational Health and Safety Act*, the Regulation for Construction Projects (213/91), and any applicable standards from the National Standards of Canada.

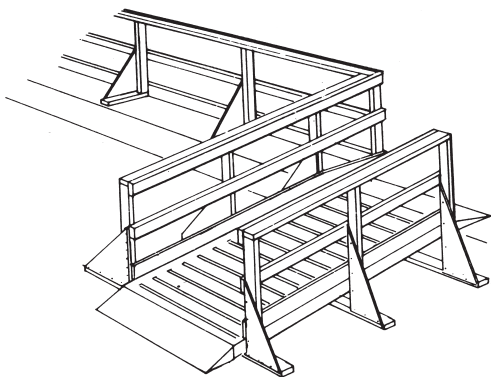
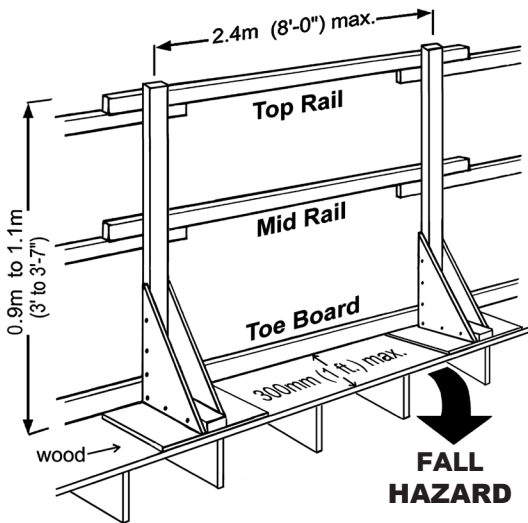

Typical dimensions for guardrails

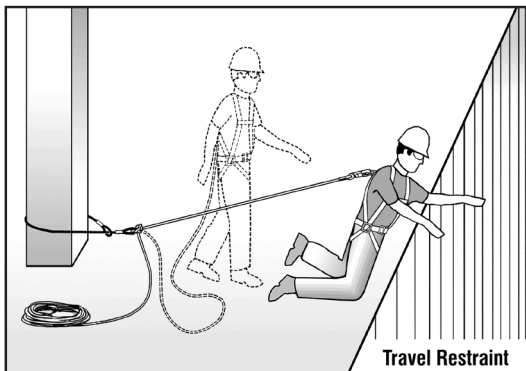

A travel restraint system lets a worker travel just far enough to reach the edge but not far enough to fall over

The employer must develop and have written procedures available to guide the rescue of a worker whose fall has been arrested. Workers using fall protection must be trained in its use and the employer must keep a written record of the training.

Safety harnesses and lanyards

- Harnesses must be snug-fitting and worn with all hardware and straps intact and properly fastened.
- Lanyards used for fall arrest must be equipped with an energy absorber to reduce the force of an arrested fall, except where clearance is limited and the energy absorber may cause the worker to strike an object or surface below.

- Choose the right length of lanyard. Calculate the total fall distance. The lanyard must be long enough to accommodate the work, yet short enough to ensure a fall will be arrested before hitting anything below. Take into account the extra distance the lanyard will extend when arresting a fall.

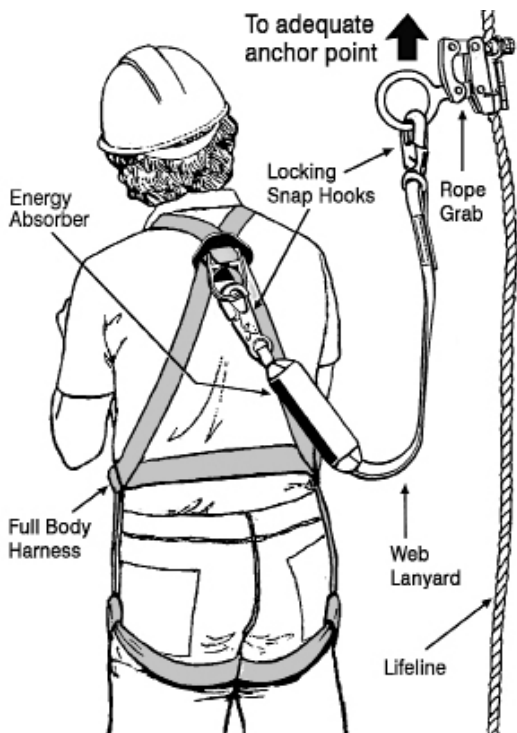

Full-body harness and fall arrest system

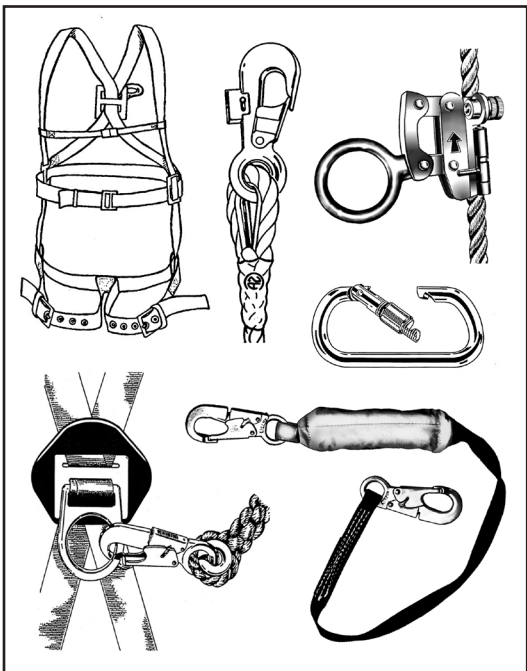

Fall arrest system components

Lifelines

All vertical lifelines must be

- securely anchored to a fixed support that meets regulated load requirements
- used by only one worker at a time
- protected from any danger of chafing
- free of cuts, abrasions, and other defects
- long enough to reach the ground

(or a level above ground where the worker can safely exit) or be knotted at the end to prevent the lanyard from running off the lifeline.

All horizontal lifelines must be designed by a professional engineer.

Retractable lifelines offer flexibility. They can provide for worker movement and minimize free-fall distance when providing fall protection, or they can be used as travel restraint.

Rope grab devices

Minimize the distance you could fall by keeping the rope grab as high as is practical—at shoulder height or higher for example.

Portable Ladders

IHSA has produced a document called “**Ladder Use in Construction Guideline**”. It has been prepared to assist workplace parties in understanding their obligations under the *Occupational Health and Safety Act* (OHSA) and its regulations. It is available for viewing at **www.ihsa.ca**. Employers and supervisors should review this document when determining policies for ladder use.

The Guideline refers to a hazard risk assessment. IHSA has produced a document called “**Hazard Risk Assessment for Ladder use**” to aid

employers and supervisors meet the intent of the guideline. This document has been included in its entirety at the end of this section (page 124).

Follow the safe work practices listed below when working with portable ladders.

- Ensure workers receive training related to company policies for ladder use.
- Electrical contractors should provide non-conductive ladders because of electrical hazards in the trade.
- Before setting up straight or extension ladders, check the area for overhead powerlines.
- All portable ladders must be CSA approved to CSAZ11 -12 and meet requirements of Grade 1, Grade 1A, or Grade 1AA.
- Set ladders up on a firm level surface. Use a mudsill on uncompacted soil.
- Set straight extension ladders one foot out for every three or four feet up.
- Tie off or otherwise secure ladders to prevent movement. If this is not possible, one worker should hold the base of the ladder while another uses it.
- When work must be done from an extension ladder,
 - stand no higher than the fourth rung from the top,
 - keep both feet on the ladder

- use fall protection when working at 3 metres or higher
 - ensure you can achieve three-point contact
 - maintain your centre of gravity between the side rails,
 - perform only tasks that do not affect your stability.
- Always maintain three-point contact and face the ladder when climbing up and down.
 - Unless suitable barricades have been erected, do not set up ladders in passageways, doorways, driveways, or other locations where they can be struck.
 - Do not paint ladders. Paint can hide defects.
 - Ensure clear access at top and bottom of ladder.
 - Ladders transported on the top or side of vehicles should be supported and secured in proper racks to withstand braking and bumps. Check regularly for damage to the ladder where it contacts supports.
 - Nothing should be piled on ladders when stored or transported.

Refer to the section on ladders in IHSA's *Construction Health and Safety Manual* (M029).

Hazard risk assessment for ladder use

IHSA's ***Ladder Use in Construction Guideline*** has been developed to aid workplace parties in understanding their obligations under the *Occupational Health and Safety Act* and its regulations. Page 5, for example, outlines the responsibility of the employer: *"Where work is to be performed above grade from a ladder rather than a scaffold, an employer must ensure the hazards associated with the ladder work have been assessed and appropriate controls are in place to protect the health and safety of the worker"*.

Assessing the safety of using a ladder for a specific job task can be done using the ladder risk assessment guideline below. This assessment is intended for the temporary use of portable ladders. Permanently anchored ladders, job-built ladders, and portable ladders secured for permanent access and egress are not considered part of this assessment. The Regulation for Construction Projects (213/91) provides guidance on the safe installation of ladders meant for access and egress on a more permanent basis.

Conducting a ladder risk assessment

Employers can learn how to conduct a detailed hazard risk assessment (HRA) or job safety analysis (JSA) through programs at IHSA. Check with your local IHSA consultant.

For employers familiar with the process, the following link may also be useful:

www.ihsa.ca/resources/hazard_assessment_analysis_control.aspx

In general, before a ladder is selected over other options, an assessment of the work must be completed and alternatives considered. A hazard assessment must be done, hazards identified must be mitigated, and there should be evidence that these considerations have been taken into account. Following the steps below can help guide you through the process.

1. Identify the Task.

The first step in developing this assessment is to identify the task at hand. This task will often be a situation that is repeated on many jobsites (e.g., accessing a rooftop, working on the ceiling in a restricted space, or tying rebar).

2. Assess the alternatives.

When a task has been identified, there is often more than one way to accomplish it. Obvious alternatives to the use of a ladder include scaffolds and elevating work platforms. The employer has the responsibility to rate the severity and the probability of the hazards associated with each alternative in order to make a reasonable determination about which one to use.

3. Break down the task into steps.

Once you have identified the task, the next step is to break it down into steps. Each step is a part of the operation that is necessary to advance the work. Keep the steps in sequential order as much as possible. For example, the steps for using a ladder will usually involve:

- (1) removing the ladder from storage
- (2) setting up the ladder
- (3) using the ladder
- (4) dismantling the ladder
- (5) returning the ladder to storage.

4. Identify the hazards associated with each job step.

This is the most challenging part of the hazard risk assessment. Take each step and list the hazards associated with it. Think about what could go wrong from a health and safety perspective. Think about how people, equipment, materials, processes, and the surrounding environment could contribute to a hazard.

5. Determine controls for each hazard.

Each hazard identified in the previous step needs a control. The control explains how you will eliminate the hazard or how you will significantly reduce the risk of injury or illness associated with the hazard. The probability of the hazard causing harm and the severity of the outcome should be considered.

Methods of hazard control may include the following:

Eliminate/mitigate the hazard

- Install equipment in easily accessed locations.
- Improve the work environment (e.g., bring the work to floor level).
- Build permanent or portable stairs.
- Use another type of equipment to access the work (e.g., elevating equipment or scaffolding).

Contain the hazard

- Install accessible anchors for fall protection and travel restraint.
- Use ladders with work platforms.
- Use ladder stabilizers.

Revise the work procedure

- Schedule and plan work when better access can be provided.
- Get help from a co-worker.

Reduce the exposure

- Refresh worker knowledge with training.
- Use appropriate personal protective equipment such as work boots with good tread.
- Rotate jobs to reduce the length of time each worker is exposed to the hazard.

If a hazard to the worker exists, rate the severity and the probability of the hazard. Note that it is the employer and supervisor's responsibility to take reasonable precautions for the protection of the worker. They have to make a reasoned decision as to whether or not the ladder can safely be used to complete the job task once the hazards associated with the ladder work have been assessed and appropriate controls have been put in place. See the sample HRA for ladders on pages 122-123 for the kind of information that could be included in your job-specific hazard risk assessment.

Employees using the ladder must be able to show evidence that an assessment was done. Employers may provide employees with checklists similar to those provided in samples 2 and 3 on pages 124-125 and 126-127. These checklists may be suitable for repetitive work that has been supported by a more detailed assessment.

For example, hazards associated with assessing the roof of a commercial building for HVAC/R service can be assessed in detail once the workers have been trained to recognize and address the identified hazards. A custom checklist can be created for technicians to use on similar sites. For unique hazardous work, written evidence of the assessment should be kept with the ladder. The complexity of the hazard risk assessment is based upon the complexity of the work that involves the ladder.

Sample 1: Hazard Risk AssessmentPrepared by: J. SmithApplicable Projects: Ladder set-up on service callsApplicable Ladder Types: Extension ladderReference Material: Site examination; best practices**Instructions:**

1. To be prepared by a competent person familiar with the type of work.
2. Must be explained to employees who rely on this HRA.
3. Changes must be communicated to employees who rely on this HRA.
4. The employer and supervisor must make a reasonable

JOB STEPS	HAZARDS
Lifting ladder off truck from braces	Strain and sprain
Carrying and setting up ladder	Strain and sprain
	Fall
	Slip and trip
	Electrocution
Next steps...Climbing, etc.	

(HRA) for LaddersApproved by: J. Doe

decision about whether or not a ladder can be used.
Document the reasons as part of this HRA.

5. Use the table below to make a reasonable decision about whether or not the hazards associated with the ladder work have been assessed and appropriate controls have been put in place for the protection of the worker's health and safety.
6. If associated with a specific checklist, this HRA must have an identifier such as a file number and be kept by the employer.

	BARRIERS or CONTROLS
	Use mechanical leverage to raise ladder from truck bracket, or mount in an easily accessible location.
	Lift one end at a time.
	Get assistance.
	Carry ladder with feet toward the front so it's ready to set up.
	Lift ladder onto shoulder directly from truck bracket.
	Ensure good grip before walking.
	Get assistance from second worker for large ladders.
	Bend knees if setting ladder on ground.
	Set ladder feet on ground and walk towards wall raising ladder against wall. Practice this step with small ladders.
	Adjust ladder footing as required and, where applicable, secure bracing/stabilizers in place.
	Ensure ladder is not leaning, is on firm footing, and is secured from movement.
	Ensure your path of travel is clear before removing ladder from truck bracket.
	Know where obstacles are before travelling with ladder.
	Make sure you have a clear set-down area.
	Check pathway and set-up area for overhead wires.

Sample 2:

Portable Ladder Risk Checklist

Extension ladder access to commercial building rooftop

COMPANY NAME: _____

- Use this checklist only after an assessment of the work has been completed, alternatives have been considered, and it has been determined that an extension ladder is to be used for accessing the rooftop of a commercial building.
- Use this checklist in conjunction with HRA File Number 1234.
- Employees must have received instruction regarding HRA File Number 1234.
- Additional notes may be included regarding fixed-access ladders.

In all situations, ladder use is subject to the following safe work practices.

- The ladder has been visually inspected.
- The ladder is the appropriate CSA grade for its intended use and the amount of weight it will be required to support.
- The worker has received training on safe ladder use and appropriate fall protection.
- The worker has received instruction on the hazard risk assessment associated with this checklist.
- Alternatives (to a ladder) have been considered (e.g., fixed-access ladder, PEWP, scaffold, work repositioning, etc.), and a ladder is deemed most suitable for the task.
- The selected ladder type is suitable for the task (step, extension, platform, etc).
- Ergonomics of manoeuvring the ladder have been assessed and addressed.

Ensure the following checks have been addressed.

- ✓ The ladder is secured from movement. For example,
 - Firm level base, secured where possible
 - Tied at top to available structure.
- ✓ Material and/or tools can be raised or lowered by using a tool belt or rope in order to keep hands free.
- ✓ Three-point contact can be maintained while climbing.
- ✓ Ice and snow at the base and top is clear or will not affect the ladder stability or the worker's footing.
- ✓ Traffic in the area of the base and top is controlled.
- ✓ Enough space is left at the base for proper ladder angle.

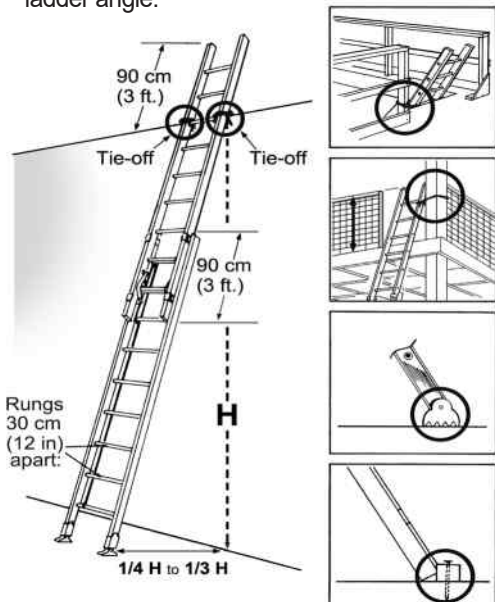

Sample 3:

Portable Ladder Risk Checklist

Insulating pipe from a stepladder

COMPANY NAME _____

- Use this checklist only after an assessment of the work has been completed, alternatives have been considered, and it has been determined that a stepladder is to be used for insulating pipe.
- Use this checklist in conjunction with HRA File Number 1234.
- Employees must have received instruction regarding HRA File Number 1234.

In all situations, the ladder must be subject to the following safe work practices.

- The ladder has been visually inspected.
- The ladder is the appropriate CSA grade for its intended use and the amount of weight it will be required to support.
- The worker has received training on safe ladder use and appropriate fall protection.
- The worker has received instruction on the hazard risk assessment associated with this checklist.
- Alternatives (to a ladder) have been considered (e.g., fixed-access ladder, PEWP, scaffold, work repositioning, etc.), and a ladder is deemed most suitable for the task.
- The selected ladder type is suitable for the task (step, extension, platform, etc).
- Ergonomics of manoeuvring the ladder have been assessed and addressed,
- Spreader bars are fully engaged.

Accessing the task

For both climbing and working from the ladder, ensure the following checks have been addressed.

Climbing

- ✓ Material and/or tools can be raised or lowered by handing things up or by using a tool belt or a rope in order to keep hands free.
- ✓ Three-point contact can be maintained while climbing.

Working from the ladder

- ✓ Traffic in the area is controlled.
- ✓ There is no need to reach below the knees or lean backwards.
- ✓ The worker's centre of gravity (middle of body at belt height) can be kept between the side rails.
- ✓ Only lightweight tools or materials are carried onto the ladder (tape, insulation, etc.)
- ✓ Tasks performed on the ladder will not affect its stability. Both feet are kept on the ladder when standing.
- ✓ Materials are received using one hand (to maintain three-point contact) or by climbing down to retrieve them.
- ✓ While working, three-point contact can be achieved by grasping the ladder or another solid object next to the worker.



Scaffolding

Erecting and dismantling scaffolds must be carried out under the supervision of a competent worker who is knowledgeable and experienced in such operations. A competent worker must also inspect the scaffold before it is used. A properly built scaffold has the following features:

1. Erected according to the manufacturer's requirements with all braces, pins, screwjacks, baseplates, and other fittings installed.
2. Guardrails are erected whenever the working platform is 2.4 metres (8 feet) or more above floor level. Guardrails require a top rail, a mid-rail, and a toeboard.
3. Platforms are at least 46 cm (18 in) wide and, if they are over 2.4 m (8 ft) high, they are planked across their full width.
4. Scaffolds with a height-to-base width ratio greater than three-to-one (including outrigger supports if used) are tied to a building or structure to prevent tipping.
5. Scaffold planks are securely fastened to prevent them from sliding.
6. Planks are made of sawn lumber that is:
 - of good quality
 - made of number 1 grade spruce
 - free of defects such as loose knots, splits, or rot
 - 48 mm x 248 mm (1-7/8 in x 9-3/4 in) or larger.

7. Scaffolds are erected, used, and maintained in an upright and plumb condition.
8. Planks are extended beyond their supports by at least 15 cm (6 in) but no more than 30 cm (12 in).
9. Scaffolds are equipped with a ladder for access.
10. Frame scaffolds over 15 m (50 ft) high and tube-and-clamp scaffolds over 10 m (30 ft) high are designed by a professional engineer and constructed in accordance with the design.
11. Wheels or casters on rolling scaffolds are equipped with braking devices and securely pinned to the scaffold frame.

Working from scaffolds

- Wheels and casters must be locked when personnel are working on a rolling scaffold.
- If the scaffold is more than 2.4 m (8 ft) high, it must not be moved with personnel on it unless,
 - a) they wear safety harnesses with the lanyards tied off to a fixed support, and
 - b) the floor is firm and level.
- Workers erecting, dismantling, or using a scaffold more than 3 m (10 ft) high must use fall protection such as guardrails or a harness and lanyard tied off to a suitable anchor.

Elevating Work Platforms and Vehicle-mounted Aerial Devices

Always familiarize yourself with the operating manual before using an elevating work platform (EWP).

Understand the device's capabilities and limitations spelled out in the manual.

Follow the requirements in sections 143 to 149 of O. Reg. 213/91 for EWPs operated on construction projects.

A worker who operates an elevating work platform shall, before using it for the first time, be given oral and written instruction on the operation and be trained to operate that class of elevating work platform.

- O. Reg. 213/91, s.147(1)

The following points offer general guidance only. Where there is a conflict, instructions in the operating manuals take precedence over these recommendations.

- A EWP that is not working properly or has sustained damage to components should not be used until it is repaired by a qualified mechanic.
- A EWP should be used only on surfaces specified by the manufacturer. These devices are heavy and can sink into the ground, so check for soft ground conditions.
- Watch for holes, depressions, trenches, or similar hazards when the EWP is driven. Be especially cautious when it is in a raised position.

- A EWP must not bear more than its rated working load. Where possible, the loads should be distributed over the platform.
- Secure loose materials to the platform when travelling.
- A EWP should not be used for pulling, pushing, or dragging materials.
- Ensure you have the right platform and the appropriate accessories for the platform. Approved accessories can increase safety and improve efficiency. Order the accessories that are available for the EWP with the supplier or manufacturer.

Lift trucks as work platforms

A lift truck must never be used to support, raise, or lower a worker on a construction site.

No worker shall use as a work place a platform, bucket, basket, load, hook or sling that is capable of moving and that is supported by a fork-lift truck, front-end loader or similar machine.

- O. Reg. 213/91, s.107

- Always maintain 3-point contact (one hand and two feet or two hands and one foot on the equipment) when getting on or off the platform.
- Use caution under windy conditions. The platform could tip over.
- Beware of new carbon monoxide emission testing requirements in section 47 of O. Reg. 213/91 regarding the operation of internal combustion engines indoors.
- EWPs used on ramps or on sloping or uneven surfaces must be designed

for such use. Refer to and follow the manufacturer's directions before attempting to use a EWP under these conditions.

- Do not operate a EWP near electrical hazards unless the necessary precautions have been taken, such as:
 - If the work takes place near an electrical hazard operating under 750 volts, take steps to remove the electrical hazard. (e.g., Lock out the power or put up a barrier to prevent the electrical contact.)
 - If the EWP is capable of reaching the "minimum distance" to an energized overhead electrical conductor, comply with the requirements of section 188 of the Regulation for Construction Projects (213/91). (e.g., The constructor must have written procedures to prevent encroaching upon the minimum permitted distances.)

NOTE: An exemption to these measures is only available if, under the authority of the owner of the electrical conductor (typically the local utility), protective devices and equipment are installed and written measures and procedures are established and implemented that are adequate to protect workers from electrical shock and burn.

Work that must be done within the minimum distances to powerlines requires special training, specific rules, and a platform device that is CSA-certified for work on energized powerlines. Vehicle-mounted aerial devices are certified

to the standard CAN/CSA C225. They are designed for working on overhead powerlines, but the work must be carried out under the *Electrical Utility Safety Rules*.

Keep the minimum distance from powerlines

Voltage Rating	Minimum Distance
750 volts to 150,000 volts	3 metres (10 ft)
More than 150,000 volts to 250,000 volts	4.5 metres (15 ft)
More than 250,000 volts	6 metres (20 ft)

Source: O. Reg. 213/91, s.188

Caution: The wind can blow powerlines, hoist lines, or your load, causing them to come closer than the minimum allowable distance.

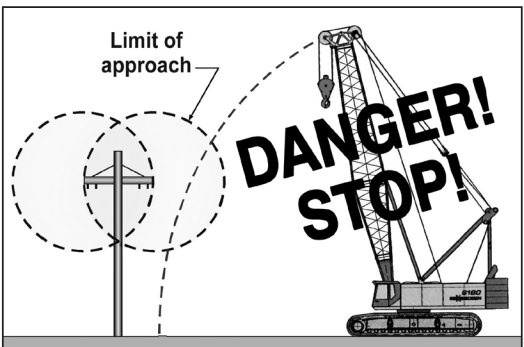

This crane boom could reach within the minimum distance

Housekeeping, Storage, and Tool Maintenance

1. Waste material and debris must be removed from work and access areas on a regular basis or at least once a day.
2. Waste material and debris must not be thrown from one level to another, but must be carried down, lowered in containers, or deposited in a disposal chute.
3. Material must be piled, stacked, or otherwise sorted to prevent tipping and collapsing.
4. Materials to be lifted by a crane or other hoisting device must not be stored under energized overhead powerlines. Items that can conduct electricity must not be used or stored so close to energized electrical equipment that they can make electrical contact.
5. It is the employer's responsibility to supply and maintain shop tools and other power equipment in good repair. It is the worker's responsibility to use such tools properly and to report any defect to the supervisor.
6. Large tools such as pipe vises and benders should be set up so as not to create a hazard to either the public or co-workers.

Fire Extinguishers

Fire extinguishers must be readily accessible, properly maintained, regularly inspected, and promptly refilled after use. Portable extinguishers are classified according to their ability to handle specific types of fires.

Note: Every worker who may be required to use a fire extinguisher must be trained in its use.

Types of fire extinguishers

Class A

For fires involving **ordinary combustible** materials such as wood, paper, plastics, textiles, etc. where a quenching, cooling effect is required.

Class B

For **flammable liquid and gas** fires, such as oil, gasoline, propane, paint, and grease, where oxygen depletion or flame interruption is essential.

Class C

For fire involving **electrical** wiring and equipment where the non-conductivity of the extinguishing agent is crucial.

Class D

For fire involving **combustible metals** such as magnesium, titanium, sodium, and potassium. These are metals that can react violently with water, air, or other chemicals.

Service trucks should carry at least a 10BC-rated extinguisher. However, at minimum, a 4A40BC-rated extinguisher must be available on a construction site (O. Reg. 213/91, s. 250(2)).



Service Vehicles

This section highlights some basic requirements specifically applicable to drivers of service trucks. If you have any questions or concerns, ask for information from the appropriate association or ministry to ensure that the responsibilities of all personnel are clearly understood.

Legislation

Highway Traffic Act

All vehicles must be operated in compliance with the *Highway Traffic Act* while on public roads and highways. Comprehensive information on the *Highway Traffic Act* can be obtained through training facilities such as IHSA.

Commercial plates

Commercial plates are required on any motor vehicle having a permanently attached truck or delivery body. The requirement for commercial plates on a van or pickup truck does not automatically classify it as a commercial vehicle.

Commercial vehicles

Loading a vehicle with equipment and supplies can quickly increase its weight. Whenever the gross vehicle weight rating, registered gross weight, or actual weight (loaded or empty) exceeds 4,500 kilograms, the vehicle and operator are subject to the regulations under the *Highway Traffic Act* that apply to

commercial vehicles and commercial vehicle operators.

Under the *Highway Traffic Act*, commercial vehicle operators are required to obtain a Commercial Vehicle Operator's Registration (CVOR) as well as adhere to additional restrictions and obligations (such as annual inspections) that the Act specifies. A trailer's weight must be added to the weight of the vehicle when determining total weight.

The *Highway Traffic Act* defines an operator as the "person responsible for the operation of a commercial motor vehicle including the conduct of the driver of, and the carriage of goods or passengers, if any, in, the vehicle, or combination of vehicles." The operator does not necessarily have to be the vehicle owner. If the vehicles are leased or contracted, the operator must hold a valid CVOR certificate.

If you have any questions or doubts about how the Highway Traffic Act is to be applied, contact the local Ministry of Transportation enforcement office.

Gross axle weight

With any commercial or passenger vehicle, the gross weight of the vehicle, or combination of vehicles (e.g. van and trailer), unless exempted under the regulations, must not exceed the manufacturer's gross axle weight rating. This rating is usually found on a sticker placed on the driver's door.

Exceeding the manufacturer's gross axle weight is an offence under the *Highway Traffic Act*. Also, the vehicle can become classified as a commercial vehicle if the gross weight is more than 4,500 kg.

Trailers

If a vehicle is towing a trailer such as a utility trailer, the trailer's weight must be added to the weight of the vehicle when determining the total weight. Add the highest weight of the vehicle to the highest of the trailer's gross vehicle weight rating (if provided on trailer) or the actual weight (empty or loaded) to determine whether the combined weight exceeds 4,500 kg.

Note: If the combined weight exceeds 4500 kg, both vehicles may be required to display an annual safety inspection decal.

Transportation of Dangerous Goods Act (TDG Act)

Whenever hazardous material is being transported on a road or highway, the *TDG Act* applies. Be aware not only of the dangers involved but also of the restrictions and obligations of the *TDG Act* that apply to both the driver and owner of the vehicle.

This section identifies only some of the regulations and exemptions that apply to a service vehicle, vehicle owner, and driver under the *TDG Act*. For more information or training, contact IHSA.

While transporting propane gas, a driver must also follow the *Propane Storage and Handling Code*. (See “*Propane Storage and Handling Code*” on page 141.) In addition, read the Material Safety Data Sheet (MSDS) of the products being transported. Specific information regarding transportation may be stated there.

If you have any questions or doubts about how the TDG Act is to be applied, contact the local Ministry of Transportation enforcement office.

Special Provisions of the TDG Regulations under the TDG Act

Regulations under the *TDG Act* always apply to transporting dangerous goods such as compressed gases. The *TDG Act* does, however, allow exemptions from some of the requirements.

Exemptions from driver training, documentation, and placarding of the vehicle may be applicable. (Placarding refers to affixing signs to the vehicle for identifying the contents being transported.) For example, certain exemptions may be provided in the following circumstances:

- When propane, acetylene, or oxygen is being transported in an open vehicle and
- the amount of such gas is less than 500 kg gross mass, or such gas is contained in not more than five cylinders.

In such a situation, the *TDG Act* requires the label on the cylinder to be visible from outside the vehicle.

- When gases are being transported in an enclosed vehicle such as a van, different restrictions apply. While transporting class 2.2 gases such as nitrogen, argon, oxygen, and most refrigerants, or class 2.1 gases (in cylinders under 45 litres) such as acetylene and propane, and the gross mass is less than 500 kg, the vehicle is exempt from placarding. However, the following is required:
 - shipping documents (TDG)
 - training certification (as required in the regulations (TDG))
 - labeling (TDG)

In all cases, the cylinders being transported must be securely stowed in the vehicle to prevent movement. A dry chemical fire extinguisher of at least 10BC rating, listed by the Underwriters' Laboratories of Canada (ULC), should be carried in the vehicle.

Many compressed gas cylinders must be stored in an upright position.

Section 42(1) of the Regulation for Construction Projects requires all storage cylinders for compressed gas be secured in an **upright** position. Check the MSDS or contact the gas supplier before storing any gas cylinders lying down.

Additional Vehicle Storage Precautions

The storage and transportation of propane cylinders in a vehicle requires special precautions. Refer to the requirements of the *TDG Act*. The following measures are additionally advised:

- Close the cylinder valve during storage.
- Keep the relief valve in contact with the vapour space at all times.
- Do not expose the cylinder to any source of ignition or to temperatures higher than 125°F (50°C).
- Ventilate the space, where cylinders are transported or stored inside a vehicle, to the outside.
- Isolate the cylinder from other flammable or oxidizing gases.

In addition, it is recommended that the space where cylinders are transported or stored in a vehicle be ventilated to the outside.

A dry chemical fire extinguisher of at least 10BC rating, listed by the Underwriters' Laboratories of Canada (ULC), should be carried in the vehicle.

During transportation, the *TDG Act* takes precedence.

Maintenance

Every employer should establish a system to periodically inspect, repair, and maintain all motor vehicles and trailers that are operated on highways.

An employer must not permit a motor vehicle to be driven or a trailer to be towed on a highway if there is reason to believe that the vehicle or trailer will not meet safety standards. A driver who reasonably believes or suspects that a vehicle or trailer does not meet safety standards should advise the employer accordingly.

Trip inspections

A basic vehicle inspection (or Daily Circle Check) should be done before each shift.

DAILY CIRCLE CHECK

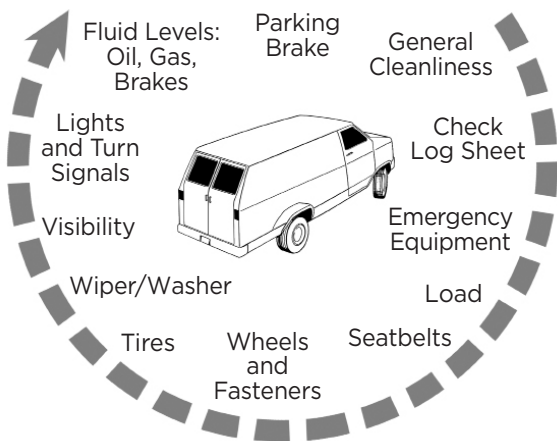

Circle check explanations:

- Parking Brake - Adequate to hold vehicle
- Fluid Levels: Oil, Gas, Brakes - Check for leaks
- Lights and Turn Signals - Functioning
- Visibility - Adjust mirrors; windows clean and intact
- Wiper/Washer - Functioning
- Tires - Pressure, tread depth, or damage
- Wheels and Fasteners - Defects in rim; loose or missing fasteners
- Seatbelts - Must be used
- Load - Secure
- Emergency Equipment - Install and inspect as required by law or company policy.

Record and report any defects to your supervisor immediately!

A MORE DETAILED INSPECTION MAY BE REQUIRED FOR COMMERCIAL VEHICLES.

Vehicle layout

Before you drive, make sure that equipment and materials are evenly distributed. Secure any cargo that could shift during travel, especially cylinders of compressed gas. Do not let scrap and debris accumulate in the vehicle.

The design and layout of service vehicles should include the following points:

1. A strong reinforced divider should separate the driver compartment from the back.
2. Compressed gas cylinders should be located in a compartment that is vented outside the vehicle. Cylinders should be solidly supported and fit in specific places.
3. A designated location should be provided for the first aid station, MSDS information, and fire extinguisher.
4. Strong storage racks for tools and supplies should be provided to allow even distribution of weight and prevent shifting in the event of sudden stops or sharp turns.

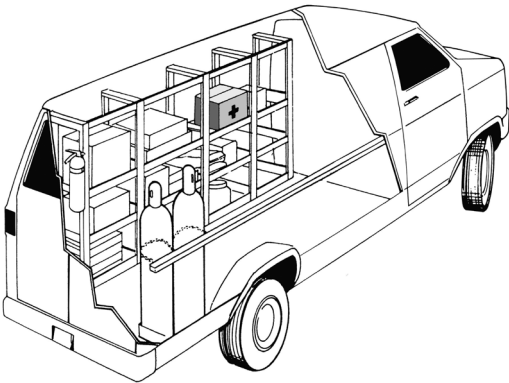

Working Alone

Electrical workers sometimes work alone, particularly during service calls. Working alone means the worker is the only person on site or is isolated from other workers. In either case, when someone is working alone and becomes injured, trapped, or otherwise incapacitated, that worker may not be able to call for help. It may be some time before anyone becomes aware of the worker's situation. That's why construction personnel working alone have died from injuries or conditions that would not have been fatal if the victims had been found sooner.

Various factors can make it difficult for an injured worker to get help:

- The worker is unable to move, cannot reach a phone, or has no means of communication.
- The worker is unconscious and cannot call for help.
- The worker is unable to move and is beyond the sight or hearing of other workers.
- No one is aware of the worker's situation because the worker does not have a scheduled time for calling in or, if a schedule is established, the interval between calls is too long.
- The location is remote and emergency services cannot respond quickly or they have difficulty locating the site or the worker.

Under section 25(2)(h) of the *Occupational Health and Safety Act*, employers and supervisors have a general duty to take every precaution reasonable in the circumstances for the protection of a worker. This includes help and support for personnel working alone.

Under section 17(1) of the Regulation for Construction Projects (213/91), the constructor must establish and implement written procedures to be followed in the event of an emergency. Under section 18, the constructor also has a duty to ensure that every worker on a project has ready access to a telephone, two-way radio, or other system of two-way communication in the event of an emergency.

Hazard awareness

The employer or supervisor should ensure that any worker working alone is

- aware of real and potential hazards in the area
- trained to recognize and control hazards
- provided with procedures and equipment to do the job safely.

All safety and work-related procedures should be spelled out under the company health and safety policy and be reviewed with personnel before they work alone.

Communication is crucial. At regular intervals, someone should check on

the worker or the worker should report to a designated person. Where hazard exposure is high, intervals for checking in should be kept short. Contact should be predetermined and understood by both parties.

In all cases, the employer or supervisor must ensure that

- a method of checking in with the worker has been established
- check-in-intervals are clearly understood
- the designated contact person is aware of the work schedule
- communication equipment is in good working order
- no obstructions or interference can block radio or phone communications.

A worker who works alone should make every reasonable effort to advise the dispatcher, on-duty person, answering service, supervisor and/or client of the job progress, expected time of completion, actual time of completion, and departure from the site.

With an answering service, the procedure involves phoning in regularly. If the worker fails to report at one of the designated times, the answering service phones the employer who goes to the project, or sends someone there, to check on the worker.

Some jobs should simply not be done by anyone working alone. These include working:

- in confined spaces
- with acutely toxic chemicals such as hydrogen sulphide, ammonia, or accumulated fumes
- with high voltages
- in extreme temperatures or weather
- in areas where a gas leak could displace oxygen and reduce the oxygen level
- on or over moving equipment or machinery.

Jobs posing a higher than normal risk when performed by an employee working alone should be identified and require extra precautions such as being assigned to at least two workers. In some situations—working in confined spaces, for instance—regulations under the Occupational Health and Safety Act prohibit entry or work without another person standing by outside the area.

Provisions for employees working alone should be included under the company health and safety policy and in the emergency response plan. Emergency services should be identified and contacted to confirm phone numbers and availability. These services may be provided by on-site emergency response personnel or through local municipal services.

5. MISCELLANEOUS INFORMATION

Metric Conversion Factors

	To convert imperial units	to metric units	multiply by
Length	inches (in)	millimetres (mm)	25.400
	feet (ft)	metres (m)	0.305
	yards (yds)	metres (m)	0.914
	miles (mi)	kilometres (km)	1.609
Area	square inches (in ²)	square centimetres (cm ²)	6.452
	square feet (ft ²)	square metres (m ²)	0.093
	square yards (yd ²)	square metres (m ²)	0.836
	square miles (mi ²)	square kilometres (km ²)	2.590
	acres	hectares (ha)	.405
Volume	cubic measure (in ³)	cubic centimetres (cm ³)	16.387
	cubic feet (ft ³)	cubic metres (cm ³)	0.028
	cubic yards (yd ³)	cubic metres (cm ³)	0.765
	fluid ounces (oz)	millilitres (ml)	28.413
	quarts (qt) (Imp)	litres (L)	1.137
	gallons (ga) (Imp)	litres (L)	4.546
Mass	ounces (oz)	grams (g)	28.349
	pounds (lb)	kilograms (kg)	0.454
	tons (2000 lbs)	tonnes (t)	0.907
Force	pounds force	newtons (N)	4.448
	tons force	kilonewtons (kN)	8.896
Pressure	pounds per square inch (lb/in ²)	kilopascals (kPa)	6.895
	pounds per square foot (lb/ft ²)	kilopascals (kPa)	0.048
	tons per square foot (t/ft ²)	megapascals (mPa)	0.096
	standard atmosphere (14.7 psi)(760 mmHg)	kilopascals (kPa)	101.325
Power	joules per second	watts (W)	1.000
	horsepower	watts (W)	746.000
	foot pound per second	watts (W)	1.356
Temperature	degrees Fahrenheit (°F)	degrees Celsius (°C)	(°F-32) x 0.555
	Illumination foot candle	Lux (lx)	10.764

Pipe Bending Charts

CONDUIT BENDING 90° segment bend

1. Determine radius: to centre of pipe
2. Mark riser height measured to centre of pipe (subtract 1/2 O.D. if measured to back; to top add 1/2 O.D.)
3. Figure Developed Length: 1.57 x radius.
4. Figure gain of pipe: 2 x radius – D.L. or .43 x radius.
5. Lay out centre of bend: subtract 1/2 gain from riser mark (measured to centre of pipe)
6. Figure spacing for 15 shots 6° each: Divide D.L. by number of shots.
7. Lay out 7 shot marks each side of centre mark (total shot distance equals D.L. minus one space).
8. Measure riser and leg: cut off full gain (to back – O.D.; to top + O.D.)
9. Move front support in one hole after 1st shot to eliminate marks on pipe.

Offset Height x Multiplier = Distance,

Degree of Bend	Multiplier	Approx. Shrink	Fraction of 90° Take up	Decimal Equivalent
10°	6	1/16 in.	1/9	1/16 = .0625
15°	3.9	1/8 in.	1/6	1/8 = .125
22 1/2°	2.6	3/16 in.	1/4	3/16 = .187
30°	2	1/4 in.	1/3	1/4 = .250
45°	1.4	3/8 in.	1/2	5/16 = .312
60°	1.2	1/2 in.	2/3	3/8 = .375
Example: Offset 6" bend 30°				7/16 = .437
Between bends				1/2 = .500
Distance between marks: 6" x 2" = 12" centre				9/16 = .562
Pipe shortens: 6" x 1/4 = 1-1/2" approx.				5/8 = .625

Rise for 90° Bends

Conduit Size	Bender Shoe Size				
1/2"	1/2"	3/4"	1"	1 1/4"	1 1/2"
1/2"	4 15/16"	7 11/16"	9 7/8"	12"	13 13/16"
3/4"		7 1/4"	9 1/2"	11 7/8"	13 15/16"
1"			9"	11 9/16"	13 3/4"
1 1/4"				11"	13 1/8"
1 1/2"					12 3/4"

Gain for 90° Bends

Conduit Size	Bender Shoe Size				
1/2"	1/2"	3/4"	1"	1 1/4"	1 1/2"
1/2"	2 3/16"	3"	3 9/16"	4 1/4"	5 5/8"
3/4"		3 1/4"	3 3/4"	4 3/8"	4 13/16"
1"			4 1/8"	4 11/16"	5 5/16"
1 1/4"				5 3/8"	5 7/16"
1 1/2"					6 1/4"

Box Offsets

Bend	Center to Center Distance				
	1/4"	3/8"	1/2"	5/8"	3/4"
5°	2 7/8"	4 5/16"	5 3/4"	7 3/16"	8 5/8"
10°	1 7/16"	2 3/16"	2 7/8"	3 9/16"	4 5/16"

Offset Travel

Bend	Travel in Inches				
	1/2"	3/4"	1"	1 1/4"	1 1/2"
5°	1/4"+	7/16"-	9/16"	3/4"	1"
10°	1/2"-	1 1/16"	1 3/16"	1 3/8"	1 11/16"
15°	1 1/16"	1 1/4"	1 9/16"	2 3/16"	2 5/8"
20°	1 5/16"	1 5/8"	2 1/8"	2 13/16"	3 7/16"
22.5°	1 1/16"	1 7/8"	2 3/8"	3 3/16"	3 11/16"
30°	1 7/16"	2 7/16"+	3 1/16"	4 1/8"	4 3/4"
40°	1 7/8"	3 3/16"	4 1/8"	5 3/8"	5 1/2"
45°	2 1/8"	3 5/8"	4 3/8"	6"	6 1/4"
60°	2 3/16"+	4 7/8"	6 1/4"	8 1/8"	9 3/8"
90°	4 3/16"	7 7/16"	9 3/8"	12 1/16"	13 13/16"

Multiply height of offset by cosecant for angle of bend.
Set bender. Mark travel distance from back of Bender's Guide.
Repeat procedure for second bend.

Kick Adjustments

Bend	Adjustment in inches				
	1/2"	3/4"	1"	1 1/4"	1 1/2"
20°	1 19/32"	2 13/32"	2 11/16"	2 13/16"	3 3/8"
22.5°	1 5/8"	2 1/2"	2 19/32"	3"	3 5/8"
30°	1 27/32"	2 11/32"	3 19/32"	3 9/16"	4 5/32"
45°	2 7/32"	3 19/32"	4 5/16"	4 5/8"	5 17/32"
60°	2 23/32"+	4 3/8"	5 13/32"	5 25/32"	7"

COSECANTS FOR OFFSET BENDING

Degree	Cosecant	Degree	Cosecant	Degree	Cosecant	Degree	Cosecant
1	57.2987	24	2.45859	47	1.36733	69	1.07114
2	28.6537	25	2.36620	48	1.34563	70	1.06418
3	19.1073	26	2.28117	49	1.32501	71	1.05762
4	14.3356	27	2.20269	50	1.30541	72	1.05146
5	11.4737	28	2.13005	51	1.28676	73	1.04569
6	9.56677	29	2.06267	52	1.26902	74	1.04030
7	8.20551	30	2.00000	53	1.25214	75	1.03528
8	7.18530	31	1.94160	54	1.23607	76	1.03061
9	6.39245	32	1.88708	55	1.22077	77	1.02630
10	5.75877	33	1.83608	56	1.20622	78	1.02234
11	5.24084	34	1.78829	57	1.19236	79	1.01872
12	4.80973	35	1.74345	58	1.17918	80	1.01543
13	4.44541	36	1.70130	59	1.16663	81	1.01247
14	4.13357	37	1.66164	60	1.15470	82	1.00983
15	3.86370	38	1.62427	61	1.14335	83	1.00751
16	3.62796	39	1.58902	62	1.13257	84	1.00551
17	3.42030	40	1.55572	63	1.12233	85	1.00382
18	3.23607	41	1.52425	64	1.11260	86	1.00244
19	3.07155	42	1.49448	65	1.10338	87	1.00137
20	2.92380	43	1.46628	66	1.09464	88	1.00061
21	2.79043	44	1.43956	67	1.08636	89	1.00015
22	2.66947	45	1.41421	68	1.07853	90	1.00000
23	2.55930	46	1.39016				

At a given degree of angle the offset desired times Cosecant equals distance between bends.

Copper Wire Gauges and Dimensions

AMERICAN STANDARD WIRE GAUGES

Dimensions of Commercial Copper Wire

B & S Gauge No.	Diameter of Bare Wire	
	mm	inches
0000 (4/0)	11.68	0.460
000 (3/0)	10.40	0.410
00 (2/0)	9.27	0.365
0	8.25	0.325
1	7.35	0.289
2	6.54	0.258
3	5.83	0.229
4	5.19	0.204
5	4.62	0.182
6	4.11	0.162
7	3.66	0.144
8	3.26	0.128
9	2.91	0.114
10	2.59	0.102
11	2.30	0.091
12	2.05	0.081
13	1.83	0.072
14	1.63	0.064
15	1.45	0.057
16	1.29	0.051
17	1.15	0.045
18	1.02	0.040

NOTES
