

With **MotorSolve**  
& **MATLAB®**

# ELECTRICAL MACHINE DESIGN

 **Pearson**

**V. RAJINI**  
**V. S. NAGARAJAN**

## About Pearson

*Pearson is the world's learning company, with presence across 70 countries worldwide. Our unique insights and world-class expertise comes from a long history of working closely with renowned teachers, authors and thought leaders, as a result of which, we have emerged as the preferred choice for millions of teachers and learners across the world.*

*We believe learning opens up opportunities, creates fulfilling careers and hence better lives. We hence collaborate with the best of minds to deliver you class-leading products, spread across the Higher Education and K12 spectrum.*

*Superior learning experience and improved outcomes are at the heart of everything we do. This product is the result of one such effort.*

*Your feedback plays a ...*

# ELECTRICAL MACHINE DESIGN

# ELECTRICAL MACHINE DESIGN

**V. Rajini**

**V. S. Nagarajan** *Department of Electrical and Electronics Engineering*  
*SSN College of Engineering, Chennai*



*Dedicated to Our Parents*

—V. Rajini and V. S. Nagarajans

# Contents

Foreword

Preface

About the Authors

## **1. Basic Design Considerations of Electrical Machines**

1.1 Principles of Design

1.2 Factors for Consideration

1.3 Classification of Design Problem

1.3.1 Need for Computer-aided Design

1.4 Specifications and Standards

1.5 Constraints of Design

1.6 Dimensions and Rating of Machines

1.7 Output Equation

1.7.1 DC Machine

1.7.2 AC Machine

1.8 Materials for Electrical Machines

1.8.1 Conducting Materials

1.8.2 Resistive Materials

1.8.3 Magnetic Materials

1.8.4 Insulation Materials

1.9 Heat Dissipation Modes

1.10 Types of Cooling (Ventilation)

1.10.1 Cooling of Turbo Alternators

1.11 Types of Enclosure

1.12 Quantity of Coolant

1.13 Types of Duties and Ratings

1.14 Determination of Temperature Rise and Fall

## Foreword

It gives me great pleasure to write the foreword to the book entitled, “Electrical Machine Design”.

Electrical machines play a vital role in domestic and industrial fronts. Hence, it is essential that students of electrical engineering have a strong grounding in electrical machines. Conventional courses in electrical machines are not adequate for the purpose of understanding as they throw light on the construction, principle, characteristics and testing. A deeper understanding is possible only when they study the design aspects and their influence on the performance of the machines. It is thus necessary to have a course on electrical machine design, suitable for study by undergraduate students of electrical engineering.

This book is designed to meet the needs of a textbook for a course in electrical machine design. It gives a comprehensive design aspects of DC and AC machines with an appropriate introduction to basic design considerations and the magnetic circuits involved. Introduction to the design and analysis of the machines using the finite element analysis is also included as one chapter, to enable the readers to have a much deeper understanding. A design process always involves a long iterative process and a designer is required to take decisions in conflicting situations. The design procedure

of all the machines is given as simple flowcharts for the reader to understand the iterative nature of design process. In addition to the worked examples, most chapters include number of problems designed to test the grasp of the subject. The readers will also appreciate the pedagogical practices followed in this book.

This book is the outcome of the long experience of the authors in teaching electrical machines and allied courses. The authors have made a commendable effort to present the contents in a clear and lucid form.

I hope this book will be well received by students, teachers and practicing engineers.

**Dr V. Kamaraj**  
*Professor and Head*  
*Department of Electrical and Electronics Engineering*  
*SSN College of Engineering*  
*Chennai*

## Preface

Electric machines have become a part and parcel of our day-to-day lives. They play an inevitable role, right from a small toy to an electric power plant. Hence, the knowledge of their operating characteristics and performance is essential to Electrical Engineering graduates. Also, it is important for them to learn the design of these machines considering various technical and economical aspects. Hence, this book is intended to serve as a textbook for those who are interested in learning the design of electrical machines.

The target audience also include academicians, students of B.E./B.Tech. (Electrical and Electronics Engineering, Electronics and Instrumentation Engineering and Instrumentation and Control Engineering) and industrial ...

## About the Authors



**V. Rajini** has been working as a Professor in the Department of Electrical and Electronics Engineering, SSN College of Engineering. She has 22 years of teaching and research experience. She was graduated from Annamalai University in 1992 and subsequently obtained her Ph.D. in High Voltage Engineering from Anna University in 2008. She has published over 90 research publications in referred journals. She has completed various projects funded by SSN Trust and AICTE and MNRE. She is currently working on the fields of Insulating Materials, High Voltage Applications in Process Technologies, Hybrid Electric Vehicles, Power Electronics for HV Applications, Solar Photovoltaic and Wind Energy Systems.

She has received Best paper awards in various conferences, has also received the Best teacher awards. Ms Rajini is the recipient of **CTS – SSN Best Faculty Award – 2011** and **distinguished scientist award – 2016** by VIRA foundation for her contributions in the field of high voltage engineering. She is a senior member of IEEE and Life member of ISTE.



**V. S. Nagarajan** has been working as an Assistant Professor in the Department of Electrical and Electronics Engineering since June 2014. He did his B.E. (EEE) in SSN College of Engineering and was ranked 2nd in the college and 21st in the Anna University. After his graduation, he joined CTS as Programmer Analyst and worked there for about a year. Later, he did his Masters in Power Electronics and Drives in SSN College of Engineering scoring a CGPA of 9.34 out of 10 and was ranked 2nd in the college and 4th in the Anna University. He is currently pursuing Ph.D. in the field of Electrical Machine Design and Control under Anna University. He was the recipient of merit scholarship both for B.E. and M.E. and also the merit scholarship by Ministry of

Human Resources and Development, Govt. of India (For GATE score). He has been awarded with four silver medals and one gold medal for being the topper of the department in various semester examinations. He has also been awarded with “The Chairman’s Silver Medal” and “College Silver Medal” for securing Anna University ranks in B.E. and M.E., respectively. He has published six papers in National/International Journals and Conferences.

# BASIC DESIGN CONSIDERATIONS OF ELECTRICAL MACHINES

## 1.1 Principles of Design

An electric machine is an electromechanical device that comprises the stationary and moving parts combined together to generate, transform or utilize the mechanical/electrical energy. Electric machines are used in applications like transportation, aerospace, defence and industrial automation industries. Electric motor-driven systems that drive pumps, fan, blower systems and air compression have become common in industries. Good engineering design is the heart of all such applications. Engineering design is the application of science, technology and invention to produce machines to perform specified tasks with optimum economy and efficiency.

All the machines are made ...

## DESIGN OF MAGNETIC CIRCUITS

### 2.1 Introduction

All electrical machines use magnetic materials for directing and shaping the magnetic field, which acts as a medium for energy conversion. While most of the rotating machines use ferromagnetic materials along with air, the transformer uses ferromagnetic materials only as the medium. The magnetic circuit acts as a medium for conversion of electrical to electrical energy in case of transformers, electrical to mechanical energy in case of motors and mechanical to electrical energy in case of generators. Hence, analysis of magnetic circuits is essential for understanding the machines.

Magnetic circuit is defined by the path travelled by magnetic flux. Magnetic flux traces a closed path, returning back to its initial point, analogous to electric current in an electric circuit. Magnetic flux is established and maintained by a Magneto Motive Force (MMF), in any magnetic material.

The significant terms used in the magnetic circuit design are defined as follows.

**Magneto motive force (MMF):** It is the force behind the production of magnetic flux in the magnetic circuit. It is represented by Ampere turn ( $AT$ ).

**Magnetic flux:** It is the magnetic lines of force established by MMF. It is represented by  $\phi$ . The unit is Wb.

**Magnetic field intensity:** At any point, it is specified by both direction and magnitude or magnetic field strength. It is measured in amperes per metre ( $A/m$ ). The magnetic field intensity around a closed contour as defined by ampere's law is equal to total current passing through any surface linking that contour and is given by  $\oint Hdl = \Sigma I$ .

**Magnetic flux density (B):** It is defined as the force acting per unit current per unit length on a wire placed at right angles to the magnetic field. Like H, B is also a vector quantity and is measured in Tesla (T). Magnetic flux density is related to magnetic field intensity by the relation  $B = \mu H$ , where  $\mu$  is the permeability of the magnetic material.

**Reluctance:** It is the property of a magnetic circuit that opposes the flow of magnetic flux. It is the ratio of MMF to magnetic flux. It is represented by  $S$ . The unit is  $AT/Wb$ .

**Permanence:** It is the property of a magnetic circuit, which allows the flow of magnetic flux. It is the ratio of magnetic flux to MMF. It is also given by the reciprocal of reluctance. It is represented by  $\Lambda$ . The unit is  $Wb/AT$ .

The magnetic flux, MMF, reluctance and permeance are related by the following relations:

$$\begin{aligned} AT &= \phi S \\ \phi &= \Lambda AT \end{aligned}$$

Further, magnetic circuits can be categorized into two types, namely simple and composite magnetic circuits, based on the number of magnetic materials used. A simple magnetic circuit consists of single magnetic material. A composite magnetic circuit consists of - minimum of two different materials (either magnetic or non-magnetic) of different magnetic properties. The magnetic circuit equivalent of transformer, induction motor, synchronous motor and dc motor are dealt in detail in the forthcoming chapters. The following section analyses the composite magnetic circuits with series and parallel connections.

It should also be noted that the analysis based on magnetic circuit theory is the most widely used. The analysis can also be done based on magneto-static finite element analysis. The magnetic model based on finite element analysis is generally more accurate than the model based on magnetic circuit theory, though at the expense of complexity of programming.

### *2.1.1 Analysis of Series Composite Magnetic Circuit*

Considering a series composite magnetic circuit as shown in [Fig. 2.1](#), it is assumed that there are three different magnetic materials of different relative

permeabilities present in the magnetic circuit along with an air gap.

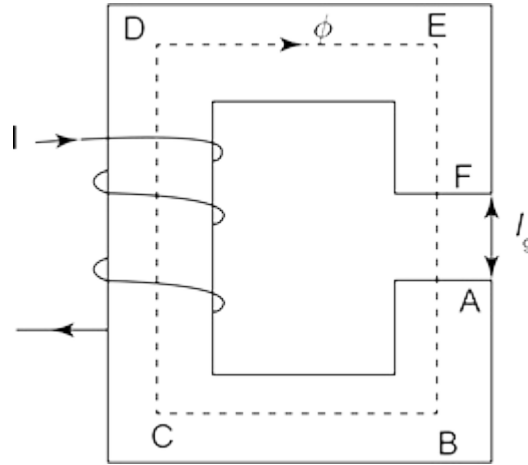

**Fig. 2.1** | Series composite magnetic circuit

For the series composite magnetic circuit in **Fig. 2.1**, **Table 2.1** gives the required parameters to establish a relation with the MMF, reluctance and magnetic flux.

**Table. 2.1** | Parameters of series composite magnetic circuit

Part of circuit	Flux	Length	Cross-sectional area	Magnetizing force	Reluctance
ABC	$\phi$	$l_1$	$a_1 = a$	$H_1$	$S_1$
CD	$\phi$	$l_2$	$a_2 = a$	$H_2$	$S_2$
DEF	$\phi$	$l_3$	$a_3 = a$	$H_3$	$S_3$
FA	$\phi$	$l_4$	$a_g = a$	$H_g$	$S_g$

From the magnetic circuit represented in **Fig. 2.1**, it is observed that the flux is constant; therefore, the total

reluctance is equal to the sum of individual reluctances of different parts.

Hence, total reluctance,  $S = S_1 + S_2 + S_3 + S_g$ .

We know that, generally

$$\text{Reluctance, } S = \frac{l}{\mu_0 \mu_r a},$$

where  $l$  is the length,  $\mu_0$  is the permeability of free space,  $\mu_r$  is the relative permeability and  $a$  is the cross-sectional area.

Therefore, substituting the length, permeability and cross-sectional area for different parts, we get

$$S = \frac{l_1}{\mu_0 \mu_{r1} a_1} + \frac{l_2}{\mu_0 \mu_{r2} a_2} + \frac{l_3}{\mu_0 \mu_{r3} a_3} + \frac{l_g}{\mu_0 \mu_{rg} a_g}$$

Total MMF in the circuit,

$$\begin{aligned} AT &= \text{Flux} \times \text{reluctance} \\ &= \phi S_1 + \phi S_2 + \phi S_3 + \phi S_g \end{aligned} \quad (2.1)$$

$$\begin{aligned}
&= \left[ \frac{\phi l_1}{\mu_0 \mu_{r1} a_1} + \frac{\phi l_2}{\mu_0 \mu_{r2} a_2} + \frac{\phi l_3}{\mu_0 \mu_{r3} a_3} + \frac{\phi l_g}{\mu_0 \mu_{rg} a_g} \right] \\
&= \frac{B_1}{\mu_0 \mu_{r1}} \times l_1 + \frac{B_2}{\mu_0 \mu_{r2}} \times l_2 + \frac{B_3}{\mu_0 \mu_{r3}} \times l_3 + \frac{B_g}{\mu_0} \times l_g \\
&\qquad\qquad\qquad \left( \because B = \frac{\phi}{a} \text{ and } \mu_{rg} = 1 \text{ for air} \right)
\end{aligned}$$

The MMF can also be represented in terms of magnetizing force and length as follows:

$$\text{Total MMF} = H_1 l_1 + H_2 l_2 + H_3 l_3 + H_g l_g \qquad \left( \because H = \frac{B}{\mu_0 \mu_r} \right)$$

It can be observed from [Eq. \(2.1\)](#) that it is similar to that of emf equation in an equivalent electrical circuit. Therefore, redrawing the series composite magnetic circuit analogous to series electrical circuit with three resistances as shown in [Fig. 2.2](#), we define the electrical analogy to magnetic circuit.

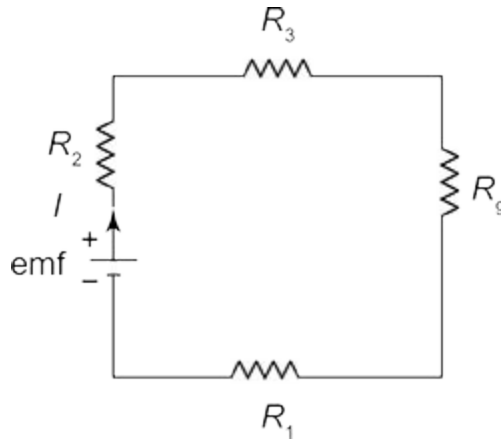

**Fig. 2.2** | Equivalent electrical circuit

From Fig. 2.2, it is observed that the total resistance of the equivalent electric circuit is equal to the individual sum of various resistance values,

$$\text{i.e., } R = R_1 + R_2 + R_3 + R_g$$

Therefore,

$$\begin{aligned} \text{Total emf, } E &= IR_1 + IR_2 + IR_3 + IR_g \\ &= \text{Current} \times \text{Total resistance} \end{aligned}$$

Thus, by analogy with respect to electric circuit,

Total MMF in magnetic circuit =  $AT$  for series paths +  $AT$  for air gap

### *2.1.2 Analysis of Parallel Composite Magnetic Circuits*

Considering a parallel composite magnetic circuit as shown in Fig. 2.3, it is assumed that there are three different magnetic materials of different relative

permeabilities present in the magnetic circuit along with an air gap.

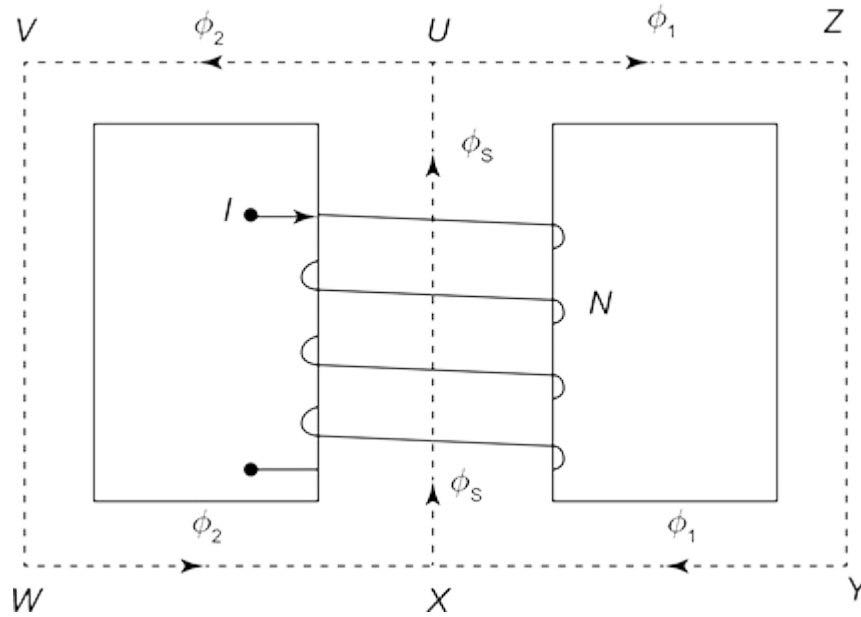

**Fig. 2.3** | Parallel composite magnetic circuit

**Table. 2.2** | Parameters of parallel composite magnetic circuit

Part of circuit	Flux	Length	Cross-sectional area	Magnetizing force	Reluctance
UZYX	$\phi_1$	$l_1$	$a_1$	$H_1$	$S_1$
UVWX	$\phi_2$	$l_2$	$a_2$	$H_2$	$S_2$
UX	$\phi_s$	$l_s$	$a_s$	$H_s$	$S_s$

For the considered parallel composite magnetic circuit in Fig. 2.3, Table 2.2 gives the required parameters to establish relation with the MMF, reluctance and magnetic flux.

In Table 2.2,  $a_1 = a_2 = a_s = a$  [∵ Area of cross-section is the same in all the parts of the magnetic circuit].

We know that the total flux in the circuit is given by

$$\phi_s = \phi_1 + \phi_2 \quad (2.2)$$

$$\text{MMF} = \phi_1 S_1 + \phi_s S_s = \phi_2 S_2 + \phi_s S_s \quad (2.3)$$

Also, as  $B = \mu H$  and  $\phi = Ba$ , we get

$$\phi = \mu H a \quad \text{and} \quad S = \frac{l}{\mu a}$$

The MMF can be represented in terms of magnetizing force and length as

$$\text{MMF} = H_1 l_1 + H_s l_s = H_2 l_2 + H_s l_s$$

From Eqs. (2.2) and (2.3), it can be observed that the equation is similar to that of emf equation in an equivalent electrical circuit. Therefore, redrawing the parallel composite magnetic circuit analogous to parallel electrical circuit with three resistances as shown in Fig. 2.3, we define the electrical analogy to magnetic circuit.

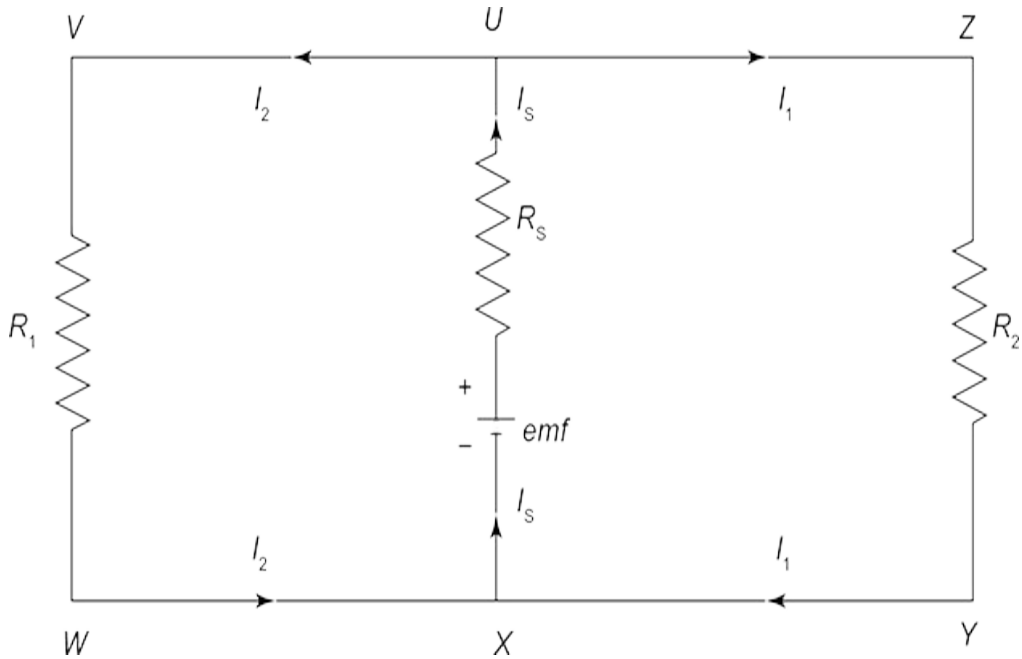

**Fig. 2.4** | Equivalent electrical circuit

**Table. 2.3** | Parameters of equivalent electrical circuit

Part of circuit	Current	Resistance
UZYX	$I_1$	$R_1$
UVWX	$I_2$	$R_2$
UX	$I_s$	$R_s$

The parameters referring to the equivalent electric circuit shown in [Fig. 2.4](#) are tabulated in [Table 2.3](#).

Total current in the circuit is given by  $I_s = I_1 + I_2$

The emf in the circuit is  $= I_1 R_1 + I_s R_s = I_2 R_2 + I_s R_s$

Thus, by analogy with electric circuit,

Total MMF required =  $AT$  for common section ( $UX$ ) +  $AT$  for any one of the parallel paths ( $VW$  or  $ZY$ )

In a parallel magnetic circuit, the total flux exists in a common section of the magnetic circuit, which contains the exciting coil. It divides into two parts, follows the different paths and recombines at the other end of the common section.

From the aforementioned analysis of series and parallel composite magnetic circuits, *Krichoff's laws for magnetic circuits* can be stated as follows:

**First Law:** The total flux towards a node is equal to the total flux away from the node in any magnetic circuit, i.e.,  $\sum \text{magnet flux} = 0$ .

**Second Law:** In any magnetic circuit, the sum of the product of the magnetizing force in each part of the magnetic circuit and the length of that part is equal to the resultant MMF, i.e.,

$$\sum \text{MMF} = \sum (\text{Reluctance} \times \text{magnetic flux}).$$

### 2.1.3 Comparison Between Magnetic Circuit and Electric Circuit

The comparison between magnetic circuit and electric circuit is shown in Table 2.4.

**Table. 2.4** | Comparison of magnetic and electric circuits

<b>S. No.</b>	<b>Magnetic circuit</b>	<b>Electric circuit</b>
1.	The closed path traced by magnetic flux is known as magnetic circuit.	The closed path traced by electric current is known as electric circuit.
2.	The driving force is magneto motive force (MMF)AT.	The driving force is electromotive force (emf)V.
3.	Magnetic flux is opposed by reluctance ( $\mathcal{R}$ )At/Wb ,	Electric current is opposed by resistance ( $R$ ) $\Omega$ .

S. No.	Magnetic circuit	Electric circuit
	$S = \frac{1}{\mu_0 \mu_r a}$ <p>where <math>\frac{1}{\mu_0 \mu_r}</math> is the relativity</p>	$R = \frac{\rho \ell}{a}$ <p>where <math>\rho</math> is the resistivity</p>
4.	Magnetic flux = $\frac{\text{MMF}}{\text{reluctance}}$ Wb	Electric current = $\frac{\text{emf}}{\text{resistance}}$ A
6.	Ohm's law is given by MMF = magnetic flux $\times$ reluctance	Ohm's law is given by emf = electric current $\times$ resistance
7.	Kirchoff's laws are given by $\sum$ magnetic flux = 0 and $\sum$ MMF = $\sum$ (reluctance $\times$ magnetic flux)	Kirchoff's laws are given by $\sum$ electric current = 0 and $\sum$ emf = $\sum$ (resistance $\times$ electric current)
8.	Permanence is given by $P = \frac{1}{R} \text{ Wb/At}$	Conductance is given by $G = \frac{1}{R}$
9.	Magnetic flux is established in a circuit and does not actually flow.	Electric current flows in a circuit, i.e., due to the movement of electrons.
10.	Energy is required to establish the magnetic flux, not to maintain it.	Energy is required to maintain the flow of electric current.

## 2.2 Determination of Reluctance and MMF of Air Gap

The study of magnetic circuits is important in the study of electrical apparatus since their operation can be characterized efficiently using magnetic circuits. So, the reluctance and MMF determination form a crucial aspect in analysis of any electric machine. The determination of

reluctance and MMF of air gap requires prior knowledge of the geometrical dimensions, in order to account for the presence of slotting, ventilating ducts for cooling and effect of saliency. Apart from the above factors, an effect of ‘fringing’, which will be discussed in the following sections, is to be considered.

Let us begin with a smooth armature surface corresponding to dc machine as shown in Fig. 2.5(a) and (b).

For the smooth armature surface shown in Fig. 2.5(b), the reluctance of air gap with respect to one slot pitch is given by

$$S_g = \frac{l_g}{\mu_0 Ly_s} \quad (2.4)$$

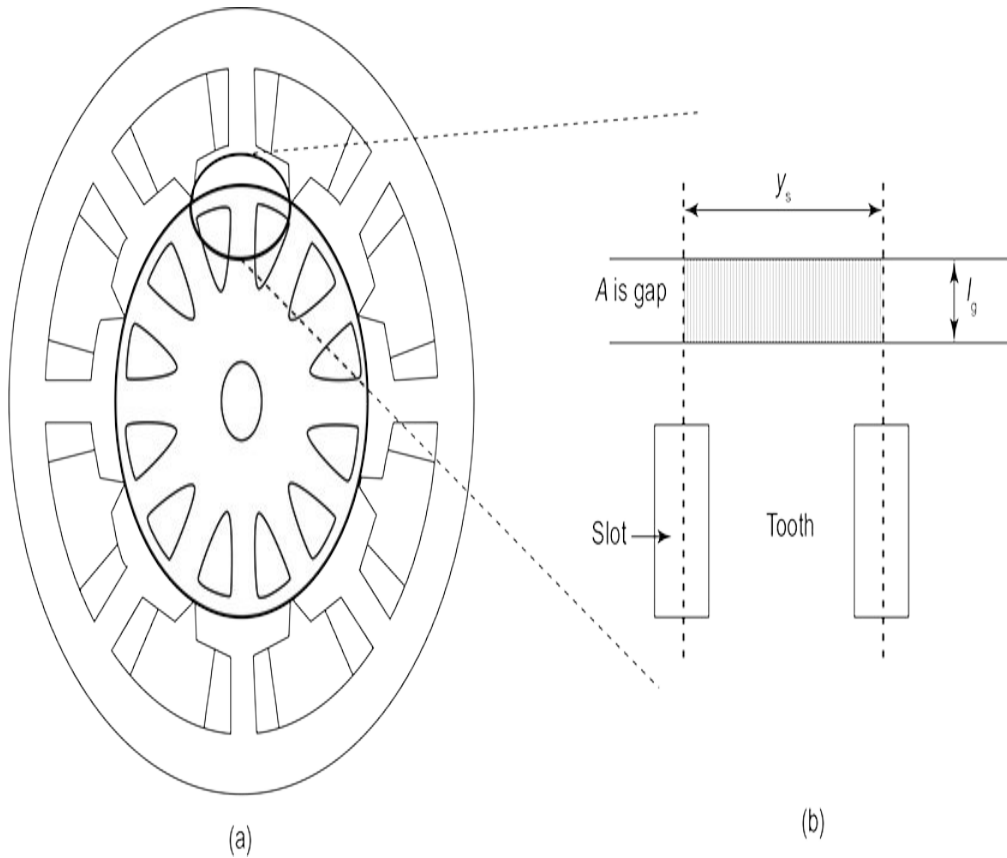

**Fig. 2.5** | (a) Simple dc machine. (b) Zoomed view of smooth armature surface

where  $l_g$  – length of air gap,  $\mu_o$  – permeability of free space,  $L$  – length of core and  $y_s$  – slot points.

A slotted armature surface corresponding to dc machine is shown in Fig. 2.6(a) and (b).

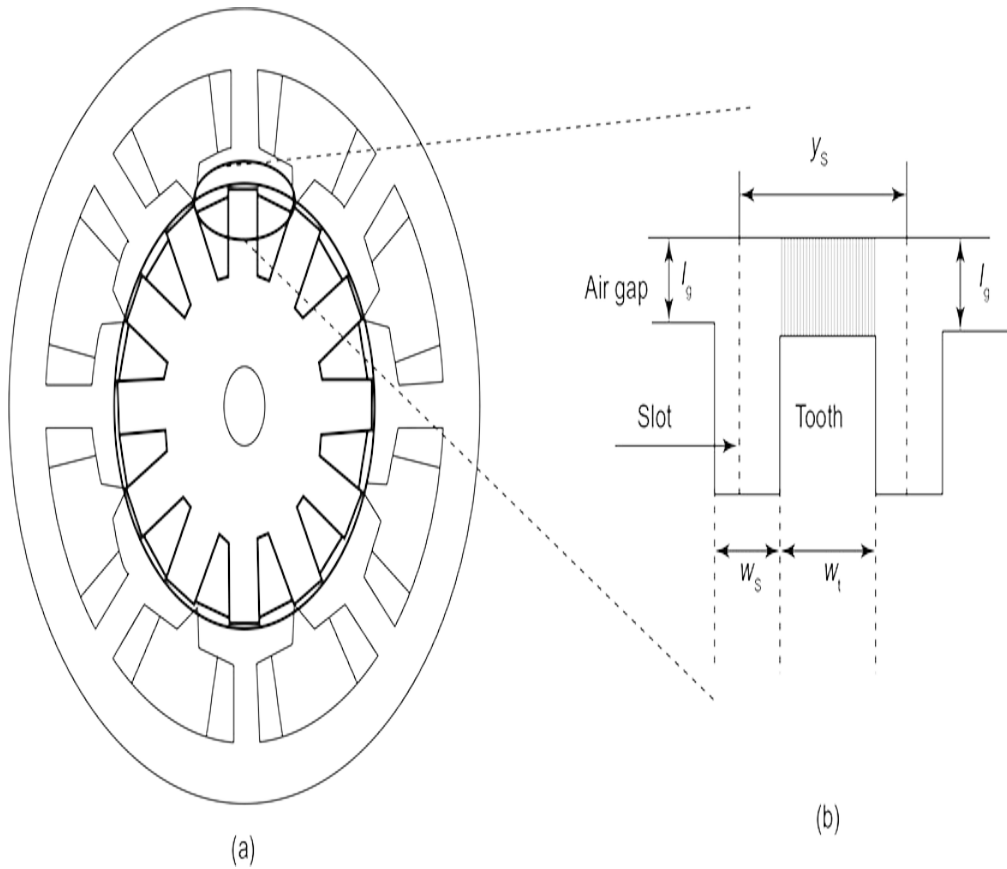

**Fig. 2.6** | (a) Simple dc machine. (b) Zoomed view of slotted armature surface

For the slotted armature shown in Fig. 2.6(b), the reluctance of air gap with an assumption that all the flux from the teeth links the pole surface in parallel without any deviation, is given by

$$S_g = \frac{l_g}{\mu_0 L (y_s - w_s)} = \frac{l_g}{\mu_0 L w_t} \quad (2.5)$$

where  $w_s$  – slot width and  $w_t$  – tooth width.

But practically, the flux from the teeth is under the effect of ‘fringing’ wherein the flux at the both ends of

teeth curves and links the pole surface as shown in Fig. 2.7. Hence, in order to account this fringing effect, Fig. 2.7 is redrawn as Fig. 2.8, with  $y_s$  being the new contracted slot pitch wherein the total flux is assumed to be confined in linking the pole surface from armature in parallel.

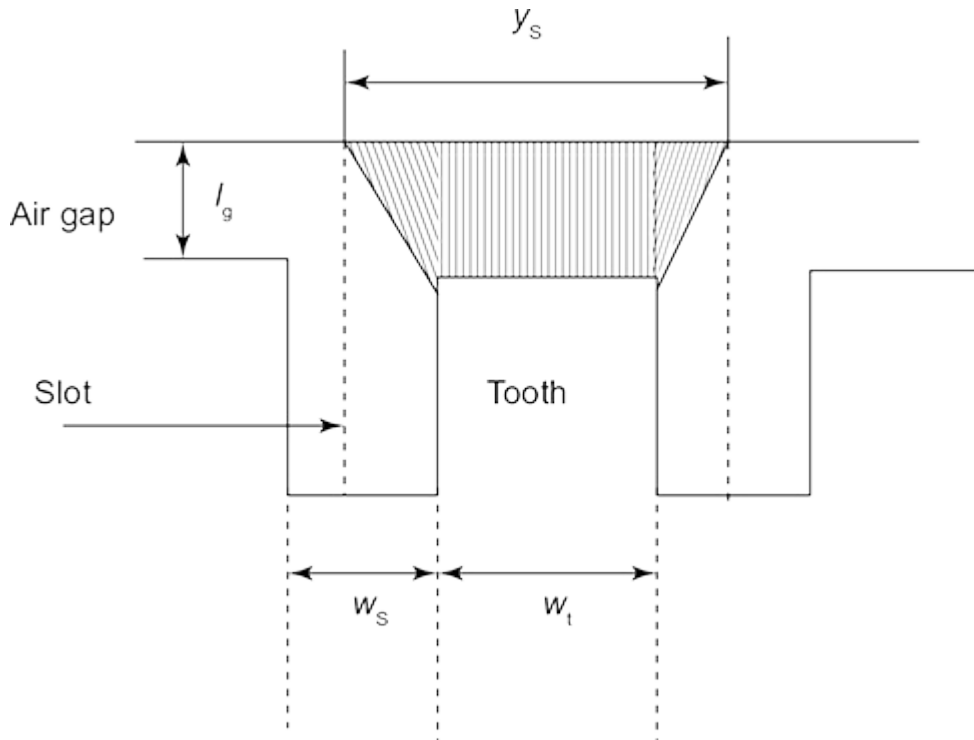

**Fig. 2.7** | Fringing of flux in slotted armature

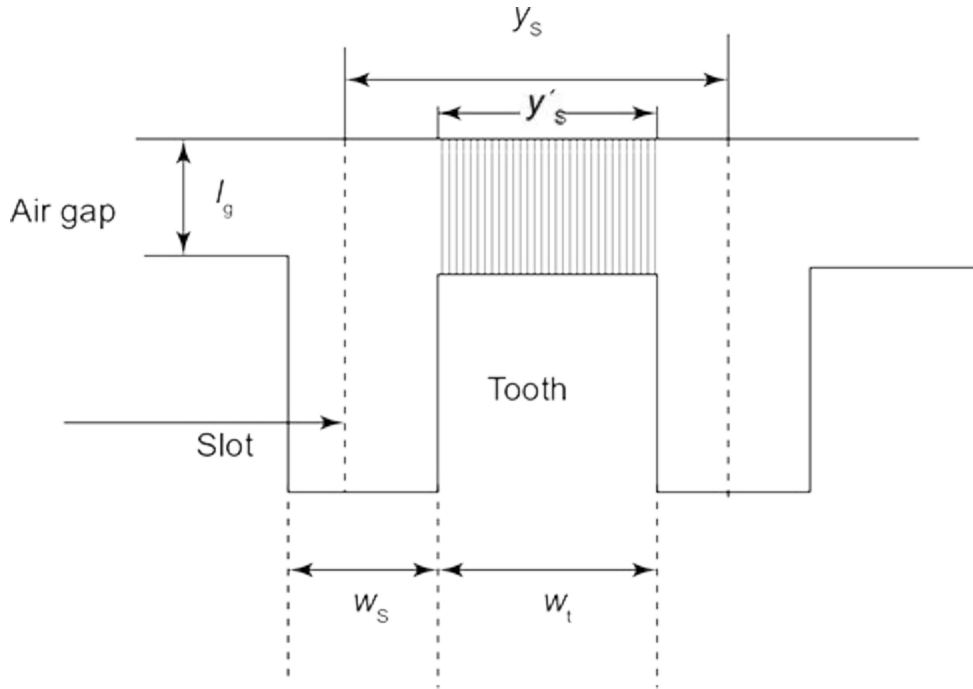

**Fig. 2.8** | Slotted armature with fringing of flux accounted for

Hence, the reluctance of air gap in this case is given by

$$S_g = \frac{l_g}{\mu_0 L y'_s} \quad (2.6)$$

where  $y'_s = w_t + \text{fraction of } w_s = w_t + xw_s \quad (2.7)$

Adding and subtracting ' $w_s$ ' to the RHS of Eq. (2.7), we get

$$y'_s = w_t + xw_s + w_s - w_s$$

On simplifying the above equation, we get

$$y'_s = w_t + w_s + xw_s - w_s$$

$$= y_s + (x - 1)w_s \quad [∵ w_t + w_s = y_s]$$

$$y'_s = y_s - (1 - x)w_s = y_s - K_{cs} w_s \quad (2.8)$$

where  $K_{cs}$  is the Carter's gap coefficient. It is determined by an empirical formula,

$$K_{cs} = \frac{1}{1 + \frac{5l_g}{w_s}}$$

Carter's coefficient for parallel-sided open slots is given by

$$K_{cs} = \frac{2}{\pi} \left[ \tan^{-1} y - \frac{1}{y} \log \sqrt{1 + y^2} \right]$$

where  $y = \frac{w_s}{2l_g}$ .

Carter's coefficient for open and semi-closed slots with respect to slot opening/gap length ratio is represented in Fig. 2.9.

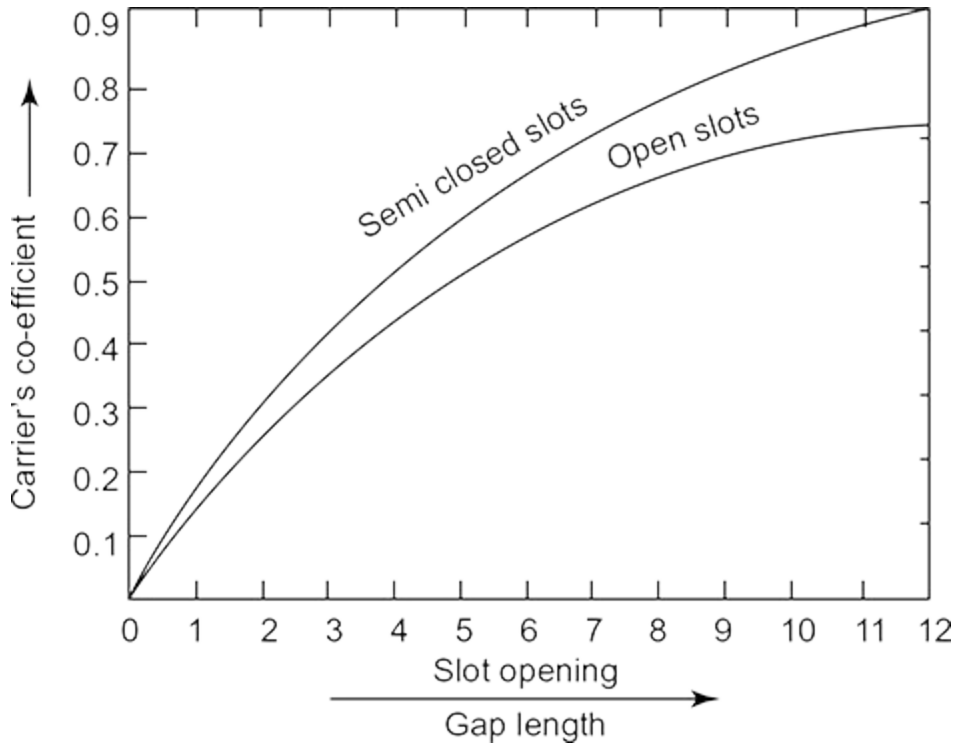

**Fig. 2.9** | Carter's coefficient for open and semi-closed slots

Substituting Eq. (2.8) in Eq. (2.6), we get

$$S_g = \frac{l_g}{\mu_0 L (y_s - K_{cs} w_s)} \quad (2.9)$$

Equation (2.9) gives the reluctance of air gap of slotted armature with the effect of fringing accounted for.

We proceed to define a term 'Gap contraction factor', ' $K_{gs}$ ', which is the ratio of reluctance of air gap of slotted armature to reluctance of air gap of smooth armature. The gap contraction factor is given by

$$K_{gs} = \frac{S_g (\text{slotted armature})}{S_g (\text{smooth armature})} \quad (2.10)$$

$$K_{gs} = \frac{\frac{l_g}{\mu_0 L (y_s - K_{cs} w_s)}}{\frac{l_g}{\mu_0 L y_s}} = \frac{y_s}{y_s - K_{cs} w_s} \quad (2.11)$$

From Eq. (2.10), it is observed that the reluctance of air gap of slotted armature is  $K_{gs}$  times the reluctance of air gap of smooth armature. From Eq. (2.11), it is observed that  $K_{gs}$  is always greater than 1.

Proceeding further, the effect of ventilating ducts on reluctance of air gap is analyzed. From Chapter 1, the necessity of ventilating ducts is observed.

The ventilating ducts in radial direction causes flux contraction in axial direction. Similar to that of fringing effect shown in Fig. 2.10, there is a reduction in effective axial length of machine and leads to increase in reluctance of air gap.

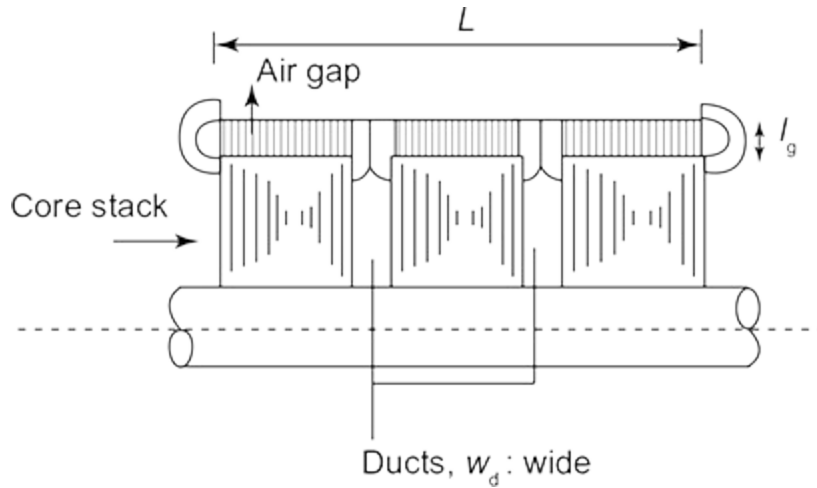

**Fig. 2.10** | Ventilating ducts in a machine

Contracted on net axial length,

$$L' = 3w_t + n_d x w_d \text{ Or } 3w_t$$

Adding and subtracting  $n_d w_d$  on the RHS of the above equation, we get

$$L' = 3w_t + n_d x w_d + n_d w_d - n_d w_d$$

$$= 3w_t + n_d w_d + n_d x w_d - n_d w_d$$

$$= L + (x-1)n_d w_d \quad [ \because 3w_t + n_d w_d = L ]$$

$$\begin{aligned}
&= L - (1-x)n_d w_d \\
&= L - K_{cd} n_d w_d \qquad (2.12)
\end{aligned}$$

where  $K_{cd}$  is the Carter's coefficient for ventilating ducts,  $w_d$  is the width of ducts and  $n_d$  is the number of ducts.

To calculate the effect of ventilating ducts on the air gap MMF, we define a term 'Gap contraction factor for ventilating ducts', ' $K_{gd}$ ', which is the ratio of reluctance of air gap of smooth armature with ducts to reluctance of air gap of smooth armature without ducts.

$$\begin{aligned}
K_{gd} &= \frac{\frac{l_g}{\mu_0 L y_s}}{\frac{l_g}{\mu_0 (L - K_{cd} n_d w_d) y_s}} \\
&= \frac{L}{L - K_{cd} n_d w_d} \qquad (2.13)
\end{aligned}$$

Reluctance of air gap with ventilating ducts and slotted armature is given by

$$\begin{aligned}
S_g &= \frac{l_g}{\mu_0 L' y'_s} \\
&= \frac{l_g}{\mu_0 (L - K_{cd} n_d w_d) (y_s - K_{cs} w_s)}
\end{aligned}$$

Reluctance of air gap with ventilating ducts and smooth armature is given by

$$S_g = \frac{l_g}{\mu_0 L' y_s}$$

$$= \frac{l_g}{\mu_0 (L - K_{cd} n_d \tau w_d) y_s}$$

We define another term ‘Total gap contraction factor for slots and ducts’, ‘ $K_g$ ’, which is the ratio of reluctance of air gap of slotted armature with ducts to reluctance of air gap of smooth armature without ducts.

$$K_g = \frac{\frac{l_g}{\mu_0 (L - K_{cd} n_d \tau w_d) (y_s - K_{cs} \tau w_s)}}{\frac{l_g}{\mu_0 L y_s}}$$

$$= \frac{L y_s}{(L - K_{cd} n_d \tau w_d) (y_s - K_{cs} \tau w_s)}$$

$$= \frac{L}{L'} \times \frac{y_s}{y'_s} = K_{gs} \times K_{gd} \quad (2.14)$$

### 2.2.1 Contraction of Air Gap Area Per Pole (Effective Air Gap Area)

We know that the magnetic field intensity  $H$  and the magnetic flux density  $B$  are related by permeability  $\mu$  of the material:

$$B = \mu H$$

For air,  $\mu = 4\pi \times 10^{-7}$ , the air gap MMF per metre,

$$H = \frac{B}{\mu} = 795774.71B$$

Hence, the MMF per metre for air gap can be approximated as  $800,000 B$  (2.15)

For smooth armature, with air gap length,  $l_g$ ,

$$\text{MMF, } (AT_g)_{\text{smooth}} = 800,000 B l_g \quad (2.16)$$

[∵ MMF = MMF/m × air gap length]

Similarly, for slotted armature, with air gap length,  $l_g$ ,

$$\text{MMF, } (AT_g)_{\text{slotted}} = 800,000 K_g B l_g \quad (2.17)$$

where  $K_g$  is the total gap contraction factor.

Substituting  $B = \frac{\phi}{A_g}$  in Eq. (2.17), we get

$$(AT_g)_{\text{slotted}} = 800,000 K_g \frac{\phi}{A_g} l_g \quad (2.18)$$

Rewriting Eq. (2.18), we get

$$\begin{aligned}
 (AT_g)_{\text{slotted}} &= 800,000 \frac{\phi}{K_g} l_g \\
 &= 800,000 \frac{\phi}{A'_g} l_g \quad \left[ \because A'_g = \frac{A_g}{K_g} \right] \quad (2.19)
 \end{aligned}$$

From Eq. (2.19), it can be observed that air gap has decreased (or contracted) to a value  $A'_g$ .

Proceeding to determine the contracted air gap area per pole, we get

$$A'_g = \frac{A_g}{K_g}$$

Expressing  $A_g$  in terms of slot pitch, the number of slots per pole and length of core and  $K_g$  from Eq. (2.14), we get

$$A'_g = \frac{\frac{S}{P} \times y_s \times L}{\frac{L y_s}{L' y'_s}} = \frac{S}{P} y'_s L' \quad (2.20)$$

Equation (2.20) describes the effective air gap area per pole.

From Eqs. (2.16) and (2.17), it can be stated that the effective air gap length has increased by the multiplication of total gap contraction factor, ' $K_g$ ' with  $l_g$  in Eq. (2.17), compared to Eq. (2.16).

Another perspective can be drawn in terms of change in air gap length, i.e., instead of stating that the air gap

for slotted armature area has decreased by  $\frac{1}{K_g}$  times air

gap area for smooth armature, the air gap length of slotted armature has increased  $K_g$  times the air gap length of smooth armature. In the above case,  $K_g$  can be termed as 'air gap expansion factor'.

### *2.2.2 Effect of Pole Saliency*

The air gap length is not a fixed value over the pole pitch for a salient pole machine. Therefore, to determine the reluctance of air gap, the magnetic flux distribution is required to be known.

The typical magnetic flux distribution of a salient pole machine is represented in Fig. 2.11(a) and (b). The flux distribution is approximated as a rectangle and is shown in Fig. 2.11(c).

Therefore, for the flux distribution considered in Fig. 2.11 (c),

$$\text{MMF of air gap, } AT_g = \text{flux} \times \text{reluctance}$$

where flux = flux density  $\times$  area =  $B_g \times$  area

$$\begin{aligned} \text{Reluctance} &= \frac{\text{Effective air gap length}}{\mu_0 \times \text{area}} \\ &= \frac{K_g l_g}{4\pi \times 10^{-7} \times \text{area}} \\ \Rightarrow AT_g &= B_g \times \text{area} \times \frac{K_g l_g}{4\pi \times 10^{-7} \times \text{area}} \\ &= 800,000 B_g K_g l_g \end{aligned}$$

In order to provide a measure for the average and maximum flux in salient pole machines, a term 'Field form factor' is defined and given by the ratio of average flux density over pole pitch to maximum flux density in air gap.

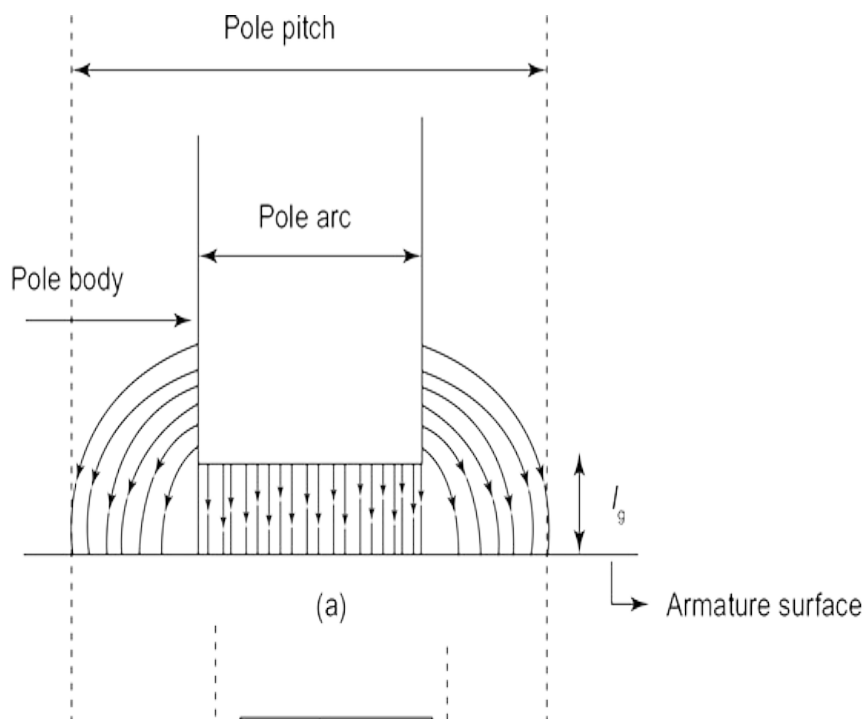

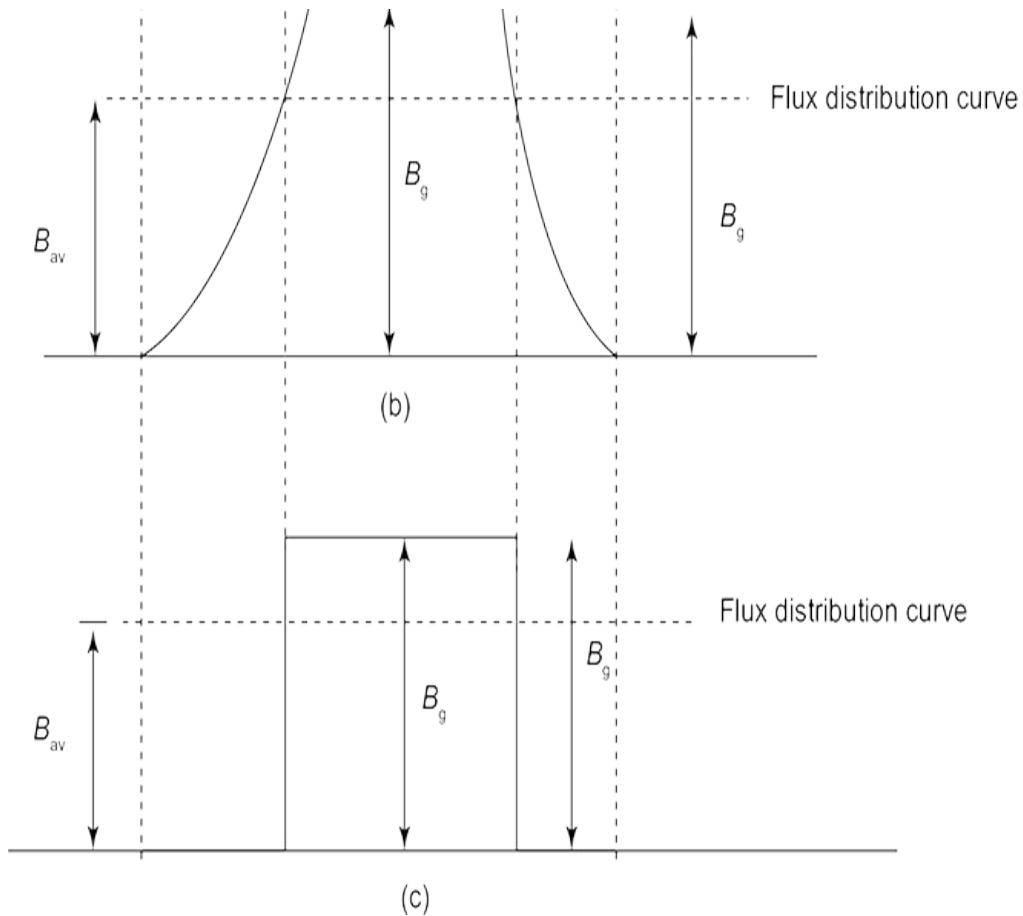

**Fig. 2.11** | (a) and (b) Magnetic flux distribution of a salient pole machine. (c) Flux distribution approximation

$$K_f = \frac{B_{av}}{B_g}$$

The above expression can be approximated as

$$K_f \simeq \frac{\text{pole arc}}{\text{pole pitch}} = \phi,$$

if the effect of fringing is neglected.

**Example 2.1: Determine the effective length of air gap of a machine having a stator with smooth surface and rotor with open slots devoid of radial ducts, with tooth width,  $w_t = 15$  mm, slot width,  $w_s = 13$  mm, air gap length,**

$$l_g = 3 \text{ mm and Carter's coefficient} = \frac{1}{1 + \frac{5l_g}{w_s}}.$$

**Solution:** Given

Tooth width,  $w_t = 15$  mm

Slot width,  $w_s = 13$  mm

Air gap length,  $l_g = 3$  mm

$$\text{Carter's coefficient, } K_{cs} = \frac{1}{1 + \frac{5l_g}{w_s}} \quad (1)$$

Substituting  $w_s$  and  $l_g$  in the above equation, we get

$$K_{cs} = \frac{1}{1 + \frac{5 \times 3}{13}} = 0.4642$$

To determine effective air gap length, it is required to find gap contraction factor for slots, which is given by

$$\text{Gap contraction factor, } K_{gs} = \frac{y_s}{y_s - K_{cs}w_s} \quad (2)$$

In the above equation, slot pitch,  $y_s$  is given by

$$\begin{aligned} y_s &= w_s + w_t \\ &= 13 + 15 = 28 \text{ mm} \end{aligned}$$

Substituting  $y_s$ ,  $k_{cs}$  and  $w_s$  in Eq. (2),

$$\begin{aligned} K_{gs} &= \frac{28}{28 - (0.4642 \times 13)} \\ &= 1.2747 \end{aligned}$$

As the radial ducts are not present, gap contraction factor for ducts,  $K_{gd} = 1$

The total gap contraction factor ( $K_g$ ) is given by

$$K_g = K_{gs} \times K_{gd} = 1.2747 \times 1$$

$$= 1.2747$$

Effective air gap length,  $l_{gs} = K_g l_g$

Substituting  $K_g$  and  $l_g$  in the above equation,

$$l_{gs} = 1.2747 \times 3 = 3.8241 \text{ mm}$$

**Example 2.2: Determine the MMF of air gap for an induction machine with the length of air gap = 4 mm, slot pitch = 63 mm, slot opening = 4.5 mm, pole arc = 180 mm, flux per pole =  $45 \times 10^{-3}$  Wb, length of core = 300 mm, number of ducts = 4, width of ducts = 8 mm and Carter's coefficient being 0.2 for slot opening/air gap length = 1.125 and 0.24 for slot opening/air gap length = 2.**

**Solution:** Given

length of air gap,  $l_g = 4$  mm,

slot pitch,  $y_s = 63$  mm,

slot opening,  $w_o = 4.5$  mm,

pole arc = 180 mm,

flux/pole = 45 mWb,

length of core,  $L = 300$  mm,

number of ducts,  $n_d = 4$ ,

duct width,  $w_d = 8$  mm

Carter's coefficient =  $\begin{cases} 0.2, & \text{for slot opening/air gap length} = 1.125 \\ 0.24, & \text{for slot opening/air gap length} = 2 \end{cases}$

In order to determine the MMF of air gap, it is required to find total gap contraction factor,  $K_g$ , length of air gap and flux density.

We know that

Gap contraction factor for slots,

$$K_{gs} = \frac{y_s}{y_s - K_{cs}w_o} \quad (1)$$

And,

$$\begin{aligned} \frac{\text{slot opening}}{\text{air gap length}} &= \frac{4.5}{4} \\ &= 1.125 \end{aligned}$$

Hence,

Carter's coefficient,  $K_{cs} = 0.2$

Substituting  $y_s$ ,  $K_{cs}$  and  $w_o$  in Eq. (1), we get

$$K_{gs} = \frac{63}{63 - 0.2 \times 4.5}$$

$$= 1.0144$$

Also,

Gap contraction factor for ducts,

$$K_{gd} = \frac{L}{L - K_{cd}n_d w_d} \quad (2)$$

And,

$$\frac{\text{duct width}}{\text{air gap length}} = \frac{8}{4} = 2$$

Hence, Carter's coefficient for ducts,  $K_{cd} = 0.24$

Substituting  $L$ ,  $K_{cd}$ ,  $w_d$  and  $n_d$  in Eq. (2), we get

$$K_{gd} = \frac{L}{L - K_{cd}n_d w_d}$$

$$= \frac{300}{300 - 0.24 \times 6 \times 8}$$

$$= 1.0399$$

Total gap contraction factor,

$$K_g = K_{gs} \times K_{gd}$$

$$= 1.0144 \times 1.0399 = 1.0548$$

Flux density at pole centre,

$$\begin{aligned} B_g &= \frac{\text{Flux/pole}}{\text{pole arc} \times \text{length of core}} \\ &= \frac{45 \times 10^{-3}}{180 \times 10^{-3} \times 300 \times 10^{-3}} \\ &= 0.8333 \text{ Wb/m}^2 \end{aligned}$$

MMF of air gap,

$$AT_g = 800,000 B_g K_g l_g$$

$$\begin{aligned} \Rightarrow AT_g &= 800,000 \times 0.8333 \times 1.0548 \times 4 \times 10^{-3} \\ &= 2812.687 \text{ A} \end{aligned}$$

**Example 2.3: Determine an average air gap flux density of an alternator, with rating 150 MVA, having number of poles = 10, length of core = 1.6 m, diameter of core = 6 m, total MMF per pole is 18,000 A, MMF required for air gap is 0.8 times of total MMF per pole, field form factor = 0.65 m, slot width = 20 mm, slot pitch = 60 mm and length of air gap**

**at the centre of pole = 25 mm. The type of stator slots used is parallel-sided open slots.**

**Solution:** Given

Power rating = 150 MVA

Number of poles = 10

Length of core,  $L = 1.6 \text{ m} = 1.6 \times 10^3 \text{ mm}$

Diameter of core,  $D = 6 \text{ m} = 6 \times 10^3 \text{ mm}$

Total MMF per pole,  $AT = 18,000 \text{ A}$

MMF required for air gap,  $AT_g = 0.8 AT$

Field form factor,  $K_f = 0.65$

Slot width,  $w_s = 20 \text{ mm}$

Slot pitch,  $y_s = 60 \text{ mm}$

Duct width,  $w_d = 8 \text{ mm}$

Length of air gap,  $l_g = 25 \text{ mm}$

Number of radial ventilating ducts,  $n_d = 40$

Since the type of stator slots used is parallel-sided open slots, Carter's coefficient is given by

$$K_{cs} = \frac{2}{\pi} \left[ \tan^{-1} y - \frac{1}{y} \log \sqrt{1+y^2} \right]$$

where

$$y = \begin{cases} \frac{w_s}{2l_g} & \text{for slots} \\ \frac{w_d}{2l_g} & \text{for ducts} \end{cases}$$

For slots,

$$\Rightarrow y = \frac{w_s}{2l_g} = \frac{20}{2 \times 25} = 0.4$$

Hence, Carter's coefficient,

$$\begin{aligned} K_{cs} &= \frac{2}{\pi} \left[ \tan^{-1} 0.4 - \frac{1}{0.4} \log \sqrt{1+0.4^2} \right] \\ &= \frac{2}{\pi} \left[ \underbrace{0.3805}_{\text{radians}} - 0.0805 \right] \\ &= 0.1909 \end{aligned}$$

In order to determine the average flux density, it is required to find MMF of air gap, gap contraction for slots, ducts and total gap contraction factor.

For ducts,

$$y = \frac{w_d}{2l_g} = \frac{8}{2 \times 25} = 0.16$$

Hence, Carter's coefficient for ducts,

$$\begin{aligned}k_{cd} &= \frac{2}{\pi} \left[ \tan^{-1} 0.16 - \frac{1}{0.16} \log \sqrt{1 + 0.16^2} \right] \\&= \frac{2}{\pi} \left[ \underbrace{0.1586}_{\text{radians}} - 0.0343 \right] \\&= 0.0791\end{aligned}$$

Gap contraction factor for slots,

$$\begin{aligned}K_{gs} &= \frac{y_s}{y_s - K_{cs} w_s} \\&= \frac{60}{60 - 0.1969 \times 20} \\&= 1.0679\end{aligned}$$

Gap contraction factor for ducts,

$$\begin{aligned}K_{gd} &= \frac{L}{L - K_{cd} n_d w_d} \\&= \frac{1600}{1600 - 0.0791 \times 40 \times 8} \\&= 1.016\end{aligned}$$

Total gap contraction factor,

$$K_g = K_{gs} K_{gd} = 1.0679 \times 1.016$$

$$= 1.0849$$

MMF required for air gap,

$$AT_g = 0.8 AT$$

Substituting the value of  $AT$  in the above equation,

$$AT_g = 0.8 \times 18,000$$

$$= 14,400 \text{ A}$$

Also,

$$AT_g = 800,000 K_g B_g l_g$$

$$\begin{aligned} \Rightarrow B_g &= \frac{AT_g}{800000 K_g l_g} \\ &= \frac{14400}{800000 \times 1.0849 \times 25} \\ &= 6.6365 \times 10^{-4} \text{ Wb/mm}^2 \\ &= 0.6636 \text{ Wb/m}^2 \end{aligned}$$

Average flux density,

$$B_{av} = k_f \times B_g$$

⇒

$$\begin{aligned} B_{av} &= 0.65 \times 0.6636 \\ &= 0.4313 \text{ Wb/m}^2 \end{aligned}$$

**Example 2.4: Determine the length of air gap of dc machine having core length = 0.1 m, slot pitch = 22 mm, slot width = 8 mm, with 2 ducts each 8 mm wide, flux density at centre of pole = 0.65 Wb/m<sup>2</sup>, MMF/pole = 3500 AT and MMF required for iron = 780 AT. Assume Carter's coefficient for slots and ducts to 0.28.**

**Solution:** Given,

Core length,  $L = 0.1$  m

Slot pitch,  $y_s = 22$  mm

Slot width,  $w_s = 8$  mm

Number of ducts,  $n_d = 2$

Width of ducts,  $w_d = 8$  mm

Flux density,  $B_g = 0.65$  Wb/m<sup>2</sup>

MMF/pole = 3500 AT

MMF for iron = 780 AT

Carter's coefficient = 0.28 (for slots and ducts)

In order to determine the air gap length, it is required to find MMF of air gap and total gap contraction factor, constituted by a gap contraction factor for slots and ducts.

MMF of air gap,

$$AT_g = \text{MMF/pole} - \text{MMF of iron}$$

$$= 3500 - 780 = 2720 \text{ AT}$$

Gap contraction factor for slots,

$$K_{gs} = \frac{y_s}{y_s - K_{cs}w_s}$$
$$= \frac{22}{22 - (0.28 \times 8)} = 1.1133$$

Gap contraction factor for ducts,

$$\begin{aligned}
K_{gd} &= \frac{L}{L - K_{cd} n_d w_d} \\
&= \frac{0.1 \times 10^3}{0.1 \times 10^3 - (0.28 \times 2 \times 8)} \\
&= 1.0469
\end{aligned}$$

Total gap contraction factor,

$$\begin{aligned}
K_g &= K_{gs} \times K_{gd} \\
&= 1.1133 \times 1.0469 \\
&= 1.1655
\end{aligned}$$

We know that MMF of air gap

$$AT_g = 800,000 B_g K_g L_g$$

⇒ Length of air gap,

$$l_g = \frac{AT_g}{800,000 \times B_g K_g}$$

Substituting the values of  $AT_g$ ,  $B_g$  and  $K_g$  in the above equation, we get

$$\begin{aligned}
 l_g &= \frac{2720}{800,000 \times 0.65 \times 1.1655} \\
 &= 4.488 \times 10^{-3} \text{ m} \\
 &= 4.488 \text{ mm}
 \end{aligned}$$

### 2.3 Determination of MMF of Teeth

The accurate determination of MMF in teeth is an arduous task due to the following reasons:

- Uniform values of flux density cannot be obtained in tapered teeth with parallel-sided slots, as the area of the flux path uniformly varies changing the flux density values along the portion of the teeth.
- The flux path can branch into slots in parallel to the teeth, creating two paths for the flow of flux. This happens due to the operation of machine in saturation region, making the permeability low in teeth causing some amount of flux to flow through depths of the slots.

### Graphical method

It is based on the construction of graph representing the variation of MMF and flux density with respect to distance from one end to the other end of the teeth (i.e., length of the teeth) as shown in Fig. 2.12(a)–(c). The mean value of MMF is calculated by integrating  $H$  over length of the teeth. Hence, the total MMF of teeth is determined by multiplying the mean value of MMF and length of the teeth (or depth of the slot).

Total MMF of the teeth,

$$\begin{aligned}
 At_t &= \text{mean ordinate} \times \text{length of the teeth (or depth of the slot)} \\
 &= at_{\text{mean}} \times l_t = at_{\text{mean}} \times d_s
 \end{aligned}$$

This method is applicable to all forms of teeth, with and without taper.

### **$B_{t1/3}$ method**

It is based on the assumption that the mean MMF of whole tooth, is the MMF, 'at' corresponding to the flux density at 1/3 tooth height from the narrow end.

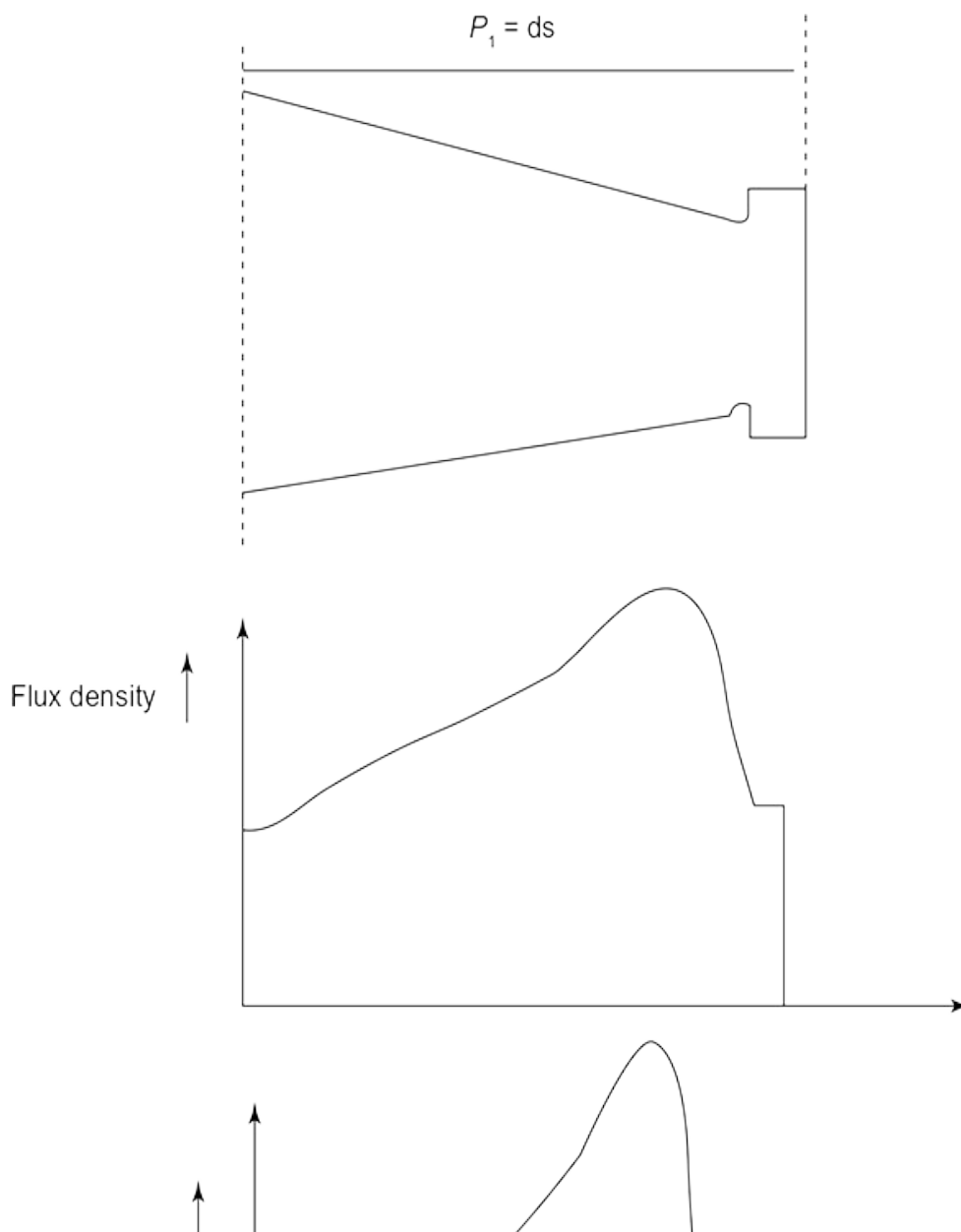



**Fig. 2.12** | (a), (b) and (c) Graphical method

Total MMF of teeth,

$$At_t = at_{1/3} \times l_t = at_{1/3} \times d_s$$

where  $at_{1/3}$  is the value of MMF/m for  $B_{t_{1/3}}$ , which is the flux density at 1/3 tooth height from the narrow end.

It is a simple method, applicable to teeth with small taper. It is also suited for operation under low saturation.

### **Simpson's rule (three ordinate method)**

This method is based on the formulation that the B-H curve relating the flux density and the MMF is a parabola. The total MMF of teeth is the mean value of MMF obtained at three points of the B-H curve, which are equidistant as shown in Fig. 2.12, with respect to ends of the teeth and centre of the teeth.

From Fig. 2.13, the mean value of MMF is given by

$$at_{\text{mean}} = \frac{at_1 + 4at_2 + at_3}{6}$$

where  $at_1$ ,  $at_2$  correspond to MMF at ends of the teeth and  $at_3$  corresponds to the mmf at the centre of the teeth.

It is used for teeth with small taper and other primitive types.

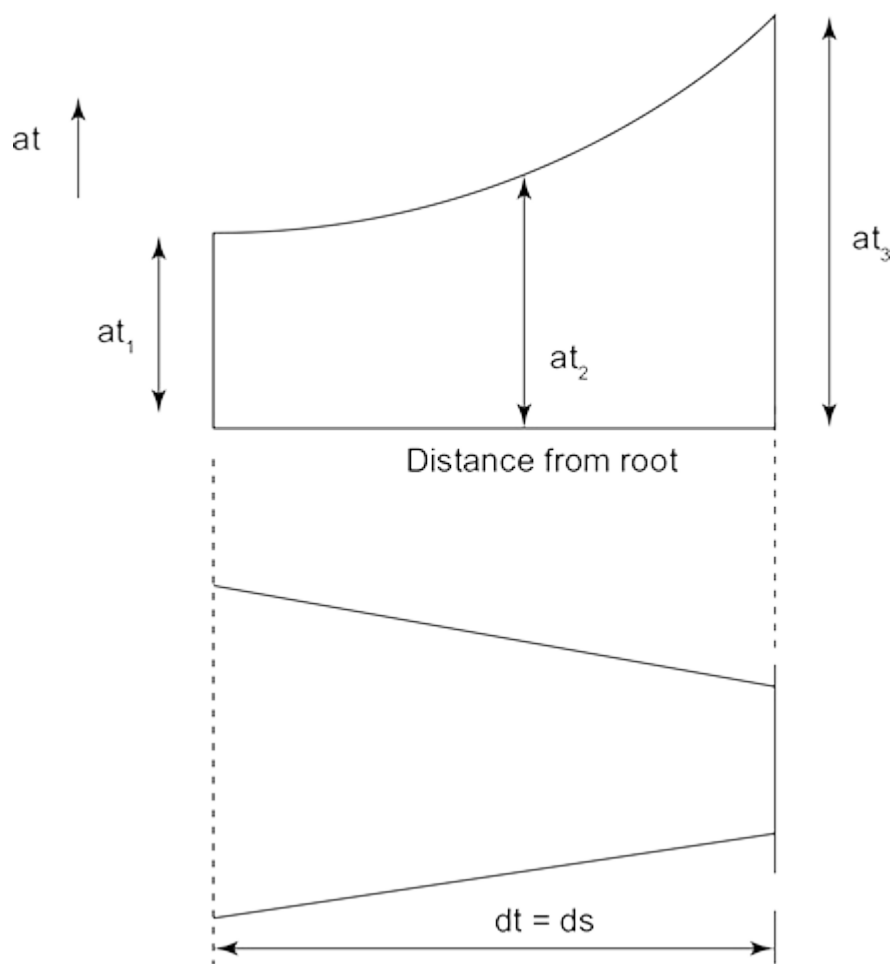

**Fig. 2.13** | Simpson's rule

**Example 2.5: Determine the MMF of tapered teeth of an electrical machine using Simpson's rule following the data: length of teeth = 20 mm, maximum width = 1.5 times the minimum width, mean flux density = 1.2 Wb/m<sup>2</sup>. The B-at curve is given by**

B(wb/m <sup>2</sup> )	1	1.1	1.2	1.3	1.4	1.5	1.6	1.7
'at' (A/m)	190	208	227	265	366	633	1490	3670

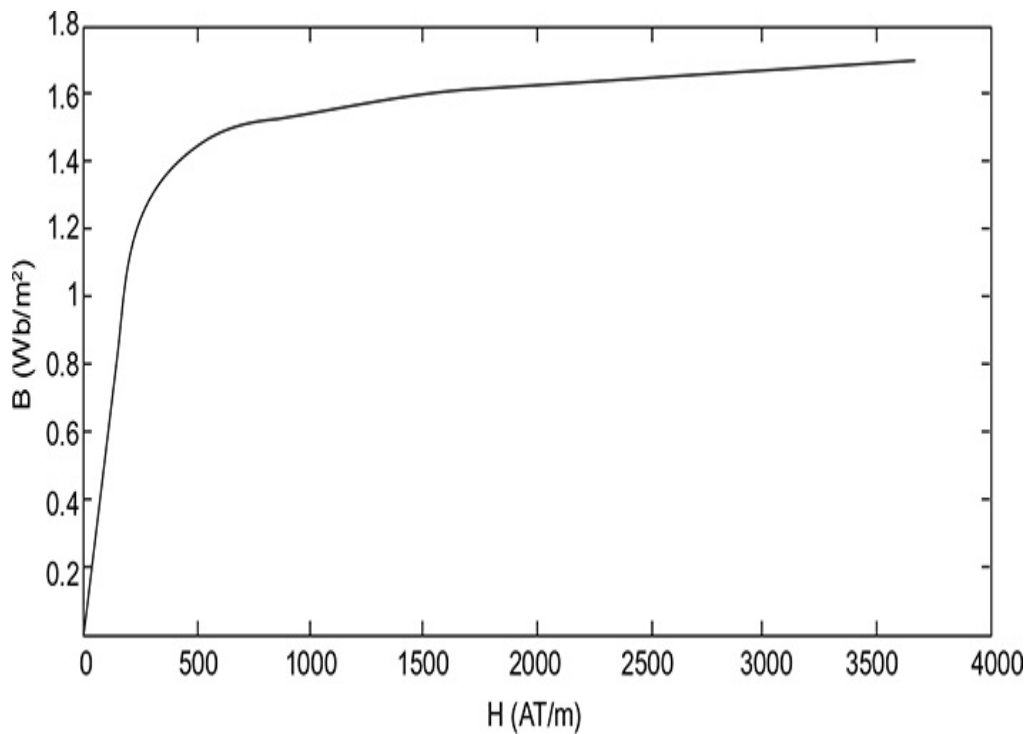

**Fig. 2.14** | B-at curve

**Solution:** Given

Length of teeth,  $l_t = 30$  mm

Maximum width = 1.5 minimum width

Mean following density =  $1.2$  Wb/m<sup>2</sup>

By Simpson's rule,

$$at_{\text{mean}} = \frac{at_1 + 4at_2 + at_3}{6} \quad (1)$$

we know that  $at_2 = 227A/m$  corresponding to  $B_{t_2} = 1.2$  wb/m<sup>2</sup>

In order to determine 'at' mean, it is required to find  $at_1$  and  $at_3$ , which in turn depends on  $B_{t_1}$  and  $B_{t_2}$ , dependent on proportionality with tooth widths.

We know that,

$$w_{t_1} = 1.5w_{t_3} \quad (2)$$

Let  $w_{t_1}$ ,  $w_{t_2}$  and  $w_{t_3}$  be the maximum, mean and minimum tooth widths.

Also,

$$wt_2 = \frac{wt_1 + wt_3}{2} \quad (3)$$

Substituting Eq. (2) in Eq. (3), we get

$$wt_2 = \frac{1.54wt_3 + wt_3}{2}$$

$$= \frac{2.5wt_3}{2} = 1.25wt_3 \quad (4)$$

And,

Flux density at any region of teeth,

$$B_t = \frac{\text{flux/teeth}}{\text{Sectional area of teeth}}$$

[where sectional area of teeth = net iron length × teeth width]

Hence, from the above equation, it is observed that

$$B_t \propto \frac{1}{\text{teeth width}}$$

$$\text{Hence, } B_{t_1} \propto \frac{1}{w_{t_1}}, \quad B_{t_2} \propto \frac{1}{w_{t_2}} \quad \text{and} \quad B_{t_3} \propto \frac{1}{w_{t_3}}$$

So, it can be stated that

$$\frac{B_{t_1}}{B_{t_2}} = \frac{w_{t_2}}{w_{t_1}} \quad \text{and} \quad \frac{B_{t_2}}{B_{t_3}} = \frac{w_{t_3}}{w_{t_2}} \quad (5)$$

Substituting the value of  $B_{t_3}$ , Eqs. (2), (4) in Eq. (5), we get

$$\frac{B_{t_1}}{1.2} = \frac{1.25 w_{t_3}}{1.5 w_{t_3}} \text{ and } \frac{1.2}{B_{t_3}} = \frac{w_{t_3}}{1.25 w_{t_3}}$$

$$\Rightarrow B_{t_1} = 1.2 \times \frac{1.25}{1.5} = 1 \text{ Wb/m}^2$$

$$\text{and } B_{t_3} = 1.2 \times 1.25 = 1.5 \text{ Wb/m}^2$$

From the B-at curve, the corresponding  $at_1$  and  $at_3$  to  $B_{t_1}$  and  $B_{t_3}$  are 190 AT/m and 633 AT/m.

Using  $at_1$ ,  $at_3$  and  $at_2$  in Eq. (1), we get

$$\begin{aligned} at_{\text{mean}} &= \frac{190 + 4(227) + 633}{6} \\ &= 288.5 \text{ AT / m} \end{aligned}$$

$$\begin{aligned} \text{The total MMF required} &= at_{\text{mean}} \times \text{length of teeth } (l_t) \\ &= 288.5 \times 0.03 = 8.655 \text{ A} \end{aligned}$$

**Example 2.6: Determine the MMF of air gap**

**and teeth using Simpson's rule and  $B_{t_1}$**

**method in a dc machine, having the following length of core = 170 mm, diameter = 250 mm,**

number of slots = 26, type of slots-parallel,  
 depth of slot = 20 mm, width of slot = 5.5 mm,  
 number of ducts = 1, duct width = 12 mm, air  
 gap length = 3.5 mm, maximum flux density =  
 $1 \text{ Wb/m}^2$ , insulation of stampings = 0.12 times  
 thickness of stampings and Carter's  
 coefficient is 0.28 for slots and 0.35 for ducts.

The B-at curve is as follows:

B (Wb/m <sup>2</sup> )	0	0.8962	1.139	1.22	1.341	1.4957	1.503	1.625	1.6624	1.706	1.7194	1.8645	1.907
H (AT/m)	0	48.70	72.36	110.5	245.62	400	450	1809	2000	4000	4100	14000	15000

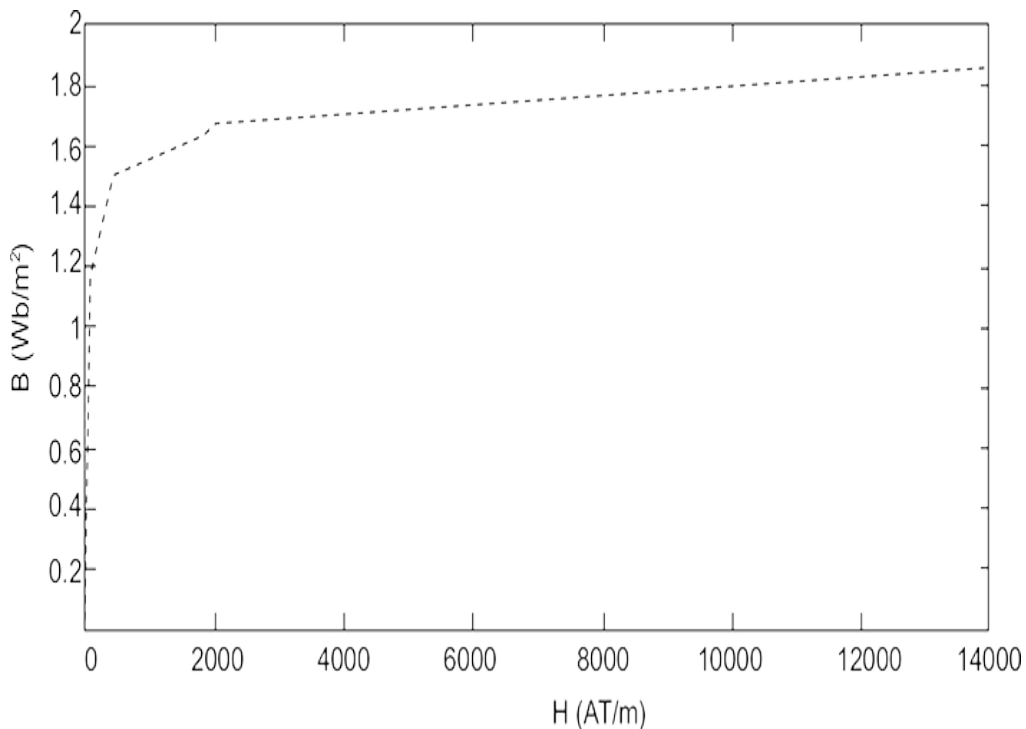

**Fig. 2.15** | B-at curve

**Solution:** Given

Length of core,  $L = 170$  mm

Insulation of stampings = 0.12 thickness of stampings

Diameter of core,  $D = 250$  mm

Number of slots,  $s = 26$

Depth of slot,  $d_s = 20$  mm

Slot width,  $w_s = 5.5$  mm

Number of ducts,  $n_d = 1$

Duct width,  $w_d = 12$  mm

Air gap length,  $l_g = 3.5$  mm

Maximum flux density,  $B_g = 1$  Wb/m<sup>2</sup>

Insulation of stampings = 0.12 (thickness of stampings)

$$\text{Carter's coefficient} = \begin{cases} 0.28 & \text{for slots} \\ 0.35 & \text{for ducts} \end{cases}$$

In order to determine the MMF for air gap and teeth, it is required to find the total gap contraction factor, flux density for different parts of tooth using tooth widths, slot pitch and diameter in each case.

Gap contraction factor for slots,

$$K_{gs} = \frac{y_s}{y_s - K_{cs}w_s} \quad (1)$$

In the above equation, slot pitch (gap surface)

$$y_s = \frac{\pi D}{s}$$

Substituting the values for  $D$  and  $s$  in the above equation, we get

$$y_s = \frac{\pi \times 250}{26} = 30.2076 \text{ mm}$$

Substituting the values of  $y_s$ ,  $K_{cs}$  and  $w_s$  in Eq. (1), we get

$$\begin{aligned} K_{gs} &= \frac{30.2076}{30.2076 - (0.28 \times 5.5)} \\ &= 1.0537 \end{aligned}$$

Similarly,

Gap contraction factor for ducts,

$$K_{gd} = \frac{L}{L - K_{cd}n_d w_d}$$

Substituting the values of  $L$ ,  $K_{cd}$ ,  $n_d$  and  $w_d$  in the above equation, we get

$$K_{gd} = \frac{170}{170 - (0.35 \times 1 \times 12)}$$

$$= 1.0253$$

We know that total gap contraction factor  $K_g = K_{gs} K_{gd}$

Substituting the values of  $K_{gs}$  and  $K_{gd}$  in the above equation, we get

$$K_g = 1.0537 \times 1.00253 = 1.0803$$

We know that MMF of air gap,

$$AT_g = 800,000 B_g K_g l_g$$

Substituting the values of  $B_g$ ,  $K_g$  and  $l_g$  in the above equation, we get

$$AT_g = 800,000 \times 1 \times 1.0803 \times 3.5 \times 10^{-3}$$

$$= 3024.84 \text{ A}$$

Proceeding to determine the MMF for teeth, we use  $B_{t\frac{1}{3}}$  method and Simpson's rule.

### $B_{t_{\frac{1}{3}}}$ method:

In this method, it is required to determine the flux

density at  $\frac{1}{3}$  of tooth height, for which the calculations of

$w_{t_1}$ ,  $w_{t_{\frac{1}{3}}}$ ,  $D_{t_{\frac{1}{3}}}$ , and  $B_{t_1}$  are to be done.

We know that

$$\frac{B_{t_{\frac{1}{3}}}}{B_{t_1}} = \frac{w_{t_1}}{w_{t_{\frac{1}{3}}}} \quad (2)$$

where  $w_{t_1} = y_s - w_s$

Substituting the values of  $y_s$  and  $w_s$  in the above equation, we get

$$w_{t_1} = 30.2076 - 5.5 = 24.776 \text{ mm}$$

And

$$w_{t_{\frac{1}{3}}} = y_{s_{\frac{1}{2}}} - w_s \quad (3)$$

where

$$y_{s_{\frac{1}{3}}} = \frac{\pi D_{\frac{1}{3}}}{S} \quad (4)$$

and

$$D_{\frac{1}{3}} = D - 2 \times \frac{2}{3} d_s$$

Substituting the values of  $D$  and  $d_s$  in the above equation, we get

$$\begin{aligned} D_{\frac{1}{3}} &= 250 - \left( 2 \times \frac{2}{3} \times 20 \right) \\ &= 223.3333 \text{ mm} \end{aligned}$$

Substituting the values of  $D_{\frac{1}{3}}$  and  $s$  in Eq. (4), we get

$$\begin{aligned} y_{s_{\frac{1}{3}}} &= \frac{\pi \times 223.3333}{26} \\ &= 26.9854 \text{ mm} \end{aligned}$$

Substituting the values of  $y_{s_{\frac{1}{3}}}$  and  $w_s$  in Eq. (3), we get

$$w_{t_1} = 26.9854 - 5.5 = 21.4854 \text{ mm}$$

$B_{t_1}$  is determined as follows:

$$B_{t_1} = \frac{\phi_t}{L_i w_{t_1}} \quad (5)$$

where  $\phi_t = B_g y_s L$

$$L_i = K_i (L - n_d w_d)$$

$$w_{t_1} = y_s - w_s$$

Therefore,

$$\phi_t = 1 \times 30.2076 \times 10^{-3} \times 170 \times 10^{-3}$$

$$= 5.135233 \text{ mWb}$$

And 
$$L_i = K_i(170 \times 10^{-3} - (1 \times 12) \times 10^{-3})$$

where 
$$K_i = 0.88 \left[ \because \frac{\text{insulation of stampings}}{\text{thickness of stampings}} \right] = 0.12$$

$$\Rightarrow L_i = 0.88(170 \times 10^{-3} - 12 \times 10^{-3})$$

$$= 0.1390$$

And 
$$w_{t_1} = y_s - w_s = 30.2076 - 5.5$$

$$= 24.7076 \times 10^{-3} \text{ m} = 0.02470 \text{ m}$$

Substituting the values of  $\phi_t$ ,  $L_i$  and  $w_{t_1}$  in Eq. (5), we get

$$B_{t_1} = \frac{5.1362 \times 10^{-3}}{0.1390 \times 0.0247} = 1.4957 \text{ Wb/m}^2 \quad (6)$$

Substituting the values of  $w_{t_1/3}$ ,  $w_{t_1}$  and  $B_{t_1}$  in Eq. (2), we get

$$\frac{B_{t_1/3}}{1.4957} = \frac{0.02470}{21.4854 \times 10^{-3}}$$

$$\Rightarrow B_{t_1/3} = 1.7194 \text{ Wb/m}^2$$

From the following table, the corresponding MMF is

$$a t_1 = 4100 \text{ A/m}$$

MMF for teeth,

$$AT = 4100 \times d_s = 4100 \times 20 \times 10^{-3} = 824$$

Total MMF of air gap and teeth = 3024.84 + 82 = 3106.84 A

**Simpson's rule:**

Top of teeth	Centre portion of tooth	Bottom of tooth
From Eq. (6), $B_{t_1} = 1.4957 \text{ Wb/m}^2$ corresponding $at_1 = 400 \text{ A/m}$	$D_{\text{centre}} \text{ or } (D_{s2}) = D - d_s$ $= 250 - 20$ $= 230 \text{ mm}$	$D_{\text{bottom}} \text{ or } (D_{s3}) = D - 2d_s$ $= 250 - 2(20)$ $= 210 \text{ mm}$
	$y_{s2} = \frac{\pi D_{\text{centre}}}{S}$ $= \frac{\pi \times 230}{26}$ $= 2.791 \text{ mm}$	$y_{s2} = \frac{\pi D_{\text{bottom}}}{S}$ $= \frac{\pi \times 210}{26}$ $= 25.3744 \text{ mm}$
	$w_{t_2} = y_{s_2} - w_s$ $= 27.791 - 5.5$ $= 22.291 \text{ mm}$	$w_{t_3} = y_{s_3} - w_s$ $= 25.3744 - 5.5$ $= 19.8744 \text{ mm}$
	$B_{t_2} = B_{t_1} \times \frac{w_{t_1}}{w_{t_2}}$ $= 1.4957 \times \frac{24.776}{22.291}$ $= 1.6624 \text{ Wb/m}^2$ Corresponding $at_2 = 2000 \text{ AT/m}$	$B_{t_3} = B_{t_1} \times \frac{w_{t_1}}{w_{t_3}}$ $= 1.4957 \times \frac{24.776}{19.8744}$ $= 1.8645 \text{ Wb/m}^2$ Corresponding $at_3 = 14000 \text{ AT/m}$

Therefore,

$$\begin{aligned}
 at_{\text{mean}} &= \frac{at_1 + 4at_2 + at_3}{6} \\
 &= \frac{400 + (4 \times 20000) + 14000}{6} \\
 &= 3733.3333 \text{ A/m}
 \end{aligned}$$

$$\begin{aligned}
 \text{MMF for teeth} &= 3733.3333 \times d_s \\
 &= 3733.3333 \times 20 \times 10^{-3} \\
 &= 74.6666 \text{ A}
 \end{aligned}$$

$$\begin{aligned}
 \text{Total MMF of air gap and teeth} &= 3024.84 + 74.6666 \\
 &= 3099.5066 \text{ A}
 \end{aligned}$$

#### 2.4 Real Flux Density and Apparent Flux Density

In case of high flux density in teeth, the MMF is quite large and acts across the slots with slots positioned parallel to teeth. Hence, this slot flux under saturation conditions cannot be neglected or (omitted) in calculation of flux density. This leads to two different flux densities, namely real and apparent flux densities represented in [Fig. 2.16](#), where real flux density is less than apparent flux density at all times.

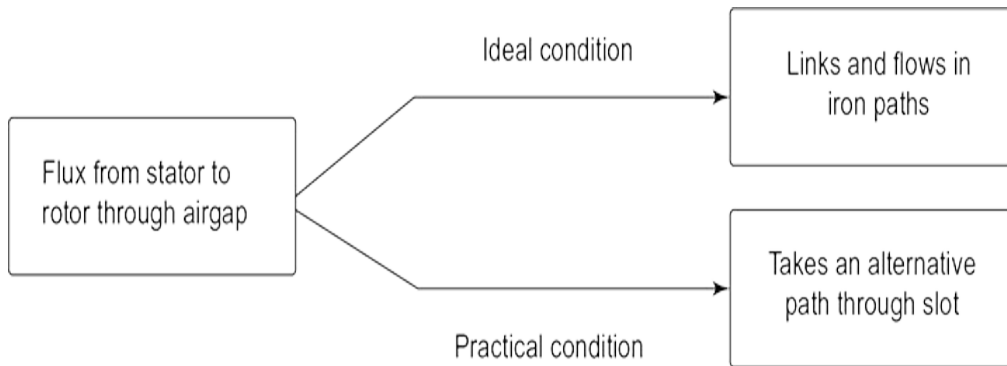

**Fig. 2.16** | Real and apparent flux densities

The flux linking the slot and teeth under practical conditions is represented in Fig. 2.17.

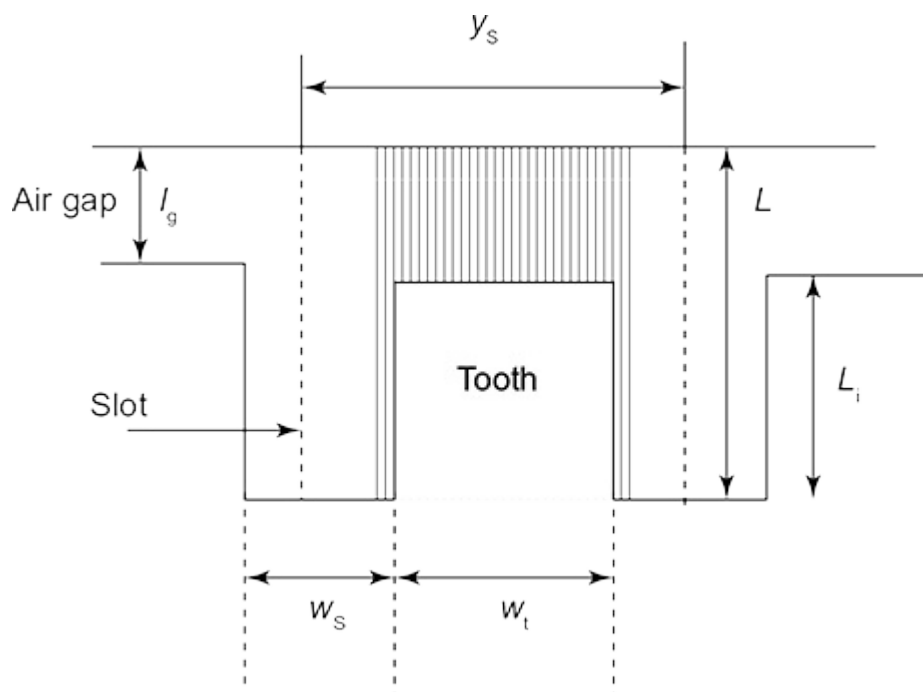

**Fig. 2.17** | Flux distribution in teeth and slot under practical conditions

The corresponding representation of real and apparent flux density is as follows:

The real flux density is defined as the ratio of actual flux in tooth to the area of tooth.

$$\text{Real flux density } B_{\text{real}} = \frac{\text{Actual flux in tooth}}{\text{Area of tooth}} \quad (2.21)$$

The apparent flux density is defined as the ratio of total flux in slot pitch to the area of tooth.

$$\text{Apparent flux density } B_{\text{app}} = \frac{\text{Total flux in slot pitch}}{\text{Area of tooth}} \quad (2.22)$$

Proceeding to find the relation between real and apparent flux densities, the following steps are followed.

We know that

Area of tooth (iron path),

$$A_i = \text{tooth width} \times \text{net iron length} = L_i w_t \quad (2.23)$$

$$\begin{aligned} \text{Area of air path, } A_a &= \text{Total area} - \text{Area of iron (or tooth)} \\ &= [\text{Core length} \times \text{slot pitch}] - L_i w_t \end{aligned}$$

$$A_g = L_{ys} - L_i w_t \quad (2.24)$$

$$\text{Total flux in slot pitch, } f_s = f_i + f_a \quad (2.25)$$

where  $f_i$  – flux in iron path,  $f_a$  – flux in air path.

From Eq. (2.25), we can state that  $f_i$  – Actual flux in tooth

Using Eq. (2.25) in Eq. (2.22), we get

$$\begin{aligned}
 B_{\text{app}} &= \frac{\phi_s}{A_i} = \frac{\phi_i + \phi_a}{A_i} = \frac{\phi_i}{A_i} + \frac{\phi_a}{A_i} \\
 &= B_{\text{real}} + \frac{\phi_a}{A_i} \left[ \because \frac{\phi_i}{A_i} = B_{\text{real}} \right]
 \end{aligned}$$

Multiplying and dividing by  $A_a$  for the second term in the above equation, we get

$$\begin{aligned}
 &= B_{\text{real}} + \frac{\phi_a}{A_i} \times \frac{A_a}{A_a} \\
 &= B_{\text{real}} + \frac{\phi_a}{A_a} \times \frac{A_a}{A_i} \\
 &= B_{\text{real}} + B_a \times \frac{A_a}{A_i}
 \end{aligned}$$

[where  $B_a$  – flux density in air =  $\mu_o H = \mu_o a t_{\text{real}}$ ]

$$B_{\text{app}} = B_{\text{real}} + B_a K$$

[where  $K = \frac{A_a}{A_i} = \frac{L y_s - L_i \omega_t}{L_i \omega_t}$  ratio of air area to iron area]

Also,

$$B_{\text{app}} = B_{\text{real}} + B_a (K_s - 1) \quad (2.26)$$

where

$$\begin{aligned} K_s &= K + 1 = \frac{\text{Total area}}{\text{Iron area}} \\ &= \frac{Ly_s}{L_i w_t} \end{aligned}$$

Hence,

$$B_{\text{real}} = B_{\text{app}} - B_a (K_s - 1) \quad (2.27)$$

Substituting in the above equation, we get

$$B_{\text{real}} = B_{\text{app}} - \mu_0 a t_{\text{real}} (K_s - 1) \quad (2.28)$$

**Example 2.7: Determine the permeability of teeth of dc machine with length of core (gross) = 350 mm, slot pitch = 20 mm, width of the teeth = 10 mm, real flux density = 2.2 T, apparent flux density = 2.5 T and stacking factor = 0.85.**

**Solution:** Given

Gross length of core,  $L = 350$  mm

Slot pitch,  $y_s = 20$  mm

Width of the teeth,  $w_t = 10$  mm

Real flux density,  $B_{\text{real}} = 2.2$  T

Apparent flux density,  $B_{\text{app}} = 2.5$  T

Stacking factor,  $S_f = 0.85$

In order to determine the permeability, it is required to find MMF for which the calculation of  $K_s$  is required.

$$B_{\text{app}} = B_{\text{real}} + B_a (K_s - 1) \quad (1)$$

where

$$B_a = \mu_0 \times at \quad (2)$$

$$K_s = \frac{Ly_s}{L_i w_t} \quad (3)$$

and  $L_i = S_f L \quad (4)$

Substituting Eq. (4) in Eq. (3), we get

$$\begin{aligned} \Rightarrow K_s &= \frac{Ly_s}{S_f L w_t} = \frac{y_s}{S_f w_t} \\ &= \frac{20}{0.9 \times 10} = 2.2222 \end{aligned}$$

Substituting  $K_s$  and  $B_a$  in Eq.(1), we get

$$B_{\text{app}} = B_{\text{real}} + \mu_0 at(2.2222-1)$$
$$\Rightarrow 1.2222at = \frac{B_{\text{app}} - B_{\text{real}}}{\mu_0}$$

Substituting the values for  $B_{\text{app}}$ ,  $B_{\text{real}}$  and  $\mu_0$  in the above equation, we get

$$at = \frac{2.5 - 2.2}{1.2222 \times 4\pi \times 10^{-7}}$$
$$= 195330.0725 \text{ AT/m}$$

Permeability of teeth,

$$\mu = \frac{B_{\text{real}}}{at} = \frac{2.2}{195330.0725}$$
$$= 11.2629 \times 10^{-6} \text{ H/m}$$

$$= 11.2629 \mu\text{H/m.}$$

**Example 2.8: Determine the apparent flux density for a teeth of dc machine with length of core = 400 mm, slot width = 11 mm, slot pitch = 20 mm, number of ducts = 6, duct**

**width = 8 mm, stacking factor = 0.85, real flux density = 1.8 Wb/m<sup>2</sup> and MMF = 80000 AT/m.**

**Solution:** Given

Length of core,  $L = 400$  mm

Slot width,  $w_t = 11$  mm

Slot pitch,  $y_s = 20$  mm

Number of ducts,  $n_d = 6$

Duct width,  $w_d = 8$  mm

Stacking factor,  $S_f = 0.85$

Real flux density,  $B_{\text{real}} = 1.8$  Wb/m<sup>2</sup>

MMF,  $at = 80000$  AT/m

In order to determine the apparent flux density, it is required to find  $K_s$ , for which the net length of iron and tooth width are to be found.

We know that

Net length of iron,

$$\begin{aligned} L_i &= K_i(L - n_d w_d) = 0.85(400 - 6 \times 8) \\ &= 299.2 \text{ mm} \\ \text{Tooth width, } w_t &= y_s - w_s = 20 - 11 = 9 \text{ mm} \end{aligned}$$

$$\text{Also, } K_s = \frac{Ly_s}{L_i w_t}$$

Substituting the values of  $L$ ,  $y_s$ ,  $L_i$  and  $w_t$  in the above equation, we get

$$K_s = \frac{400 \times 20}{299.2 \times 9} = 2.9708$$

Apparent flux density,

$$B_{\text{app}} = B_{\text{real}} + \mu_o at (K_s - 1)$$

Substituting the values of  $B_{\text{real}}$ ,  $\mu_o at$  and  $K_s$  in the above equation, we get

$$\begin{aligned} B_{\text{app}} &= 1.8 + [(4\pi \times 10^{-7}) \times 8000(2.9708 - 1)] \\ &= 1.9981 \text{ Wb/m} \end{aligned}$$

## 2.5 Iron Loss Calculation

When a core of ferromagnetic material is subjected to a changing magnetic field, as in the case of transformers, induction motors and alternators, some of the power transferred is lost in the core. These losses are called core losses or iron losses. The two components of iron or core loss are as follows:

1. Hysteresis loss
2. Eddy current loss

### 2.5.1 Hysteresis Loss

The repeated (or cyclic) magnetization of ferromagnetic material results in loss termed as hysteresis loss, which is proportional to area of the hysteresis loop as represented in Fig. 2.18 and the quality of the material.

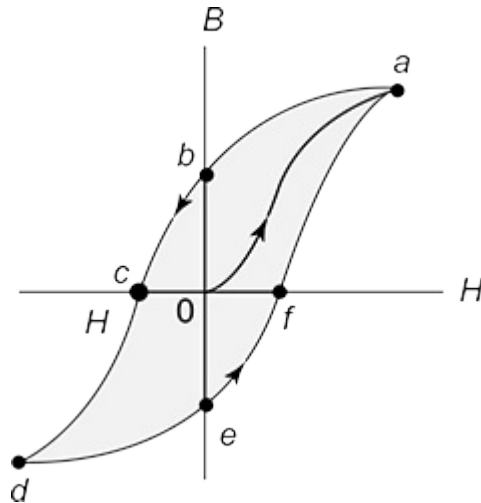

**Fig. 2.18** | Hysteresis loop of a ferromagnetic material

Hysteresis loss,

$$p_h = K A f \quad (2.29)$$

where  $k$  – constant accounting for the quantities,  $A$  – area of loop  $abcdef$ ,  $f$  – frequency.

For the Steinmetz relationship,

Hysteresis loss,

$$p_h = K_h f B_m^k \quad (2.30)$$

where  $B_m$  – maximum flux density,  $K_h$  – hysteresis coefficient,  $K$  – Steinmetz coefficient, varies between 1.5 and 2.5 and  $f$  – frequency.

Hysteresis loss is expressed in  $W/m^3$  or  $W/kg$ .

Hysteresis loss can be minimized in the following ways:

- Use of air core transformer reduces hysteresis loss, but increases leakage flux.
- Use of soft magnetic materials such as silicon steel, steel alloys, ferrite, etc., with low coercivity and remanent magnetic flux density reduces hysteresis loss.

### *2.5.2 Eddy Current Loss*

According to Faraday's law of electromagnetic induction, when an alternating magnetic field is applied to any magnetic material, an emf is induced in the material. The emf circulates currents in the material. These circulating currents are called Eddy Currents, produces a loss ( $I^2 R$  loss) in the magnetic material known as an Eddy Current Loss.

Eddy current losses can be minimized in the following ways:

- Use of laminated cores
- Reduction of thickness of stampings

Consider a thin sheet as shown in Fig. 2.19, which when subjected to a magnetic flux, causes flow of eddy currents.

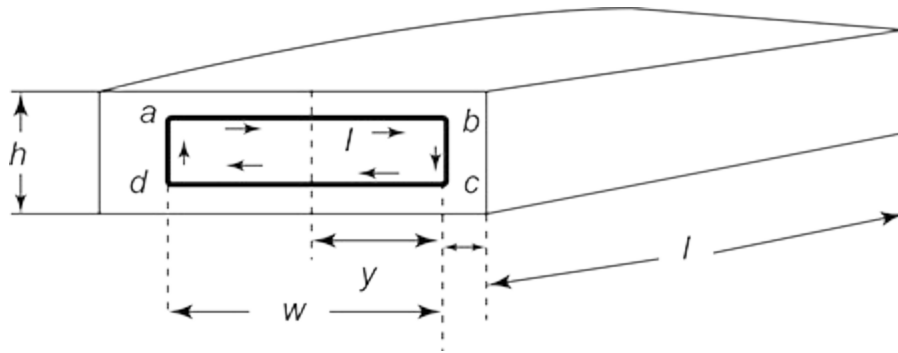

**Fig. 2.19** | Eddy currents in thin plates of laminations

The loss contributed by the eddy current is calculated as follows.

Flux in the path *abcd*,

$$\phi = B \times A \quad (2.31)$$

where  $B = B_m \sin \omega t$

$$A = h \times (y + y) = 2hy$$

Substituting the values of  $B$  and  $A$  in Eq. (2.31), we get

$$\phi = 2B_m h_y \sin \omega t$$

Instantaneous emf induced in path *abcd*,

$$\begin{aligned}
e &= \frac{d\phi}{dt} \\
&= \frac{d}{dt}(2B_m h_y \sin \omega t) \\
&= 2B_m h_y \cos \omega t \\
&= e_m \cos \omega t
\end{aligned} \tag{2.32}$$

where  $e_m = 2B_m h_y$

RMS value of emf induced,

$$\begin{aligned}
E &= \frac{e_m}{\sqrt{2}} \\
&= \sqrt{2} B_m h_y \omega
\end{aligned} \tag{2.33}$$

Resistance of eddy current path,

$$\begin{aligned}
R &= \frac{\rho \times \text{length}}{\text{area}} \\
&= \frac{\rho \times (h + h + y + y + y + y)}{l \times dy} \\
&= \frac{\rho \times (2h + 4y)}{l \times dy} \\
&\simeq \frac{2\rho h}{l dy} \quad [\because h \gg y]
\end{aligned} \tag{2.34}$$

Eddy current,

$$\begin{aligned} I_{\text{eddy}} &= \frac{E}{R} \\ &= \frac{\sqrt{2}B_m h y \omega}{\frac{2\rho h}{l \times dy}} \\ &= \frac{B_m y dy l \omega}{\sqrt{2}\rho} \end{aligned}$$

Substituting  $\omega = 2\pi f$  in the above equation, we get

$$\begin{aligned} I_{\text{eddy}} &= \frac{B_m y dy l \times 2\pi f}{\sqrt{2}\rho} \\ &= \frac{2B_m y dy l \pi f}{\rho} \end{aligned} \tag{2.35}$$

Eddy current loss in the path  $abcd$ ,

$$dP_{\text{eddy}} = I^2 R$$

$$\begin{aligned}
&= \frac{2B_m^2 y^2 (dy)^2 l^2 \pi^2 f^2}{\rho^2} \times \frac{2\rho h}{ldy} \\
&= \frac{4B_m^2 l \pi^2 f^2 h y^2 dy}{\rho}
\end{aligned}$$

Total eddy current loss,

$$\begin{aligned}
P_{\text{eddy}} &= \int dP_{\text{eddy}} \\
&= \int_{y=0}^{y=\frac{w}{2}} \frac{4B_m^2 l \pi^2 f^2 h y^2 dy}{\rho} \\
&= \frac{4B_m^2 l \pi^2 f^2 h}{\rho} \left[ \frac{y^3}{3} \right]_0^{\frac{w}{2}} \\
&= \frac{4B_m^2 l \pi^2 f^2 h}{\rho} \times \frac{w^3}{3 \times 8}
\end{aligned}$$

$$P_{\text{eddy}} = \frac{B_m^2 \pi^2 f^2 l h w^3}{6\rho} \quad (2.36)$$

We know that volume of plate,

$$V = l \times h \times w$$

Hence, eddy current loss per unit volume is given by

$$\begin{aligned}
 P_{\text{eddy}} &= \frac{B_m^2 \pi^2 f^2 l h w^3}{6\rho} \times \frac{1}{l h w} \\
 &= \frac{\pi^2 B_m^2 f^2 w^2}{6\rho} \\
 &= k_e f^2 B_m^2 \qquad (2.37)
 \end{aligned}$$

where  $k_e = \frac{\pi^2 w^2}{6\rho}$

### 2.5.3 Total Iron or Core Loss

The total iron or core loss is given by the sum of hysteresis and eddy current loss and is expressed as

$$p_i = p_h + p_e = K_h f B_m^k + K_e f^2 B_m^2 \qquad (2.38)$$

### 2.5.4 Pulsation Loss

Apart from the hysteresis and eddy current loss, air gap flux pulsations in electric machine cause losses termed as pulsation loss. These losses are mainly present due to slotted armature causing changes in reluctance, leading to change in air gap flux changes. The losses are pronounced in induction machines, where the air gap is small compared to slot openings, leading to harmonic fields with high frequencies.

**Example 2.9: Determine the specific iron loss of alloy steel with the following data: frequency = 60 Hz, maximum flux density = 2.5 Wb/m<sup>2</sup>, thickness of sheets = 0.3 mm, resistivity = 0.2 μΩm, density = 5 × 10<sup>3</sup> kg/m<sup>3</sup> and hysteresis loss/cycle = 300 J/m<sup>3</sup>.**

**Solution:** Given,

Frequency,  $f = 60$  Hz

Maximum flux density,  $B_m = 2.5$  Wb/m<sup>2</sup>

Thickness of sheets,  $t = 0.3$  mm =  $0.3 \times 10^{-3}$  m

Resistivity,  $\rho = 0.2 \times 10^{-6}$  Ωm

Density =  $5 \times 10^3$  kg/m<sup>3</sup>

Hysteresis loss/cycle = 300 J/m<sup>3</sup>

We know that

Eddy current loss,

$$P_{\text{eddy}} = \frac{\pi^2 t^2 f^2 B_m^2}{\rho}$$

Substituting the values of  $t, f, B_m$  and in the above equation, we get

$$P_{\text{eddy}} = \frac{\pi^2 \times 60^2 \times 2.5^2 \times (0.3 \times 10^{-3})^2}{6 \times 0.2 \times 10^{-6}}$$
$$= 16654.9574 \text{ W}$$

Hysteresis loss,

$$P_h = 300 \times 60 = 1800 \text{ W}$$

Total iron loss,

$$P_{\text{total}} = P_i + P_h = 16654.9574 + 1800$$
$$= 18454.9574 \text{ W}$$

$$\text{Specific iron loss} = \frac{P_{\text{total}}}{\text{density}}$$
$$= \frac{18454.9574}{5 \times 10^3}$$
$$= 3.6909 \text{ W/kg}$$

$$P_{\text{eddy}} (\text{in W/kg}) = \frac{16654.9574}{5 \times 10^3}$$
$$= 3.3309 \text{ W/kg}$$

$$P_h (\text{in W/kg}) = \frac{3000}{5 \times 10^3} = 0.6 \text{ W/kg}$$

**Example 2.10: Determine the hysteresis coefficient for silicon steel with hysteresis loss of 3 W/kg at a frequency of 60 Hz, maximum flux density of 2 Wb/m<sup>2</sup> and specific gravity of 7.55. Also determine the hysteresis loss kg at a frequency of 30 Hz and flux density of 1 Wb/m<sup>2</sup>. Use Steinmetz coefficient as 1.6.**

**Solution:** Given

Hysteresis loss = 3 W/kg

Frequency,  $f = 60$  Hz

Maximum flux density,  $B_m = 2$  Wb/m<sup>2</sup>

Specific gravity = 7.55

⇒ Density =  $7.55 \times 10^3$  kg/m<sup>3</sup>

We know that

Hysteresis loss,

$$P_h = k_h f B_m^k$$

Hysteresis loss/kg,

$$P_h = k_h f B_m^k \times 7500$$

Substituting the values of  $P_h$ ,  $f$ ,  $k$  and  $B_m$  in the above equation, we get

$$3 = k_h \times 60 \times 21.6 \times 7500$$

$$\Rightarrow k_h = 2.199 \times 10^{-6}$$

Hence, hysteresis loss/kg at 30 Hz, and flux density of is

$$\begin{aligned} P_h &= k_h f B_m^{1.6} \times 7500 \\ &= 2.199 \times 10^{-6} \times 30 \times 1^{1.6} \times 7500 \\ &= 0.494775 \text{ W/kg} \end{aligned}$$

**Example 2.11:** The total iron loss for a synchronous is 300 W at 500 rpm and 200 W at 400 rpm. Determine the total iron loss if the thickness of laminations is increased by 50%, the maximum flux density decreased by 10% and the speed is at 250 rpm. Use Steinmetz coefficient as 2.

**Solution:** Given

Total iron loss at 500 rpm,  $P_{\text{total}} = 300 \text{ W}$

Total iron loss at 400 rpm,  $P_{\text{total}} = 200 \text{ W}$

We know that

Total iron loss,

$$P_{\text{total}} = P_h + P_{\text{eddy}} \quad (1)$$

where  $P_h = k_h f B_m^k = k_h f B_m^2 \quad [ \because k = 2 ] \quad (2)$

$$P_{\text{eddy}} = k_e f^2 B_m^2 \quad (3)$$

Also,

We know that

Speed of machine,

$$N = \frac{120 f}{P}$$

$$\Rightarrow f = \frac{PN}{120}$$

$$\Rightarrow f = xN, \text{ where } x = \frac{P}{120}$$

Using the value of  $f$  in Eqs. (2) and (3), we get

$$P_h = k_h x N B_m^2 = k'_h N \quad (4)$$

$$P_{\text{eddy}} = k_e x^2 N^2 B_m^2 = k'_e N^2 \quad (5)$$

where  $k'_h = k_h x B_m$  and  $k'_e = k_e x^2 B_m^2$  are constants with  $B$  and  $x$  are fixed.

Using Eqs. (4) and (5) in Eq. (1), we get

$$P_{\text{total}} = K'_h N + k'_e N^2 \quad (5a)$$

Substituting  $P_{\text{total}}$  for different values of speed, we get

$$300 = k'_h (500) + k'_e (500)^2 \quad (6)$$

$$200 = k'_h (400) + k'_e (400)^2 \quad (7)$$

By solving Eqs. (6) and (7), we get

$$k'_h = 0.1$$

$$k'_e = 0.001$$

Proceeding to determine the total iron loss for  $0.9 B_m$ ,  $1.5t$  and speed of 1500 rpm and using  $k'_h$  and  $k'_e$  in Eq. (5a), we get

o o o o

$$P_{\text{total}} = 0.1 \times (250) \times (0.9) + 0.001 \times (250) \times (0.9) \times (1.5) \\ = 134.1562 \text{ W}$$

## 2.6 Magnetic Leakage

Not all flux flowing in a magnetic circuit is useful. Some amount of flux does not link the components of the magnetic circuit contributing towards the leakage flux, which affects the performance of the machine. The leakage flux of alternating nature can induce a voltage termed as leakage reactance voltage. **Table 2.5** describes the effects of leakage flux in various machines.

**Table. 2.5** | Effects of leakage flux in various machines

Type of machine	Effect of leakage flux
DC machine	Makes commutation difficult due to reactance voltage
Salient pole synchronous machine	Modifies the field excitation demand
Transformer	<ul style="list-style-type: none"> <li>• Affects the voltage regulation</li> <li>• May cause circulating currents to flow in tank walls</li> <li>• Causes forces to develop between windings in short circuit conditions</li> </ul>
Induction machine	Causes force to develop between windings in short circuit conditions
Alternator	Affects the voltage regulation

The leakage flux in armature of the rotating machines can be classified into the following categories as shown in **Fig. 2.20**.

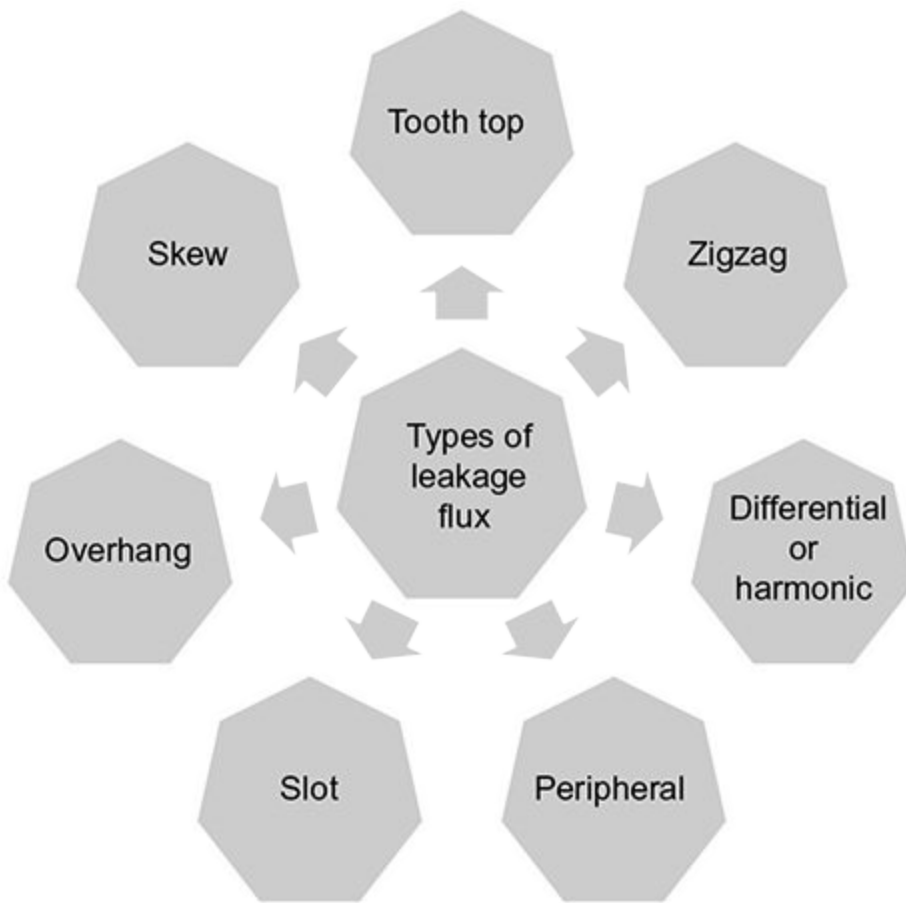

**Fig. 2.20** | Types of armature leakage flux

- **Tooth top leakage flux**

It passes from top of one teeth to another teeth's top as shown in [Fig. 2.21](#). It is pronounced in dc and synchronous machines, since the machines have a large air gap.

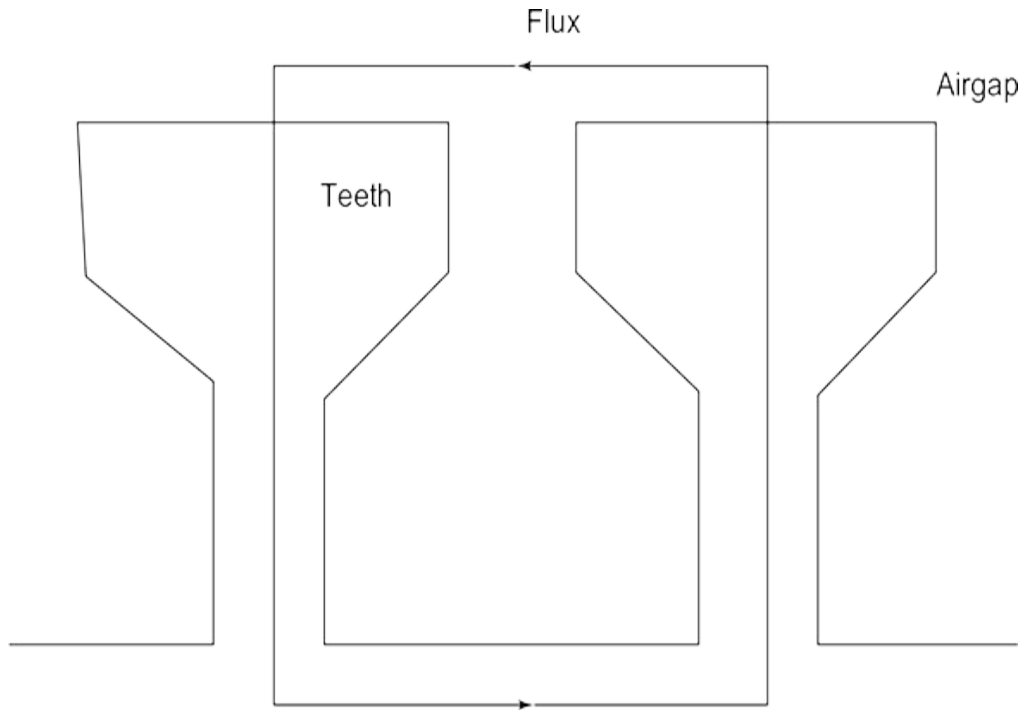

**Fig. 2.21** | Tooth top leakage flux

- **Zig-zag leakage flux**

It passes from one teeth to another teeth in zig-zag manner as shown in [Fig. 2.22](#). Its existence is based on relative to the positions of tooth tips of stator and rotor and length of air gap.

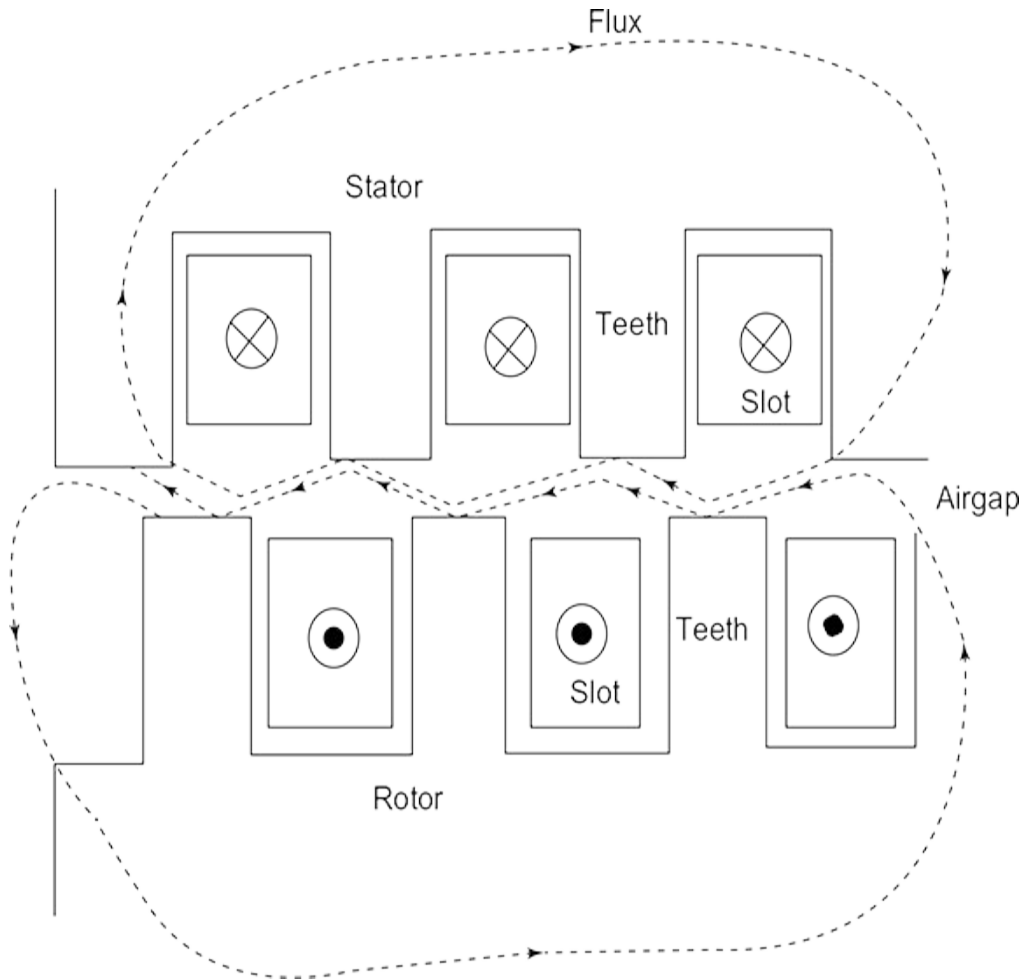

**Fig. 2.22** | Zig-zag leakage flux

- **Differential or harmonic or belt leakage flux**

It is present due to dissimilarity in harmonic contents of MMF of primary (stator) and secondary (rotor), where spatial distributions between MMFs are not the same as shown in [Fig. 2.21](#). Though squirrel cage induction machines are devoid of this flux, due to absence of harmonic leakage flux, its contribution is significant in other machines ([Fig. 2.23](#)).

- **Peripheral leakage flux**

It flows in the air gap throughout the circumference. It does not link any windings. It is insignificant in almost all the machines.

- **Slot leakage flux**

It takes a path travelling from one teeth to another teeth traversing the slot, linking the slice of conductor beneath it coming back through iron as shown in Fig. 2.22. It is present in all machines both ac and dc (Fig. 2.24).

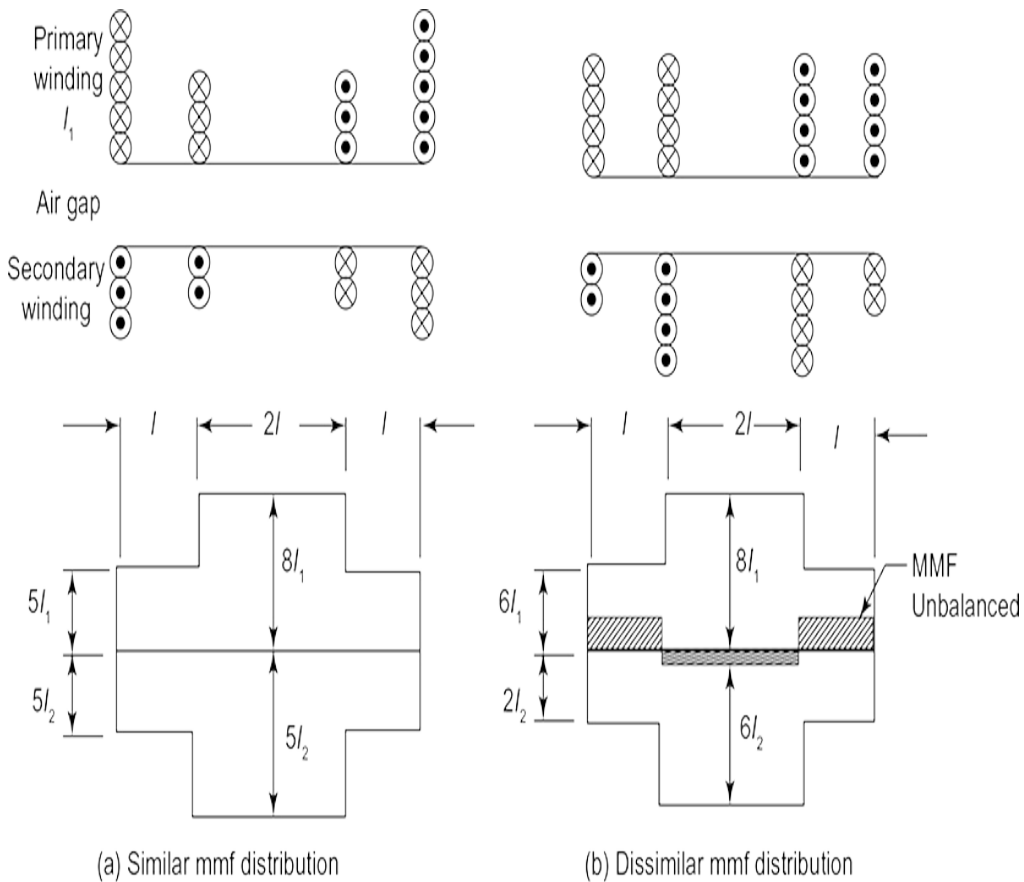

**Fig. 2.23** | Differential leakage flux for (a) similar and (b) dissimilar MMF distribution

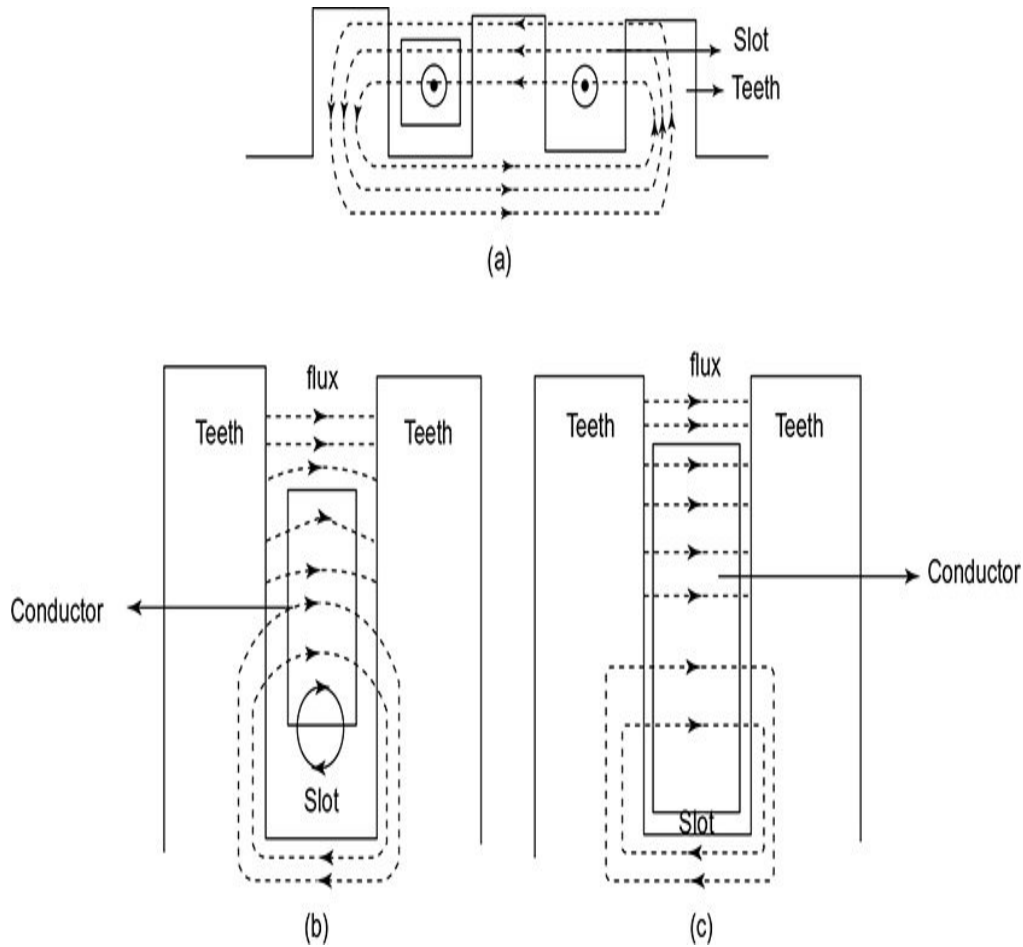

**Fig. 2.24** | (a) General representation of slot leakage flux, slot leakage flux in (b) stator and (c) rotor

- **Overhang leakage flux**

It is present due to overhang region of armature windings. It is a unique type of flux, present due to grouping of overhang and vicinity of metal masses (including core stiffness and end covers) as shown in [Fig. 2.25](#).

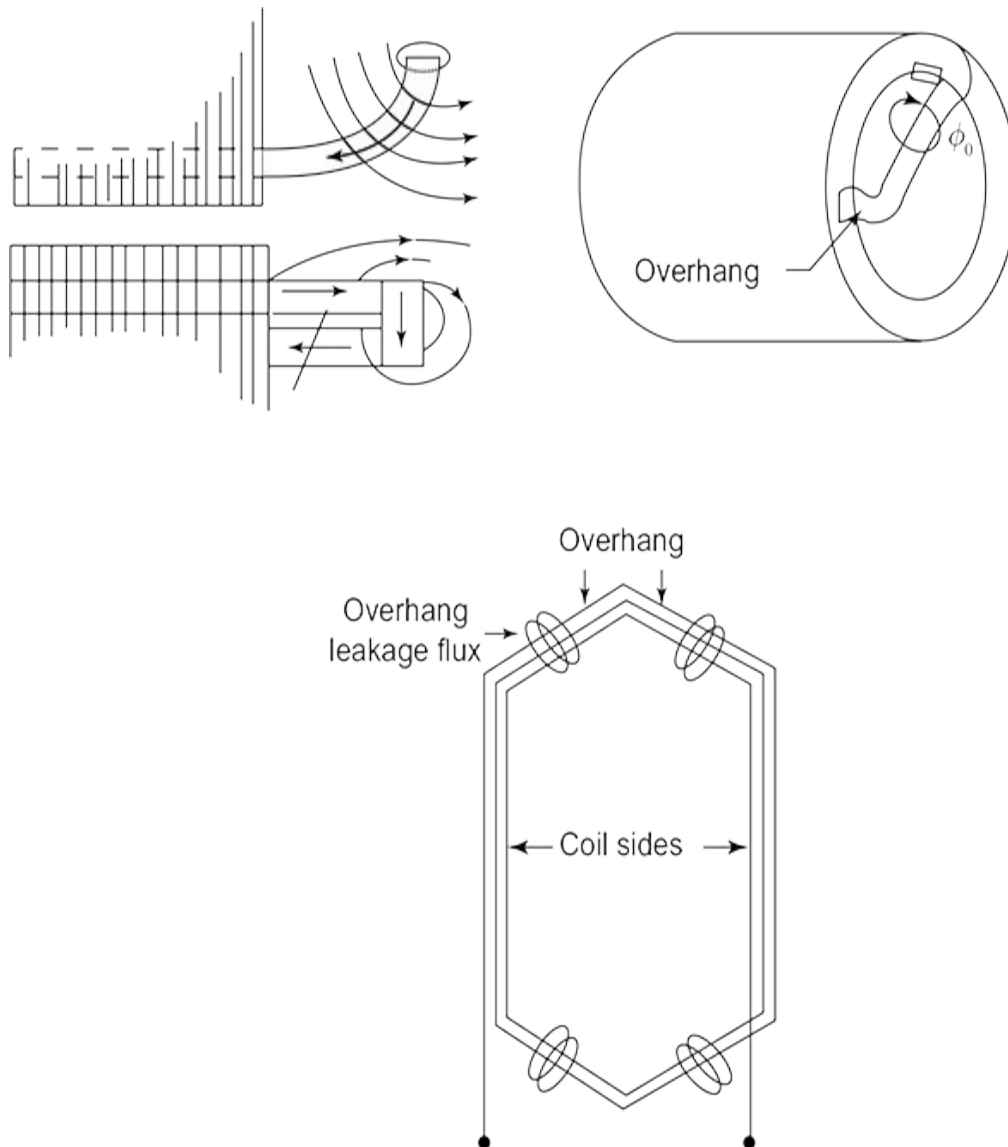

**Fig. 2.25** | Overhang leakage flux

- **Skew leakage flux**

It is present in skewed slots of motors. It is unique to induction machines in which rotors are skewed.

### 2.7 Estimation of Specific Permeance and Leakage Reactance

The following assumptions are made in estimation of specific permeance and leakage reactance of slots:

- Uniform distribution of current throughout the area of slot conductors.
- The path of leakage flux through the slot and around the iron at the bottom is straight.
- Determination of permeance is performed for air paths.
- The reluctance of iron is assumed to be zero.

The cross-section of non-conductor portion of the slot with the leakage flux is shown in Fig. 2.26.

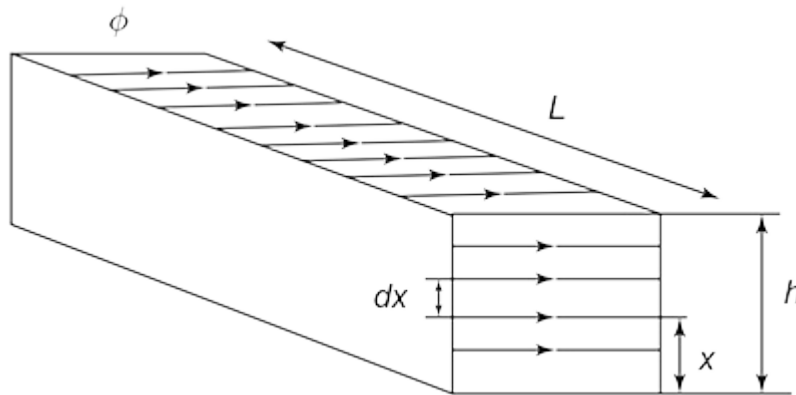

**Fig. 2.26** | Leakage flux representation in non-conductor portion of the slot

From Fig. 2.26,

$L$  – Depth of flux path

$h$  – Height of flux path

$y$  – Length of flux path

On considering a small length  $dx$  in the region as shown in Fig. 2.26, the permeance of section is given by

$$\int \Lambda_{sa} = \mu_0 \frac{Ldx}{y}$$

The total permeance of non-conductor portion of slot is calculated by integrating the above equation and is given by

$$\Lambda_{sa} = \int_0^h \mu_0 \frac{Ldx}{y} = \mu_0 L \int_0^h \frac{dx}{y}$$

The specific permeance, defined as the permeance per unit length of slot (or armature) or depth of flux path is given by

$$\lambda_{sa} = \frac{\Lambda_{sa}}{L} = \mu_0 \int_0^h \frac{dx}{y} \quad (2.39)$$

where  $Z_s$  – Total number of conductors per slot and  $Z_x$  – Number of conductors till height,  $x$ , from the bottom of slot.

The flux ( $d\phi_x$ ) in this region is given by

$$\begin{aligned} d\phi_x &= \text{MMF} \times \text{permeance} \\ &= I_Z Z_x \mu_0 \frac{Ldx}{y} \end{aligned}$$

Flux linkage linked with  $Z_x$  conductors is given by

$$dZ = Z_x d\phi_x$$

$$\begin{aligned}
&= Z_x \left( I_z Z_x \mu_0 \frac{L dx}{y} \right) \\
&= \mu_0 Z_x^2 L I_z \frac{dx}{y}
\end{aligned}$$

The total flux linkage in the conductor portion of slot is calculated by integrating the above equation and is given by

$$\begin{aligned}
\lambda_{Z_x} &= \int_0^h \mu_0 Z_x^2 L I_z \frac{dx}{y} \\
&= \mu_0 L I_z \int_0^h Z_x^2 \frac{dx}{y}
\end{aligned}$$

Hence,

$$\begin{aligned}
\text{effective flux} &= \frac{\lambda_{z_x}}{Z_s} \left[ \frac{\text{Total flux linkage}}{\text{Total number of conductors per slot}} \right] \\
&= \frac{\mu_0 L I_z}{Z_s} \int_0^h Z_x^2 \frac{dx}{y}
\end{aligned}$$

The total permeance of conductor portion of slot is given by

$$\begin{aligned}
\lambda_{sc} &= \frac{\text{Effective flux}}{\text{Total MMF}} \\
&= \frac{\frac{\mu_0 L I_z}{Z_s} \int_0^h Z_x^2 \frac{dx}{y}}{I_z Z_s} \\
&= \mu_0 L \int_0^h \left( \frac{Z_x}{Z_s} \right)^2 \frac{dx}{y}
\end{aligned}$$

The specific permeance of conductor portion of a slot is given by

$$\lambda_{sc} = \mu_0 \int_0^h \left( \frac{Z_x}{Z_s} \right)^2 \frac{dx}{y} \quad (2.40)$$

### 2.7.1 Parallel-sided Slot

A parallel-sided slot is represented in Fig. 2.27.

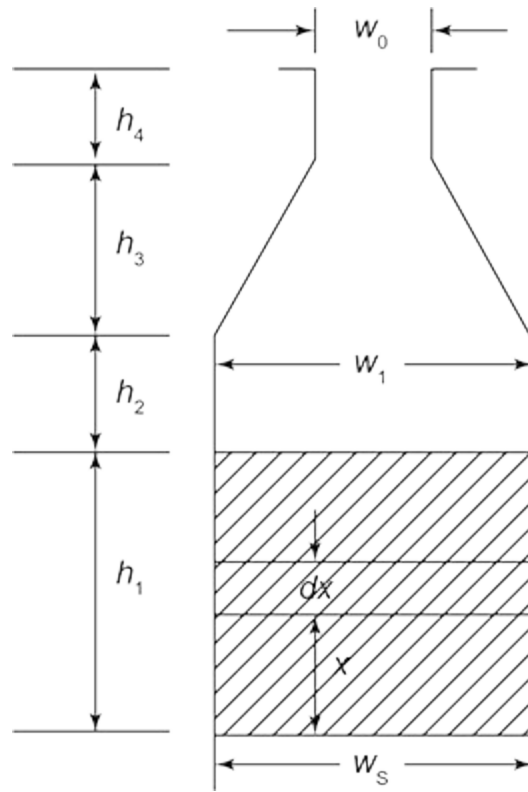

**Fig. 2.27** | Parallel-sided slot

The specific permeance is calculated as shown in [Table 2.6](#).

**Table. 2.6** | Specific permeance calculation

Parameters	$\lambda_{sa}$ (or $\lambda_{sc}$ )	$y$	$h$	$Z_x$	Derivation
Conductor portion	$\lambda_{sc} = \lambda_1$	$w_s$	$h_1$	$\frac{x}{h_1} Z_s$	$\lambda_1 = \mu_0 \int_0^{h_1} \left( \frac{\frac{x}{h_1} Z_s}{Z_s} \right)^2 \frac{dx}{w_s} = \mu_0 \int_0^{h_1} \frac{x^2}{h_1^2 w_s} dx$ $= \frac{\mu_0}{h_1^2 w_s} \int_0^{h_1} x^2 dx = \frac{\mu_0}{h_1^2 w_s} \left[ \frac{x^3}{3} \right]_0^{h_1}$ $= \frac{\mu_0}{h_1^2 w_s} \left[ \frac{h_1^3}{3} \right] = \mu_0 \frac{h_1}{3w_s}$
Non-conductor portion	$\lambda_{sa} = \lambda_2$	$w_s$	$h_2$	-	$\lambda_2 = \mu_0 \int_0^{h_2} \frac{dx}{w_s} = \frac{\mu_0}{w_s} \int_0^{h_2} dx$ $= \frac{\mu_0}{w_s} [x]_0^{h_2}$ $= \mu_0 \frac{h_2}{w_s}$

Parameters	$\lambda_{sa}$ (or $\lambda_{sc}$ )	$y$	$h$	$Z_x$	Derivation
	$\lambda_{sa} = \lambda_3$	$\frac{w_o + w_s}{2}$	$h_3$	-	$\lambda_3 = \mu_0 \int_0^{h_3} \frac{dx}{\frac{w_o + w_s}{2}} = \frac{2\mu_0}{w_o + w_s} \int_0^{h_3} dx$ $= \frac{2\mu_0}{w_o + w_s} [x]_0^{h_3} = \mu_0 \frac{2h_3}{w_o + w_s}$
	$\lambda_{sa} = \lambda_4$	$w_o$	$h_4$	-	$\lambda_4 = \mu_0 \int_0^{h_4} \frac{dx}{w_o} = \frac{\mu_0}{w_o} \int_0^{h_4} dx$ $= \frac{\mu_0}{w_o} [x]_0^{h_4} = \mu_0 \frac{h_4}{w_o}$

From Table 2.6, the total specific permeance is given by

$$\begin{aligned} \lambda_s &= \lambda_1 + \lambda_2 + \lambda_3 + \lambda_4 \\ &= \mu_0 \left[ \frac{h_1}{3w_s} + \frac{h_2}{w_s} + \frac{2h_3}{w_o + w_s} + \frac{h_4}{w_o} \right] \end{aligned}$$

### 2.7.2 Parallel-sided Slot with Double Layer Windings

A parallel-sided slot with double layer windings is represented in Fig. 2.28.

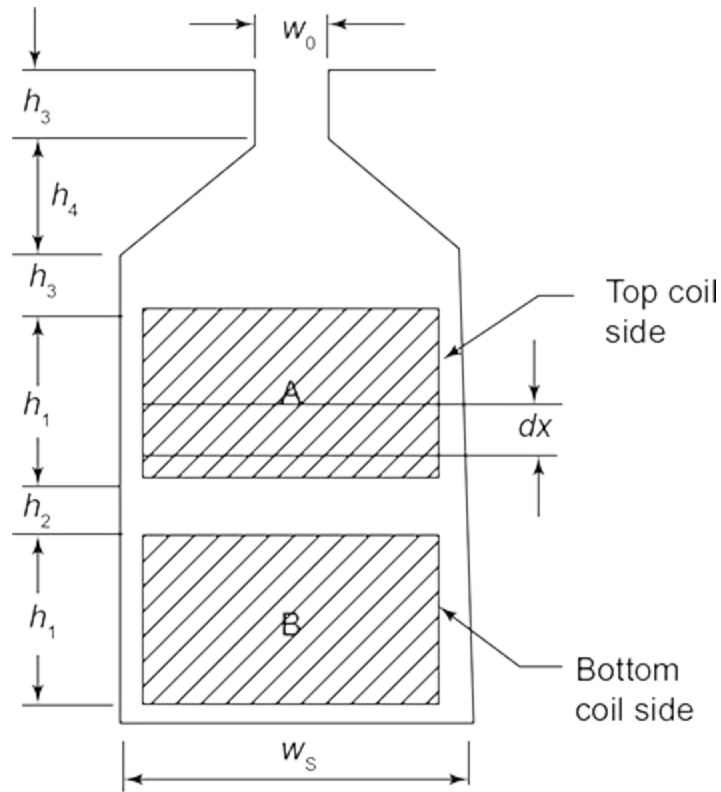

**Fig. 2.28** | Parallel-sided slot with double layer windings

The specific permeance is calculated as shown in [Table 2.7](#).

**Table 2.7** | Specific permeance calculation

Parameters	$\lambda_{sa}$ (or $\lambda_{sc}$ )	$y$	$h$	$Z_x$	Derivation
Conductor portion (A)	$\lambda_{sc} = \lambda_1$	$w_s$	$h_1$	$\frac{x}{h_1} Z_s$	$\lambda_1 = \mu_0 \int_0^{h_1} \left( \frac{\frac{x}{h_1} Z_s}{Z_s} \right)^2 \frac{dx}{w_s}$ $= \mu_0 \int_0^{h_1} \frac{x^2}{h_1^2 w_s} dx = \frac{\mu}{h_1^2 w_s} \int_0^{h_1} x^2 dx$ $= \frac{\mu_0}{2} \left[ \frac{x^3}{h_1^2 w_s} \right]_0^{h_1}$

					$h_1^2 w_s \left[ \frac{x^3}{3} \right]_0^{h_1}$ $= \frac{\mu_0}{h_1^2 w_s} \left[ \frac{h_1^3}{3} \right] = \mu_0 \frac{h_1}{3 w_s}$
Conductor portion (B)	$\lambda_{sc} = \lambda_3$	$w_s$	$h_3$	$\frac{x}{h_3} Z_s$	$\lambda_1 = \mu_0 \int_0^{h_3} \left( \frac{\frac{x}{h_3} Z_s}{Z_s} \right)^2 \frac{dx}{w_s} = \mu_0 \int_0^{h_3} \frac{x^2}{h_3^2 w_s} dx$ $= \frac{\mu}{h_3^2 w_s} \int_0^{h_3} x^2 dx$ $= \frac{\mu_0}{h_3^2 w_s} \left[ \frac{x^3}{3} \right]_0^{h_3}$ $= \frac{\mu_0}{h_3^2 w_s} \left[ \frac{h_3^3}{3} \right] = \mu_0 \frac{h_3}{3 w_s}$
Non-conductor portion (above conductor A)	$\lambda_{sa} = \lambda_2$	$w_s$	$h_2$	-	$\lambda_2 = \mu_0 \int_0^{h_2} \frac{dx}{w_s} = \frac{\mu_0}{w_s} \int_0^{h_2} dx$ $= \frac{\mu_0}{w_s} [x]_0^{h_2} = \mu_0 \frac{h_2}{w_s}$
	$\lambda_{sa} = \lambda_4$	$w_o$	$h_4$	-	$\lambda_4 = \mu_0 \int_0^{h_4} \frac{dx}{w_o} = \frac{\mu_0}{w_o} \int_0^{h_4} dx$ $= \frac{\mu_0}{w_o} [x]_0^{h_4} = \mu_0 \frac{h_4}{w_o}$

Parameters	$\lambda_{sa}$ (or $\lambda_{sc}$ )	$y$	$h$	$Z_x$	Derivation
	$\lambda_{sa} = \lambda_5$	$\frac{w_o + w_s}{2}$	$h_5$	-	$\lambda_5 = \mu_0 \int_0^{h_5} \frac{dx}{\frac{w_o + w_s}{2}} = \frac{2\mu_0}{w_o + w_s} \int_0^{h_5} dx$ $= \frac{2\mu_0}{w_o + w_s} [x]_0^{h_5} = \mu_0 \frac{2h_5}{w_o + w_s}$
	$\lambda_{sa} = \lambda_6$	$w_o$	$h_6$	-	$\lambda_6 = \mu_0 \int_0^{h_6} \frac{dx}{w_o} = \frac{\mu_0}{w_o} \int_0^{h_6} dx$ $= \frac{\mu_0}{w_o} [x]_0^{h_6} = \mu_0 \frac{h_6}{w_o}$

From Table 2.7, the total specific permeance is given by

$$\lambda_s = \lambda_1 + \lambda_2 + \lambda_3 + \lambda_4 + \lambda_5 + \lambda_6$$

$$= \mu_0 \left[ \frac{h_1}{3w_s} + \frac{h_2}{w_s} + \frac{h_3}{3w_s} + \frac{h_4}{w_s} + \frac{2h_5}{w_o + w_s} + \frac{h_6}{w_o} \right]$$

### 2.7.3 Tapered Slot

A tapered slot is represented in Fig. 2.29.

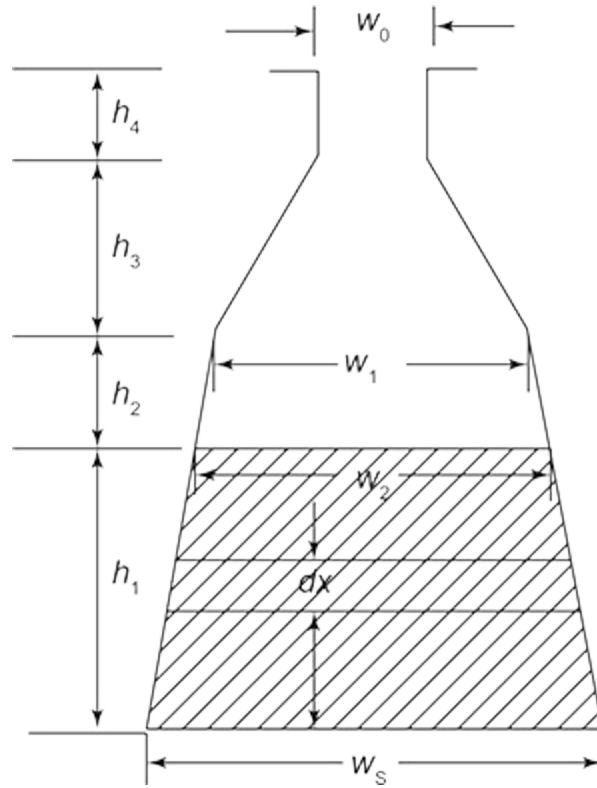

**Fig. 2.29** | Tapered slot

The specific permeance is calculated as shown in [Table 2.8](#).

**Table 2.8** | Specific permeance calculation

Parameters	$\lambda_{sa}$ (or $\lambda_{sc}$ )	$y$	$h$	$Z_x$	Derivation
Conductor portion	$\lambda_{sc} = \lambda_1$	$\frac{w_2 + w_s}{2}$	$h_1$	$\frac{x}{h_1} Z_s$	$\lambda_1 = \mu_0 \int_0^{h_1} \left( \frac{\frac{x}{h_1} Z_s}{Z_s} \right)^2 \frac{dx}{\frac{w_2 + w_s}{2}}$ $= \mu_0 \frac{2}{w_2 + w_s} \int_0^{h_1} \frac{x^2}{h_1^2} dx$ $= \mu_0 \frac{2}{(w_2 + w_s) h_1^2} \int_0^{h_1} x^2 dx$

					$= \mu_0 \frac{2}{(w_2 + w_s)h_1^2} \left[ \frac{x^3}{3} \right]_0^{h_1}$ $= \mu_0 \frac{2}{(w_2 + w_s)h_1^2} \left[ \frac{h_1^3}{3} \right]$ $= \mu_0 \frac{2h_1}{3(w_2 + w_s)}$
Non-conductor portion	$\lambda_{sa} = \lambda_2$	$\frac{w_1 + w_2}{2}$	$h_2$	-	$\lambda_2 = \mu_0 \int_0^{h_2} \left( \frac{dx}{\frac{w_1 + w_2}{2}} \right) = \mu_0 \frac{2}{w_1 + w_2} \int_0^{h_2} dx$ $= \mu_0 \frac{2}{(w_1 + w_2)} [x]_0^{h_2}$ $= \mu_0 \frac{2h_2}{w_1 + w_2}$
	$\lambda_{sa} = \lambda_3$	$\frac{w_0 + w_1}{2}$	$h_3$	-	$\lambda_3 = \mu_0 \int_0^{h_3} \left( \frac{dx}{\frac{w_0 + w_1}{2}} \right) = \mu_0 \frac{2}{w_0 + w_1} \int_0^{h_3} dx$ $= \mu_0 \frac{2}{(w_0 + w_1)} [x]_0^{h_3} = \mu_0 \frac{2h_3}{w_0 + w_1}$
	$\lambda_{sa} = \lambda_4$	$w_0$	$h_4$	-	$\lambda_4 = \mu_0 \int_0^{h_4} \frac{dx}{w_0} = \mu_0 \frac{1}{w_0} \int_0^{h_4} dx$ $= \mu_0 \frac{1}{w_0} [x]_0^{h_4} = \mu_0 \frac{h_4}{w_0}$

From Table 2.8, the total specific permeance is given by

$$\lambda_s = \lambda_1 + \lambda_2 + \lambda_3 + \lambda_4$$

$$= \mu_0 \left[ \frac{2h_1}{3(w_2 + w_s)} + \frac{2h_2}{w_1 + w_2} + \frac{2h_3}{w_0 + w_1} + \frac{h_4}{w_0} \right]$$

### 2.7.4 Circular Slot

A circular slot is represented in Fig. 2.30.

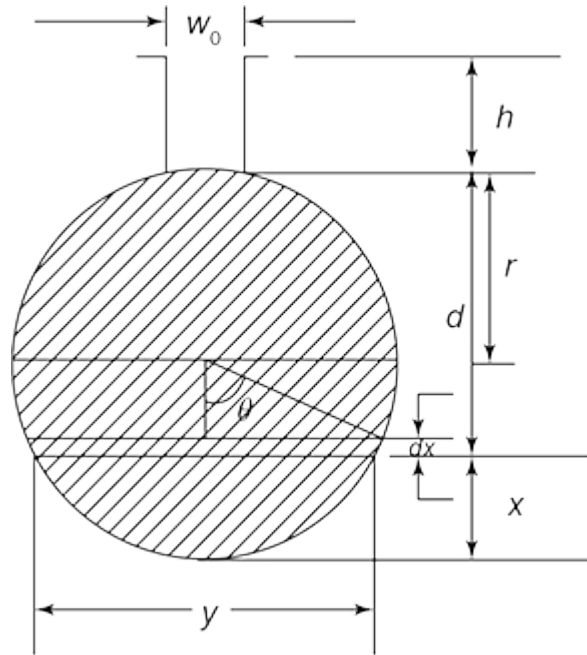

**Fig. 2.30** | Circular slot

The specific permeance calculations are as follows.

From Fig. 2.29, it is observed that

$$\sin \theta = \frac{y}{r} = \frac{y}{2r} \quad (2.41)$$

$$\cos \theta = \frac{r-x}{r} \quad (2.42)$$

$$\text{Area of segment at height } x = \frac{r^2}{2} [2\theta - \sin 2\theta]$$

Conductor portions producing flux in the strip

$$\begin{aligned} &= \frac{r^2}{2} \frac{[2\theta - \sin 2\theta]}{\pi r^2} Z_s = \frac{1}{2\pi} [2\theta - \sin 2\theta] Z_s \\ &= \frac{1}{\pi} \left[ \theta - \frac{\sin 2\theta}{2} \right] Z_s \end{aligned}$$

Flux in the strip,  $df_x = \text{MMF} \times \text{permeance}$  (2.43)

$$\text{MMF} = \frac{1}{\pi} \left[ \theta - \frac{\sin 2\theta}{2} \right] Z_s I_z \quad (2.44)$$

$$\text{Permeance} = \mu_0 \frac{L dx}{y} \quad (2.45)$$

From Eq. (2.41),

$$y = 2r \sin \theta \quad (2.46)$$

Differentiating Eq. (2.42) with respect to  $\theta$ , we get

$$\frac{d}{d\theta}[\cos \theta] = \frac{d}{d\theta} \left[ \frac{r-x}{r} \right]$$

$$-\sin \theta = \frac{d}{d\theta} \left[ \frac{r}{r} \right] - \frac{d}{d\theta} \left[ \frac{x}{r} \right]$$

$$\Rightarrow -\sin \theta = 0 - \frac{1}{r} \frac{dx}{d\theta}$$

$$\Rightarrow \sin \theta = \frac{1}{r} \frac{dx}{d\theta}$$

$$\Rightarrow dx = r \sin \theta d\theta \quad (2.47)$$

Substituting Eqs. (2.47) and (2.46) in Eq. (2.45), we get

$$\begin{aligned} \text{Permeance} &= \frac{\mu_0 L r \sin \theta d\theta}{2r \sin \theta} \\ &= \mu_0 \frac{L d\theta}{2} \end{aligned} \quad (2.48)$$

Substituting Eqs. (2.44) and (2.48) in Eq. (2.43), we get

$$\begin{aligned} d\phi_x &= \frac{1}{\pi} \left[ \theta - \frac{\sin 2\theta}{2} \right] Z_s I_z \times \mu_0 \frac{L d\theta}{2} \\ &= \frac{\mu_0 L Z_s I_z}{2\pi} \left[ \theta - \frac{\sin 2\theta}{2} \right] d\theta \end{aligned}$$

Flux linkage in strip,

$d\psi_x = d\theta_x \times$  conductor portions producing flux in the strip

$$= \frac{\mu_0 LZ_s I_z}{2\pi} \left[ \theta - \frac{\sin 2\theta}{2} \right] d\theta \times \frac{1}{\pi} \left[ \theta - \frac{\sin 2\theta}{2} \right] Z_s$$

$$= \frac{\mu_0 LZ_s^2 I_z}{2\pi^2} \left[ \theta - \frac{\sin 2\theta}{2} \right]^2 d\theta$$

Total flux linkage in the conductor portion of the slot,

$$\psi = \int d\psi_x$$

$$= \int_0^\pi \frac{\mu_0 LZ_s^2 I_z}{2\pi^2} \left[ \theta - \frac{\sin 2\theta}{2} \right]^2 d\theta$$

$$= \frac{\mu_0 LZ_s^2 I_z}{2\pi^2} \int_0^\pi \left[ \theta - \frac{\sin 2\theta}{2} \right]^2 d\theta$$

$$= \frac{\mu_0 LZ_s^2 I_z}{2\pi^2} \int_0^\pi \left[ \theta^2 + \frac{\sin^2 2\theta}{2} - \frac{2\theta \sin 2\theta}{2} \right] d\theta$$

$$= 0.623 \mu_0 LZ_s^2 I_z$$

Effective permeance of conductor portion,

$$\Lambda_c = \frac{\psi}{I_z Z_s^2} = 0.623 \mu_0 L$$

Specific permeance of conductor portion,

$$\lambda_c = \frac{\Lambda_c}{L} = 0.623 \mu_0$$

Specific permeance of slot opening,

$$\lambda_1 = \int_0^h \mu_0 \frac{dx}{y} = \mu_0 \frac{h}{w_c}$$

Total specific slot permeance,

$$\begin{aligned} \lambda_s &= \lambda_c + \lambda_1 \\ &= 0.623 \mu_0 + \mu_0 \frac{h}{w_c} \\ &= \mu_0 \left[ 0.623 + \frac{h}{w_c} \right] \end{aligned} \quad (2.49)$$

### 2.7.5 T Bar Slot (Induction Motor)

A T bar slot is represented in **Fig. 2.31**. The specific permeance calculations are as follows:

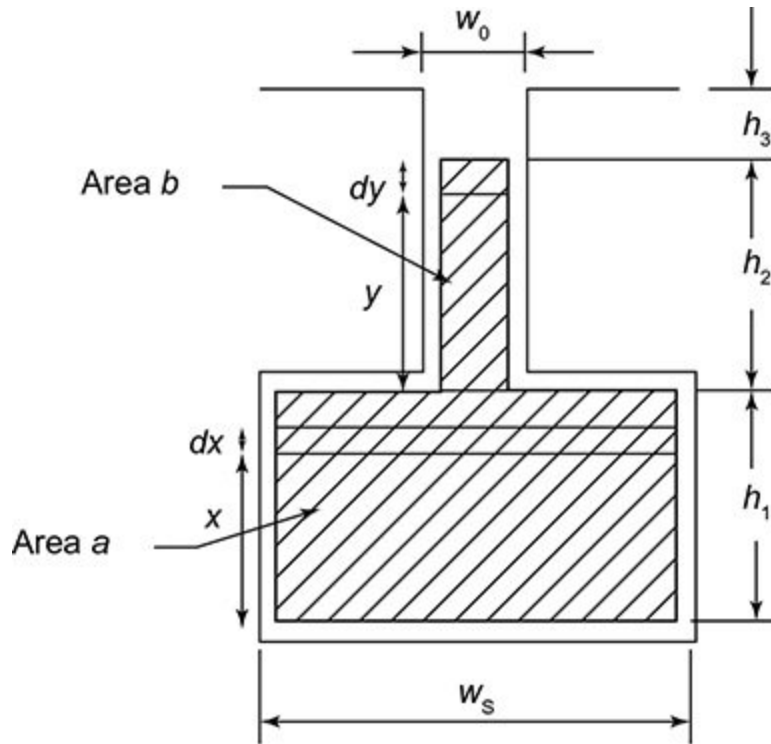

**Fig. 2.31** | T bar slot

The specific permeance calculation is shown in [Table 2.9](#).

**Table 2.9** | Specific permeance calculation

Parameters	$\lambda_{sa}$ (or $\lambda_{sc}$ )	$y$	$h$	$Z_x$	Derivation
Conductor portion ( $a$ )	$\lambda_{sc1} = \lambda_1$	$w_s$	$h_1$	$\frac{x}{h_1} \frac{a}{a+b} Z_s$	$\lambda_1 = \mu_0 \int_0^{h_1} \left( \frac{\frac{x}{h_1} \frac{a}{a+b} Z_s}{Z_s} \right)^2 \frac{dx}{w_s}$ $= \mu_0 \frac{1}{w_s} \int_0^{h_1} \frac{x^2}{h_1^2} \frac{a^2}{(a+b)^2} dx$ $= \mu_0 \frac{1}{w_s h_1^2} \int_0^{h_1} x^2 \frac{a^2}{(a+b)^2} dx$ $= \mu_0 \frac{1}{w_s h_1^2} \frac{a^2}{(a+b)^2} \left[ \frac{x^3}{3} \right]_0^{h_1}$ $= \mu_0 \frac{1}{w_s h_1^2} \frac{a^2}{(a+b)^2} \left[ \frac{h_1^3}{3} \right]$ $= \mu_0 \frac{h_1}{3w_s} \frac{a^2}{(a+b)^2}$

Parameters	$\lambda_{sa}$ (or $\lambda_{sc}$ )	$y$	$h$	$Z_x$	Derivation
Conductor portion ( $b$ )	$\lambda_{sc2} = \lambda_2$	$w_0$	$h_2$	$\frac{y}{h_2} \frac{b}{a+b} Z_s + \frac{a}{a+b} Z_s$	$\lambda_2 = \mu_0 \int_0^{h_2} \left( \frac{\frac{y}{h_2} \frac{b}{a+b} Z_s + \frac{a}{a+b} Z_s}{Z_s} \right)^2 \frac{dy}{w_0}$ $= \mu_0 \frac{h_2}{w_0} \left( \frac{a^2 + ab + b^2}{(a+b)^2} \right)$
Non-conductor portion	$\lambda_{sa} = \lambda_3$	$w_0$	$h_3$	-	$\lambda_3 = \mu_0 \int_0^{h_3} \frac{dx}{w_0} = \mu_0 \frac{1}{w_0} \int_0^{h_3} dx$ $= \mu_0 \frac{1}{w_0} [x]_0^{h_3}$ $= \mu_0 \frac{h_3}{w_0}$

## 2.8 Magnetic Pull

Magnetic pull is the force exerted between two poles of magnet, when separated by a distance as shown in Fig. 2.32.

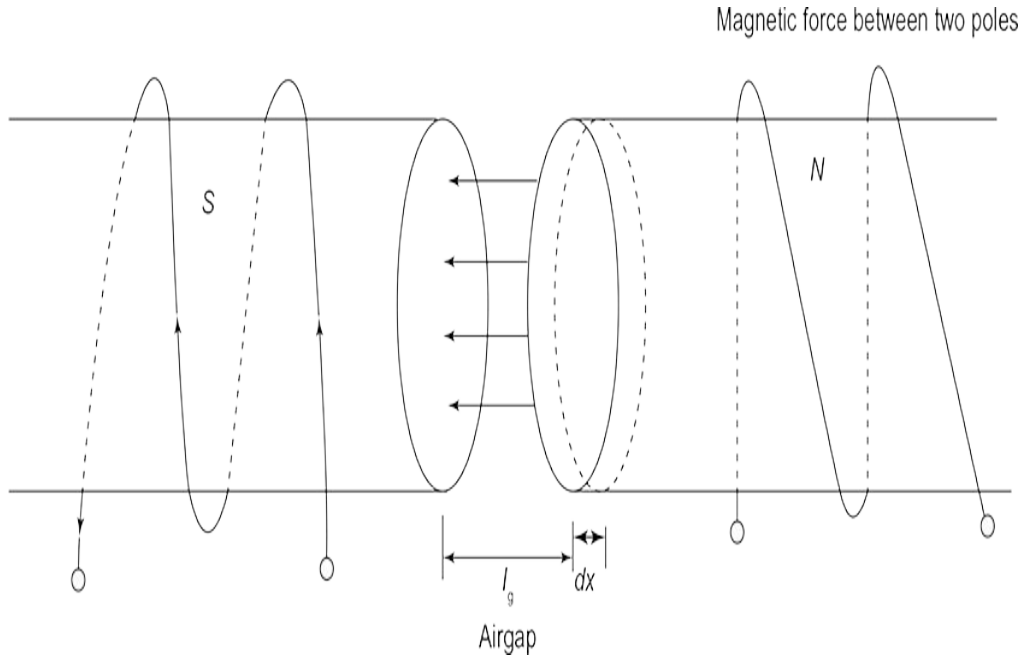

**Fig. 2.32** | Magnetic force exerted between two poles

The force can be determined from change in magnetic field energy stored in terms of energy density and volume change and is given by

$$\text{Change in magnetic field energy} = \text{Energy density} \times \text{Volume change} \quad (2.50)$$

where

Change in magnetic field energy =  $Fdy$  = work done (when one pole is moved by distance  $dy$ )

$$\begin{aligned} \text{Energy density} &= \frac{1}{2}BH = \frac{1}{2}\mu_0H^2 \\ &= \frac{1}{2} \frac{B^2}{\mu_0} \end{aligned}$$

$[\mu_0$  is used since it is a free space and relative permeability of air,  $\mu_0 = 1]$

$$\text{Volume change} = A dy$$

and  $F$  – force between two poles,  $dy$  – distance by which one pole is moved,  $B$  – magnetic flux density,  $H$  – magnetic field intensity and  $A$  – area of one pole.

Substituting the above values in Eq. (2.50), we get

$$F dy = \frac{1}{2} \frac{B^2}{\mu_0} \times A dy$$

$$\Rightarrow F = \frac{1}{2} \frac{B^2}{\mu_0} A \quad (2.51)$$

$$\Rightarrow \frac{F}{A} = \frac{1}{2} \frac{B^2}{\mu_0}$$

$$\Rightarrow P_m = \frac{1}{2} \frac{B^2}{\mu_0} \quad (2.52)$$

Thus from Eq. (2.52), it is observed that, force per unit area or magnetic pull depends on magnetic flux density of air gap which in turn depends on MMF of source of excitation.

The MMF is given by

$$AT = AT_i + AT_g$$

where  $AT_i$  – MMF of iron and  $AT_g$  – MMF of air gap.

Generally, if there is no saturation in the portion of iron, MMF  $AT_i$  is very small. Hence, MMF can be approximated as  $AT \approx AT_g$ .

Therefore, expressing magnetic flux density in terms of MMF, we get

$$B = \frac{\mu_0 AT_g}{l_g} \left[ \because B = \mu_0 H, \text{ where } H = \frac{AT}{l} \right]$$

where  $l_g$  – length of air gap.

Substituting the value of  $B$  in Eq. (2.51), we get

$$\begin{aligned} F &= \frac{1}{2} \left( \frac{\mu_0 AT_g}{l_g} \right)^2 \times \frac{A}{\mu_0} \\ &= \frac{1}{2} \mu_0 \left( \frac{AT_g}{l_g} \right)^2 A \end{aligned}$$

The above expression gives magnetic force of attraction existing between poles in terms of MMF of source of excitation.

### 2.8.1 Radial Magnetic Forces

In a rotating electrical machine, the magnetic force of attraction exists between stator and rotor poles, about the direction perpendicular to axis of shaft of rotor. This force of attraction when considered for a two-pole machine as shown in Fig. 2.32 is given by

$$F = F_T - F_B \quad (2.53)$$

where  $F_T$  – force of attraction for stator and rotor poles at the top, given by

$$F_T = \frac{1}{2} \mu_0 \left( \frac{AT}{l_g} \right)^2 A$$

$F_B$  – force of attraction for stator and rotor poles at the bottom, given by

$$F_B = \frac{1}{2} \mu_0 \left( \frac{A_T}{l_g} \right)^2 A$$

Substituting the values of  $F_T$  and  $F_B$  in Eq. (2.53), it is observed that

$$F = \frac{1}{2} \mu_0 \left( \frac{A_T}{l_g} \right)^2 A - \frac{1}{2} \mu_0 \left( \frac{A_T}{l_g} \right)^2 A$$

$$F = 0 \quad (2.54)$$

Equation (2.54) is valid for the following conditions:

1. Rotor is symmetrical and concentric with respect to stator by being a uniform cylinder.
2. Length of air gap is uniform at all places.
3. MMF of iron is negligible.
4. Flux distribution is uniform.

From Eq. (2.54), it can be stated that resultant magnetic force of attraction is zero, resulting in zero or nil radial magnetic pull on the rotor,

$$\text{since } F = 0 \Rightarrow P_m = \frac{F}{A} = 0$$

### *2.8.2 Radial Magnetic Forces and Unbalanced Magnetic Pull*

In case of ac machine, magnetic flux density,  $B = B_m \sin \theta$ . Consider a small portion from Fig. 2.33, with area,

$$A = \frac{D}{2} L d\theta$$

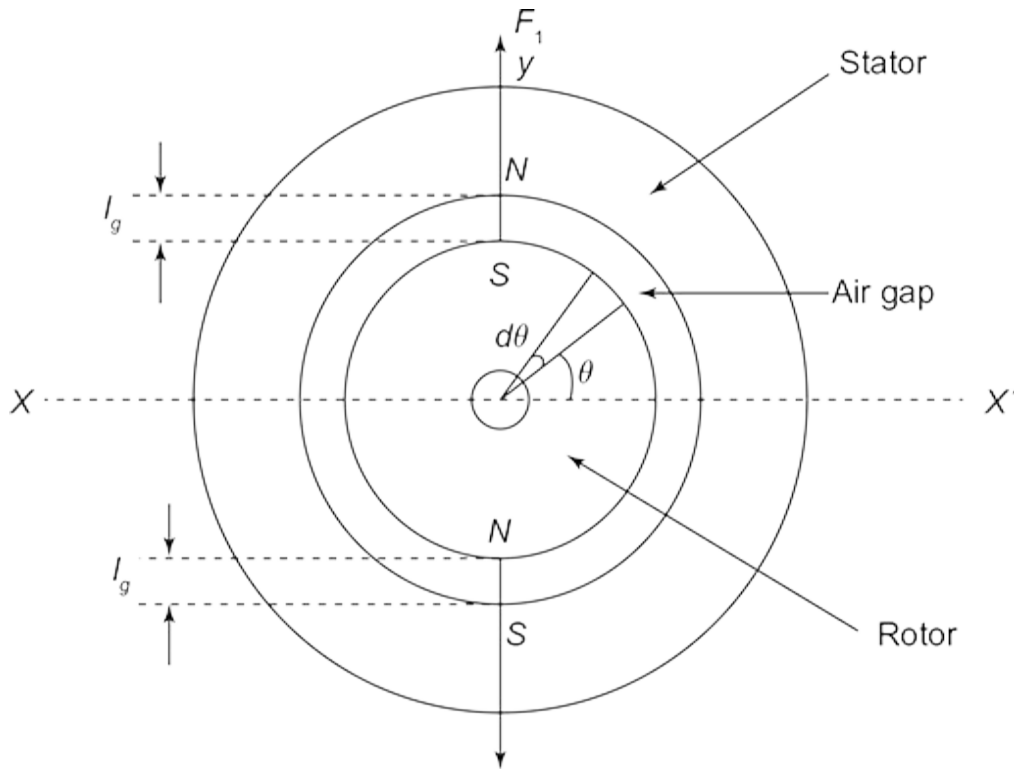

**Fig. 2.33** | Symmetrical machine with radial magnetic forces

The radial force, giving the force of attraction at top stator and rotor poles, for this small element is given by

$$\begin{aligned}
 F_T &= \frac{1}{2} \frac{(B_m \sin \theta)^2}{\mu_0} \frac{DL}{2} d\theta \\
 &= \frac{1}{4\mu_0} B_m \sin^2 \theta DL d\theta \\
 &= \frac{1}{4\mu_0} B_m DL \sin^2 \theta d\theta
 \end{aligned}$$

The vertical component of the above equation is given by

$$\begin{aligned}
 F_{T(\text{vertical})} &= \frac{1}{4\mu_0} B_m DL \sin^2 \theta d\theta \times \sin \theta \\
 &= \frac{1}{4\mu_0} B_m DL \sin^3 \theta d\theta \qquad (2.55)
 \end{aligned}$$

The resultant magnetic pull acting vertically is determined by integrating the above equation over area swept between 0 and  $\pi$ .

$$\begin{aligned}
 \Rightarrow F_{T(\text{vertical})} &= \int_0^\pi \frac{1}{4\mu_0} B_m DL \sin^3 \theta d\theta \\
 &= \frac{1}{4\mu_0} B_m DL \times \left[ \frac{1}{3} \cos^3 \theta - \cos \theta + C \right]_0^\pi \\
 &\qquad \left[ \because \int \sin^3 x dx = \frac{1}{3} \cos^3 x - \cos x + C \right]
 \end{aligned}$$

Substituting  $C = 0$  and  $\cos^3 \theta = \frac{1}{4}(\cos \theta + 3 \cos \theta)$  in the above equation and substituting the limits of integration

$$\begin{aligned}
&= \frac{1}{4\mu_0} B_m DL \left[ \frac{1}{3} \times \frac{1}{4} [\cos 3\theta + 3\cos\theta] - \cos\theta \right]_0^\pi \\
&= \frac{1}{4} B_m DL \left[ \frac{1}{12} (-4) - (-1) - \left( \frac{1}{12} (4) - 1 \right) \right] \\
&= \frac{1}{4\mu_0} B_m DL \left( \frac{4}{3} \right) = \frac{1}{3\mu_0} B_m DL
\end{aligned}$$

Similarly, for bottom stator and rotor poles,

$$F_{B(\text{vertical})} = \frac{1}{3\mu_0} B_m^2 DL$$

The net resultant radial magnetic pull is given by

$$F = F_T - F_B = 0 \quad (2.56)$$

Equation (2.56) can be arrived at integrating Eq. (2.55) over limits 0 to  $2\pi$ , covering whole machine with two poles and is given by

$$\int_0^{2\pi} \frac{1}{4\mu_0} B_m^2 DL \sin^3 \theta d\theta = 0 \quad (2.57)$$

Equations (2.56) and (2.57) hold good for conditions defined in the previous section.

In practical cases, manufacturing tolerances are allowed in dimensions defining the machine. The

manufacturing defects can be present causing a non-uniform air gap to be present between a stator and a rotor. In such cases, the resultant magnetic pull is not zero and is given by difference between the magnetic forces of attraction existing between the number of poles involved in stator and rotor of machine. The resultant unbalanced magnetic pull is determined as follows.

Consider an unsymmetrical electric machine as shown in Fig. 2.34.

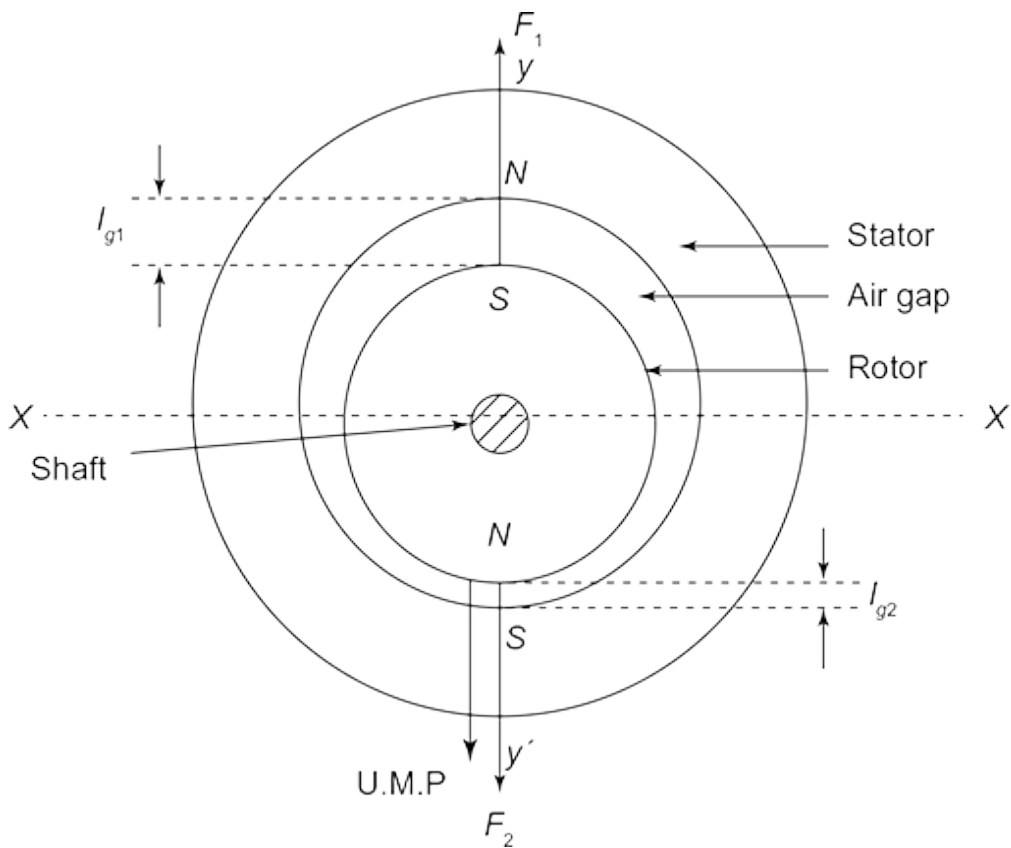

**Fig. 2.34** | Unsymmetrical machine with unbalanced magnetic pull

It is observed that the length of air gap at the top of the machine is larger than the length of air gap at the bottom of the machine, i.e., ( $l_{g1} > l_{g2}$ ).

The force of attraction at top stator and rotor poles is given by

$$F_T = \frac{1}{2} \mu_0 \left( \frac{AT}{l_{g1}} \right)^2 A$$

The force of attraction at bottom stator and rotor poles is given by

$$F_B = \frac{1}{2} \mu_0 \left( \frac{AT}{l_{g2}} \right)^2 A$$

The resultant magnetic pull or force is given by

$$F = F_T - F_B$$

$$= \frac{1}{2} \mu_0 \left( \frac{AT}{l_{g1}} \right)^2 - \frac{1}{2} \mu_0 \left( \frac{AT}{l_{g2}} \right)^2 \quad (2.58)$$

$$= \frac{1}{2} \mu_0 A_T^2 \left( \frac{1}{l_{g1}^2} - \frac{1}{l_{g2}^2} \right) \quad (2.59)$$

From Eq. (2.59), it is observed that  $F_T > F_B$  since  $l_{g2} > l_{g1}$ . This resultant magnetic pull or force is called unbalanced magnetic pull and in the above case it sets in the downward direction.

Apart from non-uniformity in air gap, asymmetrical magnetic circuit or placement of windings can result in unbalanced magnetic pull.

### 2.8.3 Determination of Unbalanced Magnetic Pull

Consider a rotating machine with diameter of rotor ( $D$ ), stack or core length ( $L$ ) as shown in Fig. 2.35(a) and (b).

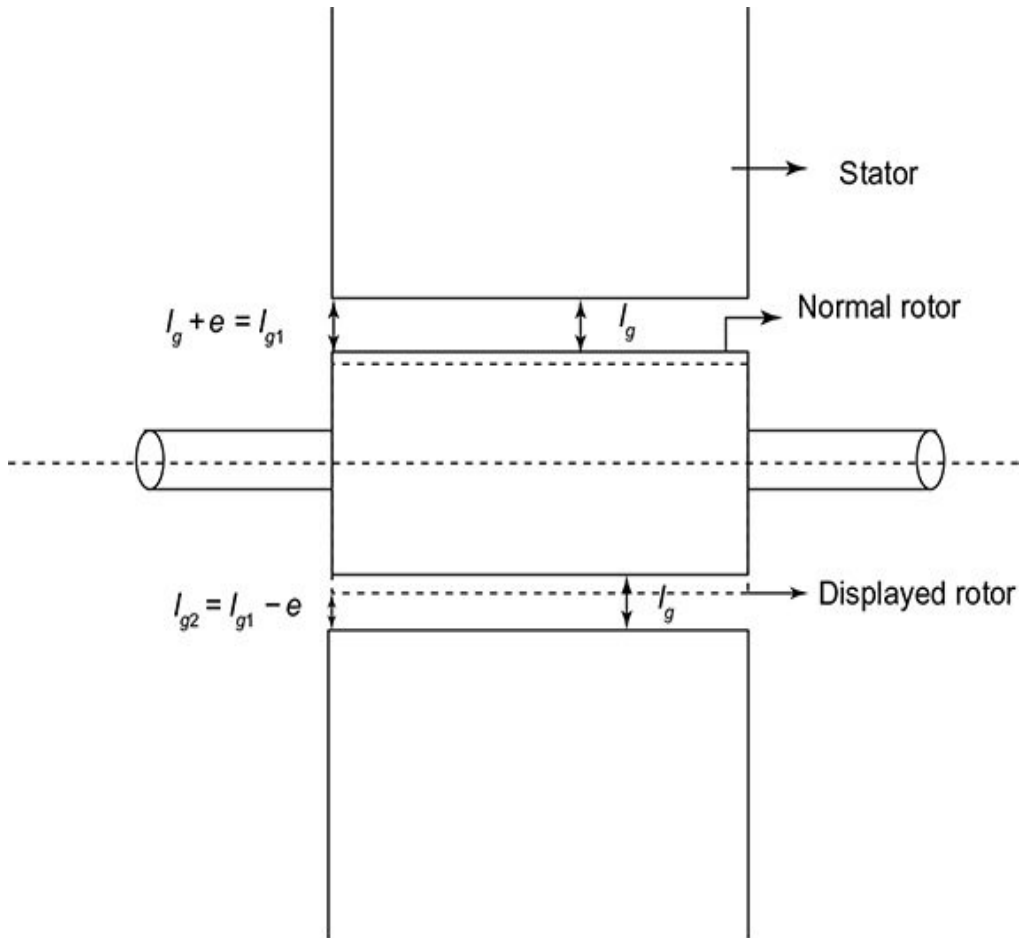

(a)

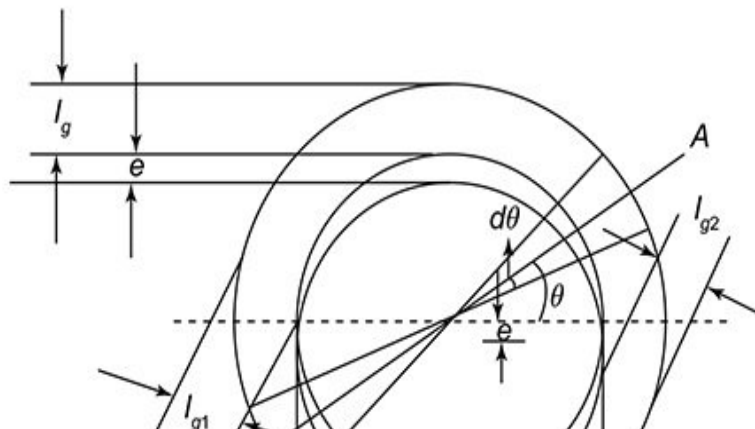

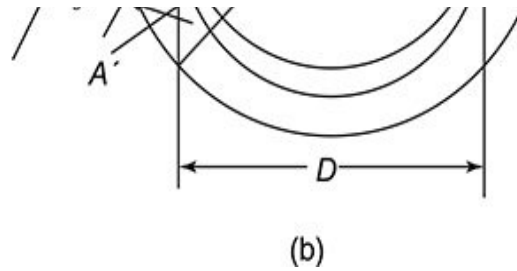

**Fig. 2.35** | (a) and (b) Unbalanced magnetic pull in electric machine with vertical rotor displacement

From Fig 2.33(a) and (b), it is observed that the new values of

$$\begin{aligned} \text{Modified length of air gap in the vertical axis at top} &= l_g + e \\ \text{Modified length of air gap in the vertical axis at bottom} &= l_g - e \end{aligned}$$

where  $e$  is the displacement of rotor from its original position in downward direction (or known as eccentricity).

For the machine to be rotating, the length of air gap is modified by angle  $q$  measured with respect to horizontal axis.

Hence,

Modified length of air gap for top half of the rotor along  $X - X'$ ,

$$l_{g_1} = l_g + e \sin \theta$$

Modified length of air gap for bottom half of the rotor along  $X - X'$ ,

$$l_{g_2} = l_g - e \sin\theta$$

Also,

The magnetic pull is represented by  $P_m$ .

The pull per unit area is given by  $P_m \times \frac{l_g^2}{l_{g(\text{modified})}^2}$

$\Rightarrow$  Pull per unit area along  $X - X'$

$$\begin{aligned}
&= P_m \left[ \text{Change in} \left( \frac{l_g^2}{l_{g(\text{modified})}^2} \right) \right] \\
&= P_m \left[ \left( \frac{l_g}{l_g - e \sin \theta} \right)^2 - \left( \frac{l_g}{l_g + e \sin \theta} \right)^2 \right] \\
&= P_m l_g^2 \left[ \frac{1}{[l_g - e \sin \theta]^2} - \frac{1}{[l_g + e \sin \theta]^2} \right] \\
&= P_m l_g^2 \left[ \frac{l_g^2 + e^2 \sin^2 \theta + 2l_g e \sin \theta - [l_g^2 + e^2 \sin^2 \theta - 2l_g e \sin \theta]}{[l_g - e \sin \theta]^2 [l_g + e \sin \theta]^2} \right] \\
&\simeq P_m l_g^2 \left[ \frac{4l_g e \sin \theta}{l_g^4} \right] \quad [\because l_g \gg e \sin \theta]
\end{aligned}$$

Therefore, pull per unit area along  $X - X'$  due to two poles of rotor

$$= \frac{4P_m e \sin \theta}{l_g}$$

Vertical component of pull per unit area

$$= \frac{4P_m e}{l_g} \sin \theta \times \sin \theta = \frac{4P_m e}{l_g} \sin^2 \theta$$

Substituting  $P_m = \frac{1}{2} \frac{B^2}{\mu_0}$  in the above equation, we get

Vertical component of pull per unit area

$$= 4 \times P_m \times \frac{e}{l_g} \sin^2 \theta = 4 P_m \frac{e}{l_g} \sin^2 \theta$$

Therefore, the vertical component of pull

$$= 4 P_m \frac{e}{l_g} \sin^2 \theta \times \text{area}$$

Substituting area =  $\frac{D}{2} L d\theta$  in the above equation, as we

consider a small area defined by  $dq$ , the vertical component of pull

$$\begin{aligned} &= 4 P_m \frac{e}{l_g} \sin^2 \theta \times \frac{D}{2} L d\theta \\ &= 2 P_m \frac{e}{l_g} \sin^2 \theta D L d\theta \end{aligned}$$

As the unbalanced magnetic pull is acting in the downward direction,

Total pull,

$$\begin{aligned}
P &= \int_0^{\pi} 2P_m \frac{e}{l_g} \sin^2 \theta DL d\theta \\
&= 2P_m \frac{e}{l_g} DL \int_0^{\pi} \frac{1 - \cos 2\theta}{2} d\theta \\
&= P_m \frac{e}{l_g} DL \left[ \theta - \frac{\sin 2\theta}{2} \right]_0^{\pi} \\
&= P_m \frac{e}{l_g} DL [\pi - 0 - 0 + 0] \\
&= \frac{\pi P_m e DL}{l_g}
\end{aligned}$$

Substituting  $P_m = \frac{1}{2} \frac{B^2}{\mu_0}$  in the above equation, we get

$$\begin{aligned}
P &= \frac{1}{2} \frac{\pi B^2 e DL}{\mu_0 l_g} \\
&= \frac{1}{2} \frac{B^2 e}{\mu_0 l_g} \pi DL \tag{2.60}
\end{aligned}$$

As we know that area per pole,

$$A = \frac{\pi DL}{2}.$$

Hence,  $P = \frac{B^2 e}{\mu_0 l_g} A = 2 P_m \frac{eA}{l_g}$

$$= 2 A P_m \frac{e}{l_g} \left[ \because P_m = \frac{1}{2} \frac{B^2}{\mu_0} \right] \quad (2.61)$$

Equation (2.61) is valid for a two-pole machine. For a machine with 'P' number of poles, Eq. (2.61) becomes unbalanced magnetic pull

$$= P \times 2 P_m \frac{eA}{l_g}$$

For sinusoidal flux distribution, substitute  $B = \frac{B_m}{\sqrt{2}}$  in Eq.

(2.62).

Therefore, unbalanced magnetic pull

$$= \frac{1}{2} \left( \frac{B_m}{\sqrt{2}} \right)^2 \frac{e}{\mu_0 l_g} \pi DL$$

$$= \frac{1}{4} \frac{B_m^2 e}{\mu_0 l_g} \pi DL \quad (2.62)$$

#### 2.8.4 Significance and Minimization of Unbalanced Magnetic Pull

**Table 2.10** provides the significant effects and prevention methods of unbalanced magnetic pull.

**Table. 2.10** | Significant effects and prevention methods of unbalanced magnetic pull

Effect	Prevention method
Unbalanced magnetic pull is pronounced in induction motors due to small air gap	<ul style="list-style-type: none"> <li>• Decrease in stack length</li> <li>• Use of high-quality ball bearings</li> <li>• Use of stator winding with equalizer connections</li> </ul>

Effect	Prevention method
Unbalanced magnetic pull is significant for certain combination of stator and rotor slots, causing vibration and noise	Choice of slot numbers in stator and rotor should properly made
Presence of homopolar flux in two-pole machines leads to asymmetry in air gap	Use of stator winding with parallel paths and equalizer connections

Review Questions

*Multiple-choice Questions*

1. In DC machines, the total mmf produced by each pole is .
  1. the mmf for pole and pole shoe
  2. the mmf for air gap and teeth
  3. the mmf for yoke and armature core
  4. all the above
2. Carter's coefficient for open slots is given by .

$$1. K_{cs} = \frac{2}{\pi} \left[ \tan^{-1} y - \frac{1}{y} \log \sqrt{1+y^2} \right]$$

$$2. K_{cs} = \frac{2}{\pi} \left[ \tan^{-1} y - \frac{1}{y} \log \sqrt{y^2} \right]$$

$$3. K_{cs} = \frac{\pi}{2} \left[ \tan^{-1} y - \frac{1}{y} \log \sqrt{1+y^2} \right]$$

$$4. K_{cs} = \frac{2}{\pi} \left[ \tan^{-1} y + \frac{1}{y} \log \sqrt{1+y^2} \right]$$

3. The mmf for air-gap in a salient pole machine is given by .
  1.  $80,000 B_g K_g l_g$
  2.  $800,000 B_g K_g l_g$
  3.  $800,000 B_g K_g$
  4.  $800,000 B_g l_g$
4. Simpson's rule is also known as .
  1.  $B_{t1/3}$  method
  2. two ordinate method
  3. three ordinate method
  4. graphical method
5. The real and apparent flux densities are related by  $B_{app} = B_{real} + B_a (K_s - 1)$ , where  $K_s$  is .
  1. ratio of air area to iron area
  2. ratio of iron area to air area
  3. ratio of iron area to total area
  4. ratio of total area to iron area
6. Hysteresis loss can be expressed in .
  1. Watts per cubic metre (W/m<sup>3</sup>)
  2. Watts per kilogram (W/kg)
  3. Both (a) and (b)

4. none of the above
7. Hysteresis loss can be minimized using .
  1. soft magnetic materials such as Si steel
  2. air core transformers
  3. both (a) and (b)
  4. none of the above
8. Pulsation losses in DC machines occur due to .
  1. Slotted armature
  2. Change in air gap flux
  3. Both (a) and (b)
  4. None of the above
9. The leakage flux produced due to dissimilar mmf harmonics in stator and rotor is .
  1. belt leakage flux
  2. harmonic flux
  3. differential flux
  4. all of the above
10. The key assumptions made while estimating specific permeance and leakage reactance of slots are .
  1. the leakage flux traverses rectilinearly through the slot and around the iron
  2. reluctance of iron is zero
  3. current is uniformly distributed throughout the area of slot conductors
  4. all of the above
11. Total specific permeance of conventional parallel-sided slots is given by .

$$1. \lambda_s = \mu_0 \left[ \frac{h_1}{3w_s} - \frac{h_2}{w_s} - \frac{2h_3}{w_0 + w_s} - \frac{h_4}{w_0} \right]$$

$$2. \lambda_s = \mu_0 \left[ \frac{h_1}{3w_s} + \frac{h_2}{w_s} + \frac{2h_3}{w_0 + w_s} + \frac{h_4}{w_0} \right]$$

$$3. \lambda_s = \mu_0 \left[ \frac{h_1}{3w_s} + \frac{h_2}{w_0} + \frac{2h_3}{w_0 + w_s} + \frac{h_4}{w_s} \right]$$

$$4. \lambda_s = \mu_0 \left[ \frac{h_1}{3w_s} + \frac{h_2}{w_0 + w_s} + \frac{2h_3}{w_s} + \frac{h_4}{w_0} \right]$$

12. The total specific permeance of tapered slots is .

$$1. \lambda_s = \mu_0 \left[ \frac{2h_1}{3(w_2 + w_s)} + \frac{2h_2}{w_1 + w_2} + \frac{2h_3}{w_0 + w_1} + \frac{h_4}{w_0} \right]$$

$$2. \lambda_s = \mu_0 \left[ \frac{2h_1}{3(w_2 + w_s)} - \frac{2h_2}{w_1 + w_2} - \frac{2h_3}{w_0 + w_1} - \frac{h_4}{w_0} \right]$$

$$3. \lambda_s = \mu_0 \left[ \frac{2h_1}{3(w_2 + w_s)} + \frac{2h_2}{w_0 + w_1} + \frac{2h_3}{w_1 + w_2} + \frac{h_4}{w_0} \right]$$

$$4. \lambda_s = \mu_0 \left[ \frac{2h_1}{3(w_2 + w_s)} + \frac{2h_2}{w_1 + w_2} + \frac{2h_3}{w_0 + w_1} + \frac{2h_4}{w_0} \right]$$

13. Total specific permeance of circular slots is given by .

$$1. \lambda_s = \mu_0 \left[ 0.632 + \frac{h}{w_c} \right]$$

$$2. \lambda_s = \mu_0 \left[ 0.623 - \frac{h}{w_c} \right]$$

$$3. \lambda_s = \mu_0 \left[ \frac{h}{w_c} - 0.623 \right]$$

$$4. \lambda_s = \mu_0 \left[ 0.623 + \frac{h}{w_c} \right]$$

14. The equation for unbalanced magnetic pull (UMP) is given by .

$$1. \frac{1}{2} \frac{B_m^2 e}{\mu l_g} \pi DL$$

$$2. \frac{1}{4} \frac{B_m^2 e}{\mu_0 l_g} \pi DL$$

$$3. \frac{1}{4} \frac{B_m^2 e}{\mu_0 l_g} \pi^2 DL$$

$$4. \frac{1}{2} \frac{B^2 e}{\mu_r l_g} \pi DL$$

15. In induction machines, UMP can be prevented by\_\_\_\_\_.
1. using high-quality ball bearings
  2. reducing the stack length
  3. using stator winding with equalizer connections
  4. all of the above

### *Answers*

1. d
2. a
3. b
4. c
5. d
6. c
7. c
8. c
9. d
10. d
11. b
12. a
13. d
14. b
15. d

### *Short Type Questions*

*Difficulty level – Easy*

1. Define magneto motive force and magnetic flux.  
Refer Section 2.1.
2. Define magnetic flux density.  
Refer Section 2.1.
3. Define reluctance and permeance.  
Refer Section 2.1.
4. Define Kirchoff's laws for magnetic circuits.  
Refer Section 2.1.2.
5. Briefly compare magnetic and electric circuit.  
Refer Table 2.4.
6. Provide the expression for reluctance of airgap for smooth armature surface with respect to one slot pitch.  
Refer Section 2.2.
7. Provide the expression for reluctance of airgap for slotted armature surface with respect to one slot pitch.  
Refer Section 2.2.
8. Explain the effect of fringing with a diagram representing fringing flux.  
Refer Section 2.2 and Fig. 2.7.
9. Provide the expression for Carter's coefficient for open and semi-closed slots.  
Refer Section 2.2.
10. Draw the graph representing Carter's coefficient for open and semi-closed slots with respect to slot opening/gap length ratio.  
Refer Fig. 2.9.
11. Define gap contraction factor and air-gap expansion factor.  
Refer Section 2.2 and 2.2.1.
12. Define gap contraction factor for ventilating ducts.  
Refer Section 2.2.
13. Define total gap contraction factor for slots and ducts.  
Refer Section 2.2.
14. Provide the expression that describes the effective airgap area per pole.  
Refer Section 2.2.1.
15. Define field form factor.  
Refer Section 2.2.2.
16. Mention the reasons why accurate determination of mmf in teeth is an arduous task.  
Refer Section 2.3.
17. Mention the methods used to determine mmf of teeth.  
Refer Section 2.3.
18. Explain about graphical method used to determine mmf of teeth.  
Refer Section 2.3
19. Explain about  $B_{t1/3}$  method used to determine mmf of teeth.  
Refer Section 2.3.

20. Explain about Simpson's rule (three-ordinate method) used to determine mmf of teeth.  
Refer Section 2.3.
21. Explain about real and apparent flux density.  
Refer Section 2.4.
22. Define iron or core loss.  
Refer Section 2.5.
23. Define hysteresis loss.  
Refer Section 2.5.1.
24. How hysteresis loss can be minimized?  
Refer Section 2.5.1.
25. Define eddy current loss.  
Refer Section 2.5.2.
26. How eddy current loss can be minimized?  
Refer Section 2.5.2.
27. Explain about pulsation loss.  
Refer Section 2.5.4.
28. Explain about magnetic leakage.  
Refer Section 2.6.
29. Provide the effects of leakage flux in various machines.  
Refer Table 2.5.
30. Give the classification of leakage flux in armature of the rotating machines.  
Refer Fig. 2.18.
31. Explain about tooth top leakage flux.  
Refer Section 2.6.
32. Explain about zig-zag leakage flux.  
Refer Section 2.6.
33. Explain about differential or harmonic or belt leakage flux.  
Refer Section 2.6.
34. Explain about peripheral leakage flux.  
Refer Section 2.6.
35. Explain about slot leakage flux.  
Refer Section 2.6.
36. Explain about overhang leakage flux.  
Refer Section 2.6.
37. Explain about skew leakage flux.  
Refer Section 2.6.
38. Provide the assumptions that are made in estimation of specific permeance and leakage reactance of slots.  
Refer Section 2.7.
39. Define specific permeance.  
Refer Section 2.7.
40. Give the expression for total permeance of non-conductor portion of slot.

- Refer Section 2.7.
41. Give the expression for total permeance of conductor portion of slot.  
Refer Section 2.7.
  42. Define magnetic pull with a diagram.  
Refer Section 2.8.
  43. Define unbalanced magnetic pull and provide the expression to determine it.  
Refer Section 2.8.2.
  44. Provide the significant effects and prevention methods of unbalanced magnetic pull.  
Refer Table 2.6.
  45. Mention the significant effects of unbalance magnetic pull and different techniques used to minimize it.  
Refer Table 2.10.

*Difficulty level – Medium to hard*

1. Define ohm's law for magnetic circuit.  
The mmf of a magnetic circuit is directly proportional to flux established in it provided that no part of the magnetic circuit is saturated. The constant of proportionality is the reluctance of the magnetic circuit. i.e.,  $\text{mmf} \propto \text{flux}$  and  $\text{mmf} = \text{reluctance} \times \text{flux}$ .
2. Explain about magnetization curve.  
Magnetization curve represents the relation between the flux density ( $B$ ) and magnetic field intensity ( $H$ ) of a magnetic material. It is used in estimation of mmf required for flux path in the magnetic material and is provided by the manufacturers of stampings or laminations.
3. Explain about loss curve.  
Loss curve represents the relation between iron loss and magnetic field intensity ( $H$ ). It is used in the estimation of iron loss of the magnetic materials and it is provided by the manufacturers of stampings or laminations.
4. Why are B-H curves generally used in magnetic circuit calculations?  
It is difficult to express the relation of magnetic flux density ( $B$ ) and the magnetizing field intensity ( $H$ ) or mmf/m (at) in terms of mathematical equation as the relation is non-linear. Therefore, to calculate the mmf per metre of flux path for a given flux density, the B-H curve is used which is provided by the manufacturers of stampings or laminations.
5. Plot the B-H curve for air. Give the value of  $H$  in terms of  $B$ .

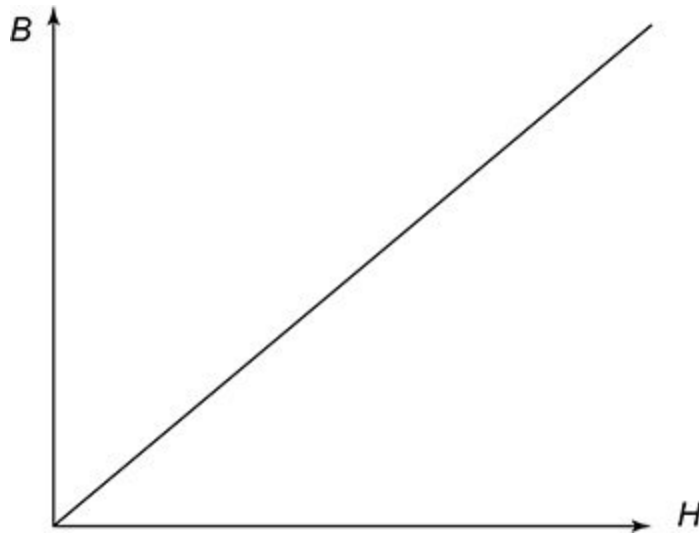

**Fig. 2.36** | B-H curve for air

As air is a non-magnetic material, it has a constant value of permeability ( $\therefore$  B-H curve for air will be a straight line passing through the origin). The  $B$  and  $H$  of air is related by  $\mu_0$  (i.e.,  $B = \mu_0 H$ ), where  $\mu_0$  is the permeability of free space and its value is  $4\pi \times 10^{-7}$  H/m.

6. Mention the differences in permeability of non-magnetic and magnetic materials.

In non-magnetic materials, the permeability is constant, whereas in magnetic materials, it is not a constant value and depends on the saturation of the magnetic material.

7. Explain about magnetic circuit calculations.

The determination of flux density, reluctance and mmf for different Sections of magnetic circuit is termed as magnetic circuit calculation.

8. Explain the process of determining mmf of a magnetic circuit.

1. The magnetic circuit is divided into different Sections which can be connected in series or parallel.
2. Then the estimation of flux density, reluctance and mmf for every Section of the magnetic circuit is done.
3. The summation of mmf of all Sections in series gives the total mmf for the magnetic circuit connected in series and the mmf of a particular branch of the circuit is the mmf of all Sections connected in parallel in case of magnetic circuit connected in parallel.

9. Mention the reasons why procedure for accurate determination of mmf in airgap cannot be generalized.

The following are the reasons for absence of generalized procedure for accurate determination of mmf in airgap:

1. The reluctance of the air-gap is altered or affected by the slot opening, radial ventilating ducts and non-uniform air-gaps.
  2. The machines might have different type of slots, modifying the flux passing through it.
  3. Some machines are provided with ventilating ducts for cooling purpose, which affects the flow of flux.
  4. Hence, the calculations of reluctance of air-gap should be carried out individually for each type of machine, accommodating different criteria.
10. Mention the factors which modify the reluctance of air-gap.  
The reluctance of air-gap is modified by
1. Slots
  2. radial ventilating ducts
  3. non-uniform air-gaps
11. Explain about ventilating ducts.
1. Ventilating ducts are small gaps of width ( $w_d$ ) in between the stacks of armature core as shown in **Fig. 2.10**.
  2. They are provided for better cooling of the core when the length of the core is greater than 0.1 metre.
12. Explain about Carter's coefficient.
1. Carter's coefficient is a parameter that can be used to estimate the effective slot pitch in case of armature employing open or semi-enclosed slots.
  2. It is expressed as function of the ratio of  $w_o/l_g$ , where  $w_o$  is slot opening and  $l_g$  is airgap length.
  3. Carter's coefficient is also used to estimate the effective length of armature when ventilating ducts are employed.
  4. In this case, it is expressed as a function of  $w_d/l_g$ , where  $w_d$  is the width of duct.
13. Briefly explain the effect of salient poles on the airgap mmf.
1. The length of airgap is not constant over the whole pole pitch in case of salient pole machines.
  2. Hence, the effective airgap length is given by  $K_g l_g$ , where  $K_g$  is the gap contraction factor.
  3. Also for calculating mmf, the maximum gap density  $B_g$  at the centre of the pole is considered instead of average airgap flux density.
  4. Mmf for airgap in salient pole machine =  $800,000 B_g K_g l_g$
14. Describe about tapered teeth and tapered slot.  
A tooth is called tapered teeth when the width of the tooth gradually increases (or decreases) from tip of tooth to root of tooth. A slot is called tapered slot when the width of the slot

gradually increases (or decreases) from the top of slot to the bottom of the slot.

15. Mention the way in which airgap length influences the design of machines.
1. The total mmf to be produced by a pole is approximately equal to mmf for airgap.
  2. Hence, the design of field system of an electric machine primarily depends on length of airgap.

16. Define leakage coefficient and explain its importance of leakage coefficient in the design of magnetic circuits.

The leakage coefficient is defined as the ratio of total flux to useful flux.

$$\text{Leakage coefficient, } C_l = \frac{\text{Total flux}}{\text{Useful flux}}$$

Since the leakage flux affects the performance of transformers and rotating machines (including excitation demand, regulation, forces on the winding under short circuit conditions, commutation, stray load losses and circulating currents in transformer tank walls), leakage coefficient is used in the estimation of leakage flux.

17. Mention the differences between fringing flux and leakage flux.

Fringing flux	Leakage flux
It is a useful flux	It is not useful (for energy transfer)
It flows in the magnetic flux path linking various parts of electric machine	It flows in unwanted path, does not link various parts of electric machine
The fringing flux increases the slot reactance	The effect of leakage flux is accounted by leakage reactance

18. Explain the ways to minimize the magnetic leakage.
1. Most of the leakage fluxes are flowing through airgap of the machine.
  2. If the airgap of the machine is kept as low as possible, there leakage fluxes can be minimized.
  3. The harmonic leakage can be minimized by balancing the stator and rotor currents.
  4. The slot leakage can be minimized if the width of the slot is more than the width of tooth.

19. What are the factors that are affected by the leakage flux?

The leakage flux affects the following in electrical machines:

1. Commutation in DC machines.
2. Voltage regulation of generators and transformers
3. Excitation demand of salient pole machines
4. Leakage reactance

5. Forces between the windings under short circuit condition
  6. Stray load losses
  7. Circulating currents in transformer tank walls
20. Briefly explain about slot leakage reactance.  
 The slot leakage reactance is the reactance accounted for slot leakage flux. The slot leakage flux will produce a reactive voltage drop which is equivalent to an inductive drop, hence the drop can be measured in terms of reactance.
- Slot leakage reactance,  $X_s = 2\pi f Z_s^2 L \lambda_s$   
 where,  $f$  – Frequency,  $Z_s$  – Conductors per slot,  $L$  – Length of armature,  $\lambda_s$  – Specific slot permeance.
21. Explain about reactance voltage. Is it a useful voltage in case of electrical machines?  
 Reactance voltage is the voltage induced due to leakage flux. It is not useful as the reactance voltage will affect commutation and produce sparking in DC machines. The reactance voltage will increase the regulation in case of transformers and rotating machines.
22. Provide the equation for slot leakage reactance per phase in polyphase machine.  
 Slot leakage reactance per phase,

$$X_s = 2\pi f pq Z_s^2 L \lambda_s$$

$$\text{Or } X_s = \frac{8\pi f T_{ph}^2 L \lambda_s}{pq}$$

### *Long Type Questions*

1. Perform the analysis of series and parallel composite magnetic circuits and obtain the relation between mmf, flux and reluctance.
2. Provide a comparison between magnetic and electric circuit.
3. Explain the methods used to determine the mmf of teeth.
4. Derive the relation between real and apparent flux density.
5. Obtain an expression for eddy current loss in laminations.
6. Explain about various types of armature leakage flux.
7. Derive an expression for determining the specific permeance of conductor and non-conductor portion of slot.
8. Derive an expression for determining the total permeance for parallel-sided slot.

9. Derive an expression for determining the total permeance for parallel-sided slot with double layer winding.
10. Derive an expression for determining the total permeance for tapered slot.
11. Derive an expression for determining the total permeance for circular slot.
12. Derive an expression for determining the total permeance for T bar slot.
13. Derive an expression for determining the total unbalanced magnetic pull (UMP).

### *Problems*

1. Determine the effective length of airgap of a machine having a stator with smooth surface and rotor with open slots devoid of radial ducts, with tooth width,  $w_t = 13$  mm, slot width,  $w_s = 11$  mm, airgap length,  $l_g = 2$  mm and Carter's coefficient

$$= \frac{1}{1 + \frac{5l_g}{w_s}}$$

2. Determine average airgap flux density of an alternator, with rating 200 MVA, having number of poles = 10, length of core = 1.5 m, diameter of core = 5 m, total mmf per pole is 17,000 A, mmf required for airgap is 0.8 times of total mmf per pole, field form factor = 0.65 m, slot width = 20 mm, slot pitch = 60 mm and length of airgap at the centre of pole = 25 mm. The type of stator slots used in parallel-sided open slots.
3. Determine the mmf of tapered teeth of an electrical machine using Simpson's rule following data: length of teeth = 25 mm, maximum width =  $1.7$  times the minimum width, mean flux density =  $1.3$  Wb/m<sup>2</sup>. The B-at curve is given by

$B$ (wb/m <sup>2</sup> )	1	1.1	1.2	1.3	1.4	1.5	1.6	1.7
'at' (A/m)	190	208	227	265	366	633	1490	3670

4. Determine the permeability of teeth of DC machine with length of core (gross) = 350 mm, slot pitch = 25 mm, width of the teeth = 15 mm, real flux density = 2.2 T, apparent flux density = 2 T and stacking factor = 0.85.
5. Determine the hysteresis coefficient for a silicon steel with hysteresis loss of 4 W/kg at frequency of 50 Hz, maximum flux

density of  $2.1 \text{ Wb/m}^2$  and specific gravity of 7.55. Also determine the hysteresis loss  $\text{kg}$  at frequency of 40 Hz and flux density of  $1.2 \text{ Wb/m}^2$ . Use Steinmetz coefficient as 1.6.

## DESIGN OF TRANSFORMER

### 3.1 Introduction

Transformers are static electromagnetic devices with two or more windings and a common magnetic circuit. They are one of the primary power apparatus used in the power system network. The transformers change the AC voltage and the associated current from one level to another level, maintaining power balance between input and output side, without change in frequency. Hence, transformers perform AC energy transformation rather than energy conversion from one or more primary side circuit/s to one or more secondary side circuit/s.

The main parts of the transformer are as follows:

- Core
- Yoke
- Winding

When the MVA rating is high, in addition to the above parts, transformer is equipped with

- Bushing
- Coolant conservator ...

### 3.23 Design of Tank with Tubes

$$\text{Dissipating surface area of tank} = S_t$$

$$\text{Dissipating surface area of tubes} = xS_t$$

$$\text{Total loss dissipation in surface area of tank} = 12.5 S_t W/^\circ C$$

$$\text{Total loss dissipation in surface area of and cooling tubes} = (12.5 + 8.8 x) S_t W/^\circ C$$

$$\begin{aligned} \text{Total loss dissipation by tubes due to convection} &= 1.35 \times 6.5 x S_t \\ &= 8.8 x S_t W/^\circ C \end{aligned}$$

$$\begin{aligned} \text{Total surface area of walls of tank and tubes} &= S_t + xS_t \\ &= (1 + x) S_t \end{aligned}$$

$$\begin{aligned} \text{Total loss dissipation} &= \frac{\text{Total loss dissipation by in surface area of tank and cooling tubes}}{\text{Total surface area of walls of tank and tubes}} \\ &= \frac{(12.5 + 8.8x) S_t}{(1 + x) S_t} \end{aligned}$$

Temperature rise with tubes,

$$\begin{aligned} (\theta) &= \frac{\text{Total loss}}{\text{Specific heat dissipation} \times \text{surface area}} \\ &= \frac{P_i + P_c}{(12.5 + 8.8x) S_t} \end{aligned}$$

From the above equation, area of tubes can be found as follows.

$$\theta = \frac{P_i + P_c}{12.5 S_t + 8.8 x S_t}$$

$$\Rightarrow 12.5 S_t + 8.8 x S_t = \frac{P_i + P_c}{\theta}$$

$$\Rightarrow 8.8 xS_t = \frac{P_i + P_c}{\theta} - 12.5 S_t$$

$$\text{Total area of tubes, } xS_t = \frac{1}{8.8} \left[ \frac{P_i + P_c}{\theta} - 12.5S_t \right]$$

Length of a tube =  $l_t$

Diameter of a tube =  $d_t$

Radius of a tube =  $r_t$

Area of a tube =  $\pi d_t l_t$

$$\text{Total number of tubes, } n_t = \frac{\text{Total area of tubes}}{\text{Area of a tube}}$$

$$= \frac{1}{8.8 \pi d_t l_t} \left[ \frac{P_i + P_c}{\theta} - 12.5S_t \right]$$

The dimensions of tank depends on the type and capacity of transformer, voltage rating and electrical clearance to be provided between the transformer and the tank, clearance to accommodate the connections and taps, clearance for base and oil above the transformer, etc. The clearance between different parts depends on rating of the transformer.

Let  $D$  = distance between adjacent limbs

$D_e$  = external diameter of outer winding

$C_w$  = width wise clearance between the outer winding and the tank wall

$C_l$  = length wise clearance between the tank wall and the outer winding

$C_h$  = height wise clearance between the tank wall and the outer winding

The various clearance values for a typical transformer of rating 1000 to 5000 kVA and 11 to 33 kV voltage rating is given in [Table 3.11](#).

**Table. 3.11** | Clearance values for a typical transformer

Clearances	$C_w$	$C_l$	$C_h$
Values	40 to 80 mm	50 to 125 mm	400 to 600 mm

The height wise clearance includes the clearance of 50 to 60 mm at the base, clearance of 150 to 250 mm above oil and space of about 200 to 250 mm for leads. [Figure 3.38](#) shows the transformer main dimensions with tank along with various clearances.

### *3.23.1 Flow Chart for Design of Cooling System*

The design procedure for design of the cooling system is given below as a flowchart in [Fig. 3.39](#). This involves the

calculation of number of cooling tubes required and suitably arranging them around the tank.

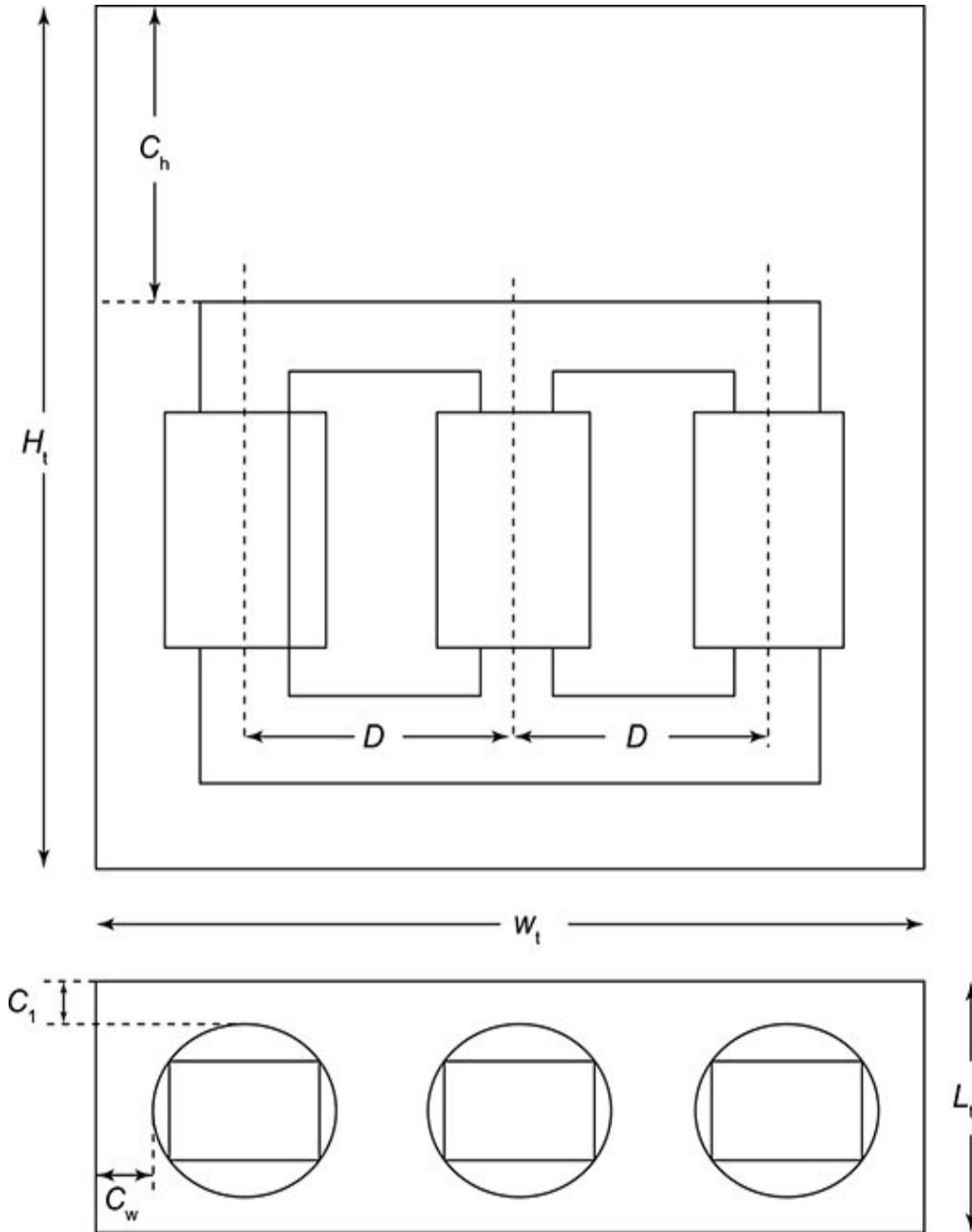

**Fig. 3.38** | Transformer main dimensions with tank along with clearances

**Example 3.16: Design a cooling system for a 3  $\phi$ , delta/star core type oil immersed**

**transformer of rating 200 kVA, 6000/400 V, 50 Hz. Allowable temperature rise for the tank walls is 50°C. Dimensions of tank are 125 cm height, 100 cm length and 50 cm width, Allowable losses is 5 kW. What will be temperature rise without the cooling arrangement?**

**Solution:** Given

Transformer rating,  $Q$  and type = 200 kVA and  $3\phi$

Voltage rating = 6600/400 V

Allowable temperature rise = 50°C

Allowable losses = 5 kW

Tank size = 1.25 × 1 × 0.5 m

We know that

$$\text{Losses} = 12.5 S_t \theta + 8.78 A_t \theta$$

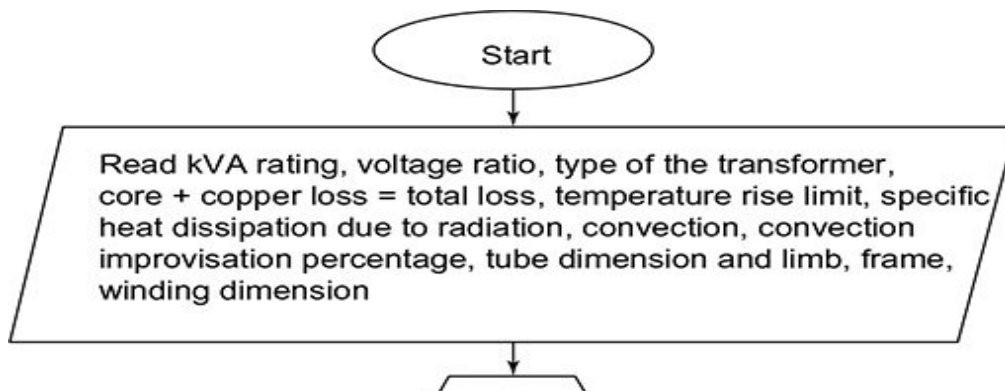

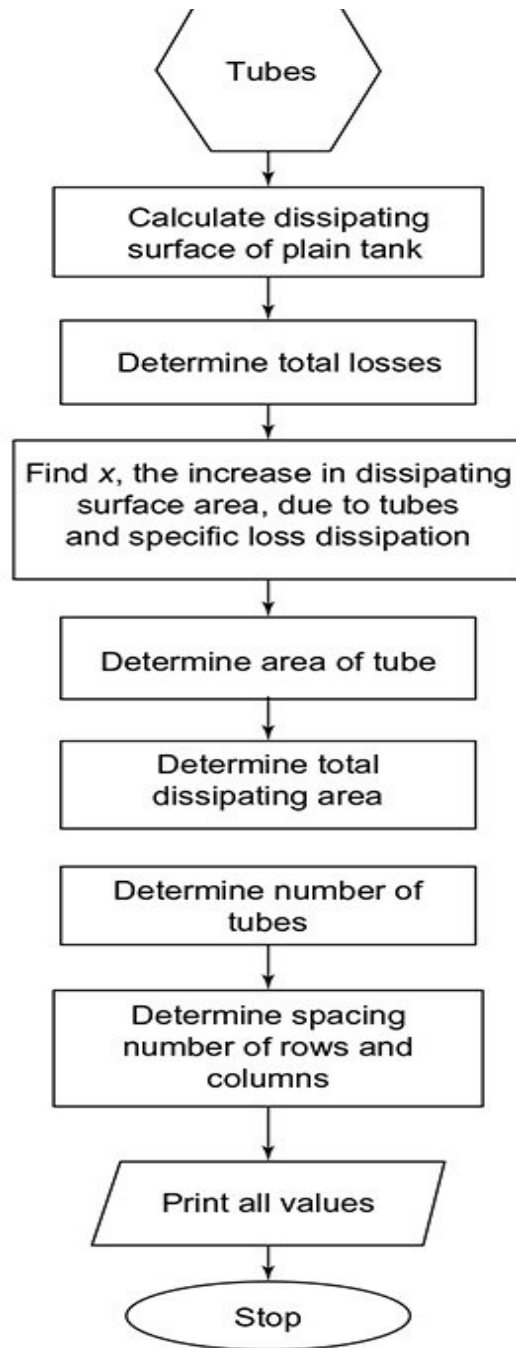

**Fig. 3.39** | Flowchart for design of tank with tubes in transformer

Dissipating surface of tank, neglecting the top and bottom surfaces is given by

$$\begin{aligned}
 S_t &= 2H_t (L_t + W_t) = 2 \times 1.25 (1 + 0.5) = 3.75 \text{ m} \\
 5000 &= (12.5)(3.75)(50) + (8.78) A_t (50) \\
 5000 &= 2343.75 + 439 A_t
 \end{aligned}$$

$$\Rightarrow A_t = 6.05 \text{ m}^2$$

Let the diameter of tube be 5 cm and the average height of tube is 105 cm.

$$\text{Dissipating area of each tube } a_t = \pi dl = \pi (0.05)(1.05) = 0.1649 \text{ m}^2$$

$$\text{Number of tubes} = \frac{6.05}{0.1647} = 36$$

If the tubes are placed 7 cm apart from centre to centre, then the number of tubes on 100 cm side and 50 cm side are 12 and 6 as shown in Fig. 3.40.

$$\text{Total tubes} = (2 \times 12) + (2 \times 6) = 36$$

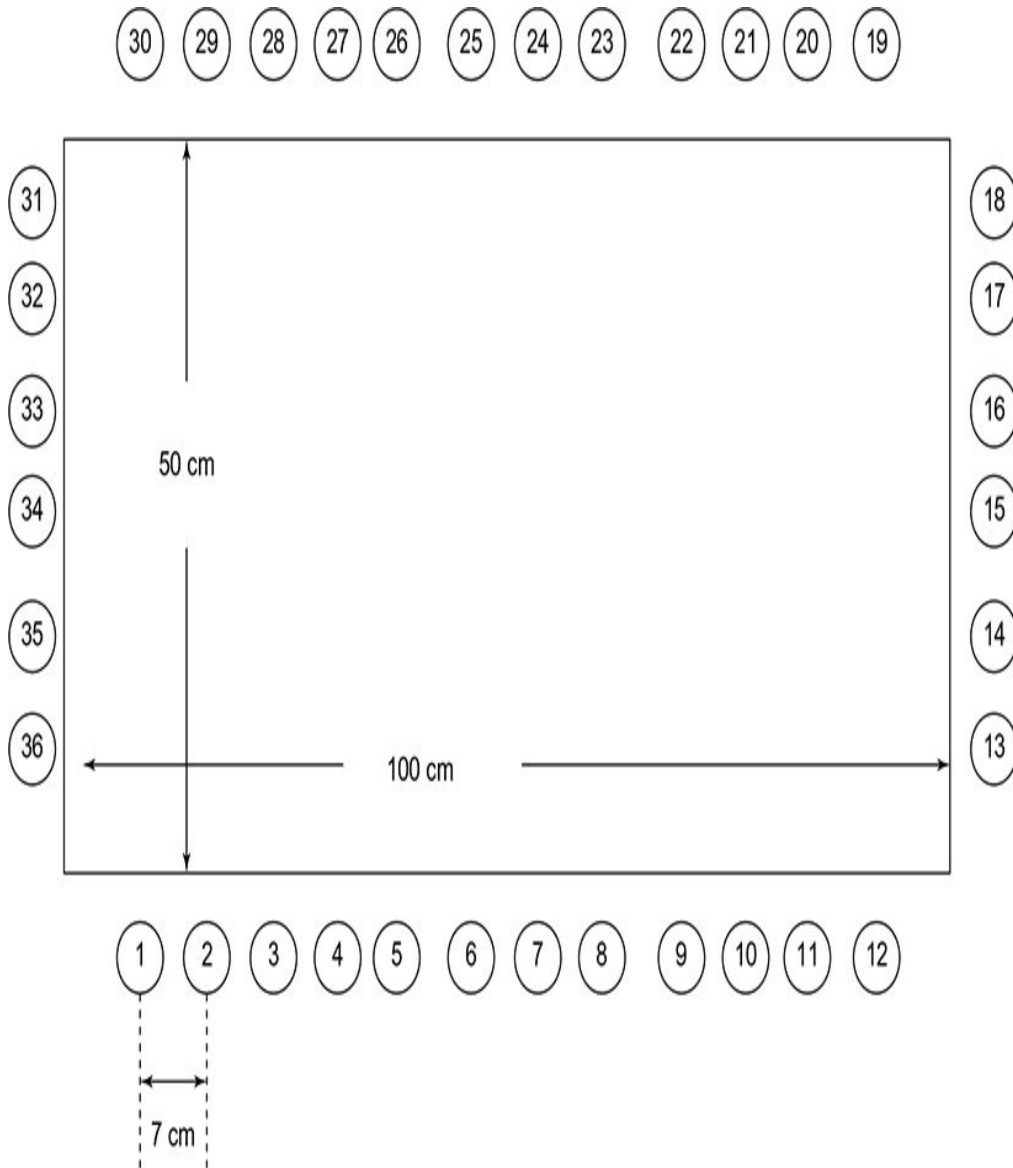

**Fig. 3.40**

Specific heat of dissipation in case of plain walled tank =  $12.5/W/m^2 / ^\circ C$

$$\text{So, temperature rise in case of plain walled tank} = \frac{5000}{12.5 \times 3.75} = 106.66^\circ C$$

To have this temperature rise within  $50^\circ C$ , additional surface is provided in the form of 36 tubes, to dissipate

heat.

**Example 3.17: Design a suitable cooling system for a 500 kVA, 6600/440 V 50 Hz, 3 $\phi$  transformer with a total full load loss of 7 kW. The transformer main dimensions are 1 m in height, 0.96 m in length and 0.47 m in breadth. Use cooling tubes of diameter 50 mm to limit the average temperature rise to 35°C. Use clearance of 50, 14 and 13 cm on the height, length and width sides.**

**Solution:** Given

Transformer rating,  $Q$  and type = 500 kVA and 3 $\phi$

Voltage rating = 6600/440 V

Tank size = 1  $\times$  0.96  $\times$  0.47 m

Clearances = 50  $\times$  14  $\times$  13 cm

Diameter of cooling tube = 50 mm

Allowable temperature rise = 35°C

Total size of transformer including clearances on all sides,

$$\begin{aligned}
 H_t \times L_t \times W_t &= (100 + 50) \times (96 + 14) \times (47 + 13) \\
 &= 150 \times 110 \times 60 \text{ cm}
 \end{aligned}$$

Total dissipating surface neglecting top and bottom surfaces

$$\begin{aligned}
 &= 2[(H_t \times L_t) + (H_t \times W_t)] \\
 &= 2[(1.5 \times 1.1) + (1.5 \times 0.6)] \\
 &= 5.1 \text{ m}^2
 \end{aligned}$$

$$\text{Total losses} = 12.5S_t\theta + 8.8A_t\theta$$

$$7000 = (12.5)(5.1)(35) + (8.8)A_t(35)$$

Area of tubes,  $A_t = 15.6 \text{ m}^2$

Let the average height of each tube =  $0.9 H_t = 0.9 \times 150$   
 $= 135 \text{ cm}$

Dissipating surface area of each tube,

$$\begin{aligned}
 a_t &= \pi D l \\
 &= (\pi)(0.05)(1.35) \\
 &= 0.212 \text{ m}
 \end{aligned}$$

$$\begin{aligned}\text{Number of tubes required} &= \frac{A_t}{a_t} \\ &= \frac{15.6}{0.212} \\ &= 73.6 \simeq 74\end{aligned}$$

If the tubes are placed 7.5 cm apart, then the number of tubes that can be placed along 110 cm and 60 cm side are  $\frac{110}{7.5}$  and  $\frac{60}{7.5}$ , respectively.

i.e., They are 15 and 8, respectively.

If 15 and 8 tubes are provided, then the total numbers of tubes used are  $2(15 + 8) = 46$ .

Since 74 tubes are to be used to dissipate the heat, an additional row of 46 tubes can be used, which increases the total number of tubes to  $46 \times 2 = 92$  tubes that is much more than 74.

Hence, we can select 13 tubes that can be provided on 110 cm and 6 tubes can be provided on 60 cm.

$$\text{Total number of tubes} = 2 [13 + 6] + 2 [13 + 6] = 76.$$

Hence, instead of 74 tubes, 76 can be used as shown in Fig. 3.41.

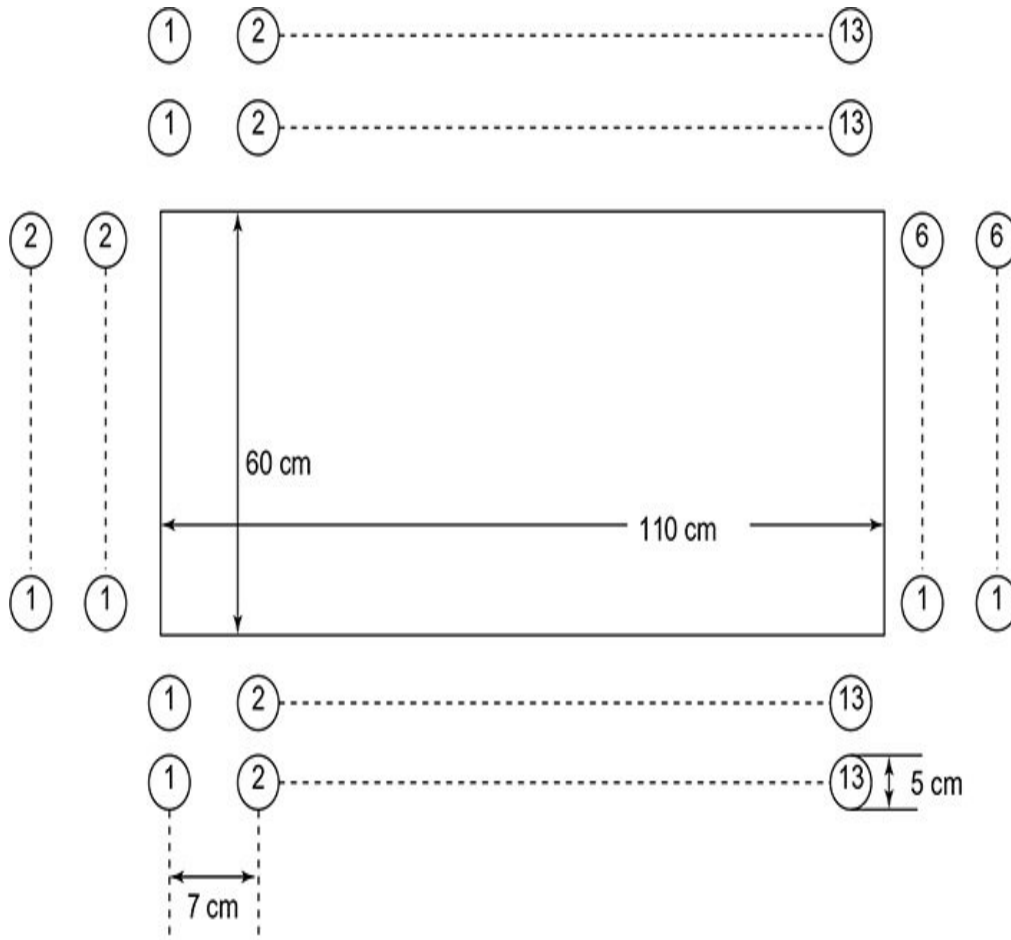

Fig. 3.41

**Example 3.18: Design a cooling system for a natural oil cooled transformer of rating 1200 kVA, with its main dimensions as  $0.6 \times 1.5 \times 1.8$  m length, breadth and height, respectively. The full load loss is 12 kW. Take loss dissipation due to radiation and convection as  $6 \text{ W/m}^2 / ^\circ\text{C}$  and  $6.5 \text{ W/m}^2 / ^\circ\text{C}$  and 35% improvement in convection is to be provided by tubes. Allowable temperature rise is  $40^\circ\text{C}$ .**

**Use cooling tubes of 5 cm diameter and 1 m length.**

**Solution:** Given

Rating of transformer = 1200 kVA

Main dimensions = 0.6×1.5×1.8 m

Full load loss = 12 kW

Allowable temperature rise = 40°C

Improvement in convection = 35%

Loss dissipation due to radiation and convection = 6 W/m<sup>2</sup>/°C and 6.5 W/m<sup>2</sup>/°C

$$\begin{aligned}\text{Total heat dissipating surface} &= 2(H_t L_t + W_t H_t) \\ &= 2 \times [(1.8 \times 0.6) + (1.5 \times 1.8)] \\ S_t &= 7.56 \text{ m} \\ \text{Loss dissipation due to radiation and convection} &= (6 + 6.5)S_t \\ &= 12.5S_t \\ \text{Heat dissipating area of tubes} &= A_t\end{aligned}$$

Given that 40% improvement in dissipation due to convection is to be provided by tubes of area  $A_t$ .

$$\text{Loss dissipated due to cooling tubes} = 6.5 \times \frac{135}{100} \times A_t = 8.77 A_t$$

$$\text{Total losses dissipating area by tank and tubes} = 12.5 S_t + 8.77 A_t$$

$$\text{Total losses} = 12.5 S_t \theta + 8.77 A_t \theta$$

$$12 \text{ kW} = (12.5 S_t + 8.77 A_t) \theta$$

$$\theta = \frac{12 \times 1000}{12.5 S_t + 8.77 A_t}$$

$$40 = \frac{12 \times 1000}{(12.5)(7.56) + 8.77 A_t}$$

$$A_t = 23.43 \text{ m}^2$$

$$\text{Total area of tubes, } A_t = 23.43 \text{ m}^2$$

$$\text{Area of each tube} = a_t = \pi D l = (\pi)(5 \times 10^{-2})(1) = 0.157 \text{ m}^2$$

$$\text{Total number of tubes} = \frac{A_t}{a_t} = \frac{23.43}{0.157} = 149$$

Let 7.5 cm be the centre to centre distance between cooling tubes.

Number of tubes on 150 cm and 60 cm sides are  $\frac{150}{7.5}$  and

$\frac{60}{7.5}$ , respectively.

So, 20 and 8 tubes can be placed.

Number of tubes in each row =  $2(20 + 8) = 56$

If two rows of tubes are placed, total number of tubes will be  $2 \times 56 = 112$

Since we have calculated only 150 tubes, the placement of tubes can be 20, 16, 20 its widthwise and 8, 4, 8 along lengthwise as shown in Fig. 3.42.

Hence, the total will be  $2(20 + 8) + 2(16 + 4) + 2(20 + 8)$   
 $= 56 + 40 + 56 = 152$  tubes.

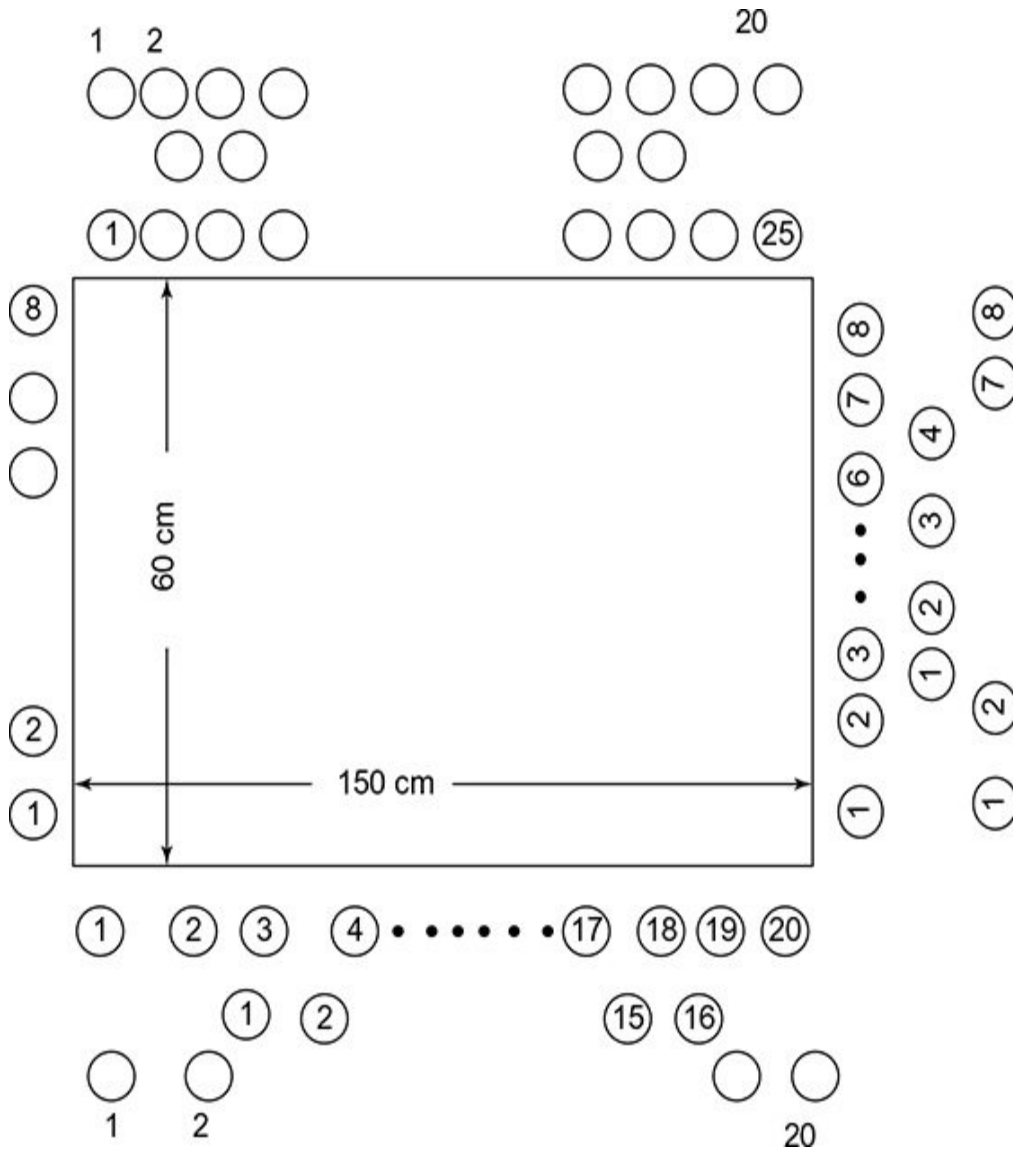

Fig. 3.42

**Example 3.19:** A 3 $\phi$ , 10 MVA, 33/6.6 kV 50 Hz, transformer has the following values on initial design. Length of transformer is 160 cm, height of transformer is 250 cm and the width is 78.5 cm. Use clearances of 50 cm, 11.5 cm and 11.5 cm, respectively, on the height, width and length for designing the tank. Total

iron loss is 25 kW and the copper loss is 100 kW.

**Calculate the temperature rise of transformer without cooling tubes. Calculate the number of tubes to limit the temperature rise to 50°C. Also, comment on the choice of cooling system and whether the cooling tubes are advisable in a practical case.**

**Solution:** Given

Transformer rating,  $Q$  and type = 10 MVA and  $3\phi$

Total copper loss = 100 kW

Voltage rating = 33,000/6600 V

Allowable temperature rise = 50°C

Total iron loss = 25 kW

Tank size = 1.60 × 2.50 × 0.785 m

Clearances = 50 × 11.5 × 11.5 cm

We know that

Tank size = Transformer size + clearances

Height × width × length of tank =  $(H + 50) \times (W + 11.5) \times (L + 90)$

$H_t \times W_t \times L_t = 300 \times 90 \times 250$  cm

Heat dissipating surface area of tank,  $S_t = 2H_t(L_t + W_t)$

$$= 2 \times 3(2.5 + 0.9)$$

$$= 20.4 \text{ m}$$

Without cooling tubes,

$$\text{Total losses} = 12.5 S_t \theta$$

$$125 \times 10^3 = (12.5)(20.4)\theta$$

$$\theta = \frac{125 \times 10^3}{(12.5)(20.4)} = 490^\circ\text{C}$$

The temperature rise without cooling tubes is  $490^\circ\text{C}$ . To limit this to  $50^\circ\text{C}$ , the dissipating surface area has to be increased by providing cooling tubes. Let  $A_t$  be the area of all cooling tubes.

$$125 \text{ kW} = 12.5 S_t \theta + 8.78 A_t \theta$$

$$125 \times 10^3 = (12.5)(20.4)(50) + (8.78)(A_t)(50)$$

$$A_t = 255.694 \text{ m}^2$$

Let the average height of tube is  $0.9 H_t = 0.9 \times 300 = 270 \text{ cm}$  and the diameter of each tube is  $5 \text{ cm}$ .

$$\text{Dissipating area of each tube} = \pi D l = (\pi)(0.05)(2.7) = 0.424 \text{ m}^2$$

$$\text{Clearances} = 50 \times 14 \times 13 \text{ cm}$$

### 3.24 Mechanical Forces

Mechanical forces are present in transformer due to leakage flux interaction, near the windings carrying current.

The forces can be classified into axial forces and radial forces, based on resolving the leakage flux component direction.

The leakage flux is represented in Fig. 3.43(a). The axial leakage field and radial leakage field are represented in Fig. 3.43(b) and 3.43(c), respectively.

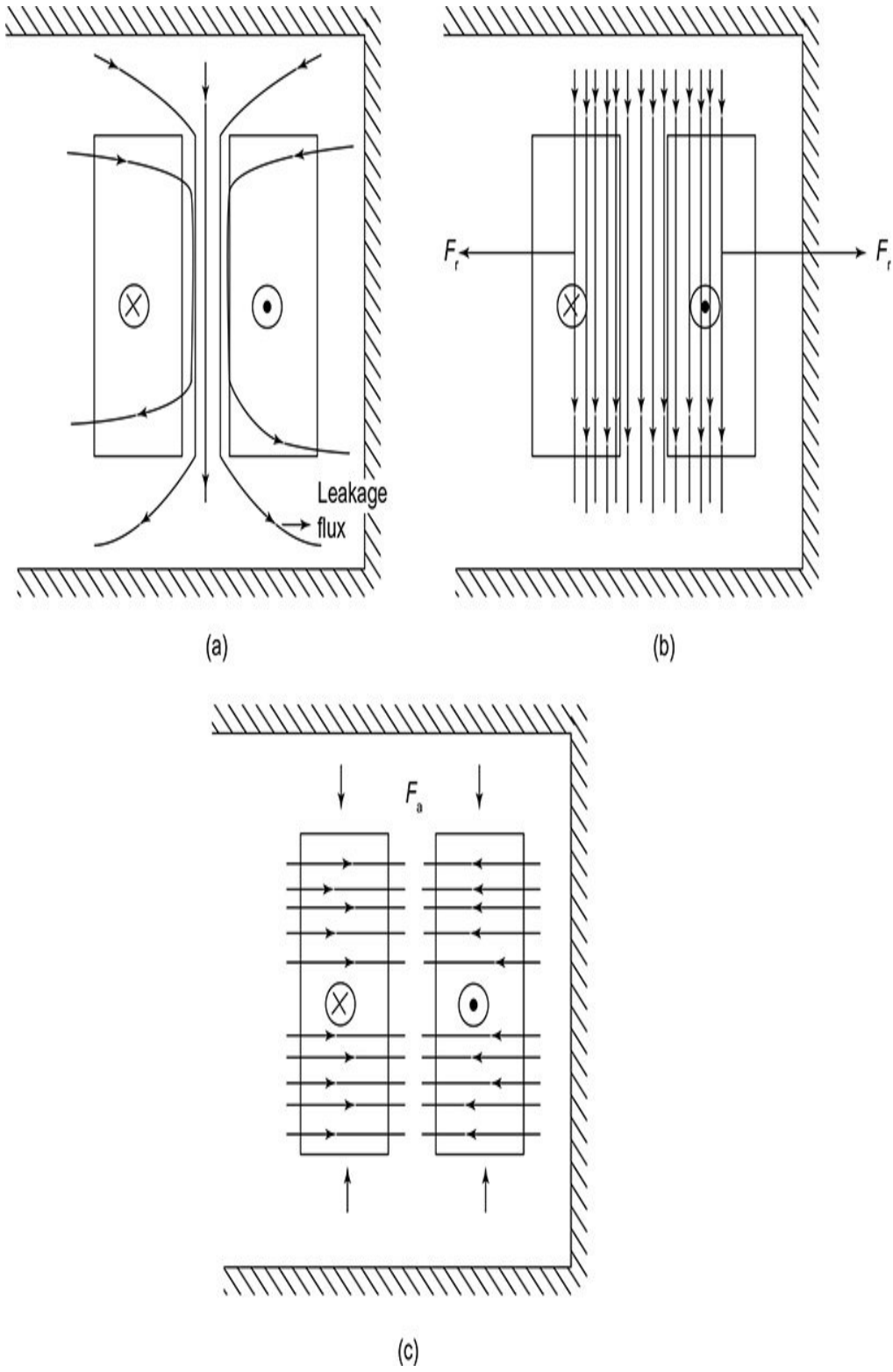

**Fig. 3.43** | (a) Leakage flux; (b) Axial leakage field; (c) Radial leakage field

Generally, Fleming’s left hand rule is used to determine the direction of forces. The cause and effect of the axial and radial forces are represented in Table 3.12.

**Table. 3.12** | Cause and effect of the axial and radial forces

Feature\Type	Axial forces	Radial forces
Nature of occurrence (cause)	<ul style="list-style-type: none"> <li>• Due to interaction of radial component of leakage flux</li> </ul>	<ul style="list-style-type: none"> <li>• Due to interaction of axial component of leakage flux</li> </ul>
Effect	<ul style="list-style-type: none"> <li>• Compression caused in windings can become tensile if an asymmetry exists in axial magnetic field</li> </ul>	<ul style="list-style-type: none"> <li>• Compression in inner winding. Tensile force in outer winding</li> </ul>

The magnitude of force acting on a conductor is proportional to the current flow in it and magnetic field intensity due to current in neighbouring conductors. Generally, as the magnetic field is proportional to the current, force is proportional to the square of current. The effect of large mechanical forces can be reduced by *bracing (reinforcing)* of windings.

### 3.25 Computer-aided Design of Transformer

Manual calculations are done for the design of transformer so far. The design of the transformer starts from the output equation based on the specifications and other parameters of the transformer. The different variables and parameters are interrelated and they have a non-linear relationship with the performance of the machine. Taking all these in to consideration, the design

has to be done to give best performance. For a particular application, several sets of design need to be carried out to find the optimum one. Hence, many iterations and parameter changes have to be done. They can be easily done with the help of digital computers. Hence, computers have become an integral part of the design process of electrical machines. Sample computer programmes for the design of transformers are given in the following sections.

**Example Program 1: Determine the main dimensions of a 350 kVA, 3 $\phi$ , 50 Hz Y/ $\Delta$ , 11000/3300V, core-type distribution transformer. Assume distance between core centres as twice the width of core.**

### **Solution:**

*Matlab program*

```
disp('DESIGN OF OVERALL DIMENSION OF  
TRANSFORMER\n');
```

```
disp('Enter the following values: ')
```

```
KVA=input('KVA rating: ');
```

```
disp('voltage per turn calculation give k :\n1 0.75-  
0.85 for 1phase core\n2 0.45 for 3phase core\n3 1-  
1.2 for 1phase shell\n4 1.3 for 3phase\n');
```

```

k=input('k: ');

Et=k*sqrt(KVA);

f=input('Line frequency: ');

m=input('Number of phases: ');

Bm=input('Flux density: ');

Ki=input('Stacking factor: ');

disp('The values of peak flux per pole, net iron
area and Gross iron area calculated are');

PHlm=Et/(4.44*f);

Ai=PHlm/Bm%net iron area;

Agi=Ai/Ki %gross core section area;

c=input('Enter the type of
core:\n1)Square\n2)Stepped\n3)3-Stepped\ n4)4-
Stepped \n');

switch c

case 1

ct=0.45;

    d=sqrt(Ai/ct) % dia od circumscribing circle
    a=sqrt(0.5)*d %width of the largest stamping

case 2

ct=0.56;

    d=sqrt(Ai/ct)

```

```

    a=0.85*d %dimensions
    b=0.53*d

case 3

ct=0.6;

    d=sqrt(Ai/ct)
    a=0.42*d %dimensions
    b=0.7*d
    c=0.9*d

case 4

ct=0.62;

    d=sqrt(Ai/ct)
    a=0.36*d %dimensions
    b=0.36*d
    c=0.78*d
    r=0.92*d

end;

disp('WINDOW DESIGN OF TRANSFORMER\n')

KV=input('Primary winding voltage: ');

deltap=input('Primary current density: ');

Kw=input('Enter window space factor: ')

Aw=(KVA*1000)/(3.33*Bm*f*Kw*deltap*Ai) %window area

ratiohw=input('Ratio - height to width of window in
the range of 2-4: '); %Range 2-4

disp('The window width and window height are');

```

$Ww = \sqrt{A_w / \text{ratio}hw}$  %window width

$Hw = Ww * \text{ratio}hw$  %window height

disp('YOKE DESIGN OF TRANSFORMER\n')

ratioyl=input('ratio - area of yoke to limbs: ');

Dy=input('Depth of yoke: ');

disp('The flux density in yoke, yoke area, gross yoke area and height of yoke are calculated as');

$FDy = B_m / \text{ratio}yl$  %flux density in yoke

$A_y = \text{ratio}yl * (PH_{lm} / B_m)$  %yoke area

$A_{gy} = A_y / K_i$  %gross area of yoke

$H_y = A_{gy} / Dy$  %height of yoke

disp('OVERALL DIMENSION OF TRANSFORMER\n')

disp('The distance betwn core centers, height, width and depth of transformers are obtained as');

$D = d + Ww$  %dist between adjacent core centres

$H = Hw + 2 * H_y$  %height of frame

$W = 2 * D + Dy$  %width of frame

$D_f = Dy$  %depth of frame

*C program*

```

#include<stdio.h>

#include<math.h>

int main() {

    printf("DESIGN OF OVERALL DIMENSION OF TRANSFORMER\n");
    printf("Enter the following values: \n");

    printf("KVA rating: ");

    double KVA;

    scanf("%lf",&KVA);

    double k;

    printf("voltage per turn calculation give k :\n1
0.75-0.85 for 1phase core\n2 0.45 for 3phase core\n3
1-1.2 for 1phase shell\n4 1.3 for 3phase\n");

    scanf("%lf",&k);

    double Et=k*sqrt(KVA);

    double f;

    printf("\nLine frequency: ");

    scanf("%lf",&f);

    double m;

    printf("\nNumber of phases: ");

    scanf("%lf",&m);

    doubleBm;

```

```

printf("\nFlux density: ");

scanf("%lf",&Bm);

double Ki;

printf("\nStacking factor: ");

scanf("%lf",&Ki);

printf("\nThe values of peak flux per pole, net iron
area and Gross

iron area calculated are ");

doublePHlm=Et/(4.44*f);

printf("\n%lf",PHlm);

double Ai=PHlm/Bm; //net iron area

printf("\n%lf",Ai);

doubleAgi=Ai/Ki; //gross core section area

printf("\n%lf",Agi);

printf("\nEnter the type of
core:\n1)Square\n2)Stepped\n3)3-Stepped\n4)4-Stepped
\n");

int core;

scanf("%d",&core);

double d,a,b,c,ct,r;

switch (core)

```

```
{  
  
case 1:  
  
ct=0.45;  
  
    d=sqrt(Ai/ct); // dia of circumscribing circle  
    a=sqrt(0.5)*d; //width of the largest stamping  
  
break;  
  
case 2:  
  
ct=0.56;  
  
    d=sqrt(Ai/ct);  
    a=0.85*d; //dimensions  
    b=0.53*d;  
  
break;  
  
case 3:  
  
ct=0.6;  
  
    d=sqrt(Ai/ct);  
    a=0.42*d; //dimensions  
    b=0.7*d;  
    c=0.9*d;  
  
break;  
  
case 4:  
  
ct=0.62;  
  
    d=sqrt(Ai/ct);  
    a=0.36*d; //dimensions  
    b=0.36*d;
```

```

        c=0.78*d;
        r=0.92*d;
break;

default:

printf("invalid");

}

printf("WINDOW DESIGN OF TRANSFORMER\n");

double KV;

printf("\nPrimary winding voltage: ");

scanf("%lf",&KV);

double deltap;

printf("\nPrimary current density: ");

scanf("%lf",&deltap);

double Kw;

printf("\nEnter Window space factor: ");

scanf("%lf",&Kw);

double Aw=(KVA*1000)/(3.33*Bm*f*Kw*deltap*Ai);
//window area

double ratiohw;

printf("\nRatio - height to width of window in the
range of 2-4: ");

```

```

scanf("%lf",&ratiohw);

doubleWw=sqrt(Aw/ratiohw); //window width

doubleHw=Ww*ratiohw; //window height

printf("\nThe window width and window height are
%lf, %lf",Ww,Hw);

printf("YOKE DESIGN OF TRANSFORMER\n");

doubleratioyl;

printf("\nratio - area of yoke to limb: ");

scanf("%lf",&ratioyl);

doubleDy;

printf("\nDepth of yoke: ");

scanf("%lf",&Dy);

doubleFDy=Bm/ratioyl; //flux density in yoke

double Ay=ratioyl*(PHlm/Bm); //yoke area

doubleAgy=Ay/Ki; //gross area of yoke

doubleHy=Agy/Dy; //height of yoke

printf("\nThe flux density in yoke,yoke area, gross
yoke area and height of yoke are calculated as %lf,
%lf, %lf, %lf \n",FDy, Ay, Agy, Hy);

printf("OVERALL DIMENSION OF TRANSFORMER\n");

double D=d+Ww; //dist between adjacent core centres

```

```

double H=Hw+2*Hy; //height of frame

double W=2*D+Dy; //width of frame

double Df=Dy; //depth of frame

printf("The distance betwn core centers, height,
width and depth of transformers are obtained as %lf,
%lf, %lf, %lf \n",D,H,W,Df);

return 0;

}

```

## Example Program 2: Computer program for overall design of transformer

### Solution:

*Matlab program*

```

disp('CORE DESIGN OF TRANSFORMER\n');

disp('Enter the following values: ')

KVA=input('KVA rating: ');

disp('voltage per turn calculation give k :\n1 0.75-
0.85 for 1phase core\n2 0.45 for 3phase core\n3 1-
1.2 for 1phase shell\n4 1.3 for 3phase\n' );

k=input('k: ');

```

```

Et=k*sqrt(KVA);

f=input('Line frequency: ');

m=input('Number of phases: ');

Bm=input('Flux density: ');

Ki=input('Stacking factor: ');

disp('The values of peak flux per pole, net iron
area and Gross iron area calculated are');

PHlm=Et/(4.44*f);

Ai=PHlm/Bm%net iron area;

Agi=Ai/Ki %gross core section area;

c=input('Enter the type of
core:\n1)Square\n2)Stepped\n3)3-Stepped\ n4)4-
Stepped \n');

switch c

case 1

ct=0.45;

    d=sqrt(Ai/ct) % dia od circumscribing circle
    a=sqrt(0.5)*d %width of the largest stamping

case 2

ct=0.56;

    d=sqrt(Ai/ct)
    a=0.85*d %dimensions
    b=0.53*d

```

case 3

ct=0.6;

d=sqrt(Ai/ct)

a=0.42\*d %dimensions

b=0.7\*d

c=0.9\*d

case 4

ct=0.62;

d=sqrt(Ai/ct)

a=0.36\*d %dimensions

b=0.36\*d

c=0.78\*d

r=0.92\*d

end;

disp('WINDOW DESIGN OF TRANSFORMER\n')

KV=input('Primary winding voltage: ');

deltap=input('Primary current density: ');

Kw=input('Enter window space factor: ');

Aw=(KVA\*1000)/(3.33\*Bm\*f\*Kw\*deltap\*Ai) %window area

ratiohw=input('Ratio - height to width of window in the range of 2-4: '); %Range 2-4

disp('The window width and window height are');

Ww=sqrt(Aw/ratiohw) %window width

```

Hw=Ww*ratiohw>window height

disp('YOKE DESIGN OF TRANSFORMER\n')

ratioyl=input('ratio - area of yoke to limbs: ');

Dy=input('Depth of yoke: ');

disp('The flux density in yoke,yoke area, gross yoke
area and height of yoke are calculated as');

FDy=Bm/ratioyl%flux density in yoke

Ay=ratioyl*(PHlm/Bm) %yoke area

Agy=Ay/Ki %gross area of yoke

Hy=Agy/Dy%height of yoke

disp('OVERALL DIMENSION OF TRANSFORMER\n')

disp('The distance betwn core centers,height, width
and depth of transformers are obtained as');

D=d+Ww%dist between adjacent core centres

H=Hw+2*Hy%height of frame

W=2*D+Dy%width of frame

Df=Dy%depth of frame

disp('LOW VOLTAGE WINDING DESIGN OF TRANSFORMER\n');

Vls=input('Secondary line voltage: ');

c1=input('Type of connection:
\n1.Star\n2.Delta:\n');

```

```

switch c1

case 1

Vsp=Vls/sqrt(3) %secondary phase voltage - star

case 2;

Vsp=Vls;%secondary phase voltage - delta

end;

disp('The no of turns per phase and current per
phase of LV winding are');

Ts=round(Vsp/Et) %no of turns per phase

Isp=(KVA*1000)/(3*Vsp) %secondary current per phase

delta=input('Enter secondary current density: ');

disp('The area of conductor of LV winding is');

as=Isp/delta %area of secondary conductor

disp('Let us choose copper rectangular conductors
and paper insulation for these conductors.');
```

x=input('Width of conductor along height of
window(mm): ');

y=input('Width of conductor along width of
window(mm): ');

z=input('Increase in dimensions because of
insulation(mm): ');

x1=x+z

```

y1=y+z%dimension with covering

ly=input('Number of layers: ');

disp('Using helical winding: ')

Ts1=round((Ts/ly)+1) %turns along axial length

Lcs=Ts1*x1 %axial length of lv winding

cls=(Hw*1000-Lcs)/2 %clearance

if(cls<6)

    {

disp('clearance is <6. Min limit not satisfied')

    }

end;

cly=input('Enter thickness of pressboard
cylinders(mm): ');

bs=2*ly*y1+cly %radial depth of lv winding

lvi=input('Enter thickness of insulation between Lv
winding and core(mm): ')

disp('The inside , outside, mean dia of LV winding
and ita mean length of turn are');

Idl=d*1000+2*lvi %inside diameter

Odl=Idl+2*bs%outside diameter

Mdl=(Idl+Odl)/2 %Mean diameter

```

```

Mlt=pi*Mdl%Mean length of turn

disp('HIGH VOLTAGE WINDING DESIGN OF
TRANSFORMER\n');

Vlp=input('primary line voltage: ');

c1=input('Type of connection:
\n1.Star\n2.Delta:\n');

switch c1

case 1

Vpp=Vlp/sqrt(3) %primary phase voltage - star

case 2;

Vpp=Vlp;%primary phase voltage - delta

end;

disp('The no of turns per phase and current per
phase of LV winding are');

Tp=round(Ts*(Vpp/Vsp)) %no of turns

Ipp=(KVA*1000)/(3*Vpp) %primary current per phase

delta=input('primary current density: ')

disp('Let us choose copper round conductors\n')

disp('The area of conductor of HV winding,Dia of
conductor,Total copper area in window and window
space factor are');

ap=Ipp/delta %area of primary conductor

```

```

dp=sqrt((4*ap)/pi) %diamater of conductor

Acw=2*(ap*Tp+as*Ts) %Total copper area in window

Kw=Acw/(Aw*10000) %window space factor

ca=input('Number of coils in HV winding: ');
%voltage/coil should not exceed 1500V

ta=input('Number of turns in each coil of HV
winding: ');

tec=Tp-ca*ta %Number of turns in end coil

ly=input('Number of layers of normal coil: ');

tly=input('Turns per layer of normal coil: ');

Mxvly=2*tly*(Vlp/Tp) %Max voltage between layers

sci=input('Size of conductor with insulation: ');

adn=tly*sci%axial depth of normal coil

lye=input('Number of layers of end coil: ');

tlye=input('Turns per layer of end coil: ');

ade=tlye*sci%axial depth of end coil

sp=input('Height of Spaces used between adjacent
coils: ');

Lcp=ca*adn+ade+ca*sp%axial length of HV winding

Cl=(Hw-Lcp)/2 %clearance

```

```

cly=input('Thickness of insulataion between layers:
');

bp=ly*sci+(ly-1)*cly%radial depth of HV coil

T=5+((0.9*Vlp)/1000)

Idh=ca*adn+2*T %Inside diameter

Odh=Idh+2*ade%Outside diameter

Mdh=(Idh+Odh)/2 %Mean diameter

disp('RESISTANCE DESIGN OF TRANSFORMER\n');

Lmtp=(pi*Mdh)/1000 %length of mean turn in HV
winding

rop=input('Resistivity of material in HV winding:
');

disp('The Resistane of conductor of LV winding is');

Rp=(Tp*Lmtp*rop)/ap%resistance in HV side

Lmts=(pi*Mdl)/1000 %length of mean turn in Lv
winding

ros=input('Resistivity of material in LV winding:
');

disp('The Resistane of conductor of HV winding,
Resistance referred to HV side and Per unit
resistance are');

Rs=(Ts*Lmts*ros)/as %resistance in HV side

Ref=Rp+(((Tp*Tp)/(Ts*Ts))*Rs) %Resistanereffered to
primary

```

```

ep=(Ipp*Ref)/Vlp%per unit resistance

disp('LEAKAGE REACTANCE DESIGN OF TRANSFORMER\n');

Dm=(Odl+Odh)/2 %Mean diameter of windings

Lmt=(pi*Dm)/1000 %Length of mean turn of winding

Lc=(Lcp+Lcs)/2 %Mean axial length of winding

disp('The leakage Reatance referred to HV side and
Per unit impedance are');

Xp=(2*pi*f*4*pi*10e-7*Tp*Tp*Lmt*(T+
(bp+bs)/3))/Lc%Leakage reactance

epx=(Ipp*Xp)/Vpp%per unit leakage reactance

epi=sqrt((ep*ep)+(epx*epx)) %per unit impedance

```

*C program*

```

#include<stdio.h>

#include<math.h>

int main()

{

const double pi=3.14;

printf("DESIGN OF OVERALL DIMENSION OF
TRANSFORMER\n");

printf("Enter the following values: \n");

printf("KVA rating: ");

```

```
double KVA;

scanf("%lf",&KVA);

double k;

printf("voltage per turn calculation give k :\n1
0.75-0.85 for 1phase core\n2 0.45 for 3phase core\n3
1-1.2 for 1phase shell\n4 1.3 for 3phase\n");

scanf("%lf",&k);

double Et=k*sqrt(KVA);

double f;

printf("\nLine frequency: ");

scanf("%lf",&f);

double m;

printf("\nNumber of phases: ");

scanf("%lf",&m);

doubleBm;

printf("\nFlux density: ");

scanf("%lf",&Bm);

double Ki;

printf("\nStacking factor: ");

scanf("%lf",&Ki);
```

```
printf("\nThe values of peak flux per pole, net iron  
area and Gross iron area calculated are ");
```

```
doublePHlm=Et/(4.44*f);
```

```
printf("\n%lf",PHlm);
```

```
double Ai=PHlm/Bm; //net iron area
```

```
printf("\n%lf",Ai);
```

```
doubleAgi=Ai/Ki; //gross core section area
```

```
printf("\n%lf",Agi);
```

```
printf("\nEnter the type of  
core:\n1)Square\n2)Stepped\n3)3-Stepped\n4)4-Stepped  
\n");
```

```
int core;
```

```
scanf("%d",&core);
```

```
double d,a,b,c,ct,r;
```

```
switch (core)
```

```
{
```

```
case 1:
```

```
ct=0.45;
```

```
    d=sqrt(Ai/ct); // dia of circumscribing circle
```

```
    a=sqrt(0.5)*d; //width of the largest stamping
```

```
break;
```

```
case 2:
```

```
ct=0.56;

    d=sqrt(Ai/ct);
    a=0.85*d; //dimensions
    b=0.53*d;

break;

case 3:

ct=0.6;

    d=sqrt(Ai/ct);
    a=0.42*d; //dimensions
    b=0.7*d;
    c=0.9*d;

break;

case 4:

ct=0.62;

    d=sqrt(Ai/ct);
    a=0.36*d; //dimensions
    b=0.36*d;
    c=0.78*d;
    r=0.92*d;

break;

default:

printf("invalid");

}

printf("WINDOW DESIGN OF TRANSFORMER\n");
```

```

double KV;

printf("\nPrimary winding voltage: ");

scanf("%lf",&KV);

double deltap;

printf("\nPrimary current density: ");

scanf("%lf",&deltap);

double Kw;

printf("\nEnter Window space factor: ");

scanf("%lf",&Kw);

double Aw=(KVA*1000)/(3.33*Bm*f*Kw*deltap*Ai);
//window area

double ratiohw;

printf("\nRatio - height to width of window in the
range of 2-4: ");

scanf("%lf",&ratiohw);

double Ww=sqrt(Aw/ratiohw); //window width

double Hw=Ww*ratiohw; //window height

printf("\nThe window width and window height are
%lf, %lf",Ww,Hw);

printf("YOKE DESIGN OF TRANSFORMER\n");

double ratioyl;

```

```

printf("\nratio - area of yoke to limb: ");

scanf("%lf",&ratioyl);

doubleDy;

printf("\nDepth of yoke: ");

scanf("%lf",&Dy);

doubleFDy=Bm/ratioyl; //flux density in yoke

double Ay=ratioyl*(PHlm/Bm); //yoke area

doubleAgy=Ay/Ki; //gross area of yoke

doubleHy=Agy/Dy; //height of yoke

printf("\nThe flux density in yoke,yoke area, gross
yoke area and height of yoke are calculated as %lf,
%lf, %lf, %lf \n",FDy, Ay, Agy, Hy);

printf("OVERALL DIMENSION OF TRANSFORMER\n");

double D=d+Ww; //dist between adjacent core centres

double H=Hw+2*Hy; //height of frame

double W=2*D+Dy; //width of frame

doubleDf=Dy; //depth of frame

printf("The distance betwn core centers, height,
width and depth of transformers are obtained as %lf,
%lf, %lf, %lf \n",D,H,W,Df);

printf("\nLOW VOLTAGE WINDING DESIGN OF
TRANSFORMER\n");

```

```
doubleVls;

printf("\nSecondary line voltage: ");

scanf("%lf",&Vls);

int c1;

printf("\nType of connection: \n1.Star\n2.Delta:\n");

scanf("%d",&c1);

doubleVsp;

switch (c1)

{

case 1:

Vsp=Vls/sqrt(3); //secondary phase voltage - star

break;

case 2:

Vsp=Vls;//secondary phase voltage - delta

break;

}

doubleTs=round(Vsp/Et); //no of turns per phase

printf("\nThe no of turns per phase and current per phase of LV winding are: %lf",Ts);
```

```
double Isp=(KVA*1000)/(3*Vsp); //secondary current
per phase

double deltas;

printf("\nEnter secondary current density: ");

scanf("%lf",&deltas);

double as=Isp/deltas; //area of secondary conductor

printf("\nThe area of conductor of LV winding is
%lf",as);

printf("\nLet us choose copper rectangular
conductors and paper insulation for these
conductors.");

double x;

printf("\nWidth of conductor along height of
window(mm): ");

scanf("%lf",&x);

double y;

printf("\nWidth of conductor along width of
window(mm): ");

scanf("%lf",&y);

double z;

printf("\nIncrease in dimensions because of
insulation(mm): ");

scanf("%lf",&z);
```

```

double x1=x+z;

double y1=y+z; //dimension with covering

doublely;

printf("\nNumber of layers: ");

scanf("%lf",&ly);

printf("\nUsing helical winding: ");

double Ts1=round((Ts/ly)+1); //turns along axial
length

doubleLcs=Ts1*x1; //axial length of lv winding

doublecls=(Hw*1000-Lcs)/2; //clearance

if(cls<6)

    {

printf("\nclearance is <6. Min limit not
satisfied");

    }

doublecly;

printf("\nEnter thickness of pressboard
cylinders(mm): ");

scanf("%lf",&cly);

doublebs=2*ly*y1+cly; //radial depth of lv winding

double lvi;

```

```
printf("\nEnter thickness of insulation between Lv  
winding and core(mm): ");
```

```
scanf("%lf",&lvi);
```

```
printf("\nThe inside , outside, mean dia of LV  
winding and its mean length of turn are");
```

```
doubleIdl=d*1000+2*lvi; //inside diameter
```

```
doubleOdl=Idl+2*bs; //outside diameter
```

```
doubleMdl=(Idl+Odl)/2; //Mean diameter
```

```
doubleMlt=pi*Mdl; //Mean length of turn
```

```
printf("\nThe inside , outside, mean dia of LV  
winding and its mean length of turn are %lf, %lf,  
%lf, %lf",Idl,Odl,Mdl,Mlt);
```

```
printf("\nHIGH VOLTAGE WINDING DESIGN OF  
TRANSFORMER\n");
```

```
doubleVlp;
```

```
printf("\nprimary line voltage: ");
```

```
scanf("%lf",&Vlp);
```

```
int c2;
```

```
printf("\nType of connection:  
\n1.Star\n2.Delta:\n");
```

```
scanf("%d",&c2);
```

```
doubleVpp;
```

```
switch (c2)
```

```

{

case 1:

Vpp=Vlp/sqrt(3); //primary phase voltage - star

break;

case 2:

Vpp=Vlp;//primary phase voltage - delta

break;

default:

printf("\ninvalid");

}

printf("\nThe no of turns per phase and current per
phase of LV winding are");

doubleTp=round(Ts*(Vpp/Vsp)); //no of turns

doubleIpp=(KVA*1000)/(3*Vpp); //primary current per
phase

printf("\nThe no of turns per phase and current per
phase of LV winding are %lf, %lf",Tp,Ipp);

printf("\nLet us choose copper round conductors\n");

doubleap=Ipp/deltap; //area of primary conductor

doubledp=sqrt((4*ap)/pi); //diamater of conductor

```

```

doubleAcw=2*(ap*Tp+as*Ts); //Total copper area in
window

double Kw1=Acw/(Aw*10000); //window space factor

printf("\nThe area of conductor of HV winding,Dia of
conductor,Total copper area in window and window
space factor are %lf, %lf, %lf, %lf",ap,dp,Acw,Kw1);

doubleca,ta;

printf("\nNumber of coils in HV winding: ");
//volt/coil should not exceed 1500V

scanf("%lf",&ca);

printf("\nNumber of turns in each coil of HV
winding: ");

scanf("%lf",&ta);

doubletec=Tp-ca*ta; //Number of turns in end coil

doublelystly;

printf("\nNumber of layers of normal coil: ");

scanf("%lf",&lystly);

printf("\nTurns per layer of normal coil: ");

scanf("%lf",&tly);

doubleMxvly=2*tly*(Vlp/Tp); //Max voltage between
layers

doublescilye,tlye;

printf("\nSize of conductor with insulation: ");

```

```

scanf("%lf",&sci);

double adn=tly*sci; //axial depth of normal coil

printf("\nNumber of layers of end coil: ");

scanf("%lf",&lye);

printf("\nTurns per layer of end coil: ");

scanf("%lf",&tlye);

double ade=tlye*sci; //axial depth of end coil

double sp;

sp=printf("\nHeight of Spaces used between adjacent
coils: ");

scanf("%lf",&sp);

double Lcp=ca*adn+ade+ca*sp; //axial length of HV
winding

double Cl=(Hw-Lcp)/2; //clearance

double clyt;

printf("\nThickness of insultaion between layers:
");

scanf("%lf",&clyt);

double bp=lys*sci+(lys-1)*clyt; //radial depth of HV
coil

double T=5+((0.9*Vlp)/1000);

```

```

double Idh=ca*adn+2*T; //Inside diameter

double Odh=Idh+2*ade; //Outside diameter

double Mdh=(Idh+Odh)/2; //Mean diameter

printf("\nThe radial depth, inner diameter, outer
diameter, mean diameter of the high are %lf, %lf,
%lf, %lf", bp, Idh, Odh, Mdh);

printf("\nRESISTANCE DESIGN OF TRANSFORMER\n");

double Lmtp=(pi*Mdh)/1000; //length of mean turn in
HV winding

double rop;

printf("\nResistivity of material in HV winding: ");

scanf("%lf",&rop);

printf("\nThe Resistance of conductor of LV winding
is");

double Rp=(Tp*Lmtp*rop)/ap; //resistance in LV side

double Lmts=(pi*Mdl)/1000; //length of mean turn in
LV winding
double ros;

printf("\nResistivity of material in LV winding: ");

scanf("%lf",&ros);

double Rs=(Ts*Lmts*ros)/as; //resistance in HV side

double Ref=Rp+(((Tp*Tp)/(Ts*Ts))*Rs); //Resistance
referred to primary

double ep=(Ipp*Ref)/Vlp; //per unit resistance

```

```

printf("\nThe Resistance of conductor of HV winding,
Resistance referred to HV side and Per unit
resistance are %lf, %lf, %lf",Rs,Ref,ep);

printf("\nLEAKAGE REACTANCE DESIGN OF
TRANSFORMER\n");

doubleDm=(Odl+Odh)/2; //Mean diameter of windings

doubleLmt=(pi*Dm)/1000; //Length of mean turn of
winding

doubleLc=(Lcp+Lcs)/2; //Mean axial length of winding

doubleXp=(2*pi*f*4*pi*10e-7*Tp*Tp*Lmt*(T+
(bp+bs)/3))/Lc; //Leakage reactance

doubleepx=(Ipp*Xp)/Vpp; //per unit leakage reactance

double epi=sqrt((ep*ep)+(epx*epx)); //per unit
impedance

printf("\nThe leakage Reactance referred to HV side
and Per unit impedance are %lf, %lf",epx,epi);

return 0;

}

```

**Example Program 3: Computer program for design of cooling system of transformer with total loss specified**

## **Solution:**

*Matlab program*

```
KVA=input('KVA rating: ');
P=input('allowable losses: ');
t=input('allowable temperature rise: ');
l=input('length of tank (including clearance): ');
w=input('width of tank (including clearance): ');
h=input('height of tank (including clearance): ');
ht=input('average height of tube: ');
dt=input('diameter of tube: ');

St=2*h*(l+w) %dissipating surface area of tank

At=(P-(12.5*St*t))/(8.78*t) %total heat dissipating
area of tubes

at=pi*dt*ht%area of each tube

Nt=round(At/at) %number of tubes
```

*C program*

```
#include<stdio.h>

#include<math.h>

int main()

{
```

```
const double pi=3.14;

doubleKVA,P,t,l,w,h,ht,dt;

KVA=printf("\nKVA rating: ");

printf("\n\enter the following parameters: ");

KVA=printf("\nKVA rating: ");

scanf("%lf",&KVA);

P=printf("\nallowable losses: ");

scanf("%lf",&P);

t=printf("\nallowable temperature rise: ");

scanf("%lf",&t);

l=printf("\nlength of tank (including clearance):
");

scanf("%lf",&l);

w=printf("\nwidth of tank (including clearance): ");

scanf("%lf",&w);

h=printf("\nheight of tank (including clearance):
");

scanf("%lf",&h);

ht=printf("\naverage height of tube: ");

scanf("%lf",&ht);
```

```

dt=printf("\ndiameter of tube: ");

scanf("%lf",&dt);

double St=2*h*(l+w); //dissipating surface area of
tank

printf("\ndissipating surface area of tank is
%lf",St);

double At=(P-(12.5*St*t))/(8.78*t); //total heat
dissipating area of tubes

printf("\ntotal heat dissipating area of tubes is
%lf",At);

double at=pi*dt*ht; //area of each tube

printf("\nArea of each tube is %lf",at);

double Nt=round(At/at); //number of tubes

printf("\nTotal number of tubes is %lf",Nt);

return 0;

}

```

## Review Questions

### *Multiple-choice Questions*

1. Magnetic material used in large transformer is \_\_\_\_\_.
  1. cast steel
  2. hot-rolled silicon steel
  3. cold-rolled grain-oriented steel
  4. either (b) or (c)
2. \_\_\_\_\_ type of cylindrical windings using circular conductors are employed in transformers.

1. Multi-layered
  2. double layered
  3. triple layered
  4. single layered
3. The main disadvantage of cylindrical winding is \_\_\_\_\_.
1. high copper loss
  2. poor mechanical strength
  3. more eddy current loss
  4. none of the above
4. Helical windings are used in \_\_\_\_\_ transformers.
1. distribution
  2. power
  3. shell-type
  4. none of these
5. Disc windings are primarily used in \_\_\_\_\_ capacity transformers.
1. low
  2. medium
  3. high
  4. any of these
6. Yokes with rectangular cross-section are used for \_\_\_\_\_ transformers.
1. small
  2. medium
  3. large
  4. any of these
7. Power transformers have ratings above \_\_\_\_\_ kVA.
1. 50
  2. 100
  3. 250
  4. 500
8. Cold-rolled grain-oriented steel has \_\_\_\_\_ in comparison to hot-rolled silicon steel.
1. better finish
  2. improved space factor
  3. much better magnetic properties
  4. all of the above
9. Typical value of window space factor is \_\_\_\_\_.
1. 0.5
  2. 0.6
  3. 0.1
  4. 0.3
10. The reason for using multi-step core is used in a transformer is to \_\_\_\_\_.
1. increase the efficiency

2. decrease the cost of core material
  3. decrease the cost of copper
  4. increase the output
11. Tappings of a transformer are provided \_\_\_\_\_.
    1. at the middle of *h.v.* side
    2. at the neutral end of *h.v.* side
    3. at the phase end of *h.v.* side
    4. at the phase end of *l.v.* side
  12. For transformer laminations, which type of silicon steel is preferred?
    1. cold rolled
    2. hot rolled
    3. grain-oriented
    4. any of these
  13. The primary and secondary windings are interlaced in a transformer for \_\_\_\_\_.
    1. reduced cost
    2. uniform heating
    3. easiness of coil making
    4. reduced leakage reactance
  14. Helical winding with rectangular strip conductors is generally used for \_\_\_\_\_.
    1. *h.v.* coils
    2. both *l.v.* and *h.v.* coils
    3. *l.v.* coils
    4. none of the above
  15. The cross-over coils in transformers are generally used for \_\_\_\_\_.
    1. *h.v.* winding
    2. *l.v.* winding
    3. both *l.v.* and *h.v.* winding
    4. none of the above
  16. The cylindrical winding in transformers is generally not used beyond \_\_\_\_\_.
    1. 6.6 kV
    2. 3.3 kV
    3. 66 kV
    4. 33 kV
  17. The percentage of silicon in the transformer core steel is \_\_\_\_\_.
    1. 2 to 3%
    2. 3 to 4%
    3. 4 to 5%
    4. 5 to 6%
  18. The transformer core laminations have thickness in the range of

- \_\_\_\_\_.
1. 3.5 to 5 mm
  2. 2 to 3 mm
  3. 0.35 to 0.5 mm
  4. 0.035 to 0.05 mm
19. The core laminations are prepared using \_\_\_\_\_ for large capacity power transformers.
1. cold-rolled grain-oriented silicon steel
  2. cold-rolled silicon steel
  3. hot-rolled silicon steel
  4. any one of the above
20. The core section in a large capacity power transformer is \_\_\_\_\_.
1. square
  2. rectangular
  3. multi-stepped
  4. Any of the above
21. Tap changer is normally provided on \_\_\_\_\_ transformer.
1. distribution
  2. step up
  3. instrument
  4. high voltage
22. A three-phase power transformer is generally of \_\_\_\_\_ type.
1. berry
  2. core
  3. shell
  4. toroidal
23. In comparison with power transformer, a distribution transformer has \_\_\_\_\_.
1. low percentage impedance and high copper iron loss ratio
  2. high percentage impedance and high copper iron loss ratio
  3. high percentage impedance and low copper iron loss ratio
  4. low percentage impedance and low copper iron loss ratio
24. What are the effects of making limb section lower than the yoke section?
1. economy in copper usage
  2. decreased iron losses
  3. decreased magnetizing current
  4. all of the above
25. Circular coils are preferred in transformers because of \_\_\_\_\_.
1. of its superior mechanical stability under short circuit conditions
  2. it becomes wasteful to employ rectangular coils
  3. both (a) and (b) above
  4. it is easier to make circular coils.

26. The reason for single-phase shell-type distribution transformer to have sandwich type winding is \_\_\_\_\_.
1. to reduce the leakage reactance
  2. to save copper
  3. to improve the voltage regulation
  4. both (a) and (c) above.
27. What is the effect of increase in the height of the window in comparison to the width in a transformer?
1. cost of copper will be reduced
  2. voltage regulation will decrease
  3. efficiency will decrease due to increase in copper losses
  4. both (a) and (b)
28. \_\_\_\_\_ causes hum in a transformer.
1. Magnetostriction
  2. Vibrations developed by laminations depending upon the tightness of clampings
  3. Cushions and paddings
  4. all of the above
29. Humming noise in a transformer can be decreased by \_\_\_\_\_.
1. using lower flux densities
  2. tightening the clampings of laminations
  3. using suitable cushions, padding and oil barriers
  4. all of the above
30. If all the dimensions of a transformer is doubled, its iron loss will be \_\_\_\_\_ compared to iron loss with the original dimensions.
1. half
  2. double
  3. four times
  4. 8 times
31. Total copper area accommodated in the window of gross area  $300 \text{ cm}^2$  of a particular transformer is 0.48 times, the net area of iron in the core of  $200 \text{ cm}^2$ . Then, the window space factor is \_\_\_\_\_.
1. 0.72
  2. 0.28
  3. 0.32
  4. 0.48
32. If the net iron area of a three stepped core is  $240 \text{ cm}^2$ , then the diameter of the circumscribing circle is \_\_\_\_\_.
1. 25 cm
  2. 18 cm
  3. 20 cm
  4. 15 cm
33. \_\_\_\_\_ to reduce hysteresis loss in a transformer.
1. Core may be laminated

2. Silicon steel may be used as the core material.
  3. Core may be constructed with any permanent magnet material such as alnico
  4. Core may be impregnated with varnish.
34. Which of the following relation must be satisfied if a transformer having constant flux and constant current density is designed for minimum cost?
1. iron loss = copper loss
  2. weight of iron = weight of copper
  3. weight of iron/weight of copper = specific cost of copper/specific cost of iron
  4. weight of iron/weight of copper = specific cost of iron/specific cost of copper
35. The criteria for a transformer to be designed for the minimum volume is \_\_\_\_\_.
1. iron loss = copper loss
  2. volume of iron = volume of copper
  3. weight of iron = weight of copper
  4. the volume of iron is minimum
36. Choice of higher core flux density in a transformer leads to \_\_\_\_\_.
1. increased overall size
  2. reduced magnetizing current
  3. reduced iron losses
  4. reduction in overall cost
37. With rise in voltage, the window space factor of a transformer \_\_\_\_\_.
1. decreases
  2. increases
  3. remains constant
  4. decreases or increases depending upon whether it is a distribution or power transformer
38. If the total area occupied by the insulating material in the window of a transformer is 72%, then the window space factor is \_\_\_\_\_.
1. 0.28
  2. 0.72
  3. 0.32
  4. 0.25
39. If the gross area of window is  $750 \text{ cm}^2$  for a particular transformer, then the approximate height of the window is \_\_\_\_\_.
1. 25 cm
  2. 75 cm
  3. 50 cm

4. 30 cm
40. If for a single phase, 6600/400V, core-type transformer, the e.m.f. per turn is 6 V, then the number of turns in *h.v.* winding is \_\_\_\_\_.
1. 1106
  2. 1122
  3. 1100
  4. 1089
41. If for a single phase, 6600/400V, core-type transformer, the e.m.f. per turn is 6 V, then the number of turns in *l.v.* winding is \_\_\_\_\_.
1. 65
  2. 66
  3. 67
  4. 68
42. If for a single phase, 6600/400V, core-type transformer, the e.m.f. per turn is 6 V, then the number of turns in *h.v.* winding with + 5% tapping is \_\_\_\_\_.
1. 1064
  2. 1178
  3. 1068
  4. 1072
43. If for a three phase, 11000/440V, delta/star, core-type transformer, e.m.f. per turn is 10.8V, then the number of turns per phase in *l.v.* winding is \_\_\_\_\_.
1. 23
  2. 23
  3. 24
  4. 40
44. If for a three phase, 11000/440V, delta/star, core-type transformer, e.m.f. is per turn is 10.8V, then the number of turns per phase in *h.v.* winding is \_\_\_\_\_.
1. 1018
  2. 600
  3. 1000
  4. 1038
45. If for a three phase, 11000/440V, delta/star, core-type transformer, e.m.f. is per turn is 10.8V, then the number of turns per phase in *h.v.* winding with - 5% tapping is \_\_\_\_\_.
1. 1050
  2. 1092
  3. 1080
  4. 1070
46. Eddy currents are reduced in high silicon steel as it provides \_\_\_\_\_.

1. increases resistivity
  2. reduces resistivity
  3. short circuits
  4. none of the above
47. In order to reduce the eddy current losses within the conductor, the thickness of the rectangular conductor selected for  $l.v.$  and  $h.v.$  winding should not be greater than \_\_\_\_\_.
1. 2 mm
  2. 2.5 mm
  3. 3 mm
  4. 3.5 mm
48. Stacking factor will be minimum for \_\_\_\_\_ type of core.
1. four-stepped
  2. three-stepped
  3. square
  4. cruciform
49. The usual values of current densities for medium and large power transformers are \_\_\_\_\_.
1. 1.5 to 2.6 A/mm<sup>2</sup>
  2. 2.4 to 3.4 A/mm<sup>2</sup>
  3. 1.5 to 2 A/mm<sup>2</sup>
  4. 1 to 2.6 A/mm<sup>2</sup>
50. If a 200/400V transformer has a secondary winding resistance of  $0.5\Omega$ , the total resistance referred to primary is \_\_\_\_\_.
1.  $0.125\Omega$
  2.  $0.5\Omega$
  3.  $1\Omega$
  4.  $2\Omega$
51. If the frequency of supply voltage to the primary of a two-winding transformer is doubled, then the induced emf is \_\_\_\_\_.
1. unaltered
  2. doubled
  3. halved
  4. none of these
52. Leakage reactance of a transformer is \_\_\_\_\_.
1. directly proportional to number of turns
  2. directly proportional to square of number of turns
  3. inversely proportional to number of turns
  4. inversely proportional to square of number of turns
53. Large value of flux density can be adopted while designing \_\_\_\_\_.
1. distribution transformer
  2. welding transformer
  3. large capacity power transformer
  4. current transformer.

54. Lower value of window space factor will be adopted in design of \_\_\_\_\_.
1. 400 kVA, 11/0.4 kV, distribution transformer
  2. 20,000 kVA, 66/11 kV, power transformer
  3. 20,000 kVA, 33/11 kV, power transformer
  4. 100 kVA, 11/0.4 kV, distribution transformer
55. Larger value of current density can be adopted for transformer employing \_\_\_\_\_ cooling.
1. oil-forced water forced
  2. oil-natural air forced
  3. oil-immersed self-cooled
  4. any of the above
56. While designing a transformer if increased window height is adopted, it may result into
1. poor voltage regulation
  2. reduced leakage reactance
  3. increased leakage reactance
  4. both (a) and (b) above
57. If the thickness of laminations is  $t$ , then the eddy current losses are proportional to \_\_\_\_\_.
1.  $t^2$
  2.  $t^3$
  3.  $t$
  4.  $t$
58. If wider window is adopted in designing a transformer, it may result in to \_\_\_\_\_.
1. reduced leakage reactance
  2. good voltage regulation
  3. increased leakage reactance
  4. both (b) and (c) above
59. In the design of a transformer, the usual value of the ratio of window height to window width used is \_\_\_\_\_.
1. 5
  2. 3
  3. 2
  4. 4
60. In a transformer, the emf per turn is determined, in terms of its kVA output rating (Q) from the relation \_\_\_\_\_.
1.  $E_t = KQ$
  2.  $E_t = K\sqrt{Q}$
  3.  $E_t = kQ^{3/2}$
  4.  $E_t = k/Q$
61. An iron cored transformer is working at a maximum flux density of  $0.8 \text{ Wb/m}^2$ . Its core is replaced by silicon steel core, working at

a maximum flux density of  $1.2 \text{ Wb/m}^2$ . If the total flux is to remain the same, what is the reduction in volume expressed as of the original volume? The frequency and voltage per turn are the same in both the cases.

1. 33%
  2. 9%
  3. 22%
  4. 11%
62. If the total losses of a transformer during its design is 500 W at 50% full load, then the total copper losses of the same transformer at 1.25 times full load will be \_\_\_\_\_.
1. 500 W
  2. 625 W
  3. 1250 W
  4. 3125 W
63. Typical value of no load current expressed as percentage of full load current in transformer is \_\_\_\_\_.
1. 10%
  2. 15%
  3. 3%
  4. 8%
64. In a transformer, iron losses and full load copper losses are 900 and 1600 W, respectively. The ratio of load for maximum efficiency in terms of full load is \_\_\_\_\_.
1. 0.56
  2. 0.85
  3. 0.75
  4. 1.0
65. Magnetic couplings are present closer in a transformer to ensure \_\_\_\_\_.
1. high efficiency
  2. good regulation
  3. good regulation and high efficiency
  4. good regulation and high power factor
66. The useful flux in a transformer links \_\_\_\_\_.
1. only *l.v.* turns
  2. only *h.v.* turns
  3. both *l.v.* and *h.v.* turns
  4. none of the above
67. Under which of the following conditions, the hysteresis loss in a transformer remains unaffected?
1. When both frequency and flux density are increased by 10%
  2. When flux density is increased by 10%
  3. When thickness of lamination is increased by 10%
  4. When frequency is increased by 10%

68. Maintaining the same thickness but selecting a higher silicon content core material for a transformer reduces eddy current loss due to \_\_\_\_\_.
1. decrease in resistivity
  2. increase in resistivity
  3. decrease in malleability
  4. both (a) and (b) above
69. In order to have minimum copper loss in the transformer windings, \_\_\_\_\_.
1. the primary and secondary currents should be equal
  2. the current densities in primary and secondary windings must be the same
  3. copper losses should be equal to iron losses
  4. none of the above
70. Transformer core is laminated to decrease \_\_\_\_\_.
1. stray loss
  2. eddy current loss
  3. copper loss
  4. hysteresis loss
71. In transformers, with rise in supply frequency, \_\_\_\_\_.
1. copper loss remains unaffected but efficiency increases.
  2. copper loss decreases but efficiency increases
  3. copper loss increases but efficiency decreases
  4. both copper loss and efficiency remain unaffected
72. In transformers, with increase in supply frequency, the iron losses \_\_\_\_\_.
1. decreases
  2. increases
  3. remain unaffected
  4. becomes zero
73. Under which situation(s), a transformer can be slightly over loaded?
1. if the ambient temperature is much below the designed value
  2. if the supply frequency is increased
  3. both (a) and (b) above
  4. none of the above
74. \_\_\_\_\_ transformer is designed for good all day efficiency.
1. Distribution transformer
  2. Current transformer
  3. High voltage transformer
  4. Power transformer
75. Mechanical forces in a transformer are developed due to \_\_\_\_\_.
1. interaction of current flowing in the winding and leakage

- flux around it
  - 2. vibrations
  - 3. gap between laminations
  - 4. none of these
76. The overload capacity in a transformer depends on \_\_\_\_\_.
- 1. supply frequency
  - 2. core size
  - 3. both (a) and (b)
  - 4. none of these
77. In \_\_\_\_\_ transformer, use of higher leakage reactance is permitted.
- 1. current transformer
  - 2. instrument transformer
  - 3. distribution transformer
  - 4. power transformer
78. In a transformer having a higher leakage reactance leads to an advantage of \_\_\_\_\_.
- 1. reducing the magnetizing current
  - 2. improving the voltage regulation
  - 3. limiting the inrush current during a short circuit
  - 4. none of the above
79. The leakage reactance of a transformer depends on \_\_\_\_\_.
- 1. configuration of the winding
  - 2. number of turns
  - 3. frequency
  - 4. all the above
80. The leakage reactance of a transformer is \_\_\_\_\_.
- 1. proportional to square of number of turns
  - 2. directly proportional to number of turns
  - 3. inversely proportional to number of turns
  - 4. proportional to inverse square of number of turns
81. Addition of cooling tubes to the transformer tank improves heat dissipation capacity because of \_\_\_\_\_.
- 1. additional dissipation by convection
  - 2. additional dissipation by radiation
  - 3. additional cooling surface
  - 4. all the above
82. A conservator tank along with the main tank of a transformer is mostly adopted \_\_\_\_\_.
- 1. to prevent formation of sludge in the main tank
  - 2. to improve the cooling
  - 3. to keep the oil in reserve
  - 4. to facilitate the periodical check up of the oil
83. \_\_\_\_\_ can be adopted for transformer cooling.
- 1. Animal oil

2. Vegetable oil
  3. Mineral oil
  4. Any oil
84. Heat dissipation by means of radiation in oil immersed transformers with cooling tubes is \_\_\_\_\_.
1. about  $6.0 \text{ W/m}^2 / ^\circ\text{C}$
  2. about  $2 \text{ W/m}^2 / ^\circ\text{C}$
  3. about  $10 \text{ W/m}^2 / ^\circ\text{C}$
  4. about  $50 \text{ W/m}^2 / ^\circ\text{C}$
85. The heat dissipation capacity of transformer exceeding 50 kVA rating is increased by providing \_\_\_\_\_.
1. fins
  2. tubes
  3. radiator tanks
  4. corrugations
  5. all of these
86. Oil used in cooling of transformer should have \_\_\_\_\_.
1. low viscosity
  2. low dielectric strength
  3. low flash point
  4. none of the above
87. Transformer oil should be devoid of \_\_\_\_\_.
1. sulphur
  2. moisture
  3. acids
  4. all the above
88. Transformer oil should possess \_\_\_\_\_.
1. high flash point
  2. high dielectric strength
  3. high viscosity
  4. both (a) and (b) above
89. How much heat can be dissipated by natural means from the plain walled tank of a transformer?
1.  $8.78 \text{ W/m}^2 / ^\circ\text{C}$
  2.  $3.72 \text{ W/m}^2 / ^\circ\text{C}$
  3.  $6 \text{ W/m}^2 / ^\circ\text{C}$
  4.  $12.5 \text{ W/m}^2 / ^\circ\text{C}$

### *Answers*

1. b
2. a
3. b

4. b
5. c
6. a
7. c
8. d
9. d
10. c
11. b
12. d
13. d
14. c
15. a
16. a
17. c
18. c
19. a
20. c
21. a
22. b
23. c
24. d
25. c
26. d
27. d
28. a
29. d
30. d
31. c
32. c
33. b
34. c
35. b
36. d
37. a
38. a
39. c
40. b
41. d
42. c
43. c
44. d
45. b
46. a
47. a
48. c

49. b
50. a
51. b
52. b
53. c
54. b
55. a
56. b
57. b
58. c
59. b
60. b
61. a
62. d
63. c
64. c
65. d
66. c
67. c
68. b
69. b
70. b
71. a
72. a
73. c
74. a
75. a
76. b
77. d
78. c
79. d
80. a
81. d
82. a
83. c
84. a
85. e
86. a
87. d
88. d
89. d

*Short Type Questions*

*Difficulty level – Easy*

1. What are the major components of a transformer?  
Refer Section 3.1.
2. What are the functions of various parts of transformer?  
Refer Table 3.1.
3. Explain the classification of transformers.  
Refer Sections 3.1.1 to 3.1.4.
4. Compare core and shell-type transformer.  
Refer Table 3.2.
5. Compare three-phase transformer bank and three-phase transformer.  
Refer Table 3.3.
6. Mention the reasons for the use of tertiary winding in transformer.  
Refer Section 3.1.4.
7. Mention the specifications of transformer.  
Refer Section 3.2.
8. What are the steps involved in the design of transformer?  
Refer Section 3.3.
9. Give the output equation of single phase core-type and shell-type transformer.  
Refer Sections 3.3.2 and 3.3.3.
10. Give the output equation of three phase core-type and shell-type transformer.  
Refer Sections 3.3.5 and 3.3.6.
11. Provide the expression for volt per turn of winding.  
Refer Section 3.4.
12. What are the values of 'K' for various types of transformers?  
Refer Table 3.4.
13. Explain about choice of flux density in a transformer.  
Refer Section 3.5.
14. What are the values of flux densities for various types of transformers?  
Refer Table 3.5.
15. Explain about choice of current density in a transformer.  
Refer Section 3.6.
16. What are the values of current densities for various types of transformers?  
Refer Table 3.6.
17. What are the types of laminations used in core and shell-type transformers?  
Refer Fig. 3.17.
18. What are the types of cores used in transformer?  
Refer Fig. 3.18.

19. Define stacking factor.  
Refer Section 3.7.
20. Provide the ratios of net and gross area to area of circumscribing circle for different types of cores.  
Refer Table 3.7.
21. Explain about design of yoke.  
Refer Section 3.8.
22. Provide the expression for area of window.  
Refer Section 3.9.
23. Give the expressions for overall dimensions of single phase core and shell-type transformers.  
Refer Sections 3.10.1 and 3.10.3.
24. Give the expressions for overall dimensions of three phase core and shell-type transformers.  
Refer Sections 3.10.2 and 3.10.4.
25. What are the different types of windings used in transformer?  
Refer Fig. 3.28.
26. Explain about the choice of windings for different types of transformer.  
Refer Table 3.8.
27. Provide the expression for resistance of winding.  
Refer Section 3.12.
28. Provide the expression for reactance of winding.  
Refer Section 3.13.
29. Give the expression for no load current in transformer.  
Refer Section 3.15.
30. Provide the expression for magnetizing volt-ampere in a transformer.  
Refer Page 3.63.
31. Provide the alternate expression for magnetizing current in a transformer.  
Refer Page 3.63.
32. Mention the different losses in a transformer.  
Refer Section 3.16.
33. Provide a brief summary on effects of variation of frequency on core loss, voltage, leakage reactance and resistance of transformer.  
Refer Table 3.9.
34. Provide the condition for obtaining minimum volume of transformer.  
Refer Section 3.18.
35. Provide the condition for obtaining minimum weight of transformer.  
Refer Section 3.18.
36. Provide the condition for obtaining minimum losses of

transformer.

Refer Section 3.18.

37. What are the various types of cooling methods for a transformer?

Refer Fig. 3.36.

38. Mention the heat transfer methods in various regions of transformer.

Refer Table 3.10.

39. Mention the typical clearance values used in providing cooling arrangements of a transformer.

Refer Table 3.11.

40. Explain about the cause and effect of axial and radial force in a transformer.

Refer Table 3.12.

*Difficulty level – Medium to hard*

1. What are the magnetic materials used for the magnetic frame?

1. Hot-rolled silicon steel;
2. Cold-rolled grain-oriented silicon steel.

2. Which magnetic material used for the magnetic frame has better magnetic properties?

Cold-rolled grain-oriented silicon steel.

3. Mention the reason for using five limb construction for three phase core-type transformer.

Five limb construction is used so as to reduce the height of the assembled transformer and thereby to overcome the transportation limitations.

4. What are the effective requirements of a properly designed core of a transformer?

The key requirements of a properly designed core include that of having minimum iron losses and no load current.

5. What are the essential properties of transformer steel?

The transformer steel should exhibit

1. high permeability
2. high resistivity
3. low coercive force

6. Provide the limiting values of flux density used with hot-rolled steel and cold-rolled grain-oriented steel.

1. hot-rolled steel – 1.4 Tesla
2. cold-rolled grain-oriented steel – 1.7 Tesla

7. Why transformers employ stepped core?

The following are the reasons for employing stepped core:

1. Low voltage and high voltage coils are circular, providing better utilization of space

2. For reducing the mean length of low voltage and high voltage turns, resulting in saving of copper material.
8. Mention the merits of using comparatively higher flux density in the core.
  1. Decrease in core and yoke cross-sectional area for same output.
  2. Reduction in mean length of low voltage and high voltage turns resulting in saving of copper material.
  3. Reduced overall size and weight of the transformer.
  4. Decrease in overall cost of the transformer.
9. Why low voltage and high voltage windings employ circular coils?
  1. To attain better mechanical strength.
  2. To lessen the mean length of low voltage and high voltage turns, leading to copper saving.
10. Mention the types of windings generally used for low voltage winding.
  1. Helical winding.
  2. Cylindrical winding with rectangular conductors.
11. What are the types of winding that are generally used for high voltage winding?
  1. Cylindrical winding with circular conductor.
  2. Continuous disc type winding.
  3. Cross-over winding.
12. Mention the demerits of sandwich winding.
  1. Difficulty in manufacturing due to requirement of high labour.
  2. Less stability under short circuit conditions.
  3. Difficulty in insulating different coils from each other and from the yoke.
13. Why are stranded conductors used for the winding in transformer?
 

Stranded conductors are used for the winding in transformer to reduce the eddy current losses within the conductor.
14. Mention the insulating materials that are used in transformers.
  1. Press board
  2. Porcelain
  3. Cable paper
  4. Insulating varnish
  5. Varnished silk
  6. Bakelite
  7. Transformer oil
15. What are the essential properties of insulating materials used in transformer?
  1. Sufficient mechanical strength to withstand the stresses.
  2. High dielectric strength to prevent break down.

3. Good oil absorbing capability.
16. Mention the reason for using different current densities in low voltage (*l.v.*) and high voltage (*h.v.*) windings.

L.v. winding is an inner winding, placed on the core, in which cooling is less compared to *h.v.* winding, which is the outer winding. Thus, *l.v.* winding should be designed with a comparatively lesser current density than the *h.v.* winding.
17. Why stranded conductors are required to be transposed?

It is essential to transpose the stranded conductors, to equalize the reactance of the strands.
18. Define interleaved winding.

Interleaved winding is a type of winding in which *l.v.* and *h.v.* coils are arranged alternately one over the other along the height of the limb.
19. What is the necessity for providing tapplings in a transformer?
  1. To maintain practically constant voltage at consumer's end,
  2. To control active and reactive power over a transmission line interconnecting two generating stations,
  3. To provide voltage regulation.
20. Provide the percentage tapplings, generally employed in transformers.

2.5% and 5%
21. Mention the advantages of providing tapping in *h.v.* winding.
  1. Precise voltage regulation, because of presence of larger number of turns.
  2. Ease of providing tapplings, as the *h.v.* winding is an outer winding.
  3. Relatively lower current is interrupted, while the taps are changed.
22. What are the different methods of changing the tapplings in a transformer?
  1. On load tap changing
  2. Off load tap changing
23. What are the properties required to be attained in designing the windings of transformer?
  1. Improved electrical performance characteristics
  2. Sufficient mechanical strength
  3. Proper ventilation
24. In which type of transformer leakage reactance can be varied over a wide range?

Shell-type transformer with sandwich winding.
25. Why power transformers are designed to have maximum efficiency at or near fullload whereas distribution transformers are designed to have maximum efficiency at loads quite lower than the full load?

Power transformers are designed to have maximum efficiency at or near full load whereas distribution transformers are designed to have maximum efficiency at loads quite lower than the full load, since power transformers are allowed to work at or near full load and switched off during light load hours, but distribution transformers are required to work all the time including light load hours.

26. Why circular coils are always preferred over rectangular coils for winding a transformer?  
Circular coils have the following advantage over rectangular coils:
1. Higher mechanical stability under short circuit conditions, due to the presence of radial forces and there is no tendency for the coil to change its shape due to mechanical forces
  2. Proper utilization of space
  3. Ease of winding
27. Why is the area of yoke of a transformer usually kept 15–20% more than that of core?  
By maintaining the area of yoke 15–20% more than the area of core, the yoke flux density is reduced, and hence reducing the iron losses in the yoke portion.
28. Why are mittred joints preferred in transformer core?  
The mittred joints make the flux lines to flow along the direction of grain orientation, thereby reducing the iron loss and the no load current.
29. Why l.v. winding is placed first on the core and then h.v. winding in case of a coretype transformer?  
By placing l.v. winding near the core, the insulation thickness reduces resulting into ease in insulation. It further reduces the length of mean turn of conducting material.
30. What are the types of transformer according to service conditions?
1. Distribution transformer
  2. Power transformer
31. Why sandwiched winding is preferred for a distribution transformer?  
Sandwich winding is preferred to reduce the leakage reactance in order to have a good voltage regulation.
32. In case of a power transformer, a higher leakage reactance is not considered a disadvantage – Justify.  
Since higher leakage reactance can limit the rush of current during a short circuit, a power transformer of a higher leakage reactance is not considered a disadvantage.
33. Why a stepped core is used in transformer?

Stepped core is used to approximate the core section near to a circle, therefore reduces the length of mean turn leading to reduction in the amount of copper.

34. Justify the use of cross-over coils for winding *h.v.* side of a transformer.  
The *h.v.* winding has larger number of turns, which when employed with a cross-over winding can be easily divided into a number of coils depending upon the voltage rating. Insulation spacers can then separate every coil, which assists in free circulation of oil.
35. Mention the reason for use of stranded conductors instead of a single conductor of large cross-section.  
Stranded conductors are preferred due to reduction in eddy current loss, compared to a single conductor of large cross-section.
36. Why stepping is not employed in yoke?  
Stepping is required in portions where winding is present. As yoke portions do not carry any winding, it is not stepped.
37. Why an elaborate clamping and tightening arrangement is required in transformer core?  
Clamping and tightening arrangement is required to overcome the large amount of mechanical forces developed during short circuit conditions.
38. What is the range of efficiency of a commercially available transformer?  
The efficiency of a commercially available transformer will be in the range of 94% to 99%.
39. Define a transformer bank.  
A transformer bank consists of three independent single phase transformers with their primary and secondary windings connected either in star or in delta.
40. How does the design of distribution transformer differ from the design of a power transformer?
  1. The distribution transformers are designed in such a way that copper loss will be higher than iron loss, whereas in power transformers the copper loss will be lesser than the iron loss.
  2. The distribution transformers are designed to have the maximum efficiency at a load much lesser than full load, whereas the power transformers are designed to have maximum efficiency at or near full load.
  3. The leakage reactance is kept low in a distribution transformer to have better regulation, whereas in power transformers the leakage reactance is kept high to limit the short circuit current.

41. What is the necessity of using sheet steel stampings in the construction of electrical machines?  
The stampings reduce the eddy current losses as the stampings are insulated by a thin coating of varnish; hence when the stampings are stacked to form a core, the resistance for the eddy current is very high. (This is due to very small area of crosssection of laminations.)
42. How the insulation is provided in the laminations of core?
1. In laminations made of hot-rolled silicon steel, a thin coating of kaolin or varnish is applied to insulate them.
  2. In laminations of cold-rolled silicon steel, a phosphate-based coating is applied to insulate them.
  3. In high capacity transformers, above 10 MVA rating in addition to phosphate coating, a coating of kaolin or varnish is applied.
43. Mention the merits of three-phase transformers over single-phase transformers.  
Three-phase transformers have the following advantages compared to single-phase transformers.
1. Less weight
  2. Less cost
44. What are the types of winding commonly employed for LV winding?
1. Helical winding
  2. Cylindrical winding with rectangular conductors
45. What are the disadvantages of using higher flux density in design of core of transformer?
1. Increased magnetizing current and iron losses.
  2. Higher temperature-rise of transformer.
  3. Lower efficiency, because of higher no load losses.
  4. Saturation of magnetic material.
46. Why the cross-section of core is taken less than yoke?  
The cross-section of yoke is larger than core so as to reduce flux density by limiting the no load current and thereby reducing iron losses.
47. Describe the placement of *low voltage* and *high voltage* winding in a single phase coretype transformer.  
On each core, half the number of *low voltage* and half the number of *high voltage* turns are placed.  
The *low voltage* winding is first placed on the core and then the *high voltage* winding is placed over the *low voltage* winding.
48. What is the reason to not use large number of steps in a stepped core?  
Even though, the large number of steps reduces the amount of copper used, it increases the labour charge which may make

implementation costlier.

49. Why window space factor is lesser for higher voltage rating transformers?  
As the voltage rating increases, larger space is required for insulation and clearances; hence, the window space factor is lower.
50. Mention the effect on leakage reactance in the construction of narrower window transformer.  
In a transformer with narrow window, the limbs are placed closer thereby the leakage flux is reduced resulting in the reduction of leakage reactance.
51. Explain the requirement of estimation of Ampere Turn in the design of transformer.  
Ampere Turn is estimated to determine the magnetizing current for the transformer.
52. Mention the reason to add the Ampere Turn required by joints in the estimation of the total A.T. required for transformer.  
As a high portion of the total Ampere Turn links the joints, it is necessary to add it to the total Ampere Turn.
53. Define window space factor.  
The window space factor is defined as the ratio of copper area in the window to the total area of window.
54. Mention the advantages of stepped cores.  
For same cross-sectional area, the stepped cores will have lesser diameter of circumscribing circle when compared to square cores. This causes reduction in length of mean turn of the winding with subsequent reduction in costs, i.e., volume of copper and copper loss.
55. Define copper space factor.  
The copper space factor is the ratio of conductor area and window area in case of transformers.  
(In case of rotating machines, it is the ratio of conductor area and slot area.)
56. Mention the factors to be considered in choosing the type of winding for a core-type transformer.
1. Current density
  2. Impedance
  3. Temperature rise
  4. Surge voltage
  5. Short circuit current
57. Mention the reason for use of delta connection of tertiary winding in a transformer.  
The unbalance in phase voltage during unsymmetrical faults in primary or secondary of transformer is compensated by the circulating currents flowing in the closed delta connection.

58. How the tank dimensions are fixed based on overall dimensions of transformer frame?
1. The dimensions of the tank are decided by the dimensions of the transformer frame and clearance required on all the sides.
  2. The clearance on the side depends on voltage and power rating of the winding.
  3. The clearance at the top depends on the oil height above the assembled transformer and the space for mounting the terminals and tap changing gear.
  4. The clearance at the bottom depends on the space required for mounting the transformer frame inside the tank.
59. Define leg spacing.  
Leg spacing is the distance between the centres of two adjacent limbs of a transformer.  
It is denoted by D.
60. What are the factors affecting the choice of flux density of core in a transformer?
1. Core area,
  2. Core loss and
  3. Magnetizing current
61. Where does the iron loss take place in a transformer?
1. Magnetic core
  2. Yoke
62. Where does the copper loss take place in a transformer?
1. High voltage winding
  2. Low voltage winding
63. What is the percentage no load current of transformers?
- 3 to 5% – small transformer  
1 to 3% – medium transformer  
0.5 to 1% – large transformer
64. Mention the nominal efficiency of transformer.
- 97 to 98% – small transformer  
98 to 99% – medium transformer  
98.5 to 99.4% – large transformer
65. Why the efficiency of a transformer is very high?
1. Mechanical losses are zero (absent), which forms great part of total losses.
  2. Iron losses are comparatively less due to use of better magnetic material in magnetic frame.
66. Why working flux density is on the lower side for distribution transformers?
- By maintaining the flux density on the lower side, the iron losses are reduced thereby improving the all day efficiency which is very important in case of a distribution transformer.

67. What is the effect of variation of frequency on eddy current loss in transformer core if the voltage is maintained constant?  
The eddy current loss will not change with the effect of variation of frequency in transformer core with the voltage is maintained constant.
68. How the leakage reactance is affected with the variation of frequency?  
The leakage reactance variation is linear with the change in frequency.
69. Mention the relation of output and losses in a transformer with variation in linear dimensions.
1. The output increases as the fourth power with linear dimensions.
  2. The loss increases as the third power with linear dimensions.
70. How the leakage reactance of a transformer can be reduced?  
By interleaving the high voltage and low voltage winding, leakage reactance of a transformer can be reduced.
71. Mention the cause of noise in transformer.  
The causes of noise in the transformer are
1. Magnetostriction effect
  2. Loosening of stampings
  3. Mechanical forces produced during operation
72. What are the main functions of cooling medium in transformers?
1. Transfer of heat by convection from the heated surface to the tank surface.
  2. Creation of good level of insulation between various conducting parts.
73. How much heat is dissipated by radiation and convection?  
Heat dissipated by radiation –  $6 \text{ W/m}^2 / ^\circ\text{C}$   
Heat dissipated by convection –  $6.5 \text{ W/m}^2 / ^\circ\text{C}$
74. Why elaborate cooling arrangement is required for large transformers whereas natural cooling is sufficient for small transformers?  
The losses are high in large transformers, requiring elaborate cooling arrangement to limit the temperature rise. As losses are less in small transformers, natural cooling is sufficient.
75. Why conservator tank has to be necessarily used along with the main tank in a transformer cooling system?  
In order to avoid the contact of air and moisture with the oil of the main tank and to keep it free from sludge formation, conservator tank has to be necessarily used along with the main tank in a transformer cooling system.
76. Mention the reason for using breather along with the conservator tank.

The reason for using breather along with the conservator tank is that it is required to allow the air of the conservator to be driven out or drawn in, for the oil level raise or fall depending upon the load on the transformer.

77. Mention the factors to be considered for selecting the cooling method of a transformer.

The factors are

1. kVA rating
2. Size
3. Application
4. The site condition where it will be installed

78. Why transformer oil is used as a cooling medium?

By using transformer oil as a coolant, the heat dissipation by convection is 10 times more than the convection due to air which is given by the values of Specific heat dissipation by convection due to air =  $8 \text{ W/m}^2 \text{ } ^\circ\text{C}$

Specific heat dissipation by convection due to oil =  $80 \text{ to } 100 \text{ W/m}^2 \text{ } ^\circ\text{C}$

79. Why cooling tubes are provided in a transformer?

Cooling tubes are provided in a transformer to increase the heat dissipating area of the tank as the cooling tubes will improve the circulation of oil. The circulation of oil is due to more effective pressure heads produced by columns of oil in tubes. The improvement in cooling is accounted by taking the specific heat dissipation due to convection as 35% more than that without tubes.

80. Explain about simple cooling and mixed cooling of transformer.

In simple cooling, the transformer is cooled by a particular method of cooling. In mixed cooling, the transformer is provided with two or more cooling methods and at a particular point of time, a single cooling method is employed depending on the amount of heat to be removed.

81. Why in mine applications transformers, oil cooling should not be used?

The oil used for transformer cooling is inflammable (i.e., can easily set on fire), which can cause leakage of cooling oil leading to fire accidents in mines.

82. What is breather?

The breather is a device fitted in transformer for breathing. In small oil cooled transformers, some air-gap is provided between the oil level and tank top surface.

When the oil is heated, it expands and air is expelled out of transformer to the atmosphere through breather. When the oil is cooled, it shrinks and air is drawn from the atmosphere into the

transformer through breather. This action of transformer is called breathing.

83. Why silica gel is used in breather of transformer?  
The silica gel absorbs the moisture when the air is drawn from atmosphere into the transformer, while cooling is employed.
84. What is conservator in a transformer?  
A conservator is a small cylindrical drum fitted just above the transformer main tank. It is used to allow the expansion and contraction of oil without contact with surrounding atmosphere. When conservator is fitted in a transformer, the tank is fully filled with oil and the conservator is half filled with oil.
85. What are the functions of transformer oil?  
Transformer oil behaves as a cooling medium and provides considerable level of insulation.
86. Why oil immersed transformers employ bushings?  
Bushings make necessary connections to external circuit with windings.
87. Why bracing is employed in case of large transformers?  
Bracing is required to take care of the large amount of mechanical forces developed during short circuit conditions.

### *Long Type Questions*

1. Explain the constructional features of the transformer.
2. Derive the output equation of  $1\phi$  core-type and shell-type transformers.
3. Derive the output equation of  $3\phi$  core-type and shell-type transformers.
4. Obtain the expression for ratio of gross core area to circumscribing circle's area for (a) square core and (b) stepped core.
5. Derive the expression for magnetizing current of  $1\phi$  transformer.
6. Derive the expression for magnetizing volt ampere and magnetizing current of  $3\phi$  transformer.
7. Explain about the types of losses in transformer.
8. What are the effects of frequency in parameters of transformer?
9. Obtain the expression for optimum design of transformer based on minimum cost, minimum volume, minimum weight and maximum efficiency.
10. Explain the various methods of cooling of transformer.
11. Obtain the expression for design of cooling tank with tubes and give the various clearance values.

## Problems

1. Determine the main dimensions of a 300 kVA,  $3\phi$ , 50 Hz Y/ $\Delta$ , 11,000/3300 V, core-type distribution transformer. Assume distance between core centres as twice the width of core.
2. A three-phase, 50 Hz oil-cooled core-type transformer has the following dimensions. Distance between core centres = 0.25 m, height of window = 0.30 m, diameter of circumscribing circle = 0.14 m. The flux density<sub>2</sub> in the core = 1.1 Wb/m<sup>2</sup>, current density in conductor = 2 A/mm<sup>2</sup>. Assume a window space factor of 0.2 and core area factor of 0.56. The core is two stepped. Estimate the kVA rating of transformer.
3. Find the dimensions of the core and yoke of a single-phase core-type transformer of rating 200 kVA, 50 Hz. Given<sub>2</sub> the volt per turn as 15 V, maximum flux density as 1.1 Wb/m<sup>2</sup>, the<sub>2</sub> window space factor as 0.3 and current density as 2.6 A/mm<sup>2</sup>. Design a square core with distance between the adjacent limbs equal to 1.45 times the width of the transformer. Assume a stacking factor of 0.8 and flux density in the yoke is 80% flux density in the core.
4. Find the no load current of a 250/100 V, 2 kVA, 50 Hz single-phase transformer with the following data. Cross-sectional area of core = 25 cm<sup>2</sup>, effective magnetic core length = 0.45 m, weight of core = 8 kg, maximum flux density = 1.5 T, magnetizing mmf = 250 AT/m and specific core loss = 1.9 W/kg.
5. Design a suitable cooling system for a 400 kVA, 6000/400V 50 Hz,  $3\phi$  transformer with a total full load loss of 6 kW. The transformer tank is 1 m in height, 0.96 m in length and 0.47 m in breadth. Use cooling tubes of diameter 50 mm to limit the average temperature rise to 37°C. Use clearance of 50, 14 and 13 cm on the height, length and width sides.
6. A  $3\phi$ , 15 MVA, 30/6.6 kV 50 Hz, transformer has the following values on initial design. Length of transformer is 160 cm, height of transformer is 250 cm and the width is 78.5 cm. Use clearances of 50 cm, 11.5 cm and 11.5 cm, respectively, on the height, width and length for designing the tank. Total iron loss is 20 kW and 110 kW is the copper loss. Calculate the temperature rise of transformer without cooling tubes. Calculate the number of tubes to limit the temperature rise to 55°C.

## Design of Three-phase Induction Motor

### 4.1 Introduction

Three-phase induction motor is an important class of electric motor, which finds its application in various industrial and agricultural sectors. More than 80% of industrial motors are induction motors.

A three-phase induction motor essentially consists of two parts, namely the stator and the rotor. The fixed stator core carries three-phase balanced stator winding placed in the stator slots. Two different types of rotors are usually used in induction motors. They are as follows:

1. Cage rotor that resembles the cage of a squirrel usually referred as squirrel cage rotor and
2. A rotor that carries three-phase winding placed in rotor slots, the ends of which are connected to slip-rings placed ...

## DESIGN OF SINGLE-PHASE INDUCTION MOTOR

### 5.1 Introduction

Single-phase induction motors are extensively used for domestic, office and agricultural applications such as fans, mixers, refrigerators, washing machines, machine tools, etc. These motors are generally available in fractional horse power ranges. These motors have no inherent starting torque and so are equipped with some starting mechanisms. Depending upon the starting mechanism, there are many types of single-phase induction motors available in the market. They also have a poor power factor and efficiency compared to their three-phase counterparts. For the same frame size, the power output of single-phase induction motor is only 50% of that of three-phase induction motor.

### 5.2 Construction

Single-phase induction motors do not have inherent starting torque. Hence, based on the various methods used for starting them, they are classified as shown in [Fig. 5.1](#). The various parts of  $1\phi$  induction motor used in ceiling fan application are shown in [Fig. 5.2](#).

The classification of single-phase induction motors are detailed as follows.

### *5.2.1 Split Phase Motors*

These motors are provided with an auxiliary winding in addition to the main winding in the stator. The main winding is also called the running winding as it is available in the circuit during running conditions apart from the time of starting. The auxiliary winding is termed as starting winding as it is primarily meant for starting the motor and is removed from the circuit with the help of a centrifugal switch after the motor has started. Both the main and auxiliary windings are connected in parallel and are in space quadrature. The necessary starting torque is obtained by producing a two-phase revolving field which in turn is obtained by supplying two currents to the two windings displaced from each other preferably by  $90^\circ$ .

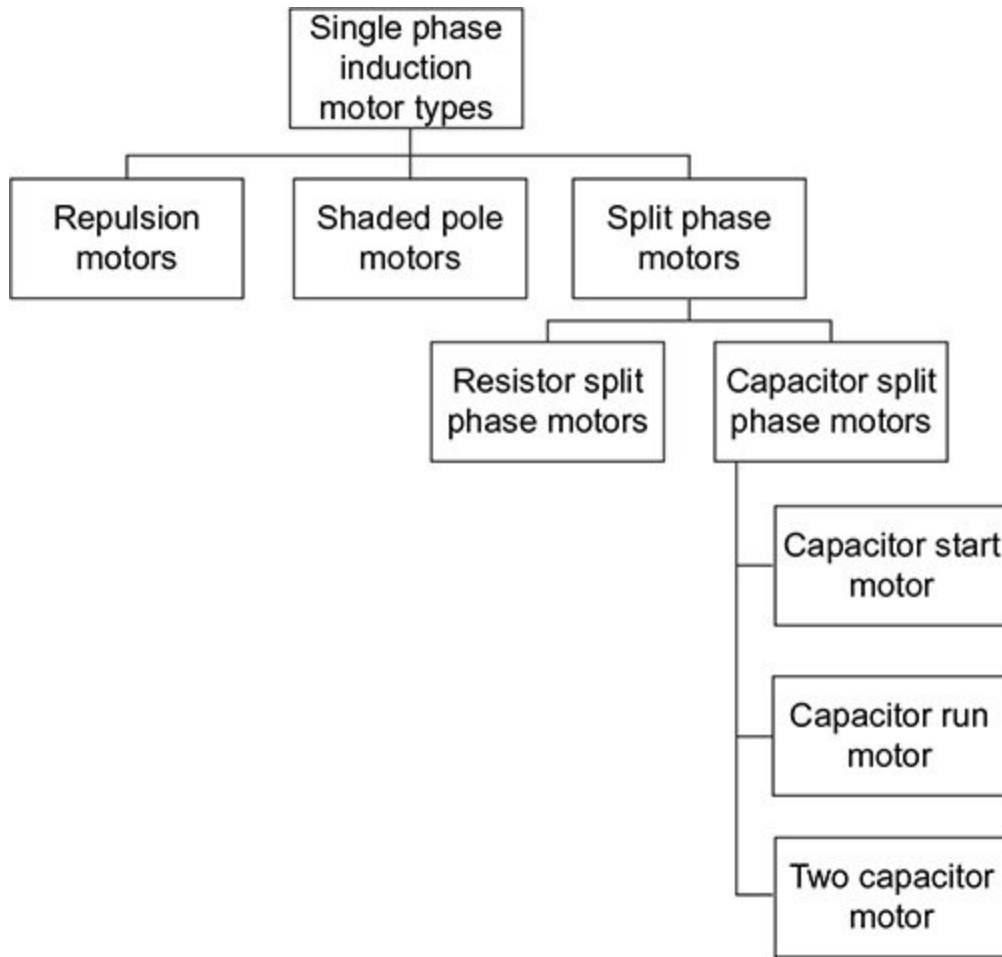

**Fig. 5.1** Classification of  $1\phi$  induction motor

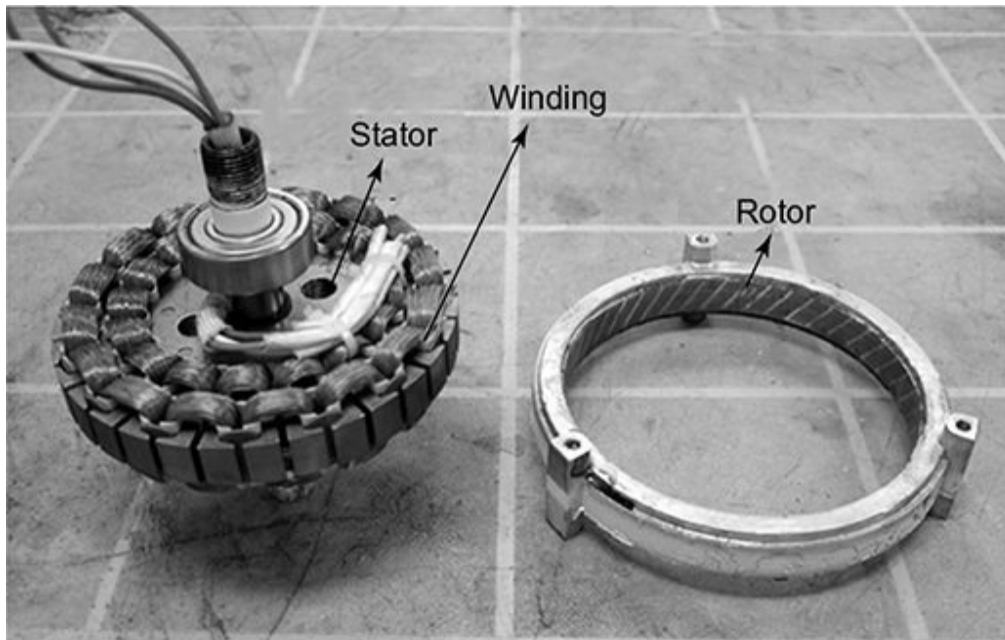

**Fig. 5.2** Cross-sectional view of  $1\phi$  induction motor and its parts

### **Resistance split phase motors**

If the phase displacement is provided either by a series resistor or by a starting winding with a high resistance, then the motor is called resistance start induction motor or simply resistance split phase motor. Such motors have a starting torque of amount 1.5 to 2 times the full load value. The starting winding is removed by a centrifugal switch after the motor attains 75% of rated speed.

### **Capacitor split phase motors**

If the phase displacement between the two currents in the main and auxiliary winding are produced by connecting a capacitor in series with the starting winding, then the motor is called capacitor split phase motor. A greater degree of phase displacement is obtained by the capacitor. This is the most widely used

type of single-phase induction motor. Depending upon the type and purpose of the capacitor used, the capacitor motors are further classified as follows.

1. **Capacitor start motors:** The capacitor along with the starting winding is open circuited by the centrifugal switch after the motor attains 75% of rated speed.
2. **Capacitor run motors:** The capacitor is left in the circuit even under running conditions to improve the power factor. This motor is also called permanent capacitor motor.
3. **Two-value capacitor motors:** When two different capacitors are used, one for starting and the other for running, then they are called capacitor start-capacitor run motors or simply two-value capacitor motors.

### *5.2.2 Shaded Pole Motors*

The main winding is a concentrated winding placed on the salient poles of the stator. A part of the salient pole is shaded by a short-circuited copper ring. This arrangement provides a phase displacement of  $20^\circ$  to  $30^\circ$  between fluxes in the shaded and the unshaded part of the pole. This produces a starting torque which is very low in magnitude. Loads up to 100 W, which demand low starting torque, use this type of motor.

### *5.2.3 Repulsion Motors*

The rotor of this motor carries a commutator winding instead of a cage winding and hence is started as a repulsion motor. The centrifugal switch short circuits the commutator segments when the motor reaches nearly 75% of the rated speed, making the commutating winding, a cage winding. Hence, the motor continues to run as an induction motor. This type of motor has a very good starting torque.

### 5.3 Design Considerations

Single-phase induction motors are built in fractional horsepower ratings. Design of such small rating motors need a special attention.

The major design considerations of a single-phase induction motor are as follows:

- Pull out torque
- Starting torque
- Operation at different voltages
- Cooling aspects

General purpose split phase motors are used in fans, blowers, machine tools, etc. They have approximately 110–220% starting torque and 200–250% pull out torque. In applications such as washing machines, split phase high torque motors are used with 200–300% starting and 250–350% pull out torque.

Capacitor start motors are built for above 300% starting and pull out torques. They are used in compressors, pumps, air conditioning equipment, etc. Motors used for refrigeration applications are generally sealed and so their cooling aspects must be given a careful consideration.

### 5.4 Specifications

The specifications for a single-phase induction motor are given as follows:

- Rated power
- Speed
- Slip on full load
- Voltage

- Frequency
- Pull out torque
- Starting torque
- Power factor
- Type of motor

## 5.5 Constructional Features

Since split phase motors are widely used, construction and design features of these motors are alone discussed. The construction of a single-phase induction motor is essentially similar to that of three-phase induction motors, with stator and rotor as major parts.

### **Stator**

Cold rolled steel punching is used as stator core for better stacking factor and to reduce the losses. Semi-closed tapered slots with parallel-sided teeth are used. The slots house both the main and the auxiliary windings. More slot space is given to the main winding compared to that of the auxiliary winding.

### **Stator winding**

Concentric windings are generally used in single-phase induction motors as shown in Fig. 5.3. The two windings of the stator, namely the main and auxiliary windings, are generally single layered and the main winding is placed at the bottom of the slots. About 70% of slots are for main winding and 30% of slots are for auxiliary windings. Few slots may have both the windings.

There are usually three or more coils per pole. The arrangement of winding is governed largely by the

necessity of minimizing harmonic fluxes, which give rise to noise and non-uniform torque. In smaller machines, the harmonics may be further reduced by having different number of conductors in each slot. This type of arrangement is called 'grading' and gives rise to a net mmf wave of nearly sinusoidal shape.

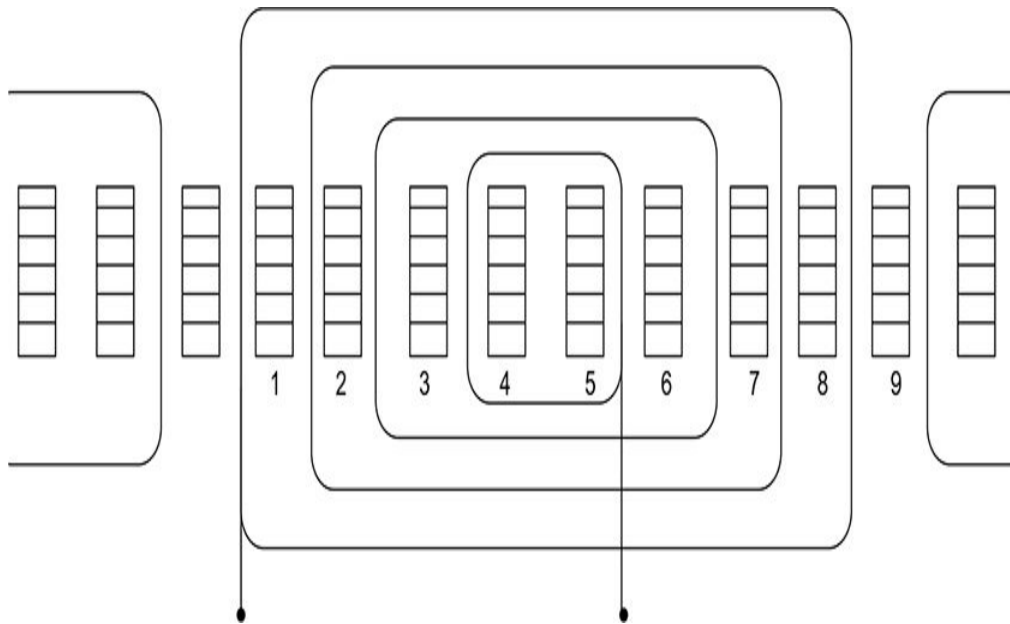

**Fig 5.3**| Stator winding in a single-phase induction motor

These windings are generally single-layered concentric ones. The spacial distribution of the main and auxiliary winding has  $90^\circ$  displacement. Enamelled copper conductors are used for both the windings and class B insulation is mostly used.

The winding arrangement is shown in [Fig. 5.3](#) has nine slots per pole with four coils per pole.

Coils (1–9), coils (2–8), coils (3–7) and coils (4–6) have a span of 8, 6, 4 and 2 slots, respectively.

To have a sinusoidal flux distribution, the numbers of turns required for each coil are calculated as shown in Table 5.1.

**Table 5.1** | Calculation of number of turns

Coil	Pitch factor	% of Turns/pole
1-9	$\sin\left(\frac{8}{9} \times 90\right) = 0.985$	$\frac{0.985}{2.836} = 34.6$
2-8	$\sin\left(\frac{6}{9} \times 90\right) = 0.866$	$\frac{0.866}{2.836} = 30.6$
3-7	$\sin\left(\frac{4}{9} \times 90\right) = 0.643$	$\frac{0.643}{2.836} = 22.7$
4-6	$\sin\left(\frac{2}{9} \times 90\right) = 0.342$	$\frac{0.342}{2.836} = 12.10$
	Total = 2.836	Total = 100

The distribution factor or winding factor

$$k_w = 0.342 \times 12.10 + 0.643 \times 22.7 + 0.866 \times 30.6 + 0.985 \times 34.6 = 79.3$$

$$\% \text{ Turns in } T_{4-6} + T_{3-7} + T_{2-8} + T_{1-9} = 0.793$$

The usual value of  $k_w$  lies between 0.75 and 0.86.

## **Rotor**

The rotor is essentially a squirrel cage rotor with skewed slots.

## 5.6 Design of Single-phase Induction Motor

The design of the single-phase induction motor involves the steps elaborated in the further sections.

### 5.6.1 Output Equation

In order to estimate the main dimensions of the stator, the output equation relating the volume of active material, speed and rating is to be derived.

Let,

$\phi$  – flux/pole (Wb)

$B_{av}$  – specific magnetic loading (Wb/m)<sup>2</sup>

$k_w$  – winding factor

$ac$  – specific electric loading (amp turns)

$f$  – frequency (Hz)

$n_s$  – synchronous speed (rps)

$T_m$  – number of turns of main winding

$\eta$  – efficiency at full load

$\cos \phi$  – full load power factor

$p$  – number of poles

$V$  – rated voltage (V)

$\tau_p$  – pole pitch (m)

$I$  – full load current in main winding (A)

$$\text{Output power (kVA)} = VI \times 10^{-3} \quad (5.1)$$

$$\text{Also,} \quad V = 4.44 k_w f \phi T_m \quad (5.2)$$

$$\phi = B_{av} \frac{\pi D}{p} L \quad (5.3)$$

$$f = \frac{n_s p}{2} \quad (5.4)$$

Substituting Eqs. (5.3) and (5.4) in Eq. (5.2), we get

$$V = 4.44 k_w \left( \frac{n_s p}{2} \right) \left( B_{av} \frac{\pi D}{p} L \right) T_m \quad (5.5)$$

Substituting Eq. (5.5) in Eq. (5.1), we get

$$kVA = 4.44 k_w \left( \frac{n_s p}{2} \right) \left( B_{av} \frac{\pi D}{p} L \right) T_m I \times 10^{-3} \quad (5.6)$$

We know that

$$ac = \frac{2T_m I}{\pi D} \Rightarrow T_m I = \frac{ac \pi D}{2} \quad (5.7)$$

Substituting Eq. (5.7) in Eq. (5.6), we get

$$kVA = 4.44 k_w \left( \frac{n_s p}{2} \right) \left( B_{av} \frac{\pi D}{p} L \right) \left( \frac{ac \pi D}{2} \right) \times 10^{-3}$$

$$\Rightarrow kVA = 1.11 \pi^2 k_w B_{av} ac \times 10^{-3} D^2 L n_s$$

$$\Rightarrow kVA = C_o D^2 L n_s \quad (5.8)$$

where  $C_o = 1.11 \pi^2 k_w B_{av} ac \times 10^{-3}$

If the rating is given in hp, then the kVA can be obtained using the following equation:

$$kVA = \frac{hp \times 0.746}{\eta \times \cos \phi}$$

Substituting Eq. (5.8) in the above equation, we get

$$C_o D^2 L n_s = \frac{hp \times 0.746}{\eta \cos \phi}$$

$$\Rightarrow D^2 L = \frac{hp \times 0.746}{C_o n_s \eta \cos \phi} \quad (5.9)$$

The speed, kVA or hp and number of poles are specified for the motor. The efficiency and power factor (p.f.) could be taken suitably from Table 5.2.

**Table 5.2** | Rating vs full load efficiency vs p.f.

Rating in W	Full load efficiency (%)	p.f.
40	38	0.45
100	50	0.5
200	60	0.6
400	68	0.65
750	72	0.67
1000	75	0.7

The value of  $C_o \eta \cos \phi$  for calculation of  $D^2 L$  may also be directly read from Table 5.3.

**Table 5.3** |  $C_o \eta \cos \phi$

Watts/rps	3.6	7.2	12	18
$C_o \eta \cos \phi$	9.5	12	15.5	18

### 5.6.2 Choice of Specific Loadings

The factors to be considered for the choice of  $B_{av}$  and  $ac$  are similar to that of three-phase induction motors.

The usual range of  $B_{av}$  is 0.32–0.56 Wb/m<sup>2</sup> and the range of  $ac$  is 5000–16000 ac/m.

### 5.6.3 Separation of $D$ and $L$

From Eq. (5.9), we know that

$$D^2L = \frac{hp \times 0.746}{C_o \times n_s \times \eta \times \cos \phi}$$

To separate  $D$  and  $L$  from  $D^2L$ , the  $L/\tau$  ratio can be used, which varies from 0.6 to 2 depending on the diameter size available in standard stamping tables.

### 5.6.4 Design of Stator

After the choice of main dimensions, to design the stator, the number of turns of main winding, cross-sectional area of conductor, the number, size and shape of stator slots, the depth of stator core, the winding resistance are to be obtained.

#### **Number of terms of main winding**

We know that, induced emf,  $E = 4.44 f \phi k_w T_m$

Taking  $E = 0.95$  V and  $k_w = 0.75$  to 0.85 for main winding, and  $\phi = B_{av} \frac{\pi DL}{p}$ , we get

Number of turns, 
$$T_m = \frac{E}{4.44 f \phi k_w} \quad (5.10)$$

Number of turns in series per pole = 
$$\frac{T_m}{p} \quad (5.11)$$

### **Area of cross-section of conductor**

We know that, 
$$kVA = \frac{hp \times 0.746}{\eta \times \cos \phi} = VI$$

Hence, current in the main winding,

$$I = \frac{hp \times 0.746}{V \times \eta \times \cos \phi} \quad (5.12)$$

Also, current density,  $\delta_m = \frac{I}{a_m}$  which ranges from 3 to 4  
A/mm<sup>2</sup>

Therefore, area of cross-section,  $a_m = \frac{I}{\delta_m}$

Substituting Eq. (5.12) in the above equation, we get

$$a_m = \frac{hp \times 0.746}{V \times \eta \times \cos \phi \times \delta_m} \quad (5.13)$$

## **Number of stator slots**

A larger number of stator slots reduce the leakage reactance by receiving the zig-zag leakage. This increases the power output, overload capacity and gives a better efficiency and power factor. A larger number of slots reduce the field harmonics too. However, the space factor for slots becomes poor and so there is always an upper limit of stator slot, decided by the size of lamination.

Lower number of stator slots reduces the cost of winding and gives a better space factor, but would result in wider slots with excessive copper in each slot.

The number of stator slots per pole is usually between 9 and 12, and the number of stator slots should be divisible by the number of poles for the winding to be balanced.

## **Size of stator slots**

The stator slots have to accommodate main and auxiliary windings. The slots do not have the same number of conductors, as some contain both running and auxiliary winding. The cross-sectional area of auxiliary winding is small. So the main winding coil with the largest number of turns will determine the size of the slot. Semi-enclosed tapered slots are usually used with a space factor of 0.35–0.40.

If  $Z_s$  is the total number of conductors per slot and  $d_1$  is the diameter of insulated conductor,

$$\text{Area required for insulated conductor} = Z_s \frac{\pi}{4} d_1^2$$

$$\text{Minimum slot area required} = \frac{Z_s \frac{\pi}{4} d_1^2}{0.4} \quad (5.14)$$

where 0.4 is the slot space factor assumed.

The slot area provided in the punching should be more than the minimum given by Eq. (5.14).

### **Flux density in stator teeth**

This should be generally in the range of 1.4–1.7 Wb/m<sup>2</sup>.

$$\text{Flux density in stator teeth, } B_{ts} = \frac{\phi_m}{\left(\frac{S_s}{p}\right) \times L_i \times W_{ts}} \quad (5.15)$$

where  $S_s$  is the number of stator slots,  $L_i = 0.95 L$  is the stacking length and  $W_{ts}$  is the width of stator teeth.

### **Flux density in stator core**

This should not exceed 1.5 Wb/m<sup>2</sup>.

$$\text{Flux density in stator core, } B_{cs} = \frac{\phi_m}{2 \times L_i \times d_{cs}} \quad (5.16)$$

Since,  $\phi_m$  – flux in core and  $d_{cs}$  – depth of stator core.

## Length of mean turn

The length of mean turn of each coil per pole is

$$L_{mt} = \frac{8.4(D + d_{ss})}{S_s} \times \text{slots span} + 2L \quad (5.17)$$

Here,  $d_{ss}$  is the depth of stator slot.

The length of mean turn of different coils is to be estimated using Eq. (5.17) and the length of mean turn of main winding.

$$L_{mtm} = \frac{\rho L_{mt1} T_1 + \rho L_{mt2} T_2 + \dots}{\text{Total turns}} \quad (5.18)$$

## Resistance of main winding

The resistance of the main winding is calculated as

$$\text{Main winding resistance} = \frac{\rho L_{mtm} \times T_m}{a_m} \quad (5.19)$$

where  $L_{mtm}$  is calculated from Eq. (5.18).

## Length of air gap

The design consideration for the change of air gap length of single-phase induction motor is similar to that of three-phase induction motor. It is given by the following empirical relation:

Air gap length, 
$$l_g = \frac{0.007 \times \text{rotor diameter}}{\sqrt{p}} \quad (5.20)$$

### 5.6.5 Design of Rotor

#### **Number of rotor slots**

The number of stator slots is fixed by the winding arrangement, number of poles, etc. So, the number of rotor slots must be adjusted to meet the above requirement.

For motors with more than two poles, for quieter operation, the number of rotor slots must be divisible by the number of pair of poles and the difference between the stator slots and the rotor slots must be more than the number of poles. Another rule is that the number of rotor slots should be equal to the number of stator slots plus twice the number of poles. There are many other combinations to get a satisfactory design. The number of rotor slots differs from the number of stator slots by 20% or more.

#### **Area of rotor bar**

For copper conductors in stator and rotor, the ratio of copper in rotor and stator ranges from 0.5 to 0.8 and this ratio changes to 1 to 1.8 for aluminium conductors in stator and rotor.

$$\frac{A_r}{A_m} = \begin{cases} 0.5 \text{ to } 0.8 & \text{for copper conductors} \\ 1 \text{ to } 1.6 & \text{for aluminum conductors} \end{cases}$$

where  $A_m = 2T_m a_m$  is the total stator copper section for main winding

$A_r = S_r a_b$  is the total rotor copper section

$S_r$  is the total number of rotor bars

$a_b$  is the area of each bar

### **Area of end ring**

We know that, end ring current,

$$I_e = \frac{S_r I_b}{\pi p} \quad (5.21)$$

where  $I_b$  is the rotor bar current.

Area of cross-section of end ring,  $a_e = \frac{I_e}{\delta_e}$

Substituting Eq. (5.21) in the above equation, we get

$$a_e = \frac{S_r I_b}{\pi p \delta_e}$$

$$a_e = \frac{S_r a_b \delta_b}{\pi p \delta_e} \quad \left[ \because a_b = \frac{I_b}{\delta_b} \Rightarrow I_b = a_b \delta_b \right]$$

$$a_e = \frac{A_r \delta_b}{\pi p \delta_e} \quad [\because A_r = S_r a_b]$$

## Rotor resistance

The value of rotor resistance should be as low as possible to reduce rotor copper losses and to maintain high efficiency, high full load speed and minimum temperature rise. The starting torque requirements are to be taken in to considerations to decide the minimum value of rotor resistance. A higher starting torque requires higher value of rotor resistance. A significant parameter is  $r'_{rm} / X_{lm}$ .

For commercial fractional kilowatt machines, the value of  $r'_{rm} / X_{lm}$  is given in [Table 5.4](#).

**Table 5.4** |  $r'_{rm} / X_{lm}$  for different motors

Type of motor	$r'_{rm} / X_{lm}$
Split phase	0.45 to 0.55
Capacitor start	0.45 to 0.8

Here,  $r'_{rm}$  refers to the rotor resistance referred to main winding.  $X_{lm}$  is the sum of leakage reactance of main winding and rotor in terms of main winding. For motors of larger horse power ratings, the above ratio is usually lower than specified values.

### Flux density in rotor teeth

As the rotor frequency is very low, the rotor teeth and core densities are relatively higher than that of the stator. But if very high values are selected, a larger magnetizing current leading to poor power factor will be obtained. Hence, the rotor teeth and core densities are usually taken slightly higher than that of the stator.

$$\text{Flux density in rotor teeth, } B_{tr} = \frac{\phi_m}{\frac{S_r}{p} \times L_i \times W_{tr}} \quad (5.22)$$

where  $W_{tr}$  is the width of rotor teeth.

$$\text{Flux density in rotor core, } B_{cr} = \frac{\phi_m}{2 \times L_i \times d_{cr}} \quad (5.23)$$

where  $d_{cr}$  is the depth of rotor core.

### 5.6.6 Magnetic Circuit Calculations

#### Air gap mmf

$$\text{MMF for air gap, } AT_{g60} = 800,000 B_{g60} K_g l_g \quad (5.24)$$

where  $B_{g60} = 1.57B_{av}$

For the single phase induction motor, due to saturation in stator teeth, the flux density distribution is a flat topped one and so value of flux density is calculated at  $60^\circ$  from interpolar axis, which is  $1.57 B_{av}$ .

### **Iron loss**

The iron loss that occurs mostly in stator teeth and core is found by calculating their flux densities and weights. Then, from the specific loss curves, the iron loss can be calculated for teeth and core. This loss at fundamental frequency can be multiplied by 1.75 to 2.2 to obtain the effect of harmonic frequencies also.

### **Friction and windage loss**

The friction and windage loss depends on the type of the bearing used and the peripheral speed. For sleeve bearings, it is usually 4–8% of the output whereas for ball bearings, the losses are more to an extent of 500W.

#### *5.6.7 Calculation of Resistance and Leakage Reactance*

For the determination of the performance of single-phase induction motor, the rotor resistance, main winding resistance and leakage reactance are to be calculated. Table 5.5 gives the formulas to calculate all the above.

**Table 5.5** | Resistance and reactance calculation

Parameter	Formulas	Details
Resistance of main winding ( $r_{sm}$ )	$r_{sm} = 0.021 \frac{T_m L_{mtm}}{a_m}$	This is the hot resistance calculated at 75°C
	$r_{sm} = 0.017 \frac{T_m L_{mtm}}{a_m}$	Cold resistance at 20°C
Resistance of rotor ( $r'_{rm}$ )	$r'_{rm} = 8T_m k_{wm}^2 \rho \left[ \frac{L_b}{S_r a_b} + \frac{2 D_s}{\pi p^2 a_e} K_{ring} \right]$	$K_{ring}$ is the multiplication factor for non-uniform distribution of current
Stator slot leakage reactance ( $X_{ss}$ )	$X_{ss} = 16\pi f (T_m K_{wm})^2 \frac{L_i}{S_s} \lambda_{ss} C_x$ <p>where</p> $C_x = \frac{(Z_1^2 + Z_2^2 + Z_3^2 + \dots)}{(Z_1 + Z_2 + Z_3 + \dots)^2} \times \frac{1}{K_{wm}} \times \frac{S_s}{4p}$	$Z_1, Z_2, Z_3, \dots$ are number of conductors in different slots. There are $2p$ groups of $Z_1, Z_2, Z_3, \dots$ conductors per slot
Rotor slot leakage reactance in terms of stator ( $X'_{sr}$ )	$X'_{sr} = 16\pi f (T_m K_{wm})^2 \frac{L}{S_r} \lambda_{sr}$	

Parameter	Formulas	Details
Total slot leakage reactance in terms of stator ( $X_s = X_{ss} + X'_{sr}$ )	$X_s = 16\pi f (T_m K_{wm})^2 \frac{L}{S_s} \left( C_x \lambda_{ss} + \frac{S_s}{S_r} \lambda_{sr} \right)$	
Zig-zag leakage reactance ( $X_z$ )	$X_z = 16\pi f (T_m K_{wm})^2 \frac{L}{S_s} \lambda_z$	$\lambda_z$ - specific permeance for zig-zag leakage

Overhang leakage reactance ( $X_o$ )	$X_o = 16\pi f (T_m K_{wm})^2 \frac{L\mu_o}{6.4S_s p}$ $[\pi(D + d_{ss}) \times \text{average coil span in slots}]$	
Skew leakage reactance ( $X_{sk}$ )	$X_{sk} = \frac{X_m \theta_s^2}{12} K_1$	$\theta_s$ - rotor bar skew angle $= \frac{\pi}{S_r / p} \times \text{rotor slot pitch}$ for which bars are skewed $K_1 = \sqrt{\frac{X_{om} - X_{lm}}{X_{om}}}$ - stator slot skewed leakage factor $\simeq 0.95$ $X_m$ - magnetizing reactance
Magnetizing reactance ( $X_m$ )	$X_m = 16\pi (T_m K_{wm})^2 \frac{\mu_o L \tau_p}{10l_g K_g p F_s}$	$\tau_p$ - pole pitch $K_g$ - air gap contraction factor $F_s$ - saturation factor
Total leakage reactance ( $X_{lm}$ )	$X_{lm} = X_s + X_2 + X_o + X_{sk}$	
Open circuit reactance referred to main winding ( $X_{om}$ )	$X_{om} = X_m + \left( \frac{X_{lm}}{2} \right)$	

### 5.7 Performance Calculation

The running performance of the single-phase induction motor can be calculated by two methods as shown in [Fig. 5.4](#).

### 5.7.1 Equivalent Circuit Method

The equivalent circuit is determined using double field revolving theory for any slip 's' shown in Fig. 5.5. Hence, the iron loss resistance is omitted and iron loss can be treated together with friction and windage loss. This can be subtracted from the gross output to obtain the net output.

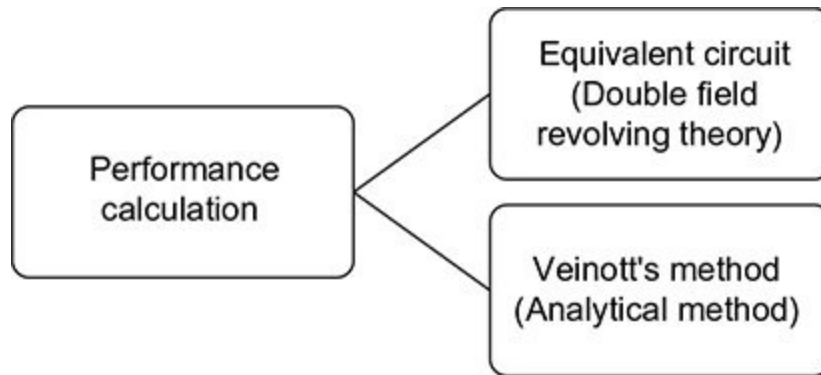

**Fig.5.4** | Performance calculation methods

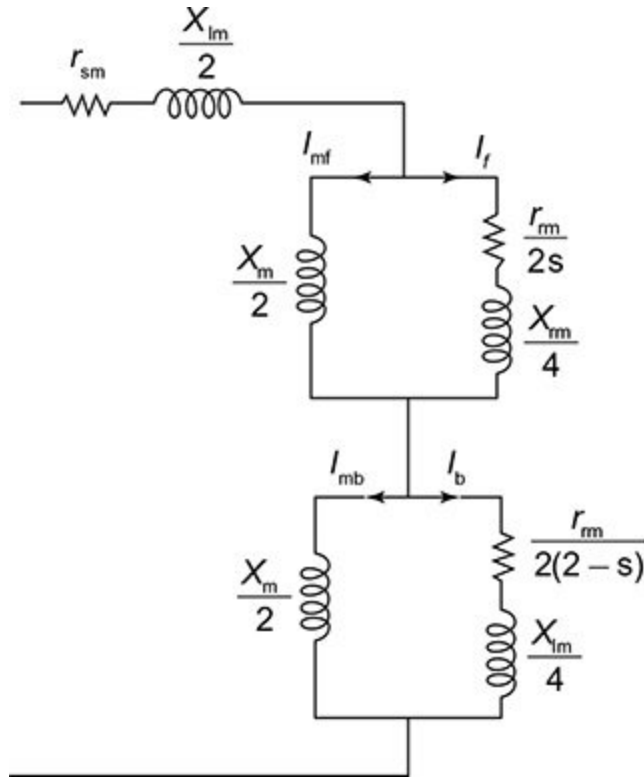

**Fig.5.5** | Equivalent circuit for single-phase induction motor using double field revolving theory

$$\text{Forward torque} = I_f^2 \frac{r'_{rm}}{2s} \text{syn Watts}$$

$$\text{Backward torque} = I_b^2 \frac{r'_{rm}}{2(2-s)} \text{syn Watts}$$

$$\text{Gross motor torque} = \frac{r'_{rm}}{2} \left( \frac{I_f^2}{s} - \frac{I_b^2}{2-s} \right) \text{syn Watts}$$

$$\text{Net motor torque} = \text{Gross torque} - (\text{iron, friction and windage loss})$$

### 5.7.2 Analytical Method (Veinott's Method)

The standard method suggested by C.G. Veinott is given below.

**Step 1:** It is required to specify the specification details as shown in Table 5.6.

**Table 5.6** | Specification details

Hp
Line voltage
Speed

**Step 2:** The following motor constants as given in Table 5.7 are to be calculated.

**Table 5.7** | Motor constants

$X_{lm}$	Core loss
$X_{om}$	Friction and windage loss
$r_{sm}$	$F_1 = (2 - K_1^2)r'_{rm}$
$r'_{rm}$	$F_2 = \frac{(2r_{sm} + r'_{rm})r'_{rm}}{X_{om}}$
$K_1$	$F_3 = (I_m r'_{rm}) \frac{r'_{rm}}{X_{om}}$
$\frac{r_{sm}}{X_{lm}}$	$F_4 = 2I_m r'_{rm}$
$\frac{r'_{rm}}{X_{om}}$	$F_5 = (I_m r'_{rm}) K_1$
$I_m = \frac{V}{X_{om}}$	$F_6 = F_5^2 r'_{rm}$
$I_m r'_{rm}$	$F_7 = VK_1$
	$F_8 = (F_7)^2 r'_{rm}$
	$F_9 = \frac{\text{core loss}}{2V}$

**Step 3:** Determination of the following values listed in **Table 5.8**.

**Table 5.8** | Determination of parameters

$c = \frac{\text{speed(in rpm)}}{\text{synchronousspeed(in rpm)}}$	$U = (1 - c^2)r'_{\text{rm}} + F_1$
$c^2$	$(1 - c^2)X_{\text{lm}}$
$1 - c^2$	$F_2$
$(1 - c^2)r'_{\text{rm}}$	$W = (1 - c^2)X_{\text{lm}} - F_2$
$F_1$	$\sqrt{U^2 + W^2}$

$(1 - c^2)V$
$F_3$
$M = (1 - c^2)V - F_3$
$F_9U$
$N = M + F_9U$
$\sqrt{N^2 + F_4^2}$
$I_1 = \frac{\sqrt{N^2 + F_4^2}}{\sqrt{U^2 + W^2}}$
$(1 - c^2)F_7$
$\sqrt{(1 - c^2)F_7 + F_5^2}$
$I_2 = \frac{\sqrt{(1 - c^2)F_7 + F_5^2}}{\sqrt{U^2 + W^2}}$
$cF_5$
$I_3 = \frac{cF_5}{\sqrt{U^2 + W^2}}$
$(1 - c^2)F_8$

$F_6$
$(1-c^2)F_8 - F_6$
Primary copper loss = $I_1^2 r_{\text{rm}}$
Secondary copper loss of main winding = $I_2'^2 r'_{\text{rm}}$
Secondary copper loss of starting winding = $I_3'^2 r'_{\text{rm}}$
Core loss of main winding = $\frac{\text{core loss}}{2}$
$\frac{((1-c^2)F_8 - F_6) \times c^2}{U^2 + W^2}$
Input = $I_1^2 r_{\text{rm}} + I_2'^2 r'_{\text{rm}} + I_3'^2 r'_{\text{rm}} + \frac{\text{core loss}}{2} + \frac{((1-c^2)F_8 - F_6) \times c^2}{U^2 + W^2}$

$\frac{\text{Core loss}}{2} + \text{friction and windage loss of main winding}$
$\text{Output} = \frac{\left( (1-c^2)F_8 - F_6 \right) \times c^2}{U^2 + W^2} - \left( \frac{\text{core loss}}{2} + \text{friction and windage loss of main winding} \right)$
$\text{Speed (in rpm)} = c \times \text{synchronous speed (in rpm)}$
$\text{Torque (in Nm)} = \frac{60}{2\pi} \times \frac{\text{Output}}{\text{speed (in rpm)}}$
$\text{Efficiency} = \frac{\text{Output}}{\text{Input}}$
$\text{Power factor} = \frac{\text{Input}}{VI_1}$
Percentage of full load
<p>Pull out torque by Veinott's relation,</p> $T_{po} = 1.27 \left( \frac{V}{115} \right)^2 \frac{p}{f} \frac{345 - 9.2(R_m / X_{lm})^2}{R_m + X_{lm}} K_r$ <p>where <math>R_m = r_{sm} + r'_{rm}</math> and <math>K_r = \frac{X_{om} - X_{lm}}{X_{om}}</math></p>

Problem on Design of Single-phase Induction Motor

**Example 5.1: Design a 450 W, 230 V, 50 Hz, 4 pole, 1430 rpm single-phase capacitor start induction motor. Take the following constraints for the design.**

1. Power factor must not be less than 0.65.

2. Full load efficiency must not be less than 0.6.
3. The starting torque at rated voltage must not be less than 85% of full load torque and the corresponding current must not be more than 5 times the full load current.
4. The pull out torque must be about 150% of full load torque.

**Solution:** Given

Power output = 450 W

Voltage,  $V = 230$  V

Frequency,  $f = 50$  Hz

Number of poles,  $p = 4$

Speed,  $N = 1430$  rpm

Synchronous speed,  $N_s = 1500$  rpm

$$\text{Synchronous speed (in rps)} = \frac{1500}{60} = 25 \text{ rps}$$

$$\text{Watts / rps} = \frac{450}{25} = 18$$

From Table 5.3, the value of  $\text{Co } \eta \cos \phi = 15.5$

We know that

$$D^2L = \frac{kW}{C_o \eta \cos \phi n_s}$$

Substituting the known values in the above equation, we get

$$D^2L = \frac{0.45}{15.5 \times 25} = 1.16 \times 10^{-3} \quad (1)$$

If we take  $\frac{L}{\tau} = 1$ ,  $\frac{L}{\frac{\pi D}{p}} = 1$

Substituting  $p = 4$  in the above equation, we get

$$\frac{L}{0.785D} = 1$$

$$\Rightarrow L = 0.785D \quad (2)$$

Substituting Eq. (2) in Eq. (1), we get

$$0.785D^3 = 1.16 \times 10^{-3}$$

$$\Rightarrow D^3 = 1.477 \times 10^{-3}$$

$$\Rightarrow D = \sqrt[3]{1.477 \times 10^{-3}} = 0.113 \text{ m}$$

Substituting the value of  $D$  in Eq. (2), we get

$$L = 0.0881\text{m}$$

Converting  $D$  and  $L$  values from 'm' to 'inches', we get

$$\begin{aligned} D &= 0.113\text{m} = 4.4 \text{ inch} \\ L &= 0.0881\text{m} = 3.0 \text{ inch} \end{aligned}$$

Selecting the nearest standard frame size available for ' $D$ ' as shown in Fig. 5.6, we get

$$D = 3.5 \text{ inch} = 8.9 \text{ cm} = 0.089 \text{ m}$$

Substituting the above value of ' $D$ ' in Eq. (2), we get

$$\begin{aligned} L &= 12.45 \text{ cm} = 0.01245 \text{ m} \\ \text{Pole pitch} &= \frac{\pi D}{p} = \frac{\pi \times 8.9}{4} = 7 \text{ cm} \end{aligned}$$

$$\text{Net iron length, } L_i = 0.95L = 11.82 \text{ cm}$$

$$\text{Peripheral velocity, } v = \pi D n_s = \pi \times 0.089 \times 25 = 7 \text{ m/s}$$

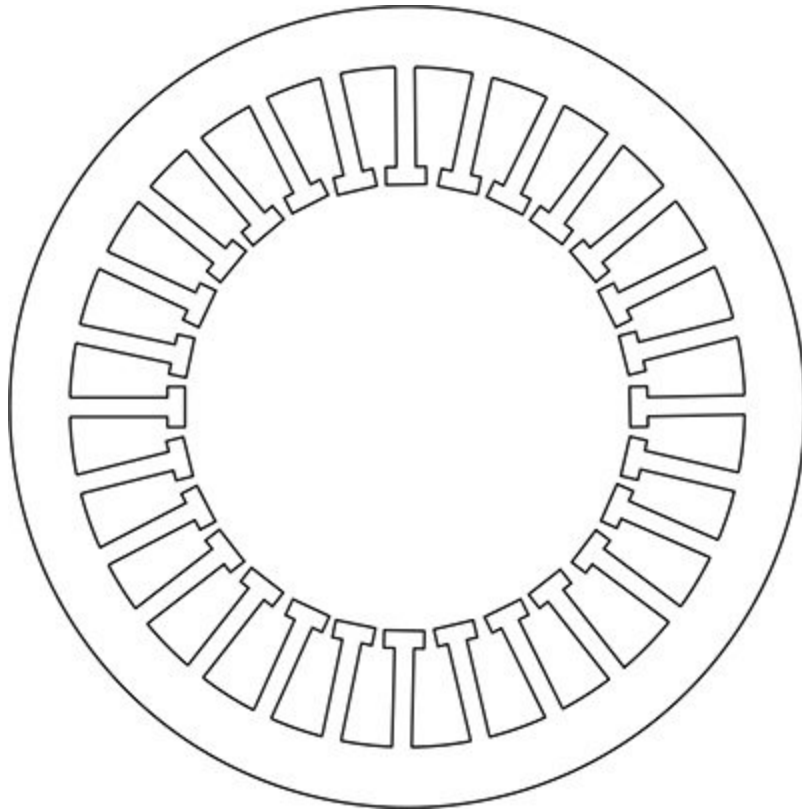

**Fig. 5.6** Standard frame size

This is well within the limits.

The selected stamping has 28 stator slots with the width of stator slot as 0.1425 inch.

The width of stator tooth,  $W_{ts} = 0.142'' = 0.362 \text{ cm}$

Let us assume a flux density of  $1.1 \text{ Wb/m}^2$  for stator teeth, then

$$\begin{aligned}\text{Flux per pole, } \phi_m &= B_{ts} \left( \frac{S_s}{p} \right) W_{ts} \times L_i \\ &= 1.1 \times \left( \frac{28}{4} \right) \times 0.00362 \times 0.1182 = 3.294 \times 10^{-3} \text{ Wb}\end{aligned}$$

For the given frame size, the outer diameter of stamping is 5.435 inch.

Outer diameter of stator lamination,

$$D_o = 5.43 \text{ inch} = 13.81 \text{ cm}$$

$$\begin{aligned}\text{Depth of stator core, } d_{cs} &= \frac{1}{2} [D_o - (D + 2d_{ss})] \\ &= \frac{1}{2} [13.81 - (8.9 + 2.91)] = 1 \text{ cm}\end{aligned}$$

The stator slot is represented in [Fig. 5.7](#).

Checking for flux density in stator core,

$$B_{cs} = \frac{\phi_m}{2d_{cs} \times L_i} = \frac{3.294 \times 10^{-3}}{2 \times 1 \times 10^{-2} \times 0.1182} = 1.39 \text{ Wb/m}^2$$

This is within the limits.

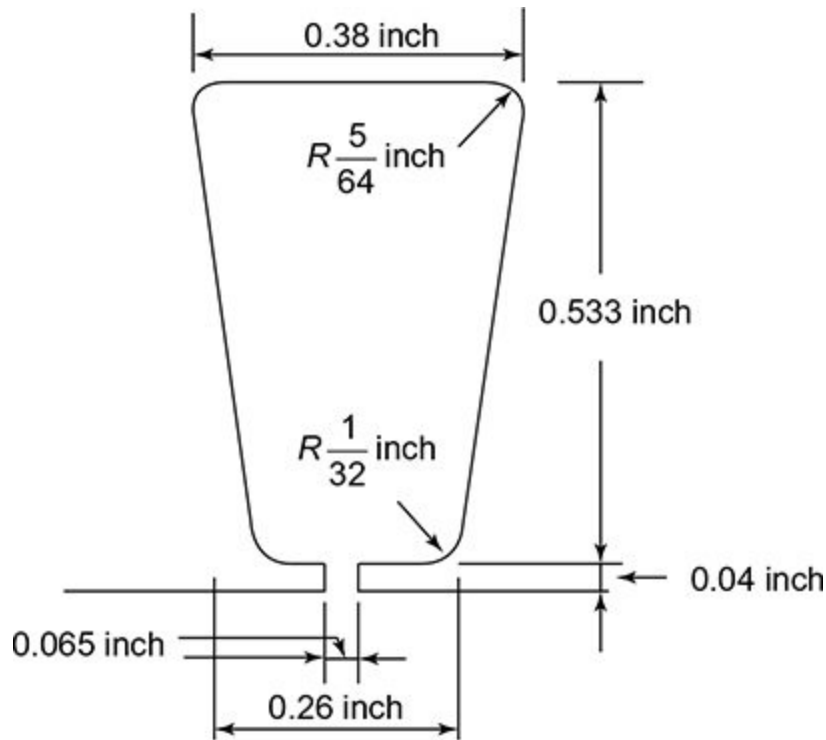

**Fig. 5.7** Stator slot

## Stator winding

Let us assume a winding factor of 0.85.

Stator induced emf,  $E = 0.95 \text{ V} = 0.95 \times 230 = 219 \text{ V}$

Number of turns in main winding,

$$T_m = \frac{E}{4.44 f \phi_m k_w}$$

Substituting the known values in the above equation, we get

$$T_m = \frac{219}{4.44 \times 50 \times 3.294 \times 10^{-3} \times 0.85}$$

$$= \frac{219}{0.621} = 352$$

$$\text{Turns in series per pole} = \frac{T_m}{p}$$

$$= \frac{352}{4} = 88$$

$$\text{Number of stator slots per pole} = \frac{28}{4} = 7$$

## Winding arrangement

Selecting 3 coils per pole for main winding, for sinusoidal distribution of flux, different number of turns in each coil is to be used. They are calculated as follows.

Coil	Span
3-5	$\sin$ of 1/2 coil span = $\sin\left(\frac{2}{7} \times 90\right) = 0.4338$
2-6	$\sin$ of 1/2 coil span = $\sin\left(\frac{2}{7} \times 90\right) = 0.7818$
1-7	$\sin$ of 1/2 coil span = $\sin\left(\frac{6}{7} \times 90\right) = 0.9749$
	Total = 2.1905

## % turns in each coil

Coil	% turns
3-5	$\frac{0.4338}{2.1905} \times 100 = 19.80$
2-6	$\frac{0.7818}{2.1905} \times 100 = 35.69$
1-7	$\frac{0.9749}{2.1905} \times 100 = 44.51$

### Number of turns in each coil

Coil	Number turns
3-5	$0.198 \times 88 = 18$
2-6	$0.3569 \times 88 = 32$
1-7	$0.445 \times 88 = 40$
	Total = 90

### Check

Number of turns of main winding =  $90 \times$  number of poles  
= 360

The winding factor is calculated as follows.

$$\begin{aligned} \text{Winding factor} &= \frac{18 \times 0.4178 + 32 \times 0.7818 + 40 \times 0.974}{90} \\ &= \frac{7.5564 + 25.01 + 28.96}{90} = 0.7947 = 0.8 \end{aligned}$$

## Conductor size

$$\text{Main winding current, } I = hp \times \frac{746}{V\eta \cos \phi} = \frac{\text{Power (in W)}}{V\eta \cos \phi}$$

$$\Rightarrow I = \frac{450}{230 \times 0.65 \times 0.6} = 5.01 \text{ A}$$

Assuming a current density of 4 A/mm<sup>2</sup>

Conductor area of main winding,

$$a_m = \frac{5.01}{4} = 1.254 \text{ mm}^2$$

$$\text{Diameter of bare conductor} = \sqrt{1.254} \times \frac{4}{\pi} = 1.425 \text{ mm}$$

Seeing the nearest wire size available in standard, let us take the bare conductor diameter as 0.95 mm.

Area of main winding conductor,

$$a_m = \frac{\pi}{4} (0.95)^2 = 0.708 \text{ mm}^2$$

$$\text{Diameter of insulated conductor} = 1.298 \text{ mm}$$

## Check for slot space factor

The largest number of turns per coil is 40.

Space occupied by 40 conductors

$$= 40 \times \frac{\pi}{4} \times (1.298)^2 = 52.27 \text{ mm}^2$$

$$\text{Average area of slot used} = 110 \text{ mm}^2$$

From stamping size,

$$\text{Slot space factor} = \frac{52.27}{110} = 0.475$$

This is below 0.5, and so it will be easy to accommodate the winding in the slot.

### **Length of mean turn of winding**

$$L_{\text{mt}} = \frac{8.4(D + d_{\text{ss}})}{S_s} \times \text{slots spanned} + 2L$$

$$\begin{aligned} L_{\text{mt}} \text{ for coil (3-5)} &= \frac{8.4(8.9 + 1.45)}{28} \times 2 + (2 \times 12.45) \\ &= 31.11 \text{ cm} \end{aligned}$$

$$\begin{aligned} L_{\text{mt}} \text{ for coil (2-6)} &= \frac{8.4(8.9 + 1.45)}{28} \times 4 + (2 \times 12.45) \\ &= 37.32 \text{ cm} \end{aligned}$$

$$L_{mt} \text{ for coil (1-7)} = \frac{8.4(8.9 + 1.45)}{28} \times 6 + (2 \times 12.45)$$

$$= 43.53 \text{ cm}$$

### Length of mean turn of main winding

$$L_{mt} = \frac{18 \times 31.11 + 32 \times 37.32 + 40 \times 43.53}{90} \times 2 + (2 \times 12.45)$$

$$= 102.54 \text{ cm}$$

### Resistance of main winding

$$r_{sm}(\text{hot}) = 0.021 \times \frac{608 \times 1.0254}{0.708} = 18.49 \Omega \text{ at } 75^\circ\text{C temperature}$$

$$r_{sm}(\text{cold}) = 0.017 \times \frac{608 \times 1.0254}{0.708} = 14.96 \Omega \text{ at } 20^\circ\text{C temperature}$$

### Rotor design

$$\text{Length of air gap, } l_g = \frac{0.007 \times \text{rotor diameter}}{\sqrt{p}}$$

$$= \frac{0.007 \times 8.9}{\sqrt{4}}$$

$$= 0.03115$$

Let us take approximately 0.3 mm as the length of air gap.

Rotor outer diameter of stamping = 8.9 cm

$l_g$  is taken as 0.3 mm

So, rotor diameter,  $D_r = 8.9 - 2(0.03) = 8.84$  cm

### **Rotor slots**

The number of rotor slots must be divisible by the number of poles and the number of rotor slots ( $S_r$ ) differ from the number of stator slots by  $2D$  or more. Hence,  $S_r = 20, 36, 44$  can be chosen for quieter operation.

Let us choose  $S_r = 20$ .

The closed type rectangular slots shown in Fig. 5.8 may be chosen.

So, area of rotor slot =  $0.3 \times 0.146$  inch = 0.0438 sq. inches = 0.28 cm<sup>2</sup>

Allowing for rounding of corners and clearances,

$$a_b = 24 \text{ mm}^2$$

Total rotor copper sectional area,

$$A_r = 20 \times 24 = 480 \text{ mm}^2$$

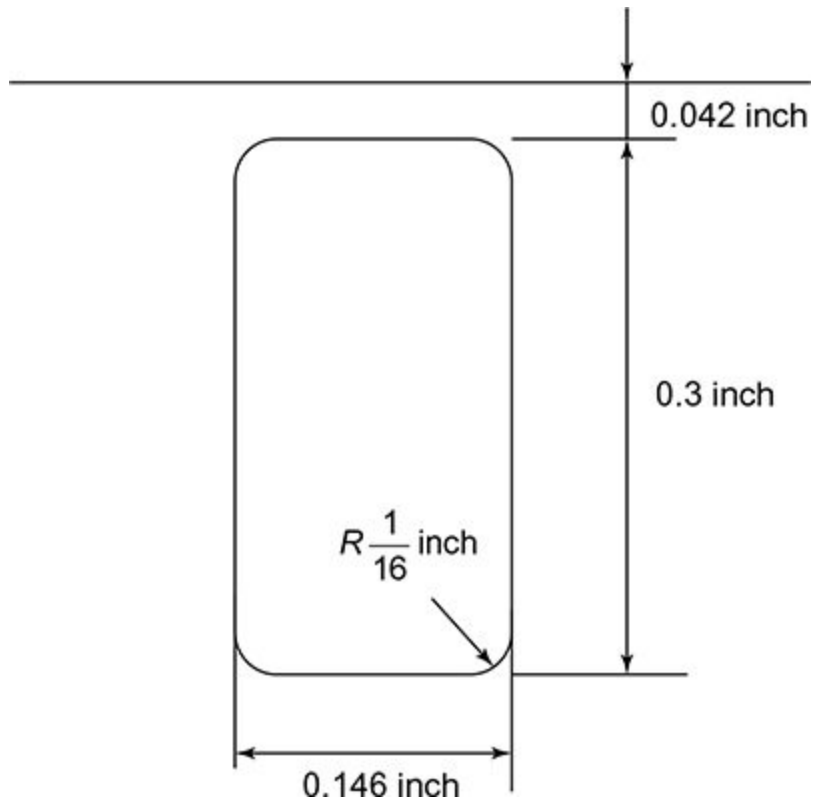

**FIGURE 5.8** | Rotor slot

Total area of conductors in main winding,

$$A_m = 2T_m a_m = 2 \times 360 \times 0.708 = 509 \text{ mm}$$

Ratio,  $\frac{A_r}{A_m} = \frac{480}{509} = 0.943$

**Area of end ring**

Area of each end ring,

$$a_e = \frac{A_r \delta_b}{\pi p \delta_e} = \frac{0.32 \times 480}{4} \quad (\text{Taking } \delta_b = \delta_e)$$

$$= 38.4 \text{ mm}^2$$

Taking depth of end ring as 8 mm and thickness as 4.8 mm, outer diameter of end ring as 8.7 cm,

$$\text{Inner area of end ring} = 7.1 \text{ cm}^2$$

$$\text{Mean diameter of end ring} = 7.9 \text{ cm}$$

### Gap contraction factor

For stator,

$$\frac{\text{slot opening}}{\text{gap length}} = \frac{0.065 \text{ inch}}{0.3}$$

$$= \frac{1.65 \text{ mm}}{0.3} = 5.5$$

$$\text{Stator slot pitch } Y_{ss} = \frac{\pi \times 8.9}{28} = 0.9985 \text{ cm}$$

From standard charts,

Carters' coefficient for semi-enclosed slots for the ratio of 5.5 is 0.64.

$$\begin{aligned}
 k_{gss} &= \frac{Y_{ss}}{Y_{ss} - k_{cs} w_{os}} \\
 &= \frac{0.9985}{0.9985 - 0.64 \times 0.165} \\
 &= 1.118
 \end{aligned}$$

## Rotor

Though rotor slots are closed, the leakage permeance cannot be taken as infinite. To accommodate saturation effects, let us consider rotor slot to have an opening of 1 mm.

Hence,  $W_{or} = 1 \text{ mm}$

$$\text{Ratio, } \frac{\text{rotor slot opening}}{\text{gap length}} = \frac{1}{0.3} = 3.33$$

$K_{cs} = 0.48$  (from standard chart)

$$Y_{sr} = \frac{\pi \times 8.84}{20} = 1.3885$$

$$k_{gsr} = \frac{Y_{sr}}{Y_{sr} - K_{cr} W_{or}}$$

$$= \frac{1.3885}{1.3885 - 0.48 \times 0.1}$$

$$= 1.036$$

$$k_g = k_{gsr} \times k_{gss}$$

$$= 1.036 \times 1.118$$

$$= 1.158$$

### **Rotor resistance**

Let us assume that the rotor bar is skewed by 1 slot pitch equal to 1.3885 cm.

Length of rotor bar,

$$L_b = \sqrt{L^2 + Y_{sr}^2} = \sqrt{12.45^2 + 1.3885^2}$$

$$= 12.52 \text{ cm}$$

### **Rotor resistance referred to main winding**

$$r'_{rm} (\text{hot}) = 8T_m^2 K_{wm}^2 \rho \left[ \frac{L_b}{S_r a_b} + \frac{2}{\pi} \frac{D_e}{p^2 a_e} \right]$$

$$\begin{aligned}
&= 8 \times 360^2 \times 0.8^2 \times 0.021 \left[ \frac{12.52 \times 10^{-2}}{20 \times 24} + \frac{2 \times 7.9 \times 10^{-2}}{\pi \times 4^2 \times 38.4} \right] \\
&= 13934.59 \left[ 2.6 \times 10^{-4} + 8.18 \times 10^{-5} \right] \\
&= 4.77 \Omega \text{ at } 75^\circ\text{C}
\end{aligned}$$

$$r'_{\text{rm}}(\text{cold}) = \frac{0.017}{0.021} \times 4.77 = 3.86 \Omega \text{ at } 20^\circ\text{C}.$$

## Reactances

### 1. Slot leakage reactance

The parameters defining the stator slot is shown in [Fig. 5.9](#).

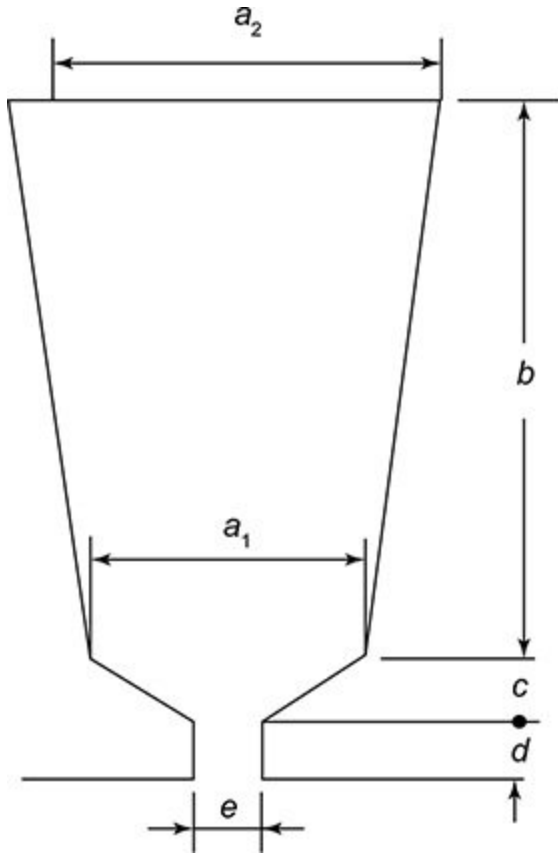

**Fig. 5.9** Parameters of stator slot

The specific slot permeance for a slot shown in [Fig. 5.9](#) is

$$\lambda_{ss} = \left[ \phi \frac{b}{a_2} + \frac{d}{e} + \frac{2c}{e + a_1} \right] \quad (3)$$

Comparing [Table 5.10](#) and [Fig. 5.9](#), we get

$$a_1 = 0.26 \text{ inch}$$

$$a_2 = 0.38 \text{ inch}$$

$$b = 0.533 \text{ inch}$$

$$c = 0$$

$$d = 0.04 \text{ inch}$$

$$e = 0.065 \text{ inch}$$

$$\frac{a_1}{a_2} = \frac{0.26}{0.38} = 0.684$$

$$\frac{b}{a_2} = \frac{0.533}{0.38} = 1.402$$

Corresponding to the above ratios, the value of  $\phi$  can be taken from the graph shown in Fig. 5.10.

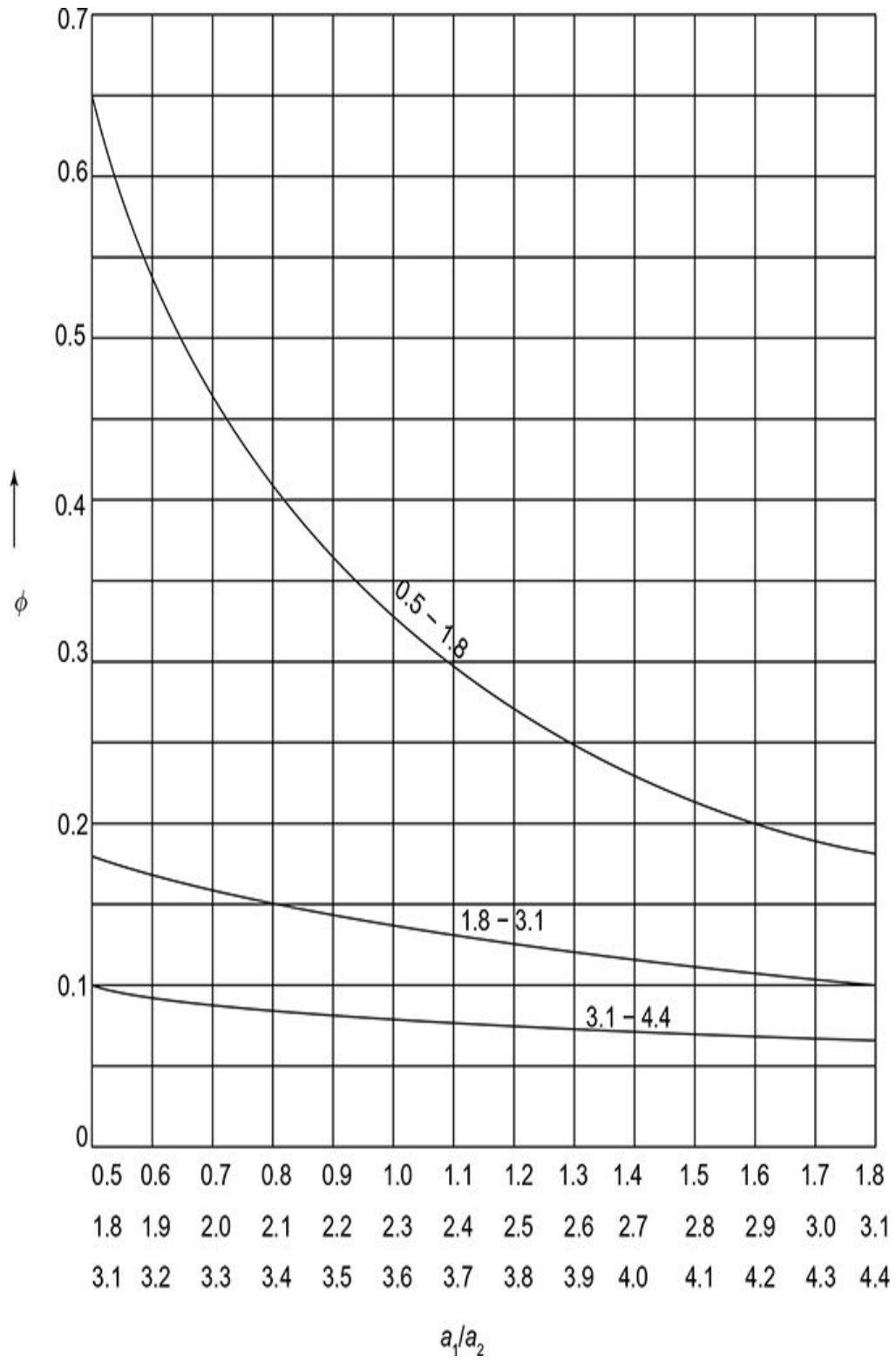

**Fig. 5.10**  $\phi$  vs  $a_1 / a_2$

From the graph, it is observed that  $\phi = 0.47$

Substituting the known values in Eq. (3), we get

Slot leakage reactance,

$$\lambda_{ss} = \left[ 0.47(1.402) + \frac{0.04}{0.065} \right] = 1.27$$

For rotor slot, the parameters defining slot is shown in Fig. 5.11.

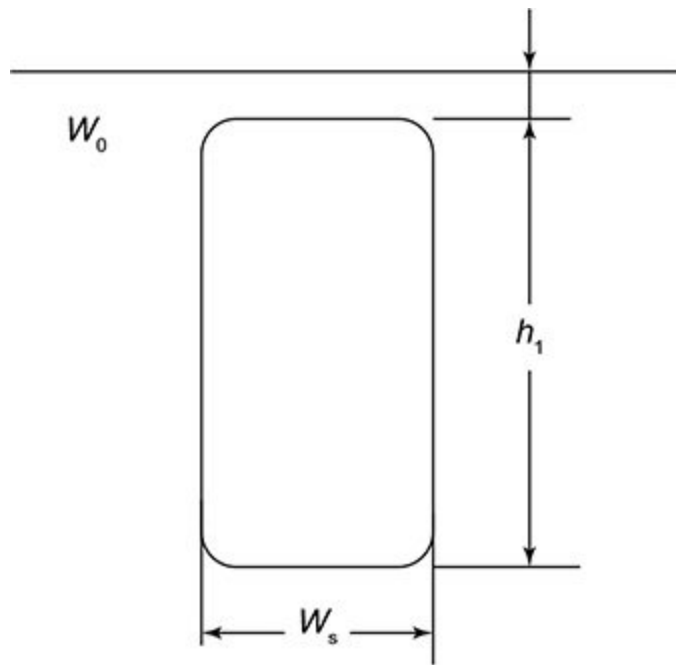

**Fig. 5.11** | Parameters of rotor slot

Slot leakage reactance for rotor slot shown in Fig. 5.11,

$$\lambda_{sr} = \left[ \frac{h_1}{3W_s} + \frac{h_4}{W_0} \right] \quad (4)$$

Comparing [Table 5.11](#) and [Fig. 5.11](#), we get

$$h_1 = 0.3 \text{ inch}$$

$$W_s = 0.146 \text{ inch}$$

$$h_4 = 0.042 \text{ inch}$$

$$W_0 = 1 \text{ mm} = 0.03937 \text{ inch}$$

Substituting the known values in [Eq. \(4\)](#), we get

$$\lambda_{sr} = \frac{0.3}{3 \times 0.146} + \frac{0.042}{0.03937} = 1.752$$

Slot leakage reactance in terms of main winding,

$$X_s = 16\pi f \mu_0 (T_m k_{wm})^2 \frac{L}{S_s} \left( \lambda_{ss} + \frac{S_s}{S_r} \lambda_{sr} \right) C_x \quad (5)$$

$$\text{where } C_x = \frac{Z_1^2 + Z_2^2 + Z_3^2}{(Z_1 + Z_2 + Z_3)^2} \times \frac{1}{k_{wm}^2} \times \frac{S_s}{4p}$$

Substituting the known values in the above equation,  
given by

$Z_1 = 18; Z_2 = 32; Z_3 = 40; k_{wm} = 0.8; S_s = 28; p = 4$ ; we get

$$C_x = \frac{18^2 + 32^2 + 40^2}{90^2} \times \frac{1}{0.8^2} \times \frac{28}{16} = 0.995$$

Substituting the determined value of  $C_x$  and other known values in Eq. (5), we get

$$\begin{aligned} X_s &= 16 \times \pi \times 50 \times 4\pi \times 10^{-7} \times (360 \times 0.8)^2 \times \frac{12.45}{28} \times 10^{-2} \left( 1.27 + \frac{28}{20} 1.752 \right) 0.995 \\ &= 3.158 \times 10^{-3} \times (82944) \times 4.446 \times 10^{-3} (3.722) \times 0.995 \\ &= 4.335 \Omega \end{aligned}$$

## 2. Zig-zag leakage reactance

Zig-zag leakage reactance,

$$X_z = 16\pi f \mu_o (T_m k_{wm})^2 \frac{L}{S_s} \lambda_z \quad (6)$$

where

$$\lambda_z = \frac{W_{ts} W_{tr} (W_{ts}^2 + W_{tr}^2)}{12 l_g y_{ss}^2 y_{sr}} \quad (7)$$

The values required for the above equation are given by

$$W_{ts} = 0.998 - 0.165 = 0.8329 \text{ cm}$$

$$W_{tr} = 1.3885 - 0.1 = 1.2885 \text{ cm}$$

$$y_{ss} = 0.9985 \text{ cm}$$

$$y_{sr} = 1.385 \text{ cm}$$

$$l_g = 0.3 \text{ mm} = 0.03 \text{ cm}$$

Substituting the above values in Eq. (7) we get

$$\lambda_z = 5.07$$

Substituting the value of  $\lambda_z$  and the other known values in Eq. (6), we get

$$\begin{aligned} X_z &= 16\pi \times 50 \times 4\pi \times 10^{-7} \times (360 \times 0.8)^2 \times \frac{12.45 \times 10^{-2}}{28} \times 5.07 \\ &= 5.90\Omega \end{aligned}$$

### 3. Over hang leakage reactance

Over hang reactance,

$$X_o = \left[ 16\pi f \mu_o (T_m k_{wm})^2 \frac{1}{6.4 S_p} \times \left[ \pi (D + d_{ss}) \times \text{average coil span in slots} \right] \right] \quad (8)$$

where average coil span =  $\frac{6+4+2}{3} = 4$  as per the coil

span selected

Substituting the known values in the above equation, we get

$$X_o = 16 \times \pi \times 50 \times 4\pi \times 10^{-7} (360 \times 0.8)^2 \frac{1}{6.4 \times 28 \times 4} [\pi (0.089 + 0.146) \times 4]$$
$$= 1.0723 \Omega$$

#### 4. Magnetizing reactance

Magnetizing reactance,

$$X_m = 16\pi f \mu_o (T_m k_{wm})^2 \frac{L \tau_p}{10 l_g k_g p F_s} \quad (9)$$

where  $F_s$  = saturation factor = 1.25

Substituting the known values in Eq. (9), we get

$$X_m = \frac{16\pi \times 50 \times 4\pi \times 10^{-7} (360 \times 0.8)^2 \times 12.45 \times 7 \times 10^{-2}}{10 \times 0.03 \times 10^{-2} \times 1.158 \times 4 \times 1.25}$$
$$= 131.44 \Omega$$

#### 5. Skew leakage reactance

Skew leakage reactance,

$$X_{sk} = X_m \frac{\theta_s^2}{12} k_1 \quad (10)$$

The angle of skew when bars are skewed through one slot pitch is given by

The rotor punching has 20 slots and

$$\theta_s = \frac{\pi}{S_s/P} \times l \times \frac{S_s}{S_r} \text{ radians}$$
$$\theta_s = \frac{\pi}{28/4} \times 1 \times \frac{28}{20} = 0.628 \text{ radians}$$

Substituting the known values in Eq. (10), we get

$$X_{sk} = 131.44 \times \frac{0.628^2}{12} \times 0.95 = 4.10\Omega$$

## **6. Total leakage reactance referred to main winding**

Total leakage reactance referred to main winding,

$$X_{lm} = X_s + X_2 + X_o + X_{sk}$$

Substituting the determined reactances in the previous steps in the above equation, we get

$$X_{lm} = 4.335 + 5.90 + 4.10 \\ = 14.81 \Omega$$

**7. Ratio  $\frac{r'_{rm}}{X_{lm}}$ , open circuit reactance and leakage**

**factor**

Ratio, 
$$\frac{r'_{rm}}{X_{lm}} = \frac{2.9}{14.81} = 0.195$$

Open circuit reactance,

$$X_{om} = X_m + \frac{X_{lm}}{2} \\ = 131.44 + \frac{14.81}{2} \\ = 138.84$$

leakage factors,

$$k_r = \frac{X_{om} - X_{lm}}{X_{om}} \\ = \frac{138.84 - 14.81}{138.84} = 0.89 \quad k_l = \sqrt{k_r} = 0.945$$

**Core losses**

Using 42 quality silicon steel, with 0.5 mm stamping thickness,

Weight of stator teeth is given by

$$\begin{aligned} \text{Weight} &= S_s \times d_{ts} \times 0.95 \times L \times W_{ts} \times \text{density of steel} \\ \text{Weight} &= 28 \times 1.46 \times 10^{-2} \times 0.95 \times 0.0881 \times 0.365 \times 10^{-2} \times 7.67 \times 10^3 \\ &= 0.957 \text{ kg} \end{aligned}$$

$$\text{Average flux density in teeth} = 1.3 \text{ Wb/m}^2$$

Maximum flux density in teeth

$$\simeq 1.3 \times \frac{\pi}{2} = 2.04 \text{ Wb/m}^2$$

Corresponding loss for 1 kg from curve = 7.8 W

Iron loss in stator teeth = Weight of stator teeth  $\times$  loss for 1 kg

$$= 0.957 \times 7.8 = 7.47 \text{ W}$$

$$\text{Mean diameter of stator core} = D_o - d_{cs} = 13.81 - 1$$

$$= 12.81 \text{ cm}$$

$$\begin{aligned} \text{Weight of stator core} &= \\ \pi \times 12.81 \times 10^{-2} \times 0.95 \times 0.0881 \times 1 \times 10^{-2} \times 7.67 \times 10^3 & \end{aligned}$$

$$= 2.58 \text{ kg}$$

$$\text{Flux density in core} = 1.39 \text{ Wb/m}^2$$

Corresponding loss/kg from curve = 4 W

Iron loss in stator core = Weight of stator core × loss for 1 kg

$$= 2.58 \times 4 = 11.4 \text{ W}$$

Total iron loss = Iron loss in stator teeth + Iron loss in stator core

$$\begin{aligned} &= 7.47 + 11.4 \\ &= 18.87 \text{ W} \end{aligned}$$

This is due to fundamental frequency flux alone.

Total iron loss due to other frequency = 2 × iron loss due to fundamental frequency flux

$$\text{Total core loss} = 2 \times 18.87 = 37.74 \text{ W}$$

Friction and windage loss is assumed to be 10 W.

### Venoitt's method

**Step 1:** It is required to specify the performance measures as shown in Table 5.9.

**Table 5.9** | Performance measures

<b>Hp</b>	0.6032 hp
<b>Line voltage</b>	230 V
<b>Speed</b>	1430 rpm

**Step 2:** It is required to specify the motor constants as shown in Table 5.10.

**Table 5.10** | Motor constants

$X_{lm}$	14.81 $\Omega$
$X_{om}$	138.84 $\Omega$
$r_{sm}$	4.48 $\Omega$
$r'_{rm}$	4.77 $\Omega$
$K_l$	0.945
$\frac{r_{sm}}{X_{lm}}$	0.302
$\frac{r'_{rm}}{X_{om}}$	0.034

$I_m = \frac{V}{X_{om}}$	1.656 A
$I_m r'_{rm}$	7.899 W
Core loss	37.74 W
Friction and windage loss	10 W
$F_1 = (2 - K_1^2) r'_{rm}$	5.28
$F_2 = \frac{(2r_{sm} + r'_{rm}) r'_{rm}}{X_{om}}$	0.466
$F_3 = (I_m r'_{rm}) \frac{r'_{rm}}{X_{om}}$	0.268
$F_4 = 2I_m r'_{rm}$	15.798
$F_5 = (I_m r'_{rm}) K_1$	7.464
$F_6 = F_5^2 r'_{rm}$	265.74
$F_7 = VK_1$	217.35
$F_8 = (F_7)^2 r'_{rm}$	225339.6
$F_9 = \frac{\text{core loss}}{2V}$	0.0820

**Step 3:** Determination of the following values listed in Table 5.11.

**Table 5.11** | Determination of parameters

$c = \frac{\text{speed (in rpm)}}{\text{synchronous speed (in rpm)}}$	0.9534
$c^2$	0.9088
$1 - c^2$	0.09115
$(1 - c^2)r'_{\text{rm}}$	0.4347

$F_1$	5.28
$U = (1 - c^2)r'_{\text{rm}} + F_1$	5.71
$(1 - c^2)X_{\text{lm}}$	1.349
$F_2$	0.466
$W = (1 - c^2)X_{\text{lm}} - F_2$	0.883
$\sqrt{U^2 + W^2}$	6.489
$(1 - c^2)V$	20.96
$F_3$	0.208
$M = (1 - c^2)V - F_3$	20.692
$F_9U$	0.468
$N = M + F_9U$	21.16

$\sqrt{N^2 + F_4^2}$	26.40
$I_1 = \frac{\sqrt{N^2 + F_4^2}}{\sqrt{U^2 + W^2}}$	4.07
$(1 - c^2)F_7$	19.85
$\sqrt{(1 - c^2)F_7 + F_5^2}$	21.21
$I_2 = \frac{\sqrt{(1 - c^2)F_7 + F_5^2}}{\sqrt{U^2 + W^2}}$	3.27
$cF_5$	7.116
$I_3 = \frac{cF_5}{\sqrt{U^2 + W^2}}$	1.096

$(1 - c^2)F_8$	20,539.70
$F_6$	265.74
$(1 - c^2)F_8 - F_6$	20,273.96
Primary copper loss = $I_1^2 r_{rm}$	74.575
Secondary copper loss of main winding = $I_2^2 r'_{rm}$	51
Secondary copper loss of starting winding = $I_3^2 r'_{rm}$	18.32
Core loss of main winding = $\frac{\text{core loss}}{2}$	18.87
$\frac{((1 - c^2)F_8 - F_6) \times c^2}{U^2 + W^2}$	437.57
Core loss of starting winding = $\frac{\text{core loss}}{2}$	

$\text{Input} = I_1^2 r_{rm} + I_2^2 r'_{rm} + I_3^2 r'_{rm} + \frac{\text{core loss}}{2}$ $+ \frac{\left( (1-c^2) F_8 - F_6 \right) \times c^2}{U^2 + W^2}$	600.335
$\frac{\text{core loss}}{2} + \text{friction and windage loss of main winding}$	28.87
$\text{Output} = \frac{\left( (1-c^2) F_8 - F_6 \right) \times c^2}{U^2 + W^2}$ $- \left( \frac{\text{core loss}}{2} + \text{friction and windage loss of main winding} \right)$	408.7
Speed (in rpm) = $c \times$ synchronous speed (in rpm)	1430
$\text{Torque (in Nm)} = \frac{60}{2\pi} \times \frac{\text{Output}}{\text{speed (in rpm)}}$	2.68
$\text{Efficiency} = \frac{\text{Output}}{\text{Input}}$	68.1%

$\text{Power factor} = \frac{\text{Input}}{VI_1}$	0.64
Percentage of full load	134%
<p>Pull out torque by Veinott's relation,</p> $T_{po} = 1.27 \left( \frac{V}{115} \right)^2 \frac{p}{f} \frac{345 - 9.2(R_m / X_{lm})^2}{R_m + X_{lm}} K_r$ <p>where <math>R_m = r_{sm} + r'_{rm}</math> and <math>K_r = \frac{X_{om} - X_{lm}}{X_{om}}</math></p>	2.86 Nm

## Design of auxiliary winding

The auxiliary winding is also concentric type and is arranged in quadrature with main winding. The design procedure is as follows.

The auxiliary winding is designed generally for maximum torque/ampere of starting current. Let us assume, due to skin effect the motor resistance is increased by 18%.

So, the total resistance of main winding,

$$\begin{aligned} R_m &= r_{sm} + 1.18r'_{rm} \text{ at } 20^\circ\text{C} \\ &= 3.65 + 1.18(3.86) = 8.17 \Omega \end{aligned}$$

Total impedance,  $Z_m = \sqrt{R_m^2 + X_{lm}^2}$

$$= \sqrt{8.17^2 + 14.81^2} = 16.91$$

Locked rotor current in main winding,

$$I_{sm} = \frac{V}{Z_m} = \frac{230}{16.91} = 13.60 \text{ A}$$

The starting current is not to exceed 5 times the full load current.

$$\text{We know that, } I_{\text{full load}} = \frac{400}{230 \times 0.6 \times 0.65} = 3.34 \text{ A}$$

Therefore, starting current,  $I_s = 5 \times 3.34 \text{ A} = 16.72 \text{ A}$

$$\text{And, ratio, } \frac{I_s}{I_{sm}} = \frac{16.72}{13.60} = 1.23$$

$$\text{Auxiliary winding reactance, } X_{la} = \frac{X_{lm}}{\left(\frac{I_s}{I_{sm}}\right)^2 - 1}$$

$$= \frac{14.81}{1.23^2 - 1} = 28.92\Omega$$

$$\text{Hence, } k^2 = \frac{X_{la}}{X_{lm}} = \frac{28.92}{14.81} = 1.95$$

$$\Rightarrow k = \sqrt{1.95} = 1.396$$

$$\text{Also, } T_a k_{wa} = 1.396 \times 360 \times 0.8 = 402.170$$

Skein type of winding may be selected, which has inside coil as many as skein and twice that of skein for outside.

Let  $T_{pa}$  be the number of sums per pole for the auxiliary winding.

$$\Rightarrow T_{pa} = \frac{T_a}{p}$$

So, there are  $\frac{1}{3} \frac{T_{pa}}{p}$  turns inside the coil and  $\frac{2}{3} \frac{T_{pa}}{p}$  turns

outside the coil.

The winding factor is

$$\text{Outside coil} - \sin\left(\frac{7}{7} 90^\circ\right) = 1.00 \times \frac{2}{3} T_{pa} = 0.666 T_{pa}$$

$$\text{Inside coil} - \sin\left(\frac{5}{7} 90^\circ\right) = 0.9 \times \frac{1}{3} T_{pa} = 0.3 T_{pa}$$

$$\Rightarrow \text{Total} = 0.666 T_{pa} + 0.3 T_{pa} = 0.966 T_{pa}$$

So, winding factor for auxiliary winding,  $k_{wa} = 0.960$ .

Turns in series (auxiliary winding),

$$T_a = \frac{402.170}{0.966} = 416$$

$$\text{Turns in series/pole, } T_{pa} = \frac{416}{4} = 104$$

$$\text{Turns in inner coil} = \frac{104}{3} = 34$$

$$\text{Turns in outer coil} = \frac{2}{3} \times 104 = 70$$

$$\begin{aligned} L_{\text{mt}} \text{ for outer coil} &= 8.4 \frac{(8.9 + 1.45)}{28} \times 7 + 2 \times 12.45 \\ &= 46.63 \text{ cm} \end{aligned}$$

$$L_{\text{mt}} \text{ for inner coil} = 8.4 \frac{(8.9 + 1.45)}{28} \times 5 + 2 \times 12.45$$

$$= 40.42 \text{ cm}$$

$$L_{\text{mta}} = \frac{46.63 \times 70 + 40.42 \times 34}{104}$$

$$= \frac{3222.1 + 1374.45}{104}$$

$$= 44.59 \text{ cm}$$

Resistance of auxiliary winding,

$$\begin{aligned}
 R_a &= \frac{R_m + Z_m \left( \frac{I_s}{I_{sm}} \right)}{\left( \frac{I_s}{I_{sm}} \right)^2 - 1} \\
 &= \frac{8.17 + 16.91(1.23)}{(1.23)^2 - 1} \\
 &= \frac{28.969}{0.512} = 56.5\Omega
 \end{aligned}$$

$$\begin{aligned}
 r_{sa} &= R_a - k^2 r'_{rm} \\
 &= 56.5 - 1.39^2 (4.77) \\
 &= 56.5 - 9.216 \\
 &= 47.2 \Omega
 \end{aligned}$$

Conductor area for auxiliary winding,

$$\begin{aligned}
 a_a &= \frac{\rho T_a L_{mta}}{r_{sa}} \\
 &= \frac{0.017(360)(4419)}{47.2} \\
 &= 0.050752 \text{ mm}^2
 \end{aligned}$$

$$\text{Diameter of bare conductor} = \sqrt{\frac{4}{\pi} \times 0.0572} = 0.26 \text{ mm}$$

The impedance of auxiliary winding under locked motor,

$$\begin{aligned}
 Z_a &= \sqrt{R_a^2 + X_a^2} = \sqrt{56.5^2 + 28.92^2} \\
 &= \sqrt{192.25 + 836.356} \\
 &= 63.47 \Omega
 \end{aligned}$$

Auxiliary winding rotor current (under locked rotor),

$$I_{sa} = \frac{V}{Z_a} = \frac{230}{63.47} = 3.62 \text{ A}$$

$$\text{Current density} = \frac{I_{sa}}{a_a} = \frac{3.62}{0.0572} = 63.35 \text{ A/mm}^2$$

$$\begin{aligned}
 T_s &= \frac{1}{2\pi} \frac{pkC_r r'_{rm}}{f} V^2 \left[ \frac{R_a X_{lm} - R_m X_{la}}{Z_m^2 Z_a^2} \right] \\
 &= \frac{1}{2\pi} \frac{4 \times 1.39 \times 0.89 \times 4.77 \times 2.30^2}{50} \left( \frac{(56.5 \times 14.81) - (8.17 \times 28.92)}{(16.91)^2 (63.47^2)} \right) \times 10^4 \\
 &= 2.069 \text{ Nm}
 \end{aligned}$$

$$\text{Ratio, } \frac{\text{Starting torque}}{\text{Full load torque}} = \frac{2.069}{2.68} = 0.772$$

### **Design of starting winding for capacitor start motor**

The parameters of main and auxiliary winding are

$R_m = 8.17 \Omega$ ;  $R_a = 56.5 \Omega$ ;  $X_{lm} = 14.81 \Omega$ ;  $X_{la} = 28.92 \Omega$ ;  $k = 1.39$

The capacitive reactance,

$$\begin{aligned} X_c &= X_{la} + \frac{R_a R_m}{Z_m + X_{lm}} \\ &= 28.92 + \frac{56.5(8.17)}{16.91 + 14.81} \\ &= 28.92 + \frac{461.60}{31.72} = 43.47 \Omega \end{aligned}$$

Capacitance,

$$\begin{aligned} C &= \frac{10^6}{2\pi f C} = \frac{10^6}{2\pi \times 50 \times 43.47} \\ &= \frac{10^6}{13656.2} = 73.22 \mu\text{F} \end{aligned}$$

Starting torque,

$$T_s = \frac{1}{2\pi} \frac{pKC_r r'_{rm}}{f} V^2 \left[ \frac{R_a X_{lm} - R_m (X_{la} - X_c)}{(R_m^2 + X_{lm}^2)(R_a^2 + (X_{la} - X_c)^2)} \right]$$

Substituting the known values in the above equation, we get

$$T_s = \left[ \frac{1}{2\pi} \frac{4 \times 1.39 \times 0.89 \times 4.77}{50} 230^2 \times \left[ \frac{(56.5)(14.81) - 8.17(28.92 - 43.47)}{(8.17^2 + 14.81^2)(56.5^2 + (8.92 - 43.4)^2)} \right] \right]$$

$$= 3.03 \text{ Nm}$$

Impedance,

$$Z_a = \sqrt{R_a^2 + (X_{la} - X_c)^2}$$

$$= \sqrt{56.5^2 + (28.92 - 43.41)^2}$$

$$= \sqrt{3192.25 + 211.70} = 58.34 \Omega$$

Locked rotor current of auxiliary winding,

$$I_{sa} = \frac{230}{58.34} = 3.94 \text{ A}$$

$$\text{Current density in aux winding} = \frac{3.94}{0.0572} = 68 \text{ A/mm}^2$$

Starting current

$$I_s = I_{sm} \frac{\sqrt{(R_a + R_m)^2 + (X_{lm} + (X_{la} - X_c)^2)}}{\sqrt{R_a^2 + (X_{la} - X_c)^2}} = 75.39 \text{ A}$$

### Review Questions

### Short Type Questions

1. Provide the classification of single-phase induction motor.  
Refer Fig. 5.1.
2. Explain briefly about split phase single-phase induction motor.  
Refer Section 5.2.1.
3. Explain briefly about shaded pole single-phase induction motor.  
Refer Section 5.2.2.
4. Explain briefly about repulsion single-phase induction motor.  
Refer Section 5.2.3.
5. Explain the major design considerations of single-phase induction motor.  
Refer Section 5.3.
6. Provide the specifications of single-phase induction motor.  
Refer Section 5.4.
7. Provide the choice of specific electric and magnetic loading of single-phase induction motor.  
Refer Section 5.6.2.
8. What are the methods used in performance calculation of single-phase induction motor.  
Refer Section Fig.5.4.
9. Draw the equivalent circuit of single-phase induction motor.  
Refer Fig. 5.5.

### Long Type Questions

1. Derive the output equation of single-phase induction motor.
2. Explain the design of stator and rotor of single-phase induction motor.
3. Explain about equivalent circuit method in performance calculation of single-phase induction motor.
4. Explain about Veinott's method in performance calculation of single-phase induction motor.

## DESIGN OF SYNCHRONOUS MACHINE

### 6.1 Introduction

Synchronous machines are AC machines having the field circuit excited by external DC source and the armature circuit with three phase balanced winding excited by an AC source. The armature circuit forms the stator of the synchronous machine and the field circuit constitutes the rotor of the machine. However, for low power synchronous machines, the arrangement similar to DC machine can also be used with the field on the stator side and the armature on the rotor side.

### 6.2 Types of Synchronous Machine

Synchronous machines, in general, are classified as shown in Fig. 6.1.

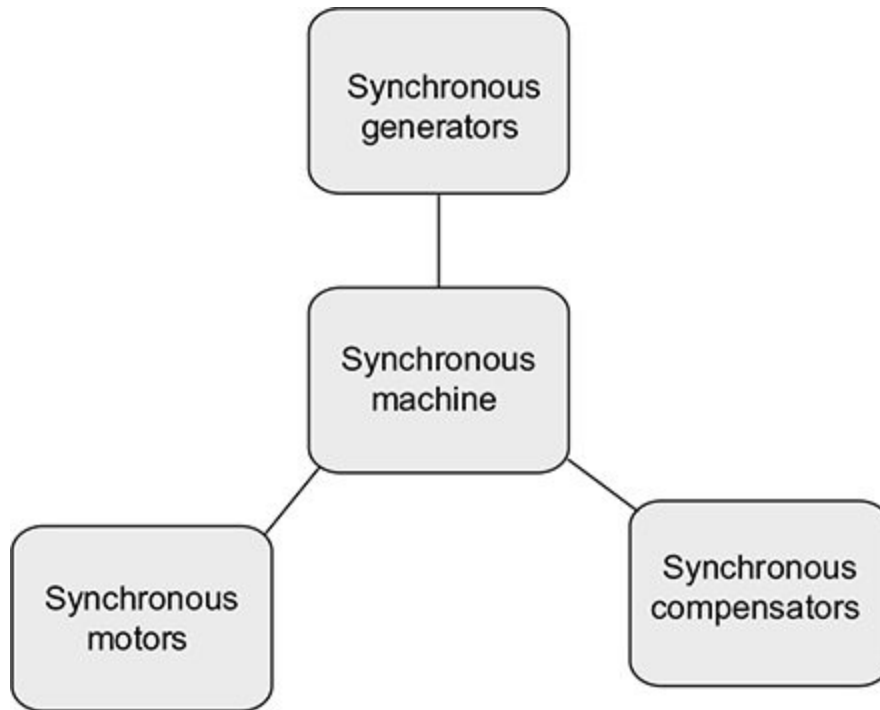

**Fig. 6.1** | Classification ...

## DC MACHINE

### 7.1 Introduction

DC machines were widely used in power generation and distribution in earlier days. DC machines can conveniently work both in generating mode and in motoring mode. DC generators were the prime source of supply both to industries and to domestic consumers during Edison's period. All electric networks were based on DC in those days. However, the AC systems due to their flexibility, lower cost of generation and transmission and higher efficiency, replaced the DC systems and now AC systems are almost universally used.

However, DC machines are used in many applications like aircrafts, ships, wind mills, etc. as DC machines are capable of acting both as a motor and as a generator. In generating mode, the machine is driven by a prime mover and the mechanical power supplied is converted as electrical power. In motoring mode, the machine is powered electrically and drives a mechanical load.

### 7.2 Construction

The DC machine has three main parts, namely

- Field or excitation system, represented in Fig. 7.1(a)
- Armature, represented in Fig. 7.1(b)
- Commutator, represented in Fig. 7.1(b)

### 7.2.1 Field or Excitation System

The field system is stationary in DC machines and the field winding is wound on salient poles. The field system produces the magnetization required for the machine and is called as the stator of the machine.

The stator of a DC machine consists of

- Yoke or frame
- Main poles
- Interpoles
- Field winding

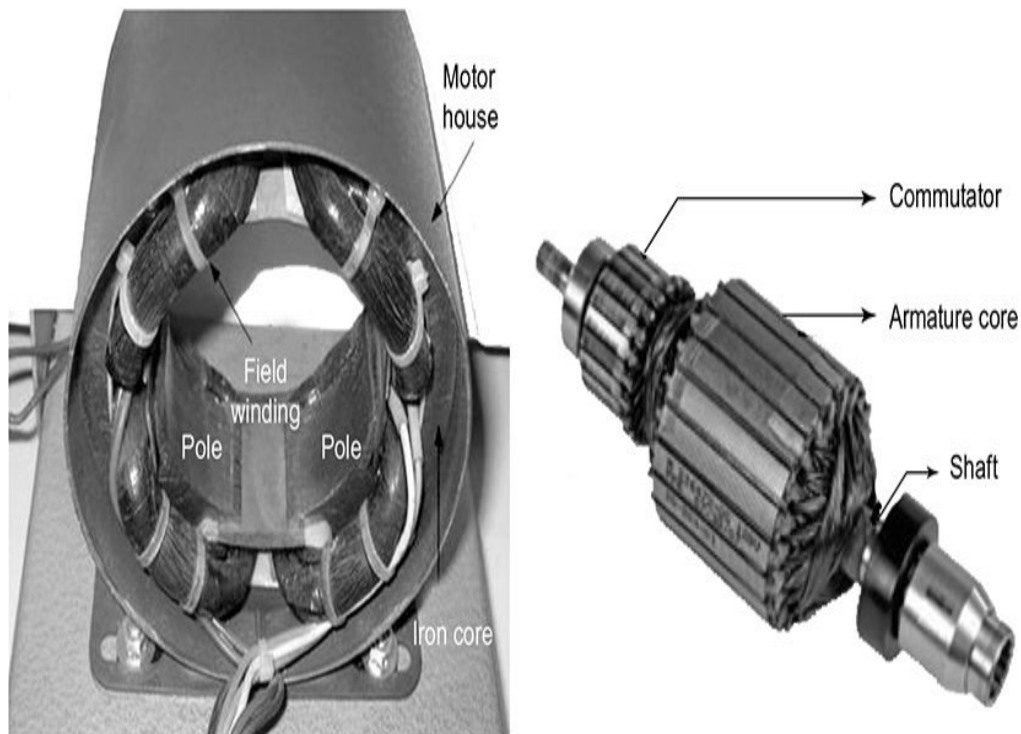

**Fig. 7.1** | Construction of DC machine: (a) Field or excitation system; (b) Armature and commutator

## **Yoke or frame**

Yoke or frame is the part of the magnetic circuit of the DC machine. It also provides mechanical support to the machine. The yoke need not be laminated as the field system is stationary.

## **Main poles**

Main poles are designed to produce the main magnetic flux. It consists of pole core and pole shoe. The pole shoe has dual functionality, i.e., it

1. Supports the field coils
2. Spreads the flux in airgap

As the cross-section of pole shoe is increased, it reduces the reluctance of the magnetic path. The complete pole is built of laminations of sheet steel and is bolted together. They are bolted through the yoke in to the pole body.

## **Interpoles**

Interpoles are provided to improve commutation and thus they ensure sparkless operation of the machine. They are made of laminated low carbon steel in case of large machines. Solid low carbon steel poles are used in case of small machines. They are tapered or parallel sided. To avoid magnetic saturation at the root, they are tapered to have sufficient sectional area.

## **Field winding**

It is of two types: main field winding and interpole winding.

### **Main field winding**

The main field winding consists of field coils wound with round copper wires for small and medium size machines. Rectangular conductors are used for large size machines. They are form wound for the correct dimension. The former is removed and the wound coil is placed over the pole body. The field winding can be wound with both series and shunt coils. The series field coil has a larger cross-section and is placed below the shunt coil.

### **Interpole winding**

Similar to main field winding, the interpole winding is also made of round or square strip wire in case of smaller machines and are made of rectangular strips in case of larger machines.

#### *7.2.2 Rotor*

The rotor of a DC machine consists of the following:

- Armature core
- Armature winding
- Commutator
- Brush arrangement
- Bearings

### **Armature core**

The armature core houses the armature conductors and provides low reluctance path to the magnetic flux. Armature core is made of silicon steel stampings of about

0.35–0.5 mm thick. These stampings are insulated from each other by a thin coating of varnish.

Slots are cut or punched on the outer periphery of circular core stampings. Radial ventilation spacers are provided in between the core dividing it in to packets, to achieve better cooling.

### **Armature winding**

The armature windings are generally form wound. The conductors are insulated from each other and are placed in slots. These armature slots are lined with a thin insulating material called latheroide paper. Normally, two-layered windings are used. The two coil sides of a coil are placed approximately one pole pitch away, i.e., if one coil side is placed on the top of a slot, the other coil side is placed at the top of a slot at a distance of one pole pitch. Lap winding is used for low voltage, high current machines with number of parallel paths equal to number of poles. For high voltage, low current machines, wave winding is used with number of parallel paths equal to two.

### **Commutator**

The commutator facilitates collection of current from armature conductors. It rectifies the AC current induced in the armature conductors in to DC current for the external load circuit. It is a cylindrical structure placed at one end of the armature. It is built up of wedgeshaped segments of high conductivity hard drawn copper. These copper bars or segments are insulated from each other by a thin layer of mica or micanite. The copper segments

are connected to armature conductors by means of a copper lug or riser.

### **Brush arrangement**

The brushes used for collection of current are made of natural graphite, hard carbon, electro graphite or metal graphite. They are placed in brush holders. The box type holders are the most widely used ones. The number of brush holders will be equal to number of poles. The holder is mounted on a spindle and the brush slides in a rectangular slot in the holder. It is present on the commutator by a spring whose tension can be adjusted by a small level. At the top of the brush, a flexible copper pig tail is mounted. This conveys the current collected by the brush to the holder. There may be several brushes per spindle depending on the magnitude of current.

### **Bearings**

Ball bearings are used on either end of small machines. For larger machines, roller bearings are used generally at the driving end and ball bearings are used at the non-driving end. When silent running is warranted, sleeve bearings are used.

#### *7.2.3 Specifications of DC Machine*

The major specifications of DC machines are given as follows.

1. Output: kW (for generators); *hp* (for motors)
2. Rated speed: rpm
3. Voltage: V
4. Type: series, shunt, compound, separately excited
5. Duty type

6. Excitation volts: V
7. Insulation type
8. Temperature rise: °C
9. Full load current: A
10. Pull out torque: Nm (for motors)

### 7.3 Output Equation

The output of a DC machine has to be related to its main dimensions.

Power developed by the armature in kW,

$$P_a = E \times I_a \times 10^{-3} \quad (7.1)$$

where  $P_a$  – armature power developed,  $E$  – generated emf,  $I_a$  – armature current.

We know that

$$\text{Generated emf, } E = \frac{\phi p Z N}{60 a} = \phi \frac{p}{a} Z n \quad (7.2)$$

where  $p$  – number of poles,  $\phi$  – flux per pole,  $Z$  – number

of armature conductors,  $n = \frac{N}{60}$  – speed in rps.

Substituting Eq. (7.2) in Eq. (7.1), we get

$$P_a \text{ (in kW)} = \phi \frac{p}{a} Z n \times I_a \times 10^{-3}$$

$$= (p\phi) \left( \frac{I_a}{a} \times Z \right) \times n \times 10^{-3}$$

$$\Rightarrow P_a \text{ (in kW)} = (p\phi)(I_z Z) \times n \times 10^{-3} \quad (7.3)$$

$$\left[ \because \text{Current per parallel path, } \frac{I_a}{a} = I_z \right]$$

The specific magnetic loading,

$$B_{av} = \frac{p\phi}{\pi DL}$$

$$\text{Hence, } p\phi = B_{av} \pi DL \quad (7.4)$$

$$\text{The specific electric loading, } ac = \frac{I_z Z}{\pi D}$$

$$I_z Z = \pi D ac \quad (7.5)$$

Substituting Eqs. (7.4) and (7.5) in Eq. (7.3), we get

$$P_a \text{ (in kW)} = (B_{av} \pi DL) (ac \pi D) \times n \times 10^{-3}$$

$$= (\pi B_{av} ac \times 10^{-3}) \times D L n$$

$$\Rightarrow P_a \text{ (in kW)} = C_o D^2 L n$$

where  $C_o = (\pi^2 B_{av}^2 \times 10^{-3})$  is referred as the output coefficient of a DC machine.

### 7.3.1 Estimation of Power, $P_a$

The output equation  $P_a \text{ (in kW)} = C_o D^2 L n$  relates the power developed by the armature of a DC machine to its main dimensions  $D$  and  $L$ . But for DC generators and motors, the power output,  $P$ , is alone specified as the main specifications. Now, let us relate  $P_a$  with  $P$  for motors and generators.

- **For motor**

Power developed by armature,

$$P_a = \text{output power } (P) + \text{rotational losses}$$

where rotational losses include friction, windage and iron losses.

- **For generator**

Power developed by armature,

$$\begin{aligned} P_a &= \text{input power} - \text{rotational losses} \\ &= \frac{\text{Output power } (P)}{\text{Efficiency } (\eta)} - \text{rotational losses} \end{aligned}$$

**For large machines**, the rotational losses are very small. Thus, the difference between  $P_a$  and  $P$  is very small. So, the rotational losses could be neglected. Hence,

$$P_a = P \text{ for motors}$$

$$P_a = \frac{P}{\eta} \text{ for generators.}$$

**For small machines**, the rotational losses constitute considerable percent of output power and thus could not be neglected. Let us assume the friction, windage and iron loss is equal to  $1/3^{\text{rd}}$  of total loss in the machine.

$$\text{i.e., Rotational loss} = \frac{1}{3} \text{ Total loss}$$

$$\text{Total loss} = \text{Input power} - \text{Output power}$$

$$= \frac{P}{\eta} - P = P \left( \frac{1-\eta}{\eta} \right)$$

Rotational loss (including friction, windage and iron loss)

$$= \frac{1}{3} P \left( \frac{1-\eta}{\eta} \right)$$

Also, for small motors, we know that

$$\begin{aligned}
 P_a &= \text{output power } (P) + \text{rotational losses} \\
 &= P + \frac{1}{3}P \left( \frac{1-\eta}{\eta} \right) \\
 &= P \left( \frac{1+2\eta}{3\eta} \right)
 \end{aligned}$$

Also, for small generators, we know that

$$\begin{aligned}
 P_a &= \frac{P}{\eta} - \text{rotational losses} \\
 &= \frac{P}{\eta} - \frac{1}{3}P \left( \frac{1-\eta}{\eta} \right) \\
 &= P \left( \frac{2+\eta}{3\eta} \right)
 \end{aligned}$$

#### 7.4 Choice of Specific Loadings of DC Machine

The value of the output coefficient depends on  $B_{av}$  and  $ac$ . Therefore, it is necessary to consider all factors influencing  $B_{av}$  and  $ac$ .

##### 7.4.1 Choice of Specific Magnetic Loading ( $B_{av}$ )

The various factors affecting the choice of  $B_{av}$  are given in Fig. 7.2.

- **Frequency**

The iron loss in the machine is proportional to frequency and  $B_{av}$ .

Higher frequency will result in increased iron losses in the armature core and teeth. So, for machines having higher frequency, one should

not choose higher value of  $B_{av}$ , to keep teeth flux density within permissible limit.

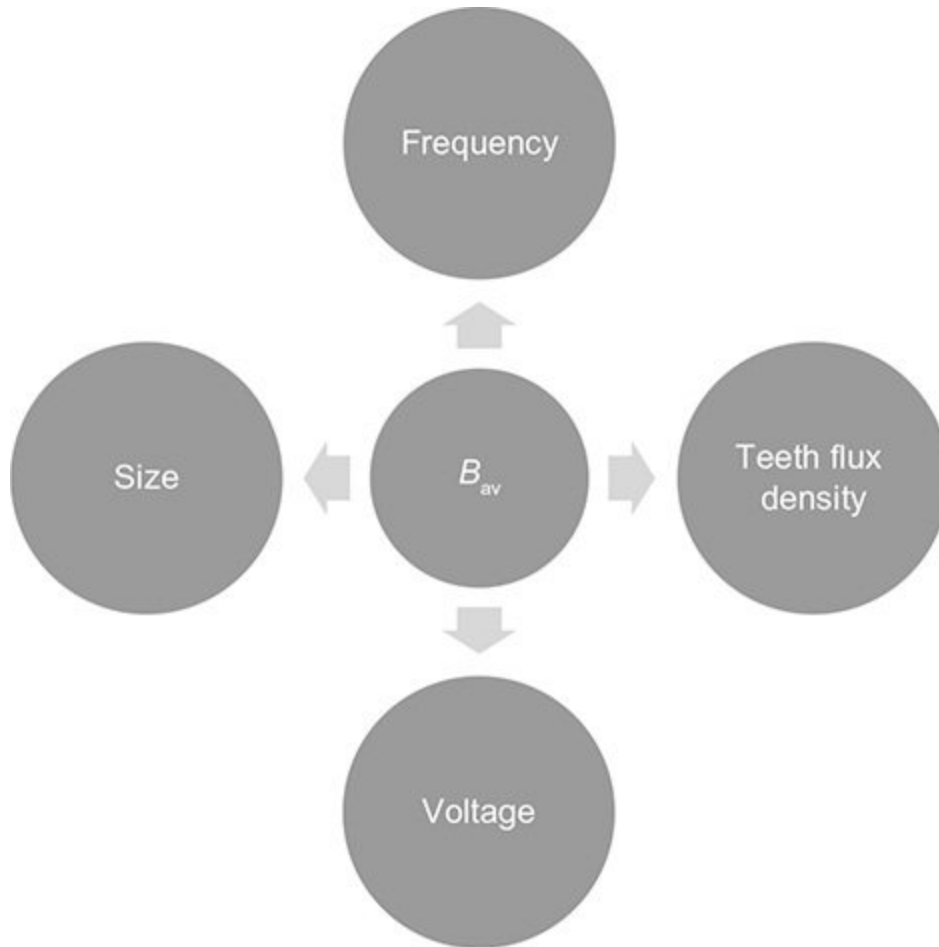

**Fig. 7.2** | Factors influencing choice of specific magnetic loading

- **Teeth flux density**

With higher values of flux density, the flux density of teeth at its minimum section also increases. Generally, this should be kept within  $2.2 \text{ Wb/m}^2$ . Values above this will increase iron loss. Higher ampere turns are also required to pass flux through teeth. This may increase the copper loss. Hence, higher values of  $B_{av}$  should not be chosen.

- **Voltage**

For machines of high voltage rating, more space is required for insulation. So, for the given diameter of machine, less space will be available for iron, leading to narrower teeth. If a higher value of  $B_{av}$  is chosen, then the teeth flux density may go above permissible limit increasing the losses and decreasing efficiency.

- **Size**

With the higher values of  $B_{av}$ , the tooth flux density increases. To avoid magnetic saturation, the width of tooth has to be increased. This increases the diameter of the armature. With increased diameter, the volume and size will also increase.

The suitable value of  $B_{av}$  usually ranges from 0.45 to 0.75 Wb/m<sup>2</sup>.

#### *7.4.2 Choice of Specific Electric Loading ( $ac$ )*

The various factors affecting the choice of specific electric loading  $ac$  are given in Fig. 7.3.

- **Temperature rise**

High value of  $ac$ , increases the copper loss and hence heat produced will be more. High value of  $ac$  means either the diameter is less or more copper is used. When the diameter is less, heat dissipation may be poor due to reduced surface area. When more copper is used, the overall insulation thickness will be more, leading to poor dissipation.

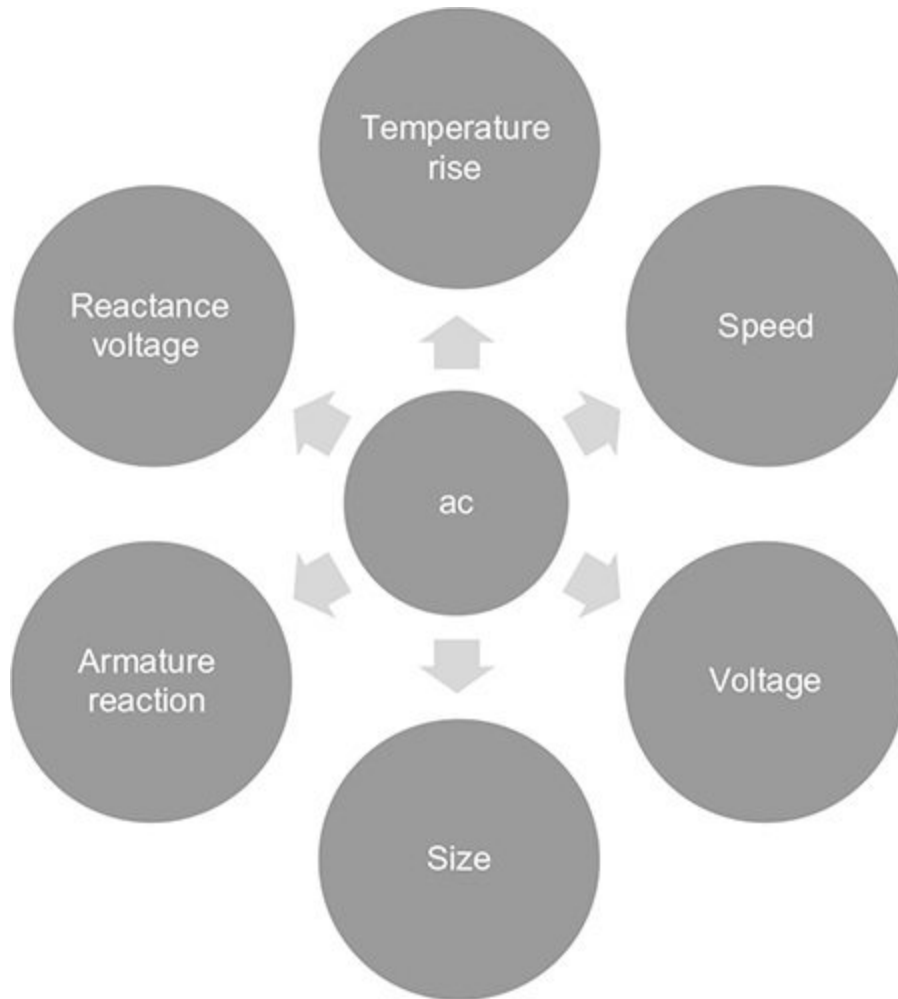

**Fig. 7.3** | Factors influencing choice of specific electric loading

- **Speed**  
For high-speed machines, as the ventilation is more, more losses could easily be dissipated. Hence, high-speed machines can use higher value of  $ac$ .
- **Voltage**  
High voltage rating machines require more space for insulation. Thus, the space available for iron and copper is less. Because of the limitation imposed by flux density in teeth, it may not be possible to reduce the space for iron, so the space for copper is reduced. In such cases, lower value of ' $ac$ ' has to be used.
- **Size**  
Large size machines have larger space for iron and copper. Hence, higher value of ' $ac$ ' could be used.
- **Armature reaction**

With higher values of 'ac', the armature current increases, increasing the armature mmf. The armature reaction, which is the distortion of field mmf due to armature mmf also increases. So, higher values of ac should not be chosen. To compensate for the distortion, field ampere turns are increased, which increases the cost of copper.

- **Reactance voltage**

It is the voltage drop due to leakage reactance of armature winding. The reactance voltage increases due to higher 'ac', as higher 'ac' increases armature current and hence the drop is caused. When reactance voltage is increased, commutation is delayed.

The value of 'ac' usually varies from 15,000 to 50,000 A/m.

### 7.5 Choice of Number of Poles

The number of poles of an AC machine is fixed by

frequency and speed, by the relation  $P = \frac{120 f}{N}$ . In DC

machines, any number of poles can be used. However, only a small range of number of poles is economically suitable. The factors that govern the choice of number of poles are listed in Fig. 7.4.

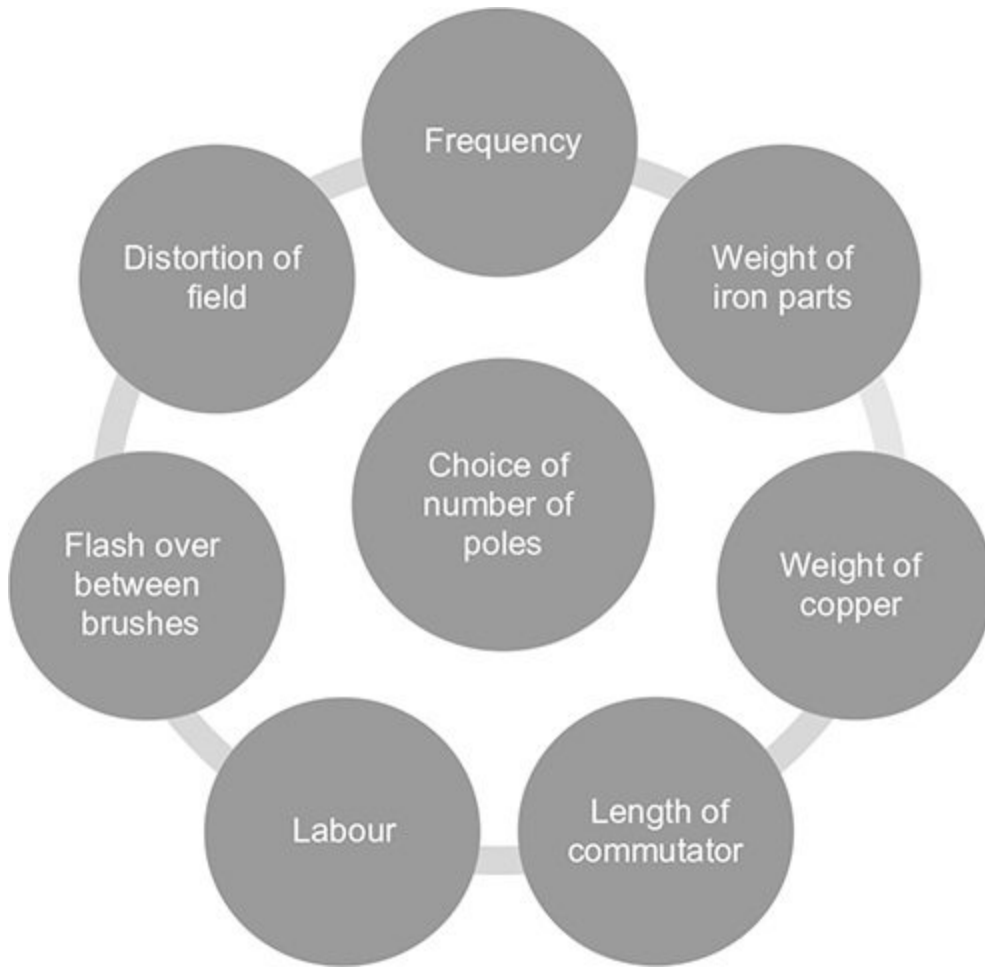

**Fig. 7.4** | Factors that govern the choice of number of poles

**1. Frequency**

The frequency of flux reversal is given by  $f = PN/120$  when number of poles increases, the frequency becomes high, increasing core losses. Usually, 25 to 30 Hz is satisfactory.

**2. Weight of iron parts**

- **Yoke**

For a two-pole machine, with  $\phi$  as flux per pole, the yoke carries half the flux/pole. If the number of poles increases to 4, the flux in yoke changes to  $\phi/4$ . So, if the number of poles are doubled, yoke flux reduces to half. By keeping yoke flux density the same, the weight of iron in yoke decreases proportionately, as the yoke area decreases. The distribution of flux in the yoke and armature core for a two-pole and four-pole DC machine is given in [Fig. 7.5\(a\)](#) and [\(b\)](#), respectively.

- **Armature core**

The flux per pole divides in to two parallel paths in the armature core. For a two-pole machine, the flux in armature core is  $\phi/2$  whereas for a four-pole machine, it is  $\phi/4$ .

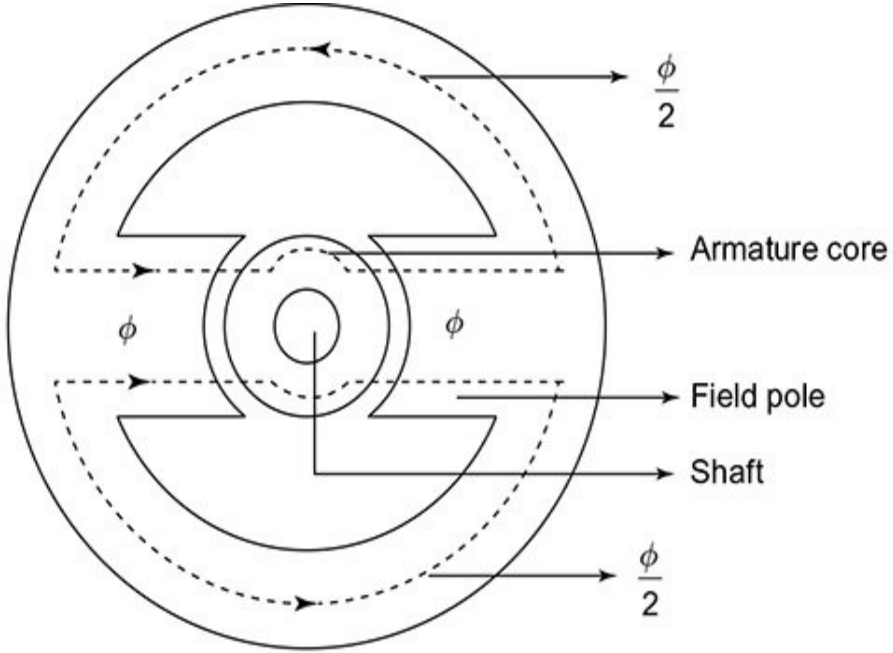

(a)

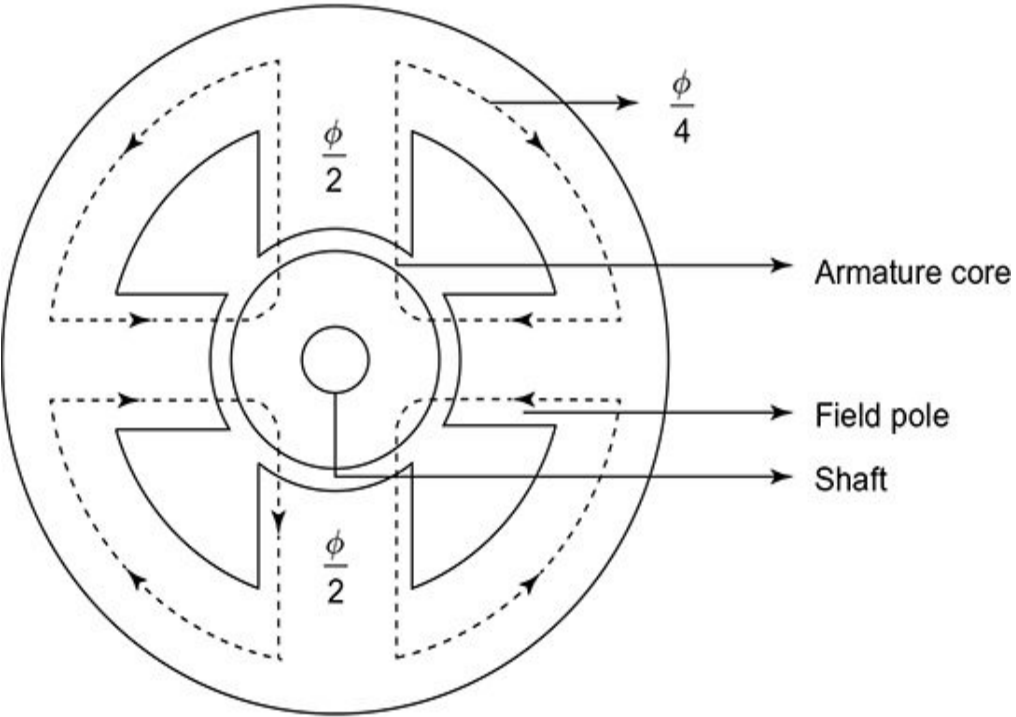

(b)

**Fig. 7.5** | Distribution of flux in the yoke and armature core for (a) a two-pole DC machine and  
(b) a four-pole DC machine

Hence, increasing the number of poles not only decreases the armature flux but also increases the frequency of flux reversals in the armature core. The increase in frequency increases the core losses. Let us compare a two-pole machine with a four-pole machine in the aspect of losses. The comparison between the two-pole and four-pole machines with respect to eddy current and hysteresis loss is shown in [Table 7.1](#).

From [Table 7.1](#), it can be inferred that, for the same hysteresis loss, the armature core area, and hence the weight of iron in armature core can be reduced by increasing the number of poles.

- ***Field magnets***

For a given field ampere turns, the ampere turns developed by each field coil will decrease with the increase in the number of poles. Reduced ampere turns per pole means reduced height of the pole for the same depth of field winding. Reduction in height lowers the amount of iron and reduces the overall diameter of the machine.

**Table 7.1** | Comparison between the two-pole and four-pole machines with respect to eddy current and hysteresis loss

	Two-pole machine	Four-pole machine
(i) Eddy current loss	$P_{e_1} \propto B^2 f_1^2$ $\propto \left(\frac{\phi}{2A_1}\right)^2 f_1^2$ $\propto \frac{\phi^2}{4A_1^2} f_1^2$	$P_{e_2} \propto B^2 f_2^2$ $\propto \left(\frac{\phi}{4A_2}\right)^2 f_2^2$ $\propto \frac{\phi^2}{16A_2^2} f_2^2$ $\propto \frac{\phi^2}{16A_2^2} (2f_1)^2$ $\propto \frac{\phi^2}{4A_2^2} f_1^2$
	<p>Since <math>f_2 = 2f_1</math>, when <math>A_1 = A_2</math>,</p> <p><math>\Rightarrow P_{e_1} = P_{e_2}</math></p>	
(ii) Hysteresis loss	$P_{h_1} \propto B^{1.6} f_1$ $\propto \left(\frac{\phi}{2A_1}\right)^{1.6} f_1$ $\propto \left(\frac{\phi}{A_1}\right)^{1.6} \left(\frac{1}{2}\right)^{1.6} f_1$	$P_{h_2} \propto B^{1.6} f_2$ $\propto \left(\frac{\phi}{4A_2}\right)^{1.6} f_2$ $\propto \left(\frac{\phi}{A_2}\right)^{1.6} \left(\frac{1}{4}\right)^{1.6} 2f_1$
	<p>Since <math>f_2 = 2f_1</math>, when <math>A_1 = A_2</math></p> <p><math>\Rightarrow P_{h_2}</math> is lower than <math>P_{h_1}</math></p>	

1. c. **Weight of copper**

- **Armature copper**

The armature ampere conductors are independent of number of poles. The total weight of active copper does not vary with the number of poles. But the inactive copper, i.e., the copper at the overhang decreases as the number of poles increases, i.e., overall length of copper and overall length of machine reduce as shown in Fig. 7.6 for two-pole and four-pole DC machines.

- **Field copper**

Since field ampere turns are fixed, with the increase in the number of poles, the field ampere turns/pole reduces and the area of cross-section of turns/pole reduces.

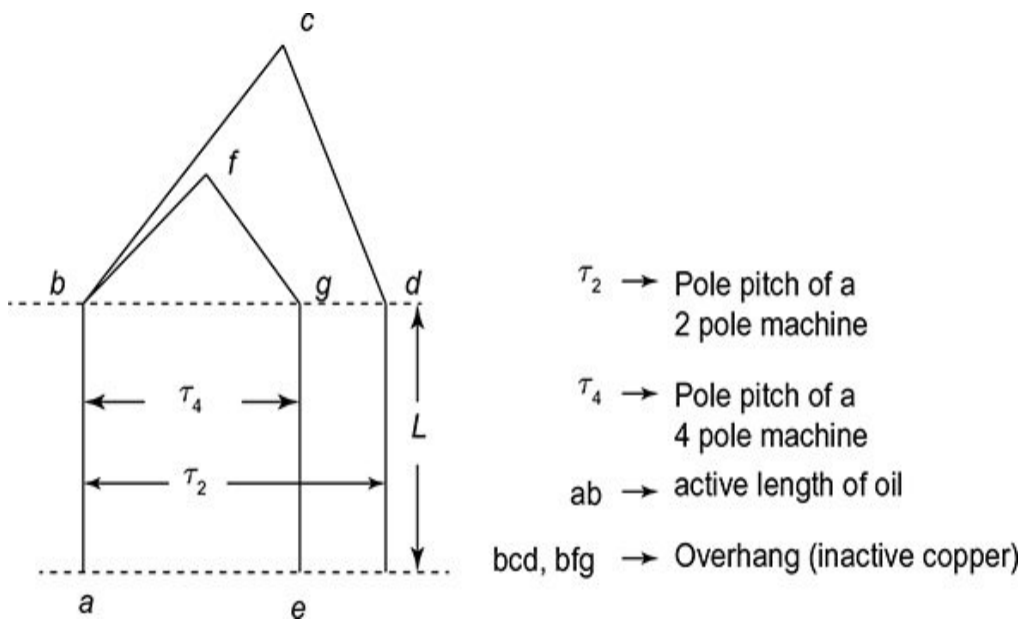

**Fig. 7.6** | Armature winding of two-pole and four-pole DC machines

1. d. **Length of commutator**

For a lap wound machine with  $p = 2$  as shown in Fig. 7.7(a),

$$\text{Current per path in armature} = \frac{I}{2}$$

Current per brush arm = I

For a lap wound machine with  $p = 4$  as shown in Fig. 7.7(b),

$$\text{Current per path in armature} = \frac{I}{4}$$

$$\text{Current per brush arm} = \frac{I}{2}$$

From the above equations, it is observed that the current per brush arm decreases with the increase in  $p$ . The area of brush will also decrease. Since the thickness of brush is decided by the number of commutator segments, the length of brush arm and therefore the length of commutator decrease with the increase in the number of poles.

#### 1. e. Labour

We know that, emf induced,  $E = \frac{\phi p Z n}{a}$

$$\Rightarrow E \propto \frac{Z n}{a} \text{ as } p\phi \text{ is constant for any given DC machine.}$$

And  $E \propto \frac{Z n}{p}$  for lap wound machine [ $\because p = a$ ]

For a constant emf, with the increase in the number of poles, the number of armature conductors is proportionately increased. For larger number of poles, larger armature coils are to be wound, insulated and soldered to commutator; so labour charges will increase. For larger values of number of poles, more number of field coils are to be wound, which further increases the labour.

#### 2. f. Flash over between brushes

The number of brush arms will increase with the increase in the number of poles. For the same diameter of DC machine, the distance between adjacent brush arm reduces increasing the possibility of flash over.



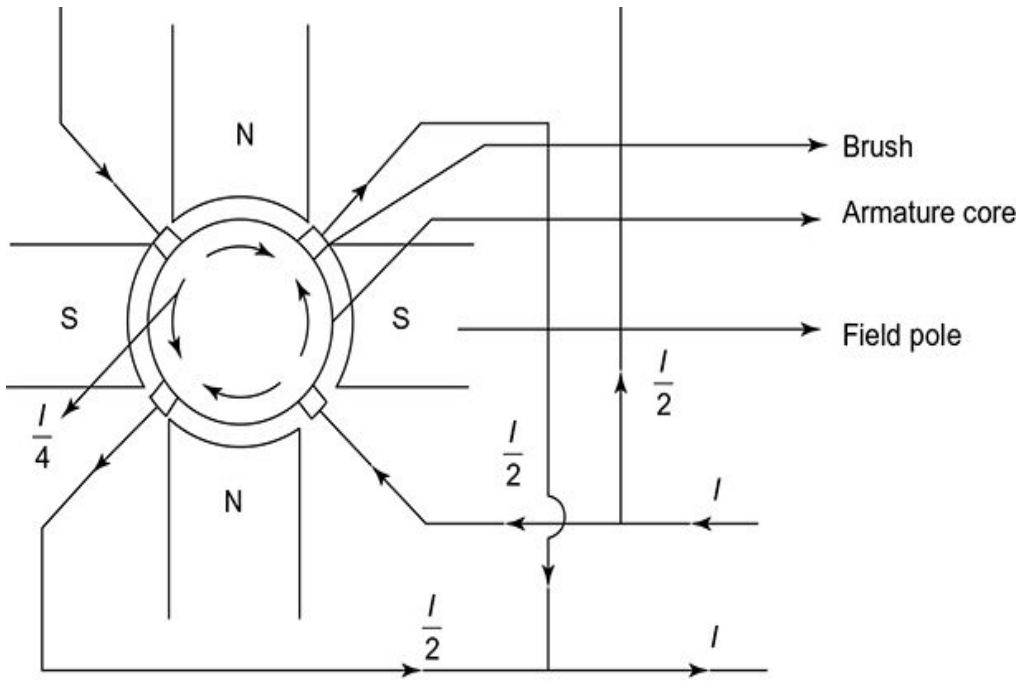

(a)

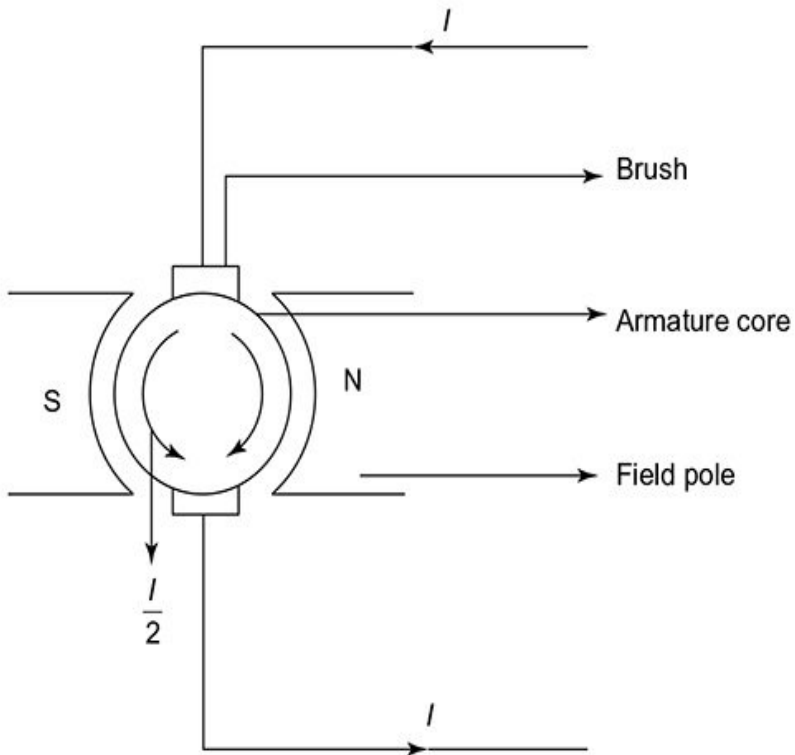

(b)

**Fig. 7.7** | Brush arrangement for (a) two-pole and (b) four-pole DC machines

### 1. g. Distortion of field

We know that, armature ampere turns per pole =  $\frac{ac\pi D}{p}$ .

With smaller number of poles, armature ampere turns per pole increases and because of armature reaction, the field is more distorted. Also sparking of brushes will be more.

From the above listed factors, the advantages and disadvantages of having higher number of poles are described as follows.

### Advantages:

- Weight of iron is reduced
- Cost of copper in field and armature is reduced
- Overall diameter and length are reduced
- Length of commutator is reduced
- Distortion in the field is less

### Disadvantages:

- Iron loss is more
- Flashover between brush arm increases
- Cost of material increases
- Cost of labour increases

Hence, the choice of number of poles has to be judiciously made considering all the above factors.

#### *7.5.1 Guidelines for the Selection of Poles*

1. Keep the frequency of flux reversal,  $f = \frac{pn}{2}$  as 25 to 50 Hz.
2. Current per parallel path  $I_z = \frac{I_a}{a}$  must be limited to 200 A.
3. Current/brush  $I_b = 2I_z$  mmf must be limited to 400 A.

4. Armature mmf/pole

$$AT_a = \frac{I_z Z}{2p} = \frac{ac \times \pi D}{2p} = \frac{ac \pi D}{2 P} = \frac{ac}{2} \tau, \text{ must be}$$

limited to 12,500 AT, where  $\tau$  is the ratio of pole arc to pole pitch.

Table 7.2 gives the values of  $AT/\text{pole}$  for various ratings of DC machine.

**Table. 7.2** | Values of  $AT/\text{pole}$  for various ratings of DC machine

Output rating (kW)	$AT_a/\text{pole}$
Up to 100	$\leq 5000 AT$
100 to 500	5000 to 7500 $AT$
500 to 1500	7500 to 10,000 $AT$
Above 1500	$\leq 12,500 AT$

### 7.6 Limitations of $D$ and $L$

The following factors affecting choice of  $D$  and  $L$ .

#### **Factors affecting ‘ $D$ ’:**

Peripheral speed,  $v_a = \pi D n$

With increase in diameter ‘ $D$ ’, peripheral speed and centrifugal force increase. To provide mechanical stability, peripheral velocity should not be greater than 30 m/s.

## Factors affecting 'L':

1. **Commutation:** The emf induced per conductor is higher for a DC machine with longer length. This increases the voltage between adjacent commutator segments leading to bad commutation. So, voltage between commutator segments should not exceed 20 V on open circuit.
2. **Cost:** The ratio of inactive copper to active copper is less for larger 'L' making the DC machine less costly.
3. **Cooling:** The temperature rise in the middle portion of a longer length DC machine will be high and is difficult to ventilate.

### 7.6.1 Limiting Values of Core Length (L)

As mentioned earlier, when diameter is large, core length is small. Overhang copper is more and so volume, weight and cost of copper are higher.

We know that, emf induced in a conductor,

$$e_Z = B_{av} L v_a \quad (7.6)$$

where  $B_{av}$  – Average flux density,  $V_a$  – Peripheral velocity of armature.

$$\text{Limiting value of emf in conductor} = \frac{7.5}{T_c N_c} \quad (7.7)$$

where  $T_c$  – Turns/coil,  $N_c$  – Number of coils between

$$\text{adjacent segments} = \begin{cases} 1 & \text{for simplex lap winding} \\ \frac{1}{2} & \text{for simplex wave winding} \end{cases}$$

From Eqs. (7.6) and (7.7), we get

$$B_{av}Lv_a = \frac{7.5}{T_c N_c}$$

$$\Rightarrow L = \frac{7.5}{T_c N_c B_{av} v_a} \quad (7.8)$$

Let us take simplex lap winding with single turn coil, i.e.,  
 $T_c = 1, N_c = 1$ .

From Eq. (7.6), with  $v_a = 30$  m/s and  $B_{av} = 0.75$  Wb/m<sup>2</sup>,

Emf induced in the conductor,  $e_z = 7.5$  V

Substituting the above values in Eq. (7.8), we get

Limiting value of core length,

$$L = \frac{7.5}{1 \times 1 \times 0.75 \times 30} = 0.33 \text{ m}$$

#### *7.6.2 Limiting Value of Armature Diameter (D)*

We know that, power output,

$$P = EI_a \times 10^{-3} \quad (7.9)$$

And emf,

$$E = e_z(\text{emf/conductors}) \times \frac{Z}{a} (\text{number of conductors/path})$$

Substituting the above equation in Eq. (7.9), we get

$$\begin{aligned} P &= e_z \left( \frac{z}{a} \right) I_a \times 10^{-3} \\ &= e_z \left( \frac{I_a}{a} \right) z \times 10^{-3} \\ &= e_z \pi D a c \times 10^{-3} \quad \left( \because ac = \frac{I_z z}{\pi D} \right) \end{aligned}$$

$$D = \frac{P \times 10^{-3}}{\pi a c e_z}$$

Assuming  $ac = 30,000$ ,  $e_z = 10$  V for a DC machine with power output  $P = 1000$  kW

$$\text{Limiting value of diameter, } D = \frac{1000 \times 10^{-3}}{\pi \times 30,000 \times 10} = 1 \text{ m}$$

### 7.7 Separation of $D$ and $L$

To separate  $D$  and  $L$  obtained from the output equation, a suitable relation between  $D$  and  $L$  is necessary. This is achieved by the following selection criteria.

#### 1. Pole proportions

The pole proportions be selected such that minimum copper for a given field ampere turns per pole is met. Pole body should be selected to give minimum mean turn of copper. So circular poles

can be selected, but it requires solid casting. Poles are normally laminated as shown in Fig. 7.8. Generally, square poles which give minimum peripheral length could be selected.

We know that, pole length = core length =  $L$

And pole arc = width of pole shoe =  $W_{ps}$

$$\text{Pole pitch} = \frac{\pi D}{P} = \tau$$

Generally,  $\frac{\text{pole arc}}{\text{pole pitch}} = \frac{W_{ps}}{\tau} = \frac{L}{\tau}$  (for square poles) must

be in the range of 0.55–1.1.

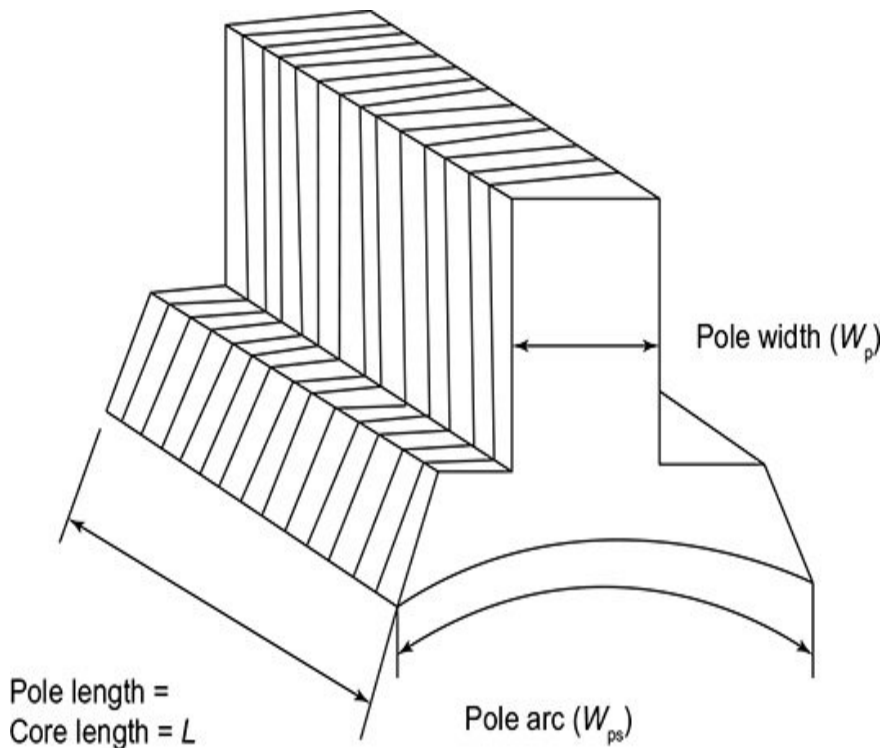

Fig. 7.8 | Laminated field pole

## 2. Ventilating ducts

If the length of core is greater than 12–14 cm, radial ventilating ducts are provided for every 7–8 cm of core length. The width of duct is 0.8–1 cm.

We know that, total core length =  $L$

And gross iron length,  $L_g = L - n_d w_d$

where  $n_d$  – number of ducts,  $w_d$  – width of ducts.

Iron length,  $L_i = k_s L_g$

where  $k_s$  – stacking factor = 0.85 to 0.9.

*Problems on Main Dimensions of DC Machine*

**Example 7.1: A 10 kW, 500 V, 4-pole, 1500 rpm DC shunt generator has the average flux density in the air gap as  $1.2 \text{ Wb/m}^2$  and the specific electric loading is 20,000 A/m. Find the main dimensions of the machine if it has to be designed with square pole face. Assume the ratio of pole arc to pole pitch as 0.6 and full load efficiency as 80%.**

**Solution:** Given

$$P = 10 \text{ kW}$$

$$\text{Voltage} = 500 \text{ V}$$

$$N = 1500 \text{ rpm}$$

$$B_{av} = 1.2 \text{ Wb/m}^2$$

$$ac = 20,000 \text{ A/m}$$

$$\eta = 0.8$$

$$\frac{L}{\tau} = 0.6$$

For a DC generator,

$$\text{Power developed by armature, } P_a = P \left[ \frac{2 + \eta}{3\eta} \right]$$

$$\Rightarrow P_a = 10 \left[ \frac{2 + 0.8}{3 \times 0.8} \right] = 11.66 \text{ kW}$$

Output coefficient,

$$C_o = \pi^2 B_{av}^2 ac \times 10^{-3}$$
$$= \pi^2 \times 1.2 \times 20,000 \times 10^{-3} = 236.8$$

$$\text{Speed in rps, } n = \frac{N}{60} = 25 \text{ rps}$$

$$\text{Volume, } D^2L = \frac{P_a}{C_o n} = \frac{11.66}{236.8 \times 25}$$

$$= 1.96 \times 10^{-3} \text{ m}^2 \quad (1)$$

For a square pole face,  $\frac{L}{\tau} = 0.6$

Substituting  $\tau = \frac{\pi D}{p}$  in the above equation, we get

$$\frac{L}{\frac{\pi D}{p}} = 0.6$$

$$\Rightarrow L = 0.6 \times \frac{\pi D}{4} = 0.471D \quad (2)$$

Substituting Eq. (2) in Eq. (1), we get

$$D^2 \times 0.471D = 1.9 \times 10^{-3}$$

$$\Rightarrow D^3 = \frac{1.96 \times 10^{-3}}{0.47} = 0.16 \text{ m}$$

Substituting the above value in Eq. (2), we get

$$L = 0.471 \times 0.16 = 0.075 \text{ m}$$

$D = 0.16 \text{ m}$
$L = 0.075 \text{ m}$

**Example 7.2:** Compute the main dimensions of a DC generators rated for 50 kW, number of poles are 4 and it runs at 600 rpm. Full load terminal voltage is 220 volts. Maximum gap flux density is  $0.83 \text{ Wb/m}^2$  and specific electric loading is 30,000 A/m. Full load armature voltage drop is 3 percent of rated terminal voltage. Field current is 1% of full load current. Ratio of pole arc to pole pitch is 0.67 with a square pole face. Find also the number of slots and conductors.

**Solution:** Given

$$P_o = 50 \text{ kW}$$

$$p = 4$$

$$N = 600 \text{ rpm}$$

$$B_g = 0.83 \text{ Wb/m}^2$$

$$ac = 30,000 \text{ A/m}$$

$$\text{Armature voltage drop} = I_a R_a = 3\% \text{ of } 220 \text{ V}$$

$$\frac{L}{\tau} = 0.67$$

$$I_f = 1\% \text{ of } I_L$$

The equivalent circuit of shunt generator is represented in Fig. 7.9.

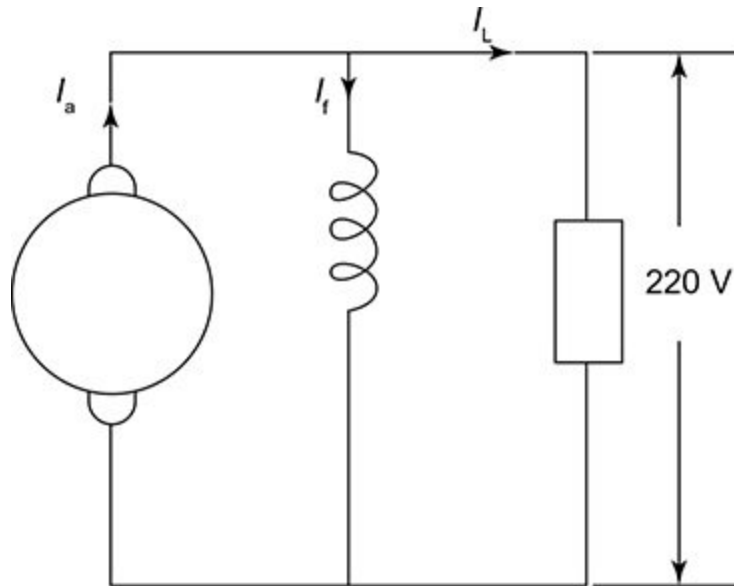

**Fig. 7.9** | Equivalent circuit of shunt generator

For a shunt generator,

$$I_a = I_f + I_L$$

$$\text{Power developed by Armature} = EI_a \times 10^{-3}$$

where

$$\text{Emf, } E = V + I_a R_a = V + \text{Armature drop}$$

$$= 220 + 0.03 \times 220 = 226.6 \text{ V}$$

$$\text{Full load current, } I_L = \frac{50 \times 10^3}{220} = 227 \text{ A}$$

$$\text{Field current, } I_f = 0.01 \times 227 = 2.27 \text{ A}$$

Therefore, armature current,  $I_a = I_L + I_f = 227 + 2.27 = 229.27 \text{ A}$

Hence, power developed by armature,

$$P_a = EI_a \times 10^{-3} = 226.6 \times 229.27 \times 10^{-3} \\ = 51.95 \text{ kW}$$

Speed in rps,  $n = \frac{600}{60} = 10 \text{ rps}$

We know that  $P_a = C_o D^2 L n$  (1)

where output coefficient,  $C_o = \pi^2 B_{av} ac \times 10^{-3}$  (2)

Average flux density,  $B_{av} = B_g \times \text{form factor} = 0.83 \times 0.7$

$$= 0.581 \text{ Wb / m}^2$$

Substituting the values of  $B_{av}$  and  $ac$  in Eq. (2), we get

$$C_o = \pi^2 \times 0.581 \times 30,000 \times 10^{-3} = 172$$

Substituting the values of  $C_o$ ,  $n$  and  $P_a$  in Eq. (1), we get

$$D^2L = \frac{P_a}{C_o n} = \frac{51.95}{172 \times 10} = 0.0302 \quad (3)$$

Given  $\frac{L}{\tau} = 0.67$

Substituting  $\tau = \frac{\pi D}{p}$  in the above equation, we get

$$\frac{L}{\frac{\pi D}{p}} = 0.67$$

$$\Rightarrow L = 0.67 \times \frac{\pi D}{4} = 0.526D \quad (4)$$

Substituting Eq. (4) in Eq. (3), we get

$$0.526D^3 = 0.0302$$

$$\Rightarrow D^3 = \frac{0.0302}{0.526}$$

$$\Rightarrow D = \sqrt[3]{\frac{0.0302}{0.526}} = 0.385 \text{ m}$$

Substituting the value of D in Eq. (4), we get

$$L = 0.526 \times D = 0.526 \times 0.385 = 0.202 \text{ m}$$

$$\begin{array}{l} D = 0.385 \text{ m} \\ L = 0.202 \text{ m} \end{array}$$

We know that

$$\text{Emf, } E = \frac{\phi p Z N}{60 A}$$

Therefore, the number of armature conductors,

$$Z = \frac{60 E A}{\phi p N} = \frac{60 \times 226.6 \times A}{\phi p \times 600} \quad (5)$$

Let us assume lap winding with  $A = p$

Therefore, Eq. (5) can be rewritten as

$$Z = \frac{60 \times 226.6}{\phi \times 600} \quad (6)$$

Also, we know that  $B_{av} = \frac{p\phi}{\pi DL}$

Therefore,  $\phi = \frac{\pi B_{av} DL}{p}$

Substituting the values of  $B_{av}$ ,  $D$ ,  $L$  and  $p$  in the above equation, we get

$$\phi = \frac{\pi \times 0.581 \times 0.385 \times 0.202}{4} = 0.035 \text{ Wb}$$

Substituting the value of  $\phi$  in Eqn. (6), we get

$$Z = \frac{60 \times 226.6}{0.035 \times 600} = 647.4 \approx 648 \text{ conductors}$$

**Example 7.3: Find suitable values of diameter and length of armature core for a 100 kW, 250 V, 750 rpm DC generator. Apply suitable checks.**

**Solution:** Given

$$P = 100 \text{ kW}$$

$$\text{Voltage} = 250 \text{ V}$$

$$N = 750 \text{ rpm}$$

Let us assume  $\eta = 0.9$ ,  $B_{av} = 0.5 \text{ Wb/m}^2$  and  $ac = 25,000 \text{ A/m}$

We know that

$$P_a = C_o D^2 L n \quad (1)$$

We know that

$$\begin{aligned} C_{20} &= \pi B_{av}^2 ac \times 10^{-3} \\ &= \pi \times 0.5 \times 25,000 \times 10^{-3} \\ &= 123.37 \end{aligned}$$

$$\begin{aligned} P_a &= P \left[ \frac{2+\eta}{3\eta} \right] = 100 \left( \frac{2+0.9}{3 \times 0.9} \right) \\ &= 107.4 \text{ kW} \end{aligned}$$

$$\text{Speed in rps, } n = \frac{750}{60} = 12.5 \text{ rps}$$

Substituting  $C_o$ ,  $P_a$  and  $n$  in Eq. (1), we get

$$\begin{aligned} 107.4 &= 123.37 \times D^2 L \times 12.5 \\ \Rightarrow D^2 L &= \frac{107.4}{1542.125} = 0.0696 \end{aligned} \quad (2)$$

To separate  $D$  and  $L$ , it is necessary to find the number of poles

1. The frequency is to be within 25–50 Hz.

$$\text{For } p = 4, f = \frac{pn}{2} = 25 \text{ Hz}$$

$$p = 6, f = 37.5 \text{ Hz}$$

For  $p = 6$ , frequency is neither low nor high. So let us choose  $p = 6$ .

2. The current per brush arm must be within 200 A.

$$\text{Armature current, } I_a = \frac{P}{V} = \frac{100 \times 10^3}{250} = 400 \text{ A}$$

$$\text{For } p = 4 \text{ current/brush arm} = \frac{2 \times 400}{4} = 200 \text{ A}$$

$$\text{For } p = 6 \text{ current/brush arm} = \frac{2 \times 400}{6} = 133.33 \text{ A}$$

Let us choose  $p = 6$ . Though  $p = 4$  can also be chosen, since the current/arm is near the limit, let us choose  $p = 6$ .

$$\text{Let } \frac{L}{\tau} = 0.67$$

Substituting  $\tau = \frac{\pi D}{p}$  in the above equation, we get

$$\frac{L}{\frac{\pi D}{p}} = 0.67$$

$$\Rightarrow L = \frac{0.67 \times \pi \times D}{6} = 0.3508D \quad (3)$$

Substituting Eq. (3) in Eq. (2), we get

$$0.52D^3 = 0.0696$$

$$\Rightarrow D = \sqrt[3]{\frac{0.0696}{0.3508}} = 0.58323 \text{ m}$$

$$\boxed{\begin{array}{l} D = 0.58323 \text{ m} \\ L = 0.2046 \text{ m} \end{array}}$$

Peripheral speed,  $v_a = \pi D n = \pi \times 0.58323 \times 12.5 = 23$  m/s

This is well within the permissible limit of 30 m/s.  
Hence, the value of  $D$  &  $L$  determined are correct.

**Example 7.4: The diameter and length of a 1200 kW, 500 volts, 300 rpm, DC machine is 1.45 m and 0.35 m, respectively. Calculate the mean emf per conductor, total flux and the number of conductors connected in series. Armature drop is 6.5 volts at full load and maximum flux density in the air gap is  $1.01 \text{ Wb/m}^2$ .**

**Solution:** Given

$$P = 1200 \text{ kW}$$

$$\text{Voltage} = 500 \text{ V}$$

$$N = 300 \text{ rpm}$$

$$D = 1.45 \text{ m}$$

$$L = 0.36 \text{ m}$$

$$I_a R_a = 6.5 \text{ volts}$$

$$B_g = 1.01 \text{ Wb/m}^2$$

We know that

$$B_{av} = B_g \times \text{form factor} = 1.01 \times 0.7 \\ = 0.707 \text{ Wb/m}^2$$

$$\text{Speed in rps, } n = \frac{300}{60} = 5 \text{ rps}$$

$$\begin{aligned} \text{Mean emf/conductor} &= B_{av} L v_a = B_{av} L \pi D n \quad [ \because v_a = \pi D n ] \\ &= 0.707 \times 0.36 \times \pi \times 1.45 \times 5 = 5.79 \text{ V} \\ \text{Total flux} &= B_{av} \pi D L = 0.707 \times \pi \times 1.45 \times 0.36 = 1.15 \text{ Wb} \end{aligned}$$

Induced emf on full load,

$$E = V + I_a R_a = 500 + 6.5 = 506.5 \text{ V}$$

$$\begin{aligned} \text{Number of conductors in series} &= \frac{\text{Induced emf on load}}{\text{Emf induced/conductor}} \\ &= \frac{506.5}{5.79} = 88 \end{aligned}$$

**Example 7.5: A 500 kW, 375 rpm DC generator has  $B_{av} = 0.6 \text{ Wb/m}^2$  and specific**

electric loading is 35,000 ampere conductors per metre. The ratio of pole arc to pole pitch is 0.66. Armature is lap connected. Find the main dimensions of the machine if the maximum value of voltage between adjacent commutator segments is not to exceed 30 V and the peripheral speed is not to exceed 30 m/s. Assume the maximum value of gap flux density at full load is 13 times that of no load and full load efficiency = 0.91.

**Solution:** Given

$$P = 500 \text{ kW}$$

$$N = 375 \text{ rpm}$$

$$B_{av} = 0.6 \text{ Wb/m}^2$$

$$\frac{L}{\tau} = 0.66$$

$$\eta = 0.91$$

Neglecting rotational losses,

$$P_a = \frac{P}{\eta} = \frac{500}{0.91} = 550 \text{ kW}$$

We know that

$$\text{Speed in rps} = \frac{375}{60} = 6.25 \text{ rps}$$

$$\begin{aligned} \text{Output coefficient, } C_o &= \pi^2 B_{av} ac \times 10^{-3} \\ &= \pi^2 \times 0.6 \times 35,000 \times 10^{-3} = 207.5 \end{aligned}$$

$$\text{Also, } D^2 L = \frac{P_a}{C_o n} = \frac{550}{207.5 \times 6.25} = 0.423 \quad (1)$$

To separate  $D$  and  $L$ , a relation between  $D$  &  $L$  is required.

$$\text{We know that } \frac{L}{\tau} = 0.66$$

Substituting  $\tau = \frac{\pi D}{p}$  in the above equation, we get

$$\frac{L}{\frac{\pi D}{p}} = 0.66$$

$$\Rightarrow L = \frac{0.66 \pi D}{p} \quad (2)$$

To choose  $p$ ,  $f$  must be between 25 and 50 Hz.

$$\text{For } p = 4, f = \frac{pn}{2} = 12.5 \text{ Hz}$$

$$p = 6, f = 18.5 \text{ Hz}$$

$$p = 8, f = 25 \text{ Hz}$$

$$p = 10, f = 31.25 \text{ Hz}$$

$$p = 12, f = 37.5 \text{ Hz}$$

Let us choose  $p = 12, f = 37.5 \text{ Hz}$

Therefore, on substituting the value of  $p$  in Eq. (2), we get

$$L = 0.67 \frac{\pi D}{12} = 0.175 D \quad (3)$$

Substituting Eq. (3) in Eq. (2), we get

$$0.175D^3 = 0.423$$

$$D = \sqrt[3]{\frac{0.423}{0.175}} = 1.342 \text{ m}$$

Substituting the value of  $D$  in Eq. (3), we get

$$L = 0.234 \text{ m}$$

### **Check**

Peripheral velocity must be within 30 m/s.

Peripheral velocity,  $v_a = \pi D n = \pi \times 1.342 \times 6.25 = 26 \text{ m/s}$

This is well within limits.

$$\text{Maximum flux density on no load} = \frac{B_{av}}{\psi} = \frac{0.6}{0.66} = 0.9 \text{ Wb/m}^2 \quad [ \because \psi = \frac{L}{\tau} ]$$

Maximum flux density on load,  $B_m = 13 \times 0.9 = 1.17$   
 $\text{Wb/m}^2$

Maximum voltage between adjacent commutator segments at full load

$$= 2B_m L v_a$$

$$= 2 \times 1.17 \times 0.234 \times 26 = 14.2 \text{ V}$$

This is also well within limits. Hence, the value of  $D \& L$  determined is correct.

## 7.8 Estimation of Length of Air Gap

The estimation of air gap is discussed in the following section.

### 7.8.1 Factors Affecting Air Gap Length

The length of air gap is influenced by the following factors.

#### **Armature mmf**

When the armature ampere turns per pole is greater than the field mmf, there will be trouble due to field distortion as the armature reaction effect will be more. So, field mmf must be made larger than the armature mmf. For higher field mmf, the length of air gap has to be large to consume the same.

### **Unbalanced magnetic pull**

In machines without interpoles, the air gap has to be large to prevent distortion of field. But in machines with commutating poles, there is no demagnetizing effect of armature reaction, the length of air gap can be reduced to 30–50%.

### **Cooling**

Ventilation is better in machines having larger air gap.

#### *7.8.2 Estimation of $l_g$*

The following two methods are adopted to estimate the length of air gap.

#### **Method 1**

The air gap length,  $l_g$ , may be estimated by the following empirical formula:

For machines with  $p \leq 8$ , air gap length,

$$l_g = (0.04 \text{ to } 0.047) \frac{D}{p}$$

For machines with  $p > 8$ , air gap length,

$$l_g = (0.048 \text{ to } 0.053) \frac{D}{p}$$

where  $p$  – number of poles,  $D$  – diameter of machine.

## Method 2

The length of air gap can also be estimated from air gap mmf by the following procedure.

$$\text{Armature mmf, } AT_a = \frac{ac \pi D}{2 p} = \frac{ac}{2} \tau$$

$$\text{Air gap mmf, } AT_g = 0.5 \text{ to } 0.7 AT_a = 800,000 B_g k_g k_{gd}$$

(The value of 0.5 or 0.7 is made based on the choice of salient pole machine with slots and ducts on one side and/or salient poles on the other side)

$$\Rightarrow l_g = \frac{(0.5 \text{ to } 0.7) AT_a ac \pi D}{2p \times 800,000 B_g k_g k_{gd}} = \frac{(0.5 \text{ to } 0.7) AT_a ac \tau p}{2 \times 800000 B_g k_g k_{gd}} \left[ \because \tau = \frac{\pi D}{p} \right]$$

where  $k_g, k_{gd}$  – Carter's gap and duct coefficients.

## 7.9 Design of Armature

The design of armature involves the determination of the parameters as shown in Fig. 7.10.

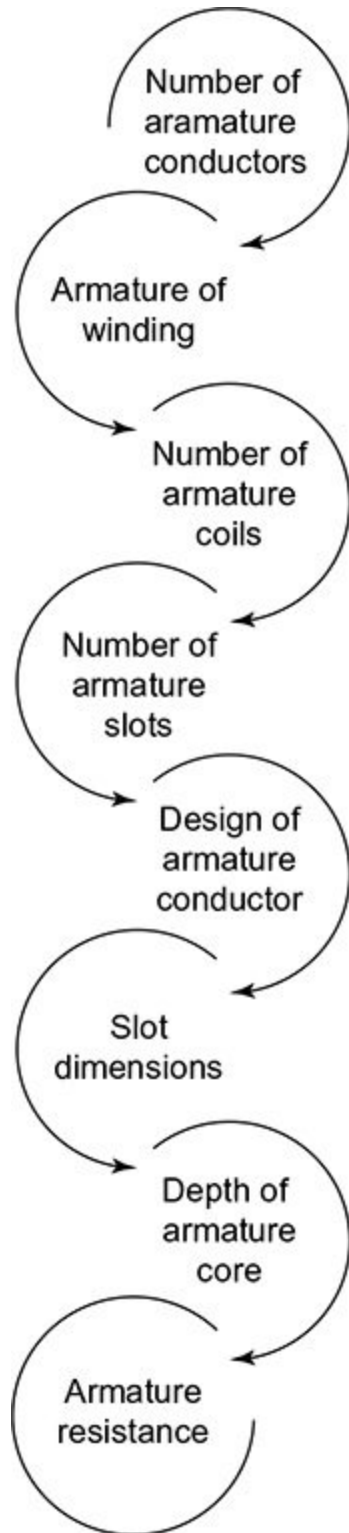

**Fig. 7.10** | Steps for design of armature

## 1. Number of armature conductors

The number of armature conductors is estimated by the following two methods.

### Method 1

We know that

Mean emf induced in a conductor,  $e_z = B_{av} L v_a$

where  $v_a = \pi DN$  is the peripheral speed.

The generated emf in armature  $E = V + I_a R_a$  (for generators)

And  $E = V - I_a R_a$  (for motors)

where  $V$  is the terminal voltage and  $I_a R_a$  is the armature voltage drop.

Assume  $I_a R_a = 2$  to  $2.5\%$  of  $V$  for machines with  $500$  V rating and more and

$I_a R_a = 5$  to  $10\%$  of  $V$  for small machines with  $250$  V rating.

Number of conductors in series,  $Z_c = \frac{E}{e_z}$

For simplex lap winding, since the number of paths = number of poles,  $Z_c$  represents the total number of

armature conductors/pole.

For simplex wave winding,  $Z_c$  represents half the total number of conductors on the armature as number of poles = 2

## Method 2

We know that,

$$\text{Emf, } E = \frac{\phi p Z N}{60 A} = \frac{\phi p Z n}{a} \quad \left[ \because \frac{N}{60} = n \right]$$

$$\Rightarrow \text{Number of armature conductors, } Z = \frac{E a}{\phi p n}$$

Also, we know that

$$\text{specific electric loading, } ac = \frac{I_z Z}{\pi D}$$

$$\Rightarrow \text{Number of armature conductors, } Z = \frac{ac \pi D}{I_z}$$

$$\text{From slot capacity, } Z_s = \frac{Z}{S}$$

⇒ Number of armature conductors,  $Z = Z_s S$

where  $S$  – number of armature slots.

## 2. Armature winding

- Simplex lap winding is used for machines with current rating greater

than 400 A as current in each path =  $\frac{I}{p}$  of full load current.

- Simplex wave winding is used for machines with current rating less than about 400 A. Here, check has to be made to find whether the voltage between adjacent commutator segments is within 30 V. If multiplex windings are used, equalizer rings are necessary, making machine costlier.

## 3. Number of armature coils

Total number of conductors,  $Z = p \times Z_c$  for simplex lap winding

$Z = 2 \times Z_c$  for simplex wave winding

$$\text{Number of armature coils} = \begin{cases} \frac{Z}{2} & \text{for single turn coil} \\ \frac{Z}{2T_c} & \text{for multi-turn coil} \end{cases}$$

where  $T_c$  is the number of turns in one coil.

Number of commutator segments = number of coils

Voltage induced between adjacent commutator segments at no load,

$$\begin{aligned}
 E_c &= \text{volt induced/conductor} \times \text{number of conductors between adjacent} \\
 &\quad \text{commutator segments} \\
 &= e_z \times 2 \times \text{Number of turns between adjacent commutator segments} \\
 &= e_z \times 2 \times \text{Number of turns/coil} \times \text{number of coils between segments on no} \\
 &\quad \text{load}
 \end{aligned}$$

$$\Rightarrow E_c = 2e_z T_c N_c$$

Substituting  $e_z = B_{av} L v_a$  in the above equation, we get

$$E_c = 2B_{av} L v_a T_c N_c$$

Maximum voltage induced between adjacent commutator segments on no load,

$$E_{c_{mo}} = 2B_g L v_a T_c N_c \quad [\because B_{av} = B_g \text{ on no load}]$$

Maximum voltage induced between adjacent commutator segments on load,

$$\begin{aligned}
 E_{c_{ml}} &= 2 \times 1.3 B_g L v_a T_c N_c \\
 &\quad [\because B_g \text{ on load} = 1.3 \text{ times } B_g \text{ on no load}]
 \end{aligned}$$

$$\Rightarrow E_{\text{cml}} = 2.6B_g L v_a T_c N_c \quad \left[ \because B_g = \frac{B_{\text{av}}}{\psi} \right]$$

Substituting  $\psi = 0.68$  in the above equation, we get

$$\Rightarrow E_{\text{cml}} = 4B_{\text{av}} L v_a T_c N_c$$

Substituting  $v_a = \pi D n$  in the above equation, we get

$$E_{\text{cml}} = 4B_{\text{av}} L \pi D n T_c N_c$$

Substituting  $B_{\text{av}} = \frac{p\phi}{\pi DL}$  in the above equation, we get

$$\begin{aligned} E_{\text{cml}} &= 4 \frac{p\phi}{\pi DL} L \pi D n T_c N_c \\ &= 4p\phi n T_c N_c \\ &= 4p \frac{Ea}{Zpn} n T_c N_c \quad \left( \because E = \frac{\phi p Z n}{a} \Rightarrow \phi = \frac{Ea}{Zpn} \right) \\ &= 4 \frac{Ea}{Z} T_c N_c \\ E_{\text{cml}} &= 4 \frac{Ea}{2CT_c} T_c N_c \end{aligned}$$

$$\left[ \because \text{Number of turns/coil, } T_c = \frac{Z}{2 \times \text{number of coils (C)}} \Rightarrow Z = 2CT_c \right]$$

$$\Rightarrow E_{\text{cml}} = \frac{2Ea}{C} N_c$$

And minimum number of armature coils,

$$C_{\text{min}} = \frac{2EaN_c}{E_{\text{cml}}}$$

For lap winding,

We know that  $a = p$ . Choosing  $N_c = 1$  and  $E_{\text{cml}} = 30 \text{ V}$

Minimum number of coils,

$$\begin{aligned} C_{\text{min}} &= \frac{2EaN_c}{E_{\text{cml}}} \\ &= \frac{2 \times E \times p \times 1}{30} = \frac{Ep}{15} \end{aligned}$$

For wave winding,

We know that  $a = 2$ . Choosing  $N_c = p/2$  and  $E_{\text{cml}} = 30 \text{ V}$

Minimum number of coils,

$$\begin{aligned}
C_{\min} &= \frac{2EaN_c}{E_{\text{cml}}} \\
&= \frac{2 \times E \times 2 \times p / 2}{30} \\
&= \frac{Ep}{15}
\end{aligned}$$

Hence, the minimum number of coils remains the same irrespective of whether the machine is lap wound or wave wound.

We know that

$$\begin{aligned}
E_{\text{cml}} &= 4B_{\text{av}}Lv_a T_c N_c \\
E_{\text{cml}} &= 4e_z T_c N_c \quad [ \because e_z = B_{\text{av}}Lv_a ]
\end{aligned}$$

Substituting  $E_{\text{cml}} = 30$  V in the above equation, we get

$$\begin{aligned}
30 &= 4e_z T_c N_c \\
e_z &= \frac{30}{4T_c N_c} = \frac{7.5}{T_c N_c}
\end{aligned}$$

#### 4. Number of armature slots

The factors affecting the choice of number of armature slots are shown in [Fig. 7.11](#).

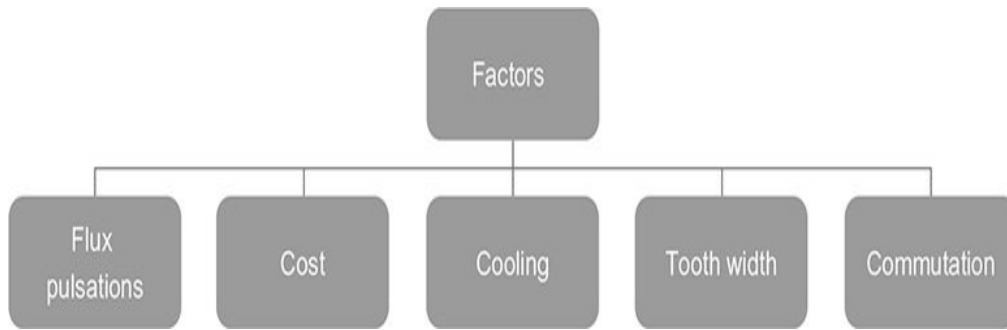

**Fig. 7.11** | Factors affecting the choice of number of armature slots

## Flux pulsations

Flux pulsations give rise to eddy current losses in pole shoes and produce magnetic noise. These pulsations are produced due to change in air gap flux because of change in air gap reluctance due to slots, pole faces, etc.

To avoid flux pulsations, the following selections are to be made.

- Number of slots per pole = integer +  $\frac{1}{2}$
- Number of slots per pole per pole shoe = integer +  $\frac{1}{2}$

In actual design, it may not be possible to fulfill both the above conditions. So in such cases, the number of slots per pole should be an integer with slots/pole equal to

integer +  $\frac{1}{2}$ .

## **Cost**

The cost of punching the slots, cost of slot insulation increases with the increase in number of slots.

## **Cooling**

For larger number of slots, number of conductors/slot will be lesser and hence better ventilation is provided.

## **Tooth width**

The slot pitch reduces with larger number of slots. The tooth width will also be lesser. The flux density at the minimum section of tooth increases increasing the iron loss. Also, it is difficult to support the teeth at the ventilating ducts without obstructing the ventilation.

The choice of slot pitch,  $\tau_s = \frac{\pi D}{s}$ , should be in the

range of 2 and 4 cm.

## **Commutation**

Large number of slots and smaller number of conductors per slot are better from commutation point of view.

For better commutation, number of slots per pole should be chosen in the range of 9 and 16.

The overall guideline for selection of number of armature slots is given in Table 7.3.

**Table. 7.3** | Overall guideline for selection of number of armature slots

S. No.	Parameter	Guiding value
1.	Slot pitch, $\frac{\pi D}{s}$	2 to 4 cm
2.	Slot loading $I_z Z_s$ ( $Z_s$ - number of conductors per slot)	$\leq 1500$
3.	For good commutation: slots/pole	9 to 16
4.	To reduce flux pulsations: slots/pole	Integer + $\frac{1}{2}$
5.	Slots/pole arc	Integer
6.	Number of conductors/slot, $Z_s = \frac{Z}{S}$	Even number
7.	Number of turns/coil = $\frac{\text{Number of conductors/slot}}{\text{Number of coil sides per slot}}$	Even integer
8.	For lap winding, number of slots, $S$	Multiple of pole pair
9.	For wave winding, number of slots, $S$	Should not be a multiple of pole pair
10.	Current density	4.5 to 7 A/mm <sup>2</sup>
11.	Pitch of commutator segment	4 to 9 mm

## 5. Dimensions of armature conductor

$$\text{Armature current, } I_a = \frac{P_a \times 10^3}{E}$$

$$I_a = I_L + I_f \text{ for generators}$$

$$I_a = I_L - I_f \text{ for motors}$$

$$\text{Conductor current, } I_z = \frac{I_a}{a}$$

Area of cross-section of conductor,

$$A_a = \frac{I_z}{\delta_z} \text{ (} \delta_z \text{ is the current density)}$$

The values of current density are given in Table.7.4.

**Table. 7.4** | Current density

S. No.	Machine	Current density, $\delta_z$ (A/mm <sup>2</sup> )
1.	Large machines with very good ventilation	45
2.	Large machine with normal ventilation	5
3.	Fairly high-speed fan ventilated machine	6 to 7

Enamel-coated round wires of cross-section up to 10 mm<sup>2</sup> are used for small machines. Rectangular or square conductors are used with cotton or enamel covering for cross-section above 10 mm<sup>2</sup>. The cross-sectional area is limited to 50 mm<sup>2</sup>, because of eddy loss in conductors. If it exceeds 50 mm<sup>2</sup>, laminated conductors (or) stranded conductors are to be used. When the frequency is less

than 25 Hz, the depth of single conductor is limited to 19 mm.

## 6. Slot dimensions

Cross-section of slot represented in Fig. 7.12 is given by

$$A_s = w_s \times d_s$$

where  $w_s$  and  $d_s$  are the width and depth of slot, respectively.

The slot dimensions should be so chosen that the required number of conductors can be accommodated with sufficient insulation.

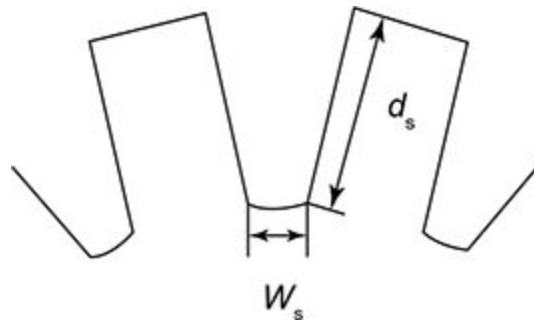

**Fig. 7.12** | Armature slot

## 7. Depth of armature core

The armature core is represented in Fig. 7.13.

$$\text{Flux in the armature core} = \frac{\text{flux/pole}}{2}$$

Flux density in armature core,

$$B_c = \frac{\phi/2}{\text{area of armature core}} = \frac{\phi/2}{d_c L_i}$$

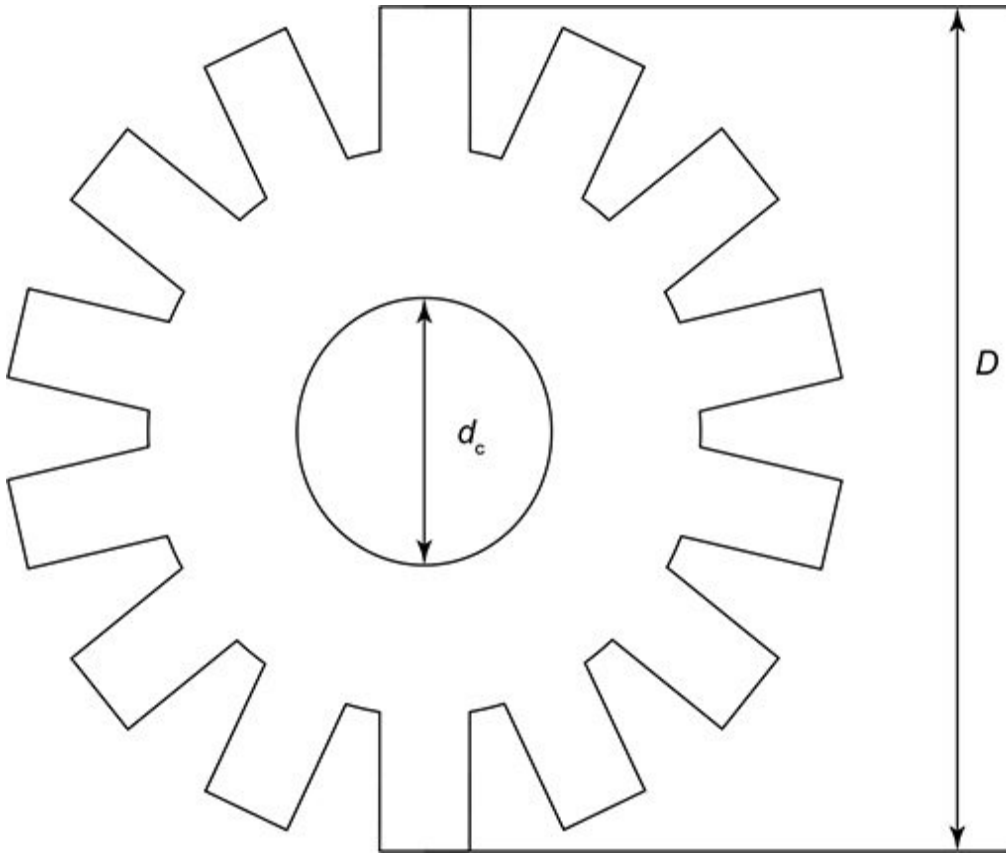

**Fig. 7.13** | Armature core

where  $d_c$  – depth of armature core,  $L_i$  – core length.

Flux density in armature core can vary between 1 and 1.4  $\text{Wb/m}^2$ .

Assuming suitable value of  $B_c$ ,  $d_c$  can be determined.

Inner diameter of armature core,

$$D_i = D - 2(d_s + d_c)$$

where  $d_s$  – depth of slot,  $D$  – armature diameter.

## 8. Determination of armature resistance

We know that

Length of mean turn of armature winding (in m),

$$L_{mt} = 2L + 2.3\tau_p + 5d_s$$

where  $L_i$  – core length,  $\tau_p$  – slot pitch,  $d_s$  – depth of slot.

$$\text{Resistance of each conductor} = \frac{1}{2} \frac{\rho L_{mt}}{A_a}$$

where  $A_a$  – area of armature core.

$$\text{Resistance of each parallel path} = \frac{1}{2} \frac{Z}{a} \frac{\rho L_{mt}}{A_a}$$

$$\text{Total resistance of armature winding} = \frac{1}{a} \left( \frac{1}{2} \frac{Z}{a} \frac{\rho L_{mt}}{A_a} \right)$$

### 7.10 Design of Commutator and Brushes

The segments of commutators are made of hard drawn copper and are separated from each other by thin strips of mica or micanite. The diameter of commutator is between 0.6 and 0.8 times that of armature diameter

with the peripheral speed of about 15 m/s. The distance between the brush spindles may be taken as 25–30 cm for a 500 V machine. The number of commutator segments is equal to the number of coils. The length of commutator is decided by the space required for brushes, number of brushes per arm, area required to dissipate heat generated by commutator losses.

Total number of commutator segments = number of coils

$$= C = \frac{1}{2} uS$$

where  $u$  – number of coil sides/slot,  $S$  – number of slots.

The minimum number of segments to give a voltage of 15 V between segments at no load,

$$C_{\min} = \frac{Ep}{15}$$

where  $E$  – emf induced in armature,  $p$  – number of poles.

Length of commutator (in mm),

$$L_c = n_b(w_b + c_b) + c$$

where  $n_b$  – number of brushes,  $w_b$  – width of brush,  $c_b$  – clearance between brushes, chosen in the range of 3–5 mm,  $c$  – clearance for staggering the brushes and clearance at ends, chosen in the range of 15–40 mm.

### 7.10.1 Brush Dimensions

The number of brush arms in a machine is equal to the number of poles. There may be more than one brush in a brush arm, as decided by the maximum current. The collection of brushes in one arm is called brush spindle and they have same polarity.

Current carried by each brush arm,  $I_b = \frac{2I_a}{p}$

Current density in brush,  $\delta_b = 6 \text{ to } 15 \text{ A/cm}^2$

Total brush contact area per arm,  $A_b = \frac{2I_a}{p\delta_b}$

where  $w_b$ ,  $t_b$  are the width and thickness of brush. The brush thickness should not cover more than 2 to 3 commutator segments as shown in [Fig. 7.14](#). Otherwise, number of coils undergoing commutation will be excessive.

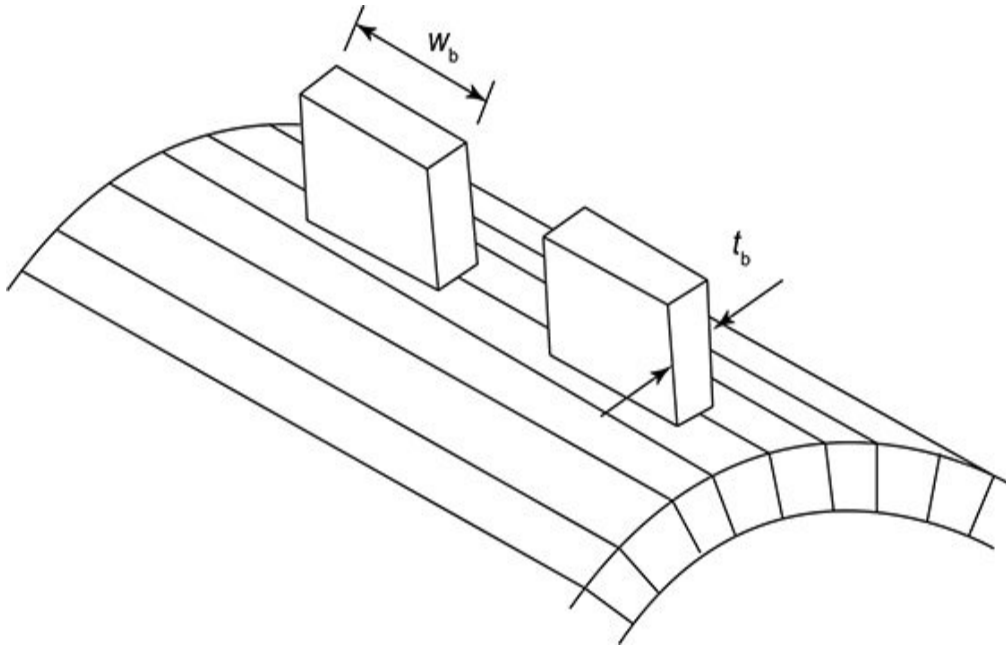

**Fig. 7.14** | Brush arrangement over commutator

### 7.10.2 Commutator Losses and Temperature Rise

The losses in commutator are due to brush friction loss and brush contact loss.

Brush friction loss,  $P_{bf} = \mu P_b A_b v_c \times 981 \times 10^{-5}$

where  $\mu$  – coefficient of friction, ranges from 0.12 to 0.3,  
 $P_b$  – brush pressure on commutator, ranges from 100 to 150 g/cm<sup>2</sup>,  
 $A_b$  – contact area of all brushes cm<sup>2</sup>,  $v_c$  – peripheral speed of commutator in m/s =  $\pi D_c n$ .

Brush contact loss,  $P_{bc} = \text{voltage drop per brush set} \times \text{armature current}$   
 $= V_b I_a$

$$\text{Temperature rise} = \frac{120 \times \text{loss in W/cm}^2}{1 + 0.1 v_c}$$

This should be below 40–50°C.

Problems on Armature Design of DC Machine with  
Commutator

**Example 7.6: A 300 kW, 500 V, 500 rpm, 6-pole DC generator has average flux density over pole as 0.67 Wb/m<sup>2</sup> and specific electric loading as 25,000 A/m. The ratio of core length to pole pitch is 0.75. Estimate suitable dimensions of core diameter, length, number of armature conductors, number of slots and number of commutator segments.**

**Solution:** Given

$$P_a = 300 \text{ kW}$$

$$\text{Voltage} = 500 \text{ V}$$

$$p = 6$$

$$B_{av} = 0.67 \text{ Wb/m}^2$$

$$ac = 25000 \text{ A/m}$$

$$N = 500 \text{ rpm}$$

$$\frac{L}{\tau} = 0.75$$

### Main dimensions

$$\text{Speed in rps, } n = \frac{500}{60} = 8.33 \text{ rps}$$

$$P_a = \pi^2 B_{av} ac \times 10^{-3} D^2 Ln$$

Substituting the values of  $P_a$ ,  $B_{av}$ ,  $ac$  and  $n$  in the above equation, we get

$$\begin{aligned} 300 &= \pi^2 \times 0.67 \times 25,000 \times 10^{-3} D^2 L \times 8.33 \\ \Rightarrow D^2 L &= \frac{300}{\pi^2 \times 0.67 \times 25000 \times 10^{-3} \times 8.33} \\ &= \frac{300}{1377.08} = 0.217 \end{aligned} \quad (1)$$

$$\text{Given } \frac{L}{\tau} = 0.75$$

Substituting  $\tau = \frac{\pi D}{p}$  in the above equation, we get

$$\frac{L}{\frac{\pi D}{P}} = 0.75$$

$$\Rightarrow L = \frac{0.75 \times \pi \times D}{6} = 0.392D \quad (2)$$

Substituting Eq. (2) in Eq. (1), we get

$$0.392D^3 = 0.217$$
$$D^3 = \frac{0.217}{0.392}$$

$$\Rightarrow D = \sqrt[3]{\frac{0.217}{0.392}} = 0.821 \text{ m}$$

Substituting the value of  $D$  in Eq. (2), we get

$$L = 0.321 \text{ m}$$

## Check

Checking for peripheral velocity

$$v_a = \pi D n = \pi \times 0.821 \times 8.33$$
$$= 21.48 \text{ m/s}$$

This is well within the permissible limit of 30 m/s.

## Armature winding

$$\text{Armature current, } I_a = \frac{P_a}{V} = \frac{300 \times 10^3}{500} = 600 \text{ A}$$

$$\text{With wave winding, current per parallel path} = \frac{600}{2} =$$

300 A. This exceeds the limit of 200 A/path. Therefore, simplex wave winding cannot be used for this machine.

$$\text{With lap winding, current per path, } I_z = \frac{600}{p} = \frac{600}{6} = 100$$

A. This is well within the limit of 200 A/path. So, a simplex lap winding can be used for the machine.

### **Armature conductors**

Average emf induced per conductor,

$$\begin{aligned} e_z &= B_{av} L v_a \\ &= 0.67 \times 0.321 \times 21.48 = 4.61 \text{ V} \end{aligned}$$

Number of conductors per path,

$$Z_c = \frac{500}{4.61} = 108.45$$

Taking  $Z_c$  to be 110

$$\text{Total number of conductors, } Z = Z_c \times a = 110 \times 6 = 660$$

$Z = 600$  is fixed temporarily

## Number of slots

1. Slot pitch,  $\frac{\pi D}{S}$  will vary from 2.5 to 3.5 cm

So, number of slots,  $S = \frac{\pi D}{(\text{Slot pitch}) Y_s}$  will vary from  $\frac{\pi D}{0.025}$

to  $\frac{\pi D}{0.035}$

i.e.,  $S$  will vary from 66 to 92.

2. For better commutation,  $\frac{S}{p}$  will vary from 9 to 16.

So, number of slots =  $p \times 9$  to  $p \times 16$

For  $p = 6$ , number of slots = 54 to 96

Hence, slots could be taken in the range of 66 to 92.

3. For lap winding, the number of slots should be a multiple of pole pair (3 in this case). Hence, the number of slots,  $S$ , can be 66, 69, 72, 75, 78, 81, 84, 87 and 90.

4. To reduce flux pulsations, number of slots/pole = integer +  $\frac{1}{2}$

So, we can have slots as follows.

<b>S</b>	$\frac{S}{p}$	<b>Integer + <math>\frac{1}{2}</math></b>
66	11	✗
69	11.5	✓
72	12	✗
75	12.5	✓
78	13	✗
81	13.5	✓
84	14	✗
87	14.5	✓
90	15	✗

So, the slots of 69, 75, 81 and 87 can be chosen.

Also, number of slots/pole shoe = increase +  $\frac{1}{2}$  or integer. But, both

the conditions cannot be satisfied.

<b>S</b>	$\frac{S}{\text{Pole shoe}} = \frac{S}{p} \times \frac{L}{\tau}$
69	8.625
75	9.375
81	10.125
87	10.875

Let us choose 81, where slots/pole shoe is nearly an integer, i.e.,  $S = 81$ .

- Number of conductors per slot should be an even integer.

So, number of conductors/slot,  $Z_s = \frac{660}{81} = 8.1$

Let us take this to the nearest integer, i.e.,  $Z_s \approx 8$

So,  $Z_{\text{revised}} = 8 \times 9 = 648$

6. Slot loading  $I_z Z_s$  should be within 1500 A.

$$I_z Z_s = (100)(8) = 800 \text{ A}$$

This is within the limit of 1500 A.

7. Pitch of commutator segment

Number of commutator segments = number of coils

$$= \frac{648}{2} = 324$$

Assuming commutator diameter =  $0.7D = 0.7 \times 0.821 = 0.5747 \text{ m}$

Pitch of commutator segment

$$\begin{aligned} &= \frac{\pi \times \text{commutator diameter}}{\text{Number of commutator segments}} \\ &= \frac{\pi \times 0.5747}{324} \\ &= 5.5 \text{ mm} \end{aligned}$$

This is well within the limit of 4 to 9 mm.

**Example 7.7: Determine the main dimensions and number of armature conductors winding type and slots of a 50 kW, 115 V, 1000 rpm, 4-pole DC shunt generator. The ratio of pole arc to pole pitch is 0.7 and the ratio of arm length to pole arc is 1.1. The field current is 10 A and the voltage drop in the armature circuit is 4 V. Assume specific loadings as  $0.5 \text{ Wb/m}^2$  and  $26,000 \text{ A/m}$ .**

**Solution:** Given

Power,  $P = 50 \text{ kW}$

Voltage = 115 V

$p = 4$

$B_{av} = 0.5 \text{ Wb/m}^2$

$ac = 26,000 \text{ A/m}$

$$\frac{L}{\text{pole arc}} = 1.1$$

$$\frac{\text{pole arc}}{\tau} = 0.7$$

$N = 1000 \text{ rpm}$

$I_f = 10 \text{ A}$

$I_a R_a = 4 \text{ V}$

$$\text{Load current, } I_L = \frac{P}{V} = \frac{50 \times 10^3}{115} = 434 \text{ A}$$

Armature current of shunt generator,

$$I_a = I_L + I_f = 434 + 10 = 444 \text{ A}$$

$$\text{Induced emf, } E = V + I_a R_a = 115 + 4 = 119 \text{ V}$$

$$\text{Power developed in armature, } P_a = EI_a \times 10^{-3} = (119)(444) \times 10^{-3} = 52.83 \text{ kW}$$

$$\text{Speed in rps, } n = \frac{N}{60} = \frac{1000}{60} = 16.66 \text{ rps}$$

We know that

$$P_a = \pi^2 B_{av}^2 ac \times 10^{-3} D^2 Ln$$

Hence,

$$\begin{aligned} D^2 L &= \frac{P_a}{\pi^2 B_{av}^2 ac \times 10^{-3} \times n} \\ &= \frac{52.83}{\pi^2 \times 0.5 \times 26,000 \times 10^{-3} \times 16.66} = 0.0247 \end{aligned} \quad (1)$$

$$\text{Also, } L = 1.1 \text{ pole arc} \quad (2)$$

$$\text{And } \text{pole arc} = 0.7\tau \quad (3)$$

Substituting Eq. (3) in Eq. (2), we get

$$L = (0.1)(0.7\tau) = 0.77\tau$$

Substituting  $\tau = \frac{\pi D}{p}$  in the above equation, we get

$$L = 0.77 \frac{\pi D}{p} = \frac{0.77 \times \pi \times D}{4} = 0.604D \quad (4)$$

Substituting Eq. (4) in Eq. (1), we get

$$0.604D^3 = 0.0247$$

$$\Rightarrow D^3 = \frac{0.0247}{0.604} = 0.0409$$

$$\Rightarrow D = \sqrt[3]{0.0409} = 0.344 \text{ m}$$

Substituting value of D in Eq. (4), we get

$$L = 0.208 \text{ m}$$

## **Winding**

Armature current,  $I_a = 444 \text{ A}$

For wave winding, current/path =  $\frac{444}{2} = 222 \text{ A}$

This is greater than the limiting value of 200 A. So wave winding cannot be chosen.

$$\text{For lap winding, current/path} = \frac{444}{4} = 111 \text{ A}$$

This is within the limit of 200 A.

So lap winding is chosen.

### **Armature conductors**

Since average emf is known, let us consider total armature conductors from emf equation.

$$\text{Emf, } E = \frac{\phi p Z N}{60 a} = \frac{\phi p Z n}{a}$$

$$\Rightarrow Z = \frac{E a}{\phi p n} = \frac{119 \times 4}{\phi \times 4 \times 16.66} \quad (5)$$

To find  $\phi$ , let us use  $B_{av}$ ,

$$\text{We know that } B_{av} = \frac{p \phi}{\pi D L}$$

$$\Rightarrow \phi = \frac{B_{av} \pi D L}{p}$$

Substituting the values of  $B_{av}$ ,  $D$ ,  $L$  and  $p$  in the above equation, we get

$$\phi = \frac{0.5 \times \pi \times 0.344 \times 0.208}{4}$$

$$\phi = 0.028 \text{ Wb}$$

Substituting the value of  $\phi$  in Eq. (5), we get

$$Z = \frac{119 \times 4}{0.0284 \times 4 \times 16.66} = 255$$

### Number of armature slots

1. The slot pitch must be in the range of 2.5 to 3.5 cm.  
So, the number of armature slots must be between

$$S = \frac{\pi D}{(\text{Slot pitch})Y_s}$$

$$= \frac{\pi \times .344}{0.025} \text{ to } \frac{\pi \times .344}{0.035}$$

i.e.,  $S = 43$  to  $30$

2. For lap winding,  $S/p$  must be multiple of pole pair (here it is 2).  
So, the number of slots,  $S$  can be 30, 32, 34, 36, 38, 40 and 42.
3. To reduce flux pulsations,

$$\text{number of slots/pole, } \frac{S}{p} = \text{integer} + \frac{1}{2}$$

So, we can have slots as follows.

<b>S</b>	$\frac{S}{p}$	<b>Integer + <math>\frac{1}{2}</math></b>
30	7.5	✗
32	8	✓
34	8.5	✗
36	9	✓
38	9.5	✗
40	10	✓
42	10.5	✗

So, number of slots can be 30, 34, 28 and 42.

4. Also, number of slots/pole shoe = integer +  $\frac{1}{2}$  (or) integer. But both

can be satisfied

<b>S</b>	$\frac{S}{p}$	$\frac{S}{\text{Pole shoe}} = \frac{S}{p} \times \frac{L}{\tau}$
30	7.5	5.775
34	8.5	6.545
28	9.5	7.315
42	10.5	8.085

Let us choose  $S = 42$ , as slot/pole shoe is nearly an integer.

Hence,  $S = 42$ ,

5. Number of conductors/slot = even integer

$$Z_s = \frac{Z}{S} = \frac{255}{42} = 6.07$$

Let us take this as integer 6.

So, revised number of armature conductors = 6 × number of slots

$$Z_{\text{revised}} = 42 \times 6 = 252$$

6. Slot loading  $I_z Z_s$  should be less than 1500 A

$$I_z Z_s = (111) \cdot (6) = 666 \text{ A}$$

This is well within limits.

7. Number of commutator segments,

$$C = \frac{1}{2} u S$$

Minimum number of commutator segments,

$$C_{\min} = \frac{E p}{15} = \frac{119 \times 4}{15} \simeq 32$$

For coil side/slot  $u = 2$ ,  $C = \frac{1}{2} \times 2 \times 42 = 42$

$$u = 4, C = \frac{1}{2} \times 2 \times 42 = 42$$

Choose the number of coils such that conductor/slot is divisible by coil side per slot. Here, 6 is divisible by 2. So, number of coils = 42, number of commutator segments = 42.

**Example 7.8: Obtain the main dimensions and design the armature of a 25 hp, 500 V, 600 rpm, 4-pole DC series motor with an efficiency of 85%. Take  $B_{av} = 0.6 \text{ Wb/m}^2$  and**

$$ac = 17,000 \text{ A/m and } \frac{L}{\tau} \text{ as } 0.67.$$

**Solution:** Given

$$P_{\text{output}} = 25 \text{ hp}$$

$$\text{Voltage} = 500 \text{ V}$$

$$N = 600 \text{ rpm}$$

$$p = 4$$

$$\eta = 0.85$$

$$B_{\text{av}} = 0.6 \text{ Wb/m}^2$$

$$ac = 17,000 \text{ A/m}$$

$$\frac{L}{\tau} = 0.67$$

$$P_{\text{output}} \text{ (in kW)} = 25 \times 746 = 18.65 \text{ kW}$$

$$\text{Speed in rps, } n = \frac{600}{60} = 10 \text{ rps}$$

We know that

$$P_a = \pi^2 B_{\text{av}}^2 ac \times 10^{-3} D^2 Ln$$

$$\text{Therefore, } D^2 L = \frac{P_a}{\pi^2 B_{\text{av}}^2 ac \times 10^{-3} n}$$

Substituting the values of  $P_a$ ,  $B_{\text{av}}$ ,  $ac$  and  $n$  in the above equation, we get

$$D^2L = \frac{18.65}{\pi^2 \times 0.6 \times 17,000 \times 10^{-3} \times 10} = 0.0185 \quad (1)$$

$$\text{Also, } \frac{L}{\tau} = 0.67$$

Substituting  $\tau = \frac{\pi D}{p}$  in the above equation, we get

$$\frac{L}{\frac{\pi D}{4}} = 0.67$$

$$\Rightarrow L = 0.67 \times \frac{\pi D}{4} = 0.526D \quad (2)$$

Substituting Eq. (2) in Eq. (1), we get

$$D^3 = \frac{0.0185}{0.526} = 0.0351$$

$$\Rightarrow D = \sqrt[3]{0.0351} = 0.327 \text{ m}$$

Substituting the value of D in Eq. (2), we get

$$L = 0.172 \text{ m}$$

## Design of armature

$$\text{Power input, } P_i = \frac{P}{\eta} = \frac{18.65 \times 10^3}{0.85} = 21.94 \text{ kW}$$

$$\text{Line current, } I_L = \frac{P \times 10^3}{V} = \frac{21.94 \times 10^3}{500} = 43.88 \text{ A}$$

In series motor,  $I_a = I_L = 43.88 \text{ A}$

Since armature current is less than 200 A, wave winding is preferred.

$$\text{Flux/pole, } \phi = B_{av} \frac{\pi DL}{p}$$

$$= \frac{0.6 \times \pi \times 0.327 \times 0.172}{4}$$

$$= 0.02 \text{ Wb}$$

We know that induced emf,

$$E = \frac{\phi p Z N}{60a} = \frac{\phi p Z n}{a} \quad (3)$$

where

$$E = V + I_a R_a = 500 + 1\%(V), \text{ accounting for } I_a R_a \text{ drop as } R_a \text{ is not specified}$$

$$= 500 + 5 = 505 \text{ V}$$

Substituting the values of  $\phi$ ,  $p$ ,  $n$ ,  $a$  and rewriting Eq. (3), we get

$$\Rightarrow Z = \frac{Ea}{\phi pn} = \frac{505 \times 2}{0.02 \times 4 \times 10} = 1262.5$$

Slot pitch must lie between 2.5 and 3.5 cm.

Therefore, number of slots,  $S$ , must lie between

$$\frac{\pi D}{2.5 \times 10^{-2}} \text{ and } \frac{\pi D}{3.5 \times 10^{-2}}$$

$$\text{i.e., } \frac{\pi \times 0.327}{0.025} \text{ and } \frac{\pi \times 0.327}{0.035}, \text{ which is from 41 to 29.3.}$$

Let us take it as 41 to 30.

For wave winding, the slots/pole should not be a multiple of pole pair (here 2)

So, we have to select odd numbers as number of slots.

So,  $S$  can be 31, 33, 35, 37, 39 and 41.

To reduce flux pulsations, to avoid dummy coils,

$$\text{slot/pole arc} = \text{integer} + \frac{1}{2}$$

$S$	$\frac{S}{p}$	Slots per pole arc = slots per pole $\times \frac{\text{pole arc}}{\text{pole pitch}}$
31	7.75	5.19
33	8.25	5.52 ✓
35	8.75	5.86
37	9.25	6.19
39	9.75	6.53 ✓
41	10.25	6.86

Since slot/pole arc = integer +  $\frac{1}{2}$  5.5 or 6.5 and corresponding  $S$  of 33 or 39 can be chosen.

Let  $S = 33$

Therefore, conductors/slot =  $\frac{1262}{33} = 38.2 \simeq 38$

Number of coils,  $C = \frac{1}{2} uS$

Minimum number of coils,  $C_{\min} = \frac{Ep}{15} = \frac{505 \times 4}{15} \simeq 134$

Number of coils for  $u = 2$ ,  $C = \frac{1}{2} \times 2 \times 33 = 33$

$u = 4$ ,  $C = \frac{1}{2} \times 4 \times 33 = 66$

$u = 6$ ,  $C = \frac{1}{2} \times 6 \times 33 = 99$

$u = 8$ ,  $C = \frac{1}{2} \times 8 \times 33 = 132$

$u = 10$ ,  $C = \frac{1}{2} \times 10 \times 33 = 165$

For  $u = 10$ ,  $C = 165$  is greater than  $C_{\min}$  which is 134.

So number of coils is chosen as 165.

Problems on Design of Commutator and Brushes

---

**Example 7.9: Design suitable commutator and brushes for an 850 kW, 440 V, 10-pole, 300 rpm DC machine. The armature diameter is 150 cm with 450 coils. The commutator is to be designed with commutator diameter equal to 0.6 times armature diameter. The peripheral speed of commutator must be greater than 16 m/s, with commutator pitch < 7 mm. Take the current density in brushes to be equal to 6.5 A/cm<sup>2</sup> with brush current greater than 65 A. The brush drop is 2 V, and brush/pressure is 1250 kg/m<sup>2</sup>.**

**Solution:** Given

$$\text{Power, } P = 850 \text{ kW}$$

$$\text{Voltage} = 440 \text{ V}$$

$$p = 10$$

$$N = 300 \text{ rpm}$$

$$D = 150 \text{ cm}$$

$$c = 450$$

$$D_c = 0.6 D$$

$$v_c = 16 \text{ m/s}$$

$$\delta_b = 6.5 \text{ A/cm}^2$$

$$I_b > 65 \text{ A}$$

$$I_b R_b = 2 \text{ V}$$

$$P_b = 1250 \text{ kg/m}^2 = 125 \text{ g/cm}^2$$

We know that

Commutator diameter,  $D_c = 0.6D$  (armature diameter)

$$\Rightarrow D_c = 0.6 \times 1.50 = 90 \text{ cm}$$

Peripheral speed of commutator,  $v_c = \pi D_c n$

$$\begin{aligned} &= \pi \times 90 \times \frac{300}{60} = 1413.7 \text{ cm/s} \\ &= 14.137 \text{ m/s} \end{aligned} \quad \left[ \because n = \frac{N}{60} \right]$$

Number of commutator segments = number of coils = 450

Pitch of commutator segment

$$\begin{aligned} &= \frac{\pi \times \text{commutator diameter}}{\text{Number of commutator segments}} \\ &= \frac{\pi \times 900}{450} = 6.28 \text{ mm} \end{aligned}$$

This is less than the given limit of 7 mm.

$$\text{Armature current, } I_a = \frac{P}{V} = \frac{850 \times 1000}{440} = 1931.8 \text{ A}$$

If lap wound armature is chosen,

$$\text{Current/brush arm} = \frac{2I_a}{p} = \frac{2 \times 1931.8}{10} = 386.36 \text{ A}$$

If the brush current is 65 A (as per the limit specified in the problem),

Number of brushes per brush arm,

$$n_b = \frac{\text{Current/brush arm}}{\text{Brush current}} = \frac{386.36}{65} \\ = 5.944 \approx 6$$

Let us take  $n_b = 6$ .

So, new brush current,

$$I_b = \frac{\text{Current/brush arm}}{n_b} = \frac{386.36}{6} \\ = 64.39 \text{ A}$$

$$\text{And, contact area/brush} = \frac{I_b}{\delta_b} = \frac{64.39}{6.5} = 9.90 \text{ cm}^2$$

The brush should not cover more than three commutator segments.

So,

$$\begin{aligned}\text{Brush thickness} &= 3 \times \text{commutator pitch} \\ 3 \times 6.28 &= 18.84 \text{ mm} \\ &\approx 20 \text{ mm}\end{aligned}$$

Taking brush thickness as 20 mm, i.e., 2 cm,

$$\text{Brush width, } w_b = \frac{A_b}{t_b} = \frac{9.90}{2} = 4.95 \text{ cm}$$

Take 0.5 cm as clearance between brushes ( $c_b$ ), 4 cm for staggering of brushes and end clearance( $c$ ),

$$\text{length of commutator, } l_c = n_b(w_b + c_b) + c$$

$$= 6(4.95 + 0.5) + 4 = 36.7 \text{ cm}$$

Brush contact loss,

$$\begin{aligned}P_{hc} &= 2 \times I_a = 2 \times 1931.8 = 3863.6 \text{ W} \\ \text{Contact area of one brush} &= w_b t_b = 4.95 \times 9.9 \text{ cm}^2\end{aligned}$$

Contact area of stall rusher in one spindle,

$$A_b = \text{Contact area of one brush} \times n_b \\ = 9.9 \times 6 = 59.4 \text{ cm}^2$$

Brush friction loss,

$$P_{b_f} = \mu P_b A_b v_c \times 981 \times 10^{-5} \text{ W}$$

Taking  $\mu_p = 0.25$ , substituting the values of  $P_b$ ,  $A_b$  and  $v_c$  in the above equation, we get

$$P_{b_f} = 0.25 \times 125 \times 1413.7 \times 59.4 \times 981 \times 10^{-5} \\ = 24713.48 \text{ W}$$

$$\text{Total commutator loss} = P_{h_c} + P_{b_f}$$

$$= 3863.6 + 24713.48 = 28577.08 \text{ W}$$

$$\text{Cooling surface of commutator} = \pi D d_c$$

$$= \pi \times 90 \times 36.7 = 10376.68 \text{ cm}^2 \\ = 1.03 \text{ m}^2$$

Temperature rise of commutator

$$\theta = \frac{120 \times \frac{28577.08}{10376.68}}{1 + (0.1 \times 14.137)} = 136.91^\circ\text{C formula}$$

**Example 7.10: A 25 hp, 4-pole, 300 volts, 1000 rpm wave wound DC machine has its armature diameter as 25 cm, number of armature slots = 41, with 4 coil side/slot,**

**current density in brush = 6 A/cm<sup>2</sup> and turns/coil = 2. Design a suitable commutator brush assembly.**

**Solution:** Given

$$\text{Power} = 25 \text{ hp} = 25 \times 746$$

$$= 18.65 \text{ kW}$$

$$p = 4$$

$$\text{Voltage} = 300 \text{ V}$$

$$N = 1000 \text{ rpm}$$

$$D_a = 25 \text{ cm}$$

$$S = 41$$

$$\text{Coil sides/slot} = 4$$

$$\delta_b = 6 \text{ A/cm}^2$$

$$T_c = 2$$

$$\text{Number of conductors/slot} = \text{Number of coil sides/slot} \times 2 = 4 \times 2 = 8$$

Total number of conductors,

$$\begin{aligned} Z &= \text{Number of slots}(S) \times \text{number of conductors/slot} \\ &= 41 \times 8 = 328 \end{aligned}$$

$$\text{Number of coils} = \frac{Z}{2} \times \frac{1}{\text{Turns/coil } (T_c)}$$

$$= \frac{328}{2} \times \frac{1}{2} = 82$$

For a wave winding, number of coils should not be a multiple of pole pair. In this case, number of pole pairs is 2 (which is a multiple of pole pair).

So, let us take one coil to be a dummy one and number of active coils = 81.

Commutator diameter,

$$\begin{aligned} D_c &= 0.7 \times \text{Armature diameter} \\ &= 0.7 \times 25 = 17.5 \text{ cm} \end{aligned}$$

Peripheral speed,

$$\begin{aligned} v_c &= \pi D_c \frac{N}{60} = \pi D_c n = \pi \times 17.5 \times \frac{1000}{60} \times 10^{-2} \\ &= 9.16 \text{ m/s} \end{aligned}$$

This is within limit of 20 m/s.

$$\begin{aligned}
 \text{Commutator pitch} &= \frac{\pi D_c}{\text{number of segments}} \\
 &= \frac{\pi D_c}{\text{number of coils}} \\
 &= \frac{\pi \times 17.5}{81} \\
 &= 0.678 \text{ cm}
 \end{aligned}$$

Assuming brushes cover three segments,

Thickness of brush,

$$\begin{aligned}
 t_b &= 3 \times \text{Commutator pitch} = 3 \times 0.678 \\
 &= 2.0362 \text{ cm}
 \end{aligned}$$

Armature current,

$$\begin{aligned}
 I_a &= \frac{P / \eta}{V} = \frac{18.65 \times 1000}{0.8 \times 300} \\
 &= 77.7 \text{ A} \qquad \qquad \qquad [\text{assuming } \eta = 0.8 ]
 \end{aligned}$$

Area of brush,

$$A_b = \frac{2I_a}{a \delta_b} = \frac{2 \times 77.7}{2 \times 6} = 12.95 \text{ cm}^2$$

reason for 2 and a

Let the width of each brush be 1.6 cm.

Number of brushes,

$$n_b = \frac{A_b}{t_b \times w_b} = \frac{12.95}{2.0362 \times 1.6} = 3.9 \simeq 4$$

Take 0.5 cm as clearance between brushes ( $c_b$ ), 4 cm for staggering of brushes and end clearance( $c$ ),

Length of commutator,

$$\begin{aligned} l_c &= n_b(w_b + c_b) + c \\ &= 4(1.6 + 0.5) + 4 = 12.4 \text{ cm} \end{aligned}$$

**Example 7.11: A 350 kW, 400 V, 8-pole, 600 rpm DC generator has commutator diameter as 63 cm, number of segments as 304, current density in brushes as 5 A/cm<sup>2</sup> and current per brush as 50 A. Assume brushes occupy three segments. Determine the axial length of commutator.**

**Solution:** Given

Power = 350 kW

$D_c = 63$

Voltage = 400V

$C = 304$

$p = 8$

$d_b = 5\text{A/cm}^2$

$I_b = 50\text{A}$

Armature current,  $I_a = \frac{P}{V} = \frac{350 \times 10^3}{400} = 875 \text{ A}$

Let us assume lap wound machine.

$$\text{Current per brush arm} = \frac{2I_a}{p} = \frac{2 \times 875}{8} = 218.75 \text{ A}$$

Since limit of current per brush,  $I_b = 50 \text{ A}$

Number of brushes/arm,

$$n_b = \frac{\text{Current per brush arm}}{\text{Current per brush}}$$
$$= \frac{218.75}{50} = 4.375 \simeq 5$$

So, new brush current,

$$I_b = \frac{\text{Current/brush arm}}{n_b}$$

$$= \frac{218.75}{5} = 43.75 \text{ A}$$

This is safe brush current.

$$\begin{aligned} \text{Number of coils} &= \text{number of commutator segments} \\ &= 304 \end{aligned}$$

Pitch of commutator segment =

$$\frac{\pi D_c}{\text{Number of commutator segments}}$$

$$= \frac{\pi \times 63}{304} = 0.651 \text{ cm}$$

As brush thickness covers three segments,

So, brush thickness =  $3 \times 0.651 = 1.95 \text{ cm}$

$$\text{Area of brush, } A_b = \frac{I_b}{\delta_b} = \frac{43.75}{5} = 8.75 \text{ cm}^2$$

$$\text{Brush width, } w_b = \frac{A_b}{t_b} = \frac{8.75}{1.95} = 4.4 \text{ cm}$$

Take 0.5 cm as clearance between brushes ( $c_b$ ), 4 cm for staggering of brushes and end clearance( $c$ ),

length of commutator,

$$\begin{aligned}l_c &= n_b(w_b+c_b)+c \\ &= 5(4.4+0.5)+4 \\ &= 28.5\text{cm}\end{aligned}$$

### 7.11 Design of Field System of DC Machine

This section describes about the type, height and area of poles along with the design of field winding.

#### *7.11.1 Design of Pole*

The poles are laminated and are bolted to the frame.

The flux in the pole body = useful flux per pole  $\times$  leakage coefficient

where the values of leakage coefficient for different ratings of machine is given in Table 7.5.

**Table. 7.5** | Leakage coefficient for different ratings of DC machine

<b>Output of DC machine (kW)</b>	<b>Leakage coefficient</b>
50	1.125 to 1.22
100	1.11 to 1.22
200	1.10 to 1.20
500	1.09 to 1.18
1000	1.08 to 1.16
2000	1.06 to 1.12

Flux density in pole body can be assumed to be between 1.5 and 1.7 Wb/m<sup>2</sup> for laminated poles.

So, area of pole body,  $A_p = \frac{\phi_p}{B_p}$

Gross area,  $A_{p_{gross}} = \frac{A_p}{0.95}$ , where 0.95 is the stacking

factor.

To avoid magnetic centreing and to allow end play, the length of pole is made less than the length of armature by 10–15 mm.

$$L_p = L - (0.001 \text{ to } 0.015)$$

Width of pole body, 
$$W_p = \frac{A_p}{L_p} = \frac{\phi_p}{B_p L_p}$$

To find the height pole, the field *mmf* to be provided by the pole at full load has to be determined. This is calculated from magnetization curve of machine.

The height of pole is decided based on (i) sufficient space for series, shunt or both coils and (ii) cooling surface for dissipating the losses.

Let us take cylindrical coils and neglecting the cooling surfaces of top and bottom.

$$\text{Cooling surface area} = 2L_{mt}h_f$$

where  $L_{mt}$  – length of mean turns of field winding,  $h_f$  – height of field winding.

Let  $P_e$  be permissible loss/unit area of cooling surface.

⇒ Total permissible loss =  $P_e \times$  total cooling surface area

Copper space factor for field coil,

$$\sigma_f = \frac{\text{Net copper area (without insulation)}}{\text{Gross copper area (with insulation)}}$$

If  $d_f$  is the depth of filed coil,

$$\text{Gross copper volume of field coil} = L_{\text{mt}} d_f h_f$$

Net copper volume of filed coil,

$$V_e = \sigma_f L_{\text{mt}} d_f h_f$$

Power lost in each field coil =  $I_f^2 R_f$

$$= \delta_f^2 a_f^2 \frac{\rho L_{\text{mt}}}{a_f}$$

$$\left[ \because \delta_f = \frac{I_f}{a_f} \Rightarrow I_f = \delta_f a_f \text{ and } R_f = \frac{\rho L_{\text{mt}}}{a_f} \right]$$

$$= \delta_f^2 a_f \rho L_{\text{mt}}$$

$$= \delta_f^2 \rho \sigma_f d_f h_f L_{\text{mt}} \quad [\because a_f = \sigma_f d_f h_f]$$

Power lost in each field coil

$$= \delta_f^2 \rho V_e \quad [\because V_e = \sigma_f d_f h_f L_{\text{mt}}]$$

We know that

Permissible loss/unit height = Power required per unit height of coil

$$\Rightarrow P_e \times 2L_{mt} = \delta_f^2 \rho V_e = \delta_f^2 \rho \sigma_f d_f h_f L_{mt}$$

$$\Rightarrow 2P_e = \delta_f^2 \rho \sigma_f d_f h_f$$

$$\Rightarrow \delta_f^2 = \frac{2P_e}{\rho \sigma_f d_f}$$

$$\Rightarrow \delta_f = \sqrt{\frac{2P_e}{\rho \sigma_f d_f}}$$

Let  $T_f$  be the number of turns of field coil.

Ampere turns of each field coil,  $I_f T_f = \delta_f a_f \frac{d_f h_f \sigma_f}{a_f} = \delta_f \sigma_f d_f h_f$

$$AT / \text{unit height} = \delta_f \sigma_f d_f = \sqrt{\frac{2P_e}{\rho \sigma_f d_f}} \sigma_f d_f \quad \left[ \because \delta_f = \sqrt{\frac{2P_e}{\rho \sigma_f d_f}} \right]$$

$$\Rightarrow AT / \text{unit height} = \sqrt{\frac{2P_e \sigma_f d_f}{\rho}}$$

Taking  $\rho = 2 \times 10^{-8} \Omega m$  and  $P_e$  in  $W/m^2$  and  $d_f$  in m,

$$AT/\text{unit height (in m)} = 10^4 \sqrt{P_e \sigma_f d_f}$$

$$\sigma_f = \begin{cases} 0.4 & \text{for small round wires} \\ 0.6 & \text{for large round wires} \\ 0.75 & \text{for large conductors with square section} \end{cases}$$

$d_f$  is in the range of 0.04–0.05 m

$P_e$  should be near 700 W/m<sup>2</sup>

To find the net height of field coil, we need, field amp turns/pole( $AT_f$ )

$$\frac{AT_f}{AT_a} = \begin{cases} 1 \text{ to } 1.3 & \text{for machines without interpoles} \\ 0.6 \text{ to } 1 & \text{for machines with interpoles} \end{cases}$$

$$\text{Height of field coil} = \frac{AT_f}{AT \text{ per unit height}}$$

### 7.11.2 Design of Shunt Field Winding

The shunt field winding is designed generally to produce rated voltage at no load in shunt and compound machines whereas the series field winding is designed to maintain rated voltage at all loads.

The general design procedure for the design of shunt field winding is given below:

1. Find the total height available on pole for both the field windings

using, height of field coil

$$h_f = \frac{AT_f}{AT \text{ per unit height}}$$

2. For compound machine, height of shunt field winding,  $h_{f_{sh}} = 80\% h_p$  height of series field winding,  $h_{f_{sh}} = 20\% h_f$  For shunt machine,  $h_{f_{sh}} = h_f$
3. Number of shunt field coils = Number of poles. Assuming 15–20% of rated voltage is lost in field regulator, voltage across each shunt field coil,

$$E_f = \frac{0.8 \text{ to } 0.85 V}{P},$$

where V is the rated voltage and all shunt field coils are connected in series.

4. Calculate the length of mean turn,

$$L_{mt} = 2(L_p + b_p) + 4d_f.$$

We know that, Resistance of each field coil,

$$R_f = \frac{E_f}{I_f} = \frac{\rho L_{mt} T_f}{a_f}$$

$$\Rightarrow \text{Area of field coil, } a_f = \frac{\rho L_{mt} T_f}{R_f} = \frac{\rho L_{mt} T_f I_f}{E_f}$$

$$= \frac{\rho L_{mt} AT_f}{E_f} \left[ \because R_f = \frac{E_f}{I_f} \right]$$

and  $T_f I_f$  – field ampere turns.

5. Choose suitable conductor sections depending on the size of machine and also select suitable thickness of insulation.
6. Number of conductors/turns (depthwise),

$$N_d = \frac{d_f}{\text{depth of one insulated conductor}}$$

And number of conductors/turns (heightwise),

$$N_h = \frac{h_f}{\text{height of one insulated conductor}}$$

Adjust  $N_d$  and  $N_h$  to be whole numbers.

7.  $T_f = N_d \times N_h$ . For this  $T_f$  and  $a_f$  find

$$R_f = \frac{\rho L_{mt} T_f}{a_f} \Rightarrow I_f = \frac{E_f}{R_f}$$

8. Check for current density,  $\delta_f = \frac{I_f}{a_f} \leq 2.5 \text{ A/mm}^2$ .

If air ducts are provided,  $\delta_f \leq 3.5 \text{ A/mm}^2$ .

9. Find  $I_f T_f$

If  $I_f T_f \approx$  given value, then calculate copper loss,  $I_f^2 R_f$ .

Else If  $I_f T_f <$  given value, increase  $d_f$  else if  $I_f T_f >$  given value, decrease  $d_f$  and goto step 4.

Find cooling surface  $S = 2L_{mt} (h_f + d_f)$  and temperature rise (in  $^{\circ}\text{C}$ ),

$$\theta = \frac{120 \times \text{loss in W/cm}^2}{1 + 0.1 v_c}$$

and if  $\theta \leq 40^{\circ}\text{C}$ , design of field winding procedure is complete. Else increase surface area by increasing  $d_f$  and go to step 4.

### 7.11.3 Design of Series Field Winding

The series field winding has ampere turns per pole as 10–20% of armature ampere turns on full load.

$$AT_{se} = 10 \text{ to } 20\%AT_a$$

As  $I_{se} = I_a$

$$\Rightarrow T_{se} = \frac{AT_{se}}{I_{se}}$$

Area of cross-section of conductor of series field winding,

$$a_{se} = \frac{I_{se}}{\delta_{se}}$$

where  $\delta_{se}$  – current density in series field winding.

Problems on Design of Field Winding

**Example 7.12: Design a suitable field winding and find out the section, number of turns and rate of dissipation of heat of a 6-pole DC shunt machine, rated for 450 V. The poles are rectangular ones of dimensions (10 × 18) cm. The available winding cross-section is (10 × 1.8) cm. Use round conductors with resistivity equal to 0.02 Ω/m/mm<sup>2</sup>. The insulation thickness is 0.01 mm. A voltage drop of 30 V occurs in the field regulator. Take the field AT per pole as 6500.**

**Solution:** Given

$$\text{Voltage} = 450 \text{ V}$$

$$p = 6$$

$$AT_f = 6500 \text{ AT/pole}$$

$$L_p = 180 \text{ mm}$$

$$d_f = 18 \text{ mm}$$

$$b_p = 100 \text{ mm}$$

$$V_{\text{drop}} = 30 \text{ V}$$

$$\rho = 0.02 \text{ } \Omega/\text{m}/\text{mm}^2$$

Voltage across the shunt field winding

$$= V - V_{\text{drop}} = 450 - 30 = 420 \text{ V}$$

Number of shunt field coils = Number of poles = 6

Voltage across each field coil

$$= \frac{\text{Voltage across the shunt field winding}}{\text{Number of shunt field coils}}$$

$$= \frac{420}{6} = 70 \text{ V}$$

Length of mean turn

$$\begin{aligned}
 L_{mt} &= 2(L_p + b_p) + 4d_f \\
 &= 2(180 + 100) + 4 \times 18 \\
 &= 632 \text{ mm} = 0.63 \text{ m}
 \end{aligned}$$

Area of cross-section of field conductor,

$$\begin{aligned}
 a_f &= \frac{AT_f \rho l_{mt}}{E_f} \\
 &= \frac{6500 \times 0.02 \times 0.63}{70} = 1.17 \text{ mm}^2
 \end{aligned}$$

We know that

$$a_f = \frac{\pi (\text{Diameter of conductor})^2}{4}$$

$$\Rightarrow \text{Diameter of conductor} = \sqrt{\frac{4a_f}{\pi}}$$

$$= \sqrt{\frac{4 \times 1.17}{\pi}} = 1.22 \text{ mm}$$

Diameter of conductor with insulation = 1.22 + 0.01 =  
1.23 mm = 0.123 cm

$$\text{Number of turns in a height of 10 cm} = \frac{10}{0.123} = 81.3 \simeq 81$$

$$\text{Number of turns in a depth of 1.8 cm} = \frac{1.8}{0.123} = 14.6 \simeq 15$$

Total number of turns/pole,

$$T_f = 81 \times 15 = 1215$$

Field current,

$$I_f = \frac{I_f T_f}{T_f} = \frac{6500}{1215} = 5.349 \text{ A}$$

$$\text{Losses in field coil} = V_f I_f = 70 \times 5.349 = 374.48 \text{ watts}$$

Dissipating surface area including the two end surface,

$$\begin{aligned} S &= 2L_{mt} h_f + 2L_{mt} d_f = 2L_{mt} (h_f + d_f) \\ &= 2 \times 63.2(10 + 1.8) = 1491.52 \text{ cm} \end{aligned}$$

Since losses in field coil = 374.48 watts

Therefore,

$$\begin{aligned} \text{Dissipation} &= \frac{\text{Losses in field coil}}{\text{Dissipating surface area including the two end surface}} \\ &= \frac{374.48}{1491.52} = 0.25 \text{ watts/cm}^2 \end{aligned}$$

**Example 7.13: Design a shunt field coil which has to develop an mmf of 7500 AT and can dissipate 780 W/m<sup>2</sup>. Assume round wire of resistivity 0.021 Ω/m/mm<sup>2</sup> having a mean**

length of turn as 1.40 m and depth as 40 mm. The diameter of the insulated wire is 0.15 mm greater than that of bare wire. Assume a drop of 50 V in the coil.

**Solution:** Given

$$AT_f = 750AT$$

$$d_f = 40 \text{ mm} = 0.04 \text{ m}$$

$$\text{Dissipation} = 780 \text{ W/m}^2$$

$$L_{mt} = 1.4 \text{ m}$$

$$E_f = 50 \text{ V}$$

$$\rho = 0.021 \text{ } \Omega/\text{m}/\text{mm}^2$$

Area of cross-section of field conductor,

$$\begin{aligned} a_f &= \frac{AT_f \rho L_{mt}}{E_f} \\ &= \frac{7500 \times 0.021 \times 1.4}{50} = 4.41 \text{ mm}^2 \\ &= 4.41 \times 10^{-6} \text{ m}^2 \end{aligned}$$

We know that

$$a_f = \frac{\pi(\text{Diameter of conductor})^2}{4}$$

⇒ Diameter of conductor,

$$d = \sqrt{\frac{4a_f}{\pi}} = \sqrt{\frac{4 \times 4.41}{\pi}} = 2.36 \text{ mm}$$

Diameter of insulated conductor,

$$d_1 = 2.36 + 0.15 = 2.516 \text{ mm}^2$$

Space factor,  $s_f = 0.75 \left( \frac{d}{d_1} \right)^2$

$$= 0.75 \left( \frac{2.36}{2.516} \right)^2 = 0.6598$$

Total winding area,  $A_w = d_f \times h_f = 0.04 h_f$

Total conductor area =  $s_f \times A_w = 0.6598 \times 0.04 h_f = 0.0263 h_f$  (1)

Also, we know that

Total conductor area =  $a_f T_f = 4.41 \times 10^{-6} T_f$  (2)

Equating Eqs. (1) and (2), we get

$$\Rightarrow T_f = \frac{0.0263 h_f \times 10^6}{4.41} = 5.96 \times 10^3 h_f \quad (3)$$

Total dissipating surface area (including all sides, top, bottom),

$$\begin{aligned} S &= 2L_{mt} h_f + 2L_{mt} d_f \\ &= 2L_{mt} (h_f + d_f) \\ &= 2 \times 1.4 (h_f + 0.04) = 2.8h_f + 0.112 \end{aligned}$$

Also, we know that

$$\text{Dissipation (in W/m}^2\text{)} = 780 = \frac{\text{Loss}}{\text{Total dissipating surface area}}$$

$$\Rightarrow 780 = \frac{I_f^2 R_f}{2.8h_f + 0.112}$$

$$\Rightarrow I_f^2 R_f = 780(2.8h_f + 0.112)$$

$$\Rightarrow \frac{E_f^2}{R_f} = 2184 h_f + 87.36$$

Substituting  $R_f = \frac{\rho L_{mt} T_f}{a_f}$  in the above equation, we get

$$\Rightarrow \text{Loss} = \frac{E_f^2 a_f}{\rho L_{mt} T_f} = 2184 h_f + 87.36$$

Substituting the values of  $\rho$ ,  $L_{mt}$ ,  $E_f$  and  $a_f$  in the above equation, we get

$$\frac{50^2 \times 4.41 \times 10^{-6}}{0.021 \times 10^{-6} \times 1.4 \times T_f} = 2184 h_f + 87.36$$

$$\frac{0.375 \times 10^6}{T_f} = 2184 h_f + 87.36$$

$$\Rightarrow T_f = \frac{0.375 \times 10^6}{2184 h_f + 87.36}$$

Substituting Eq. (3) in the above equation, we get

$$5.96 \times 10^3 h_f = \frac{0.375 \times 10^6}{2184 h_f + 87.36}$$

Simplifying and rewriting the above equation, we get

$$13.016 \times 10^6 h_f^2 + 520665.6 h_f - 0.375 \times 10^6 = 0$$

Solving the above equation, we get

$$h_f = 0.150 \text{ m}$$

Substituting the value of  $h_f$  in Eq. (3), we get

$$T_f = 5.96 \times 10^3 \times 0.150 = 894$$

⇒

$$\begin{aligned} \text{Loss} &= \frac{E_f^2}{R_f} = \frac{E_f^2 a_f}{\rho L_{mt} T_f} \\ &= \frac{0.375 \times 10^6}{T_f} \\ &= \frac{0.375 \times 10^6}{894} \\ &= 419.4 \text{ watts} \end{aligned}$$

$$\text{Field current, } I_f = \frac{\text{loss}}{E_f} = \frac{419.4}{50}$$

$$= 8.38 \text{ A}$$

**Example 7.14:** A rectangular filed coil has to produce 7000 AT when dissipating 200 watts at 55°C. The inner dimensions of coil are 0.25 × 0.12 × 0.14 m. The dissipation is 35 watts/m<sup>2</sup>°C from the outer surface alone neglecting the top and bottom surfaces of coil. Ambient temperature is 25°C. Calculate the space factor, thickness of coil and current density. Assume resistivity as 0.02 Ω/m/mm<sup>2</sup>.

---

**Solution:** Given

$$AT_f = I_f T_f = 7000 AT$$

Loss = 200 watts at  $55^\circ\text{C}$

Inner dimensions of coil

$$h_f = 0.14 \text{ m}$$

$$\text{Width, } b_p = 0.12 \text{ m}$$

$$\text{Length, } L_p = 0.25 \text{ m}$$

$$\text{Heat dissipation} = 35 \text{ watts/m}^{20} \text{ }^\circ\text{C}$$

$$\rho = 0.021 \text{ W/m/mm}^2$$

Ambient temperature =  $25^\circ\text{C}$

We know that

$$\text{Length of inner turn, } L_i \text{ (or) } L_{mt} = 2(L_p + b_p) + 4d_f$$

Substituting the values of  $L_p$  and  $b_p$  in the above equation, we get

$$L_i = 2(0.25 + 0.12) + 4d_f = 0.74 + 4d_f \quad (1)$$

Also,

$$\text{Length of outer turn, } L_o = L_i + 4d_f = 0.74 + 8d_f$$

$$\begin{aligned}\text{Temperature rise} &= \text{actual temperature} - \text{ambient temperature} \\ &= 55 - 25 = 30^\circ\text{C} \\ \text{Loss dissipated/unit surface} &= \text{temperature rise} \times \text{heat dissipation} \\ &= 30 \times 35 = 1050 \text{ W/m}^2\end{aligned}$$

From the given data, we know that

$$\text{Permissible loss} = 200 \text{ W}$$

Hence,

$$\begin{aligned}\text{Outer area required (excluding ends)} &= \frac{\text{Permissible loss}}{\text{Loss dissipated/unit surface}} \\ &= \frac{200}{1050} = 0.190 \text{ m}^2\end{aligned}$$

$$\text{Also, Outer area (excluding ends)} = L_o \times h_f$$

Substituting the values of outer area (excluding ends),  $L_o$  and  $h_f$  in the above equation, we get

$$0.190 = (0.74 + 8d_f) \times 0.14$$

⇒

$$0.190 = 0.1036 + 1.12d_f$$

$$d_f = 0.07714 \text{ m} = 77.14 \text{ mm}$$

Substituting the value of  $d_f$  in Eq. (1), we get

$$\begin{aligned}
 L_{mt} &= 0.74 + 4df \\
 &= 0.74 + 4(0.0688) \\
 &= 1.0485\text{m}
 \end{aligned}$$

We know that

$$\text{Copper loss in field winding} = I_f^2 R_f$$

Substituting the value for copper loss and expression for resistance of field winding, we get

$$200 = I_f^2 \frac{\rho L_{mt} T_f}{a_f}$$

Simplifying the above equation, we get

$$200 = \frac{I_f}{a_f} \rho L_{mt} I_f T_f$$

Substituting the values of  $\rho$ ,  $L_{mt}$  and  $I_f T_f$  in the above equation, we get

$$\Rightarrow 200 = \frac{I_f}{a_f} \times 0.021 \times 1.0485 \times 7000$$

$$\Rightarrow \frac{I_f}{a_f} = 1.301 \text{ A/mm}^2 = \text{Current density } (\delta_f)$$

$$\text{Total area of conductors} = T_f a_f \times 10^{-6}$$

$$= T_f \times \frac{I_f}{\delta_f} \times 10^{-6} \quad \left[ \because \frac{I_f}{a_f} = \delta_f \Rightarrow a_f = \frac{I_f}{\delta_f} \right]$$

$$= \frac{AT_f}{\delta_f} \times 10^{-6} \quad [\because T_f I_f = AT_f]$$

Substituting the values of  $AT_f$  and  $\delta_f$  in the above equation, we get

$$\text{Total area of conductors} = \frac{7000}{1.301} \times 10^{-6} = 0.00538 \text{ m}^2$$

$$\text{Total winding area, } A_w = h_f d_f = 0.14 \times 0.077 = 0.0107 \text{ m}^2$$

Space factor,

$$S_f = \frac{\text{Total conductor area}}{\text{Total winding area}} = \frac{0.00538}{0.0107} = 0.5028$$

## 7.12 Design of Interpoles

The current in the armature winding of a DC machine changes its direction as the conductor changes its position alternatively under opposite poles. The commutator converts the alternating current into unidirectional current. The current is collected by brushes that cover 2 to 3 segments of commutator. Brushes short circuit the coils in which current reversal takes place, from  $+I_c$  to  $-I_c$  or vice versa. This change of

current is opposed by the self-induced emf in the coil called reactive voltage.

In the coil undergoing commutation, to reverse the current, a reverse emf has to be developed which is sufficient to overcome the reactance voltage. This reverse emf is provided by interpoles or compoles located between two consecutive main poles. These poles carry a winding called compensating winding connected in series with the armature and are excited to provide a field of required strength and polarity. Generating machines will have interpoles of polarity same as that of the main pole ahead and a motoring machine will have the polarity of interpole same as that of main pole behind in the direction of rotation.

So, the ampere turns required from interpoles must be sufficient enough to neutralize armature reaction and to overcome reactance voltage due to commutation.

*Mmf* due to armature reaction without compensating winding,

$$AT_a = \frac{I_z Z}{2p}$$

*Mmf* due to armature reaction with compensating winding,

$$AT_a = \frac{I_z Z}{2p} \left( 1 - \frac{\text{pole arc}}{\text{pole pitch}} \right)$$

$Mmf$  in the air gap at interpoles =  $800,000 B_{gi} k_{gi} l_{gi}$ ,  
 where  $l_{gi} = 1.5$  to  $1.75 l_g$

$Mmf$  required for interpoles,

$$AT_{ip} = 800,000 B_{gi} k_{gi} l_{gi} + AT_a$$

The width of interpoles = distance through which the armature moves during commutation

$$w_{ip} = [\text{brush thickness} + (N' - 1) \text{ pitch of commutator segment}] + \frac{D_a}{D_c}$$

where  $N'$  – Number of coil sides/layer in the slot,  $D_a$  – Diameter of armature,  $D_c$  – Diameter of commutator.

The reactance voltage can be calculated by calculating the permeance of slot, tooth top and overhang.

Permeance coefficient of slot,

$$\lambda_s = \frac{h_1}{3w_s} + \frac{h_2}{w_s} + \frac{2h_3}{w_s + w_o} + \frac{h_4}{w_o}$$

Permeance coefficient of tooth top,

$$\lambda_t = \frac{w_i}{6l_{gi}}$$

Permeance coefficient of overhang,

$$\lambda_o = \frac{L_{tr}}{L} \left( 0.23 \log_{10} \frac{L_{tr}}{b} + 0.07 \right)$$

$L_{tr}$  – Free length of overhang

$b$  – Periphery of one complete layer of winding

Total coefficient permeance,  $\lambda = \lambda_s + \lambda_t + \lambda_o$

The effective leakage flux for a slot with  $Z_s$  conductors carrying  $I_z$  current

$$= \text{mmf / slot} \times m \times \text{permeance coefficient} \times \text{length}$$

$$= I_z Z_s \mu \lambda L$$

Since, there are 2 coils, total flux lining a coil =  $2\mu\lambda L I_z Z_s$

Interpoles are made of cart steel with no pole shoe.

Flux density in interpolar gap,  $B_{g_i} = \frac{2\mu\lambda L I_z Z_s}{L_i w_i}$

Number of interpole turns,  $T_{iL} = \frac{AT_i}{I_a}$

The current density in interpole winding is 2–4 A/mm<sup>2</sup>.

Average value of reactance voltage in a coil,

$$E_{rav} = L \frac{di}{dt}$$

$$= 2T_C^2 L \lambda \frac{2I_z}{t_c} \left[ \because \frac{di}{dt} = \frac{I_z}{t_c} \right] \quad (7.10)$$

where  $t_c$  – time of commutation.

If the thickness of brush is equal to one commutator segment, then

$$t_c = \frac{\pi D_L}{C \times \pi D_L n} = \frac{1}{Cn}$$

Substituting the value of  $t_c$  in Eq. (7.10), we get

$$\Rightarrow E_{rav} = 2T_C^2 L \lambda 2I_z Cn$$

Rearranging the terms in the above equation, we get

$$= 2T_C L \lambda I_z (2CT_C)n$$

Substituting  $2CT_c = Z$  in the above equation and multiplying and dividing by  $\pi D$ , we get

$$= 2T_c L \lambda' \left( \frac{I_z Z}{\pi D} \right) \pi D n$$

$$E_{rav} = 2T_c L \lambda' ac v_a \quad [ \because v_a = \pi D n \text{ and } ac = \frac{I_z Z}{\pi D} ]$$

### 7.13 Computer-aided Design of DC Machine

Sample computer programmes for the design of DC machine are given in the following sections.

#### **Example Program 1: Determination of main dimensions of DC machine.**

#### **Solution:**

*Matlab program*

```
%Main dimensions of dc machine
```

```
Pa=300; %KW rating
```

```
V=500; %voltage rating
```

```
P=6; %number of poles of the machine
```

```

Bav=0.67; %specific magnetic loading (Wb/m^2)

ac=25000; %specific electrical loading (A/m)

N=500; %speed of machine

Rap=0.75; %ratio of core length to pole pitch

ns=N/60; %speed in rps

Co=pi*pi*Bav*ac*(10^-3); %output coefficient

D2L=Pa/(Co*ns); % volume= D*D*L

RLD=pi*Rap/P; %Value of L/D

D=(D2L/RLD)^(1/3) %Value of D

L=RLD*D %Value of L

va=pi*D*ns %Peripheral velocity

if va<=30

    disp('Peripheral velocity is within permissible
    limit of 30 m/s')

else

    disp('Va exceeds limit')

end

Ia=Pa*(10^3)/V %armature current

Iz=Ia/2 %current per parallel path

if Iz<200

```

```

disp('Simplex winding can be used')

else

disp('Current limit of 200 A/path was
exceeded.Simplex winding cant be used')

Iz=Ia/P %new current per path

if Iz<200

disp('Rather LAP winding can be used')

end

end

Ez=Bav*L*va; %average induced emf/conductor

Zc=roundn(V/Ez,1) %armature conductors per path
rounded to nearest 10

disp('Total no. of conductors')

Z=Zc*P %Total no. of conductors

disp('Condn 1: Slot pitch varies from 2.5 to 3.5
cm...')

Smin1=round(pi*D/0.035)

Smax1=round(pi*D/0.025)

disp('Condn 2: ratio of no. of slots to pole varies
from 9 to 16...')

Smin2=P*9

```

```
Smax2=P*16
```

```
disp('Final Lower & Higher bounds of no. of slots...')
```

```
Smin=max(Smin1,Smin2)
```

```
Smax=min(Smax1,Smax2)
```

```
disp('Cond 3: for lap winding no. of slots are a  
multiple of pole pair(3)...')
```

```
Smin=ceil(Smin*2/P)*P/2; %recalibrating initial  
value to multiple of P/2
```

```
A=Smin:3:Smax
```

```
disp('Cond 4: to reduce flux pulsations Slots/pole  
must be equal to integer + 0.5')
```

```
B=A(A/P==floor(A/P)+0.5)
```

```
disp('These are the possible values of no. of  
slots')
```

```
disp('Slots per pole*Rap...')
```

```
B=B*Rap/P
```

```
disp('Choosing S which is nearly an integer')
```

```
C=B-floor(B); %finding element with min fractional  
part
```

```
pos=find(C==min(C)); %position of optimal value in  
array
```

```
S= B(pos)*P/Rap
```

```
disp('No. of conductors per slot...')
```

```

Zps=Z/S

disp('As Zs must be an even integer, the revised no.
of conductors is...')

Zps=round(Zps);

Zrev=S*Zps

Sload=Iz*Zps

if Sload<1500

    disp('Slot loading is within the permissible
limit')

end

disp('No. of commutator segments...')

NC=Zrev/2 %no. of coils

disp('Pitch of commutator segments...')

PC=0.7*D*pi/NC*(10^3) %pitch of coils (in mm)

if 4<PC && PC<9

    disp('Pitch of coils is well within the
permissible limits of(4,9)')

end

```

*C program*

```

#include<stdio.h>

#include<math.h>

```

```

int main()

{

    //Main dimensions of dc machine

double const pi=3.14;

double Pa=300; //KW rating

double V=500; //voltage rating

double P=6; //number of poles of the machine

double Bav=0.67; //specific magnetic loading
(Wb/m^2)

double ac=25000; //specific electrical loading (A/m)

double N=500; //speed of machine

double Rap=0.75; //ratio of core length to pole
pitch

double ns=N/60; //speed in rps

double Co=(pi*pi*Bav*ac)/1000; //output coefficient

double D2L=Pa/(Co*ns); // volume= D*D*L

double RLD=pi*Rap/P; //Value of L/D

double D=cbrt(D2L/RLD); //Value of D

double L=RLD*D; //Value of L

printf("\nThe values of D and L are %lf and
%lf",D,L);

```

```

double va=pi*D*ns; //Peripheral velocity

printf("\nPeripheral velocity is %lf",va);

if (va<=30)

    printf("\nPeripheral velocity is within
    permissible limit of 30 m/s");

else

    printf("\nVa exceeds limit");

double Ia=Pa*(10^3)/V; //armature current

printf("\narmature current = %lf",Ia);

double Iz=Ia/2; //current per parallel path

printf("\nCurrent per parallel path= %lf",Iz);

if (Iz<200)

    printf("\nSimplex winding can be used");

else

{

    printf("\nCurrent limit of 200 A/path was
    exceeded.Simplex winding cant be used");

    Iz=Ia/P; //new current per path

if (Iz<200)

    printf("\nRather LAP winding can be used");

```

```

}

double Ez=Bav*L*va; //average induced emf/conductor

double X=V/Ez;

X=X/10;

X=round(X);

double Zc=X*10; //armature conductors per path
rounded to nearest 10

double Z=Zc*P; //Total no. of conductors

printf("\nTotal no. of conductors = %lf",Z);

printf("\nCondn 1: Slot pitch varies from 2.5 to 3.5
cm...");

double Smin1=round(pi*D/0.035);

double Smax1=round(pi*D/0.025);

printf("\nCondn 2: ratio of no. of slots to pole
varies from 9 to 16...");

double Smin2=P*9;

double Smax2=P*16;

double Smin,Smax;

if (Smin1>Smin2)

Smin=Smin1;

else

```

```

Smin=Smin2;

if (Smax1<Smax2)

Smax=Smax1;

else

Smax=Smax2;

printf("\nFinal Lower & Higher bounds of no. of
slots : %lf - %lf",Smin,Smax);

double A,B[100],C[100];

printf("\nCondn 3: for lap winding no. of slots are
a multiple of pole pair(3)...");

Smin=ceil(Smin*2/P)*P/2; //recalibrating initial
value to multiple of P/2

printf("\nCond 4: to reduce flux pulsations
Slots/pole must be equal to integer + 0.5");

printf("\nThese are the possible values of no. of
slots");

int j=0;

for(A=Smin;A<(Smax+1);A=A+3)

{

    if(A/P==floor(A/P)+0.5)

    {

        B[j]=A;

```

```

        printf("\n%lf", B[j]);

        j=j+1;
    }

    for(int i=0;i<j;i++)

    {

    B[i]=B[i]*Rap/P;

    C[i]=B[i]-floor(B[i]); //finding element with min
    fractional part

    B[i]=B[i]*P/Rap;

    }}

    printf("\nChoosing S which is nearly an integer");

    int pos;

    double min=C[0];

    for(int i=0;i<j;i++)

    {

    if(C[i]<min)

        pos=i;

        min=C[i];

    } //position of optimal value in array

    double S=B[pos];

```

```

printf(" \n Number of slots = %lf",B[pos]);

double Zps=Z/S;

printf("\nNo. of conductors per slot= %lf",Zps);

Zps=round(Zps);

printf("\nAs Zs must be an even integer, the revised
no. of conductors is= %lf",Zps);

double Zrev=S*Zps;

double Sload=Iz*Zps;

printf("\nSlot loading = %lf",Sload);

if (Sload<1500)

    printf("\nSlot loading is within the permissible
limit");

double NC=Zrev/2; //no. of coils

printf("\nNo. of commutator segments : %lf",NC);

double PC=0.7*D*pi/NC*1000; //pitch of coils (in mm)

printf("\nPitch of commutator segments: %lf",PC);

if (4<PC && PC<9)

    printf("\nPitch of coils is well within the
permissible limits of(4,9)");

}

```

## Example Program 2: Design of field winding of DC machine.

### Solution:

*Matlab program*

```
%Field winding design of dc machine
```

```
Vrat=450; %voltage rating
```

```
Vdrop=30; %Drop in field regulator
```

```
ATf=6500; %Ampere Turns per pole
```

```
hf=100; %height of winding
```

```
df=18; %depth of winding
```

```
P=6; %number of poles of the machine
```

```
Lp=180; %length of pole
```

```
Bp=100; %breadth of pole
```

```
rho=0.02; %resistivity of conductors
```

```
i=0.01; %insulation thickness
```

```
V=Vrat-Vdrop; %V across field winding
```

```
Ef=V/P; %V across each coil
```

```
Lmt=(2*(Lp+ Bp)+4*df)/(10^3); %length of mean  
turn(metres)
```

```

af=ATf*rho*Lmt/Ef; %cross-sectional area of field
conductor

Di=sqrt(4*af/pi); %diameter without insulation

D=Di+i; %total diameter(mm)

Nh=round(hf/D); %rounded no. of turns in height

Nd=round(df/D); %rounded no. of turns in depth

Tf=Nh*Nd; %Total turns per pole

If=ATf/Tf %Field current

Loss=Ef*If; %field coil losses

S=2*Lmt*(hf+df)*10; %Dissipating surface area(sq.
cm)

Dissipation=Loss/S %Dissipation in watts/sq.cm

```

*C program*

```

#include<stdio.h>

#include<math.h>

int main()

{

    //Field winding design of dc machine

    const double pi=3.14;

    const double Vrat=450; //voltage rating

```

```
const double Vdrop=30; //Drop in field regulator

const double ATf=6500; //Ampere Turns per pole

const double hf=100; //height of winding

const double df=18; //depth of winding

const double P=6; //number of poles of the machine

const double Lp=180; //length of pole

const double Bp=100; //breadth of pole

const double rho=0.02; //resistivity of conductors

const double i=0.01; //insulation thickness

double V=Vrat-Vdrop; //V across field winding

printf("V across field winding = %lf \n",V);

double Ef=V/P; //V across each coil

printf("V across each coil = %lf \n",Ef);

double Lmt=(2*(Lp+ Bp)+4*df)/(1000); //length of
mean turn(metres)

printf("length of mean turn(metres) = %lf \n",Lmt);

double af=ATf*rho*Lmt/Ef; //cross-sectional area of
field conductor

printf("cross-sectional area of field conductor =
%lf \n",af);
```

```

double Di=sqrt(4*af/pi); //diameter without
insulation

printf("diameter without insulation = %lf \n",Di);

double D=Di+i; //total diameter(mm)

printf("total diameter(mm) = %lf \n",D);

double Nh=round(hf/D); //rounded no. of turns in
height

printf("rounded no. of turns in height = %lf
\n",Nh);

double Nd=round(df/D); //rounded no. of turns in
depth

printf("rounded no. of turns in depth = %lf \n",Nd);

double Tf=Nh*Nd; //Total turns per pole

printf("Total turns per pole = %lf \n",Tf);

double If=ATf/Tf; //Field current

printf("Field current = %lf \n",If);

double Loss=Ef*If; //field coil losses

printf("field coil losses = %lf \n",Ef);

double S=2*Lmt*(hf+df)*10; //Dissipating surface
area(sq. cm)

printf("Dissipating surface area(sq. cm) = %lf
\n",S);

```

```

double Dissipation=Loss/S; //Dissipation in
watts/sq.cm

printf("Dissipation in watts/sq.cm = %lf
\n",Dissipation);

return 0;

}

```

## Review Questions

### *Multiple-choice Questions*

1. \_\_\_\_\_ is used in the construction of yoke of DC machine.
  1. Aluminium
  2. Cast steel
  3. Phosphor-bronze
  4. Brass
2. \_\_\_\_\_ limits the output of a DC machine.
  1. Commutator diameter
  2. Peripheral velocity
  3. Frequency of flux reversals
  4. Temperature rise
3. \_\_\_\_\_ are used to connect commutator segments with the armature conductors.
  1. None of the above
  2. Insulation pads
  3. Copper lugs
  4. Flexible wires
4. Dummy coils in a DC machine \_\_\_\_\_
  1. provides mechanical balance for the rotor
  2. increases the flux density
  3. improves commutation
  4. reduces eddy current loss
5. \_\_\_\_\_ does not vary with load and flux density in a DC machine.
  1. Hysteresis loss
  2. Windage loss
  3. Eddy current
  4. Copper loss
6. \_\_\_\_\_ does not influence specific electric loading in DC

- machine.
1. Magnetizing current
  2. Machine size
  3. Heating or temperature rise
  4. Speed of machine
7. \_\_\_\_\_ does not influence specific magnetic loading in DC machine.
1. Maximum flux density in the iron parts of the machine
  2. Iron losses
  3. Armature reaction and commutation
  4. All of these
8. The limiting factor for higher specific electric loading in DC machine is due to \_\_\_\_\_
1. armature reaction
  2. heat dissipation
  3. commutation
  4. all of these
9. The yoke of a DC machine
1. must be made of non-magnetic material
  2. should preferably be made of magnetic material but can be of non-magnetic material
  3. must be made of magnetic material
  4. is partially made of magnetic material and partially made of non-magnetic material
10. type of conductors are used in large DC machine \_\_\_\_\_.
1. Rectangular
  2. Triangular
  3. Circular
  4. None of these
11. The width of ventilating ducts usually varies from
1. 2 to 3 mm
  2. 4 to 5 mm
  3. 8 to 10 mm
  4. 12 to 15 mm
12. DC machines designed with high current density causes increase in
1. efficiency
  2. temperature rise
  3. copper losses
  4. both (b) and (c)
13. Reactance voltage in DC machine varies with \_\_\_\_\_ apart from rate of change of current.
1. square root of turns on the coil
  2. number of turns on the coil
  3. square of turns on the coil

4. none of these
14. Lamination of poles is done in DC machine in order to \_\_\_\_\_
1. reduce iron weight
  2. dissipate more
  3. heat reduce armature reaction
  4. reduce pulsation loss
15. The number of poles in DC machine is generally decided by \_\_\_\_\_
1. weight of copper
  2. weight of iron parts
  3. frequency of flux reversals
  4. all of the above
16. Increase in the number of poles of DC machine will increase \_\_\_\_\_.
1. overall size of the machine
  2. weight of iron parts
  3. frequency of flux reversals
  4. weight of copper
17. Use of interpoles in DC machines reduces \_\_\_\_\_.
1. sparking
  2. temperature rise
  3. iron loss
  4. hunting
18. A lap wound DC generator has 400 conductors and 8 poles. The voltage induced per conductor is 2 V. The machine generates a voltage of \_\_\_\_\_.
1. 400 V
  2. 200 V
  3. 100 V
  4. 600 V
19. Poles of DC machines are usually laminated in order to \_\_\_\_\_.
1. reduce iron weight
  2. reduce armature reaction
  3. dissipate more heat
  4. reduce pulsation loss
20. \_\_\_\_\_ are the conditions to be satisfied in the design of DC machine.
1. the number of slots per pole should be at least 9
  2. the number of slots per pole pair should be an odd integer
  3. the number of slots per pole usually lies between 9 and 16
  4. all the above
21. The mmf of an interpole is proportional to \_\_\_\_\_.

1. product of armature and field currents
  2. field current
  3. armature current
  4. ratio of armature and field currents
22. In DC machine, the commutator diameter is chosen between \_\_\_\_\_ and \_\_\_\_\_ times of armature diameter.
1. 0.25, 5
  2. 0.6, 0.8
  3. 1.2, 1.5
  4. 1.414, 1.732
23. If the number of poles in a DC machine is increased, it reduces \_\_\_\_\_.
1. overall diameter and length of the machine
  2. length of commutator
  3. weight of core and yoke
  4. all the above
24. Increase in the number of poles of DC machine will decrease \_\_\_\_\_.
1. length of commutator
  2. frequency of flux reversals
  3. labour charges
  4. danger of flashover between brushes
25. The diameter of armature is chosen based on \_\_\_\_\_ in a DC machine.
1. peripheral speed
  2. pole pitch
  3. core length
  4. both (a) and (b)
26. Larger core length is preferred in a DC machine as it \_\_\_\_\_.
1. facilitates ventilation
  2. results in bad commutation
  3. reduces the cost of the machine
  4. both (b) and (c)
27. Air gap in a DC machine is \_\_\_\_\_ compared to induction machine.
1. very small
  2. small
  3. large
  4. equal
28. In a DC machine, air gap at the pole tips is kept more than that of the centre of the pole in order to reduce \_\_\_\_\_.
1. effect of armature reaction

- 2. losses in armature core
  - 3. reactance voltage
  - 4. noise of machine
29. Choice of large air gap in DC machine \_\_\_\_\_.
- 1. reduces distortion effect
  - 2. reduces pulsation losses
  - 3. provides better ventilation
  - 4. all the above
30. The air gap is \_\_\_\_\_ in DC machines with smaller diameters and lesser number of poles.
- 1. longer
  - 2. smaller
  - 3. either of the above
  - 4. none of the above
31. Design of armature with higher air gap flux density will lead to \_\_\_\_\_.
- 1. reduction in iron losses
  - 2. reduction in weight
  - 3. improved commutation
  - 4. increased efficiency
32. In a duplex wave winding, the number of parallel paths for current is \_\_\_\_\_.
- 1. 2
  - 2. 4
  - 3. 8
  - 4. 10
33. In the design of armature, use of lesser number of slots will lead to \_\_\_\_\_.
- 1. reduced output
  - 2. noisy operation
  - 3. improved commutation
  - 4. all of these
34. \_\_\_\_\_ in a DC machine if larger number of slots is used in the armature.
- 1. Cooling is likely to be poor
  - 2. Cost will increase
  - 3. The flux pulsation will increase
  - 4. Commutation will be poor
35. The armature winding resistance of a DC machine depends on \_\_\_\_\_.
- 1. cross-section area of conductor
  - 2. number of conductors
  - 3. length of conductor
  - 4. all the above
36. \_\_\_\_\_ are used in reduction of armature reaction in a DC

machine.

1. Compensating windings
  2. Interpoles
  3. Both (a) and (b)
  4. None of the above
37. The peripheral speed of armature should not normally exceed \_\_\_\_\_.
1. 12 m/s
  2. 20 m/s
  3. 30 m/s
  4. 60 m/s
38. Consider a DC machine with same values of  $\phi$ , Z and N. Which of the following statements is correct?
1. Armature emf is more with wave winding than with lap winding
  2. armature emf is less with wave winding than with lap winding
  3. armature emf depends on whether the machine is running as motor or generator
  4. none of the above
39. The number of parallel paths for a four-pole duplex lap winding is \_\_\_\_\_.
1. 2
  2. 4
  3. 8
  4. 16
40. A DC machine with larger number of armature slots \_\_\_\_\_.
1. will have poor commutation
  2. will have poor flux pulsation
  3. will cost be more
  4. will have poor cooling
41. \_\_\_\_\_ winding is used in DC machine with output current more than 400 A.
1. Simplex wave
  2. Duplex wave
  3. Simplex lap
  4. Duplex lap
42. The width of carbon brush in a DC machine should be equal to \_\_\_\_\_.
1. less than the width of one commutator segment
  2. the width of 1 to 2 commutator segments
  3. the width of 2 to 3 commutator segments
  4. the width of more than 3 commutator segments
43. \_\_\_\_\_ type of brushes in DC motors is suitable for

rotation in any direction.

1. Trailing
  2. Radial
  3. Reaction
  4. Any of the above
44. The major reason for wearing of brush in DC machine is due to \_\_\_\_\_.
1. imperfect contact
  2. severe sparking
  3. rough commutator surface
  4. either of the above
45. \_\_\_\_\_ is used in brushes of DC machine.
1. Copper
  2. Electro graphite
  3. Aluminium
  4. Brass
46. In the use of simplex DC wave winding, the number of brush arms is made sometimes equal to the number of poles in order to \_\_\_\_\_.
1. reduce the commutator length
  2. equalize the number of coils in each parallel path
  3. reduce armature reaction
  4. avoid sparking during commutation
47. The commutator pitch in DC machine should not be less than \_\_\_\_\_.
1. 0.4 mm
  2. 4 mm
  3. 2 mm
  4. 8 mm
48. Higher commutator peripheral speed causes \_\_\_\_\_.
1. ventilation difficulties
  2. commutation difficulties
  3. both (a) and (b)
  4. none of the above
49. Mica is used in the insulation of commutator segments because it \_\_\_\_\_.
1. is mechanically strong
  2. has very high specific weight
  3. is cheaper
  4. both (a) and (b)
50. Reactance voltage in a DC machine \_\_\_\_\_.
1. increases with increase in brush
  2. increases linearly with increase in speed of machine
  3. increases thickness in direct proportion with increase in number of commutator segments

4. all of the above
51. \_\_\_\_\_ commutation takes place by increasing the current density at the leading edge and reducing the same at the trailing edge.
1. Under
  2. Linear
  3. Over
  4. None of the above
52. \_\_\_\_\_ commutation takes place by decreasing the current density at the leading edge and increasing the same at the trailing edge.
1. Under
  2. Linear
  3. Over
  4. None of the above
53. \_\_\_\_\_ brushes are used in design of DC machine with higher values of current density.
1. Metal graphite
  2. Natural graphite
  3. Hard carbon
  4. Carbon
54. Brush friction loss depends on \_\_\_\_\_.
1. brush pressure
  2. peripheral speed of commutator
  3. coefficient of friction between brush and commutator
  4. all of the above
55. Staggering of brushes is done to \_\_\_\_\_.
1. reduce brush contact loss
  2. reduce armature reaction
  3. avoid eating away of copper due to arcing
  4. avoid ridges and to have even commutator surface
56. The field mmf is made \_\_\_\_\_ that of armature mmf in order to avoid excessive distortion of field flux due to armature reaction in DC machine.
1. lesser than
  2. equal to
  3. much larger than
  4. none of the above
57. A sinusoidal voltage of 10 Hz is applied to a field of a DC shunt machine. The armature voltage wave \_\_\_\_\_
1. will be zero
  2. will be of  $10 \times N$  Hz
  3. will be of  $N/10$  Hz
  4. will be of 10 Hz

## Answers

1. b
2. d
3. c
4. a
5. b
6. a
7. c
8. d
9. c
10. a
11. c
12. d
13. c
14. d
15. d
16. c
17. a
18. c
19. d
20. d
21. c
22. b
23. d
24. a
25. d
26. d
27. c
28. c
29. d
30. b
31. b
32. b
33. b
34. b
35. d
36. c
37. c
38. a
39. c
40. c
41. c
42. c

- 43. b
- 44. d
- 45. b
- 46. d
- 47. b
- 48. b
- 49. d
- 50. d
- 51. c
- 52. a
- 53. a
- 54. d
- 55. d
- 56. c
- 57. d

### *Short Type Questions*

*Difficulty level – Easy*

1. What are the parts of DC machine?  
Refer Section 7.2.
2. What are the main parts of stator of DC machine?  
Refer Section 7.2.1.
3. State the uses of yoke in a DC machine.  
Refer Section 7.2.1.
4. Explain about the dual functionality of main poles of DC machine.  
Refer Section 7.2.1.
5. Explain the functionality of interpoles in DC machine.  
Refer Section 7.2.1.
6. What are the main parts of rotor of DC machine?  
Refer Section 7.2.2.
7. What are the functions of pole shoes in DC machine?  
Refer Section 7.2.1.
8. Explain the functionality of commutator in DC machine.  
Refer Section 7.2.2.
9. What are the materials used for brushes in DC machine?  
Refer Section 7.2.2.
10. Explain the main purpose of interpoles in DC machine.  
Refer Section 7.2.1.
11. Why tapering of interpoles is carried out in a DC machine?  
Refer **Page 7.2.**
12. Provide the specifications of DC machine.

- Refer Section 7.2.3.
13. Provide the output equation of DC machine.  
Refer Section 7.3.
  14. Give the relation between  $P_a$  and  $P$  for large DC motor and generator.  
Refer Section 7.3.1.
  15. Give the relation between  $P_a$  and  $P$  for small DC motor and generator.  
Refer Section 7.3.1.
  16. What are the factors influenced by choice of specific magnetic loading in DC machine?  
Refer Fig. 7.2.
  17. Provide the values of specific magnetic loading for DC machine.  
Refer Section 7.4.1.
  18. What are the factors influenced by choice of specific electric loading in three-phase induction motor?  
Refer Fig. 7.3.
  19. Explain about reactance voltage.  
Refer Section 7.4.2.
  20. Provide the values of specific electric loading for DC machine.  
Refer Section 7.4.2.
  21. Provide the factors governing the choice of number of poles of DC machine.  
Refer Fig. 7.4.
  22. What is the effect of number of poles on the weight of copper, frequency, weight of iron parts, length of commutator, labour, flash over between brushes and distortion of field used in DC machine?  
Refer Section 7.5.
  23. Determine the flux per pole in the section of armature core and yoke, if the useful flux per pole is  $\phi$ .
  24. What are the factors affecting the proportions (diameter and core length) of the armature core in DC machine?  
Refer Section 7.6
  25. Compare the effect of eddy current loss and hysteresis loss in two- and four-pole DC machine.  
Refer Fig. 7.1.
  26. Provide the advantages and disadvantages of having higher number of poles in DC machine.  
Refer Page 7.14.
  27. Provide the guidelines for selection of poles in DC machine.  
Refer Section 7.5.1.
  28. Provide the factors affecting the choice of length in DC machine.  
Refer Section 7.6.
  29. Provide the expression to determine the limiting value of emf in a

- conductor, length and diameter of DC machine.  
Refer Sections 7.6.1 and 7.6.2.
30. Provide the choice of pole proportions and ventilating ducts involved in the separation of diameter and length of DC machine.  
Refer Section 7.7.
  31. Discuss about the factors affecting the choice of airgap length in DC machine.  
Refer Section 7.8.1.
  32. Explain about the estimation of length of airgap of DC machine.  
Refer Section 7.8.2.
  33. Explain the steps involved in the design of armature of DC machine.  
Refer Fig. 7.10.
  34. What are the factors affecting the choice of number of armature slots of DC machine?  
Refer Fig. 7.11.
  35. What is the typical range of commutator pitch for DC machine?  
Refer Fig. 7.3.
  36. Mention the procedure to determine the number of slots for lap and wave winding.  
Refer Fig. 7.3.
  37. Provide the current density values used in D.C. machine.  
Refer Fig. 7.4.
  38. Mention the parameters governing the length of commutator.  
Refer Section 7.10.
  39. Mention the factors influencing the choice of diameter of commutator.  
Refer Section 7.10.
  40. Provide the expression for total number of commutator segments, minimum number of commutator segments required to provide voltage of 15 V between segments at no load and length of commutator of DC machine.  
Refer Section 7.10.
  41. Provide the expression for brush area and denote the location of brush in commutator of DC machine.  
Refer Section 7.10.1 and Fig. 7.14.
  42. Mention the losses occurring in the commutator of DC machine.  
Refer Section 7.10.2.
  43. Provide the expression for brush friction loss and temperature rise in DC machine.  
Refer Section 7.10.2.
  44. Explain about copper (coil) space factor.  
Refer Section 7.11.1.
  45. How the estimation of ampere turns of the series field coil is performed?

Refer Section 7.11.3.

46. What is the polarity and location of interpole with respect to main pole in a DC motor and generator?

Refer Section 7.12.

*Difficulty level – Medium to hard*

1. Mention about the determination of main dimensions of armature from  $D$  &  $L$ .

In DC machine, the ratio of pole arc to pole pitch is in the range of 0.68 and 0.7. Also, pole arc is not equal to the gross length of armature. Hence, the relationship used to separate  $D$  and  $L$  from the  $p$   $D$   $L$  by the following relation:

$$L = 0.68 \text{ to } 0.7 \frac{\pi D}{P}$$

2. How the connection of interpole winding is done with respect to armature winding?

Interpole winding is connected in series with the armature winding.

3. Why laminating the yoke of a DC machine is not necessary compared to armature?

1. As flux in the yoke of a DC machine is steady (since field system is stationary), yoke of DC machine is not laminated.
2. But in case of armature, the flux is pulsating, so it is laminated.

4. Mention the location and use of compensating winding in DC machine.

Compensating winding is placed under the pole shoe of DC machine that is used to prevent the distortion of the field flux pattern due to armature reaction.

5. Discuss about “active copper” and “inactive copper” in the design of DC machine.

Active copper describes the portion of copper coils lying in the slots of armature and field pole as they determine the electric loading of the machine.

Inactive copper describes the overhang portions of the copper coils as they establish the connection between the conductors and form coils.

6. What are the components of the magnetic circuit of a DC machine?

The magnetic circuit in DC machine consists of yoke, pole, pole shoe, teeth and armature core.

7. What are the different losses in a DC machine?

The different losses in a DC machine are

1. Copper losses
  1. Armature copper loss
  2. Field copper loss
2. Iron or core losses
  1. Hysteresis loss
  2. Eddy current loss
3. Mechanical loss
  1. Friction loss
  2. Windage loss

8. What is slot loading?

Slot loading is the product of current in the armature conductor and number of conductors per slot.

Slot loading =  $I_a Z_s$  Amp conductor

9. Mention the advantages and disadvantages of choice of less number of poles for DC machine.

**Advantages:**

1. Reduction in frequency of flux reversals and iron losses
2. Reduction in flash over between brushes
3. Reduction in labour charges and cost of assembly
4. Reduction in number of commutator segment and brushes

**Disadvantages:**

1. Increase in weight of armature core and yoke
2. Rise in cost of armature and field conductors
3. Increase in overall length and diameter of machine
4. Increase in length of commutator
5. Increase in distortion of field form under load condition

10. Mention the advantages and disadvantages of choice of large number of poles for DC machine.

**Advantages:**

1. Reduction in weight of armature core and yoke
2. Reduction in cost of armature and field conductors
3. Reduction in overall length and diameter of machine
4. Reduction in length of commutator
5. Reduction in distortion of field form under load condition

**Disadvantages:**

1. Rise in frequency of flux reversals and iron losses
2. Increase in flash over between brushes
3. Increase in labour charges and cost of assembly
4. Increase in number of commutator segment and brushes

11. What is square pole and square pole face and why it is preferred in DC machine?

Square pole has the width of the pole body equal to the length of the armature.

In case of square pole face, the pole arc is made equal to the length of the armature.

It is preferred in DC machine as the length of the mean turn of field winding is minimum. Hence, the copper requirement is reduced.

12. What are the methods to reduce armature reaction in DC machine?

The methods to reduce armature reaction are as follows:

1. Provision of interpoles
2. Use of compensating windings
3. Increase in airgap length

13. Mention the advantages of having large airgap length in DC machine.

1. Reduced armature reaction
2. Reduced circulating currents
3. Lesser noise
4. Reduced pole face losses
5. Less distortion of field form
6. Better cooling

14. What are the conditions in deciding the choice of number of slots for a large DC machine?

1. Slot loading  $< 1500$  ampere conductors.
2. The number of slots per pole  $\geq 9$  in order to avoid sparking.
3. The slot pitch should lie between 25 and 35 mm.

15. How the choice of lower value of airgap flux density affects the design of armature?

1. By the choice of lower value of flux density in airgap, armature dimensions (diameter and length) are increased, causing rise in cost due to increase in use of magnetic material.
2. But, it also leads to reduction in armature iron losses.

16. Mention the need for slot insulation.

1. The conductors are placed on the slots in the armature.
2. As the armature rotates, the conductors may get damaged due to vibrations.
3. This may cause short circuit in the conductors of armature core.
4. Hence, slot insulation is provided.

17. Mention the effects due to use of slot with increased depth in DC machine.

With increase in depth of slot, the following happens:

1. Increase in eddy current loss
2. Increase in specific permeance of slot
3. Increase in reactance voltage
4. Fabrication of lamination with narrow width at the roots of

teeth becomes difficult

18. Mention the factor that decides the minimum number of armature coils in DC machine.

Maximum voltage between adjacent commutator segments decides the minimum number of coils in DC machine.

19. Differentiate between stator winding of AC machine and armature winding of DC machine.

Stator winding of AC machine	Armature winding of DC machine
1. It carries AC current and voltage	1. It carries DC current and voltage
1. It has open coils	1. It has closed coils

20. Distinguish between lap and wave windings used in DC machine.

Lap winding	Wave winding
1. The number of parallel paths = number of poles	1. The number of parallel paths = 2
1. It is preferred for large currents	1. It is preferred for large voltages
1. Current through a conductor is $I_a/p$ , where $I_a$ is the armature current and $p$ is the number of poles	1. Current through a conductor is $I_a/2$ , where $I_a$ is the armature current
1. Emf induced in various parallel paths may differ slightly due to asymmetry in the magnetic circuit	1. Emf induced in both the parallel paths will be always equal
1. It will have large number of conductors with smaller area of cross-section	1. It will have less number of conductors with larger area of cross-section

21. Define winding pitch.

The winding pitch is defined as the distance between the starts of two consecutive coils measured in terms of coil sides.

22. Define back pitch.

Back pitch is defined as the distance between top and bottom coil sides of a coil measured around the back of armature. The back pitch is measured in terms of coil sides.

23. Define front pitch.

Front pitch is defined as the distance between two coil sides connected to the same commutator segment. It is measured in terms of coil sides.

24. Define commutator pitch.

Commutator pitch is defined as the distance between the two commutator segments to which the two ends (start and finish) of

a coil are connected. It is measured in terms of commutator segment.

25. Which coil pitch is used to determine the width of the coil (coil size or coil span) in armature winding in DC machine?  
The back pitch ( $Y_b$ ) of the winding is used to determine the width of the coil in armature winding of DC machine.
26. Explain about equalizer connection.
1. In lap winding, due to difference in the induced emf in various parallel paths, there may be circulating currents in the brushes and winding.
  2. The connections that are made to equalize the difference in induced emf and to avoid circulating currents through brushes are called equalizer connections.
  3. The connections are made using copper conductors usually in the form of rings.
27. Mention the reasons for absence of equalizer connections in wave winding.
1. As there are two parallel paths in wave winding, the conductors forming a parallel path will be distributed equally under all the poles.
  2. Therefore, both the parallel paths are equally affected by the asymmetry in the magnetic circuit.
  3. Hence, circulating current is absent in it which requires no equalizer connections.
28. Discuss about dummy coils used in DC machine.  
Dummy coils are the coils which are placed in armature slot for mechanical balance but not connected electrically to the armature winding.
29. Discuss about split coil used in DC machine.
1. Split coils are the coils which will have more than two coil sides.
  2. In this type of coils, all the top coil sides of a coil lie in one slot and corresponding bottom coil sides are placed in two different slots.
30. Mention the advantage use of fractional slot windings DC and AC machine.
1. The use of fractional slot winding in DC machine avoids the use of dummy coils in it.
  2. The use of fractional slot winding in AC machine reduces harmonics in the induced emf.
31. Mention the effect of distributing the conductor in the armature of a DC machine.  
The distribution of conductors in various armature slots leads to effective utilization of flux distributed in the airgap and causes rise in voltage rating of the machine.

32. What is the difference between simple lap and duplex lap windings?  
Simple lap winding forms single closed circuit and the number of parallel circuits in the armature winding is equal to the number of poles, whereas duplex lap winding forms two closed circuits and the number of parallel paths in the winding is twice the number of poles.
33. What is simplex and multiplex windings?  
In simplex lap winding, the number of parallel paths is equal to the number of poles and in simplex wave winding the number of parallel paths is two. In multiplex windings, the number of parallel paths will be multiples of simplex winding, i.e. in duplex winding, the number of parallel paths will be double that of simplex winding and in triplex winding the number of parallel paths is thrice that of simplex winding and so on.
34. What is the number of parallel paths in a duplex wave winding?  
The number of parallel path in duplex wave winding is 4, irrespective of number of poles.
35. What is the minimum number of slots per pole used in the design of DC machine to minimize sparking in the commutator segments?  
The minimum number of slots per pole should not be less than 9 so as to minimize sparking in the commutator segments.
36. What are the factors on which brush friction loss depends in DC machine?  
The factors on which brush friction loss depends in DC machine are
1. Coefficient of friction between brush and commutator
  2. Peripheral speed of commutator
  3. Total contact area of all the brushes
  4. Brush pressure on the commutator
37. Mention the location of commutator in DC machine.  
Commutator is placed midway between the main poles of DC machine.
38. What is the main reason of sparking at the brushes in DC machine?  
Presence of reactance voltage is the main cause for sparking at the brushes in DC machine.
39. How interpoles in DC machine are used to achieve sparkless commutation?  
Design of interpoles is done in order to induce an *emf* in the short-circuited coil undergoing commutation to oppose and neutralize the reactance voltage built in it, ensuring sparkless commutation.
40. Why carbon instead of copper is used in the brushes of a DC

machine?

By use of copper, wear and tear of brushes near the commutator surface will be large, requiring repeated service and replacements. Therefore, brushes in DC machine are made of carbon.

41. Why are the brushes staggered in DC machine?
  1. The brushes are staggered in DC machine so as to prevent grooving and damage to the commutator.
  2. Staggering of brushes is displaying the positive brush sets in one direction and negative brush sets in the other direction.
  3. This ensures uniform wearing of commutator segments or surface (and avoids steps between brush sets).
42. Why more number of brushes per spindle are used in DC machine instead of single big brush?
  1. Brushes in standard sizes of small widths are easy to replace and maintain.
  2. In case of high-speed machines, commutation becomes difficult.
  3. Hence, use of more brushes, small in size provides better commutation.
43. Define commutation in DC machine.

The process of current transfer/reversal in a coil is called commutation.
44. What are the different types of commutation used in DC machine?

The different types of commutation used in DC machine are

  1. Resistance commutation
  2. Retarded commutation
  3. Sinusoidal commutation
  4. Accelerated commutation
45. State the conditions of electrical symmetry of commutator windings.
  1. In DC machine, electrical symmetry in armature windings is achieved if the conductors are placed symmetrically with regard to the field systems.
  2. This condition can be achieved when the number of slots and commutator segments is multiple of pairs of poles.
46. What is the reason for the use of mica strip between two adjacent commutator segments?

Mica is placed in between two commutator segments in order to insulate the segments from each other.
47. Mention the factors to be considered in the design of commutator.

The factors to be considered in the design of commutator are

1. Peripheral speed
  2. Voltage between adjacent commutator segments
  3. Number of coils in the armature
  4. The number of brushes
  5. Commutator losses
48. What type of copper is used in commutator segments of DC machine?  
The commutator segments are made of hard drawn copper or silver copper (0.05% silver).
49. What is the relation between the armature diameter and commutator diameter various ratings of DC machines?  
Generally, the diameter of the commutator is chosen as 60–80% of the armature diameter with the limiting factor being the peripheral speed.  
Typical choices of a commutator diameter for various voltage ratings are
1. For 350–700 V machine, commutator diameter = 0.62 D
  2. For 200–2500 V machine, commutator diameter = 0.68 D
  3. For 100–125 V machine, commutator diameter = 0.75 D.
50. What is the typical range of commutator pitch for DC machine?  
 $4 \text{ mm} \leq \text{Commutator pitch} \leq 10 \text{ mm}$
51. Why is the commutator placed in the rotor of a DC machine?  
Commutator facilitates collection of current from the armature conductors, which is the rotating part of the DC machine. Hence, it is placed in the rotor of the DC machine, where  $D$  = armature diameter
52. Discuss about the design of number of brushes for a DC machine.
1. The number of brushes and its location are decided by the type of winding.
  2. For lap winding, the number of brushes is equal to the number of poles.
  3. For wave winding, the number of brushes is always two.
  4. In each location, there may be more than one brush mounted on a spindle, whenever the current per brush location is more than 70 A.
  5. Hence, the number of brushes in a spindle is selected such that each brush does not carry more than 70 A.
53. Mention the advantages and disadvantages in design of the field system in a DC machine for a larger ratio of field mmf to armature mmf.

**Advantages:**

1. Field distortion due to armature reaction is reduced.
2. The flash over rate in brushes during sudden overloading is minimized in case of generators.
3. Flash over can be minimized in wide speed range operation

of motors.

**Disadvantages:**

1. Quantity of copper required for the field winding is increased.
  2. Winding space required is more, leading to increase in pole height.
  3. Increase in cost of field system.
54. Differentiate between series and shunt field windings of DC machine.

Series field winding	Shunt field winding
1. It is designed to carry heavy current	1. It is designed to carry low current
1. It is made of thick conductors	1. It is made of thin conductors
1. It has lesser number of turns	1. It has larger number of turns

55. What is the length of mean turn of field coil? Provide the expression for it.

Length of the turn in the centre of the field coil is called length of mean turn. It can be calculated from the dimensions of the field pole and the depth of field coil as shown in Fig. 7.15.

Length of mean turn,  $L_{mt} = 2(L_p + b_p + 2d_f)$

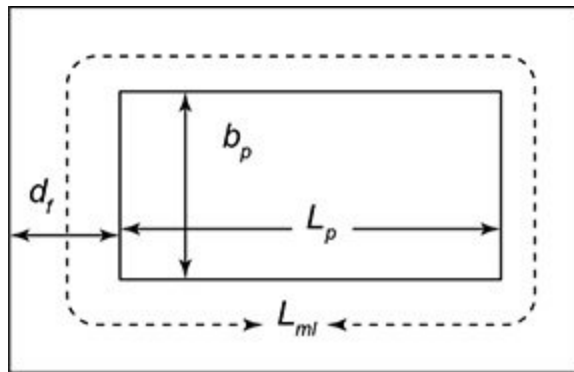

**Fig. 7.15** | Length of mean turn of field coil

56. Mention the factors to be considered for the design of shunt field coil.

The factors to be considered for the design of shunt field coil are

1. Current density in the field conductors
  2. mmf per pole
  3. Flux density
  4. Loss dissipated from the surface of field coil
  5. Resistance of the field coil
57. State the relationship between the number of armature coils and

the number of commutator segments in a DC machine.

The relationship between the number of armature coils and the

number of commutator segments in a DC machine is  $\beta = \frac{\pi D_c}{C}$

where  $\beta_c$  Regular Commutator segment pitch

$C$  = Number of coils

$D_c$  Regular Diameter of commutator

### *Long Type Questions*

1. Derive the output equation of DC machine in terms of main dimensions.
2. Describe about the factors influencing the choice of (a) specific electric loading and (b) specific magnetic loading for DC machine.
3. Describe about the factors influencing the choice of number of poles for DC machine.
4. Explain about limiting values of armature diameter ( $D$ ) and core length ( $L$ ) of DC machine. Also explain the separation of  $D$  and  $L$ .
5. Describe the estimation of length of airgap of DC machine.
6. Explain the design of armature of DC machine.
7. Explain the design of commutator and brushes of DC machine.
8. Describe the procedure for design of field system of DC machine.
9. Describe the procedure for design of interpoles of DC machine.

### *Problems*

1. A 5 kW, 400 V, 4 pole, 1500 rpm DC shunt generator has the average flux density in the airgap as  $1.2 \text{ Wb/m}^2$  and the specific electric loading is 21,000 A/m. Find the main dimensions of the machine if it has to be designed with square pole face. Assume the ratio of pole arc to pole pitch as 0.6 and full load efficiency as 70%.
2. The diameter and length of a 1100 kW, 400 volts, 300 rpm, DC machine is 1.4 m and 0.3 m, respectively. Calculate the mean emf per conductor, total flux and the number of conductors connected in series. Armature drop is 7 volts at full load and max flux density in the airgap is  $1 \text{ Wb/m}^2$ .
3. A 350 kW, 400 V, 500 rpm, 6 pole DC generator has average flux density over pole as  $0.6 \text{ Wb/m}^2$  and specific electric loading as

25,000 A/m. The ratio of core length to pole pitch is 0.7. Estimate suitable dimensions of core diameter, length, number of armature conductors, number of slots and number of commutator segments.

4. Design suitable commutator and brushes for an 800 kW, 450 V, 10 pole, 300 rpm DC machine. The armature diameter is 145 cm with 450 coils. The commutator is to be designed with commutator diameter equal to 0.6 times armature diameter. The peripheral speed of commutator must be greater than 16 m/s, with commutator pitch  $< 7$  mm. Take the current density in brushes to be equal to  $6.5 \text{ A/cm}^2$  with brush current greater than 65 A. The brush drop is 2 V, and brush/pressure is  $1200 \text{ kg/m}^2$ .
5. Design a suitable field winding and find out the section, number of turns and rate of dissipation of heat of a six-pole DC shunt machine, rated for 500 V. The poles are rectangular ones of dimensions  $(10 \times 18)$  cm. The available winding cross-section is  $(10 \times 1.8)$  cm. Use round conductors with resistivity equal to  $0.02 \text{ } \Omega/\text{m/mm}^2$ . The insulation thickness is 0.01 mm. A voltage drop of 25 V occurs in the field regulator. Take the field AT per pole as 7500.

## COMPUTER-AIDED DESIGN AND ANALYSIS OF ELECTRIC MOTORS

### 8.1 Introduction

The necessity of accurate models for design and analysis of the electrical machines has promoted the use of numerical models, based on Maxwell's equations for determining electric and magnetic fields. Determination of analytical solution becomes difficult, due to complex geometrical machine structures and the nonlinearities in the magnetization curve of the motor steel laminations. Hence, Finite Element Analysis (FEA) method, a numerical technique, provides an alternative approach to predict the performance of an electric machine. In FEA, the entire field problem domain is divided into elementary subdomains, which are called finite elements, and the field equations are ...

# Index

## **A**

AC machine [1.9](#)  
Air gap [4.3](#)  
Analytical method (Veinott's method) [5.14](#)  
Apparent flux density [2.32](#)  
Armature [6.1](#)  
Armature core [7.3](#)  
Armature winding [7.3](#)  
Auxiliary winding [5.1](#)  
Axial forces [3.87](#)  
Axial leakage [3.86](#)  
Axial length [2.11](#)

## **B**

Bearings [4.3](#)  
Brush arrangement [7.3](#)  
Bt1/[2.22](#)

## **C**

Capacitor run motors [5.3](#)  
Capacitor split phase motors [5.2](#)  
Capacitor start motors [5.3](#)  
Carter's coefficient [2.10](#), [4.47](#)  
Circle diagram [4.54](#)  
Circular slot [2.55](#)  
Cogging [4.30](#)  
Commutator [7.3](#)  
Conducting materials [1.11](#)  
Conduction [1.25](#)  
Constraints [1.5](#)  
Convection [1.26](#)  
Cooling [1.29](#), [1.60](#), [3.8](#), [3.72](#)  
Core loss [2.40](#), [3.69](#), [4.47](#)  
Core-type transformer [3.2](#)

Crawling [4.30](#)  
Critical speed [6.3](#)  
Current density [3.18](#)  
Cylindrical rotor [6.2](#)

## **D**

Damper winding [6.21](#)  
DC machine [1.8](#)  
Dielectric loss [1.21](#)  
Differential or harmonic or  
belt leakage flux [2.45](#)  
Dispersion coefficient [4.57](#)  
Distribution transformer [3.5](#)  
Double field revolving theory [5.13](#)  
Double layer windings [2.51](#)  
Duties [1.47](#)  
Duty factor [1.50](#)

## **E**

Eddy current loss [2.37](#), [3.67](#)  
Efficiency [3.6](#)  
Electric machine [1.1](#)  
Enclosure [1.42](#)  
Equivalent circuit method [5.13](#)

## **F**

Field winding [6.17](#), [7.1](#), [7.2](#)  
Finite element analysis (FEA) [8.1](#)  
Flash over [7.12](#)  
Flux density [3.17](#)  
Frequency [3.8](#), [3.68](#)  
Fringing [2.7](#)

## **G**

Generator [6.2](#)  
Graphical method [2.22](#)

## **H**

Hard magnetic materials [1.17](#)  
Heating [1.59](#)  
Hydrogen cooling [1.41](#)  
Hysteresis loss [2.36](#), [3.67](#)

## **I**

Indian standard (IS) [1.3](#)  
Insulation materials [1.21](#)  
Interpoles [7.1](#)  
Iron loss [2.36](#)

## **L**

Laminations [3.19](#)  
Leakage [3.48](#)  
Leakage reactance [2.47](#)  
Length of airgap [6.9](#)

## **M**

Magnetic circuit [1.2](#)  
Magnetic field intensity [2.1](#)  
Magnetic flux [2.1](#)  
Magnetic flux density (B) [2.2](#)  
Magnetic materials [1.16](#)  
Magnetic pull [2.59](#)  
Magnetizing current [4.7](#)  
Magneto motive force (MMF) [2.1](#)  
Main dimensions [4.8](#)  
Main poles [7.2](#)  
Main winding [5.1](#)  
MMF [4.47](#)  
Motorsolve [8.1](#)

## **N**

No load current [3.60](#)  
No load losses [3.67](#)

## **O**

Output equation [1.8](#), [4.4](#), [6.6](#)  
Overhang leakage flux [2.47](#)

## **P**

Parallel-sided slot [2.49](#)  
Peripheral leakage flux [2.45](#)  
Peripheral speed [6.2](#)  
Permanence [2.2](#)  
Pole saliency [2.14](#)  
Power factor [4.28](#)  
Power transformer [3.6](#)

Pull out torque [5.3](#)  
Pulsation loss [2.40](#)

## **R**

Radial forces [3.87](#)  
Radial leakage [3.86](#)  
Radial magnetic forces [2.61](#)  
Radiation [1.27](#)  
Rating [1.47](#), [3.8](#)  
Reactance [3.47](#)  
Real flux density [2.32](#)  
Reluctance [2.2](#)  
Repulsion motors [5.3](#)  
Resistance [4.53](#)  
Resistance split phase motors [5.2](#)  
Resistive materials [1.15](#)  
Results [8.15](#)  
Rotor [6.1](#), [7.3](#)  
Runaway speed [6.4](#)

## **S**

Salient pole [6.2](#)  
SCR [6.20](#)  
Semi-closed slots [2.10](#)  
Shaded pole motors [5.3](#)  
Shaft [4.3](#)  
Shell-type transformer [3.4](#)  
Short circuit ratio [6.20](#)  
Silicon steel [1.18](#)  
Simpson's rule  
    (Three ordinate method) [2.24](#)  
Single-phase induction motors [5.1](#)  
Single-phase transformer [3.6](#)  
Skewing [4.51](#)  
Slip-ring rotor [4.1](#)  
Slot leakage flux [2.45](#)  
Smooth armature [2.11](#)  
Soft magnetic materials [1.17](#)  
Specific electric loading [6.8](#)  
Specific magnetic loading [6.7](#)  
Specific permeance [2.47](#)  
Squirrel cage rotor [4.1](#)  
Starting torque [5.3](#)  
Stator [6.1](#)

Stator slots [6.11](#)  
Steinmetz coefficient [2.41](#)  
Synchronous machine [6.1](#)  
Synchronous speed [4.5](#)

## T

Tapered slot [2.53](#)  
T bar slot [2.58](#)  
Temperature fall [1.60](#)  
Temperature rise [1.55](#), [3.75](#)  
Three-phase induction motor [4.1](#)  
Three-phase transformer [3.6](#)  
Tooth top leakage flux [2.44](#)  
Transformer [3.1](#)  
Tubes [3.76](#)  
Turbo alternators [1.38](#)  
Turns per phase [6.13](#)  
Two-value capacitor motors [5.3](#)

## U

Unbalanced magnetic pull [2.62](#), [6.11](#)

## V

Ventilating ducts [2.11](#)  
Ventilation [1.29](#)  
Voltage [3.8](#)  
Volt – ampere [3.63](#)  
Volt per turn of winding [3.17](#)

## W

Winding [6.4](#)  
Window [3.24](#)  
Wound rotor [4.1](#)

## Y

Yoke [3.24](#)  
Yoke or frame [7.2](#)

## Z

Zig-zag leakage flux [2.45](#)

*Editor—Acquisitions: R. Dheepika**Editor—Production: M. Balakrishnan*

**Copyright © 2018 Pearson India Education Services Pvt. Ltd**

This book is sold subject to the condition that it shall not, by way of trade or otherwise, be lent, resold, hired out, or otherwise circulated without the publisher's prior written consent in any form of binding or cover other than that in which it is published and without a similar condition including this condition being imposed on the subsequent purchaser and without limiting the rights under copyright reserved above, no part of this publication may be reproduced, stored in or introduced into a retrieval system, or transmitted in any form or by any means (electronic, mechanical, photocopying, recording or otherwise), ...