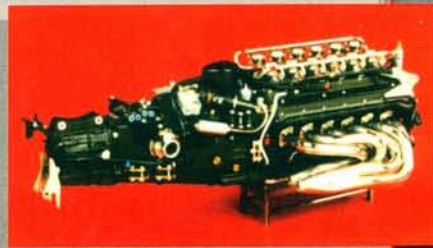


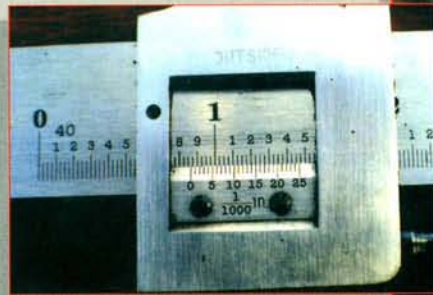
MODELS



TIPS AND TECHNIQUES



PROTOTYPES



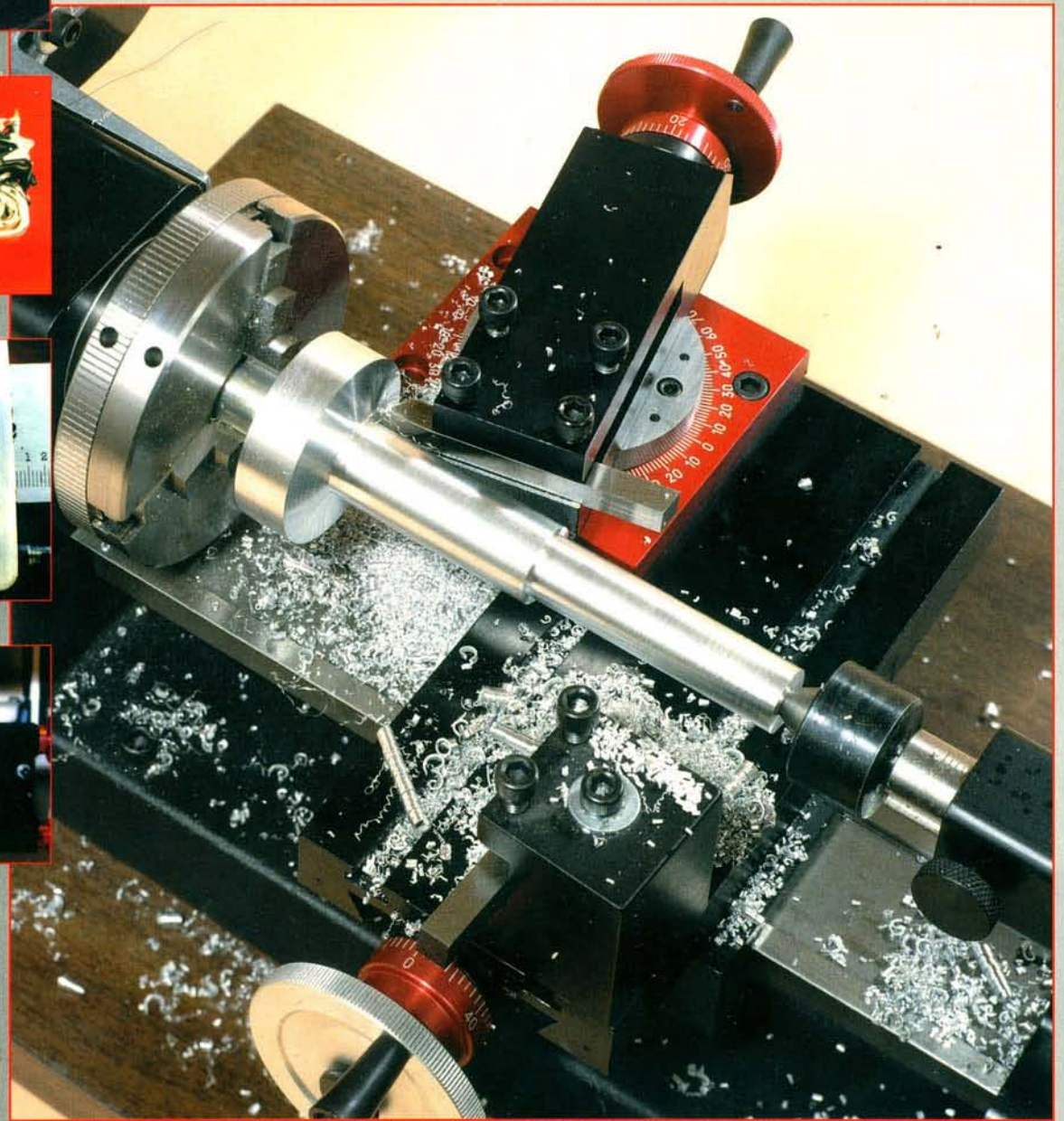
MEASURING



MACHINING SETUPS

# TABLETOP MACHINING

*A basic approach to making small parts  
on miniature machine tools*



*...what every engineer  
should know about  
machining, machinists  
and manufacturing*

**JOE MARTIN**

Photography and  
illustration by Craig Libuse

---

## A special note to engineers reading this book...

### **Machining for engineers and engineering for machinists**

At first glance the subtitle on the cover of this book could be a bit deceiving. What does tabletop machining have to do with engineering you may ask? Compare it to a book that has been written about the ocean. The sea could be described from the perspective of a young man who has just sailed around the world in a twenty-five foot sailboat or by a merchant seaman who has spent his career aboard a giant ocean liner. Each would have an entirely different view of what the ocean was all about. In a storm, the chap in the small boat would write about surviving broken masts and mountainous seas while the merchant seaman might write about seasick passengers. I believe you would learn more about the ocean from the young man in the small boat, because in a sense he was more involved in his subject. He was not just on it, he was *in* it.

### **Navigating the seas of machining**

The ocean in this case is the world of machining. The craftsman using tabletop machine tools is like the sailor in a small boat, while the professional machinist with his big CNC shop tools is like the world-traveling seaman. The process of producing complex, accurate parts cannot be described by looking in the window of a quarter million dollar CNC machine. It would be like a merchant seaman working in the engine room trying to describe a storm in the Atlantic Ocean by telling you how much extra fuel the ship used. The professional's view of the subject may be so cluttered with details that it is difficult to sort the things you really need to know to sail in rough seas or make good parts. It is the craftsman working with small tools, turning the cranks by hand, who will have the most to tell you about the real world of working with metal.

### **Looking at engineering from the craftsman's perspective**

With the aid of computers, parts can easily be drawn that can't be built. CAD programs allow a designer

to put a perfect .0001" radius on the inside corner of a pocket cut in tool steel. Hopefully after reading this book you will not ask a toolmaker to do it, but if you do, you'll at least know it is going to cost a great deal of money to try. Working with metal is far more difficult than one would imagine. A false impression is gained by looking at the beautiful yet inexpensive machined parts that we deal with daily. They have been produced in very large quantities, and that five-dollar part you may consider a "rip-off" could easily cost five hundred dollars if you had to manufacture just one. New engineers will often think a toolmaker is a failure when the seemingly simple part they design ends up costing a thousand dollars to make. Most engineers will eventually have to deal with the craftsman who turns their ideas into reality, and in reading this book I would hope you come away with a new perspective of what is really involved in producing a machined part or a product. An alternate subtitle for the book might have been "Things they should have taught you in engineering school but didn't". This book might be considered your textbook for a course called "Reality 101".

### **Seeing production from the point of view of both the engineer and machinist**

My perspective on machining could be considered unique because, in order to survive, I have had to deal with every aspect of product design from engineering to prototyping to tooling to manufacturing to sales. In this book I have tried to pass along the logic I used to solve the associated problems. Understanding how a craftsman thinks and works is an essential part of getting projects done. Unless you are willing to build your designs yourself, you are going to have to learn how to deal with the craftsman who will actually build them. The more you know about their methods, personalities and unique problems, the better your chances are for success. Smooth sailing.

—Joe Martin

## About the Author



Joe Martin worked in the construction trades after graduating from high school, but his real love was always building and flying radio controlled model airplanes. When he decided to turn his hobby into a business and start his own company making components for the radio control industry, he had to learn about machining and toolmaking on his own. He simply couldn't afford to hire anyone else to set up the tools and make the molds. He has designed and taken to market numerous products and owned several companies over the years. He began his association with Sherline Products as an importer of Australian-built lathes in the early 1970's. Since then, Joe's company has grown to become the sole manufacturer and worldwide distributor of Sherline machine tools.

Joe was one of the founders of the sport of Formula One model aircraft competition as well as one of its early champions. His competitive nature seems to find its way into whatever form of fun he pursues. He has been a winner in sports from model airplane competition to ocean sailboat racing and, most recently, automobile racing.

Never one to be a spectator in life, he has tried and mastered many skills. In this book, he passes on to

you some of his hard-won knowledge about machining. His down-to-earth style is not highly polished. In fact, if you could say that life has put a finish on him, it would probably be described as ground or honed...very accurate but not slick. I

think his heartfelt love of good tools and miniature machining will be apparent to all who read this book. Working with him these past 25 years is certainly an experience I would not have wanted to miss.

—Craig Libuse



*Joe at speed in a 1974 vintage IndyCar at Phoenix International Raceway.*

## DEDICATION



*Carl Hammons—1936-1997*

Carl Hammons, my friend and business partner for thirty years, died September 11, 1997 as I was writing this book. We shared thousands of lunches and coffee breaks over the years we worked together, and much of the knowledge I have passed on in this book came from Carl. Carl and I shared the rare distinction of having been partners not just once, but twice. We both played different roles in putting together the product line, and without him it just isn't going to be as much fun.

When we joined forces for the second time, we had an agreement that eliminated any need to financially justify the purchase of a new piece of equipment. We would buy machines that interested us and find a job for them later. The laser engraver was a perfect example of this, but now we couldn't get

along without it. It may seem contrary to smart business practice, but that's the way we did it. I have no regrets, for we were always the happiest when we were confronted with a new set of technical problems. Therefore, I dedicate this book to Carl Hammons; my business partner, my friend.

---

I should also credit the English teachers in the Cranston, Rhode Island school system for forcing a not-so-willing student enrolled in the "boys general class" to learn enough about our language to dare to take on the task of expressing difficult concepts in simple words. I graduated in 1953. You, the reader, will be the ultimate judge of their (and my) success in this undertaking.

—Joe Martin

*The photo composition above is a joint effort. The photo of Carl was taken by his wife Barbara. The photo of Swan Lake, Montana, a favorite spot of Carl's, was taken by friend Wayne Armstrong. The two images were composed in PhotoShop<sup>®</sup> by artist Elaine Collins.*

# Table of Contents

Safety Rules . . . . .	1	1. Holding parts for milling . . . . .	183		
Foreword . . . . .	3	2. Mill operating instructions . . . . .	191		
Introduction . . . . .	5	3. Squaring up a block . . . . .	205		
A gallery of machining project photos . . . . .	10	4. The rotary table and indexing attachment . . . . .	209		
<b>SECTION 1—GENERAL MACHINING</b>					
Craftsman Profile—Scotty Hewitt . . . . .	24	5. Gears and Geartrains . . . . .	219		
1. Getting information on machining . . . . .	27	6. Accessories for milling			
2. Do you need a lathe, a mill or both? . . . . .	29	• Horizontal milling conversion . . . . .	235		
3. Materials for metalworking . . . . .	39	• Rotary column attachment . . . . .	237		
4. Processes for metalworking		<b>SECTION 4—OTHER MACHINING TOPICS</b>			
4.1—Heat treating . . . . .	45	Craftsman Profiles—Dan Lutz and Paul White . . . . .	242		
4.2—Metal finishes . . . . .	46	1. Setting up a small workshop . . . . .	247		
4.3—Castings . . . . .	49	2. Lathe and mill alignment and adjustments . . . . .	251		
4.4—Other ways to form metal . . . . .	51	3. Engineering drawings . . . . .	259		
4.5—Joining metal—Soldering		4. Frequently asked questions . . . . .	265		
and welding . . . . .	52	5. Making a business out of a hobby...Joe Martin's			
5. Using hand tools and abrasives . . . . .	57	and Sherline's story . . . . .	273		
6. Cutting tools for metalworking		6. Using CNC in a home shop . . . . .	309		
6.1—General notes on cutting tools . . . . .	63	<b>SECTION 5—PROJECTS AND RESOURCES</b>			
6.2—Cutting tools for both		Craftsman Profile—Bob Breslauer . . . . .	316		
the lathe and mill . . . . .	65	Machinist's tips . . . . .	318		
6.3—Lathe cutting tools . . . . .	72	1. Plans and projects you can build . . . . .	319		
6.4—Cutters for milling . . . . .	81	1. Miniature Tap Handle...a beginning			
7. Measuring and measurement tools . . . . .	85	project you can use in your shop . . . . .	321		
8. Coolants and cutting oils . . . . .	99	2. Mill vise "soft" jaws . . . . .	325		
9. General machining terms . . . . .	101	3. Laying out a circular hole pattern			
10. Machine tool lubrication and maintenance . . . . .	107	for drilling, a handy skill to learn . . . . .	327		
<b>SECTION 2—LATHE OPERATIONS</b>					
Craftsman Profile—Jerry Kieffer . . . . .	112	4. "Millie"...a small oscillating steam			
Jerry Kieffer's Flying Pendulum Clock . . . . .	114	engine by Ed Warren, a simple project			
1. Lathe workholding . . . . .	115	from the pages of <i>Modeltec</i> magazine) . . . . .	329		
2. Lathe operating instructions . . . . .	121	5. Ordering plans for the "Little Angel"			
3. Tailstock tools and operations . . . . .	141	hit 'n miss engine...an advanced			
4. Riser blocks . . . . .	145	machining project by Bob Shores . . . . .	333		
5. Supporting long or thin work . . . . .	149	2. Contests and awards for tabletop machinists . . . . .	335		
6. Getting started in thread cutting . . . . .	157	3. Exploded views and part number listing			
7. Knurled finishes . . . . .	167	• Model 4000 and 4400 Lathes . . . . .	340		
8. Watchmaking and clockmaking tools . . . . .	171	• Model 5000 and 5400 Milling machines . . . . .	341		
9. Milling operations on a lathe . . . . .	177	• Model 2000 8-Direction Mill Column . . . . .	342		
<b>SECTION 3—MILLING OPERATIONS</b>				• Part number listing . . . . .	343
Craftsman Profile—Augie Hiscano . . . . .	180	4. A simple RPM gage for your lathe or mill . . . . .	345		
		Harold Clisby and the first Sherline lathe . . . . .	346		
		5. Index . . . . .	347		
		• Conversion factors . . . . .	350		

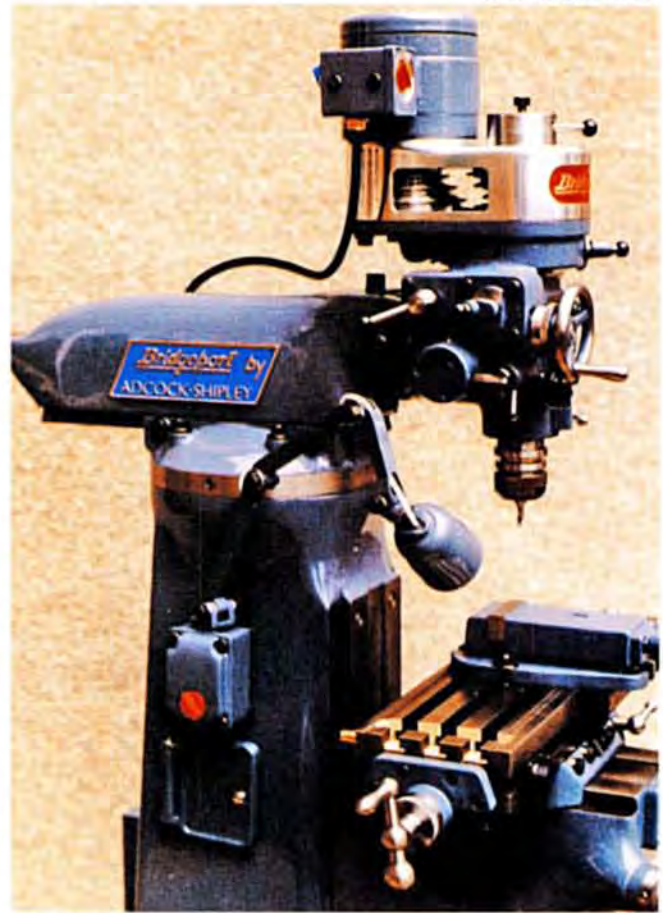
# Modeling Miniature Machine Tools

TOP TWO PHOTOS: BARRY JORDAN

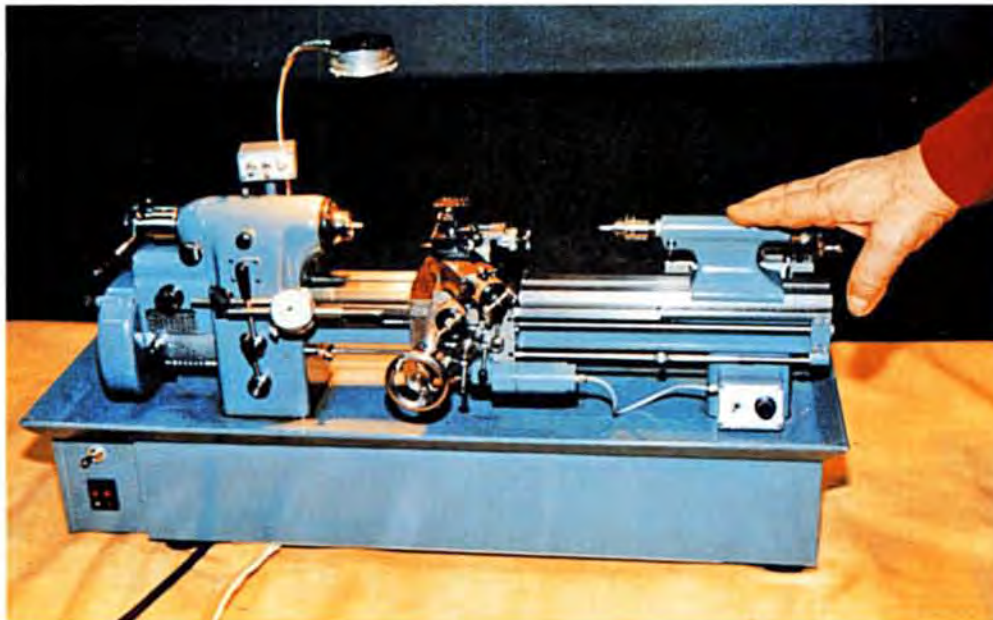
You will probably not be surprised to find that people who are interested in miniature machine tools often find it fun to make miniature models of full-size tools. This page shows beautiful examples of a lathe and a mill from two expert craftsmen.



Barry Jordan built a 2" diameter rotary table and then needed a machine to use it on. The result was this 1/5 scale Bridgeport® mill. The project was started in 1997 and completed just in time for Bridgeport's 60th anniversary in 1998. What started as a model turned into a real machine in miniature, capable of actually cutting small parts in mild steel.



The parts are all machined from aluminum and billet cast iron. No castings were used. The polished pulley cover is made from Dural. More of Barry Jordan's miniature tools can be seen on page 246.



This small but fully functional 1/6 scale Hardinge lathe was modeled by Wilhelm Huxhold of Ontario, Canada. A lifelong machinist, he shows his love for machine tools by modeling them in miniature. Unlike Barry Jordan's Bridgeport, this project took many years to complete. More of Mr. Huxhold's work can be seen on pages 22 and 217. A profile of his career is presented on page 330.

# TABLETOP MACHINING

...A basic approach to making small parts  
on miniature machine tools

**JOE MARTIN**

Design, typesetting, illustration and photography by Craig Libuse

---

### **Machining is not a "paint-by-numbers" process**

If you are looking for a book that will give you complete, step-by-step instructions on how to build your particular machining project, this is not it. In fact, that book probably does not exist. What this book will give you is all the basic knowledge you need to start machining metal. Your imagination plus the information in this book will allow you to make just about anything. The many photos showing what others have done are here to spark your imagination. None of the projects shown in the photos in this book came with detailed instructions. Most came with none at all. They are, for the most part, not beginner projects. I'd suggest you start with a relatively simple project and apply what you learn from this book. As your skill and experience increase, you'll be ready to tackle anything you see here. Read the parts about tools and materials. Read the parts about speeds and feed rates. Study the photos of setups carefully. Everything you need is right there, but you have to use some brainpower to apply it to your projects. The level of satisfaction you achieve will be directly related to the amount of effort you are willing to put forth.

The book is now in its fourth printing, and some have commented that it doesn't contain enough project plans. I have avoided adding a lot of "how to" plans in order to concentrate on the general skills, craftsmanship and techniques needed to create a good part. These will never be found in a set of plans. For those looking to take what they've learned here and apply it to a specific project, there are many sources of kits and plans on Sherline's web site at [www.sherline.com](http://www.sherline.com). Several magazines like *The Home Shop Machinist* and *Machinist's Workshop* offer new plans in every issue.

### **Thanks to those who helped**

Joe Martin and Craig Libuse would like to thank all of those who took the time to read this book word for word and sent in suggestions for corrections in the previous printings. Our thanks go to Marc Cimolino, Jim Clark, Glenn Ferguson Jr., Mort Goldberg, Alan Koski and especially Huntly Millar for their extremely diligent, voluntary efforts. Among other things, this book addresses the issue of quality and the quest for perfection, so we have made every attempt to eliminate any typographical errors. We welcome your input in a continuing effort to improve the quality of this book. Though rarely achieved, perfection is a goal always worth pursuing.

---

©2004 by Joe Martin

First printing—1998, second printing—1999, third printing—2001, fourth printing—2004

All rights reserved. Printed in China by Winco (H.K.) Co. Ltd.

The author takes no responsibility for the use or application of any of the materials or methods described in this book. All miniature projects shown were either made or could be made using tabletop machine tools similar to or identical to those described in this book.

To order additional copies of this book call:

Toll free in the USA—(800) 541-0735 • International—1-760-727-5857  
or write to: Joe Martin, 3235 Executive Ridge, Vista, California 92081

ISBN 0-9665433-0-0

# Safety rules for power tools

## A patternmaker's interview for employment

One of the best patternmakers I ever knew apprenticed in the trade for many years with his father. When he went to work for U.S. Steel in their pattern shop, the foreman who was interviewing him for the job asked him to hold out his hands. When the foreman could see that the applicant still had all ten fingers, he was hired. The foreman could see from his work that the patternmaker was a good craftsman, but he figured that if he had been working in the trade that long and still had all his fingers he must be a good, safe worker too, and that was just as important.

Spinning tools that are powerful enough and sharp enough to remove metal can also remove just about anything else that gets in their way. Though less dangerous than their larger full size shop counterparts, small power tools can still cause serious injury to those who don't show them the proper respect. Even hand tools used improperly can cause injury. Talking about safety is not nearly as fun as talking about the beautiful miniature machining projects in this book, but working safely is part of the skill of a good craftsman.

Working safely is simply a series of habits that you develop. Once they become habits, it takes no longer and is no less enjoyable to work that way than to work with unsafe habits. Injuries definitely take the fun out of working with tools, and fun is what miniature machining is all about. Please read these rules and apply them until they become habits so that you can enjoy your hobby to the fullest.

---

**1. KNOW YOUR POWER TOOL**—Read the owner's manual carefully. Learn the tool's application and limitations as well as the specific potential hazards peculiar to this tool.

**2. GROUND ALL TOOLS**—If a tool is equipped with a three-prong plug, it should be plugged into a three-hole receptacle. If an adapter is used to accommodate a two-prong receptacle, the adapter wire must be attached to a KNOWN GROUND. Never remove the third prong. (See drawing on next page.)

**3. KEEP GUARDS IN PLACE**—and in working order.

**4. REMOVE ADJUSTING KEYS AND WRENCHES**—Form a habit of checking to see that keys and adjusting wrenches are removed from the tool before turning on your machine.

**5. KEEP WORK AREA CLEAN**—Cluttered areas and benches invite accidents.

**6. AVOID DANGEROUS ENVIRONMENT**—Do not use power tools in damp or wet locations. Keep your work area well illuminated.

**7. KEEP CHILDREN AWAY**—All visitors should be kept a safe distance from the work area.

**8. MAKE WORKSHOP KID PROOF**—with padlocks, master switches or by removing starter keys.

**9. DO NOT FORCE TOOL**—Do not force a tool or attachment to do a job for which it was not designed. Use the proper tool for the job.

**10. WEAR PROPER APPAREL**—Avoid loose clothing, neckties, gloves or jewelry that could become caught in moving parts. Wear protective head gear to keep long hair styles away from moving parts.

**11. USE SAFETY GLASSES**—Also use a face or dust mask if cutting operation is dusty.

**12. SECURE WORK**—Use clamps or a vise to hold work when practicable. It is safer than using your hand and frees both hands to operate the tool.

**13. DO NOT OVERREACH**—Keep your proper footing and balance at all times.

**14. MAINTAIN TOOLS IN TOP CONDITION**—Keep tools sharp and clean for best and safest performance. Follow instructions for lubrication and changing accessories.

**15. DISCONNECT TOOLS**—Unplug the tool before servicing and when changing accessories such as blades, bits or cutters.

**16. AVOID ACCIDENTAL STARTING**—Make sure the switch is "OFF" before plugging in power cord.

**17. USE RECOMMENDED ACCESSORIES**—Consult the owner's manual. Use of improper accessories may be hazardous.

**18. TURN SPINDLE BY HAND BEFORE SWITCHING ON MOTOR**—This ensures that the workpiece or chuck jaws will not hit the lathe bed, saddle or crossslide, and also ensures that they clear the cutting tool.

**19. CHECK THAT ALL HOLDING, LOCKING AND DRIVING DEVICES ARE TIGHTENED**—At the same time, be careful not to overtighten these adjustments. They should be just tight enough to do the job. Overtightening may damage threads or warp parts, thereby reducing accuracy and effectiveness.

**20. WHEN WORKING THROUGH THE SPINDLE, DO NOT LET LONG, THIN STOCK PROTRUDE FROM THE BACK END OF THE SPINDLE SHAFT**—The end of unsupported stock turned at high RPM can suddenly bend and whip around.

**21.** It is not recommended that the lathe be used for grinding. The fine dust that results from the grinding operation is extremely hard on bearings and other moving parts of your tool. For the same reason, if the lathe or any other precision tool is kept near an operating grinder, it should be kept covered when not in use.

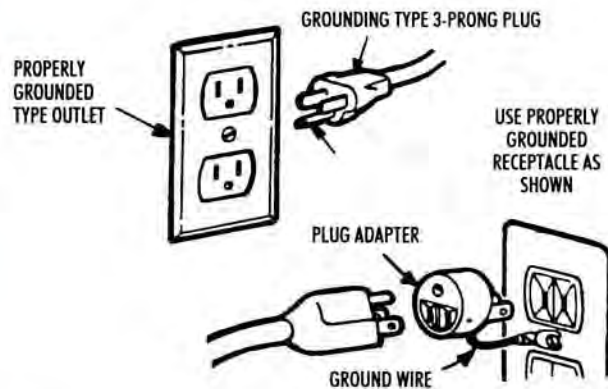
**22. WEAR YOUR SAFETY GLASSES**—Foresight is better than NO SIGHT! The operation of any power tool can result in foreign objects being thrown into the eyes, which can result in severe eye damage. Always wear safety glasses or eye shields before commencing power tool operation. We recommend a Wide Vision Safety Mask for use over spectacles or standard safety glasses.

---

### ELECTRICAL CONNECTIONS

The power cord used is equipped with a 3-prong grounding plug which should be connected only to a properly grounded receptacle for your safety. Should an electrical failure occur in the motor, the grounded plug and receptacle will protect the user from electrical shock. If a properly grounded receptacle is not available, use a grounding adapter to adapt the 3-prong plug to a properly grounded receptacle by attaching the grounding lead from the adapter to the receptacle cover screw.

**NOTE:** Electrical circuits designed into the speed control of the Sherline lathe or mill read incoming current and automatically adapt to supply the correct 90 volts DC to the motor. As long as you have a properly wired, grounded connector cord for your



*Proper grounding of electrical connections.*

source, the machine will operate on any current from 100 to 240 volts AC and 50 or 60 Hz. without a transformer\*. This should include just about any country in the world. Prior to 1994, an AC/DC motor was used. Use the AC/DC motor ONLY with the power source for which it was intended. It will not automatically adapt to any other current and using it with an improper power source will burn out the motor or speed control.

#### Older AC/DC motors available from Grainger

Sherline's supply of older AC/DC motors is slowly being depleted. A very large run must be custom ordered to get more, and this is not economically feasible. However, the Grainger catalog stocks a 1/5 horsepower motor identical to the one used on early Sherline tools. The catalog number is 2M139. They have locations in every state and can be found in the Yellow Pages under "Electric Motors". Their web address is [www.grainger.com](http://www.grainger.com). Your other option would be to upgrade your motor and speed control to the newer, more powerful DC version.

\*The first DC units built in early 1994 did not include the circuits to adapt to other currents. The capability to include that feature was not available to Sherline at that time. As soon as it was, it was included. If you think you may have an early DC model, remove the plastic speed control housing and look for a label on the aluminum speed control frame. If it has a small metallic label on top of the frame that lists input voltage as 120VAC, DO NOT ATTEMPT TO CONVERT THIS UNIT TO OTHER CURRENTS. Models that can be used with any current have a paper label on the end of the speed control frame which lists the model number as KBLC-240DS.

---

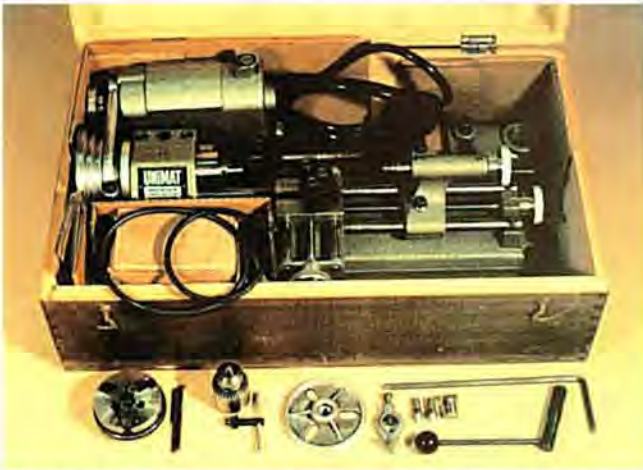
*"Common sense is instinct, and enough of it is genius."*  
— Josh Billings (1818-1885)

---

## FOREWORD

### What is “tabletop machining”?

Tabletop machining is about operating miniature machine tools. These are machines that can be picked up and set on a small bench or, if need be, a kitchen table, and used to build precise metal parts. They are inexpensive compared to their full-size shop equivalents, but are just as versatile and accurate as long as the size of the part is appropriate for the machine. The “Unimat” was the first miniature lathe mass produced and well known. Thousands of Unimats were sold, and today many are still in use. It had a wide variety of accessories manufactured for it and a price that was affordable. A number of other miniature machine tools have been manufactured since the Unimat, and the company I own, Sherline Products Inc., has become today’s leader for this class of machine. I believe the fact I am both a hobbyist and toolmaker gave me more insight into what our customers needed when it comes to both accessories and instructions.



*The original Unimat lathe was the first miniature machine tool to achieve international popularity. It came in a professional looking wood box and offered a versatile design and many accessories at a reasonable price. Its two-rail bed design made it too flexible for jobs requiring a high degree of accuracy, but it introduced many people to the fun of machining in miniature.*

### Beating the system

For me there has always been something special about projects that have been built on these small machines. The machinist who works with miniature machine tools will have beaten the system by not spending thousands of dollars on tools. These

craftsmen build beautiful projects for enjoyment, not wages. These are special people who may suddenly have an urge to accurately build that model they have dreamed of for years. The machinists who are successful will realize there is a learning curve involved in accomplishing this. This book is about shortening that learning curve and giving you a new sense of what craftsmanship is all about.

### Not just the “how”, but also the “why”

The tables and charts can be found in *Machinery’s Handbook*, and I don’t plan to duplicate them in this book. Library shelves are full of books of this nature. The information in this book won’t be found in charts and graphs. I’m going to attempt to give you the information to actually start making “parts”. Instructions that tell you “how” to do a job too often skip the most basic information, and that is “why” you would want to do a job this way or that way. I believe the customers who purchase miniature machines are intelligent enough to find the specific information they need at a library. These customers just don’t happen to know much about machining. However, I also believe this book contains enough general rules to get a job done. Get started on a project as soon as you have your tools set up and working. Read a little, machine a little. Never cut metal without a plan that includes dimensions. “Making chips” without a plan can develop terrible work habits. This trade has few choices when it comes to parts fitting together. To work in unison they must be accurate, and your first task should be to make parts “to size”.

### How to read this book

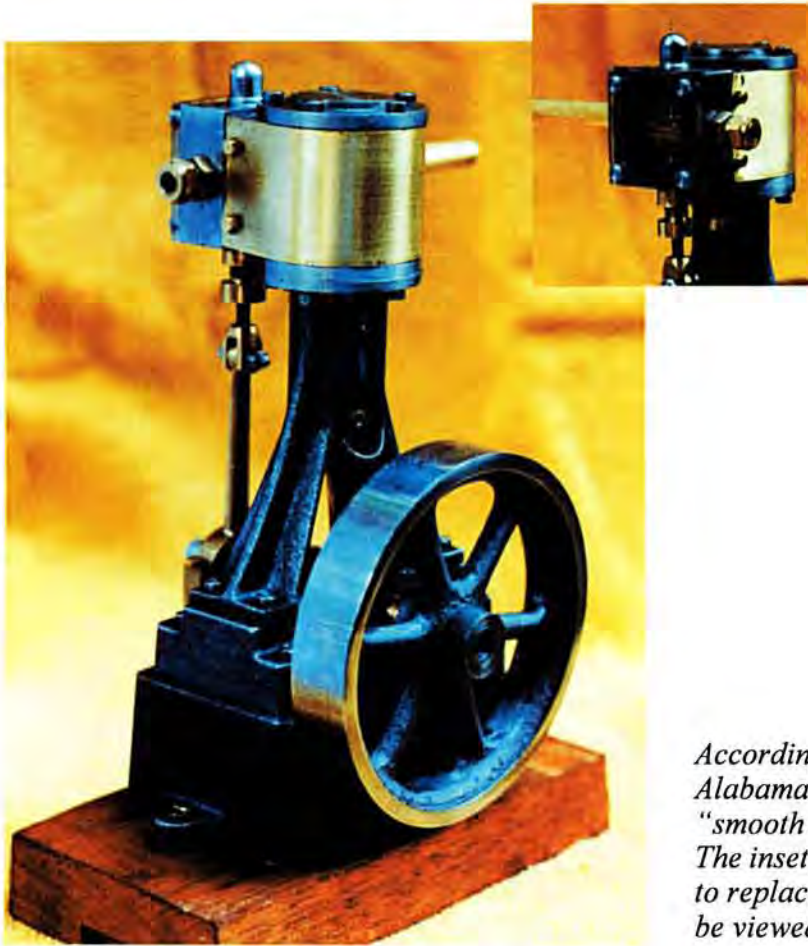
A book like this doesn’t need to be read from front to back like a novel. You will probably skip around reading first the sections that interest you the most. Therefore, this book may seem at times to be redundant. I have attempted to make each chapter relatively complete in and of itself, and some rules apply to more than one machining operation. Some of the more important ones may be repeated wherever they apply. To keep you interested and make the book more fun, we have included many pictures of actual projects and the people who made them. The examples of what has actually been done using tabletop machine tools speak more eloquently about their capabilities than anything I could say.

### Why Sherline tools are used in the examples

I must say up front that Sherline tools will be used in the examples throughout this book. It is not my intention to use this book as a tool to sell Sherline tools, but rather to use these tools to demonstrate the techniques I am discussing. The reason should be obvious; that is, they are what I have available and what I know the most about. The principles involved in using these tools are pretty much typical of all machine tools, even larger full size shop tools, so what you learn through these examples should be able to be applied to whatever brand of tools you are using. Also, we have sold many thousands of these tools over the past twenty-five years, so the knowledge specific to Sherline tools will be of additional benefit to those of you who are using them as you work with this book. In addition, I hope the information I've included about how this tool line was developed and how our business is run might inspire some of you to follow your dreams and start a business of your own, whether it is in the area of machining or in any area that interests you.



*Craig Libuse is seen at the drawing board with author Joe Martin. Craig has been doing all of Sherline's illustrations, instruction sheets, magazine advertisements and catalogs since shortly after Joe started the company in the mid-1970's. He ran his own graphic design studio for 22 years doing Sherline's work on contract before coming on board full time as Marketing Director in 1995.*



*According to builder Edward J. Young of Mobile, Alabama, this model Stuart 10H steam engine runs "smooth as silk" when powered by compressed air. The inset photo shows the plexiglass cover he made to replace the plate over the valve so its action can be viewed as the engine runs.*

---

## INTRODUCTION

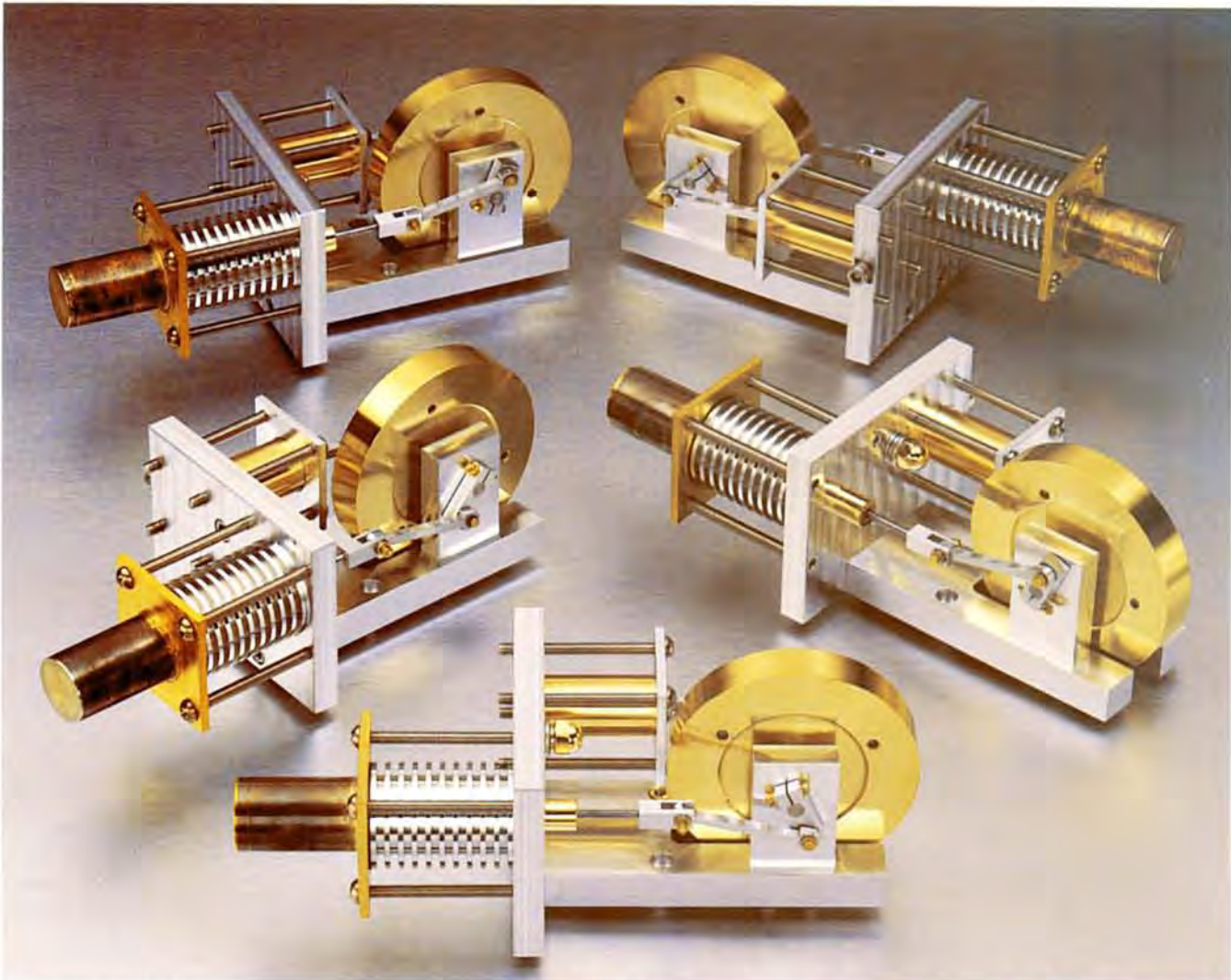
### The essence of "craftsmanship"

I wrote the introduction to this book last. That's because when I started writing, I didn't quite know where I was headed. I knew that over the years I had written many instructions for our products which contained enough knowledge and advice to be valuable. I also figured I could start writing answers to questions that had been asked of me over the years. I could fill the remainder of the book with pictures and charts and end up with a book that wouldn't be any different or better than what was already out there. For me, therefore, the most important part was to try and instill in a potential machinist the value of good craftsmanship. Great

craftsmen not only get the job done, they add a certain "look" to parts they build. It is almost a signature. I have seen the same part made by two different craftsmen using the same drawing. They were both highly skilled toolmakers. Both parts met the specifications perfectly, yet I could easily tell who built each part. Machining should be considered a form of art.

### Some pretty good advice

On the wall of my Uncle's shop when I was a boy was a sign which I still remember. I'm not sure who said it, but I think it expresses what I'm trying to say pretty well. It said:



*Professional photographer, Tim Schroeder of Michigan built these five identical Stirling hot air engines to polish his skill as a new machinist. By making each part five times, he was able to get in more machining time with each setup and learn more in a shorter period...a pretty good way to learn.*

*“A man who works with his hands is a laborer.  
A man who works with his hands and his brain  
is a craftsman.  
A man who works with his hands, his brain and  
his heart is an artist.”*

When I was building model aircraft, my friends and I had an interesting way of judging the quality of a model. We would set the model aircraft on the ground and start backing away from it until it looked good. A three-foot model would be considered superb and a fifty-foot model was one that was pretty crude. There were also models that wouldn't look good no matter what the distance was or the viewing angle. In those cases, the failure was in the design, and the best craftsman in the world can't make a bad design look good.

**The best design is usually not your first design**

The home machinist usually has more control over a design he is working with than a professional does. Don't use the first idea that comes into your head without proving to yourself that it's the **best** way. When a product has been designed properly, no one would even consider building it in a different way.

It is the way it is supposed to look because it's obvious. Unfortunately, these are the designs that are the hardest to come up with. They are also the designs you will get the least credit for even though they are your best. The assumption is that the obvious solution is also the easy solution, but this is usually not the case. The home craftsman also doesn't have to work within the constraints of commercial products where costs limit your choices. For us, time is not money, it's fun!

This is what craftsmanship is all about. Too few citizens really appreciate what good craftsmen do. Because their work doesn't fail it is taken for granted. A good craftsman can tell at a glance when someone's work is better than his, and he can start improving his work to be Number One. It is almost a form of competition between craftsmen where time and quality are considered at the same time. Do you think Michaelangelo would be considered a great artist if he had only carved one statue and painted one picture? He produced so much good work in his lifetime that he set a standard that is still sought after today. One good part doesn't make you a craftsman. You are judged on the body of your work.



*Author Joe Martin is shown with some of the miniature machine tools produced by Sherline Products. The small size of miniature machine tools makes them easy to use and not too intimidating for new machinists.*

I not only wanted my writings to be useful to the hobbyist/machinist who builds parts for pleasure, but also to those future craftsman who want to build parts that have that “look”. Please realize the parts being referred to in this book are not production parts. Machinists who produce these kinds of parts have the training and skill to make automatic machines build good parts. The only thing an automatic machine will manufacture automatically is scrap. It still takes that craftsman’s touch to make machines run perfectly. The parts being discussed in this book will be parts built one at a time...“one off”. These parts are usually part of another assembly that would be considered the final product.

#### **You don’t become a machinist by buying a machine**

You should strive from the beginning to make better and more accurate parts than you think you need. Work to closer tolerances than the job demands. Be on the lookout for ways to make a job easier or better. I hope you will enjoy the process of creating accurate parts from raw metal. Buying a machine won’t make you a machinist, but using it along with the skill and knowledge you acquire along the way eventually will.

#### **What new machinists like most and least**

If you are new to machining, you may find it to be either one of the most rewarding skills one can learn or the most frustrating thing you have ever attempted. What makes machining fun for some is



*Jewel-like projects like this miniature marine winch are a showcase for the kind of craftsmanship machinists strive for. Being able to display your work on a desk or coffee table or even carry it with you in your pocket is an advantage of working on small projects.*

the complexity and challenge. The same thing will drive others up the wall. One person may be overjoyed because he can now make parts that were not available for purchase. Another may wonder why he just spent all day making a part that is similar to one he could have purchased for two dollars. (The difference, of course, is that it is *not* the same as the two dollar part—it is *exactly* the part needed.)

#### **There are no shortcuts**

Machining is a slow process because parts are made one at a time. The interesting thing is, a skilled machinist may take almost as long to make the same part as a novice. Shortcuts usually end in failure. Unlike some other trades, mistakes cannot be covered up. There are no erasers, white-out or “putting-on tools” for machinists. You simply start over. Do a lot of thinking before you start cutting. To expand a little on an old rule: “*Think three times, measure twice and cut once!*”

#### **Anticipation of a tool’s limitations is the craftsman’s strength**

The skill in machining isn’t just “moving the dials”. It is a combination of engineering and craftsmanship. A file is just as useful a tool to a machinist as a multi-thousand dollar machine tool. Tools “deflect” or bend under load, and anticipating this bend is what it is all about. Sharp tools deflect less than dull tools, but with each pass the tool dulls a little and the deflection becomes greater. If you try to machine a long shaft with a small diameter, the center will always have a slightly larger diameter than the ends because the part deflects away from the tool where it has less support. You can go crazy trying to machine it straight, or you can simply pick up a good, flat mill file and file it straight in a few moments. Machine tools will never replace the “craftsman’s touch”, and machining is a combination of both good tools and good technique.

#### **The great parts about running a business like this**

I’m a hobbyist who has been lucky enough to make a living at a hobby I enjoy. I own and manage Sherline Products Inc. and enjoy coming up with new products. After working at it for over twenty-five years, this has become more of a hobby to me than a business. I still work the same number of hours, but it’s more fun now that I don’t have to worry about making payroll. I have a good staff to take care of the day-to-day business, and I get to spend most of the day thinking about better ways of doing things and deciding which new products to



*Here's a miniature machine tool you won't often see. The ManSon lathe is a fully functional miniature machine tool made in the 1940's by a Los Angeles company. It had a number of accessories available, but its extremely small size limited the projects you could actually make on it. It is one of a number of miniature machine tools collected for display by the author. (Sherline chuck and toolpost are for size comparison.)*

make. I appreciate it all the more because it wasn't always that way. At first I had to do it all; buying and maintaining machines, making parts, assembling, packaging and shipping them, doing the bookkeeping and paying the taxes. I realized I had reached a real benchmark in business when I found that a product had gone from raw material to delivery and I didn't know one thing about it.

**The satisfaction of watching others progress**

Another thing I enjoy is determining how a particular part will be run through the shop. Designing new

products has become easier for me now because of the wide assortment of tools we own—about a million dollars worth. In 1985, I could set up and operate every machine I owned, but that time has passed. I don't operate my own machines now because they are too complex to casually start pushing buttons. I have to rely on my employees, and I get a lot of enjoyment out of watching employees progress as they become accomplished craftsmen in their chosen trade. However, I still don't believe anyone in the shop knows more about making good parts than I do. I may not know what

button to push any more but I'm still the best at solving problems in the shop. I've learned a lot about machining over the last 30 years and I'm going to try to pass on some of that knowledge. Because of my experience I can compare methods used by a hobbyist and a professional machinist. I've also added information that I hope you will find interesting about machining. It will give me a lot of satisfaction if I inspire readers to strike out on their own and start a new business with a product that has been "prototyped" on Sherline machines.

**The Inspection Department only finds mistakes after it's too late**

Most of this knowledge I've gathered has been learned the hard way because money was too tight to hire experts. At Sherline we make all of our own parts and only contract out the plating, heat treating, and powder coating. In the past, we have also done a lot of contract machining and I've learned the problems one can get into by finding errors in the inspection department. It's just too late. Parts must be inspected as they are built, not after. Errors found after the parts are made mean you start over. Design errors found after the parts are made will always result in scrap. The only difference is who pays for the scrap.

**Work extra hard to eliminate errors when "the chips are down"**

I've never met a good craftsman who wants to do a job over, even when he is getting paid for it. It goes against his nature. I have also never met a good craftsman who has never had to do a job over because of his own mistakes. This is a good time to stay away from him, because he is mad at himself. The fact is, you can't work with this many types of tools, dimensions, and materials without making an occasional error. The trick is not to make errors when it counts. Good toolmakers will work with an entirely different attitude when they are making an inexpensive fixture than they will when working on a part that has thousands of dollars worth of material and labor in it.

**Inattention can lead to more than just scrapped parts**

You can't have a couple of beers and machine good parts. The job is too demanding. Machining is a serious business. Inattention can result in scrap or, worse yet, injury. You can always make another part but you can't grow a new hand. Even a machine as small as a Sherline lathe or mill can give you a nasty cut. Machinists may have to work for days at a time

with their hands in close proximity to moving cutters and parts, yet there are few injuries. They pay attention to what they are doing.

**The credit for a good part goes to the craftsman**

Good craftsmen know when they have made an exceptional part and get much satisfaction from it. They also have the ability to produce good work on machines that should be in a junkyard. It just takes them longer. I have a great respect for good craftsmen, because they have to work without excuses or erasers. I try to keep reminding you of this fact in this book, because it is the craftsman, not the machine, who builds the beautiful things we see daily in this world. Modern machines have given this talented group of people a way to produce more and better work, but it will always be their "touch" that makes those parts beautiful. In my eyes they just don't seem to get enough respect.

**An open invitation**

If you ever travel to San Diego, California, the Sherline factory is less than an hour away to the North. It's also about two hours South of Los Angeles. I always offer an open invitation for anyone to stop by to see how modern production machines produce parts used in Sherline tools.

---

*"You've achieved success in your field when you don't know whether what you're doing is work or play."*

—Warren Beatty

---



*Sherline's facility has a showroom where you can see the entire line of tools and accessories as well as some sample projects built on the tools. Factory tours are available for anyone who would like to see how miniature machine tools are manufactured.*

## PROJECTS...A gallery of miniature craftsmanship

This section is devoted to showing you some of the great projects made on tabletop machine tools like those discussed in this book. After all, it isn't really the tools you are interested in so much as what can be made with them. A column of figures about the size and accuracy of a machine will tell you how big it is and how well it is built, but it still won't tell you what can be built with it. These photos are some of the most important in the book because they show what these tools in the hands of craftsmen have actually done. And yet, as impressive as some of these projects are, they still only represent the best of what has been done to date, not the best that will ever be done. That is up to you.

Hundreds of years ago, craftsmen made timepieces and mechanical calendars that required tremendous precision.

Modelmakers made tiny ships in bottles and detailed display models of ships. In fact, before naval architects began drawing plans of ships and shipwrights knew how to read them, ship designers built models and the builders used that as a guide. Despite the quality, accuracy and detail of these old projects, the tools they had to work with were crude by today's standards. As tools and materials have improved, it has become easier and more fun to make very precise parts. Almost all of the projects shown here were made by hobbyists, not professional machinists. If you have patience, some skill with your hands and a desire to make projects like these, today's tools will bring you a lot of satisfaction and enjoyment. There is not a project here that couldn't have been built on a tabletop in your own kitchen, den or home shop.



*An American quarter and dime are used for size reference in many photos in this book. For those outside the United States who might not be familiar with these coins, they are shown here at actual size. A quarter (\$.25) is .950" or 24.1mm in diameter, while a dime (\$.10) is .705" or 17.9mm in diameter.*



**Steam tractor, Dennis Franz, Newton, Kansas**

A lot of detail is packed into a very tiny package. This model won 2nd prize at the 1995 Sherline Machinist's Challenge contest in Michigan.

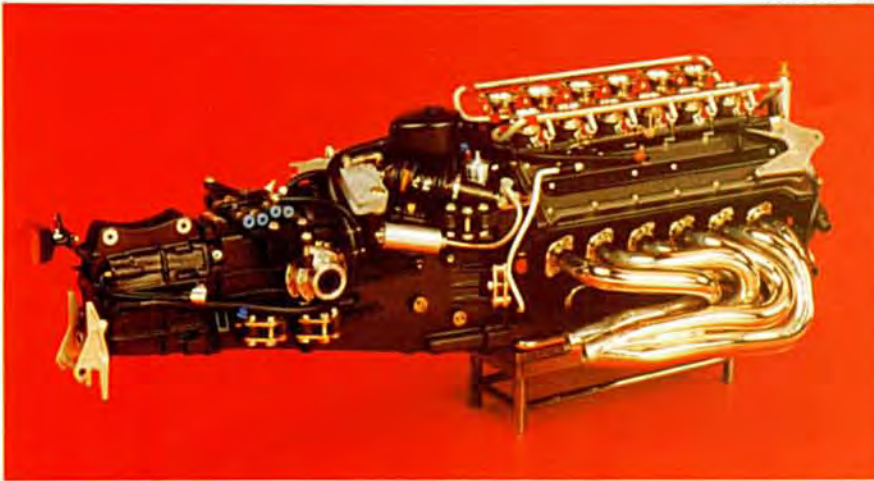


PHOTOS: DAN PAPP

**Stover "hit 'n miss" gas engine  
George Luhrs, Shoreham, New York**

Paint and pinstripes add a nice finish to this model which finished 4th in 1995. It has a 7/16" bore and 5/8" stroke. The speed control is quite detailed and complicated.

PHOTO: BOB BRESLAUER



**1/12 Ferrari V-12 F1 Engine**  
**Bob Breslauer**  
**Ft. Lauderdale, Florida**

Approximately 1500 hand made pieces went into this display model engine and transmission. More photos of it can be seen in the profile on Bob on page 311 at the beginning of Section 5.

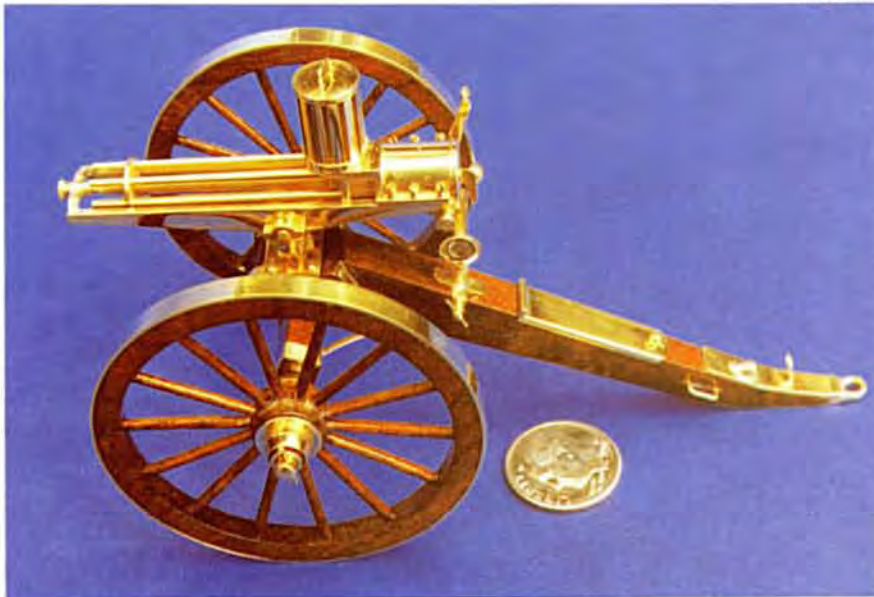
PHOTO: DAN PAPP



**Single action steam engine**  
**Chris Thompson**  
**Colorado Springs, Colorado**

At the extreme small end of the size scale is this tiny steam engine with a 1/8" (3.2 mm) bore and stroke.

PHOTO: DAN PAPP



**Gatling gun, George Britnell, Strongsville, Ohio**

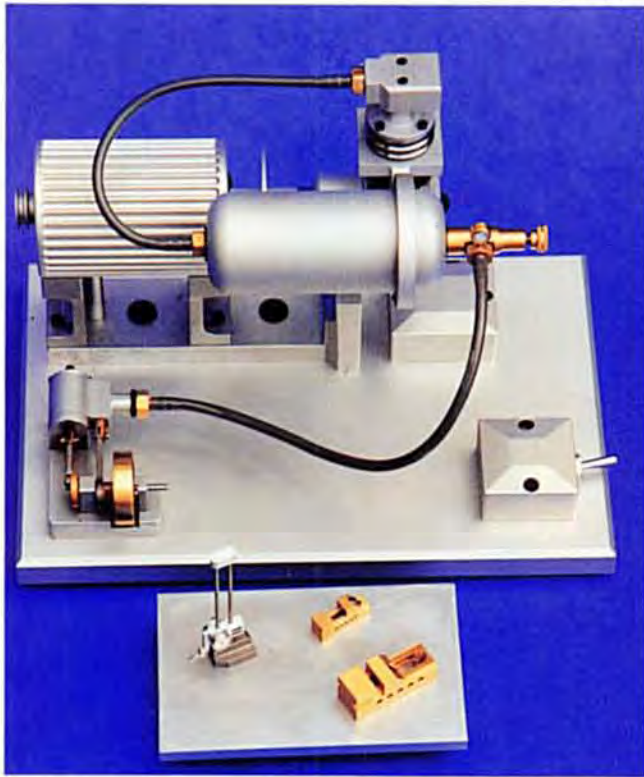
This walnut and brass gun took 3rd place in the 1995 Sherline Machinist's Challenge contest. The barrels rotate and the elevation mechanism also works. The quality of finish on every part is superb.



**Miniature micrometer, Dennis Scherf, Cedarburg, Wisconsin**

Miniature tools are a popular subject for modelers. This tool and felt-lined box can easily be carried in a pocket and is a great "conversation starter."

PHOTO: DAN PAPP



**Air Compressor, steam engine and miniature tools  
Kurt Schulz, Harper Woods, Michigan**

Not just a steam engine, but the air compressor to drive it too, this handsome model is an interesting combination of round and hard edged parts, satin and shiny surfaces. At the bottom are some other of Kurt's projects: a miniature height gage and two small mill vises sitting on a ground surface plate. The small vise would make an interesting tie tack!



**Hot air engine, Scotty Hewitt, Van Nuys, California**

This delicate engine is powered by the difference in temperature above and below it. Set it on a hot cup of coffee, give it a turn and it will spin like crazy for over 15 minutes. Scotty produced a short run of these to sell in toy stores.

PHOTO: JON WALTON



**Lunkenheimer oiler, Jerry Kieffer, DeForest, Wisconsin**

Just like the full size prototype, this tiny oiler delivers measured amounts of oil to a bearing or cylinder. The "sight hole" through the base allows the engineer to check the drip rate visually.



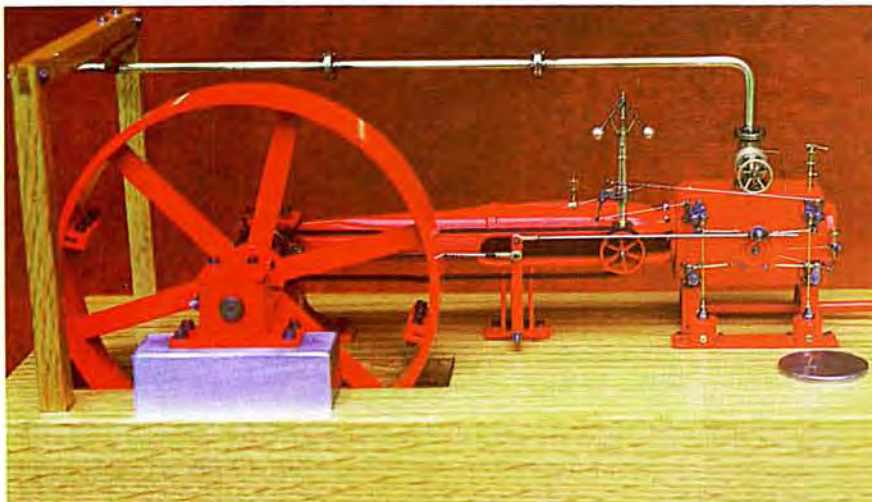
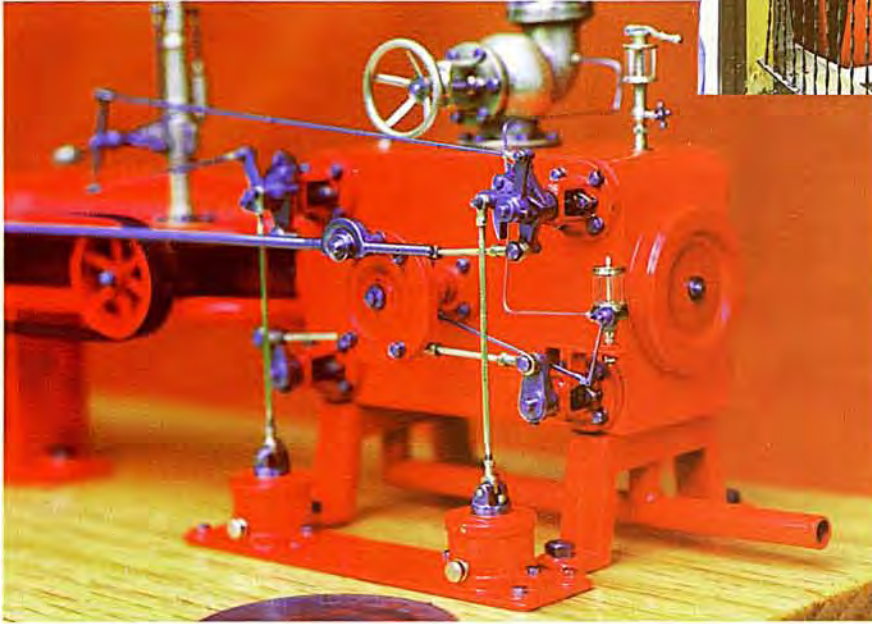
**.010 Diesel model aircraft engine**

A simple design and nicely made aluminum parts make for an interesting little engine. Not much in material cost here!

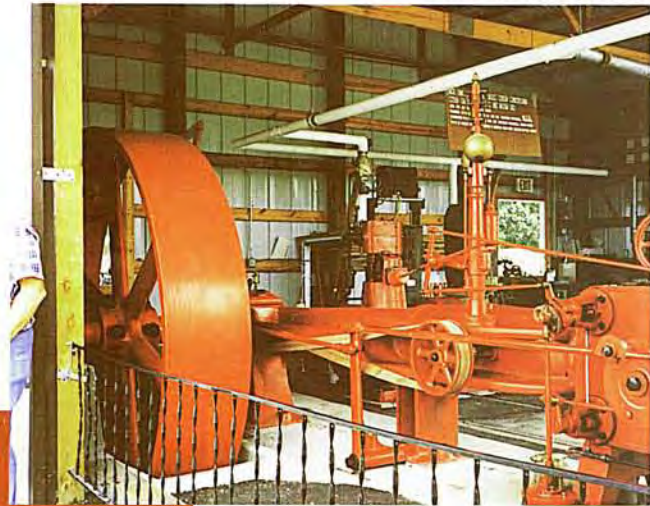
### 1/30 Corliss steam engine Jerry Kieffer, DeForest, Wisconsin

(Below) This model represents Jerry Kieffer's determination to build to scale down to the smallest detail. Even 1/4-20 bolts are scaled to 1/30 size. Though modelers will often use hidden springs to return the valve gear, the "pots" at the bottom actually pull a vacuum just like the real ones. A portion of a quarter can be seen at the bottom for scale. (More on Jerry and this engine can be found on page 112.)

PHOTOS: JON WALTON



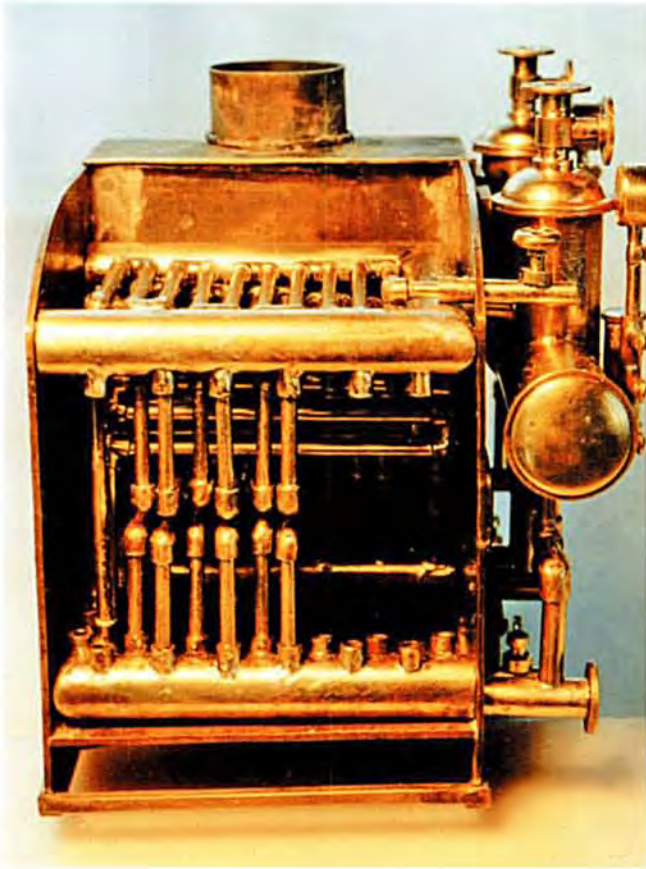
This masterfully built model runs flawlessly on air supplied from a tiny aquarium air pump. Though others told Jerry he would not be able to achieve good performance in a model this small if he insisted on scaling every part, he proved them wrong.



Above is a photo of the real 1909 Vilter Corliss engine Jerry used as a prototype for his model. It can be seen in a steam engine display in Sussex, Wisconsin. It is said to produce about 200 horsepower at 90 RPM, had a 15" bore and 36" stroke and a 10-foot diameter flywheel. The Vilter company still exists in Milwaukee and now makes refrigeration equipment.



The photoengraved name plate is typical of Jerry's devotion to detail. Notice the hollow air line going into the large brass elbow. It has a functional compression fitting and is made from a hypodermic syringe needle.



**U.S.S. Roosevelt  
Richard DeVynck  
U.S. Virgin Islands**

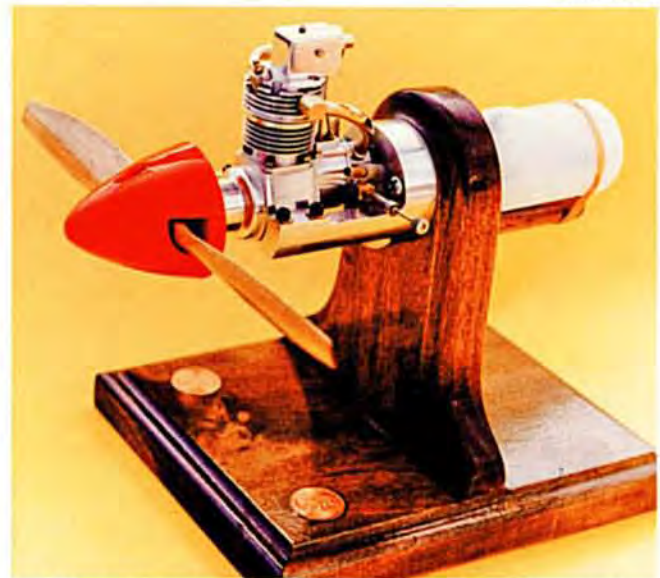
This model is now on display at the Bowdoin College Museum in Maine. To the left is a detail of the ship's boiler. Below can be seen the stack and some of the deck details. The model is left unplanked so that all the interior details can be seen.

PHOTOS: RICHARD DEVYNCK



PHOTO: DAN PAPP

PHOTO: JESSE BRUMBERGER



**1-Cylinder 4-cycle overhead valve model airplane engine  
Ron Colonna, McKeesport, Pennsylvania**

(Above) Ron built this engine from a design by Eric Whittle of England. The highly polished pieces and wood base make it a good display as well as a nice piece of engineering.

**3-Cylinder engine, Jesse Brumberger, Macedon, NY**

(Above left) This radial model airplane engine was an entry in the 1996 Sherline Machinist's Challenge.

**Assorted small projects, Robert Culpepper**

(Left) A small shop can turn out plenty of nice work.

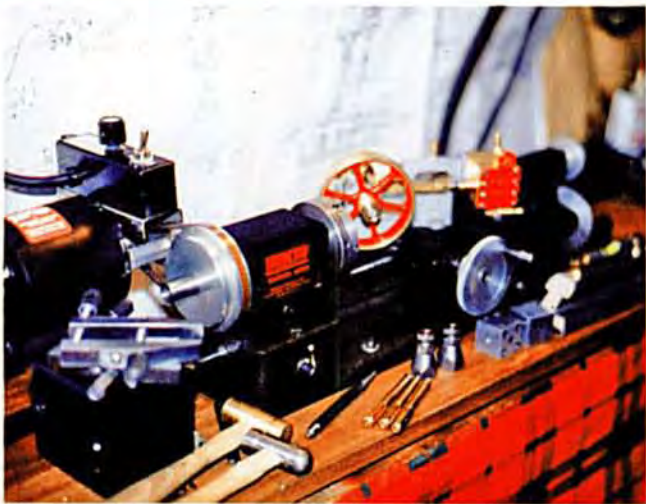
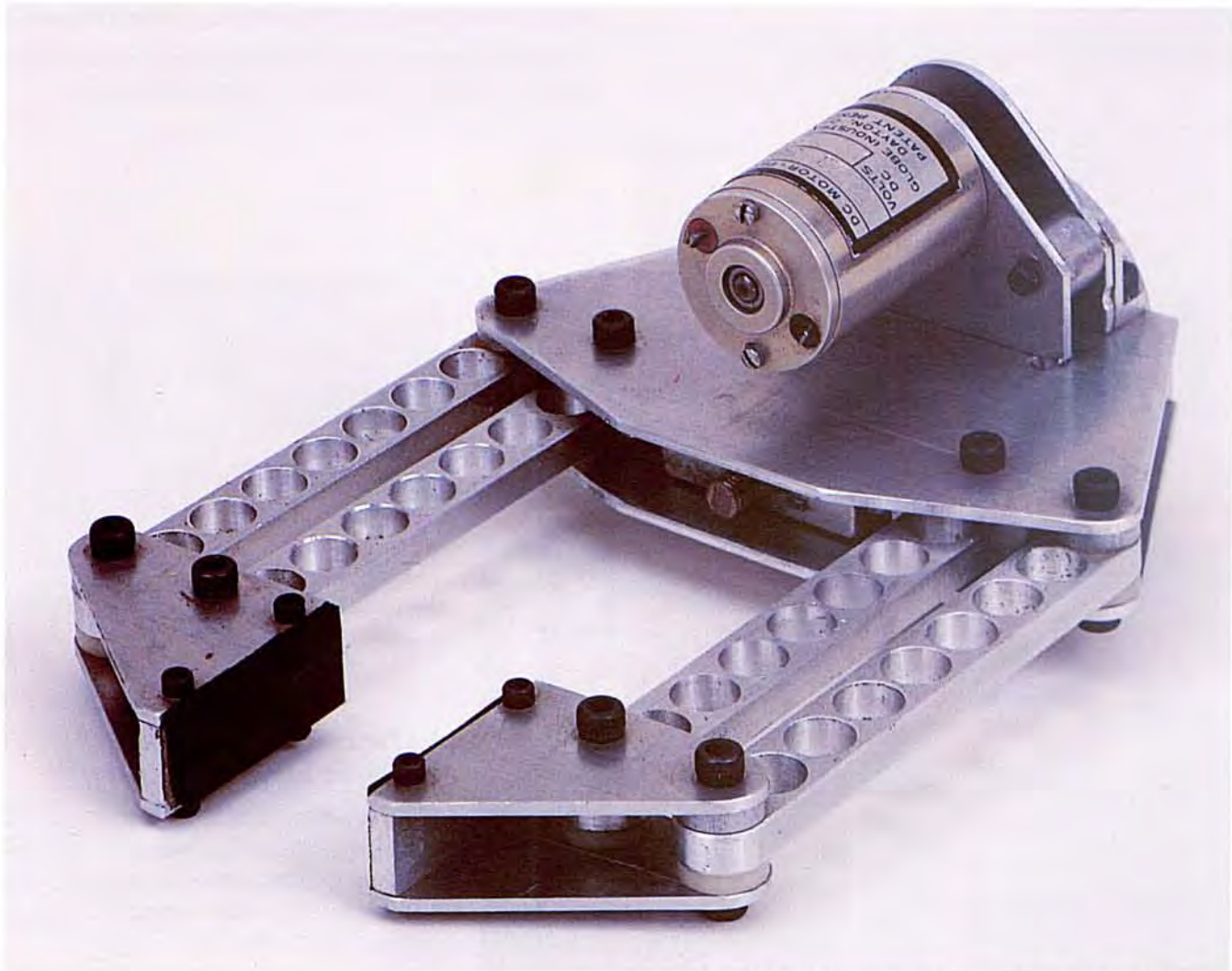


PHOTO: ROBERT CULPEPPER



**Robot Hand, Carl Hammons, Escondido, California**

Joe's partner Carl was interested in robotics and motion control. He built this 4" hand to test a concept he had in mind for gripping.



**Fantasy Gun, John Winters, Seattle, Washington**

Lost wax castings and machined parts are combined in this air powered, B-B firing gun that looks as if it came straight from a Buck Rogers episode.

**Custom silver key ring, Jim Grabner, Leucadia, California**

The spiral and radial geometric pattern on this silver key ring helped it win a blue ribbon at the San Diego County Fair in Del Mar. Projects like these are not what comes to mind when most people think about "machine tools", but in the hands of a creative person, a good tool makes many things possible. Jim used a rotary table on the mill to create the patterns.

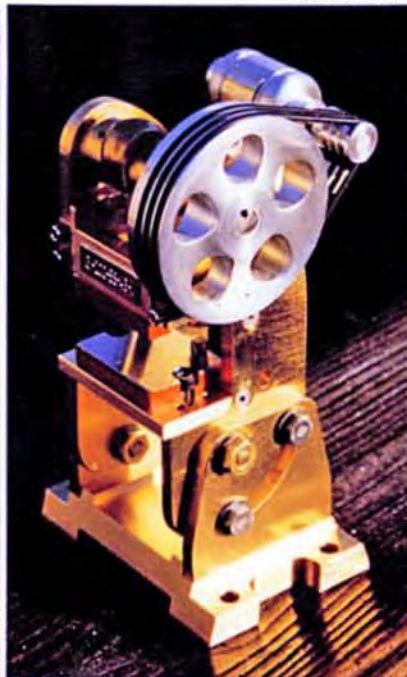




**Hula-hula radial engine, Russell Kutz, Clinton, Wisconsin**

(Left) This engine gets its name from the interesting action of the six oscillating radial cylinders.

PHOTOS: GLENN BUSCH



**Gap frame stamping press  
Glenn Busch, St. Clair Shores, Michigan**

Here are two views of a solidly built and nicely finished model. The contrast of brass and aluminum parts give it a very rich look.

**Gyroscope  
Tim Schroeder, St. Joseph, Michigan**

(Right) This nicely finished gyroscope includes details like lightening holes in the support arms and chamfered holes and edges on the wheel. Tim is a professional photographer, so even the photos of his work are done with great attention to detail.

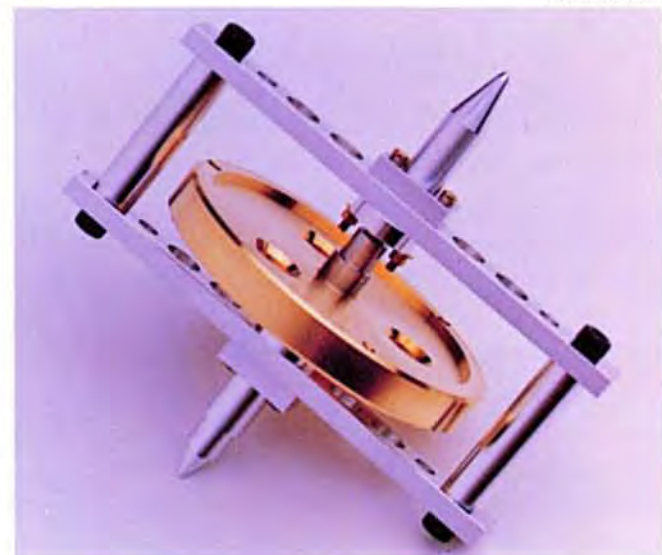


PHOTO: TIM SCHROEDER



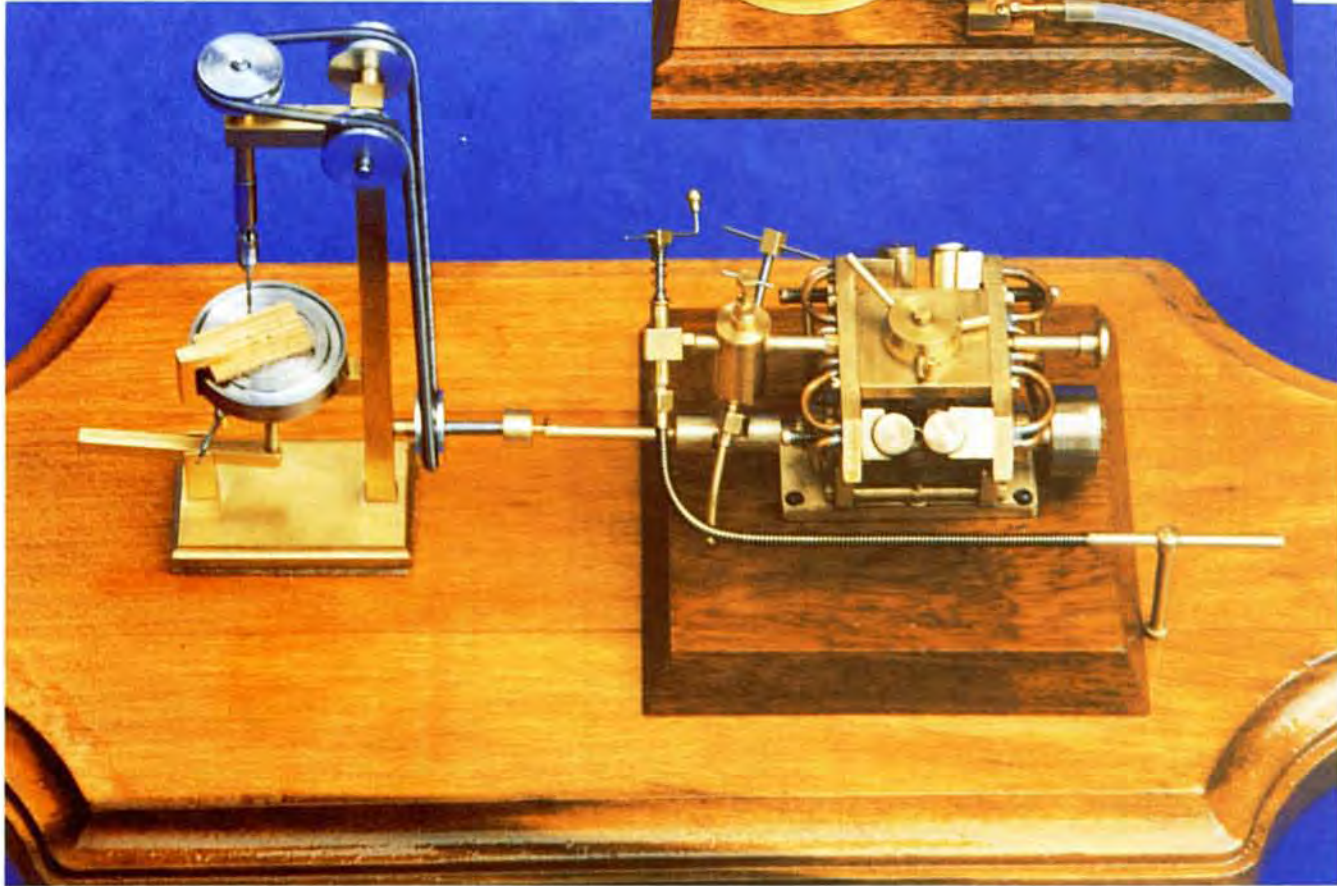
PHOTO: PETE WEISS

**1/6 Porsche piston and cylinder  
Pete Weiss, Escondido, California**

(Above) As part of a project to build a running 1/6 scale Porsche flat 6-cylinder engine, Pete has so far built a number of the components. See page 120 for more photos.

**Marine engine and drill press/Water pump  
Scotty Hewitt, Van Nuys, California**

Scotty's main project won 1st place in the 1995 Sherline Machinist's Challenge, but he also took 5th place with this one. To the right is another of Scotty's projects; an air powered water pump. Scotty's work always combines many materials, skills and a lot of imagination. Notice how the wood bases add a finishing touch like a good frame on a nice painting. For more photos and a profile on Scotty see page 24.



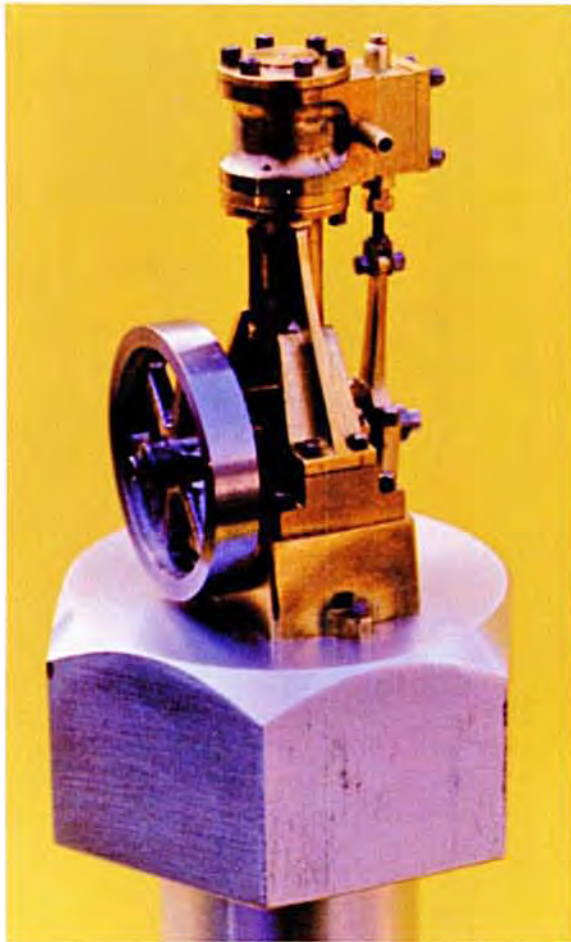
PHOTOS: DAN PAPP



**Radar study model  
Frank Libuse, Carlsbad, California**

This waterline model was used to test radar targeting systems for antiship missiles. A number of small deck fittings had to be fabricated from metal. Simpler models were also made to see how much detail was needed for a missile to be able to recognize and target a particular ship.

Frank is a pilot and industrial designer who started his own design firm and industrial model shop after retiring from the Air Force. He is also Craig's father, and Craig worked with Frank for several years in the design and model business before starting his own design firm.



**Miniature Stuart 10V steam engine**  
**Chris Dinardo**  
**Springfield, Illinois**

The large hex bolt used as a display base really points out how small this engine is. Despite its small size, all the working details are still there, modeled in bronze, brass and steel.

PHOTOS: DAN PAPP



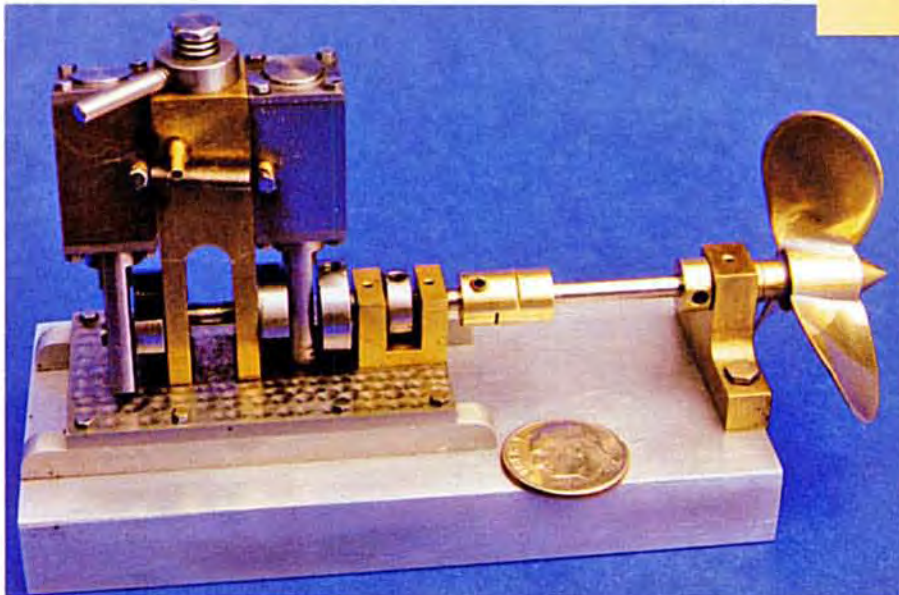
PHOTO: DAN PAPP



**2-Cylinder marine engine**  
**Raymond Hasbrouck, New Platz, New York**

(Below) This model exhibits a nice combination of materials and finishes. Notice the engine-turned pattern on the base. The custom propeller is an interesting project all its own. (To learn how to make one, see page 56.)

PHOTO: DAN PAPP



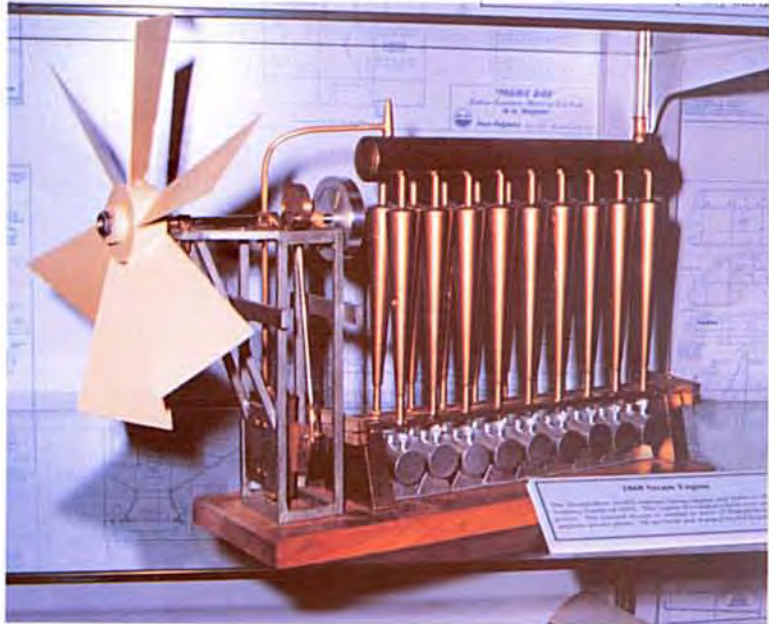
**Thimble steam engine**  
**Richard Long**  
**Wichita, Kansas**

(Above) This tiny butane powered engine drives a stamping mill. Using the thimble as part of the design is a clever way to emphasize small size.

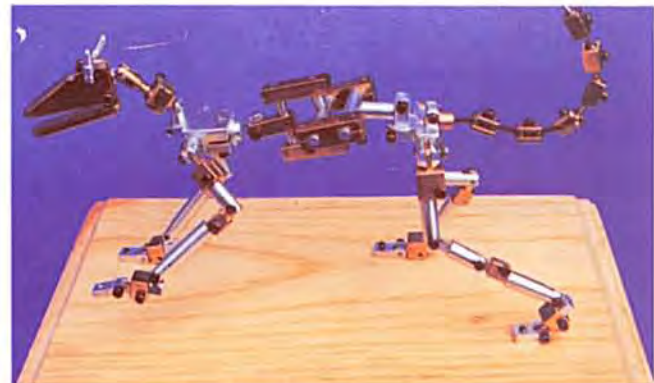


**Model airplane display engines**  
**Edwin Teachworth, San Diego, California**

This display model of a 1911 compressed air engine was built for an exhibition on the history of model aviation at the San Diego Aerospace Museum. Though it looks like metal, it is made from cut and machined styrene components and painted to look like metal. Styrene is easy to work with, glues together quickly and is popular for modeling.



This is another display model from the same exhibit and is a model of a Stringfellow steam model airplane engine. It is made from a combination of materials including styrene, wood and brass. The original engine won a prize for engine design in 1868 and developed about 1 horsepower. Display models need only look like the prototype, while function is less important than looks, cost and ease of building.



**Stop motion animation dog, Tom Brierton, Illinois**

With all the joint movements of a real dog, this framework is covered in clay and then photographed one frame at a time as it is moved in progressive steps.

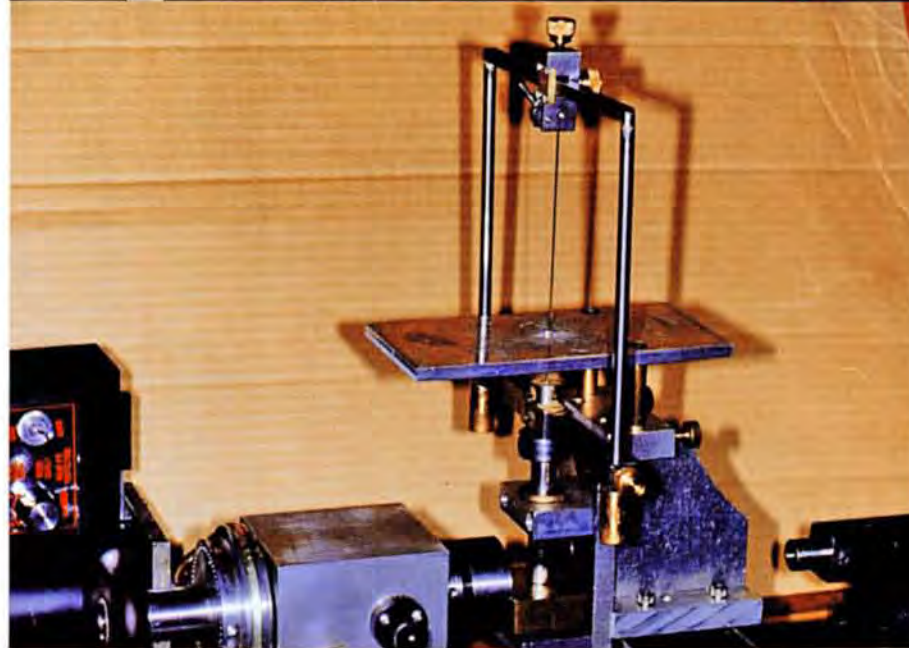
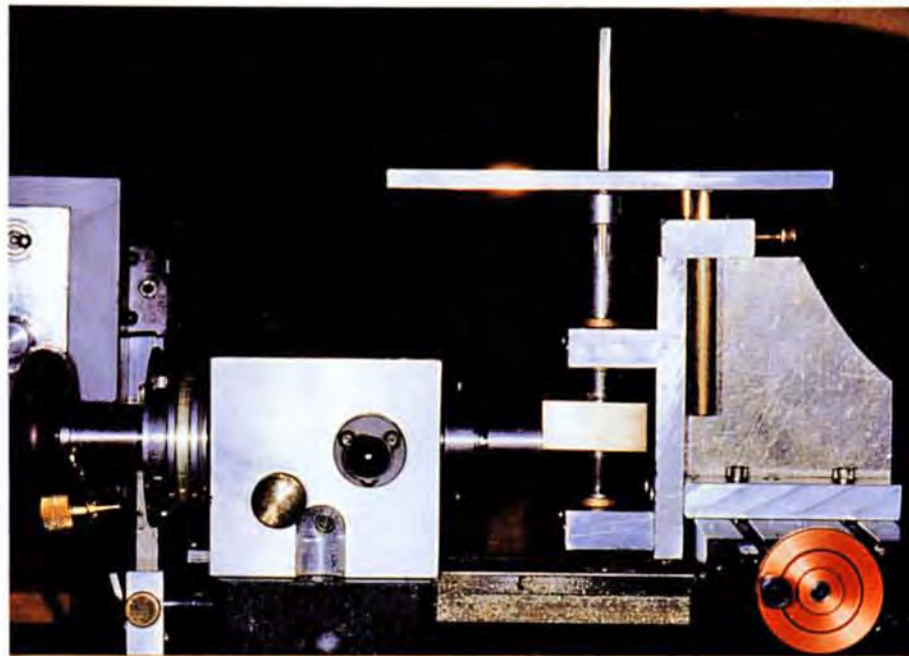
**Pre-lubricator for steam or air engine**  
**Salvatore Rubino, Naperville, Illinois**

This device provides oil under pressure to lubricate bearings before an engine is started. This extends engine life substantially since most wear occurs when bearings are dry.



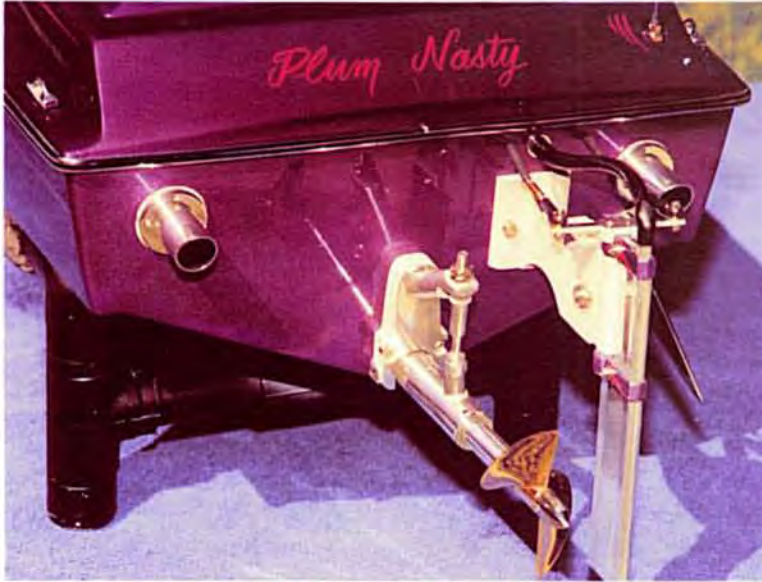
**Scroll saw and die filer conversion**  
**Milo Bresley, Bloomington, Minnesota**

Mr. Bresley designed and built a die filer and scroll saw powered by his Sherline lathe. The die filer is driven by the "Scotch yoke" principle. Many people find the chief source of enjoyment in their hobby is designing and making new accessories for their machines. It not only provides a fun and challenging project, but your machine shop is that much more complete when you are done.



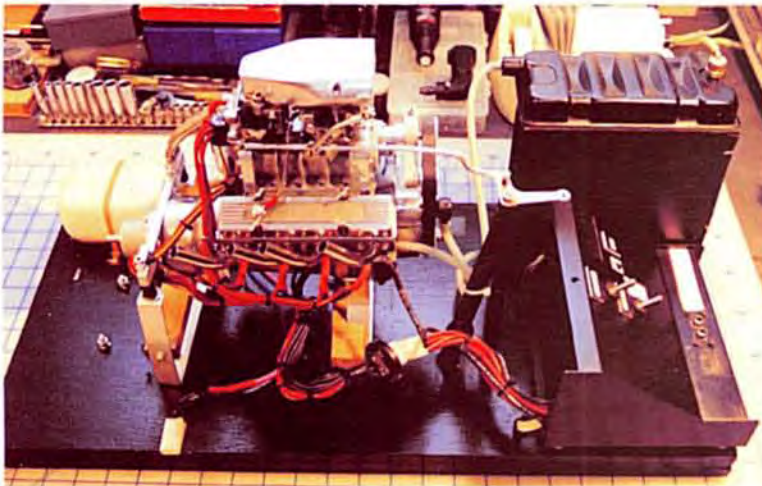
**Quick-change tool holders**  
**Roland F. Gaucher, Spencer Massachusetts**

This working model of an Aloris toolholder is built 3/10 the size of the #1 size holder used for full size machines. These holders follow big machine practice, allowing tools to be quickly locked onto a special dovetailed holder. This is another good example of using the tools in your shop to build accessories to make your shop that much better equipped.



**Custom model boats and engines  
Don Martin, Sacramento, California**

Don's small shop turns out some excellent R/C drag boats. All his tools are within easy reach and a vacuum cleaner rests under the

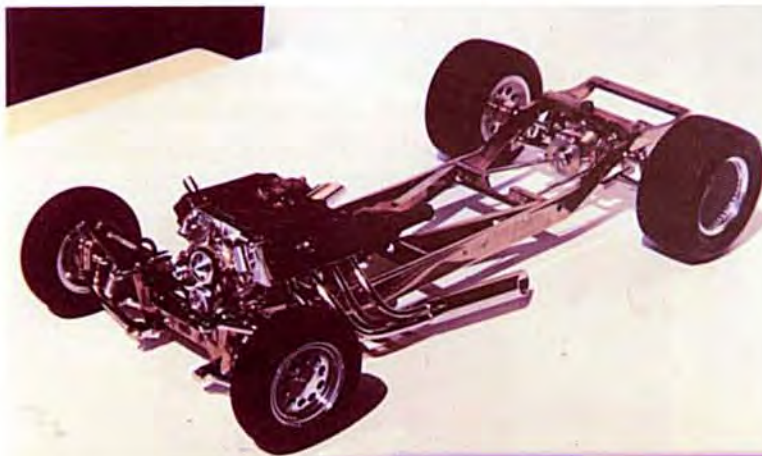


(Above left) High performance machined out-drive components and exhaust tips sparkle on *Plum Nasty's* transom.

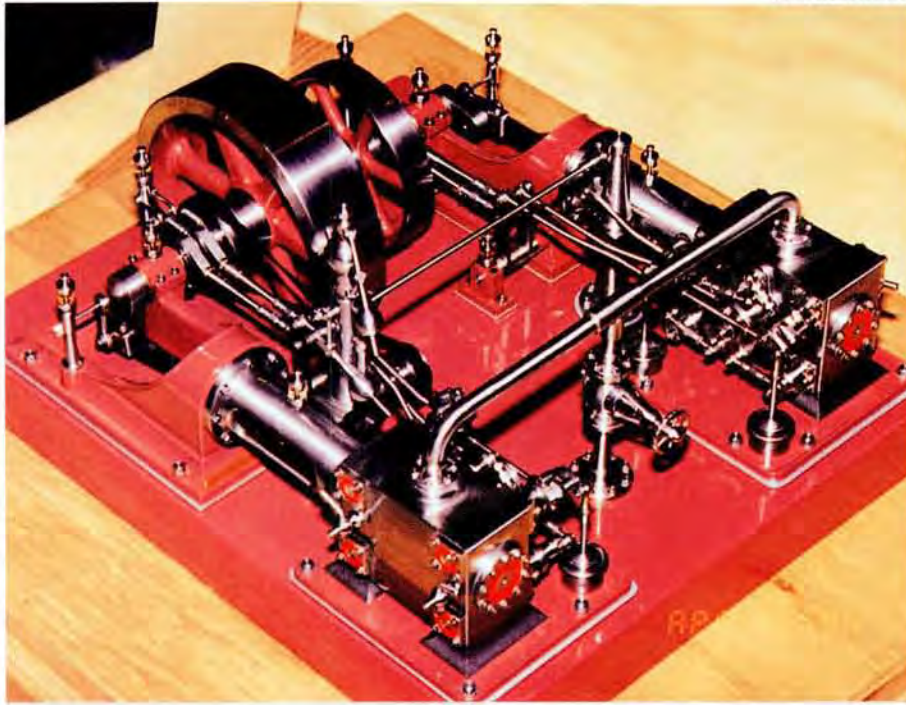
(Left) A Connolly V-8 with supercharger sits on its test stand. The rig provides readings on temperature and RPM.

**Model hot rod, Augie Hiscano, Miami, Florida**

This 1/25 scale hot rod won the top national award for model cars. Shown here is just the engine and frame. Notice the scale Jaguar independent rear suspension made up of almost 100 separate parts.

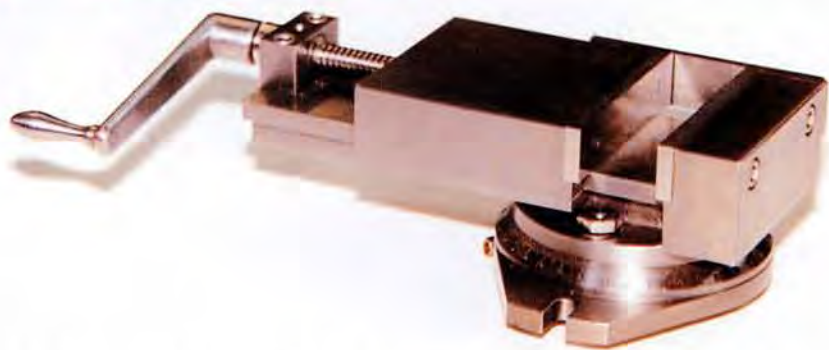


Shown above is the front part of the hot rod engine being machined from an aluminum block. Behind it is the photo of the actual Ford 427 engine Augie used for reference in detailing his model. More on Augie and his award winning models can be found in a profile on page 180.



**Double Corliss steam engine  
Wilhelm Huxhold  
West Hill, Ontario, Canada**

This beautiful and ambitious project demonstrates why retired machinist Wilhelm Huxhold's work is considered among the best being produced. The closer you look at every part, the better they look. Although Mr. Huxhold's shop is equipped with many full-size machines, his favorite projects are very small in size and are well within the capabilities of the tabletop machine tools discussed in this book. Now that he is retired, he still puts in a full day's work, but he gets to choose the projects.



**Triple expansion steam engine (left) and machinist's vise (above)**

This highly detailed steam engine won the 1997 Sherline Machinist's Challenge contest. The vise is only a few inches long and duplicates every detail of the original right down to the engraved angle scale. The handle is removable.



**Naval cannon display (left) and steam engine (below)  
Timmy Perreira, Haiku, Maui, Hawaii**

This 17th Century 24-pound naval cannon is set in its own diorama. The ship's deck setting adds a sense of purpose to the brass and oak cannon. Below is a Rudy Kouhoupt-designed steam engine Mr. Perreira built from brass, aluminum and cold rolled steel.



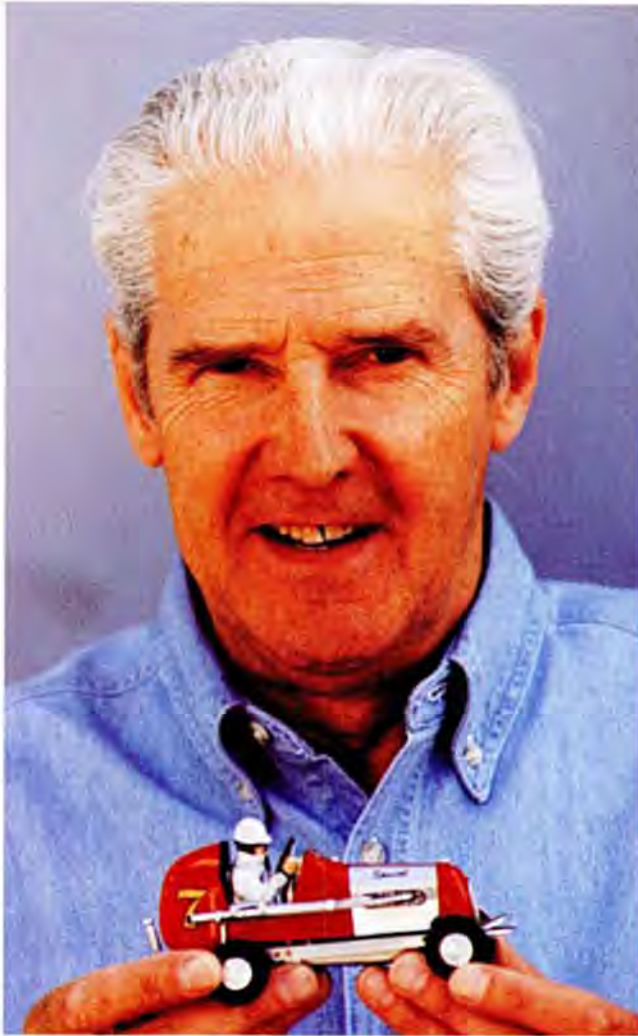
## SECTION 1—GENERAL MACHINING

Craftsman Profile—Scotty Hewitt . . . . .	24
1. Getting information on machining . . . . .	27
2. Do you need a lathe, a mill or both? . . . . .	29
3. Materials for metalworking . . . . .	39
4. Processes for metalworking	
4.1—Heat treating . . . . .	45
4.2—Metal finishes . . . . .	46
4.3—Castings . . . . .	49
4.4—Other ways to form metal . . . . .	51
4.5—Joining metal (Soldering and welding) . . . . .	52
5. Using hand tools and abrasives . . . . .	57
6. Cutting tools for metalworking	
6.1—General notes on cutting tools . . . . .	63
6.2—Cutting tools for both the lathe and mill . . . . .	65
6.3—Lathe cutting tools . . . . .	72
6.4—Cutters for milling . . . . .	81
7. Measuring and measurement tools . . . . .	85
8. Coolants and cutting oils . . . . .	99
9. General machining terms . . . . .	101
10. Machine tool lubrication and maintenance . . . . .	107



*One of Scotty Hewitt's fun projects—a 1930's air powered race car. For more on Scotty, see the next page.*

## SCOTTY HEWITT...as much an artist as an artisan



Compressed air powered vintage racer



Scotty Hewitt of Van Nuys, California is a relative newcomer to miniature machining. Scotty spent his life as a race car driver, but miniature tools always held a fascination for him. After seeing a Sherline display at a hobby show he decided to take up the hobby. Joe traded him a Sherline mill in exchange for some lessons in driving a race car. Since then his skills as a machinist have improved much faster than Joe's have as a race car driver, but a chance meeting took each of their lives in a new and fun direction.

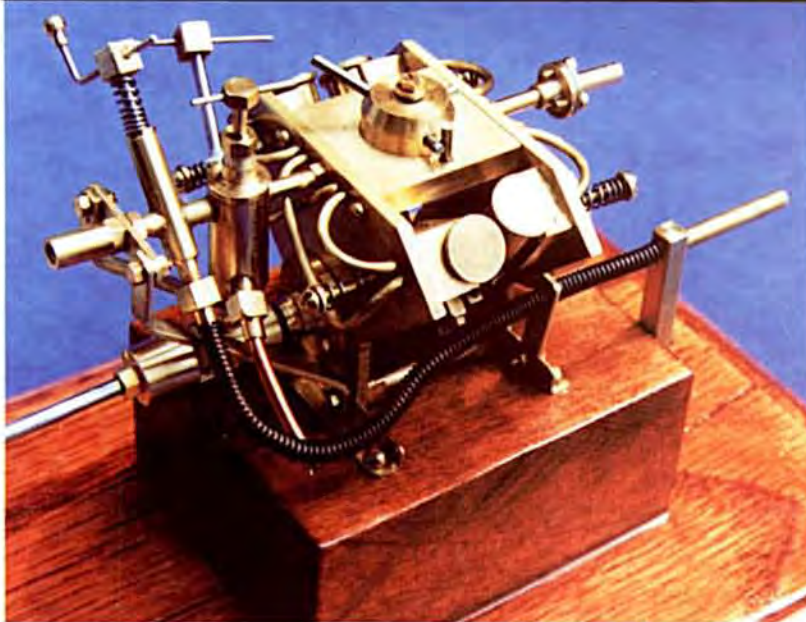
Scotty's work is the perfect example of a craftsman developing an artistic style of his own. The toy-like quality of his models combines finely machined metal parts with brightly colored, hand carved wooden bodywork on his race cars. His marine engines are also nicely displayed on wooden bases or in models of skiffs and tugboats. The appeal of his work has been put to the test in Sherline's Machinist's Challenge contest at the North American Model Engineering Society's show in Wyandotte, Michigan. As judged by the show's spectators, Scotty's work won first place for three years in a row.

The projects Scotty produces are not copies of other people's work nor are they built from standard kits or plans. They are uniquely his own. Scotty builds not just with his hands or with his brain but with his heart as well. He is a machinist, but more, he is also an artist.

*This bright red racer won 1st place in the 1996 Machinist's Challenge. Probably not the best machined or most complicated entry in the contest that year, it did have a special appeal that spanned the range of spectators who do the voting on the contest entries. Just about everybody who voted gave one of their five votes to this car.*

*Building things that are fun to display is part of the joy of tabletop machining. You don't have to be a machinist to appreciate a project like this. When friends or grandkids see it on your display shelf, you get the added satisfaction of being able to say, "I made it myself."*

Project: 4-cyl. oscillating marine engine



(Left) One of Scotty's first winning projects was this marine engine which won first place at the N.A.M.E.S. contest in 1994. It features a throttle, lubricator, drain valve and forward and reverse mechanism which are all fully functional.



(Above) In 1995, Scotty made the engine in a much smaller size, displayed it in a model of a wooden skiff and took first place again.

Project: 5" Steam tugboat



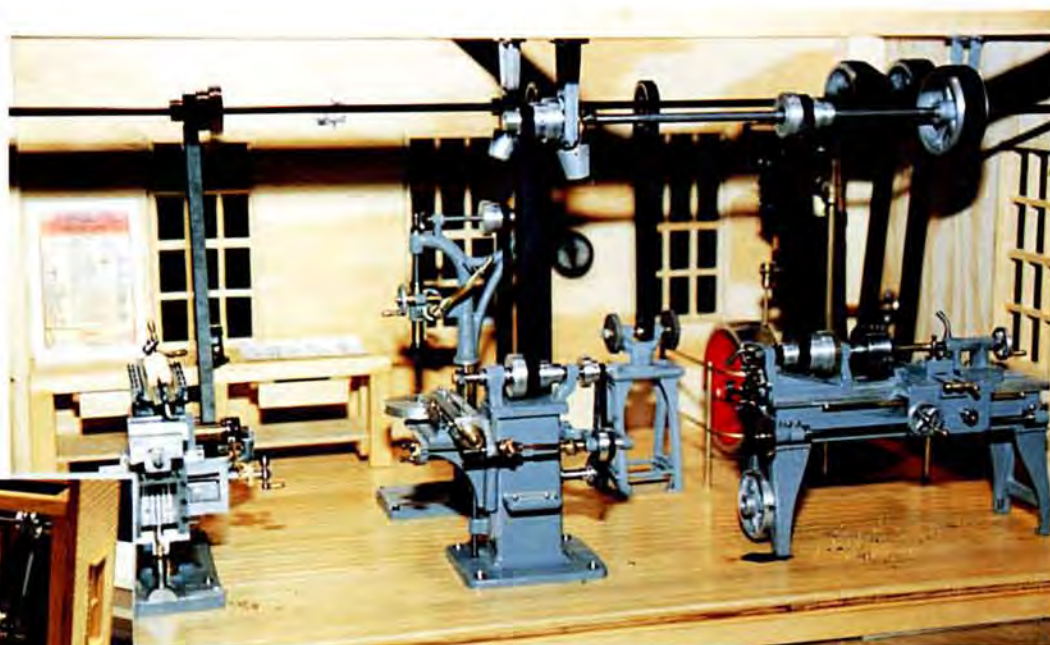
This little tugboat is another good example of effective display and features a fully functional marine engine and boiler made from brass. It finished 3rd place in the 1996 N.A.M.E.S. contest.

Project: 5" CO<sub>2</sub> powered vintage racer



Under the hand carved wooden body is a complete frame and CO<sub>2</sub> engine that drives the rear wheels. The hand carved driver also adds a lot of character to the project and shows another facet of Scotty's skills as a modelmaker. The detailed display background makes the car seem much more real. Except for the quarter in the foreground, the photo looks almost as if it could have been taken at a race track in the 1930's.

*Scaled-down machine tools and complete miniature shops are always popular subjects for machinists. Notice the details like charts and clocks on the wall.*



*These two excellent shops were seen at the North American Model Engineering Society (N.A.M.E.S.) Exposition in Wyandotte, Michigan. Both date from the days when machines were driven by a system of overhead pulleys and belts.*

PHOTOS: MIKE FOTI



*Mike Foti is a young man in his 20's hailing from Hillsboro, Oregon. He designed and built this American LaFrance hot rod fire truck, forming the bodywork by hand from brass and soldering the pieces together. All the small parts are machined. It was built to compete in the hot rod division of the national modeling contest in Salt Lake City for 1999. Mike is among the new generation inspired by the work of master modeler Augie Hiscano. (See profile on page 180.) Although he didn't beat Augie, he got some good tips from "the Master" and will be back with even hotter projects in the future.*



PHOTO: JOHN D. WHITE



*Robert Shipley of Knoxville, Tennessee designed and built this case to display an old clock from the dashboard of a 1920's automobile. The case is detailed identically on the back where the works of the clock can be seen behind the glass cover. In addition to providing protection, this case turns a simple clock into an impressive display.*

## Chapter 1—Getting information on machining

### The book every machinist needs

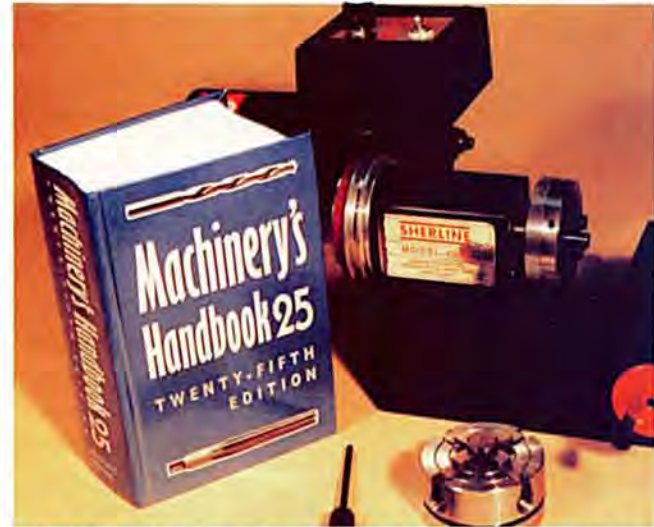
People new to machining are bound to have many questions. How fast should I turn my cutter for a particular material? How do I figure out the pitch of a gear? What are the tolerances for a “sliding fit” or a “press fit?” The most traditional sources for this type of information are books that can be found in your local library or bookstore. On-line sources like [www.amazon.com](http://www.amazon.com) and [www.barnesandnoble.com](http://www.barnesandnoble.com) make shopping for books even easier.

The single source I have always turned to first is *Machinery's Handbook*, which is published by Industrial Press. This book has been published since 1914 and is updated every few years. The small but thick book has over 2500 pages of information. A larger “easy-read” version is also available.

I used to recommend this book without reservation and always suggested that a purchaser get the most recent version available. After picking up a copy of the latest edition, however, I am inclined to change my opinion on the subject. I have noticed that the direction Industrial Press has chosen to go with the book is to direct it more to the engineer than the machinist. Information about machining has been deleted to make room for information about the strength of gear teeth and other details that will never be of concern to the average machinist. In light of this development, I now recommend that rather than coughing up \$80.00 for the latest edition, you can get all the valuable information you need about machining and save money too by buying a used earlier edition from a used book store or over the Internet. Auction sites like [eBay.com](http://eBay.com) often have issues for sale. The most valuable information on metals, formulas and processes hasn't changed significantly for the past few years, and the 20th will probably provide all you need for a lifetime of machining. Use the money you save to buy an accessory or another book.

### The Internet gives instant access to a world of information

If you are one of those who is resisting getting hooked up to the Internet, you are putting yourself at a great disadvantage in today's world. With computers as cheap as they are now, there is no excuse for missing out on this great resource. A



*Machinery's Handbook should be considered the basic reference source for metalworking questions.*

connection to the Internet gives you access to search engines that can find information about any subject almost instantly. Newsgroups can also put you in touch with others who share your interests and allow you to ask and answer questions about your hobbies. You also have instant access to product information about tools, accessories, raw materials and other resources for your hobby or business. More importantly, you will be missing out on a lot of fun, as, in addition to pure information, the Internet also gives you access to personal sites that feature projects made by many talented individuals. You may even find that you want to have a web site of your own where you can display your machining accomplishments to the world.

With a computer, a scanner or digital camera and an Internet connection, you are plugged into a new world of information. Internet access can cost as little as \$20 a month or less for a regular phone line connection to \$50 or more a month for higher speed connections. It just depends on how fast you want the pictures and information to load on your screen. They say “time is money,” and in this case, less time is more money.

### Search Engines do the work for you

It amazes me that I can type in a few words on a search engine and have it search the entire worldwide web for those words in a few seconds. For example, I just did a search for the word “lathe” on my favorite

search engine, [www.google.com](http://www.google.com). It took just .15 seconds to return a list of 183,000 sites using the word lathe. Of course, if I were looking for more specific information, I would have refined my search with other words like a brand name or model number, but the fact that a free resource can search so much information so quickly is simply incredible. Keep in mind that, unlike an encyclopaedia, anyone can post information to the Internet, so the responses turned up by your search have to be judged by you as to their authenticity and reliability.

### **Newsgroups and chat groups**

There are special interest groups on virtually any subject you can think of where people of like interest can ask and answer questions by e-mail. Machinists have many groups they can join that can be about machining specific projects like steam engines or about using specific machines like Sherline tools. For example, the Sherline group can be found by going to <http://www.yahogroups.com> and doing a search for the word "Sherline". As of June, 2001 the group had 579 members.

Newsgroups generally offer a list of "threads" of conversation that you can read. If you feel like responding, you can send your message to the group via e-mail. Your message will be posted and others can respond to it. Chat groups are more personal and are more like talking to other people through your keyboard. You type a response and the answers pop up on the screen as fast as others who are online at the time can type them in.

### **Model engineering societies and clubs**

There are local and national groups for modelers and machinists that have meetings and shows. This can be a good source of meeting people in your area that not only share your interests but who can also help you in learning a new skill. They may have tools that you don't for special jobs or they may have experience in an area like heat treating or casting that you need to learn about. A couple of examples are the North American Model Engineering Society in the Midwest ([www.modelengineeringsoc.com](http://www.modelengineeringsoc.com)) and the Pacific Rim Model Engineering Society in the West ([www.evmes.org](http://www.evmes.org)). These organizations each have an annual show that is open to the public. Many areas also have local metalworking clubs that meet monthly. This can be a great source of information for the new machinist, because it puts you in touch with people with years of experience who are willing to share their expertise with you. A

list of local clubs that have web sites can be found at <http://www.metalworking.com/clubs.html>.

### **Robot battles on TV**

This is a little off the subject of learning about machining, but a new trend on television has the potential to bring a new and younger audience into machining. Several television shows now offer competition for home-built robots that include speed and agility tests as well as the ultimate test of a person's building ability—competition. While some robot purists see this as a negative portrayal of robotic abilities, I see it as an excellent introduction to the need for precision metal parts for a whole new group of young thinkers and builders. Shows like Comedy Central's BattleBots® and The Learning Channel's Robotica® follow the lead started by a British show called "Robot Wars." Events include racing around a figure "8" course or through a maze of obstacles. The final winners are usually determined in bot-to-bot combat. Although these "robots" are actually just armored radio-controlled vehicles, they do exhibit many innovative features and it requires a great deal of skill to build a winner. Despite the juvenile over-dramatization of some of the shows, the heart of the matter is that they are getting kids thinking about actually building things that will stand up to the rigors of competition. I feel this is a healthier trend than encouraging them to simply lose themselves in video games, and I hope that its success will lead to more bright kids finding satisfaction in building things. This is the group that will become the future engineers and designers who will shape the inventions of our future.

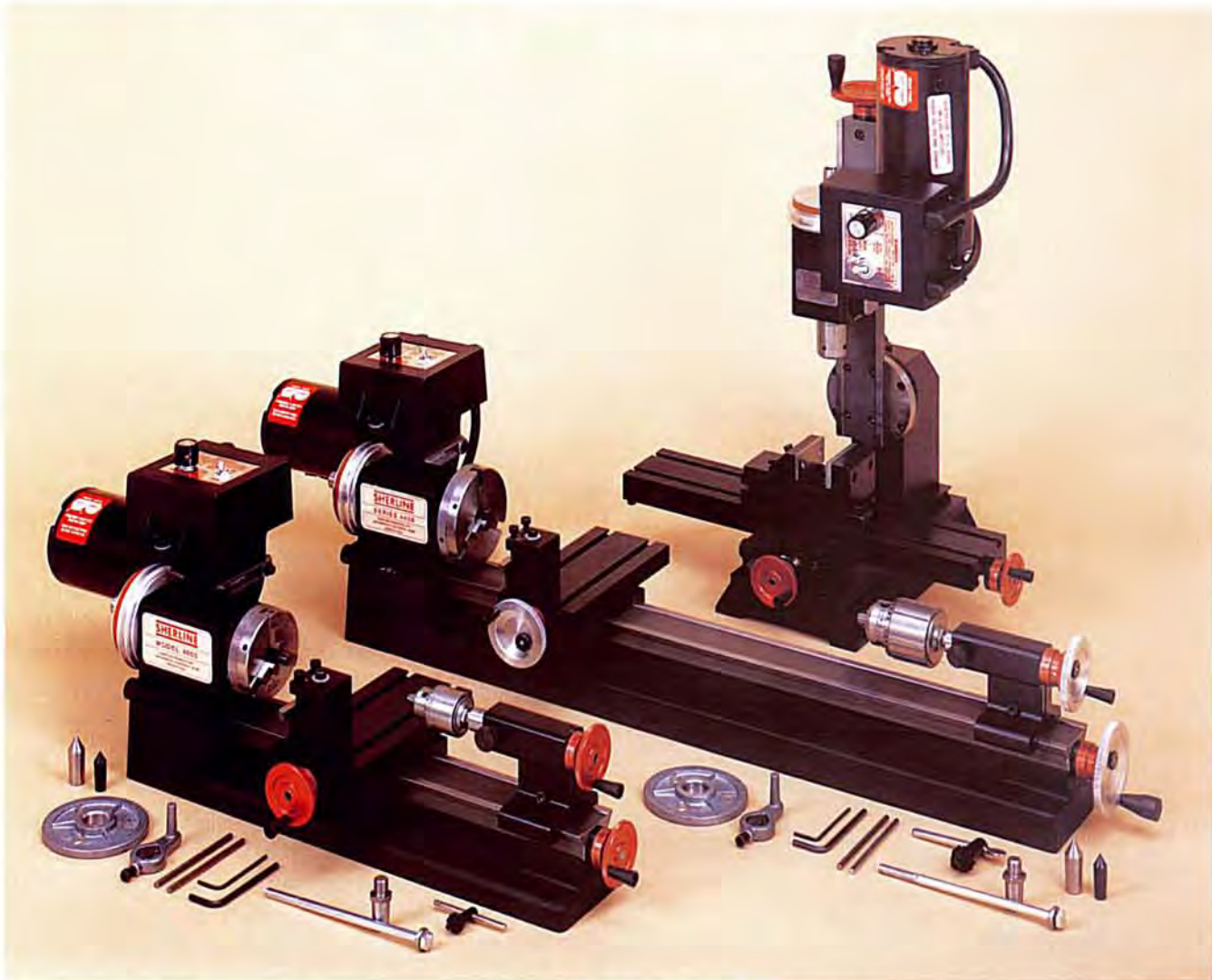
### **So universal they made toolbox drawers just to hold it**

Toolboxes made for machinists have a number of flat, felt lined, drawers to hold cutting tools and measuring instruments. In addition, many have an oddly shaped vertical drawer right in the center. It was designed to hold *Machinery's Handbook*. It was and still is considered as important as any other tool in the machinist's toolbox.

*This old machinist's toolbox was made by H. Gerstner & Sons. The company is still producing high quality wood toolboxes. The clock must have been added by the machinist who wanted to know when it was getting to be "quittin' time".*



## Chapter 2— Do you need a lathe, a mill or both?



*The lathe and the vertical milling machine each have their place in the machine shop. Though the lathe is a basic metalworking tool, the mill is the workhorse in most machine shops. Unless your needs are very limited, you will eventually need the capabilities of both to be able to accomplish all your machining tasks.*

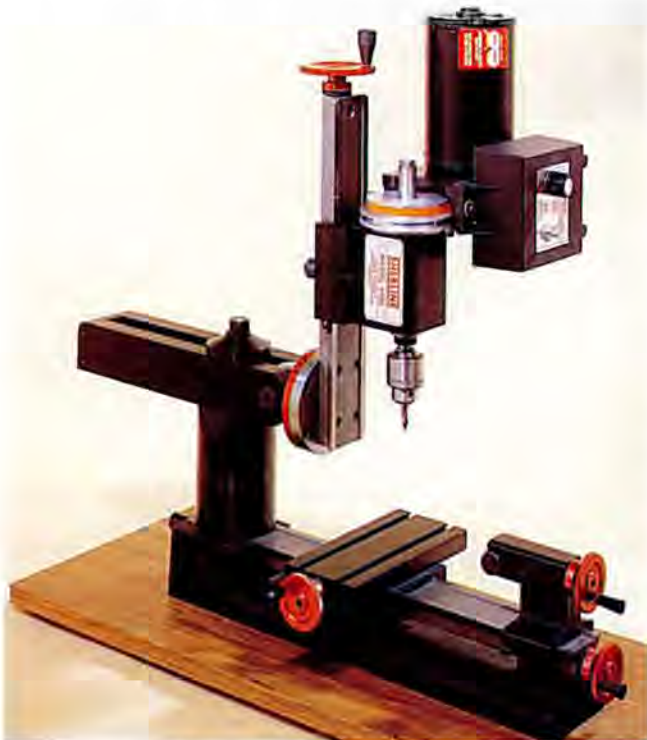
### **Which tool is the most important when getting started?**

The lathe is the first complex piece of machinery an apprentice machinist will use to cut metal. A mill is the machine an apprentice machinist will use to make his or her first complex part. Lathes have always been a great way to learn about cutting metal, but as soon as you have that urge to build a miniature version of a steam engine, you'll find out that a mill is needed more than a lathe. The truth is, to make complex parts you need both. I would estimate I have spent 90% of my time working with a mill compared to a lathe; however, when a part has to be turned and threaded you need a lathe.

A lathe is a good place for a novice to start. It will allow you to find out about cutting metal and requires a smaller investment. I don't recommend buying every metal cutting tool in sight until you know you like cutting metal. Metal cutting is a complex, slow process that should be enjoyable before any large investment is made. I would suggest that if your funds are limited and you still want full machine shop capabilities, get started by buying the best mill you can afford and the least expensive lathe you can get by with. The reason is that most likely the majority of critical operations you will perform will require a vertical milling machine.

### The difference between mill and lathe isn't just square or round parts

The main difference between a lathe and mill is that the work turns on a lathe while the tool turns on a mill. Most people believe the difference would be rectangular vs. round material. This isn't true. A four-jaw independent chuck can be used to hold a rectangular part on a lathe. Four-jaw independent chucks allow the work to be mounted with the center being wherever you want it. The only problem is the offset weight of the part can make for a very out-of-balance setup. When tools are cutting, the material being cut doesn't care which is turning, and the same cutting speed laws govern the process whether it is a lathe or mill. Old manuals on machining will show many ingenious setups using lathes. Mills were slow to catch on because the end mills we use today were not available. The new tool steels that improve modern day cutting tools constantly affect the design of the machine tools to which they are mounted as engineers take advantage of these new materials and products.



*A lathe with the optional vertical milling column attachment allows most milling jobs to be done at minimal expense. Later, the column can be added to the XY base to create a complete mill. The headstock/motor unit is then swapped between the lathe and mill which takes only a few seconds. (See page 176 for a photo of the new 8-way column.)*

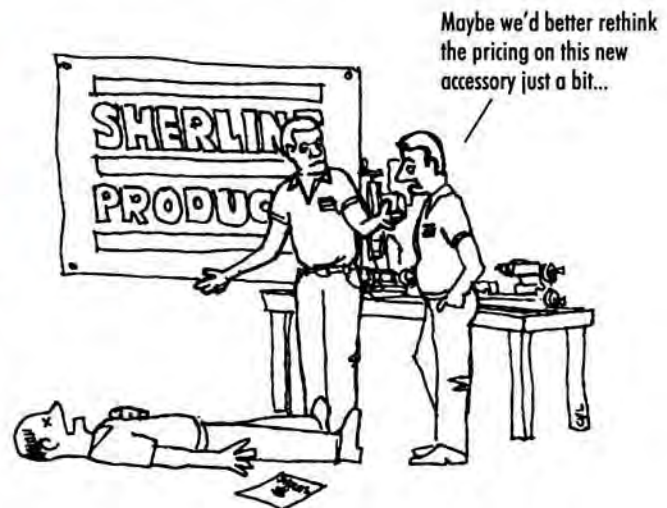
### Milling with a lathe and vertical milling column attachment

Sherline has an attachment to turn a lathe into a mill that works well as long as the work is small enough. A lathe doesn't have to be as rigid as a mill because the cutting loads are lower; therefore, in this configuration the XY portion will not be as rigid as a mill. This accessory is called the vertical milling column. It is basically the same as the vertical slide on the Sherline mill; in fact, the vertical column attachment that is presently manufactured could be bolted directly to the XY milling base. The headstock/motor/speed control assembly from the lathe is exactly the same as the one used on the mill and can be switched from one to the other in less than a minute. This allows a novice to work or buy his way into miniature machining a little at a time.

To summarize, money saving alternatives that would allow both lathe and mill operations to be performed would then consist of 1) a lathe with a vertical milling column, or 2) a lathe and mill XYZ base. The headstock/motor/speed control unit would be switched back and forth between the two machines saving the cost of duplicating a second drive unit. The first alternative is the least expensive but results in slightly reduced milling capabilities. If most of the parts you make are turned on a lathe and you only occasionally need to do a milling operation this would be a good choice. The second alternative, although it takes a few seconds to change drives from one machine to the other, results in no compromise in milling capabilities.

### Pricing based on the "flinch factor"

In the future we may manufacture a mill that could be turned into a lathe, but that would result in a



higher initial investment for customers. I try to come up with prices that are set by what I call a “flinch factor”. This is what prospective customers automatically do when they find out what something costs at a trade show. If they walk away without asking any questions, the price may be too high. If they take out their hard-earned money on the spot and buy one, it may have a price that could be raised. I price things accordingly, and I don’t necessarily make the same percent of profit on each item. I try to make a profit on the overall product line rather than each item. I guess I will always be more of a hobbyist than a businessman.

### **Inch vs. metric machines**

Machine tools come calibrated in either inch or metric increments. Choosing a system of measurement will be one of the more basic choices you will have to make. For a more thorough discussion of the advantages and disadvantages of each system see Chapter 5 in this section on measuring. The simplest advice I can give is to buy

a machine in the system you are most familiar with and for which you already have measuring tools. If you grew up with the inch system, buy an inch machine. If you think in millimeters, buy a metric machine. All Sherline tools and accessories are offered in either system at the same price. There is no significant advantage in accuracy to a machine calibrated in one system as opposed to the other.

Converting dimensions from one system to the other is a pain and a possible source for errors. If you buy a metric machine thinking that is the way the world is going, but you are buying plans for projects that are dimensioned in inches and own inch micro-meters, you are going to be in for a lot of extra work. Although it is possible later on to convert a Sherline machine from inch to metric or vice versa, it involves more than just swapping handwheels as the leadscrews and nuts must also be changed. In most cases, the choice of which system to use will be an easy one for you, and that is to simply choose the system with which you are most comfortable.

---

## **Finding the right Sherline tool for your needs... a guide through the product lineup**

The motor and speed control are the same on all Sherline lathes and mills, so the difference in tools is mainly in size and included features. Assuming you have made a choice of your system of measurement, I will describe the differences and advantages of the various machines in the Sherline tool line.

(NOTE: Where model or product numbers are listed, the inch version is listed first followed by the metric version in parenthesis.)

### **LATHES**

*Model 4000*—The basic Sherline lathe is the Model 4000 (4100) which has a 15" bed with 8" of clearance

between centers. This is the modern version of the original Australian-designed Model 1000 lathe introduced in the early 1970’s. All Sherline lathes come with a faceplate and drive dog, two dead centers, hex adjustment keys, tool post, presharpener 1/4" cutting tool and spindle bar.

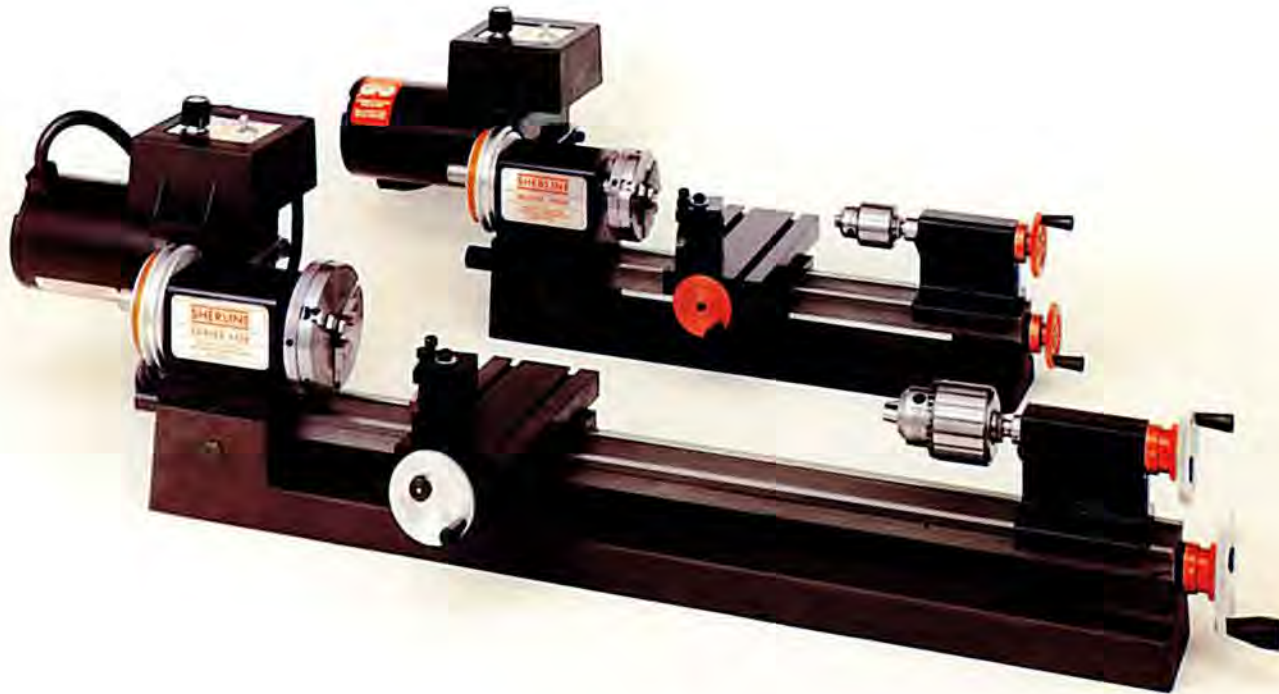
*Model 4400*—The longer lathe Model 4400 (4410) has a 24" bed with 17" of clearance between centers. It also comes with adjustable “zero” handwheels on the leadscrew, crossslide and tailstock spindle. It replaces the standard tool post with a rocker tool post. This allows you to precisely control the height of the cutting edge of the tool,



*The Sherline 3.5" x 8" Model 4000A lathe*



*The Sherline 3.5 x 17" Model 4400A lathe*



*This photo shows the relative size of the two lathes. The main difference is the length of the bed which provides 8" between centers on the Model 4000 and 17" between centers on the Model 4400. (This photo shows the older style tailstock without the cutout for table clearance which was added in 1996.)*

which gives better control over the cut. This is particularly useful when using older, resharpened cutting tools where the height of the cutting tip may have changed when it was resharpened.

**Is Sherline's bigger lathe worth the extra money?**

Additional capacity may just be wasted if you don't need it. If you don't need 17" between centers you might as well save the workbench space and spend the money you save on more accessories. If you do need it, however, the relatively small extra cost is well worth it. The additional 9" of distance between centers obviously allows larger parts to be worked on. It also allows for greater versatility in setup and the use of a larger 3/8" tailstock chuck. Using larger chucks and tools on the smaller machine is difficult as the length of the chuck and tool eats up a good portion of your available 8" leaving little space left for a part. The longer bed lathe was only introduced in 1993, but it now accounts for just about half the Sherline lathe sales. Though more expensive, because of the extra features it offers as well as the increased capacity, I feel that dollar for dollar it is the better bargain of the two.

**What you need will be determined by the hardness of the parts you intend to make**

That gives you the physical limitations of the machine, but what does the hardness of the material you wish to turn do to those numbers in the real world? A good rule to remember when it comes to purchasing any lathe is to take the average diameter you plan to work with and multiply that times 3 for free machining materials and times 4 for tough materials like stainless steel. If the materials you plan to work with are free machining (aluminum, brass and free machining steel), you will be pleased with a Sherline Lathe if the average part you make is approximately 1" (25mm) in diameter. Wood and plastic are so easy to machine that only size limitations need be considered. I don't mean to imply that you can't machine a 3" flywheel, but if you are planning to consistently make parts of that size, you will probably be happier with a larger machine and more horsepower. Removing large amounts of metal on a small machine takes time. If you have lots of time, the size of the part is less critical. Users of any machine are happier with its performance when they are not consistently pushing the limits of its

capabilities. If you usually make small parts well within the capabilities of the Sherline lathe and every once in a while need to turn a part sized near the machine's limits, you will be very satisfied with the its performance.

#### **Accessory Packages offer more "bang for the buck"**

The accessory or "A" packages are a good investment for a new purchaser, as they include the most popular accessories in a package that offers a price savings over purchasing them separately. These are all accessories you would no doubt be buying anyway, so you might as well save some

money. In addition to the standard equipment mentioned previously, the "A" packages include a 3-jaw chuck and tailstock chuck, chuck key and arbor with drawbolt to use the tailstock chuck as a drill chuck in the headstock. A 4-jaw chuck may be substituted for the 3-jaw if you already have one, but in most cases, the 3-jaw is what most people will want to start out with. In the case of the Model 4000A (4100A) the 3-jaw chuck is 2.5" in diameter and the tailstock chuck is a 1/4" Jacobs chuck. The longer Model 4400A (4410A) includes a larger 3.1" 3-jaw chuck and a 3/8" Jacobs tailstock chuck and key.

### **VERTICAL MILLING MACHINES**

#### **The physical limits of a mill**

A vertical milling machine is capable of holding larger parts than a lathe of similar size because the part is held and only the tool turns. A mill also has a much longer table throw (X-axis). A deluxe version of the Sherline mill also is available which

offers an additional 2" of Y-axis travel compared to the standard Mill. It also includes a mill headstock spacer block which adds 1-1/4" to the throat distance (clearance between the tool and the vertical column). With the addition of a horizontal milling conversion, surfaces up to 6" x 9" can be machined without moving the part. This is a very large machinable area for a tool of this compact size.

Because of its importance in the machine shop, adding a vertical milling machine was one of my first priorities when I took over production of the Sherline tool line in the early 1970's. The standard Sherline mill is the Model 5000 (5100) which has a 10" base. It has 8" (203mm) of clearance between the table and spindle. The travels of the three axes of movement are: X = 9.00" (228mm), Y = 3.00" (76mm) and Z = 6.50" (165mm). It has red anodized handwheels with laser engraved markings.

#### **The Model 5400 Deluxe Mill**

An upgraded or "Deluxe" Model 5400 (5410) mill is also available which offers a 12" base. This increases "Y" Axis travel from 3.00" to 5.00" (127mm). It comes with a headstock spacer block which increases the throat distance from 2.25" (50mm) to 3.50" (90mm). (This spacer is available as an option on the standard mill.) It also includes a 1/4" drill chuck, arbor and drawbolt. In addition, the base and table have laser engraved scales cut into them which makes keeping track of positions and movements easier. Adjustable "zero" handwheels are standard on all three axes. (See photo on page 36.)



*Sherline's basic Model 5000 mill.*

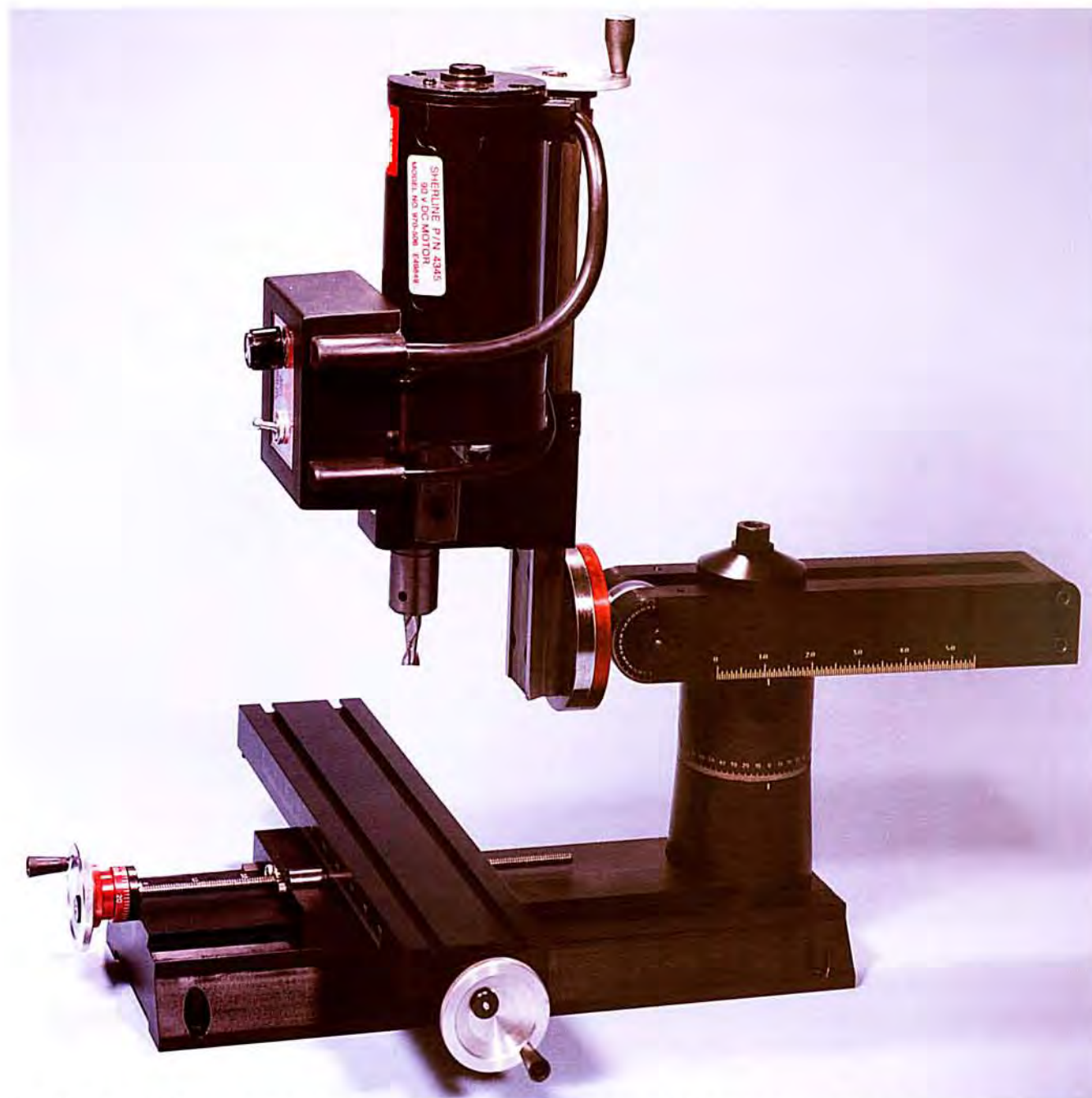


*The Model 5400 mill adds 2" more Y-axis travel, laser engraved markings, a headstock spacer block and a 1/4" drill chuck and key.*

**The Model 2000 8-Motion Mill**

The latest addition to the model line is patterned after the movements available on the most widely used and imitated full size machine tool in the

world—the Bridgeport mill. In addition to the standard handwheel adjustable movements of the X, Y and Z axes, and the pivoting headstock, the new mill offers four additional movements. The new



*The Model 2000 mill takes tabletop machining into the year 2000 and beyond. With eight directions of movement for the part or tool, a part can be milled or drilled from any angle while mounted square to the table. For more on the development of the new mill see page 193.*

round column base allows the column to be moved in and out and pivoted left or right. The addition of the rotary column attachment allows the column to be rotated in a clockwise or counterclockwise direction up to 90° either way. A “knuckle” on the back of the rotary column attachment allows the column to tilt forward or back. Laser engraved scales on each of these movements make it easy to set the column to angled settings.

The Model 5000 or 5400 mills can mill an angle by rotating the headstock. To drill an angled hole, however, requires either mounting the part on an angle or adding the optional rotary column attachment. The Model 2000 mill allows a part to be drilled or machined from any angle while it is mounted square to the table. These additional movements bring all the capabilities of professional mills down to tabletop machine shop size.



*Adjustable "zero" handwheels follow large machine tool practice by allowing you to return your handwheel setting to zero at any time without moving the leadscrew. They can be ordered on new machines or added as a retrofit to older machines.*

#### **ADJUSTABLE "ZERO" HANDWHEELS**

Most expensive full size machine tools allow the machinist to reset the handwheel to "zero" (or any desired setting) at any time during the machining operation. All Sherline tools now offer that option.

Operation is simple. Just release the locking nut while holding the handwheel. Then reset the handwheel barrel to "zero" and retighten the locking nut. Now you can dial in the amount of feed you want starting from zero without having to calculate your stopping point. It's a great time saver and also reduces the chance for errors.

If you own an older Sherline machine, the adjustable handwheels can be ordered separately and swapped for the standard handwheels. The old handwheels come off by simply releasing a set screw. The new ones go on just as easily. If you are buying a new machine, you can save some money compared to switching later by ordering a machine with the adjustable handwheels already installed. The Model 4400 (4410) lathe and Model 5400 (5410) mill already come with these timesaving handwheels installed. It costs about an additional \$40 on a lathe and \$60 on a mill to order them with adjustable "zero" handwheels. This saves about \$20-\$35 (1998) over buying them later, plus you don't have to install them. A standard lathe with adjustable handwheels is known as Model 4500 (4530). A Model 4000A (4100A) becomes a Model 4500A (4530A). A Model 5000 (5100) mill changes to a Model 5500 (5510) when adding the adjustable handwheels.

Naturally, the XY base and the XYZ base can also be ordered with or without adjustable "zero" handwheels. Rather than quote even more model numbers, it's easier just to say that information can be found on Sherline's web site or in their price list. My main purpose here was just to let you know they exist and that any handwheel on any Sherline tool, new or used, can be replaced with an adjustable one to make your life a little easier.

#### **Things to ask when buying a used machine**

Like full size equipment, a well maintained used miniature machine tool can be just as good as a new one and sometimes much cheaper. Check for obvious signs of abuse like major cuts in the table or noticeable play in the movement of the parts. Check for excessive backlash in the leadscrews.

Many people buy machines thinking they will use them only to find out the hobby doesn't really appeal to them. Older tools can sometimes be found that have seen almost no use. If you happen to find a good used machine, you can usually check with a manufacturer to find out if that model is still available and if parts are still offered for it. With Sherline tools this isn't a problem, but there are used tools on the market made by companies that no longer do business in the United States, and getting parts for them could be a problem.

#### **Accessories sweeten the deal**

If you can find a good used machine for sale ask what accessories come with it. If the sale includes a number of expensive accessories, you could be getting a really good deal. Even if you may not think you need them now, you'll probably be glad you have them later on as you learn how to use them.

#### **Check new prices to make sure it's a good deal**

Regardless of the manufacturer, before you buy a used machine, check the latest factory product literature for current models and prices. Sometimes the "bargain" prices asked for used machines might be only slightly lower than what you would pay for a new one and you wouldn't be getting any warranty. Though the product numbers and sizes listed in this book for Sherline machines are correct at the time of printing, in the future, additional models and features will undoubtedly become available.

#### **CNC versions of miniature machine tools**

As we move into the 21st century, the computer will continue to enter more phases of our lives. One could not hope to become a production machinist these days without learning to program a CNC machine.

Even one-off and prototype jobs are often done on machines that offer the option of hand cranking the dials or using computer controls for appropriate operations. As machinists become more familiar with using computer controlled machines in their work, they sometimes wish to extend those advantages into the small parts they make, either at work or at home. Even those who have never worked with computer controlled machines can learn to use these smaller versions if they have the need or simply the desire. Just like their larger counterparts, these machines can take the drudgery out of making the same part over and over and can also machine three-dimensional shapes that would be difficult or impossible by hand.

### **CNC machines for education**

Educators have found that training new machinists to use computer controlled machines is done at much lower cost using small machines that duplicate all the functions of the larger ones the future machinists will eventually be using. Also, a mistake in a program that causes a tool to crash into a chuck can do some very expensive damage to a full-size machine. It is better to make your mistakes in miniature as you learn.

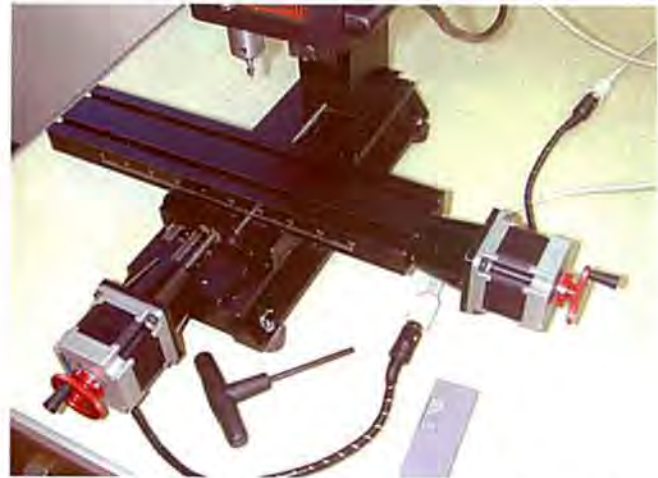
### **A number of manufacturers to choose from**

Because of the demand for small CNC machines, in addition to Sherline Products, there are now several companies that offer both conversions for existing Sherline machines or complete, turn-key miniature CNC machining centers based on Sherline machines. There is a broad range of price depending on how many “bells and whistle” you require, but the basic models are

PHOTO: LIGHT MACHINES CORPORATION



*A CNC machining center designed for educational or industrial use has all the features of larger shop CNC machines, but these features add to the price.*



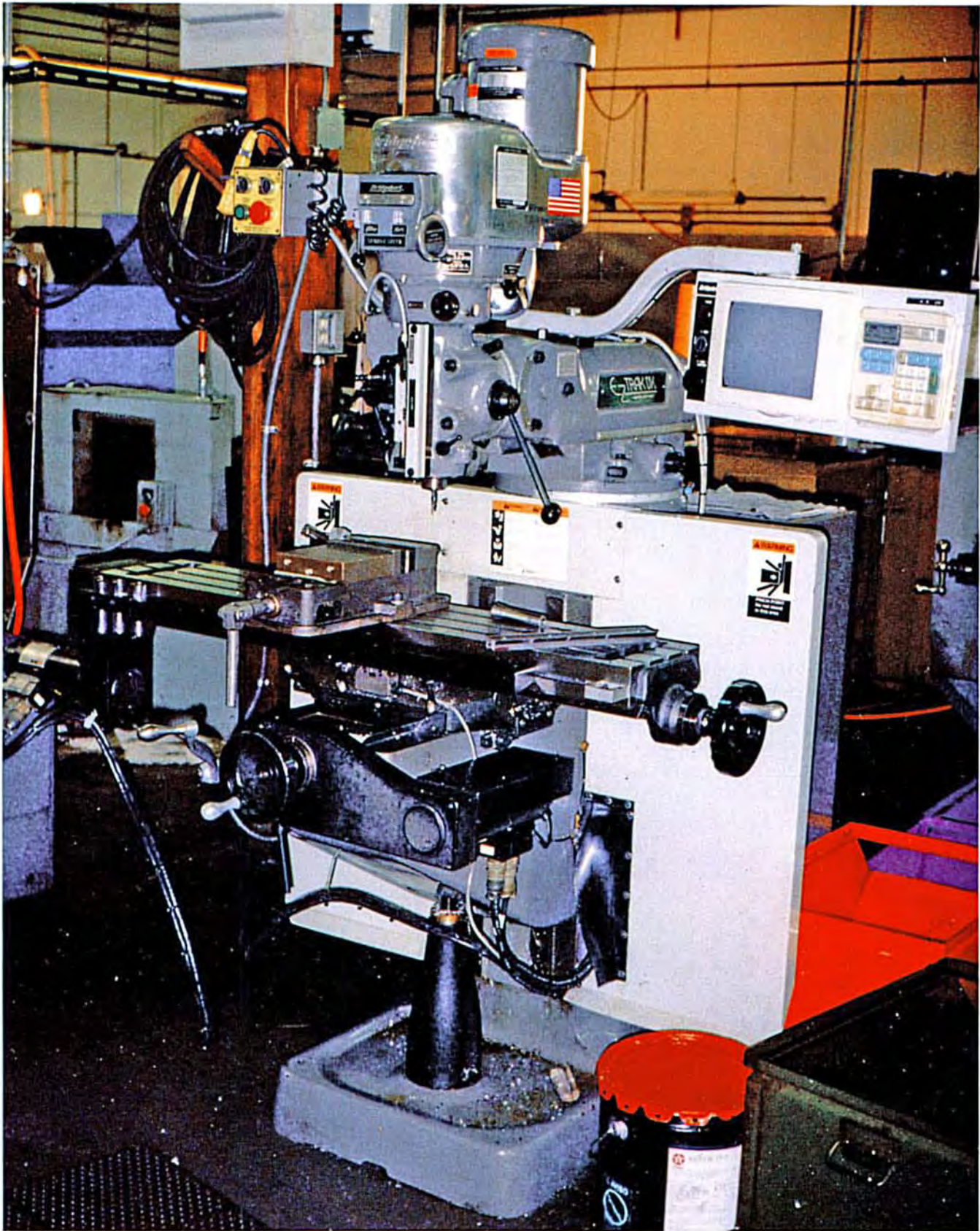
*Stepper motors drive the threaded leadscrews on each of the machine's axes to produce controlled movements based on coded instructions sent from a computer. They produce good results at a much lower cost than the servo motors and ball lead screws used on larger, more expensive CNC machines. Shown here are stepper motors with handwheels mounted to the rear shafts. This provides the operator the option of manual control when appropriate.*

amazingly inexpensive. Stripped-down home versions are available, while the educational models come with housings and safety features that duplicate those found on full-size machines. A complete CNC Sherline mill including three stepper motors, four drivers with power supply and even a new computer with pre-installed operating system and software can be purchased for under \$2500.00 (2004) with retrofit kits for your own machine starting under \$1800.00. A fourth (rotary) axis can be added for \$395.00. CNC lathes and complete CNC lathe/mill/accessory shop packages are also available. Versions where you supply your own computer offer additional cost savings for those who have the computer skills to install the appropriate operating systems and software.

A list of companies that offer CNC retrofits or complete machines can be found in the “dealers” section of Sherline’s web site at [www.sherline.com/cncdlrs.htm](http://www.sherline.com/cncdlrs.htm).

*“Any technology sufficiently advanced is indistinguishable from magic.”*

—Arthur C. Clarke



*A full size Bridgeport vertical milling machine. Unlike its miniature counterpart, this one cannot be stored on a closet shelf and requires a forklift to move it. The mill shown combines old and new technology. The handwheels can be cranked by hand or driven by computer numeric control (CNC). The directions of movement of this machine served as a model for the Sherline Model 2000 mill.*

## Chapter 3— Materials for metalworking

### Some good materials to work with

As with many of the other sections of this book, I am purposely staying away from engineering data and only giving the practical information you need to get started. The book I would recommend for technical information would be *Machinery's Handbook*. This book is the best book ever written on metals and the machining of metal (See chapter 1 of this section.) As a beginner, I would also avoid complex parts that require heat treating. If you try to accomplish this with a torch, you will find it an excellent way to destroy perfectly good parts. This can be heartbreaking to novices because they haven't "started over" enough in their life. I recommend using "leadloy" 12L14 for soft steel parts. "Stress proof" steel is the next real improvement in steels. It is a better material that is a little harder to machine. Use 4130 or 4140 steel for extra strong or tough parts, 6061-T6 for aluminum parts, and 303 for round stainless steel parts. These materials are readily available and work quite well. Ordering stock sizes that aren't readily available can be a waste of time. If you only have one part to make, it may take just a few minutes to cut a piece of stock to its proper starting diameter, but it could take an hour on the phone to find the perfect size.



*A good cutoff saw is an important time-saver in any shop. Miniature machine tools weren't meant to remove a lot of metal in a hurry, so getting a rough part as close to size as possible with a cutoff saw saves a lot of time and wear and tear on your machines.*

PHOTO: PETE WEISS



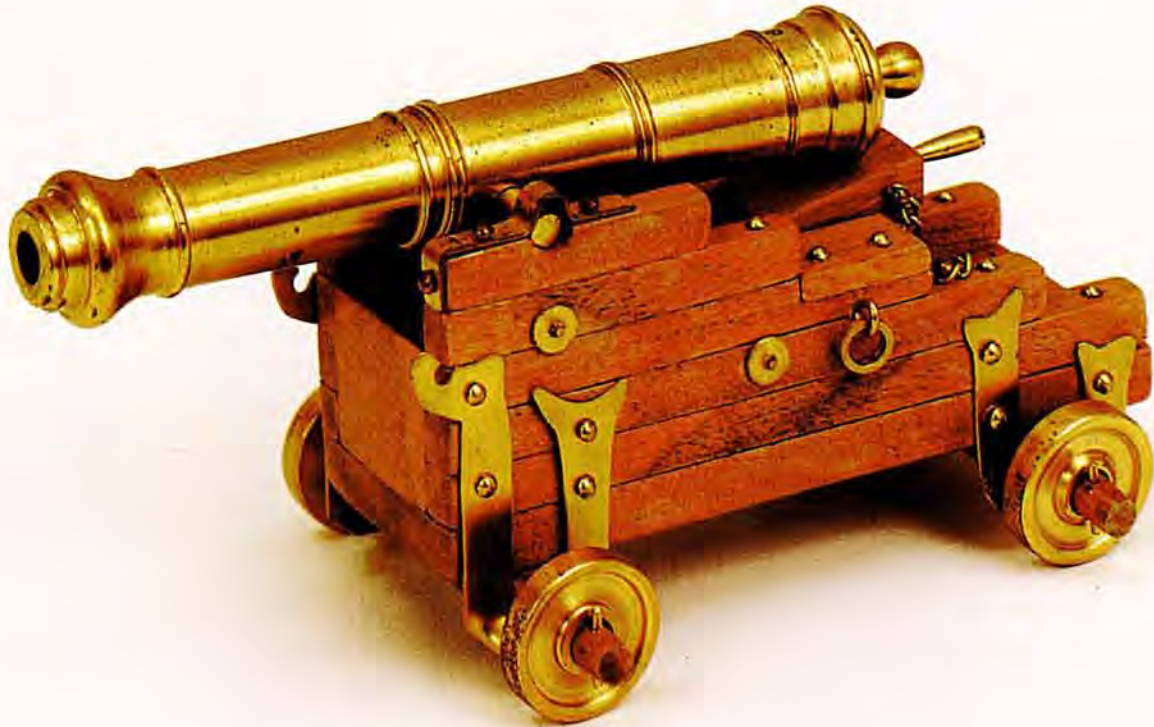
*A treasure trove of raw materials can be found at most scrap yards. Knowing the properties of the material you are looking for is helpful, because often it is not marked.*

### Eliminate machining time by cutting material close to size first

A good investment for your miniature machine shop is a cutoff saw. There is a saw available at many discount tool stores that is sold for less than \$200 (1998) that is just right for home shop use. It uses a band saw design and can cut off diameters to four inches (100mm). It can also be used in a vertical position making a standard band saw out of it. You need to have a way to cut metal to length in a pleasant fashion, and, believe me, trying to saw off a large piece of stock with a hacksaw isn't pleasant. It will drive you out of the hobby faster than anything I know. When you are working with small machines it is very important to eliminate as much machining as possible by cutting stock to its proper length before starting. A little cutting oil now and then will help the process and keep blades sharper longer. If you have a friend with a good saw it is almost as good, but eventually you'll want your own.

### Cut off tool cautions

A cutoff tool or "parting-off" tool shouldn't be used in place of a cutoff saw. Cut your material to size with the cutoff saw, and only use the cutoff tool on the lathe for separating the finished piece from the blank. By the way, don't attempt to use a cutoff tool holder and tool on a lathe at any place other than close to the three-jaw chuck. It will bind in the



*Brass is easy to work with and polishes up nicely so it is a popular material for model work. The chips are like little splinters, so work with it carefully.*

material and get ripped out of its holding device and may end up damaging your machine.

#### **Dealing with minimum orders and small quantities**

The choices for metal seem endless, but there is a problem. It's called the "minimum order". Let's say you want to start on a project that contains several types of steel, brass, aluminum, and cast iron. Chances are each of these products will be sold by a different supplier; each with their own rules when it comes to extra charges for small orders. You should also understand that most bar material used in machine shops comes in twelve-foot lengths and material used in construction and fabrication shops comes in twenty-foot lengths. It may cost as much as \$25 to have a single bar cut to length. If you call up one of these suppliers and try to order a four-inch piece (100mm) of half-inch (12mm) aluminum they will probably ask if you are joking. You will then find they will not deliver orders this small and that it would be cheaper to buy the whole bar rather than paying the cutting charge. These companies

exist to service manufacturing companies that buy in very large quantities, not for the home hobbyist.

#### **Sources other than the big industrial suppliers**

You will have to order from a supplier that caters to the hobby market. We have several listed on our web site and we wish them well because they provide a service that is well worth the extra cost. You can order all your materials from one source at one time. This allows you to spend your time building things, not talking on the phone to somebody who considers your order not worth the effort. If you are a novice, always buy enough material to make three parts in case you have to start over.

#### **Salvage yards**

If you are lucky, there could be a salvage yard in your area that sells bar stock. Bring your own hacksaw because they will not cut it for you without a high cutting charge. If you find a good surplus yard that has useable materials, it might be wise to anticipate your needs and buy for future use if the



PENS MADE BY CHIP IVESTER.

*Wood can also be machined on miniature machine tools with the use of a tool post to support the hand held cutting tools. Small items like pens made from exotic woods are popular items as gifts. Kits are available for the working parts of the pen. Because these projects require such small pieces of material you can afford to use beautiful and exotic woods. Low material cost is one of the big advantages of working on small projects.*

price is right. Surplus yards don't have a standard inventory, and just because they may have a good assortment of material today, it doesn't mean it will be there tomorrow. What is available quite often are bar ends. These are pieces left over after a bar of stock has been cut up which are too short to use for their particular part. The problem is knowing what the material is.

#### **Identifying various aluminum materials in a scrap yard**

Material is usually color coded with paint on the end of the bar. I wish I could put a chart of colors vs. material in this book, but for some idiotic reason, each producer has its own colors. Aluminum will have the grades printed on the entire length of the bar. The grade I recommend is 6061-T6. The "T" indicates the hardness. Another grade you may find in a salvage yard is 2011-T3. This has a texture similar to cast iron and it was developed for making round parts on automatic machines. The chips are

splinters and will not tangle a machine up with long, stringy chips. Softer grades of aluminum don't machine very well and lack the stiffness required in mechanical parts. The extruded aluminum shapes sold in hardware stores are usually a soft, gummy aluminum such as 6063-T3. Another type of aluminum available is the 2000 series which is usually found in extruded shapes such as rectangles and squares. The last one worth mentioning is the 7000 series. This grade is commonly used for aircraft parts and is available in a hardness to T8. This grade can have a surface hardness equal to some steels so it can be very useful for tooling.

#### **Buying scrap steel is a little tougher**

A whole new set of problems arises when you try to buy steel at surplus yards, for it isn't labeled. If it is rusty, it probably is "hot rolled", which is a terrible material to work with for small parts. These are fabrication materials that, as an example, are good



*Aluminum grades are normally printed on the bar stock. Color coded ends also identify each type of aluminum, but color coding varies depending on who produced it.*

for making a wrought iron gate. The best steel material to machine is called “leadloy” or 12L14. It is available in round and square cross sections and can be case hardened. Using 12L14 will ease much of the pain of machining steel as it is a pleasure to cut. Many of the parts of Sherline tools are made of this material. Excellent finishes are easy to attain. The chips break as they are machined off, eliminating the danger of long, sharp chips.

A material called “stress proof” would be the next real improvement over leadloy. It isn’t too expensive and machines better than cold rolled. Cold rolled steel is miserable stuff to machine by comparison. It is tough and gummy and has a low cutting speed, but it is slightly better for case hardening than leadloy. Normally you would have to grind it to get a good finish. For some reason that I don’t understand, you can cut cold rolled and similar hard-to-machine steels at cutting speeds way above the recommended speeds (as much as four times) and get a mirror finish. The catch is you have to use carbide insert tools. These tools can cut machine times in half and are a basic cutting tool in a modern machine shop. (See Chapter 6 on Cutting Tools in this section.) The chips are very hot and care should be taken to protect yourself.

Tools steels can be hardened completely, not just the outside as in case hardening, and can be very expensive and hard to machine. They are used when high strength or holding a sharp edge is important. A stamping die would be a good example. I would recommend that you purchase these materials only when the material is clearly identified. It takes too long to make parts out of this material to have them

ruined in heat treating. Because of the many uses of steels and the many kinds available, I’m limiting the information I provide on these materials. I would end up with a book filled with charts and tables that would be just like the books that line the shelves of your library’s engineering section. Before starting on a project that requires heat treating, get the advice of a local heat treat shop.

#### **The positives and negatives of brass, copper and bronze**

Brass is usually sold in a half-hard condition and is very easy to machine. I don’t like to machine it because the chips are like small splinters that stick in your hands and break off. However, the parts always look nice and can be easily polished and plated. Copper can be machined but the surface has a tendency to “tear” as it is being cut making for poor finishes. Diamond tools are used to cut copper in a production environment if good surface finishes are a must. Some grades of bronze can also be difficult to machine because they will wear tools, even carbide, at an alarming rate.

#### **Cast iron**

Cast iron can be purchased as bar stock or cut out of an old piece of junk that contains cast iron. It is easy to machine, but also dirty. The chips look like powdered coal, and you should clean up your equipment after cutting it. The good part about cast iron is it is very stable and will not warp as it is machined. It is surprising how much some materials can warp when cut. Manufacturers of complex, close tolerance parts will have materials “normalized”



*With the addition of the wood tool rest, small wooden parts are easy to turn on a Sherline lathe. Here, exotic woods are used to make a handsome key fob and a small flute. Model ships and dollhouse miniatures also require small turned wooden parts.*

several times between machining operations to counteract these forces. The bigger the part the bigger the problem unless you are using cast iron.

### **Woods and plastics**

Wood and plastic can be easily machined with tools designed to cut metals. For best results when machining wood, use a very hard, fine grained wood such as maple. Soft woods will crush rather than cut. This causes poor finishes and splintering. Use two-fluted end mills when machining these materials.

The problem with plastic is “melting”. You can’t allow the chip to clog up the cutting action when machining any type of plastic. For example, if a drill feed is low and the RPM is high, the chips will be numerous and thin. They pile up in the drill’s flutes and not only create heat from friction but also work as an insulator. The plastic melts and you have ruined your part. Plastic has a very high temperature expansion rate when compared with other materials and it might be wise to take the close tolerance cuts when the part has cooled down to room temperature. Use high feed rates and sharp tools to eliminate or minimize these problems.

### **Don’t knock plastic...sometimes it’s the best material for the job**

I was at a trade show once when a youngster in his teens stopped by our booth. He brought with him a complex part used in the front end of a radio controlled model car. It was made out of plastic and



*A plastic mold used to make a housing for the new digital readout for a Sherline mill. It can take a very expensive mold to produce what looks like a simple part. The longer the machine runs, however, the cheaper the parts become.*



*A selection of plastic raw materials. The dark brown block in the upper left is phenolic. Next to it is black Delrin. The red block is fiberglass. At the far left is a piece of white Delrin and next to it is a block of white Nylon. The two piles are new clear beads and recycled black chips used for injection molding.*

the part was constantly failing in crashes. He wanted to buy a machine to build this particular part out of metal and save money. He thought he was getting ripped off because the plastic parts cost \$3.00 each. I told him I could not build a part to replace the one he showed me in less than six hours and a metal part probably would not last any longer, because metal will not spring back to its original shape like the plastic part. I don’t think he ever understood why it would take me six hours to make a three-dollar part.

Plastics have changed the way we think about value. To injection mold a complex part, it takes a complex mold, yet the machine cycle time and the skill to run this plastic injection machine remain constant. The machine time is based on the thickest cross-section, not the complexity of the part. In order for the mold to work it must be made with very tight tolerances, even if the part itself has liberal tolerances. With a good mold, plastic parts can be manufactured so inexpensively we consider them disposable, but don’t think for a moment that all plastic parts are junk.

Take for example your new cellular phone. The molded forms of the body would be very difficult to produce in any material other than plastic. They are sturdy, light in weight and have the desired color molded in so they don’t have to be painted. If they were made out of metal they would be heavier, more expensive and no more attractive. Plastics can be formulated to achieve just about any desired characteristic from flexibility to heat resistance to

color or clarity. The development of plastics in our lifetime is probably the most important advance in materials since the discovery of how to work with metals many centuries ago.

### Buying plastic for molding and machining

Plastic can be purchased in granular form for injection molding or in bar stock for machining. For machining I prefer Nylon where strength is important and Delrin for general work. In bar form, plastic can be very expensive. A two-inch diameter Delrin rod may cost over one dollar per inch compared with two dollars a pound in granules for injection molding (1998). Injection molded products are the preferred choice for use in manufacturing. As always, the tooling costs are high in order to produce a low cost part. If you are thinking about a new product to be produced in high volume you have to consider using plastic.

### Machining plastics

Machining plastic can be fun. You don't need coolant and the chips are easy to control and clean up. Use an RPM that allows heavy feed rates and use sharp tools. This will keep the plastic part from melting as it is being machined. When drilling holes use a very fast feed rate to keep the drill flutes from clogging. We ran a very profitable screw machine part by drilling a hole in Delrin at 10 times the suggested rate. The plastic would extrude out the flutes without generating any heat yet the drilled hole had a better finish and tolerance than our previous slower method. Remember that the surface of plastic is slippery and softer than metal. You have to consider this when work is held in a vise or chuck. Thin sections can be easily deformed when clamped. Temperature is also a factor. Plastic has a high coefficient of expansion, and a two-inch part can vary several thousandths of an inch from a hot day to a cool day.

### Galling of materials in close fits

In summary, I find aluminum the nicest material to work with. It is clean, strong and rust free. You should also be aware that aluminum can "gall", which is the surface of one part sticking to another of the same material. This usually happens when you check a fit by putting a shaft in a hole made of the same material. Stainless steel can be just as bad as aluminum when it comes to galling. If you have to do a lot of work in these two materials plan to use



*This 7" high display model of a 1911 "Baby" model airplane engine by Edwin Teachworth was built entirely of styrene and painted to look like metal. It is on display in the San Diego Aerospace Museum.*

an anti-galling agent on close fits. It is available in automotive shops.

### Hard-to-find fittings

Novices believe that some catalog somewhere will always have what they need, and all they have to do is order it. This is not always the case. Many catalogs are filled with sizes that won't actually be produced unless they get a substantial order. When you try to use "off-the-shelf" items, you often must compromise your design. Of course, I'm not suggesting that you make things like nuts or bolts, but you might have to make that special washer. There are plans around for interesting projects that were drawn with the materials that were available then. (Try and buy a BSA screw at your local hardware store and you will understand the problem.) Unless you are building "super scale", you can save yourself a lot of grief and use the materials and fasteners available today. Fortunately, you have chosen a hobby that gives you an alternative if the exact part you are looking for can't be found. You can always make it yourself.

## Chapter 4—Processes for metalworking

This chapter contains information on the processes used to harden, plate, finish, cast and join metals. While some of these processes can be done in the home shop, a number of them are best sent out to a vendor as they require equipment and processes that are not practical to set up in a home shop. Understanding these processes, whether you attempt them yourself or not, is an interesting part of working with metal.

### 4.1—HEAT TREATING

#### Some “do-it-yourselfers” have more success than others

I’ve got to be honest with you, heat treating is something I know less about than I’d like to. After investing three days labor in a part only to destroy it trying to heat treat it myself, I decided to have contract heat treating companies take care of the small amount of heat treat work I generate. If you have a small heat treating furnace available capable of heating up to 2000°F you can do simple heat treating jobs. If you plan to make parts that require heat treating I would use “air hardening” steels such as A-2 for standard use or S-7 for parts subject to shock loads. Don’t consider using a torch unless you’re treating a very small part made of drill rod. It is very important that the type of steel you use is



*A heat treating oven heats items to be hardened almost to their melting points making temperature control critical.*

documented so that proper heat treat information is used.

#### Case hardening vs. tool steels

Tool steels harden all the way through and case hardened steels are only hardened on the outer surface of the part. This gives a very hard surface that can be controlled by the time it is heated to harden to a specific depth. The part is brought to temperature in a cyanide bath where carbon atoms change the makeup of the surface to allow it to be hardened. There is a limit to the depth of this process (up to .010" or .25mm), but case hardening is inexpensive in production quantities. You can case harden low carbon steels in a home workshop with a marvelous material called “Kasenite”. After the part has been brought to about 1650°F it is dipped into the powdered Kasenite. The powder adds carbon atoms to the surface, allowing the surface to be hardened. You can get more depth with this process by repeating it several times.

#### Hardening your own parts

The part should be placed in a stainless steel “envelope” to protect it from excess oxidation. The stainless is 316 shim stock which is .002" thick and goes by the trade name of “Tool wrap”. It is very thin and can be easily folded. The envelope should be as small as possible and sealed with a sharp fold. Stainless steel wire can also be used to hold the envelope in place. A heat treat furnace is a must and the temperature must be accurately controlled. Be sure the work is allowed to “soak” at the recommended setting so that the entire part has time to be brought to the proper temperature. A general guideline is one hour for each inch of thickness. The makeup of the material you are dealing with in heat treating must be known to properly heat treat metals, and these rules must be followed exactly. The temperatures used in heat treating are very close to the melting point of the material. The parts being heat treated must be heated evenly. An acetylene torch used carelessly may “burn” the corners off while never getting the center of the part hot enough to be hardened.

#### Rockwell testing for hardness

After the part has been hardened it is reheated to “draw” the part to a specific hardness. The lower

the drawing temperature the harder the part. As steel gets harder it also becomes more brittle. The numbers arrived at will usually be a compromise. There are several ways to determine the hardness, the most popular being “Rockwell” testing. A diamond point is pressed into the surface of the hardened part and the amount the diamond penetrates the surface at a given pressure can determine the hardness.



*A Rockwell tester is used for determining the hardness of a material by measuring the penetration of a diamond point into the material's surface.*

If you ever have the time, look up the ingredients in a good steel and compare these ingredients to stainless steel. The ingredients may be close, but the final product is entirely different. In most cases, stainless can't rust and is non-magnetic. I would recommend working with popular, common materials...nothing exotic. Talk to your local heat treat company for suggestions.

#### **Annealing is the opposite of hardening**

The term “annealing” is used frequently and is basically the opposite of hardening ferrous steels. As an example, materials that have been work hardened by machining may have to be annealed after being “roughed out” to size. Annealing is usually accomplished by heating the part to a temperature determined by the composition of the material and allowing it to cool slowly. Nonferrous metals can be annealed by heating them to the desired temperature and quenching them in water.

#### **Hardening and aging aluminum**

Aluminum can be hardened at much lower temperatures than ferrous materials. A period of several days after heat treating may be required to get to the required hardness. This is called “aging”.

### **4.2—METAL FINISHES**

#### **Black oxide**

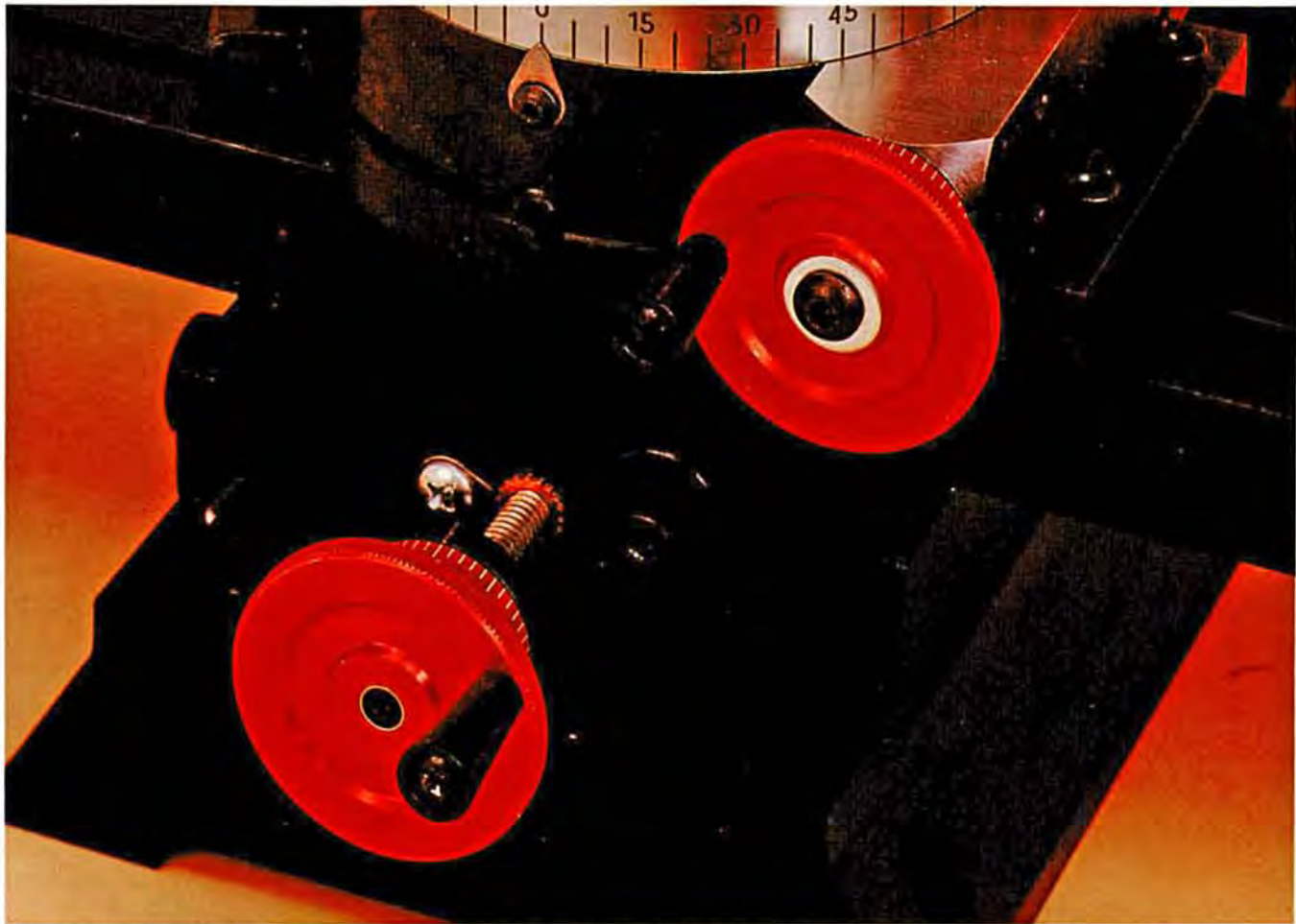
There are a variety of finishes that can be put on metal. A popular finish for steel parts is “black oxide”. This is basically “gun bluing” and a gun shop would be a good place to purchase small amounts of the material needed to do this at home. Fingerprints that haven't been removed can leave blemishes on the final product in all plating processes. You have to work in a very clean way in a very messy process to do plating. If you have a plating company do a small job for you, it may save money if you don't demand fast service so they can run the part with a larger order.



*These parts have a tough black oxide finish. This finish is often used on guns as it offers good protection as well as a nice looking blue-black color.*

#### **Attempting plated finishes at home**

There aren't many other plating methods that can be done without building special equipment. The process of plating is more electrical than chemical. I've seen some interesting articles over the years on how to build plating tanks and rectifiers to accomplish plating at home. Some craftsmen prefer to control the quality of every step of their project. I believe the average machinist would be heading in a direction with little rewards if they try plating at home. The chemicals are difficult to buy in small quantities. It would be like developing your own film if you only used one roll of film a year.



*Anodized finishes like the black of the table and the red of the handwheels provide a tough, easy-to-care-for finish on aluminum parts. In this case, they also provide the additional benefit of helping the laser engraved markings show up in high contrast. The laser cuts through the finish into the raw aluminum underneath making what appears to be white lettering. Several other colors of anodized finish are also available. The process gives a good looking finish and is not particularly expensive.*

### **Chromium plating is a multistep process**

Decorative chrome plating like you see on automobile bumpers doesn't work well for small machined parts. The process has several steps and the first step is to plate copper on to the steel surface. The copper is polished and a plating of nickel is then added to the surface. Nickel has a "smoothing" effect to the surface but also has a slight yellow color. Chrome is then plated on the nickel in very small amounts which gives you a beautiful finish for bumpers, but it is not too good for precise mechanical parts. This is because the chroming process is done in layers with lots of polishing, and detail can be lost in small parts. Plating also builds up more on corners than flat surfaces, and chrome is so hard that it can't be machined off. A tapped hole on a part that has been plated may cause problems even if you use an oversized tap. The first



*This 1/12 scale model of a blacksmith's trip hammer by Jerry Kieffer remains unpainted to show that no fillers were used or mistakes covered up. Sometimes the ultimate finish is no finish at all.*

thread may build up with plating material and the remaining threads will not be plated. Plating doesn't get into holes unless special electrodes are used. A tapped hole that will not accept a standard machine screw may be the result in this type of plating process. Remember, a polished steel surface can have the appearance of chrome if it is done properly.

#### **Hard chroming has specific uses**

There is another chrome plating process called "hard chrome". This is expensive and doesn't give the shiny surface usually associated with chrome. The process is controlled by carefully positioning the part and electrode to control where the chrome is applied. This method is used to create a good wear surface. Molds that are subject to abrasive materials have their cavities hard chromed. Hard chrome has to be polished or precision ground. It is also used as a "putting on tool" to save a worn or undersize shaft, but the home hobbyist may find the cost of doing this too expensive. When one-off parts are hard chromed you can expect the cost to be over one hundred dollars.

#### **Barrel plating large quantities of small parts**

Barrel plating is a production method used on small parts. Screws would be a good example of this type of plating. The parts are not "racked" one at a time but are plated by the barrel as the name implies. Nickel and cadmium finishes are commonly used with this process.

#### **Colored anodized finishes on aluminum**

Anodizing is the preferred method of finishing aluminum. This is a method that forms aluminum oxide on the surface. Parts will have their surfaces grow slightly with this process. The oxide finish has a "porous surface". This allows it to accept colored dyes with excellent results. Black and red are two colors that anodize well. The surface is then "sealed" with hot water, but please don't ask me how that works. You should realize that colors will vary because of the many variables that take place in the process. It is not an exact science unless you are willing to pay for new chemicals and test runs. I would not bid a contract part if I had to be responsible for the plating color. Many perfectly good parts have found their way to the scrap heap because a buyer didn't like the color. This is one of the reasons I gave up contract machining. There are a hundred ways to lose, and you only win if everything goes exactly as planned.

#### **Hard anodizing**

Just like hard chroming, the anodizing process has hard anodizing. This allows the surface to be built up with one of the hardest materials on earth, aluminum oxide. It can be used to protect the surface against wear; however it isn't very strong and can only be applied a few thousandths deep. One half the thickness of the plating will be impregnated into the metal and the other half will be added to the surface. As an example, if a 1" diameter bar were hard anodized .002", the bar's diameter would increase by .002". This is somewhere around the maximum amount you can hard anodize. If machining is attempted on a part that has been anodized, enough material should be cut on the first pass to keep the cutter from rubbing on the anodized surface. Carbide tools will help but the oxide surface is still harder than carbide.



*Though not particularly exotic and certainly not expensive, a nicely done painted finish does add realism and appeal to a model. An airbrush will give the most control, but good technique with a spray can yields good results too.*

#### **There's always good old paint**

Painted finishes need special attention when working on miniature replicas of machines. You just can't slap on a couple of coats of paint and be satisfied with your work. You should carefully mask the surface to keep paint off the areas where it shouldn't be. A primer should be used to assure the proper adhesion of the paint. This should be applied in very light coats. I have always preferred lacquer based paints because a surface can be built up with many coats to get the desired results. The inside corners must be painted using very light, dry coats or the lacquer may pull away from these areas because paint shrinks as it dries. Enamels may wrinkle if a second coat is added without allowing enough

drying time between coats. The thinners in the paint must be allowed time to evaporate before the next coat is applied.

### 4.3—CASTINGS

There are many ways to cast metal parts, but this is not a process I would recommend trying at home. This section is provided as general information so you have some idea how metal casting is done. If you are one of those builders who likes to do every operation yourself, read up on casting techniques before buying or building any equipment.

#### Casting techniques from the jewelry trade work well for small parts

The type of castings that could be used for miniature projects at home actually come from the jewelry trade. They have developed a small centrifugal casting machine that slings the molten metal into a ceramic mold that has been made by the “lost wax” method. Commercial casting companies use a sprue system. This is a method of getting molten metal to the mold and casting more than one part at a time. It resembles a funnel and many parts may be cast at one time by pouring molten metal into the sprue system which feeds each part. The top of this assembly has provision for a small pool of molten metal to continue to feed the parts as they cool and shrink. They call this assembly a “tree”. The sprue



*Die cast lathe bases as they come from the foundry and before they are machined. Proper draft angles and shrink rates must be considered in the design so that the parts will release from the mold and end up the right size.*

can be attached to the part in a manner to allow variations in length which is normal to the casting process. The part is then machined to its final length as the sprue is cut from the casting.

#### Making molds for investment casting

The ceramic mold is made by coating the wax pattern with a slurry mix that air dries. It may take several layers to get the desired thickness. The wax is then removed from the inside of the mold with steam or heat. This leaves a mold with no parting line. The ceramic mold is then heated to over 1000°F to harden it and burn away any remnants of the wax. After the mold has been filled with molten metal and cooled, the mold is destroyed as it is broken away from the casting. This is called “precision investment casting”. The part is produced by casting or machining a wax model of the final product. If many parts must be made, a mold can be built to cast the wax pattern. The molds can be simple if you are willing to accept some second operations machining the wax pattern.

#### Shrink rates of various cast materials must be considered

The model must have the appropriate amount of shrink rate figured in so the final casting is to size. If the wax model was machined, the shrink rate of the wax doesn't have to be figured in, but if it is cast it has to be calculated from information that is available from the companies that manufacture wax. If you want a close tolerance cast part it may be worth the effort to run a test part to determine the shrink rate for a particular shape. The test part does not need the detail the final product has, just the general size and shape. From this information a wax pattern can be built that is surprisingly accurate. This is a very accurate process and parts like turbine blades for jet engines are made this way. The part finish of small model parts will usually duplicate that of its full size counterpart. It is possible to cast many types of metals with this method. Making the wax pattern and having a professional casting company do the final casting may be the way to go. By taking off on tangents like this you may end up never completing what you started and end up making jewelry, but projects done in home workshops are for fun so do whatever you enjoy. As you can see, it takes a lot of steps to make a good casting and if you're only making one part, it could be easier to machine it from bar stock and sandblast it to get the look of a cast piece.

### Die casting for commercial parts

Most complex metal shapes found in commercial products are “die cast”. The molds are similar to injection molds for plastic. These molds are built to withstand internal pressures of 10,000 P.S.I. (1800 kg/cm<sup>2</sup>). These types of molds are very expensive and should only be considered for production parts made in high quantities. As an example, the Sherline steady rest mold would cost over \$10,000 to replace. Molds of this type are attached to the platens of die casting machines. The hot side is fixed and the ejection side can be moved. Leader pins align the two halves with the utmost precision as the mold is closed. These machines are rated by how many tons of force it would take to spread the two halves apart once they have clamped. A 100-ton machine would be considered small. They may use a past-center clamping arrangement or a hydraulic cylinder to keep it closed. After injecting molten material into the mold, the casting is allowed to cool for several seconds. Cooling time is dependent on the thickest cross section of the part and the cooling method. When the ejector side of the mold is pulled away from the hot side, a plate on the ejector side is pushed forward. Attached to this plate are ejector pins. Die casting molds may have over fifty pins. These pins push the part from the mold and let it drop out. The mold then closes to start the sequence over again. I believe mold making is the best and most interesting job in the machine trades, but it is very demanding. The parts you work with daily are too valuable to get careless and screw one up.

### Sand casting...an old method that is still in use today

The oldest method of casting metals which is still used today is sand casting. The tooling to produce cast parts can be a wooden (usually Honduras Mahogany) model of the finished product you want to cast. The expert craftsmen who make these wooden molds are called patternmakers. The trade requires not only good woodworking skills, but a vast knowledge of how metal will react when molded. Shrink rate has to be accounted for and draft angles are needed on sides that would otherwise drag when the wooden model is lifted from the sand. The model is set in a “box” and sand is packed around one half of the model. The opposite side is done the same way and the model usually has some method to increase the accuracy of this process. At the same time a sprue system is added. Sand used in sand casting has been treated to stick together. A hollow section in the casting can be obtained by having a “core”. Cores are made of a processed sand that will



*A mahogany pattern is the first step in the sand casting process. A skilled patternmaker requires not only a knowledge of the properties of metal and how it will react as it cools, but also requires masterful woodworking skills. Here Howard Parry applies a wax bead to an inside joint. A heated metal ball tool is used to shape the wax into the desired radius fillet.*

harden with temperature. The cores are very fragile and are designed to be this way so they can be broken into small pieces to remove them from the finished casting. Cores are held in place by the parting line of the mold. The two halves are put together and molten metal is poured into the mold through the sprue system. The sprue system will normally have an extra pool of melted material that helps keep the mold filled while the metal cools. After the metal is cooled the sand is knocked away from the part and the sprues are removed. It is difficult to get the degree of accuracy needed in miniature models with sand castings, but they are an inexpensive method to produce large parts in low quantities. The base for our 24" (609mm) lathe is produced by the Edelbrock Company. They have a sand casting facility that is second to none. They use automated equipment that can fill a mold every 45 seconds. The sand molds are made in two halves by automatic machines. The molds are also a cast product and are usually aluminum. I made a model of what I wanted and they used this model to build a three-cavity mold. The tooling cost was less than \$5000.00 and the part price was reasonable by doing three at a time. You may be familiar with the Edelbrock name because they manufacture many fine products like manifolds and other performance parts for hot rods and race cars.

### Casting using matched plates and gravity

There is also a method of casting that uses matched plates. This is simply a metal mold made in two

halves. The major difference between these molds and die cast molds is the cavity is filled by gravity, not the very high pressures used in die cast molding.

#### **Dealing with foundries to get your parts made at a price you can afford**

Most foundries specialize in only one material. It could take several different foundries to get the parts you need and each one may have a minimum order. Be sure to remind the foundry that this is a model project where time isn't as important as money, and see if it would be possible to run your job with other commercial parts to keep the price low. You have to be nice to large casting companies who are willing to take an order to run a few parts for you even though they probably still wouldn't make a profit on them at twice the price.



*The quality of castings that come in kits varies from good like the ones shown above to downright unusable.*

#### **Beware of poor castings in some kits**

Many steam engine kits contain castings that belong in the junkyard. The tolerance of the part can be lost in a deformed casting. The manufacturers of these castings do the industry a disservice by selling castings of poor quality. A novice may believe they are at fault when a kit can't be finished, but the truth could be the castings are in error. The sorry part is that sometimes these novices give up and go on to another less demanding hobby because of it. Kits should always be designed to make the

project easier and more fun to build. If the model engine kit manufacturers would switch to precision investment castings for their kits, both manufacturer and customers would benefit.

## **4.4—OTHER WAYS TO FORM METAL**

### **Extrusions**

Extrusions are something we are very familiar with at Sherline. Most of the cross sections for the lathe and mill started out as an extrusion. The basic method of producing a extruded shape is similar to decorating a cake. The frosting is forced through a hole which gives the material coming out the shape of the hole. A cross section with a hole can be extruded by forcing the material around a core piece that is shaped like a torpedo.

It takes a lot of power to push a 500-pound billet of aluminum through a small hole, so the first thing you need to extrude metal is a gigantic hydraulic ram. The aluminum billet is heated but not melted as it is loaded into the cylinder. The method of loading is similar to loading a cartridge into the barrel of a rifle. The aluminum shape will usually be twisted and crooked as it leaves the extrusion die. This shape is then pulled from both ends to straighten it. It is the same method used to straighten a piece of wire or copper tubing only the forces used to straighten a shape with a large cross section are tremendous. This method doesn't allow tight tolerances. At Sherline we have to machine all mating parts on the extrusions we buy.

Extrusion dies are relatively inexpensive, around \$1,000, and the cost to produce these dies has come down because of a new machine tool called a "wire EDM". A wire about .010 inches in diameter cuts the shape as it is fed through the part by using the "spark erosion" method. The wire never touches the part it is cutting. The sparks that jump the small gap between the wire and the part erode the material away. This isn't a fast process, but it does the impossible. The tool steel die can be heat treated before the shaped hole is cut. The table is computer controlled and very accurate. A process called "cold drawn" is also used to more accurately shape extruded parts in metals. This is similar to extruding but it is accomplished in more than one pass.

### **Forging**

Forging is taking a slug of metal and reshaping it in a die mounted in a press that acts like two giant

hammers hitting the part at the same time. One of the main advantages of this process is the strength of the part produced. The “grain” of the metal can be controlled by forging making the part much stronger and less likely to fail. It isn’t something a home hobbyist could do but worth mentioning.

Quality wrenches are forged. This method can be more exact than you could imagine. On TV I saw a complete frame for a handgun made in a few seconds by forging, and it was a very complicated part. Forging tooling can be quite expensive.

#### **Powdered or sintered metal parts**

Powdered metal parts are made in a specialized press that compresses “powdered metal” from both the top and the bottom at the same time. This produces a part that has a more equal density than one hit from only one side. The cast part then goes through a “sintering oven” where the powdered metal is fused together. Additional strength can be added by filling in the microscopic voids with a material such as copper. After sintering a piece of copper is placed on the part and it is run through the furnace again. If done correctly the copper will disappear into the part making it stronger. Door locks are usually manufactured in this manner.

---

## **4.5—JOINING METAL**

### **Soldering irons and flux core solder**

The method of putting two pieces of metal together that most hobbyists are familiar with is soldering. This type of soldering is called “soft soldering”. Soft solder melts at temperatures below 800°F and is a combination of lead and tin. Hobbyist have built many ingenious devices by soldering together piano wire and brass tubes. These standard items are sold in hobby shops and are used to build gadgets that are held together with solder. The first thing you find out about soldering is the surfaces to be joined have to be clean and free from oxidation. A flux is used to clean and protect the surface from oxidation as the parts are heated. Many solders have a flux core. These are fine for work that will be heated with a soldering iron. If you are heating the part with a soldering iron, the iron should be cleaned by wiping. If a new iron is used or a thin coat of solder doesn’t cover the tip of the iron, the tip of the iron has to be “tinned”. This is accomplished by a dipping the tip of the hot iron directly into the flux and melting solder on the tip and then wiping the

tip with a rag. Repeat until you get the desired results...a shiny silver tip on the iron. It is then ready to use.

### **Soldering torches and solid core solder**

For larger parts that have to be heated with a torch a paste flux must be used. This keeps the area around the joint clean as the part is being heated. Propane torches are somewhat dirty and flux is a must. Acetylene torches work better but they are too costly for the average hobbyist. In general, solder will flow towards the heat source (even if it is uphill). It is usually best to heat the side with the most mass and apply the solder to the opposite side. Always use a little flux and solder to transfer heat from the iron to the part. When soft soldering a part that is dependent on the strength of the joint use a solder that contains about 65% or more lead. A 60% tin content is used for soldering electronic circuit boards and cabling. Flux should always be removed from the joint after the solder has hardened. It will cause a corrosion problem because it contains acid. You can also wipe the excess solder and flux away with a rag before the joint has hardened. Plumbers use this trick to get an excellent appearance when they solder copper tubing. In general, soldering is a skill that has to be learned, and the best way to learn is by doing. Try soldering on a similar piece of scrap material before trying to solder a part that may contain a lot of work.



*Here's a close-up detail of part of the blacksmith's triphammer shown on page 47. The silver soldered parts are perfectly joined, filleted and finished to look like castings. Jerry Kieffer's skills as a modelmaker are highlighted by the number of different metalworking techniques he has mastered.*

### Brazing and silver soldering provides more strength

When strength is critical brazing should be considered. Brazing materials melt above 800°F and below the melting temperature of the materials being brazed. Some brazing materials may penetrate the surface of the materials being joined giving very strong joints. They will always “wet” the surface for a successful braze. Silver solder is probably the best known brazing material. It is expensive but it is also used in such small amounts that cost shouldn't be an issue. Flux is a must and surprisingly it is usually water based. Liberally apply the flux to the area around the joint and heat the work in such a way that you don't boil off the flux. I usually use a soft flame to start and get the water out of the flux. This will leave a white coating. The part is then brought up to silver soldering temperature. More flux may have to be added to insure clean soldering surfaces. Heat the silver solder rod and dip it into the flux. This coating will protect it from oxidizing as it is applied. Just like soft soldering, the melted brazing material will go towards the heat. Try to bring the work up to temperature evenly and apply the brazing material to the opposite side of the heat source. I have found that when the flux melts and wets the surface of the joint the temperature is ready for the silver solder to be added. If it doesn't flow the work temperature must be raised. Keep adding flux if necessary. Holding any materials at high temperatures for a long period of time with a torch can cause problems. Propane torches are usually not hot enough to silver solder large parts successfully. They also have a dirty flame that creates problems at the higher temperatures used in silver soldering. If you attempt to silver solder with propane you must use an excess of flux.



Some sample aluminum welds. Controlling the puddle of molten metal is the key to a good weld.



A close-up of an expert weld in aluminum shows a good, even bead with proper penetration. Like all skills, welding takes a lot of practice and a good knowledge of your tools and materials to get good results. Being able to do some basic welding is probably one of the more useful skills you can obtain. Though not often used in miniature machining, it can come in handy for many other construction and repair projects you will run across.

### Arc welding

The small parts normally made with Sherline tools are too small for arc welding, which is the most common way to weld. Unlike brazing, welding is a process which melts the material being joined and the joint can be as strong as the original material.



Some welding shops specialize in exotic metals. Welding titanium such as this Mako mountain bike frame requires special tools and a lot of skill. The advantage gained here is a frame that weighs 2.5 pounds instead of the 5 pounds it would weigh if made from steel.

COURTESY OF MAXWELL ENTERPRISES WELDING

There are several ways to weld, and the difference is mainly where the heat comes from. Low voltage and high amperage is the usual source. Arc welding starts by dragging a flux coated rod across the weld joint until an arc is established. A very steady hand is required to control the end of the rod that may be 10" away from handle and clamp that is holding the rod. The puddle of molten metal is controlled by minute movements. Good welders can arc weld a perfect joint standing on their heads if need be. A poor quality weld in a hard to get place can fail as easily as a weld on the front side. The weld temperature is controlled by the machine settings and rod diameter. The "ground" has to be perfect to weld properly. Welds must be perfect for they must hold buildings, bridges and a large part of the industrial world together. Our lives are much more dependent on the skill of this group of tradesmen than one would think.

### Spot welding

Resistance or spot welding is very common in our lives. It holds together most of the automobiles that we drive daily. It is a quick process but only certain materials can be spot weld successfully. The metal is clamped together by two copper tips. A short blast of electrical energy is fed across the joint and the metal fuses together. The welds done at automobile factories are now done by CNC robots and have thankfully eliminated this job from assembly lines. I have used spot welders that are very small and called "tweezers welders. They can be used to attach thin shim stock to thicker parts.

### GMAW welding (or MIG welding)

Another type of welding that is becoming very popular is technically known as GMAW welding which stands for "Gas Metal Arc Welding", but it is more popularly called MIG welding. An inert gas such as argon floods the area to keep oxygen away from the melted surface. The welding material is a spool of wire that is mechanically fed down the center of the welding cable. It comes out through the torch through the center of a ceramic cup where the inert gas is also streaming out. The rate and amperage has to be adjusted so the material will melt at the same rate it is fed. The first time I tried it I moved the torch away from the work and in less than a second I had a 6" long wire that was incredibly hot. I realized this was going to take some getting used to. MIG welders have come down in price over the years and can be useful to build stands and trailers, but it would be hard to find a use for them



*Though an oxy/acetylene torch may be the first thing many of us think of when we hear the word "welding", most industrial welding is done using electrical current as a heat source. Shown here is a TIG (Tungsten Inert Gas) welding setup that brings the price down in the "home shop" range. This foot pedal controlled unit sells for about \$1300 (1998) with the wheeled cart adding another \$170.*

on parts normally associated with miniature machining.

### TIG welding

TIG (Tungsten Inert Gas) welding is a method that may be of some use when working with small parts. The tungsten rod is located in the center of a ceramic cup that directs an inert gas such as argon over a clean surface that is going to be welded. A high frequency contact is made between the work and the tungsten tip. An arc is established and the high frequency is turned off automatically. The size of this arc can be very accurately controlled by machine settings and a foot pedal similar to an accelerator. You have to hold the tungsten very close to the work to TIG weld. The diameter of the

tungsten has to be proper for the welding machine settings to keep it from melting. If a weld is critical, any tungsten that falls or is broken off in the weld must be ground out. If the tungsten is dipped into the melted puddle, the melted material will attach itself to the tungsten and form a small glob. When this happens the torch is hard to control and an arc may suddenly shoot out on an angle and destroy a delicate part. The point of the tungsten must be shaped to a point to accurately aim the “flame”. I prefer a fine tip with an elliptical shaped taper going to the outside diameter of the tungsten. One thing that you can do with TIG welding is fuse two pieces of metal together. Stainless steel can easily be fused together and very delicate welds can be done by fusing. When welding very small parts a “chill block” may have to be used to protect the main body of the part from excessive heat. These are usually made of copper and clamped just below the weld.

#### **TIG welding aluminum**

When aluminum is TIG welded it must be very clean. The entire part to be welded has to be cleaned with an acid bath before welding to insure a good weld. Because aluminum can dissipate heat so quickly, large parts have to be preheated. I use an oxygen/acetylene torch. By turning down the oxygen the flame will create “soot”. This soot will stick to the part and will be released from the aluminum surface when the aluminum is the right temperature to weld. Aluminum never looks hot, and a hot piece that has just been welded should never be left alone to cool where someone may inadvertently touch it. At least put a sign on it. Don’t cool it with water as you may anneal or soften the material.

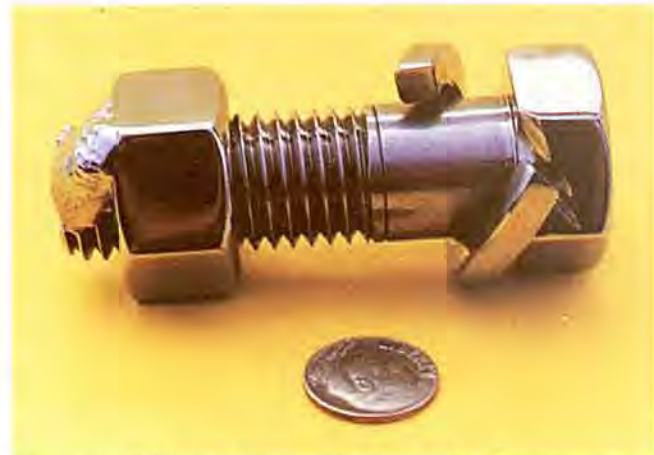
#### **Star Wars welding with lasers and electronic beams**

Exotic fusion welds are now being done with lasers and electronic beam welding. These can be microscopic welds that are controlled with the utmost precision. This type of welding is used by laboratories and production equipment, and because of the high cost it normally wouldn’t be considered for the home hobbyist.

#### **Taking your skills in these areas to the next level**

In closing this section I want to remind you that I’m not an expert in these fields. I have dabbled with each process enough to know that I would need a

lot more practice to be really good at any of them. On the other hand, trying your hand at something really helps you appreciate a good job when you see it done by an expert in the field, and there is a certain satisfaction in simply knowing a good piece of work when you see it. Books have been written about each subject mentioned and you really need to understand the process more than I described it before attempting welding or brazing. If you have a friend who understands these processes, buy them dinner and pick their brain, but remember there aren’t many welders who work with parts as small as we work with daily. It will very seldom be useful to fix a mistake by welding a small part and, like it or not, the best way will usually be starting over.



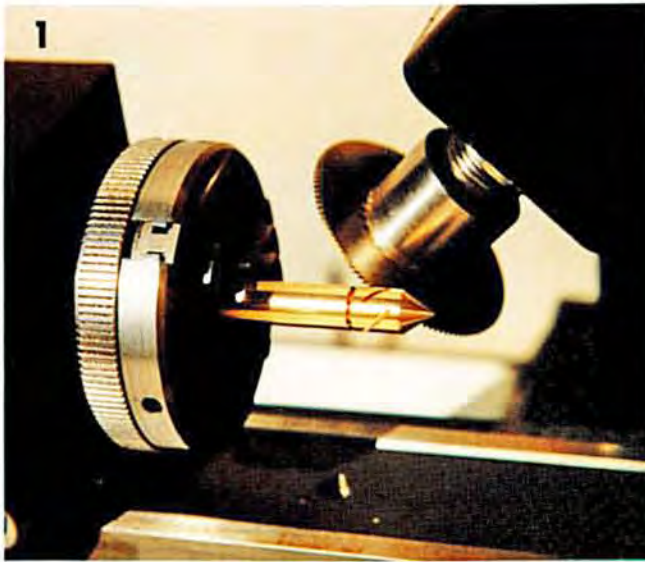
*How would you remove this nut which appears to be thoroughly welded to the bolt? This fun puzzle by Larry Lamp was an entry in the 1995 Machinist's Challenge contest in Michigan.*

PHOTOS: DAN PAPP



*The solution is obvious once you know how it works, but many spectators took one look at the massive weld and said it was impossible.*

# Modeling tricks of the trade from Phil Mattson



## Making a brass ship's propeller

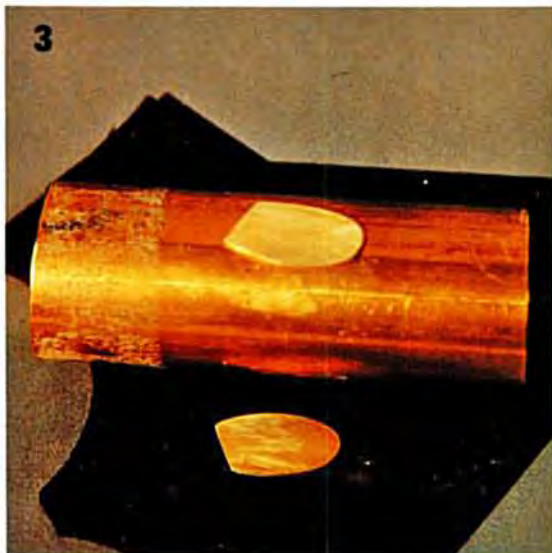
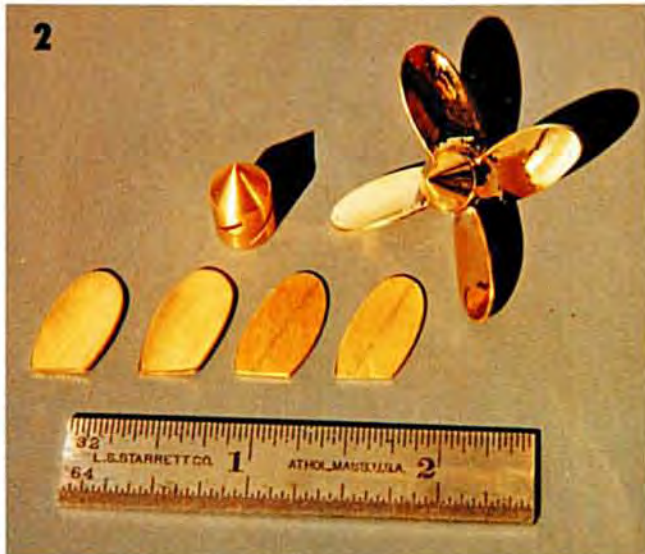
Most kits come with a cast propeller which you file to final finish. If you are building a model from scratch, making a nice looking scale propeller can be a tough project unless you have a plan. Phil Mattson has made many of them, and here's how he does it.

1. A hub is turned on the lathe and left on the end of its piece of stock. The chuck is put onto the indexing attachment (or a rotary table) and held on the mill. The headstock is offset to the angle of the desired pitch for your blades and a slot is cut for each blade.

2. Four blade profiles are cut from sheet brass and filed to shape. The photo shows the hub and the four flat blades along with a finished prop.

3. Each blade is placed on a block of hard rubber and a brass billet of the proper diameter is laid on top of it. The billet is hit with a hammer (protect it with a piece of wood) and the proper curve is bent into the blade. The photo shows a flat blade on the rubber sheet and a finished blade on top of the billet.

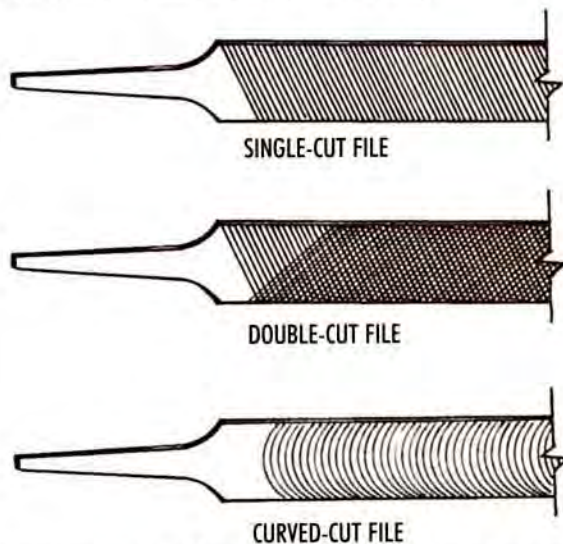
4. The hub is placed on the shaft and blades are soldered into each of the slots. As a final touch, the prop is polished to a mirror finish.



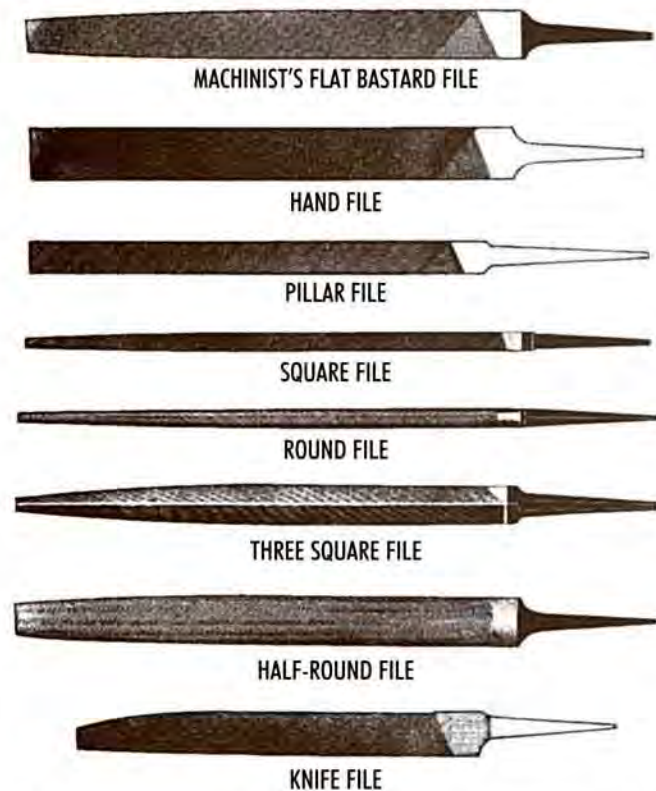
## Chapter 5— Using hand tools and abrasives

The Nicholson® file company started manufacturing files in 1864 and produces files that have become the standard for the world. Today (1998) you can still purchase an 8" mill file, smooth, for \$6.12. There are cheaper files, but I believe a good file is worth the extra money and is really a bargain when you consider what can be accomplished with one. Files give a machined part its final shape and finish. Too often I see parts that have been accurately made to size, but lack that special appearance that a good craftsman can add. The “final touch” is usually accomplished with a simple file, a good set of hands and a good mind controlling the process. When machining parts for pleasure, you are in a sense a sculptor, and your medium is metal. Parts should do more than just work. They should have the detail to make them look perfect even if they are scrutinized under magnification. Try as we may to eliminate the craftsman with fancy CNC machines, it is still a craftsman’s touch that produces “beautiful” parts. You can’t expect the average person to appreciate this extra effort, but your peers will.

I am going to stay within the bounds of using files on small metal parts. The material being filed must be hard enough to be successfully filed. Soft materials like wood should be sanded.



*The grooves in files can be cut at a number of different angles. For the purposes of miniature machining, a single-cut mill file will be the most useful tool.*



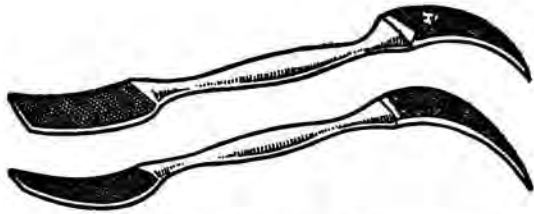
*Files come in all sorts of shapes and sizes. Each has a particular purpose and having a good assortment on hand can make your life a lot easier.*

### File shapes

Files come in all sizes and shapes. Round, flat, triangular, square and half round are just a few of the standard shapes. These shapes and sizes can be ordered through mail order industrial suppliers. We have several listed on our web site that have hundreds of styles listed, and it is up to the craftsman to find the right tool to do the job. One point worth noting is that files can be ordered with blank or “safe” edges. This is very helpful when filing up to a shoulder. Swiss pattern needle files are sold in sets that have been manufactured throughout the world and have become one of the real bargains for the home machinist. A good needle file set is a “must”.

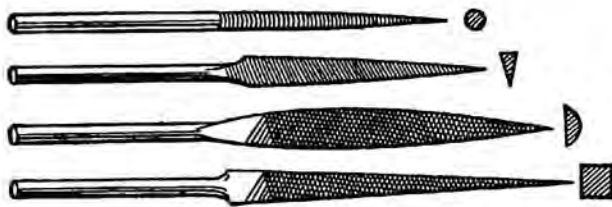
### Riffles

There is another type of file that not too many people know about. They are called “riffles” or “rifflers”. They are great to add detail to parts that have non-standard shapes. Riffles were developed for tool makers to put the final touches on complex shapes.



*Rifflers are used for filing the finishing touches onto complex shapes. There are many choices of shape to choose from.*

The files have many cross sections and have a file on each end of the handle that have been “bent” to get into tight places. When you get working at this level of detail, engraving would better describe the work you are performing.



*Needle files are also good for working in small areas and come in a large selection of cross sections and shapes. Files are amazingly inexpensive considering the work involved in making them.*

#### **Powered rotary files**

I’m sure everyone has seen kits that have a high speed motor to drive a wide assortment rotary tools. Dremel is by far the largest manufacturer of these neat little sets. They can be real handy but don’t use them in a small cavity. If they dig in, they bounce to the opposite side and you can destroy a part in a split second. It is really worth the extra effort to machine good finishes in cavities. They are very difficult to clean up later.

#### **Working with files**

A single-cut, flat mill file is my personal favorite. These files have ridges in only one direction rather than two directions. This doesn’t allow them to remove material quite as fast, but when you are working with small parts, time isn’t as important as quality. Mill files have straight teeth angled to the body. This creates a self-cleaning action. For general work such as deburring, I use a 6” to 8” long file with a smooth cut.

When a file first comes in contact with a part, it should be allowed to find its resting point before any pressure is applied. This keeps the edges from digging in. The direction the file is driven should

be at an angle that allows the teeth to cut the part at an angle. If the teeth hit an edge squarely they have a tendency to chatter. Remember, a file has a built in angled cutting edge.

#### **Keep your files clean and sharp**

Files should be replaced when they get dull. The sharpness of files should be judged by their performance. When files start cutting on their ends better than in the middle they are worn and it is time to replace them. A file should cut with little “downforce”. To cut properly they need to be clean. The grooves on the backside of the cutting edges are the same as the flutes in a drill or mill cutter. A drill wouldn’t be expected to work with its flutes clogged and a file will not work properly unless it is frequently cleaned. I use a small wire brush that has the shape of a toothbrush.

#### **Precautions when working on spinning parts**

A file used on a lathe can be very dangerous. If the point of the file comes in contact with the three-jaw chuck, it will be driven backwards into your hand. These can be nasty injuries and can only be avoided by concentrating on the job at hand. Machining is a process that requires hands to be in close proximity of moving cutters and spindles. When operating manual machines, the only safety device that really works is the brain keeping the hands out of trouble.

#### **Putting handles on files**

For safety, all files should have handles on them when they are used, but it is especially important when lathe-filing. By the way, the proper way to seat a file in a handle is to bang the handle end down on the workbench, using the file’s momentum to seat it into the handle. Never hold the handle end up and hit the metal file end on the workbench.

#### **Magnifying eyewear makes miniature work easier**

I strongly recommend a magnifying headset for doing work like this. It is wise to use the minimum amount of magnification that can be used to get the desired results. Powerful lenses distort your surroundings so much they hurt more than they help. They must be comfortable to wear. Magnifying glasses are inexpensive and should also be considered a necessary tool for fine finishing.

#### **Deburring the edges and corners of a block**

If the edges on a small rectangular block need deburring, the amount of corner break should be equal on all edges. This is when your eyes become more accurate than you thought they were. You can



*The photo above shows blocks in various stages of finish. The unfinished block on the left has square, machined corners and a drilled hole. Its fly-cut surface shows machining marks. The block in the middle has been lightly sanded in two directions with 320 grit sandpaper on a flat surface and has had the corners slightly softened with a flat mill file. The hole has been chamfered with a chamfering tool. In addition to surface sanding, the right block has had the edges beveled with a mill file and then sanded. The corners have been slightly rounded off. The hole has been chamfered and lightly spot-faced with a counterbore.*

easily distinguish a difference of only .005" (.127mm). If appearance is important on this block I will go one more step to put the final touches on exposed corners. The chamfered edges now have the appearance of three separate edges joining. They would look better if these surfaces flowed together. After the edges have been equally chamfered, use your file with light pressure and file around the corner. This will round off the corner on one side. Sides two and three are done the same way. The final corner will have a beautiful shape that can be polished to perfection. This should only be done to corners that do not mate with another part.

#### **Removing tool marks and final finishing**

The part is now complete, or is it? It has been milled to shape and carefully deburred, but it doesn't have the look you want. You remember the parts you saw which were built by one of the masters of our hobby. They looked more like pieces of jewelry than mechanical parts. If this is what you want, the part still needs a lot more work. The next step is removing tool marks. Nothing looks worse to me than a surface that has been polished too soon. The shiny surface will magnify the flaws.

#### **Polishing stones**

If you have a nice, flat, machined surface that shows a few tool marks, it will not be improved by filing. I switch to abrasives. Inexpensive "polishing stones" that come in a variety of shapes, sizes and grits are



*A selection of small polishing stones. Keep them clean by frequently dipping them in kerosene as you work. Work from rougher to finer grits to achieve the finish you need.*



*The photos in the background show the actual deck fittings from a vintage Chris Craft boat. In the foreground is a model part that duplicates the highly polished sheen of the chrome on the original bow light. The model is by M.H. Ellett.*

PHOTO: M.H. ELLETT

available. These aren't things that are sold at your local hardware stores and a mail order company would be your best source. I have found a 1/4" square shape the most useful. The end can be shaped on a bench grinder to get into tight spaces. The stone is dipped into kerosene frequently to keep the surface being cut awash with fluid. I've found that by changing the direction of cut as much as possible on each pass across the surface, the process will be speeded up. You make as many passes as it takes to get rid of all tool marks. Do not try to do large surfaces at one time. This is a very slow process and the average person will get very sloppy if they try to take on too big an area. The next step is to use a finer grit stone and remove the scratches left by the previous stone. This process is repeated until you have a finish that is flat and free from all but microscopic scratches. The next process is polishing the surface.

### **Sandpapers**

I have gotten excellent results with 320A wet and dry sandpaper glued to small sticks. I buy these wooden sticks at hobby shops and prefer spruce. I glue the sticks to the paper with instant "super glue" and make up a batch of them at one time. The glue hardens immediately and the sandpaper can be trimmed to the stick size. This glue works well because it doesn't seem to break down with the kerosene that must be used to maintain a cutting action. Many times this is all that is needed to finish a part to your satisfaction. Highly polished parts don't always look good because the finish will exaggerate any flaws.

These "sticks" will work well for most metals, but may be too slow to remove deep gouges in the harder materials. The 320A paper is the only type I would recommend. Coarser papers don't cut as well. I believe a metal surface is just too hard for them, and the maximum pressure that can be applied doesn't allow them to work. On the other hand, finer grits like 400 or 600 cut so slowly they can be a waste of time. If you want a better finish than you can get with 320A, polish it.

320A wet and dry paper is also useful to finish flat surfaces. Larger surfaces must be very flat or it will be easy for you to notice variations. The full size sheet of paper is laid on a flat surface and soaked with kerosene. The part is then dragged across the paper with little down pressure. This helps keep the part square to the flat surface. I always use a surface plate. Again, I have found I get better results by taking straight cuts from a variety of angles.

### **Powdered and liquid abrasive polishes**

Most any abrasive powder can work, but diamond powder is by far the best and also the most expensive. Most any abrasive type polish will work as well. Automobile rubbing compounds will work and they should also be applied with a stick. The diamonds come mixed with an oil. A small amount is put on a clean stick and the stick is used like a polishing stone. The diamonds become imbedded in the stick and will keep cutting as long as a very small amount of kerosene is used. Of course, the diamonds will be eventually be worn and washed



*A commercial "tumbler" uses abrasive particles to remove rough edges from machined parts.*

away and more diamond compound will have to be added. You have to be careful you do not contaminate the sticks with any grit and the part has to be meticulously clean. You wouldn't polish a new Ferrari without washing it first. One little piece of coarse grit can make a polished surface look as though it had been attacked by a graffiti vandal.

### **Tumbled finishes**

Production parts will be finished in a machine called a "tumbler". The parts are put into the drum of the tumbler along with a quantity of an abrasive medium, which comes in a variety of different shapes and sizes. When the machine is turned on, the random abrasion between part and abrasive medium will rub the tool marks off. For the home use, a small rotary tumbler used by the jewelry trade may be helpful and costs less than industrial models. It isn't a fast process, but the only labor is mixing the parts with the media and then adding water with a very small amount of detergent. The media should outweigh the parts by three times to keep the parts from damaging one another by contact. The detergent keeps the media from getting slippery from oil which would stop the cutting action. It will usually take several hours to get the desired results.

### **Sandblasted and beadblasted finishes**

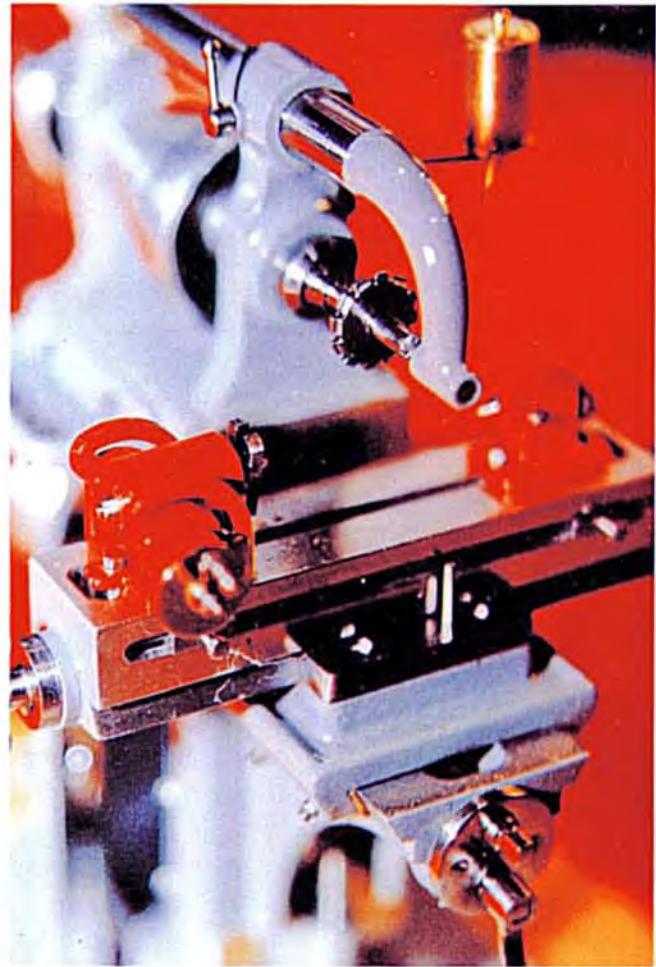
Sandblasting or beadblasting puts a soft, dull finish on metals. If you are modeling a part where you need to use machining but you want the finished part to look like a casting, sand- or beadblasting the part can give you the finish you are looking for. It's a pretty "low tech" process. All you need is a compressor, a sandblasting "gun", a hopper and a bag of silica sand, but unless you plan to do a lot of it the mess it generates just isn't worth doing it yourself. It's not very expensive to send your parts out for sandblasting and is probably worth it not to have to deal with the very abrasive silica dust. However, taking a few small parts to a professional sandblaster is usually not practical. Their equipment is too large, and they are not really not set up to handle small parts. An automotive sand blaster that has an enclosed box for sandblasting small parts is probably your best bet.

If you do try and do it yourself, be sure to wear the proper eye protection and the correct type of respirator mask. The fine particles of silica are the same as what makes up glass, and getting them in your lungs can cause silicosis, which is similar to asbestosis.

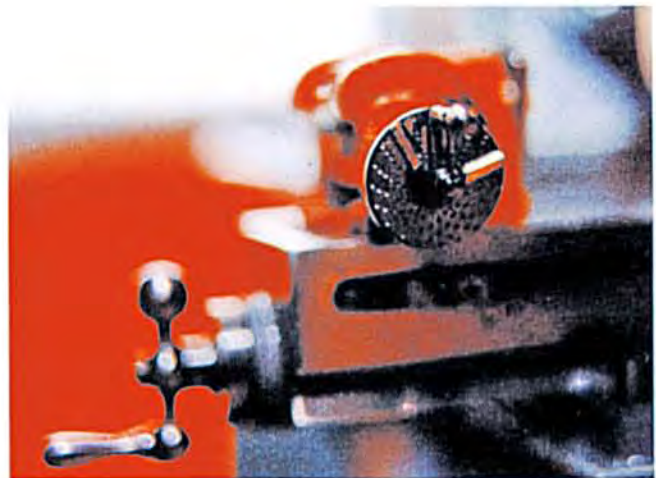


PHOTO: M.H. ELLETT

*Here's what M.H. Ellett's Chris Craft runabout looks like finished and in the water. The detailed and highly polished fittings make this model look like the real thing no matter how close you get.*



*Jerry Kieffer is seen here at a model exhibition with his 1/12 scale Brown & Sharpe Universal Milling Machine. He superdetailed his model based on photos in a reproduction of a Charles A. Strelinger & Co. machine tool catalog from 1895. Jerry is in the process of outfitting a complete 1/12 scale overhead belt driven machine shop as it might have been found in the late 1800's. As is typical of Jerry's models, every detail is represented to exact scale. Shown below is the dividing head which sits on the mill's table.*



*Jerry's fingers give a sense of scale to the small size of the dividing head. The indexing plate has the correct pattern of 119 holes, each only .008" in diameter.*

## Chapter 6—Cutting tools for metalworking

### 6.1— GENERAL NOTES ON CUTTING TOOLS

#### Tool Deflection

In machining, the cutting tools are the interfaces between the machine and the part. This is where the part is cut and shaped. Machines are built which are capable of incredibly accurate movements, but these accurate moves can't help the process if the cutter is deflecting by large amounts. A 1/2" (13mm) end mill can deflect as much as .050" (1.25mm). The deflection is a function of the diameter of the tool compared to its length, plus the sharpness of the tool, the feed rate and the depth of cut all have to be considered. You must understand this fact to successfully make machined parts. It is not a business of just numbered movements. It is a process that requires a great deal of thought and planning to produce good parts. The better you get at anticipating these basic problems, the better you will become at machining metals.



*A long, thin piece of stock will deflect away from the cutting tool. Overcoming the shortfalls of a process or the quirks of a particular machine to make consistently good parts is what separates a hacker from a craftsman.*

A machinist will use every available skill to overcome these obstacles by “sneaking up” to final dimensions to make the first part good. If more identical parts are to be made, ways can then be found to speed up the process. Common sense should tell you that if a cutter deflects a large amount on heavy cuts, it will still deflect a small amount on

light cuts. Tool or part deflection has to be considered in every case. Whether you are operating a machine the size of a locomotive or as small as a Sherline, the problems remain the same, but fortunately, the costs don't. A large part can have thousands of dollars worth of material and labor invested before a machinist touches it. How would you like to be the employee that has to tell his boss he had just bored a hole oversize in a twenty-thousand dollar forging?

The home machinist will have to learn these facts by trial and error. They don't usually have the advantage of having a skilled machinist nearby to rely on for information. I'll never understand why someone relatively new to the trade will resent a skilled craftsman suggesting a better method of doing the job. Information is being passed on that could be of tremendous help to them. I imagine they have never spent days of their own time trying to solve a problem that could have been solved in minutes by a skilled craftsman. The best and fastest way to teach yourself is by constantly checking the part as it is being machined. Learn how much the machine and tools deflect as they are being used.

#### Overcoming Problems on a Lathe

Lathes are easier to deal with than mills because the operations are straightforward. They are two dimensional machines, and diameters are easy to measure. The problems encountered with lathes usually involve the part bending. A perfectly aligned lathe will not cut absolutely straight unless the part is rigid enough to support itself. The shape of the cutting tool will influence the amount of deflection. A sharp pointed tool, with the cutting edge perpendicular to the diameter being machined, will have less deflection force than a tool with a large radius. Large radius lathe tools can be a loser if you are working on parts that are small or on a worn out machine because the forces are directed away from the headstock and towards the part. This can bend the part or load worn out slides. On a Sherline lathe a maximum tool radius shouldn't exceed .015". On high speed steel lathe tools, I will grind a small flat on the point rather than a radius to improve the finish. You can't grind the small radii required free hand, but you can grind a flat on a bench grinder which

will work almost as well. Hand ground lathe tools are described completely in the section on “grinding your own tools” later in this chapter. They can be not only the fastest method of removing metal, but also the cheapest.

### **Electrical discharge machining or “EDM”**

There is another way of cutting metal with which many home machinists are not familiar. I want you to know about this process, because I’m sure you may be curious about how a modern machine shop deals with hardened materials. It is called “Electrical Discharge Machining” or EDM. This is a slow process that does the seemingly impossible by using an electrode to remove metal. The electrode is made to the opposite shape you want to produce. (For example, a square electrode will produce a square hole.) When the electrode gets within .001" of the work, small sparks jump across the gap. The temperature of these sparks is hotter than the surface of the sun, and the metal actually disintegrates. In a sense, this happens one molecule at a time, which is why it is a slow process. It also takes place submerged in a special oil. The electrode, which is usually a pure form of graphite, has been shaped to burn a pocket into the hardened steel. The electrode also disintegrates during the process. EDM machines have controls that can be set to cut faster at the expense of the electrode; therefore, several identical electrodes are usually used to produce each shape. Each succeeding electrode makes the cut more and more accurate.



*An EDM removes metal by actually vaporizing it with a high powered electrical discharge or spark. It is capable of great accuracy and of making shapes that would be impossible with other methods.*

Debris is created as the EDM operates. This will “short out” the cutting action so the part must be flushed with oil to wash away the debris even though it is submerged in oil. Much of the skill in operating these machines is how you accomplish this. It is much more difficult than it sounds. I use an EDM machine to build plastic molds because the electrode is many times easier to shape than the cavity. Molds are built with materials which can be hard to machine.

### **Other special uses for EDM**

A simple form of EDM machine has been developed just to remove broken taps from parts. The electrode is simply a tube that has a diameter which is less than the inside diameter of the hole in which the tap has broken off. Electrolyte is pumped down the tube and the simple EDM burns the center of the tap away. The broken tap can then be “picked out” and, if done correctly, the hole will not be damaged by the sparks. There is also a highly sophisticated EDM that cuts with a small diameter wire which is fed through the part like a bandsaw. They are used to make cutting tools like punches and dies and are amazingly accurate but very expensive—around \$100,000. EDM machines have changed the way parts are designed and built. Many businesses have been started that take advantage of the capabilities of these machines which are expensive and have a limited use. I’ve even seen several designs for “homemade” EDM machines that will work as long as great deal of detail isn’t required.

### **EDM, CNC, CAD/CAM and other acronyms of the computer age**

Today, EDM electrodes are made on CNC mills which are controlled by computer programs that take information directly from the drawing that has also been produced on a computer. This type of work is where the term CAD/CAM (computer aided design/ computer aided manufacturing) came from. These can be exciting times for the machinist who learns the new rules that govern this new way of doing things.

---

*“The toughest decision a purchasing agent faces is when he is about to buy the machine designed to replace him.”*

—Dr. Laurence J. Peter

---

## 6.2— CUTTING TOOLS FOR BOTH THE LATHE AND MILL

### Using Center Drills

Center drills have been designed to drill a hole that a tailstock center will use to support the part. They have a short straight section at the end of a sixty-degree cutting edge. As the chart shows, numerous sizes are available to take care of any job. However, they do have a few problems you should be aware of. The straight section doesn't have any clearance on the sides like a drill. Without cutting oil the chips clog up the flutes and they can twist off. The reason they don't have clearance is to make them "find" the center of bar stock in a lathe. Drills that are flexible can start drilling off center without the help of a center drill to get them started. Even with cutting oil you can't drill to the required depth without backing out the center drill completely and adding cutting oil to it's tip. The straight part of the hole was to make a pocket to keep lubricants for lubricating the supporting sixty-degree tailstock dead center. A great deal of heat from friction can be generated at the center without proper lubrication. White lead was the preferred lubricant of its day because it didn't gall, but for obvious health reasons it isn't available any more. On lathes we now use live centers which rotate with the part to eliminate friction.

#### COMMONLY AVAILABLE CENTER DRILL SIZES

SIZE	BODY DIA.	DRILL DIA.	DRILL LENGTH	LENGTH OVERALL
000	1/8"	.020"	3/64"	1-1/4"
00	1/8	.025	1/16	1-1/4
0	1/8	.031	1/16	1-1/4
1	3/16	.046	3/64	1-1/4
2	3/16	.078	5/64	1-7/8
3	1/4	.109	7/64	2

### The difference between a Center Drill and a Spotting Drill

Center drills are an important tool in machining and are used as much on a mill as a lathe. It is a simple fact of life that drills will "walk" when starting a hole that hasn't been started with a short, rigid drill. Center drills were the only tools available that could start holes without wandering. The only problem was, it took too long to drill a pocket for the lubricant that wasn't needed. Years ago, I saw this problem



A center drill (top) and a spotting drill (bottom).

and started making "spotting drills" for use in our own shop. We could save minutes of machine time on one part by not using center drills. They have finally brought to the market drills of this type called "spotting drills". When compared to the complexity of a standard drill, spotting drills cost more than they should, for they could be manufactured cheaper than a center drill.



A center drill being used to find the center of a piece of stock. The 60° angle will locate the point of the tailstock center for turning between centers. The smaller hole will serve as a reservoir for lubricant if a live center is not to be used.

A drill press can be the most dangerous machine in a machine shop. They are so simple to use that operators don't give them the respect they deserve. New employees are often given drill press jobs to start their machining career. Never hold a part by hand when drilling into metal or similar types of materials. The drill can grab the part and start it spinning at the RPM the machine was set at. The greatest chance of this happening is when a hole is enlarged with a larger drill. The softer the material, the better the chance of this happening. The first part of this scenario is the where the drill screws into the part, lifting it off the table. When the drill jams in the part, the part will spin. If this happens, step away and try to safely shut down the spindle. Whatever you do, don't be a hero and try to grab the part. You could end up looking like you have

just been through a war in the 16th century. Also, when drills are broken off they may leave a very sharp point in either the spindle or the part that could cut to a depth that could result in permanent injury. Clamp your parts down firmly and cut down on injuries.

#### **Who came up with these stupid drill sizes anyway?**

Manufacturers of cutting tools sometimes have a strange way of applying logic. Take the standard drill indexes that are available today. They are still the same as sets from fifty years ago. If anyone could explain the logic of the sizes they manufacture I would love to know. They simply keep making the same old sizes they have always made without questioning the logic. Overseas manufactures aren't any better for they just copy what is available. (Obviously this is one of my pet peeves.) The quality of the better drills manufactured today is superb, but it is too bad they don't make them in the proper sizes. The better industrial suppliers may offer high and slow helix (flute twist), but I would recommend that you stick with the standard "jobber" drills. They are cheaper and work quite well. The hobbyist/machinist will want to buy a drill set for working with the miniature machine tools. My first choice would be a number 1 to 60 set. (Sizes .040" to .228".) This set will have the drills you need for drilling and tapping small holes. A miniature tool doesn't have the power or the size for large drills. On smaller machines, larger holes are bored rather than drilled.



*The metal box holds a set of drill bits sized from number 1 through 60. The red plastic box holds a selection of very small bits from number 61 through 80. In the foreground are #1, #60 and #80 sizes.*

There is a series of drills called "screw machine drills" that are shorter and better suited for small machines. They make them in both left and right hand. Only right hand drills will work on a Sherline because of the direction of rotation. Use high speed steel drills because of their low cost and long life when properly used. Stay away from carbide drills unless you have a particular need for them. They are very brittle and most small tools can't produce the spindle speeds needed for carbide to have an advantage. Printed circuit drilling machines, for example, may run carbide drills at over 60,000 RPM.

#### **Using drill bits properly**

Drills get more abuse than any other metal cutting tool made. Watching a home repair expert stick a drill back in a hole that they just drilled with a slight error and try to make the hole oblong by bending the drill should give a machinist the horrors. To begin with, the flutes on a drill were never designed to cut, but somehow they do when enough pressure is applied. They are designed to pull the chips out of the hole and a small amount of coolant is a must, especially for holes going more than two drill diameters deep. If you want accurately drilled holes, you can't abuse drills. Small diameter drills are usually discarded when dull to maintain accuracy. Hand-sharpened drills will normally drill oversize because the cutting lips are not exactly equal. To keep drills sharp, they have to be turned at a speed that is forty percent or less of the material cutting speed they are drilling. Exceeding this speed can instantly destroy the cutting edge. Dulling tools in this manner is foolish because speed is one of the easiest variables to control. Think about the way American Indians would start the campfire. They would turn a straight, dry stick back and forth with the palms of their hands until friction generated enough heat to start a fire on the wood where the stick point was rubbing. Now consider how fast they could have started that fire if they powered that stick with a five horsepower motor! Hopefully I have made my point.

With the centering hole drilled and the RPM set correctly it is time to drill the hole to size. The Sherline motor doesn't have the horsepower for large diameters and high feed rates, but that isn't a problem as long as you work within the capabilities of your tools. It just takes a little longer. The real problem is keeping a constant feed rate and knowing how deep the drill can go without "pulling" the drill.

The drill point must be lubricated and the chips must be removed from the drill flutes. With automatic production machinery, the drill can go as much as three and a half times the drill diameter into the hole before it is backed out to clear the chips. From that point on, I usually program depth of cut in one drill diameter increments. Using manual machines I would recommend two times the drill diameter for the first cut and one diameter beyond that point. When using small drills, the amount that can be drilled without clearing the drill is as small as the drill diameter. This is very important and the reason I am emphasizing it. A drill that has been broken off in a part will usually result in “scrap”. To make matters worse, when you start over again, unless you have a spare bit, the one you need is now broken. Good drilling technique makes this one problem that is avoidable.

#### **Should a hole be drilled in stepped sizes or directly to size?**

I have found that once the part is center drilled, drilling a hole to size with a single drill will give better results than enlarging a smaller hole with a series of larger drills. Every time a different tool enters a part it can pick up off center, because the drill before it may have left a sharp burred edge in the hole. If this method must be used, make sure the spotting or center drill will cut to a diameter that includes all the sizes you will be using and has a ninety or sixty degree tip. Brass is a difficult material in which to enlarge a drilled hole. In fact, it can be downright dangerous, because a standard drill can be pulled into a pre-drilled hole and lock up. Machinists often put a slight flat on the cutting lip of drills used to enlarge a hole in brass to avoid this problem.

#### **Drilling stainless steel**

First-time machinists will discover it's a whole new ball game the first time they attempt to drill a hole in a piece of stainless steel. It is called “work hardening” and it is just as the name implies. I'm sure everyone has taken a wire and bent it back and forth until it broke. What was done was the metal kept getting harder at the bend until it became so brittle it fractured. Stainless steel as well as many other exotic metals can surface harden while being machined. Small drills will make this fact even more apparent. If a drill is allowed to rub the surface without cutting, it will work harden the surface it is trying to drill. This happens at the bottom of a hole

that is being drilled. The cause can be a dull drill or not using a sufficient feed rate to keep the drill cutting. This will work harden the surface, which will dull the drill, which will work harden the surface even more until the drill will not cut at all. To work around this problem, the spindle has to be turning slow enough to have a feed rate that allows the drill tip to maintain a constant, uninterrupted cut. The calculated spindle speed may be much faster, but the machinist can't keep up with the higher RPM. Also, don't leave the drill at the bottom of a hole when it isn't cutting. Raise it immediately. If a hole gets work hardened, check the drill for sharpness and start drilling again with a slight “tap”. This will sometimes allow the drill point to break through the hardened surface and start drilling again.

#### **A Note on very large drill bits**

Drill bits at the large end of the size scale usually have a tapered shank and could never be used on a Sherline, for they are as big as the machine. However, there is still something to be learned from large diameter drills. In many cases, larger drills have a tapered shank with a “tang”. A tang is a rectangular shape on the small end of the taper that engages with a holder designed to accept it so the drill cannot spin. The added cost for manufacturing this type of drill is worth every penny if it keeps the drill from spinning, as this will ruin the shank. The way standard twist drills are kept from spinning is by tightening the drill chuck with a key to create enough friction to lock them in place. If they are not tightened enough, they will spin in the chuck, and you simply can't tighten the chuck enough by hand without a key. Many machinists never learn this fact and the results of their carelessness can be found in tool cribs around the world.



*A large drill bit with a tapered shank. On larger machine tools where cutting forces are higher the flat tang keeps the drill bit from spinning in the chuck. Miniature machine tools don't have enough power to require this kind of holding force, but you still need to tighten your chuck with a key so the drill can't be ruined by spinning in the chuck.*

Additional information on large drills is not included because it isn't very useful for small machines like the Sherline. *Machinery's Handbook* will be the best source of information for large drills. I have also

learned much information from catalogs on cutting tools printed by mail order suppliers. I would also suggest you inspect a small drill under a magnifying glass some time to appreciate the level of perfection to which these tools have been made. Their very reasonable cost will be appreciated even more once you get a really close look.



### Countersinks

The countersinks I prefer to use have only one cutting lip, and they will cause you very few problems with chatter. Countersinking tools are used to chamfer the sharp edge left after a hole has been drilled. A wide variety of angles are available. They are also used to allow flat-headed screws to fit flush with the part surface. They should be run at a very low rpm when used in manual machines. You can instantly destroy these tools in stainless steel by using excessive speed with a hand drill. If the hand drill you are working with doesn't have a speed control, keep the RPM low by pulsing the trigger switch. The speed should be such that you can see the tool cutting. If the tool is not perpendicular to the hole, the chamfer will be uneven.



### Step drills

Step drills have one or more diameters and are made to eliminate changing tools to save time in machining operations. Only consider the step drill's smallest diameter for feeds and its largest diameter for speeds. It is easy to twist the tip off if not enough cutting oil is used. They are expensive, and because of the limited sizes available will usually be custom-made by local toolmakers. Only use them when the cost is justified by the time saved.

### Counterbores

Counterbores are used to enlarge existing holes. They have a "pilot" shaft which can be changed to different sizes on larger diameters counterbores. One of the most common uses for these tools today would be counterboring a clearance screw hole for a socket head cap screw. (Many times these screws are referred to as "Allen cap screws".) Spot facing rough or curved castings so bolts can be pulled down on a



*Top: a 1/4" short shank counterbore of high speed steel. Above: a longer style counterbore is well suited for screw heads and spring pockets. There are many more styles and shapes.*



*A pilot sized to the drilled hole goes in the front of each counterbore. They are normally sold separately and are held in place with a set screw.*

flat surface is another common use. If the pilot is the right size it keeps the tool from wandering. Counterbores will usually have three flutes and a very slow helix, making their diameters difficult to measure. They have to be turned at low RPM with a moderate amount of pressure similar to using a countersink. They are expensive.



### Reamers

Reamers are available in more sizes than drills. A reamed hole will have more accurate diameters and better finishes than a drilled hole. However, if they are not used properly, a good drilled hole may be better than a reamed hole. They come with straight and spiral flutes. In theory, straight flutes will work better if the hole goes all the way through the part because a lot of chips get in front of the cutting edge. Spiral flutes will help pull the chips from the bottom of a "blind" hole. A right-hand cut, left-hand spiral will push the chips forward and should never be used in a blind hole. I always order straight flutes for general use. A feed rate of .001" per tooth is recommended, so the RPM must be slow enough to maintain this feed. Ample cutting oil must be applied, and the reamer must be pulled out of the hole often so chips can't build up in the flutes. The reamer must be located directly over the center of the hole to work properly.

The safest way is to ream the hole to size immediately after drilling. I usually allow less than .008" (.2mm) on sizes less than 5/16" (8mm) and for over this diameter I allow 1/64" (.4mm) for

clean-up with a reamer. A reamer can start cutting off-center if the drilled hole has chips lying on the hole edge; in fact on CNC machines, we occasionally put a program stop to allow the operator time to blow the chips out with an air hose. What happens is the chip will start rotating with the reamer, shutting down the cutting action on one side. The reamer will cut oversize until the chip is forced from its location. It will then start cutting on-size leaving the hole with a “bell-mouthed” entrance. Fractional inch sizes are quite a bit cheaper than decimal size reamers. Try to design your parts to have finish diameters that take advantage of this fact.



### Taps

Taps are cutting tools to cut screw threads in holes (see thread cutting instructions for thread definitions) and are made in many sizes and shapes. Taps cut several thread shapes and the sixty-degree thread is standard. The “acme” and “square” threads are not available in diameters under one half inch and will very seldom be used by the hobbyist. For the type of work done in miniature machining, I would not consider large taps. If needed, you can usually get the information from most industrial supply catalogs.

The same rules should be applied to large and small taps. Taps are defined by their diameter first, which may be a wire gauge size, and followed by the number of threads per inch. Metric taps will be defined by diameter and actual pitch. Drill and tap charts will give the information to cut 75% of a full thread. Engineers have discovered long ago that a full thread isn’t necessary. A 75% thread is almost as strong and the difficulty in cutting a full thread just isn’t worth the extra effort and cost.

To tap a high quality thread, you need to start with a proper hole size and use a lubricating cutting fluid. A chamfered hole will start the tap better and will not raise the surface where the hole is being tapped; however, thin parts may require no chamfer in order to have the maximum number of threads for a given thickness.

### Why cheap taps are a poor investment

If you have a choice as to the size you can use, look at a tool catalog and pick out a size that is readily

available. The savings in cost will be worth the effort. Remember also that just because the size may be listed doesn’t mean you can buy it at every industrial supplier, never mind a local hardware store. Buy taps before you start the job, and it would be wise to buy an extra one. They are very easy to break. If possible, I get my tapping done early on complex parts. If a tap does break and ruins the part, you are not scrapping a lot of labor. If you are having a problems tapping holes, the first question to be asked is about the quality of the taps you are using. Inexpensive tap sets can be so bad they wouldn’t cut butter. They usually are found in department stores. Stay away from them no matter how tempting they may look. Tap sets sold by industrial suppliers are better, but I still advise buying only what you need, when you need it. Buy quality taps and save hours of grief.

Taps are made in a variety of styles, and my favorite are the “spiral point gun taps”. In smaller sizes they have two flutes and are the strongest series of taps available. “Spiral pointed” means that the chip is pushed ahead of the tap. This eliminates the need to back up a tap to break the chip as four-fluted hand taps require. These taps are made with two choices for the cutting tip: “plug” and “bottoming”. Use the plug style for general use. Spiral point taps have been designed to push the chips out the bottom of the hole that is being tapped. In blind holes, the chips will pile up at the bottom and could cause a problem.



SPIRAL POINT TAP



SPIRAL FLUTE TAP

### Spiral pointed taps vs. spiral fluted taps

Don’t confuse spiral pointed taps with spiral fluted taps. Spiral fluted taps pull the chips out of the hole, which may seem like an excellent idea until the strength of the tap is considered. They break easily, because under load they “unwind” and jam in the hole. The problem eliminated by these taps can be canceled out by their inherent weakness. If possible, drill the hole deeper than it will be threaded to make room for these chips. After tapping, the chips can be removed from the hole with tweezers.

A problem can arise when a tap is reversed. The chips can jam the tip in a blind hole, breaking the tap, but tap breakage is less with two-fluted than with four-fluted “hand taps” because of the extra strength of these fine cutting tools. In small sizes, the four-fluted hand taps should be avoided but some sizes are only available in that form. “Starting” taps have a shallow cutting angle that will cover many threads. Each cutting tooth will form a small amount of the thread. While this may seem like a good idea, it does not always work well. With many threads cutting at the same time, the torque required to drive them may be higher than a plug style spiral pointed gun tap, but they do start the tap straight down the hole with less effort.

#### Tapered pipe thread taps and dies

Pipes used in plumbing use a National Pipe Thread (NPT) standard which is a tapered thread. Tightening the parts together seals them as the tapers meet, making a tight joint. When tapping a hole for a tapered thread, measure the part you will be threading into it to make sure you don’t run the tap too deep. NPT threads start at 1/16 -27 and go up to over 3 inches. You might use some of the smallest sizes on miniature plumbing fittings for steam engine models or pipe fittings in small engine blocks.

#### Hand tapping a hole

When tapping holes by hand, the tap must be perpendicular to the hole. I recommend having the part clamped down so the tap will be pointed towards the center of the earth. It is easier to line up when the tap and handle are square to its surroundings. The quickest way to break a tap is casually holding the part in your hand and a tap in the other. If the tap is not “square” it will not follow the hole and will progressively start to cut one side more than the other. This will quickly reach the point of no return when the cut exceeds the strength of the tap. It is very difficult to straighten a tapped hole. Again, you must use a cutting fluid. It not only keeps chips from sticking to the cutting edge, it also keeps the tap from sticking to the cut thread. Remember that “like” materials will gall and stick together, and this is one reason taps break at a alarming rate.

**NOTE:** Broken taps can be dangerous! Pieces of the tap can be thrown at a very high speed and easily do eye damage. Always wear eye protection. The broken tap can leave a sharp cutting edge where it has broken and give a nasty, deep cut that could require stitches.

#### Tapping stainless steel

Hand tapping a small diameter screw thread of 75% may seem impossible if the material is stainless steel. The tip of the tool will twist to the point of almost breaking before the tap will even start to cut. Dull or poor quality taps will not stand a chance in stainless. A 65% thread may help, but a change such as this must be authorized if the part isn’t for your own use, and considered if it is for your own use. Don’t use a tap until it breaks. They are disposable tools and have a life-span that can be short with exotic materials.

#### Tap wrenches

The tap wrenches for holding taps used by amateurs will usually be the standard hand tap holder. Buy the size that just goes to one-quarter inch and, if you can locate a smaller size, buy it too. It will be useful to have a very small tap wrench for the small sizes that you will encounter while working on very small parts. When you work with equipment that is too big for the job, you lose that “feel” that keeps taps from breaking. A tap wrench has a chuck similar to a drill chuck but it has only two jaws. The jaws allow the tap to be held by the square, machined end on the tap. Good quality tap wrenches will clamp the tap in line with the tap wrench body, making it easier to get the tap square with the part. When working with full size mills, I will use the spindle to line the tap over the hole. Some tap wrenches have a sliding shaft protruding from the handle. Using this shaft, the holder can then be held in a collet or drill chuck and be supported so that the holder is always square and directly over the hole. To cut successfully, taps must start square while cutting the first threads.



*A standard “T” handle tap wrench and a tap wrench with a pilot shaft for holding in a collet or drill chuck.*

#### Tapping threads on big CNC machines

Automatic tapping on a modern CNC milling machine is accomplished by reversing the spindle. The tap is held in rigid holders and the spindle is electronically synchronized with the feed to turn in relation to pitch of the tap. It does this so accurately,

a “floating” holder is not necessary. It is amazing to see a part being tapped at 2000 rpm! Metal will cut better at a higher rpm and the quality of the tapped holes will be better. Of course, you can’t do this on inexpensive equipment, but I thought you might find it interesting.



**Tapping heads for manual mills and drill presses**

What you may be able to afford some day is a small tapping head. They can be used with manual drill presses and mills. A good quality tapping head costs about \$400 (1998). They are designed to turn in one direction when the pressure is applied to drive the

tap into the part and in the opposite direction to unscrew the tap when the tapping head is raised. The tapping head is usually geared to turn the tap at twice the input rpm when backing the tap out of the work. This makes the process more efficient. They make several models, and for small taps I prefer a cone clutch design over the dog clutch. Dog clutches engage with a “snap” which has a tendency to break small taps. Also, they cannot tap left-handed threads. Cone clutches operate more smoothly.

When a tapping head is used, the operator must put enough pressure on it to start the threading process. The tap will then be screwed into the hole at the rate of its pitch. If the feed rate, controlled by the operator, does not equal the pitch of the tap, the clutch will disengage. On a drill press, the depth of the tapped hole will be controlled by the “depth control stop”. When you are tapping blind holes, you set the stop to make sure the tap will not go all the way to the bottom. Measure the distance to go and reset the stop to eliminate any error. A tap will go deeper than the stop is set because it has to disengage the clutch. When the tap is unscrewed, a slight withdrawal pressure is needed to operate the opposite clutch and any excess pressure will “tear” the thread as the tap leaves the now-threaded hole. A definite feel for the process is needed to operate these labor saving devices effectively.

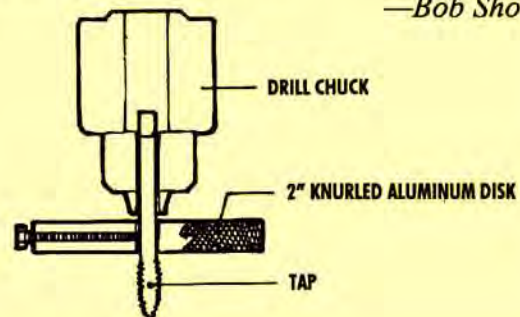
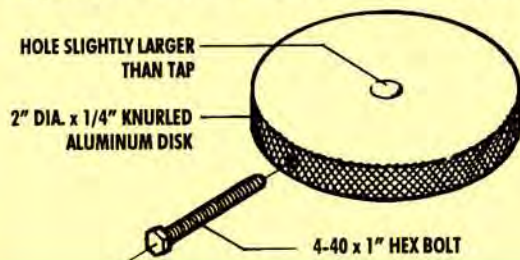
**Tricks of the trade...A tapping tip from Bob Shores**

I have read many tips on tapping holes—some good, some not. Five years ago I dreamed up a tapping method for small holes. I tap a lot of holes with 0-80 and 2-56 threads, and since I have been using this method, I have not broken a tap in five years.

After drilling the hole in your part to the proper size, the drill bit is removed from the chuck without disturbing the work. A 2" aluminum disk, knurled on the outside and drilled and tapped for a 4-40 hex bolt grips the tap just above

the flutes. The end of the tap is gripped in the drill chuck and lowered until it just touches the work. The chuck is then loosened to allow the tap to turn freely. The disk holding the tap is turned with your thumb and forefinger. The drill chuck acts as a guide to keep the tap running true, and your fingers are very sensitive to the amount of torque being applied. To break a tap you would have to apply a lot of force.

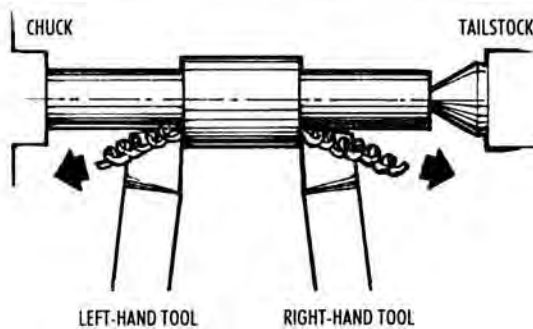
—Bob Shores



## 6.3— LATHE CUTTING TOOLS

### Right- and left-hand tool shapes

Again, the difference between a lathe and a mill is that the work turns on a lathe and the tool turns on a mill. Before we get into grinding lathe tools let's define this type of cutting tool as a single point tool that is fixed (doesn't cut by rotating) and held in a tool block on the crossslide of a lathe. By the way, lathe tools can be cut as "right-hand" or "left-hand" shapes. The reason we call a tool a "right-handed" tool when the cutting edge is on the left is because it is designated by which way the chip leaves the cutting tool. A left-handed tool is designated as such because the chip will go to the left as it cuts. The cutting edge will be on the right. The standard tool is a right-hand tool, and a right-hand ground tool bit is included with each Sherline lathe to help get a novice started. Scissors or sheet metal shears are also defined this way, because the cutoff falls to the left or right. Right-handed people will usually prefer "left-hand" shears.



*A tool is called a "left-hand tool" because the chip comes off to the left even though the cutting face is on the right. On a right-hand tool the chip comes off to the right.*

### Why you should avoid cheap carbon steel tools

The Sherline lathe has been designed to use 1/4" square tool bits. You don't have many choices when it comes to grinding your own lathe tools. The shapes you will need to produce special parts can't be made with standard cutting tools. If you read an old book on machining, it may have mentioned carbon steel tools, and these are case hardened tools. The only way you might find these inferior tools would be in cheap imported sets. Today, the labor and machine cost to produce a good cutting tool exceeds the material cost by so much that it just doesn't make sense to use cheap steels.



*A selection of 1/4" high speed steel and carbide tipped cutting tools for miniature machining. Shown are left to right: A high speed steel boring tool, right- and left-hand cutting tools, right- and left-hand carbide tools and a carbide 60° threading tool.*

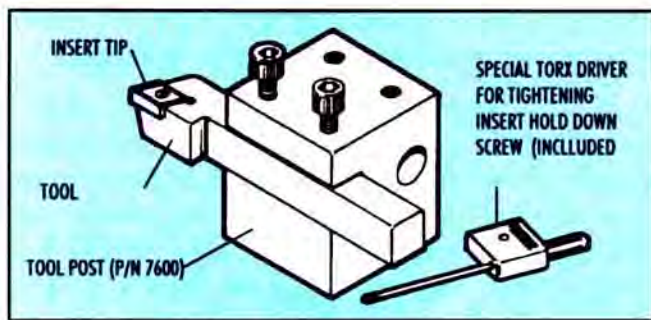
### High speed steel tools

For the average machinist, "high speed steel" will always have a use in a machine shop. It is inexpensive and easy to grind and shape. High speed steels come in a variety of grades. For the average work done in a home shop, M-2 tool steel is more than adequate. M-5 would be considered top-of-the-line. Some tool steels contain several other metals to add to their life. Cobalt is a common additive that makes the cutting edge less prone to "chipping" and is effective in adding life to a tool. Usually, the more high speed tool steel costs, the harder it will be to grind and the longer it will hold an edge. You will find the answers to all engineering problems are a trade-off, just as this one is.

### Brazed carbide and diamond tipped tools

Sherline offers brazed carbide tools in left, right, and 60° threading. Brazed carbide tools have a shorter life than inserted tip carbide tools because the carbide has been brazed to the holder and their different expansion rates can cause problems. The left-hand brazed carbide tool works well with the flycutter and is included with its purchase. They can be useful but you need a diamond wheel to resharpen them. One thing you must realize is that some materials can only be cut with carbide. You don't have a choice. These materials usually have an abrasive nature and are not that "hard". In general, hard materials (heat treated tool steels) can't be successfully machined. You can't chuck up an end mill in a lathe and machine its shank down with carbide or diamond cutting tools. Diamond cutting tools are used to get beautiful finishes on nonferrous materials and shouldn't be used on steels. The carbon in the diamond will weld to the carbon in the steel and destroy the diamond.

Heat treated tool steels are shaped by grinding, not by turning. Cutting the silver and copper material used in the armature of an electric motor would be a good application for a diamond tipped tool.



*Carbide insert tool and tool post.*

### **Inserted tip carbide tools**

I would first like to emphasize that I believe the prime method for cutting metal on a miniature lathe should be high speed steel cutting tools. They are inexpensive, easy to sharpen and can be ground to make “form” tools. On the other hand, insert tools are expensive and can’t be resharpened or shaped, but there are times they can be a lifesaver. In some applications they are the perfect tool for the job.

The obvious difference between brazed carbide tools and inserted carbide tools is that the tip is held on with a screw rather than brazed onto a piece of steel. This fact has a lot to do with the success of insert tools in recent years. Steel and carbide have slightly different expansion rates which can cause premature failure of the carbide tip. It is surprising that a small screw will hold these inserts tight enough to accurately cut metal, but it does. We run 20 horsepower computer controlled lathes at Sherline that can remove metal at a rate of 2 pounds (1 kg.) a minute with these tools and have few failures.

The reasons I believe insert tools should have a place in your shop is they are ready to use, they hold their cutting edge when cutting exotic metals or abrasive materials and they can speed up the cutting process.

### **The rules on cutting speeds are different for inserted tip tools**

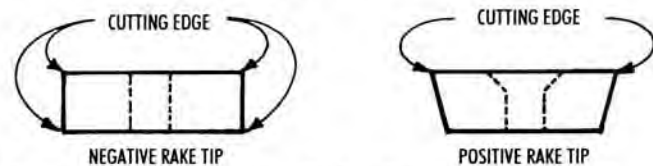
Normal cutting speed rules don’t apply to the same extent as when using high speed steel. Stainless steel can be cut at triple the rate with these tools compared to high speed steel tools. This higher RPM also puts you in a better horsepower range on a small motor. Another interesting fact is that you can get a better finish on some steels, such as cold rolled, by turning

up the RPM. Insert tools don’t need cutting oils to work well, but I still use a few drops now and then. The lack of messy cutting oil can be an important factor when working on your kitchen table, as it keeps the work area cleaner.

### **Positive and negative rake tools**

I experimented with various tools before making a choice. I wanted a cutting tool that had a positive rake. I don’t believe the tools we manufacture are rigid enough for the normal negative rake tools which cost less and are far more popular.\* These tools are designed for machines that weigh hundreds of times more than a Sherline Lathe. Positive rake tools have to be sharpened at the time of manufacture which adds to their cost, but also adds to their performance on a Sherline lathe. You can’t use any insert in these holders unless it has a positive cutting edge.

\*NOTE: Sherline also offers a negative rake tool holder designed especially for use on the Sherline lathe which allows the use of a 55° negative rake tip. Because of the design of the holder, this tool cuts like a positive rake cutter. This gives you the best of both worlds. A description of that tool can be found on the next page.



*Negative and Positive Rake Carbide Cutting Tips. Negative Rake tips can be held upside down giving 4 cutting edges. Positive Rake tips cut from one side only, but cut better.*

Another choice I made was the .015" (4mm) radius on the tip. A large tool radius can give good finishes on a full size machine, but it can cause havoc on small diameter parts or miniature machines. Large radius tools create high tool loads because of their large cutting surface. On the other hand, a radius smaller than .015" will chip too easily.

The difference between the 80° and 55° tools is that the 80° tool is a little stronger at the tip, but the 55° tool can get into corners better. If you plan to only purchase one, buy the 55°. The 80° tool is a good choice to use for rough cuts.

### **Reading the chips**

To get maximum life out of these tools be sure to increase the “feed” as you increase the RPM. The

chip should have a tight curl to it and break off into short lengths. These chips can be very **HOT**. Remember, your hands are closer to the cutting edge when using miniature machine tools, so use caution.

### Cutting harder surfaces

Another plus for insert tools is their ability to cut hard or abrasive materials. Don't plan on machining hardened tool steel with them, but you can cut through a work-hardened surface on stainless steel with ease.

Carbide tools can simplify many machining operations, but will never solve problems caused by poor machining practices. As with all machining operations, WEAR EYE PROTECTION.



*The negative rake tool holder is shown with a box of spare carbide tips and the tightening wrench. The insert is angled down slightly which provides clearance and is supported all the way down to the table, which provides support for stiffness.*

### The 3/8" IC 55° negative rake tool holder

I believe Sherline's 3/8" IC 55° negative rake indexable holder will bring a lot of enjoyment to your machining, particularly if you have trouble grinding good tools or if you choose to turn difficult materials such as stainless steel. The indexable carbide insert sits on the tool holder at a 5° negative angle. This gives the sides of the cutter clearance even though the insert has square sides. By having square sides, both the top and bottom of the insert can be used as cutting edges. This gives you front and back, top and bottom of both sides for a total of four cutting edges on each insert. Though not inexpensive, when you consider you are getting four cutting tools in one, it is really a pretty good deal.

Remember that carbide cutting tools are a little more brittle than high speed steel and take care not to break

the insert. If you break a chip out of one surface, I don't recommend that you use the cutting surface on the other side. The insert would not be properly supported on the tool holder with material missing from the lower surface which should be resting solidly on the tool holder. Damage to the tool holder can occur if you use a broken insert in this fashion.

### Precautions for making deep cuts

Keep in mind also that it is not good machining practice to feed a tool straight into a part any further than necessary. Parting-off tools are designed for this task, but regular cutting tools are not. Going straight in puts two cutting surfaces to work at once, and as you get deeper and deeper into the part, you can overload the cutting capacity of the machine and cause it to jam. If you must feed straight in to cut a groove, for example, go a short distance and then open up the slot side to side, using only one cutting surface of the tool at a time. Then go a little deeper and repeat the side to side cuts.

### Don't be afraid to crank up the RPM a bit

An advantage of this tool is that it will cut in either direction. It can also give good finishes on hard-to-machine materials such as cold rolled steel. (Note: the best finishes on soft materials such as aluminum, brass or leaded steels will still be achieved using a good, sharp high speed steel tool. However the carbide insert tool will still do a very good job and will last almost forever on these materials.) A good finish on harder materials using a carbide tool is accomplished by turning up the RPM of the spindle about three times faster than if you were using a high speed steel tool. In fact, when making most cuts with this tool, don't be afraid to turn up the RPM and feed the tool rapidly. Of course, you must have the part you are machining held in a setup sufficiently secure to accomplish this.

### Design of the negative rake tool holder

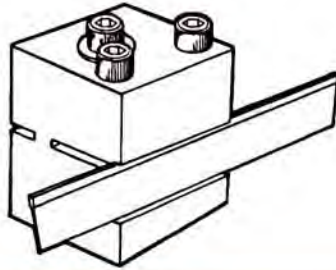
The holder is manufactured from 7075 Aluminum, which is approximately twice as hard as regular aluminum in a T6 condition. This material also costs approximately twice as much, but I felt it would be money well spent to insure a long life for the holder.

### Design of the insert cutter

The carbide insert is designed in such a way that it cuts like a positive rake cutter. Positive rake cutters don't require as much rigidity as negative rake cutters. This type of design allows the advantages of a negative rake cutter (four cutting edges per

insert) without requiring the rigidity that can't be found in bench type machines.

Replacement inserts for this holder are available both from Sherline and from a number of tool manufacturers. They are usually designated DNMG-331.



**NOTE: ALWAYS USE CUTTING OIL WHEN USING THE CUTOFF TOOL.**

### The cutoff or "parting" tool

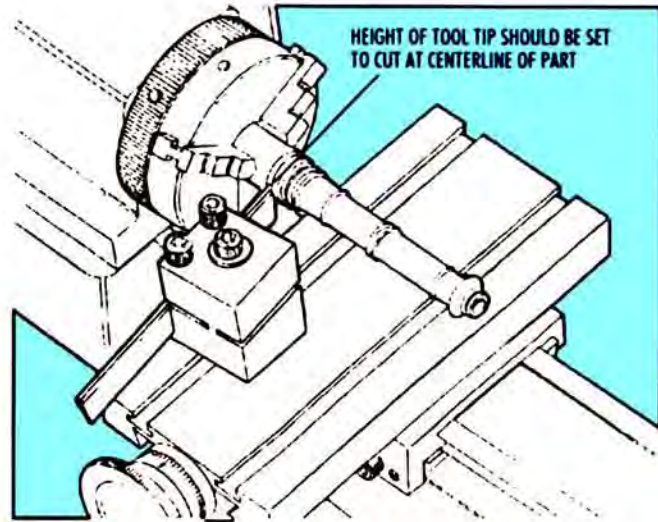
After completing a part in the lathe it is frequently necessary to separate the part from the excess material used for chucking. This operation is best accomplished with the use of a cutoff tool or "parting tool" as it is sometimes called. The Sherline cutoff tool and holder consists of a very slender high speed tool steel cutting blade mounted in a special tool holder. The thinness of the blade (.040") enables it to feed into the part quite easily and at the same time minimizes the amount of waste material. One word of caution; **never use a parting tool on a part mounted between centers.** The part may bind on the cutter and result in a scrapped part or a broken cutting tool.

### The proper way to cut off a part

Always try to lay work out so the cutoff tool is used as close to the spindle as possible. Set blade height by sliding the blade in its slot in the tool holder. It should be set so the tip is at the same height as the centerline of the part being cut. An unusual part diameter may require a shim to be placed under the front or rear of the holder to accomplish this.

**NOTE: ALWAYS USE CUTTING OIL WHEN USING THE CUTOFF TOOL.** The cut will be made much smoother, easier and cooler.

The turning speed for parting should be approximately one half the normal turning speed for any given material, and the feed rate should be a little heavy so the chip will not break up in the slot. If speed and feed are correct, there will not be any chatter, and the chip will come out as if it were being unrolled. Coolant (cutting oil) plays a major roll in this occurring properly.



*A parting tool is used to separate a completed part from its raw material workpiece.*

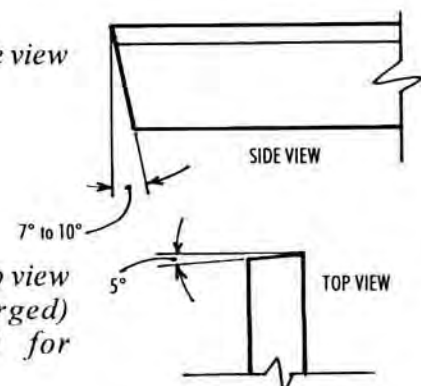
If the tool chatters, first check to see if the work is being held properly. Then decrease speed (RPM) or increase feed rate or both. Once the blade has chattered, it leaves a serrated finish which causes more chatter. Sometimes a serrated finish can be eliminated by stopping the spindle, adding a liberal amount of cutting oil, bringing the blade up so there is a slight pressure on it without the spindle turning, and then turning by hand or as slowly as possible with the speed control.

Very small work may be completely cut off when held in a chuck and allowed to fall onto the crossslide. It is too small and light to cause any damage. Hollow articles such as rings may be caught on a piece of wire whose end is held in a suitable position.

### SHARPENING INSTRUCTIONS

To sharpen the blade, use the tool support on the grinder set in such a way that it will produce a 7° to 10° angle on the blade (top to bottom). (See Figure 1 below.)

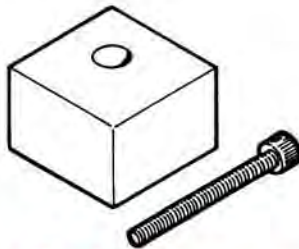
*FIGURE 1—Side view of blade.*



*FIGURE 2—Top view of blade (enlarged) when ground for "parting off"*

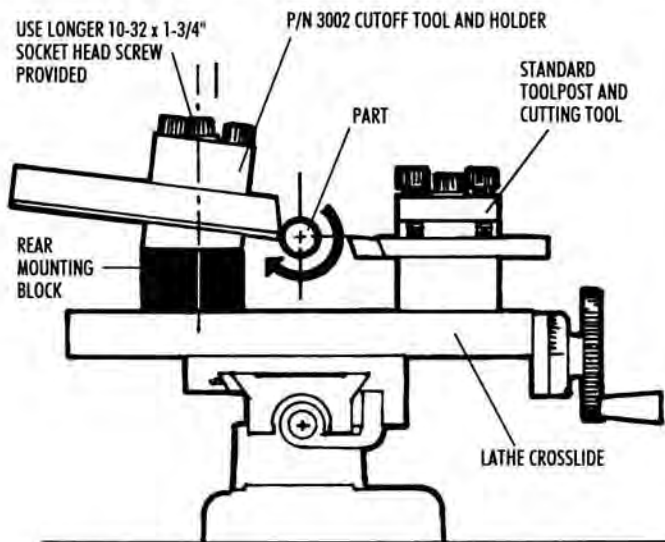
If you are sharpening the blade to “part off”, the blade should have an additional angle of approximately  $5^\circ$  when viewed from the top with the point on the right. (See Figure 2.) Normally the angle would be as high as  $15^\circ$  but the .040" thickness of the blade would not be rigid enough and the blade could bend. If you want to cut grooves, don't put any angle on the blade when seen from the top.

If the cutting edges on the sides get dull, grind off the end of the blade until you get into new material where the edges are sharp to the cutting end. New blades are available as P/N 3086 from Sherline.



#### Mounting the cutoff tool using a rear mounting block

The rear mounting block is a simple spacer block that allows you to mount the cutoff tool and holder to the table on the back side of the part. Because the part is rotating “up” on the back side, the tool must



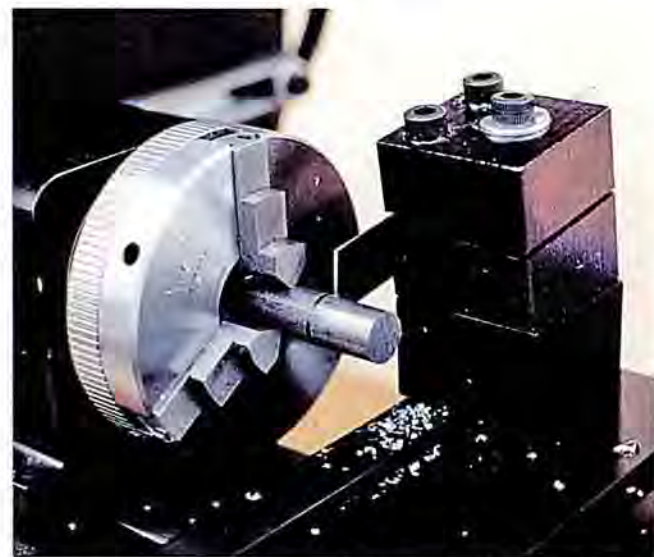
**FIGURE 3**—Seen looking from headstock toward tailstock. (Arrow shows direction of part rotation.) The rear mounting block is shown in position under the cutoff tool holder and mounted to the “back” side of crossslide table. The cutoff tool holder can now be left mounted to the table, ready for a parting operation at any time. There is no need to remove the standard tool post in order to “part off” the work.

be flipped over in the holder. The mounting block raises the tool holder the amount needed to put the tip of the tool back at the right cutting height. This will save you time by being able to leave the cutoff tool holder mounted to the table while you use the regular tool post in its normal position on the front side of the part.

The mounting block is placed between the standard cutoff tool holder (P/N 3002) and the lathe crossslide. It is mounted on the back side of the part, or the side away from the crossslide handwheel. The longer 10-32 x 1-3/4" socket head screw provided with the rear mounting block is used to attach the unit to the crossslide table. (Use the T-nut that came with the cutoff tool holder.) Note that the hole in the mounting block is not in the center. Rotate the block to find the position where the sides line up with the sides of the cutoff tool holder.

Loosen the two clamping screws which hold the cutoff tool blade in place. Turn the blade over so the cutting tip is facing down and mount it as shown in Figure 3. Adjust the tip of the tool to the desired height by sliding it back and forth in its slot. Lock it in position with the two clamping screws.

Even though the tool is upside down, all the same rules about its use still apply. The only difference is that the crossslide table is now cranked *toward* the operator to cut off a part.



A parting tool is held upside down in the tool holder which is mounted to the rear mounting block. This simple accessory is helpful if you are doing repeated cutoff operations and don't want to keep switching toolposts.

## GRINDING YOUR OWN LATHE TOOLS

As a home shop machinist you are going to have to shape tools the old fashioned way, and that means you need a grinder. A bench grinder doesn't have to be expensive to work well, but it does require good "wheels" for high speed steels. Try to find a source for grinding wheels from an industrial supplier. Some of the wheels that come with inexpensive grinders wouldn't sharpen a butter knife. Sixty grit is a good place to start. A wheel dresser is also a necessity. They cost less than \$10 and are readily available from good hardware stores.

### Using a wheel dresser to keep your wheel sharp

Grinding wheels should be considered cutting tools and have to be sharpened. A wheel dresser sharpens by "breaking off" the outer layer of abrasive grit from the wheel with star shaped rotating cutters which also have to be replaced from time to time. This leaves the cutting edges of the grit sharp and clean.



A wheel dressing tool and spare "star" cutter

A sharp wheel will cut quickly with a "hissing" sound and with very little heat by comparison to a dull wheel. A dull wheel produces a "rapping" sound created by a "loaded up" area on the cutting surface. In a way, you can compare what happens to grinding wheels to a piece of sandpaper that is being used to sand a painted surface; the paper loads up, stops cutting, and has to be replaced.

### Setting up your grinder and tool rest

For safety, a bench grinder should be mounted to something heavy enough so it will not move while being used. The tool support must be used and should be set at approximately  $7^\circ$ . Few people have the skill to make tools without a tool support and in essence it's wasted effort. Tool supports are usually made up of two pieces that allow you to set your tool rest above or below center. It really doesn't matter whether it's above or below as long as the support is at  $7^\circ$ .

The reason tool supports are designed like this is so they can be used for a variety of uses, not just tool bits. What this means is that if the tool support is above or below center, it must be adjusted as the wheel diameter changes.

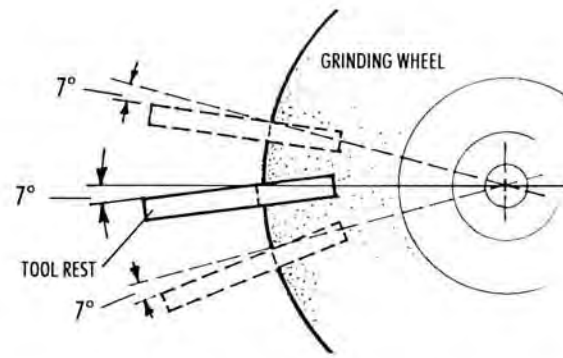


FIGURE 4—Set tool rest at any height, but at  $7^\circ$  angle from centerline of wheel.

### Getting started on making a tool

Now it's time to make a tool, and whether you turn the job into a major project is up to you!

#### CAUTION!

When working around grinders it is an absolute necessity to wear **EYE PROTECTION**. Grinding debris is thrown out at high velocities and can damage not only eyes, but also expensive glasses. Wear safety glasses or a full face shield.

If you've never sharpened a tool, take a close look at how ours are sharpened. Let's duplicate the right hand tool on the opposite end of the blank. Be careful you don't cut yourself on the blank or the sharpened end while working with it.

First dress the wheel by taking the dresser and setting it on the tool support square with the wheel and while applying a light pressure move the dresser back and forth with the grinder running. Unless the wheel is in bad shape, it should be ready to use in a few passes.

### Grinding side 1 of the tool

Turn off the grinder and set the tool support for approximately  $7^\circ$  if you haven't done it yet. If you're not good at guessing at angles use a presharpener SHERLINE tool to set the angle. Metal cutting tools are very tolerant on angles. I've always found wood cutting tools more difficult to sharpen. Too little angle and the "heel" of the tool will rub, too much angle will cause the tool to "dig in" and chatter.

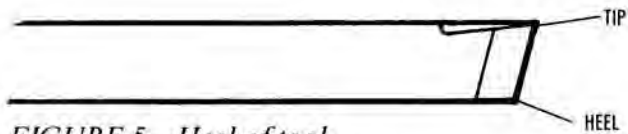


FIGURE 5—Heel of tool

Have a cup of water handy to cool the tool with, set the blank on the tool rest and start grinding side 1.

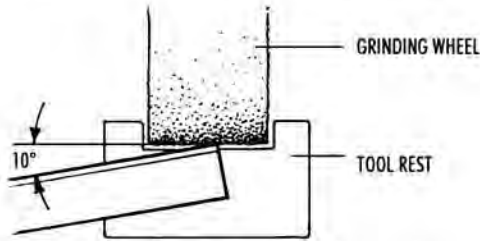


FIGURE 6—Grinding Side 1 of the tool

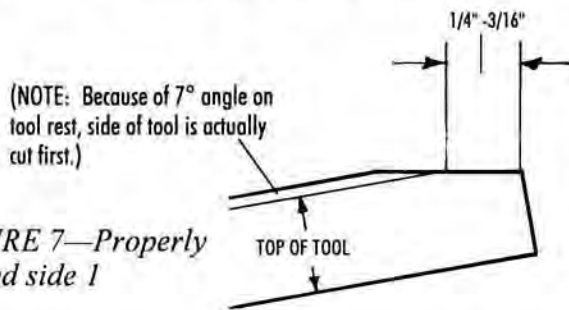


FIGURE 7—Properly ground side 1

Move the blank back and forth across the face of the wheel until you have ground a  $10^\circ$  angle on approximately  $3/16"$  ( $4\text{mm}$ ) of side 1.

This is where the “positive approach” comes in. Unless you push the tool into the wheel with enough pressure, the tool will bounce around and you’ll never get a good flat cutting surface. It isn’t necessary to worry about getting the tool too hot. Modern day tool steels don’t anneal and a little discoloration doesn’t affect the tool life in tool room use. What you should worry about is not burning yourself or grinding the tips of your fingers off! Concentrate on holding the  $10^\circ$  angle while moving back and forth. We’ll give this edge a final sharpening later, but now it’s time for side 2.

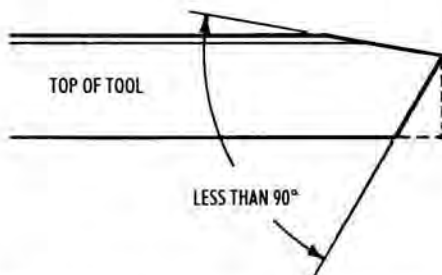


FIGURE 8—Grinding side 2 of the tool

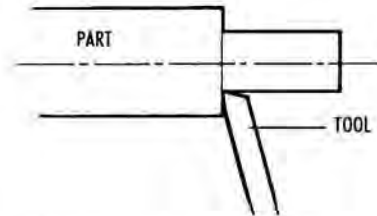


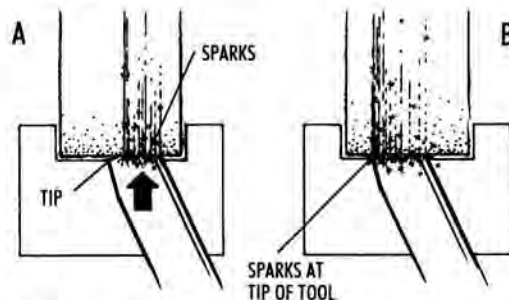
FIGURE 9—Properly ground tool cutting into a corner.

### Grinding side 2 of the tool

The reason angle B is ground less than  $90^\circ$  is to allow the tool to get into corners.

Side 2 is ground the same way as side 1, moving the tool back and forth until you have a point. After you get side 2 ground, cool the tool in the cup of water.

Now I want you to learn another aspect of tool grinding. It is important to know when you have ground the surface up to the cutting edge, especially when resharpening lathe tools. Take the tool you just ground and bring it up to the wheel at a slightly different angle than you just ground for this experiment. Watch the point that touches the wheel first and you will notice that the sparks will bounce off the cutting edge only where the wheel has ground from top to bottom.



FIGURES 10A—Tip not yet ground flat and 10B, Tool ground flat all the way to the tip.

This tells you when the tool has been sharpened without taking it away to look which allows you to grind flat and true surfaces. If you sharpen a tool for a Sherline lathe, use a  $1/4"$  square tool blank and keep the cutting edge up to the top of the blank; the tool will come out on center without shims. You will have to be precise grinding the third side to accomplish this.

### Grinding side 3

Now you will use the skill you have developed grinding the second side. Set the blank on the support with the  $10^\circ$  (side 1) up. The tool has to be brought up to the grinding wheel with a slight angle so you

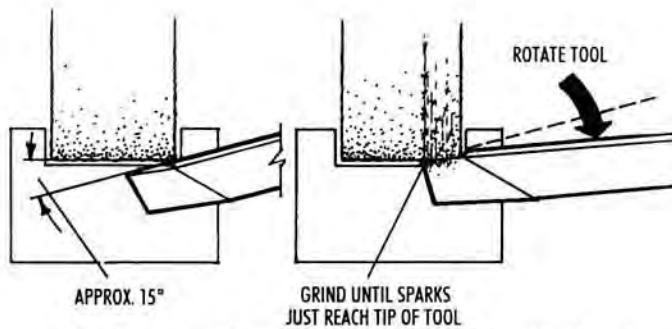
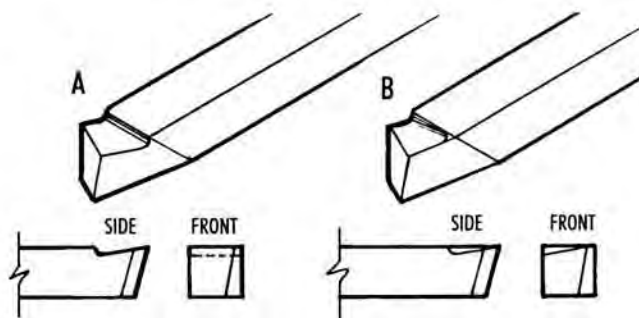


FIGURE 11—Grinding the "Hook" into side 3

don't grind the tip below center. With the tool setting on the rest, move the tool in and grind until you see sparks bouncing off the cutting edge where the corner of the wheel is lined up with the back part of the 10° face. When this happens, slowly decrease the angle without pushing the tool in any more until sparks bounce all the way to the tip. Stop as soon as this happens. You may inspect it, and the surface should be entirely ground. The recommended way is to put more "hook" on the tool than I have suggested, but I have found that the slight increase in performance is offset by the problems encountered resharping these tools.



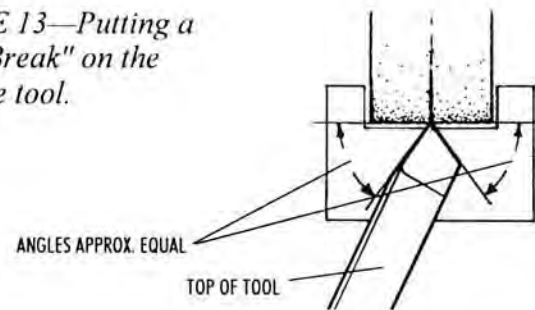
FIGURES 12A—Normally recommended "hook" ground into tool and 12B, Simpler method suggested for Sherline tools.

To put the finishing touches on your tool, you have to "kiss off" sides 1 and 2 again. You must carefully line up side 1 with the wheel and bring it to the wheel in a positive manner with very little pressure. Then watch for the sparks on the cutting edge. What you're trying to accomplish is to make the tool set against the wheel on the same plane as when you first ground side 1. If the tool is held too rigid, it will not align itself, too loose and it will bounce around.

#### "Breaking" the point

Use the same method on side 2. The tool should be ready to use except for the point. I always put about a .010" (.2mm) "break" on the point by holding the tool with the point aimed at the wheel face. Because

FIGURE 13—Putting a .010" "Break" on the tip of the tool.



two angles converge at the point, the angle in relation to the sides is greater. Think about it!

This means that if you set the tool flat on the tool rest, the tool rest angle would have to be increased to get an even flat. This wouldn't be worth the effort, so the easy way is to freehand it. I always start by touching the heel of the tool first, and then change the angle until a slight flat is put on the tip. Of course, the angle you're holding it at has to be close when starting to get desired results.

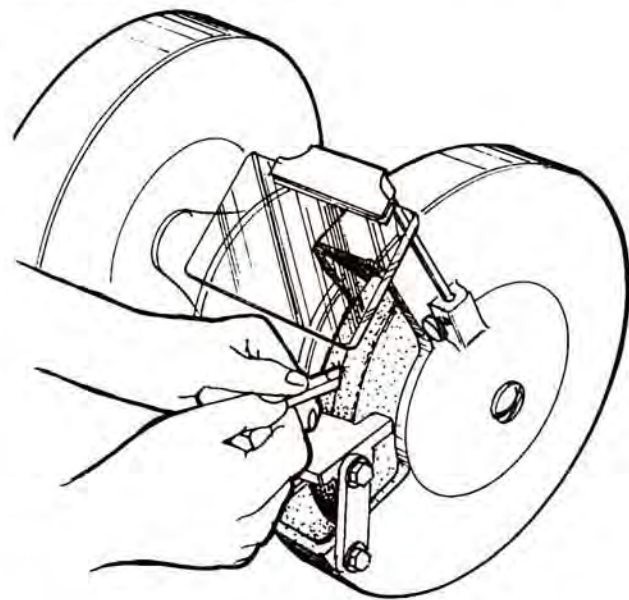


FIGURE 14—Hand holding the tool to "Break" the point saves resetting the angle on the tool rest.

The purpose of this flat is to improve finish and tool life. I don't recommend a large radius on the tip of tools used on small machines. These machines are not rigid enough to get the desired results from this practice and cause "chatter" problems.

#### Some final tips

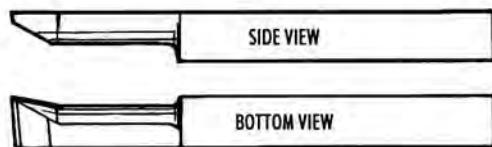
The finished product should be a right handed tool, have flat cutting surfaces (except for the radius caused by the wheel), have a slight flat on the tip, and a tip angle of less than 90°. Tools used on lathes

such as the Sherline will do all their cutting at the tip of the tool because they don't have the horsepower for 1/4" (6mm) cuts.

I don't recommend using oil stones to improve the edges. After a few minutes use with an occasional dab of cutting oil a properly sharpened tool will hone itself in.

I always believe the final sharpening to a tool should take place with the wheel cutting the cutting edge of the tool from the top of the tool to the bottom when using bench grinders.

I realize I've given a great deal of information on how to do what I call a "simple operation", but these are very difficult instructions to write because I'm trying to tell you how to control your hands, not a simple machine.



*A typical boring tool*

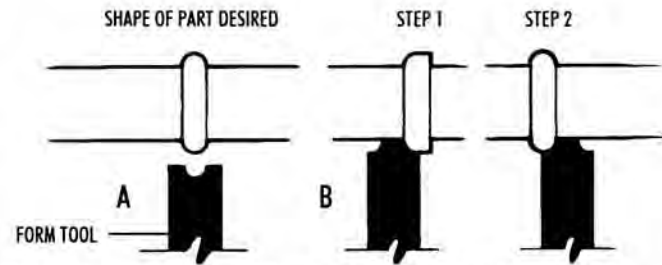
### Grinding boring tools

Boring tools are the most difficult tools to grind. They should always be made as rigid as possible. Tool angles around the "tip" can be the same as any cutting tool, but clearances of the tool body have to be considered carefully. A tool ground with enough clearance for a finished hole may not have enough clearance to start with when the hole has a smaller diameter. If you have to bore a hole in a part that has a lot of work in it, have a tool ready to use that's been checked out on a piece of scrap.

### Grinding "form" tools

Form tools are used to create a shape that is a mirror image of the shape of the tool. To grind form tools, a pattern of the finished shape should be at hand and you should have a workable design for the tool in mind. You must be able to achieve the shape you want with the tools you have to work with. For example, you can't grind a 1/8" (3mm) groove 1/4" (6mm) deep into your tool with a 1/2" (12mm) wide grinding wheel.

Intricate form tools are usually made by tool and cutter specialists who have expensive shop rates and use precision grinders, diamond dressers and the large variety of wheels available to them. However, all is not lost if we have a good pair of hands with a



*Drawing A shows a Typical Form Tool made by a custom toolmaking shop. Drawing B shows a home shop method of achieving the same finished shape in two steps with a tool that can be ground on a bench grinder.*

good mind driving them! We can use the grinding wheel corners on our \$50 grinder and generate the shape one half at a time on each side of the tool and still get our job done.

Form tools don't need any top relief (hook) to work. Use low spindle RPM and steady feed rates to prevent chatter. The width of a form tool should never exceed three times the smallest diameter of the finished part.

Like any skill, tool grinding is one that has to develop with time. It is also the skill that allows you to go one step beyond the average "hacker". Working with sharp tools makes machining much more pleasant too, so this is a skill worth spending some time developing. In the long run you will also save a lot of money by not having to continually buy new cutting tools or pay someone to sharpen them for you.



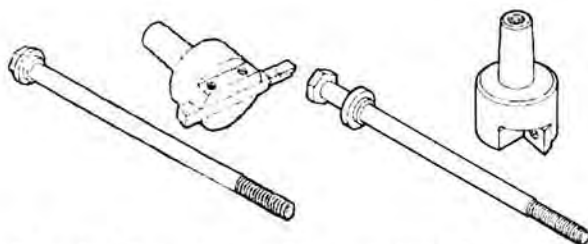
*Sparks fly as the finishing touches are put on a lathe tool using a grinding wheel. Learning to grind good cutting tools is a key to getting good finishes on your parts.*

## 6.4— CUTTERS FOR MILLING

### Fly cutters

A fly cutter is an inexpensive way to machine flat surfaces. All machining operations should be done using eye protection and it is an absolute must for fly cutting. As the term implies, the chips “fly”. The chips can be very hot and care should be taken to protect yourself. In a sense these are dangerous tools that can send an improperly clamped part flying. The cutting portion of the tool is a left-hand lathe tool which is inexpensive and easily sharpened. Sherline supplies a left-hand carbide lathe tool with a new fly cutter, but you can also use high speed steel and achieve excellent results. Even with a small milling machine such as the Sherline, the width of the cut can exceed two inches. They produce a good finish similar to a lathe and only need a small amount of coolant to keep the material from sticking to the cutter. The depth of cut is somewhat limited, and if the cutter makes a “rapping” sound, lighter cuts should be taken. They work best when the tool starts the cut from one side and exits the part on the opposite side rather than being lowered into the surface. This eliminates the “crushing” action it takes to start a cut when the cutter comes in from the top rather than the side of the part.

If a fly cutter is lowered directly into a flat surface, a circle would be cut at the edge but not in the middle. You have to understand that fly cutters do not cut to center. The work must be moved under the spindle to cut a flat surface. As you move the part under the spindle, the cutter will start cutting on the outside, and the inside of the cutter will start cutting after the work has been moved under the spindle equal to the diameter the fly cutter is set at. Of course, the milling machine spindle must be square with the table for a fly cutter to work properly, but machinists are often tricked into believing their spindle isn't square when the cutter takes a second cut on the “back” side as the part is fed under the

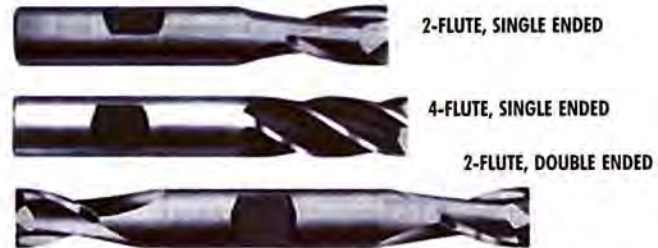


Regular fly cutter and inserted tip fly cutter

spindle. This second cut happens because the inside cutting edge remains sharp longer and the machine isn't “loaded” as much. When fly cutters are cutting correctly, a small spiral chip will be thrown from the part. A fly cutter is a very useful tool that can remove metal quickly, saving time and eliminating the use of costly end mills.

### Inserted tip fly cutter

For those who prefer the advantages of working with inserted carbide tip tools, Sherline offers an inserted tip fly cutter. It uses replaceable carbide cutting inserts which last longer than steel tools without sharpening, plus they provide an excellent finish on hard-to-machine materials like cold rolled and stainless steels. The cutter shape allows it to cut a straight shoulder on a part, something not possible with a standard fly cutter. It comes with the toolholder, a drawbolt, a 2-edged insert, a Torx T-15 driver and mounting screws. Additional inserts are available.



*Some common types of end mills. The flat on the side is where the set screw is to be tightened to hold them in place when using an end mill holder.*

### End mills

End mills are used to shape metal parts on a milling machine. The first thing you should realize about end mills is they can cut the “meat” off your hands faster than they cut metal. They are sharp! They are not just flat ended drills. Unlike drills which cut only at the tip, the sides of the flutes on an end mill have a cutting edge as well. Don't ever touch a turning end mill! The next thing to consider is that end mills can bend or “deflect” while cutting, and the direction of the bend will be determined by the direction of the cut. The terms, “conventional milling” and “climb milling” must be thoroughly understood before doing any mill work.

More detail on end mills can be found on page 201 in the instructions for milling. Also included there is a chart showing recommended cutting speeds for various diameter cutters in typical materials.



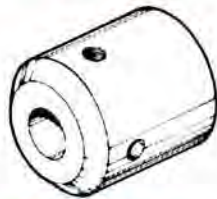
A ball end mill has a round end and will put a radius in the corners of your cuts.

### Special shaped milling cutters

Milling cutters that cut angles and shapes are available. Ball end mills are a good example of one type of shaped cutting tools. Ball end mills require very light cuts because they have a greater cutter contact area. This causes even more cutter deflection. Cuts should be taken that are so light that the feed rate doesn't have a great effect on the cutter deflection.

This section has been one of the most difficult of all the instructions I have ever written over the years. What I have tried to accomplish was to make you aware of problems that don't always have good solutions. I didn't want to scare a potential home machinist away by attempting to explain all of the intricacies of machining, however, I also want a novice to spend little time fixing mistakes. Many of the mistakes I made as I taught myself to be a machinist could have been avoided if someone had just told me some of the simple things about cutting tools that I have passed on to you.

### CUTTING TOOL HOLDERS FOR MILLING



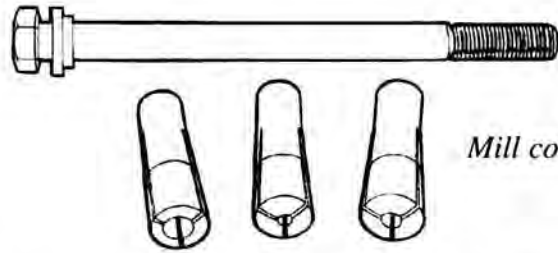
#### End mill holders

Sherline's 3/8" End mill holder. Holders like this are also available in other sizes.

The 3/8" end mill holder makes it easy to use the popular (and less expensive) 3/8" end mills. Using double-ended end mills is economical and easy with this holder as tools are changed by simply loosening a set screw and changing the tool. The holder is also available in 3/16" and 1/4" sizes to hold smaller size tools in the same manner.

#### Milling collets

The main purpose of the mill collet set is to hold end mills. The spindle nose has an internal Morse No. 1 taper, which closes the collet as the drawbolt is tightened. Morse tapers are approximately 5/8" per foot and are self-locking. Therefore, to loosen a

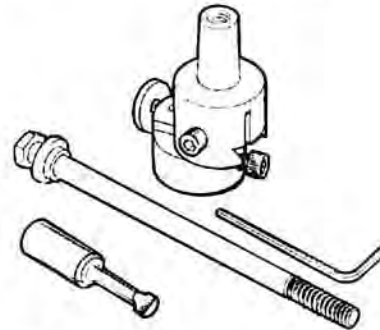


Mill collet set

collet, the drawbolt must be loosened a few turns and given a few *light* taps with a hammer.

### Boring head and boring tools

The main purpose of the boring head is to eliminate the need for a large inventory of drills and reamers. A small milling machine would not have the power or rigidity to turn a one-inch diameter drill even if one could be obtained that would fit. However, holes of even larger diameters can be accurately bored to size with a little patience and care.



Sherline's boring head and a boring tool. The bottom half of the boring head is offset to achieve the size hole you need.

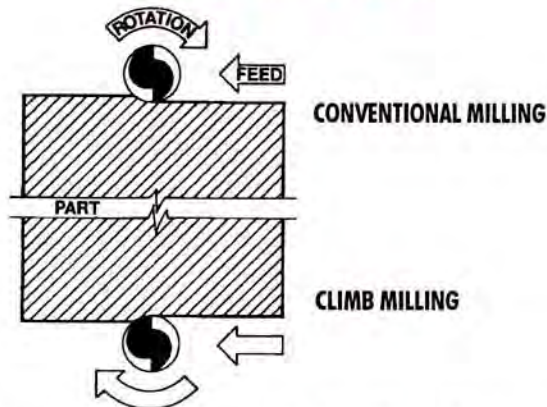
Boring heads work on the same cutting principle as lathe boring, except that the cutting tool turns while the work remains stationary. (When boring on the lathe, the work turns and the cutter remains stationary.) The boring head is designed to employ cutting tools with a 3/8" shank. Sherline offers two boring tools with lengths appropriate for the Sherline mill. It is sometimes advisable to remove excessive tool shank length from standard (non-Sherline) 3/8" boring tools in order to improve rigidity. (See page 198 for a drawing of a boring tool in use.)

Tool sizes are listed indicating the smallest diameter hole that can be bored and the maximum depth that can be cut. For best results, use the largest diameter possible with the shortest lengths. A .010" cut represents a good starting point.

If boring a hole where a flat bottom is required, it is advisable to stop the down feed at about .002" above

the desired depth, turn off the motor and cut the remaining distance by hand turning the spindle to eliminate any possibility of chatter.

### USING MILLING CUTTERS



*Conventional milling vs. climb milling. For purposes of explanation, imagine the part is fixed and the cutter is moving.*

#### Comparing "Conventional" and "Climb" milling

To explain the difference, the best analogy I can come up with would be using a shovel to dig a ditch. Consider the shovel a cutter and yourself the spindle, and you are digging a ditch that has already been started. If you dig the shovel in at the bottom of the ditch and push the shovel away and lift, the force will push you back and down. This action is the same as conventional milling. When you start the shovel at the top of the ditch and pull it towards yourself and down, you will be pulled towards the shovel and upward. Consider this action the same as climb milling. Now consider how a powered ditch digger works. They have a series of small buckets (cutters) that are attached to a round frame in a fashion similar to a "Ferris wheel". When the cutters are lowered into the ground, the forces push the machine backwards and these forces are counteracted by the tires. The feed of the machine down the ditch will never exceed the traction of these tires and the machine is doing "conventional milling". If the ditch digger were designed to have its cutters turn in the opposite direction, the cutters would climb up on the surface, pull the machine forward and the operator would be chasing the machine around the field. This represents the basic problem with climb milling. It can be downright dangerous with machines that have loose slides or excessive backlash because it pulls the work into the cutters.

Then why would you do it? Sometimes the part configuration forces cuts in this direction, or you

may decide to climb mill by choice. Lets go back to the ditch and try to understand the forces in more detail again. When conventional milling, we started with the shovel in the bottom of the trench and pushed as the shovel was lifted to remove dirt from the ditch. The lifting action also has to be considered. The first part of the cutting action is getting the shovel (cutter) to start the cutting action by taking a cut that gets progressively heavier. At the end of the cut, the cut is the greatest, which in turn, adds weight to the person using the shovel, which makes them sink deeper into the dirt at the bottom of the trench. This is just the opposite of climb milling where the lightest (depth) part of the cut is at the end. (Note that the same forces must be considered whether the cutter is vertical or horizontal. The forces involved are so much greater than gravity that it is not a consideration.)

#### Despite its drawbacks, climb milling can give a better finish

Climb milling can create a better finish in two ways. First, the lightest part of the cut is at the end of the cut. Second, the chips are tossed from the cutting area and do not affect the finish. Climb milling will deflect the cutter away from the cut. It is called climb milling because the end mill wants to climb up on the work. The major problem with machining in this direction is that the cutter may actually do just that—climb up on the part and break. Also, when a climb cut is first started the work has to be pushed into the cutter. Then the cutting action pulls the backlash out of the table leadscrew and a heavier cut is taken than planned. Look at the diagram in the previous column as it will be very useful in helping you to understand the interaction between cutter and part.

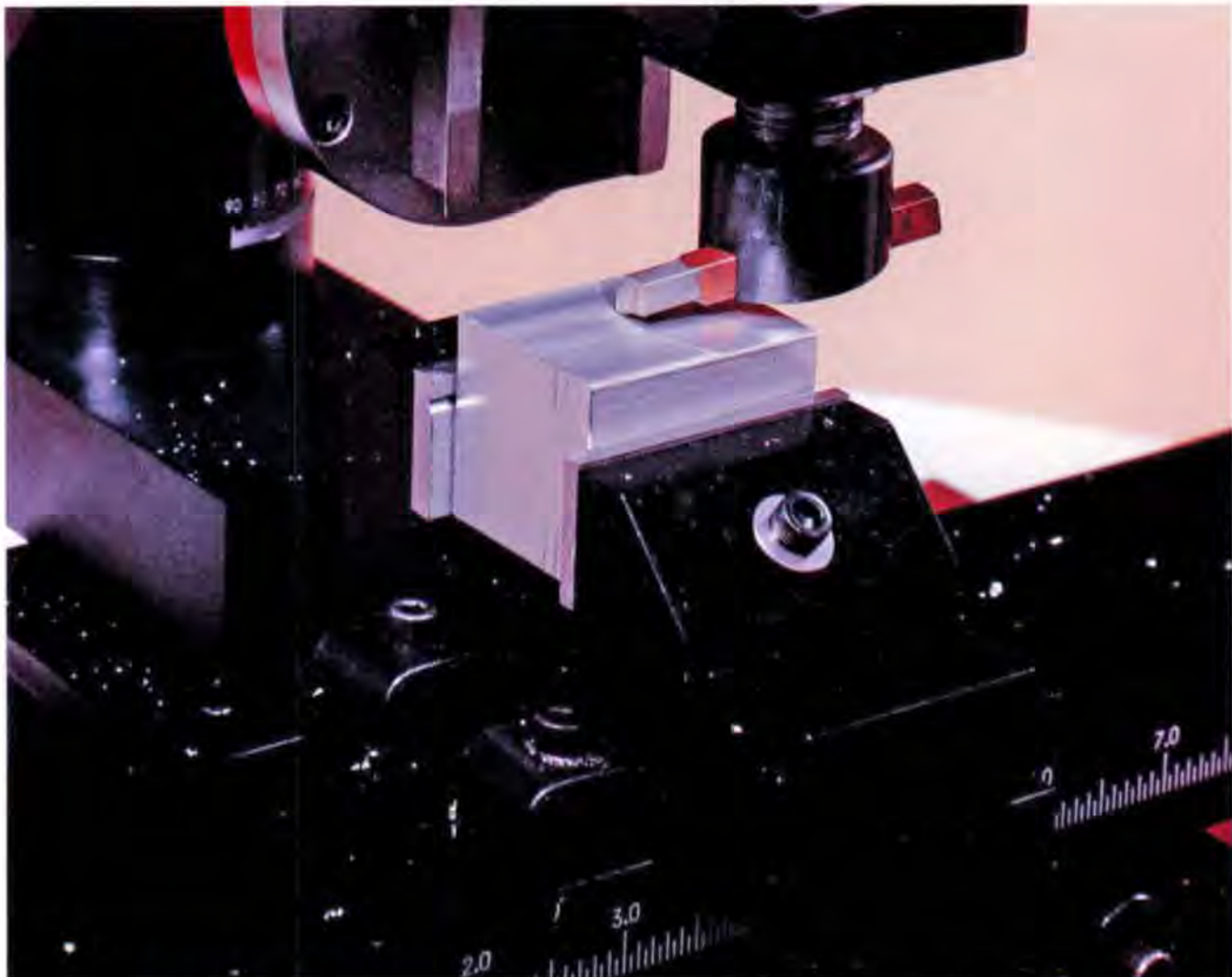
#### An example of a climb milling cut

As an example, we will consider using an end mill to cut a  $1/16"$  (.062" or 1.5mm) wide slot  $1/8"$  deep (.125" or 3mm) in a piece of aluminum. A novice might attempt to cut the slot to its final depth in one pass. The end mill would break even if the depth of the cut were halved. Next you try a .010" (.25mm) cut and lower the cutter into the part .010" at the start of each pass. This is still a heavy cut but chips are coming out and you continue on. When the cut is finally completed you measure it and find the slot is .070" (1.8mm) wide. It also has a finish that resembles a stone wall!. Cuts that deflect end mills, big or small, have these problems and you must deal with them. The shorter the end mill, the more rigid

the cutting surface will be. Short end mills can eliminate some problems and speed up the process, but the basic problem will always be there.

I would start by taking a cut of only .0015" (.04mm) to start on the slot we are using as an example. It is more of an engraving process to cut narrow slots and, when possible, a slitting saw is quicker. The problem with thin slitting saws is that they don't always track well because the teeth may be sharper on one side of the cutter than the other. On larger slots, an undersize end mill may be used to "rough cut" the slot. The "on size" end mill can then be used to bring the slot to size, but there is another problem that occurs at the end of the slot if the slot doesn't go through the side of the part. When the cutter reaches the blind end of the slot, the cutting

load changes considerably and the cutter may "chatter" and cut oversize. A drill will chatter only at the bottom of a hole and is supported by the outside diameter, but an end mill is designed to cut on the sides as well as the end and can really make a mess of a good part when this happens. If the slot is critical, after rough cutting the slot, I will "plunge cut" (feeding the end mill straight down) each end before cutting the slot to size. What can cause grief with this method is when the cutter starts cutting to its full diameter at the bottom of the hole which upsets the cutting loads causing the cutter to wobble and cut the hole or slot oversize. As long as you anticipate these potential problems, this is a method that can be used on any inside corner that you want perfect.



*A fly cutter is a good way to machine flat surfaces. It gives an excellent surface finish and makes cuts up to 2 inches wide on a Sherline mill, but cutting forces are high so parts must be held very firmly. Watch out for the chips...they are HOT, and eye protection is a must!*

## Chapter 7— Measuring and measurement tools

### Measurement throughout history

No one knows who was the first to actually measure something, but at some point in history, craftsmanship reached a point where doing things “by eye” just wasn’t good enough any more. For example, the builders of the pyramids would start the job out with a gage carved in stone. From this, each worker would mark his own measuring stick. The punishment for having a stick that wasn’t correctly calibrated was *death*. Common sense tells me that they quickly arrived at only one stone for a standard and that the craftsmen were pretty careful about marking their measuring sticks. It could ruin your whole day to have to kill your best stone mason because he got his sticks mixed up. They must have had a number of jobs going on at the same time, and I’m sure some enterprising Egyptian did good business selling calibrated sticks, saving everyone in the building trades a lot of trouble.

### The modern stick and stone

Things today really haven’t changed all that much. We still need standards for measurement and we keep coming up with ways to divide the “stick” into smaller and smaller parts. The “stone” is now a gas that is measured to the atom electronically, whether you use the inch or the metric system. The “sticks” of today are the rulers, tapes, scales and electronic readouts we use daily.

### Measurement increments had a human touch

You might find it interesting to note that most of the dimensions we are familiar with in the inch system came from parts of the human body. The inch was once based on the length of the last joint of the thumb. A yard was the distance from the tip of the nose to the end of the fingers with the arm outstretched. (A seamstress measures “yards of cloth” by pulling from nose to fingertips to this day.) A fathom is two yards, or the distance from outstretched fingertip to fingertip. The ancient Egyptians also used cubits (elbow to fingertips), digits (one finger width), palms (four digits) and hands (five digits). The height of a horse’s shoulder is still often measured in “hands”.

Time also figured into some early measurements of distance as in the acre which was the amount of land a team of oxen could plow in a day. The length of



*The tools used for measuring and checking parts in a machine shop stand ready for use on a ground granite surface plate. The parts you make will be no more accurate than your ability to measure them.*

the furrow in that acre was called a furlong. A journey was measured in hours (much as it is on the L.A. freeway system today), days or moons.

The foot is also a common unit of measurement, although deciding whose foot was to be the standard was a problem that plagued standardization throughout the ages. It would vary from place to place and time to time as each ruler declared his foot to be the standard for all. The earliest preserved standard for length comes from 2575 B.C. and is the length of the foot of a statue of Gudea, the governor of Lagash in Mesopotamia. It was about 10.41 modern inches long (they had smaller feet back then) and was divided into 16 parts. Later the Romans subdivided their version of the foot into 12 unciae, hence our inches. A Roman pace was 5 feet, and 1000 paces made up a Roman mile.

Despite the current movement to standardize the world on the metric system, my own preference is the inch system. Here’s why. When working in metal, .001" (one thousandth of an inch) is a tolerance that can be achieved with cutting tools, and .0001" (one ten thousandth of an inch) is a tolerance that can be achieved by grinding. The numbers don’t come out quite so neatly in the metric system. 1mm equals .03937", .1mm equals .0039" and .01mm equals .0004". The tolerance of  $\pm 1$ mm (.004") is too coarse for most work, and  $\pm 0.01$ mm

(.0004") is too fine. Therefore, you end up with tolerances too tight or too loose because the draftsman usually calls out a tolerance of  $\pm .01\text{mm}$  when it should be  $\pm .025\text{mm}$ . In addition, the basic unit of distance measure, the meter, is unrelated to any human increment, unless you are a basketball player who can stretch his fingertips out to 39.37 inches from his nose. On the plus side for the metric system, of course, is the fact that it is based on units of 10, and many conversions can be done in your head. In the end it will be interesting to see if the pure logic of the metric system can finally erase the human side of measurement in the inch system.

**Then or now, skill with your tools is still a part of accurate measurement**

Egyptian builders had only simple plumb lines, wood squares and rulers, but they obviously used them with great skill, because their measurements were amazingly accurate. The dimensions of the Great Pyramid of Gizeh, built by thousands of workers, boasts sides that vary no more than 0.05 percent from the mean length. That means a deviation of only 4.5 inches over a span of 755 feet. Some construction workers of today might find it hard to duplicate that accuracy. When Sherline's factory was being built, a laser level was set up in the middle of the foundation to lay out the building. I noticed a workman accidentally kick one of the legs of the level and stick it back in place by hand. If I hadn't brought it to the attention of the foreman who releveled the laser sight, our building might have resembled the leaning tower of Pisa today. This



*A dial caliper and micrometer are probably two of the home machinist's most used measuring tools. This boxed set includes a steel scale as well.*

is a good lesson that skill and technique can overcome some of the faults of poor measurement tools, but carelessness or improper technique can render even the most sophisticated tools useless.



PHOTO: BROWN & SHARPE MFG. CO.

*A large coordinate measuring machine makes accurate part measurement easier for the factory that can afford one. Unfortunately their price takes them out of the reach of the home shop machinist.*

**Machine shop measurement today**

Until a few years ago, most factory and machine shop measuring was done with a micrometer, height gage, squares and surface plates. In the past few years many new methods to measure your work have been added that take advantage of the calculating power of the computer. The most important of these new measuring systems would be the "coordinate measuring machine". It is built on a surface plate and can read all three axes of movement: "X", "Y" and "Z". What is interesting about them is the methods used to come up with dimensions. They have a small probe that very accurately informs the computer when it touches the part. To read the diameter of a hole, the probe has to touch three points in that hole which don't have to be equally spaced. The computer will triangulate these points and produce a diameter within .0001" (.0025mm) and note where the center of the hole is located on the part. The part doesn't even have to be located square with the machine, yet it can be checked accurately. The programs that run these machines can be as complicated as the programs that make the part. The cost of these marvelous machines can be several hundred thousand dollars, but they are well worth it to companies that purchase and manufacture millions of dollars worth of precision machined parts.

PHOTO: BROWN & SHARPE MFG. CO.

### Modern scrap is more costly than ever

This technology allows aerospace companies to build more perfect products, but it has also filled salvage yards across the world with some very expensive scrap parts. The problem in many cases is that manufacturer of these parts doesn't have measuring equipment that is as good as their customer's. Who can afford \$100,000 measuring tools to measure \$10 parts? Contract machine shops can go broke overnight when they find out an expensive, high quantity part has been rejected. When making machined parts for other people you have to be able to prove your parts are correct.

When making parts for yourself, you can fit one part to another and tighten the tolerances in the process. This is a very important difference, and if you work at fitting and matching parts together you become a modelmaker. Modelmakers develop a special skill to make and fit parts together so the assembly works in unison, while the machinist will produce close tolerance parts that are within the tolerance of the part drawing. In most cases, he doesn't have the luxury of test fitting it to the part it will eventually be assembled to. When you make parts for other people the drawing is "king". A machinist shouldn't have to worry about problems someone may encounter assembling parts they manufacture. They have enough problems making a part within the tolerances given. Toolmakers are the best at both skills because they usually make the parts they fit together. If you build and fit parts together you are closer to a toolmaker than a machinist. Even though your tabletop machines are small, the processes you will use in making your parts are the same as any machinist must deal with.

### Watch those divisions

If you are making parts for your own enjoyment there is nothing wrong with changing a dimension here and there to save a part that may be a few thousandths (.1mm) undersize. Of course, if it affects the strength or integrity of the assembly, I would not do it. When building small metal parts they have yet to come up with a good "putting on tool"\* so you have to get used to the idea of starting over. You can't work with dimensions all day without making an occasional error. The only people who don't make mistakes are those who do nothing. I've

\*NOTE: A long-standing joke in machining, a "putting-on" tool is what you send the new apprentice to the tool crib for when he makes his first undersize part.

found many mistakes are accurate to a very close tolerance, but off by a division. When taking a reading, always read every dimension, not just the dimension you are correcting. A good example would be when you are using a lathe and getting close to the final cut. The diameter you are reading may need a very close tolerance and you are concentrating on the thousandths of an inch or tenths of a millimeter located on the barrel of a micrometer. When you start looking only at this part of your micrometer you could screw up and get the diameter off by one full turn which would be twenty-five thousandths (.5mm). Mistakes of this magnitude will usually create scrap.

### Good measurement tools are one of the pleasures of machining

I enjoy buying measuring tools. Most people treat these tools with great respect and take pride in them. A good toolbox full of high quality measuring tools in your workshop has the same owner's sense of satisfaction as a china cabinet full of figurines has for your wife. I don't know if you will convince her of this fact, but it's worth trying. I have always been a fan of the Starrett company located in Athol, Massachusetts. Their measuring tools have set the example for the rest of the world to follow, and they are still reasonably priced. The truth is that you can get by with far fewer measuring tools than you will buy. Again, I want you to understand that I'm referring to people working at this trade to please themselves, not to please a customer.

Measuring tools don't have to be expensive to work well. Due to the number of imports on the market



*Every machinist's tool box eventually collects a number of favorite measuring tools.*

PHOTO: PETE WEISS

there is a great selection of measuring tools available that all work quite well. People seem to think tools like this are a lot more valuable than they are. I have seen people trying to sell a beat up one-inch micrometer at a swap meet that I wouldn't even use as a welding clamp. They may be asking more money than you could buy a set of three new ones at today's prices.

The cost of measuring does go up considerably when you buy specialized tools. A good one-inch micrometer could be purchased for around thirty dollars (1997), but a thread micrometer could cost three hundred dollars. As soon as you get away from the basic "mikes" you are in the hundred-dollar range.

### Working with tolerances

Before getting into measuring, there is one more concept I want you to understand and that is the concept of tolerances. Tolerances are the limits placed on any dimension by the designer of the part. They are designed to make the part price as low as possible while still making the part useable in every combination with other parts of a given assembly. Almost any engineer can design parts that will work if tight tolerances are held. These parts are almost impossible to build and can increase the cost by a factor of ten. It takes a good engineer to design parts within practical limits. The tolerances are always given on commercial drawings, in fact, we would refuse to bid a job unless every dimension had a tolerance when we did contract machining. You can't be arguing with a customer about how they assumed you would know that the part you made for them had to fit another part for which you had never seen the drawing. Making parts that don't work can be a financial tragedy when the quantities are high and costs are in the thousands of dollars. Before starting on any part, review the drawing and convince yourself the part will work. When in doubt, tighten the tolerance so you *know* it will work.

Tolerances should be thought of as a percentage of the dimension. For example, .001" (.025mm) may seem like a very tight tolerance when you are turning or boring a diameter of three inches, but it would be a two percent error on a diameter of .050" (1.27mm). If you had the same limits for a three inch part, a two percent tolerance would allow you a range of .013" (.33mm). These are boilermaker's tolerances. Obviously, small parts can't be manufactured to the same tolerances as large parts and still work. Most

hobby drawings don't have tolerances listed, and you have to decide which parts are good or bad. Don't forget that a dimension taken on a part that doesn't have the proper surface finish will come out undersize after it is polished. Allow for this fact.

### Technique and "feel" in using measuring tools

A delicate "feel" must be developed to measure the small parts manufactured on tabletop machine tools. Just because your micrometer has lines on it that represent one ten thousandth of an inch (.0025mm) it does not mean you can measure to that degree of accuracy without that special "feel". To develop this feel you should start measuring things of known dimension to see if you come up with the same answer. If you have a friend that is skilled in taking measurements, have them give you a lesson. Machinists usually own their own measuring tools. They develop confidence in these instruments and, along with that "feel", they are sure their dimensions are correct. You can't hold your head high in the metal cutting trades until you can make parts to size.

### Gage readouts

The actual readout on a measuring gage uses one of three methods to come up with an accurate dimension: The screw thread on a micrometer, the Vernier scale on height gages, calipers and angle reading devices or the new digital readouts found on all types of modern measuring tools.

The screw thread on a micrometer is forty threads per inch or has a pitch of .025" and a calibrated movement of one inch. The metric micrometer has



*The digital readout of a modern caliper makes life easy for a machinist. Readings in inches or millimeters can be taken and translated back and forth eliminating many of the math errors associated with dimension conversions.*

PHOTO: L.S. STABRETTI CO.

a .5mm pitch and 25mm total calibrated movement. One of the reasons I don't like the metric system is the way micrometers are calibrated. When you're using an inch model micrometer, all you have to do to get a reading is add the reading to the size of the gage. With metric models you have to add the range of the micrometer to the reading. The problem is the range isn't a simple number like the inch system; It is 25 millimeters. If you are using a micrometer with a range of 75mm to 100mm you can't add your reading to the number one. You have to add it to 75. This gives you an excellent way to introduce mistakes into your calculations.

Pitch is the amount of movement the screw or nut will move in one revolution. These threads have to be precise and are usually made with a precision thread roller.\* Expensive micrometers will also have a screw that has been ground. The same type of measuring assembly is used on all micrometers. They are mounted on different gages to make a very large range of sizes. Micrometers are available that have a range that can be expanded by changing a spacer at the anvil end. They can be somewhat awkward to use because they feel out of balance.

#### Getting consistent readings with a micrometer

Micrometers also have a locking lever and a ratchet thimble at the end of the barrel to allow you to apply the same pressure each time when measuring. It is still up to the user to determine if the reading is correct. You can misread a micrometer by trying to measure the surface of a part that isn't in line and parallel with the anvil. If your mike is twisted on the part or if the part is twisted, you can't get an accurate measurement. Surface finish has to be considered when measuring. To read to four places you can mentally interpolate between the lines or use the vernier scale that is engraved opposite the barrel, assuming your micrometer has this scale. I have never understood why they don't manufacture a micrometer with two inches of movement (50mm), particularly in larger sizes. This would certainly cut down on the number of micrometers needed. (Maybe I just answered my own question...)

Sherline machinists will need at least a zero-to-one-inch mike (0-25mm) to start. Calipers can take care of the larger dimensions you will come up with. As you get more interested in machining, you will find

\*A point of interest: Although the lead screws on Sherline tools are not ground, a precision thread roller is used to make them. They are accurate to within 99.97%.

needs for these lovely tools, but I wouldn't purchase too many until I had decided that cutting metal can be fun.

#### Reading Vernier scales

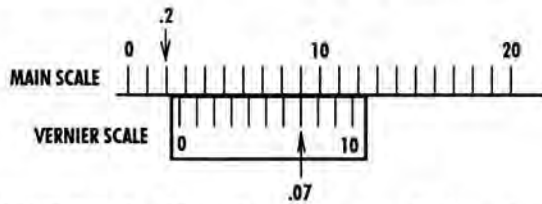
The Vernier scale, named after its inventor, is used on all kinds of products that measure lengths and angles. They are quite simple to use and can be read to .001" (.025mm). The method they use to break a scale into so many divisions without having a line for each division is clever. For this example, let's use a height gage that reads to one thousandth of one inch (.025mm). The basic scale is fixed and divided into 20 parts per inch (25mm). They can be manufactured as long as needed. Eighteen inches or 400mm would be common scales used on height gages. Opposite this scale on the inch model is a Vernier scale that has been divided into fifty parts mounted on the movable slide. The reason 50 divisions are used is because  $1/20$  (the units into which the basic scale has been divided) equals fifty thousandths of an inch. This provides an accuracy of one thousandth of an inch. The Vernier scale will have only one line on its scale that lines up with a line on the basic scale for each one thousandth inch movement unless the setting is zero. If you set the Vernier scale at zero, you will find that the length of fifty equally spaced marks on the Vernier scale is equal to exactly one division less than fifty divisions on the basic scale. On the inch model used in this example it would work out to be two inches and four hundred fifty thousandths of an inch on



*Vernier scales use a clever method to come up with a scale that reads to high levels of accuracy without requiring a division on the main scale for every increment. The reading on this scale is .867*

the basic scale. As the slide is raised, the two lines that line up with each other keep getting higher in value until you get to fifty. At this time, the zero line will also be lined up with a line on the basic scale to start the process again. This is the only time two sets of lines will line up at the same time.

The rules for reading Vernier scales are as follows: First you read the basic scale where the zero line on the Vernier lies on the basic scale in whole divisions. Then add the amount on the Vernier, which is the line on the Vernier scale that lines up with a line on the basic scale. Remember the lines on the Vernier scale only use the basic scales lines to line up with. You don't consider what these lines represent on the basic scale. To accurately read a Vernier scale you should view the lines at an angle that clearly



**EXAMPLE 1**—Here is a very simple Vernier scale and the key to how it works. In this example, divisions on the main scale correspond to tenths, divisions on the Vernier scale indicate hundredths. Ten divisions on the Vernier scale are the same length as nine divisions on the main scale, so that at any position other than zero, only one of the pairs of lines will line up exactly. The zero of the Vernier scale is past .2 on the main scale. The seventh line on the Vernier scale (.07) lines up with a line on the main scale. Therefore the reading is  $.2 + .07$  or  $.27$ .

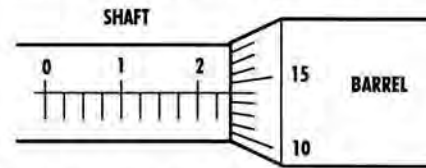


**EXAMPLE 2**—Above is an example like the one mentioned in the text. Each division on the main scale represents  $1/20''$  or  $.050''$ . The small divisions on the Vernier scale each represent  $.001''$ . The zero is just past  $.45''$  on the main scale. The 22nd line of the Vernier scale or  $.022''$  most exactly lines up with a line on the main scale. Therefore the reading is  $.450 + .022$  or  $.472''$ .

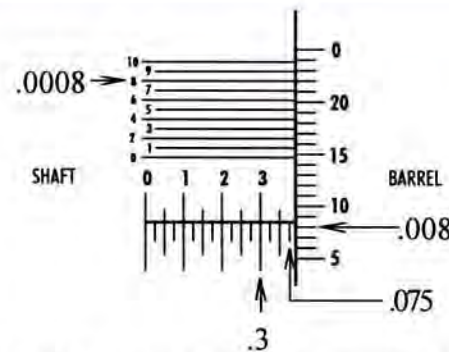
shows which single line falls on the basic scale. I start by looking where the zero on the Vernier scale is and make a guess where I should start. For example, if the zero falls about half way between the divisions, I start with the twenty-five on the Vernier. I try to look at more than one line at a time. If you stare at a scale too long, your eyes may start playing tricks on you. This usually happens right after you have found the part you have been working on for the last two hours is undersize.

### Thinking about measurement in the planning stages of your project

Before starting any complex part you should consider how you will measure it to assure its accuracy. Sometimes the calibrated machine you are using will be more accurate than your measuring tools, but few of us have that much faith. We know that the only thing worse than making a bad part is sending the defective part out or using it ourselves, so it must be checked. Once the part has been produced it is too late if it doesn't pass inspection.



**EXAMPLE 3**—A simple micrometer barrel. Each whole number on the shaft is  $.100$  (inches or millimeters). Each increment between the whole numbers on the shaft is  $.025$ . Each number on the rotating barrel is  $.001$ . This example reads  $.2 + .025 + .014$  which equals a reading of  $.239$ .



**EXAMPLE 4**—A Vernier micrometer barrel. Each whole number on the shaft is  $.100$  (inches or millimeters). Each increment between the whole numbers on the shaft is  $.025$ . Each number on the rotating barrel is  $.001$ . Each number on the Vernier scale is  $.0001$ . The reading shown here is  $.3 + .075 + .008 + .0008$  which equals a reading of  $0.3838$ .

You have to build parts that are known to be good before they get to inspection. This is what machining is all about. You need a plan that doesn't allow failure and the first line of defense is at the machine you are using to make the part. A lead screw is very accurate, and for a short movements it would be hard to measure the error, but the mechanical load of cutting metal makes cutters bend and machine tools move. You can't be taking your part into inspection after every cut because it is so difficult to mount it to the machine again exactly the same way. I have no way of solving this problem other than making you aware of it. If I wrote a book about the errors I have made in the machine trades you would have trouble picking it up it would be so heavy. The errors we encounter are very seldom the errors we

expected. We have thought these through and eliminated the possibility of these errors happening. Errors sneak up on you from the blind side and you don't see them coming. This usually happens in inspection where it is too late. Lay out the job so you have a plan to keep mistakes from happening. The job of a machinist is to make accurate parts. The inspection department will prove a part good or bad, but will never make a good part. Again, have as much of a plan on how to measure your part as you have to make it.

#### **Measuring from surface plates**

To make accurate measurements you need an accurate surface to measure from. The surface can be the part itself. If this isn't possible, a surface other than the part is used. They call this a "surface plate".



*Measuring a part using a height gage on a surface plate.*

Surface plates are usually made of a high quality granite because the material is very stable. The surface is ground to a fine, flat finish that doesn't require lubrication. I usually keep the surface clean with a spray bathroom cleaner. When the surface gets dirty with oil and grit, you increase wear between the instrument you are using and the surface plate. Worse than that, you start losing the feel it takes to get accurate measurements because the instrument doesn't slide well and feels sticky. A height gage should slide effortlessly across the surface. For the home shop I would buy a "shop grade" surface plate that is around twelve inches by eighteen inches. The extra accuracy of an "Inspection grade" plate would be hard to justify against the extra cost for home use.

The accuracy of your surface plate may be checked with a height gage and a dial indicator. Clamp a finger type dial test indicator in place of the scribe. A rigid extension will improve this process because the farther the test indicator is from the base, the more it will exaggerate the error. Set the indicator to zero by raising or lowering the slide. Move the height gage and watch the indicator. If the surface plate is perfect, the reading will always be zero. Imagine a boat that is going through waves. In a calm sea the boat is always aimed at the horizon, but in a storm the boat may be pointed above and below the horizon. You need to have room to use a height gage and square around the part you are checking. Diameters are easy to check with micrometers and calipers, but checking parts on a surface plate offers a different set of problems. Now you will be measuring the "X", "Y" and "Z" axes. Always measure the part the same way it is dimensioned on the drawing. Don't let tolerance build-up catch you sleeping. This happens when you are working with a liberal tolerance that may control a tight tolerance in another location of the part. "THINK FIRST", cut later.

### Indicators

Indicators are neat little gadgets that come in a variety of sizes. There are two types. One uses a rack gear which engages a gear attached to the dial pointer. This type has a wide range of movements available; as much as four inches (100mm), and they are accurate to less than .001" (.025mm). Their accuracy is governed by the accuracy of the rack gear. As with any piece of measuring equipment, you should determine its accuracy before using it.

PHOTO. L.L. STARRETT CO.



*A dial indicator like this Starrett 'Last Word' indicator can be used in many ways to check both the accuracy of the alignment of your machine or the size of your parts.*

Dial indicators can be set to zero by rotating a locking ring that moves the scale rather than the pointer. They also have a wide variety of tips available. Many have a magnetic base\* attached to them so you can measure the movements of slides or similar items that don't have calibrations. This type of indicator may be inexpensive, but they are not needed as often as the "finger" type.

The finger type is called a "dial test indicator", and the dial moves by the rotational movement of the finger. You can get errors in the distance indicated according to the angle of the finger in relation to the body, but the way these indicators are used, it isn't normally a problem. These indicators are used to square and locate. Their exact use is described in appropriate places in this book, but here are a few tips to be aware of: Don't buy an indicator of this type that is too accurate for the job. A "tenth" indicator, with one ten-thousandth of an inch graduations, has too limited a throw to be useful. They also bounce around so much they are difficult to read. You need a small indicator for working with Sherline tools, and I would recommend the Starrett "Last Word" indicator. It is small and very stable. The examples drawn or photographed in this book will usually show this indicator.

\*Remember that many of the components of Sherline tools are made from aluminum. For example, magnets will not stick to the slides, but the lathe and mill column bed are both steel. Sherline users have also attached steel plates to the wooden base boards to which their machines are mounted so that magnetic bases can be used.



*Height gages come in a wide variety of sizes and readouts. Shown is a dial readout, but digital readouts are also available.*

### **Height gages**

A height gage is a vertical scale attached to a precision base and used mainly on surface plates. It usually has a Vernier scale, but is now available with a digital readout as well. (By the way, just because a readout is digital, it doesn't mean it is more accurate. Know what the accuracy of digital readouts are before you put a lot of faith in them.) A removable "scribe" is attached to a slide that travels along a vertical scale. On better Vernier models the basic scale can be adjusted a small amount to zero different probes. Reading this scale has been previously discussed. The scribe is not pointed as we normally think of scribes. In most cases, the point is carbide and has only been ground from the top down. This allows the user to use the bottom surface of the scribe to measure heights. When these measurements are taken, either the part or gage should be moved to get the "feel" of how much

pressure is being applied at the point of contact. On very close tolerance dimensions, the scribe is replaced with a small finger type dial indicator. This allows you to "zero" the indicator on a known height, usually gage blocks. The reading of your height gage is taken at zero and has to be accounted for when your measurement is taken. The indicator should be set to zero with very little movement or pressure at the tip. The height gage should be used in a delicate fashion in this configuration, because a sudden jolt could move the indicator and give you a false reading. When in doubt, check it again.



*Simple calipers come in many shapes and sizes for measuring either inside or outside dimensions. These have no readouts and are designed to transfer dimensions from the part to the gage*

### **Dial, Vernier and digital calipers**

With calipers, you have a choice of dial, vernier, and digital. They are used for both lathe and mill work. The shape of a micrometer allows you to measure the diameter for which it was designed. On the other hand, measuring large diameters with calipers may be impossible because the jaws are not long enough. Calipers are a *must* for your tool box. They can read either inside or outside dimensions. Unless you are working in a very dirty environment, you will be making a choice between dial and digital calipers. Each has its own advantage. Dial calipers read directly as the slide is moved. There is a slight lag in digital calipers making them difficult to preset. Digital calipers can be reset to zero at any place on the slide, making the readings simple. They also read both metric and inch dimensions with the push of a button. On the other hand, I believe I can get more accurate readings with dial calipers because they have a better "feel".

### **Re-zeroing a dial caliper**

Dial calipers have more problems with small pieces of debris than any other type. They have a delicate



*When using dial calipers, make sure to clear all chips from the measuring surfaces. Here a part is checked for size as it is turned on the lathe. The part is held in a collet chuck which was machined to size to hold it.*

rack gear driving the dial gear and will skip a tooth if they get contaminated. This shows up when you close them completely and the dial doesn't read zero. When a dial caliper is purchased, a small, thin piece of shim stock shaped like the letter "b" is included with them to correct this problem. You purposely put this shim into the gear train and allow the dial gear to climb up on the shim, then move the shim and try to get the dial gear to drop into the proper tooth on the rack gear. It is easier to keep these tools clean so you will not have to waste time resetting them. The inside jaws can be checked by setting a micrometer to an amount and reading the gap with your calipers. You should get the same reading. If you don't, you will have to consider this error when measuring. This is also a good way to develop your skill reading calipers. Even if you are working with your own measuring tools you should always check the tool against a standard before working on an expensive part. This can be easily accomplished by checking the zero reading on calipers.



*Inside dimensions on large cylinders or between parallel surfaces are taken with telescoping gages. This set allows spacer rods of various lengths to be added to the micrometer head to measure distances of from 2 to 8 inches.*

### Inside micrometers

Inside micrometers are very seldom used by individuals and are usually only found in professional inspection rooms. Accurate readings can be taken with a device called "small hole gages" and "telescoping gages." They both offer a method of transposing a dimension to your micrometer that can then be read. You put these devices in the hole you are checking and expand them until they are touching both sides. On hole gages a tapered shaft expands a split ball. On the telescoping gage a compression spring expands the gage to the maximum allowed by the hole diameter. The telescoping gage can then be locked while the hole gage relies on friction to maintain its size. It is very important that you develop the "feel" using these tools. Rock the handle end to judge the amount of pressure the contact points are subjected to. If it clicks past center, the gage should be reset. When transcribing this setting to a micrometer, the same "feel" is important to get the reading the way it was obtained at the part. You should be able to measure hole diameters with less than .001" (.025mm) of error. Be careful of tapered parts and particularly with milled cavities. End mills deflect according to the way they are being used; that is, conventional



*On a depth micrometer the numbers read opposite a regular micrometer; that is, they get bigger as the barrel is screwed in.*

milling or climb milling, and it is possible to cut a “pocket” (square or rectangle shape cut into a flat surface) that is bigger at the bottom than the top. By dragging the gages up and down the measured surface, they can be checked for taper.

### **Depth micrometers**

Depth micrometers are handy, but to save money most home machinists will usually use the depth rod on calipers to get these dimensions. With calipers

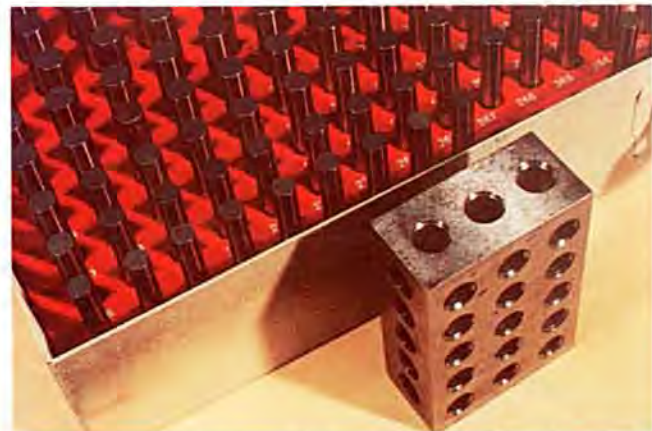


*The optical comparator in Sherline's measurement room determines dimensions that would be difficult or impossible using other methods.*

you should check the depth reading at zero on a smooth flat surface and compensate for any error. It is imperative that depth measuring instruments be held square to the surface when being used. Depth mikes are sold in sets that have interchangeable rods for each range of the micrometer. Each rod is adjustable, but they are usually set perfectly when they are purchased. They do not come with standards, so you will need to come up with a method to check them. Depth micrometers read backwards in comparison with a regular micrometer. The number gets bigger as the barrel is screwed in.

### **Optical comparators**

Comparators are optical devices and work by accurately making a shadow of the part and portraying it on a calibrated screen, usually ground glass. The slide movement can be measured, allowing the operator to measure the part. In many cases the part is too small to be measured with conventional measuring tools. You can also use them to check curves. On better comparators there are a variety of lenses to work with. These optics must be ground correctly to eliminate any distortion that would create errors. The operator must focus a comparator sharply for accurate readings. These devices are not usually found in the home workshop, but you should be aware that they exist.



*A selection of gage pins and gage blocks make measuring a specific dimension easier. In many cases you can make your own as you need them.*

### **Gage pins and gage blocks**

Gage pins and blocks are another way of checking fits and checking the gages you work with. Small holes can be very difficult to measure. The best way is to have a pin of a known size and see how it fits. This is an item that has a spot in all inspection rooms, although they are a little pricey for the home

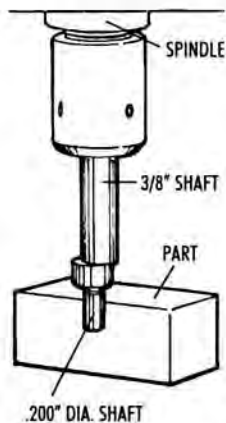
workshop. You can buy these gage pins in an amazing number of sizes. They are usually bought by the set. A set that could be useful to the miniature machinist would be one that goes to .250" (6mm) and will cost around \$100 (1998). A gage pin is included for each .001" starting at .050" (1mm). These pins are hardened and ground to precision.

Gage blocks are sometimes called "Jo blocks" after the person who invented them. They are sold in different grades and the "shop grade" should take care of the needs of a home machinist because they are amazingly accurate.

When working at home, don't think you need every device I have mentioned. Before you start a job you can make many of the gages you may need. It only takes a moment to turn and polish a diameter to size.

### Using an edge finder to locate the edge of a part

There are two quick methods of "picking up an edge" of a part on a mill. The first is to put a shaft of known diameter in the spindle and see that it runs perfectly true. Using a depth micrometer against the edge of the part, measure the distance to the outside diameter



Using an "edge finder" to accurately locate the edge of a part.



The Starrett 827A edge finder has a 3/8" shaft which will fit in a Sherline 3/8" end mill holder.

of the shaft. To that dimension add 1/2 the known shaft diameter. You now have the distance from the edge of the part to the centerline of the spindle. Rotate the handwheel on the axis being set exactly this distance and you will have the centerline of the spindle lined up with the edge of the part from which you measured.

The second method is much easier. It involves the use of a clever tool called an "edge finder". These labor saving devices have been around for years and have two lapped surfaces held together by a spring. One surface is on the end of a shaft which fits in a 3/8" end mill holder and is held in the spindle. The other is a .200" diameter shaft held to the larger shaft with a spring so it is free to slide around. With the spindle running at approximately 2000 RPM the shorter shaft will be running way off center. As this shaft is brought into contact with the edge you are trying to locate in relation to the spindle, the .200" shaft will be tapped to the center as the spindle rotates. This keeps making the .200" shaft run continually truer. When the shaft runs perfectly true it makes contact with the part 100% of the time. This creates a drag on the surface of the shaft that will "kick" it off center. At this point you know the part is exactly .100" (half the diameter) from the centerline of the spindle. Advancing the handwheel .100" (on a Sherline mill two revolutions at .050" per revolution) will bring the edge of the part into alignment with the spindle.

It is important to use a high quality edge finder such as the Starrett 827A shown in the previous column. It must have a 3/8" shaft to fit the end mill holder on the Sherline mill. Metric sized edge finders are also available which work in the same manner.

### The sine bar

The "sine bar" gage is worth mentioning. It was given this name because it uses the sine of an angle to determine how much the bar, or plate, has to be tipped up to represent that angle. (The sine of a number and other trigonometric values can be found in trig tables or determined with the push of a button on scientific calculators.) The sine of the angle is then multiplied by the length of the bar and this gives you the amount to raise the end. The base of a sine bar is two round bars that have their centers exactly spaced apart as stated. As one end is tipped up, the round bar rolls on the surface plate. The bar end you are placing the calculated amount under, usually with "jo blocks", will always rest at a point that keeps



*A sine bar uses the sine function from the trig tables and the length of the bar to accurately establish an angle for milling.*

the stated distance constant, because each end will roll the same amount. The length of the sine bar is actually the hypotenuse of a right triangle. This distance has to be very accurate because a thirty-second ( $1/120^\circ$ ) reading on a five-inch sine bar would be less than .001". They are used for accurately checking angles.

For example, suppose you had to measure an angle to degrees and minutes with a tolerance of plus or minus ten minutes of a degree. Seconds are very seldom used because a second is  $1/1,296,000$  of a revolution. This a very small amount and will never be called out exactly except by astronomers or surveyors. Using a five-inch sine bar, you look up the sine of the angle you need to set the bar to and multiply it times five. If you don't have a Jo block set you can machine a block to the right length and get it as accurate as you need. A set of sliding parallels could also be used. The plates on sine bars have holes drilled and tapped to clamp the work down with. It is imperative that the work is clamped down square with the sine bar. A second right angle plate is used to accomplish this. The angle can then be checked with dial test indicator mounted to a height gage. A zero runout would be a perfect angle.

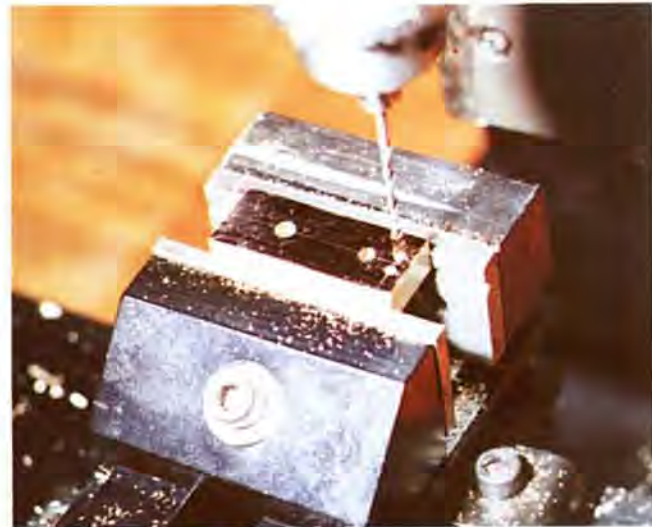
### **Working to scribed layout lines**

The most common practice when working with a mill is to lay out the hole centers and other key locations using a height gage and a surface plate. A coloring (usually deep blue) called layout fluid or

"Dykem" is brushed or sprayed on a clean surface of the part. A thin layer is best because it dries quicker and won't chip when a line is scribed. The purpose of this fluid is to highlight the scribed line.

Don't prick punch the scribed crossed lines representing a hole center. Using a center drill in the mill spindle and a magnifying glass, bring the headstock down until the center drill just barely touches the scribed cross. Examine the mark left with a magnifying glass and make any corrections needed to get it perfectly on center. The average person should be able to locate the spindle within .002" to .003" (.05mm to .075mm) of the center using this method.

Once the first hole is located in this manner, additional holes can be located using the handwheels. (This is where the optional resettable "zero" handwheels are handy.) Now the scribed marks are used as a double check and the handwheels take care of the accuracy. Don't forget to account for the backlash of the lead screw by always turning the handwheels in the same direction as you go from one point to the next. More on backlash can be found on page 258, and an example of laying out a simple hole pattern using trigonometry and your mill's handwheels is included on page 323.



*Machining to layout lines on your part is a good way to get close to your desired dimension. Final dimensions are achieved through keeping track of your handwheel inputs and double checking with accurate measurement tools.*



*A digital readout makes a machinist's life easier. Much like air conditioning on a car or a microwave oven in the kitchen, once you've gotten used to it you wonder how you ever got by without it. Now tabletop machinists using Sherline mills can benefit from the same hardware that has become so popular on full size mills by adding a D.R.O. to their mill. It reads out to three decimal places and resets to zero with the touch of a button. The readout also indicates spindle RPM at all times. Backlash can be compensated for to a half a thousandth of an inch. No more counting handwheel rotations. Just set the axes to zero and crank in the desired table position.*

## Chapter 8— Coolants and cutting oils

### Coolant in industrial applications

When you are working with machines as small as Sherline tools, calling the fluids “coolant” can be a bit misleading. In production machinery, these fluids are used to lubricate and cool the cutting process. The entire part will be flooded with coolant and it will be carrying heat and debris away. Notice that I mentioned *debris*. Chips can be made at a very rapid rate, and it takes a large volume of cutting fluid to control these chips. Most modern machines will use a ninety-five percent water based mixture for cutting metal. Water is still one of the best heat transfer materials on earth despite its ready availability and almost negligible cost.

### Water soluble coolants vs. oil type coolants

There are many types of water soluble coolants available for different materials. Water soluble oil will mix with water and was very popular until the new synthetic cutting oils came on the market. Soluble oil will go rancid if it lies still, especially in warm weather. If pure oil were used on a modern machine it would probably catch on fire. Oil type coolants are still used in machines that use the oil to lubricate both the machine and the cutting process. An “automatic screw machine” is a good example because of all the mechanisms that are exposed to the machining process. Now let’s take a look at the use of coolant in a home shop environment.



*In industrial applications, parts being cut are flooded with coolant to carry away heat and debris. In the home shop, cutting loads are lower, less heat is generated and fluids are used as a lubricant to keep material from sticking to the cutting tool. Flooding a part with coolant is messy and not necessary.*

### Coolant in the home shop

The purpose of “coolant” in the home shop is to keep material from sticking to the cutting tool. When material sticks to the tool, the flutes may clog up, generating heat from friction and stopping the cutting action. If you are determined to machine without coolant, you’ll be breaking cutters and ruining work. You really must use it to be successful, and any type of coolant is better than none. I usually use an oil type and apply it sparingly with a small acid brush. You don’t want to use an expensive brush for this operation because there is a good chance the brush may get a haircut if it gets caught by a cutter.

### Purchasing coolant in small amounts

Purchasing coolants in small amounts is a problem encountered by most home machinists. If you went to a good hardware store and asked for cutting oil, they would probably try to sell you thread-cutting oil. This type is available in small amounts, but it has a very high sulfur content and it is black. It’s dirty and smelly, but it does help produce a good thread on difficult-to-machine metals that “tear” in the cutting process. For machining, however, I would stay away from it like the plague. The next place you might try to purchase cutting oil would be an industrial supplier or a mail order company. They usually don’t sell small quantities\*, and they try to sell a mixture of ingredients that is normally used for tapping holes. The problem is that when working with small machines you often have your nose close to the machine, and the bad smell makes that a disagreeable prospect. I would even consider it a health hazard if you constantly worked with it. The easiest way out would be to buy five gallons of an oil type cutting fluid, the smallest amount sold, from a local oil company and you’ll have a lifetime supply for working with miniature machine tools. You might get some fellow machinists to split the purchase with you and you’ll all have plenty.

\*NOTE: Some industrial suppliers now offer cutting fluids in quantities as small as 1 gallon. Check with your favorite supplier. The higher unit price is well worth the savings compared to buying far more than you need.



*For home use, a small amount of lubricant applied with an inexpensive brush is sufficient. Avoid smelly, sulfur laden fluids like oils used for tapping threads.*

### Some precautions when using cutting oils

Cutting oils have a higher flash point than regular oils which reduces the chance of fire. Kerosene has been used with a mixture of oil and will give good finishes on aluminum, but I wouldn’t use it because of its smell and low flash point. Automobile oils are too “slippery” and smell too bad from detergents to work with. The surface finish will suffer from the use of these types of oil. To summarize, don’t flood the cutting surface on a miniature machine tool unless you want to make a big mess. Apply a small amount of cutting oil with a small, inexpensive brush and also brush the chips away with this same brush. Avoid smelly fluids. Wear eye protection to keep not only debris out your eyes, but also cutting fluids.

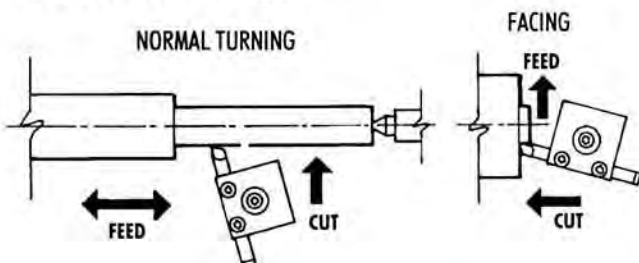
## Chapter 9— General machining terms

### General rules for cutting speeds, feed rates and depth of cut

Three terms frequently used in machining are “**speed**”, “**feed**” and “**depth of cut**”. Reference to the diagrams below will show what is meant by these terms. Normal turning on a lathe, when used to reduce the diameter of a work piece, involves advancing the cutting tool perpendicularly to the lathe bed by an appropriate amount (**depth of cut**) and feeding the tool along parallel to the lathe bed to remove material over the desired length. The diameter will be reduced by twice the depth of cut because the tool doesn’t cut just one side.

### “Cut” and “feed” on a lathe

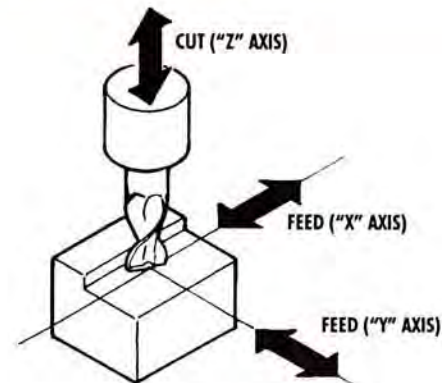
In normal machining on a Sherline lathe, the depth of **cut** can be directly set by the crossslide handwheel. Some lathes are manufactured with a dial on the crossslide that is calibrated to the actual “change in diameter”. This is common and is a good question to ask before using a different lathe. Sherline’s lathe has a crossslide that reads directly. This allows the crossslide to be used as a milling table and have the calibrated handwheels reading correctly. The **feed** is provided by the handwheel on the end of the bed. When facing off the end of a work piece held in a chuck or faceplate, the depth of **cut** is set by the handwheel on the end of the bed, and the **feed** is provided by the crossslide handwheel. If the work extends beyond the safe working limits, additional support may be needed. A center or steady rest should be considered.



*Lathe cutting terms*

### “Cut” and “feed” on a mill

When using a mill, **cut** is determined by the amount of depth the cutter is set to by the Z-axis handwheel. **Feed** is supplied by either or both the X- or Y-axis handwheels depending on the desired direction of the cut.



*Mill cutting terms*

### Effects of cutting rates on tool life

Speed, feed and depth of cut all have an effect on tool life. Speed is the rate the cutting tool is moving in relation to the material being cut. Speed has the greatest effect on tool life of any of the three variables mentioned, which is why it is mentioned so many times in this book. I don’t want you to ruin perfectly good cutting tools by breaking these simple rules. For example, a 1/4" diameter drill cutting stainless steel should have a correct cutting speed of 800 RPM. This is a speed that can easily be exceeded on all but the largest lathes. The Sherline lathe and mill are capable of 2800 RPM and at half that speed, the drill could be ruined. The largest diameter of the stock to be turned should be considered when determining the cutting speed on a lathe. With Sherline tools it is so easy to adjust the RPM that it would be beneficial to adjust the speed to the diameter you are working on.

Turning CNC machines will automatically adjust their spindle speed as the diameter is decreased, saving those valuable seconds. Remember also that the main difference between a lathe and a mill is that on a lathe the work turns, while on a mill the tool turns.

### Cutting speed vs. type of tool and material being cut

When considering cutting speeds, only the difference in speed between the tool and work should be considered. However, the type of tool that is being used may dictate a different cutting speed. Different tool shapes will have cutting speeds that not only consider the type of material being machined and the material the tool is made out of, but also consider

the chip “flow”. Drills are a good example of this. A drill, deep in a hole, can’t get rid of chips the same way a lathe tool can. Basic cutting speed charts for materials represent lathe tools. Drills and similar tools have a much lower cutting speed. A home machinist must work with speeds that are well below the calculated speeds because it is quicker in the long run. It isn’t worth the effort to calculate the exact rpm of a machine that is going to make one or two cuts, but it is time well spent if thousands of similar parts are to be made. A portion of a chart showing these differences is provided below. *Machinery’s Handbook* will provide tables in greater detail should you need more information.

#### GUIDE TO APPROXIMATE LATHE TURNING SPEEDS

MATERIAL	Cut Speed	1/4" (6mm)	1/2" (13mm)	1" (25mm)
	S.F.M.	Diameter	Diameter	Diameter
Stainless, 303	67	1000 RPM	500 RPM	250 RPM
Stainless, 304	50	800	400	200
Stainless, 316	47	700	350	175
Steel, 12L14	174	2600	1300	650
Steel, 1018	87	1300	650	300
Steel, 4130	82	1250	650	300
Gray Cast Iron	57	900	450	220
Aluminum, 7075	400	2800	2800	1400
Aluminum, 6061	375	2800	2800	1400
Aluminum, 2024	268	2800	2000	1000
Brass	400	2800	2800	1400

#### Cutting speed

Proper cutting speed is the rate a particular material can be machined without damaging the cutting edge of the tool that is machining it. It is based on the surface speed of the material in relationship to the cutter. This speed is a function of both the RPM of the spindle as well as the diameter of the part or size of the cutter, because, as the part diameter or cutter size increases, the surface moves a greater distance in a single rotation. If you exceed this ideal speed, you can damage the cutting tool. In the lathe and mill instructions we give some examples of suggested cutting speeds, but what I wanted to get across here is that the damage doesn’t occur slowly. It isn’t a case of getting only one hour of use instead of two. A tool can be destroyed in just a few seconds. The cutting edge actually melts. If you machine tough materials like stainless steel, you will ruin more tools than you care to buy if you don’t pay a lot of attention to cutting speeds.



*With big machines in a production environment, time is money, so feed rates and cutting speeds are critical. Saving time and making parts fast is not as big a factor for the home machinist.*

#### Calculating spindle speed for cutting

To calculate the RPM’s of a cutter or work piece, you first must know the cutting speed of the material that is being machined and the material from which the cutter is made. High speed steel will be our standard tool material, and cutters that use carbide tips will be considered separately. You could fill a library with all the books written on speeds and feeds, and the reason is simple. Time is money, and when parts are being manufactured in large quantities, you have to use the most efficient method to machine a part. The few seconds of time that is saved on each part will be multiplied by the total number of parts manufactured, giving the total time saved. As an example, a part might be produced for the automobile industry at a rate of three million parts per year. A clever machinist comes up with a way to save three seconds per part. This will save around 2500 hours, which would probably be worth over \$100,000 to the company. The corporation would probably award the machinist with a “thank you” and a check for around \$300 and the managers would take all the credit for the increased profits. (I guess I’ve been reading “Dilbert” comic strips for too long.) With this kind of money at stake, you must get it right, which is why books go into such detail on speeds and feeds. Home shop machinists, however, need not clutter their minds with a bunch of complicated tables. Since production speed is not usually a factor in home shop work, knowing a few simple rules and speeds will keep you out of trouble.

If you work in the inch system, there is an easy way to calculate the spindle speed. Multiply the material's recommended cutting speed (given in feet per minute) times four. Then divide the answer by the diameter of the work (lathe) or cutter (mill) given in inches. This will give you an approximate answer that is more than accurate enough to use while working on Sherline or similar miniature machine tools. Here is the formula:

$$\frac{CS \times 4}{D} = RPM$$

**CS** = Cutting Speed of the material from your table in SFM (Surface Feet per Minute)

**4** = feet-to-inches conversion factor (12) divided by  $\pi$  (3.14159) = 3.82 which is rounded off to 4

**D** = Diameter of part (lathe) or cutter (mill) in inches

**RPM** = Spindle speed

By rounding off the conversion factor, it makes this formula easy enough to do in your head in most cases, yet it is still accurate enough.

Example: On a mill, what RPM should a 3/8" (.375") diameter high speed steel cutter turn if it is to have a 100 fpm cutting speed?

$$\frac{100 \times 4}{.375} \text{ (or } \frac{100 \times 4}{3/8} = \frac{100 \times 4 \times 8}{3} \text{ )} = 1067 \text{ RPM}$$

If the metric system is used, the cutting speed will be given in meters per minute and the diameter will be given in millimeters. The same problem would be worked out as shown below using 3.14 to equal the value for  $\pi$ .

$$\frac{30.39 \times 1000}{3.14 \times 9.5} = \text{RPM or } \frac{30,390}{29.83} = 1019 \text{ RPM}$$

(1000 = the conversion from meters to millimeters in which the diameter is given.)

#### A factor for the shape of the cutting tool

There is one more factor to consider when estimating spindle speeds (RPM). Cutting speeds are given for a lathe tool unless otherwise stated. This is the most optimistic number given for cutting speeds and must be modified for other types of cutters, as using them at the suggested speeds will shorten their cutting life. Multiply the calculated spindle speed by the following factors for the following types of tools:

- End mills = .9
- Reamers = .6
- Drills = .7
- Taps = .25

Example: Since the cutter in the example above is a mill, the speed would be multiplied by .9 to give a final speed of 960 RPM (inch) or 917 RPM (metric). If the speed in the example above were for a drill, you would multiply the answer by the factor .7 which would lower the spindle RPM to 747 (inch) or 713 (metric). The factor listed for taps is, of course, only for automatic machines or for use with a tapping head, as you could never hand tap that fast.

END MILLS (Slot and side milling)				
MATERIAL	CUT SPEED (S.F.M.)	1/8" DIA.	1/4" DIA.	3/8" DIA.
Stainless Steel, 303	40	1200 RPM	600 RPM	400 RPM
Stainless Steel, 304	36	1100	500	350
Stainless Steel, 316	30	900	450	300
Steel, 12L14	67	2000	1000	650
Steel, 1018	34	1000	500	350
Steel, 4130	27	800	400	250
Gray Cast Iron	34	1000	500	350
Aluminum, 7075	300	2800	2500	2000
Aluminum, 6061	280	2800	2500	2000
Aluminum, 2024	200	2800	2500	2000
Aluminum, Cast	134	2800	2000	1300
Brass	400	2800	2800	2800

DRILLS			
MATERIAL	CUT SPEED (S.F.M.)	1/16" DIA.	1/4" DIA.
Carbon Steel	36	2000 RPM	550 RPM
Cast Iron, Soft	30	1800	450
Stainless Steel	24	1400	360
Copper	72	2000	1100
Aluminum, Bar	240	2000	2000
Aluminum, Cast	120	2000	2000

Here is a chart showing some approximate cutting speeds for end mills and drills in selected materials.

#### Feed Rates

When operating manual tools, often the operator may not be able to move the handwheels fast enough to accomplish ideal feed rates. It is a better choice to slow down the spindle speed rather than taking feed cuts that are so fine they will work harden the surface, dull the cutter or induce tool "chatter".

Other than speed, feed rate is the other great force that has an effect on tool life. Although feed is described in many ways, it is always describing the amount of material that is removed by each cutting edge per revolution of the spindle. Many times you will find it described as inches per minute (or mm/min.). With the information we now have, it is easy to calculate a single tooth's feed rate. Feed rate controls deflection by either the tool or work and turns into a load that has a very dramatic effect on accuracy. It is impossible to consistently work accurately with tools that are deflecting, and the amount they deflect is dependent on both the depth of cut and the feed rate. (See "End Mills" on page 81 in Chapter 6 of this section.)



The color screen attached to this large computer controlled shop lathe shows a tremendous amount of information about the cuts being made. The tool shape is shown in red, the cut in magenta and the part outline in blue. A real time on-screen sequence shows the tools being changed and the shape of the part as it is cut.

#### Computers in the modern machine shop

New CNC machines can be programmed to feed a given amount per revolution. Mechanical milling machines which control their feed rates with gears have the feed rate given in inches per minute. Today's professional machinists no longer must compromise their feed and speed rates by working with a few sets of gears. Their choices are unlimited. Each cut has its own ideal feed and speed. Sometimes a change of only a couple of percentage points will get rid of a harmonic vibration that is giving you fits. This can be noticed when working with manual machines as the speed or feed is changed. In the old days a machinist would be changing gears on automatic machines until they found the best compromise. Now they simply edit the computer program. Changing gears on automatic machines could be a miserable job because of their location. In the age of the computer, a machinist is now in charge of the computers that are in charge of the machines. Often these computers are many times more sophisticated than the business computers in the front office.

#### What about your machine shop?

On a manual machine the speed and feed is being controlled by the best computer in the world...your brain. If you use it, that is. When a cut is being taken on a manual machine, I prefer a depth of cut that is

light enough to allow fairly rapid feed rates. The depth of a cut has the least effect on tool life, but the most effect on tool loads. This can really become a problem when machining parts that can't always be clamped in fixtures designed for the job. You must work with what you have, and you don't need as much if fast, light cuts are taken. A part will seldom be ruined by taking too light a cut. The deeper the cut, the more successful machining will be dependent on a liberal amount of coolant.

#### The most important rule in machining

Before attempting to machine any metal, please try to remember this simple rule:

***"If the tool chatters, decrease speed and increase feed."***

Understanding this simple rule can save you many hours of grief. When the tool "chatters", it is not cutting in a continuous fashion. Metal likes to be machined in a way that allows the material to come off in a continuous strip while the tool is in contact with the metal. (See photo on page 137.) If the tool is not fed at a rate that is fast enough, the tool skips along the surface, occasionally digging in. The surface of the tool that is doing the most cutting will find a frequency of vibration that is a product of all the variables involved. This can cause anything



Chatter marks at the right hand end of this hydraulic scale piston indicate that an adjustment is needed in the speed and feed rate. Chatter means the tool is bouncing and cutting intermittently rather than peeling off material in one continuous sheet as it should be. The area to the left of the chatter marks shows the finish after the spindle speed was reduced.

from a high pitched whine on light, high speed cuts to a resonating racket that can rip the work out of the chuck on heavy cuts.

Just to see what would be a comfortable cut in several common materials, I experimented a bit and came up with some figures using a Sherline mill. For a list of sample cuts see page 191 in the section on using the mill. A chart on page 135 gives some sample lathe turning speeds for various materials and diameters.

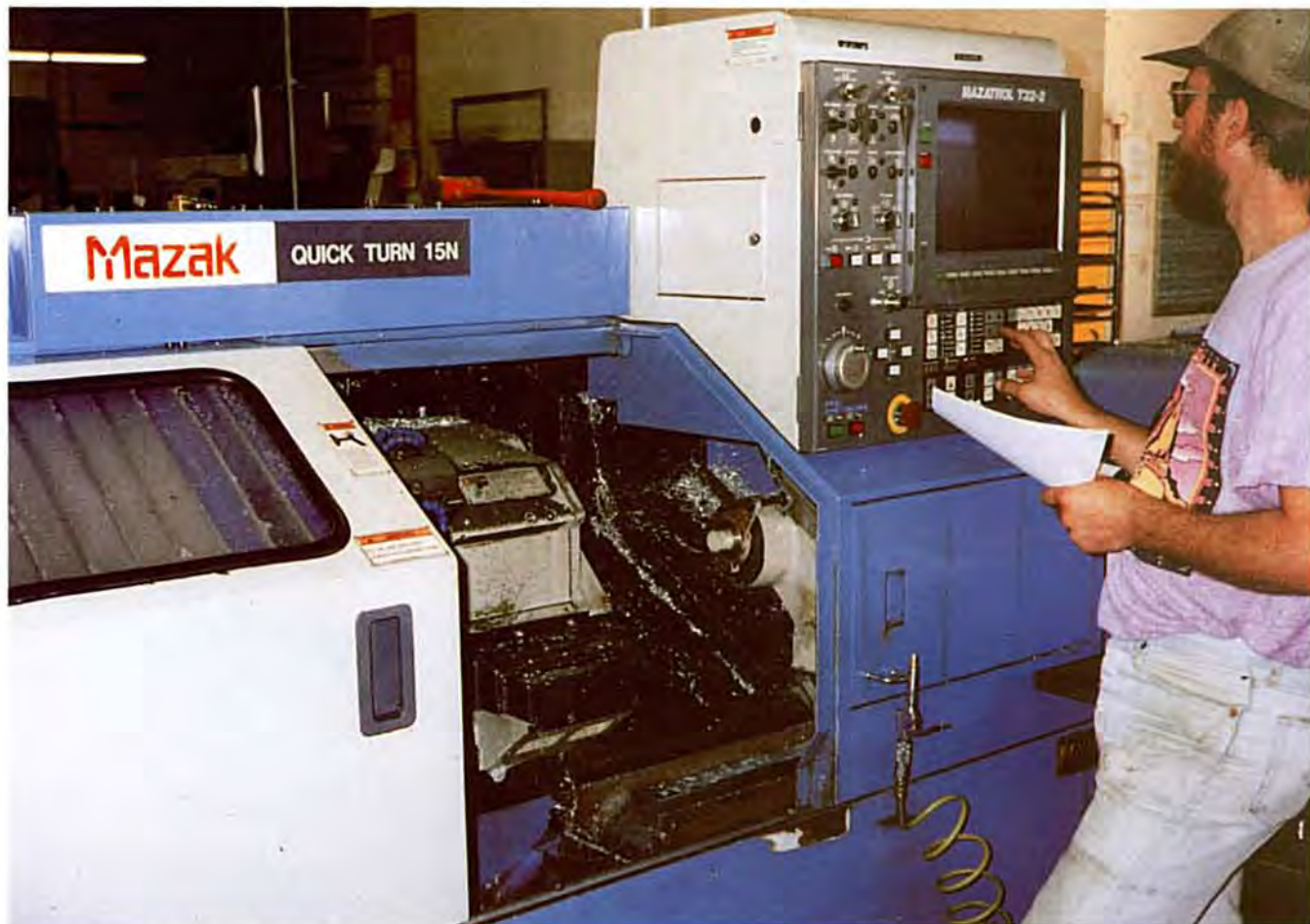
#### **How decreasing speed automatically increases feed**

If you maintain the same feed rate and reduce the RPM, the feed will *increase* because the chip will be thicker. If at first that sounds wrong, think of it this way: At the same feed rate, if you cut the RPM

in half, twice as much metal must be removed with each rotation of the tool or part to get to the end of the cut in the same amount of time. The chip is twice as thick, so the feed is *greater* at lower RPM if the feed RATE stays constant.

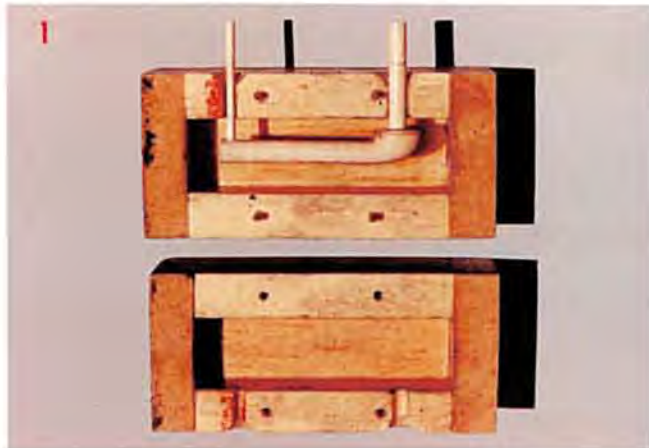
#### **A chattering tool gets dull faster**

A chattering tool will also get dull faster because the cutting edge will chip. Many times the chips may be microscopic, but they are there. This happens because the cutting edge must keep cutting through the previously machined surface which has become "work hardened". As you can imagine, there are limits to how much you can increase the feed rate, so the answer lies in adjusting both speed and feed to achieve the proper cut.



*"They don't make them like they used to," and in this case, that's good. CNC machines like this one that make parts both quickly and to very close tolerances are a big factor in how Sherline tools and other products can be made continually better while maintaining a low price.*

# Modeling tricks of the trade from Phil Mattson



## Making a hollow ship's ventilation funnel

In modeling, if you have to make one of something you might make it one way, but when you have to duplicate a number of parts, a semiproduction process is needed. Here is a clever method master modelmaker Phil Mattson came up with to make a number of ship's funnels for the *Pacific Star*.

1. A wooden model of the *inside* size of the funnel is carved from wood. A box and sprues are made to create a mold of the part.

2. The mold is filled with Redi-Mold™ material. Once hardened, the mold is opened and the wooden shape removed, leaving a cavity.

3. Cerro-Bend™ is a metallic material that melts at around the boiling point of water. It is melted on a stove and poured into the mold.

4. The mold is opened, the Cerro-Bend funnel is removed, the sprues are cut off and the shape is filed and sanded to a good finish.

5. The Cerro-Bend funnel is wired for electro-plating with copper. The copper electrode is also shown.

6. The part is plated using current from a battery charger until a coating about .015" thick is built up.

7. (Left) The coated Cerro-Bend funnels. (Right) The plating is removed from the top opening of the funnel. The funnels are reheated and the Cerro-Bend melts and flows out, leaving just the copper shell. The opening is hand finished.

8. The parts are painted and installed on the model.



## Chapter 10— Lubrication and maintenance

### Cleanliness is one of the keys to accuracy

In order to perform with consistent accuracy, all machine tools, regardless of size, must be kept clean, lubricated and adjusted. Complaints about the lack of accuracy of a machine can often be traced to a stray metal chip under a part, a dinged up thread or dent in a mating surface. Before threading a chuck or end mill holder onto a spindle, both the male and female threads as well as the seating surfaces must be free from dings and chips. Accuracy of collets or the seating of a tapered center or arbor can also be affected by chips. Keep your tools and work surface clean by brushing off chips often and sweeping or vacuuming them up.

### Lubrication

Keeping all the moving parts of your machines and accessories lubricated will not only make them easier to operate, it will also extend their life. Here are some of the main surfaces that need lubricating and some suggested lubricants to keep them in top condition:

**MACHINE SLIDES**—Use a light oil such as sewing machine oil on all points where there is sliding contact. This should be done immediately after each cleanup. At the factory, the slides are greased to ensure the lubrication stays in place during shipping, but light oil will work fine once you begin using the machine.

**LEADSCREWS**—Sewing machine oil should be placed along all the threads regularly. At the same time, check that the threads are free from any metal chips. Use a brush to keep them clean.

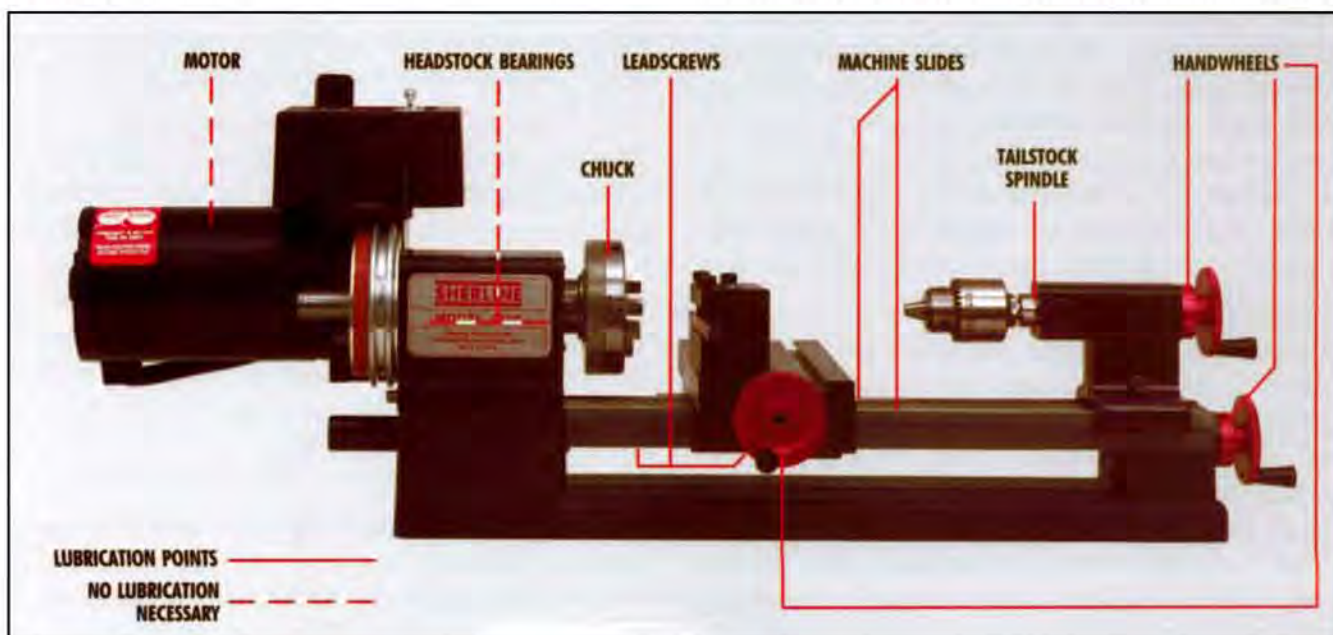
**TAILSTOCK SPINDLE**—Wind out the spindle as far as it will go, wipe it off and lightly oil it with sewing machine oil.

**HANDWHEELS**—A few drops of light oil behind the handwheel will reduce friction between surfaces and make operation easier and smoother.

**HEADSTOCK BEARINGS**—The bearings on Sherline machines are lubricated at the factory for the lifetime of the machine and should not need further lubrication. DO NOT break the seals.

**MOTOR**—Sherline machines use sealed ball bearings which require no maintenance.

**CHUCKS**—On self centering chucks you should clean and lubricate the jaws each time they are removed and reversed. Make sure they are clean and free of chips before they are reinserted back into the scroll. Independent jaw chucks like the 4-jaw should also be checked often to make sure there are no chips on the threads or working surfaces and that the threads are lubricated with light oil. Check also that the spindle threads and seating surface on the back of the chuck is clean before installing it on the spindle. Chucks may be wiped down with light oil or sprayed



with a spray lubricant/preservative when put away to keep them from rusting.

### General precautions when using miniature machine tools

- WEAR EYE PROTECTION AT ALL TIMES!
- If you haven't already done so, read the safety rules for power tools at the beginning of this book.
- **Do not attempt to use the lathe or mill without first securing them to a mounting board** or directly to your bench. The mounting board keeps them from tipping and allows the machines to be easily moved and stored. Rubber feet on the bottom of the board reduce noise and vibration that occur when the machine is mounted directly to a bench.
- **DON'T OVERTIGHTEN!** One of the biggest problems in designing and manufacturing small metal cutting tools is the fact that the operator can physically be stronger than the machine. This is not normally the case with big machines. For example, a 10-pound force applied a couple of inches out on a hex key becomes a 650-pound force at the tip of the screw. If you tighten both screws on the tool post this tight, it becomes approximately 1300 pounds of force on relatively small parts. Tools or parts can become distorted and accuracy is lost. Overtightening hold-down screws and T-nuts in their slots can distort the crossslide or mill table. It is not necessary to overtighten parts and tools because loads are smaller on equipment of this size. Save your equipment and extend its life by not overtightening and by taking lighter cuts.
- **Don't overstress the motor.** It is important to remember that you can overload the motor on a small lathe or mill. The many variables involved in machining, such as hardness of material, size of cutter, shape of cutter and diameter of stock all affect the load on the motor. Follow the suggested speed charts, and if the motor sounds overloaded, take smaller cuts. Most importantly of all, just use COMMON SENSE!

The motors on Sherline machines are thermally protected. That means they have a built-in circuit breaker that will shut down the motor if it gets too hot. This keeps the motor from burning out. The breaker will automatically reset as soon as the motor cools and you can go back to cutting. If the motor does shut down, immediately shut off the power switch and back your tool out of the work. The circuit breaker should reset in about 10 seconds.

Then turn the machine back on and resume cutting using a lighter load. If your motor is overheating on a regular basis, it means you are taking too heavy a cut or operating at too high an RPM for long periods. Slow your speed down, reduce your cut or feed rate and you should have no further problems.

Due to the nature of miniature machining, overloading the machine is a common problem. It is often tempting to try to speed up the process by working faster. Keep in mind this is a small machine and work with patience and precision. Don't be in a hurry. Your parts will come out better and your machine will last much longer.

- **Regularly Check the tightness of bolts and screws.** Vibration from operation can cause fasteners to loosen up. Also check all fittings on a new machine before using it to make sure nothing has loosened up during shipping.



*Here is a beautiful oak and plexiglass storage unit and work surface that was custom made many years ago. It includes drawers for storage of accessories.*

### Storing your machines and accessories

Your machine should be cleaned and lubricated before it is put away. It should be kept covered to keep dust and grit off the working parts. Sherline sells fitted vinyl covers for each machine which look and work great, but any type of cover will extend the life of your machine. Accessories can be kept in their original boxes or wrapped in cloth. They should not be allowed to bang around against each other in a drawer. This can cause them to collect dirt and dents which will adversely affect their accuracy.

You can bet Rembrandt took good care of his paint brushes. Miniature machine tools are also capable of producing beautiful results when maintained properly. If you expect to produce a masterpiece or

just good, accurate parts, take care of your tools and they won't let you down.

### **Transporting and carrying your machines**

Never pick up a machine by its motor. The motor on the lathe seems a particularly handy place to grab it to pick it up, but it is mounted to the headstock with a diecast part that ends up supporting all the weight of the machine...a task it was not designed for. To carry or move a machine, it is best to have it mounted to a base. Pick it up by the base rather than by the machine itself.

Several people have gone so far as to mount a brass carrying handle to each end of the machine's base board. This is an excellent idea, particularly if you cannot leave it permanently set up and must store it each time you are done with it. The handles will give you a better grip and assure the machine doesn't get dropped.



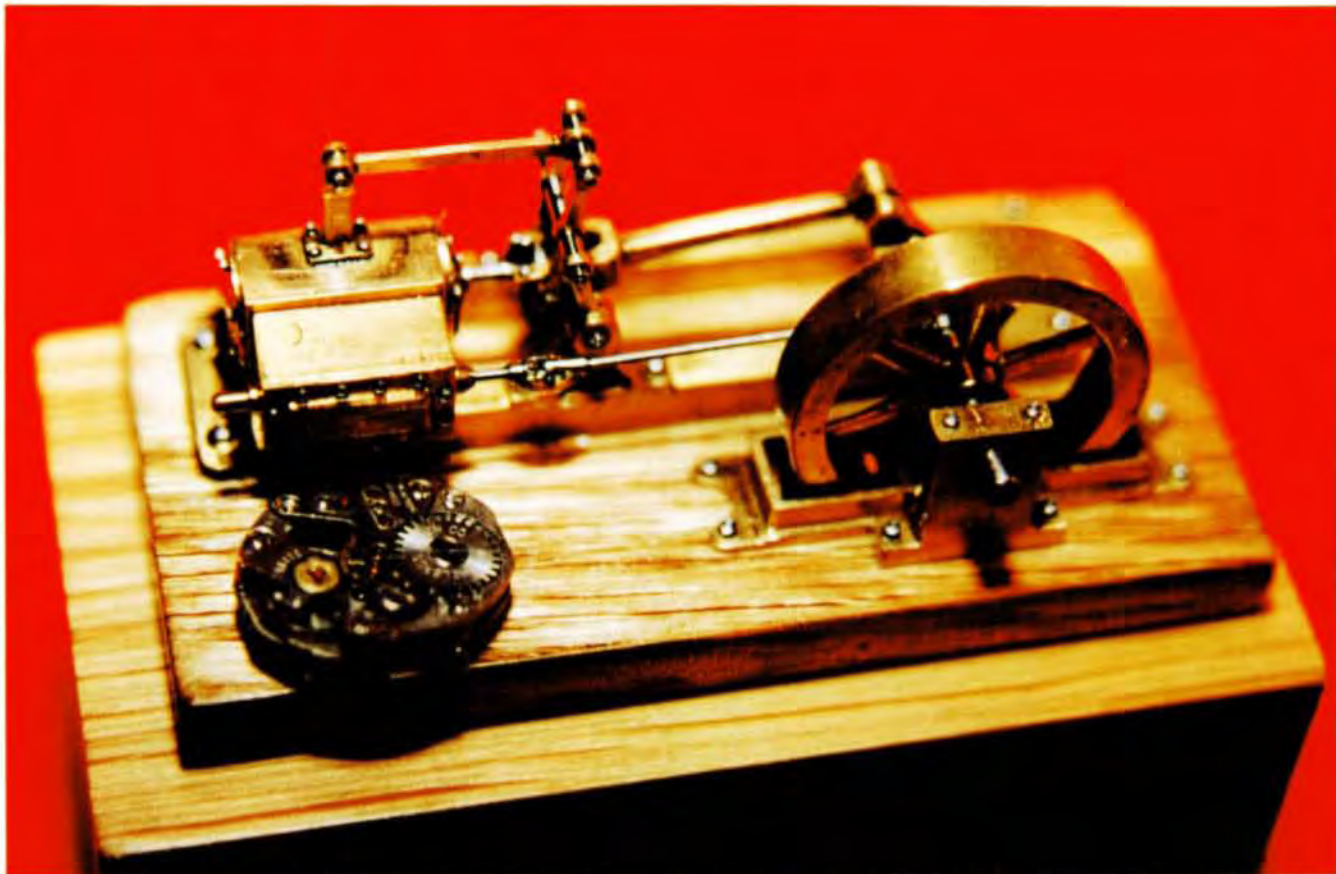
*Parts are loaded on all four sides of one pallet as another batch of parts is being cut inside this CNC machining center. Though the stakes are higher and the sizes are bigger on a machine like this, good maintenance is required for machines of any size to produce good parts.*

---

*“When I am working on a problem, I never think about beauty. I think only how to solve the problem. But when I have finished, if the solution is not beautiful, I know it is wrong.”*

—Buckminster Fuller

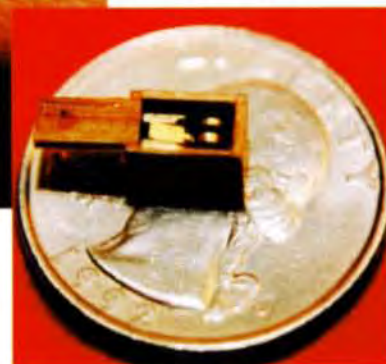
---



*This "grasshopper" crosshead steam engine was built by Jerry Kieffer. It is a 1/5 scale model of another model of the engine by Roy Ozouf, a well known modeler. One of Jerry's favorite challenges is taking something that is already small and making it even smaller. A ladies wristwatch provides size scale.*



*To carry the engine, Jerry made a tiny oak finger jointed box with sliding lid. Jerry displays it at shows by setting it atop a pencil eraser to provide scale.*



*Even Jerry Kieffer admits that he is "pushing his limits" with this tiny oscillating steam engine. It has two flywheels .085" in diameter. The bore is .029" and the stroke is .032" The intake and exhaust ports are .008" and the whole engine weighs 3.5 grains ( $1/131$  oz.)*

## SECTION 2—LATHE OPERATIONS

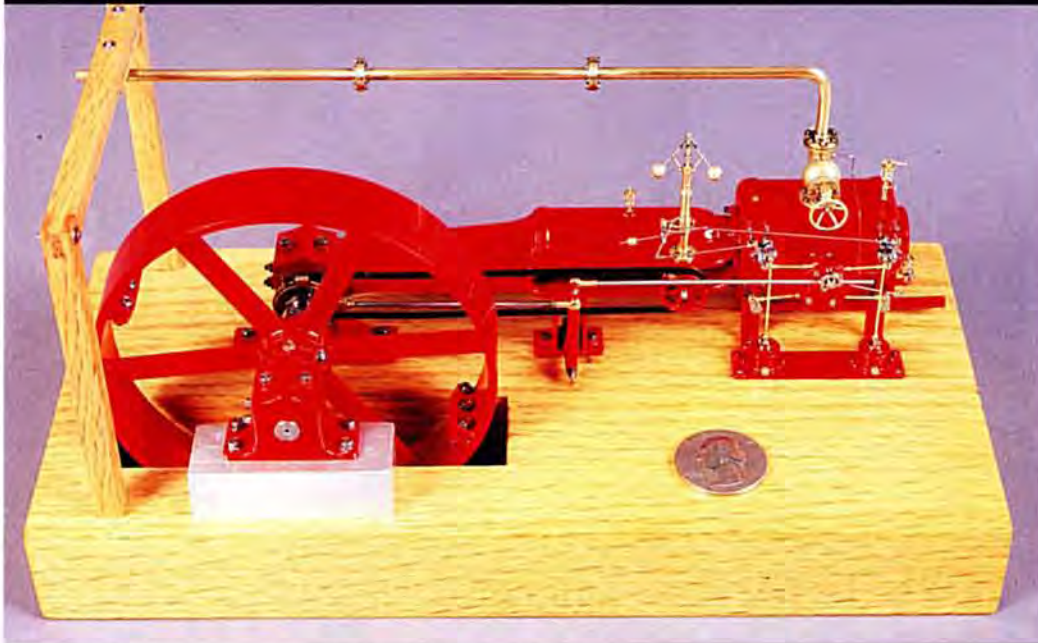
Craftsman Profile—Jerry Kieffer . . . . .	112
1. Lathe workholding . . . . .	115
2. Lathe operating instructions . . . . .	121
3. Tailstock tools and operations . . . . .	141
4. Riser blocks . . . . .	145
5. Supporting long or thin work . . . . .	149
6. Getting started in thread cutting . . . . .	157
7. Knurled finishes . . . . .	167
8. Watch and clock making tools . . . . .	171
9. Milling operations on a lathe . . . . .	177



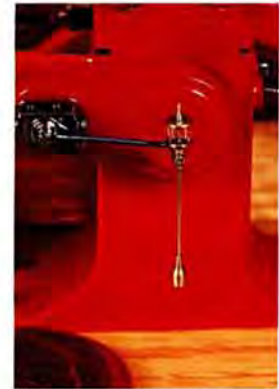
*Under the glass watch crystal is a 1/30 scale, 1/4-20 threaded hex bolt and nut along with a machined wrench to fit it. Next to it is a full size 1/4-20 bolt and nut for comparison. To learn more about a man who takes miniature craftsmanship to extremely small scale read the following profile on Jerry Kieffer.*

## JERRY KIEFFER...Craftsmanship to the smallest detail

Project: 1/30 Scale Corliss steam engine



(Left) Jerry's Corliss steam engine is done in 1/30th scale...down to the smallest 1/4-20 bolt! It runs as well as it looks.



(Above) This "banjo oiler" is typical of the model's detail.

Jerry Kieffer is not a professional machinist. He is a marketing representative for a utility company in Wisconsin. In fact, less than 10 years ago he had just about no experience with miniature machine tools at all. But he is an excellent craftsman who is good with any kind of tool and loves to make very small projects, so getting his hands on precision miniature machine tools opened up a whole new world of enjoyment for him.

His interests are wide ranging...from repairing watches and guns to making miniature engines and tools. Jerry delights in making incredibly small parts. Some of them can only be appreciated through a magnifying glass. If a friend makes a steam engine in the smallest scale possible, Jerry will make a half size model of his friend's model! He spends several hours each evening in his shop and the amount and quality of the work he has produced is truly amazing, especially when you consider the level of perfection to which it is done.

When Joe began making Sherline tools, Jerry is exactly the customer he had in mind. He uses inexpensive but accurate tools to make projects of great detail and beauty. For anyone who asks, "are tabletop machine tools accurate enough for what I want to do?", we simply pull out pictures of Jerry's work. Nothing more needs to be said.

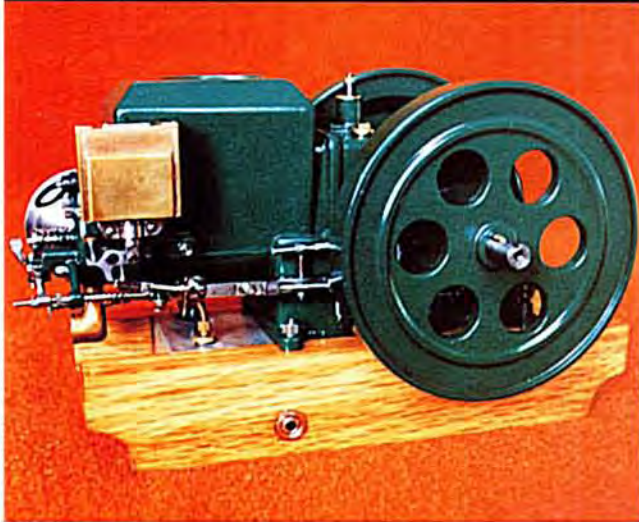


Jerry's shop is neat and simple. The magnifying loop on his glasses is necessary for working on and fitting the minuscule parts he enjoys making.



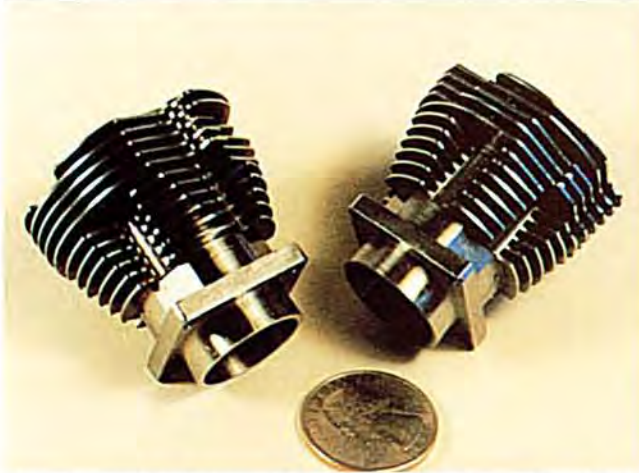
A "monkey wrench" in 1/7 scale.

### Project: Stover CT 2 Hit 'n Miss Engine



*This running Stover "hit 'n miss" engine is built in 1/6 scale and has a 1/2" cylinder bore. Though it may not look it, Jerry says this is one of the most difficult projects he has completed to date.*

### Project: Harley Davidson Cylinders



*Anyone who knows Harleys will recognize these right away. These cylinders for a 1/6 scale 1947 Harley Davidson "knucklehead" motorcycle were built to test the feasibility of a project to build a complete scale motorcycle that will not only run, but will "sound like a Harley" when it does. Jerry also plans to build a "repeater watch" from scratch. His goals are as big as his parts are small, although I don't have the slightest doubt that if he decides to take on a challenge, he will find a way to do it.*

### Project: Miniature Spark Plugs



*These working spark plugs are from top to bottom: a 1/4 scale Renz 775 spark intensifier plug, a 1/6 scale Champion "33" plug and a 1/4 scale Champion primer plug.*

### Project: Miniature nut and bolt



*This is the one that really blows people away! The hex bolt has a .010" shaft. The threads are 354 T.P.I. and .0005" deep. A hex nut is threaded onto it. Next to the bolt is a wrench with milled contours. Compare the bolt to the screw heads in the lady's wristwatch to the right which are the smallest fasteners commercially available. Jerry says making the nuts and bolts is easy once you have the taps and dies...it was figuring out how to make the taps and dies that was the hard part.*

## A Flying Pendulum Clock by Jerry Kieffer



This is a variation of the “Ignatz” clock. It is called a “flying pendulum” clock because the ball on the string wraps around first one post and then swings a pivot 180° to wrap the string around the other post, then back again. It is powered by a key-wound main spring. Although this type of clock doesn’t keep very good time (accurate to within about 10 minutes a day), it is fun to display because people are always fascinated by its unique movement.

As a future project I would like to produce a kit with plans and materials so that others can make this clock. It will include a video showing Jerry Kieffer building it so you can see not only the steps involved, but also how a superb craftsman plans and executes a job.



*Mainspring, barrel, key and components of the winding mechanism.*

PHOTO: JERRY KIEFFER

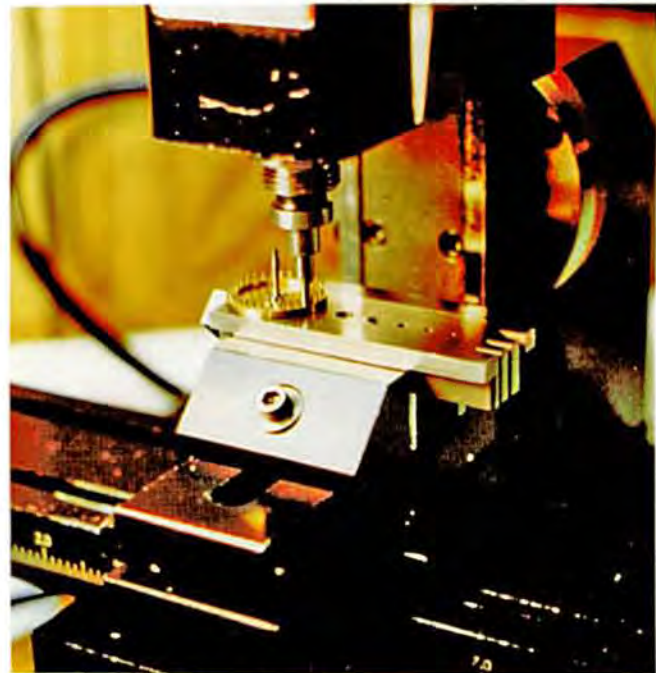


*Glass or plastic domes are a good way to protect your project. This is a traditional way to display clocks where the works are to be exposed.*



*Jerry made this nicely displayed set of staking tools to make it easier to press shafts and pins into gears.*

PHOTO: JERRY KIEFFER



*This is one of Jerry’s setups using the mill and one of his special staking tools to press-fit the pins which act as gear teeth on the third pinion gear.*

# Chapter 1 — Lathe workholding

## CHUCKS

For holding work on a lathe you have the obvious choice of using a 3-jaw or 4-jaw chuck. Sherline also offers a self-centering 4-jaw chuck and an assortment of collets. There is a safe limit to how much these chucks can be tightened without damaging them. If the “tommy bars” are being bent while tightening a chuck and the work is still coming loose you have a problem that can't be solved by tightening the chuck to its breaking point. A 3-jaw chuck is really designed to hold only round work. It has the advantage of being able to clamp material that is not perfectly round with the principle being the same as a three legged stool. Remember, if the stock isn't perfectly round it would be impossible to have it turn perfectly true. The method

you use to clamp a part in a chuck can have a profound effect on how true it runs.

### Clamping up work in the chuck

With any clamping device, you should spin the work with your fingers as it is tightened. The part should feel as though it is being held securely before the final tightening is done. Don't insert the work into the chuck until the jaws have been adjusted to their approximate position. This keeps the work, or tool in the case of a drill bit, from getting caught between two of the three jaws. This is especially true for the expensive chucks that have the jaws rotate as they are tightened. I don't like them because of this fact, and the extra cost to have a chuck run .001" or .002" truer just doesn't seem like a good investment for the home machinist.



*3-jaw, 4-jaw and tailstock chucks of various sizes for use on Sherline tools or any tool with a 3/4-16 spindle nose thread. Other threads are available to allow the chucks to be used on some Unimat, Sears and Cowells lathes. Arbors are also available to adapt them for use on watchmakers lathes. The 2.5" 3-jaw chuck in the middle of the bottom row is shown with its jaws reversed for holding larger work.*

### Factors affecting chuck "runout"

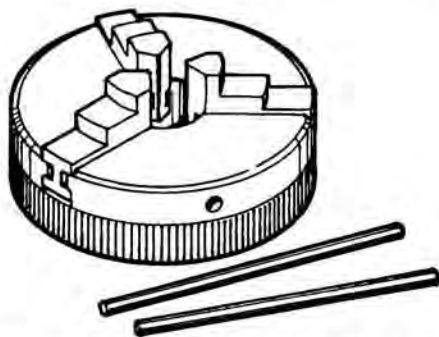
The chuck should run within .003 T.I.R. (Total Indicated Runout). This is the amount of variation an indicator would read if the work were rotated with the spindle. Getting a chuck to run perfectly true is difficult to accomplish because so many things come into play. The threads have to be true and clean along with the shoulder against which the chuck seats. If a part is accidentally ripped out of the chuck during machining both the spindle and the chuck can be damaged.

### The design of Sherline 3- and 4-jaw chucks

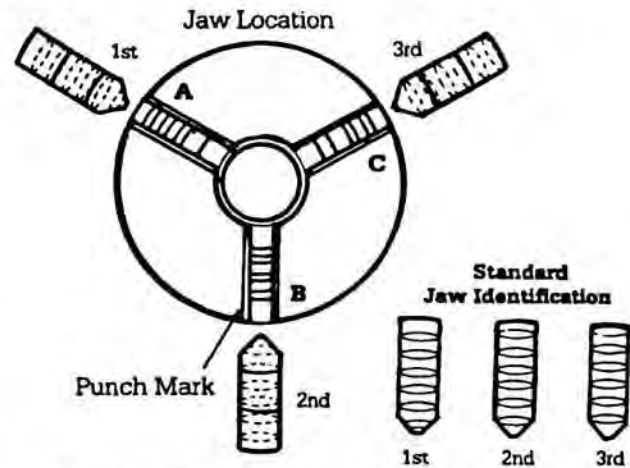
The 3-jaw self centering chuck is the most popular of all the accessories available for the Sherline lathe. It is available in both 2.5" diameter and 3.1" diameter. These chucks will grip round or hexagonal work quickly since the jaws move simultaneously to automatically center the work being held. The jaws on the chuck are designed so that the same chuck can be used for both internal and external gripping. Jaws are reversible for holding larger diameter work. Due to the nature of the design of a 3-jaw chuck, it cannot be expected to run perfectly true. Even 3-jaw chucks costing five times more than the one made for this lathe will have .002" to .003" runout. If perfect accuracy is desired in a particular operation, the use of a 4-jaw chuck is recommended. Each jaw is adjusted independently so parts can be centered with total precision. Both a 2.5" and 3.1" 4-jaw chuck are available for the Sherline lathe. A self-centering 4-jaw chuck is also available.

### Capacities of the 3-Jaw chuck

3-jaw chucks provide the quickest and easiest way of holding work in the lathe. The Sherline 3-jaw chuck is designed so that it can be used to clamp externally on bar stock or internally on tube stock. The 2.5" chuck is designed to grip from 3/32" (2mm) to 1-3/16" (30mm) diameter stock with the jaws in



*The Sherline 3-jaw chuck with 2 tommy bars for tightening the jaws to hold a workpiece.*



*Three-Jaw Chuck, standard jaw locations.*

the normal position. The 3.1" chuck handles stock up to 1-1/2" (38mm) in diameter. For larger diameter work, the jaws must be reversed. (See photo on previous page.) The reversible jaws can grip to 2-1/4" (56.0 mm) for the 2.5" chuck and up to 2.75" (70 mm) for the 3.1" chuck. The chucks have a .687" (17mm) diameter through hole with a 3/4-16 thread.

### Precautions when using a chuck

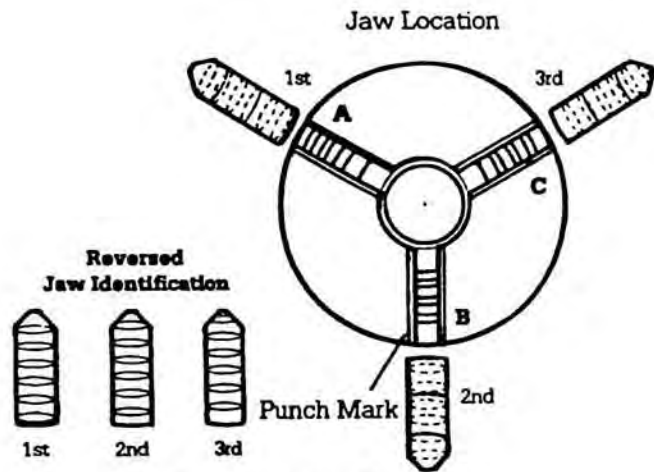
**NOTE: DO NOT TURN THE LATHE SPINDLE ON UNTIL THE CHUCK IS TIGHTENED.** The acceleration of the spindle can cause the scroll to open the chuck jaws if not tightened!

To prevent permanent damage, a 3-jaw chuck should only be used to hold finished, turned or drawn stock. For rough castings, etc., use the 4-jaw chuck.

**DO NOT OVERTIGHTEN THE CHUCK.** Use only moderate pressure with the Tommy Bars supplied.

### Reversing the chuck jaws on a 3-jaw chuck

Always start with position "A". (See illustrations above and on next page.) To reverse the chuck jaws, rotate the knurled scroll until the jaws can be removed. They can be easily identified by the location of the teeth to the end of the jaw. To maintain chuck accuracy, the 2nd jaw must always be inserted in the same slot even when the jaws are reversed. This slot was identified by a punch mark next to the slot. Newer chucks are engraved with the letters A, B and C as shown. Always insert the jaws in the order and at the location shown on the drawings. Turn the scroll counterclockwise when viewed from the face of the chuck until the outside start of the scroll thread is just ready to pass the slot for the 1st jaw. Slide the 1st jaw as far as possible into the slot. Turn the scroll until the 1st jaw is engaged.



*Reversing the Chuck Jaws.*

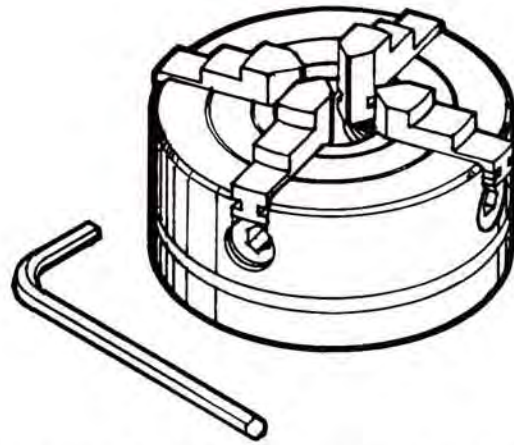
Due to the close tolerances between the slot and jaw, the most difficult part of replacing the jaws is engaging the scroll thread and 1st jaw tooth without binding. Therefore, never use force when replacing the jaws, and if binding occurs, back up the scroll slightly and wiggle the jaw until it is free to move in the slot. Advance the scroll and repeat for the 2nd and 3rd jaws. The scroll thread must engage the first tooth in the 1st, 2nd and 3rd jaws in order.

#### **Replacement jaws and chuck repairs**

A set of replacement jaws is available. Should it become necessary, you should return your chuck to the factory so that they can replace the jaws and check the alignment before returning it to you. In the case of a damaged chuck body, replacement of the entire chuck is usually more economical than attempting repairs.



*A part is shown held in a 3-jaw chuck. The 3-jaw chuck is easy to use and is the single most popular accessory for Sherline tools.*



*A 4-jaw chuck and hex key used to tighten each jaw individually. Individual jaw adjustment takes a bit longer but allows perfect centering of a part.*

#### **Using a 4-jaw chuck**

Because of the varied uses of the 4-jaw chuck it would be impossible to write a comprehensive set of safety rules to cover every specific use other than simply suggesting the use of liberal amounts of "Common Sense". If you are not sure of your setup, it probably isn't good enough. If possible, get a machinist with more experience to advise you on a safe setup. **Be sure to remove the chuck key before turning the spindle on.** Work safely!

The screws that move the jaws are 20 T.P.I. (threads per inch). A complete revolution is .050". If you keep this number in mind when indicating a part in, it can speed up the process.

First, use the lines machined on the face of the chuck to roughly align the part concentric with the chuck. Rotate the spindle and read the runout with a dial indicator. Move the jaw closest to the high or low point 30% of the total indicator reading in the proper direction. I recommend the 30% figure because the high point of a part will very seldom line up with a jaw. Moving a jaw too much can cause "chasing your tail" or simply moving the high point around the chuck.

#### *EXAMPLE:*

The indicator shows a .030" runout. 30% of .030" is approximately .010". If one revolution of the jaw feed screw is .050", then a little less than a 1/4 turn will be .010". Back the jaw out this amount and tighten the opposite jaw. **DO NOT** tighten the jaws beyond "snug" until the part is running within .005" T.I.R. Repeat this process until the part runs within your specifications. Once the part is running within



*A 4-jaw chuck can hold work of just about any shape because the jaws adjust independently. It allows for perfect centering or off-center part placement.*

.002" T.I.R. it can usually be "brought in" by a final tightening of the jaws. It should also be noted that the chuck jaws are ground with a slight angle to allow the jaws to apply equal pressure to the tip and base when properly tightened. This angle amounts to less than .001" on the jaw surface.

When reversing the jaws, be sure not to force a jaw onto the guide rails with the screw. "Wiggle" the jaw as the screw is advanced until the jaw moves in unison with the screw without binding.

If an off balance part has to be run, be sure to turn the motor on at a low RPM setting and bring the speed up slowly. Never go past the point where the machine starts to vibrate.

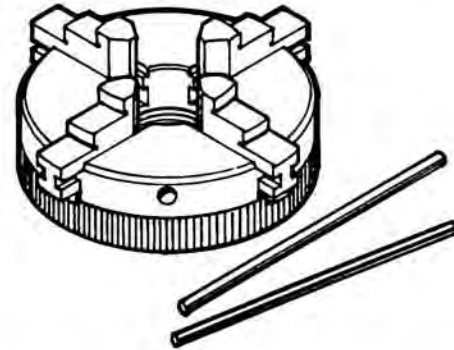
#### **4-Jaw opening ranges**

The 3.125" 4-jaw chuck opens from 3/32" (2mm) to 1-1/2" (38mm) in standard position and up to 2-3/4" (70mm) with the jaws reversed. The 2.5" 4-jaw chuck opens from 3/32" to 1-3/16" (30mm) standard and to 2-1/4" (56mm) with the jaws reversed. Both chucks have a .687" (17mm) through hole with a 3/4-16 thread.

#### **Replacing worn or damaged jaws on a 4-jaw chuck**

Should the chuck jaws ever become worn or damaged, I recommend you return your chuck to the factory where they will replace the jaws and assure that the chuck is adjusted within tolerances. If the chuck body is damaged, replacement of the entire chuck is usually more economical than attempting to repair the body. If you wish to attempt the replacement of a jaw or jaws yourself, measure

the width of the jaw you're replacing carefully with a micrometer (it is usually .312-.315"), and provide that dimension when you order a replacement so they can send you one that will fit properly. At the factory, chucks are hand assembled and jaws are custom fitted to each one to provide the best possible fit.



*The self-centering 4-jaw chuck centers square work quickly. It also offers an additional gripping surface to spread out the forces when gripping thin tubing. Because the jaws do not adjust independently, the work must be perfectly round or square for all the jaws to grip at once.*

#### **The 4-jaw self-centering chuck**

This chuck combines the ease-of-use advantages of the 3-jaw chuck with some of the advantages of a 4-jaw chuck. It will automatically center square or round stock; however, the stock must be accurately shaped for all four jaws to grip. It will also grip thin wall tubing in four places rather than three, which spreads out the load and allows more grip without crushing the tubing. Because the jaws can't be adjusted independently, the centering accuracy is similar to that of a 3-jaw chuck. While not as accurate as an independent jaw 4-jaw chuck, it is quick and easy to use if you need a little more gripping power than the 3-jaw offers or if you often work with round, square or octagonal stock.

#### **Reversing the chuck jaws on the 4-jaw self-centering chuck**

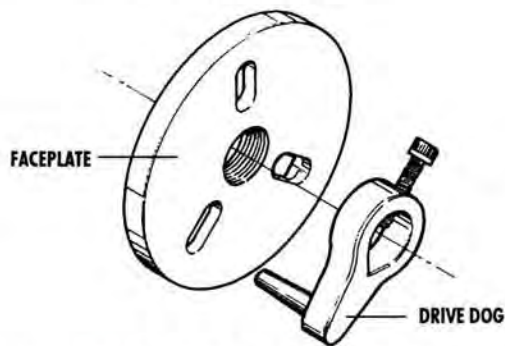
The jaws are removed by turning the scroll clockwise (when seen from the front) to back the jaws out. Each jaw has a slightly different thread engagement pattern on the bottom, so they must be reinstalled in the correct order. The instructions that come with the chuck give detailed diagrams on how to do this, but briefly the reversed jaws are installed with jaws 1 and 3 swapped in position. They are installed in the order 4-3-2-1. When reinstalling in

normal position, the order is 1-2-3-4. To keep the chuck accurate, the fits must be pretty tight, so you may have to wiggle the scroll a little as the first tooth of each jaw is started to keep the jaw from binding.

### Using a chuck with a live center

To hold work properly I try to provide as much support as possible for the part by using a chuck at one end and a live center at the other. The chuck takes care of the torsional and spindle loads while the center supports the other end and keeps it from "whipping". A "dead" center can also be used, but the live center requires no lubrication.

### THE FACEPLATE



A faceplate can be used to bolt and glue parts to. They don't cost much on a Sherline and can be turned into special holding devices. A light face cut may be required to "true" up the plate. Work held

PHOTO: BOB BRESLAUER



Parts can be bolted or glued directly to a faceplate to work on them. Faceplates are inexpensive enough to be considered "expendable" and can be drilled or machined to hold work for a particular setup. Here brass blanks are mounted to faceplates to be turned into model car wheels as shown at the bottom.

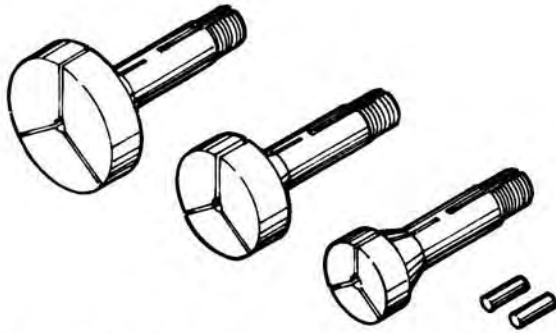
on a faceplate is usually being held in this manner because it can't be held any other way. Many times the faceplate will be out of balance when the work is attached to it. The deciding factor in your setup should be vibration. An out-of-balance part can have centrifugal forces build up and send the part flying if it is turned too fast. Sneak up on it. Faceplates are also used to drive a lathe "dog" which is another way to turn long stock between centers. (See page 126 for an illustration of a long part held between centers using a faceplate and drive dog.)

### WW COLLETS



A lathe collet set includes a drawbar (left), an adapter (center, top), a knockout bar (right) and assorted sizes of collets (center, middle).

Collets are a quick, easy method of mounting cylindrical parts or bar stock in the lathe with a great deal of centering accuracy. Each collet is actually a small precision 3-jaw chuck which fits into a special adapter which is held in the headstock. A drawbar passes through the headstock and threads onto the back side of the collet to draw it tightly into the tapered adapter. The adapter causes the jaws of the collet to close down, gripping the part to be machined. Typically collets provide a very accurate part mounting system, but each size of collet can accommodate only a small range of diameters of approximately  $\pm .001$ " (.02mm). Sherline tools use a "WW" size collet which was developed by watchmakers. WW collets differ from milling collets in that they have a hole clear through the collet and drawbar while milling collets do not. This allows long material of a diameter up to 3/16" (4.5mm) to pass entirely through the collet. WW collets larger than this diameter are sometimes referred to as "pot" or "step" collets.



Collet pot chucks come in various sizes. The dowel pins at the right are inserted into the center hole and clamped down on while the pot chuck is bored to the size required for the job. Parts are held on the face only; that is, they don't go through the pot chuck as they do in regular collets.

### Collet Pot Chucks

These collets are designed to hold larger or odd shaped pieces. They are inserted in the collet adapter and drawn down on a 1/8" dowel pin. Then a lip is turned to the exact size needed to grip your special part. The dowel pin is removed and the pot chuck is retightened with the part in place. Since there is no hole through a pot chuck, they are designed to hold

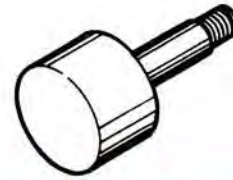


(Above) A pot chuck is being turned to the proper inside diameter to grip a particular diameter part.

A part held in a pot chuck for machining. Pot chucks allow you to quickly hold a number of same-sized parts. The flat bottom helps square them up and sets the depth.



parts only on the face end. The maximum gripping depth is about 3/16" (4.8mm). Sherline offers pot chucks in three diameters: 3/4", 1" and 1-1/4".



### Blank WW Collets

In order to make it easier for you to machine a WW collet to suit your own custom purposes, Sherline offers a WW collet blank. The end is tapered and threaded to fit the collet adapter, but the gripping end is left as a simple 1" diameter blank for you to turn to whatever shape you need. It has no center hole or slots, so you may prepare it however you like.

PORSCHE ENGINE PROJECT PHOTOS BY PETE WEISS



Here is a setup devised by Pete Weiss to machine the crankshaft for a running 1/6 scale Porsche air cooled engine he is building.



A carburetor and air inlet tubes for Pete Weiss' miniature Porsche engine project.

## Chapter 2—Lathe operating instructions

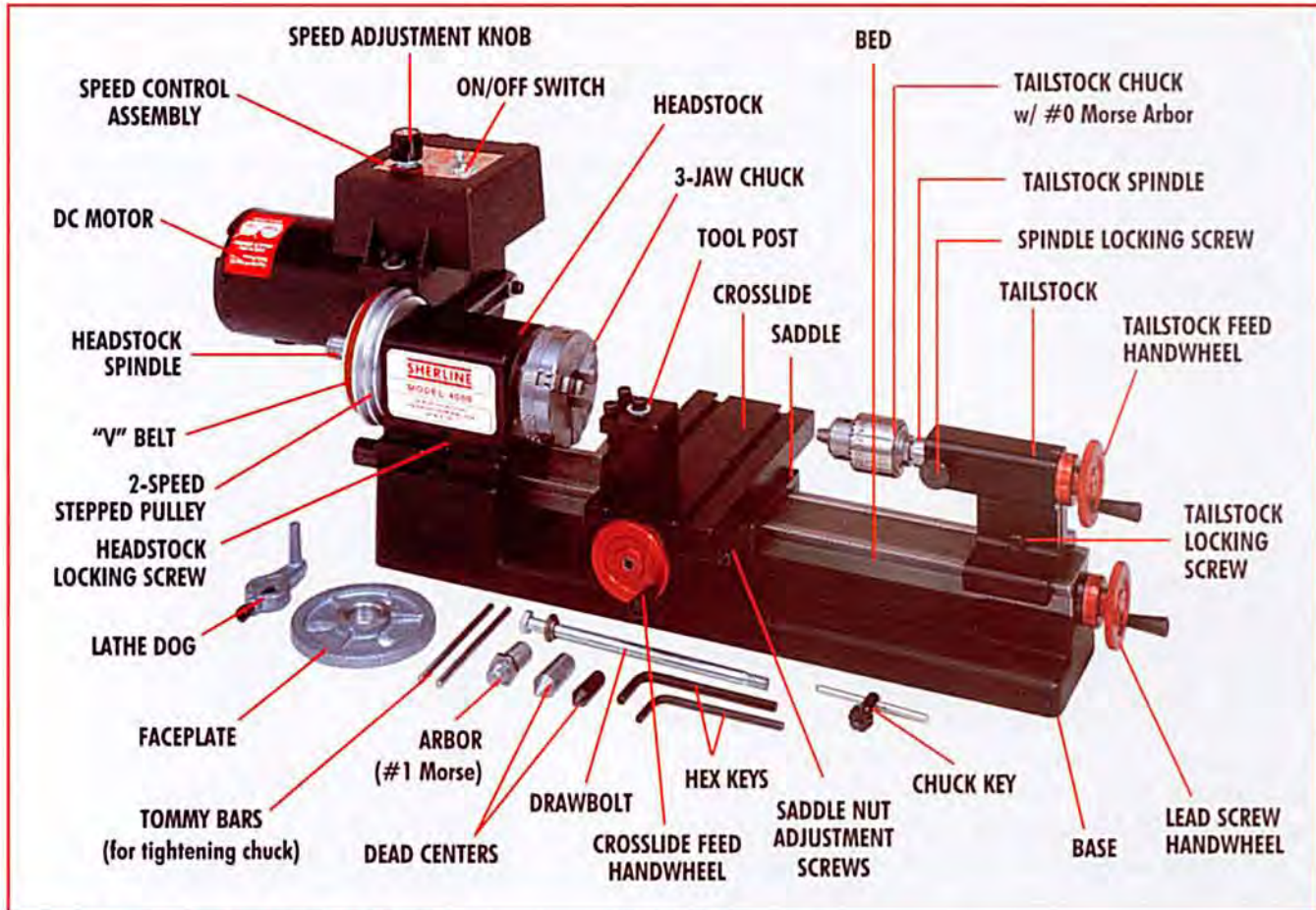


FIGURE 1—Parts of a miniature lathe.

### Taking an initial test cut

Near the end of this chapter is a section that will walk you through taking an initial test cut on your lathe. Once you have read through this chapter, use the example provided in that section to get to know your machine and to get a feel for cutting metal. The adjustments and procedures mentioned in these instructions will become much more real once you have made some chips.

### Holding the work piece

The main difference between working with metals and working with wood or similar easy-to-cut materials is how you have to hold metal to cut, shape and form it. Metal has to be held very securely in order to work with it. Machining is a series of simple operations that doesn't allow for errors. The most common error made by a novice is not taking the time to hold a part properly. A lathe is a simple device that can make very complex parts if you don't

screw up one of these simple operations along the way. Before starting on a part, come up with a plan on how you are going to hold the work and how you are going to measure or check the part for size along the way. As I constantly try to remind you, the only shortcut to producing good parts is to remember this rule: "There aren't any shortcuts".

For example, if you attempt to machine an unsupported shaft, the cutter could dig in and not only ruin your work, it could also take the chuck with it. The choices you have to hold your work piece are limited to holding the work between centers, with a 3- or 4-jaw chuck, on a faceplate or with a collet. When the work is held with a chuck or collet it usually has to be supported at the other end with the tailstock or steady rest. If the work is being turned at high speed and a center is required, a live center should be used rather than one that does not rotate with the part.

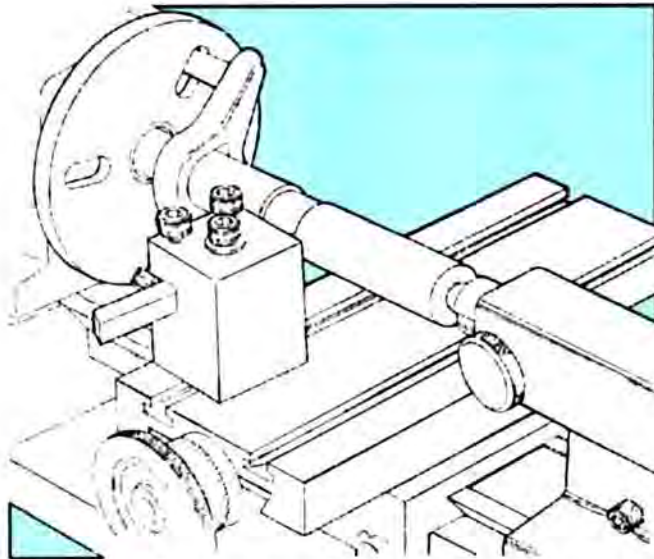


FIGURE 2—Turning between centers with a faceplate and drive dog.

### Turning between centers

I remember a documentary on India I saw when I was a boy, and what fascinated me was a craftsman turning and shaping wooden table legs. The table legs were held between centers on a lathe constructed of wood. The work was driven with a bow, similar to a violin bow, that had a couple of loops of leather wrapped around the work. By moving the bow back and forth the work would turn. The bow had to be long enough to get more than a few revolutions per stroke which meant the operator couldn't get too close to the work and still have the required throw. This problem was overcome by working and controlling the cutting tool with his toes and a simple support. Think about it. Not only did he have to operate the tool with his toes, he had to time his cuts to when the work was turning in the correct direction while moving the bow back and forth. Despite the difficulty of the method and the crudeness of the tools, the work this gentleman turned out looked good by today's standards. This has to be how turning started. I'm sure the really good craftsman ended up with help to drive their machines. We have gone from human power to water power to electric power to drive the work and to computer power to control the tool.

I had a customer come in one day who makes the lovely wooden bodied pens that have become so popular in the '90's. He was looking for a few lathe parts to build a new machine on which to make his pens. When I found out what he was really doing I gave him the parts he needed. He wanted to make and sell these wooden pens at outdoor craft fairs

where electrical hookups were rarely available. He had built a treadle powered lathe using a wooden frame, a motorless Sherline lathe and parts from a 10-speed bicycle. He had rediscovered the missing link between bow power and water power; that is, treadle power, which was also a way of turning between centers. (I suspect that part of the success of his product is not only the beautiful wood and workmanship of the pens, but also that the customers enjoy watching the pens being made right in front of them on such an interesting tool.)



Chip Ivester and his "missing link" foot powered lathe for wood turning. Some samples of Chip's work can be seen on page 41.

The point I was trying to make was that turning between centers is how lathe work started, but it isn't so common today. Usually work will be held in a 3-jaw chuck and supported with a live center if need be, but if you plan to make a lot of shafts you may disagree with me on this point. Turning between centers can be a very accurate way of working, and it is the preferred method for O.D. grinding. The headstock centers supplied with most lathes aren't hardened. This allows you to turn the center in place perfectly true if this type of accuracy is required. Center drills have a 60° angle on their point and are used to create a hole that will fit the standard 60° lathe centers. The straight section of a standard center drill leaves a pocket for oils to lubricate the center. Lathe centers are usually designed with a Morse taper that is designated by a number from #0 to #7. It is based on a taper of about 5/8" per

foot. The shallow taper makes parts “stick” together, and a tap is required to remove them. The Sherline lathe uses a #1 Morse taper in the headstock spindle and a #0 Morse taper in the tailstock. If I had it to do over again I would have used a #1 in the tailstock also. Although the #0 looks to be the “right” size, it isn’t a very popular size. #2 and #4 Morse tapers are standard for full-size tool-making machines.

#### Using a “dog” to drive the work

Of course there has to be some method of driving the work once it has been suspended between centers. This is accomplished by clamping a “dog” to the work. Why they call it a dog I don’t know, but it is simply a device that clamps to the work and has a leg coming out that engages loosely with a slot in the faceplate which turns or drives the work between the centers in the headstock and tailstock. The headstock center turns with the work; therefore no heat is generated. Centers and their mating holes must be free from debris in order to have parts that run true. The maximum diameter that can be held with the dog included with a Sherline lathe is 5/8" (15mm). (See Figure 2.) Drive dogs are easy to make, and any method that works is a good one. If the part is going to run at higher RPM, some consideration must be given to balance. This method of turning is ideal for bar work or turning steps on a bar. If the headstock or tailstock are purposely misaligned, a taper will be generated. The dog then becomes a U-joint to drive the work at an angle to the spindle. Shallow tapers are usually produced using

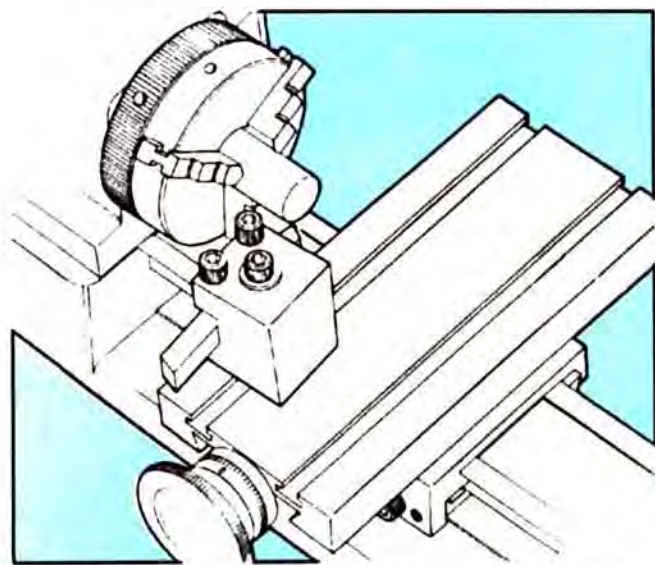


FIGURE 3—Holding a round workpiece in a 3-jaw chuck.

this method. (See Figure 8) The tailstock center must be greased to prevent overheating. An optional “live center”, such as P/N 1191, turning on ball bearings is the solution preferred by most machinists.

The headstock spindle has a Morse #1 taper in the spindle nose. The spindle thread is 3/4-16 T.P.I. Accessories held in the spindle using the Morse #1 taper on a Sherline usually have a drawbolt for additional holding power and can be removed by loosening the bolt a few turns and tapping on the head of the bolt lightly with a hammer or hard mallet. Centers can be removed with the use of a knockout rod (not supplied) approximately 3/8" in diameter and 6" long. The bar is inserted through the back of the spindle, and centers and other accessories can be removed with a few light taps. The tailstock spindle is equipped with a Morse #0 taper, and accessories such as drill chucks and centers can be removed by turning the handwheel counterclockwise until the accessory is ejected.

#### Clamping parts in chucks

In order to have the work turn as true as possible it must be carefully clamped in chucks or collets. The material should be clean and have a smooth enough surface so it can’t damage the chuck jaws or the collet. As 3-jaw chucks and collets are tightened, the part should be spun in the chuck jaws to allow the chuck jaws to seat properly before they are fully tightened. Don’t overtighten chucks. An improperly supported part can’t be machined by overtightening a work-holding device. Two wrongs will not equal a right. Read Chapter 1 in this section on work-holding devices. Don’t turn the lathe on without the

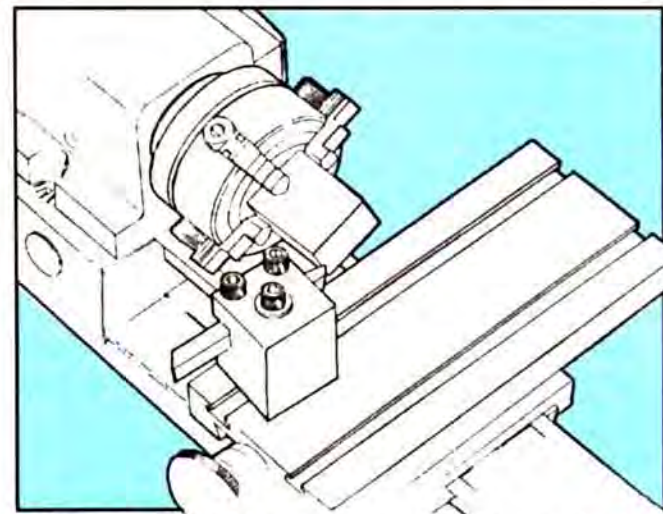


FIGURE 4—Holding a square workpiece in a 4-jaw chuck.

jaws being tight or the scroll may back the jaws out as the spindle accelerates.

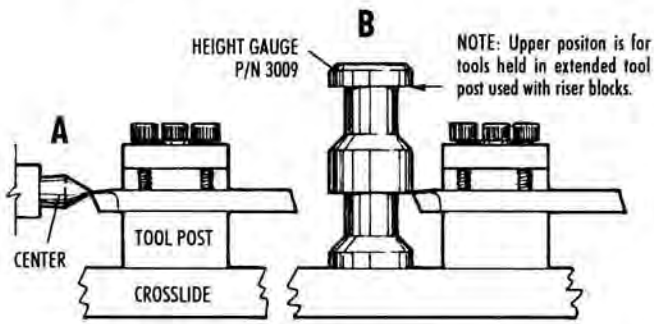


FIGURE 5—Leveling the tool using (A) the tip of a head- or tailstock center or (B) Sherline's tool height gage.

### Leveling the cutting tool

Each type of turning work requires the correct tool for the job. It is important that the cutting tool is sharp and correctly set up in the tool post. The cutting edge of the tool should be level with or a few thousandths (0.004" or .01mm maximum) below the center height of the lathe. Check this against either the headstock center or tailstock center. Sherline also manufactures a simple tool height adjustment gage which allows you to check tool height at any time by measuring from the table surface. For another method machinists use to check tool tip height, see Figure 22 on page 137.

The standard Sherline tool post is designed to hold common 1/4" square tool bits which have had a few thousandths of an inch (.01mm) ground off the top edge for sharpening. Loosen the hold-down bolt and slide the tool post as close to the center as possible. The tip of the tool bit may be raised or lowered by sliding a shim underneath it. Thin metal shim stock can be used for this purpose. If you don't have any metal thin enough, a single thickness of paper business card stock will usually do the job. Do not use more than one thickness as it will compress too much. (A rocker tool post is available which allows this adjustment to be made without shims.) Ensure that the tool is fixed securely in position by firmly tightening the socket head screws but do not overtighten. To minimize tool deflection, try not to have the tool cutting edge protruding more than 3/8" (10mm) from the tool post.

### Center drilling

Because the work turns and the drill does not on a lathe, it is necessary to use a center drill before a standard drill can be used. Due to the flexibility of a

standard drill bit, it will tend to wander on the surface of the rotating work, whereas a center drill is designed to seek the center and begin drilling. If the center drill is being used for a starting hole for a drill, the largest diameter created should be larger than the following drill diameter. This gives the drill a machined surface to start on. If the center drilled hole were undersize, the lip of the drill could be forced to start off center by coming in to a surface that isn't perfectly flat or catch a burr created by the center drill. Cutting oil is recommended for all drilling operations. A center drill should be withdrawn, cleared of chips and oiled several times during the drilling of a hole to keep the tip from breaking off. Read more about center drills in the cutting tool section on page 65. Also found there is a chart of commonly available center drill sizes.

### Tailstock drilling

Hold the work in a 3- or 4-jaw chuck. If the work is longer than approximately 3" (76mm), support the free end with a steady rest. Fit the drill chuck to the tailstock with a #0 Morse arbor and secure a center drill in the tailstock chuck with the chuck key. Drill chucks can't be tightened sufficiently by hand. Adjust the tailstock to bring the center drill close to the work and lock it in position. Be sure you have enough available spindle travel so the tailstock will not eject the chuck while it is in close proximity to the work which may be turning. Turn the tailstock handwheel to bring the center drill forward. After the hole is started with the center drill, switch to a

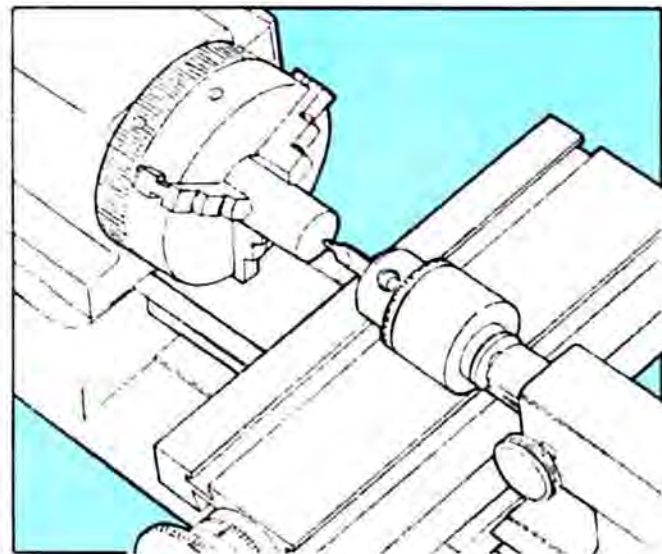


FIGURE 6—Tailstock center drilling. The work turns while the drill is held stationary in the tailstock.

standard drill bit of the desired size to drill the hole. When using drills on a production machine, a hole can be drilled to three times the drill's diameter and then it should be retracted, cleared of chips and more lubricant applied. On a manual machine, the first drilled depth shouldn't go more than two times the drill's diameter. From then on, clear chips and lubricate every one times the diameter. (For example: On a 1/8" drill you would drill 1/4", retract and lubricate. Then you would retract and lubricate at every 1/8" of depth you drill.) The reason for this is that chips clog up the flutes and cause heat to be generated. This burns the oil out of the hole, usually damaging both the drill and the part. Remember this simple rule for applying lubricant, use the chuck key for tightening, and you'll be amazed how long your drills will last.

The easiest way to center drill the end of a round shaft which has a diameter too large to be put through the spindle is to hold it in a chuck and support the other end with a steady rest (P/N 1074) while the end is being drilled. If this isn't possible, find the center with a centering square, prick punch a mark and center drill by hand. (For more details on using a steady rest, see page 149.)

I have never had good luck in using progressively larger drills to open up holes to a larger diameter. The problem is concentricity, because the drill wants to feed in too fast. In fact, drilling a second diameter in brass can be dangerous, for it can pull the drill into the existing hole as if the drill were a screw. This can pull the drill chuck and arbor out of the taper and when the drill starts turning with the spindle, the drill breaks off and the drill chuck with a sharp, broken drill sticking out of it goes flying by your head. Been there, done that.

#### Headstock drilling

On a Sherline lathe, the drill chuck comes with a #0 Morse arbor attached. This will fit the tailstock spindle. To use the drill chuck with the headstock you will need to first change to the #1 Morse arbor which is included with your lathe. To change arbors, put the drill chuck key in its hole to give you better purchase to grip the chuck while using a wrench to remove the #0 arbor. Replace it with the larger #1 arbor. Put the drill chuck in the headstock. Then put the drawbolt with its washer through the spindle hole from the other end of the headstock and tighten the drawbolt. DO NOT OVERTIGHTEN! To remove a Morse arbor, loosen

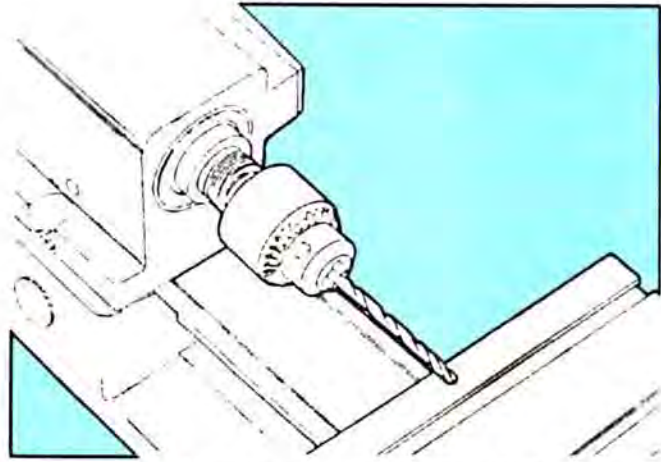


FIGURE 7—Headstock drilling. The drill turns in the headstock spindle while the work is held stationary.

the drawbolt a couple of turns. Give a light tap on the bolt head with a hammer or hard mallet to break the drill chuck arbor loose from the spindle taper before completely removing the drawbolt.

#### Reaming

Reaming is used for holes requiring accuracy within .0005" (.013mm). Very small boring tools are not satisfactory in deep holes because of their flexibility. Reamers are available in any standard size but are rather expensive and are generally not purchased to do one-of-a-kind type work. Use them only when a boring tool cannot be used because of the size or depth of the hole. Because of their length, they cannot always be used on a small lathe.

Reamers are used only to "clean up" the hole. To make an accurate hole, the work is drilled approximately .010" (.25mm) smaller than the reamer size. The work should be slowly rotated and the reamer slowly fed into the hole while applying plenty of cutting oil. The reamer should be frequently removed and cleared of chips.

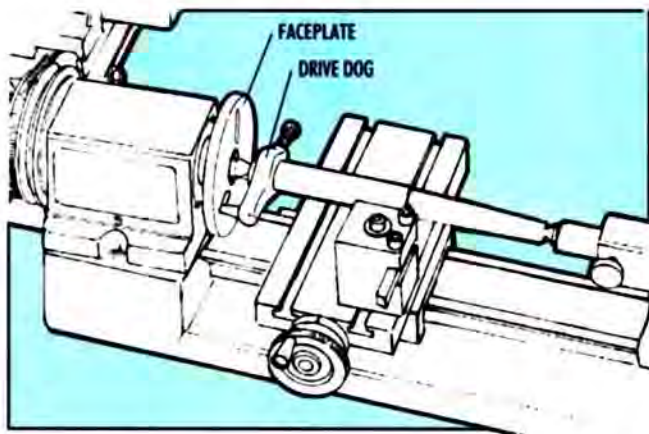
#### Faceplate turning

The faceplate has three slots which allow work to be bolted to its surface. Flat work can be screwed directly to the faceplate. Extra holes can be drilled to suit odd-shaped work unsuitable for a chuck. If the work is mounted off-center, be sure to counterbalance the faceplate and use very low RPM. Don't hesitate to drill holes in or modify the faceplate as needed to do a particular job. That's what they are for. They are inexpensive and you can afford to have several on hand which can be modified for special jobs. For more on using a faceplate see page 119.

### Taper turning

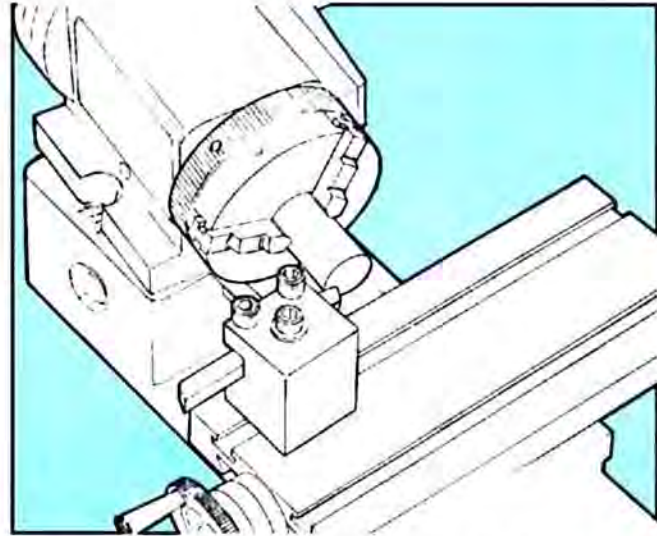
On most lathes a shallow taper can be cut between centers by offsetting the tailstock. On the Sherline lathe this is done by removing the headstock alignment key and turning the headstock to any angle away from dead center. To rotate the headstock, the alignment key must first be removed. To do this, loosen the set screw in the front of the headstock and lift the headstock and motor unit off the locating pin. Tap the alignment key out of its slot on the bottom of the headstock and replace the headstock unit on the pin. While pressing down on the headstock, rotate it to the angle you desire by referring to the angle scale on the bed. The base is calibrated in 5° increments up to 45° both left and right of dead center. (Keep in mind the calibrations on the base have no meaning when cutting a taper between centers. That taper must be established by trial and error.)

The lathe tool and crossslide handwheel can be used to measure and mark off small movements when offsetting the part. Bring the tool up to touch the part and then loosen the headstock. Rotate the headstock to move the part away from the tool and advance the tool the desired amount of offset. Then rotate the headstock and part back until it just touches the tool and lock the headstock in place. Remember also that the distance between centers gets shorter as the angle is increased. Don't be ashamed to bring a taper to final size with a good flat, single-cut mill



*FIGURE 8—Long, shallow tapers can be cut in a continuous pass by pivoting the headstock to the proper offset while supporting the other end with the tailstock. The work is driven by using a drive dog in the faceplate. The dog acts like a “universal joint” as the drive pin slides in the faceplate slot to accommodate the angle of the offset.*

file. When set to the proper angle, retighten the set screw against the pin to lock the headstock into position. Short angles can also be formed when a part is supported by a center with lathe tool clamped at an appropriate angle and plunge cut in multiple passes if needed.

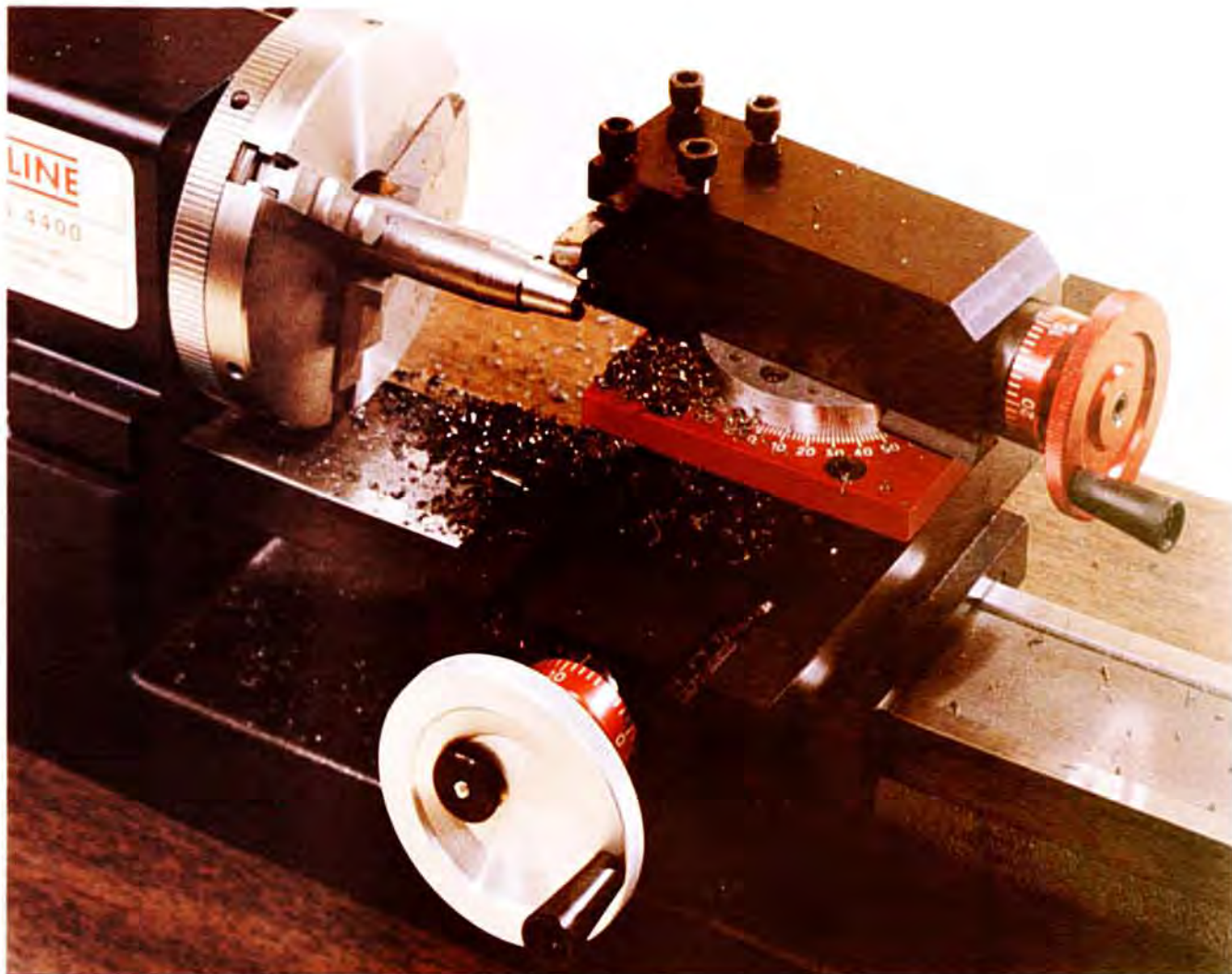


*FIGURE 9—Turning a taper on a short workpiece held in a chuck with the headstock rotated.*

Short work can be held in a 3- or 4-jaw chuck and turned as shown in Figure 9. In this case, the engraved angle markings on the lathe base can be used. A greater degree of accuracy can be obtained by measuring the angle between the face of the headstock (the side that the spindle nose protrudes from) and the edge of the crossslide. Remember that the tool must be on center for these settings to work. Tools set above or below center will cut less of an angle than is set. If the headstock is angled towards the front, the taper will cut smaller at the right of the part. This is the opposite of adjustments made when turning a taper between centers. Tapers can also be bored in the end of work held in the 3- or 4-jaw chuck.

### Taper turning or angle cutting with a compound slide

The redesigned (1998) compound slide is a third method of turning a taper. The base of the slide is attached to the crossslide table using four T-nuts. Line up the edge of the base with the front edge of the crossslide table or indicate it in to make sure it is mounted square to the spindle. The locking screws on the lock ring are loosened and the slide can then be rotated using the laser engraved markings to select the desired angle. The lock ring screws are then tightened. The large surface area of the lock ring



*FIGURE 10—The compound slide offers a different way to cut tapers on a lathe without removing the alignment key and rotating the headstock. It can also be used to cut angled slots in long pieces or to bevel the end of a part. Sherline's compound slide is designed to be used on the "back" side of the part.*

provides a lot of friction so it is easily locked into position without overtightening the screws. The tool is then advanced into the part by turning the compound slide handwheel. The 1/4" cutting tool can be mounted in grooves on either side or across the front of the compound slide.

#### **Cutting on the "back" side of the part**

Notice that the compound slide is designed to be used on the "back" side of the part. The 1/4" cutting tool is mounted "upside down" so that the cutting point is on the bottom when it is aligned with the centerline of the part. This offers several advantages. First, it moves the slide away from interference with the crossslide handwheel. Second, because of the direction of part rotation there is less tendency for the cutter to "chatter" when it is being lifted in the slide rather than being pushed down toward the table.

For more on the thought process that went into the design of this accessory as well as how it led to the design of a radius cutter, see page 132.

#### **Turning slide handwheels to avoid tool marks**

To produce a good finish on any machine tool requires more effort than just "cranking the handles". As I try to remind you all through this book, "metal likes to be cut in a continuous fashion", and it is the way you crank these handwheels that transmits this information to the cutters. The first thing to consider is whether the force of turning the handwheel can affect the finish. The force I'm referring to is that which is put into the handwheel, yet is not directed towards actually rotating the handwheel. Handwheels that are mounted directly on a slide can cause this problem. Sherline handwheels have a plastic handle for rapid cranking,



*FIGURE 11—In this setup, the compound slide is suspended out from the table and a cut is being made close to the chuck. The length of the part would have made this taper difficult to cut using the usual method of offsetting the headstock.*

but, in some cases, it is better to use your fingers to turn the handwheel using the knurls on its outer edge when feeding the tool. If a handwheel is cranked rather than turned, the cranking action will be transmitted to the slide it is mounted to, rotating it but also pushing and pulling on it. The end result would be the same as pushing and pulling on a slide that is controlling the cutting tool. This will leave a tool mark equal to the pitch of the leadscrew as you crank through the cut. Tool marks that are only 1/10,000" deep are still a visible and have to be removed if perfection is your goal. The slides on a Sherline lathe that are affected by this motion are the crossslide and the compound slide. Both have the handwheels mounted directly to the slide.

If you ever have the opportunity to watch a good toolmaker using the compound on a lathe that is older than he is, you will notice he controls the feed rate with both hands. Look a little closer and it becomes apparent that the handwheel is being driven by rotating the wrist, not cranking. By using both hands, passing the handwheel from one hand to the next, the handwheel can be kept rotating at the same speed without putting extraneous forces on the machine slide.

### Tool shapes and grinding your own tools

The shaping of cutting tools to suitable angles for the type of material and nature of work being performed can be very important to satisfactory results. When tools become dull, gently re-grind and preserve the original angles and shapes. Do not grind the top face of the tools, but confine sharpening to

the end and/or sides except form tools which are ground on the top surface.

NOTE: Because of the importance of a sharp and properly ground tool to the cutting process, I have included instructions on grinding your own lathe tools in this book. Refer to page 77.

Cutting tools are ground to various shapes according to their usage. Tools are usually ground to shape as needed by the operator. Some standard tools are described below:

**NORMAL TURNING TOOLS**—This feeds from right to left, is used to reduce work to the desired diameter and is the most frequently used of all tools. When working with full size lathes, roughing tool are used that have less cutting angle than finishing tools. With a miniature lathe, I don't use a differently shaped tool for roughing. Full size machines may be putting ten horsepower into a half-inch tool bit, but with a Sherline lathe a tool with a 55° tip will work just fine unless you have a lot of stainless steel to cut.

Reference to Figure 13 will illustrate the lateral positioning of this tool. Note the clearance behind the point between the end of the tool and the work. Insufficient clearance will cause the tool to "rub" and excessive clearance will produce a poor quality finish similar to a very fine thread due to the small length of tool edge in contact with the work. These "feed lines" become more pronounced with rapid feed. To provide a smooth finish, the sharp cutting point may be slightly rounded to a .010 radius or flat on a grinder and cleaned up with an oilstone, taking care to preserve the side clearance underneath this corner.

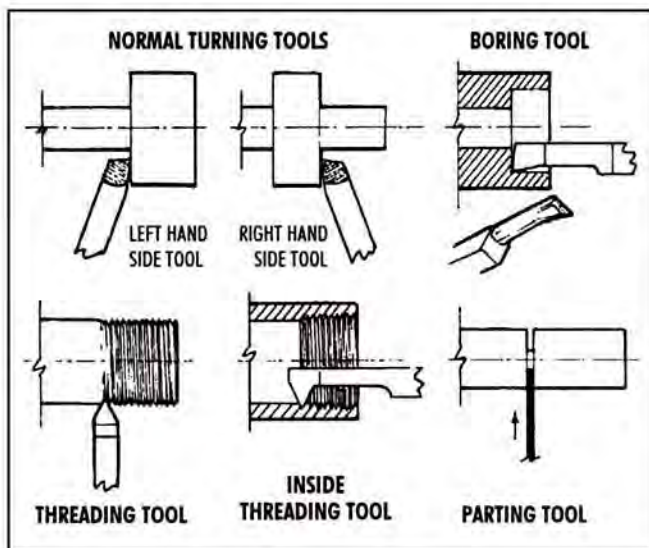


FIGURE 12—Tool shapes

This tool should not be advanced directly endwise into the work. The depth of cut is set while the tool is clear of the end of the work. The starting procedure is to advance the tool until the point just touches the work. Note the reading on the crossslide handwheel, withdraw the tool slightly and move along until clear of the end of the work. Now advance the crossslide to the above reading, add desired depth of cut and then feed the tool along the work piece the desired distance. Withdraw the tool clear of the work, having noted the reading on the crossslide handwheel, mentally note the reading on the lead screw handwheel, return the tool to starting position and advance to the previous reading plus the desired cut.

The second cut is now begun, stopping at the same or less than the previous reading of the lead screw

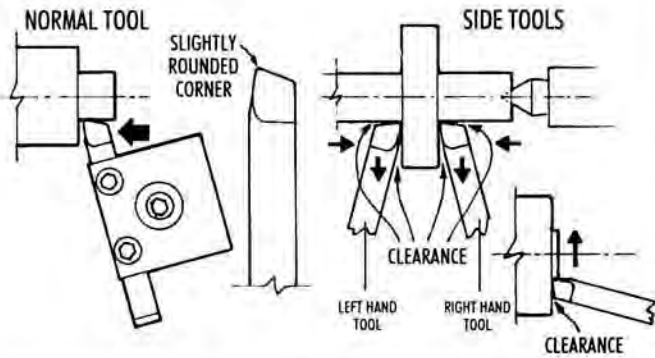


FIGURE 13—(Normal Tool and Side tools) Arrows show direction of tool feed in all diagrams.

handwheel. The face of the end surface can later be finished to length with a side tool. This procedure enables a surface to be turned to accurate length.

Repeat the procedure until the work has been reduced to within about .010" (0.25mm) of desired diameter, noting that each .015" (0.4mm) increase in depth of cut will reduce the work diameter by twice this amount, or .030" (0.8mm). For the finishing pass, advance the tool by the required amount and feed along the work just far enough to gauge the finished diameter. Adjust depth of cut if necessary and complete the final pass using a SLOW feed to obtain a smooth finish and exact size.

**SIDE TOOLS**—While these may be, and often are, used as general purpose turning tools, their specific use is for facing the sides of collars and shoulders; that is, finishing these to correct dimension and with a smooth, flat surface. They are also for facing work held on a faceplate or in a chuck. The facing of work in this manner is very useful for the production of truly flat surfaces and for producing articles to an exact thickness. The two uses of the side tools are illustrated in Figures 12 and 13. The sharp corner at the cutting point should not be slightly rounded, as may be done with the normal turning tool, as knife tools may be required to produce sharp corners.

Note that a tool which is fed from left to right is called a LEFT side tool. This is because the direction the chip comes off (in this case to the left) determines what the tool is called. (See illustration and further explanation on page 72.)

**CUTOFF OR PARTING TOOLS**—The conventional parting tool is shaped like a dovetail when viewed from above and is used to cut off work pieces by feeding the end of the tool across the lathe bed and through the work piece. Grinding a parting-off tool of this

shape that is thin enough for use on a miniature lathe is somewhat of a losing proposition. A 1/4" square tool bit ground to a width a Sherline lathe can handle will not be strong enough. Cutoff tools require a special holder on all lathes and the Sherline is no exception. The special holder allows the use of a tool that is both strong and thin. The Sherline parting tool uses a thin .040" (1mm) blade which has a slightly thicker ridge at the top to accomplish the same function of providing clearance for the tool while cutting. Parting tools thicker than .040" (1mm) will be too wide for use on your Sherline lathe. Instructions for use of the cutoff tool can be found on page 75.

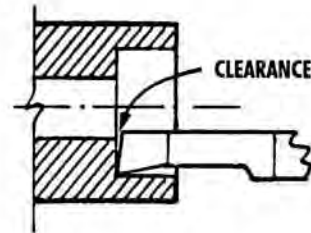


FIGURE 14—Boring tool clearance.

**BORING TOOLS**—The lathe boring tool is used in the toolpost on a lathe and ground from a square tool bit. (Boring tools used in a mill have round shanks and are used with an offsettable boring head to enlarge holes in a work piece.)

Starting with a drilled hole, the tool is used to enlarge it to the desired size. It may also be used to enlarge the bore of a tube. The work must be mounted in a chuck or on a faceplate and the boring tool set as shown in Figure 15. Note the clearance behind the cutting point as shown in Figure 14. A tool shaped like this will allow you to finish the

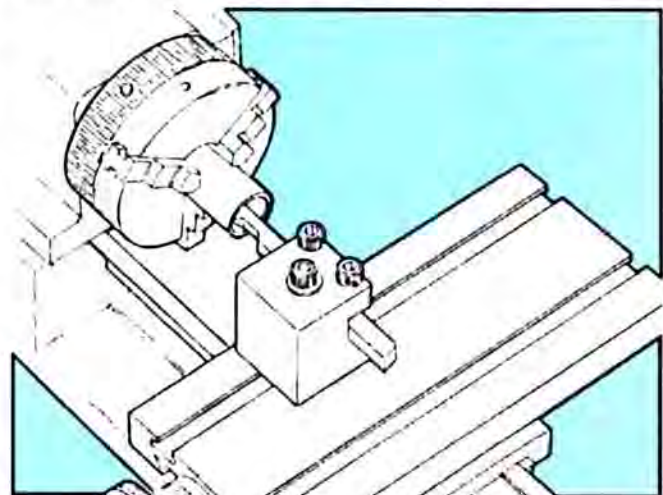


FIGURE 15—A lathe boring tool in use.

bottom of the bored hole by feeding the tool towards the center. The biggest problem you may encounter grinding your own boring tools is not the tool clearance, for the tool looks similar to any other lathe cutting tool with the cutting tool clearance rounded for the hole. The problem is the shank supporting the cutting edge of the tool may drag on the bottom back side of the tool. Many times the tool may have been ground correctly but was then clamped at an angle. If I'm boring a hole that has to be deep, I will not bore the hole full depth until I get the beginning of the bored hole enlarged to close to its final size. This will give the beginning of the shank more clearance and allow you to grind a stronger boring tool.

Withdraw the tool to allow turnings to escape from the hole whenever necessary. Care should be taken not to feed the tool beyond the depth required or to feed so deeply as to damage the chuck or faceplate.

Where a hole must be bored right through the work, the work should be located out from the faceplate to provide clearance for the tool to feed through. The leadscrew handwheel graduations can be used to indicate the correct depth at which to stop the feed. Notice that with boring, the depth of cut is increased by moving the tool and crossslide towards the operator and not away as with normal turning.

The boring of holes often necessitates greater than normal overhang of the tool from the tool post, so the depth of cut and rate of feed should be reduced from normal. Try to grind tools that are as strong as possible.

**FORM TOOLS**—A custom contour can be ground into a tool to produce a special shape like a radius in a part. The width of the cutting edge must be less than two and a half times the smallest diameter. Cutting speed must be slow and constant to prevent chatter.

The clearances ground behind the cutting edges indicate the type of material for which the tool may be used and the direction in which it is fed along the work. When grinding tool bits, correct clearances are essential or "rubbing" can occur. For more on form tools, see page 80.

#### **Inserted tip carbide tools**

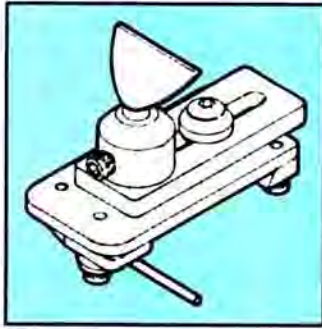
Inserted tip carbide tools allow the home shop machinist to enter the space age, as these cutting tools add a new dimension to small lathes. When working with tough metals, high speed steel tools need constant sharpening and have a relatively short



*FIGURE 16—An inserted tip tool in its holder. The blue box contains additional replacement tips. In the wooden box are various tools and tips.*

life. Brazed carbide tools cut great but chip easily. Inserted carbide cutting tools are the answer and have replaced those other tools in the modern machine shop. Carbide inserts have the ability to consistently give good finishes and long tool life at a much higher cutting speed. This is especially important with small lathes because they do not have excessive power at low RPM. With inserted carbide tools, you can cut stainless steel at the same RPM you were formerly using to cut aluminum with high speed steel tools, yet there is no sacrifice in the quality of the surface finish.

These tools are more expensive than high speed steel; however, they are worth every penny if you have problems grinding your own steel tools or are cutting exotic materials like stainless steel. Sherline offers a tool post (P/N 7600) which holds the larger 3/8" diameter tool shanks used to hold carbide or diamond inserted tips. It also has a 3/8" round hole for boring tools. A good starting point for a tool is the P/N 7615 right hand holder that uses the P/N 7605 insert. This is a 55° insert good for turning, facing and profiling. Also available are 80° inserts which are slightly less versatile but offer longer tool life because of their stronger, more square shape. These tools should not be used to cut hardened steels or piano wire. Materials such as those should be ground to shape, not cut. However, abrasive materials such as glass reinforced plastics can be easily cut with these tools. For more information on inserted tip carbide tools see page 73.



**FIGURE 17**—The T-rest allows metal to be turned with a hand held tool called a “graver”. This is a traditional method still used today by watch makers and instrument makers .

### Using a watchmaker’s T-rest and gravers

Another method of removing metal is with a hand held cutting tool called a “graver”. It is rested on and moved along a repositionable rest called a T-rest. It is traditionally associated with clock and watch makers using jeweler’s lathes, but can be a useful skill to anyone turning small, custom parts because of its freehand versatility. World renowned watch and clock maker, William R. Smith designed Sherline’s T-rest, and with it, your lathe becomes a first class jeweler’s lathe. Instructions on use of the T-rest are included in Chapter 8 of this section. Instructions on how to make your own gravers are included with the purchase of a T-rest or may be found on Sherline’s web site.

### Designing the compound slide...

#### Proof your first design isn’t always your best

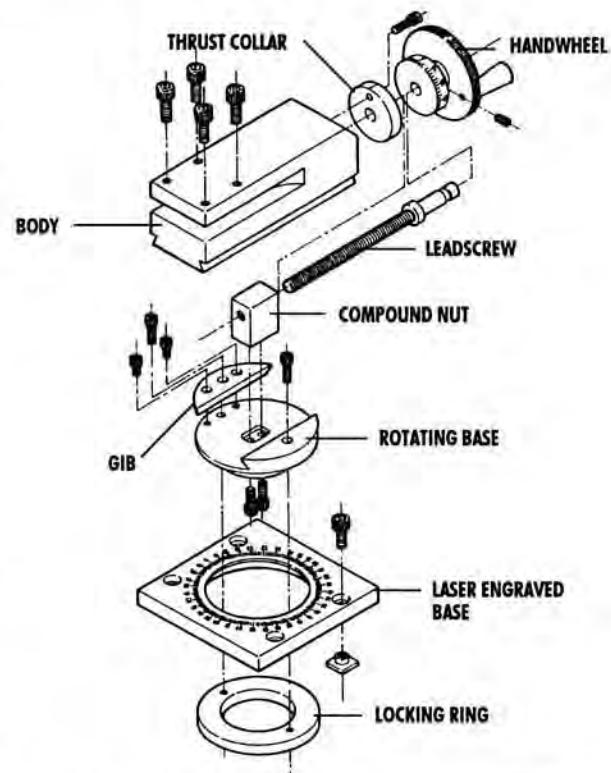
The compound slide shown in this book wasn’t the first one I designed for the Sherline lathe. The first one was a “turkey”, but at the time I couldn’t think of a better way to do it and still keep the cost down. To me the problem wasn’t making a slide that was strong enough to take the machining loads, it was making a slide that wouldn’t deform when the tool bit was overtightened. I also had the problem of the slide interfering with the crossslide handwheel. Understanding its limitations, I was able to use it with few problems, but many customers mentioned that the accessory was a weak point in an otherwise excellent line. It took me a long time to realize that the compound didn’t have to be mounted on the front side of the crossslide. Once I considered designing one that would mount only on the back side the concept became straightforward. Not having to leave a large space for a tool to be mounted either right side up or upside down meant the extra 1/4” taken up by a spacer could now go into the tool holder, making it both smaller and stronger.

The second problem was getting a cutting tool close enough to the 3-jaw chuck to be useful. When the

compound slide is mounted centered on the crossslide, the tip of a properly mounted toolbit could be as much as an inch away from the chuck. This wasn’t satisfactory because one of the biggest problems using a small lathe was keeping the rough stock as short as possible to help eliminate “chatter”. I planned to offset the compound on the crossslide to get the tool closer. This had the compound slide overhanging the crossslide more than I liked. What allowed a setup like this to work was the fact that cutting tools are less prone to chatter when the cutting loads are directed up from the slide. I learned this working with screw machines. Screw machines have front and rear slides controlled by cams, and if the slides were worn out you could get better results putting the widest cutting tools on the rear slide. The reason is that the tool is lifted rather than “digging in” if the cutting load becomes too great. We also make a rear mounted riser block for the cutoff tool holder to take advantage of this fact.

### Locking ring idea changes direction of design

The method used to lock the compound was the same as I used to lock the rotary column attachment which we had just put into production. They both use a locking ring. The large areas of the gripping



**FIGURE 18**—The components of the redesigned compound slide.



*FIGURE 19—The radius cutting attachment required some original thinking. Once you realize that lathe tools don't necessarily have to move horizontally, coming up with a workable design was a lot easier.*

surfaces provide a lot of friction and make for a very secure lock that doesn't require much tightening force be applied to the screws. My first attempt was to use a T-nut in a T-slot. Machining a small T-slot is a costly operation and I try to avoid it. T-nuts also apply a lot of force in a small area and overtightening them can damage the slot. The locking ring is what made it work. It is funny how one idea leads you to another, and as I'm typing this I'm thinking about making a rear slide cutoff holder to use with our riser block to take advantage of the fact I just

mentioned. These are all simple designs, but they are usually the most difficult to come up with. The ultimate compliment to your design is when someone calls your solution "obvious".

#### **Understanding your own market**

To make a piece of tooling for use in my own shop is easy, but to put an accessory like this into production is a different matter. In order to produce a product at a reasonable cost it must be produced in quantities, and you end up with thousands of dollars in a product before the first one is sold. Small

manufacturers don't have the dollars for market research, so you have to know your customers. Market research companies aren't any good at doing research on specialized product lines for specialized customers, and they can end up charging more for the research than the profit that could be made on the product itself. You have to go with your gut feeling and consider what a customer is willing to pay for such an accessory. The skill level required to use the product must also be considered, as a product that requires a highly skilled person to use it also cuts down on the number of potential customers.

#### **One invention leads to another...a radius cutter is born**

When I was testing the compound I noticed how freely the slide would rotate with the locking screws loose, and I cut a concave shape on a scrap piece of bar stock by rotating the slide by hand. A few weeks before, a customer had called wanting a radius cutting attachment to make, of all things, prosthetic eyeballs. I ended up putting a great deal of thought into trying to design a compound that could also be used to cut a radius. I had to give this idea up because my new compound was rapidly becoming another turkey, but my mind was still thinking about a radius attachment. I had built several radius attachments for customers over the years, but at that time I couldn't afford the time and money it would take to put an accessory with such a limited appeal into production. Things have changed now, and I realize that what makes our product unique is the vast line of unusual accessories we offer for our machines. I became determined to add a radius tool to our product line.

#### **Knowing too much can hamper the design process**

I can't understand why I didn't think of it sooner. For years I had been using a tool similar to the radius attachment I ended up making. It is a standard method used to put a radius on a grinding wheel with a diamond. A "swing" is suspended between two centers and the cutter is offset from the centerline by the length of the radius you wish to cut. The tool can be mounted to cut both concave and convex shapes. Again, what made the new design difficult to visualize was that I had my mind locked into believing the tool had to move in a horizontal plane. Getting your mind to break free of traditional methods is what makes designing so difficult. In order to see the need for new products, you have to know a great deal about the subject, but

learning a great deal about the subject narrows your mind. One other thing that limits your thinking is knowing that you have to be able to build what you design. If you didn't know what the inside of a machine shop looked like, you would design what you wanted and let someone else worry about how to make the parts. Unfortunately, products designed in this fashion, though creative, are usually too expensive to be successful.

#### **Having fun with new designs**

The radius attachment will have very limited appeal because it is a very special tool. In fact, I will be surprised if we sell over thirty units a year. I'm not working to satisfy the needs of most of my customers but rather the needs of *all* of my customers. I believe it will widen the scope of what can be built with our product line. At this stage of my business I have the tremendous advantage of working on things because they are interesting or just plain fun to work on. I think about interesting devices that allow you to do the "impossible" with tools that can be stored in a closet, and I have talented employees to put these ideas into production using a shop full of modern CNC machine tools. The best is yet to come.

---

*"Imagination is more important  
than knowledge."  
—Albert Einstein*

---



At the top is a real spark plug, below it is a 1/5 scale working model by Jerry Kieffer. Below is a closer look at another small spark plug and its components.



## GUIDE TO APPROXIMATE TURNING SPEEDS

MATERIAL	Cut Speed S.F.M.	1/4" (6mm) Diameter	1/2" (13mm) Diameter	1" (25mm) Diameter
Stainless, 303	67	1000 RPM	500 RPM	250 RPM
Stainless, 304	50	800	400	200
Stainless, 316	47	700	350	175
Steel, 12L14	174	2600	1300	650
Steel, 1018	87	1300	650	300
Steel, 4130	82	1250	650	300
Gray Cast Iron	57	900	450	220
Aluminum, 7075	400	2800	2800	1400
Aluminum, 6061	375	2800	2800	1400
Aluminum, 2024	268	2800	2000	1000
Brass	400	2800	2800	1400

FIGURE 20—Turning speeds for high speed steel cutting tools

### Turning speeds

The chart above provides a guide to approximate speeds at which work of differing materials should be rotated. Note that the turning speed is inversely proportional to the diameter of the work; that is, the larger the diameter, the slower the RPM. Material often differs in its hardness, so these figures may have to be varied. The harder the material, the slower the turning speed should be.

Keep in mind that, for the most part, turning speeds are not too critical. Overly high speeds can generate excessive heat and may also damage the tool's cutting edge or cause it to "rub" instead of cutting. Slower speeds than normal cause no harm, except by increasing the time involved. Aluminum, however, usually gives a better finish turned at high speed and lubricated. More information on cutting speeds can be found on page 102.

### Cutting small diameters

First we have to define what a small diameter is. I would define it as a diameter that isn't rigid enough to be machined. The work would deflect or bend away from the tool rather than being cut. Watch parts have shaft sizes with diameters as small as .006" (.15mm). The machines used to make these small parts in production are called "Swiss automatics". The difference between a standard lathe and a Swiss automatic is the bar stock isn't clamped where it is being machined. It is clamped by a collet that feeds the bar through a carbide bushing. The bar stock has to be held to exact diameters to eliminate slop

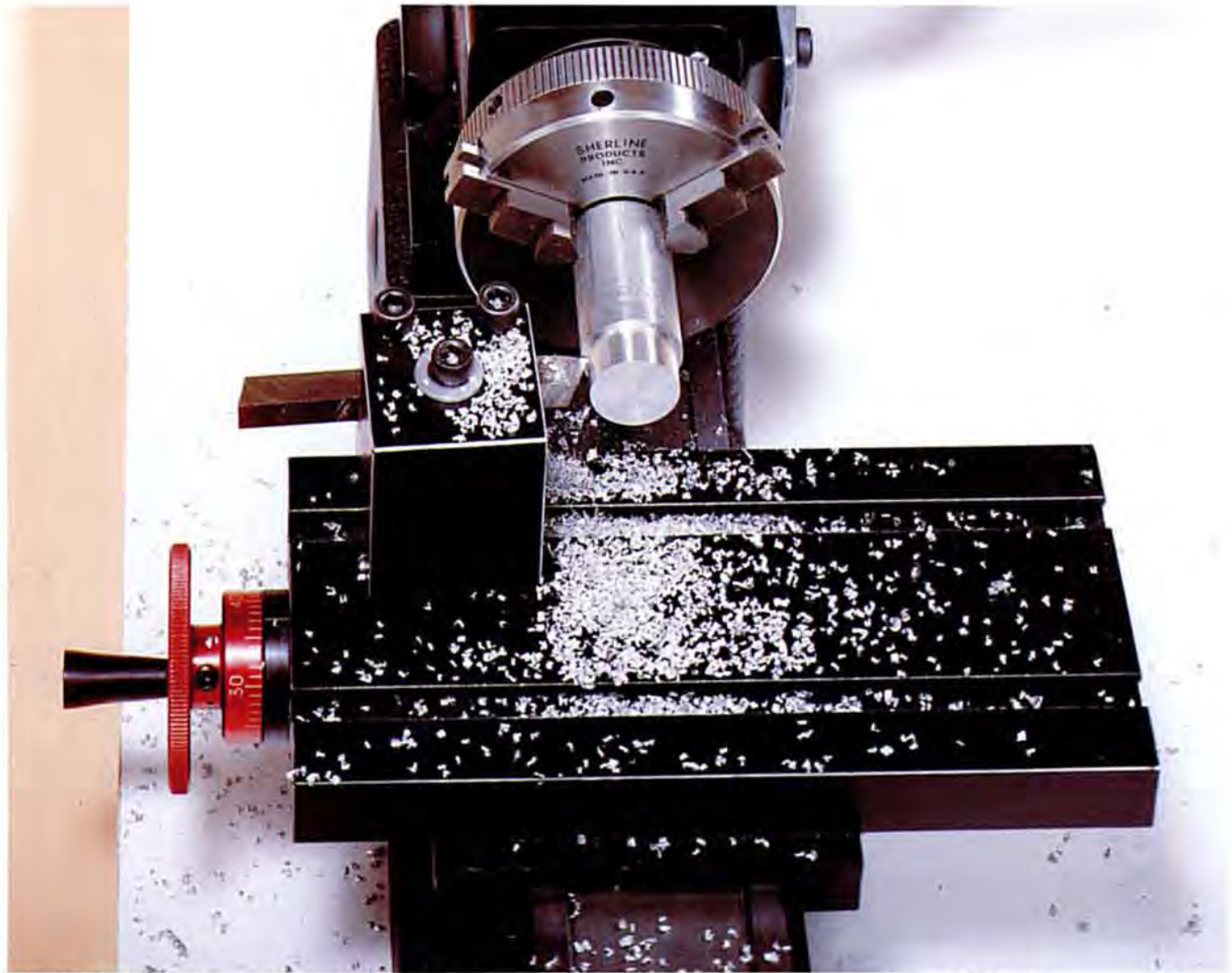
and binding. A pressure oil system keeps the bushing from "freezing up". The cutting tools are placed on machine slides which allow them to be as close as possible to the carbide bushing. This is similar to a setup using a steady rest. The bar stock is fed through the bushing while the tool cuts. The feed rate is controlled by cams, and a single tool can generate many shapes by using precision cams. If the cutting tool were to be backed out as the material was fed through the bushing a taper would be cut.

What this has to do with turning small diameters on a Sherline lathe you ask? The reason you can turn these small diameters on a Swiss machine is that the cutting loads are transferred to the bushing, and the finished diameter is turned in a single pass. Of course the geometry of the cutting tool must have very little radius to keep forces from the diameter that is being left. That is actually a pretty good description of how these small diameters are produced. The part is simply what is left over from the cut. (See photo on page 140.)

The Sherline and other standard lathes don't have a bushing, and to overcome this problem we increase the stock diameter to the point it can support itself. There is a point of no return if the part is too long for this method to work, and in this case a follower rest may have to be employed. For small diameters the tool has to be on exact centers. I would always make test cuts to establish dial settings if more than one diameter is to be cut. The diameters are then cut to length one at a time to complete the part. Small parts will usually require a better finish than can be machined with a cutting tool, so you must allow a little extra material that will be removed during polishing. See Chapter 5 in this section form more on supporting long, thin work.

### Using the part itself as a mandrel

I used this trick in a different fashion and got a contract for thousands of dollars. The contract was for some thin walled aluminum tubes that had a shape like a test tube. They had a diameter of 1.125" (28mm) and were about six inches long and had a wall thickness of .040" (1mm). The tube would simply collapse and the theory was the part would have to be placed on a mandrel to machine the final OD. I bought 1-7/16" diameter stock to do the job. The center was drilled and reamed to size, and the outside diameter was cut in a single pass. What was left over was the part they wanted. The excess



*FIGURE 21—To get started, chuck up a piece of round aluminum stock about 3/4" in diameter and get your cutting tool set to the right height.*

material that was machined off was, in a sense, the fixture that held the part while it was being machined. Think about it. The cost in wasted material was far less than the extra operation required.

## **INITIAL TEST CUTTING ON A LATHE**

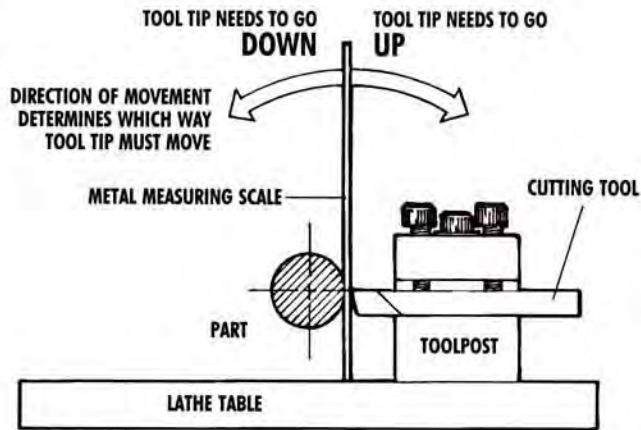
### **Getting a feel for cutting metal**

Before going on, I believe you should develop a sense of what cutting metal is all about. It will make the instructions throughout the rest of this book far more meaningful. As a hobbyist or even if you are planning to make a career in machining that includes using CNC machines, you must have full knowledge of how metal cuts. The skills you learn with manual machines will eventually have an impact on how well your programs will work. It would be next to impossible to learn a complex

computer program by simply reading the instructions. The same can be said for machining. A word like “chatter” doesn’t have much meaning until a part is ripped out of a three-jaw chuck under your nose. Metal doesn’t cut like wood, and not many rules can be transposed from wood cutting to metal cutting; however, the skills that you may have developed using tools and building projects will be invaluable. I have included a chapter on materials and it should be read before you cut any metal. (See Section 1, Chapter 3.)

### **Make your first cuts in aluminum**

Your first cuts should be on aluminum which has a hardness of around T-6. Don’t use brass. It is easy to machine, but it has some strange characteristics that could make you question the basic rules of machining. When brass is machined the chips “splinter” and it cuts similar to wood which isn’t



**FIGURE 22**—Using a scale between the tool bit and the part to check if the tool tip is on the part centerline.

the case for most materials. If you don't have a Sherline lathe use whatever you have. These rules apply to all lathes, and the way you apply them on machines other than the Sherline will be up to you. Whatever machine you are going to operate you must wear eye protection and work safely!

#### **Chucking your part and setting the tool position**

If you have never operated a lathe before, I suggest that you make a trial cut on a scrap piece of round material to learn the basic operation of a lathe. In a 3- or 4-jaw chuck, secure a piece of round aluminum stock approximately 3/4" (20mm) in diameter and 1-1/2" (40mm) long. Secure the presharpener 1/4" square cutting tool supplied with the lathe in the tool post, making sure that it is properly positioned. This tool will be on center because it has been sharpened for use with the Sherline lathe. If you are using a different brand of lathe, take the time to get the point of the tool on center. Machinists have a simple trick to check the center height of lathe tools using a 6" metal machinist's scale. Hold the scale in a vertical position flat against the outside diameter of the work. Now move the tool bit in and hold the scale in place with the tip of the tool, using only the slightest pressure so the scale isn't damaged. If the tool center is low, the top of the scale will come towards you. If the tool is high, the top of the scale will move away from you. If it stays vertical the tool height is perfect. This doesn't work very well for diameters that are so small that the part will deflect away under any load. (See page 124 for two more ways to set tool height.)

#### **Making a first cut**

Set the spindle speed at approximately 1000 rpm with gears or belts. With a Sherline, turn the speed

control all the way counterclockwise and then turn the motor on. Bring the speed up to approximately 1000 RPM (about 1/3 speed). To establish tool position in relation to the work, bring the tool in slowly until it just starts to scribe a line on the outside diameter of the work.

Move the tool towards the tailstock until it clears the end of the work. Advance the tool .010" (.25mm) using the crossslide handwheel (10 divisions on the inch handwheel scale). Using the bed handwheel, move the tool slowly across the work toward the headstock. If you didn't machine a smooth shiny finish take another look at your tool. If it looks proper try a small amount of cutting oil. Tools that are dull or have been set above center will have an important effect on the finish. The smaller the diameter, the more accurate the tool has to be set on center.

#### **Feed, speed and tool "chatter"**

Cutting tools used on lathes are designed to remove metal much as paper is removed from a roll. It takes a positive feed rate to accomplish this. If the feed rate isn't fast enough, it would be similar to tearing an individual sheet of paper off the roll. The results when cutting metal would be shorter tool life, a poor finish and tool "chatter". Chatter is a function of rigidity, but it also can be controlled by speed (RPM) and feed rate. Since you already have a piece of aluminum chucked up, experiment with speed and



**FIGURE 23**—If the metal is coming off like it is being peeled from a roll, the speed and feed settings are correct. If there is a screeching or chattering sound, you need to adjust speed and feed rates. Above are some aluminum chips that show the cutter was peeling a continuous strip of metal off the stock.

feed rate. You just took a cut of .010" (.25mm) and probably noticed that the machine didn't even slow down in the slightest. Now take a 1/2" (12mm) long cut .050" or 1mm deep, which is one revolution of the handwheel. This will change the diameter by .100". If you used the sharpened cutting tool that came with your machine it should have made the cut easily. If the tool "squealed", reduce the RPM a little and take another .050" cut while feeding the tool faster. You will probably be surprised at how easily your machine takes cuts this heavy.

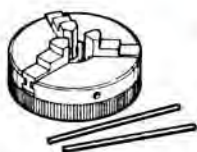
### Inducing chatter on purpose to get a feel for the effects of feed and speed

We will now purposely try to make the machine chatter. Make sure the stock you are cutting is sticking out of the chuck no more than 1 inch (25mm). Crank the handwheel two turns further in from the last setting which will give you a .100" (100 thousandths of an inch) or 2mm cut. Set the spindle speed to about 1000 RPM (1/3 speed) and feed the tool slowly into the material. Vary speed and feed until you get a substantial chatter. Without changing the depth of the cut, drop the speed to about 200 RPM and feed the tool into the work with more force. The chatter should disappear. Once you have learned to control chatter by adjusting speed and feed, you will be on your way to becoming a machinist.

### Use of lathe accessories and attachments

Once you have learned the basics of removing metal with a lathe you will find that much of the skill in making complicated parts is in learning to use accessories to accomplish special operations like knurling, threading and so on. Instructions on the use of the major accessories are provided in separate chapters in this book. In order to summarize and review some of the many accessories available for a Sherline lathe, I will close with a list and brief description of each and what it is used for. Where appropriate, a page number referencing where in this book more information can be found on that accessory is provided in blue.

#### Chucks



□ **1041 2.5" 3-Jaw Chuck**—Three jaws scroll in unison to grip round or hex stock from 3/32" (2mm) up to 1-3/16" (30mm) in diameter. Jaws are reversible for holding larger stock up to 2-1/4" (56mm)

in diameter. Has a .687" (17mm) through hole and 3/4-16 thread. —115, 123

□ **1040 3.125" 3-Jaw Chuck**—Larger version of the chuck above, it holds parts up to 1-1/2" (38mm) in diameter in normal position and up to 2-3/4" (70mm) with the jaws reversed. Has a .687" (17mm) through hole and 3/4-16 thread. —115, 123

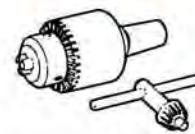


□ **1075 4-Jaw Self-Centering Chuck**—Holds round or square stock from 3/32" (2mm) up to 1-3/16". With jaws reversed, it will grip stock up to 2-1/4" (56mm). Jaws scroll in unison as on the 3-jaw chuck. (NOTE: Stock held in this chuck must be perfectly round or square to be gripped by all 4 jaws.) —115



□ **1044 2.5" 4-Jaw (Independent) Chuck**—Each jaw is adjusted independently, allowing precise adjustment for perfect centering or for holding odd-shaped parts. Four-jaw chucks take a little more time to use, but offer much greater accuracy and versatility. —115, 123

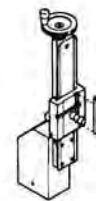
□ **1030 3.125" 4-Jaw (Independent) Chuck**—A larger version of the chuck above for holding larger work. —115, 123



□ **1072 1/4" Tailstock Chuck**—A conventional Jacobs drill chuck fitted with a #0 Morse arbor so it can be used in the tailstock for center drilling parts. It also comes with a #1 Morse arbor and drawbolt so it can be used in the headstock. Chuck key included. —124

□ **1069 3/8" Tailstock Chuck**—A larger size Jacobs chuck with arbors for use in both tailstock and headstock. (Recommended for long bed lathe where greater center-to-center distance allows the use of larger drills and reamers.) Can be used in headstock as well as tailstock. Chuck key, Morse #0 and #1 arbors and drawbolt included.—124

#### Additional Accessories



□ **3050 (3053) Vertical Milling Column**—Mounts in seconds to provide three axes of movement to do milling on your lathe. Headstock and motor/speed control mount to saddle on column. The Z-axis column provides the same 6.5" (165mm) vertical travel available on the Sherline milling machine.—177



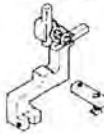
□ **3003 Two Position Tool Post**—Save time by mounting two 1/4" cutting tools at once so you can switch quickly from one to the other. P/N 3008 holds a 5/16" and 3/8" tool.



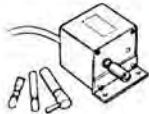
□ **3057 Rocker Tool Post**—Allows exact control of tool tip height in relation to part centerline. Tips of older, resharpened cutting tools can be adjusted up to proper cutting height without having to use shims.



□ **1074 Steady Rest**—Supports longer work with three adjustable brass pads. Keeps long parts from deflecting away from the tool or wobbling while turning. Steadies the end of long parts for center drilling. —149



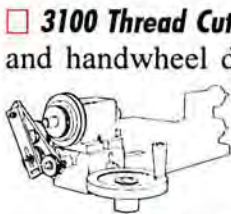
□ **1090 Follower Rest**—Moves with saddle and provides support right behind the cutting tool to keep long, thin stock from deflecting during the cut. —151



□ **3001 Power Feed**—A constant speed, single direction motor with on/off switch drives the leadscrew. Lever below headstock engages and disengages the drive. Saves a lot of hand cranking on long parts and provides smooth finishes.



□ **1160 (1178), 2100, -01, -02, 1162 (1179) Collet Sets**—Holding work in individually sized collets is a more accurate method than holding in a chuck. A number of sets of standard collets, collet pot chucks and deluxe collet sets are available. —119



□ **3100 Thread Cutting Attachment**—Special gear set and handwheel drives leadscrew to cut over 50 different thread pitches on the lathe. Inch or metric threads can be cut on either inch or metric lathes. —157



□ **1191 Live Center**—Replaces tailstock dead center for holding work. Ball bearing reduces friction while turning between centers. Requires no lubrication.



□ **1201 Adjustable Live Center**—Ball bearing live center with adjustable backing plate allows precise alignment of headstock and tailstock. Adjustable tailstock accessories like P/N 1201, 1202 and 1203 are for the craftsman seeking the ultimate in precision. —143



□ **1202 Adjustable Tailstock Chuck Holder**—Perfect centering for tailstock chuck. —143



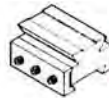
□ **1203 Adjustable Tailstock Custom Tool Holder**—Adaptable to hold any tool you wish on perfect center in the tailstock. —144



□ **2085 (WW) and 2086 (8mm) Collet Adapters**—Held in P/N 1203 adjustable tool holder above (not included), collet adapters allow you to use WW or 8mm collets in the tailstock to hold small drills accurately on center. —144



□ **1291 Headstock Riser Block**—Raises headstock 1.25" (31.7mm) for more clearance to turn larger stock. Also includes riser tool post. —145



□ **1292 Tailstock Riser Block**—Raises tailstock 1.25" (31.7mm) to align it with headstock on riser block. —146



□ **1290 Steady Rest Riser Block**—Raises steady rest to proper height for use with headstock and tailstock riser blocks. —146



□ **3035 Spur Driver**—A simple way to drive wood from the headstock in place of a 3-jaw chuck.



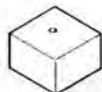
□ **3038, 3047 Wood Tool Rests**—Allows wood turning on the lathe using hand held wood cutting tools.



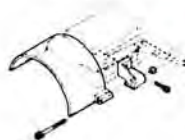
□ **1185 (1184) Vertical Milling Table**—Mounts to the table to provide a vertical "Z axis" movement of 2.25" (57mm). Although the vertical milling column (P/N 3050/3053) is the preferred method, this is a traditional method of doing small milling jobs on the lathe. Can be very useful for special setups on the vertical mill too. —177



□ **3015 Toggle Switch Dust Cover**—Protects on/off switch on speed control from fine dust generated by cutting brass or wood.



□ **3016 Cutoff Tool Rear Mounting Block**—Allows the parting tool (P/N 3002) to be used on the back side of the table. The cutoff tool blade is turned upside down in the holder and this 13/16" high spacer block keeps the tool's cutting point at the lathe's centerline. —146



□ **4360 Chip Guard**—Clear, tough polycarbonate shield mounts to headstock to contain chips and cutting fluids near chuck. Swings out of way for changing setups.



*Here is an example of the technique described on page 135 for turning a very small diameter without having to use a steady rest or follower rest. This three-stepped shaft was turned with each step being made in one heavy cut. The large diameter of the stock keeps it from deflecting and the small shaft is what is "left over" after the cut. The 3/8" stock was first turned down to a diameter of .150" which was strong enough to support the length that was to be cut. Then the first step is cut to size and length in one pass by taking a .0625" cut which reduces the diameter by .125" to leave just .025". Then the second step is cut and so on. The small shaft shown here is .025" (.64mm) in diameter so it could be easily seen in the photo, but smaller sizes can be cut. Remember that for this technique to work, the tool tip cannot be above or below center but must be accurately set to the centerline of the part. Experiment with this technique yourself, and you will be surprised at how small a shaft you can cut using this method.*

## Chapter 3— Tailstock tools and operations

The tailstock on a lathe is used for two main purposes. The first is to support the long end of work while it is driven from the headstock and turned “between centers”. The other is to hold a drill chuck or collet to center drill the end of a part. The parts held in the tailstock spindle include the dead center, live centers, drill chuck and adjustable tailstock tool holders. Here is a brief description of each and how each is used.

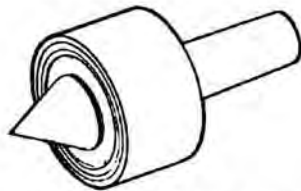


### Dead centers

A dead center is called that because it does not turn. It has a 60° pointed end which is inserted into a matching hole drilled in the end of a part to be supported. This is a system that has been in use on lathes for many years. Lubrication is an absolute must to reduce friction between the spinning part and the fixed dead center. Thermal expansion caused by the friction-generated heat can cause parts to “lock up” if the tension adjustment on the tailstock isn’t checked frequently. This is especially important if you are working with parts made from thermal plastic which have a tendency to soften and even melt as a result of too much heat.

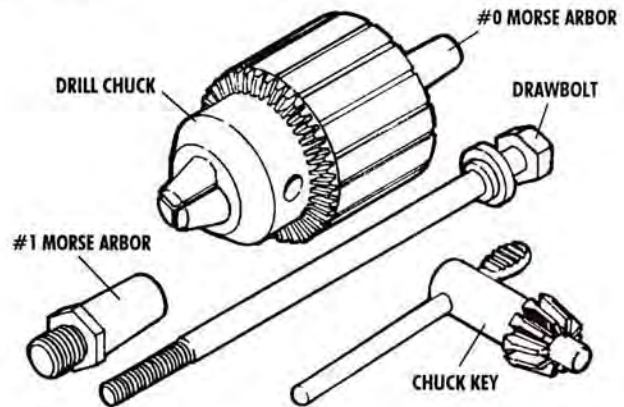
Each Sherline lathe comes with two dead centers. The larger one with a #1 Morse taper fits in the headstock spindle. The smaller has a #0 Morse taper and fits in the tailstock spindle. Removing the dead center from the spindle is accomplished by backing the spindle handwheel all the way off until the center is released from its grip.

### Live centers



The obvious answer to eliminating friction between part and center is to have the center turn with the part. A “live” center is called that because it uses a

set of ball bearings between the spindle end and the point to allow the point to turn with the part. This eliminates friction and makes life a lot easier for the machinist. This is one of the first accessories every machinist wants to acquire, and, once having worked with one, you will agree your money was well spent.



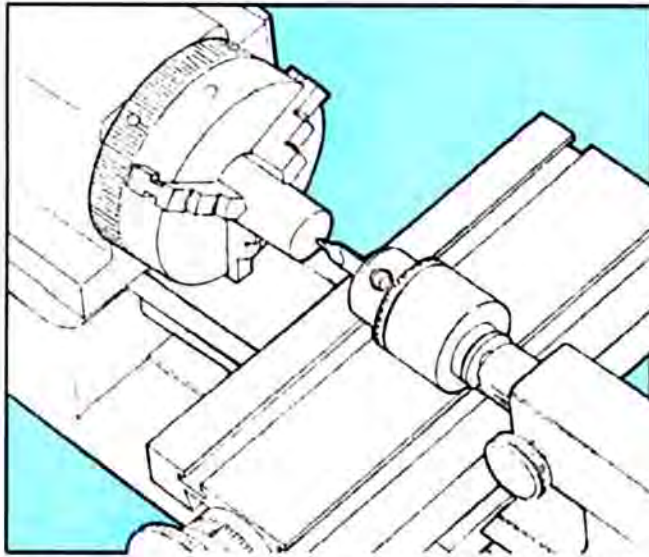
### Drill chucks

Tailstock drill chucks look pretty much like the chucks you normally see on power drills. They are equipped with a tapered end which fits into the #0 Morse taper on the tailstock spindle and are normally used to hold center drills or other types of drills for drilling operations in the ends of parts. Tightening the chuck on a drill is done with a geared “key”, which applies much more force than you could tightening it by hand. Unlike a power drill, the lathe spins the part while the drill chuck remains stationary, but the metal being removed doesn’t know the difference.

Sherline offers both 1/4" and 3/8" tailstock chucks. Included with each is an additional arbor and drawbolt so the chuck can also be mounted in the #1 Morse taper of the headstock. An example of where this might be useful on a lathe would be to drill a precision hole pattern in a part held on the vertical milling table which is mounted to the crossslide. Both size chucks will fit in either Sherline lathe, but the 3/8" chuck is recommended mainly for the longer bed lathe because of the chuck’s longer length. On the short lathe, there isn’t much room left between centers by the time the larger chuck and a long drill are mounted in the tailstock. The 1/4" chuck is a better choice for the smaller lathe.

### Using a tailstock chuck for center drilling

Because the work turns and the drill does not on a lathe, it is necessary to use a center drill before a standard drill can be used. Due to the flexibility of a standard drill bit, it will tend to wander on the surface of the rotating work whereas a center drill is designed to seek the center and begin drilling. Cutting oil is recommended for all drilling operations. A center drill should be withdrawn, cleared of chips and oiled several times during the drilling of a hole to keep the tip from breaking off.



*Tailstock center drilling. The work turns while the drill is held stationary in the tailstock chuck.*

### Tailstock drilling

Hold the work in a 3- or 4-jaw chuck. If the work is longer than approximately 3" (76mm), support the free end with a steady rest. Fit the drill chuck to the tailstock with a #0 Morse arbor and secure a center drill in the chuck. Adjust the tailstock to bring the center drill close to the work and lock it in position. Turn the tailstock handwheel to bring the center drill forward. After the hole is started with the center drill, switch to a standard drill bit of the desired size to drill the hole.

### Tightening tolerances over the years

The Sherline lathe has come a long way since its original conception in the late 1960's. It started out as a machine that could be manufactured and sold at a very reasonable price, but the accuracy was such that it had limited use. When I purchased the company in 1974 and started to produce these machines in the USA, I completely changed the manufacturing methods and "tightened the tolerances". The biggest improvement in the product came with the advent of CNC machines (computer

controlled) which is how the machines have been manufactured for the last ten years.

### Increased accuracy leads to a more demanding clientele

Along with the improved accuracy came another set of problems; customers are using Sherline tools to do work that, until now, could only be done on machines costing thousands of dollars. The weakest point of the Sherline lathe design is also the best one; that is, the headstock is removable. This allows taper cutting, milling conversions, riser blocks and numerous other setups to be made that could never be accomplished without this feature. The negative part of this design is that it is impossible to have perfect tailstock-to-headstock alignment. Engineering is always a compromise. In manufacturing the adjustable tailstock tool holders we provide a way to overcome the shortcoming but are also admitting we don't expect to achieve perfect alignment with the basic tool. I still feel the advantages of the design justify the minor compromise.

### Achieving tolerances that approach "perfect" with the use of adjustable tailstock tools

Only someone new to the machine trade would talk about "perfect" alignment. In the machine business you talk tolerances even if you can't measure an error, because now the error has to be assumed from the tolerances of your method of checking. To maximize the use of the Sherline lathe we introduced a series of three tool holders. Holders such as these have always been used in setting up turret lathes and screw machines in the machine trade to make up for the inaccuracies in machine tools or the lack of room for drill chucks, etc.

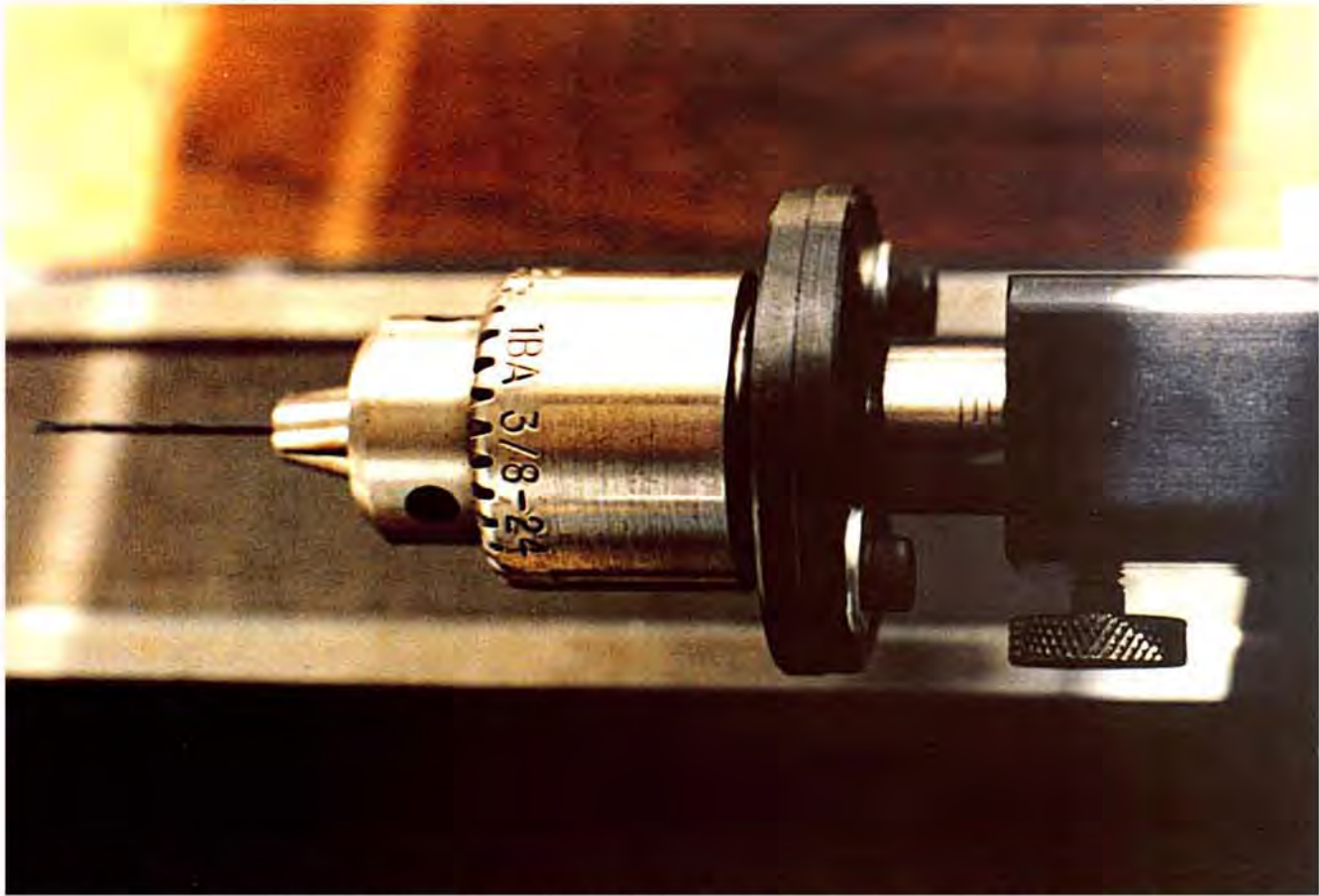
The Sherline holders have a Morse #0 taper to fit the tailstock and a choice of three tool holders: An adjustable live center, an adjustable drill chuck holder and an adjustable tool holder.

### How adjustable tool holders work

These holders are simple to use. They are divided into two parts with flanges. These flanges are bolted together with two screws. A little extra clearance in the holes for these screws allows the front to be adjusted in relation to the rear. The rear section has a witness mark (hole). This hole should always be located at the top so the holder is located the same way in the tailstock each time.

### Maximizing accuracy

The accuracy that is attainable is governed by the amount of skilled effort you put forth. Before starting, it's wise to clamp your headstock square



Here an adjustable tailstock holder allows the drill chuck to be perfectly centered for center drilling a part. A slight amount of play between the front and back half of the holder allows the drill chuck to be brought into perfect alignment with the center of the headstock.

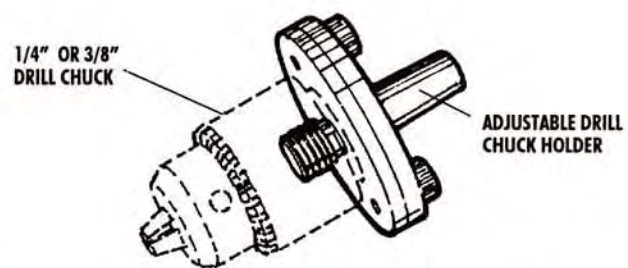
with the bed. This can usually be accomplished by loosening the headstock and pushing back evenly against the alignment key (located under the headstock) and retightening.

#### Marking the center of the part

To line up the tailstock chuck, put a scrap piece in the 3-Jaw that sticks out approximately 3/4" and face and center drill the end with your present Morse #0 arbor and drill chuck. The center drill will find center of the stock even though the chuck may not be lined up perfectly.

#### Bringing the adjustable drill chuck holder into final alignment

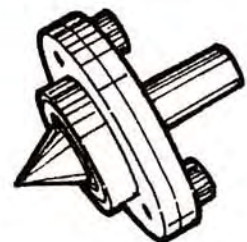
Next, mount the drill chuck on the adjustable arbor with the center drill still in it. Bring the tailstock up until the center drill is in the just drilled hole with the screws loose. Tighten when you feel it's on center in the hole. Repeat this process to assure alignment using the new adjustable arbor. This should be close enough for a drill chuck because drill chucks are only accurate within .003" when



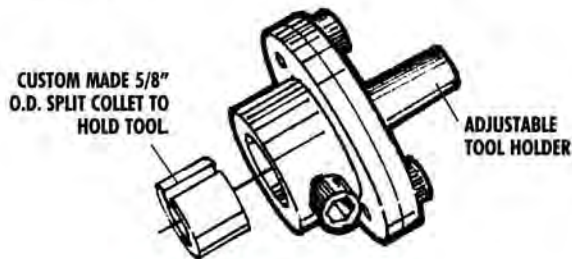
new at best. Accurate drill chucks cost approximately 4 times as much and only run within .002". They might claim .001", but I haven't seen it unless you have brand new everything. They are not a good investment for the home shop machinist.

#### Setting the adjustable live center using the same setup

With the drill chuck aligned you can use the same setup to align the adjustable live center by putting the point into the center drilled hole and tightening the screws to start.



Turn a test bar and correct any error. This can be time consuming and adjustments can be made by never locking the screws so tight that you can't move it with a few taps of a small mallet. When aligned to your satisfaction, screws can then be tightened completely.



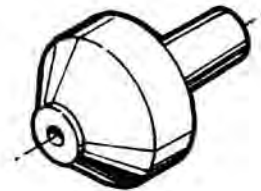
### The adjustable tool holder

The adjustable tool holder allows the use of larger drills and cutting tools that can't be held in a standard drill chuck. Tools are held in a split bushing that can easily be made. The outside diameter has to be .625" and the inside diameter is cut to fit the tool you wish to hold. The bushing is then split through one side with a hacksaw or slitting saw in the direction of the hole. The tool can now be clamped in the holder using this split bushing.

I personally don't believe a person should try to get these any more accurate than you realistically need. Machining is a process that takes place under high loads and temperatures. A perfectly aligned machine doesn't produce a perfect part without the skill of an operator who copes with the many variables. The skill of machining is making parts that are of a closer tolerance than those of the machine you are working with. If you cut a slight taper on a lathe there is nothing wrong with straightening it with a flat mill file and polishing with 320 grit wet/dry sandpaper. This should only take a couple of minutes. Trying to align your machine could take hours only to find the machine aligned to perfect specs but your cutter was dull and below center. Please, don't become a machinist who can never get a job done correctly because of the equipment on hand. I've seen beautiful parts produced in machine shops using equipment that was worn out twenty years ago. It's the machinists that build these parts not the machines!

### 1/8" Armature support

The use of electric motors in radio controlled cars and boats has seen an increase in the number of builders who wish to increase their motor's

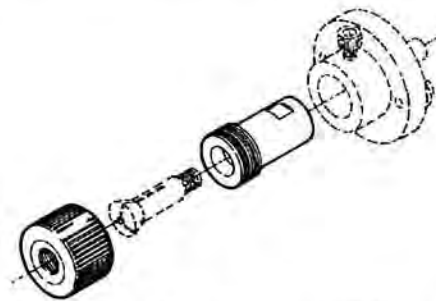


performance by "truing up" the armature. Most racing motors use a 1/8" shaft, which is held in a brass bushing on the armature support. The driven end can be held with a chuck or a 1/8" WW collet. A diamond tipped tool will give a mirror-like finish when turning copper, but a sharp high speed steel tool works fine too. This is a very specialized part for a specialized use, but typical of the kinds of things I have been asked to add to the line to make a particular job easier.

### WW Collet adapter

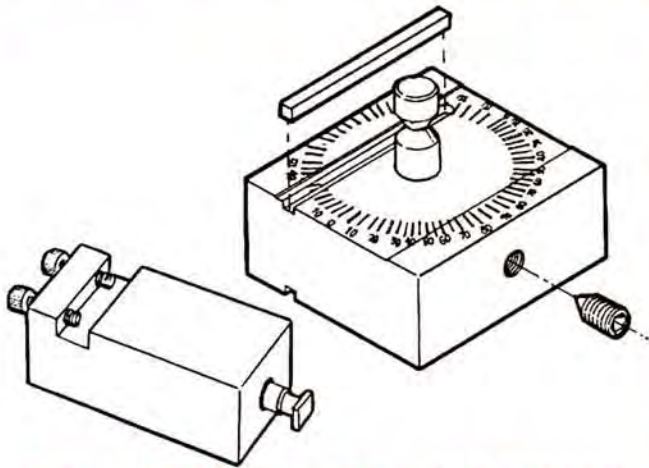


The WW collet adapter is held in the adjustable tailstock tool holder to mount WW collets in the tailstock. This allows you to hold extremely small drills accurately on center. Drills only a few thousandths of an inch in diameter are easily broken if not perfectly centered. In addition, with a 1/8" collet, it can do the same job as the 1/8" armature support above, but with even greater accuracy. When you consider that the only alternative to this kind of center drilling accuracy is a far less versatile jeweler's lathe costing thousands of dollars, the slight extra time spent to set up using the adjustable tailstock tools is very well spent.



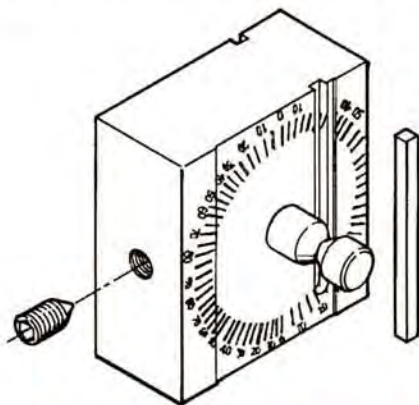
A collet is held in the adapter and the adapter is centered in the tailstock tool holder allowing perfect center drilling accuracy with extremely small drills.

## Chapter 4— Riser blocks for larger work



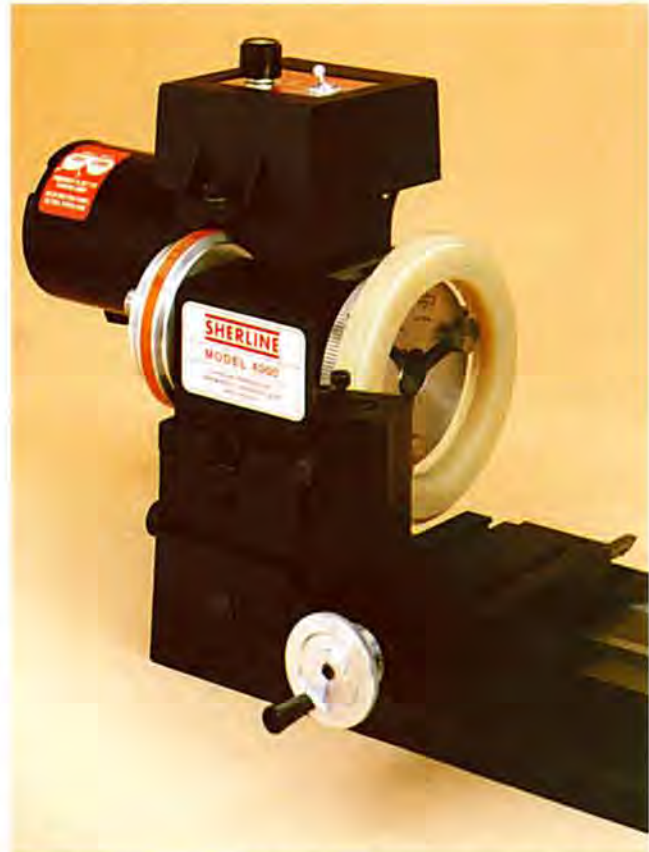
### Making a 3.5" lathe into a 6" lathe for light duty jobs

The riser block is the result of customers' requests to get more out of their Sherline tools. It is simply a block of material 1.235" (31mm) thick. The block is designed to be quickly installed under the headstock, adding twice the thickness of the riser to the diameter that can be turned. This brings the diameter that can be turned to almost six inches (150mm). Don't plan on machining parts six inches in diameter very often, for most materials this size far exceed the capabilities of a Sherline lathe. I believe a riser block could be helpful when used to make a part like a flywheel occasionally, but the machine's design wasn't intended to work with large diameters. It would be like putting a one-inch drill bit in a small hand drill. The spacer block kit also includes a correspondingly taller tool post.



### Riser block becomes a headstock spacer block on the mill

When I found that the riser block was being used on a Sherline mill to get more usable room under the

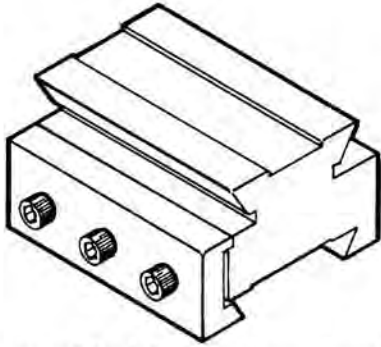


*A headstock riser block and corresponding riser toolpost make it possible to turn this large Nylon ring. A 3-jaw chuck with its jaws reversed holds the part from the inside.*

spindle I redesigned it and sold it as a separate accessory. The tool post would be useless on a mill and the original design used a two-hole offset. The new design was superior because we eliminated this. When we bought our laser engraver we were able to engrave the riser block with a pattern of degrees to show how far the headstock was rotated.

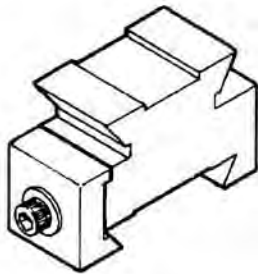
### Turning big parts between centers requires another riser at the tailstock end

It wasn't long before we began getting requests for a tailstock riser, and we manufactured one. The shortcoming of the tailstock riser was that the lathe tailstock had to be removed and installed on the riser block. To remove the tailstock the handwheel had to be removed. This isn't how I like to design products, but the purchasers have not complained. They realize there simply wasn't any other solution to the problem.



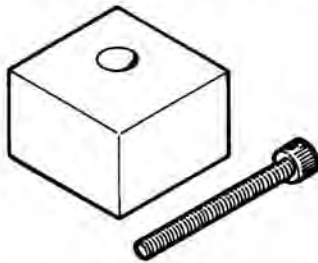
*(Above) A riser block brings the tailstock up to the proper height to align with the headstock when it is on a riser block.*

*(Below) A shorter section of the same extrusion was easy to adapt to make a special riser block for the steady rest.*



### **We learn a lesson on how some customers actually use our tools**

Next came a riser for the steady rest. A couple of customers made enough noise, and I finally gave in and produced one. I didn't realize customers were leaving their lathes set up with riser blocks and didn't want to remove them to use the steady rest. The good part about a riser block setup is you can turn larger diameters. The bad part is a customer will lose some rigidity. Another engineering compromise.



### **A riser block that's really a reversing block for the cutoff tool holder**

Sherline also manufactures a riser for the cutoff holder. In this case, however, the purpose isn't to increase the diameter that can be cut off. With the riser under the cutoff holder, the cutoff blade can be reversed and mounted on the back side of the slide. This will allow you to leave the cutoff holder mounted on the back portion of the crossslide and

out of the way for normal machining. This can be handy when making multiple parts. (Instructions for its use can be found on page 76.)

### **Staying accurate when using riser blocks**

One point to be considered is accuracy. When you start clamping several pieces together, alignment will suffer. In the real world of machining, spindles are aligned by indicating, not with pins or keys. This wouldn't be the best way for hobbyists to start, and I believe the methods we use give our average customer machining capabilities they could never have without experience. As your projects get more and more complex, these methods may not be good enough. We manufacture adjustable tool holders (for more information see page 142.) to help eliminate some of these problems caused by misalignment. If you believe alignment could be a problem, machine a piece of scrap as a test piece to get the machine lined up. Don't risk a part you may have a lot of work in.

You may have to use a little ingenuity when turning large diameters because of the limited crossslide throw on standard machines.

### **Installing lathe riser blocks**

Remove the headstock by loosening the screw that holds it onto the lathe or mill and lift it straight off. Now install the riser block using the keyway to align it. Do this by pushing the riser block back towards the keyway without a twisting motion. Put the headstock back with or without the keyway depending on your next machining operation. For example, if setting up to do taper turning you would leave the alignment key out.

To install the tailstock riser block, it is necessary to remove the tailstock. To do this you must first remove the handwheel at the end of the bed. You may have a slight problem fitting this up. The riser block is a very difficult part to make because dovetails can't be measured or machined easily. The biggest problem we have encountered is the "tip" of the dovetail on the lathe bed may interfere with the riser block. A couple of passes with a file should

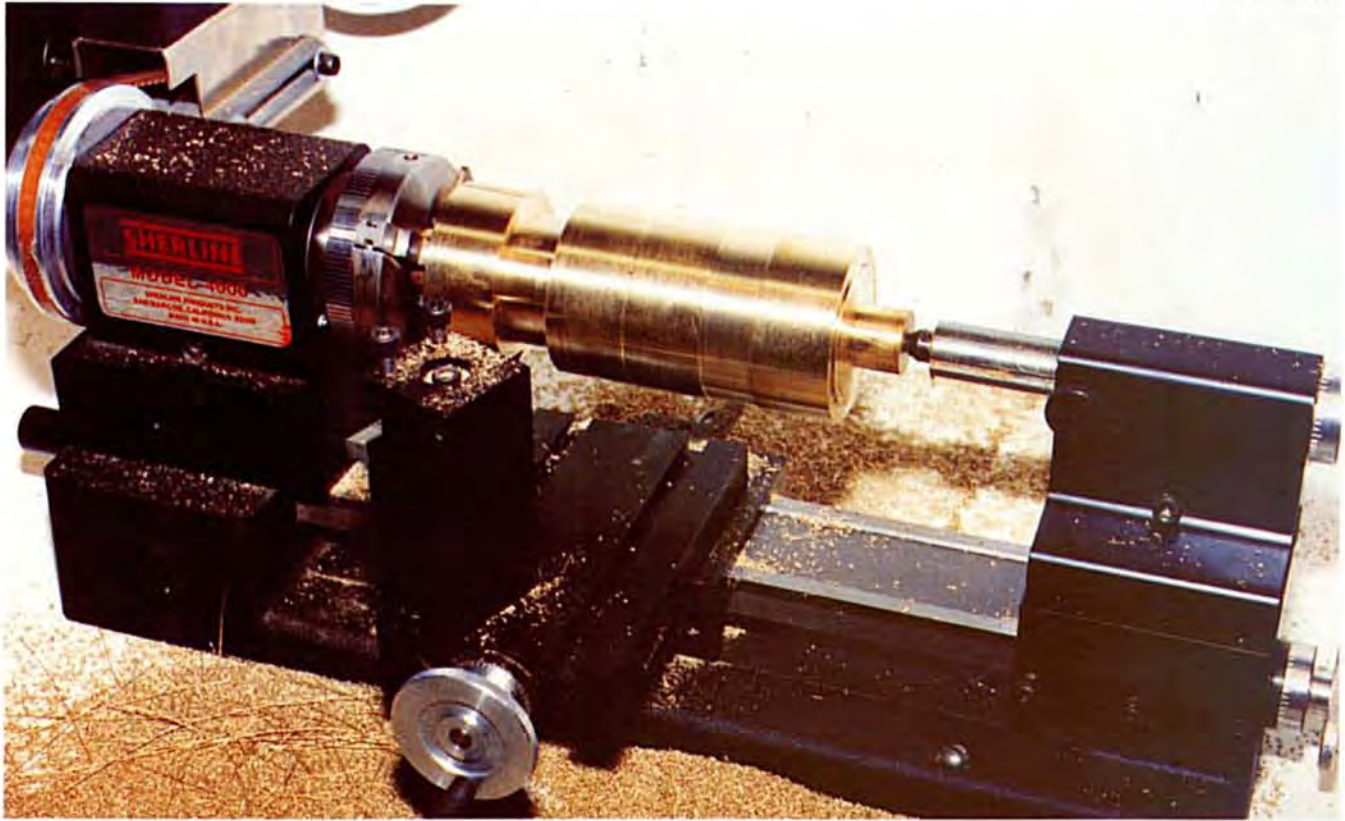


*Filing corners of bed dovetail for better fit of Tailstock Riser Block.*

fix it. Riser Blocks made after 11/93 are of a two-piece design that in most cases eliminates this fitting problem. When replacing the handwheel try to let

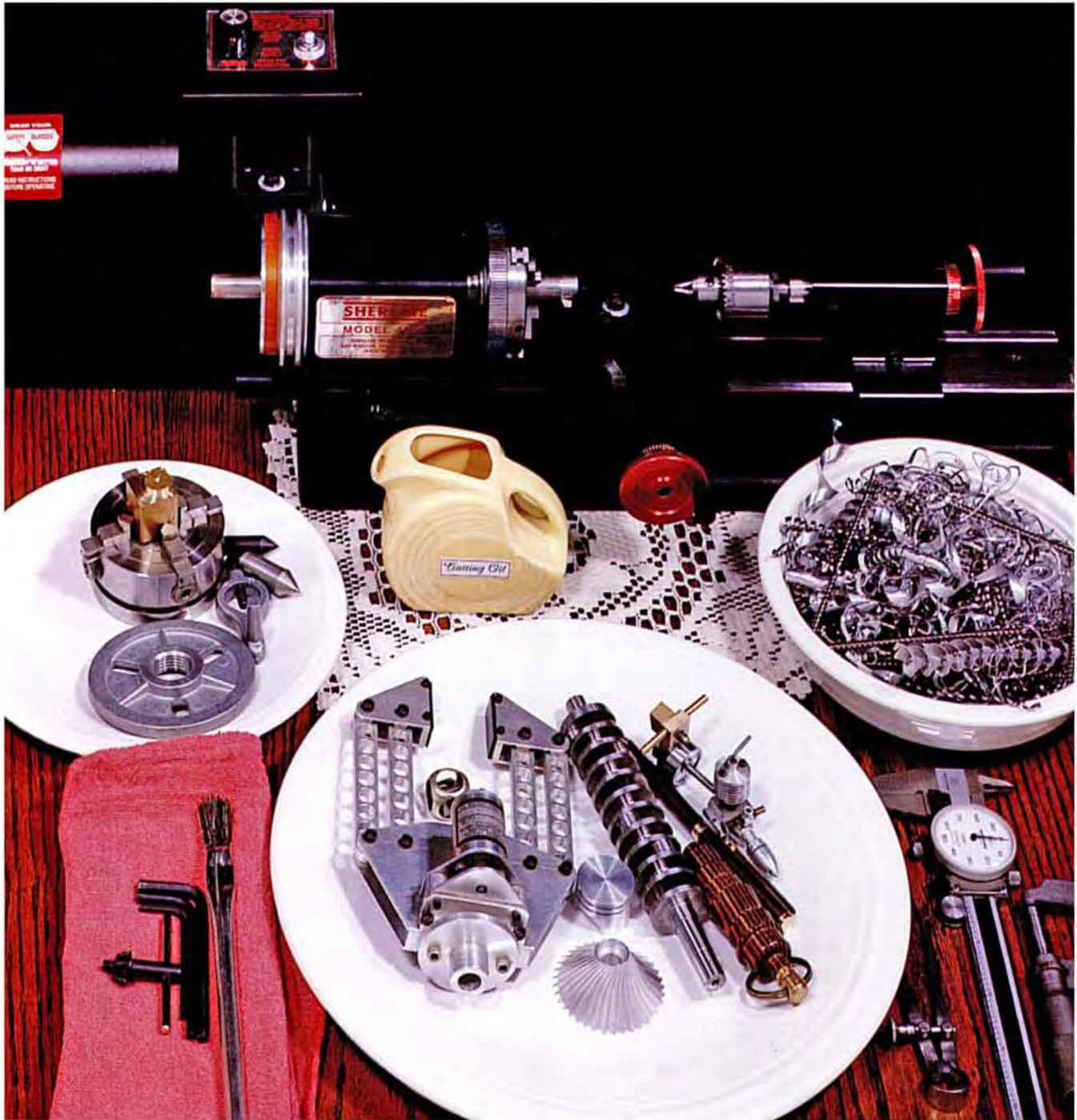
the set screw pick up the same indentation so you don't "chew up" the end of the lead screw shaft.

PHOTO: BOB BRESLAUER



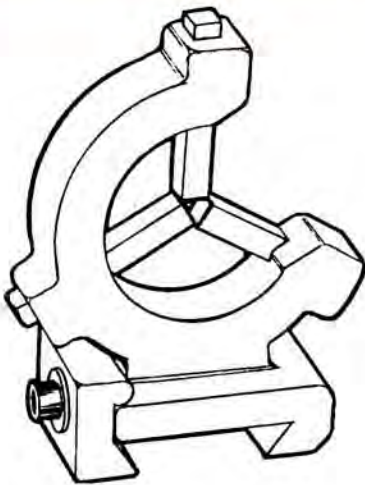
*A large part is being roughed out to size using riser blocks on both the headstock and the tailstock. The riser toolpost is used to bring the cutting tool up to the proper height. Riser blocks allow parts as large as 6" to be turned over the bed or 3.1" over the crossslide. For those who prefer to leave their lathe in this configuration and need to turn a long, thin part, a riser block is also available for the steady rest (not shown, see previous page).*

---



*A feast for the tabletop machinist. This was the first cover photo Craig shot for the book. After thinking about it for a while we had second thoughts and were afraid it might be mistaken for a cookbook in the book stores. We decided to go with a cover that was a little more descriptive but thought you might enjoy seeing this one anyway.*

## Chapter 5— Supporting long or thin work



### THE STEADY REST

The steady rest was one of the accessories that started life in Australia. When I started making the tooling to produce Sherline's lathe in America I had so many other problems I forgot all about it. I had decided to add 1/2" to the diameter the Sherline lathe could turn to make it four-inch lathe. This would give me "one up" on my main competitor, the "Unimat" lathe. To accomplish this was easy because all I had to do was add 1/4" of material to the new extrusion dies for the headstock and tailstock. The drawings were done, and I was meeting with a large metal extruder in Los Angeles. I would need several dies made, and I was getting the final costs and delivery information. For some reason, in the middle of the conversation, it occurred to me that the existing steady rest tooling wouldn't work if I made a 4" lathe. A new mold to produce a diecast steady rest would have cost \$10,000, and my new business was just barely surviving. I changed the drawing right on the spot, and the Sherline lathe remained a 3-1/2" lathe, but I still wish I had the money at that time to build a new mold.

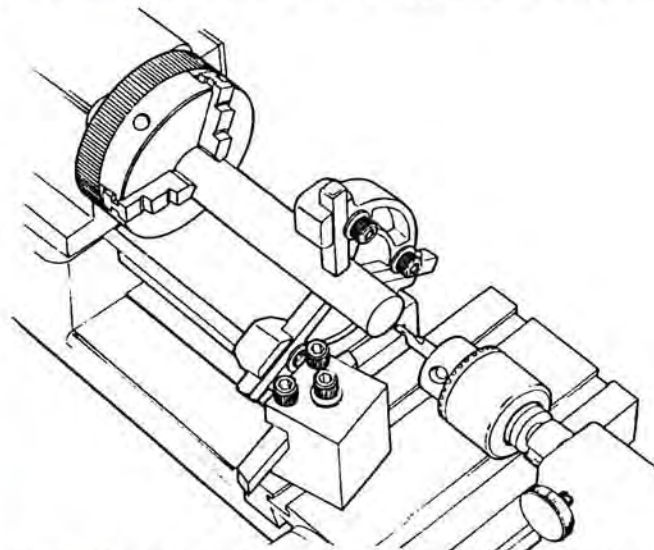
#### **Smaller lathes make use of the steady rest more often**

Tabletop machine tools all have one thing in common; that is, the hole through the spindle is small. This means you can't take a 4" long piece of 3/4" bar stock and put it in the lathe with only the end protruding from the 3-jaw chuck. The piece would have to be held with 3-1/2" of material sticking out unsupported. Even if you plan to use a supporting center you first must drill a "center" hole

with a center drill. This can be difficult if the work isn't held properly. A steady rest can come to the rescue and allow machining on the end of this bar. I have seen many worn out full size lathes with a brand new steady rest. Steady rests don't get nearly as much use on full size machines as they do on miniature lathes.

#### **When to use a steady rest and when to use a follower rest**

One of the main differences between a steady rest and a follower rest is that the steady rest is clamped to the bed and doesn't move, while the follower rest is clamped to the saddle which moves along the lathe bed. (Instructions for use of a follower rest begin on page 152.) Materials will deflect away from the cutting tool when being turned on a lathe. Long, slender parts that are not rigid enough to support cutting loads will deflect when they are machined, unless they have support. If the difference in diameter were around a few thousandths of an inch (.05mm) in the middle of the cut, I would probably just file the part to the proper diameter rather than taking the time to set up either accessory. Long pieces of bar stock that need to have their outside diameter turned need to be supported as they are



*To drill a hole in the end of a long shaft, the lathe is set up with a center drill in the drill chuck which is mounted in the tailstock. The steady rest keeps the shaft from wobbling and also assures that the hole will be concentric with the outside diameter of the part.*

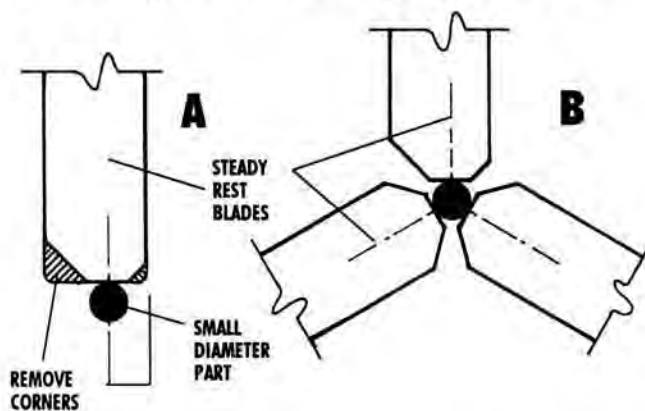
machined. For this type of work, I recommend a follower over a steady rest. For a long shaft that only needs machining in a small area, the steady rest may be a better choice.

### Using the steady rest on the unsupported end of a long part

The best way to hold a long part is with a center mounted in the tailstock. However, for one reason or another this is not always possible. As an example, it may be a piece of stock that you want to center-drill so that you can mount it between centers, or it may be a part where a center hole would ruin the looks of the part. Whatever the reason, the steady rest provides a means of supporting the part.

The Sherline steady rest has three adjustable brass blades mounted in a holder which mounts on the bed of the lathe. These blades can be set to the diameter of the part to provide necessary support while it turns.

Another advantage of the steady rest which is often overlooked is the fact that work which is held in position by the steady rest turns concentric with its outside diameter. This means that concentricity is assured when working near the steady rest because at that point it *must* be running perfectly true despite imperfections in the way it is chucked or centered at either end. The farther away the steady rest is mounted from the chuck holding the work, the more any error in chucking is canceled out.



*A) Mark each blade where it contacts the part and grind off corners for clearance. Note that the contact point may or may not be at the center of the blade.*

*B) All three blades can now contact the part without their corners interfering with each other.*

### Setting up the steady rest

The easiest way to set up a steady rest is to first mount the part to be machined in a collet or 3-jaw chuck. Then mount the steady rest onto the bed of the lathe and slide it over the free end of the part and up as close to the chuck as it will go. The three blades of the steady rest can then be adjusted in until they just contact the part, supporting it but not binding it. For small diameter parts, it may be necessary to cut or file off the corners of the blades so they contact the part without touching each other. While the blades are close to the chuck, mark where the center of the small diameter stock contacts the blade. (Because the casting is not extremely precise, the blades may not contact the part at their center. This does not affect their function.) File or grind off the corners as needed so the blades contact the part but not each other. (See drawing at lower left.) If I'm working with a close tolerance part, I may also "wear in" the pads to the exact diameter by using a little more pad pressure and some oil. I then reset their position and don't have to worry about the pads wearing as fast. Use a low RPM and lubricant on the pads to keep pad wear to a minimum.

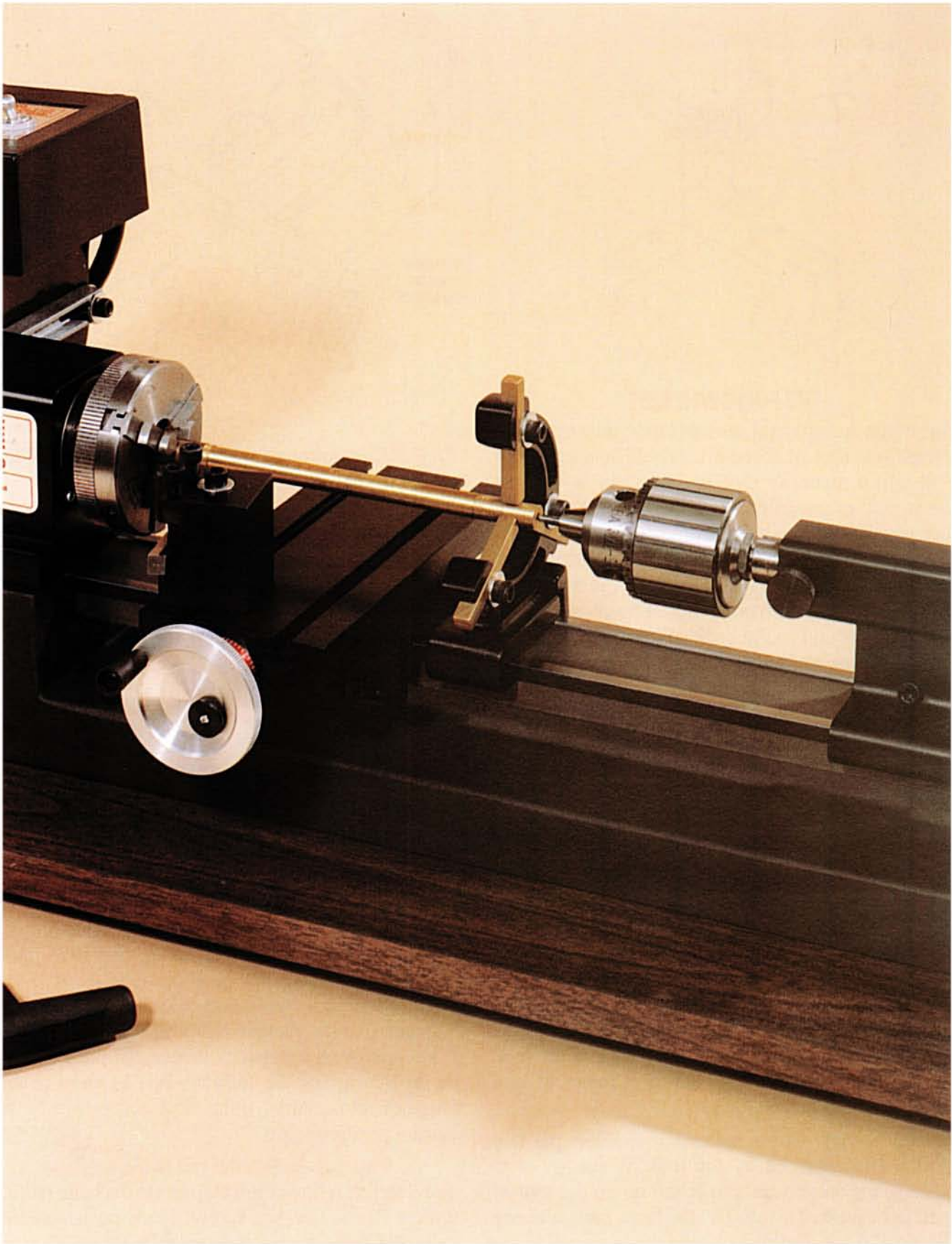
### Solving unique machining problems

A Sherline customer made pads with rollers for his steady rest, making the steady rest like its full size counterpart. Another customer had a problem when using a steady rest with Sherline's watchmaker's T-rest. When working with very small watch parts, the T-rest could not be brought close enough to the steady rest to work on the pivot. I suggested that he make special pads that protrude out to the side to solve this problem. One of the things makes machining fun is that you can solve your own problems when you have the tools to make what you need.

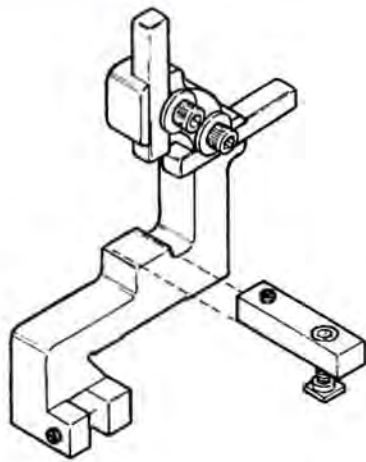
### Slide the steady rest into position and start cutting

Once the blades are set and locked in place, the steady rest can be slid back out to support the free end of the part. If you want to check the accuracy of your setup, you can use a dial indicator mounted on the crossslide. Once you are satisfied with the setup, apply a drop or two of oil where the blades come in contact with the part and you are ready to start machining. The Sherline steady rest will accommodate work up to 1.75" diameter.

NOTE: A steady rest riser block is available which makes it possible to use the steady rest on the lathe with the headstock and tailstock riser blocks in place. See page 146 for more on using riser blocks.



*A steady rest is commonly used to support the end of a long part so it can be center drilled. The hole can then be used to locate either a live or dead center in the tailstock to support the part during machining.*



### THE FOLLOWER REST

One of the design requirements I have imposed upon myself was that all accessories could be mounted to a Sherline machine tool without any additional machining or modifications. I will have failed as a designer if customers must modify their machines to mount any accessory. To accomplish this takes some good ideas, and for a long time I just couldn't seem to come up with one for a follower rest. It was bouncing around in the back of my mind for years before I came up with a solution I liked. A friend and customer, Larry Kombrink, who likes to design accessories for his lathe, started working on a design for me. Although the final follower design was quite a bit different than Larry's design, it was his design that got the wheels in my brain turning. This is a perfect example of why you should build a prototype as soon as possible. You need something physical to look at to get your mind working at 100%.

#### The purpose of a follower rest

The reason this tool is called a "follower" is because the brass supports actually move along with or "follow" the cutter. It is used to support a piece of round stock while it is being machined to keep the part from deflecting away from the tool. In a normal setup, the Sherline follower rest will lead the tool. (See Figures 1 and 4.)

A follower rest works because it counters the two main forces applied by the tool. When a tool is cutting, the stock wants to climb up on the tool as well as be pushed away. The top brass pad will keep the stock from climbing up, and the brass pad in the rear will keep the stock from being pushed away. The stock will then be cut concentric with the

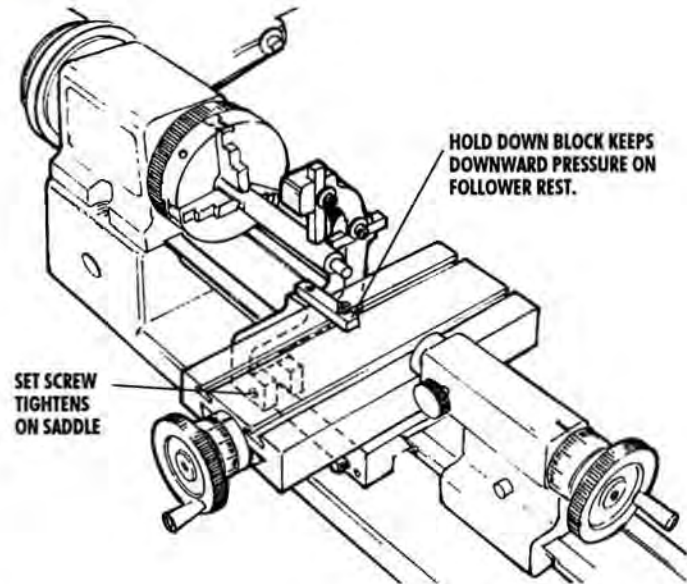


FIGURE 1—follower rest installed on lathe. (Tool post removed for clarity.)

outside diameter because that is where it is supported. It isn't necessary to have the free end of the stock supported by a center when using a follower, but it does make for a better setup, especially for larger diameters.

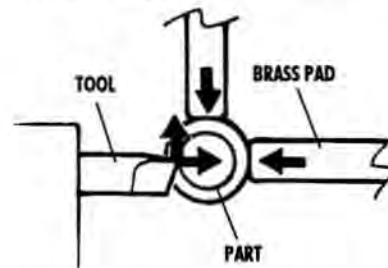


FIGURE 2—Cutting forces on a part and how they are countered by the follower rest supports.

When using a center to support the free end, newer Sherline lathes manufactured after mid-1996 have a cutout in the tailstock to allow it to overlap the table. Older machines may require the use of a tailstock spindle extension (P/N 1220) for clearance. If you are using a tailstock center, the pads should be set by moving the follower rest as close to the tailstock as possible, tightening and returning to cutting position.

#### Mounting the follower rest to the saddle

The Sherline follower rest attaches to the lathe saddle with a flat ended set screw. Push down on the follower rest as you tighten this screw so it is clamped flat on the bed. The small block which mounts by means of the crossslide "T" slot is

positioned so that the nylon tip set screw pushes down on the machined top surface of the body of the follower rest.

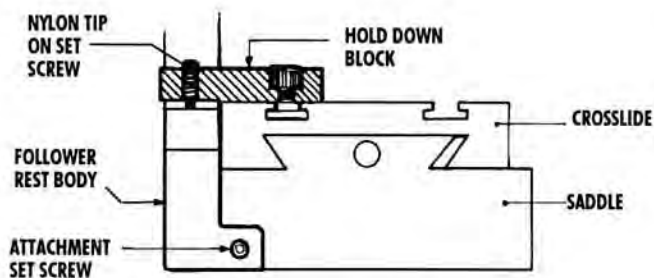


FIGURE 3—follower hold down block in position.

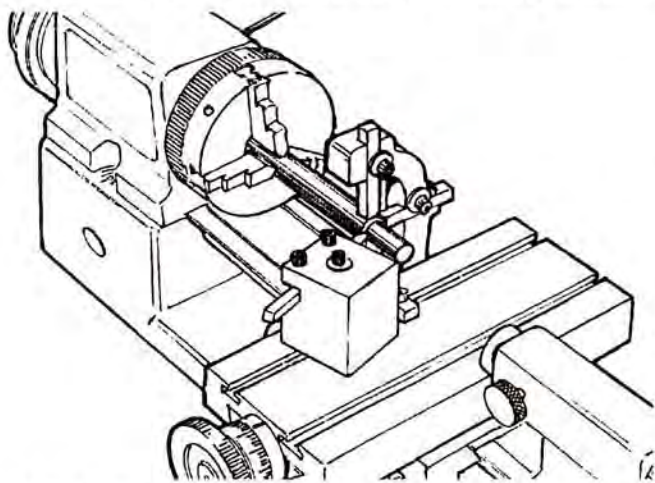


FIGURE 4—follower rest set up in normal position with pads leading the cutting tool.

#### Setting the position of the support pads

To set the pad position, put the round piece you plan to machine in the collet or chuck you will be using. Turn the spindle by hand to make sure the part runs reasonably true. Move the saddle (with the follower rest attached) close to the spindle. Loosen the pad clamping screws, bring the brass pads in contact with the part and retighten the screws to lock them in place. Then move the follower rest back to the position required for the cut and the pads will be

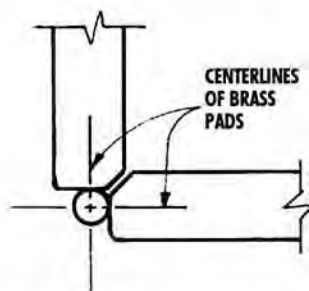


FIGURE 5—Remove the corners of the pad tips to allow them to come closer together for small parts.

aligned with the headstock end of the stock. If you are dealing with very small diameter part, it may be necessary to modify the ends of the pads to assure contact. (See Figure 5.)

With a small diameter rod held in a chuck or collet, transfer the center of the part to the side of each pad using a scribe. Because of “tolerance buildup”, the line may not fall on the exact center of the pad, but that will not affect the function of the follower.

#### Tips for using the follower rest

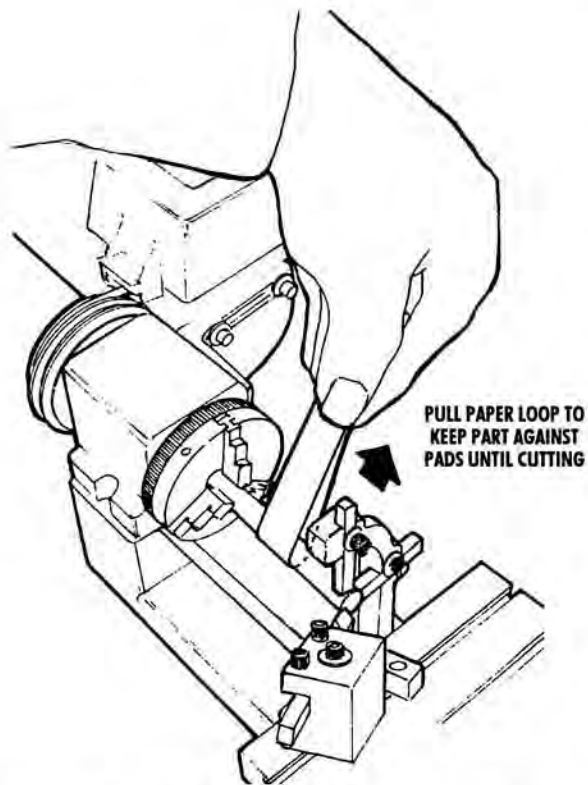
The round stock you use with this attachment should be very round and have a good finish. If the stock is not round, the finished part will have the same shape because the part rotates supported by its outside diameter. A poor surface finish on the part will cause excessive wear on the pads. This in turn can cause your part to taper. To minimize wear, always lubricate the pads with oil when cutting. It would be wise to set up with a piece of scrap of the same material and diameter as your actual stock.

When using a follower of this type, you will usually cut to the finished diameter in one pass. If you need a close tolerance part, it may be easier to turn it slightly oversize, bring it to size with a good, flat mill file and polish it with 320 grit wet/dry sandpaper. If you have a lot of pieces to make, it pays to spend a little extra time getting the setup just right.

#### Making the cut

Run the follower rest down the part until the pads are near the end and the tool is just off the end. Dial in the desired depth of cut. If the end of the part is not supported by a center, the part may tend to spring away from the pads a little when not being pressed on by the tool. If the part isn't running perfectly true, it could cause a problem at the start of the cut because the part isn't in constant contact with the brass pads. If this is the case, slip a loop of paper around the part and pull back lightly until the part rests against the pads. Paper is used because it will tear if it gets wrapped around the part, and it will not pull your hand in as could happen if you use a rag or strip of cloth.

Now run the lathe at about 200 RPM and keep the part in position with the paper loop until you begin cutting. If you don't do this, it could cause a problem if the cutter starts to cut and the end of the stock is bouncing around because it isn't running



*FIGURE 6—Supporting a long part with a paper loop is a safe way to keep it against the pads until the tool is cutting properly.*

straight or is bent. Take a heavy enough cut to keep the stock firmly against the pads but still larger than the final dimension. Cut about 1/8" (4mm) of length, stop and measure the amount of error and then adjust the crossslide accordingly. (The tool will move but the follower will not.) If the diameter is correct, cut the distance required. By cutting only 1/8" the pads are still supporting the part if you take another cut.

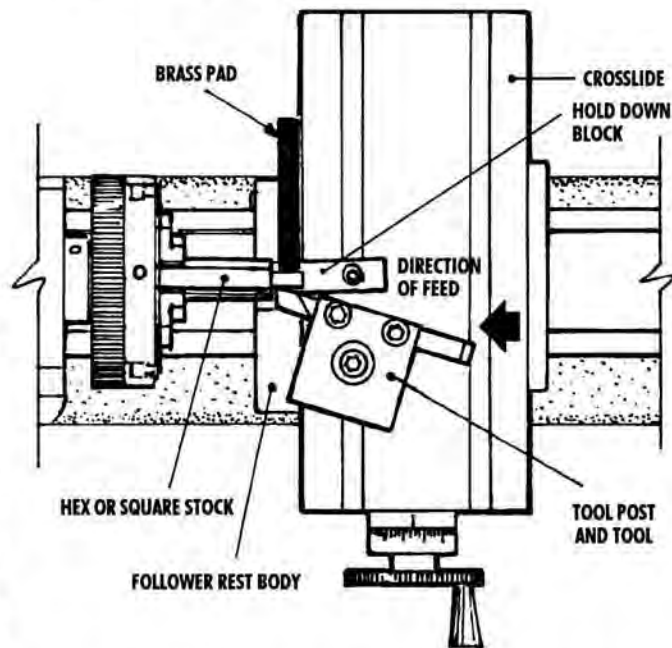
**Some more hints for getting a good cut**

The part size may vary as the pads seat in. Remember to keep them oiled. Keep the RPM down and the feed rate up. A slight radius on the tool tip will improve the finish. When you stop cutting you may

have to hold the stock against the pads to prevent "undercutting" as pressure from the tool is released.

**Turning stock other than round**

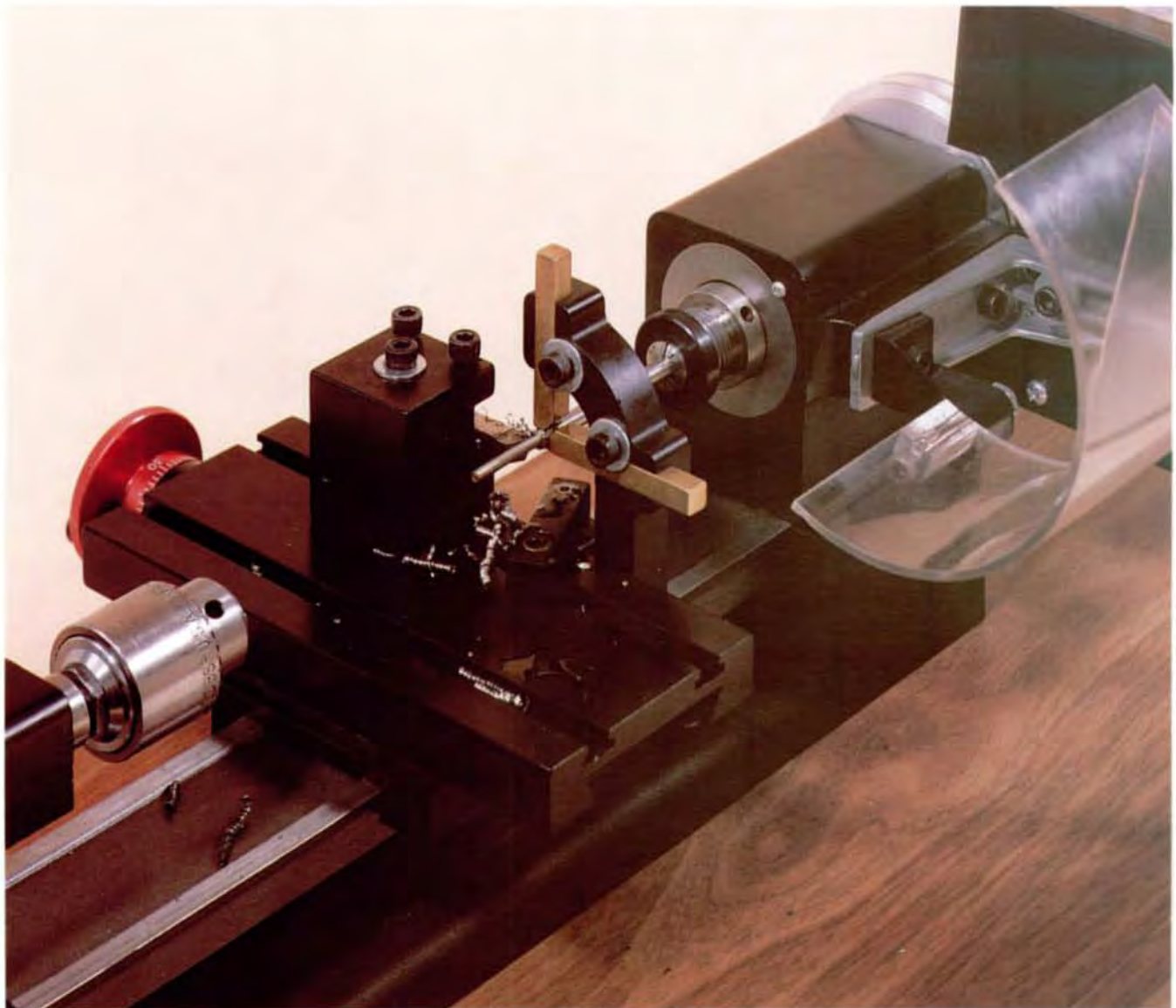
If you need to turn a round end on material that isn't round (like hex or square stock), the tool must lead the pads so that the pads are running on the round surface cut by the tool. The tool can be mounted almost parallel with the bed to accomplish this. (See Figure 7 below.) Take your initial (starting) cut with the end of the part held close to the chuck for support. Then move it out into position where the follower rest pads are supporting the newly machined round surface of the part and cut to size.



*FIGURE 7—Cutting non-round stock*

**Practice on a piece of scrap before your final cut**

I have found it best to always start with a piece of scrap material identical to your final part for experimentation with the setup. The follower rest is not hard to use, but you really need to turn a practice part first to get your speed and feed rates correct.



*A follower rest is used to support thin stock. It has the advantage of placing the support directly behind the cutting tool which keeps the part from deflecting. Unlike the steady rest which is attached to the bed and does not move, the follower rest is attached to the saddle so it moves with the cut and "follows" the tool .*



Quick change tool posts are a popular item for full size lathes. Shown above is the prototype for a quick change toolpost and holders designed to fit the Sherline lathe. It went into production in the Fall of 1998. The post has dovetails on two sides. The holders are dropped over the appropriate dovetail and the tool height is adjusted with the knurled brass knobs. The holder is then locked in place with a  $5/32$ " hex key which is the same tool used to tighten or adjust most Sherline functions. A round, spring-loaded cylinder is pushed against the inside of the dovetail which firmly locks the holder in place. Holders can be easily and quickly changed to switch tools.

Shown are holders for (left to right) a  $1/4$ " cutting tool, a  $3/8$ " round boring tool, an inserted tip carbide tool and a Sherline cutoff tool. Three of the holders will be included with the toolpost, while the holder for the inserted carbide tip will be available as a separate option. The post and holders are made from case hardened steel and have a black oxide finish. This is an accessory that has been requested often over the years, but Sherline had not produced one until a design could be formulated that offered the quality required while still keeping the cost in proportion to the tabletop tools it would be used on. It is easy to design a \$600 toolpost, but it is much harder to develop one half that price that works just as well.

Note on photo at right: George Luhrs went on to win the Sherline Machinist's Challenge contest in 2000 and 2001 with running four-cycle multi-cylinder engines even more complicated than the one shown to the right. He was selected as the Joe Martin Foundation's "Metalworking Craftsman of the Year" for the year 2001.



This could be one of the smallest running 4-cycle engines ever built. It contains 82 components and is only about an inch tall. It was built by George Luhrs of Shoreham, New York and finished second in the 1998 Sherline Machinist's Challenge contest.

## Chapter 6— Getting started in thread cutting

### Taps, dies and cutting oils

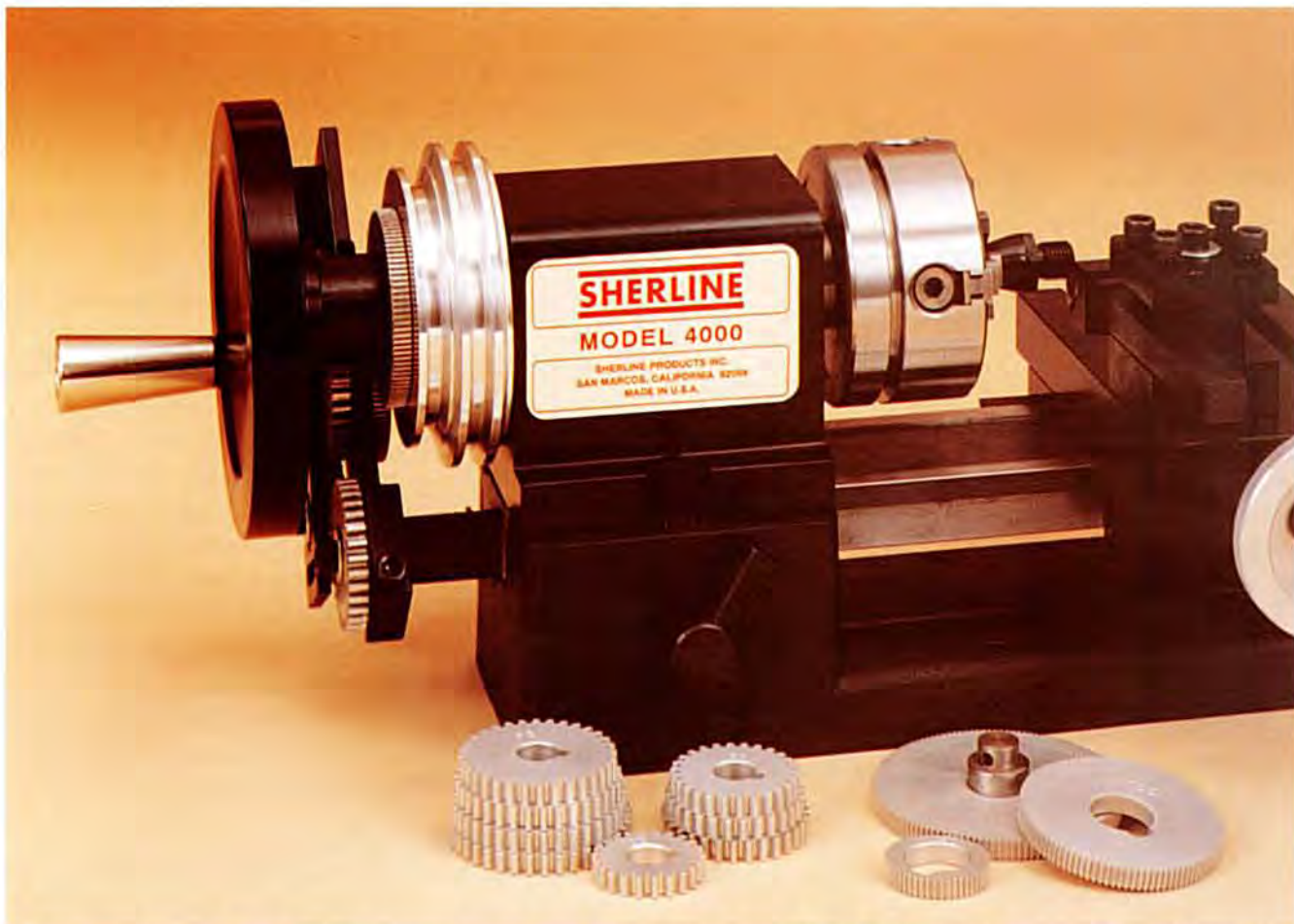
In the home shop, threads are produced on metal with taps and dies or by “single pointing” on a lathe. Taps are also discussed in the cutting tool section and it would be wise to read it before buying any. Taps put threads in holes. Dies put threads on the outside of rods. Taps and dies come in a wide variety of threads and the standard screw thread sizes are reasonably priced. For the home machinist, taps will be used more than dies because of the wide array of choices available in screws and bolts.

Adjustable split dies or “button dies” are inexpensive. They are held in a special holder and can be used for noncritical threads. They usually have a way of adjusting the thread pitch diameter size with a split slot that can be adjusted with a screw. It is important that the die is started squarely to the



*An adjustable split die, sometimes called a “button die”.*

shaft or, like a tap that hasn’t been started square, it will start cutting on one side more than the other as it is “screwed” onto the shaft. A liberal amount of cutting oil is a must to produce good threads, and if you have to put a lot of threads on “tough” materials, I would even consider that smelly, dirty high sulfur cutting oil. The type of material selected plays an important role in producing good threads. Gummy materials like cold-rolled steel should be avoided if a good thread finish is desired.



*A Sherline lathe set up with a thread cutting attachment is capable of cutting a large variety of threads in both inch and metric leads. Hand cranking the threads gives the machinist a lot of control.*

### Removing a die from the part

It is possible to cut a perfectly good thread on a shaft and ruin it when the die is unscrewed. After the shaft has been threaded to its proper length, turn the die back and forth to break the chip loose before unscrewing the die. The chip can get jammed between the thread and die and destroy the thread as the die is unscrewed. Be sure to use a little cutting oil to keep from damaging the thread. As taps and dies are making the last few turns to unscrew from the work, the tap or die has to be gently turned to keep from damaging the thread. At this point the thread on the cutting tool isn't supported and fits loosely. If the tap or die is allowed to get crooked it can tear up the first couple of threads. The thread can also be damaged at this time by using excessive force (in or out). Remember, that these first few threads are your starting threads and a damaged thread is hard to "start".

### More ways to cut threads

Production equipment offers a few more ingenious methods to produce threads, and I'll name a few. Each method has its good and bad points.



### Thread chasing

Thread chasing uses a special die to cut threads. For production use, the cutting tools are mounted on a die head. When the end of the thread is reached, the die head pops open like a 3-jaw chuck. This eliminates the need to reverse the spindle and back the die off the thread.

### Thread rolling and form tapping

Thread rolling is a process that crushes the thread form into a rod with dies that do not cut. The rod must be centerless ground to tight tolerances. This allows the displaced material to form the top half of the thread. A blank diameter that is off by only .001" can have a major effect on the finished product. Also made is a series of taps for a process called "form tapping". These taps form threads in a hole by displacing metal the same way as the thread rolling

method works. In this case the diameter of the hole has to be very accurate to produce a good thread. There aren't any chips produced and they work well in gummy material. Plenty of cutting oil is a must.

### Single pointing threads on a lathe

Single pointing threads on a lathe is interesting. The threads that you cut will usually be a section of another part. It would be foolish to waste time cutting a thread to replace a broken screw that could be easily purchased. A thread cut on the full length of a small diameter can be difficult if the shaft isn't rigid enough to withstand cutting loads without deflecting. A follower rest (see previous chapter) must be used to support the material as it is cut.

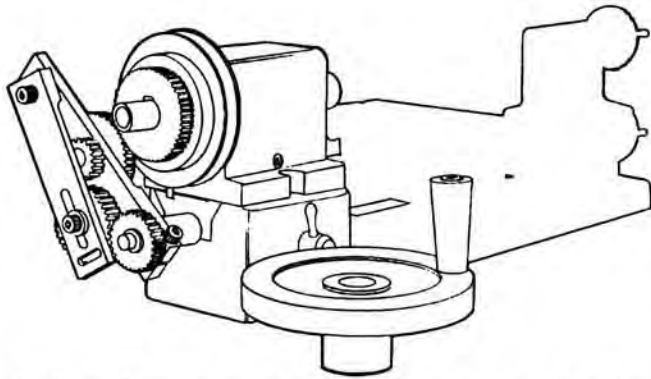
### Single point threads are concentric with the spindle

One of the main advantages of single pointed threads is often overlooked. Threads that have been produced in this fashion will run true with the spindle, and if all critical diameters are cut at the same time, the thread will run perfectly true with the part. The Sherline spindle 3/4-16 TPI is a good example of this. When I first started manufacturing the spindles, the thread was cut as a separate operation, and the matching chuck body thread was produced with a tap. It was next to impossible to have these two parts screw together without an error. Today we single point the threads, put the Morse #1 taper on during the same operation and have a thread that runs out less than .001".

### How Sherline's thread cutting attachment came about

I didn't plan on building the screw cutting attachment exactly the way it ended up. My immediate problem was to produce a set of gears that was affordable, and this I explain in a different part of the book. I purchased a "gear hobber" and figured out how to make it run. Gear tooth shapes are generated with a hob. A hob looks like a worm gear with cutting edges. The machine is then geared so the gear blank is turned at the proper speed to mate with the hob (cutter). It isn't a fast process, but there is no need to watch over it, and it turns itself off automatically at the end of the cut. Hobbing my own gears allowed me to produce gears in small quantities that didn't cost a fortune.

After cutting a set of gears for my attachment I knew I had solved only one of my problems. To cut the expanded range of threads, you couldn't disconnect the spindle from the leadscrew without losing your place. To check out my gear combinations, I took



*A thread cutting attachment (or screw cutting attachment) on a Sherline lathe. (The cranking handle is shown removed so you can see the geartrain. A small lever on the side of the lathe base just above the handle engages and disengages the leadscrew. Though hand cranking a lathe to make threads may sound like a step backwards, it actually offers several advantages.*

the motor and speed control off and put a crank handle on the rear of the spindle. I set up gears for twenty-eight threads per inch. I planned to make a 1/4" diameter, 28 threads per inch bolt. It would be easy to check because there were hex nuts around my shop I could use to check the thread. I engaged the leadscrew and took my first pass (cut) by cranking the spindle by hand. I stopped cranking when I got to the head of the bolt, backed out the crossslide, and cranked the spindle backwards until I was back at my starting point. The crossslide was returned to a position that would take the second cut and I cranked the spindle and took the second cut. It was as easy as tapping a hole with a hand tap. You could stop close to a shoulder without worrying about "crashing". It would be perfect for a novice machinist. I felt it might be a tough item to sell because hand cranking looked like a step in the wrong direction, but it really worked well so I put it into production.

#### **I was amazed I had done so much knowing so little**

After designing and putting the screw cutting attachment into production, I sat down and started reading what other people had written about cutting screw threads before writing my own instructions. It amazed me that I had been able to cut threads all these years while knowing so little. How and why I was able to do this is going to be the subject of some of the instructions that follow. There are many books available that go into additional detail on the subject if required. The following examples are based on using sharp pointed 60° tools

and cutting threads for your own use.

#### **Your advantage over a commercial shop**

The reason other books go into such great detail on the precise methods used commercially is that they are telling you how to cut threads from specifications for other people. They have to have exact methods and standards to make sure that a bolt made in California will screw into a nut manufactured in New York. Fortunately, we have the tremendous advantage of having both pieces at hand and we can just "keep cutting 'til they fit". It's as simple as that. You just select the proper gear from the chart, put in a 60° threading tool and have at it!

#### **How a lathe actually cuts a thread**

A point to ponder about thread cutting is how a lathe produces a thread. It doesn't matter whether it's a 20" lathe or a 3" lathe, the principle is the same. The leadscrew that drives the saddle is geared directly to the spindle. When the spindle turns, the

#### **A little history...**

##### **Why making the first leadscrew was a problem**

Consider this: You are a blacksmith in the 19th century and you need a screw thread. At that time no one had yet produced a screw thread. A lathe produces a thread by gearing the leadscrew to the spindle, but there weren't any screws that could be used as a standard, much less a leadscrew. (This is one of the reasons so many rivets were used in those days.) Industry mounted a concentrated effort to produce a standard thread that would produce the "father" of all screw threads. The first one would have to be made by hand. The best craftsmen in the world started on this project. They kept improving the thread by finding a section that had the best pitch and reproducing it, over and over again. Eventually the errors canceled out and they had their standard.



*Making the first leadscrew was kind of a "chicken and the egg" type problem. You need one to make one.*

saddle moves. If they were geared one-to-one, the pitch cut would be the same as the pitch of the leadscrew. On the 3" lathe, this would be 20 Threads Per Inch (TPI). If we turned the leadscrew 180° while we turned the spindle 360° (by using a 20-tooth to a 40-tooth gear arrangement) we would cut 40 TPI. Please note that we did not have to consider the stock's diameter. The only requirement is that the major diameter is at least twice the depth of the thread plus enough material to support these threads while cutting them. One gets used to hearing a diameter called out with the threads, such as 1/4-20, 6-32, 10-24, etc., but while it's unusual to think of 40 threads per inch cut on something 2" in diameter, in some cases it may be entirely practicable to do so. For example, some camera lens parts have large diameters and a very fine thread.

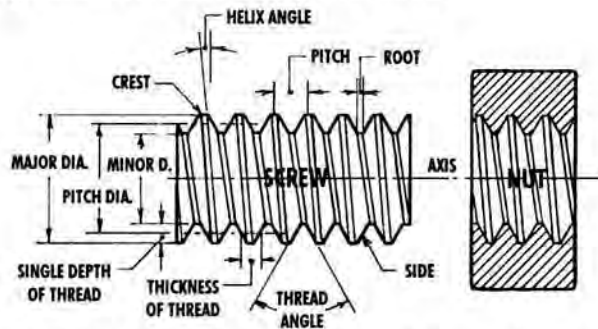


FIGURE 1—Component parts and shape of a rolled thread. A thread cut with a sharp 60° tool will not have a flat at the root of the thread but will come to a point.

### TERMS

**MAJOR DIAMETER**—Largest diameter of the thread of either the screw or the nut.

**MINOR DIAMETER**—Smallest diameter of the thread of either the screw or the nut.

**PITCH DIAMETER**—The theoretical diameter that falls on a point where the thread width and the groove width are the same.

**PITCH (P)**—The distance from thread point to thread point measured parallel to the axis. Metric threads are always expressed in Pitch

**LEAD**—The distance one screw thread advances axially in one turn. On a double lead screw, the lead is twice the pitch.

NOTE: The same methods can be used in figuring dimensions for American or metric screw threads.

$$1\text{mm} = .03937''$$

$$\text{Pitch (metric)} \times .03937'' \times .758'' = \text{depth of screw thread in inches}$$

### How can you cut a metric thread with an inch leadscrew?

It may interest you to know how a metric thread can be cut on a 3" lathe that has American National screw threads on its leadscrew. The 127-tooth conversion gear does this by driving the leadscrew at a ratio that converts 20 TPI to 1mm. Consider 100T (a 100-tooth gear) on the spindle driving a 127T. The ratio is .7874 to 1. The lead screw has 20 TPI which means one thread is .050" long. Therefore:  $.050'' \text{ P} \times .7874 = .03937'' = 1\text{mm}$ . By the same token, inch threads can also be cut on a machine with a metric leadscrew.

### Understanding "pitch diameter"

Take the time to familiarize yourself with component parts of the screw thread from Figures 1 and 3. The pitch diameter is the important one to consider. Before going on, let's take the time to really understand why. The pitch diameter determines how a screw or thread will fit, not the major diameter. Suppose you were cutting 20 TPI and the major diameter was .010 undersize and the pitch diameter was correct. About the only thing wrong would be that the flat on the point of the thread would be a little wide, but it would still have approximately 75% of its strength and work well.

Now let us suppose we cut the pitch diameter undersize by .010. We would end up with a nut that fits so loose and a thread that was so weak that we would have to scrap it. This is where "cutting to fit" comes in. You can compensate for some pretty bad errors on the major and minor diameters by having the pitch diameter correct. To get it correct, all you have to do is to keep trying it for size as you cut. Don't ever take the part out of the chuck to try it because it would be next to impossible to re-chuck

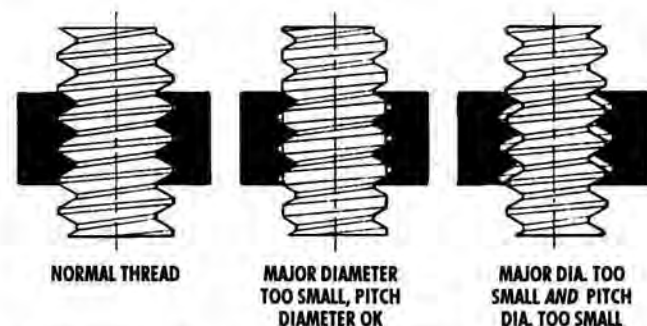


FIGURE 2—You can get by with an undersize major diameter as long as the pitch diameter is proper. There will be a bigger flat on the thread crest and less thread surface touching but the fit will still be good. If both major and pitch diameters are too small, the fit will be sloppy.

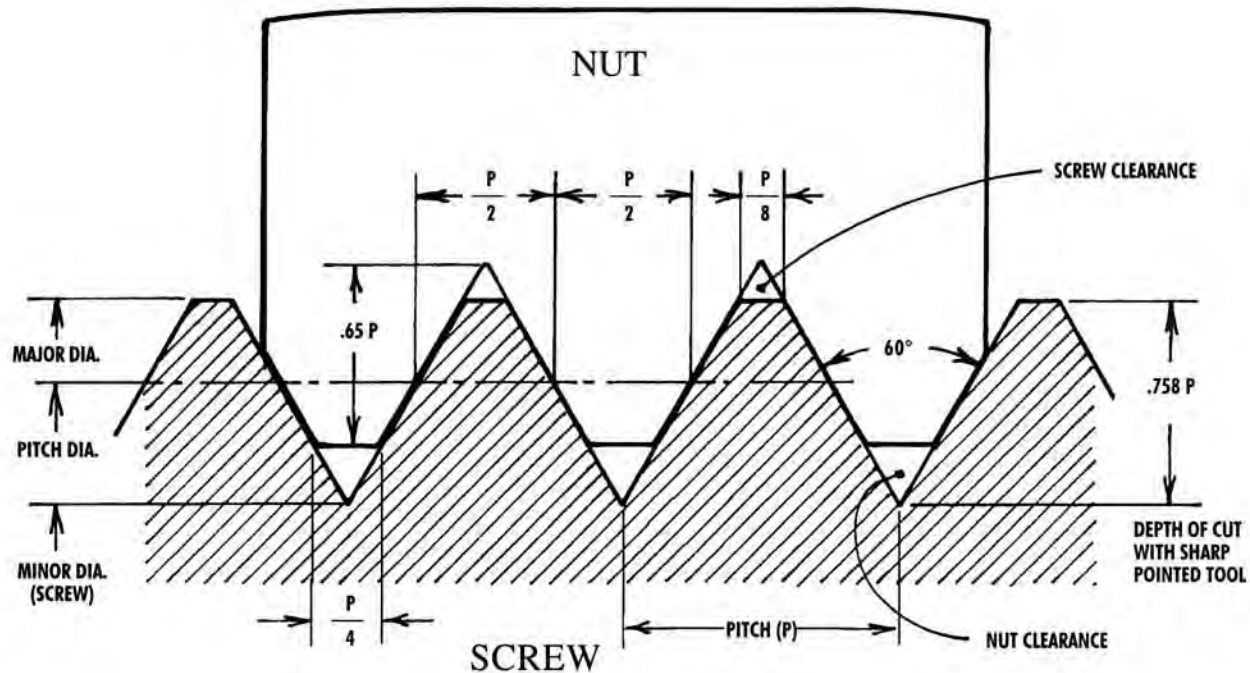
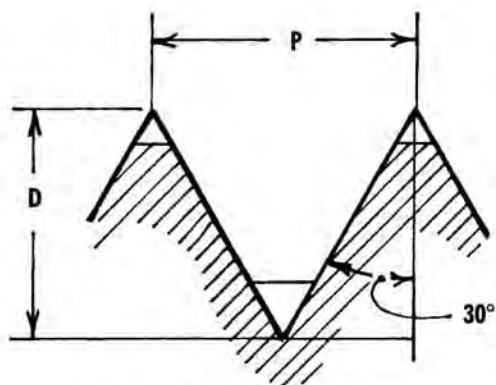


FIGURE 3—American National and Unified Screw Thread forms. These threads are cut with a sharp 60° thread-cutting tool, and the threads do not have a flat at the bottom like rolled threads.



$$D = P \times \cos 30^\circ = P \times 0.866$$

$$D = \frac{0.866}{\text{no. of threads/in.}}$$

FIGURE 4—The form of a sharp pointed V-thread. The sides of the threads form a 60° angle with each other. The formula shows how to calculate the depth of the thread when knowing the pitch. In actuality, tools rarely cut to a perfect point and a slight flat will occur. The adopted standard for this flat is about 1/25 of the pitch.

it in exactly the same place. However, the entire chuck, along with the part, could be removed from the lathe to try it for size. Don't force anything when trying the part for size, because you might move the

part slightly in the chuck, and really "screw things up".

Why have I made such a point about having the major or minor diameter wrong and still making the part work? Read on. You're probably thinking, "Joe must really be a 'hacker' if he can't cut a diameter within .010". Well, the problem, in many cases, is not how close you can cut to a diameter, but what the diameter should be.

#### A real life example

Example: Your buddy just heard you bought a nice, shiny, new lathe complete with a screw-cutting attachment, and like all good friends, he immediately goes to work trying to figure out how you and your new lathe can be of some use to him. It doesn't take him long! He has a camera which he tried to repair himself last year, but lost an important part. Of course the missing part has metric threads, but that's a "snap" for a 3" lathe. A quick check with a thread gage indicates that it has .9mm pitch. No problem...yet. It is an internal thread, so you will have to cut a screw to mate with it. Here's the problem: What is the major diameter? You can measure the diameter of the hole, but you can't be assured that the thread form is perfect and that this is really the minor diameter. You can only assume that it's close. Now, you take this dimension and add to it twice the depth of the thread, which should



Two types of gages for measuring the number of threads per inch on an existing thread. The flat tool has a thread count scale as well as a 60° point and grooves for checking thread and tool shapes.

give you the major diameter. To get the depth of one thread, multiply the Pitch x .6. (Note: Pitch x 1.2 + Minor Diameter = Major Diameter). Total depth of thread using a sharp pointed 60° tool =  $P \times .65 = .9\text{mm} \times .65 = .585\text{mm}$ . (Or, since  $.9\text{mm} = .0354\text{"}$ , then  $\text{Depth} = .0354\text{"} \times .65 = .023\text{"}.$ )

The constant .6 is not used to figure depth of an external thread; it is just one used to get you in the "ballpark" in a situation such as this.

At least we have a fairly reliable place to start now and can probably get one cut that will work on the first try. Always keep track of the total depth of cut in case it comes out undersized. At least you'll know how deep *not* to cut it on the second one!

The example I gave you was one of the more difficult situations you may run into, not only because you had to do the job for free to keep a friend, but also because you had very limited information from which to work.

#### Sometimes wrong + wrong = right

Usually, you will be cutting both the screw and nut. This is a case where two wrongs can almost equal one right. You can rectify any error you may have had in cutting the first one by compensating for it in the mating part. I don't recommend this as a standard, but it may save an otherwise good part someday.

#### Left-hand threads

Left-hand threads can be cut as easily as right-hand threads on a Sherline lathe. The only difference is

the addition of an idler gear which reverses tool movement so that it travels left to right.

#### An investment that pays off quickly

It's hard to appreciate just how much money an inexpensive lathe like this with a screw-cutting attachment can save you until you have had to have a special part made that doesn't have a standard thread size. Even though there may be taps or dies available, getting a single left-hand 1-32 TPI part made would probably cost half as much as your entire thread-cutting attachment.

#### It's easier than the books make it look

What I have tried to do in these opening remarks is to show that screw cutting really is easy and to give you the self confidence it takes to do any job well. Too often, good craftsmen are stopped from venturing forth because the only information available shows the technically perfect way to do things rather than the simple, practical methods everyone really uses.

*NOTE: The section that follows entitled "Cutting A Thread for Practice" uses the example of cutting a 28 pitch right hand thread on a 1/4" diameter piece of stock. The following numbers are based on that setup. The instructions that come with your thread cutting attachment go into detail on assembling the geartrain. I won't go over that here, but reading through the example below will give you more insight into how a typical thread is cut.*

#### CUTTING A THREAD FOR PRACTICE

I believe the time has come to "have at it", so we'll start by chucking up a piece of aluminum and turning it to 1/4" diameter. Let's cut 28 TPI on it. Be sure to have a nut to check it with. Looking at the chart we see we need an "A" 100T on the spindle, driving a "B" 100T, which is attached to the "C" 20T, driving the lead screw "D" 28T, using the idler "E" 40T that mounts on the swing arm. The gears should mesh so they run "free" and have a reasonable amount of backlash. NOTE: All gear trains have some "backlash" and it will not affect the quality of the thread, but it does have to be allowed for. This is why the tool must be backed out before the lathe spindle is reversed.

Over 90% of the threads cut on a lathe of this type will have a pitch less than .070" (2mm), and be less than 3/8" (10mm) long. Now and then you may have

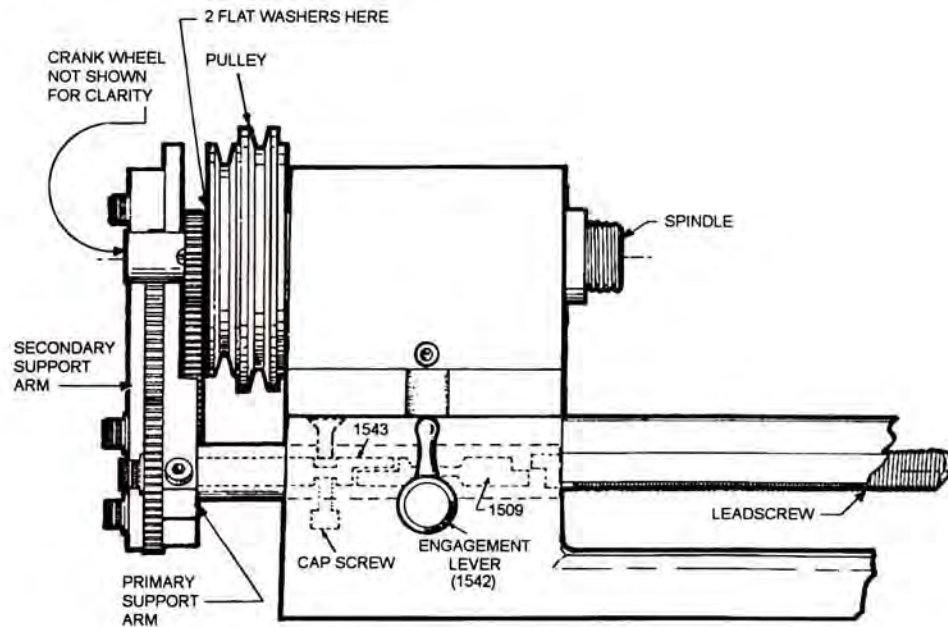


FIGURE 5—Side view, thread-cutting attachment installed. (Hand crank wheel not shown for clarity.)

GEAR	A	B	C	D	E
TEETH	100	100	20	28	40

FIGURE 6—Setup for cutting 28 Threads Per Inch.

NOTE: Idler gear "E" is used for right-hand threads. Idler gears "F" and "G" are used for left-hand threads and are, therefore, not used in this example.

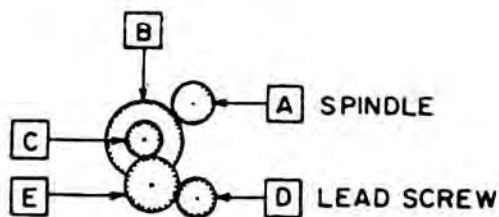


FIGURE 7—Right-hand geartrain setup diagram for the example that follows.

to cut a fairly coarse thread (more than .070" pitch), and it is a good idea to "rough out" the thread by moving the tool post slightly to the left between passes. This keeps the tool from having to cut on both sides. On a standard lathe, the tool is advanced by the compound rest which is set at 29°. This allows only one side of the tool to cut and lessens the load considerably. However, it also allows the chip to damage the thread, which can't happen when you are cutting threads straight in. For every plus you will always find a minus. The final cut is then

taken with the crossslide being advanced to "clean up" the thread. We can get the same effect by moving the tool post. When cutting fine threads you can get away with cutting "straight in". The crank drive gives you the "feel" and a precise method of stopping needed in single-pointing fine threads. Cranking the spindle counterclockwise gives you reverse. This allows you to cut the entire thread without disengaging the leadscrew.

### Establishing depth of the first cut

The threading tool must be on center and square with the part. There is a small gage designed to do this. If the tool isn't square, the included angle will remain 60° but the sides of the thread will be different. The thread form wouldn't allow a standard thread to screw on it. Establish the depth of the first cut by bringing the tool in to the point where it just touches the surface. Write the dial setting down or reset your handwheel to zero, and move the tool past the starting point of the thread. Now engage the lead screw lever. The leadscrew may have to be turned while applying slight pressure on the lever in order to get it to engage properly. **DO NOT DISENGAGE UNTIL THE THREAD HAS BEEN COMPLETELY CUT.** Now advance the tool .003" for first cut. Turn the spindle counterclockwise, when viewed from the tailstock, until the desired length of thread has been cut. Back the tool out until it is completely clear of the part.

### Making additional passes

Crank the spindle clockwise until the tool is at the original starting point. Advance the tool to its last point plus .002". I've always found it useful to write these dial settings down if you don't have resettable handwheels. It is amazing how fast you can forget one! Now take the second pass by cranking the spindle counterclockwise. The amount the tool should be advanced from this point on should be governed by the amount of force it took for the last pass. The cut will get progressively heavier each time the tool is advanced. Remember, you can't ruin your part by taking too light a cut. To figure what the total amount the tool should be advanced if you are using a sharp Vee form tool (standard form of tool used in single pointing threads) simply multiply the pitch times .758.

Example: Pitch of 28 TPI =  $1/28$

Pointed tool depth =  $P \times .758 = 1/28 \times .758 = .027$

If you are not too good with math and don't like to do it, just keep cutting and looking at the flat on the top of the thread. When the flat is  $1/8$  the pitch, the nut should fit. Either way, check it long before you think it is finished to be on the safe side until more experience is gained. The last two passes should be repeats of previous dial settings to clean up threads. Not too hard was it? No matter what type of threads you may cut, the basic method will remain the same.

### Internal threads

Internal threads are very seldom cut full depth. You don't cut internal threads that could easily be put in with an inexpensive tap. Deep, small diameter threading is next to impossible because the tools become weak and springy. To figure the hole size you should start with, take the pitch of thread you are cutting and multiply it by 1.083 and subtract this from the major diameter. To figure the total depth using a sharp pointed  $60^\circ$  tool, multiply the pitch by .65.

EXAMPLE: To cut an internal 1-1/2"-28 TPI:

Major Diameter = 1.5

$P = 1/28 = .036"$

Major Diameter -  $(P \times 1.083) =$  Hole Size

$1.500" - (.036" \times 1.083) =$  Hole Size

$1.500" - .039 = 1.461$

Hole size = 1.461



A 1/4" tool used for cutting inside threads (left) and a  $60^\circ$  carbide thread-cutting tool (right).

### Double-lead threads

A double-lead could be cut by picking change gears that are one-half the pitch and indexing the "A" gear  $180^\circ$  after cutting the first thread to depth. NOTE: There isn't any way to check a double-lead until it is completely cut; therefore, the depth must be figured mathematically. It has always been fun for me to do jobs like this, not because they were needed, but just to see if I could do it!

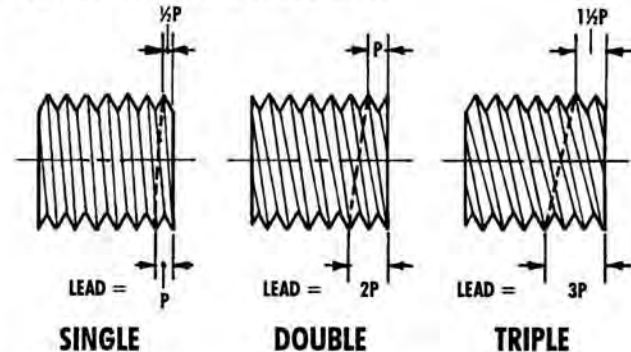


FIGURE 5—Single-, double- and triple-lead threads

### A review of screw-cutting operation

Here's a step-by-step summary of a typical thread-cutting operation. Once you've read the previous examples, this should all make sense to you.

STEP 1. Turn or bore stock to proper diameter.

STEP 2. Remove the motor and speed control assembly from the lathe.

STEP 3. Install thread-cutting tool in toolpost holder.

STEP 4. Place tool bit at starting point of thread and set for .003" cut.

STEP 5. Engage lever at base of lathe by turning

leadscrew support handle clockwise. Turn lead screw handwheel until full engagement occurs.

STEP 6. Turn spindle crank wheel until tool bit has traveled full length of intended thread.

STEP 7. Back crossslide out to clear tool from thread.

STEP 8. Turn crank wheel backwards until tool bit has traveled past starting point of thread.

STEP 9. Return crossslide to its original position plus .002".

STEP 10. Repeat STEPS 6, 7, 8, and 9 until full depth of threads has been cut. Cutting oil will make cutting easier, and will give a better finish.

### Inspecting finished thread forms

Threads are inspected in a variety of ways. The home shop machinist will usually use another part such as a nut or bolt, but this isn't always accurate enough.

The first thing that must be inspected is the thread form. The 60° included angle has to be perpendicular to the shaft. A thread form that has an error can "feel" great when it is checked with a gage but only have a 20% thread contact. Commercial threads are checked on a Comparator, but a magnifying glass will work well for an amateur. Threads will only contact their mating part on their "high" points. These high points can be quickly be worn off and the result would be a sloppy thread with little strength. Thread pitch diameter can be measured with thread wires and a standard micrometer. A chart converts the micrometer reading to pitch diameter. Of course, thread wires are sold in sets where each range of threads has a particular set of three wires. Thread micrometers are manufactured with interchangeable "tips". These tools cost too much for home use; around \$400.

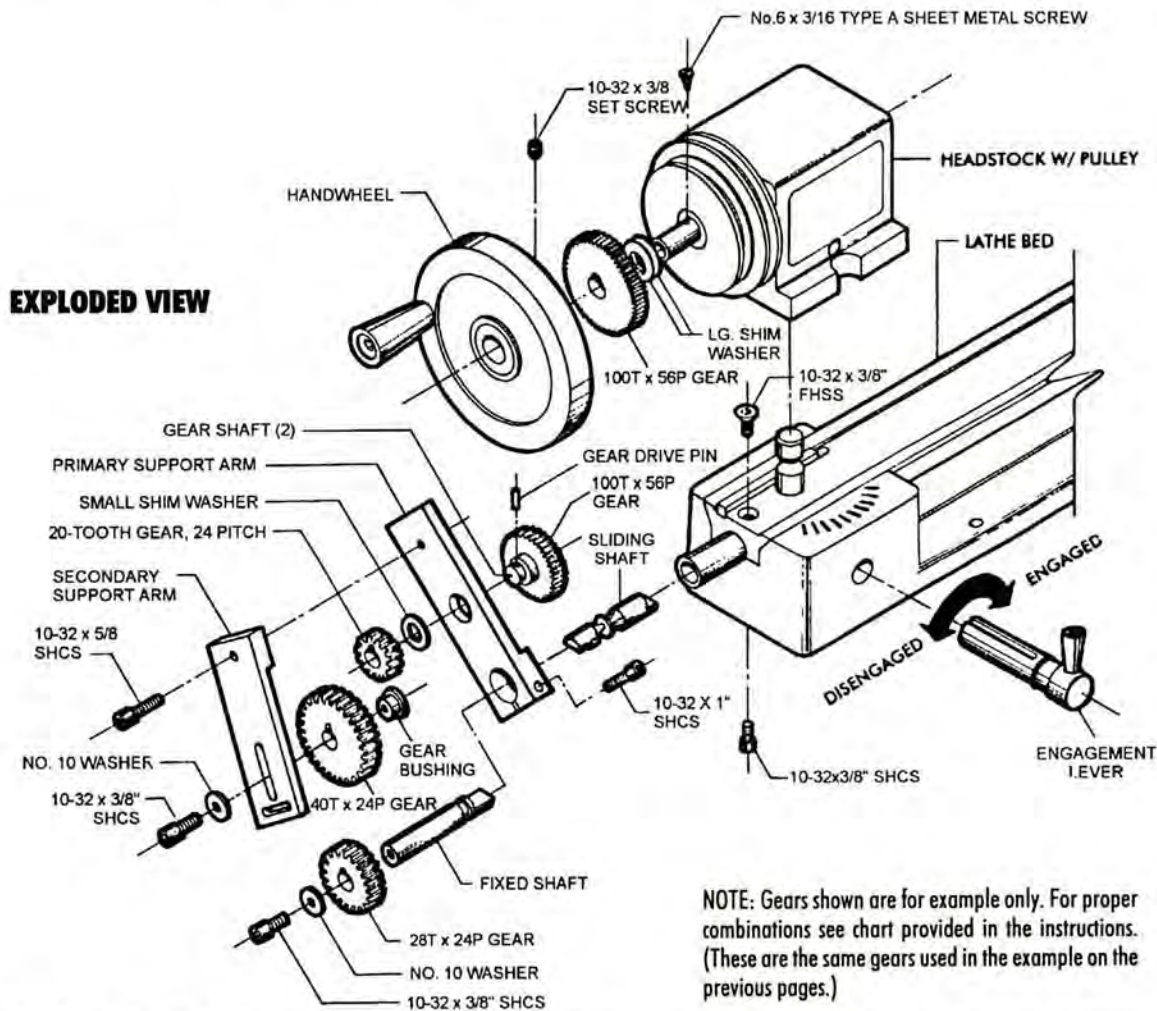


FIGURE 8—The exploded view above makes it easier to understand how the parts fit together. Part numbers and gear charts for producing a wide variety of threads are provided with the instructions that come with the attachment.

### Checking threads in tapped holes

Critical tapped holes can be checked by drilling and tapping a piece of scrap material and sawing the thread in two. The thread can then be inspected. If high quality drills and taps are used you will get good threads; however, it might be wise to check the final product if a large number of holes have to be tapped. Taps can be purchased with several pitch diameters and are defined by their "H" number. Number H3 is standard in industry, and, the higher the H number, the more clearance the thread will have. Oversize taps are used when a process such

as plating will reduce the pitch diameter after the hole has been tapped. You can get in big trouble gauging a thread with a part with an unproven size if it must mate with another thread that isn't at hand. The parties must establish a standard between them before any metal is cut, and the best standard will be gages that are a little expensive but may keep the scrap metal container from filling up. Once again, these are mostly commercial considerations that you, as a home machinist, will probably not have to deal with, but their importance in the working world makes it worth reminding you of their existence.



*This custom-made lens adapter is a good example of how useful having your own thread-cutting capability can be. Jim Clark of Lakeside, California turned and threaded this aluminum ring to attach an anamorphic (Cinemascope) lens to a 16mm projector. One side has inch threads, the other side is metric. It is unlikely that an adapter like this could be purchased, and paying a machine shop to make it for you would probably cost almost as much as buying a threadcutting attachment for your lathe.*

---

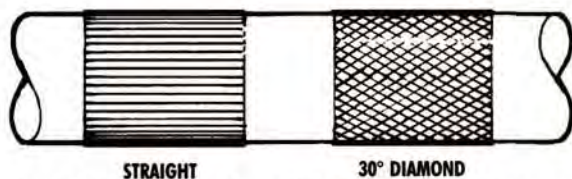
## Chapter 7— Knurled finishes

### The two types of knurls

There are two basic types of knurls available. One is based on TPI (threads per inch) and the other is based on Diametral Pitch, which is how gears are defined. *Machinery's Handbook* recommends using the DP, but if you try to purchase DP knurls, you will find that what is really available are TPI knurls. The end result is most people use the TPI type knurls because they are readily available and less expensive. The Sherline knurling tool can only use knurls that are 1/2" in diameter with a 3/16" hole. These knurls are based on the TPI system.

### Knurls for press fits

When the specifications of a knurl are placed on a drawing in detail, there is always a chance the desired outside diameter can not be met and produce a good knurl at the same time. The process has too many variables to be that exact. You can't get in too much trouble if the knurl is put on for appearance or grip, but if the purpose of a knurl is to control a press fit it may take some experimentation. This can be accomplished with simple test parts that can be pressed together and taken apart. A good setup would involve tooling that aligns the parts involved as they are pressed together. If these parts are for a customer, the customer should determine what is acceptable before the parts are run. The OD of the knurl may have less impact on the amount of "press" required when joining two parts than one would believe. The shape of the knurl at the OD determines the press as much as the outside diameter because a greater amount of material may be displaced during the press. Straight knurls have to be more carefully selected for the job if they are to be used for enlarging a shaft diameter for a press fit. In closer tolerance production work special knurls have to be made to accomplish this, so the finer the knurl the better your



A straight knurl and a 30° diamond pattern made with a pair of "left" and "right" 30° knurls.



This collet drawbar has a straight knurl while the micrometer handle uses a diamond pattern. Each provide good grip and a professional looking appearance. The knurling process embosses the pattern into the metal rather than cutting it.

chances of success. When you are dealing with "one off" parts it may be easier to machine the part in one piece rather than pressing the two parts together.

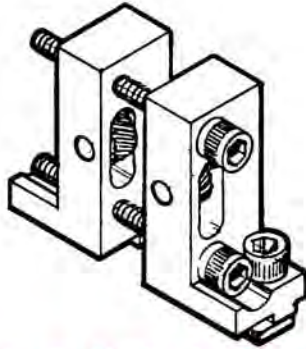
### "Bump" knurling vs. a double knurl system

Most home machinists think of knurling being done with a knurling tool held in a tool post and the knurls being forced into the part from a single side. This is called "bump knurling", and it doesn't work very well because the work isn't rigid enough to offset the high loads associated with embossing metals. A part that is only held by a short amount in a 3-jaw chuck will be destroyed if this method is attempted. It will simply get pushed out of the chuck and be destroyed. To have a more reliable system for



A knurling tool used for "bump knurling" in a standard size lathe. It is held in the toolholder and pressed into a firmly supported rotating part.

production knurling, they designed knurl holders with two or more knurls to balance the load. This is why the Sherline knurl holder uses two knurls. The machine was also too small to use the standard knurling tools that were commercially available. We had to design our own, and I'm pleased with the result.



### Using the Sherline knurling tool

The knurling holder manufactured by Sherline is designed to be used only with the Sherline lathe. The largest diameter that can be knurled is 1" (25.4mm) and the smallest is somewhat dependent on the pitch on the knurl. The higher the number of teeth per inch (TPI) the finer the knurl will be and the smaller the diameter that can be knurled.

Sherline includes a set of basic knurls (25 TPI) that will produce a medium diamond knurled pattern. This set is a left and right pair with a 30-degree helix, with each tool forming half of the diamond pattern.

### Using practice cuts to produce a good knurl

A good knurl is produced by embossing; therefore, a correct starting diameter on the work to be knurled can best be determined by trial and error on a scrap piece of similar material. When knurls are forming, they should be considered similar to one gear meshing with another. Think what would happen if you tried to mesh a 25-tooth gear with a gear that had 62-1/2 teeth. This is in effect what happens if the initial diameter is wrong, causing the tools to take a second path every other revolution. This produces an undesirable finish. The good part is that knurls have an amazing tolerance for wrong diameters when working with soft materials, and you will have better than an 70% chance of success on any given diameter.

### Hard materials shorten knurl life

Hard materials such as stainless and hardened tool steels will make for short knurl life. Never attempt to knurl hardened material such as piano wire.

### Mounting the knurling tool holder

The knurling holder is designed to mount directly to the crossslide's T-slot groove. The T-nuts that run in the groove should be tightened only enough to eliminate play, but not so tight as to keep the holder from moving freely in the groove. This allows the holder to self-center on the part to be knurled. (We recommend using aluminum for your first practice knurl, approximately 1/2" diameter).

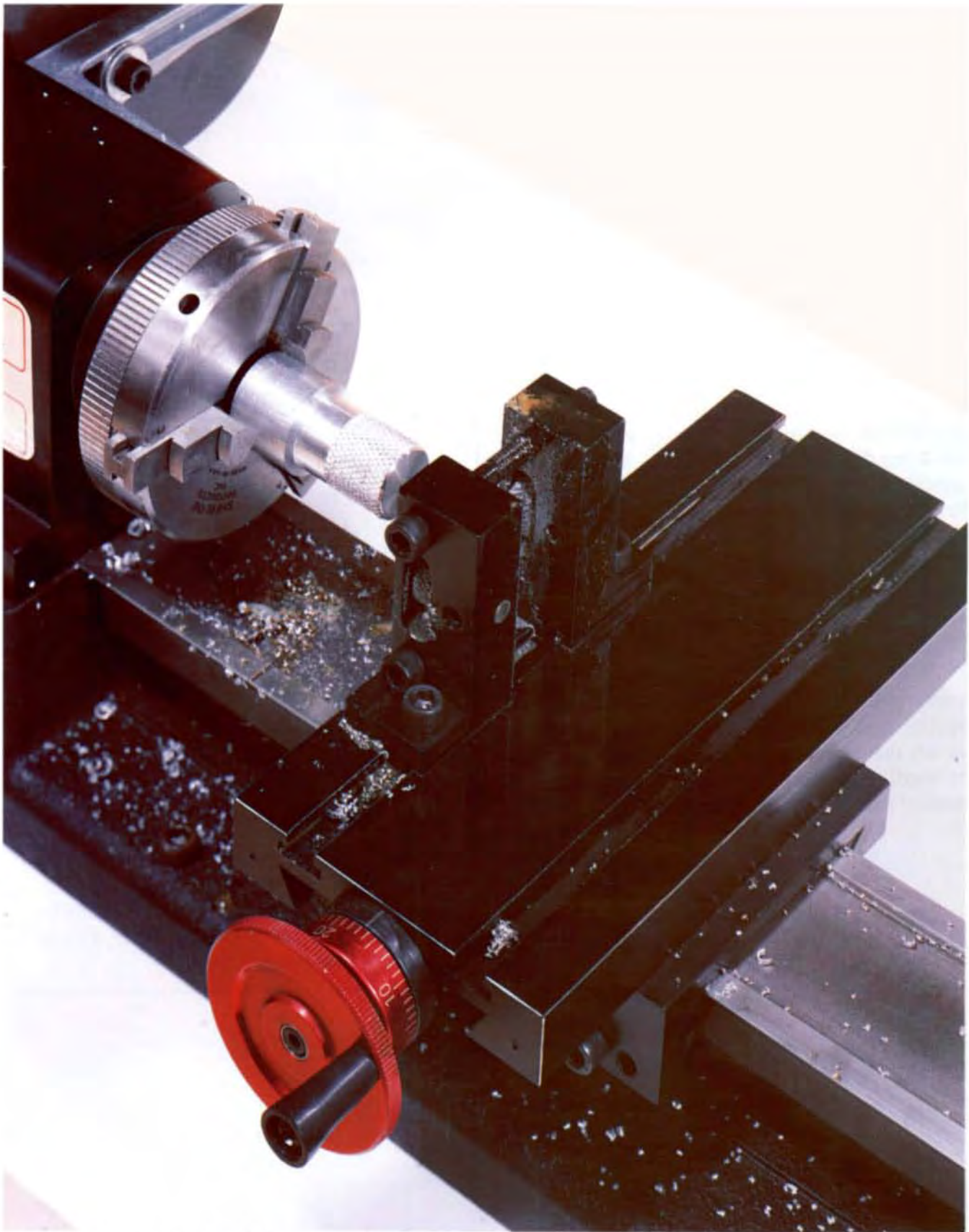
### Knurling the part

The part to be knurled or experimental part should be running true with a chamfered corner at the end of the section to be knurled. Adjust the top and bottom clamping bolts so the knurls are lightly touching the part without the spindle turning. Only about half or less of the knurl wheel should be running on the part surface. Apply a liberal amount of cutting oil to the knurls and have the spindle run at a slow speed (approximately 500 RPM for 1/2" diameter of soft material). Now start tightening the top and bottom clamping bolts evenly, one at a time until the knurls are engaged with the work in a positive manner. Without loosening the knurls, back them off the part with the feed handwheel. Stop the spindle and carefully examine the quality of the knurl. It should be full depth, clean, and sharp. The finished diameter should be larger than the starting diameter by approximately the amount shown in the chart below. If not, make the necessary adjustments.

### APPROXIMATE INCREASE IN KNURLED DIAMETERS

TPI	TOOTH ANGLE	STRAIGHT	DIAGONAL	DIAMOND MALE	DIAMOND FEMALE
12	90°	.034	.034	.038	—
16	90°	.025	.025	.029	—
20	90°	.020	.020	.023	.014
25	90°	.016	.016	.018	.011
30	90°	.013	.013	.015	.009
35	90°	.011	.011	.013	—
40	90°	.009	.009	.010	.006
35	70°	.014	—	—	—
40	70°	.012	.010	—	—
50	70°	.009	.009	.010	.006
60	70°	.007	.007	—	—
70	70°	.006	.006	—	—
80	70°	.005	.005	—	—

NOTE: If no size shown, cutters for that size are not available.



*A knurling tool and a knurled part are shown in place on a Sherline lathe. By squeezing from both sides at once, the part is supported by the tool itself during the knurling process. This allows knurling to be accomplished on small parts that would normally deflect under the load and require a lot of support.*

If the knurl isn't full depth, take in on clamping bolts with the spindle running until it is full depth. ( If the knurls are undercutting the finished diameter, the diameter should be either increased or decreased by approximately .005" (.1mm) until the knurls are working properly.) Increasing the diameter will add a tooth to the part. Decreasing the diameter will keep the knurls from having to move so much material. If the knurl isn't clean and sharp, use more cutting oil while turning the spindle slower and increasing the rate of feed.

As you can see, knurling isn't an exact science because of the many variables involved, and that is why we recommend getting good results on a scrap part before attempting to put a knurled finish on a part in which you have invested a lot of time.

### Completing the knurl

To complete the finish, the knurls are fed onto the part using the leadscrew handwheel. Start with the properly adjusted knurl wheels partially engaged on the part in the pattern you have already established, and then feed them down the part for the length that is to be knurled. Use plenty of cutting oil. When you reach the end of the pattern, reverse your handwheel direction and back the knurls off the part still using plenty of oil. You should have a knurl you can be proud of.

A very wide variety of knurls is available from tool suppliers and catalogs. The chart at the right shows the sets that are available from Sherline for use on the Sherline knurling attachment. Each comes as a matched pair of knurling wheels.



*Knurls (left to right): A straight tooth knurl, left hand and right hand 30° spiral knurls.*

### KNURL SETS AVAILABLE FROM SHERLINE

STRAIGHT TOOTH KNURLS		30° SPIRAL KNURLS**	
TOOTH ANGLE	TPI/T	TOOTH ANGLE	TPI/T
90°	16 TPI/25T	90°	20TPI/27T
90°	20 TPI/31T	90°*	25 TPI/34T*
90°	25 TPI/38T	90°	30 TPI/40T
90°	30 TPI/47T	90°	35 TPI/47T
90°	32 TPI/49T	90°	40 TPI/55T
90°	35 TPI/55T	70°	50 TPI/68T
90°	40 TPI/63T	70°	80 TPI/107T
90°	41 TPI/65T		
90°	47 TPI/73T		
70°	35 TPI/55T		
70°	50 TPI/79T		
70°	53 TPI/83T		
70°	60 TPI/94T		
70°	60 TPI/109T		
70°	80 TPI/125T		

NOTE: TPI = Threads Per Inch, T = Number of Teeth on the knurl

\* Included as the standard set with the purchase of a Sherline knurling tool.

\*\* Each pair of spiral knurls includes one left hand and one right hand wheel. Used together, they form a diamond knurl pattern.

## Chapter 8— Watch and clock making tools

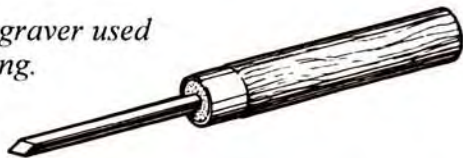


*A jeweler's or watchmaker's lathe differs significantly from an engine lathe. Though very precise and well made, they are designed for use with hand held tools and machining is done "freehand".*

### **A jeweler's lathe vs. an engine lathe**

There is a noteworthy difference between a "jeweler's lathe" and an "engine lathe" design like the Sherline. A jeweler's lathe is a very specialized machine that is really more like a small wood cutting lathe than a metal lathe. Watch- and clockmakers were also instrument makers and were around before machining was a profession. They built marvelous and beautiful instruments that measured the angles used to plot the universe and survey the landscape. What we call clockmakers were really the first machinists. They both designed

*A hand held graver used in clockmaking.*



and built their own projects and became ingenious at building precision parts that had to work together. They accomplished this using tools called "gravers" that were controlled by hand rather than held in a tool post. The methods they used 50 years ago were far different than today's machining technique and required more of a craftsman's touch. Most watch- and clockmakers still use the same methods today. Jeweler's lathes can also be very expensive, sometimes costing several thousand dollars. I believe craftsmen who use these tools enjoy making parts the old fashioned way, and I'm pleased they are keeping this tradition alive and well.

### **What's good for watch parts may not be good for building a steam engine model**

What I'm trying to convince you of is that a jeweler's lathe isn't necessarily the best way of machining if

you are about to start on a complex part. A Sherline type lathe is a small “engine” lathe. It can do anything its full size counterpart can do. A jeweler’s lathe might be great for polishing shaft ends and making clock parts, but it would make some of the operations necessary to build a complex project very difficult to accomplish.

### **The advantages of an engine lathe**

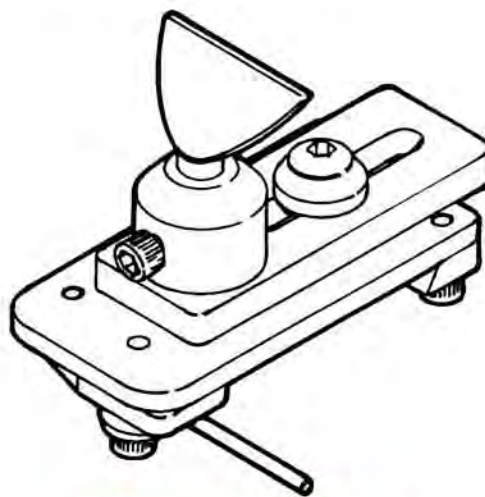
An engine lathe cuts with tool bits clamped in a tool post. Movements with accuracy less than .001” error can be easily attained. The spindle can be geared to the leadscrew for cutting threads. A jeweler’s lathe will have good tailstock alignment for drilling extremely small holes, but it only has a T-rest on which the hand held cutting tools, or gravers, are rested. The machining is done “freehand”. Mr. William Smith, who is a world renowned clockmaker and designer, gave me two days of training with a graver, and I found it a lot of fun to use; however I wouldn’t want to build miniature steam engine parts this way. When you are building parts for this type of project there is as much work done to the inside of parts as the outside. Boring straight, accurate holes can be easy with an engine lathe but next to impossible with a jeweler’s lathe. You also can’t cut threads in a normal manner with a jeweler’s lathe. A jeweler’s lathe may be useful for clockmakers, but I would advise you to select an engine lathe for building a complex mechanical project.



*Collet pot chucks and gearcutting arbors are available in sizes designed for use on jeweler’s lathes. Chuck adapters allow the use of 3- and 4-jaw Sherline chucks on a jeweler’s lathe to increase its versatility.*

### **Sherline watchmaking and clockmaking accessories**

Sherline makes a number of items that could be useful to watch- or clockmakers who still prefer working with a jeweler’s lathe. Available are several adapters to fit Sherline chucks to jeweler’s lathes, saving the customer hundreds of dollars on a 3-jaw chuck alone. Sherline also offers clockmaker’s gearcutting arbors with either #1 Morse taper for use on a Sherline lathe or 8mm and 10mm “D” ends for use on a jeweler’s lathe. 10mm “D” “pot” or “step” collets for holding odd sized work are also available in three different sizes.



### **THE WILLIAM R. SMITH T-REST** **The Purpose of a T-Rest**

This T-Rest was designed by world renowned watch- and clock maker William R. Smith. The only change we made was to eliminate locking levers from the post and pedestal base and replace them with 10-32 screws for production reasons. The same 5/32” hex key that comes with a Sherline lathe can be used to adjust them.

The T-Rest is used to support a metal-cutting tool called a “graver” which is hand-held rather than held in a toolpost like a conventional lathe tool. This traditional method of cutting metal shapes has long been used not only by watch- and clockmakers, but also by some instrument makers and model makers.

Because the tool is hand-held, there is more “feel” for the cut that is being made. Certain shapes like ball ends and special notches or ridges which would be difficult to make with conventional tools can be done quickly and easily with this technique. It can yield very precise results in the hands of one skilled in this technique; however, a certain amount of

practice may be required for a beginner to turn precise parts using this method.

### Precautions for Hand Turning

Be extra careful when using this tool on parts held in a 3-jaw or 4-jaw chuck. A graver which inadvertently hits a spinning chuck jaw could be dangerous. Because the tool is hand-held, it cannot be held as securely as a tool held in a toolpost, so use it with appropriate caution. The cutting angle, sharpness of the tool, position of the tool point and feed rate of the tool are all critical to how it cuts. In a nutshell, when the angles are right, the tool cuts. When they're not, it doesn't. Experiment as you find the best combination and get a feel for the process.

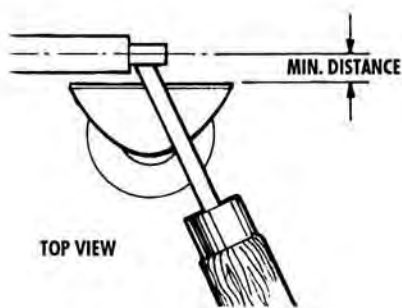


FIGURE 1—The T-Rest is set close up to the work so that the overhang of the tool is minimal. This gives you better leverage on the tool should it dig into the part. (Tool is shown being used on its side.)

### Turning Speeds and Tool Angles

Mr. Smith suggests a turning speed of about 250-500 RPM for turning a small diameter steel shaft. The speeds listed in speed tables for conventional lathe cutting tools do not really apply to cutting with gravers. The basic machining rule does still apply, however and that is:

*"If the tool chatters, reduce speed and increase feed."*

### Rake angle in cutting with a graver

Rest the tool shank on the T-Rest with the point of the tool on the top side. (See Figure 2.) Slide it along on the bottom pointed edge, holding the tool in one of the grips shown in the drawing in Figure 3. The tool can be rotated and pivoted to be used in any number of ways to achieve the type of cut you desire. The tool should be raked downwards at the handle end about 5° to 7° for cutting hard steels. For softer materials like brass, the rake angle can be reduced to near 0° to keep the tool from biting too deeply into the softer metal.

### Starting and making a cut

The angle of entry of the tool into the part varies. Start at about the part centerline and move the tool up or down slightly varying the angle until you find a position where it cuts best. You can pivot the tool left and right using pressure from your finger to swing an arc to cut a radius. As the leading edge of the tool bites in, the heel rubs on the part keeping the tool from digging too deeply. Using this method you can achieve very subtle control of your cut.

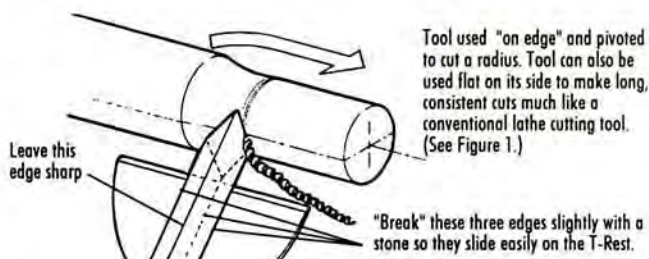


FIGURE 2—Metal peels from the edge of the tool when you find the right cutting angle.

I suggest you "break" three of the sharp edges of your graver slightly with a stone so they slide smoothly on the top of the T-Rest. If the edges are left sharp they will bite in rather than slide.

### Making your own gravers

Mr. Smith gave me a "crash course" on using gravers at his home in Tennessee, but I still don't feel I have the expertise to write complete instructions for their use. Mr. Smith has kindly given permission to use his instructions on making gravers. We include a copy of those instructions with the purchase of each T-rest made by Sherline. He is a superb craftsman and gentleman, and we appreciate the opportunity of working with him on this project.

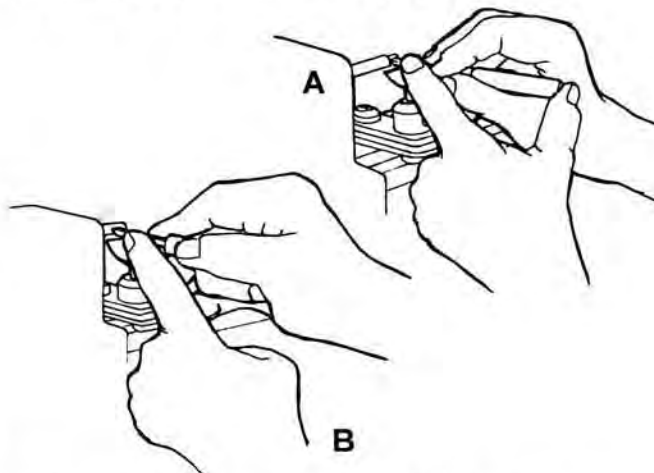


FIGURE 3—Two methods of holding a graver.



*With the addition of the W.R. Smith T-Rest, the Sherline lathe becomes a first class watchmaker's lathe. When you're done hand turning your watch parts using a graver on the T-rest, you can return to the versatility of an engine lathe design for other projects.*

#### **Where to Get More Information**

If you are new to the technique of hand turning metal, I suggest you get more information from Mr. Smith or other experts in the horological field. He has published several books and videos that show or describe the techniques required. A list of his books and videos he offers can be found in the Resources listing of Sherline's World Wide web site. He may be reached by calling (865) 947-9671 or you may

write him at: William R. Smith, 7936 Camberley Drive, Powell, Tennessee 37849. His E-mail address is: [wrsmith2@aol.com](mailto:wrsmith2@aol.com).

If you are going to be making the precise parts required in clocks, models and instruments, you will find that the Sherline lathe along with the T-Rest will yield results equal to those you would obtain on special jeweler's lathes costing many times more.

---

*(Following page) A "skeleton" wall clock designed by W.R. Smith does much more than just tell time. It is a beautiful demonstration of your ability as a craftsman that will become a treasured heirloom for future generations. Mr. Smith offers plans and information on how to build this and other clock projects. His address is listed above.*

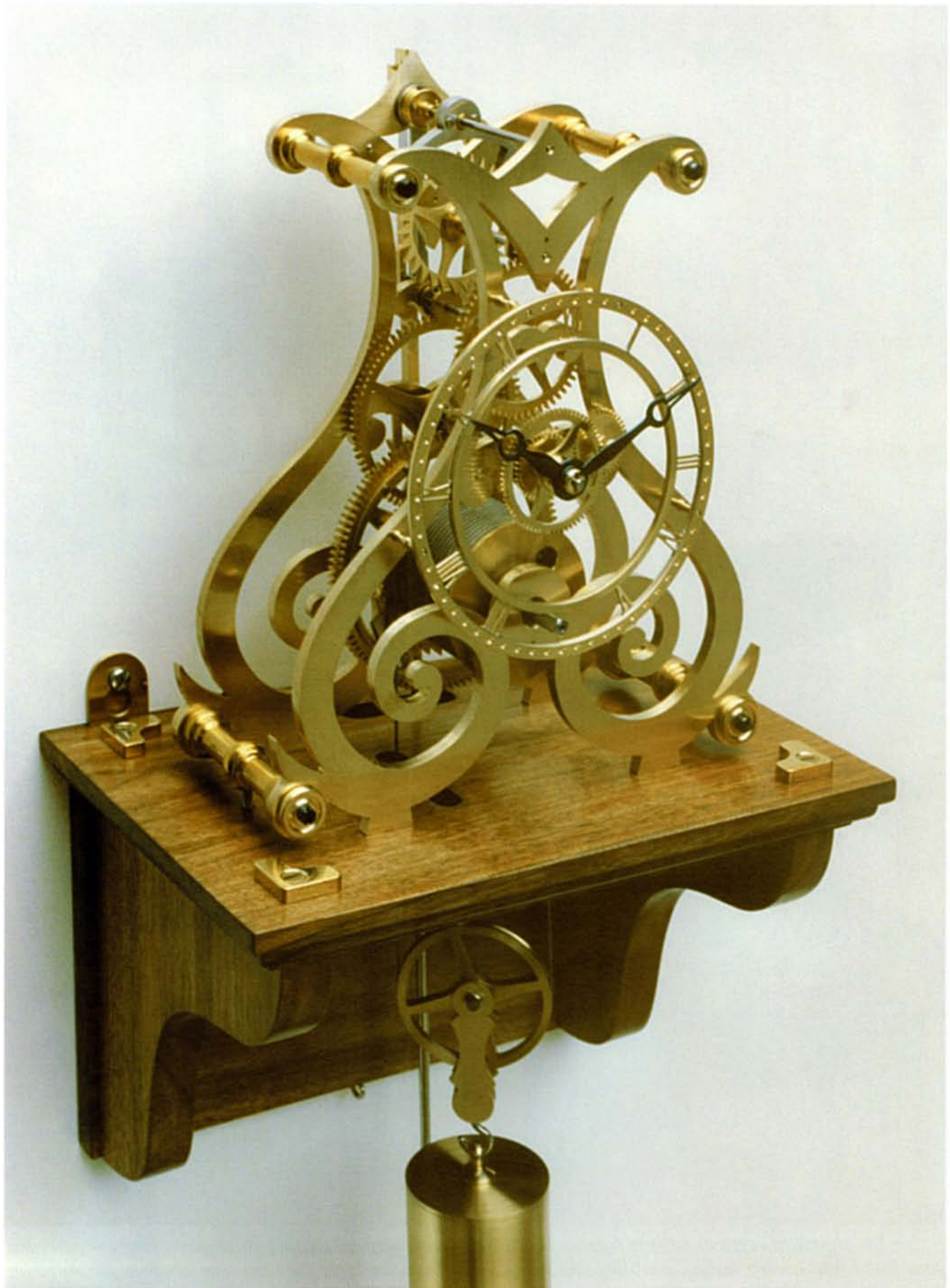
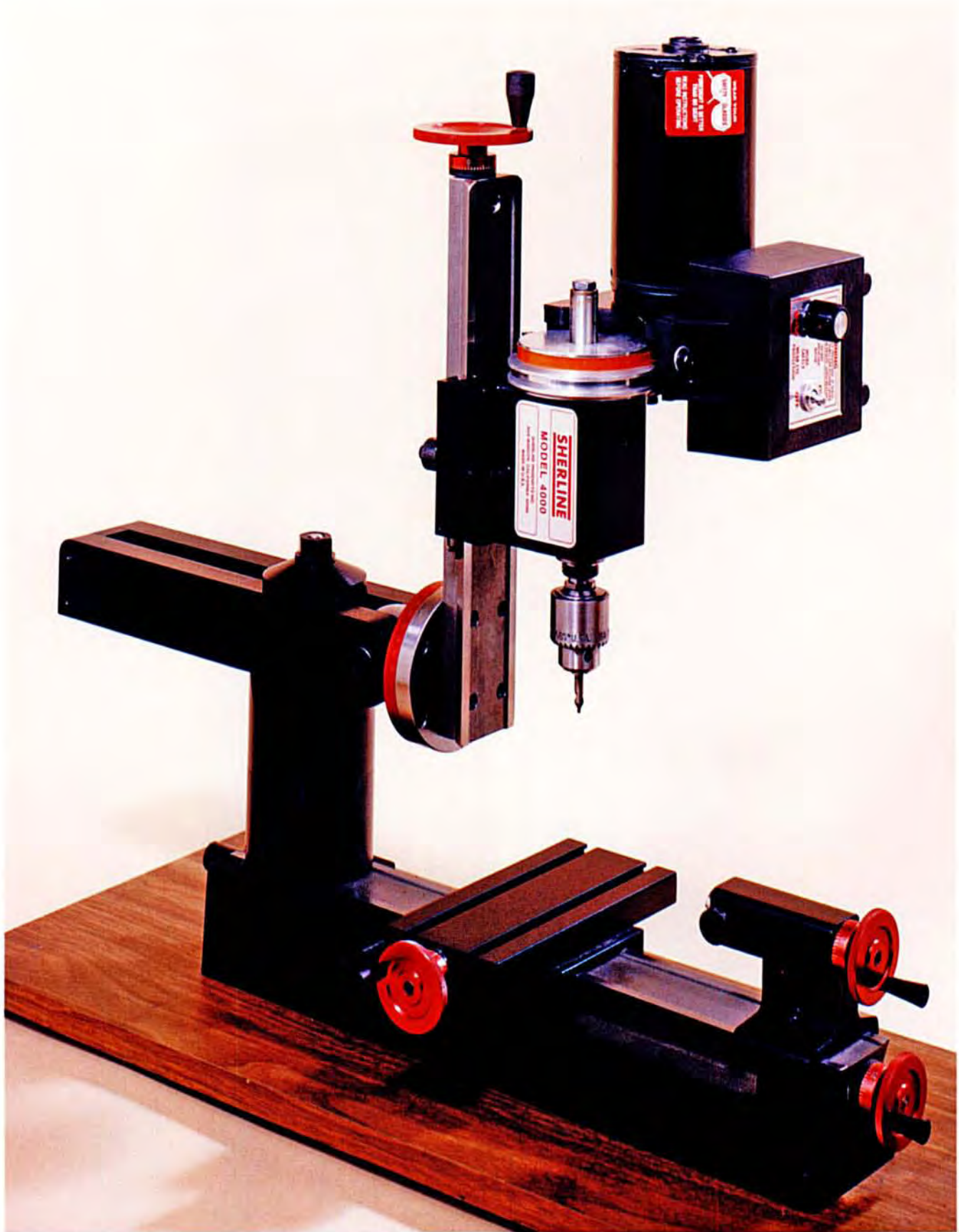


PHOTO: W.R. SMITH



*Either the standard vertical milling column or the multi-axis vertical milling column shown here can turn your lathe into a very versatile milling machine in less than a minute. See the next chapter for more on doing milling operations on a lathe.*

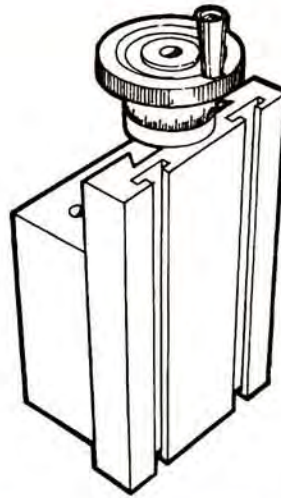
## Chapter 9— Milling operations on the lathe

### Two ways to do milling on a lathe

Sherline offers two different methods to do milling on a lathe. The time honored way of accomplishing this was mounting a vertical slide on the crossslide, and Sherline offers a vertical slide for this purpose. Many books that use Myford lathes for examples will show this type of setup. The cutter is mounted in the lathe spindle and the work is clamped to the vertical slide, or vertical milling table. This allows the work to be moved on all three axes in relation to the cutter. One of the problems encountered with a setup of this kind is that the lathe bed limits the movement of the vertical slide. If the work is small enough and you aren't concerned by this fact, then you will be happy with Sherline's vertical slide. However, I would recommend the vertical milling column because of its greater capacity.

### Coming up with a good vertical milling column design

The vertical milling column was one of the first accessories I came up with. I knew if the Sherline product line was to be successful a method had to be provided to do milling. I used several standard extrusions used in lathe production, and I made up the first prototype. It worked surprisingly well. The dovetail design of the lathe bed was a real factor in



*The vertical milling table attaches to the lathe crossslide. Parts attached to the table can be moved in three axes, while a cutting tool is held in the headstock. It is quick and easy to set up, but the size of the part that can be machined is limited.*

this. The Hardinge toolroom lathe, which could be considered top-of-the-line, uses a very similar design. Most lathe designs don't have a good method of holding the saddle to the bed. The saddle sits on the bed and a small plate is used to keep the saddle from lifting. Remember, cutting loads on a lathe are directed against the bed. Milling loads can be in many directions. As an example, consider a dovetail cutter, which is designed to cut both top and bottom at the same time. The angled part of the cutter wants to lift the work and could lift the entire slide if the



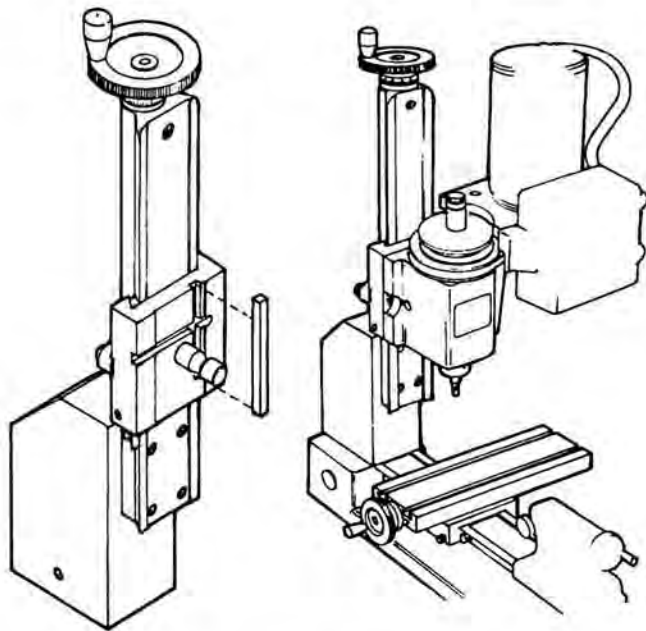
*A standard vertical milling column or the multi-direction vertical milling column shown here can be installed on the lathe in less than a minute. The column has the same "Z" axis travel as a Sherline mill, which makes it more versatile than the smaller vertical milling table. (See the previous page for a complete photo of the multi-direction vertical milling column.)*

*An optional crossslide accessory plate is also attached here to stiffen the crossslide to better handle milling loads.*

bed had a standard design. Sherline put together two dovetail slides to make an attachment many times more useful than the vertical table.

### Mounting the vertical milling column

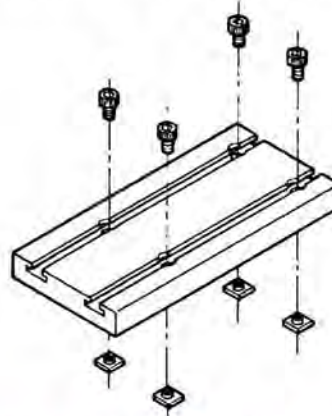
To mount the column to the lathe the headstock first must be removed. Only one screw is loosened to remove the headstock. The column is then mounted in place of the headstock by tightening a single screw. The headstock is then mounted on the column saddle by tightening another screw. With the column mounted directly to the lathe bed, the rigidity is excellent. The main problem is that the crossslide was never designed to be used as a milling table. It was designed to be as thin as possible to allow a maximum diameter stock of 1.875" (47mm) to be turned over the crossslide. If the work is clamped directly to the crossslide it could "warp" and cause binding. I realized this when I designed the first column. A workable solution turned out to be another plate that is bolted to the crossslide that has a larger cross-section, making it rigid and more suitable for milling. The mill tooling plate can also be clamped to the lathe crossslide. (See page 186.)



*The standard vertical milling column (left) and the column shown mounted on the lathe (right). The column is mounted on the same pin that held the headstock and the headstock is shifted to the milling column saddle. The whole operation takes just a few seconds.*

### An additional cost saving advantage of modular design

The vertical column presently manufactured by Sherline has an additional two tapped holes to mount it directly to the XY milling base. This allows the user to purchase a mill one part at a time. You can start with the vertical column mounted on a lathe. In the future, buy an XY base. This will give you a complete mill because the Sherline headstock and motor drive is exactly the same for both the lathe and mill. You now have a Sherline mill by sharing the spindle/motor unit between the two machines.



### When to use a crossslide accessory plate

(See photo of previous page.) Milling exerts high loads on the part being machined. A mill table must be stiff in order to keep from flexing when loads are applied to the part attached to it. The lathe table does not require this same stiffness and is made thinner in order to provide maximum clearance to turn the largest part possible over it. In order to stiffen up the lathe table to better handle the stresses of milling, an accessory plate can be attached to the crossslide. This 1/2" thick plate also acts as a "tooling plate" to protect your crossslide from accidental cuts from the milling tool or drill. It must be removed when using the machine as a lathe, as the extra 1/2" of thickness will put the cutting tool 1/2" above the part centerline in a standard toolpost. Also, the additional height would reduce the size of the part that could be turned by one inch.

### Instructions for milling

Whether you are using a lathe with a milling table or vertical milling column or a dedicated vertical milling machine, the rules for milling remain unchanged. The following section on milling will give you the details you need. If you are serious about metalworking, you will soon find out why the vertical mill is considered the "workhorse" in most machine shops.

### SECTION 3—MILLING OPERATIONS

---

Craftsman Profile—Augie Hiscano . . . . .	180
1. Holding parts for milling . . . . .	183
2. Mill operating instructions . . . . .	191
3. Squaring up a block . . . . .	205
4. Using the rotary table and indexing attachment . . . . .	209
5. Gears and geartrains . . . . .	219
6. Accessories for milling	
• Horizontal milling conversion . . . . .	235
• Rotary column attachment . . . . .	237



*This black 1933 Ford hot rod roadster looks real enough to be fired up and driven off the page, but it is actually a 1/25 scale model. Without the coin in the foreground it might be hard to tell. It won “Best of Show” in the 1997 National Championships in Salt Lake City. This is Augie Hiscano’s most recent winner, but his first National Championship win came in 1964—over 33 years ago! The following profile on Augie details this car and his amazing career as an award winning modeler.*

## AUGIE HISCANO...National Championship wins that span



PHOTO: CAROL HISCANO

*Augie's shop is small considering the National Championships that have been generated here.*

*One of the trademarks of Augie's winning cars are an abundance of custom made metal parts. Thirty-three years ago he could win with parts made with simple hand tools. Today he credits his miniature machine tools as giving him the edge he needs to remain the best in his field.*

At age 7, Augie Hiscano was already carving model airplanes out of blocks of wood. He went on to win contests in U-control model airplane flying and eventually got interested in building and super-detailing plastic model cars. In 1964 he won the biggest national model car building contest ever held; the Revell National Championships which started out with over 500,000 entries. His tools at the time were no more sophisticated than a Dremel tool and files. Contest rules prohibited former winners from entering again, so his interests over the years moved on to building real hot rods and going drag racing. He has applied his skills as a craftsman to working on guns, model trains, cars, boats and tanks and loves all things miniature. He found a job with Orange Blossom Hobbies in Miami that keeps him close to the hobbies he loves, and he has remained there for the past 33 years as manager. In 1989, he was invited back to the National Model Championships in Salt Lake City as a former winner and special guest, where he was re-inspired to build model cars again. A change in the rules meant he could enter again, but 25 years later the level of quality had risen to where he could see his hand tools would no longer be sufficient to build a winning entry. In 1990, his wife bought him a Sherline lathe and he began making machined parts.

In 1991, he received a mill and his entry in that year's contest, a 1932 Ford Victoria hot rod, won both "best of show" and "people's choice" awards. In 1993, he built what he calls "the best car that never won a 'best of show' award" and finished second at Salt Lake City. Determined to build another winner, he went to work on the black '33 roadster you see here. It won the 1997 National Championships "Best of Show" award. It is rare in any avocation to find someone whose national championship quality work spans over three decades, but Augie's has. He gives a lot of credit to his tools and says, "Without tools of this quality I could not have won in the 1990's".

Augie only had two years of Machine Shop in high school, so all he has learned has come from reading books, talking to other machinists and just plain experience. When he was young he built real hot rods, so he knows what goes into a car, but now he prefers working on the 1/25th scale variety. He says, "Today I can make my 'dream cars' and park them in my dining room."

Augie's plans include making one more run at the national championship. With each car he adds more detail and more difficult tasks to test himself. It looks like Augie plans to be the man to beat in Salt Lake City in 1999—thirty-five years after his first win.

## over three decades

Project: 1/25 scale 1933 Ford Roadster



*(Above) The side view really captures the style and classic hot rod looks of this national championship winner. Notice the nice detail in the custom aluminum wheels, the scratch-built headers and the cast brass valve covers.*



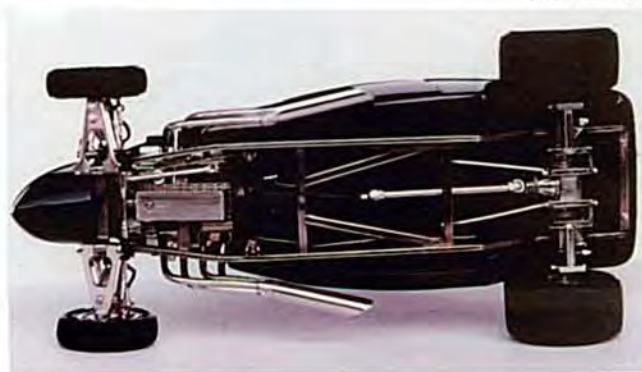
*(Left) A selection of brass parts with a fresh coat of nickel plating. The wires that held them in the plating baths are still attached. Augie does his own plating to maintain control over quality at every possible step in the process.*



*All the parts you can see except for the tires are scratch-built. The aluminum front end of the Ford 427 engine alone took over 30 hours to machine.*

*(Below) From any angle this car is a winner. The bottom side shows the machined front and rear suspensions, motor and drive line components. Even the frame is milled from two pieces of solid material and soldered together.*

PHOTOS: AUGIE HISCANO



The second printing of this book allows me the opportunity to bring you up to date on Augie's latest achievement. In 1999, Augie went back to Salt Lake City with his finest model ever for one last try at a fourth national championship win. He accomplished this goal in fine style, winning the "Best in Class"

(hot rod), "Best Engineered" and "Best of Show" awards. Now a four-time "Best in Show" winner over a 35-year period from 1964 to 1999, he vows to retire from competition and spend more of his time doing seminars to teach his skills in metalworking to others.

PHOTOS: AUGIE HISCANO

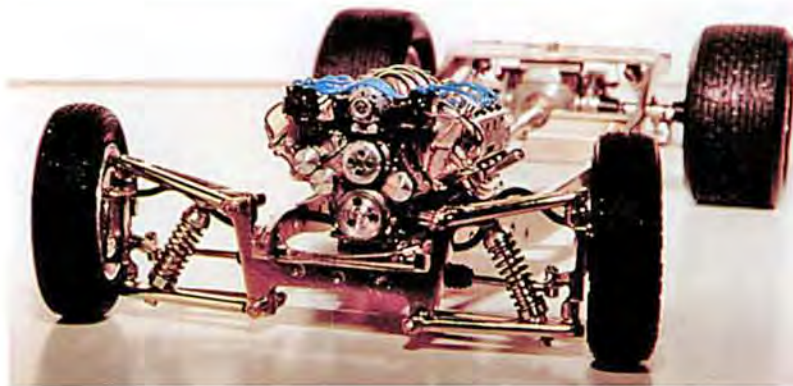
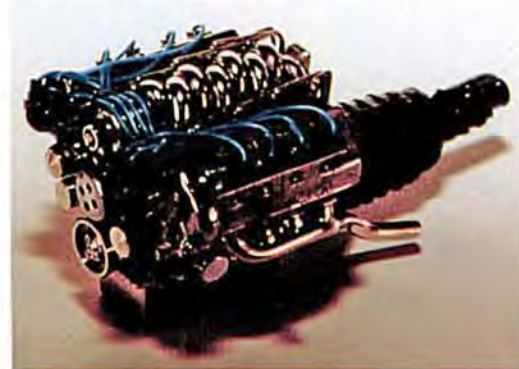
*Augie's 1/25 scale winning entry for 1999. He calls it a 1932-1/2 Ford roadster because the bodywork combines a laid-back 1932 grill with a 1933 body. The engine is a 1996 Mustang Cobra and the suspension represents the best in modern engineering. Under the nostalgic style of the bodywork resides plenty of leading-edge technology that reflects Augie's interpretation of the future of hotrodding.*



*Though the photos don't do it justice, the paint job is a mirror-smooth metallic dark green pearl color.*



*The '96 Mustang Cobra engine is loaded with detail and polished metal parts.*



*The custom front suspension (left) and Jaguar rear suspension (above) feature working steering and springs.*

## Chapter 1— Holding parts for milling

### Metal doesn't cut like wood

If you have worked with woodworking machinery in the past, you may have picked up some very bad habits if you try to go about cutting metal as you do wood. For example, on a radial arm saw, you can easily hold a large piece of lumber with one hand and pull the saw through it with your other hand. If you were to try to cut metal like that, the blade would load up, climb up on the part, break the blade and send the spindle and motor assembly towards you at an alarming rate. Metal must be held securely to successfully machine it. The forces are so great where the cutting tool comes in contact with the part that only the best setups work.

### Deciding how to clamp a part

When using a mill, one of the first decisions you must make is how to clamp the part in position for machining. The method you choose to clamp and align the part to the machine will determine the success or failure of a particular operation. The work has to be held securely to offset all machining forces. The machinist has control of many of the forces by the choice of depth of cut and the feed rate. How securely the part is held down will determine the machining forces that can be applied to it. If you are thinking all you have to do is overtighten the vise to balance this equation, you have never built a complex part. Many parts have final shapes that don't allow a vise or simple hold-downs to be used. A special fixture may have to be built to clamp the work to the machine tool. Whether one part is to be built or one hundred, the work has to be properly clamped. Light cuts will lessen the need for elaborate fixturing. It is up to the machinist to determine what will work on the first try. A novice to the trade will be tempted to machine a milling machine's table to hold a special part. Don't. If your only solution is to modify the table, Sherline has a tooling plate available for just that purpose. The first rule of machining is to leave a machine tool in better condition than you found it. Clamping the work to the machine may take more time than the actual machining. Learn to live with this fact.

### Holding castings

Castings can be one of the most difficult kinds of parts to clamp. They don't have flat sides to clamp



*An irregularly shaped casting for a steam engine is clamped down for milling. The back was flattened slightly using 320 grit sandpaper on a flat table to provide a reasonably flat surface to start from.*

to and the machining has to accommodate any faults or irregularities in the casting. A casting cannot be made to the same tolerances as the part that will be machined from it, so it must be measured very carefully to decide on a starting point. A casting may have machining operations performed from many directions, and the machining must be started from a place that puts all the operations in line with the casting. Castings for some kits may have a quality that would make a bar stock version of the same part easier to build. After completion, sandblasting would still give the part a cast look. The casting may have to be worked with hand tools in order to produce a surface that is flat enough to start the machining operations. The part may also be epoxied to something that can be easily clamped, machined with light cuts and then broken free after machining. The choices are endless.

To simplify these problems there are a number of standard ways to clamp the work to the machine, and the method you choose will be determined by the size and shape of the part and the operation to be performed on it.

### THE MILLING VISE

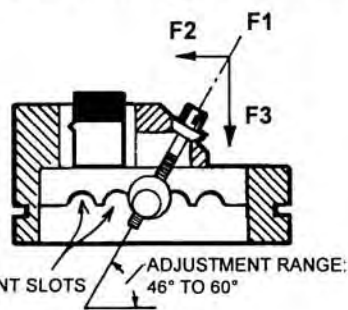
#### Special design features address the demands of milling

Probably the most versatile and popular method of holding parts for milling is the milling vise. The



*If you just purchased a milling machine and don't yet have a milling vise, you should consider getting one. It will be the single most useful accessory you can own for holding work on a mill.*

milling vise is different from drill press vises and requires a little more effort to use. The main difference is that as the milling vise is tightened, the jaw not only closes but is also pulled downward. This keeps the movable jaw from lifting if a part is being held by the top section of the jaws. A cheap drill press vise is almost useless on a mill because there is no way to keep the movable jaw from lifting.



*The mill vise's pull-down feature and the forces involved in holding parts for milling.*

The Sherline vise is machined square and has a groove around its body to allow it to be clamped firmly into position on a mill table. The vise can also be clamped on its side and held to the table with "hold-downs". The fixed jaw has both a horizontal and a vertical "V" groove to facilitate holding round bar stock. These grooves can be very useful to hold bar stock to mill the end with the vise on its side.

The advantage of the milling vise is obvious when movement of the jaw is studied. (See illustration at left.) The tightening force (F1) produces not only a force against the part (F2), but also a force pulling the jaw downward (F3). Therefore, angle "A" must exceed 45° in order to make force F3 greater than F2. This keeps the movable jaw from tipping back. Also note that extreme clamping angles beyond 60° there is too much downward pressure, but not enough clamping force. Moving the pull-down



Making “soft” aluminum jaws for your mill vise adds to its versatility. Project plans show you how to make them on page 321.

barrel to the proper position keeps the adjustment within the most effective clamping range.

To summarize, a good mill vise allows you to position a part accurately while holding it very securely.

### Clamping a part

The vise is usually clamped to the machine before the work is clamped to the vise. Sherline vises have a slot milled around the vise to accommodate hold-downs. You don’t want any kind of “alignment” built into the vise, because many times the vise has to be clamped to an angle to the mill table. To get the vise square with the machine, the fixed jaw has to be indicated in. (See illustration on page 199) Many times a vise doesn’t have to be exactly square with the machine to perform a job such as flycutting. This is perfectly acceptable as long as you remove the vise from the table when you are through with it. Never leave a machine vise clamped to a machine if it isn’t square, and never use a vise that you didn’t clamp down yourself without checking it with an indicator. If the work to be performed is “heavy”, it would be prudent to use at least three clamping points. If the vise is moving on heavy cuts, trying to solve the problem by overtightening the two clamps you are using may damage the T-slots. As with all tools of this size, it is easy for the operator to overpower it by overtightening. The machining forces applied to your part by a motor as small as is used on the Sherline mill do not require the same clamping pressures as you might apply to a part being machined in a full size mill. The fact that the operator is physically stronger than the machine is one of the basic problems working with any small

There is a right way and a wrong way to clamp work in the jaws (right). If you can’t center the work, keep the jaws square by adding a spacer the same thickness as the part.



WRONG



RIGHT



SPACER

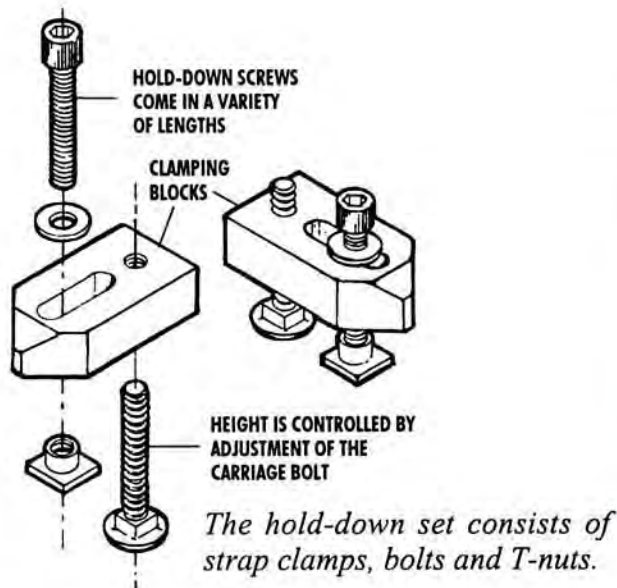
machine. I’ve even seen machines weighing thousands of pounds with their T-slots pulled out. The same type of people that pull these slots out will also pull ours out. A good craftsman will develop a “feel” for machine work that can’t be described in books.

To clamp a part, place the jaw in approximate position and start tightening the adjustment screw at an angle of 45° or greater. (The back face of the moveable jaw is machined at a 45° angle for reference.) If the angle of the adjustment screw gets up to 60° or greater and you still haven’t drawn down on the part, loosen up the screw a little and move the pull-down barrel to the next slot and retighten.

The illustration above shows the proper way to hold a part in the vise. If the part cannot be centered, use a spacer in the other end of the opening to help keep the jaws parallel. In most cases, don’t try to hold more than one piece in a vise unless they are being clamped to one another. A slight difference in sizes will leave one part loose, and it will move while being machined. Again, overtightening can distort the part or the vise, and overtightening the hold-down clamps can damage the T-slots of your mill table. Though you want your part securely mounted for milling, be reasonable in the forces you apply so that you don’t damage your part or tools.

### HOLD-DOWN CLAMPS

At least one set of these clamps should be considered a necessity for every milling machine owner. The set consists of two strap clamps complete with bolts, T-nuts, washers and a variety of socket head cap screws to accommodate parts of different thickness. The socket head screw goes through the slot in the strap clamp and into the T-nut which is in one of the slots in the mill table. The carriage bolt goes into the hole at the other end of the strap clamp with its round head resting on the mill table. It is adjusted to the proper height for the part being held, and then the socket head screw is tightened down to hold the part in position. (See illustration on next page.)



Set up two or more strap clamps on the part to be held and get them into position with the screws just finger tight. When the part is properly aligned, use a hex key to draw each clamp down a little at a time keeping an even force on all points so the part isn't distorted. If the size and shape of the part allow, it is better to spread out the clamping load by using more clamps rather than putting more pressure on fewer clamps. (See also photo on page 183.)



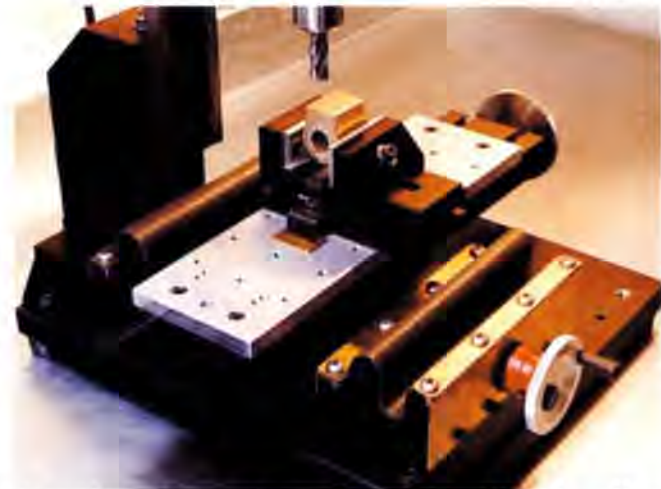
*A part clamped to a right angle plate is held perpendicular to the table for milling.*

### RIGHT ANGLE PLATES

A right angle plate is simply a device that can be clamped to the table which has a vertical surface that is exactly 90 degrees to the table. It can be very useful for squaring work to the machine and is almost a requirement when working with the horizontal milling attachment. They can be used in

so many diverse ways that they are sold without holes for clamping. They are relatively inexpensive and could be considered disposable for a tabletop machine but not for full size machines because of the large cost difference. A few holes drilled and tapped in the vertical part of the plate can make them easier to use.

PHOTO: TIM SCHROEDER



*A tooling plate mounted to the mill table offers several ways to hold parts while also protecting the table from accidental damage. Here, a mill vise is used to hold a part. Notice Tim has custom-designed his own shield to keep chips off the leadscrew.*

### TOOLING PLATES

Tooling plates are nothing more than a cast piece of aluminum plate, machined on both sides, with a number of holes in them. Their main use is to protect the mill table, and Sherline's plate has been laid out to accommodate some of the accessories that may be used in conjunction with the plate. Cast plate is interesting in the way it is made. Scrap aluminum is melted on a pool of molten lead, and the difference in their weights makes the aluminum float on top of the lead. The temperature is then lowered to the point where the aluminum hardens and the lead is still molten. The plate can be then lifted off and machined flat on both sides. What is useful about this material is that it doesn't have any built-in stresses that can cause warping during the machining process. As always, you don't get something for nothing, and that result is a material that doesn't have the strength of standard aluminum.

### THREE- AND FOUR-JAW CHUCKS

Sometimes a part held in a chuck on the lathe will need an operation performed on it on the mill. The chuck can be removed from the lathe, mounted to the mill table, the operation performed and the chuck

returned to the lathe for more operations without having to recenter the part in the chuck. Other times, a chuck may just be the simplest way to hold a part for milling. In either case, chucks are good holding devices that are easily mounted to the mill table in a couple of ways.



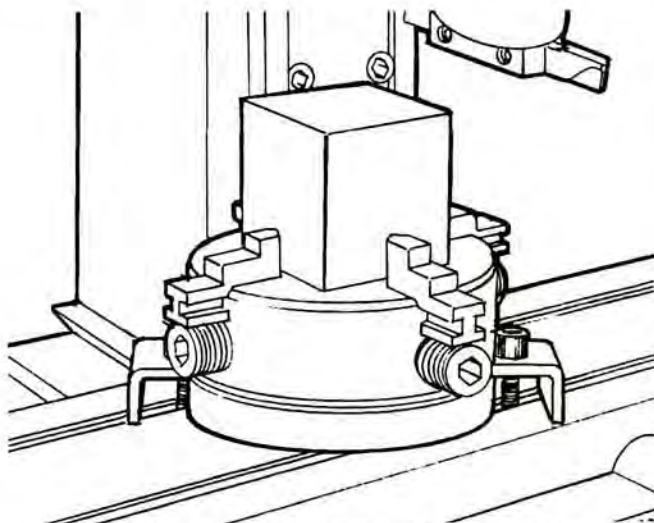
### CHUCK-TO-T-SLOT ADAPTER

The fastest way to mount a chuck to the table is with the chuck-to-T-slot adapter. This part is simply screwed a short distance into the 3/4-16 hole in the back of the chuck, and then the tab on the end is slid into the T-slot on the mill table. The chuck is slid into position and rotated on the adapter to tighten it down on the table. A special adapter is included with the rotary table to allow 3-jaw and 4-jaw chucks to be mounted in the same manner.

Keep in mind that the chuck is tightened down clockwise. Any counterclockwise forces applied by the rotating end mill will have a tendency to loosen and unscrew the chuck which could be disastrous for your part. If you are using a 3-jaw chuck, you can place a tommy bar in one of the adjustment holes and mount a small block to the table to act as a “stop” to keep the chuck from unscrewing.

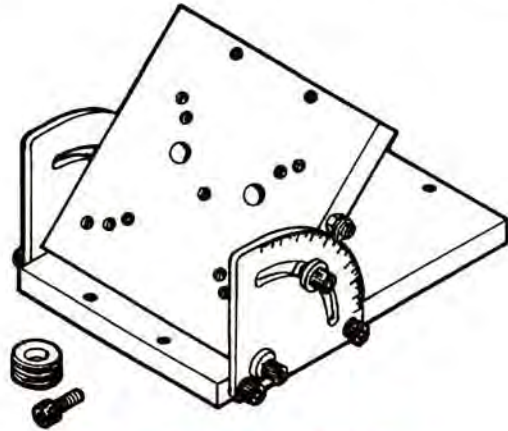
### Mounting a 4-Jaw chuck

The 4-jaw chucks have a groove machined around the outside diameter which allow them to be held down to the mill table with angle clamps. These clamps come with a number of accessories and you



*A 4-jaw chuck held in place with angle clamps.*

probably already have some on hand. If not, they can be purchased as the 4-jaw hold-down set. These clamps are held with bolts into T-nuts in the mill table T-slots. This is a more secure method of mounting and also allows the chuck to be mounted in any position on the table, not just lined up over one of the T-slots. Even if the chuck-to-T-slot adapter is used, these clamps should be used to keep the chuck from unscrewing during machining.

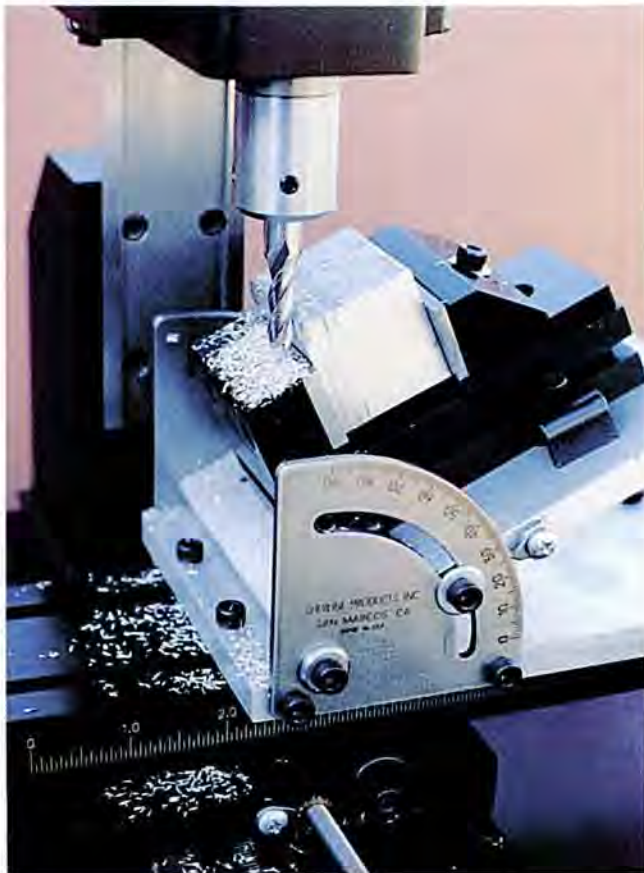


### THE TILTING ANGLE TABLE Design of the angle plate

To mill angles on a part, either the part or the cutter needs to be tilted to the proper angle. The tilting angle plate is a way to make it easy to hold the part securely while tilting it to the desired angle. A rotary column attachment is also available that allows the part to be mounted square and the column tilted to the desired angle, but using the tilting angle plate means the vertical column doesn't need to be realigned to square after the cut is made. The angle plate attachment for the Sherline mill was designed with help and many suggestions from auto engineer and Sherline machinist Graham Taylor of Livonia, Michigan. The multiple hole pattern allows the rotary table or mill vise to be attached directly to the table. Also included is a 3/4-16 adapter which attaches to the table, allowing you to directly mount Sherline 3-jaw or 4-jaw chucks to the angle plate as well.

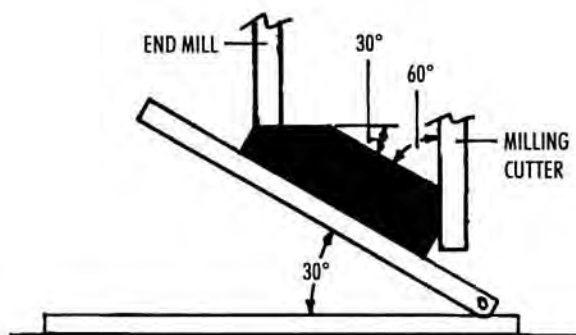
### The importance of mounting the plate square with the table

The angle plate must be mounted square to the table. The mounting hole layout should be reasonably accurate, but for very close work, use an indicator to square the plate just to be sure. The movement of a plate tilting at angles can be very confusing. It would be wise to consider how errors can accumulate



*A part held in the mill vise is mounted to the tilting angle table for milling. Drilling angled holes is also made easy using this accessory.*

by not having the table square. If square, as the table is tilted a given point moves in relation to only one axis but not the other. If not square, it moves in relation to both axes, making accurate machining almost impossible. For example, you might start a cut several thousandths deep at one side of a part and end up cutting nothing at the other side. To make this clear it is easier to picture what is happening if



*The angle of your cut is dependent on whether you are cutting with the side or end of your milling cutter.*

you visualize an extreme case where the table might be mounted  $15^\circ$  off from square. Picture the path your cutter would make if you made a pass over a part mounted that far off square and you'll see what I mean.

Always make a sketch of your setup to make sure you have the correct table angle. When using an end mill, remember that the angle of the cut depends on whether you are using the end or the side of the milling cutter. The bottom of the cutter cuts the angle indicated on the angle plate scale, while the side of the mill cutter cuts an angle equal to  $90^\circ$  minus the angle set on the table. (See illustration below left.)

#### **Mounting the angle plate to the mill or lathe table**

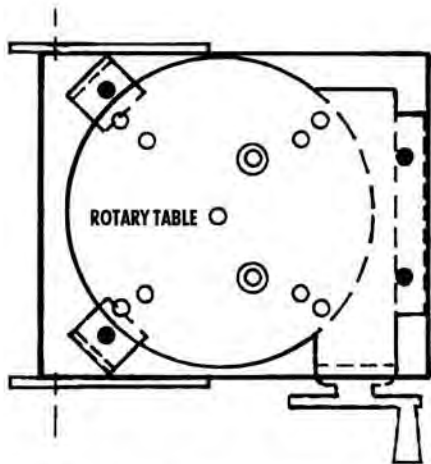
The hole pattern in the bottom of the angle plate has been designed to pick up the T-Slots in the mill table or in the crossslide table of the lathe when using the vertical milling column attachment. Use the T-nuts and socket head cap screws in four of the six mounting holes on the bottom plate. Use the two center and two of the end holes for mounting to the lathe table. For the mill table, use all four end holes.

#### **Mounting hold-down devices to the angle plate table**

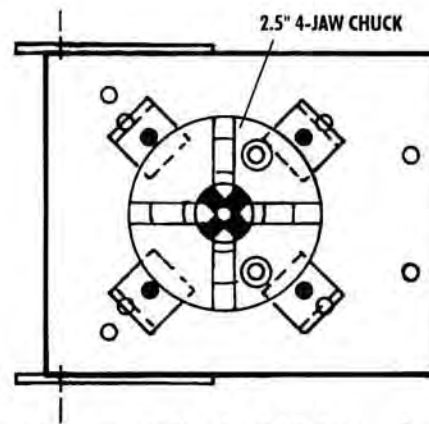
The hole pattern in the table of the angle plate has been designed to allow you to mount any of several Sherline holding devices. These include the rotary table, mill vise, 3-jaw chucks and 4-jaw chucks. This is why the hole pattern looks a bit odd. You can also drill additional 10-32 holes to meet your own unique mounting requirements. The following diagrams show which holes to use for mounting each of the accessories. As an additional feature, the rotary table location has been calculated so that when rotated to the  $90^\circ$  position, it comes out at the same height as the rotary table tailstock, which eliminates the need for the P/N 3701 right angle attachment. (See next page for illustrations.)

#### **Maintenance of the angle plate**

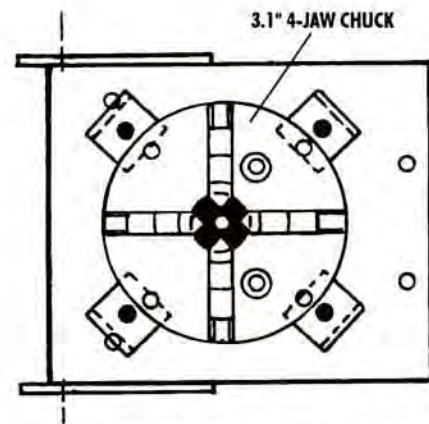
The angle graduations are laser engraved into the stainless steel side plates so you don't have to worry about rust or solvents. Do not try to polish around the engraving. Though quite easily readable, it is not very deep and could be removed in the polishing process.



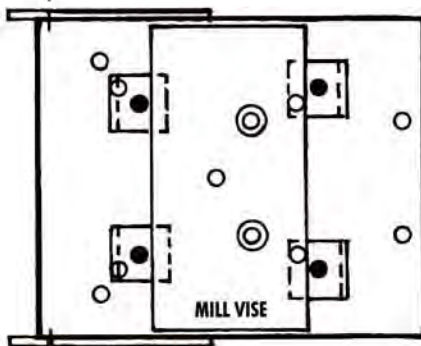
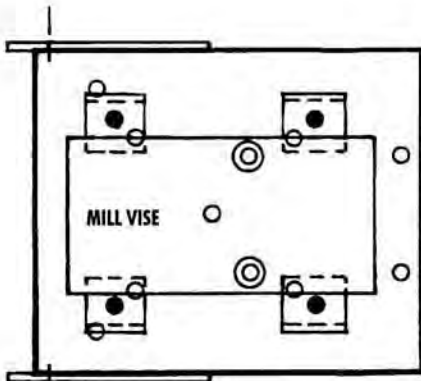
Mounting points for the rotary table. Solid black circles indicate holes used for hold down screws on this and the following diagrams.



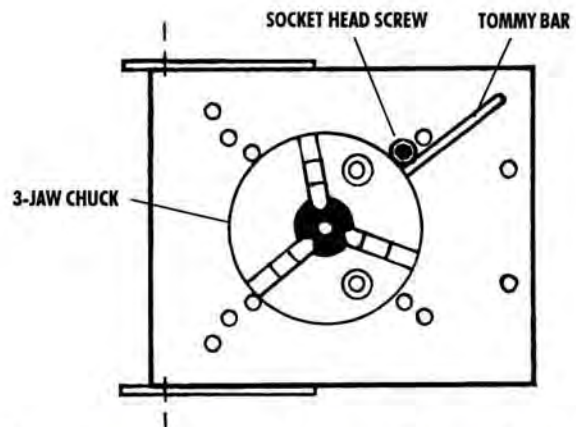
Mounting points for the 2.5" 4-jaw chuck.



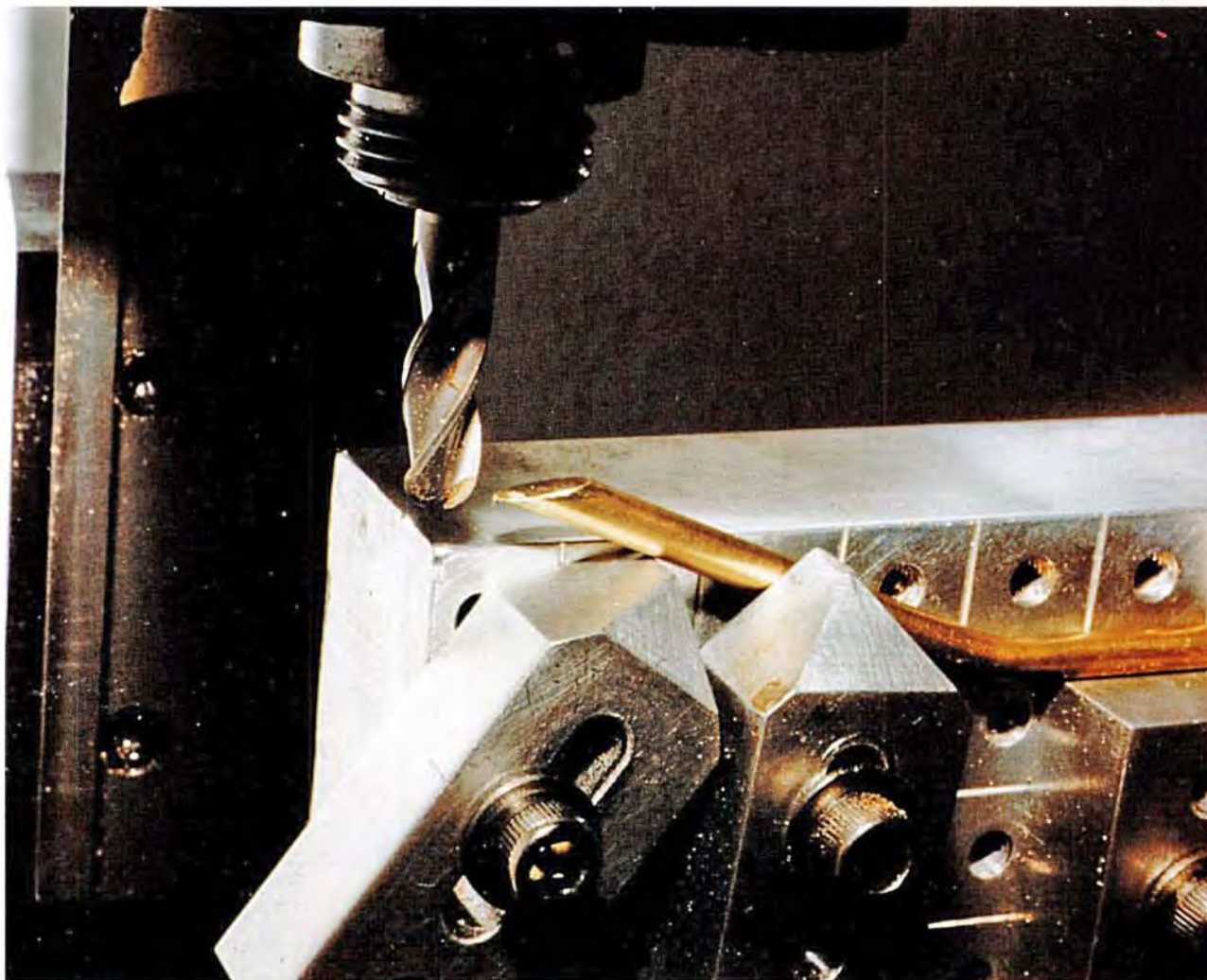
Mounting points for the 3.1" 4-jaw chuck. The center chuck mounting adapter and 4 angle clamps are used to mount 4-jaw chucks very securely.



Two methods of mounting the mill vise (above).



Use a tommy bar to keep a 3-jaw chuck from unscrewing during machining. Place the tommy bar in one of the holes in the **upper** chuck body and use a 10-32 socket head cap screw as a stop. The center chuck mounting adapter is attached to the plate from the bottom. After locating and tightening the chuck in place, set the plate to the desired angle.



*Bob Breslauer made his own tooling plate and strap clamps to make special jobs like milling the end of this brass tubing easier. He is using a ball end mill to put a radiused slot in the tubing so it can be soldered to another piece of tubing to make a motorcycle frame. Using a well designed fixture like this makes it easy to place another piece of tubing in the identical position so he can make five model Harley Davidson motorcycle frames. When making a number of identical parts, a little extra time spent in designing a good fixture pays off in the long run as the parts are both easier to make and more consistent. (The completed motorcycle frame can be seen on page 311.)*

## Chapter 2— Mill operating instructions

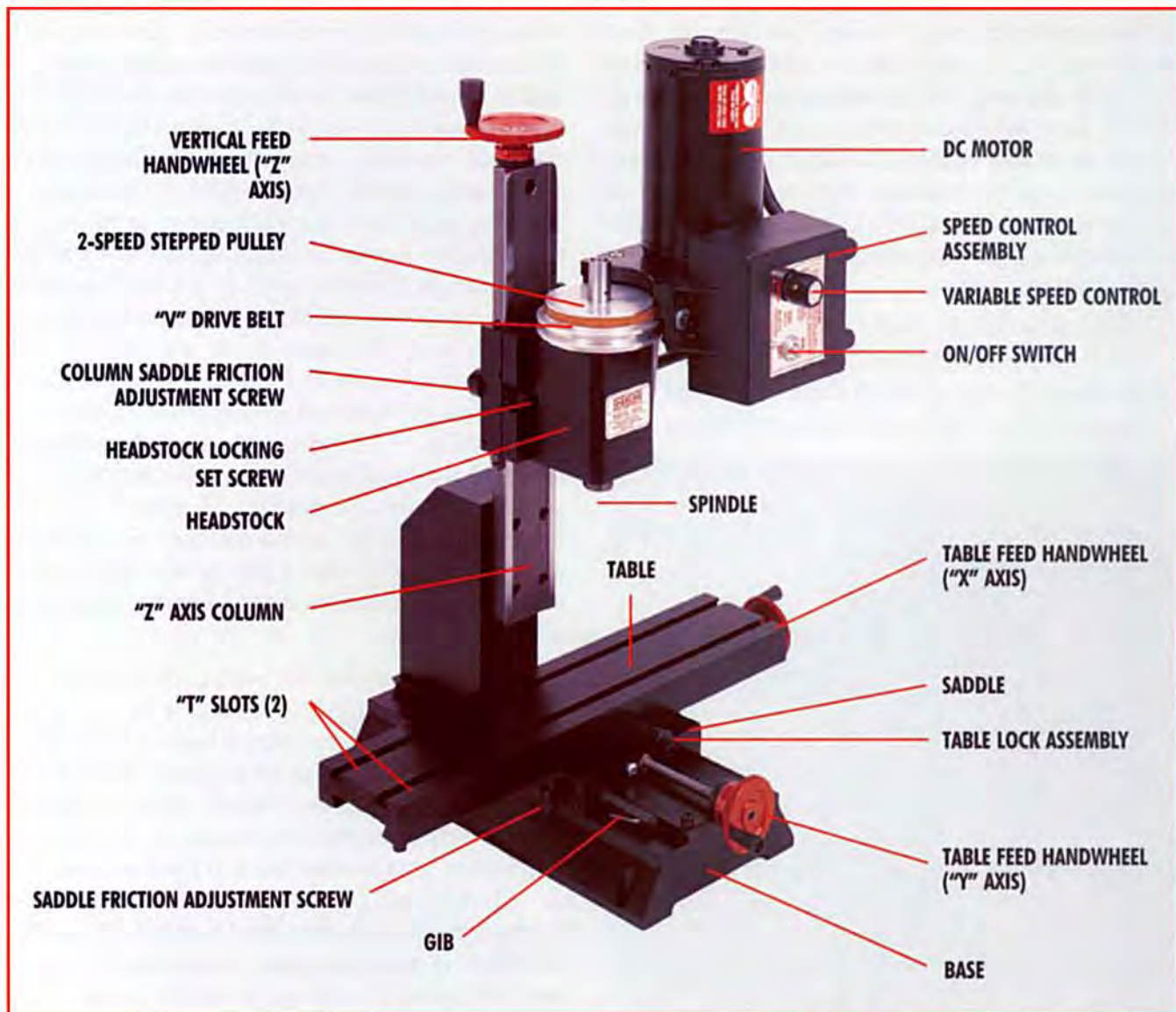


FIGURE 1—Milling Machine part terminology. (Gib shown partially pulled out for clarity.)

### Improving the way milling was done on the Sherline lathe

When the first Sherline model 4000 lathe was imported from Australia, there wasn't any method for milling except with the vertical milling table (P/N 1185). We still manufacture this device and it is a method of milling on a lathe that has been around longer than I have. The Myford and Atlas lathes used this method for milling, and I'm sure that is why Sherline Australia used it. The main problem was I didn't like it. The lathe bed always ended up being in the way, and the limited movements were only useful if very small parts were required. It took me

about two hours to build my first vertical milling column (P/N 3050) using a column block and a few parts left over from the first shipment of lathes from Australia. It looked and worked more like a milling attachment should, so I made a few to see if they would sell. They did, and there was soon a demand for the column, because it gave the customer an accurate way of controlling the "Z" axis with a feed screw.

I still wasn't completely satisfied, but the design would have to do for now. The lathe wasn't even into production yet, and here I was thinking about

what to build next. There were still way too many problems that still needed solving in order to produce the lathe. If I didn't focus there wasn't going to be a tomorrow for Sherline. The immediate problem was to have machines ready to ship to Sears. My first employee was Darrell Porter. Darrell had worked for me in the past. We got along well, and he was always good at "making things work". His skill was tested again and again as I brought old production machines into the business. Between the two of us orders were soon being filled. Darrell eventually left to become a preacher, which was definitely not a skill he learned from me.

**When you've thought about something long enough, you don't even need to draw plans**

With the lathe in production there was at last time to build a mill. I had thought about it for so long



*Geometric puzzles like this are usually made from wood. Joseph Piecznski of Flanders, New Jersey machined each of these interlocking pieces from metal. The radiused ends add a nice touch.*

that I didn't even need a drawing. I headed for the local scrap yard on a Saturday morning and picked out the pieces of metal I needed without even using a tape measure. I was on a mission. By Sunday evening I had my prototype built. About the only change that was made between the original prototype and the production model was that the table was made a quarter of an inch thicker than the lathe crossslide material I originally used. The thickness of the lathe crossslide must be held to a minimum to allow the largest possible diameter to be turned over the crossslide. Loads on the lathe table are also less than those generated by milling. It would have been nice to be able to use the same extrusion for both the lathe and mill, but I could see that the mill required more beef. The finished mill worked better than I thought it would, considering its size. The smallest size mill I had used up until then weighed around a thousand pounds, and this machine only weighed twenty-five pounds. Monday I ran a few more tests to see if I could machine something to size. If I couldn't make a part to size, how could I expect a customer to be able to? The machine passed with flying colors.

**Why hadn't anyone else made a mill like this?**

I believe the biggest advantage I had over my competitors was I knew what it took to build things both as a hobbyist and as a toolmaker. If I had only worked as a toolmaker, I would have considered making a complex part on a twenty-five pound mill impossible. On the other hand, if I had worked only as a hobbyist, I wouldn't have known that accessories like a boring head would be necessary to make the machine usable. Items like fly cutters and boring heads were not available for miniature machine tools at that time. This gave me a chance to create a whole new market for Sherline.

**The "stepping stone" process of improving the line**

Sherline manufactures a machine to build a certain size range of work. I wasn't involved with the first design of the lathe, but I'm sure it was designed to compete with the Unimat 1000. Over the years one scenario has remained constant. As soon as I designed a mill to build parts to complement the lathe, customers wanted to build parts that were a little bigger than the present lathes could handle. A flywheel for a small steam engine would be a good example. We solved the problem by making a riser block for the headstock so a bigger part could be turned. Now a customer wants a riser for the

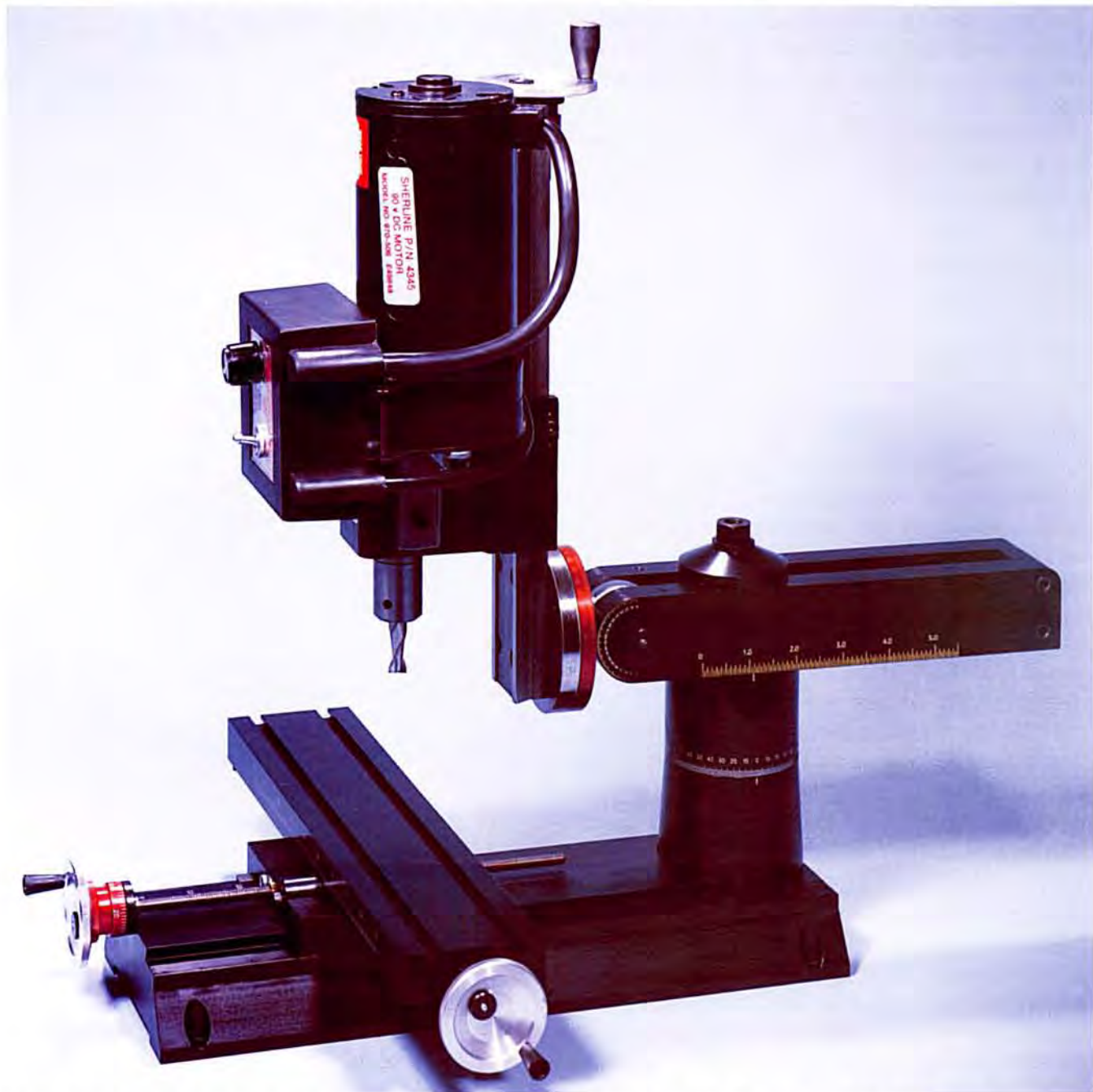
tailstock. We make that and the customer produces a part that doesn't quite fit on the mill. We modify the riser block so it can be used on the mill as well, and so it goes.

### **Designing a mill for the twenty-first century**

As I have been writing this book, I have also been working on a new design for the mill. Because it will be the new mill to carry the company into the year 2000, I plan to call it the Model 2000. A design was needed that had all the features of my favorite

full-size machine, the Bridgeport® vertical mill. The machine would have to have more capabilities but not a larger size. It had to remain affordable. It also had to be a design that wouldn't make obsolete existing equipment that had already been purchased.

I took another look at a Bridgeport to study its movements. The head was mounted on a plate that would allow it to be tilted side to side. I had just finished an accessory (the rotary column attachment) that would do this, but the Bridgeport would also



*The Sherline Model 2000 mill takes the product line into the year 2000 and beyond. With eight directions of movement, it duplicates in miniature all the functions of the industry standard full-size mill—The Bridgeport.*

allow the head to be tilted in and out. This could be accomplished by changing the adapter plate to a “knuckle”. The Bridgeport had this entire head assembly mounted on a “ram” that could be moved in and out as well as rotated side to side like a rotary-arm drill press. I came up with a simple solution by making the ram-slide out of a couple of machined rectangle bars that are held together by a bolt running through the knuckle at one end and a spacer at the other. The bolt also locks the knuckle in place when tightened. The column block has been replaced with a couple of round pieces with a shaft running through it. The shaft comes out between the rectangular bars that allow you to lock the whole assembly with a hex-nut and large custom washer. I believe it will be a logical solution for our customers that are always maxing out our present Model 5000 mill. It will improve the present line of mills but not replace them.

#### Drawing the line as far as size and price

Many customers don't need a machine this elaborate to accomplish their needs. Cost is a factor I live with daily, and it is difficult to keep it in check. We have one group of customers who say they want perfection at any cost, although I find this hard to believe. If Sherline machines were made with hardened and ground machine slides they would be so expensive we would have few customers. I don't think there is a market for miniature machine tools that cost several thousand dollars yet only work a little bit better than what we now offer. There are no plans in the future to manufacture or import a larger milling machine because we would become spread too “thin”. This part of the market is already covered nicely without my help. Sherline's future will be in manufacturing more specialized attachments for the current line. This will ensure our goal of seeing that the parts built on Sherline tools are limited only by size and the builder's imagination...not by complexity.

#### Going beyond basic milling operations

Much of the information on complex milling machine operations can be found with the attachments that must be used in conjunction with a milling machine. Reading and understanding these instructions can give much insight about solving the problems that arise in the complex world of working in 3-D. Again remember that speed on a milling machine is gained by not making mistakes. “Shortcuts” can be the quickest path to starting over.

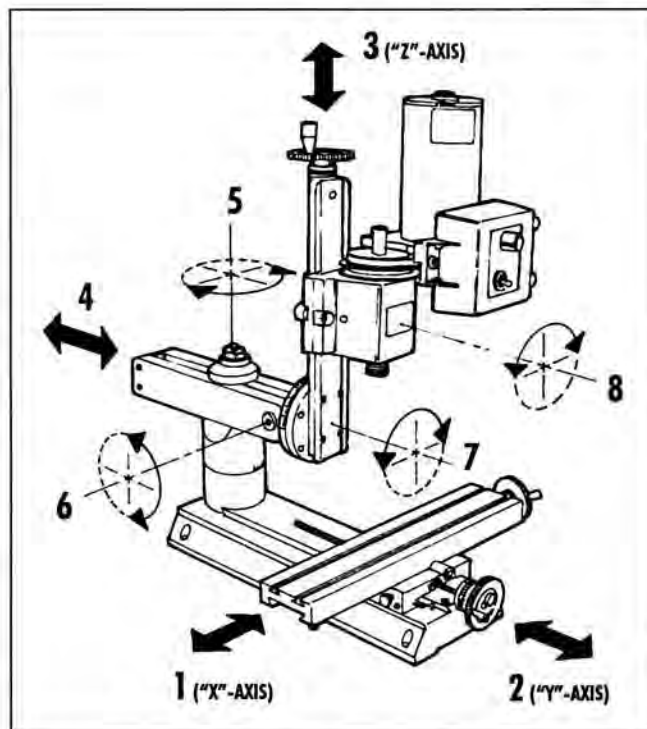


FIGURE 2—Directions of movement of the Sherline Model 2000 8-direction mill. The design is patterned after the movements of a full-size Bridgeport® mill.

#### General Description

At first glance, a vertical mill looks similar to a drill press, but there are some important design differences. For example, the spindle of a mill is designed to take side loads as well as end loads. A mill also has an accurate method of moving work in relation to the spindle on all three axes. It is wise to memorize these “X”, “Y” and “Z” axes, because since the advent of complex electronically controlled milling machines, these terms have become common “shop talk”, even outside engineering departments. Feed screws with calibrated handwheels control movements on these three axes. The handwheel calibrations are quite accurate and should be used whenever possible.

In addition to these three basic axes of movement, other directions of head rotation, swing and tilt can also be added for additional utility. See Figure 2 for the movements of Sherline's 8-motion mill.

#### The importance of keeping the spindle square to the work

Using a vertical mill correctly takes more skill and experience than is required for lathe operation because of the additional axes and the more varied type of work that can be performed. Cutters move in circular paths; and when their axis isn't square to

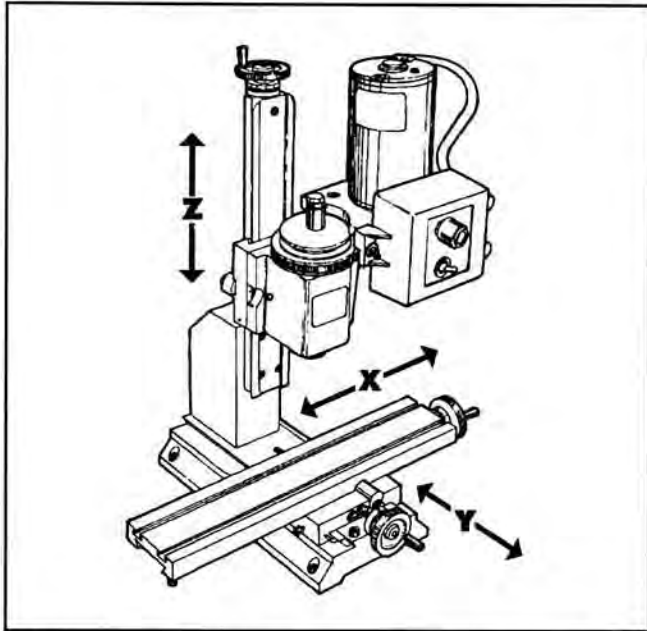


FIGURE 3—The three axes of movement on a standard milling machine

the surface they are cutting, they can produce elliptical shapes. A trick I use to understand these sometime subtle actions is to think in extremes. For example, a spindle that isn't square with the surface it is machining will leave a surface that is "dished" out when the surface is machined. This may be hard to visualize if your considering the spindle only a few thousands out of square, but if you think of the spindle aligned at 45 degrees to the work, the cutter path becomes obvious. The cutter would form an elliptical cut. You can use this fact to produce some very interesting shapes. (See page 203.)

#### **Working within the capabilities of the machine**

The machine must be well maintained, for it is subject to higher stresses than a lathe. This particular mill is one of the smallest being manufactured and is an extremely useful tool. However, it would be unreasonable to clamp a 3-pound piece of stainless steel to the work table and expect to make a 1-pound part from it. Have a cutoff saw available to remove rough stock. The key point is to work within the capabilities of the machine, and those limitations can only be determined by the operator.

#### **Securing the workpiece**

The first problem encountered will be holding the work and aligning it to the machine. It is important for reasons of safety and accuracy that the workpiece be solidly secured. This may be the most difficult task, since once the work is clamped in position,

the method of doing the entire job has been established. The previous chapter is devoted to ways to hold parts securely for milling. If you have not already read it, be sure to do so before attempting to make any cuts on your milling machine. The following contains a little review and a couple of additional thoughts.

Usually, a rectangular block can be easily held in a vise. Note that round stock may also be held using the "V" shaped slot in the vise jaw. Mill vises are specially designed to pull the movable jaw down as they tighten on it. Inexpensive drill press vises don't have the movable jaw machined accurately enough to do any serious machining. When the work is held only at the top of the vise jaw, the jaw will tip back as the jaw is tightened. This causes the jaw to rise where it comes in contact with the part as it is tightened. It is possible to spend well over an hour clamping and aligning work to perform two minutes worth of machining.

Certain objects can be secured with a 4-jaw lathe chuck. Work can be performed on a lathe and then chuck and work are clamped to the milling machine and completed. Some irregular shapes, such as steam engine castings, may present greater difficulties. Often they may be clamped directly to the table, but they will need at least one reasonably flat surface. This may require some hand work before starting. Very small or irregular shapes can be secured by epoxying them to a second, more easily held piece of material. They are broken loose after machining.

Don't overtighten hold down screws. The end result is bending the top of your T-slot groove which creates a high spot on the mill table. Remember, you are stronger than your machine with the added leverage of a screw. The same customers who damage the T-slots on Sherline machines would also break the T-slots on cast iron tables. I have seen full-size machine tools weighing thousands of pounds with their T-slots broken by improper clamping procedures. Never try to hold the work with one clamp. The work can spin, ruining the work and cutting tool and possibly damaging the machine as well. Always use two or more clamps.

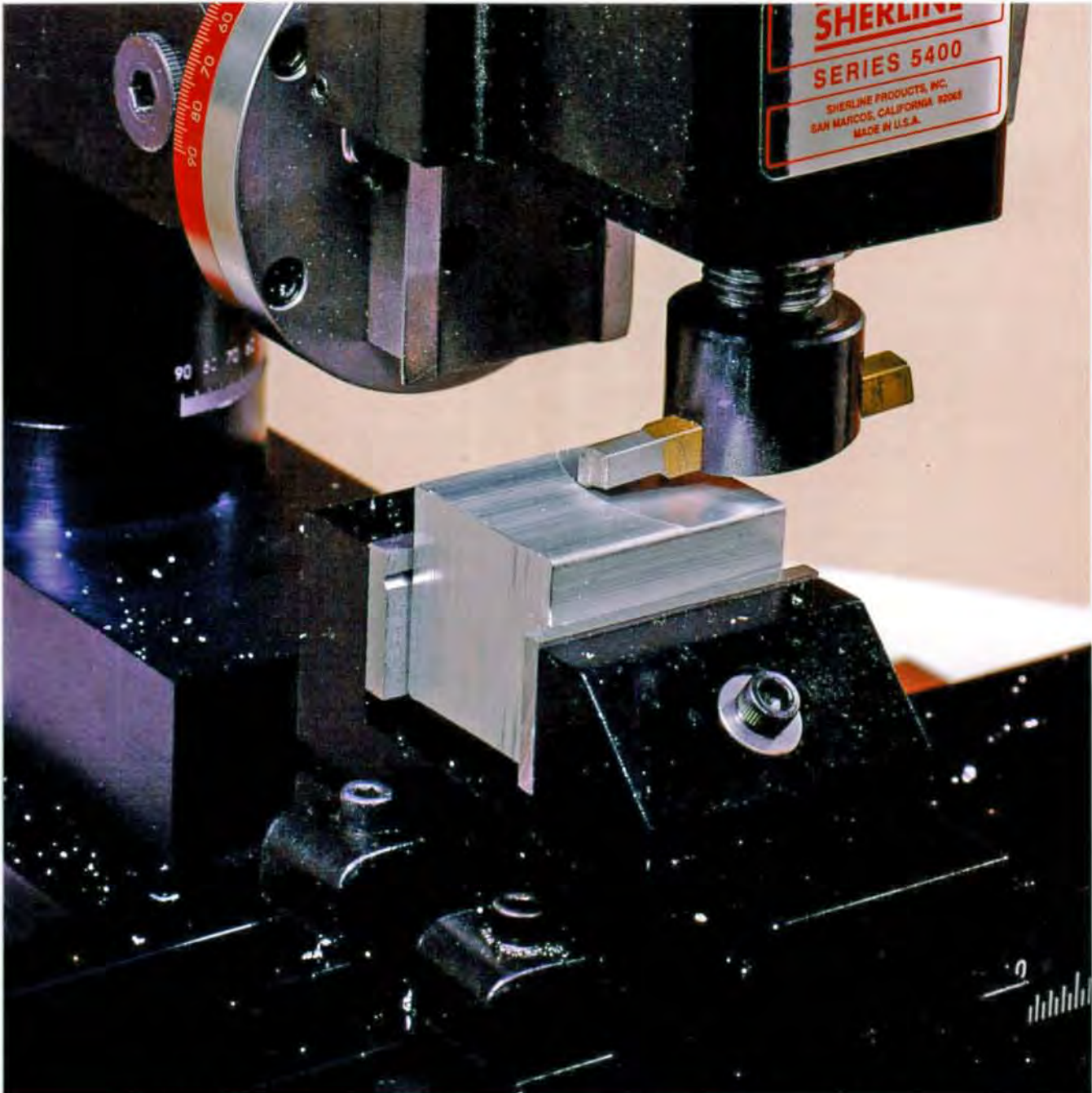
Use tooling plates to protect your mill table. Although you can purchase tooling plates, they are good rainy day projects, and they can speed up many setups. Mounting a casting that requires many machining operations on a tooling plate can save hours of setup time.

### Helpful tips for milling

- The Sherline mill is a small, light-duty mill and should not be used to remove large amounts of stock which could be easily removed with a hacksaw. For efficiency, select a piece of stock that is as close to finished size as possible.
- Stresses on a mill are quite high when cutting most materials; therefore, gib and backlash adjustments must be properly maintained.
- End mills must run true and be sharp. Holding end mills in a drill chuck is a poor practice. Use collets

or an end mill holder instead.

- Fly cutting is an excellent way of removing stock from flat surfaces. (See photo below.)
- Normal machine alignment is adequate for most work, but if the work requires extreme accuracy, shims may have to be employed to improve machine alignment. (NOTE: The Model 2000 mill can be aligned without shims.)
- For accurate setups you should have and know how to use a dial indicator.



*FIGURE 4—A flycutter removes metal fast and leaves a good surface finish.*

- Often, more time will be spent making fixtures to hold work than doing the actual machining.
- To help save time on many simple setups, a good mill vise is a must.
- Remember the basic machining rule that says: “If the tool chatters, reduce speed and increase feed.”
- It takes a long time to accumulate the knowledge, tools and fixtures required for many different types of milling operations. Do not become discouraged by starting with a job that is too complex or by using materials that are extremely difficult to machine.

### Things to consider before you start cutting

The following steps should be considered before commencing any part:

- Is the material about to be machined best suited for the job, and is it machinable with the available cutting tools and equipment? Work with aluminum, brass, plastic or cast iron whenever possible. Too often a hobbyist will pick up the first correctly-sized piece of material he finds at his local salvage dealer thinking that if it is rusty, it’s steel, and that all steels are pretty much the same. Not so! Anyone who has ever tried to machine an old automobile axle can attest to this. If the part must be steel, grade 12L14, commonly called “lead-loy”, is about the best

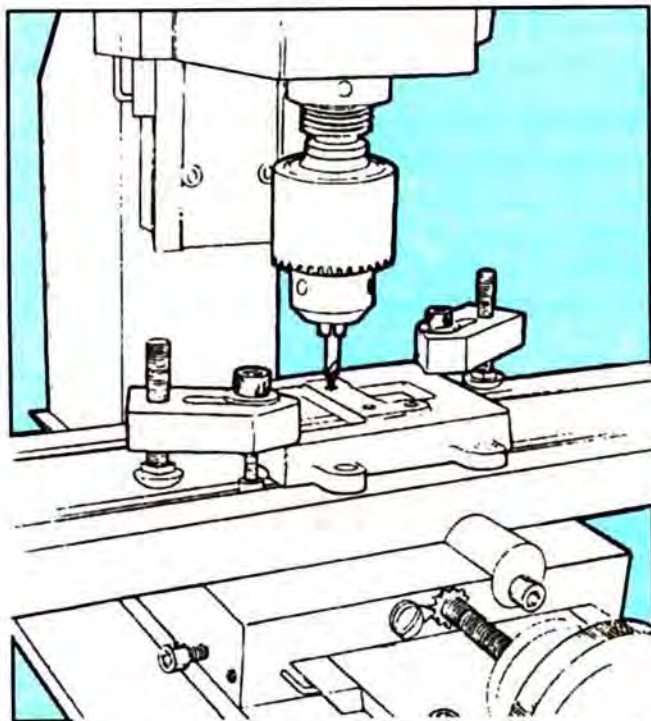


FIGURE 5—Center drilling a part clamped to the table with the hold-down set. The set includes various length 10-32 screws for height adjustment.

material for machining. It was developed for screw machine use and is available in round stock only. However, it works so well that many times it may be advisable to machine rectangular parts from it. It can also be case hardened. Your local screw machine shop will usually have scrap pieces available and may be a good source for obtaining it.

- Avoid exotic materials, such as stainless steel, unless absolutely necessary because of machining difficulty and poor milling cutter life. (Probably, if each new mechanical engineer were given a block of stainless steel to mill, drill and tap upon his graduation, stainless steel sales would drop considerably!)
- Before beginning, carefully study the part to be machined. Select the best surface from which to work (usually the flattest).
- Pick a point from which to measure that will not be machined off part way through the job.
- Decide if work should be “rough cut” to size. Some materials will warp while being machined. Close tolerance parts can be destroyed by attempting heavy machining at the end of the job rather than at the beginning.
- The method of holding the work is also determined by the type of machining to be performed. For instance, work that involves only small drilling jobs does not have to be held as securely as work to be milled.
- Lay the job out so that it can be machined with the minimum number of setups.
- Be sure to have all needed cutting tools available before starting a job.

In summary, you should become aware of the fact that milling is difficult, but not impossible. There are many more considerations than just moving the handwheels, and you should not start your first step until your last step has been determined.

**CAUTION!** Because the tool spins on a mill, hot chips can be thrown much farther than when using a lathe. Safety glasses and proper clothing are a must for all milling operations.

### Three types of work

There are three basic types of work that can be performed with a vertical milling machine: milling, drilling and boring. It would be extremely difficult to determine whether a vertical mill or a lathe would

be the most valuable machine in a shop. My personal experience is that I've had to work with mills far more than lathes. Theoretically, most vertical mills are capable of reproducing themselves with standard milling accessories such as a rotary table and centers. This would be impossible on a lathe without exotic modifications and attachments. A more detailed discussion of each of the type of cutters used in milling is provided starting on page 81 in case you want to review.

**MILLING**—Milling on a vertical mill is usually accomplished with end mills. These cutters are designed to cut with both their side and end. They can cut the meat on your hands even easier than they cut metal. They are not like drills, so give them plenty of respect.

Another type of milling is performed with an adjustable fly cutter, which may be used for surfacing. For maximum safety and rigidity, the cutting bit should project from the holder no further than necessary. A 1-1/2" diameter circle of cut is quite efficient, and multiple passes over a surface should overlap about 1/3 of the circle size. For machining aluminum, use a speed of 2000 RPM and remove about .010" (0.25mm) per pass.

Remember that what flies during fly cutting is chips. *Hot chips!* You might want to make some temporary barriers of cardboard around your machine to contain the flying chips as much as possible. This will help protect you, your other equipment and make cleanup easier. Again, eye protection and proper clothing are of particular importance during this operation.

**DRILLING**—On a machine that isn't equipped with a quill, drilling is accomplished by raising and lowering the entire milling head with the Z-axis feed screw. Center drills must be used before drilling to achieve any degree of accuracy. Note that subsequent holes may be accurately "dialed in" from the first hole by using the calibrated handwheels. Each revolution of the wheel will yield .050" of travel or 1.0mm for the metric machines. There is no need to start with the handwheel at "zero", although this can be easily accomplished with the optional resettable "zero" handwheels to make calculations easier.

You have to consider the "backlash" when using handwheels. When laying out holes, for example, I will only set my handwheels when turning clockwise. If I am cutting a pocket (a shape cut below

a surface), I will write my handwheel settings down followed by a "R" or "L", depending on the way I was turning the handwheel as I came up on the setting. Don't try to remember too many numbers, even if you are good at it. An interruption by a phone call could cause you to make a mistake that ruins your part. The act of writing down a number helps you remember it.

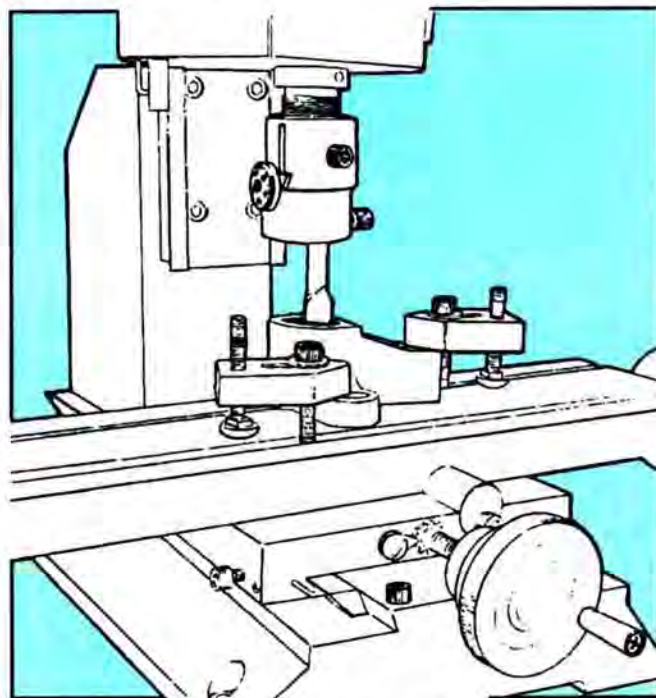


FIGURE 6—Boring the inside of a hole to exact size with a boring tool held in a boring head.

**BORING**—Boring is the best method of making accurate holes by rotating a tool with a single cutting edge, usually in an adjustable holder called a boring head. It is used to open up drilled holes or tubing to a desired diameter. Boring accurate holes separates the men from the boys when it comes to machining.

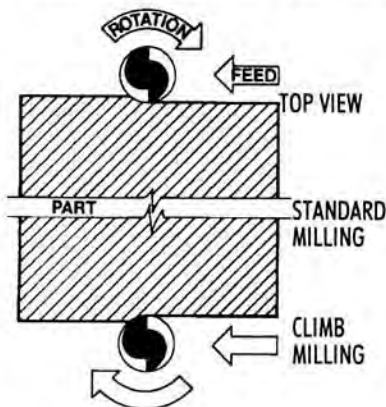
#### **Machining angles and drilling angled holes**

Angles can be machined by removing the headstock alignment key and rotating the milling head to the appropriate angle to the work or by holding the work at an angle to the spindle. (Note: Lighter than normal cuts should be taken when the alignment key is not in place.) Many additional milling possibilities are made available with the addition of the Model 2000 mill which offers four directions of movement in addition to the standard X-, Y- and Z-axis movements of the standard mill. Using the movements and settings available with this mill, parts can be machined from almost any angle.

To drill at an angle using a standard Sherline mill, the headstock must remain in alignment with the Z-axis to keep the drill movement parallel with the machine slide. Therefore, the part must be mounted at the desired angle and the drill brought straight down. Vertical mills equipped with an optional rotary column attachment can align the spindle and the column to the work without tilting the head or clamping the part at an angle. The disadvantage of moving the column is that the spindle axis must be "indicated" back to square to the machine when that particular task is completed. (See page 237 for more on the rotary column attachment.)

### Standard milling vs. climb milling

To understand that the cutting action of a milling cutter varies depending upon the direction of feed, study the relationship of cutting edges to the material being cut as shown in Figure 7. Note that in one case the tool will tend to climb onto the work, whereas in the other case the tool will tend to move



away from the cut. The result is that climb milling should be avoided except for very light finishing cuts. (For a more complete discussion of conventional and climb milling, see page 83.)

FIGURE 7—Standard vs. climb milling. (For clarity, consider the cutter moving rather than the part.)

### Working to scribed layout lines

A colored layout fluid called Dykem can be brushed or sprayed on the surface of a part. After it dries, it can be scribed with a sharp tool to make easily visible layout lines and hole centers. You can then cut to the lines in cases where accuracy is not critical or you can use the lines as a double check against your handwheel settings. This can prevent mistakes where you might lose track of your handwheel rotations and dial in one too many or too few. A photo and more details on using layout lines can be found on page 97.

### Use of a dial indicator

The basis of most accurate machining involves the use of a universal dial test indicator; a small, inexpensive indicator which is calibrated in .001"

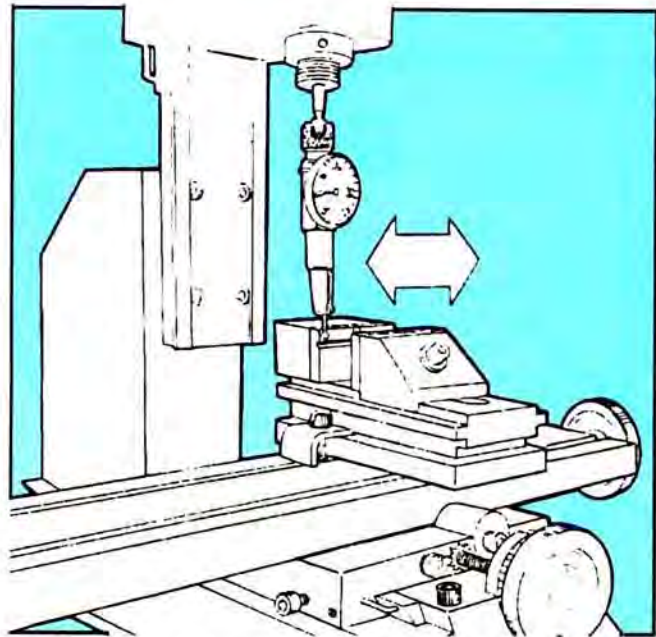


FIGURE 8—Indicating in the jaws of a vise. Shown is a Starrett "Last Word" indicator. Starrett gages are available in numerous sizes and types and can be purchased from industrial tool suppliers. For more on indicating in a mill, see page 253.

or .01mm divisions. An indicator with a large face or one that reads in finer divisions is not necessary for use with this mill. Three major tasks that can be accomplished with an indicator are:

1. Checking the squareness of a setup.
2. Finding the center of a hole.
3. Aligning the work with the machine.

A vise can be mounted or a part can be clamped down exactly parallel with the machine slides by holding the test indicator stationary and moving the slide with which you wish to align. When "indicating in" a vise, always take the reading on the fixed jaw. To start with, use approximately .005" indicator deflection from neutral. Remember that excessive pressure can cause inaccurate readings. Also, try to keep the indicator finger at a reasonable angle to the indicated part or surface. When the part is properly aligned there will not be any deflection on the indicator. If you wish to locate the spindle over an existing hole, place the indicator in the spindle and read the inside surface. Move the "X" and "Y" axes until there is no deflection when the spindle is rotated. At this point, the spindle is in perfect alignment with the center of the hole.

When aligning the spindle to used bearing holes, remember that the hole may be worn out-of-round,

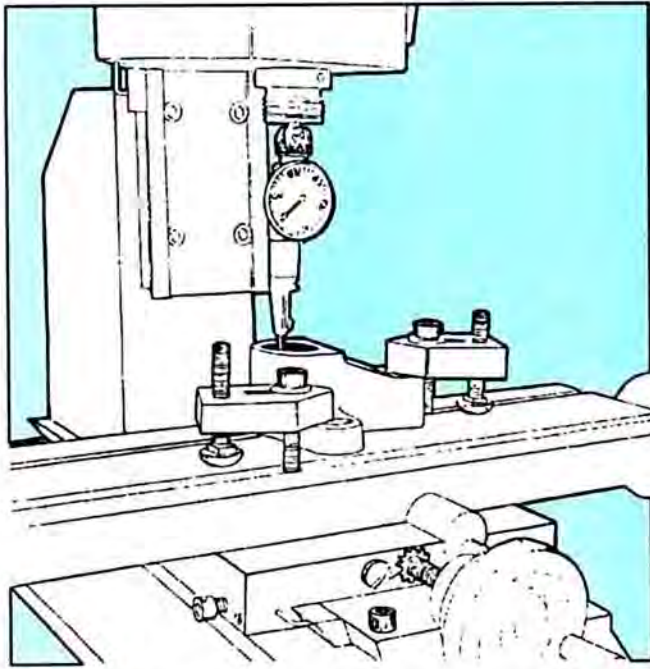


FIGURE 9—Indicating in the center of a hole.

and it may be impossible to attain zero indicator deflection reading. Boring out a worn bearing hole to a larger diameter and sleeving it with a simple bushing made on a lathe is a fairly common machining operation. With the new bushing pressed in, the bearing will be like new.

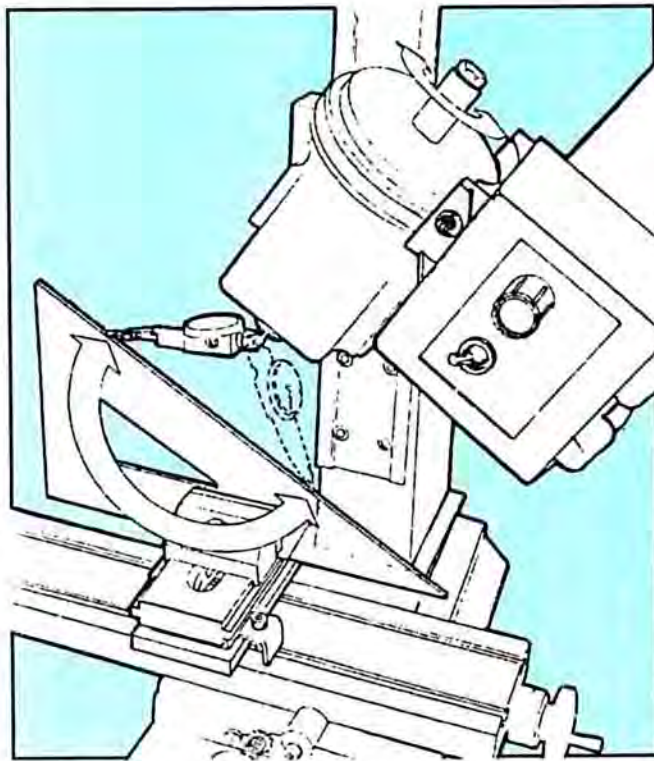


FIGURE 10—Indicating in a head tilt using a mill vise and draftsman's triangle.

The squareness of your machine may also be checked with an indicator. For example, the alignment of the head to the table can be checked by offsetting the indicator in the spindle. The tip should move on a 5-inch diameter circle. The amount of reading relative to the table is the amount of error. Don't be discouraged to find a few thousandths of an inch error in your machine. This machine has been designed to have the most accuracy commensurate with reasonable cost. In machine tool manufacturing, accuracy and cost run hand in hand. To increase accuracy only a percentage point could dramatically increase the selling price, because of the entirely different manufacturing processes required. However, you can personally improve the accuracy of your machine with a few shims if needed by employing your dial indicator. For more on squaring up your mill and checking table flatness see page 252.

The column bed is aligned with the column block at the factory. If you remove it, it will have to be realigned by mounting a known "square" on the mill table and adjusting placement of the bed by running an indicator on the square as the headstock is raised and lowered. The same method can be used to check alignment of the column bed to ensure it is square with the "Y" axis. To correct any error (which should be small) place a shim between the column block and the mill base. (See photos on pages 253 and 254.)

### Determining depth of cut

There are no firm rules other than common sense for determining depth of cut. A .030" cut depth with a 3/16" end mill in aluminum could be considered light, but a .003" cut depth in steel with a 1/32" diameter end mill would break the cutter. Start with very light cuts and gradually increase the depth until satisfactory results are achieved. Try to develop the skill of knowing how much cut is satisfactory without breaking the cutter or damaging the work.

Note that regular end mills should not be used for drilling; however, they may be employed to enlarge an existing hole. The cutting edges deserve more respect than those of drill. Even though similar in appearance; end mills are designed to cut with the sides as well as the end.

### Some sample cuts with a mill

Just to see what would be a comfortable cut in several common materials, I experimented a little

and came up with some figures using a Sherline mill. These are just examples to give you an idea of what you should be able to expect from your miniature machine tools. In most cases, beginners have more of a tendency to not feed the work into the cutter fast enough. Remember that if your tool begins to chatter or squeal, slow down your RPM and feed the part into the cutter at a faster rate. (I know I have mentioned this basic rule a number of times, but hopefully if you come away from reading this book remembering nothing but that, you will at least have learned the most important rule in machining.)

Unless noted, a 5/16" 2-flute end mill was used for the cut.

MATERIAL	DEPTH OF CUT	RPM	COMMENTS
12L14 steel	.100"	1200	use fairly slow feed rate
6061-T6 alum	.150	2800	an easy material to cut
7075 alum.	.150	2800	results equal to 6061-T6
Brass	.100	1600	good results
Stainless steel	.025	500	good results
Stainless steel	.025	500	4-flute cutter—better results

FIGURE 11—Some typical cuts with a mill

### Work accurately

It should be remembered that a good machinist is capable of making a part to much closer tolerances than those of the machine with which he is working. The accuracy of the parts you make is limited only by your skill as a craftsman and the quality of your measurement equipment. Accuracy should be the ultimate goal of every machinist!

### Cutting speeds for milling

SPEED ADJUSTMENT CHART	
SPINDLE RPM =	$\frac{3.82 \times \text{S.F.M.}}{D}$
S.F.M. =	The rated Surface Feet for Milling. For drilling, use 60% of the rated surface feet.
RPM =	The rated spindle speed in Revolutions Per Minute
D =	The diameter of work in inches

FIGURE 12—Formula for adjusting spindle speed for cutting a given diameter.

NOTE: To estimate RPM, remember that the speed range of your vertical mill is from 0 to 2800 RPM.

The lowest usable speed is about 70 RPM, so we use that in our specifications. To obtain much more torque at the lower speed ranges, the drive belt can be switched to the smaller motor pulley and the larger spindle pulley. Therefore, in the normal belt position, half speed is approximately 1450 RPM and so on. You can estimate these speeds by a combination of the setting on the speed control knob and the sound of the motor itself. If you are using the new digital readout option, estimating speed is not necessary. An electronic RPM readout is provided along with position information.

END MILLS (Slot and side milling)				
MATERIAL	CUT SPEED (S.F.M.)	1/8" DIA.	1/4" DIA.	3/8" DIA.
Stainless Steel, 303	40	1200 RPM	600 RPM	400 RPM
Stainless Steel, 304	36	1100	500	350
Stainless Steel, 316	30	900	450	300
Steel, 12L14	67	2000	1000	650
Steel, 1018	34	1000	500	350
Steel, 4130	27	800	400	250
Gray Cast Iron	34	1000	500	350
Aluminum, 7075	300	2800	2500	2000
Aluminum, 6061	280	2800	2500	2000
Aluminum, 2024	200	2800	2500	2000
Aluminum, Cast	134	2800	2000	1300
Brass	400	2800	2800	2800

DRILLS			
MATERIAL	CUT SPEED (S.F.M.)	1/16" DIA.	1/4" DIA.
Carbon Steel	36	2000 RPM	550 RPM
Cast Iron, Soft	30	1800	450
Stainless Steel	24	1400	360
Copper	72	2000	1100
Aluminum, Bar	240	2000	2000
Aluminum, Cast	120	2000	2000

FIGURE 13—End mill and drill speed adjustment chart.



### End mills

End mills are the standard vertical mill cutting tools. We recommend 3/8" shank end mills held in the 3/8" end mill holder (P/N 3079). One of the benefits of 3/8" end mills is they are available in a large range of sizes. The end mill is held with a set screw on its flat surface and it can be easily changed. They are lower in price than miniature cutters because of their popularity. You can also use miniature series end mills having 3/16" or 1/4" shank sizes which should be held in collets or end mill holders made for the



*A selection of end mills. The wooden block holds a set of six different size 3/8", 2-flute end mills. They are double-ended so you actually get 12 cutting tools. One is shown mounted in a 3/8" end mill holder. To the right is a set of single-ended, 3-flute, 1/4" end mills. The flat surface on the side of each end mill is where the set screw is tightened when holding it in an end mill holder.*

particular shank size. End mills held in collets must be single-ended, while end mills held in our end mill holders may be double-ended. We recommend using 2-flute, high-speed steel end mills for aluminum because the flutes are less prone to clog with chips. Use 4-flute cutters for cutting steels with lower RPM. The solid carbide tools are not recommended since they are very expensive and the cutting edges will chip unless used with heavy duty production equipment.

As a convenience to customers, Sherline keeps in inventory many of the popular sizes of end mills which are appropriate for use on miniature machines. End mills may also be purchased from your local industrial machine shop supply outlet (see your yellow pages under "Machine Shop Supplies") or from mail order industrial suppliers.

Because small diameter cutters (less than 1/8") are quite fragile, the largest diameter cutter possible for the job requirements should be employed. Be certain that the RPM is appropriate before attempting to remove any metal. An end mill can be instantly damaged if a cut is attempted at excessive RPM. Like all cutting tools, end mills will have a short

lifespan when used for machining certain types of steel and other exotic materials. Save new cutters for finish work. Do not use small diameter end mills with long flutes unless absolutely necessary because of excessive cutter deflection (bending).

### **Resharpener end mills**

End mills can be resharpened by your local tool and cutter grinding shop. End mills lose their cutting edge clearance after a couple of sharpenings and should no longer be reused.

### **Drills and drill chuck**

The 1/4" drill chuck available for this vertical mill is supplied complete with a Morse No. 1 arbor and a drawbolt to hold it securely in place. Drilling can be accomplished by raising and lowering the entire head with the vertical feed handwheel. This allows for very accurate control of feed rate and hole depth. For accurately located holes, I again stress the importance of using center drills.

Drills should be kept in excellent condition, either by replacement or proper resharpening. Get in the habit of always tightening a drill chuck with the key. Bits can't be held tight enough in a chuck if you only tighten by hand, and you will ruin both your drills and drill chuck if the bit is allowed to spin in the chuck. Good quality high speed steel drills should be employed. A dull or improperly sharpened drill can cut oversize by as much as 10%. When you start to drill, the initial penetration should be no more than twice the diameter of the hole before you retract the drill, clear the chips and add coolant with the tip of a small brush. From then on, do not try to drill deeper than the diameter of the drill without clearing the chips and adding coolant. For example:

<b>To drill a 1/8" diameter hole 1" deep</b>	<b>Total Depth</b>
1st Pass: 2 times diameter or 1/4"	1/4"
2nd Pass: 1 times diameter or 1/8"	3/8"
3rd Pass: 1 times diameter or 1/8"	1/2"
Etc.	

You may encounter recommendations exceeding this, but they are meant for automatic equipment with pressurized coolant systems.

It is difficult to maintain tolerances of better than +.003"-.000" with a drill. If tolerances closer than these are required, a reamer must be employed. Try to use fractional size reamers whenever possible rather than decimal sizes, because the cost difference can amount to 2 or 3 times higher. (The length of

reamers may prevent their use for some operations on machines of this size.)



### Center drills

To accurately start holes, center drills must be used. They have a small tip which accurately starts the hole, and then the shaft widens with a 60° cutting face to the final diameter. Care must be taken to employ cutting oil and to clear the drill frequently. If this is not done, the fragile tip may load up and twist off even in soft materials. Center drills are available in a variety of sizes, but for general work we recommend a No. 1. For a chart of commonly available center drill sizes, see page 65.

### Horizontal Milling

A number of milling operations require the alignment of the cutting tool from the side rather than from the top. On a Sherline mill, the headstock can be rotated 90° to accomplish this. To take full advantage of the capacity of the table, a horizontal milling conversion accessory is available. A 3/4" thick aluminum base 10.5" x 12.5" allows the mill column to be mounted separately from the base for a variety of milling configurations. The headstock is rotated 90° and work is machined from the side, allowing larger surfaces to be worked on without having to reclamp the work. For more on use of the horizontal milling conversion, see page 235.

### A digital readout/RPM gage for the mill

A joint venture between John Wettroth and Sherline was completed in 1998. (See page 98 for a photo of the digital readout option for the mill.) With this unit you can keep track of table movements, backlash and spindle RPM. The readout can be reset to "0" with the push of a button. It also keeps track of long table movements without the operator having to count handwheel revolutions. The accuracy of the Sherline/Wetroth D.R.O. is based on the leadscrew and is not based on external scales like the professional models costing over a thousand dollars. However, this unit is priced to be affordable and is very useful. To manufacture an item at a cost that we considered affordable, we had to invent an entirely different method to drive the readout. John did a remarkable job to design a reliable system using inexpensive components, and as a bonus came up with a way to provide spindle RPM that only added a small amount to the cost. Design problems always revolve around weight, cost and size. The answers to these problems are always a compromise. We have

compromised little in this D.R.O. design when compared to the full-size counterparts, and we are quite proud of the level of sophistication this option adds to our line of small machine tools.

### A computer controlled rotary table is added to the line

1998 was a busy year at Sherline, and a self-contained, computer-controlled rotary table indexer was in the final stages of the design process. It was designed with clockmakers in mind. It is time for clockmakers to enter the next century with a new and sensible method of cutting clock gears that doesn't use expensive index plates. This new product is not just for clockmakers, however. Anyone who uses a rotary table for indexing will find the computer controls make it even more useful.

Though this product has now been on the market for several years, during the early printings of this book I didn't want to give details until I was positive we could accomplish it. I have made a mistake in the past by showing customers a new project before it has been completed. I have found that just because I can visualize what the completed project may look like by looking at a mock-up, the person being shown the new product doesn't necessarily see the same thing. In the past I have heard through the "grapevine" that the new product we were about to introduce had flaws even though the project hadn't yet been completed. These rumors could only have come about from showing a product that wasn't in a package with instructions and had a price established. From this I have learned, "Don't show new ideas until you are satisfied they have been completed."



*A mill along with its many available accessories can cut almost any shape imaginable. Here is an interesting series of cuts. How would you have set up to make them? Think about it before you turn the page to see the setup that cut this part.*

The CNC rotary indexer is now in production and has achieved wide acceptance in the machining market. Much to my satisfaction it is now gaining acceptance with the new generation of clockmakers as well. Expert clockmaker William R. Smith has even included a demonstration of its use in one of his latest instructional videos and is a big proponent of its use for cutting clock gears. A photo of the CNC rotary indexer can be seen on page 234.

### **Getting creative with your setups**

Throughout this book I have tried to include a number of photos of different setups using the mill. Your unique requirements may demand some creative thinking when it comes to a particular setup. The setup shown below

is a good example. The art of using a mill is in creating good setups that hold the part securely and allow the needed operations to be performed in a logical sequence. I have been doing this for many years, but I still find I come up against problems that I am solving for the first time. That's what keeps it interesting. Machine adjustments, cutting tools and holding devices can be combined in an infinite variety of ways to do whatever job you need done. It's just a matter of considering each problem and then choosing the best methods and combinations of tools needed to accomplish it. If this type of challenge appeals to you, your miniature machine shop will bring you many, many hours of pleasure.



*The turbine-like shape on the previous page was cut using a flycutter. By offsetting a beveled part on a tilting angle table and rotating it with the rotary table, a series of indexed cuts was made. The curved path of the flycutter combined with the tilted axis of the part gives a spiral cut. The multi-direction mill column attachment allows the column to be offset to the side to provide enough room for the space taken up by the accessories in the setup. This complicated setup illustrates how a number of accessories can be combined to achieve virtually any cut you would ever need to make in a miniature part.*

## Chapter 3— Squaring up a block

A standard machining job that is performed with a vertical mill would be taking a sawed block of material and squaring all six sides to one another. These written instructions may make this look like a bigger project than it really is, but it is important to have square surfaces before starting on a job. We want to take full advantage of the squareness of the machine and vise to accomplish this. An angle plate is helpful when machining larger pieces that would be difficult to hold in the vise. Any time you are working with a piece of material of unknown squareness, you will need to follow some or all of these procedures to get the critical sides parallel and perpendicular before bringing them to final size.

### Start with a square machine

Before starting, make sure your mill column is aligned properly and the spindle is perpendicular to the mill table. Instructions on squaring up your mill are included in Section 4, Chapter 2. Make sure the vise is mounted flat on the table with no chips under it and that it is “indicated in” square with the mill table. (See figure 8, page 199.)

### Fly cutting the first flat side

First, try to saw out your block so it has one reasonably flat side from which to start working. If this isn't possible, fly cut a flat side opposite the flattest side. If the part is small enough to be clamped in the Sherline vise, a ball-shaped piece of stock should be used between the movable jaw and the work. This will hold the work against the fixed jaw even if it is not perfectly flat, but it should be flat enough to be held firmly while it's fly cut. Take light cuts until you have a flat side.

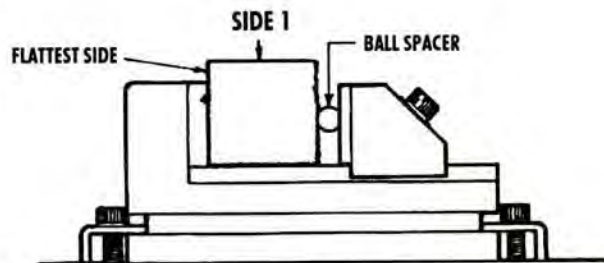


FIGURE 1—Taking a first cut to get one side flat.

What we are trying to accomplish is to get two sides square (perpendicular) to one another, and the vise is accurate enough to get these first two sides square.

If you are sloppy about these first operations, you may end up with your block having a cross section that is more of a parallelogram than a rectangle when you are done, so work carefully.

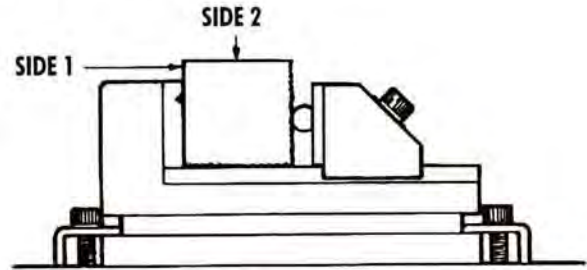


FIGURE 2—With the flat side against the fixed jaw, cut a second side perpendicular to side 1.

### Fly cutting the second side square to the first

Take the surface you just machined and put it against the fixed jaw with the side that was previously against the fixed jaw facing up and clamp it up in the vise. The ball should again be used to provide even pressure against the fixed jaw. The work should be flat against the bottom of the vise or, if too small, shimmed with a “parallel”. (A parallel is a bar whose sides are known to be parallel with each other.) Don't tap the part down against the vise, because the fixed jaw of the vise is the only surface to be concerned with at this time. We want to remove the minimum amount of material to get the second surface square with the first. If you didn't allow much material to machine, you could find the fourth side will not clean up if you clamped up the part crooked at this point.

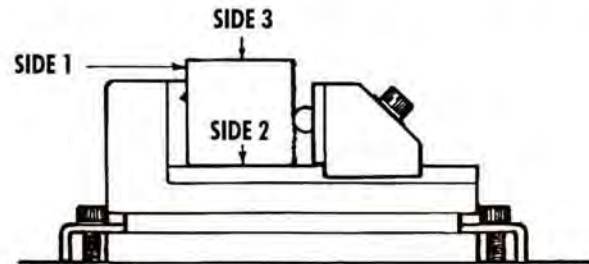


FIGURE 3—Keep side 1 against the fixed jaw and flip the part end-for-end to machine side 3 parallel to side 2.

### Fly cutting the third side

At this point the first two sides should be perpendicular to each other. The third side is next.

Flip the part over end-for-end, keeping the same side against the vise. Keep the second machined surface down against the bottom of the vise or parallel and flycut the third side. I still wouldn't try to take it to a final size on this operation. Once the block is square it can be easily be machined to size.

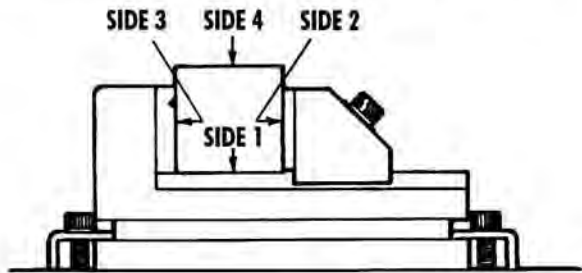


FIGURE 4—Remove the ball and machine side 4 parallel to side 1.

#### Fly cutting the fourth side

The fourth side is easy and can be clamped in the vise with the fourth side up. The ball will no longer be needed as the sides being clamped are now parallel. Errors will come from the fixed vise jaw not being perfectly aligned with the machine or the spindle not being square with the part.

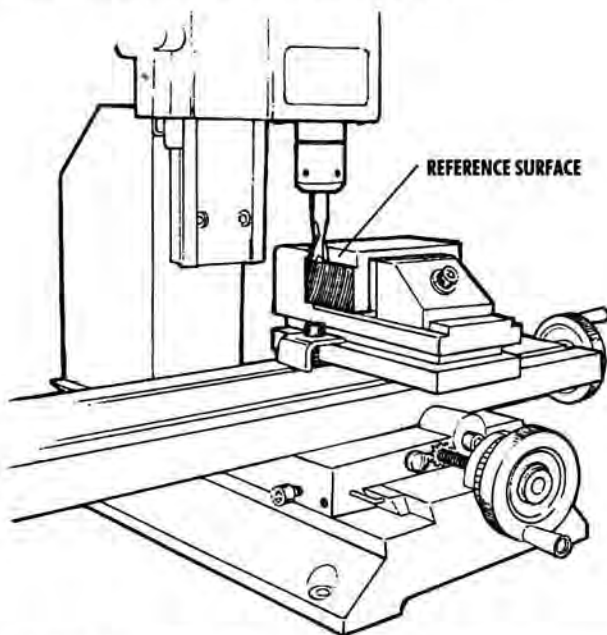


FIGURE 5—With the vise indicated in square to the mill table, use an end mill to cut a small reference surface on one end of the block.

#### The final two steps finish sides five and six

The fifth side is started without removing the part from the vise. The vise should have been accurately "indicated in" when it was first clamped to the table,

and if you believe there is any possibility that it has moved, check it before going on. This is where we will use the squareness of the machine to produce the fifth side which is perpendicular to the other four. An end mill will be used to machine a small portion of one end.

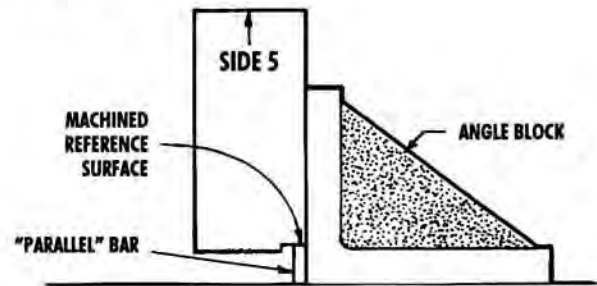


FIGURE 6—Mount the part to an angle block with the reference surface resting on a "parallel" to make sure it is aligned with the mill table's surface. (If the block is short, the mill vise can be used instead of an angle block.)

If the part is too big to stand vertically in the vise, it should be mounted to an angle plate. I am also assuming that the block is too thick to machine it using the side of an end mill. Fly cutters leave an excellent finish to use as the job progresses. Once a pass is made with an end mill the part can be clamped to the angle plate with the portion we just machined supported by a parallel. Again the flycutter is used to machine the top surface flat and square. Then the part is flipped to machine the last side. It is up to the machinist to decide when to bring it to its final dimension. I've had enough experience to realize it doesn't pay to machine a block to its final size until you are positive the time has come. I have had times when I sure could have used that extra material I had already machined off.

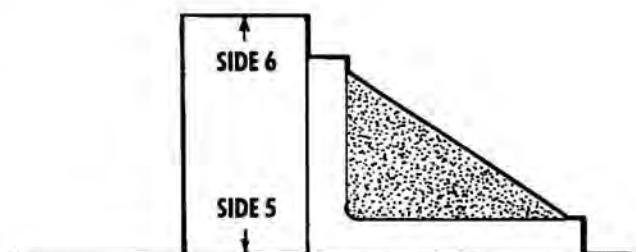


FIGURE 7—The part is flipped over and the final side is machined.

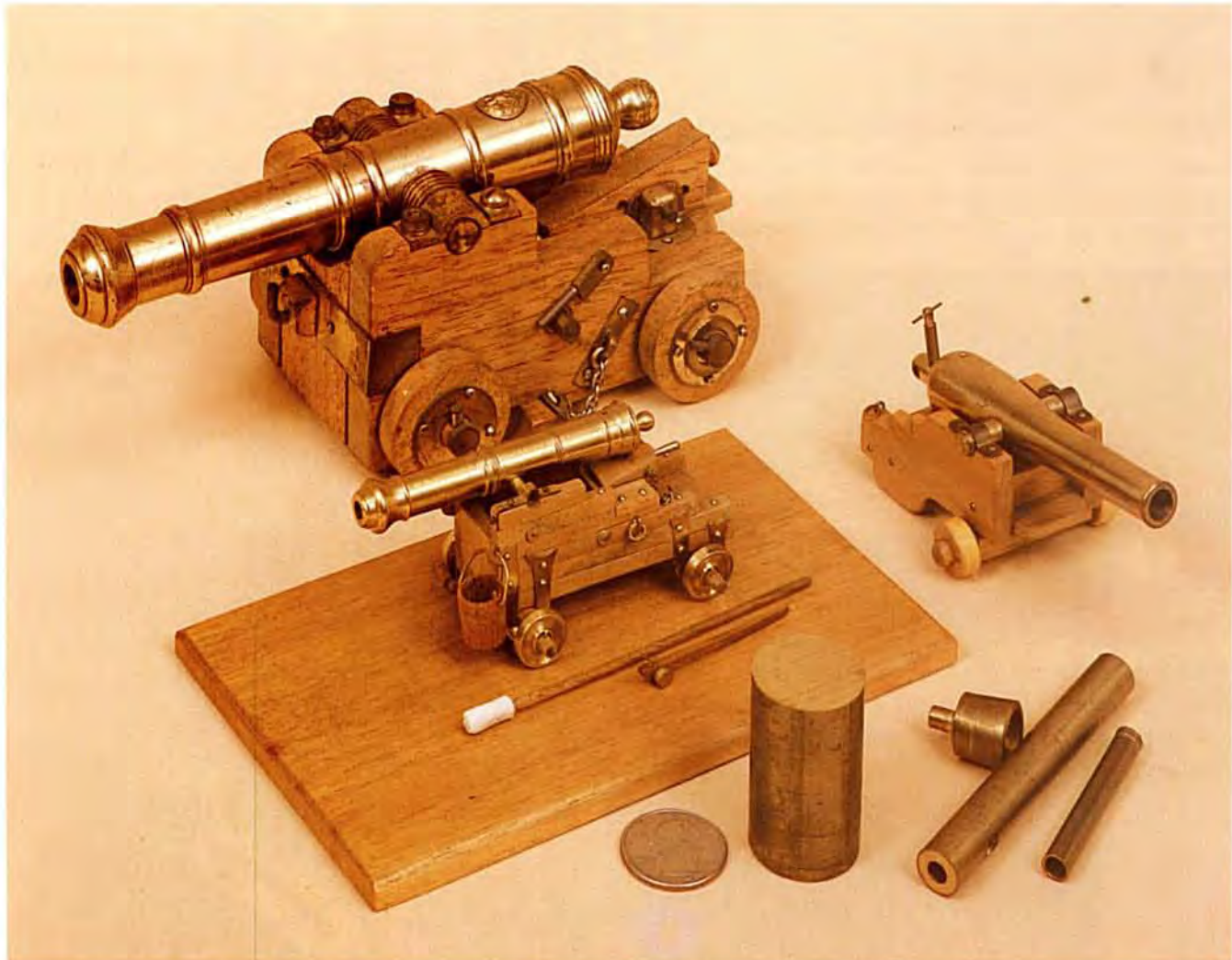
#### A quick summary of what we did

To summarize, we used the fixed jaw to get one side flat. We then put that machined surface against

the jaw and got a second side square to it. The third side was cut with the same side against the fixed jaw and the part flipped. The fourth side was cut by simply holding the part square in the vise. To get the last two ends square with the other four sides we machined a small flat to use for our final cuts.

The part was clamped vertically against a right angle plate which held it square in one direction while the second direction was controlled by using a parallel to align it with the mill table. Finally, the last side was cut parallel to the fifth side.

---



*Brass ship's cannons are among the first things many hobbyists visualize making when they consider purchasing miniature machine tools. Here is a selection of cannons donated to Sherline to display in their factory showroom. These relatively simple projects make a nice desktop or shelf display. A coat of clear finish like acrylic laquer keeps the bright brass color from tarnishing.*

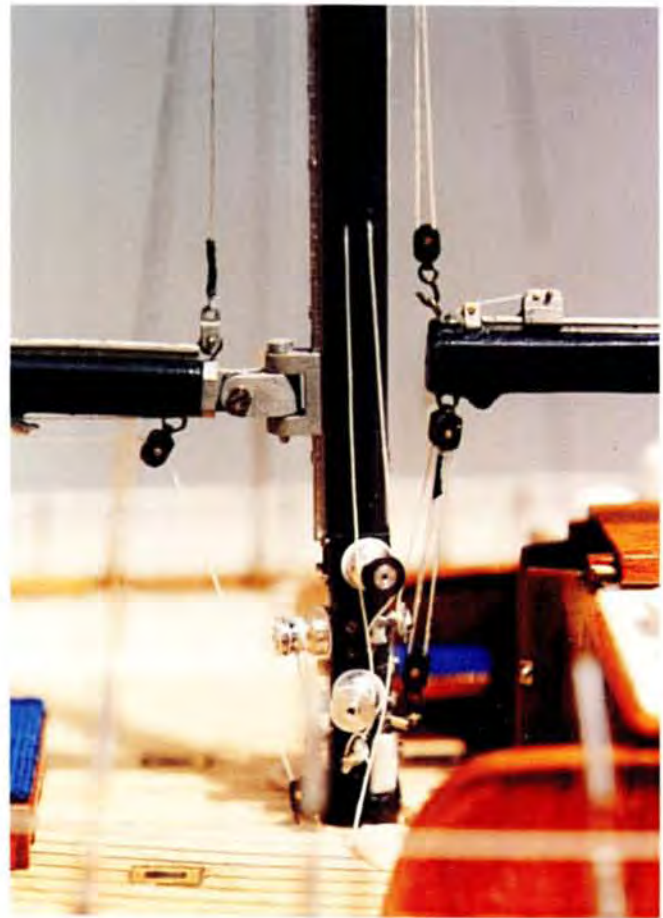
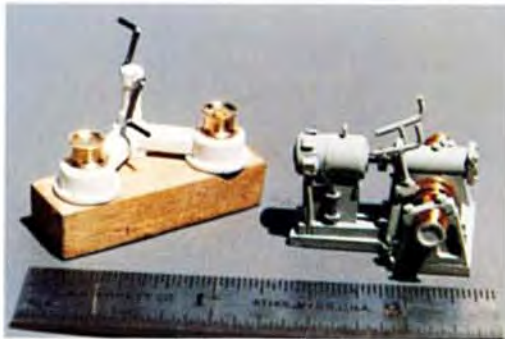
## More on Phil Mattson's ship models...



*These photos show an example of how Phil Mattson of La Jolla, California builds miniature ship's cannons. The frame parts were milled in a long section of bloodwood and then cut to width. Each canon is made up of many pieces. The cannons are to be included in a model of the British warship Alfred which Phil is now building. Each of the 74 cannons is completed to the same level of quality and detail.*



*Phil Mattson's model of the sailboat Sintra utilized many small machined parts to model the anchor winch on the foredeck and many other details like the turnbuckles, pulleys and winches on the masts.*



## Chapter 4— The rotary table and indexing head



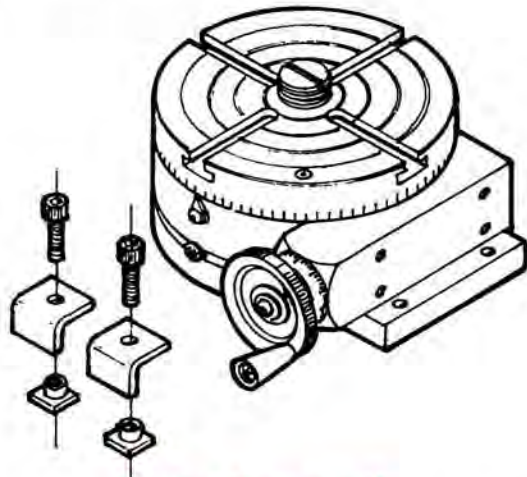
*A rotary table is set up on the mill to machine a special helicopter part. Adding a rotary axis to a vertical mill gives you a combination of tools that can theoretically reproduce themselves. Parts made with this combination are limited only by size and your imagination, not by their complexity.*

### THE ROTARY TABLE

Sherline Products' rotary table is 4" (100mm) in diameter and has been designed to be used in conjunction with their vertical mills; however, it can be easily adapted to any equipment where size and configuration would make it useful. It has a worm ratio of 72-to-1 making one revolution of the handwheel equal to 5° of table rotation. The table has been engraved with 5° lines identified every 15°, and the handwheel has 50 graduations making each graduation 1/10°. This allows a circle to be divided into 3600 parts without interpolating. The table can be locked.

This is the way rotary tables have been defined since their conception; i.e., diameter and reduction. I used the 72-to-1 ratio to keep the worm gear with the largest pitch diameter I could use and still have it centered under the spindle. This also worked out in such a way we could use our standard inch handwheels to drive it. 5° or .050" is the same. It takes 72 revolutions of the handwheel to turn the table, but who's in a hurry when working at home? Actually, I knew my customers would be cutting gears with the Sherline rotary table and I wanted to build in as much accuracy as I could. The more turns, the greater the accuracy. The other side of this coin is, the more turns, the weaker the gear train. This

happens because a higher reduction will need smaller gear teeth to fit in the same space. This is just another example of an engineering compromise that good engineers are faced with daily.



### Design of a rotary table

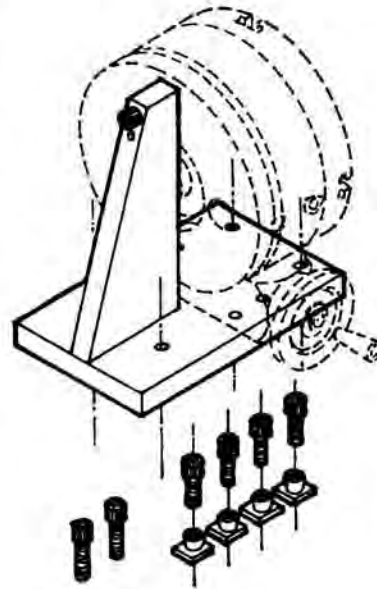
All rotary tables have a worm gear driven by a worm. This system creates a very high reduction with very few parts—only two. The other advantage of a worm drive is that it can't be driven backwards. This fact is very important because a milling cutter could engage with the work and spin the rotary table. It happens just like two gears meshing with one another, and this would be very dangerous.

The T-slots on the rotary table are the same as those on the milling table so that the same clamps and fixtures can be used on either. Once again, this is an example of how we have attempted to remain true to the original design goals of maximum versatility for Sherline tools and accessories. Actually, I am not trying to sell you a rotary table, but I am attempting to teach you the logic I use in designing products. Notice I said "design". The word "invent" is much overused today. You *invent* a laser; you *design* a can opener.

Remember that virtually any hole layout can be done with a standard mill. With very little knowledge of trigonometry and a \$15 calculator, you can calculate the XY positions of any hole closer than you can machine it. Trigonometric tables and formulas are included in *Machinery's Handbook*. A sample project using the trig tables to help you lay out a hole pattern is included in Section 5, Chapter 3 in case you want to learn more or just brush up.

### Mounting the rotary table to the mill table

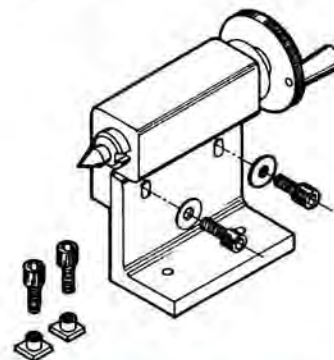
The Sherline rotary table can be mounted to a mill in several ways. The most common use would be to



The right angle attachment holds the rotary table (shown with dotted lines) in a vertical position.

The base mounts to the mill table using the T-nuts and socket head screws provided.

clamp it directly to the mill table. A right angle attachment is available to allow the rotary table to be mounted vertically. The tilting angle table attachment also is drilled and tapped to accept the rotary table. If brought to a vertical position while mounted to the tilting angle plate, the center will align with the adjustable right angle tailstock center. This will allow a part to be turned between centers using the rotary table without having to buy a right angle attachment. Although the tilting angle table is about \$50 more than the right angle attachment, it does offer many more setup possibilities because it can be fixed at any angle from 0° to 90°. The right angle attachment, on the other hand, is a simple device that locates the rotary table quickly and accurately at exactly 90° without having to be indicated in. The choice is yours.



### Adjustable right angle tailstock

The optional Sherline adjustable right angle tailstock allows for accurate turning between centers when the optional right angle attachment is used. Because of tolerance buildup, it would be just about

impossible to offer a tailstock that was perfectly on center with the rotary table/right angle attachment combination. The solution offered here is a modification of the standard tailstock which allows it to be adjusted to line up precisely with the center of the rotary table in order to allow for perfect alignment between the rotary table and the tailstock while holding long parts between centers. The base is attached to the mill table with cap screws and T-nuts. Two socket head cap screws go through elongated slots in the side of the right angle piece and allow for minor adjustments in height when making your setup.

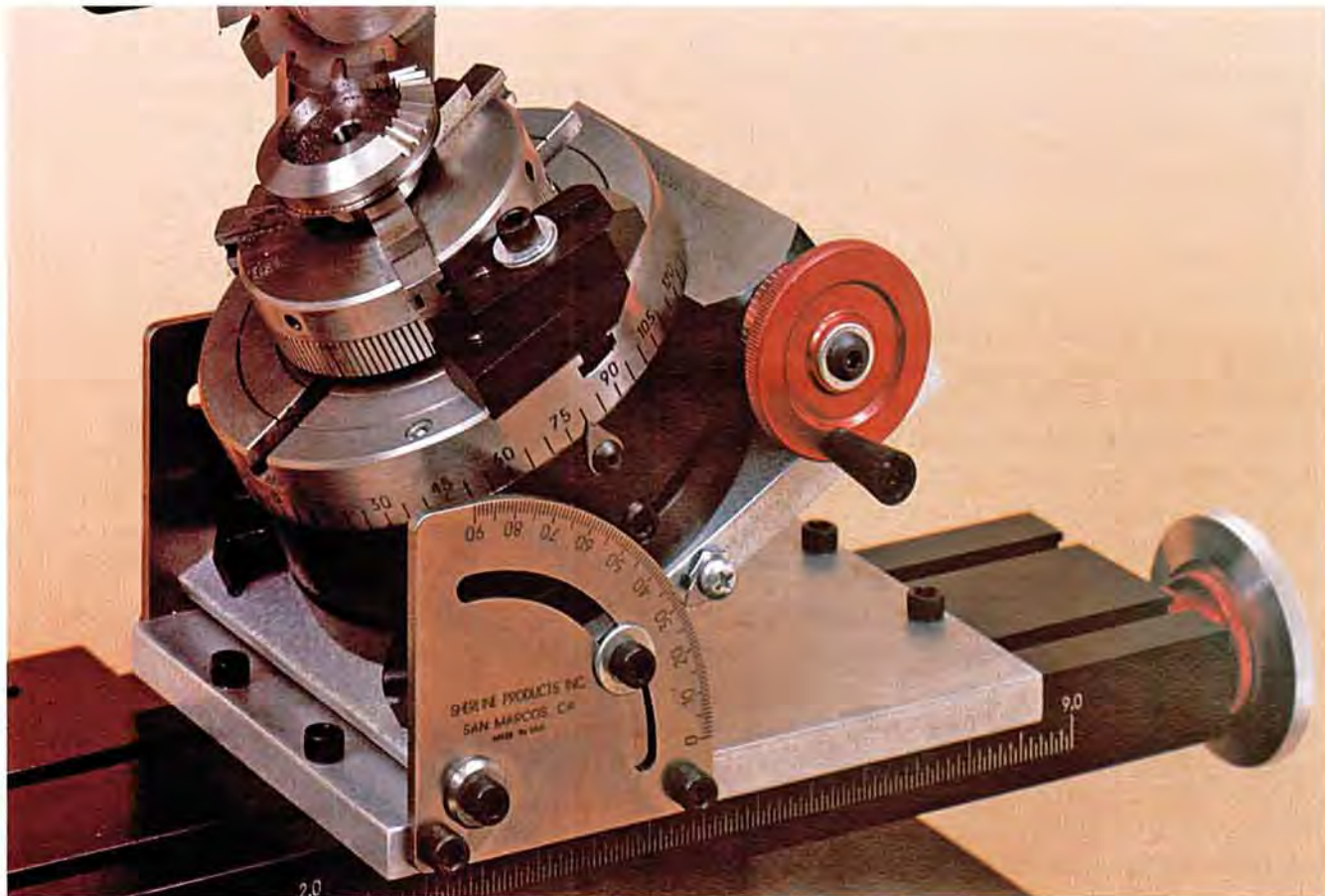
#### **An example of a rotary table job**

The following instructions have been written to show what's involved in doing a complex job accurately. I believe if you truly understand the job I will describe in detail, average jobs will be accomplished without filling your trash can with mistakes. Remember, there are not many people capable of making the complex machined products

used today, and if you can master the vertical mill and the rotary table combination, you will have come a long way toward becoming a good machinist. You will find erasers aren't much good and no one has come up with a good "putting on" tool when it comes to metal parts. Complex parts are very difficult to make. When you're making one-of-a-kind parts, don't worry how long it takes; spend your time planning and checking so you don't have to worry about starting over.

#### **A machine combination capable of reproducing itself**

When a rotary table is put on a vertical mill you end up with a machine that is theoretically capable of reproducing itself. This means the capabilities of your miniature mill are governed by the size of the part and the ingenuity of the operator. The purpose of these instructions is to give you an insight into the proper use of this accessory. An inexpensive calculator with trigonometric functions is a must for complex jobs.



*A setup with the tilting angle table holding the rotary table at 30° while a bevel gear is cut. When rotated to the 90° position, the tilting angle table puts the rotary table at the proper height to align with the adjustable right angle tailstock, which allows a shaft to be rotated between centers or a gear to be cut.*



Rotary table parts awaiting the assembly process. The bottom side of this batch of rotary tables shows the gear teeth that are driven by the worm gear to rotate it.

### Clamping the part into position

Standard milling machine setups usually involve aligning the work with the table and then with the spindle. This is easily accomplished because the table can be accurately moved with the handwheels. Aligning a part on a rotary table can be very trying because the work has to be clamped into position. When you consider the fact that the part turns, a .001" (.03mm) error in location gives a .002" T.I.R. (Total Indicated Runout) when checked with a dial indicator.

### Indicating in the center of the rotary table

Many times it is advisable to start by doing the rotary table work first, which can eliminate precision aligning. A quick way to align the milling spindle with the rotary table is by indicating the hole in the center of the rotary table. This will locate the spindle directly above the center of the rotary table if the headstock is square. Next, prick punch or spot drill the center on the work you wish to have line up with the rotary table. Put a pointer in the spindle that runs true. Set the work under the spindle and lower the head until it engages with the center mark, then clamp the part down. You now have the work reasonably aligned with the rotary table and spindle. At this time, rotate the table with the spindle running and the pointer slightly backed off. If the part is properly aligned, the pointer should always line up with the center mark, and you should write down your handwheel settings. It is also advisable to write an "R" or "L" after the handwheel setting to remember which way the mill leadscrew backlash was set.

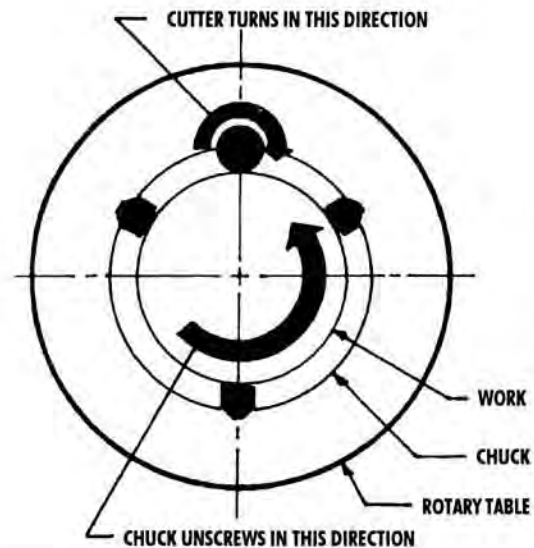


FIGURE 1—Cutter and Chuck directions of rotation.

### Mounting a chuck to the table

Included with the Sherline rotary table is an adapter that allows a Sherline chuck to be screwed directly to the table. This allows work that is of the correct size and configuration to be quickly aligned with the rotary table with reasonable accuracy. Be sure to consider the fact that a mill cutter could unscrew a 3- or 4-Jaw chuck held on in this fashion (See Figure 1). Use only very light cuts when this adapter is used. If you believe this could be a problem with your setup, add a second clamp to eliminate the possibility of the chuck unscrewing from the adapter. If you are working with a 3-jaw chuck, the tommy bar can be used along with a small block clamped to the mill table to keep the chuck from unscrewing.

### Making allowances for cutter diameter

A close look at Figure 2 will start making you aware of the complexities of working with a rotary table. Unless you are doing a hole layout, you can very seldom work with the angles and dimensions on your drawing because of the cutter diameter.

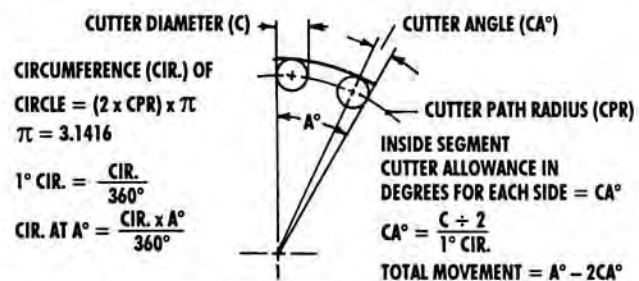


FIGURE 2—A demonstration of CPR or Cutter Path Radius. This is a reasonably accurate method without using trig. tables.

Figures 3 and 4 show the relation of cutter and part. Start considering what I refer to as CPR, which is where the center of the cutter is from the center of the rotary table.

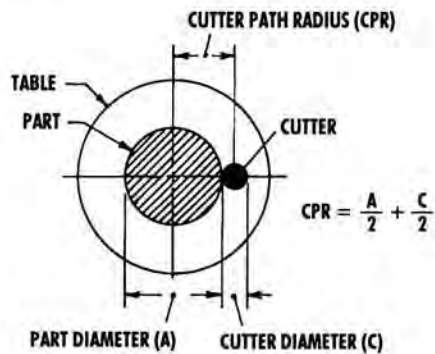


FIGURE 3—Cutter machining outside of part.

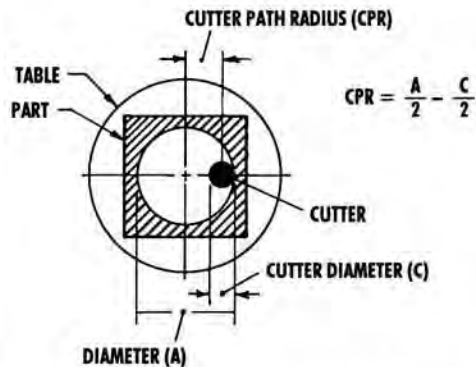
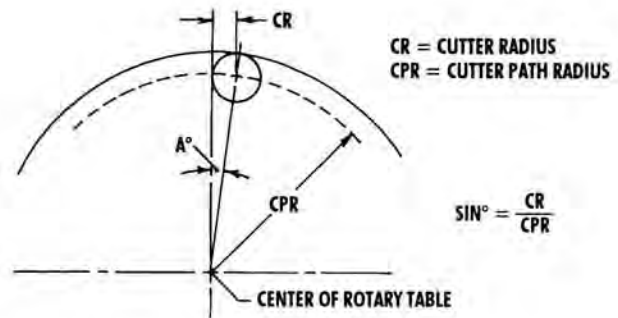


FIGURE 4—Cutter machining inside of part.

Sherline offers adjustable “zero” handwheels for the lathe and mill. This makes calculation of the feed much easier as the handwheels can be reset to “zero” each time. If you do not have the resettable handwheels, the job simply requires a bit of note-taking. If you get into the habit of writing your handwheel setting down and calculating movements, it’s really not bad. A piece of tape stuck along the edge of the mill table and mill base with a mark that shows starting and finishing points can be of considerable help. Of course, you will still have to use your handwheel numbers, but the marks will make you aware they are coming up. Counting the turns of a handwheel on long movements can have disastrous results if you’re distracted and turn one too many. One of our customers attached scales (rulers) to our mill on both the “X” and “Y” axis, which I always thought was a good idea. Deluxe mills are engraved with scales, but it still can be confusing because you can’t usually start at zero. If you have trig tables or a calculator with trig functions



CUTTER DIAMETER = .250    CPR = 1.375

CR = CUTTER DIAMETER ÷ 2 = .125

$SIN A = \frac{CR}{CPR} = \frac{.125}{1.375} = .0909$

FROM TRIG. TABLE:  $A^\circ = 5^\circ 13' = 5-13/60^\circ = 5.216^\circ$

FROM CALCULATOR:  $A^\circ = 5.215^\circ$

CUTTER ALLOWANCE DEGREES = 5.215°

FIGURE 5—This example show how easy it is to allow for the cutter diameter using trigonometry.

you can take a lot of the guesswork out of exact locations and angles.

The next problem you must be aware of is why the rotary table must be offset to cut segments. Study Figure 6 and it becomes obvious that allowing for the cutter diameter at one end of the segment will not make any correction at the other.

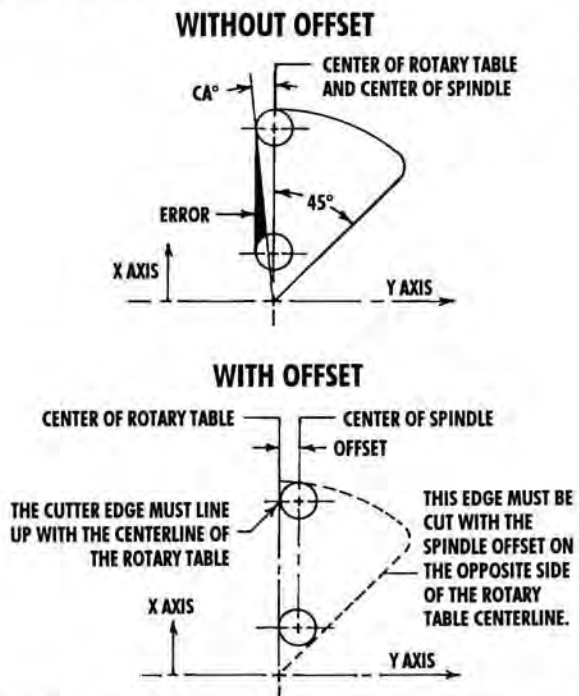
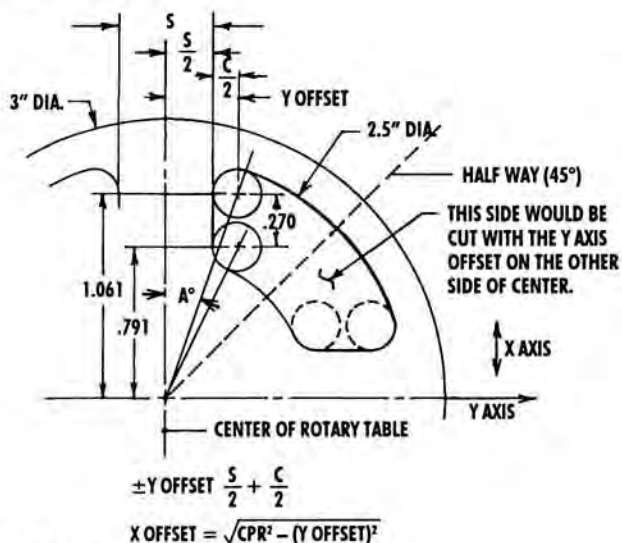


FIGURE 6—Offsetting the rotary table to cut segments.

**Example: Cutting a wheel with spokes**

When one of our customers purchases their first metal cutting tool, it is usually a lathe and somewhere in that customer's mind is a brass cannon he now has an opportunity to build. When a customer buys his first rotary table, chances are they either want to drill hole patterns which shouldn't require any instructions or make some kind of wheel with spokes in it. Therefore, I will describe how to "accurately" cut a wheel with spokes. I realize that in most cases it is not necessary to work to this degree of accuracy to do a job of this nature, but to accurately make a precision part of this type is what a rotary table is all about. In most cases, I will leave you to your own common sense as to the depth of cuts and how much to leave from roughing and finish cuts. Remember, I have never seen a part scrapped from taking too light of a cut.

Make an accurate drawing at the start showing offsets and cutter paths similar to Figure 7 below. The offsets can be calculated as shown in the sample which follows.



**CUT OUTSIDE**

GIVEN: S (SPOKE WIDTH) = .5  
 CPR (CUTTER PATH RADIUS) = 1.250 - .125 = 1.125  
 C (CUTTER DIA.) = 0.25

$\pm Y \text{ OFFSET} = \frac{S}{2} + \frac{C}{2} = \frac{.5}{2} + \frac{.250}{2} = .375$

$X \text{ OFFSET} = \sqrt{CPR^2 - (Y \text{ OFFSET})^2} = \sqrt{1.125^2 - .375^2} = \sqrt{1.266 - .1406} = 1.061$

**CUT INSIDE**

OPR = .750 (HUB RADIUS + .125 [CUTTER RADIUS]) = .875

$X \text{ OFFSET} = \sqrt{CPR^2 - Y \text{ OFFSET}^2} = \sqrt{.875^2 - .375^2} = .791$

DISTANCE BETWEEN INSIDE AND OUTSIDE OFFSETS = 1.061 - .791 = .270

FIGURE 7—Cutter path drawing and calculations.



The versatile rotary table can also be used to machine a radius. A part held on a faceplate is spun on the mill, which is in the horizontal position. A long toolpost from the riser block kit holds a cutting tool which pivots as the rotary table is cranked. The dished face was cut in the same manner.

REMEMBER...the rotary table center must be precisely located below the spindle when you start. Only one half of the segment may be cut from the calculated point, which is why only one half of the spoke width is considered. Look at the drawing again and be sure you truly understand why you can only cut one half of the segment before proceeding, or your chances for success will be dismal.

Now we have the offsets calculated and the rotary table "indicated in" in relation to the spindle. We move the X-axis the amount of the offset, moving the table to the left. Be sure to consider the backlash, and it may also be prudent to allow for roughing and finish cuts. Now move the Y-axis and the Y offset in (towards the column). This will allow the first half of the segment to be cut so that it looks like the diagram. Assuming the part is properly clamped to the rotary table and held in such a way that you can't inadvertently cut into the table, it's time to start. The example has four equal segments, which means a spoke will be cut every 90°; therefore, a lot of confusion can be eliminated if you start with your table at 0° (see Figure 8). The center of the spokes will now lay out at 0°, 90°, 180°, and 270°, and the halfway point will be at 45°, 135° etc.

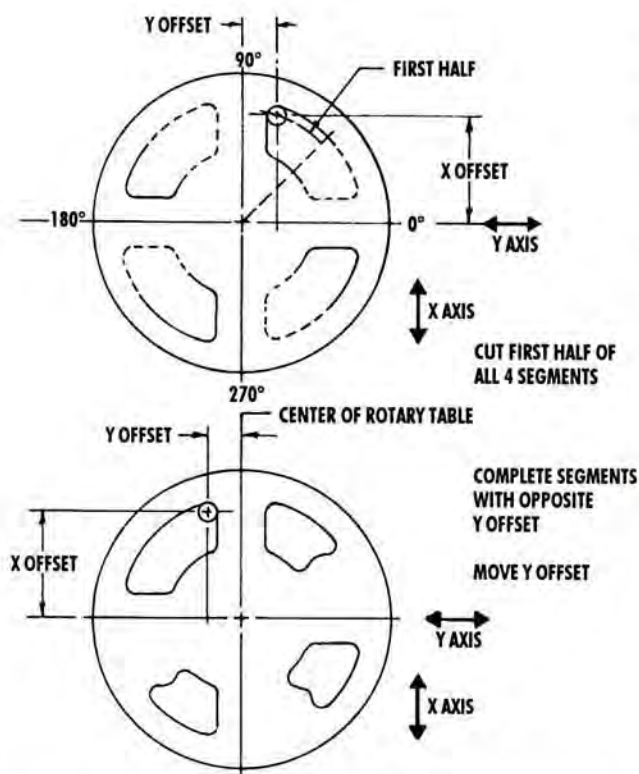


FIGURE 8—Completing the spokes of a wheel.

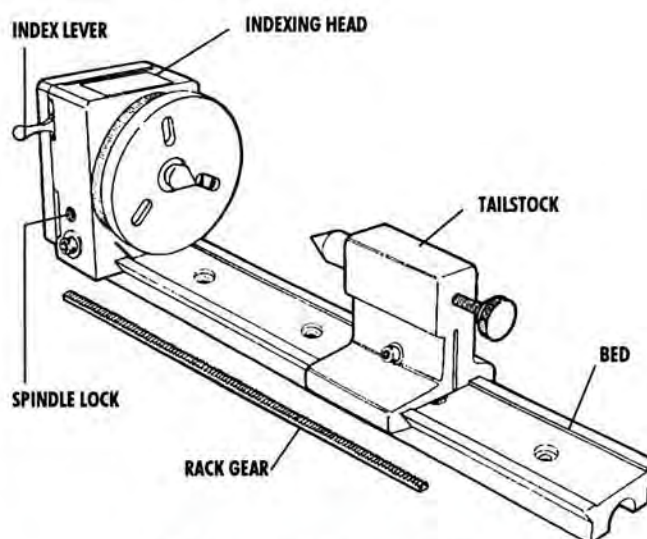
Allowance for the cutter was taken care of when the offsets were calculated. It is not necessary to calculate the value of angle “A” or other angles because you are only cutting one-half the segment at a time.

A good rule now is to take a very light cut (.001”) and convince yourself everything is correct. The real trick of machining is to do something you have never done before the “first time”, and you can’t be too careful. A one-minute check versus three hours or more to start over makes this a good investment in time. The cut along the spoke is accomplished by moving the X-axis only back and forth using the calculated points until you get through the part, and again I remind you it may be wise to take a roughing cut. Sometimes an undersize (resharpened) end mill is a good way to rough cut. Then change end mills for finish passes. This allows the same handwheel number to be used for roughing and finishing.

The rotary cuts are made with the X-axis in its proper position, and the table rotated counterclockwise. One of the really neat things in machining happens when using a rotary table to feed work into an end mill, and I believe it comes about because of the slow and precise feed that can be obtained. If a hole you’re cutting requires a bottom, great finishes can be had

from end mills and rotary tables. The rotary part of the segment only needs to be moved slightly past the half way point for the remainder of the segment will be cut with the Y-axis offset moved out from the column and the table rotated in a clockwise direction.

It is quicker to cut the first half of all 4 segments, then move the “Y” offset and complete the segments. If you’re going to try something like this for a first project, check your entire plan out with .001” cuts and be positive you’re correct before making cuts that could scrap your part (see Figure 8).



## THE INDEXING ATTACHMENT

### Using an indexing attachment or dividing head

This indexing attachment has been designed to give the average hobbyist an all-purpose method of dividing circles into an equal number of segments to aid in cutting gears or any other repetitive, circular machining operation. It is of a price and size which makes it ideal for use with miniature machines. Sometimes called a “dividing head”, the indexing attachment can be used in both horizontal and vertical modes. A rotary table is moved with a handwheel which controls the rotational movement. The indexing attachment utilizes a different method of movement and was designed to cut clock gears referred to by clock makers as “wheels”.

I actually designed this attachment before the rotary table. A group of local clock makers wanted a low cost device to cut gears with and this was my solution. At that time I didn’t believe I could sell a \$500 attachment for a \$400 mill, so I didn’t have

the luxury of designing it with expensive index plates. I wanted to have a design that could divide a circle into any number of parts, and I accomplished this by using a rack gear.

### Using a rack gear to turn circular motion into a linear dimension

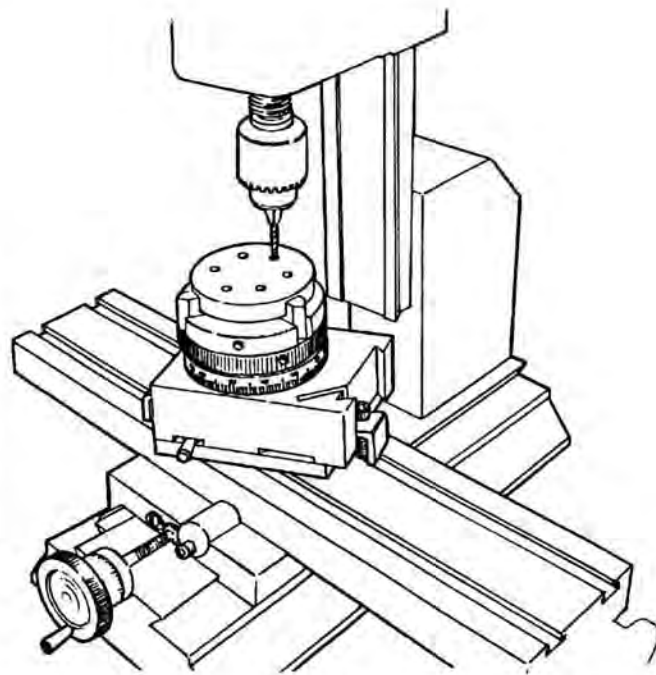
When the precision rack gear is engaged with the index gear, it takes a rotary motion and turns it in to a linear motion that can be measured. This linear motion could be divided into any number of equal parts with the aid of an inexpensive calculator. I would have used a different method if calculators had not been available. The indexing head accessory costs less than half the price of a rotary table setup. I've heard clockmakers complain that it is too slow, but I never looked at it as production equipment. It was designed to accurately get a job done at the minimum cost. If a gear or similar machining job had to be produced in any quantity, an index plate could be built using this attachment. This should be considered the major difference between plate type indexing and the Sherline indexing attachment.

I think the method I used to lock the indexing spindle was fairly clever. I didn't want to lock it with any type of set screw because set screws have a tendency to rotate the spindle as the screw is turned. I used the same method with which the headstock is held to the bed. A cone pointed screw pushes the clamp, which has an angle corresponding to the cone pointed screw, against the index gear and pinches it. This doesn't move the spindle yet still makes a positive lock. Although it has been designed to be used with the Sherline vertical mill, it can be adapted for use with other types of equipment or used for different purposes.

Before attempting any machining operation, be sure your setups use good machining principles and practices. Work in a careful, professional, craftsmanlike manner, and always wear safety glasses.

### Two methods of dividing

**1. INDEXED METHOD.** This method is quite simple and uses the indexing lever and the graduated scale on the spindle. Internally the indexing lever engages with a 72-tooth gear, and each tooth equals  $5^\circ$  of rotation. Obviously this method will allow indexing of only simple hole patterns, since you can only work in multiples of  $5^\circ$ ; however, this is usually sufficient for most jobs, with the exception of cutting



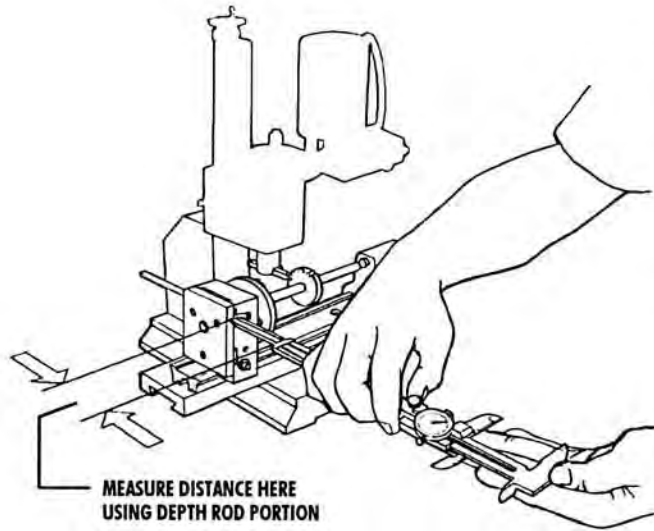
*INDEXED METHOD, Drilling a precise hole pattern.*

gears. Since very few gears will work out in even multiples of  $5^\circ$ , a second method of dividing called the "calculated method" can be used. It is described below.

It is important to remember to lock the spindle before attempting any machining. The indexing lever is NOT a lock and is not intended for any use other than to locate the index.

**2. CALCULATED METHOD.** This method will yield an infinite number of divisions but takes considerably more time. To set up the head in this mode, the indexing lever must be raised to its uppermost position. The rack gear is then inserted from either side with the teeth towards the spindle under the lever. It is important that the spindle lock is loose so the spindle is free to move as the rack is inserted. The theory behind the calculated method should be apparent now. As the spindle is rotated, the rack moves in a linear motion which can be easily measured. If the total movement of the rack for one revolution is known, any number of divisions can be made by dividing this dimension by the number of divisions required.

The calculated linear dimension for one complete revolution is 4.712 inches (119.685mm), but this dimension may vary slightly from one indexing attachment to the next. For utmost precision, it is suggested that you accurately measure your



*CALCULATED METHOD—Using the depth rod of a dial caliper to measure the position of the rack gear.*

particular indexing head and note the dimension for future use. Use a precise Vernier or dial caliper of at least 5 inches in length (6 inches is preferable) equipped with a depth rod.

To determine this dimension for your particular indexing head, drill a small hole with a center drill on the very top edge of the faceplate with the indexing head mounted on its bed. Before drilling be sure the rack is positioned in such a way that one complete revolution can be turned and still have the rack properly engaged. Make sure to lock the spindle and accurately measure from the end of the rack to the indexing head. After drilling, unlock the spindle and rotate it one revolution using the hole and center drill to index the spindle. Measure the rack again and subtract the smaller number from the larger. The difference should come out quite close to 4.712" or 119.685mm. Since the accuracy of all your machining is dependent on the precision of this measurement, it is suggested that you **DOUBLE CHECK** your work!

Once you have this dimension, dividing a part into any number of divisions is easy. Just divide 4.712" (or the dimension for your attachment if different) by the number of divisions you wish to make. This will give you the distance the rack must move for each division. The math is simple, but a small pocket calculator saves a lot of time.

An example of cutting an 83-tooth gear using the indexing attachment is included in the following chapter. An example of cutting a 29-tooth gear using the rotary table is also included so that you can compare the methods used to see which method will work best for you. The rotary table is a more versatile accessory, but the indexing attachment has some advantages too, including a lower price.

#### **Five basic rules to remember**

1. Work **ACCURATELY**.
2. Determine the best possible way of holding the part to be machined. This type of machining requires a very secure setup.
3. Carefully align the attachment with the mill table.
4. Take cuts that the setup you are using can easily withstand.
5. Don't try to rush the job! Successive machining operations make some people careless; therefore, it is wise to consider the amount of time and effort you will lose if you destroy your part rather than how much is left to do.

PHOTO: WILHELM HUXHOLD



*An indexing plate drilled with circular patterns of holes is a traditional method of dividing a circle into segments. A pin detents in the holes to index the spindle. Your choice of numbers of divisions is limited by the hole patterns provided. This miniature model of a dividing head for a Hardinge lathe was built by Wilhelm Huxhold of Ontario, Canada.*



*A custom made double rotary table setup by Bob Beslauer of Ft. Lauderdale, Florida allows for some very sophisticated rotary movements. Bob designed and machined the plate which mounts on one rotary table and then holds another rotary table. He used this setup in the mill to machine spiral spoke patterns on miniature custom automotive wheels.*

## Chapter 5— Gears and geartrains

### Prospecting for surplus treasure

I've always loved gears. They mesh in such perfect harmony and transmit power with so little loss; that is, if they have been properly designed. Did you know that the first computers were gear driven devices that solved problems mechanically? That's how I first got interested in them. I've always enjoyed shopping in industrial surplus shops. I call it "modern day prospecting". It always amazed me what large companies and the government would scrap out. In the late Sixties, many mechanical computers were coming to the end of their road in these fine establishments. Every type of gear train you could ever imagine was available in miniature, and the gears were perfect. I still have bits and pieces around my shop. Some came from World War Two aircraft gunsights which were a perfect example of mechanical computers. I can't say I ended up using many of these gears because I could never find the right combination to use on my particular project, but I just don't have the heart to get rid of them.



*Differential gears salvaged from the scrap yard. Beautifully made parts are relatively easy to find, but finding ones that will work in your particular application is much more difficult.*

### Another expensive lesson

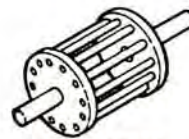
The next two things I found out about gears is that you can't usually purchase the sizes you need off the shelf, and having them custom made can be very expensive. Years ago while working for Micro Avionics, my partner and I tried to design the world's smallest radio control servo to sell commercially. We had a local gear maker cut the gears for us.

It had a "planetary" design and the gears were very small. This was in 1968 and the gears for two prototypes still cost us a thousand dollars. When we put it together, it really ran roughly. I can't remember whether it was Carl's idea or mine to add some fine lapping compound to try "lapping them in". We ruined the entire gear train in less than two minutes. That was one time I couldn't come up with a clever excuse. We decided to build the servo with a conventional gear train and mold it out of plastic. We still ended up developing the smallest servo that was available anywhere in the world at that time, so we were eventually able to turn our initial failure into a success.

### Sorry, there are no shortcuts when making your own gears

If you are going to make a complex gear train and you don't have a lot of money, you are going to have to make the gears yourself. This can be a very enjoyable task if you approach the job as an individual challenge. There is no "quick and dirty" way to produce good gears on a milling machine, and there also isn't any way I could begin to give the amount of detailed information you need to cut perfect gears. Most of the information that has been written on the subject relates to producing gears commercially. I'm going to try to get you interested in producing your own gears and give you enough information to cut gears with a Sherline mill and a rotary table or index attachment. Later in this chapter there is an example of each.

There are two basic types of gears—clock gears and power transmitting gears.



"LANTERN" PINION



CLOCK "WHEEL"

### Clock gears...Lanterns and Wheels

Clock gears are used more as indexing devices because it takes so little power to drive the mechanism. They must last for years and have little power loss because they are driven by so little energy. In clockmaker's parlance, the gears are

called “wheels”. There are also solid pinion gears and pinions called “lanterns”. The term “lantern” came about because these pinions are made up of a series of small rods mounted between two discs that are supported by a shaft. The entire assembly looks like a small lantern. The advantage of this arrangement is that the pins that drive the gears are a very simple shape. They are round. The gear only requires a slot for the round pin to enter and one cutter could be used to produce many different size gears. All you have to do is vary the depth and the cutter will form the proper shape at the top of the tooth. The lantern gears also produce beautiful gear trains that are too pretty to hide. Take a closer look the next time you see a clock on a fireplace mantel with the gear train exposed. The wheels are called “Epicycloid” when the gears are on the outside of a circle and “Hypocycloid” when the gears are formed on the inner side of a circle.

**Bill Smith: A great source of information for anyone wanting to learn more about clockmaking**

One of the nicest men I have met through my business is William Smith, who has been a clock maker for over fifty years. He has designed many

beautiful clocks that can be built by an amateur machinist. His name and accomplishments can be found on our web site, and he has written a number of books on building clocks and cutting gears. He also has several instructional videos available. If you are interested in the hobby of repairing or making clocks, Bill Smith is one name you should get to know.

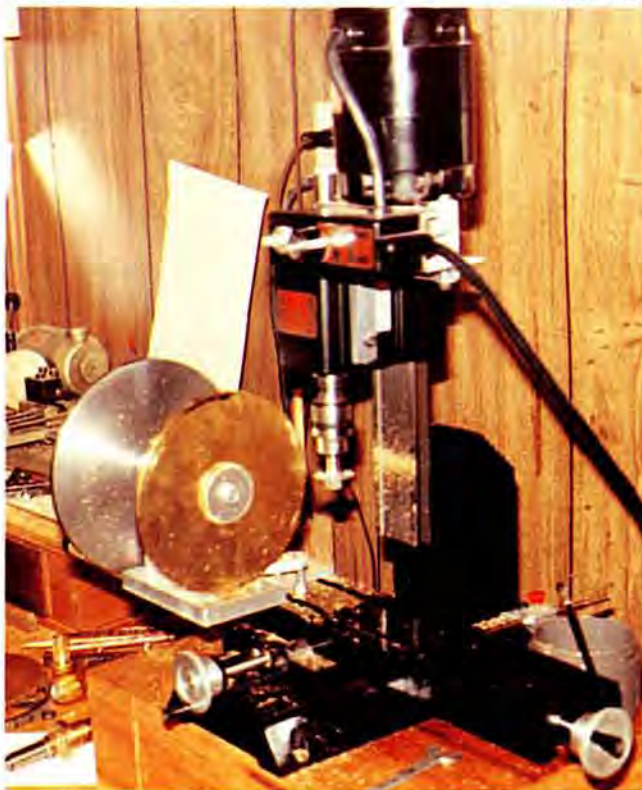


*These gears are designed to transmit power. The transmission is from a Formula Ford race car and is designed to make it easy to change gears to select different ratios depending on track configuration.*

**Power transmitting gears**

For transmitting power we use a system developed by the British using the inch system. I believe it is far superior to the metric system in this case. In fact, many metric gears are actually the same size as inch gears except that their size has been converted to a metric dimension. These are called the “English module” gears to avoid confusion with the “metric module”. The differences are fully described in *Machinery’s Handbook*. Gears are governed by their size, and the basis of the size is called the “diametral pitch”. Just like a thread, the pitch is measured from a point on one gear tooth to the same point on the next tooth. The difference between a thread and a gear is that a gear has a circular shape. The term “pitch”, therefore, is called the “diametral pitch” because the pitch is measured on a circular line. The term “pitch” still is very often used to describe either diametral pitch or circular pitch. The problem with using this term loosely when speaking of threads and gears is that it can lead to some serious confusion.

PHOTO: C.D. HICKMAN



*C.D. Hickman of Virginia devised this setup to cut several large brass gears on his mill. Behind the brass disk is a custom drilled indexing wheel.*

### Measuring diametral pitch

The diametral pitch can't be measured from just any random point on a tooth. It has to be measured at a place that is called the "pitch diameter". This is not the outside diameter of the gear, but rather the point where the two gears will come in contact. The British did something quite clever to simplify this. They decided that they would start with a one-inch diameter which has a circumference of 3.1416", which equals  $\pi$  (the fixed relationship of a circle's diameter to its circumference symbolized by the Greek letter "pi"). The number of teeth that could be equally divided into this number would be the "pitch". This really simplifies things.  $\pi$  (3.1416) is a constant on both sides of the equation to figure blank diameters so it cancels itself out. The O.D. of the gear blank is larger than the pitch diameter, and it just so happens that if you add 2 to the number of teeth on the gear you can come up with the O.D. The reason the number 2 is added is that gears contact one another at exactly one half the distance from the top of the gear tooth to the bottom. Of course, there is clearance at the bottom of the tooth, but the clearance isn't considered for these simple calculations.

#### For example:

You have to make a gear that has a pitch of 24 with 40 teeth. You can come up with a blank size for the gear you wish to produce without using any complicated tables by dividing the pitch into the number of teeth plus 2:

$$\frac{40 + 2}{24} = OD = 1.75" \dots \text{What could be simpler?}$$

To determine the total depth the cutter must cut including clearance, you divide the constant 2.157 by the pitch. Say, for example, you want to know how deep a gear cutter must cut to produce a properly shaped tooth for the above gear:

$$\frac{2.157}{24} = \text{whole tooth depth} = .08987"$$

### Choosing the proper gear cutter

With the proper cutter you now have enough information to cut a gear. Notice I said "proper" cutter. There is a series of cutters called "involute gear cutters" which are used to produce gear teeth one at a time on a milling machine with an indexing device. The cutting shape is determined by the number of teeth you plan to cut. There are eight



*A typical involute gear cutter*

shapes available for each diametral pitch, and a complete set for one diametral pitch would be rather expensive. They are available with 14.5° and 20° pressure angles. I would recommend using the 20° pressure angle because of the better tooth form (less undercutting) when pinion gears are cut. (See next page for more on pressure angles.) It would be prudent to decide on the best gear tooth form for your particular use and to stick with it because of the high cutter cost.

When purchasing cutters, a part number will be derived from a list like the following depending on how many teeth you wish to cut and the diametral pitch. (See also chart on next page.)

**Chart 1—RANGE OF CUTTERS**

CUTTER NO.	CUTS GEARS FROM
1	135 teeth to rack
2	55 to 134
3	35 to 54
4	26 to 34
5	21 to 25
6	17 to 20
7	14 to 16
8	12 to 13

These cutters will produce a fairly good tooth form, but they are expensive and have a very limited range. With a little practice and time you may be able to grind a single-tooth cutter that works like a flycutter. Use Sherline's P/N 3217 gear tooth cutter for this. A 1/4" lathe tool blank is provided which fits this holder. You will need a gear similar in shape to the one you are making to use as a shape gage to grind the tip of the cutter. If you are replacing a damaged gear, it may be used for a gage to shape the cutter as long as the tooth form is correct, not worn out. The corners on a bench grinder wheel are used to generate the shape on the tool blank. At first it may seem almost impossible to do this, but it is not as difficult as it sounds. Just keep checking the tool against the gear being used for a gage by holding the two up to a light source. You'll find that the final grinding is done by "feel". Lathe tool bits are cheap and available, so it is a process worth learning.

**Chart 2—INVOLUTE GEAR CUTTERS**

	DIAMETRAL PITCH	HOLE SIZE	CUTTER DIA.
14.5° PRESSURE ANGLE	14	1	2-1/2
	16	1	2-3/8
	18	1	2-3/8
	20	1	2-3/8
	22	7/8	2
	24	7/8	1-3/4
	26	7/8	1-3/4
	28	7/8	1-3/4
	30	7/8	1-3/4
	32	7/8	1-3/4
	36	7/8	1-3/4
20° PRESSURE ANGLE	14	1	2-1/2
	16	1	2-1/2
	18	1	2-3/8
	20	1	2-3/8
	24	1	2-1/4
	32	7/8	1-3/4
	40	7/8	1-3/4
	48	7/8	1-3/4

When the tool is mounted in the holder, don't allow it to stick out any more than necessary. The drawing on page 228 shows a typical gearcutting setup. Remember, this tool would be considered a single lip cutter and the feed rate must correspond. For example, a tool like this should cut .0005" (.01mm) per revolution. If the spindle speed were 1000 rpm, the feed rate should be .5" (12mm) a minute. A tailstock isn't always necessary; however, I believe the best setups will use the tailstock. Remember, the gear blank must run true before cutting the teeth. If the teeth have been cut in such a way that they don't run true with their shaft, a gear train may run fine until all the "high points" come together at the same time. Depending on the gear train's ratio, this binding may only occur every now and then.

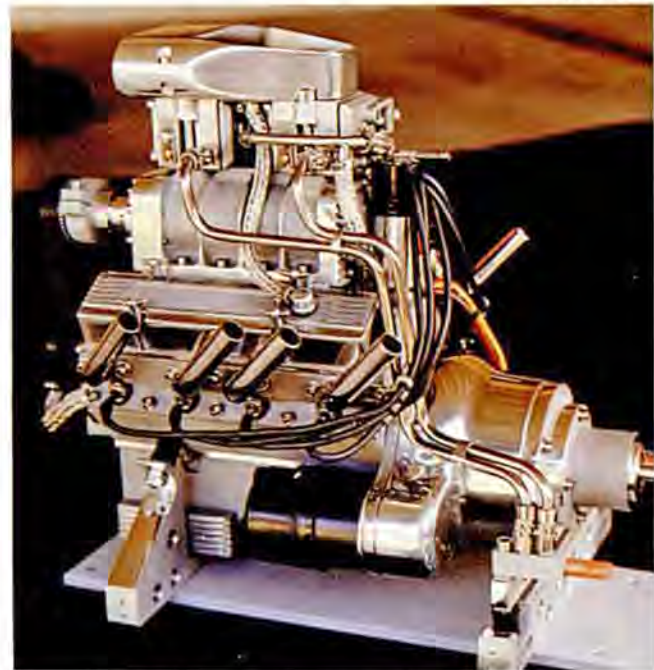
#### **Pressure angle considerations and undercutting**

A few other things must be considered before going on. A gear doesn't rub on its mating gear, it rolls. If gears rubbed against one another they would generate so much heat the gears would melt in a short time. Gears have another component called a "pressure angle" and it is expressed in degrees. If you had a rack gear that meshed with the gear you

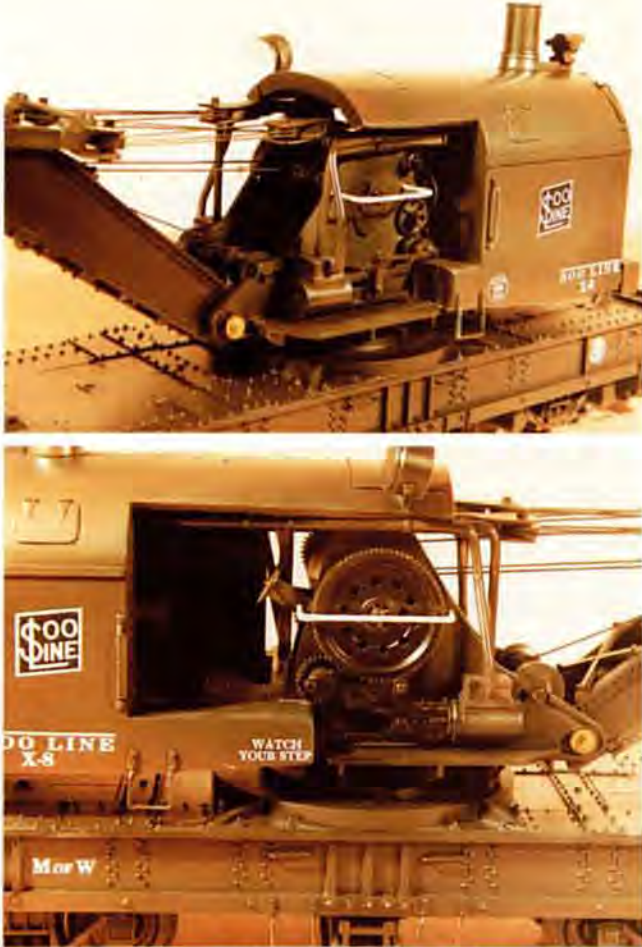
have been working with, you would find that the teeth on the rack would have sides that are straight but tilted at an angle. This angle is called the "pressure angle". 14.5° and 20° are the most common. The higher the pressure angle, the greater the force generated to separate the gear centers. The lower the pressure angle, the more a gear tooth will be "undercut" when pinion gears with less than 20 teeth are cut. Undercutting occurs when the tooth form of the pinion must allow for its mating gear tooth form.

A gear tooth has the shape of an involute curve. This is a generated shape. Suppose that a rack gear had a pressure angle of 20° and we meshed a 200-tooth gear to it. The gear tooth would be shaped almost the same as the tooth on the rack, because the gear tooth is curving away from the rack very slowly. With pinion gears, one tooth is in contact with an individual tooth on the rack for more time as it revolves. The tip of the tooth on the rack needs clearance to keep from binding, and this clearance has to be shaped into the pinion gear. The only way for these gears to mesh is to have "undercut". The problem is you can't cut a pinion with undercut one tooth at a time. They are generated shapes produced with special machines. They can also be useless because of this design flaw called undercutting.

PHOTO: DON MARTIN



*Don Martin of Sacramento, California built this beautiful supercharged V-8 drag boat engine. Notice the highly polished aluminum surfaces which show a lot of care went into this working model.*



Greg Conrad of Wisconsin made this extremely detailed railroad crane car which finished first place in a model show. Notice the detailed geartrain.

### Beating the problem of undercutting

Two methods have been used to overcome the problem of undercutting. The standard way is to increase the pressure angle on mating gears that utilize a small pinion. These pinions are found at the first stage of a gear train where the velocities are high but the loads are low. The pinion gear on a high speed motor would be a good example. Therefore, don't be surprised to find more than one pressure angle in a single gear train. A quick check would be to try to mesh the output gears with the pinion and examine the fit under magnification. The second method involves enlarging the pitch diameter on the pinion gear so that the tooth form has less undercut. Again, *Machinery's Handbook* is the best source of information on this method.

### Calculating distance between gear centers

If the gears have been cut perfectly, the distance between the centers of these gears can be calculated

by adding the total number of teeth used in the mating pair and dividing this by twice the diametral pitch.

### For example:

You want to find the distance between centers for two gears that have a diametral pitch of 24. One gear will have 30 teeth and the other will have 20 teeth.

Therefore:

$$\frac{30 + 20}{2 \times 24} = \frac{50}{48} = 1.0417''$$

It is important to notice that distance between centers is determined by the total amount of teeth used in the mating pair of gears; therefore, a combination of 24T and 26T would also work with these centers. Transmissions that have a fixed distance between shafts, such as those used in a race car, may get finer adjustments between ratios by using a non-standard diametral pitch gear to come up with a pair of gears that also uses the same distance between shaft centers. They can arrive at the diametral pitch by working the basic equation backwards.

Example: You want to produce a pair of gears with less of a ratio change than can be had with our previous example. The 20T and 30T gears have a ratio of .666667. This means that one revolution of the 20T gear would turn the driven 30T gear .666667 of a complete revolution. The next ratio higher you could come up with without changing the diametral pitch would be 21T and 29T which also totals 50. This would give you a ratio of  $21/29 = .724$ , which is a considerable change. If we used a 21T and a 30T the ratio may come closer to what we wanted.  $21 \div 30 = .7$  ratio. These fine adjustments may solve a problem for a driver who wants maximum horsepower on a particular part of a race track, but they can create lots of work for the gear cutter who has to have special cutters made to produce these "off size" gears.

We can figure the new diametral pitch. The 20T and 30T would give us a distance between centers of 2.5" if the gears had a diametral pitch of 10. We can then solve this simple equation by having the distance between centers remain fixed and modify the diametral pitch:

$$\frac{21 + 30}{2 \times DP} = 2.5''$$

Solving for DP we get:

$$\frac{21 + 30}{2 \times 2.5} = 10.2$$

The new diametral pitch would be 10.2.

One of the main reasons I wanted you to understand this is to convince you that not all gears have a standard diametral pitch. They make gages to check involute gears, but a small difference may be hard to see. Don't forget, if you know the number of teeth and the distance between centers you can always calculate the diametral pitch. Gears are too hard to make to have an error take place before the first cut has even been made.

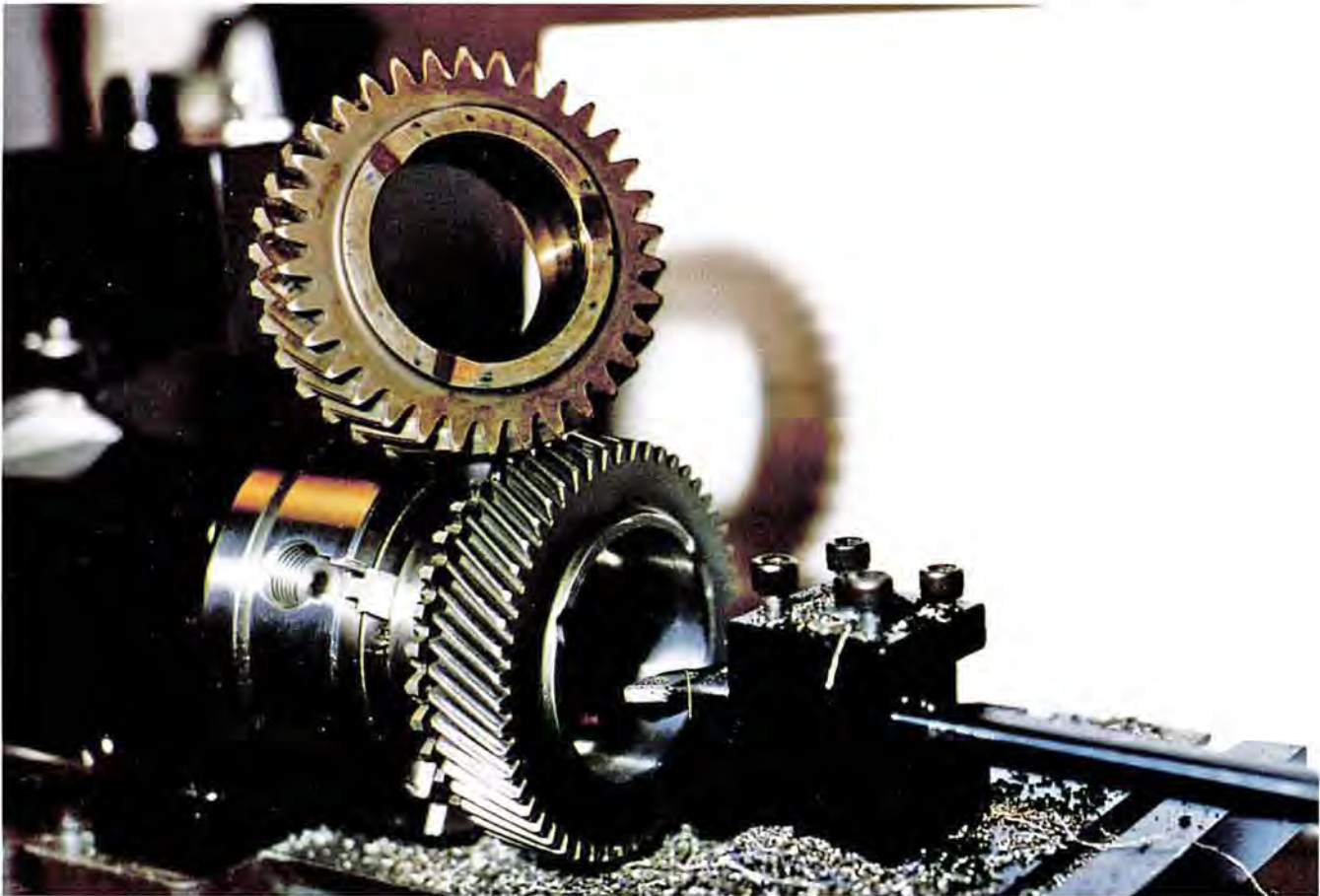
#### **Finding the distance between centers of existing gears**

Perfect gears are very difficult to produce one tooth at a time, and this is the best way I have come up with to find gear centers for a pair of gears that may not be as accurate as we planned. Mount one gear to a plate in such a way that it spins freely without

wobbling. Locate the mill spindle directly over this center and zero or record the handwheel settings. Be sure to include the backlash direction with an "L" or "R". Now mount the second gear on the spindle where it can also spin freely. The two gears can be brought together until they start to bind and then "backed off" until they spin freely again. Don't forget to use the same backlash direction, and the handwheel graduations will indicate what the perfect distance between these two gears should be.

#### **Cutting gears with just a mill and a vise**

The simplest way to produce a gear without any fancy tooling is to have a gear with the same number of teeth (or a multiple) on hand. This can be the worn gear that is being replaced. It is only being used as an index device, so the tooth form doesn't affect the final product. Mount this gear on the same shaft that the gear blank is mounted on. The shaft should be long enough to extend beyond both sides of your vise. With the index gear on one



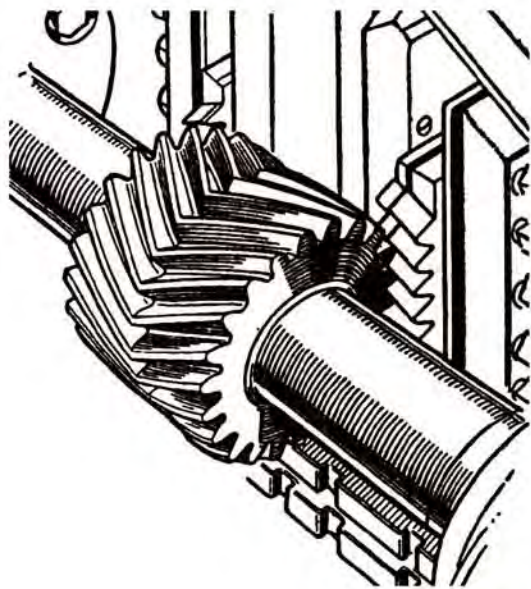
*The gear on top is the "before". A similar gear in the lathe is gripped with a 4-jaw chuck. It is being bored out so that it can be used as a sixth gear in a 5-speed Volkswagen transmission. The gear is now installed in the car and works fine. You really have to know your way around a transmission to try a project like this, but if the size is right, tabletop tools can handle even a job like this.*

PROJECT AND PHOTO: PETE WEISS

side of your vise and the gear blank on the other all you need is an index “finger” mating with the index gear to cut gear teeth. The shaft “locks” between the vise jaws and the old gear is used as an index device. By the way, this index finger must fit without any slop. If you ground your own cutter as I previously described, you have beaten the system, because you didn’t buy some very expensive accessories to get the job done.

### **Bevel, helical, worm and other types of gears**

The spur and clock gears we have considered can be machined with a standard milling machine, but there are many other types of gears. Bevel, spiral bevel, helical, internal, herringbone, and worm gears all have shapes that are very difficult to produce on a standard mill. Remember that gear teeth are a generated shape and are produced by having the cutter make multiple cuts on the tooth as the blank rolls through the cutter. This produces the proper shape by forming the tooth with many minute cuts. Gears cut on a mill are formed by the shape of the cutter. I consider some special gears like the spiral bevel, internal, and herringbone gears to be virtually impossible to cut on a standard milling machine.



*A rack-generating process planes a double-helical gear. You can see why it would be impractical to try to make a gear like this using a home shop setup.*

### **Cutting worm gears**

A worm gear could be cut one tooth at a time if the head were tilted at the appropriate angle and a proper diameter cutter is used. (The cutter diameter should be slightly larger than the worm to produce

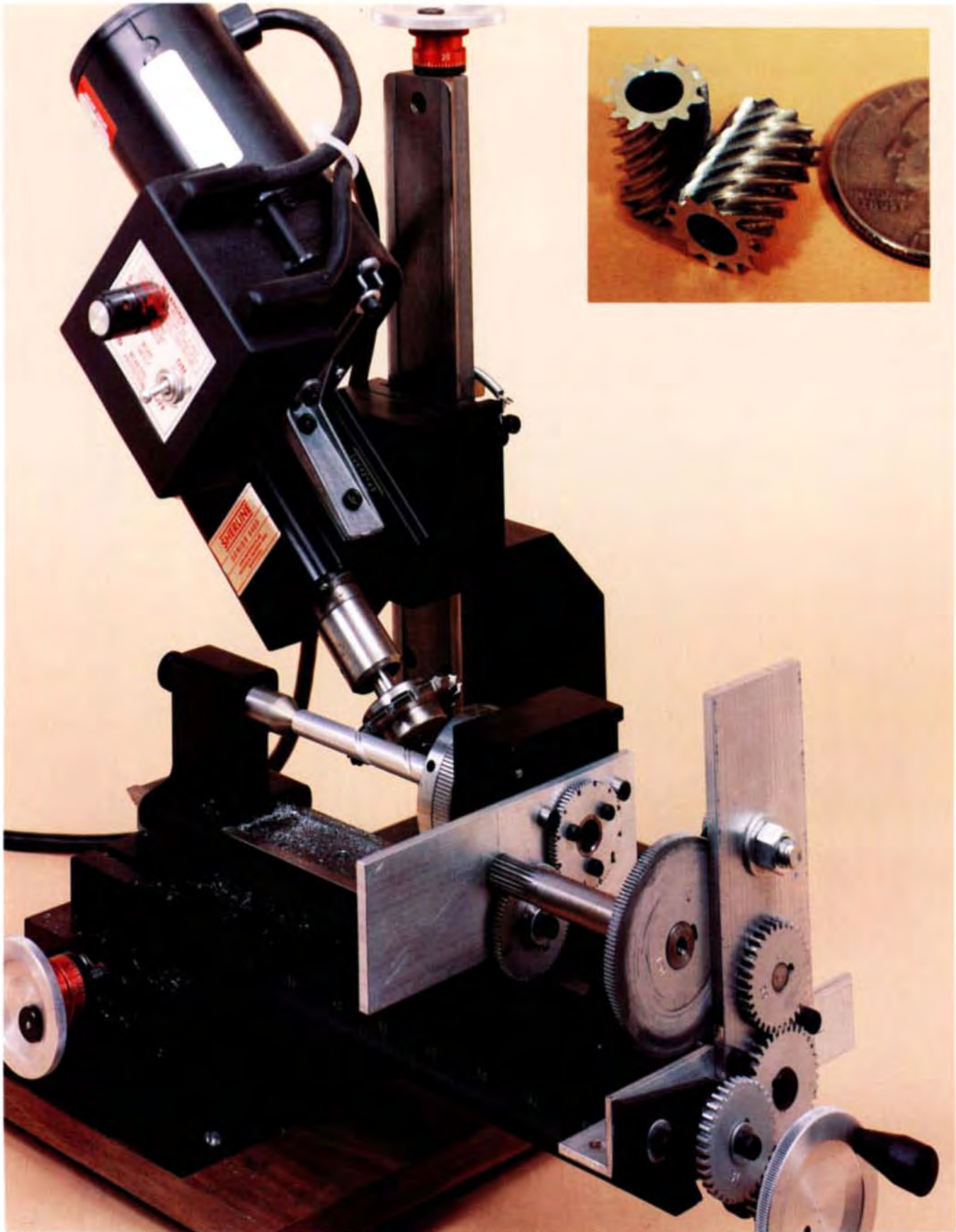


*Learning to produce the gears for Sherline’s rotary table taught me a lot about making worm gears.*

a combination with a long life.) Cutters like this probably exist, but I have never seen one. I learned quite a bit about worm gears because we cut our own gears to make the Sherline 4" rotary table. As you will recall, the diametral pitch is a curved line while the worm is a straight line. Worms that mesh gears have a pitch equal to the diametral pitch divided into  $\pi$  (3.1416). On a manual lathe these are not standard gear combinations, and you will have to build up a gear train that will turn the leadscrew at the right ratio. (The method of determining this ratio is explained in this chapter.) When viewed from the side the teeth look like a rack gear. When viewed from the top the teeth are angled. This is why the cutter must be on an angle for the gears to mesh when the worm is square to the worm gear. These gears can be made with both left- and right-hand leads. You will be very disappointed if you don’t take this into consideration and end up with a worm that doesn’t mesh with its gear. Worm gears are also produced with double and triple leads. This can increase the ratio per revolution of the worm, and, of course, the mating worm gear would have to have the teeth cut at more of an angle to accommodate the increased lead.

### **Some worm gear trivia**

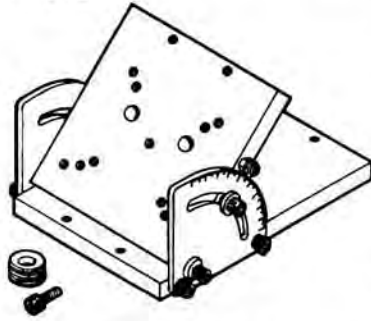
For what it’s worth, here’s a piece of information on worm gears you might someday find useful: A diametral pitch of 64 will mesh surprisingly well with the thread of a standard 1/4-20 TPI bolt.



*This setup combines components from a couple of standard Sherline accessories plus one specially produced gear to make a 45° helical gear. The inset photo shows the finished part—a drive gear for the distributor shaft of a small internal combustion engine.*

### Special projects using Sherline tools

There is a method explained in *Machinery's Handbook* that describes how to mill a bevel gear. We recently added to Sherline's accessory line a "tilting angle table" which can be used in conjunction with our rotary table to produce a bevel gear. A photo of a setup to cut a bevel gear is shown on page 232.



*A tilting angle table like this one used with a rotary table would give you the movements necessary to produce a bevel gear.*

The previous page shows the setup I used to cut a helical gear on a Sherline mill by gearing the indexing attachment to the mill table so the index attachment would rotate the part at the correct ratio to the table movement. I used screw-cutting change gears to get the proper ratio. The gear I cut was a 45° helical gear. This meant that the gear would have to rotate on its pitch diameter exactly the same amount as the table was moved. Remember, the pitch diameter of helical gears has to be enlarged to allow the tooth shape to remain proper and it becomes a function of the cosine of the angle. This is fully discussed in *Machinery's Handbook*. I only had to cut one special gear to have a gear train accurate enough to do this. I have found that calculating gear ratios is easier when writing them as fractions.

### Calculating gear ratios by using fractions

Suppose I wanted to make a gear ratio of 1.248 to 1. The 1 would be the driver and 1.248 would be the driven gear.

The formula for a gear ratio is:

$$\frac{\text{Drivers}}{\text{Driven}}$$

In this case that would be:

$$\frac{1}{1.248}$$

Multiplying top and bottom by 1000 you get:

$$\frac{1000}{1248}$$

Dividing top and bottom by 8 gives you:

$$\frac{125}{156}$$

Factoring the numbers gives you:

$$\frac{5 \times 25}{2 \times 78}$$

Factoring to add another set of gears to the gear train would yield:

$$\frac{5 \times 25 \times 2}{2 \times 39 \times 4}$$

Factor again because 25T and 39T are not standard gears to get:

$$\frac{5 \times 10 \times 5 \times 1}{2 \times 13 \times 2 \times 6}$$

Take the combinations and try to use existing gears you may already have.

The combinations used were my third attempt to use only Sherline screw cutting gears.

This fraction could also be expressed without changing its value as:

$$\frac{5 \times 10 \times 5}{6 \times 13 \times 4}$$

Remember you can do any multiplication or division to a fraction as long as you do it to both the top and bottom:

$$5/6 = 30/36$$

$$10/13 = 20/26$$

$$5/4 = 40/32$$

Lets check it out:

$$\frac{30 \times 20 \times 40}{36 \times 26 \times 32}$$

equals 1 to 1.248 exactly.

These are all gears that are included in a Sherline screw cutting accessory. They also don't contain any error. An amazing number of gear combinations can be achieved from just 10 gears by "playing with numbers". *Machinery's Handbook* also includes instructions on this and other methods to find the proper combinations of gears.

### Cutting gears with a rotary table

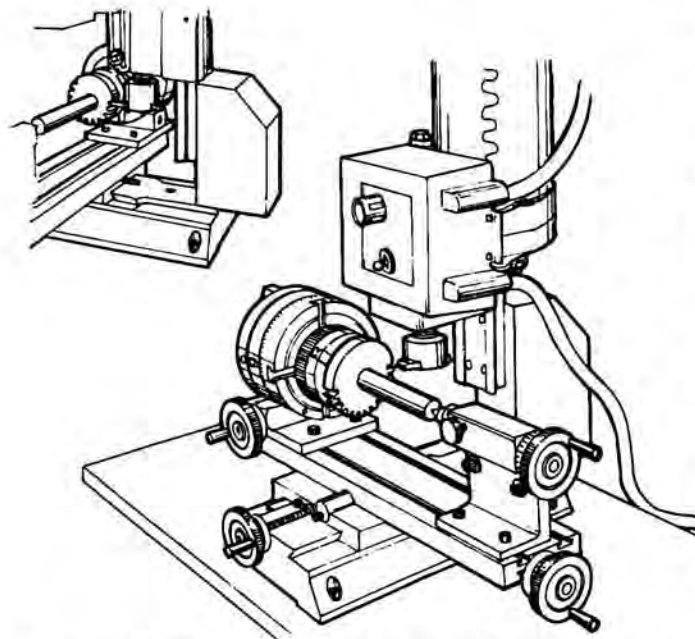
I'm going to leave it up to you to determine when you know enough about gears to try to produce one. Gears are built to a rigid set of rules, and they are more complex than you might imagine. I've tried to

describe the working of gears in the simplest of terms. On second thought, it might just be because I don't know many complex terms.

### Getting organized to cut a simple gear

I will only try to explain how to cut a simple, low-tolerance gear. You will also have to determine the blank size, depth of cut, spindle RPM and so on from the information I've given you or any other publication on gears you may have found. If you successfully cut a good gear on your first attempt, be very proud of yourself. It can be frustrating if you are not organized and thoroughly prepared.

Gears can be cut using a rotary table with a reasonable amount of precision. In many cases, gears—even inexpensive ones—are very precise. Gears are usually produced by “hobbing”. This method uses a cutter that is similar to a worm gear. (See photo on page 233.) The teeth are generated with both the cutter and the blank turning. In fact, the cutting process looks just like a worm gear running. Methods like this produce perfectly shaped teeth that are perfectly spaced. It may be theoretically possible to produce a perfect gear one tooth at a time, but your odds of success are dismal if this is the type of gear that is required. I suggest you stick with simple type involute or clock gears for your first few projects.



*A sample setup for cutting a gear. The small inset shows the column moved back to the rear hole on the standard mill to allow clearance for cutting larger diameters. The deluxe mill has a 2" longer base which makes this unnecessary in most cases.*

### Why Sherline uses a rotary table and not an index plate

First, let's consider what accuracy is attainable with a rotary table. The rotary table has a hobbled gear that is part of the table section. This gear is as perfect as you can hob a gear, and few shops could ever find an error in the gear quality. The mating worm gear has an adjustment to eliminate most of the backlash. Each degree has been divided into 10 parts that can be clearly seen. On a four-inch diameter, one tenth of a degree only represents a movement of .003"; however, this one-tenth of a degree can be interpolated. If a gear is cut with an O.D. of 2", the accuracy is doubled. This should be more than enough accuracy needed to produce usable gears. I have heard that the best way to index gears is with an index plate. Customers assume that the holes in index plates are located perfectly; I don't. A set of plates may not have the index to cut all the teeth that may be required. They also cost more than either of Sherline's methods for cutting gears. The rotary table and the indexing attachment can also be used for projects other than cutting gears. I have never designed the Sherline machines to be used for production. The methods used for building parts one at a time are simply too slow for production but will work fine in your home shop.

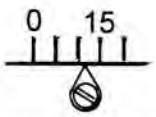
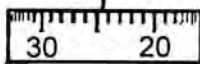
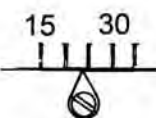
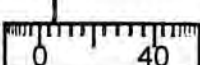
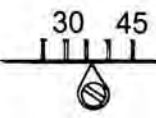
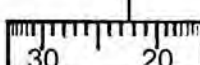
### Calculating your cuts

To figure the amount to move between cuts, an electronic pocket calculator is very helpful. Simply divide  $360^\circ$  by the number of teeth you wish to cut. This will give you an answer in degrees and tenths that can be used directly on your rotary table without conversion to degrees, minutes and seconds. Your rotary table is calibrated directly in degrees and decimal divisions of a degree.

### Example: cutting a 29-tooth gear

*(Note: I have purposely used a number of teeth that does not easily divide into  $360^\circ$  as this will often be the situation in which you will find yourself.)*

Here are the calculations and handwheel settings you would need to cut a 29-tooth gear. Remember that the table is marked every  $5^\circ$  and one revolution of the handwheel is  $5^\circ$  which is divided into 50 parts. Therefore, each line on the handwheel equals  $1/10$  of a degree. The figures that follow on the next page show the calculations and how the handwheel settings would look for the first 4 cuts on the 29-tooth gear.

	ROTARY TABLE SETTING	HANDWHEEL SETTING
<b>FIRST CUT</b>	○	○
<b>SECOND CUT</b>	 $\frac{360^\circ}{29} \times 1 = 12.4137931^\circ$ $10^\circ + 2.4137^\circ = 12.4137^\circ$ <p style="margin-left: 40px;">This part can be interpolated</p>	
<b>THIRD CUT</b>	 $\frac{360^\circ}{29} \times 2 = 24.82758621^\circ$ $20^\circ + 4.8275^\circ = 24.8275^\circ$	
<b>FOURTH CUT</b>	 $\frac{360^\circ}{29} \times 3 = 37.24137931^\circ$ $35^\circ + 2.2413^\circ = 37.2413^\circ$	

*Degree calculations and handwheel settings for making the first four cuts on a 29-tooth gear.*

The reason you should divide then multiply each time is if you “rounded off” on the first division, your error would build up by the number of teeth you were cutting. If your pocket calculator has a memory function there is an even easier method of calculating each cut. Simply store the first in memory and add it to itself each time. Because the calculator stores the number to even more decimal places than it displays on the screen, the answer is

usually so accurate the 29th calculation should yield almost exactly 360°.

1. First calculation:  $\frac{360^\circ}{29} = 12.4137931^\circ$  (2nd cut)
2. Press “Memory” key (usually [M] or [M+]) to store this figure  
(Remember that the first calculation is actually for the second cut, because the first cut is made with the handwheels both set at “0”.)
3. Press [+] key
4. Press [Recall] key
5. Press [=] key (3rd cut)
6. Press [+] key
7. Press [recall] key
8. Press [=] key (4th cut), etc.

### INDEXING ATTACHMENT

The indexing attachment can also be used to cut a gear. Following is an example that uses the “calculated method” described on pages 3-4-8 and 3-4-9 of the previous chapter.

#### EXAMPLE:

Say you want to cut an 83-tooth gear, 56 pitch (The size of the blank is arrived at by using the formula at the beginning of this chapter or from *Machinery's Handbook*.) The cutter can be purchased or ground

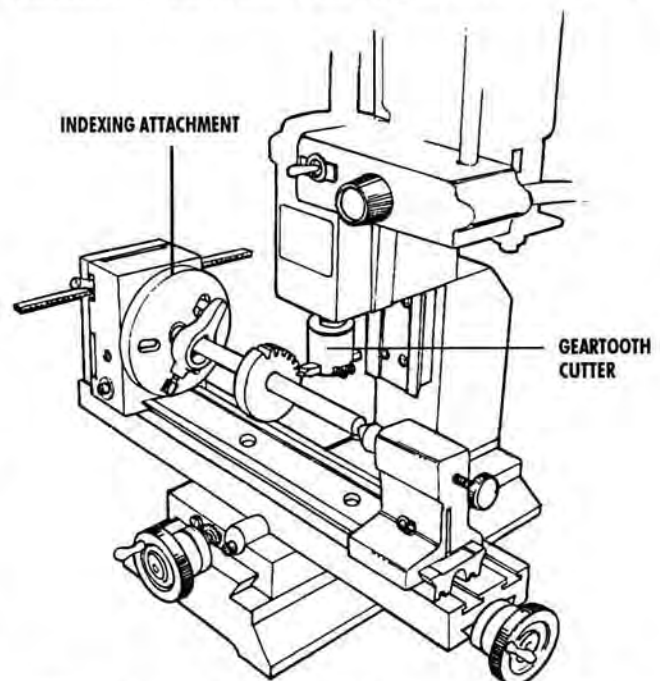


FIGURE 4— Typical setup for cutting gear teeth

from a lathe tool. The blank can be mounted on an arbor and held between centers. The dog is clamped on the arbor in such a way that it engages with the faceplate. Care must be taken to eliminate all play where the dog engages with the faceplate. The shaft must be rigid enough to withstand the forces of machining.

See that the cutter is properly held in a holder and has been located on center using the tailstock center for a reference point. The indexing attachment should be properly clamped to the machine table, aligned with an indicator and the rack gear located in such a way that a complete revolution can be turned. You are ready to begin.

### **Making the first cut**

Before you begin “making chips”, look again at your setup; is it really SAFE? Also make sure you’re wearing safety glasses. Remember, that cuts of this type require very rigid setups because of the intermittent cutting action. If the gear blank is thin, it may require additional support by sandwiching the gear blank between support pieces shaped like large washers and of a material which is easily machined.

Turn on the machine spindle and move the Y-axis toward the cutter while moving the X-axis back and forth until the cutter just starts to touch the blank. Write down the dial setting and calculate the total depth of the cut. (The information to calculate this can be found also in *Machinery's Handbook*.) The first cut should be less than .010" (.20mm) deep. Observe the cutting action carefully. Is the cutter cutting properly? Is there excessive vibration in the setup? Is the cutting speed proper? There is no book written that can give you the answer to these questions. This is where experience and craftsmanship come into play. The best way to make good parts is to work VERY CAREFULLY! To cut an 83-tooth gear means you have to do 83 successive machining operations correctly to make a good part...82 out of 83 is a waste of time!

### **Index for the next cut**

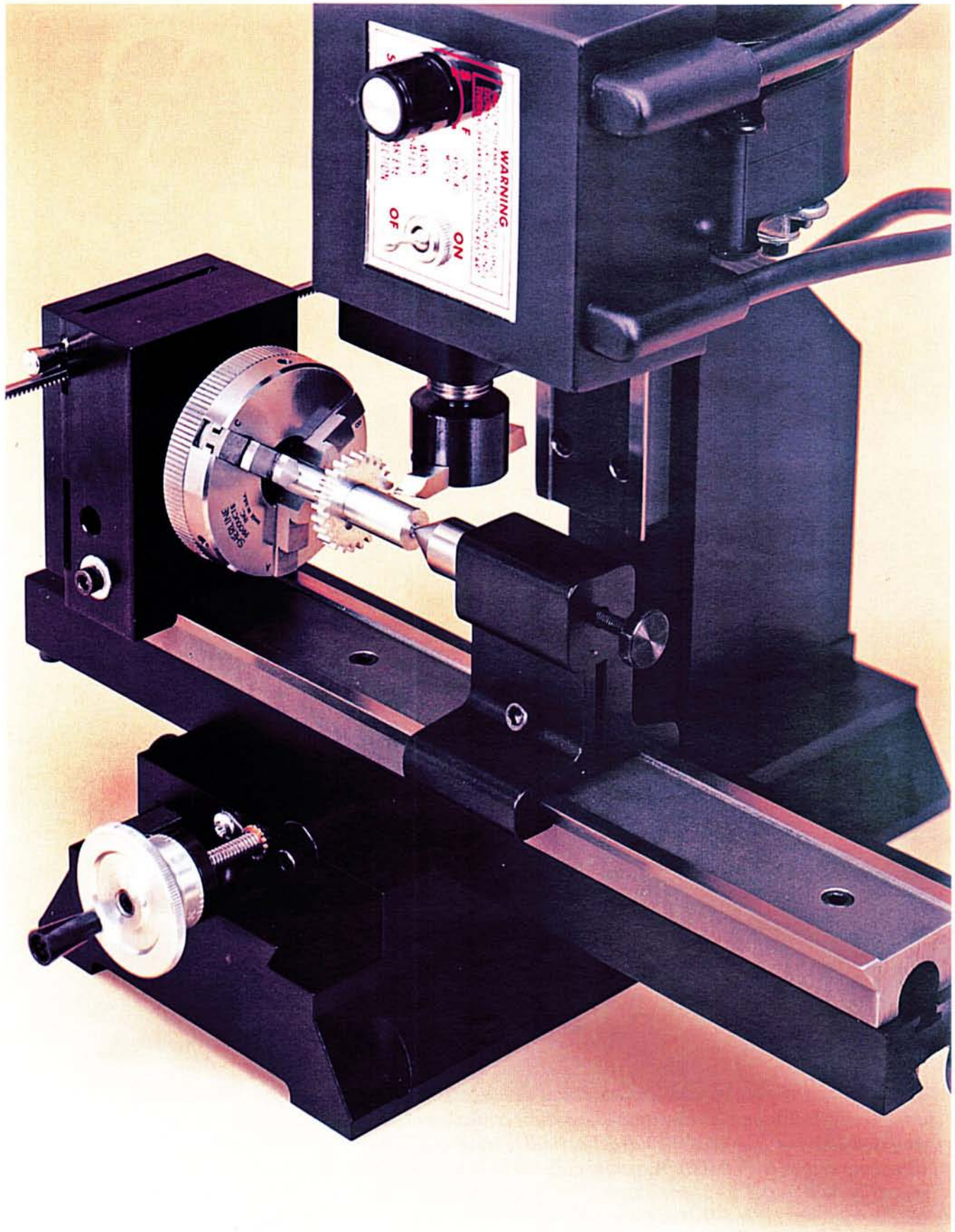
Once your cutting speed and feed are to a point you’re sure you can repeat the same operation over and over again with excellent results, finish out your first cut to its final depth. Now it is time to index for the next cut. Measure the distance from the end of the rack to the index head carefully before unlocking the spindle. Write down this dimension (it will be

referred to as “A”). From instructions in the previous chapter, you have already figured the total throw of your indexing head—say it is 4.712". You now divide this number by the number of divisions, in this case 83, to get:  $4.712 \times 1/83 = .056771$ ", or rounding off, .057". This is now added to or subtracted from dimension “A”. At first glance it would appear that all you need to do is add .057" for each cut because an error of only .000229" is so small it can be discounted. But if you multiply this error by the total number of teeth (in this case 83) you would end up with an error of .019" which would make the last tooth you cut a very “interesting” shape. This is what is known as “tolerance buildup” and is the reason you must use your basic formula at each step to calculate the next dimension rather than simply adding rounded off dimensions. The second cut and each succeeding cut are calculated as follows:  $4.712 \times 2/83 = .113542$  or .114". Add this to or subtract from dimension “A”, index and cut.

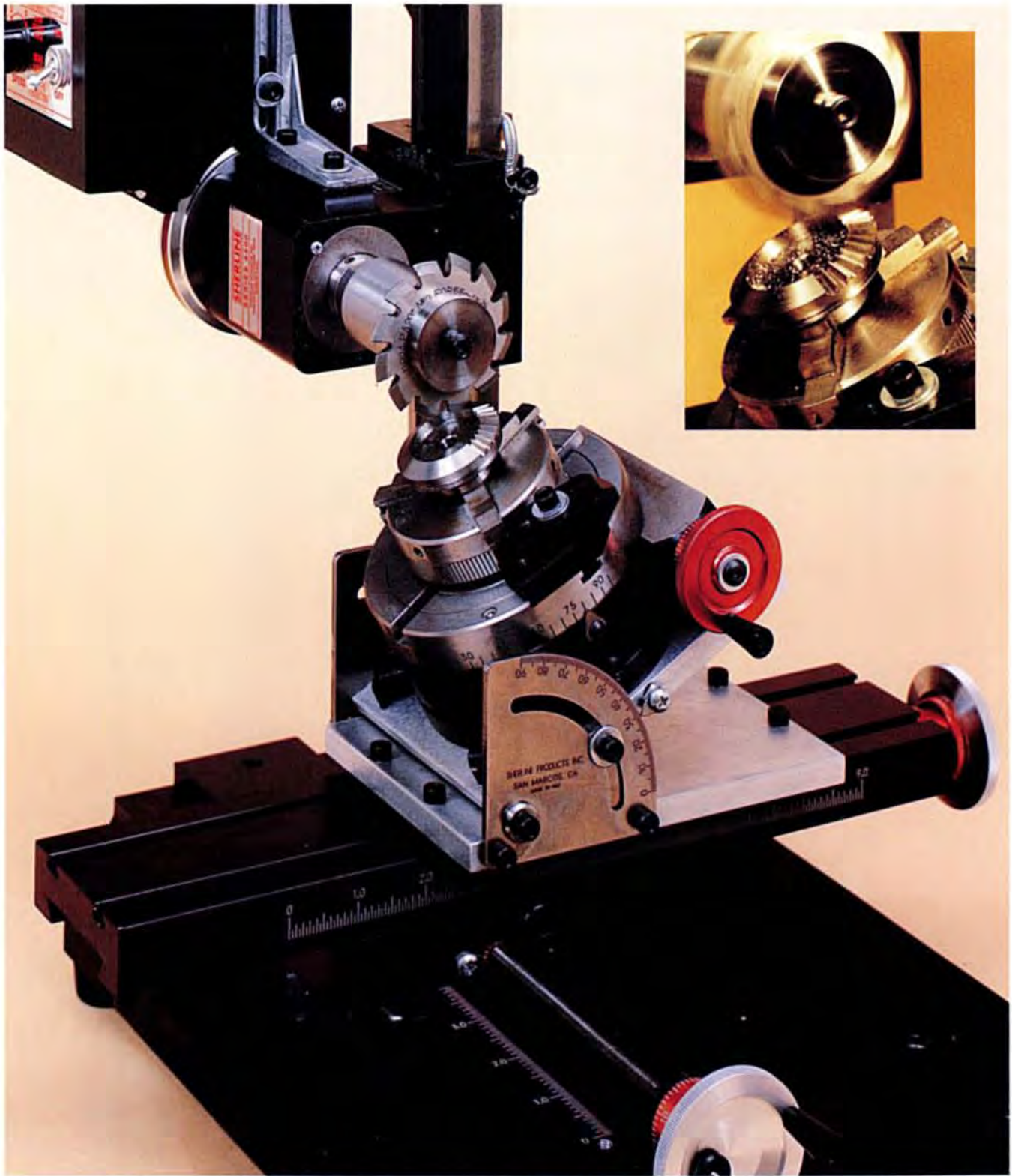
### **A calculator with a “memory” function makes the math easy**

As mentioned previously, even inexpensive modern electronic calculators usually have a “memory” function which can make your job easier. Although the calculator may only read out 6 to 8 decimal places, the figure is actually held in the calculator’s memory to a far greater level of accuracy. To make these calculations using the calculator’s memory function you would proceed as follows:

1. Measure the distance from the end of the rack gear to the body of the indexing head (dimension “A”) at the first cut.
2. The first calculation (2nd cut) is  $4.712 \times 1/83 = .056771$ " Hit the memory key to store this number (usually [M+] or [M] on most calculators). Add the rack length (dimension “A”) to this number and write it down rounded off to 3 decimal places. This is the length of the rack for the 2nd cut.
3. To figure the setting for the 3rd cut you will add the total on the calculator from step 2 to the number in memory as follows:
  - A. Hit the [+] key
  - B. Hit the [MR] or [MRC] key (Memory Recall)
  - C. Hit the [=] key and write down the total rounded off to 3 places



*Here is a photo of a setup similar to the one shown in the drawing on page 228 except an indexing attachment and 3-jaw chuck are used to hold the shaft which supports the gear that is being cut.*



*Cutting a bevel gear on Sherline tools shows how a number of accessories can work together to accomplish a complicated setup. The Model 5400 deluxe mill is set up in the horizontal configuration using the horizontal milling conversion (P/N 6100). A special cutter is held in a long gearcutting arbor in the headstock spindle. The part is held in a 3.1" 3-jaw chuck (P/N 1040) which is attached to the rotary table (P/N 3700). Two hold down clamps (P/N 3012) are used to keep the chuck from unscrewing during the cut. The rotary table is mounted to a tilting angle table (P/N 3750) which is set to a 30° angle and attached to the mill table. The inset closeup shows the gear teeth being cut.*



The [M+] and [MRC] keys on a simple electronic calculator make the math for successive operations easy and accurate to many decimal places, eliminating "tolerance buildup". This particular calculator also makes conversions between the metric and inch system.

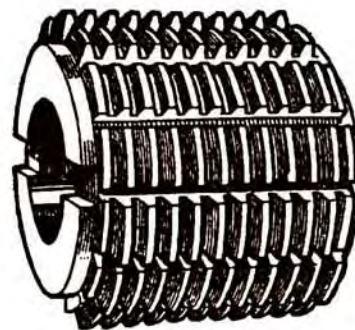
4. To figure the setting for the 4th cut you will add the total on the calculator from step 3 to the number in memory using the same sequence: [ + ] [ MR ] [ = ].
5. Continue this sequence until you have written down the settings for each of the 83 teeth. Using the memory's ability to store a number to many decimal places, your 83rd calculation should come so close to dimension "A" plus 4.712 that the error is insignificant. (On my calculator the 83rd calculation was off by .000007".)

Other indexing operations use the same methods. With each cut your understanding of the techniques involved will increase. By working and thinking in a careful manner you should be successful on the first attempt. Although the instructions given here have been related to cutting a gear, the same approach is used for any type of indexed machining operation.



Above: The gears that make up the Sherline thread cutting attachment were cut on a gear hobber. Here the gear hobber can be seen in action cutting a batch of 15 gears at one time.

Below: The worm-shaped cutter on a gear hobber accurately cuts spur or helical gears in a production shop.





*Shown here is a self-contained CNC rotary indexer based on Sherline's 4" rotary table. Included is a programmable input keypad that contains its own microprocessor. A power supply (not shown) plugs into the wall and converts 110 VAC current to 24 VDC to run the processor and stepper motor. Watchmakers or anyone with a need to do gear cutting or other radial machining or drilling jobs will find this accessory takes all the headaches out of repetitive indexing operations. At less than the cost of a complete set of high quality indexing plates, this accessory represents the future of indexing.*

*Operation is simple. After entering the number of divisions of a circle from 1 to 999 or degrees (to three decimal places) on a simple numeric keypad. The table advances quickly and precisely to the next position at the touch of a single advance key. If an error is made, previous positions can be recalled with the touch of another button. Backlash error is accommodated electronically to reduce it to zero. Basic resolution is 14,400 steps per revolution or 0.025° per step. This allows the accurate machining of items like gears with odd numbers of teeth. Computations are made internally by the microprocessor to a high degree of accuracy to avoid cumulative errors.*

*This stand-alone unit includes everything needed to make complex indexing jobs easy. In addition, the unit can be connected to an existing CNC control to function as an indexer in that system. Fixtures are available to mount the table in the vertical position as well.*

PHOTO: JAMES E. NEAL



*Three handsome display pieces. On the left is an alcohol fired thimble steam engine. On the right is a "huff-n-puff" steam engine. It has a large-mouthed intake opening so you can blow into it and watch it run. In the middle is a pocket watch for size reference. These two steam engine projects were entered in the 1997 Machinist's Challenge contest by James E. Neal of Elk River, Minnesota.*

## Chapter 6— Accessories for milling

### THE HORIZONTAL MILLING CONVERSION

#### Two configurations open up many milling possibilities

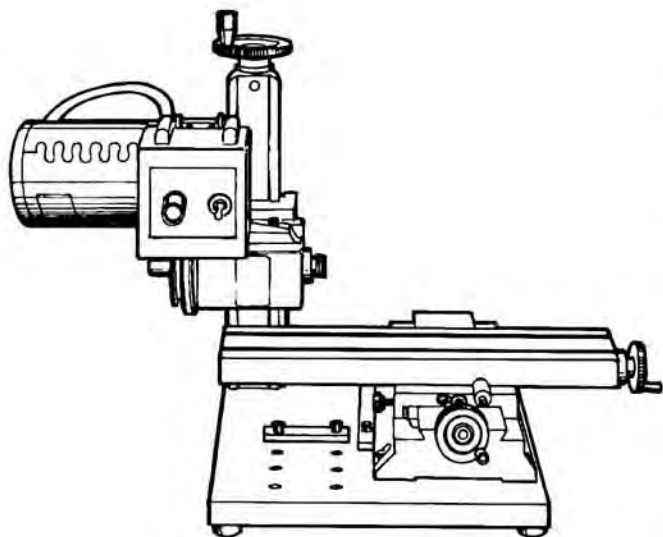
The horizontal milling conversion is a takeoff of an idea sent to us by Joseph Kubin, a toolmaker from Maryland. With this attachment, the mill spindle (in the horizontal position) can be aligned with the X- and Y-axes. There are three places the column can be mounted to the horizontal conversion base. When the spindle is lined up with the Y-axis, the outermost position is for drilling and milling (see position A in photo below).

The closest position is used for milling. The configuration of the work has a lot to do with the choice to be made, but remember, when milling, the closer the end mills are mounted to the spindle bearings, the more rigid the setup. The spindle can also be mounted lined up with the X-axis by reversing the position of the XY table on the horizontal base and mounting the column in the single set of holes.

To configure the machine so the spindle is over the X-axis, the XY base must be reversed from its



*The horizontal milling conversion is set up in position “A” to machine large surface areas using the long X-axis travel. Next to the base at the left is the end of the mill column base which has been shortened to lower the headstock. The block is replaced to return the machine to conventional height for normal milling.*



*The horizontal milling conversion set up in position "B" to take advantage of the long Y-axis travel.*

normal position, that is, with the Y-axis handwheel away from the Sherline label (see Position B).

The advantage of this setup is you have 9" of throw from the spindle nose and you could drill and bore a hole 8" from the edge that is clamped down. If the mill was in its vertical configuration the same edge would interfere with the column. A point to consider is that any axis that moves the work in and out from the end of the spindle becomes the Z-axis and the up and down of the column will usually be called the "Y" axis when the mill is in a horizontal configuration.

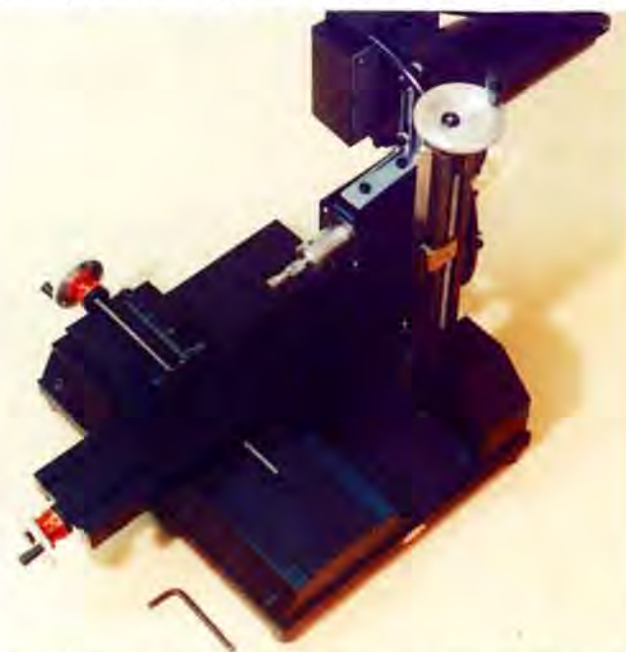
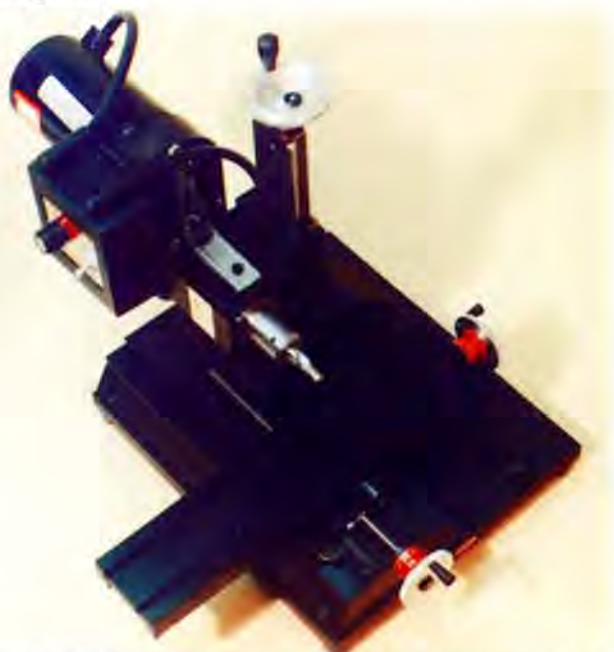
### **Using the alignment bars to save time in future setups**

The 1/4" x 1/2" alignment bars are clamped against the column base and XY table after the machine is aligned so it isn't necessary to align it every time the configuration is changed. How close the machine has to be aligned is dependent on the work to be performed. A machinist's square from the milling table to the column bed (dovetail) will usually be good enough, but a dial indicator would be helpful for close tolerance work.

NOTE: It is possible to move the Y-axis saddle to the point the lead screw disengages from the nut without the column being in place. Normally, it would hit the column base before it could disengage.

### **Modifying the mill column base for use with the conversion**

The advantage of modifying the column for this attachment is to allow the spindle center to go below the top of the table. This allows a piece of material to be clamped directly to the table and the edge overhanging the table can be machined. We also modify the column saddle with another alignment groove in the horizontal position. All vertical milling machines manufactured after 1991 will come with the groove cut. The column base is modified by cutting 2" off the bottom, making it a spacer block and retapping what's left over. This allows the column to be mounted with or without the spacer in either the horizontal or vertical configuration. If you have access to a saw and mill,



*Another view of position "A" (left) and position "B" (right). Note that in position "A", the vertical column and drive can also be mounted further toward the back of the table should your setup require it.*

you could make these modifications yourself. The drawings for these modifications are included with the conversion. If you do not wish to attempt the modification yourself, your mill column base can be returned to the factory for modification.

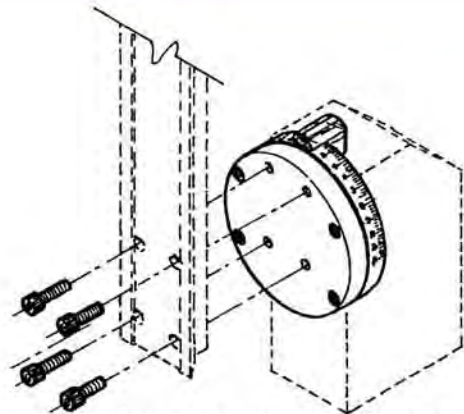
A part held vertically using the right angle plate can have a 9" x 6" area that can be machined without moving the work. If you think about it, that's a lot of movement for a machine of this size. I believe you will find this a useful accessory. The right angle plate is also a very useful accessory when used in conjunction with the horizontal milling conversion.

### Clamping instructions

To clamp the column to the horizontal milling conversion plate, use the two 1" x 1/4-20 socket head cap screws which are included. Use the 3" x 1/4-20 socket head cap screws when the spacer block is used.

To clamp the column to the XY base, use the two 1-3/4" x 1/4-20 socket head cap screws. Use the 3-3/4" x 1/4-20 socket head cap screws when the spacer block is used.

The alignment bars and the XY table are held to the base with 5/8" x 1/4-20 socket head cap screws (10 included).



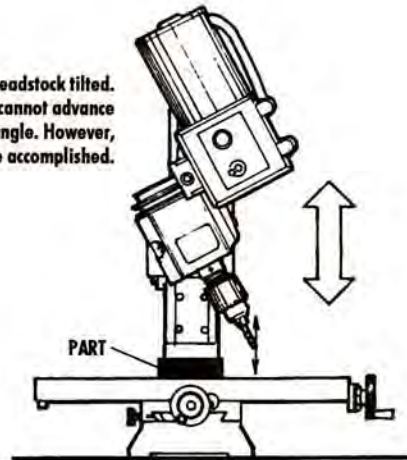
### ROTARY COLUMN ATTACHMENT

#### Angle drilling on a standard 3-axis mill

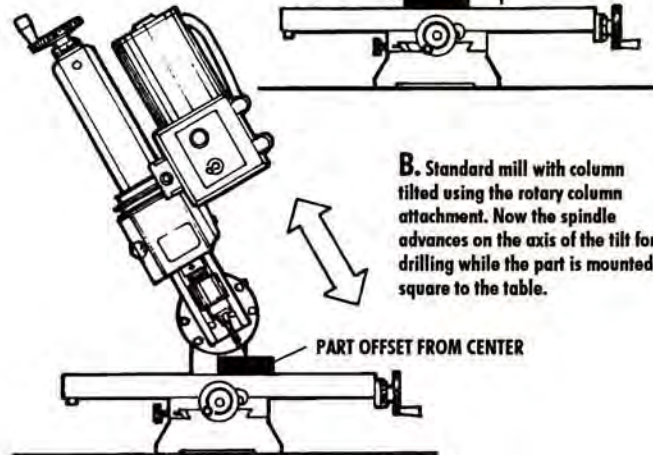
Full size milling machines have the spindle mounted in a "quill" which advances the cutting tool from the headstock. This allows a hole to be drilled on an angle because the quill can be used to move the spindle in and out to drill a hole while the headstock is angled to the side. When the quill is moving at an angle, the Z-axis is not moving. The table can still be raised and lowered on the Z-axis by a leadscrew

that actually raises the entire saddle on which the X- and Y-axes are mounted. With the headstock mounted on an angle, a standard Sherline mill couldn't be used to drill a hole unless the spindle could also be moved on its own axis. Therefore, the standard Sherline mill can only drill and bore angular holes by clamping the work on an angle, because, without a quill to advance the cutting tool, the angle has to be in relation to the movement of the vertical column. This can cause a problem because many large parts are difficult to clamp on an angle. A better setup would be to have the work clamped directly to the table and then tilt the column to the appropriate angle. It would even be easier to use if the angle could be read directly from calibrated graduations. This was the goal in the design of the rotary column attachment.

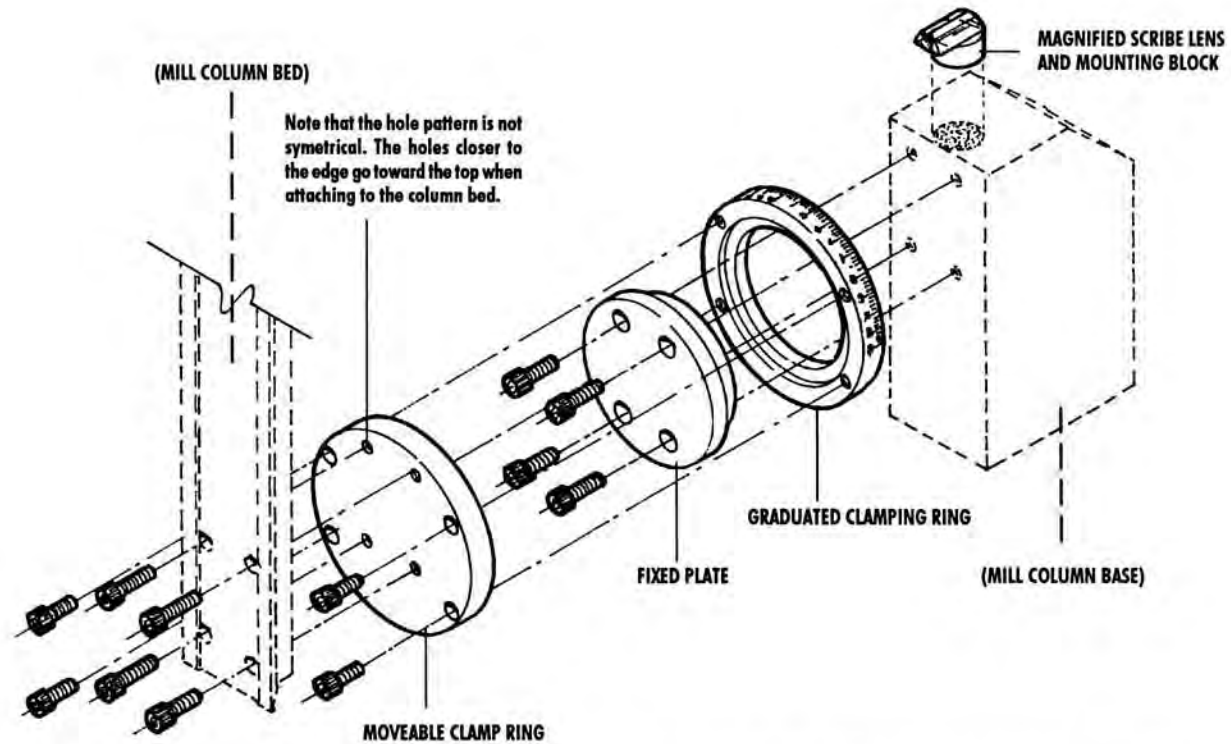
**A.** Standard mill with headstock tilted. The "Z" axis handwheel cannot advance the drill at the proper angle. However, angled milling can be accomplished.



**B.** Standard mill with column tilted using the rotary column attachment. Now the spindle advances on the axis of the tilt for drilling while the part is mounted square to the table.



Here is why drilling at an angle doesn't work on a standard Sherline mill. A) The angled headstock moves up and down on Z-axis only. The drill tip cannot be advanced on the spindle axis. B) On the tilted column, the headstock moves on the axis of the spindle to allow drilling. Note that the part needs to be offset from center on the X-axis to align with the new axis of the column.

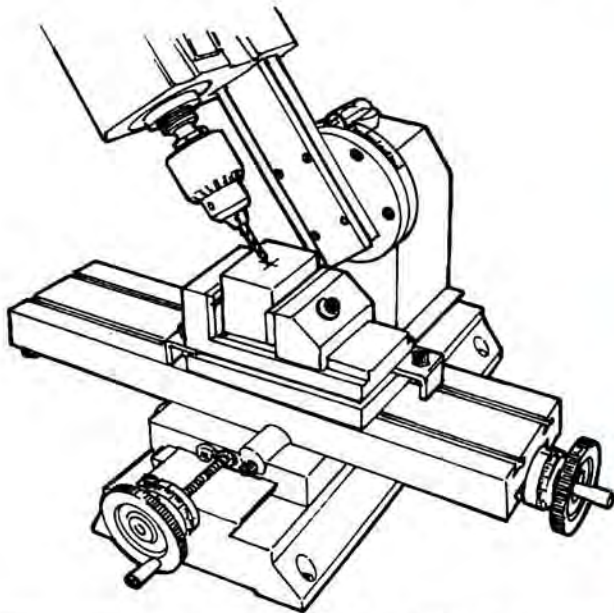


*An exploded view of the rotary column attachment shows the relationship of the parts.*

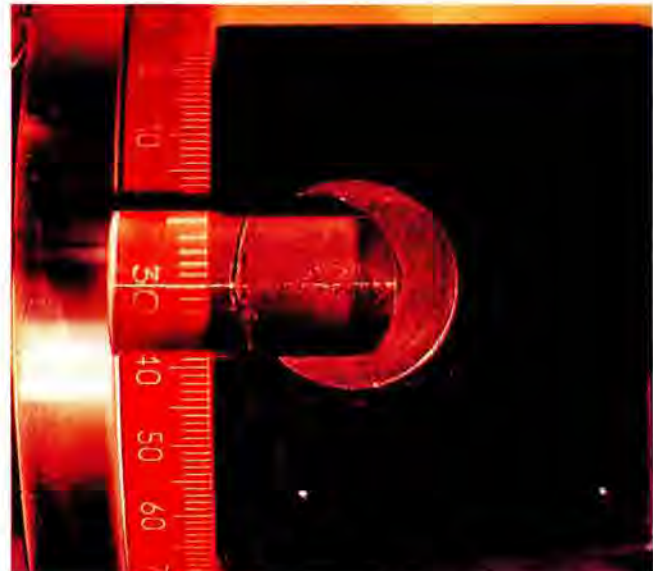
**Installing the rotary column attachment to open up more machining possibilities**

With the rotary column attachment angle drilling becomes possible because the entire column can be tilted on an angle along the X-axis (milling table).

The attachment is easy to install. It is only about .7" (17.8mm) thick, so it can be left on the machine as a permanent addition. The drawing above shows the order in which the parts are installed. The scribe lens block is simply glued to the column base.



*Tilting the Z-axis column makes drilling an angled hole easy. The calibrated adjustment ring and magnifying sight on the "zero" scribe line make setting an angle easy and quite accurate. The column can be rotated up to 90° in either direction.*



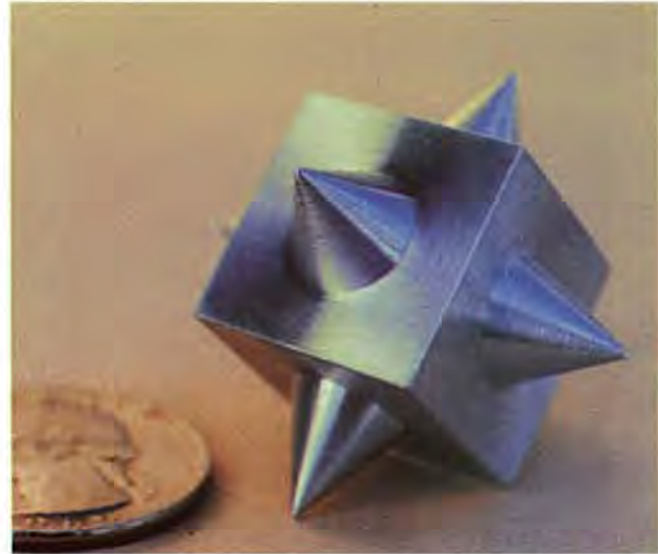
*The calibrated adjustment ring and magnifying sight on the "zero" scribe line make setting an angle easy and quite accurate. Here a 30° angle is set for drilling into a block mounted square to the table. Angles up to 90° on either side of vertical can be set using the calibrations on the adjustment ring.*

### Why “pinning” the column is not recommended

I don't recommend “pinning” the column in place with a dowel pin. This arrangement causes more problems than it eliminates. When a dowel pin fits the hole tightly enough to be considered accurate, the dowel pin is very difficult to remove. If it's loose enough to be easily removed, it's not accurate enough to do you much good. Most full size milling machines do not use any pinning methods to square up their heads because it is just not accurate enough. Each time the column is returned to the vertical position it should be “indicated in” using a dial indicator to make sure it is square with the table.

### Other accessories

Use of part holding accessories like the milling vise, tooling plate, hold-down clamps, tilting angle table and chucks are covered in chapter 1 of this section. The rotary table and indexing attachment are covered in chapters 4 and 5. A discussion of milling cutters like end mills, flycutters and boring tools is in Section 1, Chapter 6.2 and 6.4.

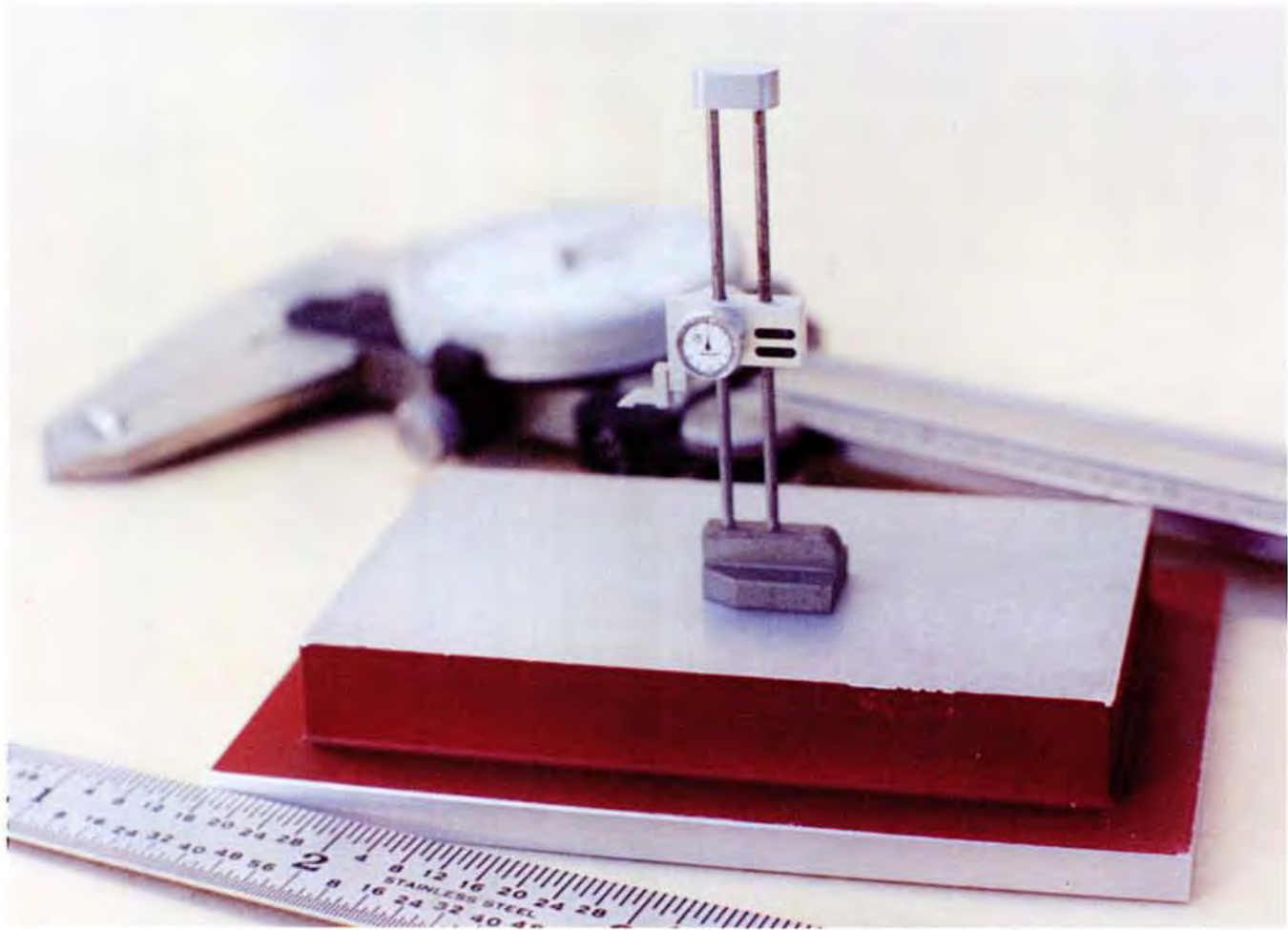


*Not everything you make has to have practical value. Sometimes it's fun to make something just because it looks cool. This interesting shape was generated by Dick Saunders of Manchester, Iowa. Dick also uses his tools to make jewelry, among other things.*



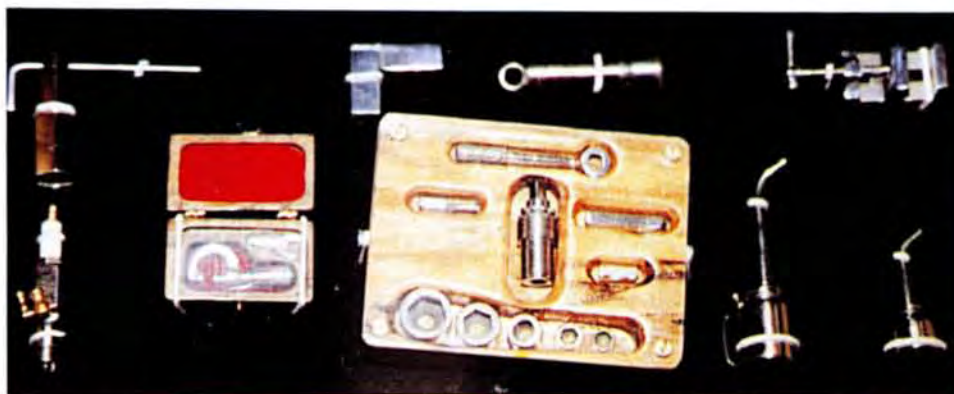
*Master modelmaker Phil Mattson (above) uses a miniature mill and lathe to make gears, pulleys, deck guns, winches, port lights, antennas, hinges and other ship deck details.*

*The quality of the Lady Dee shown at the left is enhanced by the use of many of small, custom made deck details. (Unfortunately, the builder did not put his name on the photo.)*



*Many people enjoy making small models of tools found in the shop. Kurt Schulz of Harper Woods, Michigan modeled this miniature height gage and surface table.*

*(The surface table was inadvertently photographed upside down.)*



*Here are some more miniature tools by Dennis Scherf of Cedarburg, Wisconsin. The tool set above contains a spark plug and wrench, micrometer, socket set, drill press vise and oil cans. (A more detailed shot of the micrometer can be seen on page 11.) At the right is an oxy/acetylene welding rig. Dennis builds models for friends in different trades.*



## SECTION 4—OTHER MACHINING TOPICS

Craftsman Profiles—Dan Lutz and Paul White—  
Two aircraft modelers with totally different  
approaches to their hobby . . . . . 242

1. Setting up a small workshop . . . . . 247
2. Lathe and mill adjustment and maintenance. . . . . 251
3. Engineering drawings . . . . . 259
4. Frequently asked questions . . . . . 265
5. Making a business out of a hobby...Joe Martin's  
and Sherline's story . . . . . 273
6. CNC in the home shop . . . . . 309



*Model airplane craftsman and model engine restorer Dan Lutz built this amphibian. For a look at his extensive antique model airplane engine collection and spacious shop, see the following Craftsman Profile.*

*Paul White is a friend of Dan's and another aircraft modeler, but two people couldn't approach the same hobby in more different ways. Paul's tiny mobile home shop turns out an amazing variety and quality of models, and his background is a story in itself. His profile follows Dan's as a study in contrasts.*



## DAN LUTZ...Restoring collectible treasures



*(Left) Dan Lutz's spacious shop has plenty of room for his restored Fords and flying models. The wide aisle and clean, flat floor make wheelchair access easy.*

*(Below) Dan at his workbench. A window, plenty of light and lots of room make this a pleasant place to spend time. A small floor heater takes the chill off in wintertime.*

Walking into Dan Lutz's large Fallbrook, California, shop is like walking into a museum. Down one wall are three beautifully restored Ford automobiles dating from the 1930's. Hanging from the ceiling is a collection of masterfully built model aircraft ranging from small free-flight models up to a quarter-scale biplane. Cabinets contain collections of newer collectible model aircraft engines and the wall sports posters for car shows and ads for old model airplane engines. Inside the house, packed into one oak display case, is what now occupies most of Dan's time and interest...an impressive collection of very rare vintage model airplane engines and several cast aluminum gas engine powered race cars.

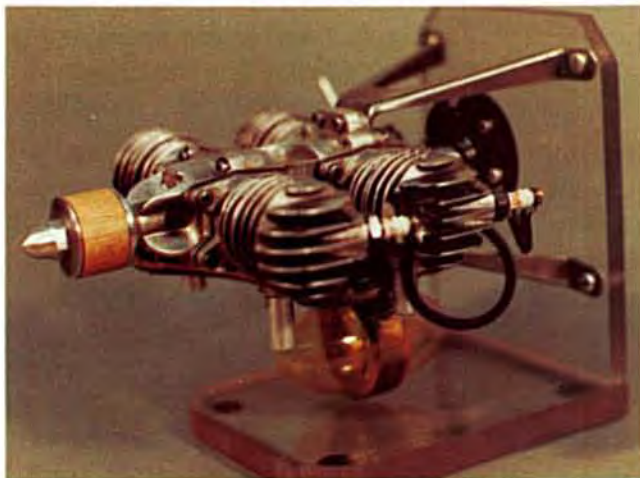
For many years Dan has been collecting and restoring these engines. In many cases this means buying an old engine at a garage sale or swap meet and making from scratch all the parts that are missing. Most of these engines are very rare, and spare parts are simply not available. Dan works from old ads, magazines and photos. When possible, he borrows a complete engine from another collector and then measures and duplicates each missing part.

His spacious shop is not overflowing with tools. He has a miniature lathe, a modest selection of



accessories and a few other small shop tools. All are set up on a simple bench where everything he needs is easily accessible from his wheelchair. The auto accident in 1983 that left Dan a paraplegic did not dampen his spirit for modeling or reduce the quality of his craftsmanship. All it did was scale down the size of his projects. Instead of restoring cars, now he restores miniature aircraft engines. In fact, after his accident and therapy, he took on the project of building the impressive quarter-scale biplane. The completion of that project restored much of his confidence. He says, "I figured if I could build that, I could do just about anything I needed." Looking at the extent of Dan's collection and the quality of his work, there does indeed seem to be nothing he can't do.

## Project: Model Airplane Engine Collection



*Clockwise from above: A rare ELF-4 from 1941 called the "Goose Egg". Less than 60 were built. Dan with the ELF-4 along with his impressive collection of engines. The engine collection also includes some attractive aluminum race cars. Another rare ELF-4; this one known as the "Pipe Model". Again, less than 60 were made. A Trojan Junior .19 cubic inch engine from 1938. Dan scratch-built a number of components to restore the engine to its original condition.*



## PAUL WHITE...A prolific craftsman driven by challenge



*Paul displays work spanning sixty years of modeling from 1938 to 1998. In one hand is a plane similar to his first rubber powered flying model. In the other is his latest scratch built jet engine. Working on real race cars and aircraft has taught Paul many skills. While crashing a model is always an unhappy event, the results of a mistake on the real thing can be much more serious. The motto on his shop wall says, "Don't get in a hurry!"*

Paul White and Dan Lutz are friends, but unlike Dan's shop, Paul's will never be confused with a museum. In fact, he is in no danger of *Good Housekeeping* suddenly bestowing their "Seal of Approval" on his shop. It is probably as cluttered and cramped as any you will ever see. As Paul says, "At least everything is within arm's reach." The difference between Paul's shop and most others, however, is in the quality, quantity and variety of the work that comes to life here.

From the outside, Paul's mobile home looks pretty much like the others that line the rows of the neat park which overlooks Vista, California and the distant mountains. Step inside, however, and you are greeted with a decor that could best be described as "work in progress". You must practically turn sideways to edge down the aisle between completed and partially built model aircraft parts to reach his shop at the end of the coach. A towel hangs across the entrance, and as you push it aside, you enter the shop of a man driven to create. Paul never stops or even slows down, and putting away tools is too much of a distraction to the work at hand. On the bench is a scale T-38 jet model that nears completion. A ducted fan engine is on another bench ready to go into the plane. It will power the model to speeds of

around 230 MPH. A scratch-built landing gear assembly for a carbon fiber model U2 spyplane, including working brakes, suspension and gear door actuators sits on the work area. Also on the bench is a model jet engine that Paul built from scratch.

The precision required to build a jet engine that will actually run is pretty much beyond the skill level of most modelers, but Paul has done it. From the hand shaped turbine fins to the molded carbon fiber inlet and "cold" end components, he made every piece. The amazing thing is that what might take other modelers years, Paul completes in days or weeks. When he starts on a project, he dives in with an intensity that shuts out all else. Being a bachelor, his schedule is his alone to set. He will often work twelve hours or more a day on a project that has his interest.

Paul's background is far from ordinary. He started out with model aircraft as a kid, building a rubber band powered aircraft at age eight. He went on to build full size race cars and airplanes. He worked in Dan Gurney's race car shop in the 1960's. They built 25 to 30 IndyCars and 5 or 6 Formula One cars one year. He helped build the only Formula One car ever made in America and driven by an American driver to win a Formula One race—Dan Gurney's Eagle.



*For those who might have been intimidated by some of the immaculate and spacious shops shown elsewhere in this book, Paul's shop offers hope. Despite the cramped size and cluttered work surfaces, so much good work comes out of this shop that Paul just never seems to find the time to clean up.*



He also built or worked on cars for Lloyd Ruby and several other Indy legends. Recently, he resurrected the old 1974 Frank Fiore designed "Spyder" IndyCar that is now raced by Joe Martin under Sherline sponsorship in vintage sports car races.

Paul has also built fifteen full-size aircraft, and some very special ones at that. Two of his planes won the "Grand Champion" award at the EAA (Experimental Aircraft Association) meet in Oskosh, Wisconsin in 1974 and 1978. In 1975, an aircraft he helped build for Phil Kraft called "Superfly" won as best aerobatic aircraft. He also restored a racer called "Shoestring" which was the first aircraft to turn a 250 MPH lap at the Reno Air Races.

Paul's miniature machine tools are about as beat up looking as any you will ever see. If there were ever an example that it is the craftsman who produces the work and not the tools, here it is. In the end, you are judged by the work that comes out of your shop, not by the neatness of your bench, and, in that regard, Paul's "Vista Skunk Works" turns out work that ranks with the best anywhere.

*(Above right) The custom designed and built U2 is made from carbon fiber and has a 10-foot wingspan. (Right) The completely home built jet engine turns at 120,000 RPM and sits on a detailed display stand.*

#### Project: Carbon fiber U2 spyplane



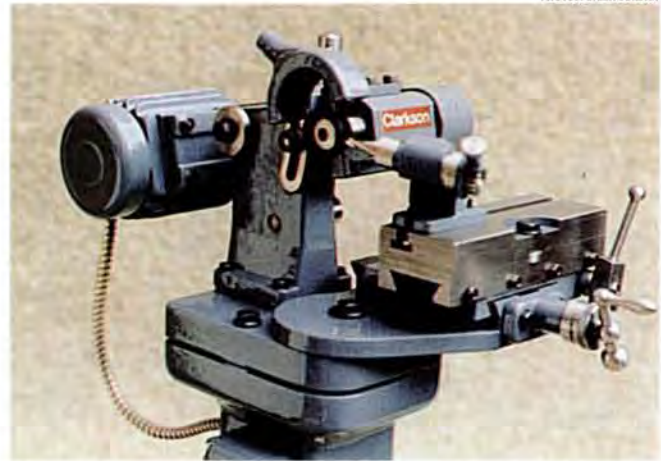
#### Project: Scratch built jet engine



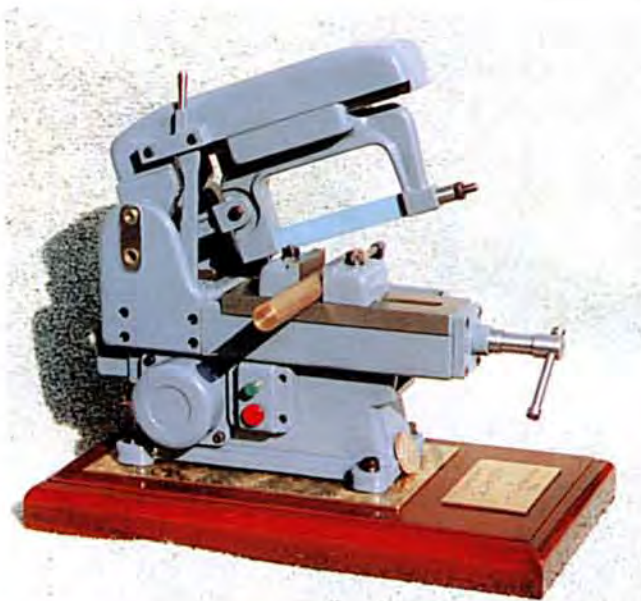
# Barry Jordan's Miniature Machine Shop

PHOTOS: BARRY JORDAN

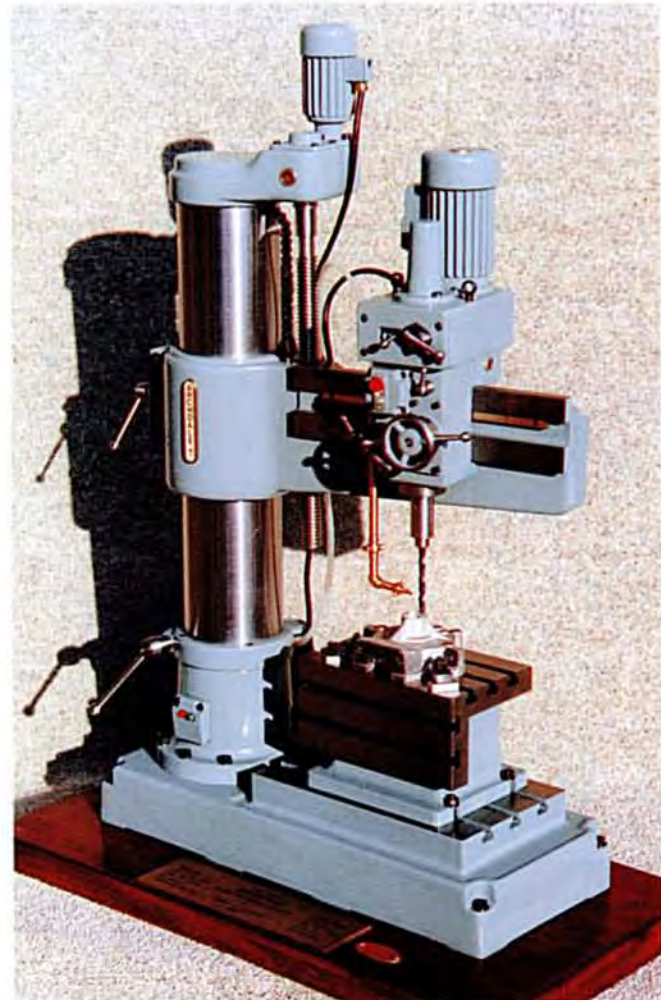
Barry Jordan of Derby, England modeled the Bridgeport® mill shown on page v plus these other 1/5 scale tools. He machines every part from solid stock rather than making castings. His models have won several prizes in model engineering exhibitions in England. The Clarkson grinder shown here won second prize (Class 7) at the Midlands exhibition and a silver medal (General Engineering) in the International show, Olympia, London. It was built in 1998.



(Left) Barry Jordan is shown with his 1/5 scale Clarkson Mk. 1 tool and cutter grinder. Above is a close-up that shows some of the model's fine detail.



Barry's most recent model is this Qualters & Smith "Sawmaster" 6-inch power hacksaw.



Barry's Archdale Type HM50 radial arm drilling machine, also built in 1998, has won three first prize awards in model engineering contests so far.

## Chapter 1— Setting up a small home workshop

### Small size opens up many possibilities

One of the best things about working in miniature is that you can have a workshop that doesn't take up much more room than a standard office desk. In fact, an old desk will work just fine. Sherline has many customers who could afford to buy the most expensive tools available today, but they chose to work with miniature machine tools because they have limited space. I also like to think they like the quality and design of our tools and don't just buy them because they are small and relatively inexpensive. You can't put full size machines in a high rise condo or apartment, but you can put a great miniature machining workshop together in that spare bedroom that isn't being used. We often use the example of using your machine on the kitchen table if need be. Machining doesn't have to be any more messy than cooking.

We show some pictures in this chapter of people's home shops. At the beginning of each section in this book is a feature on a particular craftsman. Most of them show the shop where these machinists turn out world class work. You will notice that not much in the way of space or accommodations is required when it comes to setting up a miniature machine shop.

### Working in comfort makes it more fun

You can sit down and run Sherline machine tools, but I prefer to have the tools on a bench while I sit on a drafting stool. That way I don't have to bend over so far if the need arises to view the work from a different angle. I have a small shop vacuum handy to suck up the chips produced in the machining process. If you are new to working with tools try to get in the habit of putting things away as soon as you are through with them, or at least once a day. In other words, don't be like me. Sometimes I feel like an archeologist when I'm looking for a part I just spent two days making; however, I am improving. For my own shop my next purchase is going to be one of those beautifully built wooden tool boxes. I've always wanted one, and before this year is over, I'll have one.

One of the nice things about having a shop at home is that it can be a place for your friends and modeling buddies to hang around and shoot the breeze or help



*Author Joe Martin's home workshop is in his garage. It features plenty of bench and storage space and indoor/outdoor carpet on the floor to make it easier on his legs and feet. He prefers a bench height work surface and a stool for sitting. A garage shop should be heated if you live in a cold climate or you'll end up spending little time there.*

with projects. Leave room for a few comfortable chairs and a coffee pot. Unlike a machine shop business where money is made by the hour and casual conversation or "BS sessions" are discouraged during working hours, there is no time clock to be punched in your home shop. Make it a place where you look forward to spending time, and if you like having friends around while you work or plan, make room for them too.

### **Building your tool collection**

For a machinist, collecting tools can be just as rewarding as collecting art or porcelain figurines is for someone else. Finding small, specialized tools at a swap meet early on a Sunday morning makes my day. There is something about acquiring tools in this manner that gives your collection meaning, and I enjoy it.

One Sunday I came upon a retired machinist selling his tools at a swap meet. It was a sad day for him. He was being asked to give up the tools of his trade to watch television for the rest of his life because his wife didn't want him making a mess around the house. I wish more retiring craftsman would turn their trade into a hobby when they retire and work in miniature. They may not wish to put up with the day to day rigor of their chosen trade, but the urge to build and create doesn't just go away when you hit age 65. What craftsmen have really learned in their trade is "how to get a job done". They can take the skills they have acquired over a lifetime and put them to work having fun. A true craftsman has to build and create things, just like an artist, in order for his life to have meaning.

The good part of the story is that I came home with a bunch of small fixtures that the machinist had built

PHOTO: FREDERICK POPE



*Frederick Pope of Ft. Meyers, Florida makes model ships in his garage shop. He has a bench height work surface but has built a special dropped section to hold the lathe so he can sit in a regular chair while working. As you can see, in Florida an air conditioner is a more important consideration than a heater if you want to work in your shop year around.*

PHOTO: TIM SCHROEDER



*Tim Schroeder of St. Joseph, Michigan has taken organization to an extreme in his shop. Notice also the base for the lathe has handles on the ends to make it easier to move. The work surface is metal and the backsplash keeps small parts that roll away from falling down behind the bench. Accessories are mounted on a wall board where they take up little space and can be easily reached. All wiring is bundled and kept neatly out of the way. Drill and hole size charts adorn the walls.*

for himself over the years. I didn't need his standard tools, for those I already had, but it's the "bits and pieces" that make machining easy and fun. These are the things that can take a long time to accumulate. For me, a workshop will never have enough tools, and I'm fortunate to be able to buy tools not only for my home shop but also for my "big workshop" at Sherline Products.

### **Let there be light...and plenty of it**

Lighting is just as important as any tool in a good workshop. You have to be able to see clearly what you are working on. The smaller the work and the older the eyes the more important this becomes. Take the time to install a couple of lighting fixtures in the right place right from the start. An overhead fluorescent "shop light" fixture gives good overall light and a flexible halogen or other small spotlight type light is good for shining right on the workpiece. If you are working in a bedroom or kitchen and can't add a fluorescent fixture, make sure the lights you do have offer enough wattage to throw plenty of light on your working surface. Change light bulbs to a higher wattage if you have to.

### **Don't work in a cold, damp dungeon**

I have the concrete floor in my shop carpeted with "indoor/outdoor" carpeting. It didn't cost much and chips are surprisingly easy to vacuum up. It is easy

on the feet too. Putting a workshop in a unheated garage in an area that has cold weather is a good way to never get anything done. Doing work like this should be a pleasant experience. Don't suffer, make it easy. If you are a television addict, make room for a TV on the bench along with your tools so you don't have to miss your favorite shows. There aren't any rules on how one goes about building a spot to work in when it is for pleasure. Do it your way.

#### **Getting material to rough size for machining**

The quickest way out of this hobby is to start off trying to cut off a short piece of 2" (50mm) bar stock with a dull hacksaw. If you are going to work with metal you have to have a way of cutting stock to approximate size before starting. This can be a very unpleasant task even with a sharp hacksaw. Fortunately, the discount import tool companies sell a powered band saw type cutoff saw for less than \$200 (1998). For the price they can't be beat. Cutoff



*A small band type cutoff saw is a great timesaver in a home shop. Imported ones are amazingly cheap and save you the drudgery of cutting stock to machinable size with a hacksaw.*



*A bench grinder is a necessity for sharpening and shaping tools. It generates highly abrasive dust and should be kept away from your good tools.*

saws don't have to be in the workshop near you. They can be out of the way with the bar stock you'll probably acquire. A cold garage can be just fine. You won't be using it all that often, so it doesn't need to be located right next to your workspace. What I like about this type of cutoff saw is that it can be tipped to a vertical position and used like a standard band saw. It really is a must for metal workers.

#### **You'll need a way to grind tools and deburr parts**

Another basic tool that is required is a shop grinder. (See "Grinding your own tool bits" on page 77.) Under no circumstances should you ever operate a grinder without eye protection! Sharpening and reshaping cutting tools is a basic operation of machining. Don't buy one so small it makes tool bit grinding difficult. Look closely at the quality of the tool supports and how easy they are to adjust. A grinder mounted on a pedestal out by your cutoff saw will keep your immediate work area free from the grinding dust which seems to find its way into everything. Another tool that I find very useful is the small one-inch wide belt sanders that have recently become available to the home hobbyist. They are great for deburring rough stock, and I keep finding new uses for mine.

#### **Rust is your enemy**

A can of WD40 or similar rust preventative should always be handy to keep your tools from getting rusty. If you find a spot of rust forming on a tool take the time to clean it off immediately with a Scotchbrite™ or similar abrasive pad. Having to



*A small belt sander is an excellent tool for deburring edges. You'll find many uses for it once you have one. A hand-held rotary grinder is a very handy piece of equipment to have on hand as well.*

work with rusty looking tools takes the fun out of it. Tools should be a little oily to keep them rust free.

#### **Buying cutting tools by phone or mail**

Very few people will live in an area that has cutting tools available where they can drive to the store and buy them as they need them. You'll waste a lot of time and energy discovering these items are not stocked in your local hardware store. Find a mail order industrial supplier for cutting tools and a company that sells metal by the foot through mail order. Before starting a project, figure out what you need and order it before you start. I'm sure you have heard horror stories about people ordering from mail order companies, but these weren't industrial supply houses. I've never ordered from an industrial supply house that has given me such bad service that I wouldn't order again from them. When I first moved from the Los Angeles area to North San Diego County I became very frustrated because I couldn't run out to the store and buy what I needed. I soon realized that I could order whatever I needed and have it the next day, if needed, by using these

companies. Now I don't waste any time driving around trying to find a left handed tap, for instance, that could be easily ordered from a mail order house.

#### **Inspecting and storing finished parts**

Have a special place in your shop to inspect parts and keep parts or projects that have been completed. I found if you have a complex project to do and you start working on too many things at the same time, frustration builds up, and you get the feeling you'll never get the job done. By completing the individual parts one at a time, inspecting them and putting them in a special place you feel like you are making some progress. Completion of the project then seems possible.



*In Joe's shop, an area is set aside for measurement. Keeping delicate gages separate from the dust and chips of the work area makes them easier to keep clean. The area should be very well lit so that small imperfections are easy to spot.*

#### **Using teamwork to complete complicated, long term projects**

One of the things I would like to see take place in the future is a group of home shop machinists taking on complex projects as a group to build items for museums or for sale to collectors. I believe completing projects on a time schedule with a group of other talented people would give some people the interaction that may be missing after one retires. In the future, the use of the fax machine and the World Wide Web will give us all a way of communicating to allow this to happen. Let's face it, your fellow builders aren't likely to live in the same city with you, never mind next door. However you may chose to pursue this hobby, it should be rewarding, or, better yet, just plain fun.

## Chapter 2— Tool adjustments and maintenance

### Keeping your machine in shape

Regardless of size or cost of machine tools, they will need adjustments to remain accurate. A tight tolerance part will require a machine that has been properly adjusted before starting a cut. The short travels of tabletop machine tools may make your job easier. A 1" (25mm) long cut that is .0005" (.01mm) off may well be within the tolerance of the part. That same degree of accuracy on a large machine making a 12" (305mm) long cut would put you .006" (.15mm) off at the end of your cut. This would be unacceptable. Adjustment procedures are similar regardless of the size of the machine. Make this a priority to keep your machine in adjustment.

### ALIGNING THE LATHE HEADSTOCK AND TAILSTOCK

#### A minor compromise to gain versatility

The versatile feature of Sherline machines that allows the headstock to be removed or rotated for taper turning and angle milling can keep the headstock from perfect alignment. Precision ground alignment keys are now used to make the machines accurate. In standard form, alignment should be within .003" (.08mm). This should be more than acceptable for most jobs you will attempt.

#### Maximizing accuracy

Rather than talking of "perfect" alignment, machinists speak instead in terms of "tolerances", because no method of measurement is totally without error. We believe the tolerances of your machine are sufficient for the work for which it was intended; however, for those searching for more accuracy, here are some tips for improving the accuracy of your machine.

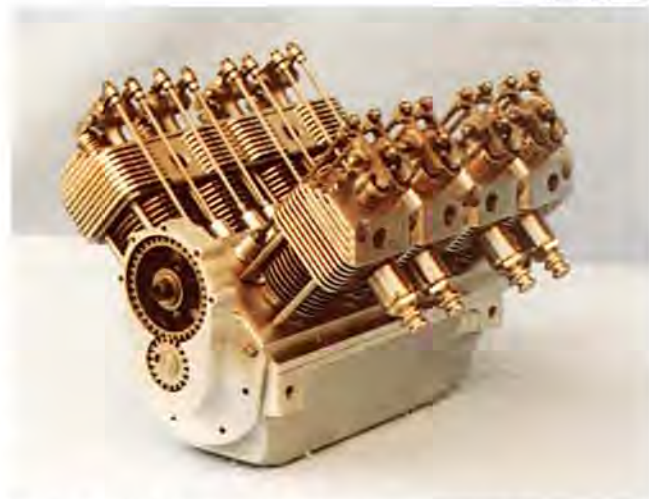
Loosen the headstock, push it back evenly against the alignment key and retighten. This will assure factory settings. To achieve greater accuracy, you would have to sacrifice one of the better features of your lathe or mill; that is, the ability to rotate the headstock.

**HEADSTOCK**— To improve headstock alignment the headstock must first be perfectly aligned and locked in place. First the headstock has to be aligned

to the bed of the lathe, not the tailstock. Remove the headstock and clean any oil from the alignment key and slot and from the area of contact between bed and headstock. Replace the headstock, pushing squarely against the key and retighten. Take a light test cut on a piece of 1/2" to 3/4" diameter by 3" long aluminum stock held in a 3-jaw chuck. Use a sharp pointed tool to keep cutting loads low so as not to cause any deflection of the part. Measure the diameter of both machined ends. If there is a difference, the headstock is not perfectly square. Now, without removing the key, tap the headstock on the left front side with a mallet if the part is larger at the outer end. (Tap on the right side if the part is larger at the headstock end.) You are trying to rotate the headstock ever so slightly when viewed from the top until the machine cuts as straight as you can measure. There should be enough movement available without removing the key, as its factory placement is quite accurate.

Take another test cut and check. Repeat this procedure until you have achieved the level of perfection you seek. Then stand the lathe on end with the alignment key pointing up and put a few drops of Loctite™ on the joint between key and headstock. Capillary action will draw the sealant in, and when it hardens, the key will be locked in place.

PHOTO: ERIC WHITTLE



*Complicated projects with many parts that must fit and work together require tight tolerances. This 1/9 scale V-8 engine is only 4" (10.16cm) long and was built by Eric Whittle.*

We prefer this method to “pinning” the head with 1/8" dowel pins, because it offers you the option to change your mind. The headstock can be removed by prying with a screwdriver blade in the slot between the bottom of the headstock and the lathe bed to break the LocTite™ loose the next time you wish to rotate the headstock.

**TAILSTOCK**—Once the headstock is aligned with the bed, the tailstock can be aligned with the headstock. First make sure that there are no chips caught in the dovetail of the bed and the tailstock spindle taper is free from chips or dents. Now put a 6" long piece between centers and take a long, light test cut. Measurements at either end will tell you if you need to make an adjustment. A light tap from a mallet to the appropriate side of the tailstock may bring your tailstock to acceptable tolerances. Disengage the tailstock from the aligning shaft (your workpiece) before using the mallet. Another choice is using an adjustable tailstock tool holder in the tailstock to achieve better tailstock alignment. We manufacture adjustable tailstock tool holders and an adjustable live center which can help you attain near perfect alignment at the tailstock should your job require it.

Remember that unless you drill very small holes (less than 1/64") or turn a lot of long shafts, locking your headstock in position means you are giving up a very useful feature to solve a problem which can usually be handled with a few passes of a good mill file. The inaccuracy inherent in any drill chuck is such that perfect machine alignment is meaningless unless you use adjustable tailstock tool holders.

---

### ADJUSTABLE TAILSTOCK TOOL HOLDERS

#### **When you need alignment that is dead-on**

For most jobs you do, the factory alignment of your lathe will be sufficient. When you need alignment between headstock and tailstock that approaches “perfection”, the final adjustment can be made at the tailstock end using these simple tools. There are versions for the Sherline lathe which hold a live center, a drill chuck or a bushing which you machine to hold a tool of your choice. In every case, they are adjusted the same.

The principle is simple. One half holds the tool, the other half mounts to the tailstock spindle. A flange on the end of each half mates in the middle. The mounting holes have just enough clearance that the



*Adjustable tailstock tools make it possible to attain alignment between headstock and tailstock that approaches perfection. Alignment errors are reduced to the point where your ability to measure them becomes the limiting factor.*

front and rear halves can be adjusted slightly in relation to each other, allowing you to compensate for minor misalignment between head- and tailstock. Complete instructions can be found for their adjustment beginning on page 142.

---

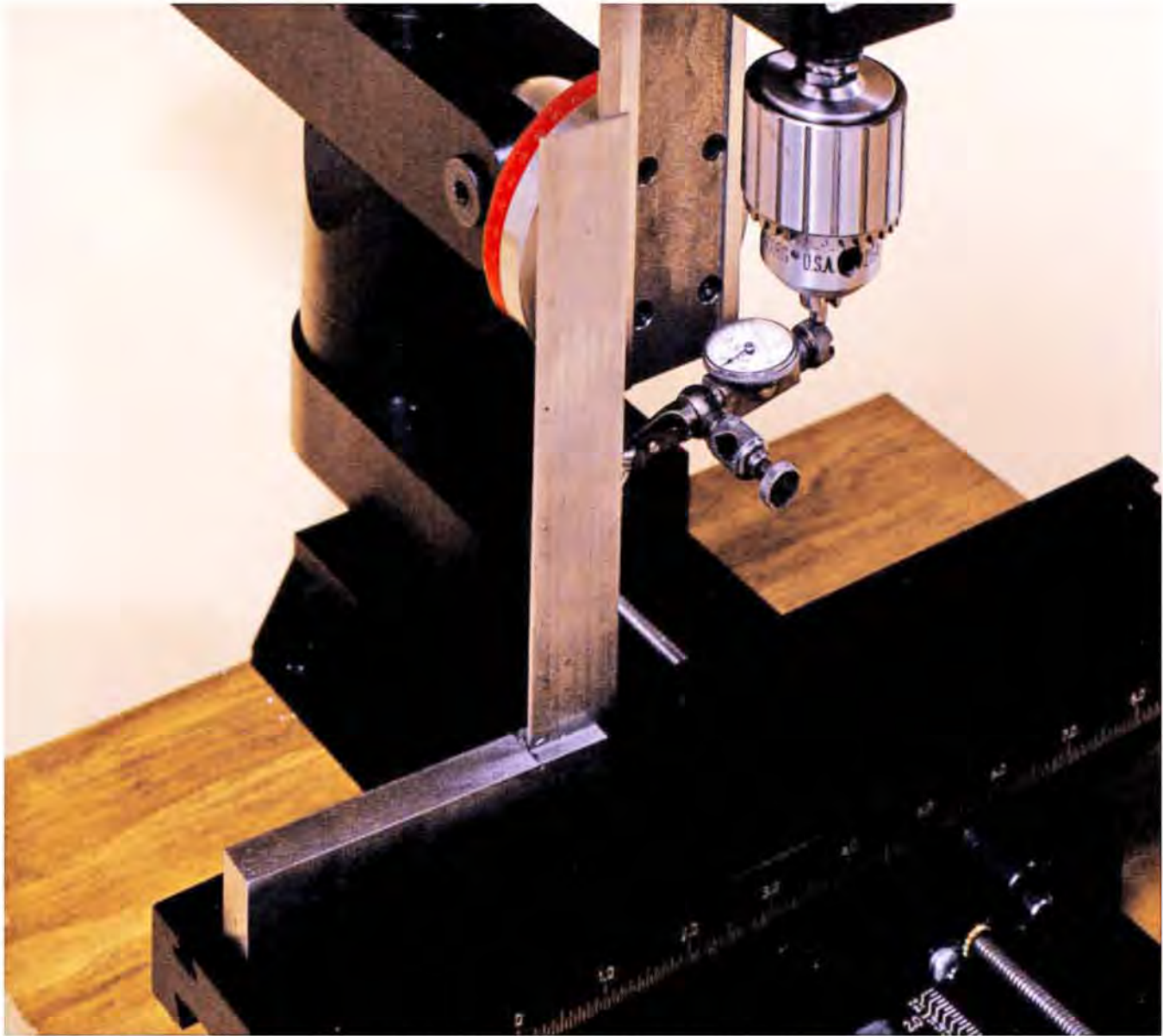
### SQUARING UP A MILL

#### **Size and price don't matter**

For many jobs, the factory alignment of your mill will be sufficient. When you want “perfection” in mill alignment, the ball game changes. This is true whether you are working with an inexpensive Sherline mill or a big \$20,000 shop mill. You can't expect to work within tolerances of .001" unless you have your machine square. On the Sherline mill a few shims and a dial indicator should get your machine square if you have something square to work to, preferably a small precision square. There is no adjustment for the X-axis in relation to the Y-axis, but these have been accurately machined at the factory. The vertical slide should be square with the table and the head and spindle should be square with the vertical slide. Remember that the size of the part has a lot to do with how square the machine has to be.

#### **Checking the table for flatness**

The first place to start to align your Sherline mill is to run an indicator on the work table to check for flatness. Move the “X” and “Y” axes independently to determine any error. These errors can be easily



*Checking the vertical alignment of the column bed against the sides of a known square part.*

eliminated with shims so the work runs perfectly true. Normally, this isn't necessary, but we are talking here about "perfection".

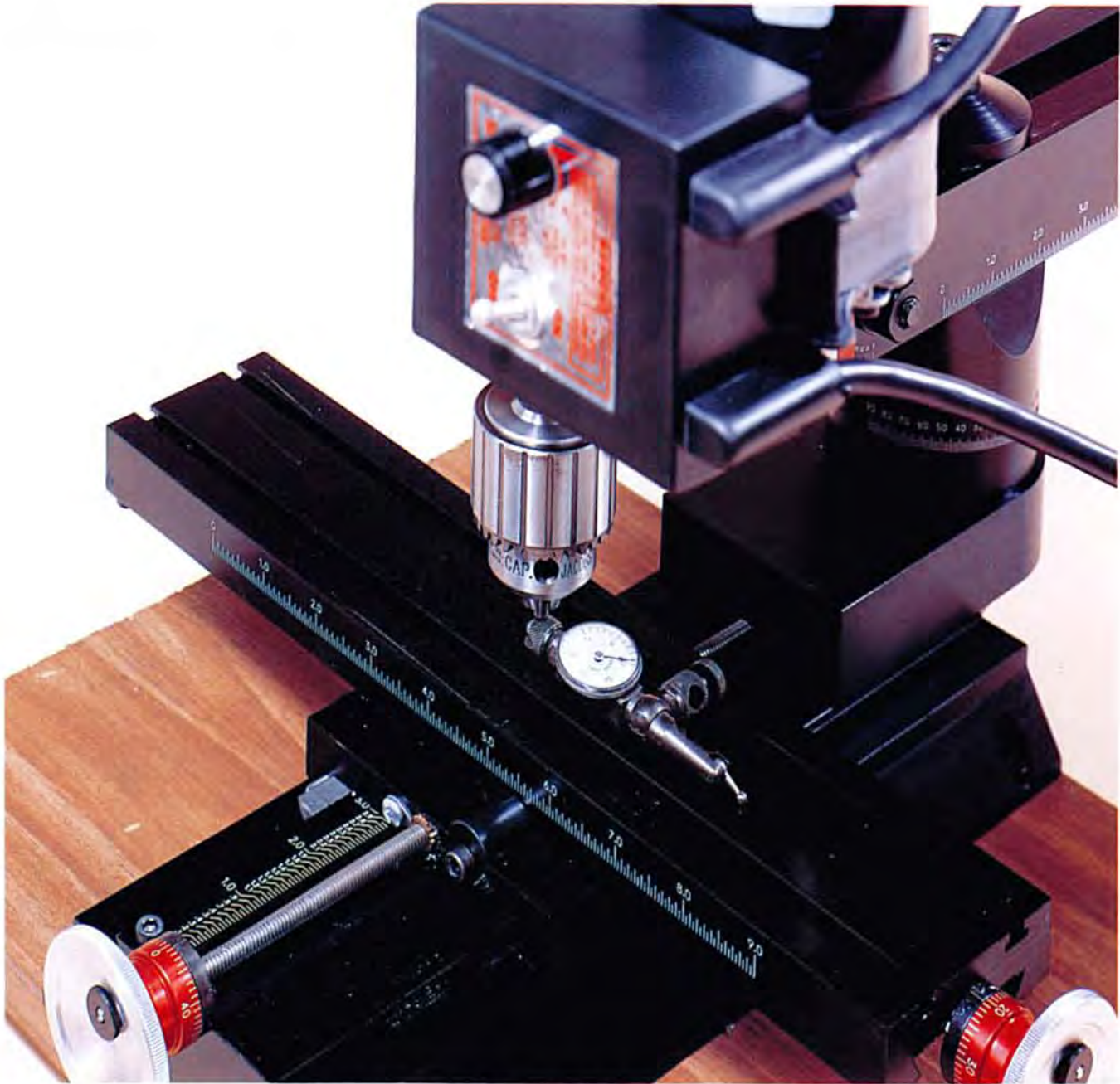
#### **Align the vertical bed**

To align the vertical bed with the X and Y slides, mount something to the table that you are sure is square. With an indicator mounted to the head, move the head up and down a couple of inches with the indicator reading a known square that is set up to read in the X-axis direction. With the four screws that hold the steel bed to the column block, adjust the bed until there is a minimum indicator movement. The Y-axis direction can be corrected with a shim between the column block and the mill base using the same method.

#### **Align the head with the rest of the machine**

With the vertical bed aligned with the base, the head can be aligned to the rest of the machine by "sweeping" the head in. The rotary table will also give a good surface to indicate in. Clamp the indicator in the spindle as shown in the photos. The head should be fairly square but can be improved upon by using the slight amount of play on the alignment key to square it up on the X-axis and a shim between the head and saddle (if needed) on the Y-axis.

Most jobs can usually be done without going through the process outlined above and using the machine as it comes. I'm only trying to educate you to what it takes to work at a precision level of machining.



*Using the indicator against the table, align the head with the rest of the machine. The indicator is rotated to either side to check the Y-axis. Then the table can be cranked forward and back with the X-axis handwheel and the spindle again rotated to check fore and aft alignment with the indicator.*

No toolmaker worth his salt would attempt to build a close tolerance part without first squaring the spindle of his vertical mill.

### **SADDLE NUT REPLACEMENT**

#### **First of all, are you sure that's really the problem?**

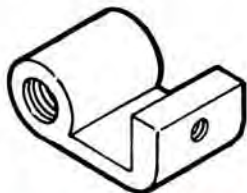
Before replacing the saddle nut, make sure that any excessive backlash you are experiencing is not caused by a loose adjustment between the leadscrew handwheel and its thrust support. If this

is the case, loosen the set screw and index the handwheel 1/3 turn so you don't pick up the old set screw mark. Push the handwheel and the leadscrew towards one another and tighten the handwheel set screw.

#### **About the Saddle Nut**

The saddle nut is made of brass and designed to be an easily replaced item. It is drilled and tapped to match the Sherline lathe and mill leadscrews which are 3/8-20 left-hand threads (Metric: 10mm x 1mm

L.H.). The reason they have a left-hand thread is so that the slide will move away from the operator when the handwheel is turned in a clockwise direction. This is standard practice for machine tools, small or large.



### Replacing the Lathe or Mill Saddle Nut

Remove the headstock/motor assembly. (Refer to the parts diagrams on pages 328 and 329.) On the lathe, remove the bed by removing the 10-32 socket head screws (P/N 4051) from the inside bottom of the lathe base. These two screws hold the bed to the base. Be sure to note washer placement on these screws during disassembly. It is important that they are reassembled the same way, as the washers are used as spacers to keep the screw from hitting the lead screw. (From here on, these instructions apply to both the lathe and the mill.) Next remove the 10-32 socket head screw (P/N 4067) that holds the saddle nut to the lathe saddle.

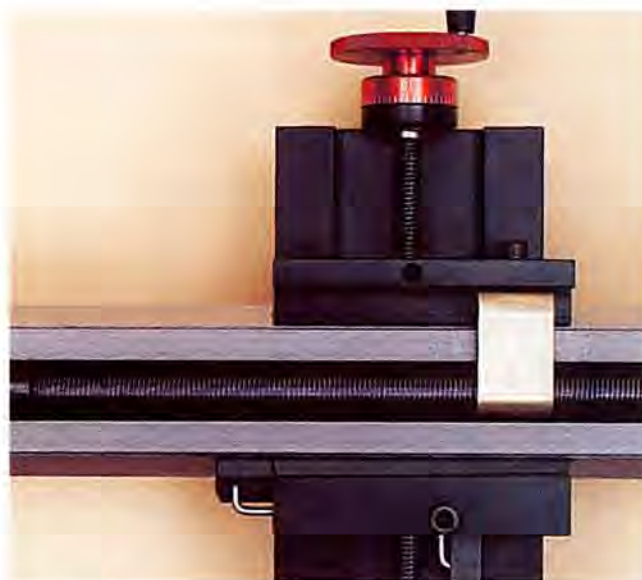
The entire leadscrew assembly may be removed by removing the 10-32 flat head screw that is located on the top of the lathe bed near the leadscrew handwheel or the front of the mill bed near the Z-axis handwheel. At this time, it is a good idea to clean up the machine.

Loosen the set screw holding the handwheel in place and remove the leadscrew from the assembly. This will allow you to remove the saddle nut from the leadscrew. Note the direction it faces before removing, and remove the saddle nut from the handwheel end of the leadscrew.

Thread on the new saddle nut, remembering that the leadscrew has a left handed thread. Thread the saddle nut approximately 1" (25mm) onto the leadscrew and put the leadscrew assembly back together. Make sure the handwheel is pushed all the way on before tightening the set screw or your machine will have excess backlash. Do not attach the base to the bed until the saddle nut has been adjusted.

### Adjusting the Saddle Nut

The adjustment for the saddle nut consists of two flat set screws on either side of a 10-32 socket head cap screw. With the saddle nut located on the



*The saddle nut is a brass part that is located on the back of the mill or underneath the lathe bed and connects the saddle to the leadscrew. It is softer than the leadscrew so it wears out first, but is designed to be inexpensive and easily replaceable.*

leadscrew close to the support (P/N 4030), loosen these two screws and slide the saddle (P/N 4091) into position over the saddle nut. Put the 10-32 socket head cap screw through the saddle and screw it into the saddle nut, but do not tighten it yet.

Adjust the set screws until the flat points touch the saddle nut and then tighten the 10-32 socket head cap screw. Watch as you tighten to see that the screw doesn't move. If it does, loosen and readjust the other set screws.

What we are attempting to accomplish is to have the saddle nut ride on the leadscrew with the minimum amount of drag. You can check the drag by turning the leadscrew handwheel. If you feel drag, tighten or loosen a single set screw while moving the saddle with the handwheel until the handwheel turns freely, but keep the saddle close to the handwheel. If you adjust the saddle nut while it is in the center of the leadscrew, it may be slightly off-center but will feel free until the saddle gets close to either end of its travel. Here, the leadscrew is supported and cannot deflect, so it will bind. If you can't eliminate the binding, try tapping the saddle nut with a plastic hammer on the leadscrew side while the saddle nut is tightly attached to the saddle and readjust. Don't use the machine with a loose saddle nut as this will cause excessive wear and backlash. If you can't seem to find the correct setting



*This 9-cylinder radial airplane engine made by Charles Herman missed winning first place in the 1994 Sherline Machinist's Challenge by only eight votes.*

yourself, send the bed/leadscrew/handwheel assembly back to Sherline and it will be installed for you for \$10.00 handling plus shipping charges.

## PRELOAD NUT ADJUSTMENT

### Removing end play from the spindle

If any end play develops in the main spindle on a Sherline machine, it can be easily eliminated by readjusting the preload nut. (See P/N 4016 in the exploded views on page 328 and 329.) When the headstocks are assembled at the factory, the preload nut is adjusted to .0002" (.005mm) of end play. This is controlled by the outer races of the bearing being held apart by the headstock case and the inner races being pulled together by the preload nut. This setting was determined through experience and, like everything in engineering, it is a compromise. If the machine is only to be run at high speed, this setting may be too "tight". The headstock will run fairly warm to the touch normally, but extended periods of high speed operation may bring about excessive temperature. If this is your case, tension on the preload nut may be reduced slightly.

### If the bearings are too tight

To change the adjustment, remove the spindle pulley, loosen the set screw in the preload nut and



*This cutaway of the headstock shows the location of the preload nut and the bearings.*

back the preload nut off 4° of rotation (counterclockwise). The bearings are lightly pressed into the case, so the inner race will not move without a sharp tap with a plastic mallet to the end of the spindle where the pulley is attached.

### If the bearings are too loose

If you find the bearings are too loose, you may want to take up on the end play. You can check them with an indicator or by spinning the spindle without the motor belt engaged. If the spindle spins freely with a chuck or faceplate on it, it is too loose for normal work. Adjust the preload nut until it turns approximately 1-1/2 turns when spun by hand.

## GIB ADJUSTMENT AND REPLACEMENT

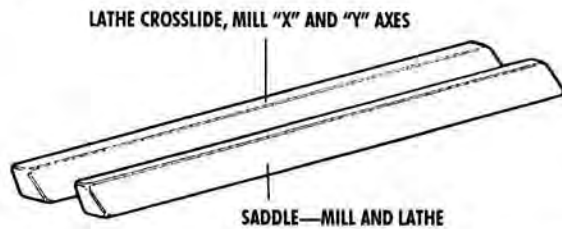
### Building up an evenly worn gib

The gib material we use contains a lubricant and should wear almost indefinitely with normal use. The only reasons you would replace a gib would be if it is broken or if it goes in to the maximum adjustment and the slide is still loose. Breaking one while it is in place on the machine would be almost impossible, and a gib that goes in too far can often be corrected by removing it and putting one or two layers of Mylar tape on the back side (the side that doesn't wear against the dovetail) to build up the

thickness. This should be done neatly and any excess tape trimmed off with a hobby knife.

### Replacing the gibs

The gibs are molded from a composite material. Their purpose is to make final adjustment on machine tool dovetails to compensate for tolerances and wear. Sherline's gibs are molded in a 5-3/4" length and each end is cut off to fit the particular slide on which it is being used. The gib that fits against the bed on the lathe and mill column is different from the gibs used on the lathe crossslide and XY base of the mill.



*The saddle gib material has a slightly thinner cross section than that used for the lathe crossslide and mill X- and Y-axes.*

Before removing the old gib, make sure you understand the way it works. A corresponding angle has been machined into the slide where the gib is located. On your Sherline tool, there is also a difference in angle between the front and back surfaces of the gib. This keeps the gib in place in all directions with just one simple gib lock.

Gibs must be held in place so they can't tighten or loosen. On Sherline tools, they are held with a P/N 4082 gib lock. Drilling the hole for this lock will be the only difficult part of the replacement procedure. We have fixtures at the factory to do this job, but it can be done at home with a little care.

After removing the old gib, clean the slide and lubricate with a light oil. Push the smaller end of the gib material into the slot from the end that has the gib lock. This is the larger end. Make sure there isn't any "play" between the gib and dovetail and that the slide can still move. Check each end of the gib by moving it up and down in the slot to make sure it fights tightly.

The tapers and angles are machined quite accurately and should work without further fitting when installed. If for some reason this is not the case, the fit can be improved by removing a very small amount of material from the end that is too thick.

Material can be removed by scraping using a sharp utility knife blade held vertically to the gib surface. Scrape to remove material from the end opposite the end that is loose. The same thing can be accomplished with 320 grit wet/dry sandpaper. Place the sandpaper face up on a flat surface and rub the end of the gib opposite the one that is loose. Once satisfied with the fit, mark the gib on each end where it exits the saddle.

Drill a 3/32" or .093" (2.36mm) diameter hole for the gib lock .400" (10mm) from the mark that represents the position the slide will fit the gib. The location and angle can be determined from the old gib. The hard part is drilling the hole into an angled surface. A center drill is a must for this job. You may want to tack glue each end of the gib to something that can be held in a vise to make it easier to work on. The part can then be broken loose from the glue when the drilling is done. The glued ends will be sawed off when the gib is trimmed to size. The hole can also be drilled slightly oversize and filled with epoxy. Put wax on the gib lock where it goes into the hole so the epoxy won't stick to it. The epoxy will fill the void and the lock will be properly located. Whatever your choice of methods, the gib lock cannot keep the gib from fitting properly. Once the hole is drilled, use a hack saw or hobby saw to cut off the excess material on the marks you made previously. Install the gib and gib lock, tighten the set screw that holds the gib lock in place, and you're ready to go back to work.

I hope that this will help you fit up a new gib. Should you find the job to be more than you wish to attempt, you may return the lathe or mill to Sherline and they will fit up new gibs for a nominal labor charge plus return shipping cost.

### Improving fit on a worn lathe bed or mill column

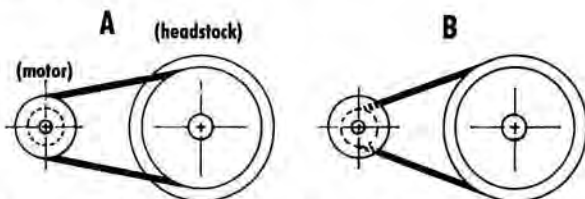
A slide that is loose in one place and binds in another is a sign that the bed is worn, normally in the middle where most of the movement occurs. If you are a good craftsman, you may improve the fit with a sharp, flat, fine pitched mill file. Using the file flat on both top rails of the bed, remove a small amount of material from the thick end or ends until the slide moves freely throughout its travel. The worst that can happen is you could end up buying a new bed, which would have been the case anyway.

---

## SHERLINE'S TWO-SPEED PULLEY

### Extra torque at low RPM

Sherline tools built after 1994 which have the DC motor in place of the older AC/DC motor use a two-position pulley system. The normal pulley position, which is with the belt on the larger motor pulley and smaller headstock pulley, will suffice for most of your machining work. Moving the belt to the other position (smaller motor pulley, larger headstock pulley) will provide additional torque at lower RPM. It is particularly useful when turning larger diameter parts with the optional riser block in place. Changing the belt from one position to the other only requires a few minutes. Instructions on how to change the belt position are included with each machine.



*The two pulley positions. Position "A" is the normal setting for most work. Position "B" offers more torque at low RPM.*

To achieve power at low RPM, older machines used a special "low speed attachment" which geared them down for more power. For high RPM a "high speed attachment" was available which geared them up. The newer DC machines have a motor powerful enough and a speed range broad enough to eliminate the need for these accessories, although they are still available for older machines.

---

## BACKLASH ADJUSTMENTS

### How much handwheel backlash is acceptable?

Backlash is the amount the handwheel can turn before the slide starts to move when changing directions. This is a fact of life on any machine tool and must be allowed for. On small machines like

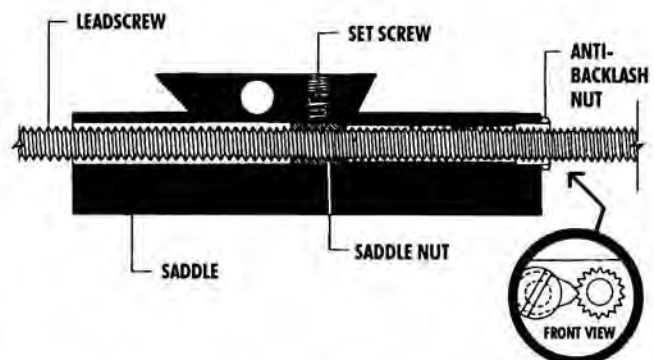
the Sherline lathe or mill it should be about .003" to .005" (.08mm to .12mm).

### For Example:

You are turning a bar to .600" diameter. The bar now measures .622" which requires a cut of .011" to bring it to a finished diameter of .600". If the user inadvertently turns the handwheel .012" instead of .011", he couldn't reverse the handwheel just .001" to correct the error. The handwheel would have to be reversed for an amount greater than the backlash in the feed screws before resetting the handwheel to its proper position.

### Adjusting the mill anti-backlash nuts.

Backlash on the X- and Y-axes of the mill may be reduced to a minimum by adjustment on the anti-backlash nuts. These nuts are located on the handwheel ends of the mill saddle. The nuts are secured by slotted pan head screws which hold a pointed locking plate that interlocks with teeth on the nut. To adjust backlash, simply loosen the pan head screw and slide the locking plate to one side. Rotate the anti-backlash nut clockwise on the X-axis and counterclockwise on the Y-axis until snug. Replace the locking plate and tighten the pan head screw. With the anti-backlash nuts properly adjusted, the lead screws will turn smoothly and have no more than the proper .003" to .005" of backlash.



*A cross section of the mill saddle shows the location of the leadscrew adjustments.*

## Chapter 3— Engineering drawings By Craig Libuse



*An ideal setup for drafting—a large work surface, good light, plenty of templates and a sturdy drafting machine. Most home shops can't afford the luxury of this much space unless you really enjoy doing drawings. Since most professional drafting is now done on the computer, drafting boards can be found at good prices on the used market.*

### **Part drawings—the machinist's "sheet music"**

A mechanical drawing is to a machinist what sheet music is to a musician. It is a graphic language used as the most clear and concise way of presenting all the information needed to get the job done. Drawings will show the shapes, dimensions and tolerances needed to produce a part that will fit with mating parts as intended by engineering. A skilled musician can play a piece properly the first time if all the notes and notations are included with the sheet music. Likewise, a skilled machinist should be able to produce a good part the first time with a good set of drawings. These skills need constant practice. A "sour note" on a machine tool can be expensive.

### **Traditional pen and ink drafting vs. computer drawing programs**

Most boys who went to high school in the 50's and 60's had to take at least one drafting course. (I don't think there was a rule against it, but I can't remember any girls in my drafting classes.) Drafting classes taught the use of traditional drawing tools to make pencil or ink drawings on paper. A traditional drawing can be judged by the quality of the line

work, however, the quality of the information given is more important. Perfectly formed letters are of little use if they convey the wrong data. Today, a new option is available with computer drafting programs such as "AutoCad"®. These programs have eliminated much of the "art" of drafting and have turned the trade towards designing and engineering. The difference in the quality of the drawings from one person to the next has become less because the computer and printer or plotter do the actual line work. It should be noted that good artists will always be able to express their skills with the tools with which they have to work, be they pen or computer.

### **Computers trade input speed for flexibility**

For me it is still faster to make most simple drawings using a traditional drafting board. The big advantage of computer drafting is making changes. A change on a computer drawing is clean, quick and simple. A good program can automatically update all related changes, helping you to avoid mistakes. Sophisticated design programs can even warn you if you design a part that can't work. A change that could ruin your beautiful ink drawing isn't any problem on a computer. After making the changes you just print out a new drawing. Complex drawings and the changes that may take place down the line will make the additional time it takes to input information a good investment. Another advantage is storing drawings on disks that allow instant access, eliminating the need for storage space and a large file of ink drawings.

### **CAD-CAM in industry**

A system called CAD-CAM which stands for "Computer Aided Design-Computer Aided Manufacturing" is in use today. Computer drawings are linked directly to the production machines that make the parts. These machines get their programming information directly from the computer, eliminating many steps in the design process. Complex projects, such as designing a new aircraft, would be impossible without the benefits of a computer. Parts can actually be test fitted and checked for interference in a 3-dimensional drafting program. Complicated shapes can be designed in 3-D before any metal is cut. Many potential mistakes

can be eliminated before the first prototype is made. Obviously, this is far beyond the needs of a home project, but computer drafting programs continue to get less expensive and easier to use. There are computer modeling programs that interface with machines which will cut a prototype part from wax or plastic directly from the computer drawings. This is a quick and inexpensive way laborwise to get a mockup of your part you can hold in your hands. The equipment it takes to accomplish this, however, is expensive compared to traditional machining.

### **Two types of machinists**

If you have been making parts for others, you are probably used to working with drawings. If you design your own parts, however, you probably fall into one of two categories. Some modelmakers prefer to do detailed drawings before making the first cut. Others start by making the first part and fitting other parts to it. This method can only work if your mind can visualize the entire project. A plan must be drawn either in your mind or on paper before starting. “As built” drawings may be sketched out later with the final dimensions taken from the part for future reference if needed. Somewhere in between is probably where most people fall. If you’re making a part that has never existed before you will most likely do a little sketching, work out some of your ideas on paper and then begin cutting a simple prototype. The more complicated the part or expensive the material, the more thinking and drawing you should do before you start cutting. Each person eventually works this process out for himself.

### **From one extreme to the other**

Wilhelm Huxhold, a retired lifelong professional machinist, makes miniature projects of incredible detail. He told me that he works out all the details in his head while watching television. He knows every cut he will make before he starts a project and needs to commit very little to paper. Jerry Kieffer, a utility company marketing representative who started machining as a hobby several years ago, makes extremely small and intricate projects. He takes detailed dimensions from an actual prototype of what he is modeling. He will also take photos and scale parts from them. However, when developing a way to make a particular part, he prefers to start cutting and says he just “plays with something until it works”. Scotty Hewitt, a three-time winner of the Sherline Machinist’s Challenge contest, works more like an artist, preferring to



*A minimum setup—a tablet of grid paper, a scale and a straightedge is all you really need for recording the information required to make a part. The part will eventually succeed or fail based on the information in the drawing, not the quality of the paper or skill of the line work.*

remove metal like a sculptor removes stone until the final piece is revealed. Personally, I prefer to make all my mistakes on paper before I waste any material. I do detailed drawings of every part before I build it. Of course, I have been working behind a drafting board for 25 years and making a drawing of something comes pretty easily. For me, seeing it on paper makes it easy to visualize potential problems before I get to them.

### **A lot depends on who the parts are for**

If you are producing parts from someone else’s plans, you’ll have to have a pretty good understanding of the conventions of drafting. If we wish to pass on the information about a part we have made to others so they can duplicate it, the mechanical drawing becomes a very important tool for describing that part accurately. To keep track of all the operations needed to produce Sherline tools, for example, good drawings are a necessity.

### **The basic parts of a mechanical drawing**

If you know nothing about drafting, there are a few basic elements necessary in a drawing to record all the needed information. They are the object lines of the part itself and dimension lines and dimensions showing the length of edges or locations of hole centerlines. In a case where a line is hidden from view, it is shown as a dotted line instead of solid. In addition, the drawing should contain information about the materials to be used, the finishes required,

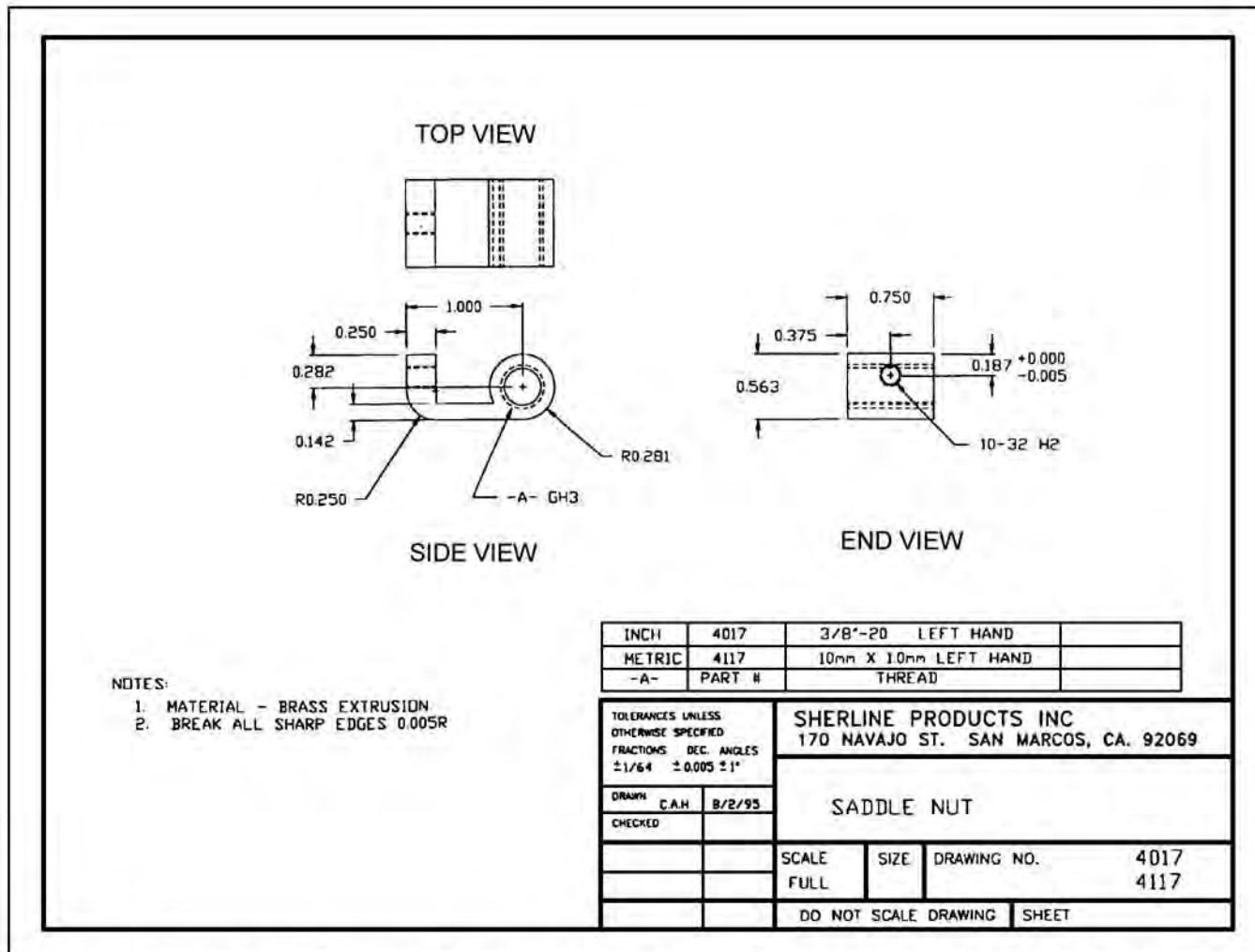


Figure 1—A typical part drawing. This is an orthographic projection done in AutoCad®. The three views show all the information necessary to make the part. (Though drawn at full scale, it is reduced in size for this illustration.)

the scale to which it is drawn and the tolerances allowed in all dimensions. Information that would be helpful to someone making the part for the first time should also be added. By the way, in traditional drafting, object lines are drawn darker than dimension lines to make the part stand out. Dotted lines have equal length dashes and centerlines use a long-short-long pattern of dashes.

### Drawing to scale

It would be impossible to make all drawings full size. Parts will usually be too big or too small. Making your drawing to an appropriate scale can help eliminate errors. If you've conceived something impossible to build, the error may become apparent when it is drawn to scale. Small parts may have to be drawn many times the actual size in order to be able to represent all the detail. Large parts must be scaled down to fit whatever size paper you are working with.

### Orthographic projections

A look at the figure above will show you how a typical part drawing is laid out. This happens to be done in AutoCad®, but it would look pretty much the same if it were hand drawn. This is a “three-view” drawing or orthographic projection. A part is drawn from the top, side and end. It is as though you placed a glass box over the part and drew on the glass what was seen from just that side. If you take what is drawn on the top, front and end of the box and laid each on the table, you would have an orthographic projection of that object. In some cases where the part has details that are hidden and are so complicated that a lot of dotted lines would be confusing, an additional view, cross section or inset detail will be drawn. A reference as to where this detail occurs is included under the detail. If a part is very simple, only one or two views may be required.

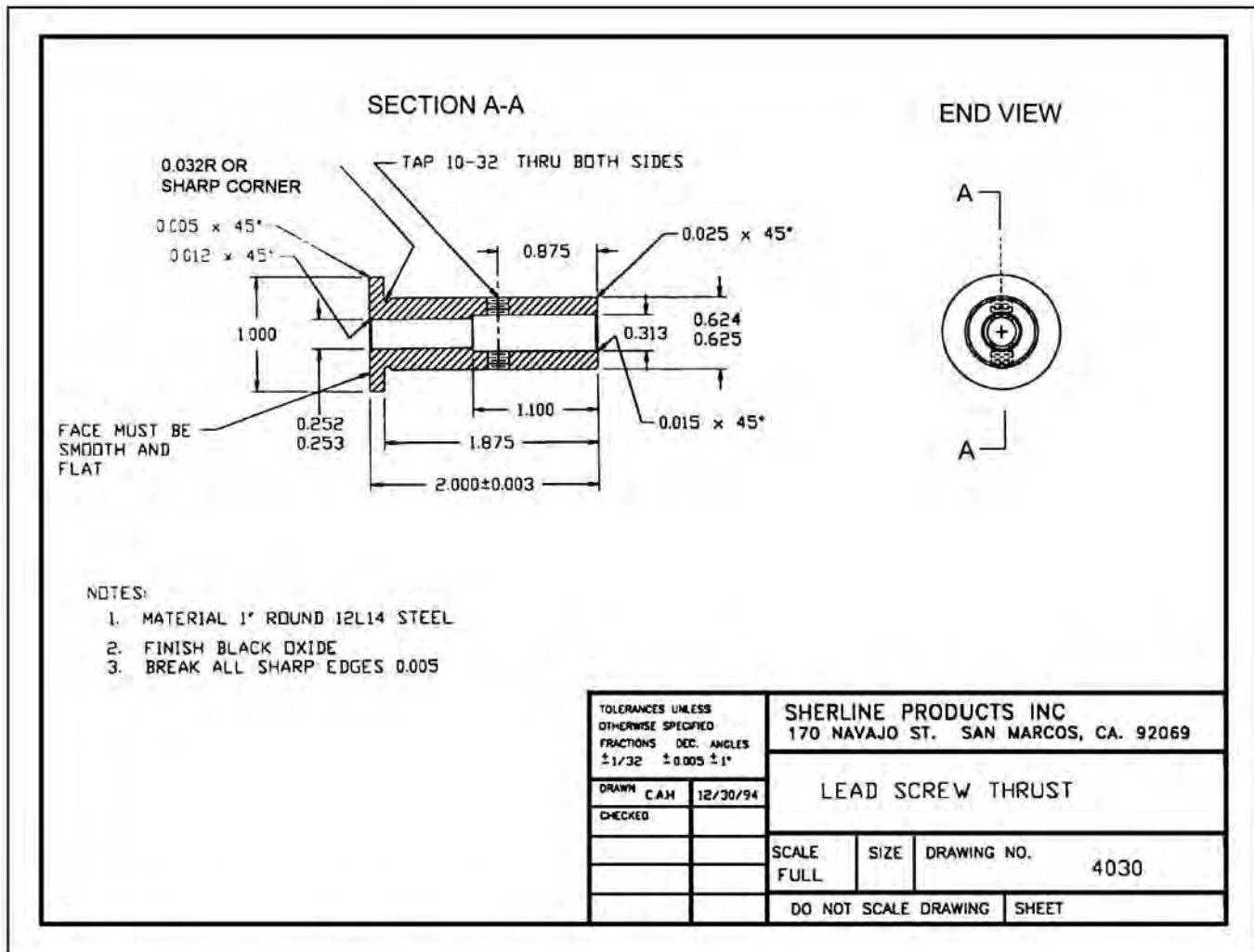


FIGURE 2—A cross section shows what you would see if you cut the part at that point. The “cross-hatch” lines on the side view indicate the surface of the cutaway. The End View has a line (A-A) indicating where the “cut” is made.

### Cross sections

A cross section is a view of a part that would be what you would see if you took a saw and cut the part at that point. They can be helpful additions to an orthographic drawing to point out details that might be hidden or unclear in the basic drawing. Usually the cut surface of the part is indicated with a series of lines called “cross-hatching”. In actual drafting practice there is a convention which has different patterns of lines to represent various materials. This means that in a cross section of a complicated part, you could visually see the difference between a bronze bushing and a steel part. Computer programs let you use colors to see these differences more easily on the screen.

### Isometric projections and isometric drawings

Isometric drawings are much easier for most people to understand, because they give a pretty good visual representation of the object in 3 dimensions.

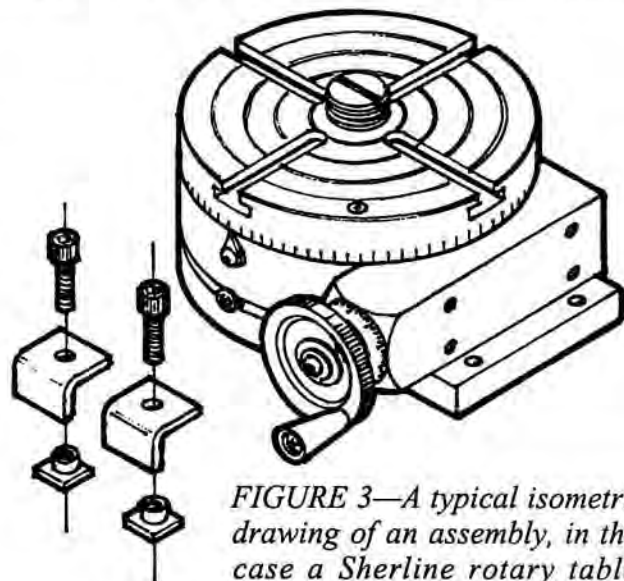


FIGURE 3—A typical isometric drawing of an assembly, in this case a Sherline rotary table. Most people can visualize a part much better in a three-dimensional drawing than they can from two-dimensional drawings, even if they have a lot of experience in reading plans.

It is special form of drawing and is not actually a “perspective” drawing where objects diminish in size as they get further away. The main axis of the part is shown using 30° angles. A special isometric ellipse guide is used to draw circles. The difference between an isometric “projection” made from a three-view drawing and an isometric “drawing” is that, on a projection, the dimensions are foreshortened on the isometric axes, while in an isometric drawing they are represented as full-size dimensions. Therefore, an isometric drawing will be slightly larger than a projection of the same part. Since a three-view drawing is not needed to construct an isometric drawing, it is easier to do and is used more often, although it is not quite as accurate a representation as a projection. In either case, these drawings make parts very easy to visualize, but they can be somewhat difficult to draw unless you have some drafting experience.

### 3-D computer drafting programs

This is a relatively new technology that is really making designing complicated parts easier. Instead of the traditional method of doing a three-view drawing and then creating a three dimensional view from that information, the part is drawn directly in three dimensions on the computer screen. It can be rotated around and viewed from any direction just as if you were looking at the actual part suspended in space. Parts can be viewed in “wireframe” mode or with texture and color mapped onto their surfaces. Even the direction of the light source can be manipulated to control the direction of the imaginary shadows. Groups of parts can be assembled and rotated too. Colors can be used to make the individual parts easier to differentiate.

Once the parts are designed to your satisfaction, the computer can translate the three dimensional image into a flat orthographic projection and even apply all the dimensions for you. Carl Hammons was experimenting with a program like that for use on Sherline’s future parts, and it promises to be an incredible design tool. The only drawback is that you need a very fast computer and a big hard drive to fully exploit the features of the program.

### Exploded views

Exploded views are often used as assembly drawings because they show all the parts and how they relate to the others in the assembly. They kind of look like what you’d see if you put dynamite in the middle of the part and then set it off, blowing the assembly



FIGURE 4—This 3-D drawing of a handwheel and sensor assembly is typical of what can be done in modern 3-D programs. This is a black and white laser print, but the drawing can be viewed in color on the screen and printed in color as well if you have a color printer.

apart. Centerlines or dotted lines can be used to show where each part or fastener goes. A tremendous amount of information about a complicated assembly can be learned from looking at a well-executed exploded view. Exploded views of the entire Sherline lathe and mill are included in Section 5 of this book. They can be quite helpful if you are working on your machine or need to order a spare part.

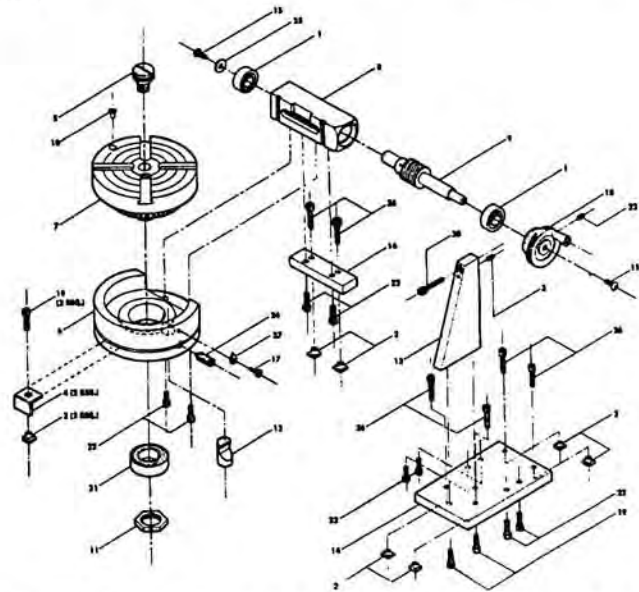


Figure 5—An exploded view of all the parts in the rotary table and right angle attachment makes it easier to see how each part relates to the others.

### **Establishing part tolerances**

The tolerance to which a part is made determines how much over- or undersize it can be and still work in its intended application. An oversize part must still fit in an undersize hole. On drawings, tolerances will be shown with a  $\pm$  (plus or minus) symbol. For example,  $1.250 \pm .002$  would mean a part that measures anywhere from 1.248 to 1.252 would be acceptable with 1.250 being ideal. It could also be given as  $1.250 +.002 -.000$ . That would mean the part could be as large as 1.252 but no smaller than the 1.250 dimension. Tolerances are often omitted from hobby drawings. Since you will be making all the parts yourself, they can be fine-tuned until they fit properly, so tolerances are not as important. In industry, however, establishing tolerances is critical to the commercial success of a product. If the

tolerances are too loose, the parts won't fit, and if they are too tight, the parts may become too expensive to be competitive. For more information on tolerances, see page 88 in the chapter on measuring.

### **Dealing with errors in the drawings**

Though no draftsman likes to admit it, the drawings a machinist works with may occasionally have an error in drawing or dimensioning. A good machinist should never build parts on blind faith assuming that the drawings are perfect. Designers, like machinists, also work with thousands of dimensions, and they can make mistakes. Don't make a big deal out of it. Someday you may need to ask them to save your butt by changing a drawing to a make a corresponding part work.

## **TOOLS FOR DRAFTING**

### **Scales and straight edges**

Triangular drafting scales are used to mark off measurements. They come engraved with different scales of measurement on each of their six edges to make it easier to draw to different scales. Plastic or metal straightedges are used for drawing the actual lines. (It is a drafting "no-no" to draw lines using your scale.) While the old "T-square and triangle" method still works, a drafting machine makes drawing angles other than  $30^\circ$ ,  $45^\circ$ ,  $60^\circ$  and  $90^\circ$  a lot easier. Since the advent of computer drafting, used ones can be found in plentiful supply at very good prices at auctions or in the newspaper classifieds.

### **Pencils and drawing pens**

Traditionally, wooden pencils of varying degrees of hardness were used for layout and final lines. They were kept sharp or the tip shaped with a piece of sandpaper. Now, the mechanical pencil with its easily replaceable 0.5mm leads makes the job much simpler. I usually use HB lead which offers a good compromise between the harder H leads and softer B grades of lead. (4H is very hard, 4B is very soft.) Final drawings used to be done in India ink using a ruling pen

that took a lot of skill to master. A drawing could easily be ruined when ink would unexpectedly creep under the edge of a straightedge. Drawing circles with a ruling pen in a compass was a skill that took a long time to learn. Now, easily filled pens like those made by Rapidograph™ dominate the market. They have easy-to-change tips of varying width and can be held in special compasses. I used one for many years, but now find that there are a number of felt tip pens that work fine for the type of drawing I do.

### **Erasing mistakes and papers for drafting**

As long as the drawings will be reproduced using a copy machine, mistakes can be covered with "white-out" instead of the old ink eradicators and scraping necessary with India ink. For blueprint reproduction, mistakes must be removed, not covered up, because light is shone through the drawing paper to expose the special blueprint paper. Special drafting papers are semi-transparent for tracing and blueprinting and have a hard surface that stands up well to erasures, but I usually work on plain bond copier paper. Almost all of the drawings for this book were done using just a felt tip pen and bond paper.

---

*"No artist is ahead of his time. He is his time. It is just that the others are behind the time."*

—Martha Graham

---

## Chapter 4— Frequently asked questions



*Instructions that come with a machine tool like this assume that the operator is already a good machinist. However, the high price of the machine is still no guarantee you'll get instructions sufficient for even an experienced craftsman to run it.*

### Several reasons you need good instructions

The main reason for writing clear instructions is that learning to use a new tool is much easier and more fun when the instructions are clear and all your questions are answered. These days, the majority of tabletop machine tools are sold through mail order. The dealers who sell by mail order have tremendous inventories of all kinds of products, and it would be impossible for them to be able to answer technical questions about every product they sell. Instead, you expect to get good instructions when you buy a product made by a reputable company. Unfortunately, this isn't always the case. Manufacturers of large machine tools can safely assume the people that will be operating them already have a certain amount of training and experience. Instructions that cover the operation and maintenance of the machine should be sufficient. With tabletop machine tools, the user is often a first-time machinist and has questions that extend beyond simply operating the machine. The instructions must be much more detailed.

### High price is no guarantee of good instructions

One of my big gripes in life is the poor quality of "question answering" done by most companies in their instructions or literature. The price of a machine is no indicator of the quality of instructions you will get either. I have paid many thousands of dollars for sophisticated machines only to find they came with a manual that doesn't tell you how to turn on the machine. You have to buy a service contract or pay \$150 an hour for a technician to answer questions that should have been in the instructions in the first place. This takes a lot of the fun out of buying a machine. I feel that if a customer can buy one of our machines while knowing nothing about machining, open the box, assemble the machine and make parts with it without ever calling the factory to ask a question, then we have done a pretty good job of writing the instructions. And amazingly enough, considering how complicated machining actually is, we do get very few calls, so hopefully our literature is doing the job it was intended to do.

### There are no stupid questions

Nevertheless, there are still certain questions that come in regularly, mostly from people who don't yet own a machine and are interested in knowing if it will do the job for them. Questions about accuracy, versatility, power of the machine or the size of parts that can be machined on them are common. Perhaps this section will answer a few of those questions you might have, saving you the time of picking up the phone and calling the company making equipment you're thinking of buying or bugging your machinist friends. These are not "stupid" questions. They are all very good questions and must be answered in your mind before you decide to get into machining. You need to know if the machine you are thinking of buying will do the job for the kind of parts you hope to make. If you are a beginner, hopefully these questions and answers will put to rest some of the things you have been wanting to ask. As I have said before, while these answers are mostly directed to the capabilities of the Sherline machines I am using as the example throughout this book, much of the knowledge can be applied to any small metalworking tools.

**Q: How accurate are miniature machine tools?**

**A:** When someone asks what is the accuracy of a machine, it is actually a rather loaded question. The more you know about the subject, the more difficult it becomes to answer. For example, I can easily turn a diameter close to the chuck on a Sherline lathe within .0002" (2 tenths of a thousandth of an inch). Does this mean the machine is built to that tolerance? No, but it does mean the leadscrew is accurate\*, the cutting tool is proper and the diameter I am cutting is large enough not to deflect. In many cases, the accuracy of your method of measuring has as much to do with the accuracy of your parts as the machine you are working on.

*\*NOTE: Sherline's leadscrews are precision rolled and are accurate to within 99.97%.*

The tools Sherline makes are as accurate as they can be built without expensive grinding and heat treating. Over a million dollars has been invested in state-of-the-art CNC machine tools and tooling to mass produce accurate parts. To increase the accuracy less than 1% would increase the cost by a factor of 10, and this simply wouldn't be a good deal for the average consumer. The jump from a \$400 lathe to a \$4000 lathe of similar size yields only a minor increase in accuracy, and often results in a loss in versatility, as more expensive machines are usually more specialized and few offer the features and accessories available from Sherline.



*A beautiful eight spoke brass wheel made on Bob Breslauer's special double rotary table setup. A lot of careful thought went into this design.*

When asking about the accuracy of the machines, what is really being asked is, "what kind of accuracy can I expect to achieve in the *parts* I make on these machines?" When you look at the pictures in this book showing some of the examples of the parts made on Sherline machines, you can see that, in the hands of a good craftsman who knows his or her machine, the parts that can be produced are as accurate as you will ever need. You will find that most problems associated with making very tight tolerance parts are not caused by the machines but rather are the result of the level of craftsmanship of the operator. As your technique improves, you'll find your machine keeps making better and better parts.

Even if the machine were "perfect", other things can affect accuracy. For example, the "spring" or deflection of the part you are making and the deflection of the cutter also affect accuracy. Taking all this into account, it is still not uncommon for a good machinist to be able to make parts accurate to within a thousandth of an inch or less on inexpensive miniature machine tools. Keep in mind that Sherline's lathe is a small engine lathe, not a jeweler's lathe. If you are a hobbyist, this small engine lathe for under \$500 will be plenty accurate and many times more useful than the most expensive jeweler's lathe made, as they are designed for different purposes.

Remember also that while you need a big machine to make big parts, it is much easier to make accurate small parts on a small machine. In addition to the advantages of being able to sit down and get close to your work, the smaller machine will give you a much better "feel" for delicate work than a large machine. For example, it is very easy to break extremely small drills if you don't have some feel for how fast to feed them. A large machine simply cannot give you the "touch" you need for doing delicate work.

**Q: How accurate is the alignment of the lathe headstock and tailstock?**

**A:** The biggest enemy of accuracy here is the versatility of the Sherline design. Because the headstock rotates to allow taper turning, returning it to a perfectly straight position is dependent on the alignment of the headstock key and keyway. The standard square key stock used for the alignment key was recently replaced with precision ground material which has increased the level of accuracy.

Factory alignment of the headstock and tailstock is within less than .003" or .08mm. Sherline also manufactures adjustable tailstock tool holders and an adjustable live center which can help you attain near perfect alignment should your job require it. (See pages 252 and 142.)

**Q: What is backlash and how much of it should leadscrews have?**

**A:** Backlash is the play in the engagement of the leadscrew threads which allows a few thousandths of an inch to be turned on the handwheel before the leadscrew starts to turn when changing directions. This is a fact of life on any machine tool and is accounted for by always making your cuts in the same direction and keeping track of which way you turned the handwheel last. On Sherline tools, backlash is usually about .003" to .005" (.08mm to .12mm). The X and Y leadscrews on the mill have a backlash adjustment, but it is still recommended that it be set to .003". (See page 257.)

**Q: What kind of materials can I machine?**

**A:** There are almost no limits to the kind of materials you can machine with a good miniature machine tool. Anything from wood or plastic to exotic materials like stainless steel can be cut as long as the part can be safely and firmly held and the proper cutting tool and cutting speed are used. (See Section 1, Chapter 3 on materials for machining.)

**Q: How big a part can I work on?**

**A:** The physical size limitations of any machine are easy to determine from its published specifications, but what does the hardness of the material you wish to turn do to those numbers in the real world? A good rule to remember when it comes to purchasing any lathe is to take the average diameter you plan to work with and multiply that times 3 for free machining materials and times 4 for tough materials like stainless steel. If the materials you plan to work with are free machining (aluminum, brass and free machining steel), you will be pleased with a 3.5" lathe like the Sherline as long as the average part you make is approximately 1" (25mm) in diameter. Wood and plastic are so easy to machine that only size limitations need be considered. I don't mean to imply that you can't machine a 3" flywheel, but if you are planning to

consistently make parts of that size, you will probably be happier with a larger machine and more horsepower.

Removing large amounts of metal on a small machine takes time. If you have lots of time, size of the part is less critical. Users of any machine are happier with its performance when they are not consistently pushing the limits of its capabilities. If you usually make small parts well within the capabilities of a 3.5" lathe and every once in a while need to turn a part sized near the machine's limits, you will be very satisfied with that lathe's performance.

A vertical milling machine is capable of holding larger parts than a lathe because the part is held and only the tool turns. It also has a much longer table throw (X-axis travel) than a lathe. On a Sherline mill with the addition of the horizontal milling conversion, surfaces up to 6" x 9" can be machined without moving the part. This is a very large machinable area for a tool of this compact size.

**Q: How powerful is the motor and what is the speed range?**

**A:** This is a good question to ask of any machine, because the more powerful the motor, assuming the design of the machine is rigid enough to handle it, the faster metal can be removed. The 90 Volt DC motor now used on Sherline tools offers a lot of



*Members of the San Diego Aerospace Museum's model staff produce miniature parts for an aircraft exhibit in their shop.*

PHOTO: ED LEISER



*A miniature grinder is part of a complete model machine shop on display at the N.A.M.E.S. show. Miniature tools are a popular subject for modelers using miniature machine tools to make them.*

torque for its size. It has substantially more usable torque and a larger speed range than the older 1/2 horsepower AC/DC motor that was used before 1994. The electronic speed control now adjusts automatically for any voltage worldwide from 100 to 240 volts, 50 or 60 Hz. An electronic circuit in the new speed control unit also compensates for load, keeping the RPM more constant during cuts. Everyone seems to be pretty impressed by how powerful the motor actually is when they use it. The electronically controlled speed range of 70 to 2800 RPM requires no changes of gears or belts to achieve, you just turn the speed control knob for any speed in that range. For example, half speed is about 1400 RPM. (It is not necessary to know the RPM exactly, because your initial approximate speed setting will be adjusted by looking at the chips and listening to the cut as you become more experienced.\*) For even higher torque at low speeds

when turning large parts, a second drive belt position is available on the motor drive and headstock pulleys. (By the way, to buy just a DC motor and speed control of this quality elsewhere could cost you more than the entire Sherline Model 4000 lathe!)

*\*NOTE: A simple RPM gage that uses the frequency of 60 cycle/sec fluorescent light is provided for your use on page 333.*

**Q: How heavy a cut can I make on a 3.5" lathe?**

**A:** This depends mostly on the diameter and type of material you are attempting to cut. It is also dependent on the sharpness of your cutter and the firmness of your setup. The high torque DC motor we use is very powerful for its size. In fact, it is more common for people to underestimate its abilities and feed the cutting tools too slowly, causing the tool to "chatter". For aluminum, you could expect to be able to take cuts of up to .060" on 3/4" diameter stock, while stainless steel would require taking no more than .015" with each pass. (In another example, on free machining steel, you could take that same .015" cut on a 3" diameter piece.) Heavy cuts at high RPM will also cause the tool to "chatter". Metal must be cut with enough feed to keep the cut continuous (keep the tool biting into the metal). Remember, rule #1 in any machining operation is: **"If the tool chatters, reduce speed (RPM), reduce depth of cut and increase the rate of feed."**

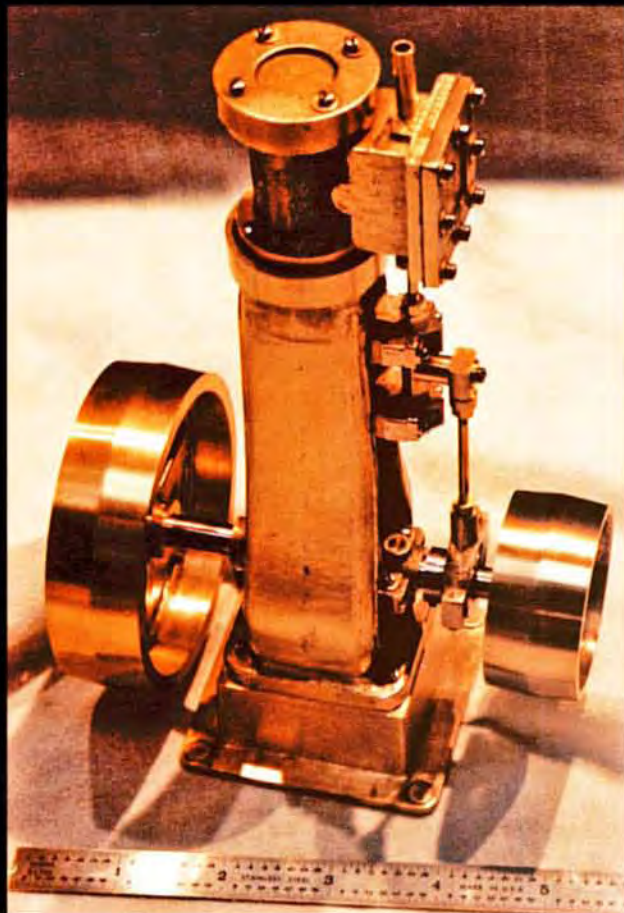
**Q: Can the lathe cut threads and what kind?**

**A:** Standard size threads are often cut with taps and dies. For any other non-standard thread or any thread you don't happen to have the proper tap or die for, threads are cut on a lathe. To cut threads, the leadscrew of the lathe must be geared to the rotation of the spindle in the proper relationship, so that as the spindle turns, a 60° thread cutting tool in the toolpost advances down the part to cut the thread. Some machines have a geartrain for thread cutting already built in. The Sherline lathe uses a simple thread-cutting attachment (P/N 3100) which is capable of cutting almost any size thread. It will machine 31 different unified thread pitches from 80 to 10 threads per inch and 28 different metric pitches from .25 to 2.0mm. You can also cut any of those as right- or left-hand threads. Inch threads can be cut on a metric machine and metric threads can be cut on

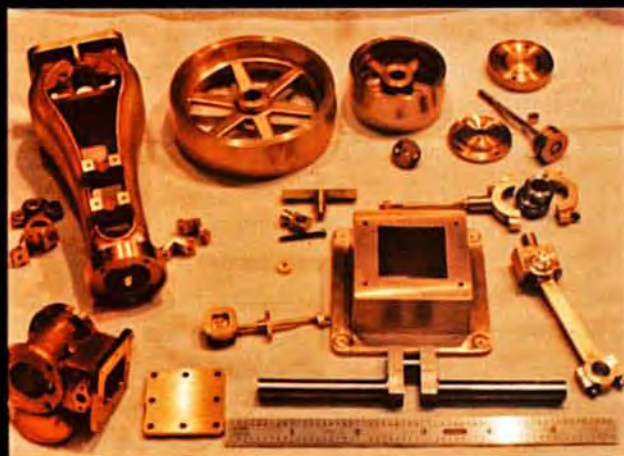
## A steam engine project, start to finish

This steam engine is built from a kit. As you can see, the castings are rather crude and require quite a bit of work to get them to final dimension. The crankshaft is made from bar stock. The project consists of a number of pieces that must work

together with close tolerances. This impressive working model was actually the builder's first attempt at using tabletop machine tools. The project was built and photographed by Chuck Sherwood of Naperville, Illinois.



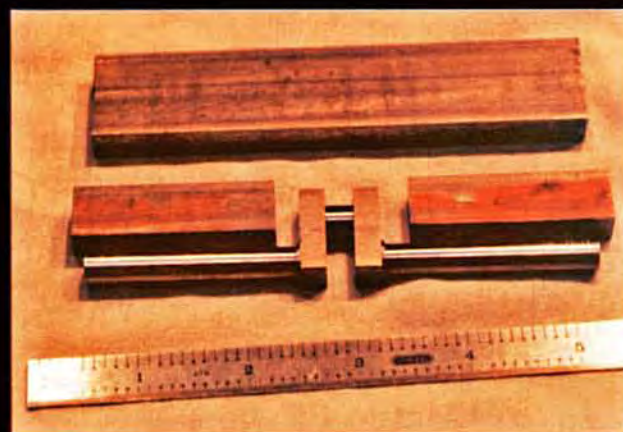
(Above) The completed engine and (Below) the finished parts that went into it. A project like this requires a number of different machining processes and techniques.



Lower cylinder head raw casting and finished part with its brass packing gland.



Another before and after comparison...A raw cylinder casting and a finished machined cylinder.



Crankshaft machined from cold-rolled steel bar stock showing full size stock blank and the pieces cut away after rod bearing was machined.



The "coke bottle" casting of the steam engine shown on the previous page is set up for boring. Note the custom attachment fixture used to help hold the casting. A steady rest supports the outer end.

an inch machine. The motor and speed control are replaced with a series of interchangeable gears and a hand crank wheel is used to advance the spindle/leadscrew geartrain. This method gives you a good feel for the cut and also allows you the advantage of cutting right up to the shoulder of a bolt. Once you can cut threads on a lathe, you'll never be limited to threads available in standard tap and die sets again!

**Q: Are accessories available to do special jobs?**

**A:** If you are thinking of buying a machine, this is an important question to ask. An off-brand or cheap import may have an attractive price, but if accessories aren't available to fit it, you will have trouble accomplishing some of the more complicated tasks you may wish to attempt in the future.

In the case of Sherline tools, the answer to this question is "yes". Over the past two decades, new accessories have been added each year to make this the most complete line available from any single machine tool manufacturer in the world, regardless of size. Any machine shop job you might attempt can be achieved in miniature on Sherline tools. Accessories include attachments for thread cutting, knurling, indexing, boring and flycutting. Available are a 4" rotary table, mill vise, power feed, wood tool rests, and a large selection of 3- and 4-jaw chucks and tool posts. Sherline also make special tools for watch and clock makers. In fact, at last count, over

140 separate chucks, collets and accessories made by Sherline were available, and the number continues to grow.

**Q: Do I have to be an expert machinist to run miniature machine tools?**

**A:** No. In fact, a good craftsman will often do better than a professional machinist on small tools. Machinists work all day with big machines that cost thousands of dollars, and will often tend to push a smaller machine too hard. It's sort of like a race car driver going to the airport in a 4-cylinder rental car...he'll have his foot to the floor the whole time and wear the car out in a hurry!

What good craftsmen will find is a whole new world in which to express their creativity. Things that were impossible to do before become simple operations. A good miniature machine tool should be designed so that it can be operated by people with a good "common sense" knowledge of mechanics. I feel Sherline also provides the most complete instructions in the industry. With good tools, the accessories you need, good instructions and a willingness to take the time to make good parts, you have everything you need to enjoy the world of miniature machining.

**Q: If I don't know anything about machining, how can I learn what I need to know to get started?**

**A:** By the time you are done reading this book, you will have all the knowledge you need to start making parts on a lathe or mill. For those who want to learn more, there are a couple of other good sources. Earlier in the book, I mentioned that my favorite source of information on machining is *Machinery's Handbook*. I provided some data on this book which shows why I feel it is an important resource for any machinist.

Other sources would be your local library or book store's section on "machining", "metalworking" or "technology". For those who may not have any machinist friends but wish to converse with other machinists to solve a particular problem or ask a question, the Internet newsgroups are an excellent source of information. Probably the most popular with home machinists is "rec.crafts.metalworking", although there are many groups tailored to specific aspects of machining and modeling.

**Q:** *I have an older lathe. If I buy a new lathe will my old accessories still work?*

**A:** Of course I can't speak for other manufacturers, but in the case of Sherline tools the answer is "yes". Part of the design criteria for any change or advancement made on Sherline tools is that they still work with all the accessories that have been made in the past. This also means that if you buy a used Sherline tool from a friend, all the new accessories will work on it, no matter when it was made. The only exception would be when an advancement eliminates the need for a particular accessory, such as the new DC motor's greater torque and speed range eliminating the need for the slow speed attachment, or the new tailstock design eliminating the need for a tailstock spindle extender.

**Q:** *Will my machine tools become obsolete?*

**A:** No. A good lathe from the 1950's is still a good lathe today, because the job of a lathe has never changed. The key is to get good equipment to start with. Sherline Products has been making tools since 1974, and all our accessories will still fit any of the tools we have ever made. We plan to keep it that way. The quality and versatility of the machines will continue to improve, but you never need worry that the machine you buy today will become outdated. Look at the functionality of a good miniature machine tool the way you might look at a pair of high-quality needle-nose pliers. It does its job so well, there is no need to redesign it, and it will still be manufactured 100 years from now.

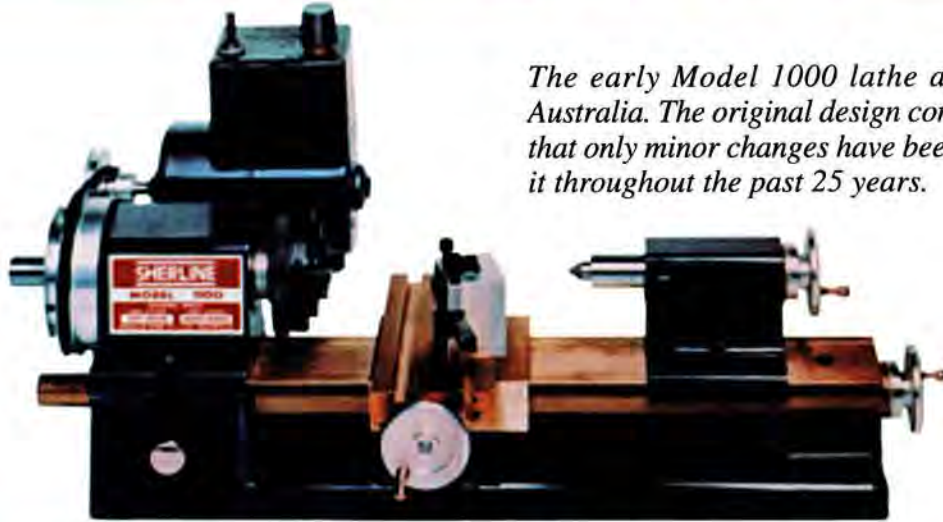


*Another view of the finished steam engine project by Chuck Sherwood.*



*Two of the most recent winners of the Joe Martin Foundation award for outstanding miniature craftsmanship are clockmaker William R. "Bill" Smith (2000) and designer and builder of ultra-miniature engines, George Luhrs (2001). Mr. Smith and one of his clocks are shown at the left and Mr. Luhrs and his 4-cylinder, 4-cycle sparkplug fired airplane engine are shown at the right. The running engine has a bore of just 1/8" and a stroke of 5/16". See page 333 for more on the Foundation.*

## Sherline's Australian roots



*The early Model 1000 lathe as it was made in Australia. The original design concept was so sound that only minor changes have been made to improve it throughout the past 25 years.*

### **First Sherline Model 1000 lathe originates "Down Under"**

The first Sherline Model 1000 lathe was originally designed and built in Australia. Conceived by designer Harold Clisby (see page 342), the original design parameters included a rigid bed to avoid twisting and a low manufacturing cost. These goals were to be achieved through the clever use of extruded parts. Mr. Clisby went on to turn his energy to developing a line of air compressors, and a Melbourne manufacturing engineer named Ron Sher took the lathe concept to reality in 1972. His knowledge of electric motors was combined with Mr. Clisby's design concept to produce the first lathe and a small line of accessories.

PHOTO: GEOFF O'GALLAGHAN



*In 1972, production of the Sherline Model 1000 lathe began in the East Bentleigh, Victoria, Australia plant of Ronald Sher Pty. Ltd.*

Ron Sher produced the lathe in his 10,000 square foot facility. The company was called Ronald Sher Pty. Ltd., and Ron registered the trademark for the Sherline name and the business or trading name of Sherline Products. Trained as an electrical engineer with a specialty in series motor design for power tools, his design and marketing experience had been gained working with the first Australian manufacturer of power tools, Sher Power Tools, which was eventually acquired by Skil Corp. With the assistance of the Australian Department of Overseas Trade (now Austrade), Sherline Products



*Ron Sher was the co-designer and first manufacturer of the original Sherline lathe.*

exhibited at various trade shows around the world including the USA. The story that follows details how Joe Martin learned of the line and contracted with Ron Sher to sell lathes in the United States. A commitment to sell the machines through Sears changed the direction of the company and brought manufacturing to the United States. From a desire to simply distribute a product, Joe ended up manufacturing tools which are now sold all over the world. The tool and accessory line has grown to become the largest and most complete of any machine tool line in the world, regardless of the physical size of the machines.

## Chapter 5— Making a business out of a hobby

### Where I'm coming from with this story

I've always been a "builder." I can't remember a time in my life when I sat around with nothing to do and idle thoughts filling my mind. Whether it was school or hobby or job, there was always another technical problem to be solved. Building a business was just like building the boat I built in high school or my latest Sherline accessory. Each has consisted of simply solving a series of problems until the project is complete, then on to the next. Writing this book hasn't been any different, and it has created many new and interesting problems for me.

The main problem I'm having with this book is similar to a design that starts out simply and then too many nuts and bolts are used to add on more pieces. This, in turn, makes the design a "loser." The "nuts and bolts" I'm referring to in this story is the



*Joe Martin on the cover of a 1964 contest program holding one of the many R/C models he has built.*

word "I." As I read and rewrite this story I can't seem to get rid of it. As I'm trying to explain the problem I keep adding it I don't want to sound like a bore at a cocktail party, but every sentence I try to put together has the word "I" in it. In thinking about the problem for a while I realized it was the result of simply not having enough money. I'm not talking about money for a better education where I might have learned more about fancy words and proper writing. I'm referring to the money it takes to be able to pay other people to solve problems and do your work for you. I have always had to solve the problems or make the decisions myself. Money to spend on something I could do myself just wasn't there, but I wouldn't have wanted it any other way.

You may also come to the conclusion that I spend too much time on CNC machines. This isn't the case, for if you wish to manufacture a product in the future, these are the new workers for the manufacturing world. The managers who control these marvelous machines will become more important to a manufacturing company than the managers who control your finances. These will be the machines that will create the profit a company needs to survive. Whether you build the product or "farm the work out," in order to have competent suppliers you must have a general knowledge of the systems available, whatever your endeavors.

### Starting a business with little or no money has its advantages

It may surprise you to learn that I believe starting a business without any money can actually be easier because you don't have anything to lose. A lot of the pressure is taken away because the worst thing that can happen to you is you may have to go back to working for someone else again. This is the logic I used when I left my good job at Kraft Systems and started out on my own again. I hope you may find a use for the philosophy I used to create Sherline Products or at least find it interesting. There are still thousands of products that haven't come to market, and the opportunity still exists to start out on your own. However, please don't take on this challenge if your success is going to be achieved at the expense of someone else. There are enough "wheelers and dealers" in this world, and we don't need any more.



*Another shot of a very young Joe Martin and his B-47 model from about 1964.*

### **Making good decisions**

My story may be useful to someone with a fair amount of skill and intelligence who is willing to work hard, but not to a person who didn't take the time to discover how things work. Standing in front of a mirror convincing yourself that you "can and will" just doesn't cut it in my world. "Feeling good about yourself" doesn't result in success; it results *from* success. Success comes from making good decisions, and decisions are simply educated compromises. You can't make good decisions without a great deal of knowledge about your subject. Being a self-taught person, I probably suffer from a bit of "tunnel vision," but I've knocked a lot of meat off my knuckles working for other people. I've been on both sides of the fence, and the conclusion I have arrived at is whatever side you're on will be the most difficult. The fence is too high to see the problems on the other side.

### **Getting an early start with radio control models**

After graduating from Cranston High School in Rhode Island in 1953, I started building radio control

model aircraft in my spare time. (My full time job was working at the building trades as an asbestos worker.) I had been building model aircraft for some time, and the radio control aspect of modeling excited me to no end. The controls at that time were still rather crude; in fact, transistors hadn't been invented yet, but having the ability to control a plane and land it in the same field from which it took off was like science fiction to me. My job in the building trades required that I travel often, but I still managed to get my models built by taking a week or so off at the end of each job.

### **A "no excuse" hobby**

What was really interesting about the hobby to me was that a good modeler could design, build and fly his creation without help. If all three of these things weren't done correctly the model aircraft would crash. A good model may have had hundreds of hours of labor and many dollars invested, which made the first flight very exciting. Your money and prestige were on the line when a model was released for its maiden flight. A good flight was a win. Success or

failure wasn't a shared experience, and that's the way I liked it. To make it more interesting, you could compete against one another at model aircraft contests. It is as much of a sport as any ball game. You are controlling an object that is traveling at speeds in excess of 100 miles per hour. The timing has to be perfect to execute the maneuvers required. Your aircraft has to be "set up" just like a racecar. It is a very difficult hobby and sport because failures are crashes. This teaches you the facts of life when it comes to designing and building anything. Do it wrong and you will crash. What a simple rule. You can't make excuses because you did it all yourself.

#### **A craftsman is accountable for his work**

Workers who build things understand this rule, for if you tell a machinist to make a part, it has to be right or he loses his respect as a craftsman. Compare this to the job of a salesman. You sit down and start negotiating on a new car. The salesman makes you so mad you leave and go to another dealer. The salesman screwed up everything so badly that his dealer lost a good customer; however, the salesman can tell everyone that the customer was an idiot who didn't understand automobiles. He has someone else he can blame for his failures. There is no good way to evaluate people in jobs like this. With a craftsman it is simple: the part is either good or bad. I believe this is why I have always preferred to have friends who build things. They don't have time to make excuses. If they don't do it right they crash.

#### **Being a business owner — my fourth best talent**

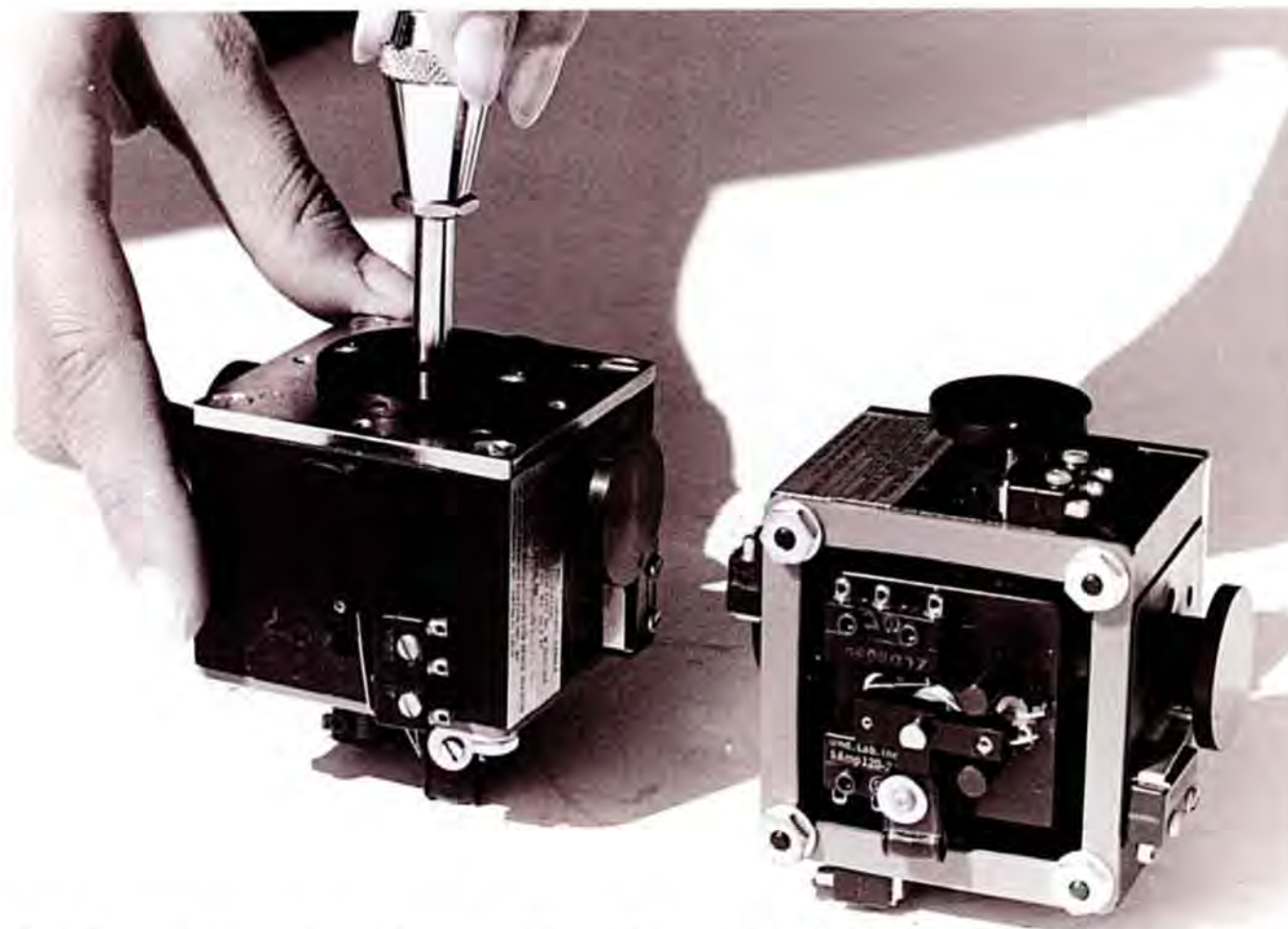
Starting a business was a natural thing for me to do. My modeling friends were starting all types of businesses to supply this new hobby. I will always consider myself a modeler first, a product designer second, a machinist and toolmaker third and a businessman fourth. Being a business owner is easier if you can do everything yourself as I can, especially when it comes to the tooling. The specialized tooling it takes to manufacture a product at a reasonable cost can be very expensive. I paid for it by working an extraordinary number of hours. Don't think for a moment that I was smarter and learning is easier for me than other people. The difference is I'm persistent. I can remember screwing up a part on a Sunday night after working all weekend on it, going home and catching a little sleep and starting over by six Monday morning. There are very few projects I seriously started on and didn't finish. People who don't finish projects on their own shouldn't start a

business unless they have enough money to pay other people to finish what they start. I don't spend much time looking back unless it is for information I can use in a positive way.

The secret to success when it comes to working with people is simply that; you work with your employees more than you have your employees work for you. All you have to be is fair and accept their mistakes as you would accept your own errors. As your company grows your own errors will grow exponentially. The reason for this is that your decisions are only the "tough ones." Your managers will make the easy decisions. You get stuck with the "damned if you do and damned if you don't" type. One of the hardest decisions to make is when to let someone else make a decision. You hear all this crap about micro-managing. These can be buzzwords for people spending other people's money, but when you're spending your own money and you don't have much to spend, it takes a lot of guts to turn your back on anything that could speed you on your way to the poorhouse.

I have a couple of rules at my company that have worked quite well over the years. One is: "You can't tell a worker how to do a job unless you can do that job yourself." I don't mind management people telling workers how many parts to make or when to make the parts. They can suggest a new method, but the craftsman who does this work has the final say unless that manager can show him how to do it better, not just tell him. Another rule I would like to slip in is "If you hired an employee, you fire them if they don't work out." My managers can't leave this nasty task to anyone but themselves. It has to go with the territory they control. Managers who can make this decision too easily are not much better than the ones that can't make it at all. If a company wants employees who "care," a company has to care for employees in a like fashion. Employees have to believe they are more than a machine that runs eight hours a day. Many managers have never learned this because they have never worked at a job where their performance was easy to check. Having a recent engineering graduate with a stopwatch stand behind a worker with twenty years of experience isn't a good way to build unity in a company.

It isn't hard to be a hero in today's business world where BS is king. We just treat customers the way we want a business to treat us. A recommendation from a satisfied customer carries far more weight to



*Joe's first experience with miniature machine tools was in building these custom joysticks designed for NASA to help learn how to land the lunar module.*

a potential buyer than what could be said in an advertisement. By the same token, a bad word from an unhappy customer can cost you sales. They say a happy customer tells ten other people, but an unhappy customer tells a hundred. Some of our most devoted and loyal customers are not the ones who have never had a problem, but rather ones who have had a problem and had it taken care of promptly and politely. Unfortunately, in today's business climate, good service is becoming more of a rarity, and it is a relatively easy place to stand out from the rest.

#### **A first experience with miniature machine tools**

My interest in miniature machine tools started while working for a company called Micro Avionics, which manufactured control systems for model aircraft in the late sixties. At that time we were using better control systems for model aircraft than the military had developed for their own use. I was asked to extensively modify a couple of model airplane joysticks to control a model of the moon lander being

developed by NASA. To simulate weightlessness in space they flew a large transport aircraft in a trajectory that temporarily eliminated gravity. For a few minutes at a time they would try to control this contraption with jet nozzles in zero gravity. Micro Avionics had taken the contract for the control electronics without giving much thought to the switches that would control the device. When we found out what they really wanted for joysticks we were in big trouble because we didn't have time to contract out the machining. I worked with mechanical devices at the company so it was my "baby." All we had for tools was an old drill press. Fortunately for me, one of my modeling buddies, Carl Hammons, who would later become my partner, had an old Unimat lathe and let me use it for a few weeks. These miniature lathes came out around 1955 and sold for \$99. They were packaged in a nice wooden box and became an immediate hit. They sold thousands. The only machining experience I had prior to that was one year of metal shop in

school, but I was a modeler. A good modeler can accomplish what needs to be done with what he has at hand. Modelers have developed this trait by simply not having enough money to do it any other way. The Unimat wasn't rigid, making it difficult to hold tight tolerances, but it was a lifesaver to me and I got the job done on time.

Don Mathes, the owner of Micro Avionics was typical of some of the real clever designers I met in my life. He drank way too much. I'll never understand why this talented group can find so much happiness in a bottle. Don was supposed to do the electronics on this project and he went on a drunk. With only two weeks to go, he showed up one morning looking like death warmed over. He was shaking so bad that if he were standing on the beach he would have disappeared into the sand. By four in the afternoon Don again took on the appearance of a human. He worked all night and laid out a circuit board with black tape at a scale of four to one. He skipped the component layout completely and laid out a board that had over a hundred components in a very short period of time. This was long before computer programs and multilayer boards. It was a work of art with the components spiraling towards center; in fact, it was so good it appeared on the cover of an electronics magazine. As soon as it was checked out, Don was off again to complete the drunk he started. He came back a couple of weeks later looking good and never mentioning where he had been. Don died long before he should have.

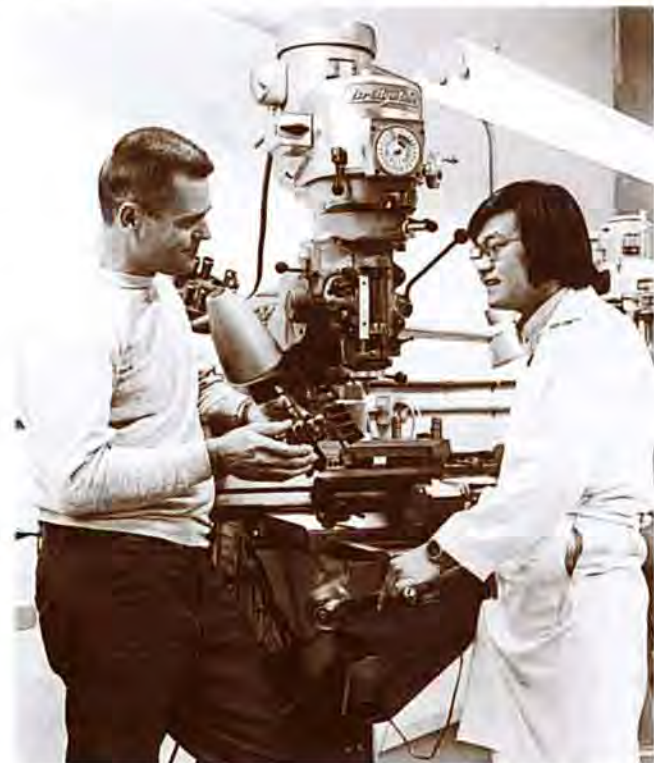
#### **With a partner, I start my first business**

My next project in machining came when Carl Hammons and I started a business to manufacture connectors for the radio control industry. Micro Avionics decided they could get along without me because I found it impossible to get along with the owner's girl friend. She had the ability to destroy perfectly good parts faster than we could make them. The straw that broke the camel's back was when she and her girlfriends were assembling servos and a gear shaft had a burr on it. She decided to use a hammer to force the shaft into a plastic gear less than a penny in size. After I showed her how to deburr the shaft and assemble the gear train properly, she reverted back to her hammer and destroyed two trays of parts worth \$500.00. I blew my top and got fired. Don and I still remained good friends because I knew he was between the old "rock and a hard place." He soon realized I was the only one who

knew how to build their connectors. He offered me an opportunity to start my own business to supply them. I rented a 1500 square foot shop in an industrial area in Upland, California and I was in business.

I didn't need many tools to produce these connectors, and I got started using the modeling tools I had at home. Summer came and I found out how hot a small shop could get. At that time my idea of a successful business was one that could afford air conditioning. I would work long into the night building tooling when it was cool, for I had to build connectors during the day to pay the rent.

In reality, I was just assembling connectors. The existing design was somewhat of a compromise, and I wanted to redesign them and make them properly. Most radio control manufactures at the time were using a connector manufactured in Mexico. Because of the low labor rates in Mexico I had to come up with a way to match their prices and at the same time make it small and easy to use. It would have to be injection molded from plastic. A local mold maker gave me a price. To build a mold for our product would cost over ten thousand dollars! This is where my career with machine tools really starts. We bought an old mill and a lathe from a company that



*Joe with machinist and longtime friend Benny Taguchi examine a molded part at Kraft Systems.*

wasn't using them any more. I was informed that these were the tools that had been used to start their business. These machines had a sentimental value to the owners, and they sold them to me at a very reasonable price. I believe they were thinking, "Maybe these tools can start one more business before they end up in a junkyard." We rescued them along with an old four-ounce Van Dorn injection-molding machine that Micro Avionics didn't need anymore after firing me.

#### **If you can't afford to hire a toolmaker, become one**

There was a mold maker in the area who suggested that I should attempt to build the mold myself. He gave me a general idea of how a plastic mold was made and where to buy components, and I was in the mold making business. Getting me pointed in the right direction at the start was my friend's real contribution, and it would be hard to evaluate how much time he saved me. I have always found if you need help on a project don't ask for too much. I started on the project and didn't ask for help until I really needed it. I read what I could on the subject, but my friend saved me from a many time consuming errors. I consider it an accomplishment that we were even better friends after the mold was completed. You shouldn't attempt to have your teachers do your work, because at that point you start using them. Who wants to help a lazy person?

#### **Production machinist vs. toolmaker**

Another point that should be discussed is the notion that a production machinist doesn't have to be as skilled as a toolmaker. These were my thoughts until I went from building plastic molds to setting up production equipment. I didn't have a clue as to how little I knew about the process of cutting metal. When building tooling, I would put a little cutting oil on the work and control speed and feed by the amount of smoke I was generating. You have to know more than that to cut metal in a production environment. Feeds and speeds are controlled by gears, cams and computers that don't allow for errors. If you are drilling one hole in a piece of tooling it doesn't make much difference whether it takes one minute or two, but if you have 10,000 holes to drill, that difference will cost 10,000 more minutes, which is an extra 167 hours of machine time. When you consider that most CNC machines cost over \$60 an hour (a dollar a minute) to operate, that extra minute you wasted drilling a hole comes out to \$10,000 lost.

#### **Minor irritations in working with hand-me-down tools**

The milling machine we purchased would "drive me up a wall" when I started building tooling for plastic molds. The handwheel for the table turned in the opposite direction from the way it should. Normally, if you turn a handwheel clockwise on any machine tool, the slide will move away from you. This may seem simple, but when you have a cutter in a mold cavity that you have been working on for a week, you take the chance of ruining it by turning the handwheel in the wrong direction. Just thinking about it would make me break out in a cold sweat. Also, if you allow a cutter to run in a corner too long it may chatter and undercut the cavity. This wouldn't ruin the job, but it could take countless hours to get rid of the flaw with polishing stones. This backwards handwheel never came naturally to me, and it was like trying to drive a car that had the steering reversed.

A few doors away from my shop there was a machine shop that allowed me to use a surface grinder to put the finishing touches on my mold. Each time I used it I would clean the grinder up to show my appreciation. Since then, I have helped several people in the same way and let them use the equipment in my shop when they were in a bind; however, I never seem to find my machine any cleaner when they are done.

It took about three months to complete my connector mold, and I was quite proud of it. It was what is called a "family" mold, which means a complete group of parts is produced at every cycle. When the mold closed, 180 pins had to mate with the opposite side, and the diameter of many of these pins was only 1/32" (0.8mm). Now I had to teach myself how to operate an injection molder. The injection molder we purchased was old, and old machines had a plunger-type injection system which left much to be desired and didn't have any instructions; however, I didn't know enough about it to realize how much of a problem they could be. Setting up this machine was a big deal for me because it was my first experience with an automatic piece of equipment. This fascinated me because it could be doing work without me standing over it. It took about four hours to get a good "shot," and soon the machine was producing good parts at a rate of 90 cycles per hour. I sat in the office with a big smile on my face listening to the old molding machine make good parts. You would think that now, after thirty years

of owning and operating automatic machines, they would have lost their fascination to me, but they haven't.

The contacts for the connector would have to be made on a Swiss type screw machine. It is a specialty type machine, and I didn't have the skill or the time to produce these parts myself. It was by chance that I contacted a company called Screwamatic, which was listed in the Yellow Pages. I could never have found a better source. The Yellow Pages have been very useful over the years, and it is where I usually start looking for something new. The next choice at that time was the *Thomas Register*, which is a collection of books that lists manufacturers of most everything. Today I use the World Wide Web or the Internet to help locate new sources, but sometimes I still start with the telephone directory. Many companies will refer you to another if they can't help you. We started with orders for 25,000 pins and worked our way up to ordering a million pins at a time. Their quality was 100% and it inspired me to improve every project I have worked on since then.

Each new tool I acquired was treated like a treasure in my shop. They were always used and somewhat worn out, but I could usually find a way to get them running and put them to good use. I soon had enough tools and skill to build simple plastic molds and did a small amount of contract work. How I wished I could have afforded the time to work for a mold shop for a couple have years where I could have properly learned the mold making trade. I really liked that type of work. I found it exciting to test a new mold I built and see if I didn't make any errors.

Looking back at it I often wondered whether I would have been better off buying one new machine rather than buying several used machines. I could have contracted out the work that required these specialized machines and concentrated on only doing basic machining. In some cases learning to operate some of these specialized machines was, in fact, learning a new trade. As I think about it, the main thing I learned was how to teach myself how to do different things without a teacher. On the other hand, each time I contracted out work, I would end up with problems with their delivery dates or price. At least I had control over my old equipment, and I found it less frustrating to fix a machine than argue with a supplier.

Our next project was a servo for RC aircraft. At that time, it was to be the smallest servo on the market.

PHOTO: GEOFF O'GALLAGHAN



*The Australian factory of Ron Sher Pty. Ltd. where the first Sherline machines were produced. Loose production tolerances of the early machines caused assembly to be a time consuming "mix and match" process.*

Injection plastic molds were a lot harder to build at that time because EDM machines (electrical discharge machine) were not available to small shops. To build a new mold and keep the doors open at the same time with only two employees took great effort on my part. It could take over 500 hours to build the mold. I usually worked on it when I was alone after hours. Twelve-hour, seven-day weeks were normal. A vacation was going to Los Angeles to a machine tool auction.

#### **Kraft Systems takes control of my company**

We started selling our connectors, but we weren't surviving financially. Carl, my partner, was still working at General Dynamics as an engineer, and the business was more of a hobby to him. Carl might come up with a few hundred dollars to buy an interesting machine, but when it was necessary to pay the thousand dollars of bills for rent, labor and supplies, he wasn't interested. I would have to go without a paycheck. Phil Kraft, owner of Kraft Systems Inc., offered to buy me out and start another company to manufacture our connectors for his company. We would also supply connectors to "Heath Kit" for their radio control kits. I would be a 25% owner and Carl would be a 10% owner of this new corporation that would be called Multicon Corp. At this time, Kraft Systems was rapidly becoming the largest manufacturer of radio control products in the world.



*This YAG laser gives Sherline the capability to engrave its own parts in-house. Doing as many jobs as possible in-house not only helps you control your own schedule and costs, it also gives you an excuse to buy more neat machines. If you look closely, the small bright spot of light in the green window on the door to the laser enclosure is the point of the laser beam actually burning numbers into a part.*

My job would be to integrate our connectors into their products and develop products for the model aircraft industry. The servo Carl and I developed would be turned over to another division. I wasn't too happy about this arrangement but realized it could create problems if I marketed it. We had hundreds of hours of labor and design in this project and were only paid for the outside cost we had spent. Unfortunately I wasn't in a position to argue this point. Kraft Systems sold over one hundred thousand of these servos, and it pleased me that our design was accepted, but the fact that Carl and I never made a penny on it always bothered me.

Kraft Systems was profitable and could afford to pursue new ideas. A division was also formed to manufacture a model aircraft engine. I sat in on an early meeting to discuss this project and lost faith in its success when we were told to the penny what it would take to build an engine. It would be impossible to predict costs this accurately, and I don't trust people that BS me. Roger Thibal proved me wrong about having the skill to build an engine but also proved I was right when it came to anticipating cost, which was off by 100%. We beat our brains out trying to build an engine that could be sold at a retail cost of under \$100.00. The biggest error we made was not realizing how much the future modelers would pay for a good product. We should have been trying to build a \$300.00 engine that was really better than any model engine currently on the market.

Phil Kraft, the sole owner of Kraft Systems Inc., was an interesting person to be around because of his many interests. He started in business by designing a small, single-channel radio control receiver that would fit into the plastic case that nickel cadmium batteries were sold in at that time. Transistors and nickel cadmium were new to the market at that time, and modelers were putting both to good use. Phil even put the box to good use. It was one of the few receivers that actually worked, and it gave Phil a good name in this new industry. It wasn't long before Kraft Systems was a leader in producing new radio control equipment. A spin-off business that became successful was manufacturing the joysticks we used to control our models. One of our first customers for joysticks was a manufacturer of electric wheelchairs. Then, the computer people found a use for joysticks when computer games started to become popular and sales took off. They became the major part of sales for Kraft Systems after Phil left his company.

The fact that Phil was a serious contender at any R/C contest and even won the world championship was of great value. I remember a photo session taken outside of the Kraft building in Vista where all the modelers (aircraft) who worked for Phil Kraft lined up with the trophies they had won on the ground in front of them. This picture wasn't rigged, and we had so many trophies on the ground we couldn't put them all in the picture. How I wish I could have had the advantage of all this input into my own company. In thirty years of business I've only had two employees take an interest in hobbies that would use the equipment we manufacture. The reason could be that it isn't a diversion for people who work with machine tools for a living. Never pass up a potential employee who takes an interest in the products you manufacture.

Phil was also buying expensive sports cars and aerobatic aircraft at the same time. I'm sure you have heard the expression "He who dies with the most toys wins." Phil was and still is a serious contender in this event.

### **Valuable lessons learned**

I was becoming a mold maker who could make molds for my own products but was not really good enough to make molds for industrial customers. This didn't particularly bother me, because I wanted only to make molds for my own products, not do contract work. I made several other products, such as a joystick and a retractable landing system for the

R/C industry at Kraft Systems. I learned a lot while doing it. Phil wanted me to develop a ready-to-fly R/C aircraft, and I was working diligently on the project until he told me he wanted a retail selling price under \$100 with a 45% discount to dealers. It became an impossible mission because I had over \$30 in outside cost. It wouldn't be worth the effort financially because it left only \$25 to build, package, advertise and sell it. I couldn't work on the project without an attainable goal and wanted out.

All and all, I learned about good design, tooling, packaging, advertising and the value of good instructions while there. All of what I learned would come in handy later. As I look back at my stay at Kraft Systems it was good for me, and I believe it was good for Kraft Systems as well.

### My first look at a Sherline lathe

Kraft Systems owned part of a company in Australia that assembled and distributed Kraft products in the South Pacific. They sent us a Sherline lathe, which was built in Australia, for evaluation. It was of interest to me because of the experience I had with the Unimat working on the NASA project. The Sherline design was far more rigid and had some other features that were superior to the Unimat. My love of tools told me there was a market for a small lathe such as this. At about the same time Phil Kraft decided to sell Kraft Systems Inc. to Carlisle Corp. There wasn't any interest in the Sherline lathe at Kraft because radio control and joystick sales were growing rapidly, and with the new owners taking over, the lathe was forgotten by everyone but me.

I stayed on at Kraft for a year or so but the interest in the job I had before the sale just wasn't there any more. This fact was brought to my attention when another partner, Chuck Hayes, asked me during a conversation at lunch, "If you're so dammed smart, why in the hell are you working here?" I thought about that for about five minutes and gave my two-week notice that afternoon. I was a person who needed to have more control than I could have while working for someone else. It was very difficult to work on a project I didn't believe in, and I wanted to make my own way. Chuck only brought this fact to the surface, and I didn't leave because I didn't like the people I was working with.

Once I had made up my mind to leave I was fascinated by how fast I lost all interest in the company. Until then, I would wake up in the morning

thinking of the days, weeks or year's task to perform at my job. Suddenly the interest was gone. It was as if someone flushed all the problems from my mind. I slept like a baby even though I wasn't sure where I was headed. It was obvious that this was a good decision for me.

My friends and family thought it was a very bad decision and wasted a lot of time trying to talk me out of it. I didn't get any help from any of the contacts I made while I was at Kraft Systems but I didn't expect any. My biggest loss was not having the time to be a real modeler anymore and drifting away from my modeling friends.

### The next venture: a great hobby knife that didn't sell

I took the money from my portion of the sale, \$40,000 after taxes, and started another company. Carl, my old partner and friend stayed at Kraft while I started Martin Enterprises. I contacted Ron Sher, the manufacturer of the Sherline lathe in Australia, and told him that I had left Kraft and was interested in marketing his products in the United States. Ron needed someone to represent him in this country and, at that time, I don't believe he had too many choices. We agreed to take this to the next level, and I ordered a few machines to start the venture.

**NEW**  
FOR MODEL BUILDERS  
HOBBYISTS  
ARTISTS  
CRAFTSMEN

**E-Z-LOC**

**BLADE HOLDER**  
DESIGNED FOR POPULAR BLADES

- UNIQUE DESIGN LOCKS BLADE SECURELY AND KEEPS IT LOCKED
- KHURLED END FOR EASY LOCKING OR LOOSENING OF BLADES, AN IMPORTANT SAFETY FEATURE
- PLATED STEEL BARREL OFFERS MAXIMUM STRENGTH AND RIGIDITY
- EXTRA LENGTH KHURLED GRIP
- PERFECT BALANCE
- LIFETIME GUARANTEE
- SLOTTED END ACCEPTS ALL POPULAR TYPE BLADES
- STANDARD DEALER DISCOUNT

SMALL HOLDER (200 SERIES) 1-1/4" Dia. x 1"	\$2.95
LARGE HOLDER (201 SERIES) 1-1/2" Dia. x 1"	\$3.95
SET OF BOTH HOLDERS (200-201 SERIES)	\$6.95

MARTIN ENTERPRISES • P.O. BOX 407 • SAN MARCOS, CA. 92069

A catalog sheet for the E-Z-LOC knife...a "b moustrap" that had no one beating a path to the door.

I had lots of time while waiting for the first machines and started thinking about a new product I could make. I wasn't lacking ideas, but the product had to be one that could be produced with limited funds. The first product I chose was a hobby knife that locked from the back end. I had used tools like this for years, and what I disliked about them was the blade would come loose if you turned the handle counterclockwise when the blade was taking a heavy cut. I had given myself a nasty cut because of this flaw, so I designed one that would eliminate this defect and use the standard blades available. I had a screw machine shop make me the parts for two sizes. I didn't know enough about manufacturing at the time and added too many costs to the product with my inexperience. It never sold well enough to make it worth the effort. The money to be made on products of this type has to be made producing the components or purchasing them in such large quantities that a reasonable retail price is attainable.

From this venture I learned that if you build a better product, the world would not beat a path to your door unless a distributor can make more money on your product than he is presently making on the similar product he is now marketing. The first question usually asked by distributors was, "What's the discount?" If they didn't like the discount they wouldn't even listen to your sales pitch. It makes more sense to me now that I realize sales organizations are more interested in selling the products they already have on the shelves than they are in selling yours. They will stock something new



*Here's a project that was made strictly for fun, not function. This cube within a cube within a cube is an interesting conversation piece. Made from one solid piece, the cubes will not fit through the holes. How would you make it? This very small example was made by Dick Saunders.*

only when they are forced to by consumer demand. I also learned that if you advertise your product and it isn't on the shelves in the appropriate retail market, you might end up selling your competitor's product. The storekeeper is going to try to sell what is on his shelves first. In other words, if a Sherline ad inspires you to purchase a lathe and you go to your local hobby shop where they have an old Unimat on the shelves, that is what they will try to sell you.

#### **Australian Trade Office gets help in contract with Sears**

Before Ron Sher and I had any agreement, the Australian Consulate in Chicago had Sears interested in selling the Sherline lathe, and for Sears to sell the lathes they needed to deal with a U.S. representative. We met in Chicago at the Sears Tower. A representative from the local Australian trade office had arranged the meeting. A representative of Sherline Australia, a buyer for Sears and I were there. We all knew what the other party was going to pay for the product and charge for the product as it passed through our companies. It still took another trip to Chicago to get the order. The buyer was very apologetic and informed me the sample machine we had sent them was stolen. Jokingly I told him that our product was so good people will steal it if they can't buy it. Actually I was glad it was missing, because I never had a chance to go through it, and from what I had seen of the quality so far, I was worried. Sears gave us an order to produce the lathe with a "Craftsman" label, but I'll always wonder if we got that order out of sympathy because they lost our machine. I was in business again. The main problem for my family and I was eating regularly until these orders materialized.

#### **An expensive first fifty machines**

It was never my intention to manufacture this product. I only wanted to import and service the machines and possibly make a few accessories for it. The first fifty machines were supposed to have been air freighted in time for an upcoming trade show in Toledo, Ohio. They didn't make it in time for the show, but I still sold around twenty machines. At the time, air cargo rates to the South Pacific were very expensive, about \$30 for each lathe. The shipment to me was late, so they were delivered to the customers by UPS air to keep them happy. Now I had \$50 in each machine just in shipping. The machines were also sold at a very reasonable price

to get the product introduced. It worked out that \$40 per machine was lost even if overhead and my labor weren't included. In addition, the quality of the product as it came from Australia just wasn't good enough for the American market, and I had to rework the machines by matching parts and had to cannibalize several machines for parts. Not too good a way to start a new business.

On the other hand, there are few products that can be manufactured and be financially successful on the first go-around. The profit in manufacturing comes from low manufacturing cost, and this isn't possible at the introduction of a new product. There are only two ways to lower production cost. You have a choice of higher quantities or better "tooling". Consider another advantage of CNC machines that lowers nonrefundable tooling cost. The machines may seem expensive, but these machines also hold their value. Compare that with a special machine designed to produce a special part that may take a year to be built and cost more than a standard CNC machine. You'll be lucky to get one cent on the dollar for it if your product bombs out. I would never recommend going for higher quantities as you could end up without any money and with a lot of product that was worthless if it didn't sell. It would be better to take a loss as I did on the first machines to see if the product will sell than to have thousands of dollars in parts left over. Price the product so it reflects a price that could be charged if it becomes successful.

### **Bigger holes won't solve the problem**

The biggest problem I had with the quality of the Australian-made machines was sloppy tolerances. A good example to explain this type of problem would be two holes drilled and tapped in a plate. Now you have second plate you want to bolt onto that plate using the tapped holes. You go to assemble the two plates and the holes don't quite line up. Now you have two choices; either start over with tighter tolerances or drill larger clearance holes in the second plate. If you are dealing with production parts and you make a choice to drill bigger holes you will find out why Henry Ford succeeded when others failed. It becomes impossible to profitably manufacture a product that doesn't have tight enough tolerances. When the tolerances get sloppy it takes your best and highest paid employees to assemble that product, because they have to "mix and match" parts. Never get into the habit of drilling larger holes.

### **Problems with the Sears contract shifts production to the USA**

My name was on the contract with Sears, and I knew I was in trouble if I couldn't get the quality improved. The amount of profit I would receive from a sale wouldn't allow me to spend time reworking the machines. Before going on with this venture I decided to visit Ron in Australia. It is important to realize that by this time I was running out of money at an alarming rate. The visit with Ron Sher and his staff gave me more confidence in his organization. I believed we solved a couple of technical problems and I returned home. I had about four months to get ready for my first shipments to Sears when I got a telegram from Australia. I can still remember it as if it were yesterday. It said, "Dear Joe, losing our bloody ass down here. As of today the products will cost \$\_\_\_\_." The problem was the new cost to me would amount to a \$50 loss on each machine Sears would buy even if I didn't have to do any work on them. Ron wasn't totally to blame because things were changing rapidly in Australia, and he was a victim of circumstances. However, it was my name on the contract with Sears. In reality, I didn't have anything to lose because I was flat broke, but I'd be damned if I would fail and not live up to what I agreed to. Ron agreed to help me set up production of the Sherline lathe in the USA. I had a Bridgeport mill and an old lathe in my garage and I started making parts. Sherline Australia would send me the parts I couldn't manufacture such as the die-castings. They were very helpful, and I will always appreciate how Ron Sher and his staff handled this matter. I found a motor in the Grainger catalog that I could purchase in production quantities and built a simple speed control. Sherline lathes were now "Made in the USA."

### **It's "make it or break it" time**

I was on my own and had to do it all myself. The first major change I made was to grind the lathe bed. I found an old surface grinder for a \$1000, repaired it and put it to work. The imported machine used an extruded brass bed that wasn't very straight. Extrusions are not perfectly straight and have tolerances that allow 0.010° twist per foot. This was unacceptable for any machine tool. The twist and

---

*"I am a great believer in luck, and I find the harder I work the more I have of it."*

—Thomas Jefferson

---

size variation would also cause too many assembly problems, but what was more important was the fact that American customers wouldn't accept a metal lathe that wasn't accurate.

I wasn't even sure I could grind brass. I built a couple of fixtures to hold the bed, but my first attempt was a disaster because the grinding wheel loaded up so fast. I thought I had taken on an impossible task. I added coolant and changed coolant but still no success. What eventually made it work was a new type of grinding wheel that had just become available that was very porous. This worked like a charm, and we only had to "dress" the wheel a couple times a day. Grinding the bed turned out to be the most expensive machine operation in building the lathe then and now, but it was necessary. A tool has to perform the work it was intended to do no matter how low the selling price.

An interesting problem arose later over the angle I chose to grind the bed dovetail. When I built the tooling to hold the bed for grinding, I simply copied the existing angle using an indicator so it would match the associated parts. I never accurately checked the actual angle. I wished at that time that it were a standard dovetail angle because I wouldn't have to make special cutters that we matched to a gage. I later measured the angle and it turned out to be 55.5°. Twenty years later I was accused of using that angle because it couldn't be easily copied. When I found it being discussed on the Internet and few believed me I began to understand how politicians feel when these complex conspiracy theories are laid in their laps.

At the same time I was looking for and found an extrusion company to produce the basic lathe parts needed. There wasn't any other way to produce the machine at a reasonable cost. Customers sometime believe that we could produce a machine with heat-treated and ground steel slides for just a few dollars more. The truth is, it could easily cost twenty times more. I believe the choices we have made give the customer the most "bang for the buck."

The method Sherline Australia was using for a gib (the adjustable piece used to remove "slop" in machine dovetails) was unsatisfactory. It was hard to adjust and keep in adjustment because of the setscrews used. I had to come up with something different. I just couldn't stop and wait until I came up with a better idea. We had to go full speed ahead on all the parts that I knew how to make. The design

for a gib I preferred was used on many machine tools. The gib was a wedge shaped piece adjusted from the end; however, a corresponding angle had to be machined in one section of the dovetail. A gib of this type would be difficult and time consuming to produce. It was on a Thursday when I realized that I could build a simple injection mold to produce this part. I immediately set to work and had the mold completed by Sunday night. A friend allowed me to run a batch of parts on his injection-molding machine to help me get started, and I had another major problem solved in an inexpensive manner.

Building the first machines wasn't that hard unless you wanted to make a profit. The parts are relatively easy to make, and having machines on the shelves was my only interest. The main effort had to be getting production machines running if we were going to last beyond our first shipment. CNC machines were not available, and it took many operations to produce some parts. Each operation would increase the chances for errors. "Scrap" was a word that took on a new meaning. We had to walk a very narrow line. If we scrapped out every part that wasn't perfect we couldn't ship anything. If we used every part that wasn't perfect, we would produce junk. My job became very difficult. I started to learn about the tolerances we could manufacture parts to as well as the tolerances the product needed to work properly. This was a lot more difficult than one would think, and many hours were spent reworking parts. The main problem then and now is we are trying to hold tighter tolerances than the process allows. Successful companies all work within these constraints. If it were easy, everyone would do it.

### **Dealing with Sears**

The buyer from Sears, who later went on to become marketing director for my main competitor Unimat, encouraged me and was amazingly understanding of my plight. In later years, I enjoyed seeing him at trade shows and never felt as if I were betrayed. It was just business. The space allowed for my products in the Sears catalog kept getting smaller and our sales dropped proportionally. Sears eventually dropped our product line, and their new policy was to sell only the most popular items. Every similar company took the same approach and they all started selling the same products. This has hurt Sears because successful merchants meet the needs of all their customers, not just most of them. Just

think where Sears could have been today if they had “hung in there” with their catalog sales and complemented them with Internet marketing.

Sears is actually a very nice company to deal with if you produce a product their customers like. I’m sure you have heard the same horror stories I heard when people found I was going to sell to Sears. “They will take you over after they order more parts than you can produce.” This was not the case, and I have nothing but good things to say about Sears even though they no longer sell our products.

On the other hand, losing Sears as a distributor wasn’t as important to me as you may think, because I had several ways to market the product other than Sears. I always make sure I don’t have “all my eggs in one basket.” Sears was always asking for special reports and could be a pain at times. If you sold 10 or 10,000 you still had to abide by the same rules. One time when I went to Chicago for a meeting, the buyer didn’t have any interest or knowledge in tools. She should have been buying fur coats not power tools. I always had the feeling that a horn could blow at any time during the day and all the buyers could have moved to a different office, like a game of “musical chairs,” and picked up the conversation

PHOTO: BRENT BACHIM



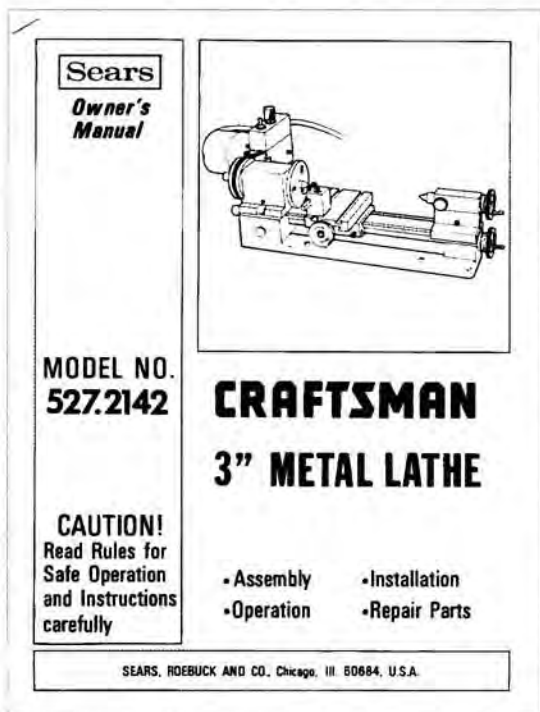
*When the Department of Engineering at Texas Christian University in Ft. Worth, Texas decided that students and teachers needed to get some “hands-on” experience to better understand the machining process as it relates to manufacturing engineering, they chose Sherline tools for their shop. They also use the tools to teach an “Introduction to Fabrication” course to high school students.*

without missing a word. What really impressed me at the Sears Tower was a gold plated radial arm saw in the office. It was the one millionth manufactured. Think about the warehouse area that it takes to store products used in these incredible amounts.

### **An American company’s place in the world market**

American manufacturers are at a disadvantage when it comes to selling throughout the rest of the world. The U.S. market is the largest market in the world, and we now have a great distribution method to get products to the consumer with very little markup. The discount chain stores have such a large buying power it allows them to deal directly with manufacturers throughout the world. Products are shipped directly to their warehouses with no middleman markups. This is a great deal for consumers, but it makes for tough competition for an American manufacturer.

This distribution system isn’t available to an American manufacturer wishing to sell a product outside the United States. Outside the U.S., a broker may import a product and sell it to a distributor who sells it to retail stores, and finally it is sold to the consumer. The problem is that everyone wants to make 40% when they handle it. A U.S. product gets marked up so many times that it is no longer a good buy, but it isn’t the fault of the manufacturer. Import duty also can add to the cost of the product. I have had complaints from Japan, for example, where someone thinks our \$1500 lathe should be more



*The high standards required by Sears in their instruction manuals established a precedent for all Sherline instructions which would follow.*



*A complete accessory line takes a long time to design and produce, but it is one of the things that gives a prospective buyer confidence in the basic product. No matter what you may want to attempt with your machine down the line, an accessory is available to help make the job easier. Despite the small size of the machines, the sheer number of custom accessories makes Sherline able to claim "the most complete tool line in the world, regardless of size." This photo only shows the smaller accessories. Larger ones like the vertical milling column, horizontal milling conversion, etc. are not shown here.*

accurate for the price. I can only tell them that it is very accurate for a \$460 lathe, but I have no control over all the markups between here and there that turned it into a \$1500 lathe. Unfortunately, middlemen contribute to increasing the price with no corresponding increase in the quality of the product.

To make matters worse, U.S. manufacturers must compete with companies that sell products here that don't have to deal with the higher safety and environmental standards set by OSHA and the EPA. I'm not suggesting we should do away with these agencies, for I believe they are needed to protect our workers and citizens. I'm only reminding you of some of the problems that face U.S. manufacturers.

#### **Good instructions make things easy for everyone**

Being self taught made me appreciate good instructions, for I'm sure I have spent at least a thousand hours trying to sort out the incomplete instructions that came with some very expensive machines. I have tried to write instructions that would be useful and give a novice some insight as to not only "how" but also "why" you would want to use an accessory. Once the customer understands this, their imagination takes over and they may use an accessory in a fashion I never dreamed of. Sears

once complained that my instructions were too "folksy." I asked them how many customers have called with a question about that particular instruction and who they had available to answer such a question if one were asked. Sears decided that my instructions weren't so bad after all.

Sherline's customers are intelligent people who just don't happen to know too much about machining, so I don't have to write everything in a style that an idiot could understand. The more you know about a subject, the more you know there is always an exception to a rule. This can make for very boring and cumbersome instructions if all these variations are included. Most manufactures of tools solve the problem of instructions by not giving any except assembly and safety rules. They do this primarily to cover themselves in case of a lawsuit. The instructions also read as if they were written by a lawyer—which they probably were.

I also know that the longer the instructions, the less likely they will be read. The trick is to make instructions for a difficult task short enough so that they will be read but long enough to get across all the important information. By carefully choosing my words I can avoid writing about all these variations and still be accurate. Craig Libuse then takes my writing and arranges it with some of his marvelous

drawings and photographs, which he takes himself in our own in-house studio. The process has been simplified since we purchased a digital camera. This book, for instance, will go to the printer on a single CD that will be used to directly make the printing plates. No more time consuming typesetting, pasting and stripping. When we are done, we have a book, sales literature or instructions that we are proud of.

For me the fact that all the work, except printing, has been done "in house" is great. It gives me complete control over the entire process. I can be my own publisher; however, I do lose the marvelous marketing capabilities of large publishing houses. I am fortunate to have the resources now to publish the book myself, because I don't have the time or the desire to go from publisher to publisher begging to get my book printed.

I look at instructions the same as tooling to build the product. The better the instructions, the lower the overall costs. We constantly update our instructions to try and eliminate confusion. All our instructions can be found on our Worldwide Web site (<http://www.sherline.com>) and can be downloaded for free for your own personal use. I can't understand why more companies don't use the Internet in this fashion. Most of the rules for cutting metal remain the same whether your machine tools are full size or miniature like Sherline tools. Many amateur machinists, whether customers or not, find the information we provide there useful. They appreciate this and we gain by their kind words and referrals.

Good instructions also have another key function. Customers usually ask questions that can only be answered by the most important and costly people in the organization. This keeps them from doing the work you had hired them for. Good instructions allow these key people to do their jobs without constant interruptions with questions that should have been answered in the instructions in the first place.

#### **We ever misrepresent our products**

One thing we try to never do is misrepresent the capabilities of our machines. If anyone has ever called Sherline to ask, we answer honestly, and they know we never try to sell a machine to anyone when it wouldn't be appropriate for their projects. I don't want to waste time on the phone explaining to an unsatisfied customer why you can't make a tool steel shaft three inches in diameter on a three-inch lathe.



*Over the years we have seen many Sherline tools used in production setups. Sometimes only parts of them, such as the slides or motor and speed control are used, because it is cheaper to buy a whole Sherline lathe or mill than to buy or build a specialized industrial component. In 1998 I introduced a line of small manual and CNC-ready industrial slides based on our machine components to address this market. Sometimes a small change is all that is required to adapt a product to meet the needs of an entirely new market.*

Actually, I am sometimes amazed at some of the projects that are built on Sherline equipment, not only because of the complexity of the project, but also because of the size. I have seen projects done that really were too big for the machine, but the job was completed because the builder worked with what he had. Working with what you have is what it's all about with hobby projects. Time is not money when working for enjoyment in your home workshop. Being a hobbyist myself, I've been asked many times how I have the patience to spend so many hours working on a model aircraft that could crash. My answer has always been that it doesn't take any. If you are doing something you enjoy it doesn't take patience. What takes patience is working at a job or for a boss you don't like just to keep food on the table for your family. Non-hobbyists believe it takes patience to do small, precise work only because they don't enjoy doing work like that themselves.

#### **A vision for miniature machining**

You can spend quite a bit of time and scale down a set of plans to fit miniature tools, and I believe you'll have a better model because of it. In the future, I can see plans for hobby projects being sold on a disk that includes a drafting program. After deciding the size you want to build the project, the program will print out a set of dimensioned drawings in the scale you choose. Actually you could do this today

with AutoCad®, but no one is yet selling plans in this format. The problem with this at the present time is that you can't scale off-the-shelf items such as screws, and the model would be very difficult to build with non-standard fasteners and threads. It will happen eventually though, because it is a better way. This will make scaling things down to smaller sizes easier. Throughout the ages, miniatures have always had a fascination all their own. Miniature models are treated like jewelry. Their appeal is based in part on their size alone, and that helps make them attractive to people who might otherwise have no interest in the subject of the model itself.

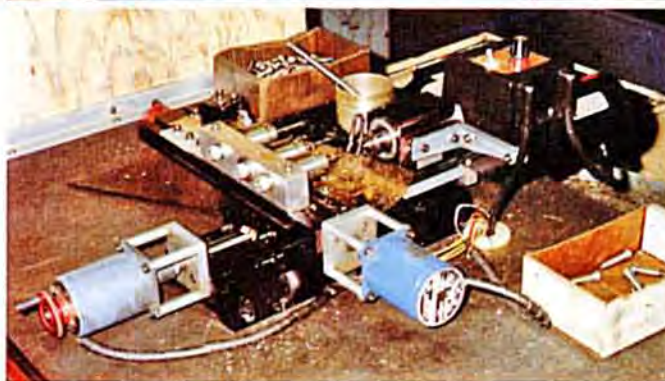
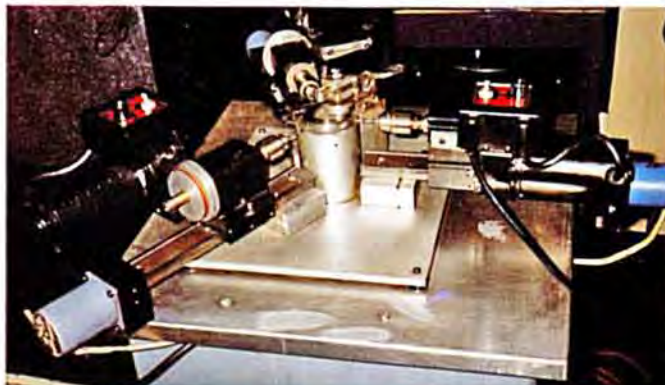
### **Wheelin' and dealin' for production tools**

When I originally imported the lathe from Australia, the only accessories that were available for the Model 4000 lathe were three and four-jaw chucks, steady rest, live center and a screw cutting attachment. This represented about ten percent of what was needed for a good accessory line. For me to take on producing these machines was a monumental task without considering the accessories. Fortunately, I just wasn't smart enough at the time to realize it.



*The Sherline bearing journal boring machine is still going strong after over 25 years. It has turned out to be one of my all-time best machine buys.*

I knew I would need machine tools to produce the parts I needed and this gave me an excuse to start buying machine tools. This is the part I loved. I would go to South Santa Fe Street in Los Angeles and look for bargains. One machine I came across had two opposing spindles that would be perfect to



*Sherline uses some of their own tools for small jobs in their production line. Shown here are a number of special tools used for making chucks and collets. Clockwise from top left: Drilling tommy bar holes, grinding inside of chuck jaws, checking chuck runout and a setup to center drill, drill, ream and face collets.*

bore the headstock for the bearings. It would require little modification. There were three of them. The only problem was they wanted \$8,000 for each machine. This was a bargain when you considered that they cost over \$20,000 new, but I couldn't afford even \$2,000. I bored my first run on my Bridgeport and kept a quiet eye on these machines. Machinery sales were terrible at this time and the price was falling. I made my move right before Christmas when I believed that dealer, like everyone else, would need money the most. I offered \$1,500 for one of them. We negotiated for a while and I ended up paying \$1,700. Every mill or lathe I have sold since then has had its bearing journals bored on that machine. I think I made a pretty good deal.

### **Making chucks turns into quite a challenge**

Manufacturing the three-jaw chuck was my biggest problem, as it was not a straightforward machining problem. At the time you couldn't just program a CNC machine to cut the spiral scroll, so a special machine had to be designed and built to do the job. I ended up milling the spiral using a rotary table that was geared to the table feed at the correct ratio. The rotary table, an item that I rescued from a pile of junk, was driven by an adjustable speed drive that I found in a junkyard where I also purchased the limit switches I needed. I ended up spending less than \$300 and three days on the project. It took three and one half minutes to machine the scroll, but the actual labor was only the time to load the part. It



*With modern CNC machines I can now produce all the parts for this chuck in 15 machine operations, which is less than 50% of the operations of our first attempts and 33% of the time. The quality also improved by 200%...another reason that I love CNC machines.*

turned itself off automatically. I shudder to think what it would cost to do a similar project in my own shop today.

To cut the teeth on the chuck jaws I used a suggestion from the Sherline shop foreman in Australia. It wasn't the way they were generating the teeth at the time, but he told me if he had it to do over again he would try his idea. I bought my first electronically controlled machine to accomplish this and cut the teeth. It worked great and we still machine them that way. It took every penny I had to get the chuck into production because I had to also purchase a large screw machine to make the chuck bodies. We kept trying different methods to improve the accuracy. It took many secondary operations to improve the three-jaw chucks a couple percentage points. Many people are still surprised that we manufacture our own chucks. After going through the learning curve, I can see why others might not want to take it on such a project.

### **First new Sherline accessory—a new screw cutting attachment**

The first accessory I decided to build was a replacement for the Australian screw cutting attachment. At this time the thought of producing the entire product line wasn't even considered, and I was just "fooling around." The Australian screw cutting attachment was limited and did not have enough gear combinations. I wanted to cut more threads in right- and left-hand leads. Most common threads are cut with taps and dies. You don't cut threads on a lathe unless you have to. It is a slow and costly. The threads you may have to cut are unique, and taps and dies either can't be purchased or are very expensive. To be worthwhile, a complete range of threads was needed. The present system didn't have enough combinations to be useful. To build this accessory, gears would be needed. Contract gear makers could cut the gears, but the cost would be around two dollars each in relatively high quantity. I had to cut them myself in order to keep the price low enough to have a customer for this product. A machinery dealer, who didn't ask for a commission, found me a dirty old gear hobber with a complete set of gears for less than a thousand dollars. I cleaned it up and painted it. It worked great and has cut every gear since. If you are just starting out and are willing to work, it is amazing how much help is out there if you are not looking just for money.

### **An apparent step backward becomes a step forward**

After cutting a set of gears for my attachment I knew I had solved only one of my problems. To cut the expanded range of threads, you couldn't disconnect the spindle from the lead screw without losing your place. I wanted to check out my gear combinations; so I took the motor and speed control off and put a crank handle on the rear of the spindle. I set up the gears for twenty-eight threads per inch. I planned to make a 1/4-inch diameter, 28 threads per inch bolt (abbreviated as 1/4-28). I figured that would be a good size because there were hex nuts of that size around my shop I could use to check the thread. I engaged the lead screw and took my first pass (cut) by cranking the spindle by hand. I stopped cranking when I got to the head of the bolt, backed out the crossslide, and cranked the spindle backwards until I was at my starting point. The crossslide was returned to a position that would take the second cut, and I cranked the spindle and took the second cut. It was as easy as tapping a hole with a hand tap. You could stop close to a shoulder without worrying about "crashing." I realized it would be perfect for a novice machinist. This was going to be a tough item to sell, as hand cranking might appear to be a step in the

wrong direction, but it really worked well. I decided to put it into production.

### **Personalizing the Instructions**

I think it is also worth noting that this is when I decided the style of instructions I would write. The only thing I did change later was to put my name at the end of these instructions. At that time I didn't believe my name had any value, and I was trying to establish a value for the "Sherline" brand name. About ten years later I began to realize that customers took an interest in what I wrote. I added "Joe Martin, president and owner" to all the instructions I had written and still do. I enjoy the fact that people are finding what I write worth remembering.

### **Carl Hammons comes aboard again and the business grows**

Carl, my friend and ex-partner, joined forces with me again in Martin Enterprises. There aren't too many people who have been partners twice, but we worked well together. I had acquired a surprising amount of operating machinery, and Carl's job would be to find contract machining jobs. Carl wouldn't own any Sherline stock because this corporation was already formed and Sherline Australia was part



*When going from miniature machine tools to full-size shop tools, the costs go up dramatically. Just moving them can be expensive, so do a lot of homework before you buy. Sherline's shop represents over a million dollars in tool purchases over the years.*

owner. Carl called Hewlett Packard on a day that they were looking for a new shop to do some contract machining, and before we knew it we had 35 of our 55 employees doing outside contract work. Our main customer became Hewlett Packard.

### **A simple agreement**

I was too far along with Sherline and unwilling to give up any ownership to Carl. This was my “baby” and I wanted complete control. I had been working at the new business for three years when Carl and I joined forces again and had spent \$90,000 for equipment; therefore, I felt Carl should invest \$45,000 in additional machine tools and work one year without wages for one-third ownership in a new company dedicated to doing contract machining. Carl agreed and we became partners in Martin Enterprises. I was now flat-ass broke, and to survive I had to make a profit from this time forward.

### **Business is great!**

I had two major mail order companies selling our machines within a year of starting: Sears and Brookstone. Both were good customers and paid their bills within 30 days. A major point I'd like to emphasize at this time is that when you're dealing with large selling organizations they will always be more interested in their customers than in your well being. They are being ethical to their customers when doing this and not being unfair to you. Don't expect them to cover your mistakes and risk their good name. Don't expect them to not go to another supplier who offers better quality at the same price or the same quality at lower prices. It is possible to make a great deal of money dealing only with a single organization like Sears, but you have to remember where their loyalty lies.

Sherline had about 25 employees at this time and we were cruising. I had three rented 2000 square foot shops next to one another. Darrell, my shop foreman was doing a good job, and every now and then I began to feel a twinge of success.

### **More work means new and bigger problems**

The new contract machining work became a nightmare for me. The problems I had to solve were no longer just my own. We would be overly optimistic bidding jobs and lose our ass doing them. Most of the problems were caused by inexperience in holding tight tolerances. Customers would be late on payment, and I would have to dig into Sherline funds to make payroll. If a customer had made an error on their drawing and we had already run their



*An operator takes advantage of the CNC controls that can be added to a newer Bridgeport mill. Regardless of size, if you plan to buy equipment to do machining, buy the best mill you can afford. Most of the deficiencies of a worn out lathe can be overcome by good technique, but it is almost impossible to make good parts on a worn out mill.*

part, they would try to find a way to reject it and not pay us. We were doing over \$400,000 a year in contract machining and I gave all up.

What brought this about was my hand got caught in a screw machine that was running H-P parts. I was trapped for 30 minutes before an employee found me. The machine had to be taken apart to free me. The reason I was running this machine was the screw machine setup man was out on another drunk and H-P wanted their parts. My hand was squashed but not broken, and while I was sitting in the office recovering, the buyer from H-P called and threatened to go elsewhere with their work if I didn't quote on a job that I believed had tolerances that were impossible to hold. Of course, the buyer didn't know that I had just squashed my hand making H-P parts, and I wasn't in any mood to take any crap from anyone, but it happened. I retaliated by increasing their prices by 20%, and guess how much work I was doing for them the following year? You've got it - \$0. This is one case where we both won.



*Chips from this CNC lathe are carried off by a conveyor belt as metal is removed at a rate of over two pounds a minute. Despite this huge capacity and the ability to make rapid tool changes, the level of accuracy it can produce is astounding.*

I never did learn how to bid work, and I didn't own the new machine tools it takes to do the work that pays well. I should be writing a book called "How to lose your ass doing contract machining." I guess we weren't very good at contract work because nobody seemed to miss us. I tried to be a hero and find work for my existing employees and lost about \$75,000 in six weeks. Everyone slowed down because there wasn't much work around at the time, and the layoff that should have happened six weeks before finally happened. I vowed that I would never make that mistake again. It would be hard for the average person to realize just how hard it was to come up with the \$100,000 working capital I had. To waste it on employees who would rather be collecting unemployment was inexcusable.

We kept our best employees and everyone worked in a more relaxed atmosphere. I found out that just getting "shop time" doesn't make you any money no matter what the overall sales may be. We ended

up with a lot of specialized machinery to make unique parts for other companies. I traded all this specialized equipment for a couple of new CNC machines. We would learn to use these new machines to build Sherline parts. The most interesting thing was rather than going broke, Sherline started having money left in the checking account when I stopped doing contract machining.

### **A new home for Sherline**

I started the business in my garage and then moved into an industrial complex. The first unit rented had 2000 square feet and was quickly filled it up. Each time a neighboring unit would become available I would rent it. Having enough room for employees to work efficiently was important. The end result was I ended up with five units and had a considerable rent payment each month. A Realtor stopped by one day and offered me an opportunity to buy some industrial land. It looked pretty good so I offered the price that was asked. I waited for several weeks for an answer. I then found out that my Realtor didn't have any agreement with the seller. He was trying to get that agreement with the seller before making my offer. Maybe this is why I avoid dealing with Realtors to this day. By this time, however, I had convinced myself I needed my own building. The salesman both succeeded in whetting my appetite to own a building and encouraged my tendency not to believe salesmen at the same time.

### **Looking for some land to build on**

I remembered a couple longtime model aircraft friends, Granger and Larry Williams, who had some industrial land for sale. Their agreement had just ended with a Realtor who had their property listed over two years without a sale. They agreed to discount the Realtor's commission and offered me the land for \$36,000. I agreed on the spot. I would worry how to pay for it later. The best part came later when I was informed that they didn't want the money in one lump sum for tax reasons. I didn't think it could get any better than this but it did. I learned a whole new term at our next meeting: "subordinate." What it meant is that they would allow me to build on the property before it was completely paid for. I still didn't fully understand the implication but started looking for a contractor. Lusardi Construction was building most of the industrial buildings in our area so I approached them. They had a design-and-build plan that would be perfect for a business like mine. I had a modest



*When I moved into my first building at 170 Navajo Street, I had so much room to spare that I considered renting a section out. After much soul searching I decided I didn't want to be a landlord and soon filled the remaining space with machines producing parts for contract customers.*

building in mind that I thought we could afford. Lusardi looked over the property and came back with their suggestions. They proposed a building design that was twice the size we had asked for. It was also three times the amount of money we could come up with for a down payment.

#### **Good fortune keeps smiling on us**

I was banking with the Bank of America at the time and I knew Bernie Koston, the president of the local branch, quite well. I had made and paid back several small loans to convince him I was a man of my word and could be trusted. Bernie and my contractor had a meeting. This is when I found out how important subordination was. The bank considered the land to be completely paid for because the land had been subordinated. The bank felt the lot was worth \$55,000 even though we only had \$9,000 in it. This gave us the \$55,000 down payment we needed. We found out later that we had purchased the last reasonably priced land in the area. Bruce, the representative from Lusardi Construction, convinced my banker that it would be foolish to build a small building on such a good lot. Carl and I took a break from this meeting and we both agreed we were getting in over our heads. We looked over at Bruce and Bernie making plans for payment schedules for the construction loan. I finally said, "Carl, let's just keep nodding our heads until someone says we can't do it." Before long, the bulldozers were tearing up our lot and our 18,000 square foot building was

started. Carl and I couldn't believe it, for we still only had \$9,000 in the project at that time. I had worked in the building trades for 13 years after high school and it taught me how to get a job done. Although I wasn't a carpenter or an electrician, I hired a carpenter and, with his help, built the interior of the building myself to save money. We were going to need it.

#### **Stretching to grab the brass ring as opportunity passes by**

I believe a person goes through life and has opportunities pass by. The opportunities are there but you have to "stretch" to grab them. Most of the population let these opportunities pass on by and then complain about the opportunities that got away. Getting our building started and finished was a perfect example of "stretching". When opportunity knocks, answer the door...don't just sit in your chair and yell, "Who's there?" Opportunity drops by now and then, but it doesn't wait around long.

#### **CNC equipment brings us to a new level of quality**

When we bought our first CNC lathe it eliminated many operations and improved the quality of the parts at the same time. I couldn't believe the accuracy that could be attained with these machines. It was love at first cut. I immediately started looking for a NC mill with a tool changer and ended up purchasing a CNC mill. The difference between NC (numerical control) and CNC (computer numerical control) is that to edit the program on a NC machine you had to change the paper tape that controlled the electronics. On CNC machines you could edit the program that was contained within the computer. The tool path was generated directly from the software as the machine cut.

As an example, consider cutting an angle on a CNC milling machine. The machine must move both the X-axis and Y-axis in unison to generate an angle. A CNC machine would calculate the amount of movement as it was cutting and could cut at over 100 inches a minute. This fact would change the way metal parts would be made in the future, for no longer would you have to use special cutters and operations to make complex parts. You could cut a complex shape at the same speed as you cut a straight line. In most cases you could generate shapes with standard cutting tools using just a few lines of code. This allowed me to design parts the way I really wanted them. You no longer had to work within the old constraints of what was possible.

### **Ball lead screws make precision CNC cutting possible**

The lead screws used on these machines should be mentioned. They are the interface between the computers and the mechanics. The problem of backlash was solved with "ball lead screws". These screws have recirculating balls that roll in a groove ground into a shaft at a pitch of two tenths of an inch. The pitch on these screws has increased over the years to achieve speeds over 1000 inches (25 meters) per minute. At a pitch of .200" (5mm), a lead screw would have to turn at 5000 RPM to accomplish this speed and is why ball lead screws have as high as one inch in pitch. Even more amazing was the fact that they improved the accuracy as they increased the pitch. You can make a .0001" (.025mm) correction on a good CNC lathe. Think about that. A slide will accelerate to a speed of over 1000 inches a minute in less than a second, move a short distance and decelerate, stop and still be accurate to one ten thousandth of an inch. The ball screws must be very precise because a lead screw would be useless if it had any backlash (the amount you have to rotate a lead screw before the slide moves). Ball lead screws are very difficult to make which makes them quite expensive; several thousand dollars for each axis. The people who solved the lead screw problem should be commended as much as the electronic geniuses who came up with the computer controls. At Sherline, we have machines that have been running over ten years and still don't have any noticeable backlash.

### **Machines sometimes pay for themselves in one part run**

In many cases, I could buy an old machine, fix it up, make my parts and have it cost me less money than I would have spent on a single production run of parts from an outside source. I also had control of when they were run. At Sherline, we make all our own parts in house. I only contract out plating, painting and a few screw machine products. Even

these I could make if I had to. This has given us an independence that few companies with a complex product line have.

### **Cutting speed vs. tool wear and deflection**

In order to drill a hole in the most efficient manner you need to know the correct feed and RPM, but it's still not that simple. At one feed rate you can drill a thousand holes before the drill will get dull and start drilling oversize. A faster feed rate may save 15



*Coolant and chips fly and coat the windows inside this Mazak H400N machining center. Since you can't see what is going on, you had better be sure you know exactly what is going to happen before you push the "cycle start" button. Surprises are usually unpleasant.*

seconds per hole but the drill will have to be changed every 200 parts. I'm sure you are thinking, "What is so hard about that?" It isn't until you consider the other machining operations that are also being done to this part at the same time, each with its own set of problems, then you can see how complicated it can get.

For example, end mills deflect or bend according to the load, diameter, and sharpness of these cutters. A long end mill can deflect over ten percent of its diameter at the cutting end. This is always changing; therefore programs must be created that allow cutters to get dull while still keeping the part in tolerance. We very seldom write a program that will make a good part efficiently on the first try. It usually takes three or four tries until we are satisfied.

Production equipment runs parts inside the machine. The part is deluged with coolant so it is hard

to see what is going on, yet you have to know. If you stuck your head in there to see what was going on you might lose it. Setting up CNC machines today is like test flying a new aircraft each time you check out a new program. You will never appreciate how far these machines will go to try and please you until you put in an offset that is off by one decimal place (a number entered into a CNC machines to offset the actual diameter and tool length), and you get to watch your machine try to mill your \$1000 vise off the table! When I first started programming NC machines (machines that were controlled by a 1-inch wide paper tape with holes punched in it) I would

write programs that would rapid feed up to within 1/10" of the part and then start feeding at a programmed rate. We soon learned that if the machine failed, you wouldn't have time to push the "stop" button before it crashed even if the rapid feed was shut down two inches from the part. With nothing to lose but time, we switched to bringing the tool as close in as possible.

### **Push the button and hold your breath**

We now bring tools to within 1/100" (2.5mm) of the part at a feed rate of over 1000 inches (25 meters) a minute. When you consider that on a lathe these cutting tools may also be aimed at a three-jaw chuck turning at 3000 RPM, it takes a lot of faith to watch it happen without flinching. This is how modern machine tools operate. Spindle gears have been replaced by elaborate electronic drives that will work in unison with a computer to keep constant surface cutting speeds on a lathe even as the diameter changes. Complicated gearboxes have been replaced by a servo drive system that works in unison with the spindle to cut threads or tap holes at spindle speeds considered impossible a few years ago. Manufacturers can take a CNC machine and turn it into a very sophisticated device to build their product out of metal in one day. That process could have taken years to accomplish 25 years ago.

### **Corporate "logic" is sometimes hard to explain**

I can never understand the logic large corporations use today where they avoid making their own parts. They come up with "just in time" suppliers that must anticipate that corporation's future needs. Instead of having craftsman, they have purchasing agents. Instead of machines, they have computers to control the flow of these products from outside vendors. Without considering costs, I believe we would have more people working for us if we contracted out the parts we use. If we run out of a part, we can put it into production that day if needed. A purchasing agent may spend three days trying to find a new supplier who could deliver the part in three weeks. Many times I can produce this part with less labor than the agent would spend finding a new supplier. I believe the corporations have chosen this path because it gives managers a method of shifting the blame when ideas fail. Of course, when quantities get into the hundreds of thousands it could be more economical to farm the work out. The type of person I'm trying to advise isn't working for a large corporation that buys in these quantities, but an



*Labor is another factor in product cost that is not necessarily related to part size. Often greater skill and more attention to detail is required when dealing with smaller parts.*

individual starting out without enough money. My product couldn't be competitive if parts were purchased from outside suppliers. The costs involved would eliminate our product line because there is a limit to what customers will pay.

### **How our company makes money**

I always try to make money by having automatic machines running. I design products that can be manufactured on the machines we have. This gives me control of the costs needed to produce these parts. I have the choice whether to use shop time or just an employee's direct wages to make a part. This is very important; because I have to produce a product at a price a customer will pay. Odd as it might sound, prices can actually be raised easier than they can be lowered. Lowering prices without coming out with a new and better model will irritate customers who paid the higher price and dealers that already have this product on their shelves. I usually put off arriving at a final price until I have produced a small production run of parts.

I always start by deciding on a projected selling price for a new product that should get me in the "ballpark." I take away the discounts I must give in order to sell it to a dealer. This leaves the amount I have available for designing, manufacturing, advertising and selling this product. From this I can figure the amount I have left to spend on manufacturing. I never add my design cost and tooling to the final selling price of a new Sherline product. I plan for these products to be sold for a very long time. With this being the case, this cost



*These tailstock extrusions would take no longer to cut off if they were twice as long or ten times as long. Small parts often require just as much or more labor than larger parts.*

becomes insignificant to an individual sale if you amortize it over a long period. You don't have to make money on every product as long as you can make money on the complete product line. You have to know your customers to accomplish this. It would be difficult to be a success at a new business if you have to hire people to give you this information. In other words, "If you want to lose your ass, get involved financially in something you know little about."

#### **Build to succeed, not to "not fail"**

When I became committed to building the Sherline tool line, I never considered the possibility of failure. That helped me make a very important decision as to how many parts to build. If you build too many, you may run out of money and your creditors will put you out of business. Banks only want to lend money to companies that don't need it. On the other hand, if you don't make enough parts, you'll lose your customers by not being able to deliver what you promised. What I did was not make a batch of say, two hundred lathes. The logic I used was that after I sold the two hundred machines I would be in exactly the same situation...out of machines. I was somewhat broke, so I built a thousand or so of the parts that didn't have any expensive material and down to a hundred of the parts that were high in labor or materials. This kept me from running out of everything on the same day.

#### **Today's problems are more important than tomorrow's**

We always take care of today's business first. These are problems you can solve and customers will be

happy. The marketplace is too complex for long-term planning. We should spend as much time as it takes to keep our product quality high. Profit has to be secondary for long-term success. I have always kept a list of things other companies have done to me that could be considered irritating. I make sure we don't make the same mistakes. For example, you won't talk to an answering machine when you telephone Sherline Products. Sometimes people seem amazed when they call us and an actual person answers the phone. Long voice mail menus are almost universally hated, yet most big companies use them anyway. This is a perfect example of a company that thinks their own time is more important than that of their customers, and that is not the message I want to send to people trying to call my company.

#### **Accessory line developed to augment the machines' capabilities**

After putting the Sherline lathe into production in the United States my ambition was to come up with accessories that would allow my customers to make very complex parts on their "kitchen table." One of the problems of manufacturing machines of this size is you can't use accessories from other manufacturers. Manufacturers of full-size machines have the advantage of not having to build all the accessories and attachments for them. We didn't have that "advantage," and I've always looked at this as a plus. The market is simply too small for someone to produce an accessory that will just fit one machine, leaving the market for Sherline accessories to me. The average vise we use in our plant costs more than any machine I sell, so you can see why no one else is interested in building accessories that sell for less than \$100 to a very limited market. I started out by producing the most popular accessories and have made new accessories available every year. I keep thinking I have finally finished when I get a telephone call from a customer with a particular problem. This, in turn, gives me an idea for another accessory. Not all are big sellers, but they give a certain group of customers the ability to build that very complex part on their "kitchen tables". It has finally worked out because now the accessories actually represent a high percentage of our sales.

One of the problems I have is dealing with the ideas that come in from customers. If I look at it and tell them it is something I'm planning to manufacture

anyway, I'm sure they will be very skeptical. Ideas can be easy to come up with on a product such as this. All I have to do is look in a catalog and make what they make for full-size machines. The real problem is coming up with a way of manufacturing them at a cost that we believe the customer will pay. I have made arrangements to pay royalties on a few occasions to people who have put a special effort into their idea. I don't copy other people's products, but some things are so basic that there is only one way to build them. These items will always look the same.

### **The Martin-Hammons Carburetor**

Carl and I came up with a carburetor for model airplane engine for which we received a patent. Carl came up with the basic idea, which was a variable venturi, and I came up with a fuel metering system to control the speed. The prototype worked reasonably well, and we applied for a patent. I was busy doing contract machining, and Carl put it into production. It turned out to be a disaster. We just didn't have the skill or the correct production tools to make the low cost, highly accurate parts needed for this type of product. Carl was spending a great deal of time working on the patent. When I took a closer look I found out that various similar patents had been awarded on carburetors of this type, and the patent that Carl had been working on was only for the slot that controlled the rate the cone was raised or lowered. To me the patent was worthless and the parts we made over and over again weren't much better. Carl salvaged enough parts to put about 500 together and they lasted for more years than I care to remember. I think it was too different to be successful.



*The M-H variable venturi carburetor for model aircraft engines earned a patent of limited value.*

### **The dubious value of a patent**

What if someone does decide to steal your design? Even if you have a patent, you will find you probably can't afford to defend it in court if the company stealing your design can afford more lawyers than you can. Carl and I hold the basic patent on computerized timekeeping. We applied for it long before IBM had a PC on the market. Today there are millions of dollars spent on products that should fall under the control of our patent. We spent several thousand dollars and a tremendous amount of effort to get that patent, and, in a sense, that effort was wasted. Patent attorneys don't inform you how hard it is to protect a patent, because they make their living getting the patent for you. The standard defense against your patent is to try and prove that your idea was common knowledge. Most people don't realize that a patent on a new process or product can be impossible to enforce if it has been suggested in print anywhere in the world. You could end up wasting a lot of time and money to have a patent certificate to decorate your wall. On the other hand, it is wise to have a thorough patent search done to keep from producing a product that already has an enforceable patent on it. Of course, I'm not an attorney and I'm talking in generalities to make you aware of the problems with patents, but I do have a couple of patents that never made any money for anyone except the patent attorney. Again, remember that the patent attorney makes money by getting you a patent and may be the last one to inform you that your patent could be worthless and impossible to enforce.

### **Necessity is the mother of production**

I started buying old machine tools that I believed I needed for production. I became an expert at taking a worn out machine, fixing it, and putting it back to work. I have a natural love for machinery similar to that of a farmer who loves his land. It is hard to describe, but it is very rewarding to set up a machine to make parts automatically. I'm sure a farmer gets the same feeling when watching his crop being harvested. I remember an injection molder running at Kraft Systems that had a 45-second cycle time to make a plastic part. The worst profit we could make was five dollars per shot, and the machine would run all day unattended. It was like having an oil well in your back yard. I have never been nearly as successful as that machine, but I keep on trying.

Today we have to put our efforts in new and modern equipment. Old CNC machines can be like a fleet

of old trucks. They can become more of a problem than an asset. Machine tools are the great equalizer in a world economy. Machine tools cost the same to operate worldwide, and when the cost of the machine becomes greater than the cost of labor, low-cost labor doesn't have such an effect and gives me an opportunity to compete.

#### **For me, it's a sporting event**

Don't get me wrong. I don't invest in my new ideas just to make money. I've always found that the people who work only for money don't seem to have much. To me, it is more like a sporting event where my machines are my players and I'm the coach. Of course, I have employees and they are very important to the company, but in today's market there are few products that could be manufactured with manual machines. Computer controlled machines have allowed a low volume producer like me to exist because they allow one machine to do many tasks. In a sense, you are teaching the machine how to make the parts and teaching the employees how to set up and program the machine. A good employee today is no longer a tireless worker with quick hands, but rather a very intelligent person who knows how to make a CNC machine work harder. CNC machines are marvelous machines that never complain, and every day they are doing jobs once considered impossible. I love them.

The score of this game is tallied in the sales figures, and I'm gratified when someone buys our product. The difference between a salesperson and me is that I'm happy because someone thought my idea and product was good enough to spend their money on, while a salesperson is happy because they closed a deal. The skill of "closing a deal" was one I never excelled at, so my satisfaction comes from the acceptance of our products.

#### **What's the worst that could happen?**

Before starting on a new venture, I arrive at an estimate of the percentage I have for success. This number is really just an educated guess, but it does give me some insight into the odds. I always know I may fail before I start a new project, and if I do fail I can put it behind me. Not knowing what is going to happen tomorrow makes life exciting, and I'm very happy I have a choice.

When I first started marketing Sherline tools I was held back because of the customers' reluctance to buy a product that was relatively new on the market. I would get questions that would express a potential

customer's distrust of my company's success. At that time, the machines cost less than three hundred dollars, and yet the same customers who were reluctant to buy a Sherline tool were buying imported cars for thousands of dollars, which didn't have a track record and had fewer guarantees than my machine. The money spent on hobby tools has to be justified to the customer, and even after manufacturing this product line for more than thirty years we still encounter customers who are reluctant. On the other hand we have the nicest customers anyone could ever ask for, because hobbyists are a great group of honest, hard working, intelligent people. When I was first starting out I had to attend trade shows by myself, and when nature called I would walk away from my booth and leave it unattended. I can't ever remember something being stolen. I don't think I would try that with any other group.

#### **Working with skilled employees**

Machining is a slow process because parts are made one at a time. The interesting thing is, a skilled machinist may take almost as long to make the same part as a novice. Shortcuts usually end in failure. Unlike some other trades, mistakes cannot be covered up. There are no erasers, whiteout or "putting-on tools" for machinists.

I've never met a good craftsman who wants to do a job over, even when they get paid for it. It's against their nature. I also never met a good craftsman who didn't have to do a job over because of his own mistakes. This is a good time to stay away from them because they are mad at themselves. The fact is you can't work with this many types of tools, dimensions, and materials without making an occasional error. The trick is not to make errors when it counts. Good toolmakers will work with an entirely different attitude when they are making an inexpensive fixture than they will when they work on a part that has thousands of dollars worth of material and labor in it. I can compare it to a driving a racecar at over 100 mph to cruising down the highway at 65 mph.

Another thing I enjoy is determining how a particular part will be run through the shop. Designing new products has become easier for me now because of wide assortment of tools we own—about a million dollars worth. Ten years ago, I could set up and operate every machine I owned, but that time has passed. I don't operate my own machines now because they are too complex to casually start

pushing buttons. I have to rely on my employees, and I get a lot of enjoyment out of watching them progress to become accomplished craftsmen in their chosen trade. However, I still don't believe anyone in the shop knows more about making good parts than I do. I may not know what button to push any more, but I'm still the best at solving problems in the shop.

Most of this knowledge I've gathered has been learned the hard way because money was too tight to hire experts. At Sherline we make all of our own parts and only "contract out" the plating, heat-treating, and powder coating. In the past, we have also done a lot of contract machining and I've learned the problems one can get into by finding errors in "inspection". It's just too late. Parts must be inspected as they are built, not after the entire batch has been run. Errors that are found after the parts are made mean you start over. Design errors found after the parts are made will always result in scrap. The only difference is who pays for the scrap.

#### **The credit for a good part goes to the craftsman**

Good craftsmen know when they have made an exceptional part and get much satisfaction from it. They also have the ability to produce good work on machines that should be in a junkyard; it just takes them longer. I have a great respect for good craftsmen because they have to work without excuses or erasers. I try to keep reminding you of this fact in this book because it's the craftsman, not the machine, who builds the beautiful things we see daily in this world. Modern machines have given this talented group of people a way to produce more and better work, but it will always be their "touch" that makes those parts beautiful. In my eyes, they just don't seem to get enough respect.

#### **Taking advantage of the Internet**

Our web site has been a very good investment for both the customers and Sherline dealers. What inspired me to put the effort into having Craig make a very complete site was I believe it is the way of the future, and I didn't want to be left behind. What I really like about it is you don't have to live with mistakes because you just had 25,000 copies of something printed. Information is easily corrected or updated—instantly. I felt that if we did a really good job we wouldn't have to change it, and it could be useful for years, just like the good tooling I keep referring to. I believe we have created a useful site by including plenty of good information such as



*An Internet site is an inexpensive way to reach a lot of people who might not be able to find you in other ways. Another advantage is that it goes world wide.*

instructions for our machines and accessories for our customers and potential customers to examine. We also reach a readership that is worldwide. This can be impossible with standard advertising methods. We have picked up a number of new distributors in other countries because of our web page. Our dealers and we have also made an increased number of direct sales overseas because fax and e-mail communications make it easy for anyone looking at a web page to order. Time of day, long distance phone calls and the language barrier are much less of a problem. The bulk of the web site was put together over a period of about four months, and has been constantly expanded and improved over the years. The most interesting thing is how inexpensive it is. It costs only \$500 to \$700 a year for a very large site. Compare that with a two by three inch ad that costs \$1,000 and is history once the next issue comes out. I believe only the surface of the Internet has been scratched and it will keep growing for many years. It represents the leading edge of the "information revolution" that is to our era what the industrial revolution was to our grandparents and great grand parents.

#### **Steps in the design of a new product**

I enjoy having customers call and tell me about a business they started by being able to build prototypes with Sherline machines. You should never commit yourself to a design until you have at least built a crude mock-up that you could hold in your hand. Looking at it from every possible angle will be very helpful to you. Usually you will start making changes in your design before your prototype

to. A ball bearing would be an example of this. Then Carl would make a quick set of drawings. From this we build a mock-up to get an idea how it will look. The next step is to consider manufacturing methods while trying to work with the equipment you have. This is where you can go astray. A product has to have a certain look, and that look shouldn't be sacrificed to make it easy to manufacture. Don't make it look like the design was picked because it was easy to manufacture.

There are now 3-D computer programs that can do this on the screen amazingly well. We have one, but we still build a prototype as well, the old fashioned way...one part at a time. For \$300,000 you can even buy a machine that will make a plastic part directly from your CAD designs. When large companies spend this much money for a machine that is only good to develop a shape you can look at, it should give you some idea of the value of what can be gained from seeing an actual prototype. Again, don't design a product that is just easy to build. It has to look good enough for a potential customer to buy it. Some products need a compact, modern look and others require a massive look, but these designs should always be pleasing to the eye. Don't use the first idea that pops into your head. I very seldom (if ever) come up with an original idea after nine AM because I am a "morning person." I don't have any problems running the business in the afternoon, but new ideas come to me long before I get to work. It is wise to analyze yourself so you know when is the best time for you to plan for the future.

After we have decided on a suitable design, detailed drawings are prepared in a computer aided drafting program called AutoCad®. We may have to change the design again as we make the first production run of parts, and we run these parts in a sequence that allows for change whenever possible.

#### **Towing a racecar leads to another product line**

I was towing my racecar home after a race and something just didn't seem right. The tow vehicle was a 29-foot motorhome and the racecar was in a 26-foot enclosed trailer. It was dark when I stopped and looked inside the trailer, checked the tires and hitch and couldn't find anything wrong. I went on my way, but it still felt like the car was loose in the trailer. I made it home, but the next morning I found that I was towing the trailer with all the hitch welds broken except one. When I looked into it, I found I had the hitch overloaded by a factor of 2.5. The hitch shouldn't have had over 350 pounds loaded on to it.



*PRODUCT EXAMPLE—This racecar alignment system is typical of many of the products I've produced because I've gotten involved in what they are used for. This system had many advantages considering it sold for less than \$2000. It never returned a profit because I misread the market. I should have made a \$3000 unit with digital readouts. It took me longer to write the instructions than to design the product.*

Why the motorhome manufacturer put a light-duty hitch on a big motorhome is beyond me, but I was the one at fault for not checking its rating. Of course I immediately had a better hitch put on my motorhome, but I felt I needed a simple way to check the hitch weight. I made a simple hydraulic scale by making the piston and cylinder equal to one square inch of surface area



*The hydraulic trailer tongue weight scale was easy to make and addressed a portion of a market that was without competition.*

*The suspended version of the Sherline hydraulic scale was conceived of as a companion unit to the trailer scale to aid truckers loading heavy items for shipping. It started out as a slow seller but has now found entirely new markets among farmers, elevator companies, utility companies and many other applications we had not considered when designing it. Like the trailer scale it is also easy to make and has been a profitable sideline.*



hitch on a big motorhome is beyond me, but I was the one at fault for not checking its rating. Of course I immediately had a better hitch put on my motorhome, but I felt I needed a simple way to check the hitch weight. I made a simple hydraulic scale by making the piston and cylinder equal to one square inch of surface area and using an inexpensive pressure gauge that reads in pounds per square inch (PSI). One pound of weight creates one pound of pressure on the one square inch cylinder, so the PSI gauge reads in pounds. It worked well, and I decided to produce one that looked more professional than my prototype. This was something I could easily manufacture, and I considered this a good gamble. Along with the scale we included a useful booklet that Craig and I put together on towing trailers. We were lucky to find a nationwide distributor to market it for us. They have sold several thousand units now, and I believe we made the roadways a little safer for all of us. It all came about because of my error, yet it ended up making a few bucks for the company.

I then thought that the world needed a low cost 2.5-ton hanging scale using the same simple hydraulic method. These are usually called crane scales and are quite expensive. I felt that a scale would be still useful even if it weren't accurate to .5%. It could still be useful for loading. You don't get into trouble making 50-pound errors when it comes to loading trucks. Trouble comes when they make big errors, and this scale would help prevent that. I was right, and we found a good mail order company to market it.

While I wouldn't want to own a company that only offered these two scales as a product line, these two

products are easy to manufacture in my facility and add to our overall profit.

### **Battling poorly written manuals to learn AutoCad® myself**

My dear friend and partner Carl passed away in September, 1997. This was a great loss for me as we had been through a lot together. I also realized that I now had no option but to learn a computer-drafting program. Up until then, Carl had done all my detailed drawings and there wasn't anyone else in the organization who had the time to take on this task. I couldn't go to school because we needed our drawings done now, not several months from now when a class would graduate. I was reluctant to hire someone because it wasn't a full time position. I decided it would be easier for me to learn computer drafting than to teach a new employee our product line. Carl and I worked together for so long I knew I couldn't replace him, and it helped me to ease the pain of his death by diving into this new endeavor. I started working at home to eliminate the constant interruptions at work. The difference between a word processing program and a drafting program is that a letter can be written with a word processing program without knowing the slightest bit about the program. This isn't the case with drafting programs. At first I had trouble just putting a line on the screen. I went out and bought a couple of the popular books on the subject. When I finally drew a box and wanted to dimension it, I looked up that subject in the index and found the first information about dimensions was on page 700. I knew then that I was in trouble, but I had an "ace in the hole"—Friends.

### **Studying at the "University of Friends"**

My friend Jerry Nelson had started teaching himself computer drafting several months before and was "over the hump" on learning this program. I called him and he taught me enough over the phone in 15 minutes to do my first drawing. I couldn't get this much usable information from the books after studying them for the previous week. The books I read were typical of the technical manuals I've had to deal with for the better part of my life. It isn't that the subject is so difficult, it is the method that the information is fed to you. You never know whether you are getting the main course or a snack. The main purpose of an engineered drawing is to convey dimensions to the person who is going to build or use the part. To give you 700 pages of BS before getting into the meat of the matter is another example

of a failed attempt to teach a subject. As the instructions I write keep getting longer and more complex I use these as examples to remind myself how not to do it.

### **Learning AutoCad®**

The first task I took on to learn the program was to lay out and design a set of bevel gears that could be cut on a Sherline mill using a rotary table mounted on an angle plate. By drawing the cross sectional view accurately, the angles needed to cut this gear could be taken directly off the drawing without using a trig table or a calculator. I was beginning to see the light.

I'm getting pretty good at using the program now, and it has put a lot of the fun back in designing for me. Looking over Carl's shoulder at an assembly designed by computer was of no help for me. I would need a standard, full-size or larger layout to design with. I've since found that doing the design totally myself has become the perfect way for me to work. I love the program. It has made me more productive than ever.

I'm fascinated with the program because it does a drawing without errors when used properly. The program eliminates much of the boredom of adding and subtracting numbers as you go. Accuracy isn't attained by the precision of your lines but rather by the accuracy of the information the program is given. Angles are not derived from a protractor and using divider points but from calculations by a computer to as many decimal places as needed. I learned drafting in high school back in the fifty's. My problem was I was a slob when it came to drafting a pretty drawing. My numbers and views would be correct, but my lettering and lines weren't neat enough. Things have changed now with the aid of this program, and my lettering is just as good as the best. I can no longer spill gobs of ink on an almost completed drawing and have to start over. I can change my mind as much as I want without irritating anyone. I'm a happy man.

### **Opening the floodgates of design**

Since learning the program, I have added many accessories and put many new products into production. As I became better at using the program I found that I now could easily design a new product. I had many ideas in the back corners of my mind. I would take a break from the boredom of reviewing and redoing the hundreds of existing drawings and design something new. It was a piece of cake. In a

couple of days I could produce what used to take several months. You should also note that when I design a new part the design includes how the part will be made in our machine shop. As an example, I designed the quick-change tool post along with the tool holders over a single weekend. I'd be working on several new projects at the same time. If I ran into a problem with the design, I'd switch to another project until I'd come up with an answer to the problem. If I weren't inspired with a good idea I'd work on the existing drawings. I don't think any of my employees believed I would ever finish the drawings; however, they weren't around when I started and would work an unbelievable amount of hours to finish a project on time. They didn't realize how persistent I could be. I'm happy to state that all our drawings (around 900 now) are up to date and in the same format today.

### **Getting the shop to develop flow charts**

For years I had been trying to get the machine shop to document the procedures to manufacture each part. I had talked for hours on the subject to Carl, my partner, and Karl, my shop foreman, to no avail. I even hired someone to help them. You just can't threaten the most important people in your business to get something done. The loss of Carl drove home the need to get this done. I was burying Karl with new parts to make, and he finally realized there wasn't a chance in hell of remembering all the procedures needed to produce all the different complex parts we now manufacture. Finally we have job folders on each part that have the machining sequence, machining times, programs, tooling, setup instructions and exactly where the tooling and programs are stored. This was also no small undertaking, and the job folders took many thousands of dollars worth of time to document.

I then entered the machine time and labor cost and material cost obtained into a marvelous Microsoft spreadsheet program called Excel that allowed me to get our true manufacturing costs of each product. Until then I was relying on an old job-costing sheet for these numbers. It turned out that it wasn't being updated properly and we were losing money on some sales. When you're selling something for less than it cost to manufacture it you can't make up for it with increased sales. I raised prices and restructured the discount schedule. These are the "dammed if do and damned if you don't" type of decisions you get stuck with as you get bigger.



*Once I learned AutoCad®, new designs poured out in a hurry. Between 1997 and 1999 these are just some of the new products that were added to the line. Also introduced were the industrial line on page 287 and a new quick-change tool post system.*

#### **A little advise on purchasing full size machines**

I would like to give you some views I have come up with after spending well over a million dollars on machinery. I'm addressing this mainly to the portion of our customers who will end up moving up in size to standard machine tools. The first machine I would buy would be a Bridgeport® vertical mill. These machines haven't changed for years because they are just right the way they are. More successful businesses have been started with this marvelous machine than any other. You can build prototypes, tooling and production parts with this machine. There are imported copies of the Bridgeport, but they don't seem to have the quality of the original. Although this book is written about home shop machining, I'm also trying to give you some insight into producing metal products. If you happen to come up with a great idea, you may want to build these parts yourself and start a business.

A mill is usually more important than a lathe; therefore, it has to be in better condition. You can still make good parts on a lathe that may have made parts for the First World War. A little filing and polishing and you have a good part. On the other hand, trying to work with a mill that has worn out slides creates a different problem. The forces that are generated as end mills cut can come from any direction. A lathe generates most cutting forces straight down toward the bed. You can always bring a diameter to size with a file on a lathe with worn

out ways, but to file a bored hole to its correct position is next to impossible. The things you do on a mill have to be done right the first time. If you plan on stepping up from miniature tools to full-size machinery, the cost, particularly the cost of accessories, will rise dramatically. Another thing you will find is that these machines aren't as much fun to operate.

Before buying any full-size machinery, I would give it a lot of thought, because the cost and space this type of equipment take is substantial. Even if you can afford the extra money and have the space, they will not bring you happiness unless you have a definite need for them.

#### **Buying used machines at an auction**

I have purchased machinery from every source available, but I like auctions the best. It is a game that is played for high stakes, and high-dollar machines are often sold in less time than a fifty-dollar vise. It takes two people who really want a particular machine to get the price it is actually worth. If you have many bidders, the price may go way beyond what would be considered a good buy. At that time the auction may turn into a bidding contest that leaves common sense behind. Know your limit before you start bidding and know what the machine is really worth. Of course, I didn't always follow this rule and ended up buying a few "turkeys", but that was part of the fun. Buying used machines from a dealer has some advantages, and many times it can be more economical than an auction. In addition, you can usually get a money-back guarantee. You can't even get that on a new machine. Putting large machines in place is costly for both parties, so you have to be sure of your decisions.

#### **Choosing between mechanical and CNC machines**

If you are trying to build a product and you need to produce a particular part, you may have a choice between a computer control and a mechanical machine. CNC machines have been more reliable than mechanical machines for me. There are more employees available today who are trained to operate these machines. If you bought an old CNC machine without documentation you may have bought a piece of junk unless there is someone in your area who can fix it. You must know if you can get it fixed before you buy it. A technician a thousand miles away will not be of much help if it is going to cost you \$2000 in travel expenses to fix a \$100 problem.

I look at CNC machines differently than mechanical machines. They are more like automobiles and have a limited life. If you can afford it, buy a new CNC machine. Often they will be able to make a better part in half the time it takes a machine that is seven years old, and time is money.

### **A new home for Sherline**

The last few years had become the most productive years of my life and I'm still amazed by the amount of work I produced. My partner, Carl died when I was just starting to write this book. You can't help but take a close at your own life after your best friend passes on. I did and realized I had only scratched the surface of what I wanted to accomplish, but where to start? What I wanted more than anything was a modern manufacturing facility that I could truly be proud of. The building I had built almost twenty years earlier now was turning into a junkyard because of the limited floor space. I had more equipment than room, but I had to deal with my more immediate problems first.

### **Back to seventy hours a week**

I was at a point with this book that I was committed to finishing it. I got Craig started on creating the format I wanted him to follow throughout the book. This allowed me to take a break from writing while Craig caught up with me with the graphics and switched my attention to my most immediate problem: the product drawings. I never realized what a mess I had on my hands until I had to find a drawing myself. I'd find several drawings of the same part with several variations. There were also several variations of the AutoCad drawings stored on disk. Carl had the ability to keep these sorted in his head and could pick out the proper drawing from a pile stacked on his desk in moments. We couldn't. The



*The facility at 2350 Oak Ridge Way was a nice building, but even before we moved in I realized it was not going to be big enough for our future needs. It became our temporary home for two years.*

closer I looked, the worse it got. Now that I knew more about AutoCad, I realized the drawings didn't have any standard. Carl must have stopped working on the drawing the moment the printed version was suitable to send to the shop. We had around 450 different drawings at that time drawn in many formats. You have to realize just how serious a problem this was. If we manufactured a part to the wrong version of his drawings it could result in thousand of dollars worth of scrap. This was a problem that I had to sort out because I was the only one in the company who truly understood how the parts had to fit together and the allowable tolerances.

Since right after Carl died I had started waking very early and it became a blessing. All the drawings were brought up to date between 4 AM and 10 AM. This is the time my mind is at its best. I hired a professional to help me decide on a drawing format. I still didn't know enough about the program to get me started on this gigantic task. I then started to replace any drawing in doubt before putting it on the production floor. The first drawings were very time consuming for me to produce, and having ten hours in a drawing wasn't unusual. If I found something I didn't like about the format we were using, I would go back and change all the drawings I had done up to that point to the same format. I wasn't going to fall into that trap again. It took about eighteen months of hard work to get the production drawings to the point I began to have confidence in them again.

I still had to be very involved in the day-to-day operations; however, I could solve problems such as these on the spot at any time of day. I finished the missing chapters in this book and again started thinking about a new home for Sherline. An advertisement came in from an industrial Realtor that had pictures of a building that looked just right. I looked around but this still seemed to be the best deal in town. The building was around 30,000 square feet and was to be built in a brand new industrial area. I didn't want a building that was surrounded by old buildings. Modern industrial parks and buildings in California have changed dramatically in the last few years. The buildings are designed to look good, withstand earthquakes and have sprinkler systems. I wanted one. The selling price was around \$2.2 million including improvements, and I eagerly put my name on the contract. It would take about six months to complete the new building.

### **The new accessories bring home the need for more manufacturing floor space**

The new building turned out great and I moved Sherline into it and left Martin Enterprises in the old building. Remember that Martin makes the parts and Sherline assembles, sells and ships the product. Sherline hadn't even moved completely when I realized I had screwed up. I not only didn't allow enough room for Sherline, there also wasn't any way I could fit the machine shop in there without crowding the machines. Can you imagine the thoughts going through my mind when I had just purchased a \$2.2 million building and it was too small? I never moved the machines into that building and started putting money aside for my next move. Putting money aside was difficult because I was also buying Carl's share of the Martin Enterprise partnership from his wife at the same time.

There was an empty lot across the street that would be perfect to put up a building for the machine shop on. The people that I bought the new building from owned it. I talked to them about it and couldn't get a direct answer and was getting upset when calls were not getting returned. I needed to make plans now because sales were up another 30% and the employees at Martin were packed in like sardines. When I found out that they sold all their remaining lots to another developer I was pissed and on the move again.

### **Home at last**

I thought about it for about an hour and remembered some nice lots I had been driving by on the road

between the two shops. There were some nice looking buildings in that area and a "Build to Suit" sign on the remaining lots. There was one lot on top of the hill on the end of a cul-de-sac that I had to have. A beautiful ocean breeze would come through every afternoon, and it overlooked a small valley with a residential area with expensive homes on the opposite side. It had a better view than the homes did. It also was located next to a 16-acre green space area and would have an ocean view from the west facing second floor. This is where I was going to build my monument (building) "come hell or high water."

When I finally got to talk to the developers I found out that the builders were a family operation. After having the last building built by a large corporation, I liked the thought of being able to talk directly to the people that could make it happen, and we struck a deal for a building with a 55,000 sq ft (5120 sq meters) pad on 3.5 acres (12,263 sq meters). The building would be of tilt-up concrete construction 25 feet high. The architect came up with a basic design. He also worked in AutoCad and said he would e-mail me the design to work with. I changed the basic layout so the building faced the valley rather than the street and made a change to the shape so the building looked and fit the lot better. The office would have a glass front overlooking the valley. My office would have an additional view of the ocean. Now all I had to do was come up with more money than I had to pull this deal off.



*We got it right with the building at 3235 Executive Ridge. My office window looks out on the Pacific Ocean to the left and the windows facing the camera look out over a valley with the mountains in the distance to the South. This is a fitting monument to the company's success and offers room for future growth.*



*Enjoying what you are doing is what it should be all about. Scotty Hewitt's little 5" tugboat is shown with another version of a single cylinder oscillating steam engine that could be considered large only in comparison to Scotty's. Plans for the larger engine are included in Section 5 so you can begin having fun with your tabletop machine tools.*

Think about this. When this building was completed but not ready to move into the payments for all three buildings came up to \$85 an hour, 24 hours a day and 7 days a week. I didn't want to turn the old buildings over to a Realtor because I believed I could sell them myself quicker and save the commission that would amount to many thousands of dollars. I was turning down at least two Realtors a week who all told me they had a potential buyer if I would sign up with them. If you didn't think it took a lot of balls to stand firm you must have a hell of a lot more money than I did. Fortunately I was right and leased both buildings with an option to buy in four months. I was also spending thousands of dollars to move into the new building at the same time. I'm somewhat broke now but the main thing for me is I did it on my own again.

As I look back on my life now I realize that I was the happiest when I got into deals like this when I

wasn't sure whether I could stretch out and grab that elusive "brass ring" again.

### **Don't forget to have fun**

The information I have provided in this book comes from all sorts of places. Sometimes you learn something when everything goes right. Most of the really valuable things I have learned, however, came along with a certain amount of either physical or financial pain. If I have saved you some of that pain and provided some entertainment in the process, this chapter has been a success. The main point I want to leave you with is too not to put so much importance on the destination that you forget to enjoy the journey. I have always found that I am happier and more enthusiastic when starting a new project than I am right after I have finished one. Before I am done with anything, I find I am usually thinking about what I want to do next. Strive to take your work beyond the level of a laborer or even a craftsman. Work not only with your hands and your brain but also with your heart. When you are done, your project will be more than just a bunch of nicely machined parts. It will be a work of art.

### **The end of a journey**

At 66, for the first time in my life I feel like I have finished what I started. I'm a self-taught man who started with nothing and now owns a beautiful manufacturing facility that is worth several million dollars. If I died tomorrow the company will be left in good shape and will have the organization to continue to give our customers good service. The equipment and inventory is completely paid for and I have passed on the skills to keep the business running smoothly. I never screwed anyone to get to this point and always paid my bills on time. The only money that I really risked was my own and only invested it in my own ideas. I still enjoy working with new ideas but I know that I no longer plan to get myself into a position where there is a great deal of risk. There is just too much to lose now. Employees, customers, dealers and suppliers all have to enter into the equation. It's no longer a one-man show, and it's time for me to kick back and just enjoy what I've created.

---

*"Art is not a thing, it is a way."*

—Elbert Hubbard

---

*The media seems to enjoy portraying modelers as meek little people sitting at home and never venturing far from their desk or workbench. Joe Martin belies this image. In business or pleasure, Joe has always found a challenge in putting his skills to the test, whether it is building a business, sailing, flying R/C models or racing fast machines.*



*Top left: Joe windsurfing at Lake Lopez. Joe is an experienced windsurfer, having speed-sailed at “The Ponds”, a high wind spot in the California desert (which has since been fenced off), and surf-sailed in Southern California and Maui, Hawaii. Above: Joe’s former Erickson 32 ocean racer in the Newport-to-Ensenada race. Top right: Joe is shown at the helm of the Erickson. Above right: All you can see is Joe’s head sticking out of this mini version of a 12-meter yacht here being raced in light air in Oceanside harbor.*



*It doesn't matter if the top speed is 15 knots or 185 MPH, if it goes fast and you can get in it, Joe will put numbers on it and go racing. Top: Joe's first venture into auto racing was a Triumph Spitfire raced in the production classes of vintage sports car racing. Above: Joe at speed at Willow Springs Raceway in a Swift DB-1 Formula Ford. He was San Diego Sports Car Club of America (SCCA) Regional Champion in that class in 1994.*

*Sometimes you're just in the wrong place at the wrong time. At an SCCA race in Holtville, CA, Joe (#80) is caught by surprise by a spinning car that entered the turn too fast behind him. Fortunately, his car didn't flip, but ended up back on its wheels with a badly damaged suspension.*



## Chapter 6 — CNC in the home shop

### A quick history of CNC

I have been personally involved with CNC since the early seventies and soon realized this was the way to make things. Back then all sorts of ideas were being tried to simplify the mass production of machined parts. Many manufacturers were using hydraulic power and came up with some interesting systems. They were called NC (numerical control) machines because the storage device was a one-inch wide paper tape. The method of choice before NC was a system that duplicated parts by tracing them with a hydraulic mechanism controlled by a really neat valve that was controlled by a stylus that the operator would move like a probe and the machine would duplicate his movements. Gigantic machines were built around this idea for the aircraft industry.

### Hydraulic CNC systems?

It was only natural that this was the group of manufacturers would be the first to try this new field, and did they ever come up with some weird systems! You also have to realize that electronics were pretty crude during that same time period. My first NC machine was a Cinematic manufactured by Cincinnati machine tool. It had ball lead screws driven by hydraulic motors and was fairly reliable and quite popular at the time. Tool changers were still in their infancy. I ran it until it was so out-dated that I gave it away even though it still ran. Another interesting point is this machine had a “wire wrapped” control with few circuit boards. If a recent graduate of electronic engineering had ever



*Designed for production jobs, these two Bridgeport TC3's are relatively compact but cost about \$50,000 each and fit into the third category above.*

looked into the control enclosure, I'm sure his or her first comment would be “impossible.”

### I thought I bought a telephone company

My first machine that was controlled by DC motors turned out to be a disaster. I bought it used, and it had a stack of manuals 18 inches high. I never dreamed I was going to look at every page but I did. When I opened the control and looked inside I thought I had bought a telephone company. I believe there were 120 individual circuit boards and thousands of individual transistors. It was manufactured by Edlund. We used to call it a “Deadlund.” I wasted more time and money on that machine than I care to admit, and I felt relieved as it was loaded on a truck for its final journey to the junk yard.

### Problems with no memory storage

The way this machine stored memory was interesting. At this time there weren't any memory storage devices invented for commercial use. What this control did was feed a single block of code into a very long piece of NiChrome wire. (A block of code contained the instructions the machine needed to make a single move.) The high resistance of the wire would delay the signal long enough so the signal could be amplified at the other end and sent back on the same wire without interference. The signal would then bounce back and forth until the machine had moved to a location that corresponded to that block of code.

### Sometimes I can be persistently stupid

New machines were thousands of dollars more than I could afford and not that reliable either. I remember a friend who had a three year old machine that cost over \$100,000 that needed service. The first thing the technician said was, “I didn't think they had any of these old bastards still running.” You can imagine how my friend felt when he made that \$2500 payment each month.

You think I would have learned by then, but I can be persistently stupid at times. My next disaster was a MOOG milling machine. It used a Bridgeport base and didn't have leadscrews. It was entirely controlled by hydraulics. Movement was controlled by thin plates that moved with the machine slides with accurate holes located at every inch. Pins about 0.187" (5mm) in diameter would engage the proper hole and then another plate with holes spaced at 0.200" would come into play. The last 0.200" relied on a single turn of a leadscrew. The machine finally arrived at a position within a 0.001"

of accuracy. I didn't realize it when I bought it, but I was horrified to find that this mother worked like a player piano. The one-inch wide paper tape wasn't read with switching devices like other machines. It actually was more like a valve that allowed or prevented air from getting to cylinders that controlled hydraulic valves. When it read a block of tape (around 10 lines of holes of 8 holes each) the SOB sounded like a steam engine. I chalked that one off to having more balls than brains; however, we actually made more parts with it than we did with the Deadlund.

It should also be noted that I'm sure that these early NC machines were the best that could be designed with what was available, and the solutions they came up with were quite ingenious at the time. I'm looking back at it from a slightly humorous position and in no way mean to infer that the designers of that era weren't up to the task. They just didn't have the tools to work with that we do today.

### **The course is set**

At this time, NC machines could only cut straight paths, and as soon as the electronics were available to store just a small amount of memory the new rage became "look-ahead" control systems. This meant the cutting tools wouldn't hesitate as the next block of information was read and create machining problems. Stepper motors were used for a short period to drive the lead-screws; however, within a few short years the entire industry switched to DC motors. Encoders or resolvers were used to keep track of position. The DC motors were controlled by fast computers. Working in unison with accurate ball leadscrews, they created a system



*These small helical gears were cut using the X, Y and A axis on a CNC Sherline mill. The 25T and 34T gears were cut to full .089" depth in one pass.*

that was very close to where we are today; however, they were slower and very expensive. Today servo drives use AC motors controlled by varying the frequency to the windings, eliminating the brushes needed with DC motors. The latest innovation is linear motors that can move machine slides at incredible speeds.

### **A new way of thinking**

The marvelous part of the CNC revolution wasn't just the fact that it was eliminating workers from sometimes very strenuous and boring jobs; it was that there was finally a method of cranking multiple handles in unison to do things that the best machinist in the world couldn't accomplish manually. By moving screws on the X- and Y-axes in unison, you could machine tapers, circles and, in fact, any shape you wanted. This allowed engineers to design parts with the shapes they wanted, not just shapes that were possible to machine using the old methods. Machines that had cost thousands of dollars suddenly became scrap iron. These new CNC machines didn't care if they were cutting a complex shape or a straight line. Whether the tolerance was tight or not the machine was always "right on," and the tolerances were determined by the tools used.

### **Carbide insert tooling changed the entire machine tool industry**

At the same time, carbide insert tooling became available and took over the market like a storm. I don't think I could have ever convinced a machinist in the fifties that some day they would be taking 0.300" cuts on cold rolled steel at a cutting speed around 400 to 600 feet per minute (200 meters/min) using a 40 horsepower lathe at a 0.020" (.5mm) feed rate for each revolution and that this would be done with little carbide tools made using powered metal technology held in place with little tiny screws, and they'd still get marvelous finishes on gummy old cold rolled at the same time. Well, they do, and we at Sherline take advantage of all these things to give our customers a lot of "bang for the buck." The consumers of products that are manufactured using this technology benefit as much as the manufactures that use them.

Because NC lathes could also produce these types of moves, large and expensive form tools were on there way out. This may not seem significant, but by generating shapes rather than forming them, shapes could be far more precise, and at the same time machines didn't have to be so massive to prevent tools from chattering. Hand scraped ways were replaced by ingenious frictionless slides that lasted for years with little maintenance.

Because there is always the possibility of a crash, machines are no longer built where the headstock is an integral part of the base casting, and in most cases they can be realigned if one of these disastrous events should happen.

### **Why I love cnc robots**

In closing this section, I firmly believe that these machines that we call CNC are the robots of the future and I truly love them. They have allowed me, Joe Martin the designer, to design the parts that I've always wanted to design without dumping my problems on Joe Martin the machinist, who must produce parts for Joe Martin the businessman, who can supply you, the customer, a fairly priced quality product. At the same time this allows Joe Martin the owner, a reasonable profit to buy more of these marvelous CNC machines, of course. And so it goes.

Even though this doesn't do the subject justice, I thought you might find these facts interesting. It's always wise to see at least a brief history on a subject before becoming part of it.

### **CNC moves from industry to the Home Shop**

Anyone now thinking of working as a machinist in an industrialized country would have to expect to learn how to operate CNC machinery in order to be able to earn a decent wage. This has been the trend since the 1980's, and there is now an ever-growing pool of people for whom CNC machining is a simple fact of life. As they transition from the production shop to their home shop, they are now finding that both the size and price of CNC systems have dropped to the point where they are suitable



*Turn-key benchtop 4-axis mill CNC systems like this one that include even the computer with software already installed are now available for under \$3000.00. They are ready to plug in and use.*

for home use. Because of their experience, running a CNC machine doesn't faze them at all. Even the general public has been exposed to CNC through television shows, and many people have a basic understanding that many of the products they use are now made by computer controlled machines, although they might think it is a much easier process than it really is. When these people, be they jewelers, gunsmiths or hobbyists need parts, many of them hope to be able to take advantage of the availability of low cost CNC systems to help them make the parts they need. To satisfy the demands of both the experienced, computer-savvy machinist and the neophyte who wants to learn to make parts using computer control, a number of companies including Sherline now offer complete turnkey CNC machining systems at prices unheard of when this book was first written in 1998.

### **Are you ready for a computer controlled machine?**

On page 1 of this book I compare the experience of production machining on large, expensive CNC machines to that of a merchant seaman who has spent his life aboard large ships on the oceans of the world. My comparison is to a sailor in a small boat who is representing the hobbyist starting out with manual tools. This explains why I believe you should first learn the rules of cutting metal with manual machines. On the other hand, I believe it is always helpful to know something about the CNC machines I love.

If this is the first time you are reading about machining, you are probably wondering how useful CNC machine tools would be to a hobbyist and whether manual machines are becoming obsolete in the age of computers. There are no simple rules to answer these questions, because the uses for the machines and the individual's background are such a major consideration in the answer. I can tell you that if you don't know how to use computers or how to operate machine tools, your chances of success in CNC are small. It's just too complicated to learn how to do both at the same time. You have to know how metal cuts before you can write instructions (the program) on how to make a part.

### **Four classes of CNC machine, but fewer choices for the home hobbyist**

From here on I'm going to stick with people who are machining for the fun of it. Let's first think about the type of CNC machines available.

- 1) Simple add-ons that use a PC computer are available for machines from as small as a Sherline up to full-size machines. These inexpensive systems use stepper motors to drive the threaded leadscrews

and usually don't have ball leadscrews. This is an inexpensive way to get CNC control. Costs start at less than \$2,500 for the control only for bench type machines. These are the machines on which hobbyists usually start CNC machining.

The next step up is adding an encoder. The advantage of this type of system is that when a signal is sent to a stepper motor, without an encoder you have to assume the motor moved, and with an encoder you *know* it moved; however, it has little advantage over a properly used stepper system when it comes to accuracy. (See photos page 37.)

2) These are fairly sophisticated machines without tool changers used by toolmakers and also as simple production machines. Professional systems used to use DC motors until recently but now use AC motors. These systems can cut contours at over 100 inches per minute. A vertical mill that can be run in either the CNC or manual mode is a very useful tool for a modern toolmaker. Costs are around \$20,000 for a mill or \$30,000 for a lathe. Don't buy a used CNC machine until you are positive you can get them serviced locally. You can't afford to pay huge travel expenses to fix an inexpensive problem. (See photos on pages 38 and 291.)

3) Machines in this category are designed to run production jobs. They have tool changers, cutting tools that are flooded with coolant and enclosures to contain the chips and coolant. They are a lot more complex, use three-phase current with a minimum

of 5 HP spindle drives and have ground ball leadscrews that can't be driven manually. Cost for a new machine is in the \$50,000 range for either the mill or lathe. These are the machines that allow new businesses to be competitive and may even find a use in a home business operated in a garage using a converter to create 3-phase current. (Power companies usually only offer 3-phase current in industrial areas.)

4) This last category represents the true workhorses of the machining industry. They are designed to run 24 hours a day and operate for years without problems. They are also very expensive. These are not tools a hobbyist should consider purchasing. This is the type of equipment I own, and most individuals wouldn't have the time and money to keep it operating properly. Service starts at \$100+ an hour and replacement parts cost about five to ten times more than you'll think they are worth. Costs start around \$100,000. (See photo page 290.)

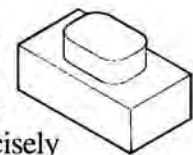
#### **What can you do with an inexpensive CNC system?**

You have to be realistic as to what an inexpensive CNC machine tool can do. There are some amazingly good systems available for under \$3000, but they can't compare with a full-blown CNC machine. The big difference is the ball leadscrews. These are very precise and expensive. The cost starts at \$1000 per axis and they are much too large to use on small machines. Don't get me wrong and think that I don't find these inexpensive control systems useful, but at 10% of the cost, don't expect them to perform like their larger counterparts. Don't be disappointed by what these machines can't do. Be happy with the fact that they now can do machining jobs that would have been considered impossible thirty years ago on machines costing many thousands of dollars.

Consider milling a rectangular protrusion on a block that must have accurately radiused corners. A simple CNC program will cut the corners precisely with very little code. To do the same task with a manual machine would involve cutting the protrusion and then putting the radius on each corner one at a time using a rotary table. This is why they used to manufacture rotary tables with an X-Y slide fitted to the bottom of it. Believe me, this wasn't something you could use after you had just one beer. It took 100% of your attention. Another good example would be milling and counter-boring a large hole through a plate. A simple program could be written that could cut this hole, and it could be



*A driver box like this Sherline P/N 8760 4-axis box makes it possible to drive stepper motors from any PC computer. Cables plug into the X, Y, Z and A axis stepper motors. A 25-pin cable goes to the computer's parallel port. A power supply is included.*



done with an end mill. The expensive ball leadscrew machines cut these holes almost perfectly round. The smaller machines I'm referring to in this paragraph can do the job but the hole will not be as perfect; however, it is usually acceptable. To use a manual machine it would take a rotary table or many passes with a boring head.

### Codes for CNC machining

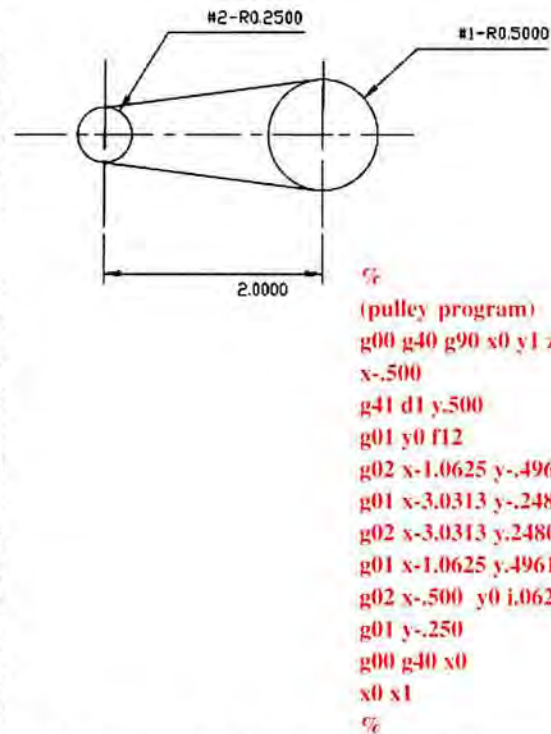
The standard programming systems available to hobbyists use "G" and "M" codes. The "G" defines the type of movement, and "M" controls the systems available. As an example "G00 X-1.000 M03" is telling the machine to move rapidly 1 inch on the X-axis in a minus direction and turn the spindle on. This would position the cutter at the edge of the part, and the next line of code may read, "G01 X-2.000 F10 M08." The G01 will use the F10 to determine that the table should now move to the new position X-2.000 at a programmed feed rate of 10 inches per minute and the M08 will turn the coolant pump on. Once the cut has been made, the table can be moved to its home position with the line of code, "G00 X2.000 M05 M09." This means that the table will rapidly travel to home position (The starting point of every program) and turn off the coolant and spindle.

This should give you a general idea of how programs are written, but remember that they can get complicated very quickly. If this were a milling program, the Z-axis would have to be considered. If a radius or arc had to be programmed, the starting points and the finishing points in "I" and "J" values have to be entered. CNC machines have to be programmed to make every move, and it's amazing how hard they will try to carry out a programming error, even if it means self-destruction.

The last thing I'd like to mention on this subject is that when I purchase a new CNC production machine, I find it takes anywhere from six months to a year before I believe we are using the machine to its full potential. Remember that skilled people are learning to operate the CNC control and producing work at the same time. Despite the high price, these machines usually come with hundreds of pages of poorly written, out of date instructions. This is one area where consumer level CNC products often outperform their big brothers

### Generating the G-code for a complicated part

For simple pockets, hole patterns and regular geometric shapes, G-code is usually written directly. Running it in a "backplot" program confirms that you have written it correctly before you run the part. For complicated 3D shapes, writing code for the tool path by hand would be impossible. In these applications, the part is first



*An example of G-code. Shown above is the drawing for a pulley shaped path along with the G-code that will generate that tool path. A complete explanation of the math to generate these numbers as well as other examples can be found on the Sherline web site. The "%" sign starts and ends the program.*

drawn in a CAD program and saved in .dxf or .stl format. Then the file is run through a second translator program that converts the drawing data into a G-code text file. This file is entered into your control computer's software and run. Most high quality CAD/CAM programs can output G-code directly from your drawing. If you would like to learn more about understanding and writing G-code, you can download the instructions I wrote which are posted on Sherline's web site at [www.sherline.com/CNCinstructions.htm](http://www.sherline.com/CNCinstructions.htm)

### Prices keep coming down...

There are several factors that have reduced prices: 1) Computers themselves continue to become both more powerful and less costly, 2) Stepper and servo motors are readily available at reasonable prices, 3) While expensive professional level CAD/CAM programs have become more capable, so have inexpensive and even free programs grown in number and sophistication and 4) highly capable open source operating systems and software like Linux and EMC have made it possible to drive sophisticated CNC systems without paying one cent to Bill Gates. As of 2004—all the following prices in this CNC section are based on 2004 prices—it is possible to buy a benchtop 4-axis CNC milling system

## G-Code List

<b>g0</b> rapid positioning	g58 use preset work coordinate system 5
<b>g1</b> linear interpolation	g59 use preset work coordinate system 6
<b>g2</b> circular/helical interpolation (clockwise)	g59.1 use preset work coordinate system 7
<b>g3</b> circular/helical interpolation (counterclockwise)	g59.2 use preset work coordinate system 8
<b>g4</b> dwell	g59.3 use preset work coordinate system 9
g10 coordinate system origin setting	g80 cancel motion mode (includes canned)
<b>g17</b> xy plane selection	g81 drilling canned cycle
<b>g18</b> xz plane selection	g82 drilling with dwell canned cycle
<b>g19</b> yz plane selection	g83 chip-breaking drilling canned cycle
<b>g20</b> inch system selection	g84 right hand tapping canned cycle
<b>g21</b> millimeter system selection	g85 boring, no dwell, feed out canned cycle
<b>g40</b> cancel cutter diameter compensation	g86 boring, spindle stop, rapid out canned
<b>g41</b> start cutter diameter comp. left	g87 back boring canned cycle
<b>g42</b> start cutter diameter comp. right	g88 boring, spindle stop, manual out canned
g43 tool length offset (plus)	g89 boring, dwell, feed out canned cycle
g49 cancel tool length offset	<b>g90 absolute distance mode</b>
g53 motion in machine coordinate system	<b>g91 incremental distance mode</b>
g54 use preset work coordinate system 1	g92 offset coordinate systems
g55 use preset work coordinate system 2	g92.2 cancel offset coordinate systems
g56 use preset work coordinate system 3	g93 inverse time feed mode
g57 use preset work coordinate system 4	g94 feed per minute mode
	g98 initial level return in canned cycles

## M-Code List

<b>M0</b> program stop	M8 flood coolant on
M1 optional program stop	M9 mist and flood coolant off
M2 program end	M26 enable automatic b-axis clamping
M3 turn spindle clockwise	M27 disable automatic b-axis clamping
M4 turn spindle counterclockwise	M30 program end, pallet shuttle, and reset
M5 stop spindle turning	M48 enable speed and feed overrides
M6 tool change	M49 disable speed and feed overrides
M7 mist coolant on	M60 pallet shuttle and program stop

Listed above are the meanings of the various G- and M-Codes you might encounter. Only the ones highlighted in bold, red type would be needed by someone using a benchtop CNC system.

that sells for under \$3000.00. This price not only includes the milling machine, stepper motors, drivers and rotary table, it also includes the computer, operating system and 4-axis software to run it.

### ...but things didn't get any easier

Lower prices have brought the expectation that because it costs less it must also have gotten easier, but this is not the case. Most manufacturers assume a certain level of computer and machining knowledge on the part of the buyer, and if you don't have it, you are in for a steep learning curve. In fact, having a computer and stepper motors drive your machine to make your part for you adds another level of complication to an already substantial task. Now, in addition to understanding how to hold the work, what tool to use to cut it, what order in which to make the cuts, how much to take off with each cut and so on, you must also learn the language to tell the computer to do all these things for you.

### Stepper motors vs. servo motors and "open loop" vs. "closed loop" systems

Stepper motors divide one rotation of the motor shaft into steps, usually 200 per revolution. Each step signal

sent to the stepper motor causes it to move 1.8° or 1/200<sup>th</sup> of a revolution. Half-stepping or micro-stepping can increase the number of divisions to 400 divisions. When using a leadscrew with 20 TPI (0.050" pitch) that means that each step resolves to .000125" or just over one ten-thousandths of an inch. These motors work very well and are capable of making very accurate movements without stalling as long as they are not overloaded. Stepper-motors have more power at slower feed rates because the length of the power pulse is longer. If a stepper-motor is overloaded due to any number of reasons, the motor may skip one or more steps. What makes this a disaster is that the error is carried forward because the home position has changed. In an "open loop" system, there is no cross-check between the signal sent to the motor and the amount it actually moved.

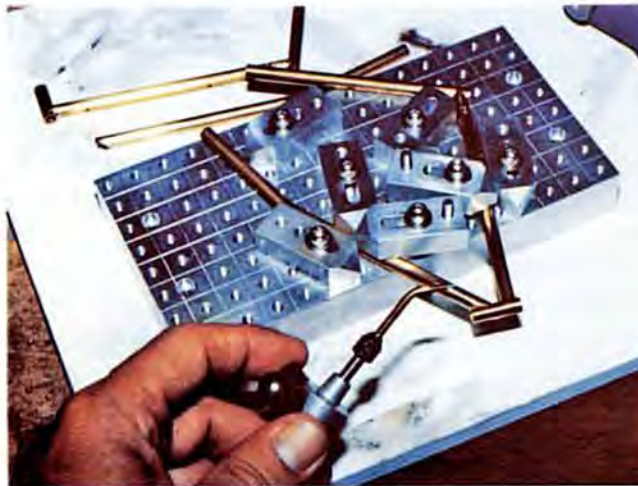
In order to have a "closed loop" system that compares intended movement to actual movement you need to include an encoder on the motor shaft that measures its movement. In this case, DC servo motors are usually used. The encoder translates a distance dimension into rotation and keeps track of shaft rotation to stop the motor exactly when it reaches the intended distance. If the motor is overloaded the encoder will keep applying power until the intended distance is achieved. The disadvantage for the home-shop machinist is higher initial cost and more complexities to the overall system.

### What's next for the home shop

Home shop tool trends seem to follow what is available in the professional shop. Adjustable "zero" handwheels, digital readouts, inserted tip carbide cutters and other items developed for the professional machinist rapidly trickled down to the home shop user. CNC is following this trend and will no doubt become more and more prevalent in the home shop. Despite its increasing presence, however, it is unlikely to ever totally replace manual machining. Simple jobs like drilling a hole or milling a single slot can still be done more quickly on a manual machine, and basic training should be obtained on manual machines so that machinists gain a feel for what are reasonable speeds and feed rates so they can properly program their CNC machines. CNC tools may make multiple parts faster and can machine three-dimensional surfaces impossible to do by hand, but there will always be jobs for manual machines and machinists who prefer to turn the handwheels for themselves rather than sitting at a computer writing code.

## SECTION 5—PROJECTS AND RESOURCES

Craftsman Profile—Bob Breslauer . . . . .	316
Tips for Machinists . . . . .	318
1. Plans and projects for you to build . . . . .	319
1. Tap Handle...a beginning project to use in your shop . . . . .	321
2. Mill vise “soft” jaws...a simple project that uses both a lathe and mill . . . . .	325
3. Laying out a circular hole pattern for drilling . . . . .	327
4. “Millie”...a small oscillating steam engine by Ed Warren from <i>Modeltec</i> magazine . . . . .	329
5. Ordering plans for the “Little Angel”, a “hit-n-miss” engine by Bob Shores . . . . .	333
2. Shows and awards for machinists . . . . .	335
3. Exploded views and part number listings . . . . .	339
• Lathe . . . . .	340
• Vertical milling machine . . . . .	341
• 8-direction mill . . . . .	342
• Part number listing . . . . .	343
4. A simple RPM gage . . . . .	345



*Bob Breslauer produced this professional looking jig for holding brass tubing to accurately solder miniature Harley Davidson frames. He even machined both the fixture plate as well as the strap clamps.*

PHOTOS: BOB BRESLAUER

*Here is one of five finished Harley frames mounted to a Sherline tooling plate. More on Bob and his progression from part-time modeler to full-time professional museum modelmaker can be found on the next two pages.*



## BOB BRESLAUER...a hobby turns into a profession



*Custom Harley Davidson front fork and disk brake details. The love of making models like this led Bob to a new career.*

PHOTOS: BOB BRESLAUER

In 1988, Bob Breslauer had a lot of time on his hands. His wife worked for United Airlines and he was a professional musician, but the arrival of a new baby meant that somebody had to be home during the day. His wife's schedule was not flexible, so Bob took a job as a bridge tender on the midnight shift in Fort Lauderdale, Florida, raising a drawbridge so ships and sailboats could move up and down the Intercoastal Waterway. Ship traffic is light in the middle of the night, so he had a lot of time with nothing to do.

About that time he happened to walk into Orange Blossom Hobbies in Miami looking for a plastic model kit to build to fill the long hours. There he saw a display of beautiful metal car parts made by Augie Hiscano. He was fascinated by their detail, quality and small size and decided right then and there that he wanted to be able to make parts like that. He has the "smaller is better" fascination with detail shared by many modelers and believes that if detailed part is good, a part that is just as detailed but half the size is *twice* as good. He bought a Sherline lathe and mill and was allowed to set them up on the job. Whenever the bridge didn't need to be raised, he would crank out miniature race car model parts all night long.

His skill grew as the parts he made became more and more sophisticated. Eventually the skills he obtained making model cars on the midnight shift bridge tender's job led to a position as a modelmaker in the Gallery of Transportation Museum in Coral Gables, Florida where he now has a "Disneyland of tools" to work with. From EDM to CNC, their fully equipped shop has it all. It is a modeler's and tool lover's paradise. He now works full time making models for the museum, most of his time being devoted to making Gauge 1 locomotives for their collection. In less than 10 years, Bob turned a part time hobby and a love of making model race cars into a full time profession in modelmaking.



*A 1/43 scale wire wheel of incredible detail for its tiny size.*

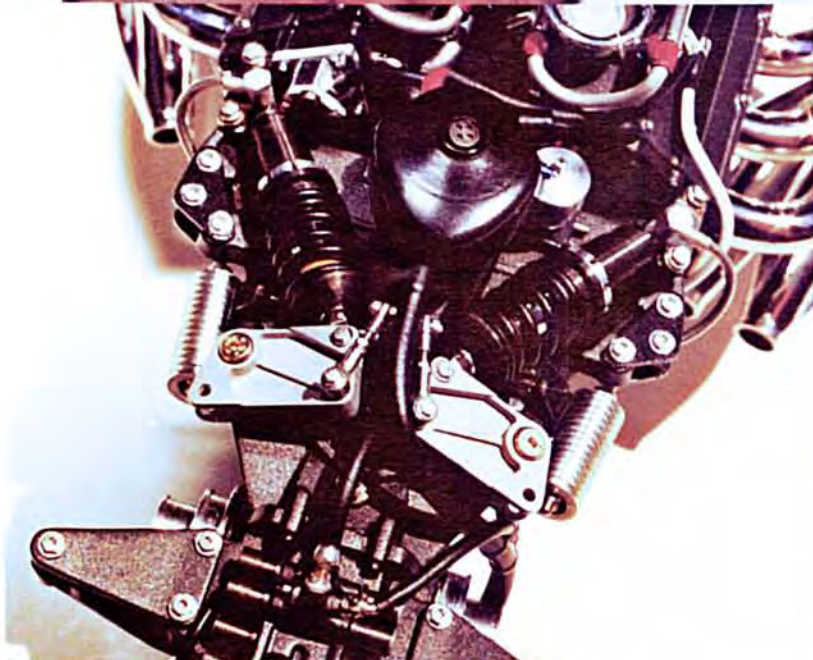
**Projects: Ferrari Formula I engine and car**



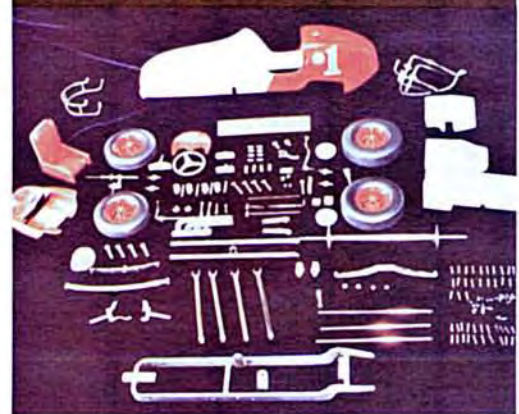
*This 1/12 scale engine and transmission are modeled after Ayrton Senna's 1990 F190 Formula I Ferrari. The major blocks are cast in resin. Over 1500 hand made metal parts make up the details.*



*This sprint car hub is typical of the fine quality found throughout Bob's models.*



**Project: Vintage Sprint Car**



*(Above) The components to make this sprint car are all scratch built including the wire wheels. Below is the finished car on display.*



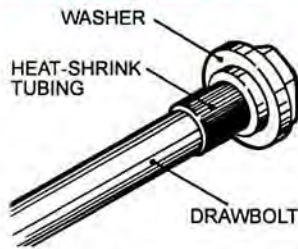
*The wheels for this 1/12 scale model of Jody Scheckter's Ferrari 312-T4 Formula I car are made in multiple pieces just like the prototype.*



# Tips for Machinists

With experience, craftsmen often discover ways to make things better, faster or easier. Fortunately, some of them have taken the time to pass on their knowledge to help save all of us some time and trouble. Here are a few suggestions that might make working with your tools a bit more fun.

## **DRAWBOLT WASHER RETAINER—Steven Smith**



*Here's a simple and good-looking way to keep a drawbolt and washer together.*

Mr. Smith of San Mateo, California notes that when you lift a drawbolt out of

the mill spindle, the washer can easily slide down the bolt and fall off. The bolt and washer can also become separated while rolling around in your toolbox. A short length of heat-shrink tubing slipped over the bolt shaft will keep the washer in place.

## **CENTERING WORK IN A 4-JAW CHUCK—Edward Ewell, Klamath Falls, Oregon**

If you have the 3/8" insert tool holder (P/N 7600), the 3/8" hole in this holder will hold a one-inch travel dial indicator nicely. Mr. Ewell uses this to center his work in the 4-jaw chuck. After centering, he removes the dial indicator and installs the cutting tool and positions the holder for the cutting process. He makes camera repair parts and says the accuracy he needs can only be obtained with the 4-jaw chuck.



*Mr. Ewell's setup with the dial indicator being held in the 3/8" hole of the P/N 7600 toolpost.*

## **Another good tip from Edward Ewell on using magnetic indicator stands...**

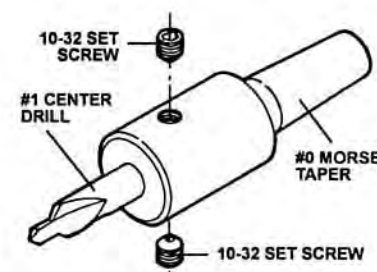
Many components on Sherline lathes and mills are aluminum which is nonmagnetic. In order to be able to use indicators with magnetic bases, Mr. Ewell mounted his Sherline lathe and milling machine on a 1/8" steel plate to allow the use of magnetic dial indicator stands. This goes on top of the normal mounting board. With this setup you can indicate your work from either side of the machine. If you don't have a single plate large enough to cover your entire base, you can just screw down a couple of smaller plates in the appropriate areas on your base where you will be using your magnetic indicators.

## **NEW GREASE IMPROVES MACHINE PERFORMANCE—Henry Scherer, Suisun, California**

Mr. Scherer purchased a small canister of Mobil 1® synthetic grease at an auto parts store. When he put it on the slides and leadscrews of his machines he noticed an immediate improvement in performance. Since he passed on this tip, all new Sherline machines now go out of the factory with a similar Teflon-based grease. It really does work better.

## **#0 MORSE TAPER HOLDER FOR A #1 CENTER DRILL—Ross Heitt, Saskatchewan, Canada**

At work, Ross Heitt runs 30" manual and CNC machines for a Canadian gear manufacturer, but at home he works on miniature machine tools. One of his first projects when he got his new lathe was to make a center drill holder to see how well it could turn a Morse taper. It worked fine, and he finds his center drill holder a very convenient fixture. This one is sized to hold a #1 center drill and fits a tailstock with a #0 Morse taper. For your own information, a Morse taper is based on a taper of approximately 5/8" per foot.



This holder was turned from 5/8" diameter 12L14 steel and has a .188" hole for a #1 center drill. The #0 Morse taper starts at a size of .361/.362" and tapers to .319" over a distance of .846". The overall length of the part is 1.9" and the body portion is .95" long.

# Chapter 1—Plans for projects you can build

## Putting your machines to work

Now that you've read about cutting metal and seen some of the projects that experienced craftsmen have built, you probably want to make something yourself. Depending on your level of expertise (and sense of adventure), I have provided some sample projects that vary from fairly simple to quite complex. If you have never made a metal project before, I suggest you start with one of the first two to get a feel for how metal cuts. One thing that will quickly discourage a new metalworker is starting on a project that is too complex.

## The projects



### Tap Handle

This lathe project requires little raw materials and a few basic operations like turning tapers, drilling

holes and tapping a thread. You will end up with a nice little tap handle that will come in handy for future miniature projects.



### Soft Jaws for your mill vise

The jaws that come with a mill vise are made from steel. When holding parts that have been machined, they can damage the surface

finish. For holding soft or finished parts firmly, you can make a set of aluminum "soft" jaws to replace the standard jaws. This project is good practice for learning to use a mill, plus you'll end up with a custom set of jaws that can be used on future projects.

---

*"Inventing is a combination of brains and materials. The more brains you use, the less material you need."*

—Charles F. Kettering

---



### Laying out a 6-hole or 8-hole pattern

An indexing head or rotary table can make it easy to lay out complex hole patterns, but more often than not, the parts you will make will require

simple patterns. Though I hesitate to use the word "trigonometry" for fear of turning you off before we even get started, this project will show you how easy it is to "trig out" a simple hole pattern so that you can dial in the hole centers with your handwheels. It's more accurate than working to scribed lines and requires nothing more than some simple calculations.



### A little steam engine named "Millie"

*Modeltec* magazine published an article by Ed Warren on how to build a simple steam engine. It is a great starter project that is sized just right for tabletop machine tools.

The magazine and Ed

have kindly given their permission to reprint the article here for your enjoyment.



*Young C. Park of Hawaii scratch-built this 1/16 scale aluminum cutaway model of an F4U-1D Corsair from photos and undimensioned drawings found in WWII aircraft maintenance manuals.*

### **Purchasing plans for the *Little Angel* hit 'n miss and other engines by Bob Shores**

The *Little Angel* is a gas powered hit 'n miss engine. Making a running engine is quite a test of machining skill, but when you're ready to take it on, this project is well designed and the plans are very complete. Hundreds of them have been built by craftsmen all over the world. It is sized for tabletop machine tools. If you can build this and get it to run, you can definitely call yourself a machinist.

Bob now offers plans and casting kits for other engines that are appropriately sized for small machine tools. The new Hercules engine, for example, is perfect for Sherline and similarly sized machines. For more details on how to order, see Project 5 in this section.



*Building this "Little Angel" offers quite a challenge.*

#### **Casting kits**

Many castings offered in kits are of such poor quality that you would be better off making the parts from bar stock. The companies listed below offer consistently good castings in their kits to give you a starting source. See Sherline's "resources" web page for a current and more complete list of sources.

**PM Research Inc.**—4110 Niles Hill Road, Wellsville, NY 14895. Phone: (716) 593-3169  
Web site: [www.pmresearch.com](http://www.pmresearch.com)

**Mechanical Models**—Stirling engine kits.  
Web site: [www.mechanicalmodels.com](http://www.mechanicalmodels.com)

**Morrison Miniature Engines**—A source for high quality Stuart steam engine kits. Call (501) 753-1749 or see [www.mmmachines.com](http://www.mmmachines.com).

#### **Metal stock and small fasteners**

Buying from large industrial suppliers requires minimum orders and cutting charges that make them impractical as a source for small home projects. A couple of places

that sell metal in a good selection of sizes and with no minimum quantities or cutting charges are:

**ASAP Source**—284 S. Industrial Hwy., Ann Arbor, MI 48104 Phone (734) 213-2727  
E-mail: [sales@asapsource.com](mailto:sales@asapsource.com)  
Web site: [www.asapsource.com](http://www.asapsource.com).

**Metal by the foot, Inc.**, 2700 E. Truman Road, Kansas City, MO 64127. Phone: (816) 241-5550.

**Onlinemetals.com**—Seattle, WA. Order online or call (800) 704-2157 or (206) 285-8603.  
E-mail: [sales@onlinemetals.com](mailto:sales@onlinemetals.com)  
Web site: [www.onlinemetals.com](http://www.onlinemetals.com)

**Small Parts, Inc.**—13980 NW 58th Ct., Miami Lakes, FL 33014-0650. Phone: (800) 220-4242 to order or ask for their complete catalog.  
Web site: [www.smallparts.com](http://www.smallparts.com).

#### **Magazines for tabletop machinists**

Here are some addresses in case you want to look further at magazines that offer machining projects. Not all of the projects are appropriate for tabletop size tools, but even larger projects can always be scaled down to half or quarter size and made to fit your tools. As I've noted before, this offers not only the advantage of saving on materials, it also makes the project that much more challenging to build and fun to look at when it's done. The following addresses and phone numbers were correct as of 2004. Many of these magazines are available at the magazine racks of larger bookstores.

Village Press publishes *The Home Shop Machinist*, *Machinist's Workshop* and *Live Steam* Magazines. Their address is: Village Press, 2779 Aero Park Drive, Traverse City, MI, 49686. Phone: 800/327-7377

For those interested in internal combustion engines, an excellent source of information was a magazine called *Strictly I.C.* Though they ceased publication a few years ago, back issues are still available. Their address is: Strictly I.C. Publishing, 24920 43rd Avenue South, Kent, WA 98032-4160. E-mail: [strictlyic@earthlink.net](mailto:strictlyic@earthlink.net) or see their web site at [www.strictlyic.com](http://www.strictlyic.com).

England has a strong tradition in miniature model engineering and a very good magazine called *Model Engineer* that has been on the market longer than any other such publication. They also have a companion publication that is published several times a year called *Model Engineer's Workshop*. Contact: *Model Engineer*, Nexus House, Boundary Way, Azalea Drive, Swanley, Kent BR8 8HU, England. Phone: 01322 660070.

## Project 1— Making a miniature tap handle

### Getting the most out of a small project

No book on basic machining would be complete without plans and instructions to build a tap-holding wrench. It was the first machining project I was given in Cranston High School in 1951. I can still remember my teacher's name, Mr. Charles Cutler, so he must have made an impression on me. What I liked about him was that he could have made a living doing machine work and was never intimidated by the machines around him. As a matter of fact, the students intimidated him even less. We got our first taste of what working was all about from him because he ran his shop class like a business, and I remember cutting a gear before my year in his class was over. He was a fine teacher. I'm assuming this may be your first project, so I'm putting a little extra effort with these instructions to get your mind in the right mode for making close-tolerance metal parts. I want you to do the best possible job you can do on this project, and don't feel you have failed if you don't make a good part on the first try. I didn't. You only will have failed if you accept less than perfection on the final product. Of course I wouldn't want to have you spend the rest of your life building the perfect miniature tap handle. Just don't accept a less than perfect job by calling it a perfect one. Always have a way of improving the next one in your mind, and this would encompass quality, method, and time. Strive for perfection, but have the common sense to realize it will only be an abstract term to a good craftsman who will always know the flaw in his "perfect" job.

### Why a small tap handle is worth building

To get back to the subject at hand, small taps are very easy to break and a broken tap will usually result in a scrapped part. They also get expensive as the size goes down so there are two good reasons why this project is worthwhile. Just like miniature machine tools give you a good "feel" when making small parts, a small tapping wrench will transmit more information to your brain on how the tapping process is going. All you need in the way of material is a piece of 3/8" diameter free machining (12L14) steel about 6" long and a 10-32 socket head cap screw (SHCS) with 3/8" of thread. I designed the tap to be clamped using a 5/32" Allen wrench which



*The finished miniature tap handle is shown holding a #0-80 tap. Small taps are expensive and easily broken if not properly held, so an accessory like this is a good thing to add to your tool box. This small tap handle is also fun to build and will give you some good practice with several basic machining operations.*

is the same size as the one used with the products Sherline manufactures. If you don't have a jeweler's saw, purchase one from a hobby shop along with a couple packages of blades. These saws are marvelous tools, and it is amazing what you can cut with them. They are also inexpensive so you can afford the best one available. I would also recommend a magnifying headpiece for doing close work like this. I don't believe it is necessary to heat treat the steel used on an item like this, since it won't be used commercially.

### Making the square hole for the tap

The hardest part of the project is making a square hole to accommodate the tap. I designed it for use with #10 taps and smaller. The square hole is just large enough to hold a #10 tap so you can use one as a gage when you are filing the square hole to size. If you have never attempted to do a project like this I would suggest practicing on a scrap piece of metal first rather than doing a poor job on the finished part. Make this first project perfect so you can be proud to show it to your friends.

### Making a practice hole

To practice making a square hole, machine (mill) a piece of material .220" thick and center drill the



*Another view of the tap handle showing the tap removed. The 5/32" hex key is used to tighten the socket head cap screw in the end of the handle to hold the tap in place. This is the same tool used to tighten or adjust most Sherline accessories.*

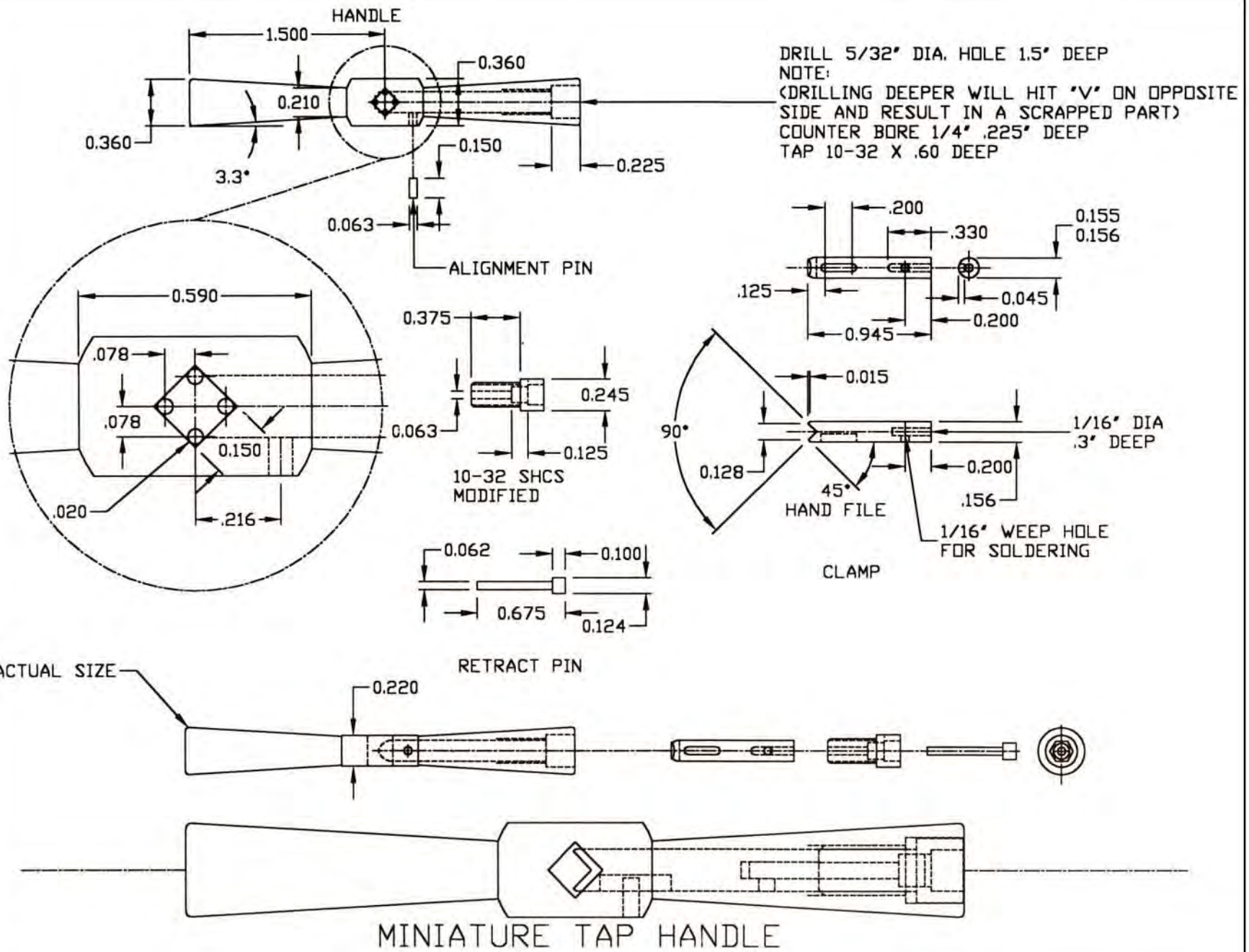
.078" hole pattern with a #0 center drill using the calibrated handwheels. Drill through with a #60 drill (.040" or 1mm), remembering to clear and lubricate the drill tip every drill diameter of depth. To do your layout lines, apply a light coat of "Dykem" or use a felt tip marking pen to highlight the scribed lines joining the holes together. Remember that the more accurately you saw out the square hole the less filing you will have to do. To accomplish this the work has to be held in such a fashion that you can saw it to within a few thousands of an inch. This isn't impossible if you take the time to make a good setup. I've never had much success using a jewelers saw to cut an outline with the work held in a vise in a vertical position because it is difficult to see the work. Many times I'll use a woodworking clamp that is clamped to the worktable or vise to hold a part while I saw it. It is imperative that the work is held square to its surroundings in order to easily line up the saw and cut squarely. Thread the saw blade through the predrilled holes and clamp the blade to the jeweler's saw body. Carefully follow the scribed line with the saw until the next hole is reached. You may have to reclamp the part for each leg of the cut. Be sure you don't hold the saw out of square and take too much material off the bottom where you can't see the path of the saw blade. On the other hand, trying to leave material purposely will result in a part that is difficult to file. Filing the hole to its final size also requires the same clamping procedures. I used a square needle file for this. Don't put the file in the hole and believe by simply moving it you will end up with a perfectly square hole. Each pass of the file should be planned to cut a particular spot. Therefore, each pass must be properly aligned before moving the file. This is the fastest way to do

a job like this, and, as I keep reminding you, "shortcuts usually end in failure". By the way, if the part were being made in production quantities the square hole would have been broached. This is done with a long cutting tool that doesn't revolve and is pushed or pulled through a predrilled hole to generate the square hole. Broaching tools are very expensive, but the operation itself is inexpensive. The second choice would be electrical discharge machining (EDM) for low quantities or tight tolerances. The reason for this somewhat lengthy discussion is that I'm trying to teach you the skillful use of your hands, which can be much more difficult to describe than the operation of a simple machine.

### **Making the handle**

If you are satisfied with your first square hole, you are either starting off with more natural skill than I had or you are not as fussy. Whatever the case may be it is time to make some chips, but study the drawing one more time before starting. Clamp the 3/8" material in a 3-jaw chuck with 1/2" protruding and face the end off. Move it out so it can be cut to length with an allowance for finishing (3.03"). Turn it over and face the unfinished end and reclamp it with 2" protruding. Center drill the end with a #2 center drill. Drill a 5/32" hole exactly 1-1/2" deep. Counterbore with a 1/4" drill .225" deep. Use a 10-32 spiral point tap and have the tap go in at least .6" deep.

Turn the entire length down to .360" making sure you get a good finish on the 3/4" section close to the chuck. Remove the alignment key under the headstock and rotate the headstock counterclockwise 3 degrees. Mark the bar 1.205" from the end with the turning tool. Set the tool so the cutting edge is at approximately the same angle as the drawing. This isn't too critical and only affects the appearance of your cut. Take a couple of cuts to get the angle set correctly. This is sort of a trial and error method and you can use the point of your tool to help control the movements by having the tool against the part when the headstock is loosened. Remember the pivot center is from the center of the headstock, not the part itself; therefore you can't simply dial in the change you want. Be sure the small end doesn't go undersize because the wall thickness will suffer and make the part weak. Leave the angle set in the headstock and, with the spindle turning around 400 RPM, take a couple of passes with a flat single-cut mill file, being sure you don't let it load up. Radius



the edge with a file to a .020" radius. Polish both the tapered and straight cut with 320 wet/dry sandpaper using a light oil or kerosene as a lubricant. We want this to be pretty so do a good job. Now turn the part over in the chuck and hold it on the .360" diameter you have already turned. By leaving the angle set in the headstock you can now cut exactly the same angle on the opposite side. Turn the taper, polish the surface and you're done with the lathe work on the handle.

#### **Turning the small pins**

Replace the alignment key under the headstock so that you can make the alignment and retract pins. Before starting them, read again what I wrote about "turning small diameters" on page 135. These parts are sized appropriately for that technique.

#### **Making the clamping pin**

Take a piece of 3/8" stock about 1.5" long and clamp it in the mill vise at a 45 degree angle. Mount the mill vise on the milling machine. Using an end mill, cut the "V" slot on the end of the bar-stock. One side of the "V" will be produced with the side of the end mill and the opposite side will be produced with the end of the end mill. Adjust the cutter and table position so the center of the "V" is cut on the exact center of the bar stock. By cutting the "V" first you can get to center by trial and error without risking a completed part. Now clamp this part in the 3-jaw chuck on the lathe with "V" protruding 1.1". Turn this diameter down to .155" for 1" in length using the method you just learned making the pins. Cut it off to the proper length. Drill the 1/16" hole on the opposite end.

#### **Modifying the socket head cap screw**

The last lathe job to do on the project is modifying the socket head cap screw (SHCS) to drive the clamping and retract pins. Make sure the screw isn't hardened and can be machined. The SHCS doesn't have to be 3/8" long to start because it can be cut off to size after modification. Be careful you don't damage the threads if you must clamp on them. Turn the O.D. of the head of the screw down to .245". Center drill with a #1 CD. Drill through with a 1/16" drill. Counterbore 1/8" deep with a 1/8" drill. This completes the lathe operations.

#### **"Indicate in" your vise**

With the vise square with the milling machine table, use an edge finder to align the center of the spindle exactly over the edge of the fixed jaw of the vise.

Zero your handwheel or note the handwheel setting and the direction the backlash has been set.

#### **Machining the flat on the handle**

Mount the handle in the mill vise in such a way one side can be machined flat on the center section. A spacer or parallel can be used to get it to the proper height. Note that the spacer doesn't have to be between the vise and the part. It can instead be between the mill tabletop and the part. Mill to the proper size in a series of light, fast cuts. If the handle has been made to size the flat will finish .005" above the small diameter of the handle. Leave a few thousandths for polishing. Turn the part over, locate on the surface you have just machined and machine the opposite side to the proper thickness. Now lay out the hole pattern for the square. This time it's for real, so don't screw it up. We know the setting for the fixed vise jaw, so it is a simple matter to "dial" over to the center of the part and locate the center on the other axis with calipers. Drill your holes and turn the part 90 degrees and drill the alignment pin hole. (Note: this could also be a 2-56 set screw if you want to be able to take it apart some day. Your choice.) Saw out the square hole and file to size.

#### **Cutting the slot and drilling the side of the clamp shaft**

I aligned the clamp in the vise by placing a drill or small shaft in the "V" groove, "eyeballing" it square and then milling the alignment slot. The drill gives you a larger surface to look at while squaring the clamp to the vise. I then drilled the weep hole for soldering in the clamp with the same end mill.

#### **Assembling the parts**

We are now ready to put it together. Slide the retract pin through the SHCS and solder or Loc-Tite™ the pin to the clamp, making sure the SHCS can still rotate independently from the clamp. Screw the assembly into the handle, making sure it moves freely. If it doesn't, correct the problem. The alignment pin can then be put in place, and any scratches that may have been added since polishing can be removed. Remember that you can't back the clamping screw past the alignment pin once the tap handle has been assembled.

The tap handle is now ready to use or, better yet, show to your peers. Someone asking how you put the square hole through the shaft should be considered the ultimate compliment. It means that you have done the job so well it doesn't look homemade.

## Project 2— Making soft jaws for your mill vise



PHOTO: PETE WEISS

*A set of custom aluminum “soft” jaws has been bored to exact size to grip this aluminum piston as it is machined. Time invested in making a fixture like this is well spent, because it eventually saves time in clamping up oddly shaped parts. In addition, the aluminum jaws also won’t damage the part’s finish. In this case, a number of operations will be performed on six pistons using these jaws.*

### Custom jaws grip hard-to-hold parts

I had Pete Weiss make up a set of special jaws to give you some idea of the type of tooling you might make in the future to make a particular machining job easier to do when you have multiple parts to make. Another reason for building special work-holding devices can be to attain an accuracy that wouldn’t have been possible otherwise. Work like this doesn’t have to be pretty, but it should be functional. Before starting on the initial design think about a second use for it. Many times by making the device a little larger it could be used for several different parts in the future. Building special tools takes time, so you have to balance the time it takes to build the tooling against the time it will save making the part without it. However, the most important consideration will always be the quality of the work you will be able to produce with or without it.

### Making the basic blank jaws

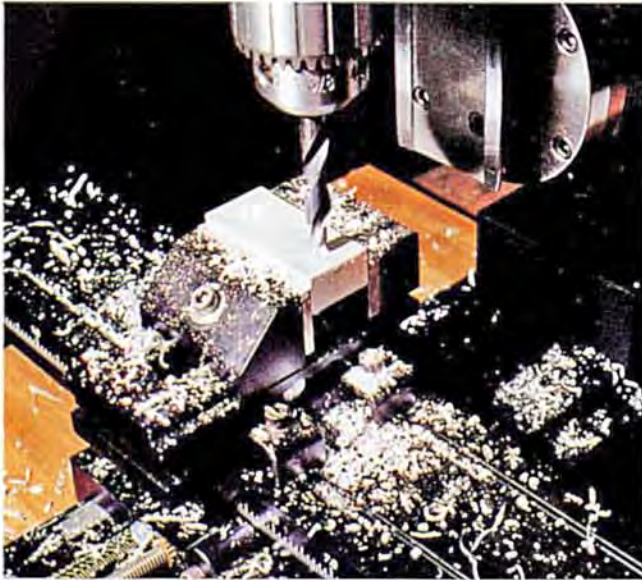
The special soft jaws are quite easy to make, and it’s a good rainy day project. Making several sets of the basic jaws at the same time can save a lot of time on future projects. Square up the blocks and drill and counterbore the movable jaw. (See Section 3, Chapter 3 for more on squaring up a block.) Drill and tap the 10-32 hole in the fixed jaw and you have your basic set.

### Customizing the jaws for your particular job

The next part is to customize the blank jaws for a particular use. Clamp the jaws up on a piece of material that will give you the proper gap you need on your final

product. Pete used an edge-finder to find the center of the gap. If you know the dimension of the gap you can easily get to center if you have the spindle located over the fixed jaw by dialing over  $\frac{1}{2}$  the distance of the gap. If a closer tolerance is needed, a dial indicator in the spindle could be used by rotating the spindle and moving the appropriate axis until the same reading is attained on the inside edge of each jaw. Pete used a boring head to create the actual clamping surface to hold the piston. Normally the jaws would be cut to a specific depth eliminating the need for parallel bars, but Pete had a second use planned for the jaws that required the additional machined depth. Jaws used for production may have a slight undercut on the bottom of the clamping surface to allow for burrs on the corners of the part itself or the debris that tends to build up in the inside corners of clamping devices.

I realize a novice to machining may believe that any time spent working on a fixture that doesn’t become part of the final project is time wasted, but let me assure you it isn’t. At Sherline we have spent thousands of dollars on special part-holding devices to produce a single part that may have multiple operations. The design effort that goes into these special tools can be greater than the design of the part itself.



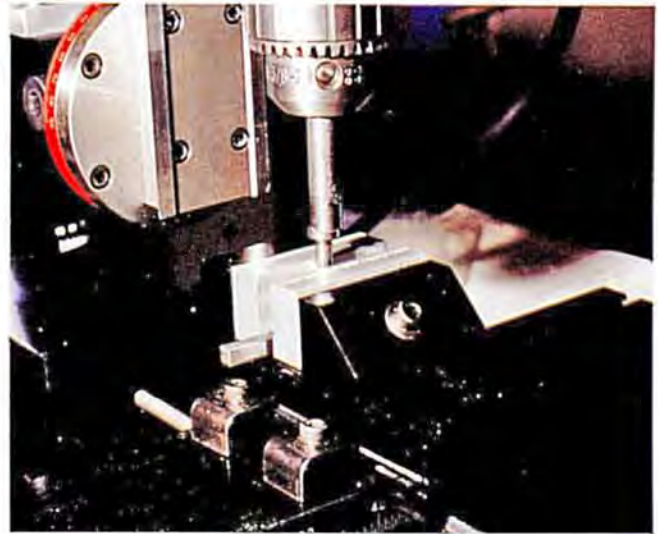
1. After the blocks are squared up, they are drilled and counterbored so they can be bolted to the vise. In this case, a stepped drill is being used that will drill and counterbore the hole in one operation.



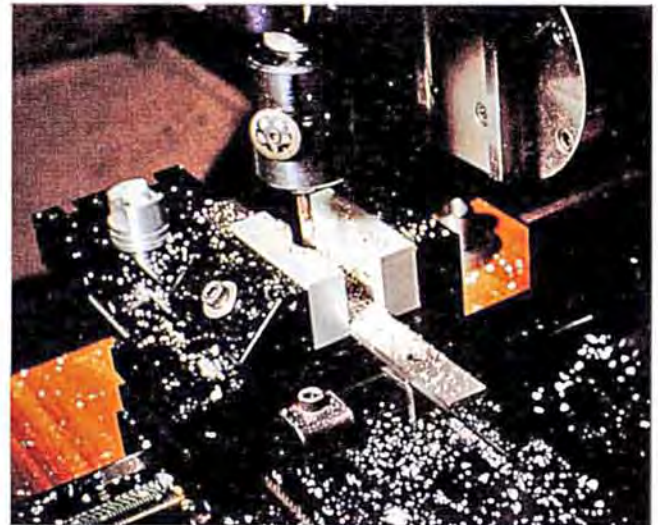
2. The holes in the fixed jaw are tapped using a 10-32 tap. A tapping guide is used to align the tap with the hole to make sure it goes in squarely.



3. The finished jaws attached to the vise ready to be customized for your particular job.



4. An edge finder is used to find the center of the gap to prepare for boring it to hold a round part.



5. Once properly located and spaced, the jaws are bored to hold the round piston. The jaws are clamped on a piece of stock of the proper dimension to provide the desired gap. The final step on your own jaws would be determined by the shape of the part to be held.

PHOTOS: PETE WEISS

## Project 3— Laying out a 6-hole or 8-hole pattern

### Why you should have listened in trigonometry class

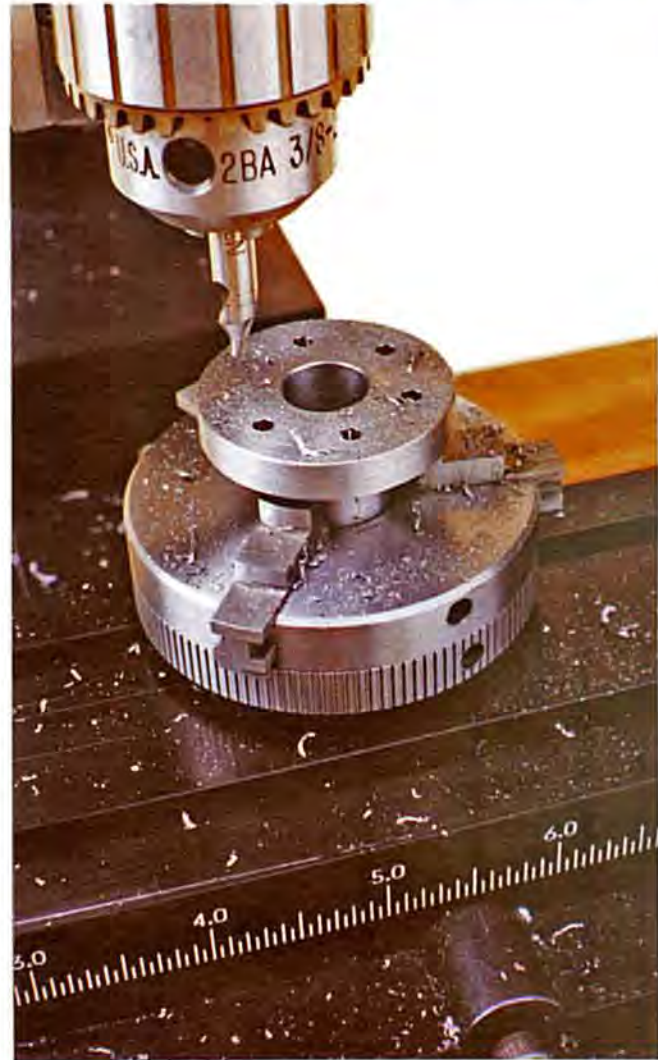
If our customers knew how easy it is to lay out a six-hole or eight-hole bolt circle I believe sales on indexing devices would fall dramatically. I mention using “trig” tables quite often, but it usually falls on deaf ears. I am going to give it one more try, and if you don’t want to learn some real simple math it is okay with me, because I’m always happy to sell another rotary table.

### A couple of simple numbers make it easy to figure

Only three numbers from the trig tables are needed to lay out any six- or eight-hole bolt circle, and they are .866, .707, and .5. If you can’t deal with these three numbers you may be getting into the wrong hobby. I hesitate to call these numbers the sine and cosine of the angle of the radius of the bolt circle for fear of losing you before we even get started. These terms may bring back the horrible memories of math class. Perhaps you didn’t pay attention because you never thought you’d have a need for the knowledge, but now you wish you had listened and learned. All is not lost, because I’m going to give you a second chance. All you need to know is these three simple numbers and you’ll be able to tell your friends that you “trigged” out the hole pattern, and in this day and age they will automatically be impressed.

If you want to do a six-hole pattern the numbers you need are .866 (cosine) and .5 (sine). Multiply these numbers by the radius of your bolt circle and you will have the amount you must offset the X and Y slides from the center of the bolt circle to have the hole locate on the bolt-circle radius at 60 degrees. Study the diagram and you’ll see how simple it is. You only have to know one number to do an eight-hole pattern because both the X and Y offsets from center are the same for 45 degrees in either direction and that number is .707 (sine and cosine are the same). It just doesn’t get any simpler than this because now you can lay out any six- or eight-bolt circle knowing only the bolt-circle radius. It can be as small as the head of a pin or as large as the circular net of roads leading into Washington DC and it will still work.

In the example on the following page the hole circle diameter is .313”.



*The last hole of a 6-hole pattern is about to be drilled using only the handwheel settings calculated by trigonometry to locate the hole centers. This is a more accurate method than trying to mark hole centers and “eyeball” your drill into position. When you can take advantage of the accuracy of your handwheels and “trig out” a hole pattern, you are on your way to becoming a machinist.*

The job is a lot easier if you can reset the handwheels to zero, but the hardest part will be working with the same number in two different directions.

### Cranking in the numbers in both positive and negative directions

The first rule for laying out hole patterns is to always turn the handwheels in the same direction you used to locate the center when coming up to a new setting.

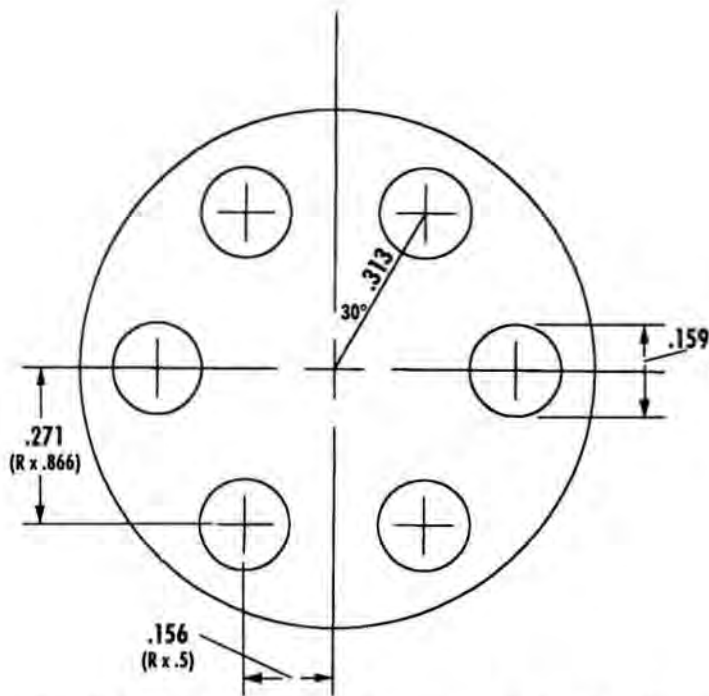


FIGURE 1—X- and Y-axis offsets for a 6-hole pattern. (Drawings not to scale.)

Remember this is to allow for backlash. You have no doubt heard this term a number of times by now, but I figured it wouldn't hurt to inject it into your brain one more time.

Here's something to keep in mind regarding backlash: in one direction the numbers get larger in a positive fashion when moving from zero (or the current number on handwheels if they can't be reset to zero); in the opposite direction the number must be *subtracted* from .050" (1mm). Be sure you understand this before you do any machining, and calculate and write down the handwheel settings for the entire hole layout before drilling any holes. It takes more skill to keep track of these movements than to calculate what the movements should be. Once you've done it a few times the process gets

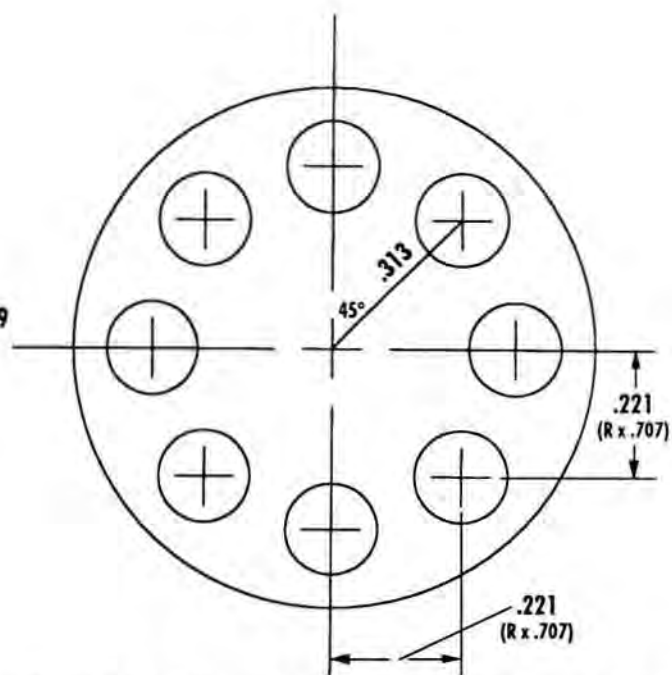


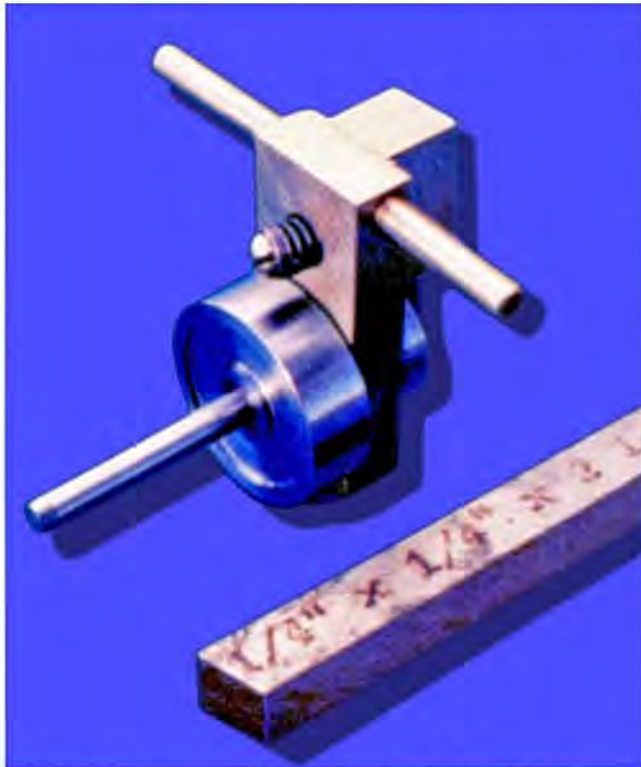
FIGURE 2—X- and Y-axis offsets for an 8-hole pattern. At 45° the sine and cosine are the same.

easier, but it still demands a lot of concentration from even a skilled machinist. As with any complicated machining operation, a mistake at any step can scrap out the part, so the fastest way to a good part is to work slowly and carefully.

#### **Another accessory can make it even easier**

A digital readout (see page 98) can take most of the misery out of dialing in these figures. First of all, you can establish your zero reading with the push of a button at your starting point. Then, it is just a simple matter to dial in the distance (positive or negative) you have calculated for the hole position. After you get used to using a D.R.O., you will see why most machine shops now have them on their full-size shop equipment.

## Project 4—A little steam engine called “Millie”



“Millie” as a completed engine. Pete Weiss made this sample from the plans on the pages that follow. He chose to add brass tubing extensions to make it easier to attach an air or steam hose to run it, although they were not shown on the plans. Which side the air is attached to determines in which direction the engine runs.

### A project from the pages of *Modeltec* magazine

There are a number of magazines on the newsstands that offer information for those wishing to make projects of their own. *Modeltec*\*, along with *The Home Shop Machinist*, *Machinist's Workshop*, *Live Steam* and, in England, *Model Engineer* and *Model Engineer's Workshop* all cater to those wishing to build working projects in metal. Publisher George Broad and author Ed Warren were kind enough to let us reproduce this 2-page article from the May, 1997 issue of *Modeltec* for your enjoyment. The engine shown here was built on Sherline tools. On page 332 I have included a few photos of the project as it was being completed. For the spring, it was found that a ball point pen spring which was cut to length worked just fine.

PHOTO: P. WEISS



Here are the finished components before assembly. Only 8 parts and a spring are needed to make this simple but fun steam engine.

\**Modeltec* magazine ceased publication in 2004 but has been purchased by another publisher. Watch for it to return soon.

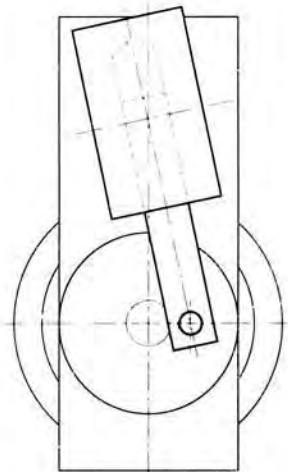
---

*A couple of fun evenings could be spent on*  
**Making Milly Move**

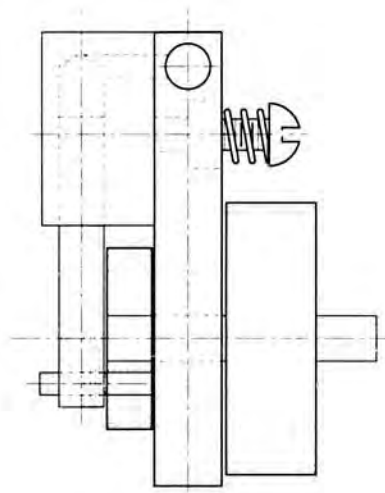
by Ed Warren

Photos by the Author and G. R. Broad  
Drawings adapted for publication from CAD originals by the Author.

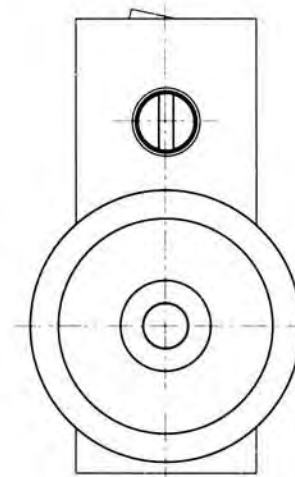
---



CYLINDER END



SIDE VIEW



FLYWHEEL END

Viewed from the side, everything but the spring is visible. The hole facing the camera is for the steam (air) supply—or else the exhaust, depending on which direction you want *Milly* to move.

The parts for *Milly*, laid out on Ed Warren's workbench. The 6" rule demonstrates the small size of this engine. That and its simplicity would make it a great project for introducing a young machinist to the hobby!

Ed is facing *Milly's* cylinder after using the natural offset derived from chucking a four-sided piece of stock in a three-jaw chuck to locate the cylinder bore for drilling and reaming.



Over the years I've seen teeny weeny steam engines and always wanted to build one. I should have done that a long time ago, when my eyes were a lot younger, as it would have been a lot easier. Now I have to use glasses to see close up. Otherwise, everything is blurred.

Whether you have to squint through glasses or not when you mark out the lines, be very careful when you center punch them so the holes are in the right place. The smaller a steam engine is, the more accurate your work needs to be.

Starting with the **Cylinder Mount**, lay out the holes and drill them. Next do the **Cylinder**. Here's a tip you can use. Whenever a square piece of material is put into a three-jaw chuck, the center of the square will be offset. I use this to my advantage in drilling and reaming the bore in the square stock. The offset leaves enough room between the back of the piston and the cylinder mount plate to put the crank disk between them. That's how *Milly's* cylinder was made.

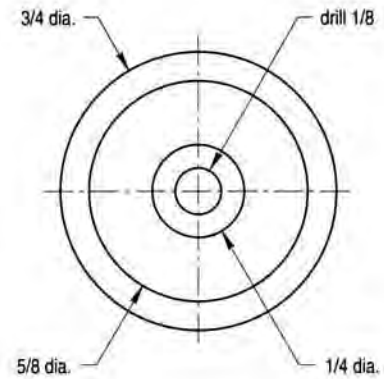
When the hole pivot was drilled in the cylinder for the 2-56 screw, I drilled on into the cylinder bore, but when I tapped the hole, I didn't go all the way through. That was so the incomplete threads would jam the end of the screw and keep it from vibrating out. Yes, it really does work okay this way. If you don't break into the cylinder with the drill, then be sure to use a bottoming tap.

For making the **Crank Pin** and **Crankshaft**, use stainless steel and polish them up a bit.

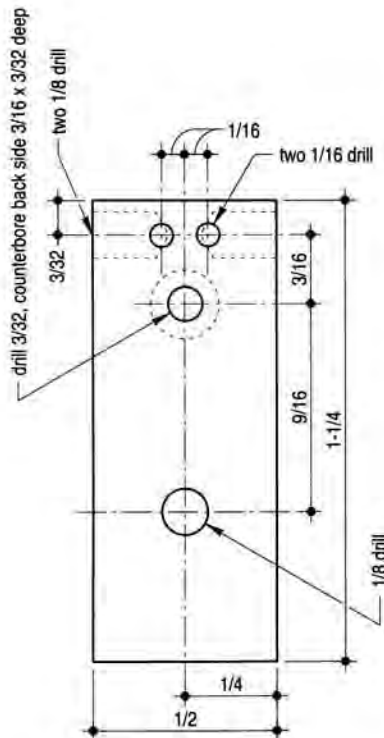
The **Flywheel** will look a lot better if the recesses are turned on both sides. It's made out of stainless steel, also.

This engine is so teeny that when it was assembled, Loctite was used to hold the flywheel and crank disk on the crankshaft instead of trying to find any set-screws small enough.

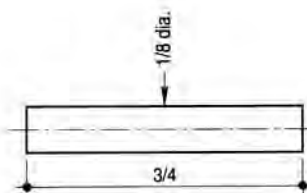
The first time I tried to run *Milly*, she just refused to do anything like run—but don't give up keep trying. Once she gets broken in, she'll take off and *moovooe*.



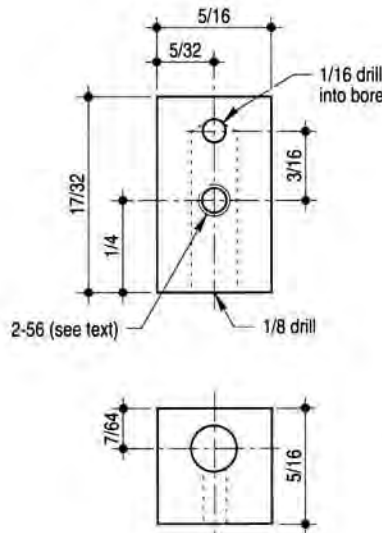
**FLYWHEEL**  
1/4 Steel, 1 Required



**CYLINDER MOUNT**  
3/16 Brass, 1 Required

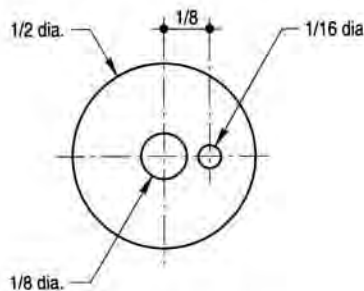


**CRANKSHAFT**  
Stainless Steel, 1 Required

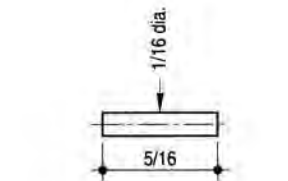


**CYLINDER**  
Brass, 1 Required

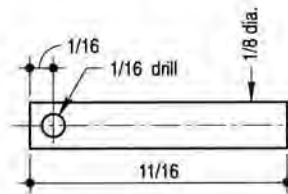
Drawings sare twice actual size.



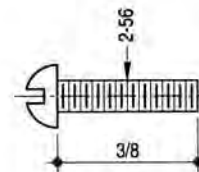
**CRANK DISK**  
1/8 Stainless Steel, 1 Required



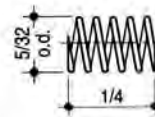
**CRANKPIN**  
Steel, 1 Required



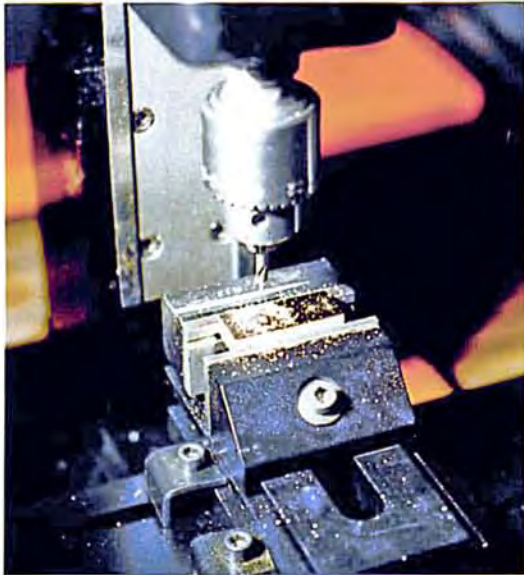
**PISTON**  
Steel, 1 Required



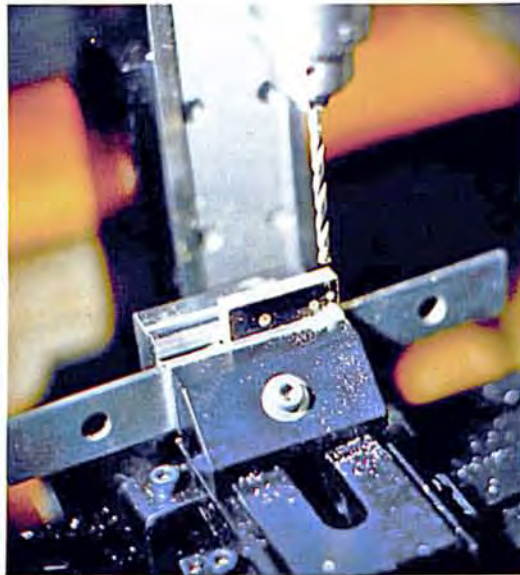
**BOLT**  
Brass, 1 Required



**SPRING**  
.016 or .018 Wire, 1 Required



*(Left) Center drilling the cylinder mount.*



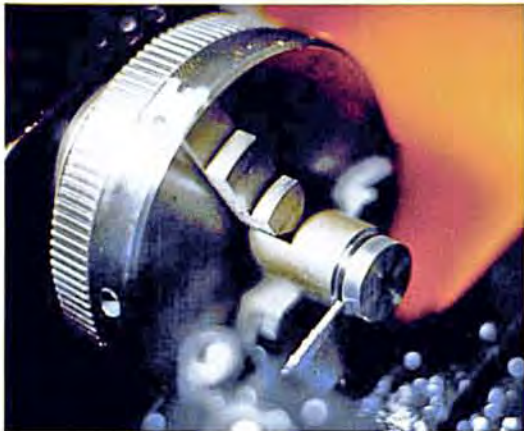
*(Right) Drilling the 1/8" holes for input/output tubes.*



*(Left) Drilling the center of the crank disk.*



*(Right) Reaming the center 1/8" hole in the flywheel.*



*(Left) Parting off the crank disk.*



*(Right) The completed crank disk.*

PHOTOS: PETE WEISS

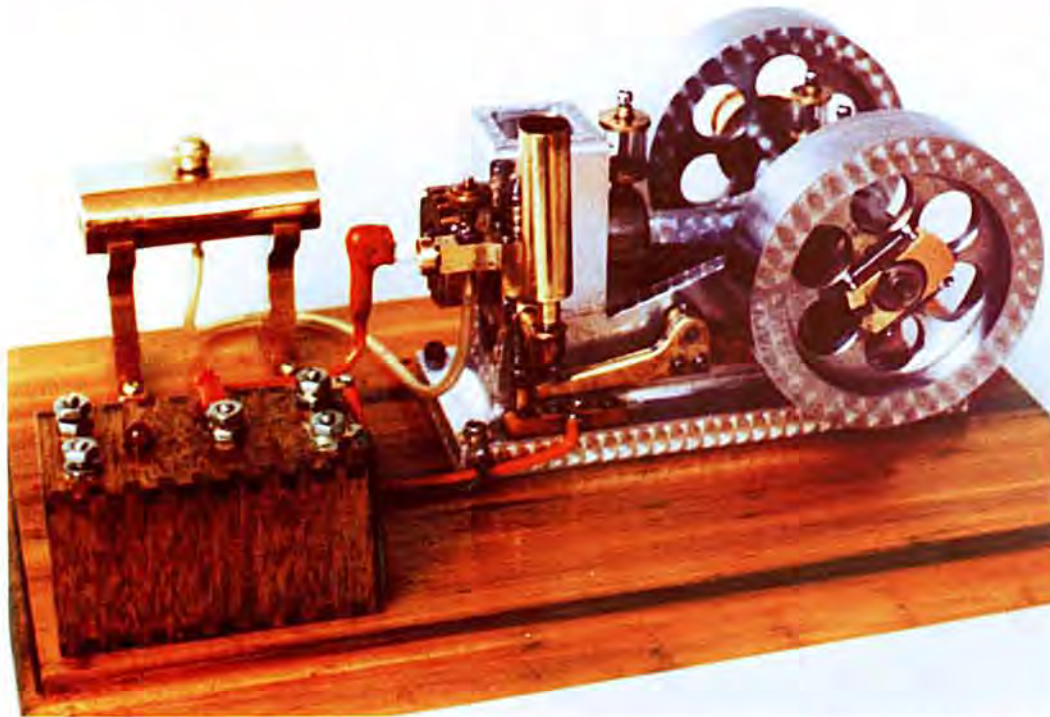
## **"Millie" under construction**

as built by Pete Weiss



*(Right) Indicating in the surface of the flywheel for milling. The part is left in the 3-jaw chuck so it can be returned to the lathe for parting off without recentering.*

## Project 5— The “Little Angel” hit ‘n miss engine



*The “Little Angel” is an attractive gas engine that runs on Coleman lantern fuel. A standard auto ignition coil can be used with a 6-volt battery to fire the sparkplug, or smaller model coils can also be used.*

### Building the “Little Angel”

Bob Shores built the model shown above and offers plans for sale so you can build it too. It is a fairly advanced project for a machinist with some experience and skill. The plans cost \$25 which barely covers Bob’s cost to blueprint and ship them, so he is doing this pretty much for the fun of it. As of December 1997, about 291 “Little Angels” had been built. Axel Nielson in Oregon built seven of them and gave one to each of his grandchildren. All the parts can be built on miniature machine tools. The plans include five expertly drawn, blueprinted sheets with parts shown full size. Also included is a 10-page typed instruction booklet plus a sheet to help you with timing settings.

To order plans contact:

Bob Shores  
108 Carmelina Street  
Ruskin, FL 33570  
e-mail: bobshores@msn.com

Brochures on the engine are free upon request. As of 2004, plans are \$25 which includes postage. (\$30 for shipment outside the USA.) See [www.bobshores.com](http://www.bobshores.com) for the most current price and ordering information.

### Common questions about the engine

Here are some answers to questions people often ask about the “Little Angel”:

- The cylinder bore is 1/2". The stroke is also 1/2".
- The flywheels are 2.5" in diameter.
- It runs on a mixture of 90% lantern fuel and 10% WD40 during break-in, 5% WD40 after break-in.
- A regulator controls engine speed. After break-in it is normally set to run at about 300 to 400 RPM.
- The engine will run continuously for 23 days on one gallon of fuel.
- The compression ratio should be 7:1 or less.

### The “Hercules” ...a larger project

Also available are plans for an engine called “Hercules” which is a 2-cylinder in-line design that is perfectly sized for miniature machine tools. It is a scaled down version of Bob’s “Silver Angel”, which is also available. Despite its larger size, a number of them have been built using Sherline tools. Contact Bob Shores for more information on prices for plans and casting kits.

## Wilhelm Huxhold...Contest Winner and Metalworking Craftsman

Wilhelm Huxhold grew up in Germany, and the first time he saw a lathe in school he knew he had to build a model of one. (See page v.) He showed an aptitude for working in metal, so he followed in his father's footsteps and entered an apprenticeship program in 1945 as a machine fitter which is similar to a tool and die maker in the USA. After a 3-year apprenticeship, he went to work in a glass factory where his machining skills were used to keep production equipment running. Here he learned to make parts not only accurately but quickly. A broken machine had to be brought back on-line fast or production fell behind.

In 1953 he immigrated to Canada with hopes of finding work, but, speaking little English, he ended up taking a "temporary" job in construction which lasted for the next thirteen years. Finally, he secured a job with the Canadian government developing and

realigning meteorological instruments which took advantage of his machining skills. Seven years later he foresaw government cutbacks and began a business of his own in the same field. Soon the government was his biggest customer. Seven years ago he retired, keeping the best of his shop equipment to outfit his roomy 15' x 36' home shop.

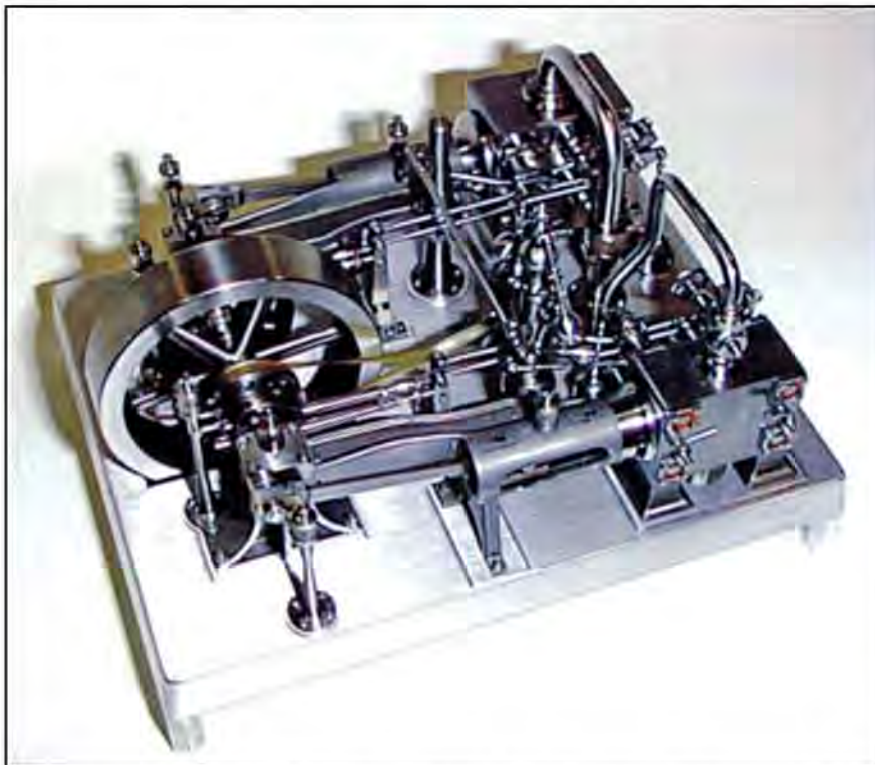


Wilhelm "Bill" Huxhold

provided him with a pattern for how to take a project from start to finish. Though he doesn't commit much to paper, he plans each step of a project in his head until he knows every cut he will make. He trusts nothing to "trial and error", as years of machining parts for a living taught him that could get expensive. Now it is not money but time that concerns him most. Like many hobbyists, he has enough projects on his list to last several lifetimes, so he tries to make his shop time as productive as possible. He now challenges himself by working on smaller and more detailed projects.

### Honored for a lifetime of excellence in craftsmanship

Mr. Huxhold was selected as the Joe Martin Foundation's Metal-working Craftsman of the Year in 1999. Each piece of his work has the unmistakable signature of a true master. More about contests and awards follows.



*Bill Huxhold's 5-inch long compound Corliss engine is made from stainless steel, Meehanite and aluminum. With proper care, machinists a thousand years from now will still be admiring this project.*

It should be noted that of the first eight winners of the Joe Martin Foundation award only two use Sherline tools on a regular basis. Though Joe is the owner of Sherline Products, the foundation is not connected in any way with the company, and those selected are chosen based solely on the quality of their work regardless of the equipment used to produce it.

## Chapter 2—Contests and awards for machinists

### The Sherline Machinists' Challenge

Each year since 1992, Sherline has sponsored a contest at the North American Model Engineering Society (N.A.M.E.S.) show in Michigan. Originally called the “Sherline Machinist’s Shootout” it was conceived as a way to accomplish a couple of goals that I feel need to be accomplished. First, I would like to encourage more projects to be built at the small end of the scale as it offers a number of advantages to the builder. Secondly, I would like to see those who take the time to make a really nice project rewarded with both money and recognition. I feel that sports heroes and movie stars get far too much recognition in comparison to the people who really make this country work: the thinkers and builders. This is my own small attempt at throwing some light on those who have worked hard to develop a valuable skill. Rather than spending time in front of a TV, these people are actually making things, and that is where the future of this country lies.

### Encouraging people to “think small”

The rules to the contest encourage entries of all types, from steam and gas engines to jewelry to models of shop equipment. All it has to be is a device that has a number of precise parts that work together and exhibit precise fits and demonstrate good skills with hand and machine tools. What makes this contest different is that we put a maximum size limit on the projects which requires that they be small. In recent years, the definition has been 64 cubic inches of volume with a maximum single dimension of 5 inches. This does not include the display base or protective case. In the case of a ship’s cannon, for example, it would not include the diorama of a partial deck that would serve to display the cannon.

What I hope to accomplish by this is to show that projects of this size offer a number of advantages. Number one, the materials involved are minimal, which keeps the cost down. Also, the machines required are smaller, which means that a machinist could set up a complete miniature machine shop for less than the cost of a major accessory for a full-size machine. Secondly, I feel that projects increase in interest as they get smaller. A model of a radial



*This 6-cylinder “hula-hula” engine was entered in the 1997 contest by John Kirkbride of Bellingham, Washington. It features an interesting motion and beautifully polished surfaces, but much of the appeal of this model comes from its small size. At less than 4" in diameter it could be displayed just about anywhere. One of the purposes of the contest is to get more builders to appreciate the fact that building small projects offers a number of advantages.*

airplane engine that is 16 inches in diameter is certainly a marvel to look at, although you would probably have to go out to the builder’s garage or workshop to view it, as it would be too big and heavy to be displayed in the house. That same engine built 4 inches in diameter or smaller approaches the appeal of fine jewelry. It may have the same number of pieces and each may be made to the same quality of finish, but its small size adds another dimension to its appeal. People who might

not even be interested in airplane engines will be interested in the model simply because of its small size and intricate detail. The builder can display it on a desk, coffee table or shelf in the house and easily carry it around with him to show it off to others. It will become a treasured heirloom to be passed down to other members of the family rather than a large object under a dust cover in the garage. Many of the projects that have attracted a lot of attention at the contest have been small enough to be carried in a pocket.

Though Sherline Products puts up the prize money, there is no requirement that the projects be built using Sherline tools. Size and content only determine the project's eligibility for entry.

### **An interesting way to judge a contest**

The first year of the contest we had a panel of judges who decided on the winners. This was far from ideal for many reasons. The following year we developed a formula which has worked great ever since. We let the spectators at the show do the judging. That accomplishes two goals: 1) It removes any possibility that the contest organizers have slanted voting toward any particular entry, and 2) It involves the spectators at the show in looking more closely at the entries, as they are now the judges.

Next to each entry we place a cup. Spectators at the show are given five tokens each and asked to select their five favorite projects and vote for each by placing their tokens in the cups next to those projects. They have to spread them out over five different projects and cannot place all five in one cup. Each vote is worth one dollar to the builder of the project when the tokens are counted up on Sunday afternoon.

### **Projects that appeal to many are the key to success**

The interesting thing about having the spectators do the judging is that the results end up rewarding a different type of project than if it were just judged by machinists and engineers. When the wives, friends and kids of the show participants vote too, you get a much better idea of what the average person finds interesting and appealing. On the whole, the best projects are recognized by everyone as being superior and they receive everyone's first vote, but the other four votes go to a wide range of projects. One year Dick Saunders entered a pair of machined earrings. I don't think they got too many votes from the engineers in the crowd, but all the women voted

for them. Scotty Hewitt won the contest three years in a row with entries that had a toy-like appeal that spanned all age and experience levels. Though his entries may not have been the best machined, virtually everyone from machinist to novice found something in them that appealed to them enough to give them one of their five votes. In the seven years of contests to date I don't think anyone has ever won less than about \$30, and several have won many hundreds of dollars. Since it costs nothing to enter, everyone has come away happy. The total prize purse is as much as \$2500 if there are twenty-five or more entries.



*Judges at the contest are now the show's exhibitors and spectators. They vote on what appeals to them, so the winning projects are the ones that span a wide range of interests. Since it is unlikely that everyone who views your own projects will be an engineer or machinist, it's something to keep in mind when deciding what to build.*

### **Making project plans available to others**

One of the other goals that I had hoped to accomplish with the contest does not seem to be working out too well. I have specified in the entry form that anyone who comes up with plans for their projects is welcome to sell or distribute them at the contest or through our web site. One of the things people need when they first become interested in a hobby is a project to build to hone their skills. Most people don't buy a machine and then look around for something to make with it. When you go to the hardware store to buy a drill, it's not because you want a drill, it's because you want a hole. People get into the hobby because a particular project

attracts their interest, and they want to learn the skills and own the tools of miniature machining so that they can make that cannon or miniature steam engine to put on their display shelf.

The manufacturers of kits and the people who sell plans offer a decent selection, but many of them are too large to build using tabletop machine tools. I am hoping that as miniature machine tools become more widely distributed the demand for small project plans will increase and more will become available. The experienced machinist is capable of scaling down existing plans or designing his own projects, but a beginner needs entry level projects with well written and illustrated instructions.

### **I'm not giving up**

It's still not too late. I hope my appeal here will reach some of you who have built or will build nice projects in the future. Take a little extra time when you are done to compile your "as built" drawings into a set of plans so that others can enjoy the satisfaction you felt in completing your project. Some sketches, photos or written descriptions of key setups would also be helpful to a beginner. I will be glad to publicize any plans or kits which are made available for projects that are suitable for miniature machine tools on Sherline's World Wide Web site at no charge. I realize there is little money to be made in selling plans, but I would hope some of you will take on the challenge just for the satisfaction of bringing more people into the hobby and helping offer them a wider selection of projects to be built so that they can enjoy their first miniature modeling experience.

### **A foundation is funded to award craftsmanship**

In 1997, I decided to put aside a sum of money to start The Joe Martin Foundation for Outstanding Craftsmanship. Each year, the interest generated by that fund will pay for a \$1000 award to the best craftsman of the year in the field of miniature metalworking.

Many of the builders of really outstanding projects are not ones who would necessarily enter them in a contest, but generally each member of any group of craftsmen knows and can agree on who is "the best" in their particular field. For the first year, I selected the winner myself. In the years to come, I will ask an individual or group to guide the selection of a person from their field of interest. I have specified that the award is not a "popularity contest" for

someone who has just been around a hobby for a long time. The award is based strictly on quality of work. The person's age, level of experience, personality or number of friends should have nothing to do with selection.

### **Jerry Kieffer, 1997's winner**

For 1997, I selected Jerry Kieffer to be the first recipient of the "Metalworking Craftsman of the Year" award. You can see many examples of his work throughout this book, and he has produced an amazing quantity of some of the best miniature work I have ever seen. More amazingly, he has done it in a fairly short amount of time and with no formal training as a machinist. He only started working on miniature machining projects about 8 years ago. He has a regular daytime job and works on projects in the evenings and on weekends in his shop. His total unwillingness to accept any result other than perfection makes it even more amazing that he has completed so many projects and mastered so many



*Jerry Kieffer displayed some of his work at the 1997 N.A.M.E.S. show in Michigan. Jerry's models are not only totally scale down to the smallest bolt, they also run beautifully.*

disciplines. He really is a “perfectionist”, meaning he keeps working on a problem until he gets it right, even if the results will never be seen by anyone but himself. A broken tap could be drilled out and the hole sleeved if a cover will be bolted over it and no one would know. Jerry would start over on the part feeling that someday, someone may remove the cover and find that he had made a mistake. His desire for perfection and devotion to scale is the most uncompromising I have ever seen.

#### Alan Ingersoll is the winner for 1998

For 1998’s winner I asked Robert Washburn and the people at *Strictly I.C.* magazine to find the person they felt was the outstanding builder of small internal combustion engines. They submitted the name of Alan Ingersoll of San Mateo, California. After seeing photos of his Curtiss P6-E biplane with operational scale V-12 engine I agreed with their selection. His award was presented at the 1998 N.A.M.E.S. show in Wyandotte, Michigan. (See page 340 for a photo.)

#### Goals for the future

One of the goals I hope to accomplish with the foundation is to bring well-deserved recognition to the skill of those who make small, precise projects in metal. I am interested in finding ways to help establish a value for projects such as you see in this book that adequately reflect the time and skill that went into making them. You see auctions and sales for art, watches and jewelry that fetch tremendous prices for work done by the recognized “masters”

in these fields. I feel it takes no less talent to produce beautiful work in this field, and it would be nice if this foundation could help to raise the level of awareness of the public to include some of the masters in modeling and metalworking.

I would like to find a way to bring these masterpieces to the public’s attention in the form of a museum. Many builders produce an impressive amount of work in their lifetime. They may have no family or anyone who would appreciate it to leave it to. I would like to be able to find a way to help them either sell their work at a good price or receive a substantial tax break by donating it for display.

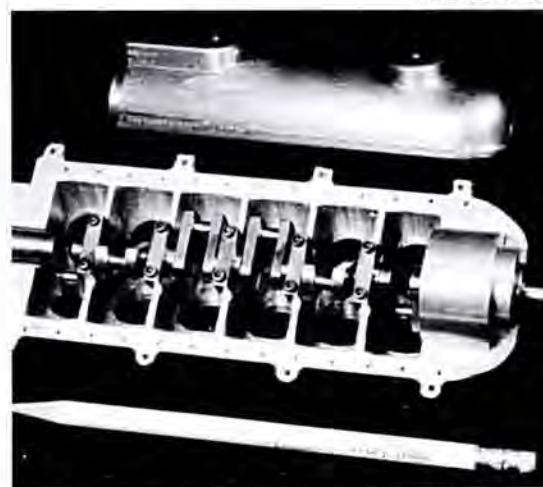
Also being considered is video documentation of some of these masters, because I feel there are others like me who will find their stories and techniques interesting. To me it is not only the projects that are interesting. The reasons why a builder chose a particular project and the way he went about building it can also tell you a lot. I’m sure we could learn a lot more in a half hour interview with Leonardo DeVinci than we could from an analysis of the Mona Lisa by some art critic. Probably any who find this book interesting would also enjoy hearing the thoughts and seeing the shops of the people who built the projects in the photos.

Right now these and other projects are still in the thinking and planning stage and are some of the foundation’s long-term goals. I wanted to mention them here in case you would like to offer help or suggestions on how to get them accomplished.

PHOTOS: ALAN INGERSOLL



Alan Ingersoll’s 1:6 scale Curtiss P6-E biplane is shown uncovered so the construction detail can be appreciated. It will be displayed in the Hiller Aviation Museum in San Carlos, California. The project took over 12 years to complete.



A detail of parts of the Curtiss V-12 engine under construction. The entire engine is only 9 inches long. All parts were machined from solid bar stock. No castings were used.

## Chapter 3— Exploded Views and Part Numbers

The following pages contain exploded view parts drawings of the lathe, mill and rotary table. These will help you understand how the machines are assembled should you need to make repairs. They will also help you identify part numbers should you need to order replacement parts.

When you look at the drawings, compare the machines to the most complicated project you have attempted. Consider all the fits and tolerances that must be held for a machine of this type to provide accurate movement while minimizing unwanted movements like flex and

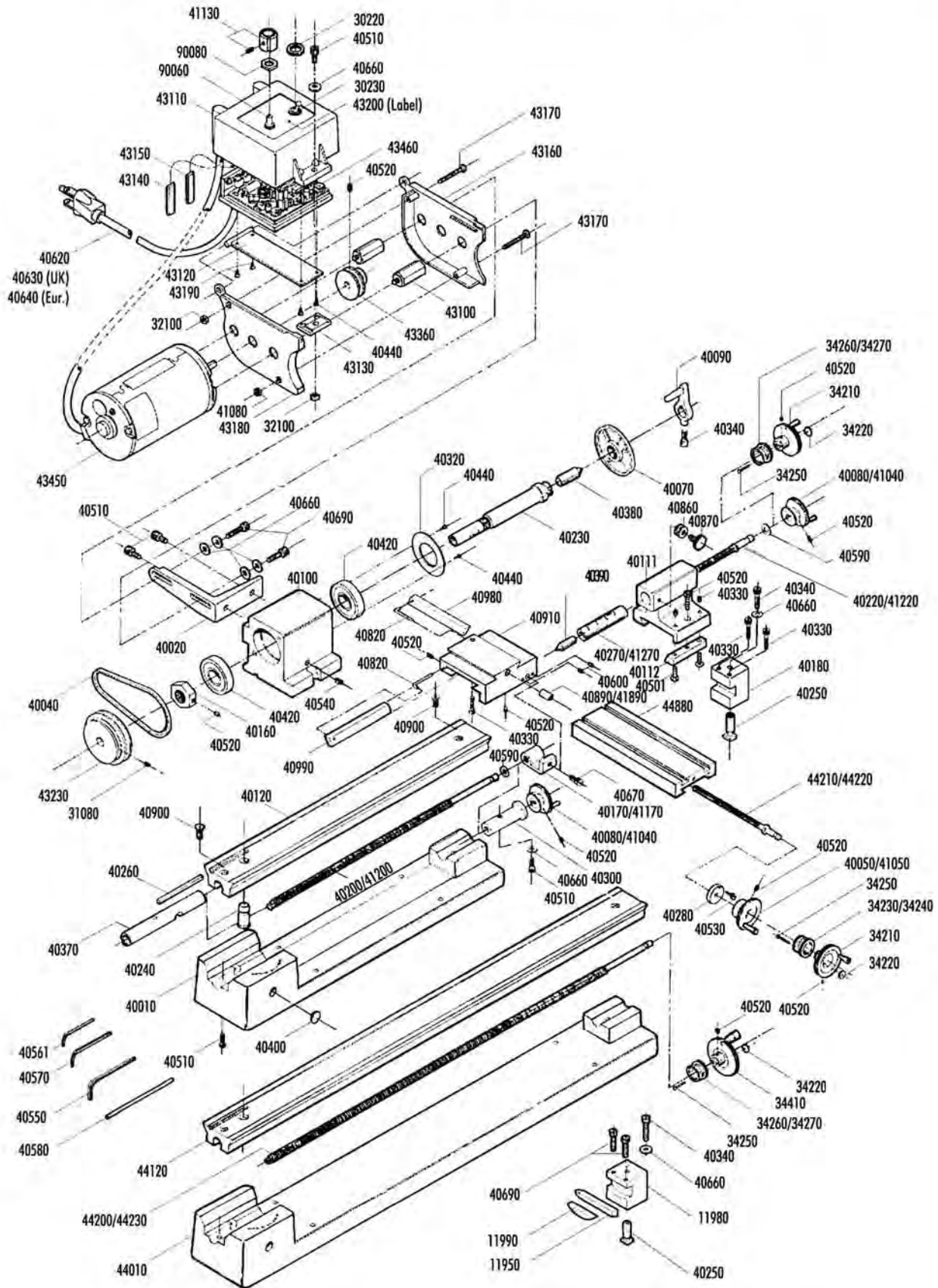
play. With what you have learned from this book you will gain a new appreciation of how difficult it is to make so many parts work together while trying both to maintain accuracy and to keep costs down. I think you will gain a new appreciation of not only how well miniature machine tools work, but you will also come to see in a new light the design successes and failures in many products you use daily, from the blender in your kitchen to the automobile in your garage.



*Here's an interesting setup. By mounting a tool post and lathe cutting tool on the rotary table, a part bolted to a faceplate is spun on the Z axis of the mill to machine a radiused surface. Several concave radii are shown on this one part. The modular nature of these miniature machine tools allows you to create setups to accomplish virtually any machining job you can conceive of.*

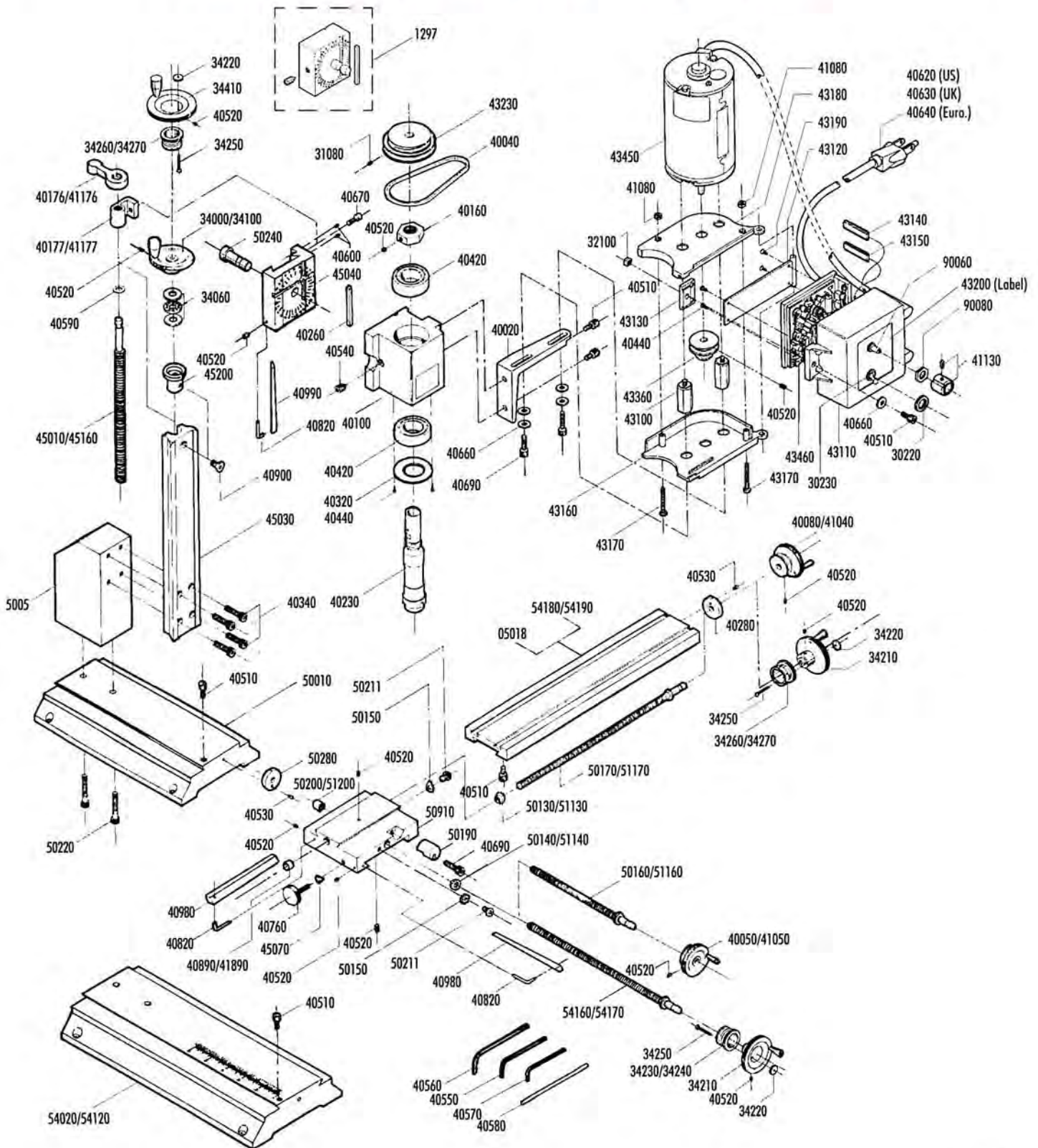
# SHERLINE LATHE EXPLODED VIEW AND PART NUMBER LISTING

NOTE: Where different, Inch part number is given first, followed by Metric part number.



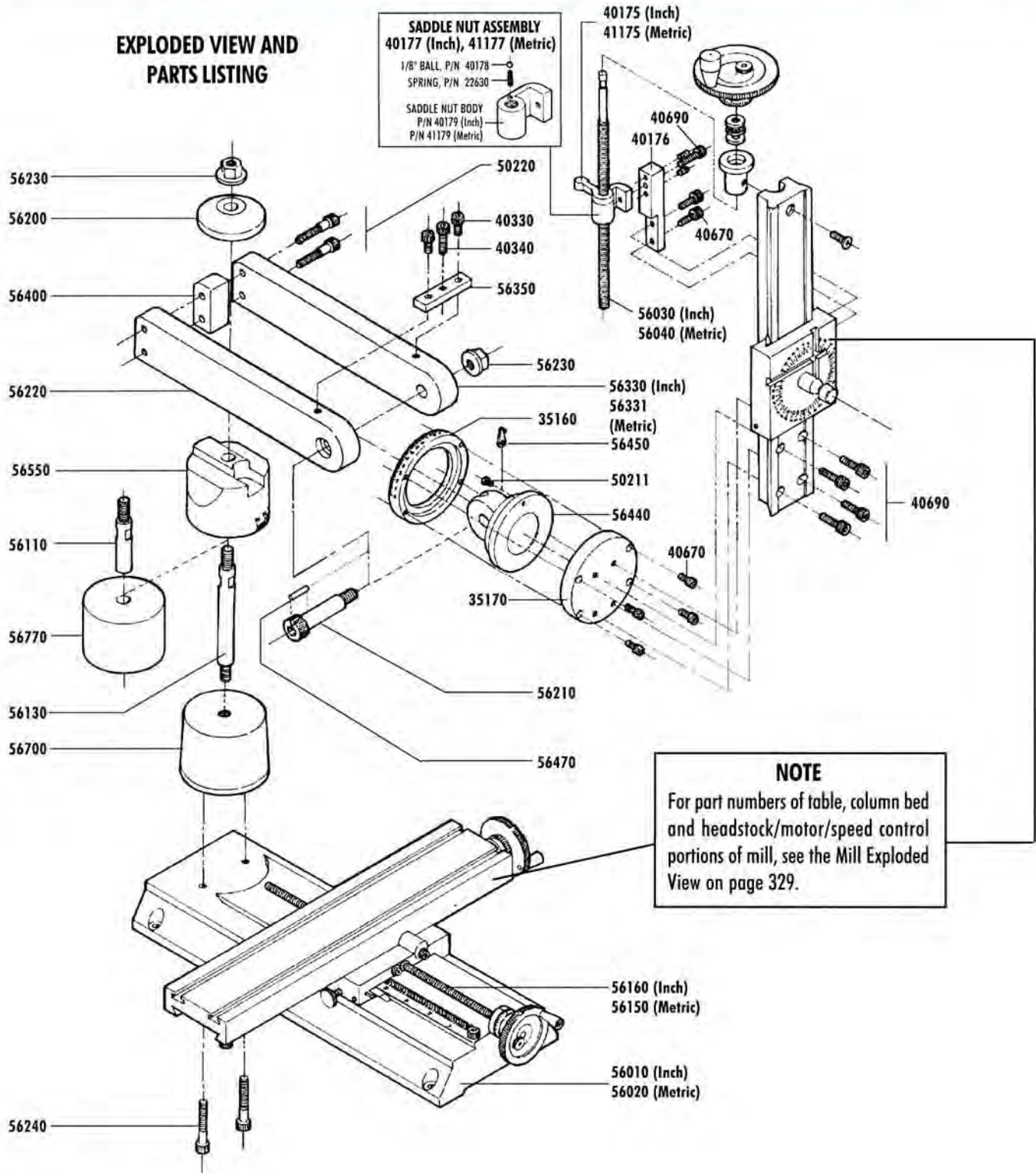
# SHERLINE VERTICAL MILLING MACHINES EXPLODED VIEW AND PART NUMBER LISTING

NOTE: Where different, Inch part number is given first, followed by Metric part number.



# EXPLODED VIEW, SHERLINE MODEL 2000 MILL COLUMN

## EXPLODED VIEW AND PARTS LISTING



**NOTE**  
For part numbers of table, column bed and headstock/motor/speed control portions of mill, see the Mill Exploded View on page 329.

# PART NUMBERS AND DESCRIPTIONS, SHERLINE LATHES AND MILLS

KEY TO MATERIALS: A=Aluminum, B=Brass, C=Composite, DC=Die Cast, P=Plastic, U=Urethane, S=Steel

PART NO.	DESCRIPTION	MATERIAL	PART NO.	DESCRIPTION	MATERIAL	PART NO.	DESCRIPTION	MATERIAL
1195	1/4" HSS Right hand cutting tool	S	40580	Spindle Bar	S	50220	1/4-20 x 1-3/4" Socket Head Cap Screw	S
1297	Headstock Spacer Block (Deluxe Mill)	A/S	40590	1/4" I.D. Washer	S	50240	Headstock Pivot Pin, Mill	S
11980	Rocker Tool Post Body	A	40600	10-32 x 1/4" Flat Point Set Screw	S	50280	Thrust Collar, Mill	S
11990	Rocker Tool Post Center	S	40620	Power Cord, USA	--	50910	Saddle	A
22630	Spring (in Z-Axis Saddle Nut)	S	40630	Power Cord, UK	--	51130	Backlash Nut, X Axis (Metric)	B
30220	Toggle Switch Retaining Ring	S	40640	Power Cord, Europe	--	51140	Backlash Nut, Y Axis (Metric)	S
30230	Toggle Switch	--	40660	3/16" I.D. Washer	S	51160	Leadscrew, Y Axis (Metric)	S
31080	10-32 x 3/8" Flat Point Set Screw	S	40670	10-32 x 1/2" Socket Head Cap Screw	S	51170	Leadscrew, X Axis (Metric)	S
32100	10-32 Hex Nut	S	40690	10-32 x 3/4" Socket Head Cap Screw	S	51200	Nut, Y Axis (Metric)	B
34000	Oversize Handwheel (Inch)	A	40760	10-32 x 5/8" Thumbscrew	S	54020	12" Mill Base, Deluxe Engraved (Inch)	A
34060	Thrust Bearing Washer Set	Ball	40820	Gib Lock	S	54120	12" Mill Base, Deluxe Engraved (Metric)	A
34100	Oversize Handwheel (Metric)	A	40860	Tailstock Locking Screw Grommet	P	54160	Leadscrew, Y Axis, Deluxe Mill (Inch)	S
34200	2" Zero Adjustable Hndwhl. Asby., (Inch)	A/S	40870	Tailstock Spindle Locking Screw	S	54170	Leadscrew, Y Axis, Deluxe Mill (Metric)	S
34210	2" Handwheel Body	A	40890	Slide Screw Insert (Inch)	B	54180	Mill Table, Deluxe Engraved (Inch)	A
34220	Handwheel Locking Nut	S	40900	10-32 x 3/8" Flat Head Socket Screw	S	54190	Mill Table, Deluxe Engraved (Metric)	A
34230	Y Axis/Crossslide Collar (Inch)	A	40910	Saddle	A	56010	#2000 Mill Base (Inch)	A
34240	Y Axis/Crossslide Collar (Metric)	A	40980	Gib, lathe crossslide, mill X- and Y-axes	C	56020	#2000 Mill Base (Metric)	A
34250	6-32 x 7/8" Pan Head Screw	S	40990	Gib, lathe saddle, mill Z-axis	C	56110	Extension Bolt	S
34260	X, Z Axis and Leadscrew Collar (Inch)	A	41040	1-5/8" Handwheel, X Axis/Leadscrew (Metric)	A	56130	#2000 Arm Hold-down Bolt	S
34270	X, Z Axis and Leadscrew Collar (Metric)	A	41050	1-5/8" Handwheel, Y Axis/Crossslide (Metric)	A	56150	#2000 Y-Axis Leadscrew (Metric)	S
34300	2" Zero Adjustable Hndwhl. Asby., (Met.)	A/S	41080	6-32 Hex Nut	S	56160	#2000 Y-Axis Leadscrew (Inch)	S
34400	2-1/2" Zero Adjust. Hndwhl. Asby., (Inch)	A/S	41110	Tailstock Casing (Old Style without gib)	A	56200	#2000 Arm Hold-down Washer	A
34410	2-1/2" Handwheel Body	A	41130	DC Speed Control Knob and Set Screw	P/S	56210	3/8-16 x 2" Shouldered Bolt	S
34500	2-1/2" Zero Adjust. Hndwhl. Asby., (Met.)	A/S	41170	Saddle Nut	B	56220	#2000 Swing Arm Side	A
35160	Graduated Clamping Ring	A	41174	Saddle Nut Body Only (Metric)	B	56230	Flange Nut	S
35170	Moveable Clamping Ring	S	41175	Column Locking Lever (Metric)	B	56240	1/4-20 x 1-1/2" SHCS	S
40010	15" Lathe Bed	DC	41177	Saddle Nut Assembly w/ Ball, Z-Axis (Metric)	B	56330	#2000 Swing Arm Side (Engraved, Inch)	A
40020	Motor Bracket	DC	41200	Leadscrew (Metric)	S	56331	#2000 Swing Arm Side (Engraved, Metric)	A
40040	Drive Belt	U	41220	Feed Screw (Metric)	S	56350	Column Adjustment Block	A
40050	1-5/8" Handwheel, Y Axis/Crossslide (Inch)	A	41270	Tailstock Spindle (Metric)	S	56400	#2000 Arm Spacer Block	A
40070	Faceplate	DC	41890	Slide Screw Insert (Metric)	B	56440	#2000 Arm Mount	S
40080	1-5/8" Handwheel, X Axis/Leadscrew (Inch)	A	43100	DC Motor Standoff	A	56450	Index Tab	S
40090	Drive Dog	DC	43110	DC Speed Control Case	P	56460	8-32 x 1/4" Button Head Screw	S
40100	Headstock Casing	A	43120	DC Speed Control Hinge Plate	P	56470	3/32" x 1/2" Dowel Pin	S
40111	Tailstock Casing (Gib style)	A	43130	DC Speed Control Cover Mounting Plate	P	56550	#2000 Column Top	A
40112	Tailstock Gib	B	43140	DC Speed Control Tab, Small	P	56660	#2000 Column Base	A
40120	Lathe Bed	S	43150	DC Speed Control Tab, Large	P	56770	Column Spacer	A
40160	Preload Nut	S	43160	Belt Guard, Outer	P	90060	DC Speed Control 5K Potentiometer	--
40170	Saddle Nut (Inch)	B	43170	6-32 x 1-3/8" Pan Head Screw	S	90080	3/8-32 Hex Nut	S
40174	Saddle Nut Body Only (Inch)	B	43180	Belt Guard, Inner	P			
40175	Column Locking Lever (Inch)	B	43190	#2 x 1/4" Flat Head Sheet Metal Screw	S			
40176	Column Saddle Travel Extension	S	43200	DC Speed Control Label	Fail			
40177	Saddle Nut Assembly w/ Ball, Z-Axis (Inch)	B	43230	Stepped Main Spindle Pulley	A			
40178	1/8" Ball	S	43360	Stepped Motor Pulley	A			
40180	Tool Post	A	43450	DC Motor	--			
40200	Leadscrew (Inch)	S	43460	DC Speed Control Electronics	--			
40220	Feed Screw (Inch)	S	44010	24" Lathe Base	DC			
40230	Headstock Spindle	S	44120	24" Lathe Bed	S			
40240	Headstock Pivot Pin, Lathe	S	44200	24" Leadscrew (Inch)	S			
40250	Tool Post Tee Nut	S	44210	Slide Screw (Inch)	S			
40260	Head Key	S	44220	Slide Screw (Metric)	S			
40270	Tailstock Spindle (Inch)	S	44230	24" Leadscrew (Metric)	S			
40280	Thrust Collar	S	44880	Crossslide	A			
40300	Leadscrew Thrust	S	45010	Leadscrew, Z Axis (Inch)	S			
40320	Bearing Washer	S	45030	Column Bed	S			
40330	10-32 x 5/8" Socket Head Cap Screw	S	45040	Saddle, Z Axis	A			
40340	10-32 x 1" Socket Head Cap Screw	S	45070	Lock, Teflon	P			
40370	Leadscrew Support	S	45160	Leadscrew, Z Axis (Metric)	S			
40380	#1 Morse Center	S	45170	Column Saddle Lock	P			
40390	#0 Morse Center	S	45180	3/16" Ball Bearing	S			
40400	Plug Button	P	45190	#10 Type B Washer	S			
40420	Headstock Bearing	Ball	45200	Leadscrew Thrust, Bored	S			
40440	Self Tapping Screw	S	50010	10" Mill Base	A			
40500	10-24 x 7/8" Socket Head Cap Screw	S	50050	Column Base	A			
40501	10-32 x 1/2" Button Head Socket Screw	S	50120	Backlash Lock	S			
40510	10-32 x 3/8" Socket Head Cap Screw	S	50130	Backlash Nut, X Axis (Inch)	B			
40520	10-32 x 3/16" Cup Point Set Screw	S	50140	Backlash Nut, Y Axis (Inch)	S			
40530	5-40 x 3/8" Socket Head Cap Screw	S	50160	Leadscrew, Y Axis (Inch)	S			
40540	5/16-18 X 3/4" Cone Point Set Screw	S	50170	Leadscrew, X Axis (Inch)	S			
40550	5/32" Hex Key	S	50180	Mill Table	A			
40560	3/16" Hex Key	S	50190	X Axis Lock	S			
40561	1/8" Hex Key	S	50200	Nut, Y Axis (Inch)	B			
40570	3/32" Hex Key	S	50210	8-32 x 1/4" Pan head Screw	S			



*Joe with the staff of Sherline Products. The success of a company is more than just a one-man effort. Karl Rohlin is Shop Foreman and has been with the company for twenty-two years. Charla Papp is Sherline's General Manager. She started out working as a secretary and has been with the company for over twenty-two years. Craig Libuse is Marketing Director and has been doing Sherline's artwork, instructions and catalogs for over twenty-five years, originally as an independent graphic artist and now as an employee. The average length of employment for the people in the shop is over seven years, all of which speaks well of the company's working conditions.*

*Alan Ingersoll (right) receives an award plaque and a check as the 1998 Joe Martin Foundation "Metalworking Craftsman of the Year". It is being presented by Mr. Robert Washburn, publisher of Strictly I.C. magazine. Under Mr. Washburn's left hand is the Curtiss V-12 engine shown on page 334. On the table also are some of the winning entries in the magazine's contest for internal combustion engines.*



## Chapter 4 — A Simple RPM Gage

Knowing the exact speed your machine is running is not all that critical. It is how the cut is progressing that will determine final adjustments to the speed and feed. Normally, starting at 1/4, 1/3, 1/2 speed, etc., on the speed control knob will get you close enough. However, some people find it interesting to know what speed their machine is actually running, and this simple gage can help you determine that.

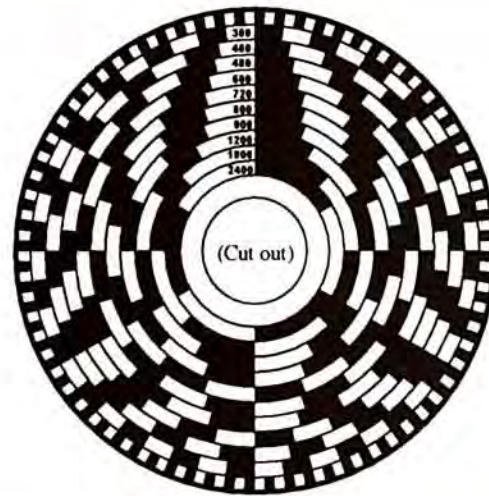
### How the gage works

The gage was posted on one of the Internet newsgroups and has been passed around long enough that who actually came up with it first is unclear. It is similar to gages that were used to adjust the speed of record players to exactly 45 or 33-1/3 RPM. Under light from a fluorescent bulb that runs on 60 Hz. current, the gage will give you an accurate reading when you are running at one of the speeds on the gage. The “flashing” of the fluorescent bulb at 60 cycles per second will cause one of the bands to appear to stop moving at the RPM indicated by that band. The gage will not work very well with an incandescent light bulb because the filament glows and doesn't dim much during the cycling of the current. The speeds indicated on the gage from the outer ring in are: 100, 300, 400, 480, 600, 720, 800, 900, 1200, 1800 and 2400 RPM.

The circular gage can be copied on a copy machine and the copy cut out. It is then glued to the pulley of your machine. Rubber cement or spray adhesive are the best for this purpose.

### A way to make the gage easier to read

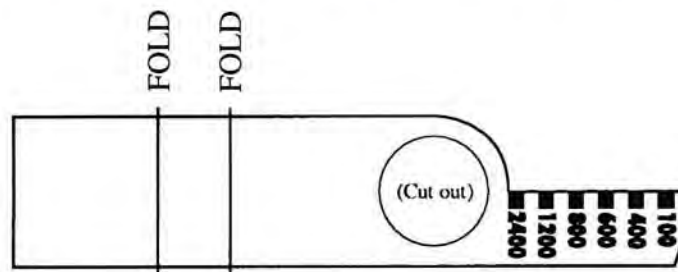
Because the gage spins, the numbers can't be read once the machine is turned on. If you wish, the indicator at the right can also be copied, cut out, pasted to thin shirtback cardboard, trimmed to size and mounted to the speed control housing as a reference. Fold an offset into the indicator at the lines shown so that it runs just above the surface of the pulley. The center fits over the spindle shaft and the numbers line up with the rings of the gage to help you tell which ring is which when the motor is turning. The easiest way to mount it to the speed control housing is with double sided Scotch® tape. A layer of clear packing tape over each will make them easier to keep clean.



RPM GAGE



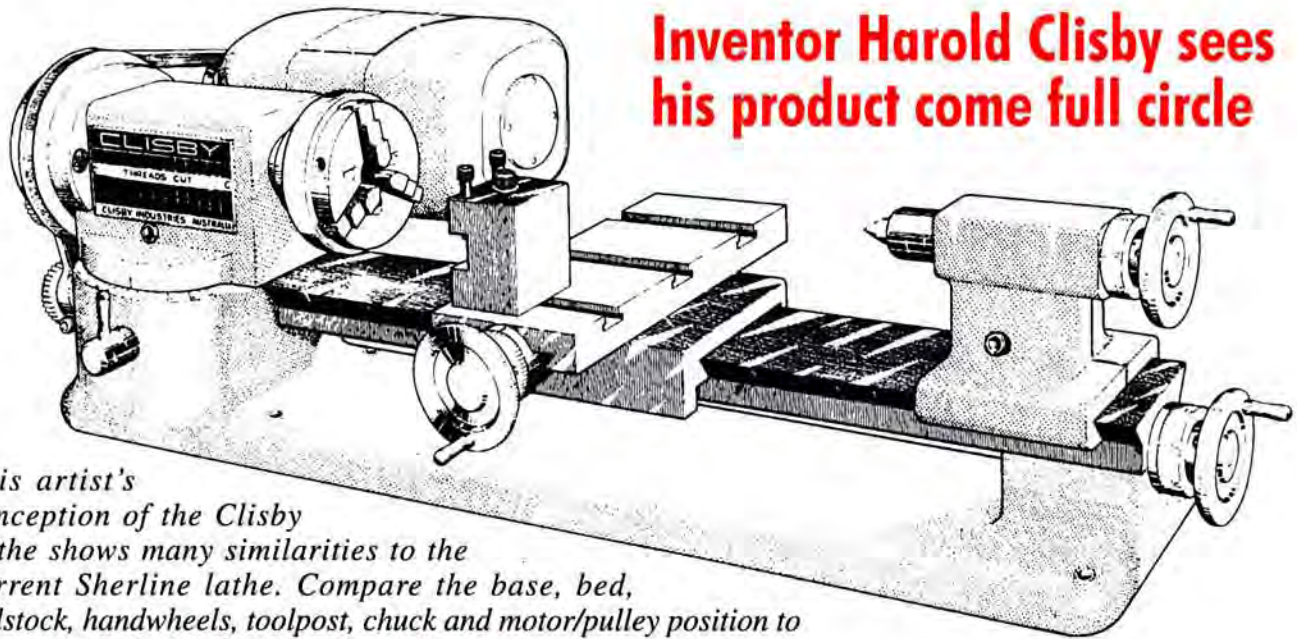
The RPM gage and indicator mounted to a lathe. Though sized for a Sherline pulley, the gage may be resized for use in other applications as well.



FIXED RING INDICATOR

For more information on determining what the proper speed for your particular cut should be, see pages 102 and 103.

## Inventor Harold Clisby sees his product come full circle



*This artist's conception of the Clisby Lathe shows many similarities to the current Sherline lathe. Compare the base, bed, tailstock, handwheels, toolpost, chuck and motor/pulley position to those of the Model 4000 Sherline lathe.*

### Harold Clisby's place in Sherline history

Though the Sherline product name was taken from the first manufacturer in Australia, Ron Sher, the designer of the original lathe and accessory line was an Australian engineer named Harold Clisby. In the late 1960's Mr. Clisby noted the flexibility of the then popular Unimat lathe and decided that extruded shapes could be used to make an inexpensive yet rigid small lathe. He went to electrical engineer Ron Sher for help in motor application for the lathe and eventually ended up turning the production of the machines over to Ron's company, Ronald Sher Pty. Ltd., when he went on to pursue other projects. In the early 1970's, Joe Martin became the U.S. distributor for the product and eventually the sole worldwide manufacturer of the line, but as you can see from the drawing above, the basic concept of the machine has remained virtually unchanged from Mr. Clisby's original design.

### A visit to Sherline and an all new Clisby lathe

In May, 1998, Mr. Clisby and his son Orville visited Sherline's plant in Vista, California. He stopped by not only to see how the product he fathered was doing thirty years later, but to introduce us to his latest project. After several successful business ventures in Australia, many years later Mr. Clisby is again in the lathe business. His new Clisby Lathe is a 2.5" model powered by a 12-volt DC motor. The overall length of the desktop-sized tool is less than 12". Information on the tiny lathe can be found on the Internet at [www.clisby.com.au](http://www.clisby.com.au). Mr. Clisby's contribution to the miniature machine tool industry

has gone relatively unheralded for the past thirty years. Perhaps the introduction of his new lathe will bring some well deserved notice to the man who invented what has now become the world's most popular small machine tool, the Sherline lathe.



*Harold Clisby (right) is seen in the cover photo from Overseas Trading magazine in March, 1971 presenting the Clisby lathe to potential buyers.*

*NOTE: Mr. Harold Clisby and his son, Orville, visited Sherline's facility after this book was in it's final form, so this article's inclusion here may seem somewhat of an afterthought. He is such a gentleman and his contribution to the Sherline tool line so great, I felt you might want to learn a little more about him. He was kind enough to provide the drawings and photos from his archives. —Joe Martin*

# Index

12L14 (see "leadloy steel")

3-jaw chuck—39, 115, 116, 118, 119, 121, 123, 126, 132, 137, 138, 145, 149, 172, 173, 186, 188, 189, 231, 232, 280, 282, 293

4-jaw chuck—107, 115, 116, 117, 118, 121, 126, 137, 138, 186, 187, 188, 189, 212, 224, 280

- Independent Jaw chucks—30
- Self-centering 4-jaw—118, 138

## A

Abrasives—59, 60

Adjustable "zero" handwheel—33, 36, 97, 213

Adjustable tailstock tools—141, 146, 252, 267

- Adjustable live center—139, 143, 252, 267
- Adjustable right angle tailstock—210
- Adjustable tailstock chuck holder—139, 143
- Adjustable tailstock custom tool holder—139

Alignment key—127, 251

Angle block (See "Right angle block")

Annealing—46

Anodizing—47, 48

Arbor—121, 124, 125, 142

Atlas lathe—191

AutoCad®—259, 261, 289, 290

## B

Backlash—36, 97, 90, 196, 198, 214, 254, 267

- Adjusting—257

Band saw—39, 249

Barrel plating (See "Plating")

Bead blasting—61

Bed (lathe)—149, 155, 200

- Improving fit when worn—257

Belt sander—250

Bench grinder—60, 63, 77, 249

Bevel gear (See "Gears")

Black oxide—46

Boring—66, 172, 197, 198

- Grinding a tool for—156
- Quick change holder for—156
- Tool—72, 82, 130, 131, 239

Boring head—82, 198

Brazing—53

Breslauer, Bob—11, 119, 147, 190, 218, 266, 315, 316, 317

Bresley, Milo—20

Bridgeport mill—34, 38, 193, 194, 282, 290

Brierton, Tom—19

Britnell, George—11

Brown & Sharpe Mfg. Co.—86

Brumberger, Jesse—14

Busch, Glenn—16

## C

CAD—i

CAD-CAM—64, 259

Calibrations, (inch vs. metric)—31

Calipers—88, 89

- Dial—93, 94
- Digital—93
- Rezerowing a dial caliper—93
- Vernier—93

Carbide cutters—48, 74

- Brazed tip—72, 131
- Inserted tip—131

Carlisle Corporation—281

Case hardening—45

Castings

- Die—49, 51
- Holding for milling—183
- Investment—49
- Lost wax—49
- Model—51, 183, 308
- Sand—50

CD-ROM—30

Chamfering tool—59

Chatter—75, 77, 80, 84, 103, 104, 105, 127, 132, 136, 137, 138, 173, 196, 268

Chips—40, 43, 67, 68, 69, 72, 73, 74, 75, 99, 100, 102, 107, 125, 131, 158

Chip guard—139

Chuck (See also "3-jaw chuck", "4-jaw chuck" and "Tailstock chuck")—115, 119, 128, 130, 252, 288

- Jaws—116, 117, 119
- Lubrication—107
- Mounting—187, 212
- Scroll—116, 117
- T-slot adapter—187

Chrome plating (See "Plating")

Clamps—185, 189, 190, 239

Clark, Jim—166

Clisby, Harold—272, 338

CNC— i, 36, 37, 54, 64, 69, 70, 101, 105, 109, 134, 136, 142, 266, 282, 283, 287, 291, 292, 293, 307, 308

Collets—70, 139, 196, 288

- Adapter—144
- Milling—82, 202
- WW—119, 120

Collet pot chuck—119, 120, 172

Colonna, Ron—14

Comparitor (See "Optical comparitor")

Compound slide—119, 127, 128, 129, 132

Computer—104

Conrad, Greg—223

Conversion factors—350

Coolant—99, 100, 104

Coordinate Measuring Machine—86

Core—50

Counterbores—68

Countersinks—68

Crossslide—121, 129, 132, 150, 154, 163, 165, 192, 285

Crossslide accessory plate—177, 178

Culpepper, Robert—14

Cutler, Charles—317

Cutoff saw—39, 195, 249, 295

Cutoff tool—39, 75, 76

- Quick change—156
- Rear mounting block—76, 139, 146

Cutter path radius—212, 213

Cutting speed—42, 73, 74, 75, 101, 102, 103, 104, 105, 135, 201, 293

Cutting tools—129, 131, 155

- Grinding your own—72, 77, 129
- High speed steel—72, 74, 77, 102
- Inserted tip—73

—Lathe—72

—Left hand—72, 130

—Right hand—72, 79

—Side tool—130

## D

Dead center—119, 120, 151

Deburring—249, 250

Deflection—7, 63, 83, 103, 155, 293

Depth of cut—101, 104, 129, 153, 200, 201

DeVynck, Richard—14

Diametral pitch—220, 221, 223, 224

Dies—157, 158, 268

- Split or Button—157

Digital calipers (See "Calipers")

Digital readout (for mill)—98

Dinardo, Chris—18

Dividing head or dividing plate (See "Indexing Plate")

Dog (See "Drive dog")

Draft angle—50

Drills/Drilling—67, 69, 197, 198

- Angled holes—35, 237
- Center—65, 122, 124, 125, 141, 143, 144, 149, 151, 198, 217
- For drilling stainless steel—67
- Jobber—66
- Screw machine—66
- Speed—44, 103
- Spotting—65
- Stepped—68
- Using large bits—67

Drill chuck—34, 70, 123, 124, 141, 142, 143, 202, 252

Drill press—65, 71, 194

- Vise—184

Drive dog—119, 121, 126

Dykem™—87, 199, 322

## E

Edelbrock Company—50

Edge finder—96

EDM—51, 64

Ellett, M.H.—60, 61

End mills—43, 81, 84, 94, 103, 188, 196, 198, 200, 201, 202, 215, 239

- Ball end—82
- Deflection of—63, 81, 94

End mill holders—82, 107

Engine lathe—128

Ewell, Edward—318

Extrusion—51

## F

Fabergé, egg—281

Faceplate—119, 121, 125, 126, 130

Feed (rate)—43, 44, 66, 68, 73, 75, 101, 103, 104, 105, 108, 129, 137

Files, hand—57, 58, 59

- Using/installing handles—58

"Flinch factor"—30

Fly cutter/Fly cutting—81, 84, 196, 198, 205, 206, 221, 239

- Inserted tip carbide—71

Follower rest—139, 152, 153, 154, 155

Forging—51, 52

Form tapping (See "Threads/Threading")

Form tool—80, 131

Foti, Mike—26

Foundry—51

Franz, Dennis—10

## G

Gage block—95, 96

Gage pin—95

Gall—44

Gaucher, Roland—20

Gears—219

- Bevel—225, 232
- Clock—2, 219
- Cutters—221, 229
- Epicycloid/Hypocycloid—220
- Helical—225, 226, 233
- Undercutting—223
- Worm—225

Gear hobber—158, 228, 233

Gib—191, 196

- Adjusting/replacement—256

Grabner, Jim—15

Graver—132, 171, 172, 173, 174

Grinding (See "Cutting tools")

## H

Hacksaw—39

Hammons, Carl—iii, 15, 219, 263, 276, 277, 279, 290, 291, 293, 297, 300, 301, 302, 305

Handwheel (See also "Adjustable 'zero' handwheel")—31, 34, 38, 101, 107, 121, 127, 131, 138, 191, 194, 236, 254, 267

- Removing/replacing—255

Hard chrome (See "Plating")

Hardinge lathe—217

Hasbrouck, Raymond—18

Hayes, Chuck—281

Headstock—34, 35, 119, 126, 128, 141, 194, 212, 237, 256

- Aligning with tailstock—251, 267

Headstock spacer block—33, 34, 139

Heat treating—42, 45

- Heat treated tools—72, 73

Height gage—88, 92, 93

- Miniature—240

Heitt, Ross—306

Hermann, Charles—256

Hewitt, Scotty—12, 17, 23, 24, 25, 260, 306, 336

Hickman, C.D.—221

Hiscano, Augie—21, 179, 180, 181, 182

Hiscano, Carol—180

Hook (on cutting tool)—79

Horizontal milling conversion—232, 235, 237, 267, 286

Huxhold, Wilhelm—v, 22, 217, 260, 334

## I

Indexing attachment—215, 216, 217, 229, 231, 239

Indexing plate—215, 216, 217, 228

"Indicating in"—206, 214, 239, 254, 324, 332

Indicator (dial test)—92, 97, 196, 199, 252

Industrial Press—27

Ingersoll, Alan—338, 344

Injection molding—43, 44

Inspection department—9, 91

Ivester, Chip—122

## J

Jeweler's lathe—144, 171, 172, 295

"Jo block"—96

Joe Martin Foundation—337, 344

Jordan, Barry—v, 246

## K

Kasenite™—45

Keyway—146

Kieffer, Jerry—12, 13, 47, 52, 62, 110, 111, 112, 113, 114, 134, 260, 337

Kirkbride, John—334

Knockout bar—119

Knurling tool—168, 169, 170

Knurls

- Straight, diamond—167, 170
- Bump—167

Kombrink, Larry—152

Koston, Bernie—293

Kraft, Phil—245, 279, 280

Kraft Systems, Inc.—273, 279, 280, 281, 297

Kubin, Joseph—235

Kutz, Russell—16

## L

Lamp, Larry—55

Lathe—29, 32, 51, 58, 63, 65, 78, 107, 108, 122, 130, 177, 252, 267, 271, 291

- Aligning headstock and tailstock—251
- Exploded view—336
- Full size—129
- Initial test cutting on—136
- Model 1000—31, 272
- Model 4000/4100—31, 36, 280
- Model 4000A/4100A—33, 36
- Model 4400/4410—31, 36
- Model 4400A/4410A—33
- Model 4500/4510—36

Lathe dog (See "Drive dog")

Lead (thread)—160, 164, 197

Leadloy steel—39, 42

Leadscrew—31, 36, 37, 97, 107, 159, 160, 163, 266, 267

- Removing—255

Leiser, Ed—267

Libuse, Craig—ii, 4, 24, 112, 113, 180,  
242, 259, 286, 299, 316, 344  
Libuse, Frank—17  
Live center—119, 123, 139, 151, 252, 281  
Long, Richard—18  
Lubrication—65, 67, 107, 108, 122, 141,  
153  
Luhrs, George—10, 156, 271  
Lutz, Dan—241, 242, 243

## M

*Machinery's Handbook*—3, 27, 28, 39, 67,  
102, 167, 210, 220, 223, 227, 229,  
230, 270  
Machinist's Challenge contest—331  
Major diameter (thread)—160, 162  
ManSon lathe—8  
Martin, Don—21, 222  
Martin, Joe—i, ii, iii, 4, 6, 247, 273, 274,  
290, 299, 307, 308  
Mathes, Don—277  
Mason, George—13  
Mattson, Phil—56, 106, 208, 239  
Maxwell, Tom—53  
Micro Avionics—276, 277, 278  
Micrometer—88, 89, 90, 95, 118, 165

- Depth—95
- Inside—94

Mill (See vertical milling machine)  
Milling—198

- Conventional vs. climb—83,  
94, 197
- Horizontal—203

Milling vise—183, 184, 185, 188, 195,  
197, 205, 224, 239, 319

- Making soft jaws for—325, 326

Minor diameter (thread)—160, 162  
Modelmaker—10, 87, 106, 239  
Morse taper—122, 123, 141, 158, 202  
Multicon Corporation—279  
Myford lathe—177, 191

## N

N.A.M.E.S show—335, 337  
NASA—276, 281  
Neal, James E.—234  
Nelson, Jerry—289

## O

Optical comparitor—95, 165

## P

Papp, Charla—344  
Parallel—205, 206, 207, 325  
Parry, Howard—50  
Parting off tool (see cutoff tool)  
Pattern—49, 50  
Patternmaker—1, 50

Perreira, Timmy—22  
Piecznski, Joseph—192  
Pitch (thread)—160, 161  
Pitch diameter

- Of gear—221, 227
- Of thread—160, 166

Plastic—32, 43  
Plating—9, 46, 166

- Barrel—48
- Chrome—47
- Hard Chrome—48

Polishing stones—59  
Pope, Frederick—298  
Porter, Darrell—192  
Powder coating—9  
Power feed—139  
Powered metal (See "Sintered metal")  
Preload nut—256  
Pressure angle (gears)—221, 222  
"Putting-on tool"—7, 87, 211

**Q**  
Quick-change tool post—156

## R

Radius cutting attachment—133, 134  
Rake ( of cutter)

- Positive vs. negative—73
- Negative rake tool holder—74

Reamers—68, 69, 102, 125, 202  
Rifflers (or ruffles)—57, 58  
Right angle attachment—210  
Right angle plate—186, 205, 206, 237  
Riser blocks (See also "Cutoff tool rear  
mounting block")—145, 147, 150,  
214

- Headstock—145, 147
- Tailstock—145, 146, 147
- Steady rest—146, 147

Riser tool post (See "Tool post")  
Rocker tool post—124, 147  
Rockwell hardness (testing)—45, 46  
Rohlin, Karl—302, 340  
Rotary column attachment—35, 237, 238  
Rotary table—189, 203, 204, 209, 211,  
212, 214, 215, 218, 227, 228, 232,  
239, 253, 262, 289

- CNC indexer—234
- Exploded view—263, 343

Rubino, Salvatore—19  
Runout—97, 116, 212, 288

## S

Saddle—149, 152, 153, 155, 160, 191,  
237  
Saddle nut—254

- Replacing—255

Sand blasting—61  
Sandpaper—60, 153, 183  
Saunders, Dick—239, 282, 336  
Scherer, Henry—320  
Scherf, Dennis—11, 240  
Schroeder, Tim—5, 16, 186, 248  
Schulz, Kurt—240  
Screw-a-matic—279  
Sears Roebuck & Co.—192, 278, 279, 282,  
283, 284, 285, 286, 291  
Sher, Ron—270, 279, 281, 282  
Sherline Products Inc.

- Australian roots—272, 278
- As examples—4

Sherwood, Chuck—269, 270, 271  
Shores, Bob—71, 333  
Shrink rate—50  
Schultz, Kurt—12  
Side tool (See "Cutting tools")  
Sine bar—96, 97  
Sintered metal—52  
Smith, Steven—306  
Smith, William R.—132, 172, 175, 220, 271  
Soldering—52, 56

- Silver—53

Speed (See "Cutting speed")  
Spindle—70, 96, 107, 116, 123, 159, 164,  
191, 194, 195, 212, 217, 235, 236

- Removing end play—256

Spur driver—139  
Starrett, L.S. Company—88, 92, 93, 94, 95,  
96, 199  
Steady rest—50, 139, 149, 150, 151, 155,  
281  
Step collet (see "Collet pot chuck")  
Stepper motor—37  
Stress-proof steel—39, 42  
Surface plate—91, 92

- Miniature—244

## T

T.I.R. (See "Runout")  
Table (mill)—191, 192, 200  
Taguchi, Benny—277  
Tailstock—107, 121, 137, 143, 151, 193,  
211

- Aligning—142
- Drilling with—251, 267

Tailstock chuck—32, 33, 115, 138, 142, 143  
Taper cutting—126, 127, 128  
Tapping guide—326  
Tapping head—71  
Taps—69, 71, 103, 157, 268

- Bottoming—69
- Cheap—69
- Checking tapped holes—166

- Hand—70
  - Handle—70, 319
    - Making your own—321
  - Plug—69
  - Spiral fluted—69
  - Spiral point—69
  - Wrench—70, 285
- Taylor, Graham—187
- Teachworth, Edwin—19
- Thomas Register—279
- Thompson, Chris—11
- Threads/Threading—2, 158, 172
- Cutting for practice—162
  - Form tapping—158
  - Internal—164
- Threads/Threading (Continued)
- Left hand—162
  - Rolling—158, 161
  - Single pointing—158, 163
- Thread chasing—162
- Thread cutting attachment—139, 158, 159, 163, 164, 233, 281, 284
- Threading tool
- Inside—164
  - Standard 60°—159, 161, 164
- Tilting angle table—187, 188, 204, 210, 211, 227, 239
- T-nut—76, 126, 168, 186, 187, 211
- Tolerances—142, 251, 279
- Buildup—153
  - Establishing—264
- Tommy bars—115, 121, 189, 212, 288
- Tool chatter (See “Chatter”)
- Tool height gage—124
- Tool post—76, 121, 124, 130, 131
- Riser tool post—145, 147, 214
- Tool Wrap™—45
- Tooling plate—177, 186, 195, 239
- Toolmaker—i, 5, 9, 133, 192, 254, 292
- T-slot—133, 152, 168, 185, 187, 191, 195, 210
- Tumbler—60, 61
- Two-position tool post—139

## U

- Unimat lathe—3, 149, 192, 276, 277, 281, 282, 284

## V

- Vernier scale—88, 89
- Reading—90
- Vertical milling column
- Multi-direction—176, 177
  - Standard—30, 138, 176, 177, 178, 286

- Vertical milling machine—29, 101, 108, 130, 197, 201, 203, 204, 211, 224, 267, 289, 291
- Adjusting worn column—257
  - Aligning—252
  - Exploded view—341
  - Model 2000/2010—35, 38, 193, 194, 204
  - Model 5000/5100—33, 35, 36, 194
  - Model 5400/5410—34, 35, 36, 232

Vertical milling table—139, 177

Vise—44

## W

- Warren, Ed—325, 326
- Washburn, Robert—334, 340
- Weiss, Pete—16, 120, 214, 224, 325, 326, 329, 330
- Welding
- Arc—53
  - MIG—54
  - Spot—54
  - TIG—54, 55

- Wheel dresser—77
- White, John D.—26
- White, Paul—241, 244, 245
- Whittle, Eric—14, 251
- Williams, Granger and Larry—292
- Winters, John—15
- Wood—32, 41, 43, 136, 183
- Wood tool rest—42, 139
- Work hardening—105
- Worldwide Web—279, 287
- Worm gear—225

## X

- XY base—30, 36, 178, 236
- XYZ base—30, 36

## Y

- Young, Edward J.—4

## Conversion factors

TO CONVERT FROM	TO	MULTIPLY BY
<b>LENGTH</b>		
Inches	Meters	.0254
Meters	Inches	39.3701
Inches	Centimeters	2.54
Centimeters	Inches	.3937
Inches	Millimeters	25.40
Millimeters	Inches	.03937
Feet	Meters	.3048
Meters	Feet	3.2808
<b>VOLUME</b>		
Cubic Inches	Cubic Centimeters	16.3871
Cubic Centimeters	Cubic Inches	.06102
<b>WEIGHT</b>		
Troy Ounces	Grams	31.1035
Grams	Troy Ounces	.03215
Avoir. Ounces	Grams	28.3495
Grams	Avoir. Ounces	.03527
Grains	Grams	.0648
Grams	Grains	15.432
Troy Ounces	Avoir. Ounces	1.0971
Avoir. Ounces	Troy Ounces	.91146
<b>FORCE</b>		
Foot Pounds	Newton-meters	1.35582
Newton-meters	Foot Pounds	.73756
Inch Pounds	Foot Pounds	.0833