

# Theory and Design for Mechanical Measurements

**SOLUTION MANUAL**

Fourth  
Edition

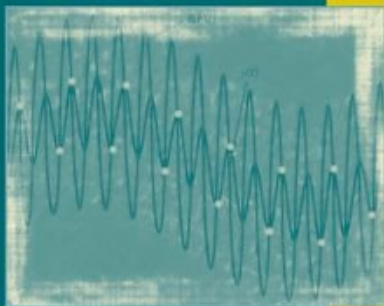

**Richard S. Figliola / Donald E. Beasley**

[www.EngineeringBooksPdf.com](http://www.EngineeringBooksPdf.com)

## PROBLEM 1.1

**FIND:** Explain the hierarchy of standards. Explain the term *standard*. Cite example.

### SOLUTION

The term *standard* refers to an object or instrument, a method or a procedure that provides a value of an acceptable accuracy for comparison.

A *primary standard* defines the value of the unit to which it is associated. *Secondary standards*, while based on the primary standard, are more readily accessible and amenable for use in a calibration. There is a hierarchy of secondary standards: A *transfer standard* might be maintained by a national standards lab (such as NIST in the United States) to calibrate industrial “laboratory standards”. It is costly and time-consuming to certify a laboratory standard, so they are treated carefully and not used too regularly. A *laboratory standard* would be maintained by a company to be used to certify a more common in-house reference called the *working standard*. A working standard would be calibrated against the laboratory standard. The working standard is used on a more regular basis to calibrate everyday measurement devices or products being manufactured. Working standards are more the norm for most of us. A working standard is simply the value or instrument that we assume is correct in checking the output operation of another instrument.

Example: A government lab maintains the primary standard for pressure. It calibrates an instrument called a “deadweight tester” (see C9 discussion) for high pressure calibrations. These form its transfer standard for high pressure. A company that makes pressure transducers needs an in-house standard to certify their products. They purchase two deadweight testers. They send one tester to the national lab to be calibrated; this becomes their laboratory standard. On return, they use it to calibrate the other; this becomes their working standard. They test their manufactured transducers using the working standard – usually at one or two points over the transducer range to assure that it is working. Because the working standard is being used regularly, it can go out of calibration. Periodically, they check the working standard calibration against the laboratory standard.

See ASME PTC 19.2 Pressure Measurements for a further discussion.

A *test standard* defines a specific procedure that is to be followed.

## PROBLEM 1.2

**FIND:** Why calibrate? What does calibrated mean?

**SOLUTION:**

The purpose of a calibration is to evaluate and document the accuracy of a measuring device. A *calibration* should be performed whenever the accuracy level of a measured value must be ascertained.

An instrument that has been calibrated provides the engineer a basis for interpreting the device's output indication. It provides assurance in the measurement. Besides this purpose, a calibration assures the engineer that the device is working as expected.

A periodic calibration of measuring instruments serves as a performance check on those instruments and provides a level of confidence in their indicated values. A good rule is to calibrate measuring systems annually or more often as needed.

ISO 9000 certifications have strict rules on calibration results and the frequency of calibration.

## PROBLEM 1.3

**FIND:** Suggest methods to estimate the accuracy and random and systematic errors of a dial thermometer.

### SOLUTION:

Random error is related to repeatability: how closely an instrument indicates the same value. So a method that repeatedly exposes the instrument to one or more known temperatures could be developed to estimate the random error. This is usually stated as a statistical estimate of the variation of the readings. An important aspect of such a test is to include some mechanism to allow the instrument to change its indicated value following each reading so that it must readjust itself.

For example, we could place the instrument in an environment of constant temperature and note its indicated value and then move the instrument to another constant temperature environment and note its value there. The two chosen temperatures could be representative of the range of intended use of the instrument. By alternating between the two constant temperature environments, differences in indicated values within each environment would be indicative of the precision error to be expected of the instrument at that temperature. Of course, this assumes that the constant temperatures do indeed remain constant throughout the test and the instrument is used in an identical manner for each measurement.

Systematic error is a fixed offset. In the absence of random error, this would be how closely the instrument indicates the correct value. This offset would be present in every reading. So an important aspect of this check is to calibrate it against a value that is at least as accurate as you need. This is not trivial.

For example, you could use the ice point ( $0^{\circ}\text{C}$ ) as a check for systematic error. The ice point is formed from a carefully prepared bath of solid ice and liquid water. As another check, the melting point of a pure substance, such as silver, could be used. Or easier, the steam point.

Accuracy requires a calibration to assess both random and systematic errors. If in the preceding test the temperatures of the two constant temperature environments were known, the above procedure could serve to establish the systematic error, as well as random error of the instrument. To do this: The difference between the average of the readings obtained at some known temperature and the known temperature would provide an estimate of the systematic error.

## PROBLEM 1.4

**FIND:** Discuss interference in the test of Figure 1.3

**SOLUTION :**

In the example described by Figure 1.3, tests were run on different days on which the local barometric pressure had changed. Between any two days of different barometric pressure, the boiling point measured would be different – this offset is due to the interference effect of the pressure.

Consider a test run over several days coincident with the motion of a major weather front through the area. Clearly, this would impose a trend on the dataset. For example, the measured boiling point may be seen as increasing from day to day.

By running over random days separated by a sufficient period of days, so as not to allow any one atmospheric front to impose a trend on the data, the effects of atmospheric pressure can be broken up into noise. The measured boiling point might then be high one test but then low on the next, in effect, making it look like random data scatter, i.e. noise.

## PROBLEM 1.5

**FIND:** How does resolution affect accuracy?

### SOLUTION

The resolution of a scale is defined by the least significant increment or division on the output display. Resolution affects a user's ability to resolve the output display of an instrument or measuring system.

Consider a simple experiment to show the effects of resolution. Under some fixed condition, ask several competent, independent observers to record the indicated value from a measurement system. Collect the results – this becomes your dataset. Because the indicated value is the same for each observer, the scatter in your dataset will be close to the value of the resolution of the measurement system.

Data scatter contributes to the random error. As such, the output resolution of a measurement system forms a lower limit as to the random error to be expected.

The resolution would not contribute to systematic error. Systematic error is an offset.

## PROBLEM 1.6

**FIND:** How does hysteresis affect accuracy?

### SOLUTION

Hysteresis error is the difference between the values indicated by a measurement system when the value measured is increasing in value as opposed to when it is decreasing in value; this despite the fact that the value being measured is actually the same for either case.

A common cause of hysteresis in analog instruments is friction in the moving parts. This can cause the output indicator to 'stick'. In digital instruments, hysteresis can be caused by the discretization.

If hysteresis error is ignored, the effect on any single measurement can be seen as a systematic error. On multiple measurements in any one direction, the effect can be to impose a 'trend' on the data set. The use of randomization methods can break up the trends incorrectly implied by hysteresis effects. Randomization makes systematic errors behave as random errors, which are more easily interpreted. If randomization methods are not used, the hysteresis effect behaves as a systematic error.

## PROBLEM 1.7

### SOLUTION

This problem is open-ended and has no unique solution. We suggest that the instructor use this Problem as the basis for an in-class or small group discussion.

## PROBLEM 1.8

**FIND:** Identify measurement stages for each device.

### SOLUTION

a) *thermostat*

Sensor/transducer: bimetallic thermometer

Output: displacement of thermometer tip

Controller: mercury contact switch (open:furnace off; closed:furnace on)

b) *speedometer*

Method 1:

Sensor: usually a mechanically coupled cable

Transducer: typically a dc generator that is turned by the cable producing an electrical signal

Output: typically a pointer/scale (note: often a galvanometer is used to convert the electrical signal in a mechanical rotation of the pointer)

Method 2:

Sensor: A magnet attached to the rotating shaft

Transducer: A Hall Effect device that is stationary but detects each sensor passage by creating voltage pulse

Signal Conditioning: A pulse counting circuit; maybe also digital-analog converter (if analog readout is used)

Output: An analog or digital readout calibrated to convert pulses per minute to kph or mph.

c) *Portable CD Stereo Player*

Sensor: laser with optical reader (reflected light signal differentiates between a "1" and "0")

Transducer: digital register (stores digital information for signal conditioning)

Signal conditioning: digital-to-analog converter and amplifier (converts digital numbers to voltages and amplifies the voltage)

Output: headset/speaker (note: the headset/speaker is a second transducer in this system converting an electrical signal back to a mechanical displacement)

d) *anti-lock braking system*

Sensor: brake activation switch senses brakes 'on'; encoder counts wheels revolutions per unit time

Signal conditioning: timing circuit

Output: a feedback signal that pulsates brake action overriding the driver's constant pedal pressure

e) *audio speaker*

Sensor: coil (to which the input terminals are connected)

Transducer: coil-magnet-speaker cone that acts as a miniature electrical dc motor responding to changes in current applied.

Output: speaker cone displacement

## PROBLEM 1.9

**KNOWN:** Data of Table 1.5

**FIND:** input range, output range

### SOLUTION

By inspection

$$0.5 \leq x \leq 100 \text{ cm}$$

$$0.4 \leq y \leq 253.2 \text{ V}$$

The input range ( $x$ ) is from 0.5 to 100 cm. The output range ( $y$ ) is from 0.4 to 253.2V. The corresponding spans are given by

$$r_i = 99.5 \text{ cm}$$

$$r_o = 252.8 \text{ V}$$

### COMMENT

Note that each answer has units shown. By themselves, numerical answers are meaningless. Always show units for data, for each step of data reduction and in all reported results.

## PROBLEM 1.10

**KNOWN:** Data set of Table 1.5

**FIND:** Discuss advantages of different plot formats for this data

**SOLUTION:**

Both rectangular and log-log plots are shown below.

Rectangular grid (left plot below):

An advantage of this format is that it displays the data clearly as having a non-linear relationship. The data trend, while not immediately quantifiable, is established.

A disadvantage with this data set is that the poor resolution at low x values makes quantification at low values difficult.

Log-log grid (right plot below):

An advantage of this format with this particular data set is that the data display a linear relationship of the form:  $\log y = m \log x + \log b$ . This tells us that the data have the relationship,  $y = bx^m$ . Because of these facts, resolution is equally good over the whole scale.

A disadvantage with this format is that one must remember the data has been conditioned to look linear. We are no longer plotting x versus y. This is particularly important to remember when attempting to find the slope of y against x.

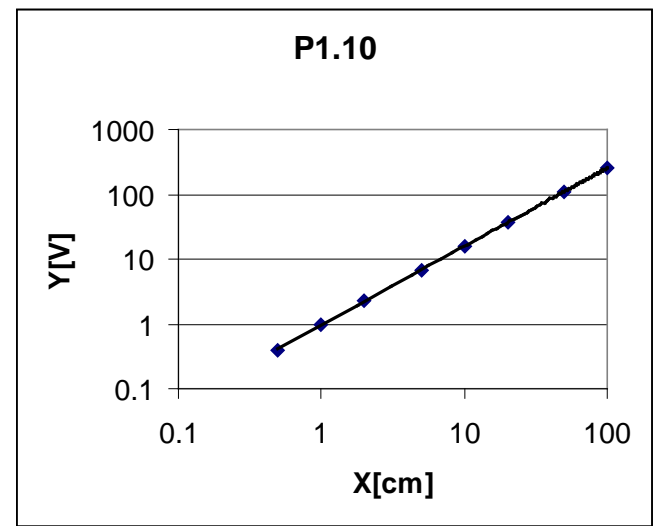
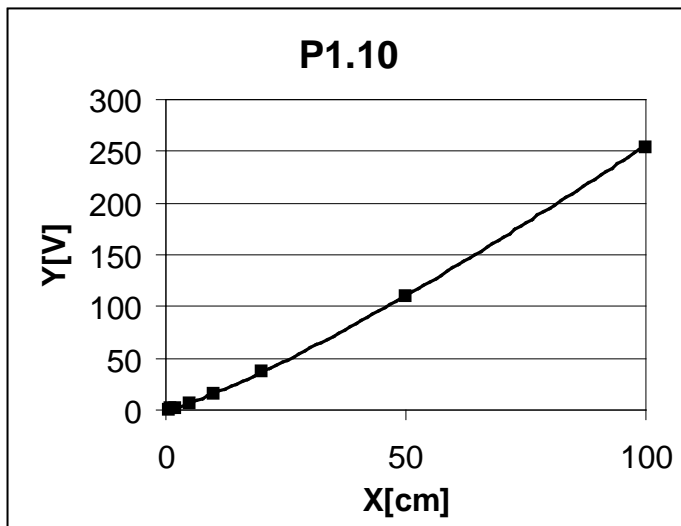

## PROBLEM 1.11

**KNOWN:** Calibration data of Table 1.5

**FIND:**  $K$  at  $x = 5, 10, 20$  cm

**SOLUTION:**

The data reveal a linear relation on a log-log plot suggesting  $y = bx^m$ . That is:

$$\log y = \log (bx^m) = \log b + m \log x \quad \text{or}$$
$$Y = B + mX$$

From the plot,  $B = 0$ , so that  $b = 1$ , and  $m = 1.2$ . Thus, we find from the calibration the relationship

$$y = x^{1.2}$$

Because  $K = [dy/dx]_x = 1.2x^{0.2}$ , we obtain

$x$ [cm]	$K$ [V/cm]
5	1.66
10	1.90
20	2.18

We should expect that errors would propagate with the same sensitivity as the data. Hence for  $y=f(x)$ , as sensitivity increases, the influence of the errors on  $y$  due to errors in  $x$  between would increase.

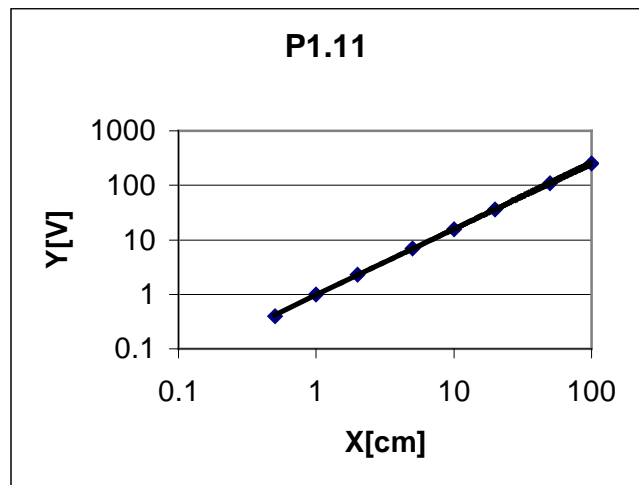

## COMMENT

A common shortcut is to use the approximation that

$$dy/dx = \lim_{x \rightarrow 0} \Delta y / \Delta x$$

This approximation is valid only for very small changes in  $x$ , otherwise errors result. This is a common mistake. An important aspect of this problem is to draw attention to the fact that many measurement systems may have a static sensitivity that is dependent on input value.

## PROBLEM 1.12

**KNOWN:** Sequence calibration data set of Table 1.6

$$r_i = 5 \text{ mV}$$

$$r_o = 5 \text{ mV}$$

**FIND:**  $\%(e_h)_{\max}$

**SOLUTION**

By inspection of the data, the maximum hysteresis occurs at  $x = 3.0$ . For this case,

$$\begin{aligned} e_h &= (e_h)_{\max} = y_{\text{up}} - y_{\text{down}} \\ &= 0.2 \text{ mV} \quad \text{or} \end{aligned}$$

$$\begin{aligned} \%(e_h)_{\max} &= 100 \times (0.2 \text{ mV} / 5 \text{ mV}) \\ &= 4\% \end{aligned}$$

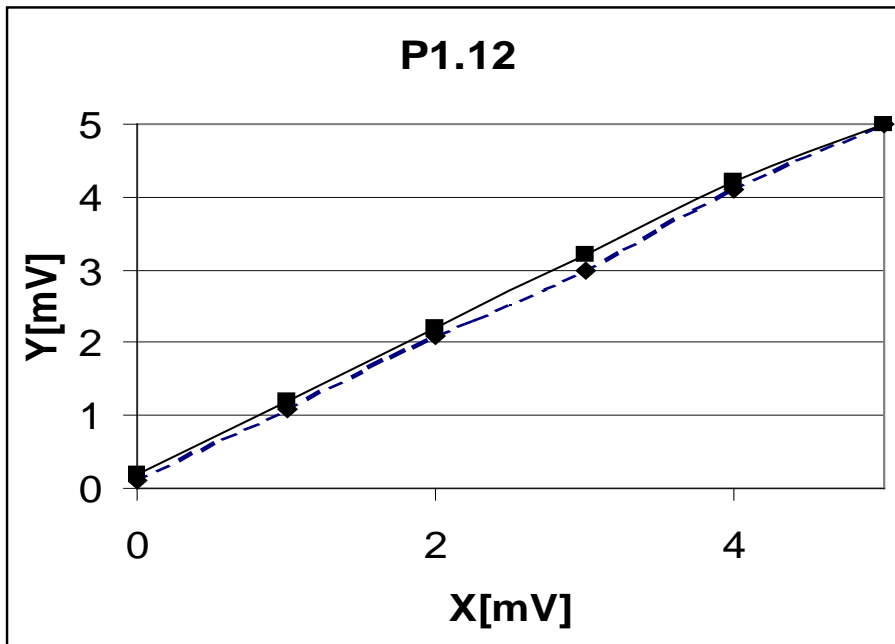

## Problem 1.13

**KNOWN:** Comparison of three clock outputs with standard time

**FIND:** Discuss estimated accuracy

### SOLUTION

Clock A shows a bias error of 2:23 s. The bias would appear to be increasing at a rate of 1 s/hr. However, clock resolution is 1 s which by itself can lead to precision error (data scatter) of  $\pm \frac{1}{2}$  s; this can create the situation noted here. Another reading would clarify this.

Clock B shows a bias error of 5 s. There does not appear to be any precision error in the output.

Clock C shows a 0 s bias error and a precision error on the order of  $\pm 2$  s.

Because of the calibration, we now know the values of bias error for each clock. Correcting for bias error, we can consider Clock B to provide the more accurate time. Over time, the bias error in Clock A could become cumbersome to deal with, that is if the bias is indeed increasing in time. Therefore, it provides the least reliable value of time.

# PROBLEM 1.14

## SOLUTION

Each curve is plotted below in a suitable format to yield a linear shape.

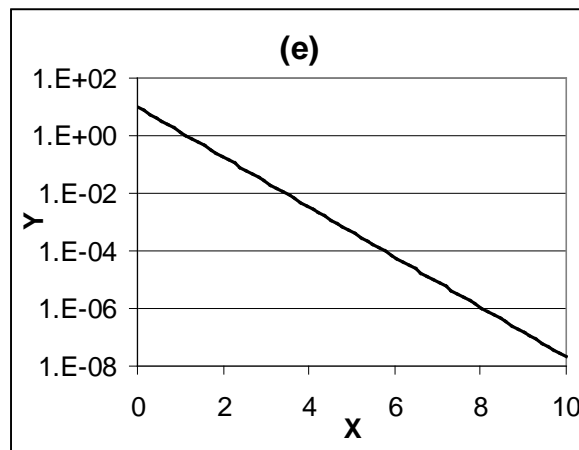
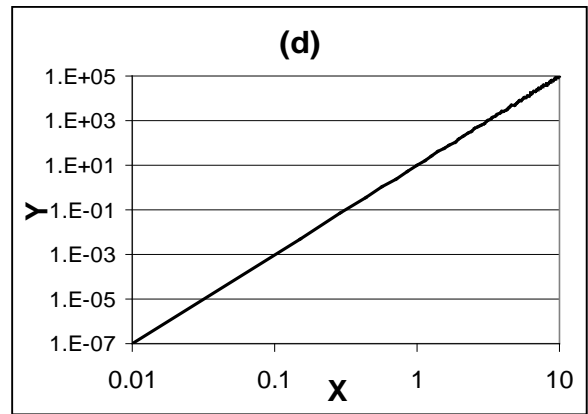
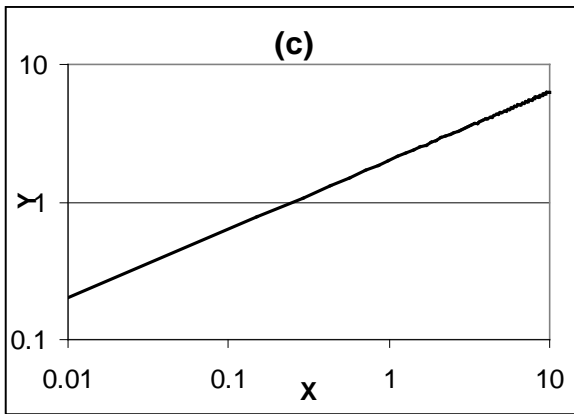
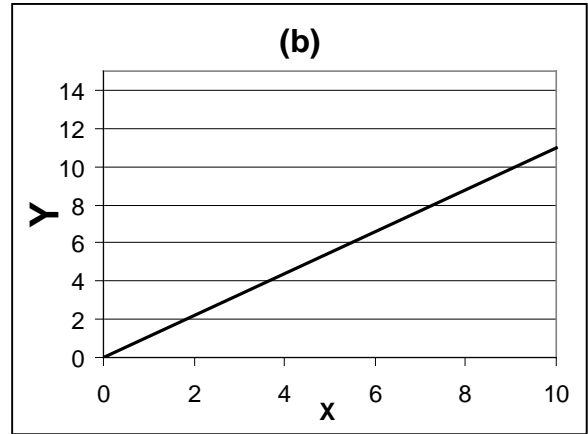
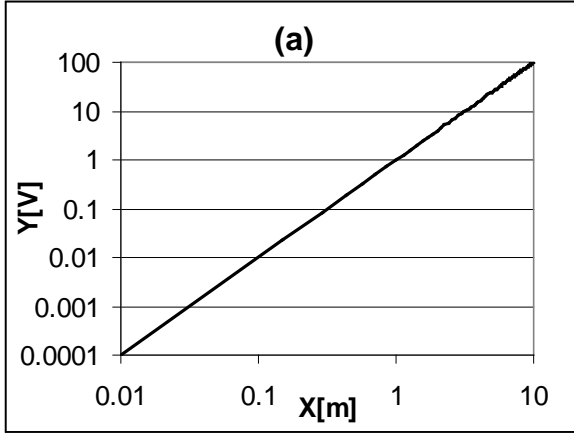

## PROBLEM 1.15

KNOWN:  $y = 10e^{-5x}$

FIND: Slope at  $x = 0, 2$  and  $20$

### SOLUTION

The equation has been plotted below. The slope of the equation at any value of  $x$  can be found graphically or by the derivative

$$dy/dx = -50e^{-5x}$$

$x$ [V]	$dy/dx$ [V/unit]
---------	------------------

0	-50
---	-----

2	-0.00227
---	----------

20	0
----	---

The sensitivity of  $y$  to  $x$  decreases with  $x$ .

### COMMENT

An important aspect of this problem, is to draw attention to the fact that many measurement systems may have a static sensitivity that is dependent on input value. While it is desirable to have a constant  $K$  value, the operating principle of many systems will preclude this or incorporate signal conditioning stages to overcome such nonlinearity. In Chapter 3, the concept that system's also have a dynamic sensitivity that is frequency dependent will be introduced.

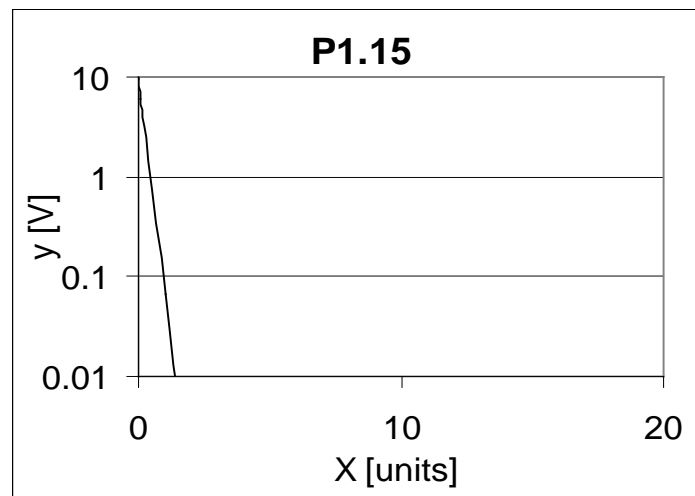

## PROBLEM 1.16

### SOLUTION

The data are plotted below. The slope of a line passing through the data is 1.365 and the y intercept is 2.12. The data can be fit to the line  $y = 1.365x + 2.12$ . Therefore, the static sensitivity is  $K = 1.365$  for all  $x$ .

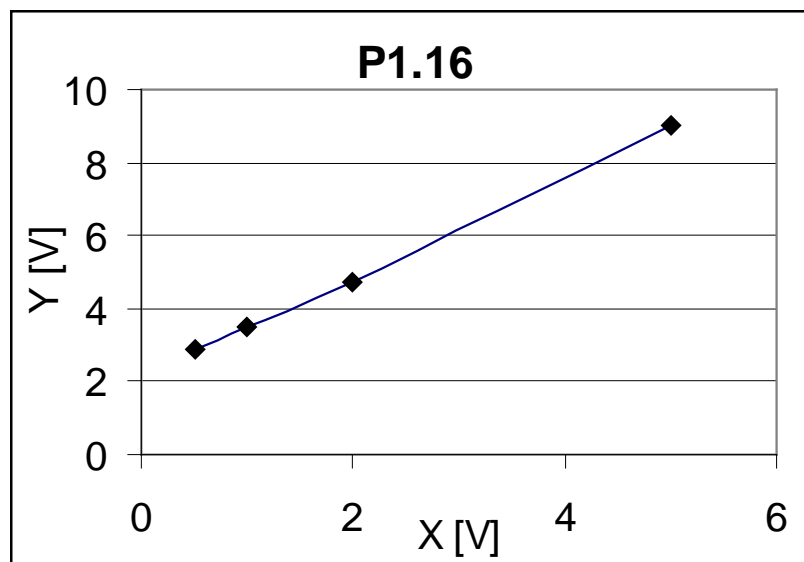

## PROBLEM 1.17

**KNOWN:** Data of form  $y = ax^b$ .

**FIND:** a and b; K

### SOLUTION

The data are plotted below. If  $y = ax^b$ , then in log-log format the data will take the linear form

$$\log y = \log a + b \log x$$

A more or less linear curve results with this data. From the plot, the curve fit found is

$$\log y = -0.23 + 2x$$

This implies that

$$y = 0.59x^2$$

so that  $a = 0.59$  and  $b = 2$ . The static sensitivity is found by the slope  $dy/dx$  at each value of  $x$ .

$$x \text{ [m]} \quad K(x_1) = dy/dx \big|_{x_1} \text{ [cm/m]}$$

0.5	0.54
2.0	2.16
5.0	5.40
10.0	10.80

### COMMENT

An aspect of this problem is to draw attention to the fact that many measurement systems may have a static sensitivity that is dependent on input value. The operating principle of many systems will determine how  $K$  behaves.

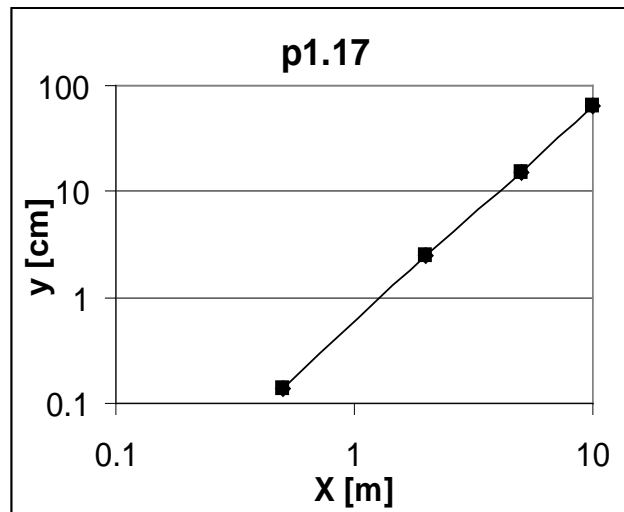

## PROBLEM 1.18

**KNOWN:** Calibration data

**FIND:** Plot data. Estimate K.

### SOLUTION

The data are plotted below in semi-log format. A linear curve results. This suggests  $y = ae^{bx}$ . Plotting  $y$  vs  $x$  in semi-log format is equivalent to plotting

$$\log y = \log a + bx$$

From the plot,  $a = 5$  and  $b = -1$ . Hence, the data describe  $y = 5e^{-x}$ . Now,  $K =$

$dy/dx \big|_x$ , so that

X [psi]	K
0.05	-4.76
0.1	-4.52
0.5	-3.03
1.0	-1.84

The magnitude of the static sensitivity decreases with  $x$ . The negative sign indicates that  $y$  will decrease as  $x$  increases.

### COMMENT

An aspect of this problem is to draw attention to the fact that many measurement systems may have a static sensitivity that is dependent on input value. The operating principle of many systems will determine how  $K$  behaves.

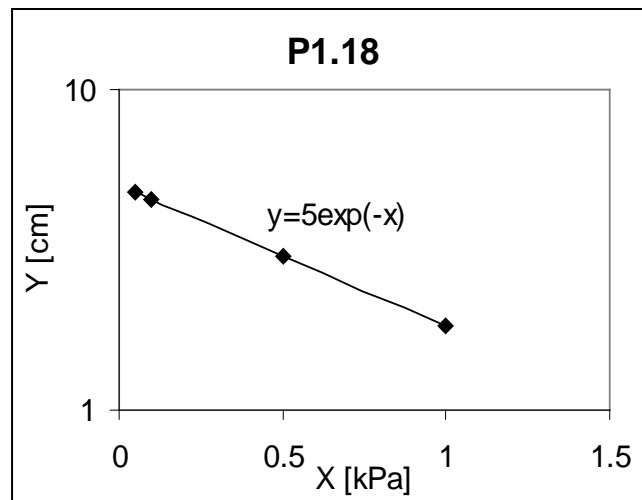

## PROBLEM 1.19

**KNOWN:** A bulb thermometer is used to measure outside temperature.

**FIND:** Extraneous variables that might influence thermometer output.

### SOLUTION

A thermometer's indicated temperature will be influenced by the temperature of solid objects to which it is in contact, and radiation exchange with bodies at different temperatures (including the sky or sun, buildings, people and ground) within its line of sight. Hence, location should be carefully selected and even randomized. We know that a bulb thermometer does not respond quickly to temperature changes, so that a sufficient period of time needs to be allowed for the instrument to adjust to new temperatures. By replication of the measurement, effects due to instrument hysteresis and instrument and procedural repeatability can be randomized.

Because of limited resolution in such an instrument, different competent temperature observers might record different indicated temperatures even if the instrument output were fixed. Either observers should be randomized or, if not, the test replicated. It is interesting to note that such a randomization will bring about a predictable scatter in recorded data of about  $\frac{1}{2}$  the resolution of the instrument scale.

## PROBLEM 1.20

**KNOWN:** Input voltage, ( $E_i$ ) and Load ( $\tau_L$ ) can be controlled and varied.

Efficiency ( $\eta$ ), Winding temperature ( $T_w$ ), and Current ( $I$ ) are measured.

**FIND:** Specify the dependent, independent in the test and suggest any extraneous variables.

### SOLUTION

The measured variables are the dependent variables in the test and they depend on the independent variables of input voltage and load. Several influencing extraneous variables include: ambient temperature ( $T_a$ ) and relative humidity  $R$ ; Line voltage fluctuations ( $e$ ); and each of the individual measuring instruments ( $m_i$ ). The variation of the independent variables should be performed separately maintaining one independent variable fixed while the other is systematically varied over the test range. A random test procedure for the independent variable will randomize the effects of  $T_a$ ,  $R$  and  $e$ . Replication methods using different test instruments would be one way to randomize the effects of the  $m_i$ ; alternatively, calibration of all measuring instruments would provide a good degree of control over these variables.

$$\eta = \eta(E_i, \tau_L; T_a, R, e, m_i)$$

$$T_w = T_w(E_i, \tau_L; T_a, R, e, m_i)$$

$$I = I(E_i, \tau_L; T_a, R, e, m_i)$$

## PROBLEM 1.21

**KNOWN:** Specifications Table 1.1  
Nominal pressure of 500 cm H<sub>2</sub>O to be measured.  
Ambient temperature drift between 18 to 25 °C

**FIND:** Magnitude of each elemental error listed.

### SOLUTION

Based on the specifications:

$$r_i = 1000 \text{ cm H}_2\text{O}$$

$$r_o = 5 \text{ V}$$

Hence,  $K = 5 \text{ V} / 1000 \text{ cm H}_2\text{O} = 5 \text{ mV/cm H}_2\text{O}$ . This gives a nominal output at 500 cm H<sub>2</sub>O input of 2.5 V. This assumes that the input/output relation is linear over range but we are told that it is linear to within some linearity error.

$$\text{linearity error} = e_L = (\pm 0.005)(1000 \text{ cm H}_2\text{O})$$

$$= \pm 5 \text{ cm H}_2\text{O}$$

$$= \pm 0.025 \text{ V}$$

$$\text{hysteresis error} = e_h = (\pm 0.0015)(1000 \text{ cm H}_2\text{O})$$

$$= \pm 1.5 \text{ cm H}_2\text{O}$$

$$= \pm 0.0075 \text{ V}$$

$$\text{sensitivity error} = e_K = (\pm 0.0025)(500 \text{ cm H}_2\text{O})$$

$$= \pm 0.75 \text{ cm H}_2\text{O} = \pm 0.00375 \text{ V}$$

$$\text{thermal sensitivity error} = (\pm 0.0002)(7^\circ\text{C})(500 \text{ cm H}_2\text{O})$$

$$= \pm 0.7 \text{ cm H}_2\text{O}$$

$$= \pm 0.0035 \text{ V}$$

$$\text{thermal drift error} = (0.0002)(7^\circ\text{C})(1000 \text{ cm H}_2\text{O})$$

$$= 1.4 \text{ cm H}_2\text{O}$$

$$= 0.007 \text{ V}$$

$$\text{overall instrument error} = (5^2 + 1.5^2 + 0.75^2 + 0.7^2 + 1.4^2)^{1/2} = 5.501 \text{ cm H}_2\text{O}$$

## PROBLEM 1.22

KNOWN: FSO = 1000 N

FIND:  $e_c$

SOLUTION

From the given specifications, the elemental errors are estimated by:

$$e_L = 0.001 \times 1000\text{N} = 1\text{N}$$

$$e_H = 0.001 \times 1000\text{N} = 1\text{N}$$

$$e_K = 0.0015 \times 1000\text{N} = 1.5\text{N}$$

$$e_z = 0.002 \times 1000\text{N} = 2\text{N}$$

The overall instrument error is estimated as:

$$e_c = (1^2 + 1^2 + 1.5^2 + 2^2)^{1/2} = 2.9\text{N}$$

COMMENT

This root-sum-square (RSS) method provides a "probable" estimate (i.e. the most likely estimate) of the instrument error possible in any given measurement. "Possible" is a big word here as error values will most likely change between measurements.

## PROBLEM 1.23

### SOLUTION

Repetition through repeated measurements made under a fixed set of operating conditions provides a measure of the time (or spatial) variation of a measured variable.

Replication through the duplication of tests conducted under similar operating conditions provides a measure of the effect of control of the operating conditions on the measured variable.

Repetition refers to repeating the measurement during a test.

Replication refers to repeating the test (to repeat the measurements).

## PROBLEM 1.24

### SOLUTION

Replication is used to assess the ability to control any aspect of a test or its operating condition. Repeat the test resetting the operating conditions to their original set points.

## PROBLEM 1.25

### SOLUTION

Randomization is used to break-up the effects of interference from either continuous or discrete extraneous (i.e. uncontrolled) variables.

## PROBLEM 1.26

### SOLUTION

This problem does not have a unique solution. We suggest that the instructor use this problem as a basis for an in-class or small group discussion.

## PROBLEM 1.27

**FIND:** Test matrix to correlate thermostat setting with average room setting

### SOLUTION

Although there is no single test matrix, one method of solution follows.

Assume that average room temperature,  $T$ , is a function of actual thermostat setting, spatial distribution of temperature, temporal temperature distribution, and thermostat location. We might imagine that for a controlled (fixed) thermostat location, a direct correlation between setting and  $T$  could be achieved. However, factors could influence the temperature measured by the thermostat such as sunlight directly hitting the thermostat or the wall on which it is attached or a location directly exposed to furnace forced convection, a condition aggravated by air conditioners or heat pumps in which delivered air temperature is a strong function of outside temperature. Assume a proper location is selected and controlled.

Further, the average room temperature must be defined because local room temperature will vary with position within the room and with time. For the test matrix, the room should be divided into equal areas with temperature sensing devices placed at the center of each area. The output from each sensor will be averaged over a time period that is long compared to the typical furnace on/off cycle.

Select four temperature sensors: A, B, C, D. Select four thermostat settings:  $s_1, s_2, s_3, s_4$ , where  $s_1 < s_2 < s_3 < s_4$ . Temperatures are to be measured under each setting after the room has adjusted to the new setting. One matrix might be:

### BLOCK

- 1  $s_1$ : A, B, C, D
- 2  $s_4$ : A, B, C, D
- 3  $s_3$ : A, B, C, D
- 4  $s_2$ : A, B, C, D

Note that the order of set temperature has been shuffled to attempt to randomize the test matrix (hysteresis is a common problem in thermostats). The four blocks will yield the average temperatures,  $T_1, T_4, T_3, T_2$ . The data can be presented in a form of  $T$  versus  $s$ .

## PROBLEM 1.28

**FIND:** Test matrix to evaluate fuel efficiency of a production model of automobile

**ASSUMPTIONS:** Automobile model design is fixed (i.e. neglect options). Require representative estimate of efficiency.

### SOLUTION

Although there is no single test matrix, one method of solution follows. Many variables can affect auto model efficiency: e.g. individual car, driver, terrain, speed, ambient conditions, engine model, fuel, tires, options. Whether these are treated as controlled variables or as extraneous variables depends on the test matrix. Suppose we "control" the options, fuel, tires, and engine model, that is fix these for the test duration. Furthermore, we can fix the terrain and the ambient conditions by using a mechanical chassis dynamometer (a device which drives the wheels with a prescribed mechanical load) in an enclosed, controlled environment. In fact, such a machine and its test conditions have been specified within the U.S.A. by government test standards. By programming the dynamometer to start, accelerate and stop using a preprogrammed routine, we can eliminate the effects of different drivers on different cars. However, this test will fail to randomize the effects of different drivers and terrain as noted in the government statement "... these figures may vary depending on how and where you drive ... ." This leaves the car itself and the test speed as independent variables,  $x_a$  and  $x_b$ , respectively. We defer considering the effects of the instruments and methods used to compute fuel efficiency until a later chapter, but assume here that this can be done with sufficient accuracy.

With this in mind, we could choose three representative cars and three speeds with the test matrix:

#### BLOCK

- 1  $x_{a1}: x_{b1}, x_{b2}, x_{b3}$
- 2  $x_{a2}: x_{b1}, x_{b2}, x_{b3}$
- 3  $x_{a3}: x_{b1}, x_{b2}, x_{b3}$

Note that since slight differences will exist between cars that can not be controlled, the autos are treated as extraneous variables. This matrix randomizes the effects of differences between cars at three different speeds and yields a curve for fuel efficiency versus speed.

As an alternative, we could introduce a driver into the matrix. We could develop a test track of fixed (controlled) terrain. And we could have three drivers drive three cars at three different speeds. This introduces the driver as an extraneous variable, noted as  $A_1$ ,  $A_2$  and  $A_3$  for each driver. Assuming that the tests are run under similar ambient conditions, one test matrix may be

	$X_{a1}$	$X_{a2}$	$X_{a3}$
$A_1$	$X_{b1}$	$X_{b2}$	$X_{b3}$
$A_2$	$X_{b2}$	$X_{b3}$	$X_{b1}$
$A_3$	$X_{b3}$	$X_{b1}$	$X_{b2}$

## PROBLEM 1.29

### SOLUTION:

#### Test stand:

Here one would operate the engine under simulated conditions similar to those encountered at the track – such as anticipated engine RPM and engine load (load: estimated mechanical loads on the engine due to mechanical losses, tire rolling resistance, aerodynamic resistance, etc).

Measure:

- fuel and air consumption
- torque and power output
- exhaust gas temperatures to set air:fuel ratio

#### Track:

Here one would operate the car at conditions similar to those anticipated during the race.

Measure:

- lap time
- wind and temperature conditions (to normalize lap time)
- depending on team other factors can be measured to estimate loads on the car and car behavior. *Clemson Motorsports Engineering has been active in test method development for professional race teams.*

#### Obvious major differences:

- Environmental conditions, which effect engine performance, car behavior and tire behavior.
- Engine load on a test stand is well-controlled. On track, the driver does not execute exactly on each lap, hence varies load such as due to differences in drive path 'line' and this affects principally aerodynamic loads and tire rolling resistance. Incidentally, all of these are coupled effects in that a change in one affects the values of the others.
- Ram air effect of moving car can be simulated but difficult to get exactly
- Each engine is an individual. Even slight differences affect handling and therefore, how a driver drives the car (thus changing the engine load).

## PROBLEM 1.30

**KNOWN:** Four lathes, 12 machinists are available to produce batches of machine shafts.

**FIND:** Test matrix to estimate the tolerances held within a batch

### SOLUTION

If we assume that batch precision,  $P$ , is only a function of lathe and machinist, then

$$P = f(\text{lathe, machinist})$$

We can set up a test matrix using all four lathes,  $L_1, L_2, L_3, L_4$ , and all 12 machinists, A, B, ..., L. The machinists are randomly assigned.

### BLOCK

- 1  $L_1$ : A, B, C
- 2  $L_2$ : D, E, F
- 3  $L_3$ : G, H, I
- 4  $L_4$ : J, K, L

Data from each lathe should be indicative of the precision associated with each lathe and the total ensemble of data indicative of batch precision. However, this test matrix neglects the effects of shift and day of the week.

One method which treats machinist and lathe as extraneous variables and reduces test size selects 4 machinists at random. Suppose more than one shaft size is produced at the plant. We could select 4 shaft diameters,  $D_1, D_2, D_3, D_4$  and set up a Latin square matrix:

	$L_1$	$L_2$	$L_3$	$L_4$
B	D1	D2	D3	D4
E	D2	D3	D4	D1
G	D3	D4	D1	D2
L	D4	D1	D2	D3

Note that neither matrix includes shift or day of the week effects and these could be incorporated in an expanded test matrix.

## PROBLEM 1.31

### SOLUTION

#### Linearity error

A random static calibration over a specified range will provide the input-output relationship between  $y$  and  $x$  (i.e.  $y = f(x)$ ). A first-order curve fit to this data, for example using a least squares regression analysis, will provide the fit  $y_L(x)$ . The linearity error is simply the difference between the measured value of  $y$  at any value of  $x$  and the value of  $y_L$  predicted by the fit at that  $x$ .

A manufacturer may wish to keep the linearity error below some target value and, hence, may limit the recommended operating range for the system for this purpose. In your experience, you may notice that some systems can be operated outside of their specification range but be aware their elemental errors may exceed the manufacturer's stated values.

#### Hysteresis error

A sequential static calibration over a specified range will provide the input-output behavior between  $y$  and  $x$  during upscale-only and downscale-only operations. This will tend to maximize any hysteresis in the system. The hysteresis error is the difference between the upscale value and the downscale value of  $y$  at any given  $x$ .

## PROBLEM 1.32

**KNOWN:** 4 brands of tires  
8 cars of the same make

**FIND:** Test matrix to evaluate performance

### SOLUTION

Tire performance can mean different things but for passenger tires usually refers to braking and lateral load adhesion during wet and dry operations. For a given series of performance tests, performance will depend on tire and car (a tire will perform differently on different makes of cars). For the same make, subtle differences in production models can affect test results so we treat the car as an individual and extraneous variable.

We could select 4 cars at random (1,2,3,4) to test four tire brands (A,B,C,D)

- 1: A, B, C, D
- 2: A, B, C, D
- 3: A, B, C, D
- 4: A, B, C, D

This provides a data pool for evaluating tire performance for a make of car. Note we ignore the variable of the test driver but this method will incorporate driver variation by testing four cars. Other strategies could be created.

## PROBLEM 1.33

KNOWN: Water at 20°C

$$Q = f(C, A, dp, \rho)$$
$$C = 0.75; D = 1 \text{ m}$$
$$2 < Q < 10 \text{ cmm}$$

FIND: Expected calibration curve

### SOLUTION

Part of a test matrix is to specify the range of the independent variable and to anticipate the range resulting in the dependent variable. In this case, the pressure drop will be measured so that it is the dependent variable during a static calibration. To anticipate the output range of the calibration then:

Rearranging the known relation,

$$dp = (Q/CA)^2 \rho / 2$$

For  $\rho = 998 \text{ kg/m}^3$  (Appendix C), and  $A = \pi D^2/4$ , we find:

Q (cmm)	dp (N/m <sup>2</sup> )
2	1.6
5	10
10	40

This is plotted below. It is clear that K will not be a constant as  $K = f(Q)$ .

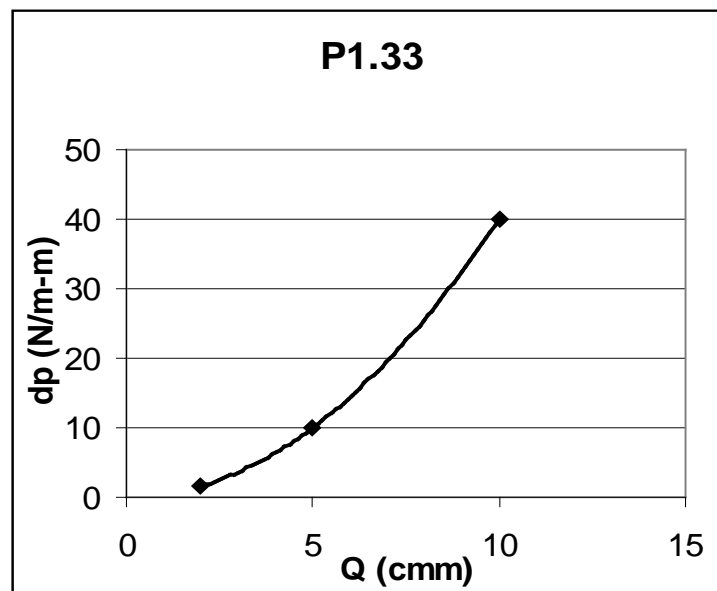

## PROBLEM 1.34

### SOLUTION

Because  $Q \propto dp^{1/2}$  and is not linear, the calibration will not be linear. The term ‘linearity’ should not be applied directly. The nonlinear calibration result is just a normal consequence of the physics.

However, a signal conditioning stage could be inserted within the signal path to produce a linear output. This is done using logarithmic amplifiers. To illustrate this, plot the calibration curve in Problem 1.33 on a log-log scale (see C1.6). The result will be a linear curve.

Alternately, you could take the log of each column and plot them on a rectangular scale to get that same result. A logarithmic amplifier (Chapter 6) performs this same function (as the plot scale or log key) directly on the signal. A linearity measure can then be extracted with some meaning.

As flow rate is the variable varied and pressure drop is the variable measured in this calibration, pressure drop is the dependent variable. The flow rate and the fixed values of area and density are independent variables.

## PROBLEM 1.35

KNOWN:      pistons are sent out for plating  
                    four subcontractors

FIND: Test matrix for quality control

### SOLUTION

Consider four subcontractors as A, B, C, D. One approach is to number the pistons and allocate them to the four subcontractors with subsequent analysis of the plating results. For example, send 24 pistons each to the four subcontractors and analyze the resulting products separately. The variation for each subcontractor can be estimated and can be statistically tested for significant differences.

## PROBLEM 1.36

### SOLUTION

Controlled variables

A and B (i.e. control the materials of two alloys)

$T_2$  (reference junction temperature)

Independent variable

$T_1$  (measured temperature)

Dependent variable

E (output voltage measured)

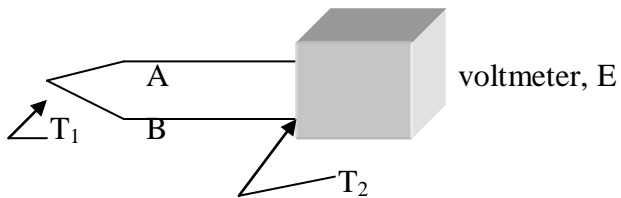

## PROBLEM 1.37

### SOLUTION

Independent variables

micrometer setting (i.e. the applied displacement)

Controlled variable

power supply input

Dependent variable

output voltage measured

Extraneous variables

operator set-up, zeroing of system, and reading of micrometer  
ability to set control variables

### COMMENT

If you try this you will find that the power supply excitation voltage can have a significant influence on the results. The ability to provide the exact voltage on replication is important in obtaining consistent results in many transducers. Even if you use a regulated laboratory variable power supply, this effect can be seen in your data variation on replication as a random variation. If you use an unregulated source, be prepared to trace these effects as they change from hour to hour or from day to day.

Many LVDT units allow for use of dc power, which is then transformed to ac form before being applied to the coil. It is easiest to see the effect of power setting on the results when using this type of transducer.

## PROBLEM 1.38

### SOLUTION

To test for repeatability in the LVDT, we might displace the core to various random values over a selected range, such as its expected range, and develop a data base. Data scatter about a curve fit will provide a measure of repeatability for this instrument (methods are discussed in Chapter 4).

Reproducibility involves re-testing the system at a different facility or equivalent (such as different instruments and test fixtures). Think of this as a duplication. Even though a similar procedure and test matrix will be used to test for reproducibility, the duplication involves different individual instruments and test fixtures. A reproducibility test is a special type of replication – by using the different facility constraint added. The combined results allow for interference effects to be randomized.

Bottom Line: The results leading to a reproducibility specification are more representative of what can be expected by the end user (YOU!).

## PROBLEM 1.39

### SOLUTION:

(i) Running the car on a chassis dynamometer, which applies a desired load to the wheels as the car is operated at a desired speed so as to simulate the car being driven, provides a controlled test environment for estimating fuel consumption. The operating loads form a 'load profile' to simulate the road course.

Allowing a driver to operate a car over a predetermined course provides a realistic simulation of expected consumption. No matter how well controlled the dynamometer test, it is not possible to completely recreate the driving situation that a real driver provides. However, each driver will drive the course a bit differently.

Extraneous variables include: individual entities of driver and of car that affect consumption in either method; road variations and differences between the test methods; road or weather conditions (which are both variable) that change the simulation.

(ii) The dynamometer test is well controlled. In the hands of a good test engineer, valuable information can be ascertained and realistic mileage values obtained. Most important, testing different car models using a predetermined load profile forms an excellent basis for comparison between car makes – this is the basis of a 'standardized test.'

The variables in a test affect the accuracy of the simulation. Actual values obtained by a particular driver and car are not tested in a standardized test.

(iii) If the two methods are conducted to represent each other, than these are concomitant methods. Even if not exact representations, information obtained in one can be used to get realistic estimates to be expected in the other. For example, a car that gets 10 mpg on the chassis dynamometer should not be expected to get 20 mpg on the road course.

## PROBLEM 1.40

### SOLUTION:

This is not an uncommon situation when siblings own similar model cars.

The drivers, the cars, and the routes driven are all extraneous variables in this direct comparison. Simply put, you and your brother may drive very differently. You both drive different cars. You likely drive over different routes, maybe very different types of driving routes. You might live in very different geographic locations (altitude, weather). The maintenance of the car would play a role, as well.

An arbitrator might suggest that the two of you swap cars for a few weeks to compare. If the consumption of each car remains the same under different drivers (and associated different routes, location, etc), then the car is the culprit. If not, then driver and other variables remain involved.

## PROBLEM 1.41

### SOLUTION:

The measure of 'diameter' represents an average or nominal value of the object. Differences along and around the rod affect the value of 'diameter.' Try this with a rod and a micrometer.

Measurements made at different positions along the rod show 'noise', that is data scatter, which is handled statistically (that is, we average the values to obtain a single diameter). Using just a single measurement introduces interference, since that one value may not be the same as the average value.

Tabulated values of material properties represent average or nominal values. These should not be confused as being exact values, regardless of the number of decimal places found in the tables (although the values can be assumed to be reasonably representative to within a decimal place). Properties of a material will vary with individual specimens – as such, differences between a nominal value and the actual specimen value will behave as an interference.

## PROBLEM 1.42

### SOLUTION

Independent variable:

Applied tensile load

Controlled variable:

Bridge excitation voltage

Dependent variable:

Bridge output voltage (which is related to gauge resistance changes due to the applied load)

Extraneous variables:

Specimen and ambient temperature will affect gauge resistance

A replication will involve resetting the control variable and specimen and duplicating the test.

## PROBLEM 1.43

### SOLUTION

To test repeatability, apply various tensile loads at random over the useful operating range of the system to build a data base. Be sure to operate within the elastic limit of the specimen. Direct comparison and data scatter about a curve fit will provide a measure of repeatability (specific methods to evaluate this are discussed in C4).

Reproducibility involves re-testing the system at a different facility or equivalent (such as different instruments and test fixtures). Think of this as a duplication. Even though a similar procedure and test matrix will be used to test for reproducibility, the duplication involves different individual instruments and test fixtures. Note that the reproducibility test is also a replication but with the different facility constraint added. The combined results allow for interference effects to be randomized.

Bottom Line: The results leading to a reproducibility specification are more representative of what can be expected by the end user (YOU!).

## PROBLEM 1.44

This problem is open-ended and does not have a unique solution. This forms a good opportunity for class discussion.

## PROBLEM 1.45

### SOLUTION

A car rolling down the hill whose speed is determined by two sensors separated by a distance  $s$ . Car speed could be determined as:  $\text{speed} = (\text{distance traveled})/(\text{elapsed time}) = s/(t_2 - t_1)$ . The following is a list of the minimum variables that are important in this test:

L: length of car

s: distance between measurements (distance traveled)

$\theta$ : angle of inclination

$(t_2 - t_1)$ : elapsed time

where

$t_1$ : instance car passes sensor 1

$t_2$ : instance car passes sensor 2

Intrinsic assumptions in this test that affect the accuracy of the result:

(1) the speed of the car is actually an average between the speed of the car as it passes sensor 1 and then as it passes sensor 2. The assumption is that any speed change is small in regards to the measured value. This assumption imposes a systematic error on the measured result.

(2) The length of the car could be a factor if it affects how the sensors are triggered. The car is assumed to be a point. This assumption may introduce a systematic error into the results.

As for a concomitant approach:

If we consider the gravitational pull as constant (reasonable over a sensible distance), then the car's acceleration is simply,  $a = g \sin \theta$ . So its acceleration is easily anticipated and the ideal velocity at any point along the path can be calculated directly from simple physics. The actual velocity will be the ideal velocity reduced by resistance effects, including frictional effects, such as between the car's wheels and the track and within the wheel axles, and aerodynamic effects. The actual velocity will be a bit smaller than the ideal velocity, a consequence of the systematic error in the assumptions. But what it does give us is a value of comparison for our measurement. If the measured value is markedly different, then we will know we have some problems in the test.

## PROBLEM 1.46

### SOLUTION

The power ( $P$ ) to move a car at any speed ( $U$ ) equals the aerodynamic drag ( $D$ ) plus mechanical drag ( $M$ ) times the speed plus the parasitic power ( $P_p$ ) required to turn the compressor and other mechanical components in the car: i.e.

$$P = (D+M)U + P_p$$

With the air conditioning (A/C) off, the parasitic power due to the compressor goes down but because the windows would then be rolled open, the aerodynamic drag goes up. The aerodynamic drag increases with speed while the compressor power remains fairly constant with speed.

To test this question, you might develop a test plan as follows:

Operate the car at several fixed, but well separated, speeds  $U_1, U_2, U_3$  in each of two configurations, A and B. Configuration A uses the compressor and all windows are rolled up closed. Configuration B turns the compressor off but driver window is rolled down (open). Obviously, there can be alternate configurations by rolling down differing windows, but the idea is the same.

A:  $U_1, U_2, U_3$

B:  $U_1, U_2, U_3$

Concomitant approach: An analytical approach to this problem would tradeoff the power required to operate the vehicle at different speeds under the two configurations based on some reasonable published or handbook values (for example, most modern full-sized sedans have a drag coefficient of about 0.33 based on a frontal area of about  $2.1 \text{ m}^2$  (these exact values are for a Toyota Camry) for windows closed, increasing to 0.36 with driver window open) and maybe about 3HP to run the compressor. But you might research these numbers.

## PROBLEM 1.49

This problem is open-ended and does not have a unique solution. Most of these codes can be found in a library with a quality engineering section or at the appropriate website for the professional group cited. The results from these searches form a good opportunity for class discussion.

## PROBLEM 1.50

### SOLUTION

Transform each relation into the linear form  $Y = a_1X + a_0$

(a) KNOWN:  $y = bx^m$

This function can be rearranged as

$$\log y = \log bx^m = \log b + m \log x$$

so if we let

$$Y = a_1 + a_0X$$

then

$$X = \log x ; Y = \log y ; a_0 = \log b ; a_1 = m$$

(b) KNOWN:  $y = be^{mx}$

identity:  $\ln x = 2.3 \log x$

This function can be rearranged as

$$\ln y = \ln b + \ln e^{mx} = \ln b + mx$$

so if we let

$$Y = a_1 + a_0X$$

then

$$X = x ; a_1 = m ; a_0 = \ln b ; Y = \ln y$$

(c) KNOWN:  $y = b + c\sqrt[m]{x}$

This function can be rearranged as

$$y - b = c\sqrt[m]{x}$$

or  $\log (y-b) = \log c + m \log x$

so if we let

$$Y = a_1 + a_0X$$

then

$$X = \log x ; a_1 = m ; a_0 = \log c ; Y = \log (y-b)$$

## PROBLEM 2.1

**FIND:** Define signal and provide examples of static and dynamic input signals to measurement systems.

**SOLUTION:** A signal is information in motion from one place to another, such as between stages of a measurement system. Signals have a variety of forms, including electrical and mechanical.

Examples of static signals are:

1. weight, such as weighing merchandise, etc.
2. body temperature, over the time period of interest
3. length or height, such as the length of a board or a person's height

Examples of dynamic signals:

1. input to an automobile speed control
2. input to a stereo amplifier from a component such as a CD player
3. output signal to a printer from a computer

## PROBLEM 2.2

**FIND:** List the important characteristics of signals and define each.

**SOLUTION:**

1. Magnitude - generally refers to the maximum value of a signal
2. Range - difference between maximum and minimum values of a signal
3. Amplitude - indicative of signal fluctuations relative to the mean
4. Frequency - describes the time variation of a signal
5. Dynamic - signal is time varying
6. Static - signal does not change over the time period of interest
7. Deterministic - signal can be described by an equation  
(other than a Fourier series or integral approximation)
8. Non-deterministic - describes a signal which has no discernible pattern of repetition and cannot be described by a simple equation.

**COMMENT:** A random signal, or stochastic noise, represents a truly non-deterministic signal. However, chaotic systems produce signals that appear random, but are truly deterministic. An example would be the velocity in a turbulent fluid flow, that may appear random, but is actually governed by the Navier-Stokes equations.

### PROBLEM 2.3

KNOWN:

$$y(t) = 30 + 2 \cos 6\pi t$$

FIND:  $\bar{y}$  and  $y_{rms}$  for the time periods  $t_1$  to  $t_2$  listed below

- a) 0 to 0.1 s
- b) 0.4 to 0.5 s
- c) 0 to 1/3 s
- d) 0 to 20 s

SOLUTION:

For the function  $y(t)$

$$\bar{y} = \frac{1}{t_2 - t_1} \int_{t_1}^{t_2} y(t) dt$$

and

$$y_{rms} = \sqrt{\frac{1}{t_2 - t_1} \int_{t_1}^{t_2} [y(t)]^2 dt}$$

Thus in general,

$$\begin{aligned} \bar{y} &= \frac{1}{t_2 - t_1} \int_{t_1}^{t_2} (30 + 2 \cos 6\pi t) dt \\ &= \frac{1}{t_2 - t_1} \left[ 30t + \frac{2}{6\pi} \sin 6\pi t \right]_{t_1}^{t_2} \\ &= \frac{1}{t_2 - t_1} \left[ 30(t_2 - t_1) + \frac{2}{6\pi} (\sin 6\pi t_2 - \sin 6\pi t_1) \right] \end{aligned}$$

and

$$\begin{aligned} y_{rms} &= \left\{ \frac{1}{t_2 - t_1} \int_{t_1}^{t_2} (30 + 2 \cos 6\pi t)^2 dt \right\}^{1/2} \\ &= \left\{ \frac{1}{t_2 - t_1} \left[ 900t + \frac{120}{6\pi} \sin 6\pi t + 4 \left( \frac{1}{12\pi} \sin 6\pi t \cos 6\pi t + \frac{1}{2} t \right) \right]_{t_1}^{t_2} \right\}^{1/2} \end{aligned}$$

The resulting values are

$$\text{a) } \bar{y} = 31.01 \quad y_{rms} = 31.02$$

$$\text{b) } \bar{y} = 28.99 \quad y_{rms} = 29.00$$

$$\text{c) } \bar{y} = 30 \quad y_{rms} = 30.03$$

$$\text{d) } \bar{y} = 30 \quad y_{rms} = 30.03$$

**COMMENT:** The average and rms values for the time period 0 to 20 seconds represents the long-term average behavior of the signal. The values which result in parts a) and b) are accurate over the specified time periods, and for a measured signal may have specific significance. If we examined the period 0 to  $1/3$ , it would represent one complete cycle of the simple periodic signal and results in average and rms values which accurately represent the long-term behavior of the signal.

## PROBLEM 2.4

**KNOWN:** Discrete sampled data, corresponding to measurement every 0.4 seconds.

**FIND:** The mean and rms values of the measured data.

**SOLUTION:**

The mean value for  $y_1$  is 0 and for  $y_2$  is also 0.

However, the rms value of  $y_1$  is 13.49 and for  $y_2$  is 17.53.

**COMMENT:** The mean value contains no information concerning the time varying nature of a signal; both these signals have an average value of 0. But the differences in the signals are made apparent when the rms value is examined.

## PROBLEM 2.5

**KNOWN:** The effect of a moving average signal processing technique is to be determined for the signal in Figure 2.21 and  $y(t) = \sin 5t + \cos 11t$

**FIND:** Discuss Figure 2.22 and plot the signal resulting from applying a moving average to  $y(t)$ .

**ASSUMPTIONS:** The signal  $y(t)$  may be represented by making a discrete representation with  $\delta t = 0.05$ .

**SOLUTION:**

- The signal in Figure 2.22 clearly has a reduced level of high frequency content. In essence, this emphasizes longer term variations, while removing short-term fluctuations. It is clear that the peak-to-peak value in the original signal is significantly higher than in the signal that has been averaged.
- The figures below show in the effect of applying a moving average to  $y(t)$ .

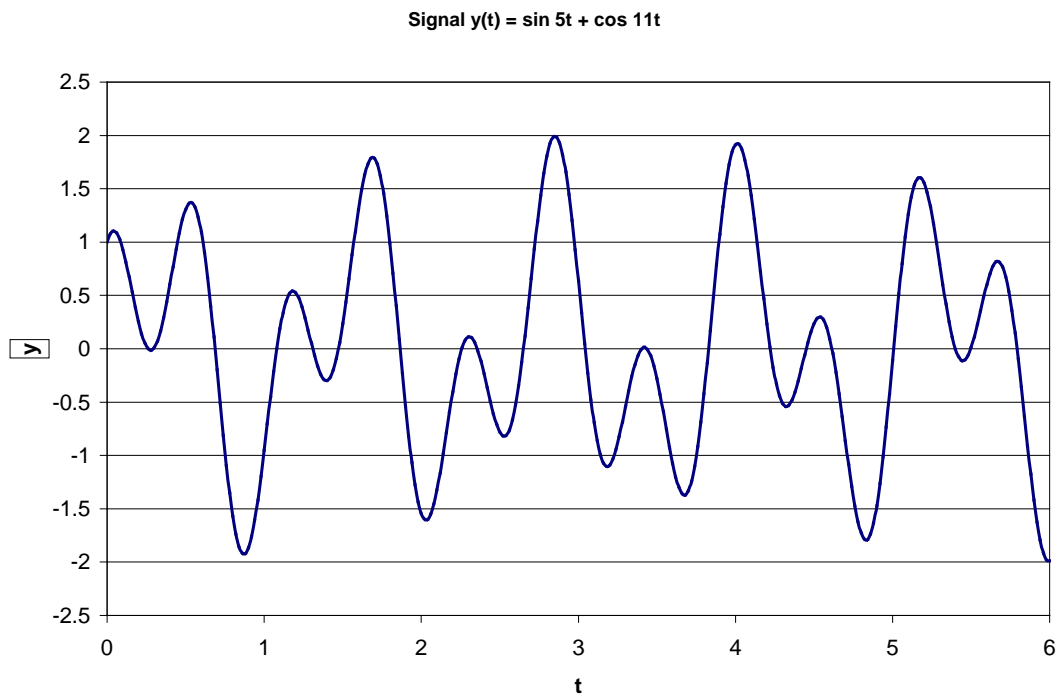

Four Point Moving Average

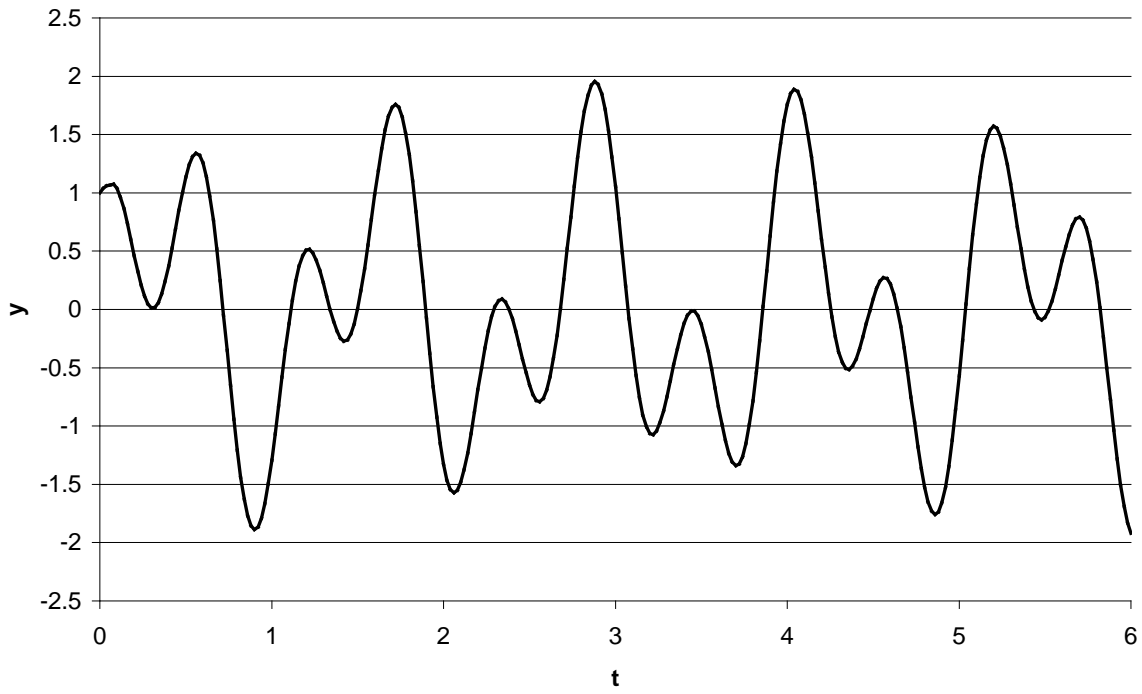

30 point moving average

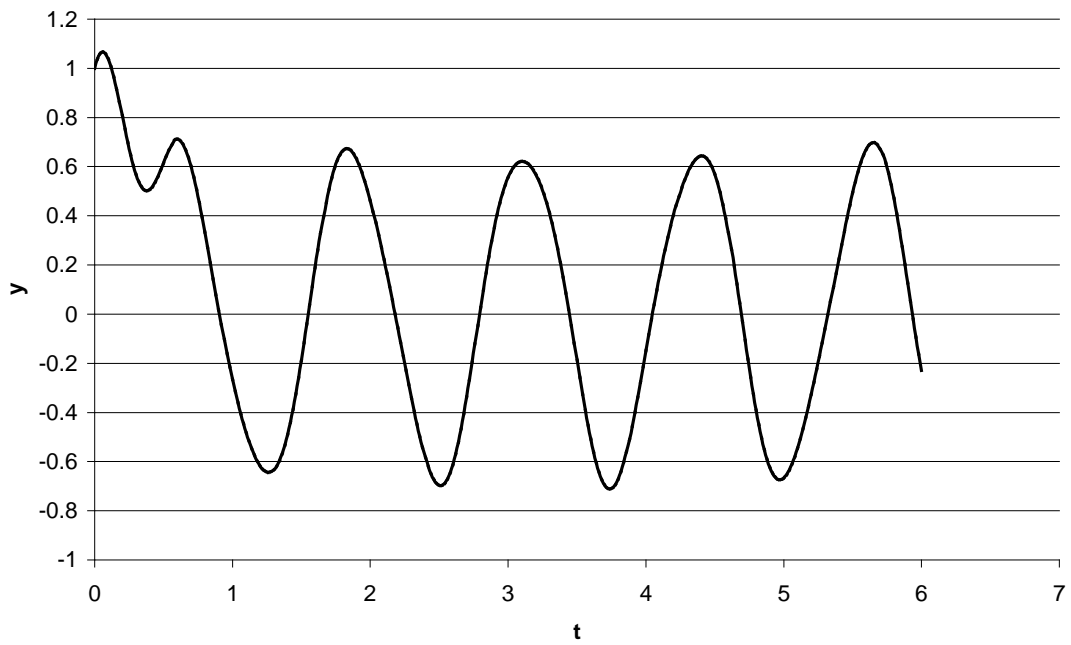

## PROBLEM 2.6

KNOWN: A spring-mass system, with

$$m = 0.5 \text{ kg}$$
$$T = 2.7 \text{ s}$$

FIND: Spring constant,  $k$ , and natural frequency  $\omega$

SOLUTION:

Since

$$\omega = \sqrt{\frac{k}{m}}$$

(as shown in association with equation 2.7)

and

$$T = \frac{2\pi}{\omega} = \frac{1}{f} = 2.7 \text{ s}$$
$$\omega = 2.33 \text{ rad/s}$$

The natural frequency is then found as  $\omega = 2.33 \text{ rad/s}$

And

$$\omega = 2.33 = \sqrt{\frac{k}{0.5 \text{ kg}}}$$
$$k = 2.71 \text{ N/m (kg/sec}^2\text{)}$$

## PROBLEM 2.7

KNOWN: A spring-mass system having

$$\begin{aligned}m &= 1 \text{ kg} \\k &= 5000 \text{ N/cm}\end{aligned}$$

FIND: The natural frequency in rad/sec ( $\omega$ ) and Hz ( $f$ ).

SOLUTION:

The natural frequency may be determined,

$$\omega = \sqrt{\frac{k}{m}} = \sqrt{\frac{5000 \frac{\text{N}}{\text{cm}} 100 \frac{\text{cm}}{\text{m}}}{1 \text{ kg}}} = 707.1 \text{ rad / s}$$

and

$$f = \frac{\omega}{2\pi} = 112.5 \text{ Hz}$$

## PROBLEM 2.8

KNOWN: Functions:

a)  $\sin \frac{2\pi t}{5}$

b)  $5 \cos 20t$

c)  $\sin 3n\pi t$  for  $n = 1$  to  $\infty$

FIND: The period, frequency in Hz, and circular frequency in rad/s.

SOLUTION:

a)  $\omega = 2\pi/5$  rad/s

$f = 0.2$  Hz

$T = 5$  s

b)  $\omega = 20$  rad/s

$f = 3.18$  Hz

$T = 0.31$  s

c)  $\omega = 3n\pi$  rad/s

$f = 3n/2$  Hz

$T = 2/(3n)$  s

## PROBLEM 2.9

**KNOWN:**  $y(t) = 5 \sin 4t + 3 \cos 4t$

**FIND:** Equivalent expression containing a cosine term only

**SOLUTION:** From Equations 2.10 and 2.11

$$y = C \cos(\omega t - \phi) \quad \phi = \tan^{-1} \frac{B}{A}$$

and with

$$A \cos \omega t + B \sin \omega t = \sqrt{A^2 + B^2} \cos(\omega t - \phi)$$

we find

$$C = \sqrt{A^2 + B^2} = \sqrt{5^2 + 3^2} = 5.83$$

$$\phi = \tan^{-1} \frac{5}{3} = 1.03 \text{ rad}$$

and

$$y(t) = 5.83 \cos(4t - 1.03)$$

## PROBLEM 2.10

KNOWN:  $y(t) = 4\sin 2\pi t + 15\cos 2\pi t$

FIND:

- a) Equivalent expression containing a cosine term only
- b) Equivalent expression containing a sine term only

SOLUTION: From Equations 2.10 and 2.11

$$y = C \cos(\omega t - \phi) \quad \phi = \tan^{-1} \frac{B}{A}$$

$$y = C \sin(\omega t + \phi^*) \quad \phi^* = \tan^{-1} \frac{A}{B}$$

and with

$$A \cos \omega t + B \sin \omega t = \sqrt{A^2 + B^2} \cos(\omega t - \phi)$$

$$A \cos \omega t + B \sin \omega t = \sqrt{A^2 + B^2} \sin(\omega t + \phi^*)$$

we find

$$C = \sqrt{A^2 + B^2} = \sqrt{15^2 + 4^2} = 15.52$$

$$\phi = \tan^{-1} \frac{4}{15} = 0.26 \text{ rad}$$

$$\phi^* = \tan^{-1} \frac{15}{4} = 1.31 \text{ rad}$$

and

$$y = 15.52 \cos(2\pi t - 0.26) \quad \text{Answer (a)}$$

$$y = 15.52 \sin(2\pi t + 1.31) \quad \text{Answer (b)}$$

## PROBLEM 2.11

KNOWN:  $y(t) = \sum_{n=1}^{\infty} \frac{2\pi n}{6} \sin n\pi t + \frac{4\pi n}{6} \cos n\pi t$

FIND:

a) Equivalent expression containing a cosine term only

SOLUTION: From Equation 2.19

$$y = \sum_{n=1}^{\infty} C_n \cos(\omega t - \phi_n) \quad \phi_n = \tan^{-1} \frac{B_n}{A_n}$$

with

$$C_n = \sqrt{A_n^2 + B_n^2}$$

and with

$$C_n = \sqrt{\left(\frac{2\pi n}{6}\right)^2 + \left(\frac{4\pi n}{6}\right)^2} = \sqrt{\frac{5}{9}}\pi n \quad \text{and} \quad \phi_n = \tan^{-1} \frac{\left(\frac{2\pi n}{6}\right)}{\left(\frac{4\pi n}{6}\right)} = \tan^{-1} 0.5 = 0.46 \text{ rad}$$

we find

$$y(t) = \sum_{n=1}^{\infty} \sqrt{\frac{5}{9}}\pi n \cos(n\pi t - 0.46)$$

## PROBLEM 2.12

**KNOWN:**  $T$  is a period of  $y(x)$

**FIND:** Show that  $nT$  for  $n=2,3,\dots$  is a period of  $y(x)$

**SOLUTION:** Since  $T$  is a period of  $y(x)$

$$y(x + T) = y(x)$$

Letting  $x_1 = x + T$  yields

$$y(x_1) = y(x) = y(x + T)$$

But since  $T$  is a period of  $y(x)$

$$y(x + 2T) = y(x_1 + T) = y(x)$$

By analogy then

$$y(x + nT) = y(x)$$

## PROBLEM 2.13

KNOWN:

$$y(t) = \sum_{n=1}^{\infty} \frac{3n}{2} \sin nt + \frac{5n}{3} \cos nt$$

FIND:      a) fundamental frequency and period  
              b) cosine series

SOLUTION:

a) The fundamental frequency corresponds to  $n = 1$ , so  $\omega = 1$  rad/s;  $T = 2\pi$

b) From equation 2.19

$$y(t) = A_o + \sum_{n=1}^{\infty} C_n \cos\left(\frac{2n\pi t}{T} - \phi_n\right)$$
$$C_n = \sqrt{A_n^2 + B_n^2} \quad \tan \phi_n = \frac{B_n}{A_n}$$

For this Fourier series

$$C_n = \sqrt{\left(\frac{3n}{2}\right)^2 + \left(\frac{5n}{3}\right)^2} = \sqrt{\frac{181}{36}} n$$
$$\phi_n = \tan^{-1}\left(\frac{9}{10}\right) \Rightarrow \phi = 0.7328$$

Thus the series may be written

$$y(t) = \sum_{n=1}^{\infty} \sqrt{\frac{181}{36}} n \cos(nt - 0.7328)$$

## PROBLEM 2.14

KNOWN:

$$y(t) = 4 + \sum_{n=1}^{\infty} \frac{2n\pi}{10} \cos \frac{n\pi}{4} t + \frac{120n\pi}{30} \sin \frac{n\pi}{4} t$$

FIND:

a)  $\omega_1$  and  $f_1$

b)  $T_1$

c)  $y(t) = A_o + \sum_{n=1}^{\infty} C_n \sin \left( \frac{2n\pi t}{T} + \phi^* \right)$

SOLUTION:

a) When  $n = 1$ ,  $\omega_1 = \pi/4$ ,  $f_1 = 1/8$

b)  $T_1 = 8$  sec

c) From Eq. (2.21)

$$C_n = \sqrt{A_n^2 + B_n^2} \quad \text{and} \quad \tan \phi^* = \frac{A_n}{B_n}$$

$$C_n = \sqrt{\left(\frac{2n\pi}{10}\right)^2 + \left(\frac{120n\pi}{30}\right)^2} = 4n\pi$$

$$\phi_n^* = \tan^{-1} \frac{(2n\pi/10)}{(120n\pi/30)} = \tan^{-1} \left( \frac{1}{20} \right) = 0.05 \text{ rad}$$

and the Fourier sine series

$$y(t) = 4 + \sum_{n=1}^{\infty} 4n\pi \sin \left( \frac{n\pi t}{4} + 0.05 \right)$$

## PROBLEM 2.15

KNOWN:

$$y(t) = 0 \text{ for } -\pi \leq t \leq 0$$

$$y(t) = -1 \text{ for } 0 \leq t \leq \pi/2$$

$$y(t) = 1 \text{ for } \pi/2 \leq t \leq \pi$$

FIND: Fourier series for  $y(t)$

SOLUTION: Since the function is neither even nor odd, the Fourier series will contain both sine and cosine terms. The coefficients are found as

$$\begin{aligned} A_o &= \frac{1}{T} \int_{-T/2}^{T/2} y(t) dt = \frac{1}{2\pi} \int_{-\pi}^{\pi} y(t) dt \\ &= \frac{1}{2\pi} \left[ \int_{-\pi}^0 0 dt + \int_0^{\pi/2} -1 dt + \int_{\pi/2}^{\pi} 1 dt \right] \\ &= \frac{1}{2\pi} \left[ \left( -\pi/2 - 0 \right) + \left( \pi - \pi/2 \right) \right] = 0 \quad \therefore A_o = 0 \end{aligned}$$

Note: Since the contribution from  $-\pi$  to 0 is identically zero, it will be omitted.

$$\begin{aligned} A_n &= \frac{2}{2\pi} \left[ \int_0^{\pi/2} -1 \cos \frac{2n\pi t}{T} + \int_{\pi/2}^{\pi} 1 \cos \frac{2n\pi t}{T} \right] dt \\ &= \frac{1}{\pi} \left\{ \left[ \frac{-1}{n} \sin nt \right]_0^{\pi/2} + \left[ \frac{1}{n} \sin nt \right]_{\pi/2}^{\pi} \right\} \\ &= \frac{-1}{\pi n} 2 \sin \left( \frac{n\pi}{2} \right) \end{aligned}$$

$$\begin{aligned} B_n &= \frac{2}{2\pi} \left[ \int_0^{\pi/2} -1 \sin \frac{2\pi nt}{T} dt + \int_{\pi/2}^{\pi} 1 \sin \frac{2\pi nt}{T} dt \right] \\ &= \frac{1}{n\pi} \left\{ \left[ \cos nt \right]_0^{\pi/2} + \left[ -\cos nt \right]_{\pi/2}^{\pi} \right\} = \frac{1}{n\pi} \left[ -\cos(0) - \cos(n\pi) \right] \end{aligned}$$

Noting that  $A_n$  is zero for  $n$  even, and  $B_n$  is zero for  $n$  odd, the resulting Fourier series is

$$y(t) = \frac{2}{\pi} \left[ -\cos t - \frac{1}{2} \sin 2t + \frac{1}{3} \cos 3t - \frac{1}{4} \sin 4t - \frac{1}{5} \cos 5t - \frac{1}{6} \sin 6t + \frac{1}{7} \cos 7t - \dots \right]$$

## Problem 2.15

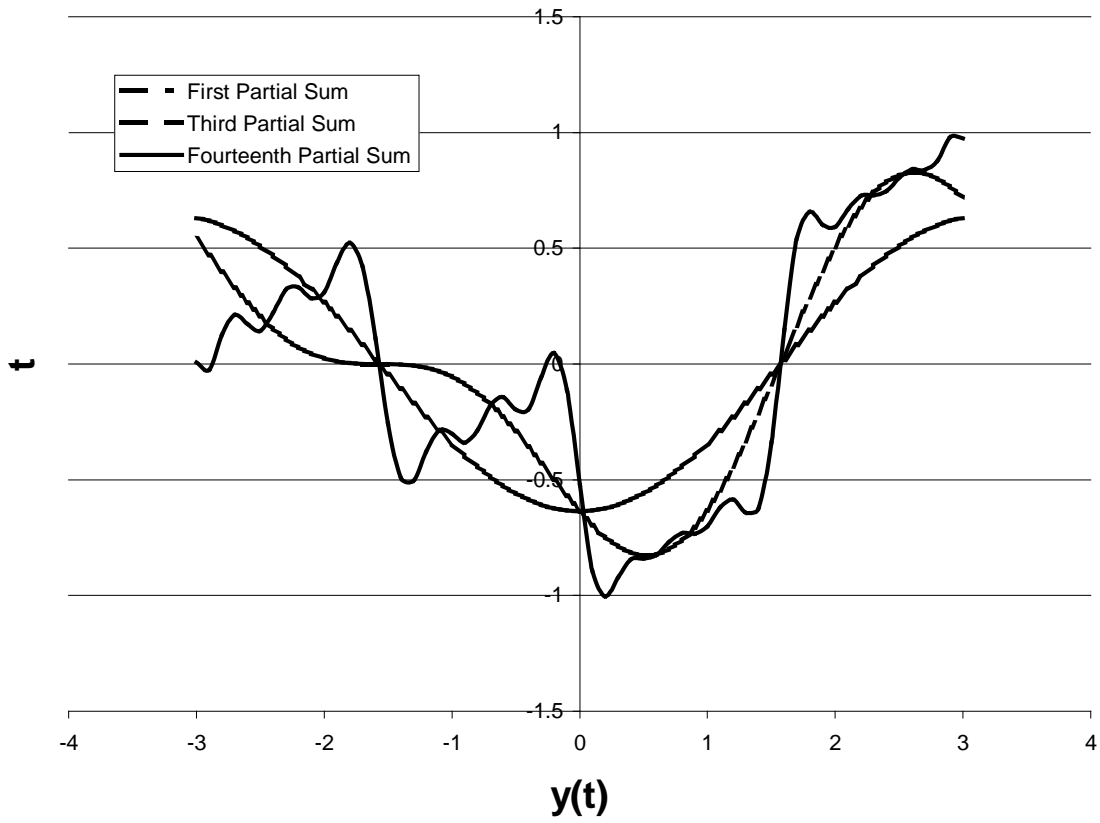



$$B_n = \frac{2}{10} \left[ \left( \frac{5}{n\pi} \right)^2 \sin \frac{2n\pi t}{10} - \frac{10t}{2n\pi} \cos \frac{2n\pi t}{10} \right]_{-5}^5$$

$$= \frac{2}{10} \left[ \left( \frac{5}{n\pi} \right)^2 \{ \sin(n\pi) - \sin(-n\pi) \} - \left( \frac{50}{2n\pi} \right) \{ \cos(n\pi) + \cos(-n\pi) \} \right]$$

for n even  $B_n = \frac{-10}{n\pi}$

for n odd  $B_n = \frac{10}{n\pi}$

The resulting Fourier series is

$$y(t) = \frac{10}{\pi} \sin \frac{2\pi t}{10} - \frac{10}{2\pi} \sin \frac{4\pi t}{10} + \frac{10}{3\pi} \sin \frac{6\pi t}{10} - \frac{10}{4\pi} \sin \frac{8\pi t}{10} + \dots$$

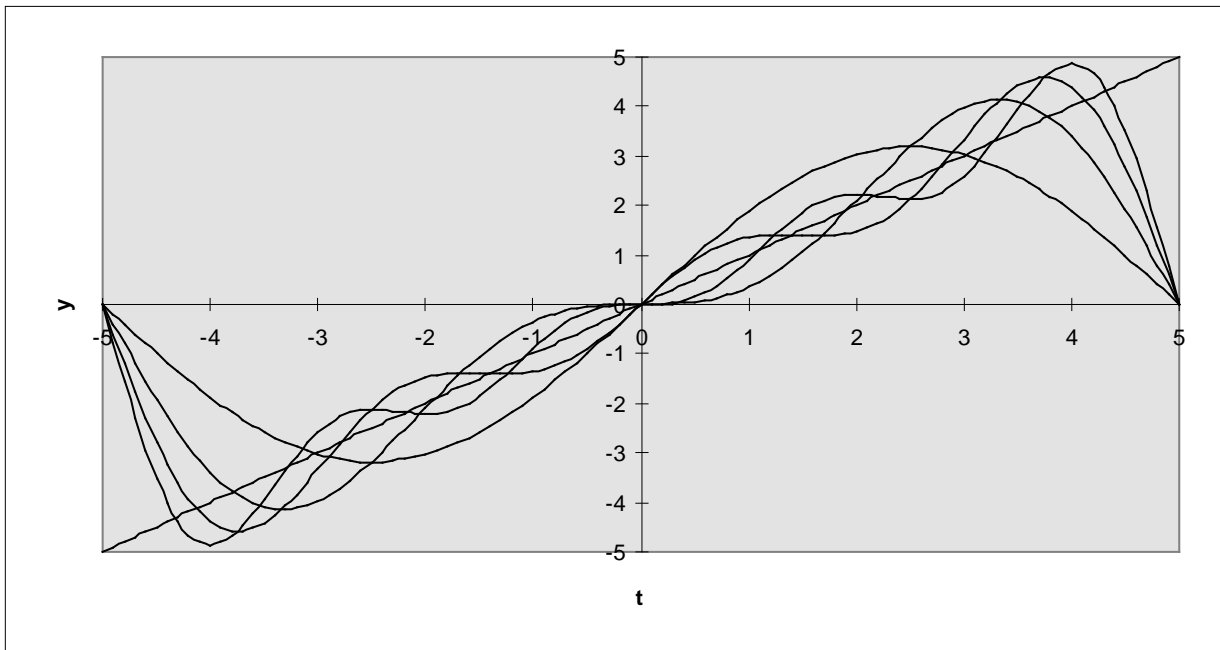

## PROBLEM 2.17

**KNOWN:**  $y(t) = t^2$  for  $-\pi \leq t \leq \pi$ ;  $y(t + 2\pi) = y(t)$

**FIND:** Fourier series for the function  $y(t)$ .

**SOLUTION:**

Since the function  $y(t)$  is an even function, the Fourier series will contain only cosine terms,

$$y(t) = A_0 + \sum_{n=1}^{\infty} A_n \cos \frac{2n\pi t}{T} = A_0 + \sum_{n=1}^{\infty} A_n \cos n\omega t$$

The coefficients are found as

$$A_0 = \frac{1}{T} \int_{-T/2}^{T/2} y(t) dt = \frac{1}{2\pi} \int_{-\pi}^{\pi} t^2 dt = \frac{\pi^2}{3}$$

$$A_n = \frac{1}{\pi} \int_{-\pi}^{\pi} t^2 \cos \frac{2n\pi t}{2\pi} dt$$

$$\begin{aligned} &= \frac{1}{\pi} \left[ \frac{2t \cos nt}{n^2} + \frac{n^2 t^2 - 2}{n^3} \sin nt \right]_{-\pi}^{\pi} \\ &= \frac{1}{\pi} \left[ \frac{2\pi}{n^2} \cos(n\pi) + \frac{2\pi}{n^2} \cos(-n\pi) \right] \end{aligned}$$

for  $n$  even  $A_n = 4/n^2$  for  $n$  odd  $A_n = -4/n^2$  and the resulting Fourier series is

$$y(t) = \frac{\pi^2}{3} - 4 \left[ \cos t - \frac{1}{4} \cos 2t + \frac{1}{9} \cos 3t - + \dots \right]$$

a series approximation for  $\pi$  is

$$y(\pi) = \pi^2 = \frac{\pi^2}{3} - 4 \left[ \cos \pi - \frac{1}{4} \cos 2\pi + \frac{1}{9} \cos 3\pi - + \dots \right]$$

$$\text{or } \frac{\pi^2}{6} = 1 + \frac{1}{4} + \frac{1}{9} + \frac{1}{16} + \dots$$

## PROBLEM 2.18

KNOWN:

$$y(t) = \begin{cases} t & \text{for } 0 < t < 1 \\ 2 - t & \text{for } 1 < t < 2 \end{cases}$$

FIND: Fourier series representation of  $y(t)$

ASSUMPTION: Utilize an odd periodic extension of  $y(t)$

SOLUTION:

The function is extended as shown below with a period of 4.

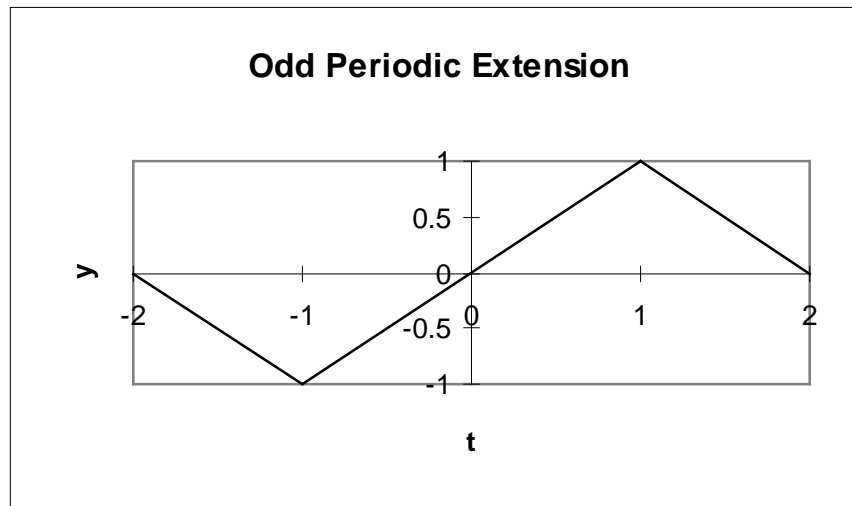

The Fourier series for an odd function contains only sine terms and can be written

$$y(t) = \sum_{n=1}^{\infty} B_n \sin \frac{2n\pi t}{T} = \sum_{n=1}^{\infty} B_n \sin n\omega t$$

where

$$B_n = \int_{-T/2}^{T/2} y(t) \sin \frac{2n\pi t}{T} dt$$

For the odd periodic extension of the function  $y(t)$  shown above, this integral can be expressed as the sum of three integrals

$$B_n = \int_{-2}^{-1} -(2+t) \sin \frac{2n\pi t}{4} dt + \int_{-1}^1 t \sin \frac{2n\pi t}{4} dt + \int_1^2 (2-t) \sin \frac{2n\pi t}{4} dt$$

These integrals can be evaluated and simplified to yield the following expression for  $B_n$

$$B_n = 4 \frac{-\sin(n\pi) + 2 \sin\left(\frac{n\pi}{2}\right)}{n^2 \pi^2}$$

Since  $\sin(n\pi)$  is identically zero, and  $\sin(n\pi/2)$  is zero for  $n$  even, the Fourier series can be written

$$y(t) = \frac{8}{\pi^2} \left[ \sin \frac{\pi t}{2} - \frac{1}{9} \sin \frac{3\pi t}{2} + \frac{1}{25} \sin \frac{5\pi t}{2} - \frac{1}{49} \sin \frac{7\pi t}{2} + \dots \right]$$

The first four partial sums of this series are shown below

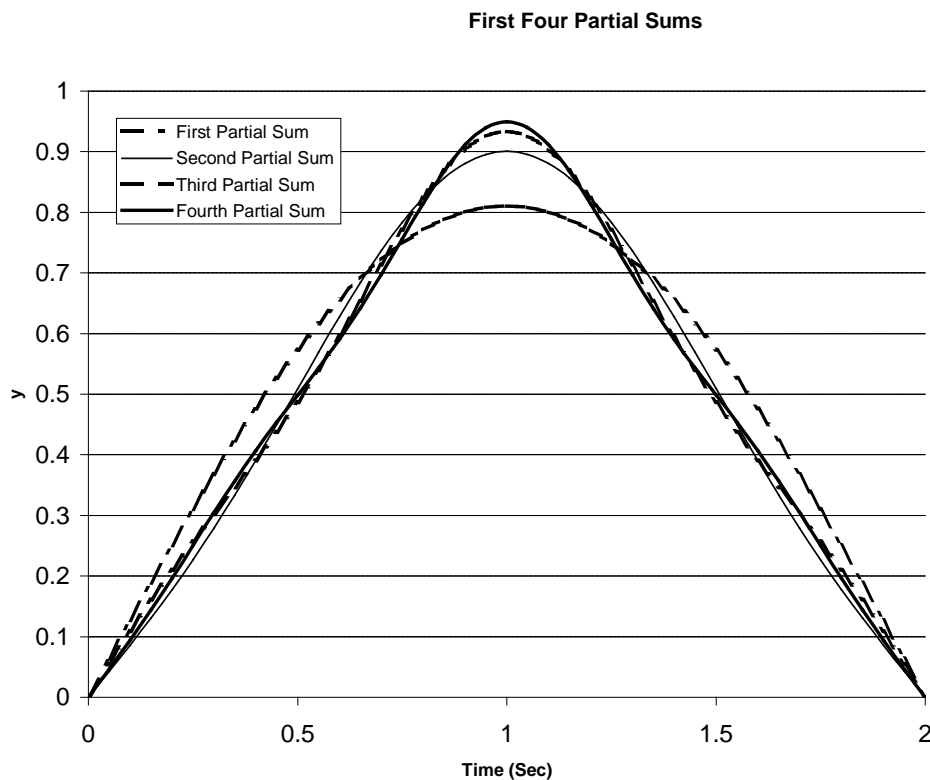

## PROBLEM 2.19

KNOWN:

- a)  $\sin 10t$  V
- b)  $5 + 2 \cos 2t$  m
- c)  $5t$  s
- d)  $2$  V

FIND: Classification of signals

SOLUTION:

- a) Dynamic, deterministic, simple periodic waveform
- b) Dynamic, deterministic periodic with a zero offset
- c) Dynamic, deterministic, unbounded as  $t \rightarrow \infty$
- d) Static, deterministic

## PROBLEM 2.20

KNOWN: At time zero ( $t = 0$ )

$$x = 0$$

$$\frac{dx}{dt} = 5 \text{ cm/s} \quad f = 1 \text{ Hz}$$

FIND:

- a) period,  $T$
- b) amplitude,  $A$
- c) displacement as a function of time,  $x(t)$
- d) maximum speed

SOLUTION:

The position of the particle as a function of time may be expressed

$$x(t) = A \sin 2\pi t$$

so that

$$\frac{dx}{dt} = 2A\pi \cos 2\pi t$$

Thus, at  $t = 0$   $\frac{dx}{dt} = 5$

From these expressions we find

- a)  $T = 1$  s
- b) amplitude,  $A = 5/2\pi$
- c)  $x(t) = A \sin 2\pi t$
- d) maximum speed = 5 cm/s

## PROBLEM 2.21

### KNOWN:

- a) Frequency content
- b) Amplitude
- c) Magnitude
- d) Period

### FIND:

Define the terms listed above

### SOLUTION:

- a) Frequency content - for a complex periodic waveform, refers to the relative amplitude of the terms which comprise the Fourier series for the signal, or the result of a Fourier transform.
- b) Amplitude - the range of variation of a particular frequency component in a complex periodic waveform
- c) Magnitude - the value of a signal, which may be a function of time
- d) Period - the time for a signal to repeat, or the time associated with a particular frequency component in a complex periodic waveform.

## PROBLEM 2.22

KNOWN:

Fourier series for the function  $y(t) = t$  in Problem 2.16

$$y(t) = \frac{10}{\pi} \sin \frac{2\pi t}{10} - \frac{10}{2\pi} \sin \frac{4\pi t}{10} + \frac{10}{3\pi} \sin \frac{6\pi t}{10} - \frac{10}{4\pi} \sin \frac{8\pi t}{10} + \dots$$

FIND:

Construct an amplitude spectrum plot for this series.

SOLUTION:

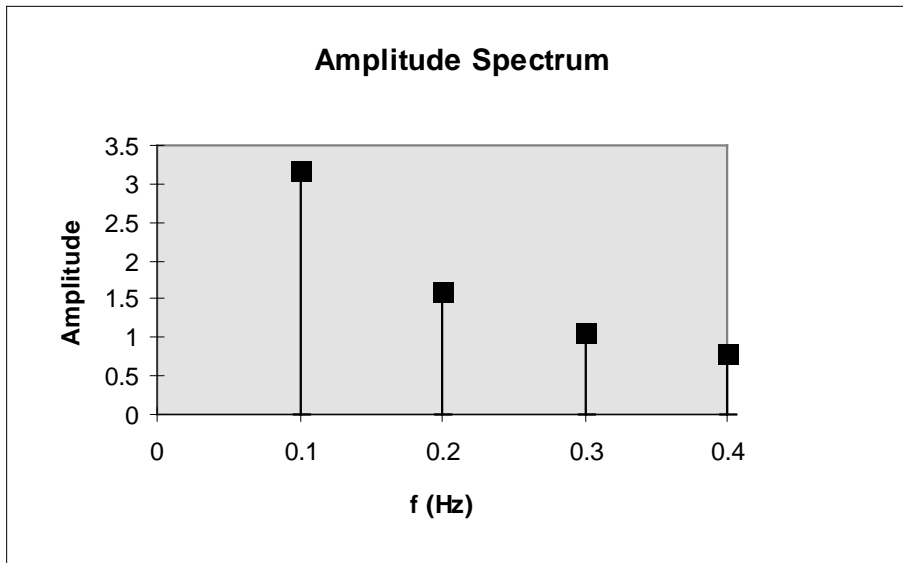

## PROBLEM 2.23

**KNOWN:** Fourier series for the function  $y(t) = t^2$  in Problem 2.17

$$y(t) = \frac{\pi^2}{3} - 4 \left( \cos t - \frac{1}{4} \cos 2t + \frac{1}{9} \cos 3t - + \dots \right)$$

**FIND:**

Construct an amplitude spectrum plot for this series.

**SOLUTION:**

The corresponding frequency spectrum is shown below

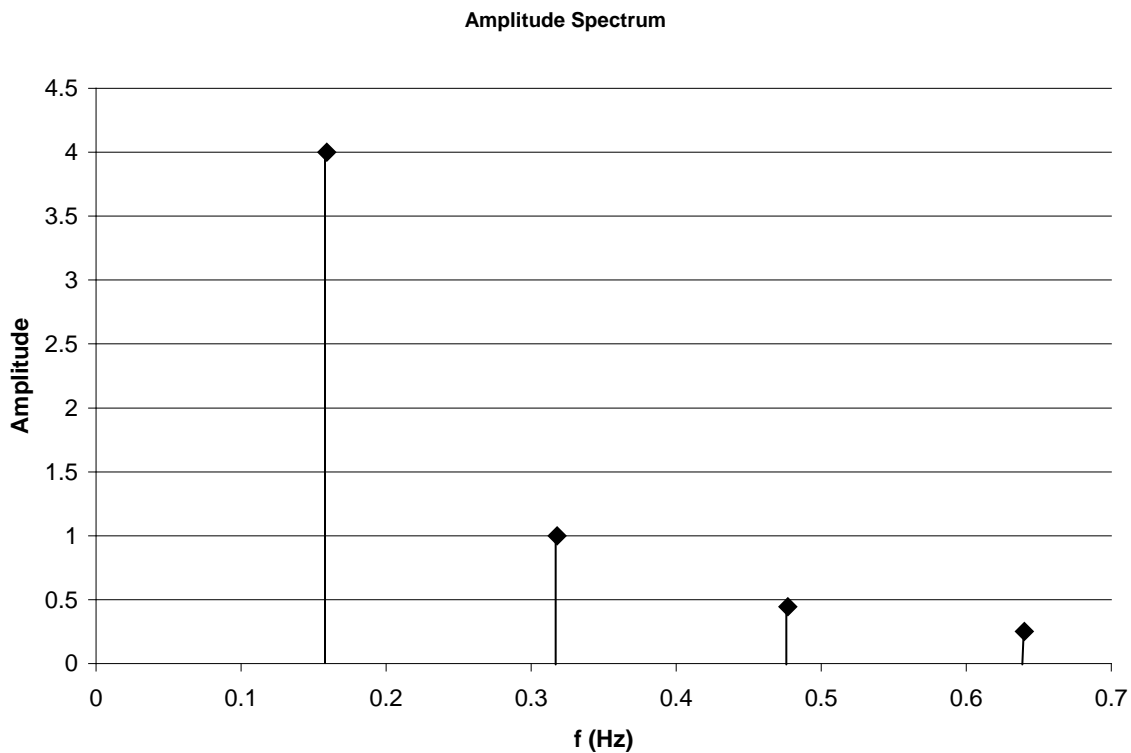

**COMMENT:** The relative importance of the various terms in the Fourier series as discerned from the amplitude of each term would aid in specifying the required frequency response for a measurement system. For example, the term  $\cos 4x$  has an amplitude of  $1/16$ , which for many purposes may not influence a measurement, and would allow a measurement system to be selected to measure frequencies up to 0.6 Hz.

## PROBLEM 2.24

KNOWN: Signal sources:

- a) thermostat on a refrigerator
- b) input to a spark plug
- c) input to a cruise control
- d) a pure musical tone
- e) note produced by a guitar string
- f) AM and FM radio signals

FIND: Sketch representative signal waveforms.

SOLUTION:

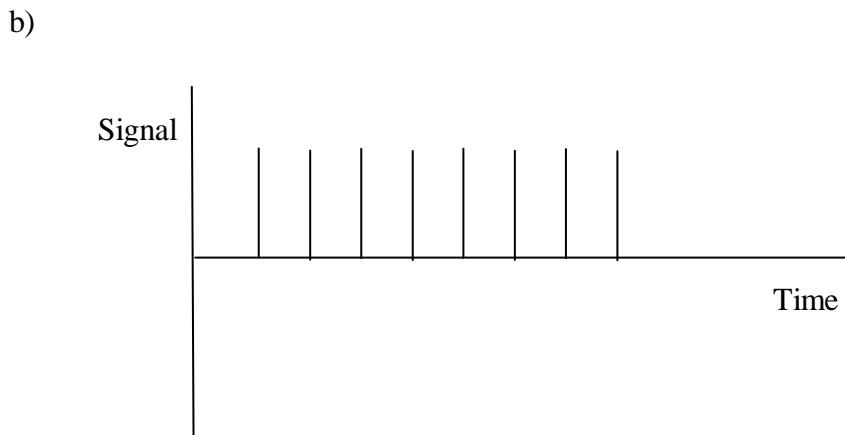
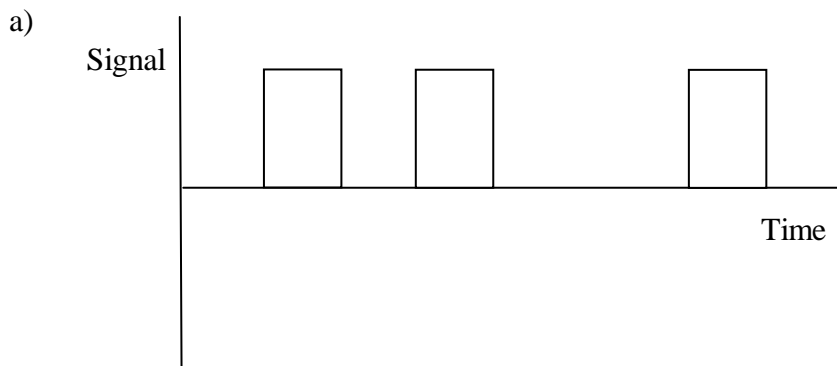

c)

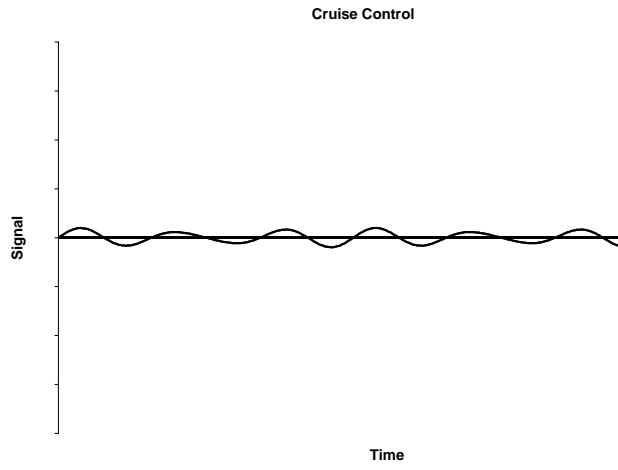

d)

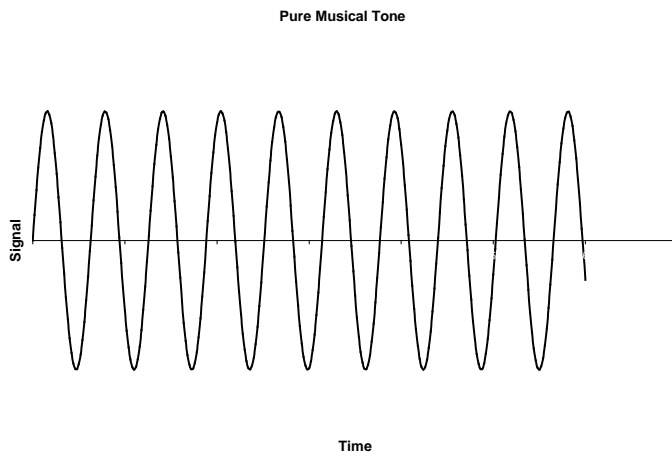

e)

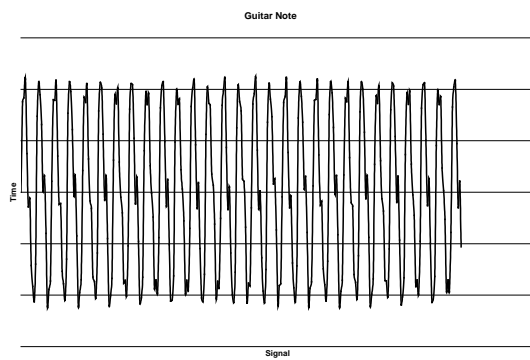

f)

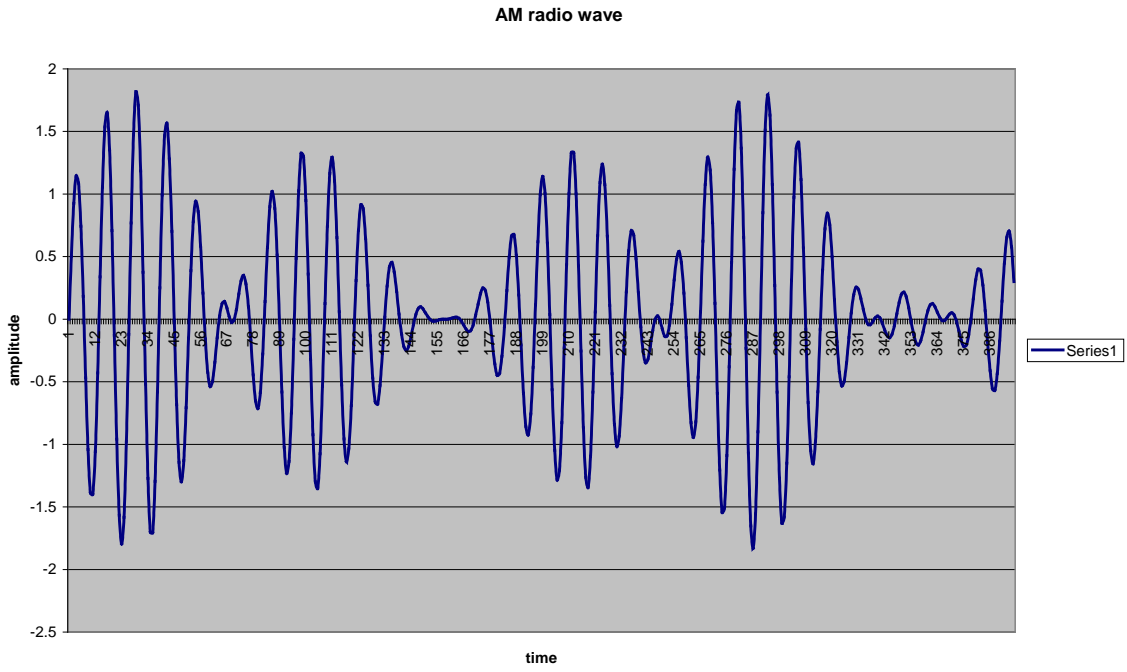

FM Radio Wave

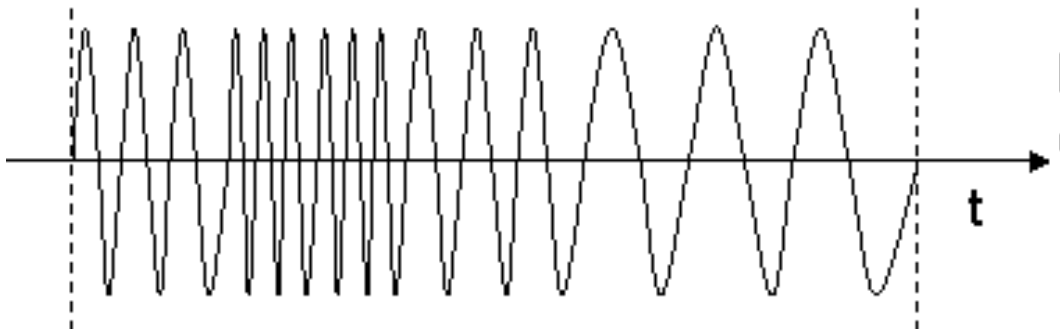

## PROBLEM 2.25

**KNOWN:**  $e(t) = 5 \sin 31.4t + 2 \sin 44t$  Volts

**FIND:**  $e(t)$  as a discrete-time series of  $N = 128$  numbers separated by a time increment of  $\delta t$ . Find the amplitude-frequency spectrum.

**SOLUTION:**

With  $N = 128$  and  $\delta t = 1/N$ , the discrete-time series will represent a total time (or series length) of  $N \delta t = 1$  sec. The signal to be represented contains two fundamental frequencies,

$$f_1 = 31.4/2\pi = 5 \text{ Hz} \quad \text{and} \quad f_2 = 44/2\pi = 7 \text{ Hz}$$

We see that the total time length of the series will represent more than one period of the signal  $e(t)$  and, in fact, will represent 5 periods of the  $f_1$  component and 7 periods of the  $f_2$  component of this signal. This is important because if we represent the signal by a discrete-time series that has an exact integer number of the periods of the fundamental frequencies, then the discrete Fourier series will be exact.

Any DFT or FFT program can be used to solve this problem. Using the companion software disk, issues associated with sampling continuous signals to create discrete-time series. The time series and the amplitude spectrum are plotted below.

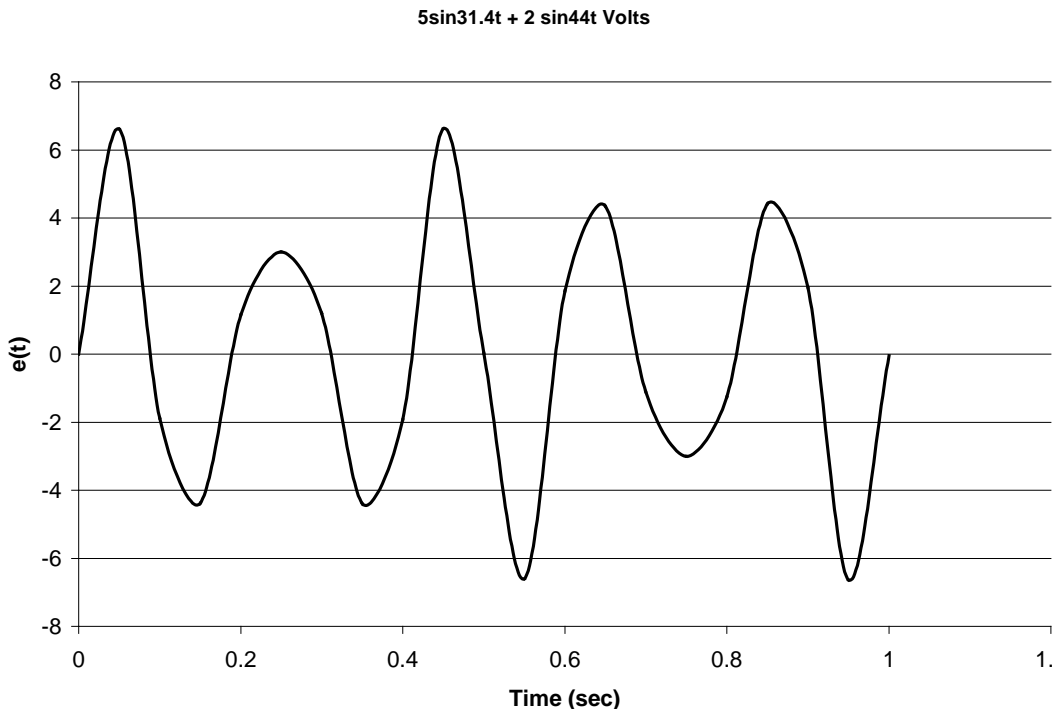

### Amplitude Spectrum

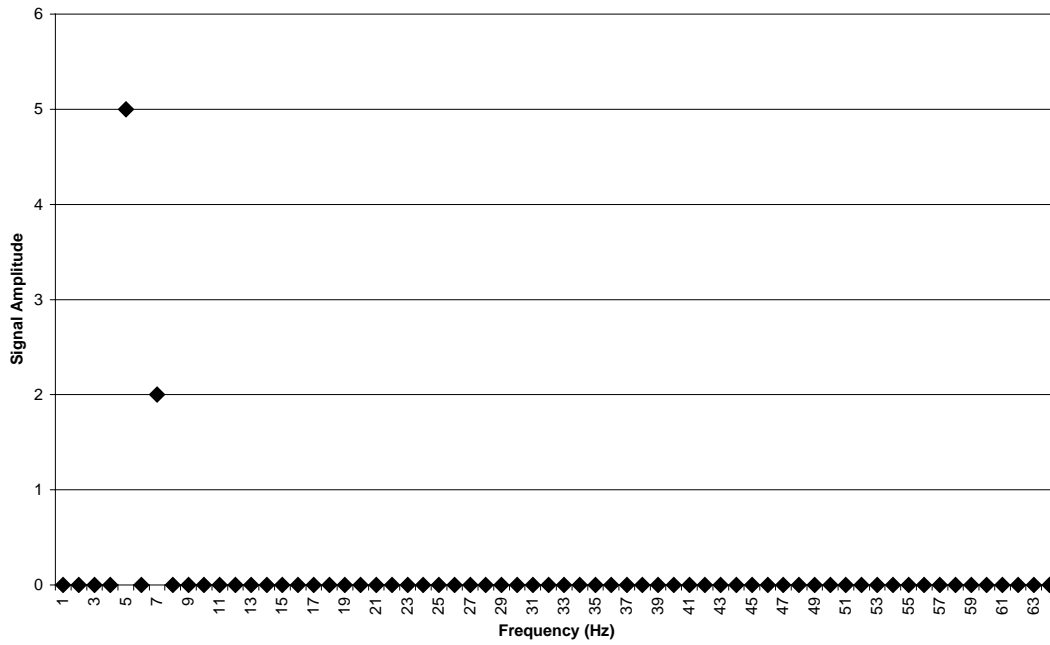

## PROBLEM 2.27

KNOWN:  $3250 \mu\epsilon < \epsilon < 4150 \mu\epsilon$ ,  $f = 1 \text{ Hz}$

FIND:       a) average value  
              b) amplitude and frequency when the output is expressed as a simple periodic function  
              c) express the signal,  $y(t)$ , as a Fourier series.

SOLUTION:

a)  $A_o = \text{average value} = (3250 + 4150)/2 = 3700 \mu\epsilon$

b)  $C_1 = (4150 - 3250)/2 = 450 \mu\epsilon$   
 $f_1 = 1 \text{ Hz}$

c)  $y(t) = 3700 + 450 \sin\left(2\pi t \pm \frac{\pi}{2}\right) \mu\epsilon$

## PROBLEM 2.28

**KNOWN:** A force input signal varies between 100 and 170 N ( $100 < F < 170$  N) at a frequency of  $\omega = 10$  rad/s.

**FIND:** Signal average value, amplitude and frequency. Express the signal,  $y(t)$ , as a Fourier series.

### SOLUTION:

The signal characteristics may be determined by writing the signal as

$$y(t) = 135 + 35 \sin 10t \text{ [N]}$$

- a)  $A_0 = \text{Average value} = (170 + 100)/2 = 135 \text{ N}$
- b)  $C_1 = (170 - 100)/2 = 35 \text{ N}$ ;  $f_1 = \omega/2\pi = 10/2\pi = 1.59 \text{ Hz}$
- c)  $y(t) = 135 + 35 \sin (10t \pm \pi/2)$

## PROBLEM 2.29

**KNOWN:** A periodic displacement varies between 2 and 5 mm ( $2 < x < 5$ ) at a frequency of  $f = 100$  Hz.

**FIND:** Express the signal as a Fourier series and plot the signal in the time domain, and construct an amplitude spectrum plot.

### SOLUTION:

Noting that

$$A_o = \text{Average value} = (2 + 5)/2 = 3.5 \text{ mm}$$

$$C_1 = (5 - 2)/2 = 1.5 \text{ mm}$$

$$f_1 = 100 \text{ Hz}$$

The displacement may be expressed

$$y(t) = 3.5 + 1.5 \sin\left(200\pi t \pm \frac{\pi}{2}\right) \text{ mm}$$

The resulting time domain behavior is a simple periodic function; an amplitude spectrum plot should show a value of 3.5 mm at zero frequency and a value of 1.5 mm at a frequency of 100 Hz.

## PROBLEM 2.30

**KNOWN:** Wall pressure is measured in the upward flow of water and air. The flow is in the slug flow regime, with slugs of liquid and large gas bubbles alternating in the flow. Pressure measurements were acquired at a sample frequency of 300 Hz, and the average flow velocity is 1 m/sec.

**FIND:** Construct an amplitude spectrum for the signal, and determine the length of the repeating bubble/slug flow pattern.

### SOLUTION:

The figure below shows the amplitude spectrum for the measured data. There is clearly a dominant frequency at 0.73 Hz. Then with an average flow velocity of 1 m/sec, the length is determined as

$$L = \frac{1 \text{ m/sec}}{0.73 \text{ Hz}} = 1.37 \text{ m}$$

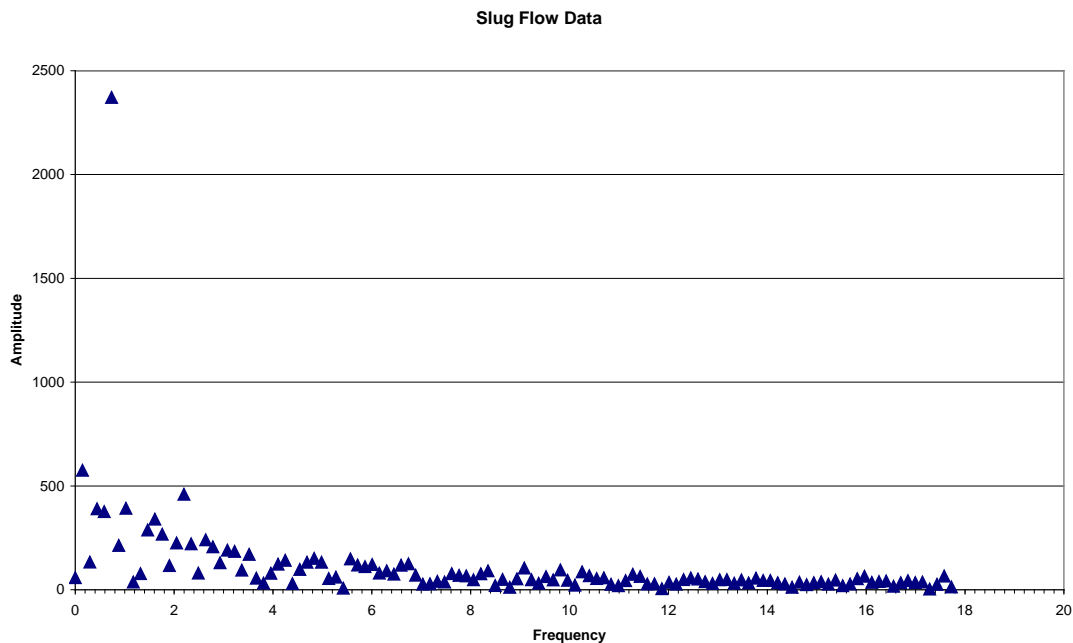

## PROBLEM 2.31

### KNOWN:

Signals,

- a) Clock face having hands
- b) Morse code
- c) Musical score
- d) Flashing neon sign
- e) Telephone conversation
- f) Fax transmission

**FIND:** Classify signals as completely as possible

### SOLUTION:

- a) Analog, time-dependent, deterministic, periodic, steady-state
- b) Digital, time-dependent, nondeterministic
- c) Digital, time-dependent, nondeterministic
- d) Digital, time-dependent, deterministic
- e) Analog or digital, time-dependent, nondeterministic
- f) Digital, time-dependent, nondeterministic

## PROBLEM 2.32

**KNOWN:** Amplitude and phase spectrum for  $\{y(r\delta t)\}$  from Figure 2.26

**FIND:**  $\{y(r\delta t)\}$ ,  $\delta f$ ,  $\delta t$

**SOLUTION:**

By inspection of Figure 2.27:

$$\begin{aligned}C_1 &= 5 \text{ V} & C_2 &= 0 \text{ V} & C_3 &= 3 \text{ V} & C_4 &= 0 \text{ V} & C_5 &= 1 \text{ V} \\f_1 &= 1 \text{ Hz} & f_2 &= 2 \text{ Hz} & f_3 &= 3 \text{ Hz} & f_4 &= 4 \text{ Hz} & f_5 &= 5 \text{ Hz} \\ \phi_1 &= 0 \text{ rad} & \phi_2 &= 0 \text{ rad} & \phi_3 &= 0.2 \text{ rad} & \phi_4 &= 0 \text{ rad} & \phi_5 &= 0.1 \text{ rad}\end{aligned}$$

and  $\delta f = 1 \text{ Hz}$ .

The signal can be reconstructed from the above information, as

$$y(t) = 5 \sin(2\pi t) + 3 \sin(6\pi t + 0.2) + \sin(10\pi t + 0.1)$$

The exact phase of the signal relative to  $t = 0$  is not known, so  $y(t)$  is ambiguous within  $\pm \pi/2$  in terms of its overall phase.

A DFT returns  $N/2$  values. Therefore 5 spectral values implies that  $N = 10$ . Then

$$\delta f = 1/N\delta t = 1 \text{ Hz} = 1/10 \delta t \text{ giving } \delta t = 0.1 \text{ sec or } f_s = 10 \text{ Hz}$$

Alternatively, by inspection of the plots

$$f_N = f_s/2 = 5 \text{ Hz giving } f_s = 10 \text{ Hz or } \delta t = 0.1 \text{ sec}$$

## PROBLEM 2.33

KNOWN:

$$y(t) = (4C/T)t + C \quad -T/2 \leq t \leq 0$$

$$y(t) = (-4C/T)t + C \quad 0 \leq t \leq T/2$$

FIND: Show that the signal  $y(t)$  can be represented by the Fourier series

$$y(t) = A_o + \sum_{n=1}^{\infty} \frac{4C(1 - \cos n\pi)}{(\pi n)^2} \cos \frac{2n\pi t}{T}$$

SOLUTION:

a) Since the function  $y(t)$  is an even function, the Fourier series will contain only cosine terms,

$$y(t) = A_o + \sum_{n=1}^{\infty} A_n \cos \frac{2n\pi t}{T} = A_o + \sum_{n=1}^{\infty} A_n \cos n\omega t$$

The value of  $A_o$  is determined from Equation (2.17)

$$A_o = \frac{1}{T} \int_{-T/2}^{T/2} y(t) dt$$

$$A_o = \int_{-T/2}^0 \left( \frac{4Ct}{T} + C \right) dt + \int_0^{T/2} \left( \frac{-4Ct}{T} + C \right) dt$$

integrating yields a value of zero for  $A_o$

$$A_o = \frac{1}{T} \left\{ \left[ \frac{2Ct^2}{T} + Ct \right]_{-T/2}^0 + \left[ \frac{-2Ct^2}{T} + Ct \right]_0^{T/2} \right\} = 0$$

Then to determine  $A_n$

$$A_n = \frac{2}{T} \left\{ \int_{-T/2}^0 \left( \frac{4Ct}{T} + C \right) \cos \frac{2n\pi t}{T} dt + \int_0^{T/2} \left( \frac{-4Ct}{T} + C \right) \cos \frac{2n\pi t}{T} dt \right\}$$

$$A_n = -2 \frac{C(-2 + 2 \cos(n\pi) + n\pi \sin(n\pi))}{(n\pi)^2}$$

Since  $\sin(n\pi) = 0$ , then the Fourier series is

$$y(t) = \sum_{n=1}^{\infty} \frac{4C(1 - \cos n\pi)}{(\pi n)^2} \cos \frac{2n\pi t}{T}$$

The values of  $A_n$  are zero for  $n$  even, and the first three nonzero terms of the Fourier series are

$$\frac{8C}{(\pi)^2} \cos \frac{2\pi t}{T} + \frac{8C}{(3\pi)^2} \cos \frac{6\pi t}{T} + \frac{8C}{(5\pi)^2} \cos \frac{10\pi t}{T}$$

The first term represents the fundamental frequency.

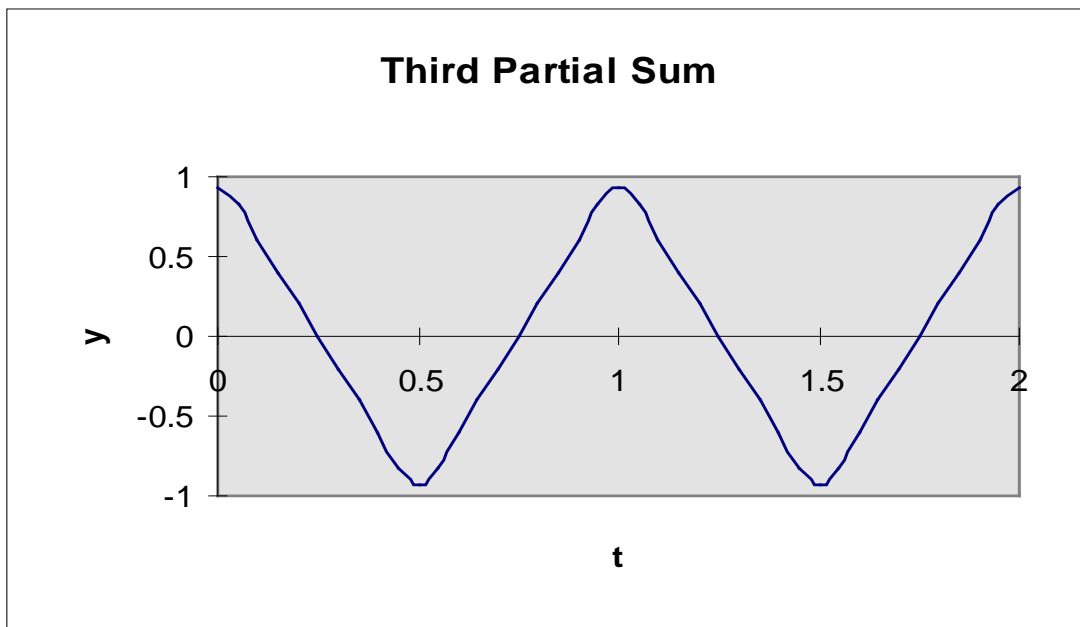
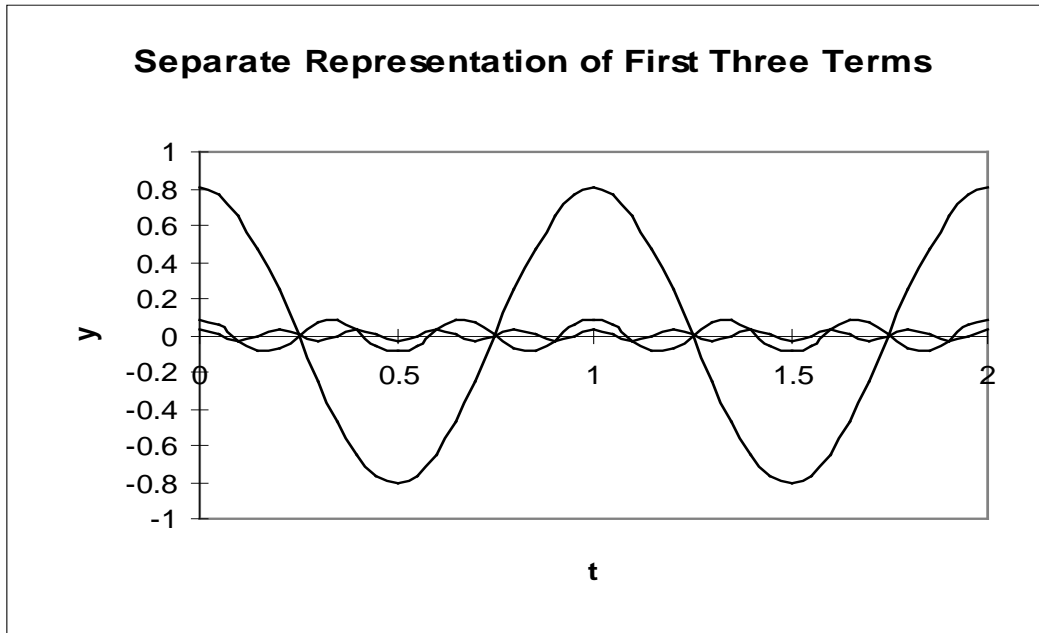

## PROBLEM 2.33

**KNOWN:** Figure 2.16 illustrates the nature of spectral distribution or frequency distribution on a signal.

**FIND:** Discuss the effects of low amplitude high frequency noise on signals.

### SOLUTION:

Assume that Figure 2.16a represents a signal, and that Figures 2.16 b-d represent the effects of noise superimposed on the signal. Several aspects of the effects of noise are apparent. The waveform can be altered significantly by the presence of noise, particularly if rates of change of the signal are important for specific purposes such as control. Generally, high frequency, low amplitude noise will not influence a mean value, and most of the signal statistics are not affected when calculated for a sufficiently long signal.

## PROBLEM 3.1

**KNOWN:**  $K = 2 \text{ V/kg}$   
 $F(t) = \text{constant} = A$   
Possible range of  $A$ : 1 kg to 10 kg

**FIND:**  $y(t)$

### SOLUTION

We will model the input as a static value and interpret the static output that results. To do this, this system is modeled as a zero order equation.

$$y(t) = KF(t) \quad \text{where } F(t) \text{ is constant for all time; so } y(t) \text{ is constant}$$

At the low end of the range,  $F(t) = A = 1 \text{ kg}$ , then

$$y = KF(t) = (2 \text{ V/kg})(1 \text{ kg}) = 2 \text{ V}$$

At the high end of the range,  $F(t) = A = 10 \text{ kg}$ , then

$$y = KF(t) = (2 \text{ V/kg})(10 \text{ kg}) = 20 \text{ V}$$

Hence, the output will range from 2 V to 20 V depending on the applied static input value.

Clearly, the model shows that if  $K$  were to be increased, the static output  $y$  would be increased. Here  $K$  is a constant, meaning that the relationship between the applied input and the resulting output is constant. The calibration curve must be a linear one. Notice how  $K$ , through its value, takes care of the transfer in the units between input  $F$  and output  $y$ .

### COMMENT

Because we have modeled this system as a zero order responding system, we have eliminated any accommodation for a transient response in the system model solution. The forcing function (i.e., input signal) is constant (i.e., static) for all time. So in the transient sense, this solution for  $y$  is valid only under static conditions. However, it is correct in its prediction in the steady output value following any change in input value.

## PROBLEM 3.2

KNOWN: System model

FIND: 75%, 90% and 95% response times

ASSUMPTIONS: Unless noted otherwise, all initial conditions are zero.

### SOLUTION

We seek the rise time to 75%, 90% and 95% response. For a first order system, the percent response time is found from the time response of the system to a step change in input. The error fraction for such an input is given by

$$C(t) = e^{-t/\tau}$$

from which the percent response at time  $t$  is found by

$$\begin{aligned}\% \text{ response} &= (1 - \Gamma(t)) \times 100 \\ &= (1 - e^{-t/\tau}) \times 100\end{aligned}$$

from which  $t$  is computed directly. Alternatively, Figure 3.7 could be used.

For a second order system, the system response depends on the damping ratio and natural

$$a) 0.4\dot{T} + T = 4U(t)$$

frequency of the system and can be established from either (3.15) or Figure 3.14.

By direct comparison to the general model of a first order system,  $\tau = 0.4$  s. Hence,

$$75\% = (1 - e^{-t/0.4}) \times 100 \quad \text{or} \quad t_{75} = 0.55 \text{ s}$$

$$90\% = (1 - e^{-t/0.4}) \times 100 \quad \text{or} \quad t_{90} = 0.92 \text{ s}$$

$$95\% = (1 - e^{-t/0.4}) \times 100 \quad \text{or} \quad t_{95} = 1.2 \text{ s}$$

Alternatively, Figure 3.7 could be used.

Problem 3.2 continued

$$b) \ddot{y} + 2\dot{y} + 4y = U(t)$$

By direct comparison to equations (3.12) and (3.13),

$$\zeta = 0.5 \text{ and } \omega_n = 2 \text{ rad/s}$$

Then using Figure 3.14 as a guide, for a response of

$$75\%: \omega_n t \sim 1.75 \text{ so that } t_{75} \sim 0.9 \text{ s}$$

$$90\%: \omega_n t \sim 2 \text{ so that } t_{90} \sim 1.0 \text{ s}$$

$$95\%: \omega_n t \sim 2.4 \text{ so that } t_{95} \sim 1.2 \text{ s}$$

$$c) 2\ddot{P} + 8\dot{P} + 8P = 2U(t)$$

By direct comparison to equations (3.12) and (3.13),

$$\zeta = 1.0 \text{ and } \omega_n = 2 \text{ rad/s}$$

Then using Figure 3.14 as a guide, for a response of

$$75\%: \omega_n t \sim 2.6 \text{ so that } t_{75} \sim 1.3 \text{ s}$$

$$90\%: \omega_n t \sim 3.7 \text{ so that } t_{90} \sim 1.9 \text{ s}$$

$$95\%: \omega_n t \sim 4.6 \text{ so that } t_{95} \sim 2.3 \text{ s}$$

$$d) \dot{y} + 5y = U(t)$$

By direct comparison to the general model of a first order system,  
 $\tau = 1 \text{ s}$  and  $K = 0.2 \text{ units/unit}$ .

$$75\% = (1 - e^{-t/\tau}) \times 100 \quad \text{or } t_{75} = 1.4 \text{ s}$$

$$90\% = (1 - e^{-t/\tau}) \times 100 \quad \text{or } t_{90} = 2.3 \text{ s}$$

$$95\% = (1 - e^{-t/\tau}) \times 100 \quad \text{or } t_{95} = 3.0 \text{ s}$$

### PROBLEM 3.3

**KNOWN:** let  $X = \% \text{ vapor}$

$X$	$y$ [units]
0	80
50	40
100	0

**FIND:**  $K$

#### SOLUTION

The data fit the linear curve,

$$y = -0.8x + 80$$

The static sensitivity is defined as

$$K = \left. \frac{dy}{dx} \right|_x = -0.80 \text{ units/\% vapor}$$

where  $K$  is independent of input  $x$ .

#### COMMENT

Because this system's calibration curve is linear, the static sensitivity remains constant over the input range.

Be certain to always provide units for all answers; magnitudes alone are not sufficient.

## PROBLEM 3.4

**KNOWN:** System model equation

$$K = 1 \text{ unit/unit}$$

$$F(t) = 100U(t)$$

$$y(0) = 75 \text{ units}$$

**FIND:**  $y(t)$

### SOLUTION

(a) The solution to the system model was shown to be given by the general form,

$$y(t) = y_{\infty} + (y(0) - y_{\infty})e^{-t/\tau}$$

where here,

$$y(0) = 75 \text{ units}$$

$$y_{\infty} = 100 \text{ units}$$

$$\tau = 0.5 \text{ s (determined from the system equation)}$$

then,

$$y(t) = 100 + (75 - 100)e^{-t/0.5} \text{ units}$$

Alternatively, by direct solution and with  $y(0) = 75$  units,

$$0.5 \dot{y} + y = 100U(t)$$

for  $t \geq 0^+$

$$y(t) = y_h + y_p$$

$$= Ce^{-t/\tau} + B$$

By substitution,  $B = 100$ . Then, if  $y(0) = 75$  and  $\tau = 0.5$ ,  $C = -25$ .

$$y(t) = 100 - 25e^{-t/0.5}$$

(b) The input signal and output signal are shown below.

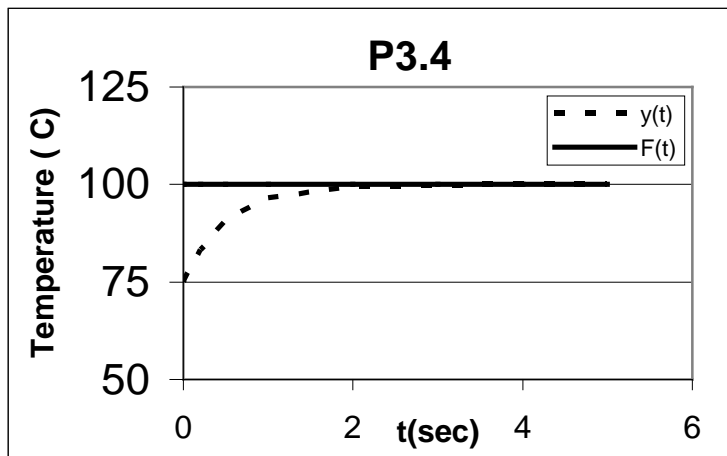

## PROBLEM 3.5

**KNOWN:** Thermometer similar to Example 3.3  
First order system model  
 $K = 1 \text{ } ^\circ\text{F}/^\circ\text{F}$   
 $\tau = 30 \text{ s}$   
 $F(t) = AU(t) = (120 - 32 \text{ } ^\circ\text{F})U(t)$   
 $T(0) = 32 \text{ } ^\circ\text{F}$

**FIND:**  $T(t)$ ; 90% rise time

### SOLUTION

(a) From Example 3.3,

$$mc\dot{T} + hA[T(t) - T(0)] = hA[T_\infty - T(0)]U(t)$$

or

$$\tau\dot{T} + T = 120^\circ F$$

for  $t \geq 0^+$  with  $T(0) = 32 \text{ } ^\circ\text{F}$ . Subbing yields

$$T(t) = 120 - 88e^{-t/30} \text{ for } t \geq 0^+$$

This response is plotted below.

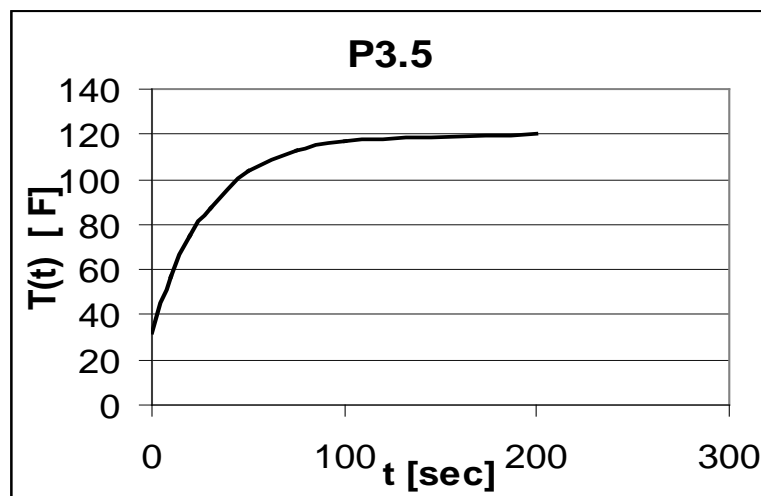

(b) To find the 90% response or rise time,

$$\% \text{response} = 1 - \Gamma(t) = 1 - e^{-t/\tau}$$

For  $\tau = 30$  s and  $\Gamma = 0.1$ , this yields

$$t_{90} = 69 \text{ s}$$

## PROBLEM 3.6

### SOLUTION:

We saw in Example 3.3 that the time constant for a thermal system was dependent on ambient conditions. Specifically, the heat transfer coefficient is dependent on such conditions.

If a student were to remove a sensor from hot water and transfer it to cold water by hand, it would be in motion part of the time. Further, one student may hold the sensor in the cold bath more steadily than another. Movement will change the heat transfer coefficient on the sensor by a factor of from 2 to 5 or more. Hence, the variation in time constant noted between students was simply a lack of control of the heat transfer coefficient – that is, a lack of control of the test condition.

Their answers (results) are not incorrect, just inconsistent! The results simply show the effects of a random error, in this case due to variations in the test condition. By proper test plan design, they can obtain a reasonable result that is bracketed by their test uncertainty. This uncertainty can be quantified by methods developed in Chapters 4 and 5.

## PROBLEM 3.7

**KNOWN:** First order instrument  
 $\tau = 20 \text{ ms}$

**FIND:** Rise time

### SOLUTION

The percent response of a first order system subjected to a step input is

$$\% \text{response} = 1 - \Gamma(t) = 1 - e^{-t/\tau}$$

For example, for a 90% rise time,  $\Gamma(t) = 0.1$ . Solving for time,

$$\begin{aligned} t_{90} &= 2.3\tau \\ &= 46 \text{ ms} \end{aligned}$$

## PROBLEM 3.8

**KNOWN:** Dynamic calibration using a step input

$$y_{\infty} - y(0) = 100 \text{ units}$$

$$y(t = 1.2 \text{ s}) = 80 \text{ units}$$

$$y(0) = 0 \text{ units}$$

**FIND:**  $\tau$ ,  $y(t = 1.5 \text{ s})$

### SOLUTION

A first order system subjected to a step input can be modeled as

$$\tau \dot{y} + y = KA U(t)$$

with  $y(0)$ . The solution is given by (3.5) as

$$y(t) = KA + (y(0) - y_{\infty}) e^{-t/\tau}$$

From the information provided, we establish that  $KA = 100$  units. Then,

$$y(t) = 100 - 100 e^{-t/\tau}$$

Using the information that  $y(1.2) = 80$  units, we solve for  $\tau$ ,

$$y(1.2) = 80 \text{ units} = 100 - 100 e^{-1.2/\tau} \text{ units}$$

then

$$\tau = 0.75 \text{ s.}$$

At time 1.5 s,

$$y(1.5) = 100 - 100 e^{-1.5/0.75} \text{ units} = 86.5 \text{ units}$$

## PROBLEM 3.9

**KNOWN:** First order system  
 $\tau = 0.7 \text{ s}$   
 $KF(t) = KA \sin 4\pi t$  (note here,  $\omega = 2\pi f$  where  $f = 2 \text{ Hz}$ )

**FIND:**  $\delta$

### SOLUTION

The dynamic error is defined as

$$\delta(\omega) = M(\omega) - 1$$

where for a first order system

$$M(\omega) = 1/[1 + (\tau\omega)^2]^{1/2}$$

Now,  $\omega = 2\pi f$  so that

$$M(f) = 1/[1 + (2\pi f \tau)^2]^{1/2}$$

By direct substitution,

$$M(f) = 1/[1 + (2.8\pi)^2]^{1/2} = 0.11$$

So that the dynamic error,

$$\delta(2 \text{ Hz}) = \delta(4\pi \text{ rad/s}) = -0.89$$

### COMMENT

This result means that the output amplitude of the 2 Hz signal will be 89% smaller than the sensed input amplitude KA. That is, the value KA will be attenuated by a factor of 0.89. Attenuation results with a negative value for  $\delta$  while a positive value indicates a gain.

## PROBLEM 3.10

**KNOWN:** First order instrument  
 $\tau = 1$  s  
 $K = 1$  unit/unit  
 $F(t) = 10\cos 2.5t = 10\sin (2.5t \pi/2)$   
 $y(0) = 0$

**FIND:**  $y_{\text{steady}}(t)$ ,  $\beta_1$

### SOLUTION

For a first order system subjected to a simple periodic waveform input signal, the output response has the form

$$y(t) = ce^{-t/\tau} + M(\omega)K\text{Asin}(2.5t + \pi/2 + \phi(\omega))$$

The steady response is given by the second term on the right side where

$$M(\omega) = 1/[1 + (\tau\omega)^2]^{1/2}$$

$$\phi(\omega) = -\tan^{-1} \tau\omega$$

or these can be found from Figures 3.12 and 3.13. With  $\omega = 2.5$  rad/s,

$$M(2.5) = 0.37$$

$$\phi(2.5) = -68^\circ = -1.19 \text{ rad}$$

Then,

$$\begin{aligned} y_{\text{steady}}(t) &= (0.37)(1)(10)\sin(2.5t + \pi/2 - 1.19) \\ &= 3.7\sin(2.5t + 0.38) \end{aligned}$$

The time lag arising between input and output signals is given by

$$\begin{aligned} \beta_1 &= \phi(\omega)/\omega \\ &= -1.19/2.5 = 0.48 \text{ s} \end{aligned}$$

## COMMENT

The dynamic error in this problem is -63%, and this is a very large number. In effect, the measurement system cannot respond quickly enough to follow the input signal. This creates a filtering effect whereby a significant portion of the signal amplitude is attenuated (the term "attenuation" refers to a reduction in value and is indicated by a negative dynamic error).

This system is more effective as a filter than it is as a measuring system. Associated with this large dynamic error is a large phase shift and associated time lag.

## PROBLEM 3.11

**KNOWN:** First order system  
 $\tau = 2$  s  
 $0.98 \leq \delta(\omega) \leq 1.02$  required

**FIND:** The maximum frequency that can be measured  $\omega_{\max}$

### SOLUTION

The dynamic error is defined as

$$\delta(\omega) = M(\omega) - 1$$

A first order system cannot have a value of  $M(\omega)$  that is greater than 1. So based on the constraint for dynamic error, we want

$$1 \geq M(\omega) \geq 0.98$$

or

$$0.98 \leq 1/[1 + (\tau\omega)^2]^{1/2}$$

At  $\tau = 2$  s, we find

$$\omega \leq 0.10 \text{ rad/s}$$

For this to be true,

$$\omega_{\max} = 0.10 \text{ rad/s}$$

or in terms of cyclical frequency

$$f_{\max} = 2\pi\omega_{\max} = 0.016 \text{ Hz}$$

and

$$\beta_1 = -1.97 \text{ seconds}$$

## PROBLEM 3.12

**KNOWN:** First order system  
 $\tau = 0.01 \text{ s} = 10 \text{ ms}$   
 $\delta(\omega) \leq \pm 0.10$

**FIND:**  $M(\omega)$ ,  $\phi(\omega)$ . Frequency range to meet  $\delta$  constraint.

**ASSUMPTION:** Input of the form,  $F(t) = A \sin \omega t$

### SOLUTION

For a first order system subjected to a periodic waveform input, the magnitude ratio and phase shift are given by (3.10) and (3.9) respectively. For this particular system,

$$M(\omega) = 1/[1 + (0.01\tau\omega)^2]^{1/2}$$

$$\phi(\omega) = -\tan^{-1} 0.01\omega$$

or

$\omega$ [rad/s]	$M(\omega)$	$\phi(\omega)$
1	1.0	$-0.6^\circ$
10	0.995	$-5.7^\circ$
100	0.707	$-45^\circ$
1000	0.10	$-84^\circ$

Note that at  $\omega = \tau$ , that  $M(\omega) = 0.707$ , a value that defines the bandwidth of a system.

For a first order system,  $M(\omega)$  will always be equal or less than unity. So that the dynamic error constraint reduces to  $\delta(\omega) \leq -0.1$ . For this to be true,

$$-0.1 \geq (1/[1 + (0.01\omega)^2]^{1/2}) - 1$$

solving,

$$\omega \leq 48.5 \text{ rad/s}$$

It is clear that for all  $\omega$  such that  $0 \leq \omega \leq 48.5 \text{ rad/s}$ , the constraint is met.

### PROBLEM 3.13

**KNOWN:** First order system  
 $\tau = 0.15 \text{ s}$   
 $K = 5 \text{ mV}/^\circ\text{C}$   
 $T(0) = 115 \text{ }^\circ\text{C}$   
 $F(t) = T(t) = 115 + 12\sin 2t \text{ }^\circ\text{C}$

**ASSUMPTIONS:** Output signal is linearly proportional to input signal (that is,  $K$  is constant)

**FIND:** Output response,  $E(t)$ ;  $\delta(\omega)$ ;  $\beta_1$

### SOLUTION

We see immediately from the units of static sensitivity that this first order instrument senses temperature and outputs a voltage signal. Hence, a good system model can be written as

$$\tau \dot{E} + E = KF(t) \quad (3.4),$$

where  $E(t)$  represents the output voltage signal. Specifically, the system model is written as

$$0.15 \dot{E} + E = 5(115 + 12\sin 2t) \text{ mV}$$

with  $E(0) = KT(0) = 575 \text{ mV}$ .

To solve for  $E(t)$ , we assume a solution consisting of both homogeneous and particular parts,

$$E(t) = E_h + E_p$$

Because a first order system has only one root, the solution to the characteristic equation has the form,

$$E_h = Ce^{-t/\tau} = Ce^{-t/0.15}$$

We guess a particular solution of the form,

$$E_p = A + B\sin 2t + D\cos 2t$$

substitute back into the model with  $E(t) = E_p$  and

$$E_p = 2B\cos 2t - 2D\sin 2t$$

This leads to  $A = 575$ ,  $B = 64.95$  and  $D = 16.51$ . The full solution then has the form,

$$E(t) = Ce^{-t/0.15} + 575 + 64.95 \sin 2t + 16.51 \cos 2t$$

Evaluating at  $E(0) = 575$  yields that  $C = -16.51$ . Lastly, the measurement system's output response to this input can be rewritten as

$$E(t) = 575 + 67 \sin(2t + 0.254) - 16.51e^{-t/0.15} \text{ mV}$$

The dynamic error at  $\omega = 2$  rad/s can be expressed as

$$\delta(2) = M(2) - 1$$

Using equation 3.10 to solve for  $M(\omega)$  yields

$$M(2) = 1/[1 + ((2)(0.15))^2]^{1/2} = 0.96$$

so that  $\delta(2) = -0.04$ .

The time lag can be found from

$$\beta_1(\omega) = \phi(\omega)/\omega$$

Using (3.9) at  $\omega = 2$  rad/s,

$$\phi(2) = -\tan^{-1}(2)(0.15) = -16.7^\circ = 0.29 \text{ rad}$$

so that the time lag is  $\beta_1(2) = 0.29/2 = 0.15$  s.

## PROBLEM 3.14

**KNOWN:** First order instrument  
 $F(t) = 100U(t)$  °C  
Five seconds are available to interpret signal and provide control signal back to process.

**FIND:**  $\tau_{\max}$

### SOLUTION

In such a situation, we will want the system to commence a shut-down when the output signal achieves some set threshold value. We must set this threshold value. However, we probably do not wish to set it too low or we run the risk of an unnecessary shut down resulting from just random noise. Suppose we set the error fraction at 10%, that is at

$$\Gamma \leq 0.10$$

reactor shut down will commence. Then with this value we can find the acceptable time constant using

$$\Gamma = e^{-t/\tau}$$

With  $\Gamma = 0.10$  and  $\tau \leq 5$  s, we solve that  $\tau \leq 2.17$  s.

### COMMENT

We should note that as the set threshold value is pushed to lower values of error fraction, the value for time constant becomes smaller. For example, at  $\Gamma = 0.01$ ,  $\tau \leq 0.92$  s. This places a more restrictive design constraint on the sensor and installation selected.

## PROBLEM 3.15

**KNOWN:** Single loop LR circuit (see below) used as filter  
 $R = 1$  million ohm  
 $\tau = L/R$

**FIND:**  $L$  such that  $M(2000\pi) \leq 0.5$

### SOLUTION

For the LR filter circuit shown, we can use the voltage loop law to write

$$L \frac{dI}{dt} + IR = E_i(t)$$

But across the resistor,  $I = E_o(t)/R$ . So the system governing equation is given by

$$\frac{L}{R} \dot{E}_o + E_o = \frac{1}{R} E_i(t)$$

with  $E_i(t) = A \sin \omega t$ . This is a first order system which has a magnitude ratio defined as

$$M(2000\pi) = 1/[1 + (2000\pi\tau)^2]^{1/2} \leq 0.5$$

Solving leads to  $\tau \leq 0.276$  ms. From which

$$L = R\tau = (1 \times 10^6 \Omega)(0.000276 \text{ s}) = 276 \text{ H}$$

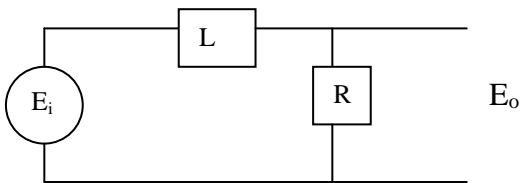

## PROBLEM 3.16

**KNOWN:**  $F(t) = 2U(t)$   
 $\omega_n = 0.5 \text{ rad/s}; \zeta = 0.5; K = 0.5 \text{ m/V}$

$$\dot{y}(0) = y(0) = 0$$

**FIND:** 90% rise time and settling time

### SOLUTION

From (3.14a), for  $t \geq 0^+$

$$y(t) = 0.5(2) - 0.5(2)e^{-0.5(0.5)t} \left[ \frac{0.5}{\sqrt{1-0.5^2}} \sin 0.43t + \cos 0.43t \right] = 1 - e^{-t/4} [0.58 \sin 0.43t + \cos 0.43t]$$

where  $\omega_d = 0.43 \text{ rad/s}$ .

By inspection,

$$90\% \text{ rise time} = 2.74 \text{ s}$$

$$90\% \text{ settling time} = 9.5 \text{ s}$$

## PROBLEM 3.17

**KNOWN:** Second order system  
 $\zeta = 0.6, 0.9, 2.0$

**FIND:** Plot  $M(\omega)$  and  $\phi(\omega)$ .  
 Find the frequency range in which  $\delta(\omega) \leq \pm 5\%$

### SOLUTION

The magnitude ratio and phase shift of a second order system is given by (3.21) and (3.19), respectively,

$$M(\omega) = 1 / [(1 - \{\omega/\omega_n\}^2)^2 + (2\zeta\omega/\omega_n)^2]^{1/2}$$

$$\phi(\omega) = \tan^{-1} -(2\zeta\omega/\omega_n) / (1 - [\omega/\omega_n]^2)$$

These are plotted below.

For a constraint of  $\delta(\omega) \leq \pm 5\%$ :  $0.95 \leq M(\omega) \leq 1.05$ . Either from the plots or from (3.21) directly, for  $\delta(\omega) \leq \pm 5\%$ , then

$$\zeta = 0.6; 0 \leq \omega/\omega_n \leq 0.84$$

$$\zeta = 0.9; 0 \leq \omega/\omega_n \leq 0.28$$

$$\zeta = 2.0; 0 \leq \omega/\omega_n \leq 0.08$$

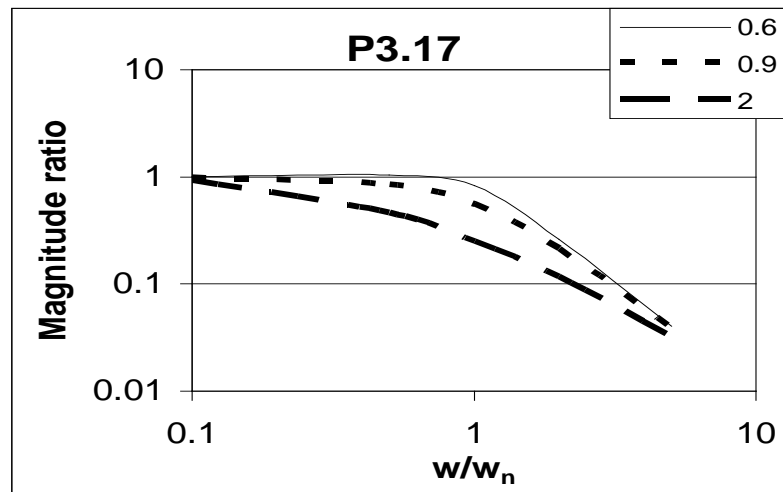

### PROBLEM 3.18

**KNOWN:** Input:  $30 \leq C_1 \leq 40^\circ\text{C}$  with  $f_1 = 10 \text{ Hz}$   
 $\delta \leq -0.01$

**FIND:**  $T(t)$ ,  $\tau_{\max}$

**ASSUMPTIONS:** First-order system (i.e.  $\tau$  requested)  
 $K = 1 \text{ unit/unit}$

### SOLUTION

The input signal has the form:

$$\begin{aligned} T(t) &= (40 + 30)/2 + [(40 - 30)/2] \sin(2\pi(10\text{Hz})t \pm \pi/2) \\ &= 35 + 5 \sin(20\pi t \pm \pi/2) \end{aligned}$$

The dynamic error  $\delta(\omega) = M(\omega) - 1$  so setting  $M(\omega) \geq 0.99$ :

$$0.99 \geq 1/[1 + (20\pi\tau)^2]^{1/2}$$

$$\tau \leq 2.27 \text{ ms}$$

## PROBLEM 3.19

**KNOWN:** Step test imposed on a second order system  
Damped oscillating response, therefore  $\zeta < 1$

**FIND:** Test plan to find  $\omega_n$  and  $\zeta$

### SOLUTION

The step test response for an underdamped system is plotted in Figure 3.14 (and the concept further explored in the Example surrounding Figure 3.15). The period of oscillation gives  $T_d = 2\pi/\omega_d$  where

$$\omega_d = \omega_n (1 - \zeta^2)^{1/2} \quad (1)$$

and the decay of the oscillations (i.e. the decay of the peaks of each cycle) follows  $e^{-\omega_n \zeta t}$ . The test plan should impose the step input and system output recorded at time intervals much less than  $T_d$  (e.g. 20 measurements per cycle). The peak values (maximum amplitudes), or alternatively the minimum amplitudes, should be plotted versus time. Because the decay is exponential, that is  $y_{\max} = e^{-\omega_n \zeta t}$ , a plot using semi-log will yield

$$\ln y_{\max} = \ln (e^{-\omega_n \zeta t}) = -\omega_n \zeta t$$

where the slope of this plot ( $\ln y_{\max}$  vs.  $t$ ) is

$$m = -\omega_n \zeta \quad (2)$$

Equations 1 and 2 provide for the two unknowns.

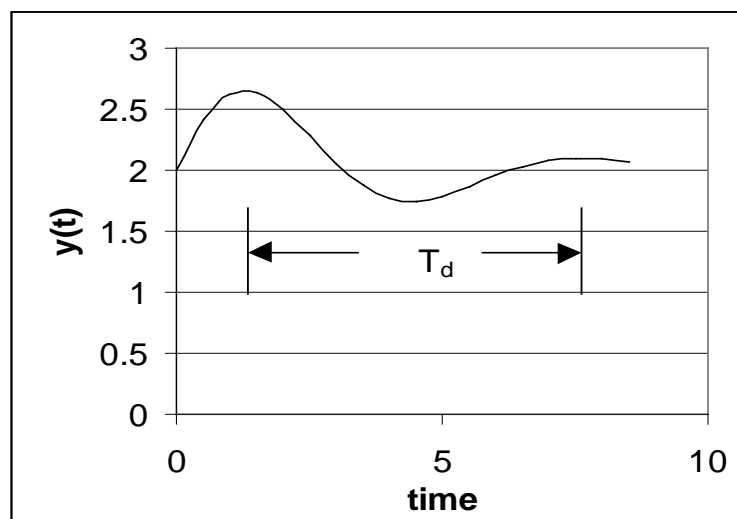

## PROBLEM 3.20

**KNOWN:**  $T_d = 0.577$  ms from a step test  
Second-order system due to oscillations observed

**FIND:**  $\omega_d$

### SOLUTION

The period of oscillation of a step test is the period of ringing.  
Accordingly, the ringing frequency is

$$\omega_d = 2\pi/T_d = 1089 \text{ rad/s}$$

or  $f_d = \omega_d / 2\pi = 173 \text{ Hz}$ .

## PROBLEM 3.21

**KNOWN:**  $\zeta = 0.8$

$$\omega_d = 2000\pi \text{ rad/s} \quad (\text{where } \omega \text{ [rad/s]} = 2\pi f \text{ [Hz]} \text{ and } f = 1000 \text{ Hz})$$

$$K = 1.5 \text{ V/V}$$

$$F(t) = (12 + 24)/2 + [(24 - 12)/2]\sin 600\pi t = 18 + 6\sin 600\pi t$$

**FIND:**  $y_{\text{steady}}(t)$

**ASSUMPTIONS:** Second order system

### SOLUTION

The steady response to this input will have the form

$$y_{\text{steady}}(t) = KA + KAM(\omega)\sin \omega t + \phi(\omega)$$

where

$$M(\omega) = 1/[(1 - \{\omega/\omega_n\}^2)^2 + (2\zeta\omega/\omega_n)^2]^{1/2}$$

$$\phi(\omega) = \tan^{-1} -(2\zeta\omega/\omega_n)/(1 - [\omega/\omega_n]^2)$$

The natural frequency is readily computed from the measured ringing frequency by

$$\omega_d = \omega_n (1 - \zeta^2)^{1/2}$$

yielding  $\omega_n = 3333\pi \text{ rad/s}$ . Then at  $\omega = 600\pi$ ,

$$M(600\pi) = 0.99$$

$$\phi(600\pi) = -0.289 \text{ rad}$$

Hence,

$$y_{\text{steady}}(t) = 27 + 8.9 \sin 600\pi t - 0.289$$

### COMMENT

Recall that the steady response is the output signal after all transients have died out. The transient response is found from the homogeneous solution to the equation model.

## PROBLEM 3.22

**KNOWN:**  $F(t) = A \sin 500\pi t$  (recall  $\omega$  [rad/s] =  $2\pi f$  [Hz] and  $f = 250$  Hz)

Constraint:  $\delta \leq \pm 0.02$

Available  $\omega_n = 1200\pi$  rad/s (recall  $\omega$  [rad/s] =  $2\pi f$  [Hz] and  $f = 600$  Hz)

Available values of  $0.5 \leq \zeta \leq 1.5$

**FIND:**  $\zeta$  required to meet the dynamic error constraint.

**ASSUMPTIONS:** Second order system

### SOLUTION

For  $\delta \leq \pm 0.02$ , we want  $0.98 \leq M(\omega) \leq 1.02$ . From the information given, the frequency ratio is  $\omega/\omega_n = 0.417$ . Then solving for  $\zeta$  in the equation (3.19),

$$0.98 \leq 1/[(1 - \{\omega/\omega_n\}^2)^2 + (2\zeta\omega/\omega_n)^2]^{1/2}$$

yields

$$\delta \leq 0.72$$

Repeating at the other limit,

$$1.02 \leq 1/[(1 - \{\omega/\omega_n\}^2)^2 + (2\zeta\omega/\omega_n)^2]^{1/2}$$

yields

$$\delta \leq 0.63$$

Thus, either a transducer having  $\delta = 0.65$  or  $0.7$  will work.

## PROBLEM 3.23

**KNOWN:** Second order system responding to a sine wave as an input

$$2 \leq f \leq 40 \text{ Hz}$$

$$M(f) \leq 0.5$$

**FIND:**  $m, k, c$

### SOLUTION

Because we wish to attenuate frequency information at and above 2 Hz, we can initiate the design of the system so that it meets the attenuation constraint at 2 Hz. Then we want,

$$M(f) = M(\omega/2\pi) = 1/[(1 - \{\omega/\omega_n\}^2)^2 + (2\zeta\omega/\omega_n)^2]^{1/2} \leq 0.5$$

A freebody diagram is constructed from a model below. The system model will have the form,

$$m \ddot{y} + c \dot{y} + ky = F(t)$$

so that,  $\omega_n = (k/m)^{1/2}$ ;  $\zeta = c/2(mk)^{1/2}$ ;  $K = 1/k$ . Now at  $f = 2 \text{ Hz}$  or  $\omega = 2\pi f = 12.57 \text{ rad/s}$ ,  $\omega/\omega_n = 0.4$ . Use Figure 3.16 as a guide, note that for  $\omega/\omega_n = 0.4$  and  $M = 0.5$ , we will need to have  $\zeta < 2.5$ . Also from the Figure, it is apparent that this value will meet the constraint at 40 Hz as well. Suppose we select  $m = 2 \text{ kg}$  as a reasonable estimate for the mass of a turntable and select  $k = 4000 \text{ N/m}$ , a value that allows the isolation pad to deflect 5 mm. Then, the damping coefficient of the pad should be 447 N-s/m. Of course, the actual values selected will depend on availability.

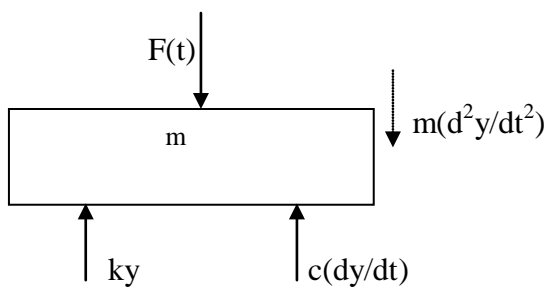

Freebody diagram

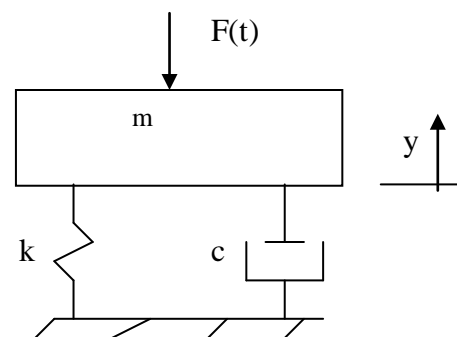

Idealized model

PROBLEM 3.24

KNOWN: RCL circuit:  $L = 2 \text{ H}$ ;  $C = 1 \text{ } \mu\text{F}$ ;  $R = 10\text{k}\Omega$

$$E_i(t) = 1 + 0.5 \sin 2000t \text{ V}$$

$$I(0) = dI(0)/dt = 0 \text{ (initial conditions)}$$

ASSUMPTIONS: Values for  $R$ ,  $C$ ,  $L$  remain constant.

FIND: Governing equation and steady output form

SOLUTION

For a single loop RCL circuit, we apply the voltage law to the RCL loop,

$$E_R(t) + E_C(t) + E_L(t) = E_i(t)$$

But,

$$E_R = IR; \quad E_L = L \frac{dI}{dt}; \quad E_C = \frac{1}{C} \int Idt$$

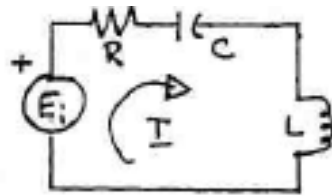

Substituting back into the loop equation and differentiating once gives,

$$L \frac{d^2I}{dt^2} + R \frac{dI}{dt} + \frac{1}{C} I = \frac{dE_i}{dt}$$

This is of the form for a second order system. It follows that

$$\omega_n = \sqrt{1/LR}; \quad \zeta = R / 2\sqrt{LC}; \quad K = 1/C$$

$$\omega_n = 707 \text{ rad/s}; \quad \zeta = 3.54; \quad K = 1 \times 10^{-6}$$

From equations 3.21 and 3.19, respectively with  $\omega = 2000 \text{ rad/s}$ ,

$$M(2000 \text{ rad/s}) = 0.05$$

$$\phi(2000 \text{ rad/s}) = -1.23 \text{ rad}$$

Then, with  $dE_i/dt = 1000 \sin 2000t$

$$[I(t)]_{\text{steady}} = 1 + 0.025 \sin(2000t - 1.23) \text{ } \mu\text{A}$$

### PROBLEM 3.25

KNOWN: Second order instrument

$$\zeta = 0.7$$

$$\omega_n = 2000\pi \text{ rad/s} \quad (\text{recall } \omega [\text{rad/s}] = 2\pi f [\text{Hz}] \text{ and } f = 1000 \text{ Hz})$$

$$\text{Input: } 0 \leq \omega \leq 1500\pi \text{ rad/s}$$

FIND: Does transducer meet a +/- 10% dynamic error constraint?

□SOLUTION □

The dynamic error is defined by

$$\delta(\omega) = M(\omega) - 1$$

where for a second order system

$$M(\omega) = \frac{1}{\left\{ \left[ 1 - \left( \omega/\omega_n \right)^2 \right]^2 + \left( 2\zeta \omega/\omega_n \right)^2 \right\}^{1/2}}$$

The dynamic error constraint can be rewritten as

$$0.9 \leq M(0 \leq \omega \leq 1500\pi) \leq 1.10$$

Inspection of Figure 3.16 shows that the magnitude ratio will never exceed a value of 1.10 over this frequency range. However, its value can fall below 0.90. If we test the frequency response at  $1500\pi$  rad/s, we can check this. Solving with for  $M(\omega)$  at  $\omega/\omega_n = 0.75$  and  $\zeta = 0.7$  yields  $M(1500\pi) = 0.88$ .

This gives a dynamic error of -12%. So the transducer does not meet the constraint over the entire frequency range of interest.

PROBLEM 3.26

KNOWN:  $t_{90} = 100$  ms

$$f_d = 1200 \text{ Hz}$$

$$\zeta = 0.8$$

Recall  $\omega$  [rad/s] =  $2\pi f$  [Hz]; and so  $\omega/\omega_n = f/f_n$ , and so forth

FIND:  $\delta$  (1 Hz),  $\beta_1$

SOLUTION

$$f_d = f_n \sqrt{1 - \zeta^2} \quad \text{or} \quad f_n = 1200 / \sqrt{1 - 0.8^2} = 2000 \text{ Hz}$$

The dynamic error is given by  $\delta(f) = M(f) - 1$ :

$$\begin{aligned} M(f=1) &= \frac{1}{\left\{ \left[ 1 - (f/f_n)^2 \right]^2 + (2\zeta f/f_n)^2 \right\}^{1/2}} \\ &= \frac{1}{\left\{ \left[ 1 - (1/2000)^2 \right]^2 + (2(0.8)1/2000)^2 \right\}^{1/2}} = 1.0 \end{aligned}$$

so  $\delta$  (1 Hz) = 0.0.

The time lag is given by

$$\beta_1 = \frac{\Phi(\omega)}{\omega} = \frac{\Phi(f)}{2\pi f} = \left[ -\tan^{-1} \frac{2\zeta f/f_n}{1 - (f/f_n)^2} \right] / 2\pi f = 7.3 \text{ ms}$$

COMMENT

The dynamic error of zero indicates that the amplitude of the input signal  $Kf(t)$  and the steady output signal are essentially equal. The time lag indicates that the output signal appears at a time  $\beta_1$  after the input signal is applied.

### PROBLEM 3.27

KNOWN:  $\omega_R = 1414$  rad/s

$$\zeta = 0.5$$

$$f = 6000 \text{ Hz}$$

$$\text{Recall } \omega \text{ [rad/s]} = 2\pi f \text{ [Hz]}$$

FIND:  $\delta$  (6000 Hz),  $\Phi$  (6000 Hz)

SOLUTION

For resonance,

$$\omega_R = \omega_n \sqrt{1 - 2\zeta^2} \quad \text{or} \quad 1414 = \omega_n \sqrt{1 - 2(0.5)^2}, \text{ so } \omega_n = 2000 \text{ r/s}$$

That means,  $f_n = 318$  Hz (because  $\omega$  [rad/s] =  $2\pi f$  [Hz])

The ratio  $f/f_n = 6000/318 = 18.87$ ;  $\zeta = 0.5$  and so for  $f = 6000$  Hz,

$$M(f) = \frac{1}{\left\{ \left[ 1 - (f/f_n)^2 \right]^2 + (2\zeta f/f_n)^2 \right\}^{1/2}}$$

or  $M(6000 \text{ Hz}) = 0.0028$ .

The dynamic error,

$$\delta (6000 \text{ Hz}) = M(6000 \text{ Hz}) - 1 = -0.997$$

The phase shift is

$$\Phi (6000 \text{ Hz}) = -\tan^{-1} \frac{2\zeta f/f_n}{1 - (f/f_n)^2} = -\tan^{-1} \frac{2(0.5)(18.87)}{1 - (18.87)^2} = 3.04 \text{ rad} = -174^\circ.$$

So the input signal amplitude is attenuated 99.7% at 6000 Hz with a  $174^\circ$  phase shift between the input and output signals. The instrument effectively filters out the information at 6000 Hz.

PROBLEM 3.28

KNOWN: Second-order instrument

$$0 \leq \omega \leq 100 \text{ rad/s}$$

Constraint:  $\delta(\omega) \leq \pm 10\%$

FIND: Select appropriate values for  $\omega_n$  and  $\zeta$

SOLUTION

The most demanding application will be at the highest input frequency because  $\delta(\omega) = M(\omega) - 1$ . Inspection of Figure 3.16 or use of equation 3.21 proves useful to find:

$\omega_n$ [rad/s]	$\zeta$	$\frac{\omega}{\omega_n}$	$M(\omega)$	$\delta(\omega)$
200	0.4	0.5	1.18	0.18
200	1.0	0.5	0.64	-0.36
200	2.0	0.5	0.47	-0.53
500	0.4	0.2	1.03	0.03
500	1.0	0.2	0.96	-0.04
500	2.0	0.2	0.80	-0.20

So  $\zeta$  between 0.4 through 1 and with  $\omega_n = 500$  rad/s will meet the constraint.

### PROBLEM 3.29

KNOWN: First order system:  $\tau = 0.2$  s;  $K = 1$  V/N

$$F(t) = \sin t + 0.3 \sin 20 t \text{ N} \quad (\text{and so } A_1 = 1\text{N and } A_2 = 0.3\text{N})$$

FIND: Steady response output signal

SOLUTION

This system must respond to two frequencies  $\omega_1 = 1$  rad/s and  $\omega_2 = 20$  rad/s. The steady output will have the form,

$$y_{\text{steady}} = KA_1 M(\omega_1) \sin(\omega_1 t + \Phi_1) + KA_2 M(\omega_2) \sin(\omega_2 t + \Phi_2)$$

For a first order system, we use equations 3.10 and 3.9 to solve for each  $M$  and  $\Phi$  :

$$M(1 \text{ rad/s}) = 0.98 \quad \Phi(1 \text{ rad/s}) = -0.197 \text{ rad}$$

$$M(20 \text{ rad/s}) = 0.24 \quad \Phi(20 \text{ rad/s}) = -1.326 \text{ rad}$$

so that,

$$y_{\text{steady}} = 0.98 \sin(t - 0.197) + 0.072 \sin(20t - 1.326)$$

COMMENT

While the  $\omega_1$  information is passed onto the output signal with a minor attenuation (2%), the  $\omega_2$  information is well attenuated (filtered) by 76%. This measurement system is not a good choice for measuring the  $\omega_2$  information.

### PROBLEM 3.30

KNOWN: Second order system accelerometer:

$$\zeta = 0.5$$

$$f_n = 4000 \text{ Hz} \quad (\text{recall } \omega \text{ [rad/s]} = 2\pi f \text{ [Hz]})$$

$$f = 2000 \text{ Hz}$$

FIND:  $\delta(f), f_R$

SOLUTION

For any system,

$$\delta(f) = M(f) - 1$$

where  $M(f) = \frac{1}{\left\{ \left[ 1 - (f/f_n)^2 \right]^2 + (2\zeta f/f_n)^2 \right\}^{1/2}}$ . Then, for this system

$$M(2000) = 1.11$$

so that

$$\delta(2000) = +0.11$$

The output magnitude from this system at this frequency will be 11% greater than the input magnitude, KA. The system fails the criterion of +/- 10%.

The resonance frequency is found from

$$f_R = f_n \sqrt{1 - 2\zeta^2} = 2828 \text{ Hz} \quad \text{or about } 2800 \text{ Hz.}$$

### PROBLEM 3.31

KNOWN: Second order transducer

$$\zeta = 0.4$$

$$f_n = 18,000 \text{ Hz}$$

$$F(t) = A \sin 9000 \pi t \quad (\text{recall } \omega \text{ [rad/s]} = 2\pi f \text{ [Hz]} \text{ and } f = 4500 \text{ Hz})$$

FIND:  $\delta(f), f_R, \Phi(f)$

SOLUTION

For any second order system,

$$\delta(f) = M(f) - 1$$

where  $M(f) = \frac{1}{\left\{ \left[ 1 - (f/f_n)^2 \right]^2 + (2\zeta f/f_n)^2 \right\}^{1/2}}$ . Then, for this system

$$M(4500 \text{ Hz}) = 1.04$$

So output amplitude B is 4% higher than input amplitude A. This means the dynamic error is

$$\delta(4500\text{Hz}) = + 0.04$$

The phase shift is found from equation 3.19. For this system,

$$\Phi(4500) = -\tan^{-1} \frac{2\zeta f/f_n}{1 - (f/f_n)^2} = -\tan^{-1} \frac{2(0.4)(0.25)}{1 - (0.25)^2} = - 0.21 \text{ rad}$$

That is about a  $12^\circ$  lag between input and output signals. The resonance frequency is found to be

$$f_R = 18000 \sqrt{1 - 2(0.4)^2} = 14,843 \text{ Hz}$$

PROBLEM 3.32

KNOWN: Seismic Accelerometer of Example 3.1

$$F(t) = x_0 \sin \omega t$$

FIND:  $M(\omega)$  and  $\Phi(\omega)$

SOLUTION

From example 3.1,

$$m\ddot{y} + c\dot{y} + ky = c\dot{x} + kx$$

which can be rewritten,

$$\frac{1}{\omega_n^2} \ddot{y} + \frac{2\zeta}{\omega_n} \dot{y} + y = \frac{2\zeta}{\omega_n} \dot{x} + x$$

Assuming zero value initial conditions,  $\dot{y}(0) = y(0) = 0$

$$y(t) = y_h + \frac{(\omega/\omega_n) \sin[\omega t + \Phi(\omega)]}{\left\{ \left[ 1 - (\omega/\omega_n)^2 \right]^2 + (2\zeta \omega/\omega_n)^2 \right\}^{1/2}}$$

Then,

$$M(\omega) = \frac{(\omega/\omega_n)}{\left\{ \left[ 1 - (\omega/\omega_n)^2 \right]^2 + (2\zeta \omega/\omega_n)^2 \right\}^{1/2}}$$

$$\Phi(\omega) = -\tan^{-1} \frac{2\zeta \omega/\omega_n}{1 - (\omega/\omega_n)^2}$$

By inspection, this instrument will be best suited to measure signals having frequency content that is greater than its natural frequency.

COMMENT

The instructor may wish to augment this problem with material from Section 12.5 or refer students to this section of the text for further reading.

### PROBLEM 3.33

KNOWN: Second order system pressure transducer

$$\zeta = 0.6$$

$$\omega_n = 8706 \text{ rad/s}$$

FIND:  $M(\omega)$ ,  $\Phi(\omega)$ ,  $\omega_R$

SOLUTION

For a second order system the magnitude ratio and phase shift are

$$M(\omega) = \frac{1}{\left\{ \left[ 1 - \left( \frac{\omega}{\omega_n} \right)^2 \right]^2 + \left( 2\zeta \frac{\omega}{\omega_n} \right)^2 \right\}^{1/2}}$$

$$\Phi(\omega) = -\tan^{-1} \frac{2\zeta \omega / \omega_n}{1 - (\omega / \omega_n)^2}$$

Using the known values, we construct the frequency response as

$\omega$ [rad/s]	$M(\omega)$	$\Phi(\omega)$ [rad]
10	1.0	0
1000	1.0	-0.14
4607	1.04	-0.72
8706	0.83	-1.57
87000	0.01	-3.02

For underdamped systems, the maximum value for  $M(\omega)$  occurs at  $\omega_R$ ,

$$\omega_R = \omega_n \sqrt{1 - 2\zeta^2} = 4607 \text{ rad/s}$$

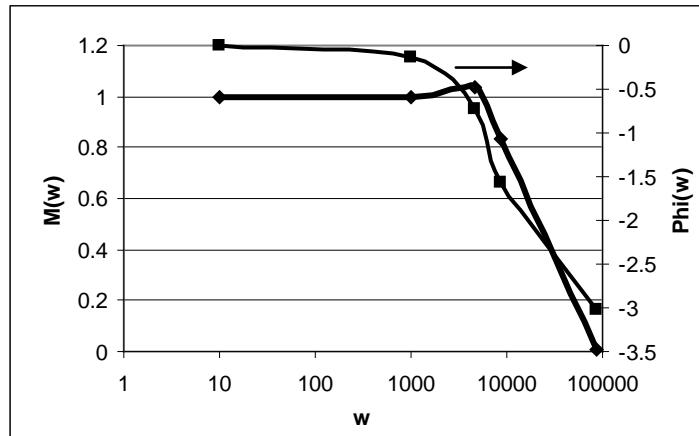

so  $M(4607) = 1.042$ . The resonance is slight for  $\zeta = 0.6$  as verified in the magnitude ratio plot in the text.

### PROBLEM 3.34

KNOWN: Coupled first and second order systems

$$F(t) = 10 + 50 \sin 628t \text{ } ^\circ\text{C}$$

Input Stage Device:

$$\tau = 1.4 \text{ ms}$$

$$K = 2 \text{ V}/^\circ\text{C}$$

Output Stage Device

$$K = 1 \text{ V/V}$$

$$\zeta = 0.9$$

$$\omega_n = 10000 \pi \text{ rad/s}$$

FIND: Steady portion of output signal  $y(t)$

SOLUTION

For a coupled system of two components, call them 1 and 2, the system output is defined by

$$KG(s) = K_1 G_1(s) K_2 G_2(s) = K_1 K_2 M_1 M_2 e^{i(\Phi_1 + \Phi_2)}$$

with

$$M(\omega)_{system} = M_1(\omega) M_2(\omega)$$

$$K_{system} = K_1 K_2$$

$$\Phi_{system} = \Phi_1(\omega) + \Phi_2(\omega)$$

For  $\omega = 628 \text{ rad/s}$ ,

$$M_1(628 \text{ rad/s}) = \frac{1}{\{1 + (\omega\tau)^2\}^{1/2}} = 0.75,$$

$$M_2(628 \text{ rad/s}) = \frac{1}{\left\{ \left[ 1 - \left( \frac{\omega}{\omega_n} \right)^2 \right]^2 + \left( 2\zeta \frac{\omega}{\omega_n} \right)^2 \right\}^{1/2}} = 1.0,$$

$$\Phi_1(628 \text{ rad/s}) = -\tan^{-1} \omega\tau = -0.721 \text{ rad},$$

$$\Phi_2(628 \text{ rad/s}) = -\tan^{-1} \frac{2\zeta \omega/\omega_n}{1 - (\omega/\omega_n)^2} = -0.036 \text{ rad}$$

Then, with  $K_{system} = (2\text{V}/^\circ\text{C})(1 \text{ V/V})$ ,

$$\begin{aligned} y_{steady}(t) &= (10)(2)(1) + (50)(2)(1)(1)(.75)\sin(628t + (-0.721-0.036)) \\ &= 20 + 75 \sin(628t - 0.757) \text{ V} \end{aligned}$$

### PROBLEM 3.35

KNOWN: Two coupled second order systems

Input signal:  $2 \leq C_1 \leq 5 \text{ mm}$  and  $f_1 = 85 \text{ Hz}$

Constraint:  $\delta(\omega) \leq \pm 0.05$

FIND:  $\omega_n, \zeta$  for each of the two measurement system stages

#### SOLUTION

There are a number of ways to approach this problem and there is not one answer. The following is one approach to choosing a system.

The input function has the form,

$$\begin{aligned} F(t) &= (5+2)/2 + [(5-2)/2]\sin 170\pi t \text{ mm} \\ &= 3.5 + 1.5 \sin 170\pi t \text{ mm} \end{aligned}$$

Now in order to set the specifications, we need to examine how the system as a whole will respond to the input of frequency  $170\pi \text{ rad/s}$ . For coupled systems,

$$KG(s) = K_1 G_1(s) K_2 G_2(s) = K_1 K_2 M_1 M_2 e^{i(\Phi_1 + \Phi_2)}$$

with

$$M(\omega)_{\text{system}} = M_1(\omega) M_2(\omega)$$

$$K_{\text{system}} = K_1 K_2$$

$$\Phi_{\text{system}} = \Phi_1(\omega) + \Phi_2(\omega)$$

In general, for second order systems,

$$M_2(\omega) = \frac{1}{\left\{ \left[ 1 - (\omega/\omega_n)^2 \right]^2 + (2\zeta \omega/\omega_n)^2 \right\}^{1/2}}$$

$$\Phi_2(\omega) = -\tan^{-1} \frac{2\zeta \omega/\omega_n}{1 - (\omega/\omega_n)^2}$$

The dynamic error of the system is found from

$$\delta(\omega)_{\text{system}} = M(\omega)_{\text{system}} - 1$$

If we accept,  $\delta(\omega) \leq \pm 0.05$  as a maximum constraint, then this means

$$0.95 \leq M_1 M_2 \leq 1.05$$

So choose any value for  $M_1$  and  $M_2$  that is within this constraint.

For example, we could take,

$$M_1 = 0.98 \text{ and } M_2 = 1.02$$

as one possible design target. With these values selected, we examine each stage in the system.

#### Input Stage Device

Suppose we fix  $\zeta_1 = 0.7$ , then for  $M_1(170\pi) = 0.98$ ,  $\omega_{n_1} = 81\pi$  rad/s. The phase shift then becomes,  $\Phi_1(170\pi) = -0.71$  rad.

#### Output Stage Device

Suppose we fix  $\zeta_2 = 0.6$ , then for  $M_2(170\pi) = 1.02$ ,  $\omega_{n_2} = 48\pi$  rad/s. The phase shift then becomes,  $\Phi_2(170\pi) = -0.35$  rad.

#### COMMENT

The actual values for  $\zeta$  and  $\omega_n$  may be limited due to availability from vendors. But the problem demonstrates one approach to dealing with such an open ended problem. Note also that the phase shift for the system selected is about  $-0.61$  rad, which is well tolerated for most purposes and is within the range in which phase is linear with frequency.

### PROBLEM 3.36

**KNOWN:**  $\omega_R = 82.5 \text{ rad/s}$

$$\zeta = 0.4$$

$$K = 2 \text{ V/N}$$

$$F(t): A_0 = 3 \text{ N}, C_1 = C_2 = 1 \text{ N}, \omega_1 = 8 \text{ rad/s} = 1.27 \text{ Hz}, \omega_2 = 165 \text{ rad/s} = 26.26 \text{ Hz}$$

**FIND:**  $y(t)$

### SOLUTION

$$y(t) = y_h + 3K + KC_1M(8) \sin[8t + \phi(8)] \\ + KC_2M(165) \sin[165t + \phi(165)]$$

For this system the natural frequency is

$$\omega_n = \omega_R / (1 - 2\zeta^2)^{1/2} = 82.5 \text{ r/s} / (1 - 2(0.4)^2)^{1/2} = 100 \text{ rad/s}$$

With  $\omega_1 / \omega_n = 0.08$  and  $\omega_2 / \omega_n = 1.65$  and  $\zeta = 0.4$ , use of Figure 3.16 and 3.17 or equations 3.21 and 3.19 give:

$$M(8 \text{ rad/s}) = 1.004 \text{ (using equations)}$$

$$M(165 \text{ rad/s}) = 0.46$$

$$\phi(8 \text{ rad/s}) = -3.7^\circ$$

$$\phi(165 \text{ rad/s}) = -142.5^\circ$$

The transient response  $y_h$  is given by equation 3.14a and appropriate initial conditions.

$$y(t) = y_h + 6 + 2 \sin[8t - 3.7^\circ] + 0.92 \sin[165t - 142.5^\circ]$$

Program Sampling (companion disk) was used to generate the amplitude spectrum for  $y(t)$

Problem 3.36 (cont)

### 3.36

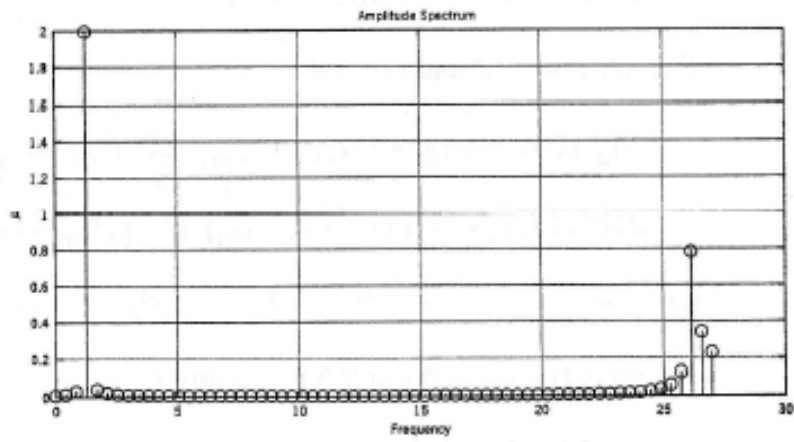
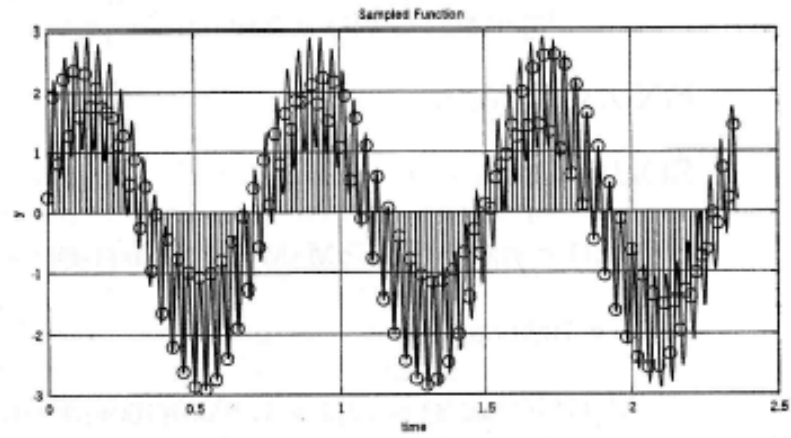

### PROBLEM 3.37

KNOWN: First stage:  $\tau_1 = 0.10$  s,  $K_1 = 1$  V/V

Second stage:  $K_2 = 100$  V/V,  $f_n = 15000$  Hz,  $\zeta = 0.8$

Input signal:  $F(t) = 5 \sin 2000 t$  [mV]

FIND:  $y(t)$ ,  $\zeta(f)$ ,  $\beta_1$

SOLUTION

$$y(t) = y_h(t) + K_1 K_2 M_1 M_2 * 5 \sin(1000t + \Phi_1 + \Phi_2) \text{ mV}$$

For  $\omega = 1000$  rad/s:

$$M_1(1000\text{rad/s}) = \frac{1}{\{1 + (\omega\tau)^2\}^{1/2}} = \frac{1}{\{1 + (1000 * 0.1)^2\}^{1/2}} = 0.995$$

$$\Phi_2(\omega) = -\tan^{-1} \omega\tau - \tan^{-1}(1000 * 0.100) = -5.7^\circ$$

For  $\omega/\omega_n = 0.42$  and  $\zeta = 0.8$ :

$$M_2(1000) = \frac{1}{\left\{ \left[ 1 - (\omega/\omega_n)^2 \right]^2 + (2\zeta \omega/\omega_n)^2 \right\}^{1/2}} = 0.95$$

$$\Phi_2(1000) = -\tan^{-1} \frac{2\zeta \omega/\omega_n}{1 - (\omega/\omega_n)^2} = -39.2^\circ$$

so:

$$y(t) = y_h(t) + 0.467 \sin[1000t - 44.9^\circ] \text{ mV}$$

COMMENT

This output is amplified by the second stage ( $K_2 = 100\text{V/V}$ ).

A second stage with a higher natural frequency would bring  $M_2$  closer to unity and decrease the phase shift.

## PROBLEM 3.38

KNOWN: frequency bandwidth 0 to 20,000 Hz  $\pm 1\text{dB}$

FIND: Translate this specification into words

### SOLUTION

A typical audio amplifier increases the output amplitude relative to the input amplitude by some amount and that amount is called its gain. You may be more familiar with the term 'power' instead of gain, such as in the expression 100 Watts power. This power is simply another way to state the gain.

Now in our equations, the gain is just the static sensitivity,  $K$ , for the amplifier at some reference frequency. So the amplifier gain is stated at some reference frequency. In literature pertaining to amplifiers, the static sensitivity is called the static gain – but it all means the same thing.

This system specification states that for an input frequency within 0 to 20,000 Hz the amplifier gain does not vary by more than  $1\text{dB}$ . Another way to write this is:  $-1\text{dB} \leq KM(0 \leq f \leq 20000\text{Hz}) \leq 1\text{dB}$  where  $KM$  is the output amplitude. So the product  $KM(f)$  is frequency dependent and therefore the amplifier gain is frequency dependent.

Now, from the definition of decibel,  $+1\text{dB}$  is equivalent to  $M(f) = 1.12$  or  $\delta(f) = +0.12$  or a 12% increase over the reference amplifier gain. The  $-1\text{dB}$  is equivalent to  $M(f) = 0.89$  or  $\delta(f) = -0.11$  or a 11% decrease over the reference amplifier gain. So between 0 and 20,000 Hz, the signal amplitude is essentially constant to within  $\pm 1\text{dB}$ . A typical audio amplifier will have some spikes and troughs across its frequency response. But the specification is explicit that the amplitude never varies by more than the  $1\text{dB}$ .

Music signals are a series of sinusoidal frequency terms. Even single notes, such as a middle C, consist of a fundamental frequency and harmonics. The harmonics give distinction to the source of the sound so that different instruments are recognizable. Under normal circumstances, we would want the reproduction electronics to neither add nor detract from the signal information (i.e. we want  $M(f) = 1$  across the spectrum).

### PROBLEM 3.39

KNOWN: Input Stage Device

$$\begin{aligned} K_1 &= 10 \text{ mV/mm} \\ \omega_{n_1} &= 10000 \text{ rad/s} \\ \zeta_1 &= 0.6 \end{aligned}$$

Output Stage Device

$$\begin{aligned} K_2 &= 1 \text{ mm/mV} \\ \omega_{n_2} &= 700 \text{ rad/s} \\ \zeta_2 &= 0.7 \end{aligned}$$

$$y_{\text{steady}}(t) = 90 \sin(4\pi t + \Phi_1) + 50 \sin(80\pi t + \Phi_2)$$

FIND: Determine if measurement system specifications are adequate for the input signal.

SOLUTION

Both devices are second order systems:

$$M(\omega) = \frac{1}{\left\{ \left[ 1 - (\omega/\omega_n)^2 \right]^2 + (2\zeta \omega/\omega_n)^2 \right\}^{1/2}} \quad \Phi(\omega) = -\tan^{-1} \frac{2\zeta \omega/\omega_n}{1 - (\omega/\omega_n)^2}$$

For the output signal given, the input signal must have the form

$$F(t) = 90/KM(4) \sin 4\pi t + 50/KM(80\pi) \sin 80\pi t$$

For coupled systems,

$$KG(s) = K_1 G_1(s) K_2 G_2(s) = K_1 K_2 M_1 M_2 e^{i(\Phi_1 + \Phi_2)}$$

Then for second order systems,

$$\begin{aligned} M_1(4\pi) &= 1 & \Phi_1(4\pi) &= 0 \\ M_1(80\pi) &= 1 & \Phi_1(80\pi) &= 0 \\ M_2(4\pi) &= 1 & \Phi_2(4\pi) &= -0.02 \text{ rad} \\ M_2(80\pi) &= 0.99 & \Phi_2(80\pi) &= -0.52 \text{ rad} \end{aligned}$$

Hence,

$$\begin{aligned} M_{\text{system}}(4\pi) &= 1 & \Phi_{\text{system}}(4\pi) &= -0.02 \text{ rad} \\ M_{\text{system}}(80\pi) &= 0.99 & \Phi_{\text{system}}(80\pi) &= -0.52 \text{ rad} \\ K_{\text{system}} &= 10 \text{ mm/mm} \end{aligned}$$

The excellent response characteristics of the measurement system make it a suitable choice for this measured signal.

### PROBLEM 3.40

KNOWN:  $F(t) = A_1 \sin 170\pi t + A_2 \sin 254\pi t + A_3 \sin 904\pi t$

Input Stage Device Availability

$$1000\pi \leq \omega_n \leq 2000\pi \text{ rad/s}$$

$$\zeta = 0.5$$

Output Stage Device

$$\delta(0.1 \leq f \leq 250\text{kHz}) \leq -3 \text{ dB}$$

FIND: Select an acceptable value for  $\omega_n$

#### SOLUTION

There are numerous approaches and solutions to this problem. We offer one possible solution to illustrate the design selection approach.

The second order displacement transducer will be most heavily tested at the highest input frequency. Suppose we impose the restriction on the transducer that  $\delta_1(\omega) \leq \pm 0.1$  where we let  $\delta_1(\omega)$  be the dynamic error due to the transducer. Then, for a second order device,

$\omega_n$ [rad/s]	$M(904\pi)$	$M(254\pi)$	$M(170\pi)$	$\omega_R$ [rad/s]
$1000\pi$	1.03	1.03	1.01	$707\pi$
$1500\pi$	1.14	1.01	1.00	$1060\pi$
$1750\pi$	1.12	1.01	1.00	$1237\pi$
$2000\pi$	1.09	1.01	1.00	$1414\pi$

But lets check this performance out. A quick inspection of Figure 3.16 shows that the input transducer will experience some resonance behavior if  $\omega_n$  is too close to the input frequencies. For example, with  $\omega_n = 1000\pi$  rad/s, the  $904\pi$  rad/s input frequency drives the transducer into the post peak resonance region of the graph. That is not good.

So it would better to select a transducer where  $\omega \ll \omega_R$ . To do this, raise the natural frequency. So we select  $\omega_n = 2000\pi$  rad/s. Now we should meet our criterion without resonance problems. The spectrum measurement device will not be a factor owing to its wide frequency response relative to these input frequencies.

### PROBLEM 3.41

**KNOWN:** Three Amplitudes at three times  
 $\omega_d = 10 \text{ rad/sec}$

**FIND:**  $\omega_n$  and  $\zeta$

### SOLUTION

Three amplitudes of  $A_1 = 17 \text{ mV}$ ,  $A_{16} = 9 \text{ mV}$ , and  $A_{32} = 5 \text{ mV}$  occur at times:

$t_1 = T_d/2 = 0.3142 \text{ s}$ ,  $t_{16} = 15T_d + t_1 = 9.739 \text{ sec}$ , and  $t_{32} = 31T_d + t_1 = 19.792 \text{ s}$

The amplitudes decay at the rate given by:

$$y_{\max} = e^{-\omega_n \zeta t}$$

Taking the log of both sides:

$$\ln(y_{\max}) = \ln(e^{-\omega_n \zeta t}) = -\omega_n \zeta t$$

If plotted, the slope of this relation will be:  $m = -\omega_n \zeta$

The data follow the relation:  $Y = -0.06X + 2.838$ . The slope is  $-0.06$ .

$$\omega_n \zeta = 0.06$$

$$\omega_n = \omega_d / (1 - \zeta^2) = 10 / (1 - \zeta^2)$$

Solving simultaneously gives:  $\omega_n = 10.01 \text{ rad/sec}$ ;  $\zeta = 0.006$

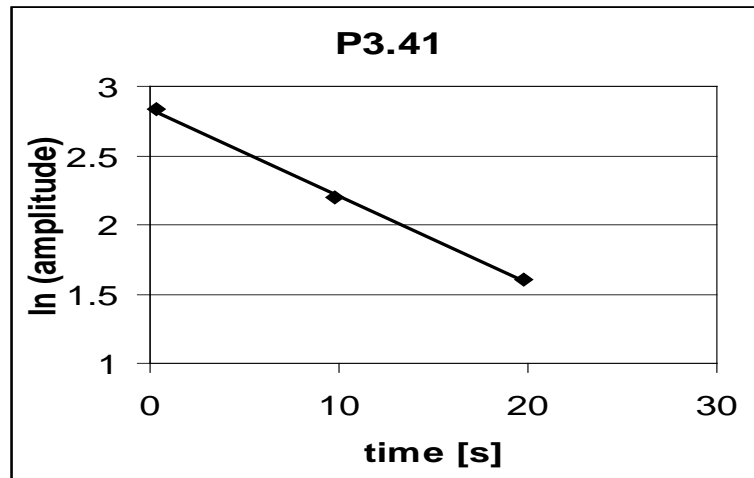

## PROBLEM 3.42

This problem exercises the ability to articulate an understanding of the concepts of static sensitivity, natural frequency and damping ratio relative to a measurement system. The short essay should be written in the student's own words rather than a restating of text material. Each student understands material in their own individual way. So this is an opportunity for written technical communication between instructor and student.

### PROBLEM 3.43

KNOWN: RL circuit (only one reactive element here, therefore first order)

$$R = 4 \Omega$$

$$L = 0.1 \text{H}$$

$$E_i(t) = 50 \text{ V for } t > 0$$

$$t(0) = 0$$

FIND:  $I(t)$

SOLUTION

At  $t = 0$ , the switch closes applying the 50V potential across the RL circuit. This is a step function input as the circuit sees it, i.e.,  $E_i(t) = 50U(t)$  V where  $E_i(t) = 0$  for  $t < 0^-$  and  $E_i(t) = 50$  V for  $t > 0^+$ . Around the loop:

$$E_i(t) - RL - L \frac{dI}{dt} = 0 \quad t > 0$$

or

$$\frac{L}{R} \dot{I} + I = \frac{1}{R} E_i(t) \quad t > 0$$

This is of the form  $\tau \dot{y} + y = KF(t)$ , so by inspection:  $\tau = L/R$ ;  $K = 1/R$ ,  $F(t) = E_i(t)$ .

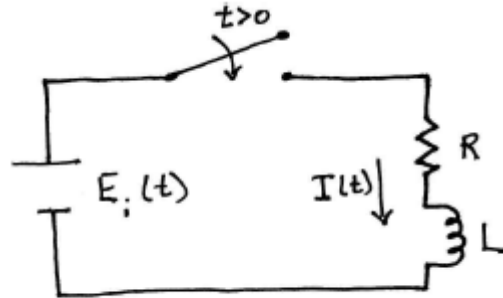

$$I(t) = \frac{E_i(t)}{R} + \left(0 - \frac{E_i(t)}{R}\right) e^{-tR/L} = 12.5 - 12.5e^{-t/0.025} \quad \text{for } t > 0^+$$

$$= 12.5(1 - e^{-t/0.025}) \quad \text{amps for } t > 0^+$$

COMMENT

In practice, a halfwave rectifier  $D_1$  with a free-wheeling diode  $D_2$  would be added to the circuit to avoid an inductive voltage spike that can arise when applying a current surge to an inductor.

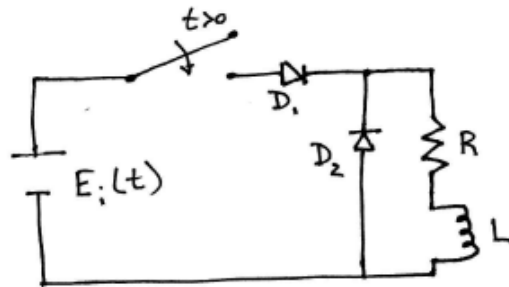

## PROBLEM 3.44

KNOWN: RC circuit (it is first order because there is only one reactive element)

$$R = 1 \text{ k ohm}$$

$$C = 1000 \mu\text{F}$$

$$E_B = 6 \text{ V } (= E_i(t) \text{ for } t > 0^+)$$

$$E_c(0) = 0 \text{ (this assumes capacitor is initially totally discharged)}$$

FIND:  $t_{90}$  time for capacitor to reach 90% of its maximum energy level.

### SOLUTION

For a flash circuit initially at zero potential, the closing of the switch is a step function change in voltage, i.e.  $E_i(t) = E_B U(t)$  and  $E_i(t < 0^-) = 0$  and  $E_i(t > 0^+) = E_B$ .

Lets start by estimating the total energy that can be stored in the capacitor,

$$e = \frac{1}{2} C E_c^2 = \frac{1}{2} C E_B^2 = (0.5)(1000 \times 10^{-6} \text{F})(6 \text{ V})^2 = 18 \times 10^{-3} \text{J}$$

so, 90% of this amount is  $e_{90} = (0.9)(18 \times 10^{-3} \text{J}) = 16.2 \times 10^{-3} \text{J}$ . For the capacitor to reach this energy level, its voltage  $E_c$  is  $e_{90} = \frac{1}{2} C E_c^2$  or  $E_c = 5.692 \text{ V}$ . So we seek the time required to charge the capacitor to this voltage level.

For the RC circuit for  $t > 0$ , we want to examine the capacitor voltage as a function of time as driven by the applied battery voltage:

$$\dot{E}_c - \frac{1}{RC} E_c - \frac{1}{RC} E_B = 0$$

or

$$RC \dot{E}_c - E_c = E_B$$

But this is of first order form

$$\tau \dot{E}_c - E_c = KF(t)$$

So,  $\tau = RC = (1000 \Omega)(1000 \times 10^{-6} \text{ F}) = 1 \text{ s}$ , and  $K = 1 \text{ V/V}$ , and  $F(t) = E_B$ .

$$\Gamma(t) = 0.1 = \frac{E_c(t) - 6\text{V}}{0 - 6\text{V}} = e^{-t/\tau} = e^{-t}$$

with  $E_c(t) = 5.692 \text{ V}$ , then  $t_{90} = 2.97 \text{ s}$ .

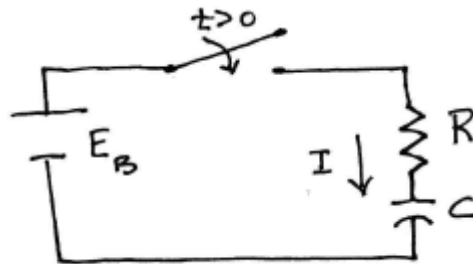

## PROBLEM 3.45

Program Thermal Response plots the time response from a first order device. The input magnitude is controlled by the user and may be varied with time. The instrument time constant is set by the user and may be varied with time. The user should select a time constant and an amplitude, start the program, and then vary the amplitude – creating a step change in input.

The system response slows down (relative to time) as the time constant is increased independent of the magnitude of the step change imposed.

## PROBLEM 4.1

**KNOWN:**  $N > 1000$ ;  $\bar{x} = 9.2$  units ;  $S_x = 1.1$  units

**FIND:** Range of  $x$  in which 50% of all measurements should fall.

**ASSUMPTIONS:** Measurand follows a normal density function  
Data set sufficiently large such that  $\bar{x} \approx x'$  and  $S_x \approx \sigma$

### SOLUTION

By assuming that the data is sufficiently large such that its population behaves as an infinite population, we can find the interval defined by

$$x' - z_1 \sigma \leq x_i \leq x' + z_1 \sigma$$

as follows. We can find  $P(x' + z_1 \sigma)$  from the one-sided integral solution to

$$P(z_1) = \frac{1}{[2\pi]^{1/2}} \int_0^{z_1} e^{-\beta^2/2} d\beta$$

This solution is given in Table 4.3 for  $p(z_1) = 0.25$  (one half of the 50% probability sought) as  $z_1 = 0.674$ . Then, we should expect that 50% of the  $x_i$  values lie in the interval given by

$$9.2 - 0.7425 \leq x_i \leq 9.2 + 0.7425 \quad (50\%)$$

### COMMENT

We can see from Table 4.4 that as  $N$  becomes large the value for  $t$  approaches a value given by  $z_1$ .

## PROBLEM 4.2

**KNOWN:**  $N > 10\,000$ ;  $\bar{x} = 204$  units ;  $S_x = 18$  units

**FIND:**  $x' - z_1\sigma \leq x \leq x' + z_1\sigma$  at  $P = 90\%$

**ASSUMPTIONS** Measurand follows a normal density function  
Data set sufficiently large such that  $\bar{x} \approx x'$  and  $S_x \approx \sigma$

### SOLUTION

Using the definition  $z_1 = (x_1 - x')/\sigma$  we find the  $z_1$  value corresponding to the one-sided probability integral  $p(z_1) = 0.45$  from Table 4.3. This gives,

$$z_1 = 1.65$$

Then,

$$1.65 = (x_1 - x')/\sigma$$

or

$$1.65\sigma = x_1 - x'$$

or

$$x_1 = x' + 1.65\sigma$$

But a normal (Gaussian) distribution is symmetric about the mean value. Hence, for 90% probability (2)(0.45),

$$x' - 1.65\sigma \leq x \leq x' + 1.65\sigma \quad (90\%)$$

or

$$174.3 \leq x \leq 233.7 \text{ units } (90\%)$$

### PROBLEM 4.3

KNOWN:  $\bar{x} = 121.6$  psi  
 $S_x = 14$  psi  
N is very large

FIND:  $P(x > 150 \text{ psi})$

ASSUMPTIONS: Normal distribution  
 $S_x \approx \sigma$ ;  $\bar{x} \approx x'$

### SOLUTION

The z variable is defined by

$$z_1 = -(x_1 - x') / \sigma = -(121.6 - 150) / 14 = 2.028$$

We look up  $P(2.028)$  from Table 4.3. Interpolation gives

$$P(2.028) = 0.4786$$

This expresses the probability that  $121.6 \leq x \leq 150$  psi. Then, the probability that  $x > 150$  psi is

$$0.5 - 0.4786 = 0.0214$$

or there is a 2.14% probability that any measurement will yield a value in excess of 150 psi.

## PROBLEM 4.4

**KNOWN:** Toss of four coins

**FIND:** Develop the histogram for the outcome of any toss.  
State the probability of obtaining three heads on one toss.

### SOLUTION

A coin has two distinct sides, so each toss has two possible outcomes. With four coins, there will be  $2^4 = 16$  possible outcomes of any one toss of the four coins. The probability of three heads is 4 in 16 or 25%. The possible outcomes are:

Number of Heads	$n_j$
4	1
3	4
2	6
1	4
0	1

The histogram is shown below. Because of the few number of tosses, the development of the histogram is primitive. But the symmetry is obvious. This type of distribution is best

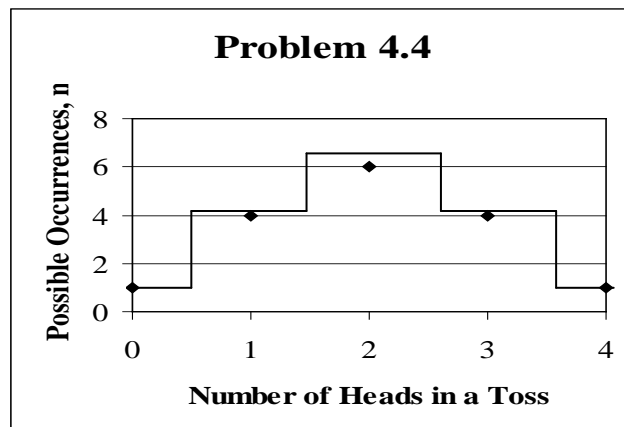

described as a Binomial distribution (see Table 4.2).

### COMMENT

The binomial distribution shape is similar to the Gaussian (normal) distribution, except that it can lack the extended "tails" found with the Gaussian shape. As the number of possible outcomes (number of coins tossed) becomes large (say 30 or more), the two distributions become nearly identical over a wide interval about the mean and the Gaussian distribution can be used for ease.

## PROBLEM 4.5

### SOLUTION

In the matchbox game, the frequency distribution will more closely resemble a Gaussian (normal) distribution as  $N$  becomes larger. This is because each shot is independent of the other and each shot differs from the other by random variation.

A 'better' player will have a mean distance in the outcome that is close to the target point and have a low variance. That is, the player will have a low systematic error (average distance from target point) and low random error (variations from the average point).

This game and its interpretation are similar to the dart game discussed in Chapter 1 in the discussion of random and systematic error. In the US, a variation of this game is called 'matchbook football' where the objective is to slide the matchbook across a table so that it just overhangs the table edge.

## PROBLEM 4.6

**FIND:** Histogram for Table 4.8, Column 1.

### SOLUTION

A distribution is not unique and we give one possible solution.  
For  $N = 20$  values,  $K = 7$  is selected. The interval (bin) values are

Bin #	Interval range
1	<49
2	49 - 49.6
3	49.6 - 50.2
4	50.2 - 50.8
5	50.8 - 51.4
6	51.4 - 52
7	>52

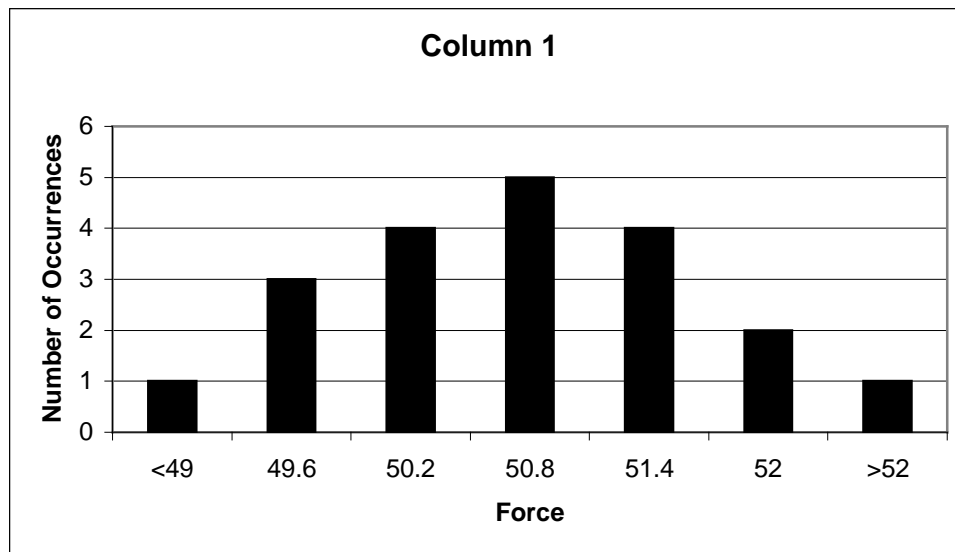

## PROBLEM 4.7

**FIND:** Frequency distribution for Table 4.8, Column 3.

### SOLUTION

A distribution is not unique and we give one possible solution. For  $N = 20$  values,  $K = 7$  is selected. The interval (bin) values are

Bin #	Interval range
1	<49
2	49 - 49.6
3	49.6 - 50.2
4	50.2 - 50.8
5	50.8 - 51.4
6	51.4 - 52
7	>52

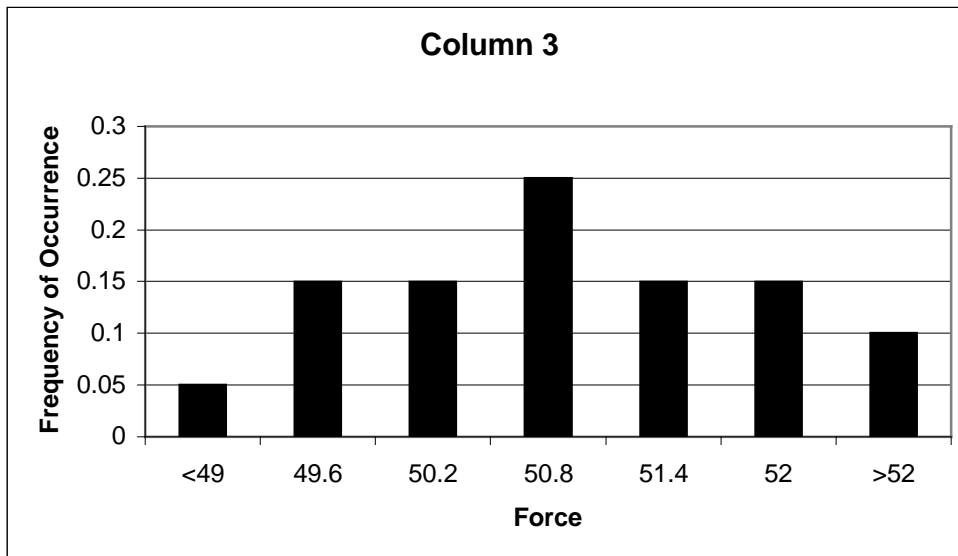

## PROBLEM 4.8

**FIND:** Compare and discuss histograms for Table 4.8, Column 1,2 and 3.

### SOLUTION

A distribution is not unique and we give one possible solution. For  $N = 20$  values,  $K = 7$  is selected. The interval (bin) values are

Bin #	Interval range
1	<49
2	49 - 49.6
3	49.6 - 50.2
4	50.2 - 50.8
5	50.8 - 51.4
6	51.4 - 52
7	>52

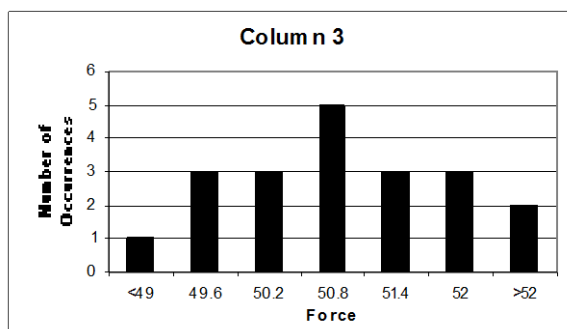
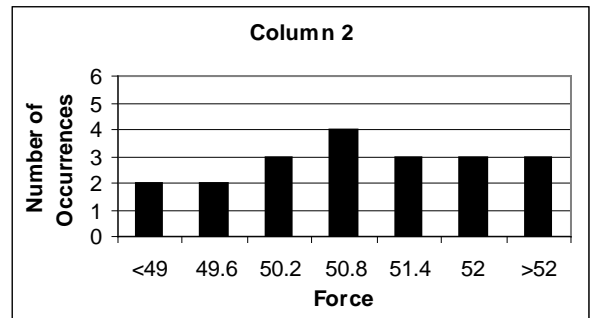
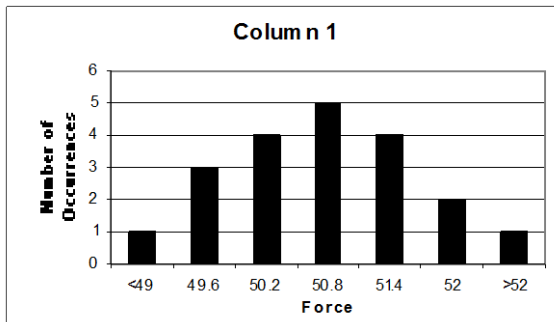

The variations seen are likely a consequence of (1) normal variation due to finite data sets, (2) random errors in each measurement. Each histogram clearly shows a central tendency and in each case it is in bin 4.

## PROBLEM 4.9

**KNOWN:** Three datasets from Table 4.8 Column 1,2, and 3  
 $N = 20$

**FIND:**  $\bar{F}$ ,  $S_F$ , and  $S_{\bar{F}}$

### SOLUTION

The mean value for each dataset is

$$\bar{F} = \frac{1}{N} \sum_{i=1}^N F_i$$

$$\bar{F}_1 = 50.5 \text{ N} \quad \bar{F}_2 = 50.7 \text{ N} \quad \bar{F}_3 = 50.6 \text{ N}$$

The standard deviation for each dataset is

$$S_F = \left[ \frac{1}{N-1} \sum_{i=1}^N (F_i - \bar{F})^2 \right]^{1/2}$$

with  $\nu = N - 1 = 19$  for each individual dataset.

$$S_{F_1} = 1.00 \text{ N} \quad S_{F_2} = 1.21 \text{ N} \quad S_{F_3} = 1.01 \text{ N}$$

The standard deviation of the means expected based on each individual dataset is

$$S_{\bar{F}} = \frac{S_F}{(N)^{1/2}}$$

$$S_{\bar{F}_1} = 0.22 \text{ N} \quad S_{\bar{F}_2} = 0.27 \text{ N} \quad S_{\bar{F}_3} = 0.23 \text{ N}$$

The standard deviation of the means value simply reflects the possible random error in the mean value of the dataset relative to the true mean value of the data population due to data scatter.

## PROBLEM 4.10

**KNOWN:** Data from Table 4.8 , Column 1,2, and 3  
N = 20

### SOLUTION

Dataset: 1      2      3  
Minimum: 48.9 48.7 48.9 N  
Maximum: 52.4 52.6 52.4 N  
Means:      50.5 50.7 50.6 N

While each dataset shows a range (maximum – minimum) of possible values, the data clearly show a preference for a value in the range 50.2 to 50.8 N (or bin 4). This is what is meant by a central tendency in a population – a tendency for a data point to have or be close to one value over all others.

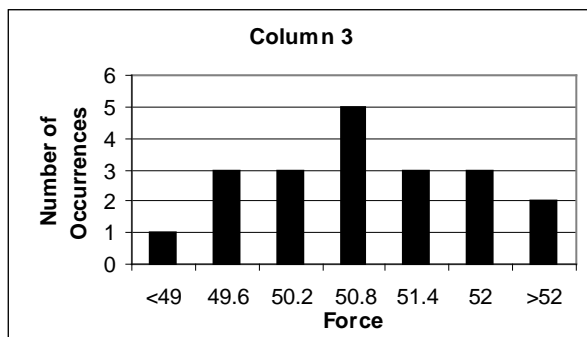
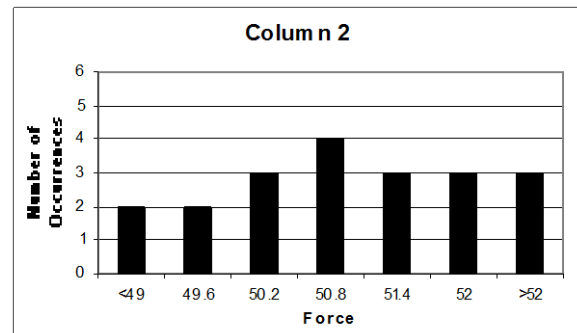
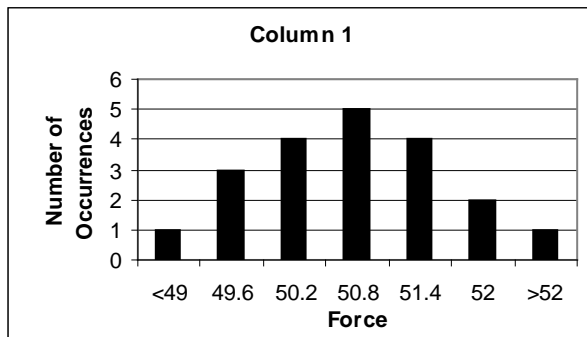

## PROBLEM 4.11

**KNOWN:** Data of Table 4.8, Column 1  
 $N = 20$

**FIND:**  $\bar{F} \pm tS_F$  (95%)

### SOLUTION

For this dataset in Column 1:

$$\bar{F} = \frac{1}{N} \sum_{i=1}^N F_i = 50.5N$$

$$S_F = \left[ \frac{1}{N-1} \sum_{i=1}^N (F_i - \bar{F})^2 \right]^{1/2} = 1.00N$$

with  $\nu = N - 1 = 19$ . Then from Table 4.4,  $t_{19,95} = 2.093$ . The scatter of the measured data set can be expressed by

$$F_i = \bar{F} \pm t_{19,95} S_F \quad (95\%) = 50.5 \pm (2.093)(1.00) = 50.5 \pm 2.1 N \quad (95\%)$$

Here  $F_i$  denotes the value of any measurement of force,  $F$ .

$$\text{Column 2:} \quad F_{i_2} = \bar{F} \pm t_{19,95} S_F \quad (95\%) = 50.7 \pm 2.53 N \quad (95\%)$$

$$\text{Column 3:} \quad F_{i_3} = \bar{F} \pm t_{19,95} S_F \quad (95\%) = 50.6 \pm 2.11 N \quad (95\%)$$

### COMMENT

The above probability statement reflects the scatter of the data set. In effect, it provides a range of values in which any measured value is expected to fall with 95% probability. A 95% probability with this statistical statement implies that at least 19 out of every 20 measurements are expected to fall in the range defined for  $F_i$ . Indeed, inspection of the dataset shows that this is a true statement.

## PROBLEM 4.12

**KNOWN:** Data of Table 4.8, Column 1  
 $N = 20$

**FIND:**

$$\bar{F} \pm tS_{\bar{F}} \quad (95\%)$$

### SOLUTION

For this dataset in Column 1:

$$\bar{F} = \frac{1}{N} \sum_{i=1}^N F_i = 50.5N$$

$$S_F = \left[ \frac{1}{N-1} \sum_{i=1}^N (F_i - \bar{F})^2 \right]^{1/2} = 1.00N$$

$$S_{\bar{F}} = \frac{S_F}{N^{1/2}} = 1.0 / \sqrt{20} = 0.22N$$

with  $\nu = N - 1 = 19$ . Then from Table 4.4,  $t_{19,95} = 2.093$ . Then, we can expect that the true mean value should lie within the interval defined by

$$\bar{F} \pm tS_{\bar{F}} \quad (95\%) = 50.5 \pm 0.47N(95\%)$$

This gives the mean value for this data set and a statement of the range of mean values we would expect to find from any data set. A 95% probability indicates that at least 19 out of every 20 complete data sets should show a sample mean value within the range. Compare the meaning of this statement to that found in Problem 4.11. They are very different!

$$\text{Column 2: } \bar{F} \pm tS_{\bar{F}} \quad (95\%) = 50.7 \pm 0.57N(95\%)$$

$$\text{Column 3: } \bar{F} \pm tS_{\bar{F}} \quad (95\%) = 50.6 \pm 0.47N(95\%)$$

In all three datasets, the mean values fall within an overlapping ring, as predicted.

### COMMENT

The reasoning behind this confidence interval for the mean value lies within the limitations of finite statistics. While the sample mean value defines the mean value of the 20 data points exactly, it is not necessarily the true mean value of the measured variable (compare the

results for these three real data sets in columns 1,2, and 3 – each has a different sample mean). Different data sets of the same variable will give somewhat different mean values. As  $N$  becomes large, the sample mean will approach the true mean and the confidence interval will go to zero. Remember this assumes that there is no systematic error acting on the measurement.

## PROBLEM 4.13

**KNOWN:** Data of Table 4.8, Column 3  
One additional measurement

**FIND:**  $\bar{F} - t_{95} S_F \leq F_{21} \leq \bar{F} + t_{95} S_F$

### SOLUTION

We can show that

$$F_{i_3} = \bar{F} \pm t_{19,95} S_F \quad (95\%) = 50.6 \pm 2.11 \text{ N} \quad (95\%)$$

where  $F_i$  denotes the value of any measurement of force,  $F$ . Hence, an additional measurement of  $F$  would be expected to fall within the range of 48.49 to 52.71 with 95% probability (likelihood).

## PROBLEM 4.14

**KNOWN:** Data of Table 4.8, Columns 1, 2 and 3.

$N = 19$  (repetitions)

$M = 3$  (replications)

**FIND:**  $\langle \bar{F} \rangle \pm t_{95} \langle S_{\bar{F}} \rangle$

**ASSUMPTIONS:** Data sets in Columns 1,2 and 3 represent duplicate data sets of the same measured variable under similar operating conditions.

### SOLUTION

We can find the pooled mean value of the combined data sets

$$\langle \bar{F} \rangle = \frac{1}{MN} \sum_{j=1}^M \sum_{i=1}^N F_{ij} = \frac{1}{M} \sum_{j=1}^3 \bar{F}_j = 50.6N$$

Where  $M = 3$  and  $N = 20$ . The pooled standard deviation

$$\langle S_F \rangle = \left( \frac{1}{M(N-1)} \sum_{j=1}^M \sum_{i=1}^N (F_{ij} - \bar{F}_j)^2 \right)^{1/2} = 1.06N$$

The pooled standard deviation of the means is

$$\langle S_{\bar{F}} \rangle = \frac{\langle S_F \rangle}{(MN)^{1/2}} = 0.14N$$

with degrees of freedom,  $\nu = M(N-1) = 57$ . From Table 4.4,  $t_{57,95} = 2.00$ . Then, the best estimate of the true value is given by

$$F' = \langle \bar{F} \rangle \pm t_{95} \langle S_{\bar{F}} \rangle = 50.6 \pm 0.28N \quad (95\%)$$

### COMMENT

We can see that the confidence interval for the ensemble mean value is reduced over any one dataset. While column 3 predicts the ensemble mean value the closest, all three are well within the confidence band. We learn that the more information (measurements) we have about a dataset, the more confident we become in their true values. Yet, very reasonable estimates can be made from smaller datasets. The number of measurements, required confidence, and the cost of additional measurements all must be carefully weighted.

## PROBLEM 4.15

KNOWN: Table 4.8, Column 1 dataset

$$\bar{x} = 50.5N$$

$$S_x = 1 N$$

FIND: Test to determine if the dataset follows a normal (Gaussian) distribution

SOLUTION

With  $x' \approx \bar{x}$  and  $\sigma_x \approx S_x$ , we test. The data lends itself to 7 intervals:

j	interval	$n_j$	$n_j'$	$(n_j - n_j')^2 / n_j'$
1	0 - 49	1	1.34	0.0863
2	49 - 49.6	3	2.35	0.1823
3	49.6 - 50.2	4	3.96	0.0004
4	50.2 - 50.8	5	4.71	0.0179
5	50.8 - 51.4	4	3.96	0.0004
6	51.4 - 52	2	2.34	0.0494
7	52 - above	1	1.34	0.0863
			$\Sigma =$	0.423

As an example, consider  $j = 2$ , where the number of observations is  $n_2 = 3$ . The expected number of outcomes for a normal distribution is estimated to be 2.346, as follows:

$$P(49 < x_i < 50.5) - P(49.6 < x < 50.5) = P(z_a) - P(z_b)$$

$$z_a = \frac{x - x'}{\sigma} = \frac{49 - 50.5}{1} = -1.5 \quad z_b = \frac{x - x'}{\sigma} = \frac{49.6 - 50.5}{1} = -0.9$$

so,  $P(z_a) - P(z_b) = 0.4332 - 0.3159 = 0.1173$

for  $N = 20$ ,  $n_j' = 20 * .1173 = 2.346$ . So we expect  $\sim 2.35$  occurrences and we observe 3:

Then,  $(n_2 - n_2')^2 / n_2' = 0.182$ . This is the deviation between expected and observed.

For 7 intervals and using calculated values of the 2 statistical quantities,  $\bar{x}$  and  $S_x$ , we have  $\nu = 7 - 2 = 5$  degrees of freedom.

For  $\chi^2_\alpha(5) = 0.423$ ,  $\alpha \sim 0.995$ . So,  $P(\chi^2) = 0.005 < 0.05$  So the test is unequivocal: the distribution is a normal distribution.

## PROBLEM 4.16

KNOWN:  $x' = 100 \text{ N}$   
 $\sigma^2 = 400 \text{ N}^2$  (so,  $\sigma = 20 \text{ N}$ )

FIND: For  $N = 16$ ,  $P(90 \leq \bar{x} \leq 110) = ?$

SOLUTION

Begin by finding the  $z$  value for a corresponding  $\bar{x}$

$$z = \frac{\bar{x} - x'}{\sigma / \sqrt{N}}$$

$$\text{For } \bar{x} = 90 \text{ N, } z = \frac{90 - 100}{20 / \sqrt{16}} = -2.0$$

$$\text{For } \bar{x} = 110 \text{ N, } z = \frac{110 - 100}{20 / \sqrt{16}} = 2.0$$

$$\text{So, } P(90 \leq \bar{x} \leq 110) = P(-2.0 \leq z \leq 2.0) = 0.9544$$

So, there is about a 95% chance.

## PROBLEM 4.17

KNOWN: Large sample of grades (i.e. infinite statistics applies)

FIND: Number of A, C, D grades awarded (per 100 students)

SOLUTION

Referring to the probability graph below:

A:  $P(1.6) = 0.4452$  so that the area under the 'A' region is:  
 $0.5 - P(1.6) = 0.0548$ . Hence, 5.48% (or between 5 and 6) are A's.

C:  $P(0.4) + P(0.4) = 2P(0.4) = 0.3108$   
Hence, 31.08% (or about 31) are C's

D:  $P(1.6) - P(0.4) = 0.4452 - 0.1554 = 0.2898$   
Hence, 28.98% (or about 30) are D's.

Likewise, 5.48% are F's and 28.98% are B's.

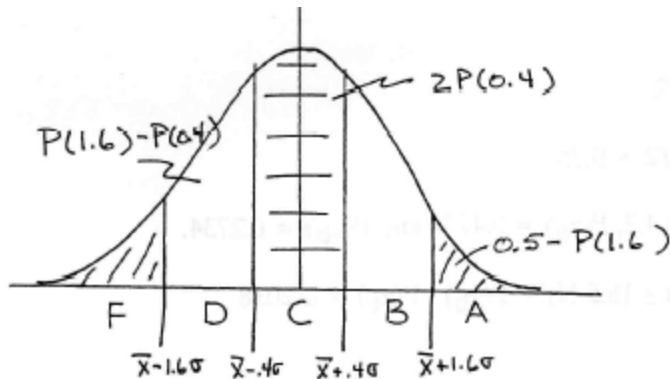

## PROBLEM 4.18

KNOWN:  $x' = 20 \mu\text{m}$ ;  $\sigma = 30 \mu\text{m}$

FIND:  $P(x_i \geq 80 \mu\text{m})$ ;  $P(50 \leq x_i \leq 80 \mu\text{m})$

### SOLUTION

$$P(x_i \geq 80 \mu\text{m}) = P(z \geq z_1)$$

So computing  $z_1$ :  $z_1 = (80 - 20)/30 = 2$

Then,  $P(z \geq 2) = 0.0228$  or a 2.28% chance (1 in 44).

$$P(50 \leq x_i \leq 80 \mu\text{m}) = P(z_a \leq x_i \leq z_b)$$

So computing:  $z_a = (50 - 20)/30 = 1.0$        $z_b = (80 - 20)/30 = 2.0$

$$P(z_a) = 0.1587$$

$$P(z_b) = 0.0228$$

So:  $P(50 \leq x_i \leq 80 \mu\text{m}) = P(z_a \leq x_i \leq z_b) = 0.1587 - 0.0228 = 0.1359$  or about a 14% chance (that's about 1 in 7).

## PROBLEM 4.19

KNOWN:  $N = 10$ ;  $x_i$

FIND:  $\bar{x}$ ;  $S_x^2$ ;  $P(x \leq 203 \mu\text{m})$

ASSUMPTION: Data represents infinite population

### SOLUTION

Based on the data given, we compute:

$$\bar{x} = 209.6 \mu\text{m}$$

$$S_x^2 = 2753.1 \mu\text{m}^2$$

$$S_x = 52.5 \mu\text{m}$$

Using these values as representative of an infinite population:

$$P(x_i \leq 203 \mu\text{m}) = P(z \leq z_1)$$

$$z_1 = (203 - 209.6)/52.5 = 0.126$$

$$P(z_1) = 0.05$$

Or about 5% of the data fall between the mean value and  $203 \mu\text{m}$ . Since 50% of the data lie above the mean value, then

$$P(z \leq z_1) = 0.5 - P(z_1) = 0.45 \text{ or about 45\% will fall below } 203 \mu\text{m}.$$

## PROBLEM 4.20

KNOWN:  $p(x)$  where  $x$  is in hours

FIND: mean value of  $x$

SOLUTION

The mean value can be found from the known probability density function:

$$\begin{aligned}\bar{x} &= \int_{-\infty}^{\infty} xp(x)dx = \int_{-\infty}^{\infty} 0.001xe^{-0.001x}dx \\ &= 1000 \text{ hrs.}\end{aligned}$$

The average expected life of the bulb is 1000 hours (60,000 minutes).

## PROBLEM 4.21

### SOLUTION

In the absence of systematic error, the sample mean value estimates the true mean value with a confidence interval given by  $\pm t S_x = \pm t (S_x / \sqrt{N})$ . The value of  $S_x$  represents the standard random error in the mean value.

As the number of measurements,  $N$ , increases, the confidence improves, i.e. the interval gets smaller at a rate of  $1/N^{1/2}$ . There is some gain as the value of  $t$  drops as  $N$  becomes larger, but  $N$  is essentially 2 after 30 measurements and approaches an asymptotic value of 1.96 as  $N$  goes to infinity.

Hence, the indicator  $S_x$  in  $N = 16$  measurements improves to only twice that of  $N = 4$  measurements despite quadrupling the number of measurements:

$$S_x / \sqrt{16} \text{ versus } S_x / \sqrt{4}$$

Likewise, increasing  $N$  from 25 to 100 only halves the value of  $S_x$ .

### COMMENT

For small sample sizes, the gain in this random error is impressive for making some extra measurements. But as  $N$  increases, this gain requires considerably more measurements. Doubling  $N$  from 10 to 20 is more efficient than increasing  $N$  from 1000 to 2000. This is the "diminishing returns" in using  $N$  to improve random error.

## PROBLEM 4.22

KNOWN:  $N = 270$  with  $\bar{x} = 6.92 \text{ MN/m}^2$  and  $S_x^2 = 6.89 \text{ (MN/m}^2\text{)}^2$

FIND:  $\pm tS_x$  at 95%

### SOLUTION

The true mean value of these bricks is given by

$$x' = \bar{x} \pm tS_x (95\%)$$

With  $N = 270$ ,  $t_{269,95} = 1.96$ , so with  $S_x = [6.89 \text{ (MN/m}^2\text{)}^2]^{1/2} = 2.62 \text{ MN/m}^2$

$$\pm tS_x = \pm(1.96)(2.62 \text{ MN/m}^2) / \sqrt{270} = 0.313 \text{ MN/m}^2$$

This is the estimate for the random error in the mean value due to variation in the dataset.

We can state that

$$x' = 6.92 \pm 0.313 \text{ MN/m}^2 \quad (95\%)$$

Based on the dataset (and in the absence of other errors), there is a 95% probability that  $x'$  lies between 6.61 and 7.23  $\text{MN/m}^2$ .

## PROBLEM 4.23

KNOWN:  $N = 61$   
 $\bar{x} = 44.20 \text{ N}$   
 $S_x^2 = 4 \text{ N}^2$

FIND:  $P(45.56 \leq x \leq 48.20 \text{ N})$

### SOLUTION

The t value is defined by  $t = (x - \bar{x})/S_x$  where  $S_x = 2 \text{ N}$ . With this

$$t_a = (45.56 - 44.20)/2 = 0.68$$

We use Table 4.4 but must recognize that it is a two sided t chart (includes equal area on both sides of the mean value) and so we must correct to a one-sided value. For  $\nu = N - 1 = 60$ , we find  $P \approx 50\%$  or 0.50. So that  $P(44.20 \leq x \leq 45.56 \text{ N}) = 0.5/2 = 0.25$ . Similarly,

$$t_b = (48.20 - 44.20)/2 = 2.0$$

Again, from the two sided t chart (Table 4.4) at  $\nu = N - 1 = 60$ ,  $P \approx 95\%$  or 0.95. So that  $P(44.2 \leq x \leq 48.2 \text{ N}) = 0.95/2 = 0.475$ . Then,

$$P(45.56 \leq x \leq 48.20 \text{ N}) = 0.475 - 0.25 = 0.225$$

So there is a 22.5% chance that a measured value of x will fall within this interval.

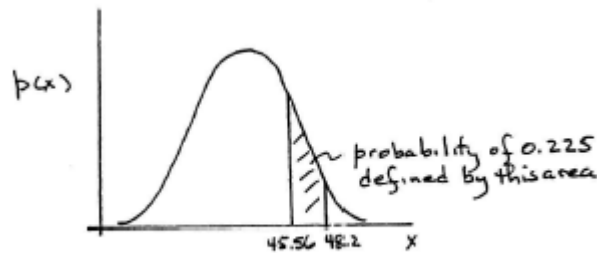

## PROBLEM 4.24

KNOWN:  $\bar{x} = 924.2 \text{ MPa}$   
 $S_x = 18 \text{ MPa}$   
 $N = 36$

FIND:  $\bar{x} \pm tS_x$

### SOLUTION

$$S_x = 18 / \sqrt{36} = 3.0$$

For  $\nu = 36 - 1 = 35$  degrees of freedom, . So in the absence of other errors, the estimate of the mean shear strength is

$$\bar{x} \pm tS_x = 924.2 \pm 6 \text{ MPa (95\%)}$$

The 95% confidence interval is 918.2 to 930.2 MPa for mean shear strength.

## PROBLEM 4.25

KNOWN:  $M = 3$  pooled data sets

FIND:  $v$ ,  $\langle \bar{x} \rangle$ , and  $\langle \bar{x} \rangle \pm \langle tS_x \rangle$  (95%)

ASSUMPTIONS: The three data sets are replicate measurements of a variable under similar conditions.

### SOLUTION

For pooled statistics of a single variable with  $M = 3$  replications,

$$v = \sum_{j=1}^M v_j = \sum_{j=1}^M (N_j - 1) = 15 + 20 + 8 = 43$$

The weighted pooled mean value is

$$\langle \bar{x} \rangle = (32 + 30 + 34) / 3 = 32 \text{ units}$$

The pooled standard deviation is

$$\langle S_x \rangle = [(15 * 3^2 + 20 * 2^2 + 8 * 6^2) / (15 + 20 + 8)]^{1/2} = 3.42 \text{ units}$$

The standard deviation of the means is

$$\langle S_x \rangle = 4 / \sqrt{(16 + 21 + 9)} = 0.59 \approx 0.6 \text{ units}$$

Then,  $t_{43,95} \sim 2.018$  (interpolation) or just use 2.0 (as a general approximation for  $N > 30$ ).

$$x' = 32 \pm (2.018)(0.59) = 32 \pm 1.2 \text{ units (95\%)}$$

### COMMENT

In this problem we are faced with three somewhat different results obtained from measuring the same variable on three separate occasions. The variations in the statistics between each data set reflect (1) the ability to duplicate the operating conditions for each test exactly, and (2) the limitations of finite statistics. Please review "replication" discussed in Chapter 1.

## PROBLEM 4.26

KNOWN:  $\bar{x} = 3027$  psi  
 $N = 11$   
 $S_x = 53$  psi

FIND: Is  $x' \geq 3000$  psi at 95% probability

### SOLUTION

In the absence of other errors, we know that

$$x' = \bar{x} \pm t S_{\frac{s}{x}} \quad (95\%)$$

For  $N = 11$ ,  $v = 10$  and  $t_{10,95} = 2.228$ . The standard deviation of the means for this data set is

$$S_{\frac{s}{x}} = 53 / \sqrt{11} = 15.98 \text{ psi}$$

Then,

$$x' = 3027 \pm 35.6 \text{ psi} \quad (95\%)$$

or there is a 95% probability that the true mean strength of the footing is in the interval

$$2991 \leq x' \leq 3063$$

The data suggest the possibility that the footing does not meet the code with a 95% probability. In particular, we know that the footings are prepared in sections as the concrete trucks arrive, unload, and depart. Therefore, portions of the footing likely do not meet the code for strength. Oops - Time to break up and repour!

## PROBLEM 4.27

KNOWN: Data set of  $N = 10$  values

FIND: Check for outliers.

ASSUMPTIONS: Fixed operating conditions.  
Measured variable has a normal distribution.

SOLUTION

The statistics for this data set are found to be

$$\bar{x} = \sum_{i=1}^N x_i = 923.7 \text{ N}$$

$$S_x = \left[ \frac{1}{N-1} \sum_{i=1}^N (x_i - \bar{x})^2 \right]^{1.2} = 8.13 \text{ N}$$

The modified three sigma test introduces the modified  $z$  variable,  $z_o$

$$z_o = \left| (x_i - \bar{x}) / S_x \right|$$

A visual survey of the data indicates that data point #3 could be suspect. Computing a value for  $z_o$  with  $x_i = 908 \text{ N}$  gives,  $z_o = 1.93$ . From Table 4.3,  $P(1.93) = 0.4732$ . Then,

$$N[0.5 - P(1.93)] = 0.27$$

Since this value exceeds 0.1, the value for data point #3 apparently falls within the bounds to be expected from normal scatter and is NOT an outlier. **No outliers are detected in this data set.**

Using  $t_{9,95} = 2.262$ , and  $S_{\bar{x}} = S_x / \sqrt{N} = 2.57$ ,

$$x' = 923.7 \pm 5.8 \text{ N (95\%)}$$

## PROBLEM 4.28

KNOWN:  $N = 20$  measurements taken from a large batch

Sample statistics:  $\bar{x} = 47.5$  mm     $S_x = 8.4$  mm

Claim:  $x' = 42.1$  mm (for batch)

FIND: Is claim supported by the data set?

ASSUMPTION: Sample is representative of the batch.

SOLUTION

For  $N = 20$ ,  $\nu = 19$  so that at the 95% level,  $t_{19,95} = 2.093$ . The true mean based on the batch statistics is

$$x' = 47.5 \pm (2.093)(8.4)/20^{1/2} = 47.5 \pm 3.93 \text{ mm} \quad (95\%)$$

The claim is not supported by the sample.

## PROBLEM 4.29

KNOWN:  $\bar{x} = 37.84$  mm ;  $\sigma = 0.13$  mm

FIND:  $P(37.58 \leq x \leq 38.1$  mm)

### SOLUTION

$$P(37.58 \leq x \leq 38.1 \text{ mm}) = P(z_a \leq x \leq z_b)$$

$$z_a = (38.1 - 37.84)/.13 = 2$$

$$z_b = (37.58 - 37.84)/0.13 = -2$$

$$P(z_a) = 0.4772$$

$$P(z_b) = 0.4772$$

Recognizing that  $z_a$  and  $z_b$  are on opposite sides of the mean value,

$$P(z_a \leq x \leq z_b) = P(z_a) + P(z_b) = 0.9544 \text{ or about } 95\%.$$

## PROBLEM 4.30

KNOWN: Data set provided.  
 $N = 5$

FIND: Best curve fit to the data set and 95% confidence interval.

### SOLUTION

The best curve fit is the one that best fits the physics of the problem. Not knowing that, we try several curve fits below.

The data can be fit to:  $y_c = a_0 + a_1x + \dots + a_mx^m$

m	$a_0$	$a_1$	$a_2$	$a_3$	$v$	$t_{v,95}$	$S_{yx}$	$tS_{yx}$
1	1.90	1.37	----	----	3	3.182	0.648	2.06
2	2.70	0.44	0.17	----	2	4.303	0.37	1.59
3	1.89	2.25	-0.71	0.11	1	12.706	0.09	1.14

The best fit would depend on the problem physics. But a third order fit reduces  $tS_{yx}$  to a minimum and appears to fit the data well. The data are plotted below.

This first plot shows the curve fit and its uncertainty band based on  $\pm tS_{yx}$ . For most engineering problems where the error in y is much greater than the error in the controlled variable x, this approach gives reasonable numbers and is quick and easy.

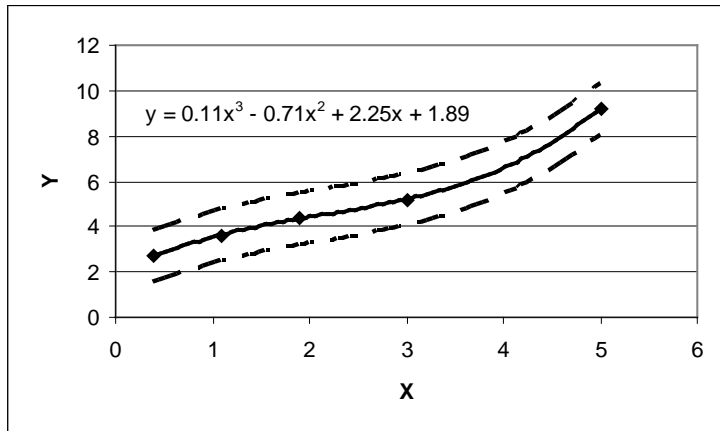

This second plot shows the curve fit and its uncertainty band based

on  $\pm tS_{yx} \left[ \frac{1}{N} + \frac{(x_i - \bar{x})^2}{\sum_{i=1}^N (x_i - \bar{x})^2} \right]$ . Here

the value of  $\sum_{i=1}^N (x_i - \bar{x})^2 = 25.29$

and  $\bar{x} = 6.16$ . The differences between the two results are nearly indistinguishable (hence, we plotted them separately).

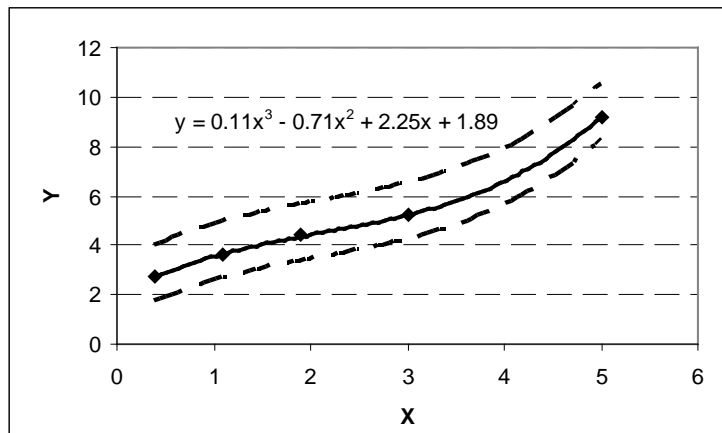

## PROBLEM 4.31

KNOWN: Data set provided.  
 $N = 6$

FIND: Best curve fit to the data set and 95% confidence interval.

### SOLUTION

Using a least squares regression, a third order polynomial fits the dataset

$$y = 1.8245x^3 - 10.12x^2 + 44.097x$$

better than the second order polynomial  $y = 17.219x^2 - 54.826x + 46.779$ .

(Incidentally, when using a spreadsheet, such as Excel<sup>R</sup>, the polynomial can be estimated by plotting the data, clicking on the data on the plot, and setting the trendline option to the polynomial order desired - or you can attempt another transformation.)

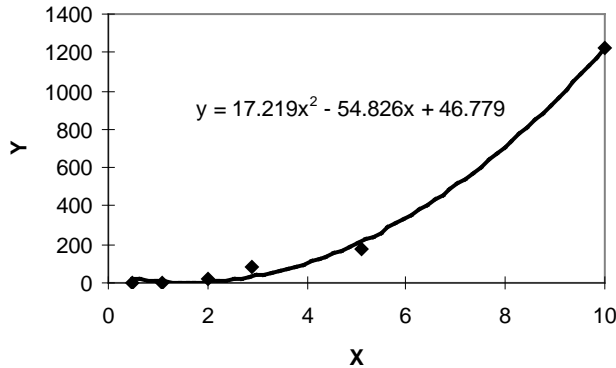

Looking at this data set, it is attractive to try a transformation of the form

$$\log y = m \log x + \log b \text{ or } Y = mX + B$$

where  $Y = \log y$ ;  $X = \log x$  and  $B = \log b$ . This is equivalent to  $y_c = bx^m$ .

The data are plotted below on a log-log plot and fit to the curve  $y_c = 5.05x^{2.3}$ . For  $t_{4,95} = 2.770$  and  $S_{yx} = 0.025$ , the confidence interval is shown on the log-log plot.

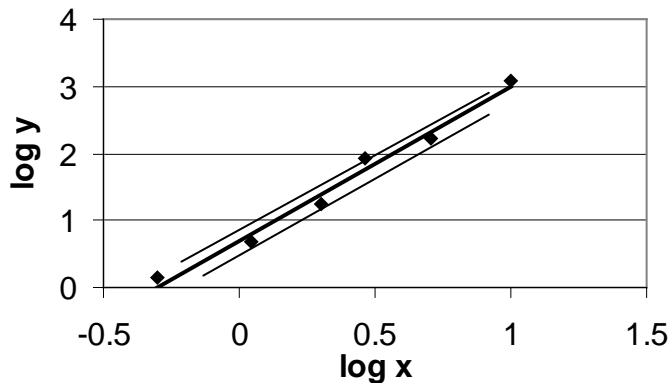

## PROBLEM 4.32

KNOWN: Data set provided.  
N = 4

FIND: Best curve fit to the data set and 95% confidence interval.

SOLUTION

The data are plotted below and fit to the curve  $y_c = 0.586x^{2.04}$ .  
The t value is found to be  $t_{2,95} = 4.303$  and  $S_{yx} = 0.021$  and shown on the log-log plot.

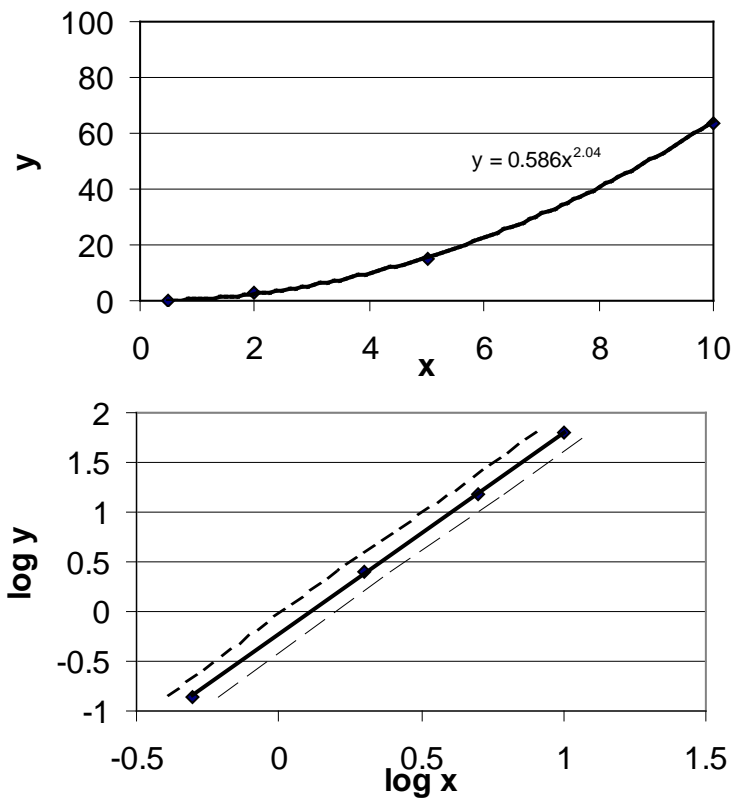

## PROBLEM 4.33

KNOWN: Fan test data for Q and h

FIND:  $h = f(Q)$

SOLUTION

Linear regression is used to find  $h = f(Q)$  as an  $m$ th order polynomial of the form:

$$h = a_0 + a_1Q + a_2Q^2 + \dots + a_m Q^m$$

To keep the regression coefficients reasonable, the polynomial will be based on Q in thousands of cms, i.e. kcms. A first order fit does not appear reasonable, so it is not attempted.

m	$a_0$	$a_1$	$a_2$	$a_3$	r	$S_{yx}$	$t_{95}S_{yx}$
2	4.9886	0.2906	-0.0211	-----	0.9987	0.1246	0.396
3	5.2991	0.1468	-0.0064	-0.0004	0.9999	0.0329	0.013

While an inspection of  $tS_y$  shows that the third order polynomial fits this data best, the problem physics require that we use the second order polynomial – that is the best fit based on known fan curves. Note how the r value is not very sensitive here and is generally not a good indicator of how 'well' data fits a curve.

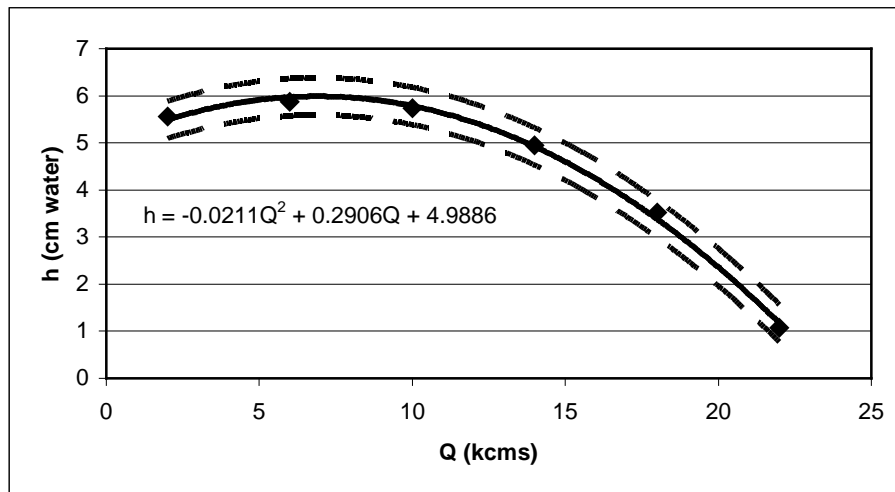

## PROBLEM 4.34

KNOWN: Constraint: want  $\sigma^2 \leq 1.25 \times 10^{-4}$

$S_x^2 = 2.1 \times 10^{-4}$  based on  $N = 30$  for a large batch

FIND: Is rejection of the batch based on  $S_x^2$  prudent?

SOLUTION

With  $\nu = 29$

$$\chi_{\alpha}^2(\nu) = \nu S_x^2 / \sigma^2 = (29)(2.1 \times 10^{-4}) / (1.25 \times 10^{-4}) = 48.7$$

Inspection of Table 4.5 shows,  $\chi_{0.015}^2(29) \approx 48.7$ , so  $\alpha \approx 0.015$ .

So there is about a 1.5% chance that this batch actually meets the constraint despite the  $S_x^2$  value of the sample. Rejecting this batch is prudent (or at least prudent with 98.5% confidence!).

## PROBLEM 4.35

KNOWN:  $\bar{x} = 5.060$  mm with  $S_x = 0.0025$  mm based on  $N = 30$  measurements  
Constraint: want  $x' = 5.000$  mm based on  $N = 10,000$  units.

FIND: Does the sample mean support the intention so that the constraint is met?

### SOLUTION

In bearing grinding operations, the tooling setup determines the mean diameter of the finished product.

For  $\nu = 29$ ,  $t_{29,95} \sim 2.045$ . The confidence interval of the mean based on the variation in the dataset (and no other errors) is given by  $\pm t S_x / \sqrt{N} = \pm t S_{\bar{x}} \sim 0.001$  mm. This data set suggests

$$5.059 \leq x' \leq 5.061 \text{ mm} \quad (95\%)$$

No, the constraint is not being met for bearing diameter. Stop the machine and reset the tooling set-up.

### COMMENT

Clearly there is a systematic error in the bearing grinding setup causing the bearing diameter mean value to be greater than the intended bearing diameter. The problem is not in the random error (random variations in diameter between bearings). The whole setup is shifted to making too large a bearing.

## PROBLEM 4.36

KNOWN: Constraint:  $CI = \pm 0.010$  mm  
 $S_1 = 0.0025$  mm based on  $N_1 = 30$

FIND:  $N_T$

SOLUTION

When the confidence interval  $\pm t S_x / \sqrt{N} = \pm t S_{\bar{x}}$  based on a reasonable number of measurements (such as 30 or more such that the  $t$  value does not change appreciably with increased  $N$ ) is met, no further measurements are necessary.

Here we want  $\pm t S_{\bar{x}} \leq 0.01$  mm and, in fact,  $\pm t S_{\bar{x}} \approx 0.001$  mm . So the criterion is met.  
So  $N_T = N_1$ .

## PROBLEM 4.37

**KNOWN:** Failure time for  $N = 6$  pumps

**FIND:** Mean and its 95% confidence interval  
Number of specimens tested to reduce confidence in mean value to within 50 hrs.

**ASSUMPTIONS:**  $\sigma$  is approximated by  $S_x$

### SOLUTION

i.) Based on the data set provided:

$$\bar{x} = \sum_{i=1}^N x_i = 1372.2 \text{ hrs}$$

$$S_x = \left( \frac{\sum_{i=1}^N (x_i - \bar{x})^2}{N-1} \right)^{1/2} = 125.6 \text{ hrs}$$

$$S_{\bar{x}} = S_x / N^{1/2} = 51.3 \text{ hrs}$$

Here  $t_{5,95} = 2.571$ .

So the true mean value is estimated by  $x' = \bar{x} \pm t S_{\bar{x}}$ :

$$x' = 1372.2 \pm 131.8 \text{ hrs. (95\%)}$$

ii.) To reduce the interval of 131.8 hrs to an interval of 50 hrs at 95% confidence,

$$N_T = \left( \frac{t_{N-1,95} S_x}{d} \right)^2 = 167$$

So a first guess is that 167 additional measurements would need to be taken. This would be tested again following these measurements.

## PROBLEM 4.38

FIND:  $\bar{x}, S_x$  Test the hypothesis of a normal distribution.

SOLUTION

Tons	$x_j$	$n_j$	$n'_j$	$(n_j - n'_j)^2 / n'_j$
421-480	450.5	4	2.9	0.42
481-540	510.5	8	9.6	0.27
541-600	570.5	12	7.8	2.26
601-660	630.5	6	4.2	0.77

$$\bar{x} = \frac{\sum_{i=1}^N x_i}{N} = \frac{\sum_{j=1}^4 n_j x_j}{N} = 550.5 \text{ MPa}$$

$$S_x = \left( \frac{\sum_{j=1}^4 n_j x_j^2 - N\bar{x}^2}{N-1} \right)^{1/2} = 57.53 \text{ MPa}$$

Do the data support the hypothesis of a normal distribution?

The expected occurrences  $n'_j$  are listed above. For example, for the first interval:

$$z_a = (421 - 550.5)/57.53 = 2.25 \quad z_b = (480 - 550.5)/57.53 = 1.23$$

$$P(421 \leq x_1 \leq 480) = P(2.25) - P(1.23) = 0.4878 - 0.390 = 0.098$$

So for  $N = 30$ :  $n'_1 = (30)(.098) = 2.9$  whereas we observe  $n_1 = 4$ .

For all the intervals:

$$\chi^2_\alpha = \sum_{j=1}^K (n_j - n'_j)^2 / n'_j = 3.72$$

Then, for  $K = 4$  here:  $\nu = 2$ , and  $\chi^2_\alpha(2) = 3.72$ . Interpolation of Table 4.5 or using

a more extensive math handbook table, we find that  $\alpha \approx 0.85$ . There is a 85% chance that the discrepancy between  $n_j$  and  $n'_j$  is due to random variation alone. Or we can look at this as  $P = 1 - \alpha = 0.15$ , a 15% chance it is not due to random variation. This result is equivocal, that is the hypothesis is possible and is not disproved: the sample could follow a normal distribution.

### PROBLEM 4.39

KNOWN: For  $N_1 = 30$ ,  $\bar{x} = 550.5$  MPa,  $S_1 = 57.53$  MPa

FIND:  $N_T$  required to attain  $CI = \pm 0.03 \bar{x}$

SOLUTION

$$CI = \pm (0.03)(550.5 \text{ MPa}) = \pm 16.52 \text{ MPa}$$

For  $d = CI/2 = 16.52$  MPa,

$$N_T = \left( t_{N-1} S_1 / d \right)^2 = [(2.042)(57.53)/16.52]^2 = 51$$

An additional 21 measurements should be taken to meet the constraint. The statistics should then be recomputed to verify that the constraint is met.

### PROBLEM 4.40

KNOWN: For  $N_1 = 6$ ,  $\bar{x} = 71,327$  psi and  $S_1 = 8345$  psi

FIND:  $N_T$  required to achieve  $CI$  within  $0.05 \bar{x}$  (total range)

SOLUTION

For a total range of  $(0.05)(71,327 \text{ psi}) = 3566$  psi,  $CI = \pm 1783$  psi. With  $d = CI/2 = 1783$  psi:

$$N_T = \{(6)(8345)/(1783)\}^2 = 145$$

An additional 139 measurements are required to reach this constraint level of random error. Because  $N_1$  is quite small relative to  $N_T$ , it would be prudent to reevaluate the sample statistics after some intermediate number of measurements were taken.

## PROBLEM 4.41

KNOWN:  $CI = 0.1 \text{ g}$   
 $S_x = 2 \text{ g}$

FIND:  $N$

SOLUTION

Let  $d = CI/2 = 0.05 \text{ g}$ . We are looking for the number of measurements required to keep  $tS_{\bar{x}} \leq 0.05 \text{ g}$  at 95%.

$$N = (tS_x / d)^2$$

If we select a large number of measurements, such that  $t_{N,95} = 1.96$ , then

$$N \approx 6150$$

For this value, the  $t$  value remains unchanged. Thus, a large number of measurements are required due to the close restriction on  $CI$ .

## PROBLEM 4.42

KNOWN:  $N_1 = 60$

$$S_{x1} = 1.52 \text{ V}$$

$$CI = 0.28$$

FIND:  $N_T$

ASSUMPTIONS: 95% confidence required.

$S_{x1}$  is representative of  $\sigma$ .

SOLUTION

With  $N_1 = 60$ ,  $\nu = 59$  and  $t_{59,95} = 2.00$ . Setting  $d = CI/2 = 0.14$ , then

$$N_T = \left( t S_x / d \right)^2 = [(2)(1.52)/0.14]^2 = 472$$

As a first estimate, at least 472 total measurements will be needed to achieve the desired precision levels. Hence, another 412 measurements are needed. This CI is a tight constraint on random error given the large variations seen in the dataset ( $S_{x1}$  value).

## PROBLEM 4.43

FIND:  $P(\chi^2(10) > 19.0)$

SOLUTION

From Table 4.5:  $0.05 \leq \chi^2(10) \leq 0.025$

that is, the probability lies between 2.5 and 5%.

## PROBLEM 4.44

KNOWN: Expect 0.07 breaks per meter.

FIND:  $p(x)$  for a wire of length  $L = 5$  m.

ASSUMPTION: Model using poisson distribution

### SOLUTION

From the given information, the most probable number of breaks to be expected over the 5 m length is:

$$\lambda = x' = (0.07)L = (0.07)(5) = 0.35$$

$$p(x) = 0.035^x e^{-0.35} / x!$$

x	p(x)
1	0.247
2	0.043
3	0.005
4	0.0004
10	0.0000

For example, there is a 4.3% probability of finding 2 breaks over the stated length, L.

## PROBLEM 4.45

KNOWN: 2 out of every 100 screws are defective  
 $x$  is the number of defectives.

FIND:  $p(x)$

### SOLUTION

The binomial distribution models the number of occurrences  $x$  of a defective part in  $N = 100$  observations assuming the probability of finding either a defective part or a nondefective part with any observation remains the same (that is, removing a part does not alter the remaining population of defective parts). For  $N = 100$ ,  $P(x) = 0.02$ . So  $p_b$  will take the form:

$$p_b(x) = \left[ \frac{N!}{(N-x)!x!} \right] P^x (1-P)^{N-x} = \left[ \frac{100!}{(100-x)!x!} \right] 0.02^x (1-0.02)^{100-x}$$

The poisson distribution models the events occurring randomly over a number of observations.  $p_p(x)$  refers to the probability of observing  $x$  defects in just 100 observations. Take  $\lambda = x' = 2$  as the number of expected defects in each 100 parts over an infinite population:

$$p(x) = 2^x e^{-2} / x!$$

(Hint: use a spreadsheet or programmable calculator to solve each – those factorials get large): For  $x$  defective parts in any 100 samples

$x$	$p_b$	$p_p$
0	0.1326	0.1353
1	0.2707	0.2707
2	0.2734	0.2707
4	0.0902	0.0902
10	0.0000	0.0000

Or there is about a 27% chance you will find 2 defective parts, a 13% chance of finding no defective parts, but it is unlikely that you will find 10 defective parts.

### COMMENT

Under certain circumstances the poisson distribution will approximate the binomial distribution. This is because the former is the limiting case of the latter, a case often proven in statistics texts. When  $N \rightarrow \infty$  and  $P \rightarrow 0$  such that the product of  $N \cdot P$  is constant, the two are exact. We see that the results above come close to this condition.

## PROBLEM 4.46

KNOWN: Particle passage through a small volume  
Average particles passing in time period  $t_1$  is 4:  $\lambda = 4$

FIND:  $p(x)$  using a poisson distribution model

SOLUTION

Using  $\lambda = x' = 4$  as the most probable expected value,

$$p(x) = 4^x e^{-4} / x!$$

x	p(x)
1	0.0733
2	0.1465
3	0.1954
4	0.1954
5	0.1563
10	0.0053

For example, there is a 15.63% chance of observing 5 particles in the defined time period,  $t_1$ .

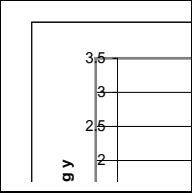

### PROBLEM 4.47

Finite Population estimates the histogram and finite statistics of an internally generated signal representing a random variable. The signal is continually measured and the statistics and histogram are constantly updated.

The histogram tends towards a Gaussian distribution as  $N$  becomes larger.

The values of the finite statistics change as new values are added to the data set. However, clearly there is a tendency towards a mean value of zero. The maximum and minimum values stay between  $+3$  and  $-3$  most (actually 95%) of the time.

### PROBLEM 4.48

Running Histogram estimates the histogram of an internally generated signal. The user can vary the number of intervals  $K$  and the number of data points  $N$  used in each histogram. The program updates the histogram for each block of  $N$  data points.

As interval number is increased, the number of observations (magnitude) of each interval decreases. But as the number of samples  $N$  is increased the signal increases (with time), the histogram evolves towards a Gaussian shape. With the appropriate number of intervals for the  $N$  samples, a very accurate portrayal of the sample tendency is found.

Values “out of range” are the random and rare occurrences that have values outside of the limits of the histogram. In most cases, these could be considered as “outliers.”

### PROBLEM 4.49

Probability Density estimates the probability density function of an internally generated signal. The user can vary the number of intervals  $K$  and the number of data points  $N$  used in each plot. The program creates a new pdf each time the program is rerun.

The signal has its own statistics and pdf, but each sample is but a snapshot of finite length of the infinite signal. The pdf will change with each new data set because the finite statistics of the data set (finite population) do not exactly estimate the statistics of the infinite data set (infinite population).

*“Learn by writing” methods are valuable for developing understanding of a new concept. Questions 5.1 – 5.4 provide some topics for “Learn to Write” exercises.*

## PROBLEM 5.1

### SOLUTION

Systematic error is a constant error that shifts all measured values of a variable by a fixed amount. In effect, the sample mean value will be offset from the true mean value by this fixed amount. Randomization methods break up some of the trends brought on by interference, a result of systematic errors, Randomization makes systematic errors behave as random errors, which are more easily quantified using statistics. Calibration is an excellent way to isolate, identify, quantify and thereby reduce systematic errors.

Random error leads to scatter in the measured values obtained during the measurement of a variable under otherwise fixed operating conditions. Unlike systematic errors, random errors will change in magnitude between repeated measurements bringing on the noted scatter.

Both systematic and random errors are present in any measurement to some degree. For the engineer, the difficult task is assigning the probable values of these errors. That’s where the test plan comes into importance. By incorporating repetition into a test plan, random errors can be statistically estimated with some amount of predictability. Incorporating replication strengthens the random error estimates and allows estimates of control to be made, which may include some of the systematic errors.

## PROBLEM 5.2

### SOLUTION

Systematic errors are usually estimated by comparison methods. These methods include: (i) calibration, (ii) concomitant methods, (iii) interlaboratory or different facility comparisons, or (iv) experience.

Random errors are manifested by measured data scatter and their effects on the estimate of the true value of the measured variable can be estimated statistically using the methods discussed previously in Chapter 4.

**ERRORS ARE NOUNS; UNCERTAINTIES ARE NUMBERS.** An error refers to a difference between the measured value and the true value. Because this exact amount is unknown, a probable range of the error is estimated. This numerical estimate is the uncertainty.

## PROBLEM 5.3

### SOLUTION

**TRUE VALUE:** The actual value of the measured variable. The value sought by measurement. Most often refers to the true mean value of the variable which would result from an infinite sampling under perfect test control.

**BEST ESTIMATE:** The nearest approximation of the true value that can be made with the data set available. It is based on the data set and the precision and the bias errors involved in the measurement. It is usually offered by the sample mean value and qualified by its precision interval.

**MEAN VALUE:** Exact statement of the mean or central tendency of a measured data set. The mean value of a finite data set is given by its sample mean value.

**UNCERTAINTY:** Estimate of the precision and bias errors involved in estimating the value of a variable. It is the range of probable errors which affect the outcome of a measurement.

**CONFIDENCE INTERVAL:** The range (or interval) of values within which the true value is expected to lie with some probability. The confidence interval is in part based on the precision-based interval ( $tS_{\bar{x}}$ ) discussed in Chapter 4 due solely on the variations in the measured data set, but it will also include all other random errors and systematic errors involved in the measurement.

## PROBLEM 5.4

KNOWN: Tire pressure gauge; single sample uncertainty estimates

FIND: Difference between  $u_d$  and  $u_N$

### SOLUTION

The *design-stage uncertainty* is a first estimate that is based on information immediately available. Generally, it does not include measurement control estimates, which makes it very different from an Nth order analysis. The simplest form for  $u_d$  is an estimate by

$$u_d = \sqrt{u_o^2 + u_c^2}$$

where  $u_o$  is based on the expected instrument interpolation error and  $u_c$  is based on the instrument error. It can also include other sources of error known at the time of analysis. This value provides a good guess of the uncertainty to be expected when minimal information is available.

*Nth order uncertainty* is applied to those measurement situations where a number of repeated measurements cannot or will not be taken. The analysis focuses on the control of the test and how that would affect the outcome. The Nth order uncertainty includes all conceivable errors, but its most important distinguishing feature is that it estimates the effect of test process control on the measurement. It is estimated by

$$u_N = \sqrt{u_c^2 + \sum_{i=1}^{N-1} u_i^2}$$

where  $u_i$  are uncertainties related to the measurement procedure controllability.

Suppose we want to measure the pressure of a tire and make only one reading per tire during a normal tire installation or during a tire pressure check. This is the way we tend to do it – isn't it? How good might we expect that one value of pressure to be? To quantify our methodology, we conceive of a test where we try out our measurement technique with a surrogate set of measurements. So  $u_1$  might be estimated by a simple surrogate experiment whereby a fixed pressure is repeatedly measured (say 20 times) and the outcome stated as  $tS_p$ . Assuming that the pressure did not change, variations in measured pressure would be due to measurement procedure control, as well as instrument repeatability. This gives us an estimate for how the pressure might be affected during our normal single measurement. We bank this information for subsequent use. The values for  $u_d$  and  $u_N$  differ by the errors which enter during the conduct and control of the test.

## PROBLEM 5.5

KNOWN: Micrometer  
Resolution: 0.001 inch (0.025 mm)

FIND:  $u_d$  at 95% confidence

ASSUMPTIONS: Instrument error is negligible compared with error due to resolution.

### SOLUTION

The interpolation error due to instrument resolution of an analog instrument is approximated by half its least increment:

$$u_o = 0.0005 \text{ inch or } 0.0125 \text{ mm}$$

It is not unusual for this type of instrument to have mostly negligible instrument errors. However, its zero set point can only be controlled to within the precision of the resolution, so we set  $u_c \sim u_o$ .

Then, the design-stage uncertainty becomes

$$u_d = \pm(u_o^2 + u_c^2)^{1/2} = \pm 0.0007 \text{ inch (95\%)} = \pm 0.0180 \text{ mm (95\%)}$$

## PROBLEM 5.6

KNOWN: Analog Tachometer  
Resolution: 5 rpm  
Accuracy: within 1% reading

FIND:  $u_d$  at 10, 500, 5000 rpm

### SOLUTION

The design-stage uncertainty is

$$u_d = \pm(u_o^2 + u_c^2)^{1/2}$$

where

$$u_o = \pm 2.5 \text{ rpm}$$

$$u_c = 1\% \text{ of reading}$$

This yields

speed [rpm]	$u_c$ [rpm]	$u_o$ [rpm]	$u_d$ [rpm]
10	0.1	2.5	$\pm 2.5$
500	5	2.5	$\pm 5.6$
5000	50	2.5	$\pm 50$

The uncertainty increases with rotational speed. At low speeds it is dominated by the ability to read the tachometer (resolution). At higher speeds the instrument errors dominate.

### COMMENT

The statement "accuracy" is a manufacturer catch-all term that is rarely clearly defined. The "accuracy" statement is presumed to mean that the overall errors do not exceed 1%. We suspect the term to describe the combined effects of all known elemental errors. This misnomer causes confusion. Insist on a detailed description.

## PROBLEM 5.7

KNOWN: Speedometer

Resolution: 5 mph (8kph)

Accuracy: within  $\pm 4\%$  reading

FIND:  $u_d$  at 60 mph (90 kph)

SOLUTION

The design-stage uncertainty is

$$u_d = \pm(u_o^2 + u_c^2)^{1/2}$$

where

$$u_o = \pm 2.5 \text{ mph (4 kph)}$$

$$u_c = \pm 4\% \text{ of reading} = \pm 2.4 \text{ mph at 60 mph} = \pm 3.6 \text{ kph at 90 kph}$$

This yields

$$u_d = \pm(2.5^2 + 2.4^2)^{1/2} = \pm 3.5 \text{ mph (95\%)} = \pm 5.4 \text{ kph (95\%)}$$

COMMENT

In the United States, automobile speedometers and their connected odometers have acceptability tolerance limits set by the government at  $u = \pm 4\%$  of the reading.

During the tight fuel availability times in the western hemisphere of the 1970's, some automakers were known to misrepresent (legally) automobile performance by holding a tighter precision (lower random error) on their units while purposely building a 2 to 4% systematic error into their automobile odometers. This made the vehicle slightly more attractive to a fuel cost conscious consumer. Unless the consumer actually made a careful test of the speedometer and odometer performance, usually by some comparison means such as a road sign check, they never would have reason to disbelieve their car's indicated, but inaccurate, performance. Caveat emperor!

## PROBLEM 5.8

KNOWN: Temperature sensor  
Error limit:  $\pm 0.5^\circ\text{C}$   
Readout Device  
Resolution:  $0.1^\circ\text{C}$   
Accuracy:  $0.6^\circ\text{C}$

FIND:  $u_d$

### SOLUTION

The design-stage uncertainty is for the combined system is

$$u_d = \pm[(u_d)_R^2 + (u_d)_S^2]^{1/2}$$

where  $(u_d)_R$  is the design-stage uncertainty of the readout device and  $(u_d)_S$  is that of the sensor. In either case, the individual design-stage uncertainty is found from

$$u_d = \pm(u_o^2 + u_c^2)^{1/2}$$

Sensor

$u_o = 0$  (i.e. no output stage in the sensor; readout is separate)  
 $u_c = \pm 0.5^\circ\text{C}$

$$(u_d)_S = (0^2 + 0.5^2)^{1/2} = 0.5^\circ\text{C}$$

Readout Device

$u_o = 0.05^\circ\text{C}$  and  $u_c = 0.6^\circ\text{C}$

So that

$$(u_d)_R = (0.05^2 + 0.8^2)^{1/2} = 0.8^\circ\text{C}$$

Then, the design-stage uncertainty for this combined system becomes

$$u_d = \pm(0.5^2 + 0.8^2)^{1/2} = \pm 0.8^\circ\text{C} \quad (95\%)$$

### COMMENT

Although the error limit on the sensor was given in this problem, similar information is available through various publications – an example of estimating error by using published values. For example, there are readily available ASTM and ASME standards (e.g., ASME/ANSI PTC 19.3; also given in the textbook as Table 8.5) governing the error limits on thermocouples, which are common temperature sensors, and to which a manufacturer's product must adhere.

## PROBLEM 5.9

KNOWN: Four resistors are available: two rated at  $R = 500 \pm 50 \Omega$  and two rated at  $R = 2000 \pm 5\% \Omega$ .

FIND: Best design combination to form  $R_T = 1000 \Omega$

### SOLUTION

We can combine the resistors in series or in parallel. Consider as Case 1, a series arrangement and as Case 2, a parallel arrangement.

Case 1

$$R_T = R_1 + R_2$$

If we use the two  $500 \Omega$  resistors, then

$$u_{d_{R_1}} = \pm 50 \Omega$$

$$u_{d_{R_2}} = \pm 50 \Omega$$

The propagation of uncertainty through to  $R_T$  is estimated by

$$(u_d)_{R_T} = \pm \left[ \left( \frac{\partial R_T}{\partial R_1} u_{d_{R_1}} \right)^2 + \left( \frac{\partial R_T}{\partial R_2} u_{d_{R_2}} \right)^2 \right]^{1/2} = \pm [(1 * u_{d_{R_1}})^2 + (1 * u_{d_{R_2}})^2]^{1/2} = \pm 71 \Omega \quad (95\%)$$

Case 2

$$R_T = \frac{R_1 R_2}{R_1 + R_2}$$

If we use the two  $2000 \Omega$  resistors, then

$$u_{d_{R_1}} = \pm 100 \Omega$$

$$u_{d_{R_2}} = \pm 100 \Omega$$

The propagation of uncertainty through to  $R_T$  is estimated by

$$\begin{aligned}
(u_d)_{R_T} &= \pm \left[ \left( \frac{\partial R_T}{\partial R_1} u_{d_{R_1}} \right)^2 + \left( \frac{\partial R_T}{\partial R_2} u_{d_{R_2}} \right)^2 \right]^{1/2} \\
&= \pm \left[ \left( \left\{ \frac{R_2}{R_1 + R_2} - \frac{R_1 R_2}{(R_1 + R_2)^2} \right\} * u_{d_{R_1}} \right)^2 + \left( \left\{ \frac{R_1}{R_1 + R_2} - \frac{R_1 R_2}{(R_1 + R_2)^2} \right\} * u_{d_{R_2}} \right)^2 \right]^{1/2} \\
&= \pm 35\Omega \text{ (95\%)}
\end{aligned}$$

Case 2 provides the smaller uncertainty at the design-stage. We should proceed using this design.

#### COMMENT

This is a classic illustration of using uncertainty analysis to determine the better of differing approaches.

Although each individual resistor in Case 2 has a larger absolute uncertainty than those in Case 1, we find that the weighted combination of the two resistors in Case 2 yields a substantially lower uncertainty. This is not obvious by inspection alone. Our design results from a close analysis of the sensitivity of the resultant to each contributing uncertainty. The combination in Case 2 is just less sensitive to the individual uncertainties.

## PROBLEM 5.10

KNOWN:  $p = 20 \text{ kPa}$  @ FSO (see Note below)

$$(u_o)_3 = 0.01 \text{ kPa}$$

$$(u_o)_4 = 0.001 \text{ kPa}$$

FIND: Select 3 1/2 or 4 1/2 digit display based on uncertainty

### SOLUTION

A design-stage analysis is appropriate here as the selection pertains to identical instruments having only different output resolutions. At full-scale, the units will indicate 19.99 (3½) or 19.999 (4½)

The instrument uncertainty is given by:

$$e_1 = 0.0015 \times 20 \text{ kPa} = 0.03 \text{ kPa}$$

$$e_2 = .002 \times 20 \text{ kPa} = 0.04 \text{ kPa}$$

$$e_3 = 0.0025 \times 20 \text{ kPa} = 0.05 \text{ kPa}$$

$$\text{So that: } u_c = (.03^2 + .04^2 + .05^2)^{1/2} = 0.071 \text{ kPa}$$

At FSO, the readout will display 19.99 or 19.999:

$$3 \text{ 1/2 digit: } u_d = (.07^2 + .01^2)^{1/2} = 0.07 \text{ kPa}$$

$$4 \text{ 1/2 digit: } u_d = (.07^2 + .001^2)^{1/2} = 0.071 \text{ kPa}$$

The uncertainty is virtually identical regardless of the resolution in the readout. Meter resolution does not affect the uncertainty to any practical extent.

Note: A true problem found several times in catalog of a major supplier of engineering sensors and readouts in US.

## PROBLEM 5.11

KNOWN:  $G = f(L, T, R, \theta)$

$$u_L/L = u_T/T = u_R/R = u_\theta/\theta = 0.01$$

FIND:  $(u_d)_G$

SOLUTION

The shear modulus is found by  $G = 2LT/\pi R^4\theta$  using the best estimates of  $L$ ,  $T$ ,  $R$ , and  $\theta$ . Its uncertainty is evaluated by

$$u_G/G = \pm \left[ \left( u_L/L \right)^2 + \left( u_T/T \right)^2 + \left( 4u_R/R \right)^2 + \left( u_\theta/\theta \right)^2 \right]^{1/2} = \pm 0.04 = 4\%$$

Note that even if  $u_L = u_T = u_\theta = 0$ , the uncertainty  $u_G/G$  is dominated by the uncertainty in  $R$ . The shear modulus uncertainty is most 'sensitive' to the radius uncertainty.

## PROBLEM 5.12

KNOWN:  $\eta = f(T_c, T_h)$

$$u_\eta / \eta \leq 0.01$$

$$T_h = 40^\circ\text{C} = 313 \text{ K}$$

$$T_c = 20^\circ\text{C} = 293 \text{ K}$$

FIND:  $u_h, u_c$  required

SOLUTION

We will assume that the uncertainties in measuring either temperature are the same (i.e.,  $u_T = u_{T_c} = u_{T_h}$ ). Note that temperatures must be in absolute and that a  $1^\circ\text{C}$  change equals a 1 K change.

$$u_\eta = \pm \left[ \left( \frac{\partial \eta}{\partial T_c} u_{T_c} \right)^2 + \left( \frac{\partial \eta}{\partial T_h} u_{T_h} \right)^2 \right]^{1/2} = \pm \left[ \left( u_{T_c} / T_h \right)^2 + \left( u_{T_h} T_c / T_h^2 \right)^2 \right]^{1/2}$$

Then,  $u_\eta / \eta \leq 0.01$  requires:  $u_T (= u_{T_c} = u_{T_h} \text{ assumed}) \leq 0.1 \text{ K or } 0.1^\circ\text{C}$

In a laboratory environment, this low magnitude of uncertainty value in a measured temperature would be attainable but with considerable care and calibration. In most engineering processing plant applications, this value would be very difficult to attain.

## PROBLEM 5.13

KNOWN: Heat transfer from a rod is to be determined.

$Nu = hD/k$  is the nondimensional heat transfer.

$u_h = 150 \pm 7\% \text{ W/m}^2\text{-K}$  (95%)

$u_d = 20 \pm 0.5 \text{ mm}$  (95% assumed)

$u_k = 0.6 \pm 2\% \text{ W/m-K}$  (95% assumed)

FIND:  $u_{Nu}$

SOLUTION

At the known level of uncertainty provided:  $Nu = f(h,D,k)$  then,

$$u_{Nu} = \pm \left[ \left( \frac{\partial Nu}{\partial h} u_h \right)^2 + \left( \frac{\partial Nu}{\partial D} u_D \right)^2 + \left( \frac{\partial Nu}{\partial k} u_k \right)^2 \right]^{1/2} =$$

$$u_{Nu} = \pm \left[ \left( \frac{D}{k} u_h \right)^2 + \left( \frac{h}{k} u_D \right)^2 + \left( \frac{-hD}{k^2} u_k \right)^2 \right]^{1/2} =$$

$$u_{Nu} = \pm \left[ \left( \frac{0.02}{0.6} 10.5 \right)^2 + \left( \frac{150}{0.6} 0.005 \right)^2 + \left( \frac{-150 \times 0.02}{0.6^2} 0.012 \right)^2 \right]^{1/2} = \pm 0.4$$

where

$$u_h = (0.07)(150) = 10.5 \text{ W/m}^2\text{-K}$$

$$u_D = 0.0005 \text{ m}$$

$$u_k = (0.02)(0.6) = 0.012 \text{ W/m-K}$$

Then, we estimate the Nusselt number here to be

$$Nu = hD/k \pm u_{Nu} = 5 \pm 0.4 \text{ (95\%)}$$

So, Nusselt number can be determined within about 8% in this range of values.

COMMENT

The level of uncertainty analysis (design-stage, advanced design-stage, ...) in the result depends on the level of uncertainty values given or available. This problem solution provides the propagation of uncertainty from the variables to the result.

## PROBLEM 5.14

KNOWN:  $R = 30 \Omega$

$P = 500 \text{ W}$

Ohmmeter

Resolution:  $1 \Omega$

Accuracy: within 5% of reading

Ammeter

Resolution:  $100 \text{ mA}$

Accuracy: within 0.1% of reading

FIND:  $(u_d)_E$

SOLUTION

From Ohm's Law:  $E = IR$  or in terms of power,  $P = I^2 R$ . For the nominal values of power and resistance given, expect a current,  $I = (P/R)^{1/2} = 4.08 \text{ A}$ . Hence,

Ohmmeter

$$\begin{aligned} (u_d)_R &= (u_o^2 + u_c^2)^{1/2} \\ &= ((0.005 \times 30 \Omega)^2 + (0.5 \Omega)^2)^{1/2} \\ &= 0.52 \Omega \quad (95\%) \end{aligned}$$

Ammeter

$$\begin{aligned} (u_d)_I &= (u_o^2 + u_c^2)^{1/2} \\ &= ((50 \times 10^{-3} \text{ A})^2 + (0.001 \times 4.08 \text{ A})^2)^{1/2} \\ &= 50.2 \times 10^{-3} \text{ A} \quad (95\%) \end{aligned}$$

Then, since voltage  $E = f(I, R)$ :

$$\begin{aligned} (u_d)_E &= \pm \left[ \left( \frac{\partial E}{\partial I} (u_d)_I \right)^2 + \left( \frac{\partial E}{\partial R} (u_d)_R \right)^2 \right]^{1/2} = \pm \left[ \left( R (u_d)_I \right)^2 + \left( I (u_d)_R \right)^2 \right]^{1/2} \\ &= \pm \left[ (30 \Omega \times 0.0502 \text{ A})^2 + (4.08 \text{ A} \times 0.52 \Omega)^2 \right]^{1/2} = \pm 2.61 \text{ V} \quad (95\%) \end{aligned}$$

COMMENT

Compare the groups in the  $(u_d)_E$  term:

$$\text{Resistance: } \frac{\partial E}{\partial R} (u_d)_R = 2.05 \text{ V} \qquad \text{Current: } \frac{\partial E}{\partial I} (u_d)_I = 1.51 \text{ V}$$

Hence, the resistance measuring device contributes most to the uncertainty in voltage measurement at the design stage. Focusing on reducing the uncertainty in the resistance measurement would be a good starting place to reduce  $(u_d)_E$ .

Note that the units in each of the working equations are consistent. The equations would not be logical otherwise.

## PROBLEM 5.15

### SOLUTION

**Design-Stage Analysis:** Provides a quick (but not accurate) estimate in uncertainty based on a planned approach. In general, this analysis is performed at a time when only information about the uncertainties in measuring equipment and appropriate engineering constants required for analysis are known or estimated. The analysis assumes perfect control of the measurement process and its procedure.

**Advanced-Stage Analysis:** Provides an accurate estimate of the uncertainty in a result based on a detailed knowledge of the measurement process. Used when only a single (or very few) measurement(s) is planned. Such an analysis builds on a design-stage analysis estimate to include estimates of uncertainty, such as procedural control, setability of operating conditions, and repeatability of the measured variable.

## PROBLEM 5.16

### SOLUTION

Replication provides a measure of the control of the operating conditions and test procedure. It does this by permitting the test engineer to quantify the differences in test results obtained from distinctly duplicate tests conducted under nominally identical conditions. For example, in a typical university lab course, several groups might setup and perform the same lab exercise – but with different people at different times, etc. – *these duplicate tests are replications*. Note: Often, a special type of replication, one in which the same test is performed at a different test facility is referred to as a reproducibility test).

Repetition provides a measure of repeatability during the same test, so that the subtle differences between test conduct (such as in a replication) are not included. For example, in a typical university lab course, a group might take multiple data points at the same operating condition from a test – *these data points are repetitions*.

In an advanced-stage analysis, replication effects are included as a higher-order uncertainty based on estimates found by a trial of tests designed to measure such controllability. In a multiple-measurement analysis, replication effects are usually entered as a precision error evaluated from pooled statistics analysis.

## PROBLEM 5.17

KNOWN: Displacement Transducer Instrument specifications

Linearity:  $e_1 = \pm 0.25\%$  reading

Drift:  $e_2 = \pm 0.05\%/^{\circ}\text{C}$  reading

Sensitivity:  $e_3 = \pm 0.25\%$  reading

Output Device specifications

Resolution:  $10\ \mu\text{V}$

Accuracy: within  $\pm 0.1\%$  reading

Expect a  $10^{\circ}\text{C}$  variation during measurements.

Expect a nominal displacement of  $x = 2\ \text{cm}$ .

FIND:  $(u_d)_x$

SOLUTION

$$u_{d_x} = \pm [u_{d_T}^2 + u_{d_E}^2]^{1/2} \quad \text{so find design-stage uncertainty in transducer and voltmeter:}$$

Displacement Transducer

From the instrument specifications, we can assume that the static sensitivity of the displacement transducer is  $K = 5\ \text{V}/5\ \text{cm} = 1\ \text{V}/\text{cm}$ . Then combining the elemental errors for this transducer and expecting a displacement of  $x = 2\ \text{cm}$  and a temperature variation of up to  $10^{\circ}\text{C}$ :

$$u_{d_T} = \pm [u_o^2 + u_c^2]^{1/2}$$

where

$$u_{o_T} = 0 \quad (\text{not relevant})$$

$$\begin{aligned} u_{c_T} &= [e_1^2 + e_2^2 + e_3^2]^{1/2} \\ &= [(0.0025 \times 2)^2 + (.005 \times 10^{\circ}\text{C} \times 2)^2 + (0.0025 \times 2)^2]^{1/2} \\ &= 0.01225\ \text{V} \end{aligned}$$

$$u_{d_T} = 0.01225\ \text{V}$$

Voltmeter

$$u_{d_E} = \pm [u_o^2 + u_c^2]^{1/2}$$

where

$$u_{o_E} = 5 \times 10^{-6}\ \text{V}$$

$$u_{c_{E\delta}} = (2\ \text{V} \times .001) = 0.002\ \text{V}$$

$$u_{d_E} = 0.002\ \text{V}$$

Then, the design-stage uncertainty in measurement system becomes:

$$u_{d_x} = \pm [u_{d_T}^2 + u_{d_E}^2]^{1/2} = \pm 0.0124 \text{ V or (since } K = 1 \text{ V/cm)} = \pm 0.0124 \text{ cm (95\%)}$$

#### COMMENT

Comparing each term in  $u_{d_x}$ , we see that the transducer contributes most to the uncertainty in measured displacement at the design stage. Keep in mind that at this level of uncertainty only the intrinsic instrument errors and no procedural errors are considered.

## PROBLEM 5.18

KNOWN: Measurement system of Problem 5.17

$$N = 20 \quad \bar{x} = 17.2 \text{ mm} = 1.72 \text{ cm} \quad S_x = 1.7 \text{ mm} = 0.17 \text{ cm}$$

FIND:  $x'$

ASSUMPTIONS: Measurement is sufficiently controlled such that all errors have been randomized and considered in the measured data.

### SOLUTION

The measurements have provided additional information about the uncertainty involved in the using this measurement system and involved in measuring this particular variable. We will approach the problem as a multiple measurement uncertainty analysis problem. Using the procedure of problem 5.17 but with  $\bar{x} = 1.72 \text{ cm}$  (recall Problem 5.17 used 2.0 cm),

$$u_{d_T} = \pm 0.0105 \text{ cm (95\%)}$$

$$u_{d_E} = \pm 0.0017 \text{ cm (95\%)}$$

Then, we can identify two elements of systematic error at the data acquisition source (see Table 5.2) error due to the transducer,  $B_2$ , and error due to the output device,  $B_4$  (Note: the subscripts used refer to the order in which these particular errors are listed in Table 5.2 – we could easily just list them as known error 1 and known error 2).

$$B_2 = u_{d_T} = \pm 0.0105 \text{ cm}$$

$$B_4 = u_{d_E} = \pm 0.0017 \text{ cm}$$

We can set the random error in both of these elements to zero (no data provided).

$$P_2 = P_4 = 0$$

The twenty measurements are assumed to be made in a manner that best randomizes the extraneous effects on the measured variable. The measurements provide a set of finite statistics from which a precision interval in estimating the true mean value can be made. Begin by estimating the random error due to temporal variation in the measurand:

$$P_g = S_{\bar{x}} = S_x / \sqrt{N} = 0.038 \text{ cm}$$

with degrees of freedom,  $\nu = 19$ .

The measurement systematic error can be expressed as:

$$B = \left[ B_2^2 + B_4^2 \right]^{1/2} = 0.0108 \text{ cm}$$

and the measurement standard random error is given by

$$P = 0.038 \text{ cm}$$

The uncertainty interval is found from

$$\begin{aligned} u_x &= \pm \left[ B^2 + (t_{19,95} P)^2 \right]^{1/2} \\ &= \pm 0.08 \text{ cm} \quad (95\%) \end{aligned}$$

with  $t_{19,95} = 2.093$ . The best estimate for mean mass displacement is

$$x' = 1.72 \pm 0.08 \text{ cm} \quad (95\%)$$

based on the information provided.

#### COMMENT

Note that we could use this information as the basis for a single sample uncertainty estimate by using the test performance obtained at 17.2 mm as representative for the measurement system and procedure used and variable measured. This information could be used to update the design stage analysis in the previous Problem.

## PROBLEM 5.19

KNOWN: Nominal pressure value to be measured is 100 psi at 70°F

Pressure transducer

Accuracy: within 0.5% reading

Output device

Resolution: 0.1 psi

Sensitivity:  $e_1 = 0.1$  psi

Linearity:  $e_2 = 0.1\%$  reading

Drift:  $e_3 = 0.1$  psi/6 months provided  $32 < T < 90$  °F

ASSUMPTIONS:  $K = 1$  V/psi for the transducer

FIND:  $u_{d_p}$

SOLUTION

For the transducer:

$$u_{d_t} = \pm [u_o^2 + u_c^2]_T^{1/2} = u_c = \pm 0.005 \times 100 \text{ psi} = \pm 0.5 \text{ psi}$$

For the output device

$$u_{d_d} = \pm [u_o^2 + u_c^2]_D^{1/2} = \pm 0.18 \text{ psi}$$

where

$$u_o = \pm 0.05 \text{ psi}$$

$$\begin{aligned} u_c &= \pm [(e_1)^2 + (e_2)^2 + (e_3)^2]^{1/2} = \pm (0.1^2 + .1^2 + 0.1^2)^{1/2} \\ &= \pm 0.17 \text{ psi} \end{aligned}$$

Note: we have assumed a value for drift equivalent to that expected over the first 6 months of operation following calibration. This value would be adjusted accordingly in an actual situation. Then,

$$u_{d_p} = \pm [u_{d_t}^2 + u_{d_d}^2]^{1/2} = \pm 0.53 \text{ psi} \quad (95\%)$$

We anticipate an uncertainty of 0.53% of the reading at 100 psi due to the instrument errors alone.

## PROBLEM 5.20

KNOWN:  $\bar{p} = 8610 \text{ lb/ft}^2$        $\bar{D} = 6.1 \text{ in.} = 0.508 \text{ ft}$        $\bar{t} = 0.22 \text{ in.} = 0.018 \text{ ft}$   
 $S_p = 273.1 \text{ lb/ft}^2$        $S_D = 0.18 \text{ in.}$        $S_t = 0.04 \text{ in.}$   
 $N_p = 10$        $N_D = 10$        $N_t = 10$   
 $B_p = 1\% \text{ rdg}$        $B_D = \pm 1\% \text{ rdg}$        $B_t = \pm 1\% \text{ rdg}$

FIND:  $\sigma'$

SOLUTION

$$\sigma = \sigma(p, D, t)$$

$$P_p = S_p / \sqrt{N_p} = 86.4 \text{ lb/ft}^2$$

$$P_D = S_D / \sqrt{N_D} = 0.06 \text{ in} = 0.005 \text{ ft};$$

$$P_t = S_t / \sqrt{N_t} = 0.01 \text{ in} = 0.00105 \text{ ft.}$$

$$P_\sigma = \left[ \left( \frac{\partial \sigma}{\partial p} P_p \right)^2 + \left( \frac{\partial \sigma}{\partial D} P_D \right)^2 + \left( \frac{\partial \sigma}{\partial t} P_t \right)^2 \right]^{1/2} = \left[ \left( \frac{D}{2t} P_p \right)^2 + \left( \frac{p}{2t} P_D \right)^2 + \left( \frac{-pD}{2t^2} P_t \right)^2 \right]^{1/2}$$

$$= \left[ 1197^2 + 1127^2 + 7087^2 \right]^{1/2} = 7275 \text{ lb/ft}^2$$

where  $p = \bar{p}$ ,  $D = \bar{D}$ ,  $t = \bar{t}$ .

The value of  $\nu_\sigma$  is obtained from the Welch-Satterthwaite relation for a result that is a function of variables:

$$\nu_R = \frac{\left\{ \sum_{i=1}^L (\theta_i P_{x_i})^2 \right\}^2}{\sum_{i=1}^L (\theta_i P_{x_i})^4 / \nu_{x_i}} = \frac{\left[ \left( \frac{D}{2t} P_p \right)^2 + \left( \frac{p}{2t} P_D \right)^2 + \left( \frac{pD}{2t^2} P_t \right)^2 \right]^2}{\frac{\left( \frac{D}{2t} P_p \right)^4}{\nu_p} + \frac{\left( \frac{p}{2t} P_D \right)^4}{\nu_D} + \frac{\left( \frac{pD}{2t^2} P_t \right)^4}{\nu_t}} = 10$$

$$B_\sigma = \left[ \left( \frac{\partial \sigma}{\partial p} B_p \right)^2 + \left( \frac{\partial \sigma}{\partial D} B_D \right)^2 + \left( \frac{\partial \sigma}{\partial t} B_t \right)^2 \right]^{1/2} = \left[ \left( \frac{D}{2t} B_p \right)^2 + \left( \frac{p}{2t} B_D \right)^2 + \left( \frac{-pD}{2t^2} B_t \right)^2 \right]^{1/2}$$

With  $B_p = 0.01 \times 8610 = 86.1 \text{ lb/ft}^2$ ,

$$B_D = 0.01 \times 6.1 = 0.061 \text{ in} = 0.005 \text{ ft},$$
$$B_t = 0.01 \times 0.22 = 0.0022 \text{ in} = 0.0002 \text{ ft},$$

and  $p = \bar{p}$ ,  $D = \bar{D}$ ,  $t = \bar{t}$

$$B_\sigma = \left[ 1194^2 + 1174^2 + 1349^2 \right]^{1/2} = 2150 \text{ lb/ft}^2$$

Then, with  $t_{10,95} = 2.228$  and  $\bar{\sigma} = \bar{p}\bar{D}/2\bar{t}$  :

$$\begin{aligned} \sigma' &= \bar{\sigma} \pm \left[ B^2 + (tP)^2 \right]^{1/2} = 121,497 \pm \left[ 2150^2 + (2.238 \times 7275)^2 \right]^{1/2} \\ &= 121,500 \pm 16,425 \text{ lb/ft}^2 \text{ (95\%)} \\ &= 5.82 \pm 0.786 \text{ MPa (95\%)} \end{aligned}$$

## PROBLEM 5.21

KNOWN: Calibration source elemental errors,  $K = 3$

FIND: Random uncertainty due to calibration errors

SOLUTION

For three known random errors

$$P = [P_1^2 + P_2^2 + P_3^2]^{1/2} = [0.9^2 + 1.1^2 + 0.09^2]^{1/2} \\ = 1.424 \text{ N/m}^2$$

with degrees of freedom,

$$\nu = \frac{\left( \sum_{k=1}^3 P_k^2 \right)^2}{\sum_{k=1}^3 P_k^4 / \nu_k} = \frac{(0.9^2 + 1.1^2 + 0.09^2)^2}{\frac{0.9^4}{20} + \frac{1.1^4}{9} + \frac{0.09^4}{14}} \approx 23$$

## PROBLEM 5.22

KNOWN: Systematic and random source errors in a measurement of force.

$$\bar{F} = 200 \text{ N}$$

FIND: Estimate  $F'$

SOLUTION

The source errors can be combined to find the measurement systematic and random uncertainties. The measurement systematic uncertainty is given by

$$B = [B_1^2 + B_2^2 + B_3^2]^{1/2} = [2^2 + 4.5^2 + 3.6^2]^{1/2} = 6.1 \text{ N}$$

Likewise, the measurement standard random uncertainty is given by

$$P = [P_1^2 + P_2^2 + P_3^2]^{1/2} = [0^2 + 6.1^2 + 4.2^2]^{1/2} = 7.41 \text{ N}$$

The degrees of freedom in the measurement standard random uncertainty is,

$$\nu = \frac{\left( \sum_{k=1}^3 P_k^2 \right)^2}{\sum_{k=1}^3 \frac{P_k^4}{\nu_k}} = \frac{(0^2 + 6.1^2 + 4.2^2)^2}{\frac{6.1^4}{17} + \frac{4.2^4}{19}} \approx 32$$

Then, using  $t_{32,95} = 2.042$  (note: for  $\nu \geq 30$  a value of  $t_{95} = 2$  is commonly used as an engineering approximation)

$$F' = \bar{F} \pm [B^2 + (tP)^2]^{1/2} = 200 \pm [6.1^2 + (2 \times 7.4)^2]^{1/2} \text{ N}$$

$$F' = 200 \pm 16 \text{ N} \quad (95\%)$$

## PROBLEM 5.23

KNOWN:  $A = XY$

X and Y Instrument Accuracy: within 0.5% reading

FIND: Estimate the uncertainty in land area

SOLUTION

The land area is found by  $A = XY$ . Then, the most probable estimate of the mean area is:

$$A = XY = 556 \times 222 = 123,432 \text{ m}^2$$

In the measurement of length X (note: the subscripts refer to the order in which the particular errors are listed in Table 5.2 – otherwise, they offer no special meaning):

$$B_x = B_2 = 0.005 \times 556 = 2.8 \text{ m}$$

$$P_x = P_9 = S_x/N^{1/2} = 1.9 \text{ m}$$

In the measurement of length Y:

$$B_y = B_2 = 0.005 \times 222 = 1.1 \text{ m}$$

$$P_y = P_9 = S_y/N^{1/2} = 0.8 \text{ m}$$

The propagation of these errors to the resultant area is found by

$$B_A = \pm \left[ \left( \frac{\partial A}{\partial X} B_x \right)^2 + \left( \frac{\partial A}{\partial Y} B_y \right)^2 \right]^{1/2} = \pm \left[ (YB_x)^2 + (XB_y)^2 \right]_{X=\bar{X}, Y=\bar{Y}}^{1/2} = 873 \text{ m}^2$$

$$P_A = \pm \left[ \left( \frac{\partial A}{\partial X} P_x \right)^2 + \left( \frac{\partial A}{\partial Y} P_y \right)^2 \right]^{1/2} = \pm \left[ (YP_x)^2 + (XP_y)^2 \right]_{X=\bar{X}, Y=\bar{Y}}^{1/2} = 606 \text{ m}^2$$

The degrees of freedom in  $P_A$  is found using a Welch-Satterthwaite relation

$$v_R = \frac{\left\{ \sum_{i=1}^L (\theta_i P_i)^2 \right\}^2}{\sum_{i=1}^L (\theta_i P_i)^4 / v_{x_i}} = \frac{\left[ (YP_x)^2 + (XP_y)^2 \right]^2}{\frac{(YP_x)^4}{v_x} + \frac{(XP_y)^4}{v_y}} \approx 14$$

Then, with  $t_{14,95} = 2.145$ ,

$$\begin{aligned} A' &= \bar{A} \pm \left[ B^2 + (tP)^2 \right]^{1/2} = 123,432 \pm \left[ 873^2 + (2.145 \times 606)^2 \right]^{1/2} \\ &= 123,432 \pm 1500 \text{ m}^2 \quad (95\%) \end{aligned}$$

COMMENT

This uncertainty is about 1.75% of the measured area. The contribution from the instrument itself is barely 0.7% of area. If we assume that the measurand does not change during measurement (so barring seismic activity somewhat safely), the rest is due to lack of control in procedure.

## PROBLEM 5.24

KNOWN:  $\bar{\sigma} = 1061$  kPa

$$S_{\sigma} = 22 \text{ kPa}$$

$$N = 23$$

FIND:  $P$  (listed as  $P$  due to temporal variation in Table 5.2)

ASSUMPTIONS: Scatter is due to temporal variations

SOLUTION

The standard random uncertainty,  $P$ , in the mean value of stress,  $\bar{\sigma}$ , due to random error by data scatter,  $S_{\sigma}$ , is

$$P = S_{\sigma} / \sqrt{N} = 22 / \sqrt{23} = 4.6 \text{ kPa}$$

with  $\nu = N - 1 = 22$  degrees of freedom.

## PROBLEM 5.25

KNOWN:  $N = 6$  with  $S_x = 1.23$  MPa  
 $B_x = 1.48$  MPa

FIND:  $u_x$

SOLUTION

The uncertainty in the mean value of strength is given by

$$u_x = \pm \left[ B_x^2 + (tP_x)^2 \right]^{1/2}$$

where  $P_x = S_x = S_x / \sqrt{N}$  is the standard random uncertainty.

For  $t_{5,95} = 2.571$  and  $S_x = 1.23 \text{ MPa} / 6^{1/2} = 0.50$  MPa

$$u_x = \pm \left[ 1.48^2 + (2.571 \times 0.5)^2 \right]^{1/2} = \pm 1.96 \text{ MPa} \quad (95\%)$$

Both systematic and random errors contribute about the same.

## PROBLEM 5.26

KNOWN: Standard:  $B_1 = \pm 0.5 \text{ psi}$   $P_1 = 0$   
Voltmeter:  $B_2 = \pm 10 \mu\text{V}$   $P_2 = 0$   
Measurement:  $B_3 = \pm .5 \text{ psi}$   
Calibration Curve fit:  $P_4 = S_{yx} = 0.746$  based on  $\nu = 4$

FIND:  $u_p$

SOLUTION

From the calibration data, a least squares fit yields:

$$y = a_o + a_1 x \pm tS_{yx} \quad \text{or} \quad p \text{ [psi]} = 0.54 + 24.03E \text{ [mV]} \pm (2.776)(.746)$$

so that,

$$P_4 = S_{yx} = 0.746$$

based on  $\nu = 4$ . Because  $P_4$  is the only random error involved, the measurement standard random uncertainty is  $P = P_4 = 0.746$ .

Also, from the curve we find that  $K = \partial p / \partial E = 24.03 \text{ psi/mV}$ . We use this sensitivity to convert between psi and mV.

$$\begin{aligned} B &= \pm \left[ B_1^2 + B_2^2 + B_3^2 \right]^{1/2} = \pm \left[ (0.5 \text{ psi})^2 + (0.01 \text{ mV} \times 24.03 \text{ psi/mV})^2 + (0.5 \text{ psi})^2 \right]^{1/2} \\ &= \pm 0.707 \text{ psi} \end{aligned}$$

Then, with  $t_{4,95} = 2.776$ , the combined uncertainty is

$$u_p = \pm \left[ B_p^2 + (tP_p)^2 \right]^{1/2} = \pm \left[ 0.707^2 + (2.776 \times 0.746)^2 \right]^{1/2} = \pm 2.19 \text{ psi} \quad (95\%)$$

## PROBLEM 5.27

KNOWN: Density of metal composite is determined by mass estimation.

Sample ingot is cylindrical in shape.

Nominal\* values for typical ingot:

$$m \approx 4.5 \text{ lb}_m \quad u_{o_m} = 0.1 \text{ lb}_m$$

$$L \approx 6 \text{ in.} \quad u_{o_L} = 0.05 \text{ in.}$$

$$D \approx 4 \text{ in.} \quad u_{o_D} = 0.0005 \text{ in.}$$

$$u_{c_m} / m = 1\% \text{ reading; } u_{c_L} / L = 1\% \text{ reading; } u_{c_D} / D = 1\% \text{ reading}$$

\* "nominal" means 'approximate' or 'typical' values for a given situation

FIND:  $u_{d_\rho}$

SOLUTION

$$\forall = \pi D^2 L / 4 \quad \text{and} \quad \rho = m / \forall = 4m / \pi D^2 L$$

$$\begin{aligned} u_\rho &= \pm \left[ \left( \frac{\partial \rho}{\partial m} u_m \right)^2 + \left( \frac{\partial \rho}{\partial D} u_D \right)^2 + \left( \frac{\partial \rho}{\partial L} u_L \right)^2 \right]^{1/2} \\ &= \pm \left[ \left( \frac{4}{\pi D^2 L} u_m \right)^2 + \left( \frac{-8m}{\pi D^3 L} u_D \right)^2 + \left( \frac{4m}{\pi D^2 L} u_L \right)^2 \right]^{1/2} \end{aligned}$$

$$u_m = \left[ u_o^2 + u_c^2 \right]^{1/2} = [0.1^2 + (0.01 \times 4.5)^2]^{1/2} = 0.11 \text{ lb}_m$$

$$u_D = \left[ u_o^2 + u_c^2 \right]^{1/2} = [0.0005^2 + (0.01 \times 4)^2]^{1/2} = 0.04 \text{ in} = 0.0034 \text{ ft}$$

$$u_L = \left[ u_o^2 + u_c^2 \right]^{1/2} = [0.05^2 + (0.01 \times 6)^2]^{1/2} = 0.078 \text{ in} = 0.0065 \text{ ft}$$

$$\begin{aligned} u_\rho &= \pm \left[ (0.0133 \times 0.11)^2 + (0.0298 \times 0.04)^2 + (0.0597 \times 0.078)^2 \right]^{1/2} \\ &= \pm 0.0050 \text{ lb}_m / \text{in}^3 = \pm 8.680 \text{ lb}_m / \text{ft}^3 \end{aligned}$$

The mass measurement contributes most to the uncertainty at the design stage (= 0.0133 x 0.11), although just more than the diameter measurement, and deserves first attention to reducing the uncertainty in density. The uncertainty contribution due to length (= 0.005 x 0.078) is one order of magnitude smaller than mass or diameter.

## PROBLEM 5.28

KNOWN:  $M = 3$  replications with  $N = 10$  repetitions each.  
Sample mean and sample standard deviation values.

FIND:  $\langle \bar{d} \rangle \pm u_{\bar{d}}$

SOLUTION

We will assume that errors enter only at the data acquisition stage. Elemental errors from data acquisition sources will consist at least as a systematic error due to instrument error ( $B_1$ ), a random error due to the variation in readings measured at each cross-section ( $P_2$ ), and spatial-dependent random errors along the ingot length ( $P_3$ ).

The pooled mean diameter is found by

$$\langle \bar{d} \rangle = \frac{1}{3}(3.992 + 3.9892 + 3.9961) = 3.9924 \text{ inches}$$

and provides the most probable estimate in the true mean diameter. The variation in readings taken at each cross-section location is estimated by the pooled standard deviation relative to the pooled mean. For  $N = 10$  at  $M = 3$ ,

$$\langle S_{\bar{d}} \rangle = \langle S_d \rangle / \sqrt{MN} = \sqrt{\frac{1}{3}(0.005^2 + 0.001^2 + 0.0009^2)} / \sqrt{3 \times 10} = 0.00055 \text{ inches}$$

with  $\nu = M(N - 1) = 3 \times (10 - 1) = 27$ . This yields a measure of the standard random error due to data scatter  $P_2$ .

The spatial variation in mean values is estimated by the standard deviation

$$S_d = \left[ \frac{\sum_{m=1}^M (d_m - \langle \bar{d} \rangle)^2}{M - 1} \right]^{1/2} = 0.0034 \text{ inches}$$

with  $\nu = M - 1 = 2$ . The standard random error due to spatial errors  $P_3$  is then

$$P_3 = S_d / \sqrt{M} = 0.0017 \text{ in.}$$

Then,

From the previous problem, the instrument error in diameter measurement is 1% of the reading. So

$$B = B_2 = B_{c_D} = 0.040 \text{ in.}$$

$$P = [P_2^2 + P_3^2]^{1/2} = [0.00055^2 + 0.0017^2]^{1/2} = 0.0018 \text{ in.}$$

with

$$\nu = \frac{\left(\sum_{k=1}^2 P_k^2\right)^2}{\sum_{k=1}^2 \frac{P_k^4}{\nu_k}} = \frac{(0.00055^2 + 0.0017^2)^2}{\frac{0.00055^4}{27} + \frac{0.0017^4}{2}} = 2.5 \approx 2$$

so  $t_{2,95} = 4.303$  (note:  $\nu$  gets rounded down).

$$u_d = \pm [B^2 + (tP)^2]^{1/2} = \pm 0.041 \text{ in.}$$

$$B = 0.040 \text{ in.} \quad P = 0.0018 \text{ in.} \quad \nu = 2$$

$$d' = 3.9924 \pm 0.041 \quad \text{in. (95\%)}$$

#### COMMENT

The large systematic error in the diameter measuring device dominates this problem. Even though all the readings appear to be well behaved with some variations in position and between positions, the systematic error implies these readings may all have an offset.

This problem also provides a nice example of how the statement of a value of a variable such as the diameter of an ingot or of a shaft is actually a statistical statement. We often think of such non-temporal variables as being fixed and absolute. Because they are statistical statements, there is an associated uncertainty in their values.

## PROBLEM 5.29

KNOWN: Measurements of mass and length and results of Problem 5.28

FIND: Estimate  $\rho'$

SOLUTION

We will assume that errors enter only at the data acquisition stage.

Elemental errors from data acquisition sources will consist at least as a systematic error due to instrument error ( $B_1$ ), a random error due to the scatter in data ( $P_2$ ). We will also use the systematic and random error estimates from the diameter measurement information in Problem 5.28. These give:

$$B_d = 0.040 \text{ inch}, P_d = 0.0018 \text{ inch}, \nu = 2$$

The instrument error is estimated at 1% of the reading for each variable.

$$B_m = B_{2m} = 0.045 \text{ lb}_m \quad B_L = B_{2L} = 0.06 \text{ inch}$$

The scatter in the data creates a random error in estimating the mean value. The random error estimates in the mean values are assumed as

$$P_m = P_{2m} = S_m/N^{1/2} = 0.1/21^{1/2} = 0.022 \text{ lb}_m \quad \nu_m = 20$$

$$P_L = P_{2L} = S_L/N^{1/2} = 0.1/11^{1/2} = 0.0302 \text{ in.} \quad \nu_L = 10$$

With  $\rho = 4m/\pi D^2 L$ ,

$$B_\rho = \pm \left[ \left( \frac{\partial \rho}{\partial m} B_m \right)^2 + \left( \frac{\partial \rho}{\partial D} B_D \right)^2 + \left( \frac{\partial \rho}{\partial L} B_L \right)^2 \right]^{1/2}$$

$$= \pm \left[ \left( \frac{4}{\pi D^2 L} B_m \right)^2 + \left( \frac{-8m}{\pi D^3 L} B_D \right)^2 + \left( \frac{4m}{\pi D^2 L} B_L \right)^2 \right]^{1/2}$$

$$P_\rho = \pm \left[ \left( \frac{\partial \rho}{\partial m} P_m \right)^2 + \left( \frac{\partial \rho}{\partial D} P_D \right)^2 + \left( \frac{\partial \rho}{\partial L} P_L \right)^2 \right]^{1/2}$$

$$= \pm \left[ \left( \frac{4}{\pi D^2 L} P_m \right)^2 + \left( \frac{-8m}{\pi D^3 L} P_D \right)^2 + \left( \frac{4m}{\pi D^2 L} P_L \right)^2 \right]^{1/2}$$

Subbing:

$$B_{\rho} = \pm \left[ \left( \frac{4}{\pi \times 3.9924^2 \times 5.85} 0.045 \right)^2 + \left( \frac{-8 \times 4.4}{\pi \times 3.9924^3 \times 5.85} 0.040 \right)^2 + \left( \frac{4 \times 4.4}{\pi \times 3.9924^2 \times 5.85} 0.06 \right)^2 \right]^{1/2}$$

$$B_{\rho} = \pm 0.00385 \text{ lb}_m/\text{in}^3$$

$$P_{\rho} = \pm \left[ \left( \frac{4}{\pi \times 3.9924^2 \times 5.85} 0.022 \right)^2 + \left( \frac{-8 \times 4.4}{\pi \times 3.9924^3 \times 5.85} 0.0018 \right)^2 + \left( \frac{4 \times 4.4}{\pi \times 3.9924^2 \times 5.85} 0.032 \right)^2 \right]^{1/2}$$

$$P_{\rho} = \pm 0.00194 \text{ lb}_m/\text{in}^3$$

where each term is evaluated at the mean values for m, L and d.

$$v_R = \frac{\left\{ \sum_{i=1}^L (\theta_i P_i)^2 \right\}^2}{\sum_{i=1}^L (\theta_i P_i)^4 / v_{x_i}} \approx 22$$

so that with  $u_{\rho} = \pm [B^2 + (tP)^2]^{1/2}$  with  $t_{22,95} = 2.07$

$$u_{\rho} = \pm [0.00385^2 + (2.07 \times 0.00194)^2]^{1/2} = \pm 0.0056 \text{ lb}_m/\text{in}^3 \quad (95\%)$$

$$\bar{\rho} = 4\bar{m} / \pi \bar{D}^2 \bar{L} = 0.0596 \text{ lb}_m/\text{in}^3$$

Then,

$$\rho' = 0.0596 \pm 0.0056 \text{ lb}_m/\text{in}^3 \quad (95\%)$$

The updated value here contains additional information relative to a design stage analysis. In this updated analysis, the random errors are based on actual measured data scatter and are larger than the previous estimate that was based on resolution error ( $u_o$ ) alone. The systematic errors are the same as the  $u_c$  values used previously.

## PROBLEM 5.30

KNOWN: Calibration against a standard.  
Calibration data are provided.

FIND: a.) Calibration curve fit. b.) Uncertainty in any estimated T.

SOLUTION

a.) To compute a calibration curve fit, the data are fit to a polynomial using a least squares analysis (spreadsheet programs have this capability). An acceptable first order curve fit of the form  $y = a_0 + a_1x \pm tS_{yx}$  is found to be:

$$E \text{ [mV]} = -0.0219 + 0.0416T[\text{°C}] \pm 0.086 \text{ mV (95\%)} \text{ with } t_{4,95} = 2.770 \text{ and } S_{yx} = 0.031 \text{ mV}$$

This curve has a static sensitivity of  $0.0416 \text{ mV/°C}$ . It corresponds to the curve:

$$T[\text{°C}] = 0.540 + 24.03E[\text{mV}] \pm 2.08\text{°C (95\%)} \text{ with } S_{yx} = 0.75\text{°C}$$

which has a static sensitivity of  $24.03\text{°C/mV}$ . We see that a very small change in voltage corresponds to a large change in temperature! This is typical of thermocouples.

b.) From the problem statement, we can identify two errors from the calibration source:

$$B_1 = 0.05\text{°C}$$

$$B_2 = 5\text{°C/m} \times 0.010\text{m} = 0.05\text{°C}$$

Each value of independent variable is measured once and the results combined to form the curve fit in part a. Voltage measurement system systematic errors are not indicated but will be present in the measured data. Lacking other information, we will make the assumption that these errors are of the magnitude of the resolution of the instrument, so that we set:

$$B_3 = 0.001\text{mV} = 0.024\text{°C}$$

(Note: from experience or manufacturer specifications, we might change this value up or down – but we leave as is here).

Random errors in the measurement system are presumed included in the calibration curve. The random error in the calibration curve is estimated as

$$P_4 = S_{yx} = 0.75\text{°C} \text{ with } \nu = 4.$$

So,

$$B = \left[ B_1^2 + B_2^2 + B_3^2 \right]^{1/2} = \left[ 0.05^2 + 0.05^2 + 0.024^2 \right]^{1/2} = 0.075\text{°C}$$

$$P = 0.75\text{°C} \quad \nu = 4$$

$$u_T = \pm \left[ B^2 + (tP)^2 \right]^{1/2} = \pm \left[ 0.075^2 + (2.77 * 0.75)^2 \right]^{1/2} = \pm 2.08\text{°C (95\%)}$$

Here the data scatter on the curve fit has the greatest effect on the uncertainty. In practice, systematic errors can be more than an order of magnitude higher than used here.

## PROBLEM 5.31

KNOWN:  $P = E^2/R$

$R \approx 100\Omega$        $P \approx 100 \text{ W}$  (nominal values)

Ohmmeter

Resolution:  $1 \Omega$

Error: 1% reading

Voltmeter

Resolution:  $1 \text{ V}$

Error: 1% reading

FIND:  $u_o$  and  $u_d$  for power

SOLUTION

For a nominal power of  $100 \text{ W}$ , we get a nominal value for voltage:

$$E = \sqrt{PR} = \sqrt{(100\Omega)(100\text{W})} = 100 \text{ V}$$

Uncertainty in power is due to uncertainties in  $E$  and  $R$ :

$$u_P = \pm \left[ \left( \frac{\partial P}{\partial E} u_E \right)^2 + \left( \frac{\partial P}{\partial R} u_R \right)^2 \right]^{1/2} = \pm \left[ \left( \frac{2E}{R} u_E \right)^2 + \left( \frac{-E^2}{R^2} u_R \right)^2 \right]^{1/2} \quad (1)$$

To find uncertainty at any order (e.g.,  $u_o$  or  $u_d$ ), use the uncertainties at that order and evaluate (1) using  $E = 100 \text{ V}$  and  $R = 100\Omega$ .

### Zero-order uncertainty

$$u_{o_E} = \pm 0.5 \text{ V} \quad u_{o_R} = \pm 0.5 \Omega$$

so substituting these values into (1),  $u_{o_P} = \pm 1.12 \text{ W}$  (95%).

### Design-stage uncertainty

$$u_d = \left[ u_o^2 + u_c^2 \right]^{1/2}$$

The estimates for  $u_o$  are given above. The estimates for  $u_c$  are

$$u_{d_E} = \pm(100\text{V})(.01) = \pm 1 \text{ V} \quad u_{d_R} = \pm(100\Omega)(0.01) = \pm 1 \Omega$$

so,

$$u_{d_E} = \pm 1.12 \text{ V}$$

$$u_{d_R} = \pm 1.12 \Omega$$

Substituting these values into (1):

$$u_{d_P} = \pm 2.5 \text{ W} \quad (95\%)$$

The uncertainty estimate becomes more accurate as each new piece of information is added.

## PROBLEM 5.32

KNOWN:  $P = 10, 1000, 10000 \text{ W}$   
 $P = E^2/R$  or  $P = IE$   
 Instrument specifications in Table

FIND: Design (select) a best method using uncertainty analysis

SOLUTION

**This problem is open-ended and this solution is offered as a guide.**

Suppose we fix  $E = 100\text{V}$ . This determines  $R$  and  $I$  for analysis. With the information available, a design-stage analysis is possible.

For  $P=f(E,R)$ :

$$u_P = \pm \left[ \left( \frac{\partial P}{\partial E} u_E \right)^2 + \left( \frac{\partial P}{\partial R} u_R \right)^2 \right]^{1/2} = \pm \left[ \left( \frac{2E}{R} u_E \right)^2 + \left( \frac{-E^2}{R^2} u_R \right)^2 \right]^{1/2}$$

or in terms of fractional percent, the relative uncertainty is (divide through by  $P=E^2/R$ )

$$u_P / P = \pm \left[ \left( 2u_E / E \right)^2 + \left( u_R / R \right)^2 \right]^{1/2} \quad (1)$$

For  $P=f(I,E)$

$$u_P = \pm \left[ \left( \frac{\partial P}{\partial E} u_E \right)^2 + \left( \frac{\partial P}{\partial I} u_I \right)^2 \right]^{1/2} = \pm \left[ \left( Iu_E \right)^2 + \left( Eu_I \right)^2 \right]^{1/2}$$

or, the relative uncertainty (divide through by  $P = EI$ )

$$u_P / P = \pm \left[ \left( u_E / E \right)^2 + \left( u_I / I \right)^2 \right]^{1/2} \quad (2)$$

At the design stage:  $u_d = \left[ u_o^2 + u_c^2 \right]^{1/2}$

$$u_{dE} = \left[ 0.5^2 + (0.005 \times E)^2 \right]^{1/2} \quad \text{voltage}$$

$$u_{dA} = \left[ 0.25^2 + (0.01 \times A)^2 \right]^{1/2} \quad \text{current} \quad (3)$$

$$u_{dR} = \left[ 0.5^2 + (0.005 \times R)^2 \right]^{1/2} \quad \text{resistance}$$

Method 1: Solve for  $P = E^2/R$ , equation (3) and then equation (1)

P	E	R	$u_P / P$
[W]	[V]	[ $\Omega$ ]	[%]
10	100	1000	1.5
100	100	10	2.9
1000	100	1	50.0

Method 2: Solve for  $P = EI$ , equation (3) and then equation (2)

P	E	I	$u_P/P$
[W]	[V]	[A]	[%]
10	100	0.1	250
100	100	10	2.8
1000	100	100	1.3

Method 1 is better at low power levels while method 2 is better at high levels.

#### COMMENT

Different values of E will produce different results. A broader look of this problem would vary E and optimize to determine a basis for preferred operating conditions (in E, R, and I).

## PROBLEM 5.33

KNOWN: Composite material is function of cure temperature,  $\sigma = f(T)$ .

Possible cure temperature range: 20°C to 60°C

Oven controllability to be tested at 30°C:

Oven divided into quadrants:  $j = 1$  to  $J$

$N$  measurements taken in each quadrant:  $i = 1$  to  $N$

$M$  replications to be made of entire test:  $m = 1$  to  $M$

Method 1:  $N = 5$ ,  $M = 5$ ,  $J = 4$  i.e.  $J \times N \times M = 100$

Method 2:  $N = 25$ ,  $M = 1$ ,  $J = 4$  i.e.  $J \times N \times M = 100$

FIND: If uncertainty in the oven test temperature is to be estimated, discuss information obtained by the two different methods.

ASSUMPTIONS: In order to simplify the solution we assume that sensor installation effects and measurement system operating conditions are properly controlled. We also neglect data reduction errors. In both cases the effects will be the same for either method.

### SOLUTION

**Open-ended problem.** This is an excellent problem for an instructor-directed group discussion.

Our goal is to estimate the uncertainty associated with the  $\sigma(T)$  test due to controllability of the independent variable,  $T$ . This test is really one of oven performance. By setting the oven to one representative condition, we can estimate typical oven performance at other temperatures through a single measurement analysis.

At any set temperature:

(i) By dividing the oven into quadrants and determining the mean quadrant temperature, we obtain information concerning the typical oven spatial variation in temperature.

(ii) By repetition, we obtain information about the typical oven temporal variation in temperature.

(iii) By replication, we obtain information about our ability to repeat the exact conditions on subsequent attempts (obviously, variations in the actual achieved oven temperature, despite the fact that the oven controls are seemingly reset exactly the same on each replication, affects strength).

Define:

$u_1$ : temporal variation effect on mean oven temperature

$u_2$ : spatial variation effect on mean oven temperature

$u_3$ : set controllability (repeatability) of the mean oven temperature

$u_c$ : instrument error associated with the measuring equipment

Mean temperature of any quadrant on any replication:

$$\bar{T}_{jm} = \frac{1}{N} \sum_{i=1}^N T_{ijm}$$

Grand pooled mean temperature:

$$\langle \bar{\bar{T}} \rangle = \frac{1}{M} \sum_{m=1}^M \langle \bar{T}_m \rangle$$

Pooled mean oven temperature on any replication:

$$\langle \bar{T}_m \rangle = \frac{1}{J} \sum_{j=1}^J \bar{T}_{jm}$$

Spatial temperature variation on any replication:

$$S_{T_m} = \left[ \frac{1}{J-1} \sum_{j=1}^{J-1} (\bar{T}_{jm} - \langle \bar{T}_m \rangle)^2 \right]^{1/2}$$

Temporal temperature variation on any replication:

$$\langle S_{T_m} \rangle = \left[ \frac{1}{J(N-1)} \sum_{j=1}^{J-1} \sum_{i=1}^N (T_{ijm} - \langle \bar{T}_m \rangle)^2 \right]^{1/2}$$

Set controllability of mean temperature:

$$\langle S_{\bar{T}} \rangle = \left[ \frac{1}{M-1} \sum_{m=1}^M (\langle \bar{T}_m \rangle - \langle \bar{\bar{T}} \rangle)^2 \right]^{1/2}$$

The Nth order uncertainty is found from

$$u_N = \pm [u_1^2 + u_2^2 + u_3^2 + u_c^2]^{1/2} \quad (\text{P}\%)$$

Method 1:

$$u_1 = t \langle S_{T_m} \rangle / \sqrt{JN}$$

$$u_2 = t S_{T_m} / \sqrt{J}$$

$$u_3 = t \langle S_{\bar{T}} \rangle / \sqrt{M}$$

Method 2:

$$u_1 = t \langle S_{T_m} \rangle / \sqrt{JN}$$

$$u_2 = t S_{T_m} / \sqrt{J}$$

$u_3 =$  information not available without replication

Without replication we will have no information on our ability to control the oven set temperature. This will be an important omission if we intend to use the oven for batch production.

#### COMMENT

There may be other options as to how to approach this problem and the above analysis presents but one approach. One alternative performs a multiple measurement analysis to estimate our ability to control the oven at 30°C. Using,

$$P_1 = \langle S_{T_m} \rangle / \sqrt{JN} ; P_2 = S_{T_m} / \sqrt{J} ; P_3 = \langle S_{\bar{T}} \rangle / \sqrt{M} ; B_4 = u_c$$

we obtain a similar result.

## PROBLEM 5.34

KNOWN:  $N_1 = 50$   
 $\bar{x} = 2.112 \text{ V}$   
 $S_1 = 0.387$   
 $CI \leq 0.10$  at 95%

FIND:  $N_T$

SOLUTION

The confidence interval is a two sided interval given by

$$CI = \pm tS / N^{1/2}$$

For a  $CI = 0.10$ , if  $d = CI/2 = |tS / N^{1/2}|$ , then  $d = 0.05$ . Evaluate an  $N_T$  based on the available  $S_1$ . Then,

$$N_T \approx (t_{N-1,95} S_1 / d)^2 \times 0.387 / 0.05)^2 = 242$$

## PROBLEM 5.35

KNOWN:  $N = 10$  measurements made at  $M = 4$  locations  
Micrometer: Resolution: 0.001 in.; Accuracy:  $< 0.001$  in.

FIND:  $D'$

ASSUMPTIONS: We will restrict the solution to errors due to data acquisition sources.

SOLUTION

A pooled estimate of the diameter of the shaft is given by

$$\langle D' \rangle = \frac{4.494 + 4.499 + 4.511 + 4.522}{4} = 4.506 \text{ in.}$$

with standard deviation

$$\langle S_D \rangle = \frac{0.006^2 + 0.009^2 + 0.01^2 + 0.003^2}{4} = 0.0075 \text{ in.}$$

We can recognize elemental errors due to instrument error and due to spatial variations effects on the computed mean value and procedural variation errors which bring about data scatter at each cross section. Instrument errors will be treated as a systematic error,

$$B_1 = u_c = 0.001 \text{ in.}$$

This value reflects the manufacturer accuracy statement. The procedural variations bring on a random error in each measured mean value as estimated by

$$P_2 = \langle S_{\bar{D}} \rangle = \langle S_D \rangle / (MN)^{1/2} = 0.0012 \text{ in.}$$

with degrees of freedom,  $\nu = M(N_j - 1)$ . The spatial error arises because the diameter is not uniform along its length such that the mean values vary. This spatial error affects the pooled mean value and is estimated by

$$S_D = \left[ \sum_{m=1}^{M=4} \frac{(\bar{D}_j - \langle \bar{D} \rangle)^2}{M-1} \right]^{1/2} = 0.0126 \text{ in.}$$

$$P_3 = S_{\bar{D}} = S_D / M^{1/2} = 0.006 \text{ in.}$$

Collecting random errors,

$$P = [P_2^2 + P_3^2]^{1/2} = 0.006 \text{ in.}$$

with degrees of freedom from the Welch-Satterwaite approach

$$v_D = \frac{(0.001^2 + 0.006^2)^2}{\frac{0.001^4}{36} + \frac{0.006^4}{3}} \approx 3$$

The uncertainty estimate can be given by

$$u_D = [B^2 + (t_{3,95}P)^2]^{1/2} = [0.001^2 + (3.182 \times 0.006)^2]^{1/2}$$

$$D' = 4.506 \pm 0.019 \text{ in. (95\%)}$$

#### COMMENT

Some observations on how the Welch-Satterwaite formula weights the degrees of freedom:

- in cases where one degree of freedom is substantially less than another while the random errors are of the same order of magnitude, that smaller degree of freedom dominates

in cases where one random error is substantially greater than the other while the degrees of freedom are either small but not too different or all are large ( $>30$ ), the larger random error value dominates.

## PROBLEM 5.36

KNOWN: Pressure is measured using a dial gauge.

$$\bar{p} = 50 \text{ psi} \quad S_p = 2 \text{ psi} \quad M = 30 \quad N = 1$$

Dial gauge:

Resolution: 0.1 psi

Accuracy: within 0.5 psi

FIND: Estimate the uncertainty in vessel pressure.

### SOLUTION

During a process the pressure is known to vary due to the set point of the compressor. Pressure will be set at  $p$  and readings are to be taken. We are asked to estimate the uncertainty in the set pressure at any measurement. We do this by running a trial set of data for pressure set point versus actual process pressure:

Single measurement analysis: From the manufacturer statement, we set

$$u_c = 0.5 \text{ psi}$$

The variations in vessel pressure upon each replication are estimated by

$$S_p = 2 \text{ psi}$$

such that,

$$u_1 = t_{29,95} S_p = (2.047)(2) = 4.1 \text{ psi}$$

So if during a test we set the vessel pressure, then the uncertainty in the process pressure during any one measurement is

$$u_N = \pm [0.5^2 + 4.1^2]^{1/2} = \pm 4.1 \text{ psi (95\%)}$$

### COMMENT

On 30 trials, we found a standard deviation in the set point to be 2 psi. The uncertainty in the set point during any one trial should be about twice this number for 95% probability. Notice how this is quite different then trying to determine the average set point over 30 trials (which works out to be only 0.9 psi at 95% - see below). This is an example of the advanced stage analysis applied to access uncertainty in a single trial (sample).

The uncertainty in the actual mean set point is:

$$u_1 = t_{29,95} S_p / M^{1/2} = (2.047)(2) / 30^{1/2} = 0.75 \text{ psi}$$

$$u_N = \pm [0.5^2 + 0.75^2]^{1/2} = 0.91 \text{ psi (95\%)}$$

## PROBLEM 5.37

KNOWN: Transducer, readout specifications.

M = 4 replications with N = 10 repetitions each.

FIND:  $\bar{x} \pm u_x$

SOLUTION

From the data, the pooled mean:  $\langle \bar{x} \rangle = (4.3 + 3.8 + 4.2 + 4.0)/4 = 4.08$

At the design-stage, only information known prior to the test are included:

For the transducer, we estimate the instrument error from the elemental errors:

$$e_L = \pm (0.0025)(4\text{m}) = 0.01 \text{ m}$$

$$e_R = \pm (0.0025)(4\text{m}) = 0.01 \text{ m}$$

$$e_K = \pm (0.001)(5\text{m}) = 0.005 \text{ m}$$

$$e_z = \pm (0.005/^\circ\text{C})(3^\circ\text{C})(5\text{m}) = 0.0075 \text{ m}$$

so that,

$$u_{c_t} = (.01^2 + .01^2 + .005^2 + .0075^2)^{1/2} = 0.0167 \text{ m}$$

The transducer has a sensitivity  $K_t = 1\text{V/m}$  so that the voltmeter output can be restated in terms of displacement [m].

For the voltmeter:

$$u_{c_E} = \{[(0.001)(4\text{m})(1\text{m/V})]^2 + [(5 \mu\text{V})(1\text{m/V})]^2\}^{1/2} = 0.004 \text{ m}$$

For the transducer-voltmeter system, the design-stage uncertainty is:

$$u_d = \pm (.004^2 + .0167^2)^{1/2} = \pm 0.017 \text{ m} \quad (95\%)$$

We can use this information for the multiple-measurement analysis where we assign instrument errors:

$$B_1 = u_{c_t} = 0.0167 \text{ m} \quad B_2 = u_{c_E} = 0.004 \text{ m}$$

The uncertainty in the applied input estimates the control of the input forcing function.

Assuming  $F = kx$ , then  $K = (2000 \text{ N})/(4 \text{ m}) = 500 \text{ N/m}$ . Hence, we assign:

$$B_3 = \left[ \left( \frac{\partial x}{\partial F} u_F \right)^2 \right]^{1/2} = 0.2 \text{ m}$$

The temporal or repetition error in the mean values is estimated from the given deviations:

$$P_4 = [(S_1^2 + S_2^2 + S_3^2 + S_4^2)/4]^{1/2}/(MN)^{1/2} = 0.04 \text{ m with } \nu_4 = 36$$

The temporal error or replication error in the overall pooled mean is:

$$P_5 = \left[ \sum_{m=1}^4 (\bar{x}_j - \langle \bar{x} \rangle)^2 / (M - 1) \right]^{1/2} = 0.11 \text{ m with } \nu_5 = 4$$

$$\nu = \frac{[0.04^2 + 0.11^2]^2}{\frac{0.04^4}{36} + \frac{0.11^4}{4}} = 4$$

with  $t_{4,95} = 2.770$ . Then, for the measurement:

$$B = (.0167^2 + .004^2 + .2^2)^{1/2} = 0.2 \text{ m}$$

So, the ability to control the applied force dominates the systematic error.

$$P = (.11^2 + .04^2)^{1/2} = 0.12 \text{ m}$$

$$\text{Then, } u_x = \pm (.2^2 + [(2.770)(.12)]^2)^{1/2} = \pm 0.39 \text{ m (95\%)}$$

$$\text{Hence, } x' = \bar{x} \pm u_x = 4.08 \pm 0.39 \text{ m (95\%)}$$

## PROBLEM 5.38

KNOWN: First-order system:

$$u_{\Gamma}/\Gamma = \pm 0.02 \text{ (95\%)}$$

$$u_t/t = \pm 0.01 \text{ (95\%)}$$

FIND:  $u_{\tau} / \tau$

ASSUMPTION:  $\tau = f(\Gamma, t)$  with no other influences.

SOLUTION

$$\Gamma = e^{-t/\tau}$$

Rearranging,  $\tau = -t / \ln \Gamma$

$$u_{\tau} = \pm \left[ \left( \frac{\partial \tau}{\partial t} u_t \right)^2 + \left( \frac{\partial \tau}{\partial \Gamma} u_{\Gamma} \right)^2 \right]^{1/2} = \pm \left[ \left( \frac{u_t}{\ln \Gamma} \right)^2 + \left( \frac{u_{\Gamma}}{\Gamma (\ln \Gamma)^2} \right)^2 \right]^{1/2}$$

in relative terms,

$$u_{\tau} / \tau = \pm \left[ \left( \frac{u_t}{t} \right)^2 + \left( \frac{u_{\Gamma}}{\Gamma (\ln \Gamma)} \right)^2 \right]^{1/2}$$

$\Gamma$	$u_{\tau} / \tau$
.1	0.013
.5	0.031
.8	0.090
.9	0.190
1.0	$\infty$

## PROBLEM 5.39

KNOWN: Transducer, readout specifications.

$M = 3$  replications with  $N = 20$  repetitions each.

FIND:  $\bar{T} \pm u_T$

SOLUTION

From the data,  $\langle \bar{T} \rangle = (181.0 + 183.1 + 182.1)/3 = 182.1 \text{ }^\circ\text{C}$

From the problem statement, we can assign

$B_1 = e_1 = 1 \text{ }^\circ\text{C}$  measuring system error

$B_2 = e_2 = 1.2 \text{ }^\circ\text{C}$  installation error

The temporal or repetition error in the mean values is estimated from the variations in the data sets:

$$P_3 = [(\bar{S}_1^2 + S_1^2 + S_3^2)/3]^{1/2} / (MN)^{1/2} = 0.38 \text{ }^\circ\text{C} \text{ with } \nu_3 = M(N_m - 1) = 57$$

The temporal error or replication error in the overall pooled mean is:

$$P_4 = \left[ \sum_{m=1}^3 (\bar{T}_m - \langle \bar{T} \rangle)^2 \right]^{1/2} / M^{1/2} = 0.61 \text{ m with } \nu_4 = (M-1) = 2$$

Then, for the measurement:

$$B = (1^2 + 1.2^2)^{1/2} = 1.56 \text{ }^\circ\text{C}$$

$$P = (.38^2 + .61^2)^{1/2} = 0.72 \text{ }^\circ\text{C}$$

with, using the Welch-Satterthwate estimate,  $\nu = f(\nu_3, \nu_4) = 3.8 \approx 4$

and  $t_{4,95} = 2.770$ . Then,

$$u_T = \pm (1.56^2 + [(2.770)(.72)]^2)^{1/2} = \pm 2.5 \text{ }^\circ\text{C} \text{ (95\%)}$$

Hence,  $T' = \langle \bar{T} \rangle \pm u_T = 182.1 \pm 2.5 \text{ }^\circ\text{C} \text{ (95\%)}$

## PROBLEM 5.40

### SOLUTION

Exact answers will depend on user experience and specific instruments user has experience with. As a class exercise, it would be interesting to discuss why different people chose their numbers.

As a guide:

bathroom scale:

spring scale:  $\pm 5$  to  $10$  N

balance beam scale:  $\pm 1$  N

plastic ruler: to within its resolution

micrometer: to within its resolution

kitchen thermometer:  $\pm 1$  °C

speedometer:  $\pm 4\%$  reading (in USA this is by law)

## PROBLEM 5.41

KNOWN: Air @  $T = 25 \pm 2 \text{ }^\circ\text{C}$  (95%)  
 $u_p/p = 0.01$  (95%)

FIND:  $u_\rho / \rho$

ASSUMPTIONS: Ideal gas  $p = \rho RT$ . Neglect uncertainty in gas constant R.

SOLUTION

$$\rho = f(p, T)$$

$$u_\rho / \rho = \left[ (u_p / p)^2 + (u_T / T)^2 \right]^{1/2}$$

A change in  $1 \text{ }^\circ\text{C}$  equals a change of  $1 \text{ K}$ . So we can rewrite temperature as

$$T = (25 + 273) \pm 2 \text{ K} = 298 \pm 2 \text{ K} \quad (95\%)$$

$$u_\rho / \rho = \left[ (0.01)^2 + (2\text{K} / 298\text{K})^2 \right]^{1/2} = \pm 0.012 \quad \text{or} \quad \pm 1.2\% \quad (95\%)$$

## PROBLEM 5.42

KNOWN: Air at  $T = 25^\circ\text{C}$  with  $u_T = \pm 1^\circ\text{C}$  (95%)

$$u_\rho / \rho = \pm 0.005$$

FIND:  $u_p/p$

ASSUMPTIONS: Ideal gas  $p = \rho RT$ . Neglect uncertainty in gas constant,  $R$ .

SOLUTION

$$u_p / p = \pm \left[ (u_\rho / \rho)^2 + (u_T / T)^2 \right]^{1/2}$$

A change in  $1^\circ\text{C}$  equals a change of 1 K. So,  $T = 298 \pm 1 \text{ K}$  (95%). Subbing terms,

$$u_p / p = \pm \left[ (0.005)^2 + (1\text{K} / 298\text{K})^2 \right]^{1/2} = \pm 0.0037 \text{ or } \pm 3.7\% \quad (95\%)$$

## PROBLEM 4.43

KNOWN:  $T = e^{-KEW}$  and  $0 \leq T \leq 1$   
 $E = 2 \pm 0.04$  (95%)  
 $u_T/T = \pm 0.01$  (95%)  
 $u_W/W = \pm 0.01$  (95%)

FIND: Is  $u_K / K \leq 0.05$ ? 0.10?

### SOLUTION

The solids density is found by

$$K = -(\ln T)/EW$$

so that,

$$u_K / K = \pm \left[ (u_T / T \ln T)^2 + (u_E / E)^2 + (u_W / W)^2 \right]^{1/2}$$

$$= \pm \left[ (0.01 / \ln T)^2 + (0.04 / 2)^2 + (0.01)^2 \right]^{1/2}$$

Then for values of transmission factor, T :

T	u <sub>K</sub> /K
.5	0.027
.8	0.05
.9	0.0975
1.	∞

So  $u_K/K$   
 approaches 5% at  
 $T = 0.8$  and 10%  
 at  $T = 0.9$ .

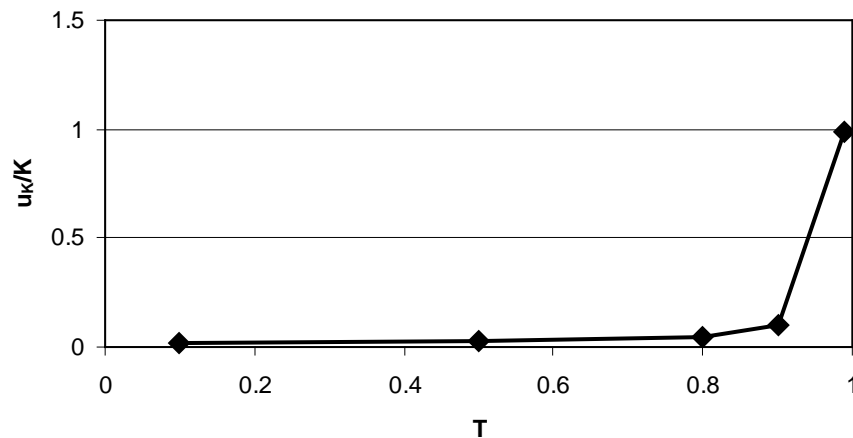

We see that

$$u_K / K \rightarrow \infty \text{ as } T \rightarrow 1.$$

## PROBLEM 5.44

KNOWN: First-order system:

$$u_{\Gamma}/\Gamma = \pm 0.02 \text{ (95\%)}$$

$$u_t/t = \pm 0.005 \text{ (95\%)}$$

FIND:  $u_{\tau} / \tau$

ASSUMPTION:  $\tau = f(\Gamma, t)$  with no other influences.

SOLUTION

$$\Gamma = e^{-t/\tau}$$

Rearranging,  $\tau = -t / \ln \Gamma$

$$u_{\tau} = \pm \left[ \left( \frac{\partial \tau}{\partial t} u_t \right)^2 + \left( \frac{\partial \tau}{\partial \Gamma} u_{\Gamma} \right)^2 \right]^{1/2} = \pm \left[ \left( \frac{u_t}{\ln \Gamma} \right)^2 + \left( \frac{u_{\Gamma}}{\Gamma (\ln \Gamma)^2} \right)^2 \right]^{1/2}$$

in relative terms,

$$\begin{aligned} u_{\tau} / \tau &= \pm \left[ \left( \frac{u_t}{t} \right)^2 + \left( \frac{u_{\Gamma}}{\Gamma (\ln \Gamma)} \right)^2 \right]^{1/2} \\ &= \pm \left[ (0.005)^2 + \left( \frac{0.02}{\ln \Gamma} \right)^2 \right]^{1/2} \end{aligned}$$

$\Gamma$	$u_{\tau} / \tau$
.1	0.010
.5	0.029
.8	0.090
.9	0.190
1.0	$\infty$

Because  $\tau$  approaches steady state asymptotically as  $\Gamma$  goes to 1, this behavior is to be expected.

## PROBLEM 5.45

KNOWN: acceleration,  $a = f(L, s, t_1, t_2)$

$$L = 5.0 \pm 0.5 \text{ cm} \qquad s = 100.0 \pm 0.2 \text{ cm}$$

$$t_1 = 0.054 \pm 0.001 \text{ s} \qquad t_2 = 0.031 \pm 0.001 \text{ s}$$

all uncertainties stated at 95% confidence

FIND:  $u_a$

SOLUTION

We know that

$$a = \frac{L^2}{2s} \left( \frac{1}{t_2^2} - \frac{1}{t_1^2} \right)$$

Applying the nominal values into the equation gives,

$$a = \frac{5^2}{2 \times 100} \left( \frac{1}{0.031^2} - \frac{1}{0.054^2} \right) = 87.21 \text{ cm/s}^2$$

And  $u_a = f(u_L, u_s, u_{t_1}, u_{t_2})$ . Expanding,

$$u_a = \pm \left[ \left( \frac{\partial a}{\partial L} u_L \right)^2 + \left( \frac{\partial a}{\partial s} u_s \right)^2 + \left( \frac{\partial a}{\partial t_1} u_{t_1} \right)^2 + \left( \frac{\partial a}{\partial t_2} u_{t_2} \right)^2 \right]^{1/2}$$

where

$$\frac{\partial a}{\partial L} = \frac{2L}{2s} \left( \frac{1}{t_2^2} - \frac{1}{t_1^2} \right) \qquad \frac{\partial a}{\partial s} = \frac{L^2}{s^2} \left( \frac{1}{t_2^2} - \frac{1}{t_1^2} \right)$$

$$\frac{\partial a}{\partial t_2} = \frac{L^2}{2s} \left( \frac{2}{t_2^3} \right) \qquad \frac{\partial a}{\partial t_1} = \frac{L^2}{2s} \left( -\frac{2}{t_1^3} \right)$$

$$\frac{\partial a}{\partial L} u_L = \frac{5}{100} \left( \frac{1}{0.031^2} - \frac{1}{0.054^2} \right) (0.05)$$

$$\frac{\partial a}{\partial t_1} u_{t_1} = \frac{5^2}{200} \left( -\frac{2}{0.054^3} \right) (0.001)$$

$$\frac{\partial a}{\partial s} u_s = \frac{5^2}{100^2} \left( \frac{1}{0.031^2} - \frac{1}{0.054^2} \right) (0.2)$$

$$\frac{\partial a}{\partial t_2} u_{t_2} = \frac{5^2}{200} \left( \frac{2}{0.031^3} \right) (0.001)$$

$$u_a = \pm (1.744^2 + 1.744^2 + 1.587^2 + 8.392^2)^{1/2} = \pm 8.89 \text{ cm/s}^2$$

and so the acceleration is best estimated as

$$a = 87.21 \pm 8.89 \text{ cm/s}^2 \quad (95\%) \qquad \text{or } u_a/a \text{ is about } 10.2\%$$

As a concomitant check, we can estimate acceleration from  $a = g \sin \alpha$ . Note that if  $\alpha$  is measured, then acceleration  $a$  is easily anticipated. Of course, such an estimate neglects errors due to systematic effects, such as friction. But friction effects are built into the first estimate and the differences will reflect the magnitude of this systematic error. With  $g = 9.806 \text{ m/s}^2 = 980.6 \text{ cm/s}^2$ , we assign an uncertainty of  $u_g = \pm 0.1 \text{ cm/s}^2$  to this gravitational constant (equal to its roundoff error).

For example, for an angle  $\alpha = 30$ . Then with,

$$u_a = \left[ (u_g \sin \alpha)^2 + (g u_\alpha \cos \alpha)^2 \right]^{1/2}$$

For  $u_a \leq 8.89 \text{ cm/s}^2$ , we need  $u_\alpha \leq 0.6^\circ (= 0.01047 \text{ rad})$ .

As  $\alpha$  increases, the uncertainty becomes less sensitive to the angle measurement and more sensitive to gravity. Note that as  $\alpha \rightarrow 90^\circ$ ,

$$u_a = \left[ (u_g \sin \alpha)^2 + (0)^2 \right]^{1/2} \rightarrow u_g$$

and the uncertainty in acceleration becomes independent of the uncertainty in  $\alpha$ .

## PROBLEM 5.46

**KNOWN:**

Measured data relating golf ball carry distance to launch angle and initial velocity

**FIND:**

Uncertainty in carry distance,  $D$ , as determined from initial velocity,  $V_o$  and launch angle,  $\phi$

**SOLUTION:**

The uncertainty in distance is determined from

$$u_D = \sqrt{\left(\frac{\partial D}{\partial V_o} u_{V_o}\right)^2 + \left(\frac{\partial D}{\partial \phi} u_\phi\right)^2}$$

with the partial derivatives approximated numerically from measured data. The units of angle used in the equations is radians.

Initial Velocity (MPH)	Launch Angle (degrees)	Carry Distance (yds)	$\frac{\partial D}{\partial V_o}$	$\frac{\partial D}{\partial \phi}$	$u_D$
165.5	8	254.6	1.48	1.8	1.49
167.8	8	258.0	1.55	1.8	1.55
170	8	261.4	1.55	1.7	1.56
172.2	8	264.8	1.55	1.6	1.56
165.5	10	258.2	1.48	1.2	1.49
167.8	10	261.6	1.41	1.0	1.42
170	10	264.7	1.45	1.0	1.45
172.2	10	267.9	1.45	1.0	1.45
165.5	12	260.6	1.48	1.0	1.48
167.8	12	263.7	1.41	1.0	1.41
170	12	266.8	1.45	1.0	1.45
172.2	12	269.8	1.45	1.0	1.45

So a single value of uncertainty, approximately 1.5 yds (1.37 m), can be used to quantify the effects of errors in the measurement of  $V_o$  and  $\phi$ . Note that the only significant contribution to uncertainty results from uncertainty in the initial velocity.

## PROBLEM 5.47

**KNOWN:**

Measured data relating pressure drop and volumetric flow rate

**FIND:**

Required uncertainty in pressure drop to yield a 0.25% uncertainty in volumetric flow rate

**ASSUMPTION:**

For this problem, assume that the only errors enter in the measurement of pressure drop. In practice, errors related to dimensions and hydraulic coefficients will add additional errors.

**SOLUTION:**

The uncertainty in flow rate is

$$u_Q = \left[ \left( \frac{\partial Q}{\partial \Delta P} u_{\Delta P} \right)^2 \right]^{1/2} \quad \text{or in relative terms we can reduce this to } \frac{u_Q}{Q} = \left| \frac{u_{\Delta P}}{\Delta P} \right|$$

$Q$ (m <sup>3</sup> /min)	$\Delta P$ (Pa)	$\frac{\partial Q}{\partial \Delta P} \times 10^3$	Required $u_{\Delta P}$ (Pa)
10	1000	3.06	$\pm 2.5$
20	4271	2.16	$\pm 10.7$
30	8900	1.4	$\pm 22.3$
40	16023	1.2	$\pm 40.0$

Note that the required value of uncertainty in pressure drop is 0.25%.

**COMMENT:** The accuracy of pressure transducers is often reported as a percentage of the full scale reading. To achieve the requirement of  $\pm 2.5$  Pa for a transducer having a full scale reading of 20,000 Pa (3 psi) would require an uncertainty of  $\pm 2.5/20,000$  or 0.0125%. It is not likely that a single transducer could yield the desired accuracy over the range of pressures required in the present problem.

## PROBLEM 5.48

This problem is open-ended and developed by the user. Classroom/lab instructors will want to use this problem as a basis for round-table discussions.

## PROBLEM 5.49

This problem is open-ended and developed by the user. Classroom/lab instructors will want to use this problem as a basis for round-table discussions.

## PROBLEM 5.50

KNOWN:  $\sigma = FL(t/2)/I = FL(t/2)/(wt^3/12)$   
 $L = 100 \text{ mm} = 0.1 \text{ m}$        $F = 980 \text{ N}$   
 $t = 0.01 \text{ m}$                        $w = 0.03 \text{ m}$

FIND: maximum stress

SOLUTION

The best estimate for maximum stress is determined using the working values for each variable. Plugging in the known values,

$$\bar{\sigma} = \sigma = FL(t/2)/(wt^3/12) = 196 \times 10^6 \text{ Pa} = 196 \text{ MPa}$$

where  $I = wt^3/12 = 2.5 \times 10^{-9} \text{ m}^4 = 2500 \text{ mm}^4$

All uncertainties can be treated as systematic errors. There are no statistics to compute random errors (so  $P_\sigma = 0$ ). Then, the systematic errors in length are taken as  $\frac{1}{2}$  the ruler increment:

$$\begin{aligned} B_L &= u_L = 0.5 \text{ mm} = 0.0005 \text{ m} \\ B_t &= u_t = 0.5 \text{ mm} = 0.0005 \text{ m} \\ B_w &= u_w = 0.5 \text{ mm} = 0.0005 \text{ m} \\ B_F &= u_F = 10 \text{ N} \end{aligned}$$

$$B_I = \left[ \left( \frac{\partial I}{\partial w} B_w \right)^2 + \left( \frac{\partial I}{\partial t} B_t \right)^2 \right]^{1/2} = \left[ \left( \frac{t^3}{12} B_w \right)^2 + \left( \frac{wt^2}{36} B_t \right)^2 \right]^{1/2} = 5.89 \times 10^{-11} \text{ m}^4 = 58.9 \text{ mm}^4$$

$$\begin{aligned} B_\sigma &= \left[ \left( \frac{\partial \sigma}{\partial F} B_F \right)^2 + \left( \frac{\partial \sigma}{\partial L} B_L \right)^2 + \left( \frac{\partial \sigma}{\partial t} B_t \right)^2 + \left( \frac{\partial \sigma}{\partial I} B_I \right)^2 \right]^{1/2} \\ &= \left[ \left( \frac{Lt}{2I} B_F \right)^2 + \left( \frac{Ft}{2I} B_L \right)^2 + \left( \frac{FL}{2I} B_t \right)^2 + \left( \frac{-FLt}{2I^2} B_I \right)^2 \right]^{1/2} = 14,739,060 \text{ Pa} \end{aligned}$$

so,

$$u_\sigma = \left[ B_\sigma^2 + (tP_\sigma)^2 \right]^{1/2} = B_\sigma = 14.74 \text{ MPa}$$

$\sigma = 196.0 \pm 14.74 \text{ MPa}$  (95%) or the uncertainty is about 7.5% of the maximum stress.

## PROBLEM 5.51

KNOWN:  $\dot{Q} = f(T_1, T_2)$

$$\bar{T}_1 = 180^\circ\text{C} \quad \bar{T}_2 = 90^\circ\text{C}$$

$$B_{T_1} = B_{T_2} = 0.2^\circ\text{C}$$

$$S_{\bar{T}_1} = S_{\bar{T}_2} = 0.1^\circ\text{C}$$

FIND:  $u_{\dot{Q}}$  assuming (1) totally correlated and (2) totally uncorrelated errors

ASSUMPTION: Large sample size

SOLUTION

Based on the measured mean values, the mean value of the result in heat transfer rate is

$$\bar{\dot{Q}} = 5(\bar{T}_1 - \bar{T}_2) = 5(180 - 90^\circ\text{C}) = 450\text{kJ/s}$$

Now,  $u_{\dot{Q}} = f(u_{T_1}, u_{T_2})$

where  $u_{\dot{Q}} = \left[ B_{\dot{Q}}^2 + (tP_{\dot{Q}})^2 \right]^{1/2}$  with  $t_{95} \sim 2$  (value is consistent with large sample size and engineering practice – e.g., see PTC 19.1).

The standard random uncertainty is estimated by

$$P_{\dot{Q}} = \left[ \left( \frac{\partial \dot{Q}}{\partial T_1} P_{T_1} \right)^2 + \left( \frac{\partial \dot{Q}}{\partial T_2} P_{T_2} \right)^2 \right]^{1/2} = \left[ \left( 5P_{T_1} \right)^2 + \left( -5P_{T_2} \right)^2 \right]^{1/2} = 0.71\text{kJ/s}$$

where  $P_{T_1} = S_{\bar{T}_1}$  and  $P_{T_2} = S_{\bar{T}_2}$ .

For totally uncorrelated systematic errors, the systematic errors are independent of each other:

$$B_{\dot{Q}_{\text{uncor}}} = \left[ \left( \frac{\partial \dot{Q}}{\partial T_1} B_{T_1} \right)^2 + \left( \frac{\partial \dot{Q}}{\partial T_2} B_{T_2} \right)^2 \right]^{1/2} = \left[ \left( 5B_{T_1} \right)^2 + \left( -5B_{T_2} \right)^2 \right]^{1/2} = 1.41\text{kJ/s}$$

For correlated errors, the errors will move in the same direction (high or low) and are corrected from the uncorrelated estimate,

$$\begin{aligned}
 B_{\dot{Q}_{\text{cor}}} &= \left[ \left( \frac{\partial \dot{Q}}{\partial T_1} B_{T_1} \right)^2 + \left( \frac{\partial \dot{Q}}{\partial T_2} B_{T_2} \right)^2 + 2 \left( \frac{\partial \dot{Q}}{\partial T_1} \right) \left( \frac{\partial \dot{Q}}{\partial T_2} \right) B_{T_1} B_{T_2} \right]^{1/2} \\
 &= \left[ (5 \times 0.2)^2 + (-5 \times 0.2)^2 + 2(5)(-5)(.2)(.2) \right]^{1/2} = 0 \text{ kJ/s}
 \end{aligned}$$

So,

$$u_{\dot{Q}} = \left[ B_{\dot{Q}}^2 + (tP_{\dot{Q}})^2 \right]^{1/2} = \left[ B_{\dot{Q}}^2 + (2P_{\dot{Q}})^2 \right]^{1/2}$$

$$u_{\dot{Q}_{\text{uncor}}} = 2 \text{ kJ/s} \quad \text{such that} \quad \dot{Q} = 450 \pm 2 \text{ kJ/s} \quad (95\%)$$

$$u_{\dot{Q}_{\text{cor}}} = 1.4 \text{ kJ/s} \quad \text{such that} \quad \dot{Q} = 450 \pm 1.4 \text{ kJ/s} \quad (95\%)$$

#### COMMENT

The errors could be uncorrelated if (1) the different thermocouples came from different batches or manufacturers, or (2) the thermocouples were calibrated against different standards or methods. A portion of the uncorrelated error could come from the use of different measuring devices, which themselves were calibrated against different standards. If so, it is possible to assign an uncorrelated portion and a correlated portion of the systematic error and proceed as above.

On the other hand, if the thermocouples came from the same spool of wire (fairly common) and/or were calibrated against the same standard, the errors are correlated.

## PROBLEM 5.52

KNOWN:  $R = p_2/p_1$   
 $\bar{p}_2 = 54.7 \text{ MPa}$        $\bar{p}_1 = 42.0 \text{ MPa}$   
 $B_{p_2} = B_{p_1} = 0.50 \text{ MPa}$

FIND: Compare results if errors are (1) uncorrelated and (2) correlated

### SOLUTION

For values given:

$$\bar{R} = \bar{p}_2 / \bar{p}_1 = 54.7/42.0 = 1.30$$

$$B_{R_{\text{uncor}}} = \left[ \left( \frac{\partial R}{\partial p_1} B_{p_1} \right)^2 + \left( \frac{\partial R}{\partial p_2} B_{p_2} \right)^2 \right]^{1/2} = \left[ \left( \theta_{p_1} B_{p_1} \right)^2 + \left( \theta_{p_2} B_{p_2} \right)^2 \right]^{1/2}$$

where  $\theta_{p_1} = \frac{-p_2}{p_1^2} = 0.031$  and  $\theta_{p_2} = \frac{1}{p_1} = 0.025$ , and

$$B_{R_{\text{cor}}} = \left[ \left( \frac{\partial R}{\partial p_1} B_{p_1} \right)^2 + \left( \frac{\partial R}{\partial p_2} B_{p_2} \right)^2 + 2 \left( \frac{\partial R}{\partial p_1} \right) \left( \frac{\partial R}{\partial p_2} \right) B_{p_1} B_{p_2} \right]^{1/2}$$

$$= \left[ \left( \theta_{p_1} B_{p_1} \right)^2 + \left( \theta_{p_2} B_{p_2} \right)^2 + 2 \left( \theta_{p_1} \right) \left( \theta_{p_2} \right) B_{p_1} B_{p_2} \right]^{1/2}$$

So,

$R = 1.30 \pm B$  (95%) where

$$\text{if } B = B_{R_{\text{uncor}}} = \left[ (0.031 \times 0.5 \text{ MPa})^2 + (0.024 \times 0.5 \text{ MPa})^2 \right]^{1/2} = 0.020 \text{ MPa}$$

but

$$\text{if } B = B_{R_{\text{cor}}} = \left[ (0.031 \times 0.5 \text{ MPa})^2 + (0.024 \times 0.5 \text{ MPa})^2 + 2(-0.031)(0.024)(0.5)(0.5) \right]^{1/2}$$

$$= 0.0035 \text{ MPa}$$

The effect of having correlated errors nearly cancels out the effects of the individual systematic errors.

The functional relationship can have an impact on whether correlated errors have an effect on the uncertainty. Here  $R = p_2/p_1$  allows for a decrease.

## PROBLEM 5.53

KNOWN:  $m = 22\text{ kg}$        $B_m = 0.001\text{ kg}$   
 $V = 8\text{ m/s}$        $B_V = 0.27\text{ m/s}$   
 $\overline{\text{KE}} = 717\text{ N-m}$        $S_{\text{KE}} = 60.7\text{ N-m}$  with  $N = 24$

FIND:  $u_{\text{KE}}$  @ 68% and  $u_{\text{KE}}$  @ 95%

### SOLUTION

The confidence level in the uncertainty affects the value reported but not the fundamental methods used to assess uncertainty. The “expanded” uncertainty (term used in PTC 19.1 – 2005) is the uncertainty at 95%,

$$u_{\text{KE}} = \left[ B^2 + (t_{95}P)^2 \right]^{1/2} \quad (95\%)$$

while the combined standard uncertainty is the uncertainty at 68%.

$$u_{\text{KE}} = \left[ (B/2)^2 + (P)^2 \right]^{1/2} \quad (68\%)$$

So find B and P:

Beginning with  $\text{KE} = \frac{1}{2} mV^2$ ,

$$\begin{aligned} B_{\text{KE}} &= \left[ \left( \frac{\partial \text{KE}}{\partial m} B_m \right)^2 + \left( \frac{\partial \text{KE}}{\partial V} B_V \right)^2 \right]^{1/2} = \left[ \left( V^2 B_m / 2 \right)^2 + \left( m V B_V \right)^2 \right]^{1/2} \\ &= \left[ 0.0032^2 + 47.5^2 \right]^{1/2} = 47.5\text{ N-m} \end{aligned}$$

$$P_{\text{KE}} = S_{\frac{\text{KE}}{\text{KE}}} = S_{\text{KE}} / \sqrt{N} = 60.7\text{ N-m} / \sqrt{24} = 12.4\text{ N-m}$$

with  $v = 23$ . Then,  $t_{23,95} = 2.06 \sim 2$

So, we can correctly state at either confidence level:

$$u_{\text{KE}} = \left[ 47.5^2 + (2 \times 12.4)^2 \right]^{1/2} = 53.5\text{ N-m} \quad (95\%)$$

$$u_{\text{KE}} = \left[ (47.5/2)^2 + (12.4)^2 \right]^{1/2} = 26.8\text{ N-m} \quad (68\%)$$

## PROBLEM 5.54

KNOWN:  $\sigma_{\max} = K_t \sigma_o$ ;  $\sigma_o = F/A$ ;  $A = (w - d)t$

FIND: Uncertainty in  $\sigma_{\max}$

ASSUMPTION: Uncertainty in  $K_t$  is negligible

SOLUTION:

Develop an expression for  $\sigma_{\max}$  in terms of its known variables:

$$\sigma_{\max} = K_t \frac{F}{(w - d)t}$$

$$u_{\sigma_{\max}} = \pm \left[ \left( \frac{\partial \sigma_{\max}}{\partial w} u_w \right)^2 + \left( \frac{\partial \sigma_{\max}}{\partial d} u_d \right)^2 + \left( \frac{\partial \sigma_{\max}}{\partial t} u_t \right)^2 + \left( \frac{\partial \sigma_{\max}}{\partial F} u_F \right)^2 \right]^{1/2}$$

$$\frac{\partial \sigma_{\max}}{\partial w} = - \frac{K_t F}{t(w - d)^2} = 7.82 \times 10^{10}$$

$$\frac{\partial \sigma_{\max}}{\partial d} = \frac{K_t F}{t(w - d)^2} = 7.82 \times 10^{10}$$

$$\frac{\partial \sigma_{\max}}{\partial t} = - \frac{FK_t}{(w - d)t^2} = 117.3 \times 10^9$$

$$\frac{\partial \sigma_{\max}}{\partial F} = \frac{K_t}{(w - d)t} = 58.7 \times 10^3$$

where  $d = 0.5w$ ;  $K_t = 2.2$ ;  $F = 10,000 \text{ N}$ ;  $w = 1.5 \text{ cm} = 0.015 \text{ m}$ ;  $t = 0.5 \text{ cm} = 0.005 \text{ m}$   
and  $u_w = 0.02 \text{ cm} = 0.0002 \text{ m}$ ;  $u_F = 500 \text{ N}$ ;  $u_d = 0.5u_w$

$$u_{\sigma_{\max}} = \pm [(15.6 \times 10^6)^2 + (17.6 \times 10^6)^2 + (23.5 \times 10^6)^2 + (29.3 \times 10^6)^2] = 44.3 \times 10^6 \text{ N/m}^2$$

so putting it all together,

$$u_{\sigma_{\max}} = 26.7 \times 10^7 \pm 44.3 \times 10^6 \text{ N/m}^2 \quad (95\%)$$

## PROBLEM 6.1

**KNOWN:** A current loop having

$$N = 20$$

$$A = 1 \text{ in}^2 = 0.000645 \text{ m}^2$$

$$I = 0.02 \text{ A}$$

$$B = 0.4 \text{ Wb/m}^2$$

**FIND:** Torque on the current loop,  $T_\mu$ .

**ASSUMPTIONS:** The magnetic field is oriented at an angle of  $90^\circ$  to the current flow direction.

**SOLUTION:**

From (6.3)

$$T_\mu = NIAB \sin \alpha$$

The maximum torque occurs when  $\sin \alpha = 1$ , which yields

$$\begin{aligned} T_\mu^{\max} &= NIAB \\ &= 20(0.02 \text{ A})(0.000645 \text{ m}^2)(0.4 \text{ Wb/m}^2) \end{aligned}$$

$$T_\mu^{\max} = 1.03 \times 10^{-4} \text{ N-m}$$

## PROBLEM 6.2

**KNOWN:** A voltage dividing circuit with  $R_T = 5000 \Omega$  (as shown in Figure 6.16)

**FIND:**  $R_m$  such that the loading error is less than 12% of the full scale value.

**SOLUTION:** Since the full-scale output is  $E_i$  (with  $e$  as the error)

$$\frac{e}{E_i} = \frac{R_1 - R_T + (R_T - R_1) \left( \frac{R_1}{R_m} + 1 \right)}{R_T + \left( \frac{R_T^2}{R_1} - R_T \right) \left( \frac{R_1}{R_m} + 1 \right)}$$

A plot of the error as a function of meter resistance and  $R_1$  is shown below

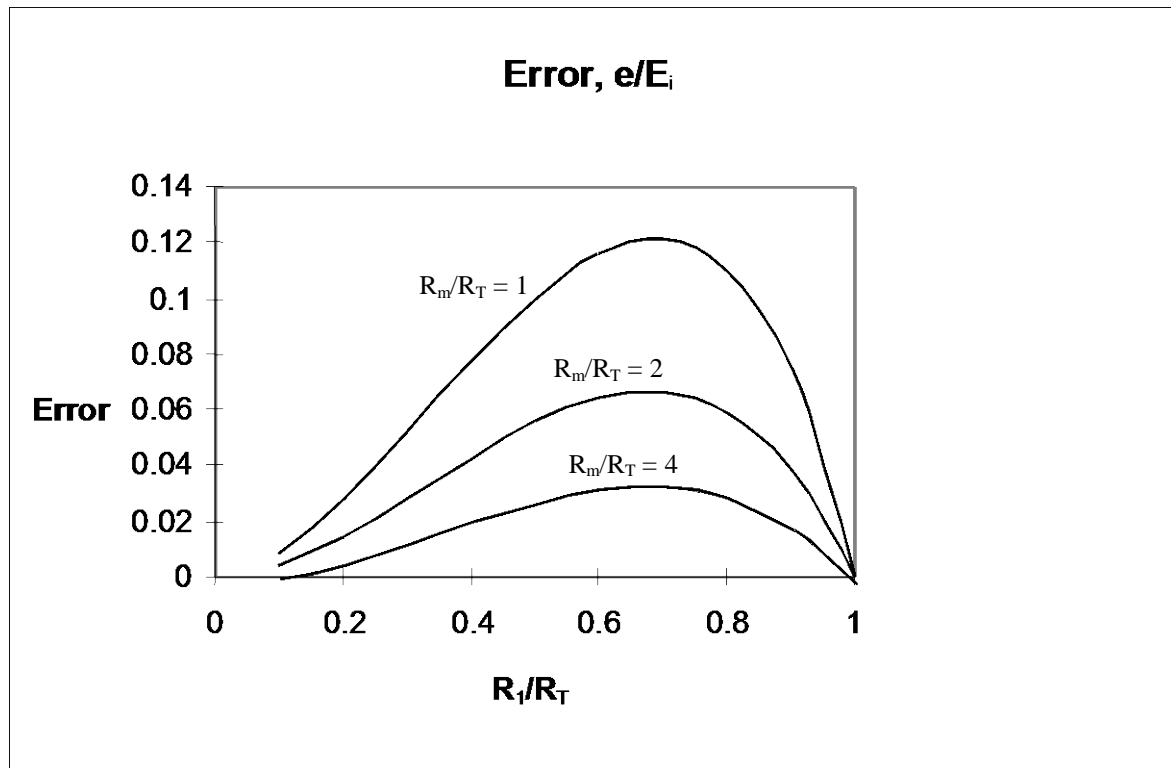

## PROBLEM 6.3

**KNOWN:**  $R_T = R_1 + R_2 = 500 \Omega$      $R_m = 10,000 \Omega$

$$R_1 = kR_T \quad k = 0.5 \quad E_i = 10 \text{ V}$$

**FIND:**

- Loading error as a percentage of the output
- Loading error as a percentage of the full scale output

**SOLUTION:**

The loading error may be defined as

$$e = E'_o - E_o$$

and in terms of a percentage of the output

$$\frac{E'_o - E_o}{E_o} = \frac{E'_o}{E_o} - 1$$

which yields, in terms of  $k$

$$k \left[ 1 + \frac{(1-k)}{k} \left( k \frac{R_T}{R_m} + 1 \right) \right] - 1$$

The loading error for this condition is 0.0125 or 1.25%.

As a percentage of full-scale output,  $E_i$ ,

$$\frac{E'_o - E_o}{E_i} = k - \frac{k}{k + (1-k) \left( \frac{kR_T}{R_m} + 1 \right)}$$

which produces a value for loading error of 0.62%. Since  $E_o$  is one-half of  $E_i$ , the loading errors are each 0.062 Volts.

## PROBLEM 6.4

### KNOWN:

$$R_3 = R_4 = 200 \Omega$$

$R_2$  = variable resistor

$$R_1 = 40x + 100 \Omega$$

### FIND:

- $R_2$  to balance the bridge with  $x = 0$
- Find a general expression for  $x = f(R_2)$

**ASSUMPTIONS:** Zero Galvanometer error

**SOLUTION:** At balanced conditions

$$\frac{R_2}{R_1} = \frac{R_4}{R_3}$$

Thus  $R_2 = (1)(100)$  and  $R_2 = 100 \Omega$

and in general  $R_2 = 40x + 100 \Omega$ .

## PROBLEM 6.5

### KNOWN:

A Wheatstone bridge with  $R_1 = 20x^2$  ( $x$  is a measured variable)

$R_3 = R_4 = 100 \Omega$   $R_2 = 46 \Omega$  at balanced conditions

### FIND: $x$

**SOLUTION:** Since at balanced conditions

$$\frac{R_2}{R_1} = \frac{R_4}{R_3} = 1$$

Thus

$$\frac{46}{20x^2} = 1 \quad x = \sqrt{\frac{46}{20}} = 1.52$$

## PROBLEM 6.6

**KNOWN:** A sensor has a resistance of  $500\ \Omega$  under conditions of no load, and a static sensitivity of  $0.5\ \Omega/\text{N}$ . The bridge circuit has

$$R_1 = R_2 = R_3 = R_4 = 500\ \Omega \quad (\text{initially})$$

- FIND:**
- a)  $E_o$  for applied loads of 100, 200, and 350 N.
  - b)  $I_I$
  - c) Repeat parts (a) and (b) with

$$R_m = 10\ \text{k}\Omega$$

$$R_s = 500\ \Omega$$

**SOLUTION:** For a bridge in which all resistances are initially equal

$$\frac{E_o}{E_i} = \frac{\frac{\delta R}{R}}{4 + 2\left(\frac{\delta R}{R}\right)}$$

and with a load of magnitude  $F_L$

$$\delta R = 0.5F_L$$

$$\frac{E_o}{E_i} = \frac{0.5F_L / 500}{4 + 2\left(\frac{0.5F_L}{500}\right)}$$

This yields

$F_L$ [N]	$\delta R$ [ $\Omega$ ]	$E_o$ [V]
100	50	0.238
200	100	0.455
350	150	0.652

The current flow through the sensor is  $I_1$  and for an infinite meter resistance is

$$I_1 = \frac{E_i}{R_1 + R_2}$$

which yields

$F_L$ [N]	$R_1+R_2$ [ $\Omega$ ]	$I_1$ [Amps]
100	1050	0.00952
200	1100	0.00909
350	1150	0.00870

c) Consider the circuit shown below, with values of  $\delta R$  equal to those for part (a)

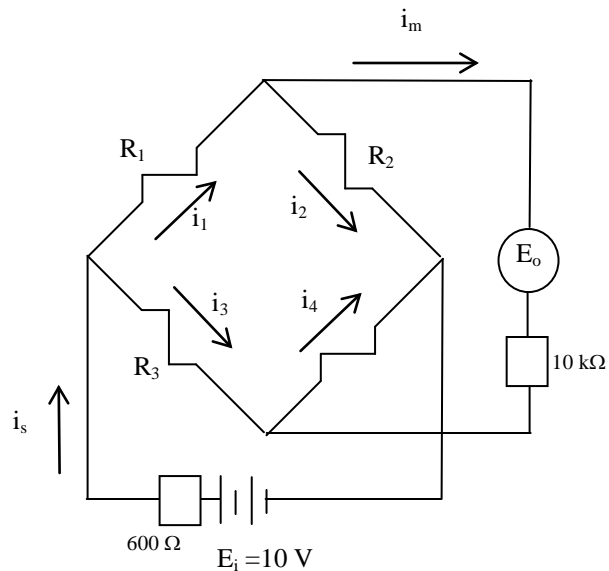

A circuit analysis of this bridge yields the following simultaneous equations governing the currents and potentials:

$$E_i = I_s R_s + I_1 (R_1 + R_2) - I_m R_2$$

$$I_1 R_1 + I_m R_m - I_3 R_3 = 0 \quad I_m R_m + I_4 R_4 - I_2 R_2 = 0$$

$$I_m + I_3 - I_4 = 0 \quad I_s = I_1 + I_3$$

$$E_i = I_s R_s + I_3 R_3 + I_4 R_4 \quad E_o = I_m R_m$$

Solving these equations simultaneously yields

$R_1$ [ $\Omega$ ]	$E_o$ [V]	$I_1$ [A]
550	0.104	0.0044
600	0.201	0.0042
650	0.291	0.0041

## PROBLEM 6.7

**KNOWN:** Bridge circuit of Figure 6.36

**FIND:** Show that

$$C_2 = C_1 \left( \frac{R_1}{R_2} \right)$$

is the requirement for a balanced bridge.

**SOLUTION:** With impedances (for an AC circuit)

$$Z_1 = R_1 \quad Z_2 = R_2 \quad Z_3 = \frac{1}{j\omega C_1} \quad Z_4 = \frac{1}{j\omega C_2}$$

from

$$E_o = E_i \left[ \frac{Z_3}{Z_3 + Z_4} - \frac{Z_1}{Z_1 + Z_2} \right]$$

For this case

$$E_o = E_i \left[ \frac{1}{1 + \frac{C_1}{C_2}} - \frac{1}{1 + \frac{R_1}{R_2}} \right]$$

which yields for  $E_o = 0$

$$C_1 = C_2 \left( \frac{R_1}{R_2} \right)$$

## PROBLEM 6.8

**KNOWN:** A bridge circuit is to be used to calibrate a 500 Hz frequency source. The bridge resonance frequency is  $f = \frac{1}{2\pi\sqrt{LC}}$

**FIND:** Bridge components  $L$  and  $C$  to yield a resonance frequency of 500 Hz.

**SOLUTION:** The product  $LC$  must be  $(1000\pi)^2$  and

$$500 = \frac{1}{2\pi\sqrt{LC}}$$

which yields

$$LC = 9.87 \times 10^6 \text{ sec}^2$$

Combinations of  $L$  and  $C$  which yield the appropriate resonance frequency are shown below.

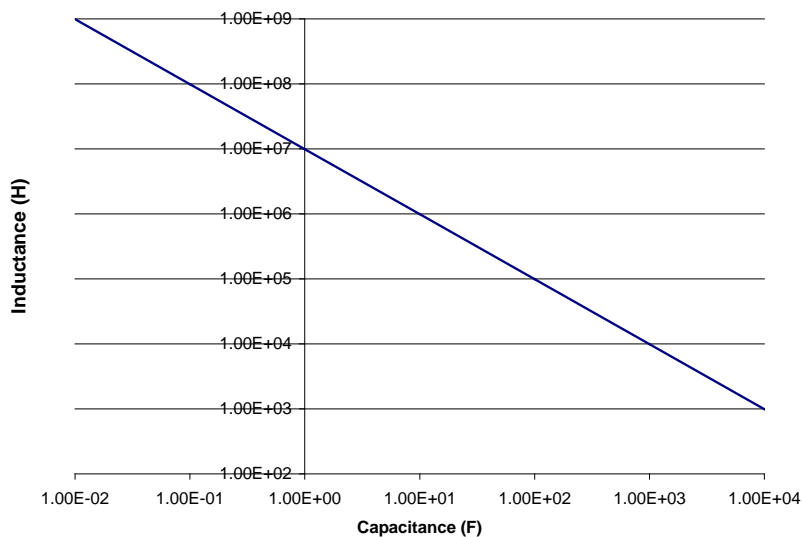

## PROBLEM 6.9

**KNOWN:** A Wheatstone bridge with

$$\begin{aligned} R_1 &= 200 \, \Omega & R_2 &= 400 \, \Omega \\ R_3 &= 500 \, \Omega & R_4 &= 600 \, \Omega & E_i &= 5 \, \text{V} \end{aligned}$$

**FIND:** a)  $E_o$   
b)  $E_o$  for  $R_1 = 250 \, \Omega$ .

**ASSUMPTIONS:** The meter resistance  $R_g$  is infinite.

**SOLUTION:**

From (6.14)

$$E_o = E_i \left[ \frac{R_1}{R_1 + R_2} - \frac{R_3}{R_3 + R_4} \right] = 5 \left[ \frac{200}{200 + 400} - \frac{500}{500 + 600} \right] = -0.606 \, \text{V}$$

or with  $R_1 = 250 \, \Omega$

$$E_o = 5 \left[ \frac{250}{250 + 400} - \frac{500}{500 + 600} \right] = -0.35 \, \text{V}$$

**COMMENT:** Clearly the bridge output is non-linear with  $R_1$  over this range of values for  $R_1$ .

## PROBLEM 6.10

**KNOWN:** A Wheatstone bridge having all resistances  $500 \Omega$ .

**FIND:** Plot the output voltage for :

- $R_1$  varies from  $500$  to  $1000 \Omega$
- $R_1$  and  $R_2$  change equally and in opposite directions between  $500$  and  $600 \Omega$
- $R_1$  and  $R_3$  change equally over the range  $500$  to  $600 \Omega$

**SOLUTION:** The bridge output is given by

$$E_o = E_i \left( \frac{R_1}{R_1 + R_2} - \frac{R_3}{R_3 + R_4} \right)$$

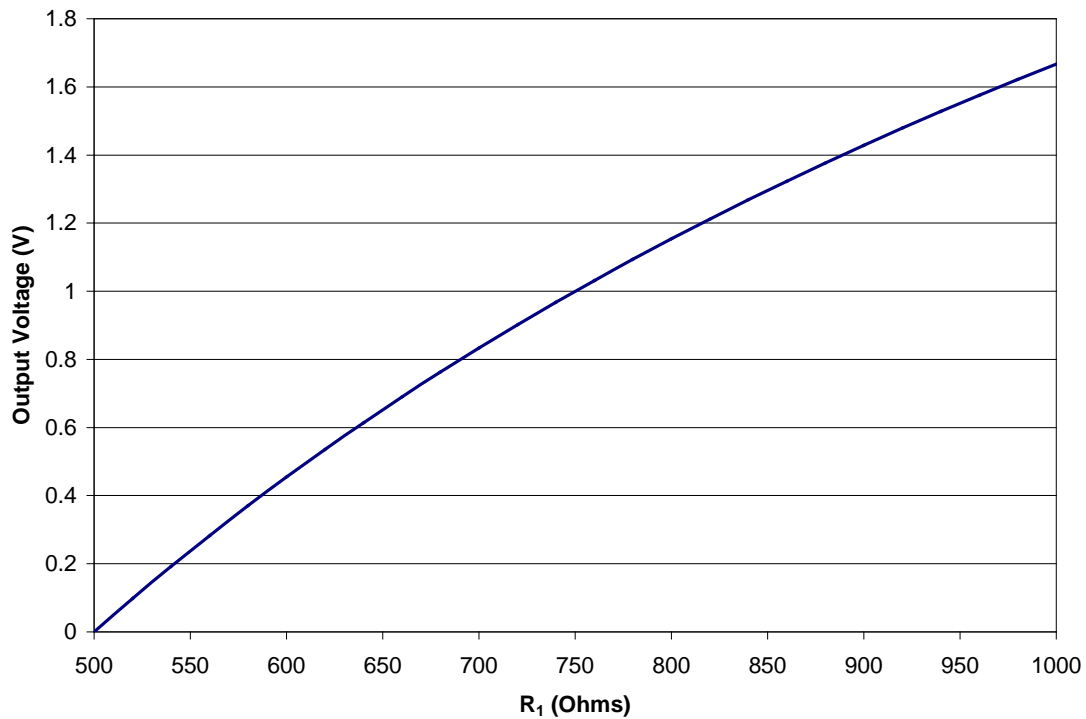

b)

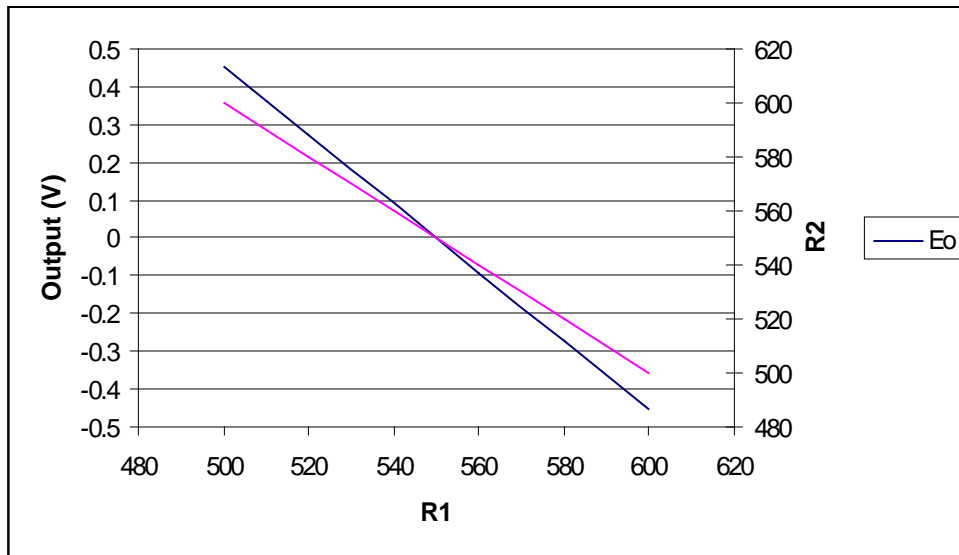

c) Identically Zero!

## PROBLEM 6.11

**KNOWN:** Potentiometer as shown in Figures 6.10 and 6.11.

$$\begin{aligned} E_i &= 10 \pm 0.1 \text{ V} & R_T &= 100 \pm 1 \text{ } \Omega \\ R_g &= 100 \text{ } \Omega & R_x &= \text{reading} \pm 2\% \end{aligned}$$

Null condition has negligible error.

**FIND:**

Design stage uncertainty in a measured value of voltage at nominal values of 2 and 8 V.

**ASSUMPTIONS:** Loading errors should be included in the analysis.

**SOLUTION:** From 6.35 (see Figure 6.16)

$$\frac{E_o}{E_i} = \frac{1}{1 + \frac{R_2}{R_1} \left( \frac{R_1}{R_g} + 1 \right)}$$

Then at the design stage

$$u_{E_o} = \left[ \sum \left( \frac{\partial E_o}{\partial x_i} u_{x_i} \right)^2 \right]^{1/2}$$

For this case  $E_o = f(E_i, R_x, R_g, R_T)$  and  $R_T = R_1 + R_2$ . At

$$\begin{aligned} E_o = 2 \text{ V } R_1 &= 23.6 \text{ } \Omega & R_2 &= 76.4 \text{ } \Omega \\ E_o = 8 \text{ V } R_1 &= 88.3 \text{ } \Omega & R_2 &= 11.7 \text{ } \Omega \end{aligned}$$

The sensitivity indices may be evaluated as

$$\frac{\partial E_o}{\partial E_i} = \frac{E_i}{1 + \frac{R_2}{R_1} \left( \frac{R_1}{R_g} + 1 \right)}$$

$$\text{at } 2 \text{ V } \frac{\partial E_o}{\partial E_i} = 2, \quad \text{and at } 8 \text{ V } \frac{\partial E_o}{\partial E_i} = 8$$

$$\frac{\partial E_o}{\partial R_2} = \frac{-E_i / R_1 \left( \frac{R_1}{R_g} + 1 \right)}{\left[ 1 + \frac{R_2}{R_1} \left( \frac{R_1}{R_g} + 1 \right) \right]^2} \quad \text{at 2 V } \frac{\partial E_o}{\partial R_2} = 0.021 \quad \text{at 8 V } \frac{\partial E_o}{\partial R_2} = 0.137$$

$$\frac{\partial E_o}{\partial R_1} = \frac{E_i \left[ \frac{-R_2}{R_1^2} \left( \frac{R_1}{R_g} + 1 \right) + \frac{R_2}{R_1} \left( \frac{1}{R_g} \right) \right]}{\left[ 1 + \frac{R_2}{R_1} \left( \frac{R_1}{R_g} + 1 \right) \right]^2} \quad \text{at 2 V } \frac{\partial E_o}{\partial R_1} = -0.055 \quad \text{at 8 V } \frac{\partial E_o}{\partial R_1} = -0.00096$$

$$\frac{\partial E_o}{\partial R_g} = \frac{\left( \frac{-R_2}{R_g^2} \right) E_i}{\left[ 1 + \frac{R_2}{R_1} \left( \frac{R_1}{R_g} + 1 \right) \right]^2} \quad \text{at 2 V } \frac{\partial E_o}{\partial R_g} = -0.0031 \quad \text{at 8 V } \frac{\partial E_o}{\partial R_g} = -0.0075$$

The uncertainty in  $R_2$  is estimated as

$$R_2 = R_T - R_1$$

$$u_{R_2} = \left[ u_{R_T}^2 + u_{R_1}^2 \right]^{\frac{1}{2}} \quad \text{at 2 V } u_{R_2} = 1.11 \Omega \quad \text{at 8 V } u_{R_2} = 2.03 \Omega$$

At 2 V the uncertainty is estimated as

$$u_{E_o} = \left[ (2 \times 0.1)^2 + (0.021 \times 1.11)^2 + (-0.055 \times 0.47)^2 \right]^{\frac{1}{2}}$$

$$= \pm 0.203 \text{ V}$$

And at 8 V as

$$u_{E_o} = \left[ (8 \times 0.1)^2 + (0.137 \times 2.03)^2 + (0.00096 \times 1.8)^2 \right]^{\frac{1}{2}}$$

$$= \pm 0.847 \text{ V}$$

## PROBLEM 6.12

**KNOWN:** Sinusoidal inputs having specific phase relations

**FIND:** Lissajous diagrams for the specific phase relations

**SOLUTION:** See Figures below.

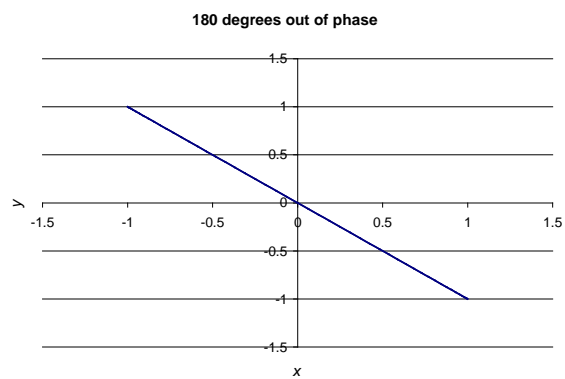
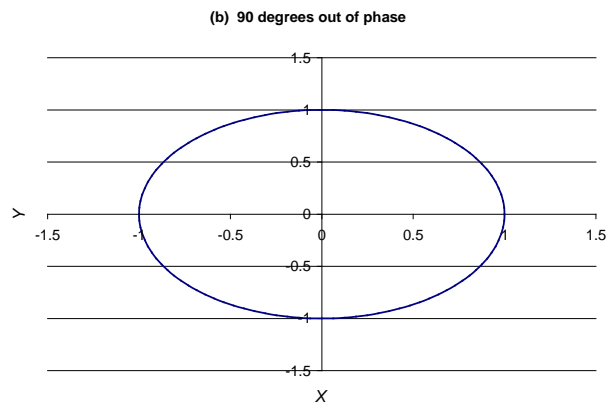
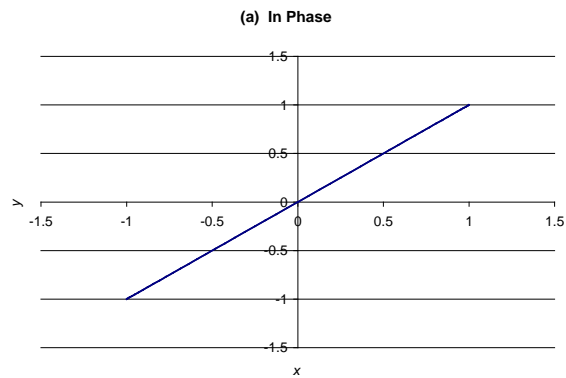

## PROBLEM 6.13

KNOWN:  $\sin \phi = \frac{y_i}{y_a}$

FIND: Show that the phase relationships can be determined from a Lissajous diagram using the equation above.

### SOLUTION:

Assume that the two sine waves with a phase delay of  $\phi$  are the input to the x and y terminals of an oscilloscope. Referring to Fig. 6.38, the figure below shows  $y_a$  and  $y_i$ .

When  $y = y_a$  then the y signal is a maximum, with  $\sin \omega t = 1$  and with  $y = A \sin \omega t$  and  $y_a = A$ . At the y-intercept where  $x=0$   $y_i = A \sin \phi$ . Eliminating the amplitude A between these equations,

$$\frac{y_i}{y_a} = \frac{A \sin \phi}{A} = \sin \phi$$

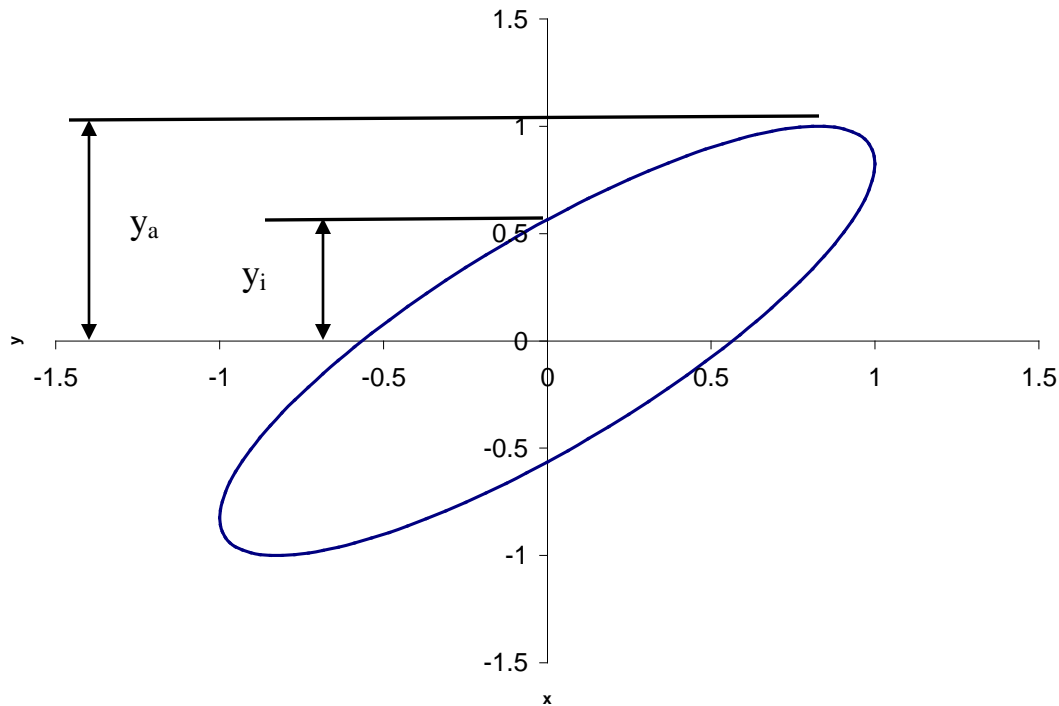

## PROBLEM 6.14

**KNOWN:** Phase lag occurs in electronic circuits

**FIND:** Design an arrangement which uses Lissajous diagrams to determine phase lag

**SOLUTION:**

The arrangement shown below will allow measurement of phase lag in an electronic circuit. See Problem 6.15 for representative Lissajous diagrams.

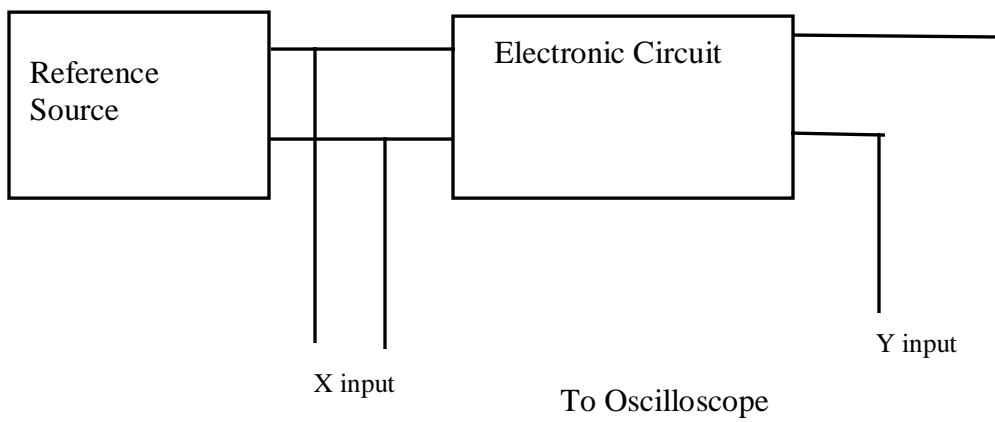

## PROBLEM 6.15

**KNOWN:** Two sinusoidal signals are to be compared using a dual trace oscilloscope. The frequency ratios are

a) 1:1 b) 1:2 c) 2:1 d) 1:3 e) 2:3 f) 5:2

**FIND:** Construct appropriate Lissajous diagrams

**SOLUTION:**

a)

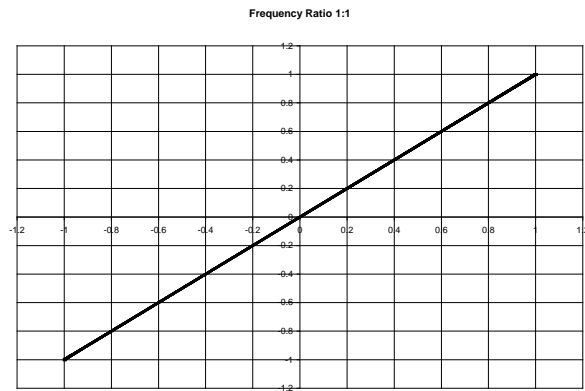

b)

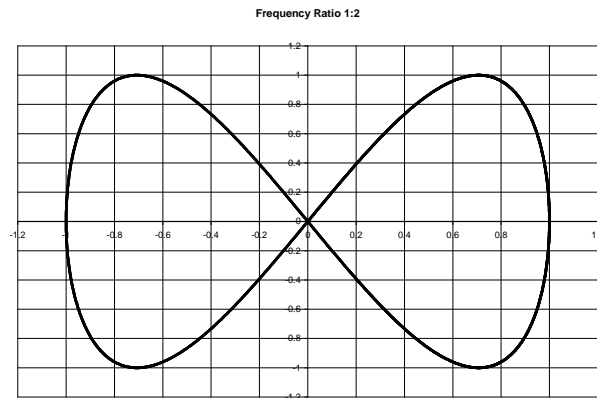

c)  
d)

Frequency Ratio 2:1  
Frequency Ratio 1:3

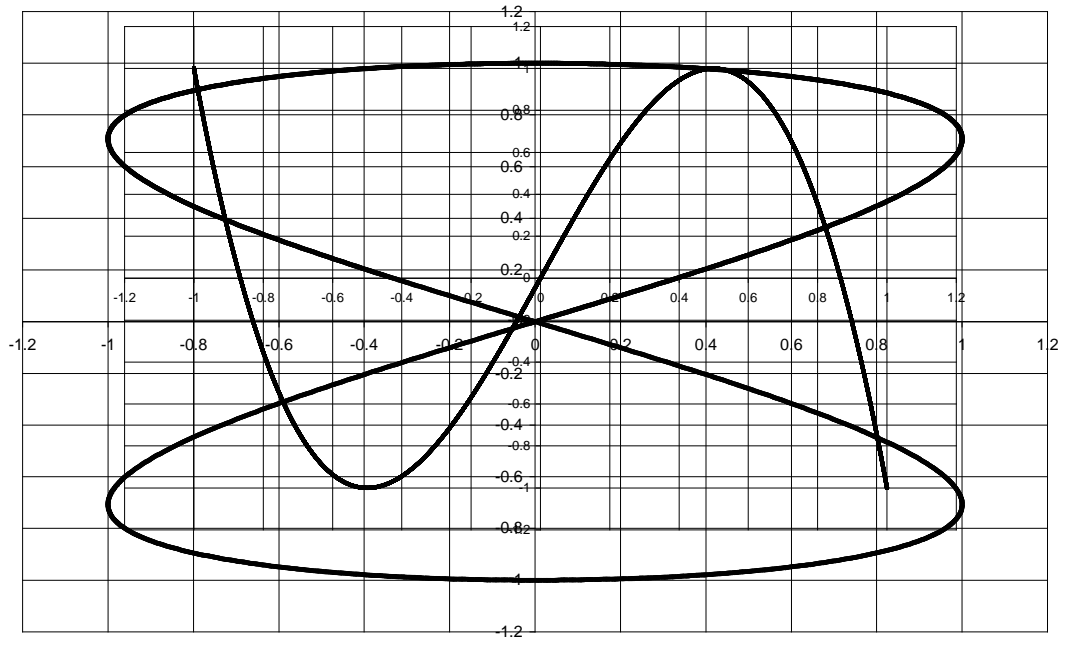

e)

f)

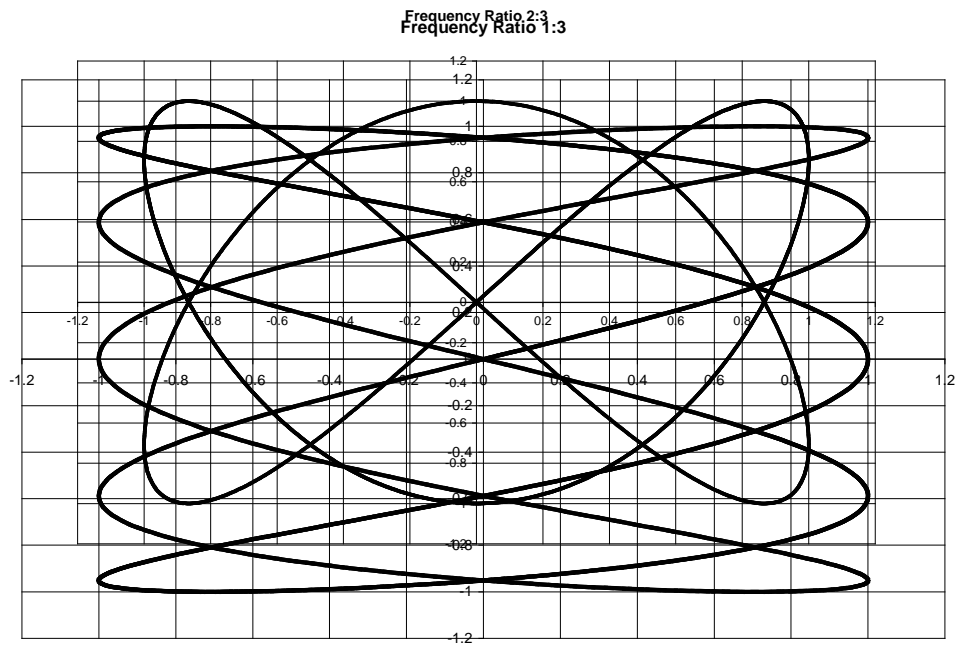

## PROBLEM 6.16

**KNOWN:** RC filter:  $k = 1$ ;  $f_c = 100$  Hz

**FIND:** Attenuation at 10, 50, 75, and 200 Hz

**ASSUMPTIONS:** Filter is of the low-pass, Butterworth type

**SOLUTION:**

For a low-pass RC Butterworth filter,

$$M(f) = 1 / \left[ 1 + (f/f_c)^{2k} \right]^{0.5}$$

Recall that “attenuation” means reduction. In the context of a filter, a device that reduces the output amplitude of targeted frequencies  $M(f) < 1$  it must correspond to a negative value of the dynamic error. Dynamic error is given by

$$\delta(f) = M(f) - 1$$

Recall also that a “gain” refers to a positive value of dynamic error.

For a low-pass RC Butterworth filter,  $M(f) < 1$  always which is consistent with first-order system behavior.

$f$ (Hz)	$M(f)$	$\delta(f)$	Attenuation %
10	0.995	-0.005	0.5
50	0.894	-0.105	10.5
75	0.800	-0.200	20.0
200	0.447	-0.553	55.3

## PROBLEM 6.18

**KNOWN:** LC low-pass Butterworth filter  
 $-3 \text{ dB} \leq M(0 \leq f \leq 5 \text{ kHz})$   
 $M(f \geq 10 \text{ kHz}) < -30 \text{ dB}$

**FIND:** Values for L, C and k

### SOLUTION

This problem is an open-ended design and one possible solution follows. For a low-pass, Butterworth filter such as shown in Figure 6.31, we begin by fixing the cut-off frequency and then estimating the order (number of reactive stages) k. We end by specifying the C and L values. For the filter:

$$M(f) = 1/[1 + (f/f_c)^{2k}]^{1/2}$$

We set  $f_c = 5 \text{ kHz}$ , such that  $M(5 \text{ kHz}) = 0.707 = -3 \text{ dB}$ , and meet one constraint of the design.

The next step in the design is to determine the number of filter stages required to meet the attenuation constraint at 10 kHz. For at least 30 dB attenuation

$$-30 \text{ dB} = 20 \log M(10 \text{ kHz}) \quad \text{or want} \quad M(10 \text{ kHz}) \leq 0.0316$$

then,

$$M(10 \text{ kHz}) \leq 0.0316 = 1/[1 + (10 \text{ kHz}/5 \text{ kHz})^{2k}]^{1/2}$$

This gives  $k = 4.98 \approx 5$ . Note: k can be found by trial and error or by direct estimate as follows.

By trial and error:

k	M(10 kHz)
1	0.45
3	0.12
5	0.0312

By direct estimate, with  $f/f_c = 10000/5000 = 2$  and  $M = 0.0316$ :

$$k = \frac{\log\left(\frac{1 - M^2}{M^2}\right)}{2\log(f/f_c)} = 4.98$$

A five-order filter has five reactive elements. To specify the capacitors and inductors, we refer to Table 6.1 with its scaling equations (6.60)

$$C = C_i \frac{1}{2\pi f_c R}$$

$$L = L_i \frac{R}{2\pi f_c}$$

Hence, for a normalized value of  $R = 1\Omega$  and  $f_c = 5,000$  Hz values for C and L yield:

$$C_1 = 20\mu\text{f}$$

$$C_3 = 64\mu\text{f}$$

$$C_5 = 20\mu\text{f}$$

$$L_2 = 52\mu\text{h}$$

$$L_4 = 52\mu\text{h}$$

## PROBLEM 6.19

**KNOWN:** Circuit of Figure 6.39.

**FIND:** Thevenin equivalent.

In open-circuit operation,

$$E_o = I_n R_n$$

In short-circuit operation,

$$I_n = E_{th}/R_{th}$$

or,

$$E_{th} = I_n R_n$$

and

$$R_{th} = E_{th}/I_n$$

## PROBLEM 6.20

KNOWN:  $Z_1 = 500\Omega$      $Z_m = 100,000\Omega$

FIND:  $E_1/E_m$

### SOLUTION

From Figure 6.17 and corresponding equation (6.38)

$$E_m/E_1 = 1/(1 + Z_1/Z_m) = 1/(1 + 500/100,000) = 0.995$$

So,

$$E_1/E_m = 1.005$$

$$e_1 = 0.005E_1$$

Loading error is about 0.5% of  $E_1$ .

## PROBLEM 6.21

FIND:  $E_m/E_1$  versus  $Z_1/Z_m$

### SOLUTION

From Figure 6.17 and corresponding equation (6.38)

$$E_m/E_1 = 1/(1 + Z_1/Z_m)$$

The results for a range of independent values of  $Z_1/Z_m$  is plotted below.

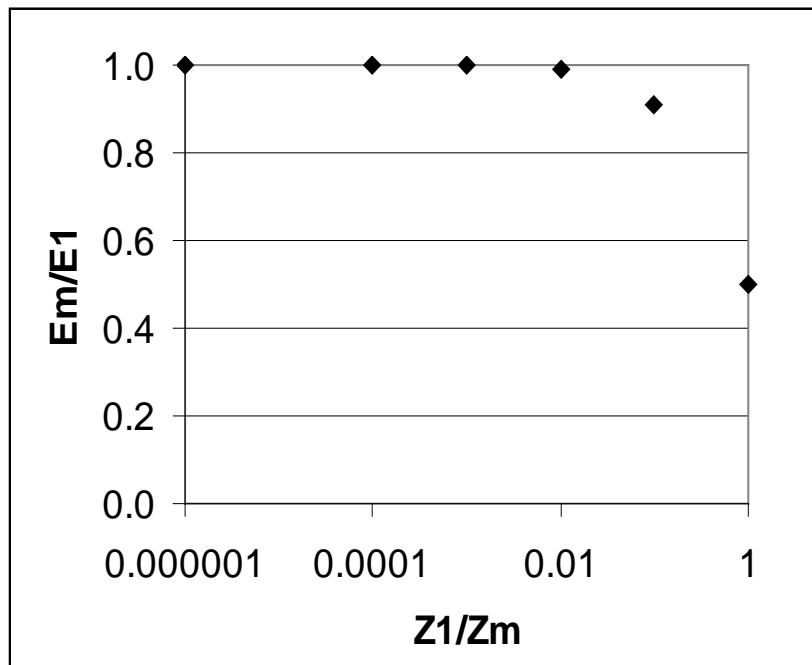

As the loading error goes to 0 as  $E_m/E_1$  goes to 1,  $Z_1$  should be much less than  $Z_m$  to minimize loading error. To reduce error to 1% (which is still a significant error), the ratio must be at least 1:100; to 0.01% (a good goal), the ratio must be at least 1:10,000 and so forth.

## PROBLEM 6.22

KNOWN:  $Z_1 = 1 \times 10^9 \Omega$

FIND:  $Z_m$  required to keep  $E_1/E \leq 0.1\%$

SOLUTION:

For the circuit in Figure 6.40, Equation 6.38 can be written

$$E_m = E_1 Z_m / (Z_m + Z_1)$$

where  $E_1$  is the Thevenin equivalent voltage. For  $Z_1 = 10^9 \Omega$

$$E_m / E_1 = Z_m / (Z_m + 10^9)$$

Then the relative loading error or signal attenuation is

$$e_1 / E_1 = 1 - E_m / E_1 \quad (6.39)$$

$Z_m \Omega$	$(1 - E_m / E_1) \%$
$10^6$	99.9%
$10^9$	50%
$10^{12}$	0.1%

$Z_m$  must be at least  $10^{12} \Omega$  to meet the constraint. This requires  $Z_m / Z_1 = 10^{12} / 10^9 \geq 1000$

**COMMENT:** Loading error is only a problem if it goes undetected. It can be prevented by proper design as it is easily predicted.

## PROBLEM 6.23

**KNOWN:** Circuit of Figure 6.41

**FIND:**  $E_o/E_i$  for the circuit

**SOLUTION:** Across the divider, (6.8) gives

$$E_o = E_i(60)/160 = 0.375E_i \quad \text{or} \quad (E_o/E_i)_{\text{divider}} = 0.375$$

This is equivalent to a gain of

$$G \text{ [dB]} = 20 \log(E_o/E_i) = -8.5 \text{ dB}$$

The overall circuit gain based on  $G_{\text{amp}} = +32 \text{ dB}$ ,  $G_{\text{filter}} = -12 \text{ dB}$ , and the divider circuit is

$$E_o/E_i = (32 - 12 - 8.5) \text{ dB} = 11.5 \text{ dB} = 3.76$$

## PROBLEM 6.24

**KNOWN:** Temperature measurement system employing a resistance temperature detector and a Wheatstone bridge circuit having the following characteristics

$$R = R_o [1 + \alpha(T - T_o)] \quad R_o = 100 \, \Omega \text{ at } 0^\circ\text{C} \quad R_3 = R_4 = 500 \, \Omega$$

There are two error sources, the sensitivity of the galvanometer, and the accuracy of the fixed resistors.

**FIND:** Design a combination of uncertainty in the fixed resistors and the current flow through the galvanometer to provide an uncertainty in temperature of  $\pm 1^\circ\text{C}$

### SOLUTION:

The sensitivity indices are needed to determine the required accuracy of the detector resistance measurement to yield an uncertainty of  $\pm 1^\circ\text{C}$ , and the uncertainty of the measurement of  $R_1$  in the bridge. The required level of uncertainty in the resistance measurement can be determined from

$$\frac{\partial R}{\partial T} = \frac{\partial}{\partial T} [R_o [1 + \alpha(T - T_o)]] = \alpha R_o$$

Knowing that  $u_T = \pm 1^\circ\text{C}$  the required uncertainty in  $R_1$  is found from

$$u_R = \frac{\partial R}{\partial T} u_T = \alpha R_o u_T = (0.00395)(100)(1) = 0.395 \, \Omega$$

Then to evaluate the sensitivity of  $R_1$  to the uncertainty in  $I_g$  sequential perturbation can be employed with equation 6.22 to yield a value of 0.000045 A/ $\Omega$  or 22.2  $\Omega/\text{mA}$ . The uncertainty in  $R_1$  may be expressed

$$u_{R_1} = \sqrt{\left(\frac{\partial R_1}{\partial I_g} u_{I_g}\right)^2 + \left(\frac{\partial R_1}{\partial R_2} u_{R_2}\right)^2 + \left(\frac{\partial R_1}{\partial R_3} u_{R_3}\right)^2 + \left(\frac{\partial R_1}{\partial R_4} u_{R_4}\right)^2}$$

where

$$\frac{\partial R_1}{\partial R_2} = \frac{R_3}{R_4} \quad \frac{\partial R_1}{\partial R_3} = \frac{R_2}{R_4} \quad \frac{\partial R_1}{\partial R_4} = \frac{-R_2 R_3}{R_4^2}$$

With appropriate assumptions of uncertainties in the values of the  $R$ 's and  $I_g$  the value of  $u_T$  can be evaluated, and an iterative process used to satisfy the constraint.

## PROBLEM 6.25

**FIND:** Design low pass filter with  $f_c = 100$  Hz  
Want  $M(50 \text{ Hz}) \geq 0.95$ ;  $M(200 \text{ Hz}) \leq 0.01$

**KNOWN:**  $R_L = R_S = 10 \Omega$

### SOLUTION

For a Butterworth filter having  $k$  reactive elements, the frequency response is given by

$$M(f) = 1/[1 + (f/f_c)^{2k}]^{1/2}$$

rearranging and solving for  $k$ :

$$k = \frac{\log\left(\frac{1 - M^2}{M^2}\right)}{2\log(f/f_c)}$$

In terms of  $f/f_c$ , where  $f_c = 100$  Hz, we want  $M(50/100 = 0.5) \geq 0.95$ ;  $M(200/100 = 2) \leq 0.01$ . The highest value of  $k$  will satisfy both conditions. Solving yields  $k(f/f_c = 0.5) \geq 2$  and  $k(f/f_c = 2) \geq 4$ . Choose  $k \geq 4$ .

If we select a  $k = 5$  order filter, there will be 5 reactive elements. To specify the capacitors and inductors, we refer to Table 6.1 with its scaling equations (6.60)

$$C = C_i \frac{1}{2\pi f_c R}$$

$$L = L_i \frac{R}{2\pi f_c}$$

Hence, for a normalized value of  $R = R_S/1\Omega = R_L/1\Omega = 10\Omega$  and  $f_c = 100$  Hz values for  $C$  and  $L$  yield:

$$C_1 = 98\mu\text{f}$$

$$C_3 = 318\mu\text{f}$$

$$C_5 = 98\mu\text{f}$$

$$L_2 = 26\text{ mh}$$

$$L_4 = 26\text{ mh}$$

## PROBLEM 6.26

**FIND:** Design *high pass* filter with  $f_c = 5000$  Hz  
Want  $M(2500 \text{ Hz}) \geq -20\text{dB}$ ;  $M(8000 \text{ Hz}) \leq -0.45 \text{ dB}$

**KNOWN:**  $R_L = R_S = 10 \Omega$

### SOLUTION

For a high pass Butterworth filter having  $k$  reactive elements, the frequency response is given by equation (6.61):

$$M(f) = 1/[1 + (f_c/f)^{2k}]^{1/2}$$

rearranging and solving for  $k$ :

$$k = \frac{\log\left(\frac{1-M^2}{M^2}\right)}{2\log(f_c/f)}$$

Since  $\text{dB} = 20 \log M(f)$ , then:  $M(8000) \geq 0.95$  and  $M(2500) \leq 0.1$ .

In terms of  $f/f_c$ , where  $f_c = 5000$  Hz, we want  $M(8000/5000 = 1.6) \geq 0.95$ ;  $M(2500/5000 = 0.5) \leq 0.1$ . The highest value of  $k$  will satisfy both conditions. Solving yields  $k(f/f_c = 0.5) \geq 3.3$  and  $k(f/f_c = 1.6) \geq 2.36$ . Choose  $k \geq 4$ .

If we select a  $k = 5$  order high pass filter, there will be 5 reactive elements. To specify the capacitors and inductors, we refer to Table 6.1 with its scaling equations (6.60)

$$C = C_i \frac{1}{2\pi f_c R}$$

$$L = L_i \frac{R}{2\pi f_c}$$

Hence, for a normalized value of  $R = R_S/1\Omega = R_L/1\Omega = 10\Omega$  and  $f_c = 5000$  Hz values for  $C$  and  $L$  yield:

$$C_1 = 2\mu\text{f}$$

$$C_3 = 6.4 \mu\text{f}$$

$$C_5 = 2\mu\text{f}$$

$$L_2 = 515 \text{ mh}$$

$$L_4 = 515 \text{ mh}$$

## PROBLEM 6.27

**FIND:** Design *low pass* filter with  $f_c = 10,000$  Hz using 741 op-amp

**KNOWN:**  $C_2 = 0.1\mu\text{F}$      $K = 20$   
first-order (only one reactive element)

### SOLUTION

*This design problem has an open-ended solution. One possible solution follows.*

Use the design of Figure 6.33a.

The cut-off frequency is  $f_c = \frac{1}{2\pi R_2 C_2} = 10,000$  Hz

With  $C_2 = 0.1\mu\text{F} = 100$  nF,  $R_2 = \frac{1}{2\pi f_c C_2} = 159$   $\Omega$

The gain is  $K = R_2/R_1 = 20$ , so  $R_1 = R_2/20 = 8$   $\Omega$

Program *Low Pass Butterworth Active Filter* can also be used to complete this problem. An advantage with the software is that it provides a ready visual on the effects of changing the R and C values on the gain and cut-off frequency. Output for this problem is shown.

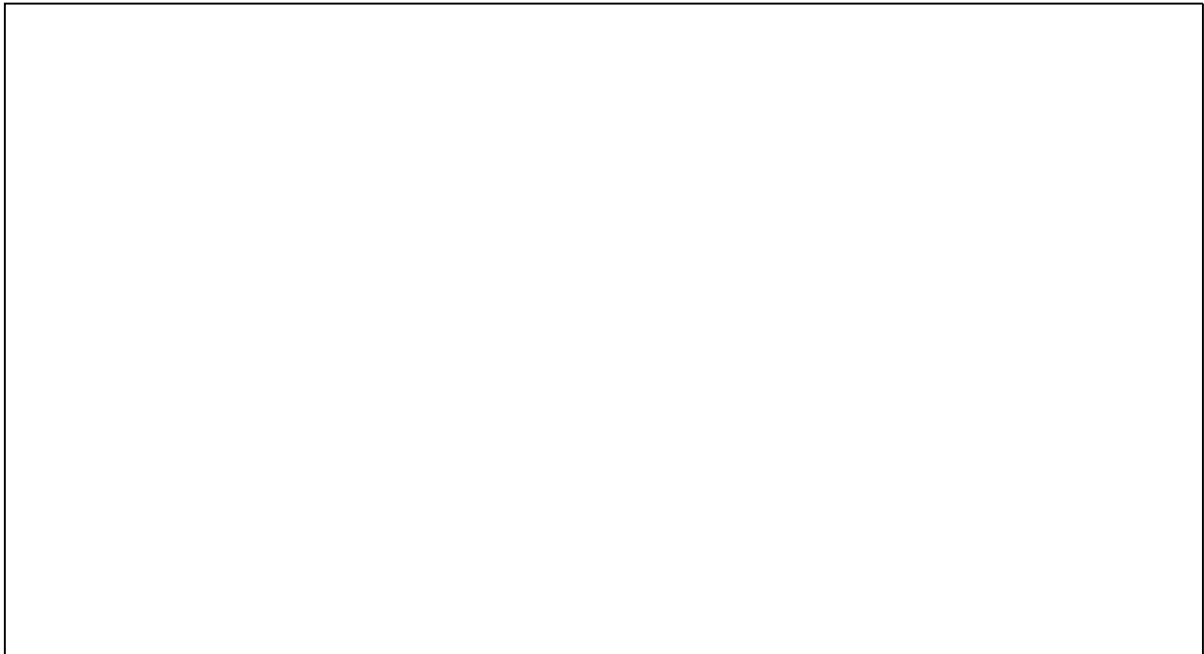

## PROBLEM 6.28

**FIND:** Design *high pass* filter with  $f_c = 10,000$  Hz using 741 op-amp

**KNOWN:**  $C_1 = 0.1\mu\text{F}$      $K = 10$   
first-order (only one reactive element)

### SOLUTION

Use the design of Figure 6.33b.

The cut-off frequency is

$$f_c = \frac{1}{2\pi R_1 C_1} = 10,000 \text{ Hz}$$

With  $C_1 = 0.1\mu\text{F}$ ,

$$R_1 = \frac{1}{2\pi f_c C_1} = 160 \Omega$$

The gain is  $K = R_2/R_1 = 10$ , so

$$R_1 = R_2/10 = 16 \Omega$$

## PROBLEM 6.29

Program *Oscilloscope* offers the user a very simple but functionally correct two-channel oscilloscope. Two input signals are provided. The user can vary the time sweep and the amplifier gains. A trigger is available off of Channel B and the effect of changing trigger levels can be explored.

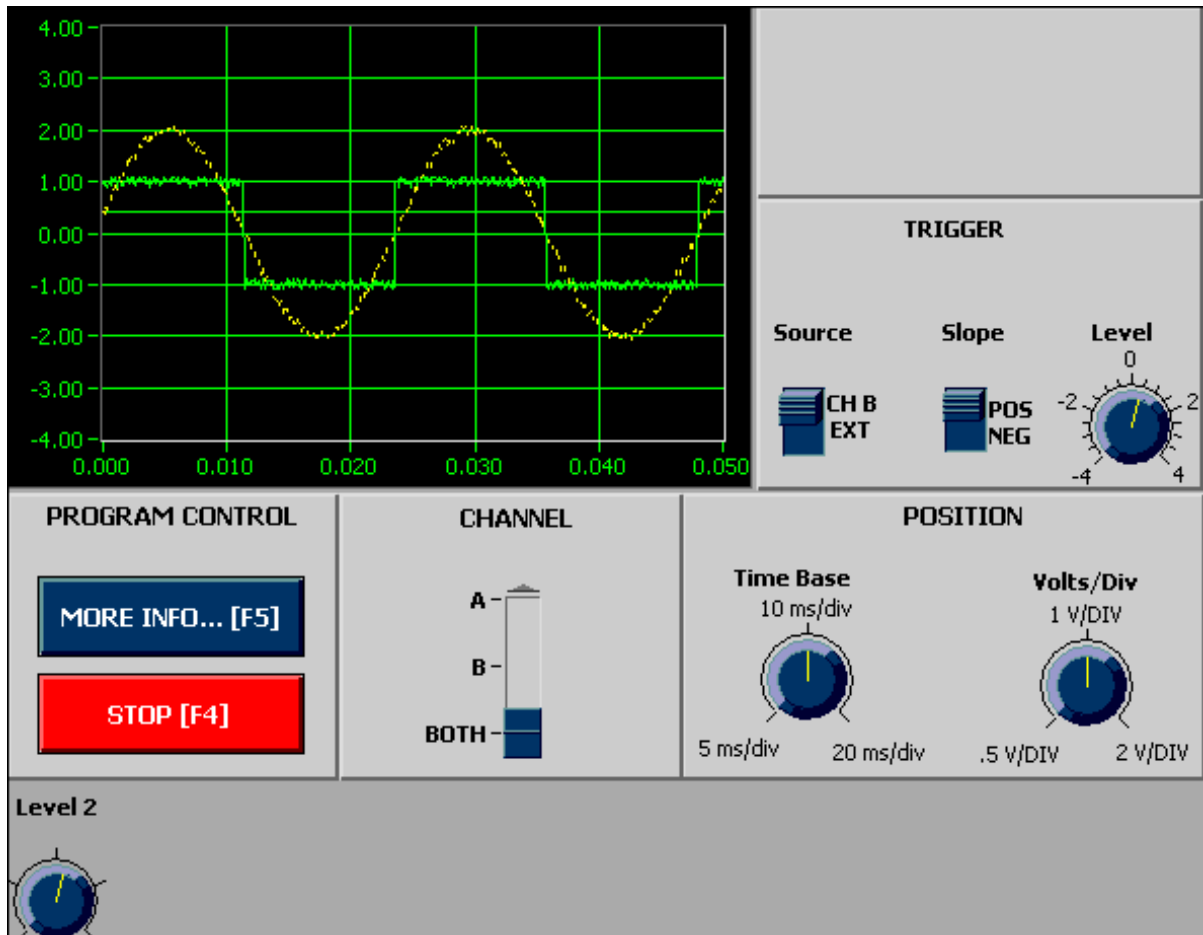

## PROBLEM 6.30

Program *Butterworth Filters Overall* can be used to examine the effect of using a low pass, a high pass or a bandpass Butterworth filter on a signal of variable frequency. The output signal and output amplitude spectra are displayed.

For example, with a signal frequency of 400 Hz, the lowpass ( $f_c = 300$  Hz) and highpass ( $f_c = 500$  Hz) filters show a definite attenuation ( $\sim 0.8$ V amplitude for lowpass and  $\sim 1$ V for high pass) whereas the bandpass filter ( $300 < f_c < 500$  Hz), passes the full signal amplitude ( $\sim 2$ V or 0dB).

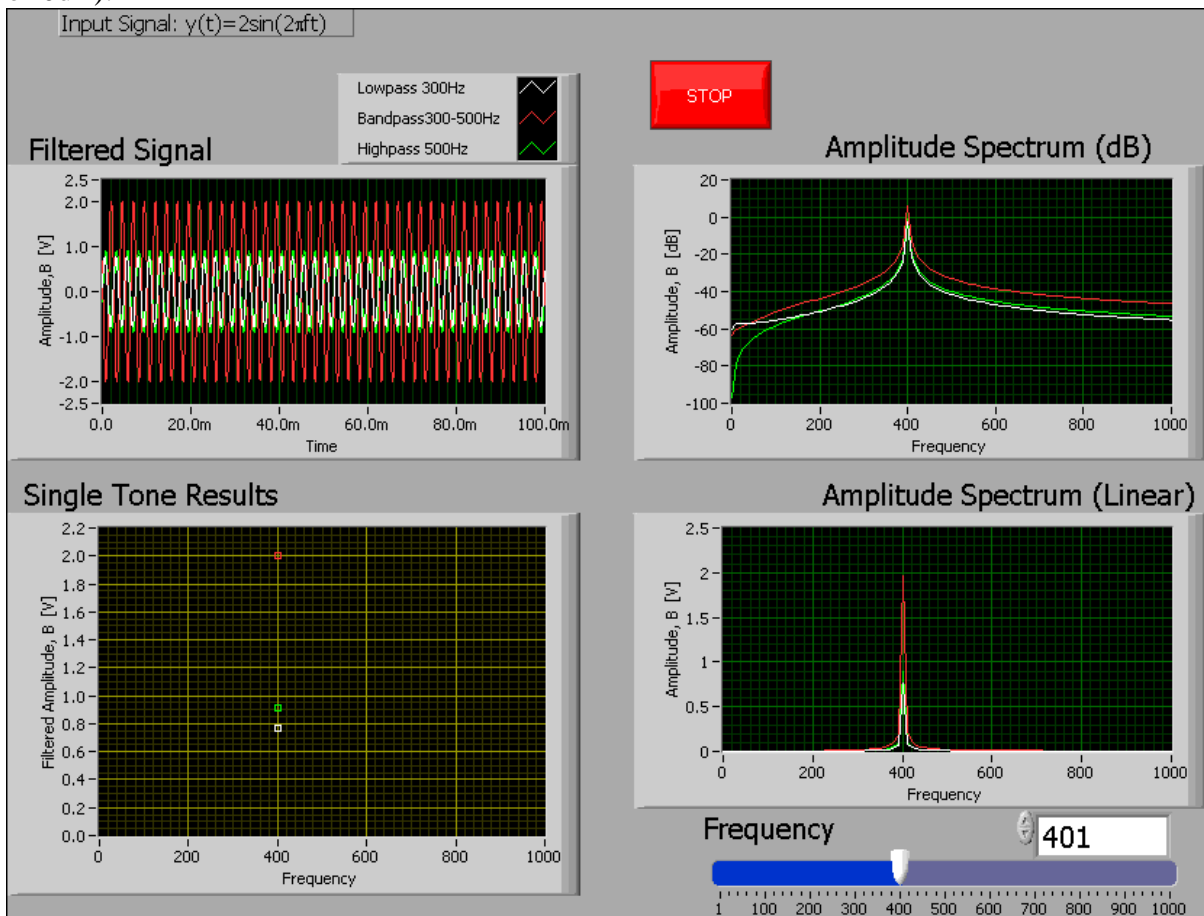

## PROBLEM 6.31

Program *Bessel Filters Overall* can be used to examine the effect of using a low pass, a high pass or a bandpass Bessel filter on a signal of variable frequency. The output signal and output amplitude spectra are displayed.

For example, with a signal frequency of 400 Hz, the lowpass ( $f_c = 300$  Hz) and highpass ( $f_c = 500$  Hz) filters show a definite attenuation ( $\sim 0.6$  V amplitude or  $-6$  dB) whereas the bandpass filter ( $300 < f_c < 500$  Hz), passes the full signal amplitude ( $\sim 2$  V or  $0$  dB).

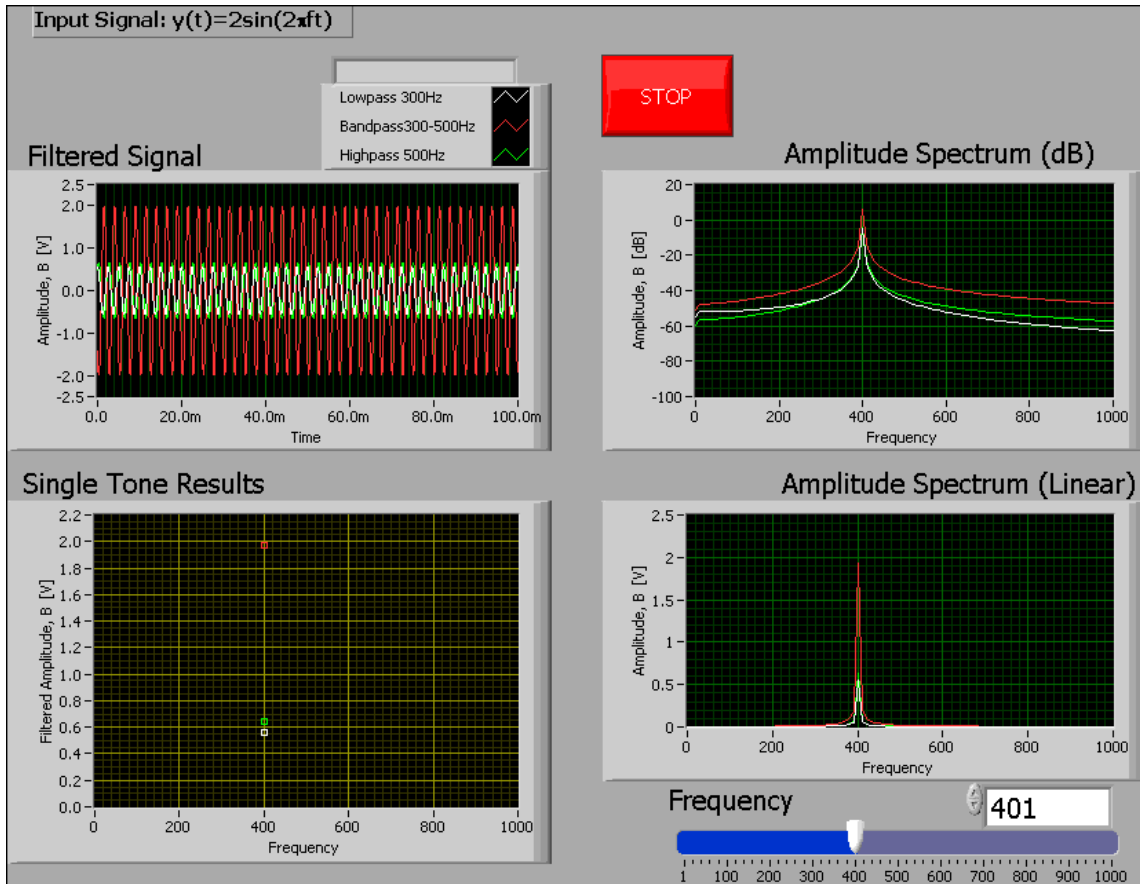

## PROBLEM 6.32

Program *LP Butterworth Noise* can be used to study the effect of using a low pass Butterworth filter on a sinusoidal signal of variable frequency and filter order number. A high frequency noise signal is superimposed on the sine wave. The output signal and output amplitude spectra are displayed.

The signal becomes cleaner as the number of stages is increased.  $k=4$  or  $5$  work well. Observe how the signal is shifted in time as  $k$  is increased (watch the value near  $t = 0$  shift). Increasing the stages, increases the phase shift. This may or may not be important in an application.

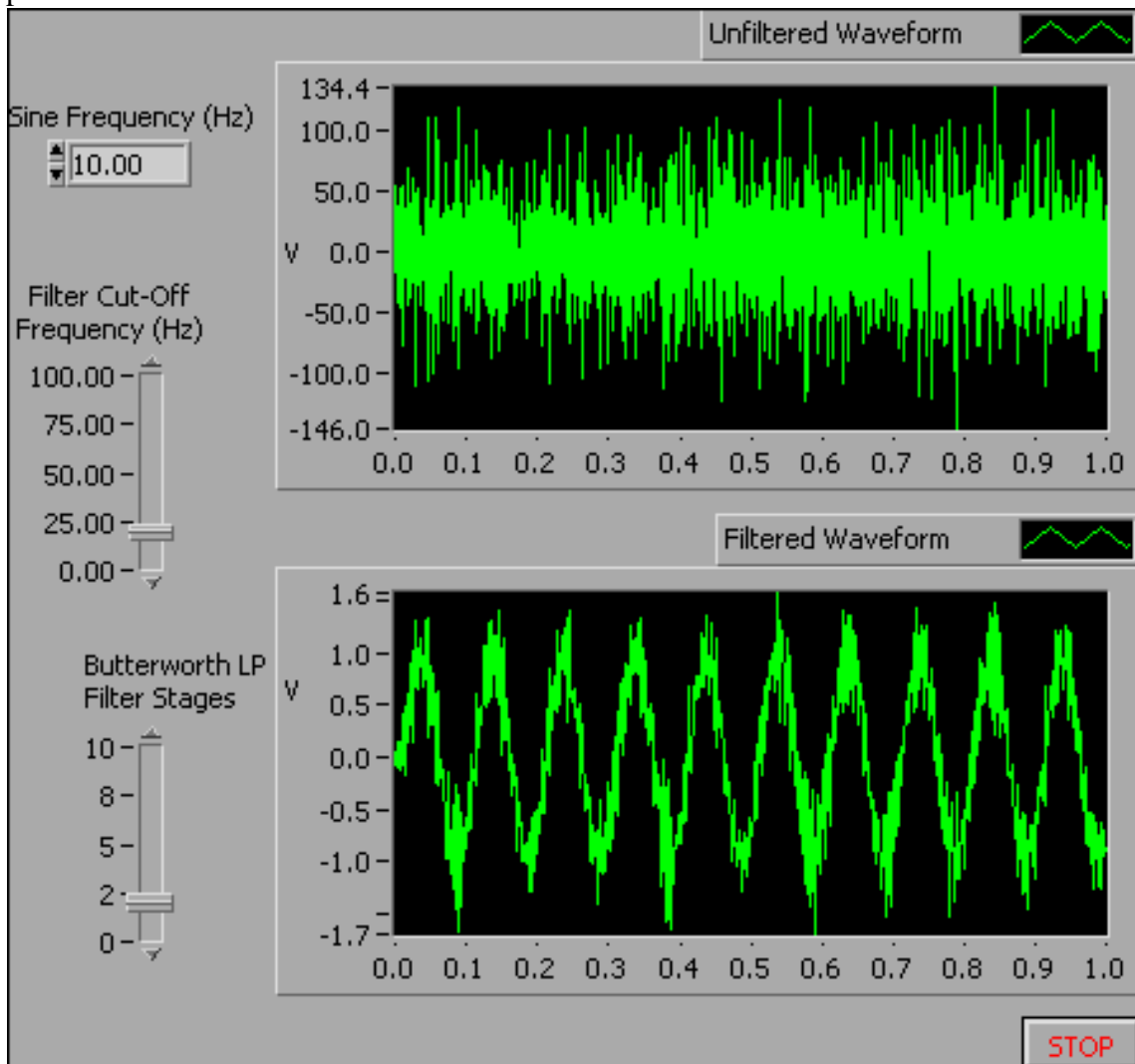

## PROBLEM 6.33

Program *Monostable* simulates an operating monostable integrated circuit. It is called a one-shot for the reason seen in its output signal: when activated, it produces a single square waveform of time duration  $t$ .

The three output charts are:

- trigger value: the trigger is HIGH until engaged (LOW). Internally, transistor T2 is on until the trigger is engaged whereby T2 goes off momentarily allowing a jump in the output voltage.
- capacitor output value: on trigger, the capacitor fires. Note the width of the output signal is coincident with the capacitor value.
- circuit output signal: the monostable provides a single square wave having a duration determined by the R and C values.

Different values will create a 1 s duration wave. For example,  $500\Omega$  and  $1.82\mu\text{F}$  work.

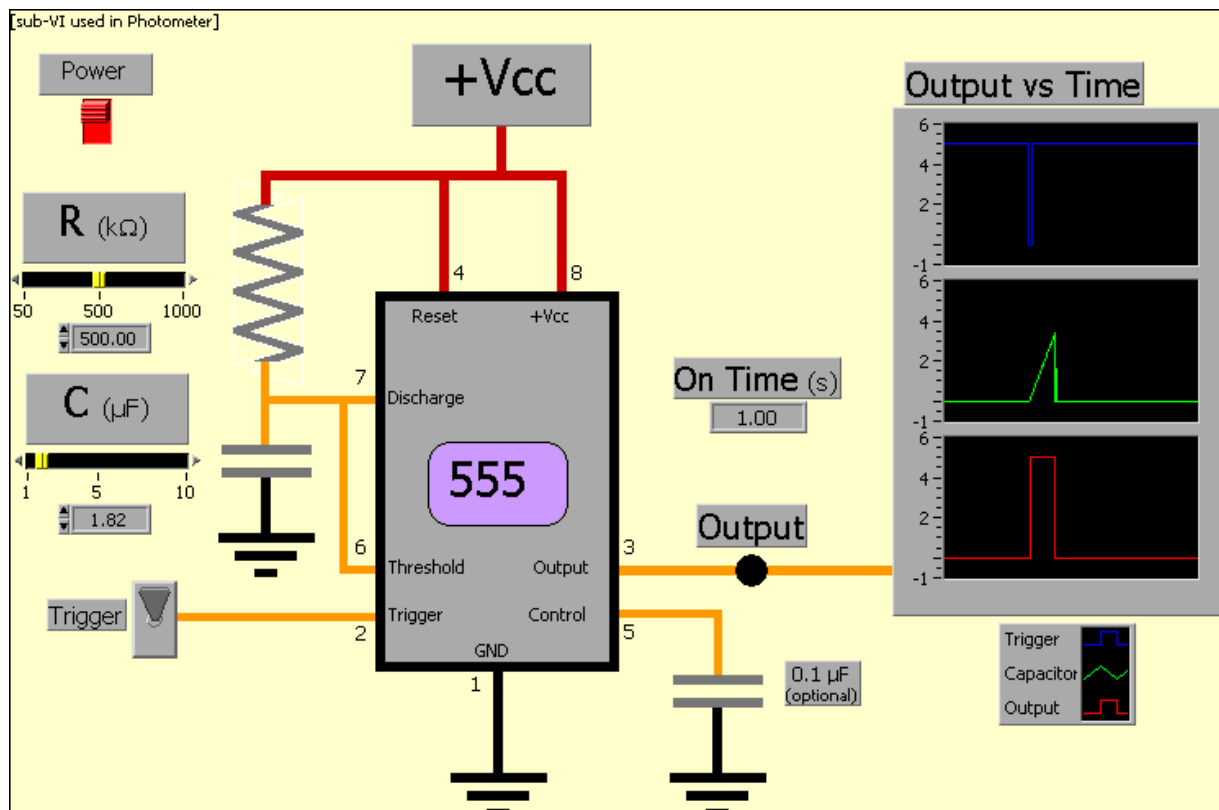

## PROBLEM 6.34

Program 741 *Opamp* simulates an inverting operating amplifier integrated circuit. The user can vary the gain characteristics.

The opamp is inverting. A negative value of  $V_{in}$  produces a positive value of  $V_{out}$ .

The opamp has a gain given by  $K = R_2/R_1$ . Any combination of  $R_2 = 5R_1$  will yield a gain of 5. Likewise, any combination of  $R_2 = 0.5R_1$  yields a gain of 0.5 (an amplifier is called an **attenuator** when  $0 < G < 1$ ).

The opamp's output is governed by its operating voltage, +/- 15V here. This unit shows a +/- 14V maximum output.

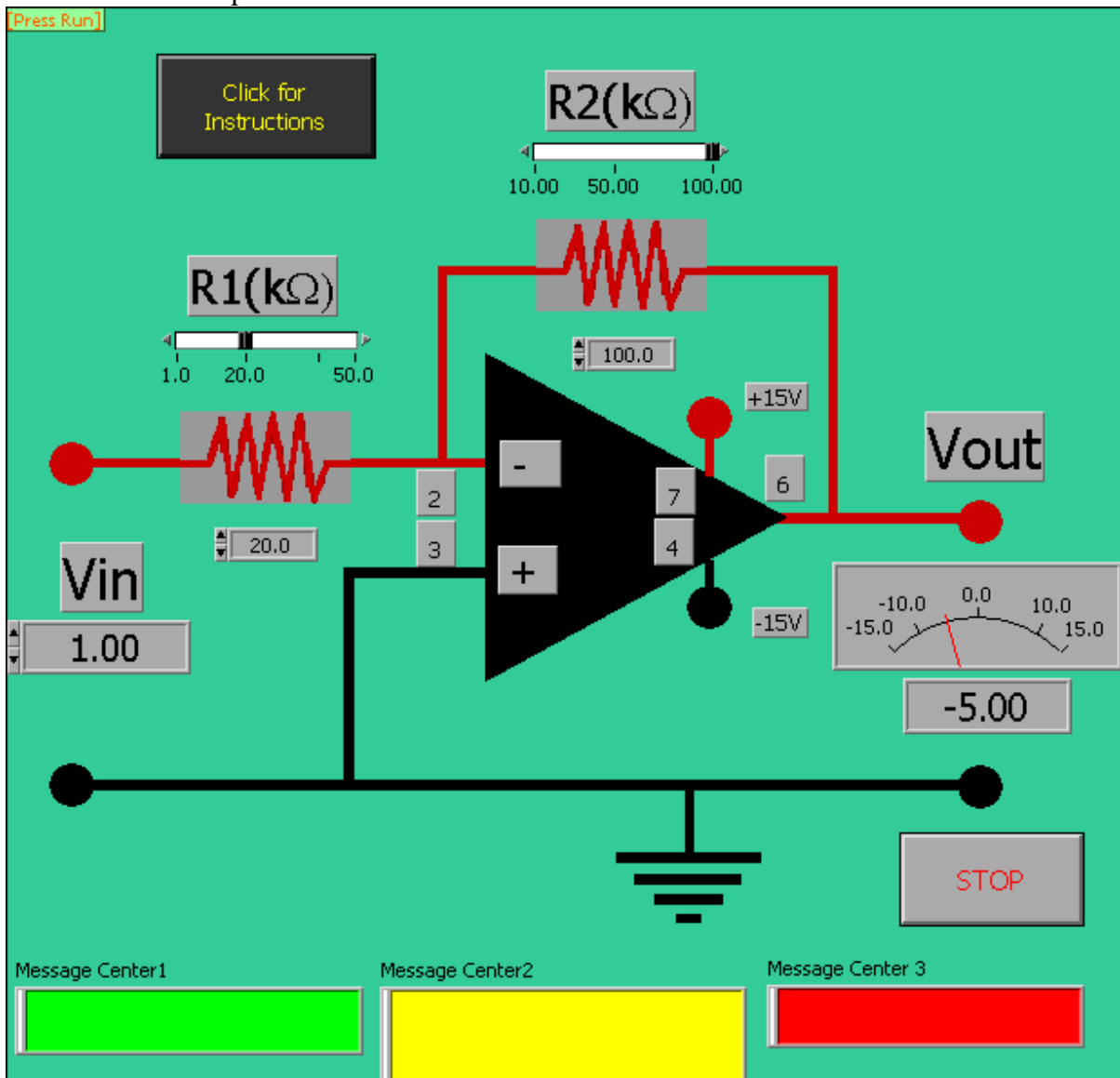

## PROBLEM 7.1

KNOWN:  $E(t) = 5 \sin 2\pi t$  mV

FIND: Convert to a discrete time series and plot

SOLUTION

The signal is converted to a discrete time series for using  $N = 8$  and sample time increments of 0.125, 0.30, and 0.75 s and plotted below. The time increments of 0.125 and 0.30 s produce discrete series with a period of 1 s or frequency of 1 Hz. The series created with a time increment of 0.75 s, which fails the Sampling Theorem criterion, portrays a signal with a different frequency content; this frequency is the alias frequency.

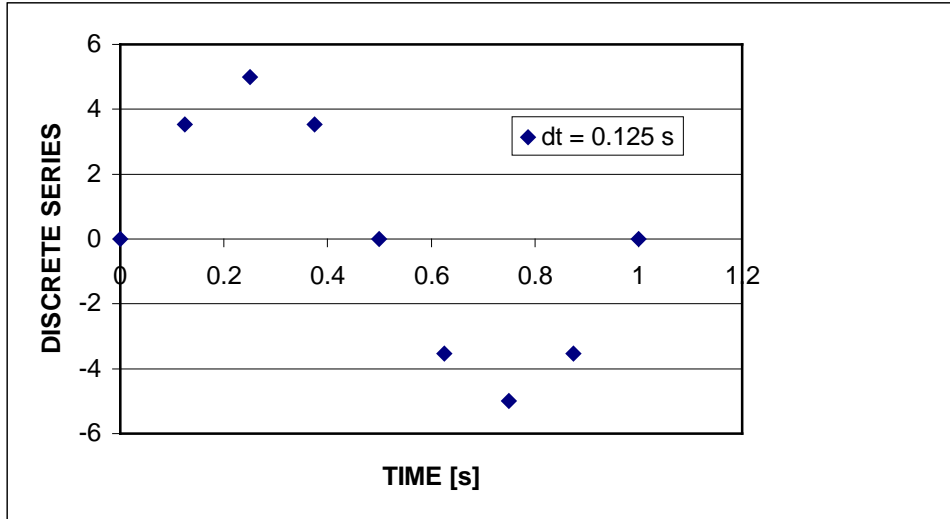

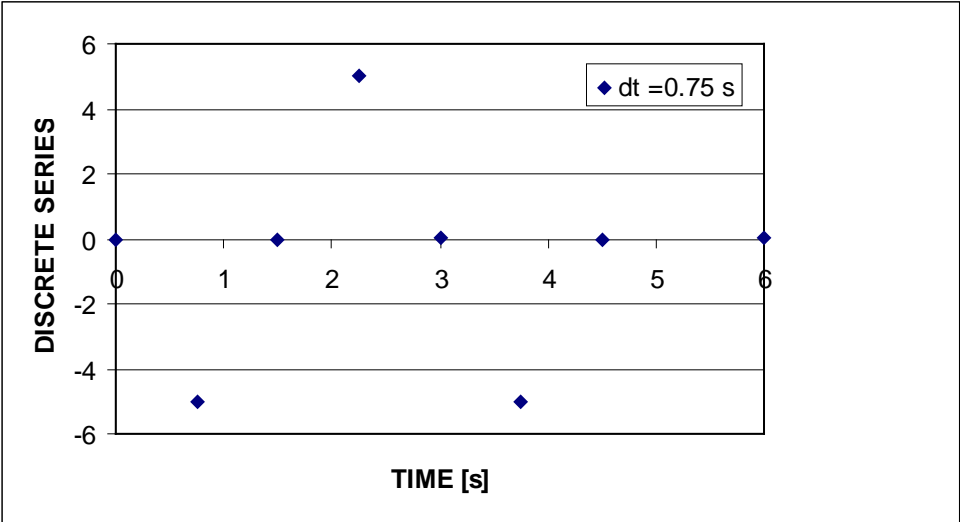
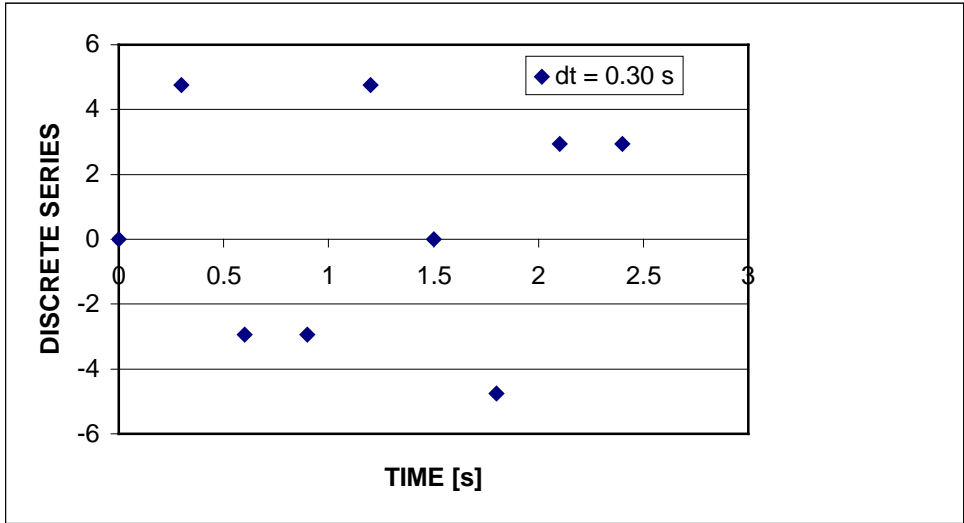

## PROBLEM 7.2

KNOWN: Repeat Problem 7.1 using  $N = 128$  points.

FIND: The discrete Fourier transform for each series.

### SOLUTION

The DFT for the time series representations of  $E(t)$  using  $N = 128$  and  $\delta t = 0.125, 0.30,$  and  $0.75$  s, respectively was executed using a DFT algorithm (any such algorithm on the companion software or using the approach described in Chapter 2 will work) and shown below. The DFT returns an exact Fourier transform of the discrete time series but not necessarily the time signal from which it is based. Whether this DFT exactly represents  $E(t)$  depends on the criteria:

- (1)  $f_s = 1/\delta t > 2f$
- (2)  $m/f_1 = N\delta t \quad m = 1, 2, 3, \dots$

With  $f = 1$  Hz and  $f_1 = f$ : (a)  $\delta t = 0.125$  s and  $N = 128$ :

$$f_s = 1/0.125\text{s} = 8 \text{ Hz} > 2 \text{ Hz}$$

$$m/1 \text{ Hz} = 128/0.125 \quad \text{or} \quad m = 16 \text{ an exact integer value.}$$

Another way to look at this second criterion: the DFT resolution  $\delta f = 1/N\delta t = 0.0625$  Hz, to which 1 Hz is an exact multiple.

Both criteria are met. Therefore, this DFT will exactly represent  $E(t)$  in both frequency and amplitude, as shown below.

(b)  $\delta t = 0.3$  s and  $N = 128$

$$f_s = 1/0.3\text{s} = 3.3 \text{ Hz} > 2 \text{ Hz}$$

$$m/1 \text{ Hz} = 128/0.3 \quad \text{or} \quad m = 38.4 \text{ not an exact integer value.}$$

Criterion (1) is met but Criterion (2) is not met. Therefore, an alias frequency will not appear. But this DFT will not exactly represent  $E(t)$  in amplitude and spectral leakage will occur, as seen below. So we find an amplitude less than 5 at a frequency centered at 1 Hz.

(c)  $\delta t = 0.75$  s and  $N = 128$

$$f_s = 1/0.75\text{s} = 1.33 \text{ Hz} < 2 \text{ Hz}$$

$$m/1 \text{ Hz} = 128/0.75 \text{ or } m = 96 \text{ an exact integer value.}$$

Criterion (1) is not met but Criterion (2) is met. Therefore, this DFT will not exactly represent  $E(t)$  in frequency. However, it does represent the signal amplitude exactly. An alias frequency at 0.33Hz appears in the DFT.

Note how the frequency resolution scale changes between plots.

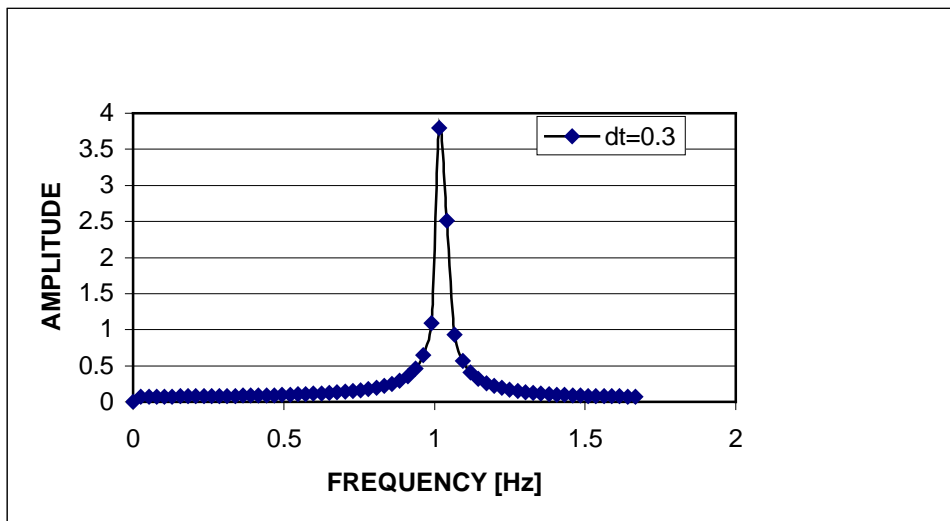
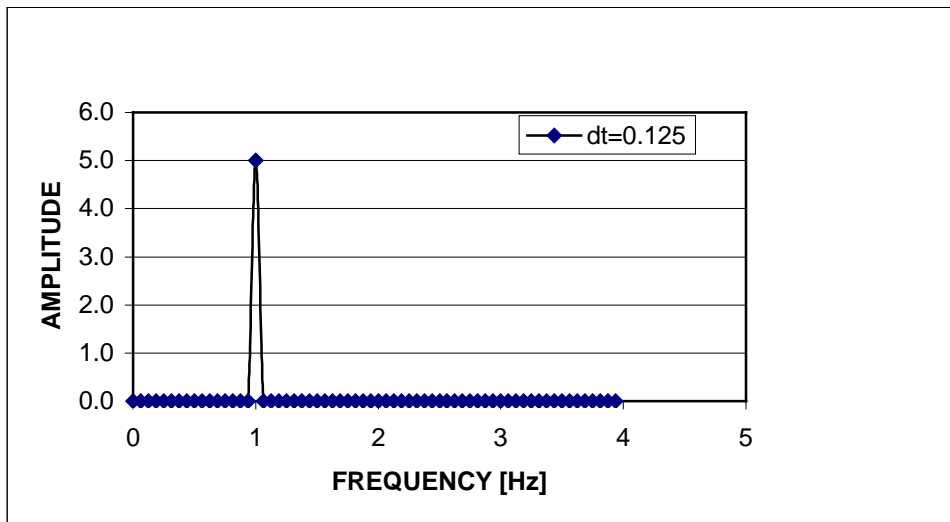

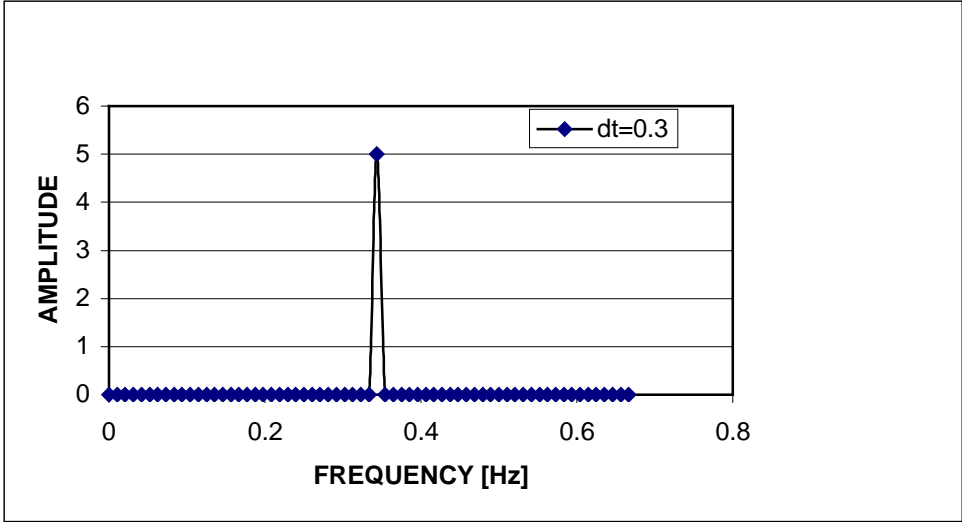

## PROBLEM 7.3

KNOWN:  $T(t) = 2 \sin 4\pi t$  °C  
 $f_s = 4$  and  $8$  Hz;  $N = 128$

FIND: Compute the Fourier transform from the resulting series.

### SOLUTION

The fundamental frequency of this signal is  $f_1 = 2$  Hz. From the Sampling theorem, an appropriate sample rate is

$$f_s > 2f_1 \quad \text{or} \quad f_s > 4\text{Hz}$$

At  $f_s = 4$  Hz the Sampling Theorem is not upheld whereas at  $f_s = 8$  Hz the Sampling theorem is upheld. For  $f_s = 4$  Hz, see the COMMENT below.

For amplitude fidelity,  $mT_1 = N \delta t$  which can be written as  $m/f_1 = N/f_s$   $m = 1, 2, \dots$   
With  $f_s = 8$  Hz and  $N = 128$ ,  $m = Nf_1/f_s = N \delta t/T_1 = 8$  an exact integer. We can expect that the resulting DFT will be an exact representation of  $T(t)$ , as seen below.

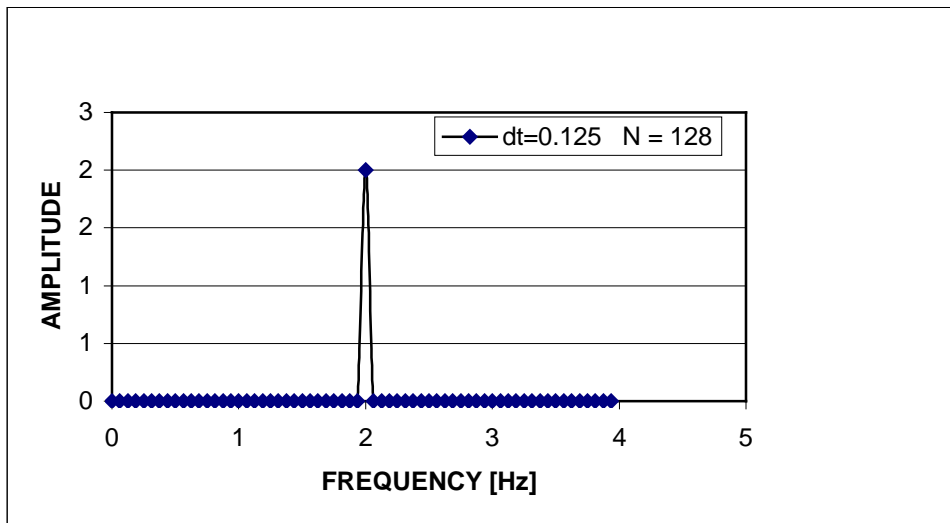

### COMMENT

The result of sampling at  $f_s = 2f$  is somewhat interesting. A non-unique reconstruction of  $T(t)$  can result which will depend wholly on the initial condition of  $T(t)$  at the time sampling commences. Because of this, we **can not** write the Sampling Theorem criterion as  $f_s \geq 2f$  as is sometimes found in texts. Try this.

## PROBLEM 7.4

KNOWN: Signal frequency,  $f_1$ , and the sample rate,  $f_s$

FIND: Any alias frequency,  $f_a$  arising

### SOLUTION

The Nyquist or folding frequency is defined as  $f_N = f_s/2$ . All frequencies in the sampled signal that are above  $f_N$  will be folded back to lower frequencies below  $f_N$ , a process depicted by the folding diagram (Figure 7.3).

(a)  $f_1 = 60 \text{ Hz}$        $f_s = 90 \text{ Hz}$

$$f_N = f_s/2 = 45 \text{ Hz.}$$

The ratio,  $f/f_N = 1.33$ , that is  $f = 1.33f_N$ . Referring to The folding diagram, a frequency of  $1.33f_N$  will be folded back to a frequency of  $0.67f_N$ . So  $f_1 = 60 \text{ Hz}$  but in the sampled signal it behaves as  $f_a = 0.67f_N = 30 \text{ Hz}$  and out-of-phase with the original signal.

(b)  $f_1 = 1200 \text{ Hz}$        $f_s = 2000 \text{ Hz}$

$$f_N = f_s/2 = 1000 \text{ Hz.}$$

The ratio,  $f/f_N = 1.2$ , that is  $f = 1.2f_N$ . Referring to The folding diagram, a frequency of  $1.2f_N$  will be folded back to a frequency of  $0.8f_N$ . So  $f_1 = 1200 \text{ Hz}$  but in the sampled signal it behaves as  $f_a = 0.8f_N = 960 \text{ Hz}$  and out-of-phase with the original signal.

(c)  $f_1 = 10 \text{ Hz}$        $f_s = 6 \text{ Hz}$

$$f_N = f_s/2 = 3 \text{ Hz.}$$

The ratio,  $f/f_N = 3.3$ , that is  $f = 3.3f_N$ . Referring to The folding diagram, a frequency of  $3.3f_N$  will be folded back to a frequency of  $0.7f_N$ . So  $f_1 = 10 \text{ Hz}$  but in the sampled signal it behaves as  $f_a = 0.7f_N = 7 \text{ Hz}$  and in-phase with the original signal.

(d)  $f_1 = 16 \text{ Hz}$        $f_s = 8 \text{ Hz}$

$$f_N = f_s/2 = 4 \text{ Hz.}$$

The ratio,  $f/f_N = 4$ , that is  $f = 4f_N$ . Referring to The folding diagram (and projecting its behavior beyond the values shown), a frequency of  $4f_N$  will be folded back to a frequency of 0. So  $f_1 = 16 \text{ Hz}$  but in the sampled signal it behaves as  $f_a = 0 \text{ Hz}$ . It will be seen as a constant (dc) signal.

## PROBLEM 7.5

KNOWN:  $E(t) = \sin 2\pi t + 2 \sin 8\pi t$   
 $f_s = 16 \text{ Hz}$

FIND: DFT (amplitude spectrum) of a discrete time series representation of  $E(t)$ .  
Reconstruct  $E(t)$  from the Fourier transform.

### SOLUTION

Begin by generating a discrete time series. We can rewrite  $E(t)$  as

$$E(t) = \sin 2\pi f_1 t + 2 \sin 2\pi f_2 t$$

with  $f_1 = 1 \text{ Hz}$  and  $f_2 = 4f_1 = 4 \text{ Hz}$ . An exact DFT representation of the  $E(t)$  will result if the discrete time series is created using

- (1)  $f_s > 2f_2$
- (2)  $mT_1 = N \delta t$  or  $m/f_1 = N/f_s$   $m = 1, 2, \dots$

For (1) to be true,  $f_s > 8 \text{ Hz}$ . This constraint is met, so frequency will be correctly represented. For (2) to be true, we need

$$N = mT_1 / \delta t = mf_s / f_1 = m(16 \text{ Hz}) / 1 \text{ Hz} = 16m$$

That is for amplitude to be correctly represented,  $N$  must be an exact multiple of 16 (e.g. 16, 32, ...). We use  $N = 32$  to construct the discrete time series. The time series and its DFT are computed using a DFT algorithm. The time signal is then reconstructed from the spectral information by

$$E(t) = \sum_{k=1}^{N/2} C_k \sin(2\pi f_k t + \tan^{-1} A_k / B_k)$$

The DFT and the respective reconstructed time signal are shown below. The reconstructed signal is exact as expected.

Try this problem at different sample rates.

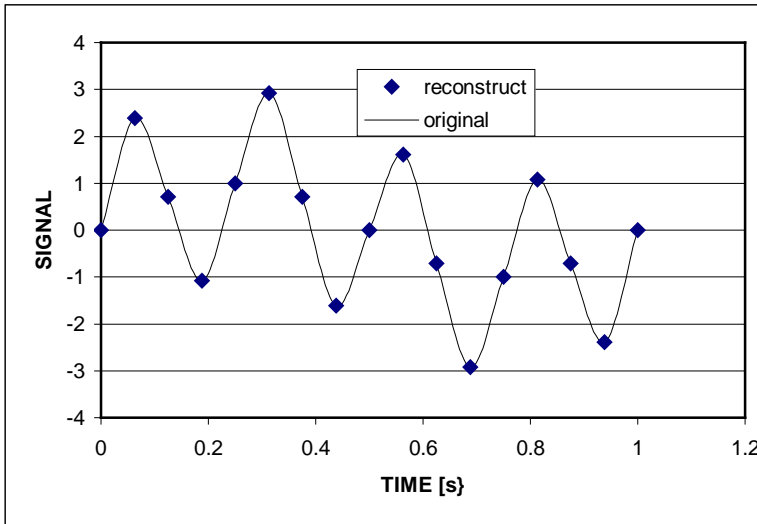
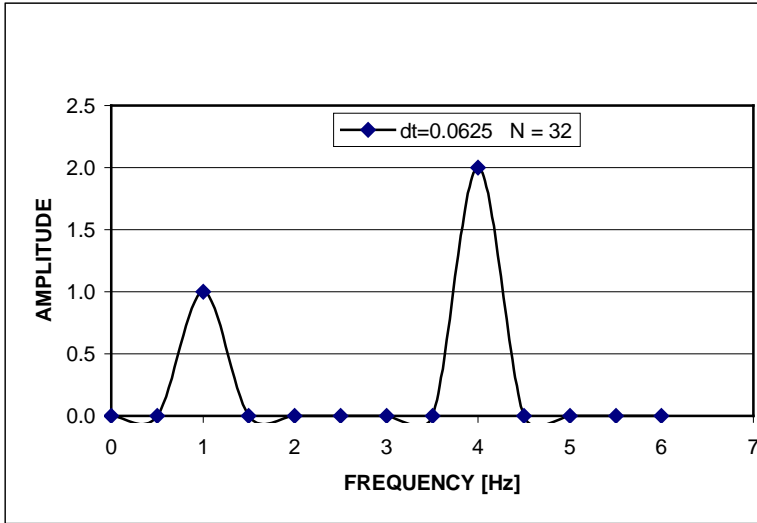

## PROBLEM 7.6

KNOWN:  $y(t) = \sum (4/(2n-1)\pi) \sin[2\pi(2n-1)t/10]$

FIND: Appropriate values for  $f_s$  and  $N \delta t$  with  $f_m \leq 2$  Hz and  $N = 2^M$ .

### SOLUTION

Filtering the signal at and below 2 Hz limits this series representation of  $y(t)$  to 5 terms. Each  $n^{\text{th}}$  term of the series has the frequency  $f_n = (2n-1)/10$ . The fundamental frequency ( $n=1$ ) is  $f_1 = 0.1$  Hz.

In order to properly construct a discrete time series, the following criteria should be met:

- (1)  $f_s > 2f_m$  Sampling Theorem criterion for frequency content
- (2)  $mT_1 = N \delta t$   $m = 1, 2, \dots$  Criterion for amplitude content

where  $T_1 = 1/f_1$ . Because  $f_m = 2$  Hz, criterion (1) is met by setting  $f_s > 4$  Hz.

There are many different correct solutions to this problem. One such solution is to set  $f_s = 8$  Hz. Then this requires,

$$m(10 \text{ s}) = N(1/8 \text{ Hz}) \quad m = 1, 2, \dots$$

Also, we must set  $N = 2^M$  where  $M$  is an integer. Criterion (2) is met with  $N = 2^{10} = 1024$ . Hence,

$$f_s = 8 \text{ Hz} \quad N = 1024 \quad \text{and} \quad N \delta t = N/f_s = 1024/8 = 128 \text{ s}$$

### COMMENT

We stress that there can be different combinations of  $f_s$  and  $N \delta t$  that will meet the criteria of (1) and (2) in a given problem. In a practical problem, additional restrictions, such as the maximum sample rate available, the maximum data set size that can be stored, or the available range of anti-alias filters will limit the number of possible combinations.

## PROBLEM 7.7

KNOWN: Straight Binary Number

FIND: Equivalent base 10 representation

SOLUTION

$$(a) 1010 = 1*2^3 + 0*2^2 + 1*2^1 + 0*2^0 = 10_{10}$$

$$(b) 11111 = 1*2^4 + 1*2^3 + 1*2^2 + 1*2^1 + 1*2^0 = 31_{10}$$

$$(c) 10111011 = 1*2^7 + 0*2^6 + 1*2^5 + 1*2^4 + 1*2^3 + 0*2^2 \\ + 1*2^1 + 1*2^0 = 187_{10}$$

$$(d) 1100001 = 1*2^6 + 1*2^5 + 0*2^4 + 0*2^3 + 0*2^2 + 0*2^1 + 1*2^0 = 97_{10}$$

## PROBLEM 7.8

### SOLUTION

(a) 1100111.1101 into decimal

$$\begin{aligned} 1100111 &= 1*2^6 + 1*2^5 + 0*2^4 + 0*2^3 + 1*2^2 + 1*2^1 + 1*2^0 = +103_{10} \\ .1101 &= 1*2^{-1} + 1*2^{-2} + 0*2^{-3} + 1*2^{-4} = 0.8125_{10} \end{aligned}$$

So  $1100111.1101 = 103.8125_{10}$

(b) 4B2F into binary

$$4B2F = 0100\ 1011\ 0010\ 1111 = 0100101100101111$$

(c)  $278.632_{10}$  into binary

$$278 = 100010110$$

$$.632 = .101000011$$

So  $278.632_{10} = 100010110.101000011$

## PROBLEM 7.9

FIND: Equivalent two's complement representation

### SOLUTION

For example, assuming a 12 bit binary number, two's complement assigns a 0 to the MSB is (+) with successive bits in straight binary (0 HIGH, 1 LOW), or a 1 if (-) with successive bits complementary (1 HIGH, 0 LOW). Because two's complement has only a single zero add 1 to its count (negative number).

(a)  $10_{10} = 0000\ 0000\ 1010$

(b)  $-10_{10} = 1111\ 1111\ 0110$

(c)  $-247_{10} = 1111\ 0000\ 1000$

(d)  $1013_{10} = 0011\ 1111\ 0101$

## PROBLEM 7.10

KNOWN: Two's complement code;  $M = 8$

### SOLUTION

Two's complement code uses the MSB as the sign bit, with a 0 for a positive number (+), and then straight binary. The largest positive number is:

$$\begin{aligned} 0111\ 1111 &= (+) 2^6 + 2^5 + 2^4 + 2^3 + 2^2 + 2^1 + 2^0 \\ &= (+) 64 + 32 + 16 + 8 + 4 + 2 + 1 = 127_{10} \end{aligned}$$

Adding a one to this binary number yields a negative number. Negative numbers use complementary binary (0 = HIGH, 1 = LOW). Note: Because two's complement has only a single zero add 1 to a negative count.

$$1000\ 0000 = (-)2^7 = (-)128 = -128_{10}$$

## PROBLEM 7.11

KNOWN: Two's complement code with  $M = 8$

### SOLUTION

Two's complement code uses the MSB as the sign bit, with a 1 for a negative number, and complementary binary (0 = HIGH, 1 = LOW). Note: Because two's complement has only a single zero, you add 1 to its negative count. The largest negative number is:

$$\begin{aligned} 1000\ 0000 &= (-1) + 2^6 + 2^5 + 2^4 + 2^3 + 2^2 + 2^1 + 2^0 \\ &= (-1) + 64 + 32 + 16 + 8 + 4 + 2 + 1 = -128_{10} \end{aligned}$$

Subtracting one from this (the binary not the decimal) number:

$$\begin{aligned} 0111\ 1111 &= (+) 2^6 + 2^5 + 2^4 + 2^3 + 2^2 + 2^1 + 2^0 \\ &= (+1)127 = +127_{10} \end{aligned}$$

## PROBLEM 7.12

KNOWN: Dual-slope integration A/D

FIND: List error sources. Derive a relationship between the uncertainty in the digital result and the slope of the integration process.

SOLUTION

Possible error sources include (see Figure 7.11): 1. errors in controlling  $t_1$  ; 2. errors in measuring  $t_m$  ; 3. errors in applied  $E_{ref}$

Since the slope is proportional to  $E_{ref}$ , then  $E_i = E_{ref}(t_m/t_1)$ . The uncertainty in the measured voltage can be expressed as:

$$u_{E_i} = \pm \left[ \left( \frac{\partial E_i}{\partial E_{ref}} u_{ref} \right)^2 + \left( \frac{\partial E_i}{\partial (t_m)} u_{t_m} \right)^2 + \left( \frac{\partial E_i}{\partial (t_1)} u_{t_1} \right)^2 \right]^{1/2}$$

The ratio  $t_m/t_1$  could be treated as a single entity but we separate the two variables here.

The value of  $E_{ref}$ , which determines the slope, then contributes to the uncertainty in two ways: 1. The uncertainty in  $E_{ref}$  will vary linearly with  $t_m$ . 2. Because the sensitivity index for the uncertainty in  $t_m/t_1$  equals  $E_{ref}$ , the slope directly affects the sensitivity of the measured voltage through the uncertainty in time determination.

The devices that contribute to these uncertainties are associated with the frequency source and the counter.

## PROBLEM 7.13

KNOWN: A/D Converter  
M = 4, 8, 12, 16  
-5 to 5 V bipolar

FIND: Q, dynamic range

### SOLUTION

The resolution of an M-bit A/D converter is expressed as

$$Q = E_{\text{FSR}}/2^M$$

For this problem,  $E_{\text{FSR}} = 10 \text{ V}$  (i.e. -5 to 5 V)

The dynamic range can be expressed in terms of the signal-to-noise ratio (SNR),

$$\text{SNR [dB]} = 20 \log 2^M$$

M	Q [V]	SNR [dB]
4	0.62500	-24
8	0.03906	-48
12	0.00244	-72
16	0.00015	-96

## PROBLEM 7.14

KNOWN: A/D Converter:  $M = 12$ ;  $E_{\text{FSR}} = 5\text{V}$ ;  $e_1/E_{\text{FSR}} = 0.0003$

FIND:  $e_Q$ ,  $e_{\text{max}}$ ,  $u_E/E$

SOLUTION

$$Q = 5\text{V}/2^{12} = 1.2 \text{ mV}$$

$$e_Q = \pm Q/2 = \pm 0.6 \text{ mV}$$

The maximum error that could be present in any measurement is found by summing all known errors:

$$u_{\text{max}} = e_Q + (E_{\text{FSR}})(e_1/E_{\text{FSR}}) = 0.6 + 1.5 = 2.1 \text{ mV}$$

However, the probable error provides a reasonable estimate:

$$u_E = \pm (e_Q^2 + e_1^2)^{0.5} = \pm (.6^2 + 1.2^2)^{1/2} = 1.6 \text{ mV} \quad (95\%)$$

or  $u_E/E = 0.032\%$ .

COMMENT

A maximum error assumes that all possible errors are at their maximum value during a measurement. It is different from a probable error.

## PROBLEM 7.15

KNOWN: Single ramp A/D converter:  $M = 8$ ;  $E_{FSR} = 10 \text{ V}$ ;  $f_{\text{clock}} = 2.5 \text{ MHz}$

Comparator:  $E_{\text{th}} = 1 \text{ mV}$

(i)  $E_i = 6.000 \text{ V}$  (ii)  $E_i = 6.035 \text{ V}$ .

FIND: Resolution. Binary output. Conversion times.

### SOLUTION

(i) Resolution:  $Q = 10 \text{ V}/2^8 = 39 \text{ mV}$  (or 0.4% FSO) for a ramp slope equivalent to 0.039 V/time step.

For  $E_i = 6.000 \text{ V}$ , the number of steps required is:

$$E_i/Q = 153.6 \approx 154 \text{ steps}$$

With a single count for each step,  $154_{10} = 1001 \ 1010$  in straight binary.

(ii) Repeating for  $E_i = 6.035 \text{ V}$ :  $Q = 39 \text{ mV}$ .

$$E_i/Q = 155 \text{ steps or } 155_{10} = 1001 \ 1011 \text{ in straight binary.}$$

For either case:

With  $f_{\text{clock}} = 2.5 \text{ MHz}$ , each step requires  $0.4 \mu\text{s}$ . So the conversion times are:

$$E_i = 6.000 \text{ V: } t = (0.4 \mu\text{s})(154) = 61.1 \mu\text{s}$$

The maximum conversion time required for a given input occurs at its maximum count or  $2^8$ :  
 $t_{\text{max}} = (0.4 \mu\text{s})(256) = 102.4 \mu\text{s}$ .

$$\text{The average conversion time is: } t_{\text{avr}} = (0.4 \mu\text{s})(128) = 51.2 \mu\text{s}$$

## PROBLEM 7.16

KNOWN: A/D converter:  $M = 10$ ;  $E_{\text{FSR}} = 10 \text{ V}$ .  $f_{\text{clock}} = 1 \text{ MHz}$ .

FIND: Compare conversion times for successive approximation versus dual-ramp operation.

### SOLUTION

Successive approximation Method: A maximum conversion time would result after  $M$  trials.  
For  $M = 10$ ,

$$t_{\text{max}} = M/f_{\text{clock}} = 10/1 \text{ MHz} = 10 \mu\text{s}$$

Dual-ramp methods: A maximum conversion time results after  $(2)(2^M) = (2^{M+1})$  trials.  
For  $M = 10$ ,

$$t_{\text{max}} = 2^{M+1}/f_{\text{clock}} = 2^{11}/1 \text{ MHz} = 2048 \mu\text{s}.$$

## PROBLEM 7.17

KNOWN: D/A converter:  $M = 8$

$$E_o = 3.58 \text{ V if register} = 10110011$$

FIND:  $E_o$  if register = 01100100.

ASSUMPTION: Straight binary code.

SOLUTION

$10110011 = 179_{10}$  or 179 counts. For a known  $E_o$  this is equivalent to:

$$Q = 3.58 \text{ V}/179 = 0.020 \text{ V}$$

Then, for  $01100100 = 100_{10}$  or 100 counts:

$$E_o = (0.020 \text{ V})(100) = 2.000 \text{ V}.$$

## PROBLEM 7.18

KNOWN: Successive approximation converter:  $M = 4$ ;  $E_{FSR} = 10 \text{ V}$ ;  
 $E_i = 4.9 \text{ V}$

FIND:  $E^*$ . Required  $M$  for  $Q \leq 2.5 \text{ mV}$ .

### SOLUTION

(i) Resolution:  $Q = 10 \text{ V}/2^4 = 0.625 \text{ V}$  So with  $E_i = 4.9 \text{ V}$ , the number of register counts is  $4.9 \text{ V}/0.625 \text{ V} = 7.8$ . Referring to Figure 7.7, if we assume the A/D uses a straight encoding scheme whereby  $e_Q = 1 \text{ bit} = 0.625 \text{ V}$ , the register will show  $7.8 \Rightarrow 7$  counts, or  $7_{10} = 0111$ . Hence,  $E^* = (7)(0.625 \text{ V}) = 4.375 \text{ V}$ . Note that  $E_i - E^* < e_Q$ .

On the other hand: If the A/D used a bias shift (offset) encoding whereby  $e_Q = \pm 1/2 \text{ bit} = \pm 0.3125 \text{ V}$ , the register will show  $7.8 \Rightarrow 8$  counts, or  $8_{10} = 1000$ . Hence,  $E^* = 5.000 \text{ V}$ . Again,  $E_i - E^* < e_Q$ .

(ii) For  $|E_i - E^*| = e_Q < 2.5 \text{ mV}$ : requires either  $M = 12$  (for a straight encoding scheme) or  $M = 11$  (for a bias shifted scheme).

## PROBLEM 7.19

### SOLUTION

Resolution:  $Q = E_{\text{FSR}}/2^M$  regardless of the conversion method.

Maximum Conversion time: For a given clock speed,  $f_{\text{clock}}$ ,

Successive Approximation:  $t = M/f_{\text{clock}}$

Ramp:  $t = 2^M/f_{\text{clock}}$

Parallel:  $t = 1/f_{\text{clock}}$

For any converter, resolution improves with bit number equally. The trade-off is seen in the required conversion times. Ramp times increase exponentially with bit number. Parallel method conversion times are essentially independent of bit number, but their component costs increase exponentially with bit number.

## PROBLEM 7.20

KNOWN: A/D converter:  $M = 10$ ;  $E_{\text{FSR}} = 10 \text{ V}$ ; register = 1010 1101 11

FIND:  $E_i$

SOLUTION

For a straight binary code, 1010 1101 11 =  $695_{10}$  which is equivalent to

$$E^* = (695)Q = (695)(10/2^{10}) = 6.787 \text{ V}$$

Assuming that  $e_Q = Q = 1 \text{ LSB}$ ,

$$E_i = E^* + 1 \text{ LSB} = 6.787 + 1 \text{ LSB} \quad \text{or} \quad 6.787 \leq E_i \leq 6.796 \text{ V}$$

Assuming that  $e_Q = \pm Q/2 = \pm 1/2 \text{ LSB}$ ,

$$E_i = E^* \pm 1/2 \text{ LSB} \quad \text{or} \quad 6.782 \leq E_i \leq 6.792 \text{ V}$$

## PROBLEM 7.21

KNOWN: A/D converter:  $M = 8$ ;  $E_{FSR} = 10 \text{ V}$ ; register = 1010 1011

FIND:  $E_i$

SOLUTION

For two's complement code, 1010 1011 =  $-85_{10}$  [i.e.  $-(128 - 43)$ ] which is equivalent to

$$E^* = (-85)Q = (-85)(10/2^8) = -3.320 \text{ V}$$

Assuming that  $e_Q = Q = 1 \text{ LSB}$ ,

$$E_i = E^* + 1 \text{ LSB} = -3.320 + 1 \text{ LSB} \text{ or } -3.320 \geq E_i \geq -3.359 \text{ V}$$

Assuming that  $e_Q = \pm Q/2 = \pm 1/2 \text{ LSB}$ ,

$$E_i = E^* \pm 1/2 \text{ LSB} \text{ or } -3.339 \leq E_i \leq -3.300 \text{ V}$$

## PROBLEM 7.22

KNOWN: Dual slope A/D converter:  $M = 12$ ;  $f_{\text{clock}} = 10 \text{ kHz}$ ;  
register =  $2011_{10}$

FIND  $t_c$

SOLUTION

The actual conversion time based on the register value of 2011 counts is

$$t_c = (2)(2011)/10 \text{ kHz} = 0.4022 \text{ s}$$

## PROBLEM 7.23

KNOWN: Single ramp A/D converter:  $M = 8$ ;  $f_{\text{clock}} = 1 \text{ MHz}$ ;  
register =  $173_{10}$

FIND  $t_c$

SOLUTION

The actual conversion time based on the register value of 173 counts is

$$t_c = (173)/1 \text{ MHz} = 173 \mu\text{s}$$

## PROBLEM 7.24

KNOWN: Successive approximation A/D converter:  $M = 8$ ;  $E_{FSR} = 10 \text{ V}$

$$E_i = 6.2 \text{ V}$$

FIND: Register value

SOLUTION

The resolution is:  $Q = 10 \text{ V}/2^8 = 0.039 \text{ V}$

So each register bit value counts as 39 mV.

For an input of 6.2V, the register count would be  $6.2 \text{ V}/0.039 \text{ V} = 158.9$ .

If we account for register threshold errors, we take  $158.9 \Rightarrow 159_{10} = 10011111$  (straight binary).

The comparator will see  $E^* = 6.162 \text{ V}$  after 7 steps and  $6.201 \text{ V}$  after 8 steps.

## PROBLEM 7.25

KNOWN: Balance scale:

input range: 0 to 5 kg

output range: 0 to 3.50 mV

Recorder:

$M = 12$ ;  $E_{FSR} = 10 \text{ V}$

FIND: Appropriate amplifier gain,  $G$ .

### SOLUTION

The balance scale has a sensitivity:  $K = 3.5 \text{ mV}/5 \text{ kg} = 0.7 \text{ mV/kg}$

The recorder has a resolution:  $Q = 10 \text{ V}/2^{12} = 2.44 \text{ mV}$

It is clear that the recorder resolution is large compared to the balance output. Amplification of the balance output prior to recording is in order. To improve the recorder resolution to within, say, 1% of the scale full scale output we will need,  $Q = (0.01)(3.5 \text{ mV}) = 35 \mu\text{V}$ . To achieve this,

$$G = 2.44 \text{ mV}/35 \mu\text{V} = 70$$

So, a minimum gain of about  $G = 70$  is required. A higher gain will further improve resolution.

### COMMENT

Note that when an amplifier is used the resolution would be estimated as:

$$Q = E_{FSR}/(G)(2^M)$$

where  $G$  accounts for the gain.

## PROBLEM 7.26

KNOWN:  $f \approx 2 \text{ Hz}$   
 $N \delta t = 10 \text{ s}$   
Recorder:  $M = 12$ ;  $E_{\text{FSR}} = 10 \text{ V}$

FIND:  $f_s$ ,  $y(t)$ ,  $\delta f$ ,  $f_N$

### SOLUTION

*This problem is an open-ended design. One possible solution follows.*

(i) To meet the Sampling Theorem,  $f_s > 2f_m$ . If we set  $f_m = f = 2 \text{ Hz}$ , this gives  $f_s > 4 \text{ Hz}$ . But because  $f_m$  is not known exactly, we should set  $f_s$  away from  $4 \text{ Hz}$ .

The minimum sample rate will also depend on  $N$  and the extent of spectral leakage (see amplitude ambiguity). We should make some trial runs until we achieve acceptable results.

For a  $10 \text{ s}$  block of data, i.e.  $N \delta t = N/f_s = 10 \text{ s}$ , so that with we have  $N = 10f_s$ . As an example, let  $f_s = 20 \text{ Hz}$  and  $N = 200$ .

(ii)  $y(t) = C_1 \sin 2\pi f t = 2 \sin 4\pi t \quad [\text{V}]$

(iii) From (i):  $\delta f = 1/N\delta t = f_s/N = 0.1 \text{ Hz}$ ;  $f_N = f_s/2 = 10 \text{ Hz}$ . A  $10 \text{ Hz}$  low pass filter should be used in front of the A/D converter.

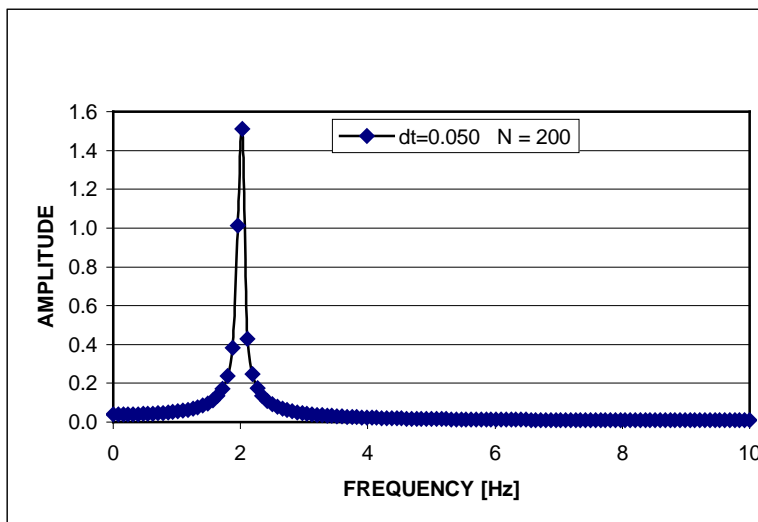

## PROBLEM 7.27

KNOWN: DAS:  $f_s = 20 \text{ kHz}$ ;  $M = 12$ ;  $N\delta t = N/f_s = 5 \text{ s}$   
Computer:  $M = 16$

FIND: Memory requirement

SOLUTION

Given that 5 s of data are acquired:  $N = (5\text{s})(20,000/\text{s}) = 100,000$   
So 100,000 12-bit data points are acquired.

A 16-bit computer stores each integer number as a 16-bit word comprised of 2 8-bit bytes. This requires that each 12-bit integer data point be stored as 2 bytes. So it takes 200,000 bytes to store the data. Now 1 kbyte = 1 kB = 1024 bytes.

So 200,000 bytes requires 195.3 kB of memory.

## PROBLEM 7.28

KNOWN: DAS:  $M = 12$ ;  $f_s = 100$  MHz  
Computer: 8 MB of 32-bit memory

FIND:  $(N\delta t)_{\max}$

### SOLUTION

Direct Memory Access (DMA) writes data directly from the acquisition process into memory. If each 12-bit data point is stored as a 32-bit (4 8-bit bytes) word, then the maximum storage is  $N = 8 \text{ MB} = 8,192,000$  bytes.

If  $f_s = 100$  MHz, then  $(N\delta t)_{\max} = 0.08192$  s.

If  $f_s = 100$  kHz, then  $(N\delta t)_{\max} = 81.92$  s.

### COMMENT

When multiple channels are sampled, the number of data points acquired per unit time is increased by the number of channels. The sample duration available is decreased by roughly the number of channels (the amount is not exact because some time is required to flip between channels). For example, a race car test might involve some 64 different sensors. Even at 100 Hz, that is 6400 data points per second to acquire and then to analyze.

## PROBLEM 7.29

KNOWN: Square wave:  $T_1 = 1$  s (Example 2.3)

FIND:  $N$ ,  $f_s$  for the sampling process.  $f_c$  for the filter.

SOLUTION

*This problem is an open-ended design. One possible solution follows.*

We need to meet the criteria for Sampling Theorem and to minimize leakage (Amplitude Ambiguity).

For the square wave of example 2.3,

$$y(t) = (4/\pi)\sin(0.2\pi t) + (4/3\pi)\sin(0.6\pi t) + (4/5\pi)\sin(\pi t) + (4/7\pi)\sin(1.4\pi t) + (4/9\pi)\sin(1.8\pi t)$$

The first five non-zero terms show a frequency of  $f_n = 2n\pi/T_1$  for  $n = 1, 3, 5, 7, 9$  with  $T_1 = 10$  s. So at  $n = 9$ ,  $f_m = 0.9$  Hz. Hence:  $f_s > 1.8$  Hz.

The amplitudes are:  $C_n = 4/n\pi$  for  $n = 1, 3, \dots, 9$ .

To minimize leakage, we want  $mT_1 = N/f_s$ . This gives:  $N = 10mf_s$ . Any combination of  $N$  and  $f_s$  will do provided  $f_s > 1.8$  Hz.

For example:  $f_s = 3.2$  Hz and  $N = 32m$  where  $m$  is a positive number. If we let  $m = 2$  (i.e., sample for 2 periods of the signal), then we want  $N = 64$ .

For the ideal filter setting: set  $f_c = f_N = f_s/2 = 1.6$  Hz.

## PROBLEM 7.30

KNOWN: Triangle wave:  $T_1 = 2$  s

FIND: Sampling process:  $f_s$ ,  $N$ . Filter:  $f_c$

SOLUTION

*This problem is an open-ended design. One possible solution follows.*

The first seven non-zero terms have the form:

$$y(t) \approx (4D_1 / \pi) \cos \pi t + (4D_1 / 3\pi) \cos 3\pi t + \dots + (4D_1 / 13\pi) \cos 13\pi t$$

To meet the Sampling Theorem: For this series,  $f_m = 13/2 = 6.5$  Hz. So that  $f_s > 2f_m > 13$  Hz.

To minimize spectral leakage (amplitude ambiguity): We want  $mT_1 = N/f_s$  to minimize leakage or  $N = 2f_s m$ .

Any combination will work provided  $f_s > 13$  Hz. For example,  $f_s = 16$  Hz,  $N = 256$ .

An ideal filter is set at the Nyquist frequency:  $f_c = f_s/2 = 8$  Hz.

## PROBLEM 7.31

### SOLUTION

*This problem is an open-ended design. One possible solution follows.*

One approach: let  $f_s = 3.2$  Hz,  $N = 64$  (developed in Problem 7.29). The discrete Fourier transform will return  $N/2 = 32$  amplitudes corresponding to the  $N/2$  frequencies spaced  $\delta f = f_s/N = 0.05$  Hz apart and up to and including  $f_N = f_s/2 = 1.6$  Hz. The time series is

$$y(t) = (4/\pi)\sin(0.2\pi t) + (4/3\pi)\sin(0.6\pi t) + (4/5\pi)\sin(\pi t) + (4/7\pi)\sin(1.4\pi t) + (4/9\pi)\sin(1.8\pi t)$$

To generate a plot, we estimate the DFT using a spreadsheet or the accompanying software.

The 5-term series provides an approximate square wave as expected (see Chapter 2) of the appropriate amplitude and period.

The amplitude spectrum returns 32 amplitude – frequency pairings. Amplitudes are zero, except at the harmonic frequencies. It shows the correct amplitude  $C_n$  at each corresponding harmonic frequency  $f_n$  for  $n = 1, 2, 3, 4, 5$ . For example,  $C_1 = 4/\pi$  at  $f_1 = 0.1$  Hz.

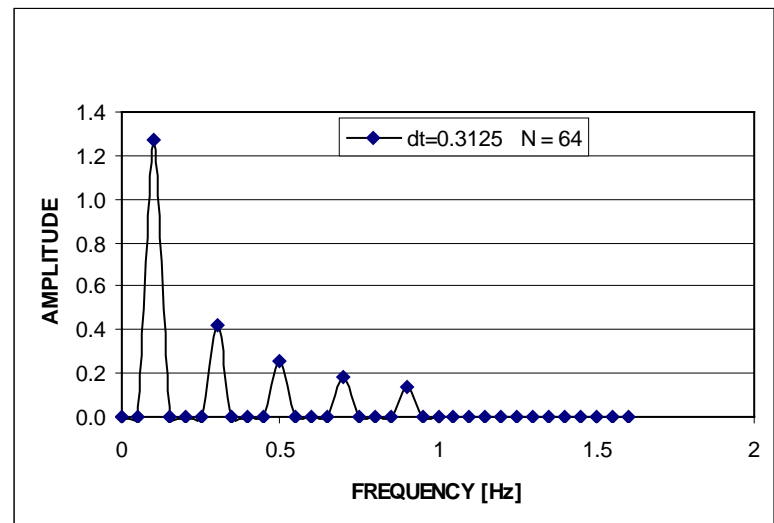
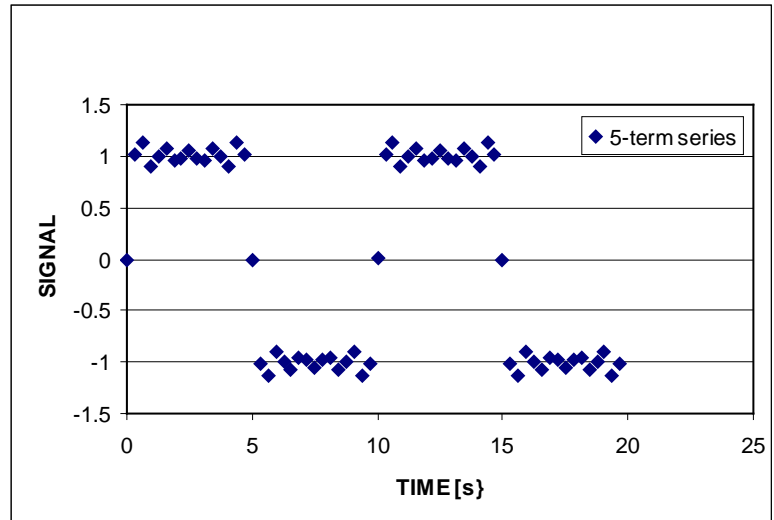

## PROBLEM 7.32

### SOLUTION

*This problem is an open-ended design. One possible solution follows.*

Using the example from Problem 7.30:  $f_s = 16$  Hz,  $N = 256$ . The discrete Fourier transform will return  $N/2 = 128$  amplitudes corresponding to the  $N/2$  frequencies spaced  $\delta f = f_s/N = 0.0625$  Hz apart up to and including  $f_N = f_s/2 = 8$  Hz.  $D_1 = 1$  V.

$$y(t) \approx (4D_1 / \pi) \cos \pi t + (4D_1 / 3\pi) \cos 3\pi t + \dots + (4D_1 / 13\pi) \cos 13\pi t$$

To generate a plot, we estimate the DFT using a spreadsheet or the accompanying software.

The 7-term series provides an approximate triangle wave (see Chapter 2) with the appropriate amplitude and period. The tips of the triangle are somewhat skewed with this short series.

The amplitude spectrum returns 128 amplitude – frequency pairs. Amplitudes are zero, except at the harmonic frequencies. It shows the correct amplitude  $C_n$  at each corresponding harmonic frequency  $f_n$  for  $n = 1, 2, 3, 4, 5, 6, 7$ . For example,  $C_1 = 4/\pi$  at  $f_1 = 0.5$  Hz.

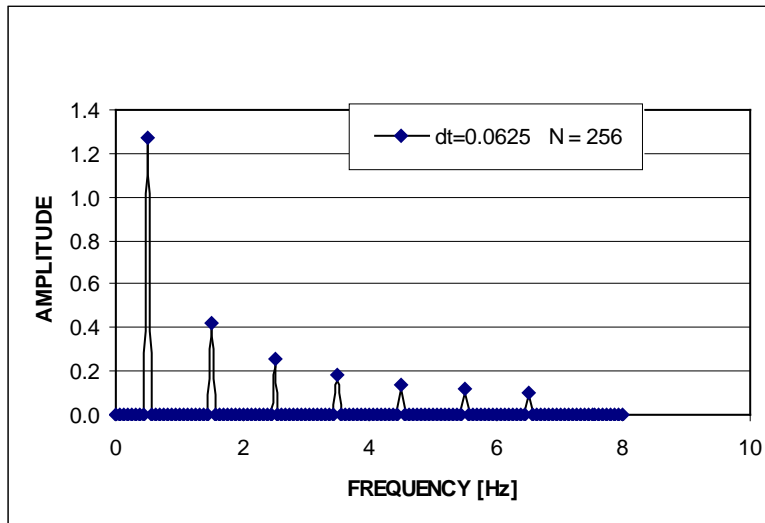
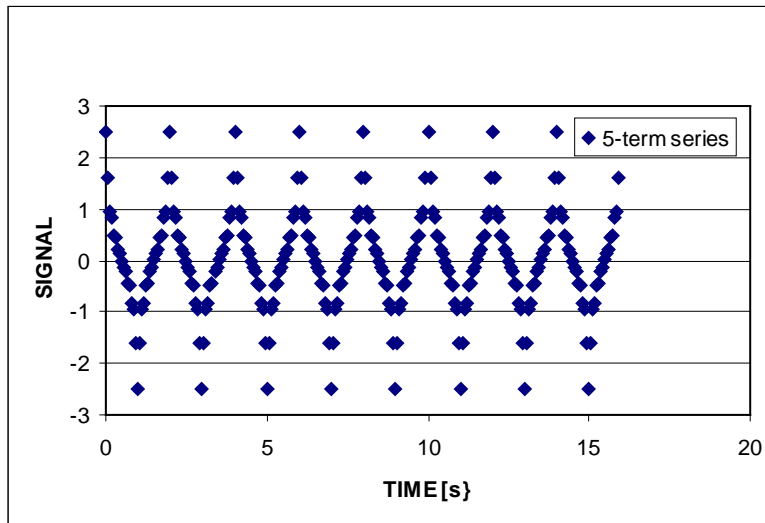

## PROBLEM 7.33

KNOWN: RC filter  
 $k = 1$   
 $f_c = 100 \text{ Hz}$

FIND: Attenuation at 10, 50, 75, and 200 Hz

### SOLUTION

For a low pass RC Butterworth filter,

$$M(f) = 1/[1 + (f/f_c)^{2k}]^{1/2}$$

where  $k = 1$  for a single-stage filter. Note that with  $k = 1$ , the filter takes on the first-order system form discussed in Chapter 3.

Recall that "attenuation" means reduction (Chapter 3). In the context of a filter, a device that reduces the output amplitude ( $M(f) < 1$ ) of targeted frequencies corresponds to a device with a negative value of dynamic error at those frequencies. Dynamic error is given by

$$\delta(f) = M(f) - 1$$

Note: Recall also that "gain" refers to a positive value of dynamic error.

f [Hz]	M(f)	$\delta(f)$	attenuation [%]
10	0.995	-0.005	0.5
50	0.894	-0.105	10.5
75	0.800	-0.200	20.0
200	0.447	-0.553	55.3

## PROBLEM 7.34

KNOWN: Low-pass LC Bessel filter with  $k = 3$ ;  $f_c = 100$  Hz

FIND: Attenuation at 10, 50, 75, 200 Hz

### SOLUTION

A three-stage, low-pass Bessel filter will have the transfer function (Chapter 6)

$$G(s) = \frac{a_o}{D_k(s)}$$

where  $D_k(s) = (2k-1)D_{k-1}(s) + s^2D_{k-2}(s)$ ,  $D_0(s) = 1$  and  $D_1(s) = s+1$ . For unit cut-off frequency and with  $k = 3$ ,  $D_3(s)$  has the form

$$D_k(s) = D_3(s) = (2k-1)D_2(s) + s^2D_1(s)$$

with  $D_1(s) = s+1$  and  $D_2(s) = s^2+3s+3$ . The three stage, unit cut-off frequency transfer function is

$$G(s) = 15/[s^3 + 6s^2 + 15s + 15]$$

With  $f_c = 100$  Hz, let  $\omega_c = 2\pi f_c = 628$  rad/s. We substitute  $s/\omega_c$  for  $s$  and solve for  $s = j\omega$  to obtain

$$\begin{aligned} G(j\omega) &= 15\omega_c^3 / \left[ (-j\omega^3 - 6\omega^2\omega_c + 15j\omega\omega_c^2 + 15\omega_c^3) \right] \\ &= M(\omega)e^{j\Phi(\omega)} \end{aligned}$$

From which, the magnitude is

$$M(\omega) = 15\omega_c^3 / \left[ \left( (15\omega\omega_c^2 - \omega^3)^2 + (15\omega_c^3 - 6\omega^2\omega_c)^2 \right)^{1/2} \right]$$

f	$\omega$	M(f)	% Attenuation (= $ M(f) - 1  * 100$ )
10	62.8	1	0%
50	314	0.98	2%
75	471	0.94	6%
200	1256	0.63	37%

## PROBLEM 7.35

KNOWN: LC low-pass Butterworth filter  
 $-3 \text{ dB} \leq M(0 \leq f \leq 5 \text{ kHz})$  and  $M(f \geq 10 \text{ kHz}) \leq -30 \text{ dB}$

FIND: Values for R, C and k

SOLUTION

*This problem is an open-ended design. One possible solution follows.*

For a k-stage, low-pass Butterworth filter,

$$M(f) = \frac{1}{\left[1 + (f/f_c)^{2k}\right]^{1/2}}$$

If we set  $f_c = 5,000 \text{ Hz}$ , then we meet the constraint  $-3 \text{ dB} \leq M(0 \leq f \leq 5 \text{ kHz})$  immediately. To meet  $M(f \geq 10 \text{ kHz}) \leq -30 \text{ dB}$ , set the attenuation at  $10,000 \text{ Hz}$  to be  $-30 \text{ dB}$ .

Find the number of stages as

$$\text{Attenuation}(dB) = 10 \log \left[ 1 + (f/f_c)^{2k} \right] \quad \text{or} \quad -30 \text{ dB} = 10 \log \left[ 1 + (10000/5000)^{2k} \right]$$

or solving to get  $k \approx 5$ .

A 5-stage filter has 5 reactive elements. To specify the capacitors and inductors, we refer to Table 6.1 and its corresponding Figure. For a normalized value of  $R_s = 1 \Omega$  and a  $f_c = 5000 \text{ Hz}$ :

$$L = L_i R_s / 2\pi f_c \qquad C = C_i / (R_s 2\pi f_c)$$

$$C_1 = 19.7 \mu\text{F} \qquad C_3 = 64 \mu\text{F} \qquad C_5 = 19.7 \mu\text{F}$$

$$L_2 = 103 \text{ mH} \qquad L_4 = 103 \text{ mH}$$

## PROBLEM 7.36

KNOWN:  $y(t)$  is a complex periodic waveform passed through a low pass RC filter and then sampled discretely.  
 $f_s = 500$  Hz  
Filter cut-off:  $f_c = 250$  Hz

FIND:  $f_m$  : The highest frequency harmonic of  $y(t)$  that can be sampled and keep  $\delta(f) \leq 0.10$

ASSUMPTION Sampling criteria selected for proper signal measurement.

SOLUTION

The input signal has the form

$$y(t) = A_o + \sum_n C_n \sin(2\pi n f_1 t + \Phi_n)$$

We are looking for the value for  $f_m = n f_1$  such that  $\delta(f_m) = M(f_m) - 1 \leq 0.10$ .

$$M(f) = \frac{1}{\left[1 + (f/f_c)^{2k}\right]^{1/2}}$$

where  $k = 1$  here. Setting  $f_c = 250$  Hz and  $M(f_m) = 0.9$ , then

$$0.9 \leq \frac{1}{\left[1 + (f_m/250\text{Hz})^2\right]^{1/2}}$$

or  $f_m \leq 121$  Hz.

With  $f_c = 250$  Hz, we know that  $M(250 \text{ Hz}) = 0.707$ .

## PROBLEM 7.37

KNOWN: A 500 Hz component is to be removed from an analog signal and passed through an A/D converter.

$$M = 8; E_{\text{FSR}} = 10 \text{ V}; f_s = 200 \text{ Hz}$$

FIND: Low-pass anti-alias filter with  $M(500 \text{ Hz}) \leq e_Q$ .

### SOLUTION

A Butterworth low-pass filter will meet this need.

$$\text{Quantization error: } e_Q = \pm 0.5[E_{\text{FSR}}/2^M] = \pm 0.5[10\text{V}/256] = \pm 0.01953 \text{ V}$$

With  $f_s = 200 \text{ Hz}$ , an appropriate anti-alias filter will have  $f_c \leq 100 \text{ Hz}$ .

We set  $f_c = 100 \text{ Hz}$ . To select the order of the filter,

$$M(500) = B/A = 1/[1 + (f/f_c)^{2k}]^{0.5} = 1/[1 + (500 \text{ Hz}/100 \text{ Hz})^{2k}]^{0.5}$$

where the magnitude ratio is defined by the ratio of the output amplitude B to the input amplitude A. The quantization error is fixed at 0.01953 V. The output amplitude at 500 Hz depends on the input amplitude and  $M(500)$ , or  $B = MA$ . Solving for k in terms of input amplitude, A:

$$k = [2\log A + 5.597]/1.3979$$

A [V]	k
-------	---

0.02	2
------	---

0.10	3
------	---

1.00	4
------	---

10.00	6
-------	---

So if  $A = 1 \text{ V}$ , a two-stage filter will work; if  $A = 10 \text{ V}$ , six stages are needed.

## PROBLEM 7.38

KNOWN: Sensor-transducer: Thermocouple

Thermocouple measures  $50^\circ \leq T \leq 70^\circ \text{C}$  and the signal output is  $2.585 \leq E \leq 3.649 \text{ mV}$ .

Signal is digitized using an A/D converter:

$M = 12$ ;  $E_{FSR} = 10 \text{ V}$  (ie -5 to +5 V, bipolar);  $\text{SNR} = 40 \text{ dB}$

FIND: (a)  $e_Q/E$

(b) gain (G) required to reduce a to 5% or less

(c) estimate SNR in (b)

### SOLUTION

(a) The quantification error of an M-bit device is estimate by its uncertainty due to its resolution

$$e_Q = \pm \left( E_{FSR} / 2^M \right) / 2 = \pm (10\text{V} / 4096) / 2 = \pm 1.22 \text{ mV}$$

The relative quantification error would vary between

$$e_Q/E = 1.22 \text{ mV} / 2.585 \text{ mV} = \pm 0.472$$

or 47% at  $50^\circ\text{C}$ , to

$$e_Q/E = 1.22 \text{ mV} / 3.649 \text{ mV} = \pm 0.33$$

or 33% at  $70^\circ\text{C}$ . Both values are significantly large.

(b) One means to reduce this relative quantization error is through amplification of the analog signal prior to quantization. To achieve 5% or less error requires an input signal of the magnitude,

$$E = e_Q / 0.05 = 1.22 \text{ mV} / 0.05 = 24.40 \text{ mV}$$

At  $50^\circ\text{C}$  (the smallest voltage quantized), this requires a linear amplifier gain of

$$G = E_o/E_i = 24.40 \text{ mV} / 2.585 \text{ mV} = 9.44 \sim 10$$

Or roughly, use an amplifier having a linear gain of 10.

(c) Any signal is composed of a magnitude attributable to deterministic signal,  $E_s$  and a magnitude attributable to noise,  $E_n$ .

$$\text{SNR} = 20 \log E_s/E_n$$

With  $\text{SNR} = 40 \text{ dB}$ ,  $E_s = 100E_n$ .

#### COMMENT

During signal amplification, all information (within the frequency range of the amplifier) will be scaled by the gain of the amplifier. So the SNR based on the incoming signal and signal noise will not change. At the analog level, amplifying a signal will not affect the SNR. You need a combination of filters and amplifiers to help with that.

But amplification of the analog signal occurs before quantization. Quantization error is added during sampling. Quantization error will manifest itself as random noise on the sampled signal. In effect, it reduces the SNR.

We see in part (a) that the sampled signal will be masked by this large quantization error noise level. We see in part (b) that the signal level is raised to a level where it will not be masked by the quantization noise. So a benefit in amplification is realized as a reduction in the relative quantization error.

## PROBLEM 7.39

KNOWN: A/D Converter:  $M = 8$  or  $12$ ;  $E_{\text{FSR}} = 10 \text{ V}$ ;  $0 < f_s \leq 100 \text{ Hz}$

FIND: Specify  $M$ ,  $f_s$ , amplifier gain  $G$ , and filter (type,  $f_c$  and  $k$ ). Estimate  $e_Q$  and  $N\delta t$  expected for your choice.

### SOLUTION

*These design problems have an open-ended solution path. To demonstrate, one possible solution is presented for each case.*

(a)  $E(t) = 2\sin 20\pi t \text{ V}$

The input signal has an amplitude of  $A = 2 \text{ V}$  and a single frequency of  $f_1 = 10 \text{ Hz}$ . Accordingly, we will want

(1)  $f_s > 2f_m$  that is  $f_s > 20 \text{ Hz}$

(2)  $mf_1 = N\delta t \quad m = 1, 2, \dots$

to correctly reconstruct both signal frequency and amplitude in the time discrete series. If we set  $f_s = 40 \text{ Hz}$  so as to satisfy (1), we should sample the signal at data rates in multiples of 4, i.e. from (2)  $N = 4m$ ,  $m = 1, 2, \dots$ . The sample period,  $N\delta t$ , will then be consistent with (1) and (2).

The 12-bit A/D converter is chosen for its better resolution and, hence, lower quantization error:

$$Q = E_{\text{FSR}}/2^M = 10 \text{ V}/4096 = 2.44 \text{ mV}$$

$$e_Q/E = \pm 0.5Q/A = \pm 0.00122 \text{ V}/(2 \text{ V}) = \pm 0.0006$$

Because  $A = 2 \text{ V}$ , which fits within the  $\pm 5 \text{ V}$  range of the converter, AND because the relative quantization error is so small, no amplification is required.

An anti-alias filter is always required. A low-pass, LC Butterworth filter is selected for its flat bandpass characteristics. Set  $f_c = f_s/2 = 20 \text{ Hz}$ . The order of filter affects signal attenuation at  $f_1 = 10 \text{ Hz}$ . The dynamic error is

$$\delta(f) = M(f) - 1 = 1/[1 + (f/f_c)^{2k}]^{1/2} - 1$$

$k$	$M(10 \text{ Hz})$	$\delta(10 \text{ Hz})$ [%]	Attenuation [%]
2	0.971	- 2.99	2.99
3	0.992	- 0.8	0.8

Set  $k = 3$  to provide an attenuation due to the filter of less than 1% at 10 Hz.

(b)  $E(t) = 1.5\sin \pi t + 20\sin 32\pi t - 3\sin (60\pi t + \pi/4) \text{ V}$

The input signal contains amplitudes of  $A_1$ ,  $A_2$  and  $A_3$  with frequencies of  $f_1 = 0.5$ ,  $f_2 = 16$  and  $f_3 = 30$  Hz, respectively. The maximum frequency in the signal,  $f_m$ , is 30 Hz. The signal does not contain a single fundamental frequency. We need

(1)  $f_s > 2f_m$  or  $f > 60$  Hz

(2)  $mT = N\delta t$   $m = 1, 2, \dots$

Criterion (2) can be rewritten as  $m/f = N/f_s$ . In order to meet both criteria for this signal requires a minimum sample rate of  $f_s = 240$  Hz with  $N = 480$  (i.e.  $Nf/f_s = 1, 32$  and  $60$ , an exact integer multiple of each of the three frequencies, respectively). Alas, the A/D converter does not have such a capability! As one compromise, setting  $f_s = 80$  Hz with  $N = 160m$  will meet the criteria for both the  $f_1$  and  $f_2$  components, but not for  $f_3$ . We should expect leakage about  $f_3$  in the discrete time series representation. An alternative approach is to use trial and error on  $f_s$  and  $N$  until leakage is reduced to acceptable levels.

The 12-bit A/D converter is chosen for its better resolution.

$$Q = E_{FSR}/2^M = 10 \text{ V}/4096 = 2.44 \text{ mV}$$

Amplitude  $A_2$  will saturate the A/D converter. We choose a linear amplifier with a gain of  $G = 0.2$  to keep the signal well within range. The relative quantization error becomes:

$$e_Q/E = \pm 0.5Q/GA_i = \pm 0.00122 \text{ V}/GA_i$$

which, for values of  $A_1$ ,  $A_2$ , and  $A_3$ , results in an  $e_Q$  of 0.004, 0.0003, and 0.002 for the three respective frequencies. Because this is below 1%, a value that we judge sufficient, the amplifier gain seems appropriate.

An anti-alias filter is always required. A low-pass, LC Butterworth filter is selected for its flat bandpass characteristics. Set  $f_c = f_s/2 = 40$  Hz.

The order of filter affects signal attenuation at each  $f_i$ . The dynamic error is

$$\delta(f) = M(f) - 1 = 1/[1 + (f/f_c)^{2k}]^{1/2} - 1$$

k	M(0.5)	M(16)	M(30)	$\delta(30)$ [%]	Attenuation [%]
3	1	1	0.92	- 8	8
5	1	1	0.97	- 3	3
7	1	1	0.99	- 0.9	0.9

Set  $k = 7$  to keep attenuation below 1% at all frequencies (see COMMENT).

## COMMENT

A seven-stage ( $k = 7$ ) filter is a high order for a passive filter circuit, but it will meet these requirements. Note that the high  $k$  required results from the sample rate. If  $f_s$ , and then  $f_c$ , were increased, the attenuation criterion could be met with a lower order filter. Try it!

$$(c) P(t) = -10\sin 4\pi t + 5\sin 8\pi t \text{ psi}; \quad K = 0.4 \text{ V/psi}$$

The voltage signal sensed by the data acquisition system will be

$$E(t) = KP(t) = -4\sin 4\pi t + 2\sin 8\pi t \text{ V}$$

The input signal has amplitudes  $A_1 = 4 \text{ V}$  and  $A_2 = 2 \text{ V}$  with  $f_1 = 2 \text{ Hz}$  and  $f_2 = 2f_1$ , respectively. The maximum frequency is  $f_m = 4 \text{ Hz}$ . We want

- (1)  $f_s > 2f_m$  or  $f_s > 8 \text{ Hz}$
- (2)  $mT_1 = N\delta t$   $m = 1, 2, \dots$

Criterion (2) can be rewritten as  $m/f_1 = N/f_s$ . If  $f_s = 10 \text{ Hz}$ , then we should sample at data rates of  $N = 2m$ .

The 12-bit A/D converter is chosen for its better resolution and small relative quantization error:

$$Q = E_{\text{FSR}}/2^M = 10 \text{ V}/4096 = 2.44 \text{ mV}$$

$$e_Q/E = \pm 0.5Q/A_i = \pm 0.00122 \text{ V}/A_i$$

For  $A_1 = 4 \text{ V}$  and  $A_2 = 2 \text{ V}$ ,  $e_Q/E = \pm 0.0003$  and  $0.006$ , respectively. Because  $A_1$  and  $A_2$  fit within the  $\pm 5 \text{ V}$  range of the converter AND because the relative quantization error is so small, no amplification is required.

An anti-alias filter is always required. A low-pass, LC Butterworth filter is selected for its flat bandpass characteristics. Set  $f_c = f_s/2 = 5 \text{ Hz}$ .

The order of filter affects the attenuation. The dynamic error is

$$\delta(f) = M(f) - 1 = 1/[1 + (f/f_c)^{2k}]^{1/2} - 1$$

k	M(2)	M(4)	$\delta(4)$ [%]
1	0.98	0.78	- 22
5	1	0.95	- 5
7	1	0.98	- 2

We set  $k = 5$  to keep attenuation below 5%.

## COMMENT

One way to improve on this attenuation number without increasing the number of required filter stages is to choose a higher value for  $f_s$ . This enables selecting a higher  $f_c$ . For example, with  $f_s = 50$  Hz,  $N = 25m$ , we could set  $f_c = 25$  Hz requiring  $k = 1$  to reduce attenuation well below 1%.

## PROBLEM 7.40

KNOWN:  $y(t) = 4 \sin 2\pi f_1 t + 2 \sin 2\pi f_2 t + 3 \sin 2\pi f_3 t$   
 where  $f_1 = 4$  Hz,  $f_2 = 10$  Hz, and  $f_3 = 21$  Hz

FIND:  $N$  and effective sample rate

### SOLUTION

The signal frequency content is found by inspection. The maximum frequency is  $f_m = 21$  Hz. To meet the Sampling Theorem criterion we will want

$$f_s > 2f_m = 42 \text{ Hz}$$

To determine the sample size, the amplitude ambiguity criterion based on the fundamental period  $T_1$  is  $mT_1 = N\delta t$ . This will eliminate spectral leakage.

This signal has no fundamental period, so its lowest frequency is used.

For  $f_1 = 4$  Hz,

$T_1 = 1/4$  s. So,  $N = m/4\delta t$ .

For  $m = 1$  integer period:  $N = 1/4\delta t = f_s/4$ . Use some reasonable combination of these. For example, if we want  $N$  to be a multiple power of 2 (useful for many DFT algorithms), then try  $N = 256$  and this sets  $f_s = 64$  Hz. This combination meets both criteria. The resulting DFT is exact.

Alternatively, a good approximation of the signal can be had by following the rule to use an  $f_s > 5f_m$ . This yields,  $f_s > 5f_m > 105$  Hz. Any  $N$ ,  $f_s > 105$  Hz combination works. Here we try  $f_s = 110$  Hz and  $N = 256$ . Note the spectral leakage with amplitude degradation. Try  $f_s = 128$  Hz and  $N = 256$ !

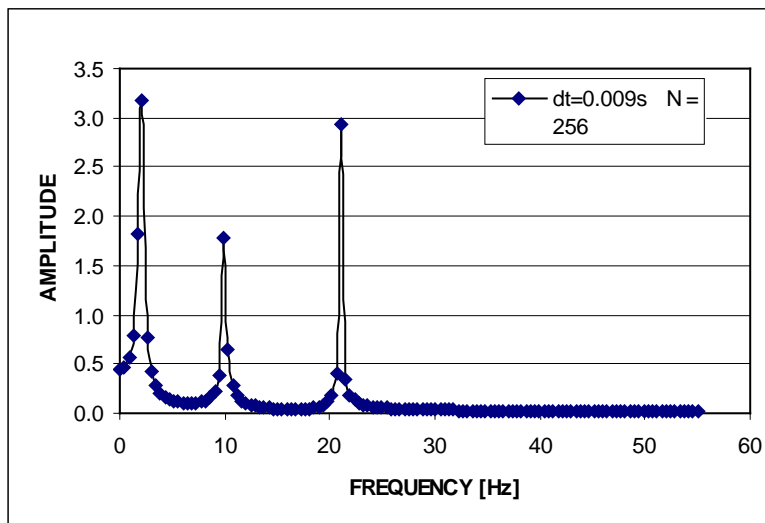
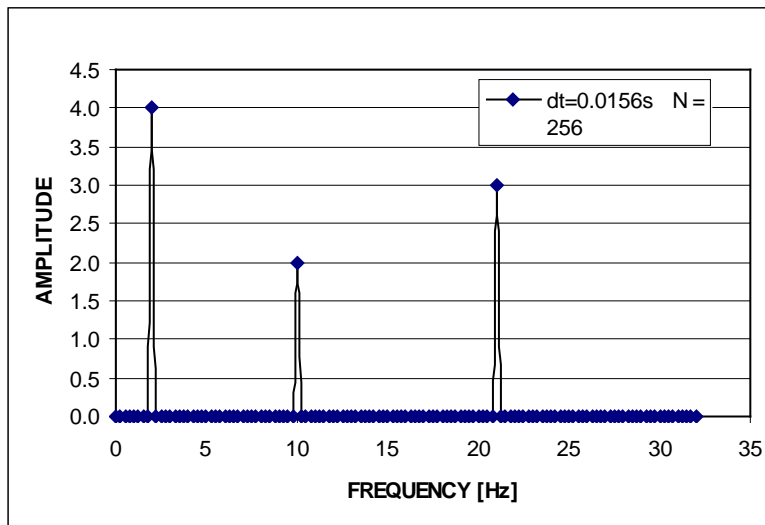

## PROBLEM 7.41

KNOWN: Transducers:  $\pm 1$  V output;  $\pm 25$  cm H<sub>2</sub>O input  
DAS:  $M = 10$ ;  $E_{\text{FSR}} = 10$  V; 4 MB memory; 10 min. battery life.  
 $T_1 = 0.5$  sec

FIND:  $N$ ,  $f_s$ ,  $f_c$ ,  $G$

### SOLUTION

The transducer sensitivity is:  $K = 2\text{V}/50 \text{ cm H}_2\text{O} = 0.04 \text{ V/cm H}_2\text{O}$ .

The A/D resolution is:  $Q = 10\text{V}/2^{10} = 0.00976 \text{ V}$ . This can be expressed as  $Q = 0.00976 \text{ V}/0.04 \text{ V/cm H}_2\text{O} = 0.244 \text{ cm H}_2\text{O/bit}$ .

Set  $G = 5$ . Although sensitivity already meets problem constraints, an analog amplifier between the transducer and the A/D with a gain of  $G = 5$  will take full advantage of the A/D range and improve resolution:

$$Q = 10\text{V}/(5)(2^{10}) = 0.00195 \text{ V} = 0.0488 \text{ cm H}_2\text{O/bit}.$$

So a full scale input on pressure ( $\pm 25 \text{ cm H}_2\text{O}$ ) corresponds to full scale to the A/D ( $\pm 5\text{V}$ ).

We are interested in mean values and signal dynamic frequency content at about  $f_1 = 1/T_1 = 2$  Hz. So any  $f_s > 4$  Hz with appropriate anti-alias filter will meet the Sampling criterion. Using the  $mT_1 = N/f_s$  criterion to minimize amplitude errors, we would try to set  $N = m(0.5)f_s$ , where  $m$  is an integer. At  $f_s = 20$  Hz, 12,000 samples will be taken per channel over a 10 minute period.

We should use an anti-alias filter set at  $f_c = f_s/2$ .

### COMMENT

You can always use higher sample rates. However, be aware that a higher sample rate means a larger data set to analyze. In many cases, this is fine but sometimes it becomes a real burden. In this example, an engineer at a race car track test might have 2 minutes to offer advice on car modifications before the next test run. Being smart during acquisition will help the engineer get the information faster (from analysis) so more time can be spent on decisions.

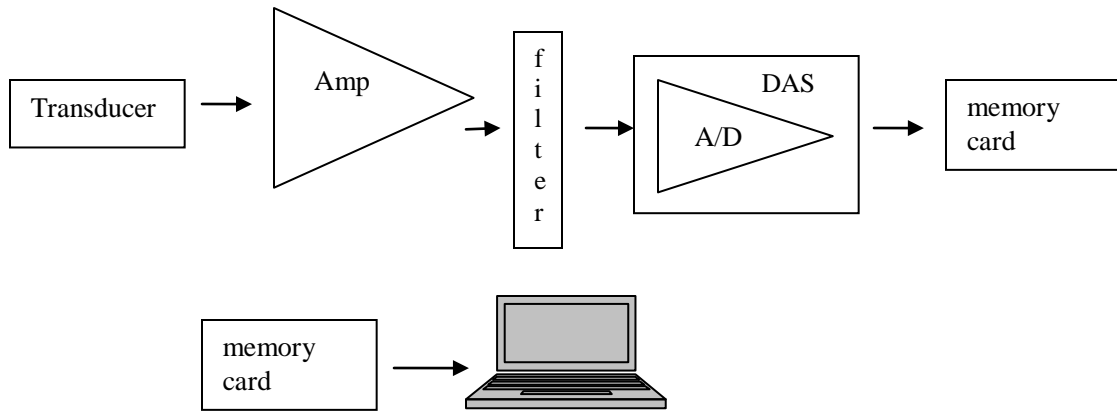

Lay-out for Problem 7.41.

## PROBLEM 7.42

KNOWN: Transducer in Problem 4.41 with accuracy of 0.25%  
Measurement (precision) uncertainty of 0.10 cm H<sub>2</sub>O noted

FIND:  $u_d$  at  $M = 10$  and  $M = 12$

### SOLUTION

The transducer sensitivity is:  $K = 2\text{V}/50 \text{ cm H}_2\text{O} = 0.04 \text{ V/cm H}_2\text{O}$

The A/D quantization uncertainty,  $u_o$ , is estimated by

$$(u_o)_{A/D} = 10\text{V}/2^{10} = 0.00976 \text{ V}$$

or in terms of pressure

$$(u_o)_{A/D} = (0.00976 \text{ V})/0.04 \text{ V/cm H}_2\text{O} = 0.244 \text{ cm H}_2\text{O}$$

This just meets the requirements.

A typical good quality A/D converter might have an overall accuracy to within 1 LSB. Using this value, the instrument error is

$$(u_e)_{A/D} = 0.244 \text{ cm H}_2\text{O}$$

The transducer has an instrument error of 0.25%. At full scale,

$$(u_e)_p = (0.0025)(25 \text{ cm H}_2\text{O}) = 0.0625 \text{ cm H}_2\text{O}$$

Then,

$$(u_d)_{\text{system}} = \pm [(0.244)^2 + (0.244)^2 + (0.0625)^2]^{1/2} = \pm 0.35 \text{ cm H}_2\text{O} \quad (95\%)$$

If we include the additional knowledge that the data scatter adds a random uncertainty of about 0.10 cm H<sub>2</sub>O, then this estimate becomes,

$$(u_d)_{\text{measurement}} = \pm [(0.35)^2 + (0.10)^2]^{1/2} = \pm 0.36 \text{ cm H}_2\text{O} \quad (95\%)$$

Note how the A/D converter qualities dominate the overall uncertainty. The random uncertainty from the measurement plays almost no role.

Improving the A/D converter to a 12-bit unit provides:

$$(u_0)_{A/D} = 0.061 \text{ cm H}_2\text{O}$$

Then, assuming an overall accuracy of 1 LSB,

$$(u_c)_{A/D} = 0.061 \text{ cm H}_2\text{O}$$

and

$$(u_d)_{\text{system}} = \pm 0.11 \text{ cm H}_2\text{O} \quad (95\%)$$

Now, the transducer and A/D converter contribute more equally to overall uncertainty while the uncertainty has been reduced notably.

Including the random uncertainty has an effect now, as

$$(u_d)_{\text{measurement}} = \pm 0.15 \text{ cm H}_2\text{O} \quad (95\%)$$

## PROBLEM 7.43

KNOWN: Set-up of Figure 7.17  
 $E_i = 3.333 \text{ V}$   
 $R_s = R_2 = R_3 = R_4 = 120 \Omega$   
 $R_{null} \approx 39 \text{ k}\Omega$

FIND: Offset null voltage,  $E_{null}$

### SOLUTION

The adjustable trim pot has a nominal value at  $39 \text{ k}\Omega$ . You adjust the value of the trim pot to achieve the desired nulling voltage required to provide a zero output when the strain gauge is not load (zero input). Consider the trim pot as the "fine tuning knob."

The offset null voltage available is found from

$$E_{null} = \pm \left[ \frac{E_i}{2} - \frac{E_i R_3 (R_{null} + R_s)}{R_{null} R_s + R_3 (R_{null} + R_s)} \right]$$

$$E_{null} = \pm \left[ \frac{3.333\text{V}}{2} - \frac{(3.333\text{V})(120\Omega)(39000\Omega + 120\Omega)}{(39000)(120) + 120\Omega(39000\Omega + 120\Omega)} \right]$$

$$= \pm 0.00256 \text{ V} = \pm 2.56 \text{ mV}$$

Notice how this value will change: (1) if you use a different excitation voltage, (2) use a different trim potentiometer resistance (often done by using a shunt resistor with the existing trim pot).

### COMMENT

The particular arrangement uses a single strain gauge sensor, known as a quarter-bridge arrangement (as opposed to two strain gauge sensors, called a half-bridge, and four strain gauge sensors, called a full-bridge).

The quarter-bridge sensor resistance is matched with a resistor of equal resistance, as indicated by fixed resistor  $R_3 = 120 \Omega$ .  $R_3$  is sometimes called the "completion resistor." Because the resistor resistance values around the bridge are nominal values (i.e., not exactly equal to  $120 \Omega$ ), the bridge will likely not be balanced at zero input conditions. Hence, a nulling voltage is used to subtract out any output voltage at zero input occurring due to slight differences in resistor values.

## PROBLEM 7.44

KNOWN: LC low-pass Butterworth filter  
 $f_c = 10 \text{ Hz}$   
 $M(f = 5 \text{ Hz}) \geq 0.95$   
 $M(f = 20 \text{ Hz}) \leq 0.10$   
 $R_s = R_L = 10\Omega$   
 FIND: Values for L, C and k

### SOLUTION

*This problem is an open-ended design and one possible solution follows.*

For a low-pass, Butterworth filter such as shown in Figure 6.31, we begin by fixing the cut-off frequency (known to be 10 Hz here) and then estimating the order (number of reactive stages) k needed to meet the constraints at 5Hz and 20 Hz. We end by specifying the C and L values. For the filter:

$$M(f) = 1/[1 + (f/f_c)^{2k}]^{1/2}$$

For  $f = 5 \text{ Hz}$ ,  $f/f_c = 0.5$ ; For  $f = 20 \text{ Hz}$ ,  $f/f_c = 2$

$$M(5\text{Hz}) = 0.95 = 1/[1 + (5/10)^{2k}]^{1/2}$$

This gives  $k = 1.6 \approx 2$ .

$$M(20\text{Hz}) = 0.10 = 1/[1 + (20/10)^{2k}]^{1/2}$$

This gives  $k = 3.3 \approx 4$ . Note: these equations can be manipulated to yield k directly as,

$$k = \frac{\log\left(\frac{1-M^2}{M^2}\right)}{2\log(f/f_c)}$$

So select the higher order filter to meet both constraints:  $k = 4$

A four-order filter has four reactive elements. To specify the capacitors and inductors, we refer to Table 6.1 with its scaling equations:

$$C = C_i \frac{1}{2\pi f_c R} \qquad L = L_i \frac{R}{2\pi f_c}$$

Hence, for a normalized value of  $R = 10\Omega$  and  $f_c = 10 \text{ Hz}$ , estimates for C and L yield:

$$\begin{array}{ll} C_1 = 1.218\mu\text{F} & C_3 = 2.94\mu\text{F} \\ L_2 = 0.294 \text{ H} & L_4 = 0.122 \text{ H} \end{array}$$

## PROBLEM 7.45

KNOWN: Second order LC low-pass Butterworth filter ( $k = 2$ )  
 $f_c = 100$  Hz

FIND: Attenuation at 10, 50, 75, 200, 400 Hz

ASSUMPTION: Input and output impedance are  $1\Omega$

### SOLUTION

For a Butterworth low pass filter, the magnitude ratio is given by:

$$M(f) = 1/[1 + (f/f_c)^{2k}]^{1/2}$$

In terms of decibels, this is  $\text{dB} = 20 \log M$ .

Attenuation =  $1 - M(f)$  or, in decibels,  $\text{Attenuation(dB)} = -20 \log M$

For  $f = 10$  Hz,  $f/f_c = 0.1$

f	f/f <sub>c</sub>	M	Attenuation
10	0.1	0.9998	0dB
50	0.5	0.970	0.26dB
75	0.75	0.872	0.6 dB
200	2	0.243	12.3 dB
400	4	0.0623	24 dB

## PROBLEM 7.46

Program *Leakage* allows the user to vary the sample rate and the sample number. It displays the original and sampled waveforms and their corresponding amplitude spectra.

Use *Leakage* as a tutorial surrounding the discussion of Figure 7.4.

## PROBLEM 7.47

Program *Aliasing* allows the user to vary the input frequency and the sample rate of a continuous signal. It displays the original and sampled waveforms and their corresponding amplitude spectra.

Use *Aliasing* as a tutorial to study the effect of sample rate on both the frequency content and the time domain waveform. Look closely at the amplitude information in the sampled signal. With this program, you can test the Sample Theorem and the Amplitude Ambiguity criteria directly.

## PROBLEM 7.48

Program *Aliasing* allows the user to vary the input frequency and the sample rate of a continuous signal. It displays the original and sampled waveforms and their corresponding amplitude spectra.

Use *Aliasing* as a tutorial to study the folding diagram (Figure 7.3).

$f_s = 10 \text{ Hz} \Rightarrow f_N = 5 \text{ Hz}$  5 Hz is displayed as the Nyquist frequency

So 5 Hz is the  $f_N$  folding point on the folding diagram

0 Hz is the other folding point and 0 Hz is always one of the folding points.

Moving the slider on the signal frequency shows:

$$f = 10 \text{ Hz} = 2f_N \Rightarrow f_a = 0 \text{ Hz}$$

$$f = 15 \text{ Hz} = 3f_N \Rightarrow f_a = 5 \text{ Hz}$$

$$f = 20 \text{ Hz} = 4f_N \Rightarrow f_a = 0 \text{ Hz}$$

$$f = 8 \text{ Hz} = 1.6 f_N \Rightarrow f_a = 2 \text{ Hz}$$

$$f = 11 \text{ Hz} = 2.1 f_N \Rightarrow f_a = 1 \text{ Hz}$$

$$f = 13 \text{ Hz} = 2.6 f_N \Rightarrow f_a = 3 \text{ Hz}$$

$$f = 16 \text{ Hz} = 3.2 f_N \Rightarrow f_a = 4 \text{ Hz}$$

## PROBLEM 7.49

Program *Signal* allows the user to vary the sample rate of a continuous signal (selected from a pull down menu). It displays the original and sampled waveforms and their corresponding amplitude spectra.

Use *Signal* as a tutorial to examine the effect of sample rate on both the time domain and frequency domain discrete representations of the original signal.

## PROBLEM 7.50

Program *Leakage* focuses on spectral leakage due to sampling. The user can select sample rate and the number of sampled points so as to control the sample period. In this way, both the length of the signal measured is controlled, as well as the spectral resolution  $\delta f$ .

As you vary sample rate and N, look at the waveform presented. This is the waveform measured. In particular, look at the last period measured. If it is a complete period, there will be no leakage, otherwise there will be some. Spectral leakage is eliminated when the dominant frequencies are

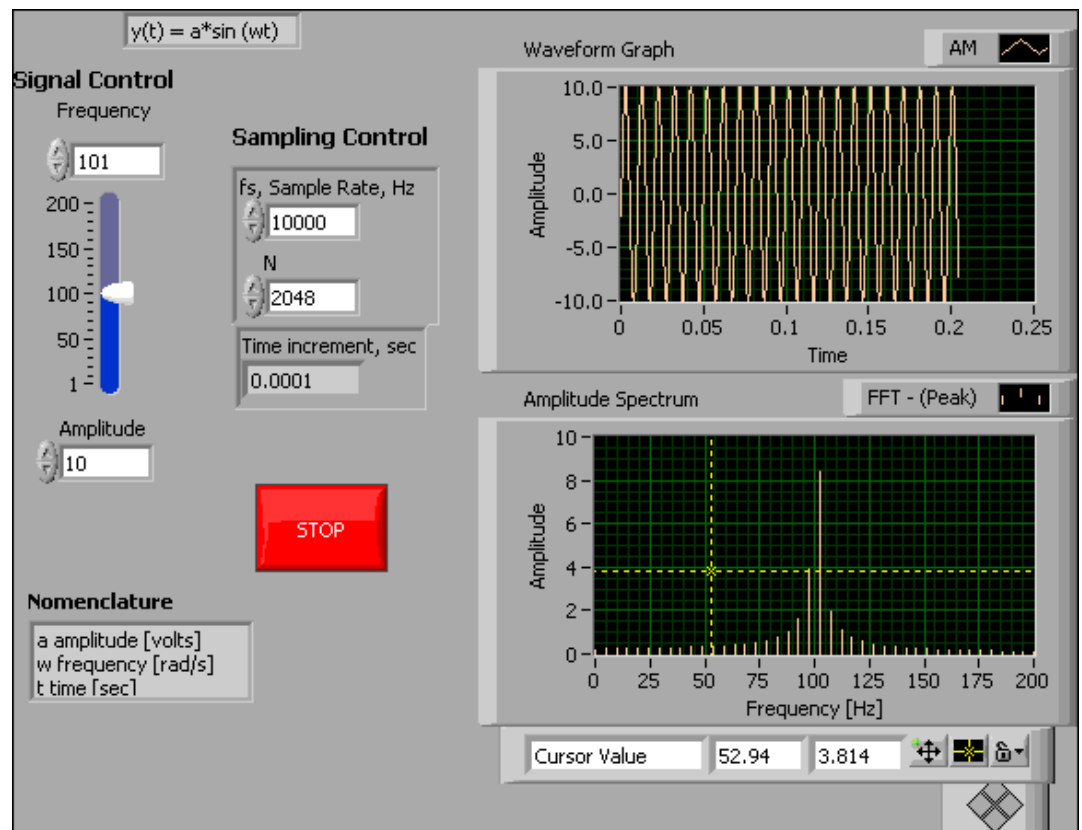

centered within the interval define by each  $\delta f$ . This is the basis for the amplitude ambiguity criterion. When a frequency is not centered within  $\delta f$ , some information spills out into adjacent intervals.

## PROBLEM 8.1

**KNOWN/FIND:** Define and discuss the significance of:

- a) temperature scale
- b) temperature standards
- c) fixed points
- d) interpolation

**SOLUTION:**

- a) temperature scale - an established relationship for assigning numerical values to measures of temperature. The absolute temperature scales are:
  - the Rankine scale, for U.S. customary units
  - the Kelvin scale, for SI units
- b) temperature standards - a formally adopted and recognized means for practical realization of temperature measurement. Standards provide a means for the measurement of temperature which can be reproduced and agrees with the thermodynamic definition of temperature.
- c) fixed points - identifiable and experimentally reproducible conditions which are associated with a certain temperature (numerical value). See Table 8.1.
- d) interpolation - a method for determining temperatures other than those defined by fixed points on a temperature scale. For the majority of applications, the interpolating instrument is a platinum RTD.

## PROBLEM 8.2

**KNOWN:** An apparatus to produce phase equilibrium points is required.

**FIND:** Describe the conditions necessary to establish phase equilibrium points. Identify the effects of elevation, weather and material purity.

### SOLUTION:

Other than the vapor-pressure-temperature points for helium and hydrogen, the fixed points for ITS-90 are freezing points, melting points or triple points.

**triple point** - The procedure for calibrating a thermometer at a triple point is:

1. completely freeze the sample (an appropriate mass of material) in a closed container
2. experimentally determine the energy required to melt the sample
3. re-freeze the sample
4. Add energy and record the thermometer output at 10, 20 40, 60, 70 and 80% melted. These readings should agree.

This procedure demonstrates that a container capable of preventing contamination of a sample of material, while allowing the removal and addition of energy, is required to establish the triple point for a material. Similar requirements are needed for melting/freezing points, with the notable exception that containers must generally be flexible, to accommodate thermal expansion. Representative values of measured temperatures agree to 0.1 mK.

A sample which is 99.9999% pure will produce measured temperatures over a phase change within 0.1 mK.

Weather and elevation should be eliminated through appropriate design of the experimental apparatus.

### PROBLEM 8.3

**KNOWN:** A length of platinum wire having:

length,  $l = 2$  m

diameter,  $D = 0.1$  cm

resistivity,  $\rho_e = 9.83 \times 10^{-6}$   $\Omega$ -cm

**FIND:** The resistance of the wire,  $R$

**SOLUTION:**

Since

$$R = \frac{\rho_e l}{A_c}$$

and

$$A_c = \frac{\pi}{4} D^2 = \frac{\pi}{4} (0.1)^2 = 0.0079 \text{ cm}^2$$

The resistance is found as

$$R = \frac{(9.83 \times 10^{-6})(2 \text{ m})(10^2 \text{ cm/m})}{0.0079 \text{ cm}^2} = 0.25 \Omega$$

**COMMENT:** An RTD would normally have a reasonably large resistance, on the order of 25  $\Omega$ . As such, a very small diameter wire or long length must be employed.

## PROBLEM 8.4

**KNOWN:** A Wheatstone bridge and RTD as shown in Figure 8.35, with

$$\alpha = 0.003925^{\circ}\text{C}^{-1}$$

$$R_o = 25 \Omega \text{ at } 0^{\circ}\text{C}$$

$$R_1 = 41.485 \Omega \text{ for balanced conditions}$$

**FIND:**

- The temperature of the RTD
- Compare the static sensitivity of this circuit to the circuit in Example 8.2

**SOLUTION:**

At balanced conditions

$$\frac{R_2}{R_3} = \frac{R_1}{R_4}$$

and when  $R_1 = 41.485 \Omega$

$$1 = \frac{41.485}{R_4} \Rightarrow R_4 = 41.485 \Omega$$

From

$$R = R_o [1 + \alpha(T - T_0)]$$

$$41.485 = 25[1 + 0.003925(T - 0)]$$

we find

$$T = \frac{\frac{41.485}{25} - 1}{0.003925} \text{ and } T = 168^{\circ}\text{C}$$

b) The static sensitivities are the same, since  $R = R_1 (R_3/R_2)$  and  $R_2 = R_3$  in both cases.

## PROBLEM 8.5

**KNOWN:** A thermistor has a resistance of  $20,000 \Omega$  at  $100^\circ\text{C}$ .

$$\begin{aligned}\beta &= 3650^\circ\text{C} \\ R_o &= 20,000 \Omega \\ R &= 500 \Omega\end{aligned}$$

**FIND:** The temperature corresponding to a thermistor resistance of  $500 \Omega$ .

**SOLUTION:**

From (8.11)

$$R = R_o e^{\beta \left( \frac{1}{T} - \frac{1}{T_o} \right)}$$

Letting  $R_o = 20,000 \Omega$

$$R = 500 = 20,000 e^{3650 \left( \frac{1}{T} - \frac{1}{373} \right)}$$

and

$$\ln 500 = \ln 20,000 + 3650 \left( \frac{1}{T} - \frac{1}{373} \right)$$

Solving for  $T$

$$T = 598.7 \text{ K} = 325.7^\circ\text{C}$$

## PROBLEM 8.6

**KNOWN:** The uncertainty in temperature  $u_T = \pm 0.005^\circ\text{C}$ .

**FIND:** Required uncertainty in measured resistance.

**ASSUMPTIONS:** Initially assume that we wish to find the required uncertainty in resistance measurement as if it were the only contributor to the total uncertainty. In addition, this problem is open-ended to some extent, in that some nominal value of  $R_o$  must be assumed, or a range of values for  $R_o$  examined.

**SOLUTION:**

With

$$R = R_o [1 + \alpha(T - T_o)]$$

and  $\alpha = 0.003925^\circ\text{C}^{-1}$ , we can express

$$u_T = \frac{\partial T}{\partial R} u_R$$

$$\text{Then } T = \frac{\left(\frac{R}{R_o} - 1\right)}{\alpha} + T_o$$

$$\frac{\partial T}{\partial R} = \frac{1}{\alpha R_o}$$

Taking  $R_o = 100 \Omega$

$$\frac{\partial T}{\partial R} = \frac{1}{(0.003925)(100)} = 2.55^\circ\text{C}/\Omega$$

and the uncertainty in resistance is

$$u_R = \pm 0.00196 \Omega$$

**COMMENT:** A parametric examination of the effect of the value of  $R_o$  on the uncertainty would contribute to the fundamental understanding of the measurement (see plot below). This is crucial at the design stage for a measurement system, and would provide information concerning the sensitivity of the design to  $R_o$ .

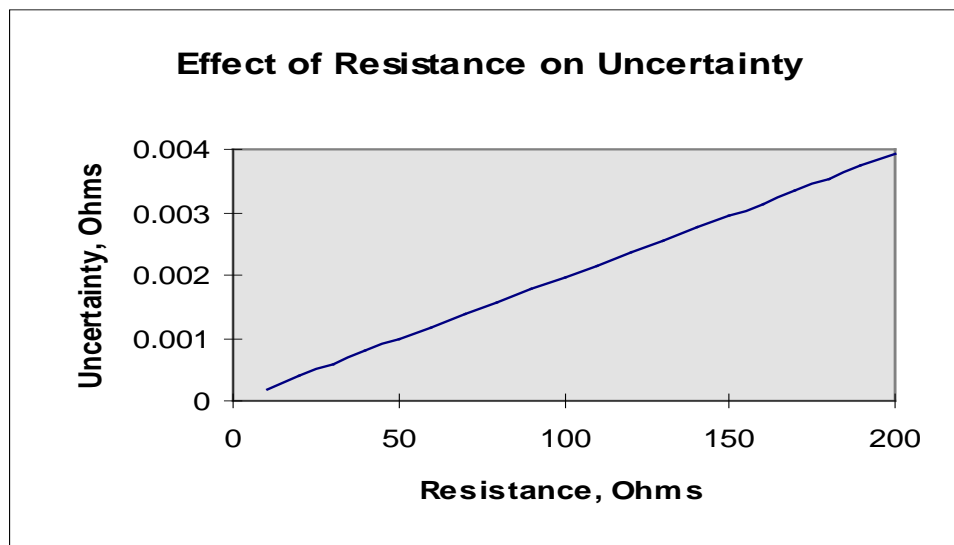

## PROBLEM 8.7

**KNOWN/FIND:** Define and discuss the following terms related to thermocouple circuits:

- a) thermocouple junction
- b) thermocouple laws
- c) reference junction
- d) Peltier effect
- e) Seebeck coefficient

### SOLUTION:

- a) thermocouple junction - electrical connection between two dissimilar metals which form a thermoelectric circuit.
- b) thermocouple laws - observed behavior of thermoelectric circuits which allow the measurement of temperature using thermocouple circuits.
- c) reference junction - an emf is present in a thermoelectric circuit having two junctions maintained at different temperatures. In order to measure temperature, one of the junctions must have a known temperature, and is called the reference junction.
- d) Peltier effect - this phenomenon results from the conversion of electrical to thermal energy at a junction.
- e) Seebeck coefficient - defines the relationship between temperature and emf for a thermocouple circuit.

## PROBLEM 8.8

**KNOWN:** For a J-type thermocouple, the measured emf at the potentiometer:  
emf = 13.777 mV, for a reference junction temperature of 0°C

**FIND:** Measuring junction temperature

**ASSUMPTIONS:** The J-type thermocouple is within NIST standards and Table 8.6 may be utilized.

**SOLUTION:**

From Table 8.6 with an emf = 13.777 mV and a reference junction temperature of 0°C the temperature is found as 254°C.

## PROBLEM 8.9

**KNOWN:** J-type thermocouple in Fig. 8.36 produces 15 mV for  $T_1 = 750^\circ\text{C}$

**FIND:**  $T_2$

**SOLUTION:**

The law of intermediate temperatures provides that

$$emf_{T_1} - emf_{T_2} = emf_{T_1 - T_2}$$

Referenced to 0°C, the emf corresponding to 750°C is 42.281 (Table 8.6)

Thus the reference junction temperature,  $T_2$ , has an emf, referenced to 0°C of 42.281-15 mV which yields 498°C.

## PROBLEM 8.10

### KNOWN:

T-type thermocouple in Fig. 8.36 produces 6 mV for  $T_1 = 200^\circ\text{C}$

### FIND:

$T_2$

### SOLUTION:

The law of intermediate temperatures provides that

$$emf_{T_1} - emf_{T_2} = emf_{T_1 - T_2}$$

Table 8.7 provides the reference function relating emf and temperature for a T-type thermocouple referenced to  $0^\circ\text{C}$ . We must solve the following polynomial for  $T_2$ :

$$6000 \mu\text{V} = \sum_{i=0}^n c_i T_1^i - \sum_{i=0}^n c_i T_2^i$$

This equation is most conveniently solved in a spreadsheet or higher-level mathematical software package. The value of  $T_2$  is  $78.46^\circ\text{C}$ .

## PROBLEM 8.11

### KNOWN:

- a) Thermocouple circuit of Fig. 8.37a yields an emf of 7.947 with  $T_{\text{ref}} = 0^\circ\text{C}$
- b)  $T_{\text{ref}} = 25^\circ\text{C}$
- c)  $T_{\text{ref}} = 0^\circ\text{C}$  with copper extension wires installed

**FIND:** The indicated temperature

**ASSUMPTIONS:** NIST standard thermocouple behavior

### SOLUTION:

a) from Table 8.6,  $T = 148.9^\circ\text{C}$

b) Knowing  $\text{emf}_1 + \text{emf}_2 = \text{emf}_3$

$$7.947 \text{ mV} = \text{emf}_{0-25} + \text{emf}_{25-148.9}$$

with  $\text{emf}_{0-25} = 1.277 \text{ mV}$  yields 6.67 mV for the output.

c)  $148.9^\circ\text{C}$

## PROBLEM 8.12

**KNOWN:** A J-type thermocouple referenced to 70°F.  
output emf = 2.878 mV with  $T_{\text{ref}} = 70^\circ\text{F}$ .

**FIND:** The temperature of the measuring junction

**ASSUMPTIONS:** NIST Standard Behavior

**SOLUTION:**

To utilize Table 8.6, convert °F to °C

$$70^\circ\text{F} = 21.1^\circ\text{C}$$

and employing the Law of Intermediate Temperatures

$$\text{emf}_{0-21.1} = 1.076 \text{ mV}$$

$$\text{emf}_{0-T} = 1.076 + 2.878 = 3.954 \text{ mV}$$

and

$$T = 75.7^\circ\text{C}$$

## PROBLEM 8.13

**KNOWN:** A J-type thermocouple referenced to 0°C;  
output emf = 4.115 mV

**FIND:** The temperature of the measuring junction

**ASSUMPTIONS:** NIST Standard Behavior

**SOLUTION:** From Table 8.6 at an emf of 4.115 mV

$$T = 78.7^\circ\text{C}$$

## PROBLEM 8.14

**KNOWN:** An uncertainty level  $u_T = 2^\circ\text{C}$  at  $200^\circ\text{C}$  is required for a temperature measurement using a T-type thermocouple. The readout device used for this temperature measurement has:

accuracy:  $\pm 0.5^\circ\text{C}$  ( $e_1$ )

resolution:  $\pm 0.1^\circ\text{C}$  ( $e_2$ )

**FIND:** Determine if the uncertainty constraint is met.

**ASSUMPTIONS:** NIST Behavior

**SOLUTION:**

The elemental errors associated with the indicator (output stage) may be combined as

$$\sqrt{e_1^2 + e_2^2} = \sqrt{0.5^2 + 0.05^2} = \pm 0.503^\circ\text{C}$$

This is the uncertainty that would result if the thermocouple exactly followed NIST Standard Behavior. The uncertainty due to variations from the NIST Standard is found from Table 8.5 as  $\pm 1.0^\circ\text{C}$  or  $\pm 0.75\%$ , whichever is larger. This yields  $\pm 1.5^\circ\text{C}$ , and

$$u_T = \sqrt{1.5^2 + 0.503^2} = \pm 1.58^\circ\text{C}$$

Yes, the uncertainty constraint is met.

## PROBLEM 8.15

**KNOWN:** Thermocouple arrangement shown in Figure 8.21 with

- $N = 3$
- J-type thermocouples
- all junctions sense  $3^\circ\text{C}$  temperature difference
- Maximum variation from NIST - 0.8%
- Voltage measurement uncertainty  $\pm 0.0005 \text{ V}$

**FIND:**

- a) thermopile output for an average junction temperature of  $80^\circ\text{C}$
- b) the design stage uncertainty in measured temperature

**SOLUTION:**

The thermopile output will be 3 times that for 1 thermocouple sensing  $\Delta T = 3^\circ\text{C}$  at  $80^\circ\text{C}$  (approximated from Table 8.6)

$$\frac{\partial emf}{\partial T} = 0.053 \text{ mV } ^\circ\text{C}^{-1}$$

The output is then

$$3 \times (3^\circ\text{C}) \times (0.053 \text{ mV}/^\circ\text{C}) = 0.477 \text{ mV}$$

b) First find the uncertainty in temperature which results from the uncertainty in the voltage measurement

$$u_T = \left( \frac{\partial T}{\partial emf} \right) u_{emf}$$

But  $\frac{\partial T}{\partial emf}$  is the slope of the emf vs T curve at  $80^\circ\text{C}$  for the thermopile. For a single thermocouple, this slope is  $1/0.053$ . For the thermopile, this slope is  $1/[3(0.053)]$  or  $0.053 \text{ mV}/^\circ\text{C}$ . This yields

$$u_T = \left( \frac{1^\circ\text{C}}{0.053 \text{ mV}} \right) (0.05 \text{ mV}) = \pm 3.1^\circ\text{C}$$

and there is a contribution due to the variation of the thermocouple from NIST standards, which is related to the uncertainty in the slope of the curve shown below

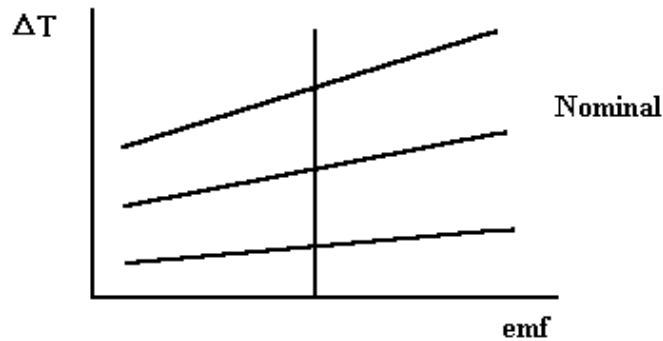

At  $\Delta T = 3^{\circ}\text{C}$ , the uncertainty in temperature based on the  $\pm 0.8\%$  yields  $\pm 0.024^{\circ}\text{C}$ ,

in the  $\Delta T$ . Thus the resulting uncertainty is given by

$$u_T = \sqrt{0.024^2 + 3.1^2} = \pm 3.1^{\circ}\text{C}$$

#### COMMENT:

The value of  $\partial emf / \partial T$  is relatively insensitive to temperature; for example, at  $400^{\circ}\text{C}$  the value is  $0.055 \text{ mV}/^{\circ}\text{C}$ . The uncertainty in voltage of  $\pm 0.5 \text{ mV}$  is unacceptable for most temperature measurements, since the resulting uncertainty is higher than the measured  $\Delta T$ . However, if the number of junctions increased to 10, the resulting uncertainty would be  $\pm 0.94^{\circ}\text{C}$ , which may be acceptable in many cases.

## PROBLEM 8.16

**KNOWN:** Values of temperature and emf for a given reference temperature

**FIND:** Complete the table of values

**ASSUMPTIONS:** NIST Standard Behavior

**SOLUTION:**

Temperature [ $^{\circ}\text{C}$ ]

<b>Measured</b>	<b>Reference</b>	<b>emf [mV]</b>
100	0	<u>5.269</u>
<u>-10</u>	0	-0.501
100	50	<u>2.684</u>
<u>96.6</u>	50	2.5

## PROBLEM 8.17

**KNOWN:** A thermopile having

4 junctions ( $N = 4$ )

$$T_{\text{ref}} = 0^\circ\text{C}$$

$$T = 125^\circ\text{C}$$

$$u_{\text{emf}} = \pm 0.0001 \text{ V} = \pm 0.1 \text{ mV}$$

**FIND:**

- a) emf
- b)  $N$  for an uncertainty of  $\pm 0.1 \text{ C}$

**ASSUMPTIONS:** NIST Standard Behavior  
J-type thermocouple

**SOLUTION:**

- a) for a single thermocouple

$$\text{emf}_1 = 6.634 \text{ mV}$$

Thus for the thermopile the output would be

$$4(6.634 \text{ mV}) = 26.536 \text{ mV}$$

- b) The static sensitivity of the thermocouple at  $125^\circ\text{C}$  is approximately  $0.055 \text{ mV}/^\circ\text{C}$  and

$$u_T = \left( \frac{\partial T}{\partial \text{emf}} \right) u_{\text{emf}}$$

Thus

$$0.1^\circ\text{C} = \frac{1}{N(0.055)} ^\circ\text{C}/\text{mV} (0.0001 \times 10^3 \text{ mV})$$

$$N = 18.2 \text{ or } 19$$

## PROBLEM 8.18

**KNOWN:** A bimetallic thermometer serves as the sensing element in a thermostat for a residential heating/cooling system.

### **FIND:**

Considerations for

- a) location for the installation of the thermostat
- b) effect of the thermal capacitance of the thermostat
- c) thermostats are often set  $5^{\circ}\text{C}$  higher in the air conditioning season

**ASSUMPTIONS:** Goal is to measure the air temperature inside the house

**SOLUTION:** Answers should address the following

1. Location should be on an inside wall to minimize conduction errors
2. Location should not be exposed to direct solar radiation, to prevent radiation errors
3. Location should not be in the direct flow from the HVAC system
4. The thermal capacitance of the bimetallic thermometer typically yields a time constant much shorter than required to regulate room temperature
5. Thermostats are typically set  $5^{\circ}\text{C}$  higher in summer primarily to save energy, but also to accommodate seasonal lifestyle changes.

## PROBLEM 8.19

**KNOWN:** A J-type thermocouple is to be used at temperatures between 0 and 100°C. A single calibration point is available, at the steam point. Barometric pressure is 30.1 in. Hg, and the measured emf = 5.310 mV

**FIND:** Develop a calibration curve for this thermocouple

**ASSUMPTIONS:**  $(\text{emf}_{\text{ref}} - \text{emf}_{\text{meas}})$  is linear from 0°C to 100°C

**SOLUTION:**

First, determine the steam point temperature for this barometric pressure

$$T_{st} = 212 + 50.422\left(\frac{30.1}{29.921} - 1\right) - 20.95\left(\frac{30.1}{29.921} - 1\right)^2$$

which yields  $T_{st} = 212.30^\circ\text{F} = 100.17^\circ\text{C}$

A calibration curve can be plotted with the dependent variable as  $(\text{emf}_{\text{ref}} - \text{emf}_{\text{meas}})$  where

$\text{emf}_{\text{ref}}^f$  = NIST standard emf value (mV)

$\text{emf}_{\text{meas}}^f$  = measured output from thermocouple (mV)

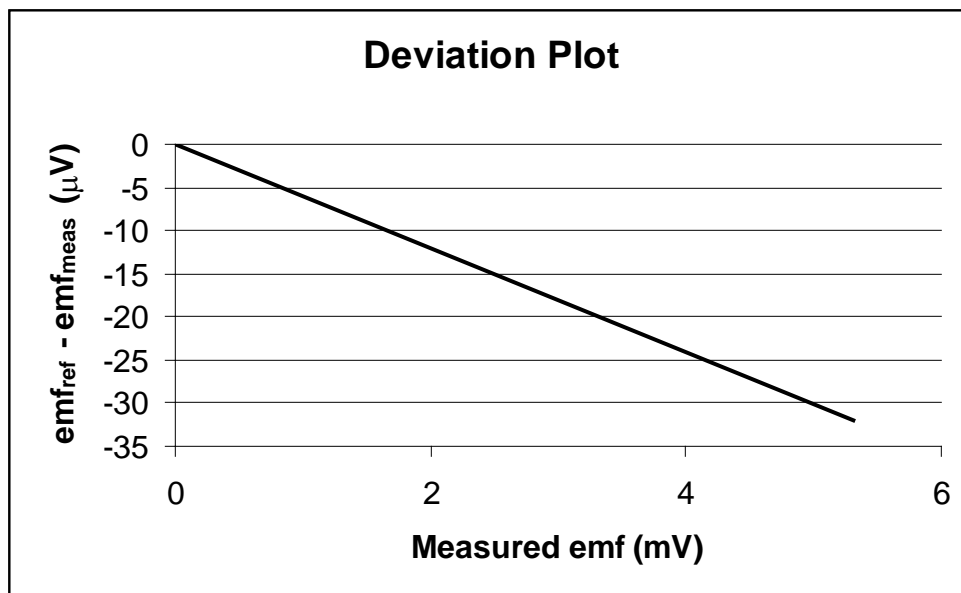

In this case, from Table 8.6

$$\text{emf}_{\text{ref}} = 5.278 \text{ mV}$$

and we have a single data point at  $T = 100.17^\circ\text{C}$  where  $(\text{emf}_{\text{ref}} - \text{emf}_{\text{meas}}) = -0.032 \text{ mV}$

A second calibration point is known, since, at  $0^\circ\text{C}$   $\text{emf}_{\text{meas}} = 0$ . Assuming linear behavior for the error between these two points yields the calibration curve shown above. The curve is used to correct a measured emf to an equivalent NIST standard thermocouple output.

b) (Note: part b of this problem requires using some judgement in setting uncertainty levels for various contributions to uncertainty)

One contribution to the uncertainty would result from the measured barometric pressure (at the design stage)

$$u_T = \left( \frac{\partial T}{\partial P} \right) u_P$$

Assume  $u_P = \pm 0.05 \text{ in. Hg}$  and from

$$T_{st} = 212 + 50.422 \left( \frac{P}{P_o} - 1 \right) - 20.95 \left( \frac{P}{P_o} - 1 \right)^2$$

$$\frac{\partial T_{st}}{\partial P} = \frac{50.422}{P_o} - \frac{2(20.95)}{P_o} \left( \frac{P}{P_o} - 1 \right)$$

at  $30.1 \text{ in. Hg}$

$$\frac{\partial T_{st}}{\partial P} = 1.677^\circ\text{F/in.Hg} = 0.93^\circ\text{C/in. Hg}$$

The contribution to uncertainty would be

$$u_T = (0.93^\circ\text{C / in. Hg})(0.05 \text{ in. Hg}) = \pm 0.047^\circ\text{C}$$

Some estimate of the uncertainty due to the assumed behavior of  $\text{emf}_{\text{ref}} - \text{emf}_{\text{meas}}$  must be made. A reasonable estimate may be to take 1/4 of the maximum deviation,  $32 \mu\text{V}$ , and assign this value of uncertainty at the midpoint of the calibration range, such that in this case at  $2.5 \text{ mV}$  the uncertainty would be

$$\pm 8 \mu\text{V}$$

yielding an uncertainty in temperature of  $\pm 0.00044^\circ\text{C}$

### COMMENT:

Without additional measured data points, a reasonable estimate of the deviation from the assumed linear behavior for  $\text{emf}_{\text{ref}} - \text{emf}_{\text{meas}}$  yields an uncertainty estimate. Engineering judgement is required in applying this estimate for decisions in interpreting measured data or in measurement system design or selection.

## PROBLEM 8.20

**KNOWN:** A J-type thermocouple is calibrated against an RTD, yielding calibration data over a range from 0°C to 100°C. The uncertainty in determining temperature using the RTD is  $\pm 0.01^\circ\text{C}$  over the range 0 to 200°C

**FIND:**

- a) a polynomial to relate temperature and emf
- b) the uncertainty in a measured temperature using the system as calibrated
- c) the uncertainty in measured temperature using a specified indicator

**ASSUMPTIONS:** The calibration polynomial curve will be employed in data reduction

**SOLUTION:**

First, second, and third order polynomials for this data are

$$y = 0.34058 + 18.833x$$

$$y = 0.10989 + 19.157x - 0.06075x^2$$

$$y = -0.079403 + 19.926x - 0.45169x^2 + 0.048639x^3$$

Choice of an appropriate polynomial can be made for a particular application, depending upon the required uncertainty level. The standard error of the fit for the third order polynomial is 0.34, and for the fourth order is 0.46.

b) Error contributions are

$$\text{RTD} - \pm 0.01^\circ\text{C}$$

$$\text{Potentiometer} - \sqrt{0.001^2 + 0.015^2} = \pm 0.015 \text{ mV}$$

which is equivalent to a temperature uncertainty of

$$0.015 \text{ mV} \left( \frac{1}{0.055 \text{ mV}/^\circ\text{C}} \right) = \pm 0.27^\circ\text{C}$$

and the value of  $s_e$  taken to be 0.34, yielding

$$u_T = \sqrt{0.01^2 + 0.27^2 + 0.34^2} = \pm 0.43^\circ\text{C}$$

c) The readout uncertainty can be substituted for the potentiometer value and

$$u_T = \sqrt{0.01^2 + 0.32^2 + 0.34^2} = \pm 0.47^\circ\text{C}$$

## PROBLEM 8.21

**KNOWN:** A thermocouple is placed in a moving gas stream with

$$U = 200 \text{ ft/sec} \quad c_p = 0.6 \text{ Btu/lb}_m \text{ R}$$

$$h = 30 \text{ Btu/hr-ft}^2\text{-R} \quad T_s = 1200 \text{ R}$$

$$T_p = 1400 \text{ R} \quad r = 0.22$$

$$F = 1 \quad \varepsilon = 1$$

**FIND:** a)  $T_\infty$

b)  $e_r$

**SOLUTION:**

a) the static temperature of the gas may be found from (8.37)

$$T_\infty = T_p - \frac{rU^2}{2g_c c_p}$$

which yields

$$\begin{aligned} T_\infty &= 1400 - \frac{(0.22)(200)^2}{2(32.174)(0.6)(778)} \\ &= 1400 \text{ R} - 0.293 \text{ R} = 1399.78 \text{ R} \end{aligned}$$

b) The radiation error may be found from (8.30)

$$hA_s(T_\infty - T_p) = FA_s \varepsilon \sigma (T_p^4 - T_s^4)$$

$$(30 \text{ Btu/hr ft}^2 \text{ R})(T_\infty - T_p) = 0.1714 \times 10^{-8} \frac{\text{Btu}}{\text{hr ft}^2 \text{ R}^4} (1400^4 - 1200^4) \text{ R}^4$$

$$T_\infty = 1501.0 \text{ R}$$

$$e_r = -101 \text{ R}$$

## PROBLEM 8.22

**KNOWN:** The static temperature of air outside an aircraft is to be measured.

$$U = 300 \text{ mph} = 438.3 \text{ ft/sec}$$

$$\text{Altitude} = 20,000 \text{ ft}$$

$$r = 0.75$$

$$c_p = 0.24 \text{ Btu/lb}_m\text{-R}$$

$$T_\infty = 413 \text{ R}$$

$$\rho_{\text{air}} = 0.0442 \text{ lb}_m/\text{ft}^3$$

**FIND:**  $T_p$

**SOLUTION:**

From (8.36)

$$\begin{aligned} T_p &= T_\infty + \frac{rU^2}{2g_c c_p} \\ &= 413 + \frac{0.75(438.3^2) \text{ ft}^2/\text{sec}^2}{2 \left( 32.174 \frac{\text{ft}\cdot\text{lb}_m}{\text{lb}\cdot\text{sec}^2} \right) \left( 0.24 \frac{\text{Btu}}{\text{lb}_m\text{R}} \right) \left( 778 \frac{\text{ft}\cdot\text{lb}}{\text{Btu}} \right)} \end{aligned}$$

which yields

$$T_p = 425 \text{ R}$$

## PROBLEM 8.23

**KNOWN:** A sheathed thermocouple, as shown in Figure 8.38.

**FIND:** An estimate of the upper limit for conduction error for such a probe.

**SOLUTION:** From (8.27)

$$e_c = \frac{T_w - T_\infty}{\cosh mL}$$

where

$$mL = \sqrt{hP/kA} L$$

For immersion depth as a parameter, an estimate of the conduction error requires a model of the effective thermal conductivity of the thermocouple probe. A conservative estimate for many constructions could be an average of the thermocouple, sheath and insulating materials. Consider the following values:

$$\begin{aligned} k_{\text{constantan}} &= 23 \text{ W/m-K} \\ k_{\text{stainless}} &= 15 \text{ W/m-K} \\ k_{\text{insul}} &= 0.05 \text{ W/m-K} \end{aligned}$$

Averaging these values yields 12.7 W/m-K. Considering the thermocouple probe to be cylindrical in shape,

$$mL = \sqrt{\frac{4h}{k_{\text{eff}} D}} L$$

For a probe having a diameter of 0.25 cm and an immersion length of 5 cm, the conduction error is plotted as a function of  $h$  in the figure below.

### Conduction Error

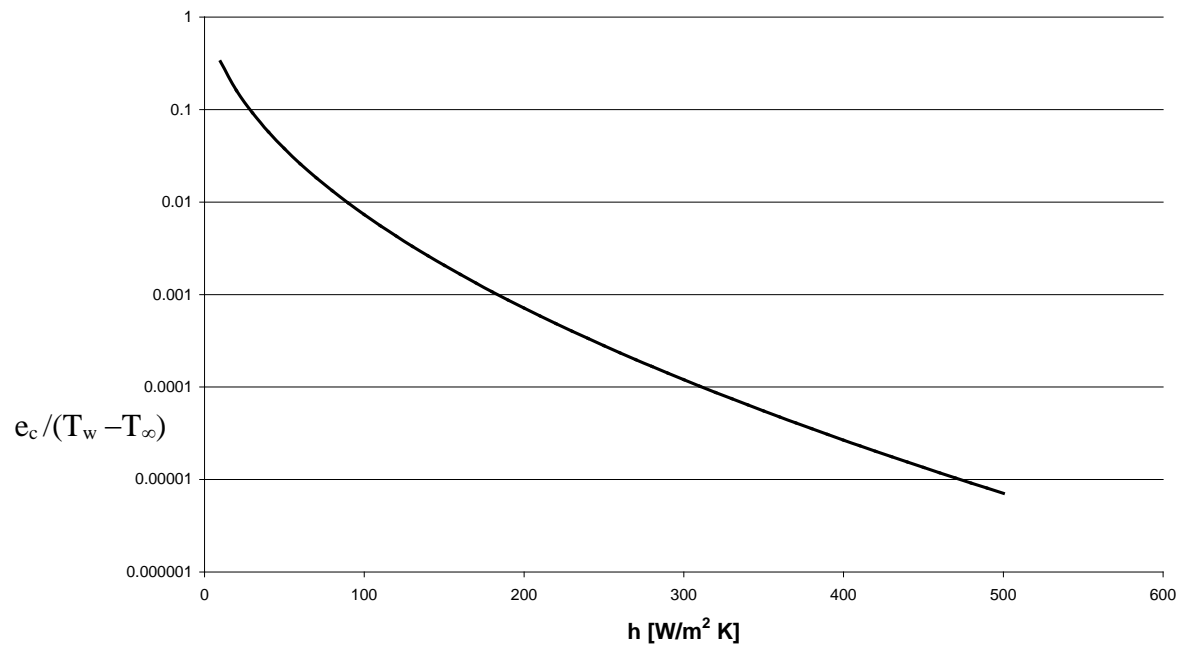

## PROBLEM 8.24

**KNOWN:** An iron-constantan thermocouple is placed in a moving gas stream (as shown in Figure 8.39)

$$T_{ref} = 100^\circ\text{C} \quad T_w = 260^\circ\text{C}$$

$$h = 70 \text{ Btu/hr}\cdot\text{ft}^2\cdot^\circ\text{F} \quad V = 200 \text{ ft/sec}$$

$$\text{emf} = 14.143 \text{ mV} \quad r = 0.7$$

$$c_p = 0.24 \text{ Btu/lb}_m \cdot ^\circ\text{F} \quad \varepsilon = 0.25$$

**FIND:**

a)  $T_p$

b)  $e_r$  and  $e_u$

**ASSUMPTIONS:** Radiation and velocity errors are additive

**SOLUTION:**

a) From Table 8.6,  $T_p = 355.8^\circ\text{C}$

b) The velocity error is given by

$$e_u = T_p - T_\infty = \frac{rU^2}{2g_c c_p} = \frac{0.7(200)^2}{2(32.174)(0.24)(778)} = 2.33 \text{ R}$$

and the radiation error by

$$e_r = T_p - T_\infty = \frac{\varepsilon\sigma}{h}(T_w^4 - T_p^4) = \frac{0.25(0.1714 \times 10^{-8})}{70}(960^4 - 1132.4^4) = -4.87 \text{ R}$$

The total error is then estimated as

$$e = e_u + e_r = 2.33 + (-4.87) = -2.54 \text{ R} = -1.4^\circ\text{C}$$

## PROBLEM 8.25

**KNOWN:**  $E_i = 1.564 \text{ V}$  At  $125^\circ\text{C}$ , from example 8.5,  $B_{RT} = 247 \ \Omega$

**FIND:** Show that  $B_{RT} = 247 \ \Omega$ , and determine the values of  $B_{RT}$  at  $150$  and  $100^\circ\text{C}$

**SOLUTION:**

Since

$$B_{R_T} = \sqrt{\left[\frac{\partial R_T}{\partial R_1}(B)_{R_1}\right]^2 + \left[\frac{\partial R_T}{\partial E_i}(B)_{E_i}\right]^2 + \left[\frac{\partial R_T}{\partial E_1}(B)_{E_1}\right]^2}$$

and

$$(B)_{R_1} = \pm 1.96 \text{ k}\Omega \quad (B)_{E_i} = \pm 1.96 \text{ k}\Omega$$

The sensitivity indices are functions of temperature with

$$R_T = R_1 \left( \frac{E_i}{E_1} - 1 \right)$$

and

Sensitivity Indices	100°C	125°C	150°C
$\frac{\partial R_T}{\partial R_1} = \left( \frac{E_i}{E_1} - 1 \right)$	0.042	0.022	0.012
$\frac{\partial R_T}{\partial E_i} = \frac{R_1}{E_1}$	86942	85238	84466
$\frac{\partial R_T}{\partial E_1} = -\frac{R_1 E_i}{E_1^2}$	90591	87076	85505

This yields values of  $B_{RT}$  of

T (°C)	$B_{RT}$ (Ω)
100	264
125	247
150	241

## PROBLEM 8.26

**KNOWN:** A thermocouple circuit emf is measured by a potentiometer having limits of error as

0.05% of reading + 15  $\mu\text{V}$  at 25°C  
and a resolution of 5  $\mu\text{V}$ .

The connecting block temperature is  $21.5 \pm 0.2^\circ\text{C}$   
and the potentiometer junctions are  $25 \pm 0.2^\circ\text{C}$ .

**FIND:**  $T_1$

**SOLUTION:**

The error sources for the potentiometer may be combined,

$$u_{emf} = \sqrt{\left(\frac{0.05}{100} 9000 \times 15\right)^2 + 2.5^2}$$

$$u_{emf} = \pm 19.66 \mu\text{V} = \pm 0.020 \text{ mV}$$

Then since

$$u_T = \left(\frac{\partial T}{\partial emf}\right) u_{emf}$$

and the sensitivity of the thermocouple is 0.055 mV/°C (from Table 8.6)

$$u_T = \left(\frac{1^\circ\text{C}}{0.055 \text{ mV}}\right) (0.020 \text{ mV}) = \pm 0.366^\circ\text{C}$$

The contribution from the uncertainty in the reference junction at the potentiometer is  $\pm 0.2^\circ\text{C}$ , and the limits of error on the thermocouple are  $\pm 2.2^\circ\text{C}$ . Thus the total uncertainty in temperature is

$$u_T = \sqrt{(0.366)^2 + (0.2)^2 + (2.2)^2} = \pm 2.24^\circ\text{C}$$

The emf referenced to 0°C would be

$$emf_{0-T} = 9\text{mV} + 1.096 \text{ mV} = 10.096 \text{ mV}$$

yielding

$$T = 187.7 + 2.24^\circ\text{C}.$$

## PROBLEM 8.27

**KNOWN:** A concentration of salt of 600 ppm in tap water will cause a  $0.05^{\circ}\text{C}$  change in the freezing point.

**FIND:** Error in ice bath temperature having 1500 ppm of salt.

**SOLUTION:**

Consider two error sources for this ice bath,

1. Salt  $\pm 0.125^{\circ}\text{C}$
2. Local temperature variations  $\pm 0.05^{\circ}\text{C}$

The resulting design stage uncertainty may be found as

$$u_T = \sqrt{(0.125)^2 + (0.05)^2} = \pm 0.135^{\circ}\text{C}$$

$$T = 0 \pm 0.135^{\circ}\text{C}$$

## PROBLEM 8.28

**KNOWN:** An RTD is to be calibrated; the RTD forms one leg of a Wheatstone bridge, and has

$$\alpha = 0.00392^\circ \text{C}^{-1} \pm 1 \times 10^{-5} (95\%)$$

$$u_R = \pm 0.001 \Omega (95\%)$$

At balanced conditions with  $T = 0^\circ\text{C}$ ,  $R_c = 100.000 \Omega$  and at  $100^\circ\text{C}$ ,  $R_c = 139.200 \Omega$ .

**FIND:**  $R_{RTD}$  at  $0^\circ\text{C}$  and  $100^\circ\text{C}$ , and the uncertainty at the design stage at these temperatures

**SOLUTION:**

At balanced conditions

$$\frac{R_{RTD}}{R_a} = \frac{R_c}{R_b}$$

Thus

$$R_{RTD} = R_c$$

$$\text{at } 0^\circ\text{C } R_{RTD} = 100.000 \Omega$$

$$\text{at } 100^\circ\text{C } R_{RTD} = 139.200 \Omega$$

Expressing the relationship between temperature and resistance as

$$T = \frac{1}{\alpha} \left( \frac{R_{RTD}}{R_o} - 1 \right) + T_o$$

the uncertainty at the design stage may be expressed, with  $\gamma = \frac{R_{RTD}}{R_o}$

$$u_T = \left[ \left( \frac{\partial T}{\partial \alpha} u_\alpha \right)^2 + \left( \frac{\partial T}{\partial \gamma} u_\gamma \right)^2 \right]^{\frac{1}{2}}$$

The sensitivities are found as

$$\frac{\partial T}{\partial \alpha} = \frac{1 - \gamma}{\alpha^2} = \left( \frac{1 - 3}{0.00392^2} \right) = -130154^\circ \text{C}^2$$

$$\frac{\partial T}{\partial \gamma} = \frac{1}{\alpha} = 255^\circ \text{C}$$

at  $R_c = 300 \Omega$   $R_{RTD} = R_c$  which implies  $R_{RTD} = 300 \Omega$ ,  $R_o = 100 \Omega$   $\gamma = 3$

We must estimate the uncertainty in  $\gamma$ . Since

$$R_{RTD} = \frac{R_a}{R_b} R_c$$

with  $u_R = \pm 0.001 \Omega$

$$u_{R_{RTD}} = (3 \times 0.001) = \pm 0.003 \Omega$$

and

$$\begin{aligned} u_\gamma &= \left[ \left( \frac{1}{R_o} u_{R_{RTD}} \right)^2 + \left( \frac{-R_{RTD}}{R_o^2} u_{R_o} \right)^2 \right]^{\frac{1}{2}} \\ &= \left[ \left( \frac{1}{100} 0.003 \right)^2 + \left( \frac{-300}{100^2} 0.001 \right)^2 \right]^{\frac{1}{2}} = \pm 0.0055 \end{aligned}$$

yielding

$$u_T = \left[ \left( -130154 \times 10^{-5} \right)^2 + \left( 255 \times 0.0055 \right)^2 \right]^{\frac{1}{2}} = \pm 1.91^\circ \text{C}$$

## PROBLEM 8.29

**KNOWN:** A T-type thermopile is used to measure the temperature difference to establish heat flux across an insulation. The pertinent variables and their values are:

$$\begin{aligned} A_c &= 15 \text{ m}^2 & k &= 0.4 \text{ W/m-K} \\ L &= 0.25 \text{ m} & \Delta T &= 5^\circ\text{C} \end{aligned}$$

The uncertainty in the measured emf is  $\pm 0.04$  mV.

**FIND:** The number of junctions in the thermopile to yield an uncertainty level of 5% in the heat flux across the insulation.

**ASSUMPTIONS:** NIST standard emf versus temperature relationship, and an average temperature in the insulation of  $40^\circ\text{C}$ .

### SOLUTION:

The heat flux is expressed as

$$Q = kA_c \frac{\Delta T}{L}$$

For the purposes of the present analysis, express the uncertainty in  $Q$  as a percentage, yielding

$$\frac{u_Q}{Q} = \frac{u_{\Delta T}}{\Delta T}$$

To determine the uncertainty in  $\Delta T$ , the sensitivity to the uncertainty in emf must be determined. From the equation in Table 8.7, the value can be determined using

$$\frac{dE}{dT} = c_1 + c_2T + c_3T^2 + c_4T^3 + c_5T^4 + c_6T^5 + c_7T^6 + c_8T^7$$

This expression yields a value of  $0.042 \text{ mV}/^\circ\text{C}$ . Thus

$$u_{\Delta T} = \frac{1}{N(0.042)} u_{emf}$$

where

$$u_{emf} = \pm 0.04 \text{ mV}$$

Then with

$$\frac{u_{\Delta T}}{\Delta T} = 5\% = \frac{1}{5N}$$

which yields  $N = 4$

### PROBLEM 8.30

**KNOWN:** A T-type thermocouple referenced to 0°C is used to measure 100°C

**FIND:** The output emf.

**ASSUMPTIONS:** NIST standard emf versus temperature relationship.

**SOLUTION:**

From Table 8.7, the polynomial expression for emf as a function of temperature yields an emf of 4.2785 mV at 100°C.

### PROBLEM 8.31

**KNOWN:** A T-type thermocouple referenced to 0°C has an output of 1.2 mV.

**FIND:** The temperature of the measuring junction.

**ASSUMPTIONS:** NIST standard emf versus temperature relationship.

**SOLUTION:**

From Table 8.7, the polynomial expression for emf as a function of temperature yields an temperature of 30.086°C for an emf of 1200  $\mu$ V.

## PROBLEM 8.32

**KNOWN:** A T-type thermocouple and voltmeter form a temperature measuring system. The temperature at the voltmeter is 25°C, and the output emf is 10 mV.

**FIND:** The temperature of the measuring junction.

**SOLUTION:**

The law of intermediate temperatures allows the following superposition to be used to establish an equivalent emf referenced to 0°C.

$$\text{emf}_{25-T} + \text{emf}_{0-25} = \text{emf}_{0-T}$$

From Table 8.7, the polynomial equation for  $E = f(T)$  yields

$$\text{emf}_{0-25} = 992 \mu\text{V}$$

and

$$\text{emf}_{0-T} = 992 + 10,000 = 10,992 \mu\text{V}$$

which yields for  $T$ , from Table 8.7, a value of 231.542°C.

**COMMENT:** A calculator or mathematical analysis software is essential to solve for a temperature from the polynomial expression in Table 8.7. NIST publications are also available that contain tables of emf as a function of temperature for a variety of thermocouple types.



## PROBLEM 9.1

**FIND:** Convert to units of gauge pressure in  $\text{N/m}^2$

### SOLUTION

Absolute pressure reference scale:

$$1 \text{ atm abs} = 14.69 \text{ psia} = 101.325 \text{ kPa abs} = 101,325 \text{ N/m}^2 \text{ abs}$$

$$1 \text{ atm abs} = 760 \text{ mm Hg abs} = 406 \text{ in H}_2\text{O abs}$$

Conversion factors:

$$14.69 \text{ psi} = 101.325 \text{ kPa} = 101,325 \text{ N/m}^2$$

$$14.69 \text{ psi} = 1 \text{ atm} = 29.92 \text{ in Hg} = 406 \text{ in H}_2\text{O} = 760 \text{ mm Hg}$$

$$1 \text{ bar} = 14.505 \text{ lb/in}^2 = 100,000 \text{ N/m}^2$$

$$p(\text{gauge}) = p(\text{absolute}) - p(\text{reference})$$

Using  $p(\text{reference}) = 101,325 \text{ N/m}^2$  :

$$\begin{aligned} \text{(a)} \quad & 10.8 \text{ psia} \times 101325 \text{ N/m}^2 / 14.69 \text{ psi} = 74\,442 \text{ N/m}^2 \text{ abs} \\ & p = 74,442 - 101,325 \text{ N/m}^2 = -26,883 \text{ N/m}^2 = -26.883 \text{ kPa} \end{aligned}$$

$$\begin{aligned} \text{(b)} \quad & 1.75 \text{ bars abs} \times 100,000 \text{ N/m}^2 = 175,000 \text{ N/m}^2 \text{ abs} \\ & p = 175,000 - 101,325 \text{ N/m}^2 = 73,675 \text{ N/m}^2 = 73.675 \text{ kPa} \end{aligned}$$

$$\begin{aligned} \text{(c)} \quad & 30.36 \text{ in H}_2\text{O abs} \times 101,325 \text{ N/m}^2 / 406 \text{ in H}_2\text{O} = 7,577 \text{ N/m}^2 \text{ abs} \\ & p = 7,577 - 101,325 \text{ N/m}^2 = -93,748 \text{ N/m}^2 = -93.748 \text{ kPa} \end{aligned}$$

$$\begin{aligned} \text{(d)} \quad & 791 \text{ mm Hg abs} \times 101,325 \text{ N/m}^2 / 760 \text{ mm Hg} = 105,458 \text{ N/m}^2 \text{ abs} \\ & p = 105,458 - 101,325 \text{ N/m}^2 = 4,133 \text{ N/m}^2 = 4.133 \text{ kPa} \end{aligned}$$

### COMMENT

Note that gauge pressure can be negative or positive relative to the reference pressure. Absolute pressure, which is measured relative to a perfect vacuum, is always a positive value.

## PROBLEM 9.2

**FIND:** Convert into absolute pressure

### SOLUTION

$$p(\text{absolute}) = p(\text{gauge}) + p(\text{reference}) \quad \text{where here: } p(\text{reference}) = 1 \text{ atm abs.}$$

Absolute pressure reference scale:

$$1 \text{ atm abs} = 14.69 \text{ psia} = 101.325 \text{ kPa abs} = 101,325 \text{ N/m}^2 \text{ abs}$$

$$1 \text{ atm abs} = 760 \text{ mm Hg abs} = 406 \text{ in H}_2\text{O abs}$$

Conversion factors:

$$14.69 \text{ psi} = 101.325 \text{ kPa} = 101,325 \text{ N/m}^2$$

$$14.69 \text{ psi} = 1 \text{ atm} = 29.92 \text{ in Hg} = 406 \text{ in H}_2\text{O} = 760 \text{ mm Hg}$$

$$(a) -0.55 \text{ psi} + 14.69 \text{ psia} = 14.14 \text{ psia} = 0.963 \text{ atm abs}$$

$$(b) 100 \text{ mm Hg} + 760 \text{ mm Hg abs} = 860 \text{ mm Hg abs} = 1.13 \text{ atm abs}$$

$$(c) 98.6 \text{ kPa} + 101.325 \text{ kPa abs} = 199.925 \text{ kPa abs} = 1.97 \text{ atm abs}$$

$$(d) 7.62 \text{ cm H}_2\text{O} + 760 \text{ mm H}_2\text{O abs} = 836.2 \text{ mm H}_2\text{O abs} = 1.10 \text{ atm abs}$$

## PROBLEM 9.3

**KNOWN:**  $H = 250 \text{ cm H}_2\text{O}$   
 $p_{\text{atm}} = 101.3 \text{ kPa abs}$

**FIND:** The tank pressure  $p_1$ .

**PROPERTIES:**  $\gamma_{\text{H}_2\text{O}} = 997 \text{ kg/m}^3$

### SOLUTION

Referring to Figure 9.5 (manometer)

$$p_1 - p_2 = p_1 - p_{\text{atm}}$$

$$p_1 = p_{\text{atm}} + \gamma_{\text{H}_2\text{O}} H$$

$$\begin{aligned} &= 101,325 \text{ N/m}^2 \text{ abs} + (997 \text{ kg/m}^3)(250\text{cm})(1\text{m}/100\text{cm})(1\text{N}/\text{kg}\cdot\text{m}/\text{s}^2) \\ &= 103,818 \text{ N/m}^2 \text{ abs} \end{aligned}$$

or

$$= 0 \text{ N/m}^2 + (997 \text{ kg/m}^3)(250\text{cm})(1\text{m}/100\text{cm})(1\text{N}/\text{kg}\cdot\text{m}/\text{s}^2) = 2493 \text{ N/m}^2$$

## PROBLEM 9.4

**KNOWN:** Deadweight tester provides a calibration pressure,  $p_c$   
 Tester:

$$\begin{aligned}
 W &= 25.3 \text{ kg}_f = 2.58 \text{ N} \quad (\text{where } g_c = 9.8 \text{ kg}\cdot\text{m}/\text{s}^2/\text{kg}_f) \\
 A_p &= 5.065 \text{ cm}^2 \\
 W_p &= 5.38 \text{ kg}_f \\
 p_{\text{amb}} &= 770 \text{ mm Hg abs} = 102.104 \text{ kPa abs} \\
 z &= 20 \text{ m (sea level datum)} \\
 \phi &= 42^\circ
 \end{aligned}$$

**FIND:**  $p_c$

**PROPERTIES:**  $\gamma_{\text{air}} = 9.8 \text{ N}/\text{m}^3$   
 $\gamma_{\text{stainsteel}} = \gamma_{\text{mass}} = 78.4 \text{ kN}/\text{m}^3$

### SOLUTION

Referring to the free-body diagram,

$$\Sigma F_y = 0 = p_i A_p + F_B - W_p - W - p_{\text{amb}} A_p$$

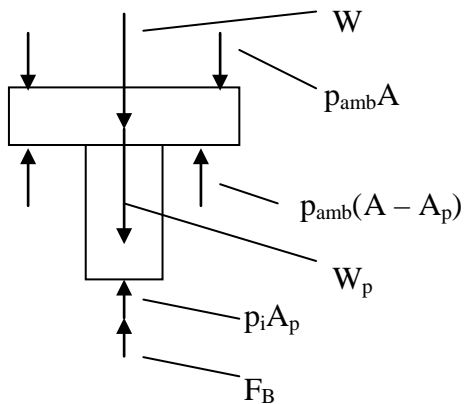

where  $F_B$  is the buoyancy force. Neglecting  $F_B$ , the indicated pressure is

$$p_i = 122,313 \text{ N}/\text{m}^2 \text{ abs}$$

Now, the actual pressure provided by the deadweight tester is estimated by

$$p_c = p_i(1 + e_1 + e_2)$$

where  $e_1$  provides a correction for altitude effects and  $e_2$  provides the correction for the neglected buoyancy effects. From (9.6a),

$$e_1 = - 0.0003$$

and from (9.9),

$$e_2 = - \gamma_{\text{air}}/\gamma_{\text{masses}} = -(9.8 \text{ N/m}^3 / 78,000\text{N/m}^3) = - 0.00012$$

Then, the actual deadweight pressure is estimated by

$$p_c = 122,313 \text{ N/m}^2 (1 - 0.0003 - 0.00012) = 122,262 \text{ N/m}^2 \text{ abs} = 122.262 \text{ kPa abs}$$

## COMMENT

By including the correction factors  $e_1$  and  $e_2$ , we corrected for a known systematic error, thus reducing the uncertainty error sources of this measurement. The error corrections do not eliminate these systematic errors but do reduce them to the level of uncertainty in the corrections themselves.

## PROBLEM 9.5

KNOWN: Inclined tube manometer

$$\Delta L = 5.6 \text{ cm H}_2\text{O}$$

$$\theta = 30^\circ$$

FIND:  $\Delta H$

SOLUTION

Referring to Figure 9.7, for an inclined manometer,

$$\Delta H = \Delta L \sin \theta$$

Further, this deflection away from a null balance condition is referenced to the pressure on the open end of the tube. So the device measures a gauge (referenced to local atmosphere pressure) or differential pressure (referenced to some other pressure).

$$\Delta H = 5.6 \text{ cm H}_2\text{O} \times \sin 30^\circ$$

$$= 2.8 \text{ cm H}_2\text{O}$$

COMMENT

Referring to Figure 9.7, if the manometer fluid deflects towards the tank, the pressure applied to the tank is below the reference pressure ( $p_2 < p_1$ ). If the deflection is away from the tank, the pressure applied to the tank is above the reference pressure ( $p_2 > p_1$ ).

## PROBLEM 9.6

FIND: Compare  $K$  for inclined and U-tube manometers.

SOLUTION

For a U-tube manometer,  $H$  is the measured output,

$$\Delta p = (\gamma_m - \gamma)H \text{ so}$$

$$K = dH/d(\Delta p) = 1/(\gamma_m - \gamma)$$

For an inclined manometer,  $H = L \sin \theta$  where  $L$  is the measured output.

$$\Delta p = (\gamma_m - \gamma)L \sin \theta \quad \text{so}$$

$$K = dL/d\Delta p = 1/[(\gamma_m - \gamma) \sin \theta]$$

## PROBLEM 9.7

KNOWN: Inclined manometer measures air using mercury as its fluid.

$$\theta = 30^\circ$$

FIND:  $K$

SOLUTION

For an inclined manometer, where  $L$  is the measured output

$$\Delta p = (\gamma_m - \gamma)H = (\gamma_m - \gamma)L \sin \theta$$

the sensitivity is

$$K = dL/d\Delta p = 1/[(\gamma_m - \gamma) \sin \theta]$$

$$= 1/\{[(13.6)(9800 \text{ N/m}^3) - 11 \text{ N/m}^3]\sin 30^\circ\} = 0.015 \text{ mm/N/m}^2$$

## PROBLEM 9.8

KNOWN: Conditions of Example 9.2.  
 $\theta \rightarrow 90^\circ$

FIND:  $u_{d_p}$

SOLUTION

From Example 9.2:

$$u_{d_p} = \pm \left[ \left( u_{\gamma_m} L \sin \theta \right)^2 + \left( u_L (\gamma_m - \gamma) \sin \theta \right)^2 + \left( u_\theta L (\gamma_m - \gamma) \cos \theta \right)^2 \right]^{1/2}$$

For a U-tube manometer at the stated conditions,  $L \approx 10.25 \text{ mm}$  and  $\theta = 90^\circ$ .  
Then with  $\gamma_m = 9770 \text{ N/m}^3$ ;  $\gamma = 11.5 \text{ N/m}^3$ ;  $u_{\gamma_m} = 49 \text{ N/m}^3$ ;  $u_L = 0.0007 \text{ m}$

$$u_{d_p} = \pm \left[ 0.5^2 + 6.8^2 + 0^2 \right]^{1/2} = \pm 6.82 \text{ N/m}^2$$

COMMENT

The uncertainty in measured pressure increases nearly 50% by going from an inclined manometer with  $\theta = 30^\circ$  (Example 9.2) to a U-tube manometer ( $\theta = 90^\circ$ ) when operating at these pressures.

## PROBLEM 9.9

KNOWN: Steel diaphragm

$$t = 0.1 \text{ in}$$

$$E_m = 30 \times 10^6 \text{ psi}$$

$$d = 2r = 0.75 \text{ in}$$

$$\rho = 0.28 \text{ lb}_m/\text{in}^3$$

$$\nu_p = 0.32$$

FIND:  $y_{\max}$ ,  $\omega_n$ ,  $\Delta p_{\max}$

SOLUTION

The maximum elastic deflection of a metallic diaphragm is about one third of the diaphragm thickness,

$$y_{\max} \sim t/3 = 0.033 \text{ in} = 0.85 \text{ mm}$$

The natural frequency can be computed directly

$$\begin{aligned} \omega_n &= 64.15 \sqrt{\frac{E_m t^2 g_c}{12(1-\nu_p^2)\rho r^4}} = 64.15 \sqrt{\frac{(30 \times 10^6 \text{ lb/in}^2)(0.1 \text{ in})^2 (32.2 \text{ lb}_m - \text{ft/s}^2 - \text{lb})(12 \text{ in/ft})}{12(1-0.32^2)(0.28 \text{ lb}_m/\text{in}^3)(0.375 \text{ in})^4}} \\ &= 2.8 \times 10^6 \text{ rad/s} \quad \text{or } 450 \text{ kHz.} \end{aligned}$$

The maximum differential pressure which can be applied across a diaphragm is limited in

part by  $y_{\max}$ . With  $y_{\max} = \frac{3(p_1 - p_2)(1 - \nu_p^2)r^4}{16E_m t^3}$  and  $y_{\max} = t/3$  gives

$$\begin{aligned} \Delta p_{\max} &= \frac{16(30 \times 10^6 \text{ lb/in}^2)(0.1 \text{ in})^4}{9(1-0.32^2)(0.375 \text{ in})^4} \\ &= 300,460 \text{ psi} = 2.07 \text{ GPa} \end{aligned}$$

COMMENT

These relatively high numbers are due to the relatively thick and small diameter steel diaphragm used. The numbers are not unusual for high pressure diaphragm transducers. Some transducers on the market permit the user to interchange diaphragms of different thicknesses to change the maximum pressure differential range allowed. This is a cost saving feature for the user.

## PROBLEM 9.10

**KNOWN:** Strain gauge, diaphragm transducer with  $\Delta p = 10, 100, 1000$  kPa

Transducer:

Accuracy: within 0.1% of reading (i.e.  $u_{\Delta p}/\Delta p = 0.001$ )

Voltmeter:

Resolution: 10 mV

Accuracy: within 0.1% reading

**FIND:**  $u_d$  in indicated pressure

**ASSUMPTIONS:** Transducer:  $K_t = 1$  V/100 kPa ; Voltmeter:  $K_E = 1$  V/V

### SOLUTION

Based on the assumptions for static sensitivity (you can assume any reasonable value), the output voltage should be:

$E_o = 1$  V @ 100 kPa,  $0.1$  V @ 10 kPa, and  $10$  V @ 1000 kPa

To estimate uncertainty:

Transducer:

$$u_{\Delta p} = 0.001 \Delta p$$

Voltmeter: (Note the inclusion of  $K_E$  for scaling and units below)

$$u_E = [u_o^2 + u_c^2]^{1/2} = [(0.005)^2 + (0.001K_E E)^2]^{1/2}$$

System: (Note the inclusion of  $K_t$  for scaling and units; that is, puts in terms of kPa)

$$u_d = \pm [u_{\Delta p}^2 + (u_E/K_t)^2]^{1/2}$$

With  $K_t = 1$  V/100kPa and  $K_E = 1$  V/V,

$\Delta p$ [kPa]	$E_o$ [V]	$u_E$ [V]	$u_d$ [kPa]
10	0.1	0.005	0.010
100	1.0	0.005	0.100
1000	10.0	0.011	1.0

## PROBLEM 9.11

**KNOWN:** U-tube manometer is used to measure gas pressure.

$$p_{\text{gas}} \leq 68,950 \text{ Pa}$$

Several manometric fluids available: oil, water, mercury

**FIND:** Choose an appropriate manometric fluid.

**PROPERTIES:** water:  $S = 1$ ;  $\gamma_{\text{H}_2\text{O}} = 9790 \text{ N/m}^3$  (given)  
mercury:  $S = 13.57$  (given);  $\gamma_{\text{Hg}} = S\gamma_{\text{H}_2\text{O}}$   
oil:  $S = 0.82$  (given);  $\gamma_{\text{oil}} = S\gamma_{\text{H}_2\text{O}}$   
gas:  $\gamma_{\text{gas}} = 10.4 \text{ N/m}^3$

**ASSUMPTIONS:** Specific weight of a gas is negligible relative to that of the manometer fluids.

### SOLUTION

To select an appropriate fluid, we must consider at least two things. (1) The manometric fluid should not be soluble with the working fluid, and (2) the manometer deflection should be of a reasonable magnitude. Neglecting the effects of the gases, the relation between pressure and manometer fluid deflection is given by,

$$p - p_{\text{atm}} = \Delta p = \gamma H$$

Water:

$$H = \Delta p / \gamma = (68950 \text{ N/m}^2) / 9790 \text{ N/m}^2 = 7.1 \text{ m} \quad (\text{that's high!})$$

Oil:

$$H = \Delta p / \gamma = (68950 \text{ N/m}^2) / (0.82 \times 9790 \text{ N/m}^2) = 8.6 \text{ m} \quad (\text{that's high, too!})$$

Mercury:

$$H = \Delta p / \gamma = (68950 \text{ N/m}^2) / (13.57 \times 9790 \text{ N/m}^2) = 0.52 \text{ m} \quad (\text{that's more like it!})$$

While sensitivity considerations will always favor the lighter fluid, the logistics of this application clearly suggest that mercury will be a workable choice.

## PROBLEM 9.12

KNOWN: Air pressure to be measured using either a mercury filled U-tube manometer or inclined tube manometer.

$$200 \leq p \leq 400 \text{ N/m}^2$$

$$T = 20^\circ\text{C}$$

U-tube Manometer:

Resolution: 1 mm; Zero error: 0.5 mm

Inclined-tube manometer

Resolution: 1 mm; Zero error: 0.5 mm;

Inclination angle:  $30^\circ \pm 0.5^\circ$

FIND:  $u_d$  in equivalent head pressure measured by either manometer

PROPERTIES: mercury:  $S = 13.57$ ; water:  $\rho = 9780 \text{ N/m}^3$

### SOLUTION

U-tube manometer:

Because the measured deflection is the equivalent head pressure, the uncertainty in equivalent head pressure at the design-stage will be due only to the ability to measure the deflection at a given pressure.

$$u_d = \pm(u_o^2 + u_c^2)^{1/2}$$

If we assume that  $u_c$  is based only on the zero pressure error uncertainty given,

$$u_o = 0.5 \text{ mm} \quad u_c = 0.5 \text{ mm}$$

$$u_d = \pm (0.5^2 + 0.5^2)^{1/2} = \pm 0.71 \text{ mm} \quad (95\%)$$

This result is independent of pressure.

Inclined-tube manometer

The equivalent head pressure is related to the manometer deflection by,

$$H = L \sin \theta$$

where  $L$  is the measured deflection. We can estimate  $L$ :

$$L = H / \sin \theta = \Delta p / \gamma \sin \theta$$

At  $200 \text{ N/m}^2$ ,  $L = 41 \text{ mm}$ . At  $400 \text{ N/m}^2$ ,  $L = 82 \text{ mm}$ .

For the inclined manometer, the uncertainty in the manometer deflection,  $L$ , at the design stage is

$$u_{d_L} = \pm [u_o^2 + u_c^2]^{1/2} = \pm [0.5^2 + 0.5^2]^{1/2} = \pm 0.71 \text{ mm}$$

where  $u_o = 0.5 \text{ mm}$  and  $u_c = 0.5 \text{ mm}$  as before. However, the uncertainty in equivalent head,  $H$ , depends on the uncertainty in two variables,  $H = f(L, \theta)$ , so

$$u_{d_H} = \pm \left[ \left( \frac{\partial H}{\partial L} u_L \right)^2 + \left( \frac{\partial H}{\partial \theta} u_\theta \right)^2 \right]^{1/2} = \pm \left[ (\sin \theta u_L)^2 + (L \cos \theta u_\theta)^2 \right]^{1/2}$$

We set  $u_\theta = 0.5^\circ = 0.0087 \text{ radians}$  from the problem statement.

At  $200 \text{ N/m}^2$ :

$$u_{d_H} = \pm \left[ (0.707 \times 0.5 \text{ mm})^2 + (41 \text{ mm} \times 0.87 \times 0.0087)^2 \right]^{1/2} = \pm 0.47 \text{ mm} \quad (95\%)$$

At  $400 \text{ N/m}^2$ :

$$u_{d_H} = \pm \left[ (0.707 \times 0.5 \text{ mm})^2 + (82 \text{ mm} \times 0.87 \times 0.0087)^2 \right]^{1/2} = \pm 0.72 \text{ mm} \quad (95\%)$$

#### COMMENT

At the lower pressure, the uncertainty is reduced by a factor of about  $\sin \theta$  by using the inclined manometer. But at higher pressures, the uncertainty in  $\theta$  becomes increasingly important. In this application, the uncertainty in  $\theta$  cancels out the benefits of the better sensitivity of the inclined instrument.

## PROBLEM 9.13

KNOWN: A water filled inclined-tube manometer.

Inclination angle is variable.

$$\Delta p \approx 10,000 \text{ N/m}^2$$

$$T = 20^\circ\text{C}$$

Manometer:

Resolution: 1 mm; Zero error: 0.5 mm; Inclination error:  $\pm 1^\circ$

FIND:  $u_d$  in pressure as a function of  $\theta$

PROPERTIES: water:  $\gamma_m = 9770 \text{ N/m}^3$

ASSUMPTIONS:  $u_{\gamma_m} / u_\gamma = 0.5\%$ . Neglect effects of the ambient air.

SOLUTION

$$\Delta p = L(\gamma_m - \gamma) \sin \theta \approx L\gamma_m \sin \theta$$

Then,  $\Delta p = f(L, \gamma_m, \theta)$ , so

$$u_{\Delta p} = \pm \left[ \left( \frac{\partial \Delta p}{\partial L} u_L \right)^2 + \left( \frac{\partial \Delta p}{\partial \gamma_m} u_{\gamma_m} \right)^2 + \left( \frac{\partial \Delta p}{\partial \theta} u_\theta \right)^2 \right]^{1/2}$$

$$= \pm \left[ (\gamma_m \sin \theta u_L)^2 + (L \sin \theta u_{\gamma_m})^2 + (L \gamma_m \cos \theta u_\theta)^2 \right]^{1/2}$$

For the inclined manometer, the uncertainty in the manometer deflection,  $L$ , at the design stage is

$$u_{d_L} = \pm [u_o^2 + u_c^2]^{1/2} = \pm [0.5^2 + 0.5^2]^{1/2} = \pm 0.71 \text{ mm}$$

where  $u_o = 0.5 \text{ mm}$  and  $u_c = 0.5 \text{ mm}$ . From the problem statement

$$u_{d_\theta} = 1^\circ = 0.0175 \text{ rad} \quad u_{d_{\gamma_m}} = (9770 \text{ N/m}^3)(0.005) = 49 \text{ N/m}^3$$

Then,

Inclination	L	$u_{\Delta p}$	
	[m]	[N/m <sup>2</sup> ]	
10°	5.894	994	$u_\theta$ dominates
30°	2.047	307	$u_\theta$ dominates
60°	1.182	113	$u_\theta$ dominates
80°	1.039	59	$u_{\gamma_m}$ , $u_\theta$ large
90°	1.024	50	$u_{\gamma_m}$ dominates

## COMMENT

At large pressures,  $u_\theta$  becomes very important (compare with Problem 9.12). In practice, the inclination angle must be carefully set. But even so, the inclined manometer is selected for deflections up to only about  $H = 0.25$  m.

## PROBLEM 9.14

KNOWN: Capacitance pressure transducer of Figure 9.14.

$$C_1 = 0.01 \pm 0.005 \mu\text{F}$$

$$E_i = 5 \pm 1\% \text{ V}$$

$$A = 8 \pm 0.01 \text{ mm}^2$$

$$t = 1.5 \pm 0.1 \text{ mm}$$

$$\Delta t = 0.2 \text{ mm}$$

FIND:  $C$  and  $E_o$

SOLUTION

We know that  $C = c\epsilon A/t$  and  $E_o = \frac{C_1}{C} E_i$

At  $t_o = 1.5 \text{ mm}$

$$C = (0.0885)(1)(8 \text{ mm}^2)/(1.5 \text{ mm})(10 \text{ mm/cm}) = 0.0472 \mu\text{F}$$

and

$$E_o = (0.01/0.0472)(5\text{V}) = 1.0593 \text{ V}$$

At  $t_o + \Delta t = 1.7 \text{ mm}$

$$C = 0.0416 \mu\text{F}$$

$$E_o = (0.01/0.0416)(5\text{V}) = 1.2006 \text{ V}$$

## PROBLEM 9.15

KNOWN: Diaphragm pressure transducer:

$$u_c = \pm 0.5 \text{ psi}$$

Voltmeter

$$u_c = \pm 10 \mu\text{V}$$

$$u_o = 1 \mu\text{V}$$

System (0 to 100 psi)

$$p = 0.564 + 24E \pm 1 \text{ psi (95\%)} \quad \text{with } N = 5$$

Installation errors:  $B = \pm 0.5 \text{ psi}$

FIND:  $u_p$

SOLUTION

The system sensitivity is:  $K = dp/dE = 24 \text{ psi/V}$ . The system uncertainty includes, Instrument errors,  $u_c$ :

transducer uncertainty  $u_t = \pm 0.5 \text{ psi}$

voltmeter uncertainty  $u_E = (1 \times 10^{-6} \text{ V})(24 \text{ psi/V}) = \pm 2.4 \times 10^{-4} \text{ psi}$

These instrument errors are normally treated as systematic errors or Type B errors.

Data reduction errors,  $u_1$ :

curve fit uncertainty  $u_{yx} = \pm 1 \text{ psi}$  with  $\nu = 4$

The curve fit error is usually treated as a random error or Type A error.

Installation effects,  $u_2$ :

installation errors  $u_{in} = \pm 0.5 \text{ psi}$

Installation errors are usually treated as systematic errors or Type B errors.

$$\text{So that: } u_p = \pm [0.5^2 + (2.4 \times 10^{-4})^2 + 1^2 + 0.5^2]^{1/2} = \pm 1.22 \text{ psi (95\%)}$$

Alternatively, we can segregate the errors into types and developed the expanded uncertainty:

$$u_t = B_t; u_E = B_E; u_{in} = B_{in}; u_{yx} = tP_{yx} = tS_{yx}/N^{1/2} \quad \text{with } \nu = 4 \text{ then,}$$

$$B = \left( \sum B_k^2 \right)^{1/2} \quad \text{and} \quad P = \left( \sum P_k^2 \right)^{1/2} \quad \text{so that}$$

$$u_p = \pm [B^2 + (tP)^2]^{1/2} = \pm 1.22 \text{ psi (95\%)}$$

COMMENT

There is no magic in uncertainty analysis. Different approaches will yield similar (but not necessarily identical) results provided that the same errors are included. The important thing is to do an analysis!

## PROBLEM 9.16

KNOWN: pressure transducer:  $t_{90} = 10$  ms;  $\omega_d = 200$  Hz;  $\zeta = 0.8$

FIND: Test plan to verify given specifications. Estimate frequency response.

### SOLUTION

*This problem is open-ended and could form the basis of a lab exercise. One solution is discussed. Second-order systems are discussed in detail in Chapter 3.*

(i) A step test should be developed to test for the rise time. An appropriate magnitude for the pressure rise is the step from atmospheric pressure to the expected pressure at top dead center for this engine (note: the compression ratio for an IC engine is about 8:1 or 9:1). Transducer output can be measured on a storage oscilloscope or suitable data acquisition system.

For a damping ratio of 0.8, the transducer will still exhibit a modest ringing during a step test. But it will require excellent resolution in the measuring device to observe and to accurately measure the amplitude changes. With adequate resolution, the maximum amplitudes in the oscillation can be plotted versus time to estimate the product  $\omega_n \zeta$  (note: this will be the slope of the line if plotted on semi-log axes). The period of oscillation will be related to  $\omega_d = \omega_n \sqrt{1 - \zeta^2}$ . The damping ratio and natural frequency are found by solving these two pieces of information simultaneously.

(ii) Car with 4-cylinder engine turning at 5000 RPM = 83 rps. This gives expected pressure changes at about  $83/4 \sim 21$  Hz. For the transducer,

$$\omega_n = \omega_d / \sqrt{1 - \zeta^2} \quad \text{or} \quad f_n = f_d / \sqrt{1 - \zeta^2} = 200 \text{ Hz} / (1 - .8^2)^{1/2} = 333 \text{ Hz.}$$

Checking out the magnitude ratio plot for a second order device:  $f / f_n \approx 0.063$  and  $M(21\text{Hz}) \approx 1$ . So yes, it could measure the pressure variations in the engine.

## PROBLEM 9.17

KNOWN: Steel diaphragm transducer:  $t = 0.001$  m;  $r = 0.003$  m

FIND:  $\omega_n$ ,  $p_{\max}$

SOLUTION

The natural frequency is given

$$\begin{aligned}\omega_n &= 64.15 \sqrt{\frac{E_m t^2 g_c}{12(1-\nu_p^2)\rho r^4}} = 64.15 \sqrt{\frac{200 \times 10^9 \text{ N/m}^2 \times (0.001 \text{ m})^2 \times 1 \text{ kg} \cdot \text{m/s}^2 \cdot \text{N}}{12(1-0.35^2)(7832 \text{ kg/m}^3) \times (0.003 \text{ m})^4}} \\ &= 173,000 \text{ r/s} \quad \text{or} \quad f_n = 127 \text{ kHz}\end{aligned}$$

The maximum elastic displacement of the diaphragm is limited to about  $t/3$ .

$$\Delta p = 16E_m t^3 (t/3) / 3(1-\nu_p^2)r^4$$

For steel with  $E_m = 200 \times 10^9$  N/m<sup>2</sup>,  $\rho = 7832$  kg/m<sup>3</sup> and  $\nu_p = 0.35$ :

$$\begin{aligned}\Delta p &= 16 \times 200 \times 10^9 \text{ N/m}^2 \times (0.001 \text{ m})^3 (0.001 \text{ m} / 3) / 3(1-0.35^2)(0.003 \text{ m})^4 \\ &= 5000 \text{ MPa}\end{aligned}$$

This is a very high pressure limit, but reflects the stiffness of steel and the relatively small radius, thick diaphragm used. A larger radius for a given thickness lowers the natural frequency and the maximum pressure: For example, doubling the radius here lowers  $\Delta p$  by 16 times ( $r^4$ ) to about 312 MPa.

## PROBLEM 9.18

KNOWN: Pressure transmission system filled with air at 20°C

$$L = 0.25 \text{ m}$$

$$d = 3.25 \text{ mm}$$

$$\nabla = 1600 \text{ mm}^2$$

Transducer:

$$f_n = 100 \text{ kHz}$$

FIND:  $\omega_{\max}$  such that  $0.9 \leq M(\omega) \leq 1.1$

PROPERTIES: Air:  $\mu = 1.8 \times 10^{-5} \text{ N}\cdot\text{s}/\text{m}^2$ ;  $R = 0.287 \text{ kJ}/\text{kg}\cdot\text{K}$

ASSUMPTIONS: Air behaves as a perfect gas

SOLUTION

$$\nabla_t = \pi d^2 L / 4 = \pi (3.25 \text{ mm})^2 (250 \text{ mm}) / 4 = 2400 \text{ mm}^3$$

With  $\nabla_t > \nabla$ ,

$$\omega_n = \frac{a}{L(0.5 + 4\nabla / \nabla_t)}$$

$$\zeta = \frac{16\mu L \sqrt{0.5 + 4\nabla / \nabla_t}}{\rho a d^2}$$

If we assume that the process occurs at a pressure near atmospheric pressure, then we can compute the density of the air by

$$\rho = p/RT = (101325 \text{ N}/\text{m}^2 \text{ abs}) / (0.287 \text{ kJ}/\text{kg}\cdot\text{K})(293 \text{ K}) = 1.16 \text{ kg}/\text{m}^3$$

The speed of sound (acoustic wave speed) is

$$a = [kRT]^{1/2} = [(1.4)(0.287 \text{ kJ}/\text{kg}\cdot\text{K})(293 \text{ K})]^{1/2} = 345 \text{ m/s}$$

Then,

$$\omega_n = 775 \text{ rad/s} \quad \zeta = 0.026$$

The frequency response is

$$M(\omega) = \frac{1}{\sqrt{[1 - (\omega/\omega_n)^2]^2 + [2\zeta(\omega/\omega_n)]^2}}$$

$\omega_n$ [rad/s]	M( $\omega$ )
10	1.00
100	1.02
200	1.07
225	1.09
250	1.12
300	1.17

The frequency response remains within the  $\pm 10\%$  constraint over the frequency band,  $0 \leq \omega \leq 230$  rad/s.

#### COMMENT

Note how the natural frequency of the tubing is much less than that of the transducer. As a consequence, the response characteristics of the connecting tubing govern the system response. The limits of the frequency response of the transducer do not come into play.

The assumption concerning the pressure affects the density of the air only. Its effect on the solution is minimal for low gauge pressures.

## PROBLEM 9.19

KNOWN: Pitot static tube used to measure velocity

FIND: Sensitivity of velocity to pressure

SOLUTION:

A pitot-static tube, such as shown in Figure 9.23, can be used to determine velocity based on the measured difference in total and static pressure through

$$U = \sqrt{2\Delta p / \rho} = C\sqrt{\Delta p}$$

where  $C$  is a coefficient.

The sensitivity is the change in output for a change in input or

$$K = \frac{\partial U}{\partial \Delta p} = \frac{1}{2} C \Delta p^{-1/2}$$

So the static sensitivity here is inversely related to the pressure. That is, the sensitivity of the pitot static tube to changes in velocity decreases as the pressure difference increases.

COMMENT

The pitot-static principle is widely used and considered a fairly accurate means of estimating velocity. This is a good example of a useful device whose sensitivity is not a constant but varies with the magnitude of the input signal.

## PROBLEM 9.20

KNOWN: Pitot-static probe measures flow in a duct.

$$H = p_v / \gamma_{H_2O} = 20.3 \text{ cm H}_2\text{O}$$

FIND:  $U$

ASSUMPTIONS: Duct flow is air at room temperature.

PROPERTIES:  $\rho_{air} = 1.16 \text{ kg/m}^3$

$$\rho_{H_2O} = 998 \text{ kg/m}^3$$

SOLUTION

$$\begin{aligned} p_v &= p_t - p = \frac{1}{2} \rho_{air} U^2 \\ U &= \sqrt{2p_v / \rho_{air}} = \sqrt{2\gamma_{H_2O} H / \rho_{air}} = \sqrt{2\rho_{H_2O} g H / \rho_{air}} \\ &= \sqrt{2(998 \text{ kg/m}^3)(9.8 \text{ m/s}^2)(0.203 \text{ m}) / (1.16 \text{ kg/m}^3)} \\ &= 58.5 \text{ m/s} \end{aligned}$$

## PROBLEM 9.21

KNOWN: Pitot-static tube in air.

FIND:  $U$ ,  $u_U$

SOLUTION

The mean velocity is determined by converting the mean voltage values to pressure and, finally, to velocity. From the given data, the pooled estimates are:

$$\begin{aligned}\langle \bar{E} \rangle &= (2.438 + 2.354 + 2.473)/3 = 2.422 \text{ V} \\ \langle S_E \rangle &= [(.01^2 + 0.009^2 + .012^2)/3]^{1/2} = 0.01 \text{ V} \quad v_E = 60\end{aligned}$$

From the calibration data,  $p = f(E)$ , so we determine:

$$\langle \bar{p} \rangle = 0.205 + 0.950E = 2.506 \text{ N/m}^2$$

Now variations in voltage are related to variations in pressure by the static sensitivity at the operating voltage (the mean voltage here), as noted in discussions related to Figures 1.6 and 5.2. Here  $K_p = dp/dE = 0.95 \text{ N/m}^2/\text{V}$ .

$$\langle S_p \rangle = K_p \langle S_E \rangle = 0.0095 \text{ N/m}^2 \quad \text{with } v_E = 60$$

The velocity is estimated by  $U = \sqrt{2p_v / \rho_{air}}$  where  $p_v$  is the dynamic pressure measured by the pitot-static tube sensor. The pooled mean estimate is

$$\langle \bar{U} \rangle = \sqrt{2(2.506 \text{ N/m}^2)(1 \text{ kg} \cdot \text{m/s}^2 - \text{N}) / (1.2 \text{ kg/m}^3)} = 2.04 \text{ m/s}$$

Variations in pressure are related to variations in velocity. Here  $K_U = dU/dp =$

$$= (2p_v / \rho_{air})^{-1/2} = 0.41 \text{ m/s/N/m}^2 \text{ at } p_v = 2.506 \text{ N/m}^2:$$

$$\langle S_U \rangle = K_U \langle S_p \rangle = K_U K_p \langle S_E \rangle = 0.004 \text{ m/s}$$

This value represents the effect of the variations in the test data during repetition. The effect of variation in the measured mean value during replication is estimated by:

$$S_U = K_U K_p S_E = K_U K_p \left[ \sum (E'_j - \langle \bar{E} \rangle)^2 / 2 \right]^{1/2} = 0.022 \text{ m/s} \quad \text{with } v = 2$$

For the voltmeter: an systematic uncertainty due to instrument error is assigned

$$B_1 = \pm 10 \mu V = \pm 10 \mu V (.95 \text{ N/m}^2/\text{V})(0.41 \text{ m/s/N/m}^2) = 4 \times 10^{-6} \text{ m/s}$$

$$P_1 = 0$$

For the pitot-static tube, a systematic uncertainty due to instrument error of 1% is assigned:

$$B_2 = (0.01)K_{Upv} = (0.01)(0.41 \text{ m/s/N/m}^2)(2.506 \text{ N/m}^2) = 0.010 \text{ m/s}$$

$$P_2 = 0$$

For the transducer: no information is given, so assume a negligible instrument error.

$$B_3 = 0 \text{ and } P_3 = 0$$

From the calibration data  $tS_{yx}/N^{1/2} = 0.002 \text{ N/m}^2$  with  $\nu = 30$ , so  $S_{yx}/N^{1/2} \sim .001 \text{ N/m}^2$  (i.e.  $t \sim 2$ )

$$P_4 = (0.001 \text{ N/m}^2)(.41 \text{ m/s/N/m}^2) = 0.00041 \text{ m/s} \quad \nu_4 = 30$$

$$B_4 = 0$$

For the measurement:

$$P_5 = 0.004 \text{ m/s with } \nu_5 = 60 \text{ (repetition effect)}$$

$$B_5 = 0$$

From the replication study,

$$P_6 = S_U = 0.022 \text{ m/s (replication effect)}$$

$$B_6 = 0$$

Collecting terms:

$$B = (B_1^2 + B_2^2 + B_3^2)^{1/2} = 0.010 \text{ m/s}$$

$$P = (P_4^2 + P_5^2 + P_6^2)^{1/2} = 0.024 \text{ m/s with } \nu = 3 \text{ (from Welch-Satterthwaite method)}$$

so,

$$u_U = [B^2 + (t_{3,95}P)^2]^{1/2} = 0.07 \text{ m/s}$$

$$U' = 2.04 \pm 0.07 \text{ m/s (95\%)}$$

## PROBLEM 9.22

KNOWN: Pitot-static tube in freestream  
 $U = 325$  kph  
(a) measured on open road  
(b) measured in open circuit tunnel (where  $p_t = 0$ )

FIND: Static, dynamic, stagnation pressures

SOLUTION

For a pitot-static tube in air,

$$U = \sqrt{2\Delta p / \rho_{air}}$$

Rearranging, the dynamic pressure is given by

$$\Delta p = \frac{1}{2} \rho_{air} U^2$$

so,

$$\begin{aligned} \Delta p &= (0.5)(1.225 \text{ kg/m}^3)(325 \text{ km/hour} \times 1 \text{ hour}/3600 \text{ s} \times 1000\text{m}/\text{km})^2 \\ &= 4991 \text{ N/m}^2 = 37.4 \text{ mm Hg} \end{aligned}$$

This is the measured pressure. Now,  $\Delta p = p_t - p_{static}$ , where  $p_t$  is the stagnation pressure and the static pressure  $p_{static}$  is the freestream pressure ( $p_\infty$ ).

On the open road:

In this case, the flow is at rest and the car (and pitot-static tube) moves through the air, causing the pressure to rise at the impact port (stagnation pressure).

$$p_\infty = 0 \text{ N/m}^2 \text{ (local atmospheric pressure)}$$

$$p_t = 4991 \text{ N/m}^2$$

In the open circuit wind tunnel:

In an open circuit wind tunnel, air is drawn from rest from outside the tunnel and accelerated to a desired speed within the test section, which houses the car.

The car is at rest and the flow is moved past it. Flow always moves from high to low pressure, from the atmospheric pressure outside the tunnel to the low pressure inside it. The pressure in the test section is the freestream pressure and clearly this must be below

atmospheric pressure for air to move through the test section. The stagnation pressure in the tunnel is zero (just the same as it is for atmospheric pressure). Another way to think of the stagnation pressure is that since the local pressure is negative, the pressure at the impact port must rise an amount to reach atmospheric pressure.

$$p_{\infty} = -4991 \text{ N/m}^2$$

$$p_t = 0 \text{ N/m}^2$$

## PROBLEM 9.23

KNOWN: Wall pressure taps connected by tubing to transducers.

FIND: Select tube size for better time response.

SOLUTION

The system is depicted in Figure 9.21. From equation (9.27):

$$\tau \propto \frac{L}{d^4} = \frac{L^2}{(Ld^2)d^2} \propto \frac{(L/d)^2}{\nabla}$$

or the system time constant is proportional to  $L/d$  per unit volume. So this indicates to keep  $\tau$  small that it is best to keep lengths as short as possible and diameters of moderate size, but certainly not very small.

In fact, very small diameter tubes can be used as effective filters to suppress higher frequency aspects from a pressure signal. This possibility is seen in equations (9.21 –9.26) in which natural frequency decreases as  $L$  increases and damping rises as diameter decreases.

## PROBLEM 9.24

KNOWN: System of Example 9.7  
Average pressures and deviations.

FIND: Uncertainty in pressure measurement

SOLUTION

This problem offers a realistic scenario and requires some straightforward thought.

The resolution of the transducer and A/D system is limited to

$$Q_{\text{transducer}} = 50.8 \text{ cm H}_2\text{O}/5\text{V} = 10.16 \text{ cm H}_2\text{O}/\text{V}$$

$$Q_{\text{A/D}} = 5\text{V}/2^{12} = 0.00122 \text{ V/digit}$$

Or, the total measuring system resolution is

$$Q = 0.00122 * 10.16 = 0.0124 \text{ cm H}_2\text{O}$$

This yields a  $u_o = 0.0124 \text{ cm H}_2\text{O}$ . The accuracy of the A/D is 2 bits, equivalent to

$$u_c = (2 \times 0.00122\text{V})(10.16 \text{ cm H}_2\text{O}/\text{V}) = 0.025 \text{ cm H}_2\text{O}.$$

The uncertainty in the A/D signal is:

$$u_{\text{A/D}} = [u_o^2 + u_c^2]^{1/2} = 0.028 \text{ cm H}_2\text{O}$$

In the wind tunnel the measurements will be sampled over a reasonable period of time to acquire a large data set. Uncertainty enters the estimation of the average pressure due to variations in the measured data. Some locations on the car will show larger variations than do others. Based on the sample data given, the variation in pressure is on the order of 0.0025 to 0.05 cm H<sub>2</sub>O. Assuming large data sets (such that  $t_{95} \approx 2.0$ ), the uncertainty in pressure due to variations alone is 0.005 to 0.10 cm H<sub>2</sub>O. The uncertainty in estimating the mean pressure will be about one order of magnitude better than this, 0.0005 to 0.01 cm H<sub>2</sub>O.

So our ability to resolve pressure is limited at one extreme by the A/D system at 0.028 cm H<sub>2</sub>O. Our precision in a pressure measurement is reasonably estimated at 0.10 cm H<sub>2</sub>O and provides the other extreme. The precision in the mean pressure estimation is set at 0.01 cm H<sub>2</sub>O. Thus,

$$u_p = [0.1^2 + 0.028^2]^{1/2} \approx 0.10 \text{ cm H}_2\text{O} \quad (95\%)$$

and

$$u_p = [.01^2 + 0.028^2] \approx 0.03 \text{ cm H}_2\text{O} \quad (95\%)$$

#### COMMENT

To put this in perspective of Example 9.7, this uncertainty level provides an uncertainty in rear down force estimation of about 10 lbs (2.2 N) out of 600 lbs (135 N) when done correctly. Incredibly, this is about the level when a top professional driver can begin to sense changes in car handling.

## PROBLEM 9.25

KNOWN: Pressure measured at  $M = 4$  stations,  $N = 20$  each.

FIND: Effects of data pooling

### SOLUTION

Pooling of the data obtained at 4 different radial planes would provide an overall average pressure which accounts for non-axisymmetric effects, that is spatial variations between cross-planes. In fact, by comparing the mean values found along each plane, an estimate of the non-symmetry can be found.

$$\langle \bar{p} \rangle = (153 + 142 + 161 + 157)/4 = 153.25 \text{ MN/m}^2$$

A measure of the average variation along any cross-section is estimated by

$$\langle S \rangle = [(7^2 + 9^2 + 9^2 + 7^2)/4]^{1/2} = 8.1 \text{ MN/m}^2$$

A measure of the spatial variation in the mean is inferred by (with  $M = 4$ )

$$S_{\bar{p}} = \left[ \sum_{j=1}^M (\bar{p}_j - \langle \bar{p} \rangle)^2 / (M-1) \right]^{1/2} = 8.2 \text{ MN/m}^2$$

Note: The closeness of  $\langle S \rangle$  and  $S$  here is just coincidence of the problem numbers.

Replications provide a means to estimate how well the test conditions and their effect on the measured results can be repeated.

## PROBLEM 9.26

**KNOWN:** Air flow measured using a pitot-static tube and a mercury filled manometer.

$$5 \leq U \leq 50 \text{ m/s}$$

**FIND:** Manometer resolution required to achieve a zero order uncertainty of 5 and 1% in measured velocity.

### SOLUTION

The velocity of a flow of fluid of density  $\rho$  bringing about a manometer deflection  $H$  is given by

$$U = \sqrt{2\gamma_{\text{Hg}} H / \rho_{\text{air}}} = \sqrt{2\rho_{\text{Hg}} g H / \rho_{\text{air}}} \quad \text{or} \quad H = \left(\frac{1}{2}\rho_{\text{air}} U^2\right) / (\rho_{\text{Hg}} g)$$

To assess the effect of  $u_H$  on  $u_U$  :

$$u_U = \pm \left[ \left( \frac{\partial U}{\partial H} u_H \right)^2 \right]^{1/2} = \pm \left[ \left( \frac{1}{2} H^{-1/2} \sqrt{\frac{\rho_{\text{Hg}} g}{\rho_{\text{air}}}} u_H \right)^2 \right]^{1/2}$$

dividing through by the expression for velocity  $U$

$$u_U / U = \pm u_H / 2H$$

So the relative uncertainty in velocity is one-half the relative uncertainty in manometer deflection. The uncertainty at any level can be found by inserting the corresponding and consistent value of uncertainty into this expression. At the zero order, our concern is only on the resolution of the measuring instrument. For example, for  $u_U/U = 0.01$ ,  $u_H/H = \pm 0.02$ , or we need a manometer resolution of 4% of the expected manometer deflection.

U [m/s]	H [mm Hg]	Resolution [mm]	
		1%	5%
5	0.115	0.00046	0.023
50	11.49	0.46	2.3

The lower velocity readings require micron level resolution if using mercury.

## PROBLEM 9.27

KNOWN: Static pressure around cylinder,  $p(\theta)$ .

$$p_v = 20.3 \text{ cm H}_2\text{O}$$

$$p_\infty = p_{\text{atm}} = 101.3 \text{ kPa abs}$$

$$T_\infty = T_{\text{atm}} = 16^\circ\text{C}$$

Manometer measures pressure using deflection of water

FIND:  $U(\theta)$

ASSUMPTIONS: Total pressure constant throughout tunnel (i.e., neglect losses).

PROPERTIES: Water:  $\rho = 1000 \text{ kg/m}^3$

$$\text{Air: } \rho = p/RT = 1.2 \text{ kg/m}^3$$

SOLUTION

For no losses, the Bernoulli equation can be written along a streamline from the freestream to the stagnation point as

$$p_t = p_\infty + 0.5\rho U_\infty^2$$

Similarly, we can relate to the pressure around the body's surface

$$p_\infty + 0.5\rho U_\infty^2 = p(\theta) + 0.5\rho U^2(\theta)$$

so that,

$$p_t = p(\theta) + 0.5\rho U^2(\theta)$$

Then, rearranging we get the velocity as a function of measured pressure

$$U(\theta) = \sqrt{\frac{2(p_t - p(\theta))}{\rho_{\text{air}}}}$$

The manometer will deflect relative to the pressure difference,  $p(\theta) - p_\infty$ . But at the  $0^\circ$  tap,  $p(\theta) = p_t$ , so the manometer will deflect to the pressure difference,  $p_t - p_\infty$ . In terms of deflection,

$$H(\theta = 0^\circ) = (p_t - p_\infty) / \gamma_{\text{H}_2\text{O}}$$

But we see that  $H(\theta = 0^\circ) = 0$ , meaning that  $p_t = p_\infty$ . This allows us to rewrite the expression for velocity as (where  $H$  [cm] and  $U$  [m/s]),

$$U(\theta) = \sqrt{\frac{2(p_\infty - p(\theta))}{\rho_{\text{air}}}} = \sqrt{\frac{2\rho_{\text{H}_2\text{O}}gH}{\rho_{\text{air}}}} = 12.65H^{1/2}$$

$\theta$	H [cm H <sub>2</sub> O]	U [m/s]
0	0	0
45	41.4	81.4
90	81.3	114.0
135	23.1	60.8
180	23.9	61.8

## PROBLEM 9.28

KNOWN: Pitot-static probe.  $T_{\text{amb}} = T_{\infty} = 20^{\circ}\text{C}$

FIND: Lowest airspeed and manometer deflection for which the viscous correction is negligible.

PROPERTIES: Air:  $\rho = 1.225 \text{ kg/m}^3$   
 $\nu = 2 \times 10^{-5} \text{ m}^2/\text{s}$   
Water:  $\gamma_m = 9780 \text{ N/m}^2$

### SOLUTION

Viscous correction is required when  $Re_r < 500$ . To keep  $Re_r > 500$ ,

$$Re_r = Ur/\nu$$

$$U > 500 \nu / r = (500)(2 \times 10^{-5} \text{ m}^2/\text{s})/r$$

or we need

$$U > (0.01/r) \text{ m/s}$$

From the pitot-static probe,

$$U = \sqrt{\frac{2\gamma_m H}{\rho_{\text{air}}}}$$

Equating with the above expression for velocity (with  $r$  and  $H$  in [m]) gives,

$$H > (\rho / 2\gamma_m)(500\nu / r)^2$$

$$> [1.225 \text{ kg/m}^2 / (2 \times 9780 \text{ N/m}^3)] \times [(500 \times 2 \times 10^{-5} \text{ m}^2/\text{s}) / r]^2$$

For a 6 mm diameter probe ( $r = 0.003 \text{ m}$ ),  $U > 3.3 \text{ m/s}$  (10.8 ft/s) and  $H > 0.7 \text{ mm}$ .

## PROBLEM 9.29

KNOWN: Anemometer circuit

$$R_3 = R_4 = 500\Omega ; \alpha = 0.00395/^\circ\text{C}$$

Sensor resistance at temperature  $T_s$ :  $R_s(20^\circ\text{C}) = 110 \Omega$

FIND:  $R_D$  if  $T_s = 60^\circ\text{C}$

SOLUTION

For a metallic resistance temperature device, the resistance temperature relation is approximated by,

$$R_s(T_s) = R_o[1 + \alpha (T_s - T_o)]$$

Using  $R_o = R(20^\circ\text{C}) = 110 \Omega$

$$\begin{aligned} R_s(60^\circ\text{C}) &= 110\Omega [1 + 0.00395(60 - 20)] \\ &= 127.38 \Omega \end{aligned}$$

If the sensor resistance is  $R_s$ , the bridge will be balanced when

$$R_s = R_D(R_3/R_4) \quad \text{so that} \quad R_D = 127.38 \Omega .$$

## PROBLEM 9.30

KNOWN: Constant resistance anemometer

FIND: Sensitivity relative to velocity

SOLUTION

For a thermal anemometer operating at constant resistance,

$$E^2 = A + BU^n$$

The sensitivity,  $K$ , is found by

$$K = (dE/dU)_U = nBU^{n-1}/2(A+BU^n)^{1/2}$$

For  $n = 0.5$ ,

$$K \propto U^{-0.75}$$

The sensitivity decreases as velocity increases.

## PROBLEM 9.31

KNOWN:  $F = 600 \text{ mm}$   
 $\theta = 5.5^\circ$   
 $\lambda = 514.5 \text{ nm}$

FIND:  $f_d$  at  $U = 1, 10, 100 \text{ m/s}$

SOLUTION

$$f_d = U [2 \sin \theta/2] / \lambda = U [2 \sin 2.75^\circ] / 514.5 \times 10^{-9} \text{ m} = 186,540 U$$

At  $U = 1 \text{ m/s}$ ,  $f_d = 186.540 \text{ kHz}$   
 $U = 10 \text{ m/s}$ ,  $f_d = 1.8654 \text{ MHz}$   
 $U = 100 \text{ m/s}$ ,  $f_d = 18.654 \text{ MHz}$

Recomputing for  $F = 300 \text{ mm}$  and  $\theta = 7.3^\circ$ ,

$$f_d = 247,517 U$$

At  $U = 1 \text{ m/s}$ ,  $f_d = 247.517 \text{ kHz}$   
 $U = 10 \text{ m/s}$ ,  $f_d = 2.47517 \text{ MHz}$   
 $U = 100 \text{ m/s}$ ,  $f_d = 24.7517 \text{ MHz}$

## PROBLEM 9.32

KNOWN: LDA measurement using dual beam mode.

$$N = 5000$$

$$U = 21.37 \text{ m/s}$$

$$\theta = 6^\circ$$

$$S_U = 0.43 \text{ m/s}$$

$$\lambda = 623.8 \pm 0.5\% \text{ nm}$$

$$B_{fd}/f_d \leq 0.9\%$$

$$B \leq 0.25^\circ$$

FIND: Estimate  $U'$ , the best estimate of the velocity, based on available information.

### SOLUTION

The relation between velocity and Doppler frequency using dual beam mode is,

$$U = f_d \lambda / [2 \sin \theta / 2]$$

with the mean Doppler frequency estimated by

$$\begin{aligned} f_d &= U [2 \sin \theta / 2] / \lambda = (21.37 \text{ m/s}) [2 \sin 3^\circ] / (623.8 \times 10^{-9} \text{ m}) \\ &= 3.5858 \text{ MHz} \end{aligned}$$

The systematic error in the velocity estimate can be estimated by

$$B_U = \pm \left[ \left( \frac{\partial U}{\partial f_d} B_{f_d} \right)^2 + \left( \frac{\partial U}{\partial \lambda} B_\lambda \right)^2 + \left( \frac{\partial U}{\partial \theta} B_\theta \right)^2 \right]^{1/2}$$

Using

$$B_\theta = 0.25^\circ = 0.0044 \text{ rad}$$

$$B_{fd} = 0.009 f_d = 32,272 \text{ Hz}$$

$$B_\lambda = (623.8 \times 10^{-9} \text{ m})(0.005) = 3.12 \times 10^{-9} \text{ m}$$

$$B_U = \pm \left[ \left( \frac{\lambda}{2 \sin \theta / 2} B_{f_d} \right)^2 + \left( \frac{f_d}{2 \sin \theta / 2} B_\lambda \right)^2 + \left( \frac{f_d \lambda}{\sin \theta / 2 \tan \theta / 2} B_\theta \right)^2 \right]^{1/2}$$

$$= \pm \left[ \left( \frac{623 \times 10^{-9} \text{ m}}{2 \sin 3^\circ} 9836 / \text{s} \right)^2 + \left( \frac{1.09 \times 10^6 / \text{s}}{2 \sin 3^\circ} 3.12 \times 10^{-9} \text{ m} \right)^2 + \left( \frac{1.09 \times 10^6 / \text{s} \times 623.8 \times 10^{-9} \text{ m}}{\sin \theta / 2 \tan \theta / 2} 0.0044 \right)^2 \right]^{1/2}$$

$$= \pm \left[ (0.19)^2 + (0.11)^2 + (3.27)^2 \right]^{1/2} = \pm 3.28 \text{ m/s}$$

The systematic error is completely dominated by the optical system error.

The random error in the mean velocity is estimated by

$$P_U = S_U / N^{1/2} = (0.43 \text{ m/s}) / 5000^{1/2} = 0.007 \text{ m/s}$$

with degrees of freedom of 4999.

The uncertainty in velocity is estimated by

$$u_U = \pm [B^2 + (t_{4999,95} P_U)^2]^{1/2} \quad (95\%)$$

$$= \pm [3.28^2 + (1.96 \times .007)^2]^{1/2} = 3.28 \text{ m/s} \quad (95\%)$$

The best estimate of the velocity may be stated as

$$U' = 21.37 \pm 3.28 \text{ m/s} \quad (95\%)$$

#### COMMENT

The error in the optical set-up dominates the overall uncertainty in measuring velocity. One can minimize this error by using a shorter focal length lens, as this will increase the value of  $\theta$ . But the value assigned for the systematic error in  $\theta$  in this problem is actually quite large for precise work. Standardized metrology equipment and methods allow vendors of high quality optics to measure  $\theta$  to better than  $0.01^\circ$ .

At  $B\theta = 0.01^\circ$ ,  $U' = 21.37 \pm 0.26 \text{ m/s}$  (95%), a 1% uncertainty.

### PROBLEM 9.33

KNOWN:  $A = 4 \text{ m}^2$  (2m by 2m duct)  
pitot static tube measurements at 9 locations, each at the center of equal rectangular areas  
Air:  $T = 15 \text{ }^\circ\text{C}$ ,  $p = 1 \text{ atm abs.}$

FIND: Flow rate

#### SOLUTION

The flow rate  $Q = \bar{U}A$  where the velocity is determined from each pitot-static tube measurement. The dynamic pressure is measured by the pitot-static tube and it is related directly to the velocity at the point of measurement by

$$p_v = p_t - p = \rho_{H_2O} gH = \frac{1}{2} \rho_{air} U^2$$

$$\bar{U} = \sqrt{\frac{2\rho_{H_2O} gH}{\rho_{air}}}$$

The value of H is obtained from the pitot-static tube. To estimate the average velocity in the duct, a spatial average of the readings is made,

$$\bar{U} = \sqrt{\frac{2\rho_{H_2O} gH}{\rho_{air}}} = \frac{4}{N} \sum_{i=1}^{N=9} H(\text{mmH}_2\text{O}) = 3.29 \text{ m/s}$$

Then,

$$Q = (3.29 \text{ m/s})(4 \text{ m}^2) = 13.1 \text{ m}^3/\text{s}$$

## PROBLEM 9.34

KNOWN: Information of Problem 9.33  
 $A = wL$        $B_w = 0.010 \text{ m}$        $B_L = 0.010 \text{ m}$

FIND: Uncertainty in flow rate

SOLUTION

The flow rate is found from the continuity relation

$$Q = UA$$

so  $\bar{Q} = \bar{U}A = 13.1 \text{ m}^3/\text{s}$  (Problem 9.33) and  $u_Q = f(u_U, u_A)$ .

The instrument error associated with a pitot-static tube is assigned an uncertainty of 1 %,

$$B_H/H = 1\% \quad (\text{Section 9.8})$$

The data variation in the 9 measurements of Problem 9.33 gives a random uncertainty in H

$$P_H = \left[ \frac{\sum_{i=1}^9 (H_i - \bar{H})^2}{9-1} \right]^{1/2} / 9 = 0.324 \text{ mm H}_2\text{O} \quad \nu = 8$$

The uncertainty in flow rate contains systematic and random uncertainties. These propagate as

$$B_Q = \left[ \left( \frac{\partial Q}{\partial U} B_U \right)^2 + \left( \frac{\partial Q}{\partial A} B_A \right)^2 \right]^{1/2} = \left[ (AB_U)^2 + (\bar{U}B_A)^2 \right]^{1/2}$$

$$P_Q = \left[ \left( \frac{\partial Q}{\partial U} P_U \right)^2 + \left( \frac{\partial Q}{\partial A} P_A \right)^2 \right]^{1/2} = \left[ (AP_U)^2 + (\bar{U}P_A)^2 \right]^{1/2}$$

But  $\bar{U} = \sqrt{\frac{2\rho_{H20}gH}{\rho_{air}}}$ . If we consider only the errors in H as affecting the uncertainty in U,

$$P_U = \left[ \left( \frac{\partial U}{\partial H} P_H \right)^2 \right]^{1/2} = \left[ ((4.0)(0.5)H^{-1/2}P_H)^2 \right]^{1/2} = 0.263 \text{ m/s}$$

$$B_U = \left[ \left( \frac{\partial U}{\partial H} B_H \right)^2 \right]^{1/2} = \left[ ((4.0)(0.5)H^{-1/2}B_H)^2 \right]^{1/2} = [2H^{1/2}B_H / H] = 0.222 \text{ m/s}$$

$A = wL$ :

$$B_A = \left[ \left( \frac{\partial A}{\partial w} B_w \right)^2 + \left( \frac{\partial A}{\partial L} B_L \right)^2 \right]^{1/2} = \left[ (LB_w)^2 + (wB_L)^2 \right]^{1/2} = 0.028 \text{ m}^2$$

$$P_A = 0$$

Then,

$$B_Q = \left[ (4 \times 0.222)^2 + (3.29 \times 0.028)^2 \right]^{1/2} = 0.893 \text{ m}^3/\text{s}$$

$$P_Q = \left[ (4 \times 0.263)^2 + (0)^2 \right]^{1/2} = 1.026 \text{ m}^3/\text{s} \quad \nu = 8$$

$$u_Q = \pm \left[ B_Q^2 + (tP_Q)^2 \right]^{1/2} = \left[ 0.893^2 + (2.306 \times 1.026)^2 \right]^{1/2} = \pm 2.53 \text{ m}^3/\text{s} \quad (95\%)$$

$$Q = 13.1 \pm 2.53 \text{ m}^3/\text{s} \quad (95\%)$$

There is about a 19% uncertainty in flow rate.

### PROBLEM 9.35

KNOWN:  $\Delta p \approx 10 \text{ kPa}$   
 $\rho_{\text{Hg}} = S \rho_{\text{H}_2\text{O}}$  where  $S_{\text{Hg}} = 13.6$

FIND:  $H$  if  $\theta = 30^\circ$  for inclined manometer

SOLUTION

Let  $H$  be the deflection in the vertical direction (such as a U-tube manometer),

$$H = \frac{\Delta p}{\gamma_m - \gamma} \approx \frac{\Delta p}{\gamma_m} = \frac{\Delta p}{S_{\text{Hg}} \rho_{\text{H}_2\text{O}} g} = \frac{10,000 \text{ N/m}^2}{(1000 \text{ kg/m}^3)(9.8 \text{ m/s}^2)13.6} = 0.075 \text{ m}$$

But for an inclined manometer

$$H = L \sin \theta$$

or

$$L = \frac{\Delta p}{S'_{\text{Hg}} \rho_{\text{H}_2\text{O}} g \sin \theta} = 0.15 \text{ m}$$

So the inclined manometer doubles the deflection for an applied head.

## PROBLEM 9.36

KNOWN: steel diaphragm transducer  
 $t = 0.5 \text{ mm}$   
 $d = 25 \text{ mm}$  (so  $r = 12.5 \text{ mm}$ )  
 $\nu_p = 0.32$   
 $E_m = 200 \text{ GPa}$

FIND: differential pressure limit ( $\Delta p$  associated with  $y_{\max}$ )

### SOLUTION

The differential pressure limit occurs at the maximum deflection of the diaphragm (after which plastic deformation of the diaphragm may occur),

$$y_{\max} = \frac{3(\Delta p)(1 - \nu_p^2)r^4}{16E_m t^3}$$

where  $y_{\max} = t/3$ . Then, rearranging

$$\Delta p = \frac{16E_m t^4}{9(1 - \nu_p^2)r^4} = \frac{16(200 \times 10^9 \text{ N/m}^2)(0.0005\text{m})^4}{9(1 - 0.32^2)(0.0125\text{m})^4} = 1 \text{ MPa}$$

## PROBLEM 10.1

**KNOWN:** Flow of air through a pipe  
 $U(r) = 25[1 - (r/r_1)^2]$  cm/s  
 $p = 1 \text{ bar abs} = 100,000 \text{ N/m}^2 \text{ abs}$   
 $T = 5^\circ\text{C} = 278 \text{ K}$   
 $d_1 = 2r_1 = 5 \text{ cm}$

**FIND:** mass flow rate

**ASSUMPTIONS:** Steady, incompressible, axisymmetric flow of a perfect gas.

### SOLUTION

Conservation of mass gives

$$\frac{\partial}{\partial t} \iiint_{cv} \rho dV + \iint_{cs} \rho \bar{U} \cdot \hat{n} dA = 0$$

which for steady, incompressible, axisymmetric flow becomes

$$\dot{m} = \int_0^{2\pi} \int_0^{r_1} \rho U(r) r dr d\theta$$

The velocity can be written in vector form as

$$\vec{U} = 25 \left(1 - \frac{r}{r_1}\right)^2 e_z$$

resulting in

$$\dot{m} = \rho \int_0^{2\pi} \int_0^{r_1} 25 \left(1 - \frac{r}{r_1}\right)^2 r dr d\theta = \frac{25}{2} \rho \pi r_1^2 = 39.3 \rho \text{ cm}^3/\text{s}$$

For a perfect gas, the density can be estimated by

$$\rho = p/RT = 1.16 \text{ kg/m}^3$$

so that (with  $1 \text{ m} = 100 \text{ cm}$ ):

$$\dot{m} = 4.5 \times 10^{-5} \text{ kg/s} = 0.16 \text{ kg/hr}$$

PROBLEM 10.2

KNOWN: Air flow through a pipe  
 diameter =  $2r_1 = 20$  cm  
 $N = 5$  velocity measurements per cross-sectional traverse  
 $M = 3$  cross-sectional traverses  
 $B_Q/Q = \pm 2\%$

FIND:  $Q'$

ASSUMPTIONS: Steady, incompressible flow of a perfect gas.  
 Flow rate remains perfectly controlled (constant) during all measurements (equivalent to the assumption that all measurements are taken simultaneously).

SOLUTION

The flow rate along each traverse line ( $j = 1, 2, 3$ ) can be approximated by

$$Q_j = 2\pi \int_0^{r_1} U r dr \approx 2\pi \sum_{i=1}^5 U_{ij} r \Delta r \quad i = 1, 2, 3, 4, 5$$

where  $\Delta r = 2$  cm and  $j = 1, 2, 3$ . Then,

$$Q_1 = 2\pi [(25.31)(1)(2) + (22.48)(3)(2) + (21.66)(5)(2) + (15.24)(7)(2) + (5.12)(9)(2)] \\ = 4446 \text{ cm}^3/\text{s}$$

Similarly,  $Q_2 = 4421 \text{ cm}^3/\text{s}$ ,  $Q_3 = 4400 \text{ cm}^3/\text{s}$ . The mean flow rate is

$$\bar{Q} = (1/3)[4446 + 4421 + 4400] \text{ cm}^3/\text{s} = 4423 \text{ cm}^3/\text{s}$$

with standard deviation,

$$S_Q = \left[ \frac{1}{2} \sum_{j=1}^3 (Q_j - \bar{Q})^2 \right]^{1/2} \\ = 23 \text{ cm}^3/\text{s}$$

and

$$S_{\bar{Q}} = S_Q / 3^{1/2} = 13.3 \text{ cm}^3/\text{s} \quad \text{with } \nu = 2$$

Then,  $t_{2,95} = 4.303$ . With  $P = S_{\bar{Q}}$ ,  $tP=57.2 \text{ cm}^3/\text{s}$  and with  $B = 0.02\bar{Q} = 88.5 \text{ cm}^3/\text{s}$ , then

$$u_Q = [88.5^2 + 57.2^2]^{1/2} = 105.3 \text{ cm}^3/\text{s}.$$

So,

$$Q' = 4423 \pm 105.3 \text{ cm}^3/\text{s} \quad (95\%)$$

#### COMMENT

Sources of systematic error include: instrument errors, errors in the control of operating conditions for all three traverses, and the approximation for the integral expression at the start of the solution.

### PROBLEM 10.3

KNOWN: Manometer measuring the pressure drop of flowing water

$$H = 10.16 \text{ cm Hg}$$

$$d_1 = 5.1 \text{ cm}$$

$$\gamma = 9800 \text{ N/m}^3 \text{ (water)}$$

$$S_m = 13.57 \text{ (mercury) so that } \gamma_m = S_m \gamma$$

FIND:  $p_1 - p_2$

ASSUMPTIONS:  $p_1$  and  $p_2$  taps are located along the same horizontal datum line.

SOLUTION

Applying the hydrostatic equation between points 1 and 2 yields

$$p_1 + L\gamma + H\gamma_m - (L+H)\gamma = p_2$$

$$p_1 - p_2 = H(\gamma_m - \gamma)$$

$$= H(13.57\gamma - \gamma) = H\gamma 12.57$$

$$= (0.1016 \text{ m})(12.57)(9800 \text{ N/m}^2)(1 \text{ Pa/N/m}^2) = 12.516 \text{ kPa}$$

## PROBLEM 10.4

KNOWN: Air flow through orifice meter

$$p_1 - p_2 = 69 \text{ kPa}$$

$$d_1 = 25.4 \text{ cm}$$

$$T = 32 \text{ }^\circ\text{C}$$

FIND: H

SOLUTION

$$p_1 - p_2 = \gamma H$$

$$H = (p_1 - p_2) / \gamma$$

with  $\gamma = 9750 \text{ N/m}^3$  (Appendix)

$$H = (69,000 \text{ N/m}^2) / 9750 \text{ N/m}^3 = 7.041 \text{ m H}_2\text{O} = 704.1 \text{ cm H}_2\text{O}$$

## PROBLEM 10.5

KNOWN: Water flow through orifice meter using flange taps.

$$d_1 = 3 \text{ in.}$$

$$T = 60^\circ\text{F}$$

$$p_1 = 100 \text{ psi}$$

$$p_2 = 76 \text{ psi}$$

$$d_o = 1.5 \text{ in}$$

$$R_{O_2} = 48.3 \text{ ft}\cdot\text{lb}/\text{lb}_m\cdot^\circ\text{R}$$

FIND: Is  $Y < 1$ ?

ASSUMPTIONS:  Steady flow

SOLUTION

$$Y = f(k, \beta, \Delta p / p_1)$$

For a diatomic gas, such as  $O_2$ ,  $k = 1.4$ .

$$\beta = d_o / d_1 = 0.5$$

$$\Delta p / p_1 = 0.24$$

Using Figure 10.7,

$$Y = 0.92$$

There is an 8% reduction in flow rate due to compressibility effects.

COMMENT

Aside from the usual sources of error in an measurement, data reduction errors enter into the obstruction meter relations from the assumed values of the various coefficients and from the ability to read these values from the tables and charts. Normally, these are treated as systematic errors unless additional information about how they were estimated is known.

## PROBLEM 10.6

KNOWN: Orifice meter using flange taps

$$d_o = 5 \text{ cm}$$

$$d_1 = 15 \text{ cm}$$

$$\text{Re}_{d1} = 250,000$$

FIND:  $C$

SOLUTION

$$C = f(\beta, \text{Re}_{d1})$$

$$\beta = d_o / d_1 = 0.33$$

$$\text{Re}_{d1} = 250,000$$

From Figure 10.6,  $K_o = CE = 0.60$ .

$$E = 1/(1 - \beta^4)^{1/2} = 1.006$$

$$C = K_o/E = 0.596 \sim 0.60$$

COMMENT

Aside from the usual sources of error in a measurement, data reduction errors enter into the obstruction meter relations from the assumed values of the various coefficients and from the ability to read these values from the tables and charts. Normally, these are treated as systematic errors unless additional information about how they were estimated is known.

## PROBLEM 10.7

KNOWN: Flow of water through orifice meter at 20°C

$$d_1 = 10 \text{ cm}$$

$$\beta = 0.4$$

FIND:  $Q$  at which  $C = f(\beta, \text{Re}_{d1})$  becomes  $C = f(\beta)$

ASSUMPTIONS: Flange pressure taps are used so that Figure 10.6 is applicable.

SOLUTION

For  $\beta = 0.4$ , Figure 10.6 shows Reynolds number independence in flow coefficient for  $\text{Re}_{d1} > 20,000$ . Because  $K_o = CE$  and because  $E$  depends only on  $\beta$ , we conclude that  $C = f(\beta)$  for all  $\text{Re}_{d1} > 20,000$ .

$$\text{Re}_{d1} = 4Q / \pi \nu d_1 > 20,000$$

$$Q > \frac{1}{4} \pi \nu d_{1\text{Re}_{d1}} = \pi (1 \times 10^{-6} \text{ m}^2/\text{s})(0.1\text{m}) (20000)/4 = 1.6 \times 10^{-4} \text{ m}^3/\text{s}$$

with  $\nu$  from the Appendix.

COMMENT

Aside from the usual sources of error in an measurement, data reduction errors enter into the obstruction meter relations from the assumed values of the various coefficients and from the ability to read these values from the tables and charts. Normally, these are treated as systematic errors unless additional information about how they were estimated is known.

## PROBLEM 10.8

KNOWN: Water flow through an orifice plate with flange taps

$$Q = 50 \text{ L/s}$$

$$T = 25^\circ\text{C}$$

$$d_1 = 12 \text{ cm}$$

$$\beta = 0.5$$

FIND:  $\Delta p, \Delta p_{loss}$

ASSUMPTIONS: Steady, incompressible ( $Y = 1$ ) flow.

SOLUTION

For an orifice meter,  $Q = CEAY\sqrt{2\Delta p/\rho}$  with A based on  $d_o$ . Now,  $d_o = \beta d_1 = 0.06\text{m}$  and  $A = \pi d_o^2/4 = .0028\text{m}^2$ :

$$K_o = CE = f(\beta, Re_{d1}) = f(0.5, 530,000) \sim 0.63$$

Using  $\nu = 1 \times 10^{-6} \text{ m}^2/\text{s}$  and  $\rho = 997 \text{ kg/m}^3$  from the Appendix ,

$$Re_{d1} = 4Q/\pi\nu d_1 = 4(0.05\text{m}^3/\text{s})/(\pi \times 1 \times 10^{-6}\text{m}^2/\text{s})(0.12\text{m}) = 530000$$

Then,

$$\begin{aligned}\Delta p &= (\rho/2)(Q/CEAY)^2 = [(1000 \text{ kg/m}^3)/2]\{(0.05\text{m}^3/\text{s})/(0.63)(0.0028\text{m}^2)(1)\}^2 \\ &= 4.017 \times 10^5 \text{ N/m}^2\end{aligned}$$

From Figure 10.8, we can expect

$$\Delta p_{loss} = 0.77\Delta p = 3.093 \times 10^5 \text{ N/m}^2$$

COMMENT

Aside from the usual sources of error in an measurement, data reduction errors enter into the obstruction meter relations from the assumed values of the various coefficients and from the ability to read these values from the tables and charts. Normally, these are treated as systematic errors unless additional information about how they were estimated is known.

## PROBLEM 10.9

KNOWN: Air flow through a flow nozzle ( $k = 1.4$ )  
 $d_o = 3 \text{ cm}$   
 $d_1 = 6 \text{ cm}$   
 $H = 75 \text{ cm H}_2\text{O}$   
 $p_1 = 94.4 \text{ kPa}$   
 $T_1 = 38 \text{ }^\circ\text{C}$

FIND:  $Q$

ASSUMPTIONS: Steady flow of a perfect gas.

SOLUTION

For a flow nozzle,  $Q = CEAY\sqrt{2\Delta p/\rho}$  with A based on  $d_o$ . Now,  $\beta = d_o/d_1 = 0.5$  and  $A = \pi d_o^2/4 = .00071\text{m}^2$ . With  $\lambda = 9800 \text{ N/m}^3$  from the Appendix,

$$\Delta p = \gamma H = (9800 \text{ N/m}^3)(0.75 \text{ m}) = 7350 \text{ Pa}$$

$$\Delta p/p_1 = 7350 \text{ Pa}/94900 \text{ Pa} = 0.078$$

The compressibility factor (Figure) is  $Y = f(k, \beta, \Delta p/p_1) \sim 0.98$ . For a perfect gas,

$$\rho_1 = p_1/RT_1 = (94,400 \text{ Pa})/(287 \text{ J/kgK})(311) = 1.06 \text{ kg/m}^3$$

We need a value for  $K_o$ . But  $K_o = f(\beta, \text{Re}_{d1})$  and  $\text{Re}_{d1}$  depends on  $Q$ .

Guess a value for  $K_o$  and iterate on a solution. From Figure 10.11, pick a value of  $K_o$  that lies on the  $\beta = 0.5$  curve. Lets choose  $K_o = 1.008$ , which is a value that lies in the flat region of the curve. Then,

$$Q = (1.008)(0.00071\text{m}^2)(0.98)[(2)(7350 \text{ Pa})/(1.06\text{kg/m}^3)]^{1/2} = 0.082 \text{ m}^3/\text{s}$$

But this uses a guessed value. So, check on the guessed value of  $K_o$ . Using our new value for  $Q$ :

$$\text{Re}_{d1} = 4Q/\pi v d_1 = (4)(0.078 \text{ cms})/(\pi)(0.06\text{m})(1.6 \times 10^{-5} \text{ m}^2/\text{s}) = 103,000$$

or from Figure 10.11,  $K \sim 1.008$ . Close enough.

So the solution remains:  $Q = 0.082 \text{ m}^3/\text{s}$ .

COMMENT

Aside from the usual sources of error in a measurement, data reduction errors enter into the obstruction meter relations from the assumed values of the various coefficients and from the ability to read these values from the tables and charts. Normally, these are treated as systematic errors unless additional information about how they were estimated is known.

## PROBLEM 10.10

KNOWN: Nitrogen ( $k = 1.4$ ) flows through an orifice meter with flange taps.

$$T_1 = 520^\circ\text{R}$$

$$p_1 = 20 \text{ psia}$$

$$p_2 = 15 \text{ psia}$$

$$d_1 = 4 \text{ in.}$$

$$\beta = 0.5$$

$$R_{\text{N}_2} = 55.13 \text{ ft}\cdot\text{lb}/\text{lb}_m\cdot^\circ\text{R}$$

FIND:  $Q$

ASSUMPTIONS: Steady flow of a perfect gas

SOLUTION

For an orifice meter,  $Q = CEAY\sqrt{2\Delta p/\rho}$  with A based on  $d_o$ . Now,  $d_o = \beta d_1 = 2 \text{ in.}$  and  $A = \pi d_o^2/4 = .0218 \text{ ft}^2$ . So find Y, E, and C:

$$Y(k, (p_1 - p_2)/p_1, \beta)$$

$$p_1 - p_2 = (20 - 15) \text{ psia} = 5 \text{ psia} = 720 \text{ psf} \quad \text{and} \quad (p_1 - p_2)/p_1 = 0.25$$

so,

$$Y(k, (p_1 - p_2)/p_1, \beta) = Y(1.4, 0.25, 0.5) = 0.92 \quad (\text{Fig. 10.7})$$

$$\rho_1 = p_1/RT_1 = (20 \text{ psi})(144 \text{ in}^2/\text{ft}^2)/(55.13 \text{ ft}\cdot\text{lb}/\text{lb}_m\cdot^\circ\text{R})(520^\circ\text{R}) = 0.1 \text{ lb}_m/\text{ft}^3$$

Now,  $K_o = f(\beta, \text{Re}_{d1})$  and  $\text{Re}_{d1}$  depends on  $Q$ . Guess a value for  $K_o$  and iterate on a solution.

From Figure 10.16, pick a value of  $K_o$  that lies on the  $\beta = 0.5$  curve. Lets choose  $K_o = 0.63$

$$Q = (0.63)(0.0218 \text{ ft}^2)(0.92)[(2)(32.2 \text{ lb}_m\cdot\text{ft}/\text{lb}\cdot\text{s}^2)(5 \text{ lb}/\text{in}^2)(144 \text{ in}^2/\text{ft}^2)/0.1 \text{ lb}_m/\text{ft}^3]^{1/2} \\ = 8.6 \text{ cfs}$$

$$\text{Checking: } \text{Re}_{d1} = 4Q/\pi v d_1 = (4)(8.6 \text{ ft}^3/\text{s})/(\pi)(1.15 \times 10^{-4} \text{ ft}^2/\text{s})(4/12 \text{ ft}) = 285655$$

and  $K_o(285,655 \text{ and } 0.5) \sim 0.63$ .

So,  $Q = 8.6 \text{ ft}^3/\text{s}$ .

## PROBLEM 10.11

KNOWN: Water flow through an orifice meter

$$T = 20^\circ\text{C}$$

$$d_1 = 38 \text{ cm}$$

$$\dot{m} \approx 200 \text{ kg/s}$$

$$H \leq 15 \text{ cm Hg (with } S = 13.57)$$

FIND: Design orifice meter by setting  $d_o$ .

ASSUMPTIONS: Steady, incompressible ( $Y = 1$ ) flow

SOLUTION

The mass flow rate for a constant density ( $\rho$ ) flow

$$\dot{m} = \rho Q = \rho C E A Y \sqrt{2\Delta p / \rho}$$

with A based on orifice diameter,  $d_o$ . Solving for  $d_o$  with  $A = \pi d_o^2 / 4$ ,

$$d_o = \left[ 4\dot{m} / (C E \pi \rho \sqrt{2\Delta p / \rho}) \right]^{1/2}$$

From the Appendix,  $\rho = 999 \text{ kg/m}^3$  and  $\mu = 9.6 \times 10^{-4} \text{ N-s/m}^2$ .

$$\Delta p = \gamma_{\text{Hg}} H = S \rho g H = (13.57)(9760 \text{ N/m}^3)(0.15 \text{ m}) = 19928 \text{ N/m}^2$$

If we were to select  $\beta = 0.5$ , then  $d_o = 19 \text{ cm}$  (trial). Then

$$\text{Re}_{d_1} = 4\dot{m} / \pi \mu d_1 = (4)(200 \text{ kg/s}) / \pi (0.38 \text{ m})(9.6 \times 10^{-4} \text{ N-s/m}^2) = 698000$$

From Figure 10.6,  $K_o = f(\beta, \text{Re}_{d_1}) = f(0.5, 698000) \sim 0.625$ , then,

$$\begin{aligned} d_o &\geq [(4)(200 \text{ kg/s}) / \{ (0.625) (\pi) (1000 \text{ kg/m}^3) [(2)(19928 \text{ N/m}^2 / (1000 \text{ kg/m}^3)]^{1/2} \}]^{1/2} \\ &= 0.25 \text{ m or } 25 \text{ cm} \quad (\text{updated value}) \end{aligned}$$

Using this new value for  $d_o$  gives  $\beta = 0.658$ .

With  $\beta = 0.658$ ,  $d_o = 25 \text{ cm}$ . Rechecking:  $K_o(0.658, 698000) \sim 0.625$  and  $d_o = 0.25 \text{ m}$ .

Converged. So, this value for  $d_o$  will meet our constraints.

We may wish to build in a safety factor on the  $\Delta p$  constraint. So setting  $\beta = 0.7$  or  $d_o = 26.6 \text{ cm}$  (Note from Figure 10.6 that this is the largest value for  $\beta$  at which the ASME tables may be used. Larger  $\beta$  values will require in situ calibration. We find  $K_o = 0.668$  and the resulting pressure head works out to  $10.8 \text{ cm Hg}$  at  $200 \text{ kg/s}$ .)

COMMENT

It is apparent that by choosing different values for  $d_o$ , the pressure drop across an obstruction meter can be altered as desired for an expected flow rate.

## PROBLEM 10.12

KNOWN: Water flowing through a venturi meter

$$T = 15^\circ\text{C}$$

$$d_1 = 10\text{-cm.}$$

$$H \leq 76\text{ cm. H}_2\text{O}$$

$$Q \approx 0.5\text{ m}^3/\text{min} = 0.0083\text{ cms}$$

FIND: Design the meter size,  $d_o$

ASSUMPTIONS: Steady, incompressible ( $Y = 1$ ) flow.  
Cast venturi meter.

### SOLUTION

From (10.14),  $Q = CEAY(2\Delta p/\rho_1)^{1/2}$  where  $A$  and  $\beta$  (in the term  $E$ ) are based on the venturi throat diameter,  $d_o$ . Using  $\rho = 998\text{ kg/m}^3$  and  $\nu = 1 \times 10^{-6}\text{ m}^2/\text{s}$  for water from Appendix C:

$$\Delta p = \gamma_{\text{H}_2\text{O}} H = (\rho g/g_c)H \leq (998\text{ kg/m}^3)(9.8\text{ m/s}^2) (76\text{ cm}/100\text{ cm/m}) (1\text{ N/kg}\cdot\text{m/s}^2) = 7433\text{ N/m}^2$$

We seek,

$$d_o \geq [4Q/\{CE\pi (2\Delta p/\rho_1)^{1/2}\}]^{1/2}$$

Using  $Re_{d1} = 4Q/\pi d_1 \nu = 4(0.0083\text{ cms})/\pi(10/100)(1.0 \times 10^{-6}\text{ m}^2/\text{s}) = 106000$ . We choose  $\beta = 0.5$  so that for the venturi,  $C = 0.984$  (see text). Then,  $E = 1/(1 - \beta^4)^{1/2} = 1.0328$ . So,

$$d_o \geq [4(0.0083\text{ cms})/\{(.984)(1.0328)\pi [2(7433\text{ N/m}^2)/(998\text{ kg/m}^3)]^{1/2}\}]^{1/2} = 0.052\text{m or } 5.2\text{ cm}$$

This yields a  $\beta$  sufficiently close to 0.5, as selected. A value of  $d_o \geq 5.2\text{ cm}$  will meet the constraint.

### COMMENT

It should be apparent that by choosing different values for  $d_o$  the pressure drop across an obstruction meter can be altered. Hence, one can specify the dimensions based on an expected flow rate so as to achieve a desired range of values.  $\square$  16

## PROBLEM 10.13

KNOWN:  $Q = 120$  cfm of water at  $60^\circ\text{F}$   
 $H \leq 20$  in. Hg  
 $d_1 = 6$  in.  
pump efficiency:  $\eta = 0.60$   
power costs: \$ 0.10/kW-hr  
operating time: 6000 hr/yr

FIND: Specify design for suitable orifice, venturi and nozzle.  
 $\Delta p_{loss}$  and operating costs for each device.

ASSUMPTIONS Steady, incompressible ( $\gamma = 1$ ) flow.

PROPERTIES water:  $\rho_1 = 62.4$  lb<sub>m</sub>/ft<sup>3</sup>  $\nu = 1 \times 10^{-5}$  ft<sup>2</sup>/s

### SOLUTION

For an obstruction flow meter,  $Q = CEAY(2\Delta p/\rho_1)^{1/2}$  where  $\Delta p = \rho gH = 1411$  lb/ft<sup>2</sup>.

At  $Q = 120$  cfm,

$$Re_{d_1} = 4Q/\pi\nu d_1 = (4)(120\text{cfm})(1\text{min}/60\text{s})/(\pi)(.5\text{ft})(1 \times 10^{-5} \text{ft}^2/\text{s}) = 5.1 \times 10^5$$

The meter throat sizes  $d_o$  are found from

$$d_o = [(4Q)/(CE \pi \sqrt{2 \Delta p / \rho_1})]^{1/2}$$

Orifice:

From Figure 10.6,  $K_o = f(\beta, Re_{d_1})$ . If we guess,  $K_o = 0.6$ , then  $d_o = 0.33$  ft for  $\beta = d_o/d_1 = 0.66$ . From Figure 10.6,  $K_o(0.66, 5 \times 10^5) = 0.65$ , so that  $d_o = 0.32$  ft for  $\beta = 0.64$ . Then from Figure 9.6,  $K_o(0.64, 5 \times 10^5) = 0.65$ . So  $\beta = 0.64$  and  $d_o = 3.84$  in.

From Figure 10.8, with  $\beta = 0.64$  and  $Re_{d_1} = 5 \times 10^5$ ,

$$\Delta p_{loss} = 0.6 \Delta p = 847 \text{ psf}$$

ASME Long Radius Nozzle:

From Figure 10.11,  $K_o = f(\beta, Re_{d_1})$ . If we guess,  $K_o = 1.0$ , then  $d_o = 0.26$  ft for  $\beta = d_o/d_1 = 0.52$ . From Figure 10.11,  $K_o(0.52, 5 \times 10^5) = 1.01$ , so that  $d_o = 0.26$  ft. So  $\beta = 0.52$  and  $d_o = 3.12$  in.

From Figure 10.8, with  $\beta = 0.52$  and  $Re_{d_1} = 5 \times 10^5$ ,

$$\Delta p_{loss} = 0.6 \Delta p = 847 \text{ psf} \quad (\text{Same as the orifice, but with smaller } \beta)$$

Venturi:

Suppose we choose a 15° cast model. The text states, based on the ASME Power Test Codes, that  $C \sim 0.98$ .

So we begin an iteration with a guess,  $K_o = CE = 0.98$ . Then,  $d_o = 0.265$  for a  $\beta = 0.53$ .  $E = (1 - \beta^4)^{-1/2} = 1.04$ . So we get  $K_o = 1.02$ . Using  $K_o = 1.02$ ,  $d_o = 0.26$  ft,  $\beta = 0.52$  and  $E = 1.04$ . This is close enough. So,  $d_o = 3.12$  in.

From Figure 10.8,

$$\Delta p_{loss} = 0.18 \Delta p = 254 \text{ psf}$$

Cost Analysis

The power use is estimated from:

$$\dot{W} = Q \Delta p_{loss} / \eta$$

and operating cost from:

$$\text{cost} = (W)(\text{operating time})(\text{cost/kW-unit time})$$

	$\beta$	$\dot{W}$ [kW]	Cost[\$/yr]
orifice	0.64	3.7	2230
nozzle	0.52	3.7	2230
venturi	0.52	0.9	538

## PROBLEM 10.14

**KNOWN:** Water flow at 27°C through an ASME long radius nozzle.  
 $\beta = 0.6$   
 $H = 25.4 \text{ cm Hg}$   
 $d_1 = 15 \text{ cm.}$

**FIND:**  $Q$

**ASSUMPTIONS:** Steady, incompressible ( $Y=1$ ) flow.

**PROPERTIES:** Water:  $\rho = 997 \text{ kg/m}^3$   $\nu = 1 \times 10^{-6} \text{ m}^2/\text{s}$

### SOLUTION

From (10.14) with  $A$  and  $\beta$  based on throat diameter  $d_o$ ,

$$Q = CEAY(2\Delta p/\rho_1)^{1/2}$$

With  $\beta = d_o/d_1 = 0.6$ ,  $d_o = (0.6)(15) \text{ cm.} = 9 \text{ cm.} = 0.09 \text{ m}$  and

$$\Delta p = \gamma_{\text{H}_2\text{O}} H = (\rho g/g_c)H = (997 \text{ kg/m}^3)(9.8 \text{ m/s}^2)(0.09\text{m})(1 \text{ N/kg-m/s}^2) = 879 \text{ N/m}^2$$

The value for  $K_o = CE = f(\beta, Re_{d1})$ . From Figure 10.11, guess  $K_o = 1.035$ . Then, with  $A = \pi(0.09)^2/4 = 0.0064 \text{ m}^2$  and  $Y = 1$  (incompressible water):

$$Q = (1.035)(0.0064 \text{ m}^2)(1)[2(879 \text{ N/m}^2)(1 \text{ kg-m/s}^2\text{-N})/997 \text{ kg/m}^3]^{1/2} \\ = 0.0088 \text{ cms}$$

Check the guess:

$$Re_{d1} = 4(0.0088\text{cms})/\pi(.09\text{m})(1 \times 10^{-6} \text{ m}^2/\text{s}) = 124,500$$

From Figure 10.11,  $K_o = (0.6, 124,500) = 1.03$ .

So,  $Q = 0.0088 \text{ cms}$

## PROBLEM 10.15

KNOWN: Orifice meter

$$d_1 = 9 \text{ cm}$$

$$d_o = 4 \text{ cm}$$

Meter to be located within 4 m of straight run of pipe.

Upstream elbow.

FIND: Meter placement

ASSUMPTIONS: Elbow is in-plane with downstream pipe.

SOLUTION

For  $\beta = d_o/d_1 = 0.44$ , we use Figure 10.13 which indicates that the meter should be located in a straight run of pipe 6.25 diameters downstream of the elbow with 3 diameters of straight run pipe downstream of the meter. Using 7 diameters upstream to be conservative, this should just fit into the available space.

## PROBLEM 10.16

**KNOWN:** Orifice meter used as a sonic nozzle to meter air flow.

$$T_1 = 40^\circ\text{C}$$

$$p_1 = 695 \text{ mm Hg abs} = 92,660 \text{ N/m}^2 \text{ abs}$$

$$p_2 = 330 \text{ mm Hg abs} = 43,996 \text{ N/m}^2 \text{ abs}$$

$$d_1 = 5 \text{ cm} = 0.05 \text{ m}$$

$$\beta = 0.4$$

**FIND:** mass flow rate

**PROPERTIES:**  $R = 287 \text{ N}\cdot\text{m}/\text{kg K}$  ;  $k = 1.4$

**ASSUMPTIONS:** Air behaves as a perfect gas.

### SOLUTION

For this flow,

$$p_2/p_1 = 330 \text{ mm Hg}/695 \text{ mm Hg} = 0.475$$

$$(p_2/p_1)_{\text{crit}} = [2/(k+1)]^{k/(k-1)} = 0.528$$

Since  $p_2/p_1 < 0.528$ , the flow in the orifice throat is choked and sonic conditions exist there. Using,

$$\rho_1 = p_1/RT_1 = (92,660 \text{ N/m}^2 \text{ abs})/(287 \text{ N}\cdot\text{m}/\text{kg K})(300 \text{ K}) = 1.076 \text{ kg/m}^3$$

$$A = \pi d_o^2/4 = \pi(0.4 \times 0.05)^2/4 = 0.0003 \text{ m}^2$$

Equation 10.18 applies using  $k = 1.4$ ,  $R = 287 \text{ N}\cdot\text{m}/\text{kg K}$ , and  $T_1 = 300 \text{ K}$ :

$$\dot{m} = \rho_1 A (2RT_1)^{1/2} [(k/k + 1)(2/k + 1)^{2k-1}]^{1/2} = 0.067 \text{ kg/s}$$

## PROBLEM 10.17

KNOWN: Air flow through an orifice meter with flange taps.

$$d_o = 0.5\text{m}$$

$$d_1 = 1\text{m}$$

$$H = 90\text{ mm H}_2\text{O}$$

$$p_1 = 2\text{ atm} = 3\text{ atm absolute}$$

FIND:  $Q$

ASSUMPTIONS: Steady flow of a perfect gas.

PROPERTIES: air:  $\nu = 1.5 \times 10^{-4}\text{ m}^2/\text{s}$   $R = 0.287\text{ kJ/kg}\cdot\text{K}$

$$\text{water: } \rho = 1000\text{ kg/m}^3$$

SOLUTION

Using equation 10.14 with  $A$  and  $\beta$  based on the orifice throat diameter  $d_o$ ,

$$Q = CEAY(2\Delta p/\rho_1)^{1/2}$$

where  $\rho_1 = p_1 / RT_1 = (3)(101,325\text{ N}\cdot\text{m}^2/\text{atm})/(287\text{ J/kg}\cdot\text{K})(293\text{K}) = 3.6\text{ kg/m}^3$

$$\Delta p = \rho gH = (1000\text{ kg/m}^3)(9.8\text{ m/s}^2)(0.09\text{ m})/1\text{ kg}\cdot\text{m/N}\cdot\text{s}^2 = 882\text{ N/m}^2$$

With  $\beta = d_o/d_1 = 0.5$  and  $\Delta p/p = 0.003$ , Figure 10.7 gives  $Y \sim 1$ . From Figure 10.6, guess  $K_o = f(\beta, Re_{d1}) = 0.633$ . Then,

$$Q = (0.633)(\pi (0.5\text{ m})^2/4)[2(887\text{ N/m}^2)/1000\text{ kg/m}^3]^{1/2} = 2.75\text{ m}^3/\text{s}$$

Checking,  $Re_{d1} = 4Q/\pi d_1 \nu = 4(2.75\text{ m}^3/\text{s})/\pi (1\text{m})(1.5 \times 10^{-4}\text{ m}^2/\text{s}) = 23,350$

From Figure 10.6,  $K_o(0.5, 23350) \sim 0.635$  or  $Q = 2.76\text{ m}^3/\text{s}$ .

Checking,  $Re_{d1} = 23,400$  and  $K_o = 0.635$ .

So,  $Q = 2.76\text{ m}^3/\text{s}$ .

## PROBLEM 10.18

KNOWN: Flow of 20°C water through an ASME Long Radius Nozzle.

$$\beta = 0.5$$

$$d_1 = 8 \text{ cm id}$$

$$0.6 \leq Q \leq 1.6 \text{ liters/s (note: 1 liter} = 0.001 \text{ m}^3)$$

Transducer:

$$u_{\Delta p} / \Delta p: 0.25\% \text{ full scale (design-stage uncertainty)}$$

FIND:  $\Delta p$  or H; design stage uncertainty in Q

ASSUMPTIONS: Steady, incompressible ( $Y = 1$ ) flow of water.

PROPERTIES: Water:  $\rho = 997 \text{ kg/m}^3$ ;  $\nu = 1.0 \times 10^{-6} \text{ m}^2/\text{s}$

SOLUTION

Rewriting equation 10.14,

$$\Delta p = (\rho/2)(Q/CEYA)^2$$

Using  $d_o = \beta d_1 = (0.5)(8) = 4 \text{ cm}$  and  $A = \pi d_o^2/4 = \pi (.04)^2/4 = 0.00126 \text{ m}^2$

At 0.6 liters/s,  $Re_{d1} = 4Q/\pi d_1 \nu = 4(0.6 \text{ liters}^3/\text{s})(0.001 \text{ m}^3/\text{liter})/\pi (.08)(1.0 \times 10^{-6} \text{ m}^2/\text{s}) = 9550$

$$K_o(0.5, 9550) = CE = 0.965$$

Then,  $\Delta p = (997 \text{ kg/m}^3/2)[(0.0006 \text{ m}^3/\text{s})/(0.965)(0.00126)]^2 = 121 \text{ N/m}^2 = 0.9 \text{ mm Hg}$

At 1.6 liters/s,  $Re_{d1} = 4Q/\pi d_1 \nu = 4(1.6 \text{ liters}^3/\text{s})(0.001 \text{ m}^3/\text{liter})/\pi (.08)(1.0 \times 10^{-6} \text{ m}^2/\text{s}) = 25,450$

$$K_o(0.5, 25450) = CE = 0.965$$

Then,  $\Delta p = (997 \text{ kg/m}^3/2)[(0.0016 \text{ m}^3/\text{s})/(0.965)(0.00126)]^2 = 863 \text{ N/m}^2 = 6.5 \text{ mm Hg}$

So a transducer with a range from about 0 to 7 mm Hg (0 to 96 mm H<sub>2</sub>O) is needed. Electronic pressure transducers are readily available with a range from 0 to 10 mm Hg, and such a transducer will be suitable. (Alternatively if a mechanical output is acceptable, a manometer filled with water would work well in this range at a fraction of the cost.)

The propagation of uncertainty to the flow rate can be written as,

$$u_Q = \pm \left[ \left( \frac{\partial Q}{\partial C} u_C \right)^2 + \left( \frac{\partial Q}{\partial E} u_E \right)^2 + \left( \frac{\partial Q}{\partial A} u_A \right)^2 + \left( \frac{\partial Q}{\partial \rho} u_\rho \right)^2 + \left( \frac{\partial Q}{\partial \Delta p} u_{\Delta p} \right)^2 \right]^{1/2}$$

or dividing by  $Q = CEA(2\Delta p/\rho)^{1/2}$ , the uncertainty on a percent basis is

$$\frac{u_Q}{Q} = \pm \left[ \left( \frac{u_C}{C} \right)^2 + \left( \frac{u_E}{E} \right)^2 + \left( \frac{u_A}{A} \right)^2 + \left( \frac{u_\rho}{2\rho} \right)^2 + \left( \frac{u_{\Delta p}}{2\Delta p} \right)^2 \right]^{1/2}$$

For the design-stage uncertainty analysis, we assume:

Transducer:	$u_{\Delta p} / \Delta p = 0.0025$	[given]
Discharge coefficient:	$u_C / C = 0.02$	[text ref. 2]
Diameters:	$u_{d1} / d_1 = u_{d0} / d_0 = 0.002$	[reasonable assumption]
Density:	$u_\rho / \rho = 0.002$	[reasonable assumption]

Then,

Area:	$u_A / A = 2u_{d0} / d_0 = 0.004$
Beta ratio:	$u_\beta / \beta = [(u_{d0} / d_0)^2 + (u_{d1} / d_1)^2]^{1/2} = .003$
Approach factor:	$u_E / E = [2\beta^3 / (1 - \beta^4)^2] u_\beta / \beta = 0.0009$

$$u_Q / Q = \pm [0.02^2 + 0.0009^2 + 0.004^2 + (0.002/2)^2 + (0.0025/2)^2]^{1/2} = \pm 0.02$$

That's an uncertainty of about 2% of the flow rate.

## COMMENT

Note how the known information about the instruments and the coefficients has been used to estimate this uncertainty. It is clear that the uncertainty in discharge coefficient dominates the uncertainty in flow rate. In situ calibration of the nozzle could reduce this uncertainty in C. The uncertainty due to the pressure transducer is too small to be an important factor in this measurement.

## PROBLEM 10.19

KNOWN: Water at 60°F flowing through an orifice meter.

$$10 \leq Q \leq 50 \text{ gpm}$$

$$d_1 = 2.3 \text{ inch}$$

$$u_{\Delta p} / \Delta p = \pm 0.005$$

Select  $C = f(\beta)$  only

FIND:  $d_o$ ; design stage uncertainty in  $Q$

ASSUMPTIONS: Steady, incompressible ( $Y = 1$ ) flow of water.

PROPERTIES: Water:  $\rho = 62.4 \text{ lb}_m/\text{ft}^3$      $\nu = 1.2 \times 10^{-5} \text{ ft}^2/\text{s}$

SOLUTION

Begin by finding  $d_o$ .

For an orifice meter,  $Q = CE A(2\Delta p/\rho)^{1/2}$ .  $E = 1/\sqrt{1-\beta^4}$ . From Figure 10.6,  $K$  becomes essentially independent of Reynolds number at the higher values. So we will try to meet the constraint at the lowest expected flow rate so that it will be met at all higher flow rates.

At 10 gpm,

$$\text{Re}_{d_1} = 4Q/\pi d_1 \nu = 4(10 \text{ gpm})(448 \text{ cfs/gpm})/\pi (1.2 \times 10^{-5} \text{ ft}^2/\text{s})(2.3/12 \text{ ft}) = 9900$$

Again, using Figure 10.6 at  $\text{Re} = 9900$ , select  $\beta = 0.3$ . The value for discharge coefficient falls within a range ( $C = K_o/E$ ):  $0.60 \leq C \leq 0.615$ . Then with  $d_o = 0.6$  inches, we can assume a constant value of  $C = 0.607$  to within 2.5% over the flow range.

The uncertainty of a result, in this case the flow rate, is estimated by propagation of terms and uncertainties,  $Q = f(C, E, A, \rho, \Delta p)$ . This gives

$$\frac{u_Q}{Q} = \pm \left[ \left(\frac{u_C}{C}\right)^2 + \left(\frac{u_E}{E}\right)^2 + \left(\frac{u_A}{A}\right)^2 + \left(\frac{u_\rho}{2\rho}\right)^2 + \left(\frac{u_{\Delta p}}{2\Delta p}\right)^2 \right]^{1/2} \quad (\text{equation 1})$$

From Chapter 10 reference 2 or 12, we find that we can estimate the error in discharge coefficient at  $\pm 6\%$  of  $C$ , i.e.,  $B_1 = \pm 0.006C$ , when using the tabulated values. We also assume that  $C$  is constant over the full flow range, which introduces a systematic error estimated at  $B_2 = 2.5\%$  of  $C$ . Together we obtain the systematic uncertainty in  $C$ ,

$$B_C / C = \left[ (B_1 / C)^2 + (B_2 / C)^2 \right]^{1/2} = \left[ (0.006)^2 + (0.025)^2 \right]^{1/2} = 0.026$$

Further, it is reasonable to expect a tolerance of 0.005 inch in all dimensional measurements. Hence, we use this value as an estimate of the systematic error in the dimensional terms,

$$B_{d_o}/d_o = 0.0083$$

$$B_{d_1}/d_1 = 0.0025$$

Then, expanding each uncertainty and plugging in values gives

$$B_A/A = 2\pi d_o B_{d_o}/4 = 2B_{d_o}/d_o = 0.0167$$

$$B_\beta/\beta = \left[ (B_{d_o}/d_o)^2 + (B_{d_1}/d_1)^2 \right]^{1/2} = 0.017$$

$$B_E/E = \left[ \left( 2\beta^3/(1-\beta^4) \right)^2 (B_\beta/\beta) \right] = 0.0009$$

It is reasonable to assume a  $\pm 0.5\%$  systematic uncertainty in density, so

$$B_\rho/\rho = 0.005$$

We will treat all of the uncertainty in the pressure transducer as a systematic uncertainty, then  $B_{\Delta p}/\Delta p = 0.005$  (because we have no other information to treat it otherwise). Subbing back into equation (1),

$$B_Q/Q = \pm \left[ 0.026^2 + 0.0167^2 + 0.0009^2 + (0.005/2)^2 + (0.005/2)^2 \right]^{1/2} = \pm 0.031$$

Finally, recognizing that all errors are treated as systematic errors, such that all  $P = 0$ , then

$$u_Q/Q = B_Q/Q = \pm 0.031$$

The uncertainty in flow rate is about 3.1%.

#### COMMENT

Certainly, the uncertainty in  $C$  dominates the uncertainty in  $Q$ . It is worth noting that as  $Re_{d_1}$  approaches 50 000 and beyond ( $Q > 40$  gpm), the value for  $C$  approaches 0.60. Using this value for all flow rates would retain the previous uncertainty value at low flow rates but would reduce  $u_Q/Q$  to less than 1.8% at the higher flow rates. Try it!

We treat all errors in this problem as systematic errors and assign them systematic uncertainties. We then propagate these systematic uncertainties through to a result. Had we simply assigned the values as uncertainties (i.e., replace all the  $B$  terms with  $u$  terms), the problem would develop exactly the same. When errors can be separated into random and systematic components, their separation serves a useful purpose.

## PROBLEM 10.20

KNOWN: Air (70°F) flow through an orifice  
 $10 \leq \Phi \leq 80\%$  where  $\Phi$  is relative humidity  
 $\rho(\Phi = 45\%)$  used

FIND:  $u_Q$  due to variation in density due to humidity changes

PROPERTIES: Using a psychrometric chart for air at standard atmosphere,  
 $\rho$  (80%) = 0.0746 lb<sub>m</sub>/ft<sup>3</sup>  
 $\rho$  (10%) = 0.0735 lb<sub>m</sub>/ft<sup>3</sup>  
 $\rho$  (45%) = 0.0741 lb<sub>m</sub>/ft<sup>3</sup>

### SOLUTION

Inspection of the properties reveals that the density can be estimated as

$$\rho = 0.0741 \pm 0.0005 \text{ lb}_m/\text{ft}^3$$

over the range of relative humidity values. This does not account for systematic errors in the actual density values obtained from the chart. For an orifice plate,

$$Q = CEA(2\Delta p/\rho)^{1/2}$$

To isolate the effects of humidity on the flow rate, we neglect all error sources except those involved with density (as density is affected by humidity). This assumes that C, A, and pressure are not affected by humidity variation, which is reasonable. Then,

$$u_Q = f(\rho) = \pm \left[ \left( \frac{\partial Q}{\partial \rho} u_\rho \right)^2 \right]^{1/2}$$

Dividing through by the flow rate, gives

$$u_Q / Q = \pm \left[ \left( u_\rho / 2\rho \right)^2 \right]^{1/2} = 0.0034$$

or an uncertainty of about 0.34% of the flow rate results due to relative humidity effects alone.

## PROBLEM 10.21

KNOWN: Air flow through an orifice meter with the conditions from Problem 10.20.

$$Q = 17 \text{ m}^3/\text{hr} = 17 \text{ cmh}$$

$$T = 20^\circ\text{C}$$

$$\beta = 0.4$$

$$d_1 = 6 \text{ cm}$$

$$u_{\Delta p} / \Delta p = 0.005$$

$$u_{d_0} = u_{d_1} = 0.1 \text{ mm}$$

$$p_1 = 96.5 \text{ kPa}$$

FIND: Design stage uncertainty in flow rate

PROPERTIES  $R = 28 \text{ N}\cdot\text{m}/\text{kg}\cdot\text{K}$

$$\nu = 1.6 \times 10^{-5} \text{ m}^2/\text{s}$$

$$k = 1.4$$

SOLUTION

For an orifice,  $Q = CEA(2\Delta p/\rho)^{1/2}$  with  $d_0 = \beta d_1 = 2.4 \text{ cm}$ . But  $K_o = CE = f(\beta, \text{Re})$ . At 17 cmh,  $\text{Re}_{d_1} = 4Q/\pi\nu d_1 = 6260$ . Then from Figure 10.6,  $K_o(0.4, 6260) = 0.63$  (at least to within  $\pm 0.005$ ). To solve equation (10.14) for  $\Delta p$ , we assume  $Y = 1$ . This yields for  $A = 0.00045 \text{ m}^2$ ,

$$\Delta p = [0.0047 \text{ cms}/(.63)(0.00045\text{m}^2)(1)]^2(1.15 \text{ kg}/\text{m}^3/2) = 157.85 \text{ N}/\text{m}^2$$

Using this value,  $\Delta p/p_1 = 0.0016$ . With  $k = 1.4$ , Figure 10.7 gives  $Y = 1$ . So  $\Delta p = 157.85 \text{ N}/\text{m}^2$ . This is equivalent to about 1.6 cm  $\text{H}_2\text{O}$ .

Based on (10.14) and the propagation of uncertainty to a resultant, dividing by (10.14), the uncertainty in flow rate can be written as

$$\frac{u_Q}{Q} = \pm \left[ \left(\frac{u_C}{C}\right)^2 + \left(\frac{u_E}{E}\right)^2 + \left(\frac{u_A}{A}\right)^2 + \left(\frac{u_Y}{Y}\right)^2 + \left(\frac{u_\rho}{2\rho}\right)^2 + \left(\frac{u_{\Delta p}}{2\Delta p}\right)^2 \right]^{1/2}$$

The uncertainty in  $C$  is due both to the intrinsic error in using tabulated values,  $u_1$ , and due to our ability to read Figure 10.6,  $u_2$ . Setting  $u_1 = 0.006C$  (see text) and  $u_2 = 0.008C$  (based on an estimated resolution of  $\pm 0.005$  from the chart):

$$u_C/C = (0.006^2 + 0.008^2)^{1/2} = 0.01$$

Other values:

$$u_{d_o}/d_o = 0.01/2.4 = 0.004$$

$$u_{d_1}/d_1 = 0.01/6 = 0.0017$$

$$u_A/A = 2u_{d_o}/d_o = 0.008$$

$$u_{\beta}/\beta = [(u_{d_o}/d_o)^2 + (u_{d_1}/d_1)^2]^{1/2} = 0.0043$$

$$u_E/E = 2\beta^3(1 - \beta^4)^{-2}u_{\beta}/\beta = 0.0009$$

$$u_Y/Y = 0.004 \Delta p/p_1 = 1.3 \times 10^{-5} \quad (\text{see text and reference 2})$$

$$u_{\Delta p}/\Delta p = 0.005$$

Lastly, the uncertainty in density will be due both to the error from the presumed humidity variations,  $u_1$ , and the error in the tabulated values,  $u_2$ . Taking  $u_1/\rho = (0.0005/1.15) = 0.0004$  and  $u_2/\rho = 0.005$  (i.e. about 0.5% of the tabulated value):

$$u_{\rho}/\rho = [0.0004^2 + 0.005^2]^{1/2} = 0.005$$

Then,

$$\begin{aligned} u_Q/Q &= \pm \left[ 0.01^2 + 0.0009^2 + 0.008^2 + (1.3 \times 10^{-5})^2 + (0.005/2)^2 + (0.005/2)^2 \right]^{1/2} \\ &= \pm 0.0133 \end{aligned}$$

Accounting for known uncertainties, the uncertainty is about 1.3% of the flow rate.

#### COMMENT

The assignment of uncertainty estimates requires time, some research into available information and good common sense. Keep in mind that the above estimate does not include the effects of control of operating conditions and the measurement procedure.

## PROBLEM 10.22

KNOWN: Air flow at 70°F through an ASME Long Radius Nozzle

$$Q = 45 \text{ cfm}$$

$$p_1 = 14.1 \text{ psia}$$

FIND:  $p_2$  and  $d_o$  required to assure choked flow at the throat.

ASSUMPTIONS: Air behaves as a perfect gas in this process

PROPERTIES:  $R = 53.3 \text{ ft}\cdot\text{lb}/\text{lb}_m\cdot^\circ\text{R}$

$$k = 1.4$$

SOLUTION

From (10.16), the critical pressure ratio is given by

$$[p_2/p_1]_c = (2/k+1)^{k/k-1} = (2/2.4)^{1.4/0.4} = 0.528$$

The critical pressure ratio sets the largest pressure possible and still choke the throat. Then, the critical downstream pressure is

$$[p_2]_c = 0.528p_1 = 7.45 \text{ psia}$$

So,  $p_2 \leq 7.45 \text{ psia}$  to choke the flow.

Under choked flow conditions, the mass flow rate is at a maximum value. Equation 10.18 gives the mass flow rate at the critical pressure ratio which must then be the maximum mass flow through the nozzle. Rearranging (10.18), we solve for the throat area at critical conditions which must represent the largest throat area that can choke the flow,

$$\begin{aligned} A_{\max} &= \frac{\dot{m} / \rho}{\sqrt{2RT} \sqrt{\frac{k}{k+1} \left(\frac{2}{k+1}\right)^{2/k-1}}} \\ &= \frac{(45 \text{ ft}^3 / \text{min} \times 1 \text{ min} / \text{s})}{\sqrt{2 \times 53.3 \frac{\text{ft} \cdot \text{lb}}{\text{lb}_m \cdot ^\circ\text{R}} \times 530^\circ\text{R} \times 32.2 \text{ lb}_m \cdot \text{ft} / \text{s}^2 \cdot \text{lb}} \sqrt{\frac{1.4}{1.4+1} \left(\frac{2}{1.4+1}\right)^{2/(1.4-1)}} \\ &= 0.0011 \text{ ft}^2 \end{aligned}$$

But  $A = \pi d_o^2 / 4$ . So  $d_o \leq 0.459$  inches would provide a suitable design.

## PROBLEM 10.23

KNOWN: Water at 20°C flows through orifice plate with flange taps.

$$d_1 = 10 \text{ cm}$$

$$H = 100 \text{ mm Hg at } Q = 2 \text{ m}^3/\text{min} = 0.033 \text{ cms}$$

FIND:  $d_o$  required

SOLUTION

We want to have  $H = 100 \text{ mm Hg}$  or  $\Delta p = (13.57)(9800 \text{ N/m}^2)(0.1 \text{ m}) = 13,300 \text{ N/m}^2$ .  
Equation 10.14 can be rewritten as:

$$d_o = [4Q / (CE\pi(2\Delta p/\rho_1)^{1/2})]^{1/2}$$

for the conditions known, this reduces to  $d_o = 0.09 / (K_o)^{1/2} \text{ [m]}$

To solve, we that  $K_o = CE = f(\beta, Re_{d1})$ . For the target flowrate,

$$Re_{d1} = 4Q / \pi v d_1 = 4(0.033 \text{ cms}) / \pi (.1 \text{ m})(1 \times 10^{-6} \text{ m}^2/\text{s}) = 425,000$$

Inspection of Figure 10.6 shows that the orifice diameter requires a  $\beta$  of nearly 1 to satisfy the flow meter equation. So an orifice meter can not be used to meet the given constraints! If an orifice meter were used, the pressure drop would be substantially less than the desired value.

## PROBLEM 10.24

KNOWN: Nozzle used to meter 20°C water.

$$d_1 = 20 \text{ cm}$$

$$5000 \text{ cm}^3/\text{s} \leq Q \leq 50,000 \text{ cm}^3/\text{s}$$

$$\beta = 0.5$$

FIND: Pressure transducer range required.

SOLUTION

Rearranging the obstruction meter equation (10.14) with  $Y = 1$  (incompressible):

$$\Delta p = (\rho/2)(Q/K_o A)^2$$

where  $K_o = f(\beta=0.5, Re_{d1})$ .

$$\text{Low } Q: Re_{d1} = 4(0.05 \text{ m}^3/\text{s})/\pi (.2\text{m})(1 \times 10^{-6} \text{ m}^2/\text{s}) \sim 32,000$$

$$\text{High } Q: Re_{d1} = 4(0.5 \text{ m}^3/\text{s})/\pi (.2\text{m})(1 \times 10^{-6} \text{ m}^2/\text{s}) \sim 320,000$$

So from Figure 10.11:  $(K_o)_{\text{low}} \sim 1.000$  ;  $(K_o)_{\text{high}} \sim 1.005$ .

Solving:

$$\Delta p_{\text{low}} = 203 \text{ N/m}^2$$

$$\Delta p_{\text{high}} = 20,100 \text{ N/m}^2$$

So the selected transducer must have a range extending from about 200 to 20,500 N/m<sup>2</sup>, one rated from 0 to 21 cm H<sub>2</sub>O will work well.

## PROBLEM 10.25

### SOLUTION

The solution to this problem is open-ended. We suggest that the instructor assign this problem and use it as a basis for an in-class or small group discussion.

## PROBLEM 10.26

KNOWN: Vortex meter metering fluid flow

$St = 0.20$  (shedder Strouhal number)

$f = 77 \text{ Hz}$  (shed frequency)

$d = 1.27 \text{ cm}$  (shedder characteristic length, see Table 10.1)

FIND: Average velocity,  $U$

SOLUTION

$$St = fd/U$$

$$U = (77 \text{ Hz})(0.0127)/0.2 = 4.89 \text{ m/s}$$

## PROBLEM 10.27

KNOWN: Air flow at 30°C metered by a thermal mass flow meter

$$d_1 = 2 \text{ cm}$$

$$\text{Power} = P = 25 \text{ W}$$

$$\Delta T = 1^\circ\text{C} = 1\text{K}$$

$$c_p = 1.006 \text{ kJ/kg-K}$$

FIND: mass flow rate

ASSUMPTIONS:  $c_p$  is constant through meter and known.

$\Delta T$  reported (measured) must be the average mixed temperature across each pipe cross section.

Power supplied to meter is 100% dissipated in fluid (i.e. no losses).

SOLUTION

$$\dot{E} = \dot{m} c_p \Delta T$$

But the energy supplied to the meter is dissipated into the flow, so that  $\dot{E} = P$ .

Then,

$$\dot{m} = P / c_p \Delta T = (25 \text{ W}) / (1006 \text{ J/kg-K})(1\text{K}) = 0.025 \text{ kg/s}$$

COMMENT

Note the many assumptions that go into using this meter. Actually, for flows of gases which can be well modeled as perfect gases, these types of meters provide excellent accuracy. For other types of fluids, they have limited applicability.

## PROBLEM 10.28

**KNOWN:** Sonic nozzle used to regulate volume flow rate of air.

**FIND:** Uncertainty due to normal changes in ambient temperature and pressure.

### SOLUTION

From (10.18),

$$\dot{m} = \rho_1 A (2RT_1)^{1/2} [(k/k + 1)(2/k + 1)^{2/k-1}]^{1/2}$$

For air,  $(p_2/p_1)_{cr} = 0.528$ . Provided that the actual  $p_2/p_1$  ratio remains below this value the throat will remain choked. From (10.3) and (10.6), we can rewrite this for volume flow rate as,

$$Q = A(2RT_1)^{1/2} [(k/k+1)(2/k+1)^{2/k-1}]^{1/2}$$

This shows that the volume flow rate will be affected by environmental changes in temperature even though constant mass flow rate is maintained in the nozzle throat (all other terms in the equation remain constant). If we look only at the effects of temperature variation over the  $\pm 5$  K range specified, then  $Q = f(T)$  only. This can be expressed as

$$\begin{aligned} u_Q/Q &= \pm [(u_T/2T)^2]^{1/2} \\ &= \pm [(5 \text{ K})/(2 \times 283 \text{ K})^2]^{1/2} \\ &= \pm 0.0088 \end{aligned}$$

or an added uncertainty in volume flow rate of 0.88% or about 1% due to temperature changes alone.

## PROBLEM 10.29

KNOWN: From Example 10.4:  $Q = 0.053$  cms (air)

$$d_1 = 6 \text{ cm}$$

$$\beta = 0.4$$

$$d_o = 2.4 \text{ cm}$$

$$H = 250 \text{ cm H}_2\text{O}$$

$$p_1 = 93.7 \text{ kPa}$$

$$T=1 = 293 \text{ K}$$

$$Y = 0.92$$

All dimensions known to  $\pm 0.025$  mm

Upstream pressure is constant

Pressure drop has systematic uncertainty  $B = \pm 0.25$  cm H<sub>2</sub>O

$S_H = 0.5$  cm H<sub>2</sub>O with  $N = 20$

FIND:  $u_Q$

PROPERTIES: water:  $\gamma = 9800 \text{ N/m}^3$ ;  $\rho = 998 \text{ kg/m}^3$

air:  $\nu = 1.6 \times 10^{-5} \text{ m}^2/\text{s}$ ;  $\rho = 1.16 \text{ kg/m}^3$

SOLUTION

The flow rate is found by

$$Q = f(C, E, A, Y, \Delta p, \rho)$$

with  $Q = CEA(2\Delta p/\rho)^{1/2}$  and  $\Delta p = (9800 \text{ N/m}^3)(2.5 \text{ m H}_2\text{O}) = 24.5 \text{ kPa}$

The systematic uncertainty in  $Q$  can be estimated on a percent basis as,

$$\frac{B_Q}{Q} = \pm \left[ \left(\frac{B_C}{C}\right)^2 + \left(\frac{B_E}{E}\right)^2 + \left(\frac{B_A}{A}\right)^2 + \left(\frac{B_Y}{Y}\right)^2 + \left(\frac{B_\rho}{2\rho}\right)^2 + \left(\frac{B_{\Delta p}}{2\Delta p}\right)^2 \right]^{1/2}$$

where

$$B_{d_o}/d_o = 0.0025/2.4 = 0.001$$

$$B_{d_1}/d_1 = 0.0025/6 = 0.0004$$

$$B_\beta = \left[ (B_{d_o}/d_o)^2 + (B_{d_1}/d_1)^2 \right]^{1/2} = 0.001$$

$$B_A/A = 2B_{d_o}/d_o = 0.002$$

$$B_E/E = 2\beta^3(1 - \beta^4)^{-2} B_\beta / \beta = 0.0002$$

$$B_Y/Y = 0.004 \Delta p/p_1 = 1.3 \times 10^{-5} \quad (\text{see text and reference 2})$$

$$B_{\Delta p}/\Delta p = 0.25/250 = 0.001$$

$$B_\rho/\rho = 0.005 \quad (\text{assumed value})$$

According to the text and reference 2, the systematic uncertainty in using the tabulated values for C amounts to 0.006C. However, we will also add an additional elemental systematic error in reading Figure 10.6 estimate with systematic uncertainty of 0.008C. Then,

$$B_C/C = (0.006^2 + .008^2)^{1/2} = 0.0094$$

Inserting yields,

$$B_Q/Q = [0.0094^2 + 0.0002^2 + 0.002^2 + 0.000013^2 + (0.005/2)^2 + (0.001/2)^2]^{1/2} = 0.01$$

Or  $B_Q = 0.00053 \text{ m}^3/\text{s}$ . Note how the systematic error in C dominates.

Likewise the random uncertainty in Q can be expressed as

$$\frac{P_Q}{Q} = \pm \left[ \left(\frac{P_C}{C}\right)^2 + \left(\frac{P_E}{E}\right)^2 + \left(\frac{P_A}{A}\right)^2 + \left(\frac{P_Y}{Y}\right)^2 + \left(\frac{P_\rho}{2\rho}\right)^2 + \left(\frac{P_{\Delta p}}{2\Delta p}\right)^2 \right]^{1/2}$$

But the only random error estimate comes from the pressure reading, so that the random uncertainty is

$$P_Q/Q = P_{\Delta p} / \Delta p$$

With  $S_H = 0.5 \text{ cm H}_2\text{O}$ ,

$$P_H = S_H/(20)^{1/2} = 0.11 \text{ cm H}_2\text{O}$$

or in correct units,

$$P_{\Delta p} = 9.8 \text{ N/m}^2 \text{ with a degrees of freedom of 19.}$$

Then,

$$P_Q/Q = \left[ \left( P_{\Delta p} / 2\Delta p \right)^2 \right]^{1/2} = [(9.8/(2)(24500))^2]^{1/2} = 0.0002$$

Or  $P_Q = 1 \times 10^{-5} \text{ m}^3/\text{s}$ .

Combining random and systematic uncertainty estimates for flow rate,

$$u_Q = \pm \left[ 0.0053^2 + (2.093 \times 1 \times 10^{-5})^2 \right]^{1/2} = \pm 0.00053 \text{ cms (95\%)}$$

## COMMENT

The uncertainty amounts to about 1% of the flow rate and is primarily due to systematic errors in the variables, notably the discharge coefficient. The user may feel more comfortable using larger values for the systematic errors as read from charts and properties obtained from tables. The point is that a careful consideration of each term relevant to the measurement has been made.

## PROBLEM 10.30

KNOWN:  $\dot{Q} = 10W$

$$\Delta T = 3^{\circ}C$$

Air:  $c_p = 1.006 \text{ kJ/kg K}$

FIND:  $\dot{m}$

ASSUMPTION: Air is a perfect gas (i.e.,  $c_p = \text{constant}$ )

SOLUTION

$$\dot{m} = \frac{\dot{Q}}{c_p \Delta T} = \frac{10W}{(1006J/kgK)(3^{\circ}C)} (1J/s/W) = 0.0033 \text{ kg/s} = 0.2 \text{ kg/min}$$

## PROBLEM 10.31

KNOWN:  $St = 0.19$  (Table 10.1 for  $Re_d > 10,000$ )  
 $d = 10 \text{ mm} = 0.010 \text{ m}$   
 $D = 10 \text{ cm} = 0.10 \text{ m}$   
 $U = 30 \text{ m/s}$   
 $T = 20^\circ\text{C}$  air

FIND:  $K_1, Q$

SOLUTION

$$f = \frac{St \times U}{d} = \frac{0.19 \times 30 \text{ m/s}}{0.01 \text{ m}} = 5,700 \text{ Hz}$$

$$K_1 = \pi d / 4St = \pi(0.01 \text{ m}) / (4 \times 0.19) = 0.0413$$

$$Q = K_1 D^2 f = (0.0413)(0.1 \text{ m})^2 (5700 \text{ Hz}) = 0.236 \text{ m}^3/\text{s}$$

$$\text{Check: } Q = UA = U \pi d^2 / 4 = 0.236 \text{ m}^3/\text{s} \quad \text{ok}$$

$$\text{Check: } Re = \rho U d / \mu = 20,000 \quad \text{so } St = 0.19 \quad \text{ok}$$

## PROBLEM 10.32

KNOWN:  $Q = 30 \text{ acmm} = 30 \text{ actual m}^3/\text{min}$   
 $p = 50 \text{ mm Hg}$   
 $T = 15^\circ\text{C}$

FIND:  $Q_{\text{standard}}$

SOLUTION

$$Q_{s \text{ tan dard}} = Q_{\text{actual}} \frac{\rho_{\text{actual}}}{\rho_{s \text{ tan dard}}} = Q_{\text{actual}} \left( \frac{293}{273 + 15\text{C}} \right) \left( \frac{760 + 50}{760} \right)$$

$$Q_{s \text{ tan dard}} = 1.0843 Q_{\text{actual}} = 32.5 \text{ scmm}$$

## PROBLEM 10.33

KNOWN:	Cast venturi		
	$C = 0.984$	with $b = 0.00375$	$P = 0$
	$d_o = 3.995$ in	with $b = 0.0005$	$P = 0$
	$d_1 = 6.011$ in	with $b = 0.001$	$P = 0$
	$\rho = 62.369$ lb <sub>m</sub> /ft <sup>3</sup>	with $b = 0.002$	$P = 0.002$ (large dataset)
	$H = 100$ in H <sub>2</sub> O	with $b = 0.15$	$P = 0.4$ (large dataset)

FIND: Best estimate of the flow rate at 95% confidence

ASSUMPTION: Neglect thermal expansion of the venturi material; Dataset is large such that  $N > 30$ , so that  $t \sim 2$  is used throughout the problem

### SOLUTION

This problem is taken from PTC 19.1 – 2005 where it was revised, edited and presented in that standard by author R. Figliola. The problem is formatted in a manner recommended by the standard, although the nomenclature has been revised to be consistent with this text.

$$\dot{m} = \rho Q = \rho C E Y A \sqrt{2 \Delta p / \rho}$$

where  $\rho$  is the density of water. With  $\Delta p = \rho g h$  and  $h$  is the equivalent head in terms of inches of water;  $Y$  is set equal to 1 for incompressible liquids;  $E = 1 / \sqrt{1 - (d/D)^4}$ ; and

$A = \pi d^2 / 4$ , we can express the mass flow rate in lb<sub>m</sub>/s as

$$\dot{m} = \frac{0.099702 C d^2 \sqrt{\rho h}}{\sqrt{1 - \left(\frac{d}{D}\right)^4}}$$

So,  $\dot{m} = f(C, d, \rho, h, D)$  and  $u_{\dot{m}} = f(B_C, B_d, B_\rho, B_h, B_D; P_C, P_d, P_\rho, P_h, P_D)$ , or using the fact that  $b = B/2$  (i.e., the standard systematic uncertainty equals one-half the systematic uncertainty) we can equivalently write  $u_{\dot{m}} = f(b_C, b_d, b_\rho, b_h, b_D; P_C, P_d, P_\rho, P_h, P_D)$ . Also,

$$b_{\dot{m}} = \left[ \left( \frac{\partial \dot{m}}{\partial C} b_C \right)^2 + \left( \frac{\partial \dot{m}}{\partial d} b_d \right)^2 + \left( \frac{\partial \dot{m}}{\partial \rho} b_\rho \right)^2 + \left( \frac{\partial \dot{m}}{\partial h} b_h \right)^2 + \left( \frac{\partial \dot{m}}{\partial D} b_D \right)^2 \right]^{1/2}$$

$$P_{\dot{m}} = \left[ \left( \frac{\partial \dot{m}}{\partial C} P_C \right)^2 + \left( \frac{\partial \dot{m}}{\partial d} P_d \right)^2 + \left( \frac{\partial \dot{m}}{\partial \rho} P_\rho \right)^2 + \left( \frac{\partial \dot{m}}{\partial h} P_h \right)^2 + \left( \frac{\partial \dot{m}}{\partial D} P_D \right)^2 \right]^{1/2}$$

so that the uncertainty in mass flow rate is found by

$$u_m = \pm \left[ (B)^2 + (2P)^2 \right]^{1/2} = \pm \left[ (2b)^2 + (tP)^2 \right]^{1/2} \quad (95\%)$$

where t has been assigned the value of  $t \sim 2$ . Or, in terms of the standard uncertainty

$$u_m = \pm \left[ (b)^2 + (P)^2 \right]^{1/2} \quad (68\%)$$

Table 1 states the known information. Table 2 states the sensitivity terms and values used in the propagation formulas. Table 3 states the contributions of each variable to the uncertainty in mass flow rate. Table 4 states the results.

We find (from Table 4) that

$$\dot{m} = 138.4 \pm 1.21 \text{ lb}_m/\text{s} \quad (95\%)$$

which is equivalent to the result

$$\dot{m} = 138.4 \pm 0.608 \text{ lb}_m/\text{s} \quad (68\%)$$

Either answer is a correct statement at its specified probability level.

Table 1: Nominal Values and Uncertainties for each Variable

Independent Parameters					
X				Absolute Systematic Standard Uncertainty	Random Standard Uncertainty of the Mean
Symbol	Description	Units	Nominal Value	$b_x$	$P_x = s_{\bar{x}}$
$C$	Discharge Coefficient	...	0.984	3.75E-03	0
$d$	Throat Diameter	inches	3.999	5.0E-04	0
$D$	Inlet Diameter	inches	6.001	1.0E-03	0
$\rho$	Water density @ 60°F [25]	lb <sub>m</sub> /ft <sup>3</sup>	62.37	0.002	0.002
$h$	Differential pressure head across venture (68°F)	in.H <sub>2</sub> O	100	0.15	0.4

GENERAL NOTES:

- The systematic and random estimates for density are based on water temperature measurements having systematic and random uncertainties of 0.2°F and 0.1°F, respectively.
- The systematic uncertainty for the differential pressure head is assumed to be one-half the least count of the manometer scale.

Table 2: Estimation of the Sensitivities for Each Variable

X	Nominal Values	Formulas for Absolute Sensitivity		Sensitivity
			$\frac{\partial \dot{m}}{\partial X}$	$\frac{\partial \dot{m}}{\partial X}$
C	0.984		$\frac{0.099702d^2\sqrt{\rho h}}{\sqrt{1-\left(\frac{d}{D}\right)^4}}$	140
d	3.999	$\sqrt{1-\left(\frac{d}{D}\right)^4}$	$(2)0.099702C\sqrt{\rho h}d - \frac{\left(0.099702C\sqrt{\rho h}\right)d^2(-4)\left(\frac{d}{D}\right)^3}{2\sqrt{1-\left(\frac{d}{D}\right)^4}D\left(1-\left(\frac{d}{D}\right)^4\right)}$	72.6
D	6.001		$-\frac{4(0.099702)Cd^6\sqrt{\rho h}}{2D^5\left(1-\left(\frac{d}{D}\right)^4\right)^{3/2}}$	-11.4
$\rho$	62.37		$\frac{0.099702Cd^2\frac{\sqrt{h/\rho}}{2}}{\sqrt{1-\left(\frac{d}{D}\right)^4}}$	1.11
h	100		$\frac{0.099702Cd^2\frac{\sqrt{\rho/h}}{2}}{\sqrt{1-\left(\frac{d}{D}\right)^4}}$	0.692

Table 3: Uncertainty Values for Each Variable

Independent Parameters								
Parameter Information (in Parameter Units)				Uncertainty Contribution of Parameters to the Result (in Result Units Squared)				
<i>X</i>	Description	Units	Nominal Value	Absolute Systematic Standard Uncertainty $b_X$	Absolute Random Standard Uncertainty $P_X = S_x$	Absolute Sensitivity $\theta_X$	Absolute Systematic Standard Uncertainty Contribution $(b_X \theta_X)^2$	Absolute Random Standard Uncertainty Contribution $(P_X \theta_X)^2$
<i>C</i>	Discharge coefficient	...	0.984	3.75E-03	0	140	0.276	0
<i>d</i>	Throat diameter	inches	3.999	5.0E-04	0	86.2	1.86×10 <sup>-3</sup>	0
<i>D</i>	Inlet diameter	inches	6.001	1.0E-03	0	-11.4	1.29×10 <sup>-4</sup>	0
$\rho$	Water density @ 60°F [25]	lb <sub>m</sub> /ft <sup>3</sup>	62.37	0.002	0.002	1.11	4.93×10 <sup>-6</sup>	4.92×10 <sup>-6</sup>
<i>h</i>	Differential pressure head across venturi (at 68°F)	in.H <sub>2</sub> O	100	0.15	0.4	0.692	1.08×10 <sup>-2</sup>	7.66×10 <sup>-2</sup>

Table 4: Uncertainty Values: Results

Description	Units	Calculated Value	Absolute Systematic Standard Uncertainty $b_m$	Absolute Random Standard Uncertainty $P_m$	Combined Standard Uncertainty of the Result $u_m$ (68%)	Total Absolute Uncertainty $u_m$ (95%)
<i>m</i> Mass Flow rate	lb <sub>m</sub> /s	138.4	0.537	0.276	0.604	1.21

COMMENT

The tables here are set up in a convenient manner to express the formulation and results of the problem. This format meets that recommended by ASME/ANSI PTC 19.1.

## PROBLEM 10.34

KNOWN: Flow nozzle  
 $d_1 = 60 \text{ mm} = 0.060 \text{ m}$   
 $Q = 0.003 \text{ m}^3/\text{s}$   
 $\rho = 790 \text{ kg/m}^3$   
 $\mu = 1.2 \times 10^{-3} \text{ N}\cdot\text{s/m}$

FIND:  $d_o$

ASSUMPTION: Incompressible flow ( $Y = 1$ )

SOLUTION

$$Q = CEAY\sqrt{2\Delta p/\rho} = K_o(\pi d_o^2/4)\sqrt{2\Delta p/\rho}$$

$$0.003 \text{ m}^3/\text{s} = K \frac{\pi}{4} d_o^2 \sqrt{\frac{2(4000 \text{ N/m}^2)}{790 \text{ kg/m}^3}}$$

rearranging

$$d_o^2 = \frac{1.20 \times 10^{-3}}{K_o}$$

We know  $K_o = CE = f(\text{Re}_{d_1}, \beta)$

$$\text{Re} = 4\rho Q/\pi d_1 \mu = \frac{4 \times 789 \text{ kg/m}^3 \times 0.003 \text{ m}^3/\text{s}}{\pi \times 0.06 \text{ m} \times 1.2 \times 10^{-3} \text{ N}\cdot\text{s/m}} = 42,200$$

From Figure 10.11, with  $\text{Re} = 42,200$ , then  $0.98 \leq K_o \leq 1.02$

Guess  $K_o = 1.00$ , then

$$d_o = \sqrt{1.2 \times 10^{-3} / K_o} = 0.0346 \text{ m}$$

Then,  $\beta = 0.0346/0.06 = 0.58$

From Fig 10.11,  $K_o = f(42,300, 0.58) \sim 1.01$

Then,  $d_o = 0.0345 \text{ m}$ ;  $\beta = 0.057$ .

From Fig 10.11,  $K_o = f(42,300, 0.57) \sim 1.01$

So,  $d_o = 0.0345 \text{ m} = 34.5 \text{ mm}$

## PROBLEM 11.1

**KNOWN:** A steel rod (circular cross-section) having:

$$L = 10 \text{ in}$$

$$D = 0.25 \text{ in}$$

$$E_m = 30 \times 10^6 \text{ lb/in}^2$$

$$m = 40 \text{ lb}_m$$

**FIND:** The change in length of the rod,  $\delta L$ ,

**ASSUMPTIONS:** Rod is elastically deformed, such that

$$\sigma = \varepsilon \cdot E_m$$

**SOLUTION:**

The force resulting from 40 lb<sub>m</sub> in standard gravity is

$$F_N = \frac{ma}{g_c} = \frac{(40 \text{ lb}_m)(32.174 \text{ ft/sec}^2)}{\left(32.174 \frac{\text{ft lb}_m}{\text{lb sec}^2}\right)} = 40 \text{ lb}$$

The resulting uniaxial stress is

$$\sigma_a = \frac{F_N}{A_c}$$

where

$$A_c = \frac{\pi}{4}(0.25)^2 = 0.049 \text{ in}^2$$

$$\sigma_a = \frac{40 \text{ lb}}{0.049 \text{ in}^2} = 814.9 \text{ lb/in}^2$$

and

$$\varepsilon_a = \frac{\sigma_a}{E_m} = \frac{814.9 \text{ lb/in}^2}{30 \times 10^6 \text{ lb/in}^2} = 2.716 \times 10^{-5}$$

The change in length is then

$$\delta L = L \cdot \varepsilon_a = (2.716 \times 10^{-5})(10 \text{ in}) = 0.00027 \text{ in}$$

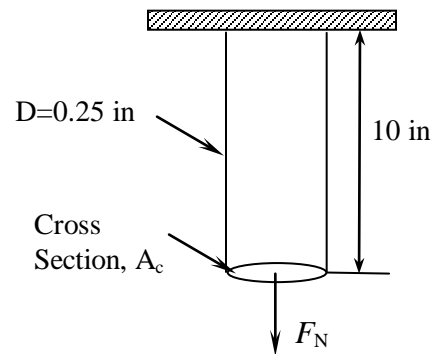

## PROBLEM 11.2

**KNOWN:** A steel rod (circular cross-section) having:

$$L = 0.3 \text{ m}$$

$$D = 5 \text{ mm}$$

$$E_m = 20 \times 10^{10} \text{ Pa}$$

$$m = 50 \text{ kg}$$

**FIND:** The change in length of the rod,  $\delta L$ .

**ASSUMPTIONS:** Rod is elastically deformed, such that

$$\sigma = \varepsilon \cdot E_m$$

**SOLUTION:**

The force resulting from 50 kg in standard gravity is

$$F_N = \frac{ma}{g_c} = \frac{(50 \text{ kg})(9.8 \text{ m/s}^2)}{\left(1.0 \frac{\text{kg m}}{\text{s}^2 \text{ N}}\right)}$$

$$F_N = 490 \text{ N}$$

The resulting uniaxial stress is

$$\sigma_a = \frac{F_N}{A_c}$$

where

$$A_c = \frac{\pi}{4} (5 \times 10^{-3})^2 = 1.96 \times 10^{-5} \text{ m}^2$$

$$\sigma_a = \frac{490 \text{ N}}{1.96 \times 10^{-5} \text{ m}^2} = 25 \times 10^6 \text{ Pa}$$

and

$$\varepsilon_a = \frac{\sigma_a}{E_m} = \frac{25 \times 10^6 \text{ Pa}}{20 \times 10^{10} \text{ Pa}} = 125 \times 10^{-6}$$

The change in length is then

$$\delta L = L \cdot \varepsilon_a = (0.3)(125 \times 10^{-6}) = 37.5 \times 10^{-6} \text{ m}$$

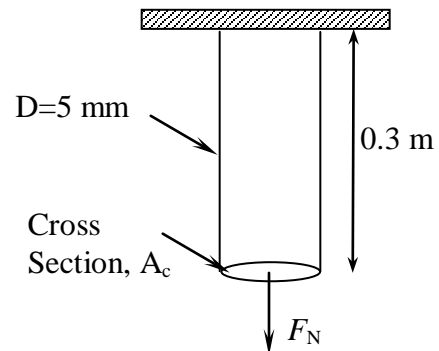

### PROBLEM 11.3

**KNOWN:** An electrical coil with

$$N = 20,000$$

$$D = 0.051 \text{ in}$$

$$r = 2.0 \text{ in}$$

**FIND:** The resistance,  $R$ .

**SOLUTION:**

We know

$$R = \frac{\rho_e L}{A_c}$$

where  $\rho_e = 1.673 \times 10^{-6} \text{ } \Omega \text{ cm}$  for copper, and

$$A_c = \frac{\pi}{4}(D)^2 = \frac{\pi}{4}\left(\frac{0.051}{12}\right)^2 = 1.42 \times 10^{-5} \text{ ft}^2$$

The length is then found as

$$L = 2\pi r(N) = 2\pi\left(\frac{2}{12}\right)(20,000) = 20,944 \text{ ft}$$

which yields a resistance of

$$R = \frac{(1.673 \times 10^{-6} \text{ } \Omega\text{-cm})(0.0328 \text{ ft/cm})(20,944 \text{ ft})}{1.42 \times 10^{-5} \text{ ft}^2}$$
$$R = 81 \text{ } \Omega$$

## PROBLEM 11.4

**KNOWN:** Aluminum having a volume of  $3.14159 \times 10^{-5} \text{ m}^3$ , and a resistivity,  
 $\rho_e = 2.66 \times 10^{-8} \Omega \text{ m}$ .

**FIND:** Resistance,  $R$ , of 2 mm and 1 mm diameter wires having the same total volume.

**SOLUTION:**

Volume for a cylindrical wire is

$$V = \frac{\pi}{4}(D^2)L$$

yielding

$$L_{2\text{mm}} = 10 \text{ m} \quad \text{and} \quad L_{1\text{mm}} = 40 \text{ m}$$

The resistance values are then calculated as

$$R_{2\text{mm}} = \frac{\rho_e L}{A_c} \quad A_c = \frac{\pi}{4} D^2$$
$$R_{2\text{mm}} = \frac{(2.66 \times 10^{-8} \Omega\text{-m})(10 \text{ m})}{\frac{\pi}{4}(2 \times 10^{-3} \text{ m})^2} = 0.085 \Omega$$
$$R_{1\text{mm}} = \frac{(2.66 \times 10^{-8} \Omega\text{-m})(40 \text{ m})}{\frac{\pi}{4}(1 \times 10^{-3} \text{ m})^2} = 1.355 \Omega$$

## PROBLEM 11.5

KNOWN: A nickel conductor with

$$\rho_e = 6.8 \times 10^{-8} \Omega \text{ m}$$

$$A_c = 5 \times 2 \text{ mm (rectangular)}$$

$$L = 5 \text{ m}$$

FIND: a)  $R$  - the total resistance

b) The diameter of a 5 m long copper wire having a circular cross-section to yield the same resistance.

SOLUTION:

The resistance is found from

$$R = \frac{\rho_e L}{A_c} \quad A_c = 10 \text{ mm}^2 \quad L = 5 \text{ m}$$

which in this case yields

$$R = \frac{(6.8 \times 10^{-8} \Omega \text{ m})(5 \text{ m})}{10 \times 10^{-6} \text{ m}^2} = 0.034 \Omega$$

For the copper,  $\rho_e = 1.7 \times 10^{-8} \Omega \text{ m}$

$$0.034 = \frac{(1.7 \times 10^{-8} \Omega \text{ m})(5 \text{ m})}{A_c}$$
$$A_c = 2.5 \times 10^{-6} \text{ m}^2 \quad D = 1.8 \text{ mm}$$

## PROBLEM 11.6

**KNOWN:** A Wheatstone bridge with all resistances initially equal to  $100 \Omega$ . The maximum power through  $R_1$  is  $0.25 \text{ W}$ .

**FIND:** Maximum applied voltage  
Bridge sensitivity

**ASSUMPTIONS:** Infinite meter resistance

**SOLUTION:** From the circuit shown below

$$i_1 R_1 + i_2 R_2 = E_i$$

$$i_1 = i_2 = i$$

$$i(R_1 + R_2) = E_i$$

But we know power,  $P$ , is given by  $P = i^2 R$ , and

$$i = \sqrt{\frac{0.25 \text{ W}}{100 \Omega}} = 0.05 \text{ A}$$

At node A

$$i_i = i_1 + i_3 = 2i \quad i_i = 0.1 \text{ A}$$

$$E_i = i_i R_B \quad \text{where } R_B \text{ is the equivalent bridge resistance}$$

$$\text{so } E_i = (0.1 \text{ A})(100 \Omega) = 10 \text{ V}$$

The bridge sensitivity is defined as

$$K_B = \frac{\delta E_0}{\delta R_1}$$

and for a bridge with all resistances initially equal and assuming  $\delta R \ll R$

$$\frac{\delta E_0}{\delta R} \approx \frac{E_i R}{4R} = \frac{(10 \text{ V})(100 \Omega)}{400 \Omega} \approx 2.5 \text{ V}/\Omega$$

## PROBLEM 11.7

**KNOWN:** A strain gauge with  $R_1 = 120 \Omega$ ,  $GF = 2$  in an equal arm Wheatstone bridge  
 $R_2 = R_3 = R_4 = 120 \Omega$ . Maximum gauge current is 0.05 A

**FIND:** Maximum input bridge voltage

**SOLUTION:** From a basic circuit analysis, assuming infinite meter resistance

$$i_1 = \frac{E_i}{R_1 + R_2}$$

and

$$E_i = i_1 (R_1 + R_2)$$

$$E_i = (0.05 \text{ A})(240 \Omega) = 12 \text{ V}$$

## PROBLEM 11.8

**KNOWN:** A strain gauge has a nominal resistance of  $350 \Omega$ , and  $GF = 1.8$ , and senses axial strain. The gauge is mounted on a  $1 \text{ cm}^2$  aluminum rod ( $E_m = 70 \text{ GPa}$ )  $E_o = 1 \text{ mV}$ ,  $E_i = 5 \text{ V}$ .

**FIND:** Applied load, assuming uniaxial tension

**SOLUTION:**

For an equal arm bridge, from (11.14)

$$\frac{\delta E_o}{E_i} = \frac{(\delta R/R)}{4 + 2(\delta R/R)} \quad \frac{0.001}{5} = \frac{(\delta R/R)}{4 + 2(\delta R/R)}$$

and

$$\delta R/R = 0.0008 \quad \delta R = 0.28 \Omega$$

Since

$$\delta R/R = \varepsilon \cdot GF \quad \varepsilon = 0.00044$$

and with

$$\varepsilon = \frac{\sigma}{E_m} \quad \sigma = \varepsilon \cdot E_m = (0.00044)(70 \text{ GPa})$$

$$\sigma = 0.0308 \text{ GPa}$$

To find the applied force,  $F_N$

$$\sigma = \frac{F_N}{A_c} \quad A_c = \frac{\pi}{4} (1 \times 10^{-2} \text{ m})^2 = 7.854 \times 10^{-5} \text{ m}^2$$

$$F_N = (7.854 \times 10^{-5} \text{ m}^2)(0.0308 \times 10^9 \text{ Pa})$$

and since  $1 \text{ Pa} = 1 \text{ N/m}^2$

$$F_N = 2419 \text{ N}$$

**COMMENT:** This force would result from a mass, in standard gravitational acceleration, of  $246.6 \text{ kg}$ .

## PROBLEM 11.9

**KNOWN:** Strain gauge installation shown in Figure 11.12.

**FIND:** Show that this installation is not sensitive to bending stresses.

**SOLUTION:**

The stresses created by a bending and axial load may be represented as

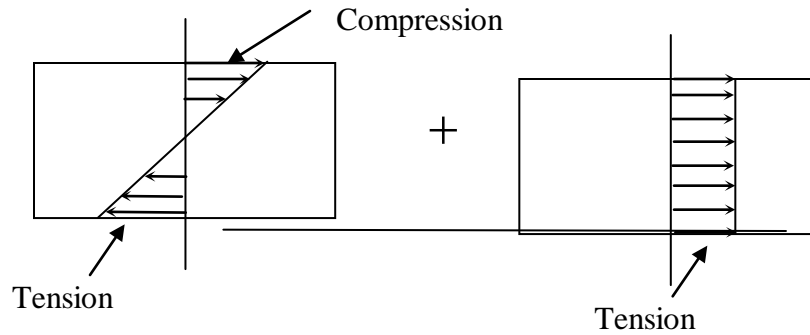

In general, for four active elements in a bridge,

$$\frac{\delta E_0}{E_i} = \frac{GF}{4} (\varepsilon_1 - \varepsilon_2 + \varepsilon_4 - \varepsilon_3)$$

or for this case

$$\frac{\delta E_0}{E_i} = \frac{GF}{4} (\varepsilon_1 + \varepsilon_4)$$

Strain may be expressed as a linear combination of the imposed loads

$$\frac{\delta E_0}{E_i} = \frac{GF}{4} \left[ (\varepsilon_m + \varepsilon_{F_N})_1 + (\varepsilon_m + \varepsilon_{F_N})_4 \right]$$

But since  $\varepsilon_{m_1} = -\varepsilon_{m_4}$  this installation is not sensitive to bending.

## PROBLEM 11.10

**KNOWN:** A steel member ( $\nu_p = 0.3$ ) subject to simple axial tension. Strain gauges are mounted on top center, and bottom center.  $GF = 2$ , All  $R$ 's =  $120 \Omega$   
 $\delta E_o = 10 \mu V$  and  $E_i = 10 V$ ,  $R = 120 \Omega$  and  $GF = 2$

**FIND:** Bridge constant, for gauge locations 1 and 4. Is the system temperature compensated? Determine the axial and transverse strains.

**SOLUTION:**

The configuration is

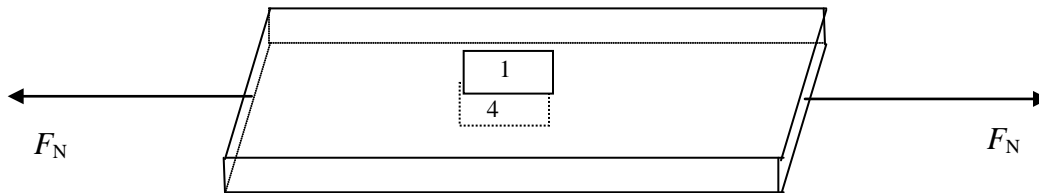

Since for any 4 gauges

$$\frac{\delta E_o}{E_i} = \frac{GF}{4} (\varepsilon_1 - \varepsilon_2 + \varepsilon_4 - \varepsilon_3)$$

and for a single gauge, sensing maximum strain

$$\frac{\delta E_o}{E_i} = \frac{GF}{4} (\varepsilon_{\max})$$

In the present case both gauges sense the maximum strain, and the outputs are additive

$$\kappa = 2$$

This installation is not temperature compensated.

For the gauge sensing maximum strain

$$\frac{\delta E_0^s}{E_i} = \left[ \frac{\varepsilon_{\max} GF}{4 + 2\varepsilon_{\max} GF} \right]$$

The actual output is then

$$\delta E_0 = \kappa \delta E_0^s$$

and

$$\delta E_0^s = 5 \text{ V}$$

Solving for  $\varepsilon_{\max}$  yields

$$\varepsilon_{\max} = 1 \times 10^{-6}$$

Therefore

$$\varepsilon_{axial} = \varepsilon_{\max} = 1 \times 10^{-6}$$

$$\varepsilon_i = 0.3 \times 10^{-6}$$

## PROBLEM 11.11

**KNOWN:** An axial and a transverse strain gauge are mounted to the top surface of a steel beam, and connected in arms 1 and 2 of a Wheatstone bridge.

$$\delta E_0 = 250 \mu\text{V} \quad \nu_p = 0.3 \quad \sigma = 2222.2 \text{ psi}$$

$$E_i = 10 \text{ V} \quad E_m = 29.4 \times 10^6 \text{ psi}$$

**FIND:** a)  $\kappa_B$

b) Average gauge factor

**SOLUTION:**

In general

$$\frac{\delta E_0}{E_i} = \frac{GF}{4} (\varepsilon_1 - \varepsilon_2 + \varepsilon_4 - \varepsilon_3)$$

which in this case, for one axial and one transverse gauge yields

$$\begin{aligned} \frac{\delta E_0}{E_i} &= \frac{GF}{4} (\varepsilon_{\max} - 0.3\varepsilon_{\max}) \\ &= \frac{GF}{4} (0.7\varepsilon_{\max}) \end{aligned}$$

for a single gauge sensing the maximum strain

$$\frac{\delta E_0}{E_i} = \frac{GF}{4} \varepsilon_{\max}$$

and

$$\kappa_B = 0.7$$

To find the average value of GF

$$\frac{\delta E_0}{E_i} = \frac{GF}{4} \varepsilon_{\max} \kappa_B$$

$$\frac{250 \times 10^{-6}}{10} = \frac{GF}{4} \varepsilon_{\max} \kappa_B$$

with  $\sigma = 2222.2$  psi and  $\varepsilon_{\max} = \sigma/E_m$

$$\varepsilon_{\max} = 7.559 \times 10^{-5}$$

and

$$GF = \frac{4(250 \times 10^{-6})}{10(0.7)(7.559 \times 10^{-5})} = 1.89$$

Comment: The chosen arrangement of strain gauges yields a bridge constant less than one, which without other considerations, is not a good choice.

## PROBLEM 11.12

KNOWN: A strain gauge, mounted on a steel cantilever, has the following characteristics:

$$R = 120 \Omega$$

$$\delta R = 0.1 \Omega$$

$$GF = 2.05 \pm 1\% \text{ (95\%)}$$

$$u_R = \pm 1\%$$

FIND: Estimate the strain,  $\varepsilon_a$ , and the uncertainty in the measured strain,  $u_\varepsilon$ .

ASSUMPTIONS: The bridge operates in a null mode and reasonable values for input voltage and galvanometer sensitivity must be assigned.

SOLUTION:

For an equal arm bridge,

$$\frac{\delta R_1}{R_1} = \varepsilon_a \cdot GF$$

which yields

$$\frac{0.1}{120} = \varepsilon_a (2.05) \quad \varepsilon_a = 0.000407$$

The uncertainty analysis can be approached in several ways. Since the bridge is operated in a null mode, a galvanometer and a calibrated resistor are employed. The following relationships are used for the bridge

$$\frac{\delta E_0}{E_i} = \left( \frac{\delta R/R}{4 + 2(\delta R/R)} \right)$$
$$R_1 = R_2 (R_3/R_4) \quad (\text{balanced bridge})$$

Let  $\gamma = (\delta R_1/R_1)$

A typical galvanometer sensitivity may be  $\pm 1 \mu\text{V}$ , and  $E_i = 10 \text{ V}$ , then

$$\varepsilon = \frac{\gamma}{GF}$$

$$u_E = \left[ \left( \frac{\partial \varepsilon}{\partial \gamma} u_\gamma \right)^2 + \left( \frac{\partial \varepsilon}{\partial GF} u_{GF} \right)^2 \right]^{1/2}$$

This equation for the uncertainty in strain contains two uncertainties, yet to be estimated. The partial derivatives which represent the sensitivity indices are evaluated at the nominal values as

$$\frac{\partial \varepsilon}{\partial \gamma} = \frac{1}{GF} = \frac{1}{2.05}$$

$$\frac{\partial \varepsilon}{\partial GF} = -\frac{\gamma}{GF^2} = -\frac{0.1}{(2.05)^2 (120)} = 2 \times 10^{-4}$$

where  $\gamma = \frac{\delta R_1}{R_1} = \frac{0.1 \Omega}{120 \Omega}$

We must examine the uncertainty in  $\gamma$ , which has contributions from the galvanometer, and from the bridge and calibrated resistors.

The analysis proceeds as

$$\gamma = \left[ \frac{4(\delta E_0/E_i)}{1 + 2(\delta E_0/E_i)} \right]$$

$$u_\gamma^b = \frac{\partial \gamma}{\partial (\delta E_0/E_i)} u_{\delta E_0/E_i}$$

$$\text{At } \delta E_0 = 0 \quad \frac{\partial \gamma}{\partial (\delta E_0/E_i)} = 4$$

Assume the only contribution to  $\delta E_0/E_i$  is the galvanometer,  $\pm 1 \mu\text{V} \Rightarrow$

$$u_{\delta E_0/E_i} = \pm 1.1 \times 10^{-7} \text{ V}$$

Additional contributions to uncertainty in  $\gamma$  result from

Bridge resistance  $R_3, R_4 \pm 1\%$

Calibrated resistor  $R_2 \pm 1\%$

and with  $R_1 = R_2 (R_3/R_4)$

$$\frac{\partial R_1}{\partial R_2} = \frac{R_3}{R_4} = 1$$

$$\frac{\partial R_1}{\partial R_3} = \frac{R_2}{R_4} = 1$$

$$\frac{\partial R_1}{\partial R_4} = -\frac{R_2 R_3}{R_4^2} = 1$$

$$u_{R_1} = \sqrt{3(0.01)^2} = \pm 0.0173 \Omega$$

$$u_{\gamma}^a = \frac{0.173}{120} = \pm 0.000144 \Omega$$

Combining  $u_{\gamma}^a$  and  $u_{\gamma}^b$

$$u_{\gamma} = \sqrt{\left[4(1 \times 10^{-7})\right]^2 + [0.000144]^2} = \pm 0.000144 \Omega$$

Then with

$$u_{\varepsilon} = \left[ \left( \frac{1}{GF} u_{\gamma} \right)^2 + \left( -\frac{\gamma}{GF^2} u_{GF} \right)^2 \right]^{1/2}$$

$$= \left[ \left( \frac{1}{2.05} 0.000144 \right)^2 + \left( -\frac{0.1/120}{2.05^2} 0.02 \right)^2 \right]^{1/2}$$

With this result, the uncertainty in strain is found as

$$u_{\varepsilon} = \pm 7 \times 10^{-5}$$

## PROBLEM 11.13

**KNOWN:**

$$R = 120 \Omega$$

Gauges mounted on opposite arms of bridge

$$E_i = 4 \text{ V}$$

$$E_o = 120 \mu\text{V}$$

$$GF = 2$$

$$E_m = 29 \times 10^6 \text{ psi}$$

**FIND:** Resistance change for each gauge

**SOLUTION:**

For this bridge

$$\frac{\delta E_o}{E_i} = \frac{GF}{4} (\varepsilon_1 - \varepsilon_2 + \varepsilon_4 - \varepsilon_3)$$

which implies a bridge constant of 2.

Thus

$$\frac{\delta E_o}{E_i} = \frac{GF}{4} (2\varepsilon_a) = \frac{\kappa_B GF}{4} (\varepsilon_{max})$$

$$\varepsilon_{max} = \left( \frac{120 \times 10^{-6}}{4} \right) \left( \frac{4}{2(2)} \right) = 3.0 \times 10^{-5}$$

Since

$$\frac{\delta R}{R} = \varepsilon_{max} GF \quad \delta R = (120 \Omega) (3 \times 10^{-5}) (2)$$

The change in resistance is

$$\delta R = 0.0072 \Omega$$

## PROBLEM 11.14

### KNOWN:

A rectangular bar in uniaxial tension, having strain gages mounted to measure axial and transverse strain. Cross-section,  $A_c = 2 \text{ in}^2$ , axial strain,  $\epsilon_a = 1500 \mu\epsilon$ , transverse strain,  $\epsilon_t = -465 \mu\epsilon$ , axial load,  $F_N = 1500 \text{ lb}$

**FIND:** Modulus of elasticity,  $E_m$ , and Poisson's ratio,  $\nu_p$

### SOLUTION:

The axial stress and strain are related as

$$\sigma_a = E_m \epsilon_a$$

$$\sigma_a = \frac{1500 \text{ lb}}{2 \text{ in}^2} = 750 \text{ lb/in}^2$$

yielding

$$E_m = \frac{\sigma_a}{\epsilon_a} = \frac{750 \text{ lb/in}^2}{1500 \times 10^{-6}} = 5 \times 10^5 \text{ lb/in}^2$$

Poisson's ratio is determined from the transverse strain,

$$\nu_p = \frac{|\text{transverse strain}|}{|\text{axial strain}|} = \frac{465}{1500} = 0.31$$

## PROBLEM 11.15

### KNOWN:

A circular bar in uniaxial tension, having strain gages mounted to measure axial and transverse strain. Cross-section,  $A_c = 3 \text{ cm}^2$ , axial strain,  $\varepsilon_a = 600 \mu\varepsilon$ , transverse strain,  $\varepsilon_t = -163 \mu\varepsilon$ , axial load,  $F_N = 10 \text{ kN}$

**FIND:** Modulus of elasticity,  $E_m$ , and Poisson's ratio,  $\nu_p$

### SOLUTION:

The axial stress and strain are related as

$$\sigma_a = E_m \varepsilon_a$$

$$\sigma_a = \frac{10 \text{ kN}}{3 \times 10^{-4} \text{ m}^2} = 33.3 \text{ MPa}$$

yielding

$$E_m = \frac{\sigma_a}{\varepsilon_a} = \frac{33.3 \text{ MPa}}{600 \times 10^{-6}} = 55.6 \text{ GPa}$$

Poisson's ratio is determined from the transverse strain,

$$\nu_p = \frac{|\text{transverse strain}|}{|\text{axial strain}|} = \frac{163}{600} = 0.27$$

## PROBLEM 11.16

**KNOWN:** A single active gauge and a dummy gauge are employed to measure strain. The active gauge experiences an axial loading with bending, and both strain gauges experience the same temperature.

**FIND:** Show that the use of the dummy gauge compensates for temperature, but not for bending

**SOLUTION:**

In general

$$\frac{\delta E_0}{E_i} = \frac{GF}{4} (\varepsilon_1 - \varepsilon_2 + \varepsilon_4 - \varepsilon_3)$$

The active gauge will experience axial, bending and temperature effects:

$$\varepsilon_1 = \varepsilon_a + \varepsilon_b + \varepsilon_T$$

The dummy gauge will experience temperature effects only

$$\varepsilon_2 = \varepsilon_T$$

Consider the case where the gauges are mounted on adjacent arms of a Wheatstone bridge. Then,

$$\frac{\delta E_0}{E_i} = \frac{GF}{4} [\varepsilon_1 - \varepsilon_2] = \varepsilon_a + \varepsilon_b + \varepsilon_T - \varepsilon_T = \frac{GF}{4} [\varepsilon_a - \varepsilon_b]$$

Axial strain is measured. Temperature effects are compensated, but bending effects remain.

## PROBLEM 11.17

**KNOWN:** Four active gauges mounted on a cylindrical shaft as per Table 11.1

**FIND:** Show axial, temperature and bending compensation

### SOLUTION

Each active gauge will experience torsional, axial, bending and temperature effects:

$$\begin{aligned}\epsilon_1 &= \epsilon_\theta + \epsilon_a + \epsilon_b + \epsilon_T & \epsilon_2 &= -\epsilon_\theta + \epsilon_a + \epsilon_b + \epsilon_T \\ \epsilon_3 &= -\epsilon_\theta + \epsilon_a + \epsilon_b + \epsilon_T & \epsilon_4 &= \epsilon_\theta + \epsilon_a + \epsilon_b + \epsilon_T\end{aligned}$$

Then, when mounted on a wheatstone bridge (such as in Figure 11.23), are balanced, and a load applied, the output voltage deflection is given by:

$$\frac{\delta E_o}{E_i} = \frac{GF}{4} [\epsilon_1 - \epsilon_2 + \epsilon_4 - \epsilon_3] = GF\epsilon_\theta$$

The arrangement measures torsional strain. The arrangement compensates for axial, bending and temperature effects. Note that this arrangement has a bridge constant of 4.

## PROBLEM 11.18

KNOWN: Bridge arrangements of Figure 11.23

FIND: Bridge constants

SOLUTION:

Using equation 11.22

$$\frac{\delta E_0}{E_i} = \frac{GF}{4} (\varepsilon_1 - \varepsilon_2 + \varepsilon_4 - \varepsilon_3)$$

For a single gauge sensing the maximum strain

$$\frac{\delta E_0}{E_i} = \frac{GF}{4} \varepsilon_{\max}$$

a)

$$\kappa_B = \frac{(GF/4) \varepsilon_1}{(GF/4) \varepsilon_{\max}} = 1$$

b)

$$\kappa_B = \frac{(GF/4)(\varepsilon_1 - \varepsilon_3)}{(GF/4) \varepsilon_{\max}} = \frac{(GF/4) [\varepsilon_1 - (-\nu_p \varepsilon_1)]}{(GF/4) \varepsilon_1}$$
$$\kappa_B = 1 + \nu_p$$

c)

$$\kappa_B = \frac{(GF/4)(\varepsilon_1 - \varepsilon_3)}{(GF/4) \varepsilon_1} = \frac{(GF/4) [\varepsilon_1 - (-\varepsilon_1)]}{(GF/4) \varepsilon_1} = 2$$

d)

$$\kappa_B = \frac{(GF/4)(\varepsilon_1 - \varepsilon_2 + \varepsilon_4 - \varepsilon_3)}{(GF/4)\varepsilon_1}$$

$$\varepsilon_2 = -\nu_p \varepsilon_1 \quad \varepsilon_3 = -\nu_p \varepsilon_4$$

$$\kappa_B = 2(1 + \nu_p)$$

e)

$$\kappa_B = \frac{(\varepsilon_1 - \varepsilon_2 + \varepsilon_4 - \varepsilon_3)}{\varepsilon_1}$$

$$\varepsilon_2 = -\varepsilon_1 \quad \varepsilon_3 = -\varepsilon_4$$

$$\kappa_B = 4$$

## PROBLEM 11.19

**KNOWN:** Four active gauges mounted to a diaphragm so as to measure displacement  $R_1$  and  $R_4$  sense tension when  $R_2$  and  $R_3$  sense compression and gauges are mounted as in Figure 11.23

$$GF = 2.0; R = 120\Omega; \varepsilon = 20\mu s; E_i = 9V$$

**FIND:**  $\delta E_o$

### SOLUTION

Each active gauge will experience axial and temperature effects:

$$\varepsilon_1 = \varepsilon_a + \varepsilon_T \quad \varepsilon_2 = -\varepsilon_a + \varepsilon_T$$

$$\varepsilon_3 = -\varepsilon_a + \varepsilon_T \quad \varepsilon_4 = \varepsilon_a + \varepsilon_T$$

Then, when mounted on a wheatstone bridge, balanced, and a load applied:

$$\frac{\delta E_o}{E_i} = \frac{GF}{4} [\varepsilon_1 - \varepsilon_2 + \varepsilon_4 - \varepsilon_3] = GF\varepsilon$$

Then,

$$\delta E_o = (2)(20 \times 10^6)(9V) = 360\mu V$$

## PROBLEM 11.20

**KNOWN:** Conditions of Problem 11.20. Oops,  $R_2$  and  $R_4$  wiring is interchanged.  $R_1$  and  $R_2$  sense tension when  $R_4$  and  $R_3$  sense compression and gauges are mounted as in Figure 11.23

**FIND:**  $\delta E_o$

### SOLUTION

Each active gauge will experience axial and temperature effects:

$$\begin{aligned}\epsilon_1 &= \epsilon_a + \epsilon_T & \epsilon_2 &= \epsilon_a + \epsilon_T \\ \epsilon_3 &= -\epsilon_a + \epsilon_T & \epsilon_4 &= -\epsilon_a + \epsilon_T\end{aligned}$$

Then, when mounted on a wheatstone bridge, balanced, and a load applied:

$$\frac{\delta E_o}{E_i} = \frac{GF}{4} [\epsilon_1 - \epsilon_2 + \epsilon_4 - \epsilon_3] = 0$$

The bridge deflection is zero. No load is sensed!

## PROBLEM 11.21

KNOWN:  $D = 1$  m, Transverse sensitivity =  $0.03 = 3\%$

FIND: Error due to transverse sensitivity

SOLUTION:

Since

$$\sigma_t = \frac{PD}{2t} \quad \text{and} \quad \sigma_l = \frac{PD}{4t} \quad \text{then} \quad \frac{\varepsilon_t}{\varepsilon_a} = \frac{\sigma_l}{\sigma_t} = \frac{\frac{PD}{4t}}{\frac{PD}{2t}} = \frac{1}{2}$$

From Figure 11.6, the error can be determined as 2.8% of  $\sigma_t$ .

## PROBLEM 11.22

**KNOWN:** Wheatstone bridge circuit, with all fixed resistances equal to  $100\ \Omega$ .  
 $R_1$  is a strain gauge with a resistance of  $100\ \Omega$  at zero strain. The strain gauge senses  $\varepsilon_1$ .  
 $t = 2\ \text{cm}$      $D = 2\ \text{m}$      $GF = 2$     Maximum power dissipation in gauge =  $0.25\ \text{W}$

**FIND:**            Maximum allowable static sensitivity, in  $\text{V/kPa}$   
 Under what conditions is  $K$  constant?

### SOLUTION:

From problem 11.6, the maximum value of  $E_1$  to limit power dissipation to  $0.25\ \text{W}$  is  $10\ \text{V}$ , and the static sensitivity is  $2.5\ \text{V}/\Omega$ , based on the resistance change of the strain gauge. In the present problem, we can write

$$\sigma_l = \frac{PD}{4t} \quad \text{and} \quad \varepsilon_l = \frac{\sigma}{E_m}$$

then  $\varepsilon_l = \frac{PD}{4E_m t}$

and with  $\frac{\delta R}{R} = \varepsilon GF$ , then

$$\frac{\delta R}{R} = \frac{PD}{4E_m t} GF$$

Taking the derivative of  $\delta R$  with respect to  $P$  yields

$$\frac{RD}{4E_m t} GF$$

and the static sensitivity is then

$$\frac{RD}{4E_m t} GFK_B \quad \text{where } K_B = \text{bridge sensitivity in } \text{V}/\Omega = 2.5$$

thus the static sensitivity for input pressure is

$$\frac{(100\ \Omega)(2\ \text{m})}{(4)(20 \times 10^7\ \text{kPa})(0.02\ \text{m})} 2(2.5\ \text{mV}/\Omega) = 0.0000625\ \text{V}/\Omega \quad \text{or} \quad 0.0625\ \text{mV}/\Omega$$

## PROBLEM 11.23

**KNOWN:** A Wheatstone bridge measurement system is to be designed to measure the tangential strain in the wall of a pressure vessel. A reasonable estimate of the resulting uncertainty is desired. The bridge is to be operated in a balanced condition.

**FIND:** The bridge input voltage, the fixed resistance values, and the galvanometer sensitivity.

### SOLUTION:

The following provides an outline for addressing this design problem. Assuming that  $R_1 = R_2 = R_3 = R_4 = 120 \Omega$  at balanced conditions and zero strain,

The change in  $R_1$  with applied strain can be expressed

$$\frac{\delta R}{R} = \varepsilon GF$$

The mathematical relations for a balanced bridge are

$$\frac{R_2}{R_1} = \frac{R_4}{R_3} \quad \text{and with the resistances equal, } \frac{u_R}{R_1} = \frac{I_g (R_1 + R_g)}{E_i}$$

The input voltage must be designed based on a trade-off between static sensitivity from the uncertainty, and the power that must be dissipated in the bridge. The strain gauge must dissipate  $I_1^2 R_1$ , and should serve as the limiting factor for the input voltage.

## PROBLEM 11.24

**KNOWN:** Steel cantilever beam (fixed at one end) equipped with four active gauges  
 $R_1$  and  $R_4$  mounted on top;  $R_2$  and  $R_3$  on bottom  
 Gauges attached to bridge circuit as per Figure 11.23  
 $F = 980\text{N}$ ;  $A = 1000$ ;  $GF = 2$ ;  $L = 0.1\text{m}$ ;  $b = 0.3\text{m}$ ;  $t = 0.01\text{m}$ ,  $E_i = 5\text{V}$

**FIND:**  $\delta E_o$

### SOLUTION

For this arrangement,

$$\frac{\delta E_o}{E_i} = \frac{GF}{4} [\varepsilon_1 - \varepsilon_2 + \varepsilon_4 - \varepsilon_3]$$

$$\varepsilon_1 = \varepsilon_a + \varepsilon_b + \varepsilon_T$$

$$\varepsilon_2 = -\varepsilon_a + \varepsilon_b + \varepsilon_T$$

$$\varepsilon_3 = -\varepsilon_a + \varepsilon_b + \varepsilon_T$$

$$\varepsilon_4 = \varepsilon_a + \varepsilon_b + \varepsilon_T$$

Then,

$$\frac{\delta E_o}{E_i} = GF\varepsilon$$

where the bridge constant  $\kappa = 4$ .

The relation between applied load,  $F$ , and strain is

$$F = \frac{2E_m I\varepsilon}{Lt}$$

or

$$F = \frac{2E_m I\varepsilon}{Lt} = \frac{2\delta E_o}{A\kappa GFE_i} = \frac{2E_m bt^2 \delta E_o}{3LA\kappa GFE_i}$$

rearranging,

$$\delta E_o = 1.0\text{V}$$

## PROBLEM 11.25

**KNOWN:** It is desired to design a strain-gauge based scale, using a cantilever beam. The beam is 21 cm long, 0.4 cm thick, and 2 cm wide. The loads are up to 200 g, applied 20 cm from the fixed end of the beam. The required uncertainty level is 4%.

**FIND:** Design a measurement system, including strain gauge placement, bridge characteristics, and signal conditioning.

**SOLUTION:** Because this design problem has a wide variety of solutions, a general approach and some representative equations and results will be provided.

The beam is made of 2024-T4 aluminum, having a modulus of 71 GPa. For a cantilever beam, the deflection at the free end is

$$f = \frac{Wl^3}{3E_m I} \quad \text{where} \quad I = \frac{bh^3}{12}$$

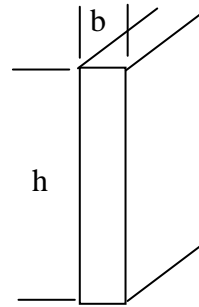

Here  $f$  is the deflection,  $W$  is the load,  $l$  is the distance from the fixed end to the load,  $I$  is the moment of inertia, and  $E_m$  is the modulus. A representative design may be examined by assuming a bridge having a single active gauge sensing the maximum axial strain. This would correspond to a location on the surface of the beam at a location where the load is applied. In this case the deflection  $f$  is

$$f = \frac{Wl^3}{3E_m I} = \frac{(1960)(0.2)^3}{3(71 \times 10^9)(2.67 \times 10^{-9})} = 2.7 \text{ cm} \quad I = \frac{bh^3}{12} = \frac{(0.004)(0.02)^3}{12} = 2.67 \times 10^{-9}$$

$$\sigma_x = \frac{Wl(h/2)}{I} = \frac{(1960)(0.2)(0.01)}{2.67 \times 10^{-9}} = 1.47 \times 10^9 \text{ Pa}$$

Then with  $E_m = 71 \text{ GPa}$

$$\varepsilon = \frac{\sigma_x}{E_m} = \frac{1.47 \times 10^9}{71 \times 10^9} = 0.0207 \quad \frac{\delta R}{R} = \varepsilon GF = 0.0207 \times 2 = 0.0414$$

$$\frac{\delta E_o}{E_i} = \frac{\delta R/R}{4} = \frac{0.0414}{4} = 0.01$$

From these relationships, the output for a bridge excitation of 5 V is about 50 mV, which would create an uncertainty from the A/D resolution of about 2.4%. The bridge can be designed in a reasonable manner to meet the uncertainty constraint.

## PROBLEM 12.1

KNOWN: A linear potentiometer having

$$\begin{aligned} D &= 0.1 \text{ mm} \\ \rho_e &= 1.7 \times 10^{-8} \Omega\text{-m} \\ R &= 1 \text{ k}\Omega \end{aligned}$$

FIND:

- a) for a core diameter of 1.5 cm, determine the range
- b) plot loading error as a function of displacement

SOLUTION:

- a) In order to determine the number of turns of wire, N

$$R = \frac{\rho_e L}{A_c} \Rightarrow L = \frac{RA_c}{\rho_e}$$

with

$$A_c = \frac{\pi}{4} (1.5 \times 10^{-2} \text{ m})^2 = 7.854 \times 10^{-9} \text{ m}^2$$

yields

$$L = \frac{(1000 \Omega)(7.854 \times 10^{-9} \text{ m}^2)}{1.7 \times 10^{-8} \Omega\text{-m}} = 462 \text{ m}$$

One turn takes  $\pi(1.5)$  cm of wire, thus

$$N = \frac{462 \text{ m}}{\pi(1.5 \times 10^{-2} \text{ m})} = 9804$$

Then since each turn occupies approximately  $D = 0.1$  mm the range is  $(9804)(0.1 \text{ mm}) = 0.98 \text{ m}$

b) The loading error for a voltage dividing circuit is found from (6.37) as

$$e_L = E_i \left[ \left( \frac{E_o}{E_i} \right)' - \left( \frac{E_o}{E_i} \right) \right]$$

$$= E_i \frac{R_1 - R_T + (R_T - R_1)(R_1 / R_m + 1)}{R_T + \left( \frac{R_T^2}{R_1} - R_T \right) (R_1 / R_m + 1)}$$

In terms of output voltage the length may be written, assuming an infinite meter resistance, from (6.8)

$$E_o = \frac{L_x}{L_T} E_i = \frac{R_x}{R_T} E_i$$

yielding

$\frac{e_l}{E_i} \times 100 =$  loading error as a percentage of full - scale deflection

A plot is shown below.

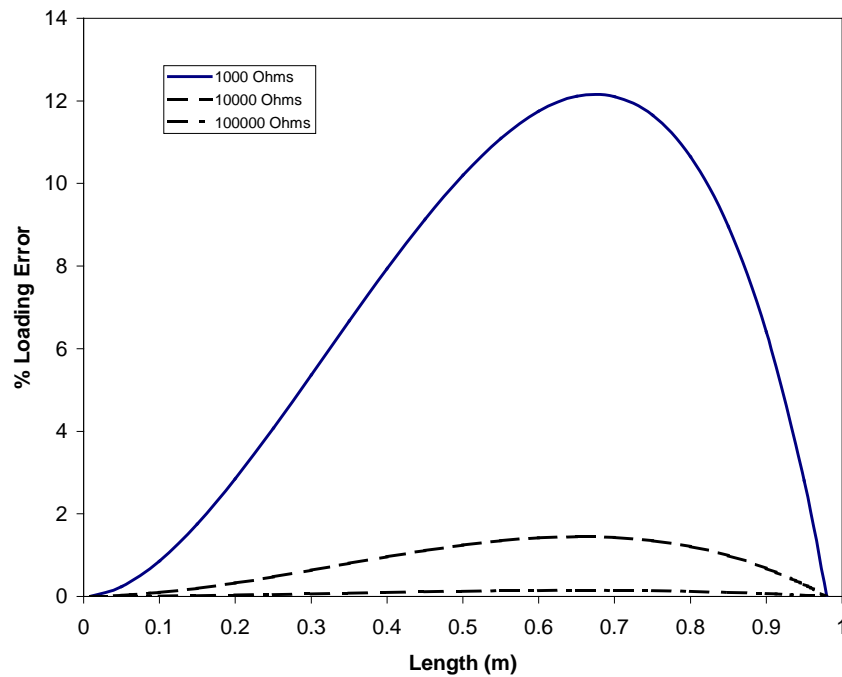

## PROBLEM 12.2

**KNOWN:** Numerous applications for linear displacement sensors.

**FIND:** Develop specifications for a selected application for a linear displacement sensor.

**SOLUTION:**

A list of potential applications is provided in the problem statement. These applications include several measurements that would easily be accomplished by a potentiometric or LVDT position sensor having an accuracy of  $\pm 1$  mm, including seat position and throttle position sensors for automotive applications.

There exist applications where errors must be on the order of microns, and a variety of sensors exist that can meet such a stringent repeatability requirement, although absolute accuracy can be a significant challenge. Applications include machine tools and rapid prototyping systems.

## PROBLEM 12.3

**KNOWN:** Potentiometers are primarily either wire-wound or conductive plastic in their construction.

**FIND:** Compare and contrast the design of wire-wound and conductive plastic potentiometers.

### **SOLUTION:**

Conductive plastic potentiometers provide continuous analog output, where wire-wound potentiometers have resolution limited by the size of the wire that forms the winding. However, production of conductive plastic having a constant resistivity, which produces a linear relationship between displacement and resistance, is not perfect. Both designs are widely applied in a variety of devices.

## PROBLEM 12.4

**KNOWN:** LVDT and potentiometric displacement transducers.

**FIND:** Compare and contrast the use of LVDT and potentiometric displacement transducers.

**SOLUTION:**

The LVDT has the following positive characteristics:

- Because there is no contact between the movable core and the coil structure, friction is extremely low, and provides for essentially infinite life
- Truly analog behavior, so that resolution is limited only by the output measuring system employed
- Very good repeatability
- Somewhat greater cost

The potentiometric sensor, has the following positive characteristics;

- Lower cost
- Good repeatability

## PROBLEM 12.5

**KNOWN:**

$$y(t) = 0.2 \cos 10t + 0.3 \cos 20t$$

where  $y$  = displacement [in.]

and  $t$  = time [sec.]

$$\zeta = 0.7$$

$$k = 1.2 \text{ lb/ft}$$

**FIND:**

a) a combination of  $m$  and  $c$  which would yield less than 10% amplitude error in measuring the input signal.

b) determine the phase response of the system

**SOLUTION:** We know

$$\omega_n = \sqrt{k/m} \quad c_c = 2\sqrt{km}$$

The amplitude error is evaluated by examining (for  $\cos = 1$ )

$$\frac{(y_r)_{steady}}{A} = \frac{(\omega/\omega_n)^2}{\left\{ \left[ 1 - (\omega/\omega_n)^2 \right]^2 + \left[ 2\zeta(\omega/\omega_n) \right]^2 \right\}^{1/2}}$$

The limiting case is for the lower input frequency, and  $(y_r)_{steady}/A = 0.9$

$$0.9 = \frac{\left( 10/\omega_n \right)^2}{\left\{ \left[ 1 - (10/\omega_n)^2 \right]^2 + \left[ 2(0.7)(10/\omega_n) \right]^2 \right\}^{1/2}}$$

Solving for  $\omega_n$  yields

$$\omega_n = 7.1 \text{ rad/s}$$

and since

$$\omega_n = \sqrt{\frac{kg_c}{m}}$$

and  $c$  is found from

$$c = 2\zeta \sqrt{km/g_c}$$

yielding

$$c = 2(0.7) \sqrt{\frac{1.2 \text{ lb/ft} (0.766 \text{ lb}_m)}{32.174 \frac{\text{ft lb}_m}{\text{lb sec}^2}}} = 0.236 \frac{\text{lb sec}}{\text{ft}}$$

b) Phase response is shown below.

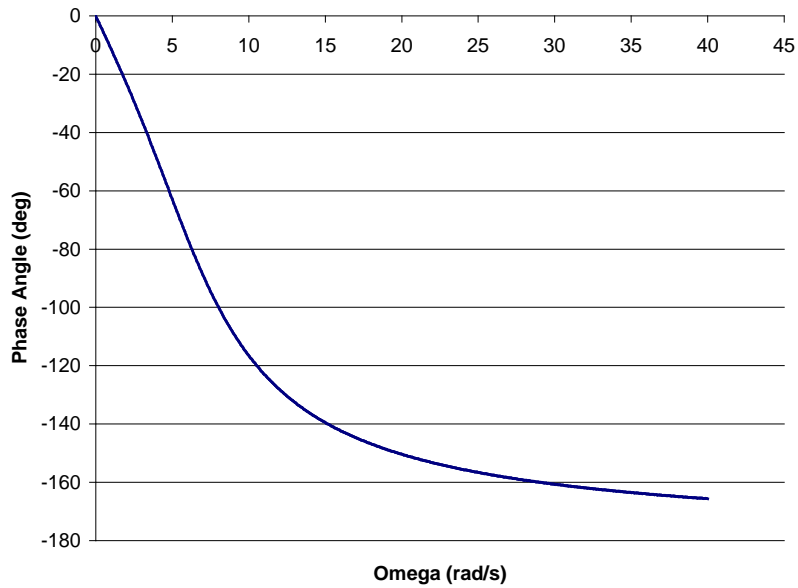

## PROBLEM 12.6

**KNOWN:** A seismic instrument has

$$\omega_n = 20 \text{ Hz} = 40\pi \text{ rad/s} \quad \zeta = 0.65$$

**FIND:** The maximum input frequency,  $\omega$  for a vibration measurement such that the amplitude error is  $< 5\%$ .

**SOLUTION:**

From (12.14)

$$0.95 \text{ or } 1.05 = \frac{1}{\left\{ \left[ 1 - \left( \frac{\omega}{\omega_n} \right)^2 \right]^2 + \left[ 2\zeta \left( \frac{\omega}{\omega_n} \right)^2 \right]^2 \right\}^{1/2}}$$

Solving for the input frequency yields 90.5 rad/s.

## PROBLEM 12.7

**KNOWN:** A seismic instrument may be designed to measure either acceleration or displacement (vibration).

**FIND:** Clearly state the requirements for the values of the spring constant, the damping coefficient, and the mass in the seismic instrument to achieve the desired output.

### SOLUTION:

For vibration measurements, the output of the seismic instrument must accurately provide the amplitude of the displacements associated with the vibrations; thus, the desired behavior of the seismic instrument would be to have an output that gave a direct indication of  $y_h$ . For this to occur, the seismic mass should remain essentially stationary in an absolute frame of reference, and the housing and output transducer should move with the vibrating object. To determine the conditions under which this behavior would occur, the amplitude of  $y_r$  at steady state can be examined.. Figure 12.9 shows  $(y_r)_{\max} / A$  as a function of the ratio of the input frequency to the natural frequency. Thus, a seismic instrument that is used to measure vibration displacements should have a natural frequency smaller than the expected input frequency. Damping ratios near 0.7 are common for such an instrument. The seismic instrument designed for this application is called a *vibrometer*.

On the other hand, the measurement of acceleration requires that the seismic mass relative position is a direct measure of acceleration. This requires a magnitude ratio of unity, and an appropriate natural frequency.

## PROBLEM 12.9

**KNOWN:** A seismic accelerometer has:

$$m = 0.2 \text{ g}$$

$$k = 20\,000 \text{ N/m}$$

Very low damping

**FIND:** Instrument bandwidth

**SOLUTION:**

The natural frequency is found as

$$\omega_n = \sqrt{k/m} = \sqrt{\frac{20,000 \frac{\text{kg m}}{\text{sec}^2 \text{m}}}{0.2 \times 10^{-3} \text{ kg}}} = 10,000 \text{ rad/sec}$$

and with a very low damping. The bandwidth may be found from Figure 3.16 with the allowed frequency range from 0 to  $0.4\omega_n$  or 0 to 4000 rad/s.

## PROBLEM 12.10

**KNOWN:** Integration reduces the effects of noise in a signal.

A moving average integrates over a fixed time interval, based on a concept called windowing.

Noise in the present case has significant amplitude, but a significantly higher frequency than the measured velocity.

**FIND:** The effect of employing a moving average on a signal

**SOLUTION:** This signal has high frequency noise present.

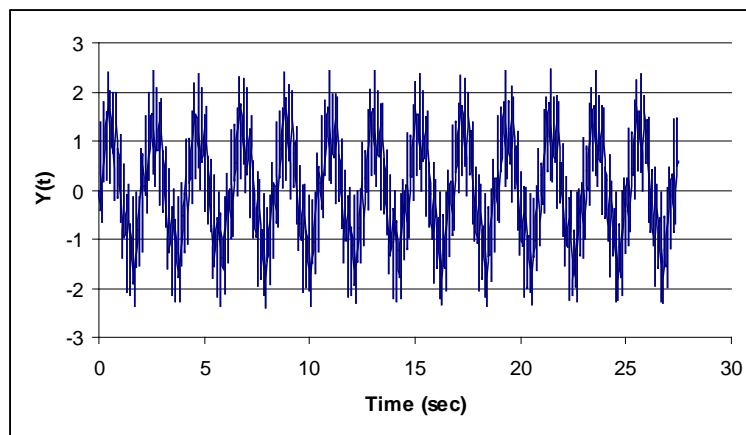

A 5 point moving average has been performed on the signal, and much of the high frequency noise removed.

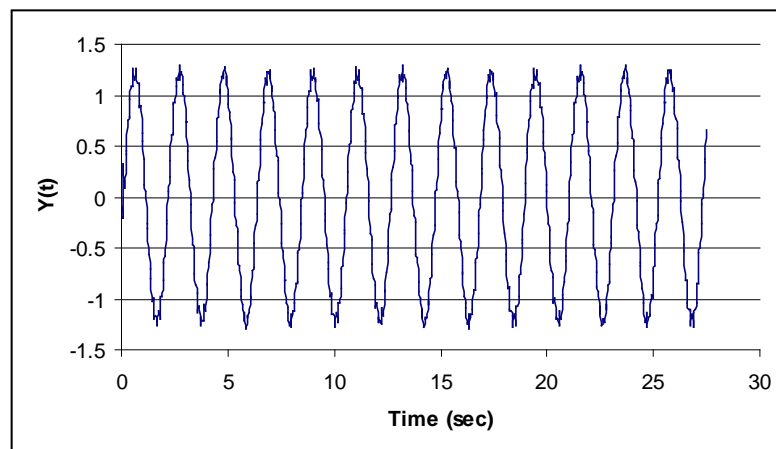

## PROBLEM 12.11

**KNOWN:** Moving coil transducer with

$$D_c = 0.8 \text{ cm} \quad l = 2 \text{ cm} \quad \frac{dy}{dt} \text{ from 1 to 10 cm/s}$$

A/D converter with 8-bit resolution and 0.1% FS accuracy

**FIND:** The required magnetic field strength as a function of  $N$  for 1% accuracy in the velocity measurement.

**ASSUMPTION:** Assume that the uncertainty in the magnetic field strength and the number of turns are negligible.

**SOLUTION:**

From equation 12.19, the emf from the moving coil can be expressed

$$emf = \pi B D_c l N \frac{dy}{dt}$$

the uncertainty in the velocity can then be expressed, with  $V = \frac{dy}{dt}$

$$\frac{u_V}{V} = \frac{u_{emf}}{emf}$$

The uncertainty in the emf has two contributions. From the resolution of the A/D, the uncertainty is  $\pm 7.8 \text{ mV}$  plus 1 mV (RSS addition) from the accuracy, yields  $u_{emf} = 7.9 \text{ mV}$ . Combining the relations for emf and the uncertainty in  $V$ , with an uncertainty in  $V$  of 1%, yields the plot below

## PROBLEM 12.13

**KNOWN:** The development of MEMS and MEMS related applications has increased the requirements for measuring very small forces.

**FIND:** Current state-of-the art in force measurement for very small forces.

**SOLUTION:**

Numerous journal articles and websites can serve as resources to assess the various limits of force measurement. For biomedical applications, micro-load cells have been developed with a range from 0 to 2 N. MEMS applications are on the order of 0.2 mN. And the Atomic Force Microscope uses forces at the atomic level to provide surface topology.

## PROBLEM 12.14

**KNOWN:** A proving ring is to be designed to serve as a calibration standard for forces over the range from 250 to 1000 N.

**FIND:** A suitable design to provide reasonable uncertainty.

**SOLUTION:** It is necessary to establish the minimum deflection which can be measured with reasonable accuracy. As an example consider a displacement transducer having a range of 0 to 1 mm for an output of 0 to 5 Volts. If sampled using an 8-bit A/D, the resolution would be 19.5 mV, corresponding to 0.004 mm. If we assumed that the proving ring would deflect 1 mm at 1000 N, we can size the ring.

Assuming the cross section of the ring is rectangular, the moment of inertia is  $bh^3/12$ , and the deflection is given by

$$\delta y = \left( \frac{\pi}{2} - \frac{4}{\pi} \right) \frac{F_n D^3}{16EI}$$

Let's assume that the ring is steel with a modulus of  $E = 20 \times 10^{10}$  Pa. By varying the cross section and the diameter, a suitable deflection can be established. As an example of the process, assume a square cross section, and a diameter of 8 cm. A deflection of 1 mm at 1000 N would be achieved with a dimension of 4.9 mm for the square cross section. Then at a load of 250 N the deflection would be 0.25 mm, yielding an output voltage of 1.2 V, which should yield a reasonable uncertainty.

## PROBLEM 12.15

**KNOWN:** Power transmission through a drive shaft results in 1800 rpm with a power transmission of 40 hp

**FIND:** Torque transmitted by the driveshaft.

**SOLUTION:**

With

$$P = \omega T$$

and  $P = 40$  hp,  $\omega = \frac{1800 \times 2\pi}{60} = 188.5$  rad/s, we find that the torque is

$$T = \frac{(40 \text{ hp})(550 \text{ ft-lb/sec-hp})}{188.5 \text{ rad/sec}} = 117 \text{ ft-lb}$$

## PROBLEM 12.16

**KNOWN:** A dynamometer can be an integral part of emissions testing for automotive applications.

**FIND:** Define and discuss the importance of a dynamometer in automotive emissions testing.

### **SOLUTION:**

Automotive emissions vary as a function of load and speed. Engine temperature and the temperature of the catalytic converter are also important parameters. Various levels of sophistication are possible for the testing of IC engine emissions. An engine analyzer combined with a dynamometer provides an extensive range of analysis capabilities. A dynamometer will allow monitoring of engine rpm and power output, and may allow a variety of measurements including throttle position, individual cylinder vacuum level, spark quality, and fuel flow rate. Clearly, for emissions testing the engine exhaust is routed through emissions testing equipment.

## PROBLEM 12.17

**KNOWN:** Linear actuators form an important component for a variety of systems.

**FIND:** Research applications for linear actuators.

**SOLUTION:**

The following list represent applications for linear actuators that provide a wealth of information online or in refereed journal publications:

- Autonomous vehicles
- Manufacturing
- Pick-and place operations
- Injection molding
- Positioning in research applications requiring precision positioning

## PROBLEM 12.18

**KNOWN:** Pneumatic cylinders provide linear actuation, primarily to yield only two positions.

**FIND:** Research the range of displacement and force that can be provided by pneumatic cylinders.

### SOLUTION:

Representative ranges for pneumatic cylinders would be:

- Bore sizes from 0.5 to 15 inches
- Stroke length up to 24 inches
- Operating pressure up to 500 psig
- Single or double acting cylinders

## PROBLEM 12.19

**KNOWN:** Flow through a control valve, at a flow rate of 32 SCFM, and an associated pressure drop of 10 psi. The line pressure (the pressure at the inlet side) is 100 psig, and the temperature and relative humidity are 68°F, 36%, respectively.

**FIND:** Research the range of displacement and force that can be provided by pneumatic cylinders.

**ASSUMPTIONS:** The effect of relative humidity on the result would be very small, and will be neglected in this analysis.

**SOLUTION:**

Continuity is applied to find the flow rate at the inlet of the valve in ACFM.

$$\rho_1 (AU)_1 = \rho_2 (AU)_2$$

where 1 represents the standard conditions ( $T = 77^\circ\text{F}$ , 1 atm) and 2 represents actual conditions. Employing the ideal gas model, we compute the two densities as

$$\rho_1 = \frac{P}{RT} = \frac{(14.7)(144)}{(53.34)(537)} = 0.074 \text{ lb}_m/\text{ft}^3$$

and

$$\rho_2 = \frac{P}{RT} = \frac{(100+14.7)(144)}{(53.34)(528)} = 0.586 \text{ lb}_m/\text{ft}^3$$

Then with

$$\text{ACFM} = \frac{\rho_1}{\rho_2} \text{SCFM}$$

we find that the flow rate in ACFM is 4 CFM. The flow coefficient for the valve is

$$\text{ACFM} = C_v \sqrt{\Delta P}$$

$$C_v = \frac{4}{\sqrt{10 \times 144}} = 0.106$$

## PROBLEM 12.20

**KNOWN:** A low profile control valve is employed for a filling and exhaust process. The volume to be filled is 500 mL. During filling the valve has  $F = 0.82$  ms/cc, with a lag time of 8 ms. During exhaust, the valve has  $F = 0.7$  ms/cc, with a lag time of 8 ms

**FIND:** The time required for the filling and exhaust processes.

**SOLUTION:**

The time is given by

$$t_{90} = m + FV$$

So for fillinf

$$t_{fill} = 8 \text{ ms} + (0.82 \text{ ms/cc})(500 \text{ cc}) = 418 \text{ ms}$$

and for exhaust

$$t_{exhaust} = 8 \text{ ms} + (0.7 \text{ ms/cc})(500 \text{ cc}) = 358 \text{ ms}$$

## PROBLEM 12.21

**KNOWN:** Research the design of a totalizing flow meter.

**SOLUTION:** Totalizing flow meters currently allow for remote reading of meters, and subsequent billing in many applications. For most residential applications, positive displacement meters allow for very accurate metering even at very low flow rates; designs include disc meters with either oscillating disk or piston. At commercial installations, turbine or propeller type flow meters are often employed. See also *Plumbing Systems and Design*, July/August 2003 pp. 70.

## PROBLEM 12.23

**KNOWN:** Research the design of a residential thermostat.

**SOLUTION:**

The two key elements of a mechanical thermostat are a mercury switch and a bimetallic thermometer, as shown below. The mercury switch is oriented so that electrical contact is created when the mercury flows from one end of the glass bulb to the other. The deadband is created by the angle of the bulb relative to gravity required to overcome friction and allow the mercury to flow.



## PROBLEM 12.24

**KNOWN:** Show that a proportional controller has a steady state error. Develop an expression for the steady state error when a proportional controller acts on a first-order plant.

**SOLUTION:**

Let the desired value of the controlled variable be represented as  $d(t)$ , and the error signal be  $e(t)$ , with the Laplace transforms of these two quantities represented as  $D(s)$  and  $E(s)$ , respectively. Then with the plant transfer function  $G(s)$ , the feedback transfer function  $H(s)$ , we can state

$$E(s) = \frac{D(s)}{1 + H(s)G(s)C(s)}$$

where  $C(s)$  represents the control function. For proportional control,  $C(s) = K_p$ . And from the final value theorem,

$$\text{steady-state error} = \frac{1}{1 + G(s)K_p}.$$