

\$200.00 USD

Know-How

Series of Self-Study Guides
from Grote Industries

The Basics of Electricity and Vehicle Lighting

Grote®

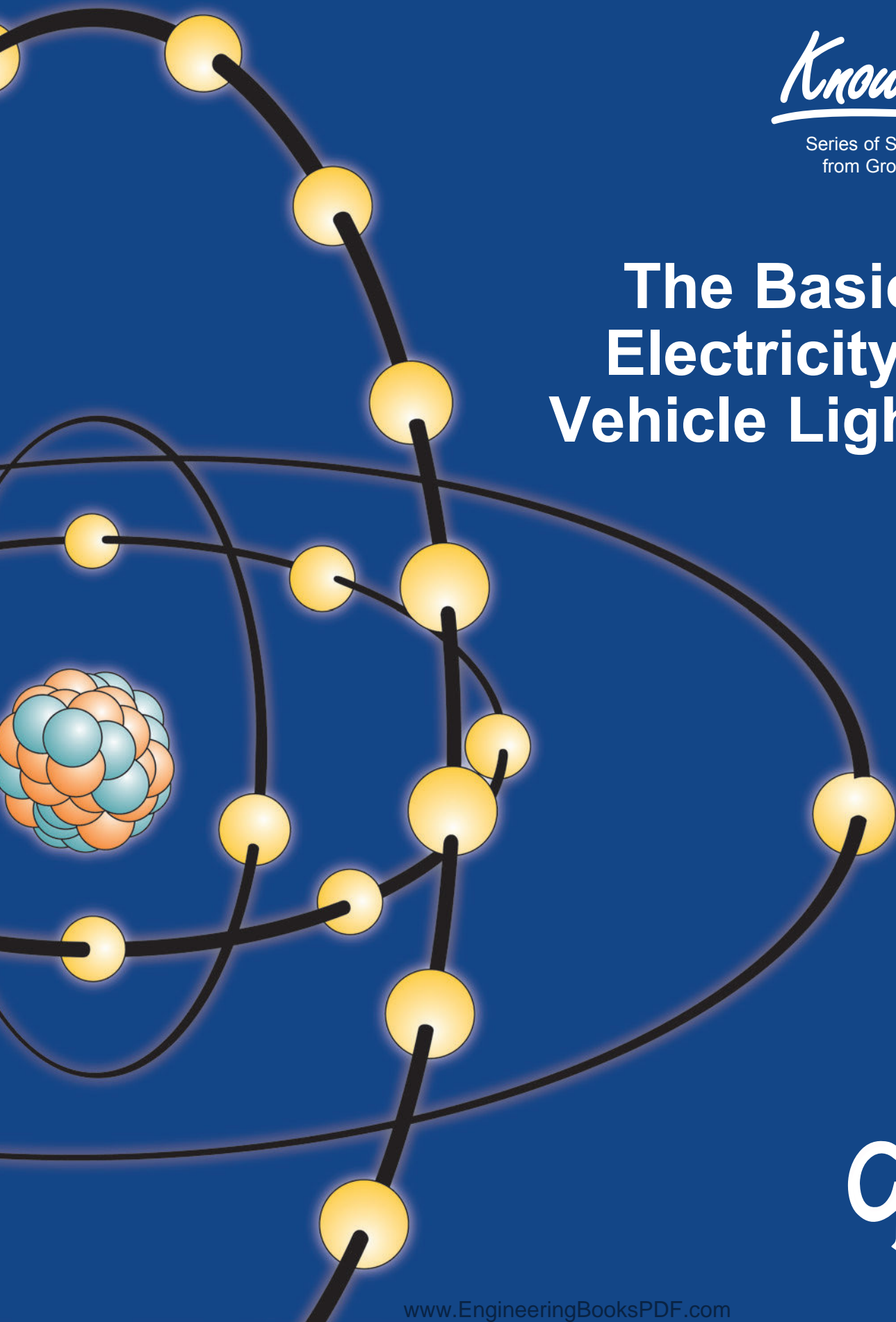

How To Use This Book

This self-study guide is divided into six sections that cover topics from basic theory of electricity to choosing the right equipment. It presents the information in text form supported by illustrations, diagrams charts and other graphics that highlight and explain key points. Each section also includes a short quiz to give the you a measure of your comprehension. At the end of the guide is a final test that is designed to measure the learner's overall comprehension of the material.

To get the most value from this study guide, carefully read the text and study the illustrations in each section. In some cases, you may want to underline or highlight key information for easier review and study later. This guide is designed to be effective for a variety of learning styles and speeds. Material can be read and studied a section at a time, a few pages at one time or even completed in one study session.

Once a section is completely read, use the quiz to determine your level of success in understanding the material. If you choose the wrong answer to a question, be certain to turn back to the relevant material in the section and re-read and re-study the information.

To use the quiz effectively, use a sheet of paper positioned so that it covers all of the quiz material except for the first question. Choose your answer. Then move the sheet

down to expose the first line of the second question. The answer to the first question is shown at the far right. Compare your answer to the answer key.

Choose an answer to the second question. Slide the cover sheet down to expose the first line of the third question and compare your answer to the answer key.

In the same manner, answer the balance of the quiz questions.

The final exam at the end of this guide presents a second test of your knowledge of the material. Be certain to use the quizzes and final exam. In the case of the final exam, fold the answer sheet as directed, and mail to the address indicated for scoring.

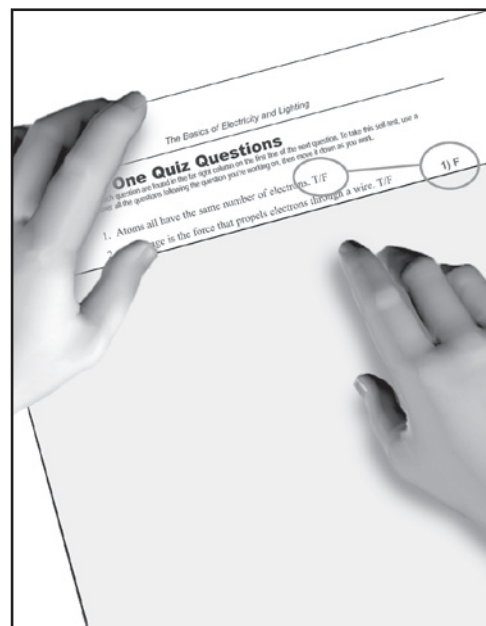

CONTENTS

Section 1 - Basics of Electricity

Mastery Statement	4
Self Study Guide	5
Questions for Review	14

Section 2 - Basics of Vehicle Wiring

Mastery Statement	18
Self Study Guide	19
Questions for Review	29

Section 3 - Vehicle Lighting

Mastery Statement	32
Self Study Guide	33
Questions for Review	43

Section 4 - Choosing Lighting Devices

Mastery Statement	46
Self Study Guide	47
Questions for Review	55

Section 5 - Making Connections

Mastery Statement	58
Self Study Guide	59
Questions for Review	68

Section 6 - Grote Know How & How

Mastery Statement	70
Self Study Guide	71
Questions for Review	76

Glossary of Terms	78
Final Exam	82
Answer Sheet	91
How to Select the Size of Electric Cable	93
CMVSS & FMVSS Requirements	94

Section One

Mastery Statement

When you have successfully completed this section, you will have mastered the following:

- How electrical energy is created.
- The definition of volts, amperage and ohms.
- The difference between conductors and insulators
- The concept of resistance and its effect on current flow
- Short circuit, grounded circuit and open circuit
- Series circuits and parallel circuits

Basics Of Electricity

The discovery of electricity changed the world. Electrical power offered inexpensive and convenient energy for homes and businesses for the first time in history. It has also made possible the internal combustion engine and many of the functions we take for granted on the cars and trucks we drive. Electricity is used to start them and keep them running. It's especially important for the lights and signals that are required on vehicles for safety and convenience. This section of the Grote Know-How Self Study Guide is devoted to understanding the basics of electricity ... what it is and how it works.

How electricity is created

Electricity is based on the interaction of the components of atoms, the basic elements that make up everything around us. Atoms have a nucleus, a center cluster of "protons" and "neutrons." The nucleus is surrounded by orbiting (circling) elements known as "electrons."

Protons have a positive charge. Neutrons are neutral – no charge. Electrons have a negative charge.

Normally, an atom has the same number of protons and electrons. With the same number of positive and negative charges, the atom is balanced. It's neither positive nor negative.

The electrons orbit the nucleus in layers or shells. In the copper atom, shown at the right, the inner shell has two electrons. The second shell has eight electrons. The third shell has 18 electrons. The outside or "valence" shell has one electron.

Electrons in the valence shell are called valence electrons.

Bring a strong negative charge (like the negative terminal of a battery) close to a copper atom, and that single valence electron can be encouraged to

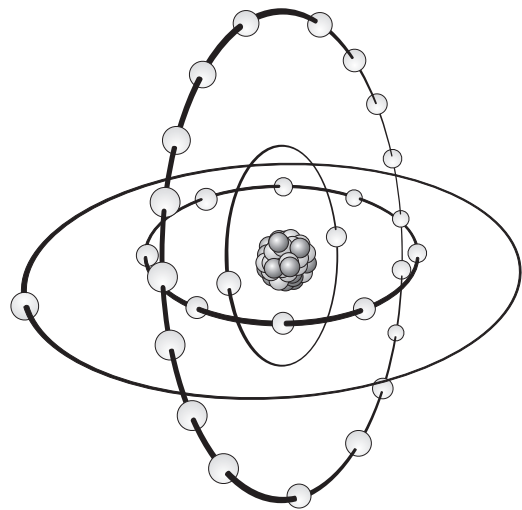

Copper Atom

break free from its orbit and head for a new orbit in a nearby atom.

But now the new atom has one too many electrons. So one of them will break free and head for yet another atom.

The movement of these free electrons from atom to atom is called electricity.

Remove the strong negative charge that started all of this, and the flow of electricity stops.

The valence shell of an atom can hold, at most, eight electrons. The more electrons in the valence shell, the more stable they will be. They won't easily jump from one atom to the next. Such materials are insulators.

Atoms with 1 or 2 valence electrons are conductors.

Atoms with 3 to 5 valence electrons are semi-conductors.

Atoms with 6 to 8 valence electrons are insulators.

Practical electricity

For electricity to be of use it must be harnessed and controlled to do work, such as powering a light or motor. Transferring electricity from an electron source to the device that needs it is the job of a conductor or wire.

There are three basic characteristics of electricity that are interrelated and control the work of electrical energy.

VOLTAGE — The pressure that pushes electricity through a wire.

AMPERAGE — The current load or volume of electricity through a wire.

OHMS — The resistance or friction encountered by the current pushed through the wire.

Understanding the relationship is easier to understand by thinking of the wire as a hose that is connected to a spigot at one end and has an adjustable nozzle at the other end. Starting with the spigot turned on and the nozzle closed, water can't flow and the pressure is at its maximum inside the hose.

When the nozzle is opened slightly (ohms of

Number of Valence Electrons	Property
1 or 2	Conductor
3, 4 or 5	Semiconductor
6, 7 or 8	Insulator

VOLTAGE

The pressure that pushes electricity through a wire.

AMPERAGE

The current load or volume of electricity through a wire.

OHMS

The resistance or friction encountered by the current pushed through the wire.

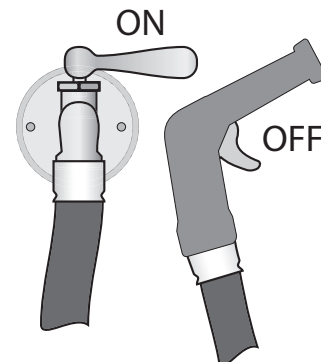

resistance lowered) the water pressure (voltage) pushes a small amount of water (current) through the hose at a high pressure sending it a considerable distance. If the nozzle is opened wide (resistance lowered more), the flow of water (current) is greater but the pressure (voltage) is lower and the stream is much shorter.

Although not exactly the same as water through a hose, the effect is similar for electricity through a wire. Voltage is the result of an over supply of electrons seeking an area with relatively fewer. The greater the difference, the greater the pressure or voltage.

The electrons, when flowing are referred to as amperage or amps, and the more that move through the wire or conductor the higher the amperage is said to be. And while it may seem that one amp is not very much, it requires the passage of 6 billion electrons/second to create that one amp. One amp at one volt will power a one watt bulb. In a 12-volt system, one amp will light a 12-watt bulb.

The resistance to the passage of electrical current is measured in ohms. Resistance is caused by the energy absorbed when electrons break free and move to another atom.

It's important to understand the relationship between volts, amps and ohms. That relationship is simply stated in a simple formula called Ohm's law where "I" stands for current, "E" for voltage and "R" for resistance. It can be stated three ways:

To find voltage: $E = I \times R$

To find amperage: $I = E \div R$

To find resistance: $R = E \div I$

Although calculating one of the three measurements using Ohms law is seldom required, it does help understanding what occurs in a vehicle electrical system and how that changes the electrical flow.

For example, cracked or broken strands in the wiring, bad or dirty switch contacts or loose con-

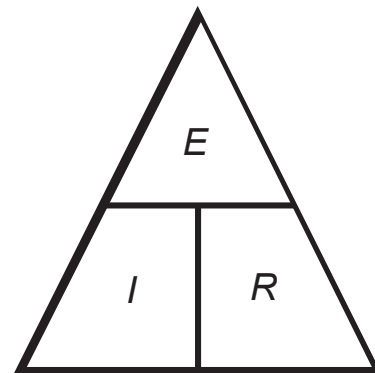
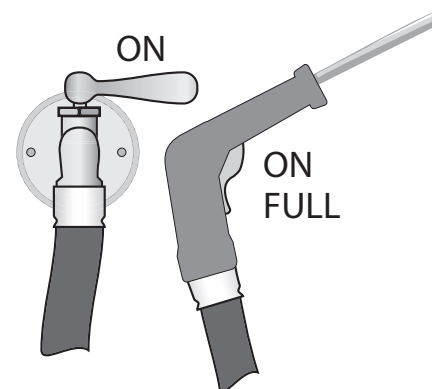
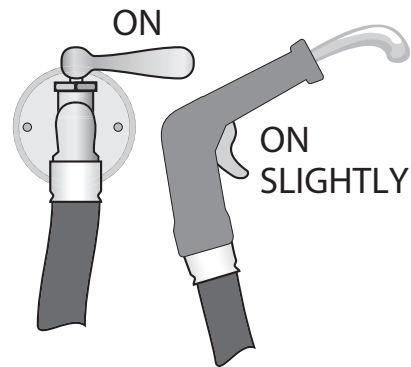

Ohm's Law Triangle serves as a reminder that ...

$$E = I \times R$$

$$I = E \div R$$

$$R = E \div I$$

VOLTS = AMPS X OHMS

$$\text{OHMS} = \frac{\text{VOLTS}}{\text{AMPS}}$$

$$\text{AMPS} = \frac{\text{VOLTS}}{\text{OHMS}}$$

nections all make it harder for current to flow through the system. If the voltage remains the same, for example 12 volts, and the resistance increases because of the deteriorated conditions, the amperage in the circuit will drop. The result will be weak or dim lighting.

On the other hand, if the resistance remains the same, and a malfunction in electrical system allows higher than normal voltage to flow, the amperage will rise. That could have a damaging effect on the electrical systems. For example, the excess amperage could overheat the filaments in light bulbs causing them to burn out.

It's apparent that volts, amps and ohms are inter-related. The rule of thumb simply stated is, it takes one volt to push one amp through one ohm of resistance.

Measuring volts, amps and ohms requires special instruments. For voltage measurements, the instrument is called a voltmeter. Voltmeters may be the traditional swinging needle type or the newer, digital type that reports the measurement values on an alphanumeric display.

Amps are measured using an ammeter. Since it measures the current flow, it must be capable of measuring the minute fractional values as well as the higher levels with out damage or injury to the user. Ammeters typically come in two categories. One is the milliammeter, used for milliamperes, which are fractions of an amp and higher amp capacity meters which are teamed with voltage measuring devices known as Voltage/amperage testers, sometimes referred to as "VAT's." Milliammeter are often teamed with voltmeters and ohmmeters in a handy unit called a "multi-meter."

Ohmmeters measure the resistance offered by an electrical circuit. Since, under most circumstances, all conductors offer resistance to the flow of current, and since resistance plays a key role in the function of electrical systems, it's worth a closer look.



A modern multimeter can measure amps, ohms and volts.

A continuity tester, as the term indicates, checks to see if a circuit is complete or broken between the two points where its leads are connected. It has a battery and a lamp that lights to signal when the circuit is complete. It says nothing about high resistance due to corrosion or a wire that is too small, low voltage or insufficient current. It is merely an “on or off” device.

Even though the continuity tester is equipped with pointed probes, *never poke the probe into a wire to check a circuit*. Even the tiniest pinhole will let moisture and chemicals in, and the wire will corrode.

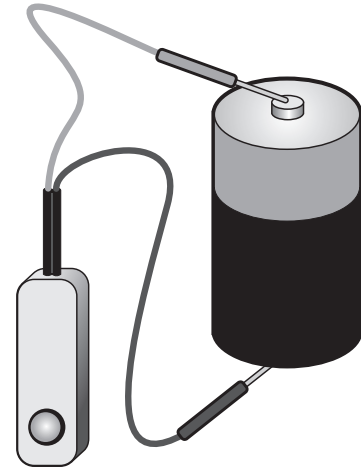

Continuity Tester

Resistance plays a key role in the function of electrical systems. The resistance of any conductor, even of the same material varies along with length, diameter (thickness) material, and temperature. A short wire with the same thickness of a longer wire of the same material at the same temperature will offer less resistance. It’s primarily due to the shorter distance the electrons are forced to travel from the area of high density to an area of less density.

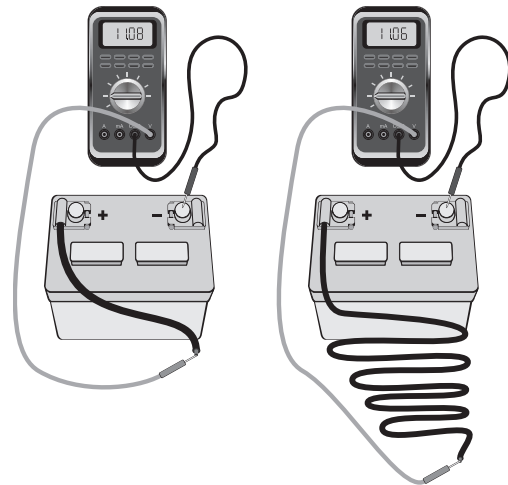

The length of the wire will affect the resistance of the wire.

The material has a lot to do with resistance. Copper, for example, gives up its one valence electron easily. So it allows electrons to flow readily. Iron, on the other hand, has two valence electrons. It’s still a conductor. But it doesn’t give up electrons as easily as copper. So iron has more resistance than copper.

Size of wire effects resistance. In general, the flow of electrons through a larger wire is easier than the same flow through a smaller one. Once again, the effect is based upon the availability of electrons.

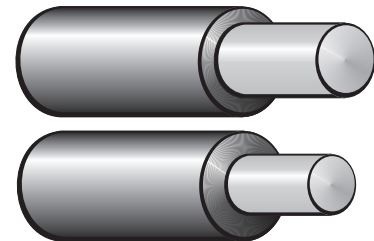

The thickness of the conductor effects resistance.

In most metal conductors, heat increases resistance. Heat causes electrons to become excited and fly off in random directions. That random movement interferes with the orderly transfer of electrons, causing resistance. As the electrons fly around within the conductor, they create additional

heat, which creates even more resistance. It's possible that in the right temperature and heavy current flow conditions a wire or cable could cause a fire or fail completely. Resistance is the reason that choosing the right capacity wire and cable is so important.

However, resistance is not always a bad thing. For example, the glow of a filament in a light bulb is the result of resistance of current flowing through a specialized metal conductor. As the current passes through it, the filament wire quickly heats up producing a very bright glow. Also, certain types of conductors are designed to produce large amounts of resistance, which produces heat. These resistance-based devices are used in countless applications where heat is required.

Working with electricity

The flow of electricity is fairly simple in both principle and in real life. Nature is constantly attempting to achieve a perfect balance of electrons from one location to another. For that reason, groups of electrons constantly seek a path from areas dense with them to areas where they are less dense. The best and easiest target for these electrons is the earth itself...the ground. Other targets are large masses of metal. For example, the metal frame of a vehicle.

In finding the shortest path, electrons will flow along the easiest possible route. Since resistance slows down and restricts the flow of electrons, they will avoid areas that offer more resistance. They take the so-called "path of least resistance." Given the opportunity it will seek the ground even though it may not be the path it is supposed to take. One type of unplanned path where the flow of electrons reaches ground before completing its designed task is called a short circuit.

In its most basic form, a short circuit occurs when a bare wire touches another wire that offers a more direct path to the ground than the designed

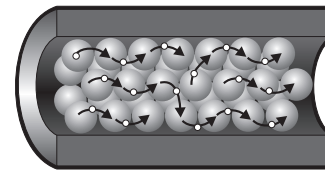

Under normal circumstances, electrons flow in one direction.

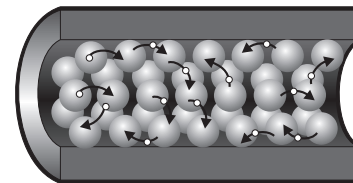

When a wire starts to heat up, electron flow becomes more random and resistance increases.

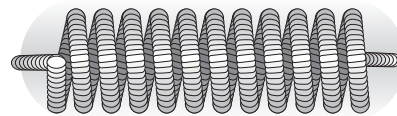

When a coiled filament heats up, it becomes white hot, giving off light.

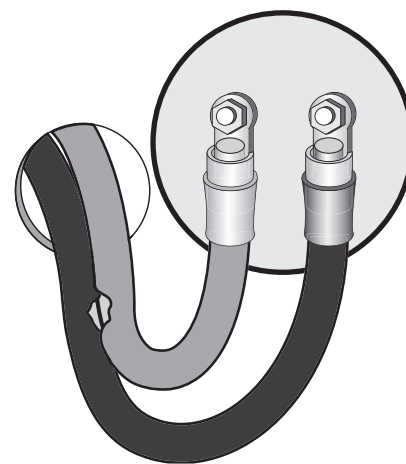

Short Circuit

path. The name comes from the fact that the current flow leaves the wire in favor of the other wire taking a shorter path or circuit.

Short circuits are typically caused when the insulation is accidentally removed. This can occur when wire is allowed to rub on a sharp object. Most typical is the case of two wires rubbing together. Both may become abraded until the two bare wires are brought into contact.

A grounded circuit is similar in result to the short circuit. However, in this case, the easier path is directly to the ground, typically a large metal mass such as a vehicle frame. Grounded circuits typically occur when a wire rubs on the frame or component of the vehicle until the bare wire is in contact with the metal. Like the short circuit, the grounded circuit represents a shorter path with less resistance than the designed path.

The open circuit is actually the opposite of the path of least resistance. With the previous two conditions, the result was electrons flowing through the wrong circuits to the ground and not accomplishing the designed work. With an open circuit condition, work is also not done because the electrons never reach a ground point. It is usually caused by a break in the conductor or a wire pulled loose from a terminal or device.

As with resistance, not all cases of open circuits are negatives. A simple switch actually produces an open circuit “on-demand” making it easier to control the flow of electricity from power source to destination.

Electricity flow is also identified by some other distinct characteristics. One of them is direction of flow.

Early in the history of electrical systems, all electrical energy flow was in one direction. The common term for this type of flow is Direct Current. But transmission of electricity over distance was difficult because of the drop in voltage

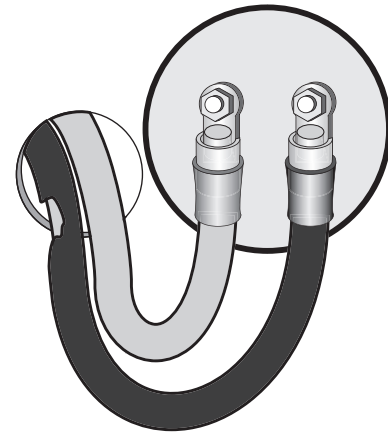

Grounded Circuit

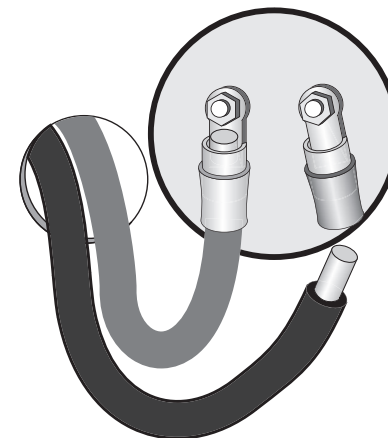

Open Circuit

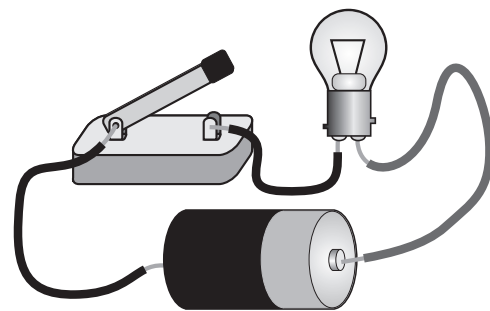

There are times when an “open” circuit is desirable. A simple switch creates an open circuit on demand.

due to resistance in the wires. The solution was to convert the DC to another form of electricity that reverses flow rapidly at precise intervals and is referred to as Alternating Current. AC as it is known allowed the use of transformers to boost the voltage of the AC to high levels for transmission over long distances and then reduce the voltage at the other end of the transmission line for use at a safer level we call “house current.”

Vehicles typically use DC because they operate at significantly lower voltages than AC systems, 12 volts compared to 120 volts in the average home. Plans are on the board for trucks with 42-volt systems to support all of the on-board electronics and other devices that require substantial amounts of electrical energy.

Another reason for DC vehicle systems is that batteries are only able to produce DC current. This works out well because of the relatively low voltage of the vehicle systems, wiring, connectors and switches along with devices can also be lighter.

Another aspect of electricity has to do with how the sources of electricity and the device that use the current are arranged and hooked together.

In the simplest circuit, the positive terminal of a battery is attached to one terminal of a bulb. The negative battery terminal is attached to the bulb’s remaining terminal. That “complete” circuit allows electrons to flow through the filament of the bulb and allowing the resistance of the filament to create light.

However, if the device in the circuit requires greater voltage, multiple 12-volt, 12 amp batteries can be wired together in a “series circuit” with the negative terminal of one battery connected to the positive terminal of the next battery with the pattern repeated until all of the batteries are linked. If four 12-volt batteries are connected in this fashion, the resulting voltage is 48 volts. The amperage remains the same. The disadvantage with the

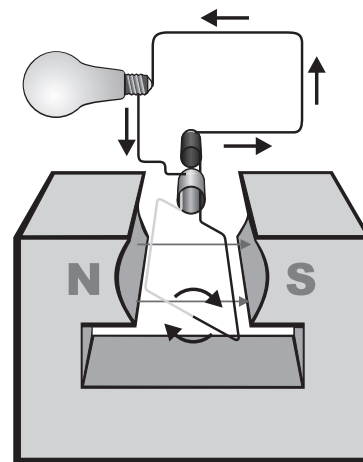
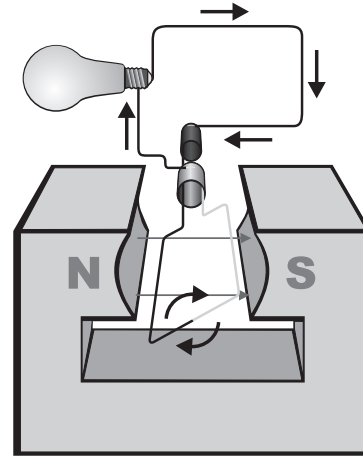

In an alternating current, the current flows first in one direction, then it reverses direction, alternating back and forth in cycles.

arrangement is that if one device in a series fails, the whole circuit fails.

A parallel circuit is created if multiple 12-volt, 12 amp batteries are connected with the negative terminal of one battery connected to the negative terminal of the next, until all negative terminals are linked. Likewise, the positive terminal is connected to the positive terminal of the second, using the same pattern until all the batteries are connected. If four 12-volt batteries are connected in this fashion, the resulting voltage is still 12 volts. But this arrangement yields a power output of 48 amps. The advantage of a parallel circuit is that, should one component fail, the circuit doesn't fail.

Series and parallel circuits may be combined. For example, a circuit with two batteries connected in series and two in parallel would result in a power output of 24 volts along with 24 amps.

Lights are another application of parallel circuits. For example: driving lights. Two 55-watt headlights in parallel draw 110 watts or 9.2 amps at 12 volts. If one fails, the other will continue to operate, using 55-watts, drawing 4.6 amps, still at 12 volts. In a series circuit, if one failed, the other would go out.

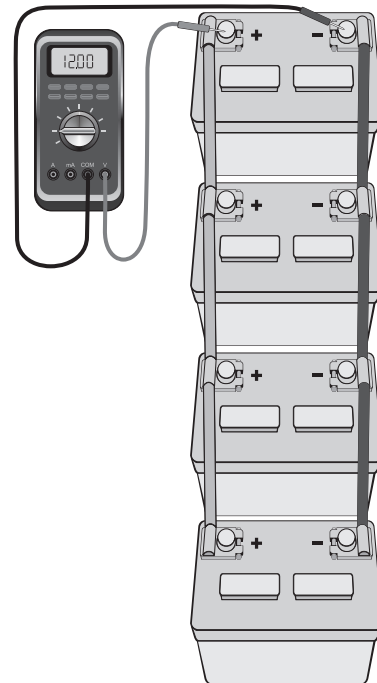

Four 12-volt batteries wired in parallel produce 12 volts.

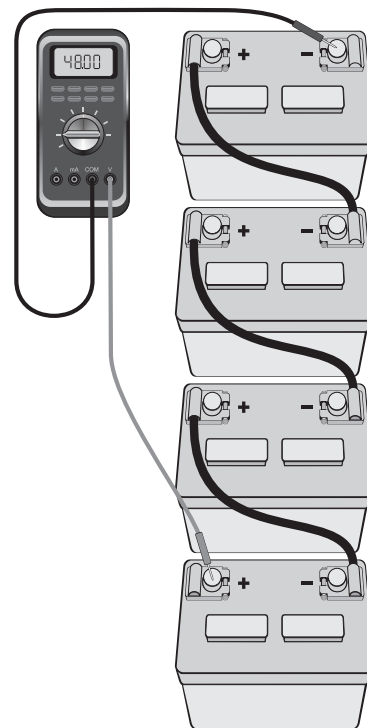

Four 12-volt batteries wired in series produce 48 volts.

Section One Quiz Questions

NOTE: Answers to each question are found in the far right column on the first line of the next question. To take this self-test, use a piece of paper to cover all the questions following the question you're working on, then move it down as you work.

1. Atoms all have the same number of electrons. T/F
2. Amperage is the force that propels electrons through a wire. T/F **1) F**
3. Copper is a good conductor because its electrons are tightly bound to its atoms. T/F **2) F**
4. Which of these is not a basic attribute that describes electricity? **3) F**
 - a) Volts
 - b) Protons
 - c) Amps
 - d) Ohms
5. The movement of electrons from one atom to the next is called electrical current. T/F **4) b**
6. In a 12-volt system, one amp is roughly the current required to light a ... **5) T**
 - a) 1 watt bulb
 - b) 6 watt bulb
 - c) 12 watt bulb
 - d) 24 watt bulb
7. Ohm's Law shows the relationship between volts (E), current or amps (I) and ohms or resistance (R). For example: $E = I \times R$. If I equals 10 and R equals 5, what is the value of E? _____ **6) c**
8. Another way to look at the relationship between the three is to discover the amps when the volts are known: $I = E \div R$. If E = 20 and R = 10, what does I equal? _____ **7) 50**
9. A third way to look at the relationship between the three is to discover the resistance when the volts and amps are known: $R = E \div I$. If E = 10 and I = 2, what does R equal? _____ **8) 2**
10. If the voltage remains the same and broken wire strands or loose connections raise resistance, what is the effect on current flow? **9) 5**
 - a) It remains the same
 - b) It drops
 - c) It rises along with the resistance
 - d) It rises
11. Increasing voltage is the best way to get more light from bulbs. T/F **10) b**
11) F

12. An ohm meter and a continuity tester are both used for testing the resistance in a wire. T/F
13. The rule of thumb for comparing volts, amps and ohms is that: It takes one volt to push one amp through one ohm of resistance. T/F **12) F**
14. The length and diameter of a conductor effect its resistance. A short wire of the same diameter and material typically offers: **13) T**
- a) More resistance
 - b) Less resistance
 - c) No resistance
15. The higher the temperature of the conductor, generally the lower the resistance drops T/F **14) b**
16. Groups of electrons are constantly seeking a path from areas of high concentration to areas of less electron density. T/F **15) F**
17. The “path of least resistance” is always through a newly installed wire. T/F **16) T**
18. A short circuit occurs when a bare conductor touches another bare conductor that offers a more direct path to the ground. T/F **17) F**
19. An open circuit occurs when there is an interruption or break in the conductor too large for electrons to cross. T/F **18) T**
20. The term “DC” refers to: **19) T**
- a) Circuit with no switch
 - b) Dedicated circuit
 - c) Current constantly reversing
 - d) Current always flowing in the same direction
21. Batteries produce ... **20) d**
- a) Direct current
 - b) Alternating current
 - c) Both
22. If four 12-volt/12 amp batteries are connected with the negative terminal of one connected to the positive terminal of the next until all are connected, it is referred to as a series circuit. T/F **21) a**
23. What is the major disadvantage of wiring four 12-volt batteries in series? **22) T**
- a) The output jumps to 48 volts
 - b) It takes a lot of room
 - c) All the same brand batteries must be used
 - d) If one battery fails the circuit fails
- 23) d**
-

24. A circuit with two 12-volt/12 amp batteries connected in series and two connected in parallel would produce
- a) 12 volts and 10 amps
 - b) 12 volts and 24 amps
 - c) 24 volts and 12 amps
 - d) 24 volts and 24 amps
25. A grounded circuit is typically created when a bare conductor is allowed to touch a ground source creating path for the electrons to flow. T/F
- 24) d**
25) T

Section Two

Mastery Statement

When you have completed this section you will have mastered the following:

- What the charging system components are and how they work
- The “one-wire circuit”, which uses the vehicle as a grounding device
- Basic wire and cable construction
- Wire and cable sizing
- The definition and use of primary wire
- Battery cables and fittings

The Basics Of Vehicle Wiring

Typical electrical system

In the earliest days of the automobile, the electrical system was simple. It was just used to ignite the fuel/air mixture in the crude internal combustion engines. Starting the engine was the job of the driver or passenger and a hand crank. Lights were just acetylene lanterns, if in fact there were lights.

By the end of the 1920s, electric starters had replaced hand cranks, electric headlights had replaced lanterns and electric horns had taken over for the hand-squeezed air horn. Today, vehicles operate with complex and extensive electrical systems with many circuits and devices that produce, store and distribute electricity.

The main component of the electrical system is the battery, which is the initial source of electricity for all the rest of the on-board systems for most vehicles. The battery is used as a storage device, supplying the power required to start the engine and operate the other systems such as clocks, alarms, radios and others while the engine is off.

The second key component in the electrical system is the alternator. It is powered by the engine and has two main functions:

- Charge the battery
- Power the electrical system when the engine is running

Along with the alternator, the charging system also includes a voltage regulator to protect on-board devices (including lights) from the effects of higher than specified electricity flow. Light bulbs are susceptible to higher than normal current levels that cause filaments to age almost instantly and “burn-out.”

The alternator (or as it is technically known, alternating current generator) uses the same general approach as other generating devices in that it depends upon electromagnetism to create an elec-

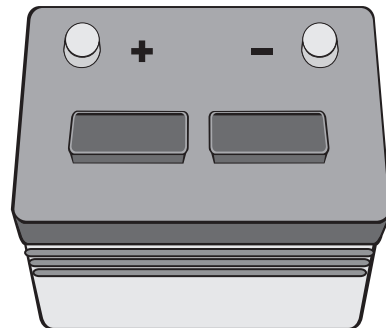

Battery

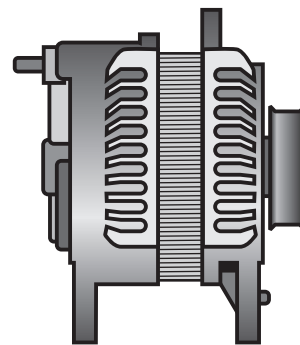

Alternator

trical current. It does so by moving one magnetic field, called a rotor, inside a fixed electromagnet called a stator. The alternator is driven off of the engine through a belt arrangement much the same as a water pump is. Mechanical energy from the engine is converted to electrical energy by electromagnetic induction (creation of a magnetic field).

The rotor consists of a coil of wire wound around an iron core, which is pressed on to a steel shaft. The stator has similar windings that create an electromagnetic field in the rotor as it spins.

The electrical energy created by the alternator is AC or alternating current. In order to be useful in a vehicle system, it must be changed to DC or direct current. That is done through the use of devices known as diodes. Diodes polarize the AC output into DC output. This process is sometimes referred to as rectifying the current. Hence, the assembly that holds the diodes is often called a rectifier.

The alternator also has built-in controls that limit its output. The regulator circuits protect the battery and the rest of the electrical system from too much output.

The starter is another basic component of the vehicle electrical system. Although it has evolved over the years into an efficient and reliable device, the starter still functions much the same as the earliest ones. It spins the engine to a sufficient speed to sustain ignition in both internal combustion and diesel engines.

Lighting is an important function of the electrical system. Most vehicle lighting operates on the same basic principles as the starting, ignition and charging systems. The vital components include the lighting sockets, bulbs or LEDs, connectors, wire and cable, switches, fuses, alternator and battery. It also includes the metal frame of the vehicle itself, which acts as the ground, becoming part of the lighting circuits. The use of the metal frame allows what can be referred to as “one wire” systems.

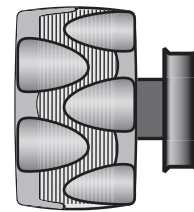

Alternator Rotor

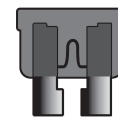
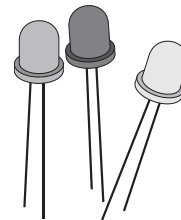

Lighting System Components

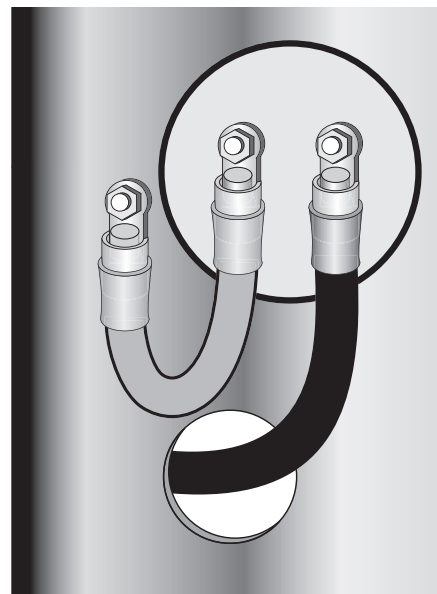

A “one-wire” system uses the vehicle frame as part of the circuit.

They are called that because typically, an electrical circuit requires a “supply” wire which carries current to the load (device requiring electrical energy) and a return wire to complete the circuit. With a vehicle system using the metal frame as the ground, that second connection isn’t required. The battery ground wire is attached to the frame. The ground wire of any individual device can simply be attached to the metal frame at a convenient spot.

It’s important to remember that in order for the frame to effectively provide a complete circuit, there must be good contact between the wire from the system devices and the metal of the frame. There has to be good metal-to-metal contact and a strong mechanical connection including the use of screws.

Because the battery is such a pivotal part of the lighting it is worthwhile to look at it a little closer.

The primary function of the battery is to provide starting energy for the vehicle and electrical power for critical systems and devices when the engine and alternator are shut down. It also acts as a stabilizer for voltage throughout the system. Modern batteries are built to withstand the primary causes of early failure: extremes of weather, severe vibration, engine heat, corrosion, extreme discharge and prolonged periods of inactivity.

Typical vehicle batteries consist of layers of positively and negatively charged lead plates. Those, along with their insulated separators, make up each of a 12-volt battery’s six 2-volt cells. They are typically made of wire mesh coated with porous lead.

These lead-acid batteries are filled with a conductive liquid called electrolyte, a mixture of two-thirds distilled water and one-third sulfuric acid. The spaces between the plates are filled with the electrolyte and the plates are exposed. The interaction of the plates and the electrolyte produces chemical energy which, when electrical devices are connected to the positive and negative terminals,

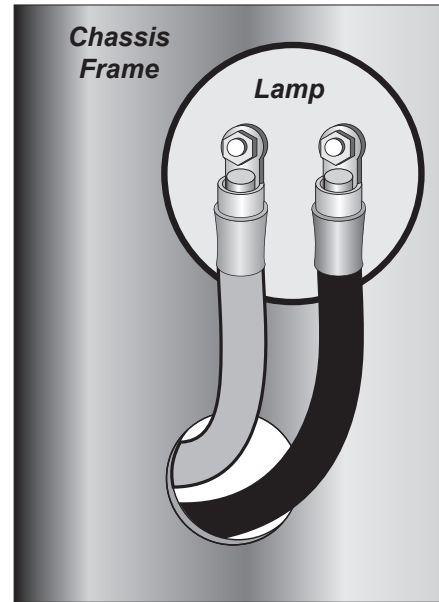

A “two-wire” system uses a separate wire to complete the circuit.

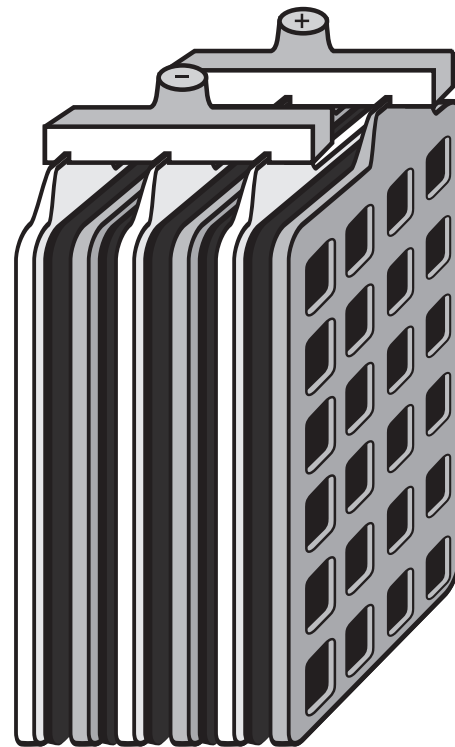

A lead-acid battery consists of layers of positively and negatively charged lead plates, sandwiched between insulated separators.

is transformed into electric current. When the battery has given up its charge to the lights and other components of the electrical system, the alternator can send electrical power to the battery, which in turn converts the input to chemical energy until the vehicle needs it again.

Wire & cable basics

Wire and cable are fundamental to the use of electricity. Some basic fundamentals of construction and how they work will help make the correct choice easier and more efficient.

First is construction. A typical wire or cable in use today has a relatively simple construction. There are two major components:

- A conductor
- An insulation layer

Of course, there are exceptions. A battery ground strap, the device that connects one terminal of a battery to the frame of the vehicle, often consists of a “woven” metal construction. That particular design requires no insulation.

Other types of cables, such as some styles of spark plug wires, require a substantially more complex construction and insulation to defeat Radio Frequency Interference (RFI) generated by current flow. But these are the exceptions. The vast majority of vehicle wiring is done with more basic types of wire and cable.

Typically, the manufacture of a wire or cable is as simple as coating a conductor with a layer of insulating material. This material is referred to as “dielectric” because of its lack of current carrying capacity. The measurement of the insulating ability of a given material is referred to in terms of its dielectric strength.

Many materials are not good conductors. In fact, the poorest conductors make the best insulation materials. The difference between an insulator and a conductor is that insulators have few if any free



*Primary Wire
Typically small gauge.*

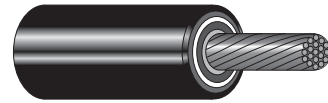

*Spark Plug Wire
Typically contains multiple layers of insulation and shielding.*

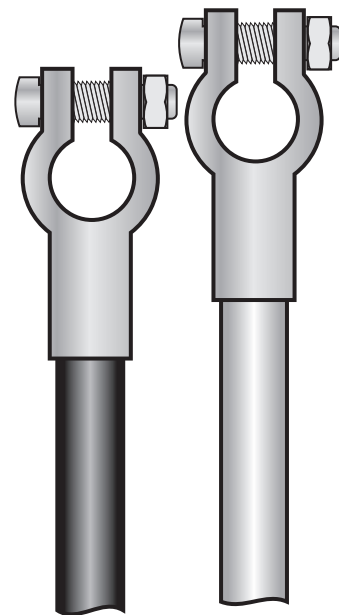

Battery Cables

electrons...those that are ready to travel from an area full of electrons to an area with less.

Insulators are made up of atoms that have electrons that are tightly bonded to them. In the past, many materials have been used as insulators in electrical systems. Rubber, cloth, paper, woven silk, glass and a number of other materials have been tried.

Before the advent of plastics, many forms of insulation were tried. Even lacquer, the same kind used to finish wood, was applied to metal conductors. However, lacquer scratches easily and was easily worn off.

After World War II a whole new generation of insulation material was created. Plastics have good dielectric strength, flexibility, abrasion resistance and resistance to chemicals. Today, insulation is made from PVC, polyethylene, and a variety of other plastics.

In wire applications, insulation plays several roles. The basic role is to separate the conductor from its surroundings and especially shield it from reaching a ground accidentally. The insulation helps maintain the intended path and prevents a short circuit or a grounded circuit.

Since insulation often has a color associated with it, it can help identify a particular wire when tracing a circuit. That makes it easier to keep electrical systems organized, especially when troubleshooting or making repairs.

Conductors are the opposite of insulators in their operating characteristics. Atoms in good conductors have an abundance of "free" electrons compared to insulators with few, if any. Examples of ordinary conductors are: copper, iron, aluminum, lead and steel.

Of the conductors, platinum, gold and silver are excellent, but they are expensive to use and are typically only found in high value applications, such as computers. In that type of use, a highly

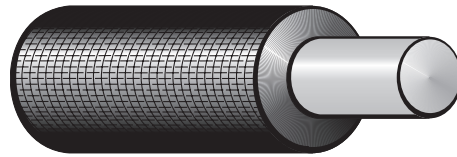

Fabric Covered Insulation

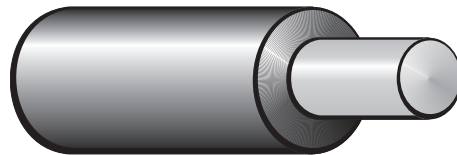

Plastic Insulation

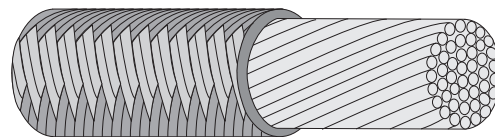

Glass Braid Insulation

efficient conductor is required because voltages are low (“pressure” pushing current is low). A good conductor helps to keep the electricity flowing.

Copper, on the other hand, is a very affordable conductor. That’s why copper wire is so common.

Conductors may be single strand or a group of strands. Stranded conductors are preferred in heavier gauges because they are more flexible and easier to work with than a comparable single strand conductor.

Comparing stranded cable sizes is simple. Stranded cable is compared using a numerical system. For example, 18/24 indicates that the conductor consists of 18 strands of 24-gauge wire. Similarly 12/12 refers to 12 strands of 12-gauge wire.

Gauge refers to the size of the conductor in a wire. The higher the gauge number, the smaller the wire. For example, a 18-gauge wire is smaller than an 12-gauge wire. And a 4-gauge wire has more than twice the diameter of a 10-gauge wire.



















When the wire size gets larger, the number reaches #0 gauge or 1/0 (one aught). Additional zeros refer to larger sizes. The next larger size above 1/0 is #00 or 2/0 (Two aught).

The capacity of a wire reflects the ability it has to carry electrical current. For example, over a distance of 50 feet, a 12-gauge wire can safely carry 10 amps. Over the same distance a 16-gauge wire can carry 3 amps. Choosing the right size wire is made easier using the Grote wire size chart found in the Grote catalog.

It’s important to remember that wire size is dependent upon the conductor size, not the outside dimensions. A cable using a 4-gauge conductor would have more than twice the capacity of a 10-gauge conductor with a heavy insulating layer, which might give it the same outside diameter.

There are two types of wire used on a vehicle: Primary and Secondary.

Wire Gauge Chart

GAUGE	S.W.G.	A.W.G. (inches)	A.W.G. (mm)	Actual Size (A.W.G.)
00	0.348	0.368	9,266	
0	0.324	0.325	8,252	
1	0.300	0.289	7,348	
2	0.276	0.258	6,543	
3	0.252	0.229	5,827	
4	0.232	0.204	5,189	
5	0.212	0.182	4,621	
6	0.192	0.162	4,115	
7	0.176	0.144	3,665	
8	0.160	0.129	3,264	
9	0.144	0.114	2,906	
10	0.128	0.102	2,588	
11	0.116	0.091	2,304	
12	0.104	0.081	2,052	
13	0.092	0.072	1,829	
14	0.080	0.064	1,628	
15	0.072	0.057	1,450	
16	0.064	0.051	1,291	
17	0.056	0.045	1,150	
18	0.048	0.040	1,024	
19	0.040	0.036	0,912	
20	0.036	0.032	0,813	
21	0.032	0.029	0,724	
22	0.028	0.025	0,643	

A.W.G. = American Wire Gauge
 S.W.G. = Imperial Standard Wire Gauge
 (British legal standard)

Primary wire refers to conductors used as part of the vehicle's electrical system.

Secondary wire is used as part of the so-called secondary circuit of the ignition system. That circuit consists of the coil secondary winding, the coil wire, the distributor cap, sparkplug wires, and spark plugs. A major characteristic of secondary wiring is that it carries high voltage. In some cases, it can exceed 50,000 volts.

Primary wire refers to most of the other wire found in the vehicle. It's reported that the typical auto contains over a mile of primary wire, with more added as cars become more complex. It can be found on parts of the ignition system and includes battery cables (relatively low voltage).

However, the majority of the primary wire is used for connecting lights and other types of on-board equipment. As such, primary wire typically carries 12-14 volts. The current it carries can vary from a few milliamps (thousandths of an amp) to as high as 100 amps.

Primary wire can be either single or multi-strand conductor surrounded by an insulating layer. As with other wire types, the function of the conductor is to provide a pathway for the passage of the current. The insulation keeps the electrons from escaping. Grote primary wire is supplied in a number of types and sizes from 18 to 4/0 gauges.

Battery cables represent a special type of wire and cable utilizing stranded conductors and heavy fittings because of the amp loads they are required to carry. The voltage is usually modest, around 12 volts. But amperage can climb as high as 100 when powering up devices such as starter motors. This is the opposite of what occurs with a spark plug, which uses high voltage to drive a relatively low level current across the gap in the plug. The battery cable has a heavy conductor and modest insulation layer. A sparkplug wire has a relatively small conductor with a substantial insulation layer.



Solid Core Wire



Multistrand Wire



Battery Cable

Battery cables have several components. First is the cable itself. It is made up of many strands of copper wire surrounded by a layer of dielectric material. The insulating layer's function is to protect the cable from shorting out while keeping away moisture that could cause corrosion.

At one end of the cable is a terminal that connects to the battery. Although there are many variations of terminals, the most common is still the “y” connector that fits over the terminal stud on the battery and clamps on to provide the most secure and efficient contact between cable and battery.

At the other end of the cable is a lug designed to connect the battery to a starter motor. The lug has a hole that fits over a stud on the starter motor and gets tightly attached with a wrench.

There are many variations of these basic connectors. For example, the Grote Quick[®] compression fittings are easy-to-use fittings that utilize a threaded insert that provides a secure, efficient connection without torch, solder or crimping tool.

Specialty fittings add utility to batteries. For example, Grote supplies a battery post to stud connector that provides a quick disconnect feature to prevent battery drain over long periods of inactivity. Top post to side post converters change the connecting points on the battery from top access to side access. For multi-battery setups, QuickHarnesses[®] allow connecting two or three separate batteries to be teamed in a parallel circuit to provide maximum starting power at the same voltage.

No matter what the variety, choosing the correct wire size for the application is critical. The key information required is the length of wire required, often referred to as the length of run, and the current load that the conductor is expected to carry in use. Knowing the “length and load” characteristics will take the guesswork out of the choice.

Voltage drop is the primary consideration when

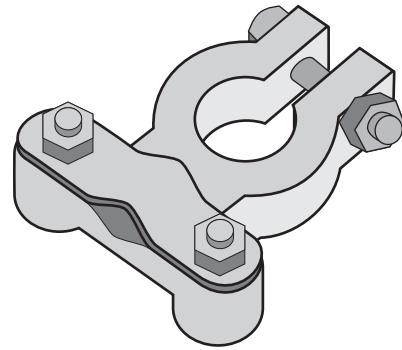

Battery Clamp

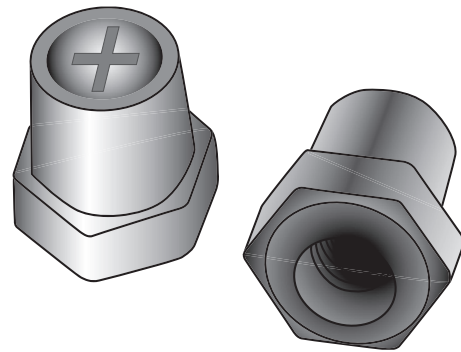

Post to Stud Adapter



Compression Lug

selecting the proper conductor size. Every conductor has a certain amount of resistance per foot. The longer the distance, the greater the resistance in the circuit. As distance from the power source increases, there is less voltage available to “push” the current through the wire and the current drops. There is also heat buildup as the resistance increases, also lessening the amount of current flow.

In low voltage systems, such as vehicles, even a small drop in voltage can have a serious effect. But there’s a simple solution. As you get further away from the power source, make the conductor larger. A larger conductor means less resistance.

Calculating the length of run requires a measurement referred to as the “most distant point.” Care must be taken to calculate the actual length. That means allowing for connections, providing slack to reach around obstacles and generally making sure that the length of run is not understated. For example, a rear trailer light mounted in the center might need to be fed from the side instead of down the center. That extra run could double the length of the wire.

With the length of run known, calculate the required amount of amps by adding together the draw for all of the devices that will require power on that circuit. With the two calculations complete, the correct wire size can be calculated.

Using the “Wire Size” chart on the next page, first find the load in amps on the left-hand edge of the chart. Choose the column that reflects the system used on the vehicle (6 volt or twelve) and go down the column to the amp load calculated.

Then find the length of run across the top of the chart. Read down that column until it intersects with the amp load line. The point at which they cross indicates the correct wire size for the job.

Since heat has the effect of increasing resistance and diminishing the capacity of the wire to carry current, it makes sense to determine the possible

Calculate The Actual Length Of Each Wire Run

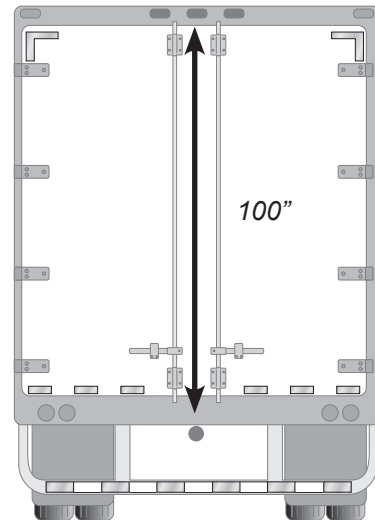

There may be 100" between the point where the wiring harness terminates (below the floor of the trailer) and the lights (above the door) that you wish to connect. However ...

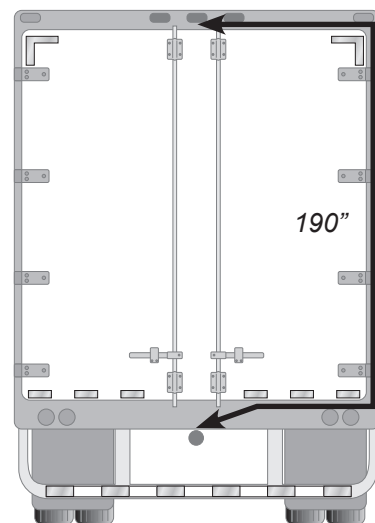

The wire must be routed over to the side of the trailer, up the wall, and back across the ceiling to the lights. The actual run is closer to 200".

effect that the operating temperature might have on the wire choice.

To do that, find the suggested wire size (from the prior exercise) on the left edge of the “Temperature Chart” at the right. On that line, read across to the temperature column that reflects the operating environment. At that intersection, read the maximum allowable amp carrying capacity. Confirm that the maximum amp load indicated is greater than or equal to the load in the new circuit. If not, choose a heavier gauge and once again check the temperature chart.

TEMPERATURE CHART			
Cable Size	Maximum Current Carrying Capacity (For 12 Volts at Listed Temperatures)		
	120° F	125° F	150° F
20 Gauge	15 Amps	13 Amps	9 Amps
18 Gauge	18 Amps	15 Amps	11 Amps
16 Gauge	22 Amps	19 Amps	14 Amps
14 Gauge	27 Amps	23 Amps	17 Amps
12 Gauge	40 Amps	32 Amps	24 Amps
10 Gauge	50 Amps	42 Amps	31 Amps

Note: Currents above those listed may increase the temperatures of the PVC above a safe design level of 180° F.

NOTE: The charts on this page also appear in the “Technical Information” section of the Grote Catalog.

WIRE SIZE CHART											
For A 12-Volt System	For A 6-Volt System	Length of Wire (Most Distant Light)									
		10'	20'	30'	40'	50'	60'	70'	80'	90'	100'
Load in Amps	Load in Amps	Wire Gauge	Wire Gauge	Wire Gauge	Wire Gauge	Wire Gauge	Wire Gauge	Wire Gauge	Wire Gauge	Wire Gauge	Wire Gauge
1.0	0.5	18	18	18	18	18	18	18	18	18	18
1.5	0.75	18	18	18	18	18	18	18	18	18	18
2.0	1.0	18	18	18	18	18	18	18	16	16	16
3.0	1.5	18	18	18	18	18	16	16	16	14	14
4.0	2.0	18	18	18	16	16	16	14	14	14	12
5.0	2.5	18	18	18	16	14	14	14	12	12	12
6.0	3.0	18	18	16	16	14	14	12	12	12	12
7.0	3.5	18	18	16	14	14	12	12	12	12	10
8.0	4.0	18	16	16	14	12	12	12	10	10	10
10.0	5.0	18	16	14	12	12	12	10	10	10	10
11.0	5.5	18	16	14	12	12	10	10	10	10	8
12.0	6.0	18	16	14	12	12	10	10	10	8	8
15.0	7.5	18	14	12	12	10	10	10	8	8	8
18.0	9.0	16	14	12	10	10	8	8	8	8	8
20.0	10.0	16	16	12	12	10	10	8	8	8	8

Section Two Questions

NOTE: Answers to each question are found in the far right column on the first line of the next question. To take this self-test, use a piece of paper to cover all the questions following the question you're working on, then move it down as you work.

1. The first cars used simple electrical devices for starting and for lighting the way over crude roads. T/F
2. The main component of the vehicle electrical system is the spark plug. T/F **1) F**
3. Which of the following is not a prime function of the alternator? **2) F**
 - a) Charge the battery
 - b) Power electrical system while engine is running
 - c) Convert AC output to DC current
 - d) Drive the water pump
4. Alternators rely on _____ to create electrical current. **3) d**
 - a) Heat
 - b) Electromagnetism
 - c) Gravitational attraction
 - d) Electron excitation
5. The rotor on an alternator is wrapped in a non-conducting material. T/F **4) b**
6. The part of the alternator, which is fixed in place is referred to as the **5) F**
 - a) Regulator
 - b) Stabillator
 - c) Diode
 - d) Stator
7. The vehicle starter turns at a rapid rate in order to generate the electricity required to start the engine. T/F **6) d**
8. The "one wire" system is one that: **7) F**
 - a) Uses a single strand of wire to connect all the vehicle lights.
 - b) Uses the vehicle frame to carry current from the battery to the lights
 - c) Uses a common ground wire for all electrical devices on the vehicle
 - d) Uses the frame of the vehicle as a ground, doesn't require a ground wire
9. At 120° F, the maximum amperage that an 18 gauge wire should carry is: **8) d**
 - a) 15 Amps
 - b) 18 Amps
 - c) 22 Amps
 - d) 27 Amps

9) b

10. A battery post to stud connector provides a quick disconnect feature to prevent battery drain over long periods of inactivity.
11. Typical batteries are made up of negatively charged plates separated from positively charged plates by insulated separators. T/F **10) T**
12. Batteries are filled with a special liquid known as _____ **11) T**
- a) Filtered water
 - b) Hydrochloric acid
 - c) Electrolyte
 - d) Hydrogen peroxide
13. The interaction between the plates and liquid in a battery produces _____ **12) c**
- a) A mechanical bond
 - b) Chemical energy
 - c) Mechanical energy
 - d) Cold fusion
14. A typical wire or cable uses a wire core surrounded by a conductor. T/F **13) b**
15. The end of a battery cable that connects to the starter motor post should be terminated with a spade connector. T/F. **14) F**
16. Wire and cable insulating material is sometimes referred to as _____ **15) F**
_____ because of its lack of current carrying capacity.
- a) Covalent covering
 - b) Electromagnetic compound
 - c) RFI
 - d) Dielectric
17. The atoms of conductors have a great many electrons loosely bonded to them, ready to leap to the next atom, whereas insulators typically have few if any. T/F **16) d**
18. Gold and silver are used in critical applications that require a highly efficient conductor because the voltages are low, the connections must be sure and the value of the device is relatively high as in computers and other electronics. T/F **17) T**
19. When using a stranded conductor, what do the numerals “18/24” stand for? **18) T**
- a) The day and hour it was manufactured
 - b) The conductor and insulation material
 - c) The quantity and gauge of the strands
- 19) c**
-

- d) The weight in pounds of 24 feet of cable.
20. When measuring wire gauge, 4 gauge wire is more than twice the thickness of 10 gauge. T/F
21. Wire gauge larger than whole numbers is shown as 1/0. T/F **20) T**
22. Secondary wire is used as part of the secondary circuit of the ignition system. Which of the following is not part of the secondary system? **21) T**
- a) Coil winding
 - b) Spark plug
 - c) Battery
 - d) Distributor cap
23. Primary wire is used to connect devices including radios, lights, heaters, etc. T/F **22) c**
24. Primary wire typically carries: **23) T**
- a) 2-6 volts
 - b) 12-14 volts
 - c) 12-24 volts
 - d) 30-55 volts
25. Most primary wire is a single conductor with an insulating layer. T/F **24) b**
26. When calculating the length of a wire run, you must allow for connections, providing slack to reach around obstacles and generally make sure that the length of run is not understated. T/F **25) T**
27. The most important consideration when choosing a wire or cable size is **26) T**
- a) Color code
 - b) Type of insulation
 - c) Voltage drop
 - d) Type of conductor
28. For the same length of wire, the larger the conductor, the greater the resistance. T/F **27) c**
29. "Most Distant Point" refers to: **28) F**
- a) Maximum distance from the battery to alternator
 - b) Location of the light furthest from the power source
 - c) Largest allowable distance between lights
 - d) None of the above
- 29) b**
-

Section Three

Mastery Statement

When you have successfully completed this section, you will have mastered the following:

- The milestones of vehicle lighting development
- The fundamentals of sealed beams, halogen, HIR, and HID forward lighting
- The basic principles and operation of incandescent and LED lighting
- The fundamentals of FMVSS-108
- The basic approach to using the Grote FMVSS-108 chart

Vehicle Lighting

One of the most important features of a vehicle electrical system is the lights. They have evolved over time becoming reliable and efficient parts of the safety equipment and they are found on almost every type of vehicle.

A look back at the history of vehicle lighting

It was early in the history of self-propelled vehicles that people recognized the need for lights. It was clear that if vehicles were to be operated close to dawn and dusk, to say nothing of nighttime, some type of lights would need to be used. An early answer was to have a person with a lantern run along in front of the vehicle both to light the way and warn people in its path. Soon after, lanterns were simply hung on some convenient projection.

The first real on-board application was oil-fired lamps like those used on the railroads. Carbon arc lamps were used in some cases as horseless carriage makers experimented with all kinds and styles of lights. But they had to have their electrodes replaced every few hours, which made them inefficient and inconvenient and often temperamental. They were, however, much brighter than an oil lamp of the same period.

Lanterns rapidly led to acetylene gas headlamps that used parabolic reflectors to concentrate more light in front of the vehicle. It wasn't until 1908 that development of modern vehicle lighting began. It was about that time electric bulbs found their way into motor vehicles. In an interesting approach to reducing glare for oncoming automobiles, the driver of one early model could manually tilt the headlamp by using a cable that ran from the headlamp to the driver. By 1915, red rear lamps and yellow brake lights were introduced. (Since that time, brake lights have been changed to red.)

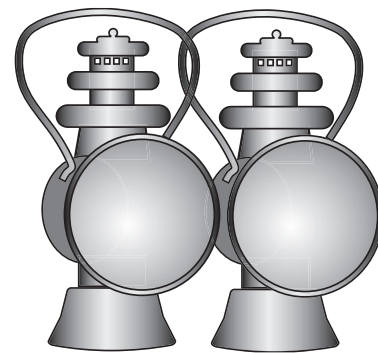

Early headlamps were kerosene powered.



The first electric headlamps were used on automobiles prior to 1910.

After the incandescent lamp was invented, it took a great deal of tinkering to make it give off enough light using a six volt system or whatever other low voltage system the car-maker decided to use.

In headlights, also referred to as “forward lighting,” the first really innovative development occurred in the early 1920s. It came in the form of the dual filament or “Duplo” brand lamp. In the early 1950s, the first lamp with a low beam and a high beam in a single sealed housing was introduced. It was called the “Duplo-D,”

In 1938, the incandescent sealed beam lamp was introduced and became a major step toward longer-life lighting. The new “sealed” lamps provided much greater protection for the filament and prevented the weather from damaging the lamp. However, despite this major step forward, the sealed beam remained an incandescent light source, subject to varying brightness and life limitations.

Sealed beams are manufactured as a completely sealed lamp assembly which plugs into a socket arrangement of a vehicle. Typically, a sealed beam used as part of a forward lighting setup contains both a high beam and a low beam component. Since the filaments are sealed completely inside the lamp, there is no way to replace the individual components. When the unit fails, it must be replaced.

Because they are factory-sealed incandescent lamps, sealed beams also share many of the shortcomings of other incandescents. For example, they are sensitive to vibration and elevated voltage levels.

Years went by before the next big development in forward lighting, the single-filament halogen bulb, available in Europe in the mid-1960s. It was new, longer lasting, took less energy than incandescents, and provided 50% more light. Dual-filament halogen lamps developed in the 1970s are used today in most US cars.

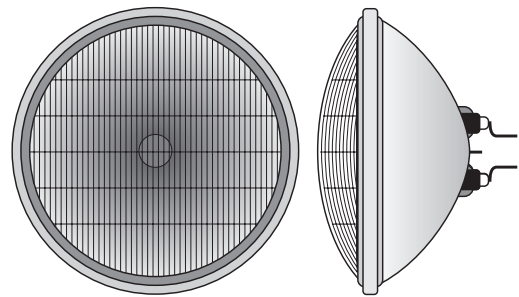

Round sealed beams were standard equipment for many years. The bulb, reflector and lens were all sold as a single, sealed unit.

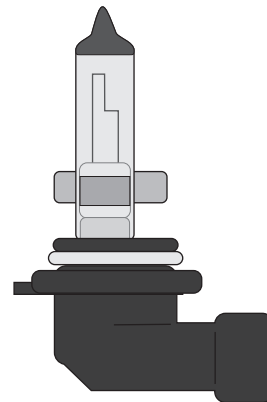

Today, most cars use halogen bulbs.

Prior to 1975, US headlights had to be round, non-halogen, U. S. Department of Transportation (DOT)-approved sealed beam units. They had to consist of two large dual-beam bulbs or four smaller single-beam units. After 1975, the DOT allowed rectangular sealed-beam bulbs, using the same layout as the round ones. In 1985, as pressure from consumers and automakers increased, the DOT adopted its current lighting standard, which allows for halogen lamps and “non-standard” headlamp shapes.

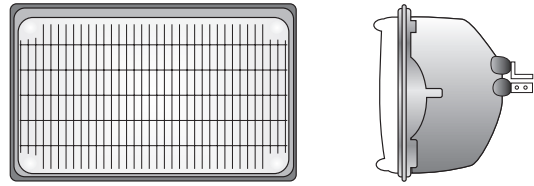

Rectangular sealed-beam began to appear after the DOT legalized them in 1975.

Advances in forward lighting

Halogen has replaced the duller and less efficient, ordinary incandescent lamps. Halogen produces a whiter light that makes objects appear closer to their true, natural color. Compared to the warm yellow cast of incandescents most drivers prefer halogen. Halogen lights also last longer and deliver more consistent performance under variable conditions.

In some ways, halogen is similar to incandescent but out performs them by a wide margin. Basically, a halogen lamp has a small amount of halogen gas added to the iodine, bromine, chlorine and fluorine mixture in the clear shell. Then when the filament begins to lose tungsten by evaporation, it combines with the halogen. But when it cools down, the tungsten is redeposited on the filament. Because of this recycling, the life of the filament is dramatically extended.

That’s why halogen, compared to various incandescent sealed beams, is known for its relatively long life and greater light output of whiter light. And, there are no blackened bulbs to rob performance. It also operates in a higher temperature range.

However, halogen is more expensive than incandescent.

An offshoot of the halogen lamp is the so-called HIR, which stands for halogen-infrared. It consists

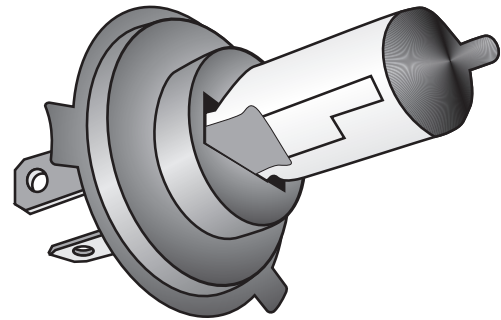

When a halogen bulb begins to cool down, the vaporized tungsten is redeposited back onto the filament. This results in increased bulb life.

of a specially shaped halogen lamp, which has a coating on the glass that reflects infrared radiation back to the filament.

The result is a more efficient light output than ordinary halogen. It also generates an even whiter light. However, the lamps are more expensive and they run hotter.

Another relatively new development is the High Intensity Discharge or HID lamp. It is designed to improve safety, improve lighting system performance and provide a light source that would last for the life of the vehicle. It was first introduced in the European market in 1991. HID was first seen in the North American market on the 1996 Lincoln Mark VIII.

HID was a significant advance in automotive lighting technology. HID doesn't employ a filament. Instead, HID bulbs generate light by creating and sustaining an electrical discharge between two electrodes in a small "arc tube." In operation, the electrical discharge excites a mixture of xenon gas and mercury that forms a brilliant white light, much closer to natural sunlight than halogen lights. HID generates up to three times the light output of halogen while using less energy.

Another feature of the HID system is that it requires ballast to start and run. The reason is that the starting voltage is approximately 20,000v, which drops to 200v and then stabilizes to run at approximately 80v.

There's no filament to degrade or break, so light output is more constant over time and HID systems can last up to 10 times longer than today's standard halogen lamps.

HID is a very efficient system and has a long life ... about 2,000 -3,000 hours. However, even though the HID lamp doesn't "burn out," it will gradually dim over time. Compared to incandescent, it is less affected by vibration.

Because of enhanced peripheral vision and

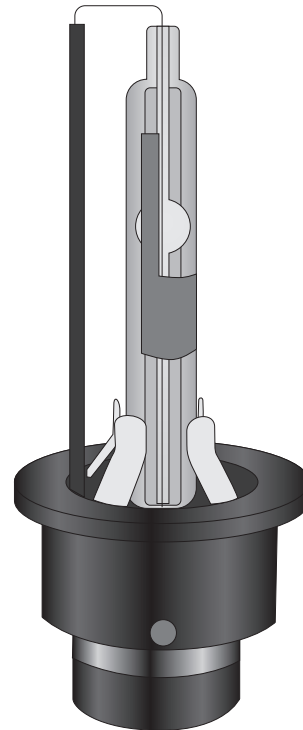

High Intensity Discharge (HID) lights are designed to improve vehicle safety and last for the life of the vehicle.

improved down-road illumination, HID is quickly becoming popular with drivers. Over time, as HID technology spreads and costs are reduced, HID will make greater penetration into mainstream vehicle applications.

On the downside, HID systems are still relatively expensive. They require very high voltages to start and they run at high temperatures.

Other types of vehicle lighting

The technology employed in taillights, stop-lights, interior lights and other vehicle lighting was relatively slow to develop. In fact, incandescent bulbs were virtually the only technology system used up until 1990.

Today's incandescent is a direct descendent of the original concept. It typically consists of a base with electrical contacts, a glass enclosure or bulb and a filament wire (typically tungsten) that is suspended inside the bulb. Incandescents can have one or multiple filaments in the same bulb.

The filament is part of the electrical circuit. As current passes through it, the wire heats up due to the resistance in the tungsten. When the current reaches a certain level, the filament begins to glow a dull color. Add enough current, and it will glow "white hot." Unfortunately, in order to operate, incandescent bulbs waste 95 percent of the energy flowing through them as heat.

If used in an atmosphere containing oxygen, the filament would quickly begin to combine with the oxygen and deteriorate. The result of that combination, corrosion, would promptly cause the lamp to fail. To prevent or slow the process, the bulbs are filled with an inactive or inert gas that doesn't combine with the filament.

Filaments used as part of incandescent vehicle lighting are typically found in three styles. It may be a straight wire, a single strand that reaches directly from one support across to another. Another style is the coiled filament, which has a

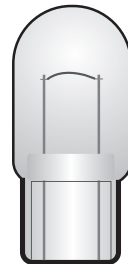
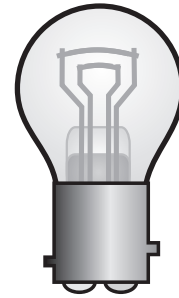

Common Incandescent Bulbs

conductor that is coiled and reaches across from one support to another. The coils provide a means of increasing the amount of filament surface area to produce more light, while concentrating the light. It also provides a spring-like action to help cushion the filament from vibration. The coiled filament is the most common type found in vehicle lamps.

A variation on the coiled filament is the coiled coil. With it, the filament wire is tightly coiled and is then wrapped again into the normal coiled shape.

Incandescent lamps have been around for many decades. They still have attributes that make them a good choice. They are relatively inexpensive to acquire and use. They are also readily available from a myriad of sources including, in some cases, grocery stores. Incandescents are available in a wide variety of sizes and styles.

On the other hand, they have a short life when compared to newer technologies. Vibration has a damaging effect on them. And over time, in many incandescents, the inside of the glass bulb becomes blackened by an aging filament, cutting down the light output.

Incandescent lamps are particularly sensitive to voltage that varies even slightly above the norm. Operating an incandescent light at just 5% over design voltage reduces the life of the bulb by 44%. At 10% over design voltage bulb life is reduced by 68%.

Light Emitting Diodes (LED's)

The most important improvement in non-forward lighting has been the advent of light-emitting diode (LED) lamps. LED's are semi-conductors, which allow current to pass through in only one direction. As the current passes through a crystal chip, it jumps from a negative plate to a positive plate, and as it does so, a "photon" (light) is generated. The light emitted by an LED is directly proportional to current passing through it. LED's can produce light in many colors, for example red, green and



Straight Wire Filament

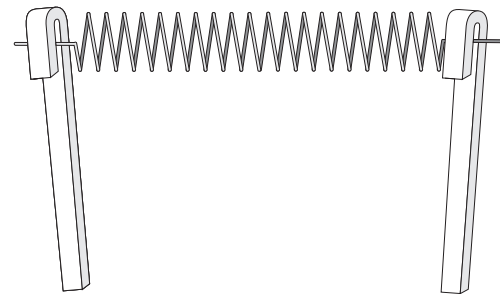

Coiled Wire Filament

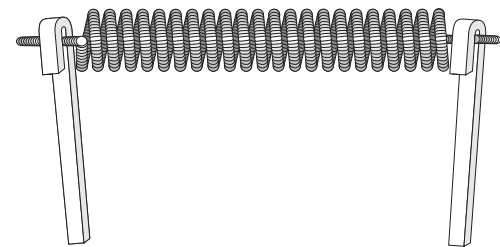

Coiled Coil Filament

amber. A recent development was the advent of the clear or colorless LED.

LED's supply a high level of illumination for vehicle applications. They make very efficient use of the electrical energy that powers them, significantly better than the traditional incandescents they replace and they run much cooler and don't "age" due to heat build-up. They start producing light the instant they are switched on. LED's have built-in color and don't require a separate color lens. They are very vibration resistant, which also helps extend the life of LED devices. They often last the lifetime of the vehicle.

Since the most susceptible component of the LED is the circuit board, quality LED boards are sealed with a special "potting" compound to protect it from the worst that Mother Nature and the vehicle wash rack can offer. The diode design offers high efficiency resulting in relatively low current draw compared to incandescent while providing light equivalent to a typical incandescent. Grote introduced the first LED lamp to the trucking industry in 1989. Since then, Grote engineering has continued to develop new and highly effective LED solutions for vehicle applications.

Truck lighting regulations

Although lighting is a major component of the safety equipment on any vehicle, nowhere is it more important than on trucks. There are some very specific regulations that apply to them, especially the amount of lights and the placement.

The ones that are encountered on a regular basis are contained in rules enforced by the National Highway Traffic Safety Administration (NHTSA). It is a federal agency with jurisdiction over the entire country, and NHTSA regulations take priority over state or local regulations. Enforcement takes the form of fines, issuing recalls and the implementation of new or modified regulations.

The Federal Motor Vehicle Safety Standard

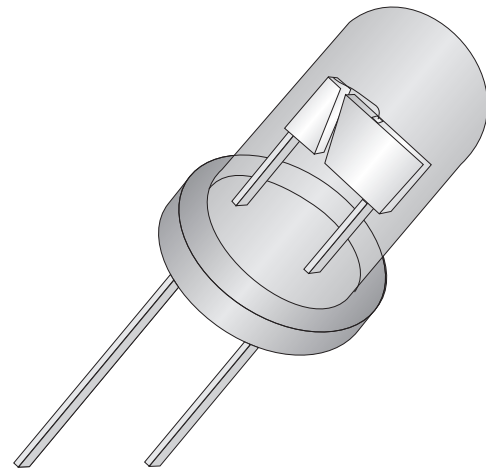

LEDs use power very efficiently and will often last the lifetime of the vehicle.

FOR YOUR CONVENIENCE

Detailed charts showing the lighting requirements established by Canadian Motor Vehicle Safety Standards and Federal Motor Vehicle Safety Standards can be found in the back of the Grote catalog and on pages 94 and 95 of this book..

(FMVSS) is a set of federal rules that specify the performance requirements, numbers and location of lights on vehicles. The standard applied to trucks is FMVSS-108. Think of FMVSS-108 as a blueprint for truck lighting requirements. Using the FMVSS 108 information chart found in the Grote catalog provides a concise explanation of the requirements and a way to become familiar with the basics of truck lighting. For example, a trailer setup.

The chart is based upon a grid. The information reading left to right across describes the equipment and the mandatory quantities and other requirements. Reading from top to bottom, the chart shows the requirements beginning with what is required for *all* trailers in the top section. Additional requirements are triggered as a trailer's *size and weight increase*. Those requirements are detailed in sections of the chart below the basic requirements toward the bottom of the chart. Keep in mind that the basic requirements are fixed and that larger and heavier means *adding* more equipment.

A closer look at a typical line in the top section titled "Basic Equipment Required On All Trailers" section will help illustrate the information layout on the chart. One way of learning how the system works is to assume that a trailer has no lights and the task is to determine what the requirements are.

The first column in the "Description" section describes the type of equipment. In this example, "Tail Lamps," corresponds to the product descriptions used in Grote catalogs and other resources. The third column describes the purpose that the device has and the roll it plays in the lighting system. In this case, it is to indicate the trailer's presence and width.

Between those two columns, there is a third that lists a code that is molded into quality lenses. It refers to the designation established to describe the function of lighting devices by the Society of Automotive Engineers (SAE) an industry profes-

Technical Information
Information Technique
Información Técnica

IMPORTANT NOTE: Every lamp, reflector, and completely assembled light for permanently attached to the location specified below and must comply with all applicable requirements prescribed by the FMVSS-108. The level of this device for its function and type should be inspected, maintained, and replaced as necessary to ensure an adequate number of operational lamps in compliance with the requirements of this standard.

IN CANADA: Requirements and quantities of vehicles over 20,000 lbs GVWR are the same as those of the United States.

BASIC EQUIPMENT REQUIRED ON ALL TRUCKS, BUSES & MPVs

Qty.	Equipment	Description	Function	Quantity	Code	Location	Height	Options
1	1	1	1	1	1	1	1	1
2	2	2	2	2	2	2	2	2
3	3	3	3	3	3	3	3	3
4	4	4	4	4	4	4	4	4
5	5	5	5	5	5	5	5	5
6	6	6	6	6	6	6	6	6
7	7	7	7	7	7	7	7	7
8	8	8	8	8	8	8	8	8
9	9	9	9	9	9	9	9	9
10	10	10	10	10	10	10	10	10
11	11	11	11	11	11	11	11	11

**ADDITIONAL EQUIPMENT FOR SPECIFIC VEHICLES
VEHICLES 9.1m (30 Ft.) LONG OR LONGER**

Qty.	Equipment	Description	Function	Quantity	Code	Location	Height	Options
12	12	12	12	12	12	12	12	12
13	13	13	13	13	13	13	13	13
14	14	14	14	14	14	14	14	14

Truck Tractors

Qty.	Equipment	Description	Function	Quantity	Code	Location	Height	Options
15	15	15	15	15	15	15	15	15
16	16	16	16	16	16	16	16	16

224

The Technical Information section of the Grote catalog contains charts based on the FMVSS-108 standard which specifies the performance requirements, numbers and locations of lights on vehicles.

Technical Information
Information Technique
Información Técnica

BASIC EQUIPMENT REQUIRED ON ALL TRAILERS

Qty.	Equipment	Description	Function	Quantity	Code	Location	Height	Options
1	1	1	1	1	1	1	1	1
2	2	2	2	2	2	2	2	2
3	3	3	3	3	3	3	3	3
4	4	4	4	4	4	4	4	4
5	5	5	5	5	5	5	5	5
6	6	6	6	6	6	6	6	6
7	7	7	7	7	7	7	7	7
8	8	8	8	8	8	8	8	8
9	9	9	9	9	9	9	9	9

**ADDITIONAL EQUIPMENT FOR TRAILERS EXCEEDING THE FOLLOWING PARAMETERS
Length 9.1m (30 Ft.) or longer**

Qty.	Equipment	Description	Function	Quantity	Code	Location	Height	Options
10	10	10	10	10	10	10	10	10
11	11	11	11	11	11	11	11	11

Width 2032mm (80 in.) or wider

Qty.	Equipment	Description	Function	Quantity	Code	Location	Height	Options
12	12	12	12	12	12	12	12	12
13	13	13	13	13	13	13	13	13
14	14	14	14	14	14	14	14	14
15	15	15	15	15	15	15	15	15
16	16	16	16	16	16	16	16	16
17	17	17	17	17	17	17	17	17
18	18	18	18	18	18	18	18	18

Width 2032mm (80 in.) or wider AND GVWR 4536 kg (10,000 lb.) or more

Qty.	Equipment	Description	Function	Quantity	Code	Location	Height	Options
19	19	19	19	19	19	19	19	19
20	20	20	20	20	20	20	20	20
21	21	21	21	21	21	21	21	21
22	22	22	22	22	22	22	22	22

225

sional group. The value of the permanent reference is that it helps avoid mix-ups where two devices may, at a glance, appear similar, but not function the same. The three ways of describing devices are the same throughout the top three sections of the chart on the trailer page.

The “Mandatory Requirements” section provides information about how to use the devices identified in the “Description” section. Under “Mandatory Requirements” on the chart, the first column tells how many are required, the second, which colors are allowed, third, the location on the trailer body and fourth how high they shall be installed.

Reading across the seven columns shows the exact stop light requirements for basic trailer tail lamp installations under the provisions of FMVSS-

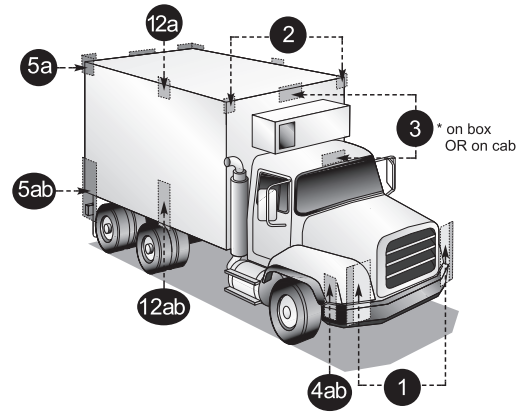

BASIC EQUIPMENT REQUIRED ON ALL TRUCKS, BUSES & MPVs							
DESCRIPTION				MANDATORY REQUIREMENTS			
Area	Equipment	SAE Lens Coding	Functional Purpose	Quantity	Color	Location	Height mm(in.) from the ground
1	Headlamps - Lower Beam US requires "DOT" lettering on lens US&Canada - light source code required on lens	(H, HR)	Forward road illumination	Minimum 2	White	On the front - symmetrical as far apart as practicable If 4 lamp system - outboard or above upper beams	560-1370 (22-54)

108. Simply using the same approach for the remaining equipment would offer a comprehensive picture of the other required equipment.

If a trailer is longer or wider, the chart offers sections below the basic equipment part for trailers 30 feet or longer and/or 80 inches wide or wider.

Another section of the chart is devoted to requirements of trailers that are 80 inches and

ADDITIONAL EQUIPMENT FOR SPECIFIC VEHICLES VEHICLES 9.1m (30 ft.) LONG OR LONGER							
DESCRIPTION				MANDATORY REQUIREMENTS			
Area	Equipment	SAE Lens Coding	Functional Purpose	Quantity	Color	Location	Height mm(in.) from the ground
12	a Intermediate Side Marker Lamps	(P2 or P3)	Indicate presence of a long vehicle	Minimum 2	Yellow	Each side near center	380 (15) minimum
	b Intermediate Side Reflex Reflectors	(A)	Indicate presence of a long vehicle	Minimum 2	Yellow	Each side near center facing sideward	380-1530 (15-60)

wider as well as 10,000 pounds or greater in weight. These requirements are shown in a slightly different but similar format.

These requirements refer to the application of “conspicuity tape.” It is highly reflective strips of

alternating color adhesive material used to make a trailer more easily seen, especially after dark. It is used along with electric lights to add to the vehicle's conspicuity.

In the conspicuity section there is a "description" section as well as a "mandatory requirements" section, which calls out the Department of Transportation (DOT) code for the tape locations and the quantity of material to be used. The other columns indicate color, location, height and any options involved in the application.

To help the visualization process, a location drawing at the bottom provides a visual resource for all of the equipment including conspicuity tape. It shows the locations described above and calls out the specific location by number and letter.

The same process is used to determine requirements for use of lighting and conspicuity markings on trucks and truck tractors to meet the requirements of FMVSS-108.

The practical use of the chart really becomes obvious in situations where a customer needs a replacement for a missing or damaged device ... for example, a stop lamp.

Find the equipment description for stop lamp in the right hand column of the Basic Equipment section of the trucks and buses chart. Read across to find the SAE lamp code (as a cross check with the suggested replacement), and confirm that the description in the Functional Purpose column matches the mission. In this case, it says "Indicate Braking," which is correct.

The "Quantity" column indicates that there needs to be at least two, and the "Color" column indicates red which matches the existing equipment. To finish the process, double check that the location and positioning shown on the chart match the current situation.

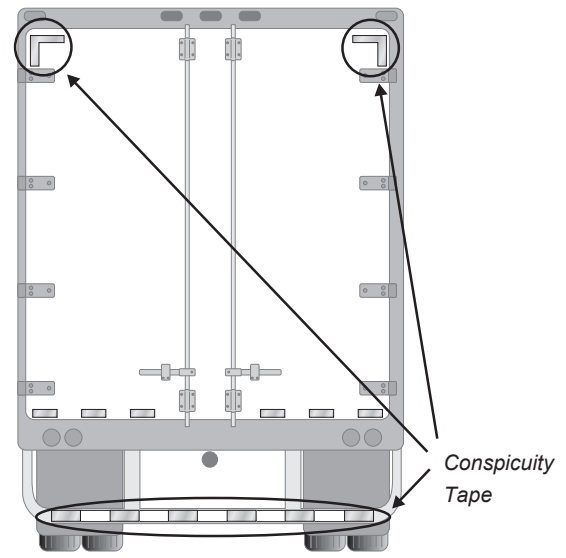

Conspicuity tape provides a bright reflective surface to enhance the visibility of a truck, making it more conspicuous to other drivers.

Section Three Quiz Questions

NOTE: Answers to each question are found in the far right column on the first line of the next question. To take this self-test, use a piece of paper to cover all the questions following the question you're working on, then move it down as you work.

1. The earliest vehicle lights were crude incandescent bulbs. T/F
2. Carbon arc lamps need little or no maintenance. T/F **1) F**
3. The use of red tail and yellow brake lights began in 1915, T/F **2) F**
4. The use of sealed-beam headlights began in **3) T**
 - a) 1922
 - b) 1908
 - c) 1938
 - d) 1945
5. The first dual filament headlight was called the "Duplo." T/F **4) c**
6. Sealed beam headlights typically **5) T**
 - a) Plug into the sill harness
 - b) Must be replaced if the filament fails
 - c) Produce whiter light than HID lamps
 - d) All of the above
7. Compared to incandescents, halogen headlights **6) b**
 - a) Are longer lasting
 - b) Use less electrical energy
 - c) Provide 50% more light
 - d) All of the above
8. Dual filament halogen headlights are used in most cars. T/F **7) d**
9. In 1975, the DOT allowed the use of rectangular and non-standard shape lamps. T/F **8) T**
10. The term "HIR" stands for High Intensity Recharge lights. T/F **9) F**
11. HIR lights have a coating on the inside, which reflects ultra-violet light back to the filament for more intense light output. T/F **10) F**
12. HID lighting is different from halogen because it **11) F**
 - a) Uses no filament
 - b) Requires a ballast
 - c) Runs at 80 volts
 - d) All of the above
13. When a HID lamp fails there is a bright flash. T/F **12) d**
13) F

14. An incandescent bulb is made up of all but what component?
a) Base with one or more contacts
b) Glass enclosure
c) Filament
d) Arc tube
15. Incandescent bulbs are inefficient and waste _____% of the energy flowing through them as heat. **14) d**
a) 25
b) 45
c) 95
d) 75
16. Incandescent bulbs are filled with oxygen to make them burn brighter. **15) c**
T/F
17. Incandescent bulbs are sensitive to voltage levels. Operating one at just 5% more than design voltage can reduce bulb life by 44%. T/F **16) F**
18. “LED” stands for Light-Extracting Diode. T/F **17) T**
19. LEDs can produce light in many different colors. T/F **18) F**
20. Sealing LED circuit boards is called “potting.” T/F **19) T**
21. A drawback to using LED’s on vehicles is that they are sensitive to vibration. T/F **20) T**
22. The main set of rules that govern truck and trailer lighting comes from **21) F**
a) NHTSA
b) ICC
c) FHASS
d) NTSB
23. On the FMVSS-108 chart, which of the following is not specified **22) a**
a) Functional purpose
b) Location
c) Wattage of light
d) Color
24. Under the “Basic Equipment Required On All Trailers,” a minimum of two reflectors is required on the rear. T/F **23) c**
25. For a trailer over 80 inches, three rear identification lamps are required. **24) T**
T/F **25) T**
-

26. On a 29 foot trailer, how many intermediate side marker lamps are required?
- a) A minimum of two
 - b) A maximum of four
 - c) A minimum of four
 - d) None of the above
27. According to FMVSS-108, license plate lights must be mounted above the plate. T/F **26) d**
28. On an 80 inch wide trailer, the rear clearance lamps are often combined with tail lamps to save space. T/F **27) F**
29. When applying conspicuity tape on the side of a trailer, it must cover at least 50% of the length of the trailer. T/F **28) F**
- 29) T**

Section Four

Mastery Statement

When you have successfully completed this section, you will have mastered:

- The basics of lenses and bases
- The concept of factory and field replaceable lamps
- Basics of Gel-Mount© and Torsion-mount© lamp bases
- The similarities and differences between lighting device categories, i.e. Clearance/Marker, Stop, Turn and Tail, etc.
- The basic trailer lighting circuit
- The concept of wiring harnesses
- The basics of pigtailed

Choosing Lighting Devices

Basics of Lighting Devices

It's important to understand what to look for in vehicle lighting when choosing the correct product for a specific application.

Lenses

Take lenses for example. Lenses are typically offered in both acrylic and polycarbonate materials.

Acrylic lenses are an economical alternative where the service environment calls for a general duty material. They provide better than average performance in many situations.

For a service environment that calls for a tough alternative to acrylic, polycarbonate offers a cost effective material choice. Polycarbonate is more durable and more resistant to breakage.

Bases

Bases are another primary and necessary component. They provide the foundation of the light. They also hold the socket for the bulb. Typically, the base contains the attachment points for the device.

Normal duty bases of ABS plastic provide an economical approach. They are available for a large number of styles and applications. Along with ABS, Grote offers Duramold[®], a tough, high performance material specially compounded for tough duty applications. It stands up to weather and harsh handling to provide a cost effective, long life product.

Some bases are available in metal. Among other things, a metal base provides extra durability for applications that must function in harsh environments. For example, die-cast metal side marker



OEM-Style Chrome-Finish Marker Lamp

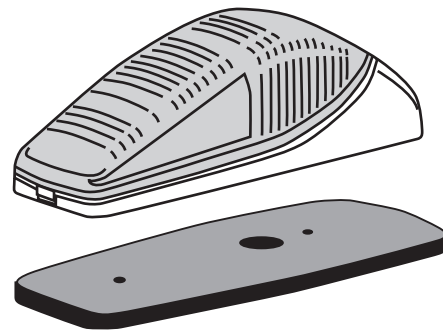

lights have bases that extend beyond the lens to help protect it from accidental impact with branches, structures or other abrasive contact. Metal bases and bezels are also used to add a decorative touch to vehicles as well as serving as functional parts.

Some bases are molded from tough plastics, but have the appearance of metal. They employ the same molding techniques used on other bases but also have a “chrome” effect applied, which adds a cost effective, decorative effect.

Other types of bases are used to support multiple lights. For example, bars are used for the top rear marker lamp clusters on semi-trailers. Installation is much more efficient compared to installing individual lights. Bars come in a variety of materials including tough plastics, enameled metal and extruded aluminum.

Incandescent vs. LED

The lighting devices used on trailers fall into two categories, incandescent and LED. Incandescents are available in many sizes and varieties and are relatively inexpensive. However, their service life is comparatively short and they are very susceptible to vibration.

LEDs (light emitting diodes) on the other hand are economical since they last longer. They are less affected by vibration and generate less heat. And they’re efficient and offer superior light output.

Another distinction to be aware of is that not all vehicle lighting devices have “field replaceable bulbs.” In other words, not all devices have bulbs that can be changed when they fail. The ones that can’t are referred to as “factory sealed.” When sealed units fail, the entire unit has to be removed and replaced.

Certain lights are constructed with an advanced development called the Torsion Mount II[®], a unique design that suspends the bulb to protect it from vibration. With it, there are no wires inside the shell of the device. Instead, a brass assembly



Incandescent Tail Light



LED Tail Light

conducts the electrical current to the bulb and acts as a cradle for it.

Some of the newer designs use Gel-Mount[®] technology. Gel-Mount also uses a brass assembly to conduct the current. But the bulb is held in place by a unique gel material that dampens vibration while protecting the contact points from moisture and corrosion.

Overview of common lighting devices & applications

There are several general categories of devices and applications that make up the majority of lighting products sold for use on vehicles. For example, let's consider truck trailers.

Clearance and Marker Lamps

Side markers are required to be on the side of the trailer at the front and rear. Clearance lamps are required on the rear of the trailer. There are a minimum of two red clearance lamps and two red rear side markers required. Also required are a minimum of two yellow front side markers. Trailers over 30 feet, require a minimum of two additional mid-mounted side markers that are yellow. See the FMVSS-108 chart for specific applications.

Stop, Tail and Turn Lamps

Another major category is the stop, tail and turn lamp group. Taillights are used on the rear to indicate the location of the vehicle, especially after dark. Stoplights are used to indicate that the vehicle is slowing or stopping. Turn lights warn other drivers that a vehicle is about turn or is in the process of turning. They come in red and yellow (amber). Tail and stop lamps must be red while turn lamps may be red or yellow according to FMVSS-108.

There are numerous shapes and sizes in this category and they are chosen depending upon the size and type of the vehicle. They can be either surface

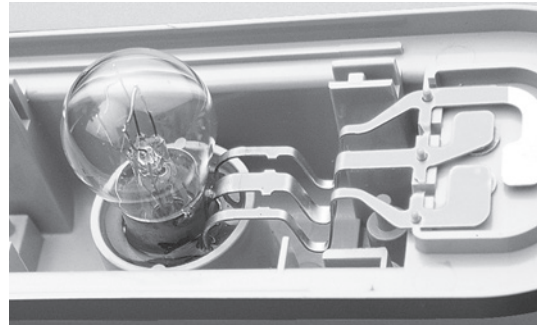

In this fixture, the lamp socket is filled with a soft gel material that dampens vibration and helps protect the contact points from moisture and corrosion.



This clearance/marker lamp features a metal lens guard to protect the lens from damage.



Stop/tail/turn lights come in modular units, like the one shown above, and as separate units.

mounted or recessed. At times, clusters of lights will be mounted in a special bolt-on metal plate. Or they may be a style that's mounted on the fender of a truck using a bracket. Other variations include devices with built-in license plate lights, back-up lights and special units with large arrows for use on school buses. Use of stop, tail and turn lamps is required and is part of the information in the FMVSS-108 chart.

License Plate Lights and Utility Lights

License plate lights always have white lights and clear lenses. License plate lamps come in a variety of shapes and sizes, some of which have a built-in bracket to hold the license plate. See the FMVSS chart for specifics on the use of license plate lighting.

Utility lighting also takes many forms. Grote supplies devices for surface-mount and recessed back-up lighting, trailer dome light applications and other applications where light is required for hooking up trailers, loading and unloading, repairs or a myriad of non-driving situations.

Forward Lighting

Another important category is forward lighting. It refers to the lights that illuminate the road ahead. Primarily, these are either round or rectangular and white (clear) or yellow (amber) in color. The category of forward lighting includes headlamps, driving lights and fog lights such as the Grote Per-Lux®. This category also includes snowplow and off-road lights and specially designed work lights for farm tractors.

Specialty Lighting

Specialty lighting includes emergency and warning devices. They come in a variety of colors including red, yellow (amber), blue and white.

These lights are seen on emergency vehicles of

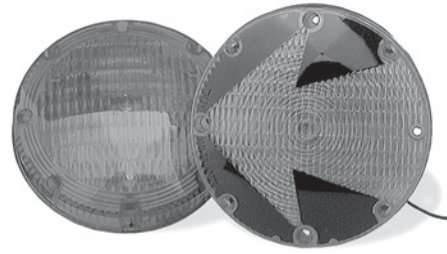

Special purpose lights come in many forms. This turn signal is designed for use on a school bus.

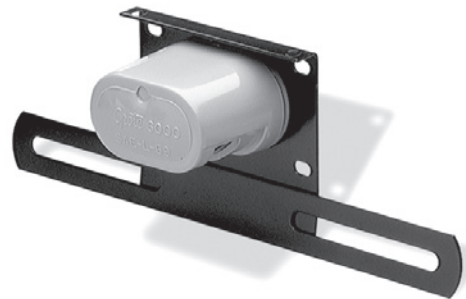

This license plate light includes a mounting bracket for the license plate.



These quartz halogen lights can be used as driving lights or fog lights.

all types: fire vehicles, police vehicles and wreckers, along with school buses and industrial lift trucks. Devices come in a number of shapes and sizes. They are available as part of a car-top light bar, as independent, round, rotating beacons and as teardrop style, magnetic based “Kojak” lights.

Reflectors

Reflectors are non-powered warning devices. They are red and yellow (amber) colored depending on the position they are placed at on the vehicle, red on the rear and yellow on the side. When placed on the side, they’re used to indicate the presence and length of the vehicle. When used on the rear, they indicate the vehicle’s width. Reflectors are attached in two primary ways, using screws on some designs and an instant-bond, long-lasting adhesive on others.

Special, reflective, “conspicuity” tape is used on many larger vehicles to indicate presence and size. The majority of the tape is used on large trailers. Conspicuity tape comes in red and silver and is used in strips of alternating colors.

Use of either reflectors or conspicuity tape must meet FMVSS-108 standards.

Circuits & connections

The electrical system of a vehicle at first may seem complicated. However, there are certain basics that carry over from one system to another. Consider for instance, the system used on trailers.

In it’s most basic form, a trailer light circuit consists of a few primary parts. First, a power source, in this case the truck tractor (power unit). A switch in the circuit controls the flow of electrical power so the light receives electrical energy when the operator chooses, although this is not required. The third component is the lamp. Fourth is the ground point. In this case, the ground uses a return wire to the tractor. Another variation is to use the “one wire” system and attach the ground wire to the



Acrylic reflectors come with bolt holes (as shown above) or adhesive backing.



Conspicuity tape is used to identify both the presence and size of a vehicle.

trailer frame. In that case, the trailer frame is used as part of the electrical system completes the circuit.

Another way of looking at the lighting circuit is to consider a trailer schematic. Each of the lighting elements of this system ties directly to a specific wire in the bundle of wires called the “wiring harness.” Those connections are color-coded to provide a standardized, consistent model both for the original installation and for repair and troubleshooting.

One of the major pieces is the main harness. It reaches from the front of the trailer to the rear. In the front, it plugs into the “nose box,” the device that provides a connection point for the seven wires of the trailer and matching wires of the tractor. It may accept connections from lighting devices in the front area.

In the rear, the main harness plugs into the “sill harness.” That consists of the wiring and fittings that provide the electrical connections from lighting devices, primarily located on the sides and rear of the trailer.

Pigtail Connections

Together, the two harnesses make up the backbone of the trailer wiring system. Connections are made in the UBS (Ultra Blue Seal) system by plugging a pigtail (the shortest of the connectors) into a light, then into a jumper, a longer cable that feeds into a trailer wiring harness such as the UBS system. Both pigtails and jumpers are available to provide a custom connection for almost any set of circumstances and configuration.

Pigtails are specially designed with a variety of “boot” (connector) configurations, wire lengths and terminations to fit most applications. Probably the most basic difference to be aware of is the distinction between male and female connection. The easy way to determine which connector to use is to check the lighting device to see whether

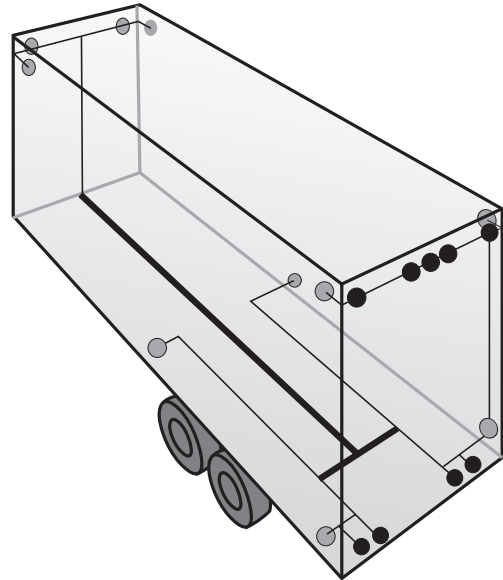

An important part of the lighting system of every truck is the wiring harness as represented by this trailer wiring schematic.



Ultra Blue Seal (UBS) connectors are designed to protect wiring and connections against moisture, corrosion and vibration.



This pigtail connector is terminated at both ends with a connector.

the terminals on the light protrude or are recessed. Protruding (male) terminals require a female connector. Recessed (female) terminals require a male connector.

Only Grote pigtails feature the new “Double Seal” version. The Double Seal effect is the result of a custom engineered, molded-in circular slot in the boot. That slot matches a corresponding ring molded into the base of the lighting device. When joined together, the Double Seal pigtail grips the ring on both sides for a secure, protective seal when compared to ordinary seals.

Another Double Seal advantage is the center grease slot. Once assembled, this slot provides an area for the grease to escape to when grease is applied to the lamp terminal during normal maintenance. Without it, the pressure from the grease could cause a bad connection between the pigtail and the lamp.

Terminations on the pigtails take one of three basic forms. One is the blunt cut, a straight cut off with the insulation stripped and ready for a terminal to be attached. Another is the ring connector, primarily used to attach to a ground point. Third is a bullet connector which plugs into the power source. Another use for a lead with a bullet connector is to connect to a ground source in cases where the truck’s metal frame is not being used for that purpose.

Pigtail assemblies come in standard types as well as a unique new development, the Thin-Line. The compact design makes it the only connector that fits under the new LEDs. In addition, Thin-Line pigtails have a patented double-seal design and grease slots for long lasting protection.

Since moisture has such a harmful effect on wiring; the UBS provides features and benefits not found in other approaches. First, it is a fully modular system. All of the elements of the system are designed and engineered to work together. UBS



Examples of pigtail connectors with a variety of wire terminations.



Thin-Line pigtails are specially designed to fit under new LEDs.

works with sealed or field resealable devices. It is a true plug-together system requiring minimal tools and splices. UBS is the first modular sealed system.

Repairs are simple to make. For example, if the sill harness is damaged it can be un-plugged from the main harness and replaced.

UBS connectors are designed to provide a durable, weatherproof seal quickly and easily. They help to prevent corrosion and exclude contamination that can shorten service life. UBS requires low maintenance. Road failure and breakdowns are minimized.

New on the market is the UBS Factory Sealed Lamp System. It uses all factory-sealed lamps with hermetically sealed, unitized lens and housing design. The devices are designed and engineered to remain tight for the life of the lamp. All of the lamps are road proven to seal out water, salt and other contaminants and are not effected by extremes of heat and cold.

This UBS system includes task matched wiring. All components needed for completing the trailer are included in the kit. This unique advance in trailer wiring assures the optimal system and provides users with a time saving ordering process.

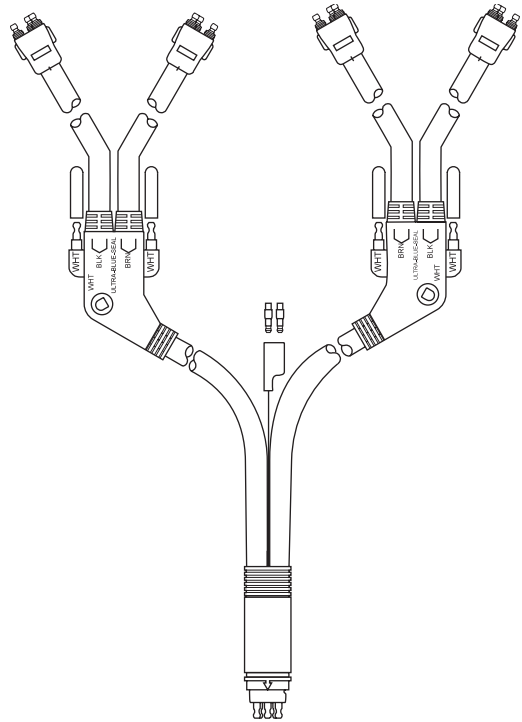

The new UBS harness system is a true plug-together system that provides a low-maintenance, weatherproof seal.

Section Four Questions

NOTE: Answers to each question are found in the far right column on the first line of the next question. To take this self-test, use a piece of paper to cover all the questions following the question you're working on, then move it down as you work.

1. For severe service or where vandalism is a problem, polycarbonate lenses are recommended. T/F
 2. Which of the following is not a function of a base? **1) T**
 - a) Attaching the device to the vehicle
 - b) Holding the socket
 - c) Acting as a foundation for the lens
 - d) Connecting a device to the wiring harness
 3. Metal bases are not used because they cause short circuits T/F **2) d**
 4. Some molded plastic bases have a chrome finish. T/F **3) F**
 5. A typical trailer light bar is used with **4) T**
 - a) Top rear identification lamps
 - b) Side marker lamps
 - c) Front clearance lamps
 - d) Stop, turn and tail lamps
 6. Light bars are available in plastic. T/F **5) a**
 7. Which of the following is not true about incandescent bulbs? They are **6) T**
 - a) Available in many types and sizes
 - b) Very resistant to vibration
 - c) Relatively inexpensive
 - d) All of the above
 8. Factory-sealed lights can be opened to change bulbs if they are carefully resealed. T/F **7) b**
 9. Gel-Mount technology is used to **8) F**
 - a) Hold bulbs in place
 - b) Dampen vibration
 - c) Seal out moisture & corrosion
 - d) All of the above
 10. Clearance/marker lamps are used to illuminate obstacles when maneuvering a truck in tight quarters at night. T/F **9) d**
 11. Clearance lamps are required on the rear of the trailer. T/F **10) F**
- 11) T**
-

12. Trailer stop lamps can be red or yellow. T/F
13. Stop, turn and tail lamps may **12) F**
- a) Be surface mounted or recessed
 - b) Have built-in license plate lights
 - c) Include back-up lights
 - d) All of the above
14. License plate lights must have clear lenses. T/F **13) d**
15. It's illegal to have a license plate holder attached to a light. T/F **14) T**
16. Forward lighting refers to the front most clearance and marker lights on a trailer. T/F **15) F**
17. Fog lamps, driving lights, snowplow lights and off-road lights are best referred to as **16) F**
- a) Utility lights
 - b) Marker Lights
 - c) Forward lighting
 - d) None of the above
18. Reflectors are non-powered warning devices. T/F **17) c**
19. Which of the following is true about reflectors: **18) T**
- a) When on the side indicates the presence and length of a trailer
 - b) If mounted on the rear, indicates the width of the trailer
 - c) Are red or yellow depending upon location on the trailer
 - d) All of the above
20. Conspicuity tape is used to indicate presence and size of a trailer. T/F **19) d**
21. The only conspicuity tape allowed to be used on trailers comes in which of these color combinations: **20) T**
- a) Yellow & black
 - b) Green & silver
 - c) Red & Silver
 - d) None of the above
22. In a simplified trailer lighting circuit, which element is not required? **21) c**
- a) Power source
 - b) Ground
 - c) Switch
 - d) Lamp
- 22) c**
-

23. A bundle of wires in a trailer lighting system is called a
- a) Harness
 - b) Loom
 - c) Circuit
 - d) Bundle
24. The nose box makes it possible to connect truck tractor wiring with a trailer wiring harness using a single connection. T/F **23) a**
25. The sill harness is typically used to plug lights into: **24) T**
- a) The front of the trailer
 - b) The rear of the trailer
 - c) The side of the trailer
 - d) All of the above
26. A pigtail is an extra-long wire that connects a jumper and a wiring harness. T/F **25) b**
27. In determining the right style of connector, a protruding terminal on a lighting device means choosing a female style connector. T/F **26) F**
28. A “Double Seal” pigtail refers to: **27) T**
- a) A single pigtail that splits into two
 - b) A slot and ring design that provides an inner and outer seal
 - c) Wrapping several layers of electrical tape around the connection
 - d) None of the above
29. pigtails primarily use three terminations: bullet connectors, blunt cut and ring connectors. T/F **28) b**
30. Replacing a damaged sill harness requires little more than unplugging it from the main harness and lights and replacing it. T/F **29) T**
- 30) T**

Section Five

Mastery Statement

When you have successfully completed this section, you will have mastered:

- The basic of wire-end connectors
- The fundamentals of choosing a switch
- Principles of good connections
- Working knowledge of shrink tubing, dielectric coating, and other connection defensive techniques
- Basic concepts of organizing wiring

Making Connections

Connectors

Although Grote's UBS system provides the most effective connections, there are times when wiring requires a more traditional approach. In those situations, it's important to understand the basics of using wire, connectors and related components.

Wire end connectors are used to connect two or more wires or attach a wire to a device. They are used because it takes much less time to make a connection than twisting wires or soldering them. Using wire-end connectors, wires are connected securely and permanently.

Ring terminals get their name from the distinctive shape of the connector. They are the most common type of connector. They are very efficient at conducting electrical current because of the amount of conductor in contact with the stud. Ring terminals are one of the best choices for security because the ring cannot be disconnected unless it is completely disengaged from the stud.

Spade terminals are popular because they can be assembled and dismounted quickly. Attaching and removing requires only that the stud be loosened.

Hook terminals get their name from their distinctive shape. They are a blend of the ring terminal and the spade terminal. The slot on the side allows them to slip under the loosened stud, while the hook shape adds an extra measure of holding power over the spade connector.

Butt connectors are used to splice two wires together end to end. It is simple to use. Just push the ends of the two wires into the butt connector and crimp it tightly.

Three-way connectors and four-way connectors function similarly to the butt connector. However, as the names implies, they join up to



Ring Terminal

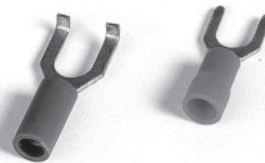

Spade Connectors

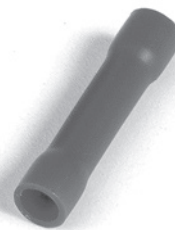

Butt Connector



Three Way Connector

four wires together.

Flat blade connectors are based upon a design featuring a flat blade male piece that fits into the corresponding slot on the opposite half of the splice. The design allows the splice to be connected and unconnected almost indefinitely. As with certain others, the quick disconnect terminals are available with heat shrink tubing.

Bullet connectors get their name from the shape of the male half of the connector set. The other half has a socket, which accepts the male half. Similar to other quick disconnect connectors, bullet connectors allow the splice to be disconnected and reconnected.

Once a connection has been crimped, shrink tubing should be used to cover the end of the connector and the end of the wire. This protects the wire and connector from moisture, corrosion and contaminants. Several of the basic connectors come complete with shrink tubing replacing the PVC insulation.

Power Cords

Connecting a trailer's electrical system and the tractor electrical system requires a power cord that is rugged and safe to use. The Grote accessories line includes several alternatives. All share a number of features that give them the ability meet demanding service environments. For example, they are totally sealed to prevent corrosion. They utilize sonic-welded terminals for minimal voltage drop along with a shockproof, molded plug body to protect users from injury. Special stainless steel springs assure tight connections and brass plated terminals provide enhanced current carrying capacity.

It's important to choose the right cord for the job. A case in point is trailers that use ABS. By law, ABS power cords must use 10 gauge wire in the red, white and blue wires. That's heavier than a standard power cord.

There are times when damage or wear requires



Four Way Connector

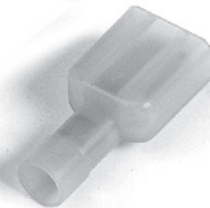
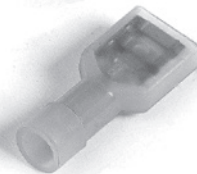
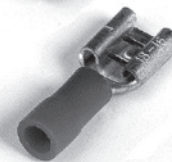

Flat Blade Connectors



Bullet Connectors

replacement of components of trailer connection systems. There is a whole line of nose boxes, receptacles, some with circuit breakers and others with replaceable solid brass pins to meet specialized needs.

Switches

Switches represent another sort of connection. They make controlling the flow of electrical current easier and, of course, much more convenient. They make controlling the flow of electrical current easier and, of course, much more convenient. Imagine having to connect wires whenever the situation calls for light and disconnect wires to shut them off.

Choosing a switch requires some basic information. Check the installation guide or service manual for any information that might help you to select the correct replacement switch.

Switches come in a variety of designs. They range from push-pull types to toggles. Ignition switches are usually complete with keys and many applications require the streamlined look of a rocker switch.

Push-pull switches are popular for use on vehicles. They are easy to operate and come in various types from standard pull-on, push-off to multi-position on-off-on or off-high-low. Push-pull switches are typically available in medium-duty, heavy-duty and extra heavy-duty.

Toggle switches can be operated with just one finger. They too come in various types. The simplest is the two-position, on-off. Variation on that are the on-off-on or the on-on. Like push-pull switches, toggles come in medium-duty, heavy-duty and extra heavy-duty.

Proper Connections

Making certain that connections are safe and secure will go a long way toward avoiding problems in the future. Creating good connections requires good techniques and practices along with the best quality terminals and ancillary products.



Push-Pull Switch

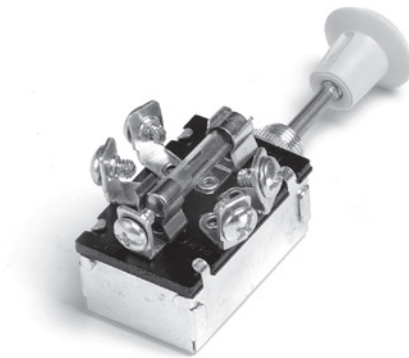

Push-Pull Switch

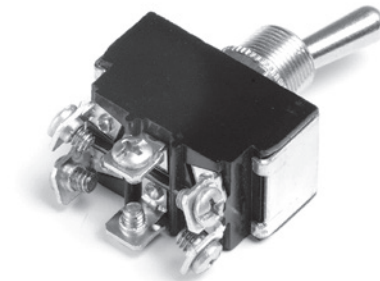

Toggle Switch



Toggle Switch

Improper technique or poor quality terminations can result in a number of problems including failure of the connections. Short of total failure, one of the most serious problems resulting from bad connections is excessive resistance in the system.

Resistance generates heat and reduces the flow of current through the connection. A case in point is a bulb that glows softly and unsteadily at times, instead of shining brightly and steadily. Depending upon the cause, the connection may fail completely and the light along with it.

Creating a good connection can be quick and sure. Start by stripping the correct amount of insulation from the wire. The bare conductor should be as long as necessary to match the length required by the terminal. If the stripped area is too long, the exposed wire may touch a metal part of the vehicle and cause a grounded circuit. Too short and there may not be enough contact area between the conductor and the terminal, possibly causing increased resistance.

Corrosion and contamination can seriously effect a terminal connection by forming a barrier between the conductor and terminal. Always clean the conductor until the exposed surface is bright and shiny before making the connection. Some even advise “tinning” the wire, putting a light coating of solder on it to create a shiny, clean surface for the connection.

Crimping is the most widely used method of securing terminal connections. To crimp a connection, simply squeeze the terminal body to hold the wire in place. It’s important to make the crimp tight enough to hold the wire securely.

Loose crimps can create excess resistance in the connection since the wire doesn’t make a good contact. Improper crimping can lead to excess heat and reduced current.

In some cases, a loose crimp can pull apart completely and create an open circuit with no current



First, strip the wire to expose the correct amount of wire for the termination you’ve selected.

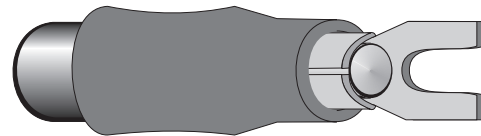

Correctly applied termination.

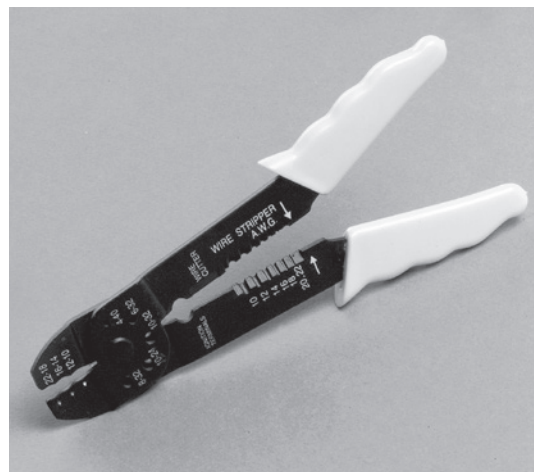

Crimping Tool

flow at all. But not all problems are caused by loose crimps.

An overly tight crimp could break the strands of wire making the conductor smaller. That can cause excess resistance as the current flows through the smaller number of strands in the conductor.

Protecting the connection is a key step in avoiding future problems. In the past, that protection came from wrapping the connection with tape. It was a time-consuming process, often with less than satisfactory results as the tape was seriously affected by moisture and extremes in temperature.

Heat Shrink Tubing

Heat shrink tubing solves all of those problems and provides a method of sealing out moisture, corrosion and other contaminants. It also provides a high level of insulation for the splice.

Shrink tubing is simple to use. Just position the tubing over the joint and add heat from a torch or heat gun. The tubing shrinks tightly around the connection providing a secure barrier. When the tubing has cooled, check that it fits snugly.

When securely in place, the tubing acts as a strain relief for the connection. It also helps immobilize the connection to prevent fatigue and eventual failure.

Single wall heat shrink tubing is the most basic type. Its function is simply to shrink around the connection. Single wall shrinks in a ratio of two to one. In other words the finished size is half of the original size.

Dual wall has an outer wall that shrinks similar to the single wall tubing. However, this product has an inner wall of sealant that flows around the connection to fill any irregularities and openings and add strength to the joint. When complete, there should be a bit of clear sealant around each end of the tube. The shrink ratio of this product is three to one.

Dual wall hot-melt adhesive is a third type heat



Heat Shrink Tubing

shrink tubing. It also has a two-layer construction. In this case though, the inner layer is made up of a hot-melt adhesive. When heated, the outer wall shrinks and the inner wall melts forming a superior barrier against moisture as well as corrosion and other contaminants. There should be evidence of clear adhesive at the each end of the tube if the inner wall has melted correctly. This product is designed especially for insulating and protecting against the underhood environment. The shrink ratio is four to one.

Dielectric Coating

A very important component of safe and secure connections is the use of a dielectric (non-conductive) coating. It functions primarily as a barrier to moisture and other contaminants, preventing them from reaching the connection. Using the dielectric coating helps prevent the development of corrosion, a major cause of failure in splices and connections.

When using a dielectric coating, apply it to all of the components of the splice or connection. Then finish the job by crimping or otherwise securing the connection. Use only enough to protect the actual joint. Using too much does not provide additional protection.

Wire and connections, by their very nature, are vulnerable to damage. They are subject to abrasion, cuts, breaks and disconnects. That's even truer for vehicle applications. Protecting the wiring is an important factor in the safe operation of any vehicle.

Unorganized wiring is harder to protect than well-organized, orderly systems. Situations where wires are run everywhere are an open invitation to damage and failures.

Well-organized wiring is easier to trace. Repairs are easier because there's less searching and testing to find the right wires.

Organizing the wiring can be done using a vari-



ety of methods. But there are some approaches to avoid and materials that are not designed for the job. As an example, avoid using discarded lengths of wire to group vehicle wires and secure bundles. That's true even if the used wire still has insulation on it.

Avoid using any kind of metal brackets with sharp and unprotected edges to drape wires over. String is inconvenient to use and a fire hazard, as is cloth. Electrical tape is often found wrapped around bundles of wire. But tape is adversely affected by heat and cold causing failure and leaves a sticky residue.

There are many wiring accessories that are specially designed to organize and secure vehicle wiring.

Cable Ties

Cable ties are made of flexible nylon, they use a specially designed ratchet patterned strap that fits into a slot on the head of the tie, holding bundles of wires snugly and securely.

They are easily the best alternative for securing groups of wires either to themselves or to structural members. Grote ties are made of a material that absorbs and releases moisture depending upon the moisture in the environment. That helps the ties remain snug over a longer life. With wires snugly gathered, they are less prone to vibration and abrasion. All black ties are ultraviolet (UV) light resistant for extended service life.

Ties come in several types and sizes.

Miniature ties are perfect for smaller bundles. And they are also used in applications where space is limited making it difficult to apply full size ties.

Standard ties are the most popular and offer all of the Grote advantages including the black, UV resistant style.

Heavy-duty ties offer the advantages of the

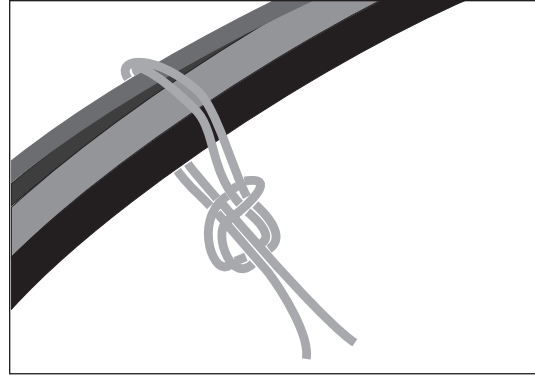

Avoid using string to wrap wire bundles.

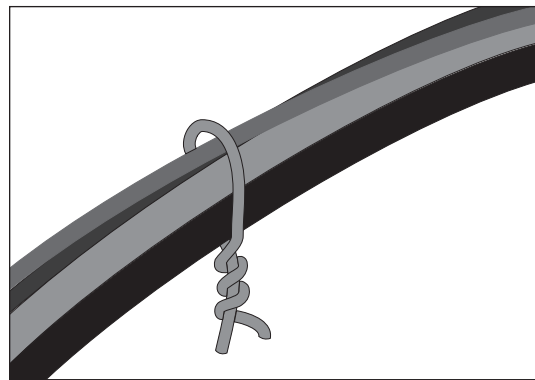

Avoid using scrap to wrap wire bundles.

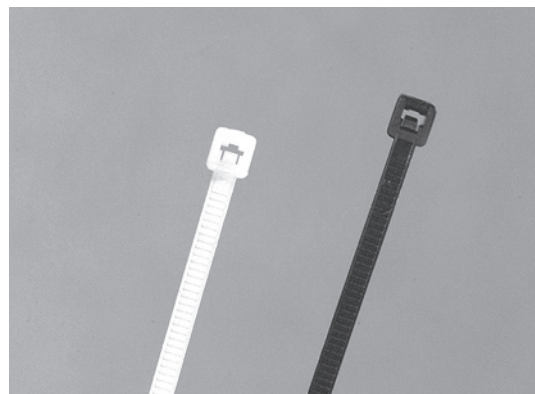

Miniature Cable Ties

standard type along with heavier construction. HD ties are the choice where bundling heavier wire and cables calls for a stronger solution.

Mounting ties come with a pre-drilled hole at the slot end. That allows the tie to be secured with a screw, holding the bundle of wires securely in place on a structural member and away from harm.

Color ties enjoy all of the general utility of the others and come in a variety of colors. This variation makes color-coding simple and easy.

Wire Tubing and Wraps

Other unitizing products include a variety of tube –like products designed to surround bundles of wires.

Spiral wrap is a spiral cut tube made so that wires can be routed in and out of the tube to separate destinations without disturbing the rest of the bundle. It has a built-in memory that allows it to be stretched to accommodate a wire and return to its original shape and size.

Split flex convoluted tubing is tough and easy to use. It's a corrugated wall tube with a slit running the total length. To use, just spread the tub open and place wires inside. Then just allow the tube to take its original form, again.

Fibre loom is a non-metallic, fibrous material that offers abrasion resistance and protection against moisture. It provides a cost-effective solution to the control and protection of vehicle wiring.

Clamps

Another category of wire routing devices is clamps. Most share the same “C” shape. Clamps are particularly valuable for holding bundles of wire when routing them around obstacles.

Nylon clamps are very tough and durable. They are non-conducting and are highly corrosion resistant and easy to install.

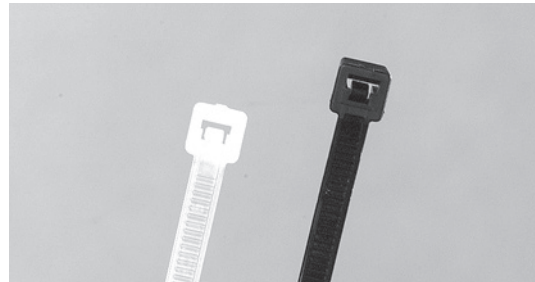

Standard Cable Ties

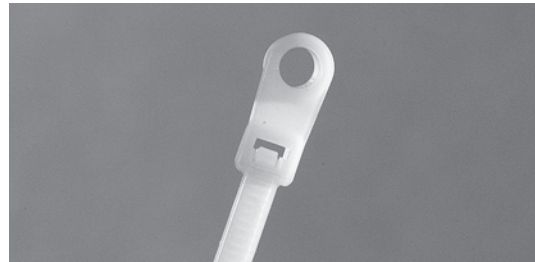

Mounting Cable Ties

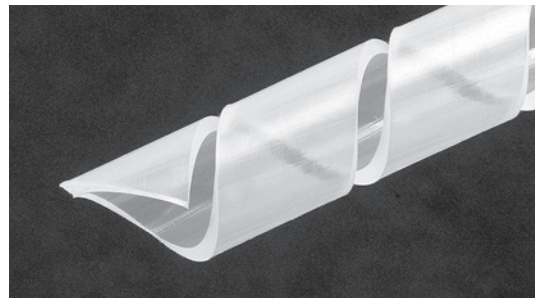

Spiral Wrap



Spiral Flex



Fibre-Loom

Neoprene rubber insulated clamps are dipped to create a cushion layer over a rugged metal base. The covering is non-conducting so it provides a layer of insulation. The neoprene also provides a vibration dampening effect.

Neoprene cushion clamps come with a thick layer of rubber cushion attached to a sturdy metal clamp. That arrangement provides a superior level of vibration dampening and excellent protection for the wire bundle.

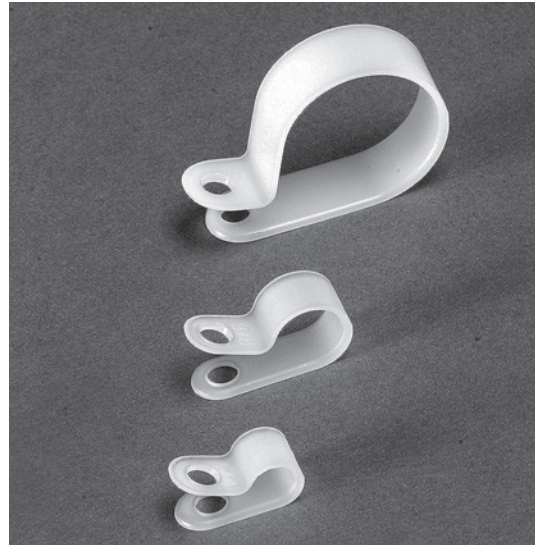

Nylon Clamps



Neoprene Rubber Cushion Clamps



Neoprene Rubber Insulated Clamps

Section Five Quiz Questions

NOTE: Answers to each question are found in the far right column on the first line of the next question. To take this self-test, use a piece of paper to cover all the questions following the question you're working on, then move it down as you work.

1. Because of their design, ring terminals make one of the most secure connections. T/F
2. Ring terminals are the second most popular of all types. T/F **1) T**
3. Spade terminals can't be disconnected unless they are completely disengaged from the stud. T/F **2) F**
4. Hook terminals **3) F**
 - a) Are a combination of a butt connectors and spade terminals
 - b) Must be lifted completely off the stud to disengaged
 - c) Have more holding power than a spade connector
 - d) None of the above
5. Three-way connectors are used to connect wires in a "T" shape. T/F **4) c**
6. Blade connectors are often used to connect and disconnect splices. T/F **5) T**
7. Bullet connectors are used in situations where the splice is to be connected and disconnected repeatedly. T/F **6) T**
8. Grote power cords **7) T**
 - a) Feature stainless steel springs
 - b) Are equipped with brass terminals
 - c) Are totally sealed
 - d) All of the above
9. In choosing a switch, it's necessary to consider **8) d**
 - a) How many terminals are required
 - b) How many amps the switch must handle
 - c) What it's function is
 - d) All of the above
10. Toggle switches are available in light-duty models only. T/F **9) d**
11. Short of total failure, the most serious problem caused by a poor connection is excessive resistance. T/F **10) F**
12. Improper wire stripping can cause increased resistance. T/F **11) T**
13. "Tinning" refers to soldering wires together. T/F **12) T**
14. Loose crimps can cause an open circuit. T/F **13) F**
14) T

15. Crimping is the most often used method of securing terminal connections. T/F
16. With single-wall heat shrink tubing, the ratio of original to finished size is as much as **15) T**
- a) 3.5 to 1
 - b) 2 to 1
 - c) 4 to 1
 - d) None of the above
17. Dual-wall shrink tubing refers to a product designed to protect wiring from the underhood environment. T/F **16) b**
18. Dielectric coating refers to **17) T**
- a) An anti-corrosion coating
 - b) A wire covering made from lacquer
 - c) A rubber covering on ring terminals
 - d) A type of solder coat applied to wires
19. When used with a layer of tape, leftover wire can be used to bundle wires. T/F **18) a**
20. Well organized wires are generally **19) F**
- a) Easier to trace
 - b) Less prone to damage
 - c) Easier to repair
 - d) All of the above
21. Cable ties are easily the best alternative for securing wires to themselves or a structural member. T/F **20) d**
22. Mounting ties are primarily used to secure lighting devices to trailer sides. T/F **21) T**
23. A spiral wrap allows routing wires in and out without disturbing others in the bundle. T/F **22) F**
24. Clamps come in a variety of shapes such as a “C” configuration. T/F **23) T**
- 24) T**

Section Six

Mastery Statement

When you have successfully completed this section, you will have mastered:

- The Grote product numbering system
- Selecting incandescent and LED replacement lights
- Selecting products to service UBS
- The competitive part number interchange
- A working knowledge of the SAE Lighting Identification Code, the Replacement Lens Chart, Sealed Beam Chart, Bulb Chart and Warranty sections.

Grote Know-How & How

So far, we've discussed the basics of electricity and vehicle lighting. We've reviewed the types of products available for lighting and wiring. We've even touched on techniques for installation and repair. Now, let's consider how to quickly locate the correct product for each task using the Grote catalog.

The Grote Product Numbering System

Grote uses a meaningful product numbering system that makes it possible to quickly locate the correct product, and verify that the correct product has been selected.

Here's the format of a typical Grote product number: 41022-4. It's five digits, followed by a hyphen, followed by a single digit.

The first two digits are the product category. For example:

- 62 stands for back-up lamps.
- 11 stands for brackets.
- 12 stands for small mirrors.

In the front of the Grote catalog, you'll find a complete listing of all product categories.

For the example used here, let's use category 41. It stands for reflectors and conspicuity tape.

The second two digits are the product number. There are many marker lamps in the Grote line. This number distinguishes one from another. In our example, reflector 02 is a three-inch reflector.

The fifth digit indicates variations in color or finish. If it's a lamp or reflector, this digit tells you the color. If it's a mirror, this digit tells you the finish of the mirror housing. In this example, the number 2 indicates that the reflector is red. You'll find a complete list of variation codes in the front of the Grote catalog.

The last digit, the one to the right of the hyphen, is optional. Some product numbers have it. Some

41022-4

Sample Grote Part Number



The first two digits, '41', are circled in a black circle.

The first two digits indicate the product category. In this case, "41" stands for reflectors and conspicuity tape.



The second two digits, '02', are circled in a black circle.

The second two digits are the product number. In this case, "02" stands for a three-inch reflector.



The fifth digit, '2', is circled in a black circle.

The fifth digit indicates variations in color and finish. In this case, "2" stands for a reflector that's red.



The last digit, '4', is circled in a black circle.

The last digit is optional. It indicates the way the product is packaged. In this case, "4" means the product is packaged in pairs.

don't. When it appears, it describes the way the product is packaged. In this case, the 4 indicates that the product comes packed in pairs. If there is no hyphenated digit, the product comes packaged in a poly bag. For a complete list of packaging codes, see the front of the Grote catalog.

Lighting The Way

There are a number of tools available that will help you in your efforts to obtain the correct part for every application.

Grote offers the following aids:

- Catalogs
- Technical Bulletins
- Website (www.grote.com)
- *G-Force* Newsletter

These tools are especially useful in learning about product specifications, application information, installation tips and troubleshooting.

Here are some examples of how you can use these tools to solve problems.

How can I find the correct replacement for a stop light?

Use the *Grote Product Catalog*. Use the table of contents, color-coded thumb index to find the category "Stop, Tail and Turn Lamps." Use the information in that section to determine type of lamp you need. Does it mount flush on the body? Attach by a bracket, or mount on a fender?

Once the lamp has been identified, there may be a choice of colors, bulbs or amperage. The data that accompanies the illustration and specifications will guide you through your selection.

At times, you'll also find a choice of materials. Polycarbonate lenses, for instance, are tougher than acrylic lenses. If your application is for a rugged-duty vehicle, this might be an important factor.

Follow the same process to locate replacement lamps of all types as well as wiring products, lens-

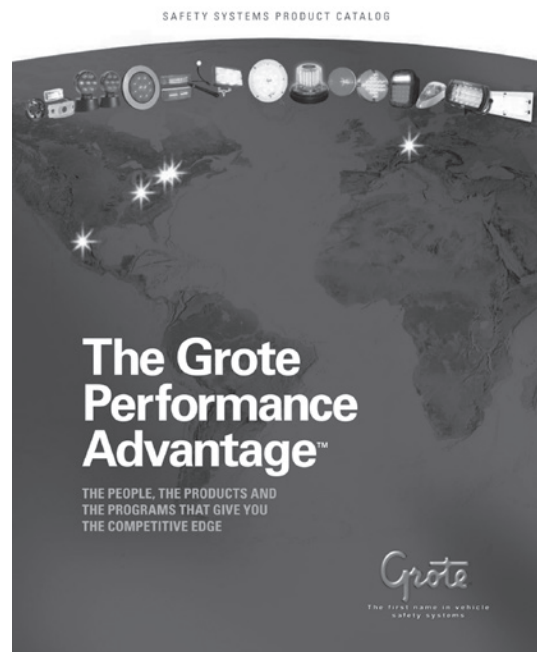

The Grote Product Catalog contains a wealth of helpful information.



Finding the correct replacement for a stop light.

es, flashers, turn signal switches, reflectors, lenses and mirror products.

How can I make sure I'm selecting the correct wire?

In the back of the Grote catalog, in the "Technical Information" section, you'll find a section titled "Trailer Wiring Data." After reading the description of "How To Select Size Of Electrical Cable," use the charts on the facing page to determine the correct wire size based on amperage, length of wire run and ambient temperature. There's also a chart that will help you to determine the insulation requirements based on SAE standards.

How can I make sure the product will fit?

Products in the *Grote Product Catalog* feature line drawings and dimensions wherever they might be needed to ensure that your product selection will fit properly. Take careful note of items like the fixture depth and the spacing of mounting bolts or bolt-holes. This feature is a great time saver and eliminates the hassle of returns.

How can I tell when an LED version is available?

Many truckers and fleets are upgrading to LEDs whenever they have to replace an incandescent fixture. You'll always know when an incandescent lamp is also available as an LED by looking for the yellow "Available in LED" icon in the *Grote Product Catalog*.

There are a number of these helpful icons in the catalog. Some call attention to new products and those that have been undergone significant improvement. The tractor symbol indicates that the product is appropriate for agricultural use.

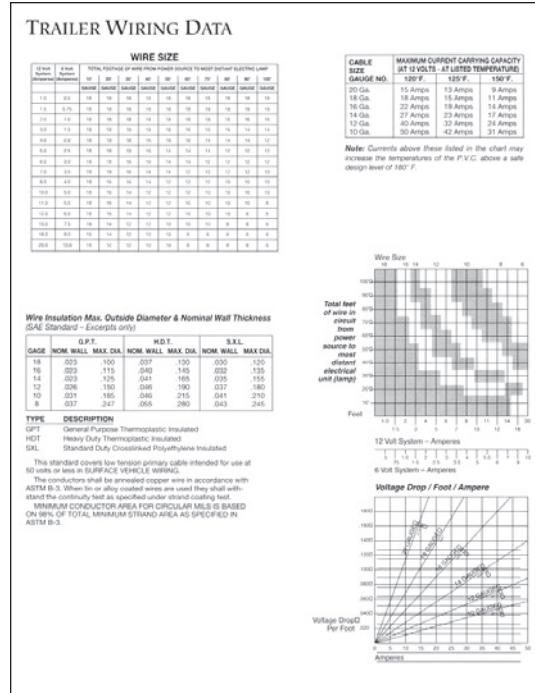

Trailer Wiring Data

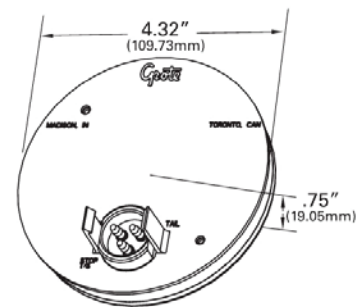

Detailed Line Drawings



Informational Icons provide helpful cross references.

How can I select the correct products to service a UBS cable system?

Begin with the UBS illustration at the beginning of the “Trailer Wiring/Communications” section. This shows a schematic layout of the UBS system and helps you to see which products are used and where they’re located.

On the following pages, you’ll find wiring harness diagrams, wiring color codes for commonly used cables, as well as product descriptions and dimensions that will help you to select the correct UBS accessory.



UBS Illustration shows the layout of a basic UBS harness.

How can I make sure my vehicle is in compliance with federal regulations?

In the back of the Grote catalog, in the “Technical Information” section, you’ll find a chart titled “Basic Equipment Required On All Trucks, Buses and MPVs.”

This color-coded chart will help you to sort through the required use of lighting, reflectors and conspicuity surfaces.

BASIC EQUIPMENT REQUIRED ON ALL TRAILERS						
Area	Equipment	SAE Level Code	Functional Purpose	Quantity	Color	Location
1	Side Marker	MS	Indicate width	Minimum	Red	On the rear - experimental
	Front Marker	MS	Indicate width	Minimum	Red	On the rear - experimental
	Rear Marker	MS	Indicate width	Minimum	Red	On the rear - experimental
	Front Reflector	MS	Indicate width	Minimum	Red	On the rear - experimental
	Rear Reflector	MS	Indicate width	Minimum	Red	On the rear - experimental
2	License Plate Light	MS	Illuminate license plate	Minimum	White	On the rear - above or at the top edge of license plate
	Red Side Marker	MS, MS2 or MS3	Indicate width	Minimum	Red	Each side of rear - above or at the top edge of license plate
3	Front Side Marker	MS, MS2 or MS3	Indicate width	Minimum	Red	Each side of front - above or at the top edge of license plate
	Rear Side Marker	MS, MS2 or MS3	Indicate width	Minimum	Red	Each side of rear - above or at the top edge of license plate
4	Front Reflector	MS, MS2 or MS3	Indicate width	Minimum	Red	Each side of front - above or at the top edge of license plate
	Rear Reflector	MS, MS2 or MS3	Indicate width	Minimum	Red	Each side of rear - above or at the top edge of license plate

ADDITIONAL EQUIPMENT FOR TRAILERS EXCEEDING THE FOLLOWING PARAMETERS Length 9.1m (30 ft.) or longer						
Area	Equipment	SAE Level Code	Functional Purpose	Quantity	Color	Location
5	Approach Light	MS or MS2	Indicate position	Minimum	White	Each side - rear center
	Retardation Light	MS or MS2	Indicate position	Minimum	White	Each side - rear center

Width 2032mm (80 in.) or wider						
Area	Equipment	SAE Level Code	Functional Purpose	Quantity	Color	Location
6	Front Marker	MS, MS2 or MS3	Indicate width	Minimum	Red	On the front - experimental
	Rear Marker	MS, MS2 or MS3	Indicate width	Minimum	Red	On the rear - experimental
7	Front Reflector	MS, MS2 or MS3	Indicate width	Minimum	Red	On the front - experimental
	Rear Reflector	MS, MS2 or MS3	Indicate width	Minimum	Red	On the rear - experimental
8	Front Side Marker	MS, MS2 or MS3	Indicate width	Minimum	Red	On the front - experimental
	Rear Side Marker	MS, MS2 or MS3	Indicate width	Minimum	Red	On the rear - experimental

Width 2032mm (80 in.) or wider AND GVWR 4536 kg (10,000 lb.) or more						
Area	Equipment	SAE Level Code	Functional Purpose	Quantity	Color	Location
9	Front Marker	MS, MS2 or MS3	Indicate width	Minimum	Red	On the front - experimental
	Rear Marker	MS, MS2 or MS3	Indicate width	Minimum	Red	On the rear - experimental
10	Front Reflector	MS, MS2 or MS3	Indicate width	Minimum	Red	On the front - experimental
	Rear Reflector	MS, MS2 or MS3	Indicate width	Minimum	Red	On the rear - experimental
11	Front Side Marker	MS, MS2 or MS3	Indicate width	Minimum	Red	On the front - experimental
	Rear Side Marker	MS, MS2 or MS3	Indicate width	Minimum	Red	On the rear - experimental
12	Front Reflector	MS, MS2 or MS3	Indicate width	Minimum	Red	On the front - experimental
	Rear Reflector	MS, MS2 or MS3	Indicate width	Minimum	Red	On the rear - experimental

Basic Equipment Required On All Trailers

What do the coded designations on each lamp lens mean?

In the back of the Grote catalog, in the “Technical Information” section, you’ll find a chart titled “SAE Lighting Identification Code.” This contains excerpts from the latest SAE specifications which explain the meaning of these codes. Alert service technicians will want to be aware of these codes to make sure that damaged units are replaced correctly.

Can I find the correct Grote replacement product based on a competitive part number?

Yes. In the back of the Grote catalog, in the “Technical Information” section, you’ll find a complete competitive part number interchange. Grote applications are divided into two sections. In column 2A, you’ll find the Grote part that most

closely matches the finish and design of the competitive part. In column 2B, you'll find Grote parts that match the competitive part in function and mounting, but differ in appearance.

How can I find the correct replacement lens for a lamp?

There may be times when a lens has been damaged, but the rest of the lamp fixture is still serviceable. In this case, you have two options. You may check the product information section, or look in the back of the Grote catalog, in the "Technical Information" section. You'll find a chart titled "Replacement Lens Chart" that will help you to determine which replacement lens to use for any serviceable Grote lamp.

How can I tell if this product is covered under a warranty program?

In the back of the Grote catalog, in the "Technical Information" section, you'll find complete details regarding all Grote warranties. It includes contact information for warranty returns and how to obtain replacement products.

PETERSON-TO-GROTE INTERCHANGE				Truck-Lite-TO-GROTE INTERCHANGE			
Peterson Part No.	Grote Form, Fit and Function	Grote Part No.	Truck-Lite Part No.	Peterson Part No.	Grote Form, Fit and Function	Grote Part No.	Truck-Lite Part No.
PS100	5000-5	PS100	5000-5	PS100	5000-5	PS100	5000-5
PS101	5001-5	PS101	5001-5	PS101	5001-5	PS101	5001-5
PS102	5002-5	PS102	5002-5	PS102	5002-5	PS102	5002-5
PS103	5003-5	PS103	5003-5	PS103	5003-5	PS103	5003-5
PS104	5004-5	PS104	5004-5	PS104	5004-5	PS104	5004-5
PS105	5005-5	PS105	5005-5	PS105	5005-5	PS105	5005-5
PS106	5006-5	PS106	5006-5	PS106	5006-5	PS106	5006-5
PS107	5007-5	PS107	5007-5	PS107	5007-5	PS107	5007-5
PS108	5008-5	PS108	5008-5	PS108	5008-5	PS108	5008-5
PS109	5009-5	PS109	5009-5	PS109	5009-5	PS109	5009-5
PS110	5010-5	PS110	5010-5	PS110	5010-5	PS110	5010-5
PS111	5011-5	PS111	5011-5	PS111	5011-5	PS111	5011-5
PS112	5012-5	PS112	5012-5	PS112	5012-5	PS112	5012-5
PS113	5013-5	PS113	5013-5	PS113	5013-5	PS113	5013-5
PS114	5014-5	PS114	5014-5	PS114	5014-5	PS114	5014-5
PS115	5015-5	PS115	5015-5	PS115	5015-5	PS115	5015-5
PS116	5016-5	PS116	5016-5	PS116	5016-5	PS116	5016-5
PS117	5017-5	PS117	5017-5	PS117	5017-5	PS117	5017-5
PS118	5018-5	PS118	5018-5	PS118	5018-5	PS118	5018-5
PS119	5019-5	PS119	5019-5	PS119	5019-5	PS119	5019-5
PS120	5020-5	PS120	5020-5	PS120	5020-5	PS120	5020-5
PS121	5021-5	PS121	5021-5	PS121	5021-5	PS121	5021-5
PS122	5022-5	PS122	5022-5	PS122	5022-5	PS122	5022-5
PS123	5023-5	PS123	5023-5	PS123	5023-5	PS123	5023-5
PS124	5024-5	PS124	5024-5	PS124	5024-5	PS124	5024-5
PS125	5025-5	PS125	5025-5	PS125	5025-5	PS125	5025-5
PS126	5026-5	PS126	5026-5	PS126	5026-5	PS126	5026-5
PS127	5027-5	PS127	5027-5	PS127	5027-5	PS127	5027-5
PS128	5028-5	PS128	5028-5	PS128	5028-5	PS128	5028-5
PS129	5029-5	PS129	5029-5	PS129	5029-5	PS129	5029-5
PS130	5030-5	PS130	5030-5	PS130	5030-5	PS130	5030-5
PS131	5031-5	PS131	5031-5	PS131	5031-5	PS131	5031-5
PS132	5032-5	PS132	5032-5	PS132	5032-5	PS132	5032-5
PS133	5033-5	PS133	5033-5	PS133	5033-5	PS133	5033-5
PS134	5034-5	PS134	5034-5	PS134	5034-5	PS134	5034-5
PS135	5035-5	PS135	5035-5	PS135	5035-5	PS135	5035-5
PS136	5036-5	PS136	5036-5	PS136	5036-5	PS136	5036-5
PS137	5037-5	PS137	5037-5	PS137	5037-5	PS137	5037-5
PS138	5038-5	PS138	5038-5	PS138	5038-5	PS138	5038-5
PS139	5039-5	PS139	5039-5	PS139	5039-5	PS139	5039-5
PS140	5040-5	PS140	5040-5	PS140	5040-5	PS140	5040-5
PS141	5041-5	PS141	5041-5	PS141	5041-5	PS141	5041-5
PS142	5042-5	PS142	5042-5	PS142	5042-5	PS142	5042-5
PS143	5043-5	PS143	5043-5	PS143	5043-5	PS143	5043-5
PS144	5044-5	PS144	5044-5	PS144	5044-5	PS144	5044-5
PS145	5045-5	PS145	5045-5	PS145	5045-5	PS145	5045-5
PS146	5046-5	PS146	5046-5	PS146	5046-5	PS146	5046-5
PS147	5047-5	PS147	5047-5	PS147	5047-5	PS147	5047-5
PS148	5048-5	PS148	5048-5	PS148	5048-5	PS148	5048-5
PS149	5049-5	PS149	5049-5	PS149	5049-5	PS149	5049-5
PS150	5050-5	PS150	5050-5	PS150	5050-5	PS150	5050-5
PS151	5051-5	PS151	5051-5	PS151	5051-5	PS151	5051-5
PS152	5052-5	PS152	5052-5	PS152	5052-5	PS152	5052-5
PS153	5053-5	PS153	5053-5	PS153	5053-5	PS153	5053-5
PS154	5054-5	PS154	5054-5	PS154	5054-5	PS154	5054-5
PS155	5055-5	PS155	5055-5	PS155	5055-5	PS155	5055-5
PS156	5056-5	PS156	5056-5	PS156	5056-5	PS156	5056-5
PS157	5057-5	PS157	5057-5	PS157	5057-5	PS157	5057-5
PS158	5058-5	PS158	5058-5	PS158	5058-5	PS158	5058-5
PS159	5059-5	PS159	5059-5	PS159	5059-5	PS159	5059-5
PS160	5060-5	PS160	5060-5	PS160	5060-5	PS160	5060-5
PS161	5061-5	PS161	5061-5	PS161	5061-5	PS161	5061-5
PS162	5062-5	PS162	5062-5	PS162	5062-5	PS162	5062-5
PS163	5063-5	PS163	5063-5	PS163	5063-5	PS163	5063-5
PS164	5064-5	PS164	5064-5	PS164	5064-5	PS164	5064-5
PS165	5065-5	PS165	5065-5	PS165	5065-5	PS165	5065-5
PS166	5066-5	PS166	5066-5	PS166	5066-5	PS166	5066-5
PS167	5067-5	PS167	5067-5	PS167	5067-5	PS167	5067-5
PS168	5068-5	PS168	5068-5	PS168	5068-5	PS168	5068-5
PS169	5069-5	PS169	5069-5	PS169	5069-5	PS169	5069-5
PS170	5070-5	PS170	5070-5	PS170	5070-5	PS170	5070-5
PS171	5071-5	PS171	5071-5	PS171	5071-5	PS171	5071-5
PS172	5072-5	PS172	5072-5	PS172	5072-5	PS172	5072-5
PS173	5073-5	PS173	5073-5	PS173	5073-5	PS173	5073-5
PS174	5074-5	PS174	5074-5	PS174	5074-5	PS174	5074-5
PS175	5075-5	PS175	5075-5	PS175	5075-5	PS175	5075-5
PS176	5076-5	PS176	5076-5	PS176	5076-5	PS176	5076-5
PS177	5077-5	PS177	5077-5	PS177	5077-5	PS177	5077-5
PS178	5078-5	PS178	5078-5	PS178	5078-5	PS178	5078-5
PS179	5079-5	PS179	5079-5	PS179	5079-5	PS179	5079-5
PS180	5080-5	PS180	5080-5	PS180	5080-5	PS180	5080-5
PS181	5081-5	PS181	5081-5	PS181	5081-5	PS181	5081-5
PS182	5082-5	PS182	5082-5	PS182	5082-5	PS182	5082-5
PS183	5083-5	PS183	5083-5	PS183	5083-5	PS183	5083-5
PS184	5084-5	PS184	5084-5	PS184	5084-5	PS184	5084-5
PS185	5085-5	PS185	5085-5	PS185	5085-5	PS185	5085-5
PS186	5086-5	PS186	5086-5	PS186	5086-5	PS186	5086-5
PS187	5087-5	PS187	5087-5	PS187	5087-5	PS187	5087-5
PS188	5088-5	PS188	5088-5	PS188	5088-5	PS188	5088-5
PS189	5089-5	PS189	5089-5	PS189	5089-5	PS189	5089-5
PS190	5090-5	PS190	5090-5	PS190	5090-5	PS190	5090-5
PS191	5091-5	PS191	5091-5	PS191	5091-5	PS191	5091-5
PS192	5092-5	PS192	5092-5	PS192	5092-5	PS192	5092-5
PS193	5093-5	PS193	5093-5	PS193	5093-5	PS193	5093-5
PS194	5094-5	PS194	5094-5	PS194	5094-5	PS194	5094-5
PS195	5095-5	PS195	5095-5	PS195	5095-5	PS195	5095-5
PS196	5096-5	PS196	5096-5	PS196	5096-5	PS196	5096-5
PS197	5097-5	PS197	5097-5	PS197	5097-5	PS197	5097-5
PS198	5098-5	PS198	5098-5	PS198	5098-5	PS198	5098-5
PS199	5099-5	PS199	5099-5	PS199	5099-5	PS199	5099-5
PS200	5100-5	PS200	5100-5	PS200	5100-5	PS200	5100-5

Competitive Interchange

Technical Information			
Information Technique		Información Técnica	
LIMITED WARRANTY			
Grote Industries, Inc. ("Grote") warrants its products to be free from defects in material and workmanship under normal use and service as set forth in this Limited Warranty. THIS LIMITED WARRANTY is the final, complete and exclusive expression of warranty to the purchaser and no other remedy, express or implied, shall be available for any product or part thereof.			
GENERAL ONE-YEAR LIMITED WARRANTY			
Subject to the following conditions, Grote warrants to the original purchaser only (and not to anyone else) that each new product made by Grote that is part thereof which proves to be defective in material or workmanship within one year from the date of manufacture by Grote will, at Grote's option, be repaired or replaced without charge upon return to Grote of the defective product, provided any defect in the product is brought to the attention of Grote within the warranty period, and does not result from accident, alteration, misuse or abuse. If the product is not installed, operated and maintained according to procedures recommended by Grote, or if the serial number, date code, or other identifying marks placed on the product by Grote are removed, destroyed or defaced, this case shall not be covered by the limited warranty. In no case shall the warranty be extended to include alterations, components, accessories or parts not made by Grote, or to include the product performance by third parties, except those performed by or on behalf of Grote authorized distributors. If any repairs are made, or any other parts are replaced during the warranty period, by any distributor other than a Grote distributor, in accordance with service manuals, parts, accessories, or attachments other than authorized by Grote for use on Grote's products, the purchaser shall pay for such repairs or parts without recourse against Grote, and Grote shall be released of responsibility for maintenance of the warranty with respect to parts or components of all repairs, other than those made by Grote.			
INSTALLATION GUIDELINES:			
Grote Systems: Grote lamp assemblies and harness products are designed to function as a complete system. Therefore, this limited warranty shall not extend to failure of any Grote products caused by the use of incompatible lens assemblies, harness products or other components.			
Heat: All electronic and lighting products produce heat. The installer is responsible for assurance that the application of the component will not result in contact with flammable material.			
Surface Mount: The following procedures need to be practiced to ensure proper installation. The lamp should be placed on a level undisturbed surface. Number 10 screws should be tightened to 25 in pounds of torque. Only Grote ULTRA-BLUE SEAL™ pigtail should interface with all Grote lamps. These guidelines will ensure the products and function and use as they were designed. Deviations from these guidelines will void any warranty.			
Design Voltage and Current: Current is provided as an approximate value and is listed for the design voltage of the lamp. The design voltage of the lamp may vary. Customers should consult Grote Industries if detailed information is required.			
IN CONSIDERATION OF THE EXPRESS WARRANTY AND OTHER TERMS HEREIN CONTAINED, THE PURCHASER AGREES THAT PURCHASER'S EXCLUSIVE REMEDY AND GROTE'S SOLE LIABILITY ON ANY CLAIM, WHETHER IN TORT, CONTRACT			
OR WARRANTY SHALL BE LIMITED TO: AT GROTE'S OPTION, REPAIR OR REPLACEMENT OF A DEFECTIVE PRODUCT, NOT OTHER REMEDY INCLUDING BUT NOT LIMITED TO INCIDENTAL OR CONSEQUENTIAL DAMAGES FOR THE PRODUCT, COST OF SALES, LIABILITY TO PERSON OR PROPERTY OR ANY OTHER INCIDENTAL LOSS OR DAMAGE. GROTE IS AVAILABLE TO PURCHASER IN NO EVENT AND FOR NO CAUSE WHATSOEVER, INCLUDING ANY BREAK OR DEFECT BY GROTE. SHALL GROTE HAVE ANY OBLIGATION TO PURCHASER IN EXCESS OF THE PRICE PAID BY PURCHASER FOR THE PRODUCT TO BE SUBSTITUTED.			
THIS LIMITED WARRANTY EXCLUDES ALL OTHER EXPRESS OR IMPLIED WARRANTIES, INCLUDING THE IMPLIED WARRANTY OF MERCHANTABILITY AND THE IMPLIED WARRANTY OF FITNESS FOR A PARTICULAR PURPOSE, AND OF ALL OTHER WARRANTIES OR LIABILITIES ON THE PART OF GROTE, NO DEALER, DISTRIBUTOR OR OTHER REPRESENTATIVE OF THE COMPANY IS AUTHORIZED TO CHANGE THIS WARRANTY IN ANY WAY OR TO GRANT ANY OTHER WARRANTY.			
Any affirmation of fact or promise made by Grote shall not be deemed to create an expressed warranty that the products that conform to the information on the product shall conform to the information on the product. Any description of the product is for the sole purpose of identifying such product and shall not be deemed to create an expressed warranty that the product shall conform to the description. Any sample or product photo for illustrative purposes only and shall not be deemed to create an expressed warranty, the whole of the products shall conform to the sample or photo. Furthermore no affirmation or promise, or description, sample or photo shall be deemed a part of the basis of the bargain between Grote and the purchaser.			
Grote assumes no responsibility that title conveyed to the purchaser is good or a transfer of title to the purchaser is rightful, or that the products shall be purchased from any security interest or other lien or encumbrance of any third party, or free from any right of claim of any third party by way of infringement or otherwise.			
NON-TRANSFERABLE			
THIS WARRANTY SHALL EXTEND ONLY TO THE ORIGINAL PURCHASER AND IS NON-TRANSFERABLE.			
EXCEPTIONS			
The general one-year (1) limited warranty shall apply that shall be shown as set forth below for the following products:			
(1) Grote Trovan Mount™ Blue Chip Series Lamps shall be subject to a three-year (3) limited warranty.			
(2) All Grote Street Lamps (1) shall be subject to a two-year (2) limited warranty unless otherwise stated.			
(3) Grote Economy sealed lamps shall be subject to a one-year (1) limited warranty.			
(4) Compactly Face shall be subject to a limited warranty. Please refer to the Grote web site for warranty time frame by part number.			
(5) Grote LED Products are subject to the terms set forth below under "Special LED Limited Warranty".			
(6) Grote ULTRA-BLUE SEAL™ Made-In-Harness shall be subject to a seven-year (7) limited warranty.			
(7) Grote ULTRA-BLUE SEAL™ Face-In (Standard) Harness shall be subject to a five-year (5) limited warranty.			
(8) Grote makes no warranty whatsoever with respect to bulbs and fluorescent tubes in lamp assemblies.			

Detailed warranty information appears in the Technical Information section of the Grote Catalog.

Section Six Questions

NOTE: Answers to each question are found in the far right column on the first line of the next question. To take this self-test, use a piece of paper to cover all the questions following the question you're working on, then move it down as you work.

1. In the Grote product numbering system, the first two digits refer to the product category. T/F
 2. The fifth digit in the product numbering system stands for 1) T
 - a) Size
 - b) Color
 - c) Base type
 - d) Category
 3. In the Grote part numbering system, the number to the right of the hyphen is optional. T/F 2) b
 4. Grote Know-How tools include ... 3) T
 - a) Technical Bulletins
 - b) G-Force Newsletter
 - c) Grote Website
 - d) All of the above
 5. There are some basic tables in the catalog that help users determine what wire size is appropriate for the task T/F 4) d
 6. Drawings that accompany product photos in the catalog are approximate and should not be used to determining correct fit. T/F 5) T
 7. In the catalog, availability of LED version of a light is shown by looking for the "New" icon in the product listings. T/F 6) F
 8. The chart labeled Basic Equipment Required On All Trucks, Buses and MPV's has a small section dedicated to lighting requirements. T/F 7) F
 9. SAE Lighting Identification Codes are molded into lenses for permanent identification. T/F 8) F
 10. Each competitor listing in the Competitive Part Number Interchange has an equivalent Grote listing that contains Finish, Design, Function and Mounting or an alternate listing with just Function and Mounting. T/F 9) T
- 10) T**

11. Most vehicles now have

- a) 18 volt systems
- b) 6 volt systems
- c) 12 volt systems
- d) 42 volt systems

12. Information covered in the Sealed Beam Chart section of the catalog includes **11) c**

- a) Color
- b) Wattage
- c) Voltage
- d) All of the above

12) d

Glossary of Terms

ALTERNATING CURRENT - Current that continuously reverses direction

ALTERNATOR - A device powered by a vehicle's engine that creates electrical energy to charge batteries and power on-board devices.

AMERICAN WIRE GAUGE (AWG) - A U.S. standard set of non-ferrous wire conductor sizes.

AMMETER - A device for measuring amps.

AMP - Short for ampere, a standard measure of electrical current. The amount of current pushed by one volt through a conductor with one ohm of resistance.

BASE - Bases provide a foundation for the rest of the lamp, hold the socket and provide the mounting points.

BATTERY - A device that stores an electric charge as chemical energy and converts it back to an electrical charge when needed to power on-board devices.

BATTERY POSTS - The metal studs that provide connection points between cables and batteries

BOOT - The end of a pigtail that attaches to a lighting device.

BRAIDED CABLE - A flat cable made from bare woven wire. Typically used as a ground cable.

BULLET CONNECTOR - Rounded end connector that fits into matching female socket for easy connect and disconnect.

BUTT CONNECTOR - Allows an end-to-end connection between two conductors.

CABLE TIES - Flexible devices, designed to hold groups of wire in bundles, that employ a ratchet action to secure the tie at the correct diameter.

COMPLETE CIRCUIT - A circuit that has a power source, a load such as a light or motor to power and a ground point.

CONDUCTOR - Typically metal that forms the core of a wire or cable that carries an electrical current.

CONSPICUITY TAPE - Conspicuity tape is a highly reflective material used on trucks and trailers to indicate the presence and extent of vehicles especially trailers.

CONTINUITY TESTER - A device used to determine if a circuit is complete or interrupted.

CONVOLUTED TUBING WRAP - A corrugated, flexible tube used to organize and protect wires.

CORROSION - A gradual destruction of metal parts by a chemical reaction. It generally results in a build-up of residue and moisture often causing failure of the connection.

CRIMP - The process of inserting a conductor in the tubular portion of a connector and using a special tool to squeeze the tube until it grips the conductor and creates a strong mechanical and electrical connection.

CURRENT - The flow of electrons through a conductor.

DIELECTRIC - A material that is a poor conductor of electrical current. Typically used as insulation for wire and cable, often applied as a coating to protect connections from moisture and corrosion.

DIODES - Part of the alternator which convert the AC current from the alternator into DC current usable by the battery and other on-board devices.

DIRECT CURRENT - A current that flows in only one direction. Typically used in vehicle electrical systems.

DOT - The Department of Transportation is an umbrella agency for most transportation related agencies.

ELECTROLYTE - A fluid made up of water and acid that reacts with plates in the battery to produce chemical energy which is then converted to electrical when called for by the electrical system.

ELECTRONS - Atomic particles orbiting the nucleus of an atom which move from atom in a conductor creating electrical current.

FACTORY SEALED - Refers to the type of lighting device that is sealed, is not accessible in the field and must be replaced if it fails.

- FHWA** - The Federal Highway Administration (FHWA) is a part of the U.S. Department of Transportation and is headquartered in Washington, D.C., with field offices across the United States.
- FIBER LOOM** - A device made with asphalt for moisture protection, used to organize and protect wires.
- FIELD REPLACEABLE** - Refers to the type of lighting device that has a replaceable bulb that can be accessed in the field.
- FILAMENT** - The part of an incandescent bulb that glows providing light.
- FMVSS-108** - The Federal Motor Vehicle Safety Standard 108, issued by NHTSA, governs lighting requirements for trucks, buses and MPV's
- FORWARD LIGHTING** - Typically headlights and forward facing utility type lighting.
- GAUGE** - Designates the size of a conductor. Typically the larger the number the smaller diameter of the conductor.
- GEL-MOUNT®** - The bulb is held in place by a unique gel providing a secure anti-vibration mounting.
- GROUND** - An electrical ground in effect drains away unwanted electrons after they have completed the task, such as creating light in a bulb. A ground can be literally the earth or large masses of metal such as a truck frame.
- GROUNDING CIRCUIT** - A type of short circuit where an accidentally bared conductor makes contact with a ground without completing the designed circuit.
- HALOGEN BULBS** - A filament type bulb with halogen gas for a whiter, longer lasting light.
- HEAT SHRINK TUBING** - Tubing designed to protect a connection from moisture and damage by shrinking to a fraction of its initial size upon application of heat.
- HID LIGHTING** - With High Intensity Discharge bulbs, light is produced by creating and sustaining an electrical discharge between two electrodes which excites a mixture of xenon gas and mercury for a bright white light.
- HIR BULBS** - Halogen-infrared is a halogen type bulb with an infrared coating for greater light output and whiter light
- HOOK TERMINAL** - A type of connector similar to a ring terminal that has a slot cut out of it giving a hook-like appearance.
- INCANDESCENT BULB** - Typically a base with electrical contacts, glass enclosure, and a filament that glows as current passes through, which produces light.
- INSULATION** - Material which is essential not conductive used to protect the conductor from accidentally being grounded.
- JUMPER** - A connector that bridges the space between the pigtail and the wiring harness.
- LED** - A Light Emitting Diode creates light when electrons pass from one plate to another and a photon is created. Light is created with almost no heat or invisible light as byproducts.
- LENS** - Typically the most visible part of the lighting device, the lens adds the required color in many situations protects the bulb and is engineered for best visibility.
- LOOM** - A device for organizing vehicle wiring, typically tubular, made to contain and control wires and protect them from damage.
- LUG** - A type of wire termination generally oval in shape with a hole to accept a stud. Typically found on battery cables.
- MILLIAMMETER** - A device that measures milliamps.
- MILLIAMP** - One thousandth of an amp.
- MOUNTING TIES** - Cable ties that have a hole for a screw or bolt to help secure the cable tie and wire bundle to the vehicle structure.
- NHTSA** - The National Highway Traffic Safety Administration publishes FMVSS-108 and regulates lighting requirements for most over-the-road vehicles.
- OEM** - Stands for Original Equipment Manufacturer. Typically refers to equipment supplied by the manufacturer.

OHM - A unit of measure of electrical resistance. It takes one volt to push one amp of current through one ohm of resistance.	SECONDARY WIRING - Refers to the wire and cables that carry higher voltages such as ignition wires and coil wires.
OHM'S LAW - Formulas that quantify the relationship between Voltage, Amperage and Ohms	SERIES CONNECTION - A circuit that is created by connecting the negative terminals and positive terminals of a group of batteries, producing higher voltage while the amperage remains the same
ONE-WIRE SYSTEM - A circuit design that uses a nearby vehicle frame member for a grounding point rather than route the ground wire back to the power source.	SHORT CIRCUIT - A condition created when two bared conductors come in contact causing the current from one to be grounded before achieving the designed task.
OPEN CIRCUIT - A circuit that has been interrupted, typically due to wire breaks and wires detached from devices.	SIDE MOUNT - A battery with connections on the side rather than on the top.
PARALLEL CONNECTION - An electrical circuit created when batteries are connected to produce higher amperage at the same voltage output.	SILL HARNESS - A special type of wiring harness used in the rear of trailers to provide power to the lights in the rear.
PATH OF LEAST RESISTANCE - The route that an electric current takes as it attempts to reach a ground. As with a short circuit, not always in the designed path.	SOCKET - The part of a lighting device that holds a bulb and provides electrical contact.
PIGTAILS - Relatively short connecting cables that connect lights and jumpers	SOLDER CONNECTION - Soldering is the process of making a connection by heating the conductors and melting a special metallic mixture into it, which is allowed to cool and solidify.
POTTING - To protect an LED circuit board from moisture, contamination and damage, it is completely sealed in an operation called potting.	SPADE TERMINAL - A connector that has parallel fingers that are designed to slip under the attaching screw.
PRIMARY WIRE - Typically wire used for radios, lights and other vehicle applications.	SPIRAL WRAP - A spiral cut flexible tube used to organize wires, which allows easy wire exit without effecting the other wires.
PUSH-PULL SWITCH - Switch that is turned on by pulling on handle, off by pushing it back to the off position.	STRANDING - The process of using many smaller wires together in place of a single large conductor.
RESISTANCE - Slowing the flow of electrons through a conductor.	TERMINALS - Fittings for use with wire and cable to connect them with other conductors and devices.
RFI - Radio Frequency Interference. Refers to the interference caused by the passage of pulsing current through a conductor.	THREE-WAY CONNECTOR - Allows connecting up to three wires.
RING TERMINALS - A type of connector that is shaped like an "O" which fits over a stud making a very secure connection.	TINNING - The process of applying a thin coat of solder to the bared conductor as a way of protecting it from corrosion.
SAE - The Society of Automotive Engineers	TOGGLE SWITCH - Switch that is turned on by moving a lever to the correct position.
SEALED BEAM - This type of lighting unit is essentially an incandescent bulb filament sealed inside a heavier, aimable glass enclosure.	TOP MOUNT - The style of battery with the posts on the top.

TORSION-MOUNT® - A special, anti-vibration mounting.

VALANCE - The outside “shell” of electrons that surrounds the nucleus of an atom

VAT - Voltage/Amperage Tester

VOLT - A measure of force which causes one amp of current to flow through a conductor with one ohm of resistance.

WIRING HARNESS - A set of unitized wires, typically color coded that form the backbone of vehicle lighting systems.

Final Exam

Congratulations on completing this Grote Know-How Self Study Guide.

To complete the Final Exam, carefully remove the “Answers” page at the end of this book by cutting along the dotted line. Fill out your personal information at the top of the page. Write your answers in the boxes provided. Fold and mail. Please allow four weeks for processing.

1. Voltage is the force that propels electrons through a wire. T/F
2. Which of the following is not a prime function of the alternator?
 - a) Charge the battery
 - b) Power electrical system while engine is running
 - c) Convert AC output to DC current
 - d) Drive the water pump
3. Sealed beam headlights typically ...
 - a) Plug into special sockets
 - b) Must be replaced if the filament fails
 - c) Produce less white light than HID lamps
 - d) All of the above
4. Which of the following is not a function of a base?
 - a) Attaching the device to the vehicle
 - b) Holding the socket
 - c) Acting as a foundation for the lens
 - d) Connecting a device to the wiring harness
5. Because of their design, ring terminals make one of the most secure connections. T/F
6. In the Grote product numbering system, the first two digits refer to the color. T/F
7. Which of these is not a basic attribute that describes electricity?
 - a) Volts
 - b) Protons
 - c) Amps
 - d) Ohms
8. Alternators rely on _____ to create electrical current.
 - a) Heat
 - b) Electromagnetism
 - c) Gravitational attraction
 - d) Electron excitation

9. Compared to incandescents, halogen headlights ...
 - a) Have a soft yellow light
 - b) Use more electrical energy
 - c) Provide 50% more light
 - d) All of the above

10. Which of the following is not true about incandescent bulbs? They are ...
 - a) Available in many types and sizes
 - b) Very resistant to vibration
 - c) Relatively inexpensive
 - d) All of the above

11. Spade terminals can't be disconnected unless they are completely disengaged from the stud. T/F

12. The fifth digit in the product numbering system stands for ...
 - a) Size
 - b) Color
 - c) Base type
 - d) Category

13. The movement of electrons from one atom to the next is called voltage. T/F

14. The part of the alternator, which is fixed in place is referred to as the ...
 - a) Regulator
 - b) Stabillator
 - c) Diode
 - d) Stator

15. The term "HIR" stands for High Intensity Recharge lights. T/F

16. Gel-Mount technology is used to ...
 - a) Attach lamps to trailer bodies
 - b) Hold groups of wires to the trailer frame
 - c) Seal out moisture & corrosion
 - d) All of the above

17. Hook terminals ...
 - a) Are a combination of a butt connectors and spade terminals
 - b) Must be lifted completely off the stud to disengaged
 - c) Have more holding power than a spade connector
 - d) None of the above

18. In the Grote part numbering system, the number to the right of the hyphen is always required. T/F
19. Ohm's Law shows the relationship between volts (E), current or amps (I) and ohms or resistance (R). For example: $E = I \times R$. If I equals 10 and R equals 5, what is the value of E? _____
20. The "one wire" system is one that ...
- a) Uses a single strand of wire to connect all the vehicle lights.
 - b) Uses the vehicle frame to carry current from the battery to the lights
 - c) Uses a common ground wire for all electrical devices on the vehicle
 - d) Uses the frame of the vehicle as a ground, doesn't require a ground wire
21. HIR lights have a coating on the inside, which reflects infrared light back to the filament for more intense light output. T/F
22. A typical location for a clearance/marker lamp is on the side of a trailer on the bottom rail. T/F
23. Blade connectors are often used to connect and disconnect splices. T/F
24. Grote Know-How tools include ...
- a) Know-How Self Study Guides
 - b) Technical Bulletins
 - c) G-Force Newsletter
 - d) All of the above
25. A third way to look at the relationship between the three is to discover the resistance when the volts and amps are known: $R = E \div I$. If $E = 10$ and $I = 2$, what does R equal? _____
26. Typical batteries are made up of negatively charged plates separated from positively charged plates by polished steel separators. T/F
27. HID lighting is different from halogen because it ...
- a) Uses no filament
 - b) Requires a ballast
 - c) Runs at 80 volts
 - d) All of the above
28. Fog lamps, driving lights, snowplow lights and off-road lights are best referred to as ...
- a) Utility lights
 - b) Marker Lights
 - c) Forward lighting
 - d) None of the above

29. In choosing a switch, it's necessary to consider ...
- a) How many terminals are required
 - b) How far away the power source is
 - c) The color of the lights being switched
 - d) All of the above
30. The end of a battery cable that connects to a starter motor should be terminated with a lug connector. T/F
31. If the voltage remains the same and broken wire strands or loose connections raise resistance, what is the effect on current flow?
- a) It remains the same
 - b) It drops
 - c) It rises along with the resistance
 - d) It rises
32. Batteries are filled with a special liquid known as ...
- a) Filtered water
 - b) Hydrochloric acid
 - c) Electrolyte
 - d) Hydrogen peroxide
33. An incandescent bulb is made up of all but what component?
- a) Base with one or more contacts
 - b) Glass enclosure
 - c) Filament
 - d) Arc tube
34. Which of the following is true about reflectors?
- a) When on the rear indicates the presence and length of a trailer
 - b) If mounted on the rear, indicates the length of the trailer
 - c) Are red or yellow depending upon location on the trailer
 - d) All of the above
35. Toggle switches are available in light-duty models only. T/F
36. Conspicuity tape is used to wrap wire splices for a waterproof connection. T/F
37. The rule of thumb for comparing volts, amps and ohms is that: It takes one volt to push one amp through ten ohms of resistance. T/F

38. Wire and cable insulating material is sometimes referred to as _____ because of its lack of current carrying capacity.
- a) Covalent covering
 - b) Electromagnetic compound
 - c) RFI
 - d) Dielectric
39. Incandescent bulbs are sensitive to voltage levels. Operating one at just 5% more than design voltage can reduce bulb life by 44%. T/F
40. The only conspicuity tape allowed to be used on trailers comes in which of these color combinations?
- a) Yellow & black
 - b) Green & silver
 - c) Blue & black
 - d) None of the above
41. Short of total failure, the most serious problem caused by a poor connection is excessive resistance. T/F
42. There are some basic formulas in the catalog that help users determine what size wire size is appropriate for the task T/F
43. Groups of electrons are constantly seeking a path from areas of low concentration to areas of greater electron density. T/F
44. When using a stranded conductor, what do the numerals “18/24” stand for?
- a) The day and hour it was manufactured
 - b) The conductor and insulation material
 - c) The quantity and gauge of the strands
 - d) The weight in pounds of 24 feet of cable.
45. Sealing LED circuit boards is called “stuffing.” T/F
46. In a simplified trailer lighting circuit, which element is not required?
- a) Power source
 - b) Ground
 - c) Switch
 - d) Lamp
47. Improper wire stripping can cause increased resistance. T/F
48. Drawings that accompany product photos in the catalog are approximate and should not be used to determining correct fit. T/F

49. An open circuit occurs when there is an interruption or break in the conductor too large for electrons to cross. T/F
50. When measuring wire gauge, 4 gauge wire is less than half the thickness of 10 gauge. T/F
51. The main set of rules that govern truck and trailer lighting comes from ...
- a) NHTSA
 - b) ICC
 - c) FHASS
 - d) NTSB
52. The sill harness is typically used to plug lights into ...
- a) At the front of the trailer
 - b) At the rear of the trailer
 - c) At the side of the trailer
 - d) All of the above
53. Loose crimps can cause a short circuit. T/F
54. In the catalog, availability of LED version of a light is shown by looking for the “LED” icon in the product listings. T/F
55. Batteries produce ...
- a) Direct current
 - b) Alternating current
 - c) Both
56. Primary wire typically carries ...
- a) 2-6 volts
 - b) 12-14 volts
 - c) 12-24 volts
 - d) 30-55 volts
57. Under the “Basic Equipment Required On All Trailers,” a minimum of three reflectors is required on the rear. T/F
58. A “Double Seal” pigtail refers to ...
- a) A single pigtail that splits into two
 - b) A slot and ring design that provides an inner and outer seal
 - c) Wrapping several layers of electrical tape around the connection
 - d) None of the above

59. With single wall heat shrink tubing, the ratio of original to finished size is as much as ...
- a) 3.5 to 1
 - b) 2 to 1
 - c) 4 to 1
 - d) None of the above
60. The chart labeled Basic Equipment Required On All Trucks, Buses and MPV's is dedicated to lighting and reflectors. T/F
61. What is the major disadvantage of wiring four 12-volt batteries in series?
- a) The output jumps to 48 volts
 - b) It takes a lot of room
 - c) All the same brand batteries must be used
 - d) If one battery fails the circuit fails
62. For the same length of wire, the larger the conductor, the greater the resistance. T/F
63. On a 29 foot trailer, how many intermediate side marker lamps are required?
- a) A minimum of two
 - b) A maximum of four
 - c) A minimum of four
 - d) None of the above
64. pigtails primarily use four terminations: bullet connectors, blunt cut, 3-way and ring connectors. T/F
65. When used with a layer of tape, leftover wire can be used to bundle wires. T/F
66. Each competitor listing in the Competitive Part Number Interchange has an equivalent Grote listing that contains Finish, Design, Function and Mounting or an alternate listing with just Function and Mounting. T/F
67. A circuit with two 12-volt/12 amp batteries connected in series and two connected in parallel would produce ...
- a) 12 volts and 10 amps
 - b) 12 volts and 24 amps
 - c) 24 volts and 12 amps
 - d) 24 volts and 24 amps
68. "Most Distant Point" refers to ...
- a) Maximum distance from the battery to alternator
 - b) Location of the light furthest from the sill
 - c) Largest allowable distance between lights
 - d) None of the above

69. When applying conspicuity tape on the side of a truck, it must cover at least 30% of the length of the trailer. T/F
70. Replacing a damaged sill harness requires little more than unplugging it from the main harness and lights and replacing it. T/F
71. Well organized wires are generally
- a) Easier to trace
 - b) Less prone to damage
 - c) Easier to repair
 - d) All of the above
72. Information covered in the Sealed Beam Chart section of the catalog includes
- a) Color
 - b) Wattage
 - c) Voltage
 - d) All of the above

Answer Sheet

R-1

STEP 1: Fill out the personal information below. Please print clearly

Name: _____

Title: _____

Company: _____

Address 1: _____

Address 2: _____

City: _____

State or Province: _____ Postal Code: _____

STEP 2: Fill in your answers in the box to the right of the question number.

1		13		25		37		49		61	
2		14		26		38		50		62	
3		15		27		39		51		63	
4		16		28		40		52		64	
5		17		29		41		53		65	
6		18		30		42		54		66	
7		19		31		43		55		67	
8		20		32		44		56		68	
9		21		33		45		57		69	
10		22		34		46		58		70	
11		23		35		47		59		71	
12		24		36		48		60		72	

STEP 3: Fold this page in thirds, affix the appropriate postage, and drop it in the mail. Allow four weeks for processing.

IN CANADA: Please fax this page to 800-267-9024

CUT ALONG THIS LINE

Fold along this line first

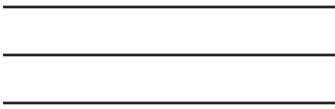

Place
Postage
Here

Grote Industries
2600 Lanier Drive
Madison, IN 47250

ATTN: Marketing Department

Then fold along this line and tape closed.

Trailer Wiring Data

HOW TO SELECT SIZE OF ELECTRICAL CABLE

Wire is used to carry current from the battery through the vehicle to various electrical components: lights, instruments, etc.

In automotive use, the grounded return system is used almost exclusively. In this system, a single wire is run from the battery through switches to the load and the vehicle itself provides the ground or return to the battery.

It is important to note that all electric components have a good ground. In a combination of vehicles (tractor-trailer) it is important that a good and adequate size ground wire be provided between the two vehicles to carry the current.

Wire has certain resistance to current flow. The smaller the wire, the greater the resistance.

Also, as the amount of current (amps) increases, the resistance (ohms) increases.

For a 12-volt system there are two factors to be considered:

- 1) Voltage drop is the primary consideration in selecting the proper electrical wire size. The length of wire in a circuit is the major contributing factor to voltage drop.
- 2) The current carrying capacity of the wire. The heavy load in an undersize wire may increase the temperature of the PVC insulation above a safe level of 180° F.

The Wire Size charts shown below are provided for easy selection of wire sizes. These charts, however, neglect losses due to connections or switches.

To use either of these charts:

- a) Determining the total wire length from the power source to the most distant point in the circuit.
- b) Determine the total electrical load on the circuit.
- c) Find the load along one edge of the chart. (6v or 12v) depending on the vehicle voltage in question, taking the next higher load if the indicated load falls between two points on the chart.
- d) Find the cable length required along the edge of the chart, taking the next higher length (if the exact length is not cited).
- e) At the intersection of the length and load column, read the minimum size wire required for that particular circuit.

Example

On a 12-volt system, operating an ambient temperature of 125° F, determine the wire size required for a clearance light circuit having eleven lights use No. 97 bulbs.

- a) Find the total ampere load in the circuit. There are 11 No. 97 bulbs. From the bulb chart at the back of the Grote catalog, you determine that each bulb is rated at 0.69 amps. The total load is 0.69 amps x 11 = 7.59 amps.

- b) Find the distance from the power source to the most distant light. Total distance = 3 + 45 + 4 + 8 + 8 + 2 = 70 ft.

- c) In the "Wire Size Chart" below, find the column with the "Length of Wire" that matches the example. Your most distant light is 70 ft. Next, find the row with the ampere load that matches the example. Hint: The next highest value above 7.59 amps is 8.0 amps. At the intersection of this row and column, you'll find a 12 gauge wire indicated. This is the correct wire size to use.

- d) Check to see if it's safe to use a 12-gauge wire at an ambient temperature of 125° F. In the "Temperature Chart" below, find the temperature column that matches the example. Your ambient temperature is 125° F. Next, find the row with the wire gauge that matches the example. Your wire is 12 gauge. At the intersection of this row and column, you'll find that the current carrying capacity of a 12-gauge wire at 125° F is 32 amps. That's well in excess of your 8-amp load, so you're okay.

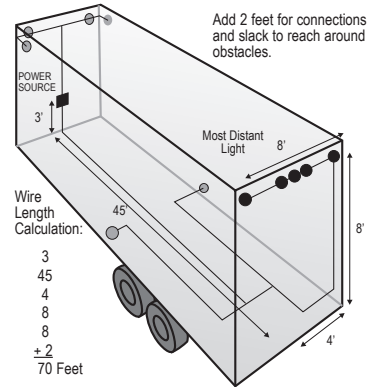

		WIRE SIZE CHART									
For A 12-Volt System	For A 6-Volt System	Length of Wire (Most Distant Light)									
Load in Amps	Load in Amps	10'	20'	30'	40'	50'	60'	70'	80'	90'	100'
		Wire Gauge	Wire Gauge	Wire Gauge	Wire Gauge	Wire Gauge	Wire Gauge	Wire Gauge	Wire Gauge	Wire Gauge	Wire Gauge
1.0	0.5	18	18	18	18	18	18	18	18	18	18
1.5	0.75	18	18	18	18	18	18	18	18	18	18
2.0	1.0	18	18	18	18	18	18	18	16	16	16
3.0	1.5	18	18	18	18	18	16	16	16	14	14
4.0	2.0	18	18	18	16	16	16	14	14	14	12
5.0	2.5	18	18	18	16	14	14	14	12	12	12
6.0	3.0	18	18	16	16	14	14	12	12	12	12
7.0	3.5	18	18	16	14	14	12	12	12	12	10
8.0	4.0	18	16	16	14	12	12	12	10	10	10
10.0	5.0	18	16	14	12	12	12	10	10	10	10
11.0	5.5	18	16	14	12	12	10	10	10	10	8
12.0	6.0	18	16	14	12	12	10	10	10	8	8
15.0	7.5	18	14	12	12	10	10	10	8	8	8
18.0	9.0	16	14	12	10	10	8	8	8	8	8
20.0	10.0	16	16	12	12	10	10	8	8	8	8

		TEMPERATURE CHART		
Cable Size	Maximum Current Carrying Capacity (For 12 Volts at Listed Temperatures)			
		120° F	125° F	150° F
20 Gauge	15 Amps	13 Amps	9 Amps	
18 Gauge	18 Amps	15 Amps	11 Amps	
16 Gauge	22 Amps	19 Amps	14 Amps	
14 Gauge	27 Amps	23 Amps	17 Amps	
12 Gauge	40 Amps	32 Amps	24 Amps	
10 Gauge	50 Amps	42 Amps	31 Amps	

CANADIAN MOTOR VEHICLE SAFETY STANDARDS & FEDERAL MOTOR VEHICLE SAFETY STANDARDS

BASIC EQUIPMENT REQUIRED ON ALL TRUCKS, BUSES & MPVs							
DESCRIPTION				MANDATORY REQUIREMENTS			
Area	Equipment	SAE Lens Code	Function	Quantity	Color	Location	Height From Ground
1	Headlamps - Lower Beam US requires DOT lettering on lens US & Canada - light source code required on lens	H, HR	Forward road illumination	Minimum 2	White	On the front - Symmetrical As far apart as practicable If 4 lamp system - outboard or above upper beams	560 - 1,370 mm 22-54 inches
	Headlamps - Upper Beam US requires DOT lettering on lens US & Canada - light source code required on lens	H, HR	Forward road illumination	Minimum 2	White	On the front - Symmetrical If 4 lamp system - inboard or below lower beams.	560 - 1,370 mm 22-54 inches
	Parking Lamps §	P	Indicate parked vehicle	Minimum 2	White or Yellow	On the front - Symmetrical As far apart as practicable	380 - 1,530 mm 15-60 inches
	Daytime Running Lamps (DRL) Canada - Required US - Optional (US requires "DRL" lettering on lens if not headlamp)	Y2	Indicate in use vehicle	Minimum 2	White or Yellow	On the front - Symmetrical As far apart as practicable	380 mm minimum 15 inches minimum Max. depends on type of DRL
	Front Turn Signal / Hazard Warning Lamps	I	Indicate direction of turn/ identify disabled vehicle	Minimum 2	Yellow	On the front - Symmetrical As far apart as practicable	380 - 2,110 mm 15 - 83 inches
2	Front Clearance Lamps†	P2, PC* or P3, PC2*	Show vehicle's width	Minimum 2	Yellow	At widest point - symmetrical on the front or near the front facing forward	As high as practicable
3	Front Identification Lamps (ID)†	P2 or P3	Indicate presence of a wide vehicle	Exactly 3	Yellow	On the front - center horizontally spaced 150 mm (6 in) to 300 mm (12 in) apart	As high as practicable or on top of the cab
4a	Front Side Marker Lamps	P2, PC*, P3, PC2*	Front and rear side marker lamps / side reflex reflector indicate vehicle's presence and length	Minimum 2	Yellow	Each side at front as far forward as practicable	380 mm minimum 15 inches minimum
4b	Front Side Reflex Reflectors	A		Minimum 2	Yellow	At front - symmetrical as far forward as practicable facing sideward	380 - 1,530 mm 15 - 60 inches
5a	Rear Side Marker Lamps**	P2, PC* or P3, PC2*		Minimum 2	Red	Each side at rear as far back as practicable	380 mm minimum 15 inches minimum
5b	Rear Side Reflex Reflectors**	A		Minimum 2	Red	Each side at rear as far back as practicable facing sideward	380-1,530 mm 15 - 60 inches
6	Rear Clearance Lamps** †	P2, PC* or P3, PC2*		Show vehicle's width, MAY NOT be combined with tail lamps	Minimum 2	Red	At widest point - symmetrical on the rear or near the rear facing rearward
7	Rear Identification (ID) Lamps** †	P2 or P3	Indicate presence of a wide vehicle	Exactly 3	Red	On the rear - center horizontally spaced 150 mm (6 in) to 300 mm (12 in) apart facing rearward	In Canada: at the top - lower if door header narrower than 25 mm In USA: as high as practicable
8	Tail Lamps	T	Indicate vehicle's presence and width	Minimum 2	Red	On the rear - symmetrical As far apart as practicable	380 - 1,830 mm 15 - 72 inches
	Stop Lamps	S	Indicate braking	Minimum 2	Red	On the rear - symmetrical As far apart as practicable	380 - 1,830 mm 15 - 72 inches
	Rear Turn Signal/ Hazard Warning Lamps	I	Indicate direction of turn / identify disabled vehicle	Minimum 2	Red or yellow	On the rear - symmetrical As far apart as practicable	380 - 2,110 mm 15 - 83 inches
	Rear Reflex Reflectors	A	Show vehicle's presence and width	Minimum 2	Red	On the rear - symmetrical As far apart as practicable	380 - 1,1530 mm 15 - 60 inches
9	Backup Lamp	R	Illuminates ground behind the vehicle and alert road users	Minimum 1	White	Rear	No requirement
10	License Plate Lamp(s)	L	Illuminates license plate	Minimum 1	White	On the rear - above or at the sides of license plate	No requirement
11	Center High Mounted Stop Lamp ‡	U3	Indicates braking	1	Red	On the rear - centerline of the vehicle	860 mm minimum 34 inches minimum

ADDITIONAL EQUIPMENT FOR SPECIFIC VEHICLES - VEHICLES 9.1 m (30 ft.) LONG OR LONGER

12a	Intermediate Side Marker Lamps	P2 or P3	Indicate presence of a long vehicle	Minimum 2	Yellow	Each side near center	380 mm minimum 15 inches minimum
12b	Intermediate Side Reflex Reflectors	A	Indicate presence of a long vehicle	Minimum 2	Yellow	Each side near center facing sideward	380 - 1,1530 mm 15 - 60 inches

TRUCK TRACTORS

DESCRIPTION		MANDATORY REQUIREMENTS					
Area	Conspicuity Treatment	DOT Code	Quantity	Color	Location	Height	Options
13	Rear Upper Body Markings	DOT-C DOT-C2 DOT-C3 DOT-C4	Exactly 2 pairs of 300 mm long strips	White	Rear upper corners of cab facing rearward	As high as practicable excluding fairings	
14	Rear Marking		Exactly 2 sections of min. 600 mm each	Red/White	Rear - facing rearward - on fenders, on mud flap brackets, or within 300 mm below the top of mud flaps	As horizontal as practicable and not higher than 1,525 mm from the ground	If mud flaps not used - on the cab or frame mounted brackets

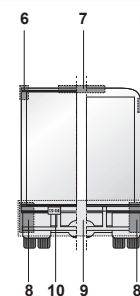
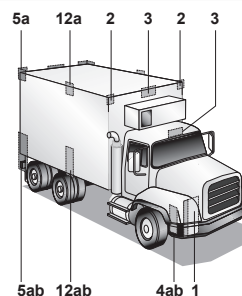
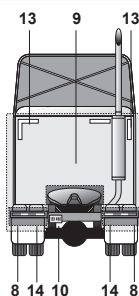
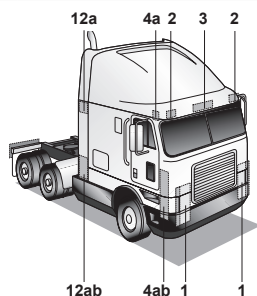

CANADIAN MOTOR VEHICLE SAFETY STANDARDS & FEDERAL MOTOR VEHICLE SAFETY STANDARDS

BASIC EQUIPMENT REQUIRED ON ALL TRAILERS							
DESCRIPTION				MANDATORY REQUIREMENTS			
Area	Equipment	SAE Lens Code	Function	Quantity	Color	Location	Height From the Ground
1	Tail Lamps	T	Indicate vehicle's presence and width	Minimum 2	Red	On the rear - symmetrical as far apart as practicable	380 - 1,830 mm 15 - 72 inches
	Stop Lamps	S	Indicate braking	Minimum 2	Red	On the rear - symmetrical as far apart as practicable	380 - 1,830 mm 15 - 72 inches
	Rear Turn Signal Lamps	I	Indicate direction of turn	Minimum 2	Red or Yellow	On the rear - symmetrical as far apart as practicable	380 - 2,110 mm 15 - 83 inches
	Rear Reflex Reflectors	A	Indicate vehicle's presence and width	Minimum 2	Red	On the rear - symmetrical as far apart as practicable facing rearward	380 - 1,530 mm 15 - 60 inches
2	License Plate Lamp(s)	L	Illuminates license plate	Minimum 1	White	On the rear - above or at the sides of license plate	No requirement
3	Rear Side Marker Lamps	P2, PC* or P3, PC2*	Front and rear side marker lamps / side reflex reflectors indicate vehicle's presence and length	Minimum 2	Red	Each side at rear as far back as practicable	380 - 1,530 mm 15 - 60 inches no max. for veh. under 2,032 mm (80 inches) wide
	Rear Side Reflex Reflectors	A		Minimum 2	Red	Each side at rear as far back as practicable facing sideward	380 - 1,530 mm 15 - 60 inches
4a	Front Side Marker Lamps	P2, PC* or P3, PC2*		Minimum 2	Yellow	Each side at front as far forward as practicable	380 mm minimum 15 inches minimum
4b	Front Side Reflex Reflectors	A		Minimum 2	Yellow	Each side at front as far forward as practicable facing sideward	380 - 1,530 mm 15 - 60 inches

ADDITIONAL EQUIPMENT FOR TRAILERS EXCEEDING THE FOLLOWING PARAMETERS
Length 9.1 m (30 ft) or longer

5a	Intermediate Side Marker Lamps	P2 or P3	Indicate presence of a long vehicle	Minimum 2	Yellow	Each side near center facing sideward	380 mm minimum 15 inches minimum
5b	Intermediate Side Reflex Reflectors	A	Indicate presence of a long vehicle	Minimum 2	Yellow	Each side near center facing sideward	380 - 1,530 mm 15 - 60 inches

Width 2,032 mm (80 inches) or wider

6	Rear Clearance Lamps	P2, PC* or P3, PC2*	Show vehicle's width MAY NOT be combined with tail lamps	Minimum 2	Red	At widest point - symmetrical on the rear or near the rear facing rearward	As high as practicable may be lower only if ID lamps are at the top
7	Rear Identification (ID) Lamps	P2 or P3	Indicate presence of a wide vehicle	Exactly 3	Red	On the rear - center horizontally spaced 150 mm (6 in) to 300 mm (12 in) apart facing rearward	In Canada: at the top - may be lower if door header narrower than 25 mm In USA: as high as practicable
8	Front Clearance Lamps	P2, PC* or P3, PC2*	Show vehicle's width	Minimum 2	Yellow	At widest point - symmetrical on the front or near the front facing forward	As high as practicable

Width 2,032 mm (80 inches) or wider AND GVWR 4,536 kg (10,000 lbs) or more

DESCRIPTION			MANDATORY REQUIREMENTS				
Area	Conspicuity Treatment	DOT Code	Quantity	Color	Location	Height	Options
9	Rear Upper Body Markings	DOT-C DOT-C2 DOT-C3 DOT-C4	Exactly 2 pairs of 300 mm long strips	White	On the rear upper corners facing rearward	At the top	Reflex reflectors may not be required if they are replaced in their required location with conspicuity treatment. Optional in Canada: Rear lower body and side conspicuity treatment may also be solid white, solid yellow, or white and yellow.
10	Bumper Bar Marking		Continuous	Red/White	On the rear bumper bar's horizontal element full width - facing rearward	No requirement	
11	Rear Lower Body Marking		Continuous	Red/White (See options)	On the rear full width of the vehicle facing rearward	As horizontal as practicable and as close as practicable to the range of 375 to 1,525 mm from the ground	
12	Side Marking		See Location	Red/White (See options)	Each side - facing sideward continuous, or evenly spaced over minimum of 50% of length starts and ends as close to the front and rear of the vehicle as practicable	As horizontal as practicable and as close as practicable to the range of 375 to 1,525 mm from the ground	

* Photometrically certified at installation angle

** Not required on truck tractors

§ Vehicles less than 2,032 mm wide

† Vehicles 2,032 mm wide or wider

‡ Vehicles less than 2,032 mm wide and 4,536 kg

IMPORTANT NOTE: Every lamp, reflex reflector, and conspicuity treatment must be permanently attached in the location specified and must comply with all applicable requirements prescribed for it by FMVSS/CMVSS 108. The face of any device on the front/rear and sides should be respectively perpendicular and parallel to the vehicle's centerline unless it is photometrically certified at installation angle. No part of the

vehicle shall prevent any device from meeting its prescribed requirements unless an auxiliary device meeting all prescribed requirements is installed.
IN CANADA: Manufacturers and importers of vehicles must have the proper certification test records demonstrating compliance of lighting components with all prescribed requirements.

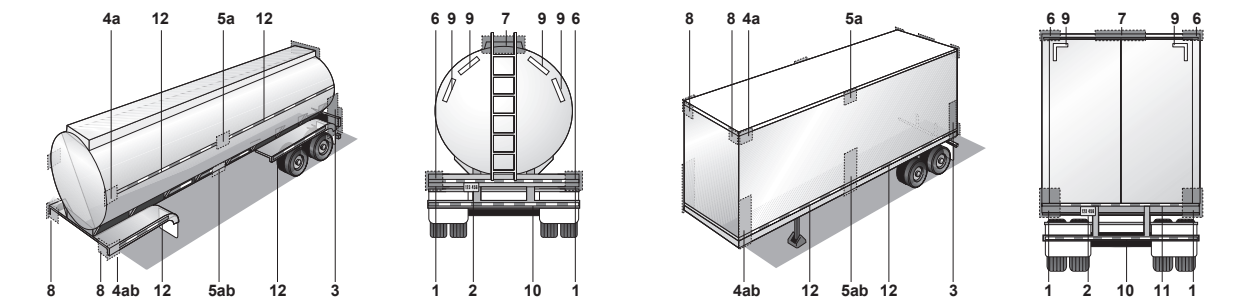

Notes

Notes

Notes

Grote Industries, Inc.
2600 Lanier Drive
Madison, Indiana 47250
USA
Phone: 812-273-1296
Phone: 800-628-0809
Fax: 812-265-8440
Email: safety@grote.com

Grote Industries, Co.
230 Travail Road
Markham, Ontario L3S 3J1
Canada
Phone: 905-209-9744
Phone: 800-268-5612
Fax: 905-209-9757
Fax: 800-267-9024
Email: canada@grote.com

**Grote Comercial Latinoamérica
S. de R.L. de C.V.**
Ave. Rogelio González
Caballero 225
Parque Industrial Stiva Aeropuerto
Apodaca, Nuevo León
México
Código Postal 66600
Phone: 011 (52) 81-8262-4400
Fax: 011 (52) 81-8262-4404
Email: mexico@grote.com

Grote Industries Europe GmbH
Am Schaidweg 3
D-94559 Niederwinkling
Germany
Phone: +49 9962 / 20008-0
Email: europe@grote.com

**Grote (Shanghai) Vehicle
Lighting Systems Co., Ltd.**
485 Xin Run Road, Xinqiao Township,
Song Jiang, Shanghai, China 201612
Phone: +86.21.5774.9633
Email: asia@grote.com

© 2010 Grote Industries
Printed in USA

GLB-2015-49
PN 56-9609-01

The logo for Grote, featuring the word "Grote" in a white, stylized, cursive font with a registered trademark symbol (®) to the right.