



# Basic Electricity and Electronics for Control:

Fundamentals  
and Applications

Third Edition

Lawrence (Larry) M. Thompson



Learning the Hard Way the Easy Way

Downloaded from [www.EngineeringBooksPdf.com](http://www.EngineeringBooksPdf.com)

**BASIC ELECTRICITY  
AND ELECTRONICS FOR CONTROL**

**FUNDAMENTALS AND APPLICATIONS**

3rd Edition

by  
Lawrence (Larry) M. Thompson



Copyright © 2006 by ISA—Instrumentation, Systems, and Automation Society

67 Alexander Drive  
P.O. Box 12277  
Research Triangle Park, NC 27709

All rights reserved.  
Printed in the United States of America.  
10 9 8 7 6 5 4 3 2

ISBN-13: 978-1-55617-988-4  
ISBN-10: 1-55617-988-X

No part of this work may be reproduced, stored in a retrieval system, or transmitted in any form or by any means, electronic, mechanical, photocopying, recording or otherwise, without the prior written permission of the publisher.

### Notice

The information presented in this publication is for the general education of the reader. Because neither the author nor the publisher has any control over the use of the information by the reader, both the author and the publisher disclaim any and all liability of any kind arising out of such use. The reader is expected to exercise sound professional judgment in using any of the information presented in a particular application. Additionally, neither the author nor the publisher have investigated or considered the affect of any patents on the ability of the reader to use any of the information in a particular application. The reader is responsible for reviewing any possible patents that may affect any particular use of the information presented.

Any references to commercial products in the work are cited as examples only. Neither the author nor the publisher endorses any referenced commercial product. Any trademarks or tradenames referenced belong to the respective owner of the mark or name. Neither the author nor the publisher makes any representation regarding the availability of any referenced commercial product at any time. The manufacturer's instructions on use of any commercial product must be followed at all times, even if in conflict with the information in this publication.

### Library of Congress Cataloging-in-Publication Data

Thompson, Lawrence M.

Basic electricity and electronics for control: fundamentals and applications / by Lawrence M. Thompson. — 3rd ed.

p. cm.

ISBN 1-55617-988-X (pbk.)

1. Electronics. 2. Electricity. 3. Electronic controllers. I.

Title.

TK7816.T45 2006

629.8—dc22

2006010559

This book is dedicated to my wife, Gavina, who gladly shared her time so that the work of this book could proceed.

# LIST OF CHAPTER OBJECTIVES

---

---

## CHAPTER 1—ELECTRICAL BASICS

1. Identify electromotive force, current, charge, and work.
2. Define Volt, Amp, and Ohm
3. Determine the fundamental relationship between potential, current, and resistance.
4. Use numerical prefixes as applied to electricity.

## CHAPTER 2—TERMINOLOGY

Define:

Accuracy  
Precision  
Measurement Uncertainty  
Resolution  
Least Count  
Primary Standard  
Secondary Standard  
Shop Standard  
Calibration  
Binary  
Octal  
Decimal  
Hexadecimal

### **CHAPTER 3—MEASUREMENT ERRORS**

1. For a given set of measurements, determine:
  - a. the arithmetic mean
  - b. individual deviation
  - c. average deviation
2. Identify the one method to consistently reduce random error in measurements.
3. Given a table of values, calculate the:
  - a. deviation
  - b. mean
  - c. standard deviation

### **CHAPTER 4—BASIC ELECTRICAL MEASUREMENT**

1. On a given circuit, determine the correct points for measurement of voltage across selected components.
2. When given two of the three basic quantities use Ohm's Law to determine the third.
3. Discuss how to measure current in a:
  - a. series circuit
  - b. parallel circuit
4. List the precautions to be taken with each type of measurement.

### **CHAPTER 5—METER MOVEMENTS**

1. List the precautions necessary when using a meter.
2. Match the digital meter display with its significant characteristic.

### **CHAPTER 6—DC VOLTAGE MEASUREMENT**

1. Select the appropriate procedures to determine the value of analog DC voltmeter multiplier resistors.
2. Draw the schematic of an analog voltmeter, labeling the values for each multiplier resistor for specified ranges.

3. Differentiate between a digital DC voltmeter and an analog DC voltmeter, listing these differences.
4. Perform the appropriate procedures to determine the multiplier values for extending DC voltmeter range.
5. For a given meter, determine the meter sensitivity.

## **CHAPTER 7—DC CURRENT MEASUREMENT**

1. Determine the total current and total resistance for multiple resistor combinations in parallel.
2. Draw the circuit position of a meter when measuring current.
3. Perform the appropriate procedures to determine the shunt values for extending DC ammeter range.
4. Determine meter error when given a list of measurements and the true values, plotting a calibration curve.

## **CHAPTER 8—DC BRIDGES**

1. Using standard bridge arithmetic, determine the value of an unknown resistor when given operating values.
2. Determine current flow in a Wheatstone Bridge.
3. Determine the multiplier resistor necessary for a bridge to measure a selected resistance range.

## **CHAPTER 9—AC FUNDAMENTALS**

1. Given an alternating current wave-form, determine the:
  - a. amplitude
  - b. frequency
  - c. phase
  - d. time period
2. Define the difference in energy content of a direct versus alternating current.

## **CHAPTER 10—AC SOURCE FUNDAMENTALS**

1. List the general procedures for using a signal/function generator to produce a specific signal frequency, amplitude, and shape.
2. List the procedure for calibrating the output of a signal/function generator in applications.

## **CHAPTER 11—THE OSCILLOSCOPE**

1. Identify and label the major components of a cathode ray tube (CRT).
2. Identify and level wave-form characteristics when given specified oscilloscope display wave-forms and input/time settings.
3. Identify and determine Lissajous patterns.

## **CHAPTER 12—REACTIVE COMPONENTS**

1. Determine the time constant for an RC circuit.
2. Determine the time constant for an LC circuit.
3. Determine the capacitive reactance when given the capacitance and frequency.
4. Determine the inductive reactance when given the inductance and frequency.
5. Determine the impedance of various reactive circuits.

## **CHAPTER 13—AC MEASUREMENT**

1. Draw the wave-forms that will be present across a resistor and diode in series for a specified applied input.
2. Identify and label a half-wave rectifying circuit.
3. Determine the output of a full-wave rectifying circuit.

## **CHAPTER 14—SOLID STATE: PRINCIPLES**

1. Identify bipolar transistors from their schematic representations.
2. Identify characteristics of bipolar transistor amplifiers.
3. Differentiates between transistors used in switching circuits versus ones used in linear circuits.

4. Draw the self-biasing circuitry for the collector to base biasing for bipolar transistors.
5. Determine the primary function of a bipolar transistor.

## **CHAPTER 15—ZENER DIODES, SCRS, AND TRIACS**

1. Determine degree of voltage regulation for a given power supply.
2. Draw the output wave-form of an SCR triggered at a selected point on the input alternations.
3. Draw the output wave-form of a TRIAC triggered at a selected point on the input alternations.
4. Draw the output wave-form of a SCR circuit using zero crossing firing on selected alternations.

## **CHAPTER 16—OPERATIONAL AMPLIFIERS**

1. Identify the basic operational amplifier circuits and determine the outputs when given inputs for the:
  - a. inverting amplifier
  - b. non-inverting amplifier
  - c. voltage follower
  - d. integrator
  - e. differentiator
  - f. differential amplifier
  - g. summing amplifier

## **CHAPTER 17—DIGITAL LOGIC**

1. When given various logic gates and their inputs, determine the outputs. This includes
  - a. AND
  - b. NAND
  - c. OR
  - d. NOR
  - e. XOR
  - f. NEGATE

## **CHAPTER 18—ANALOG/DIGITAL CONVERSION**

1. Determine the outputs for given inputs for different A/D and D/A types.
2. Determine the output of an A/D converter in natural and twos complement format.

## **CHAPTER 19—INDUSTRIAL APPLICATIONS**

1. Identify the various electrical and electronic principles learned in this course when applied to actual industrial circuitry (this objective is not measured in writing).

# PREFACE

---

---

This text started out many years ago as a lab-based text, one of the first such published by ISA—titled *Basic Electrical Measurements and Calibration*—in 1978, nearly 28 years ago. Many things in the electrical/electronics industry have changed since this first edition was published. In the years following publication, digital instrumentation has become affordable, widespread, and has almost totally displaced analog devices in automation. While analog instruments have not completely disappeared, it is no longer the technology of choice for current automation installations. With the plethora of commercial, affordable, and readily available large-scale integrated circuits, ubiquitous microprocessors, and memory, digital devices have become the low maintenance and easy-to-use form of industrial equipment now used in measurement and control. In order to have any utility in teaching the simple basics of electricity and electronics, it became apparent that the original text would have to be revised wholesale to remain current. While this has been accomplished in this edition, the focus is no longer on calibration, but on learning the basics of electricity and electronics from a behavior-oriented perspective which required a title change to more accurately reflect the book's contents. Even the test procedures and generic overviews required updating, in view of the fact that many of the maintenance philosophies, procedures, and test equipment have dramatically changed since that first book was written.

As before, the text is easy, behavior based, and uses repeatable observations. As there is a multitude of equipment that could be used to successfully accomplish lab experiments to reinforce the text, it is left to the reader to select his or her choice based on their reading of the text, availability, and affordability of equipment. A good place to start is the Radio Shack 200 or 500 in 1 kits (the author has no financial stake of any kind in Radio Shack or any of its corporate units).

It was necessary to completely revise a number of chapters and add several more to include a discussion of basic electrics, measurements, reactive devices, analog/digital conversions, and contemporary circuitry. In the end, this became a totally new and different work. Sadly, some material had to be left out due to irrelevance to modern settings. We seldom see Kelvin bridges, let alone AC bridges, and most of us no longer work with resistive attenuators (pads) to match impedances.

As stated before, this is basically a behavior-based text, *not a design-oriented or math-based course*, and it references equipment and circuitry found in most industrial and commercial facilities. It is intended as a primer for technical and non-technical persons interested in the electronic and measurement areas. The examples used in the text attempt to approximate “real-life” applications rather than prove a text-based passage. This text is applicable to the vocational, industrial, and occupational areas.

In most places this text is not rigorously mathematical; in some areas where precision in mathematics is necessary, those points are elaborated upon. Where technical sophistication, as opposed to ease of understanding exists, understanding prevails. This is *not an engineering text*, but a **basic and practical course in electrics and electronics**. It is not intended as a substitute for a technical education nor is it a pre-engineering text.

For proper use, good practice, and to ensure the readers ability to work safely, a prior knowledge of standard workplace safety procedures and techniques is required. A rudimentary knowledge of measurements and an experience in the proper use of typical test equipment will be of great benefit when reading this text.

I hope this new version will be as enthusiastically accepted as a teaching tool as was the previous edition and will give the user of the text the satisfaction that he or she has achieved a significant background in topics found in most all technical occupations.

I would like to acknowledge the many persons who helped this book come to fruition; Ed Sullivan and Gerry Thomas, ISA instructors who pointed me in the right direction; the ISA Training Staff, who pointed out the need and encouraged me; and those involved in the production process—particularly Susan Colwell—for their patience and ability to change my writing into some semblance of prose.

Lawrence (Larry) M. Thompson Sr.  
April 2006  
ESdatCo  
707 Coleman St.  
Marlin, TX 76661  
larrymthompson@hotmail.com

# ELECTRICAL BASICS

---

---

The focus of this text is electrical measurement practices. Given this topic, it will be assumed that the reader is either acquainted with or wishes to become acquainted with the basics of electricity. However, even readers with previous knowledge will differ greatly in their depth of understanding, the length of time since their study (if any) of electrical phenomena, and how deeply they absorbed the basic electrical facts.

To make this text as useful as possible to so wide a variety of readers, the first chapters provide the reader with a primer in basic electrical behavior before delving into the practices of measurement. As the focus of this book is not design but tasks of a more practical nature, explanations will employ a very limited amount of mathematics (indeed, only arithmetic). Since electricity cannot be seen and the number of complex explanations for electrical phenomena increases steadily, the text will look only at electrical behavior and use simple (yet accurate) descriptions rather than mathematical models.

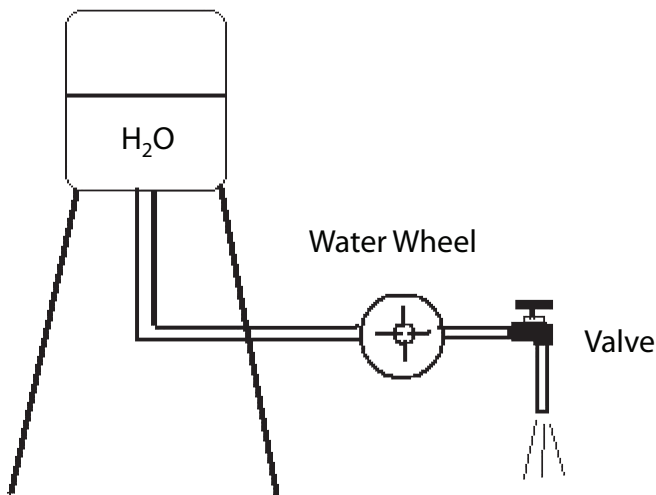
## ENERGY

What is energy? It is the force that accomplishes work. Physics tells us that work is described as “force through a distance.” An electric current can transfer electromotive force and the “source” of energy—where the force is generated—can be physically separated from the point at where the work is to be performed. An electric current will transfer energy from the source to accomplish work at the “load.” In fact, the energy in an electric current may perform the work as well as transfer the energy from some distance.

## POTENTIAL

In order for any energy to be transferred (or work to be performed) the levels of energy at the point where the work is to be performed must be different. This is a common-sense or “intuitive” concept. Similarly, water will not flow unless the source of the water is at a higher level. In fact,

water was the first analogy used to describe electric concepts. Figure 1-1 illustrates a water tower, piping, a water wheel, and a drain. If there is no water in the tower, then there will be no water pressure. The height of a water column determines the pressure exerted at the bottom of the column. In the case of Figure 1-1, this pressure causes a flow of water through the water wheel. The pressure at the bottom of the drain is now the lowest pressure in the system. Energy has been transferred from the water tower through the water wheel because of the difference in pressure between the water tower and at the drain. This is the first of a series of very important observations: *if there is no pressure difference, there is no energy to be transferred or transformed*. Because of the difference in energy, fluid will flow in the piping, operate the water wheel, and exhaust at the drain. The pressure difference itself did not power the water wheel, however; the flow did. *But there would be no flow without the pressure*. Pressure itself is “potential” energy. Pressure is defined as force over an area (pounds per square inch, etc.). Potential energy does not perform work, but it has the potential to perform work. Once the fluid is in motion some of the pressure is transformed into “kinetic” energy. Kinetic energy is force in motion. It does the work, as it will be the force acting through a distance. Since the discoverers of electricity could not see current—could not really conceive of it—they merely observed and recorded its behavior. We will do the same.



**Figure 1-1** Water tower, wheel, and drain.

## CHARGE AND CURRENT

Since the early discoverers of electricity couldn't visualize it, they equated it to water flow. They called electrical flow "current" (not terribly original, but it gets the point across). If there is no electrical pressure difference, there will be no electric current flow. An electric current performs the work. Though there are many explanations for the actual constitution of current flow, the concept we will stick to is that an electrical current is "a movement of charge." There are two (and only two) types of charges: *negative* and *positive*. Whether an item has a net negative or net positive charge depends on who is observing it and what their net charge might be. Figure 1-2 illustrates the importance of having a 0 charge reference.

In Figure 1-2, it is easy to see that the plates marked negative and positive will have a difference in charge between them and that if you observe the negative plate from the positive, it is indeed negative. The same can be said for observing the positive plate from the one marked negative; it is indeed positive. But what about observing from the more and less positive plates? If you use the less positive plate as your reference, then the more positive will be positive. However, if you observe the less positive plate using the more positive plate as your reference, it will appear to be negative. But they are both positive, no? Actually, the observation that both are positive could only come from an independent observer, one with a different (and presumably more negative) reference relative to the two positive objects. *All things are relative*. This is another point that you will need to remember throughout measurement. You must establish a reference. Though the reference may appear to be charged when observed from an independent location, the reference is our zero, so we may only determine the charge differences relative to our reference.

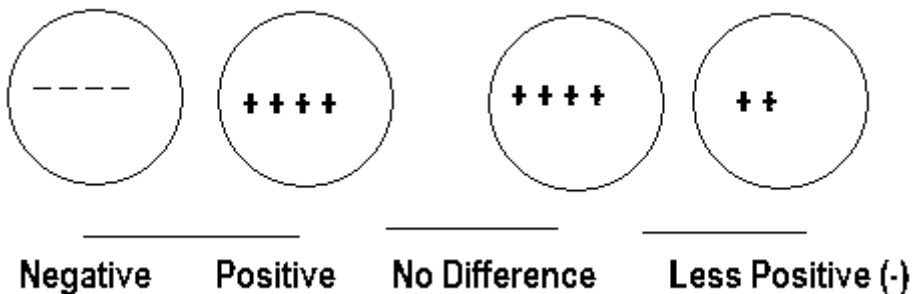


Figure 1-2 Difference in charge.

## THE COMPLETE PATH

For an electrical current to flow a complete path must exist from the point of high to the point of low pressure. This is different than our water tower analogy, yet it is still easy to understand. In order to conduct electricity, conductors are used—the pipes in the water tower analogy. *Conductors* are made of materials that easily pass electrical charges. *Insulators* are made of materials that will not easily conduct electricity. Conductors such as wires are usually made of metals such as copper or aluminum. Insulators are made of materials like rubber, plastic, and some ceramics. Insulated wires (the most common kind) have an insulator wrapped around the wire to keep the charges from contacting the environment. Figure 1–3 illustrates the need for a complete conductive path.

The source develops the electric pressure or potential (difference in charge). This source could be a battery, generator, or any method for generating a difference in charge. Again, this difference in charge is known as “potential.” In fact, it has a more formal name: “electromotive force” or “EMF.” It is the electrical pressure that will cause current to flow in the conductors (drawn as connecting lines in Figure 1–3). There must be a conductive path from the negative to the positive side of the source through the load. If this is not so, then there will be no way to equalize the difference in charge and nothing to relate one terminal to the other. If you are at the positive terminal and measure the difference along the conductor to the positive end of the load, you will detect no difference in charge. (Note: This may not be precisely true depending on the measuring equipment you use—as we explain in later sections. For our purposes here, however, any difference will be insignificant.) The same can be said for the negative terminal of the source through the conductor to the negative terminal of the load. Notice in Figure 1–3 that the entire potential is across the load.

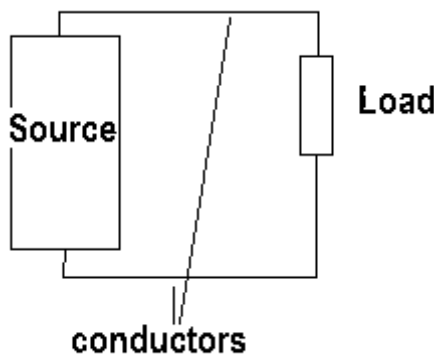


Figure 1–3 The complete conductive path.

Now the potential can do work. Whatever the load is (heating a resistance, turning a motor, etc.), energy will be used. This is work. There is one hard and fast rule for energy: "there is no free lunch." In other words, anything that is moved, heated, cooled, or changed in one way or another, generally involves work, and the energy to perform that work must be provided.

## REVIEW

*For work to be performed the energy must be available to perform that work. In order for an electric current to flow there must first be a potential difference, an electromotive force. This force can move charges through conductors. Conductors conduct charges easily; insulators do not. For a potential to cause an electric current a complete conductive path must exist between the negative and positive terminals of the source.*

## ELECTRICAL UNITS

We have discussed the big picture, so now some of the fine details must be explained. We will use standard units of measurement so that independent measurements can be related and have the same meaning. Three of these units are in common use: the *volt*, which is a measure of the electrical pressure; the *amp*, a measure of electrical current; and the *ohm*, a measure of electrical resistance. The following terms are the foundation of any electric study.

### JOULE

The basic unit of energy is the "joule," whose symbol is J. This is a very small unit of energy; several hundred thousand joules are required just to operate an incandescent lamp over an hour or so. Note that the energy required to do work and the amount of work performed is one and the same. If it takes 250,000 joules an hour to power an incandescent lamp, then the energy required was 250,000 joules an hour, and the work performed was 250,000 joules an hour. If all this energy were converted into light, the lamp would be 100 percent efficient. It is not, however, so the total energy required is the work required to light the lamp plus the work wasted (usually as heat).

### COULOMB

The basic unit of electrical charge is the "coulomb," whose symbol is C. A coulomb is defined as a number of electrons. The electron is an entity that has one negative charge, the smallest amount of charge measurable. Theoretically, this amount of charge is indivisible. In other words, there

are no half electron charges (actually, there *are* theorized partial charges in modern atomic physics, but the electron is the smallest negative charge for our purposes). A coulomb is the amount of charge represented by 6,250,000,000,000,000 electrons. Though this may seem a large number, it is not, as electrons, along with their charge, are really quite small.

## CHARGE

Charge (symbol  $Q$ ) is measured in coulombs. Stated arithmetically, for example, if  $Q = 15C$ , this means the amount of charge is 15 coulombs (don't even think of doing it in electrons).

## CURRENT

The actual electrical flow (movement of charges) is defined as 1 coulomb past a point in 1 second and is called an "ampere" (named after André Ampère). In North America, contemporary usage shortens this term to "amp." The symbol for current is  $I$ , which stands for *intensity of electrical current*. Current is measured in amperes, whose symbol is  $A$ . Stated arithmetically, if  $I = 5A$ , this means the current is 5 amps. It is important to note that *time* has become one of the variables now. Amperes are stated in coulombs per second. So it could be stated arithmetically as  $I = Q/\text{time}$ , where  $Q$  is charge in coulombs, and time is in seconds.

## ELECTROMOTIVE FORCE

The pressure that causes current to flow is called electromotive force (EMF). EMF is measured in "volts," whose symbol is  $V$  (named after Alessandro Volta). Since we need to determine (by using the volt) how much "potential" energy there is in a difference of charge, two of the terms already introduced will suffice. The joule is a basic unit of energy, the coulomb is the basic unit of charge, and since the electrical pressure is the energy in a difference of charge, it may be stated arithmetically as:

$$V \text{ (volts)} = \text{energy (in joules)}/\text{charge (in coulombs)}$$

Or in words as: a 10-volt battery means that each coulomb of charge provides 10 joules of energy (or work). By rearranging the relationship to show work (or energy), it becomes:

$$\text{WORK} = \text{VOLTS} \times \text{CHARGE}$$

## WATTS

Since we use the joule as the basic unit of energy, joules per second would be an appropriate measure of the energy required of an electrical current. Joules per second are known as “watts” (named after James Watt). A watt is a measure of power. Arithmetically stated:

$$P \text{ (power)} = \text{energy (work)}/\text{time (seconds)}$$

Note that if we combine our previous work, that is, I is Q (charge in coulombs) per second, and EMF (volts) = Work/Charge or Work/Q, we get:

$$V \text{ (volts)} = \text{joules}/Q$$

$$I \text{ (amps)} = Q/\text{second}$$

$$\text{Watts (power)} = \text{joules}/Q \times Q/\text{second} \text{ or Watts (power)} = \text{joules}/\text{second}$$

All this means that power in an electrical circuit is determined by:

$$W \text{ (watts)} = E \text{ (volts)} \times I \text{ (amps)}$$

## RESISTANCE

Charges go easily through conductors, though there is some opposition. When it comes to insulators, however, charges are presented with great opposition in flowing through the material. The opposition to current flow is known as *resistance*. All conductors have resistance; all insulators have resistance. The only substances that don't have resistance are superconductors, and they are not the subject of this text. The ease with which a charge may pass energy in a conductor is called (of all things) *conductance*. Resistance is its opposite (actually its reciprocal). The unit of resistance is the “ohm”—named after Georg Ohm. The unit of conductance is the “mho.” (There is no George Mho, but what is *mho* spelled backward? And you thought scientists didn't have a sense of humor.) A conductor will have very few ohms of resistance—in many cases so few as to be negligible. A good insulator will have many millions of ohms. Therefore, a conductor has few ohms, an insulator many. This means that a conductor will easily pass electrical current, whereas an insulator won't.

## ANOTHER REVIEW

*Of all the quantities discussed in this chapter, three are used most often in electrical measurement:*

volt—the unit of electrical pressure

amp—the unit of electrical current

ohm—the unit of opposition to electrical current

*A path with very few ohms will easily pass electrical current. A path with many ohms will pass very little electrical current. Power (as measured in watts) is equal to pressure (volts)  $\times$  current (amps).*

## SAFETY

It has been said before and will be repeated here: a little knowledge is a dangerous thing. Attempting to measure electrical properties can be dangerous. You cannot see electricity or even sense its potential until you are well into a danger zone. Electricity is energy. Like fire, it is both useful and dangerous. Since you cannot see electric potentials and currents without the aid of test equipment, you must *know* beforehand what it is you are trying to accomplish. Though the author of this book cannot foresee all instances and circumstances that you may be thrust into, *safety* is a big concern underlying all the procedures described in this text. *You must respect electricity.* Nonchalance and abuse will sooner or later cause you injury.

You (in the atoms and molecules that make up your very self) are electrical in nature. Biochemical (synapse) currents determine your every movement (voluntary and involuntary). If you allow an electrical path through your body, even a quite small amount of current, many of your body's nerve patterns can be disrupted, particularly those of the heart. Skin burns are bad enough, but to have your heart stop or beat abnormally is life-threatening. Be careful. If you follow the guidelines below you will avoid most problems:

1. *Know* the potentials involved and where they are present, and *know* what and how to measure the electrical properties in question.
2. *Do not* allow your skin to contact any current-carrying conductor.
3. *Keep* one hand in your pocket when measuring high potentials.
4. *Do not* attempt to measure high or unknown potentials *unless* you have received the appropriate training and have the appropriate safety equipment.

5. *As a rule*, when measuring potentials marked high (or unknown), *always* have a safety observer on hand to watch.
6. *Consider* any circuit as active unless you *personally* have disconnected it, tagged it as such, and locked it in such a way that no one but you can turn it on again.

Other precautionary measures will be explained throughout the text. Remember, however, that *you have the ultimate responsibility* to know what is on, what is off, what the potentials are, and what the safe procedures are. After all, it is your life!

## QUESTIONS

1. Who has the ultimate responsibility for *your* safety?
2. You are handed a voltmeter. Can you assume that this meter can safely measure any of the potentials in your area?
3. Nonchalance and disrespect for electricity will normally result in \_\_\_\_\_.

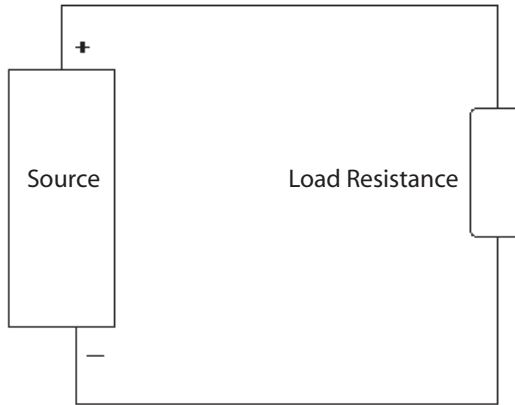
## VOLTS, AMPS, AND OHMS

Recall that volts are the measure of the potential (electrical pressure) that exists between two points, and *amps* are the measure of the amount of current (charge) that the potential can push through the resistance (measured in *ohms*) of a complete path for current flow. A circuit is one or more paths of current flow designed to accomplish some particular function.

## STEADY VOLTAGE

If a potential is held steady (kept at the same value) for a complete path, a certain amount of current will flow. If the resistance in the path is increased (more ohms) and the pressure is the same, the current will decrease (fewer amps). As an example, Figure 1–4 illustrates a circuit (one complete path of current flow, in this case).

Assume that the source is 12.6 volts (just like the battery in your car). Assume as well that the load resistance is 12.6 ohms. The amount of current in the circuit is 1 amp. If the source remains the same (12.6 volts) and the resistance is increased (doubled) to 25.2 ohms, the current will be cut in half to 1/2 amp. If the resistance is cut in half to 6.3 ohms, then



**Figure 1–4** A complete circuit.

with the source remaining steady (at 12.6 volts) the current will increase to 2 amps. To summarize:

- If the voltage is held steady and the *circuit resistance increases*, the *current in the circuit decreases*
- If the voltage is held steady and the *circuit resistance decreases*, the *current in the circuit increases*

## **OHM**

An ohm is described as that resistance through which 1 volt will push 1 amp. In circuits that pass large currents, there will be very few ohms—in fact, maybe even fractional ohms. In those circuits where small currents are used (as is the case in most electronics) the resistance varies from a few ohms to many millions of ohms.

While a million ohms may often be used in electric circuits, most currents are fractions of an amp. In order to make the volt, amp, and ohm usable (not too many zeros and certainly not too many zeros after a decimal point), prefixes are used.

## **PREFIX**

The following metric prefixes are used in almost all measurements. An easy way to remember the powers of ten is that the superscript number (exponent) is the number of zeros following the 1. For negative numbers, remember that this number is divided into 1, which explains why it has the negative sign. The prefixes are:

Prefix	Power of Ten	Symbol	Arithmetic
giga	$1 \times 10^9$	G	$(1 \times 1000000000)$
mega	$1 \times 10^6$	M	$(1 \times 1000000)$
kilo	$1 \times 10^3$	K	$(1 \times 1000)$
milli	$1 \times 10^{-3}$	m	$(1 \times 1/1000)$
micro	$1 \times 10^{-6}$	$\mu$	$(1 \times 1/1000000)$
nano	$1 \times 10^{-9}$	n	$(1 \times 1/1000000000)$
pico	$1 \times 10^{-12}$	p	$(1 \times 1/1000000000000)$ (pico was formerly micro-micro)

### SAMPLE CONVERSIONS FOR VOLTS

1. To convert from volts to kilovolts, move decimal point three places to the left:

$$\text{XXXX.00V} = \text{X.XXXKV}$$

$$\text{Example: } 1230 \text{ volts} = 1.230\text{KV}$$

2. To convert from volts to millivolts, move decimal point three places to the right:

$$0.\text{XXXV} = \text{XXXmV}$$

$$\text{Example: } 0.123\text{V} = 123\text{mV}$$

3. To convert from volts to microvolts, move decimal point six places to the right:

$$0.\text{XXXXXXV} = \text{XXXXXX}\mu\text{V}$$

$$\text{Example: } 0.00123\text{V} = 1,234\mu\text{V}$$

4. To convert from millivolts to microvolts, move decimal point 3 places to the right:

$$0.\text{XXXmV} = \text{XXX}\mu\text{V}$$

$$\text{Example: } 0.123\text{mV} = 123\mu\text{V}$$

5. To convert from microvolts to millivolts, move decimal point three places to the left:

$$\text{XXX}\mu\text{V} = 0.\text{XXXmV}$$

$$\text{Example: } 123\mu\text{V} = 0.123\text{mV}$$

6. To convert from millivolts to volts, move decimal point 3 places to the left:

$$0.\text{XXXmV} = 0.000\text{XXXV}$$

$$\text{Example: } 123\text{mV} = 0.123\text{V}$$

7. To convert from kilovolts to volts, move decimal point three places to the right:

$$0.\text{XXXKV} = \text{XXXV}$$

$$\text{Example: } 0.123\text{KV} = 123\text{V}$$

### ***VOLT CONVERSION EXERCISES***

Convert the listed voltage into other units:

	KV	V	mV	$\mu\text{V}$
1		10.0		
2	.025			
3			780	
4				100
5	1.0			
6		5.06		
7			3570	
8				65000
9		13.6		
10			551	

## SAMPLE CONVERSIONS FOR AMPS

1. To convert from amps to milliamps, move the decimal point three places to the right:

$$0.XXXXXXX = XXX.XXXmA$$

$$\text{Example: } 0.020A = 20mA$$

2. To convert from amps to microamps, move the decimal point six places to the right:

$$0.XXXXXXX = XXXXXX\mu A$$

$$\text{Example: } 0.020A = 20,000\mu A$$

3. To convert from milliamps to microamps, move the decimal point three places to the right:

$$0.XXXmA = XXX\mu A$$

$$\text{Example: } 0.22mA = 220\mu A$$

4. To convert from microamps to milliamps, move the decimal point three places to the left:

$$XXX\mu A = 0.XXXmA$$

5. To convert from milliamps to amps, move the decimal point three places to the left:

$$0.XXXmA = 0.000XXXA$$

$$\text{Example: } 250mA = 0.250A$$

## AMPERE CONVERSION EXERCISES

Convert the listed amperage into other units:

## SAMPLE CONVERSIONS FOR OHMS

1. To convert from megohms to kilohms, move the decimal point three places to the right:

$$0.XXXXXXXM\Omega = XXX.XXXK\Omega$$

$$\text{Example: } 0.24M\Omega = 240K\Omega$$

	A	mA	$\mu$ A
1	20.0		
2		380	
3			40
4	5.18		
5		7570	
6			43000
7		12.6	
8			951

2. To convert from megohms to ohms, move the decimal point six places to the right:

$$0.\text{XXXXXXM}\Omega = \text{XXXXXX}\Omega$$

$$\text{Example: } 0.24\text{M}\Omega = 240,000\Omega$$

3. To convert from kilohms to ohms, move the decimal point three places to the right:

$$0.\text{XXXK}\Omega = \text{XXX ohms}$$

$$\text{Example: } 12\text{K}\Omega = 12,000\Omega$$

4. To convert from ohms to kilohms, move the decimal point three places to the left:

$$\text{XXX ohms} = 0.\text{XXXK}\Omega$$

$$\text{Example: } 470\Omega = 0.47\text{K}\Omega$$

5. To convert from kilohms to megohms, move the decimal point three places to the left:

$$0.\text{XXXK}\Omega = 0.000\text{XXXM}\Omega$$

$$\text{Example: } 6.8\text{K}\Omega = 0.0068\text{M}\Omega$$

## OHM CONVERSION EXERCISES

Convert the listed resistance into other units:

	MΩ	KΩ	Ω
1	2.0		
2		280	
3			40
4	0.520		
5		3530	
6			43000
7		10.6	
8			951

## CHAPTER REVIEW

In this unit, we have discussed the very basics of electricity. Several facts stand out:

1. Safety is an implicit part of electrical measurement.
2. For current to flow, there must be a difference in potential and a complete circuit path.
3. The most often measured (and used) electrical variables are electromotive force (EMF) in *volts*, current in *amps*, and resistance in *ohms*.
4. There is a relationship between the amount of potential (volts), the resistance of a complete circuit (ohms), and the amount of current flowing in the circuit.
5. Various prefixes are used to ensure that measured variables will have no more than three or four significant figures (i.e., 1.56 Megohms instead of 1,560,000 ohms).

## CHAPTER EXERCISES

1. Electromotive force is another name for electrical \_\_\_\_\_.

2. For electrical current to flow in a circuit, two things are necessary (select the two from this list).
  - a. source potential
  - b. load
  - c. complete path
  - d. high resistance
3. An insulator will conduct [*more/less*] current than a conductor.
4. A zero reference is needed to determine how much \_\_\_\_\_ exists between a charged object and the reference.
5. Which actually performs the work: electromotive force or current?
6. If you have a 10 volt source and a 5 ohm load, with a complete circuit, how much current will flow?
7. If you change the load to 10 ohms, will more or less current flow?
8. If you again change the load to 2 ohms, will more or less current flow than in question 6?
9. Given 230 volts and a 70 amp load, what power is being used?
10. If an incandescent lamp is rated at 100 watts for 120 volts, what is the current required to operate the lamp (disregard inefficiency).

***Answers to chapter exercises will be found at the back of this book.***

## CONCLUSION

If you are having difficulty understanding the concepts outlined in this chapter, reread the unit carefully. If you still have questions, seek out your advisor, supervisor, or a person you know who has a good working knowledge of this subject and discuss your problems. Unanswered questions remain that way unless you seek out their answers. This chapter is important, as all other chapters in this text will be built on these basic principles. Answers to the review questions as well as the conversion exercises can be found at the end of this book.

For further information on these topics, open your Internet browser and search for the following terms in an online search engine:

**volts**

**amps**

**ohm**

**charge**

**electrical current**

**Volta**

**Ampère**

**joule**

**electron**

# TERMINOLOGY

---

---

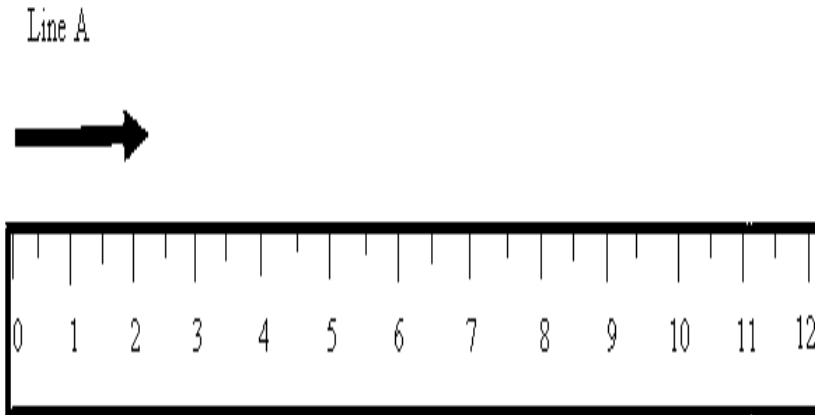
Measurement systems of one kind or another are as old as recorded history. In this book we deal with basic electrical/electronic units of measurement. We measure and explain the fundamental units—volt, ohm, ampere—of course, but we also discuss other units that are applicable to electrical and electronic technologies, namely, frequency, time, henries, farads, and impedance. Before you can begin to measure, you must first understand the meanings of measurement vocabulary terms or terminology. They are the subject of this unit. It's important that you understand the material in this chapter completely, because the language defined in it will occur throughout this text.

## ACCURACY AND PRECISION

There is no such thing as an absolutely accurate measurement. All measurements are approximations of the “true” value. Thus, when the accuracy of a measurement or set of measurements is stated, it is always stated in terms of inaccuracy or a range around the true measurement in which the given measurement may be found. *Accuracy*, *precision*, and *resolution* are terms associated with measurement. Many other terms are used to describe measurement conditions, but these three are components of every measurement, even simple measurements. As an example, consider the measurement of a simple line segment, as in Figure 2–1.

*Accuracy* is how closely you approximate the true value. The measurement shown in Figure 2–1 falls between 2" and 2 ¼". If the desired accuracy was “to the nearest inch,” then this would be an accurate estimate. However, if you wanted accuracy to 1/16" then the ruler shown in Figure 2–1 would not have the scale accuracy to measure to that degree of accuracy. You can approximate to ¼" with the given scale, but not much better than that. Trying to guess any closer to the true value would be just that, guessing.

*Precision*, particularly in instrumentation, means repeatability. You cannot have accuracy without precision. Repeatability means that each time you measure the same real value, you arrive within a given range around the same reading.



**Figure 2-1** Ruler scale.

Each time you measure Line A with the ruler in Figure 2-1, you interpolate (make an educated guess) that line A is  $2 \frac{1}{4}$ " in length. Each time you make the measurement you arrive at the same conclusion (assuming you are consistent). Therefore, the precision of the scale in Figure 2-1 is  $\frac{1}{4}$ ", that being the closest approximation you can realistically make for this measurement.

*Resolution* is the smallest change (or interval) that can be measured by a particular measurement reading scale. For the ruler in Figure 2-2, the resolution depends upon the viewer's ability to approximate a change in the two measured lines. Line A is  $2 \frac{1}{4}$ "; Line B is  $2 \frac{1}{8}$ ". As you can see, the difference in length is hard to determine, particularly if only one line was visible. If you add  $\frac{1}{4}$ " scaling marks, however, as in Figure 2-3, it is far easier to detect the small change and measure it.

By adding the  $\frac{1}{4}$ " scale you have improved the accuracy by making possible closer approximations of the real value. You have also improved the precision because you have improved the likelihood that the observer can make the same, more accurate reading each time. This really is a direct result of increasing the resolution of the scale.

*Question:* Can you have accuracy without precision?

*Answer:* No. Accuracy refers to how close the measurement value is to the actual value. To be accurate, each measurement of the same quantity should fall within the stated accuracy range around the true value. Since precision means the ability to *obtain the same reading* when measuring the same value, *you must have the necessary precision (repeatability) for the accuracy of the instrument.*

*Question:* Can you have precision without accuracy?

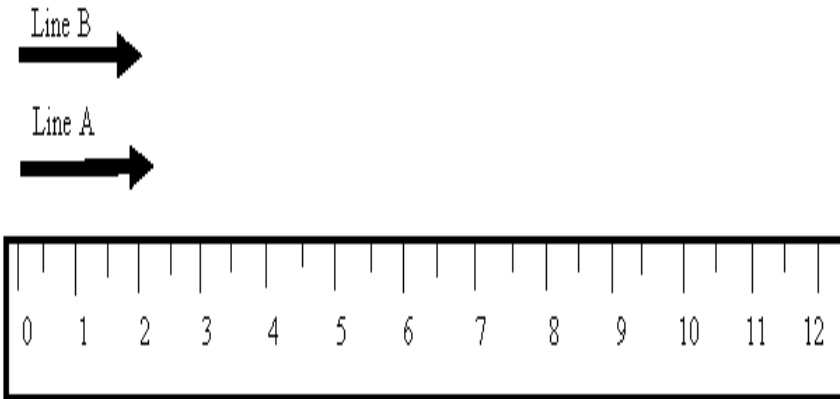


Figure 2-2 Comparison at  $\frac{1}{2}$ ".

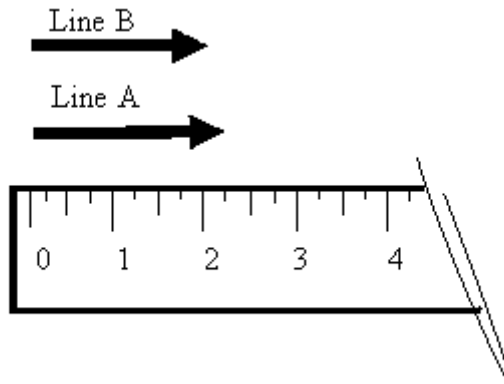


Figure 2-3 Comparison at  $\frac{1}{4}$ ".

*Answer:* Yes, you may be precisely wrong. If you obtain the same measurement value each time a real value is measured, then you have a high degree of precision. Using the rule in Figure 2-3, if, for example, the scale 0 is offset from the line by  $\frac{1}{2}$ ", then your readings may be precise, but reading the wrong value will give the wrong value each time.

## LEAST COUNT

Suppose you took four measurements and recorded the readings, as shown in Table 2-1.

The difference between readings is (+ or -) 0.05 in. No further resolution is available, so 0.05 in. is the "least count" for this set of measurements. The determination of least count is directly related to resolution and thereby

**Table 2-1** A Least Count Table

Reading	Actual Value	Deviation
2.25 in	2.25 in	0.00
2.30 in	2.25 in	0.05
2.20 in	2.25 in	-0.05
2.25 in	2.25 in	0.00

to scale divisions. The smaller the least count, the greater the number of scale divisions for any given interval.

Least count is easier to determine when you are using a digital readout. Digital meters are usually identified in terms of the number of digits in the reading, such as three and a half digits. This indicates that there will be three decimal numerals in the reading, with the half indicating that a most significant digit is a 1 or a 0. Generally, the 0 is blanked (rendered not visible electronically). As an example, for a 3 ½-digit instrument with a 2.0-volt scale, the least count is .001 (and the smallest interval between readings will be .001 volt). The upper value is indicated by 1.999 volts. Two volts will be an overrange condition.

## DIGITAL OR ANALOG

In measurement applications, the definitions of terms and the way specifications are stated can sometimes vary. To understand this, let's begin by defining some terms:

*Upper-Range Value*—The highest value in this scale.

*Lower-Range Value*—The lowest value in this scale.

*Range*—Always stated as “from [the lowest-range value] to [the highest-range value],” for example, “from 0 volts DC to 15 volts DC.”

*Span*—The difference between the upper-range value and lower-range value stated as one value. In the example “from 0 volts DC to 15 volts DC,” the span of measurement is 15 volts.

*Analog*—A measurement where the measured value may be any value between the upper- and lower-range values. In other words, the scale is continuous (at least until you reach the resolution limit of the instrument). Think of a light dimmer, in which luminance can be varied seamlessly from off to full on.

*Digital*—A measurement in which all measurements between the upper- and lower-range values lie at discrete (standalone)

points, with no measurement value existing between those discrete points. Digital is sometimes referred to as “having only on-off values,” but that is true only for a binary digital system. The very familiar decimal system is also digital: only ten numbers exist (0–9), and all representations of values are built with those basic ten numbers.

*Zero*—This is the lower-range value. In electrical/electronic voltage measurement zero is usually (but not always) the reference voltage that is known as “common,” or “ground,” and that has the value of 0 volts.

*Full Scale*—This is the zero value plus the span. If the meter measures from 0 to 15 volts, then 15 volts is full scale (or 100% of span).

*Accuracy*—Always stated in percent of inaccuracy (or measurement error). Accuracy may be determined by using several different approaches. One formula for determining it is:

$$\frac{\text{Measured Value} - \text{True Value}}{\text{True Value}} \times 100 = \text{percent reading}$$

or

$$\frac{\text{Measured Value} - \text{True Value}}{\text{Full Scale Value}} \times 100 = \text{percent full scale}$$

To avoid specmanship, we will use the first formula throughout this text in the following forms:

$$\frac{\text{Measured Value} - \text{Actual Value}}{\text{Actual Value}} \times 100 = \% \text{ accuracy}$$

or

$$\frac{\text{Measurement \#2} - \text{Measurement \#1}}{\text{Measurement \#1}} \times 100 = \% \text{ difference}$$

A digital meter’s accuracy is usually stated in terms of percent of reading (span). In the case of our typical meter the stated accuracy was 0.05%, which is accurate enough for most shop measurements. However, a more accurate measurement can be had for a higher price.

**EXAMPLE**

The following are the specifications taken from a (now obsolete) analog volt-ohm-meter (VOM) on the DC voltage ranges:

Ranges: 1, 2.5, 10, 50, 250, 1000 volts

Sensitivity: 20,000 ohms per volt

Accuracy:  $\pm 3\%$  of full-scale reading

This is a typical example of the specifications found in an instrument catalog (we will explain “sensitivity” or “ohms per volt” when discussing voltmeters in Chapter 6.

First, the “Ranges.” We will assume that you understand that they mean the following:

0 to 1 volt, 0 to 2.5 volt, 0 to 10 volts, 0 to 50 volts,  
0 to 250 volts, and 0 to 1000 volts

The “Accuracy” is a “full-scale” statement, which is the best accuracy this meter can obtain. That is, when measuring 10 volts on the 10-volt scale (a full-scale reading), the actual value may vary from 9.7 to 10.3 volts—“ $\pm 0.3$  volts.” Measuring any values lower than 10V on this scale will give worse accuracy as the +0.3-volt inaccuracy is constant across the scale.

A typical digital multimeter (or DMM) would have specifications for the DC voltage ranges similar to the following for a four-and-a-half-digit meter (note: most modern digital meters found in industrial use are “autoranging,” meaning that, if you prefer, you may select a range but that generally the meter picks the range that gives the best reading):

Ranges: 200mV, 2V, 20V, 200V, 1000V

Resolution: 100 $\mu$ V (the Greek letter  $\mu$  stands for micro), 1mV,  
10mV, 100mV, 1 V

Accuracy: (+ or  $-$ ) 0.05%

Note that the difference between the full-scale value (such as 2 volts) and the actual range value (1.999 volts) is the scale resolution. For the 2-volt scale, the resolution is 1mV or .001 volt. Add that to the 1.999-volt actual range, and you will have the 2 volts. When this value is specified as resolution in typical catalogs it really is the least-significant-digit value. Most shop-type DMMs will have this arrangement. More expensive models may offer five and a half, six, six and a half, seven and a half, or even more digits.

We mentioned earlier that the best accuracy that an analog meter (whose specifications are on full scale accuracy) could obtain is with the reading at full scale (Note—"reading" refers to the value of the measurement which is the "reading" of the meter). Let's look at the example on page 22 to find out why this is the case.

## ERROR

Error is the amount by which the measurement differs from the actual or real value. There are different sources of errors. If the error in Figure 2-3 is attributable to the scale itself—for example, the accuracy of the embossing was off or perhaps the ruler is warped—this is "systematic" error. If the error is caused by reading the wrong scale mark, then it is a human error, commonly called "gross" error.

Errors that occur periodically (i.e., they occur at a predictable frequency) are called "recurring" errors, while those that occur without apparent reason are called "random" errors. Chapter 3 discusses errors and how to compensate for them in greater detail.

## STANDARD

Measurements usually refer to some reference value, usually called a standard. For example, the unit of length now used in all scientific and technical fields is the meter. A standard meter is based on a number of radiated wavelengths of krypton (Superman had better look out), and this standard and its measuring devices are kept in Paris, France. The meter, then, is an *international* standard, meaning it is a fundamental unit of measurement and not derived from any other unit. (That is, the meter is measured directly and not derived from inch measurements, and so on.)

All countries keep their own standards, of course. These standards, known as "primary" standards, are not (as a rule) ever compared to the international standards but are, rather, independently derived using the same methodology and technology. For the United States, these standards are kept by the National Institute of Standards and Technology in Washington, DC.

Calibration shops keep standards on hand that are occasionally compared to the primary standards but are in all cases traceable to the primary standard. These are called "secondary" standards.

Finally, a "shop standard," or "working standard," is what you'll generally see in application. Most shops and manufacturing facilities have such shop or working standards. They are not as accurate as secondary standards (but do not cost as much either) and must be periodically calibrated against a secondary standard. In all cases, a shop or working

**EXAMPLE**

In Figure 2–4, the meter reading is exactly 10.0 volts. If this meter's stated accuracy is  $\pm 2\%$ , what range would contain the real value? Since  $2\% = 0.02$  and the meter reading is 10.0, the meter reading multiplied by the stated accuracy will give the range.

$$10.0 \times \pm 0.02 = \pm 0.2 \text{ volts}$$

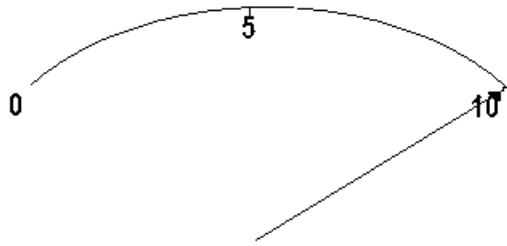
Therefore, the range at which the true voltage lies is between 9.8 volts and 10.2 volts. Note that this is not saying that for all values between 9.8V and 10.2V, the meter will read 10.0 volts. It means that the actual voltage that causes the meter to read 10.0V is actually somewhere in the range of 9.8 volts to 10.2 volts. It could just as easily be 10.0 volts as any other value in the range.

Now, if the actual voltage does not change, and each time you measure this voltage you get exactly 10.0 volts, then your meter is precise to 0.20 of a volt. However, precision should not be stated in these terms. The resolution of the scale in Figure 2–4 is 0.2 volts. If the meter is at its stated accuracy and you made ten readings that varied about 10 volts within the  $\pm 0.2$ -volt range, you could state that, within the scope of your testing, the meter was precise to 0.2 volt.

If you were to measure an exact 5.0 volt with this meter and you used the 0–10-volt range for the measurement, how accurate would your reading be? Since meters whose accuracy is stated at full scale are most accurate when they are at full scale it stands to reason that the meter will be less accurate in other parts of its scale.

The reason for this is that the  $\pm 0.2$  volts is constant throughout the range. In the case of 10.0 volts, it had an "uncertainty" of  $\pm 0.2$  volts. For 5 volts, the  $\pm 0.2$ -volt range remains, so when the meter reads exactly 5.0 volts, the actual voltage is in the range of 4.8 to 5.2 volts. This is an inaccuracy of 0.4%. If you read exactly 1.0 volt on the 10-volt scale, the actual voltage would be between 0.8 and 1.2 volts. This is a 20% error. This is why people who use an analog meter were always instructed to make measurements in the upper one-third of the scale.

There are ways to obtain a better approximation of the actual voltage with the meter in our example, but discussion of them is beyond the scope of this text. So for now, let's return to Figure 2–3. Even with this simple measurement, several types of error could creep into our measurement.



**Figure 2–4** Meter reading 10V.

standard must be able to be traced back to the primary standard, through the secondary.

## **REVIEW: MEASUREMENT TERMINOLOGY**

*We have now determined that:*

1. Accuracy is a relative measurement.
2. Precision refers to the repeatability of measurement.
3. Resolution is the smallest measurable change a measurement scale can display.
4. Gross errors are “human” errors.
5. Systematic errors are “equipment” errors.
6. Random errors are not predictable.
7. There are four major types of standards:
  - a. International
  - b. Primary
  - c. Secondary
  - d. Shop or working

## **REVIEW OF NUMBER SYSTEMS**

Before studying measurement in greater detail, we must first review number systems, their prefixes as they are used in electronics, and, of course, the binary number system. To understand digital systems you should be acquainted with the binary number system. Luckily, it should not be terribly painful. As we familiarize ourselves with binary, we will also mention a number system of historical interest—“octal”—as well as the current binary representation known as the “hexadecimal” system.

## THE DECIMAL SYSTEM

All number systems follow the same rules. You are probably quite familiar with one number system, namely, the decimal system. “Decimal” means that the number system is based on ten digits. Its “base” is ten; the only numbers allowed are 0, 1, 2, 3, 4, 5, 6, 7, 8, and 9. All the numbers we use to describe quantities are made up of those ten numbers and no others.

Figure 2–5 illustrates the powers of ten. Notice that the number 4,302, for example, is really  $4000 + 300 + 2$  or, more correctly,  $4 \times 1000$  (10 to the third power) +  $3 \times 100$  (10 to the second power) +  $0 \times 10$  (10 to the first power) +  $2 \times 1$  (10 to the zero power).

All the other number systems we discuss will be constructed in the same way, except that rather than 10 as the base, some other base is used. For the examples discussed in this review, the bases will be binary (base 2), octal (base 8), or hexadecimal (base 16)—and, of course, decimal (base 10).

In this review, we will emphasize the use of number systems as a means of pattern recognition. The number systems discussed here are the ones used in digital electronics. The electronics work only with the binary system, regardless of the number system that is presented to the human user. For that reason, we will explain the arithmetic functions for the binary system here, but the other number systems will be explained in terms of their conversions to and from binary and their use for pattern recognition.

$10^4$	$10^3$	$10^2$	$10^1$	$10^0$	$10^{-1}$	$10^{-2}$	$10^{-3}$
10000	1000	100	10	1	1/10	1/100	1/1000
4	3	2	1	0	-1	-2	-3

Figure 2–5 Powers of 10.

## THE BINARY SYSTEM

	$2^4$	$2^3$	$2^2$	$2^1$	$2^0$	binary point	$2^{-1}$	$2^{-2}$	$2^{-3}$
decimal	16	8	4	2	1	1/2	1/4	1/8	

Table 2–2 illustrates the binary values for 0 through 15 in the decimal system. The binary patterns for the decimal values 0 through 9 are called binary coded decimal (BCD). This means that the decimal numbers (0

**Table 2–2** Binary Numbers 0–15 (BCD is in bold)

Decimal	Binary Value
0	0 0 0 0
1	0 0 0 1
2	0 0 1 0
3	0 0 1 1
4	0 1 0 0
5	0 1 0 1
6	0 1 1 0
7	0 1 1 1
8	1 0 0 0
9	1 0 0 1
10	1 0 1 0
11	1 0 1 1
12	1 1 0 0
13	1 1 0 1
14	1 1 1 0
15	1 1 1 1

through 9) are each represented by four binary digits. Thus, the decimal value 1302 would appear as

10100010110

in binary, requiring eleven binary digits. It would take sixteen binary digits to represent these four decimal digits in BCD:

1 3 0 2 DECIMAL

0001 0011 0000 0010 BCD

As decimal numbers grow larger, a larger number of binary digits are needed for a BCD representation than are required for the actual binary value equal to the decimal value. The difference is that humans understand decimal, not binary. BCD coding is used to represent decimal values in a binary format.

## OCTAL NUMBER SYSTEM

Early computers used a twelve-binary-digit “word.” Therefore, breaking the word up into four three-binary digit patterns would make it possible to represent each of the three “binary digits” (bits) by its BCD value. Four-bit patterns were not desirable since using a leading “1” (BCD digits 8 and 9) wastes six patterns (10–15). This is because the patterns must be represented by a unique single digit in order to represent each bit. If the number system you choose has eight unique patterns, it is called “octal.” See Table 2–3. The binary value of the decimal number 1302 (010100010110) is represented in octal as 2426:

2 4 2 6      OCTAL

010 100 010 110      BINARY PATTERN

It is easy to convert between octal and binary and binary back to octal. You do not need (in this review anyway) to perform any arithmetic operations (or any other mathematical operation other than conversion to binary). If you do need to make arithmetical operations, inexpensive calculators are available to perform these tasks.

**Table 2–3**      Octal Number System (Octal is in bold)

Decimal	Binary Value
0	<b>0 0 0</b>
1	<b>0 0 1</b>
2	<b>0 1 0</b>
3	<b>0 1 1</b>
4	<b>1 0 0</b>
5	<b>1 0 1</b>
6	<b>1 1 0</b>
7	<b>1 1 1</b>
8	1 0 0 0
9	1 0 0 1
10	1 0 1 0
11	1 0 1 1
12	1 1 0 0
13	1 1 0 1
14	1 1 1 0
15	1 1 1 1

Converting from binary is performed by separating the binary number into groups of three, starting at the binary point. Assign the BCD value for the three-bit group, and you have performed the conversion.

### EXAMPLE

Convert 011111000110 into an octal representation.

011	111	000	110
3	7	0	6

To convert the octal representation into a binary number, assign the BCD coding for each octal digit, starting at the octal point.

### EXAMPLE

Convert 376510 octal into its binary pattern.

3	7	6	5	1	0
011 111 110 101 001 000					

Or, altogether as

011111110101001000

To convert an octal number into decimal or decimal into octal, first convert to binary and then into the desired system, or use a conversion calculator. Octal's use in the control field is limited to historical instances; its primary application was to address early programmable logic controller (PLC) modules and terminations. Octal is not used in contemporary microprocessor-based digital equipment.

## THE HEXADECIMAL SYSTEM

Hexadecimal number systems are based on the number sixteen. The binary coded decimal arrangements are shown in Table 2-4:

Note that this is the same arrangement as we used to illustrate BCD, except that patterns that were illegal in BCD (10–15) are assigned unique single-character representation. Therefore, the six patterns that were wasted can now be used. This allows us to represent sixteen unique numbers—four-bit binary patterns. Modern computers perform all operations on four-bit or some multiple of four-bit patterns. Therefore, hexadecimal representation is used often.

To convert the binary number 1302 into hexadecimal, first divide the binary number, starting from the binary point, into four-bit groups. Then assign the hexadecimal representation.

**Table 2-4** Hexadecimal Numbering System

Decimal	Binary Value
0	0 0 0 0
1	0 0 0 1
2	0 0 1 0
3	0 0 1 1
4	0 1 0 0
5	0 1 0 1
6	0 1 1 0
7	0 1 1 1
8	1 0 0 0
9	1 0 0 1
A	1 0 1 0
B	1 0 1 1
C	1 1 0 0
D	1 1 0 1
E	1 1 1 0
F	1 1 1 1

**EXAMPLE**

010100010110      BINARY

0101   0001   0110

|       |       |

5      1       6      HEX

To convert hexadecimal into binary, assign the binary four-bit pattern to each hexadecimal digit.

**EXAMPLE**

FF13 (generally written as 0FF13H, leading 0, following H):

F       F       1       3

|       |       |       |

1111   1111   0001   0011

1111111100010011

To convert from decimal into hexadecimal or vice versa, first convert to binary, then to the desired term. If you need to make frequent conversions, you can use an inexpensive calculator used.

Some patterns should be memorized, both in decimal and hexadecimal terms, because they are among the most common patterns you will encounter. These are:

0–15 (0–F Hex), listed previously.

10000 = 16 decimal, 10 Hex

100000 = 32 decimal, 20 Hex

1000000 = 64 decimal, 40 Hex

10000000 = 128 decimal, 80 Hex

11111111 = 255 decimal, FF Hex

100000000 = 256 decimal, 100 Hex

1000000000 = 512 decimal, 200 Hex

10000000000 = 1024 decimal, 400 Hex

100000000000 = 2048 decimal, 800 Hex

1000000000000 = 4096 decimal, 1000 Hex

10000000000000 = 8192 decimal, 2000 Hex

100000000000000 = 16384 decimal, 4000 Hex

1000000000000000 = 32768 decimal, 8000 Hex

1111111111111111 = 65535 decimal, FFFF Hex

You will need to use these conversions in the following applications:

1. Learning situations (when trying to understand equipment operation, etc.).
2. Diagnostics (locating problems when using equipment from different manufacturers).
3. Software programming.

Though this has not been an extensive investigation into number systems, or even a definitive explanation of number systems, it should give you a sufficient base (pardon the pun) on which to manipulate between the major counting systems used in modern electronics.

## CHAPTER REVIEW

Consider this a *review* of our review of number systems. It is important that you understand that the only number system you need to be concerned with to interpret mathematical functions is the decimal system, which is a digital system with ten discrete states. The majority of computers use a binary system, that is, an on-off, true-false, up-down, yes-no, system. It is a system in which, if a value isn't of one state, then it must be the other—a system based on two. It is advisable in this digital age that you have a working knowledge of the binary system, at least through the first sixteen binary counts.

The other mainstream number system, hexadecimal, is used to represent patterns of binary digits (bits). For the purposes of this text, that is the only way they will be used.

## CHAPTER EXERCISES

1. Define each of the following as concisely and accurately as possible:
  - a. accuracy
  - b. precision
  - c. measurement uncertainty

- d. resolution
- e. least count
- f. primary standard
- g. secondary standard
- h. shop standard
- i. calibration
- j. binary
- k. octal
- l. decimal
- m. hexadecimal

***Answers to chapter exercises will be found at the back of this book.***

## **CONCLUSION**

If you are finding it difficult to understand the concepts outlined in this chapter, reread it carefully. If you still have questions, seek out your advisor, supervisor, or a person you know who has a good working knowledge of measurement and number systems and discuss your problems with him or her. Unanswered questions remain that way unless an answer is sought. This chapter is as important as any other in this text because all subsequent concepts will be built upon this basic terminology.

Need additional information? Type the following key words in your Internet search engine. Be forewarned that the responses to your search will be at varying levels of expertise; select the one that aids your understanding best.

**accuracy**  
**measurement uncertainty**  
**least count**  
**secondary standard**  
**calibration**  
**octal**  
**hexadecimal**

**precision**  
**resolution**  
**primary standard**  
**shop standard**  
**binary**  
**decimal**

# MEASUREMENT ERRORS

---

---

In the last chapter, we discussed accuracy and how it is stated in terms of the difference between the true value and the measured value. This difference is called *error*. This chapter discusses methods for anticipating and correcting for error in measurement. This is done by applying statistical techniques and by using computer-generated calibration curves that are either manually or automatically applied. You should be familiar with the concepts found in this chapter in order to make measurements with any degree of confidence that the required accuracy will be achieved. *Remember: all measurements have some error.*

## ERROR TYPES

There are three major sources of measurement error: gross, systematic, and random.

*Gross error* is people-caused error. Causes of people error are as diverse as people are, but some of the major causes are:

- Using the wrong meter for the application.
- Using the wrong scale for the measurement.
- Interpolating a reading incorrectly.
- Committing a zero error, such as failing to accurately align the zero point of the ruler with the beginning line point (this is the same as aligning the zero incorrectly for any measurement).
- Making a parallax error by *reading the marks at any angle other than directly overhead*.
- Misreading numerals.

Although there are many more causes of such “people errors,” these will give you an idea of what gross error is all about.

The types of measurement error that occur once gross error has been ruled out are either systematic errors or random errors.

*Systematic error* is equipment error. This includes the kinds of error where the equipment's accuracy, precision, repeatability, calibration, and tolerances come into play. For our ruler example in Chapter 2, systematic error could mean:

- The ruler is physical deformed.
- The pencil and the rule marks have different widths.
- The ruler was marked inaccurately.
- Environmental deformities, such as absorption of moisture, could affect the actual physical spacing of the rule marks.
- The ruler was manufactured inaccurately.
- The standard used to develop this scale was inaccurate.

*Random error* is nonpredictable error and generally affects only one or a single series of measurements. Random errors follow the laws of probability and as such can be identified using a rigorous statistical application. Random error can only be reduced by making repetitive measurements and by applying statistical techniques to establish the measurement uncertainty of the values being measured. These statistics are explained more fully later in this chapter. Typically, random errors cause a number of small, independent errors to occur during repetitive measurements, causing the measurement results to vary in an irregular and nonpredictable pattern.

## **MORE DEFINITIONS**

*Error*—any deviation from the true (actual, real) value.

*Deviation*—as used in this chapter, the difference between the averages (arithmetic mean) of a set of measurements.

*Mean*—the average of a set of measurements.

*Tolerance*—the deviation from a standard (nominal, stated) value; is generally applied to components such as resistors and mechanical parts.

*Accuracy*—the span of error for a measurement, or the maximum amount by which a measurement may vary from the true (real or actual) value.

*Range*—as used in measurement, the lowest-range value to the highest-range value. Always stated as *from...to*. In references to error, range is the lowest to highest values that bound the span of error of a measurement.

**Table 3–1** Meter Reading

Measurement Number	Voltage Measured
1	9.8
2	10.3
3	10.0
4	9.7
5	10.2
6	10.0
7	9.9
8	10.1
9	9.9
10	10.1

## MEAN

Table 3–1 is a list of meter readings.

The meter used to gather the measurements shown in Table 3–1 has a guaranteed accuracy of 5%. The scale is 0V to 10V DC. What assumptions regarding the true value could one make by scanning these measurements?

A quick scan of the numbers in Table 3–1 seems to indicate that the true value is near 10.0 volts. Assuming that the only errors in the measurements are precision errors and are random, the average reading will be near 10.0. Experience teaches that in a list of measurements, the real value should be near the average of all the readings. Although statistical proofs of this are beyond the scope of this text, it is the average value that has the highest probability of being the real value (with no systematic error).

To find the arithmetic mean (or average), sum the readings and divide the result by the number of readings. The equation denoting this process is:

$$\frac{m_1 + m_2 + m_3 + m_4 + \dots m_n}{n} = \bar{m}$$

where  $m$  is the numbered measurement value and  $n$  is the number of measurements.

Find the arithmetic mean for the list in Table 3–2:

**Table 3–2** Finding the Mean

Measurement Number	Voltage Measured
1	9.8
2	10.3
3	10.0
4	9.7
5	10.2
6	10.0
7	9.9
8	10.1
9	9.9
10	10.1
Average	10.00

total number of measurements ( $n$ ) = 10

sum of measurement values ( $\Sigma$ ) = 100

arithmetic mean (average) =  $100/10 = 10$

## DEVIATION

The next logical step in analyzing the set of measurements is to determine each measurement's deviation from the mean. This is done by finding the difference between the actual measurement and the mean. Table 3–3 lists the measurements and their deviations.

Now is the appropriate point to determine the average deviation. Why? Because the lower the average deviation, the higher the precision of the measurement or the measuring device. The average deviation is found by using the same process as to find the arithmetic mean, with one major exception. The deviations are signed numbers and, if summed, may (as in this case) come out to 0, and it is difficult to divide zero by any number other than zero. Therefore, only the unsigned or absolute values are summed. For the figures given in Table 3–3 the sum of the deviations is 1.4. Dividing the sum by the number of measurements (10) produces the average deviation of 0.14. This means that, on the average, the meter readings differed from the arithmetic average or mean by 0.14. If another set of readings was taken with a different meter, and the average deviation was 0.09, then that meter is more precise than the one that produces 0.14.

**Table 3–3** List of Measurements and Deviations

Measurement Number	Voltage Measured	Deviation
1	9.8	–0.2
2	10.3	+0.3
3	10.0	0.0
4	9.7	–0.3
5	10.2	+0.2
6	10.0	0.0
7	9.9	–0.1
8	10.1	+0.1
9	9.9	–0.1
10	10.1	+0.1
Mean	10.00	0.14

Using a series of measurements rather than just one reading greatly reduces the probability of random and gross errors. Random effects tend to cancel over a large number of readings. Using a series of measurements will most likely not diminish the effects of systematic error since much systematic error is of the constant bias type. This means it is consistently high or low, so there is not an equal likelihood that it will be above or below the true reading. The systematic error will therefore skew a set of readings high or low.

## REVIEW OF ERROR BASICS

1. All measurements have errors.
2. An error is a deviation from the true value.
3. Deviation is the difference between the measured value and the arithmetic mean value.
4. An arithmetic mean is the average of a set of measurements.
5. The average deviation is the average of the deviations for a set of measurements.
6. The lower the average deviation, the more precise the set of measurements.
7. Using a series of measurements will tend to average out random errors, and in some cases, gross errors as well.

## STANDARD DEVIATION

Standard deviation is widely used in error analysis (or in any other statistical analysis, such as statistical process control or in some cases your grade on a test). This is because its units are the same as the measurement units. Standard deviation is obtained by:

1. Calculating the arithmetic mean for a number of measurements,
2. Determining the difference between the mean and the measurement—find the deviation,
3. Squaring each deviation (multiplying the deviation by itself),
4. Summing all the squared deviations,
5. Dividing the sum of the deviations by the number of measurements less 1, and
6. Finding the square root of the result in step 5.

This is represented as:

$$\sigma = \pm \sqrt{\frac{d1^2 + d2^2 + d3^2 + d4^2 + dn^2}{n - 1}}$$

or mathematically as

$$\sigma = \pm \sqrt{\frac{\sum d^2}{n - 1}}$$

The deviations will be positive because they are squared. Using standard deviation derives its value (pun intended) because it may be referenced to the normal (or Gaussian) curve. You are probably acquainted with the Gaussian curve because it is the curve typically used to determine grades. A *Gaussian curve* is one that represents truly random occurrences. Measurements, accidents, births, any measurement that has a random component should exhibit a standard curve if enough measurements are taken. It is a “probability” chart. Figure 3–1 shows an example of a standard curve.

Notice that most values would fall in the area about the mean. In fact, 68 percent of the values will be found within one standard deviation (plus or minus) of the mean. Ninety-five percent of the values will be found within plus or minus two standard deviations of the mean. In fact, if a set of readings has only random error, 97.5 percent of all probable readings will be within plus or minus three standard deviations.

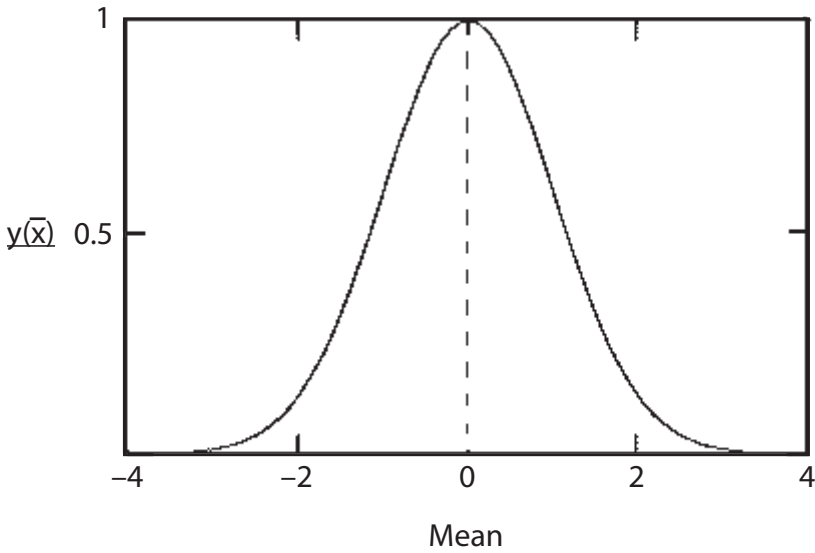


Figure 3–1 Gaussian curve.

## COMPARISON CALIBRATION

One method for correcting the systematic error in an instrument is by calibrating it against a standard. This is known as “comparison” calibration. *Comparison calibration* is where a quantity (i.e., voltage, current, temperature, etc.) is measured both against a standard and by the instrument to be calibrated. Typically, the instrument has means for making internal adjustments that allow it to be aligned with the standard. Note that when an instrument is calibrated by the comparison method, it assumes the accuracy of the standard—within the instrument’s own tolerance. If a meter with a stated accuracy of one percent is calibrated by a .05 percent standard, the meter is now accurate to one percent. The calibrated instrument cannot assume it now has .05 percent accuracy because that was the accuracy of the standard; only that it is now accurate to 1%. In other words, while individual tolerances vary, an instrument is only guaranteed to be accurate within its specifications. This might suggest that the standard used need only be as accurate as the instrument being calibrated. Though that may be true for that particular instrument, standards are expensive. The most accurate for the money should be procured as it may be used for a host of other instruments as well as future instrument requirements. Moreover, some quality standards specify that the calibrating instrument be three to four times more accurate than the device under test. While this ratio was appropriate twenty years ago, today a large number of measurement devices have microprocessors and their own internal standard, so maintaining the four-to-one ratio has become extremely expensive.

## CALIBRATION CURVES

Some plants still use calibration curves derived appropriately from a large set of measurements. However, they are not as commonly used as before since calibration curves are now ascribed into a computer's memory and are therefore transparent to the user. Calibration curves illustrate three components of error: zero, span, and linearity. These three components are common to all measuring instruments whether they are analog, digital, or anything else. Though these components may be reduced (within the instrument specifications) they are never totally eliminated, just removed from significance.

**Zero Error.** Zero error results when the instrument zero is not set at exactly the reference zero. Remember that for many instruments the zero value is the lower-range value of some increment of the measurement scale. An example would be measuring the temperature from 100 to 500° C. The lower-range value is 100° C. This is where the instrument zero would be set. The span will be 400° C (span = upper-range value – lower-range value). If the instrument zero was set at 101° C, and there is no other significant instrument error, then throughout the measured range the instrument will be off by 1° C. Zero-error curves are shown in Figure 3–2.

**Span Error.** Span error results when the instrument does not indicate full scale correctly even if the zero is correct. This is generally considered to be a linear error that increases as the value measured increases from zero. A span error is shown in Figure 3–3.

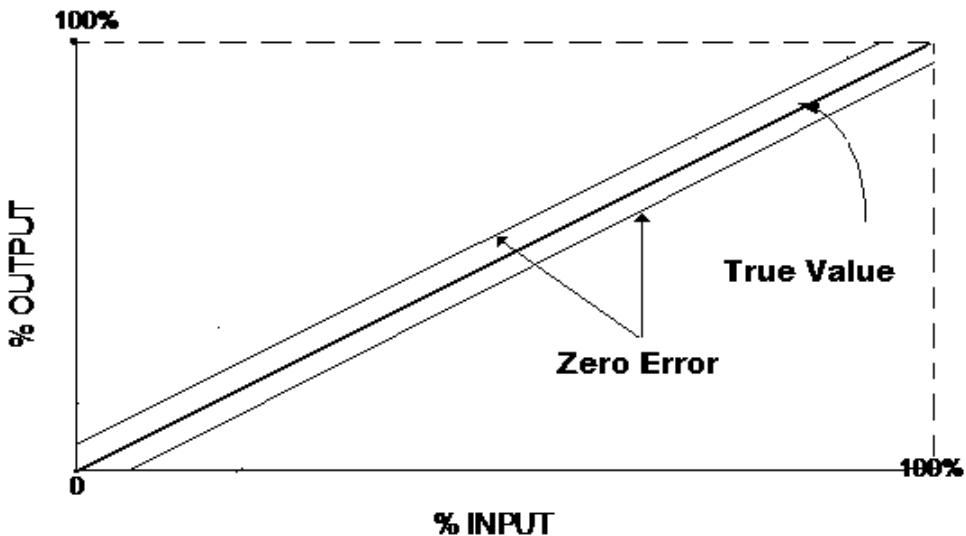


Figure 3–2 Examples of zero errors.

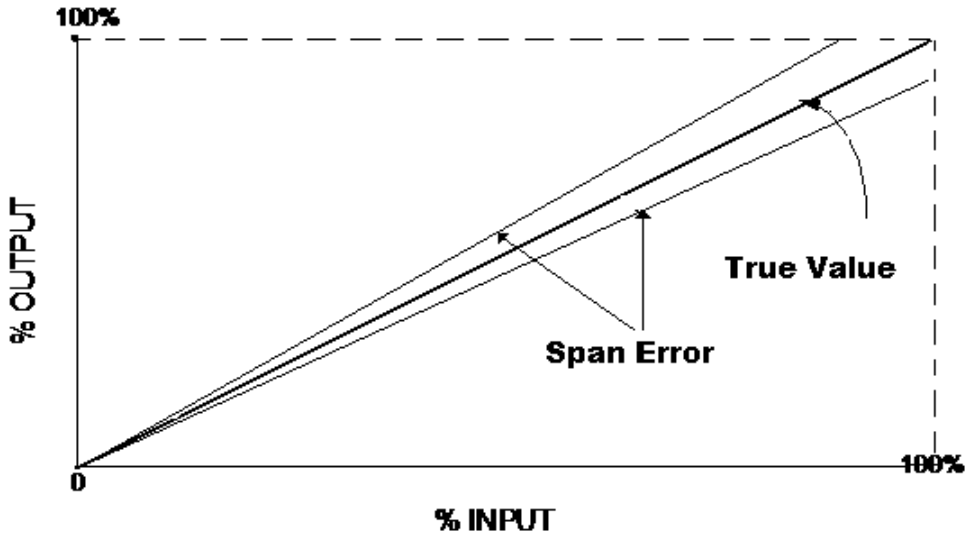


Figure 3-3 Examples of span error.

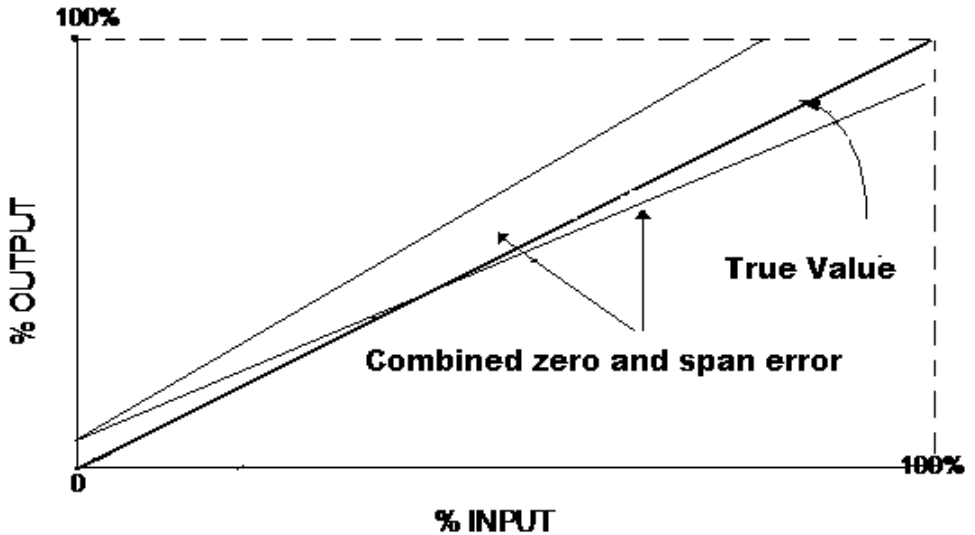


Figure 3-4 Examples of zero and span error.

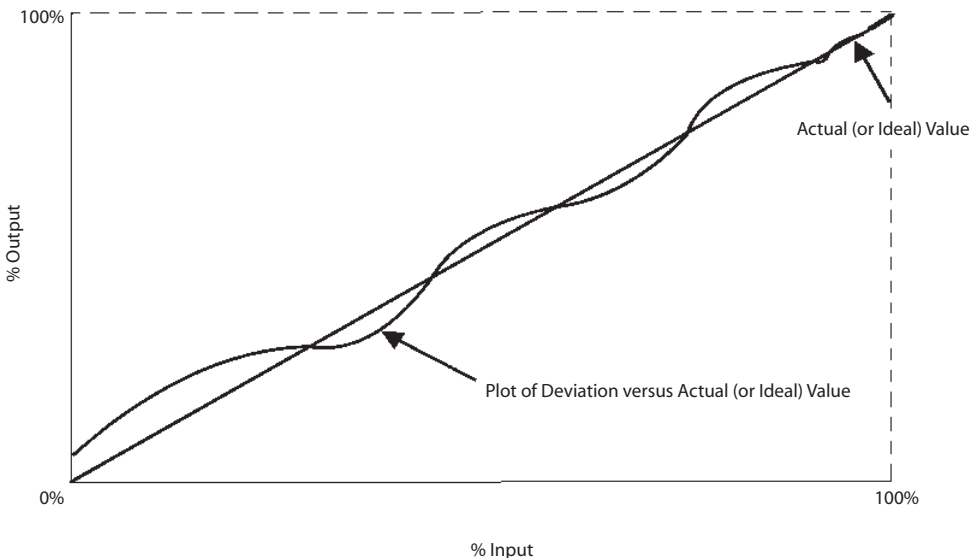
Generally, both types of error will exist in preliminary calibrations. Figure 3-4 illustrates the combination of span and zero error.

**Linearity Error.** In real life, linear errors (those of span and zero) are removed with relative ease. Linearity implies that for a change in measurement value the change in measurement error will be equal. This,

of course, is not true. All instruments have a degree of nonlinear error, and it will cause problems if it is significant for the measurements taken. Nonlinear error is extremely difficult to remove or even compensate for. Most electronic measurement instruments have compensating circuitry to remove nonlinearity. But not so many years ago this was accomplished by using a calibration curve. Several methods can be used to draw calibration curves. Figure 3–5 illustrates the complete span of measurement drawn as actual measurement value versus indicated value. A method that illustrates nonlinear error more visually is where the error is normalized (0 error is the horizontal scale) and the deviation is shown on the vertical axis. Figure 3–6 illustrates a typical calibration curve that is normalized. These curves would not be drawn on one set of measurements, but based on many sets of measurements, and each point would be the mean of all sets of measurements at that point.

Referring to the curve in Figure 3–6, is this all nonlinear error? No, there is a span component involved. Note that at full scale the instrument is about 0.3 percent from the correct reading. And at zero, there is an almost 2 percent zero error. If you have a curve like this it would be best to replace the instrument, unless the errors are within the acceptable range.

Again, the majority of modern instruments perform linearity corrections either through hardware or software, and the typical user of electronic measurement instrumentation outside of a calibration shop will probably never run across linearity problems in his normal procedures as long as the instruments are in working order.



**Figure 3–5** Deviation versus ideal.

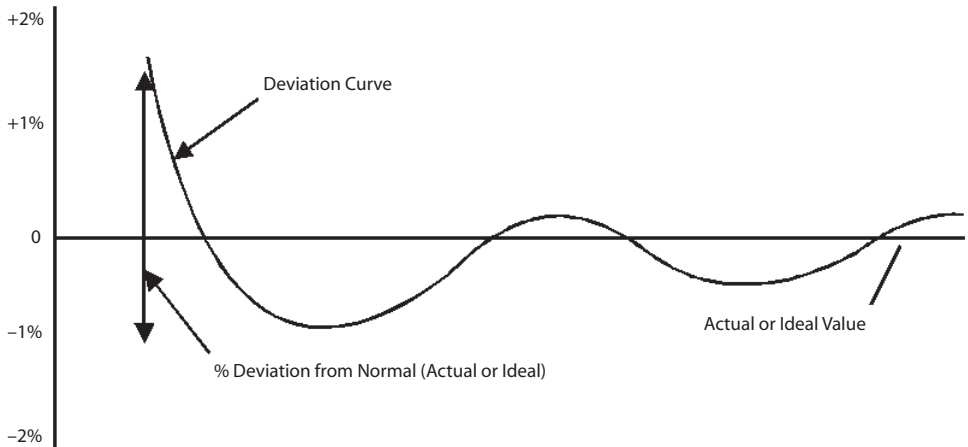


Figure 3-6 Normalized deviation curve.

## MEASUREMENT UNCERTAINTY

*Measurement uncertainty* is a term used to describe how good of a measurement a measurement will be, or, in more technical terms, how reliable the measurement will be. Measurement uncertainty depends heavily on the use of statistical and probability mathematics. In order to gauge measurement uncertainty with any degree of success, more than a single set of measurements is required. A law in statistics states that if you average the means of a number of measurements the *Central Tendency Theorem* will come into play. This theorem is central to all probability. Simply put, it states that the average of the means of a number of measurements will tend to be grouped “normally,” that is to follow the Gaussian curve. As discussed previously, the standard deviation is a measurement of how closely measurements cluster around the median or mean. This clustering is called *dispersion*.

## MEDIAN AND MEAN

We have previously discussed the mean and how to determine the standard deviation. The median, however, is different. Though the mean (the arithmetic average) is considered the best representation of a series of measurements, extreme values may cause the mean to be offset or skewed from where it would be if these “outliers” (extreme values) were not considered. The *median* is determined by taking the limits of the range of measurements and geometrically determining the center. This center value is called the median. In a true normal (random) or Gaussian curve, the mean and the median are equal in value.

## UNCERTAINTY

Intuitively, it makes sense that the greater the number of measurements, the more representative the statistical estimates will be of the actual values and associated error. In actuality, however, this is not necessarily true. Determining the correct number of measurements (or sample size) is a function of the distribution of error and judgment of the person conducting the measurements. It would seem reasonable that if experience has shown that the dispersion is not significant for a particular measurement, then one measurement will do. If, on the other hand, there is a wide span of values around some central value then more observations will have to be made.

Actually, measurement uncertainty tries to separate the systematic and random components of measurement, and in particular for an entire measurement system as opposed to just one component of the system. The random component will be compensated for by statistical methods and the systematic component by calibration. A larger discussion of measurement uncertainty is beyond the scope of this text; however, we have described the methods to reduce uncertainty, statistically treat random error, and eliminate systematic error (or at least determine its limits). Namely, use more than one set of measurements, calibrate, and select the correct measuring devices for an application. Industry is placing an ever-increasing emphasis on product quality today. Documenting systematic error (by listing the test equipment and calibration dates) used for measurement, training personnel in methods for reducing error, and using statistical methodologies on measurements are rapidly becoming the standard practice in industry.

## CHAPTER REVIEW

In this unit we've discussed the treatment of error, the definition of types of error, some of the arithmetic used to better interpret data, and finally the use of a calibration curve. Whether these methods of error treatment are performed manually or by a computerized device, they must be accomplished if the data is to be accurate. Remember, all measurement will have some error; therefore, you must give some thought to methods and equipment to establish measurement certainty and confidence in your measurements.

---

**CHAPTER EXERCISES**

1. For the following measurements, find the mean, deviation, and average deviation.

Measurement #	Value	Mean	Deviation	Average Deviation
1	10.13			
2	9.97			
3	9.99			
4	10.02			
5	10.08			
6	10.16			
7	9.86			
8	9.88			
9	10.12			
10	10.18			

2. Name one method you can use to consistently reduce random error in measurements.

3. Given the following table of values, calculate the standard deviation.

Number	Value	Deviation $\sigma =$
1	10.13	
2	9.97	
3	9.99	
4	10.02	
5	10.08	
6	10.16	
7	9.86	
8	9.88	
9	10.12	
10	10.18	
11	9.94	
12	9.91	
13	9.97	
14	10.15	
15	10.13	
16	9.95	

***Answers to chapter exercises will be found at the back of this book.***

## CONCLUSION

If you are finding it difficult to understand the concepts outlined in this chapter, reread it carefully. If you still have questions, seek out your advisor, supervisor, or a person you know to have a good working knowledge of this subject and discuss your questions. Unanswered questions remain that way unless you seek an answer. This chapter is essential to this text, as all later concepts will be built on these principles.

For further information on the concepts in this chapter, type the following terms in your favorite Internet search engine:

**measurement**

**mean**

**median**

**calibration**

**measurement uncertainty**

**average**

**bell curve**

# BASIC ELECTRICAL MEASUREMENT

---

---

Before beginning a detailed discussion of the various electrical components and their uses, a discussion of the basics of measuring the three major electrical quantities is in order. In Chapter 1 the basic physics of an electric circuit were discussed. This unit will build on those principles and illustrate the how and why of measuring current, voltage, and resistance.

## BASIC SETUP

To measure current, voltage, and resistance you must have:

1. A measuring instrument with the correct range.
2. A mental or physical diagram of the circuit to be measured.
3. A knowledge of the correct procedure for the measurement desired.

## MEASURING INSTRUMENT

It might seem obvious that if you are going to measure voltage you would have a voltmeter, for current, an ammeter, and for resistance, an ohmmeter. However, due to the relationship between the three quantities (as discussed later in this unit), you may measure voltage indirectly by determining the current through a resistance and through similar procedures. Regardless of which measurement you are going to take, the meter must have the expected value within its range of safe operation. The meter leads must be appropriate for the quantity to be measured; for example, when measuring high-potential, the meter leads should meet certain insulation specifications.

## CIRCUIT DIAGRAM

It is always preferable when measuring electrical quantities to have an up-to-date circuit diagram (or schematic) in front of you. This is not always possible. In the real world, one is occasionally called upon to

measure electrical quantities without benefit of documentation. This should *never* be attempted on suspected high potentials as the risk of shock is great, and the lack of a clear line of sight is sure to put you in harm's way. In most typical situations, the potentials will be lower, and a good mental image of the circuit will suffice, assuming that you have developed a good mental image in lieu of documentation. In either case, it is absolutely essential to have a good idea of the procedure you will be using and just where in the circuit you will be using it, before you actually begin.

## CORRECT PROCEDURE

For simple measurements there are very simple rules. The more complex the equipment or the measurement to be made the more considerations and modifications one must make to the basic measurement plan.

## THE RULES

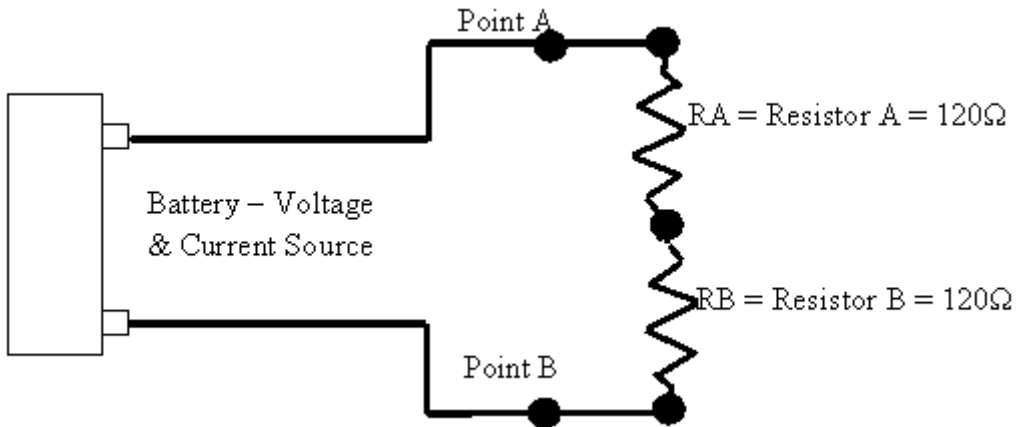
1. Voltage is always measured across the potential.
2. Current is always measured in series (when measured directly).
3. Resistance is always measured with the power off and across the resistance.

Now, those don't sound too hard, do they? Let's look at each one in a little more detail.

## MEASURING VOLTAGE

As mentioned earlier, voltage is the amount of electrical pressure that exists between two points, the amount of charge difference. This means that we must always measure voltage across the source of potential or the resistance that is causing a "drop" in potential. The word *drop* comes about because of Kirchhoff's voltage law for a *series circuit*, that is a circuit in which there is only one path of current flow. Up to this point we have been discussing electrical circuits as if they consisted only of a source, a load, and connecting conductors. Real circuits can always be reduced to nearly this simple circuit. When this is done, it is spoken of as being an "equivalent" circuit.

Many times we are asked to calculate or measure the amount of voltage across each of the resistors in a circuit such as in Figure 4-1. Since the source is an electromotive potential, it is referred to many times as a *rise* in potential. From point A to point B, it should be obvious that the entire potential will be across these points. After all, they are connected directly



**Figure 4-1** Simple series circuit.

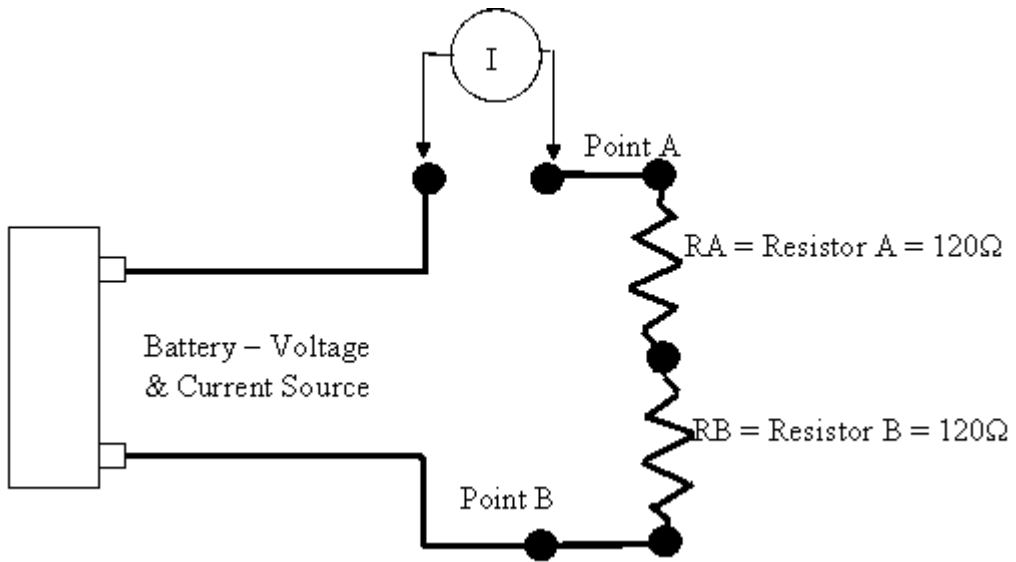
to each pole of the source. It could be said that the “rise” in potential caused by the source is “dropped” by  $R_A$  and  $R_B$ . That is, the entire potential will be found across points A and B. How much does each resistor “drop”? Since  $R_A$  and  $R_B$  have the same value, and since the same current must flow through each, they will each drop the same amount of voltage. The sum of these two voltages must equal the applied potential. Since they must drop equal voltages, and their sum must equal the potential of the source, then each resistor will have a potential across it (that it will drop) of half the applied potential.

You have just encountered a typical case of Kirchhoff’s Law on voltages in a series circuit. Roughly paraphrased it states that *the sum of the voltage drops in a series circuit must equal the applied voltage*. You also witnessed Kirchhoff’s Law of current in a series circuit: *Current is the same throughout a series circuit as no more current may arrive at one point than leaves that point*. While these laws may seem obvious, someone had to formally state them and that someone was Kirchhoff.

The key to measuring voltage then is that it is always done across the potential, so the difference in potential between the two points may be measured. *Voltage is always measured across the potential!*

## MEASURING CURRENT

When you measure current you are trying to measure current flow. Think of how you measure physical flows. Generally, some measurement sensor must be inserted into the flow. The same is true of current. (At least for the direct measurement of current.) To measure electrical current you must physically break one of the conductors and place your measurement



**Figure 4-2** Measuring current.

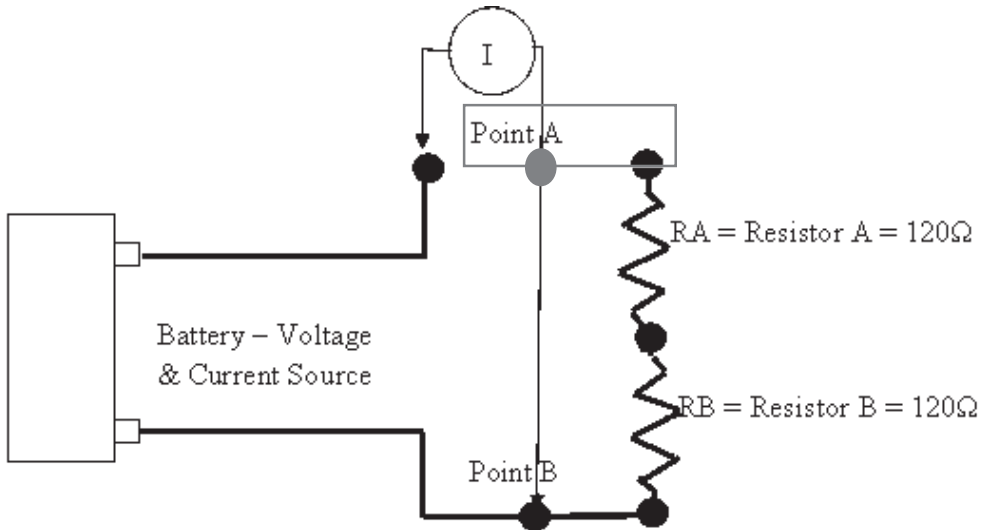
device in series with the flow. That is, the flow must go through your instrument. See Figure 4-2.

This is the measurement that gets many people in trouble. Because when you measure voltage you need a high-input resistance to limit current flow through the instrument, and when you measure current you need very low resistance from the measuring device so it will not impede the current flow. Most meters have different connections for measuring current as opposed to measuring voltage. Remember to place your meter leads in the correct position to measure current flow, which means to open the circuit and place your leads in series with the flow as shown in Figure 4-2. **DO NOT** put the leads across a potential! Placing your leads across a source of potential (see Figure 4-3) means you are trying to measure all the current the source can provide by providing a very low resistance path from the negative to positive terminal of the source.

Recall that holding the potential steady (the source voltage) and lowering the resistance (putting the current meter across the potential) will cause a larger current to flow than would flow with the normal circuit resistance. *This improper operation can be harmful to the instrument as well as to the person trying to measure: it can lead to death, disfigurement, or other bodily harm. Current is always measured in series with the flow!*

## MEASURING RESISTANCE

Measuring resistance is usually accomplished indirectly. In other words, the resistance is measured by allowing a fixed current to flow through the



**Figure 4-3** Wrong way to measure current.

resistance and measuring the voltage drop across the resistor. Why this will work is the subject of the next section of this chapter. For now it is essential to see that if you are going to use this method, then there should be *absolutely no* other sources of potential or paths of current flow to the resistance to be measured. Therefore, resistance is always measured with the *power off* to the affected resistance. In fact, one end of the resistor will generally have to be physically removed from the circuit to properly isolate the resistance so it can be measured. The leads are applied across the resistance to be measured and the result read on the meter indication.

## OHM'S LAW

Georgi Ohm discovered the relationship between voltage, current, and resistance. It is a very simple relationship. If you know any two values, then you can determine the third. What Mr. Ohm said was that if you hold the applied voltage steady, current will vary inversely with the resistance. If the resistance goes up, the current comes down, and if the resistance goes down, the current goes up. While we figured this out intuitively in the first unit, someone had to formalize it and that someone was Ohm.

Now, Ohm's Law can be stated arithmetically for each of the three variables as follows:

$$E = R \times I$$

$$I = E/R$$

$$R = E/I$$

where E = electromotive force in volts

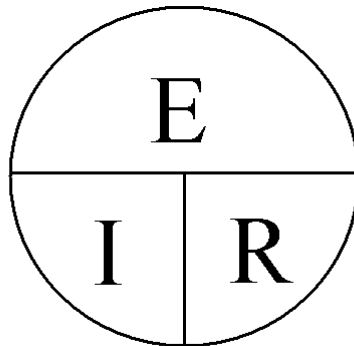
where I = intensity of current in amperes

where R = resistance to current flow in ohms

This is all well and good, but it is difficult sometimes to remember arithmetic ratios. A mnemonic (whose author is anonymous) that has been around for a while is the Ohm's Law pie (see Figure 4-4).

In order to find any one quantity, you cover that quantity over and perform the indicated operation. Notice how this effectively allows you to perform the Ohm's Law relationships. Crutches such as these are invaluable in electronics as there is so much information to be stored, digested, and remembered.

Clearly, we can now begin to understand circuit operation. Note again that this is nothing more than an extension of what we intuitively grasped in the first unit. To solidify the concept, we will perform nine exercises. The first set will be completed so we can observe the methodology and approach.



**Figure 4-4** Ohm's Law pie.

**EXAMPLE**

Determine the applied voltage when given the series current and resistance for the circuit shown in Figure 4–5.

Note the schematic symbols for the battery and load resistance. These are standard symbols and will be used throughout the text along with many others. The two circuits are identical. One is an attempt to visualize, the other an attempt to make drawings much simpler.

1. If the resistance is 100 ohms and the current is .047 amps (47mA), what is the applied voltage?

ANSWER: You know the resistance and the current, using the Ohm pie. Cover up the E, which is the value you want. To obtain this value, multiply I by R.

$$I \times R = E$$

$$047 \times 100 = 4.7 \text{ volts}$$

2. The resistance is 2200 ohms and the current is 150mA (.15 amps). What is E?
3. The current is 2.4 amps and the resistance 68 ohms. What is E?
4. The applied voltage is 85 volts; the resistance is 47 ohms. What is the current?

$$I = E/R, \text{ so}$$

$$I = 85/47$$

or

$$I = 1.81 \text{ amps}$$

5. Applied voltage = 120 volts, circuit resistance = 2200 ohms. What is I?
6. Applied Voltage = 12.6 volts  
Resistance = 820 ohms  
I =

**EXAMPLE (CONTINUED)**

For the same circuit, given the voltage and the current, what is the resistance for each of the following problems:

7. Voltage = 120V

Amps = .57

Ohms = 210 ohms

8. Voltage = 12.6V

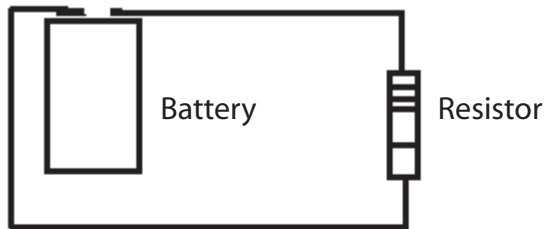
Amps = .001

Ohms =

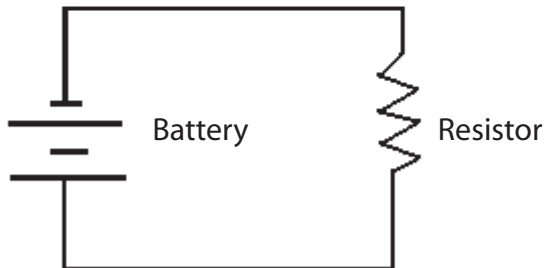
9. Voltage = 24V

Amps = .012 (*12mA or 12/1000A, pronounced milliamp*)

Ohms =



Pictorial



Schematic

**Figure 4-5** Series circuit.

If you had no problems with these nine problems (pun intended), then you are ready to move on to the next part of this section. If you did have problems and cannot resolve them by remembering that it is voltage that pushes current through the resistance, then you need to reread the first section and this section of the chapter. If you are still confused or are having conceptual problems, contact a knowledgeable person and obtain assistance. These are very important fundamental principles, and you must have a clear vision of them. That is, if you understand that it is voltage that pushes current through a resistance, see how that is defined by Ohm's Law, and can work the previous problems, then you are on your way. Do not let the prefixes block your understanding. We will give the basic unit as well as the prefix until you have been exposed to the use of these prefixes a substantial number of times.

## RESISTORS

As stated earlier, a resistance opposes the flow of current. Therefore, a resistor is the device that opposes the flow of current. Its unit of measurement is the Ohm, which is derived by the resistance required for 1 volt to push 1 ampere through the circuit. As a point of reference, 40/1000 of an amp (40mA) is generally considered to be fatal if it passes through the heart. Your body's safety depends on the resistance of your skin—don't leave home without it.

## RESISTOR TYPES

We have discussed voltage (the source or push) and current (the energy). It is now time to turn our attention to the resistance in a complete circuit. All circuits (other than superconducting varieties) have resistance—either a little amount or a large amount but all circuits have it. In many cases, the resistance is there by design, in which case we normally use a *resistor*. A resistor is a conductor with a specified resistance. It performs its task, that of dropping a particular amount of voltage, by turning the energy of the current into heat. There are a number of types of resistors for each application, and they come in a variety of sizes, shapes, and materials. We discuss how to determine a resistor's resistance just ahead in this chapter, but it should be noted that the amount of resistance has nothing to do with the physical size of the resistor. Because resistors function by turning electrical energy into heat they will vary in size according to the amount of power they must dissipate. Resistors are rated in terms of the amount of heat they may dissipate before they fry themselves out of existence. The larger the size, the more heat the resistor can dissipate.

Generally, physically small resistors are used in electronic circuitry. In fact, in modern electronic circuitry, most resistors are of the surface-mount variety and are extremely small, so much so as to be invisible without a magnifier.

When a larger amount of power dissipation is required a *power resistor* is used. These are generally wire-wound and may be extremely large. Resistors may also be made adjustable, that is, their resistance can be varied. Whenever you adjust the volume control on a car radio you are turning a variable resistor. If the resistor is meant to reduce current it is called a *rheostat* and has only two connections. If it is to be used as a variable voltage divider—a device that ratios two resistances across a source to obtain some voltage between minimum and maximum—it will have three connections and is called a *potentiometer*. Generally, rheostats are power devices and are rather large. On the other hand, potentiometers can be almost any size depending upon the application. Figure 4–6 illustrates some rheostats and potentiometers.

## RESISTOR VALUES

Even in the very early days of electronics and resistor manufacture, it was apparent that some method was needed to mark their value. Resistors could vary from a few hundreds (at that time) to several million ohms, and it would be extremely inconvenient to have to measure a resistor every time one had to be selected. Although resistors were quite large in those days, the technology for marking them with the actual resistance wasn't available. A color code was devised to mark the resistors; each color would stand for a decimal digit (0–9). A system was devised at that time (body-end-dot), however, it was superseded by the present system after World War II. Originally, this new system used three bands of color. Others have been added as the tolerances became tighter, but the basic system remains until this day. Figure 4–7 represents a typical resistor with color-coded value.

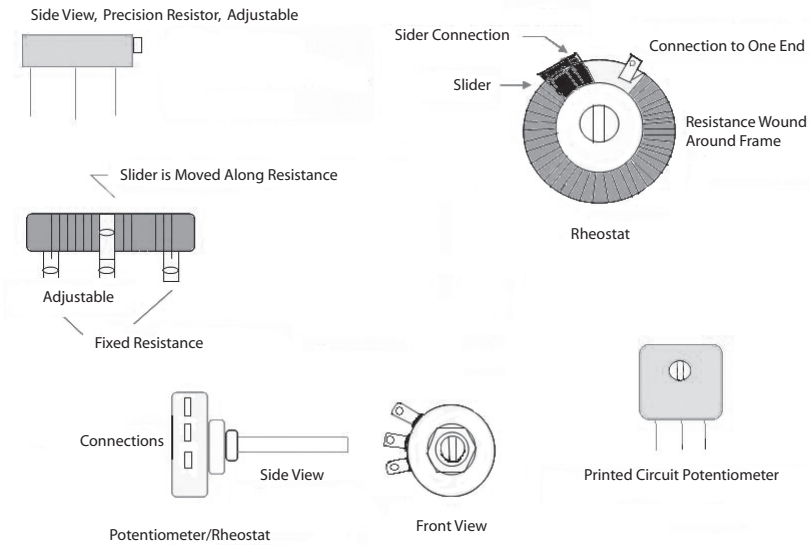
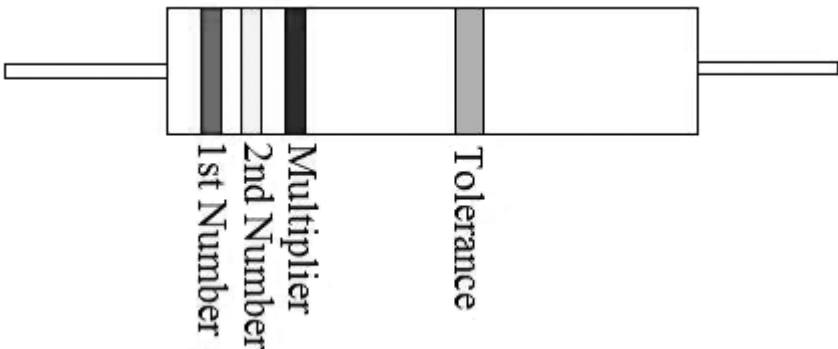
The colors were assigned by the spectrum and are known as the Resistor Color Code (see Table 4–1).

There are any number of mnemonics to help you remember this order. You can devise your own, but ensure they are not offensive to others if you wish to share your mnemonic. Any will do as long as the colors are kept in order.

The first two bands are read as just significant numbers. The third band, the multiplier, is the number of zeros that follow the numbers' bands. Here are two examples to illustrate the procedure.

**Table 4-1** Resistor Color Code

Number	Color	Number	Color
0	Black	5	Green
1	Brown	6	Blue
2	Red	7	Violet
3	Orange	8	Gray
4	Yellow	9	White

**Figure 4-6** Representations of various resistors.**Figure 4-7** Typical resistor with color-coded value.

## EXAMPLE

The resistor is marked: Red-Yellow-Brown-Silver

First Number (Red) = 2

Second Number (Yellow) = 4

Number of Zeros (Brown) = 0

Therefore, the resistor is nominally a 240-ohm resistor whose tolerance (Silver) is 10%. This means that this resistor can measure anywhere from 216 to 264 ohms and still be in specification.

## EXAMPLE

A resistor is marked: Blue-Green-Yellow-Silver

First Number (Blue) = 6

Second Number (Green) = 5

Number of Zeros (Yellow) = 0000

Therefore, this resistor is nominally 650,000 ohms. Since prefixes are used, so there won't be more than three significant figures, this would be properly known as a 650-kilohm resistor. The tolerance is 10% (Silver). What is the value this resistor may have?

Hint: 10% of 650,000 = 65,000. Therefore, the resistor will measure anywhere from 650 kilohms + 65,000 ohms to 650 kilohms – 65,000 ohms or 585,000 (585 kilohms) to 715,000 (750 kilohms) and still be in tolerance.

If the multiplier (number of zeros) band is Green or above, then the resistor will be in the millions of ohms. An example of this would be Brown-Green-Green or 1,500,000 ohms, or more properly 1.5 megohms (megohms are used for those large numbers).

## TOLERANCE

The resistance marked on a resistor is its *nominal* resistance, that is, its desired value. The resistance may vary from this value. The amount by which it is allowed to vary is called the *tolerance* and is expressed in percent. A 100-ohm resistor with 10% tolerance may have any value between 90 and 110 ohms and still be within specification. Because different applications call for differing amounts of tolerances, resistors

come in a number of tolerances. The closer the tolerance, the more you pay for the resistor. As an example, let's choose a 1000-ohm resistor and look at the differing values as we select ones with tighter tolerances. See Table 4-2.

**Table 4-2** Standard Color Code

Marked Value ohms	Tolerance %	Range of Actual Value	
		Low	High
1000	20	800	1200
1000	10	900	1100
1000	5	950	1050
1000	2	980	1020
1000	1	990	1010

In the three-band marking system there is no tolerance band, and the tolerance is assumed to be  $\pm 20\%$ . However, this tolerance is not likely to be found in any commercial or industrial equipment. In the four-band system of marking resistors, the fourth band is the tolerance band. It is supposed to be twice as wide as the value bands and offset from them, although looking at some of the smaller resistors this is hard to discern. Silver represents 10%, Gold represents 5%, Red is 2%, and Brown is 1%. It should be stated here that no four-band resistors are available with a 1% or 2% tolerance (why will be clear in a moment).

This was all there was to it until transistors came along about 1959. The bipolar devices developed during this period were current-activated rather than voltage-activated like the vacuum tube. Current-activated circuits generally use lower resistance than the voltage-activated vacuum tube circuits. The problem arises with the color code. The lowest possible resistance that can be marked is Brown-Black-Black, or 1-0- (and no zeros), a 10 ohm resistor. Unfortunately, smaller values were required. So the color code was modified. The tolerance colors Gold and Silver were to be used in the number-of-zeros band. A Silver band means you move the decimal point one place to the left (divide by 10); Gold means you move the decimal point two places to the left.

**EXAMPLE**

Green-Blue-Silver-Gold.

First Number (Green) = 5

Second Number (Blue) = 6

Number of Zeros (Silver) = 1/10

Therefore, this is a 5.6-ohm resistor with a 5% tolerance.

**EXAMPLE**

Brown-Black-Gold-Gold

First Number (Brown) = 1

Second Number (Black) = 0

Number of Zeros (Gold) = 1/100

Therefore, this is a 0.1-ohm resistor with a 5% tolerance.

**EXERCISES—COLOR CODE**

Table 4-3 is a learning exercise—*not* a quiz. If you are experiencing problems:

1. Write the color code out on a piece of paper so you can readily refer to it.
2. Do the ones you find easiest first. The answers are given at the end of this section.
3. You may find it easiest to write the color code value above the color and the number of zeros above its color. (*Remember: Black in the number-of-zeros column means no zeros; Brown is for 1 zero.*)
4. After you determine the value, convert it to the appropriate prefix (meg-, kilo-).
5. If you are still having problems, locate a knowledgeable person who understands the color code and see if they can help you.

**STANDARD VALUES**

Resistors' values are not selected as random numbers. The number of available resistors depends upon the tolerance selected. Standard values

**Table 4-3** Color Code Exercises

Problem	Band 1	Band 2	Band 3	Band 4	Value
1	Brown	Green	Red	Gold	
2	Brown	Red	Black	Gold	
3	Red	Red	Yellow	Silver	
4	White	Brown	Brown	Silver	
5	Orange	White	Gold	Gold	
6	Violet	Green	Green	Silver	
7	Yellow	Violet	Brown	Gold	
8	Blue	Gray	Silver	Gold	
9	Orange	Orange	Blue	Silver	
10	Brown	Brown	Orange	Silver	
11	Brown	Black	Gold	Gold	
12	Green	Blue	Red	Silver	
13	Orange	Blue	Black	Gold	
14	Brown	Orange	Yellow	Silver	
15	Red	Black	Black	Gold	

are those values that are generally available and chosen so the range of values have minimal overlap depending upon the required tolerance or the resistor. Figure 4-8 shows the standard values available with ten percent tolerance resistors.

10	12	15	18
22	27	33	39
47	56	68	82

**Figure 4-8** 10% standard values.

You use the chart in Figure 4–8 by placing however many zeros you wish after the standard value. That is, you may expect to find as standard values 18, 180, 1800, 18K, 180K, 1.8Meg, and 18 megohms. This reason for this is simple. Let's use the 180-ohm resistor as an example. The ten percent tolerance says that you may expect to find its resistance between 162 to 198 ohms. The 150-ohm resistor has a high tolerance of 165 ohms, and the 220-ohm resistor has a low tolerance of 198 ohms. Therefore, with a ten percent tolerance, these are the only values you can use. There would be no sense in having a 200-ohm resistor because its tolerance would allow it to wander over the 180-ohm or the 220-ohm resistors' range.

Obviously, if we cut the tolerance in half (5%) we should double the number of standard values. Figure 4–9 is the list of standard values for five percent resistors.

If you could reduce the tolerance to one percent or two percent there would be a larger number of standard values. The need for precision resistors in modern electronics is no mystery. Manufacturing, control, communications—all require much tighter tolerances in many areas of circuitry, as these circuits must be repeatable (more precise). Figure 4–10 shows the standard values for one percent and two percent resistors.

10	11	12	13	15
16	18	20	22	24
27	30	33	36	39
43	47	51	56	62
68	75	82	91	

**Figure 4–9** Standard values for 5% resistors.

## FIVE-BAND RESISTORS

The impact of one percent and two percent resistors is to require a new way of marking resistors. This is because the old four-band method with its two numbers for values and one for the number of zeros will not allow us to identify the precision types. Therefore, another band for numbers was added. Figure 4–11 illustrates a five-band resistor.

Although the five-band resistor is a modification of the standard color code for resistors, no more modification of this system is likely to occur. Because of modern manufacturing techniques, such as surface mounting, the extremely small components cannot be read by the unaided eye.

100	102	105	107	110	113	115	118	121	124
127	130	133	137	140	143	147	150	154	158
162	165	169	174	178	182	187	191	196	200
205	210	215	221	226	232	237	243	249	255
261	267	274	280	287	294	301	309	316	324
332	340	348	357	365	374	383	392	402	412
422	432	442	453	464	475	487	499	511	523
536	549	562	576	590	604	619	634	649	665
681	698	715	732	750	768	787	806	825	845
866	887	909	931	953	976				

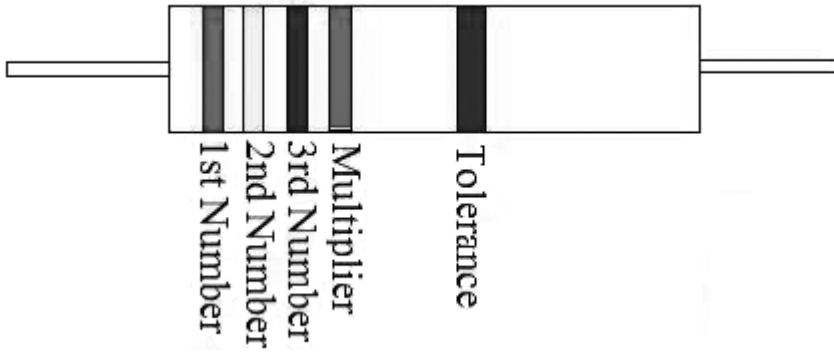
**Figure 4–10** Standard values for 1% and 2% resistors.

## NON-COLOR CODE MARKING

Some devices (particularly military resistors and many variable resistors) are marked with the numbers rather than with color bands. They are always marked with two numbers and a value for the number of zeros; tolerance will be marked elsewhere. For example, suppose you have a variable resistor marked 123. This is a 12-kilohm resistor. The first two numbers are the values, and the third number is the number of zeros. In other words, this is just like the color code but without the colors.

## CHAPTER REVIEW

This chapter discussed the measurement of the three main values, voltage, current, and resistance, as were resistors, type, and value determination. Marking science has advanced so even the smallest devices can be marked with the actual value, rendering the color code less useful. However, electric and electronic items are still built with color-coded resistors, and so technical people need to be able to use the resistor color code.



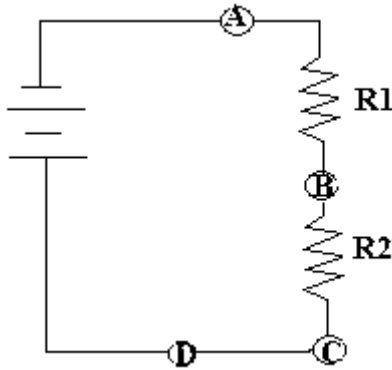
**Figure 4-11** Five-band resistor marking.

### *ANSWERS TO COLOR CODE EXERCISE*

1	1,500	1.5K	5%
2	12		5%
3	220,000	220K	10%
4	910		10%
5	0.39		5%
6	7,500,000	7.5Meg	10%
7	470		5%
8	6.8		5%
9	33,000,000	33Meg	10%
10	11000	11K	10%
11	0.10		5%
12	5,600	5.6K	10%
13	36		5%
14	130,000	130K	10%
15	20		5%

## CHAPTER EXERCISES

- Write the color code for a 1%, 124-ohm resistor.



**Figure 4-12** Circuit for exercise 3 and 4.

- What is the closest standard resistor to 8000 ohms?
- Consider the circuit shown in the above Figure 4-12. Identify the points you should use to measure the voltage of
  - R1? \_\_\_\_\_
  - R2? \_\_\_\_\_
  - the applied voltage? \_\_\_\_\_
- Referring to the Figure 4-12, if you were to measure current where would you insert your meter?
- If you have a 12.0-volt source and two 1200 resistors in series, what will be the:
  - total current flow? \_\_\_\_\_
  - total resistance? \_\_\_\_\_
- If you measure 10mA (10/1000 amp or .01 amp) and it passes through an 1800-ohm resistor, what is the voltage across the resistor? \_\_\_\_\_
- If you have a 100-volt source, and the total current measured is 2 amps, what is the total resistance? \_\_\_\_\_
- If I wish to see a 5-volt drop across a resistor for 20mA current flow, what standard value must that resistor have? \_\_\_\_\_
- For safe measurement, voltage is always measured \_\_\_\_\_ .

10. For safe measurement, current is measured \_\_\_\_\_. However, a safer way would be to measure voltage across a \_\_\_\_\_ and use Ohm's Law to determine current.
11. The primary safety consideration for measuring resistance is ensuring that the power to the component under test is \_\_\_\_\_.

***Answers to these review questions will be found at the back of this book.***

## **CONCLUSION**

If you are having difficulty in understanding the concepts outlined in this chapter, reread it carefully. If you still have questions, seek out your advisor, supervisor, or a person you know to have a good working knowledge of this subject and discuss your questions. This chapter is essential to the remaining chapters in this text, because later concepts will be built on these principles.

For further information on the topics in this chapter, use your Internet search engine to search on the following terms:

**resistor**

**voltage measurement**

**resistance measurement**

**color code**

**current measurement**

**electrical meter safety**

# METER MOVEMENTS

---

---

This chapter is concerned with the actual meter movement itself and meter displays. Meter terminology, meter accuracy, zero, full scale, the input, and internal resistance are discussed. Digital meter displays are explored (however, the mechanics of converting analog to digital values—and back—are covered in Chapter 18). We also discuss precautions when using meters. This information is essential to accurately using a meter for measurement and to understanding what level of confidence may be attached to the values resulting from the measurement.

## METER USE PRECAUTIONS

As in all procedures where measurements are to be taken from an operating process or equipment, a number of precautions must be taken to avoid injuring oneself, one's co-workers, and the equipment.

1. *Always* follow facility procedures for taking measurements on active equipment. (Ensure the circuit is deactivated, follow the LOCK-TAG-TRY [or similar] procedures as outlined by your facility. If the measurements are to be made in an intrinsically safe area, follow safety guidelines before and during the actual measurement).
2. *Always* use protective equipment as required and use it as procedure directs.
3. *Know* what measurement you are trying to take. Current is measured in *series*; voltage is measured *across*. Resistance is *never* measured with the power on.
4. *Have* equipment with the right *range*. Attempting to measure a quantity that is outside the meter's range can destroy the meter and quite possibly injure the user. Check it twice.
5. *Always* start on the highest range if the meter is *not* of the auto-ranging variety.

6. *Never* come into contact with the circuit, bare parts of the meter leads, or otherwise allow your body to become a conductor, regardless of the voltage you think may or may not be present.
7. *Ensure* that (in direct current measurements) the leads have the correct polarity. (Though this is not a requirement for most digital multimeters, an analog meter may be damaged if the wrong polarity is applied.)
8. *Never* peg (i.e., go past full scale) an analog meter, nor keep a digital meter in its overscale position.

***If it seems that undue emphasis is being placed on safety, it is your life (and those of your co-workers), so while it may sound trite please put safety first.***

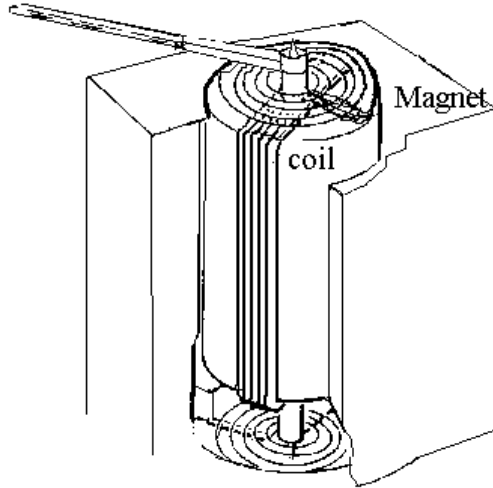
## **ANALOG METERS**

Though digital meters have become the norm in the technological arena, a review of some of the analog meter technology will be beneficial, in that the digital meter was developed to overcome the analog's shortcomings.

There are many analog meter constructions. For DC measurement there are three basic types of meter movements and many modifications of these basic movement types. The basic types are:

1. d'Arsonval.
2. Core magnet.
3. Taught band.

All of these movements are similar and differ primarily in the shape and placement of the permanent magnet and in the method of springing the movement. Since most were rendered obsolete by the digital revolution, only the most common types will be presented here. Basically, the movement is constructed to present a magnetic field to a coil (bobbin). The coil is energized by the measurement current, which creates a magnetic field. The permanent magnet's field and the coil's field interact, producing a torque. Since the bobbin is free to move, it will rotate in relation to the measurement current's strength and polarity. The coil is mounted with springs that produce a torque, which holds the coil and its attached pointer at the zero measurement point on the scale. The springs will return the pointer to zero when the measurement current is removed.



**Figure 5–1** d'Arsonval meter movement.

## D'ARSONVAL MOVEMENT

Figure 5–1 illustrates the basic structure of the d'Arsonval meter movement. The moving coil is pivoted at both ends, usually in jeweled bearings, and wound around a metallic core.

The entire bobbin assembly is precision mounted and statically balanced. Balance is provided by pointer counterbalances, which also provide a degree of damping to the pointer movement due to their inertia. The springs (known as *control springs*) carry the current to the coil bobbin and determine the meter movement's linearity. The control springs oppose the torque developed by the current through the coil bobbin and are calibrated for the required deflection current.

Most movements provide for a mechanical zero, which can usually be adjusted from the front of the meter case with a screwdriver. This adjustment is used to align the meter point with zero before current is applied to the meter. *Caution should be exercised when using this adjustment as unrestricted rotation of the external adjustment may damage the movement.*

## FULL-SCALE DEFLECTION CURRENT (FSD)

The amount of current needed to cause the complete rotation permitted (usually  $180^\circ$  to  $270^\circ$ ) by the movement is called *full-scale deflection current*. Meter movements come in a variety of full-scale deflection currents (fsd), ranging from as little as 1.0 microampere ( $1/1,000,000$  Amp) to values in the amperes.

It should be noted here that the basic meter movement is that of an ammeter, which is a current measuring device. While this ammeter-like device is adapted to measure voltage or resistance with the help of additional components, remember that to make a measurement you will have to let a certain amount of current flow through the meter circuit.

## METER MOVEMENT REVIEW

1. *d'Arsonval meter movements are current-activated devices.*
2. *The linearity of the meter depends upon the control springs.*
3. *Full-scale deflection (fsd) current is the current required to rotate the meter pointer to the upper-scale high limit.*

## METER ACCURACY

Analog meters are specified with a guaranteed accuracy at full-scale deflection. This will be the best accuracy obtainable as accuracy decreases for any other portion of the scale.

### EXAMPLE

A d'Arsonval meter movement has a 10V DC scale. It has a guaranteed accuracy of plus or minus two percent. If the meter reads exactly 10.0 volts, then the actual voltage measured can be anywhere from 9.8 to 10.2 volts. Use the formula for accuracy:

$$\frac{\text{True Voltage} - \text{Measured Voltage}}{\text{True Voltage}} \times 100 = \% \text{ accuracy}$$

The formula for accuracy can be converted to give the range of error at full-scale deflection:

$$\frac{\pm \% \text{ accuracy}}{100} \times \text{fsd voltage} = \pm \text{range true value}$$

For the preceding example:

$$\frac{0.2\text{vDC}}{100} = \pm 2\%$$

**Table 5–1** Tabulation of + Meter's Accuracy

Scale Voltage	± % Accuracy
10	2.0
9	2.2
8	2.5
7	2.8
6	3.3
5	4.0
4	5.0
3	6.6
2	10.0
1	20.0

So the range of +0.2 volts is established at full scale. This range of uncertainty remains the same for any measurement taken on this scale.

Using the meter in the preceding example and assuming that the 10V DC scale on the meter indicates exactly 5.0 volts, in what range will the true voltage be found, and what is the accuracy of reading at this point?

The range of uncertainty is the same for 5.0 volts as it is for 10.0 volts, that is, +0.2 volts. So the real voltage will be between 4.8 and 5.2 volts.

$$\frac{\pm 0.2V}{5.0 \text{ volts}} \times 100 = \pm 4\%$$

Table 5–1 tabulates the percentage of accuracy for the meter in the example for various measurements.

This example should emphasize the *importance* of taking meter readings as close to *full-scale* as possible when measuring voltage or current with an analog meter. An old rule of thumb had it that you should always take the readings in the upper third of the scale.

## OHM'S SCALE

When using analog meters, there is one exception to the rule of taking the readings in the upper third (that is, when resistance is being measured). The Ohm's scale on analog meters is a logarithmic, not linear scale. Because of the crowding of the scale at the upper end, readings there are

generally just guesses. At the lower end, the readings are quite spread out, but since this is still an analog current meter the lowest end is where the meter movement is least accurate. Readings are best taken at mid-scale. Actually, because of the proliferation of digital meters, their superior method of measuring small currents, and the clarity of their presentation, the use of analog meters for measuring resistance is best reserved for continuity checks and approximations.

## **ANALOG METER CHARACTERISTICS**

By using Ohm's Law it becomes quite apparent that an analog meter movement has a resistance. It has a *full-scale deflection (fsd) current*, and that will require some value of full-scale deflection voltage to force the fsd current through the coil windings. Since meters are generally sold on fsd current and accuracy as their specifications, to replace a meter you must know the meter's internal resistance.

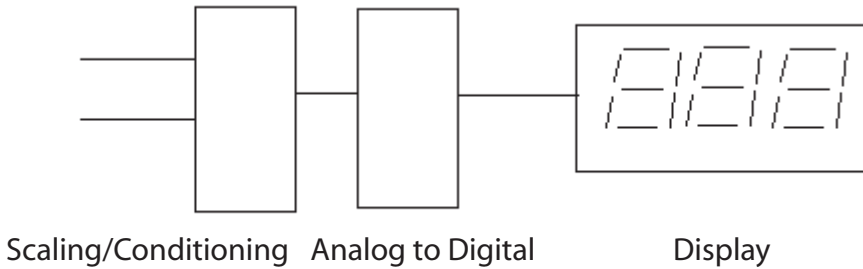
### **REVIEW**

1. *One of the important characteristics of an analog meter is its full-scale deflection (fsd) current.*
2. *Another important consideration is the internal meter resistance.*

## **DIGITAL METERS**

With the advent of large-scale integration of semiconductor circuits, many functions could be encapsulated in one small piece of silicon. Test equipment has advanced as far as other electronics applications. Only about forty years ago, digital meters were large, expensive, bulky devices that were hard to use, calibrate, read, and understand. Yet today one has only to look around to see that digital technology has rendered the analog meter obsolete.

Figure 5–2 illustrates the block diagram of a digital meter. The actual analog-to-digital conversion is discussed in Chapter 18 of this text. However, it is instructive to note that the display (in digits) removes the possibility of parallax. The meter has an input resistance of above 10 megohms, so it's not necessary to determine the internal meter resistance. The meter movement has been replaced with a display. Though this display (whether LCD, LED, or electroluminescent) is not designed to withstand a large, sustained shock, neither is it as fragile as the analog meter movement. The main decision when purchasing a digital meter is

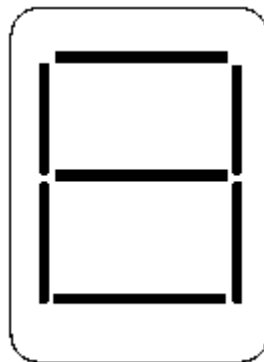


**Figure 5–2** Simplified block diagram of a digital meter.

whether its display will have  $3\frac{1}{2}$ ,  $4\frac{1}{2}$ , or a larger number of digits and what its input power requirements are.

## LED DISPLAY

Light-emitting diodes (LED) come in various colors, but for meter displays they are normally encountered in red or red-orange. LEDs do require substantial current to be activated, on the order of 10 to 20 milliamps. The display will usually be packaged with its driver electronics, although much older meters may have separate driver chips for converting the MOS voltages used in the LSI chip to the currents needed to drive the LED. Typically, the LED has a matrix, as shown in Figure 5–3. One of the disadvantages of an LED display is its tendency to wash out under bright ambient light, making the display very hard to read. However, LED displays are very easy to discern at low light levels and require no backlighting.



**Figure 5–3** LED matrix.

## LCD DISPLAYS

The liquid crystal display obtains its image by cross-polarizing the liquid crystal elements that comprise it. An AC voltage is applied to both the background and the LCD's element. When an element is to present an image, an out-of-phase voltage of the same frequency is applied only to the element. As a result, the element will reflect light. The LCD produces no light of its own, but works by reflected light. This means that under conditions of high ambient light, it is very easy to read. Under low light conditions, backlighting must be supplied so users can read the display. LCD displays are nearly as rugged as LED types, but in colder temperatures they may not be able to obtain enough twist to form an image.

## EL DISPLAYS

Electroluminescent displays (EL) use a gas discharge (much like neon) in the image element to provide a bright display, even in the presence of high ambient light. These are the forerunners of plasma televisions. The major drawback of EL displays is that they require rather high voltages to ionize the gases. Once a fairly significant problem, this has been resolved by using switching power supplies (DC to DC) integrated into the display matrix chip. EL displays need comparatively more power than either the LED or LCD types, but they do not require backlighting in low light, nor will they wash out in bright light.

## REVIEW

1. *Digital meters eliminate parallax.*
2. *Digital meters have a high input resistance as they are voltage-activated rather than current-activated (as is the analog meter movement).*
3. *LED displays require significant power, are good in low light, and tend to wash out in bright light.*
4. *LCD displays require little power for the display, but may consume significant power for backlighting in low light situations. In contrast, in high-light situations the LCD will offer an excellent image that requires little power.*
5. *EL displays require more input power than either the LED or LCD types, but do not require backlighting and are resistant to washing out in bright light.*

## CHAPTER EXERCISES

1. List the eight precautions that must be taken when making measurements.
  - a.
  - b.
  - c.
  - d.
  - e.
  - f.
  - g.
  - h.
2. Match the digital meter display with its significant characteristic (some characteristics may have more than one meter type):
 

a. LCD	_____	requires backlighting in dim light conditions
	_____	washes out in high-light conditions
b. LED	_____	has good contrast under high-light conditions
	_____	maintains good image in low-light conditions
c. EL	_____	requires the most power of all types listed
	_____	requires the least power of all types listed

***Answers to these exercises will be found at the back of this book.***

## CONCLUSION

If you are having trouble understanding the concepts outlined in this chapter, reread it carefully. If you still have questions, seek out your advisor, supervisor, or a person you know to have a good working knowledge of this subject and discuss your questions.

For further information on the topics in this chapter, use your Internet search engine to search the following terms:

**d'Arsonval meter**  
**full-scale deflection current**  
**LED display**  
**EL display**

**meter internal resistance**  
**digital meter displays**  
**LCD display**

# DC VOLTAGE MEASUREMENT

---

---

This chapter discusses the measurement of DC voltages and DC voltmeters as well as voltmeter calibration and some protective circuitry for voltmeters. As with the following chapter on current meters, it is vitally important that you have a good, thorough understanding of voltmeters—their properties and constraints—since measuring any electrical property normally requires a voltage reading.

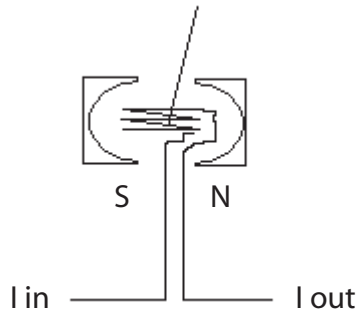
## THE DC VOLTMETER

Though digital meters are commonly used across industry, you may still find their predecessor, the analog voltmeter, in use. We dwell almost entirely on an analog voltmeter in this first section for several reasons. First, the disadvantages of analog voltmeters are precisely why digital meters excel—they overcame these intrinsic disadvantages. Second, because analog meters are relatively scarce, you may actually have to adapt an analog meter for your use using one of the methods we describe here, particularly when replacing old but still functional equipment. And finally, this section continues the application of Ohm's Law from the last chapter as well as providing some basic calibration principles.

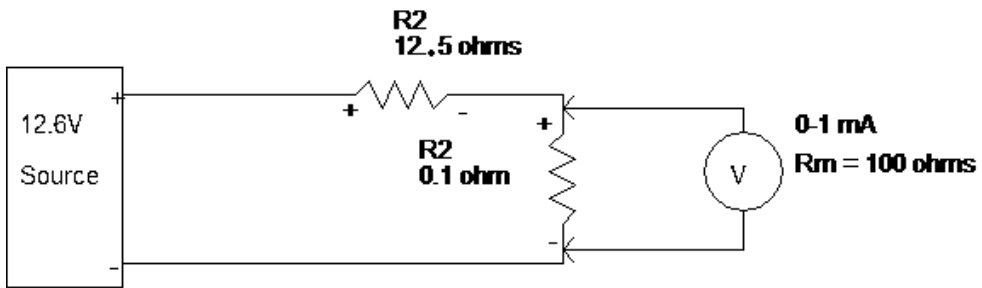
The most common form of analog voltmeter, which is basically a d'Arsonval meter movement (explained in more detail in Chapter 5), is a current-activated meter. That is, by passing a current through the meter coil, which is located in a magnetic field, a proportional to the current deflection of a pointer attached to the meter coil is obtained (see Figure 6–1).

The most important characteristics of this type of movement are the full-scale deflection current (fsd) and the resistance of the meter coil. Full-scale deflection is the amount of current required for the meter to read 100%.

Figure 6–1 shows the basic meter movement. Figure 6–2 illustrates a d'Arsonval meter movement used as a voltmeter.



**Figure 6-1** Simplified diagram of a d'Arsonval meter movement.



**Figure 6-2** A DC voltmeter.

The full-scale deflection voltage that can be measured by this meter is 0.10V. This was obtained by using Ohm's Law and by multiplying the  $I_m$  by the  $R_m$ . It is essential that you remember the following two items:

1. Voltage is *always* measured *across* a source (in parallel, *never* in series).
2. For the voltmeter to read full scale, 1.0mA of current must go through the meter. This current is drawn from the voltage source (see Figure 6-3).

Also note, from Chapter 1, that all of the voltage is dropped across the circuit (two resistors). Note too the polarity; it is relative. The nearest end toward the positive terminal is most positive, and the end nearest to the negative terminal is most negative for that component. The total resistance is 12.6 ohms. So 12.6 volts can push 1 amp through 12.6 ohms. This means the 12.5 ohm resistor will drop 12.5 volts and the .1 ohm resistor will drop .1 volt. The 1mA current flowing through the meter circuit means that the total current flow is increased by 1mA. Since this is 1/1000 of 1 amp, the error introduced by the measurement device (in this

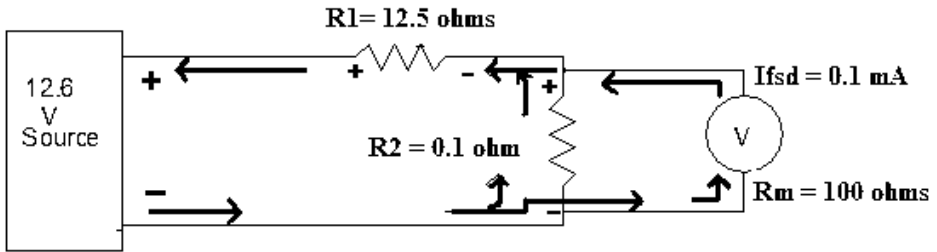


Figure 6-3 Current flow in a DC voltmeter.

particular case) is 0.1%. The meter movement itself probably has significantly more error than that.

## EXTENDED-RANGE VOLTMETER

An analog voltmeter could probably be constructed to measure any particular voltage at the time of manufacture. However, this would be quite expensive, considering the ranges of voltage that had to be measured in everyday use. Instead, a basic meter movement is used with a multiplier resistor.

Figure 6-4 shows the use of a multiplier resistor. Its purpose is to drop all but 0.1V for full-scale deflection current.

At full-scale deflection, 1mA will be flowing through  $R$  and  $R_m$ . These facts enable us to easily determine a multiplier resistor for any full-scale deflection desired.

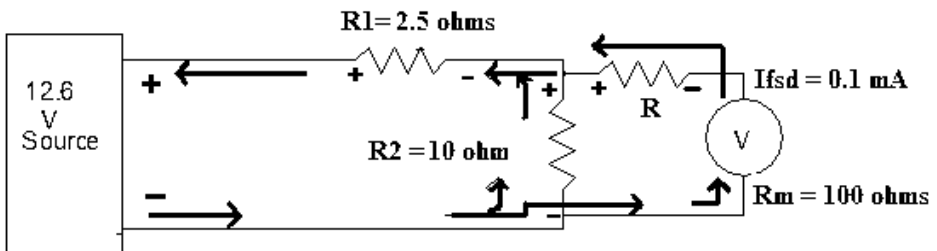


Figure 6-4 Extended-range voltmeter.

**EXAMPLE 1**

Using the meter in Figure 6-4, which has an  $I_m = 0\text{--}1\text{mA}$ ,  $R_m = 100\text{ ohms}$ , and a  $V_{fsd}$  of  $0.1\text{ volts}$ , convert this meter to measure  $10.0\text{ volts}$  full scale. Take the full-scale voltage: At  $10\text{V}$  (for full-scale deflection),  $1\text{mA}$  will flow. The resistance required to drop  $10\text{V}$  at  $1\text{mA}$  is

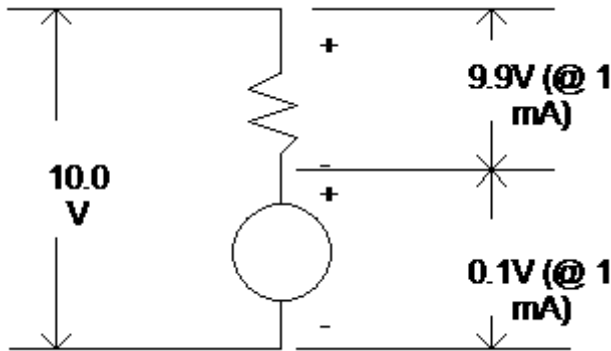
$$\frac{10\text{V}}{0.001\text{A}} = 10,000\text{ ohms}$$

Now subtract the meter resistance ( $R_m$ ) from the total resistance (10 kilohms):

$$10\text{ kilohms} - 100\text{ ohms} = 9900\text{ ohms}$$

or  $9.9\text{ kilohms}$

This is the value of the multiplier resistor. The voltage drops are shown in Figure 6-5.



**Figure 6-5** Voltage drops across extended-range voltmeter.

It should be obvious that these resistor values are not common values. A *common value, as defined here, is one with no more than three significant figures*. Values such as  $199,750$  ( $199.75\text{ kilohms}$ ) are hard to locate and would undoubtedly be of a special order. Figure 6-6 shows a way to avoid this problem.

The variable resistor enables us to use common values and provides us with a means of calibrating the voltmeter. This is necessary because if  $R_1$  in Figure 6-6 had a  $+1\%$  tolerance, the voltage drop across it could fall anywhere in the range  $89.1$  to  $90.9\text{V}$  since  $1\text{ percent of } 90$  is  $0.9\text{V}$ . *This is greater than the drop required across the meter!*

**EXAMPLE 2**

A meter has an  $I_m$  of 0–500 microamps (.0005 amp) and an  $R_m$  of 250 ohms. You want this meter to have a scale of 0–100V. What is the value of the multiplier resistor required?

First, determine the total resistance required to drop the full-scale voltage at fsd current:

$$\frac{100\text{V}}{0.0005\text{A}} = 200\text{ Kohms}$$

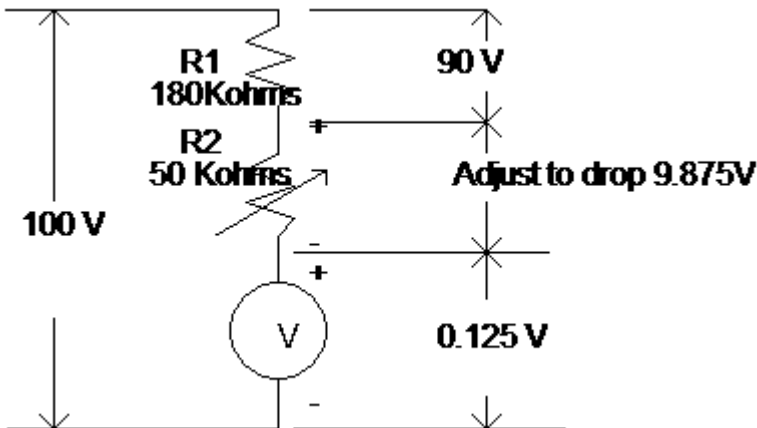
Second, subtract the meter resistance ( $R_m$ ) from this total:

$$200\text{ kilohms} - 250\text{ ohms} = 199,750\text{ ohms}$$

so

$$R\text{ (multiplier)} = 199,750\text{ ohms}$$

for a 100-V scale using a meter with an  $R_m$  of 250 ohms and an  $I_m$  of 500 microamps.



**Figure 6–6** Calibration voltage drops across extended-range voltmeter.

To calibrate this one-scale meter, a 100-V source (as measured by a standard voltmeter) is connected to the voltmeter under test and R2 is adjusted until the voltmeter under test reads exactly 100V. Then, at full scale, the voltmeter under test will have its specified accuracy.

## REVIEW

1. A current meter may be converted into a voltmeter by using a multiplier resistor.
2. To compute the multiplier resistor, find the desired fsd, divide by the meter movement fsd current, which gives the total resistance required, and subtract the meter resistance. The result is the multiplier resistor.
3. The multiplier resistor as computed is usually not a common value, and a resistor of a common value and a variable resistor in series are used to derive the correct value. This variable resistor is used to calibrate the meter initially and for later recalibrations as the components age or are replaced.

## MULTI-RANGE VOLTMETERS

Figure 6-7 shows one possible arrangement of a multi-range voltmeter. Although workable, this arrangement requires either four noncommon value resistors (if the variables are not used) or four variable resistors.

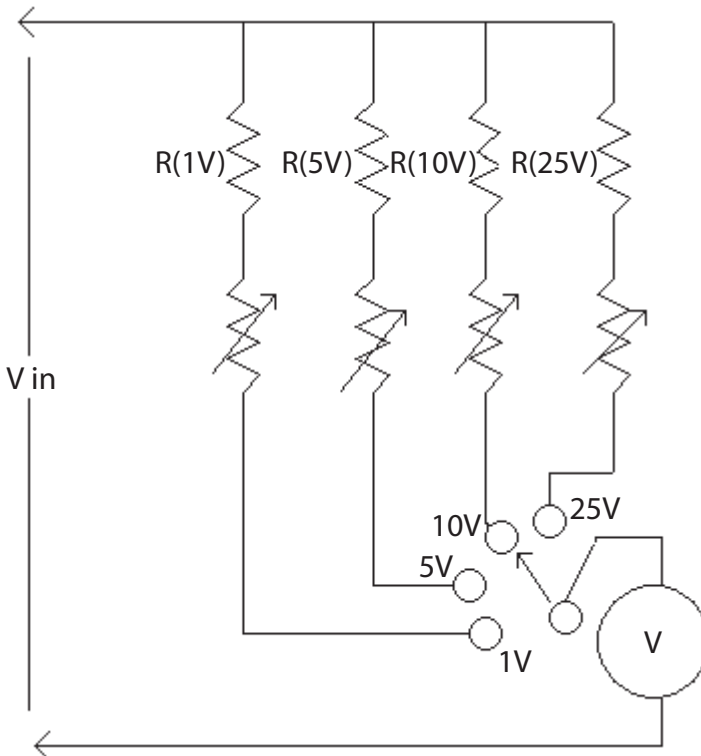
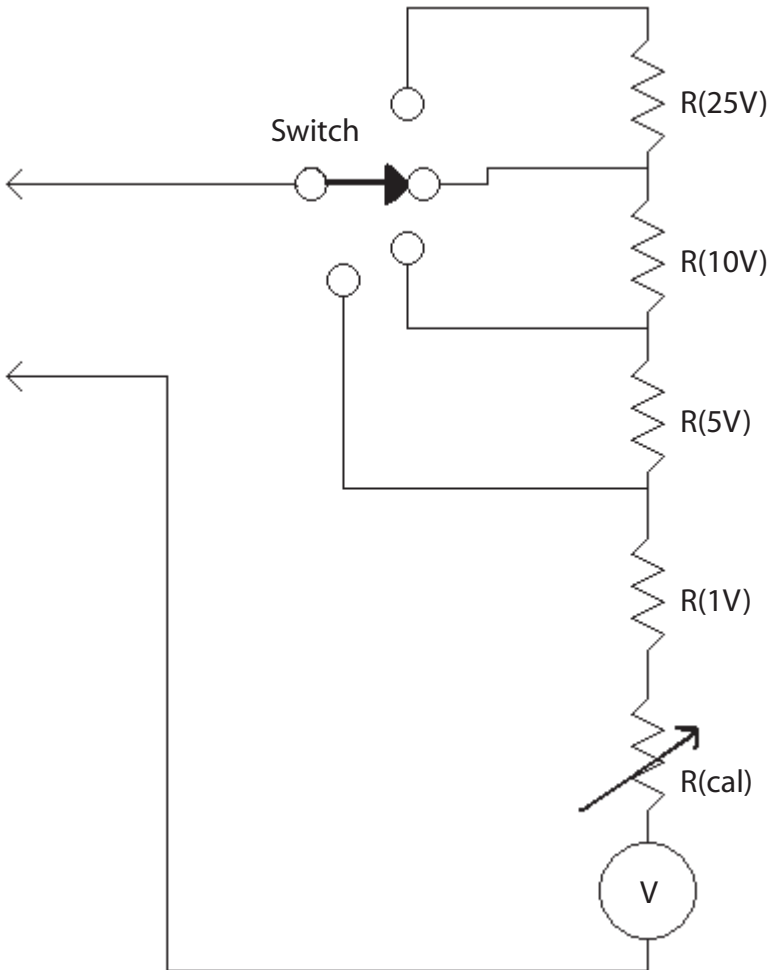


Figure 6-7 Multi-range voltmeter.

A simpler method is shown in Figure 6–8.

Figure 6–8 shows only one variable resistor. As the resistor values are developed, you will discover that you will need only common values of the fixed resistors with this circuit arrangement.

It should be noted that the percentage of error is *not* cumulative as you proceed to each higher scale.



**Figure 6–8** A series multiplier multi-range voltmeter.

**EXAMPLE**

Using the voltmeter in Figure 6–8, determine the values of R(25V), R(10V), R(5V), and R(1V). The meter movement has

$$I_m = 50 \text{ microamp (full scale)}$$

$$R_m = 500 \text{ ohms}$$

First, let's determine the total resistance required to drop the lowest-scale voltage at fsd current:

$$\frac{1\text{V}}{0.00005\text{A}} = 20 \text{ kilohms}$$

Then subtract the  $R_m$  from this value:

$$20 \text{ kilohms} - 500 \text{ ohms} = 19.5 \text{ kilohms}$$

To use a common value, select 18 kilohms (fixed) for R(1V) and a 2 kilohms variable for R(cal).

Note: 19.5 kilohms (multiplier resistor) + 0.5 kilohms (meter resistance) = 20 kilohms total, and 20 kilohms  $\times$  0.00005A = 1.0V.

To find R(5V), figure the total resistance required to drop 5V when a current of 50 microamps is flowing. Use Ohm's Law.

$$\frac{E}{I} = R = \frac{5}{0.00005\text{A}} = 100 \text{ kilohms}$$

Since 20 kilohms is already present, (R(1V) + R(cal) +  $R_m$ ), subtract this amount from 100 kilohms. This leaves

$$R(5V) = 80 \text{ kilohms}$$

*Remember:* The total resistance of the 5V range is 100 kilohms. You must subtract the resistance already in the circuit (1V scale = 20 kilohms) from the total resistance to obtain the multiplier. To find R(10V), repeat the procedure you used for R(5V). Determine the total resistance required to drop 10V at 50 microamps.

**EXAMPLE (CONTINUED)**

$$\frac{10\text{V}}{0.00005\text{A}} = 200,000 \text{ ohms (200 kilohms)}$$

Subtract the resistance already in the circuit:

$$[R(5\text{V}) + R(1\text{V}) + R(\text{cal}) + R_m] = 100 \text{ kilohms}$$

$$200 \text{ kilohms} - 100 \text{ kilohms} = 100 \text{ kilohms}$$

Therefore

$$R(10\text{V}) = 100 \text{ kilohms}$$

To find  $R(25\text{V})$ , again repeat the procedure used to find  $R(5\text{V})$  and  $R(10\text{V})$ . Find the total resistance required to drop 25V at 50 microamps.

$$\frac{25\text{V}}{0.00005\text{A}} = 500 \text{ kilohms}$$

Subtract the resistance already in the circuit:

$$[R(10\text{V}) + R(5\text{V}) + R(1\text{V}) + R(\text{cal}) + R_m] = 200 \text{ kilohms}$$

$$500 \text{ kilohms} - 200 \text{ kilohms} = 300 \text{ kilohms}$$

Therefore

$$R(25\text{V}) = 300 \text{ kilohms}$$

The final circuit will appear as in Figure 6–9.  $R(\text{cal})$ , of course, affects all ranges; however, it affects the 1V scale the most. Why? Because 2 kilohms is a larger percentage of 18 kilohms than any of the other resistors. This requires that  $R(\text{cal})$  be adjusted on the 1V scale. If it is adjusted exactly for 1.0V on the 1V scale, all of the other scales should be accurate within the tolerance of the resistors.

**EXAMPLE**

R(25V), R(10V), and R(5V) in Figure 6–9 are all  $\pm 1\%$  resistors. This gives the range for each:

$$R(5V) \ 80K \pm 1\% = 80.8 \text{ kilohms (high), } 79.2 \text{ kilohms (low)}$$

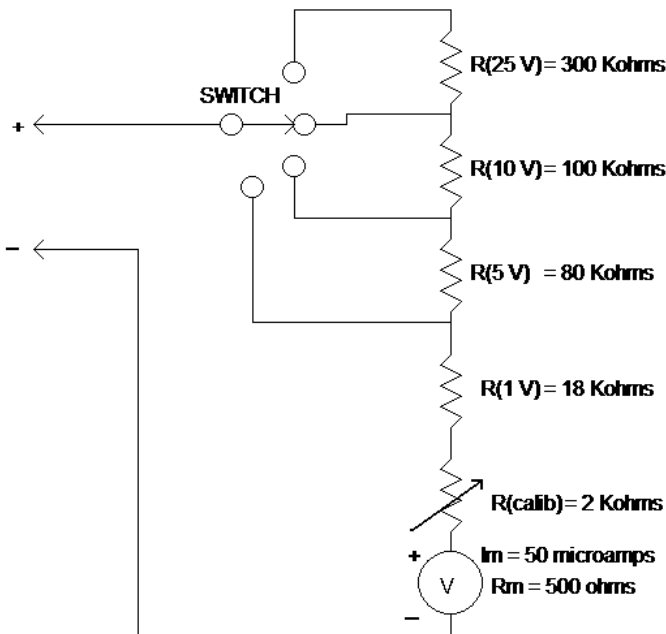
$$R(10V) \ 100K \pm 1\% = 101 \text{ kilohms (high), } 99 \text{ kilohms (low)}$$

$$R(25V) \ 300K \pm 1\% = 303 \text{ kilohms (high), } 297 \text{ kilohms (low)}$$

The total nominal resistance required for these three ranges is 480 kilohms. The sum of the upward tolerances is 484.8 kilohms; the sum of the lower tolerances is 475.2 kilohms. The deviation from the required resistance is  $\pm 4.8$  kilohms when using the 25V scale. Using the percentage-of-error formula,

$$\frac{\pm 4.8 \text{ kilohms}}{480 \text{ kilohms}} = \pm 1\%$$

Therefore, if the nominal values of resistance are used, the accuracy of each scale is the tolerance of the resistor used for the scale. The accuracy is equal to or better than the component with the greatest tolerance.



**Figure 6–9** A complete multi-range voltmeter.

**EXAMPLE**

Given a meter with  $I_m = 100$  microamps and  $R_m = 250$  ohms, determine the component values for a voltmeter with 1V, 10V, 50V, and 100V ranges. Use Figure 6–10.

1) Determine the total resistance required for the lowest scale.

$$\frac{1\text{V}}{0.0001\text{A}} = 10 \text{ kilohms}$$

2) Subtract  $R_m$  from the total resistance.

$$10 \text{ kilohms} - 250 \text{ ohms} = 9750 \text{ ohms}$$

Since 9750 ohms is not a common value, choose 8.2 kilohms (fixed for R [1V]) and 2 kilohms (variable for R [cal]).

3) Determine the total resistance required for the next scale (10V).

$$\frac{10\text{V}}{0.0001\text{A}} = 100 \text{ kilohms}$$

4) Subtract the resistance present from the previous scale.

$$100 \text{ kilohms} - 10 \text{ kilohms} = 90 \text{ kilohms}$$

$$\text{so, } R(10\text{V}) = 90 \text{ kilohms}$$

5) Determine the total resistance required for the next scale (50V).

$$\frac{50\text{V}}{0.0001\text{A}} = 500 \text{ kilohms}$$

6) Subtract the resistance that is present from the previous scales.

$$500 \text{ kilohms} - 100 \text{ kilohms} = 400 \text{ kilohms}$$

$$R(50\text{V}) = 400 \text{ kilohms}$$

7) Determine the total resistance required for the next scale (100V).

$$\frac{100\text{V}}{0.0001\text{A}} = 1 \text{ megohm}$$

8) Subtract the resistance that is present from the previous scales.

$$1 \text{ megohm} - 500 \text{ kilohms} = 500 \text{ kilohms}$$

$$R(100\text{V}) = 500 \text{ kilohms}$$

The schematic of this circuit is drawn in Figure 6–11.

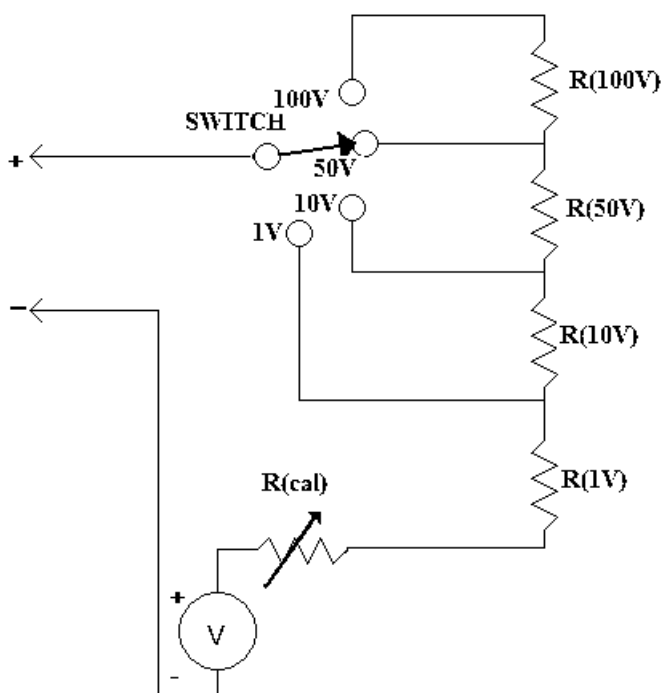


Figure 6-10 Voltmeter example.

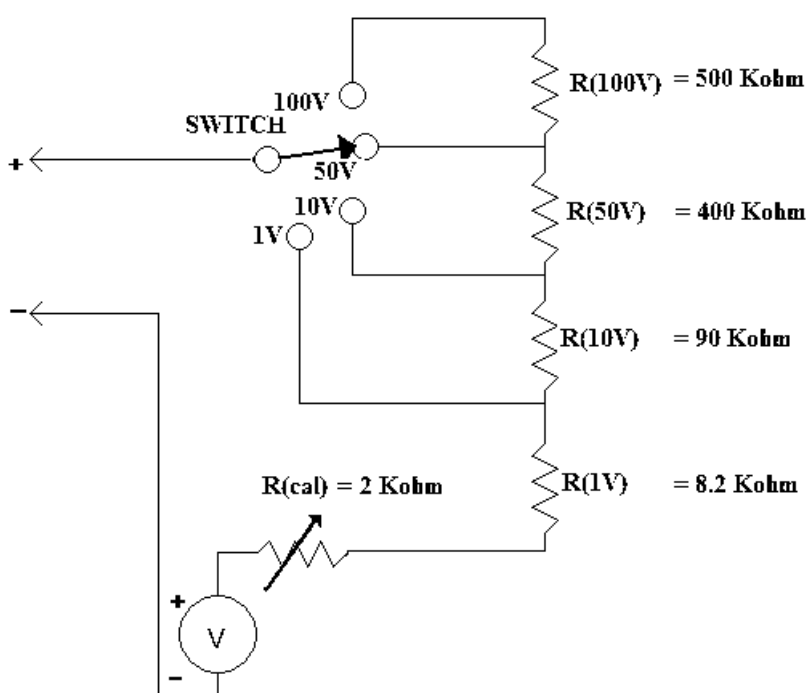


Figure 6-11 Completed voltmeter example.

## REVIEW

1. Multi-range multiplier resistors are determined by using the same procedure as for a single-range voltmeter.
2. The lowest scale is determined first.
3. Common values are used for all but the first multiplier's resistance.
4. The first multiplier's resistance may be a common value in series with a variable resistor.
5. The percentage of error is not cumulative when using higher ranges.

## METER SENSITIVITY

You should have noticed through the preceding examples of voltmeters that the smaller the meter's  $I_m$ , the higher the value of the multiplier resistors used. This is due to meter sensitivity. The less current a meter requires for full-scale deflection, the more sensitive it is. In other words, the less current a meter requires for full-scale deflection, the less current must be drawn from the source, hence the less the meter intrudes upon circuit operation.

A more sensitive meter draws less current from the source or circuit being measured. This is desirable, since a measurement should try to have the least possible affect on the quantity being measured. Meter sensitivity is quite easily determined and is given in terms of ohms per volt. To determine meter movement sensitivity, divide the full-scale deflection current into 1 volt.

### EXAMPLE

If a meter movement has an  $I_m$  of 0–1mA, what is the sensitivity of the movement?

$$\frac{1\text{V}}{0.001\text{A}} = 1000 \text{ ohms/V}$$

Notice that you are dividing current into a voltage and that the result is ohms. Since the voltage was 1V, the result is ohms per volt.

**EXAMPLE**

If the meter movement has an  $I_m$  of 0–20 microamps, what is the sensitivity?

$$\frac{1}{0.00002} = 50,000 \text{ ohms/V}$$

What about the sensitivity of meter scales in a multi-range voltmeter? Use the meter in Figure 6–11.

The total input resistance for each scale is:

100V scale	$R(100V) + R(50V) + R(10V) + R(1V) + R(\text{cal}) + R_m = 1 \text{ megohm}$
50V scale	$R(50V) + R(10V) + R(1V) + R(\text{cal}) + R_m = 500 \text{ kilohms}$
10V scale	$R(10V) + R(1V) + R(\text{cal}) + R_m = 100 \text{ kilohms}$
1V scale	$R(1V) + R(\text{cal}) + R_m = 10 \text{ kilohms}$

The meter has an  $I_m = 100$  microamps with an  $R_m = 250$  ohms. The meter movement sensitivity is:

$$\frac{1}{0.0001} = 10 \text{ kilohm/V}$$

To determine how many ohms per volt each scale has, take the total resistance for that scale and divide it by the full-scale voltage.

100V scale	$\frac{1 \text{ megohm}}{100 \text{ V}} = 10,000 \text{ ohm/V}$
50V scale	$\frac{500 \text{ kilohms}}{50 \text{ V}} = 10,000 \text{ ohm/V}$
10V scale	$\frac{1 \text{ kilohms}}{10 \text{ V}} = 10,000 \text{ ohm/V}$
1V scale	$\frac{10 \text{ kilohms}}{1 \text{ V}} = 10,000 \text{ ohms/V}$

**Notice that meter movement sensitivity determines sensitivity for all ranges.**

## REVIEW

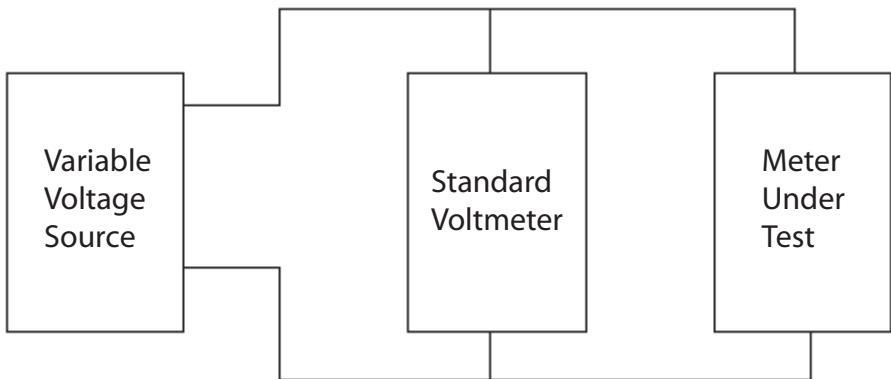
1. Meter sensitivity is determined by dividing the full-scale deflection current into 1V.
2. Meter sensitivity is expressed in terms of ohms/volt.
3. The more sensitive the meter, the less it affects the circuits it measures.
4. All ranges of a multi-range voltmeter have the same sensitivity as the meter movement.

*All of the preceding discussion has concerned analog meter movements. There is a minimum limit to the amount of current that can physically move the needle and still be produced economically and, further still, stand the rigors of field use. Meter loading (where the meter current draw affects the circuit and therefore the meter reading) is always a consideration with analog meters. The effective input resistance of 10 to 22 megohms for digital meters makes meter loading insignificant for most applications.*

## CALIBRATING VOLTMETERS

There are several methods for calibrating a voltmeter, and they are the same whether one is calibrating an analog or a digital voltmeter. The calibration method we will use in this chapter is comparison calibration. The equipment for the comparison is set up as shown in Figure 6–12.

The voltage source is expressed in increments (or discrete steps at a time) at the scale divisions on the voltmeter being tested. The true voltage as measured by the standard is noted, and the deviation by the meter under test is documented.



**Figure 6–12** Voltmeter comparison calibration.

## METER PROTECTION CIRCUITS

In this section we will discuss two meter protection circuits:

1. Meter movement overload protection.
2. Meter movement transit lock.

### METER MOVEMENT OVERLOAD PROTECTION

One way to protect the meter movement (either analog or digital) from overloads and the selection of the wrong scale is to use fast-acting fuses or circuit breakers. This was the method employed in most high-quality general-purpose analog volt-ohm-meters (VOM), known as multimeters. It was also the principal method for protecting digital meters before scaling circuits.

Diode protection is a form of protection from overloads for analog meter movements, and indeed for digital circuits in which the input may exceed allowable thresholds. A diode is a two-element electrical component that acts as a check valve for electrical current, that is, it allows current to flow in one direction only. An example of a check valve would be the valve in your automobile tire. If the air pressure inside the tire is equal to or greater than the pressure outside the valve, it remains closed, trapping the air in the tire. When you add air to the tire, the pressure from the pump will have to be greater and in the right direction (into the tire) for the check valve to open. The actual pressure from the pump will have to be a bit higher than the pressure in the tire as the pump pressure must also overcome the spring that holds the valve closed. A diode behaves in the same way, only instead of air pressure it is using electrical pressure. Current may only flow in one direction through a diode, the forward direction. Current cannot flow in the other direction, the reverse direction. Germanium and silicon diodes have a forward voltage drop (the amount of voltage in the right direction needed to overcome the diode's internal spring) of between 0.2 and 0.8 volts, depending on the diode's construction and type. This drop can be used to form a protective circuit that protects the meter movement from gross overload and the resulting meter damage.

As an example suppose the meter movement has an fsd voltage of less than 0.20 volts. As long as the voltage (in either direction) does not exceed the forward voltage of the diodes, then the meter will be the only path of current flow. When the diode's forward voltage is exceeded it will conduct, shunting the excess current around the meter. Figure 6-13 illustrates this type of protection.

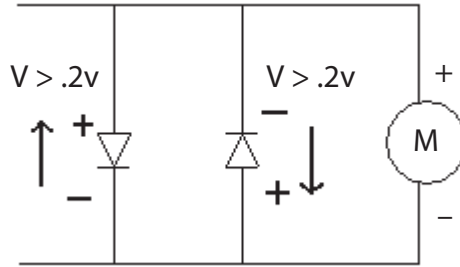


Figure 6–13 Diode protection.

## TRANSIT LOCK

Meters can be damaged during the transport of analog meter movements when the meter pointer moves rapidly because of vibration, sudden acceleration or deceleration, and so on. One form of protection against this is to put a shorting link across the meter when it is in transit. This is normally done by placing the range or power switch in the OFF position, as shown in Figure 6–14. A digital readout (whether LED, LCD, or EL) doesn't need this protection as there are no moving pointers, bobbins, or shafts. When the meter is moved by external forces, the meter movement core assembly acts as a generator. The transit lock shorts this generator, causing a heavy load to be presented to the generation of current. This dampens (diminishes) the amount of movement the core assembly can make, preventing damage to the meter movement.

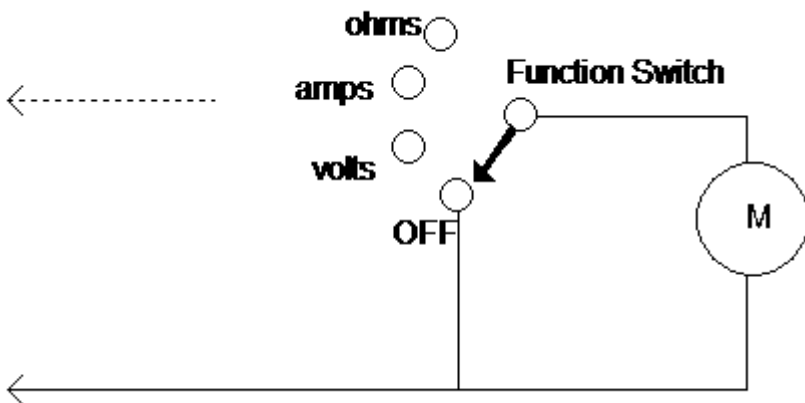


Figure 6–14 Transit lock.

## REVIEW

1. Voltmeters are calibrated against a standard and deviation from that documented standard.
2. Meters may be protected from overload by fuses, circuit breakers, diodes, or a combination of these components.
3. The transit lock prevents analog meter movements from being damaged by vibration, sudden shocks, and so on.
4. A diode acts as a check valve for electrical current. Current flows in one direction only through a diode. An increase of .2V to .8V in the potential in the direction of flow is needed to allow current to flow through a diode in the forward direction. Current cannot flow in the reverse direction through a diode.

## ANALOG VERSUS DIGITAL VOLTMETER

Analog voltmeters have a number of significant disadvantages when compared to contemporary digital meters:

1. Less accuracy of movement.
2. Less mechanical reliability.
3. Parallax problem.
4. Less meter sensitivity.
5. Cost.

In this section, we will discuss how the digital meter overcomes the analog meter's disadvantages. We will also discuss the disadvantages, if any, of the digital meter.

## ACCURACY OF MOVEMENT

The analog meter relies on its physical construction to give it accuracy. Bearing friction, nonlinearities in the tension spring, and even physical deformities in the magnet construction all limit analog accuracy to about .5% at best. Because a digital meter does not use a physical movement, it overcomes these disadvantages. Digital meters use analog-to-digital conversion circuitry (explained in Chapter 18) and essentially an electronic reference, which gives them their basic accuracy. Even inexpensive (a nicer word than "cheap") digital meters approach 0.25% accuracy, which is *better* than the most expensive analog volt-ohm-meter.

## MECHANICAL RELIABILITY

A digital meter is primarily an electronic device. Only the switch and the display itself make any contribution to unreliability from a mechanical viewpoint. Probes do create problems, but that is in analog or digital use. Some LCDs (liquid crystal displays) do not perform well in very cold weather. However, as electronic instruments go, digital meters are *considerably more rugged* than the analog types.

## PARALLAX

This is where you may obtain different readings on an analog meter depending upon your viewing angle. More expensive analog meters have a mirrored scale. The purpose of these is to line up the pointer with its image in the mirror, and then there will be no parallax. Digital meters *do not have a parallax problem*.

## METER SENSITIVITY

Most modern digital voltmeters have an input resistance of 22 megohms—period, not per volt, regardless of scale. Because a digital meter only has a bias current to operate (*in the picoampere range*), and the analog meter requires substantial (comparatively speaking) current to operate, the digital meter will have a *much higher sensitivity*.

Well then, with all of the advantages of digital meters, and with their very low cost for performance, are there any analog instruments left? A good question, but one that can be answered.

When you are trying to view a trend or null (zero) reading, an analog meter, because of the way it responds, makes it easier in many instances to visualize the quantity that is changing. If you have ever tried to record on a cassette and had to set the record level you will understand this concept. It is easier to obtain the intuitive average and separate it from the peaks using an analog meter than to try doing the same with a digital meter. However, many digital meters also display a digital bar (like a thermometer) that is more than adequate for observing trends. In other words, there is no advantage left to using the analog meter (other than analog meters that do not require batteries for volt and amp measurements).

Other than specialized uses, the analog voltmeter has been relegated to history as newer and smarter digital meters take their place. Again, at this point in the book the only discussion we will present regarding digital voltmeters is how many digits they display (accuracy), what type of display they use, and how many tricks (functions) the meter can perform.

Though the following exercises are based on analog meter types, they are good examples of Ohm's Law and voltage measurement.

**CHAPTER EXERCISES**

1. A 50-V full-scale reading is desired. What value of a multiplier resistor is required if the meter movement has

$$I_m = 10 \text{ microamp}, R_m = 500 \text{ ohms}$$

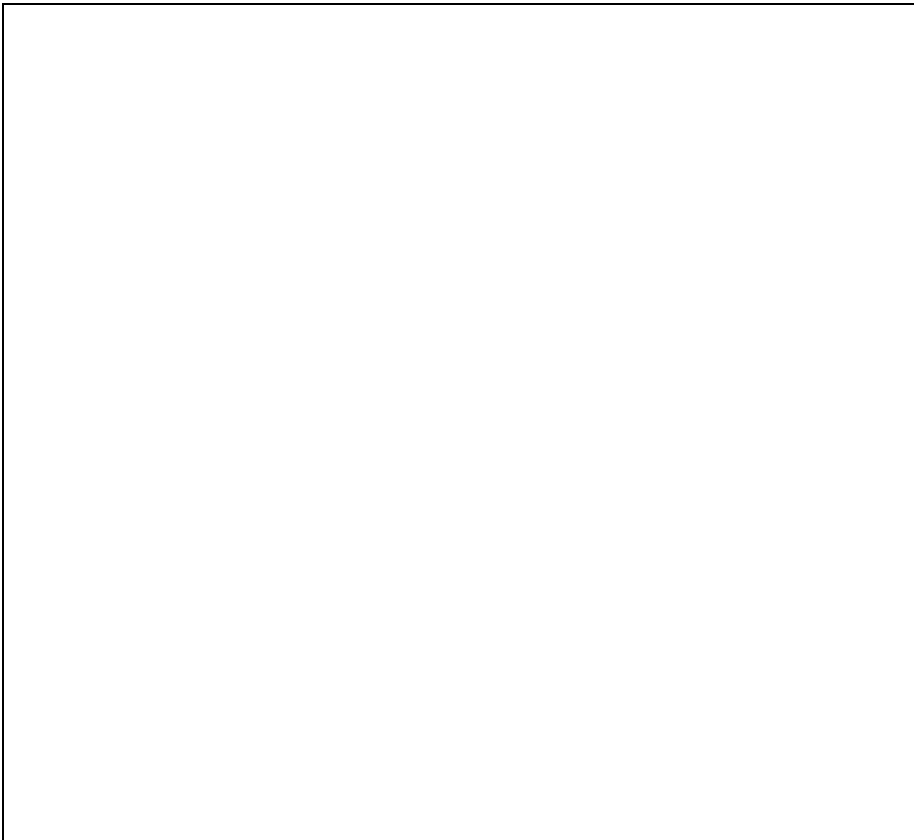
Answer: \_\_\_\_\_ ohms

2. A 10-V full-scale reading is desired. What value multiplier resistor is required if the meter movement has

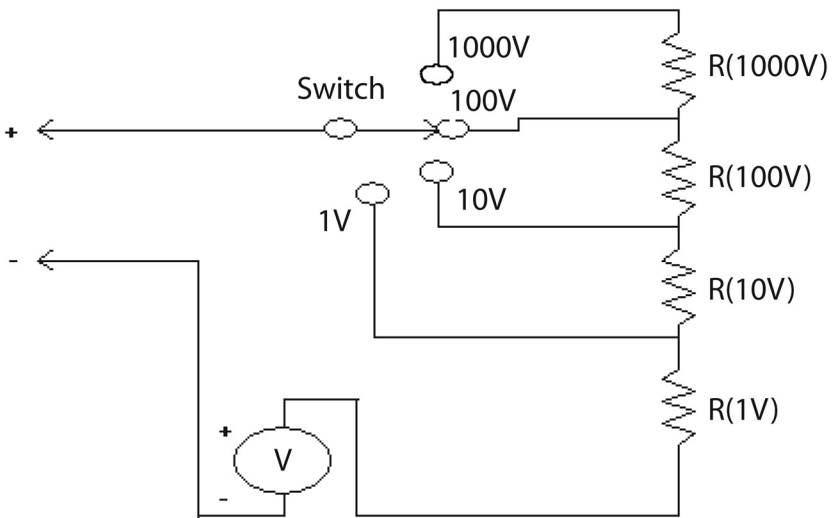
$$I_m = 1 \text{ mA}, R_m = 150 \text{ ohms}$$

Answer: \_\_\_\_\_ ohms

3. In the space below, draw a voltmeter for 25V fsd. The meter movement has an  $I_m = 0.5 \text{ mA}$  and an  $R_m = 200 \text{ ohms}$ . Use a common resistor value and a variable resistor for calibration, and label all component values.



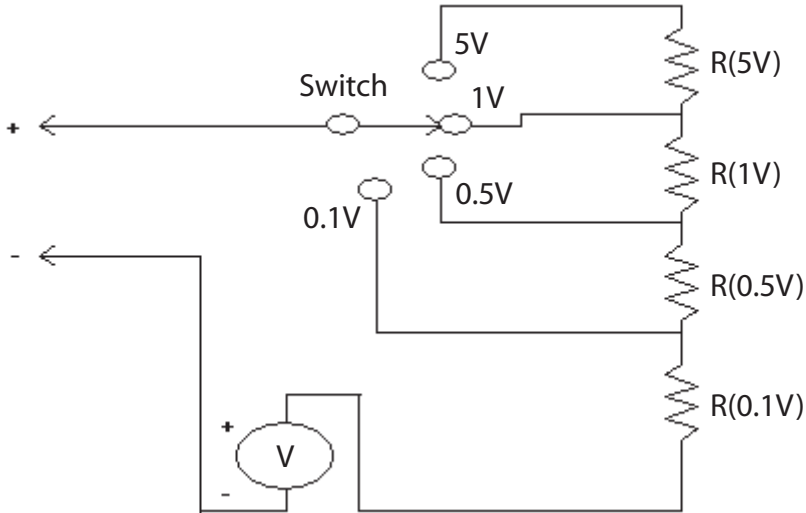
4. List the five main disadvantages of analog meters compared to digital meters.
  - a.
  - b.
  - c.
  - d.
  - e.
5. Given a meter with  $I_m = 1\text{mA}$  and  $R_m = 50\text{ ohms}$ , determine the values of the multiplier resistors for the meter shown in the following figure.



$R(1000V) = \underline{\hspace{2cm}}$   
 $R(100V) = \underline{\hspace{2cm}}$   
 $R(10V) = \underline{\hspace{2cm}}$   
 $R(1.0V) = 820\text{ ohms}, R(\text{cal}) = 200\text{ ohms}$

6. If in Problem 5, each fixed resistor has a tolerance of  $\pm 0.1\%$  and the movement has an accuracy of  $\pm 1.0\%$ , what is the accuracy when measuring 5V on the 5V scale?

7. Given a meter with  $I_m = 20$  microamps and  $R_m = 325$  ohms, determine the values of the multiplier resistors for the meter shown in the following figure.



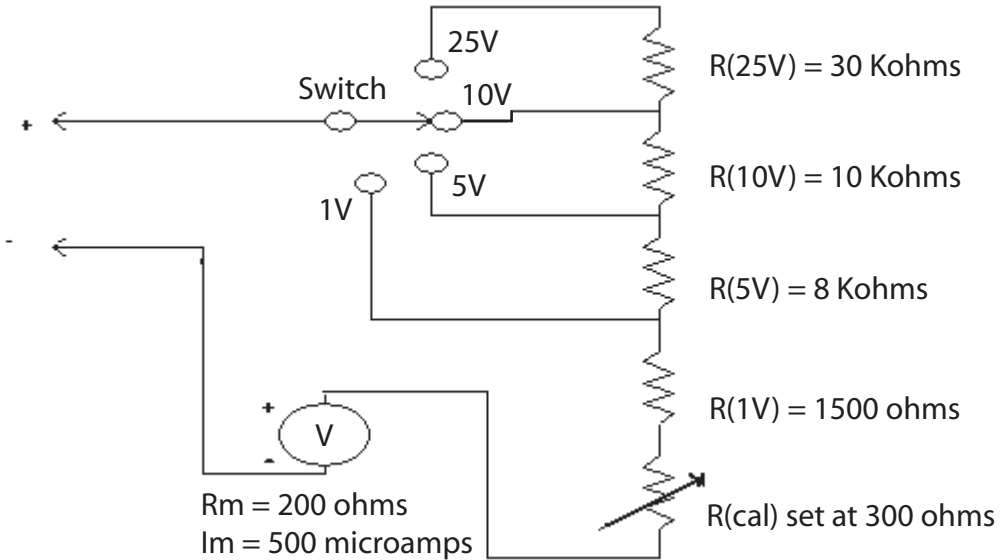
$$R(5V) = \underline{\hspace{2cm}}$$

$$R(1V) = \underline{\hspace{2cm}}$$

$$R(0.5V) = \underline{\hspace{2cm}}$$

$$R(0.1V) = \underline{\hspace{2cm}}$$

8. For the meter circuit shown in the following figure, compute the meter sensitivity and the ohms/volt of each range.



Meter sensitivity	_____ ohms/V
25-V scale	_____ ohms/V
10-V scale	_____ ohms/V
5-V scale	_____ ohms/V
1-V scale	_____ ohms/V

***The answers to these chapter exercises appear at the end of the book.***

## CONCLUSION

If you are having trouble with a particular portion of this material, first reread the chapter. If the problem persists, locate someone who has a technical understanding of the subject matter and ask him or her for help and clarification.

For further information on the concepts in this chapter, search the following terms in your Internet search engine:

**multi-range voltmeter**  
**transit lock**

**meter movement accuracy**

# DC CURRENT MEASUREMENT

---

---

## DC CURRENT METERS

Before the advent of high-input impedance meters, the moving coil meter was the basis of most small current measurements. But all current meters, whether of the contemporary or ancient variety, must use shunts to measure large (relative to the meter movement sensitivity) currents. A *shunt* is a low-resistance conductor of a precise resistance. Current is derived by the voltage dropped across the shunt (nowadays). With analog meters, the current would provide a parallel path for current flow, “shunting” a large (compared to the meter fsd current) current around the meter measuring circuit. Again, to measure currents larger than the full-scale deflection current (analog meter) or those currents beyond the range of the *built-in shunts* of a digital meter, external shunts must be employed. The purpose of this chapter is to give you a solid understanding of current-measuring devices and the precautions necessary when measuring currents.

## MOVING COIL METERS

In this section we will focus on permanent magnet-type moving coil meters (analog meters). However, many of the techniques used with these devices apply to digital meter applications as well. The main difference between analog and digital is in how the current is displayed, not in how it is measured. Permanent magnet moving coil meters indicate measurements by the amount of current flowing through the coil. This current causes the meter pointer to deflect when the coil’s magnetic field interacts with the permanent magnet field. Moving coil type meters are generally specified by their full-scale deflection (fsd) current. These currents vary widely, from 1.0 microamp to as much as 1 amp. As we’ve discussed previously, each of these meter types has an internal resistance that is determined by the construction of the meter movement. Several meters with the same fsd may have widely varying values of internal resistance.

None of these resistances will be very high, generally less than 1000 ohms. Why is this? Because the meter must be in series with the circuit load in order for current to flow through the meter movement itself and therefore for the circuit current to be measured. This is shown pictorially in Figure 7–1 and schematically in Figure 7–2.

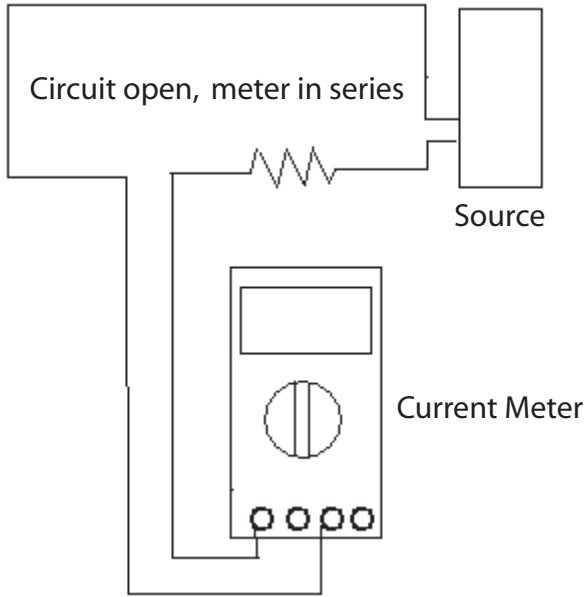


Figure 7-1 Measuring current (pictorial).

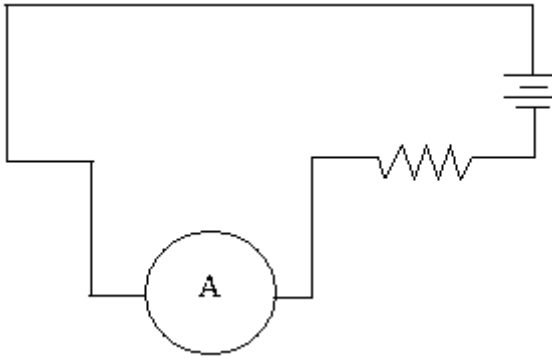


Figure 7-2 Measuring current (schematic).

**Caution**

You should *never* connect a current meter in parallel (across) a load or a voltage source. If you do, the meter will attempt to measure the current capacity of the source. Since the capacity of the source is likely to be many times the current range that was to be measured, *permanent* damage to the meter—up to and including exploding and/or tripping the circuit protection devices—will be the result.

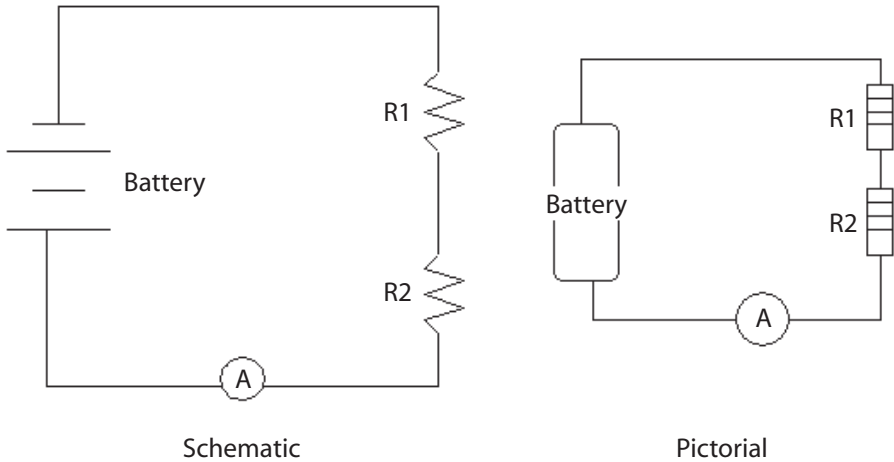


Figure 7-3 Series resistors.

## SERIES RESISTORS

Putting two or more resistors in the same current path means that the current must go through all of the resistors, and this current is the same through each resistor. This is easy to see (Figure 7-3).

According to Mr. Kirchhoff, no more current can arrive at any one point then leaves that point, so the current throughout the series circuit is the same. You might think of the two resistors in series as just parts of one large resistor, as that is how the battery sees them. To determine the resistance of series resistors, you must only add up their values.

### EXAMPLE

$R1 = 1000$  ohms,  $R2 = 2200$  ohms.

What is the total resistance?  $1000 + 2200 = 3200$  ohms. Each resistor will drop a voltage across the resistor that depends on the current running through the resistor and its resistance. These values vary with the resistance, but may be sure of one thing: the sum of their voltage drops will equal the applied voltage.

## PARALLEL CURRENT PATHS

To understand the next section on the assumed-voltage method of determining parallel resistances, you need to know how a circuit with more than one path for current flow behaves. Figure 7-4 illustrates a

parallel circuit. Note that the potential across each branch is the same, as the conductors go from each resistor to the source. Since the voltage is the same across each path, called a *branch*, the current flowing in each branch will depend on the resistance of each branch. If all the branch currents are added together the result will be the total current flow in the circuit from (or to) the battery.

### EXAMPLE

Battery = 10V, R1 = 10 ohms, R2 = 10 ohms.

What is the current flow through each branch ( $I_{R1}$  and  $I_{R2}$ ), and what is the total current flow ( $I_t$ )? Using Ohm's Law, determine the current through each resistor.  $10V/10 \text{ ohms} = 1 \text{ amp}$ . So each branch has 1 amp. Since the rule of no free lunch still applies, that current has to come from somewhere. There is a total of 2 amps, so that is the current flow from and to the battery.

What is the current flow through each branch ( $I_{R1}$  and  $I_{R2}$ ), and what is the total current flow ( $I_t$ )? Using Ohm's Law, determine the current through each resistor.  $10V/10 \text{ ohms} = 1 \text{ amp}$ . So each branch has 1 amp. Since the rule of no free lunch still applies, that current has to come from somewhere. There is a total of 2 amps, so that is the current flow from and to the battery.

### EXAMPLE

Battery = 10V, R1 = 15 ohms, R2 = 5 ohms.

What is the current flow through each branch ( $I_{R1}$  and  $I_{R2}$ ), and what is the total current flow ( $I_t$ )? Using Ohm's Law, determine the current through each resistor. For R1,  $10V/15 \text{ ohms} = .67\text{Amp}$ . For R2,  $10V/5 \text{ ohms} = 2 \text{ amps}$ . The total current is 2.67 amps.

In both these examples we have determined the total current flow. With that value we could determine the resistance that the source (in our examples, the battery) sees, that is, the value equivalent to a single resistance connected to the source. This is known as the *total resistance* (or  $R_t$ ). In the first example, with two 10-ohm resistors in parallel, the total current was 2 amps. The source was 10V, so by Ohm's Law the total resistance is  $10V/2 \text{ amps} = 5 \text{ ohms}$ .

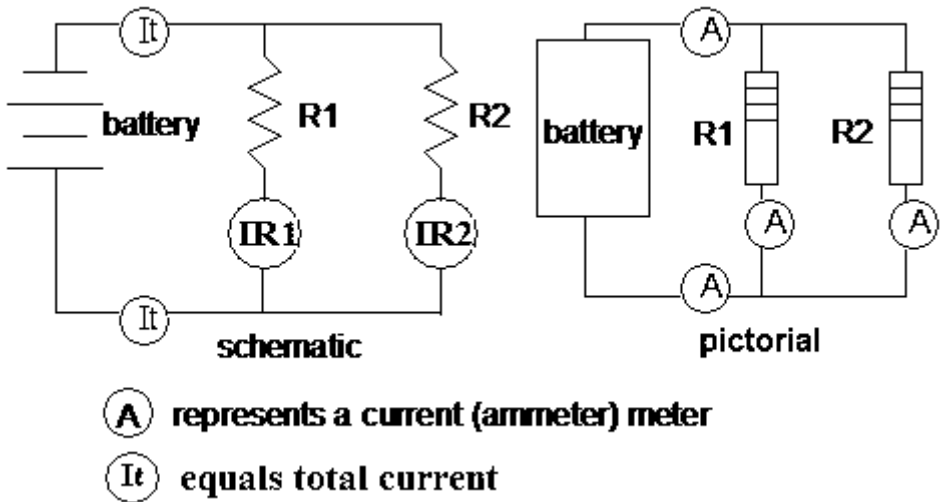


Figure 7-4 Parallel circuit.

**Hint**

Since equal resistors always pass the same current when the same potential is across them, the total resistance will be half of the resistor value for two resistors. Can you prove that it would be one third for three resistors of equal value? One quarter for four resistors of equal value?

To make a long story short, the source only “sees” the total resistance, not how it is developed, constructed, or connected. All methods for determining resistance generally are trying to find that equivalent total resistance.

**ASSUMED-VOLTAGE METHOD**

By using the same method as before we may determine the total resistance of the second example:  $10\text{V}/2.67\text{A} = 3.74$  ohms. You can always determine the total resistance by:

1. Assuming a voltage across the resistor combination,
2. Determining individual currents,
3. Obtaining the total current,
4. Dividing into the assumed voltage.

This method only assumes that you understand Ohm’s Law and parallel circuits.

## PROPORTIONAL METHOD

Another method for determining the total resistance is the proportional method (using the second example):

1. Determine the ratio of one resistance to the other ( $15/5 = 3$  to 1).

(You know that three times as much current will flow through the smaller resistor as through the larger [in this case], and there are four units of current (3 and 1). Therefore, the total current will be one quarter greater than with the 3-ohm resistor alone).

2. Divide the largest resistor by the number of current units ( $4$ ) = 3.75 ohms.

## RECIPROCAL METHOD

Actually the proportional method is nothing more than a verbal way of expressing the computational (reciprocal) method. Using the Law of Reciprocals:

$$R_t = \frac{1}{\frac{1}{R_1} + \frac{1}{R_2} \cdots + \frac{1}{R_n}}$$

$$R_t = \frac{1}{\frac{(R_2 + R_n) + (R_1 + R_n) + (R_1 + R_2)}{R_1 \times R_2 \times R_n}}$$

Our case involves only two resistors, which is a special case and can be determined by:

$$R_t = \frac{R_1 \times R_2}{R_1 + R_2}$$

For the example:  $75/20 = 3.75$  ohms

For our purposes, the assumed-voltage method (if the actual voltage is not known) works best as it uses Ohm's Law and doesn't require formulas.

## REVIEW

*In this last section, we introduced parallel circuits and showed that each branch draws a portion of the total current. To determine the total resistance of a parallel circuit, that is, the resistance that appears as a single resistance to the source, you must total up the individual branch currents and divide them into the applied (or assumed) source voltage. Other methods were outlined for determining the total resistance, but they rely upon manipulating formula rather than just Ohm's Law. One particular fact should be observed from the exercises and from common-sense observation of parallel circuits: the total circuit resistance will always be less than the lowest branch resistance. Because the circuit will always allow more current to flow than the lowest resistor (because of the other branches), the source will always see a lower total resistance.*

*We will now apply this information to the use of current shunts. A shunt is a circuit that is in parallel with (in our case) the meter. Current will flow through the shunt and through the meter in proportion to the ratio of their resistances.*

## COMBINATIONAL CIRCUITS

The dread of most two-year technical students in their early semesters is series—parallel resistive circuits (as in reality occurs all the time). It may be the mathematics they really fear, or perhaps just the brain work. At any rate, there is nothing to fear with combinational circuits. You simply must reduce the circuit to one total resistance using the methods you already know.

### EXAMPLE 1

Use Figure 7–5. The circuit values are:

Battery = 10V DC

R1 = 1K

R2 = 4K

R3 = 2K

What is  $R_T$ ?

Do the parallel circuit first (you would normally add all the series resistors first, but there is only one in this case), and using the assumed-voltage method, assume 4000V. The 1K will allow 4 amps, and the 4K will allow 1 amp, for a total current of 5 amps. Divide 4000V by 5 amps (use your Ohm's Law pie if necessary), and you will find you have a total resistance in this parallel branch of 800 ohms. Add that to the series resistance (R3), and you find you have a total of 2,800 ohms (give or take the tolerances).

**EXAMPLE 2**

Use Figure 7–6. If the circuit values are:

$$R1 = 82K$$

$$R2 = 56K$$

$$R3 = 5K$$

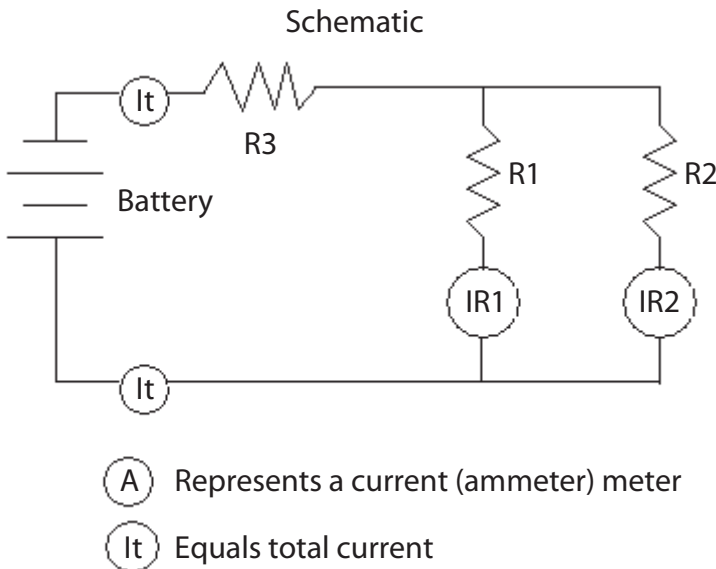
What is the total resistance?

Assume 4592 volts ( $82 \times 56$ ).  $4592V/82,000 \text{ ohms} = .056A$

$4592V/56,000 \text{ ohms} = .082A$ , then  $.056A + .082A = .138A$

$4592/.138A = 33,275 \text{ ohms}$ . Add  $R3$ ,  $5,000 + 33,275 = 38,275 \text{ ohms}$

$R_t = 38.275 \text{ kilohms}$

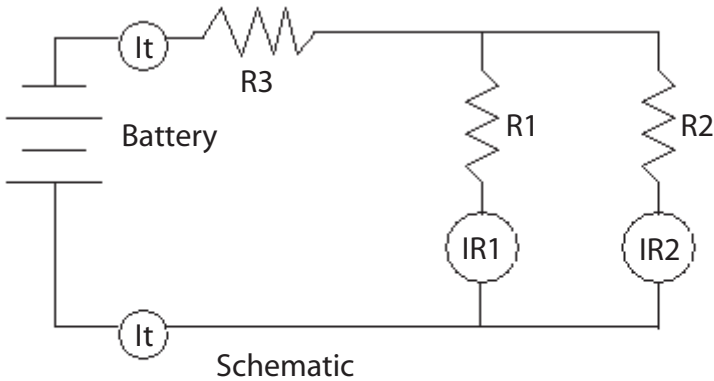


**Figure 7–5** Example 1.

**EXTENDED METER RANGES**

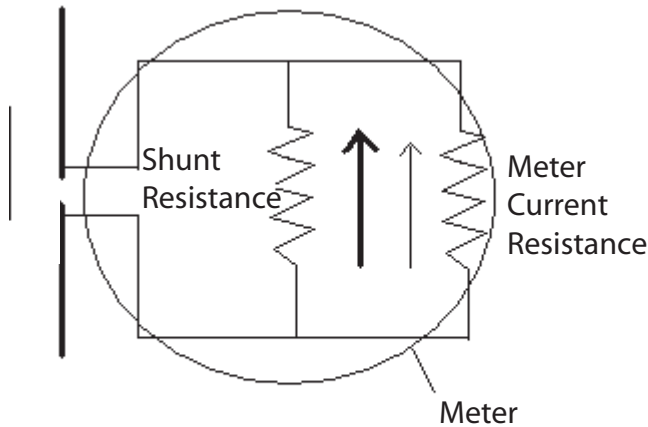
If you need to measure higher currents than the range of the digital meter (or the fsd of the analog meter) allows, you must use a shunt. The word *shunt* is descriptive of the process used to bypass current around the meter  $t$ . Figure 7–7 illustrates schematically how a shunt works.

If the meter in Figure 7–7 is a meter that measures 10 amps, then 10 amps through 0.1 ohm will drop 1.0 volt ( $E = I \times R$ ). However, suppose the meter



$$\begin{aligned}
 R3 &= 5K & \text{Assume } 30V \text{ across } R1 \text{ and } R2. IR1 &= .003A, \\
 R2 &= 15K & IR2 &= .002A. \text{ Branch total is } .005A \text{ then:} \\
 R1 &= 10K & 30/.005 &= 6000 \text{ or } 6K. \\
 & & 5K + 6K &= 11K \text{ total resistance}
 \end{aligned}$$

**Figure 7-6** Example 2—a series parallel circuit.



$$\begin{aligned}
 \text{Shunt Resistance} &= 0.00101 \text{ ohm} \\
 \text{Meter Current Resistance} &= 0.1 \text{ ohm}
 \end{aligned}$$

**Figure 7-7** Current through a shunt.

is required to measure 1000 amps? In that case, you will need some method for causing 990 amps to go around (to shunt) rather than go through the internal meter current resistance. This is because 1000 amps would cause a 100-volt drop across the meter current resistance (for an analog meter, that would be 990 amps of current actually trying to flow through the meter windings). So 1 volt is required (this is a parallel circuit so the voltage across

one resistance is the voltage across the other). The value of the resistance must be such that 1 volt will push 990 amps through this value. Therefore, using Ohm's Law ( $R = E/I$ ) a shunt of .00101 ohms is required.

## PROPERTIES OF DC CURRENT METERS

1. Permanent magnet meter movements are current-measuring devices.
2. Meter movement series resistance is *never* more than 100 ohms.
3. A current meter measures current in series with the load, *never* across a load.
4. A current meter is known as an ammeter.
5. Ammeter ranges may be extended beyond the fsd (analog) or range (digital) by using a shunt resistor.

## UNIVERSAL/ARYTRON SHUNT

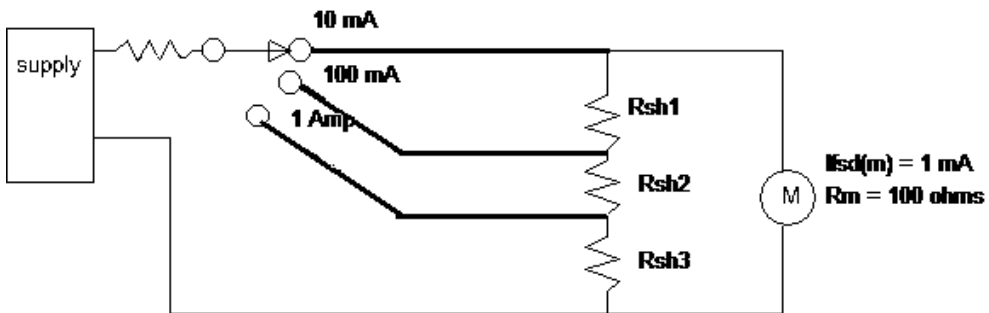


Figure 7-8 Universal or Arytron shunt.

While the design of the universal shunt is a historical fact and modern technicians do not have to concern themselves with meter shunts (other than knowing when to use an external one), the universal shunt is a great exercise in Ohm's law, and illustrates a practical use of parallel and series parallel circuits. The universal meter illustrated in Figure 7-8, has three scales: 0–10mA, 0–100mA, and 0–1 amp. There are a number of ways to determine the values, but we will use the proportional method. Since the smallest resistor will be the one for the 1-amp scale, we will determine it first.

1. The ratio of circuit fsd (1 amp) to meter fsd (1mA or 0.001 amp) is 1000 to 1. Therefore, if 1 unit of current goes through the meter, 999 units must pass through Rsh3. Divide the meter resistance ( $R_m$ ) by 999.  $100/999 = .11$  ohm for Rsh3.
2. The next scale is the 0–100mA scale. The ratio is 100 to 1. Therefore, for each unit of current that goes through the meter, 99 units must pass through Rsh2 and Rsh3. The total resistance for the Rsh2 and Rsh3 combination is the meter resistance divided by 99.  $100/99 = 1.11$  ohms. Since Rsh3 = .11 ohms, then Rsh2 must equal 1.0 ohms ( $1.11 - .11 = 1.0$ ).
3. The last scale is the 0–10mA scale. The ratio here is 10 to 1. Therefore, nine times as much current must pass through Rsh1+Rsh2+Rsh3 as passes through the meter. The total resistance of the three resistors must equal the meter resistance divided by 9.  $100/9 = 11.11$  ohms. Since the Rsh2 + Rsh3 combination = 1.11 ohms, the value for Rsh1 is 10 ohms.

The primary disadvantage of the universal shunt is that the basic meter range (in this case, 0–1mA) cannot be used unless some method for switching the shunt out of the circuit is employed. (On older analog meters there generally was a connection that allowed the basic meter range to be used.) While it is not the author's intent to have you designing shunts for analog meters, it is good practice in parallel circuits and Ohm's Law.

## MULTI-RANGE CURRENT METER FACTS

1. There are several methods for making a multi-range ammeter:
  - a. Independent shunt resistors for each range.
  - b. Universal shunt.
2. The universal shunt keeps a shunt on the meter at all times. This is really a good thing because it dampens an analog meter's movement.
3. The basic movement fsd cannot be used as part of the universal shunt (we have already shown that this is not a critical shortcoming).
4. Using the proportional method can enable you to determine the universal shunt resistor values (or any other method you are comfortable with).

## AMMETER CALIBRATION

Modern digital multimeters and the like generally require little calibration. What calibration must be performed is usually in a calibration lab. Still, the principles employed to calibrate an analog ammeter are basic to all electric calibrations. There are two methods for calibrating an analog ammeter.

1. Comparison calibration.
2. Voltmeter-precision resistor (or indirect) calibration.

## COMPARISON CALIBRATION

Figure 7–9 illustrates the equipment and connections used in a typical comparison calibration setup for an ammeter.

In this method, the current-limiting resistor is adjusted to allow varying amounts of current through the circuit, and the readings taken from the meter under test (MUT) are compared to the readings taken from the standard meter. Provided that the meter meets its specifications, the standard was at least as accurate as the meter under test's specifications (although four times the accuracy is generally preferred). Where the meter does not meet the standard, a calibration curve can be developed. When it is used with the calibration curve the meter will achieve its stated accuracy. Modern-day digital manufacturing and control instruments maintain a copy of the calibration curve and linearize themselves. Most modern instruments are trimmed to specification in the factory, and there are no field-adjustable or calibration points.

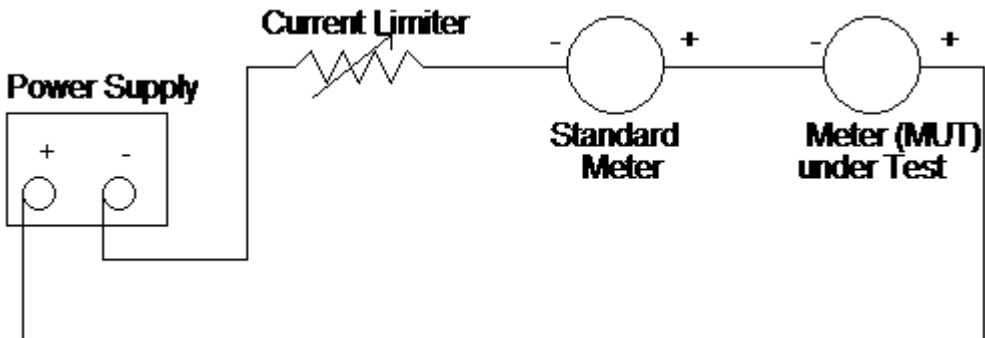


Figure 7–9 Comparison calibration, ammeter.

## VOLTMETER-PRECISION RESISTOR

Figure 7–10 illustrates the equipment and connections used in a voltmeter-precision resistor calibration setup for an ammeter.

This method utilizes Ohm's Law to determine the true current, where the voltage drop across the precision resistor divided by the resistance of the precision resistor gives the circuit current. The accuracy of this method depends on the tolerance of the precision resistor and the accuracy of the voltmeter.

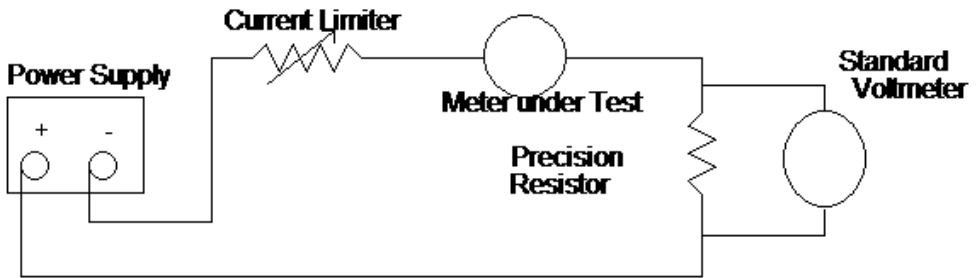


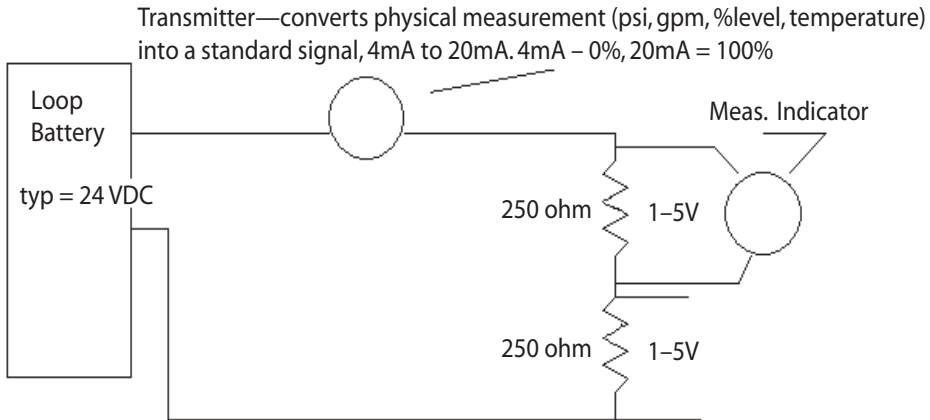
Figure 7–10 Voltmeter-precision resistor calibration, ammeter.

## INDUSTRIAL APPLICATION

There is one specific application in industrial instrumentation where the comparison calibration method, the voltmeter-precision resistor calibration method, or both methods can be used: field (scaling) calibration of an instrument loop device that uses the two-wire loop.

Figure 7–11 illustrates the two-wire loop for the *measurement* side of a control loop.

Industrial instrumentation uses several analog standard signals. These signals represent 0–100% of the range that is being measured or transmitted. The reason 0% is not 0mA (or 0 psi for pneumatics) is related to safety. Loss of loop power should never be thought of as 0% signal. While a discussion of the circuitry of the transmitter is beyond the scope of this text, a transmitter uses a *constant current* generator. This means that, *within specification*, the *voltage* across the transmitter has no effect on the *current* through the transmitter. That is, it is not an Ohm's Law device since it has active components (bipolar transistors) controlling the current. The only variable that controls the transmitter current is the measured variable. The instrument zero is set at the lower-range value (where the transmitter outputs 4mA), and full scale is at 100% or the upper-range value (where the transmitter outputs 20mA). This is the span of the measurement. As an example, say that the variable was temperature, the lower-range value was



**Figure 7-11** Instrument two-wire loop.

100°F, and the upper-range value was 500°F. In this case, you would set your instrument zero (0%) at 100°F, represented by 4.0mA, and full scale (100%) at 500°F, represented by 20.0mA. The span is then 400°F.

This means that at 100°F the transmitter outputs 4mA, and at 500°F the transmitter outputs 20mA. What would the output be at 300°F? The span is 400 degrees. 300 degrees is 200 degrees above the instrument zero (100 degrees). 200 degrees is  $\frac{1}{2}$  the span (400 degrees). Therefore, it would put out half the signal span:  $(20 - 4 = 16\text{mA})$ , half of 16 is 8mA,  $8\text{mA} + 4\text{mA}$  (0 %) = 12mA.

How could you field-calibrate this loop?

1. You could open the loop, insert an ammeter, and measure current directly. If your measuring ammeter had the required accuracy, you could then calibrate with it.
2. Notice that in modern two-wire loops, the receivers are all 1-5V. The 250-ohm resistor converts the current into a voltage output. How?

Ohm's law: 4mA through 250 ohms will have what voltage drop?

$$004 \times 250 = 1\text{V}$$

20mA through 250 ohms will have what voltage drop?

$$020 \times 250 = 5\text{V}$$

Because the current is the same through a series circuit (and the two-wire loop is a series circuit), you could place another resistor in series and use your voltmeter on the 5V range to measure the loop current. Note: the actual amount of resistance that is allowed in a loop is limited. Exceeding that amount will cause the loop to be nonfunctional. Do not place unnecessary resistances in a loop (this is only an example).

## REVIEW

*In this section we have briefly covered:*

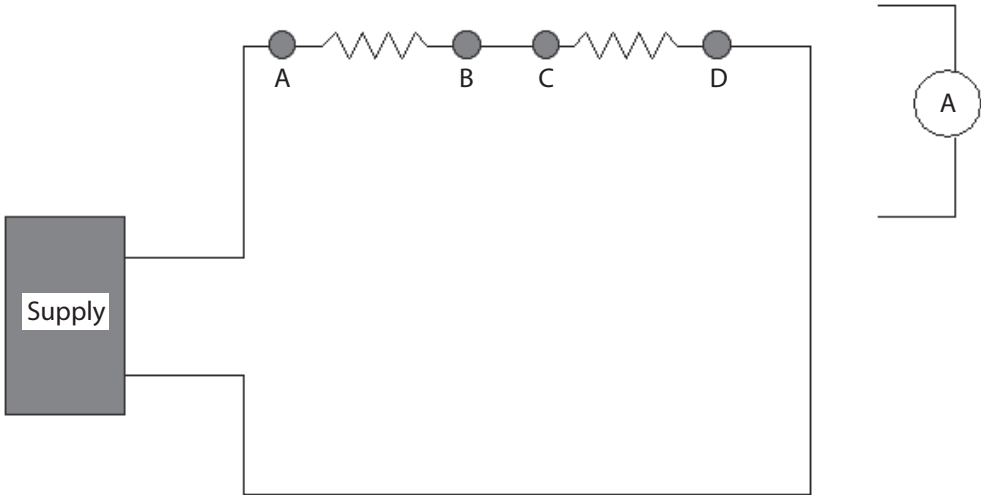
1. *Series and parallel resistive circuits.*
2. *Current meters and current measurement.*
3. *Calibrating a current meter.*
4. *Two-wire loops.*

*All of these topics will be reinforced in each and every section of this text. If you do not feel comfortable with this material, reread the sections you are having difficulty with. However, do not feel that you must have complete mastery of this subject matter as we will continue to present throughout the text.*

## CHAPTER EXERCISES

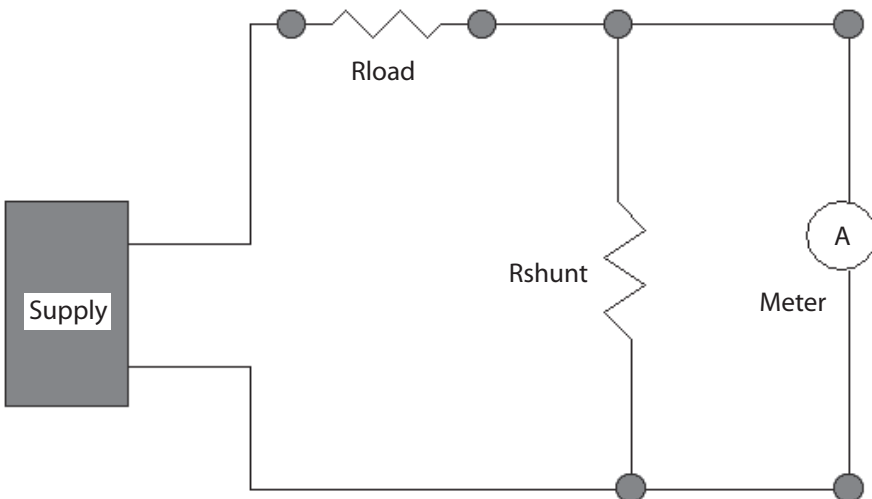
1. Determine the total current and total resistance for the following two-resistor combinations in parallel with the source voltage. All resistance is in ohms, and voltage is in volts unless otherwise stated:
  - a.  $R_1 = 47, R_2 = 22, V = 12.6$
  - b.  $R_1 = 180, R_2 = 120, V = 15$
  - c.  $R_1 = 1200, R_2 = 3900, V = 100$
2. Determine the total resistance using the assumed-voltage method for the following three resistor combinations in parallel with the source. All resistance is in ohms unless otherwise stated.
  - a.  $R_1 = 10, R_2 = 20, R_3 = 5$
  - b.  $R_1 = 1200, R_2 = 2200, R_3 = 3900$
  - c.  $R_1 = 56000, R_2 = 47000, R_3 = 82000$

3. At what point in the circuit shown in the following figure would you connect a current meter?

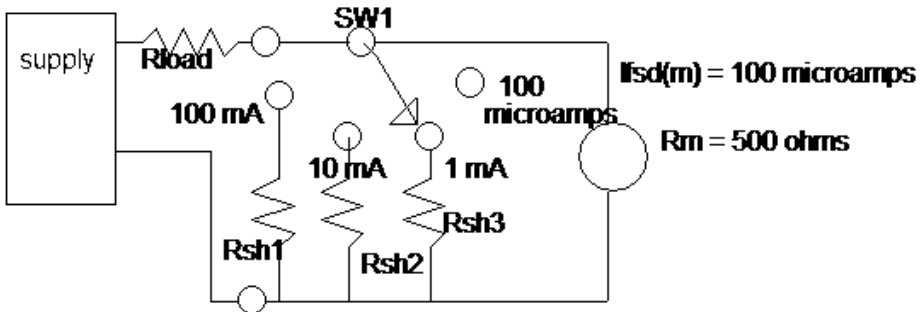


- a. Between A and B leave resistor connected.
- b. Between B and C leave wire disconnected.
- c. Between C and D leave resistor connected.

4. For this problem, use the following figure. The supply voltage is 25V,  $R_{load}$  is 2.5 kilohms,  $R_m$  (meter resistance) is 50 ohms, and  $I_{fsd}$  (full-scale deflection current) is  $500\mu A$  (.5mA or .0005 amp). If you want fsd to occur at 20mA what value must the shunt be?

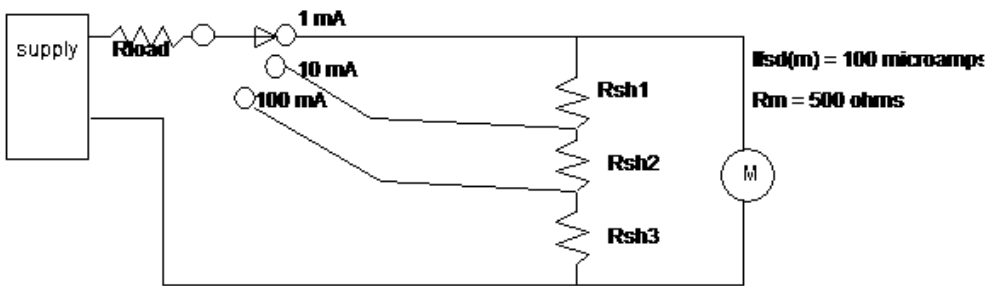


5. Refer to the figure in Problem 4.  $R_{load} = 1000$ ,  $R_m = 50$  ohms, and meter fsd is  $.5\text{mA}$  ( $.0005\text{A}$ ). In this problem, we would like the fsd to occur at  $25\text{mA}$ , so what value will  $R_{shunt}$  have?
6. Refer to the figure in Problem 4.  $R_{load} = 2500$  ohms,  $R_m = 100$  ohms, and the meter fsd is  $1\text{mA}$ . You want fsd to occur at  $10\text{mA}$ , so what is the value of  $R_{shunt}$ ?
7. Using the following figure, compute  $R_{sh1}$ ,  $R_{sh2}$ , and  $R_{sh3}$ .



$R_{sh1} =$  \_\_\_\_\_  
 $R_{sh2} =$  \_\_\_\_\_  
 $R_{sh3} =$  \_\_\_\_\_

8. Using the following figure, compute  $R_{sh1}$ ,  $R_{sh2}$ , and  $R_{sh3}$ .

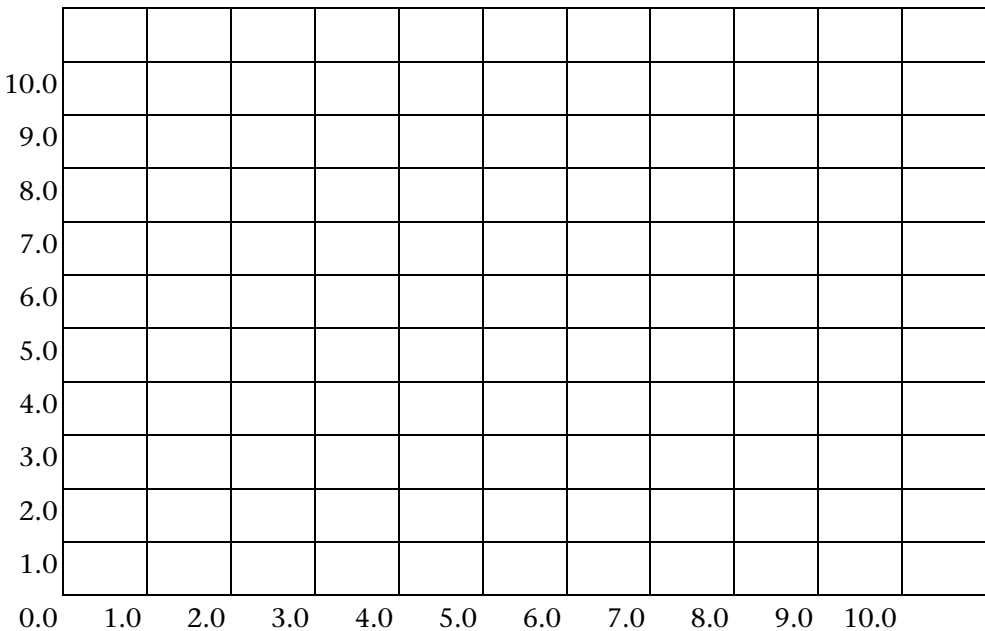


$R_{sh1} =$  \_\_\_\_\_  
 $R_{sh2} =$  \_\_\_\_\_  
 $R_{sh3} =$  \_\_\_\_\_

9. The following readings were taken from the comparison calibration of an ammeter.

Current Measured by Tested Meter (MUT)	Current Measured by Standard (mA)
0.00	0.00
1.00	0.98
2.00	1.98
3.00	3.01
4.00	4.02
5.00	5.03
6.00	6.04
7.00	7.05
8.00	8.04
9.00	9.02
10.00	10.00

Draw a calibration curve for this meter.





# DC BRIDGES

---

---

Bridges are an integral part of measurement and measurement devices. Of the many DC bridges in existence, the Wheatstone bridge is the most often used. One use is to measure unknown resistance values. This chapter explains the operation of the Wheatstone and Kelvin bridges. You must understand bridge operation thoroughly because they are fundamental to many measurements, devices, and techniques. As a plus, they will exercise your understanding of Ohm's Law and its applications.

### WHEATSTONE BRIDGE

A bridge is essentially a two-branch balancing network, which is in balance when there is no difference in potential between a point on one branch and the same point on the other branch. The advantage of the bridge's operation lies in the fact that when balance is indicated, the indicator draws *no* current, a condition called *null*.

A Wheatstone bridge used to measure resistance is illustrated in Figure 8-1.  $R_a$  and  $R_b$  in the figure are called the *ratio arms*.  $R_s$  is a variable *standard* resistance. It has a calibrated scale, so as you vary the resistance the scale tells you the resistance within the accuracy of the scale.  $R_x$  is the unknown resistance. Bridges, like the Wheatstone, are used extensively in measurement because they are a comparison measurement, that is, you are comparing an unknown value to a known value, much as in comparison calibration.

The accuracy of the Wheatstone bridge depends primarily on the tolerance of  $R_a$ ,  $R_b$ , and  $R_s$ . The meter [M in Figure 8-1] is a *null meter*. It has a center zero and reads to the left for a negative voltage and to the right for a positive voltage. Some electronic volt-ohm-meters (VOMs), or electronic multimeters, and almost all digital meters (as they read + or - from 0V) will have a center-zero scale and may be used as null meters. The scale itself is unimportant, since the meter's only purpose is to determine when there is *no* potential between points A and B, not the magnitude of the potential voltage. To explain the operation of the Wheatstone bridge, values have been assigned in Figure 8-2.

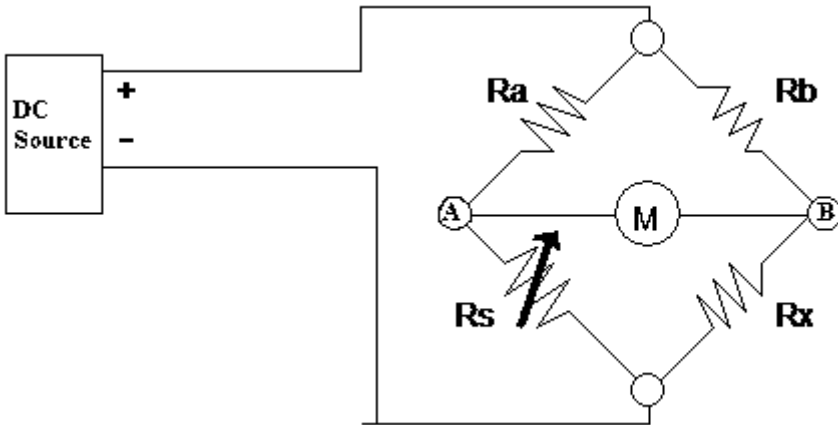


Figure 8-1 Wheatstone bridge.

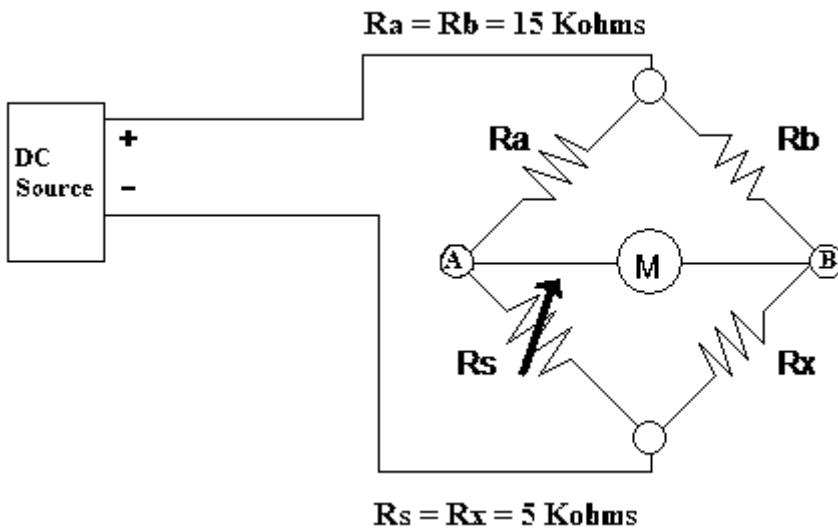


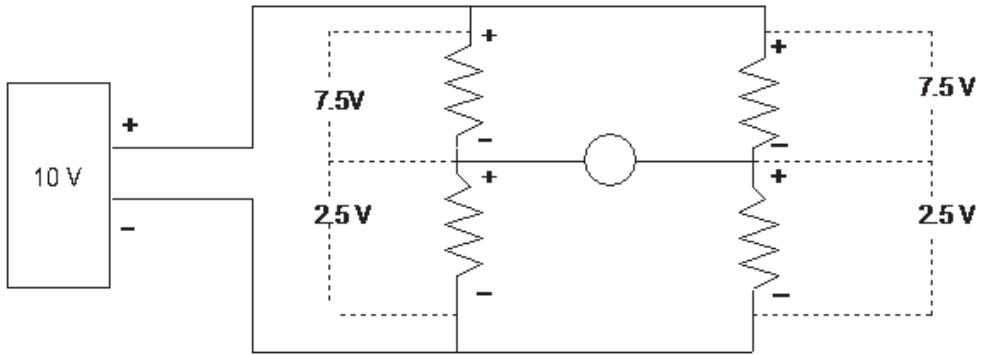
Figure 8-2 A balanced Wheatstone bridge.

If  $R_s = R_x$ , then the bridge will be “balanced” for the values of  $R_a$  and  $R_b$  in Figure 8-2. This is illustrated by redrawing Figure 8-2 as shown in Figure 8-3.

Since  $R_a = R_b = 15$  kilohms and  $R_s = R_x$ , the current in each branch will be equal. Hence, the voltage drop across the meter will be 0V.

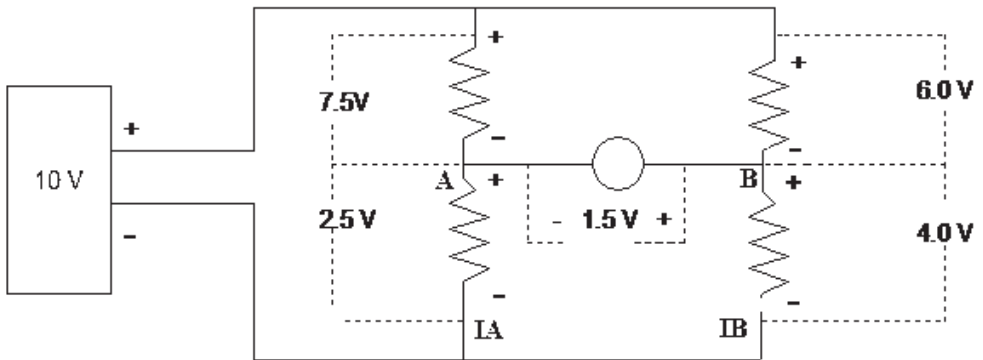
Assume that  $R_x$  is not 5 kilohms but 10 kilohms and that all other values remain the same. The resulting circuit appears in Figure 8-4.

Point A (2.5V positive) and point B (4.0 positive) differ by 1.5V. A current will flow from B to A if a path (such as the voltmeter) is connected.



$R_t = 10K, I_t = 0.001A$ , each branch has a  $1/2 I_t$  or  $0.0005A$

**Figure 8–3** Current in a balanced bridge.



$R_t = 11.1K\text{ohms}, I_t = 0.009A$ , as  $I_A = 0.0005A$  and  $I_B = 0.0004A$

**Figure 8–4** Current in an unbalanced bridge.

If you had the resistance of the meter and considered it in the circuit, then the current values and voltage drops would be different. This is because the resistance would also affect the overall current, but only slightly if a sensitive meter is used. Originally, a galvanometer—an extremely sensitive current meter that requires very little current for deflection—was used. To determine the actual currents with a meter connected would involve network theory. Fortunately, when using a bridge to measure resistance, you do not care (other than to gauge bridge sensitivity) how much current flows through the meter resistance because you adjust the bridge by varying  $R_x$  for a *no current flow* or *null* condition. For this condition, the value of  $R_x$  will equal  $R_s$  (assuming  $R_a = R_b$ ), and the resistance may be read off of the standard potentiometer dial. And that is how the bridge was and is used to determine an unknown resistance.

## BRIDGE SENSITIVITY

A manufactured bridge normally has a galvanometer for a meter movement. The more sensitive the meter movement is, the smaller the difference between  $R_s$  and  $R_x$  that can be resolved. Using the values given in Figure 8–3, the meter would have to have sensitivity in the microamp range to detect small differences in resistance.

The reason you are not concerned here with meter sensitivity (to any large degree) is that if you are using a manufactured bridge the manufacturer has determined the sensitivity for the ranges involved. If you build a bridge to measure resistance, you will use a digital meter or commercial *null* meter whose sensitivity is predetermined.

Meter sensitivity determines the amount of measurement resolution or the smallest change of resistance that the bridge can detect. It should be pointed out that meter sensitivity can be any reasonable value when measuring resistance because the value of the applied voltage and the values of the ratio arm resistors  $R_a$  and  $R_b$  can be chosen for the degree of resolution you need.

## RESISTANCE DETERMINATION

How do you determine the resistance once you have obtained a *null*? You could measure the resistance of  $R_s$ . If you have the ability to measure  $R_s$  to the accuracy desired, why not just measure  $R_x$ ? Commercial bridges have the  $R_s$  scale calibrated in ohms, so you may take the reading directly from this scale.

## BRIDGE MATHEMATICS

While an understanding bridge mathematics is not a requirement to successfully understand a bridge and the use of a bridge; if you know how to perform ratios, this section will help you understand bridge operations.

For the bridge in Figure 8–5 to be balanced (no potential difference between A and B) the following conditions must be met:

1.  $I_a R_a = I_b R_b$  (voltage drop across  $R_a$  = voltage drop across  $R_b$ ).

Ohm's Law:  $I \times R = E$

2.  $I_a = I_s = \frac{E}{R_s + R_a}$

All this is saying is that if the current through  $R_a$  is the same as the current through  $R_s$  then the bridge must be in balance. When the current through  $R_a$  is the same as current through  $R_s$  then no current flows through the *null* circuit. And by Ohm's Law  $I = E/R$ .

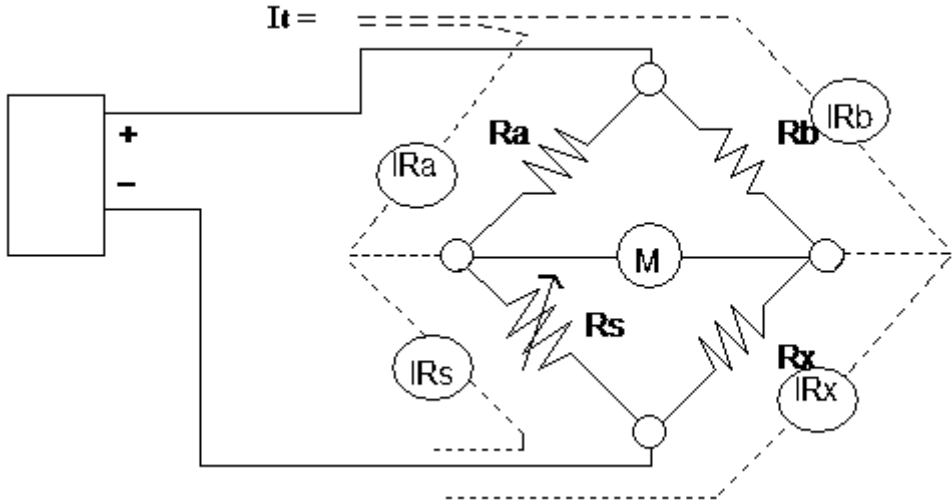


Figure 8-5 Current for bridge mathematics.

$$3. I_b = I_x = \frac{E}{R_b + R_x}$$

In other words, the current through  $R_b$  is the same as current through  $R_x$ . No current flows through *null* circuit. Remember, by Ohm's Law  $I = E/R$ .

$$4. \text{The simplest expression of a bridge is: } \frac{R_a}{R_s} = \frac{R_b}{R_x}$$

Therefore (for the bridge in Figure 8-5):

$$\frac{R_x \times R_a}{R_s} = R_b = R_x \times R_a = R_b \times R_s = R_x = \frac{R_b}{R_a} \times R_s$$

This is the standard expression of balance for the Wheatstone bridge. However, most of the time it is drawn with  $R_x$  and  $R_b$  switched, so the expression has  $R_a$  as the topmost member. If you have three of the values ( $R_a$ ,  $R_b$ , and  $R_s$ ), then you may determine  $R_x$  by solving the expression for  $R_x$ .

You may now see why  $R_a$  and  $R_b$  are called the ratio arms. When  $R_a = R_b$  the ratio is 1, so  $R_x = R_s$  when the bridge is balanced.

## REVIEW

1. Bridges provide a measurement method whose accuracy depends on the components rather than the meter movement.
2. Bridges are used so a null condition equals balance.
3. The formula for a Wheatstone bridge (as drawn in Figure 8–5) is  $R_x = R_b/R_a \times R_s$ .
4. The bridge is balanced if current through one branch equals current through the other or if  $R_a/R_s = R_b/R_x$ .

## MULTIPLIER RESISTORS

To expand the range of a bridge, particularly to the higher ranges, yet maintain the resolution of  $R_x$  used on the lower scales, manufacturers use a multiplier resistor in one of the ratio arms. In Figure 8–6,  $R_b$  has been changed to 100 kilohms, and  $R_s$  is set to 5 kilohms. When will the balance occur?

If you use the known side  $R_a$  and  $R_s$ , the current (for balance—no current through A to B) is:

$$\frac{10\text{V}}{15 \text{ kilohms}} = 0.67\text{mA}$$

which gives a voltage drop across  $R_a$  of 6.7V and across  $R_s$  of 3.3V. For the bridge to balance, the drop across  $R_b$  must equal the drop across  $R_a$ . To have a 6.7V drop across  $R_b$  (100 kilohms), a current of  $6.7\text{V}/100 \text{ kilohms} = 0.067\text{mA}$  must flow. This same  $0.067\text{mA}$  must flow through  $R_x$  to achieve a balanced condition, and must drop 3.3V so

$$R_x = \frac{3.3}{0.000067\text{A}} = 50 \text{ kilohms}$$

Note that  $R_x$  is now ten times  $R_s$ . A much faster method for determining the resistance is to use the bridge formula:

$$R_x = \frac{R_b}{R_a} \times R_s$$

As illustrated,  $R_b/R_a$  forms a ratio of ten. This same process works for fractional ratios. If  $R_b = 1 \text{ kilohm}$ , and  $R_s$  is set to 5 kilohms for balance, then in the formula

$$R_x = \frac{1 \text{ kilohm}}{10 \text{ kilohm}} \times 5 \text{ kilohm}$$

$R_x$  would equal 500 ohms because the  $R_b/R_a$  ratio was 1/10.

**Note**

Neither the applied voltage nor the meter sensitivity enters into these equations. In fact, any voltage may be used, provided that the resistor's wattage rating is not exceeded. Heat generated by too much current will cause the resistors to change in value, destroying the accuracy of the bridge. The lower the individual resistance of the ratio arms, the more overall current will flow.

*Question:* If  $R_b$  is 100 ohms,  $R_a$  is 10 kilohms (this ratio will measure resistors in the 5-ohms range), and if 10V is applied, what power must the bridge resistors dissipate?

*Answer:* 10 watts (10W). Because power ( $P$ ) =  $E$  (volts)  $\times$   $I$  (amps), and with 5 ohms or less for  $R_x$  most of  $E$  will be dropped across  $R_a$  and

$$I_a \approx 1 \text{ amp}$$

so

$$10 \times 1 = 10W$$

The majority of resistors used in bridges are of 1/8 to 1/4W rating. If 10W is dissipated, *smoke* and *damage* to the bridge are the result. A good policy to follow is to use only the voltage needed to produce the meter deflection you desire. In most cases, the voltage is supplied as part of the bridge circuitry and packaging. The limits of the Wheatstone bridge for resistance measurement run from 1 to 2 ohms to approximately 3 megohms.

The lower limit is set by the resistance of the connecting leads and *binding posts'* contact resistance. Binding posts are the physical connectors where you connect the wires to  $R_x$ . It is easy to achieve compensation for connecting leads, but it's difficult, if not impossible, to measure the contact resistance of the binding posts, let alone compensate for that resistance.

The upper limit is set by the bridge's sensitivity to unbalance. As the resistances involved become higher, the current available for the null meter decreases, until the current is too small to deflect the null meter. A more sensitive null meter and higher applied voltages (along with higher

power dissipation resistors) is required to measure increasingly higher resistances.

## LEAD RESISTANCE

To use a bridge to measure less than 1-ohm resistances, you must employ some method for compensating for meter lead resistance. The bridge circuit in Figure 8–6 illustrates the problem of trying to measure less than 1-ohm resistors with a Wheatstone bridge.

It's clear that the lead resistance will contribute 0.5 ohms uncertainty to the determination of  $R_x$ . What is worse is that the lead resistance is not necessarily fixed, varying with temperature and other environmental influences. To reduce the effect of lead resistance, a simple change is necessary: another lead is added to the bridge connection to  $R_x$ . Figure 8–7 illustrates this technique.

Note that the third lead (lead 3) now ties the bridge to the power supply return. This places the resistance of lead 2 on the  $R_s$  side of the bridge. Any voltage dropped across  $R(\text{lead 1})$  will be offset by the drop across  $R(\text{lead 2})$ .  $R(\text{lead 3})$  does not enter into the bridge equations since current from both branches must pass through it. This makes the bridge equation as follows:

$$R_x + R(\text{lead 1}) = \frac{R_b}{R_a} \times R_s + R(\text{lead 2})$$

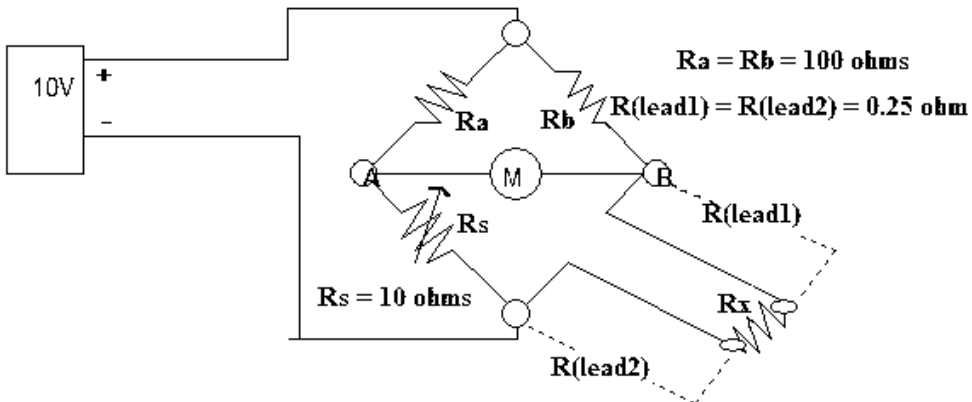
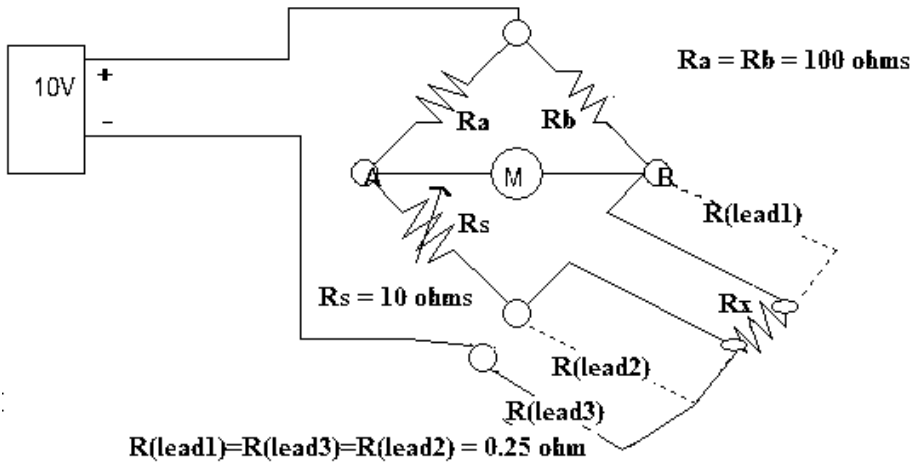


Figure 8–6 Lead resistance problem.



**Figure 8–7** Adaptation of Wheatstone bridge.

Since  $R(\text{lead } 1) = R(\text{lead } 2)$ , you may subtract this equal quantity from both sides of the equation, and you again have the bridge equation without lead resistance.

There are other bridges, such as the Kelvin bridge, which is a bridge within a bridge for compensating for binding post (connector) resistances.

## REVIEW

1. A multiplier resistor may be used with the Wheatstone bridge to expand its range.
2. Lower resistance measurements require that consideration be given to applied voltage and resistor power dissipation.
3. A Wheatstone bridge finds application in measuring resistances from near 1 ohm to 3 megohms.
4. Meter lead and contact resistance limit a Wheatstone bridge's lower resistance measurement.
5. Providing sufficient current for null meter deflection limits a Wheatstone bridge's upper resistance measurement.

## APPLICATION

One of the methods used to measure temperature is a resistance thermometer device (RTD). It operates on the principle that a conductor's resistance will change with temperature. Several materials lend themselves to very linear changes in resistance over quite large spans of

temperature. Platinum is one. A standard industrial RTD will typically have a resistance of 100 ohms at 0 degrees centigrade. It will change about .385 ohm per degree. As you can guess, to measure an RTD within 1 degree, you will have to use a method that can resolve less than 1 ohm.

Typically, a Wheatstone bridge is used with a two-wire RTD. This is the case when the bridge and the RTD are physically very close to each other. But if the conditions are such (for example, in a location where the RTD is mounted too hot for the bridge to accurately measure) that the RTD is not coupled directly to the bridge, then connecting leads will be used. The problem posed is that these leads have resistance, and worse yet, they are subject to the ambient (surrounding or environmental) temperature, which is always varying. This means that the lead resistances may change. Since both leads are the same length and are generally twisted together (although insulated from each other, of course), they will have the same resistance. How would you compensate for this problem?

Answer: use a three-wire RTD. They are manufactured for this purpose, and generally all RTD measurement devices allow for three-wire connection. The resulting circuit appears in Figure 8–8.

Using a third lead ( $R_{\text{lead3}}$ ), which has the same resistance as the other two, you connect the lead to the power supply rather than to the negative side of  $R_s$ . Current from both branches flows through  $R_{\text{lead3}}$  and therefore does not enter into any but the total resistance calculations. What this does is place  $R_{\text{lead2}}$  in series with  $R_s$ . Since  $R_{\text{lead1}}$  is in series with the RTD, the resistances of the leads (which are identical) will cancel each others' effect. This why it is stated that a three-wire RTD compensates for lead resistance.

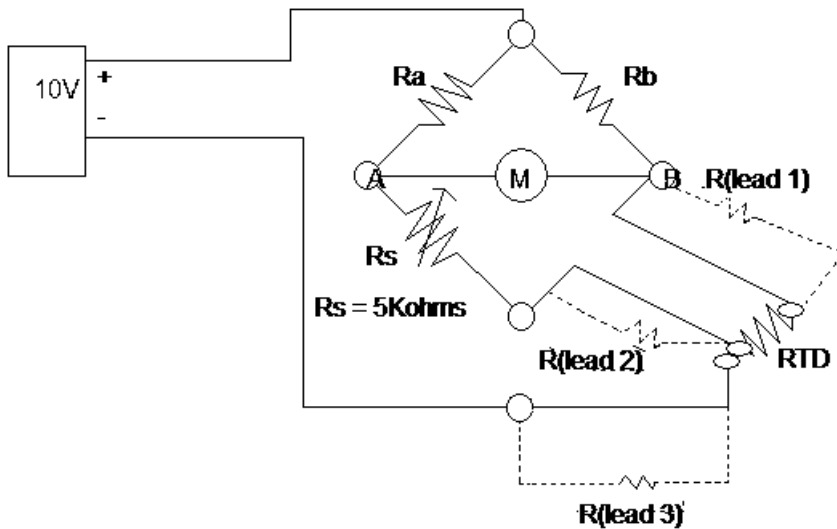
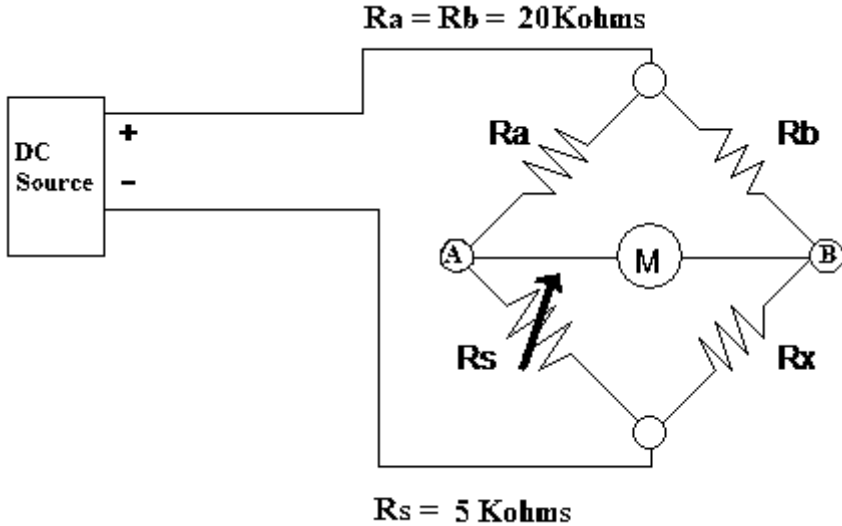


Figure 8–8 Three-wire RTD connections.

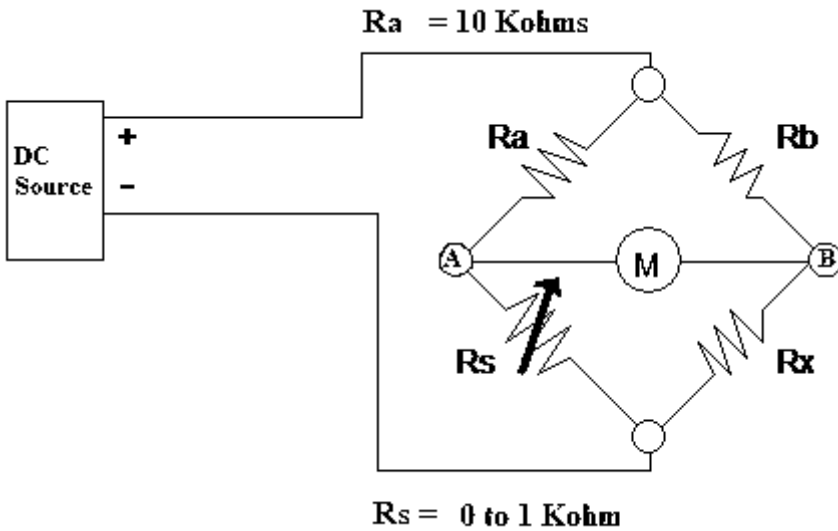
## CHAPTER EXERCISES

1. Using the following figure, answer questions a, b, and c.



- a. If  $R_s$  is set to 3.850 kilohms for a balanced condition, what is the value of  $R_x$ ?  
 \_\_\_\_\_ ohms
- b. If the DC source = 10V at balance what current flows in the  
 $R_a$ - $R_s$  branch \_\_\_\_\_ mA  
 $R_b$ - $R_x$  branch \_\_\_\_\_ mA  
 $A$ - $B$  branch \_\_\_\_\_ mA
- c. What is the range (in ohms) that can be measured with this bridge?  
 \_\_\_\_\_ ohms to \_\_\_\_\_ ohms

2. In the following figure determine the value of the multiplier resistor to measure resistance in the range of:



- 10 ohms to 1 kilohm \_\_\_\_\_ ohms
- 5 kilohms to 10 kilohms \_\_\_\_\_ ohms
- 0.1 megohm to 1 megohm \_\_\_\_\_ ohms
- 50 kilohms to 100 kilohms \_\_\_\_\_ ohms
- 1–100 ohms \_\_\_\_\_ ohms

**Answers to the Chapter Exercises can be found at the back of this book.**

## CONCLUSION

You have reached the end of Chapter 8. If you are having difficulty with any concepts, please reread the text. If the difficulty persists, locate a peer, mentor, supervisor, or someone with technical knowledge about DC bridges and ask for their help.

For further information on the concepts in this chapter, search the following terms in your Internet search engine:

**Wheatstone Bridge**

**Two-wire RTD**

**Four-wire RTD** (not mentioned in text, but an exploratory search)

**Kelvin Bridge**

**Three-wire RTD**

# AC FUNDAMENTALS

---

---

Alternating current (AC) is the most naturally occurring form of energy in the universe. If you have a fair grasp of direct current (DC) then alternating current is a relatively easy concept. It is *essential* that you understand the behavior of alternating current. Most of the modern world uses these behaviors to run industry, provide information, support medical therapies, the list of uses is endless. To understand AC is to understand the *why* of modern technology.

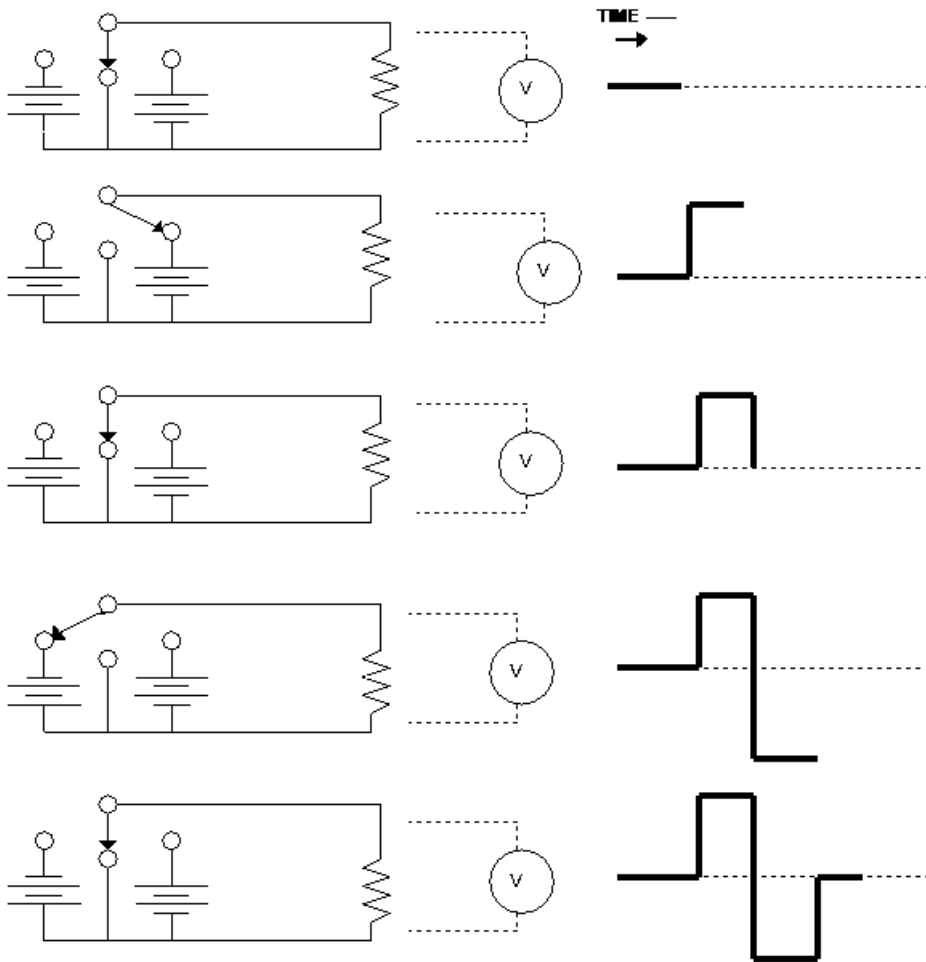
## ALTERNATING CURRENT DEFINED

Alternating current (AC) is defined as an electrical current that changes amplitude continuously and periodically changes polarity. A little investigation will show that we have already discussed most of the concepts of AC. For example, it still obeys Ohm's Law (for the instantaneous amplitude and polarity it exhibits at any selected moment).

Understanding alternating current only requires a modification of what you've already learned. The following explanation, though simplistic, it is also quite true: we can simulate AC by a *switched* or *square wave* and this will meet our definition for changing amplitude and periodically changing phase.

Figure 9–1 is an illustration of the procedure for mechanically generating a form of AC using two batteries and a switch. The wave-form is the voltage across the resistor as a result of the present switch condition plus each switch condition prior to this condition, so there is history in the wave-form (in all wave-forms). The wave-form is a graphic (or actually, a graph) of the voltage across the resistor for a period of time and, in our case, in a number of different switch conditions.

Note that the switched wave-forms fit the description (almost) of alternating current. That is, they are continuously changing in amplitude (except at plateaus) and periodically changing polarity. *Amplitude* is the magnitude of positive or negative current (or voltage). *Polarity* is the direction of current or the direction the voltage would push current through a load symbolized by the resistor in Figure 9–1. This a good place



**Figure 9-1** Switched wave-forms.

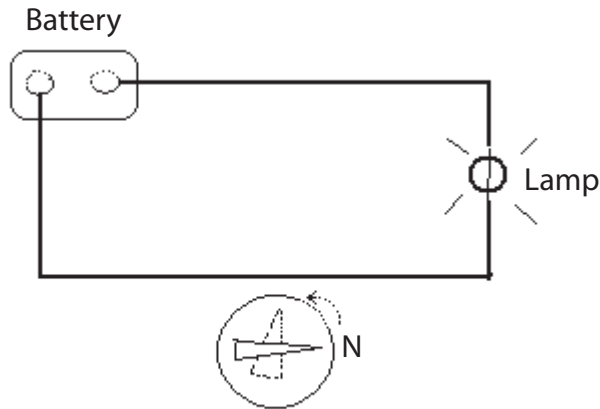
to introduce some other definitions. The time it took for the current to be switched from zero, positive, zero, negative, and back to zero (the time it took for our switch conditions to be completed) is known as the *period*. It is measured in time. If you were operating the switch and decided to switch it faster and faster, the period of time would decrease, and the number of positive and negative alternations would increase. We call the complete zero to positive to zero to negative to zero a *cycle*. The number of cycles in one second is expressed as hertz (Hz).

This is probably not how you pictured alternating current. You have in your mind's eye a sinusoidal wave shape. *And it is true*, most alternating current is of the sinusoidal variety.

## ELECTROMAGNETISM

A sinusoidal wave-form is easily generated mechanically. But first you must understand magnetism and its effect upon conductors. One of the earliest noticed behaviors of electricity was the presence of a magnetic field around a wire carrying current. This was proved by placing a compass next to a wire carrying direct current (in a complete circuit, of course), as illustrated in Figure 9–2.

When the current was switched on, the magnet would deflect; when the power was removed the magnet would return to its normal position. It was also noticed that the greater the current, the greater the deflection. Winding the wire in a coil seemed to amplify the effect (it concentrates the magnetic field). Placing an iron core in the center of this coil really enhanced the power of this field (the ferrous core further concentrates the magnetic field). This was an electromagnetic field. *Electro-* because it is caused by an electric current, *magnetic* because the result is a magnet just like a permanent (natural) magnet. *Any conductor carrying current has a magnetic field.*



Compass needle deflected due to current

Figure 9–2 Magnetism and electric current.

### FIELD DEFINED

The best description of a field (any kind of field—*magnetic*, *electrostatic*, *gravitational*, *ether*) the author remembers came from an ARRL Radio Amateurs Handbook circa 1953. Roughly paraphrased it states:

*If an event occurs at A that causes an event to occur at B, and there is no visible or physical connection, we say they are in the same field.*

Engineers describe fields as “areas of influence.” The exact mechanism is not known perhaps, but the behavior is very well modeled, meaning that we can predict quite reliably what the effects of a magnetic field will be. To visualize a field, imaginary lines of force are drawn depicting the field strength in the area of influence. You’ve seen simulations of these lines when iron filings are placed on a glass above a magnet (or paper or cloth). For magnetic fields, the lines are drawn from the South to the North Pole; they never cross as they are always parallel to each other. The more of these imaginary lines of force there are in an area, the stronger the field. By coiling the conductor, we concentrate the lines of force within the coil area. Placing an iron core in the center of the coil allows the lines of force to concentrate since iron is a magnetic substance through which the lines of force travel easily. These imaginary lines of force are anything but imaginary in real life. They power electric motors, bring power into businesses and homes, generate the spark for your gasoline engine, and perform countless other chores, many of which will be described later in this text.

There is a corollary to the current in a conductor causing a magnetic field phenomenon. That is, if a conductor cuts across (not parallel to) a magnetic field or the magnetic field cuts across the conductor, and there is relative motion (one or both are moving), then an electric current will be induced in the conductor. The amount of current will depend on:

1. The strength of the field.
2. The number of conductors cutting the field.
3. The geography of the conductors (wound in a coil?).
4. The speed of the relative motion.

For our discussion here we are only interested in one conductor. Figure 9–3 illustrates how a coil, placed in a magnet field and rotated, will generate an electric current. The arrow points to the portion of the curve that is generated by moving the coil to that position from the previous position.

## **SINUSOIDAL WAVE SHAPE**

Figure 9–4 illustrates why this is called a *sine wave*. With the radius as the amount of voltage generated by a single coil (seen previously in Figure 9–3), start at 0 degrees rotation, and rotate the radius through 360 degrees counterclockwise so it is aligned with where it started, just as in Figure 9–3.

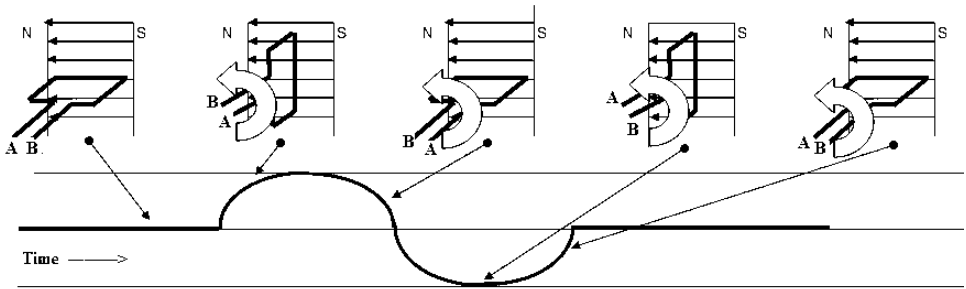


Figure 9-3 Generating an alternating current.

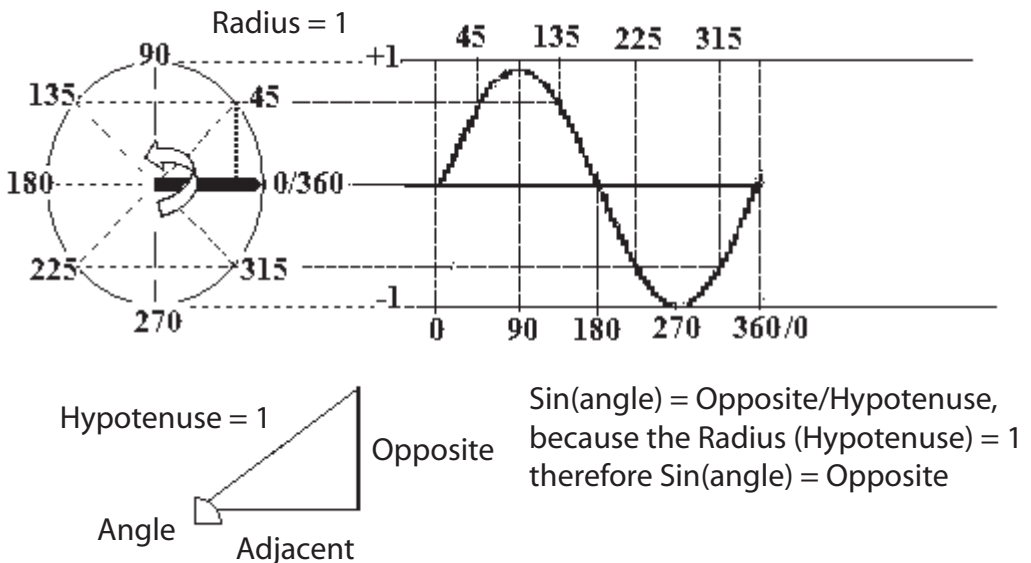


Figure 9-4 Sine wave.

The radius for this circle is 1. The voltage generated will be the sine (sin) of the angle that the radius forms during rotation relative to where it started (0 degrees).

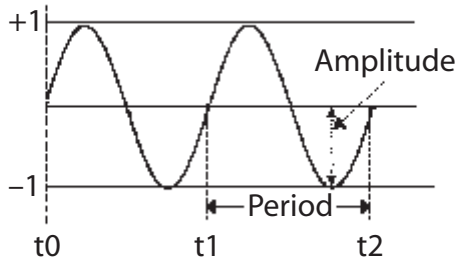
Because the sine of an angle is equal to the ratio of the opposite side (in our case, the amplitude) divided by the hypotenuse, which is 1, the amplitude of this wave shape is described as tracing the sine of the rotating radius. If you can remember your high school geometry, you will recall that the circumference of a circle (the length of the line starting at 0 degrees and tracing the outer boundary of the circle to 360 degrees) is  $2\pi r$  (pronounced "2 pie r"), where  $\pi \approx 3.17$ . This means that if you stretched a piece of string around the circle shown in Figure 9-4 if it had a radius of 1" the string would be 6.34 inches long. A sine wave is mathematically known as  $2\pi f$ , where  $f$  is the number of wave shapes that appear in one

second. Sine waves have some fascinating properties; some of which will be discussed in this chapter.

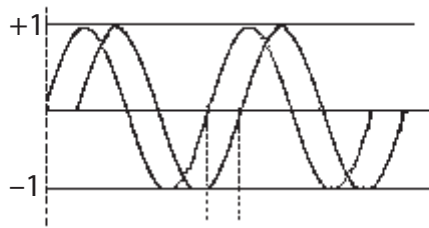
## ALTERNATING VOLTAGE AND CURRENT

We now need to visualize this sine wave along with our switched system and see what is actually taking place. Ohm's Law will not be repealed. Let us use the drawing in Figure 9–6 and define a few terms.

1. *Peak-to-peak voltage*—measured from the positive-most excursion to the negative-most excursion. In Figure 9–4, the peak-to-peak value is 2.0.
2. *Peak voltage*—measured from the center (0) axis to either the negative-most or the positive-most excursion. It is half of the peak-to-peak value for a sine wave. For Figure 9–4 the peak value is 1.0.
3. *RMS (root-mean-square, also called the effective) value*—this is the value of alternating current that produces the same heating effect as a direct current with this same value. For example, 0.707Vrms will produce the same heating effect as 0.707V DC. The majority of alternating voltage/current values are RMS. In Figure 9–6, the RMS value is 0.707. To find the RMS value from the peak voltage, multiply the peak voltage by 0.707. To find the peak voltage from the RMS value, multiply the RMS value by 1.414. (If you want to know why, 1.414 is the reciprocal [divided into 1] of 0.707.)
4. *Frequency*—the number of occurrences in a specified time period (identified in Figure 9–6), usually one second. It is measured from one point on a recurrent wave-form to the same point on the following wave-form. In Figure 9–4, 0 degrees would be one point, and 360 degrees is the other end of the complete wave-form. It is called a cycle because it completes 360 degrees in one period and then repeats. The number of cycles per second was formerly expressed as “cycles per second,” but this has been changed to hertz. It is incorrect to say “Hertz per second” unless you are talking about the change in frequency per second. You may determine frequency by dividing the time of the period into 1 second.
5. *Period*—If the frequency is known, you may calculate the period by dividing the frequency into 1 second.
6. *Phase*—is the angular position of a wave shape from “its” starting (0°) location point. Phase difference as used in this book is the number of degrees separating the two signals of the same frequency. This is illustrated in Figure 9–6. Which one is leading the other and which one is lagging depends on which one is the reference.



**Figure 9-5** A sinusoidal wave-form.



**Figure 9-6** Phase difference in degrees.

Both signals have the same frequency and amplitude; they are separated by  $90^\circ$ , which is the phase difference. Note: A continuing change of phase in one direction will cause a change in frequency. *Phase* and *frequency* are related and are called the *angular* components of a sinusoidal wave shape.

## REVIEW

1. A sinusoidal wave shape is described by amplitude, frequency, and phase.
2. RMS is the AC equivalent to DC in terms of heating power.
3. If you know one amplitude measurement, you may calculate the others.
4. Frequency is the number of occurrences in 1 sec.
5. Frequency is determined by dividing the time of the period into one (1).
6. Phase is the angular position of a wave shape from its ( $0^\circ$ ) starting point.
7. Phase difference is the number of degrees separating two signals of the same frequency.

## VALUES OF ALTERNATING CURRENT

Aside from looking at the wave shape of alternating current, there must be an understanding regarding the relationships between voltage and current that are sinusoidal wave shapes. As stated before, Ohm's Law has not been repealed, and it still takes voltage (potential) to push current (flow) through the resistance (opposition).

Figure 9-7 illustrates a complete alternating circuit. We will use this circuit to calculate the power (in watts) of an AC circuit with a 10-volt RMS source (marked AC in Figure 9-7). The sinusoidal wave-form in the diagram is that of current. Recall that this would be 1 amp if 10 volts DC were applied.

Use Table 9-1 to determine values of current and power.

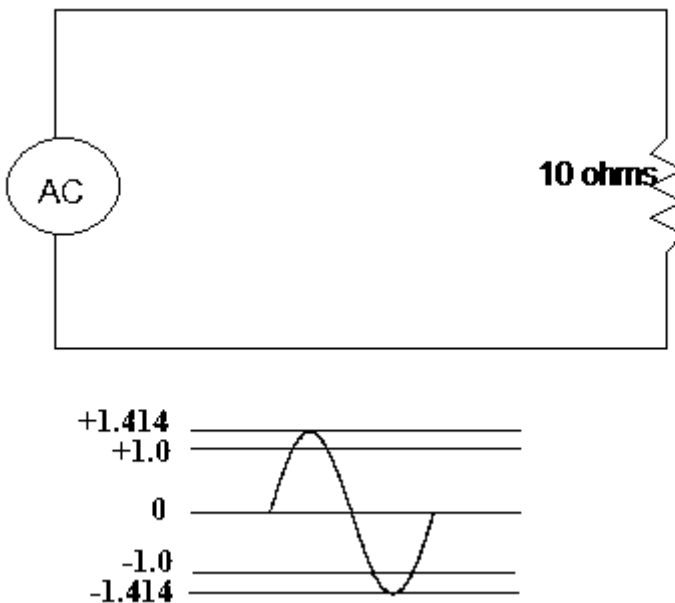
$$\text{Power: } P \text{ (watts)} = E \times I$$

Perform a little algebraic magic (called substitution), where

$$E = I \times R \text{ (Ohm's Law),}$$

and place that representation in the power formula:

$$P = I \times R \times I \text{ or } P = I^2 \times R$$



**Figure 9-7** Basic AC circuit.

**Table 9-1** Instantaneous AC Values

Degrees	I	I <sup>2</sup>	P (watts)
0	.000	.000	.000
10	.245	.060	.600
20	.486	.236	2.36
30	.707	.500	5.00
40	.909	.826	8.26
50	1.083	1.173	11.73
60	1.225	1.500	15.00
70	1.329	1.766	17.66
80	1.393	1.940	19.40
90	1.414	2.000	20.00

## **RMS ENERGY**

You will notice that at times the resistor is dissipating 20 watts, which means 1.4 amps are flowing through it. Well, yes. But the actual DC power equivalent is only 10 watts. This is determined by multiplying the peak voltage by 0.707. ( $1.414 \times 0.707 = 1$ ). With alternating current an *old* but very important parameter has come back into our measurements: time. Since electricity was first debated, it was claimed that current really didn't flow, that "flow" was just a way for early investigators of electrical phenomena to understand and visualize electricity. With alternating current, current would "flow" one way for a period of time and then "flow" the other way for an equal amount of time (for a sine wave). The average current then would be zero if you were counting polarity and current really did flow. But if you consider it as energy being transferred and to transfer the effect from DC to AC, you chose to heat a resistor, then it is apparent that work will be done by the alternating current. From Table 9-1, note that over half of a cycle (any 90° section), different amounts of energy are expended at different times. That is why Table 9-1 is called "Instantaneous AC values." Polarity is not a factor in resistive heating.

You have to determine the amount of energy dissipated in the resistor over the time it was dissipated. True, you have 2.0 amps flowing at the negative and the positive peaks, but those peaks only exist for a very short period of time compared to the wave shape as a whole. The average energy dissipated over one cycle will equal 10 watts (just what Ohm's Law says it should be). This process, averaging over a period of time, is

mathematically called *integration*. It is used to find the area under the curve—or the energy over time. Anyone who has ever calculated his or her average speed when traveling from one city to another has averaged over time, or technically, performed integration.

In other words, to heat a resistor so it will dissipate ten watts with the circuit in Figure 9–7 using DC would require 1 amp.  $P = I \times I \times R$ , or  $1A \times 1A \times 10 \text{ ohms} = 10 \text{ watts}$ . Using AC to get the same heating effect would require a 1.414A peak current. As we've seen, the term *RMS* stands for *root mean square*. This is a mathematical process for finding the area (or power) under the curve (amplitude). Almost all AC is given in RMS terms because that is the DC equivalent.

### EXAMPLE

You are told that the voltage available at the wall socket of your residence is 120Vac. What does this mean?

It means that the voltage available will heat a resistor the same amount as a DC voltage of that amount (120Vdc). It also means that the peak voltage (the highest voltage in either a positive or negative direction) will be almost 170 volts. The peak voltage is determined by multiplying the RMS value, 120, by 1.414.

### POWER

The figures in Table 9–1 illustrate a number of facts regarding the power of an alternating current. For example, note that the instantaneous power is actually twice the RMS power, however, it only lasts an instant (pun intended). Note also that the half power point is at  $30^\circ$  where the current is .707 (of its RMS value), which gives the power as 0.500.

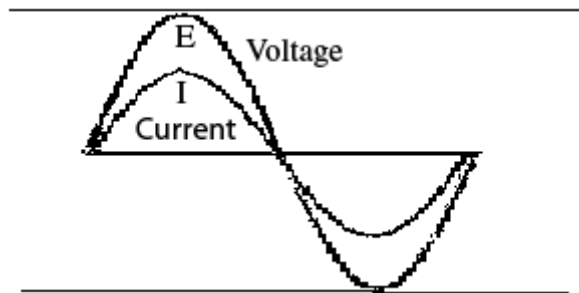
Here are some conversions that should be committed to memory:

1. If you have the *peak*, multiply it by 0.707 to obtain *RMS* (effective) value.
2. If you have the *effective* (RMS) multiply it by 1.414 to obtain the *peak*.

In a sinusoidal or symmetrical wave shape, peak to peak is twice the peak. Note, too, that for heating the resistor, voltage and current were in phase, that is, the greater the voltage, the greater the current—just like Mr. Ohm told us.

**EXAMPLE**

Figure 9–8 illustrates the statement that voltage and current are in phase through a resistive circuit. It illustrates that through a resistive circuit time does not enter into the calculations except when trying to determine the instantaneous values of voltage, current, or power. These values depend on the source power wave-form. Voltage and current are in phase (peaks are at the same time; zero crossings are at the same time).



**Figure 9–8** Relationships between E, I in a resistive circuit.

**REVIEW**

1. *Alternating current changes amplitude continuously and direction periodically.*
2. *RMS values are the transfer values. That is, the RMS value will provide the same heating effect as a DC voltage of that value.*
3. *To determine the peak voltage or current, multiply the RMS (effective) value by 1.414.*
4. *To determine the RMS (effective) value, multiply the peak by 0.707.*
5. *1.414 is the reciprocal of 0.707. That is,  $1/1.414 = 0.707$  and  $1/0.707 = 1.414$ .*

**ELECTROMAGNETIC RADIATIONS**

As was stated at the beginning of this unit, alternating current is the most commonly occurring form of energy. Radio, light, television are all forms of alternating current. The term *electromagnetic wave* is used to talk about energy that is freely propagating itself through space in most cases. When energy is cyclic, that is, an alternating voltage or current, it carries with it certain phenomena. (Phenomena are things we can observe and measure

and predict but can't explain very well). Fact 1: a difference in potential creates an electrostatic field—this is the potential difference that pushes current. Its “area of influence” is between two points of different charge (this also creates lightning—when the potential overcomes the resistance of the insulator between the charged bodies). If a difference of potential can cause a current to flow, then the current will vary as the potential (Ohm's Law). Fact 2: current flowing through a conductor sets up an electromagnetic field. The strength of this field is determined by the amount of current (among other parameters).

A wave length is the distance that field can move at the speed of light (pretty fast) in one cycle. At about one-sixth of the wave length, the magnetic field, if it is dominant, (usually in low-voltage, high-current environments) will create an electrostatic field at right angles to it and the direction of travel. Or if the electrostatic field is dominant (usually in high-voltage, low-current environments) it will create an electromagnetic field at right angles to itself and the direction of travel. In either case, one will make the other, and they are self-perpetuating (propagating) after that. This leads to radiated energy. The key here is that they must be alternating fields to cause this to happen. Direct current does no such thing. The higher the frequency of the alternations (and the shorter the wave length), the easier it is to propagate. Table 9–2 lists the alternating currents in order of their frequency and band designations.

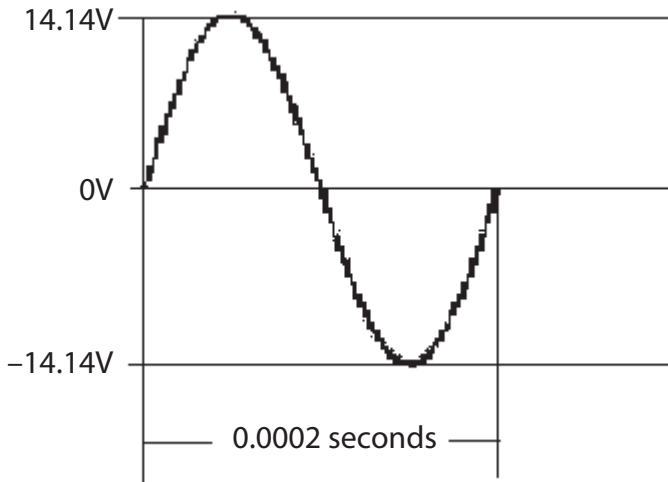
As you can see, almost all energy is of the alternating current variety; that is, it has a frequency. Of course, the higher the frequency, the more the characteristics of propagation differ also.

**Table 9-2** Electromagnetic Spectrum

Frequency	Wave length (meters)	Designation
0-20Hz	infinity-10,000,000	Sub audible
20-10,000Hz	10,000,000-300,000	Audio
10KHz-30K	300,000-10,000	Very Low Frequency (VLF)
30KHz-300KHz	10,000-1000	Low Frequency (LF)
300KHz-3MHz	1000-100	Medium Frequency (MF)
3MHz-30MHz	100-10	High Frequency (HF)
30MHz-300MHz	10-1	Very High Frequency (VHF)
300MHz-3GHz	1-.1	Ultra High Frequency (UHF)
3GHz-30GHz	.1-.01	Super High Frequency (SHF)
30GHz-300GHz	.01-.001	Extra High Frequency (EHF)
	.001-.00001	Infrared
	.00001-.000001	Visible Light
	.000001-.0000001	Ultraviolet
	.0000001-.000000001	X-rays
	.000000001-.00000000001	Gamma rays
	.00000000001 <	Cosmic Rays

## CHAPTER EXERCISES

1. Questions a–e refer to the following figure.



- What is the peak-to-peak amplitude of this signal? \_\_\_\_\_ V
  - What is the peak amplitude of this signal? \_\_\_\_\_ V
  - What is the RMS value of this signal? \_\_\_\_\_ V
  - What is the period (in seconds) of this signal? \_\_\_\_\_ sec
  - What is the frequency of this signal? \_\_\_\_\_ Hz
- An AC signal has an effective value of 12.6V and a period of 16.6 msec (.01667 sec).
    - What is the peak voltage? \_\_\_\_\_ V
    - What is the frequency? \_\_\_\_\_ Hz
  - A sinusoidal AC signal has a peak-to-peak voltage of 35.6 volts and a frequency of 1Khz (1000Hz).
    - What is the peak voltage \_\_\_\_\_ V?
    - What is the effective voltage \_\_\_\_\_ V?
    - What is the period of one cycle \_\_\_\_\_ sec?
  - What is the peak instantaneous power dissipated by a 10-ohm resistor if 15 watts is dissipated by the effective value?

5. Voltage and current are \_\_\_\_\_ phase in a resistive circuit.
  - a. in
  - b. out of
  - c. neither of the above
6. You have observed a 100V peak-to-peak signal with a period of .000025 sec in a series circuit with a 47-ohm resistor. What is the:
  - a. effective voltage
  - b. frequency
  - c. effective power dissipated
  - d. peak power dissipated

***Answers to chapter exercises will be found at the back of this book.***

## CONCLUSION

You have reached the end of Chapter 9. If you are having difficulty understanding portions of this chapter, please reread the text. If your difficulty persists, locate a peer, mentor, supervisor, or someone with technical knowledge of alternating current and have them assist you.

To explore the concepts in this chapter consult the following resources:

*Public or company library*—look under alternating current, electromagnetic radiation, and radio waves in the card catalog.

*Internet*—search for any of the following terms (or any other area in which the text is not clear to you) in your search engine. Be forewarned that the responses to your search will be at varying levels of expertise; select the one that aids your understanding best.

**alternating current basics  
electromagnetic radiation  
magnetic fields**

**alternating current theory  
electrostatic fields**

# AC SOURCE FUNDAMENTALS

---

---

This chapter is a review of some of the common AC sources used in the technical arenas: namely, the function and signal generators. It also provides a generic procedure for calibrating the voltage output of a signal or function generator. To determine alternating voltages or currents correctly, you must use some method for determining the output of the source, and this chapter will familiarize you with one of these procedures.

## SIGNAL-FUNCTION GENERATOR

A signal generator and a function generator both provide AC voltage of different frequency, amplitude, and, in the function generator's case, wave shape. The primary difference is that most signal generators provide a sinusoidal (sine wave-like) output only. The function generator provides a sinusoidal output and, normally, a square wave and a triangular wave output. A function generator may be considered a signal generator with wave shaping. The operation and output calibration procedure of both are similar, and in fact most of these functions today are built into the test equipment used to measure wave shapes, so you will have a source available.

There are many different models of signal and function generators, all with different control panel layouts and even different types of controls. The different models have similar basic functions and procedures for operating.

## FREQUENCY-DETERMINING GROUP

In the group of frequency-determining controls, modern signal generators and function generators will have a digital arrangement. Many are under software control and are operated from a form of operator interface. They differ widely in appearance, operation, and characteristics. No attempt will be made to explain their operation in this text as specific instruments come with their own instructions or they may be downloaded off the Internet. However, the general concept will still be the same as those explained here; there are just many more bells and whistles. Less

expensive instruments typically have then analog-type interface typical of older generation devices, consisting of a vernier control and (a) multiplier switch(es).

The vernier control provides a fine adjustment of frequency where the multiplier switch(es) offers a coarse adjustment of frequency. The multiplier switch(es) may appear similar those in Figure 10–1.

## VERNIER CONTROL

The vernier control will appear similar to the left-hand dial shown in Figure 10–1. Notice that it is variable from 1 to 10. Modern instruments will have a digital readout of the output frequency (unless they are extremely economical units—that is, inexpensive). So attempting to read from the vernier dial is another skill much like reading of a slide rule: they have both faded into antiquity.

To select the frequency, first select the range of frequency you desire using the coarse (multiplier) switch(es), then dial in the desired frequency using the vernier dial.

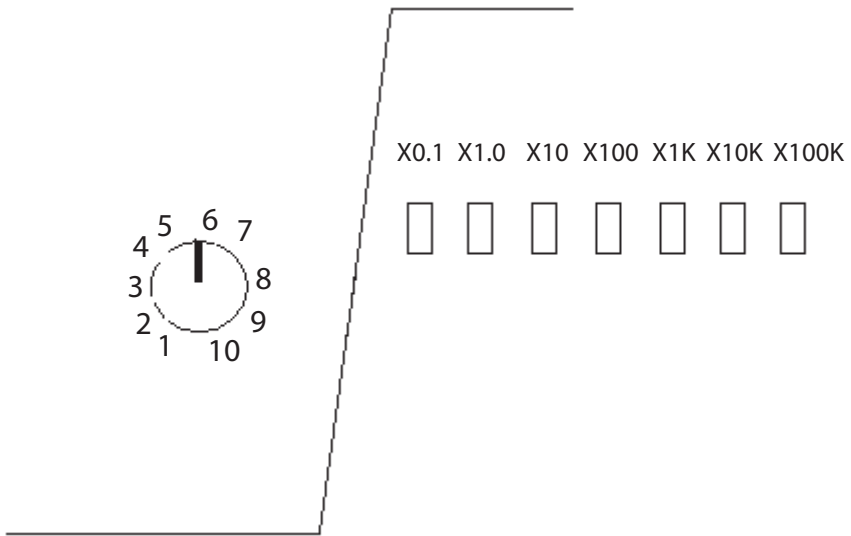
## EXAMPLE

For those of you who just have to know how it was done before digital, it is extremely simple, as the following example illustrates:

5100Hz is desired, which is  $5.1 \times 1000\text{Hz}$ . Therefore, the  $\times 1000$  multiplier is selected. Next, the vernier fine adjustment is made by setting the vernier to 5.1. For a function generator, the only difference in procedure is that before selecting the multiplier (coarse) frequency, you must select the desired wave-form (square, sinusoidal, or triangular).

## OUTPUT CALIBRATION

Most modern signal and function generators have an output level control that is set for a desired level of output. Modern devices have internal standards that ensure that the output is what it says it is at the frequency and wave shape chosen. Some older models will have a calibrated attenuator, and a few will have a calibrated output-level indicator. Modern units read the output on the operator display.



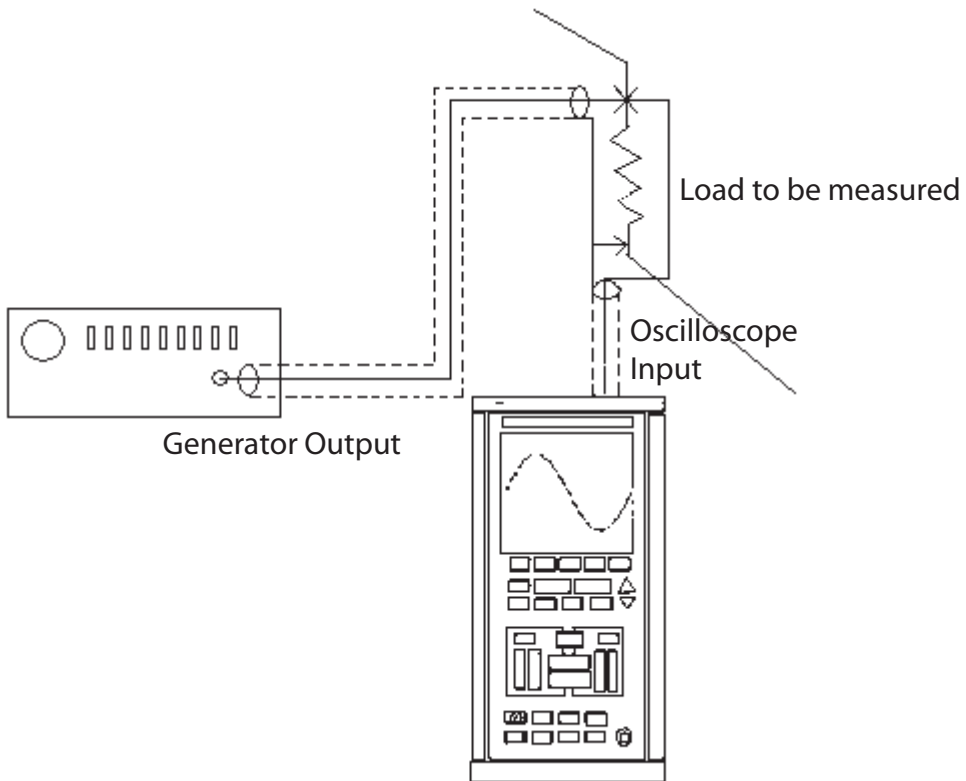
**Figure 10–1** Multiplier switches.

A word of caution! To compensate for possible mismatching, you must use some method for checking the output voltage (at a set of specific frequencies) while driving a circuit of unknown impedance. The simplest way is to use an oscilloscope or true RMS meter (on many modern signal display devices the generator functions are built in). The equipment is set up as in Figure 10–2.

The operation and characteristics of oscilloscopes are explained in the next chapter. Understand that, for now, an oscilloscope is a device that displays a voltage wave-form. Oscilloscopes come in many varieties, however, most will have at least one calibrated vertical channel gain (or a standard to calibrate the channel to).

The oscilloscope is set in its calibrated mode for the vertical channel to be used. The signal generator or function generator is adjusted for the desired output level while driving the load. If the frequency is changed, you may need to readjust the output level to maintain a constant output.

When reading the output level from the signal generator, always consider whether an attenuator (if any) is being used. You will need to gain practice in measuring generator output levels to become comfortable with the procedures.



**Figure 10–2** Setup for calibrating generator output.

**Caution**

Regardless of today's digital wizardry (and whether you have it or not, or are using an old-fashioned analog generator), the displayed output or the calibrated attenuator and/or calibrated output level indicator are *only* correct if the circuit being fed from the generator (the load) has the *same* impedance (opposition to alternating current) as the output circuit of the generator. Some generators have an output impedance of 600 ohms; others have 50 ohms; still others have 75 ohms or 150 ohms. Worse yet, many times, the input impedance of the load is unknown or is variable and depends on frequency.

## GENERIC PROCEDURE FOR CALIBRATING GENERATOR OUTPUT

To set up a signal/function generator to have a specified output at a specified frequency, the procedure is as follows:

1. Select the wave-form (if you are using a function generator; if not start with step 2).
2. Select the coarse (multiplier) range.
3. Select fine (vernier) to desired frequency.
4. Set output level to *minimum*.
5. Connect generator into circuit.
6. Connect oscilloscope, with calibrated vertical channel, across generator output.
7. Adjust output level control and attenuator (if any) to desired level.
8. If frequency is changed, check output level and readjust if necessary.

This chapter is merely a general guide to the use of signal/function generators. As with all electronic equipment, *a thorough reading of the user's (or operation) manual will prove most beneficial.*

## NONSINUSOIDAL WAVE-FORMS

If a standard multimeter were actually used to ensure the output of a function generator using non-sinusoidal waveforms, some drastic differences would be evident between the voltage displayed and what is read on a calibrated voltmeter. This is because the RMS values for a square wave differ from those of a sine wave, which in turn differs from a triangular wave shape.

Your choices here are limited. (1) Use a true RMS meter for nonsinusoidal wave-forms, or (2) understand how to correct for these nonsinusoidal wave-forms. There are no other options.

## REVIEW

1. *Signal/function generators that are not digital in nature have controls that fall into two general groups:*
  - a. *Frequency.*
  - b. *Level.*

*The digital devices also have the same flavors (frequency and level), but with different displays and control nomenclatures.*

2. *The frequency group is divided (in general) into coarse (multiplier) and fine (vernier) adjustments.*
3. *The output level is usually adjustable; some models include a calibrated attenuator, and some models have a calibrated output indicator.*
4. *Calibrated output attenuators and calibrated output indicators are only accurate when the input (load) impedance of the circuit being driven is equal to the output impedance of the generator.*

## CHAPTER EXERCISES

1. List the steps for determining the output frequency of a function generator.
2. List the steps for calibrating the output of a signal generator.

***Answers to chapter exercises will be found at the back of this book.***

## CONCLUSION

If you are having difficulty with the concepts explained in this chapter, please reread the text. If your difficulty persists, locate a peer, mentor, supervisor, or someone with technical knowledge of signal and function generators and ask them for help.

For additional information on the concepts in this chapter, type the following key words in your Internet search engine:

**signal generator**  
**sinusoidal signals**

**function generator**  
**nonsinusoidal signals**

## THE OSCILLOSCOPE

---

---

The oscilloscope is probably the most useful and important piece of test equipment you will use when analyzing the operation of electronic equipment. It is particularly useful in observing AC wave-forms, and that use will be discussed in this text. This chapter explains the block diagram of a simple oscilloscope and briefly outlines some of the generic operations performed with oscilloscopes. Understanding the oscilloscope's various circuit functions will help you to use this amazingly versatile equipment correctly.

### CATHODE RAY TUBE

The cathode ray tube (CRT) is probably one of the last vacuum tubes still used in new designs. It is the heart of the oscilloscope. Although many newer designs use liquid crystal display or plasma displays, the genesis of the oscilloscope was (and in many cases still is) the CRT.

Figure 11-1 shows the general structure of a single-beam oscilloscope CRT.

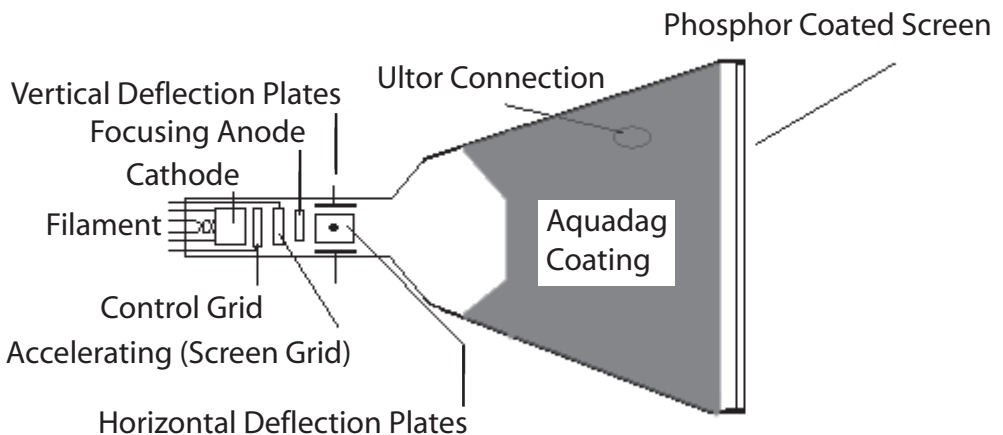


Figure 11-1 Cathode ray tube.

The CRT consists of the following main parts:

1. An electron gun assembly consisting of the filament, cathode, control, and accelerating grids. It generates, focuses, and determines the intensity of the electron stream.
2. Deflection plates, which determine the direction the electron beam will take, hence where it converges on the phosphor screen.
3. A phosphor-coated screen. On the inside of the faceplate, this phosphor coating phosphoresces (illuminates) at the point the electron stream contacts it. This is observed as a point of light on the outside of the faceplate. The aquadag coating provides the high-voltage attraction for the electron stream and collects the electrons after they bounce off of the phosphor-coated screen.

## ELECTRON GUN ASSEMBLY

The filament heats the cathode to a temperature where it will emit electrons.

The control grid contains the electrons and allows them to be emitted through an aperture in a stream (or beam). The accelerating anode, which is positively charged, causes the electron stream to greatly increase in velocity. The electron beam has begun to disperse into a wider cross-section as it traverses the accelerating anode. The focusing anode is negatively charged (with respect to the previous anode), and the potential on this element is adjusted so the electron beam will converge into a small point on the phosphor screen.

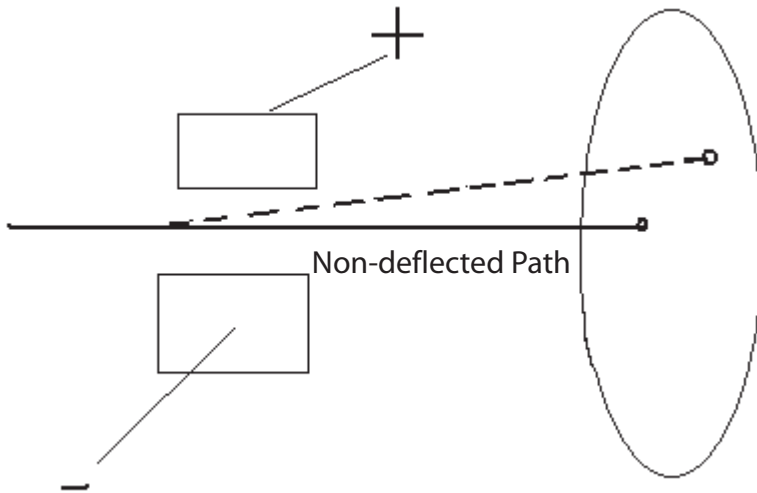
## DEFLECTION PLATES

Deflection plates direct the electron beam. As shown in Figure 11–2, the polarity and intensity of the charges on the deflection plates will cause the electron beam to be deflected in the direction of the positive plate. The amount of deflection is determined by the intensity of the charges on the deflection plates.

## PHOSPHOR SCREEN

Many different phosphors are used to coat oscilloscope CRT screens. The most common is P-31, which is a medium-persistence phosphor that emits a light green. *Persistence* refers to how long light remains after the electron beam is removed.

In the storage oscilloscope the phosphor is given a varying persistence by including another element in the screen assembly: a fine grid, whose



**Figure 11–2** Electron beam deflection.

potential determines the persistence. Some oscilloscopes use phosphors that emit colors other than green light.

It should be noted that a very-high positive potential (in relation to the cathode) is created on this screen by way of a connection through the aquadag coating to the ultor (anode) contact. This potential is from 1KV to 15KV.

## DEFLECTION CIRCUITRY

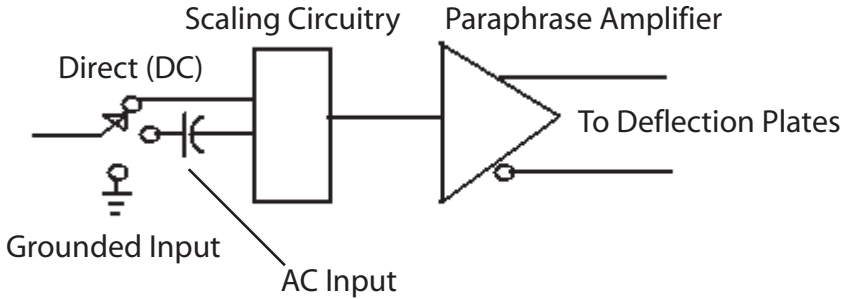
Although useful in itself, the CRT becomes an oscilloscope only with the addition of external circuitry, in particular, the vertical and horizontal deflection circuitry.

## VERTICAL DEFLECTION

A block diagram of a typical vertical deflection circuit is shown in Figure 11–3.

The input selection switch chooses between the following:

1. A direct connection for observing DC levels.
2. A ground to adjust the trace to the desired vertical position and perform balance/gain adjustments.
3. A series capacitor to remove a signal's DC component. This is necessary if small changes must be observed and if these changes are riding (superimposed) on a large DC value (in comparison to the magnitude of the signal's change).



**Figure 11–3** Typical vertical deflection circuitry.

The scaling circuit is used to restrict the percentage of the input signal that reaches the DC amplifiers. Because the oscilloscope is a voltage-measuring device, the input to the scaling circuitry is designed much like the multiplier resistors in a voltmeter. Most oscilloscope vertical inputs (which are calibrated) have several elements in order to maintain constant impedance to the input and to the DC amplifiers.

Impedance and impedance matching are covered in greater detail later in the text. It is sufficient here to point out that the input voltage is reduced in steps (as in a multi-range voltmeter), while the DC amplifier operates at a constant gain.

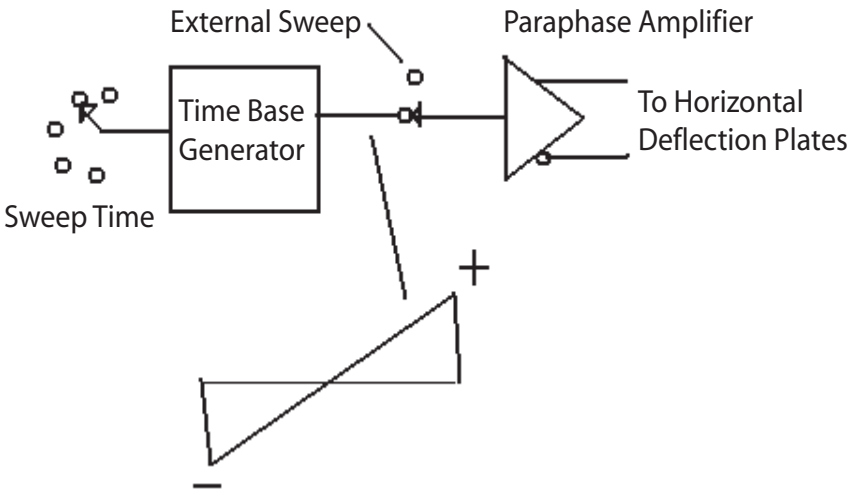
In an oscilloscope that can measure DC (all modern units), the vertical amplifiers must be DC amplifiers. Much more about amplifiers will be covered in Chapters 14 and 16. The amplifier will have one or more gain adjustments for calibration and compensation for the aging of components. These are not operated by a user or normally accessible, and are intended for use only by calibration personnel. The paraphase amplifier must be capable of producing two opposite-phase, equal-amplitude voltages in order to drive the deflection plates.

## HORIZONTAL DEFLECTION

A block diagram of a horizontal deflection circuit for a time-base oscilloscope is shown in Figure 11–4.

The user can choose inputs between the external or internal drive by selecting the internal/external sweep switch. The time-base generator develops a linear-rising (sawtooth) voltage that rises in a straight slope from a negative to a positive voltage of the same magnitude. This slope is normally called a *ramp*. The return of the ramp from its most positive voltage to its most negative is the retrace (flyback) portion.

Notice that the retrace time, though finite, is a very small part of the overall sweep time. The amount of time that the ramp takes to go from – to + is the



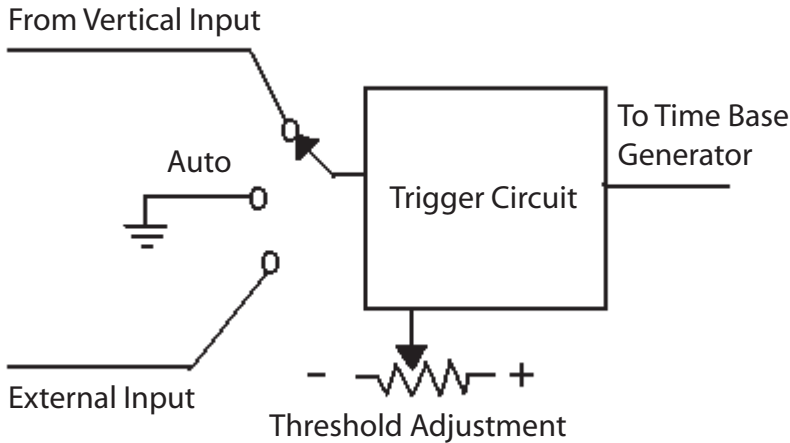
**Figure 11–4** Horizontal deflection circuitry.

sweep time. The gain of the horizontal amplifier is calibrated so this line takes a certain length, usually the length of the horizontal divisions of the graticule across the CRT face. The faster the sweep rate, the smaller interval of time the sweep occupies. What starts the sweep? It could be free running, but then you would have no control over when it started in relation to a signal you wished to observe. To obtain this relationship, called *synchronization*, a triggering circuit is used. The block diagram of the triggering circuit is shown in Figure 11–5.

The trigger circuit decides where on the input wave-form the trace (hence the observed wave shape) should be started. Normally, there is a preset AUTO trigger that will produce a trace even in the absence of an input signal. A manual trigger adjustment is provided so you may set the trigger point exactly at any location of the input wave-form. On some models, a delay circuit is provided if the trace will be started at some time after the trigger point occurs.

## DUAL-TRACE OSCILLOSCOPE

The typical oscilloscope used in many industrial application shops is a dual-trace, delayed, triggered-sweep, DC to 20MHz (or higher) model. Several circuits have been added to achieve dual-trace operation (using just one beam in the case of CRT types and one scan for the LCD types). There are now two complete vertical amplifier sections. These are electronically switched (multiplexed) into the vertical deflection circuitry.



**Figure 11–5** Typical trigger circuitry.

Many dual-trace oscilloscopes give you a choice of ways in which the signals are to be multiplexed (such as alternate, chopped, added). Two of the most common ways are the alternate and chopped modes. In the *alternate* mode, a complete sweep for channel A is made, and then a complete sweep for channel B is made. This is useful if short intervals of time (signals of high frequency) are to be observed. However, at slow sweep times this alternate switching becomes hard to observe, and comparisons of simultaneous or near simultaneous signals on channel A and channel B cannot be performed. For this case, the chopped mode is used. In the *chopped* mode the electronic switch free-runs above 10kHz or higher, sampling each channel 10,000 times or more a second.

## OTHER FEATURES

Fuller-featured oscilloscopes may have additional circuitry, such as:

1. Provision for algebraically adding the two channel signals. This allows concurrent portions of the two signals that are in phase to be of greater amplitude than out-of-phase portions.
2. Z-axis input for modulating intensity. Portions of the input signal that are in concurrence with the signal on the z-axis will be brightened. This means that when the z-axis is positive the trace will be brightened for only the time that the z-axis is positive. This is used to show timing concurrence, particularly with digital circuitry.
3. A delayed by B. This circuitry triggers the A trace when the second trace, B, occurs.

4. Calibration point. This is usually a 1kHz square wave with a peak-to-peak voltage of 1V for calibrating attenuator probes.
5.  $\times 5$  or  $\times 10$  trace stretching. This takes one-tenth of the displayed wave-form (one graticule division) and displays it over 5 ( $\times 5$ ) or 10 ( $\times 10$ ) graticule divisions. This is currently called ZOOM in other display technologies.

## REVIEW

1. *The cathode ray tube consists of:*
  - a. *Glass envelope.*
  - b. *Phosphor-coated screen.*
  - c. *Electron gun assembly.*
  - d. *Deflection plate assembly.*
2. *The circuitry of a typical time-base oscilloscope contains the following major circuits:*
  - a. *Power supply (not discussed but assumed).*
  - b. *Vertical deflection.*
  - c. *Horizontal deflection.*
  - d. *Vertical input scaling and amplifier.*
  - e. *Time-base generator.*
  - f. *Trigger circuitry.*
3. *The circuitry of a typical dual-trace, time-base oscilloscope contains all of the circuitry described in item 2 plus:*
  - a. *Additional vertical input scaling and amplifier.*
  - b. *Channel switch.*
  - c. *Z-axis input circuitry.*
  - d. *Delayed sweep circuitry.*

## OSCILLOSCOPE APPLICATIONS

Although an understanding of the construction of the time-base sweep, DC amplifier oscilloscope is important, its applications are even more so. This section of the chapter reviews the use of typical oscilloscope controls, voltage calibration, frequency determination, and the application of Lissajous patterns. Knowing how to use the oscilloscope and apply it will greatly enhance an electronic technician's ability to perform and interpret many electric/electronic measurements.

## OSCILLOSCOPE CONTROLS

A DC amplifier-type oscilloscope can be used to display a multitude of different wave-forms. It can measure and/or compare signals with a versatility that no other type of test equipment possesses. Using the controls correctly is the key to proper use of the oscilloscope to make measurements.

Although each model of oscilloscope has a different control layout, they share many similarities:

1. Vertical channel controls
2. Sweep controls
3. Sync controls
4. Trace characteristics controls

### VERTICAL CHANNEL CONTROL GROUP

There are several different controls in this group, all of which relate to vertical  $y$ -axis deflection. We will focus on two of them here: scale and vertical control.

#### SCALE

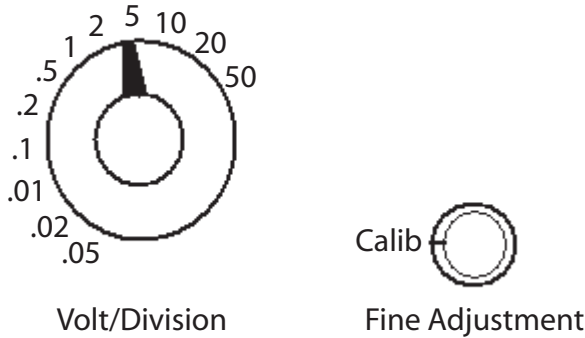
The scaling switch control normally consists of a range switch (coarse) and a variable-gain adjustment (fine-calibrate). The fine-adjust/calibrate switch is normally kept in the calibrate position if voltage is being measured.

The coarse adjust or range switch determines the amount of deflection (in volts per graticule division) that a signal will cause (provided, of course, that the fine-adjust switch is in the calibrate position).

---

**Note**

The scale is stepped off in a 1-2-5 sequence. All modern oscilloscopes have controls scaled in this manner. It should be noted that ScopeMeters (handheld dual-trace portable scopes with LCD displays) place most of these controls under software control, and the control functions and positions vary with the particular device. However, the same functions are performed.



**Figure 11-6** Vertical scale settings and display.

**VERTICAL POSITION**

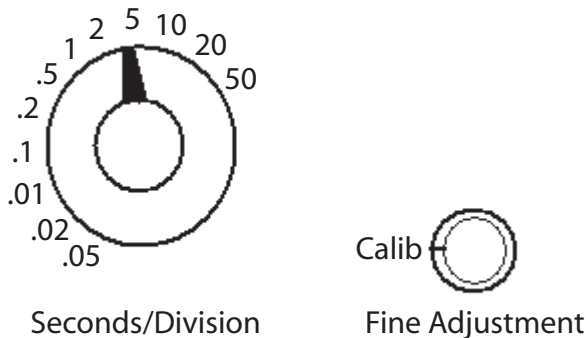
The vertical position control determines the location of the 0V or vertical reference line vertically on the screen.

**HORIZONTAL CONTROL GROUP**

There are several different controls in this group; all affect the horizontal (x-axis) sweep.

**TIME/DIVISION (TIME/DIV.) SWITCH OR SWEEP CONTROL**

A typical Time/Div. control (“TIME/CM” on some models) is illustrated in Figure 11-6.



**Figure 11-7** Horizontal time-base control.

The variable control provides a vernier adjustment of sweep time based on the range selector position. That is, it provides a variable time between the preceding lower range to the maximum Time/Div. setting of the range switch. As with the vertical controls, ScopeMeters (handheld dual-trace portable scopes with LCD displays) place most of these controls under software control, and the control functions and positions depend on the particular device. However, the same functions will be performed.

## EXAMPLE

The *sweep switch* is set at 2 millisecc/div. The center variable control will adjust the time between 1 millisecc/div. to 2 millisecc/div. The variable control is normally kept in the CALIB position, which means that the range-switch reading is the trace Time/Div. The *range switch* determines the time it takes the trace to traverse one graticule division. The complete horizontal trace takes ten times the Time/Div. (or TIME/CM) setting.

If the setting is for 5ms (millisecc) per division and the wave-form fills the screen, starting at  $t_0$  and finishing at  $t_{10}$  (ten divisions), then the period of the wave-form is 50ms. For the same setting with four complete wave-forms filling the ten divisions, then the period would be  $50/4$  or 12.5ms. Most modern oscilloscopes read out the period and frequency in alphanumeric on the display.

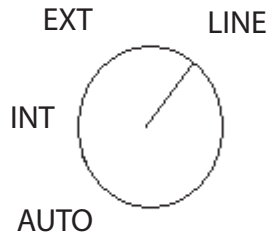
Now, if the vertical deflection per division was set at 2 volts/div. and the wave-form fills three divisions, then vertically the display would indicate a peak-to-peak value of 6 volts ( $3 \text{ div.} \times 2 \text{ volts per div.}$ ). If it was a sinusoidal wave-form then you could say that the peak was 3 volts and the effective RMS was about 2.121 volts. If it is not a sinusoidal wave-form then you will have to have a true RMS meter (generally built into modern oscilloscopes) to determine the actual voltage. The advantage of modern microprocessor-based scopes is that they can determine all this and display it simultaneously with the wave-form.

## SYNC CONTROL GROUP

Triggered oscilloscopes have a number of controls that determine when the trace will start. We will discuss sync selection here.

### SYNC SELECTION

A typical sync selection switch is shown in Figure 11–8.



**Figure 11–8** Sync selection.

This switch determines the type of synchronization to be used:

1. LINE—means a 60-Hz line-frequency signal is used for the trigger.
2. INT—means that the trigger is obtained from the vertical channel.
3. EXT—means the trigger is obtained from an external source.
4. AUTO—means that when the control is in the auto position, a trace will be displayed, even if an input signal is not present.

In a dual-trace oscilloscope, typically a selection switch determines which channel will provide the trigger. Some oscilloscopes use an external adjustment to preset a voltage at which the auto sweep will trigger on. The AUTO position will attempt to synchronize an input signal. However, typically there is a variable control, the manual SYNC LEVEL control, that must be used when the INT or EXT Sync Selection is made. It must be used to establish a stable display of the waveform. This control determines at what level of the signal and at what polarity the trace will start.

## Z-AXIS

Modulating the intensity of the CRT beam is often helpful in determining concurrence of events. The z-axis modulation normally intensifies the beam (makes it brighter) when a positive voltage is applied to this input. This means that the parts of the input signal that occur at the same time that the z-axis input is positive will appear much brighter on the screen. Not all oscilloscopes offer this option; some have different methods for achieving the same results.

## DETERMINING FREQUENCY WITH LISSAJOUS PATTERNS

Determining the frequency directly from the graticule of an oscilloscope provides several opportunities for error:

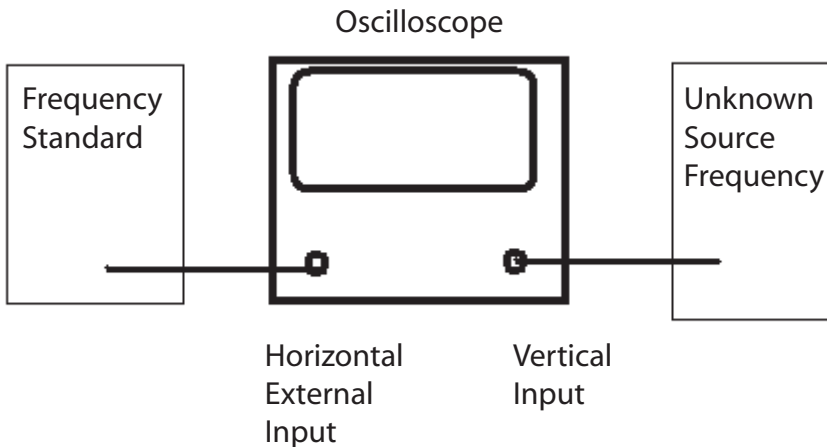
1. If the oscilloscope's time base is not correctly calibrated.
2. If the trace does not fill exactly ten divisions when the time base is calibrated.

If a frequency standard is available then an alternate method is available for determining the frequency of a signal. Most modern oscilloscopes will display the frequency or repetition rate along with the signal, so the following method is nothing more than a curiosity.

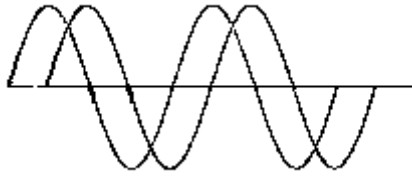
The Lissajous pattern method requires that the unknown signal be input to the vertical channel and that the standard signal be input to the horizontal channel. This means that the horizontal sweep control should be switched to EXT HORIZ, or in some dual-trace oscilloscopes to  $x$ - $y$ , where one vertical amp is the  $y$ -axis and the other vertical amp is the  $x$ -axis (horizontal). The equipment setup as shown in Figure 11–9.

Assume the standard signal and the unknown signal as shown in Figure 11–10.

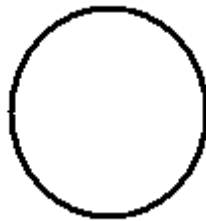
Using the Lissajous setup, the display will appear as in Figure 11–11.



**Figure 11–9** Setup for Lissajous patterns.



**Figure 11-10** Dual trace comparison of same frequency inputs.



**Figure 11-11** Lissajous pattern, 90° out of phase.

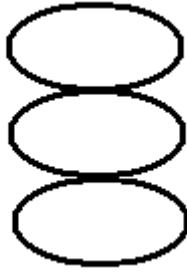
Two signals that have exactly the same frequency but differ by 90° will form a circle on the oscilloscope screen. If the two signals differ in amplitude, an ellipse will be displayed.

For signals of the same frequency that are more or less than 90° (or 270°), an elongated ellipse will be generated. If both signals are of the same frequency, amplitude, and phase, then a straight line left to right and from the lower to upper portion of the CRT will result. If the signals were 180° out of phase, then the result would be a line in the opposite direction.

These patterns are useful in determining when an unknown frequency is the same as the standard. What if signals are submultiples or multiples of the standard? Then they produce varied patterns, known as Lissajous patterns. Some patterns in which the unknown frequency is lower than the standard frequency are shown in Figure 11-12.

To determine the fraction of frequency, count the number of loops vertically. This number is used as the denominator, while the number horizontally is the numerator. This combination of numerator and denominator determines the fraction of the standard frequency.

To determine the unknown frequency at which the frequency is higher than the standard (shown in Figure 11-13), first count the horizontal loops.



**Figure 11-12** Frequency lower than standard.



**Figure 11-13** Frequency higher than standard.

This is the multiplier (or numerator). Divide this figure by the number of vertical loops; the resulting fraction determines the multiple of the standard.

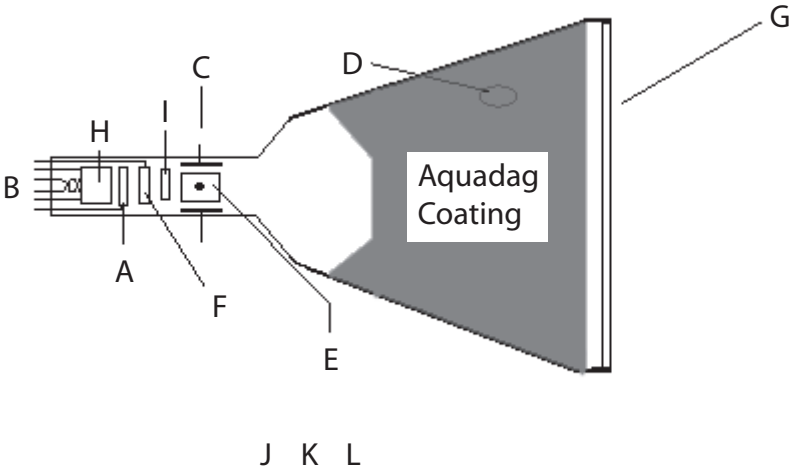
To use Lissajous patterns to determine frequency, normally you need to adjust the standard and its output frequency until the desired pattern is obtained. To adjust an unknown frequency to a standard, set the standard at the desired frequency, and adjust the unknown until the desired pattern is obtained.

## **REVIEW OF LISSAJOUS PATTERNS**

- 1. Lissajous patterns do not use the oscilloscope time base to determine frequency.*
- 2. Lissajous patterns can determine multiples and submultiples of a standard frequency.*
- 3. The standards are normally input to the x-axis (horizontal) for Lissajous patterns.*
- 4. Lissajous patterns are not a part of normal operations today since modern oscilloscopes generally have frequency counters that display the frequency of the major wave-form simultaneously with the wave-form.*

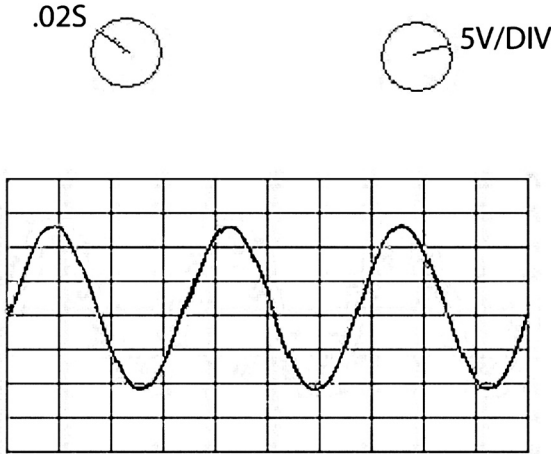
**CHAPTER EXERCISES**

1. Identify and label the parts of the CRT shown in the following figure that are identified by a letter.

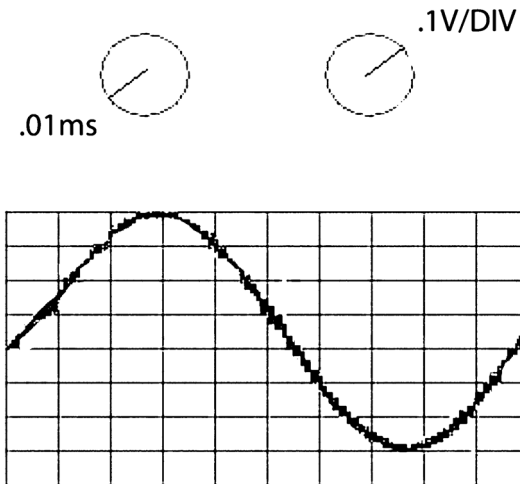


- a. \_\_\_\_\_
- b. \_\_\_\_\_
- c. \_\_\_\_\_
- d. \_\_\_\_\_
- e. \_\_\_\_\_
- f. \_\_\_\_\_
- g. \_\_\_\_\_
- h. \_\_\_\_\_
- i. \_\_\_\_\_

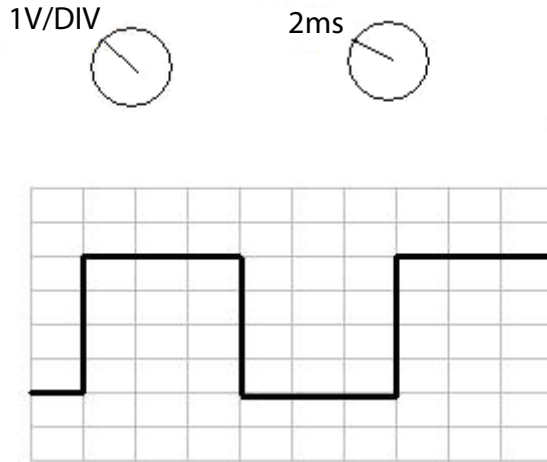
2. Given the signals on the graticules illustrated in the following three figures, determine and list the approximate voltages and frequencies displayed.



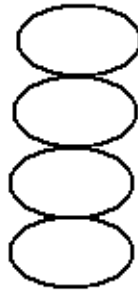
- a. Peak-to-peak voltage \_\_\_\_\_  
 b. Peak voltage \_\_\_\_\_  
 c. Frequency \_\_\_\_\_



- a. Peak-to-peak voltage \_\_\_\_\_  
 b. Peak voltage \_\_\_\_\_  
 c. Frequency \_\_\_\_\_



- a. Peak-to-peak voltage \_\_\_\_\_
  - b. Frequency (repetition rate) \_\_\_\_\_
3. The standard frequency is 5kHz. Referring to the following figure, what is the unknown frequency?



***The answers to these chapter exercises can be found at the back of this book.***

## CONCLUSION

This chapter has provided a cursory review of oscilloscope controls. Each oscilloscope arranges the controls differently, and only typical controls have been presented here. You must read the operator's manual for each type of oscilloscope that you will operate. You must be familiar with each control on the oscilloscope. If you aren't, then your measurements may be wrong or your oscilloscope may be damaged.

You will benefit greatly by locating an oscilloscope (whether one used in your shop or one you may be given access to) and familiarizing yourself with its controls and the measurement of different input signals.

**Warning**

From a safety standpoint, you should stay with low-voltage, low-current signals unless a mentor or other knowledgeable person is observing you. Under no circumstances should you attempt to remove the cover of an oscilloscope; the CRT voltages on some models are as high as 25,000 volts. Unless you are under the immediate supervision of a trained person or knowledgeable supervisor, DO NOT attempt to measure line voltage, switching power-supply voltages, or *any voltage* above 24 volts.

If you are having difficulty with the material in this chapter, please re-read the text. If you are still unsure, locate a peer, mentor, supervisor, or someone with technical knowledge of oscilloscopes and ask for their help.

For additional information on this subject, enter the following topics in your Internet search engine:

**oscilloscope principles****DC amplifiers****oscilloscope manufacturers****cathode ray tubes****Lissajous patterns****wave-form analysis**

# REACTIVE COMPONENTS

---

---

In this chapter you will learn about inductance and capacitance. Many measurement techniques and functions depend on these reactive components. By the end of this chapter, you will have to have a basic understanding of inductance and capacitance and be able to identify their effects. This will enable you to know how, when, and why measurements are made as they are.

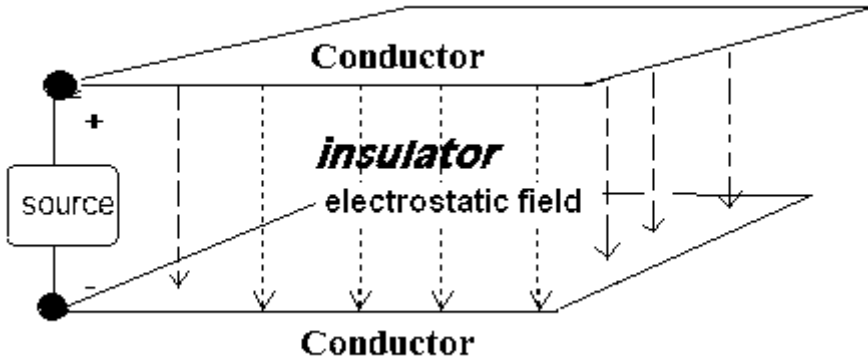
## REACTIVE COMPONENTS

Up to a point we have generally discussed measurement in terms of direct current (DC) and Ohm's Law. Alternating current (AC) operates somewhat different than these. There is still no free lunch, yet like life, measurements are not always what they appear to be. Two components of any electrical circuit that only come into play when there is a change (and of course AC is always changing) are capacitance and inductance.

## CAPACITANCE

Basically, a capacitance exists between any two conductors that are separated by an insulator. So almost all circuitry has capacitance. If there is a difference in potential between the two conductors, then an electrostatic field will exist between the two through the insulator. Figure 12-1 illustrates this concept.

The greater the difference in potential, the stronger the field. Remember that the electrostatic field is caused by the difference in the number of charges between the conductors. If we moved the two conductors closer together, then the field strength would be stronger because field strength is determined by the square of the distance. For a certain strength field, the closer together the two conductors are, the stronger the field per unit area. Another way to increase the strength of the electrostatic field is to change the conductors for plates. This would expose more area to each conductor, allowing more charges over a larger area, and hence a stronger field.



**Figure 12–1** Electrostatic field.

Actually, if we could find a fairly good insulator such as glass, mica, or pure water and used it to fill the area between our two conductors, this would allow the lines of force to concentrate (much like an iron core does for a magnetic field). We would then have an even stronger field.

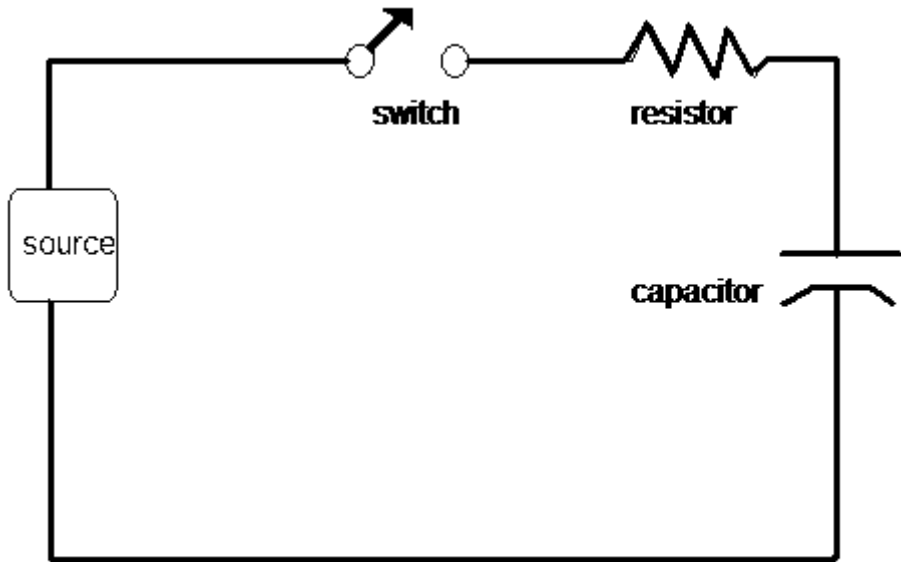
In sum, we can increase the strength of an electrostatic field between two conductors by moving them physically closer together, making their exposed surfaces larger, or by replacing the insulator that lies between them with that has the ability to concentrate the electrostatic lines of force. When we manufacture devices that have these specified properties we call them *capacitors*.

So what's the point? The point is this question: how did those charges get there? If the charges were in motion (energy was transferred), then work was performed. We can look at Figure 12–1 and intuitively understand that the source potential is going to be all along each conductor, so where and when was the work done? Look at Figure 12–2. It is a schematic of a source, a resistor (that is actually the resistance of the conductors), and the symbol used for a capacitor, and a switch.

When the switch is open, and assuming it hasn't ever been closed before, no difference in potential exists across the capacitor. Close the switch. Charges must now be transported to the capacitor so the potential difference supplied by the source can be across the capacitor. These are charges in motion, so this is a current. As soon as the charges across the capacitor equal the applied (source) voltage, current flow will cease.

If you open the switch, the charges just stay there (ideally). Close the switch again, and since the capacitor is already charged and equals the applied voltage, no current flows.

The one little hitch is that this current had to flow through the resistor. The bigger the resistor, the more it would limit the amount of charges



**Figure 12–2** Capacitor in circuit.

that could flow, so the longer it will take to charge the capacitor up to the source voltage.

You might consider a capacitor as being analogous to the tire on your car. If the tire is flat (and you have repaired the leak), then when you apply air pressure to it the tire will fill up until the pressure in the tire is the same as the pressure applied. Note that the tire did not fill up immediately but was restricted by the size of the supply tube, valve stem, and pressure applied. Remove the pressure, and (assuming the valve is OK) the tire remains pressurized. The tire has a certain air capacity. Bicycle tires can have the same pressure as a car tire, but hold much less air. It is a question of capacity. The same is true of capacitors. They come in many different capacities and can withstand many different pressures. Only, instead of air, we are filling them with charges, and the pressure across them is measured not in pounds per square inch, but in volts.

Before going any deeper into the whys and wherefores of capacitors, let us look at how they are physically constructed and how they are identified.

## WORKING VOLTAGE

All capacitors are defined at least by their working voltage. Because capacitance increases the closer the conductors are placed together, it is reasonable to assume that they will be manufactured as close as possible. The problem is that the fields become quite strong the closer the conductors are to each other. At some point, this electrical pressure is

going to overcome the resistance of the insulator. Given enough potential, anything will conduct electricity. So capacitors are designed to withstand a particular amount of pressure based on the strength of the insulator, which is called a *dielectric* when it is used in a capacitor. This design voltage is normally derated so it includes tolerances and a safety factor, and this derated voltage is called the *working voltage*. This voltage must not be exceeded. To do so is to ask for catastrophic failure. And remember, this isn't the average or RMS voltage we are referring to, but the peak voltage under any circumstance.

## DIELECTRIC

Many times, capacitors are named for their dielectric. The dielectric properties are a primary determinant in how much capacity a given physical design can have. Table 12–1 lists the properties of some common dielectric materials compared to air. Air has a dielectric constant of nearly 1, the same as a vacuum. What the constant means is that for conductors of a given size and spacing, replacing air with the dielectric material would give you capacitance that many more times greater.

Most capacitors generally use some form of synthetic, generally plastic, as a dielectric. These have a constant of from 3 to 10.

## ELECTROLYTIC CAPACITORS

To achieve an even higher capacitance for a given area, electrolytic capacitors are manufactured. In these capacitors, a liquid, paste, or solid dielectric is placed between the conductors, and a current is passed through them. This will coat one plate with a thin (very thin) insulating film. These conductors will be very close, and they will have a high capacitance for their physical size. There is a penalty to pay, however. These are directional capacitors. In other words, they are polarized, and they must be connected correctly in a circuit where current cannot pass through them in a reverse direction. If it does, it will attempt to form them in the opposite direction. Since this forming will require the electrolytic dielectric to have a fairly low resistance, much current will pass. This generally heats the capacitor to the point that it explodes. (Yes, I said explode.) So this is not a good thing to do. Electrolytic capacitors are typically very plainly marked. If they are of American manufacture (assuming you can find one manufactured in the U.S. anymore), the positive side is generally identified. If they are of Asian manufacture, generally the negative side is identified. Usually, they are identified by a positive (+) or a (–) marking.

**Table 12–1** Dielectric Materials

Material	Constant
Vacuum	1.0000
Air	1.0006
Paraffin paper	3.5
Glass	5–10
Mica	3–6
Petroleum	2
Pure water	81

## CAPACITOR VALUES

Capacitance is measured in *farads* (for Michael Faraday). One farad is a very, very large unit. Two plates ten feet high, ten feet apart and parallel for forty miles would approximate one farad. Actually, the capacity of a typical 12V car battery is about 1 farad. The most generally used measurement of a capacitor will be one millionth ( $1/1000000$ ) of a farad, or the microfarad, which uses the symbol “ $\mu\text{fd}$ .” Even that is a large unit sometimes, and so the basic unit of capacitance is the picofarad, that is:

a millionth of a millionth ( $1/1000000000000$ )

Europeans use an intermediate term between the microfarad and the picofarad called the nanofarad. While the world is rapidly becoming a global village, this text will restrict itself to just *micro-* and *pico-*. *Pico-* was formally known as “micro-micro” and used the symbol “ $\text{mmfd}$ ,” but the push to metric laid that aside. It is now symbolized as “ $\text{pfd}$ .” In texts, *microfarad* is sometimes written as “ $\text{mfd}$ ” instead of  $\mu\text{fd}$ . This is not confusing, as no *milli-* prefix is used in capacitance.

Though capacitors have a color code much like resistors, most of the color codes date from a time when components were large enough to see. With modern technology most capacitors have the value written on them, although it may be a three-number code. The first two numbers are values, while the third is the number of zeros. In this case, the values will always be in picofarads. In fact, unless otherwise printed “ $\text{mfd}$ ” the value is in picofarads.

**REVIEW**

1. Capacitors store charge.
2. Capacitors have a maximum working voltage that shouldn't be exceeded.
3. Capacitors have a basic value of the picofarad, which is one millionth of a farad.
4. Electrolytic capacitors are directional and must be inserted in the circuit in the correct polarity.

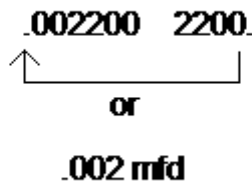
**EXAMPLE**

A capacitor has a value of 2200pfd (picofarads). Determine that value in microfarads. Since a picofarad is one millionth of a microfarad, the decimal point should be moved to the *left* six places. That is how you find how many millionths a value really represents. See Figure 12–3.

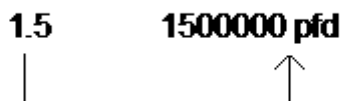
**EXAMPLE**

A capacitor has a value of 1.5 $\mu$ fd. What is that value in pfd?

In this case, you must multiply by one million, so the decimal point will be moved six places to the *right*. See Figure 12–4.



**Figure 12–3** Pico- to microfarads.



**Figure 12–4** Micro- to picofarads.

## CAPACITORS IN PARALLEL

Connecting capacitors in parallel, as shown in Figure 12–5, increases the area that is exposed to each conductor. Simple addition of the values will give the resulting capacity. Remember, the working voltage rating will be the lowest rating of any one of the capacitors.

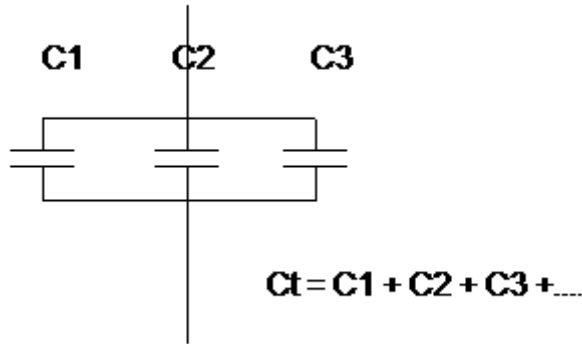


Figure 12–5 Capacitors in parallel.

## CAPACITORS IN SERIES

As Figure 12–6 illustrates, capacitors in series present a more difficult concept than those in parallel.

In this case, you are actually separating the top plate of  $C_1$  and the lower plate of  $C_3$ . This will reduce the capacitance. How much less? Less than the lowest-capacity capacitor in the series. This is because the amount of charge that can be stored between the lower plate of  $C_3$  and the upper plate of  $C_1$  depends on the capacity of those conductors (plates) in between.

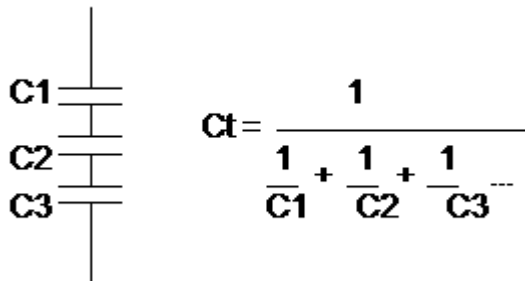


Figure 12–6 Capacitors in series.

You may have two, five, or as many capacitors as you want in series. We have chosen three here as an illustration, but the concept extends to as many as are in series.

The working voltage, theoretically, becomes the sum of all the working voltages. However, it is not a good idea for series capacitors to have placed across them the higher working voltage theoretically obtainable by placing them in series, because the distribution of the voltage drops depends on the capacitive values, leakage currents, and the circuit application. If one should fail by passing current, then the high voltage will be across the remaining capacitors and they then will also fail. In other words, in practice, the lowest working voltage of the series capacitors, as a rule, should not be exceeded even though theory says you can.

## THE RC TIME CONSTANT

Let us revisit the circuit from Figure 12–2, redrawn here as Figure 12–7.

The circuit in Figure 12–7 is called an RC circuit because it contains a resistor (R) and a capacitor (C). Assume that the source is at 10V DC and that the switch has not been previously closed. The voltmeters will both read 0V because no charges are in motion in the circuit. The RC circuit does not provide a complete path for current flow. Assume that the resistor is 1 megohm (1,000,000 ohms) and the capacitor is 1 $\mu$ fd (microfarad or 1/1,000,000 of a farad). What happens when the switch is closed?

1. At the instantaneous closure (in copper wire about half the speed of light) of the switch, the maximum amount of charges will move to the conductors (plates) of the capacitor.
2. After this instantaneous rush, all other movement of charge will be diminished because the charges will start to build up on the plates of the capacitor. This will lessen the potential difference between the source and the capacitor, and so the push to the charges.
3. For the values given, the readings and the time elapsed are as follows:

Time	V resistor	V capacitor
1 sec	3.72	6.28
2 sec	1.35	8.65
3 sec	0.50	9.50
4 sec	0.20	9.80
5 sec	0.00	10.00

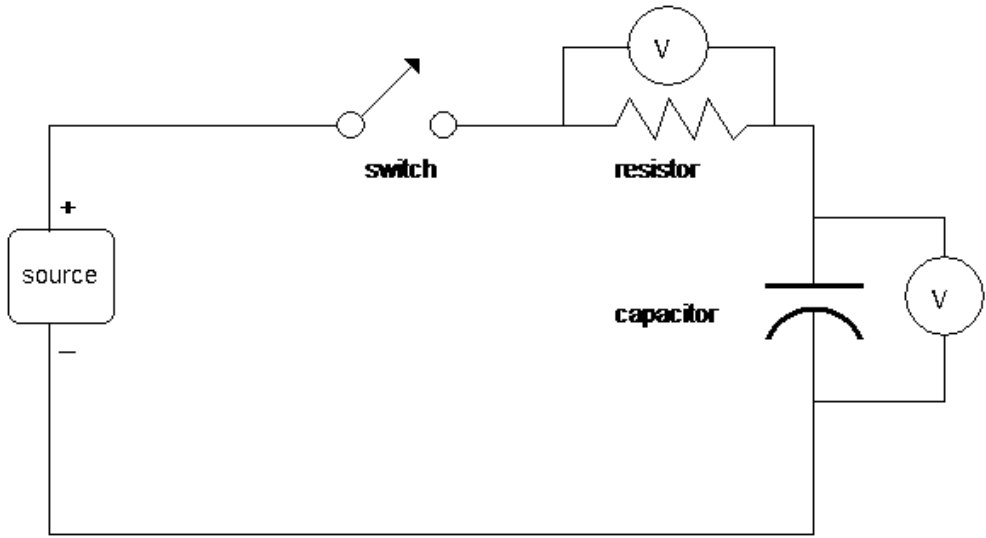


Figure 12-7 RC circuit.

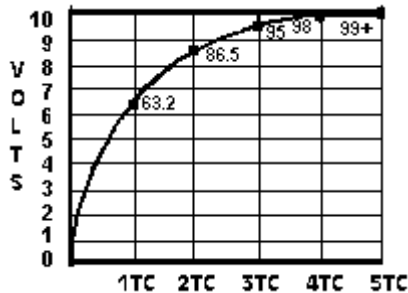


Figure 12-8 RC time constant curve.

Notice that after five seconds, when the capacitor has the same charge across it as does the source, no current will flow. How do you know this? Because the only time you can have a voltage drop across a resistor is when current is flowing through it (you do remember Ohm's Law?). So, now if the switch is opened or closed, it will make no difference as long as the charge remains on the capacitor and the source voltage does not change. Figure 12-8 is a graph of the voltage across the capacitor. The numbers inside are percentage of charge.

This curve is universal in nature. It is called a time-constant curve, and for all change there is a time constant. Nothing in the universe is instantaneous, so there is a time-constant curve for every change. Note that the key word here is *change*. Capacitors are often described as "blocking DC," that is, not letting DC pass. That is not exactly true. If there are no changes, once the circuit is charged (and many applications of DC are

steady voltages for some period of time), no current will flow in a circuit like the one shown in Figure 12–8. The other keyword here is *time*. Previously, our discussions were about direct current and resistance, where any change had a proportional effect upon the circuit constants. With the reactive components, time enters as a key element into the magnitude of the effect that the reactive components will have on circuit operation.

As you may ascertain from the previous discussion, how long it will take to completely charge the capacitor depends on a proportion that applies to the value of  $R$  and  $C$ . Actually, it is quite simple:

$$1 \text{ TC (time constant)} = R \text{ (ohms)} \times C \text{ (farads)}$$

or to be more useful:

$$1 \text{ TC (time constant)} = R \text{ (megohms)} \times C \text{ (microfarads)}$$

And it requires 5 TC to completely charge the capacitor. One TC is the time it takes for the capacitor to charge to 63.2 percent of its total charge. Each subsequent time constant will be 63.2 percent of the remainder.

### EXAMPLE

Use the values from the preceding discussion—1 megohm for the resistor, 1 $\mu$ fd for the capacitor:

$$1 \text{ TC} = 1 \text{ megohm (1000000 ohms)} \times 1\mu\text{fd (1/1000000 farad)} = 1 \text{ second}$$

In one second, the voltage across the capacitor will be 63.2 percent of the total 10V or 6.33 volts. This leaves 3.67V remaining for total charge. During the second time constant, the capacitor will charge up an additional 63.2 percent of 3.67 volts: 2.32 volts, for a total of 8.65 volts. During the third time constant the capacitor will charge up an additional 63.2 percent of 2.32 volts and so on.

If you do this with a calculator you will find that you equal 10V at about the third time constant. This is because of the rounding off of the constant and percentages. That is why some industrial vendors use three time constants rather than five for the 100 percent point.

For those of you with mathematical training, you may say, whoa, it will never be completely charged because there will always be only 63.2 percent of the remainder still to be charged. Maybe so, but for all intents and purposes the capacitor is completely charged in five time constants and is so in reality.

Figure 12–9 illustrates a modification of our basic circuit.

In this circuit, we can charge the capacitor through  $R$ , and we can discharge the capacitor through  $R$ . When the switch is thrown, making the resistor return to the other side of the capacitor rather than the battery, the capacitor will discharge. How long will it take to discharge? As long as it took to charge. Figure 12–10 illustrates the discharge graph.

The discharge curve is the reverse image of the charge chart. Here it will discharge 63.2 percent of its total charge in one time constant, becoming fully discharged in five time constants.

One aspect of reactive components that is often overlooked is the fact that they do not dissipate power. They store energy and release it. The losses come about because of the resistance of conductors, impurity of insulators, and so on. In the circuit shown in Figure 12–10, the resistor will dissipate the power. The capacitor uses none; it merely stores and returns a charge when the circuitry is correct.

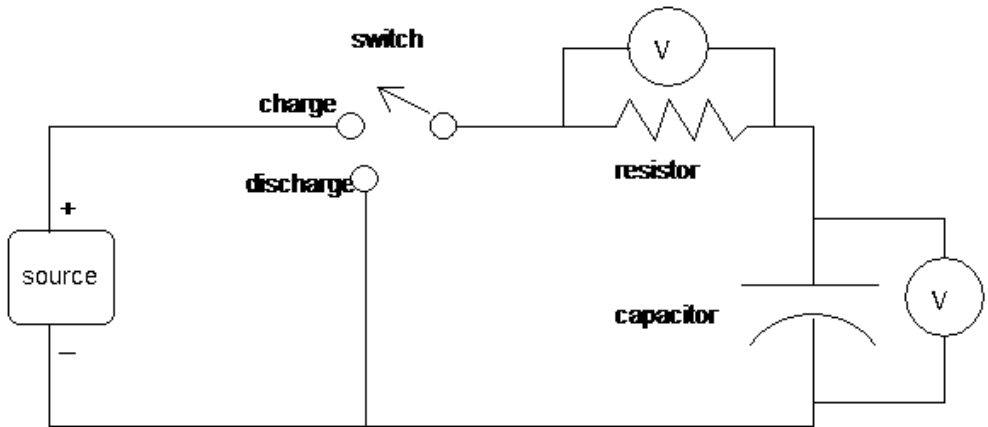


Figure 12–9 Modified RC circuit.

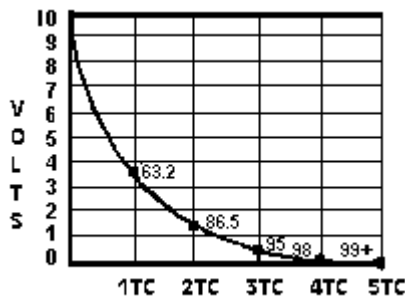


Figure 12–10 RC discharge curve.

## REVIEW

1. A capacitor takes a finite time to charge, that is, it is not instantaneous.
2. A resistor will limit the amount of charges (current) available to the capacitor when it is charging. Hence, the larger the resistor, the longer the time it takes to charge.
3. The larger the resistor, the longer it will take a capacitor to discharge.
4. The relationship between time and values is expressed as:

$$1 \text{ TC} = R \text{ (ohms)} \times C \text{ (farads)}$$

or more usefully as:

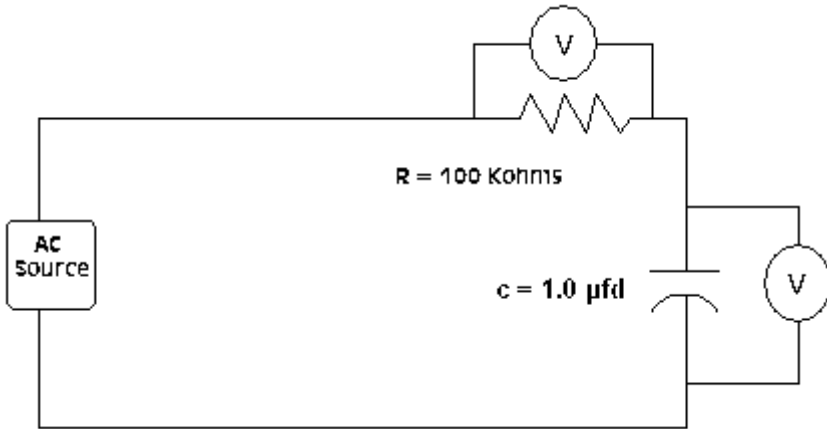
$$1 \text{ TC} = R \text{ (Megohms)} \times C \text{ (microfarads)}$$

5. It takes five time constants to fully charge or discharge.
6. Before a capacitor affects a circuit, there must be a voltage (potential) change in a defined period of time. Otherwise, the capacitor acts as an open circuit for direct current once it is charged.

## CAPACITIVE REACTANCE

Let's look back at the two curves from the circuit shown in Figure 12-9: charge (Figure 12-8) and discharge (Figure 12-10). What would be the effect of waiting 5 TC with the switch in charge and at that time, throwing the switch to discharge, waiting another 5 TC for it to discharge, then returning the switch to charge, and continuing this process so that each time the circuit is fully discharged or fully charged you throw the switch to cause the opposite condition? The effect would be to fully cycle the RC. Suppose the switch was thrown after one time constant. Using the values of the original example, where one time constant equals one second, you would find that current was always moving in this circuit. To the source it would appear as if it had to supply current continuously. Now, using the circuit in Figure 12-9, substitute an AC source for the DC one, as shown in Figure 12-11.

Assume that the AC source has a  $\pm 10\text{V}$  output (P-P). This means that when the AC wave-form is rising positive, the capacitor will charge in that direction. When the AC wave-form is going negative, the capacitor will charge in that direction. The time constant for the circuit is 0.1 second. If the period of the wave-form is less than 0.01 second (1/10 of the time constant), you can readily see that there will be AC current flow through the resistor. In fact, the resistor will probably drop almost all of the source voltage. Why? Because the capacitor is never able to even reach one time



**Figure 12–11** Alternating-current source for RC circuit.

constant before the potential across it reverses direction. This is the portion of the time constant curve that is near maximum current flow. It would appear to the AC source that the capacitor is offering very little opposition to alternating current. That is not quite a true statement. If you decreased the frequency of the alternating current, then the current would start to fall off according to the time constant curve. It would become apparent that the capacitor was being alternately charged and discharged. If you reduced the frequency low enough you, of course, come to direct current (0Hz), and other than the initial change, no current would flow.

The opposition that a capacitor offers to alternating current depends on the value of the capacitance, the frequency of the AC, and the other circuit components. If a capacitor was connected alone across a DC potential, its effect would only be noticeable on voltage changes. There is a relationship defined for the amount of opposition that a capacitor exhibits to alternating current. As you would expect, this opposition goes down as the frequency goes up. The opposition has a name: *capacitive reactance*. It has a symbol,  $X_C$ , and is expressed in ohms. The relationship is as follows:

$$X_C = \frac{1}{2\pi fC}$$

where C is in farads and f is in Hz (or f is in MHz and C is in  $\mu\text{fd}$ ).

If you may recall from Chapter 10 on alternating current, the  $2\pi$  in the capacitive reactance equation describes a sine wave, and the f stands for how many in a second (Hz). Let us apply this relationship to the circuit in Figure 12–11.

**EXAMPLE**

Determine the capacitive reactance of a 1.0 $\mu$ fd capacitor at the frequencies in Table 12–2.

As you can see, when the frequency goes up, the opposition goes down. At 1.59Hz for the 1- $\mu$ fd capacitor, the  $X_C$  will equal 100 kilohms. This is the amount of R in the Figure 12–11 circuit. In a circuit where the  $X_C$  is equal to the R, then the voltage drops across both will be equal.

**Table 12–2** Capacitive Reactance

Frequency (Hz)	$X_C$
0	infinity $\infty$
1	159K $\Omega$
10	15.9K $\Omega$
100	1.6K $\Omega$
1000	0.16K $\Omega$
10000	16 $\Omega$
100000	1.6 $\Omega$ s

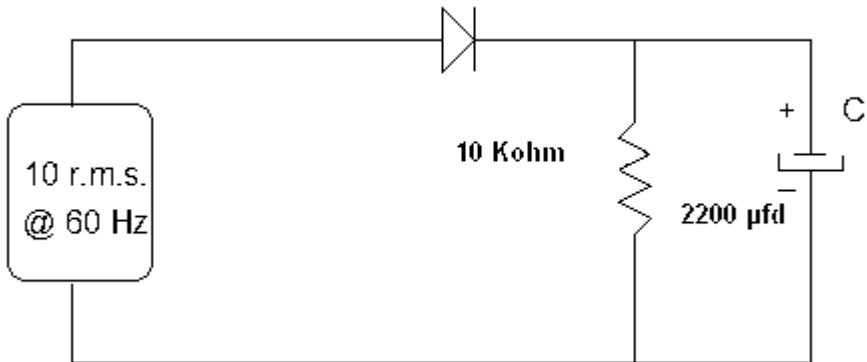
**REVIEW**

1. *The opposition to alternating current presented by a capacitor is called capacitive reactance.*
2. *The relationship is expressed by:*

$$X_c = \frac{1}{2\pi fC}$$

A rectified power supply—the diode illustrated by the arrow and line in Figure 12–12, conducts current in one direction only—much like a check valve for flow. In rectified power supplies, capacitive filters are used to filter out the ripple frequency. Using Figure 12–12, determine the reactance of the filter capacitor C and the effect it will have on the ripple frequency of 60Hz.

At DC 0Hz the capacitor offers an infinite resistance. At 60Hz, the ripple frequency, 2200 $\mu$ fd offers 1.2 ohms' resistance. This means that the 60-Hz component (changing current) will be conducted to the reference



**Figure 12–12** Power supply filter.

(bottom) lead. This results in only a DC voltage level (unchanging) being left as the charge level. In other words, the ripple is reduced greatly, and if you looked at the voltage across the capacitor with an oscilloscope you would only observe a voltage of 14.14 volts since the capacitor will charge to the peak of the incoming voltage. With a 10-kilohm load resistance and 2200 $\mu$ fd capacitor, 1 TC is 22 seconds.

The voltage will remain constant across the capacitor because the charge time constant is very short (because only the forward resistance of the diode limits the current) compared to the filter RC time constant. Charging and discharging occur at a 16.67ms rate.

You could think of this as a large-capacity air tank at the outlet of an air pump. The air is pumped in surges, yet the tank, once full, will maintain the peak pump pressure if little is pulled out by the load. The tank will supply air when the pump is between surges and dampen the surges as they come.

## PHASE IN AN RC CIRCUIT

We now come to a problem that is difficult to express in words. While mathematics makes it easy to express, mathematics like any language requires training and practice. This text was designed for those with little of either in mathematics, so the reader who has a math background will have to bear with the following explanation of the phase relationships in a capacitive circuit.

In the circuits discussed so far, and particularly the DC charge circuit, notice that when the current is maximum the voltage drop across the capacitor is minimum. When the capacitor is fully charged, current is minimum and voltage is maximum. The current can be represented by the voltage drop across the resistor: the more the current, the greater the

voltage drop across the resistor. This gives us a way to examine what happens in an RC circuit. If we take the circuit in Figure 12–9 and plot the voltage across the resistor and the capacitor for a charge, it would be similar to Figure 12–13.

If we alternate between charge and discharge, then there is a definite phase relationship between the two components: voltage and current through a capacitor. Now before you begin to believe that Mr. Ohm was prevaricating, remember, the voltage we are talking about is the voltage *across* the capacitor. The current is still pushed by the source! And note, too, that when a capacitor is going to discharge, the maximum voltage across the capacitor will cause the maximum current to flow. It is the measurement across a capacitor in an alternating-current circuit that is the problem. Because the maximum voltage drop does not occur until the capacitor is charged, we say that “current leads voltage through a capacitor.” A convenient way to remember this is the word *ICE*: I for current, C for capacitor, and E for voltage. I leads E through C.

In a purely capacitive circuit (there is no such thing; they all have resistance), the current would always lead the voltage by 90 degrees. That is, if you plotted the current through a capacitor by the voltage drop across it, the two wave-forms would be like those shown in Figure 12–14.

In Figure 12–14, the voltage wave-form was made twice the amplitude of the current wave-form for better visibility. Note that this is for a pure capacitance circuit. What it, in effect, tells you is that the maximum power will be at the point where the product of E and I is the greatest. Though this is beyond the scope of this chapter, it should be noted that in a purely capacitive circuit the maximum power will occur where the two lines cross (approximately 45, 135, 225, and 315 degrees, with 0 power at 90, 180, 270, and 360 degrees). Minimum power occurs when there is no current. The reason this relationship is not necessarily pursued is that few purely capacitive circuits are found in practice.

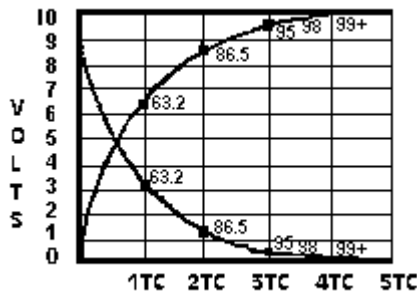
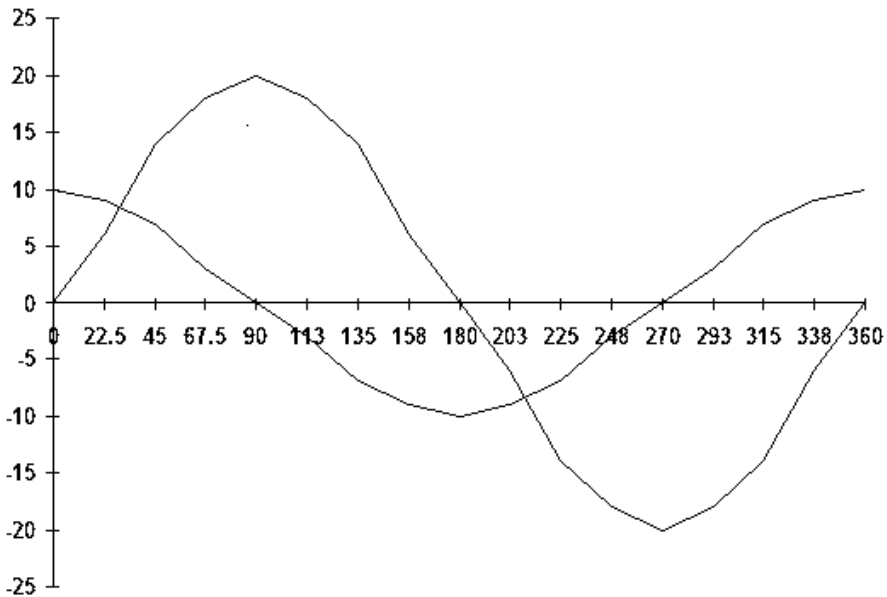


Figure 12–13 RC charge curves.



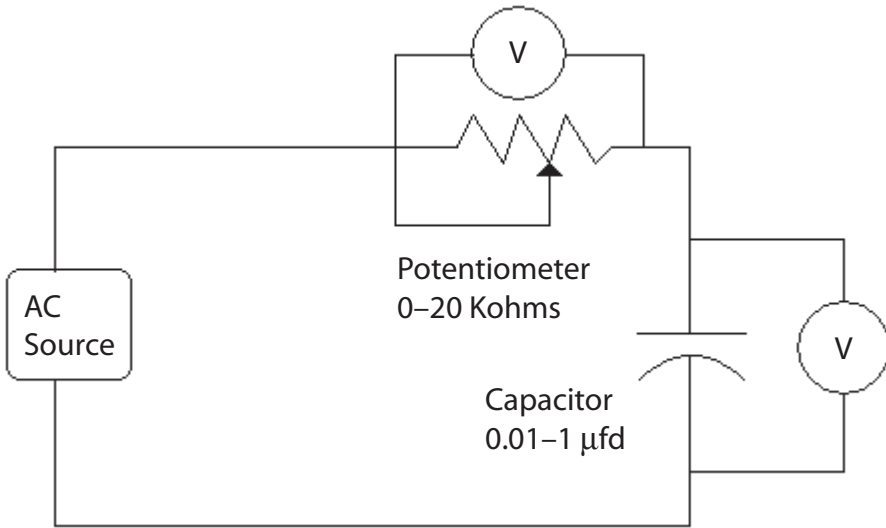
**Figure 12-14** Phase relationship E and I through C.

When you add resistance to the circuit, the phase difference between the voltage and current diminishes. This is easy to visualize. There is no phase difference through a resistor; there is a phase difference of  $90^\circ$  through a pure capacitor. The greater the resistance, the more the circuit acts as a resistance. Normally, the phase difference is a design phenomenon and not necessarily a concern of persons doing basic measurements. Yet when making measurements in an AC circuit that has capacitance, you must realize that when measuring an AC voltage across a capacitor, you cannot use the voltage read in any circuit determinations without allowing for the phase difference.

## APPLICATION

Find the  $X_C$  of an unknown capacitor by measurement. You have determined that the capacitor is somewhere between .01 and  $1\mu\text{fd}$  by its size and construction.

1. Obtain a function generator as an AC source and a 20-kilohm potentiometer, and connect them in the circuit as shown in Figure 12-15.
2. Start at a frequency of from 10 to 200Hz. Choose 100Hz as a start.



**Figure 12-15** Determining  $X_C$ .

3. Apply a magnitude of AC that allows easy measurement but does not exceed the ratings of the capacitor or the potentiometer.
4. Adjust the potentiometer until the voltage drop across the resistor and the capacitor are equal. If this cannot be done, try a different frequency range. If you guessed wrong on the range of the capacitor, you will have to try a larger potentiometer. Assume that at 100Hz you were able to reach equality of voltage drops across the resistor and capacitor. At this point, the phase angle will be  $45^\circ$ , and the resistance of the potentiometer and  $X_C$  are equal.
5. Remove the potentiometer from the circuit, and measure its value. The measurement will be the approximate value of  $X_C$  for that capacitor, depending on the tolerance of the resistor and the accuracies of the two meters involved. Also, the source frequency should not be so high as to render the meters inaccurate. Assume in our application that the value of resistance measured is 15.9 kilohms.
6. Use the formula for  $X_C$  rearranged to obtain the capacitor's value.

$$C = \frac{1}{2\pi f X_C}$$

7. Obtain the value, which with the numbers in our example is 0.1μfd.

If you desire a better measurement of a capacitance, any number of available instruments are capable of accurately measuring capacitance.

## REVIEW

1. In a purely resistive circuit, voltage and current are in phase.
2. In a purely capacitive circuit, current leads voltage by  $90^\circ$ .
3. Most circuits are combinations of resistance and capacitance, so the current through the capacitor will not be  $90^\circ$  but something less.
4. At  $45^\circ$ , equal currents flow through the resistive and capacitive components in a series RC circuit.
5. ICE stands for: "current (I) leads voltage (E) through a capacitance (C)."

## INDUCTANCE

The other reactive component is inductance. We discussed electromagnetism earlier, and in this section we will continue that discussion. As stated earlier, an electric current flowing through a conductor creates a magnetic field that is at right angles to its direction of travel. Also, a conductor moving through a magnetic field at right angles to the field will have a current induced in the conductor.

Now try and picture this. Suppose we coil the conductor to concentrate the magnetic field. During the creation of the magnetic field, current builds up the field as the current builds up in the conductor. Doesn't this magnet field, which is in motion, cut across the conductors of its own coil?

The answer is yes. In fact, the current induced in the coil runs in the opposite direction of the change of the current causing it. The greater the change, the greater the opposition. Look at Figure 12–16.

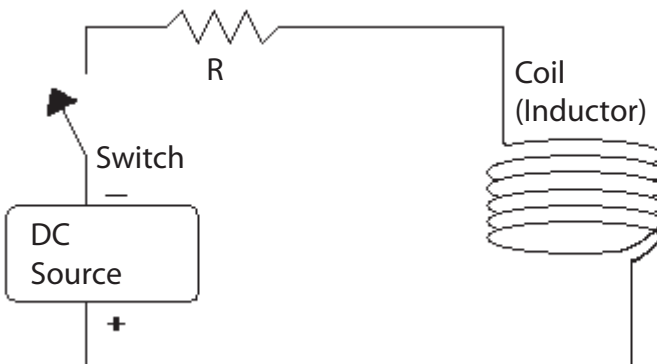


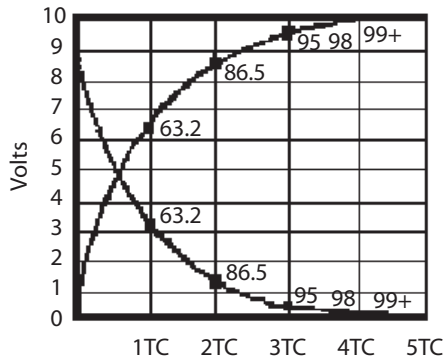
Figure 12–16 An R-L circuit.

When the switch is open it is obvious that no current flows. It is also apparent that after the switch is closed and has remained closed for some time, that maximum current will flow. The only limit to current will be  $R$ , which might represent the resistance of the windings of the coil, an external resistance, or both. In any case, the resistance of the coil is included in  $R$ .

But what of the moment when the switch is closed? At the time of closure, the rate of change of current in the circuit is maximum. Any time you go from zero to something in a very small increment of time, the rate of change is rapid. Current attempts to flow through the coil. Because of the rapid rate of change, a large current is induced in the opposition direction as the current tries to set up a magnetic field. As time elapses, the rate of change, which, of course, is the amount of change divided by the time the change occurs in, becomes less and less. This allows more and more current to flow and the magnetic field to increase. Eventually, the amount of current limited by the source potential and the resistance of the circuit is flowing, and the magnetic field is at its maximum. Figure 12–17 illustrates the charge concept.

The curves in Figure 12–17 represent a series R-L circuit that has a resistance of 10 ohms and a supply voltage of 10V DC. The upward rising curve represents the voltage drop across the resistor, while the decreasing line represents the voltage drop across the coil.

“Wait,” you say, “those curves look a lot like those for a capacitor, only reversed.” You are absolutely right. Time constants apply here as well as for the capacitor. Since 1 TC is equal to  $R$  in ohms times  $C$  in farads for a capacitor, and since the inductor behaves in the opposite way of a capacitor, 1 TC for an inductive circuit is  $L$  (in henries) divided by  $R$  (in ohms) or  $L/R$ .



**Figure 12–17** R-L circuit curves.

Applying common sense to this formula (actually, it's a ratio), we see that the ratio means that the lower the amount of resistance to the amount of inductance, the greater will be the time constant. Because less resistance means less opposition to current flow, the initial rate of change will be greater and take longer to overcome.

The voltage produced by the opposition current is called *counter electromotive force (CEMF)*. The magnetic field contains energy. It takes energy to produce this field. It is not lost nor dissipated as heat. The counter EMF is the *opposition to setting up this field*. Just like charging a capacitor requires a *change in voltage* to cause charges to be put into motion (current), inductance requires a *change in current* to create (or discharge) a magnetic field and the resulting CEMF (or *back voltage* as it is sometimes called).

Inductance is common to all conductors. Its unit of measurement is the henry (H), which is defined as: 1H is the *inductance* that will cause a *change of 1 amp per second to produce 1V of CEMF*.

## REVIEW

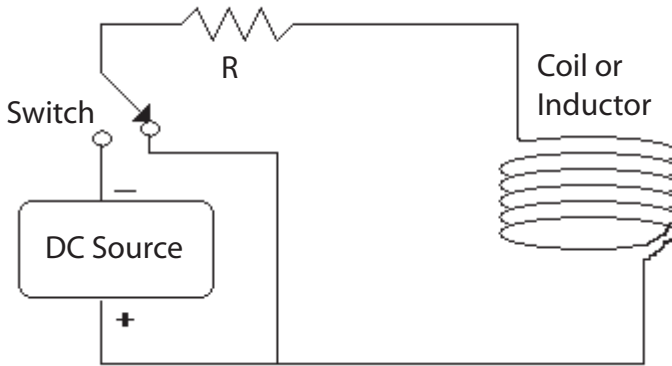
1. All conductors have inductance.
2. An inductance produces a CEMF to current changes.
3. There is no energy lost in a magnetic field, but it takes energy to set up.
4. The greater the rate of change, the greater the CEMF.
5. An R-L circuit's time constant is determined as  $1\text{ TC} = L\text{ (henrys)}/R\text{ (ohms)}$ .

## DISCHARGING THE MAGNETIC FIELD

Refer to Figure 12–18.

When the switch is thrown to the position shown in Figure 12–18, the magnetic field will collapse. All of the energy stored will be released by the collapse of the field. As the field collapses, the magnetic lines of force cut across the conductors, inducing into the conductor a current that will oppose the change. When the circuit charged, the counter EMF was in opposition so the polarity would have been the point where the end of the coil next to the source negative was negative. In discharge, this end of the coil is positive. It causes current to flow in the same direction as the charge current (opposing the decrease change).

What if the discharge path wasn't there? Suppose you just decided to open the switch? It's not nice to fool Mother Nature. This will require us to recall the concept of power. There is instantaneous power, but the power we are most interested in is the average power. In order to average you must have time. It took the coil some finite time to charge, as



**Figure 12–18** Discharge of R-L circuit.

determined by  $L/R$ . The charge amount was the power it took to set up the magnetic field. Now, no power is lost in the field, and then you open the switch. You are asking for the circuit to make an extremely rapid rate of change. Where it took some amount of time to charge, you wish the coil to discharge instantly. True, the coil will collapse rapidly. This will set up a rather large voltage. How large? Large enough to ionize the air around the switch as you are opening it and to arc the field energy across the switch contacts. Remember that power is equal to  $(E \times I)/\text{Time}$ . For example, suppose you make power a fixed number—the amount it took to set up the field, say, for example, 1 watt over 1 second. This could mean 10V at 0.1 amp, yielding 1 watt per second. Now, you are trying to discharge the circuit in, let's say,  $1/10,000$  of a second. That means the product of  $E \times I$  must be 10,000 to create the same amount of power in the reduced interval of time. This means that  $I$  could have 50,000V at 0.2 amp for  $1/10,000$  of a second. You are not getting something for nothing. Rather, it is like saving \$50 a month for ten years of your life (\$6,000) and then going to Las Vegas and spending it all in one night. Same amount of money, just over a different period of time.

## INDUCTORS

All conductors have inductance. However, special devices—called *inductors*—have been developed that have specified amounts of inductance. Conductors, coils and transformers all have inductance. It is an effect that you must consider. Inductors are designed for the frequency range they will operate over. Generally, inductors range from those with ferrous cores (relatively low frequency) to those with air cores (generally higher frequencies). The most common classification of inductors is by their core.

**Caution**

This principle stating that the voltage will rise to any level to dissipate the energy stored in the collapsing field is known as *inductive kick*. It is the principle that is used to develop the 50,000V spark plugs required by a car's 12V DC battery. You must take inductive kick into account. Not to do so could be hazardous. Large inductive loads on DC circuits must have some means, besides the switch, of discharging the field energy. The arcs they create could cause severe burns, even fatality. Even small inductive loads store energy and are responsible for destroying many unwary users' switch contacts and semiconductor outputs.

Ferrous core inductors may have a solid ferrous core, a laminated ferrous core, or a powdered-ferrite core. The reason for the different cores is to prevent currents from being set up in the core that would dissipate their energy as heat and make the coil inefficient.

Inductors designed for audio and radio frequencies are sometimes called *chokes* because of their ability to impede high-frequency currents. Laminated core chokes are most often used at power frequencies because they provide a large amount of inductance.

Toroidal inductors are those formed as a "doughnut" of powdered iron. They have a very high inductance for their size. Ferrite cores are toroids of a certain length that are slipped over conductors to provide the effect of a choke.

Other than the amount of inductance, expressed in henrys or millihenrys (mH), the only other rating of concern for inductors is voltage rating. This is the maximum amount of voltage that the insulation around the conductors can withstand. It should not be exceeded.

## INDUCTIVE REACTANCE

As with the capacitor, the opposition that an inductor offers an alternating current depends on frequency. This opposition is called *inductive reactance* or  $X_L$ , L being the symbol associated with inductors. It is easy to see that the more rapid the change, the more opposition an inductor offers to the change in current. For that reason, the inductive reactance is going to rise with frequency. Sure enough, the relationship between frequency, inductance, and reactance is expressed as

$$X_L = 2\pi fL$$

where  $f$  is in Hz and  $L$  is in henrys.

## REVIEW

1. When an electromagnetic field is collapsed, the energy will be dissipated either through intended paths or through arcing.
2. An inductor's ability to raise the CEMF to whatever value is needed to discharge the energy is known as inductive kick.
3. Inductors come in different sizes and shapes and are generally identified as "air core" or "iron core."
4. Inductive reactance is identified as  $X_L$ .
5. Inductive reactance is expressed as  $X_L = 2\pi fL$

## INDUCTIVE PHASE RELATIONSHIPS

As with capacitors, phase relationships come into play when inductors are in a circuit. In Figure 12–19, when the switch is closed to charge the coil there will be minimum current and maximum voltage drop across the coil. When the fifth time constant has passed, there will be minimum voltage drop across the coil but maximum current through the coil. This would appear to be just the opposite of a capacitor, and indeed it is. Where current led voltage through a capacitor, voltage leads current through an inductor. The mnemonic for this is ELI, where E stands for voltage, L stands for inductance, and I stands for current. Together, these memory tags can be remembered as "ELI the ICEman." You will have to ask your grandparents what an *iceman* was.

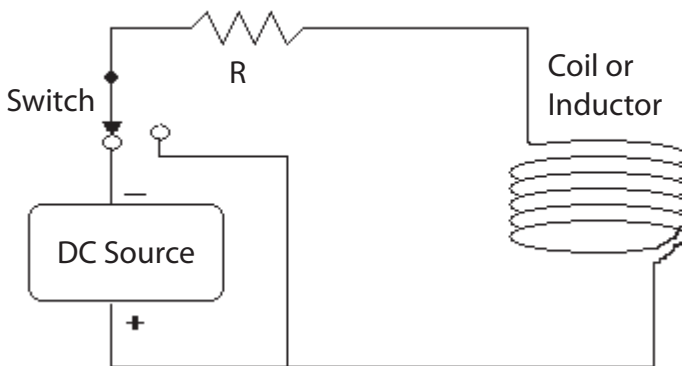
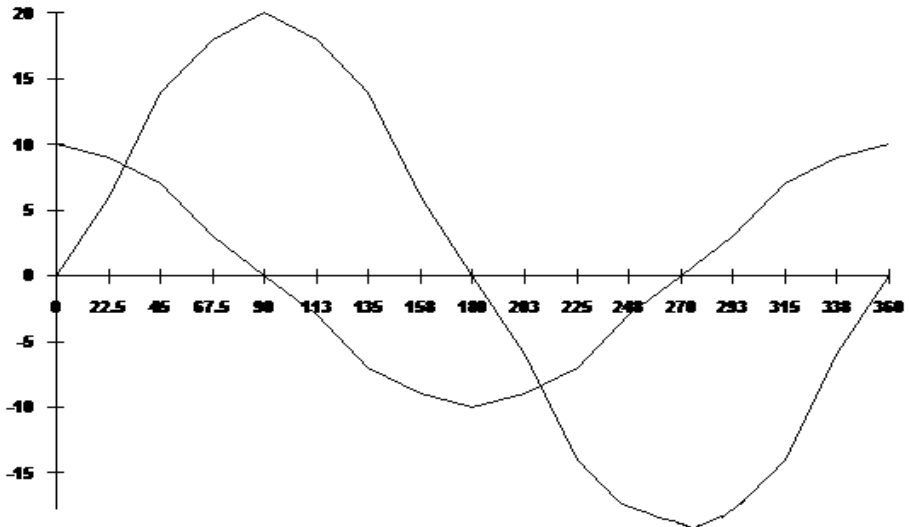


Figure 12–19 Switched R-L circuit.



**Figure 12–20** Phase relationships in an R-L circuit.

A graph of the relationships between voltage and current for an inductor is shown in Figure 12–20.

Here, the voltage is represented by the line that starts out at 10, the current at 0. In this graph, the current is twice the amplitude of the voltage in order to increase visibility.

The graph in Figure 12–20 is only good for illustrating the theoretical idea of an inductor that has no resistance. Perhaps in the super-conducting mode, this is possible but not in the normal world today. All inductors will have resistance themselves, plus the resistance in the circuit. This will reduce the phase difference. As before, phase difference is a design concern. So aside from stating that it exists and noting its effects on measurement and the behavior of circuits, we will investigate phase difference no further in this book.

## REVIEW

1. *There is a phase difference between the current that goes through a transformer and the voltage across the transformer.*
2. *In a pure inductive circuit the phase difference between voltage and current is 90 degrees.*
3. *Voltage (E) leads current (I) through an inductor (L): ELI.*

## RCL CIRCUITS

Figure 12–21 illustrates a series RCL circuit.

What is the behavior of this circuit? Let us list what we know about RL and RC circuits. First, they behave in the opposite manner of the other. Current leads voltage in the capacitor; voltage leads current in the inductor, and in the resistor both are in phase. The actions of the inductor and the capacitor both depend on frequency.

If we adjust the frequency so both C and L drop the same voltage, then their reactances are equal. Since they are opposite in effect, they cancel at this point, and only the resistance is left. This condition, where  $X_L$  and  $X_C$  are equal, is called *resonance*. The frequency that this occurs at is called the *resonant frequency*. In this case, the smaller the R, the greater the amount of current that may flow. At higher or lower frequencies, either the inductive (at higher frequency) or the capacitive (at lower frequency) will offer more opposition. So the minimum opposition that this circuit offers is at resonance, at the resonant frequency.

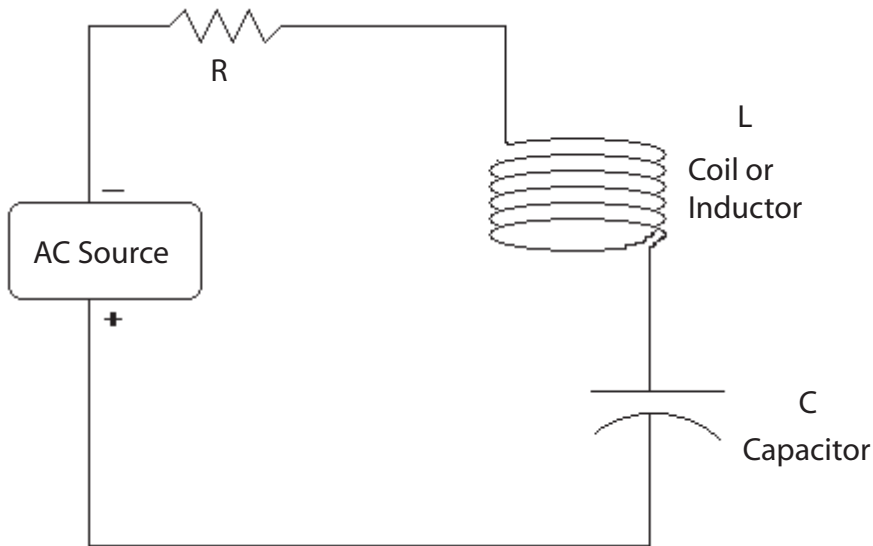


Figure 12–21 Series RCL circuit.

## IMPEDANCE

The total opposition that an RL, RC, or RCL circuit offers to alternating current is called *impedance*, which is measured in *ohms*. Remember that reactance is offered by the capacitor or inductor by itself, without resistance. Since there are very few uses for an inductor or capacitor by

themselves, their use is generally restricted to resistances and to each other in practical applications.

Resistance is considered the *real* part of the impedance equation. Inductive and capacitive reactance have phase shifts and are called *imaginary* (or mathematical) components of the total impedance. Take no heed of the word, their effects are real and extremely useful, just hard to determine at times. Impedance can (and will) vary if the frequency of interest varies because it determines the imaginary components of the inductive and capacitive reactance. The formula for impedance is

$$Z = \sqrt{R^2 + (X_L - X_C)^2}$$

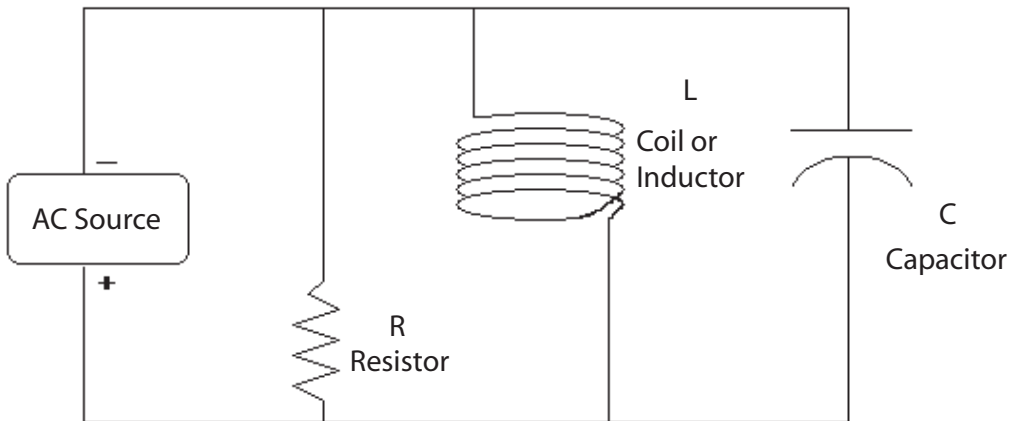
Of particular note is when  $X_L = X_C$ , the resonant condition. The square root of R squared is R. Gee, this is just what we said earlier. If there is just inductive reactance or just capacitive reactance then the Z is just that term.

$$Z = \sqrt{R^2 + X_C^2}$$

$$Z = \sqrt{R^2 + X_L^2}$$

## PARALLEL RCL

Figure 12–22 illustrates a parallel RCL circuit.



**Figure 12–22** Parallel RCL circuit.

Again, at some frequency the inductive reactance and capacitive reactance will become equal, leaving only the R in the circuit. In this case, R will be the maximum opposition to current flow. At lower frequencies, the inductor will offer less opposition. At higher frequencies, the capacitor will offer less opposition. Only at resonance will you obtain the maximum resistance and voltage drop, or the least amount of current.

## APPLICATION

In your radio or TV there must be a means for selecting the station you wish over all the others available. Typically, a parallel RCL circuit that has a variable capacitor or inductor is used. You tune the resonance of the RCL circuit to the carrier frequency (the frequency that the station is identified by), varying the reactive component. Only that frequency will produce a significant voltage; all others are shunted by the capacitive or inductive branch. The signal is then amplified and detected for your listening enjoyment.

## REVIEW

1. *Resonance is the frequency at which the inductive and capacitive reactances are equal.*
2. *Impedance is the total opposition that a circuit offers to alternating current and is measured in ohms.*
3. *The formula for impedance is*

$$Z = \sqrt{R^2 + (X_L - X_C)^2}$$

## TRANSFORMERS

Transformers are a particular kind of inductor. Up to now we have been dealing with self-induction, and calling the result CEMF. If we put two (or more) coils in the same moving magnetic field, then both will have a current induced in them. We call this effect *mutual induction*, and it too is measured in henrys. One henry of mutual induction is where 1 volt is induced in a coil by a change in current of 1 ampere per second in another coil in the same magnetic field. Figure 12–23 shows four types of transformer schematics. We use transformers for several primary reasons:

1. To change voltage levels.
2. To match impedances.
3. To provide isolation.

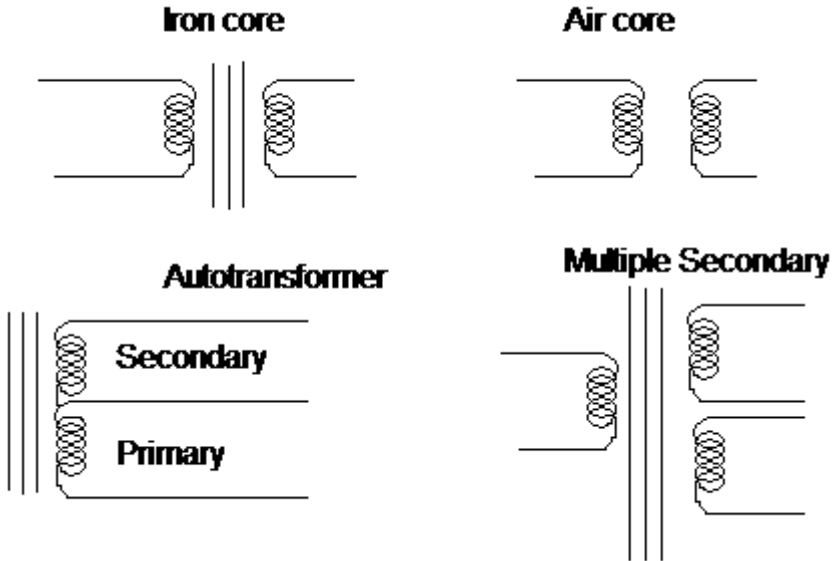


Figure 12–23 Transformer schematics.

Just keep in mind that what we said earlier about inductors is true of transformers as well. Transformers are nothing more than a number of inductors in the same magnetic field.

## PRIMARY AND SECONDARY

Transformers transfer power from the primary to secondary windings. This is done totally by way of magnetic coupling, without a direct conducting connection of any type. Since the primary and secondary are insulated (electrically) from each other, a transformer isolates the primary circuit from the secondary circuit.

The designation *primary* is given to the transformer coil that is driven by the power source. The *secondary* is the designation given to the winding that drives the load. Generally, a transformer will have one primary and one or more secondary windings.

## COEFFICIENT OF COUPLING

How tightly coupled the primary and secondary are, that is, how many of the lines of magnetic flux they share, is referred to as the *coefficient of coupling*. Power transformers and those with ferrous (iron-like materials) for cores generally have high coefficients of coupling. If 100 percent of the lines of force (flux) are common to both the primary and secondary, they have a coefficient of coupling of 100 percent. Air-core transformers have a much lower coefficient of coupling.

## URNS RATIO

A transformer can step a voltage up or step a voltage down. That is, it can change voltage levels from the primary to the secondary. This is determined by the transformer's "turns ratio." If you assume 100 percent for the coefficient of coupling, the turns ratio will tell you exactly what secondary voltage you will have with any primary voltage. The following ratio expresses that relationship:

$$\frac{\text{Turns Primary}}{\text{Turns Secondary}} = \frac{\text{Voltage Primary}}{\text{Voltage Secondary}}$$

or

$$\frac{\text{Turns Primary}}{\text{Voltage Primary}} = \frac{\text{Turns Secondary}}{\text{Voltage Secondary}}$$

So, if the transformer had a 10-to-1 (the primary is always given first) turns ratio and 120V RMS input to the primary, then: 120 is to ten as 12 is to 1, so 12 volts would be the secondary voltage. Note: This is only true for a coefficient of coupling that is near 100 percent.

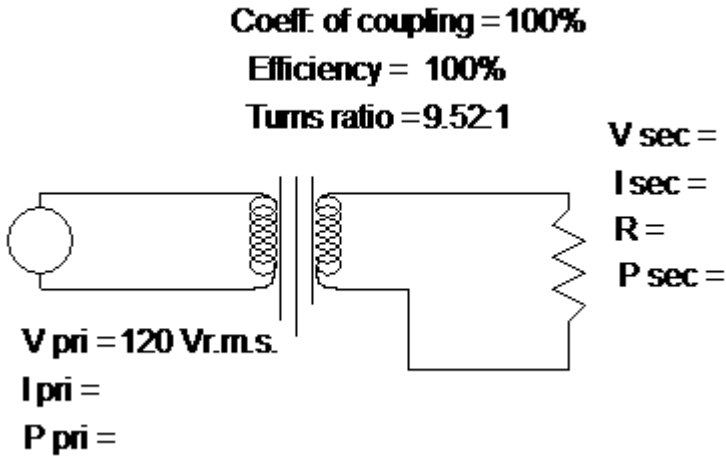
Conversely, if the turns ratio was 1-to-10 then if 12 volts RMS was applied to the primary, the secondary would be 120 volts RMS. Now, before you think that this is an ideal way to a free lunch—remember power. The secondary cannot create power. The power supplied by the secondary must come from the primary source.

Figure 12–24 illustrates a transformer circuit.

If  $R = 10$  ohms, what is the secondary voltage, secondary current, secondary power, primary current, and primary power?

The turns ratio is 9.52 to 1. For 120V RMS, the secondary voltage will be 12.6V RMS; 12.6V (effective) across 10 ohms will have a current of 1.26A. The power will be  $(P = E \times I) = 15.8$  watts. Assuming 100 percent coupling and efficiency, the same power will be drawn in the primary. So  $15.8 = 120 \times \dots?$  The primary current will be 132mA. You could solve the power formula algebraically ( $I = P/E$ ), or you could simply divide the secondary current by the turns ratio. For 100 percent coupling and 100 percent efficiency, the following relationship holds true:

$$\frac{I_{\text{sec}}}{I_{\text{pri}}} = \frac{V_{\text{pri}}}{V_{\text{sec}}}$$



**Figure 12–24** Transformer circuit.

As you can see, an inverse relationship exists between the current in the secondary and the turns ratio. Actually, the transformer’s efficiency is never in reality going to be 100 percent. This is because of losses in the transformer core and the resistance of the windings. So the power consumed in the primary is always going to be more than is used in the secondary. The point is that any power consumed in the secondary is drawn from (reflected to) the primary. The efficiency of a transformer is expressed as

$$\text{Eff} = \frac{P_{\text{sec}}}{P_{\text{pri}}} \times 100$$

While it is always true that the primary will draw as much or more power than the secondary, the turns ratio will not predict the secondary voltage as neatly when the coefficient of coupling is less than 100 percent.

### APPLICATION

Conductor size determines the *ampacity* of a conductor. The larger the cross-section of the conductor, the greater that conductor’s amount of current or ampacity. When distributing power, the utility company has to be concerned about ampacity. If your residence draws 100 amps then a certain size wire will be required. Multiply that by the number of residences in a given distribution area, and the wire would have to carry nearly 100 Kamps. It would be a big wire. It would cost a great deal. Instead, the utility company will step up the voltage of the generated electricity using a transformer. Figure 12–25 illustrates a typical distribution.

As you can see, the long-distance transmission at 400KV makes it possible to use smaller conductors. There are many intermediate voltages; this is only an example. A simple look at Figure 12–25 should demonstrate that when the 120V end-user uses 10 amps (1200 watts), this is a draw of about .88A—about .003A on the 400KV line and about .12A drawn on the 10KV generator.

Suppose there is no load on the secondary, what does the primary do? It becomes an inductor with a large amount of reactance at the frequency of operation. With no load and only the resistance of the winding and losses in the core, the primary winding without secondary load approaches  $90^\circ$  voltage leading current. Very little power is consumed. As the secondary load increases, this phase angle becomes smaller and smaller. The efficiency of a transformer increases as the load increases (up to the specification current).

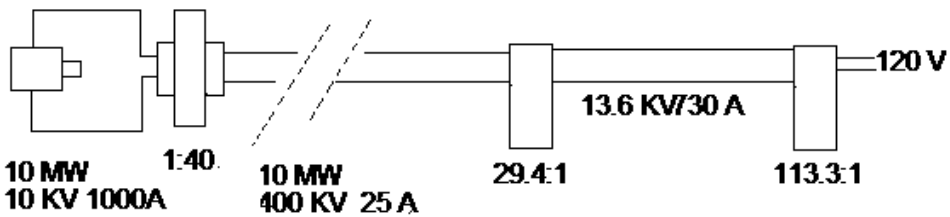


Figure 12–25 Electrical distribution.

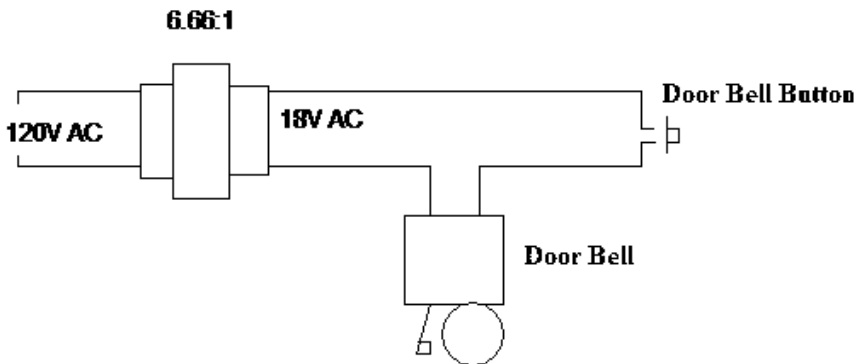


Figure 12–26 Doorbell circuit.

## EXAMPLE

If your house has a doorbell, then it has a doorbell transformer. The doorbell transformer is usually mounted in the attic or out-of-the-way place. Figure 12–26 illustrates a doorbell circuit

Notice that the 120V AC is not brought to the door button; that would be hazardous. The doorbell transformer is always across the line. It does not draw power until the doorbell button is depressed. In fact, the transformer is not designed to supply a steady current to the doorbell, and in fact it is overloaded when activating the doorbell. This has two advantages. First, the doorbell transformer can be cheaper and smaller. Second, it can be designed to be quite efficient when it is not supplying power, generating little heat and having low core losses.

## IMPEDANCE MATCHING

Before we explain how transformers match impedances, this is a good place to discuss why you would want to match impedances. It is a fact that for maximum power transfer impedances must be matched. Impedance has been previously defined, so let's see what this really means.

Matching impedances means that the source impedance matches the load impedance. Using only the resistive values (and at 0 degrees phase angle, loads are resistive in inductive circuits), Figure 12–27 illustrates power transfer.

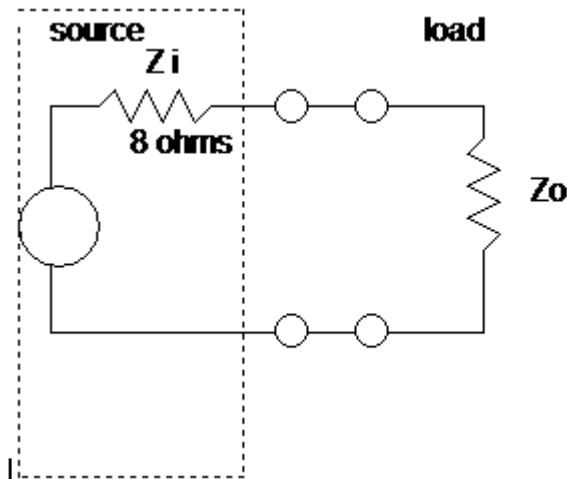


Figure 12–27 Power transfer.

Assume that the supply provides 8V. Table 12–3 shows the various values of power for differing values of  $Z_o$ .

Notice that the maximum power for the load was transferred when  $Z_o$  equaled the  $Z_i$  of 8 ohms. Transformers can match impedances because the secondary load is reflected in the primary. There is a direct relationship between the turns ratio and impedance transformation. The relationship is expressed as

$$\frac{Z_{\text{pri}}}{Z_{\text{sec}}} = \left[ \frac{N_{\text{pri}}}{N_{\text{sec}}} \right]^2$$

or

$$\text{turns ratio } \frac{N_{\text{pri}}}{N_{\text{sec}}} = \sqrt{\frac{Z_{\text{pri}}}{Z_{\text{sec}}}}$$

The turns ratio squared is the impedance ratio.

### EXAMPLE

$Z_{\text{primary}} = 7200$  ohms

$Z_{\text{secondary}} = 8$  ohms

What turns ratio is required to match these impedances?

$$\frac{Z_{\text{primary}}}{Z_{\text{secondary}}} = \frac{7200}{8} = 900$$

$$\text{turns ratio} = \sqrt{900}$$

$$\text{turns ratio} = 30$$

transformer must have a 30 to 1 turns ratio.

**Table 12–3** Power Transfer Example

$Z_o$	$R_t$	$I_t$	$V_{Z_o}$	$P_{Z_o}$ (W)
0	8	8	0	0
2	10	0.80	1.6	1.28
4	12	0.67	2.7	1.81
6	14	0.57	3.4	1.94
8	16	0.50	4.0	2.00
10	18	0.44	4.4	1.94
12	20	0.40	4.8	1.92
14	22	0.36	5.1	1.84

## REVIEW

1. Maximum power is transferred from a source to a load when the source and load impedances are matched (equal).
2. A transformer can match impedances by using the relationship

$$\text{turns ratio} \frac{N_{\text{pri}}}{N_{\text{sec}}} = \sqrt{\frac{Z_{\text{pri}}}{Z_{\text{sec}}}}$$

## ISOLATION

Because transformers couple energy by way of a magnetic field and not by direct connection, they are isolating the primary from the secondary circuits. This separation will diminish noise and break up ground loops (unintentional currents flowing in the grounding system because of variances in ground potentials geographically).

Transformers specifically designed for isolation are called *isolation transformers*, and they should be in every measurement facility. Isolation transformers have an equal number of primary and secondary windings. Their purpose is not to step up or step down, but to electrically isolate the secondary equipment from any other grounds, paths, and the like. Making measurements in a switching power supply with a line-powered oscilloscope absolutely requires that you use an isolation transformer. This is because the neutral and chassis ground of the power system are not the same reference used in the switching power supply. The oscilloscope will have its chassis wired to the third-wire ground. If the probe ground were connected to the common (negative side of the bridge), part of the

bridge in the nonisolated schematic would be shunted. Isolation transformers should be used on all bench measurements (other than chassis and isolation measurements) to prevent leakage and fault currents from disturbing the measurements.

## REVIEW

1. *Transformers separate the primary and secondary electrically by coupling energy through magnetic lines of flux.*
2. *An isolation transformer should be used with all line-powered test equipment that is used to measure other line-powered equipment.*

## CHAPTER EXERCISES

1. A capacitor has a value of  $.04\mu\text{fd}$ . What is its value in pfd?
2. A capacitor has a value of  $27000\text{pfd}$ . What is its value in  $\mu\text{fd}$ ?
3. A capacitor has a value of  $.01\mu\text{fd}$ . What is its value in pfd?
4. A capacitor has a value of  $680\text{pfd}$ . What is its value in  $\mu\text{fd}$ ?
5. A capacitor has a value of  $.15\mu\text{fd}$ . What is its value in pfd?
6. A capacitor has a value of  $1000\text{pfd}$ . What is its value in  $\mu\text{fd}$ ?
7. A capacitor has a value of  $10\mu\text{fd}$ . What is its value in pfd?
8. A capacitor has a value of  $5600\text{pfd}$ . What is its value in  $\mu\text{fd}$ ?
9. A capacitor has a value of  $.001\mu\text{fd}$ . What is its value in pfd?
10. A capacitor has a value of  $91000\text{pfd}$ . What is its value in  $\mu\text{fd}$ ?
11. Determine the time constant (TC) for the following values:
  - a. 47 kilohms,  $15\mu\text{fd}$
  - b. 1.2 megohms,  $0.001\mu\text{fd}$
  - c. 1200 ohms,  $150\mu\text{fd}$
  - d. 2.2 megohms,  $2200\mu\text{fd}$
  - e. 390 kilohms,  $2200\text{pfd}$
12. If a circuit has 450-kilohm resistance and  $.015\text{-}\mu\text{fd}$  capacitance, how long will it take to fully charge this circuit from a 100-volt DC source? To fully discharge it?
13. Determine the  $X_C$  of the following capacitors at the given frequency:
  - a. 100kHz,  $.015\mu\text{fd}$
  - b. 60HZ,  $2200\mu\text{fd}$
  - c. 1MHz,  $680\text{pfd}$

- d. 25kHz, 1.5 $\mu$ fd
  - e. 300kHz, .002 $\mu$ fd
14. Determine the TC of the following RL circuits:
- a. 12H, 1.2 kilohms
  - b. 1.5H, 10 ohms
  - c. 7H, 25 ohms
  - d. 450mH (millihenrys), 4.7 kilohms
  - e. 180mH, 120 ohms
15. Determine  $X_L$  for the following values:
- a. 100Hz, 10H
  - b. 1kHz, 35mH
  - c. 1Hz, 1H
  - d. 30kHz, 400mH
16. Determine the resonant frequency for a 1- $\mu$ fd capacitor and a 0.10-H inductor.
17. Determine the impedance of the following circuits at the frequency given:
- a. 1kHz, 1H, 2 kilohms
  - b. 12kHz, 0.15 $\mu$ fd, 3.3 kilohms
  - c. 330kHz, 360pfd, 1mH, 5 kilohms
18. A transformer has a 1:25 turns ratio. Is it a step-up or step-down transformer?
19. A transformer with a 9.521 turns ratio has 220V AC applied to the primary. What is the secondary voltage?
20. If a transformer primary has 1.5 amps at 120V AC and the secondary supplies 12.6V AC and draws 10 amps, what is the efficiency of the transformer at this level of secondary power?
21. If the source impedance is 16 ohms and the secondary requires 3.6 kilohms, what turns ratio will satisfy the requirement?
22. Suppose the turns ratio = 25:1. If the source impedance equals 10 kilohms, what is the secondary impedance?

**Answers to chapter exercises will be found at the back of this book.**

## **CONCLUSION**

With the completion of these exercises, you have come to the end of Chapter 12. This chapter has discussed quite a few concepts. Remember, the purpose of this text is not to provide design knowledge, but to give you an understanding of the behavior of different circuit components. Successful completion of this chapter means you now know the three fundamental components of any electrical circuit and can consider these when measuring and calibrating.

For additional information on this subject, enter the following topics in your Internet search engine:

**Impedance**

**Electrical distribution**

**Inductors**

**Inductive reactance**

**Transformers**

**Capacitors**

**Capacitive reactance**

**Resonance**

# AC MEASUREMENT

---

---

This chapter explains rectification for measurement and rectifying instruments.

Knowledge of the circuit principles will help you use these instruments properly and measurements alternating current correctly.

One of the most common and economical methods for measuring alternating currents is to rectify these currents and read the resultant DC on an analog or digital volt-ohm meter (VOM). You need to take many considerations into account when using rectification: what type of rectification you use, what scale conversion you will need, and the sensitivity of the meter.

## RECTIFICATION

Alternating current periodically changes direction, which is why it is called *alternating current*. Direct current, on the other hand, maintains one direction or polarity of current. Rectification is the process of changing an alternating current into a direct current. Whether we use one direction (half cycle or half wave) or both directions (full cycle or full wave) is determined by the circuitry.

## THE DIODE

In half-wave rectification only one diode is used. As you will recall from previous chapters, a diode is a check valve for electrical current. Current may flow only in one direction through a diode. It obtains its name from *di-*, meaning two, and *-ode* for electrodes. The electrodes are named the anode (positive electrode) and cathode (negative electrode). There are many different kinds of diodes. We will restrict ourselves here to just two types, germanium and silicon. The only differences between the two that are significant to us will be the:

1. Voltage necessary to maintain current flow in the positive direction—approx. 0.1 to 0.3 for germanium, approx. 0.5 to 0.9 for silicon.

2. Peak inverse voltage rating (explained in the text).
3. Power-handling capability (silicon is far more capable).

Figure 13–1 represents a diode schematically. Current flow is shown as electronic (negative to positive).

The cathode is the bar, and the arrowhead is the anode. This schematic diagram came about because the original diode was as shown in Figure 13–2.

This was the original diode used in the “crystal radio.” The operator would scratch on the galenium crystal until a rectifying junction was found and then, all other things being proper, the operator would hear an AM radio station. Note the similarity between the actual physical cat whisker device and the schematic of a diode.

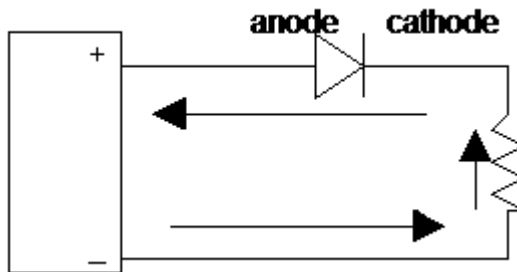


Figure 13–1 Schematic of diode in circuit.

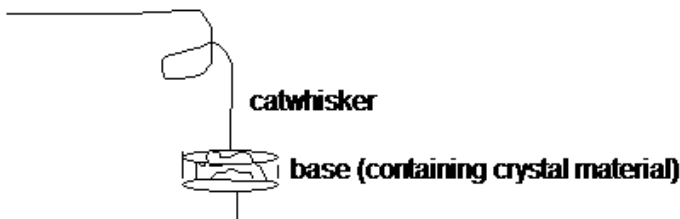


Figure 13–2 Cat whisker and crystal.

## FORWARD CURRENT

One of the more important parameters for a diode is how much current it can safely pass before it is damaged or destroyed. Diodes are generally given one of two ratings: average and peak. Typically, a diode with a 1-amp average current capability can pass 10 amps for a cycle or two, no more. This capability is called *forward current*.

## FORWARD VOLTAGE DROP

Forward voltage drop is the amount of voltage required to maintain current through the diode. In a mechanical check valve the pressure of the fluid in the correct direction must be high enough to overcome the pressure on the reverse side of the check valve, and a bit more to overcome the spring of the check valve. So too, a diode must have more than just equal voltages to conduct. In germanium diodes, this is anywhere from 0.1V to 0.3V for germanium and 0.5V to 0.9V for silicon diodes.

## PEAK INVERSE VOLTAGE

Just as in the mechanical check valve, if pressure on the reverse side becomes high enough (in relation to the forward side), the valve will be destroyed. There is always a limit. Since voltage is pressure, diodes have this limit as well. The specifications always give the amount of voltage in the nonconducting direction that the diode can withstand. This is the reverse potential across the diode. If it is exceeded, a rectifying diode will be destroyed.

## RECTIFICATION

The process of converting AC to DC will require one or more diodes. A number of rectifying circuits are available, each with its own advantages and disadvantages.

## HALF-WAVE RECTIFIER

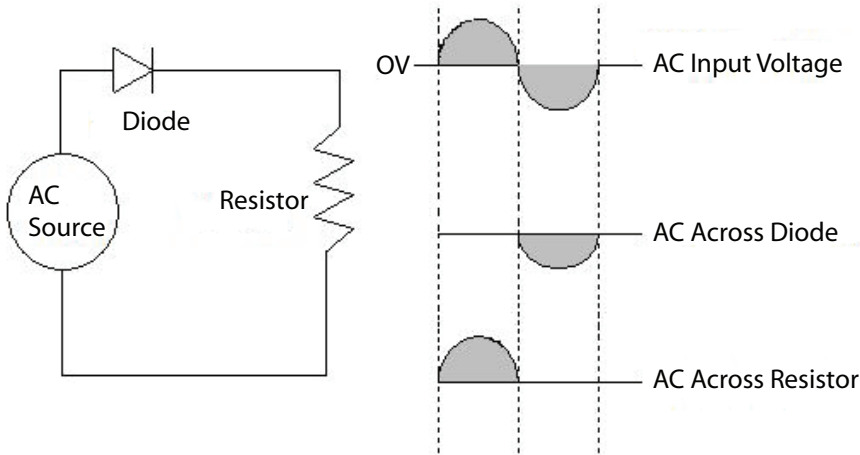
Figure 13–3 illustrates a half-wave rectifying circuit. We are really interested in the magnitude of these voltages. As you can see from the figure, the current through the load (and through the diode) is for only half of the wave shape (hence the name “half-wave rectifier”). The voltage across the resistor when the diode is conducting will range from just above 0 to the peak voltage input.

### EXAMPLE

If the AC source is 12.6V RMS, then what is the voltage across the resistor? The diode? Since the input is in effective RMS, multiply the effective by 1.414 to obtain the peak.

$$12.6 \times 1.414 = 17.8\text{V (peak)}$$

This will be exhibited as a positive peak across the resistor (due to the direction of current flow). When the diode is off there will be a potential of 17.8V peak across the diode and 0V across the resistor because no current is flowing. Since the sum of all the voltage drops must equal the applied voltage and 0V is across the resistor, the applied voltages must all appear across the diode.



**Figure 13–3** Half-wave rectification.

## RIPPLE FREQUENCY

When we have spoken of frequency previously in this book, it has been in regard to a sinusoidal wave-form. However, the output across the resistor in the half-wave rectifier can be defined in terms of frequency because it is continuously changing in amplitude and occurs at a periodic rate. There will be one output wave-form for each cycle of input wave-form. The input frequency is the “ripple” frequency for a half-wave rectifier.

### EXAMPLE

If the source voltage is at a 60Hz rate, then what is the ripple frequency for a half-wave rectifier? Answer: 60Hz; for half-wave circuits the ripple frequency is the same as the input frequency.

## FULL-WAVE RECTIFIER

A full-wave rectifier uses both alternations of the input wave shape to develop power across a load. There are two common circuits for producing full-wave rectification: the center-tapped transformer and the bridge. We will limit discussion at this point to the bridge circuit since it is by far the most common circuit in use today for full-wave rectification. Figure 13–4 illustrates a bridge rectifier circuit.

Figure 13–4a shows the complete circuit. Figure 13–4b is the current path when the upper source terminal is positive with respect to the lower source terminal. Figure 13–4c is the current path when the lower source terminal is

positive with respect to the upper source terminal. Notice that both alternations of the input wave-form are used. What is the ripple frequency for a full-wave rectifier?

### EXAMPLE

Determine the full-wave rectifier ripple frequency if the input frequency is 60Hz.

The output now has two alternations or occurrences per input cycle. Therefore, the ripple frequency is two times the input frequency for a full-wave rectifier. In this example, the ripple frequency would be  $2 \times 60 = 120\text{Hz}$ .

It should be obvious that the full-wave circuit will supply more power per input cycle than the half-wave circuit. Table 13–1 gives the conversion factors for determining the effective and average values for half-wave and full-wave rectification.

It is the average current that is measured by most meters (other than the true RMS types).

**Table 13–1** Conversion Factors

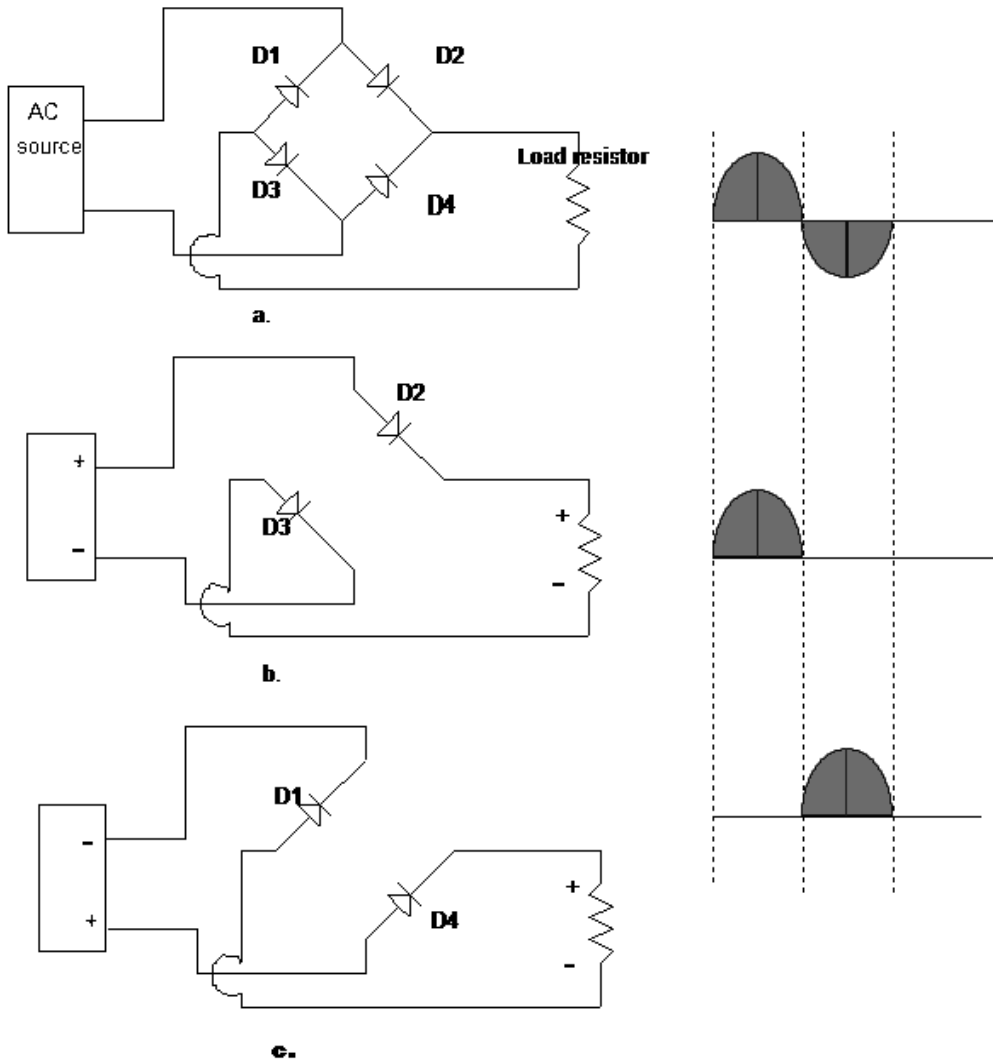
	HALF-WAVE	FULL-WAVE
AVERAGE	$0.45 \times \text{R.M.S.}$	$0.90 \times \text{R.M.S.}$
RMS	$1.11 \times \text{AVERAGE}$	$2.22 \times \text{AVERAGE}$

## AC METERS

The AC meter circuit we will explain first is the analog full-wave type for voltage measurement.

### FULL-WAVE METERS

Analog meters basically consist of a DC meter behind an input rectifier. The meter deflection current is first rectified by the full-wave bridge whose rectified current is what activates the meter. However, this current is not true DC, but a pulsating DC. This will require correction both in the meter scale and when the multiplier resistance is determined. The current that activates the meter is the average value of the input signal. Although some other meter types use the effective (RMS) voltage, a typical rectifying meter uses the average current. This is because there is no filtering of the pulsating DC and



**Figure 13-4** Full-wave rectifier.

the inertia of the meter movement limits the amount of travel that the meter movement can make in trying to follow each pulsation. For very low frequency AC voltages, the meter movement may approach the RMS value. However, at 60Hz, one of the more common AC frequencies, only the average value will be measured.

As most measurements of AC are in RMS, the *meter scale* is converted from average to RMS. This means that the DC scales cannot be used because the average voltage using full-wave rectification is 0.9 of the RMS value for a sinusoidal wave-form. *Sinusoidal wave-forms are the only ones under discussion here* for full-wave and half-wave rectifying meters. To determine the multiplier resistance, you must consider the average-versus-RMS scale.

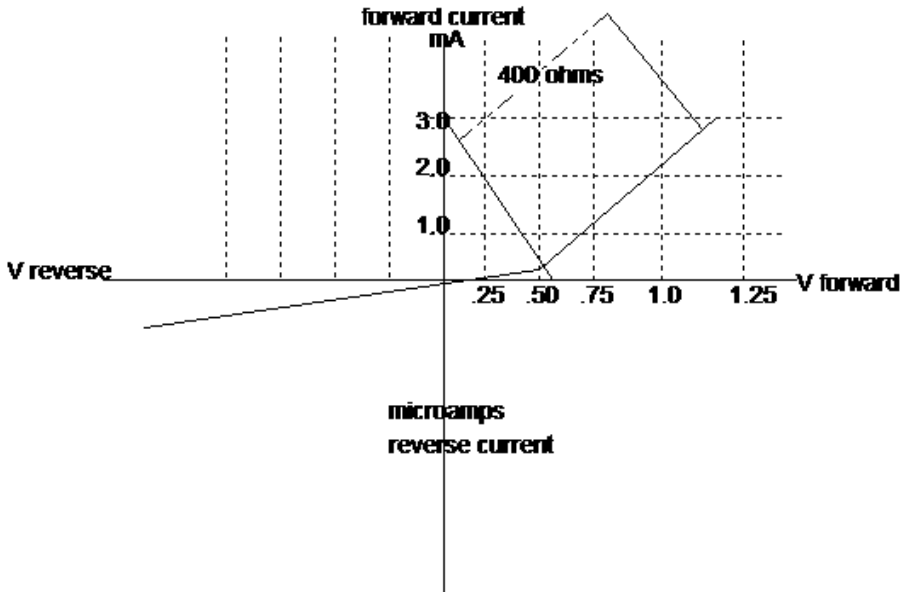


Figure 13-5 Typical diode curve.

### EXAMPLE

Assume that you want to measure 10V RMS at full scale. The meter movement is a 1mA fsd with 100 ohms resistance. What is the multiplier resistor value?

Determine the average voltage for the value of RMS at full scale. At 10V RMS (full scale), the average (for full-wave rectification) is  $0.9 \times \text{RMS}$ , so  $10\text{V} \times 0.9 = 9\text{V}$ . Therefore, when you want to measure 10V RMS, you want 9V to give full-scale deflection. This means that the multiplier must be figured for 9V, not 10V.

The total resistance needed to drop 9V at 1.0mA is 9,000 ohms. The meter has 100 ohms, so the multiplier resistor will be 8,900 ohms. Even though the meter had a DC sensitivity of 1000 ohms/V, the AC sensitivity using full-wave rectification is 900 ohms/V. This is essentially caused by measuring the average voltage and converting the scale to RMS.

You will also have to consider the resistance of the diodes in practice when determining multiplier resistors.

**EXAMPLE**

Any circuit path through the bridge must go through two diodes. Therefore, if the diode resistances of D through D4 were 54 ohms (a realistic value), the total diode resistance for the diodes in this example is 104 ohms.

$$R_m + D + d + R = 9000 \text{ ohms}$$

$$100 + 54 + 54 + R = 9000 \text{ ohms}$$

$$R = 9000 - 204 \text{ ohms}$$

$$R = 8796 \text{ ohms}$$

The diode resistances for a multirange meter are included in the computation of the first meter range only.

One factor that must be considered is the forward voltage drop of the diodes. The voltage drop across the diode obeys Ohm's Law in the linear portion of the diode characteristic, as shown in Figure 13-5.

The linear portion of the diode curve shown in Figure 13-5 has a 400-ohm forward resistance. Below the linear portion (approximately 0.6V) the resistance rapidly increases. At 0.5V, it is 1000 ohms and rises rapidly; at 0.1V it is approaching 10 kilohms.

The diode is a *current-activated device*, in that the forward voltage drop across the diode is the result of the amount of forward current. A current of more than 1.0mA (requiring approximately 0.6V) for the diode curve shown in Figure 13-5 will cause the diode to operate in the linear portion of its characteristic curve.

For a bridge circuit, these voltage drops, as well as the diode's forward resistance, must be added.

**EXAMPLE**

In the circuit shown in Figure 13-3 on page 218, if the diodes had a forward drop of 0.6V (to operate in the linear portion of their curve), then the combined drop would be 1.2V. This drop has the effect of crowding the low end of the AC scale (in this case, any voltage below 1.2V). This means that other techniques must be used to measure very small AC voltages.

## REVIEW

1. An analog meter movement using rectifiers will measure average voltage.
2. The average voltage (for full-wave rectifications of a sinusoid) is 0.9 times the RMS voltage.
3. Scales are calibrated to read in RMS while they actually measure average voltage.
4. A full-wave rectifier circuit reduces accuracy on the lower scales because of diode voltage drops.
5. The sensitivity of the meter is reduced because the meter measures average current but is scaled to RMS values.

## HALF-WAVE METERS

To overcome some of the disadvantages of the bridge-type AC rectifier, the half-wave circuit shown in Figure 13–6 is used in most general-purpose analog multimeters.

$D2$  in Figure 13–6 is used to pass the negative alternation to ground, preventing a high peak inverse voltage across  $D1$  and the resultant leakage currents.  $Rsh$  is a shunt resistor. It is usually the same value as  $Rm$ , but it may be less. For  $Tsh = Rm$ , twice the current will flow for a given voltage. This will cause the diode to operate on the linear portion of its characteristic curve for lower applied voltages. This will, however, reduce the sensitivity by half.

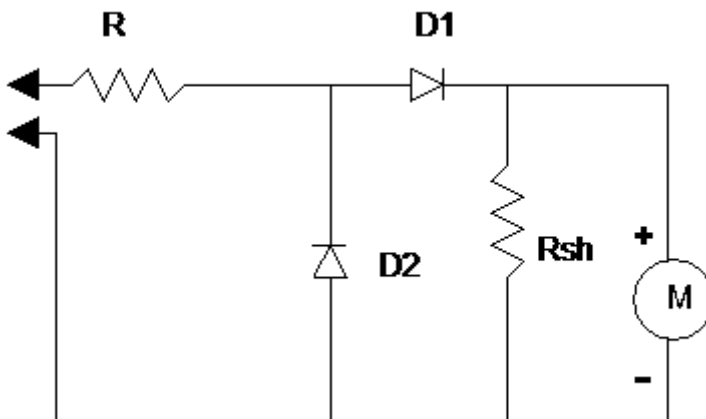


Figure 13–6 Half-wave meter.

To determine the multiplier resistor value, you must use the combined (total) current value. It should be pointed out that when using a half-wave circuit (and a sine-wave input) the average current will be 0.45 of RMS. This entails some vigorous meter scaling, particularly when using the shunt resistor.

## REVIEW

1. *To convert RMS to average for a half-wave circuit, the factor 0.45 is used for sinusoidal wave-forms.*
2. *The half-wave rectifier meter uses a shunt resistor to measure lower voltages accurately.*
3. *The half-wave circuit with a shunt resistor reduces the sensitivity of the circuit.*
4. *Both half-wave and full-wave rectifying instruments require a sinusoidal wave-form and have an upper frequency limit for measurement accuracy.*
5. *The diode forward voltage drop is less in a half-wave meter circuit, which thereby increases the accuracy of the lower scale.*

## DIGITAL AC METERS

The primary difference between digital and analog meters is that the analog types depend upon the fsd current of the meter to achieve their sensitivity and to filter the pulsations. This, of course, is work and is why the meters read average (although scaled to RMS).

Digital meters have the advantage in that they are powered, usually by a battery or line adapter. However, with modern electronics it takes very little power to perform many complex operations. Figure 13–7 is a block diagram of the AC-measuring circuitry from a typical digital voltmeter (DVM).

The precision divider generally divides in units of ten. The signal presented to the rectifier amplifier is in the 0–200mV range. The amplifier is used to bring the signals to an amplitude that will force the rectifiers (small-signal germanium) to operate in the linear portion of their range (among other things). After rectification, the signal is filtered and applied to the converter/scaler, which outputs a DC signal that is proportional to the input on the 0-to-200mV span input to the Analog to Digital Converter (A/D), which is normally a dual-slope-type converter. The measured signal, because it is rectified, is an average, but the scaler outputs the voltage as an RMS value.

There are a number of calibration points on the digital multimeters, but these are normally performed in a calibration shop by experienced and qualified personnel.

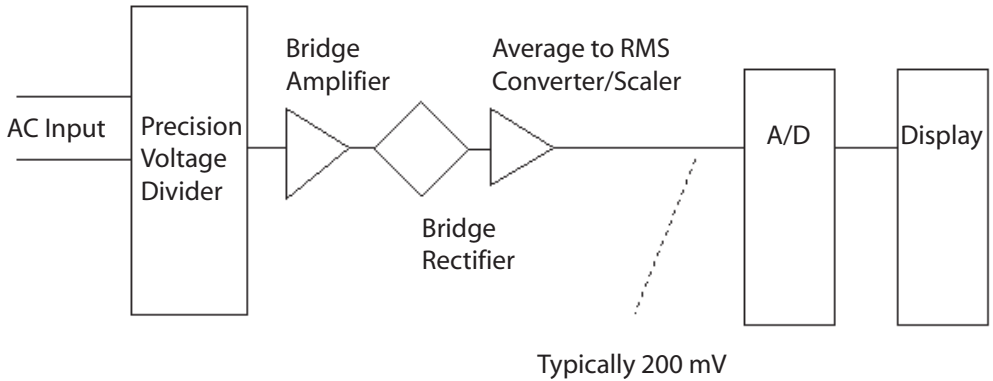


Figure 13–7 Typical AC portion of digital voltmeter.

## CONSIDERATIONS WHEN USING AC METERS

There are two main considerations to keep in mind when using AC meters.

1. Frequency of input signal.
2. Wave-form of input signal.

### FREQUENCY OF INPUT SIGNAL

The frequency of the input signal affects both digital and analog meters, but it affects the analog meters more. As frequency continues upward there are inductive and capacitive effects that tend to reduce the amount of AC current available to operate the meter. As the frequency continues upward, the actual indicator response will drop off, so even if the source is at 10V RMS, the meter may not read 1V RMS, or even less. This drop-off starts at a fairly low frequency for analog meters, generally anywhere above 500Hz. Because of the way digital meters are constructed the effects aren't noticeable until much higher frequencies (in many cases, 10kHz). Remember, however, these devices generally use a slow integrating analog-to-digital converter, and at some frequency the sampling rate will not permit accurate measurement.

### WAVE-FORM OF INPUT SIGNAL

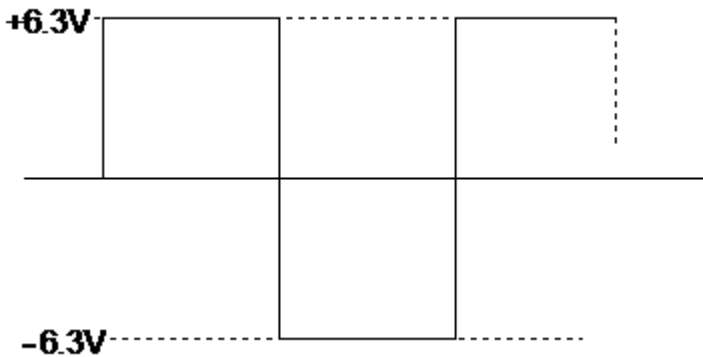
The wave-form of the input signal affects both the analog and digital types, which use rectification equally. All the conversions between peak and average, peak and RMS, and so on that we have discussed so far require a sinusoidal wave-form. Many AC wave-forms are not sinusoidal and are not measured very well with a rectifying type of AC meter.

**EXAMPLE**

Referring to Figure 13–8, determine the average power and peak voltage.

If you would half-wave rectify this signal you would have one or the other alternation. In either case, the average voltage would equal one half the peak (conversion factor of 0.5). In full-wave rectification, the average voltage would equal the peak voltage (conversion factor of 1.0). Obviously, if your meter is using the average voltage and scaling it to RMS, this wave shape will not read correctly.

Very few measurements of AC involve pure sine waves. Even the 60-Hz power line has harmonic (multiples of the frequency) information. This is why the oscilloscope was historically necessary, and why it is still necessary today to view nonsinusoidal wave-forms.



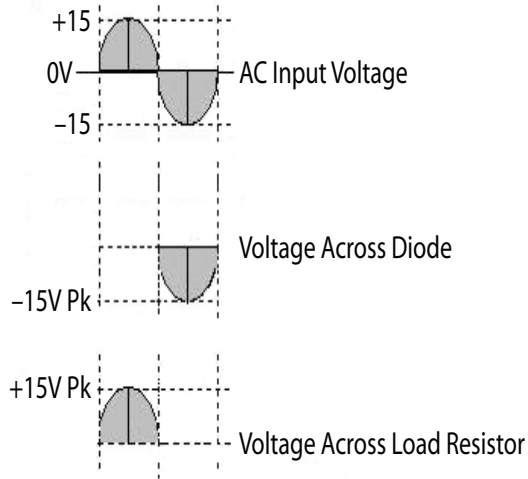
**Figure 13–8** Square wave.

**REVIEW**

1. *The frequency of the input signal has an effect upon measurement by rectifying meters.*
2. *The wave shape of the input signal affects measurement by rectifying meters.*

**CHAPTER EXERCISES**

- Using the following figure, draw the wave-forms that will be present across the resistor and the diode. Label these wave-forms with the voltage levels for each wave-form.



- Draw the output wave-form for a full-wave rectifier (without filter), assuming an input frequency of 400Hz at 100V RMS.

3. In problem 2, what is the average voltage? What is the peak voltage?

***Answers to these review questions will be found at the back of this book.***

## **CONCLUSION**

If you are encountering difficulties with the concepts presented in this chapter, please re-read the text. If your difficulties persist, locate someone with technical knowledge of AC measurement and have them assist you.

For further information on the topics in this chapter, use your Internet search engine to search the following terms:

**Rectification**

**Full-wave rectifiers**

**Measurements of non-sinusoidal wave-forms**

**Half-wave rectifiers**

**Dual slope A/D conversion**

# SOLID STATE: PRINCIPLES

---

---

This introduction to solid-state principles approaches the topic a bit differently than do traditional texts. Most modern industrial equipment has very few solid-state devices other than large-scale integrated circuits. There are occasional operational amplifiers, transistors, and, in some equipment, discrete power-handling devices such as silicon-controlled rectifiers. With this in mind, rather than devote pages to the manufacture and design of a bipolar transistor, this chapter focuses on solid-state behavior and operation in circuitry. A large variety of solid-state electronic devices are in use today. The following discrete (not integrated) devices are discussed in this chapter:

1. Bipolar devices:
  - NPN
  - PNP
2. Unipolar devices:
  - Junction field-effect transistors (JFETs)
  - Insulated gate field-effect transistors (IGFETs)

Other solid-state devices, their operation, and their applications are discussed in the following three chapters, 15, 16, and 17.

## PN JUNCTION

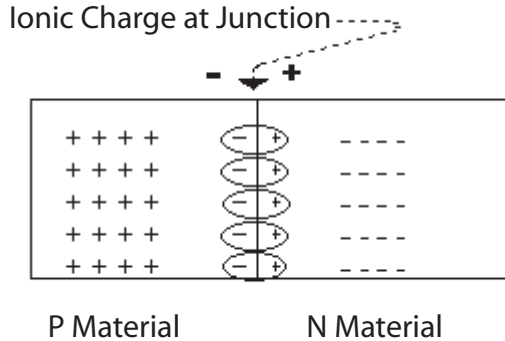
Any discussion of modern semiconductor operation must begin with the operation of a single junction: the PN junction. A PN junction starts out as a crystal of extremely pure semiconductor material. It is so pure that it is actually an insulator. It has no carriers for current flow, which means that its constituent atoms are in a lower energy state, and thus require larger amounts of energy to allow energy transfer (called current flow) than does less-pure material. The PN's semiconductor material is a "monolithic" crystal structure, meaning that the atoms have arranged themselves in a geometric pattern (inasmuch as we can't see atoms, we mathematically model them in a crystalline structure). To do this, they

must enter a lower energy state. In other words, using a contemporary analogy, all of the outer-shell (valence) electrons are shared with other atoms to satisfy a requirement that the outer shell be filled. In doing so, the outer-shell (valence) electrons enter a state of less energy. This means that more external energy is required to move these electrons, that is, give them the energy to overcome their state.

**Note**

There are many explanations for how a semiconductor junction works. Some are based on the Bohr model of the atom, others on the quantum theory model (which has had great success in predicting behavior and apparently has not yet been proved wrong), or on other simplified models. However, which theory of formation and operation is correct is of little concern to someone using a junction device (as opposed to designing the device). The behavior of the device in its circuit is the important focus. Whatever mental picture you create of a transistor's operation at the atomic/subatomic level is fine if it enables you to visualize the operation. Whatever picture works for you, keep it.

If the semiconductor material remained in its pure state only, it would be of little use as a device since less expensive insulators are available. However, by “doping,” or adding impurity atoms that raise the energy level (contribute either positive or negative charges to the material), we change the semiconductor material into either “N” type (contains negative charges) or “P” type (contains positive charges). These charges are local; they remain (and are electrically chained) around the impurity atom. External energy applied to these materials can force the charges to move. As they are at a higher energy level than the atoms in the crystal structure, smaller amounts of energy are required to put them into motion. A charge in motion constitutes an electric current. A semiconductor material is “doped” as it is grown. There is no mechanical method for creating a junction of materials; rather, the material is alternately doped. This process will create a PN junction. When the junction of two materials is formed (*and only at that time*), there will be a combination of N-type (electrons) and P-type (holes) carriers. This leaves an area (depletion region) that is devoid of current carriers and has ionized atoms along its boundary—a result of the P-type material accepting an electron (and the N-type material giving up an electron, which makes that atom positive in charge). An ion is a charged atom. Normal atoms are essentially neutral, having a balanced number of positive and negative charges. When an atom is forced to accept an



**Figure 14–1** Junction ionic charge.

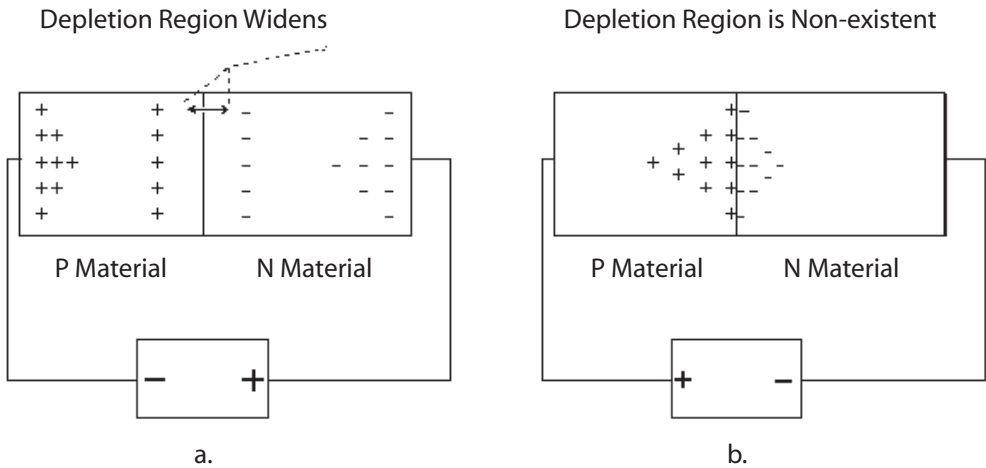
electron (giving it a net negative charge) or when an electron is stripped from an atom (giving it a net positive charge), it has a local charge.

Refer to Figure 14–1. Note that the *ionic charge* illustrated here is counter to the inherent charge of the type of material. This charge will have to be overcome if current (movement of charge) is to cross the “depleted” region.

If a conductor is connected from the N side to the P side, no current will flow. Kirchhoff stated that no more current can arrive at any one point than leaves that point. That is true whether one is speaking of an electrical current in a conductor or a semiconductor. If a potential source (such as a battery) is connected with the negative side to “P” material and the positive side to the “N” material, the only effect will be to attract the current carriers toward the connections (none will leave because that would constitute current flow) and effectively widen the depletion area (see Figure 14–2a).

If the negative source is connected to the N-type material and the positive source is connected to the P-type material, the following will happen. If the source potential is less than the amount needed to overcome the ionic charge, conditions will remain as before. When the potential is greater than the amount needed to overcome the ionic charge (0.2 volt to 0.4 volt in germanium, 0.6 volt to 0.9 volt in silicon), then the negative carriers are forced to combine with the positive carriers (see Figure 14–2b).

As each pair combines, a vacancy of charge is created in each of the materials (and this is strictly prohibited by Mother Nature). A negative carrier (electron) must then be injected into the N material while an electron must be extracted (creating a positive charge or hole) from the P material. This, of course, happens at near the speed of light; what is observed in the external circuit is that current is flowing.



**Figure 14-2** Left: Reverse bias. Right: Forward bias.

The conclusion to be reached is that *if* there is:

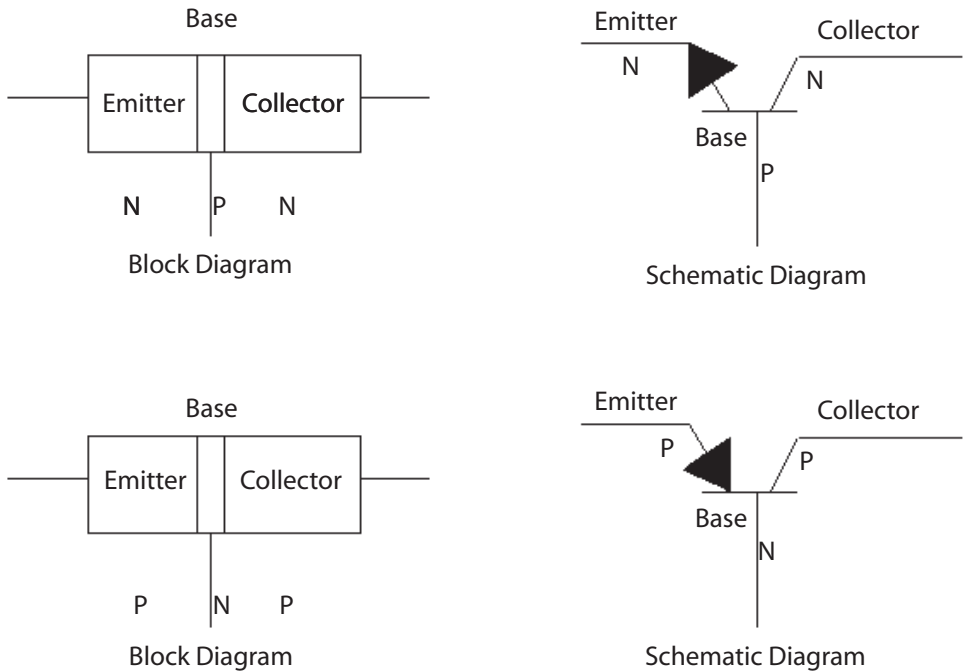
1. No battery applied, or
2. A battery applied with – to P and + to N, or
3. A battery applied with – to N and + to P (and with battery potential less than that needed to overcome the ionic charge at the depletion region), then *no current* will flow in the external (or internal) circuit. Moreover, if the battery is connected – to N and + to P and the battery is sufficient to overcome the depletion region ionic charge, then *current will flow* in the external (and internal) circuit.

The connections bringing about *no* current flow are called *reverse bias*. The polarity of the connection causing current flow is called *forward bias*. Since there are two active electrodes (the N and P materials), this device is called a *diode*. The principal function of a diode is that it conducts current in one direction only. The operation of a diode was covered in Chapter 13 on measuring alternating current.

## BIPOLAR TRANSISTOR

It is possible, of course, to create two PN junctions by growing P-N-P or N-P-N crystals. If the middle material is made sufficiently thin, a *transfer resistor* (transistor) is formed (see Figure 14-3).

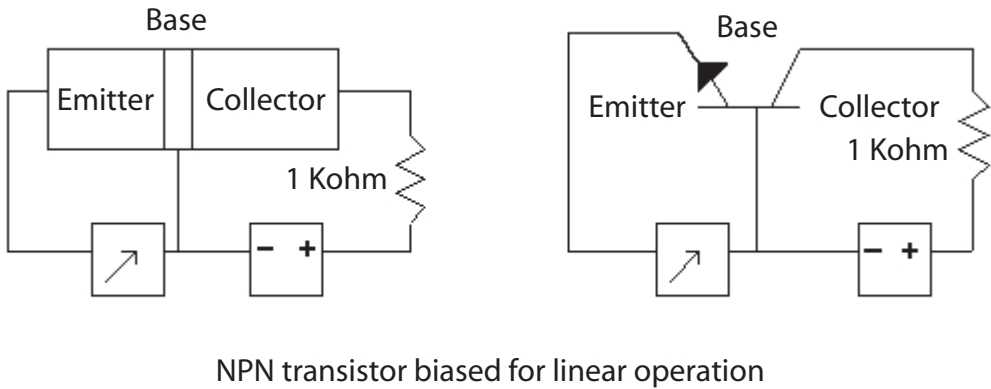
For linear and most switched operations, the material designated “collector” is *reversed biased* (+ to N, – to P). As the example in Figure 14-3 uses an N-P-N transistor, the collector has a positive charge relative to the



**Figure 14–3** Bipolar transistors.

thin material designated “base” (the base is P-type). This means that no current flows between the collector and the base. *Note, however, that if an N-type carrier ever got into the base region, it would proceed with great haste to the large positive charge on the collector.* This is only possible if the positive carriers in the base are occupied or otherwise not readily available. Having an N-type carrier in the base is not possible under the conditions so far described. The large attractive force (in this case positive) on the collector is supplied by a power source or battery, typically called  $V_{cc}$ . In series with  $V_{cc}$  and the collector is a resistor, one whose value is large compared to all the other resistances found in the Figure 14–4 circuit. The value used here is 1000 ohms.

Nothing will change and no current will flow as long as the “emitter” circuit (the other N side) has no battery applied to it or has reverse bias applied, or if the junction is forward biased and the applied voltage does not exceed the ionic charge (approximately 0.7 volts for silicon). When the emitter to the base junction is forward biased, current will flow in the emitter base circuit. However, the base is physically very small and has few carriers (compared to the emitter and collector). When current flows in the emitter base circuit, a large number of the emitter’s N-type carriers can cross into the base region but will find no P-type carrier to combine with. As stated before, if an N-type carrier found itself in the base without



NPN transistor biased for linear operation

**Figure 14-4** Correct biasing for NPN common base.

meeting a P-type carrier it would be attracted to the large positive on the collector. This is precisely the condition brought about by current flowing in the emitter base circuit. The larger the emitter base current, the larger the number of N-type carriers introduced into the base without partners. This emitter base current is the greatest factor in determining how many carriers leave the emitter and go to the collector. If a carrier leaves the emitter, then one must be injected from the external circuit. And, as a carrier from the emitter arrives at the collector one must be ejected into the collector's external circuit. This is current flow. Generally, less than 2% of the total emitter current will be found in the base circuit, which means that 98% of the emitter current will arrive at the collector. You might wonder, of course, where the gain is if only 98% of the current is available at the collector. The gain is a power gain. The emitter circuit has approximately 10 to 50 ohms of forward resistance, because a forward-biased junction has a very low impedance. The collector circuit, being reverse biased, has an extremely high resistance, but current is not flowing from the collector to the base. It is flowing in the external collector circuit, which has 1000 ohms. The formula for power is  $P = I \times I \times R$ . The input circuit power is  $1 (100\%) \times 1 \times 50 = 50$ , and the output power is  $.98 \times .98 \times 1000 = 960.4$ .  $960/50 > 19$ , so there is a power gain in excess of 19. Inasmuch as the device transfers current from a low-resistance circuit to one of higher resistance, it is a "transfer resistor." Though understanding the operation is nice, one must remember two essential points about a bipolar device:

1. The primary control of the collector current is the emitter forward-bias current. Within reason, the collector voltage may change significantly with very little effect on the collector current (provided it is sufficient to overcome all resistances in the collector circuit).

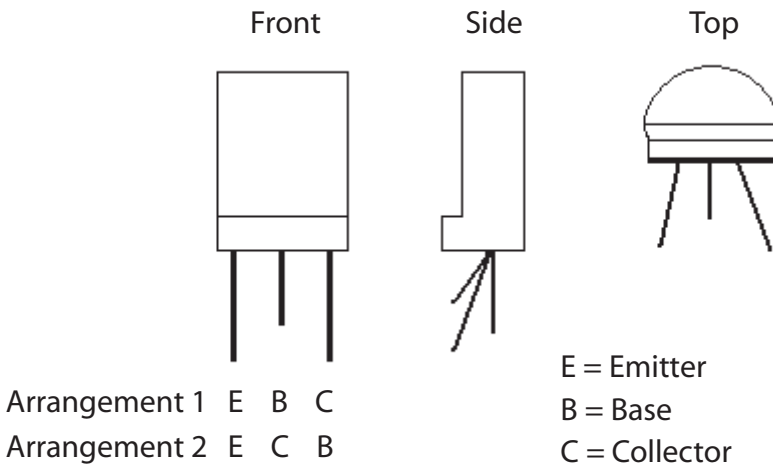
2. The emitter forward-bias voltage will be the ionic voltage (0.62V to 0.82V for silicon), regardless of the emitter forward current, until either the emitter base current is in saturation or there is not sufficient voltage to cause forward current.

## LEAD IDENTIFICATION

Identifying the leads on transistors can be time consuming. Generally, if you replace a transistor, it is good policy to replace it with the very same type, which of course will have the same lead arrangement. This is not always possible, however.

Transistors come in a variety of packages, too numerous to illustrate here. In each of these packages, the three leads may be arranged in any particular manner. Figure 14–5 illustrates a TO-92 package (not actual size) and shows the two most common arrangement of leads.

Not so many years ago, several methods were taught when training people in identifying transistor leads by use of an analog voltmeter. However, given the generally low price of transistors, if you don't know the transistor's leads, why are you using it to replace another? In professional environments, only new transistors should ever be used as replacements. To identify the leads of a transistor in a circuit, check the circuit components (the maintenance manual is not a bad place to start). This will generally identify the lead placement. On some circuit boards, the leads are identified. From a measurement perspective, it will be hard to take measurements without some documentation. Not impossible, just time consuming.

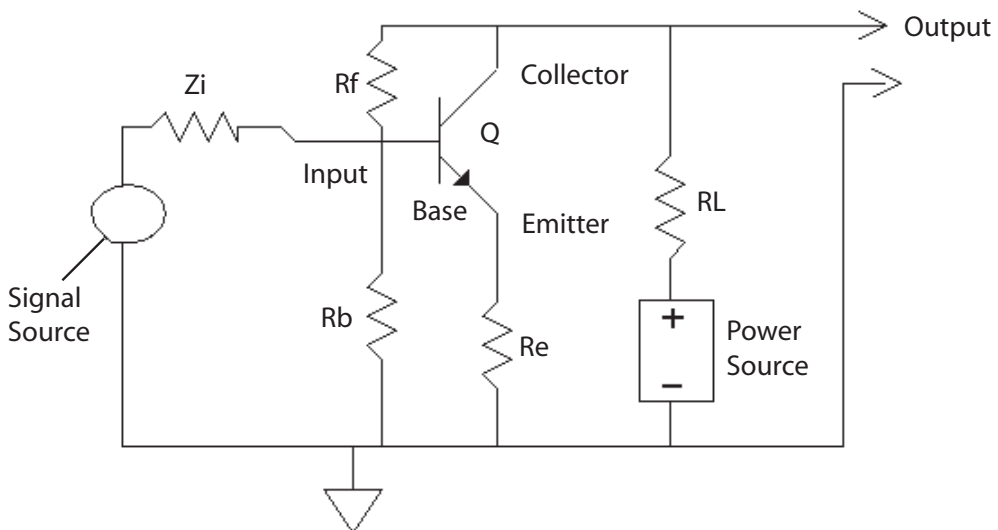


**Figure 14–5** Lead arrangement.

Measuring the operating voltages (you cannot measure currents directly with an oscilloscope) can help you locate defective stages. After all, if there is about 0.7V across the junction of a silicon transistor, then you can be assured it is biased correctly and that at least the emitter base junction is OK. Taking resistance readings can be misleading. Analog voltmeters use a large enough battery to forward bias most PN junctions. Digital volt-ohm-millimeters (DVMs) do not. Most DVMs will have a special scale for checking the drop across a PN junction. This is a good test, except when the two junctions you are checking are shunted by a low impedance (like a transformer winding). *The key to understanding a bipolar transistor is to know that you are using a small current (the emitter base current) to control a larger one (the emitter collector current).* The transistor cannot amplify by itself; it must be placed in a circuit with the appropriate voltages and resistances.

## AMPLIFIERS

The transistor alone will not do anything; it must be connected in a circuit to perform some function. There are three basic configurations of amplifiers. They are classified by which of three leads is common to both the input and the output signals. The most common configuration is the common emitter (CE), illustrated in Figure 14-6.



**Figure 14-6** NPN common emitter configuration.

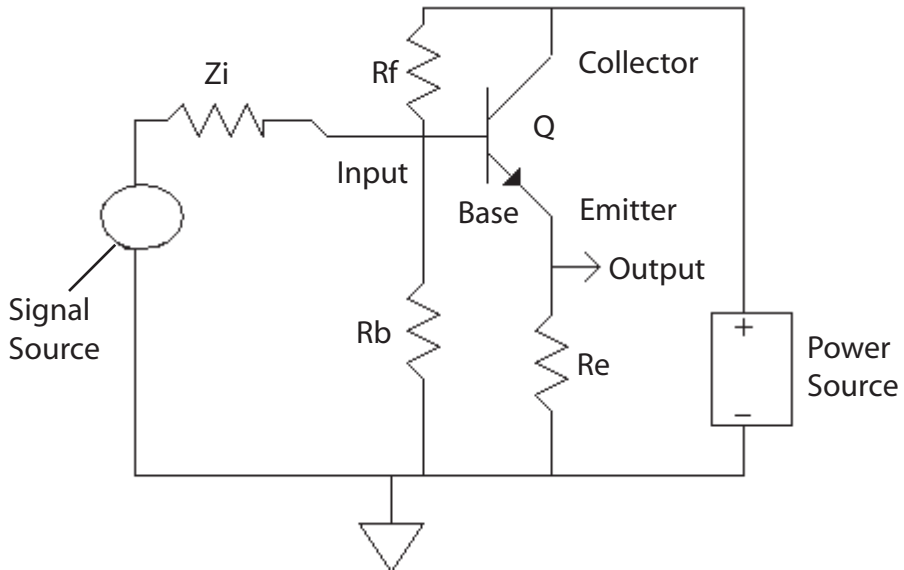
Note that in this configuration the *input signal supplies only the emitter base current*. Using the previous example of 2% for the emitter base current

would mean that this 2% controls the 98%, for a current gain of 49%. The important consideration here is that by causing changes in the emitter base current, the emitter collector current is changed. Generally, a very small change in emitter base current causes a rather large change in collector current. These are current-activated devices and as such have relatively low input impedances and only moderate output impedances.

Other configurations of amplifiers are the common base (the configuration discussed vis-à-vis basic transistor operation), common emitter (illustrated in Figure 14-6), and common collector. In a common collector (illustrated in Figure 14-7), the collector is common to the input and output signals. (The battery is considered a short as far as the signal currents are concerned.)

The configuration shown in Figure 14-7, also known as an emitter follower, has a very high input resistance, a very low output resistance, and a voltage gain of less than one. It is used for isolation and impedance matching.

Table 14-1 contains information on each amplifier type.



**Figure 14-7** Common collector (emitter follower).

**Table 14-1** Amplifier Characteristics

TYPE	Z in	Z out	V gain	I gain	P gain
Common Base (CB)	Low	High	High	<1	Moderate
Common Emitter (CE)	Moderate	Moderate	Moderate	Moderate	High
Common Collector (CC)	High	Low	<1	High	Moderate

**EXAMPLE**

*NOTE: The following is a very detailed analysis of the operation of an amplifier. You do not need to complete this section to understand the remainder of this chapter or the text. It is provided simply to illustrate how a discrete amplifier works.*

Figure 14-8 is a typical common emitter amplifier, with the values given. The *beta* of the transistor is its DC current gain in the common emitter configuration. A better figure is the *h<sub>fe</sub>* (static current transfer ratio) from transistor data charts.

Notice *R<sub>f</sub>* and *R<sub>b</sub>* in Figure 14-8. They are used to bias the emitter base junction forward. Since the bipolar transistor is a normally off device, to operate it must be turned on during the entire input cycle of the input signal. Generally, amplifiers used in linear operation are biased to output about half the power source potential with no input signal. In our case, this would be 5V. The beta is a ratio of input current change to output current change. Every one-unit input to the emitter base will produce seventy units in the emitter collector circuit. To drop 5V, our 5-kilohm resistor must have .001 amp flowing through it. The emitter base current needed to cause that will be 1/70 of .001A or 14.3 microamps.

The voltage at the emitter base will be near .7V (for a silicon transistor). The combination of *R<sub>f</sub>* and *R<sub>e</sub>* (20K) will have 1mA (at 10V). The current needed for operation is less than 2 percent of the current flowing in the series combination. The voltage at the emitter with respect to ground will be near 1.3V. The voltage across the transistor will be 3.7V. The output will be at 5V (3.7 + 1.3). With a ±14.3-microamp input signal the amplifier will swing between ±5V.

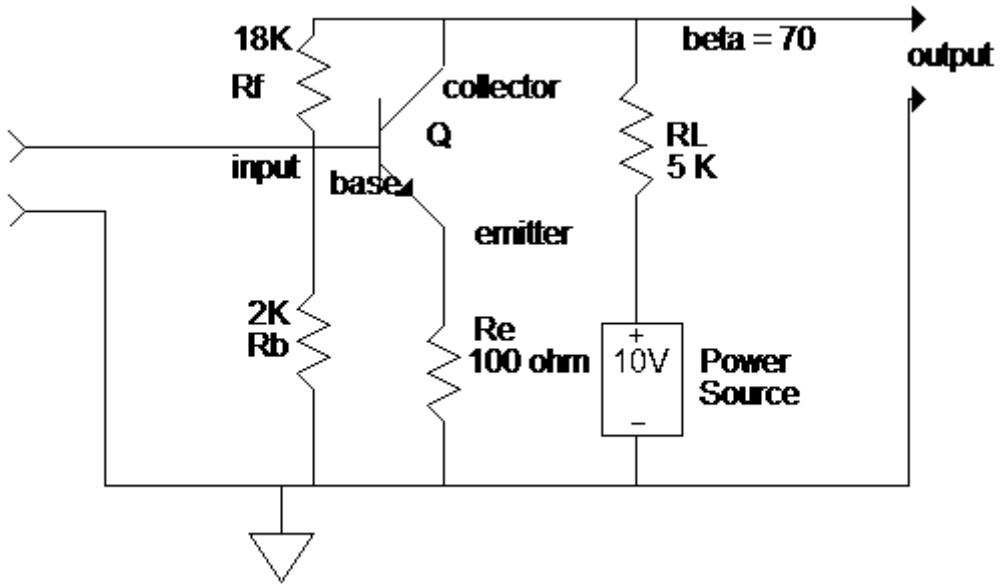


Figure 14–8 Typical amplifier.

## AMPLIFIER TROUBLESHOOTING

Rather than make a design exercise out of every amplifier circuit, what should you examine to understand if the amplifier is working correctly?

1. Look at the collector voltage in reference to ground.
  - If it is at the source (Vcc) potential, then the transistor is not conducting.
  - If it is 0V, then the transistor is full on or the source is not applied.
    - If the source voltage is not at the collector circuit you could have a bad power supply, connection, open lead, or dropping resistor between the amp and power source.
    - If the transistor is full on (and is not supposed to be), it could have an emitter-to-collector short (the typical cause) or input problems.
  - If the output is somewhere between 0V and Vcc, then the DC portion of the circuit operation is probably working.
  - Signal (oscilloscope time) is deformed or not at the right amplitude (if it is OK, the stage is working—look elsewhere)

## 2. Look at the input.

- Is the signal what it should be (refer to the maintenance documentation if any is available; otherwise, you will have to decide based on experience).
- No signal (go to previous stage).
- Signal is deformed—either the previous stage is faulty or there is a transistor fault.

Transistors may be used as amplifiers (linear operation) or as switches (switched operation). In switched operation, the transistor is either full on or full off, never in between. In either the switched or linear operation you are basically *still using a small current to control a large current*.

## APPLICATION

A transistor in the linear mode with a 30Vcc and .5-amp maximum collector current will have to dissipate up to 5 watts (because of varying  $V$  for  $I_c$ , it does not equal 15 watts). And because of the different combinations of voltage and current that a transistor in linear mode experiences, a good deal of power is lost through heat dissipation. The transistor (along with its heat sink, if any) must lose the heat or suffer catastrophic failure. In the switching mode, with the same values (500mA collector current, 30 volts Vcc) the transistor can have a much smaller dissipation rate, depending on the duty cycle (the ratio of on to off time). The reason for this is:

- When the transistor is off there is 30V at the collector, but no current is flowing, so the power use is 0.
- When the transistor is full on, there is nearly 0V across the transistor, and .5A is flowing, but the power ( $E \times I$ ) used is almost insignificant. Where a switching transistor begins to heat up depends on:
  - How long it takes to switch—anytime spent between full on and full off draws current and dissipates heat.
  - How many times it is switched on and off—the frequency of switching.

Because the transistor cannot switch instantly between on and off, energy is dissipated. More frequent switching means more energy is dissipated.

## REVIEW

1. A PN junction will pass current in one direction (forward) and not in the other (reverse).
2. A bipolar transistor consists of two materials of the same type with a thin region of the oppositely charged material sandwiched between.
3. Bipolar transistors can be PNP or NPN.
4. The function of a bipolar transistor is to allow a small current to control a large one.
5. The three elements of a bipolar transistor are known as the emitter, base, and collector.
6. Normally, the collector base junction is always reversed biased.
7. The emitter base junction controls the emitter collector current.
8. The collector voltage has little effect on collector current (assuming correct polarities and voltages).
9. Identifying the transistor lead is best done with a technical manual.
10. An operating transistor will have 0.2V to 0.4V (germanium) and 0.5V to 0.8V (silicon) across the emitter base junction.
11. Bipolar transistors are normally off and require external voltages to put them in the on condition.
12. A transistor must be in an amplifier circuit to amplify.
13. There are three configurations of amplifiers:
  - common emitter
  - common collector
  - common base

## FIELD-EFFECT TRANSISTORS

Field-effect transistors, also called unipolar transistors because the current channel is made of one type material, come in three distinct varieties:

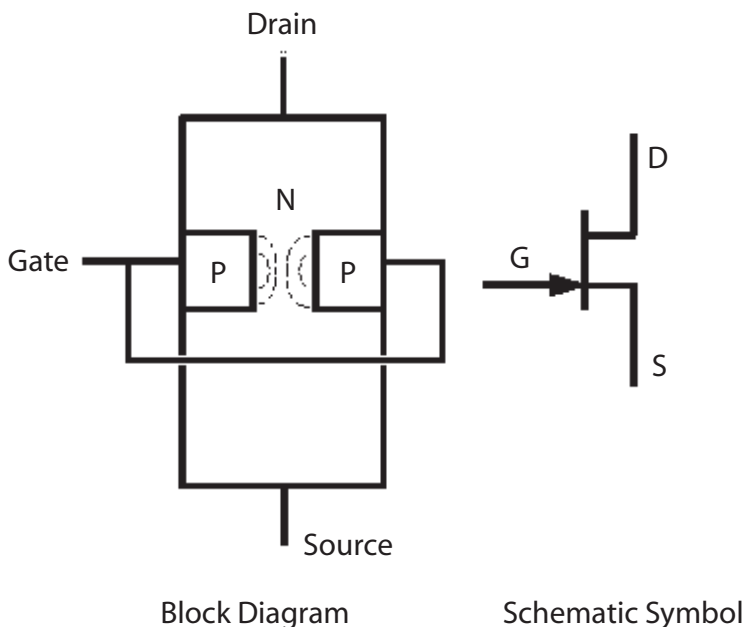
- junction field effect
- depletion mode insulated gate
- enhanced mode insulated gate

Most of these transistors are also called MOSFETs, meaning “metallic oxide semiconductor field effect transistors.” Most modern circuitry, whether discrete or integrated, is a MOSFET. As with bipolar transistors, these come in N and P variations for each of the three main groups.

## JUNCTION FIELD-EFFECT TRANSISTORS

Figure 14–9 shows a simplified drawing of the operation of a junction field-effect transistor (JFET).

Figure 14–9 shows an N-channel JFET. The N-type material is the current channel. The gate is a PN junction in the channel, which is reverse biased. This means that no current flows in the PN junction circuit and that it has a very high impedance (between 10 to 30 Megohms). By varying the amount of reverse bias, the strength of the electrostatic field between the reverse-biased junction and the N channel is varied. This is a normally “on” device, that is, if the reverse bias isn’t present, current will flow from the source to the drain. The greater the reverse bias, the more the field constricts the channel, allowing fewer and fewer charges to pass through until the bias is great enough to stop the current flow altogether. This point is called the *pinch-off* point. Therefore, all the incoming signal has to do is affect the junction *voltage*, *not current*, in order to control the drain current. Here we have a case (as with all the unipolar devices) of using *a small voltage to control a large current*. As voltage-activated devices, the unipolar devices have extremely high input impedances. This means they are vulnerable to static damage. Never handle a board populated with these devices without taking the proper static precautions. The P-type JFET operates the same as the N channel except that all the polarities are reversed. The same amplifier configurations (albeit with a little different circuitry and certainly different values) provide the same features as with their bipolar cousins.



**Figure 14–9** JFET operation.

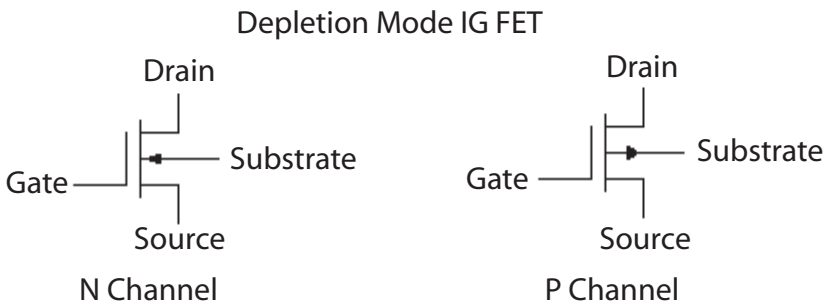
## INSULATED GATE FETS

Rather than use a reverse-biased diode as the gate, over time semiconductor techniques advanced to where a very small amount of material insulated by a thin layer of oxide could be used, in effect a very small capacitor. These insulated gate (IG) field-effect transistors are the predominate technology of integrated circuitry. NMOS (N-channel insulated gate types), PMOS (P-channel insulated gate devices), and CMOS (complimentary—both P- and N-channel devices on the same substrate). By using an extremely small area, the electrostatic field is concentrated in a small region of the channel, allowing control of the larger current channel. With the advent of MOS technology came two different types of devices: the *enhancement* and *depletion* types.

### DEPLETION MODE

Depletion-mode devices operate much as the same as JFETs. Increasing amounts of reverse (to the current channel) bias will choke off current in the channel. Schematic symbols for the N- and P-channel depletion devices are shown in Figure 14–10.

Again, these are normally on devices and require bias to be turned off.

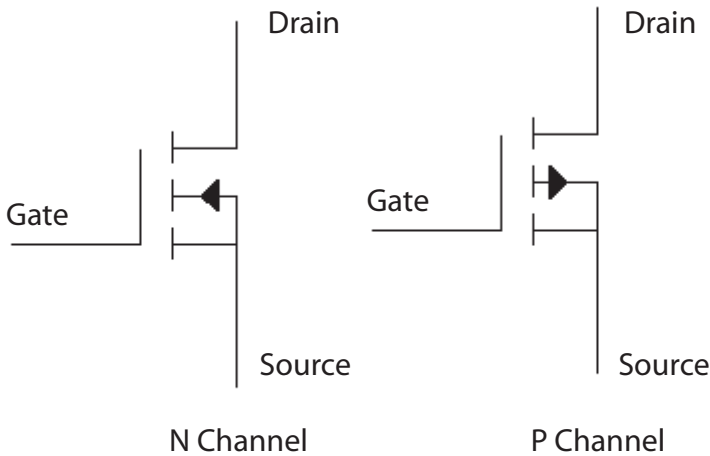


**Figure 14–10** Depletion-mode MOSFETs.

### ENHANCEMENT MODE

Another construction of the insulated gate field effect transistor is the enhancement mode type. This is a normally *off* device, and bias must be applied to turn it on. Figure 14–11 illustrates the schematic diagrams for the enhancement types.

Other than the JFETs (either channel), most of the IG MOSFET devices are found in integrated circuits rather than as discrete transistors. JFETs are predominately used as discrete devices because they (as a rule) have lower



**Figure 14–11** Enhancement-type MOSFETs.

noise in practical circuits. Chapter 18 on operational amplifiers will demonstrate why there are very few discrete amplifying devices used below 50MHz.

Because of the extremely high gate impedance and the very thinness of the oxide coating, relatively small voltages (around 30V) can penetrate the oxide and render the device useless. It takes very little induced current to create a 30V drop in this large impedance, so these devices are extremely static sensitive. They should never be handled out of circuit without the device leads shorted together and the handler exercising static precautions, including grounding with a wrist strip and using conductive mats on the bench top. Production facilities may wish to use an air ionizer or other methods to ensure that the probability of creating static electricity is low.

## REVIEW

1. *Field-effect transistors come as two basic types: junction (JFET) and insulated gate (IG MOSFET).*
2. *JFETs come in N channel and P channel and are normally on devices.*
3. *JFETs require a reverse-biased gate.*
4. *Sufficient reverse bias to cut off the current is called the “pinch-off” point.*
5. *IG MOSFETs come in two distinct operating modes: enhancement and depletion.*
6. *Depletion types are normally on; enhancement types are normally off.*

7. *Both depletion and enhancement types come in N- and P-channel varieties.*
8. *All FETs require the use of static precautions when they are handled.*

## CHAPTER EXERCISES

1. When the emitter arrow points to the base it indicates this is what type of transistor?
  2. Which amplifier configuration has the highest power gain?
  3. Does a switching transistor require a higher or lower heat dissipation rating than a transistor in linear operation, all other things being equal.
  4. Draw the self-biasing circuitry for the collector to base the biasing of an NPN and a PNP transistor. (Refer to Figure 14–8.)
- 
5. What is the primary function of a bipolar transistor?

***Answers to these review questions will be found at the back of this book.***

## CONCLUSION

You have reached the end of Chapter 14. If you are having difficulty with any of the concepts presented within the chapter, please re-read the chapter. If you are still uncertain, locate someone with technical knowledge of semiconductor devices and ask them for help. Remember that how they operate is far more important than how to design them.

For further information on the topics in this chapter, use your Internet search engine to search the following terms:

**J-FET**

**Enhancement mode transistors**

**CMOS**

**IG MOSFET**

**Depletion mode transistors**

# ZENER DIODES, SCRS, AND TRIACS

---

---

Although Zener diodes may sound different than silicon-controlled rectifiers (SCRs), they are both found where voltages must be controlled or regulated. This chapter describes how Zener diodes operate and what their typical applications are. The behavior of SCRs and triode alternating current switches (TRIACs) is discussed as are their typical applications. These are important subjects because these devices are found everywhere in modern electronic circuitry that involves power and power applications.

## ZENER DIODES

A Zener diode is a diode designed to be operated in its reverse-bias condition. Normally, when you exceed a diode's peak inverse voltage (PIV) rating, the diode is ruined. However, by doping a diode's junction in a particular manner a diode is developed, which, though it will operate in its forward-bias mode, is intended to operate at its designed PIV or Zener voltage.

Why would someone want to do this? Because within the dissipation rating of the diode, the diode will conduct any amount of current (above a minimum current) while maintaining the same drop across the diode. The diode in a forward direction requires about a 0.7-volt (silicon) drop to conduct and will maintain that drop until saturated (that is, until there is no further increase in emitter current for an increase in voltage across the emitter base junction). In the same way, the Zener will maintain the Zener voltage until the current is so great that the heat generated destroys the diode.

The Zener diode is ideal for use as a voltage reference or as a voltage regulator. Figure 15–1 illustrates a Zener diode (schematic symbol) in a voltage-regulating circuit.

**EXAMPLE**

Assume  $V_{in} = 30$  volts.  $V_{out}$  is desired to be 12 volts. So a 12-V Zener is chosen. The load is nominally 48 ohms. To determine  $R_s$ , you must know the current through the load. Using Ohm's Law:

$$12V/48 \text{ ohms} = 0.250A$$

The drop necessary across  $R_s$  will have to be  $30V - 12V = 18V$

In our example, we want the Zener to be able to control as large a range as possible. So the Zener current is set to equal the nominal load current, in this case 0.250A (although the Zener is designed to have the Zener current be set five to ten times the nominal load current normally). In this case, the total current through  $R_s$  will be 0.500A. Its value then will be:

$$18V/0.500A = 36 \text{ ohms.}$$

Now, if the load current should drop to 200mA, the Zener will conduct harder. This will lower its resistance so it can make up the difference, and it will conduct 300mA. The net through the resistor  $R_s$  is still 500mA. If the load should then draw more current up to, say, 300mA, the Zener will increase its resistance and draw less current: 200mA. The net current through  $R_s$  is still 500mA. Regardless of the current excursions by the load (within reason), the Zener will conduct more or less to maintain the 12V across its junction. If the load was disconnected or just didn't draw any current, the Zener would have to be capable of drawing 500mA. On the other hand, the Zener must maintain a minimum amount of current in order to drop 12V across its junction. While it differs for different Zener ratings and dissipations, typically this minimum current is in the 10- to 20-mA range.

This circuit can maintain 12V for a load current draw of 0mA to 480/490mA. What dissipation rating must this diode have? Maximum current comes at the no-load current point, and to maintain 12V by dropping 18 across  $R_s$ , the diode must pass 500mA. Using the power formula  $P = E \times I$ ,

$$P = 12 \times .5A$$

$$P = 6 \text{ watts}$$

a 10-watt Zener would therefore be required since diodes normally come in  $\frac{1}{4}$ -,  $\frac{1}{2}$ -, 1-, 5-, and 10-watt varieties.

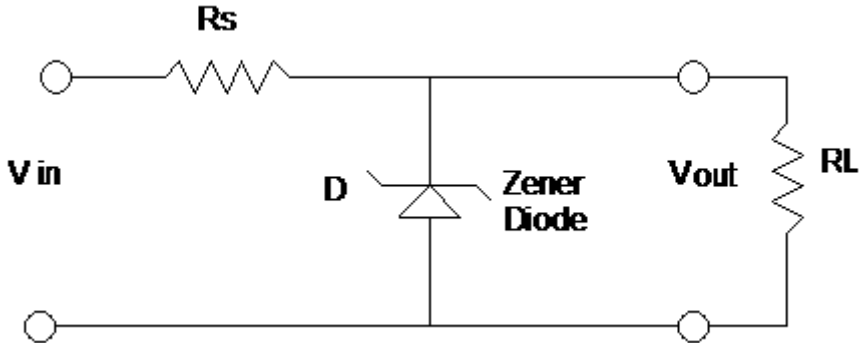


Figure 15–1 Zener diode circuit.

## VOLTAGE REGULATION

In discussions about a particular supply or regulator, when the term *regulation* comes up it is generally referring to what is known as *load regulation*: the change in output voltage for a change in load current. A more common way of expressing *load regulation* is as a value called *percent regulation*:

$$\frac{\text{No load voltage} - \text{Full load voltage}}{\text{No load voltage}} \times 100 = \% \text{ regulation}$$

### EXAMPLE

A power supply has a no-load voltage of 5.2V DC. When fully loaded, the output is 4.9V DC. What percent regulation does this supply have?

$$\% \text{ regulation} = \frac{5.2\text{V} - 4.9\text{V}}{5.2\text{V}} \times 100$$

$$\% \text{ regulation} = 0.0577 \times 100$$

$$\% \text{ regulation} = 5.77\%$$

## SERIES PASS REGULATOR

The requirement for a typical Zener circuit is to have the Zener current five to ten times the nominal load current. Moreover, Zeners larger than

1 watt are quite expensive. For these reasons, a better design is to combine the Zener with a bipolar transistor. The bipolar transistor will take the place of  $R_s$ , and use the Zener as a reference to the base of the transistor, using the current gain (Beta or  $h_{fe}$ ) of the transistor to amplify the Zener's effect. Figure 15–2 is a series pass regulator circuit.

In the circuit in Figure 15–2, assume an  $h_{fe}$  (for our simplified discussion, Beta) value of 50. The Zener current is set to five times the base current when Q is under full load. The current ratio for Q is 50, and for each unit of base current the output changes 50. For each five units of current in the Zener circuit, the base emitter circuit changes one, so the transistor multiplies the Zener current by ten. For a Zener current of  $100\text{mA} \pm 20\text{mA}$  the base current will change  $\pm 4\text{mA}$ , resulting in a  $\pm 200\text{mA}$  change in output current. The output voltage will be about 0.7V less than the Zener voltage (for silicon transistors), so if the Zener you've chosen has a 6.8V Zener voltage, the output will be at 6.1V.

The circuit operation for a transistor regulator with a zener as reference is summed up as follows:

- If the load is constant, the output will be  $V_{\text{Zener}} - V_{\text{(emitter base)}}$ .
- If the load increases, the output voltage will tend to decrease. Decreasing the output voltage will lower the emitter-base voltage. The Zener that maintains a constant voltage will then decrease its conduction. This will allow the total current to remain constant through  $R_{\text{Zener}}$ . This in turn increases the emitter-base current, causing Q to conduct harder (lowering its series resistance), and the output voltage is maintained.
- if the load decreases, the output voltage will tend to increase. If the output voltage increases the emitter-base voltage will also increase. The Zener that maintains a constant voltage will then increase its conduction. This will allow the total current to remain constant through  $R_{\text{Zener}}$ . This in turn lowers the emitter-base current, causing Q to conduct less (raising its series resistance), and the output voltage is maintained.

## REVIEW

1. Zener diodes are manufactured for a specific Zener voltage.
2. Zener diodes are used as voltage references and regulators.
3. Zener diodes are selected based on their Zener voltage and dissipation rating.
4. Zener diodes are operated in reverse-biased condition for the Zener effect.

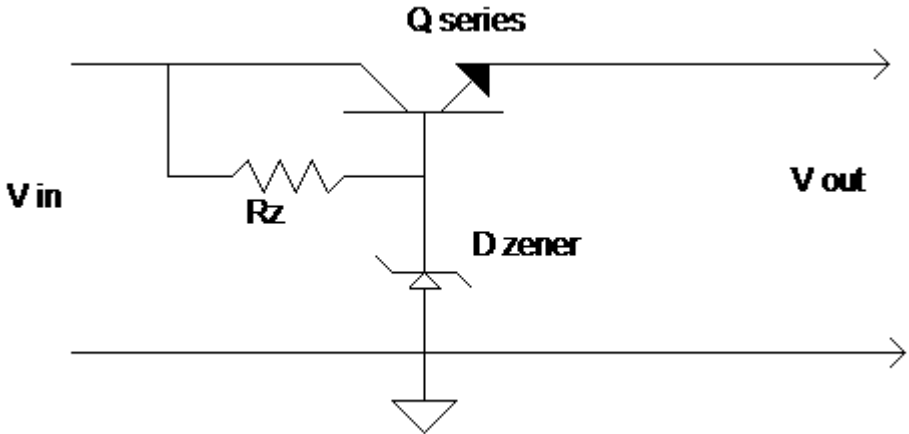


Figure 15–2 Series pass regulator.

5. *Percent regulation is:*

$$\frac{\text{No load voltage} - \text{Full load voltage}}{\text{No load voltage}} \times 100 = \% \text{ regulation}$$

6. *A series pass transistor is often used to multiply the Zener current so a Zener with a lesser dissipation may be used.*

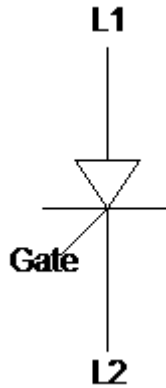
## SILICON-CONTROLLED DEVICES

Silicon-controlled devices are a special class of semiconductor device that is primarily used for phase control and regulation. In this section we will discuss the four-layer silicon-controlled devices: silicon-controlled rectifiers (SCR); the five-layer devices: diode AC switches (DIACs); the four-quadrant devices: triode-alternating current switches (TRIACs); and the thyristor devices: silicon-controlled switches (SCS).

### SILICON-CONTROLLED RECTIFIERS

The schematic symbol for a silicon-controlled rectifier is illustrated in Figure 15–3.

The operation of the SCR or four-layer semiconductor can be illustrated by several explanations. The simplest is merely to state what it does. Without the appropriate current input at the gate the SCR is an open. That is, if there is no gate current, regardless of the polarity across the



**Figure 15–3** SCR schematic symbol.

diode, it will not conduct. Assuming that the gate current is of the appropriate magnitude and the diode is forward biased (the line current is in the correct polarity + to anode, – to cathode), then and only then will the SCR conduct. And once it conducts, during that half cycle it will not stop until the forward bias across the diode is removed (by the next alternation for AC). If you fire the SCR, it will remain fired (conducting current), regardless of what the gate current does, until the forward polarity is removed from the diode’s terminals. Figure 15–4 illustrates the operation of an SCR.

Once the gate has put the SCR into conduction, it remains in conduction until the forward voltage is removed. When using AC, this is accomplished at every alternation. Figure 15–3 illustrates two different gate firings. In the lower drawing, the gate was fired (appropriate current pulse) when the input voltage started its positive climb from 0V. In the upper output diagram, the gate was fired when the input voltage was at its peak. Note that once fired, the SCR will conduct until the voltage across it reaches 0V.

An SCR may also be used as a “crowbar” (in that it shorts across the power supply to blow the fuse) for over-voltage conditions as well as in numerous motor control circuits. This is so because SCRs can handle large amperage (up to 10,000A in some models).

Figure 15–5 illustrates a light dimmer that uses an SCR. One word of caution here: the light is only going to receive half the power it normally receives, so if this were a 12.6-volt AC input, then here, in this circuit, you should use a 6.3-volt lamp.

A little explanation of circuits might be helpful here. *C1* is a filter to keep transients from triggering the SCR. *C2*, on the other hand, is in cahoots with *R1* and *R2* to shift the phase of the AC voltage across the lamp and with the SCR to trigger later into its conducting half cycle. When the line

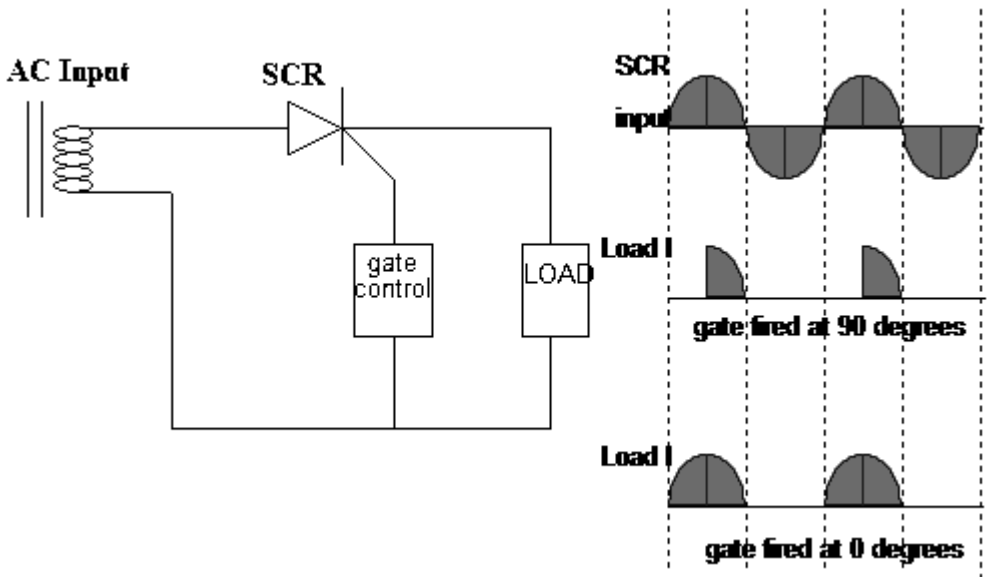


Figure 15-4 SCR operation.

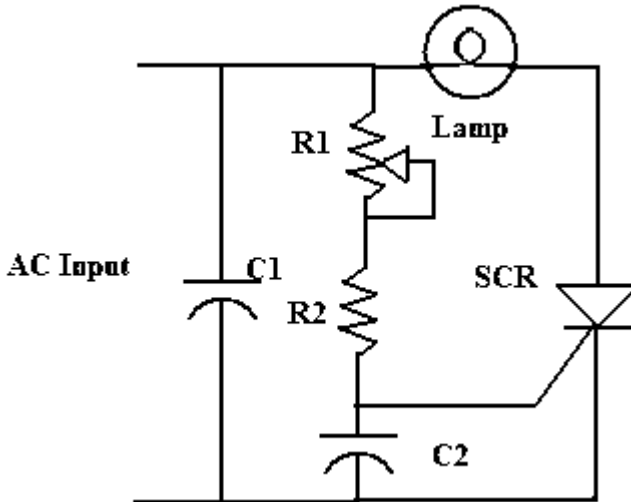


Figure 15-5 SCR lamp dimmer.

voltage is negative to the SCR anode it does not conduct. When the line voltage is positive to the SCR anode and the variable resistor has set the  $RC$  time constant where the phase-shifted voltage will reach triggering levels, then the SCR will conduct and continue to conduct until the line current crosses zero, at which time it will turn off.

## DIAC

A diode AC switch (DIAC) is functionally equivalent to taking two Zener diodes and connecting them, as shown in Figure 15–6.

As can be seen, whichever alteration you use, one diode will conduct and the other must have the drop exceed the Zener voltage in order for any current to pass. If the Zener voltage for both was 2.6 volts and you applied a 6.3-volt AC signal across the DIAC, then the diode would conduct from +2.6 to +6.3 volts and –2.6 to –6.3 volts. This would leave a band between  $\pm 2.6$  volts that no current would flow through the diodes. Why do this? Because a DIAC is typically used with a TRIAC (coming up next) to prevent false triggering.

## TRIAC

*TRIAC* stands for “triode AC Switch.” For lower voltage AC work a TRIAC is used. This is essentially two SCRs facing in opposite directions, so the TRIAC may be gated on for both of the alternations. Figure 15–7 is a schematic representation of an SCR. Note that the trigger circuit has a DIAC.

The DIAC is used to suppress false triggering. As we explained previously, a DIAC is essentially two back-to-back Zener diodes. This construction ensures that the trigger pulse must be above a minimal voltage range before the TRIAC may be fired.

False triggering occurs frequently in poorly designed SCR and TRIAC circuits. If an inductive load is being switched, the transient voltages are many, and some are of a large magnitude. The problem is that with the gating shown so far, the SCR or TRIAC is gated on during a portion of its conducting alternation. Rather than do this, which has the advantage of being inexpensive and simple, using slightly more circuitry you can derive a *zero-crossing* gate circuit. In this case, if you wish to have half power (for example) from a TRIAC, rather than gating it on at 90 degrees you would gate it on at 0 degrees every *other* alternation. Over time, the net power is the same without the requirement that you switch the TRIAC (or SCR) in the middle of an alternation.

Figure 15–8 is a typical application of a TRIAC that uses simple triggering.

Figure 15–9 is a photo-coupled relay. When the correct voltage is present in the trigger circuit, the photo diode emits and triggers the internal SCR, which in turn will pulse the SCR. Any number of circuitry types can drive the input. It could be a zero crossing detector, it could be the output from an audio amplifier, it could be any number of applications.

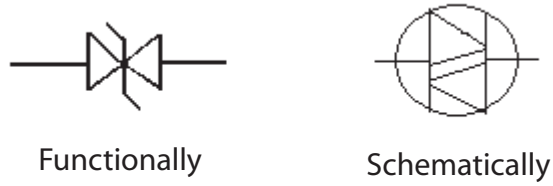


Figure 15-6 DIAC.

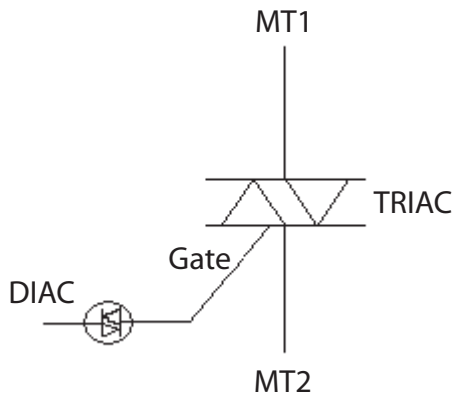


Figure 15-7 TRIAC with DIAC.

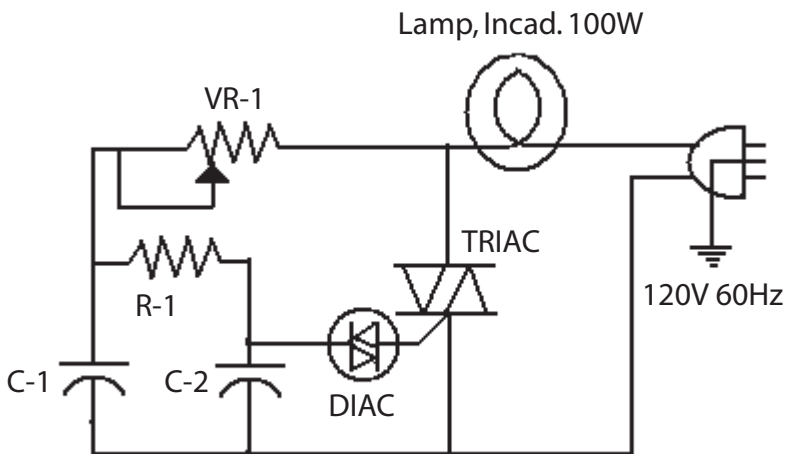
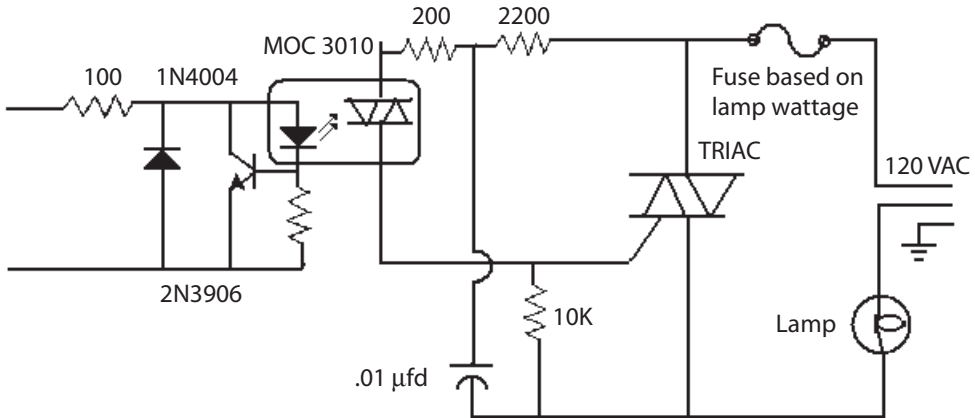


Figure 15-8 Simple TRIAC triggering.



**Figure 15–9** Photo trigger of SCR.

While TRIACs are prevalent in commercial circuitry for low voltage (230V AC or lower), for higher powers (above 12 amps and anything above 230V AC) or industrial use SCR circuits should be used because the TRIAC is somewhat leaky (that is, it tends to latch on and allows some current to flow even in the off state).

Figure 15–10 shows a light dimmer whose output is determined by a count signal that indicates when it should turn off the photo transistor, which will gate on the SCR for that half cycle. (This is not a practical circuit but merely demonstrates the operation of a zero-crossing trigger, which because it requires more technical knowledge than has been provided to this point, is just drawn as a box.) The SCR is turned on at the beginning of the TRIAC output for that half cycle. If the SCR skips one half cycle, leaving the TRIAC untriggered, half-wave power is supplied to the lamp. If you leave the photo transistor on for two transitions, you will miss a full wave. Assuming that you trigger it the next half cycle, this will leave you with a half cycle on, full cycle off, and half cycle on for about one-third of the full-on power.

Zero-crossing circuits produce far less radio frequency interference than do the phase-shift types. However, they are not really good for light dimmers because they do not allow the smooth transition from full on to full off. A more sophisticated digital control could do it, however. This would require a bit more circuitry than shown in Figure 15–9. Even as shown, for inductive loads this would be a better circuit than the phase-control types.

The voltage divider, which consists of the 5360/330-ohm resistor, supplies the collector voltage for the photo transistor. When the transistor is on (lighted), it pulls the current through it, preventing any from reaching the TRIAC. When it is off, the current will flow into the TRIAC gate, triggering it on.

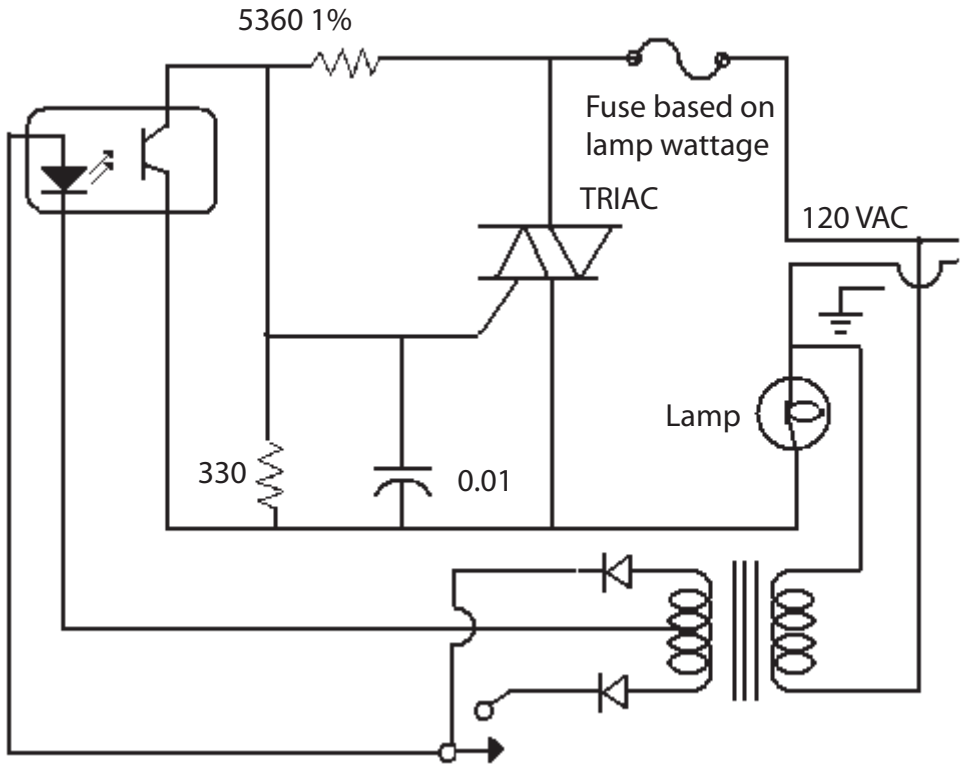


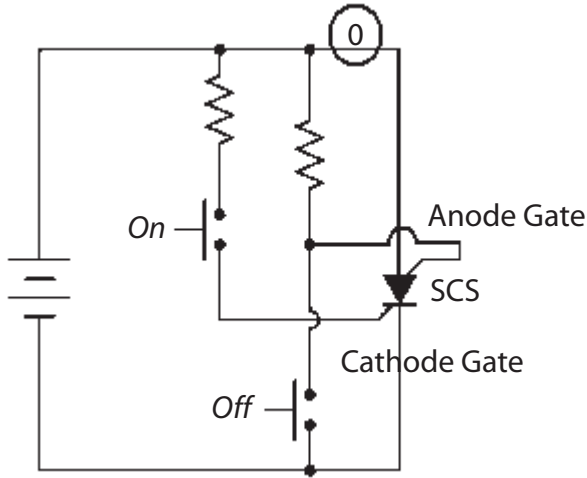
Figure 15–10 Example of zero-crossing circuit.

## SILICON-CONTROLLED SWITCH

The silicon-controlled switch (SCS) is an implementation of a four-layer device that can be turned on or off by gate pulses. For a number of reasons, the SCS never achieved the popularity of its SCR counterpart. However, you may still stumble upon one of these in power circuits, developed in the 1970s and 1980s. It can be triggered on and triggered off by a positive pulse to the appropriate gate. Figure 15–11 illustrates both an application and the schematic of the SCS.

### **Warning**

It should go without saying, but if you work on, build, experiment, or otherwise come into contact with the TRIAC and SCR circuits shown in this chapter, or are building your own, *use caution*: you are dealing with voltages that can be lethal. Please observe all safety precautions when working around energized equipment, particularly when you are practicing the procedures in the following section!



**Figure 15–11** Silicon-controlled switch.

## TROUBLESHOOTING

To properly troubleshoot these devices you should have an appropriate tester (to test under load), although the majority of these testers will require that the device be removed from the circuit. However, you can perform some simple troubleshooting by using a digital multimeter that has a diode test feature (most of them do). We will assume that you have determined that you have the appropriate circuit voltages when the power is on. If the device is shorted, there will be blown fuses, and you will have to check for appropriate voltages on the hot side of the fuse or breaker. You will normally need an oscilloscope to determine the gate drive, if the power supply side is normal. Here are the steps for determining the status of an SCR/TRIAC.

1. Ensure that power is removed from the circuitry (no ifs, no ands, and no buts).
2. Disconnect either the anode or the cathode lead (MT1 or MT2 for TRIACs).
3. Use the diode check to ascertain if the device is shorted (the normal failure mode).
4. If the device is not shorted, then check the gate to anode resistance. One polarity of lead connection should indicate a diode connection. If not, the gate connection may be open.
5. Determine that the load circuit is correct and not drawing excessive current. This will cause the device to fail.

6. Replace the device with a good one and repower the unit. If it is still not working your problems are most likely not with the device in question.

## REVIEW

1. *An SCR is a unidirectional device that may be triggered on anywhere during an alternation that is of the correct polarity.*
2. *Once on, the SCR will not turn off until the correct polarity voltage is removed.*
3. *A TRIAC is a bidirectional device intended for use in AC circuits in that it may be fired at each alternation of a cycle.*
4. *A TRIAC is usually used with a DIAC to prevent false triggering.*
5. *Zero-crossing type gating makes for a quieter and longer lasting power supply.*

## CHAPTER EXERCISES

1. Suppose the voltage input to a Zener regulator circuit is 40V, the desired output is 12, the no-load current is 20mA, and the full-load current is 40mA. Using a Zener that will conduct 150mA at the nominal load current of 30mA, what is the value of the series resistor required? *Hint:* Remember that the Zener will conduct 160mA when the load current is at 20mA, and it will conduct 140mA when the load current is at 40mA—a total of 180mA.
2. If the no-load voltage is 12.7V and the full-load voltage is 12.5V, what is the percent regulation?
3. Draw the output wave-form of an SCR that is triggered on at the peak of its applied positive alternation.

4. Draw the output wave-form of a TRIAC that is triggered on at the peak of its applied alternations.
  
  
  
  
  
  
  
  
  
  
5. Draw the output wave-form of a SCR circuit using zero crossing that is fired every third alternation.

***Answers to these review questions will be found at the back of this book.***

## **CONCLUSION**

You have reached the end of Chapter 15. Please reread the chapter. If you have not encountered any problems with the concepts explained in this chapter, you may go on to the next chapter. If you are encountering problems, please re-read the text. If the problems persist, locate a peer, mentor, supervisor, or someone with technical knowledge of Zeners, SCRs, and TRIAC devices and have them assist you.

To find additional information on the key concepts in this chapter, enter the following terms in your browser's search engine:

**Zener diode**

**silicon-controlled switch**

**TRIAC**

**silicon-controlled rectifier**

**DIAC**

**zero-crossing SCR circuits**

# OPERATIONAL AMPLIFIERS

---

---

Operational amplifiers, “op-amps” for short, are utilized in many areas of electronics, in filters, amplifiers, analog-to-digital and digital-to-analog converters, and in any circuit (below VHF frequencies) that requires gain and/or isolation. Op-amps have been the basic building block of analog instrumentation, and whether they are integrated into an application-specific integrated circuit (ASIC) or are used in stand-alone form they play a very important role in analog instrumentation.

## BASIC OP-AMP

An op-amp is basically a direct current (DC)-coupled, multistage, linear amplifier. It is not necessary to understand the operation of the internal components of an operational amplifier. There are just two rules, actually assumptions, that are necessary for proper understanding of operational amplifiers. But to use these assumptions, you must understand the characteristics of an operational amplifier.

1. It is a direct-current amplifier; in other words, when a DC level is placed on the input, an amplified proportional change will be obtained in the output.
2. Operational amplifiers have extremely high gain, above 100,000 when they are in the “open”-loop (no negative feedback) mode. This means that if you put a 1-microvolt change on the input, 0.1V change would appear in the output.
3. Op-amps use a differential input. They measure the difference in voltage between the two inputs, not any voltage that is common to both inputs.

Let’s look at a discrete version of an operational amplifier. Though this is not a very good op-amp, it does illustrate the basic characteristics of op-amps.

## THE DISCRETE OP-AMP CIRCUIT

Figure 16–1 illustrates the basic op-amp circuit.

$RL1$  and  $RL2$  are load resistors,  $Q1$  and  $Q2$  form a differential amplifier pair, and  $Q3$  is a constant current generator. A bipolar transistor with fixed bias will allow a collector current determined by the gain of the transistor ( $h_{fe}$ ) and the base current determined by the 20K and 4.7K resistors ( $R3$  &  $R4$ ) in  $Q3$ 's base circuit. The voltage at the collector of  $Q3$  has very little effect on the current, provided the voltage is some value more positive than the base, which in turn must be a diode drop more positive than the emitter. The effectiveness of this constant current circuit determines in large part the operating characteristics of the input amplifier. *Input 1* is an inverting input. That is, if a signal goes positive on *input 1* in relation to *input 2*, the output will go negative. If the signal on *input 1* goes negative in relation to *input 2*, then the output will go positive. *Input 1* is marked with the negative sign (-) to show it is the inverting input. The noninverting input (*Input 2*) is marked with a + sign. A signal on the noninverting input in relation to *input 1* will cause the output to go in the same direction.

Figure 16–2 replaces the amplifier in Figure 16–1 with a triangle—the standard symbol for an amplifier—and adds two resistors.

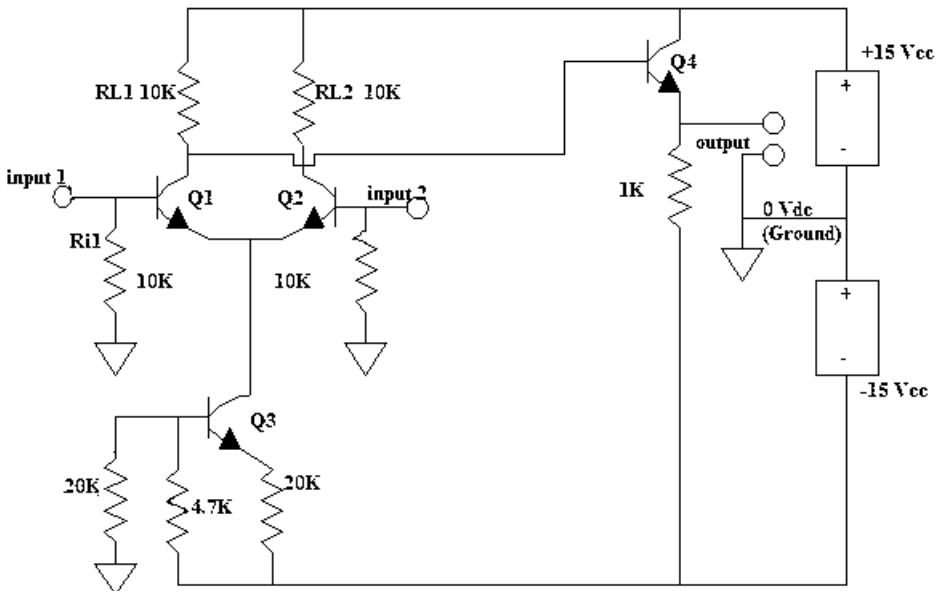


Figure 16–1 Discrete op-amp.

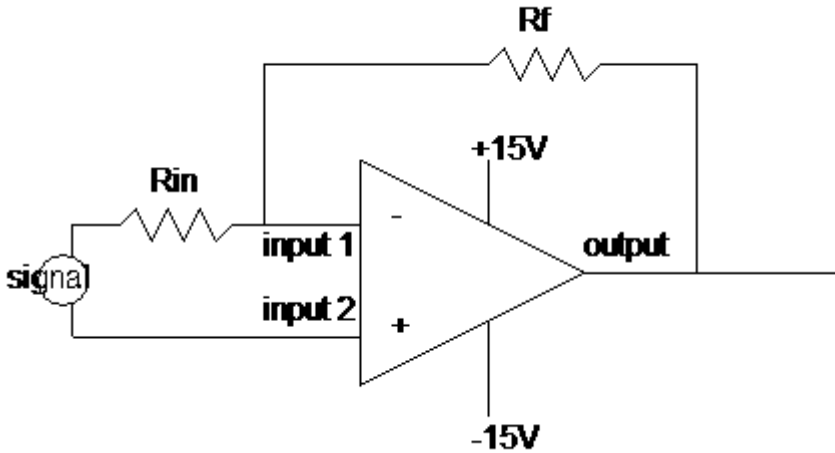


Figure 16–2 Op-amp circuit.

The difference between Figure 16–1 and Figure 16–2 is that Figure 16–1 is the circuit of a typical early *op-amp* and all of that circuitry (with the exception of the power sources) is contained in the triangle in Figure 16–2. This is completely appropriate in that you cannot physically see these components or measure any of the internal voltages. It is for all intents and purposes a black box (triangle!), which gives the output specified for the inputs specified with no concern for how the internal circuit is configured. Figure 16–2 is an *op-amp circuit*, complete with resistors  $R_f$  and  $R_{in}$ . Note that these resistors divide the output and feed a portion of the output into the input circuit, the inverting input to be specific. This is called *negative feedback* because it is 180 degrees out of phase with the input signal. That is, if the input on the inverting side goes positive, the output goes negative. The portion fed back to the input then is always in the opposite direction of the input.

Positive and negative supplies are used with these op-amps so that if 0V is input, 0V will be the output. This is a normal condition for industrial measurements because most signals vary above and below ground. An op-amp can be used on a single supply, however; the reference will usually be made at half of the supply voltage.

An operational amplifier by itself will not do anything. It must be in a circuit. Op-amps normally have an extremely high “open-loop” gain. If the power source is connected to the op-amp, an extremely small signal is input to the amplifier, and the output is measured, the gain would be in the hundreds of thousands (for most contemporary op-amps). Obviously, with a gain of 100 dB it would take only a very small voltage to drive the output to one or the other of the supply voltages. Because this would accomplish very little, most op-amps (in linear circuits) are normally in

circuits with large amounts of negative feedback. This allows for good linearity, while component aging, variances in component tolerances, distortion, temperature, and other physical changes have very little effect on the amplifier circuit. This is the typical case.

**Note**

This chapter deals only with op-amps that are operational voltage amplifiers (OVA). There is another class of op-amps, however, the operational transconductance amplifiers (OTA). The OVA transfer characteristic is described in terms of input voltage to output voltage, while the OTA is described as input voltage to output current. With the appropriate components, an OTA op-amp can be made to act as an OVA, but the reverse is not true. OTAs are generally used in gyrators (simulated inductances) and are not included in this textbook's discussion.

## ASSUMPTIONS

It will be easier to understand the operation of op-amp circuits if you make two assumptions, assumptions that are necessary to diagnosing and determining how an op-amp operates in any number of circuits:

### ASSUMPTION #1

*No current flows into or out of either op-amp input.*

$R_f$  and  $R_{in}$  provide a path for the input current to the output transistor and ground. While very small bias currents do flow into (or out of) either input, it will be *assumed* that the output of the op-amp will be in a direction to prevent any current flow into (or out of) either input.

### ASSUMPTION #2

*There is no voltage difference between the two inputs.*

This is not strictly true either. If the circuit is saturated, the voltage across one or the other inputs may vary considerably from the other. In most cases, however, the voltage difference between the two leads will be less than several dozen millivolts. The entire input voltage will appear to drop across resistor  $R_f$  or  $R_{in}$ .

In Figure 16–3, the noninverting input is tied to ground (as shown); then there is a *virtual ground* at the inverting input. This is why Assumption #2 is important.

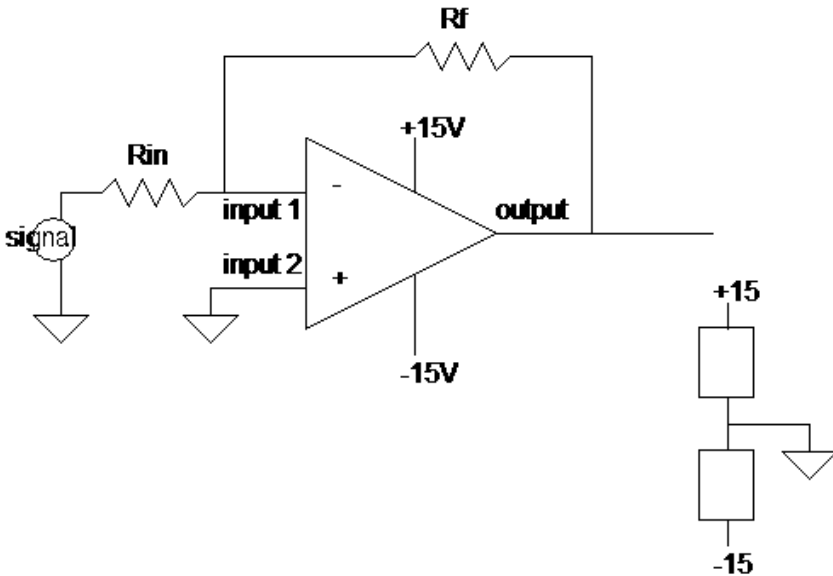


Figure 16–3 Inverting amplifier circuit.

## OPERATION

To explain the operation of a discrete op-amp circuit, use a value of 1K for  $R_{in}$  and 10K for  $R_f$ . If the signal at input 1 is 0 volts, then the output will be at 0 volts. If the signal at input 1 goes from 0 volts to  $-1$  volts then the output will tend toward a positive output. How positive? Since  $R_{in}$  is 1 kilohm and the change was  $-1$  volt, there will be a current inward of  $-1$ mA. This is contrary to our Assumption #1. The output will therefore rise (go positive) to whatever value it takes to force  $+1$ mA into the junction of  $R_f$  and  $R_{in}$ . This current will effectively cancel the input current.

The term used for this canceling is *summed*, referring to an algebraic sum. In Figure 16–3,  $R_f$  is 10 kilohms, so it will take 10 volts (positive) to force 1mA into the summing junction (1mA through 10 kilohms). Since there was a change of 1 volt in for a change of 10 volts out the gain of the circuit is 10 (actually  $-10$  since it is inverted). Note that the gain of the op-amp circuit is set by the external resistors. Since the open-loop gain (without the negative feedback) is 100,000 or more, the closed gain can be any value below that (generally held to less than 100 per stage). The formula for an inverting op-amp gain is

$$A_g = -\frac{R_1}{R_2}$$

As long as the sum of the currents at the summing junction equals zero, the op-amp is being operated in its linear range.

## TERMINOLOGY

There is, of course, a specific terminology for op-amps (see Table 16–1).

## REVIEW

1. *An op-amp is a high-gain direct-coupled amplifier.*
2. *Op-amps use a differential input stage (or one that acts like a differential).*
3. *Op-amps have open-loop gains in excess of 100,000.*
4. *Op-amps have an inverting and noninverting input.*
5. *The schematic representation of an op-amp is a triangle.*
6. *There are two assumptions regarding op-amp operation that will explain most op-amp circuits:*

### ASSUMPTION #1

*No current flows into or out of either op-amp input.*

### ASSUMPTION #2

*There is no voltage difference between the two inputs*

7. *Op-amp amplifiers use external components to determine the amplifier's parameters.*
8. *The junction at the inverting input between the input resistor and the feedback resistor is known as a virtual ground.*
9. *With a signal on the inverting input, the output op-amp will drive in the opposite direction until the current through the feedback resistor equals the input current.*

## LINEAR OP-AMP CIRCUITS

As with any amplifier, there are a few basic circuits that the majority of applications use as a foundation. The three basic linear circuits are:

- Inverting amplifier
- Noninverting amplifier
- Voltage follower

We will discuss these first.

**Table 16–1** Op-amp Terminology

Bandwidth	This is normally the frequency limits at which the output voltage falls to 0.707 of the voltage present at the center frequency. It is measured in Hz. Since an op-amp is normally a DC amplifier, bandwidth is from 0Hz to some upper frequency, which is also known as the half-power point.
Common-mode rejection ratio	This is a ratio of the change in output caused by a common-mode voltage (a simultaneous change on both inputs) divided into the change in output by an input signal (differential gain). This ratio is converted into a dB value and is known as <i>common-mode rejection</i> . For modern op-amps, this value is from 65 to 120 dB.
Input bias current	The average of the two input bias currents.
Input common-mode voltage range	The range of common-mode voltage (on the inputs) that the amplifier can withstand without destruction.
Input offset current	Using dual supplies, with the output at 0 volts, input offset current is the difference between the two input currents. Ideally, these currents are equal, but in actuality there are minor differences that show up as an output offset. For example, with 0 volts on both inputs, the output will be offset from 0 volts by the difference in input currents.
Input resistance	With one input grounded, input resistance is the ratio of change in input voltage to change in input current in the nongrounded lead.
Output impedance	With the source and load resistance specified, output impedance is the ratio of output voltage to output current.
Settling time	With a step-function input (a large instantaneous change from one level to another), settling time is the time it takes the output to arrive at a steady-state value that represents the new input level.
Slew rate	The fastest rate of change that the amplifier is capable of, usually measured from one output peak to the opposite output peak. Slew rate depends on supply voltage, input voltage overdrive, amount of loading, and device design constraints.
Unity gain bandwidth	The frequency range from 0Hz to the upper frequency at which the amplifier's open-loop gain becomes 1.

## INVERTING AMPLIFIERS

Figure 16–4 illustrates an op-amp connected as an inverting amplifier.

The formula for the output voltage is:

$$V_{out} = -\frac{R_f}{R_{in}} \times V_{in}$$

The input impedance of this amplifier is approximately the value of  $R_{in}$ .

## NONINVERTING AMPLIFIER

Figure 16–5 illustrates the basic noninverting amplifier.

The input signal appears on the noninverting input. Unlike the inverting amplifier, the noninverting amplifier will always have a gain greater than 1. This is because of the way the input is biased. The gain is:

$$V_{out} = \left( \frac{R_f}{R_{in}} + 1 \right) \times V_{in}$$

At 0V input, there will be 0V on both inputs, so the output will be 0V. If the inverting input changes in a positive manner that will place some positive voltage on the input. Our assumption says no voltage difference. The output will go positive, as positive as necessary to place the same voltage at the junction of  $R_f$  and  $R_{in}$  as is on the noninverting input.

### EXAMPLE

Refer to the circuit shown in Figure 16–5. Give  $R_{in}$  the value of 1 kilohms and  $R_f$  the value of 5 kilohms. A change from 0V to +1V occurs at the noninverting input. The output goes positive and will continue to go positive until the voltage drop across  $R_{in}$  equals +1V.  $R_{in}$  is a 1-kilohm resistor so it will require 1mA of current to drop 1V. One mA through 5 kilohms requires 5V. Add the 1V across  $R_{in}$  and the 5V across  $R_f$  and you get 6V. So for a 1-V change in, there is a 6-V change out—a gain of 6. The reason that the noninverting op-amp cannot have a gain of less than 1 is that the voltage that appears at the noninverting input must be dropped across  $R_{in}$  in order to meet our Assumption #2.

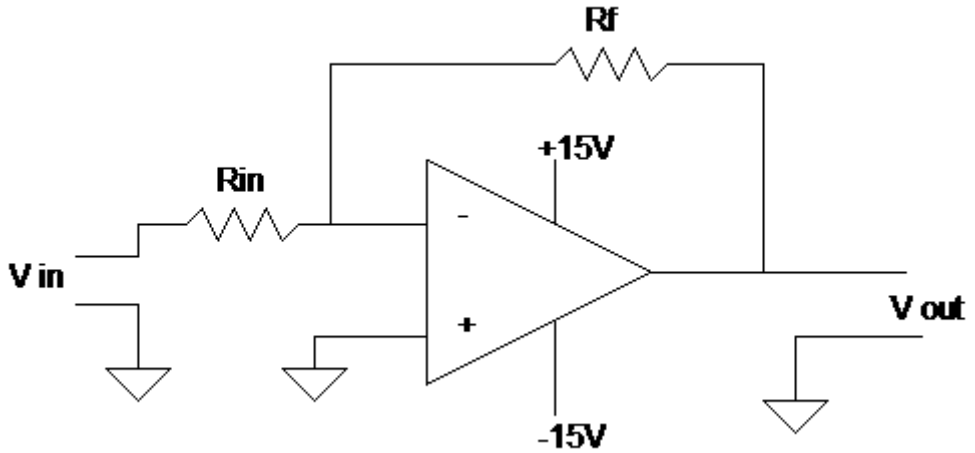


Figure 16-4 Inverting amplifier.

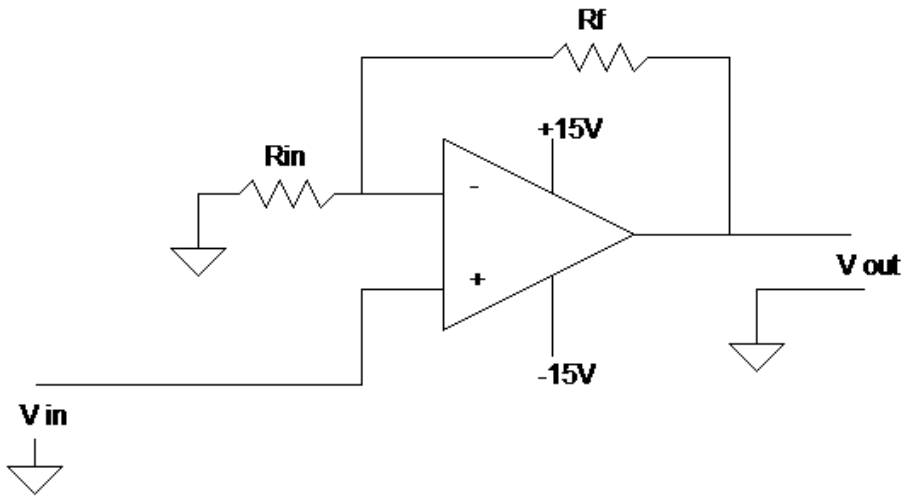
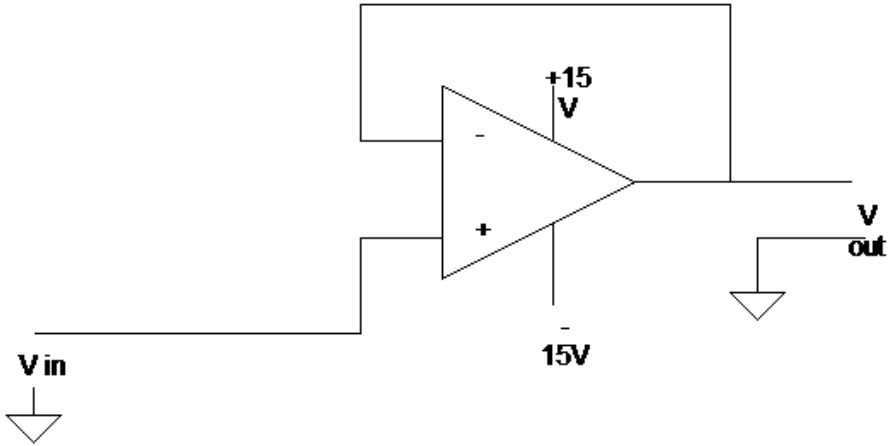


Figure 16-5 Noninverting amplifier.

## VOLTAGE FOLLOWER

The voltage follower, sometimes called a source follower, is illustrated in Figure 16-6.

The voltage follower is a unity-gain noninverting amplifier. As with the noninverting amplifier described previously, the source follower has an extremely high input resistance while its output resistance is very low. As with the transistor emitter follower, this circuit is used primarily for isolation, buffering, and impedance matching.



**Figure 16–6** Voltage follower.

Applying the assumption about no voltage difference between the two inputs will demonstrate how this circuit works. If 0V is on the input, then 0V will be on the output and the inverting input. If a  $-1V$  change is made on the input lead, then in order to maintain equal voltage across the two inputs, the output goes to  $-1V$ , which is also the inverting input lead. Whatever signal appears on the input lead (within the amplifier's operating range), the output will follow that signal, placing the same voltage on the input-inverting input to maintain no difference.

## OUTPUT OFFSET VOLTAGES

An ideal op-amp will output 0 volts when 0 volts is input. One of the main reasons for using a split-power supply ( $\pm V$ ) is so you can operate with input signals that vary above and below ground by small amounts. However, as you may have guessed, since an ideal op-amp should output 0 volts with 0 volts in, *a real-world op-amp won't exactly*. Practical op-amps have some offset, that is, with 0 volts in; the output will be some voltage above or below 0 volts. The output is the result of three input offsets:

- Input bias current
- Input offset current
- Input offset voltage

To understand input bias current offset, assume that both inputs are grounded.

Though we have made the assumption that no current flows into either lead, this is not strictly true. There are small-bias currents, which are the forward currents of the input transistors. There are unequal paths for the input bias current to travel in. One method for compensating for the unequal paths is to include an equivalent resistor in the noninverting path. Since it is the  $R_f || R_{in}$  (parallel combination of  $R_f$  and  $R_{in}$ ) pair that causes the unequal path, the equivalent resistor must be equal to that value. While this method will certainly reduce the output offset, it presents some problems. The value of bias current given in the specification is the average of the two inputs bias currents; it does not mean they are equal. Since there will be some small difference in these currents when multiplied by the gain of the op-amp, there will be an offset even with the compensatory resistor. Other methods are available, most of which involve external components to compensate for whatever offset is left if compensation is necessary for the circuit to operate correctly.

## APPLICATION

An application point should be made here. If you require linear operation and you are going to operate from a single supply (for example, 12 volts), you must bias the op-amp so the output will be at  $1/2V_{cc}$  (in our example this will be 6 volts) in order to ensure maximum output swing without distortion. Using our assumption of no voltage difference between the two inputs, if you bias the noninverting input at 6 volts (done by using a resistive divider between  $V_{cc}$  and ground), then the output will operate around 6 volts, and the noninverting input will also add algebraically around 6 volts.

## REVIEW

1. *The inverting op-amp circuit offers a gain that is based on the ratio between the feedback and input resistor.*
2. *The noninverting op-amp circuit always has a gain of 1 or greater.*
3. *The voltage (source) follower has a gain of 1.*

## COMPARATORS

Earlier in this chapter, we discussed using an op-amp in its linear mode as an amplifier. You may also use the op-amp for other nonlinear functions. Because of the op-amp's high open-loop gain it may be used as a switching circuit. One type of circuit that uses an op-amp as a switch is

the *comparator*. This circuit compares the voltage on one lead (input voltage) with the voltage on the other lead (reference voltage). Any significant difference multiplied by the open-loop gain causes the output to be driven to either the most positive or the most negative supply. Figure 16–7 illustrates the basic comparator circuit.

If a device is a general purpose op-amp that you are using as a comparator, the one you choose should have as high a slew rate as possible. Moreover, since external compensation tends to slow the slew rate, you would not use compensation. Since the comparator is a widely used circuit, op-amp circuits are designed expressly for this use, and logically called comparators.

## COMPARATOR OPERATION

Figure 16–8a and Figure 16–8b illustrate the two different output states of the basic noninverting comparator. Figure 16–9a and Figure 16–9b illustrate the basic inverting comparator.

Most comparators are high-gain devices that may easily oscillate with less than optimum lead placement. These oscillations tend to show up during output transitions when the comparator is changing states. A technique for reducing the chance of such oscillations is to add hysteresis to the circuit. This is done by inserting a small amount of positive feedback. Figure 16–10 illustrates the basic comparator with hysteresis.

Hysteresis is generally unnecessary if the signal is a pulse that has sharp rise and fall times. Similarly, it is most often required when dealing with signals that have a slow rise and fall (as is found in process control).

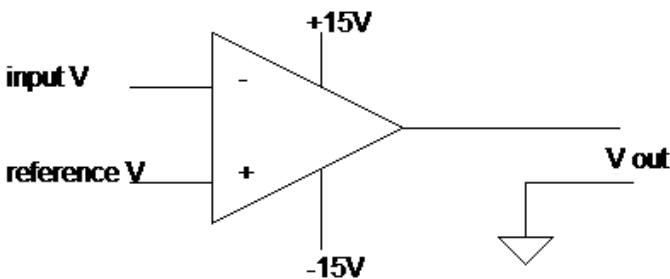


Figure 16–7 Comparator.

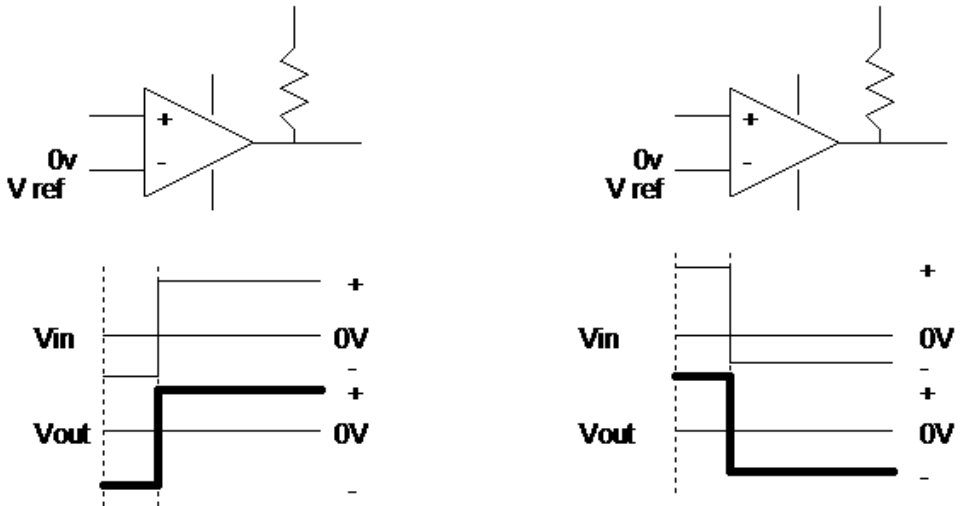


Figure 16-8 Comparator operation, noninverting; (a) left, (b) right.

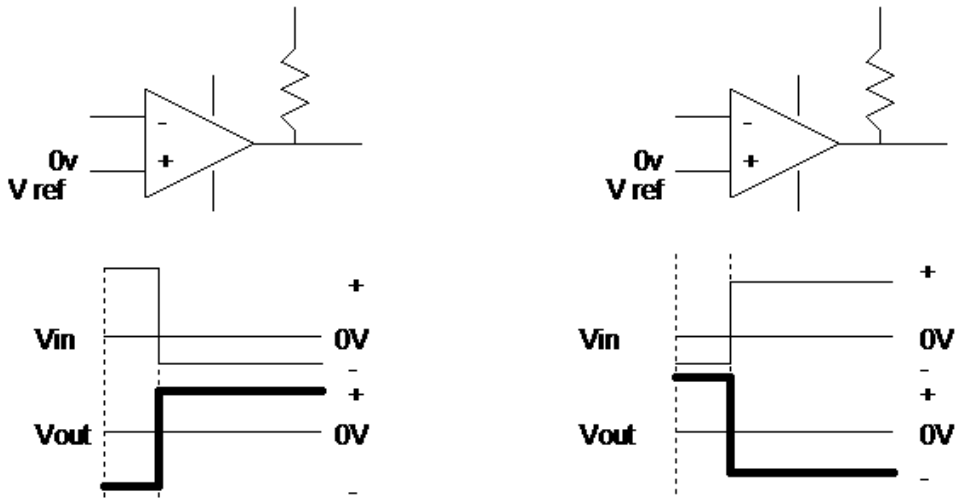


Figure 16-9 Comparator operation, inverting; (a) left, (b) right.

## REVIEW

1. Comparators are used to determine when a signal exceeds a reference voltage.
2. Comparators are designed with a high slew rate.
3. Comparators can be connected as inverting or noninverting comparators.
4. A slight positive feedback will add hysteresis to the comparator circuit.

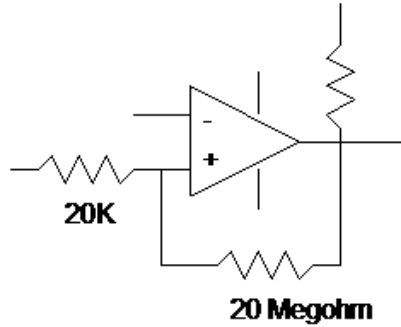


Figure 16–10 Adding hysteresis.

## FUNCTIONAL CIRCUITS

### INTEGRATOR

Figure 16–11 illustrates an op-amp used as an *integrator*.

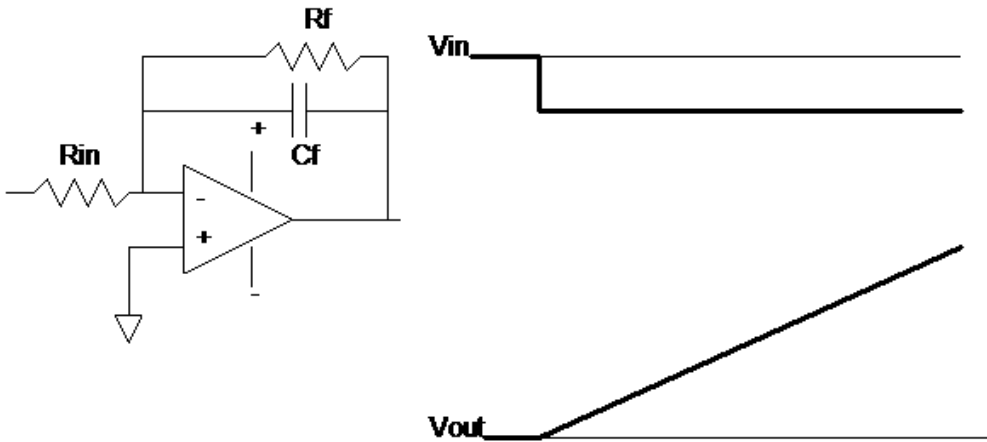


Figure 16–11 Op-amp integrator.

In this particular circuit, the integrating action is caused by the feedback circuit, which consists of the capacitor ( $C_f$ ) and a parallel resistor ( $R_f$ ). The resistor serves to limit the DC (static) gain. The capacitor, along with the input resistor ( $R_{in}$ ), provides the integration. When there is a step change on the input, as shown, the capacitor will immediately feedback a large current. The current will fall off by the RC time-constant rate ( $1\text{ TC} = R \times C$ ,

with  $R$  in ohms,  $C$  in farads, and  $T$  in seconds). The current will have decayed 63 percent from its maximum amount in one time constant. Therefore, to try and keep the voltage difference between the two inputs at 0V, the output must keep changing toward the supply voltage, in this case, the positive supply. This results in a linear slope (until the supply limit is reached). The greater the magnitude of the input change, the steeper the slope of the output wave-form.

To perform integration means (in this text) to average over time. The output of the integrator rises toward its limit (also set by  $R_f$ ) of the supply voltage. For a small change, this might take a long time because the output only has to change slowly to maintain the summing current. If the input changes are quite large, then the output will have to rise faster to meet the demands of the summing current.

If you input a series of alternate step changes (a square wave), at the correct frequency, the output of the integrator will be a triangular wave shape. If you input sinusoidal changes rather than step functions, this circuit is a low-pass filter (you cannot integrate or differentiate a sine wave, only change its amplitude and phase). This low-pass filter provides maximum attenuation to higher frequencies where the reactance of the capacitor is low and the feedback current high. Where the rate of change (frequency) is low, the capacitor offers a large amount of reactance, thereby limiting the amount of feedback current. The transfer function for nonsinusoidal wave-forms can be modeled as an integral of the input signal over time, hence the name integrator.

## DIFFERENTIATOR

Figure 16–12 is an op-amp connected as a differentiator.

Note that in this case (in contrast to the integrator) the op-amp has a capacitor in the input lead ( $C_{in}$ ) and a resistor as a feedback path ( $R_f$ ). For a step-function change, the rise time will be coupled through the capacitor, and the input current will fall off by the  $RC$  time constant of  $R_f \times C_{in}$ . The output will therefore also fall off as it tries to maintain 0V difference between the two inputs. The faster (higher-frequency) signal components appear to the feedback resistor as if they have a very low input resistance, while the slower-changing components appear to have higher input resistances. Since gain is determined by the ratio of  $R_f/X_{C_{in}}$  ( $X_C$  is Capacitive reactance) the faster-changing components will have the most amplification. If sinusoidal signals are input this circuit will act as a high-pass filter. That is, it will pass high-frequency signals and attenuate lower frequency signals based on the values of  $R_f$  and  $C_{in}$ . The faster the step change, the greater the output swing. This circuit is a rate-of-change detector in that slow signals (relative to  $R_f \times C_{in}$ ) will have very little output, while very quick (and large) input changes will cause a large output.

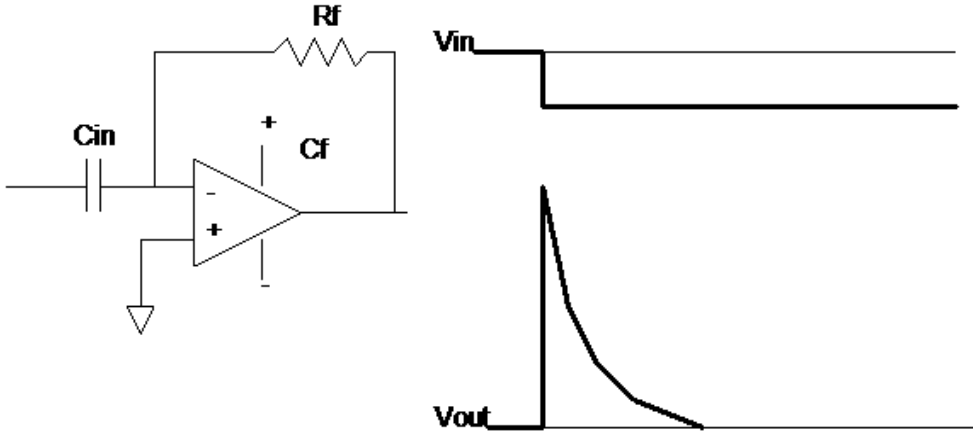


Figure 16–12 Op-amp differentiator.

## SUMMER

Figure 16–13 illustrates a basic inverting summer.

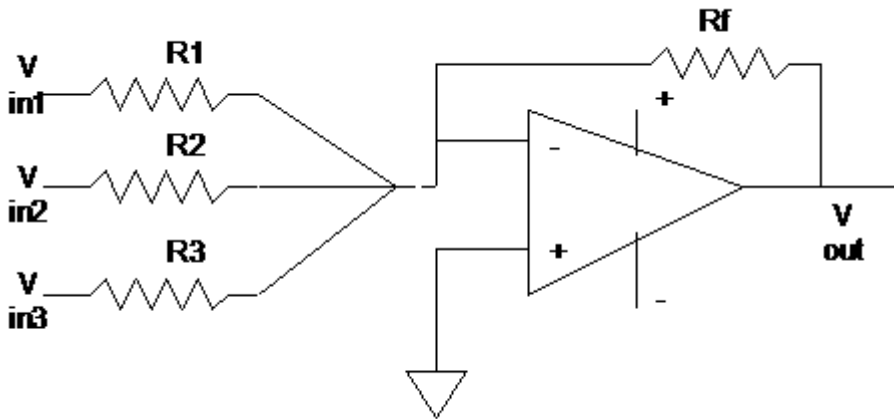


Figure 16–13 Op-amp summing amplifier.

The algebraic sum of the currents at the  $\Sigma$  junction must be balanced by the current through  $R_f$  and so is proportional to the sum of the inputs.

**EXAMPLE**

$$R_f = R_1 = R_2 = R_3 = 10 \text{ kilohms}$$

$$V_{in1} = +2V$$

$$V_{in2} = -1V$$

$$V_{in3} = -3V$$

Determine the output.

1. Using Ohm's Law,

$$I_{R1} = +2/10,000 = +.2\text{mA}$$

$$I_{R2} = -1/10,000 = -.1\text{mA}$$

$$I_{R3} = -3/10,000 = -.3\text{mA}$$

2. Sum the currents:

$$+.2\text{mA} - .1\text{mA} - .3\text{mA} = -.2\text{mA}$$

3. What voltage must the output be in order to push  $-.2\text{mA}$  through  $10\text{K}$ ?

$-.2 \times 10,000 = -2$ . This is an inverting amp;  $+2V$  is the output. And if you sum the voltages you will get  $-2V$ ; invert, and the output is  $+2V$ .

**DIFFERENTIAL AMPLIFIER**

This is a circuit that only amplifies the difference between the voltages on the input leads. A differential amplifier is shown in Figure 16–14.

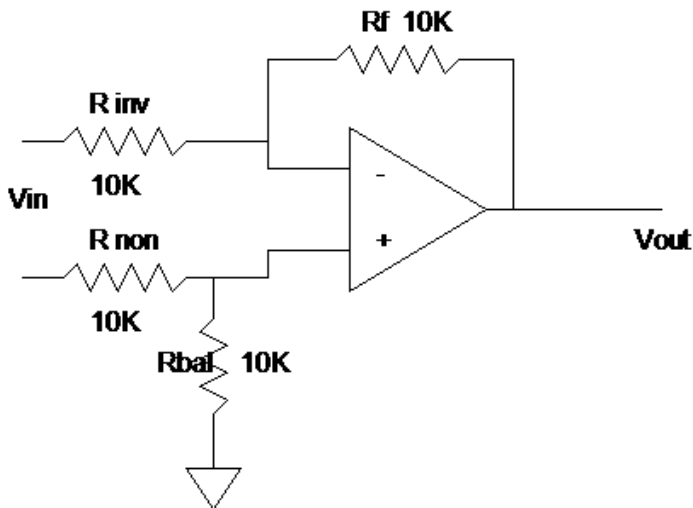


Figure 16–14 Differential amplifier.

Using your two assumptions from earlier in this chapter will make this explanation much easier to understand than trudging through some formulas.

### EXAMPLE

1. Input: 0V on the inverting input, 0V on noninverting input. Output will be 0V.
2. Input 0V on inverting input, +1V on noninverting input. Since the input voltage on the noninverting input will be divided by  $R_{non}$  and  $R_{bal}$ , the actual difference between the two leads is +0.5V. To match that, the output will have to rise to +1V (0.5 across  $R_f$  and 0.5 across  $R_{inv}$ ).
3. +1V on inverting input, +1V on noninverting input. Again, +1 on noninverting side puts +0.5 at the input. The output must match that by going to 0V, so the input 1V will be divided between  $R_f$  and  $R_{inv}$ , with 0.5V across each.
4. +2V on the inverting side, +1 on the noninverting side. The summing junction must be at +0.5V. The output must cause  $R_f$  and  $R_{inv}$  to divide +1V. By going negative 1V (+2V - 1V = +1V), this condition will be reached.

The other solutions are left to you.

### REVIEW

1. *Op-amps are the main active component in most analog circuits below 10MHz.*
2. *They provide a gain that is determined by external components.*
3. *Op-amps utilize large amounts of negative feedback to reduce distortion and noise.*
4. *They have a high-input resistance, thereby limiting circuit loading, and near 0-ohm output impedance, which provides good transfer characteristics.*
5. *Op-amps may be used in comparators, inverting and noninverting amplifiers, integrators, differentiators, and summers.*
6. *Using two simple assumptions, you can gain a sufficient understanding of circuit operation without having to know the internal construction or circuitry of the individual op-amp.*

7. *An inverting op-amp inverts the input signal and amplifies it by the  $R_f/R_{in}$  ratio.*
8. *Noninverting amplifiers do not invert the signal; they amplify it by the  $R_f/R_{in} + 1$ .*
9. *Source followers have a gain of 1.*
10. *Comparators will change state for small-input voltage differences from the reference.*
11. *Op-amp integrators produce a linear rising (or falling) slope depending on the magnitude of input change over time.*
12. *Differentiators output a peaked signal that corresponds to the rate of change of the input signal.*
13. *An integrator with sinusoidal wave-form inputs is a low-pass filter that attenuates the high-frequency signals.*
14. *A differentiator with sinusoidal wave-form inputs is a high-pass filter that attenuates at low-frequency signals.*
15. *A summer algebraically adds the input signals.*
16. *A differential amplifier outputs the algebraic difference between two signals.*

## CHAPTER EXERCISES

1. Given an inverting op-amp circuit,  $R_{in} = 2.2K$ ,  $R_f = 6.8K$ . What is the gain of this circuit?
2. Referring to the circuit in problem 1, a  $-100mV$  input change will cause what output voltage change?
3. Given an inverting op-amp circuit,  $R_{in} = 10K$ ,  $R_f = 4.7K$ . What is the gain of this circuit?
4. If a voltage follower with  $\pm 15V$  as supply has  $+2V$  applied to the input what will the output be?
5. For the circuit in problem 4, if the input was  $+16V$  what would the output be?
6. When using a comparator, when is hysteresis necessary?
7. How does the comparator differ from other op-amp circuits?
8. If you input a square wave to an integrator (of the appropriate frequency) what wave-form will the output have?
9. If you input a square wave to a differentiator (of the appropriate frequency) what wave-form will the output have?
10. An inverting summer has four inputs. Input 1 has  $-2.5V$ , Input 2 has  $+1V$ , Input 3 has  $+1.5V$ , and Input 4 has  $+0.5V$ . If the summer has a gain of 1, what will the output voltage be?

11. A noninverting amplifier has  $R_f = 5K$  and  $R_{in} = 10K$ . With  $V_{in}$  equal to 6 volts, what will the output be?
12. A source follower has an input impedance of 100K and an output impedance of 100 ohms. With +4 volts on the input, what voltage will be on the output?
13. Using an integrating circuit, you input a signal with a band of frequencies from 100Hz to 15KHz. Which end of the frequency band will be attenuated most?
14. Using a differentiating circuit, you input a signal with a band of frequencies from 100Hz to 15KHz. Which end of the frequency band will be attenuated most?

***Answers to these review questions will be found at the back of this book.***

## **CONCLUSION**

You have concluded Chapter 16. Review the chapter objectives found at the front of the text. If you have successfully met these objectives, proceed to the next chapter. If you are having problems with these concepts, seek out a peer, mentor, supervisor, or other technical person with knowledge of operational amplifiers to assist you.

For further information on the concepts in this chapter, search the following terms in your Internet search engine:

**Op-amp**

**Op-amp non-inverting amplifier**

**Op-amp differentiator**

**Op-amp differential amplifier**

**Op-amp inverting amplifier**

**Op-amp voltage follower**

**Op-amp integrator**

**Op-amp comparator**

# DIGITAL LOGIC

---

---

Digital logics are the building blocks of the digital revolution. From simple gates to highly complex application-specific integrated circuits (ASICs), digital logic is found everywhere. While this chapter is not a comprehensive review of all current digital logic (that would take several volumes), it will introduce you to various logic families and functions.

## FUNCTIONS

All digital circuitry consists of combinations of ANDs, ORs, XORs, NEGATEs, NORs, NANDs, counters, registers, and memory. In the beginning, logics were manufactured out of discrete components. This gave way to small-scale integration (SSI) and very quickly into large-scale integration (LSI). Today, a central processing unit (CPU) (microprocessor) is made up of millions of gates, registers, and counters.

To gain an understanding of digital logic a good place to start is with the gate circuits.

## GATES

There are but four basic gate structures, just four. Complex logic is built out of various combinations of these gates. They are quite simple to understand. While all the gates discussed here have just two inputs, understand that gates may have many more than two inputs. The logic is the same.

## OR

The rule for the OR gate is simple. A 1 on any input will give a 1 on the output. Referring to a two-input OR gate, the rule reads, "A 1 on input A OR a 1 on input B will cause the output to be a 1." Figure 17-1 illustrates the OR symbol, and Figure 17-2 shows a map of the logic.

To read the logic math, note that the inputs are on the outside, as an example  $A = 1$  and  $B = 0$ . If you start at the  $A=1$  row (top) and move down into the block 1 row, that is the  $B=0$  row. The value in that intersecting

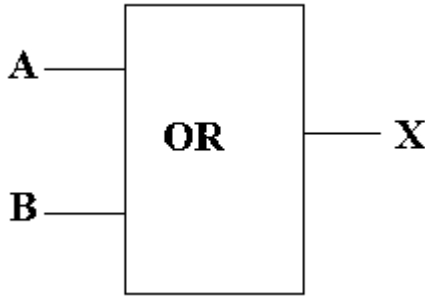


Figure 17-1 An OR gate.

		A	
		0	1
B	0	0	1
	1	1	1

Figure 17-2 Logic map for an OR.

block is the output, in this case a 1. Note that if either A or B is a 1, the output is a 1.

## AND

The AND gate rules are also simple. All inputs must have a 1 for the output to be a 1. For the two-input AND: “It takes a 1 on input A AND a 1 on input B to have a one on the output.” Figure 17-3 is the symbol for an AND; Figure 17-4 is the logic map for an AND gate.

## XOR

An XOR or “exclusive OR” has a rather simple rule: if both inputs are the same state, the output is a 0. If the inputs are at a different state, the output is a 1, or more succinctly, evens give a 0, odds give a 1. Figure 17-5 is the figure for an exclusive OR (XOR), while Figure 17-6 is the logic map for an XOR.

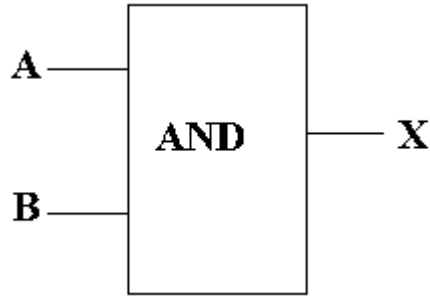


Figure 17-3 AND symbol.

		A	
	B	0	1
0	0	0	0
1	0	0	1

Figure 17-4 Logic map for an AND.

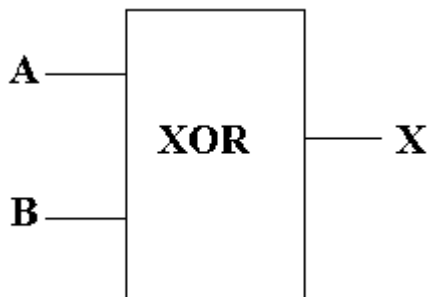


Figure 17-5 XOR.

		A	
	B	0	1
0	0	0	1
1	1	1	0

Figure 17-6 Logic map for XOR.

The XOR circuit goes by many names. It is first of all a binary half adder, that is, it is a binary adder without a carry (the half part), to wit:

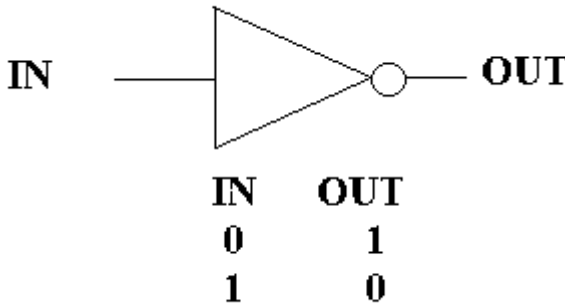
	0	0	1	1
	0	1	0	1
<b>Add</b>	0	1	1	0

As you may ascertain, evens give you 0, and odds give you 1 on the output.

Another name the XOR can go by is the Modulo-2 (or Mod2) circuit. In Modulo arithmetic, the number in question is divided by the base (in this case two), and the remainder is listed. In modulo arithmetic the number of times the base goes into the number is not important, just the remainder. A little thought here will show that if you divide 0 by 2 the result is 0, and if you divide 2 (binary 10) by two, the remainder will be 0. However, if you divide 1 by 2, it will go into it 0 times, with a remainder of 1. These are the same results as an XOR.

## NEGATE

The NEGATE function is not really a gate but an inverter. Its logic is quite simple. A 1 on the input gives a 0 out; a 0 on the input gives a 1 out. The negate function is normally indicated by a small circle or bubble on the affected path, usually an output. Figure 17-7 illustrates a NEGATE circuit.



**Figure 17-7** NEGATE.

## NOR

A NOR circuit is an OR circuit with an inverter on the output. Figure 17–8 illustrates a NOR gate and its logic map.

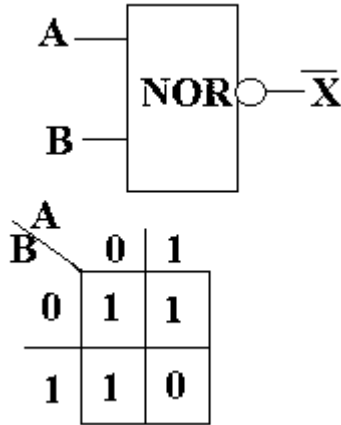


Figure 17–8 NOR and logic map.

## NAND

A NAND gate is an AND gate with an inverter on the output. Figure 17–9 illustrates a NAND gate and its logic map.

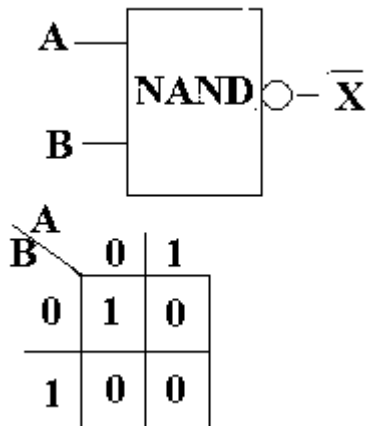
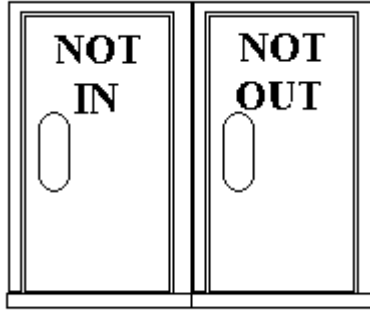


Figure 17–9 NAND and logic map.

## COMBINATIONAL LOGIC

Figure 17–10 illustrates a common quandary: which door do you go in?



**Figure 17–10** Door quandary.

It should be obvious that you would go in the NOT OUT door and go out the NOT IN door. This is how you have to approach combinational logic. While Boolean algebra enables you to mathematically determine the logic, most outcomes can be determined with a little thought.

### EXAMPLE

Refer to Figure 17–11. With the inputs given, what is the output of this combinational circuit?

Start at the left-hand side, where the inputs are. You can see the two middle ANDs. They have 1s on their outside inputs. However, to have a 1 out (it will require three 1s on the output circuit for a 1) means they have to have a 1 from the NORs. The only way to get a 1 from the NORs is to have two 0s in. They do, so you have a 1 from the NORs to the ANDs, and the OR in the center has 1s on both inputs. The output of the two ANDs and the OR is a 1, so the output AND is satisfied and will output a 1.

If any on the NOR inputs is a 1 or either of the ANDs' outside inputs is a 0, then the output of this circuit will be 0.

As you can see, by using combinational logic we can derive highly complex scenarios. Just the logic is not enough, however. To form our digital logic completely, we need storage (counters, flip-flops, registers, etc.), and we need computational circuits.

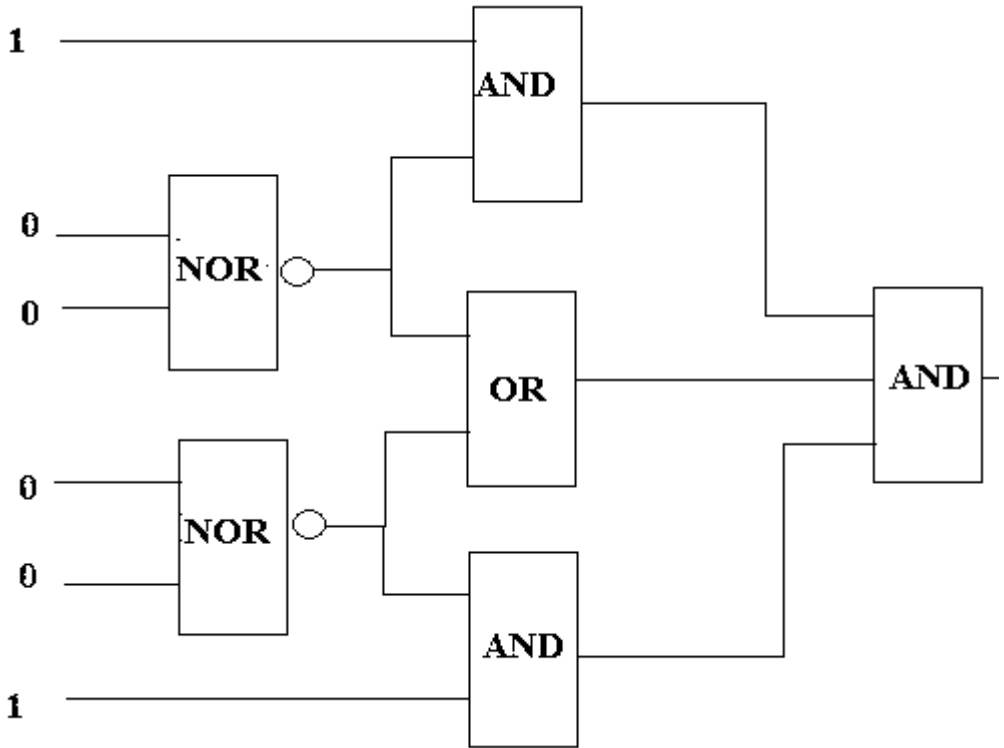


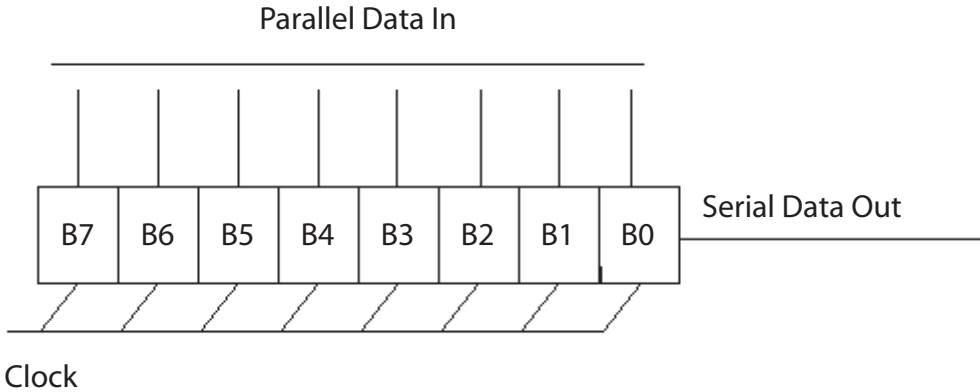
Figure 17–11 Combinational logic.

## STORAGE

It's essential to store the results of a logic decision so you can compare them to past or future results, for historical reasons, for trending, to count events, or to determine a past state in order to adjust the next state. The basic storage unit in the early days was the multivibrator, a bistable multivibrator to be exact. Coined a “flip-flop,” it stored one bit, and made decisions about when to change the bit, under what conditions, and so on. By tying flip-flops together based on a common clock or data line, a register came into being.

## REGISTERS

A register is simply a designated place of storage. It can be anywhere from a nibble (4 bits) to dual 64 bits (128) or even greater. A register differs from memory in that it has a specified length and is typically used over and over again as temporary storage for addresses and results of computations. Figure 17–12 shows the logical diagram of a shift register.



**Figure 17–12** A parallel-to-serial register.

The job of the register in Figure 17–12 is to accept eight bits of data from a parallel bus and then clock them out one at a time, converting the parallel data into serial data. Most registers are shift registers in that they can rotate data one direction, or for many registers both directions, with commands called “shift right” or “shift left.” (If you dwell on the topic you should be able to see that shifting data to the left is multiplying it by 2 and shifting it to the right is dividing it by 2.)

## COUNTERS

Sometimes it is necessary to count some event. A shift register is converted into a counter by simply adding one binary count to the contents of the register for each event (or in some cases, by taking one binary count away from the register at each event).

## MEMORY

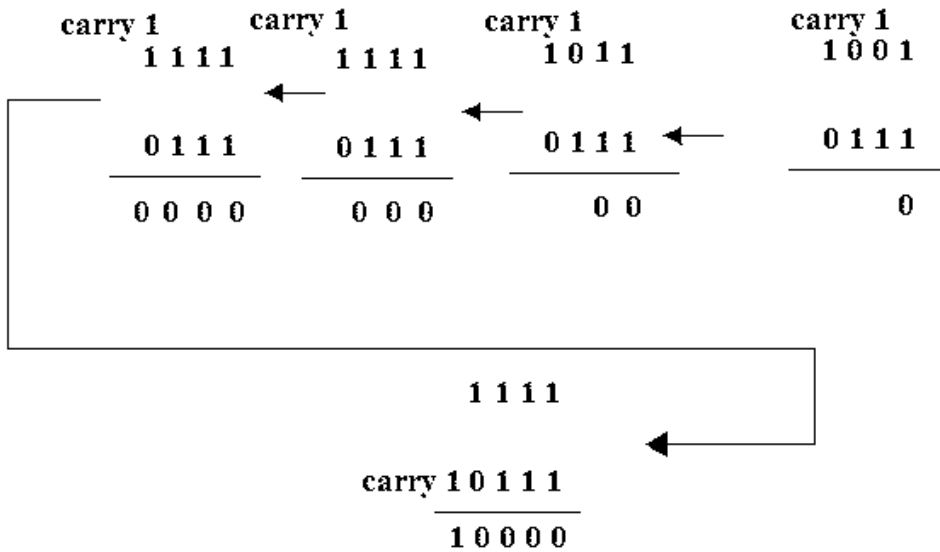
Memory is an addressed storage space. You could consider counters and registers to be memory (and in many cases that is exactly what they are). Generally, however, when you think of memory’s function, it is to store information. There are many, many types of memory. You have the rotating memories (disk drives, CDs, DVDs, etc.), and you have the solid-state memories (RAM, ROM, EAPROM, EEPROM) and the different varieties and technologies of each of these (DDR, SRAM, etc.). In most digital technology, memory is addressed, so you know how to find each location. Memory stores whatever it is you need stored as long as it consists of 1s and 0s. How to address memory, how to select memory type, and how memory actually stores a state, while quite interesting, is beyond the scope of this text. However, there are many good technical books, papers, and guides to assist you if you care to study the matter further.



**EXAMPLE**

Refer to Figure 17–14. Add the binary equivalent of 9 and 7 (which of course you know to be 16):

Decimal 9 = Binary 1 0 0 1  
 Decimal 7 = Binary 0 1 1 1 ADD  
 Decimal 16 = Binary 1 0 0 0 0



**Figure 17–14** Binary addition example.

**REPRESENTING BINARY PATTERNS**

In this text, and in most of the real world, there are three ways to represent binary numbers: (1) the binary pattern, (2) the decimal equivalent of the binary value of the pattern, and (3) the hexadecimal equivalent, used only for determining the binary pattern.

For example, if you have the binary pattern represented by *10 Hex*, it is 0001 0000, which has a decimal value of 16.

Binary	Decimal	Hexadecimal
0000	0	0
0001	1	1
0010	2	2
0011	3	3
0100	4	4
0101	5	5
0110	6	6
0111	7	7
1000	8	8
1001	9	9
1010		A
1011		B
1100		C
1101		D
1110		E
1111		F

Figure 17–15 Binary equivalents.

## APPLICATION

Explain to yourself how eight bits can represent the decimal value 0–255.

Assign the value (of the power of two) to every column with a 1:

128 64 32 16 8 4 2 1 (power of two expressed in decimal value)  
 0 0 0 0 0 0 0 0 which is Hex 0 and Decimal 0

or

1 1 1 1 1 1 1 1 which is Hex FF and Decimal 255

*HINT:* Add

128
64
32
16
8
4
2
<u>1</u>
255

**EXAMPLE**

What is the decimal value of Hex C6?

C      6

1. make it binary 1 1 0 0 0 1 1 0

2. 128 64 32 16 8 4 2 1

1 1 0 0 0 1 1 0

3. 128

64

4

2

198 is the answer.

**SUBTRACT**

Subtraction as taught in elementary school is a mechanical process for finding the difference. Subtraction is not how the number system works, however, nor is borrowing a method that will work for mechanical or electronic computations. To subtract means to add the complement of a number. A *complement* is the difference between the numbers you have and the other end of the number system. Let's do it in decimal first before we try it in binary.

There are ten numbers in the decimal number system, 0–9. The complement of 0 is 9, 1 is 8, 2 is 7, and so on—that is, the complement is how far it is to 9 from the number you have. If you have the number 4, you achieved that number by counting 0, 1, 2, 3, 4. So how far is it to the other end of the number system (9)? It is 5. In decimal, 5 is the complement of 4.

**EXAMPLE**

Find the difference between 5 1 3 7 and 4 3 6 8

Remember how were you taught to do this? You cannot take 8 from 7, so you borrowed 10 from the next column, and now you have 17 and can subtract 8 from it. However, neither mechanical adding machines nor electronic ones can be designed to add and subtract by borrowing. The difference, as stated before, is found by adding the complement of a number to the one you wished to find the difference for.

5 1 3 7            5 1 3 7

4 3 6 8

how far is it from 4 to 9? 5            5 6 3 1

how far is it from 3 to 9? 6

how far is it from 6 to 9? 3

how far is it from 8 to 9? 1

You have complemented the lower number.

Now add the two together:            1 0 7 6 8

Since you know the result has to be less than either value, what are you to do with the carry? The carry means it is a positive number, and since you must compensate for 0 not being in the middle, but rather being a positive number, you add the 1 to your result, which will give you 0 7 6 9.

This is the principle that all mechanical adding machines used. We do the same in binary. The method just described is called tens complement (because if you have a carry it is a positive number and you add the one to the number). In binary, we use a method called twos complement. It is just easier to complement because all you need to do is just invert (that is, change all the 1s to 0s and vice versa).

**EXAMPLE**

Find the difference between HEX 10 and Hex 07

1 0000 (decimal 16)

0 0111 (decimal 7)

Complement: 1 0000

1 1000

Add: 10 1000 You had a carry so add the 1

Result: 1001 (Hex 9 and decimal value 9)

Remember: if you have a carry it is a positive number. What is a negative number like? It will be in complement form, and if you want to see it is a positive number form with a sign in front you will have to re-complement.

**EXAMPLE**

In decimal, find the difference between 23 and 67.

23                      23

67 complement      32

Add                      55

At which point you say, "Hey, that's not right." But it is; it is a complement representation of a negative number. To get the positive number with a negative sign, re-complement:

55                      -44

which is the right answer!

**MULTIPLY**

To multiply in binary means to multiply by two. This is done simply by shifting a register to the left.

Value in register now:

0 0 0 0 1 0 0 0 (decimal 8)

To multiply by two, shift all digits to the left one:

0 0 0 1 0 0 0 0 (decimal 16)

**EXAMPLE**

Value in register now:

0 0 0 1 0 1 0 1 (decimal 21)

Multiply by 4, so shift all numbers to the left twice:

0 1 0 1 0 1 0 0 (decimal 84)

To multiply by an odd value (say 3) you would shift once ( $\times 2$ ) and add the original value ( $\times 2 + 1 = \times 3$ ).

**DIVIDE**

To perform division by two, shift the register to the right once. To divide by three, shift the register twice (divide by four), and add the original value (now divide by three).

**REVIEW**

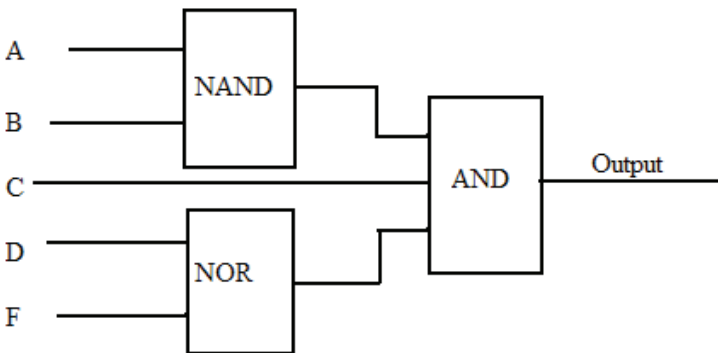
1. *Digital gates consists of AND, OR, and XOR.*
2. *Negation (NEGATE) is an inverter.*
3. *Inverting an AND gives a NAND and an OR a NOR.*
4. *AND rules: It takes all 1s to get a 1 out; NAND: it takes all 1s in to get a 0 out.*
5. *OR rules: Any 1 in will give a 1 out; NOR: any 1 in will give a 0 out.*
6. *XOR rules: Evens in give a 0; odds give a 1.*
7. *Storage the form of registers, counters, and memory.*
8. *Binary addition and subtraction are performed using twos complement.*
9. *A complement is the distance from a number to the other end of the number system.*
10. *Multiplication is a shift-left, division a shift-right process.*

## CHAPTER EXERCISES

1. In Circuit 1 (below): Input A = 1, B = 0, C = 1. What is the output?



2. If Circuit 1 were an NOR with the same inputs, what would the output be?
3. If Circuit 1 were an AND and Input A = 1, B = 1, C = 1, what would the output be?
4. If a shift-left register had the original value 00110010 and it was shifted twice, what would the decimal value of the original value and the resultant value be?
5. XOR these two patterns:  
 110001011011  
 011000010111
6. Convert Hex F7 into a decimal value (Hint: convert Hex into binary pattern first).
7. Convert decimal 57 to Hex (Hint: determine the binary value of 57 first).
8. In Circuit 2 (below): A=0, B=1, C=1, D= 0, F = 0. What is the output?



**Answers to these review questions will be found at the back of this book.**

## **CONCLUSION**

This completes Chapter 17 on digital logic. Please review the chapter exercises to determine if you have successfully mastered the concepts in this chapter. If so, proceed to the next. If you are having difficulty, ask a peer, mentor, supervisor, or anyone with knowledge of digital logic to help you meet the chapter objectives.

For further information on the concepts in this chapter, search the following terms in your Internet search engine:

**Digital Logic**

**OR logic**

**NAND logic**

**Boolean arithmetic**

**AND logic**

**NOR logic**

**XOR logic**

# ANALOG/DIGITAL CONVERSION

---

---

Modern electronic controllers are digital. But while some transmitters and the majority of systems communicate in digital format, the measurements found in industry operate in a continuous world. This is the analog world of measurement. In order for the digital device to communicate (and control), analog-to-digital (A-to-D) and digital-to-analog (D-to-A) conversions are required. There are different methods for performing both types of conversion, and this chapter will outline some of the more prevalent ones.

Before we can perform conversions of any type, however, we must have some way to represent values as binary numbers. These representations are called binary codes. The first part of this chapter concerns number systems, primarily the binary number system. Though this subject was introduced in Chapter 17, this chapter will focus more on conversion and values than on binary logic.

## THE DECIMAL SYSTEM REVIEW

All number systems follow the same rules. You are familiar with the decimal system. Decimal means that the number system is based on ten digits. Its base is ten. The only numbers allowed in the decimal system are 0, 1, 2, 3, 4, 5, 6, 7, 8, and 9. All the numbers that we can use to describe numerical quantities in decimal are made up of those ten numbers and no others.

Figure 18–1 illustrates the powers of ten. Notice that a number, such as 4,302.63, is really  $4000 + 300 + 2 + .6 + .03$ , or more correctly,  $4 \times 1000$  (10 to the third power) +  $3 \times 100$  (10 to the second power) +  $0 \times 10$  (10 to the first power) +  $2 \times 1$  (10 to the 0 power or 1) +  $6 \times 1 \times 1/10$  (10 to the  $-1$  power) +  $3 \times 1 \times 1/100$  (10 to the  $-2$  power).

The number represented in Figure 18–1 is 4302.63

$1 \times 1000$	$1 \times 100$	$1 \times 10$	$1 \times 1$	Decimal Point	$1 \times -1/10$	$1 \times 1/100$
4	3	0	2	.	6	3

**Figure 18–1** Example of Powers of 10.

All other number systems will be constructed in the same way, except that rather than ten as the base, they are based on a different number, for example, two if binary or sixteen if hexadecimal.

For this chapter’s review of number systems, the emphasis will be on using the number system as a form of pattern recognition. The number systems chosen here are the ones currently used in data communications. Binary is the number system used by computers, decimal is used to represent binary values so they make sense to humans, and hexadecimal is used to reduce binary streams to recognizable patterns. Computers presently only work with binary patterns, and humans only really understand decimal.

## THE BINARY SYSTEM

Figure 18–2 illustrates the binary values for 0 through 15 in decimal form. The binary patterns for the decimal values 0 through 9 are called binary coded decimal (BCD). This means that the decimal numbers (0 through 9) are each represented by four binary digits:

1	3	0	2	Decimal
0001	0011	0000	0010	BCD

This coding (BCD) was done so humans could see familiar-looking numbers rather than strings of ones and zeros. BCD coding is used to represent decimal values in a binary format.

Early computers used a twelve-bit “word.” Therefore, breaking the word up into four three-bit patterns would allow computers to represent each of the three bits by its BCD value. Four-bit patterns were not desirable because using a leading “1” (BCD digits 8 and 9) wastes six patterns (10–15) in that the patterns must be represented by a unique single digit in order to represent each pattern. Since the BCD coding for 0 through 7 only uses three bits and has eight unique patterns, it is called *octal*.

Binary	Octal	Decimal	Hexadecimal
0000	0	0	0
0001	1	1	1
0010	2	2	2
0011	3	3	3
0100	4	4	4
0101	5	5	5
0110	6	6	6
0111	7	7	7
1000		8	8
1001		9	9
1010			A
1011			B
1100			C
1101			D
1110			E
1111			F

**Figure 18–2** Binary numbers 0–15.

Conversion from binary is performed by separating the binary number into groups of three, starting at the binary point. Assign the octal value for the three-bit group, and you have performed the conversion.

## THE HEXADECIMAL SYSTEM

Note that Figure 18–3 is the same arrangement we used to illustrate BCD, except that patterns that were illegal in BCD (10–15) are now assigned unique single-character representation for hexadecimal. Therefore, the six patterns that were wasted can now be used. This allows us to represent sixteen unique four-bit binary patterns. Modern computers perform all operations on four-bit or some multiple of four-bit patterns; therefore, hexadecimal representation is most often used.

Binary	Decimal	Hexadecimal
0000	0	0
0001	1	1
0010	2	2
0011	3	3
0100	4	4
0101	5	5
0110	6	6
0111	7	7
1000	8	8
1001	9	9
1010		A
1011		B
1100		C
1101		D
1110		E
1111		F

Figure 18–3 Decimal and hexadecimal.

## TO CONVERT A BINARY PATTERN TO HEXADECIMAL

First, separate the binary pattern *starting from right digit* next to the hexadecimal point into four-bit groups, and assign the hexadecimal representation to each group.

### EXAMPLE

Pattern: 0111010010100101

Separate into groups of four from the right-most digit:

0111 0100 1010 0101

7 4 A 5

## TO CONVERT A HEXADECIMAL NUMBER TO A BINARY PATTERN

Write out the four-bit patterns for each number. Hexadecimal numbers are generally written as “0hexnumbersH, leading 0, following H.”

### EXAMPLE

0FF13H (FF13 is hex representation)

F	F	1	3
1111	1111	0001	0011
1111111100010011			

## DECIMAL-TO-HEXADECIMAL CONVERSION

The steps for decimal-to-hexadecimal conversion are as follows:

1. Convert to binary.
2. Convert to hexadecimal.

Some patterns should be memorized, both decimal and hexadecimal, because they are among the most common patterns encountered (see Table 18–1). These are 0–15 (0–F Hex) (listed previously).

To convert a binary number to decimal (and then to hexadecimal), you use the powers chart (see Table 18–2).

Simply add up the columns that have a 1:

1024
256
64
16
<u>2</u>

1362 is the decimal equivalent of 10101010010

To convert a decimal number to binary, you perform a procedure much like long division.

**Table 18–1** Popular Conversion Numbers

Binary pattern	Decimal	Hex
1 0000	16	10
10 0000	32	20
100 0000	64	40
1000 0000	128	80
1111 1111	255	FF
1 0000 0000	256	100
10 0000 0000	512	200
100 0000 0000	1024	400
1000 0000 0000	2048	800
1 0000 0000 0000	4096	1000
10 0000 0000 0000	8192	2000
100 0000 0000 0000	16384	4000
1000 0000 0000 0000	32768	8000
1111 1111 1111 1111	65535	FFFF

**Table 18–2** Powers Chart

Power of Two	Decimal Value	Sample Binary Number
0	1	0
1	2	1
2	4	0
3	8	0
4	16	1
5	32	0
6	64	1
7	128	0
8	256	1
9	512	0
10	1024	1
11	2048	0
12	4096	0
13	8192	0
14	16384	0
15	32768	0

**EXAMPLE**

Using the powers-of-two chart, what is the largest power of two that will go into 953?

It is 512. Using a twelve-bit binary number means that all of the higher bits until 512 will be 0s (see Table 18-3):

$512 + 256 = 768$ . This is less than 953, so put a 1 in the 256 column.

$512 + 256 + 128 = 896$ . Less than 953, so put a 1 in the 128 column.

$512 + 256 + 128 + 64 = 950$ . Keep a 1 in the 64 column.

$512 + 256 + 128 + 64 + 32 = 982$ . Put a zero in the 32 column.

$512 + 256 + 128 + 64 + 16 = 966$ . Put a zero in the 16 column.

$512 + 256 + 128 + 64 + 8 = 958$ . Put a zero in the 8 column.

$512 + 256 + 128 + 64 + 4 = 954$ . Put a zero in the 4 column.

$512 + 256 + 128 + 64 + 2 = 952$ . Keep a 1 in the 2 column.

$512 + 256 + 128 + 64 + 2 + 1 = 953$ . Keep a 1 in the 1 column.

The resulting binary pattern 001111000011 prepared for Hex is:

0011 1100 0011  
3 C 3

**Table 18-3** Conversion Table for Example

Power of two											
11	10	9	8	7	6	5	4	3	2	1	0
Decimal equivalent											
2048	1024	512	256	128	64	32	16	8	4	2	1
Binary number											
0	0	1	1	1	1	0	0	0	0	1	1

You will find it necessary to use these conversions in learning situations (trying to understand equipment operation, etc.), diagnostics (locating problems using equipment from different manufacturers), and software/programming.

If you find yourself having to move between decimal and binary (or hexadecimal), it is better to use a calculator for this purpose. It is far less time consuming and usually a great deal more accurate. Conversion

between hex (hexadecimal) and binary only requires that you know (or memorize) sixteen patterns, two of which are the same for both (0 and 1). This chapter is not meant to be an extensive review of number systems, but it should provide you with a sufficient foundation for switching between the most commonly used number systems.

## **BINARY CODES**

So far, we have reviewed the binary number system, along with binary, BCD, octal, and hexadecimal representations. Analog/digital conversions involve coding. Different converters output (A-to-D) and input (D-to-A) different codes. To properly understand analog/digital conversions, you must understand these codings.

The binary number system can be used in its natural format. If the binary number system uses binary 0 to represent the least positive voltage and a binary 1 to represent the most positive voltage, then the coding system is called *natural binary*.

## **NATURAL BINARY**

Natural binary is also called “unipolar” because it is used to represent voltages (currents, etc.) that have only one polarity (an example is 0 to +5 volts). The binary number system we discussed in preceding sections (values 0 to 15 represented by 0 to F Hex) would be natural binary if it was used to represent 0 to some positive value. Binary numbers are used in their fractional form in many industrial settings. Table 18–4 illustrates a four-bit fractional code.

$$Q = \frac{\text{Full scale}}{\text{Number of bits}}$$

Note that if a four-bit number is used to represent 0 to 1 volt or 0 to 100 percent of full scale, there is an *error inherent* in the representation. This is 1/16 or .0625. There is always one least-significant-bit (LSB) error in the binary representation of a range if 0 is chosen to be the binary zero value and the scale corresponds to the binary fractions. At any part of the input range of the A-to-D conversion process there is a constant value between digital codes (in this case  $\pm 0.0625$  volts). This is the least amount of error (with the number of bits used) for the system. In real systems, this error can be determined as follows:

$Q$  = quantization error or quantization noise, which is the uncertainty of the measurement as a result of the conversion process. The only way to

reduce this error is by increasing the number of bits used. In industrial systems, the bit numbers shown in Table 18–5 are used.

Generally, full scale is standardized at either 0 to +5 volts or 0 to +10 volts for unipolar converters.

**Table 18–4** Natural Binary Values

MSB	B2	B3	LSB	Decimal	Fraction	
1	1	1	1	0.9375	15/16	
1	1	1	0	0.8750	14/16	7/8
1	1	0	1	0.8125	13/16	
1	1	0	0	0.7500	12/16	3/4
1	0	1	1	0.6875	11/16	
1	0	1	0	0.6250	10/16	5/8
1	0	0	1	0.5625	9/16	
1	0	0	0	0.5000	8/16	1/2
0	1	1	1	0.4375	7/16	
0	1	1	0	0.3750	6/16	3/8
0	1	0	1	0.3125	5/16	
0	1	0	0	0.2500	4/16	1/4
0	0	1	1	0.1875	3/16	
0	0	1	0	0.1250	2/16	1/8
0	0	0	1	0.0625	1/16	
0	0	0	0	0.0000	0/16	0/4

**Table 18–5** Common Conversion Word Sizes

Bits in Conversion Word	± (Error)
8	0.00391
10	0.00097
12	0.00024
14	0.00006
16	0.000015

## BIPOLAR CODES

If you wish to represent  $\pm$  values, you will use a bipolar coding. The standard bipolar values are  $\pm 2.5$ ,  $\pm 5.0$ , and  $\pm 10.0$  volts. To represent these values, you can use straight or natural binary by allowing the “all-zeros” state to represent the most negative value and the “all-ones” state to represent the most positive value. Table 18–6 illustrates a four-bit natural binary bipolar coding.

When natural binary is used to represent bipolar values, the halfway value, 1000, is used to represent the value 0. So 1000 (binary) is the “offset” from binary 0000. This is why natural binary is called *offset binary* when it is used to represent bipolar values.

While many other codes exist for representing bipolar values, the two's complement is the most common in computer-driven systems. Two's complement coding is illustrated in Table 18–7.

**Table 18–6** Bipolar Coding Using Natural Binary

Natural Binary	Decimal
1111	+7/8
1110	+6/8
1101	+5/8
1100	+4/8
1011	+3/8
1010	+2/8
1001	+1/8
1000	+0/8
0111	-1/8
0110	-2/8
0101	-3/8
0100	-4/8
0011	-5/8
0010	-6/8
0001	-7/8
0000	-8/8

**Table 18–7** Twos Complement

Natural Binary	Twos Complement	Decimal
1111	0111	+7/8
1110	0110	+6/8
1101	0101	+5/8
1100	0100	+4/8
1011	0011	+3/8
1010	0010	+2/8
1001	0001	+1/8
1000	0000	+0/8
0111	1111	-1/8
0110	1110	-2/8
0101	1101	-3/8
0100	1100	-4/8
0011	1011	-5/8
0010	1010	-6/8
0001	1001	-7/8
0000	1000	-8/8

Several aspects of twos complements coding should be noted. Zero value is represented by 0 binary. If you add a positive number and the same negative number (for example, +2/8 added to -2/8), the result is 0 with a carry. Actually, twos complement is the offset (natural) binary system that has the most significant bit (MSB) inverted (complemented). Most binary computers perform arithmetic operations using twos complement, so its use in these systems is understandable. Generally, throughout this chapter we will use natural binary representing 0 to 10 volts to explain conversion operations.

## DIGITAL-TO-ANALOG CONVERSION

We will discuss digital-to-analog conversions first several reasons, the primary one being that most successive-approximation analog-to-digital converters use a digital-to-analog converter (either internally or externally) as a reference.

Many different techniques are used to convert digital values to either voltage or current values. Almost all contemporary converters are of the

parallel type, meaning that they convert the entire number of bits simultaneously to the voltage or current value.

## WEIGHTED-RESISTOR NETWORKS

One of the more popular D-to-A methods used by discrete circuitry or hybrid integrated circuit converters uses a weighted-resistor network. This is illustrated in Figure 18–4.

In Figure 18–4, the switches are either on or off, and the current-limiting resistors have a binary weight. Note that this is a simplified diagram.  $R$  is set at 50 ohms. The switches are put in the ON state by a positive voltage (representing the 1 state), OFF by 0 volts (representing the 0 state). If the binary number “1 0 0 0”, with “1” as the most significant bit (MSB), is applied to this circuit, the switch with  $R$  will be on; the others are off. The output voltage will be  $V_{REF}/2$ , because  $R$  is equal to  $R$ . This means that the voltage at the output will be what you would expect with a four-bit system that uses natural binary coding since binary “1000” = 1/2 full scale (FS).

Note that each bit has a resistor that is twice the value of the preceding resistor. If the output voltage with the current through  $R$  is 5.0 volts, then half that current (which is the current value if  $2R$  is ON only) will give an output of 2.5 volts. If  $4R$  is ON only, the output will be 1.25 volts; if  $8R$  is ON only, 0.625 volt. Since the currents are summed, if more than one resistor is ON, you only have to add the current values to obtain the output. Note: This is a simplified diagram that assumes that half the current will go through  $2R$ , one-fourth of the current will go through  $4R$ , and one-eighth of the current will go through  $8R$ .

If  $R$  had a realistic value, it would be closer to 10,000 ohms. This means that  $8R$  would be 80,000 ohms. While these values are not unreasonable, the requirements with an 8-bit D-to-A converter, the resistor  $128R$ , would be 1.28 Megohms. This large range of required resistance values is generally not feasible on integrated circuits.

## R-2R NETWORKS

One of the more common methods of D-to-A conversion uses a resistive network that is comprised of only two values. It is called the *R-2R ladder method*. It is used primarily with the successive-approximation type A-to-D converters. It is quite suitable for integrated circuit construction since the range of resistance values required is just two.

Figure 18–5A illustrates a R-2R ladder. Only a three-bit ladder is shown to simplify the explanation of its operation. If we assume the binary value for half of the full-scale range (100), then the equivalent circuit is developed through a series of steps, illustrated in Figures 18–5A, -B, -C, -D, -E, and -F. We will leave developing other combinations up to you.

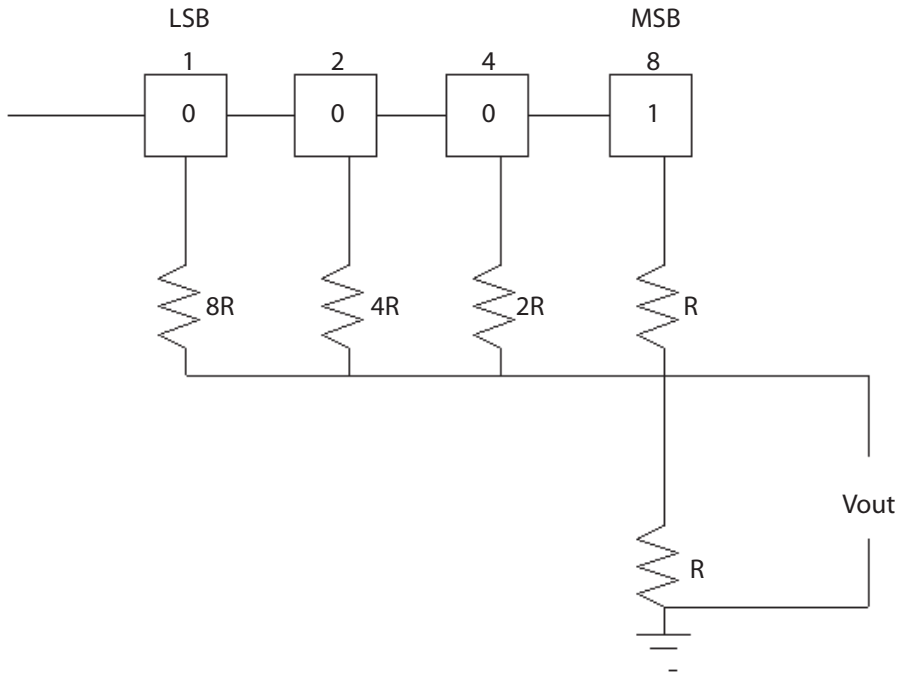


Figure 18-4 Weighted-resistor network.

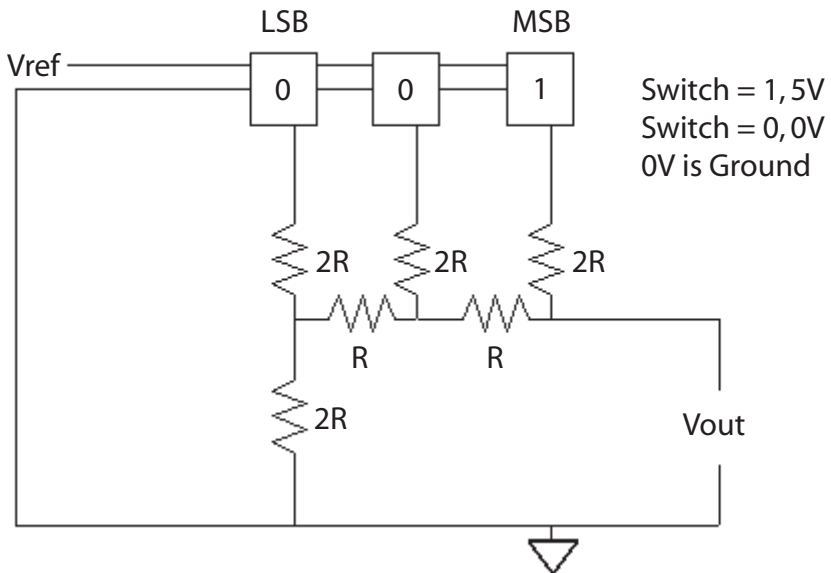
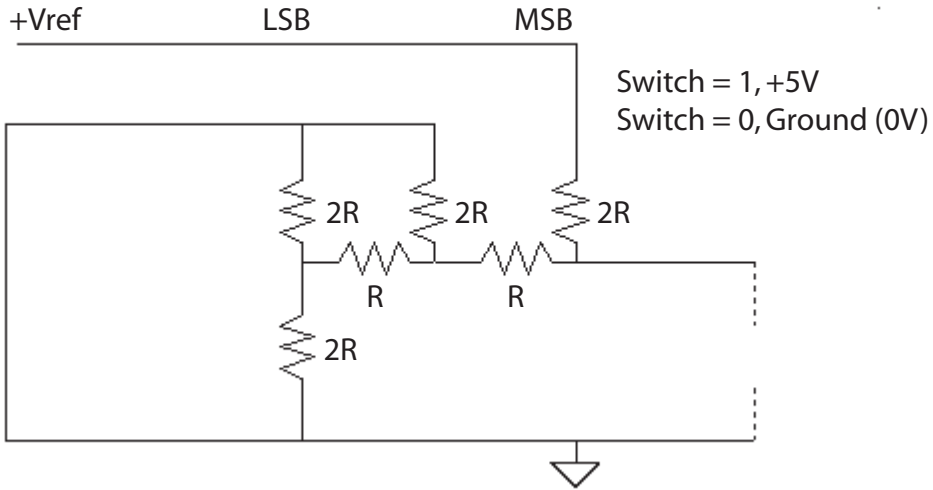
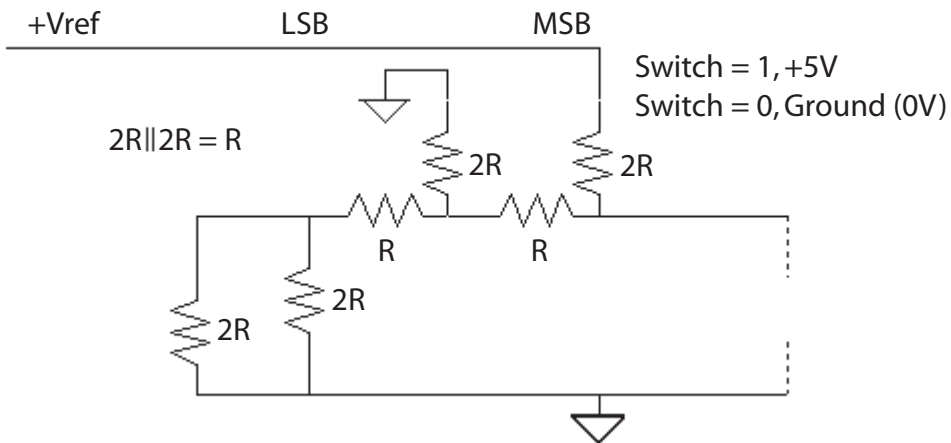


Figure 18-5A R-2R ladder.



**Figure 18-5B** R-2R ladder.

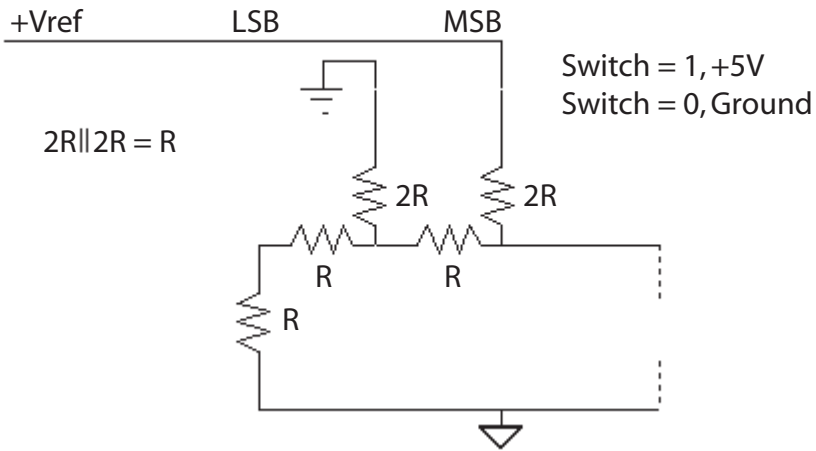


**Figure 18-5C** R-2R ladder.

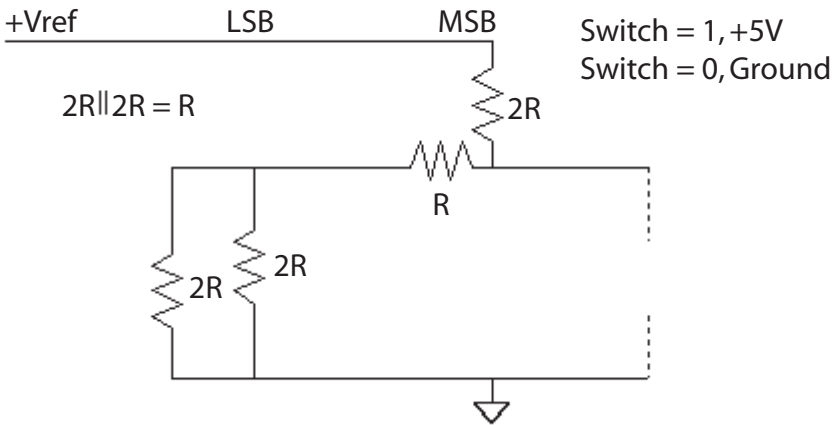
This is really just an exercise in Ohm's Law. Earlier, we learned that if two resistors of the same value are in parallel, then the equivalent resistance is half the value. In this case, if you have  $2R \parallel 2R$ , then the equivalent is  $R$ .

## OTHER CONSIDERATIONS

Whatever method you use, the output will not be continuous but rather a series of levels, switching each time that a new binary value is placed into the D-to-A unit. A typical wave shape is illustrated in Figure 18-6.



**Figure 18-5D** R-2R ladder.



**Figure 18-5E** R-2R ladder.

To smooth out the switching transients, the output signal is averaged over time (integrated). This may be accomplished by using a low-pass filter or an integrating device. While the integrated output is an approximation of the output, the approximation approaches the binary representation the more bits are used. In other words, the lower the rate of change from one level to another, the lower the frequency of the signal will be and the more accurately the output will represent the binary value.

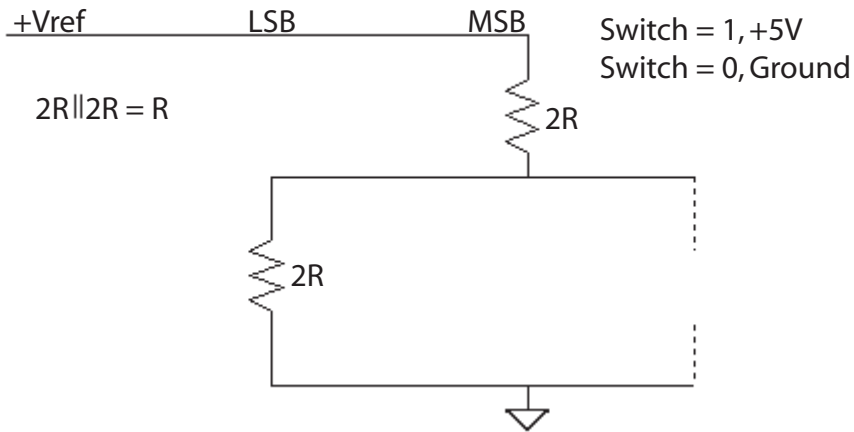


Figure 18–5F R-2R ladder.

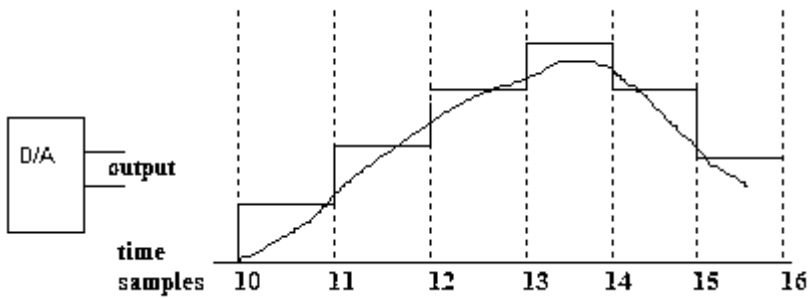


Figure 18–6 Digital-to-analog output wave shape.

## ANALOG-TO-DIGITAL CONVERSION

The three types of analog-to-digital conversions we will discuss in this section are: (a) integrating, (b) successive approximation, and (c) parallel.

### INTEGRATING

One common method for converting low-frequency signals (which includes most industrial process variables) is the integrating type. Two different techniques are currently utilized:

- dual slope
- voltage to frequency

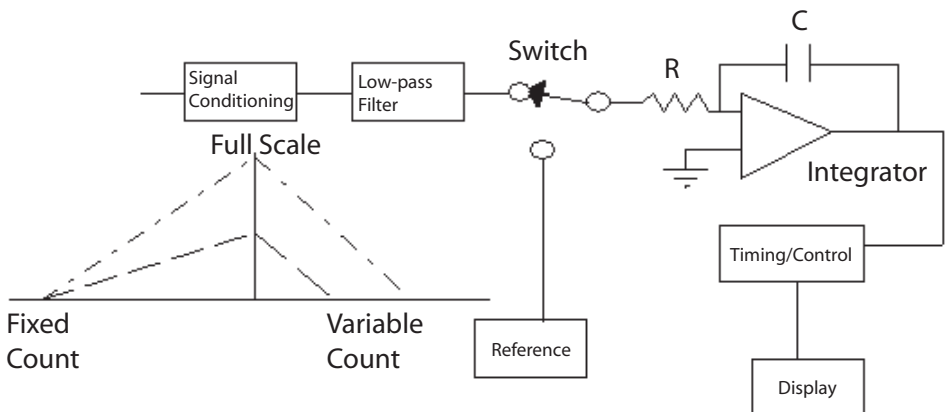
## DUAL SLOPE

Figure 18–7 illustrates a simplified block diagram of a dual-slope A-to-D converter. The operation has two distinct phases. There is a fixed time (or number of counts) that the capacitor  $C$  is connected to the unknown input voltage. The capacitor  $C$  and the resistor  $R$  form a time constant. The capacitor will charge through the resistor to an amount that is proportional to the input voltage.

Actually, this *charge* is an integral of the input voltage because it is done over a fixed period of time. When the count is finished, the capacitor is connected through the switch to the reference voltage, which has the opposite polarity of the input voltage. The counter again starts and counts until the voltage across the capacitor is zero. This count is then displayed as the voltage.

Although it would seem easier to just count the time to charge, doing so would make the conversion accuracy depend on the time-constant values ( $C$  and  $R$ ) and the frequency of the clock. The dual-slope method uses the same time constant to charge the capacitor as to discharge the capacitor. It uses the same clock frequency to count the charge period as the discharge period. Therefore, the only limitation on accuracy (theoretically) is the reference voltage. Figure 18–7 illustrates the integrator's output versus the charge/discharge times. Note that the charge time is a fixed number of counts, and at the end of the fixed period the output of the integrator is at some value, depending on the input voltage.

The time to discharge then depends on the integrator output (which depends on the input voltage). For a small voltage input the time to discharge is small, and for a full-scale input voltage, the time to discharge is proportionately longer.



**Figure 18–7** Dual-slope operation.

Because this is an integrating circuit, noise that has a time constant of less than the fixed count (namely, higher frequencies) will be integrated or averaged out. The dual-slope type of converter is relatively inexpensive, will not miss any code combinations, and offers excellent linearity. However, the very features that are its strengths also cause its primary weakness: conversion speed. It is slow. Because of this limitation, this type of converter is used mostly for digital voltmeters and panel meters.

## VOLTAGE TO FREQUENCY

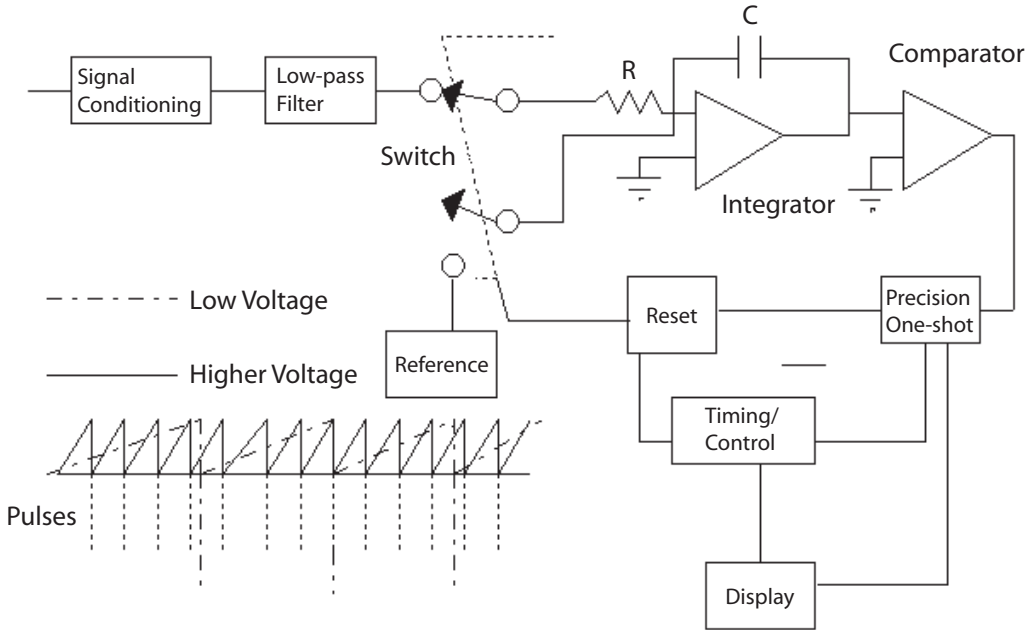
This method is currently used in many industrial process controllers as well as many of the A-to-D conversion modules designed for use with personal computers. Figure 18–8 shows a simplified block diagram of a charge-balancing converter (voltage to frequency).

Charge-balancing converters generate a pulse train (a series of pulses) whose frequency is proportional to the input voltage. They then count the pulses over some period of time. Assume a positive input at the integrator input. This will drive the integrator output in the opposite direction. When the integrator output crosses zero, the output of the comparator will change. This will trigger a precision one shot (a flip-flop which produces only one specific pulse for each trigger, hence “one-shot”), whose output is a pulse of a precise width. This causes the electronic switch to connect C to the reference. This in turn will cause the output of the integrator to change rather quickly, the comparator will change, and the switch will go back to normal. Note, however, that a pulse was generated each time the integrator output reached a certain value. Each time the comparator changes, a pulse is generated (which operates the switch, which discharges the integrator capacitor). Therefore, the number of pulses that are generated depends on the magnitude of the input voltage. The larger the voltage, the greater the number of pulses produced because the integrator must ramp up and down faster. The timer circuit will have a fixed period (usually 1 second), which produces a direct correlation between the input voltage and the number of pulses counted.

## APPLICATION

When typically used in an industrial single-loop process controller, the voltage-to-frequency converter is set to give 10,000Hz per volt over the 1- to 5-volt range. The output will therefore be in the area of 10,000 to 50,000. Since twelve bits is a resolution of 1 in 4096, thirteen bits provides a resolution of 1 in 8192, and fourteen bits 1 in 16,384, the output of such a converter has a resolution on the order of thirteen to fourteen bits.

While the conversion speeds are slow, these converters offer excellent linearity. It is inherent in their design. Most do not sample more than



**Figure 18–8** Voltage-to-frequency conversion.

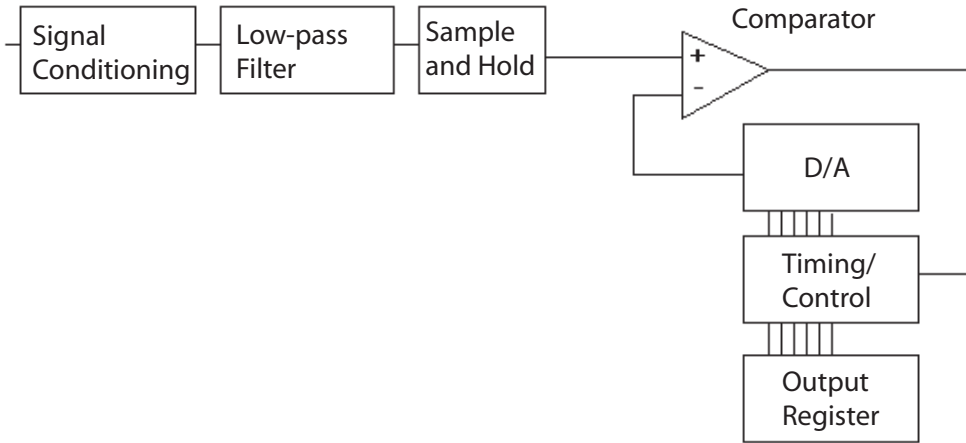
three to ten readings a second, so the voltage-to-frequency converter is used in many A-to-D converters destined for industrial process control.

## SUCCESSIVE APPROXIMATION

Successive approximation is one of the most widely used techniques for analog-to-digital conversion. Compared to the integrating methods, it is quite complex and has the disadvantage of losing some code combinations if the design is not carefully considered. But it is quite fast. Modern integrated circuit designs can approach 500,000 conversions per second in a relatively inexpensive package. The basic block diagram of a successive-approximation converter is illustrated in Figure 18–9. Note that there is a D-to-A that is used as a reference. The successive-approximation converter uses the principle of binary division to make the least number of decisions necessary to locate a random number in its range.

The operation is as follows:

1. The signal is input through conditioning circuits, some form of attenuator, and an amplitude limiter. There is also a low-pass filter, which limits the upper frequency of the input signal. This is crucial to the converter's proper operation.



**Figure 18–9** Successive-approximation block diagram.

2. The signal is then gated through to one leg of a comparator. The other leg of the comparator is connected to the D-to-A.
3. At the start of conversion, the D-to-A is fed by a timing and control register with the binary ( $\frac{1}{2}$  full scale—100000 binary) placed in it by the control circuit. As a result, if the input voltage is above the reference voltage (above  $\frac{1}{2}$  full scale) the comparator output will be a “1” state. If the input voltage had been below the reference, the output of the comparator would have been a “0” state. If the output were a 1, then the 1 in the control register would remain there. If the output were a 0, then the control register bit would be set to a 0.
4. In either event, the next bit will be set to a “1” (in case the previous decision was for a “1,” the D-to-A register would now contain 110).
5. The input signal is again tested against this new value, with the same operation. The control bit remains a 1 if the comparator output is a 1 and is set to a 0 if the comparator output is a 0.
6. Each succeeding bit is treated the same way.

Note the logic involved. It is first determined to which half (upper or lower) the input voltage is closest. Then the remaining half is divided into two, which determines to which quarter the input signal is closest. The quarter is divided into half ( $1/8$ ), and the half that the input voltage is closest to is chosen, and so on for the number of bits used. In this way, successive tests approximate the input signal level closer and closer to its true value.

The input signal must remain unchanging while the conversion process is underway. For this reason, a sample-and-hold circuit is used to hold the

input at one value while the binary signal is developed. A sample-and-hold circuit generally contains an FET (field-effect transistor) switch and a high-quality capacitor, among other components. When the FET switch is closed (sample time), the capacitor is charged to the input voltage. The length of time that the switch is closed is the “acquisition time.” The switch is then opened, and the conversion begins. The capacitor must retain the input voltage during this conversion time. The sample-and-hold circuit helps to avoid “jitter,” that is, the jumping back and forth of the least significant bit(s).

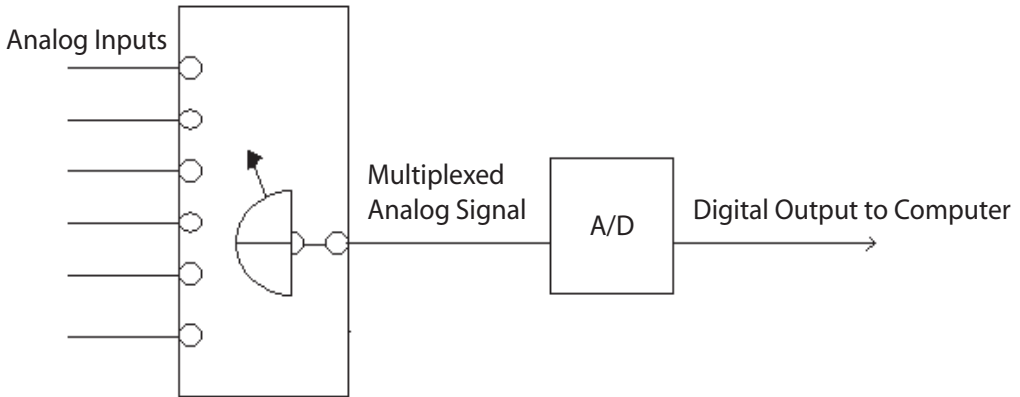
The sample clock (the frequency at which the sample-and-hold circuit is switched) must be at least twice the highest frequency expected. It could be many times more, but at the very least it must be twice. This is to ensure at least two samples per wave-form. If the sample clock is 8,000 samples per second, the sample period is 125 microseconds ( $1/8,000$ ). During this period, the decisions regarding number of bits must be made. For a three-bit converter, that means that each bit must be no more than 41.667 microseconds or one-third of  $1/8,000$  of a second ( $125\mu\text{sec}/3$ ), so the bit clock must run at approximately 24Kbps (bits per second). You may correctly conclude from this example that the bit rate is the number of bits times the sample rate.

If a twelve-bit converter like that typically found in industrial instrumentation is used, then for our 8,000 sample rate the bit rate must be 96Kbps. This requires an excellent A-to-D converter. Most signals used in the process and manufacturing industry seldom have more than a 100-Hz change rate, so the sample rate can be relatively slow (300–600 samples per second) per channel. In this case, a number of channels can be multiplexed, that is, more than one signal can be placed on the same wire or channel. One high-speed A-to-D unit can convert each channel one at a time. Figure 18–10 shows the simplified block diagram of an analog multiplex system. It is an analog system because each of the channels is analog through the multiplex, and then a single A-to-D unit converts the signals in turn to a digital format. At the receive end a computer is de-multiplexes the signal, using the digital representations for further processing.

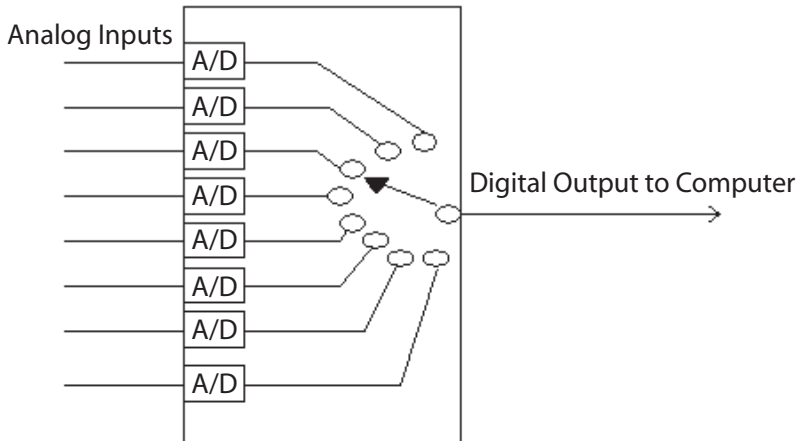
Since the advent of quite inexpensive A-to-D chips, a form of digital multiplexing, illustrated in Figure 18–11, may now be used. In this method, each of the signals is converted first to a digital signal, and then each digital output is multiplexed into a digital stream. The receiving end will see the same signal as in the analog multiplex method.

## FLASH (PARALLEL) CONVERSION

Figure 18–12 illustrates parallel conversion, also known as “flash” conversion. This is the fastest method for A-to-D conversion. The speed is limited only by the settling time of the comparators and the gate

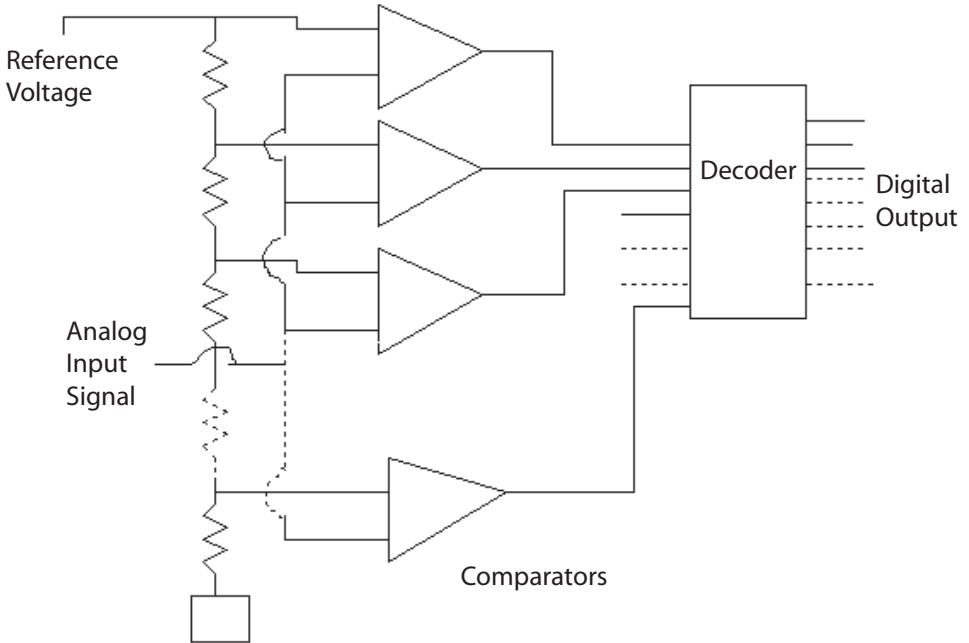


**Figure 18–10** Digital multiplexing.



**Figure 18–11** Analog multiplexing.

propagation time of the decoder logic. A precision reference is divided down between each of the comparators. The number of required comparators is one less than two raised to the number of bits, i.e., an eight-bit flash converter will require 255 comparators. Since this is a rather large number of comparators (even for modern integrated circuitry), methods that combine two four-bit converters (each requiring 15 comparators) are used, but at the penalty of slightly slower operation. Technology has been used to reduce the price of flash converters so that they are now competitive against successive approximation types, yet they still have the very high speed of conversion needed for some applications (such as video/television, etc.).



**Figure 18–12** Flash A-to-D conversion.

## COMPARING A-TO-D METHODS

Table 18–8 lists the different types of converters and their characteristics for easy comparison.

**Table 18–8** Comparison of A-to-D Methods

Type	Relative Speed	Applications
Dual Slope	Slow, typically 3–6 conversions/second	DVMs, Panel Meters
Voltage to Frequency	Slow, typically 3–6 conversions/second	Process Instrument
Successive Approximations	Medium to fast	General Purpose, Multiplexers
Flash (parallel)	Ultrafast	Television, Video

## SUMMARY

We have discussed several A-to-D and D-to-A techniques in this section. While we have provided only a brief overview of the subject, it should be sufficient to enable you to understand the methods used by most data acquisition systems. The design considerations you need to weigh when selecting the correct converter for use in instrumentation are beyond the scope of this text. However, numerous texts are available that supply the information and techniques for that purpose. The majority of maintenance operations will be locating a malfunctioning unit. Most modern converters have few alignment requirements, other than an occasional zero and span when major maintenance has been performed. Linearity and other adjustments (monotonicity) are no longer available in most cases, since they are functions of chip manufacturing.

## CALIBRATION

The procedure for calibrating an analog-to-digital converter described in this section is generic and not intended for any specific instrument. Always follow the manufacturer's and your facility's procedures; they have precedence over a generic procedure anytime.

1. Obtain an adjustable voltage standard (generally an adjustable power supply and a shop-standard digital voltmeter) as well as a device for reading the output of the A-to-D card (usually a computer; if so, you will need a program to display the output of the A-to-D too).
2. Input the voltages shown in Table 18–9 into the converter. Full scale (FS) is a positive voltage on unipolar systems; there will be an  $-FS$  and a  $+FS$  on bipolar ( $\pm$ ) systems. Assume a 12-bit system. If that's not the case, adjust the output readings accordingly.

**Table 18–9** A/D Calibration

Type	Voltage	Output Reading	Adjustment	Range
Unipolar zero	0.0000	0000	Zero	0–10V
Unipolar FS	9.9975	+4094/4095	+FS	0–10V
Bipolar	5.0000	–2048	–FS	$\pm 5V$
Bipolar zero	0.0000	0000	Zero (in some cases +FS)	
Bipolar	4.9975	+2047	+FS	$\pm 5V$

The FS voltage may vary depending on the input selection, typically  $\pm 2.5$ ,  $\pm 5$ , and  $+10$  (unipolar). In Table 18–7,  $\pm 5\text{V}$  and  $0\text{--}10\text{V}$  ranges were used.

3. You may input other voltages to check linearity as required. *However, most modern A-to-D devices do not include a field (user) linearity adjustment.*

Use the following three-step procedure to calibrate a digital-to-analog converter unless your facility's or the manufacturer's procedures are different, in which case the facility's or manufacturer's procedures take precedence:

1. Obtain a standard voltmeter and a digital driver (normally a computer with a calibration program).
2. Input the following numbers into the D-to-A (assume a 12-bit D-to-A) (see Table 18–10).
3. You may input other voltages to check linearity as required. *However, again, most modern D-to-A devices do not include a field (user) linearity adjustment.*

**Table 18–10** Input for D-to-A

Range	Adjustment	Input	Output
0–10V	Zero	0000	0.0000V
0–10V	+FS	+4095	+9.9975V
$\pm 2.5\text{V}$	–FS	–2048	–2.5000V
$\pm 2.5\text{V}$	Zero	0000	0.0000V
$\pm 2.5\text{V}$	+FS	+2047	+2.4975V
+5.0V	–FS	–2048	–5.0000V
+5.0V	Zero	0000	0.0000V
+5.0V	+FS	+2047	+4.9975V

## CHAPTER EXERCISES

- Using a 12-bit successive approximation converter, what should the output be (in 1s and 0s) if the input voltage range is 0 to 5V, and 2.5V is input:
  - Offset binary \_\_\_\_\_
  - Twos complement \_\_\_\_\_
- If the digital signal in problem 1 is presented to a R-2R D-to-A what will the output be (with a 10-volt supply to the D-to-A)?  
\_\_\_\_\_V
- If +0.0025V is presented to a 12-bit A-to-D, the output code will be:
  - in natural binary (0–10V range) \_\_\_\_\_
  - in offset binary ( $\pm 5V$  range) \_\_\_\_\_
  - in twos complement ( $\pm 5V$  range) \_\_\_\_\_

*Hint:* Twelve bits means 4,096 divisions, so  $10V/4096 = 0.00244V$  for the LSB; .0025 volts is greater than 1LSB but less than 2LSBs.

**Answers to these review questions will be found at the back of this book.**

## CONCLUSION

Now that you have reached the end of Chapter 18, and if you have successfully completed the exercises, you may go on to the next chapter. If you are having difficulty understanding the concepts and/or exercises in this chapter, please reread the text. If your difficulties persist, locate a peer, mentor, supervisor, or someone with technical knowledge of analog and digital conversion and ask them for help.

For further information on the concepts in this chapter, search the following terms in your Internet search engine:

<b>Analog to digital conversion</b>	<b>Digital to analog conversion</b>
<b>R-2R networks</b>	<b>Parallel A-to-D converters</b>
<b>Charge-balance analog to digital conversion</b>	
<b>Successive approximation A-to-D converters</b>	

# INDUSTRIAL APPLICATIONS

In this chapter, we will build on the concepts you've learned in the preceding chapters and observe how they apply to industrial applications. After all, the purpose of this book is to bring you to the level where you can understand the whys and wherefores of industrial usage.

Understand that the examples in this chapter are a very limited set of those available. The field of measurement and control is application dependent, and there are an infinite number of applications and environments where you will find electric and electronic equipment, so in order to keep the text a reasonable size, only a few examples can be presented. But understanding those presented is very important, they are the basis of many circuits you will find in industry.

## TWO-WIRE LOOP

One of the most common circuits you will find in contemporary process control is the two-wire loop. It earned its name because it uses two wires and supplies both the power and the signal on the same lines. In the loop illustrated in Figure 19-1, you can see that there are actually two loops, a measurement loop and an output or control loop.

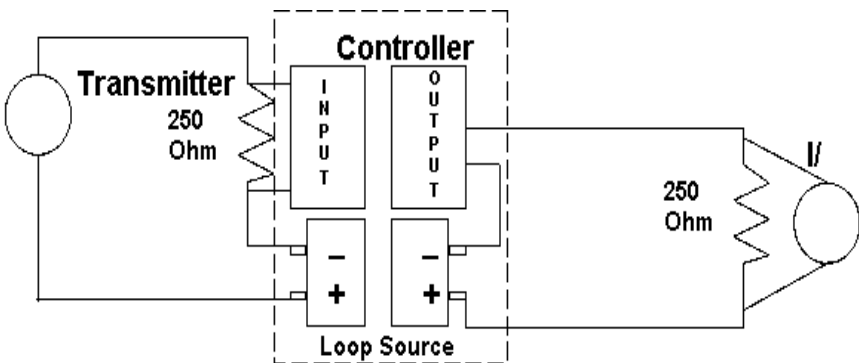


Figure 19-1 Two-wire loop.

The transmitter is a constant current device, that is, a device that outputs a current that is determined by external factors and does not vary (within reason) with the voltage across the device. The external factors here would be pressure, level, flow, or temperature, whatever variable you were trying to measure. The *loop source* supplies 24V DC (typically). The transmitter is scaled so the output at 0 percent (whatever value that is, say, 100°C, or 0 psig, or 20 gpm) will output 4mA. The maximum value, 100 percent, (say, 500°C, 50 psi, or 200 gpm) will output 20mA.

At the input of the controller there is a 250-ohm resistor. Using Ohm's Law to determine the voltage across the resistor at 4 and 20mA will yield 1V for 4mA and 5V for 20mA. This is the input to the controller, and it operates in the 0-to-100 percent area or with inputs of 1V to 5V. If you think this out, that means there are 19 to 23 volts across the transmitter (less the line-resistive losses), 23 volts when it is outputting 4mA and 19V when it is outputting 20mA. Most older transmitters require a minimum of 11 volts to operate, so this application is operable. Newer devices require less voltage, sometimes as little as 3 volts. What this means is that you could have several 250-ohm resistors in series for, say, a chart recorder and a visual display. If you ran three resistors in series, the current would remain the same (current in a series circuit is the same throughout). What would change is the voltage across the transmitter. At 4mA, the resistors combine to give a 3-volt drop; at 20mA, they combine to give a 15-volt drop. The voltage across the transmitter will now vary from 9 volts to 21 volts. It would be wise to check the minimum operating voltage of the transmitter before attempting this circuit.

## CHECKING CURRENT

In a two-wire loop circuit, you must periodically check the 4 to 20mA when calibrating. How is that done? You could break one of the lines and insert a current meter. This has the undesirable result of "bumping" the process. That is, when you disconnect the line it goes below the 0 percent input, and as a result the process will have to be in manual when you do this. You could be "Ohm smart" and measure the 1–5 volts across the resistor instead. Or you could use a diode; many manufacturers have installed these in their instruments. Figure 19–2 illustrates this method.

You will recall that to conduct a silicon diode requires about 0.7 volt across the diode in the forward direction. Without the meter in the circuit, it adds a 0.7-volt drop to the line loss, generally an inconsequential amount. When the current meter is placed across the diode, it typically has a voltage drop of less than 0.1 volt. (It is trying to measure current without interfering with the circuit under test.) As the meter is in parallel with the diode and drops 0.1 volt the diode is opened, and all the current then flows through the meter. Remove the meter, and current flow is again totally in the loop.

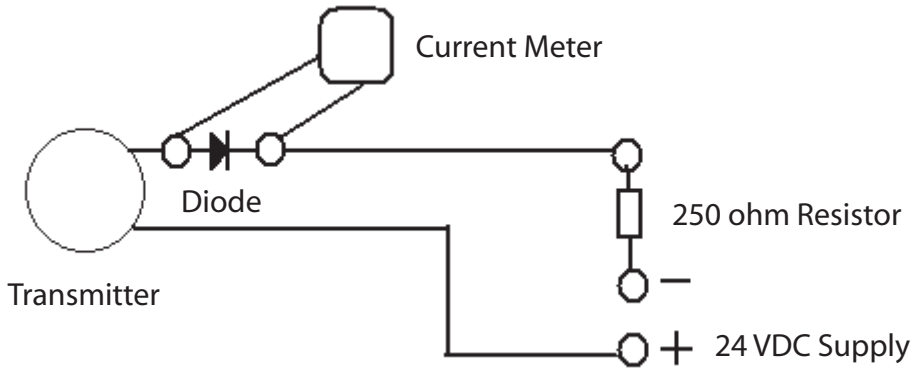


Figure 19–2 Diode for current check.

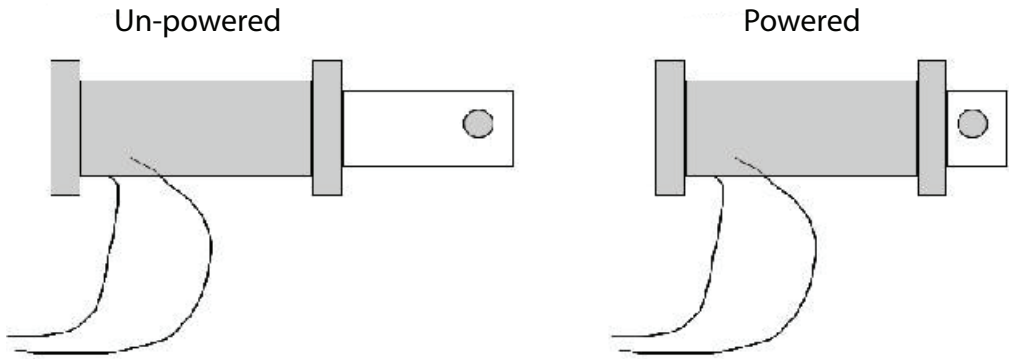
## SOLENOIDS

Basically, an electrical solenoid is an insulating core, coil winding, and a ferrous armature that has the capacity to be connected to other mechanical linkages. Figure 19–3 illustrates an electromechanical solenoid, both powered and unpowered. When the solenoid is de-energized (unpowered), some form of mechanical or electrical force is used to bring the armature part of the way out of the coil. When energized, the immersed part of the coil has many lines of force compared to the area of the core where the armature is vacant. This imbalance causes the armature to move inward with considerable force (depending on the number of turns, coil’s diameter and material, and amount of current passing through the coil) until it is balanced between the coil ends.

Figure 19–3 shows a graphic representing the solenoid in the powered and unpowered state. Mechanical linkage connected to the solenoid causes it to open/close valves, dampers, or, in many cases, a set of contacts. When operating a set of contacts, the solenoid-contact arrangement is referred to as a *contactor*.

The solenoid’s physical construction will differ according to the type of coil activation current used. Alternating-current solenoids will have, in general, fewer turns (than a DC solenoid) and generally a core designed to prevent chattering. Chattering is caused when the AC current goes through 0 during the power-on cycle(s). This will generally cause the coil to release the armature slightly and then abruptly pull it back, causing a “chattering” effect. To reduce chatter, armatures are typically laminated to reduce eddy current loss, and the core is designed for a higher persistence than a DC solenoid.

The AC solenoids require fewer turns because they expect the inductive reactance ( $X_L$ ) to limit current. Because the reactance when the armature



**Figure 19-3** Solenoid.

is out of the coil is much less than when the armature is fully engaged, if an AC solenoid is held open it will quickly burn out.

Typically, DC solenoids have many turns of wire to limit the amount of current that is needed to pull in the armature and maintain it in the closed position. (There will be no inductive reactance to limit current except upon power-up and power-down.) The armature is typically a solid core. Direct-current solenoids can be made more sensitive than AC varieties (which require smaller current to throw) because as much wire as is necessary can be wound on the core since there is no reactance, other than at power-up and power-down.

When the solenoid armature is attached to switching contacts, the assembly is called a *contactor*. There are a myriad of contactors. From DC-operated contactors for control circuits to AC-operated three-phase motor controls. Figure 19-4 is a typical three-phase motor control circuit.

The solenoid is *CR1*. Besides its main three contacts (*CR1-1, -2, -3*), there is typically a set of normally open auxiliary contacts to be used as a sealing circuit. Assuming there is control power, if the start switch is depressed, the solenoid will pull in, closing the contacts. The *CR-AUX* contacts will then seal in the start switch, and it may be allowed to return to the open state. Depressing the stop switch removes current from the solenoid, and it opens the contacts, stopping the motor. The weird hook-like devices are symbols for thermal overloads, which may also be located in the contactor but can be located externally. The documentation should state this fact.

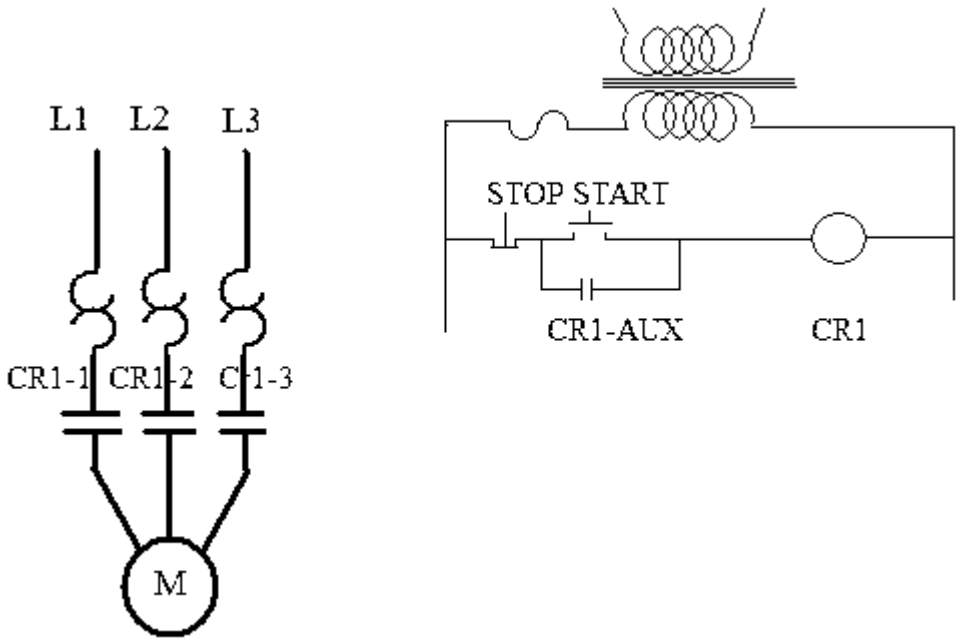


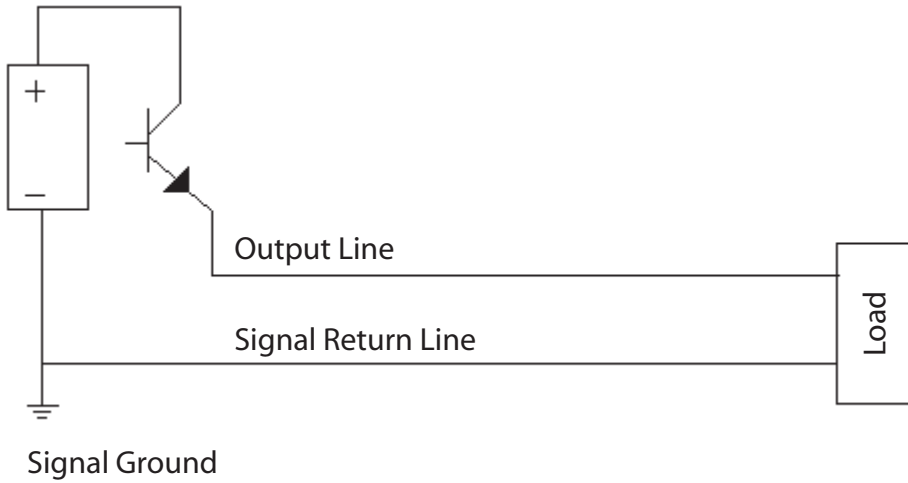
Figure 19-4 Typical motor control circuit.

## UNBALANCED-TO-GROUND CIRCUIT

Although this section is primarily about communications circuits, it is applicable in many ways to all circuits. *Unbalanced-to-ground* simply means that the power-signal line and the return line (remember that it requires a complete circuit for current to flow) have different impedances to ground. Figure 19-5 illustrates this nicely.

It should be obvious to you (by now at any rate) that even if *you* measured the DC resistance from the output-line-to-ground and the signal-return-line-to-ground there would be a considerable difference. In fact, this difference develops the signal in this case. Every measurement taken in this circuit will be taken using the signal ground as the 0-volt reference.

Since this is the way in which we explained almost all previous circuitry (except for the differential amplifier), you might wonder what the downside to this arrangement is. Having just one signal-return line for many signals would certainly save cable. Yet there are considerable drawbacks to this arrangement. For one thing, noise is also measured using the signal ground as the 0-volt reference. And if a noise pulse (such as a transit), a capacitive coupled noise, or in industrial areas a magnetically coupled noise would cut across the signal conductors, then the signal-ground line would hold the noise (within limits) to near 0 volts because it is at ground potential. However, the induced noise on the



**Figure 19–5** Unbalanced-to-ground circuit.

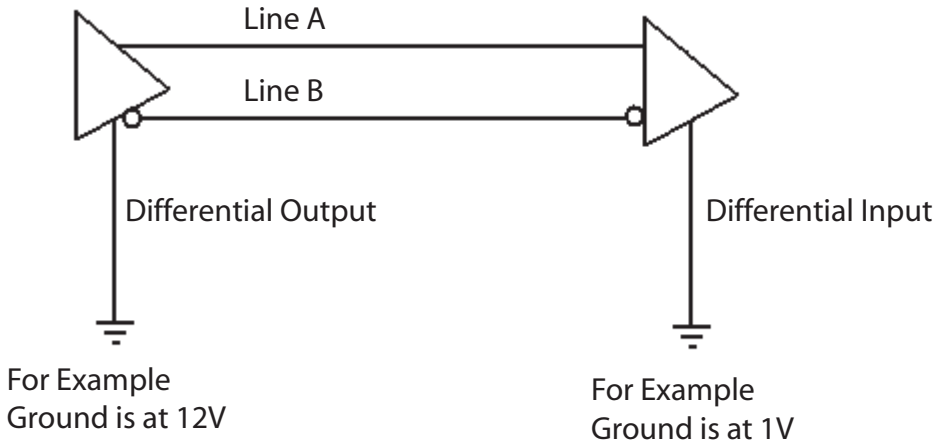
signal line would, in reference to the signal-ground line, be the full-noise voltage and would be across the load (in this case). You will hear this referred to as *common mode noise* or *longitudinal noise*.

This noise effectively limits the speed at which you can change information on the line. Using binary signaling (0 volts to 5 volts or  $-10$  to  $+10$ ), this would be how fast you could change from one state to the other. In an unbalanced-to-ground circuit, the noise and the charge/discharge characteristics of the media determine the allowable speed.

## BALANCED-TO-GROUND CIRCUIT

To get around the disadvantages of the unbalanced-to-ground system, a balanced-to-ground system is used. Here, there is a pair of wires for every signal (no common ground), and the signal is measured relative to the other wire. We could say that if wire A is positive relative to wire B, this is a 1, and if wire A is negative relative to wire B it is a 0. Both wires have the same impedance to ground! Figure 19–6 illustrates a balanced-to-ground circuit.

If the difference between the lines A and B (the desired signal) is 3V Peak to Peak (Pk to Pk), with A the hot side and B the reference side, then the difference in ground is a net 11V Pk to Pk. This would be added to the A side and the B side since they have equal impedance to ground, giving a voltage on the A side of 14V Pk to Pk and on the B side, 11V Pk to Pk. The difference in voltage will be all the input is looking at, and the difference between the two wires will be 3V Pk to Pk.



**Figure 19–6** Balanced-to-ground circuit.

This arrangement removes the noise as a speed-limiting factor, and now it becomes more a question of ensuring that the impedance matching of the lines is correct. This is how a line that looks like a telephone wire (which can support 300 to 3300kHz as an unbalanced line) but has twists in tight conformance can pass 100 MBps of information (i.e., a category 5 line that is in a balanced-to-ground arrangement).

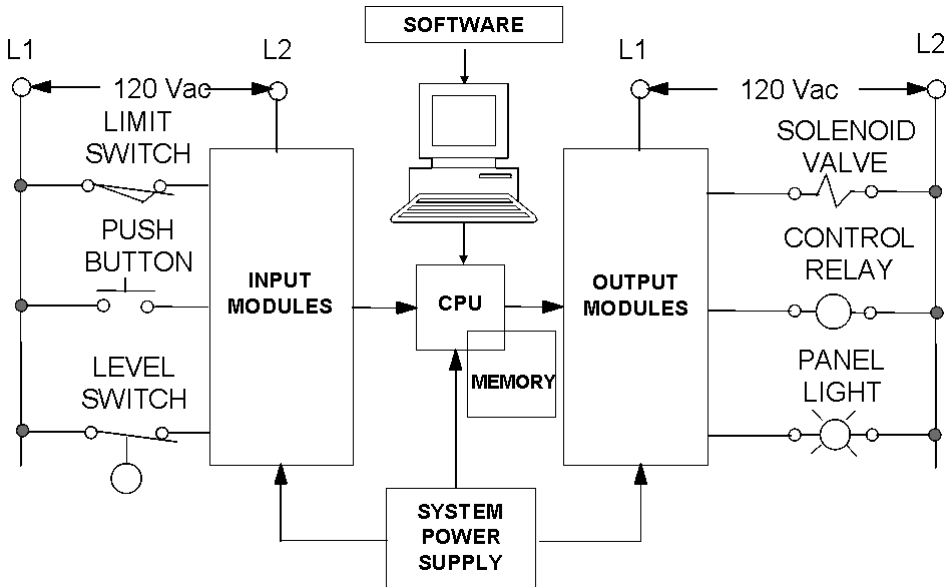
The main difference in the lines (other than the number of twists per inch and the conformance of the twists) is that the unbalanced arrangement has a common ground while the balanced-to-ground arrangement uses a pair in which each wire in the pair has equal impedance to ground (requiring differential inputs and outputs).

## PROGRAMMABLE LOGIC CONTROLLER (PLC)

One of the devices that greatly changed how manufacturing is accomplished is the programmable logic controller (PLC). It is beyond the scope of this text to provide a thorough explanation of the PLC and its operation. Our purpose here is to use it as an application of what you have learned so far. Figure 19–7 is a block diagram of a PLC.

The CPU first scans the outputs to see what state they are in. Then it scans the inputs, scans memory to see what should be the corresponding output for an input state, and changes the outputs on the next scan accordingly.

Whether you will program PLCs or deal with the CPU configuration is entirely beyond the scope of this text. What is in its scope is the I/O, the inputs and outputs. On the particular model shown in Figure 19–7, we have AC I/O. That is, determining if an input is open or closed means



**Figure 19–7** Block diagram of a PLC.

detecting that an AC current flows or, in the case of open, does not flow. The outputs are energized by AC, which is switched on or off by the output module. Not shown in Figure 19–7 is that output module circuits are generally fused (and the inputs may be as well) for their protection.

One of the first troubleshooting techniques to use on an output with no AC would be, of course, to check the fuse. Inputs are generally a broken wire or maladjusted switch. But by looking at the block diagram you could use what you have learned in these chapters to determine if either the input or the output needed maintenance.

## CONCLUSION

This has been a short chapter on some of the infinite number of manufacturing applications where knowledge of electricity and electronics is of invaluable benefit in being able to understand discussions about manufacturing equipment, let alone knowing how to perform some function with or on the equipment.

This book has provided an introductory course in electricity and electronics that focuses on the behavior but not the design concept. If this text has fulfilled all you ever needed to know about the subject then that is absolutely fantastic. If this course has caused you to question more deeply one facet or another, or indeed the whole subject, then the author recommends a rigorous course in electricity and electronics, along with

the related mathematics and design. It is not a short-term project. The author has worked and learned in this area for over forty years, and is still learning new ideas, concepts, and applications. Yet the basics he learned all these many years ago still apply. And the way he learned them is just the way they were presented in this book: as a set of rules and behaviors—“given this set of conditions and this device, the following happens...” Of course, the author’s applications didn’t always seem to obey the rules (*they* actually did, but the author had the wrong set or applied them without thinking things through). So this provided a path for further learning. The author wishes you continuing success in your endeavors with electricity and electronics.

If there is a section of the book that you think could be presented more clearly, or you think some part that was not included should have been (or some things included that shouldn’t have been), kindly inform the author or the publisher (ISA). The author can be reached at [larrymthompson@hotmail.com](mailto:larrymthompson@hotmail.com), and ISA at [www.isa.org](http://www.isa.org).

# ANSWERS TO CHAPTER EXERCISES

---

---

## CHAPTER 1

1. Electromotive force is another name for electrical ***potential***.
2. For electrical current to flow in a circuit, two things are necessary (pick the two from this list).  
  
⇒a. ***source potential***  
   b. load  
⇒c. ***complete path***  
   d. high resistance
3. An insulator will conduct (more or ***less***) current than a conductor.
4. A zero reference is needed to determine how much ***potential difference*** exists between a charged object and the reference.
5. Which actually performs the work, electromotive force or ***current***?
6. If you have a 10 volt source, and a 5 ohm load, with a complete circuit, how much current will flow? ***2.0 amperes***
7. If you change the load to 10 ohms, will more or less current flow? ***Less (1.0 amp)***
8. If you again change the load to 2 ohms, will more or less current flow than in question 6? ***More (5.0 amps)***
9. Given 230 volts and a 70 amp load, what power is being used? ***16.1 kilowatts (apparent power)***
10. If an incandescent lamp is rated at 100 watts for 120 volts, what is the current required to operate the lamp (disregard inefficiency). ***0.833 amps***

## CHAPTER 2

1. Define each of the following as concisely and accurately as possible:

a. accuracy

**Closeness to true value**

b. precision

**Repeatability**

c. measurement uncertainty

**Probability of error**

d. resolution

**Smallest change/interval that can be measured by a particular measuring scale**

e. least count

**The value assigned to the smallest scale unit or interval**

f. primary standard

**Kept at NIST; the most accurate standard**

g. secondary standard

**Occasionally compared to primary; used to calibrate all lower standards**

h. shop standard

**Calibrated unit used in shop to calibrate devices**

i. calibration

**To bring a measuring device within manufacturer's specifications**

j. binary

**Number system based on number two; only has a 1 or a 0**

k. octal

**Number system based on number eight; only has a 0 through 7**

l. decimal

**Number system based on number ten; only has a 0 through 9**

m. hexadecimal

**Number system based on number 16; only has a 0 through F**

**CHAPTER 3**

1. For the listed measurements, find the mean, deviation, and average deviation.

Measurement #	Value	Mean	Deviation	Average Deviation
1	10.13	10.039	0.091	
2	9.97	10.039	0.091	
3	9.99	10.039	0.069	
4	10.02	10.039	0.049	
5	10.08	10.039	0.041	
6	10.16	10.039	0.041	
7	9.86	10.039	0.121	
8	9.88	10.039	0.179	
9	10.12	10.039	0.081	
10	10.18	10.039	0.141	

The average deviation is: **0.0904**

2. Name one method you can use to consistently reduce random error in measurements?

**Ensure a large number of measurement points.**

3. Given the following table of values, calculate the standard deviation.

Number	Value	Deviation $\sigma = 0.010844$
1	10.13	0.010506
2	9.97	0.003306
3	9.99	0.001406
4	10.02	5.63E-05
5	10.08	0.002756
6	10.16	0.017556
7	9.86	0.028056
8	9.88	0.021756
9	10.12	0.008556
10	10.18	0.023256
11	9.94	0.007656
12	9.91	0.013806
13	9.97	0.003306
14	10.15	0.015006
15	10.13	0.010506
16	9.95	0.006006

**CHAPTER 4**

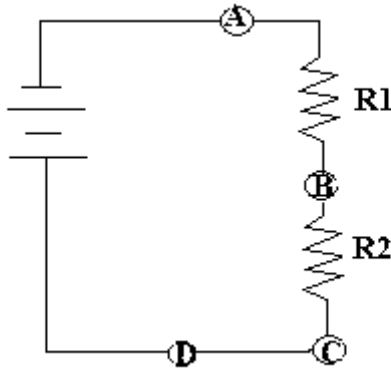
1. Write the color code for a 1%, 124-ohm resistor?

**Brown, Red, Yellow, Brown, Brown (1, 2, 4, Multiplier = 1, Tolerance = 1%)**

2. What is the closest standard resistor to 8000 ohms?

**8060 ohms**

3. Consider the circuit shown in Figure 4-12.



**Figure 4-12** Circuit for exercise 3 and 4.

Identify the points you should use to measure the voltage of

- a. R1? A->B
  - b. R2? B->C
  - c. the applied voltage? A->D
4. Referring to the Figure 4-12, if you were to measure current where would you insert your meter?

**Between D and C**

5. If you have a 12.0-volt source and two 1200 resistors in series, what will be the

a. total current flow?

**0.005 amp (5.0mA)**

b. total resistance?

**2400 ohms**

6. If you measure 10mA (10/1000Amp or .01 amp) and it passes through an 1800-ohm resistor, what is the voltage across the resistor?

**18 volts**

7. If you have a 100-volt source, and the total current measured is 2 amps, what is the total resistance?

**50 ohms**

8. If I wish to see a 5-volt drop across a resistor for 20mA current flow, what standard value must that resistor have?

**249 ohms**

9. For safe measurement, voltage is always measured ***across***.

10. For safe measurement, current is measured ***in series***. However, a safer way would be to measure voltage across a ***resistance*** and use Ohm's Law to determine current.

11. The primary safety consideration for measuring resistance is to ensure that the power to the component under test is ***off or removed***.

**CHAPTER 5**

1. List the eight precautions that must be taken when making measurements.
  - a. Always follow facility procedures for taking measurements.
  - b. Always use protective equipment as required and as procedure directs.
  - c. Know what measurement you are trying to take.  
Current is measured in series.  
Voltage is measured across.  
Resistance is never measured with the power on.
  - d. Have the right range equipment.
  - e. Always start on the highest range.
  - f. Never come into contact with the circuit, bare parts of the meter leads, or otherwise allow your body to become a conductor, regardless of the voltage you think may or may not be present.
  - g. Ensure that (in direct-current measurements) the leads are of the correct polarity. (While this is not a requirement for most digital multimeters, an analog meter may be damaged if you apply the wrong polarity.)
  - h. Never peg (go past full scale) an analog meter, nor keep a digital meter in its over-scale position.
2. Match the digital meter display with its significant characteristic (some characteristics may have more than one meter type)
  - a. LCD
    1. requires backlighting for dim-light conditions
    2. has good contrast under high-light conditions
  - b. LED
    1. washes out at high-light conditions
    2. has good image in low-light conditions
  - c. EL Displays
    1. requires the most power of all types listed

Which display requires the least power of all types listed is not stated in the text and is quite dependent upon which generation of technology is applied.

**CHAPTER 6**

1. A 50-V full-scale reading is desired. What value of a multiplier resistor is required if the meter movement has  $I_m' = 10$  microamp,  $R_m = 500$  ohms

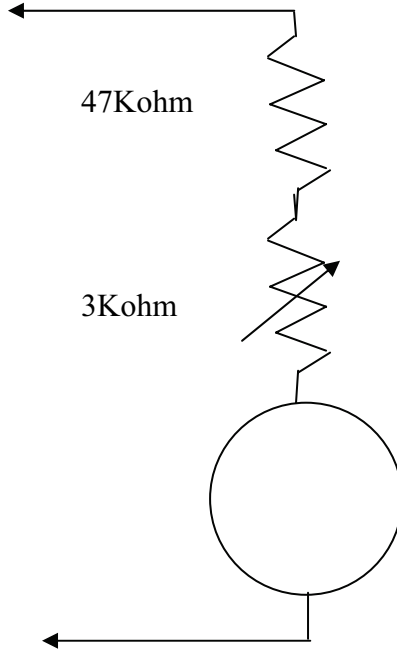
*Answer: 4999500 ohms or 4.9995 Megohm*

2. A 10-V full-scale reading is desired. What value multiplier resistor is required if the meter movement has:

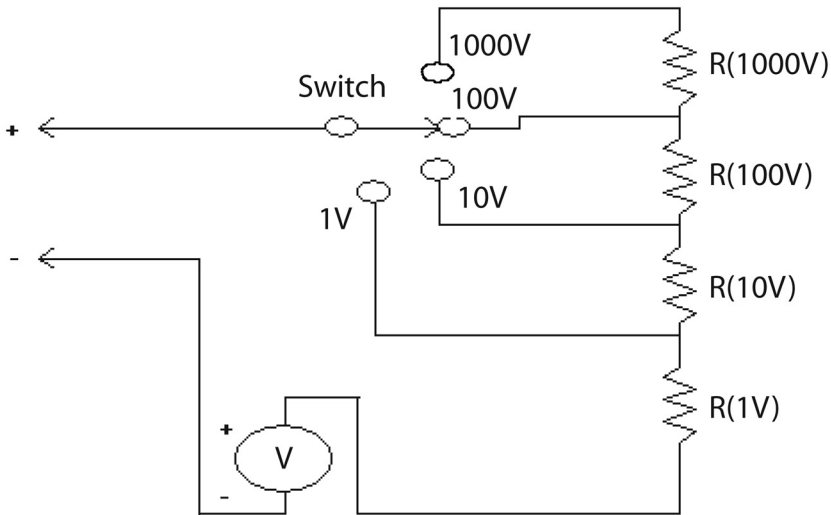
$I_m = 1\text{mA}$ ,  $R_m = 150$  ohms

*Answer: 9850 ohms*

3. In the space provided by the following figure, draw a voltmeter for 25V fsd. The meter movement has an  $I_m = 0.5\text{mA}$  and an  $R_m = 200$  ohms. Use a common resistor value and a variable resistor for calibration, and label all component values.



4. List the five main disadvantages of an analog meter compared to a digital meter.
- Accuracy of movement.
  - Mechanical reliability.
  - Parallax problem.
  - Meter sensitivity.
  - Costs.
5. Given a meter with  $I_m = 1\text{mA}$  and  $R_m = 50\text{ ohms}$  determine the values of the multiplier resistors for the meter shown in the following figure.



$$R(1000\text{V}) = 900000\text{ ohms}$$

$$R(100\text{V}) = 90000\text{ ohms}$$

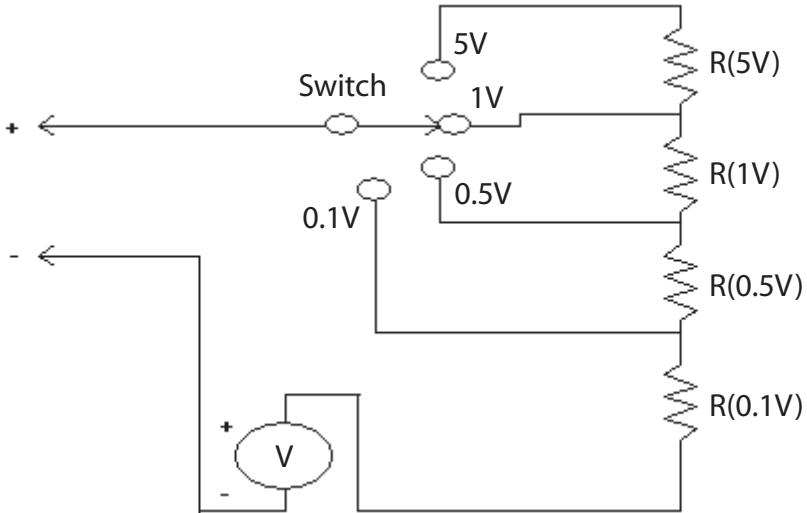
$$R(10\text{V}) = 9000\text{ ohms}$$

$$R(1.0\text{V}) = 820\text{ ohms}, R(\text{cal}) = 200\text{ ohms}$$

6. If in Problem 5, each fixed resistor has a tolerance of  $\pm 0.1\%$  and the movement has an accuracy of  $\pm 1.0\%$  what is the accuracy when measuring 5V on the 5V scale?

**5V + 0.25V (the 1% of the meter is far greater than the 0.1% of the resistor)**

7. Given a meter with  $I_m = 20$  microamps and  $R_m = 325$  ohms, determine the values of the multiplier resistors for the meter shown in the following figure.



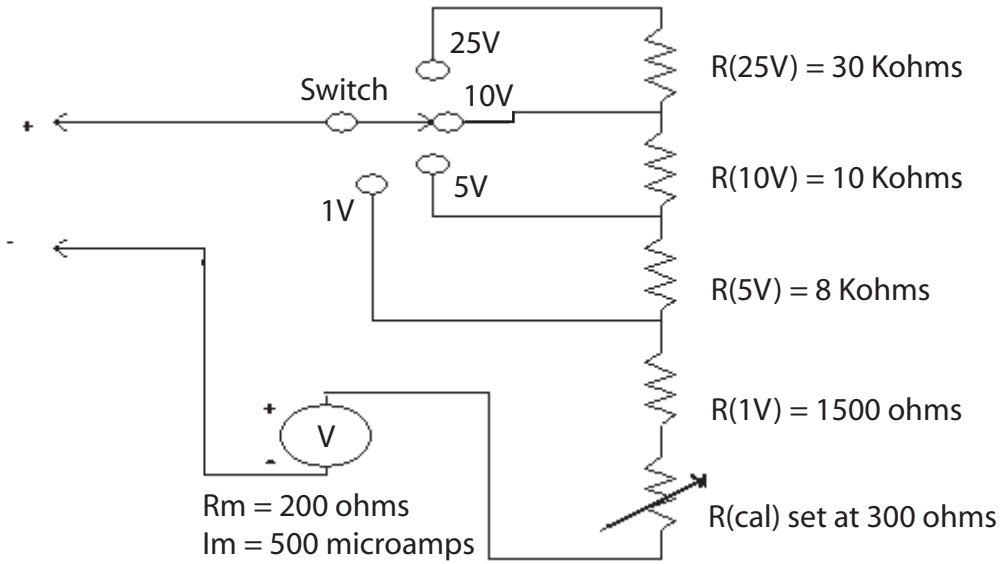
$$R(5V) = 200 \text{ kilohms}$$

$$R(1V) = 25 \text{ kilohms}$$

$$R(0.5V) = 20 \text{ kilohms}$$

$$R(0.1V) = 4675 \text{ kilohms}$$

8. For the meter circuit shown in the following figure, compute the meter sensitivity and the ohms/volt of each range.



<b>Meter sensitivity</b>	<b>2000 ohms/V</b>
<b>25-V scale</b>	<b>2000 ohms/V</b>
<b>10-V scale</b>	<b>2000 ohms/V</b>
<b>5-V scale</b>	<b>2000 ohms/V</b>
<b>1-V scale</b>	<b>2000 ohms/V</b>

**CHAPTER 7**

1. Determine the total current and total resistance for the following two resistor combinations in parallel with the source voltage. All resistance is in ohms and voltage is in volts unless otherwise stated:
  - a.  $R_1 = 47, R_2 = 22, V = 12.6$   **$R_t = 14.9$  ohms,  $I_t = 840mA$**
  - b.  $R_1 = 180, R_2 = 120, V = 15$   **$R_t = 72$  ohms,  $I_t = 210mA$**
  - c.  $R_1 = 1200, R_2 = 3900, V = 100$   **$R_t = 918$  ohms,  $I_t = 110mA$**
2. Determine the total resistance using the assumed-voltage method for the following three resistor combinations in parallel with the source. All resistance is in ohms unless otherwise stated.

- a.  $R_1 = 10, R_2 = 20, R_3 = 5$

Assume 20V,  $I_{R1} = 2, I_{R2} = 1, I_{R3} = 4, I_t = 7, 20/7 = 2.86$  ohms

- b.  $R_1 = 1200, R_2 = 2200, R_3 = 3900$

Assume 1029600V,  $I_{R1} = 858, I_{R2} = 468, I_{R3} = 264$

$I_t = 1590$  amps  $R_t = 1029600/1590 = 648$  ohms

- c.  $R_1 = 56000, R_2 = 47000, R_3 = 82000$

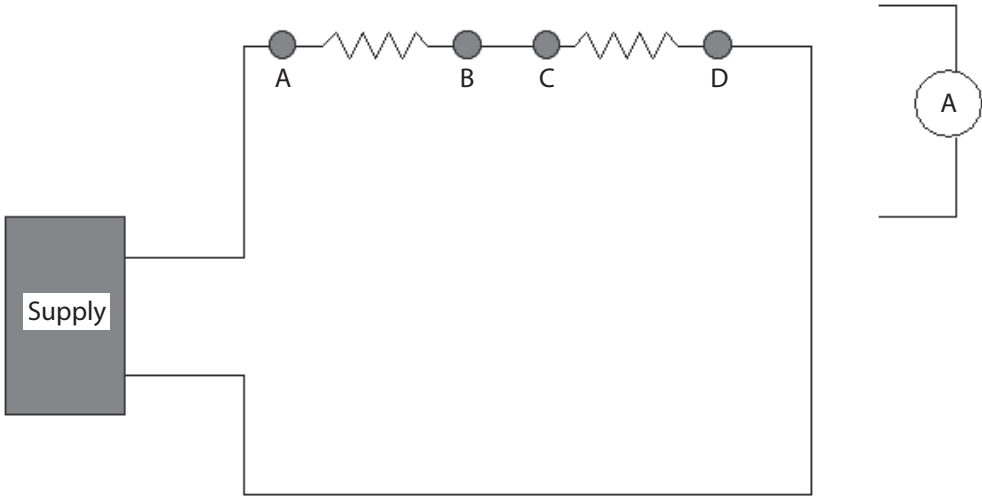
Assume 215824000 volts,  $I_{R1} = 3854,$

$I_{R2} = 4592, I_{R3} = 2632, I_t = 11078,$

$R_t = 215824000/11078 = 19482$  ohms

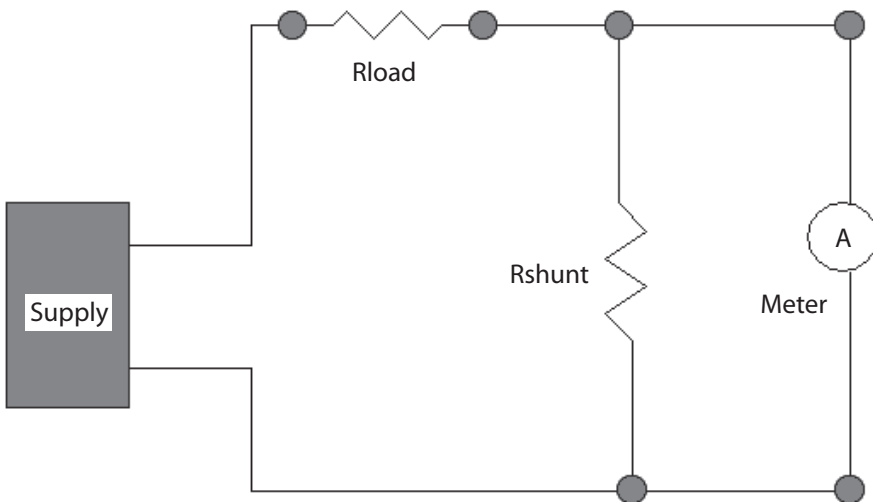
3. At what point in the circuit shown in the following figure would you connect a current meter?

**Between B and C (choice "b")**



- a. Between A and B leave resistor connected.  
 b. Between B and C leave wire disconnected.  
 c. Between C and D leave resistor connected.

4. For this problem use the following figure. The supply voltage is 25V,  $R_{load}$  is 2.5 kilohms,



$R_m$  (meter resistance) is 50 ohm and  $I_{fsd}$  (full scale deflection current) is  $500\mu\text{A}$  (.5mA or .0005 amp). If fsd is desired to occur at 20mA what value must the shunt be?

**1.282 ohms**

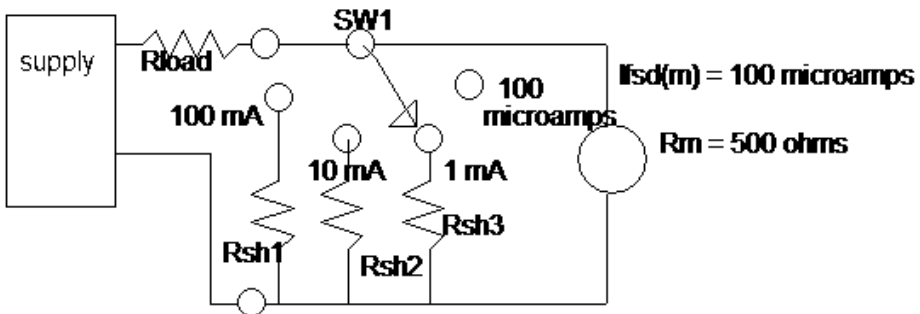
5. Refer to the figure in Problem 4.  $R_{load} = 1000$ ,  $R_m = 50$  ohms, and meter fsd is .5mA (.0005A). In this problem, we would like the fsd to occur at 25mA, what value will  $R_{shunt}$  have?

**1.020 ohms**

6. Refer to the figure in Problem 4.  $R_{load} = 2500$  ohms,  $R_m = 100$  ohms, and the meter fsd is 1mA. You want fsd to occur at 10mA, so what is the value of  $R_{shunt}$ ?

**11.11 ohm**

7. Using the following figure, compute  $R_{sh1}$ ,  $R_{sh2}$ , and  $R_{sh3}$ .

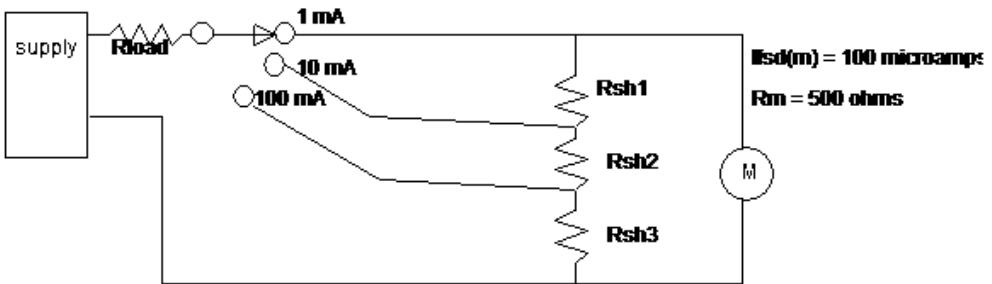


**$R_{sh1} = 0.5$  ohms**

**$R_{sh2} = 5.05$  ohms**

**$R_{sh3} = 55.56$  ohms**

8. Using the following figure, compute  $R_{sh1}$ ,  $R_{sh2}$ , and  $R_{sh3}$ .



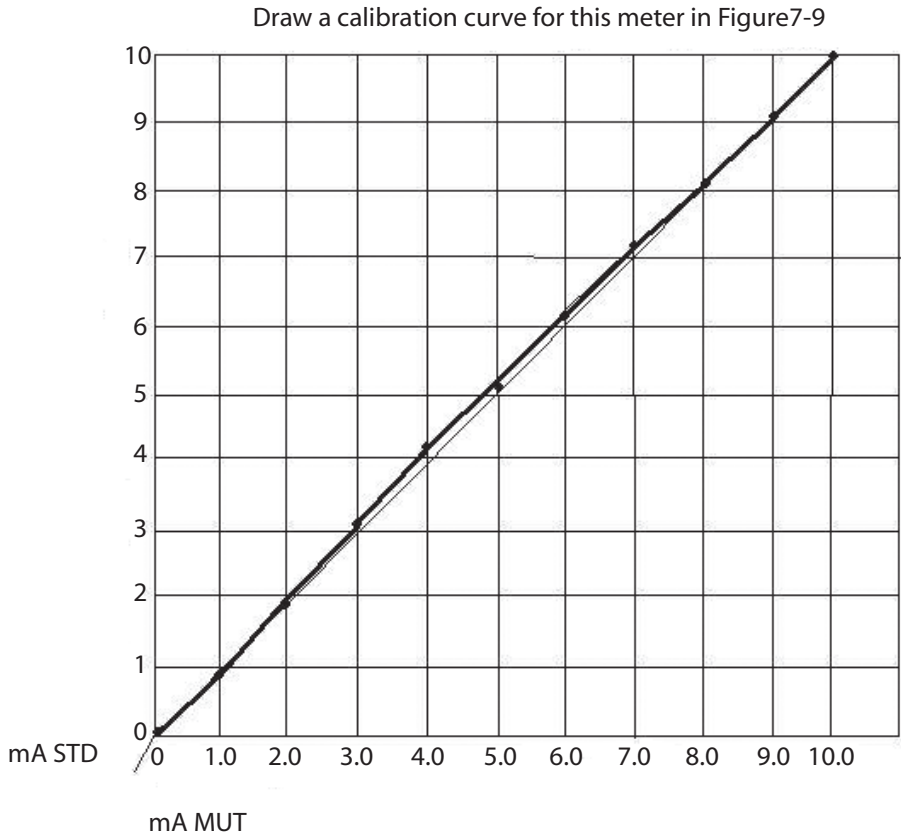
$$R_{sh1} = 55.5 \text{ ohm}$$

$$R_{sh2} = 4.55 \text{ ohm}$$

$$R_{sh3} = .50 \text{ ohm}$$

9. The following readings were from the comparison calibration of an ammeter.

Current Measured by Tested Meter (MUT)	Current Measured by Standard (mA)
0.00	0.00
1.00	0.98
2.00	1.98
3.00	3.01
4.00	4.02
5.00	5.03
6.00	6.04
7.00	7.05
8.00	8.04
9.00	9.02
10.00	10.00



10. What determines the accuracy of the meter under test (MUT) in Problem 9 if the correction table is used?

**The standard used and the manufacturer's specified accuracy for this instrument.**

11. The following readings were taken using the voltmeter-precision resistor method. The precision resistor is 10 ohms  $\pm 0.05\%$ ; the standard voltmeter accuracy is  $\pm 0.05\%$ .

Reading #	MUT Reading	Standard Voltmeter Reading
1	0.00mA	0.00 volts
2	25.0mA	0.28 volts
3	50mA	0.46 volts
4	75mA	0.70 volts
5	100mA	0.88 volts

- a. List the percentage of error for each reading:

1 0 %

2 12 %

3 8.0 %

4 6.7 %

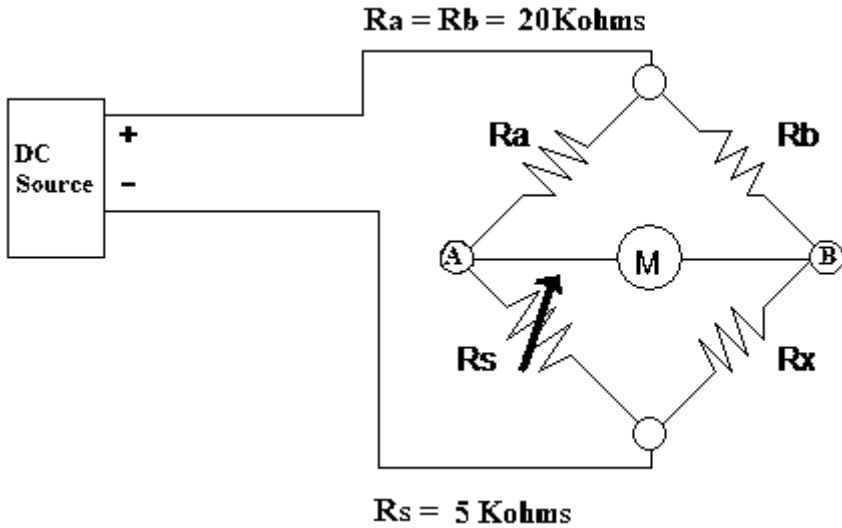
5 12 %

- b. What is the most likely cause of this error? (Hint: refer to discussions of error in previous chapters.)

**It is nonlinear error, probably from meter misuse, and the item should be discarded if it cannot (and probably it can't) be brought back into calibration.**

**CHAPTER 8**

1. Using the following figure, answer a, b, and c.



- a. If  $R_s$  is set to 3.850 kilohms for a balanced condition, what is the value of  $R_x$ ?

**3.850 kilohms**

- b. If the DC source is 10V at balance what current flows in the

(1)  $R_a$ - $R_s$  branch 0.42mA

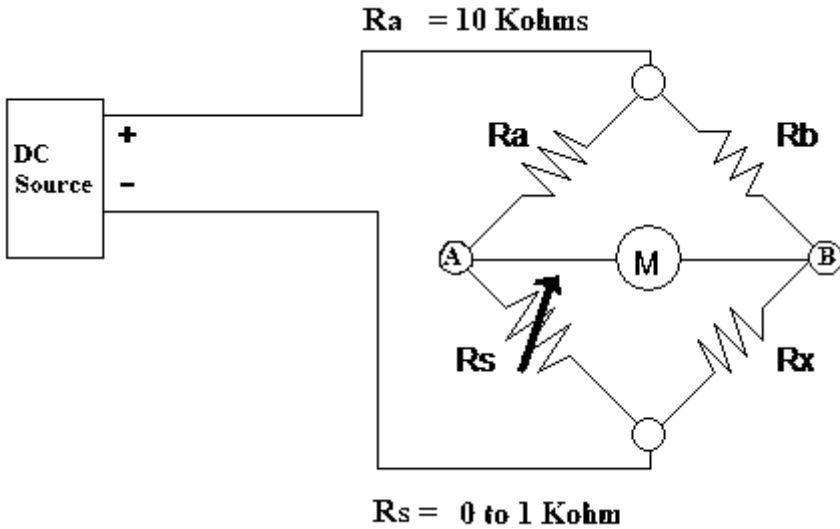
(2)  $R_b$ - $R_x$  branch 0.42mA

(3)  $A$ - $B$  branch 0.0mA

- c. What is the range (in ohms) that can be measured with this bridge?

**Approx: 0 ohms to 5000 ohms**

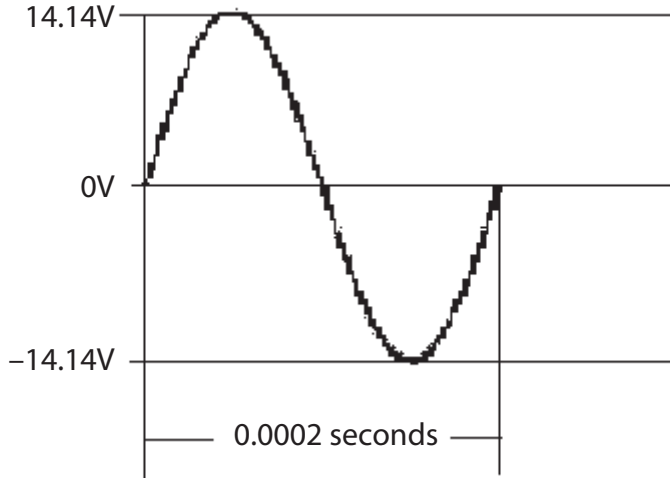
2. In the following figure determine the value of the multiplier resistor to measure resistance in the range of:



- 10 ohms to 1 kilohms 10 kilohms
- 5 kilohms to 10 kilohms 20 kilohms
- 0.1 megohm to 1 megohm 2 megohms
- 50 kilohms to 100 kilohms 200 kilohms
- 1–100 ohms 100 ohms

**CHAPTER 9**

1. Questions a–e refer to the following figure.



- a. What is the peak-to-peak amplitude of this signal? **28.28V**
  - b. What is the peak amplitude of this signal? **14.14V**
  - c. What is RMS value of this signal? **10.0V**
  - d. What is the period (in seconds) of this signal? **0.0002 sec**
  - e. What is the frequency of this signal? **5000Hz**
2. An AC signal has an effective value of 12.6V and a period of 16.67msec (.01667 sec).
    - a. What is the peak voltage? **17.8V**
    - b. What is the frequency? **60Hz (actually 59.98)**
  3. A sinusoidal AC signal has a peak-to-peak voltage of 35.6 volts and a frequency of 1kHz (1000Hz).
    - a. What is the peak voltage? **17.8V**
    - b. What is the effective voltage V? **12.6**
    - c. What is the period of one cycle? **0.001 sec**
  4. What is the peak instantaneous power dissipated by a 10-ohm resistor if 15 watts is dissipated by the effective value? **30 watts**

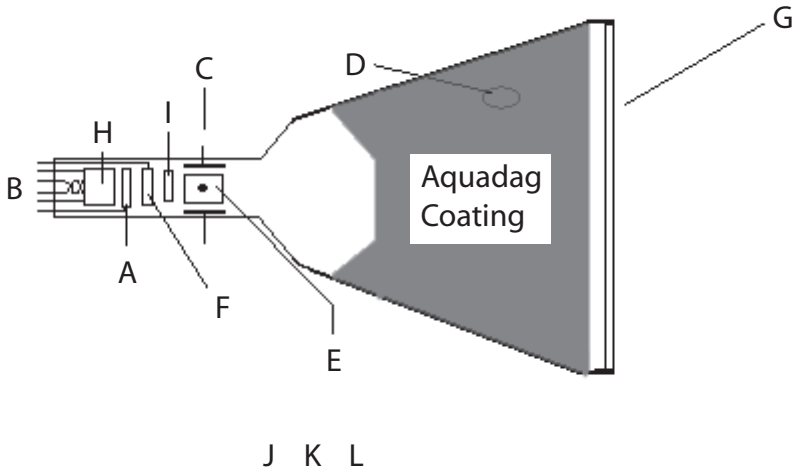
5. Voltage and current are \_\_\_\_\_ phase in a resistive circuit.
- in***
  - out of
  - neither of the above
6. You have observed a 100V peak-to-peak signal with a period of .000025 sec in a series circuit with a 47-ohm resistor. What is the:
- effective voltage ***35.35V***
  - frequency ***40kHz***
  - effective power dissipated ***26.59 watts***
  - peak power dissipated ***53.2 watts***

**CHAPTER 10**

1. List the steps for determining the output frequency of a function generator.
  - 1) **Select the range of frequency desired using the coarse (multiplier) switch(s).**
  - 2) **Dial in the desired frequency using the vernier dial.**
2. List the steps for calibrating the output of a signal generator.
  - 1) **Select wave-form (if a function generator; if not, start with step 2).**
  - 2) **Select coarse (multiplier) range.**
  - 3) **Select fine (vernier) to desired frequency.**
  - 4) **Set output level to minimum.**
  - 5) **Connect generator into circuit.**
  - 6) **Connect oscilloscope, with calibrated vertical channel, across generator output.**
  - 7) **Adjust output level control and attenuator (if any) to desired level.**
  - 8) **If frequency is changed, check output level and readjust if necessary.**

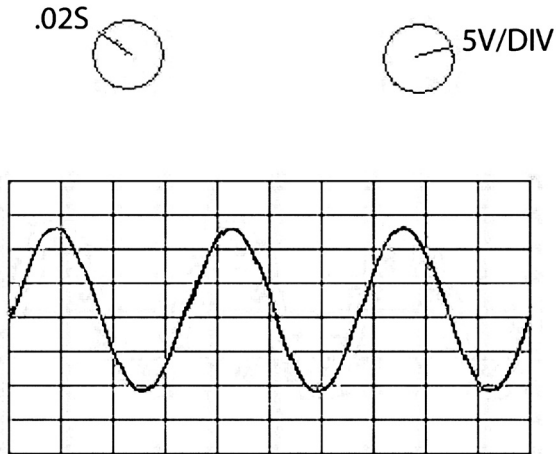
**CHAPTER 11**

1. Identify and label the parts of the CRT shown in the following figure that are identified by a letter.

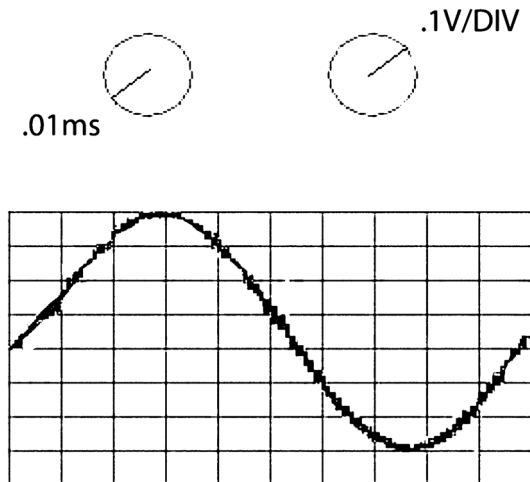


- a. Control grid
- b. Filament
- c. Vertical deflection plates
- d. Ultor
- e. Horizontal deflection plates
- f. Screen grid
- g. Phosphor screen
- h. Cathode
- i. Focus element

2. Given the signals on the graticules as illustrated in the following three figures, determine and list the approximate voltages and frequencies displayed.



- a. Peak-to-peak voltage Approximately 23V (4.6 divisions)
- b. Peak voltage Approximately 11.5V
- c. Frequency 14.7Hz (approx 3.7 div \* 5)

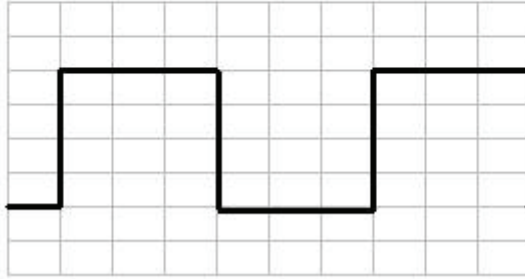


- a. Peak-to-peak voltage 0.7V
- b. Peak voltage 0.35V
- c. Frequency 10kHz

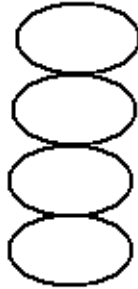
1V/DIV



2ms



- a. Peak-to-peak voltage **4V**
  - b. Frequency (repetition rate) **166.67Hz**
3. The standard frequency is 5kHz. Using the following figure, what is the unknown frequency?



**1250Hz (1/4 of 5kHz)**

**CHAPTER 12**

1. A capacitor has a value of  $.047 \mu\text{fd}$ . What is its value in pfd?  
**47000pfd**
2. A capacitor has a value of  $27000\text{pfd}$ . What is its value in  $\mu\text{fd}$ ?  
**0.027 $\mu\text{fd}$**
3. A capacitor has a value of  $.01 \mu\text{fd}$ . What is its value in pfd?  
**10000pfd**
4. A capacitor has a value of  $680\text{pfd}$ . What is its value in  $\mu\text{fd}$ ?  
**0.000680 $\mu\text{fd}$**
5. A capacitor has a value of  $.15 \mu\text{fd}$ . What is its value in pfd?  
**150000pfd**
6. A capacitor has a value of  $1000\text{pfd}$ . What is its value in  $\mu\text{fd}$ ?  
**0.001 $\mu\text{fd}$**
7. A capacitor has a value of  $10 \mu\text{fd}$ . What is its value in pfd?  
**10000000pfd**
8. A capacitor has a value of  $5600\text{pfd}$ . What is its value in  $\mu\text{fd}$ ?  
**0.0056 $\mu\text{fd}$**
9. A capacitor has a value of  $.001 \mu\text{fd}$ . What is its value in pfd?  
**1000pfd**
10. A capacitor has a value of  $91000\text{pfd}$ . What is its value in  $\mu\text{fd}$ ?  
**0.091 $\mu\text{fd}$**

11. Determine the time constant (TC) for the following values:
- 47 kilohms,  $15\mu\text{fd} = \underline{0.705\text{S}}$
  - 1.2 megohms,  $0.001\mu\text{fd} = \underline{1.2\text{S}}$
  - 1200 ohms,  $150\mu\text{fd} = \underline{0.18\text{S}}$
  - 2.2 megohms,  $2200\mu\text{fd} = \underline{4840 (1.344 \text{ HRS})}$
  - 390 kilohms,  $2200\text{pfd} = \underline{0.000848\text{S}}$
12. If a circuit has 450-kilohm resistance and  $.015\mu\text{fd}$  capacitance, how long will it take to fully charge this circuit from a 100-volt DC source? To fully discharge it?
13. Determine the  $X_C$  of the following capacitors at the given frequency.
- 100kHz,  $.015\mu\text{fd} = \underline{0.11 \text{ ohms}}$
  - 60Hz,  $2200\mu\text{fd} = \underline{1.21 \text{ ohms}}$
  - 1MHz,  $680\text{pfd} = \underline{234 \text{ ohms}}$
  - 25kHz,  $1.5\mu\text{fd} = \underline{4.2 \text{ ohms}}$
  - 300kHz,  $.002\mu\text{fd} = \underline{1590 \text{ ohms}}$
14. Determine the TC for the following RL circuits:
- 12H, 1.2 kilohms  $0.01\text{S}$
  - 1.5H, 10 ohms  $0.15\text{S}$
  - 7H, 25 ohms  $0.28\text{S}$
  - 450mH (milliHenry), 4.7 kilohms  $0.000957\text{S}$
  - 180mH (milliHenry), 120 ohms  $.0015\text{S}$
15. Determine  $X_L$  for the following values:
- 100Hz, 10H  $= \underline{6280 \text{ ohms}}$
  - 1kHz, 35mH  $= \underline{219.8 \text{ ohms}}$
  - 1Hz, 1H  $= \underline{6.28 \text{ ohms}}$
  - 30kHz, 400mH  $= \underline{75360 \text{ ohms}}$
16. Determine the resonant frequency for a  $1\text{-}\mu\text{fd}$  capacitor and a 0.10-H inductor.

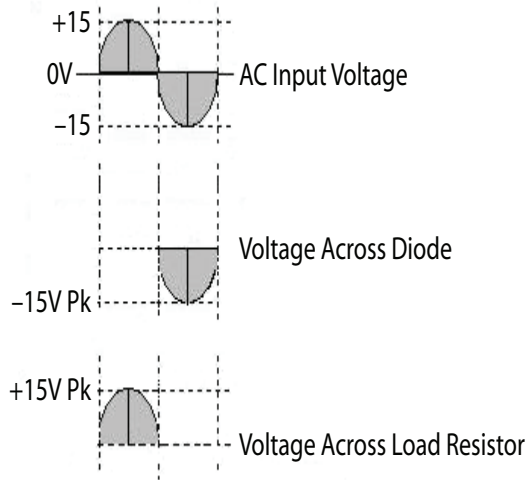
$$f_R = \frac{1}{2\pi\sqrt{LC}} \text{ so the answer is } 503.54 \text{ or } 504\text{Hz,}$$

where  $X_L$  and  $X_C$  are equal.

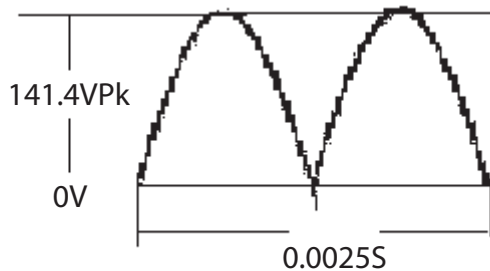
17. Determine the impedance of the following circuits at the frequency given:
  - a. 1kHz, 1H, 2 kilohms = 2001.6 ohms (note mostly R)
  - b. 12kHz, 0.15 $\mu$ fd, 3.3 kilohms = 3300.01 ohms (note all R)
  - c. 330kHz, 360pfd, 1mH, 5 kilohms = 5000.03 ohms (all R)
18. A transformer has a 1:25 turns ratio. Is it a ~~step-up~~ or step-down transformer?
19. A transformer with a 9.52:1 turns ratio has 220V AC applied to the primary, what is the secondary voltage? 23.1V
20. If a transformer primary has 1.5 amps at 120V AC and the secondary supplies 12.6V AC and draws 10 amps, what is the efficiency of the transformer at this level of secondary power? 70%
21. If the source impedance is 16 ohms, and the secondary requires 3.6 kilohms what turns ratio will satisfy the requirement? 1/15
22. Suppose the turns ratio = 25:1. if the source impedance equals 10 kilohms, what is the secondary impedance? 16 ohms; the turns ratio squared is the impedance ratio

## CHAPTER 13

- Using the following figure, draw the wave-forms that will be present across the resistor and the diode. Label these wave-forms with the voltage levels for each wave-form.



- Draw the output wave-form for a full-wave rectifier (without filter), assuming an input frequency of 400Hz at 100V RMS.



- In Problem 2, what is the average voltage? What is the peak voltage?

**90V average, 141 volts Pk**

## CHAPTER 14

1. When the emitter arrow points to the base it indicates this is what type of transistor?

**PNP**

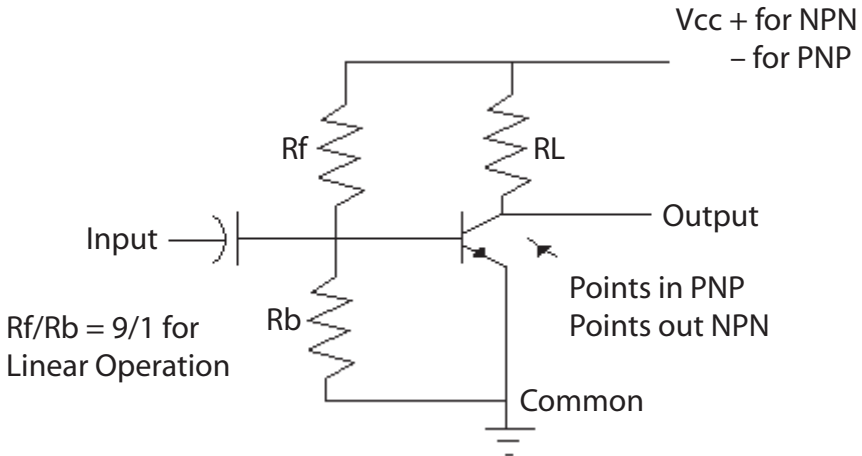
2. Which amplifier configuration has the highest power gain?

**Common emitter (CE)**

3. Does a switching transistor require a higher or lower heat dissipation rating than a transistor in linear operation, all other things equal?

**Lower**

4. Draw the self-biasing circuitry for the collector to base the biasing of an NPN and a PNP transistor.



5. What is the primary function of a bipolar transistor?

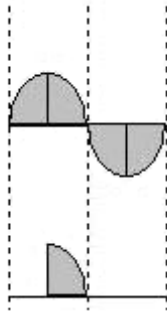
**To use a small current (emitter base) to control a much larger one (emitter collector).**

## CHAPTER 15

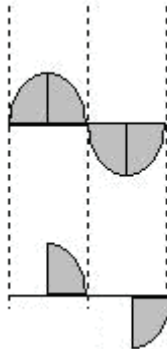
1. Suppose the voltage input to a Zener regulator circuit is 40V, the desired output is 12, the no-load current is 20mA, and the full-load current is 40mA. Using a Zener that will conduct 150mA at the nominal load current of 30mA, what is the value of the series resistor required? Hint: Remember that the Zener will conduct 160mA when the load current is at 20mA, and it will conduct 140mA when the load current is at 40mA—a total of 180mA.

**156 ohms**

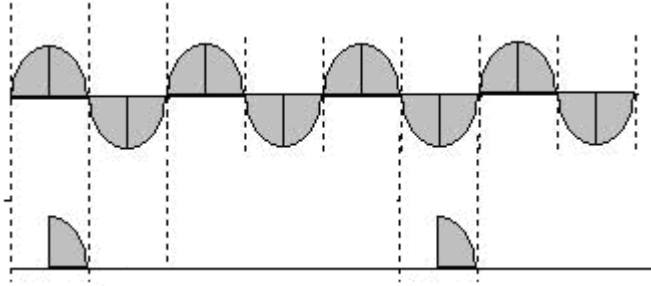
2. If the no-load voltage is 12.7V and the full-load voltage is 12.5V, what is the percent regulation? 1.5%
3. Draw the output wave-form of an SCR that is triggered on at the peak of its applied positive alternation.



4. Draw the output wave-form of a TRIAC that is triggered on at the peak of its applied alternations.



5. Draw the output wave-form of a SCR circuit using zero crossing that is fired every third alternation.



**CHAPTER 16**

1. Given an inverting op-amp circuit,  $R_{in} = 2.2K$ ,  $R_f = 6.8K$ . What is the gain of this circuit? **3.1**
2. Referring to the circuit in problem 1, a  $-100mV$  input change will cause what output voltage change? **+310mV**
3. Given an inverting op-amp circuit,  $R_{in} = 10K$ ,  $R_f = 4.7K$ . What is the gain of this circuit? **0.47**
4. If a voltage follower with  $\pm 15V$  as supply has  $+2V$  applied to the input what will the output be? **+2V**
5. For the circuit in Problem 4, if the input was  $+16V$  what would the output be?

**Approximately  $-14.3V$  (1 diode drop less  $-V_{cc}$ )**

6. When using a comparator, when is hysteresis necessary?

**For slow-changing signals**

7. How does the comparator differ from other op-amp circuits?

**It operates in a switch mode rather than linearly**

8. If you input a square wave to an integrator (of the appropriate frequency) what wave-form will the output have?

**Triangular wave-form**

9. If you input a square wave to a differentiator (of the appropriate frequency) what wave-form will the output have?

**A peaked wave-form**

10. An inverting summer has four inputs. Input 1 has  $-2.5V$ , Input 2 has  $+1V$ , Input 3 has  $+1.5V$ , and Input 4 has  $+0.5V$ . If the summer has a gain of 1, what will the output voltage be?

**+0.5V**

11. A noninverting amplifier has  $R_f = 5K$  and  $R_{in} = 10K$ . With  $V_{in}$  equal to 6 volts, what will the output be?

**9V (gain is  $1 + 0.5$  or 1.5)**

12. A source follower has an input impedance of 100K and an output impedance of 100 ohms. With +4 volts on the input, what voltage will be on the output?

**+4V**

13. Using an integrating circuit, you input a signal with a band of frequencies from 100Hz to 15KHz. Which end of the frequency band will be attenuated most?

**15kHz**

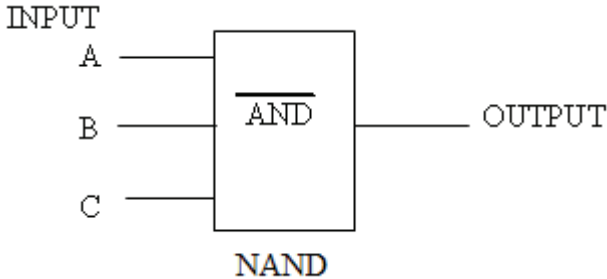
14. Using a differentiating circuit, you input a signal with a band of frequencies from 100Hz to 15KHz. Which end of the frequency band will be attenuated most?

**100Hz**

**CHAPTER 17**

1. In Circuit 1 Input A = 1, B = 0, C = 1. What is the output?

Circuit 1



**OUTPUT = 1**

2. If Circuit 1 were a NOR with the same inputs, what would the output be?

**OUTPUT = 0**

3. If Circuit 1 were an AND and Input A = 1, B = 1, C = 1, what would the output be?

**OUTPUT = 1**

4. If a shift-left register had the original value 00110010 and it was shifted twice, what would the decimal value of the original value and the resultant value be?

**Original = 50 Shifted = 200**

5. XOR these two patterns: 110001011011

**011000010111**

**101001001100**

6. Convert Hex F7 into a decimal value (Hint: convert Hex into binary pattern first).

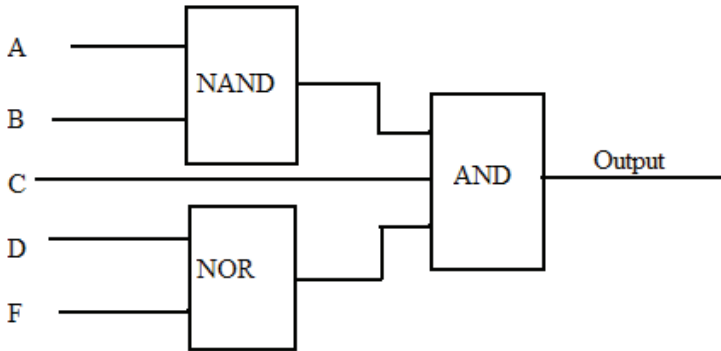
**247**

7. Convert Decimal 57 to Hex (HINT: determine the binary value of 57 first)

**39H**

8. In Circuit 2: A=0, B=1, C=1, D=0, F = 0. What is the output?

Circuit 2



**OUTPUT = 1**

**CHAPTER 18**

1. Using a 12-bit successive approximation converter, what should the output be (in 1s and 0s) if the input voltage range is 0 to 5V, and 2.5V is input:
  - a. Offset binary 1000 0000 0000
  - b. Twos complement 0000 0000 0000
2. If the digital signal in problem 1 is presented to a R-2R D-to-A what will the output be (with a 10-volt supply to the D-to-A)?

5.0V

3. If +0.0025V is presented to a 12-bit A-to-D, the output code will be:
  - a. in natural binary (0–10V range) 0000 0000 0001
  - b. in offset binary ( $\pm 5V$  range) 0000 0000 0001
  - c. in twos complement ( $\pm 5V$  range) 1000 0000 0001

*Hint:* Twelve bits means 4,096 divisions, so  $10V/4096 = 0.00244V$  for the LSB; .0025 volts is greater than 1LSB but less than 2LSBs.

**A**

accelerating anode	160	
accuracy	17	
equations for	21–23	
of meters	74–75	
addition	289	
air	181	
alternating current (AC)	137–138	
basic circuit	144	
power	146	
RMS energy	145–146	
sources	153–157	
values	144–145	
alternating current (AC) meters	219–225	
digital	224	
frequency of input signal	225	
full-wave	219–220	
half-wave	223–224	
wave-form of input signal	225	
<i>See also</i> current meters		
ammeters	115	
comparison calibration	116	
voltmeter-precision resistor		
calibration	117	
ampacity	207–208	
Ampère, André	6	
amperes	6	13
amplifiers	236–240	
characteristics	238	
differential	277–278	
inverting	268	
noninverting	268	
troubleshooting	239–240	
amplitude	137	

---

analog measurements	20
analog meters	72
accuracy	98
characteristics	76
mechanical reliability	99
Ohm's scale	75–76
parallax	99
sensitivity	99
<i>See also</i> digital meters	
analog voltmeters	81–83
accuracy	98
mechanical reliability	99
parallax	99
sensitivity	99
vs. digital voltmeters	98–99
<i>See also</i> voltmeters	
analog-to-digital conversions	314–323
calibration	322–323
comparison of	321
dual-slope	315–316
integrating	314–317
parallel	320–321
successive approximation	317–319
voltage to frequency	316
<i>See also</i> digital-to-analog conversions	
AND gate	282
anodes	160
armatures	327–328
arytron shunts	114–115
assumed-voltage method	109
audio frequency	149
AUTO sync selection	169
average	37–38

**B**

back voltage	197	
balanced-to-ground circuits	330–331	
bandwidth	267	
binary coded decimal	26–27	300
binary digits	289	
binary patterns	290–295	
conversion from hexadecimal		
numbers	303	
binary patterns (continued)		
conversion to hexadecimal		
numbers	302	
conversion to octals	28–29	
binary system	26–27	
binary coded decimal	300–301	
bipolar codes	308–309	
natural binary	306–307	
bipolar codes	308–309	
bipolar transistor	232–235	
bits	289	
blocking DC. See capacitors		
bobbins	72	
Bohr model	230	
branch currents	108	
bridges	125–134	
applications	133–134	
lead resistance	132–133	
mathematics	128–130	
multiplier resistors	130–132	
resistance	128	
sensitivity	128	
Wheatstone	125–128	
bytes	289	

**C**

calibration	116–119	
analog-to-digital conversions	322–323	
comparison	41	116
of generator output	157	
industrial application	117–119	
output	154–157	
voltmeter-precision resistor	117	
of voltmeters	95	
calibration curves	42–44	
capacitance	177–179	
measurement	193–194	
capacitive reactance	188–191	
capacitors	177–179	
dielectric	180	
electrolytic	180	
parallel	183	
series	183–184	
values	181	
working voltage	179–180	
cathode ray tube (CRT)	159–160	
central processing unit (CPU)	281	
Central Tendency Theorem	45	
charge	3	6
chattering	327	
chokes	199	
circuit diagrams	51–52	
coefficient of coupling	205	
coils	72	
combinational circuits	111–112	
combinational logic	286–287	
common collector	237–238	
common emitters	236–237	
common mode noise	330	

---

common-mode rejection ratio	267
comparators	272
comparison calibration	41 116
complement	292 308–309
conductance	7
conductors	4 207–208
contactors	327–328
control springs	73
cosmic Rays	149
coulombs	5
counter electromotive force	197
counters	288
crystal radio	216
current	6
and charges	3
checking	326
flow	229
forward	216
measurement of	53–54
current meters	105
assumed voltage method	109
combinational circuits	111–112
extended ranges	112–114
moving coil	105–106
multi-range	115
parallel circuits	107–109
properties	114
proportional method	110
reciprocal method	110
series resistors	107
shunts	114–115
current-activated devices	222

**D**

d'Arsonval meter	73	82
DC current meters	105	
assumed-voltage method	109	
combinational circuits	111–112	
extended ranges	112–114	
moving coil	105–106	
multi-range	115	
parallel circuits	107–109	
properties	114	
proportional method	110	
reciprocal method	110	
series resistors	107	
shunts	114–115	
<i>See also</i> current meters		
decimal system	26	299–300
decimal-to-hexadecimal conversion	303–306	
deflection circuitry	161–163	
deflection plates	160	
depletion-mode devices	243	
deviation	38–39	
dielectric capacitors	180	
dielectric materials	181	
differential amplifiers	277–278	
differentiators	275	
digital AC meters	224	
digital logic	281–295	
binary patterns	290–295	
combinational	286–287	
computational	289	
functions	281–286	
storage	287–288	
digital measurements	20	
digital meters	76–77	

---

accuracy	98	
block diagram	77	
mechanical reliability	99	
parallax	99	
sensitivity	99	
<i>See also</i> analog meters		
digital voltmeters	98–99	
AC portion	225	
accuracy	98	
mechanical reliability	99	
parallax	99	
<i>See also</i> voltmeters		
digital-to-analog conversions	309–313	
R-2R ladder method	310–312	
weighted-resistor networks	310	
<i>See also</i> analog-to-digital conversions		
diode AC switch (DIAC)	254	
diode protection	96	
diodes	215–216	232
discrete operational amplifiers	262–264	
dispersion	45	
division	295	
doping	230	
dual-slope A-to-D conversion	315–316	
dual-trace oscilloscopes	163–164	
duty cycles	240	

## E

effective value	142
electrical units	5–7
amperes	6
coulombs	5
joules	5

---

ohms	7	
watts	7	
electroluminescent displays	78	
electrolytic capacitors	180	
electromagnetic spectrum	149	
electromagnetic wave	147–148	
electromagnetism	139	
electromotive force	4	6
electron gun assembly	160	
emitter follower	237–238	
emitters	233–235	
energy	1	
enhancement mode devices	243	
errors	23	
gross	35	
linearity	43–44	
random	36	
span	42–43	
systematic	36	
zero	42	
exclusive OR gate	282–284	
EXT sync selection	169	
extended-range voltmeters	83–85	
extra high frequency (EHF)	149	

## F

Faraday, Michael	181	
field-effect transistors	241–244	
insulated gate	243–244	
junction	242	
fields	139–140	
five-band resistors	66	
flash conversion	320–321	
flip-flops	287	

---

forward bias	232	
forward current	216	
forward voltage drop	217	
frequency	142	
frequency-determining controls	153–154	
full scale	21	
full-scale deflection current	73–74	81–82
full-wave meters	219–220	
full-wave rectifiers	218–219	
function generators	153	157
gamma rays	149	
gates	281–285	

## G

Gaussian curve	40	
germanium diodes	96	
glass	181	
gross errors	23	35
ground	21	

## H

half-wave meters	223–224	
half-wave rectifiers	217	
hertz	138	
hexadecimal system	30–32	301–306
high frequency (HF)	149	
horizontal controls	167–168	
horizontal deflection circuits	162–163	

## I

impedances	202–203	209–210
inductance	195–197	
inductive kick	199	

---

inductive reactance	199
inductors	198–199
infrared	149
input bias current	267
input common-mode voltage range	267
input offset current	267
input resistance	267
input resistors	274
input signals, wave-forms of	225
insulated gate FETs	243–244
insulators	4
INT sync selection	169
integration	146
integrators	274–275
international standards	23
inverting amplifiers	268
isolation transformers	211–212

**J**

joules	5
junction field-effect transistors	242

**K**

Kelvin bridge	133
kilohms	13–14
kilovolts	11
kinetic energy	2
Kirchhoff's Law	52–53

**L**

lead resistance	132–133
least count	19–20
light-emitting diodes (LEDs)	77

---

LINE sync selection	169
linear operational amplifiers	266
linearity error	43–44
liquid crystal displays (LCDs)	78
Lissajous patterns	170–172
load regulation	249
longitudinal noise	330
loop source	326
loops	117–119
low frequency (LF)	149
lower-range value	20

**M**

magnetic field	197–198
magnetism	139
marking	180
mean	37–38      45
measurement uncertainty	45
measurements	51–67
circuit diagrams	51–52
of current	53–54
instruments	51
procedures	52–55
of resistance	54–55
of voltage	52–53
median	45
medium frequency (MF)	149
megohms	13–14
memory	288
metallic oxide semiconductor FET	
(MOSFETs)	241
meters	71–78
accuracy	74–75
analog	72

---

d'Arsonval	73
digital	76–77
electroluminescent displays	78
full-scale deflection current	73–74
light-emitting diodes (LEDs)	77
liquid crystal displays (LCDs)	78
Ohm's scale	75–76
overload protection	96
precautions	71–72
sensitivity	93–94
transit lock	97
mho	7
mica	181
microamps	13
microfarads	181
microvolts	11–12
milliamps	13
millivolts	11–12
Modulo-2 circuit	284
motor control circuits	329
moving coil meters	105–106
multimeters	96
multiplication	294
multiplier resistors	130–132
multi-range ammeters	115
multi-range voltmeters	86–87
mutual induction	204

**N**

NAND gate	285
nanofarads	181
natural binary	306–307
NEGATE function	284
negative charge	3

---

negative feedback	263
nibble	289
noninverting amplifiers	268
non-sinusoidal waveforms	157
NOR circuit	285
N-type materials	230–232
null	125
null meter	125
number systems	25–32
binary	26–27 300–301
decimal	26 299–300
hexadecimal	30–32 301–306
octal	28–29

## O

octal number system	28–29	300
octet	289	
offset binary	308	
Ohm, Georg	7	55
Ohm's Law	55–59	108
Ohm's scale	75–76	
ohms	5	7 10 13–14
operational amplifiers	261–278	
application	271	
assumptions	264	
comparators	272	
differential	277–278	
differentiators	275	
discrete	262–264	
integrators	274–275	
inverting	268	
linear	266	
noninverting	268	
operation	265	

---

output offset voltages	270–271
summer	276
terminology	266–267
voltage follower	269–270
operational transconductance	
amplifiers	264
operational voltage amplifiers	264
OR gate	281
oscilloscopes	159–172
applications	165
cathode ray tube (CRT)	159–160
controls	166
deflection circuitry	161–163
oscilloscopes (continued)	
deflection plates	160
dual-trace	163–164
electron gun assembly	160
features	164
horizontal controls	167–168
horizontal deflection	162–163
Lissajous patterns	170–172
phosphor screens	160–161
scaling switch controls	166
sweep controls	167–168
switch controls	167–168
sync controls	168–169
time/division controls	167–168
vertical channel controls	166–167
vertical deflection	161–162
vertical position controls	167
output calibration	154–157
output impedance	267
output offset voltages	270–271
overloads, protection from	96

**P**

paraffin paper	181	
parallax	99	
parallel capacitors	183	
parallel circuits	107–109	
parallel conversion	320–321	
parallel RCL circuits	203–204	
parallel resistors	274–275	
peak inverse voltage	217	247
peak voltage	142	
peak-to-peak voltage	142	
percent regulation	249	
period	138	142
persistence	160	
petroleum	181	
phase	142	
phenomena	147	
phosphor screens	160–161	
picofarads	181	
pinch-off point	242	
PN junction	229–232	
polarity	137	
positive charge	3	
potential	4	
potential energy	1–2	
potentiometer	60	
power	144	146
power resistor	60	
precision	17	
precision resistors	117	
prefixes	10–15	
pressure	2	
primary transformers	205	
programmable logic controllers	331–332	

---

proportional method 110  
 P-type materials 230–232

**Q**

quantum theory 230

**R**

R-2R ladder method 310–312  
 R-2R networks 310–312  
 ramps 162  
 random errors 23 36  
 range 20 36  
 range switches 168  
 ratio arms 125  
 RC circuits 184–187 191–193  
 RCL circuits 202  
 reactance  
   capacitive 188–191  
   inductive 199  
 reactive components 177  
   capacitance 177–179  
   capacitive reactance 188–191  
   dielectric 180  
   electrolytic capacitors 180  
   impedance 202–203  
   inductance 195–197  
   inductive reactance 199  
   inductors 198–199  
   magnetic field 197–198  
   parallel capacitors 183  
   parallel RCL circuits 203–204  
 RC circuits 184–187  
 RCL circuits 202

---

series capacitors	183–184
transformers	204–212
working voltage	179–180
reciprocal method	110
rectification	215–219
rectifiers	251–253
full-wave	218–219
half-wave	217
silicon-controlled	251–253
recurring errors	23
registers	287–288
repeatability	17
resistance	7
determination of	128
lead	132–133
measurement of	54–55
nominal	61
total	108
resistance thermometer device	133–134
resistors	59
five-band	66
input	274
multiplier	130–132
non-color code markings	67
parallel	274–275
precision	117
series	107
standard values	64–66
tolerance	61–66
types	59–60
values	60
resolution	18
resonance	202
resonant frequency	202
reverse bias	232

---

rheostat	60	
ripple frequency	218	
RMS energy	145–146	
root-mean-square (RMS) value	142	
<b>S</b>		
safety	8–9	
scaling circuits	162	
scaling switch controls	166	
ScopeMeters	166	168
screen	167	
secondary standards	23	
secondary transformers	205	
semiconductors	229–231	
sensitivity	93–94	
bridges	128	
meters	99	
series capacitors	183–184	
series pass regulator	249–250	
settling time	267	
shop standards	23	
shunts	105	114–115
signal generators	153	157
silicon diodes	96	
silicon-controlled devices	251–259	
diode AC switch (DIAC)	254	
silicon-controlled rectifiers (SCRs)	251–253	
silicon-controlled switch (SCS)	257	
triode AC switch (TRIAC)	254–256	
troubleshooting	258–259	
silicon-controlled switch (SCS)	257	
sine waves	140–142	220
slew rate	267	
solenoids	327–328	

---

solid-state devices	229–244	
amplifiers	236–240	
bipolar transistor	232–235	
field-effect transistors	241–244	
insulated gate FETs	243–244	
junction field-effect transistors	242	
PN junction	229–232	
source follower	269–270	
span	20	
span error	42–43	
square wave	226	
standard deviation	40–41	
standards	23–25	
static current transfer ratio	238	
sub audible frequency	149	
subtraction	292	
successive approximation	317–319	
summer	276	
super high frequency (SHF)	149	
superconductors	7	
sweep switches	168	
synapse	8	
sync selection switch	168–169	
synchronization	163	
systematic errors	23	36

## T

time/division controls	167–168	
tolerance	36	61–66
total resistance	108	
transfer resistor	232	
transformers	204–205	
coefficient of coupling	205	
impedance matching	209–210	

---

isolation	211–212
primary	205
secondary	205
turns ratio	206–207
transistors	232–235
application	240
field-effect	241–244
insulated gate FETs	243–244
junction field-effect	242
lead identification	235–236
transit lock	97
triode AC switch (TRIAC)	254–256
turns ratio	206–207
two-wire loop	325–326

**U**

ultra high frequency (UHF)	149
ultraviolet	149
unbalanced-to-ground circuits	329–330
uncertainty	46
unity gain bandwidth	267
universal shunts	114–115
upper-range value	20

**V**

vacuum	181
valence	230
vernier control	154
vertical channel controls	166–167
vertical deflection circuits	161–162
vertical position control	167
very high frequency (VHF)	149
very low frequency (VLF)	149

---

virtual ground	264			
visible light	149			
Volta, Alessandro	6			
voltage	9–10			
forward voltage drop	217			
measurement of	52–53			
output offset	270–271			
peak	142			
peak inverse	217	247		
peak-to-peak	142			
regulation	249			
working	179–180			
voltage follower	269–270			
voltage to frequency	316			
voltmeter-precision resistor	117			
voltmeters	81–99			
accuracy	98			
analog	81–83			
analog vs. digital	98–99			
calibration	95			
extended-range	83–85			
mechanical reliability	99			
multi-range	86–87			
parallax	99			
sensitivity	93–94	99		
volts	5	6	9	11–12

## W

water	181
water tower	2
water wheel	2
Watt, James	7
watts	7
wave length	148

wave-forms	137	
weighted-resistor networks	310	
Wheatstone bridge	125–128	
wires	4	
work	1	6
working standards	23	
working voltage	179–180	

**X**

XOR gate	282–284	
X-rays	149	

**Z**

Zener current	249–251	
Zener diodes	247	
zero	21	
zero error	42	
zero-crossing gate	254	